



Manual of Test Procedures for Materials



State of Illinois
Illinois Department of Transportation



Illinois Department
of Transportation

This Page Intentionally Left Blank

Manual of Test Procedures for Materials

Prepared and Published by
Illinois Department of Transportation
Central Bureau of Materials

Springfield, Illinois

December 1, 2021

This Page Intentionally Left Blank

Revision History and Document Control for December 1, 2021 Edition of *Manual of Test Procedures for Materials*

Per Departmental Policy MAT-13, it is the policy of the Department of Transportation to publish and maintain a manual that provides test procedures for quality control, quality assurance, and acceptance testing of aggregates, hot mix asphalt, Portland cement concrete, and soils. Test procedures for other materials may be included.

The Manual of Test Procedures for Materials will be reviewed annually by the Engineer of Concrete and Soils for adequacy and updated annually to reflect current test methods. Hard copy editions prior to January 1, 2015 are controlled. Archives are available from Policy Distribution. Current editions are available online.

Revisions to the documents listed below are denoted within by a vertical line in the left margin. Effective dates are as indicated on the individual documents and within the tables of contents.

Standard	Description of Revisions
Illinois Specification 201	Revised Fine Aggregate Gradation and Large Sized Aggregate Gradation Tables.
Illinois Test Procedure 2.	Removed. Refer to AASHTO R 90 (Illinois Modified).
Illinois Test Procedure 301	Revised various sections.
Illinois Test Procedure 302	Revised various sections.
Illinois Test Procedure 303	Revised various sections.
Illinois Test Procedure 306	Removed.
Illinois Test Procedure 307	Revised Section V.
ASTM C 1074	Revised Illinois Modified Section 2.1.
ASTM D 8159	Revised Illinois Modified Sections 2.1 and 7.2.1.
ASTM D 4791	Revised Illinois Modified Sections 2.1, 7.1 and 7.2.
ASTM D 5821	Revised various Illinois Modified Sections.
AASHTO T 11	Removed Illinois Test Procedure 11. Inserted AASHTO T 11 (Illinois Modified).
AASHTO T 19	Removed Illinois Test Procedure 19. Inserted AASHTO T 19 (Illinois Modified).
AASHTO T 22	Revised Illinois Modified Section 2.1.
AASHTO T 23	Removed. AASHTO T 100 replaced AASHTO T 23. Refer to AASHTO R 100 (Illinois Modified).
AASHTO T 27	Removed Illinois Test Procedure 27. Inserted AASHTO T 27 (Illinois Modified).
AASHTO T 30	Updated to new version. Revised Illinois Modified Sections 2.1 and A2.2.
AASHTO T 84	Removed Illinois Test Procedure 84. Inserted AASHTO T 84 (Illinois Modified).
AASHTO T 85	Removed Illinois Test Procedure 85. Inserted AASHTO T 85 (Illinois Modified).
AASHTO T 99	Updated to new version. Revised various Illinois Modified sections.
AASHTO T 119	Revised Illinois Modified Section 2.1.
AASHTO T 121	Revised Illinois Modified Section 2.1.
AASHTO T 134	Revised Illinois Modified Section 2.1.
AASHTO T 152	Revised Illinois Modified Section 2.1.
AASHTO T 164	Revised Illinois Modified Sections 2.1 and 2.4.
AASHTO T 166	Updated to new version.
AASHTO T 177	Updated to new version. Revised Illinois Modified Section 2.1.
AASHTO T 180	Updated to new version. Revised various Illinois Modified sections.

(continued)

**Revision History and Document Control for December 1, 2021 Edition of *Manual of Test Procedures for Materials*
(continued)**

Standard	Description of Revisions
AASHTO T 191	Revised Illinois Modified Section 2.1.
AASHTO T 196	Revised Illinois Modified Section 2.1.
AASHTO T 209	Updated to new version. Revised various Illinois Modified sections and added a new Illinois Modified section.
AASHTO T 231	Updated to new version.
AASHTO T 255	Removed Illinois Test Procedure 255. Inserted AASHTO T 255 (Illinois Modified).
AASHTO T 267	Revised Illinois Modified Sections 2.1 and 4.1.
AASHTO T 283	Updated to new version. Revised various Illinois Modified sections and added new Illinois Modified sections.
AASHTO T 287	Revised Illinois Modified Section 2.1.
AASHTO T 288	Revised Illinois Modified Sections 2.1 and 6.3.
AASHTO T 289	Revised Illinois Modified Sections 2.1 and 6.2.
AASHTO T 290	Revised Illinois Modified Sections 2.1 and 7.2.
AASHTO T 291	Revised Illinois Modified Sections 2.1 and 7.2.
AASHTO T 308	Updated to new version. Revised various Illinois Modified sections.
AASHTO T 310	Revised Illinois Modified Section 2.1.
AASHTO T 312	Revised Illinois Modified Sections 2.1 and 8.2.3.
AASHTO T 318	Revised Illinois Modified Section 2.1.
AASHTO T 324	Revised various Illinois Modified sections and added new Illinois Modified sections.
AASHTO T 325	Revised Illinois Modified Section 2.1.
AASHTO T 393	AASHTO T 393 replaced AASHTO TP 124.
AASHTO M 323	Updated to new version. Revised various Illinois Modified sections.
AASHTO M 325	Updated to new version. Revised Illinois Modified Section 2.1.
AASHTO R 30	Revised various Illinois Modified sections.
AASHTO R 35	Updated to new version. Revised Illinois Modified Section "All Sections".
AASHTO R 39	Revised Illinois Modified Section 2.1.
AASHTO R 46	Revised Illinois Modified Section 2.1.
AASHTO R 76	AASHTO R 76 replaced AASHTO T 248. Refer to AASHTO R 76 (Illinois Modified).
AASHTO R 90	AASHTO R 90 replaced AASHTO T 2. Refer to AASHTO R 90 (Illinois Modified).
AASHTO R 100	AASHTO R 100 replaced AASHTO T 23. Refer to AASHTO R 100 (Illinois Modified).
AASHTO TP 124	Discontinued. AASHTO T 393 replaced AASHTO TP 124. Refer to AASHTO T 393 (Illinois Modified).
Illinois Test Procedure SCC-1	Revised Section III.
Illinois Test Procedure SCC-6	Revised various sections.
Illinois Test Procedure SCC-8	Revised various sections.
Illinois Provisional Test Procedure SCC-9	Revised various sections.
Illinois Test Procedure 601	Revised various sections.
Appendix A.1	Revised Sections A and D.
Appendix A.2	Revised various sections.
Appendix B.1	Revised extensively.
Appendix B.2	Revised extensively.

**Revision History and Document Control for December 1, 2021 Edition of *Manual of Test Procedures for Materials*
(continued)**

Standard	Description of Revisions
Appendix B.3	Revised extensively.
Appendix B.4	Revised extensively.
Appendix B.5	Revised extensively.
Appendix B.6	Revised extensively.
Appendix B.7	Revised extensively.
Appendix B.8	Revised various sections.
Appendix B.9	Revised extensively.
Appendix B.10	Discontinued.
Appendix B.11	Revised extensively.
Appendix B.13	Revised various sections.
Appendix B.14	Revised extensively.
Appendix B.20	Revised various sections.
Appendix B.23	Revised extensively.
Appendix B.25	Revised various sections.
Appendix B.27	Revised extensively.
Appendix B.28	New Appendix.
Appendix C.3	Revised "Making Strength Specimens (Cylinders or Beams)" section.
Appendix D.1	Removed. Refer to IDOT Website.
Appendix D.4	Revised extensively.
Appendix D.5	Revised extensively.
Appendix D.7	Updated to new version. Revised Illinois Modified Section.
Appendix D.8	Revised Illinois Modified Section 2.1.
Appendix D.9	Revised address.
Appendix E.1	Revised extensively.
Appendix E.2	Revised various sections.
Appendix E.3	Revised extensively.
Appendix E.4	Revised extensively.
Appendix E.5	Revised extensively.
Appendix E.6	Revised extensively.
Appendix E.7	Revised extensively.
Appendix E.8	New Appendix.

This Page Reserved

SEQUENTIAL TABLE OF CONTENTS

MANUAL OF TEST PROCEDURES FOR MATERIALS

Standard	Description	Page
Illinois Specification 201 (Effective 12/01/21)	Aggregate Gradation Sample Size Table	1
Illinois Test Procedure 2	See AASHTO R 90 (Illinois Modified)	
Illinois Test Procedure 11	See AASHTO T 11 (Illinois Modified)	
Illinois Test Procedure 19	See AASHTO T 19 (Illinois Modified)	
Illinois Test Procedure 27	See AASHTO T 27 (Illinois Modified)	
Illinois Test Procedure 84	See AASHTO T 84 (Illinois Modified)	
Illinois Test Procedure 85	See AASHTO T 85 (Illinois Modified)	
Illinois Test Procedure 202 (Effective 05/01/07) (Revised 12/01/17)	Leachate Determination in Crushed Slag Samples.....	5
Illinois Test Procedure 248	See AASHTO R 76 (Illinois Modified)	
Illinois Test Procedure 255	See AASHTO T 255 (Illinois Modified)	
Illinois Test Procedure 301 (Effective 12/01/21)	Fine Aggregate Moisture Content by Flask Method.....	7
Illinois Test Procedure 302 (Effective 12/01/21)	Aggregate Specific Gravity and Moisture Content by Dunagan Method	13
Illinois Test Procedure 303 (Effective 12/01/21)	Fine or Coarse Aggregate Moisture Content by Pycnometer Jar Method	21
Illinois Test Procedure 304 (Effective 03/01/13)	Pull-off Test (Surface Method)	25
Illinois Test Procedure 305 (Effective 03/01/13)	Pull-off Test (Overlay Method)	29
Illinois Test Procedure 307 (Effective 12/01/21)	Sampling and Testing of Controlled Low-Strength Material (CLSM).....	33

SEQUENTIAL TABLE OF CONTENTS
(continued)
MANUAL OF TEST PROCEDURES
FOR MATERIALS

<i>Standard</i>	<i>Description</i>	<i>Page</i>
Illinois Test Procedure 501 (formerly 401) (Effective 04/01/10) (Revised 01/01/17)	Dynamic Cone Penetration (DCP).....	35
Illinois Test Procedure 502 (formerly 402) (Effective 04/01/10) (Revised 01/01/17)	Static Cone Penetration (SCP).....	41
Illinois Test Procedure 4791	See ASTM D 4791 (Illinois Modified)	
Illinois Test Procedure 5821	See ASTM D 5821 (Illinois Modified)	
ASTM C 1064/C 1064M-12 (Illinois Modified 02/01/14)	Temperature of Freshly Mixed Portland Cement Concrete.....	45
ASTM C 1074-19 (Illinois Modified 12/01/21)	Estimating Concrete Strength by the Maturity Method	47
ASTM C 1231/C 1231M-15 (Illinois Modified 12/01/17)	Use of Unbonded Caps in Determination of Compressive Strength of Hardened Concrete Cylinders.....	49
ASTM D 2950-14 (Illinois Modified 01/01/17)	Determination of Density of Bituminous Concrete in Place by Nuclear Methods (Density Modified)	53
ASTM D 8159-18 (Illinois Modified 12/01/21)	Automated Extraction of Asphalt Binder from Asphalt Mixtures	59
ASTM D 4791-19 (Illinois Modified 12/01/21)	Flat Particles, Elongated Particles, or Flat and Elongated Particles in Coarse Aggregate.....	63
ASTM D 5821-13 (2017) (Illinois Modified 12/01/21)	Determining the Percentage of fractured Particles in Coarse Aggregate.....	67
ASTM E 29-13 (2019) (Illinois Modified 12/01/19)	Using Significant Digits in Test Data to Determine Conformance with Specifications ...	71
ASTM D 1188-07 (2015) (Illinois Modified 01/01/17)	Standard Test Method for Bulk Specific Gravity and Density of Compacted Bituminous Mixtures Using Coated Samples	51

SEQUENTIAL TABLE OF CONTENTS
(continued)
MANUAL OF TEST PROCEDURES
FOR MATERIALS

<i>Standard</i>	<i>Description</i>	<i>Page</i>
AASHTO T 2	See AASHTO R 90 (Illinois Modified)	
AASHTO T 11-20 (Illinois Modified 12/01/21)	Materials Finer Than 75- μ m (No. 200) Sieve in Mineral Aggregates by Washing	73
AASHTO T 19/T 19M-14 (2018) (Illinois Modified 12/01/21)	Bulk Density ("Unit Weight") and Voids in Aggregate	77
AASHTO T 22-20 (Illinois Modified 12/01/21)	Compressive Strength of Cylindrical Concrete Specimens	81
AASHTO T 23	See AASHTO R 100 (Illinois Modified)	
AASHTO T 24-M/T 24-15 (2019) (Illinois Modified 12/01/19)	Obtaining and Testing Drilled Cores and Sawed Beams of Concrete	85
AASHTO T 27-20 (Illinois Modified 12/01/21)	Sieve Analysis of Fine and Coarse Aggregates	87
AASHTO T 30-19 (Illinois Modified 12/01/21)	Mechanical Analysis of Extracted Aggregate ..	91
AASHTO T 84-13 (2021) (Illinois Modified 12/01/21)	Specific Gravity and Absorption of Fine Aggregate	93
AASHTO T 85-21 (Illinois Modified 12/01/21)	Specific Gravity and Absorption of Coarse Aggregate	99
AASHTO T 99-21 (Illinois Modified 12/01/21)	Moisture - Density Relations of Soils Using a 2.5-kg (5.5-lb) Rammer and a 305-mm (12-in.) Drop	105
AASHTO T 119M/T 119-18 (Illinois Modified 12/01/21)	Slump of Hydraulic Cement Concrete	111
AASHTO T 121M/T 121-19 (Illinois Modified 12/01/21)	Density (Unit Weight), Yield, and Air Content (Gravimetric) of Concrete	113
AASHTO T 134-19 (Illinois Modified 12/01/21)	Moisture-Density Relations of Soil-Cement Mixtures	115

SEQUENTIAL TABLE OF CONTENTS
(continued)
MANUAL OF TEST PROCEDURES
FOR MATERIALS

<i>Standard</i>	<i>Description</i>	<i>Page</i>
AASHTO T 141	See AASHTO R 60 (Illinois Modified)	117
AASHTO T 152-19 (Illinois Modified 12/01/21)	Air Content of Freshly Mixed Concrete by the Pressure Method	119
AASHTO T 164-14 (2018) (Illinois Modified 12/01/21)	Quantitative Extraction of Asphalt Binder from Hot Mix Asphalt (HMA)	123
AASHTO T 166-21 (Illinois Modified 12/01/21)	Bulk Specific Gravity (G_{mb}) of Compacted Asphalt Mixtures Using Saturated Surface-Dry Specimens	127
AASHTO T 177-17 (2021) (Illinois Modified 12/01/21)	Flexural Strength of Concrete (Using Simple Beam with Center Point Loading)	129
AASHTO T 180-21 (Illinois Modified 12/01/21)	Moisture-Density Relations of Soils Using a 4.54-kg (10-lb) Rammer and a 457-mm (18-in.) Drop ..	131
AASHTO T 191-14 (2018) (Illinois Modified 12/01/21)	Density of Soil In-Place by the Sand-Cone Method	137
AASHTO T 196M/T 196-11 (2019) (Illinois Modified 12/01/21)	Air Content of Freshly Mixed Concrete by the Volumetric Method	139
AASHTO T 209-20 (Illinois Modified 12/01/21)	Theoretical Maximum Specific Gravity (G_{mm}) and Density of Asphalt Mixtures	141
AASHTO T 217-14 (2018) (Illinois Modified 12/01/19)	Determination of Moisture in Soils by Means of a Calcium Carbide Gas Pressure Moisture Tester ..	143
AASHTO T 224	Discontinued. See AASHTO T 99 (Illinois Modified and AASHTO T 180 (Illinois Modified) ..	145

SEQUENTIAL TABLE OF CONTENTS
(continued)
MANUAL OF TEST PROCEDURES
FOR MATERIALS

<i>Standard</i>	<i>Description</i>	<i>Page</i>
AASHTO T 231-17 (2021) (Illinois Modified 12/01/21)	Capping Cylindrical Concrete Specimens	147
AASHTO T 245-15 (2019) (Illinois Modified 12/01/19)	Resistance to Plastic Flow of Asphalt Mixtures Using Marshall Apparatus	149
AASHTO T 248	See AASHTO R 76 (Illinois Modified)	
AASHTO T 255-00 (2021) (Illinois Modified 12/01/21)	Total Evaporable Moisture Content of Aggregate by Drying	151
AASHTO T 265-15 (2019) (Illinois Modified 12/01/19)	Laboratory Determination of Moisture Content of Soils	153
AASHTO T 267-86 (2018) (Illinois Modified 12/01/21)	Determination of Organic Content in Soils by Loss on Ignition	155
AASHTO T 272-18 (Illinois Modified 12/01/18)	One Point Method for Determining Maximum Dry Density and Optimum Moisture	159
AASHTO T 283-21 (Illinois Modified 12/01/21)	Resistance of Compacted Bituminous Mixture to Moisture Induced Damage	163
AASHTO T 287-20 (Illinois Modified 12/01/21)	Asphalt Binder Content of Asphalt Mixtures by the Nuclear Method (Bituminous Concrete QC/QA document)	171
AASHTO T 288-12 (2021) (Illinois Modified 12/01/21)	Determining Minimum Laboratory Soil Resistivity	177
AASHTO T 289-91 (2018) (Illinois Modified 12/01/21)	Determining pH of Soil for Use in corrosion Testing.	181
AASHTO T 290-95 (2020) (Illinois Modified 12/01/21)	Determining Water-Soluble Sulfate Ion Content in Soil	183
AASHTO T 291-94 (2018) (Illinois Modified 12/01/21)	Determining Water-Soluble Chloride Ion Content in Soil	191
AASHTO T 305-09	Determination of Draindown Characteristics in Uncompacted Asphalt Mixtures	199

SEQUENTIAL TABLE OF CONTENTS
(continued)
MANUAL OF TEST PROCEDURES
FOR MATERIALS

<i>Standard</i>	<i>Description</i>	<i>Page</i>
AASHTO T 308-21 (Illinois Modified 12/01/21)	Determining the Asphalt Binder Content of Asphalt Mixtures by the Ignition Method	201
AASHTO T 309M/T 309	See ASTM C 1064/C 1064 M (Illinois Modified)	
AASHTO T 310-19 (Illinois Modified 12/01/21)	In-Place Density and Moisture Content of Soil and Soil-Aggregate by Nuclear Methods (Shallow Depth)	207
AASHTO T 312-19 (Illinois Modified 12/01/21)	Preparing and Determining the Density of Asphalt Mixture Specimens by Means of the Superpave Gyratory Compactor	213
AASHTO T 318-15 (2019) (Illinois Modified 12/01/21)	Water Content of Freshly Mixed Concrete Using Microwave Oven Drying.....	219
AASHTO T 324-19 (Illinois Modified 12/01/21)	Hamburg Wheel-Track Testing of Compacted Hot Mix Asphalt (HMA).....	225
AASHTO T 325-04 (2020) (Illinois Modified 12/01/21)	Estimating the Strength of Concrete in Transportation Construction by Maturity Tests.....	231
AASHTO T 383-18 (Illinois Modified 12/01/21)	Evaluation of Asphalt Release Agents (ARAs).....	233
AASHTO T 393-21 (formerly TP 124) (Illinois Modified 12/01/21)	Determining the Fracture Potential of Asphalt Mixtures Using the Illinois Flexibility Index Test (I-FIT)	237
AASHTO M 323-17 (2021) (formerly MP 2-99) (Illinois Modified 12/01/21)	Superpave Volumetric Mix Design	241
AASHTO M 325-08 (2021) (formerly MP 8-01) (Illinois Modified 12/01/21)	Stone Matrix Asphalt (SMA).....	247
AASHTO R 30-02 (2019) (formerly PP 2-99) (Illinois Modified 12/01/21)	Mixture Conditioning of Hot-Mix Asphalt (HMA).....	251
AASHTO R 35-17 (2021) (formerly PP 28-99) (Illinois Modified 12/01/21)	Superpave Volumetric Design for Asphalt Mixtures .	257

SEQUENTIAL TABLE OF CONTENTS
(continued)
MANUAL OF TEST PROCEDURES
FOR MATERIALS

<i>Standard</i>	<i>Description</i>	<i>Page</i>
AASHTO R 39-19 (formerly T 126) (Illinois Modified 12/01/21)	Making and Curing Concrete Test Specimens in the Laboratory	261
AASHTO R 46-08 (2021) (formerly PP 41-01) (Illinois Modified 12/01/20)	Designing Stone Matrix Asphalt (SMA)	263
AASHTO R 60-12 (2020) (formerly T 141) (Illinois Modified 12/01/20)	Sampling Freshly Mixed Concrete	265
AASHTO R 75-16 (2020) (Illinois Modified 12/01/20)	Developing a Family of Curves	267
AASHTO R 76-16 (2020) (formerly T 248) (Illinois Modified 12/01/21)	Reducing Samples of Aggregate to Testing Size	269
AASHTO R 90-18 (formerly T 2) (Illinois Modified 12/01/21)	Sampling of Aggregates	273
AASHTO R 100-21 (formerly T 23) (Illinois Modified 12/01/21)	Making and Curing Concrete Test Specimens in the Field.....	277
AASHTO TP 124 (Replaces ITP 405)	See AASHTO T 393 (Illinois Modified)	281
AASHTO PP 86-17 (Illinois Modified 11/15/19)	Emulsified Asphalt Content of Cold Recycled Mixture Designs	283

SEQUENTIAL TABLE OF CONTENTS
(continued)
MANUAL OF TEST PROCEDURES
FOR MATERIALS

<i>Standard</i>	<i>Description</i>	<i>Page</i>
Self-Consolidating Concrete Provisional Test Methods		
Illinois Test Procedure SCC-1 (Effective 12/01/21)	Sampling, Determining Yield and Air Content, and Making and Curing Strength Test Specimens of Self-Consolidating Concrete	285
Illinois Test Procedure SCC-2 (Effective 04/01/08)	Slump Flow and Stability of Self-Consolidating Concrete	287
Illinois Test Procedure SCC-3 (Effective 05/01/07)	Passing Ability of Self-Consolidating Concrete by J-Ring and Slump Cone	293
Illinois Test Procedure SCC-4 (Effective 03/01/05)	Passing Ability of Self-Consolidating Concrete by L-Box	295
Illinois Test Procedure SCC-6 (Effective 12/01/21)	Static Segregation of Hardened Self-Consolidating Concrete Cylinders	297
Illinois Test Procedure SCC-8 (Effective 01/01/08) (Revised 12/01/21)	Assessment of Dynamic Segregation of Self-Consolidating Concrete During Placement.....	301
Illinois Provisional Test Procedure SCC-9 (Effective 12/01/21)	Dynamic Segregation of Fresh Self-Consolidating Concrete by Flow Trough.....	303
Illinois Test Procedure SCC-10 (Effective 01/01/16)	Determining Formwork Pressure of Fresh Self-Consolidating Concrete Using Pressure Transducers.....	305
Internally Cured Concrete Test Methods		
Illinois Test Procedure ICC-1 (Effective 01/01/16)	Specific Gravity and Absorption of Lightweight Aggregate for Internally Curing Concrete.....	309

SEQUENTIAL TABLE OF CONTENTS
(continued)
MANUAL OF TEST PROCEDURES
FOR MATERIALS

<i>Standard</i>	<i>Description</i>	<i>Page</i>
Illinois Flexibility Index Test (I-FIT)		
Illinois Test Procedure 405	See AASHTO T 393 (Illinois Modified)	317
Chemical Test Methods		
Illinois Test Procedure 601 (Effective 09/01/21)	ATR-FTIR Spectroscopy and Comparison Method ..	319
Pavement Tests		
Illinois Test Procedure 701 (Effective 01/01/21)	Ride Quality Testing Using the International Roughness Index.....	323
Illinois Test Procedure 702 (Effective 01/01/21)	Ride Quality Testing Using a Straight Edge	327
Illinois Test Procedure 703 (Effective 01/01/21)	Mean Roughness Index (MRI) Analysis in ProVAL ..	329
Illinois Test Procedure 704 (Effective 01/01/21)	Rolling Straightedge Simulation in ProVAL	341
 A—Aggregate		
APPENDICES: IDOT POLICIES, PROCEDURES, AND SPECIFICATIONS FOR QUALITY CONTROL/QUALITY ASSURANCE (QC/QA) AND LABORATORIES AND EQUIPMENT		
Appendix A.1 (Effective 01/01/94) (Revised 12/01/21)	Development of Gradation Bands on Incoming Aggregate at Hot-Mix Asphalt and Portland Cement Concrete Plants (prior HMA QC/QA stand-alone document).....	A.1
Appendix A.2 (Effective 11/01/95) (Revised 12/01/21)	Quality Control (QC) Manager / Aggregate Technician / AGCS Technician / Mixture Aggregate Technician / IDOT Inspector / Gradation Technician Responsibilities (Chapter 7, Aggregate Technician Course Manual) (formerly Appendix A.3)	A.3

SEQUENTIAL TABLE OF CONTENTS
(continued)
MANUAL OF TEST PROCEDURES
FOR MATERIALS

Standard	Description	Page
Appendix A.3 (Effective 11/01/95) (Revised 12/01/17)	Aggregate Producer Control Chart Procedure (Chapter 9, Aggregate Technician Course Manual) (formerly Appendix A.4)	A.9
Appendix A.5 (Effective 11/10/97) (Revised 06/01/12)	Guideline for Sample Comparison (formerly Appendix A.7)	A.17
B—Hot Mix Asphalt (HMA)		
Appendix B.1 (Effective 05/01/93) (Revised 12/01/21)	Model Annual Quality Control (QC) Plan for Hot-Mix Asphalt (HMA) Production	B.1
Appendix B.2 (Effective 07/01/95) (Revised 12/01/21)	Model Quality Control (QC) Addendum for Hot-Mix Asphalt (HMA) Production	B.9
Appendix B.3 (Effective 05/01/01) (Revised 12/01/21)	Procedure for Correlating Nuclear Gauge Densities with Core Densities for Hot-Mix Asphalt	B.11
Appendix B.4 (Effective 05/01/93) (Revised 12/01/21)	Hot-Mix Asphalt Concrete QC/QA Start-Up Procedures	B.17
Appendix B.5 (Effective 05/01/93) (Revised 12/01/21)	Hot-Mix Asphalt QC/QA QC Personnel Responsibilities and Duties Checklist	B.21
Appendix B.6 (Effective 05/01/93) (Revised 12/01/21)	Hot-Mix Asphalt QC/QA Initial Daily Plant and Random Samples	B.31
Appendix B.7 (Effective 05/01/93) (Revised 12/01/21)	Hot-Mix Asphalt QC/QA Procedure for Determining Random Density Locations	B.43
Appendix B.8 (Effective 05/01/93) (Revised 12/01/21)	Hot-Mix Asphalt QC/QA Control Charts	B.45
Appendix B.9 (Effective 01/01/02) (Revised 12/01/21)	Hot-Mix Asphalt Mixture Design Verification Procedure.....	B.49

SEQUENTIAL TABLE OF CONTENTS
(continued)
MANUAL OF TEST PROCEDURES
FOR MATERIALS

Standard	Description	Page
Appendix B.10	Discontinued	B.57
Appendix B.11 (Effective 01/01/02) (Revised 12/01/21)	Calibration of Equipment for Asphalt Binder Determination (Nuclear Asphalt Binder Content Gauge and Ignition Oven).....	B.59
Appendix B.12 (Effective 01/01/98) (Revised 12/01/17)	Hot-Mix Asphalt Mix Design Procedure for Dust Correction Factor Determination	B.63
Appendix B.13 (Effective 01/01/02) (Revised 12/01/21)	Calibration of the Ignition Oven for the Purpose of Characterizing Reclaimed Asphalt Pavements (RAP)	B.71
Appendix B.14 (Effective 01/01/02) (Revised 12/01/21)	Hot-Mix Asphalt Composite Sample Blending and Splitting Diagram	B.75
Appendix B.15 (Effective 05/01/04) (Revised 05/01/07)	Hot-Mix Asphalt (HMA) Production Gradation Windage Procedure for Minus #200 (minus 75 μ m) Material.....	B.79
Appendix B.16 (Effective 11/20/03) (Revised 01/01/14)	Stripping of Hot-Mix Asphalt Mixtures Visual Identification and Classification	B.81
Appendix B.17 (Effective 03/07/05) (Revised 12/01/20)	Procedure for Introducing Additives to Hot Mix Asphalt Mixtures and Testing in the Lab	B.85
Appendix B.18 (Effective 05/01/05) (Revised 05/01/07)	Ignition Oven Aggregate Mass Loss Procedure	B.99
Appendix B.19 (Effective 05/01/05) (Revised 01/01/17)	Quick Reference Guides and Procedure for Internal Angle Calibration of Superpave Gyratory Compactors (SGC) Using the Dynamic Angle Validator (DAV-2)	B.101
Appendix B.20 (Effective 12/01/21)	Segregation Control of Hot-Mix Asphalt.....	B.107
Appendix B.21 (Effective 05/01/07) (Revised 12/01/19)	Determination of Aggregate Bulk (Dry) Specific Gravity (Gsb) of Reclaimed Asphalt Pavement (RAP) and Reclaimed Asphalt Shingles (RAS)	B.109

SEQUENTIAL TABLE OF CONTENTS
(continued)
MANUAL OF TEST PROCEDURES
FOR MATERIALS

Standard	Description	Page
Appendix B.22 (Effective 01/31/08) (Revised 12/01/19)	Use of Correction Factors for Adjusting the Gradation of Cores to Estimate the Gradation of the In-Place Pavement	B.123
Appendix B.23 (Effective 04/01/10) (Revised 12/01/21)	Off-Site Preliminary Test Strip and Modified Start-Up Procedures.....	B.125
Appendix B.24 (Effective 03/01/13)	Determination of Residual Asphalt in Prime and Tack Coat Materials.....	B.129
Appendix B.25 (Effective 01/01/16) (Revised 12/01/21)	Procedure for Field Permeability Testing of Hot-Mix Asphalt Pavements	B.131
Appendix B.26 (Effective 08/22/19)	Illinois Test Procedure 406, Asphalt Binder Film Thickness of Ultra Thin Bonded Wearing Course (UBWC)	B.135
Appendix B.27 (Effective 12/01/19) (Revised 12/01/21)	Hot-Mix Asphalt Production Inspection Checklist	B.139
Appendix B.28 (Effective 08/22/19)	Hot-Mix Asphalt Rounding Test Values.....	B.145

C—Portland Cement Concrete (PCC)

Appendix C.1 (Effective 12/01/93) (Revised 12/01/17)	Model Quality Control Plan for Concrete Production	C.1
Appendix C.2 (Effective 12/01/93) (Revised 01/01/14)	Qualifications and Duties of Concrete Quality Control Personnel.....	C.15
Appendix C.3 (Effective 12/01/93) (Revised 12/01/21)	Required Sampling and Testing Equipment for Concrete.....	C.21
Appendix C.4 (Effective 12/01/93) (Revised 11/01/17)	Method for Obtaining Random Samples of Concrete.....	C.27

SEQUENTIAL TABLE OF CONTENTS
(continued)
MANUAL OF TEST PROCEDURES
FOR MATERIALS

<i>Standard</i>	<i>Description</i>	<i>Page</i>
Appendix C.5 (Effective 04/01/10) (Revised 12/01/17)	IDOT Concrete Quality Control and Quality Assurance Documents.....	C.31
Appendix C.6 (Effective 06/01/19)	PCC Production Inspection Checklist	C.33

D—Laboratories and Equipment

Refer to IDOT Website (Effective 02/09/18)	Policy Memorandum 6-08.3, Minimum Private Laboratory Requirements for Construction Materials Testing or Mix Design Private Laboratories (formerly Appendix D.2)	
Appendix D.3 (Effective 10/01/95) (Revised 12/01/20)	Aggregate Laboratory Equipment	D.1
Appendix D.4 (Effective 04/01/97) (Revised 12/01/21)	Hot-Mix Asphalt Concrete QC/QA Laboratory Equipment	D.3
Appendix D.5 (Effective 04/01/99) (Revised 12/01/21)	Illinois Specification 101, Minimum Requirements for Electronic Balances	D.9
Appendix D.6 (formerly AASHTO M 92) ASTM E11-17	Wire-Cloth Sieves for Testing Purposes	D.11
Appendix D.7 AASHTO M 201-21 (Illinois Modified 12/01/21)	Mixing Rooms, Moist Cabinets, Moist Rooms, and Water Storage Tanks Used in the Testing of Hydraulic Cements and Concretes	D.13
Appendix D.8 AASHTO M 205-11 (2019) (Illinois Modified 12/01/21)	Molds for Forming Concrete Test Cylinders Vertically	D.15
Appendix D.9 AASHTO R 18-18	Establishing and Implementing a Quality System for Construction Materials Testing Laboratories	D.17

SEQUENTIAL TABLE OF CONTENTS
 (continued)
MANUAL OF TEST PROCEDURES
FOR MATERIALS

<i>Standard</i>	<i>Description</i>	<i>Page</i>
E – End Result Specification		
Appendix E.1 (Effective 04/01/10) (Revised 12/01/21)	PFP Quality Level Analysis.....	E.1
Appendix E.2 (Effective 05/01/08) (Revised 12/01/21)	PFP Hot-Mix Asphalt Random Plant Samples	E.13
Appendix E.3 (Effective 04/01/10) (Revised 12/01/21)	PFP and QCP Random Density Procedure	E.17
Appendix E.4 (Effective 04/01/11) (Revised 12/01/21)	PFP and QCP Hot Mix Asphalt Random Jobsite Sampling	E.31
Appendix E.5 (Effective 04/01/10) (Revised 12/01/21)	Hot Mix Asphalt PFP Dispute Resolution	E.43
Appendix E.6 (Effective 01/01/12) (Revised 12/01/21)	QCP Pay Calculation	E.49
Appendix E.7 (Effective 04/01/12) (Revised 12/01/21)	Best Practices for PFP and QCP Implementation	E.57
Appendix E.8 (Effective 12/01/21)	Hot-Mix Asphalt PFP and QCP Calculations of Monetary Deductions.....	E.61

CATEGORICAL TABLE OF CONTENTS

MANUAL OF TEST PROCEDURES FOR MATERIALS

<u>Standard</u>	<u>Description</u>	<u>Page</u>
AGGREGATE		
Illinois Specification 201 (Effective 12/01/21)	Aggregate Gradation Sample Size Table.....	1
Illinois Test Procedure 202 (Effective 05/01/07) (Revised 12/01/17)	Leachate Determination in Crushed Slag Samples	5
ASTM D 4791-19 (Illinois Modified 12/01/21)	Flat Particles, Elongated Particles, or Flat and Elongated Particles in Coarse Aggregate	63
ASTM D 5821-13 (2017) (Illinois Modified 12/01/21)	Determining the Percentage of Fractured Particles in Coarse and Fine Aggregate.....	67
AASHTO T 2	See AASHTO R 90 (Illinois Modified)	
AASHTO T 11-20 (Illinois Modified 12/01/21)	Materials Finer Than 75- μ m (No. 200) Sieve in Mineral Aggregates by Washing	73
AASHTO T 19/T 19M-14 (2018) (Illinois Modified 12/01/21)	Unit Weight and Voids in Aggregate	77
AASHTO T 27-20 (Illinois Modified 12/01/21)	Sieve Analysis of Fine and Coarse Aggregates .	87
AASHTO T 84-13 (2021) (Illinois Modified 12/01/21)	Specific Gravity and Absorption of Fine Aggregate.....	93
AASHTO T 85-21 (Illinois Modified 12/01/21)	Specific Gravity and Absorption of Coarse Aggregate.....	99
AASHTO T 248	See AASHTO R 76 (Illinois Modified)	
AASHTO T 255-00 (2021) (Illinois Modified 12/01/21)	Total Moisture Content of Aggregate by Drying .	151
AASHTO R 76-16 (2020) (Illinois Modified 12/01/21)	Reducing Samples of Aggregate to Testing Size	269
AASHTO R 90-18 (Illinois Modified 12/01/21)	Sampling Aggregate Products	273

CATEGORICAL TABLE OF CONTENTS
 (continued)
MANUAL OF TEST PROCEDURES
FOR MATERIALS

<u>Standard</u>	<u>Description</u>	<u>Page</u>
	Aggregate QC/QA Policies and Procedures	
Appendix A.1 (Effective 01/01/94) (Revised 12/01/21)	Development of Gradation Bands on Incoming Aggregate at Mix Plants (prior HMA QC/QA stand-alone document)	A.1
Appendix A.2 (Effective 11/01/95) (Revised 12/01/21)	Quality Control (QC) Manager / Aggregate Technician / AGCS Technician / Mixture Aggregate Technician / IDOT Inspector / Gradation Technician Responsibilities (Chapter 7, Aggregate Technician Course Manual) (formerly Appendix A.3)	A.3
Appendix A.3 (Effective 11/01/95) (Revised 12/01/17)	Aggregate Producer Control Chart Procedure (Chapter 9, Aggregate Technician Course Manual) (formerly Appendix A.4)	A.9
Appendix A.5 (Effective 11/10/97) (Revised 06/01/12)	Guideline for Sample Comparison (formerly Appendix A.7)	A.17
	Aggregate Laboratories and Equipment	
Appendix D.3 (Effective 10/01/95) (Revised 12/01/20)	Aggregate Laboratory Equipment.....	D.1
Appendix D.6 (formerly AASHTO M 92) ASTM E 11-17	Wire-Cloth Sieves for Testing Purposes.....	D.11

CATEGORICAL TABLE OF CONTENTS
(continued)
MANUAL OF TEST PROCEDURES
FOR MATERIALS

<u>Standard</u>	<u>Description</u>	<u>Page</u>
HOT-MIX ASPHALT (HMA)		
ASTM D 1188-07 (2015) (Illinois Modified 01/01/17)	Standard Test Method for Bulk Specific Gravity and Density of Compacted Bituminous Mixtures Using Coated Samples	51
ASTM D 2950-14 (Illinois Modified 01/01/17)	Determination of Density of Bituminous Concrete in Place by Nuclear Methods (Density Modified)	53
ASTM D 8159-18 (Illinois Modified 12/01/21)	Automated Extraction of Asphalt Binder from Asphalt Mixtures	59
AASHTO T 30-21 (Illinois Modified 12/01/21)	Mechanical Analysis of Extracted Aggregate	91
AASHTO T 164-14 (2018) (Illinois Modified 12/01/21)	Quantitative Extraction of Asphalt Binder from Hot Mix Asphalt (HMA).....	123
AASHTO T 166-21 (Illinois Modified 12/01/21)	Bulk Specific Gravity (Gmb) of Compacted Asphalt Mixtures Using Saturated Surface-Dry Specimens.	127
AASHTO T 209-20 (Illinois Modified 12/01/21)	Theoretical Maximum Specific Gravity (Gmm) and Density of Asphalt Mixtures.....	141
AASHTO T 245-15 (2019) (Illinois Modified 12/01/19)	Resistance to Plastic Flow of Asphalt Mixtures Using Marshall Apparatus.....	149
AASHTO T 283-21 (Illinois Modified 12/01/21)	Resistance of Compacted Bituminous Mixture to Moisture Induced Damage	163
AASHTO T 287-20 (Illinois Modified 12/01/21)	Asphalt Binder Content of Asphalt Mixtures by the Nuclear Method (<u>Bituminous Concrete QC/QA document</u>).....	171
AASHTO T 305-09	Determination of Draindown Characteristics in Uncompacted Asphalt Mixtures.....	199
AASHTO T 308-21 (Illinois Modified 12/01/21)	Determining the Asphalt Binder Content of Asphalt Mixtures by the Ignition Method.....	201

CATEGORICAL TABLE OF CONTENTS
(continued)
MANUAL OF TEST PROCEDURES
FOR MATERIALS

<u>Standard</u>	<u>Description</u>	<u>Page</u>
AASHTO T 312-19 (Illinois Modified 12/01/21)	Preparing and Determining the Density of Asphalt Mixture Specimens by Means of the Superpave Gyrotory Compactor.....	213
AASHTO T 324-19 (Illinois Modified 12/01/21)	Hamburg Wheel-Track Testing of Compacted Hot Mix Asphalt (HMA)	225
AASHTO T 383-18 (Illinois Modified 12/01/21)	Evaluation of Asphalt Release Agents (ARAs)	233
AASHTO T 393-21 (formerly TP 124) (Illinois Modified 12/01/21)	Determining the Fracture Potential of Asphalt Mixtures Using the Illinois Flexibility Index Test (I-FIT).....	237
AASHTO M 323-17 (2021) (formerly MP 2-99) (Illinois Modified 12/01/21)	Superpave Volumetric Mix Design	241
AASHTO M 325-08 (2021) (formerly MP 8-01) (Illinois Modified 12/01/21)	Stone Matrix Asphalt (SMA)	247
AASHTO R 30-02 (2019) (formerly PP 2-99) (Illinois Modified 12/01/21)	Mixture Conditioning of Hot-Mix Asphalt (HMA)	251
AASHTO R 35-17 (2021) (formerly PP 28-99) (Illinois Modified 12/01/21)	Superpave Volumetric Design for Asphalt Mixtures	257
AASHTO R 46-08 (2021) (formerly PP 41-01) (Illinois Modified 12/01/21)	Designing Stone Matrix Asphalt (SMA)	263
AASHTO TP 124 (Replaces ITP 405)	See AASHTO T 393 (Illinois Modified)	281
AASHTO PP 86-17 (Illinois Modified 11/15/19)	Emulsified Asphalt Content of Cold Recycled Mixture Designs	283
Illinois Flexibility Index Test (I-FIT)		
Illinois Test Procedure 405	See AASHTO T 393 (Illinois Modified)	317

CATEGORICAL TABLE OF CONTENTS
(continued)
MANUAL OF TEST PROCEDURES
FOR MATERIALS

<u>Standard</u>	<u>Description</u>	<u>Page</u>
	HMA QC/QA Policies and Procedures	
Appendix B.1 (Effective 05/01/93) (Revised 12/01/21)	Model Annual Quality Control (QC) Plan for Hot-Mix Asphalt (HMA) Production	B.1
Appendix B.2 (Effective 07/01/95) (Revised 12/01/21)	Model Quality Control (QC) Addendum for Hot-Mix Asphalt (HMA) Production	B.9
Appendix B.3 (Effective 05/01/01) (Revised 12/01/21)	Procedure for Correlating Nuclear Gauge Densities with Core Densities for Hot-Mix Asphalt .	B.11
Appendix B.4 (Effective 05/01/93) (Revised 12/01/21)	Hot-Mix Asphalt Test Strip Procedures	B.17
Appendix B.5 (Effective 05/01/93) (Revised 12/01/21)	Hot-Mix Asphalt Concrete QC/QA QC Personnel Responsibilities and Duties Checklist.....	B.21
Appendix B.6 (Effective 05/01/93) (Revised 12/01/21)	Hot-Mix Asphalt Concrete QC/QA Initial Daily Plant and Random Samples	B.31
Appendix B.7 (Effective 05/01/93) (Revised 12/01/21)	Hot-Mix Asphalt QC/QA Procedure for Determining Random Density Locations	B.43
Appendix B.8 (Effective 05/01/93) (Revised 12/01/21)	Hot-Mix Asphalt QC/QA Control Charts	B.45
Appendix B.9 (Effective 01/01/02) (Revised 12/01/21)	Hot-Mix Asphalt Mixture Design Verification Procedure.....	B.49
Appendix B.10	Discontinued	B.57
Appendix B.11 (Effective 01/01/02) (Revised 12/01/21)	Calibration of Equipment for Asphalt Binder Determination (Nuclear Asphalt Binder Content Gauge and Ignition Oven).....	B.59

CATEGORICAL TABLE OF CONTENTS
(continued)
MANUAL OF TEST PROCEDURES
FOR MATERIALS

<u>Standard</u>	<u>Description</u>	<u>Page</u>
Appendix B.12 (Effective 01/01/98) (Revised 12/01/17)	Hot-Mix Asphalt Concrete Mix Design Procedure for Dust Correction Factor Determination.....	B.63
Appendix B.13 (Effective 01/01/02) (Revised 12/01/21)	Calibration of the Ignition Oven for the Purpose of Characterizing Reclaimed Asphalt Pavements (RAP).....	B.71
Appendix B.14 (Effective 01/01/02) (Revised 12/01/21)	Hot-Mix Asphalt Composite Sample Blending and Splitting Diagram	B.75
Appendix B.15 (Effective 05/01/04) (Revised 05/01/07)	Hot-Mix Asphalt (HMA) Production Gradation Windage Procedure for Minus #200 (minus 75 µm) Material.....	B.79
Appendix B.16 (Effective 11/20/03) (Revised 01/01/14)	Stripping of Hot-Mix Asphalt Mixtures Visual Identification and Classification	B.81
Appendix B.17 (Effective 03/07/05) (Revised 12/01/20)	Procedure for Introducing Additives to Hot Mix Asphalt Mixtures and Testing in the Lab ...	B.85
Appendix B.18 (Effective 05/01/05) (Revised 05/01/07)	Ignition Oven Aggregate Mass Loss Procedure	B.99
Appendix B.19 (Effective 05/01/05) (Revised 01/01/17)	Quick Reference Guides and Procedure for Internal Angle Calibration of Superpave Gyratory Compactors (SGC) Using the Dynamic Angle Validator (DAV-2)	B.101
Appendix B.20 (Effective 12/01/21)	Segregation Control of Hot-Mix Asphalt.....	B.107
Appendix B.21 (Effective 05/01/07) (Revised 12/01/19)	Determination of Aggregate Bulk (Dry) Specific Gravity (Gsb) of Reclaimed Asphalt Pavement (RAP) and Reclaimed Asphalt Shingles (RAS)	B.109

CATEGORICAL TABLE OF CONTENTS
(continued)
MANUAL OF TEST PROCEDURES
FOR MATERIALS

<u>Standard</u>	<u>Description</u>	<u>Page</u>
Appendix B.22 (Effective 01/31/08) (Revised 12/01/19)	Use of Correction Factors for Adjusting the Gradation of Cores to Estimate the Gradation of the In-Place Pavement	B.123
Appendix B.23 (Effective 04/01/10) (Revised 12/01/21)	Off-Site Preliminary Test Strip and Modified Start-Up Procedure	B.125
Appendix B.24 (Effective 03/01/13)	Determination of Residual Asphalt in Prime and Tack Coat Materials	B.129
Appendix B.25 (Effective 01/01/16) (Revised 12/01/21)	Procedure for Field Permeability Testing of Hot-Mix Asphalt Pavements.....	B.131
Appendix B.26 (Effective 08/22/19)	Illinois Test Procedure 406, Asphalt Binder Film Thickness of Ultra Thin Bonded Wearing Course (UBWC).....	B.135
Appendix B.27 (Effective 12/01/19) (Revised 12/01/21)	Hot-Mix Asphalt Production Inspection Checklist	B.139
Appendix B.28 (Effective 12/01/21)	Hot-Mix Asphalt Rounding Test Values.....	B.145
HMA Laboratories and Equipment		
Appendix D.4 (Effective 04/01/97) (Revised 12/01/21)	Hot-Mix Asphalt Laboratory Equipment.....	D.3
HMA End Result Specifications		
Appendix E.1 (Effective 04/01/10) (Revised 12/01/21)	Hot-Mix Asphalt PFP Pay Adjustments	E.1
Appendix E.2 (Effective 05/01/08) (Revised 12/01/21)	Hot-Mix Asphalt PFP and QCP Random Plant Samples.....	E.13

CATEGORICAL TABLE OF CONTENTS
(continued)
MANUAL OF TEST PROCEDURES
FOR MATERIALS

<u>Standard</u>	<u>Description</u>	<u>Page</u>
Appendix E.3 (Effective 04/01/10) (Revised 12/01/21)	Hot-Mix Asphalt PFP and QCP Procedures for Determining Random Density Locations	E.17
Appendix E.4 (Effective 04/01/11) (Revised 12/01/21)	Hot-Mix Asphalt PFP and QCP Random Jobsite Sampling.....	E.31
Appendix E.5 (Effective 04/01/10) (Revised 12/01/21)	Hot Mix Asphalt PFP Dispute Resolution	E.43
Appendix E.6 (Effective 01/01/12) (Revised 12/01/21)	Hot-Mix Asphalt QCP Pay Adjustments.....	E.49
Appendix E.7 (Effective 04/01/12) (Revised 12/01/21)	Best Practices for Hot-Mix Asphalt PFP and QCP..	E.57
Appendix E. 8 (Effective 12/01/21)	Hot-Mix Asphalt PFP and QCP Calculations of Monetary Deductions	E.61
PORTLAND CEMENT CONCRETE (PCC)		
Illinois Test Procedure 301 (Effective 12/01/21)	Fine Aggregate Moisture Content by Flask Method.....	7
Illinois Test Procedure 302 (Effective 12/01/21)	Aggregate Specific Gravity and Moisture Content by Dunagan Method.....	13
Illinois Test Procedure 303 (Effective 12/01/21)	Fine or Coarse Aggregate Moisture Content by Pycnometer Jar Method	21
Illinois Test Procedure 304 (Effective 03/01/13)	Pull-off Test (Surface Method)	25
Illinois Test Procedure 305 (Effective 03/01/13)	Pull-off Test (Overlay Method)	29
Illinois Test Procedure 307 (Effective 12/01/21)	Sampling and Testing of Controlled Low-Strength Material.....	33

CATEGORICAL TABLE OF CONTENTS
(continued)
MANUAL OF TEST PROCEDURES
FOR MATERIALS

<u>Standard</u>	<u>Description</u>	<u>Page</u>
ASTM C 1064/C 1064M-12 (Illinois Modified 02/01/14)	Temperature of Freshly Mixed Portland Cement Concrete	45
ASTM C 1074-19 (Illinois Modified 12/01/21)	Estimating Concrete Strength by the Maturity Method	47
ASTM C 1231/C 1231M-15 (Illinois Modified 12/01/17)	Use of Unbonded Caps in Determination of Compressive Strength of Hardened Concrete Cylinders.....	49
AASHTO T 22-20 (Illinois Modified 12/01/21)	Compressive Strength of Cylindrical Concrete Specimens.....	81
AASHTO T 23	See AASHTO R 100 (Illinois Modified)	83
AASHTO T 24M/T 24-15 (2019) (Illinois Modified 12/01/19)	Obtaining and Testing Drilled Cores and Sawed Beams of Concrete	85
AASHTO T 119M/T 119-18 (Illinois Modified 12/01/21)	Slump of Hydraulic Cement Concrete	111
AASHTO T 121M/T 121-19 (Illinois Modified 12/01/21)	Density (Unit Weight), Yield, and Air Content (Gravimetric) of Concrete.....	113
AASHTO T 141	See AASHTO R 60 (Illinois Modified)	117
AASHTO T 152-19 (Illinois Modified 12/01/21)	Air Content of Freshly Mixed Concrete by the Pressure Method.....	119
AASHTO T 177-17 (2021) (Illinois Modified 12/01/21)	Flexural Strength of Concrete (Using Simple Beam with Center Point Loading).....	129
AASHTO T 196M/T 196-11 (2019) (Illinois Modified 12/01/21)	Air Content of Freshly Mixed Concrete by the Volumetric Method	139
AASHTO T 231-17 (2021) (Illinois Modified 12/01/21)	Capping Cylindrical Concrete Specimens	147
AASHTO T 309M/T 309	See ASTM C 1064/C 1064M (Illinois Modified)	205

CATEGORICAL TABLE OF CONTENTS
(continued)
MANUAL OF TEST PROCEDURES
FOR MATERIALS

<u>Standard</u>	<u>Description</u>	<u>Page</u>
AASHTO T 318-15 (2019) (Illinois Modified 12/01/21)	Water Content of Freshly Mixed Concrete Using Microwave Oven Drying.....	219
AASHTO T 325-04 (2020) (Effective 12/01/21)	Estimating the Strength of Concrete in Transportation Construction by Maturity Tests...	231
AASHTO R 39-19 (formerly T 126) (Illinois Modified 12/01/21)	Making and Curing Concrete Test Specimens in the Laboratory	261
AASHTO R 60-12 (2020) (formerly T 141) (Illinois Modified 12/01/20)	Sampling Freshly Mixed Concrete	307
AASHTO R 100-21 (formerly T 23) (Illinois Modified 12/01/21)	Making and Curing Concrete Test Specimens in the Field	277

Self-Consolidating Concrete Provisional Test Methods

Illinois Test Procedure SCC-1 (Effective 12/01/21)	Sampling, Determining Yield and Air Content, and Making and Curing Strength Test Specimens of Self-Consolidating Concrete.....	285
Illinois Test Procedure SCC-2 (Effective 04/01/08)	Slump Flow and Stability of Self-Consolidating Concrete.....	287
Illinois Test Procedure SCC-3 (Effective 05/01/07)	Passing Ability of Self-Consolidating Concrete by J-Ring and Slump Cone.....	293
Illinois Test Procedure SCC-4 (Effective 03/01/05)	Passing Ability of Self-Consolidating Concrete by L-Box.....	295
Illinois Test Procedure SCC-6 (Effective 12/01/21)	Static Segregation of Hardened Self-Consolidating Concrete Cylinders.....	297
Illinois Test Procedure SCC-8 (Effective 12/01/21)	Assessment of Dynamic Segregation of Self-Consolidating Concrete During Placement	301
Illinois Provisional Test Procedure SCC-9 (Effective 12/01/21)	Dynamic Segregation of Fresh Self-Consolidating Concrete by Flow Trough.....	303
Illinois Test Procedure SCC-10 (Effective 01/01/16)	Determining Formwork Pressure of Fresh Self-Consolidating Concrete Using Pressure Transducers	305

CATEGORICAL TABLE OF CONTENTS
(continued)
MANUAL OF TEST PROCEDURES
FOR MATERIALS

<u>Standard</u>	<u>Description</u>	<u>Page</u>
Internally Cured Concrete Test Methods		
Illinois Test Procedure ICC-1 (Effective 01/01/16)	Specific Gravity and Absorption of Lightweight Aggregate for Internally Curing Concrete	309
PCC QC/QA Policies and Procedures		
Appendix C.1 (Effective 12/01/93) (Revised 12/01/17)	Model Quality Control Plan for Concrete Production.....	C.1
Appendix C.2 (Effective 12/01/93) (Revised 01/01/14)	Qualifications and Duties of Concrete Quality Control Personnel	C.15
Appendix C.3 (Effective 12/01/93) (Revised 12/01/21)	Required Sampling and Testing Equipment for Concrete	C.21
Appendix C.4 (Effective 12/01/93) (Revised 11/01/17)	Method for Obtaining random Samples of Concrete	C.27
Appendix C.5 (Effective 04/01/10) (Revised 12/01/17)	IDOT Concrete Quality Control and Quality Assurance Documents	C.31
Appendix C.6 (Effective 12/01/19)	PCC Production Inspection Checklist.....	C.33
PCC Laboratories and Equipment		
Appendix D.7 AASHTO M 201-21 (Illinois Modified 12/01/21)	Mixing Rooms, Moist Cabinets, Moist Rooms, and Water Storage Tanks Used in the Testing of Hydraulic Cements and Concrete.....	D.13
Appendix D.8 AASHTO M 205-11 (2019) (Illinois Modified 12/01/21)	Molds for Forming Concrete Test Cylinders Vertically	D.15

CATEGORICAL TABLE OF CONTENTS
(continued)
MANUAL OF TEST PROCEDURES
FOR MATERIALS

<u>Standard</u>	<u>Description</u>	<u>Page</u>
SOILS		
Illinois Test Procedure 501 (formerly 401) (Effective 04/01/10) (Revised 01/01/17)	Dynamic Cone Penetration (DCP).....	35
Illinois Test Procedure 502 (formerly 402) (Effective 04/01/10) (Revised 01/01/17)	Static Cone Penetration (SCP).....	41
AASHTO T 99-21 (Illinois Modified 12/01/21)	Moisture-Density Relations of Soils Using a 2.5-kg (5.5-lb) Rammer and a 305-mm (12-in.) Drop	105
AASHTO T 134-19 (Illinois Modified 12/01/21)	Moisture-Density Relations of Soil-Cement Mixtures	115
AASHTO T 180-21 (Illinois Modified 12/01/21)	Moisture-Density Relations of Soils Using a 4.54- kg (10-lb) Rammer and a 457-mm (18-in.) Drop.....	131
AASHTO T 191-14 (2018) (Illinois Modified 12/01/21)	Density of Soil In-Place by the Sand-Cone Method	137
AASHTO T 217-14 (2018) (Illinois Modified 12/01/19)	Determination of Moisture in Soils by Means of a Calcium Carbide Gas Pressure Moisture Tester	143
AASHTO T 224	Discontinued. See AASHTO T 99 (Illinois Modified and AASHTO T 180 (Illinois Modified))	145
AASHTO T 265-15 (2019) (Illinois Modified 12/01/19)	Laboratory Determination of Moisture Content of Soils.....	153
AASHTO T 267-86 (2018) (Illinois Modified 12/01/21)	Determination of Organic Content in Soils by Loss on Ignition	155
AASHTO T 272-18 (Illinois Modified 12/01/18)	One-Point Method for Determining Maximum Dry Density and Optimum Moisture	159
AASHTO T 288-12 (2021) (Illinois Modified 12/01/21)	Determining Minimum Laboratory Soil Resistivity...	177

CATEGORICAL TABLE OF CONTENTS
(continued)
MANUAL OF TEST PROCEDURES
FOR MATERIALS

<u>Standard</u>	<u>Description</u>	<u>Page</u>
AASHTO T 289-91 (2018) (Illinois Modified 12/01/21)	Determining pH of Soil for Use in Corrosion Testing.....	181
AASHTO T 290-95 (2020) (Illinois Modified 12/01/21)	Determining Water-Soluble Sulfate Ion Content in Soil.....	183
AASHTO T 291-94 (2018) (Illinois Modified 12/01/21)	Determining Water-Soluble Chloride Ion Content in Soil.....	191
AASHTO T 310-19 (Illinois Modified 12/01/21)	In-Place Density and Moisture Content of Soil and Soil-Aggregate by Nuclear Methods (Shallow Depth)	207
AASHTO R 75-16 (2020) (Illinois Modified 12/01/20)	Developing a Family of Curves	267
CHEMICAL TEST METHODS		
Illinois Test Procedure 601 (Effective 09/01/21)	ATR-FTIR Spectroscopy and Comparison Method	319
PAVEMENT TESTS		
Illinois Test Procedure 701 (Effective 01/01/21)	Ride Quality Testing Using the International Roughness Index.....	323
Illinois Test Procedure 702 (Effective 01/01/21)	Ride Quality Testing Using a Straight Edge	327
Illinois Test Procedure 703 (Effective 01/01/21)	Mean Roughness Index (MRI) Analysis in ProVAL	329
Illinois Test Procedure 704 (Effective 01/01/21)	Rolling Straightedge Simulation in ProVAL	341

CATEGORICAL TABLE OF CONTENTS
 (continued)
MANUAL OF TEST PROCEDURES
FOR MATERIALS

<u><i>Standard</i></u>	<u><i>Description</i></u>	<u><i>Page</i></u>
GENERAL		
ASTM E 29-13 (2019) (Illinois Modified 12/01/19)	Using Significant Digits in Test Data to Determine Conformance with Specifications	71
General Laboratories and Equipment		
Refer to IDOT Website	Policy Memorandum 6-08.1, Minimum Private Laboratory Requirements for Construction Materials Testing or Mix Design Private Laboratories (formerly Appendix D.1)	
Appendix D.5 (Effective 04/01/99) (Revised 12/01/21)	Illinois Specification 101, Minimum Requirements for Electronic Balances	D.9
Appendix D.9 AASHTO R 18-18	Establishing and Implementing a Quality System for Construction Materials Testing Laboratories	D.17

COPYRIGHT NOTICE

This Manual includes Illinois Modified Test Procedures to be used in conjunction with and according to the noted ASTM and AASHTO test methods. ASTM and AASHTO test methods cannot be reproduced in this manual due to copyright. Individual ASTM and AASHTO standards may be requested from the respective addresses below:

ASTM
100 Barr Harbor Drive, P.O. Box C700
West Conshohocken, PA 19428-2959
(610) 832-9500
www.astm.org

Contact:
Mark Axelman
ASTM International
Email: maxelman@astm.org

AASHTO
555 12th St., N. W.
Suite 1000
Washington, D.C. 20004
(202) 624-5800
www.transportation.org

This Page Reserved

Illinois Specification 201
 Illinois Department of Transportation (IDOT)
 AGGREGATE GRADATION SAMPLE SIZE TABLE & QUALITY CONTROL SIEVES
 Effective December 1, 2021

COARSE AGGREGATE GRADATION TABLE																			
CA(CM) ^{1,2}	Minimum Field Sample Size ³	Minimum Test Sample Size ³	3"	2 1/2"	2"	1 3/4"	1 1/2"	1"	3/4"	5/8"	1/2"	3/8"	1/4"	#4	#8	#16	#40	#50	#200
CA01	110 lbs (50 kg)	10,000 g	X	X ^{MN}	X		X	X											X
CA02	110 lbs (50 kg)	10,000 g		X	X ^{MN}		XC	X	XC		X			X		X	X		X
CA03	110 lbs (50 kg)	10,000 g		X	X ^{MN}		X	X			X								X
CA04	110 lbs (50 kg)	10,000 g			X		X ^{MN}	X	XC		X	XC		X		X	X		X
CA05 ⁵	110 lbs (50 kg)	10,000 g				X	X ^{MN}	X ^{MB,6}	XC		X			X ⁶					X
CA06	55 lbs (25 kg)	5,000 g					X	X ^{MN}	XC		X	XC		X		X	X		X
CA07 ⁵	55 lbs (25 kg)	5,000 g					X	X ^{MN}	XC	XC	X ^{MB,6}	XC	XC	X ⁶					X
CA08	55 lbs (25 kg)	5,000 g					X	X ^{MN}	X	XC	X	XC	XC	X		X			X
CA09	55 lbs (25 kg)	5,000 g					X	X ^{MN}	XC	XC	X	XC	XC	X		X			X
CA10	55 lbs (25 kg)	5,000 g						X	X ^{MN}	XC	X	XC	XC	X		X	X		X
CA11 ⁵	55 lbs (25 kg)	5,000 g						X	X ^{MN}	XC	X ^{MB,6}	XC	XC	X		X ⁶			X
CA12	35 lbs (16 kg)	2,000 g							X		X ^{MN}	X	XC	X	XC	X	X		X
CA13 ⁵	35 lbs (16 kg)	2,000 g							X		X ^{MN}	X	XC	X ^{MB,6}	XC	X ⁶			X
CA14 ⁵	35 lbs (16 kg)	2,000 g								X	X ^{MN}	X ^{MB,6}	XC	X ⁶					X
CA15	35 lbs (16 kg)	2,000 g									X	X ^{MN}	XC	X	XC	X			X
CA16 ⁵	25 lbs (11 kg)	1,500 g									X	X ^{MN}	XC	X ^{MB,6}	XC	X ⁶			X
CA17	35 lbs (16 kg) ⁴	4,000 g ⁴	X		XC			XC			XC	XC		X ^{MN,4}		X		X	X
CA18	35 lbs (16 kg) ⁴	4,000 g ⁴	X					X ^{MN,4}			XC	XC		X		X		X	X
CA19	35 lbs (16 kg) ⁴	4,000 g ⁴	X					X ^{MN,4}			XC	XC		X		X	X	X	X
CA20	25 lbs (11 kg)	2,000 g									X	X ^{MN}	XC	X	X	X			X

Note: See footnotes below Fine Aggregate Gradation Table for explanation of symbols

Illinois Specification 201
 Illinois Department of Transportation (IDOT)
 AGGREGATE GRADATION SAMPLE SIZE TABLE & QUALITY CONTROL SIEVES
 Effective December 1, 2021

FINE AGGREGATE GRADATION TABLE															
FA(FM) ^{1, 2}	Minimum Field Sample Size ³	Minimum Test Sample Size ³	1"	1/2"	3/8"	#4	#8	#10	#16	#30	#40	#50	#80	#100	#200
FA01	25 lbs (11 kg)	500 g			X	X ^{MN}	X ^{MB}		X	X ^{MB}		X		X	X
FA02	25 lbs (11 kg)	500 g			X	X ^{MN}	X ^{MB}		X	X ^{MB}		X		X	X
FA03	25 lbs (11 kg)	500 g			X	X ^{MN}		X			X		X		X
FA04	25 lbs (11 kg)	500 g			X				X ^{MN}						
FA05	25 lbs (11 kg)	500 g			X	X ^{MN}								X	X
FA06	25 lbs (11 kg)	500 g	X	X	X	X ^{MN}								X	X
FA07	25 lbs (11 kg)	100 g				X		X ^{MN}			X		X		X
FA08	25 lbs (11 kg)	100 g					X				X ^{MN}			X	X
FA09	25 lbs (11 kg)	100 g					X					X ^{MN}		X	X
FA10	25 lbs (11 kg)	100 g						X			X ^{MN}		X		X
FA20 ⁵	25 lbs (11 kg)	500 g			X	X ^{MN}	X ^{MB}		X	X ^{MB, 6}		X		X	X ⁶
FA21 ⁵	25 lbs (11 kg)	500 g			X	X ^{MN}	X ^{MB}		X	X ^{MB, 6}		X		X	X ⁶
FA22 ⁵	25 lbs (11 kg)	500 g			X	X ^{MB}	X ^{MB, 6}		X						X ⁶
FA23 ⁵	25 lbs (11 kg)	500 g			X	X ^{MN}	X ^{MB}		X	X ^{MB, 6}		X		X	X ⁶
FA24 ⁵	25 lbs (11 kg)	500 g			X	X ^{MN}	X ^{MB}		X	X ^{MB, 6}		X		X	X ⁶

Notes below apply to Fine and Coarse Aggregate Gradation Tables Only

X = Required Gradation Specification Sieves

XC = Required Cutter Sieves

MB = Master Band Sieves for Category I Coarse Aggregate for PCC and HMA Mixes; Bituminous use only for fine aggregate.

MN = Maximum Nominal Sieve for Crushed Gravels – Maximum Nominal Size is defined as the first specification sieve in the product gradation on which material may be retained.

1 = CA = Coarse Aggregate; CM = Coarse Aggregate, Modified; FA = Fine Aggregate; FM = Fine Aggregate, Modified

2 = CM and FM gradations shall be sampled and tested the same as the corresponding CA and FA gradations.

3 = Slag should be adjusted accordingly due to its lighter or heavier mass.

4 = Will vary with the gradation of the material being used

5 = Control Charts Required

6 = Required Sieve for Control Charts

Illinois Specification 201
 Illinois Department of Transportation (IDOT)
 AGGREGATE GRADATION SAMPLE SIZE TABLE & QUALITY CONTROL SIEVES
 Effective [December 1, 2021](#)

LARGE SIZED AGGREGATE GRADATION TABLE										
CS/RR ^{1,2}	Minimum Test Sample Size ³	8"	6"	4"	3"	2"	1 ½"	1"	½"	#4
CS01	50,000 g	X	X	X	XC	X		XC	XC	X
CS02	50,000 g		X	X	XC	X		XC	XC	X
RR01	20,000 g				X	XC	X	XC	XC	X
RR02	20,000 g			X	XC	X	XC	XC	XC	X

Notes below apply to Large Sized Aggregate Gradation Table Only

X = Required Gradation Specification Sieves

XC = Required Cutter Sieves

1 = CS = Coarse Aggregate Subgrade; RR/RRM = Rip Rap

2 = Dry Gradations Only

3 = Slag should be adjusted accordingly due to its lighter or heavier mass.

4 = A round nosed shovel may be used for sampling

5 = Metal plates with precisely sized square holes may be used for the gradation

6 = Test sample size shall be taken in the field. No splitting is required.

This Page Reserved

ILLINOIS TEST PROCEDURE 202

Leachate Determination in Crushed Slag Samples

Effective: May 1, 2007
Revised Date: December 1, 2017

1.0 SAMPLING PROCEDURE

The following sampling method shall be used for obtaining samples of air-cooled blast furnace slag for leachate tests.

- 1.1 Sampling. The material to be shipped should be sampled as the stockpile is being built. Each sample shall be taken in random increments over each 1500 tons stockpiled.
- 1.2 Obtaining the Sample After the Stockpile Is Built. The sample shall be taken by shovel. The sample shall be selected randomly from both the exterior and interior of the stockpile. The producer must use the services of heavy equipment for the excavation of interior material.
- 1.3 Sample Size and Sample Reduction. The field sample should be 80 to 100lbs. (35 to 45kg) in mass. From this field sample, a test sample of 20 to 25lbs. (9 to 11kg) shall be quartered or mechanically split as detailed in Illinois Test Procedure 248.
- 1.4 Sampling Frequency. The sampling frequency shall be a minimum of one sample per 1500 tons of material with a five-sample minimum per stockpile.
- 1.5 Documentation. Stockpile location and test results shall be maintained at the plant and shall be available to the Illinois Department of Transportation.

2.0 SULFUR LEACHATE TEST

The test procedure involves soaking the slag material in water for a specified period of time and observing the color of the water. A greenish-yellow coloration indicates a problem. The smell of H₂S usually accompanies the observation of colored water.

2.1 Required Test Equipment

The following equipment is needed to perform the test:

- 2.1.1 One 676oz (20L) bucket for soaking the sample
- 2.1.2 Filter paper for filtering the water
- 2.1.3 One funnel through which to filter the water
- 2.1.4 One clear glass container for observing the water
- 2.1.5 The rock color chart used for color comparisons
(Distributed by the Geological Society of America)

ILLINOIS TEST PROCEDURE 202

Leachate Determination in Crushed Slag Samples

Effective: May 1, 2007
Revised Date: December 1, 2017

2.2 Test Procedure

The test procedure is as follows:

- 2.2.1 Prepare a test sample of approximately 20 to 25lbs. (9 to 11kg) from a field sample of approximately 100lbs. (45kg).
- 2.2.2 The test sample should then be rinsed over a No. 4 (4.75mm) sieve to remove any fines that may be clinging to the larger particles. If the material to be tested is a densely graded material, eliminate this step.
- 2.2.3 Next, place the test sample in a bucket and fill the bucket with water until the sample is covered by at least 1/2in. (12.5mm) of water. Allow the sample to soak for 24 hours.
- 2.2.4 After soaking for 24 hours, thoroughly mix the water and collect a water sample of approximately 3.38oz. (100mL).
- 2.2.5 Filter the water sample to remove any suspended solids which may interfere with the color observations.
 - (a) If the color of the filtered water is equal to or darker than the moderate greenish-yellow color from the rock chart (HUE 10 Y), this material fails.
 - (b) If the water appears clear, allow the sample to soak another 24 hours and repeat steps 2.2.4 and 2.2.5. If after 48 hours no color appears, the material is assumed to have aged long enough to eliminate any leachate problems, and the sample is acceptable.

NOTE: This procedure is referenced in IDOT Policy Memorandum "Crushed Slag Producer Certification and Self-Testing Program".
--

Illinois Test Procedure 301

Effective Date: February 1, 2014

Revised Date: [December 1, 2021](#)

Fine Aggregate Moisture Content by the Flask Method

Reference Test Procedure(s):

1. Illinois Specification 101, Minimum Requirements for Electronic Balances
2. AASHTO M 231, Weighing Devices Used in the Testing of Materials
3. [AASHTO R 90 \(Illinois Modified\)](#), Sampling of Aggregates
4. [AASHTO T 84 \(Illinois Modified\)](#), Specific Gravity and Absorption of Fine Aggregate
5. [AASHTO R 76 \(Illinois Modified\)](#), Reducing Samples of Aggregate to Testing Size
6. ASTM E 29 (Illinois Modified), Standard Practice for Using Significant Digits in Test Data to Determine Conformance with Specifications

To maintain brevity in the text, the following will apply:

Example: AASHTO M 231 will be designated as “M 231.”

ASTM E 29 (Illinois Modified) will be designated as “ASTM E 29.”

A. FINE AGGREGATE MOISTURE CONTENT

1. GENERAL

This Illinois Test procedure was developed to replace AASHTO T 142, “Surface Moisture in Fine Aggregate,” which was AASHTO discontinued. The equivalent ASTM designation is C 70. The test is a convenient procedure for field determination of **free moisture** (surface moisture) of fine aggregate, if specific gravity values are known.

The accuracy of the test procedure depends upon accurate information on the bulk specific gravity of the material in a saturated surface-dry condition.

All rounding shall be according to ASTM E 29.

2. EQUIPMENT

- a. Balance – The balance or scale shall conform to M 231 and Illinois Specification 101.
- b. Flask – A suitable container or flask, preferably of glass or non-corrosive metal. The container may be a pycnometer, volumetric flask, graduated volumetric flask, or other suitable measuring device. The volume of the container shall be from two to three times the loose volume of the test sample. The container shall be so designed that it can be filled to the mark, or the volume of its contents read, within 0.5 ml or less.

3. PROCEDURE

Select a representative sample of the fine aggregate to be tested for free moisture content. The sample shall be obtained according to [R 90](#) and [R 76](#). Protect the sample from moisture loss until weighing. The test sample shall have a minimum mass of 200 grams. However, larger test samples will yield more accurate results. If a Chapman Flask is used, as described in Section 5, then a 500 gram test sample shall be required.

The free moisture content may be determined either by mass or by volume. In each case, the test shall be performed at a temperature range of 18 to 29 °C (65 to 85 °F).

- a. Determination by Mass—Determine the mass of the container filled with water to the known volume mark. Before placing the test sample into the container, reduce the water level to prevent the water from going over the mark when the test sample is added. Introduce the test sample into the container, and remove entrapped air. Refill the container to the mark, and determine the mass of the container and test sample. Calculate the amount of water displaced by the test sample as follows:

$$V_S = W_C + W_S - W$$

Where: V_S = Mass of Water Displaced by the Test Sample, nearest 1 gram.

W_C = Mass of Container Filled to the Mark with Water, nearest 1 gram.

W_S = Mass of Aggregate Sample, nearest 1 gram.

W = Mass of Container, Aggregate Sample, and Water Filled to the Mark, nearest 1 gram.

- b. Determination by Volume—Measure a volume of water (ml) sufficient to cover the test sample, and place in the container. Introduce the test sample into the container, and remove entrapped air.

When a graduated flask is used, determine the combined volume of the test sample and the water by direct reading. When a pycnometer or volumetric flask of known volume is used, fill the container to the known volume mark with an additional measured volume of water. The flask or pycnometer volume is then equal to the combined volume of the test sample and water. Calculate the amount of water displaced by the test sample as follows:

$$V_S = V_2 - V_1$$

Where: V_S = Volume of Water Displaced by the Test Sample, nearest 1 ml.

V_2 = Combined Volume of the Test Sample and Water, nearest 1 ml.

V_1 = Total Volume of Water in the Container Required to Cover the Test Sample and Bring the Level up to the Known Volume Mark, nearest 1 ml.

Note: 1 ml of water has the mass of 1 gram.

4. CALCULATION

a. Percentage of Free Moisture in Terms of Saturated Surface-Dry Aggregate

$$P = [(V_S - V_D) - (W_S - V_S)] \times 100$$

Where:

P = Free Moisture in Terms of Saturated Surface-Dry Fine Aggregate, nearest 0.1 percent.

V_S = Mass of Water Displaced, nearest 1 gram.

V_D = Mass of Test Sample, nearest 1 gram, Divided by the Bulk Specific Gravity of the Fine Aggregate in a Saturated Surface-Dry Condition, nearest 0.01, Determined According to [T 84](#).

W_S = Mass of Test Sample, nearest 1 gram.

b. Percentage of Free Moisture in Terms of Dry Aggregate with Known Absorption

$$P_D = P \times \left(1 + \frac{P_A}{100}\right)$$

Where:

P_D = Free Moisture in Terms of Dry Fine Aggregate, nearest 0.1 percent.

P = Free Moisture in Terms of Saturated Surface-Dry Fine Aggregate, nearest 0.1 percent.

P_A = Absorption of the Fine Aggregate, nearest 0.1 percent, Determined According to [T 84](#).

Total moisture content, on a dry aggregate basis, is the sum of the free moisture, P_D , and the absorption, P_A .

5. FINE AGGREGATE MOISTURE CONTENT BY THE FLASK METHOD

The Chapman Flask is graduated as discussed in Section 3b. The Chapman Flask can be used to determine the percent of free moisture (surface moisture) of fine aggregate.

For example, assume a fine aggregate with a known saturated surface-dry specific gravity (G_s) of 2.62. The Chapman Flask is filled with water to the 200 ml line, which is located between the two bulbs of the flask. A 500 gram test sample of fine aggregate is then poured into the flask, and agitated to remove any entrapped air. The flask is then placed on a level surface, and the water level is read on the neck of the flask. For this example, assume a final reading (V) of 400 ml. The percent free moisture, P , is calculated to the nearest 0.1 percent as follows:

$$P = \left(\frac{V - 200 - \frac{500}{G_s}}{700 - V} \right) \times 100$$

$$P = \left(\frac{400 - 200 - \frac{500}{2.62}}{700 - 400} \right) \times 100$$

$$P = 3.1 \text{ percent}$$

The percent of free moisture can also be determined from the following tables using the above formula. Using the values from the previous example, enter the table at the final reading from the flask (e.g. $V = 400$ ml), read horizontally to the specific gravity column desired (e.g. $G_s = 2.62$), and read the percent moisture directly as 3.1 percent.

$$\text{FORMULA USED: PERCENT FREE MOISTURE, } P = \left(\frac{V - 200 - \frac{500}{G_s}}{700 - V} \right) \times 100$$

PERCENT FREE MOISTURE, P: CHAPMAN FLASK METHOD FOR 500 GRAM TEST SAMPLE

READING FROM FLASK	G _s	G _s	G _s	G _s	G _s	G _s	G _s	G _s	G _s	G _s	G _s	G _s	G _s
	2.70	2.69	2.68	2.67	2.66	2.65	2.64	2.63	2.62	2.61	2.60	2.59	2.58
391	1.9	1.7	1.4	1.2	1.0	0.8	0.5	0.3	0.1	0.0	0.0	0.0	0.0
392	2.2	2.0	1.8	1.5	1.3	1.1	0.8	0.6	0.4	0.1	0.0	0.0	0.0
393	2.5	2.3	2.1	1.9	1.6	1.4	1.2	0.9	0.7	0.5	0.2	0.0	0.0
394	2.9	2.7	2.4	2.2	2.0	1.7	1.5	1.3	1.0	0.8	0.6	0.3	0.0
395	3.2	3.0	2.8	2.5	2.3	2.1	1.8	1.6	1.4	1.1	0.9	0.6	0.4
396	3.6	3.3	3.1	2.9	2.6	2.4	2.2	1.9	1.7	1.5	1.2	1.0	0.7
397	3.9	3.7	3.4	3.2	3.0	2.7	2.5	2.3	2.0	1.8	1.5	1.3	1.1
398	4.2	4.0	3.8	3.5	3.3	3.1	2.8	2.6	2.4	2.1	1.9	1.6	1.4
399	4.6	4.4	4.1	3.9	3.7	3.4	3.2	3.0	2.7	2.5	2.2	2.0	1.7
400	4.9	4.7	4.5	4.2	4.0	3.8	3.3	3.3	3.1	2.8	2.6	2.3	2.1
401	5.3	5.1	4.8	4.6	4.4	4.1	3.7	3.7	3.4	3.2	2.9	2.7	2.4
402	5.6	5.4	5.2	4.9	4.7	4.5	4.0	4.0	3.7	3.5	3.3	3.0	2.8

$$\text{FORMULA USED: PERCENT FREE MOISTURE, } P = \left(\frac{V - 200 - \frac{500}{G_s}}{700 - V} \right) \times 100$$

PERCENT FREE MOISTURE, P: CHAPMAN FLASK METHOD FOR 500 GRAM TEST SAMPLE

READING FROM FLASK	G _s	G _s	G _s	G _s	G _s	G _s	G _s	G _s	G _s	G _s	G _s	G _s	G _s
	2.70	2.69	2.68	2.67	2.66	2.65	2.64	2.63	2.62	2.61	2.60	2.59	2.58
403	6.0	5.8	5.5	5.3	5.1	4.8	4.6	4.3	4.1	3.8	3.6	3.4	3.1
404	6.4	6.1	5.9	5.7	5.4	5.0	4.9	4.7	4.4	4.2	4.0	3.7	3.5
405	6.7	6.5	6.2	6.0	5.8	5.5	5.3	5.1	4.8	4.6	4.3	4.1	3.8
406	7.1	6.8	6.6	6.4	6.1	5.9	5.6	5.4	5.2	4.9	4.7	4.4	4.1
407	7.4	7.2	7.0	6.7	6.5	6.3	6.0	5.8	5.5	5.3	5.0	4.8	4.5
408	7.8	7.6	7.3	7.1	6.9	6.6	6.4	6.1	5.9	5.6	5.4	5.1	4.9
409	8.2	7.9	7.7	7.5	7.2	7.0	6.7	6.5	6.2	6.0	5.7	5.5	5.2
410	8.6	8.3	8.1	7.8	7.6	7.4	7.1	6.9	6.6	6.4	6.1	5.8	5.6
411	8.9	8.7	8.4	8.2	8.0	7.7	7.5	7.2	7.0	6.7	6.5	6.2	6.0
412	9.3	9.1	8.8	8.6	8.3	8.1	7.8	7.6	7.3	7.1	6.8	6.6	6.3
413	9.7	9.4	9.2	9.0	8.7	8.5	8.2	8.0	7.7	7.5	7.2	7.0	6.7
414										7.8	7.6	7.3	7.1

Illinois Test Procedure 302

Effective Date: February 1, 2014

Revised Date: [December 1, 2021](#)

Aggregate Specific Gravity and Moisture Content by the Dunagan Method

Reference Test Procedure(s):

1. Illinois Specification 101, Minimum Requirements for Electronic Balances
2. AASHTO M 231, Weighing Devices Used in the Testing of Materials
3. [AASHTO R 90 \(Illinois Modified\)](#), Sampling of Aggregates
4. [AASHTO T 84 \(Illinois Modified\)](#), Specific Gravity and Absorption of Fine Aggregate
5. [AASHTO T 85 \(Illinois Modified\)](#), Specific Gravity and Absorption of Coarse Aggregate
6. [AASHTO R 76 \(Illinois Modified\)](#), Reducing Samples of Aggregate to Testing Size
7. ASTM E 29 (Illinois Modified), Standard Practice for Using Significant Digits in Test Data to Determine Conformance with Specifications

To maintain brevity in the text, the following will apply:

Example: AASHTO M 231 will be designated as “M 231.”

ASTM E 29 (Illinois Modified) will be designated as “ASTM E 29.”

A. SPECIFIC GRAVITY – DUNAGAN METHOD

1. GENERAL

The specific gravity is determined, as specified by the Department, according to [T 84](#) and [T 85](#).

The Dunagan apparatus (specific gravity and moisture determinator) developed by Professor W.M. Dunagan is used as a convenient method for checking the specific gravity and moisture content of aggregate in the field.

All rounding shall be according to ASTM E 29.

2. EQUIPMENT

The Dunagan apparatus is a specially designed balance for determining an aggregate sample's mass in water and in air. As an alternative to acquiring a Dunagan apparatus kit, a homemade Dunagan apparatus can be assembled by acquiring the following equipment:

- a. Electronic Balance – The electronic balance shall conform to M 231 and Illinois Specification 101. The electronic balance shall have a weight below hook.
- b. Tank – The tank shall be made of non-corrosive material, and shall have an overflow spout. The tank shall be of sufficient size for the pail. The pail shall not touch the bottom or sides of the tank when submerged in the water held by the tank.

- c. Pail – The pail shall be made of non-corrosive material, and shall be of sufficient size to hold the aggregate sample.
- d. Stand – The stand shall be able to support the weighing operation. To allow for the balance's weigh below hook, a hole is required in the center of the stand. The stand shall have sufficient height to easily remove the submerged pail from the tank.

3. PROCEDURE FOR MASS OF AGGREGATE SAMPLE IN WATER

- Dunagan Apparatus Kit

The equipment is set up as illustrated in Figure 1. Fill tank "A" with water up to the overflow spout "B". The empty pail "C" is immersed in water and suspended from the balance. Place a clean, dry scoop "D" on the right hand scale pan and adjust the scales to balance. To perform the initial balance, it may be necessary to add washers on the left hanger "E" to act as counterweights. Thereafter, the final adjustment may be performed with the calibration screw on the balance.

Remove the pail from the tank. Partially fill the pail with water taken from the tank, and slowly pour the sample into the pail. Pouring the sample into the water will prevent the entrapping of air with the sample. The submerged sample shall be stirred to dislodge entrapped air. If material clings to the inside of the scoop, place the scoop in the mouth of the pail and rinse with the water. Then slowly immerse the pail obliquely into the tank, allowing water to flow slowly over one side of the pail. This immersion should be done carefully to prevent material from washing out of the pail. Suspend the pail from the end of the left hanger. If necessary, add water to the tank to bring the water level up to the overflow spout. Permit any excess water to overflow. Obtain the immersed mass, by placing weights in the scoop and adjusting the rider.

- Homemade Dunagan Apparatus

Fill the tank with water up to the overflow spout. The empty pail is immersed in water, and suspended from the end of the electronic balance weigh below hook. Tare the electronic balance.

Remove the pail from the tank. Partially fill the pail with water taken from the tank, and slowly pour the sample into the pail. Pouring the sample into the water will prevent the entrapping of air with the sample. The submerged sample shall be stirred to dislodge entrapped air. If material clings to the inside of the scoop, place the scoop in the mouth of the pail and rinse with the water. Then slowly immerse the pail obliquely into the tank, allowing water to flow slowly over one side of the pail. This immersion should be done carefully to prevent material from washing out of the pail. Suspend the pail from the end of the electronic balance weigh below hook. If necessary, add water to the tank to bring the water level up to the overflow spout. Permit any excess water to overflow. Obtain the immersed mass.

4. PROCEDURE FOR MASS OF AGGREGATE SAMPLE IN AIR

- Dunagan Apparatus Kit – Whole Number Kilograms

The Dunagan apparatus can be used to measure samples in whole number kilograms. This is convenient when the specified sample size is 1, 2, or 3 kilograms, as in Sections A.5., A.6., B.2., and B.3. The equipment is set up as illustrated in Figure 1. Adjust the scales to balance evenly as explained in the first paragraph of Section A.3 “Dunagan Apparatus Kit.” Place the slotted kilogram weights on the left hanger, and pour enough material into the scoop to balance the scales.

- Dunagan Apparatus Kit – Fractional Kilograms

The Dunagan apparatus can be converted to a balance which measures samples in fractional kilograms, such as 1.5 kilograms. This is convenient if an electronic balance is not required by specifications; or if the slotted kilogram weights discussed in “Dunagan Apparatus Kit – Whole Number Kilograms” are not available.

The equipment is set up as illustrated in Figure 2. Be advised that the pans are not interchangeable, and should be marked “L” and “S” respectively. “L” designates the pan for the long stirrup, and “S” is the pan which has been balanced for the short stirrup.

Place a clean, dry scoop “D” on the left hand scale pan and adjust the scales to balance evenly. To perform the initial balance, it may be necessary to use a counterweight constructed from a can and shot. Thereafter, the final adjustment may be performed with the calibration screw on the balance.

Place the sample in the scoop. Determine the sample mass by placing weights in the short stirrup pan, and adjusting the rider. The scale can measure to the nearest 0.1 gram.

- Homemade Dunagan Apparatus

Determine the sample mass by weighing on top of the electronic balance.

5. COARSE AGGREGATE SPECIFIC GRAVITY

The specific gravity of saturated surface-dry coarse aggregate is determined as follows:

- Select a representative sample of the coarse aggregate to be tested. The sample shall be obtained according to [R 90](#) and [R 76](#).
- Measure approximately 3,000 grams of coarse aggregate sample per Section A.4. Soak the sample in water for 24 hours. Surface-dry the sample to a saturated condition according to [T 85](#).
- Measure a 2,000 gram test sample per Section A.4.
- Determine the mass of the immersed test sample to the nearest 1 gram per Section A.3. This mass will be designated “W” for the test sample.

- Calculate the saturated surface-dry specific gravity of the coarse aggregate as follows:

$$G_s = \frac{2000}{2000 - W}$$

Or per Figure 3, which is the simpler method to use. To determine G_s from Figure 3:

- Start at a point which corresponds to the immersed mass (submerged weight) “W” of the test sample.
- Project this point horizontally until it intersects the vertical line of zero free moisture, and determine the specific gravity, G_s , by interpolation, to the nearest 0.01.

As an example: Suppose “W” for a 2,000 gram test sample is 1,230 grams. Projecting this point horizontally to intersect the line of zero free moisture, it is found that G_s is approximately 2.60.

6. FINE AGGREGATE SPECIFIC GRAVITY

To determine the specific gravity of saturated surface-dry fine aggregate, the test is identical to coarse aggregate, except as follows:

- After soaking, spread a sample of 2,300 grams or more on a flat surface, and air dry until the surface moisture has evaporated. Do not heat the sample to speed the process. The saturated surface-dry condition is reached when the material will roll freely from a scoop or trowel without sticking.
- Measure a 1,000 gram test sample per Section A.4.
- Calculate the saturated surface-dry specific gravity of the fine aggregate as follows:

$$G_s = \frac{1000}{1000 - W}$$

Or per Figure 3, which is the simpler method to use.

B. MOISTURE CONTENT DETERMINATION – DUNAGAN METHOD

1. GENERAL

This test will determine whether the aggregate has free moisture or will absorb moisture. The test is based upon a given sample of material (not in the saturated surface-dry condition) which will measure, when immersed in water, less or more than a sample of the same mass of material in the saturated surface-dry condition. This depends upon whether it contains free moisture or will absorb moisture.

For conducting this test, the equipment is set up as illustrated in Figure 1.

All rounding shall be according to ASTM E 29.

2. COARSE AGGEGATE MOISTURE CONTENT

To determine the free moisture or absorption of a sample of coarse aggregate, the test is conducted in the following manner:

- Select a representative sample of the coarse aggregate to be tested. The sample shall be obtained according to R 90 and R 76. Protect the sample from moisture loss until weighing.
- Measure a 2,000 gram test sample, as per Section A.4.
- Determine the mass of the immersed test sample to the nearest 1 gram. The immersed mass is obtained as per Section A.3., except the test sample shall remain in the pail for 10 minutes. This mass will be designated “W₁” for the test sample.
- If “W₁” is less than the “W” determined per Section A.5, the aggregate contains free moisture; if “W₁” is greater than “W,” the aggregate will absorb moisture. The percentage of free moisture or absorption is determined by one of the following formulae:

$$\text{If } W_1 < W: \text{ Free Moisture (percent)} = \frac{0.05G_s \times (W - W_1)}{G_s - 1}$$

$$\text{If } W_1 > W: \text{ Absorption (percent)} = \frac{0.05G_s \times (W - W_1)}{0.8G_s - 1}$$

NOTE: G_S is the saturated surface-dry specific gravity of the coarse aggregate.

The factor, 0.8, is based on the assumption that the sample will become 80% saturated in 10 minutes.

The simpler method is to use Figure 3 and the immersed mass (submerged weight) “W₁.” To determine the moisture content from Figure 3:

- Start at a point which corresponds to the immersed mass (submerged weight) “W₁” of the test sample.
- Project this point horizontally, until it intersects the line corresponding to the specific gravity of the aggregate, G_S.
- Project this point of intersection vertically and read the percentage of free moisture or absorption from the scale, at the bottom of the chart to the nearest 0.1. The value is interpolated.

As an example: Suppose G_S for the test sample is 2.56, and “W₁” is 1,170 grams. The vertical projection of the point of intersection of the line (representing these values) shows a free moisture content of approximately 4.0 percent.

3. FINE AGGREGATE MOISTURE CONTENT

To determine the free moisture or absorption of fine aggregate the test is identical to coarse aggregate. However, measure a 1,000 gram test sample and use one of the following formulae:

$$\text{If } W_1 < W: \text{ Free Moisture (percent)} = \frac{0.1G_s \times (W - W_1)}{G_s - 1}$$

$$\text{If } W_1 > W: \text{ Absorption (percent)} = \frac{0.1G_s \times (W - W_1)}{0.8G_s - 1}$$

NOTE: G_s is the saturated surface-dry specific gravity of the fine aggregate.

Again, the simpler method is to use Figure 3 for a 1,000 gram test sample.

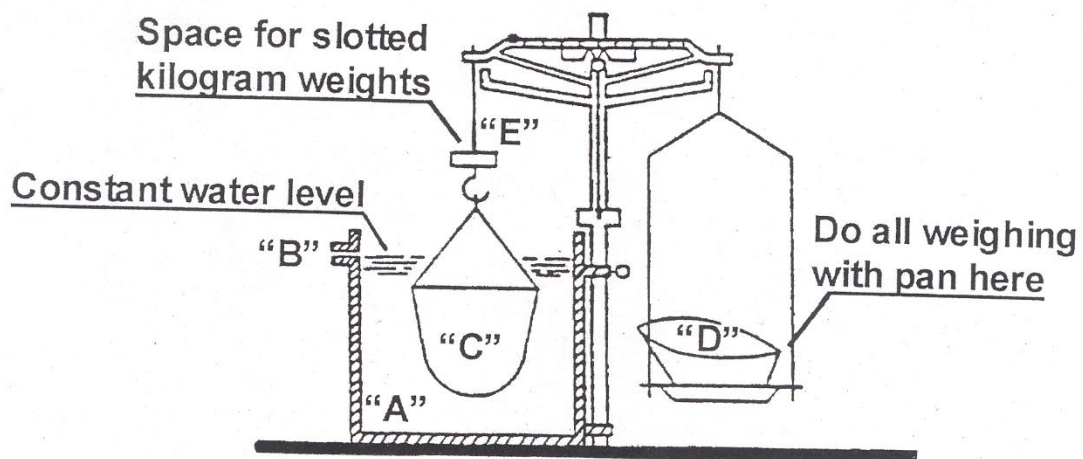

FIGURE 1

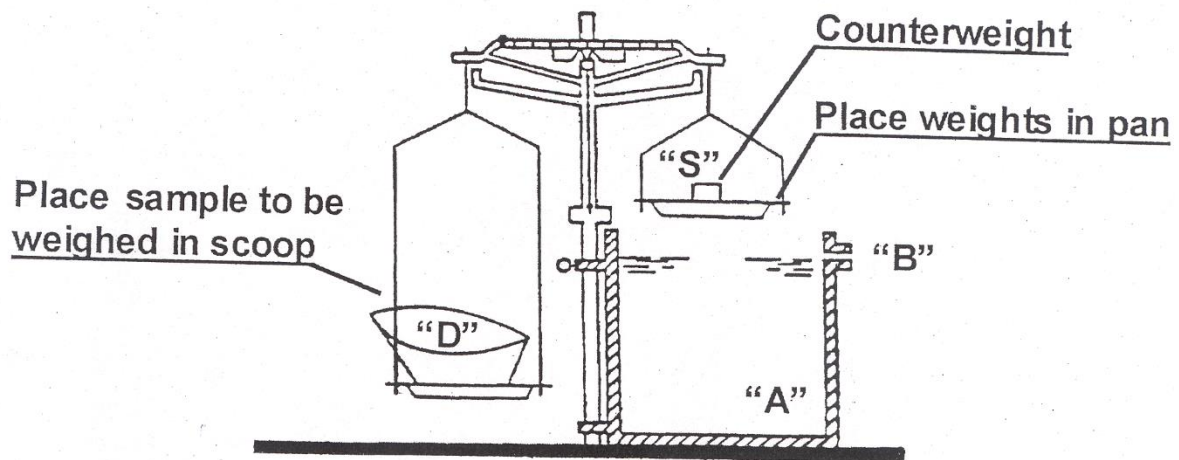
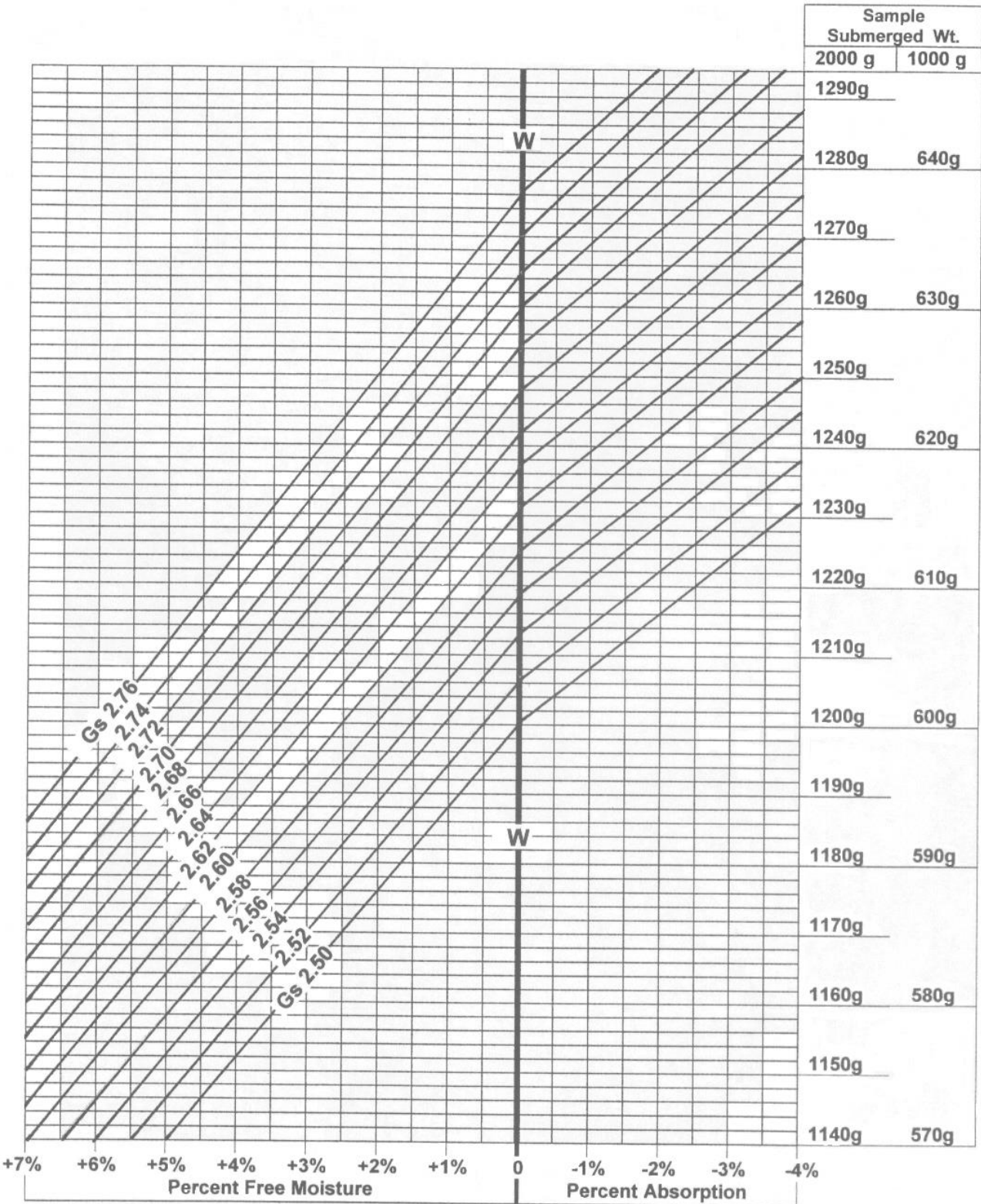

FIGURE 2

Figure 3
Chart for Determining Specific Gravity and Free Moisture or Absorption for either 1000 or 2000
Gram Samples Tested in the Specific Gravity and Moisture Determinator



Illinois Test Procedure 303
Effective Date: February 1, 2014
Revised Date: December 1, 2021

**Fine or Coarse Aggregate Moisture Content
by Pycnometer Jar Method**

Reference Test Procedure(s):

1. Illinois Specification 101, Minimum Requirements for Electronic Balances
2. AASHTO M 231, Weighing Devices Used in the Testing of Materials
3. [AASHTO R 90 \(Illinois Modified\)](#), Sampling of Aggregates
4. [AASHTO R 76 \(Illinois Modified\)](#), Reducing Samples of Aggregate to Testing Size
5. ASTM E 29 (Illinois Modified), Standard Practice for Using Significant Digits in Test Data to Determine Conformance with Specifications

To maintain brevity in the text, the following will apply:

Example: AASHTO M 231 will be designated as “M 231.”

ASTM E 29 (Illinois Modified) will be designated as “ASTM E 29.”

A. FINE OR COARSE AGGREGATE MOISTURE CONTENT

1. GENERAL

This Illinois Test procedure has been used for many years by District 2 (Dixon), but the District is uncertain as to the origin of the test. However, this test is similar to a test procedure used by the Iowa Department of Transportation. The test is a convenient procedure for field determination of **free moisture** (surface moisture) of fine or coarse aggregate, if specific gravity values are known.

The accuracy of the test procedure depends upon accurate information on the bulk specific gravity of the material in a saturated surface-dry condition.

All rounding shall be according to ASTM E 29.

2. EQUIPMENT

- a. Balance – The balance or scale shall conform to AASHTO M 231 and Illinois Specification 101.
- b. Pycnometer – A glass jar, gasket, and conical pycnometer top. A 0.946 L (1 qt.) jar is used for fine aggregate, and a 1.892 L (2 qt.) jar is used for coarse aggregate. Typically, a canning jar is used.

- c. Funnel – A conical shape utensil which can be of any type of material. The funnel shall be of sufficient size for placement on top of the glass jar.

3. MATERIALS

- a. Potable Water
- b. Water Resistant Grease
- c. Aggregate Sample

4. PROCEDURE

Select a representative sample of the fine or coarse aggregate to be tested for free moisture content. The sample shall be obtained according to [R 90](#) and [R 76](#). Protect the sample from moisture loss until weighing.

a. Mass of Pycnometer Filled with Water

- Apply a light coat of grease to the side of the gasket which will be in contact with the glass jar.
- Screw the pycnometer top tightly on the glass jar.
- Place a mark on the pycnometer top and glass jar to indicate the position of the tightened top. Always tighten the pycnometer top to this position. If the pycnometer top is ever tightened beyond the mark on the glass jar, re-mark the top of the jar.
- Fill the glass jar nearly full of water and screw on the pycnometer top. Finish filling the pycnometer by pouring water until a bead of water appears above the top's opening.
- Wipe off all exterior water on the pycnometer, and then weigh to the nearest 1 gram. Record the value as M_1 .

b. Mass of Aggregate Sample

- When testing fine aggregate, measure a 1000 gram test sample.
- When testing coarse aggregate, measure a 2000 gram test sample.

c. Mass of Pycnometer Filled with Water and Aggregate

- Use the funnel to pour the aggregate sample into the glass jar. The jar shall contain approximately 50 mm (2 in.) of water.
- Fill the glass jar nearly full of water, and screw on the pycnometer top to the marked position. The water temperature shall be within ± 1.7 °C (3 °F) of the water used for calibrating the pycnometer. Finish filling the pycnometer.

- Place a finger over the pycnometer top opening, and gently roll and shake the pycnometer several times to remove entrapped air in the aggregate sample. When further rolling and shaking brings no more air bubbles to the top, finish filling the pycnometer. The pycnometer is filled when a bead of water appears above the top's opening.
- Wipe off all exterior water on the pycnometer, and then weigh to the nearest 1 gram. Record the value as M_2 .

5. CALCULATION

a. Mass of Water Displaced by the Aggregate Sample

$$V_S = M_1 + M_S - M_2$$

Where:

V_S = Mass of Water Displaced by the Aggregate Sample, nearest 1 gram.

M_1 = Mass of Pycnometer Filled with Water, nearest 1 gram.

M_S = Mass of Aggregate Sample (1000 grams for fine aggregate and 2000 grams for coarse aggregate).

M_2 = Mass of Pycnometer Filled with Water and Aggregate, nearest 1 gram.

b. Moisture Content

Calculate moisture content to the nearest 0.1 percent using the following equations:

$$\text{Fine Aggregate Free Moisture (percent)} = \frac{V_S - (1000 \div G_S)}{1000 - V_S} \times 100$$

$$\text{Coarse Aggregate Free Moisture (percent)} = \frac{V_S - (2000 \div G_S)}{2000 - V_S} \times 100$$

Where:

V_S = Mass of Water Displaced by the Aggregate Sample, nearest 1 gram.

G_S = Saturated Surface-Dry Specific Gravity of Aggregate, nearest 0.01.



Date: (mm/dd/yyyy) _____
 Producer No.: _____
 Producer Name: _____
 Location: _____

	Coarse Aggregate	Fine Aggregate
1. Aggregate Specific Gravity at Saturated Surface-Dry (SSD).....	<input type="text"/>	<input type="text"/>
2. Sample Size, g.....	2000	1000
3. Sample Size ÷ Specific Gravity..... Line 2 ÷ Line 1	<input type="text"/>	<input type="text"/>
4. Mass of pycnometer full of water, g.....	<input type="text"/>	<input type="text"/>
5. Mass of pycnometer containing sample and water, g.....	<input type="text"/>	<input type="text"/>
6. Mass of water displaced by sample, g..... Line 2 + Line 4 - Line 5	<input type="text"/>	<input type="text"/>
7. Difference, g..... Line 6 - Line 3	<input type="text"/>	<input type="text"/>
8. Sample Size minus water displaced, g..... Line 2 - Line 6	<input type="text"/>	<input type="text"/>
9. Percent Surface Moisture, <i>P</i> , +/- %..... Line 7 ÷ Line 8 × 100	<input style="border: 2px solid black;" type="text"/>	<input style="border: 2px solid black;" type="text"/>

Coarse Aggregate Surface Moisture,
$$P = \left[\frac{V_s - (2000/G_s)}{2000 - V_s} \right] \times 100$$

Fine Aggregate Surface Moisture,
$$P = \left[\frac{V_s - (1000/G_s)}{1000 - V_s} \right] \times 100$$

Where: *P* is the surface moisture, to the nearest 0.1 %
V_s is the mass of water displaced by the aggregate sample, to the nearest 1 g
G_s is the aggregate specific gravity at saturated surface-dry, to the nearest 0.01

Illinois Test Procedure 304

Effective Date: March 1, 2003

Revised Date: March 1, 2013

PULL-OFF TEST (SURFACE METHOD)

Reference Test Procedures:

1. American Concrete Institute Manual of Concrete Practice ACI 503R-93, (Reapproved 1998), Appendix A (Test Methods).
2. Virginia Test Method for Testing Epoxy Concrete Overlays for Surface Preparation and Adhesion, VTM-92.
3. ASTM C 1583/C 1583M-04, Standard Test Method for Tensile Strength of Concrete Surfaces and the Bond Strength or Tensile Strength of Concrete Repair and Overlay Materials by Direct Tension (Pull-off Method)

1. GENERAL

This test method outlines the procedure for determining the surface preparation quality of an existing concrete surface that is to be overlaid.

2. EQUIPMENT

- a. Pull-off testing device with sufficient capacity and capable of applying load at the specified rate,
- b. Pull-off caps, 50 – 100 mm (2 – 4 inches) in diameter,
- c. Ruler or measuring device,
- d. Marker for outlining area,
- e. Putty knife for cleaning caps,
- f. Small propane torch,
- g. Gloves, heat-resistant,
- h. Gloves, solvent-resistant.

3. MATERIALS

- a. Rapid-curing epoxy compound with a working (pot) life of 3 to 10 minutes. Pot life is the time after mixing during which the epoxy retains sufficient workability for proper use.
- b. Cleaning solvent.

4. PROCEDURE

- a. After all cleaning has been performed in preparation for overlay placement, determine test locations. If random sample locations for testing are required, determine according to the Department's "Method for Obtaining Random Samples for Concrete." Test locations shall be adjusted a maximum of 0.3 m (12 inches) when they are too close to a joint, parapet, or other obstruction, or when they are over a patch or other area that has not been mechanically scarified. The center-to-center distance of adjacent test specimens shall be a minimum of two disk diameters. If the concrete contains reinforcement, do not test at locations where the concrete cover is less than 20 mm ($\frac{3}{4}$ in.). A cover meter (pachometer) or other methods may be used to locate reinforcement and verify the concrete cover.
- b. Using a marker, mark a circle at each location using a pull-off cap as a template.
- c. The test area must be thoroughly dry. No additional cleaning or surface preparation should be performed at the test locations. A small propane torch may be used to dry an area to be tested. Heating the surface to a temperature exceeding 50° C (120° F) may damage the surface and result in a lower pull-off strength. Allow the surface to cool to ambient temperature before testing.
- d. Mix the epoxy according to the manufacturer's instructions. Place a thin layer of epoxy within the marked area on the deck surface and on the bottom of the cap. Carefully center the cap within the marked circle. Twist and lightly press the cap to ensure that there are no gaps between the cap and the epoxy-covered test area. Wipe off excess epoxy around the cap.
- e. Allow the epoxy to set in accordance with the manufacturer's instructions. As an option when air temperature is below 15° C (60° F), a small propane torch may be used to heat the top of the cap for very short intervals. The temperature of the cap should not exceed 50° C (120° F). Allow the cap to cool to air temperature before testing.
- f. If the area immediately surrounding the cap is subjected to moisture (i.e. rain) after the cap has been attached to the test area, the area must be allowed to dry before conducting the test. Moisture can significantly reduce the tensile (pull-off) strength.
- g. Attach the pull-off test equipment to the cap. Follow the manufacturer's instructions. Use a loading rate of 35 ± 14 kPa per second (5 ± 2 psi per second).
- h. Determine the mode of failure, according to the following definitions.

Failure of Epoxy – Epoxy pulled away from either the cap or the surface of the concrete.

Failure of Concrete Surface – Failure within 6 mm ($\frac{1}{4}$ inch) of the top surface of the concrete. At least 90 percent of the failure surface consists of concrete.

Failure of Underlying Concrete – Failure plane is greater than 6 mm ($\frac{1}{4}$ inch) below the surface of the concrete.

- i. If the mode of failure is "Failure of Epoxy" or "Failure of Underlying Concrete," then repeat the test at a location at least 0.15 m (6 inch), and not more than 0.6 m (2 feet), from the previous test. However, if the mode of failure is "Failure of the Epoxy" or "Failure of Underlying Concrete" and the tensile (pull-off) strength is greater than the specification requirement, repeating the test is not necessary.
- j. Record the load at failure in kN (lbs.).
- k. Measure the diameter of the failed concrete surface at four evenly spaced locations around the circumference. Average the four measurements and record as the average diameter in millimeters (inches) to the nearest ± 3 mm (±1/8 inch).

5. CLEANING PROCEDURE FOR PULL-OFF CAPS

- a. After performing a pull-off test, pull-off caps shall be cleaned properly to ensure that epoxy can bond adequately to their surface. Cap cleaning should be performed in a well ventilated area.
- b. Place the cap on a heat-resistant, non-flammable surface. Verify with the epoxy and equipment manufacturer that a small propane torch may be used. Using the propane torch, direct the flame on the concrete/epoxy material to be removed until the epoxy becomes pliable. Use a putty knife to remove as much of the epoxy and concrete as possible. **Warning: The use of a propane torch to remove the epoxy from the pull-off cap may generate hazardous fumes.**
- c. Allow the cap to cool to room temperature (approximately 77° F) or immerse the cap in water. Clean the cap according to instructions provided by the epoxy manufacturer, using the solvent they recommend. The following procedure is for when acetone may be used.
- d. Read and follow the label on the acetone container, which provides instructions and cautions. Read and follow the Material Safety Data Sheet (MSDS) for acetone safety, handling, and disposal. **Warning: Acetone is extremely flammable and vapors are harmful.**
- e. Fill a clean metal gallon can with enough acetone to cover the caps.
- f. Place a lid on the container loosely, and protect the container from tipping. Keep the container at room temperature (approximately 77° F) and in a well ventilated area. **Warning: Resident Engineer's field office is not appropriate for this step.**
- g. Soak the caps for 8-24 hours. The longer the soaking period, the easier the cleaning.
- h. Remove the caps and clean the grooves carefully using a sharp, pointed object.
- i. Once the majority of the epoxy has been removed, take a small amount of acetone and a clean rag and wipe the surface clean. The acetone will air dry and leave no oily residue.
- j. The acetone can be reused. Discontinue use and properly dispose of the acetone when it becomes contaminated and no longer cleans effectively.
- k. Store caps in a clean plastic bag or a sealed container.
- l. New pull-off caps will require cleaning with acetone. Even a small amount of oil or residue will prevent the epoxy from bonding to the cap.
- m. Disclaimer: The cleaning procedure for pull-off caps is provided as an aid for field personnel. In all cases, field personnel are responsible for contacting the epoxy and equipment manufacturers to determine the best method for cleaning pull-off caps.

6. CALCULATIONS

Calculate the tensile (pull-off) strength of the concrete surface as follows, to the nearest 10 kPa (1 psi).

When load (L) is given in kN:

$$T = \frac{L}{\pi/4 \times (D)^2}$$

Where: T = tensile strength, kPa
L = load at failure, kN
 $\pi = 3.1416$
D = diameter, meters

When load (L) is given in lbs.:

$$T = \frac{L}{\pi/4 \times (D)^2} \quad \text{or simplified,} \quad T = \frac{L}{D^2} \times 1.273$$

Where: T = tensile strength, psi
L = load at failure, lbs.
 $\pi = 3.1416$
D = diameter, inches

NOTE: 1 psi = 6.897 kPa

7. REPORT

Report the following information:

- a. Date of final cleaning of the concrete surface, and date of pull-off testing,
- b. Type of equipment used for final cleaning of the concrete surface (i.e. shotblasting, high-pressure water blasting, abrasive blasting).
- c. Length and width of each lot or subplot.
- d. Station location for each random sample test location.
- e. Individual load, average diameter of failed concrete surface, and tensile strength for each individual test.
- f. Mode of failure.

8. CALIBRATION

The pull-off testing device shall be calibrated on an annual basis according to the manufacturer's recommended procedure or a procedure approved by the Department. A calibration log shall be maintained and kept with the equipment.

Illinois Test Procedure 305

Effective Date: March 1, 2003

Revised Date: March 1, 2013

PULL-OFF TEST (OVERLAY METHOD)

Reference Test Procedure(s):

1. American Concrete Institute Manual of Concrete Practice ACI 503R-93, (Reapproved 1998), Appendix A (Test Methods).
2. Virginia Test Method for Testing Epoxy Concrete Overlays for Surface Preparation and Adhesion, VTM-92.
3. ASTM C 1583/C 1583M-04, Standard Test Method for Tensile Strength of Concrete Surfaces and the Bond Strength or Tensile Strength of Concrete Repair and Overlay Materials by Direct Tension (Pull-off Method)

1. GENERAL

This test method outlines the procedure for determining the bond strength of a portland cement concrete or thin polymer overlay.

2. EQUIPMENT

- a. Coring equipment,
- b. Pull-off testing device with sufficient capacity and capable of applying load at the specified rate,
- c. Pull-off caps, 50 – 100 mm (2 – 4 inches) in diameter,
- d. Wire brush,
- e. Ruler or measuring device,
- f. Marker for outlining area,
- g. Putty knife for cleaning caps,
- h. Small propane torch,
- i. Gloves, heat-resistant,
- j. Gloves, solvent-resistant.

3. MATERIALS

- a. Rapid-curing epoxy compound with a working (pot) life of 3 to 10 minutes,
- b. Cleaning solvent.

4. PROCEDURE

- a. Determine test locations. If random sample locations for testing are required, determine according to the Department's "Method for Obtaining Random Samples for Concrete." Test locations shall be adjusted a maximum of 0.3 m (12 inches) when they are too close to a joint, parapet, or other obstruction, or when they are over a patch or other area that has not been mechanically scarified. The center-to-center distance of adjacent test specimens shall be a minimum of two disk diameters. If the concrete contains reinforcement, do not test at locations where the concrete cover is less than 20 mm (¾ in.). A cover meter (pachometer) or other methods may be used to locate reinforcement and verify the concrete cover.
- b. Using a marker, mark a circle at each location using a pull-off cap as a template.
- c. Core completely through the overlay and at least 13 mm (1/2 inch) into the underlying concrete.
- d. The top of the intact core must be thoroughly dry. A small propane torch may be used to dry an area to be tested. Heating the surface to a temperature exceeding 50 °C (120 °F) may damage the surface and result in a lower pull-off strength. Allow the surface to cool to air temperature before testing.
- e. Carefully clean the surface of the core with a wire brush to remove any debris or film left from the coring operations.
- f. Mix the epoxy according to manufacturer's instructions. Place a thin layer of epoxy on both the top of the core and the bottom of the cap. Carefully center the cap. Twist and lightly press the cap to ensure that there are no gaps between the cap and the epoxy-covered core. Wipe off excess epoxy around the cap. Do not allow the epoxy to run down the side of the core into the annular cut.
- g. Allow the epoxy to set in accordance with the manufacturer's instructions. As an option when air temperature is below 15 °C (60 °F), a small propane torch may be used to heat the top of the cap for very short intervals. The temperature of the cap should not exceed 50 °C (120 °F). Allow the cap to cool to air temperature before testing.
- h. Attach the pull-off test equipment to the cap. Follow the manufacturer's instructions. Use a loading rate of 35 ± 14 kPa per second (5 ± 2 psi per second).
- i. Determine the mode of failure, according to the following definitions.

Failure of Epoxy – Epoxy pulled away from either the cap or the surface of the overlay.

Failure of Overlay Surface – Failure within 6 mm (1/4 inch) of the top surface of the overlay.

Failure in Overlay – Failure plane is deeper than 6 mm (1/4 in.) below the top surface of the overlay and above the bond line between the overlay and underlying concrete.

Failure at Bond Line – Failure plane is at the bond line between the overlay and underlying concrete. The bottom of the overlay is covered with less than 50 percent (by area) of material from the underlying concrete.

Failure of Underlying Concrete Surface – Failure plane is just below the bond line. The bottom of the overlay is covered with at least 50 percent (by area) of material from the underlying concrete. The layer is less than 6 mm (1/4 inch) thick.

Failure of Underlying Concrete – Failure plane is greater than 6 mm (1/4 inch) below the bond line.

- j. If the mode of failure is "Failure of Epoxy," "Failure of Overlay Surface," "Failure in Overlay," "Failure of Underlying Concrete," then repeat the test at a location at least 0.15 m (6 inch), and not more than 0.6 m (2 feet), from the previous test. However, if the mode of failure is "Failure of Epoxy," "Failure of Overlay Surface," "Failure in Overlay," or "Failure of Underlying Concrete," and

the tensile (pull-off) strength is greater than the specification requirement, repeating the test is not necessary.

- k. Record the load at failure in kN (lbs.).
- l. Measure the diameter at four evenly spaced locations around the circumference of the core. Average the four measurements and record as the average diameter in millimeters (inches) to the nearest ± 3 mm ($\pm 1/8$ inch).
- m. Measure the length of the core and record in millimeters (inches) to the nearest 3 mm (1/8 inch).

5. CLEANING PROCEDURE FOR PULL-OFF CAPS

- a. After performing a pull-off test, pull-off caps shall be cleaned properly to ensure that epoxy can bond adequately to their surface. Cap cleaning should be performed in a well ventilated area.
- b. Place the cap on a heat-resistant, non-flammable surface. Verify with the epoxy and equipment manufacturer that a small propane torch may be used. Using the propane torch, direct the flame on the concrete/epoxy material to be removed until the epoxy becomes pliable. Use a putty knife to remove as much of the epoxy and concrete as possible. **Warning: The use of a propane torch to remove the epoxy from the pull-off cap may generate hazardous fumes.**
- c. Allow the cap to cool to room temperature (approximate 77 °F) or immerse the cap in water. Clean the cap according to instructions provided by the epoxy manufacturer, using the solvent they recommend. The following procedure is for when acetone may be used.
- d. Read and follow the label on the acetone container, which provides instructions and cautions. Read and follow the Material Safety Data Sheet (MSDS) for acetone safety, handling, and disposal. **Warning: Acetone is extremely flammable and vapors are harmful.**
- e. Fill a clean metal gallon can with enough acetone to cover the caps.
- f. Place a lid on the container loosely, and protect the container from tipping. Keep the container at room temperature (approximately 77 °F) and in a well ventilated area. **Warning: Resident Engineer's field office is not appropriate for this step.**
- g. Soak the caps for 8-24 hours. The longer the soaking period, the easier the cleaning.
- h. Remove the caps and clean the grooves carefully using a sharp, pointed object.
- i. Once the majority of the epoxy has been removed, take a small amount of acetone and a clean rag and wipe the surface clean. The acetone will air dry and leave no oily residue.
- j. The acetone can be reused. Discontinue use and properly dispose of the acetone when it becomes contaminated and no longer cleans effectively.
- k. Store caps in a clean plastic bag or a sealed container.
- l. New pull-off caps will require cleaning with acetone. Even a small amount of oil or residue will prevent the epoxy from bonding to the cap.
- m. Disclaimer: The cleaning procedure for pull-off caps is provided as an aid for field personnel. In all cases, field personnel are responsible for contacting the epoxy and equipment manufacturers to determine the best method for cleaning pull-off caps.

6. CALCULATIONS

Calculate the tensile (pull-off) strength of the overlay as follows, to the nearest 10 kPa (1 psi):

When load (L) is given in kN:

$$T = \frac{L}{\pi/4 \times (D)^2}$$

Where: T = tensile strength, kPa

L = load at failure, kN

π = 3.1416

D = diameter, meters

When load (L) is given in lbs.:

$$T = \frac{L}{\pi/4 \times (D)^2} \quad \text{or simplified,} \quad T = \frac{L}{D^2} \times 1.273$$

Where: T = tensile strength, psi

L = load at failure, lbs.

π = 3.1416

D = diameter, inches

NOTE: 1 psi = 6.897 kPa

7. REPORT

Report the following information:

- a. Date of overlay placement and date of pull-off testing,
- b. Type of equipment used for final cleaning of the concrete surface (i.e. shotblasting, high-pressure water blasting, abrasive blasting),
- c. Stating location for each test location.
- d. Individual load, average diameter of failed specimen at failure plane, and tensile strength for each individual test.
- e. Mode of failure.

8. CALIBRATION

The pull-off testing device shall be calibrated on an annual basis according to the manufacturer's recommended procedure or a procedure approved by the Department. A calibration log shall be maintained and kept with the equipment.

Illinois Test Procedure 307

Effective Date: April 1, 2009

Revised Date: [December 1, 2021](#)

Sampling and Testing of Controlled Low-Strength Material (CLSM)

I. SAMPLING OF CLSM

Sampling freshly mixed controlled low-strength material (CLSM) shall be performed according to Illinois Modified AASHTO R 60, except the elapsed time for obtaining the composite sample shall not exceed two minutes. The flow test shall start within five minutes of obtaining the composite sample. The molding of strength test specimens shall start within ten minutes of obtaining the composite sample. The sample is to be routinely mixed during the testing process because CLSM may segregate.

II. TEMPERATURE OF CLSM

The temperature test shall be according to Illinois Modified ASTM C 1064.

III. FLOW CONSISTENCY OF CLSM

The flow test shall consist of filling a 76 mm (3 in.) inside diameter by 152 mm (6 in.) long plastic cylinder. The maximum variation from the normal inside diameter and length shall be 3 mm (1/8 in.). The plastic cylinder shall be smooth, rigid, nonabsorbent, and open at both ends. The test method shall consist of the following:

- Dampen the inside of the cylinder.
- Place the cylinder on a flat, level, firm nonabsorbent surface that is free of vibration or other disturbances.
- Hold the cylinder firmly in place and fill in one lift without vibration, rodding, or tapping.
- Strike off the top of the cylinder to form a level surface while holding the cylinder in place. Remove surplus material from around the base of the cylinder.
- Immediately raise the cylinder vertically a minimum distance of 150 mm (6 in.) in 3 ± 1 seconds without any lateral or torsional motion.
- When the material has stopped flowing, measure the maximum diameter of the resulting spread and measure the diameter perpendicular to the maximum. Each measurement shall be to the nearest 10 mm (0.5 in.). If the two measurements differ by more than 50 mm (2 in.), verify working surface to be level, and test again.
- Calculate the average of the two measured diameters and report to the nearest 5 mm (0.25 in.).

IV. AIR CONTENT OF CLSM

The air content test shall be according to Illinois Modified AASHTO T 121 or Illinois Modified AASHTO T 152, except the bowl shall be filled in one lift without vibration, rodding, or tapping.

V. COMPRESSIVE STRENGTH OF CLSM

Compressive strength test specimens shall be made and cured according to Illinois Modified AASHTO R 100, except for the following:

- The 152 mm x 305 mm (6 in. x 12 in.) cylinders shall be filled in one lift without vibration, rodding, or tapping. When bleed water appears at the top of the mold after a few minutes, the mold shall be refilled.
- The curing method shall be modified by not removing the covered specimen from the mold until the time of testing.

Compressive strength test specimens shall be tested according to Illinois Modified AASHTO T 22, except for the following:

- Neoprene caps shall be used for compressive testing, and a wire brush may be used to flatten test specimens that are not plane.
- The compression machine loading rate shall be 20 ± 10 kPa/s (3 ± 2 psi/s).
- Strength is defined as the average of two or more cylinder breaks.
- Compressive strength shall be calculated to the nearest 1.0 kPa (1.0 psi).

Illinois Test Procedure 501

Effective Date: April 1, 2010

Revised Date: January 1, 2017

Dynamic Cone Penetration (DCP)

1.0 GENERAL

- 1.1 This method covers the procedure for conducting the DCP test on treated and untreated subgrade materials.
- 1.2 This method does not address safety problems associated with using the DCP equipment. It is the operator's responsibility to determine the limitations prior to its use. At a minimum, the operator is cautioned not to hold the DCP from the anvil, to avoid injury to the fingers by the falling hammer.

2.0 SIGNIFICANCE AND USE

- 2.1 The DCP is used to indirectly determine the immediate bearing value (IBV) of treated or untreated subgrade material (Note 1).
- 2.2 The IBV is used to evaluate the subgrade stability, and to determine the depth of subgrade treatment according to the Department's Subgrade Stability Manual.

NOTE 1 – The IBV is considered to be equivalent to the in situ Illinois Bearing Ratio (IBR), or the laboratory IBR obtained immediately after compacting the material, without soaking.

3.0 REFERENCED DOCUMENTS

- 3.1 ASTM D 4429 (latest edition), "Standard Test Method for CBR (California Bearing Ratio) of Soils in Place"

ASTM D 6951 (latest edition), "Standard Test Method for Use of Dynamic Cone Penetrometer in Shallow Pavement Applications"

IDOT, Geotechnical Manual (latest edition), Appendix B.2, "Method of Determining the IBR and the IBV of Soils, Treated Soils and Aggregates"

IDOT, Subgrade Stability Manual (latest edition).

Sowers, G.F. and Hedges, C.S. (1966), "Dynamic Cone for Shallow In Situ Penetration Testing", Vane Shear and Cone Penetration Resistance Testing of In Situ Soils, ASTM STP 399.

Livneh, M. and Ishai, I. (1987), "Pavement and Material Evaluation by a Dynamic Cone Penetrometer", Sixth International Conference on the Structural Design of Asphalt Pavement, Ann Arbor, Michigan.

Maur, M.C. and de Beer, M. (1988), "Computer Programs to Plot DCP Data – Users Manual", Division of Roads and Transport Technology, Pretoria.

4.0 EQUIPMENT

- 4.1 Material: The DCP components shall be made of stainless steel.
- 4.2 As shown on Figure 1, the DCP consists of:
- a) A 60-degree *cone*, with 0.787 in. (20 mm) base diameter (Note 2).
 - b) A graduated *rod*, 40 in. (1 m) long (variable), 5/8 in. (16 mm) diameter, with 0.2 in. (5 mm) graduations. The rod should be threaded on both ends to allow for attachment to the cone on one end and the anvil on the other end. A ruler may be used for measuring the cone penetration, in lieu of having graduations on the rod. Refer to ASTM D 6951 for a picture that shows the device with a ruler attached.
 - c) An 17.6 lb (8 kg) sliding *hammer*, which slides along a 5/8 in. (16 mm) diameter *upper rod*, whose length should accommodate for the hammer length and a free fall of 22.6 in. (575 mm). The upper rod is threaded (or welded) to a driving *anvil* on one end and to a *handle* on the other end.

Note 2 – A disposable cone, meeting the requirements of 4.2 a), may be used in hard materials to avoid damage to the equipment, which may be caused by driving the hammer upward in an attempt to extract the cone from the ground.

- 4.3 A mechanically operated device mounted on a truck is also acceptable.

5.0 TEST PROCEDURE

- 5.1 Check the DCP components for deficiencies, replace any damaged part, and assemble the equipment as shown in Figure 1.
- 5.2 Hold the DCP vertically, from the handle, and seat the cone such that the cone base is flush with the surface of the material to be tested. The initial (reference) reading will be taken from the cone base (Note 3). A straight edge next to the DCP will make a good reference point. Do not record the number of blows required to seat the cone.

Note 3 – In soft materials, the cone might penetrate into a depth beyond the cone base under the hammer weight. In this case, record the current reading, under the hammer weight, as the initial reference point.

- 5.3 Raise the hammer carefully all the way to the top, without impacting the handle, and let it drop freely on the anvil to drive the cone into the material. The cone will penetrate the material to a depth which depends on the material resistance.
- 5.4 Measure the number of blows for every 6 in. (150 mm) penetration into the material, or measure the amount of penetration after each blow if the single blow penetration is greater than 6 in. (150 mm). This may depend on the material variability and resistance. Penetration readings are recorded to the nearest 0.2 in. (5 mm).

- 5.5 Repeat the procedure in 5.3 and 5.4 to the desired depth into the material. A depth of 36 in. (900 mm) is typical.

6.0 CALCULATIONS

- 6.1 The penetration rate (PR), inches per blow, is the amount of penetration (6 in. (150 mm)) divided by the number of blows in that increment. If the single blow penetration is greater than 6 in. (150 mm), the PR is the amount of penetration per blow. The PR value is recorded to the nearest 0.2 in. (5 mm) per blow. (Note 4)

Note 4 – Layers of the subgrade that have similar PR values should be averaged to determine the PR for each layer. Engineering judgment will be necessary to group the PR values and assess the validity of high or low penetrations.

- 6.2 Using the average PR value and Figure 2, obtain the equivalent IBV for each 6 in. (150 mm). The IBV may be used to obtain an equivalent compressive strength (Q_u) as indicated on the DCP form (BMPR SL30).
- 6.3 Use the attached DCP form (BMPR SL30) to record all data obtained from 6.2 at different stations.

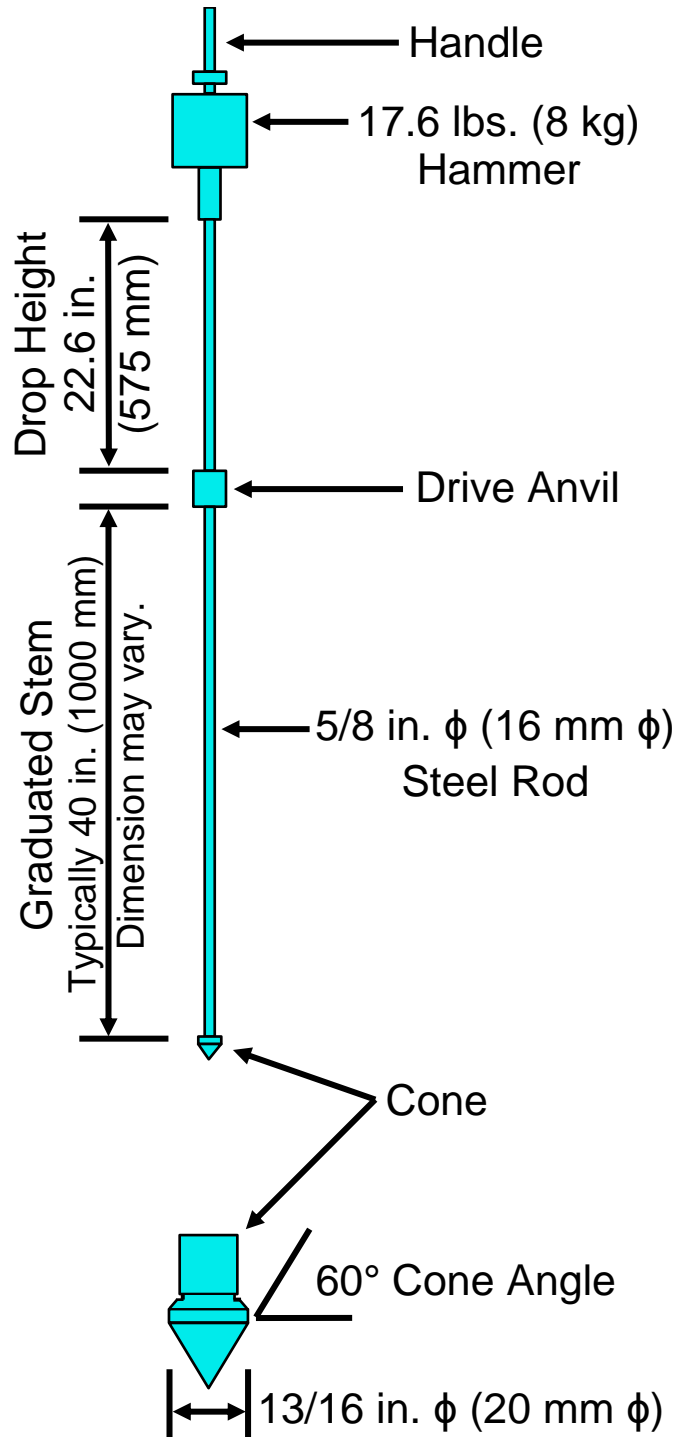
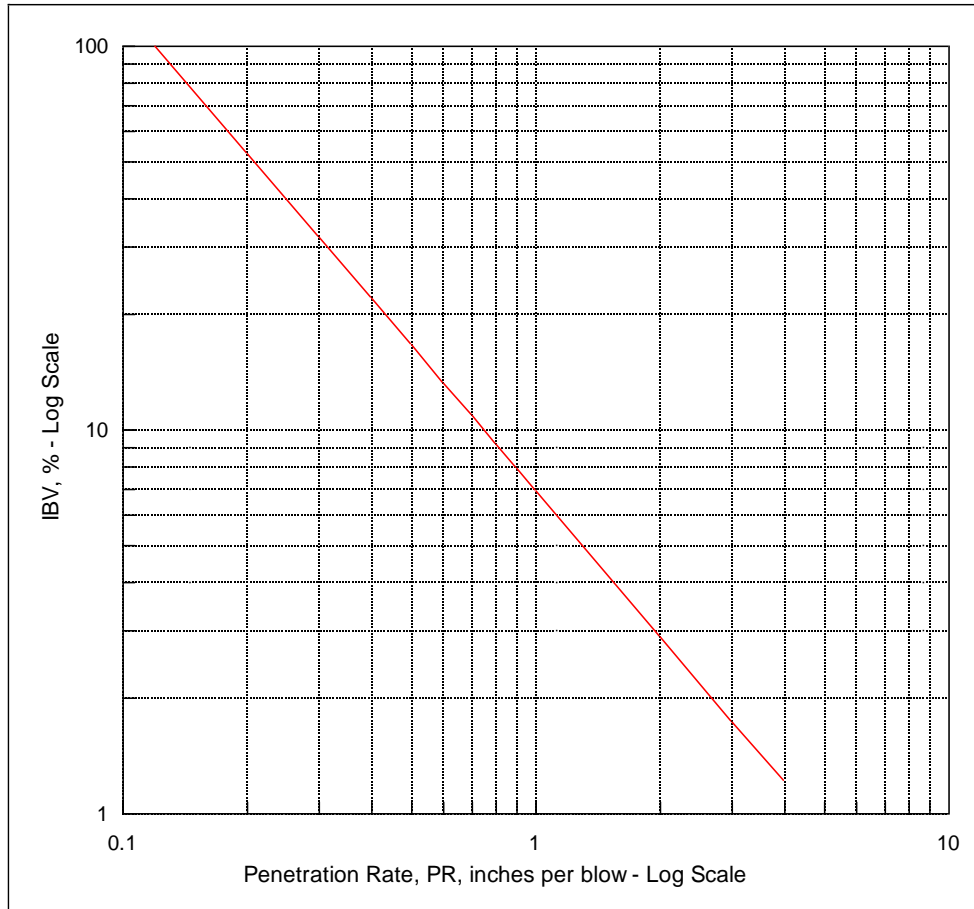

Figure 1 – The DCP equipment.



$$IBV = 10^{0.84 - 1.26 \times \text{LOG} [\text{PR (inches/blow)}]}$$

Figure 2 – The IBV as a function of the penetration rate (PR).



**Illinois Department
of Transportation**

Dynamic Cone Penetration Test

Date: _____
 Weather: _____
 Inspector: _____
 Company (Consultants): _____
 Design No.: _____
 Sheet No.: _____
 Contractor: _____

County: _____
 Section: _____
 Route: _____
 District: _____
 Contract No.: _____
 Job No.: _____
 Project: _____

Subgrade Foundation

Test Location ^a and Remarks ^b	Initial Depth						
		Depth ^c					
		Blows					
		Rate ^d					
		IBV					
		Q _u					
		Depth					
		Blows					
		Rate					
		IBV					
		Q _u					
		Depth					
		Blows					
		Rate					
		IBV					
		Q _u					
		Depth					
		Blows					
		Rate					
		IBV					
		Q _u					
		Depth					

^a Indicate station and offset.

^b Include soil type, moisture, rutting, or cut/fill information as applicable.

^c Depth is cumulative in inches.

^d Rate is inches of penetration per blow.

Comments:

Rate	IBV	Q _u *	Rate	IBV	Q _u *
0.5	17	5.4	1.3	5	1.6
0.6	13	4.2	1.5	4	1.3
0.7	11	3.5	2.0	3	1.0
0.8	9	2.9	2.6	2	0.6
0.9	8	2.6	3.0	1.7	0.5
1.0	7	2.2	3.3	1.5	0.5
1.1	6	1.9	4.6	1	0.3
1.2	5.5	1.8	>4.6	<1	<0.3

*Q_u value calculated from IBV whole number.

$$IBV = 10^{0.84 - 1.26 \times \text{LOG}(\text{Rate})}$$

$$Q_u \text{ (tsf)} = 0.32 \times IBV$$

BMPR SL30 (Rev. 03/17/10)

Illinois Test Procedure 502

Effective Date: April 1, 2010

Revised Date: January 1, 2017

Static Cone Penetration (SCP)

1.0 GENERAL

- 1.1 This method covers the procedure for conducting the SCP test on treated and untreated subgrade materials.
- 1.2 This method does not address safety problems associated with using the SCP equipment. It is the operators responsibility to determine the equipment limitations prior to its use.

2.0 SIGNIFICANCE AND USE

- 2.1 The SCP is used to determine the cone index (CI) of treated or untreated subgrade material (Note 1).
- 1.1 The CI is used to evaluate the subgrade stability, and to determine the depth of subgrade treatment according to the Department's Subgrade Stability Manual.

Note 1 – The CI is a strength value which is equal to the penetrometer load (in pounds) divided by the base area (in.²), and it has the units of psi (not expressed).

3.0 REFERENCED DOCUMENTS

- 3.1 IDOT, Geotechnical Manual (latest edition), Appendix B.2, "Method of Determining the IBR and the IBV of Soils, Treated Soils and Aggregates"

IDOT, Subgrade Stability Manual (latest edition).

4.0 EQUIPMENT

- 4.1 Material: The metal components of the SCP shall be made of stainless steel.
- 4.2 As shown in Figure 1, the SCP consists of:
 - a) A 30-degree *cone*, with a 0.5 in.² (315 mm²) base area.
 - b) A graduated *rod*, 19 in. (0.48 m) long (variable), 5/8 in. (16 mm) diameter, marked at 6 in. (150 mm) intervals. The bottom 6 in. (150 mm) interval is marked at 1 in. (25 mm) subintervals.
 - c) A 150 lb capacity proving ring with a handle and a factory calibrated dial indicator, calibrated direct 0 to 300 psi in 5 psi increments. Alternatively, a displacement dial indicator may be used with a factory calibrated proving ring and a calibration chart.

5.0 TEST PROCEDURE

5.1 Check the SCP components for deficiencies, replace any damaged part, and follow the manufacturer's recommendations to assemble the equipment as shown in Figure 1 (Note 2).

Note 2 - The dial indicator is a sensitive instrument which should be protected against water, dust, and rough usage. Make sure the dial indicator is on the zero reading prior to the test.

5.2 Hold the SCP vertically, from the handle, and seat the cone such that the cone base is flush with the surface of the material to be tested. The initial (reference) reading will be taken from the cone base (Note 3).

Note 3 – The SCP test should be conducted after the subgrade has been stressed with several passes of a loaded truck. Any crust formed on the subgrade, from drying, must be removed before seating the cone. Crusted subgrades give high readings that do not reflect the strength of the weaker underlying material.

5.3 Holding the handle firmly, push the cone down into the subgrade material at a steady, uniform rate and record the cone index, from the dial indicator readings, every 6 in. (150 mm) of the cone penetrations.

5.4 Continue the procedure in 5.3 until: 1) the maximum depth of 18 in. (450 mm) is reached, or 2) high resistance is encountered, or 3) the maximum ring capacity is reached; whichever occurs first.

5.5 Use the attached SCP form (BMPR SL31) to record the CI values at different depths and stations. Record the CI value to the nearest whole number. The CI can also be converted to an equivalent compressive strength (Q_u) by using the equations on the SCP form (BMPR SL31). Normally, an equivalent IBV is determined.

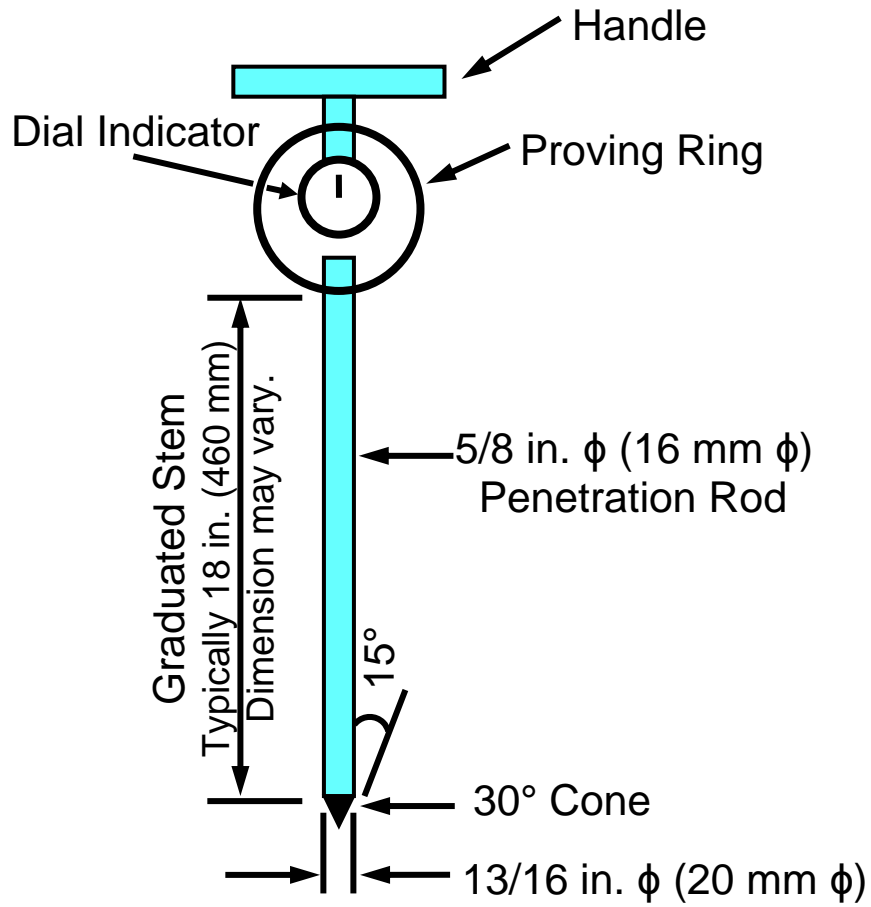

Figure 1 – The SCP equipment.



**Illinois Department
of Transportation**

Static Cone Penetration Test

Date: _____
 Weather: _____
 Inspector: _____
 Company (Consultants): _____
 Design No.: _____
 Sheet No.: _____
 Contractor: _____

County: _____
 Section: _____
 Route: _____
 District: _____
 Contract No.: _____
 Job No.: _____
 Project: _____

Test Location ^a and Remarks ^b	<input type="checkbox"/> Subgrade		<input type="checkbox"/> Foundation			
		Depth ^c				
	Dial Reading ^d					
	IBV					
	Q _u					
	Depth					
	Dial Reading					
	IBV					
	Q _u					
	Depth					
	Dial Reading					
	IBV					
	Q _u					
	Depth					
	Dial Reading					
	IBV					
	Q _u					
	Depth					
	Dial Reading					
	IBV					
	Q _u					

^a Indicate station and offset.

^b Include soil type, moisture, rutting, or cut/fill information as applicable.

^c Depth is cumulative in inches.

^d Dial Reading = Cone Index (CI)

IBV = CI ÷ 40

Q_u (tsf) = 0.32 x IBV

Cone Index	IBV	Q _u *
320	8	2.6
280	7	2.2
240	6	1.9
200	5	1.6
160	4	1.3
120	3	1.0
80	2	0.6
40	1	0.3

*Q_u value calculated from IBV whole number.

BMPR SL31 (Rev. 03/17/10)

Illinois Modified Test Procedure
Effective Date: February 1, 2014

Standard Practice
for
Temperature of Freshly Mixed Hydraulic Cement Concrete

Reference ASTM C 1064/C 1064M-12
(formerly AASHTO T 309)

NOTE: This test method cannot be reproduced here due to copyright. The Contractor shall provide a copy of the ASTM test method to the Engineer if requested.

ASTM Section	Illinois Modification
2.1	Replace as follows: AASHTO R 60 (Illinois Modified) for ASTM C172 To maintain brevity in the text, the following will apply: Example: AASHTO R 60 (Illinois Modified) will be designated as "R 60."

Standard Test Method
For
Temperature of Freshly Mixed Hydraulic Cement Concrete

Reference ASTM C 1064/C 1064M-12

The ASTM standard test method is not reproduced herein, but a copy is available to individuals who have taken the Portland Cement Concrete Level I Technician Course.

For convenience to the individual using this manual, the ASTM standard test method for measuring the temperature of freshly mixed concrete is summarized as follows.

1. Obtain the concrete sample according to R 60. The sample size shall be sufficient to provide a minimum 75 mm (3 in.) concrete cover around the thermometer sensor in all directions.
2. Use an ASTM approved thermometer which is accurate to $\pm 0.5^{\circ}\text{C}$ ($\pm 1^{\circ}\text{F}$), and has a range that is adequate for concrete temperatures encountered. Refer to the Standard Specifications for Road and Bridge Construction for concrete temperature limitations.
3. Place the thermometer in the concrete sample, which was collected in a damp, non-absorbent container. The thermometer sensor shall be submerged a minimum of 75 mm (3 in.). The concrete temperature may also be measured in placement forms, or anywhere the minimum 75 mm (3 in.) cover is provided.
4. Gently press the concrete around the thermometer to prevent air temperature affects.
5. Read the temperature after a minimum of 2 minutes of when the temperature readings stabilize.
6. Complete the temperature measurement within 5 minutes after obtaining the sample.
7. Record the temperature to the nearest 0.5°C (1°F).

Illinois Modified Test Procedure
Effective Date: [December 1, 2021](#)

Standard Method of Test
for
**Estimating Concrete Strength by the
Maturity Method**

Reference ASTM C 1074-19

NOTE: This test method is to be used in conjunction with and according to Illinois Modified AASHTO T 325, “Estimating the Strength of Concrete in Transportation Construction by Maturity Tests”. According to Illinois Modified AASHTO T 325, the Contractor shall provide a copy of the ASTM test method to the Engineer if requested.

ASTM Section	Illinois Modification
2.1	<p>Replace as follows: AASHTO T 22 (Illinois Modified) AASHTO R 100 (Illinois Modified) (formerly AASHTO T 23) AASHTO T 119 (Illinois Modified) AASHTO T 152 (Illinois Modified) AASHTO T 177 (Illinois Modified) AASHTO T 196 (Illinois Modified) AASHTO T 309 (Illinois Modified)</p> <p>To maintain brevity in the text, the following will apply: Example: AASHTO T 22 (Illinois Modified) will be designated as “T 22.”</p>
5.1	<p>Replace as follows: This standard can be used to estimate the in-place strength of concrete pavement patches and bridge deck patches. These estimates provide guidance useful in making decisions concerning opening to traffic.</p>
8.1	<p>Replace the first sentence with the following: The batch of concrete from which samples are taken shall be a minimum 2 yd³ (1.5 m³) (4 yd³ (3.0 m³) recommended), and the project’s actual batching and mixing equipment shall be used. Air content shall be within $\pm 0.3\%$ of the maximum allowed by specification.</p>
8.3	<p>Replace with the following: Mold and cure the specimens in accordance with T 23, except specimens shall be moved within 30 minutes of batching to cure in air at 73 ± 3 °F (23 ± 2 °C). Record the slump, air content, and temperature of the concrete. Protect the specimens from disturbance, direct sunlight, and wind.</p>

Illinois Modified Test Procedure
Effective Date: [December 1, 2021](#)

Standard Method of Test
for
**Estimating Concrete Strength by the
Maturity Method**

(continued)

Reference ASTM C 1074-19

ASTM Section	Illinois Modification																		
8.4	<p>Revise as follows: Delete the first sentence. Refer to the following table for suggested test ages for pavement or bridge deck patching:</p> <p>Table 1. Suggested Test Ages</p> <table border="1" style="margin-left: auto; margin-right: auto;"> <thead> <tr> <th style="text-align: center;">2-Day Patch Age (hours)</th> <th style="text-align: center;">1-Day Patch Age (hours)</th> </tr> </thead> <tbody> <tr><td style="text-align: center;">24</td><td style="text-align: center;">2</td></tr> <tr><td style="text-align: center;">26</td><td style="text-align: center;">4</td></tr> <tr><td style="text-align: center;">28</td><td style="text-align: center;">6</td></tr> <tr><td style="text-align: center;">30</td><td style="text-align: center;">8</td></tr> <tr><td style="text-align: center;">32</td><td style="text-align: center;">10</td></tr> <tr><td style="text-align: center;">34</td><td style="text-align: center;">12</td></tr> <tr><td style="text-align: center;">36</td><td style="text-align: center;">16</td></tr> <tr><td style="text-align: center;">48</td><td style="text-align: center;">48</td></tr> </tbody> </table> <p>The Engineer reserves the right to verify the Contractor's strength tests. If the difference between the Engineer's and the Contractor's split sample strength test results is greater than 6200 kPa (900 psi) compressive strength or 620 kPa (90 psi) flexural strength, the Contractor's test will be considered invalid, which will invalidate the strength-maturity relationship.</p>	2-Day Patch Age (hours)	1-Day Patch Age (hours)	24	2	26	4	28	6	30	8	32	10	34	12	36	16	48	48
2-Day Patch Age (hours)	1-Day Patch Age (hours)																		
24	2																		
26	4																		
28	6																		
30	8																		
32	10																		
34	12																		
36	16																		
48	48																		
Section 9.	Delete the section.																		

Illinois Modified Test Procedure
Effective Date: December 1, 2017

Standard Practice
for
**Use of Unbonded Caps in Determination of
Compressive Strength of Hardened Cylindrical Concrete Specimens**

Reference ASTM C 1231/C 1231M-15

NOTE: This test method is to be used in conjunction with and according to Illinois Modified AASHTO T 22, "Compressive Strength of Cylindrical Concrete Specimens."

ASTM Section	Illinois Modification
5.3	Add as follows: The retainers shall be free of rust and other foreign material.
6.1	Add as follows: One method of measuring the perpendicularity of ends of cylinders is to place a try square across any diameter and measure the departure of the longer blade from an element of the cylindrical surface. An alternative method is to place the end of the cylinder on a plane surface and support the try square on that surface. A deviation from the perpendicularity of 0.5° is equal to a slope of approximately 1 mm in 100 mm (1/8 in. in 12 in.).

This Page Reserved

Illinois Modified Test Procedure
Effective Date: April 1, 2011
Revised Date: January 1, 2017

Standard Method
for
**Bulk Specific Gravity and Density of Compacted Bituminous Mixtures Using Coated
Samples**

Reference ASTM D1188-07 (2015)

ASTM Section	Illinois Modification
2.1	Replace the individual Standards as follows: IL Modified standards in the Illinois Department of Transportation <i>Manual of Test Procedures for Materials (current edition)</i>

This Page Reserved

Illinois Modified Test Procedure
 Effective Date: January 1, 2002
 Revised Date: January 1, 2017

Standard Test Method
 for
Determination of Density of Bituminous Concrete in Place by Nuclear Methods
 Reference ASTM D 2950-14

AASHTO Section	Illinois Modification
2.1	Replace the individual Standards as follows: IL Modified ASTM Standards in the Illinois Department of Transportation <i>Manual of Test Procedures for Materials</i> (current edition)
3.5	Replace with the following: The density results obtained by this test method are relative. If an approximation of core density results is required, a correlation factor will be developed to convert nuclear density to core density by obtaining nuclear density measurements and core densities at the same locations. The Department's "Standard Test Method for Correlating Nuclear Gauge Densities with Core Densities" shall be used to determine the appropriate correlation. It may be desirable to check this factor at intervals during the course of the paving project. A new correlation factor should be determined when there is a change in the job mix formula (outside the allowable adjustments); a change in the source of materials or in the materials from the same source; a significant change in the underlying material; a change from one gauge to another; or a reason to believe the factor is in error.
3.6 New Section	All projects containing 2750 metric tons (3000 tons) or more of a given mixture will require a correlation factor be determined and applied for measurement of density testing.

Standard Test Method
 for
Determination of Density of Bituminous Concrete in Place by Nuclear Methods
 Reference ASTM D 2950-14

AASHTO Section	Illinois Modification
3.7	<p><u>Definitions:</u></p> <p>Density Test Location: The random station location used for density testing.</p> <p>Density Reading: A single, one minute nuclear density reading.</p> <p>Individual Test Result: An individual test result is the average of three to five nuclear density readings obtained at each random density test location. One to three “individual test results” will be required per “density test location” depending on the following conditions:</p> <ul style="list-style-type: none"> • If two confined edges are present, one “individual test” result representing all five density readings across the mat shall be reported. (Confined edge density readings are included in the average.) • If one confined and one unconfined edge is present, two “individual test results” shall be reported for each density test location. <ul style="list-style-type: none"> ○ One “individual test result” representing the average of four density readings across the mat, including the one confined edge and excluding the unconfined edge density readings. ○ One “individual test result” representing the average of three density readings on the unconfined edge. • If two unconfined edges are present, three “individual test” results shall be reported for each density test location. <ul style="list-style-type: none"> ○ One “individual test result” representing the average of three density readings across the mat, excluding the unconfined edge density readings. ○ One “individual test result” representing the average of three density readings on the unconfined edge. ○ One “individual test result” representing the average of three density readings on the opposite unconfined edge. <p>Daily Average Density Value: The “daily average density” is the average of the “density readings” of a given offset for the given days production.</p> <p>Density Test Site: Correlation term use to describe each physical location the nuclear density gauge is placed where a density value is determined.</p> <p>Density Value: Correlation term used to describe the density determined at a given density test site from the average of two or potentially three readings.</p>

Standard Test Method
 for
Determination of Density of Bituminous Concrete in Place by Nuclear Methods
 Reference ASTM D 2950-14

AASHTO Section	Illinois Modification
3.8 New Section	When the "Hot Mix Asphalt (HMA) Individual Density Site Modified QC/QA" special provision is included, "daily average density values" shall also be determined.
4.2.1	Add the following at the end: The user should recognize that density readings obtained on the surface of thin layers of bituminous concrete may be erroneous if the density of the underlying material differs significantly from that of the surface course.
4.2.2	Add the following at the end: Accuracy of the nuclear test modes (Backscatter vs. Direct Transmission) is not equal and is affected by the surface texture and thickness of the mixture under test. The nuclear test mode to be used and the number of tests required to determine a satisfactory factor are dependent on the conditions stated above.
4.5	Replace with the following: If samples of the measured material are to be taken for purposes of correlation with other test methods, the procedures described in the Department's "Standard Test Method for Correlating Nuclear Gauge Densities with Core Densities" shall be used.
5.5 New Section	<i>Readout Instrument</i> , such as scaler or direct readout meter.
7.1	Add the following at the end: Dated inspection reports shall be kept and be made available to the Engineer upon request.
7.1.1 New Section	The calibration check shall provide proof of five-block calibration. Calibration standards shall consist of magnesium, magnesium/aluminum, limestone, granite, and aluminum. All calibration standards should be traceable to the U.S. Bureau of Standards. Proof shall consist of documented and dated calibration counts accompanied by copies of an invoice from the calibrating facility.
7.1.2 New Section	At least once a year and after all major repairs which may affect the instrument geometry, the calibration curves, tables, or equation coefficients shall be verified or reestablished.

Standard Test Method
 for
Determination of Density of Bituminous Concrete in Place by Nuclear Methods
 Reference ASTM D 2950-14

AASHTO Section	Illinois Modification
8.2.1	Replace with the following: The reference standard count shall be taken a minimum of 10 m (30 ft.) from another gauge and a minimum of 5 m (15 ft.) away from any other masses or other items which may affect the reference count rate. In addition, the reference count shall be taken on material 1510 kg/m ³ (100 lbs./ft. ³) or greater.
8.2.2	Revise the first sentence as follows: Turn on the apparatus prior to standardization and allow it to stabilize, a minimum of 20 minutes.
8.2.3	Replace with the following: All reference standard counts shall consist of a 4-minute count.
8.2.4	Replace with the following: The density reference standard count shall be within 1 percent of the average of the last four daily reference standard counts.
8.2.5 New Section	If four reference standard counts have not been established, then the reference standard count shall be within 2 percent of the standard count shown in the count ratio book.
8.2.6 New Section	If the reference standard count fails the established limits, the count may be repeated. If the second count fails also, the gauge shall not be used. The gauge shall be adjusted or repaired as recommended by the manufacturer.
8.2.7 New Section	Record all daily reference standard counts in a permanent-type book for a gauge historical record. This also applies to direct readout gauges.
8.3	Delete the first sentence.
9.1	Revise as follows: In order to provide more stable and consistent results: (1) turn on the instrument prior to use to allow it to stabilize, a minimum of 20 minutes; and (2) leave the power on during the day's testing.

Standard Test Method
 for
Determination of Density of Bituminous Concrete in Place by Nuclear Methods
 Reference ASTM D 2950-14

AASHTO Section	Illinois Modification
9.3	Replace with the following: Select a test location, using the Department's "Determination of Random Density Test Site Locations". Each random density test site location shall consist of five equally spaced nuclear density offsets across the mat. These density offsets shall be positioned to provide a diagonal configuration across the mat. The outer density offsets shall be located at a distance equal to the lift thickness or a minimum of 2 in. (50 mm), from the edge of the mat, whichever is greater. <ul style="list-style-type: none"> • If the edge is unconfined, an "individual test result" shall represent the average of three "density readings" spaced 10 feet apart longitudinally along the unconfined edge. • If the edge is confined, the density reading will be averaged with the remaining offset "density readings" to provide an "individual test result" representing everything except unconfined edges.
9.4	Replace with the following: Maximum contact between the base of the instrument and the surface of the material under test is critical. Since the measured value of density by backscatter is affected by the surface texture of the material immediately under the gauge, a smoothly rolled surface should be tested for best results. A filler of limestone fines or similar material, leveled with the guide/scrapper plate, shall be used to fill open surface pores of the rolled surface.
9.5	Replace with the following: For the Direct Transmission Method use the guide/scrapper plate and drive the steel rod to a depth of at least 50mm (2 in.) deeper than the desired measurement depth.
9.6	Add the following at the end: All other radioactive sources shall be kept at least 10 m (30 ft.) from the gauge so the readings will not be affected.
9.7	Delete.
9.8	Delete.
Note 6	Delete.
Note 7	Delete.

Illinois Modified Test Procedure
 Effective Date: January 1, 2002
 Revised Date: January 1, 2017

Standard Test Method
 for
Determination of Density of Bituminous Concrete in Place by Nuclear Methods
 Reference ASTM D 2950-14

AASHTO Section	Illinois Modification
10.1	Delete.
10.1.1	Delete.
10.2	Delete.
11.1.1	Replace with the following: Gauge number,
11.1.2	Revise as follows: Date of calibration data,
11.1.5	Revise as follows: Density test site description as follows: (1) project identification number, (2) location, including station and reference to centerline, (3) mixture type(s), including mix design number and surface texture, e.g., open, smooth, roller-tracked, etc., and (4) number and type of rollers
11.1.6	Replace with the following: Layer (bottom lift = .1, second lift = .2, etc.) and thickness of layer,

Standard Method of Test
 for
Automated Extraction of Asphalt Binder from Asphalt Mixtures

Reference ASTM D8159-18

AASHTO Section	Illinois Modification
2.1	Replace ASTM D979/979M with AASHTO T168 Replace ASTM D1461 with AASHTO T110 Replace ASTM D1856 with AASHTO R59 Replace ASTM D2042 with AASHTO T44 Replace ASTM D2172/2172M with IL Modified AASHTO T164 Replace ASTM D2872 with AASHTO T240 Replace ASTM D3666 with AASHTO R89 Replace ASTM D4753 with AASHTO M231 Replace ASTM D5444 with AASHTO T30 Replace AASHTO R47 with IL Modified AASHTO R76
5.2	Replace the first paragraph with the following: Washing Drum (Fig. 2)—A stainless steel washing drum able to contain the specimen. The cylindrical wall is made of mesh having an aperture of 0.075 mm. The mesh shall be interchangeable and resistant to wear and impacts from the aggregates during the test. The mesh should be maintained and verified according Appendix X1. The drum shall have a closing system (lid). The connection between the parts of the drum and the closing lid will ensure the sealing with regards to fine particles. (Any aperture should be smaller than the mesh filtering grade.)
5.3	Replace with the following: Centrifuge Cup (Fig. 3)—A stainless steel cup to collect mineral filler. Centrifuge cup capacity minimum capacity is 200 g. The total estimated mineral filler content passing through the washing drum mesh should not exceed the capacity of the centrifuge cup in order to avoid overflowing into recovery plant. NOTE 3—Centrifuge cup geometry varies; refer to manufacturer for appropriate centrifuge cup specifications.
6.2	Replace with the following: Solvent – One of the following solvents shall be used. No other solvents are approved for use in this procedure. The pH of the solvent shall meet the requirements of the manufacturer and shall be verified according to manufacturer recommendations.
6.2.1	Delete the last two sentences.
6.2.2	Delete the last two sentences.

Standard Method of Test
 for
Automated Extraction of Asphalt Binder from Asphalt Mixtures
 (continued)
 Reference ASTM D8159-18

AASHTO Section	Illinois Modification																
7.2.1	<p>Replace with the following:</p> <p>Separate specimen by hand spatula or trowel, then split and reduce specimen to required testing size listed in Table 1 in accordance with Illinois Modified AASHTO R76. If specimen is not able to be separated or split, place specimen in a large, flat pan and warm it in a $110 \pm 5^{\circ}\text{C}$ ($230 \pm 9^{\circ}\text{F}$) oven only until splitting can be performed.</p> <p>Table 1 Test Specimen Size and Cycles</p> <table border="1" style="margin-left: auto; margin-right: auto;"> <thead> <tr> <th style="text-align: center;">Material</th> <th style="text-align: center;">Minimum Mass of Sample, g</th> <th style="text-align: center;">Wash Cycles</th> <th style="text-align: center;">Dry Cycles</th> </tr> </thead> <tbody> <tr> <td style="text-align: center;">RAS</td> <td style="text-align: center;">750</td> <td style="text-align: center;">12</td> <td style="text-align: center;">5</td> </tr> <tr> <td style="text-align: center;">IL4.75, IL9.5, IL9.5FG, RAP, FRAP, 9.5SMA</td> <td style="text-align: center;">1250</td> <td style="text-align: center;">10</td> <td style="text-align: center;">5</td> </tr> <tr> <td style="text-align: center;">12.5 SMA, IL19.0, IL19.0FG</td> <td style="text-align: center;">1750</td> <td style="text-align: center;">10</td> <td style="text-align: center;">5</td> </tr> </tbody> </table> <p>NOTE 8—When the mass of the test specimen exceeds the capacity of the equipment used (specifically, the capacity of the centrifuge cup is the limiting factor for sampling in this particular method), the test specimen may be divided into suitable increments, tested, and the masses of each increment combined before calculating the asphalt binder content (Section 9).</p>	Material	Minimum Mass of Sample, g	Wash Cycles	Dry Cycles	RAS	750	12	5	IL4.75, IL9.5, IL9.5FG, RAP, FRAP, 9.5SMA	1250	10	5	12.5 SMA, IL19.0, IL19.0FG	1750	10	5
Material	Minimum Mass of Sample, g	Wash Cycles	Dry Cycles														
RAS	750	12	5														
IL4.75, IL9.5, IL9.5FG, RAP, FRAP, 9.5SMA	1250	10	5														
12.5 SMA, IL19.0, IL19.0FG	1750	10	5														
7.2.2	<p>Replace the last sentence with the following:</p> <p>Constant mass shall be defined as the mass at which further drying does not alter the mass by more than 0.5 g when weighed at 1 hour intervals.</p>																
8.7	<p>Replace with the following:</p> <p>Via the built-in HMI system, set the number of washing and drying cycles in accordance with Table 1.</p>																

Illinois Modified Test Procedure
 Effective Date: February 28, 2019
 Revised Date: [December 1, 2021](#)

Standard Method of Test
 for
Automated Extraction of Asphalt Binder from Asphalt Mixtures
 (continued)
 Reference ASTM D8159-18

AASHTO Section	Illinois Modification
8.8.1	<p>Replace with the following:</p> <p>Start the extraction process in accordance with manufacturer instructions. If the solvent is not running at least light straw or running clear as seen through the inspection window (Fig. 1, #3), continue increasing the number of washing cycles until removal of the binder from the mixture is complete. If the number of wash cycles is greater than Table 1, report the actual number of wash cycles completed. Once the set number of washing cycles is achieved, the drying phase begins automatically.</p>
8.9.2	<p>Add the following sentence after the first sentence:</p> <p>Brush any remaining aggregate from the washing chamber into the filler cup.</p>
9.3	<p>Add the following:</p> <p>Record and calculate M1 – M9 values to the nearest 0.1 g. Calculate the PB to the nearest 0.1%</p>

This Page Reserved

Illinois Modified Test Procedure
Effective Date: [December 1, 2021](#)

Standard Test Method
for
**Flat Particles, Elongated Particles, or Flat and Elongated Particles
in Coarse Aggregate**

Reference ASTM D 4791-19

ASTM Section	Illinois Modification																		
2.1	Revise the individual Standards as follows: ASTM C 136 is replaced by AASHTO T 27 (Illinois Modified). ASTM C 702 is replaced by AASHTO R 76 (Illinois Modified). ASTM D 75 is replaced by AASHTO R 90 (Illinois Modified). ASTM E 11 is replaced by AASHTO T 92 (Illinois Modified).																		
7.1	Replace with the following: Sample the coarse aggregate according to AASHTO R 90 (Illinois Modified). The field sample size shall meet the minimum requirements in the IDOT Aggregate Sample Size Table.																		
7.2	<p>Replace with the following: Field samples of aggregate shall be reduced to approximate test sample size before testing according to AASHTO R 76 (Illinois Modified). Reduction to an exact predetermined mass shall not be permitted. Sieve the approximate test sample according to AASHTO T 27 (Illinois Modified) and retain all plus 4.75-mm (No. 4) material as the test sample. The mass of the test samples shall conform to the following:</p> <table style="margin-left: auto; margin-right: auto;"> <thead> <tr> <th style="text-align: center;"><u>Nominal Maximum Size Square Openings, mm (in.)</u></th> <th style="text-align: center;"><u>Minimum Mass of Test Sample, kg (lb.)</u></th> </tr> </thead> <tbody> <tr> <td style="text-align: center;">9.5 (3/8)</td> <td style="text-align: center;">0.5 (1)</td> </tr> <tr> <td style="text-align: center;">12.5 (1/2)</td> <td style="text-align: center;">0.5 (1)</td> </tr> <tr> <td style="text-align: center;">19.0 (3/4)</td> <td style="text-align: center;">1.25 (3)</td> </tr> <tr> <td style="text-align: center;">25.0 (1)</td> <td style="text-align: center;">1.25 (3)</td> </tr> <tr> <td style="text-align: center;">37.5 (1 1/2)</td> <td style="text-align: center;">2.5 (5.5)</td> </tr> <tr> <td style="text-align: center;">50.0 (2)</td> <td style="text-align: center;">5.0 (11)</td> </tr> <tr> <td style="text-align: center;">63.0 (2 1/2)</td> <td style="text-align: center;">5.0 (11)</td> </tr> <tr> <td style="text-align: center;">75.0 (3)</td> <td style="text-align: center;">7.5 (16.5)</td> </tr> </tbody> </table>	<u>Nominal Maximum Size Square Openings, mm (in.)</u>	<u>Minimum Mass of Test Sample, kg (lb.)</u>	9.5 (3/8)	0.5 (1)	12.5 (1/2)	0.5 (1)	19.0 (3/4)	1.25 (3)	25.0 (1)	1.25 (3)	37.5 (1 1/2)	2.5 (5.5)	50.0 (2)	5.0 (11)	63.0 (2 1/2)	5.0 (11)	75.0 (3)	7.5 (16.5)
<u>Nominal Maximum Size Square Openings, mm (in.)</u>	<u>Minimum Mass of Test Sample, kg (lb.)</u>																		
9.5 (3/8)	0.5 (1)																		
12.5 (1/2)	0.5 (1)																		
19.0 (3/4)	1.25 (3)																		
25.0 (1)	1.25 (3)																		
37.5 (1 1/2)	2.5 (5.5)																		
50.0 (2)	5.0 (11)																		
63.0 (2 1/2)	5.0 (11)																		
75.0 (3)	7.5 (16.5)																		
8.1	Replace with the following: The test sample shall be dried back to constant mass in an oven specifically designed for drying, set at and capable of maintaining a uniform temperature of 110 ± 5 °C (230 ± 9 °F). Constant mass is defined as the sample mass at which there has not been more than a 0.5 gram mass loss during one hour of drying. This should be verified occasionally.																		

Illinois Modified Test Procedure
Effective Date: [December 1, 2021](#)

Standard Test Method
for
**Flat Particles, Elongated Particles, or Flat and Elongated Particles
in Coarse Aggregate**
(continued)

Reference ASTM D 4791-19

ASTM Section	Illinois Modification
8.2	Delete.
8.3	Replace with the following: <i>Flat Particle Test and Elongated Particle Test</i> —Test each of the particles in the test sample and place in one of three groups: (1) Flat, (2) Elongated, (3) Neither flat nor elongated.
8.3.2	Replace with the following: Determine the mass of each group.
8.4	Replace with the following: <i>Flat and Elongated Particle Test</i> —Test each of the particles in the test sample and place in one of two groups: (1) flat and elongated or (2) not flat and elongated.
8.4.2	Replace the last sentence with the following: The particle is flat and elongated if the particle thickness can be completely passed through the smaller opening.
8.4.3	Replace with the following: Determine the mass of each group.
9.1	Replace with the following: Calculate the percentage of flat, elongated, and/or flat and elongated particles to the nearest 1 percent in using the following formula: $\% = \frac{GM}{TSM} \times 100$ where: GM = each group mass, and TSM = test sample mass.
9.2	Delete.
10.1.3.1	Delete.

Illinois Modified Test Procedure
Effective Date: [December 1, 2021](#)

Standard Test Method
for
**Flat Particles, Elongated Particles, or Flat and Elongated Particles
in Coarse Aggregate**

(continued)

Reference ASTM D 4791-19

ASTM Section	Illinois Modification
10.1.3.2	Replace with the following: Percentages, calculated by mass for: (1) flat particles, (2) elongated particles, and (3) total flat and elongated particles, and
10.1.4.1	Delete.
10.1.4.2	Replace with the following: Percentages, calculated by mass, for flat and elongated particles,
10.1.5	Delete.

This Page Reserved

Illinois Modified Test Procedure
 Effective Date: [December 1, 2021](#)
 Standard Test Method
 for

Determining the Percentage of Fractured Particles in Coarse Aggregate

Reference ASTM D 5821-13 (2017)

ASTM Section	Illinois Modification
1.1	Replace with the following: This test method covers the determination of the percentage, by mass of a coarse aggregate sample that consists of fractured particles meeting specified requirements.
2.1	Delete the following: C136 Test Method for Sieve Analysis of Fine or Coarse Aggregate ² C702 Practice for Reducing Filed Samples of Aggregate to Testing Size ² D75 Practice for Sampling Aggregate ³ E11 Specification for Wire-Cloth Sieves for Testing Purposes ⁴
2.2 New Section	AASHTO Standards: R 90 (Illinois Modified) Sampling T27 (Illinois Modified) Sieve Analysis of Fine and Coarse Aggregate M92 (Illinois Modified) Wire Cloth Sieves for Testing Purposes R 76 (Illinois Modified) Reducing Field Samples of Aggregate to Testing Size
3.1.1	Replace with the following: Fractured face, n- a broken surface of an aggregate particle created by crushing. (see Terminology D8)
5.4	Replace with the following: Forceps or similar tool to aid in sorting.
5.5	Other Apparatus – A lighted magnifying lamp.
5.6	Oven—An oven of sufficient size, capable of maintaining a uniform temperature of 110 ± 5°C (230 ± 9°F). The oven shall be specifically designed for drying.
6.1	Replace with the following: Sample the aggregate in accordance with AASHTO R 90 (Illinois Modified).
7.1	Replace with the following: Dry the sample sufficiently to obtain a clean separation of fine and coarse material in the sieving operation. Sieve the sample over the 4.75 mm (No. 4) sieve in accordance with AASHTO T 27 (Illinois Modified) and then reduce the portion retained on the sieve using a splitter in accordance with R 76 (Illinois Modified) to appropriate size for test.

Standard Test Method
 for
Determining the Percentage of Fractured Particles in Coarse Aggregate
 (continued)
 Reference ASTM D 5821-13 (2017)

ASTM Section	Illinois Modification																						
7.2	Replace table with the following: <table style="margin-left: auto; margin-right: auto; border: none;"> <thead> <tr> <th style="text-align: center;"><u>Nominal Maximum Size Square Openings, mm (in.)</u></th> <th style="text-align: center;"><u>Minimum Test Sample Mass, g (Approx. lb)</u></th> </tr> </thead> <tbody> <tr> <td style="text-align: center;">4.75 (No. 4)*</td> <td style="text-align: center;">100 (.2)</td> </tr> <tr> <td style="text-align: center;">9.5 (3/8)</td> <td style="text-align: center;">1200 (1)</td> </tr> <tr> <td style="text-align: center;">12.5 (1/2)</td> <td style="text-align: center;">1500 (1)</td> </tr> <tr> <td style="text-align: center;">19.0 (3/4)</td> <td style="text-align: center;">2500 (3.3)</td> </tr> <tr> <td style="text-align: center;">25.0 (1)</td> <td style="text-align: center;">2500 (3.3)</td> </tr> <tr> <td style="text-align: center;">37.5 (1 1/2)</td> <td style="text-align: center;">4200 (9.3)</td> </tr> <tr> <td style="text-align: center;">50.0 (2)</td> <td style="text-align: center;">10000 (22)</td> </tr> <tr> <td style="text-align: center;">63.0 (2 1/2)</td> <td style="text-align: center;">30000 (66)</td> </tr> <tr> <td style="text-align: center;">75.0 (3)</td> <td style="text-align: center;">60000 (132)</td> </tr> <tr> <td style="text-align: center;">90.0 (3 1/2)</td> <td style="text-align: center;">90000 (198)</td> </tr> </tbody> </table> <p>*Sieve over a No. 30 sieve per Section 7.1.</p>	<u>Nominal Maximum Size Square Openings, mm (in.)</u>	<u>Minimum Test Sample Mass, g (Approx. lb)</u>	4.75 (No. 4)*	100 (.2)	9.5 (3/8)	1200 (1)	12.5 (1/2)	1500 (1)	19.0 (3/4)	2500 (3.3)	25.0 (1)	2500 (3.3)	37.5 (1 1/2)	4200 (9.3)	50.0 (2)	10000 (22)	63.0 (2 1/2)	30000 (66)	75.0 (3)	60000 (132)	90.0 (3 1/2)	90000 (198)
<u>Nominal Maximum Size Square Openings, mm (in.)</u>	<u>Minimum Test Sample Mass, g (Approx. lb)</u>																						
4.75 (No. 4)*	100 (.2)																						
9.5 (3/8)	1200 (1)																						
12.5 (1/2)	1500 (1)																						
19.0 (3/4)	2500 (3.3)																						
25.0 (1)	2500 (3.3)																						
37.5 (1 1/2)	4200 (9.3)																						
50.0 (2)	10000 (22)																						
63.0 (2 1/2)	30000 (66)																						
75.0 (3)	60000 (132)																						
90.0 (3 1/2)	90000 (198)																						
7.3	Delete.																						
8.1	Add the following after the first sentence: Constant mass is defined as the sample mass at which there has not been more than a 0.5-gram mass loss during 1 hour of drying. This should be verified occasionally.																						
8.3	Replace with the following: Hand-examine each individual particle of the sample to determine if it is fractured. Separate the particles into specified categories: (1) fractured particles based on whether the particle has the required number of fractured faces, (2) particles not meeting the specified criteria.																						
8.4	Replace with the following: Determine the mass of particles in the fractured particle category, and the mass of the particles not meeting the specified fracture criteria. Use mass to calculate percent fractured particles.																						
8.5	Delete.																						

Illinois Modified Test Procedure
Effective Date: [December 1, 2021](#)

Standard Test Method
for
Determining the Percentage of Fractured Particles in Coarse Aggregate
(continued)
Reference ASTM D 5821-13 (2017)

ASTM Section	Illinois Modification
9.1	<p>Replace with the following: Report the mass percentage of the particles with the specified number(s) of fractured faces to the nearest 0.1% in accordance with the following:</p> $P = (F/Q) \times 100$ <p>where: P = percentage of particles with the specified number of fractured faces, F = mass of fractured particles with at least the specified number of fractured faces, Q = total mass of original test specimen</p>
9.5	Delete.

This Page Reserved

Illinois Modified Test Procedure
Effective Date: December 1, 2019

Standard Method of Test
for
**Using Significant Digits in Test Data to
Determine Conformance with Specifications**

Reference ASTM E 29-13 (2019)

Note: Several test procedures reference ASTM E 29 for rounding of test results. Results for Illinois Department of Transportation tests shall follow the "round up from five" rule, i.e.:

When the digit beyond the last place to be retained (or reported) is equal to or greater than 5, increase by 1 the digit in the last place retained.

The following modification to ASTM shall apply:

ASTM Section	Illinois Modification
6.4.2	Revise as follows: When the digit next beyond the last place to be retained (or reported) is equal to or greater than 5, increase by 1 the digit in the last place retained.
6.4.3	Delete.
6.4.4	Delete.

This Page Reserved

Standard Test Method
for
Materials Finer Than 75- μ m (No. 200) Sieve in Mineral Aggregates by Washing
Reference AASHTO T 11-20

AASHTO Section	Illinois Modification
1	<p>Revise Section 1 with the following:</p> <p>1.1. Replace “method” with “procedure” in the first sentence of paragraph.</p> <p>1.2. Replace with the following: “There are two methods allowed for this procedure. The first method uses only water for the operation. The second allows the use of a wetting agent to assist in the loosening of the material finer than the No. 200 (75-μm) sieve from the coarser material. A wetting agent such as detergent or dispersing solution is recommended.”</p> <p>1.4. Delete the first sentence of paragraph.</p> <p>To maintain brevity in the text, the following will apply: Example: SI units will be listed first while metric units will be in parentheses “No. 200 (75-μm)”.</p>
2	<p>Revise Section 2 with the following:</p> <p>2.1. Insert and add (Illinois Modified) after “AASHTO Standards”:</p> <p>2.2. Replace with the following: Illinois Specifications:</p> <ul style="list-style-type: none"> ▪ Illinois Specifications 201, Aggregate Gradation Sample Size Table <p>2.3. Add and insert the following: ASTM Standards:</p> <ul style="list-style-type: none"> ▪ E 11, Woven Wire Test Sieve Cloth and Test Sieves ▪ E 29 (Illinois Modified), Using Significant Digits in Test Data to Determine Conformance with Specifications ▪ C 125, Standard Terminology Relating to Concrete and Concrete Aggregates
3	<p>Revise Section 3 with the following:</p> <p>3.1. Delete “or water containing a wetting agent, as specified” from the first sentence of paragraph.</p>
4	<p>Revise Section 4 with the following:</p> <p>4.2. Replace “in” with “with” in the first sentence of paragraph. Revise the second sentence to read: “In some cases, the finer material is adhering to the larger particles, such as some clay coatings and coatings on aggregates that have been extracted from bituminous mixtures.”</p>
5	<p>Revise Section 5 with the following:</p> <p>5.2. Add sentence to end of paragraph: “The sieve cloth shall be mounted on substantial frames constructed in a manner that will prevent loss of material during sieving.”</p> <p>5.4. Add sentences to end of paragraph: “The oven shall be specifically designed for drying. In addition, a gas burner or electric hot plate may be used. Microwave ovens are <u>not</u> permitted for drying aggregate gradations samples.”</p> <p>Note 1 Revise with the following: “A mechanical device, such as a Ploog Washer, may be used for coarse aggregate samples providing its results match the manual procedure. When using a mechanical washing device, loss of fines from damage to the drum or dripping water will not be allowed. Applying wax to the rim of the drum will help prevent water from dripping down the outside of the drum.”</p>
6	<p>Revise Section 6 with the following:</p> <p>6.1. Replace with the following: “Field samples of aggregate shall be taken according to Illinois Modified AASHTO R90. The field sample size shall meet the minimum requirements in the Illinois Specifications 201.”</p> <p>6.2. Replace 6.2 with the following: “Field samples of aggregate shall be reduced to test sample size before testing according to Illinois Modified AASHTO R76.”</p> <p>Add and insert: “Test sample size for aggregate gradation samples shall meet the minimum requirements found in Illinois Specifications 201.” to the end of the paragraph.</p>
7	<p>Replace Section 7 SELECTION OF PROCEDURE with the following: PROCEDURE</p> <p>7.1. The test sample shall be dried back to constant mass in an oven specifically designed for drying, set at and capable of maintaining a uniform temperature of 230\pm9°F (110\pm5°C). Constant mass is defined as the sample mass at which there has not been more than a 0.5-gram mass loss during an additional 1 hour of drying. This should be verified occasionally.</p> <p>The sample may also be dried to constant mass in a pan on an electric hot plate or gas burner. The technician shall <u>continually attend</u> the sample when drying on the electric hot plate or gas burner. The electric hot plate or gas burner should be operated on a low-as-needed heat to prevent popping,</p>

Standard Test Method
for
Materials Finer Than 75-µm (No. 200) Sieve in Mineral Aggregates by Washing
Reference AASHTO T 11-20

AASHTO Section	Illinois Modification
	<p>crackling, and/or sizzling noise from the aggregate during drying. If these noises occur, the heat must be turned down and/or the sample must be constantly stirred during drying to prevent potential aggregate particle breakdown.</p> <p>After the test sample has been dried to constant mass and cooled down to room temperature, the sample shall have its mass determined to the nearest 1 gram for coarse aggregate and to the nearest 0.1 gram for fine aggregate. All balances or scales shall be tared before being used to determination of mass required by this test procedure. This procedure provides the "Total Dry Mass, g" (TDM) of the original test sample.</p> <p>7.2. After drying and determining the mass, place the test sample in the container and add sufficient water to cover it. If a wetting agent is warranted as stated in 4.2, add the wetting agent to the water (Note 2). Agitate the sample with sufficient vigor to result in complete separation of all particles finer than the No. 200 (75µm) sieve from the coarser particles, and to bring the fine material into suspension. The use of a large spoon or other similar tool shall be used to stir and agitate the aggregate in the wash water. Once the wash water becomes clear pour the wash water containing the suspended and dissolved solids over the nested sieves, arranged with the coarser sieve on top. Take care to avoid, as much as feasible, the decantation of coarser particles of the sample.</p> <p>Note 2 – There should be enough wetting agent to produce a small amount of suds when the sample is agitated. The quantity will depend on the hardness of the water and the quality of the detergent. Excessive suds may overflow the sieves and carry some material with them.</p> <p>7.3. Add a second charge of water to the sample in the container, agitate, and decant as before. Repeat this operation until the wash water is clear.</p> <p>Note 3 – If mechanical washing equipment is used, the charging of water, agitating, and decanting may be a continuous operation.</p> <p>Note 4 – A spray nozzle or a piece of rubber tubing attached to a water faucet may be used to rinse any of the material that may have fallen onto the sieves. The velocity of water, which may be increased by pinching the tubing or by use of a nozzle, should not be sufficient to cause any splashing of the sample over the sides of the sieve. 7.4. Return all material retained on the nested sieves by flushing per note 5. Dry the washed test sample to constant mass and determine the mass of the test sample in the same manner as detailed in 8.1 herein. This procedure provides the "Total Wash Mass, g" (TWM).</p> <p>Note 5 – Following the washing of the sample and flushing any material retained on the No. 200 (75µm) sieve back into the container by washing from the back of the sieve. No water should be decanted from the container except through the No. 200 (75µm) sieve, to avoid loss of material. Excess water from flushing should be evaporated from the sample in the drying process."</p>
8	<p>Replace Section 8 PROCEDURE A-WASHING WITH PLAIN WATER with the following:</p> <p>"CALCULATION</p> <p>8.1. The "Percent Minus 75µm (No. 200) by Washing" shall be determined by using the following formula:</p> $\% \text{ - No. 200 (-75}\mu\text{m) by Washing} = \frac{TDM-TW}{TDM} * 100$ <p>TDM = Total Dry Mass, g. TWM = Total Wash Mass, g."</p>
9	<p>Replace Section 9 PROCEDURE B-WASHING USING A WETTING AGENT with the following:</p> <p>"REPORT</p> <p>9.1. The test results shall be rounded to the nearest 0.1 percent and recorded on the Illinois Department of Transportation (IDOT) gradation form. All rounding shall be according to ASTM E 29 (Illinois Modified)."</p>

Standard Test Method
for
Materials Finer Than 75- μ m (No. 200) Sieve in Mineral Aggregates by Washing
Reference AASHTO T 11-20

AASHTO Section	Illinois Modification
10	Delete: Section 10 CALCULATION
11	Delete: Section 11 REPORT
12	Delete: Section 12 PRECISION AND BIAS
13	Delete: Section 13 KEYWORDS

This Page Reserved

Standard Method of Test
 for
Bulk Density (“Unit Weight”) and Voids in Aggregate
 (continued)
 Reference AASHTO T 19 / T 19M-14 (2018)

AASHTO Section	Illinois Modification
1.2	Revise “AASHTO M 92” to read “AASHTO M 92 (Illinois Modified)”.
2.1	Revise the individual Standards as follows: AASHTO M 92 (Illinois Modified) AASHTO R 90 (Illinois Modified) AASHTO T 84 (Illinois Modified) AASHTO T 85 (Illinois Modified) AASHTO T 121 (Illinois Modified) AASHTO R 76 (Illinois Modified) Illinois Specification 201
3.2.1.1	Revise "AASHTO T 19/T 19M" to read "AASHTO T 19/T 19M (Illinois Modified)".
5.2	Revise as follows: <i>Tamping Rod</i> —A round, straight steel rod, 16 mm (5/8 inch) in diameter and a minimum of 584 mm (23 inches) long, having one end rounded to a hemispherical tip of the same diameter as the rod.
5.3.1	Revise "AASHTO T 121" to read "AASHTO T 121 (Illinois Modified)".
5.6 New Section	<i>Source of Heat</i> —An oven of sufficient size, specifically built for drying, capable of maintaining a uniform temperature of 110 ± 5 °C (230 ± 9 °F) shall be used for drying. In addition, a gas burner or electric hot plate may be used. Microwave ovens are not permitted for drying unit weight or voids test samples.
6.1	Replace with the following: Field samples of aggregate shall be taken according to AASHTO R 90 (Illinois Modified). Field sample size shall conform to the minimum requirements in the Illinois Specification 201. Reduction of field samples shall be according to AASHTO R 76 (Illinois Modified).
7.1	Replace the second sentence with the following: The test sample shall be dried to constant mass in an oven, specifically built for drying, set at and capable of maintaining a uniform temperature of 110 ± 5 °C (230 ± 9 °F). Constant mass is defined as the sample mass at which there has not been more than a 0.5-gram loss during 1 hour of drying. This should be verified occasionally.

Illinois Modified Test Procedure
Effective Date: December 1, 2021

Standard Method of Test
for
Bulk Density (“Unit Weight”) and Voids in Aggregate
(continued)

Reference AASHTO T 19 / T 19M-14 (2018)

AASHTO Section	Illinois Modification
7.1 (cont.)	<p>The sample may also be dried to constant mass in a pan on an electric hot plate or gas burner. The technician shall <u>continually attend</u> the sample when drying on the electric hot plate or gas burner. Microwave ovens are <u>not</u> permitted for drying unit weight or voids test samples.</p> <p>The electric hot plate or gas burner should be operated on a low-as-needed heat to prevent popping, crackling, and/or sizzling noise from the aggregate during drying. If these noises occur, the heat must be turned down and/or the sample must be constantly stirred during drying to prevent potential aggregate particle breakdown.</p>
7.1	<p>Add the following: When more than one size of coarse aggregate is to be used in IDOT's mortar-voids design method for portland cement concrete mixtures, the void content shall be determined from a sample consisting of the coarse aggregate combination.</p>
9.1	<p>Replace with the following:</p> <p>The compact bulk density shall be determined by the rodding procedure for aggregates having a nominal maximum size of 37.5mm (1 ½ in.) or less, or by the jiggling procedure for aggregates have a nominal maximum size greater than 37.5mm (1 ½ in.) and not exceeding 125mm (5 in.).</p>
10.1	<p>Add the following: The tamping rod may be used as a straightedge.</p>
12.1	Delete.
12.2	Delete.
13.1	<p>Revise the first sentence as follows: <i>Unit Weight</i>—Calculate the unit weight for the rodding or jiggling procedure as follows:</p>
13.1.1	<p>Revise "AASHTO T 84" to read "AASHTO T 84 (Illinois Modified)" and "AASHTO T 85" to read "AASHTO T 85 (Illinois Modified)".</p>
13.2	<p>Revise the first sentence as follows: <i>Void Content</i>—Calculate the void content in the aggregate using the unit weight determined by either the rodding or jiggling procedure as follows:</p>

Illinois Modified Test Procedure
Effective Date: [December 1, 2021](#)

Standard Method of Test
for
Bulk Density (“Unit Weight”) and Voids in Aggregate
(continued)

Reference AASHTO T 19 / T 19M-14 (2018)

AASHTO Section	Illinois Modification
13.2	Revise "AASHTO T 84" to read "AASHTO T 84 (Illinois Modified)" and "AASHTO T 85" to read "AASHTO T 85 (Illinois Modified)".
13.3 New Section	When more than one size of coarse aggregate is used in IDOT's mortar-voids design method for concrete mixtures, the void content is determined from a sample consisting of the coarse aggregate combination. To perform the calculation in Section 13.2, the bulk specific gravity (dry basis) shall be a weighted average of the coarse aggregate combination. Example: A Aggregate = 2.601 specific gravity / 40% blend B Aggregate = 2.676 specific gravity / 60% blend Blend Specific Gravity = $(2.601 \times 0.4) + (2.676 \times 0.6) = 2.646$
14.1	Revise as follows: Report the results for unit weight to the nearest 1 kg/m^3 (1 lb/ft^3).
14.1	Add the following: All rounding shall be according to ASTM E 29 (Illinois Modified).
14.1.3	Delete.
14.2.3	Delete.
15.4	Revise “AASHTO T 84” to read “AASHTO T 84 (Illinois Modified)” and “AASHTO T 85” to read “AASHTO T 85 (Illinois Modified)”.

This Page Reserved

Illinois Modified Test Procedure
Effective Date: [December 1, 2021](#)

Standard Method of Test
For
Compressive Strength of Cylindrical Concrete Specimens

Reference AASHTO T 22-20

AASHTO Section	Illinois Modification
2.1	<p>Revise as follows: AASHTO R 39 (Illinois Modified) AASHTO R 100 (Illinois Modified) (formerly AASHTO T 23) AASHTO T 24 (Illinois Modified) AASHTO T 231 (Illinois Modified)</p> <p>To maintain brevity in the text, the following will apply: Example: AASHTO T 24 (Illinois Modified) will be designated as "T 24."</p>
2.2	<p>Add as follows: ASTM E 29 (Illinois Modified) Standard Practice for Using Significant Digits in Test Data to Determine Conformance with Specifications</p> <p>To maintain brevity in the text, the following will apply: Example: ASTM E 29 (Illinois Modified) will be designated as "ASTM E 29."</p>
4.4 New Section	For QC/QA projects, refer to the Level I PCC Technician duties in the "Qualifications and Duties of Concrete Quality Control Personnel" document for training requirements.
5.1	<p>Add as follows: The testing machine shall not be mounted on rollers.</p>
5.1.1.1	<p>Revise as follows: Replace "13 months" with "12 months."</p>
6.2	<p>Add to the end of the second sentence as follows: (Note: ASTM C 1231 is approved for use.)</p>
8.3.2	<p>Revise the first sentence as follows: When the density is determined from submerged weighing, calculate the density as follows:</p>
8.4 New Section	All rounding shall be according to ASTM E 29.

This Page Reserved

This Page Reserved

AASHTO T 23 is discontinued. Please refer to AASHTO R 100.

This Page Reserved

AASHTO T 23 is discontinued. Please refer to AASHTO R 100.

Illinois Modified Test Procedure
Effective Date: December 1, 2019

Standard Method of Test
for
Obtaining and Testing Drilled Cores and Sawed Beams of Concrete

Reference AASHTO T 24M/T 24-15 (2019)

AASHTO Section	Illinois Modification
2.1	<p>Revise as follows: AASHTO R 39 (Illinois Modified) AASHTO T 22 (Illinois Modified) AASHTO T 231 (Illinois Modified)</p> <p>To maintain brevity in the text, the following will apply: Example: AASHTO R 39 (Illinois Modified) will be designated as “R 39.”</p>
3.4	<p>Revise the last sentence as follows: The 24 hour-dry conditioning procedure included herein is intended to provide a quicker estimation of the in situ compressive strength of the concrete, and is based on recommendations made in ICT project R27-137, “Evaluation of PCC Pavement and Structure Coring and In Situ Testing Alternatives” (Popovics, Spalvier, & Hall, 2016). The report also discusses strength estimation accuracy.</p>
5.1.2	<p>Replace with the following: Refer to ICT project R27-137 report for information on embedded reinforcement.</p>
7.3 7.3.1 7.3.2 7.3.3 7.3.4	<p>Revise as follows:</p> <p>7.3 <i>24-Hour Dry Conditioning</i>—Condition cores as follows unless otherwise directed by the Engineer.</p> <p>7.3.1. After cores have been drilled, wipe off surface water and allow remaining surface moisture to evaporate. When surfaces appear dry, but not later than 1 hour after drilling, place cores in separate plastic bags or nonabsorbent containers and seal to prevent moisture loss. Maintain cores at ambient temperature, and protect cores from exposure to direct sunlight. Transport the cores to the testing laboratory as soon as practicable.</p> <p>7.3.2 If water is used during sawing or grinding of core ends, complete these operations as soon as practicable, but no later than 2 days after drilling of cores. Minimize the duration of exposure to water during end preparation. After completing end preparation, wipe off surface moisture, allow the surfaces to dry, and place the cores in sealed plastic bags or nonabsorbent containers until 24 hours prior to testing. Testing shall be conducted as soon as practicable taking into account the time for conditioning according to Section 7.3.3.</p>

Standard Method of Test
 for
Obtaining and Testing Drilled Cores and Sawed Beams of Concrete
 (continued)

Reference AASHTO T 24M/T 24-15 (2019)

AASHTO Section	Illinois Modification
7.3 7.3.1 7.3.2 7.3.3 7.3.4 continued	<p>7.3.3. 24 hours prior to testing, remove the cores from their plastic bags or containers and place them on end in front of a box-type fan with approximate dimensions of 21 by 21 in. (533 by 533 mm). The cores shall remain under constant airflow until testing.</p> <p>As shown in the figure below, cores shall be placed approximately 15 in. (381 mm) from the face of the fan, and shall be laterally spaced approximately 2 in. (38 to 51 mm) between each other. A second row of cores may be placed approximately 3 in. (76 mm) directly behind the first row. Cores shall not be placed beyond the width of the fan. The fan shall be set on medium or high for a three-speed fan, and high for a two-speed fan. The core specimens shall not be rotated during the 24 hour period.</p> <div data-bbox="347 903 1430 1501" data-label="Diagram"> <p>The diagram illustrates the setup for testing concrete cores. On the right is a box-type fan with a width of 21 in. (533 mm). Four arrows labeled 'Air Flow' point from the fan towards the left. In the center, there are two rows of four circular concrete cores. The distance from the fan's face to the cores is 15 in. (381 mm). The cores in the second row are 3 in. (76 mm) behind the first row. The lateral spacing between cores in a row is 2 in. (51 mm). The vertical spacing between the two rows is 4 in. (100 mm).</p> </div> <p>7.3.4 When direction is given to test cores in a condition other than achieved according to Section 7.3.1, 7.3.2, and 7.3.3, report the alternative procedure.</p>
7.8	Revise as the 2 nd sentence as follows: Test the specimens within 3 days after coring, unless specified otherwise.
7.11 7.11.1 7.11.2	Delete these sections.

Standard Test Method
for
Sieve Analysis of Fine and Coarse Aggregates
Reference AASHTO T 27-20

AASHTO Section	Illinois Modification
1	<p>Revise Section 1 with the following: 1.4. Delete first sentence of paragraph.</p> <p>To maintain brevity in the text, the following will apply: Example: SI units will be listed first while metric units will be in parentheses “No. 200 (75-μm)”.</p>
2	<p>Revise Section 2 with the following: 2.1. Replace “AASHTO Standards” with “Illinois Modified AASHTO Standards” 2.2. Replace with the following: Illinois Specifications: <ul style="list-style-type: none"> ▪ Illinois Specifications 201, Aggregate Gradation Sample Size Table 2.3. Add and insert the following: ASTM Standards: <ul style="list-style-type: none"> ▪ E 11, Woven Wire Test Sieve Cloth and Test Sieves ▪ E 29 (Illinois Modified), Using Significant Digits in Test Data to Determine Conformance with Specifications ▪ C 125, Standard Terminology Relating to Concrete and Concrete Aggregates </p>
5	<p>Revise Section 5 with the following: 5.1. Replace “method” with “procedure” in the first sentence of paragraph in 5.1. 5.2. Replace “T 11” with “T 11 (Illinois Modified)” in the second sentence of the paragraph.</p>
6	<p>Revise Section 6 with the following: 6.2. Add sentence to end of paragraph: “When running Coarse Aggregate samples 12in (305mm) are required, if running Fine Aggregate samples 12in (305mm) or 8in (203mm) sieves are acceptable.” Delete: Note 1 from section 6.2. Delete: Note 2 from section 6.3. 6.4. Add sentences to end of paragraph: “The oven shall be specifically designed for drying. In addition, a gas burner or electric hot plate may be used. Microwave ovens are <u>not</u> permitted for drying aggregate gradations samples.”</p>
7	<p>Revise Section 7 with the following: 7.1. Replace 7.1 with the following: “Field samples of aggregate shall be taken according to Illinois Modified AASHTO Standards R90. The field sample size shall meet the minimum requirements in the Illinois Specifications 201.” 7.2. Replace 7.2 with the following: “Field samples of aggregate shall be reduced to test sample size before testing according to Illinois Modified AASHTO Standards R76.” Add insert after 7.2: “Test sample size for aggregate gradation samples shall meet the minimum requirements found in Illinois Specifications 201.” 7.3. Replace 7.3 with the following: “In the event that the amount of material finer than No. 200 (75μm) sieve is to be determined by Illinois Modified AASHTO Standards T11, proceed as follows: use the procedure described in Section 7.3.1 or 7.3.2, whichever is applicable.” 7.3.1. Add 7.3.1 and insert the following: “Use the same test sample for testing by AASHTO Standards T 11 (Illinois Modified) and by this method. First test the sample according to T 11 (Illinois Modified) through the final drying operation, and then dry-sieve the sample as stipulated in Sections 8.2 through 8.6 of this method.” 7.3.2. Add 7.3.2 and insert the following: “If the test sample is not to be tested by Illinois Modified AASHTO Standards T 11, follow Section 8, “Procedure.”” 7.4. Delete. 7.5. Delete. 7.6. Delete. 7.7. Delete. 7.7.1. Delete. 7.7.2. Delete. 7.7.3. Delete.</p>

Standard Test Method
 for
Sieve Analysis of Fine and Coarse Aggregates
 Reference AASHTO T 27-20

AASHTO Section	Illinois Modification
8	<p>Revise Section 8 with the following:</p> <p>8.1. Replace 8.1 with the following: "If the test sample has not been subject to testing by T 11 (Illinois Modified), the test sample shall be dried back to constant mass in an oven specifically designed for drying, set at and capable of maintaining a uniform temperature of 230±9° F (110±5° C). Constant mass is defined as the sample mass at which there has not been more than a 0.5-gram mass loss during an additional 1 hour of drying. This should be verified occasionally.</p> <p>The sample may also be dried to constant mass in a pan on an electric hot plate or gas burner. The technician shall continually attend the sample when drying on the electric hot plate or gas burner. Microwave ovens are not permitted for drying gradation samples.</p> <p>The electric hot plate or gas burner should be operated on a low-as-needed heat to prevent popping, crackling, and/or sizzling noise from the aggregate during drying. If these noises occur, the heat must be turned down and/or the sample must be constantly stirred during drying to prevent potential aggregate particle breakdown.</p> <p>After the test sample has been dried to constant mass and cooled down to room temperature, the sample shall have its mass determined to the nearest 1 gram for coarse aggregate and to the nearest 0.1 gram for fine aggregate. All balances or scales shall be tared before being used for determination of mass required by this test procedure. This procedure provides the "Total Dry Mass", g (TDM) of the original test sample. When testing Recycled Asphalt Pavement (RAP) samples shall be air dried to a constant mass."</p> <p>8.2. Replace 8.2 with the following: "A nested set of sieves (8 inch [203mm] or 12 inch [305mm]) shall be gathered and stacked. As the sieves are being stacked, they should be inspected for cracks, breaks, or any other problem which would exclude their continued use. The size of the sieves used shall conform to the gradation specifications of the aggregate tested. The No. 200 (75µm) sieve is required to be part of all nested sets when running a gradation test. It is also required that 8-inch (203mm) and 12-inch (305mm) round sieves use additional cutter sieves beyond the specified gradation sieves for all coarse aggregate gradations. Some cutter sieves may be required for fine aggregate gradations if overloading of individual sieves occurs. Gradations CA/CM 7 and 11 require the 5/8-inch (16.0mm), 3/8-inch (9.5mm), and 1/4-inch (6.3mm) sieves as cutter sieves, while the gradations CA/CM 13, 14, and 16 require the 1/4-inch (6.3mm) and the No. 8 (2.38mm) sieves. Cutter sieves for other gradations can be found in Illinois Specification 201.</p> <p>The sample shall then be introduced into the nested set of sieves and placed in a mechanical shaker. The shaker shall impart a vertical, or lateral and vertical, motion to the nested set. This causes the aggregate particles to bounce and turn so as to present different particle orientations to the sieves. This allows every chance for the particle to pass a certain sized sieve.</p> <p>The shaker shall be run for 7 minutes, controlled by an automatic shut-off timer. Seven (7) minutes of shaking shall be considered the standard unless reduced shaker efficiency can be demonstrated through finish hand-shaking as described in Section 8.4. Shaking time shall be increased if necessary, to comply with the finish hand-shaking procedure in Section 8.4. Shaking time shall not exceed 10 minutes."</p> <p>8.3. Replace 8.3 with the following: "Extreme care shall be taken not to overload individual sieves or even approach the overload limits. An overload is defined as several layers of particles, one on top of the other, which do not permit the top layers of particles access to the sieve openings. Sample results which show overloading, or a borderline situation are immediately suspect. If samples continually overload a sieve or sieves, then future samples shall be run in the appropriate number of portions to prevent overloading, or additional cutter sieves shall be added to the nested set to correct the problem."</p> <p>8.3.1 Delete. 8.3.1.1 Delete. 8.3.1.2 Delete. 8.3.1.3 Delete.</p>

Standard Test Method
for
Sieve Analysis of Fine and Coarse Aggregates
Reference AASHTO T 27-20

AASHTO Section	Illinois Modification
	<p>8.3.1.4 Delete. 8.3.1.5 Delete. Table 1 Delete.</p> <p>8.4. Add paragraph to beginning of Section 8.4: "After mechanical shaking, all sieves shall be finished off by hand-shaking. When hand-shaking, the largest sieve that contains material shall be removed from the stack, visually inspected for overload, and inverted over an empty pan. While inverted, all particles shall be cleaned from the sieve. The material shall then be placed back on the same sieve and hand-shaken over an empty pan. Any amount of material that is considered to be an overload or to be approaching an overload shall be hand-shaken in a least two increments. Any appreciable amount of particles passing a sieve may indicate poor mechanical shaking or overloading. The finish hand-shaking described in the following paragraph shall then be initiated."</p> <p>8.5. Replace 8.5 with the following: "After hand-shaking, material shall be removed from the sieve. Particles shall not be forced through the sieves. The sieve shall be inverted and lightly tapped on the sides to facilitate removal for weighing. A dowel rod or putty knife may be used to gently remove wedged particles from all sieves down through the No. 10 (2.00mm). A soft brass-wired brush shall be used on the No. 16 (1.18mm) through the No. 40 (425µm) sieve. A soft china brush shall be used on the No. 50 (300µm) through the No. 200 (75µm) sieve. Any material that passed the sieve during hand-shaking shall be placed on the next smaller sieve. After use, all sieves shall be inspected for cracks, breaks, or any other problem which would exclude their continued use.</p> <p>Note: The dowel rod can be made of any material that will not deposit foreign material into the test sample or cause damage to the sieves during the removal of wedged particles."</p> <p>8.6. Replace 8.6 with the following: "After hand-shaking and cleaning, the material retained on each sieve shall have its mass determined and the mass recorded. All determination of mass shall start with the largest sieve in the nested set and proceed down to the pan. Determination of mass shall be to the nearest 1 gram for coarse aggregate and to the nearest 0.1 gram for fine aggregate. The total mass of the material after sieving should check closely with original mass of samples placed on the sieves. If the amounts differ by more than 0.3 percent, based on the original dry sample mass, the results should not be used for acceptance purposes."</p>
9	<p>Revise Section 9 with the following:</p> <p>9.1. Replace 9.1 with the following: "Calculation of test results shall follow the procedure described below:</p> <p>Calculated the "Cumulative Mass Retained" for each sieve by adding its "Individual Mass Retained" and the "Individual Mass Retained" for each larger sieve in the nested set of sieves. Record the "Cumulative Mass Retained".</p> <p>Calculated the "Cumulative Percent Retained" for each sieve by using the following formula and record it by rounding to the nearest 0.1 percent:</p> $\text{Cumulative \% Retained} = \frac{\text{CMR}}{\text{TDM}} * 100$ <p>where CMR = Cumulative Mass Retained and TDM = Total Dry Mass</p> <p>Calculated the percent passing each sieve by using the following formula:</p> $\% = 100 - \text{Cumulative \% Retained}$ <p>These results shall be recorded to the nearest 0.1 percent."</p> <p>9.1.1 Delete.</p>
10	<p>Revise Section 10 with the following:</p> <p>10.2. Replace 10.2 with the following: "All percent passing results except the washed minus No. 200 (75µm) and minus No. 200 (75µm) shall be reported on the gradation form as whole numbers. The washed minus No. 200 (75µm) and minus No. 200 (75µm) results shall be reported to the nearest</p>

Illinois Modified Test Procedure
Effective Date: December 1, 2021

Standard Test Method
for
Sieve Analysis of Fine and Coarse Aggregates
Reference AASHTO T 27-20

AASHTO Section	Illinois Modification
	0.1 percent. Illinois Department of Transportation (IDOT) gradation forms or forms approved by IDOT shall be used. These forms shall be completed with all required information.” 10.3. Replace 10.3 with the following: “Rounding shall be according to ASTM E 29 (Illinois Modified).” 10.4. Add 10.4 and insert the following: “For all sieves that are considered overloaded and split in more than one increment. An “S” next to the sieve must be notated on the worksheet.”
11	Replace Section 11 PRECISION AND BIAS with the following: “ COMPARISON PROCEDURE 11.1. All comparison testing shall be conducted in accordance with the most current version of the Illinois Department of Transportation Manual of Test Procedures for Materials (Appendix A7).”
12	Delete: Section 12 KEYWORDS

Standard Method of Test
for
Mechanical Analysis of Extracted Aggregate

Reference AASHTO T 30-21

AASHTO Section	Illinois Modification
2.1	Replace AASHTO Standard T 164 with the following: <ul style="list-style-type: none">• Illinois Modified AASHTO T 164 Replace AASHTO Standard T 255 with the following: <ul style="list-style-type: none">• Illinois Modified AASHTO T 255 Replace AASHTO Standard T 308 with the following: <ul style="list-style-type: none">• Illinois Modified AASHTO T 308
7.1	Replace the first sentence with the following: The sample shall be dried until further drying at 110 ± 5 °C (230 ± 9 °F) does not alter the mass more than 0.5 gram in 1 hour.
A2.2	Replace the second sentence with: This mass is shown in Table A2.1 for three sieve-frame dimensions in common use.

This Page Reserved



Standard Test Method
for
Specific Gravity and Absorption of Fine Aggregate
Reference AASHTO T 84-13 (2021)

AASHTO Section	Illinois Modification
1	<p>Revise Section 1 with the following:</p> <p>1.1. Replace “method” with “procedure” in the first sentence of paragraph in 1.1. Delete 23/23°C (73.4/73.4°) from section 1.1.</p> <p>1.4. Delete first sentence of paragraph in 1.4. To maintain brevity in the text, the following will apply: SI units will be listed first, metric units will be in parentheses. Example: “No. 200 (75-µm)”.</p>
2	<p>Revise Section 2 with the following:</p> <p>2.1. Replace 2.1 with the following: AASHTO Standards (Illinois Modified):</p> <ul style="list-style-type: none"> ▪ R 90, Sampling Aggregate Products ▪ T 19, Bulk Density (“Unit Weight”) and Voids in Aggregate ▪ T 85, Specific Gravity and Absorption of Coarse Aggregate ▪ R 76, Reducing Samples of Aggregate to Testing Sizes ▪ T 255, Total Evaporable Moisture Content of Aggregate by Drying ▪ M 231, Weighing Devices Used in the Testing of Materials <p>2.2. Replace 2.2 with the following: Illinois Specifications:</p> <ul style="list-style-type: none"> ▪ Illinois Specifications 201, Aggregate Gradation Sample Size Table <p>2.3. Insert and add the following: ASTM Standards:</p> <ul style="list-style-type: none"> ▪ E 29 (Illinois Modified), Using Significant Digits in Test Data to Determine Conformance with Specifications
5	<p>Revise Section 5 with the following:</p> <p>5.1. Replace 5.1 with the following: “Balance - The balance shall have sufficient capacity, be readable to 0.1 percent of the sample mass, or better, and conform to the requirements of AASHTO M 231.”</p> <p>5.2. Replace 5.2 with the following: “Sample Container – A solid bucket of approximately equal breadth and heights with a capacity of approximately 366 in³ (6000 cm³) shall be used. The bucket shall be constructed in a way to prevent the trapping of air when the container is submerged.”</p> <p>5.3. Replace 5.3 with the following: “Mold – A metal mold in the form of a frustum of a cone with dimensions as follows: 1.57±0.12in. (40±3mm) inside diameter at the top 3.54±0.12in. (90±3mm) inside diameter at the bottom, and 2.95±0.12in. (75±3mm) in height, with the metal having a minimum thickness of 0.03in. (0.8mm).”</p> <p>5.4. Replace “25 ± 3 mm” with “0.98±0.12in. (25±3mm)”.</p> <p>5.5. Add 5.5 and insert the following: “Oven – An oven of sufficient size, capable of maintaining a uniform temperature of 230±9°F (110±5°C). The oven shall be specifically designed for drying. No other heat source for drying is permitted.”</p> <p>5.6. Add 5.6 and insert the following: “Water Tank – A watertight tank into which the sample and container are placed for complete immersion while suspended below the balance, equipped with an overflow outlet for maintaining a constant water level.”</p> <p>5.7. Add 5.7 and insert the following: “Suspended Apparatus – A nonabsorbent line of material (wire, fishing line, etc.) that suspends the sample container such that the entire handle of the sample container is below the surface of the water.”</p>
6	<p>Revise Section 6 with the following:</p> <p>6.1 Replace 6.1 with the following: “Field samples of fine aggregate shall be taken according to R90 (Illinois Modified). Field sample size shall meet the minimum requirements in the Illinois Specification 201.”</p>
7	<p>Revise Section 7 with the following:</p> <p>7.1. Replace 7.1 with the following: “Obtain a test sample of approximately 4000 grams of fine aggregate from the field sample by procedures described in R76 (Illinois Modified).”</p> <p>7.1.1. Replace 7.1.1 with the following: “The sample shall not be dried. Cover the sample with water and permit to stand 15 to 19 hours.”</p> <p>7.1.2. Delete.</p>

Standard Test Method
 for
Specific Gravity and Absorption of Fine Aggregate
 Reference AASHTO T 84-13 (2021)

AASHTO Section	Illinois Modification
	<p>7.2. Replace 7.2 with the following: “Decant excess water with care to avoid loss of fines, spread the sample on a flat, nonabsorbent surface exposed to a gentle current (lowest setting if using a fan) of air, and stir frequently to assure uniform drying. No mechanical aids shall be used. Hand-stirring or diagonally lifting a nonabsorbent sheet corner-to-corner may be used. Care shall be exercised not to lose any of the test sample. As the material begins to dry sufficiently, it may be necessary to work it with the hands in a rubbing motion to break up any conglomerations, lumps, or balls of material that develop. Follow the procedure in Section 7.2.1 to determine whether or not surface moisture is present on the fine aggregate particles. The first trial of the cone test shall be made with some surface water in the specimen. This first trial shall be performed every time, even on samples that have been dried past saturated surface-dry condition and remoistened. Continue drying with constant stirring, and if necessary, work the material with a hand-rubbing motion, and test at frequent intervals until the test indicates that the specimen has reached a surface-dry condition.”</p> <p>7.2.1 Replace 7.2.1 with the following: “Place the mold firmly on a smooth, nonabsorbent surface with the large diameter down. Place a portion of the partially dried fine aggregate loosely in the mold by filling until overflow occurs. Hold the mold down tightly and remove any loose fine aggregate from around the base of the mold. Lightly tamp the fine aggregate into the mold with 25 light drops of the tamper. Each drop should start about 0.2in. (5mm) above the top surface of the fine aggregate. Permit the tamper to fall freely under gravitational attraction on each drop. Adjust the starting height to the new surface elevation after each drop and distribute the drops over the surface. Lift the mold vertically. Assess the results using the following criteria:”</p> <p>7.2.1.1. Add 7.2.1.1 and insert the following: “If surface moisture is still present, the fine aggregate will retain the molded shape. See Fig. 1.”</p>  <p>Figure 1</p> <p>7.2.1.2. Add 7.2.1.2 and insert the following: “If the first trial of the surface moisture test indicates that moisture is not present on the surface, it has been dried past the saturated surface-dry condition. In this case, thoroughly remoisten the fine aggregate and permit the specimen to stand in a covered container for a minimum of 30 minutes. Then resume the process of drying and testing at frequent intervals for the onset of the surface-dry condition. See Fig. 2.”</p>

Standard Test Method
for
Specific Gravity and Absorption of Fine Aggregate
Reference AASHTO T 84-13 (2021)

AASHTO Section	Illinois Modification
	<div data-bbox="561 352 1312 850"></div> <p data-bbox="889 850 982 877">Figure 2</p> <p data-bbox="451 877 1372 961">7.2.1.3. Add 7.2.1.3 and insert the following: "For rounded and crushed natural sands, surface dry condition is reached when all the material on the sides slumps off leaving a nickel-sized plateau in the middle. See Fig. 3."</p> <div data-bbox="565 961 1307 1453"></div> <p data-bbox="889 1453 982 1480">Figure 3</p> <p data-bbox="451 1480 1383 1560">7.2.1.4. Add 7.2.1.4 and insert the following: "For all other manufactured sands, surface dry condition is reached when at least ¼ of a side of the molded cone shape slumps off. See Fig. 4."</p>

Standard Test Method
 for
Specific Gravity and Absorption of Fine Aggregate
 Reference AASHTO T 84-13 (2021)

AASHTO Section	Illinois Modification
	 <p style="text-align: center;">Figure 4</p>
<p style="text-align: center;">8</p>	<p>Revise Section 8 with the following: 8.2. Replace 8.2 with the following: "Obtain two 1000.0-gram test samples from the saturated surface-dry fine aggregate. This mass is the "Wet Mass." Immediately introduce one of the test samples into the sample container and determine its mass in water at 73.4±3° F (23.0±1.7° C) using the specified balance or scale. Take care to remove all entrapped air before weighing by agitating the test sample. Let the fines settle out before submerging. Discard sample after determining its mass in water. This determination of mass establishes the "Submerged Mass." Delete: Note 3 from section 8.2. Delete: Table 1 from section 8.2. 8.2.1. Delete. 8.2.2. Delete. 8.3. Replace 8.3 with the following: "Dry the second 1000.0-gram sample immediately to constant mass in the specified oven at 230±9° F (110±5° C). After the test sample has been dried to constant mass and cooled to room temperature; determine the mass to the nearest 0.1 gram. Constant mass is defined as the sample mass at which there has not been more than a 0.5-gram mass loss during an additional 1 hour of drying. This should be verified occasionally. This determination of mass establishes the "Oven-Dry Mass." 8.3.1. Delete. 8.4. Delete. 8.4.1. Delete.</p>
<p style="text-align: center;">9</p>	<p>Revise Section 9 with the following: 9.1. Replace 9.1 with the following: "BULK SPECIFIC GRAVITY (OVEN-DRY) Calculate the bulk specific gravity, as follows: $Bulk\ sp\ gr = \frac{A}{B - C}$ Where: A = oven-dry mass, g, B = wet mass, g, and C = submerged mass, g." 9.1.1. Delete.</p>
<p style="text-align: center;">10</p>	<p>Revise Section 10 with the following:</p>

Standard Test Method
 for
Specific Gravity and Absorption of Fine Aggregate
 Reference AASHTO T 84-13 (2021)

AASHTO Section	Illinois Modification
	10.1. Replace 10.1 with the following: “BULK SPECIFIC GRAVITY (SATURATED SURFACE-DRY BASIS) Calculate the bulk specific gravity, on the basis of weight of saturated surface-dry aggregate as follows: $\text{Bulk sp gr (saturated surface - dry)} = \frac{B}{B-C}$ Where: B = wet mass, g, and C = submerged mass, g.” 10.1.1. Delete.
11	Revise Section 11 with the following: 11.1. Replace 11.1 with the following: “APPARENT SPECIFIC GRAVITY Calculate the apparent specific gravity, as follows: $\text{Apparent sp gr} = \frac{A}{A-C}$ Where: A = oven-dry mass, g, and C = submerged mass, g.”
12	Revise Section 12 with the following: 12.1. Replace 12.1 with the following: “ABSORPTION Calculate the percentage of absorption as follows: $\text{Absorption, percent} = \frac{B-A}{A} * 100$ Where: A = oven-dry mass, g, and: B = wet mass, g.”
13	Revise Section 13 with the following: 13.1. Replace 13.1 with the following: “Report all specific gravity results to the nearest 0.001 and all absorption results to the nearest 0.1 percent. All rounding shall be according to ASTM E 29 (Illinois Modified).” 13.2. Delete.
14	Delete: Section 14 PRECISION AND BIAS
15	Delete: Section 15 KEYWORDS
	Delete: APPENDIXES

This Page Reserved



Standard Test Method
for
Specific Gravity and Absorption of Coarse Aggregate
Reference AASHTO T 85-21

AASHTO Section	Illinois Modification
1	<p>Revise Section 1 with the following: 1.2. Replace “method” with “procedure” in the first sentence of paragraph in 1.1. 1.3. Delete first sentence of paragraph in 1.3. To maintain brevity in the text, the following will apply: SI units will be listed first, metric units will be in parentheses. Example: “No. 200 (75-μm)”.</p>
2	<p>Revise Section 2 with the following: 2.1. Replace 2.1 with the following: AASHTO Standard (Illinois Modified):</p> <ul style="list-style-type: none"> ▪ R 90, Sampling Aggregate Products ▪ T 19, Bulk Density (“Unit Weight”) and Voids in Aggregate ▪ T 85, Specific Gravity and Absorption of Coarse Aggregate ▪ R 76, Reducing Samples of Aggregate to Testing Sizes ▪ T 255, Total Evaporable Moisture Content of Aggregate by Drying ▪ M 231, Weighing Devices Used in the Testing of Materials <p>2.2. Replace 2.2 with the following: Illinois Specifications:</p> <ul style="list-style-type: none"> ▪ Illinois Specifications 201, Aggregate Gradation Sample Size Table <p>2.3. Insert and add the following: ASTM Standards:</p> <ul style="list-style-type: none"> ▪ E 29 (Illinois Modified), Using Significant Digits in Test Data to Determine Conformance with Specifications
4	<p>Replace Section 4 SUMMARY OF METHOD with the following: 4 SIGNIFICANCE AND USE</p> <p>4.1. “Bulk specific gravity is the characteristic generally used for calculation of the volume occupied by the aggregate in various mixtures containing aggregate, including Portland cement concrete, bituminous concrete, and other mixtures that are proportioned or analyzed on an absolute volume basis. Bulk specific gravity is also used in the computation of voids in aggregate in T 19 (Illinois Modified). Bulk specific gravity (SSD) is used if the aggregate is wet, that is, if its absorption has been satisfied. Conversely, the bulk specific gravity (oven-dry) is used for computations when the aggregate is dry or assumed to be dry.”</p> <p>4.2. “Apparent specific gravity pertains to the relative density of the solid material making up the constituent particles not including the pore space within the particles which is accessible to water.”</p> <p>4.3. “Absorption values are used to calculate the change in the mass of an aggregate due to water absorbed in the pore spaces within the constituent particles, compared to the dry condition, when it is deemed that the aggregate has been in contact with water long enough to satisfy most of the absorption potential. The laboratory standard for absorption is that obtained after submerging dry aggregate for approximately 15 to 19 hours in water. Aggregates mined from below the water table may have a higher absorption when used, if not allowed to dry. Conversely, some aggregates when used may contain an amount of absorbed moisture less than the 15-hour soaked condition. For an aggregate that has been in contact with water and that has free moisture on the particle surfaces, the percentage of free moisture can be determined by deducting the absorption from the total moisture content determined by T 255 (Illinois Modified).”</p>
5	<p>Replace Section 5 SIGNIFICANCE AND USE with the following: “APPARATUS”</p> <p>5.1. “Balance – The balance shall have sufficient capacity, be readable to 0.1 percent of the sample mass, or better, and conform to the requirements of AASHTO M 231 (Illinois Modified). For accurate SSD determination; a metal weigh pan with the capability of showing the water marks should be utilized.”</p> <p>5.2. “Sample Container – A solid bucket of approximately equal breadth and heights with a capacity of approximately 366 in³ (6000 cm³), or a wire mesh basket with No. 10 (0.2mm) mesh or smaller, may be used. The bucket/basket shall be constructed in a way to prevent the trapping of air when the container is submerged.”</p> <p>5.3. “Water Tank – A watertight tank into which the sample and container are placed for</p>



Standard Test Method
for
Specific Gravity and Absorption of Coarse Aggregate
Reference AASHTO T 85-21

AASHTO Section	Illinois Modification														
	<p>complete immersion while suspended below the balance equipped with an overflow outlet for maintaining a constant water level.”</p> <p>5.4. “Suspended Apparatus – A nonabsorbent line of material (wire, fishing line, etc.) that suspends the sample container such that the entire handle of the sample container is below the surface of the water.”</p> <p>5.5. “Sieves – A No. 8 (2.36mm) sieve, conforming to ASTM E 11.”</p> <p>5.6. “Oven – An oven of sufficient size, capable of maintaining a uniform temperature of 230±9°F (110±5°C). The oven shall be specifically designed for drying. In addition, a gas burner or electric hot plate may be used. Microwave ovens are not permitted for drying aggregate gradation samples.”</p> <p>5.7. “Weigh Pan- An uncoated Aluminum pan used on a balance that can visually show the presence of moisture.”</p>														
6	<p>Replace Section 6 APPARATUS with the following: “SAMPLING”</p> <p>6.1. “Field samples of coarse aggregate shall be taken according to R90 (Illinois Modified). Field sample size shall meet the minimum requirements in the Illinois Specification 201.”</p> <p>6.2. “Thoroughly mix the sample of aggregate and reduce it to the approximate quantity needed using the applicable procedure in R76 (Illinois Modified). Reject all material passing the No. 8 (2.36mm) sieve by dry sieving.”</p> <p>6.3. “The minimum mass of test sample to be used is given below. When testing gradations that are too large to fit in the sample container, the sample may be split into multiple samples. If multiple samples are tested the weights will be combined prior to calculations.”</p> <table border="1" style="width: 100%; border-collapse: collapse;"> <thead> <tr> <th style="text-align: left;">Gradations</th> <th style="text-align: left;">Minimum Mass of Test Sample, g</th> </tr> </thead> <tbody> <tr> <td>CA/CM 01</td> <td>9,700 – 9,800</td> </tr> <tr> <td>CA/CM 02 & 03</td> <td>7,800 – 8,200</td> </tr> <tr> <td>CA/CM 04 & 05</td> <td>4,800 – 5,200</td> </tr> <tr> <td>CA/CM 06 – 09</td> <td>3,800 – 4,200</td> </tr> <tr> <td>CA/CM 10 – 11</td> <td>2,800 – 3,200</td> </tr> <tr> <td>CA/CM 12 – 20</td> <td>1,900 – 2,100</td> </tr> </tbody> </table>	Gradations	Minimum Mass of Test Sample, g	CA/CM 01	9,700 – 9,800	CA/CM 02 & 03	7,800 – 8,200	CA/CM 04 & 05	4,800 – 5,200	CA/CM 06 – 09	3,800 – 4,200	CA/CM 10 – 11	2,800 – 3,200	CA/CM 12 – 20	1,900 – 2,100
Gradations	Minimum Mass of Test Sample, g														
CA/CM 01	9,700 – 9,800														
CA/CM 02 & 03	7,800 – 8,200														
CA/CM 04 & 05	4,800 – 5,200														
CA/CM 06 – 09	3,800 – 4,200														
CA/CM 10 – 11	2,800 – 3,200														
CA/CM 12 – 20	1,900 – 2,100														
7	<p>Replace Section 7 SAMPLING with the following: “PROCEDURE”</p> <p>7.1. “Immerse the aggregate in water at room temperature for period of 15 to 19 hours.”</p> <p>7.2. “Decant the water off the test sample. Thoroughly wash the sample in cool water to remove dust or other coatings from the surface. Decant off excess water. Place sample on large, absorbent cloth. Roll particles with a clean, dry towel until all visible signs of water are removed. Take care to avoid evaporation of water from aggregate pores during the operation of saturated surface drying. Once the material is at surface dry condition (see 7.3), gently introduce the sample to the weigh pan. Do not agitate the material once in the weigh pan. Determine the mass of all test samples, while in the saturated surface dry condition, to the nearest 1 gram on a specified balance or scale.”</p> <p>7.3. “To check for an accurate saturated surface dry condition, the water streaks in the weigh pan shall be used. After obtaining the surface dry weight introduce the test sample into the sample basket/bucket, do not immerse. Tilt the weigh pan so the bottom of the pan is vertical. Then immediately check the bottom of the weigh pan for the presence of water spots. The following figures and descriptions shall be used to access the sample for accurate saturated surface dry condition:”</p> <p>7.3.1. “If there are no or very few spots present (see Fig. 1); the sample is too dry and must be re-soaked for a minimum of 30 minutes. Then resume the process of drying the test sample to saturated surface dry condition (see 7.2).”</p>														

Standard Test Method
for
Specific Gravity and Absorption of Coarse Aggregate
Reference AASHTO T 85-21

AASHTO Section	Illinois Modification
	 <p data-bbox="889 940 980 970">Figure 1</p> <p data-bbox="451 970 1393 1075">7.3.2. "If there is enough water present for the spots to run or the water to pool at the bottom of the weigh pan, then the sample is too wet and must be spread back out on the absorbent cloth and continue drying to obtain the saturated surface dry condition (see Figures 2 & 3)."</p>  <p data-bbox="889 1663 980 1692">Figure 2</p>

Standard Test Method
for
Specific Gravity and Absorption of Coarse Aggregate
Reference AASHTO T 85-21

AASHTO Section	Illinois Modification
	 <p data-bbox="889 932 980 961">Figure 3</p> <p data-bbox="451 961 1406 1045">7.3.3. "Accurate saturated surface dry condition is obtained when the bottom of the weigh pan has water streaks present but there is no sign of pooled water anywhere (see Figures 4 & 5)."</p>  <p data-bbox="889 1629 980 1659">Figure 4</p>

Standard Test Method
for
Specific Gravity and Absorption of Coarse Aggregate
Reference AASHTO T 85-21

AASHTO Section	Illinois Modification
	 <p data-bbox="889 932 980 957">Figure 5</p> <p data-bbox="451 961 1409 1066">7.4. "After determining the mass, immediately place the saturated-surface-dry test sample in the sample container and determine its mass in water at 73.4±3°F (23.0± 1.7°C), having a density of 62±0.1lb/ft³ (997± 2 kg/m³). Take care to remove all entrapped air before determining the mass by agitating the container while immersed."</p> <p data-bbox="451 1071 1419 1205">7.5. "Dry the test sample to a constant mass in a specified oven at a temperature of 230±9°F (110±5°C). After the test sample has been dried to constant mass and cooled to room temperature; determine the mass to the nearest 1 gram. Constant mass is defined as the sample mass at which there has not been more than a 0.5-gram mass loss during an additional 1 hour of drying. This should be verified occasionally."</p>
8	<p data-bbox="451 1209 1218 1234">Replace Section 8 PROCEDURE with the following: "CALCULATIONS"</p> <p data-bbox="451 1239 688 1264">8.1. "Specific Gravity:"</p> <p data-bbox="451 1268 1253 1293">8.1.1. "Bulk Specific Gravity – Calculate the bulk specific gravity, as follows:</p> $Bulk\ sp\ gr = A/(B-C)$ <p data-bbox="526 1373 607 1398">Where:</p> <p data-bbox="643 1428 1276 1512">A = Mass of oven-dry test sample in air, g; B = Mass of saturated-surface-dry test sample in air, g; and C = Mass of saturated test sample in water, g."</p> <p data-bbox="451 1541 1396 1596">8.1.2. "Bulk Specific Gravity (Saturated-Surface-Dry) – Calculate the bulk specific gravity, as follows:</p> $Bulk\ SpG\ (saturated-surface-dry) = B / (B - C)"$ <p data-bbox="451 1675 1354 1701">8.1.3. "Apparent Specific Gravity – Calculate the apparent specific gravity, as follows:</p> $Apparent\ SpG = A / (A - C)"$ <p data-bbox="451 1785 1185 1810">8.2. "Absorption – Calculate the percentage of absorption, as follows:</p> $Absorption, percent = [(B - A) / A] * 100$
9	Replace Section 9 CALCULATIONS with the following: " REPORT "

Illinois Modified Test Procedure
Effective Date: December 1, 2021

Standard Test Method
for
Specific Gravity and Absorption of Coarse Aggregate
Reference AASHTO T 85-21

AASHTO Section	Illinois Modification
	9.1. "Report all specific gravities to the nearest 0.001. All rounding shall be according to ASTM E 29 (Illinois Modified)." 9.2. "Report the absorption result to the nearest 0.1 percent."
10	Delete: Section 10 REPORT
11	Delete: Section 11 PRECISION AND BIAS
12	Delete: Section 12 KEYWORDS
	Delete: APPENDIXES

Illinois Modified Test Procedure
 Effective Date: April 1, 2011
 Revised Date: [December 1, 2021](#)

Standard Method of Test
 for
**Moisture - Density Relations of Soils Using a
 2.5-kg (5.5-lb) Rammer and a 305-mm (12-in.) Drop**

Reference AASHTO T 99-21

AASHTO Section	Illinois Modification
1.7	<p>Revise as follows:</p> <p>The values stated in either SI units or inch-pound units are to be regarded separately as standard. The values stated in each system may not be exact equivalents in this standard. Combining values from the two systems may result in non-conformance with the standard, and diligence is advised when using unit conversions to combine the two systems. Results shall be reported in inch-pound units.</p>
2.1	<p>Revise as follows:</p> <p>AASHTO T 19 (Illinois Modified) AASHTO T 85 (Illinois Modified) AASHTO R 76 (Illinois Modified) AASHTO T 265 (Illinois Modified) AASHTO T 310 (Illinois Modified)</p> <p>Delete as follows: T 217 T 255</p> <p>To maintain brevity in the text, the following will apply: Example: AASHTO T 265 (Illinois Modified) will be designated as “T 265”.</p>
2.2	<p>Revise as follows:</p> <p style="text-align: center;">ASTM E 29 (Illinois Modified) Standard Practice for Using Significant Digits In Test Data to Determine Conformance with Specifications</p> <p>To maintain brevity in the text, the following will apply: Example: ASTM E 29 (Illinois Modified) will be designated as “ASTM E 29.”</p>
3.1.1	<p>Add as follows: This mold volume is historically known as the 1/30 ft³ sized mold.</p>
3.1.2	<p>Add as follows: This mold volume is historically known as the 1/13.33 ft³ sized mold.</p>
3.2.3	<p>Revise the first sentence as follows: The circular face rammer shall be used, but a sector face must be used as an alternative when using the mechanical compactor and a 6-inch mold, provided the report shall indicate type of face used other than the 50.8-mm (2-in.) circular face, and it shall have an area equal to that of the circular face rammer.</p>

Illinois Modified Test Procedure
 Effective Date: April 1, 2011
 Revised Date: [December 1, 2021](#)

Standard Method of Test
 for
**Moisture - Density Relations of Soils Using a
 2.5-kg (5.5-lb) Rammer and a 305-mm (12-in.) Drop**

Reference AASHTO T 99-21

AASHTO Section	Illinois Modification
4.3	Replace the second sentence as follows: When the sample has oversized particles, particles retained on the 4.75-mm (No. 4) sieve, keep separate from material passing 4.75-mm (No. 4) sieve and see Annex A1.
4.4	Revise as follows: Reduce the sample passing the 4.75-mm (No. 4) sieve to a mass of 3 kg (7 lb) or more in accordance with R 76 . If performing the coarse particle correction in Annex A1, Section A.1.3 shall be completed prior to proceeding with the sample reduction.
5., 7., 9., 11., and 12	Add as follows: All rounding shall be according to ASTM E 29.
Note 7 (After 5.2.)	Renummer Note 7 to Note 5.
5.3.1	Replace as follows: Following compaction, remove the collar; carefully trim the compacted soil even with the top of the mold by means of the straightedge, and determine the mass of the mold, base plate, and moist soil in kilograms to the nearest one gram, or determine the mass in pounds to the nearest 0.002 pounds. Calculate the wet density, W_1 , as described in Section 12.1 or 12.3 and 12.4.
5.4	Revise the second sentence as follows: Obtain a representative sample of the material, weighing not less than 500 g, by slicing vertically through the center of the molded material and removing one of the cut faces (Figure 3) or from the center of the pile if the material falls apart.
5.5	Replace the third sentence as follows: Continue this series of determinations until there is either a decrease or no change in the wet unit mass, W_1 , per cubic meter (cubic foot) of the compacted soil (Note 7).
5.5.1	Delete.
7.1	Revise the second sentence as follows: Calculate the wet density, W_1 , as described in Section 12.1 or 12.3 and 12.4.
8.3	Replace the second sentence as follows: When the sample has oversized particles, particles retained on the 19.0-mm (3/4-in.) sieve, keep separate from material passing 19.0-mm (3/4-in.) sieve and see Annex A1.

Standard Method of Test
 for
**Moisture - Density Relations of Soils Using a
 2.5-kg (5.5-lb) Rammer and a 305-mm (12-in.) Drop**

Reference AASHTO T 99-21

AASHTO Section	Illinois Modification
8.4	Revise as follows: Reduce the sample passing the 19.0-mm (3/4-in.) sieve to a mass of 5 kg (11 lb) or more in accordance with R 76 . If performing the coarse particle correction in Annex A1, Section A.1.3 shall be completed prior to proceeding with the sample reduction.
9.3.1	Revise the fourth sentence as follows: Calculate the wet density, W_1 , as described in Section 12.1 or 12.3 and 12.4.
9.4	Revise the second sentence as follows: Obtain a representative sample of the material, weighing not less than 500 g, by slicing vertically through the center of the molded material and removing one of the cut faces (Figure 3) or from the center of the pile if the material falls apart.
9.5	Replace the third sentence as follows: Continue this series of determinations until there is either a decrease or no change in the wet unit mass, W_1 , per cubic meter (cubic foot) of the compacted soil.
9.5.1	Delete.
11.1	Revise the second sentence as follows: Calculate the wet density, W_1 , as described in Section 12.1 or 12.3 and 12.4.
12.1	Add after the first sentence: Refer to Section 12.3 and 12.4 for alternative calculation of W_1 using mold factor methods.
12.2	Revise as follows: w = moisture content (percent) of the specimen, as determined by T 265.
12.3 New Section	Add as follows: The mold factor can be related to the volume of the mold as follows: $F = 1 / V \tag{3}$ Where: F = mold factor, and V = volume of mold. If using a balance or scale that measures the soil and mold mass in grams and the mold volume is in ft ³ , the Mold Factor requires a unit conversion as follows: $F = \frac{1}{V} \times \frac{1 \text{ lb}}{454 \text{ g}} \tag{4}$ Note 8 –The Mold Factor is a conversion factor incorporating the volume of the mold and, if needed, the conversion of grams to pounds.

Standard Method of Test
 for
**Moisture - Density Relations of Soils Using a
 2.5-kg (5.5-lb) Rammer and a 305-mm (12-in.) Drop**

Reference AASHTO T 99-21

AASHTO Section	Illinois Modification
12.4 New Section	<p>Add as follows: Alternatively, the wet density can be determined using the mold factor. For masses recorded in kilograms, the unit of wet density is kilograms per cubic meter of compacted soil. However, equation 4 from Section 12.3 may be used to convert grams to pounds to determine the unit of wet density in pounds per cubic foot of compacted soil. For masses recorded in pounds, the unit of wet density is pounds per cubic foot of compacted soil.</p> $W_1 = (A - B) \times F \quad (5)$ <p>Where: A = mass of compacted specimen and mold; B = mass of mold; F = mold factor as calculated in Section 12.3 W₁ = wet density.</p>
13.1	<p>Revise the second sentence as follows: The oven-dry densities of the soil shall be plotted as ordinates, and the corresponding moisture content as abscissas (Note 9).</p> <p>Add as follows at the end of the paragraph: Note 9 – (Optional) The wet densities of the soil may also be plotted as ordinates, and the corresponding moisture content as abscissas.</p>
13.2	<p>Revise the first sentence as follows: <i>Optimum Moisture Content</i> – When the densities and corresponding moisture contents for the soil have been determined and plotted as indicated in Section 13.1, it will be found that by connecting the plotted points with smooth line, a curve is produced (Note 10).</p> <p>Add as follows at the end of the paragraph: Note 10– (Optional) As an aid for interpreting the dry density smooth line curve between the dry points plotted in section 13.1, connect the plotted points from Note 8 with a smooth line to create a wet density curve. Then, select 2 to 3 intermediate points on the wet density curve near the apparent peak of the dry curve, and back calculate the dry density of these points from their wet densities and corresponding moisture contents. Plot those intermediate dry densities and corresponding moisture content points to the points plotted in Section 13.1.</p>

Illinois Modified Test Procedure
 Effective Date: April 1, 2011
 Revised Date: [December 1, 2021](#)

Standard Method of Test
 for
**Moisture - Density Relations of Soils Using a
 2.5-kg (5.5-lb) Rammer and a 305-mm (12-in.) Drop**

Reference AASHTO T 99-21

AASHTO Section	Illinois Modification
14.1.3	Revise as follows: The maximum dry density to the nearest 1 kg/m ³ (0.1 lb/ft ³).
14.1.5	Revise as follows: Oversized particle correction, if performed.
14.1.5.1	Revise as follows: The adjusted maximum dry density to the nearest 1 kg/m ³ (0.1 lb/ft ³), if calculated.
14.1.5.2	Revise as follows: The corrected optimum moisture content to the nearest 0.1 percent, if calculated.
14.1.5.3	Revise as follows: The oversized particles to the nearest 0.1 percent of the original dry mass of the sample, if calculated.
14.1.5.4	Revise as follows: G_{sb} of oversized particles to the nearest 0.001, if determined.
A1.3.2	Revise the third sentence as follows: The moisture content shall be determined by T 265.

This Page Reserved

Illinois Modified Test Procedure
Effective Date: [December 1, 2021](#)

Standard Method of Test
for
Slump of Hydraulic Cement Concrete

Reference AASHTO T 119M/T 119-18

AASHTO Section	Illinois Modification
2.1	<p>Revise as follows: AASHTO R 100 (Illinois Modified) (formerly AASHTO T 23) AASHTO T 121 (Illinois Modified) AASHTO R 60 (Illinois Modified) AASHTO T 152 (Illinois Modified) AASHTO T 196 (Illinois Modified)</p> <p>To maintain brevity in the text, the following will apply: Example: AASHTO T 121 (Illinois Modified) will be designated as “T 121.”</p>
5.1	<p>Revise the eighth sentence as follows: The mold shall be free from dents, deformations, and adhered mortar.</p> <p>Add tenth sentence as follows: A funnel and a swing handle (attached to the base plate for measuring vertical distance) may be used.</p>
5.1.2, 5.1.2.1, and 5.1.2.2	<p>Delete</p> <p>Comment: Plastic molds are not permitted under any circumstances despite approval in ASTM C 143.</p>
7.6	<p>Add the following:</p> <p>If the funnel is used when placing the top layer, raise it slightly to prevent it from becoming wedged inside the cone.</p>

This Page Reserved

Standard Method of Test
 For
Density (Unit Weight), Yield, and Air Content (Gravimetric) of Concrete

Reference AASHTO T 121M/T 121-19

AASHTO Section	Illinois Modification
2.1	Add as follows: AASHTO M 231 Weighing Devices Used in the Testing of Materials Revise as follows: AASHTO T 19 (Illinois Modified) AASHTO R 100 (Illinois Modified) (formerly AASHTO T 23) AASHTO T 119 (Illinois Modified) AASHTO R 60 (Illinois Modified) AASHTO T 152 (Illinois Modified) AASHTO T 196 (Illinois Modified) To maintain brevity in the text, the following will apply: Example: AASHTO R 100 (Illinois Modified) will be designated as “R 100.”
2.2	Add as follows: ASTM E 29 (Illinois Modified) Standard Practice for Using Significant Digits in Test Data to Determine Conformance with Specifications To maintain brevity in the text, the following will apply: Example: ASTM E 29 (Illinois Modified) will be designated as “ASTM E 29.”
2.3 New Section	Illinois Standard: Illinois Specification 101 Minimum Requirement for Electronic Balances.
4.1	Replace the first sentence with the following: The balance or scale shall conform to M 231 and Illinois Specification 101.
8.1	Add as follows: The test result shall be rounded to the nearest 1 kg/m ³ (0.1 lb/ft ³).
8.2	Add as follows: The test result shall be rounded to the nearest 0.01 m ³ (0.1 ft ³).
8.3	Add as follows: The test result shall be rounded to the nearest 0.01.
8.4	Add as follows: The test result shall be rounded to the nearest 1 kg/m ³ (1 lb/yd ³).
8.5	Add as follows: The test result shall be rounded to the nearest 0.1 percent.
8.6 New Section	All rounding shall be according to ASTM E 29.

This Page Reserved

Standard Method of Test
 for
Moisture-Density Relations of Soil-Cement Mixtures

Reference AASHTO T 134-19

AASHTO Section	Illinois Modification
1.5 New Section	Add as follows: The values stated in either SI units or inch-pound units are to be regarded separately as standard. The values stated in each system may not be exact equivalents in this standard. Combining values from the two systems may result in non-conformance with the standard, and diligence is advised when using unit conversions to combine the two systems. Results shall be reported in inch-pound units.
2.1	Revise as follows: AASHTO M 92 (Illinois Modified) AASHTO M 231 (Illinois Modified) AASHTO T 19 (Illinois Modified) AASHTO T 99 (Illinois Modified) AASHTO T 265 (Illinois Modified) Remove as follows: AASHTO R 11 (replaced by Illinois Modified ASTM E 29) To maintain brevity in the text, the following will apply: Example: AASHTO T 265 (Illinois Modified) will be designated as "T 265."
2.2	Revise as follows: ASTM E 29 (Illinois Modified) Standard Practice for Using Significant Digits in Test Data to Determine Conformance with Specifications To maintain brevity in the text, the following will apply: Example: ASTM E 29 (Illinois Modified) will be designated as "ASTM E 29."
5.7	Revise the second sentence as follows: Obtain a representative sample of the material, weighing not less than 500 g, by slicing vertically through the center of the molded material and removing one of the cut faces or from the center of the pile if the material falls apart.
Note 7	Revise the first sentence as follows: This oversize procedure is different than used in Annex A of T 99.

Standard Method of Test
 for
Moisture-Density Relations of Soil-Cement Mixtures

Reference AASHTO T 134-19

AASHTO Section	Illinois Modification
8.1	<p>Add as follows: All rounding shall be according to ASTM E 29.</p> <p>Add after the first sentence: Refer to Section 8.2 and 8.3 for alternative calculation of W_1 using mold factor methods.</p> <p>Revise as follows: w = moisture content (percent) in the specimen, based on oven-dry mass of soil-cement and as determined by T 265 (refer to Section 5.7).</p>
8.2 New Section	<p>Add as follows: The mold factor can be related to the volume of the mold as follows:</p> $F = 1 / V \quad (3)$ <p>Where: F = mold factor, and V = volume of mold.</p> <p>If using a balance or scale that measures the soil and mold mass in grams and the mold volume is in ft^3, the Mold Factor requires a unit conversion as follows:</p> $F = \frac{1}{V} \times \frac{1 \text{ lb}}{454 \text{ g}} \quad (4)$ <p>Note 8 –The Mold Factor is a conversion factor incorporating the volume of the mold and, if needed, the conversion of grams to pounds.</p>
8.3 New Section	<p>Add as follows: Alternatively, the wet density can be determined using the mold factor. For masses recorded in kilograms, the unit of wet density is kilograms per cubic meter of compacted soil. However, equation 4 from Section 8.2 may be used to convert grams to pounds to determine the unit of wet density in pounds per cubic foot of compacted soil. For masses recorded in pounds, the unit of wet density is pounds per cubic foot of compacted soil.</p> $W_1 = (A - B) \times F \quad (5)$ <p>Where: A = mass of compacted specimen and mold; B = mass of mold; F = mold factor as calculated in Section 8.2 W_1 = wet density.</p>

This Page Reserved

AASHTO T 141 has been replaced by AASHTO R 60.

This Page Reserved

AASHTO T 141 has been replaced by AASHTO R 60.

Illinois Modified Test Procedure
 Effective Date: [December 1, 2021](#)
 Standard Method of Test
 For

Air Content of Freshly Mixed Concrete by the Pressure Method

Reference AASHTO T 152-19

AASHTO Section	Illinois Modification
2.1	<p>Revise as follows: AASHTO R 39 (Illinois Modified) AASHTO R 60 (Illinois Modified) AASHTO R 100 (Illinois Modified) (formerly AASHTO T 23) AASHTO T 119 (Illinois Modified) AASHTO T 121 (Illinois Modified) AASHTO T 196 (Illinois Modified)</p> <p>Add as follows: AASHTO M 231 Weighing Devices Used in the Testing of Materials</p> <p>To maintain brevity in the text, the following will apply: Example: AASHTO T 119 (Illinois Modified) will be designated as “T 119.”</p>
2.2	<p>Add as follows: ASTM E 29 (Illinois Modified) Standard Practice for Using Significant Digits in Test Data to Determine Conformance with Specification</p> <p>To maintain brevity in the text, the following will apply: Example: ASTM E 29 (Illinois Modified) will be designated as “ASTM E 29.”</p>
2.3 New Section	<p>Illinois Standards: Illinois Specification 101 Minimum Requirement for Electronic Balances</p>
6.1	<p>Add as follows: The maximum calibration interval is 12 months for the Type A air meter, and 3 months for the Type B air meter.</p>
7.1	<p>Add as follows: The average correction factor test may be performed on separate samples of fine and coarse aggregate. Refer to Section 7.5 for more information.</p>

Standard Method of Test
 For
Air Content of Freshly Mixed Concrete by the Pressure Method
 (continued)
 Reference AASHTO T 152-19

AASHTO Section	Illinois Modification
7.5 New Section	<p>Add as follows:</p> <p><i>Alternate Aggregate Correction Factor Determination Using Department Type A Meter.</i></p> <p>Prepare separate representative samples of fine and coarse aggregate, each in the amount which will be used in a volume of concrete exactly sufficient to fill the container, which for this purpose may be considered as having a capacity of 0.2 cubic foot. To do so, it is necessary to know or estimate the proportions of the materials which will be used in the work. If the size of samples used are later found to be in error to any important degree, the test should be repeated after the proportions have become definitely established.</p> <p>Fill the container about half full of water, pour the fine aggregate slowly into the container and stir vigorously by hand for five minutes so that the fine aggregate will be completely inundated with no entrapped air around or between the particles. It is very difficult to remove all of the entrapped air and much care should be taken in performing this operation or the test will show erroneous results.</p> <p>Finish filling the container with water. Wipe the contact surfaces clean and clamp the cover of the apparatus firmly to the container.</p> <p>Close the lower petcock and open the upper petcock and the funnel valve. Pour water through the funnel until it stands at a level slightly above the arrow mark on the graduated scale. Close the funnel valve and adjust the water level to the arrow mark on the graduated scale by means of the lower petcock.</p> <p>Close the upper petcock and apply pressure with the bicycle tire pump until the gage reads 103 kPa (15 psi). Read and record the subsidence of the water level.</p> <p>Release the pressure by opening the upper petcock. Release the water by opening the C-clamps. Repeat the test on other samples until it is apparent from the results obtained that all the air entrapped between the fine aggregate particles is being stirred out.</p> <p>Repeat the entire procedure with the coarse aggregate sample(s).</p> <p>The sum of the readings obtained for the two samples is the subsidence of the water level due to the air held within the aggregate particles, and is the correction to be applied in determining the air content of the concrete. The test can be made on the samples of fine and coarse aggregate combined, but more difficulty will be experienced in stirring out entrapped air.</p>

Illinois Modified Test Procedure
Effective Date: [December 1, 2021](#)

Standard Method of Test
For
Air Content of Freshly Mixed Concrete by the Pressure Method
(continued)
Reference AASHTO T 152-19

AASHTO Section	Illinois Modification
9.3 9.3.1, 9.3.2, 9.3.3, 9.3.4, and 9.3.5	<p>Replace as follows:</p> <p style="text-align: center;"><i>Procedure—Department Type A Meter:</i></p> <ol style="list-style-type: none"> 1. Thoroughly clean the flange or rim of the bowl and moisten the cover assembly. This will ensure that when the cover is clamped, a pressure-tight seal will be obtained. 2. Close the lower petcock. Open the upper petcock and the funnel valve. Add water through the funnel until the level is slightly above the index mark, or until water flows from the upper petcock. 3. Close the funnel valve. Using the lower petcock, adjust the bottom of the meniscus (water level) to be level with the index mark. The index mark is to account for the expansion of the air meter, and is above the zero mark. The expansion is primarily a result of the C-clamps elongating. Always read the water level at the bottom of the meniscus. Close the lower petcock. 4. Close the upper petcock. 5. Using the hand pump, apply 103 kPa (15 psi) pressure. 6. Read the water level and record the apparent air content to the nearest tenth of a percent. If the water level cannot be read at 103 kPa (15 psi), reduce the air pressure to 69 kPa (10 psi) and multiply the reading by 1.25. If the water level cannot be read at 69 kPa (10 psi), reduce the air pressure to 34 kPa (5 psi) and multiply the reading by 2.00. 7. Release the air pressure by slowly opening both petcocks before unclamping and removing the cover. <p>If the water glass needs cleaning, remove the valve from the funnel valve assembly. Clean the inside of the glass with a strip of cloth and one of the wire guards of the water glass.</p>
11.1.1	<p>Replace as follows:</p> <p>All rounding shall be according to ASTM E 29. The test result shall be rounded to the nearest 0.1 after subtracting the aggregate correction factor.</p>
Annex A1	<p>Delete the Section and replace as follows:</p> <p>The air meter shall be calibrated according to the instructions provided in the Portland Cement Concrete Level I Technician Course Manual. The balance or scale shall conform to M 231 and Illinois Specification 101.</p>

This Page Reserved

Standard Method of Test
 for
Quantitative Extraction of Asphalt Binder from Hot Mix Asphalt (HMA)

Reference AASHTO T 164-14 (2018)¹ (ASTM D 2172 / D 2172M-11)

AASHTO Section	Illinois Modification
2.1	Delete Reference to AASHTO Standard T 168
2.2	Add the following: <ul style="list-style-type: none"> • Illinois Modified ASTM D8159, Standard Test Method for Automated Extraction of Asphalt Binder from Asphalt Mixtures
New Section 2.4	Replace all references to AASHTO T 168 with the following Manual of Test Procedures Appendices: <ul style="list-style-type: none"> • Appendix B6 – HMA QC/QA Initial Daily Plant and Random Samples • Appendix B7 – Determination of Random Density Procedures • Appendix E3 – PFP & QCP Random Density Procedure • Appendix E4 – PFP & QCP HMA Random Jobsite Sampling
3.2	Replace with the following: <i>Constant mass</i> – shall be defined as the mass at which further drying does not alter the mass by more than 0.5 g when weighed at 1 hour intervals.
4.1	Replace with the following: The HMA mixture is extracted with trichloroethylene; <i>normal</i> -propyl bromide; or methylene chloride, using the extraction equipment applicable to Test Method A, B, E or F. The asphalt binder content is calculated by differences from the mass of the extracted aggregate and moisture content, and mineral matter in the extract (when using centrifuge extraction from Test Method A and when using the automated extraction in Method F . The asphalt binder content is expressed as a mass percent of moisture-free mixtures.
5.1	Replace the first sentence with the following: Method A, B, or F shall be used for quantitative determinations of asphalt binder in HMA mixtures and pavement samples for specification acceptance, service evaluation, quality control, and research.
7.4	Delete
Note 4	Delete
9.2.1	Add at the end: Illinois requires the material to be split to the sample size by use of the splitter specified in Illinois Test Procedure 248 and further as specified in IL Modified AASHTO T 312.

Standard Method of Test
 for
Quantitative Extraction of Asphalt Binder from Hot Mix Asphalt (HMA)

Reference AASHTO T 164-14 (2018)¹ (ASTM D 2172 / D 2172M-11)

AASHTO Section	Illinois Modification
9.2.2	Add at the end: Refer to IL Modified ASTM D8159 for the sample size requirements when using Method F.
10.1	Replace with the following: When required, calculate the moisture content of the mixture. Moisture content in the sample is defined as follows: $\frac{\text{Original Mass} - \text{Oven Dry Mass}}{\text{Oven Dry Mass}} \times 100$
Note 9	Delete
12.3	Replace the first sentence with the following: Cover the test portion in the bowl with trichloroethylene, methylene chloride, or <i>normal</i> -propyl bromide extractant, and allow sufficient time for the solvent to disintegrate the test portion (not more than 1 h).
12.4	Allow the machine to stop; add 200 mL (or more as appropriate for the mass of the sample) of trichloroethylene, methylene chloride, or <i>normal</i> -propyl bromide extractant, and repeat the procedure.
12.6	Replace with the following: When centrifuge extraction from Test Method A is used, the amount of mineral matter in the extract shall be determined. Any of the test procedures specified in Annex A1 may be used to determine the amount of mineral matter.
13.	Replace with the following: If centrifuge extraction from Test Method A is used, or when any other method of extraction is used and the amount of mineral matter in the extract is determined, then the asphalt binder content in the test portion shall be calculated as follows: $\text{Asphalt Binder Content, \%} = \frac{(W_1 - W_2) - (W_3 + W_4)}{W_1 - W_2} \times 100$ (continued next page)

Standard Method of Test
 for
Quantitative Extraction of Asphalt Binder from Hot Mix Asphalt (HMA)

Reference AASHTO T 164-14 (2018)¹ (ASTM D 2172 / D 2172M-11)

AASHTO Section	Illinois Modification
13. (cont'd)	<p>Where:</p> <p>W₁ = mass of test portion, W₂ = mass of water in test portion, W₃ = mass of extracted mineral aggregate, and W₄ = mass of mineral matter in the extract.</p> <p>When method B, E, or F is used and the amount of mineral matter in the extract is not determined, then the percent asphalt binder content in the test portion shall be calculated as follows:</p> $\text{Asphalt Binder Content, \%} = \frac{\text{Sample Mass, Dry} - \text{Aggregate Mass, Dry}}{\text{Sample Mass, Dry}} \times 100$
14.1.1.2	<p>Revise the first sentence as follows: <i>Cylindrical Metal Frames</i>, two.</p>
16.2.1	<p>Replace with the following: Dry two sheets of filter paper for each metal frame to a constant mass in an oven at 110 ± 5 °C (230 ± 9 °F). Fold each filter paper into quarters. Place the first filter paper into the metal frame in the shape of a cone with three layers on one side and one layer of filter paper on the other side. Place the second filter paper in the cone in the opposite direction, creating four layers of filter paper around the basket.</p>
16.2.2	<p>Replace with the following: Determine the mass of each sample, weighing the pan, sample, and filter paper to the nearest 0.1 gram.</p>
16.2.3	<p>Delete the last two sentences.</p>
16.2.6	<p>Replace the second sentence as follows: Dry the frames in the vented hood; transfer the sample and filters into the original tared pan; and place the pan, sample, and filters in a vented oven at 110 ± 5 °C (230 ± 9 °F) for 3 hours before determining the constant mass. Record the mass.</p>

Illinois Modified Test Procedure
 Effective Date: June 1, 2012
 Revised Date: [December 1, 2021](#)

Standard Method of Test
 for
Quantitative Extraction of Asphalt Binder from Hot Mix Asphalt (HMA)

Reference AASHTO T 164-14 (2018)¹ (ASTM D 2172 / D 2172M-11)

AASHTO Section	Illinois Modification
Test Method D	Delete: Test Method D
18	Delete
19	Delete
20	Delete
Note 18	Delete
25.2.6	Delete the third and fourth sentences.
New Section	After Section 26.1, add the heading: TEST METHOD F
New Section 27	Add the following: Extraction to determine asphalt content and gradation may be done according to Illinois Modified ASTM Designation D8159.
27	Re-number old Section 27 to be Section 28.
27.1	Re-number old Section 27.1 to be Section 28.1. Delete the last sentence.
27.2	Re-number old Section 27.2 to be Section 28.2. Delete the last sentence.
28	Re-number old Section 28 to be Section 29.
28.1	Re-number old Section 28.1 to be Section 29.1.
A1.2.2.1	Replace the third sentence with: Transfer all of the extract (from Method A, B, E, or F as appropriate) to an appropriate (feed) container suitably equipped with a feed control (valve or clamp, etc.).

Standard Method of Test
 for
**Bulk Specific Gravity (G_{mb}) of Compacted Asphalt Mixtures Using Saturated
 Surface-Dry Specimens**

Reference AASHTO T 166-21, Methods A and C

AASHTO Section	Illinois Modification
2.1	Replace with the following: <i>Referenced Illinois modified AASHTO Standards:</i> ■ M231, Weighing Devices Used in the Testing of Materials
2.2 New Section	<i>Referenced Illinois modified ASTM Standards:</i> ■ D1188, Bulk Specific Gravity and Density of Compacted Bituminous Mixtures Using Coated Samples
3.1.2	Replace with the following: Constant mass shall be defined as the mass at which further drying at 52 ± 3 °C (125 ± 5 °F) for 2 hours, at 110 ± 5 °C (230 ± 9 °F) for 1 hour, or when weighed after at least two drying cycles of the vacuum-drying apparatus required in ASTM D7227/D7227M does not alter the mass more than 0.5 grams. Samples being saved for Quality Assurance testing shall not be dried at 110 ± 5 °C (230 ± 9 °F).
4.2	Revise as follows: <i>Size of Specimens</i> —It is required that the (1) minimum diameter of the gyratory compacted specimens be 149.90 mm (5.90 inches), (2) minimum diameter of the cored specimens be 92.1 mm (3 5/8 inches), and (3) thickness of specimens be a minimum of 19.0 mm (¾ in.).
4.6	Replace with the following: When cores from HMA pavement are used and two or more layers are attached together, a saw or other suitable means shall be used to separate the pavement layers. Care should be exercised to ensure that the specimens are not damaged during the separation process.
5.3	Replace with the following: <i>Water Bath</i>
5.3.1 New Section	For immersing the specimen in water while suspended under the weighing device, equipped with an overflow outlet for maintaining a constant water level.

Illinois Modified Test Procedure
 Effective Date: January 1, 2002
 Revised: [December 1, 2021](#)

Standard Method of Test
 for
**Bulk Specific Gravity (G_{mb}) of Compacted Asphalt Mixtures Using Saturated
 Surface-Dry Specimens**

Reference AASHTO T 166-21, Methods A and C

AASHTO Section	Illinois Modification
5.3.2 New Section	Constant Temperature Water Bath – Shall meet the requirements listed in the Illinois Department of Transportation document, “Hot-Mix Asphalt QC/QA Laboratory Equipment”.
6.2	Replace the first sentence with the following: Cool the specimen to room temperature at 25 ± 5 °C (77 ± 9 °F) and brush it to remove any loose particles. Weigh the specimen and record the result as the original dry mass, "A". Measure the thickness of the specimen in three places to the nearest 1.0 mm (1/16 inch) to obtain an average.
8	Delete
9	Delete
10	Delete
11.1	Add the following: Method C (Rapid Test) shall not be used if cores are being saved for Quality Assurance testing.
13.1.1	Replace with the following: The method used (A or C).
Footnote ¹	Delete

Illinois Modified Test Procedure
Effective Date: [December 1, 2021](#)

Standard Method of Test
for
Flexural Strength of Concrete
(Using Simple Beam with Center-Point Loading)

Reference AASHTO T 177-17 ([2021](#))

AASHTO Section	Illinois Modification
2.1	<p>Revise as follows: AASHTO R 39 (Illinois Modified) AASHTO R 100 (Illinois Modified) (formerly AASHTO T 23) AASHTO T 231 (Illinois Modified)</p> <p>To maintain brevity in the text, the following will apply: Example: AASHTO T 231 (Illinois Modified) will be designated as “T 231.”</p>
2.2	<p>Add as follows: ASTM E 29 (Illinois Modified) Standard Practice for Using Significant Digits in Test Data to Determine Conformance with Specifications</p> <p>To maintain brevity in the text, the following will apply: Example: ASTM E 29 (Illinois Modified) will be designated as “ASTM E 29.”</p>
4.1	<p>Revise as follows: Replace the second sentence with: “Hand-operated testing machines having pumps that do not provide a continuous loading to failure in one stroke are permitted, and the machine’s span length shall be between 400 mm (15 3/4 in.) and 464 mm (18 1/4 in.). When calibrating hand-operated testing machines according to T 67, the accuracy requirement is ± 3 %.”</p>

Illinois Modified Test Procedure
Effective Date: [December 1, 2021](#)

Standard Method of Test
for
Flexural Strength of Concrete
(Using Simple Beam with Center-Point Loading)
(continued)

Reference AASHTO T 177-17 ([2021](#))

AASHTO Section	Illinois Modification
6.4 New Section	<p>The Department test procedure for a hand pump beam breaker is as follows:</p> <p>Fins that may have formed in finishing the beam shall be removed. The beam shall be placed in the machine, with the formed sides in contact with the loading crosshead and reaction rollers (i.e. finished side vertical). The beam shall be inserted to engage properly the bottom rollers, and shall have a minimum of 25 mm (1 in.) overhang. The beam shall be properly centered on the bottom rollers. The hand wheel is then rotated to bring the loading crosshead firmly into contact with the beam. The release valve is then closed finger tight by turning it clockwise, and the gauge check valve is placed in the "ON" position. The pump is then operated continuously and without shock. The load shall be applied rapidly until approximately 50 percent of the estimated breaking load is obtained. Thereafter, the load rate shall be $1,035 \pm 175$ kPa/min. (150 ± 25 psi/min.) until rupture occurs. The reading of the hydraulic gauge is then recorded, the gauge check valve brought to the "OFF" position, the release valve opened by turning it counterclockwise, and the hand wheel rotated to raise the loading crosshead. When using the 762 mm (30 in.) long beam, the remaining length is inserted for the second break. The same test procedure is used. Note for Department Made Beam Breaker: If during the test a value of 6,900 kPa (1,000 psi) flexural strength is obtained, and the beam has not ruptured, testing may be discontinued to avoid damage to the hand pump beam breaker. The value shall be recorded as 6,900+ kPa (1,000+ psi). For a minimum design flexural strength that is greater than 5,500 kPa (800 psi), the Department made beam breaker should not be used.</p>
7., 8. and 9.	<p>Add as follows: All rounding shall be according to ASTM E 29.</p>

Illinois Modified Test Procedure
 Effective Date: April 1, 2011
 Revised Date: [December 1, 2021](#)

Standard Method of Test
 for
**Moisture - Density Relations of Soils Using a
 4.54-kg (10-lb) Rammer and a 457-mm (18-in.) Drop**

Reference AASHTO T 180-21

AASHTO Section	Illinois Modification
1.7	Revise as follows: The values stated in either SI units or inch-pound units are to be regarded separately as standard. The values stated in each system may not be exact equivalents in this standard. Combining values from the two systems may result in non-conformance with the standard, and diligence is advised when using unit conversions to combine the two systems. Results shall be reported in inch-pound units.
2.1	Revise as follows: AASHTO T 19 (Illinois Modified) AASHTO T 85 (Illinois Modified) AAHSTO R 76 (Illinois Modified) AASHTO T 265 (Illinois Modified) AASHTO T 310 (Illinois Modified) Delete as follows: T 217 T 255 To maintain brevity in the text, the following will apply: Example: AASHTO T 265 (Illinois Modified) will be designated as "T 265."
2.2	Add as follows: ASTM E 29 (Illinois Modified) Standard Practice for Using Significant Digits In Test Data to Determine Conformance with Specifications To maintain brevity in the text, the following will apply: Example: ASTM E 29 (Illinois Modified) will be designated as "ASTM E 29."
3.1.1	Add as follows: This mold volume is historically known as the 1/30 ft ³ sized mold.
3.1.2	Add as follows: This mold volume is historically known as the 1/13.33 ft ³ sized mold.

Illinois Modified Test Procedure
 Effective Date: April 1, 2011
 Revised Date: [December 1, 2021](#)

Standard Method of Test
 for
**Moisture - Density Relations of Soils Using a
 4.54-kg (10-lb) Rammer and a 457-mm (18-in.) Drop**

Reference AASHTO T 180-21

AASHTO Section	Illinois Modification
3.2.3	Revise the first sentence as follows: The circular face rammer shall be used, but a sector face must be used as an alternative when using the mechanical compactor and a 6-inch mold, provided that the report shall indicate type of face used other than the 50.8-mm (2-in.) circular face, and the sector face rammer shall have an area equal to that of the circular face rammer.
4.3	Replace as follows: Sieve the soil over the 4.75-mm (No. 4) sieve. When the sample has oversized particles, particles retained on the 4.75-mm (No. 4) sieve, keep separate from material passing 4.75-mm (No. 4) sieve and see Annex A1. Reduce the sample, to a mass of 3 kg (7 lb) or more in accordance with R 76 . If performing the coarse particle correction in Annex A1, Section A.1.3 shall be completed prior to proceeding with the sample reduction.
5., 7., 9., 11., and 12.	Add as follows: All rounding shall be according to ASTM E 29.
5.3.1	Replace as follows: Following compaction, remove the collar; carefully trim the compacted soil even with the top of the mold by means of the straightedge, and determine the mass of the mold, base plate, and moist soil in kilograms to the nearest one gram, or determine the mass in pounds to the nearest 0.002 pounds. Calculate the wet density, W_1 , as described in Section 12.1 or 12.3 and 12.4.
5.4	Revise the second sentence as follows: Obtain a representative sample of the material, weighing not less than 500 g, by slicing vertically through the center of the molded material and removing one of the cut faces (Figure 3) or from the center of the pile if the material falls apart.
5.5	Replace the third sentence as follows: Continue this series of determinations until there is either a decrease or no change in the wet unit mass, W_1 , per cubic meter (cubic foot) of the compacted soil (Note 7).
5.5.1	Delete.
7.1	Revise the second sentence as follows: Calculate the wet density, W_1 , as described in Section 12.1 or 12.3 and 12.4.
8.3	Replace the second sentence as follows: When the sample has oversized particles, particles retained on the 19.0-mm (3/4-in.) sieve, keep separate from material passing 19.0-mm (3/4-in.) sieve and see Annex A1.

Standard Method of Test
 for
**Moisture - Density Relations of Soils Using a
 4.54-kg (10-lb) Rammer and a 457-mm (18-in.) Drop**

Reference AASHTO T 180-21

AASHTO Section	Illinois Modification
8.4	Revise as follows: Reduce the sample passing the 19.0-mm (3/4-in.) sieve to a mass of 5 kg (11 lb) or more in accordance with R 76. If performing the coarse particle correction in Annex A1, Section A.1.3 shall be completed prior to proceeding with the sample reduction.
9.3.1	Revise the fourth sentence as follows: Calculate the wet density, W_1 , as described in Section 12.1 or 12.3 and 12.4.
9.4	Revise the second sentence as follows: Obtain a representative sample of the material, weighing not less than 500 g, by slicing vertically through the center of the molded material and removing one of the cut faces (Figure 3) or from the center of the pile if the material falls apart.
9.5	Replace the third sentence as follows: Continue this series of determinations until there is either a decrease or no change in the wet unit mass, W_1 , per cubic meter (cubic foot) of the compacted soil.
9.5.1	Delete.
11.1	Revise the second sentence as follows: Calculate the wet density, W_1 , as described in Section 12.1 or 12.3 and 12.4.
12.1	Add after the first sentence: Refer to Section 12.3 and 12.4 for alternative calculation of W_1 using mold factor methods.
12.2	Revise as follows: w = moisture content (percent) of the specimen, as determined by T 265.
12.3 New Section	Add as follows: The mold factor can be related to the volume of the mold as follows: $F = 1 / V \tag{3}$ Where: F = mold factor, and V = volume of mold. If using a balance or scale that measures the soil and mold mass in grams and the mold volume is in ft ³ , the Mold Factor requires a unit conversion as follows: $F = \frac{1}{V} \times \frac{1 \text{ lb}}{454 \text{ g}} \tag{4}$ Note 8 –The Mold Factor is a conversion factor incorporating the volume of the mold and, if needed, the conversion of grams to pounds.

Standard Method of Test
 for
**Moisture - Density Relations of Soils Using a
 4.54-kg (10-lb) Rammer and a 457-mm (18-in.) Drop**

Reference AASHTO T 180-21

AASHTO Section	Illinois Modification
12.4 New Section	<p>Add as follows: Alternatively, the wet density can be determined using the mold factor. For masses recorded in kilograms, the unit of wet density is kilograms per cubic meter of compacted soil. However, equation 4 from Section 12.3 may be used to convert grams to pounds to determine the unit of wet density is pounds per cubic foot of compacted soil. For masses recorded in pounds, the unit of wet density is pounds per cubic foot of compacted soil.</p> $W_1 = (A - B) \times F \quad (5)$ <p>Where: A = mass of compacted specimen and mold; B = mass of mold; F = mold factor as calculated in Section 12.3 W₁ = wet density.</p>
13.1	<p>Revise the second sentence as follows: The oven-dry densities of the soil shall be plotted as ordinates, and the corresponding moisture content as abscissas (Note 9).</p> <p>Add as follows at the end of the paragraph: Note 9 – (Optional) The wet densities of the soil may also be plotted as ordinates, and the corresponding moisture content as abscissas.</p>
13.2	<p>Revise the first sentence as follows: <i>Optimum Moisture Content</i> – When the densities and corresponding moisture contents for the soil have been determined and plotted as indicated in Section 13.1, it will be found that by connecting the plotted points with smooth line, a curve is produced (Note 10).</p> <p>Add as follows at the end of the paragraph: Note 10 – (Optional) As an aid for interpreting the dry density smooth line curve between the dry points plotted in section 13.1, connect the plotted points from Note 9 with a smooth line to create a wet density curve. Then, select 2 to 3 intermediate points on the wet density curve near the apparent peak of the dry curve, and back calculate the dry density of these points from their wet densities and corresponding moisture contents. Plot those intermediate dry densities and corresponding moisture content points to the points plotted in Section 13.1.</p>
Note 8 (After 14.3.)	<p>Renumber Note 8 to Note 11.</p>

Illinois Modified Test Procedure
 Effective Date: April 1, 2011
 Revised Date: [December 1, 2021](#)

Standard Method of Test
 for
**Moisture - Density Relations of Soils Using a
 4.54-kg (10-lb) Rammer and a 457-mm (18-in.) Drop**

Reference AASHTO T 180-21

AASHTO Section	Illinois Modification
15.1.3	Revise as follows: The maximum dry density to the nearest 1 kg/m ³ (0.1 lb/ft ³).
15.1.5	Revise as follows: Oversized particle correction, if performed.
15.1.5.1	Revise as follows: The adjusted maximum dry density to the nearest 1 kg/m ³ (0.1 lb/ft ³), if calculated.
15.1.5.2	Revise as follows: The corrected optimum moisture content to the nearest 0.1 percent, if calculated.
15.1.5.3	Revise as follows: The oversized particles to the nearest 0.1 percent of the original dry mass of the sample, if calculated.
15.1.5.4	Revise as follows: G_{sb} of oversized particles to the nearest 0.001, if determined.
A1.3.2	Revise the fourth sentence as follows: The moisture content shall be determined by T 265.

This Page Reserved

Standard Method of Test
 for
Density of Soil In-Place by the Sand-Cone Method

Reference AASHTO T 191-14 (2018)

AASHTO Section	Illinois Modification
1.3 New	<p>Add as follows:</p> <p>The values stated in either SI units or inch-pound units are to be regarded separately as standard. The values stated in each system may not be exact equivalents in this standard. Combining values from the two systems may result in non-conformance with the standard, and diligence is advised when using unit conversions to combine the two systems. Results shall be reported in inch-pound units.</p>
2.1	<p>Revise as follows:</p> <p>AASHTO T 19 (Illinois Modified) AASHTO T 99 (Illinois Modified) AASHTO T 217 (Illinois Modified) AASHTO T 265 (Illinois Modified)</p> <p>To maintain brevity in the text, the following will apply: Example: AASHTO T 99 (Illinois Modified) will be designated as “T 99”.</p>
2.2	<p>Revise as follows:</p> <p style="text-align: center;">ASTM E 29 (Illinois Modified) Standard Practice for Using Significant Digits In Test Data to Determine Conformance with Specifications</p> <p>To maintain brevity in the text, the following will apply: Example: ASTM E 29 (Illinois Modified) will be designated as “ASTM E 29.”</p>
4.1.1 and 4.3.3	<p>Add Note 5 as follows:</p> <p>Note 5—Vibration of the sand during any mass-volume determination may increase the bulk density of the sand and decrease the accuracy of the determination. Appreciable time intervals between the bulk density determination of the sand and its use in the field may result in change in the bulk density caused by a change the moisture content or effective gradation.</p>
4.2.4	Revise (Step 4.1.3) to (Step 4.1.2).
5. and 6.	<p>Add as follows:</p> <p>All rounding shall be according to ASTM E 29.</p>

This Page Reserved

Illinois Modified Test Procedure
Effective Date: [December 1, 2021](#)

Standard Method of Test
for
Air Content of Freshly Mixed Concrete by the Volumetric Method

Reference AASHTO T 196M/T 196-11 (2019)

AASHTO Section	Illinois Modification
2.1	<p>Revise as follows: AASHTO T 19 (Illinois Modified) AASHTO R 100 (Illinois Modified) (formerly AASHTO T 23) AASHTO T 119 (Illinois Modified) AASHTO T 121 (Illinois Modified) AASHTO R 60 (Illinois Modified) AASHTO T 152 (Illinois Modified)</p> <p>To maintain brevity in the text, the following will apply: Example: AASHTO T 119 (Illinois Modified) will be designated as “T 119.”</p>
2.2	<p>Add as follows: ASTM E 29 (Illinois Modified) Standard Practice for Using Significant Digits in Test Data to Determine Conformance with Specifications</p> <p>To maintain brevity in the text, the following will apply: Example: ASTM E 29 (Illinois Modified) will be designated as “ASTM E 29.”</p>
5.1	<p>Revise as follows: Replace “three-year intervals” with “1-year intervals.”</p>
8.3 New Section	<p>All rounding shall be according to ASTM E 29. The test result shall be rounded to the nearest 0.1 percent.</p>

This Page Reserved

Standard Method of Test
 for
Theoretical Maximum Specific Gravity (G_{mm}) and Density of Asphalt Mixtures

Reference AASHTO T 209-20

AASHTO Section	ILLINOIS MODIFICATION
2.1	Delete Reference to AASHTO Standard R 97
New Section 2.3	Replace all references to AASHTO R 97 and T 168 with the following Manual of Test Procedures Appendices: <ul style="list-style-type: none"> • Appendix B6 – HMA QC/QA Initial Daily Plant and Random Samples • Appendix B7 – Determination of Random Density Procedures • Appendix E3 – PFP & QCP Random Density Procedure • Appendix E4 – PFP & QCP HMA Random Jobsite Sampling
3.1.2	Replace with the following: <i>Residual Pressure</i> – the pressure remaining in the vacuum vessel after a vacuum (negative pressure) is applied. The residual pressure is based on, and measured with, an absolute manometer.
5.4.1	Replace with the following: When a vacuum pump is used, a suitable trap of one or more 1000-ml filter flasks, or equivalent, may be installed between the vacuum vessel and vacuum source to reduce the amount of water vapor entering the vacuum pump.
5.8	Replace with the following: <i>Drying Oven</i> – A thermostatically controlled drying oven capable of maintaining a temperature of $110 \pm 5^{\circ}\text{C}$ ($230 \pm 9^{\circ}\text{F}$).
5.9.1	Replace with the following: The water bath shall be maintained at a constant temperature of $25 \pm 1^{\circ}\text{C}$ ($77 \pm 1.8^{\circ}\text{F}$) during testing.
5.9.3	Replace with the following: When using the mass determination-in-water technique (Section 11.1), the water bath must be suitable for immersion of the suspended container with its deaerated sample.
7.2.1	Replace the first sentence with the following: Dry the sample to a constant mass at a temperature of $105 \pm 5^{\circ}\text{C}$ ($221 \pm 9^{\circ}\text{F}$). Constant mass shall be defined as the mass at which further drying does not alter the mass more than 0.5 gram in 1 hour.

Standard Method of Test
 for
Theoretical Maximum Specific Gravity (G_{mm}) and Density of Asphalt Mixtures

Reference AASHTO T 209-20

AASHTO Section	Illinois Modification
10.1	Replace the third sentence with the following: Agitate the container and contents during the vacuum period by vigorously shaking the container or moderately striking the side of the container with a rubber mallet each at intervals of about 2 min.
13	This section shall be used only with approval of the Engineer.
13.3	Replace with the following: To calculate the specific gravity of the sample, substitute the final surface-dry mass determined in Section 13.2 for A in the denominator of Equation 1 or 2 as appropriate.
A1.1.1	Replace the fourth sentence with the following: If the three masses are within 0.3 g, use the average as B in Equation 1.
A1.2.1	Replace the sixth sentence with the following: If the three masses are within 0.3 g, use the average of the three masses as D in Equation 2.

This Page Reserved

This Page Reserved

AASHTO T 224 is discontinued. Please refer to AASHTOs T 99 and T 180.

This Page Reserved

AASHTO T 224 is discontinued. Please refer to AASHTOs T 99 and T 180.

Illinois Modified Test Procedure
Effective Date: [December 1, 2021](#)

Standard Method of Test
for
Capping Cylindrical Concrete Specimens

Reference AASHTO T 231-17 ([2021](#))

AASHTO Section	Illinois Modification
2.2	Add as follows: ASTM E 29 (Illinois Modified) Standard Practice for Using Significant Digits in Test Data to Determine Conformance with Specifications Revise as follows: ASTM C 1231 (Illinois Modified) To maintain brevity in the text, the following will apply: Example: ASTM E 29 (Illinois Modified) will be designated as "ASTM E 29."
5.2.1	Add as follows: All rounding shall be according to ASTM E 29.
5.2.2	Add as follows: All rounding shall be according to ASTM E 29.

This Page Reserved

Illinois Modified Test Procedure
 Effective Date: January 1, 1998
 Revised Date: December 1, 2019

Standard Method of Test
 for
Resistance to Plastic Flow of Asphalt Mixtures Using Marshall Apparatus

Reference AASHTO T 245-15 (2019)

AASHTO Section	Illinois Modification
3.3	Replace the first sentence with the following: <i>Ring Dynamometer Assembly</i> – One-ring dynamometer (Figure 2) of 44.4 kN (10,000 lb) capacity and sensitivity of 44.5 N (10 lb) up to 4.45 kN (1,000 lb) and 111.2 N (25 lb) between 4.45 and 44.4 kN (1,000 and 10,000 lb) shall be equipped with a micrometer dial.
3.4	Replace with the following: Flow testing is optional. However, if it is tested then one X-Y stress-strain recorder graduated to 0.25 mm (0.01 inch) is required.
5.2	Revise the first and second sentences as follows: Bring the specimens prepared with asphalt cement to the specified temperature by immersing in the water bath for 1 hour. Maintain the bath temperature at 60 ± 1 °C (140 ± 1.8 °F).
5.2	Revise the fifth sentence as follows: Thoroughly clean the guide rods and the inside surfaces of the test heads prior to conducting the test and lubricate the guide rods and breaking head with a kerosene cloth.
5.2	Delete references to the flowmeter; it is not required.
5.3	Delete reference to manually recording the maximum load and flowmeter reading; it is not required.

This Page Reserved

Illinois Modified Test Procedure
Effective Date: [December 1, 2021](#)

Standard Method of Test
For
Total Evaporable Moisture Content of Aggregate by Drying

Reference AASHTO T 255-00 ([2021](#))

AASHTO Section	Illinois Modification
1.1	Add the following: Aggregate moisture content may be run on a gradation sample prior to gradation testing or on a separate test sample.
2.1	Revise the individual Standards as follows: AASHTO R 76 (Illinois Modified) AASHTO R 90 (Illinois Modified) AASHTO T 19/T 19M (Illinois Modified) AASHTO T 84 (Illinois Modified) AASHTO T 85 (Illinois Modified)
2.2	Delete the individual Standard as follows: ASTM C 670
5.2	Add the following: The oven shall be specifically designed for drying. All the other specified sources of heat may be used for drying except for a microwave oven or an electric heat lamp. A microwave oven or an electric heat lamp may be used only when drying a non-gradation test sample.
6.1	Replace with the following: Field samples of aggregate shall be taken according to AASHTO R 90 (Illinois Modified) . The field sample size shall meet the minimum requirements in the IDOT Aggregate Gradation Sample Size Table. Field samples shall be stored in sealable, nonabsorbent bags or containers prior to splitting to prevent moisture loss.
6.2	Replace with the following: Field samples of aggregate shall be reduced to test sample size before testing according to AASHTO R 76 (Illinois Modified) . Test sample size for non-gradation samples shall meet the minimum test sample size in Table 1. Test sample size for gradation samples also having aggregate moisture content performed shall meet the minimum requirements in the IDOT Aggregate Gradation Sample Size Table. Test samples shall be stored in sealable, nonabsorbent bags or containers prior to determining mass to start the test.
7.1	Replace with the following: The test sample shall have its mass determined to the nearest 1 gram for coarse aggregate and to the nearest 0.1 gram for fine aggregate. This procedure provides the “Original Sample Mass, g” (OSM).
7.2	Replace with the following: The test sample shall be dried back to constant mass by the selected source of heat as specified herein.

Illinois Modified Test Procedure
Effective Date: [December 1, 2021](#)

Standard Method of Test
For
Total Evaporable Moisture Content of Aggregates by Drying
(continued)
Reference AASHTO T 255-00 ([2021](#))

AASHTO Section	Illinois Modification
7.2.1	Add the following: When a gas burner or electric hot plate is used for drying, the technician shall <u>continually attend</u> the sample. The gas burner or electric hot plate should be operated on a low-as-needed heat to prevent popping, crackling, and/or sizzling noise from the aggregate during drying. If these noises occur, the heat must be turned down and/or the sample must be <u>constantly stirred</u> during drying to prevent potential aggregate particle breakdown.
7.3	Delete.
7.3.1	Delete.
7.4	Replace with the following: Constant mass is defined as the sample mass at which there has not been more than a 0.5-gram mass loss during 1 hour of drying.
7.5	Replace with the following: After the test sample has been dried to constant mass and cooled sufficiently so as not to damage the balance or scale, determine the mass of the test sample to the nearest 0.1 gram for fine aggregate. The test sample shall have its mass determined as soon as the pan or container can safely be handled to prevent additional moisture from being pulled from the air into the aggregate structure. This procedure provides the “Total Dry Mass, g” (TDM). The TDM will also be used for calculation of gradation samples.
8.1	Replace with the following: The “Aggregate Moisture Content” shall be determined by using the following formula: $P = \frac{100(OSM - TDM)}{TDM}$ where P = Aggregate Moisture Content (%) OSM = Original Sample Mass, g. and TDM = Dried Sample Mass, g. Results shall be reported as required and in the appropriate plant diary. Test results shall be rounded to the nearest 0.1 percent. All rounding shall be according to ASTM E 29 (Illinois Modified).

Illinois Modified Test Procedure
 Effective Date: March 1, 2006
 Revised Date: December 1, 2019

Standard Method of Test
 for
Laboratory Determination of Moisture Content of Soils

Reference AASHTO T 265-15 (2019)

AASHTO Section	Illinois Modification
1.2	Revise as follows: The following applies to all specified limits in this standard: For the purposes of determining conformance with these specifications, an observed value or a calculated value shall be rounded off according to <u>Illinois Modified ASTM E 29.</u>
2.2	Revise as follows: ASTM E 29 (Illinois Modified) Standard Practice for Using Significant Digits In Test Data to Determine Conformance with Specifications To maintain brevity in the text, the following will apply: Example: ASTM E 29 (Illinois Modified) will be designated as “ASTM E 29.”

This Page Reserved

Standard Method of Test
 for
Determination of Organic Content in Soils by Loss on Ignition

Reference AASHTO T 267-86 (2018)

Modifications apply only when testing material according to Articles 1003.07 and 1004.06 of the Standard Specifications for Road and Bridge Construction for select fill in Mechanically Stabilized Earth Retaining Walls (Article 522.02).

AASHTO Section	Illinois Modification
Note 1 New (After 1.1.)	This test procedure is used for Mechanically Stabilized Earth (MSE) wall select fill materials, which may be full graded crushed aggregates, containing a large amount of material passing the 4.75 mm (No. 4) and/or fines. Test results of full gradation samples with an abundance of fines tend to be higher, may fail, and usually exhibit more variability and less repeatability upon retesting or when testing split samples.
2.1.	<p>Replace R 58 as follows:</p> <p>AASHTO R 76 (Illinois Modified) Standard Practice for Reducing Samples of Aggregate to Testing Size</p> <p>Add as follows:</p> <p>AASHTO T 288 (Illinois Modified) Standard Method of Test for Determining Minimum Laboratory Soil Resistivity</p> <p>AASHTO T 290 (Illinois Modified) Standard Method of Test for Determining Water-Soluble Sulfate Ion Content in Soil</p> <p>AASHTO T 291 (Illinois Modified) Determining Water-Soluble Chloride Ion Content in Soil</p> <p>To maintain brevity in the text, the following will apply: Example: AASHTO T 290 (Illinois Modified) will be designated as “AASHTO T 290” or “T 290”.</p>
2.2.	<p>Revise as follows:</p> <p>ASTM E29 (Illinois Modified) Standard Practice for Using Significant Digits In Test Data to Determine Conformance with Specifications</p> <p>To maintain brevity in the text, the following will apply: Example: ASTM E29 (Illinois Modified) will be designated as “ASTM E29.”</p>

Illinois Modified Test Procedure
 Effective Date: October 15, 2012
 Revised Date: [December 1, 2021](#)
 Standard Method of Test
 for

Determination of Organic Content in Soils by Loss on Ignition

Reference AASHTO T 267-86 (2018)

AASHTO Section	Illinois Modification
4.1.	Replace as follows: A representative sample with a mass of at least 100 g shall be taken by the use of the sampler or by splitting and quartering in accordance with R 76 from the thoroughly mixed portion of the material passing the 2.00-mm (No. 10) sieve that has been obtained in accordance with T 288. This preparation requires all coarse aggregate samples to be initially be crushed to 2.00 mm (No. 10) or less material before a representative sample is obtained. However, a minimum of 500 g of material passing the 2.00 mm (No. 10) sieve is required as outlined in Section 5.2 of T 288 when T 267 is to be performed along with T 289, T 290, and T 291.
4.2.	Replace as follows: The sample for ignition loss is taken from the remainder of the oven-dried ($110 \pm 5^{\circ}\text{C}$) sample used for AASHTO T 291 chloride and AASHTO T 290 sulfate ion analysis that was placed in a desiccator until needed.
Note 1 (After 4.2.)	Renumber Note 1 to Note 2.
5.1.	Replace as follows: Measure out 10 grams of dried sample into a weighed porcelain crucible and record this mass (crucible + sample) to 4 decimal places (This is wt. #1 in 6.1. below) or to nearest 0.01 g if balance does not allow more places. (Note: No rounding should take place until all calculations are performed.)
Note 2 (After 5.1.)	Renumber Note 2 to Note 3.
Note 4 New (After 5.1. Note 2)	Due to the amount of time necessary for muffle furnaces to come up to temperature and the time necessary to preheat and cool porcelain crucibles for this test (both before the sample is weighed out and after the ignition period), the samples may be weighed into the crucibles the day before and kept in a desiccator until placed in the muffle furnace.
5.2.	Replace as follows: Turn muffle furnace to $455 \pm 10^{\circ}\text{C}$ and place the crucible containing the sample into the muffle furnace while it is heating up to temperature. As soon as the set temperature is reached, set a timer for 6 hours.

Standard Method of Test
 for
Determination of Organic Content in Soils by Loss on Ignition

Reference AASHTO T 267-86 (2018)

AASHTO Section	Illinois Modification
Note 5 New (After 5.2)	<p>It shall be noted that constant mass may not be reached for all samples during the prescribed 6 hour time, however this standard specifies this specific time and <u>does not say</u> until constant mass.</p> <p>For aggregate material testing (MSE will select fill materials, etc.), if samples are left in muffle furnace longer than the 6 hour period (i.e. overnight), highly dolomitic sources which contain magnesium carbonate compounds can start to decompose at temperatures as low as 400°C and may erroneously exceed and fail the maximum specified organic content if these materials continue to lose mass. To get increased accuracy for organic content results of dolomitic aggregate materials, a lower temperature should probably be used, but the current standard must be followed.</p> <p>All materials shall be run as prescribed at 455±10°C for 6 hours only regardless of whether constant weight is obtained or not.</p>
5.3.	<p>Replace as follows: After 6 hours, take the crucible(s) out of the muffle furnace and place in a desiccator to cool for approximately 1 hour (depending on number of crucibles in the desiccator). (This time should be the same as that used for preheating the empty crucibles). When cool, weigh and record this mass (crucible + residue) to 4 decimal places (This is wt. #2 in 6.1. below) or to nearest 0.01 g if balance does not allow more places. (Note: No rounding should take place until all calculations are performed.)</p>
6.1.	<p>Replace as follows: Calculate percent organic matter to the nearest 0.1% using the following formula:</p> $\% \text{ organic matter} = \frac{(wt. \#1 - wt. \#2)}{\text{Sample Weight}} \times 100$ <p>Where: wt.#1 = mass of crucible + dried sample, before ignition wt.#2 = mass of crucible + sample, after ignition Sample Weight = mass of dried sample before ignition (Section 5.1.)</p>

Standard Method of Test
for
Determination of Organic Content in Soils by Loss on Ignition

Reference AASHTO T 267-86 (2018)

AASHTO Section	Illinois Modification
Note 6 New (After 6.2.	<p>Add the following: For MSE wall select fill material, the organic content shall be a maximum 1.0 percent as specified in Article 1003.07(f)(4) and Article 1004.06(f)(4) of the current version of the Standard Specifications for Road and Bridge Construction.</p> <p>If any initial individual measurement result falls within 0.15 of the 1.0 max value (0.85-1.15), then two additional measurements will be required. The average of these three measurements will be considered the test result.</p> <p>If any initial individual measurement result falls outside the above defined band, the initial measurement will be considered the test result.</p>

Illinois Modified Test Procedure
 Effective Date: January 1, 2017
 Revised Date: December 1, 2018
 Standard Method of Test
 for

One-Point Method for Determining Maximum Dry Density and Optimum Moisture

Reference AASHTO T 272-18

AASHTO Section	Illinois Modification						
1.3	<p>Revise as follows: The values stated in either SI units or inch-pound units are to be regarded separately as standard. The values stated in each system may not be exact equivalents in this standard. Combining values from the two systems may result in non-conformance with the standard, and diligence is advised when using unit conversions to combine the two systems. Results shall be reported in inch-pound units.</p>						
2.1	<p>Revise as follows: AASHTO R 75 (Illinois Modified) AASHTO T 99 (Illinois Modified) AASHTO T 180 (Illinois Modified) AASHTO T 265 (Illinois Modified)</p> <p>Delete as follows: T 217 T 255</p> <p>To maintain brevity in the text, the following will apply: Example: AASHTO T 99 (Illinois Modified) will be designated as “T 99.”</p>						
2.2	<p>Revise as follows:</p> <table style="width: 100%; border: none;"> <tr> <td style="width: 40%;">ASTM D 4643</td> <td>Standard Test Method for Determination of Water (Moisture) Content of Soil by Microwave Oven Heating</td> </tr> <tr> <td>ASTM D 4959</td> <td>Standard Test Method for Determination of Water Content of Soil by Direct Heating</td> </tr> <tr> <td>ASTM E 29 (Illinois Modified)</td> <td>Standard Practice for Using Significant Digits In Test Data to Determine Conformance with Specifications</td> </tr> </table> <p>To maintain brevity in the text, the following will apply: Example: ASTM E 29 (Illinois Modified) will be designated as “ASTM E 29.”</p>	ASTM D 4643	Standard Test Method for Determination of Water (Moisture) Content of Soil by Microwave Oven Heating	ASTM D 4959	Standard Test Method for Determination of Water Content of Soil by Direct Heating	ASTM E 29 (Illinois Modified)	Standard Practice for Using Significant Digits In Test Data to Determine Conformance with Specifications
ASTM D 4643	Standard Test Method for Determination of Water (Moisture) Content of Soil by Microwave Oven Heating						
ASTM D 4959	Standard Test Method for Determination of Water Content of Soil by Direct Heating						
ASTM E 29 (Illinois Modified)	Standard Practice for Using Significant Digits In Test Data to Determine Conformance with Specifications						
Note 1 New After 3.2	<p>Note 1—Inherent variability of soils places limitations on this method of test. The person using this test method must realize this and become thoroughly familiar with the material being tested. Knowledge of the AASHTO and Illinois Department of Highways (IDH) Soil Classification System and ability to recognize the gradation of soils are requirements for this work.</p>						

Illinois Modified Test Procedure
 Effective Date: January 1, 2017
 Revised Date: December 1, 2018

Standard Method of Test
 for
One-Point Method for Determining Maximum Dry Density and Optimum Moisture

Reference AASHTO T 272-18

AASHTO Section	Illinois Modification
5.1	Revise as follows: See T 99 or T 180, Section 3, except a thermostatically controlled drying oven is not required to dry soil for field tests. A microwave oven, hot plate, electric heat lamp, kitchen stove, camp stove, grill or any other apparatus capable of drying soil to a constant mass may be used. Care shall be made to not degrade or otherwise adversely affect the soil (Note 2). Drying by microwave oven shall be according to ASTM D 4643. Drying by all other non-thermostatically controlled oven means shall be according to ASTM D 4959.
6.1.2	Add as follows: For field tests, sieving according to T 99 or as referenced herein is not required. As an alternative, thoroughly break up soil aggregations until no piece is larger than 12 mm (0.5 in.). Discard any piece larger than 12 mm (0.5 in.).
7.	Add as follows: All rounding shall be according to ASTM E 29.
7.1	Add the following after the first sentence: The need for adding water is determined by moisture content of the field sample.
7.4	Revise as follows: Determine the moisture content using one of the following methods: ASTM D 4643, ASTM D 4959, or T 265.
Note 2 New After 7.4	Burning the soil may drive off organic material, which will result in moisture measurements higher than the true value. Rapid heating of the soil may cause particles to explode and loss of material, which will also result in moisture measurements higher than the true value. Therefore, stir the soil sample when drying to accelerate the operation and avoid localized overheating.
8.3.	Add as follows: Use either the district or project specific family of curves as directed by the District Geotechnical Engineer (DGE).
Note 3 New After 8.3	Refer to R 75 for development of a family of curves as needed per the direction of the DGE.

Illinois Modified Test Procedure
 Effective Date: January 1, 2017
 Revised Date: December 1, 2018

Standard Method of Test
 for
One-Point Method for Determining Maximum Dry Density and Optimum Moisture

Reference AASHTO T 272-18

AASHTO Section	Illinois Modification
8.3.3	Revise as follows: If the one-point falls on the curve or within 2.0 lb/ft ³ below a curve at the one-point moisture content (Figure 2), use the maximum dry density and optimum moisture content defined by the above curve. When the one-point falls within the family but is more the 2.0 lb/ft ³ below a curve at the one-point moisture content, a new curve may be drawn through the plotted one-point parallel and in character with the nearest existing curve in the family of curves or perform a full moisture-density relationship as directed by the DGE.
9.1.1.1 New Section	Add as follows: <u>In Methods C and D, indicate if the material retained on the 19.0-mm (0.75 in.) sieve was removed or replaced, if applicable.</u>
9.1.1.2 New Section	Add as follows: <u>Type of rammer face if other than 50.8-mm (2 in.) circular.</u>
10.1	Add as follows: <u>compaction; family of curves; one-point method; one-point Proctor; soil density; soil moisture</u>

This Page Reserved

Standard Method of Test
 For
Resistance of Compacted Bituminous Mixture to Moisture-Induced Damage

Reference AASHTO T 283-21

AASHTO Section	Illinois Modification
1.1	Replace the first sentence with the following: This method covers preparation of specimens and the measurement of the change of diametral tensile strength resulting from the effects of water saturation and accelerated water conditioning of compacted asphalt mixtures.
2.1	Replace with the following: <i>Referenced Illinois modified AASHTO Standards:</i> <ul style="list-style-type: none"> ▪ R 30, Mixture Conditioning of Hot-Mix Asphalt (HMA) ▪ T 166, Bulk Specific Gravity of Compacted Bituminous Mixtures Using Saturated Surface-Dry Specimens ▪ T 209, Theoretical Maximum Specific Gravity and Density of Bituminous Paving Mixtures ▪ T 245, Resistance to Plastic Flow of Bituminous Mixtures Using Marshall Apparatus ▪ T 312, Preparing and Determining the Density of Hot-Mix Asphalt (HMA) Specimens by Means of the Superpave Gyratory Compactor
2.1.1	Illinois Manual of Test Procedures: <ul style="list-style-type: none"> ▪ Appendix B4, Hot-Mix Asphalt Test Strip Procedures ▪ Appendix B6, Hot-Mix Asphalt QC/QA Initial Daily Plant and Random Samples ▪ Appendix B7, Hot-Mix Asphalt QC/QA Procedure for Determining Random Density Locations ▪ Appendix B17, Procedure for Introducing Additives to Hot Mix Asphalt Mixtures and Testing in the Lab ▪ Appendix E3, PFP and QCP Random Density Procedure ▪ Appendix E4, PFP and QCP Hot Mix Asphalt Random Jobsite Sampling
2.2	Delete
3.1	Replace the first sentence with the following: This method is intended to evaluate the effects of saturation and accelerated water conditioning of compacted asphalt mixtures.
3.2	Replace with the following: Numerical indices of retained indirect-tensile properties are obtained by comparing the properties of laboratory specimens subjected to moisture conditioning with the similar properties of dry specimens.

Standard Method of Test
 For
Resistance of Compacted Bituminous Mixture to Moisture-Induced Damage

Reference AASHTO T 283-21

AASHTO Section	Illinois Modification
4.1	Replace the fourth sentence with the following: The other subset is subjected to vacuum saturation, followed by a warm-water soaking cycle, before being tested for indirect tensile strength.
5.1	Replace with the following: Equipment for preparing and compacting specimens from T 312.
5.3	Replace with the following: Balance and water bath from T 166 for immersing the specimen under water while suspended under a weighing device.
5.5	Delete
5.6	Delete
5.7	Delete
5.12	Replace the second sentence with the following: For 100 mm (4 in.) diameter field-mixed, field-compacted pavement cores only, the loading strips shall be 12.7 mm (0.5 in.) wide and for all specimens 150 mm (5.91 in.) diameter, the loading strips shall be 19.05 mm (0.75 in.) wide.
6.1	Replace the first paragraph with the following: Prepare mixture for at least six specimens for each test, half to be tested dry and the other half to be tested after partial saturation and moisture conditioning (Note 1).
6.1.2.1 New Section	When an anti-stripping additive is used, the procedure in Appendix B17 of the Illinois Manual of Test Procedures for adding and mixing the additive shall be followed.
6.1.2.2 New Section	Odor neutralizing additives, if used, shall be added to the asphalt binder according to the manufacturer's recommended dosage rate and procedure prior to mixing the asphalt with the heated aggregates.
6.2	Replace the first two sentences with the following: Prepared compacted specimens shall be 7.0 ± 1.0 percent air voids. This level of voids can be obtained by adjusting the mass of the mixture, or adjusting the number of gyrations or specimen height in T 312. The most effective way to adjust voids, while maintaining a compacted height of 95 mm is to make slight changes in the weight of the loose material to be compacted.

Illinois Modified Test Procedure
 Effective Date: March 1, 2003
 Revised Date: December 1, 2021

Standard Method of Test
 For
Resistance of Compacted Bituminous Mixture to Moisture-Induced Damage

Reference AASHTO T 283-21

AASHTO Section	Illinois Modification
6.3	Replace with the following: Specimens 150 mm (5.91 in.) diameter by 95 ± 5 mm (3.75 ± 0.20 in.) thick are used.
6.4	Replace with the following: Place the mixture in a pan and cool at room temperature.
6.5	Replace with the following: Short-term aging of laboratory prepared mixtures shall be done according to Illinois-modified AASHTO R 30.
6.6	Replace with the following: Compact the specimens according to the method in T 312. The mixture shall be compacted to 7.0 ± 1.0 percent air voids.
6.7	Delete
6.8	Add the following before the first sentence: Allow the extracted specimens to cool to a room temperature 25 ± 5 °C (77 ± 9 °F).
6.9	Replace the second sentence with the following: The air void content shall be within 7.0 ± 1.0 percent.
7.1	Replace with: Obtain field-mixed asphalt mixture sample in accordance with Appendix B.6 or E.4 of sufficient size to determine G_{mm} and make at least six specimens. Appendix B.6 shall be used in QC/QA applications and Appendix E.4 shall be used in QCP or PFP applications.
7.3	Replace with the following: Make at least six specimens for each test, half to be tested dry and the other half to be tested after partial saturation and moisture conditioning (Note 3).
7.3.1	Replace the first two sentences with the following: Prepared compacted specimens shall be 7.0 ± 1.0 percent. This level of voids can be obtained by adjusting the mass of the mixture, or adjusting the number of gyrations or specimen height in T 312. The most effective way to adjust voids, while maintaining a compacted height of 95 mm is to make slight changes in the weight of the loose material to be compacted.

Standard Method of Test
 For
Resistance of Compacted Bituminous Mixture to Moisture-Induced Damage

Reference AASHTO T 283-21

AASHTO Section	Illinois Modification
7.4	Replace with the following: Specimens 150 mm (5.91 in.) in diameter by 95 ± 5 mm (3.75 ± 0.20 in.) thick are used.
7.5	Replace with the following: No loose-mix curing as described in Section 6.5 shall be performed on the field-mixed samples. After sampling, place the mixture in an oven until it reaches the compaction temperature ± 3°C (5°F). Then, compact the specimen according to the method in T 312. The mixture shall be compacted to 7.0 ± 1.0 percent air voids.
7.6	Add the following before the first sentence: Allow the extracted specimens to cool to a room temperature of 25 ± 5°C (77 ± 9°F).
7.7	Replace with the following: Determine the air voids according to Sections 9.3 and 9.4. The air void content shall be within 7.0 ± 1.0 percent.
8.1	Replace the first sentence with the following: Select locations on the completed pavement to be sampled and obtain cores according to Appendix B.7 or E.3. Appendix B.7 shall be used in QC/QA applications and Appendix E.3 shall be used in QCP or PFP applications.
8.1.1 New Section	The pavement may be cored with the objective of performing a forensic analysis of the in-situ conditions of the in-place, compacted mixture. In that case, the core specimens should be kept in a leak-proof plastic bag until testing to preserve the in-situ conditions. The testing should be conducted as soon as possible after coring.
9.1	Replace with the following: Use the gyratory compactor height printout sheet to determine the specimen thickness (t). If the gyratory height printout sheet is not available determine the specimen thickness by taking four measurements at approximately quarter points on the periphery of the specimen and recording the average of these measurements as the thickness of the specimen.

Standard Method of Test
 For
Resistance of Compacted Bituminous Mixture to Moisture-Induced Damage

Reference AASHTO T 283-21

AASHTO Section	Illinois Modification
9.6	Replace the first sentence with the following: For those specimens to be subjected to vacuum saturation and a warm-water soaking cycle, calculate the volume of air voids (V_a) in cubic centimeters using the following equation:
10.1	Replace with the following: One subset will be tested dry, and the other will be partially vacuum-saturated and soaked in warm water before testing.
10.2	Replace with the following: The dry subset will be stored at room temperature until testing. The specimens shall then be placed in a $25 \pm 1^\circ\text{C}$ ($77 \pm 1.8^\circ\text{F}$) water bath for 2 hrs \pm 10 min with a minimum 25 mm (1 in.) of water above their surface. Then test the specimens as described in Section 11.
10.3	Delete
10.4.1	Replace with the following: Place the specimen in the vacuum container. Fill the container with potable water at room temperature so that the specimens have at least 25 mm (1 in.) of water above their surface.
Note 5	Replace with the following: Apply a vacuum of 13 to 67 kPa absolute pressure (10 to 26 in. Hg partial pressure) for a short time (approximately 1 to 10 minutes).
10.4.3	Replace with the following: Remove the vacuum and leave the specimen submerged in water for a short time (approximately 1 to 10 minutes).
10.4.9	Delete.
10.4.10	Replace the first sentence with the following: Place the specimens, flat side down, into a $60 \pm 1^\circ\text{C}$ ($140 \pm 1.8^\circ\text{F}$) water bath for 24 hrs \pm 1 hr. Delete the last sentence.

Standard Method of Test
 For
Resistance of Compacted Bituminous Mixture to Moisture-Induced Damage

Reference AASHTO T 283-21

AASHTO Section	Illinois Modification
10.4.11	<p>Replace the first sentence with: After 24 hrs ± 1 hr in the 60 ± 1°C (140 ± 1.8°F) water bath, remove the specimens and place them in a water bath at 25 ± 1°C (77 ± 1.8°F) for 2 hrs ± 10 min.</p> <p>Replace the fourth sentence with: Not more than 15 min should be required for the water bath to reach 25 ± 1°C (77 ± 1.8°F).</p>
11.1	<p>Replace with: Determine the indirect-tensile strength of dry and conditioned specimens at 25 ± 1°C (77 ± 1.8°F).</p>
11.1.1	<p>Replace the first sentence with the following: Remove the specimen from the 25 ± 1°C (77 ± 1.8°F) water bath.</p> <p>Insert the following at the end: Note 7: If a chart recorder is used, the 10,000 pound scale should be used for 150 mm (5.91 in.) specimens and the 5,000 pound scale should be used for 4 in. (100 mm) field pavement core specimens.</p>
11.1.2	<p>Replace the last sentence with the following: Inspect the interior surface for evidence of cracked or broken aggregate; visually estimate the approximate degree of moisture damage on a scale from “1” to “3” (with “3” being the most stripped) according to the Illinois procedure “Stripping of Hot-Mix Asphalt Mixtures Visual Identification and Classification” and record the observations.</p>
12.1 New Notes	<p>Add the following at the end: Note 8. The actual diameter of a gyratory specimen is 150 mm (5.91 in.).</p> <p>Note 9: If the strength is converted from metric to English units, use the factor: 1 kPa = 0.14504 psi (1 psi = 6.895 kPa).</p> <p>The minimum acceptable tensile strength shall be 60 psi for unmodified asphalt binders and 80 psi for modified asphalt binders except modified PG XX-28 or softer asphalt binders which shall have a minimum tensile strength of 70 psi.</p>

Illinois Modified Test Procedure
Effective Date: March 1, 2003
Revised Date: [December 1, 2021](#)

Standard Method of Test
For
Resistance of Compacted Bituminous Mixture to Moisture-Induced Damage

Reference AASHTO T 283-21

AASHTO Section	Illinois Modification
12.2	<p>Replace the first sentence with the following: Express the numerical index of resistance of asphalt mixtures to the detrimental effect of water as the ratio of the original strength that is retained after the moisture conditioning.</p> <p>Add the following at the end: The minimum TSR for 150 mm (5.91 in.) specimens shall be 0.85.</p> <p>The minimum TSR for 4-inch (100 mm) field-mixed, field-compacted pavement cores only shall be 0.75.</p>
15.1	Delete.

This Page Reserved

Standard Method of Test
 For
Asphalt Binder Content of Asphalt Mixtures by the Nuclear Method

Reference AASHTO T 287-20

AASHTO Section	Illinois Modification
2.1	Replace the individual AASHTO Standards with the appropriate Illinois modified AASHTO Standards:
2.1	Add the following: <ul style="list-style-type: none"> • AASHTO Standard R 90
2.2 New Section	Manufacturer's instruction manual
3.3	Replace the first sentence with the following: Accurate results are dependent upon proper calibration of the nuclear gauge to the material being tested as covered in Appendix A.
3.4	Replace the second and third sentences with the following: The moisture sample shall be weighed immediately, prior to beginning the test count, and this value shall be recorded as the original sample weight. The sample to be tested for moisture content shall be placed in a 110 ± 5 °C (230 ± 9 °F) oven at the time the mixture test count is being performed. Drying of the moisture sample shall continue until it reaches constant mass. Constant mass (oven dry) is defined as less than 0.5 g loss in 1 hour. This weight shall be recorded as the oven-dry weight. Moisture content is determined as follows: $\text{Moisture Content} = \left(\frac{[\text{Original Sample Weight} - \text{Oven Dry Weight}]}{\text{Oven Dry Weight}} \right) \times 100$
3.4 New Note	Add New Note 1 : Note 1 —The moisture content determined from the previous test can be used to adjust the apparent asphalt content for quality control purposes only. The actual moisture content of the current sample shall be determined and used to correct the apparent asphalt content (nuclear gauge reading). The corrected asphalt content is plotted on the control charts and used for acceptance purposes.

Standard Method of Test
 For
Asphalt Binder Content of Asphalt Mixtures by the Nuclear Method

Reference AASHTO T 287-20

AASHTO Section	Illinois Modification
4.1	Replace with the following: Nuclear asphalt binder content gauge system, capable of at least a 3-point calibration, consisting of:
4.2	Replace with the following: Mechanical mixer with a minimum 10-kg (22-lb) capacity, capable of producing a completely mixed, well-coated, homogenous asphalt mixture.
4.6.2	Delete.
4.8	Replace with the following: Thermometers, metal-stemmed, armored type, with a temperature range 10 to 260 °C (50 to 500 °F), readable to 3 °C (5 °F).
4.9.1 New Section	Heat-resistant gloves.
5.2	Add the following between the second and third sentences: The location of the gauge for field-testing requires the gauge to be in the exact location used during calibration.
6.1	Replace with the following: Once a calibration is performed on a specific gauge, no mathematical transfer of the calibration to another gauge will be allowed. The original calibration pans shall be used to calibrate the new gauge.
7.2	Replace with the following: If the background count has not changed by more than 1.0 percent from the average of the previous 4 background counts, then the apparatus shall be considered stable and acceptable for use. If the gauge has been moved or the surrounding conditions have changed, additional background counts must be obtained until the 1.0 percent standard is satisfied.
8.	Rename: PROCEDURE FOR PRODUCTION TESTING

Illinois Modified Test Procedure
 Effective Date: June 1, 2012
 Revised Date: [December 1, 2021](#)

Standard Method of Test
 For
Asphalt Binder Content of Asphalt Mixtures by the Nuclear Method

Reference AASHTO T 287-20

AASHTO Section	Illinois Modification
8.1	Replace with the following: Obtain samples of freshly produced asphalt concrete according to Illinois Department of Transportation document, "Hot Mix Asphalt QC/QA Initial Daily Plant and Random Samples".
8.3	Add the following at the end: The material shall be rodded into the corners of the gauge pan to eliminate large voids.
8.4	Replace with the following: Place additional asphalt mixture into the pan until the required mass, as determined in Appendix A, is reached within ± 5 g.
8.6 Note 1	Change to Note 2
8.6 New Note	Add New Note 3 : Note 3 - Asphalt samples should not remain in the oven to re-heat for longer than 4 hours prior to placement in the gauge. Loss of hydrogen could cause an inaccurate count.
8.7	Add the following at the end of the second sentence: "or according to the manufacturer's instructions".
8.8	Replace the second sentence with the following: Record the uncorrected asphalt binder content obtained from the reading taken in section 8.7 to the nearest 0.1 percent.
10.1	Replace with the following: The report shall be the Illinois Department of Transportation MI 308 form or on the form generated by the Department's Quality Management Program (QMP) software.
10.2 New Section	<i>Information to be recorded in a data book or diary:</i>
10.1.1 through 10.1.13	Rename as sections 10.2.1 through 10.2.13

Standard Method of Test
 For
Asphalt Binder Content of Asphalt Mixtures by the Nuclear Method

Reference AASHTO T 287-20

AASHTO Section	Illinois Modification
Annexes	Replace with the following: APPENDICES
A1.1	Replace with the following: This appendix covers the preparation of samples for, and the calibration of, nuclear asphalt binder content gauges.
A3.5	Delete.
A3.5.1	Delete.
A3.5.2	Delete.
A3.5.3	Delete.
A4.1	Add at the end of the second sentence: according to the Manual of Test Procedures Appendix B17, <i>Procedure for Introducing Additives to Hot Mix Asphalt Mixtures and Testing in the Lab</i> , Section 4.0 (D) (5) Liquid Anti-strip.
A4.2.1	Replace the last paragraph with the following: Asphalt binder contents will be chosen at the optimum asphalt binder content and at increments of ± 1.0 percent from the optimum asphalt binder content. The minimum three samples are 1.0 below optimum, optimum, and 1.0 above the optimum asphalt binder content. Additional samples at other binder contents may be required by the Engineer.
A4.3	Delete.
A4.3.1	Delete.
A4.3.2	Delete.

Standard Method of Test
 For
Asphalt Binder Content of Asphalt Mixtures by the Nuclear Method

Reference AASHTO T 287-20

AASHTO Section	Illinois Modification
A6.1 Note A3	Replace with the following: Note A3 - To find an appropriate starting mass, place the dry aggregate in a gauge-sample pan. Fill the sample pan one-half full, evenly distributing the sample in the pan. Level the HMA mixture with a trowel or spatula. Fill the remainder of the pan until the weight of the HMA mixture in the pan equals the dry aggregate weight. If the pan is not full, fill the pan to the point that the HMA mixture is mounded slightly above the top of the pan. Record the weight of the HMA mixture in the pan. This is the weight that is to be used for all calibration and test samples using this calibration. Level the top of the HMA mixture using a spatula or trowel. Use the metal plate or plywood to consolidate the HMA mixture until it is even with the top edge of the pan. All specimens should be compacted at a temperature between 121° and 149° ± 6°C (250° and 300° ± 10°F) to ensure that the mix will compact properly.
A6.4	Add the following after the first sentence: The material shall be rodded into the corners of the pan to eliminate large voids.
A7.2	Replace the last sentence with the following: At a minimum, use 1.0 percent below optimum, optimum, and 1.0 percent above the optimum asphalt binder content when making the calibration-curve pans.
A8.1	Replace the first sentence with the following: Prepare four aggregate samples, or number recommended by the manufacturer, using the target mass determined in Section A6.7.
A8.5	Add the following after the first sentence: The material shall be rodded into the corners of the gauge pan to eliminate large voids.
A8.8 New Note	Add New Note A4 : Note A4 - If the gauge does not have temperature compensation capabilities, determine and record the temperature of the HMA mixture compacted into the pan to use as the target temperature for testing field samples.
A8.9 Note A4	Change to Note A5 :

Illinois Modified Test Procedure
 Effective Date: June 1, 2012
 Revised Date: [December 1, 2021](#)

Standard Method of Test
 For
Asphalt Binder Content of Asphalt Mixtures by the Nuclear Method

Reference AASHTO T 287-20

AASHTO Section	Illinois Modification
A10	Delete Entire Section
Appendix B New Section	Dry Aggregate Standard Count
B1 New Section	Turn on the equipment and allow for stabilization of the equipment in accordance with the manufacturer's recommendations.
B2 New Section	Fill the sample pan one-half full of hot dry aggregate dried to constant weight and at the temperature of the aggregate sample used during calibration $\pm 6^{\circ}\text{C}$ ($\pm 10^{\circ}\text{F}$). Place the dry hot aggregate in a tared sample pan in two equal layers. For each layer, raise and drop the pan approximately one inch, four times. Be sure that the pan bottom strikes evenly. Use a spatula to distribute the aggregate to avoid segregation. Add to or remove aggregate until the weight of aggregate in the pan is equal to the weight of aggregate used in the calibration. Using a straightedge, level the top of the aggregate sample until it is even with the top of the sample pan. Obtain and record the temperature of the sample.
B3 New Section	Place the hot blended aggregate into the gauge and proceed as per manufacturer's instruction for operation of the equipment and the sequence of operation. This dry aggregate count is used to determine changes in aggregates which affect counts.
B3 New Note	Add New Note B1 : Note B1 - If a significant change is noted (± 0.5 percent) from the calibration aggregate count, a new calibration should be run.

Illinois Modified Test Procedure
 Effective Date: October 15, 2012
 Revised Date: [December 1, 2021](#)

Standard Method of Test
 for
Determining Minimum Laboratory Soil Resistivity

Reference AASHTO T 288-12 ([2021](#))

Modifications apply only when testing material according to Articles 1003.07 and 1004.06 of the Standard Specifications for Road and Bridge Construction for select fill in Mechanically Stabilized Earth Retaining Walls (Article 522.02).

AASHTO Section	Illinois Modification								
2.1.	<p>Revise as follows:</p> <p>AASHTO R 76 (Illinois Modified) AASHTO R 90 (Illinois Modified)</p> <p>Add as follows:</p> <table style="width: 100%; border: none;"> <tr> <td style="width: 40%;">T 267 (Illinois Modified)</td> <td>Determination of Organic Content in Soils by Loss on Ignition</td> </tr> <tr> <td>T 289 (Illinois Modified)</td> <td>Determining pH of Soil for Use in Corrosion Testing</td> </tr> <tr> <td>T 290 (Illinois Modified)</td> <td>Determining Water-Soluble Sulfate Ion Content in Soil</td> </tr> <tr> <td>T 291 (Illinois Modified)</td> <td>Determining Water-Soluble Chloride Ion Content in Soil</td> </tr> </table> <p>To maintain brevity in the text, the following will apply: Example: AASHTO T 267 (Illinois Modified) will be designated as “T 267”.</p>	T 267 (Illinois Modified)	Determination of Organic Content in Soils by Loss on Ignition	T 289 (Illinois Modified)	Determining pH of Soil for Use in Corrosion Testing	T 290 (Illinois Modified)	Determining Water-Soluble Sulfate Ion Content in Soil	T 291 (Illinois Modified)	Determining Water-Soluble Chloride Ion Content in Soil
T 267 (Illinois Modified)	Determination of Organic Content in Soils by Loss on Ignition								
T 289 (Illinois Modified)	Determining pH of Soil for Use in Corrosion Testing								
T 290 (Illinois Modified)	Determining Water-Soluble Sulfate Ion Content in Soil								
T 291 (Illinois Modified)	Determining Water-Soluble Chloride Ion Content in Soil								
2.2.	<p>Revise as follows:</p> <p>ASTM E 29 (Illinois Modified) Standard Practice for Using Significant Digits In Test Data to Determine Conformance with Specifications</p> <p>To maintain brevity in the text, the following will apply: Example: ASTM E 29 (Illinois Modified) will be designated as “ASTM E 29.”</p>								
3.1.	<p>Add as follows:</p> <p>This dry preparation procedure shall also apply to the preparation of soil and soil-aggregate samples, as received from the field, to be tested for other corrosion properties according to T 267, T 289, T 290, and/or T 291 which are typically performed along with this test method.</p>								
4.6. New	<p>Crusher Apparatus – A mechanical devices suitable for crushing soil-aggregate particles passing the 25 mm (1 inch) sieve size or greater and reducing the size of individual particles to 2.00 mm (No. 10) or less.</p>								

Standard Method of Test
 for
Determining Minimum Laboratory Soil Resistivity

Reference AASHTO T 288-12 ([2021](#))

AASHTO Section	Illinois Modification
5.2. New	When organic content and chemical analyses test T 267, T 289, T 290 and T 291 are to be performed, a minimum of 500 g of additional material passing the 2.00 mm (No. 10) sieve is required. This results in a total minimum of 2000 g (1500 g + 500 g) of material of material passing the 2.00 mm (No. 10) sieve required to perform T 288 along with T 267, T 289, T 290 and T 291.
6.2.	Revise 6.2 as follows: The portion of the dried sample selected for minimum soil resistivity testing, organic content and chemical analyses shall be separated into fractions by one of the following methods, except all coarse aggregate samples shall initially be crushed to 2.00 mm (No. 10) or less material before separating into fractions.
6.3. New	When T 267, T 289, T 290 and T 291 are to be performed along with T 288, the sample obtained in 6.2. to 6.2.3. shall be mixed thoroughly and, by the use of the sampler or by splitting and quartering in accordance with R 76 , a representative sample of approximately 500 g shall be obtained for performing the organic content and chemical analyses. The remainder of the sample (approximately 1500 g) shall be used for determining the minimum soil resistivity.
8.3.	Add the following after the first sentence: Other size soils boxes will not be permitted.
11.2.	Delete the following sentence in Note 8: If other size soil boxes are used, it will be necessary to determine the correct multiplier.

Standard Method of Test
 for
Determining Minimum Laboratory Soil Resistivity

Reference AASHTO T 288-12 ([2021](#))

AASHTO Section	Illinois Modification
<p>Note 9 New (After 11.2.)</p>	<p>For MSE wall select fill material, the resistivity shall be greater than 3,000 ohm-cm for galvanized reinforcement and 1,500 ohm-cm for aluminized Type 2 reinforcement as specified in Article 1003.07(f)(1) and Article 1004.06(f)(1) of the current version of the Standard Specifications for Road and Bridge Construction. However, the resistivity requirement is not applicable to CA 7, CA 8, CA 11, CA 13, CA 14, CA 15, and CA 16 per Article 1004.06(f)(1) of the current version of the Standard Specifications for Road and Bridge Construction.</p> <p>If any initial individual resistivity measurement result falls within 300 ohm-cm of the 3,000 ohm-cm minimum value (2,700-3,300 ohm-cm) for galvanized reinforcement, then two additional measurements will be required. The average of these three measurements will be considered the test result.</p> <p>If any initial individual resistivity measurement result falls within 300 ohm-cm of the 1,500 ohm-cm minimum value (1,200-1,800 ohm-cm) for aluminized Type 2 reinforcement, then two additional measurements will be required. The average of these three measurements will be considered the test result.</p> <p>If any initial individual measurement result falls outside the above defined bands the initial measurement will be considered the test result.</p>

This Page Reserved

Standard Method of Test
 for
Determining pH of Soil for Use in Corrosion Testing

Reference AASHTO T 289-91 (2018)

Modifications apply only when testing material according to Articles 1003.07 and 1004.06 of the Standard Specifications for Road and Bridge Construction for select fill in Mechanically Stabilized Earth Retaining Walls (Article 522.02).

AASHTO Section	Illinois Modification
Note 1 New (After 1.1.)	This test procedure is used for Mechanically Stabilized Earth (MSE) wall select fill materials, which may be full graded crushed aggregates, containing a large amount of material passing the 4.75 mm (No. 4) sieve and/or fines.
2.1.	<p>Revise as follows: AASHTO R 90 (Illinois Modified) AASHTO R 76 (Illinois Modified)</p> <p>Add as follows: AASHTO T 288 (Illinois Modified) Standard Method of Test for Determining Minimum Laboratory Soil Resistivity</p> <p>To maintain brevity in the text, the following will apply: Example: AASHTO T 288 (Illinois Modified) will be designated as “AASHTO T 288” or “T 288”.</p>
2.2.	<p>Add as follows: ASTM D1193 Standard Specification for Reagent Water</p> <p>Revise as follows: ASTM E29 (Illinois Modified) Standard Practice for Using Significant Digits In Test Data to Determine Conformance with Specifications</p> <p>To maintain brevity in the text, the following will apply: Example: ASTM E29 (Illinois Modified) will be designated as “ASTM E29.”</p>
6.1.	Replace the last sentence as follows: A representative sample to perform the pH test shall then be obtained as per 6.2.

Standard Method of Test
 for
Determining pH of Soil for Use in Corrosion Testing

Reference AASHTO T 289-91 (2018)

AASHTO Section	Illinois Modification
6.2.	Replace as follows: A representative sample shall be taken by the use of the sampler or by splitting and quartering in accordance with R 76 from a thoroughly mixed portion of the material passing the 2.00-mm (No. 10) sieve that has been obtained in accordance with T 288. This preparation requires all coarse aggregate samples to be initially be crushed to 2.00 mm (No. 10) or less material before a representative sample is obtained.
6.2.1. – 6.2.3.	Disregard these sections when preparing samples received from the field according to Section 6. of T 288.
8.1.	Add as follows: Equipment shall be equivalent to Oakton Waterproof pHTestr5 with automatic temperature correction, 3-point calibration, and 0.01 pH accuracy.
8.5.	Add as follows: Reagent water conforming to the numerical limits for Type II (ASTM D1193) may be used in any reference referring to water.
8.7.	Disregard if pH meter has automatic temperature control.
9.5.	Disregard the last sentence if pH meter has an automatic temperature function.
10.2.	Add as follows: If pH stick electrode is not stored where kept moist, rehydrate or condition it by placing in storage solution for pH or ORP electrodes (3-3.5M potassium chloride solution KCl) 15-30min before using or follow manufacturers recommended procedure. (This can be done for the hour sample prep time or meter may be kept upright in beaker with tip in storage solution when not in use. This is the preferred method.)
Note 7 New (After 11.1.)	For MSE wall select fill material, the pH shall be 4.5 to 9.0 when geosynthetic soil reinforcement is used for permanent applications and 3.0 to 10.0 for temporary applications as specified in Articles 1003.07(e)(1) and 1004.06(e)(1) of the current version of the Standard Specifications for Road and Bridge Construction. When steel reinforcement is used, the pH shall be 5.0 to 10.0 as specified in Articles 1003.07(e)(2) and 1004.06(e)(2) of the current version of the Standard Specifications for Road and Bridge Construction.

Standard Method of Test
 for
Determining Water-Soluble Sulfate Ion Content in Soil

Reference AASHTO T 290-95 (2020)

Modifications apply only when testing material according to Articles 1003.07 and 1004.06 of the Standard Specifications for Road and Bridge Construction for select fill in Mechanically Stabilized Earth Retaining Walls (Article 522.02).

AASHTO Section	Illinois Modification
Note 1 New (After 1.1)	This test procedure is used for Mechanically Stabilized Earth (MSE) wall select fill materials, which may be full graded crushed aggregates, containing a large amount of material passing the 4.75 mm (No. 4) and/or fines. Test results of full gradation samples with an abundance of fines tend to be higher, may fail, and usually exhibit more variability and less repeatability upon retesting or when testing split samples.
Note 2 New (After Note 1)	Determination of Water-Soluble Sulfate Ion Content utilizing Method A: Gravimetric Method (Sections 8 to 16) shall be performed on MSE Wall select fill materials. This method is less liable to interference than turbidimetric method B.
2.1	<p>Revise as follows: AASHTO R 90 (Illinois Modified)</p> <p>Add as follows: AASHTO R 76 (Illinois Modified) Reducing Samples of Aggregate to Testing Size</p> <p>AASHTO T 265 (Illinois Modified) Standard Method of Test for Laboratory Determination of Moisture Content of Soils</p> <p>AASHTO T 288 (Illinois Modified) Standard Method of Test for Determining Minimum Laboratory Soil Resistivity</p> <p>AASHTO T 291 (Illinois Modified) Determining Water-Soluble Chloride Ion Content in Soil</p> <p>To maintain brevity in the text, the following will apply: Example: AASHTO T 291 (Illinois Modified) will be designated as "T 291."</p>

Standard Method of Test
 for
Determining Water-Soluble Sulfate Ion Content in Soil

Reference AASHTO T 290-95 (2020)

AASHTO Section	Illinois Modification
2.2.	Revise as follows: ASTM E 29 (Illinois Modified) Standard Practice for Using Significant Digits In Test Data to Determine Conformance with Specifications Add as follows: ASTM C 114 Standard Test Methods for Chemical Analysis of Hydraulic Cement ASTM D 859 Standard Test Method for Silica in Water ASTM E 200 Standard Practice for Preparation, Standardization, and Storage of Standard and Reagent Solutions for Chemical Analysis To maintain brevity in the text, the following will apply: Example: ASTM E 29 (Illinois Modified) will be designated as “ASTM E 29.”
6.1.	Add as follows: When T 290 is to be performed along with T 291 and one sample is to be prepared for both tests, a minimum of 250 g of material passing the 2.00 mm (No. 10) sieve is required as outlined in Section 5.2 of T 288.
7.1.	Replace the last two sentences as follows: A representative sample to perform the sulphate ion content test shall be obtained as per 7.2.
7.2.	Replace as follows: A representative sample shall be taken by using the sampler or by splitting and quartering in accordance with R 76 from a thoroughly mixed portion of the material passing the 2.00-mm (No. 10) sieve that has been obtained in accordance with T 288. This preparation requires all coarse aggregate samples to be initially be crushed to 2.00 mm (No. 10) or less material before a representative sample is obtained.
7.2.1. – 7.2.3.	Disregard these sections when preparing samples received from the field according to Section 6 of T 288.

Standard Method of Test
 for
Determining Water-Soluble Sulfate Ion Content in Soil

Reference AASHTO T 290-95 (2020)

AASHTO Section	Illinois Modification
9.1.	Delete the words “silica and other” from the sentence. See 13.4. below.
10.1.	Delete the words “silica or other” from the second sentence. See 13.4. below.
12.1.	Disregard ammonium hydroxide. It is not used in this method.
12.4	Disregard hydrofluoric acid. It is not used for removal of silica as reference in 13.9. See 13.4. below.
12.5	Replace the concentration of methyl orange with the following from ASTM E 200: Methyl Orange Indicator Solution (0.1 g/100 mL)-Dissolve 0.01 g methyl orange in hot deionized water using magnetic stir bar and stirrer. Cool and bring volume to 100 mL. Other concentrations may be used as appropriate.
12.7	Disregard picric acid. It is not used in this method.
12.9	Disregard sulfuric acid. It is not used for removal of silica as reference in 13.9. See 13.4. below.
13.1	Revise as follows: Weigh 100 g of oven-dried sample into a 500-mL Erlenmeyer flask. (See Note 4 below. Sample drying is done using T 265 moisture loss procedure and sample is kept in desiccator until use per T 291 Section 22.1.)
13.2	Revise as follows: Add 300 mL deionized water. Slide a magnetic stir bar down the side into the flask without splattering. Stopper or cover appropriately and shake mix vigorously by hand for 20 to 30 seconds. Swirl to remove any adherent material from sides and place the flask on a stir plate. Stir as vigorously as possible for <u>at least</u> 15 minutes. Note 4 – For increased lab efficiency, the sample is prepared so that one prepared sample may be utilized for both T 291 and T 290. Therefore, the same sample preparation procedure appears in this standard and in AASHTO T 291.

Standard Method of Test
 for
Determining Water-Soluble Sulfate Ion Content in Soil

Reference AASHTO T 290-95 (2020)

AASHTO Section	Illinois Modification
13.3	<p>Revise as follows: Appropriately weigh and balance enough liquid for testing in centrifuge tubes and centrifuge at 10,000 rpm for 10 to 15 minutes. (Program set for 10 minutes.) [Three (3) tubes should be enough liquid for duplicate 30 mL aliquots for SO₄ and a 90 mL aliquot for chloride. Five (5) tubes will allow for duplicate chloride tests.]</p> <p>Decant off the liquid in a separate beaker and add 1 to 2 drops of nitric acid with stirring to settle out finely divided suspended matter. After allowing a settling period, vacuum-filter the sample slowly (using no water at any point) through a Kontes 47 mm membrane filter apparatus with fritted glass support and nitrocellulose water-testing membrane filters with a 0.45 µm pore size or an equivalent filtering apparatus/set-up.</p> <p>Note 5 – If there is more than one sample, the filter apparatus shall be washed out and dried thoroughly with air between filtering. Filter flasks shall also be dry.</p>
13.4	<p>Replace with the following: Pipette a 30 mL aliquot of the vacuum-filtered solution into a 400 mL tallform beaker. Adjust the volume to 200 mL with deionized water. Add 1 to 2 drops methyl orange (solution should already be acidic due to nitric acid addition in 13.3 and add 10 mL HCl (1:9). If an aliquot other than 30 mL is used, adjust end calculation to reflect actual aliquot used.</p>
Note 6	<p>Renumber Note 4 to Note 6 and revise as follows: Silica is not removed before applying this method. Silica is only slightly soluble in water and if present usually comes from the gradual degradation of minerals over time (see ASTM D 859 5.2) which will not occur under the small amount of preparation time in this test method. Representative materials for MSE wall select fill have not exhibited appreciable amounts of silica that needs removal.</p>
13.5	<p>Disregard this section. It is a differently worded repeat of section 13.4.</p>

Standard Method of Test
 for
Determining Water-Soluble Sulfate Ion Content in Soil

Reference AASHTO T 290-95 (2020)

AASHTO Section	Illinois Modification
13.6	Revise as follows: Heat the acidified solution to boiling over a Bunsen burner apparatus set-up (ring stand/ring/wire gauze/burner) under a hood or on a hot plate. Remove from burner or hot plate and slowly add 5 mL BaCl ₂ while stirring. Return to burner or hot plate and bring back to boiling. Once it is boiling, move to a hot plate if it is on a burner, and adjust the temperature of to keep the solution just below boiling and allow a settling period of at least 2 hours or overnight at this temperature. In no case should this settling period be less than 2 hours.
Note 5 (After 13.6)	Delete Note 5 located after 13.6 as picric acid is not used in this test method.
13.7	Revise as follows: Filter the suspension of BaSO ₄ on a Whatman #42, ashless filter paper and wash the precipitate with hot water until the washings are substantially free of chlorides, as indicated by testing the last portion of the washings with AgNO ₃ solution (Note 8). Avoid excessive washing. If any BaSO ₄ passes through the filter, pour the filtrate through the paper a second time (Note 9). Note 7 – Extreme care should be used in filtering process: If gravity filtering, do not fill funnels too full, direct wash sprays downward from the top of paper, and do not allow the precipitate to crawl up the paper and up on the glass where it can be washed down the folded seam of paper. This may cause loss and low inaccurate test results. In all cases, extreme care must be taken to ensure complete transfer of all precipitate material to the crucible.
Note 8	Renumber Note 6 to Note 8.
Note 9	Renumber Note 7 to Note 9.
13.8	Revise “Note 4” to “Note 6” in the first sentence. (Note 6 is located after Section 13.4 above.)

Standard Method of Test
 for
Determining Water-Soluble Sulfate Ion Content in Soil

Reference AASHTO T 290-95 (2020)

AASHTO Section	Illinois Modification
Note 10 (After 13.8)	Even though silica removal is not done, platinum crucibles shall be used for accuracy and repeatability of the small ppm measurements. Porcelain crucibles shall not be used because results using porcelain crucibles may exhibit greater weight variability under changing laboratory temperatures, cooling times, and laboratory humidity which may greatly affect the accuracy and repeatability of small ppm measurements.
13.9	Disregard this section. See Note 6 after Section 13.4 above.
Note 11 New (After 13.9)	<p>Although appreciable amounts of silica have not been found in the typical MSE wall select fill materials tested to date (see Note 6 after Section 13.4 above), if desired, this step may be done by following Sections 13.8 and 13.9 with the following modifications noted below:</p> <p>This procedure involves the placing of the filter paper and contents into a <u>platinum</u> crucible, drying on hot plate, burning off without inflaming, and cooking in muffle furnace at about 800°C for minimum of 1 hour. After cooling, 1 drop of concentrated H₂SO₄ and a few drops of concentrated HF are added, and the sample evaporated to dryness under a hood (to expel any silica as SiF₄). To protect the thermocouple and equipment, any remaining fumes <u>shall</u> be driven off using a Bunsen burner under a hood <u>before</u> the sample is again placed in the muffle furnace at about 800°C for approximately 5 minutes. (This procedure is similar to that in ASTM C 114 Section 8.2.3.2). The second weight is used as the mass of the BaSO₄ in calculations.</p> <p>To perform this procedure, it is vital that proper hoods and PPE and emergency exposure first aid procedures be in place as hydrofluoric acid (HF) exposure is extremely dangerous and delayed pulmonary edema from exposure can cause death and body contact can cause deep-seated injury to tissue and bone that is very difficult to treat.</p>
14.1	Disregard Sulfate Ion Content in Soil mg/kg moisture free calculation formula shown in Equation 2. The use of a previously dried sample in section 13.1 above (as specified for in the T 291 chloride procedure) makes the calculation in 14.1 a moisture free measurement of the sulfate ion in the soil thus rendering this calculation unnecessary. (See Note 4. Sample drying is done using T 265 moisture loss procedure and sample is kept in desiccator until use per T 291 Section 22.1.)

Standard Method of Test
 for
Determining Water-Soluble Sulfate Ion Content in Soil

Reference AASHTO T 290-95 (2020)

AASHTO Section	Illinois Modification
15.1.	<p>Replace “14.2 on a moisture-free basis in units of milligrams per kilogram (mg/kg)” in the first sentence with “14.1. Equation (1) (which is already on a moisture-free basis due to sample preparation) in units of ppm (a mg/kg equivalent)”.</p> <p>Note 12— For MSE wall select fill material, the sulfates shall be less than 200 parts per million (ppm) as specified in Article 1003.07(f)(3) and Article 1004.06(f)(3) of the current version of the Standard Specifications for Road and Bridge Construction.</p> <p>If any initial individual measurement result falls within 40ppm of the 200ppm max value (160-240ppm), then two additional measurements will be required (2 more separate flask preps). The average of these three measurements will be considered the test result.</p> <p>If any initial individual measurement result falls outside the above defined band, the initial measurement will be considered the test result.</p>
Note 8 (After 21.2)	Rename Note 8 to Note 13.
Note 9 (After 22.1)	Rename Note 9 to Note 14.
Note 10 (After 23.4)	Rename Note 10 to Note 15.
Note 11 (After 23.6)	Rename Note 11 to Note 16.

This Page Reserved

Standard Method of Test
 for
Determining Water-Soluble Chloride Ion Content in Soil

Reference AASHTO T 291-94 (2018)

Modifications apply only when testing material according to Articles 1003.07 and 1004.06 of the Standard Specifications for Road and Bridge Construction for select fill in Mechanically Stabilized Earth Retaining Walls (Article 522.02).

AASHTO Section	Illinois Modification
Note 1 New (After 1.1.)	This test procedure is used for Mechanically Stabilized Earth (MSE) wall select fill materials, which may be full graded crushed aggregates, containing a large amount of material passing the 4.75 mm (No. 4) and/or fines. Test results of full gradation samples with an abundance of fines tend to be higher, may fail, and usually exhibit more variability and less repeatability upon retesting or when testing split samples.
Note 2 New (After Note 1)	Determination of Water-Soluble Chloride Ion Content utilizing a pH/MV Meter (Method B) (Sections 17. to 28.) is performed on MSE Wall materials.
2.1.	<p>Revise as follows: AASHTO R 90 (Illinois Modified)</p> <p>Add as follows: AASHTO R 76 (Illinois Modified) Reducing Samples of Aggregate to Testing Size</p> <p>AASHTO T 260 Standard Method of Test for Sampling and Testing Chloride Ion in Concrete and Concrete Raw Materials</p> <p>AASHTO T 265 (Illinois Modified) Standard Method of Test for Laboratory Determination of Moisture Content of Soils</p> <p>AASHTO T 288 (Illinois Modified) Standard Method of Test for Determining Minimum Laboratory Soil Resistivity</p> <p>AASHTO T 290 (Illinois Modified) Standard Method of Test for Determining Water-Soluble Sulfate Ion Content in Soil</p> <p>To maintain brevity in the text, the following will apply: Example: AASHTO T 290 (Illinois Modified) will be designated as “AASHTO T 290” or “T 290”.</p>

Standard Method of Test
 for
Determining Water-Soluble Chloride Ion Content in Soil

Reference AASHTO T 291-94 (2018)

AASHTO Section	Illinois Modification
2.2.	Revise as follows: ASTM E 29 (Illinois Modified) Standard Practice for Using Significant Digits In Test Data to Determine Conformance with Specifications To maintain brevity in the text, the following will apply: Example: ASTM E 29 (Illinois Modified) will be designated as “ASTM E 29.”
Note 1 (After 5.3.)	Renumber Note 1 to Note 3.
Note 2 (After 5.4.)	Renumber Note 2 to Note 4.
6.1.	Add as follows: When T 291 is to be performed along with T 290 and one sample is to be prepared for both tests, a minimum of 250 g of material passing the 2.00 mm (No. 10) sieve is required as outlined in Section 5.2 of T 288.
7.1.	Replace the last two sentences as follows: A representative sample to perform the water-soluble chloride ion content test shall be obtained as per 7.2.
Note 3 (After 7.1.)	Renumber Note 3 to Note 5.
7.2.	Replace as follows: A representative sample shall be taken by using the sampler or by splitting and quartering in accordance with R 76 from a thoroughly mixed portion of the material passing the 2.00-mm (No. 10) sieve that has been obtained in accordance with T 288. This preparation requires all coarse aggregate samples to be initially be crushed to 2.00 mm (No. 10) or less material before a representative sample is obtained.

Standard Method of Test
 for
Determining Water-Soluble Chloride Ion Content in Soil

Reference AASHTO T 291-94 (2018)

AASHTO Section	Illinois Modification
7.2.1 – 7.2.3	Disregard these sections when preparing samples received from the field according to Section 6 of T 288.
17.2.	At the end of the second sentence, revised “(Note 5)” to “(Note 8)”.
Note 6 New (After 18.1.)	<p>Although ionic strength buffers “fix” solutions so the concentration and activity are equal, this is only necessary with solutions with many ions. In dilute solutions, the concentration and activity are practically identical which is why dilute samples are used for ion selective electrode (ISE) measurement.</p> <p>Typical MSE wall select fill materials have not exhibited significant differences with or without buffer solutions to date, therefore buffer solutions are not specified for chloride test methods with dilute solutions using ISE specified in this method.</p> <p>If use of buffer solution is desired, see the following guidelines:</p> <p>For appropriate use of recommended buffer in this test method using 100 g/300 ml for sample preparation, the 90 mL aliquot sample (which represents a 30 g sample and is equivalent to the 30 mL of the 100 g/100 mL) would require an equal amount of the 0.2M KNO₃ buffer (90 mL) which would cause an overflow during titration due to titrator beaker size for the automatic turret.</p> <p>If the use of an I.S.A.B (ionic strength adjustment buffer) is desired and this combined preparation procedure which increases laboratory efficiency is used, it is possible to use the 0.2M KNO₃ for the standard (i.e. 10 mL 0.01N NaCl standard + 10 mL 0.2M KNO₃ buffer) and 0.6M KNO₃ buffer solution for the sample (i.e. 90 mL sample + 30 mL 0.6M KNO₃ buffer). Increasing the concentration by a factor of 3 allows the use of 1/3 of the prescribed amount. This gives a total volume of 120 mL which will allow the titrator program to add the full amount of 0.01N AgNO₃ (in case a result does not “catch”) and still not overflow the beaker.</p> <p>The 0.6M KNO₃ buffer can be made up using 60.66 g KNO₃ diluted up to 1000 mL with deionized water (or for smaller volume 6.066 g/100 mL).</p>
19.1.	Disregard reference to removing interferences with a peroxide treatment. Unless samples contain large amounts of slag material, they should not contain significant sulfide which would cause interferences. If sulfide interference is suspected, hydrogen peroxide must be added under guidance of a different procedure (i.e. AASHTO T 260 6.3.2) as no guidance is given in AASHTO T 291.

Standard Method of Test
 for
Determining Water-Soluble Chloride Ion Content in Soil

Reference AASHTO T 291-94 (2018)

AASHTO Section	Illinois Modification
20.1.	Replace as follows: Automatic Titrator—Hanna Instruments HI902 Automatic Potentiometric Titrator equipped with an autosampler, electric stirrer, and HI4115 Silver/Sulfide Combination electrode (filled with purchased 1M or 1N KNO ₃) or equivalent equipment/setup for analysis.
20.2.	Disregard this section if using automatic titrator. (See 20.1. above)
21.1.1.	Disregard this section if using automatic titrator with ISE electrode. (See 20.1. above)
21.1.2.	Add “or purchased 1M KNO ₃ solution” after “1 L” at the end of the first sentence. (See 20.1. above)
21.1.3.	See discussion in Note 6 above.
Note 4 (After 21.1.3.)	Renumber Note 4 to Note 7.
21.1.4.	Revise “(Note 5)” to “(Note 8)” at the end of the first sentence. Add the following: Alternatively, the following solution may be used as standard: <i>0.01N Sodium Chloride Stock Solution</i> —Dry NaCl overnight in oven at 110 ± 5°C and cool in desiccator. Dissolve 0.5844 g in deionized water and dilute to one liter.
Note 5 (After 21.1.4.)	Renumber Note 5 to Note 8.
21.1.5.	Add “or alternatively sodium chloride” after “potassium chloride”.
21.1.6. New	<i>Deionized reagent water</i> —Conforming to the numerical limits for Type II (ASTM D1193) is used where any mention of water is made.
21.1.7.	<i>0.01N Silver Nitrate Solution</i> —Dissolve 1.7g AgNO ₃ in deionized water and dilute to 1 L (titration solution for automatic titrator).

Standard Method of Test
 for
Determining Water-Soluble Chloride Ion Content in Soil

Reference AASHTO T 291-94 (2018)

AASHTO Section	Illinois Modification
22.1.	<p>Replace as follows: Dry a representative portion (approximately 250 g per section 6.1.1.) in large porcelain/ceramic dish overnight (15 hour minimum) at 110±5°C as in AASHTO T 265 Moisture loss procedure and cool in desiccator where sample is kept until use.</p> <p>Note 9—For greater lab efficiency, a sample is prepared so that one prepared sample may be utilized for both chloride and sulfate ion analysis (T 290). (The aliquot specified in 25.1. for chloride analysis is adjusted therefore in the modified 25.1. section to reflect the change from the 1:1 ratio originally called for in 22.2. below to the 1:3 ratio used in T 290 sections 13.1. and 13.2. for sulfate analysis).</p>
22.2.	<p>Replace as follows: Weigh 100 g of the dried sample into a 500-mL Erlenmeyer flask and add 300 mL deionized water.</p> <p>Slide a magnetic stir bar down the side into the flask without splattering. Stopper or cover appropriately and shake mix vigorously by hand for 20 to 30 seconds. Swirl to remove any adherent material from the sides and place the flask on a magnetic stir plate. Stir as vigorously as possible for <u>at least</u> 15 minutes.</p> <p>Note 10—The 1:3 sample ratio in 22.2. (above) is from AASHTO T 290 for sulfates where 30 mL aliquot = 10 g sample equivalent. Since this is different than the 1:1 ratio specified here, a 90 mL sample aliquot representing the 30 g sample is used to represent an equivalent amount as is called for in this test method in 25.1.)</p>
22.3.	<p>Replace as follows: Appropriately weigh and balance enough liquid for testing in centrifuge tubes and centrifuge at 10,000 rpm for 10 to 15 minutes. (Program set for 10 minutes.) [Three (3) tubes should be enough liquid for duplicate 30 mL aliquots for SO₄ and a 90 mL aliquot for chloride. Five (5) tubes will allow for duplicate chloride tests.]</p> <p>Decant off the liquid in separate beaker and add 1 to 2 drops of nitric acid with stirring to settle out finely divided suspended matter. After allowing a settling period, vacuum-filter the sample slowly (<u>using no water at any point</u>) through a Kontes 47 mm membrane filter apparatus with fritted glass support and nitrocellulose water-testing membrane filters with a 0.45 µm pore size or an equivalent filtering apparatus/set-up.</p> <p>Note 11—If there is more than one sample, the filter apparatus shall be washed out and dried thoroughly with air between filtering. Filter flasks shall also be dry.</p>

Standard Method of Test
 for
Determining Water-Soluble Chloride Ion Content in Soil

Reference AASHTO T 291-94 (2018)

AASHTO Section	Illinois Modification
24.1.1.	<p>Replace as follows: Calibrate the instrument using appropriate dilutions of selected standard stock solution (i.e. 0.01N or 0.01M NaCl solution) as appropriate using the SEQ0006 Normality program set up on the titrator or an equivalent program for titrating equipment. Range should be such as to cover the range of material being tested.</p> <p>Note 12—A 10 mL aliquot of above solution should read approximately 354 ppm (mg/L) Cl on the titrator (when diluted up to 100 mL with deionized water and 1 to 2 drops concentrated nitric acid added to match that of the prepared sample) which should be a suitable upper limit to catch MSE wall sample amounts—even previously failed ones have not typically exceeded this number.</p>
24.1.2.	See discussion in Note 6 above.
24.1.3	<p>Disregard this section for automatic titrating equipment.</p> <p>Automatic instrumentation programs do all plots and calculations and return the answer in the appropriate ppm value.</p>
25.1.	<p>Replace as follows: Measure out a 90 mL aliquot (a 90 mL aliquot represents 30 g dried sample) of the vacuum-filtered liquid with a graduated cylinder and transfer to an automatic titrator beaker adding 10 mL of water to bring total volume to 100 mL and analyze using method designated as method SEQ0005 Chloride Weight LR or an equivalent program for titrating equipment. (These samples already contain 1 to 2 drops concentrated nitric acid from settling out the finely suspended matter in 22.3. above during the sample preparation).</p>
25.2.	See discussion in Note 6 above.
25.3.	Disregard this section if using automatic titrating equipment. Follow 25.1. above.
25.4.	Disregard this section if using automatic titrating equipment. Follow 25.1. above.
25.5.	Disregard this section if using automatic titrating equipment. Follow 25.1. above.

Standard Method of Test
 for
Determining Water-Soluble Chloride Ion Content in Soil

Reference AASHTO T 291-94 (2018)

AASHTO Section	Illinois Modification
25.6.	Replace as follows: Record the displayed reading in ppm from titrator display.
25.7.	Disregard this section if using automatic titrating equipment. Follow 25.1. above.
25.8.	Disregard this section if using automatic titrating equipment. Follow 25.1. above.
25.9.	Disregard this section if using automatic titrating equipment. Follow 25.6. above.
27.1.	Replace “mg/kg” with “ppm”.
Note 13 New (After 27.1.)	<p>For MSE wall select fill material, the chlorides shall be less than 100 parts per million (ppm) as specified in Article 1003.07(f)(2) and Article 1004.06(f)(2) of the current version of the Standard Specifications for Road and Bridge Construction.</p> <p>If any initial individual measurement result falls within 15ppm of the 100ppm max value (85-115ppm), then two additional measurements will be required (2 more separate flask preps). The average of these three measurements will be considered the test result.</p> <p>If any initial individual measurement result falls outside the above defined band, the initial measurement will be considered the test result.</p>

This Page Reserved

AASHTO T 305

Determination of Draindown Characteristics in Uncompacted Asphalt Mixtures

AASHTO T 305 test method, Determination of Draindown Characteristics in Uncompacted Asphalt Mixtures, cannot be reproduced in this manual due to copyright. AASHTO standards may be requested from the address below:

AASHTO
555 12th St., N. W.
Suite 1000
Washington, D.C. 20004
(202) 624-5800
www.transportation.org

This Page Reserved

Illinois Modified Test Procedure
 Effective Date: January 1, 2002
 Revised Date: [December 1, 2021](#)

Standard Method of Test
 For
**Determining the Asphalt Binder Content of Asphalt [Mixtures](#) by the
 Ignition Method**

Reference AASHTO T 308-21

AASHTO Section	Illinois Modification
1.1	Revise the first sentence as follows: This test method covers the determination of asphalt binder content of HMA by ignition of the asphalt binder at 482 °C (900 °F) in a furnace.
2.1	Revise reference to the individual Standards as follows: T 30 (Illinois Modified)
2.1	Delete: R 66 R 76 R 97
2.1.1	Illinois Manual of Test Procedures: <ul style="list-style-type: none"> ▪ Appendix B4, Hot-Mix Asphalt Test Strip Procedures ▪ Appendix B6, Hot-Mix Asphalt QC/QA Initial Daily Plant and Random Samples ▪ Appendix B7, Hot-Mix Asphalt QC/QA Procedure for Determining Random Density Locations ▪ Appendix E3, PFP and QCP Random Density Procedure ▪ Appendix E4, PFP and QCP Hot Mix Asphalt Random Jobsite Sampling
5.1	Revise the second sentence as follows: The convection-type furnace must be capable of maintaining a temperature of 482 ± 5°C (900 ± 9°F).
5.3	Replace with the following: <i>Oven</i> —An oven of sufficient size, specifically built for drying, capable of maintaining a uniform temperature of 110 ± 5 °C (230 ± 9 °F) shall be used. No other heat source for drying is permitted.
5.6	Replace with the following: <i>Miscellaneous Equipment</i> —A pan with dimensions (L x W x H) 600 mm x 600 mm x 150 mm (24 in. x 24 in. x 6 in.) minimum for transferring specimens after ignition.

Standard Method of Test
 For
**Determining the Asphalt Binder Content of Asphalt Mixtures by the
 Ignition Method**

Reference AASHTO T 308-21

AASHTO Section	Illinois Modification
6.1	Replace with the following: Obtain samples of freshly produced asphalt mixture according to the appropriate Appendix in the Manual of Test Procedures.
6.2	Replace with the following: The specimen shall be the end result of reducing a larger sample according to the appropriate Appendix in the Manual of Test Procedures. A specimen of 1 kg, minimum, shall be split out to determine the moisture content.
7.1.1	Revise the first sentence as follows: For the Convection-type furnace, preheat the ignition furnace to 482 °C (900 °F).
7.2	<p>Replace with the following: Obtain and split a HMA sample(s) according to Sections 6.2, 6.4, and A2.2 herein.</p> <p>Test for moisture as follows: Determine the mass of the moisture content sample immediately after splitting as outlined in Section 6.2 herein. Record this value as the original sample mass. Place this sample in a 110 ± 5 °C (230 ± 9 °F) drying oven and continue drying until it reaches a constant mass. Constant mass shall be defined as the mass at which further drying does not alter the mass more than 0.5 gram in 1 hour.</p> <p>Moisture content is determined as follows:</p> $\% \text{ Moisture Content } (M_C) = \frac{(\text{Original Sample Mass}) - (\text{Constant Mass})}{\text{Constant Mass}} \times 100$
8.1	Replace with the following: Preheat the ignition furnace to 482 °C (900 °F).

Standard Method of Test
 For
**Determining the Asphalt Binder Content of Asphalt Mixtures by the
 Ignition Method**

Reference AASHTO T 308-21

AASHTO Section	Illinois Modification
8.2	<p>Replace with the following: Obtain and split a HMA sample(s) according to Sections 6.2, 6.4, and A2.2 herein.</p> <p>Test for moisture as follows: Determine the mass of the moisture content sample immediately after splitting as outlined in Section 6.2 herein. Record this value as the original sample mass. Place this sample in a 110 ± 5 °C (230 ± 9 °F) drying oven and continue drying until it reaches a constant mass. Constant mass shall be defined as the mass at which further drying does not alter the mass more than 0.5 gram in 1 hour.</p> <p>Moisture content is determined as follows:</p> $\% \text{ Moisture Content } (M_c) = \frac{(\text{Original Sample Mass}) - (\text{Constant Mass})}{\text{Constant Mass}} \times 100$
8.7	<p>Revise the second sentence with the following: Burn the HMA sample in the furnace for at least 60 minutes.</p>
8.7 NOTE 7	Delete the second sentence.
8.8	<p>Replace with the following: After ignition, open the chamber door, remove the specimen and specimen basket assembly from the furnace, and place it on a cooling plate or block. Place the protective cage over the specimen basket assembly and allow it to cool in a 110 ± 5 °C (230 ± 9 °F) drying oven until the specimen stabilizes at 110 ± 5 °C (230 ± 9 °F). Weigh and record the constant mass (M_f).</p>
8.9 through 8.15	Delete.

Illinois Modified Test Procedure
 Effective Date: January 1, 2002
 Revised Date: [December 1, 2021](#)

Standard Method of Test
 For
Determining the Asphalt Binder Content of Asphalt Mixtures by the Ignition Method

Reference AASHTO T 308-21

AASHTO Section	Illinois Modification
9.3 New Section	Correct the aggregate gradation by subtracting the degradation computed in Section 9.2 herein from the percent passing on the respective sieves.
A1.1	Revise the third sentence as follows: Correction factor(s) must be determined each time a change in the mix ingredients or design occurs.
A1.2	Delete the first two sentences.
A2.4	Revise the first sentence as follows: According to the requirements of the current Hot Mix Asphalt QC/QA Level III (Design) Course, prepare two calibration specimens at the design asphalt content.
A2.5	Revise the second sentence as follows: If allowed to cool, the specimens must be preheated in a 110 ± 5 °C (230 ± 9 °F) oven for 25 minutes prior to placement in the specimen basket assembly.
A2.8.1	Delete.

This Page Reserved

AASHTO T 309 has been replaced by ASTM C1064/C1064M.

This Page Reserved

AASHTO T 309 has been replaced by ASTM C1064/C1064M.

Standard Test Method
 for
**In-Place Density and Moisture Content of Soil
 and
 Soil-Aggregate by Nuclear Methods (Shallow Depth)**

Reference AASHTO T 310-19

AASHTO Section	Illinois Modification								
1.1	Replace with the following: This test method describes the procedure for determining the in-place density of soil and soil-aggregate by use of nuclear gauge. The density of the material shall be determined by the direct transmission method. The moisture of the material is only determined from measurements taken at the surface of the soil (i.e., Backscatter).								
2.1	Revise as follows: AASHTO T 99 (Illinois Modified) AASHTO T 180 (Illinois Modified) AASHTO T 191 (Illinois Modified) AASHTO T 217 (Illinois Modified) AASHTO T 255 (Illinois Modified) AASHTO T 265 (Illinois Modified) AASHTO T 272 (Illinois Modified) Add as follows: All references to “AASHTO T 224” shall be understood to refer to Annex A1 of AASHTO T 99 (Illinois Modified). To maintain brevity in the text, the following will apply: Example: AASHTO T 99 (Illinois Modified) will be designated as “T 99.”								
2.2	Add as follows: <table style="width: 100%; border: none;"> <tr> <td style="width: 40%;">ASTM E 29 (Illinois Modified)</td> <td>Standard Practice for Using Significant Digits In Test Data to Determine Conformance with Specifications</td> </tr> <tr> <td>ASTM D 2216</td> <td>Standard Test Method for Laboratory Determination of Water (Moisture) Content of Soil and Rock Mass</td> </tr> <tr> <td>ASTM D 4643</td> <td>Standard Test Method for Determination of Water (Moisture) Content of Soil by Microwave Oven Heating</td> </tr> <tr> <td>ASTM D 4959</td> <td>Standard Test Method for Determination of Water Content of Soil by Direct Heating</td> </tr> </table> To maintain brevity in the text, the following will apply: Example: ASTM E 29 (Illinois Modified) will be designated as “ASTM E 29.”	ASTM E 29 (Illinois Modified)	Standard Practice for Using Significant Digits In Test Data to Determine Conformance with Specifications	ASTM D 2216	Standard Test Method for Laboratory Determination of Water (Moisture) Content of Soil and Rock Mass	ASTM D 4643	Standard Test Method for Determination of Water (Moisture) Content of Soil by Microwave Oven Heating	ASTM D 4959	Standard Test Method for Determination of Water Content of Soil by Direct Heating
ASTM E 29 (Illinois Modified)	Standard Practice for Using Significant Digits In Test Data to Determine Conformance with Specifications								
ASTM D 2216	Standard Test Method for Laboratory Determination of Water (Moisture) Content of Soil and Rock Mass								
ASTM D 4643	Standard Test Method for Determination of Water (Moisture) Content of Soil by Microwave Oven Heating								
ASTM D 4959	Standard Test Method for Determination of Water Content of Soil by Direct Heating								
3.4	Replace T 265 with ASTM D 2216.								

Standard Test Method
 for
**In-Place Density and Moisture Content of Soil
 and
 Soil-Aggregate by Nuclear Methods (Shallow Depth)**
 (continued)
 Reference AASHTO T 310-19

AASHTO Section	Illinois Modification
4.2.1	<p>Replace with the following:</p> <p>The chemical composition of the sample may dramatically affect the measurement and adjustments may be necessary. Hydrogen in forms other than water, as defined by ASTM D 2216, and carbon will cause measurements in excess of the true value. Examples are road oil and asphalt. Chemically bound water such as found in gypsum will cause measurements in excess of the true value. Some chemical elements such as boron, chlorine, and minute quantities of cadmium will cause measurements lower than the true value. Soils containing iron or iron oxides, having a higher capture cross section (absorption of neutrons), will cause measurements lower than the true value.</p> <p>To obtain an accurate in-place moisture content when the soil material may adversely affect measurements, or an unfamiliar soil material is used, the following procedure shall be followed:</p> <p>Adjustment of Measured Soil Moisture as Obtained by the Nuclear Gauge</p> <p>Step 1. Perform 10 moisture determinations by nuclear method according to T 310.</p> <p>Step 2. Perform 10 oven-dry moisture determinations according to T 265 on samples obtained according to Section 9.6.</p> <p>Step 3. Perform 10 wet density determinations by nuclear method according to T 310.</p> <p>Step 4. Convert oven-dry moisture (%) obtained in Step 2, to oven-dry moisture in kg/m³ (lbm/ft³) using the following:</p> $\frac{\text{OVEN-DRY MOISTURE (\%)} \times \text{NUCLEAR WET DENSITY (kg/m}^3 \text{ or lbm/ft}^3\text{)}}{\text{OVEN DRY MOISTURE (\%)} + 100}$ <p>= OVEN-DRY MOISTURE (kg/m³ or lbm/ft³)</p> <p>Step 5. Average the 10 values of oven-dry moisture (kg/m³ or lbm/ft³) obtained in Step 4. Average the 10 values of nuclear moisture (kg/m³ or lbm/ft³) obtained in Step 1.</p> <p>Step 6. Subtract the average oven-dry moisture obtained in Step 5 from the average nuclear moisture obtained in Step 5.</p> <p>Step 7. Apply the average difference obtained in Step 6, as an "adjustment factor", to all subsequent nuclear moisture test results for the given soil.</p>

Standard Test Method
 for
**In-Place Density and Moisture Content of Soil
 and
 Soil-Aggregate by Nuclear Methods (Shallow Depth)**
 (continued)
 Reference AASHTO T 310-19

AASHTO Section	Illinois Modification
4.2.1 continued	<p>FIELD OPTION FOR DRYING SOIL</p> <p>For field work, a thermostatically controlled drying oven is normally not available, as mentions in AASHTO T 265. Therefore, a microwave oven, hot plate, electric heat lamp, kitchen stove, camp stove, grill or any other apparatus capable of drying soil to a constant mass may be used. When using any of the previously mentioned equipment, care must be made to not degrade or otherwise adversely affect the soil (Note 1). Drying by microwave oven shall be according to ASTM D 4643. Drying by all other non-thermostatically controlled oven means shall be according to ASTM D 4959.</p> <p>Note 1: Burning the soil may drive off organic material, which would cause moisture measurements higher than the true value. Rapid heating of the soil may cause some particles to explode and loss of material, which would also result in moisture measurements higher than the true value. . Therefore, stir the soil sample when drying to accelerate the operation and avoid localized overheating.</p>
8.3 New Section	<p>Add as follows:</p> <p>All rounding shall be according to ASTM E 29.</p>
9.5.1	<p>Replace with the following:</p> <p>The following procedures shall be used for measurements using the nuclear method in trenches, and around abutments, culverts or other objects either buried or protruding from the surface of the ground.</p>
9.5.1.1	<p>OBJECTS BURIED BELOW THE SURFACE OF MATERIAL TO BE TESTED</p> <p>(a) Backscatter moisture tests may be used if a minimum of 150 mm (6 in.) of cover material is present.</p> <p>(b) Direct transmission density tests may be used if a minimum of 75 mm (3 in.) of cover material is present below the probe tip. The hole shall be a minimum of 50 mm (2 in.) deeper than the desired measurement as per 9.5.2, plus an additional minimum 25 mm (1 in.)</p>

Standard Test Method
 for
**In-Place Density and Moisture Content of Soil
 and
 Soil-Aggregate by Nuclear Methods (Shallow Depth)**
 (continued)
 Reference AASHTO T 310-19

AASHTO Section	Illinois Modification
9.5.1.2	<p>TRENCHES, ABUTMENTS, CULVERTS AND OTHER OBJECTS</p> <p>(a) Direct transmission density tests may be taken in trenches immediately adjacent to the earth walls, with either the nose or side of the gauge toward the wall.</p> <p>(b) Direct transmission density tests may be taken next to abutments, culverts, and other objects if the nose of the gauge is a minimum of 150 mm (6 in.) from the object or the side of the gauge is a minimum of 300 mm (12 in.) from the object.</p> <p>(c) Backscatter moisture tests may be taken if the following procedures are used to cancel the effect of the object on the test.:</p> <ol style="list-style-type: none"> (1) The standard count should be taken a minimum of 4.5 m (15 ft.) from any object that will affect the count. (2) Take a standard count in the location (next to object) where the test is to be taken. This count will be higher than the count taken in step (1). Subtract the standard count taken in step (1) from the standard count taken on the spot where the test is to be run. The result is the correction factor. (3) Remove the reference block and take the moisture count (next to the object). Now subtract the correction factor from this moisture count. (4) Divide this corrected moisture count by the standard count taken away from the object in step (1). This gives the corrected count ratio to be used.
9.7 New Section	<p>Add as follows:</p> <p>All rounding shall be according to ASTM E 29.</p>
10.2.2 New Section	<p>Add as follows:</p> <p>If representative samples of material are to be taken for purposes of correlation with other test methods or rock correction, the volume measured can be approximated by a 200-mm (8-in.) diameter cylinder located directly under the center line of the radioactive source and detector(s). The height of the cylinder to be excavated will be the depth setting of the source rod when using the Direct Transmission method or approximately 75 mm (3 in.) when using the Backscatter Method.</p>

Illinois Modified Test Procedure
 Effective Date: June 1, 2012
 Revised Date: [December 1, 2021](#)

Standard Test Method
 for
**In-Place Density and Moisture Content of Soil
 and
 Soil-Aggregate by Nuclear Methods (Shallow Depth)**
 (continued)
 Reference AASHTO T 310-19

AASHTO Section	Illinois Modification
10.2.3 New Section	<p>Add as follows:</p> <p>An alternate to the correction for oversize particles that can be used with mass density methods or minimal oversize situations involves multiple tests. Three tests may be taken at adjacent locations and the results averaged to get a representative value.</p> <p>Comparisons need to be made to evaluate whether the presence of a single large rock or void in the soil is producing unrepresentative values of density. Whenever values obtained are questionable, the test volume site should be excavated and visually examined.</p>
10.3 New Section	<p>Add as follows:</p> <p>All rounding shall be according to ASTM E 29.</p>
11.1.10 New Section	<p>Add as follows:</p> <p>Date of last instrument calibration or calibration verification.</p>
A1.1	<p>Revise the last sentence as follows:</p> <p>The gauge shall be calibrated at a minimum frequency of 12 months.</p>
A1.8	<p>Replace with the following:</p> <p>The calibration check shall provide proof of five-block calibration. Calibration standards shall consist of magnesium, aluminum, laminated magnesium/aluminum, granite, and limestone. A sixth calibration standard, utilized for moisture calibrations, shall consist of either laminated magnesium/polyethylene or aluminum/polyethylene. All calibration standards shall be traceable to the National Institute of Standards and Technology (N.I.S.T.). Proof shall consist of documented and dated calibration counts accompanied by copies of an invoice from the calibrating facility.</p>
A2.1	<p>Revise the last sentence as follows:</p> <p>The gauge shall be calibrated at a minimum frequency of 12 months.</p>

This Page Reserved

Illinois Modified Test Procedure
 Effective Date: May 1, 2007
 Revised Date: [December 1, 2021](#)

Standard Method of Test
 For
**Preparing and Determining the Density of Asphalt Mixture Specimens
 by Means of the Superpave Gyrotory Compactor**

Reference AASHTO T 312-19

AASHTO Section	Illinois Modification
2.1	Replace with the following: <i>Referenced Illinois modified AASHTO Standards:</i> <ul style="list-style-type: none"> ■ M 231, Weighing Devices Used in the Testing of Materials ■ R 30, Mixture Conditioning of Hot-Mix Asphalt (HMA) ■ R 35, Superpave Volumetric Design for Asphalt Mixtures ■ T 166, Bulk Specific Gravity of Compacted Asphalt Mixtures Using Saturated Surface-Dry Specimens ■ T 209, Theoretical Maximum Specific Gravity (G_{mm}) and Density of Asphalt Mixtures ■ R 76 Reducing Samples of Aggregate to Testing Size
2.3 New Section	<i>Referenced Illinois modified ASTM Standards:</i> <ul style="list-style-type: none"> ■ D1188, Bulk Specific Gravity and Density of Compacted Bituminous Mixtures Using Coated Samples
2.4 New Section	<i>Illinois Procedures:</i> <ul style="list-style-type: none"> ■ Illinois Procedure for Internal Angle Calibration of Superpave Gyrotory Compactors (SGCs) using the Dynamic Angle Validator (DAV-2)
4.1	Replace the fourth sentence with the following: The compactor shall tilt the specimen molds at an average internal angle of 1.16 ± 0.02 degrees ($20.2 \pm .035$ mrad) determined by the Illinois Procedure for Internal Angle Calibration of the Superpave Gyrotory Compactor using the Dynamic Angle Validator (DAV-2).
4.8	Add the following at the end: In addition, the hold-down clamps on the PINE AFG-2 compactor should be adjusted according to the manufacturer's instructions to minimize variability in the characteristics of the final compacted specimen.
4.9 New Section.	<i>Mold-loading Chute</i> —A mold-loading chute having a minimum length of 22 in. (560 mm) and a minimum capacity of 130 in. ³ (2,130 cm ³). It shall be capable of loading an entire gyrotory sample in one motion without spillage or segregation.

Illinois Modified Test Procedure
 Effective Date: May 1, 2007
 Revised Date: [December 1, 2021](#)

Standard Method of Test
 For
**Preparing and Determining the Density of Asphalt Mixtures Specimens
 by Means of the Superpave Gyrotory Compactor**

Reference AASHTO T 312-19

AASHTO Section	Illinois Modification
6.	Replace entire section with the following: <i>Calibration</i> —The gyrotory compactor internal angle shall be calibrated according to the “Illinois Procedure for Internal Angle Calibration of Superpave Gyrotory Compactors (SGCs) using the Dynamic Angle Validator (DAV-2)”. The ram pressure, height and rate of gyration shall be calibrated according to the manufacturer’s instructions and shall be completed prior to the internal angle calibration. The internal angle, ram pressure, height and rate of gyration shall be calibrated at a minimum frequency of once per month. The monthly internal angle calibration may be conducted utilizing the external angle verification as outlined in the “Illinois Procedure for Internal Angle Calibration of Superpave Gyrotory Compactors (SGCs) using the Dynamic Angle Validator (DAV-2)”.
8.1.2.1	Replace with the following: The mixing temperature for unmodified asphalt shall be 295 ± 5 °F (146 ± 3 °C). The mixing temperature for polymer-modified asphalt shall be 325 ± 5 °F (163 ± 3 °C).
8.1.2.1 NOTE 4	Delete.
8.1.4.1 New Section	When necessary, reduce the sample according to Illinois Test Procedure 248 and the following: Place the splitter on a level surface. The splitter and accessory equipment may be heated, not to exceed 110°C (230°F), as determined by a noncontact temperature device. Surfaces of the mechanical splitter that will come in contact with the HMA shall be lightly coated with an approved asphalt release agent to prevent a buildup and loss of asphalt binder and fines. The release agent shall not contain any solvents or petroleum-based products that could affect asphalt binder properties.
8.1.7.1	Revise as follows: The compaction temperature shall be 295 ± 5 °F (146 ± 3 °C) for unmodified binder; 305 ± 5 °F (152 ± 3 °C) for modified binder.

Illinois Modified Test Procedure
 Effective Date: May 1, 2007
 Revised Date: [December 1, 2021](#)

Standard Method of Test
 For
**Preparing and Determining the Density of Asphalt Mixture Specimens
 by Means of the Superpave Gyratory Compactor**

Reference AASHTO T 312-19

AASHTO Section	Illinois Modification
8.2.3	<p>Replace with the following:</p> <p>Reduce the sample according to IL modified AASHTO R 76 and the following:</p> <p>Place the splitter on a level surface. The splitter and accessory equipment may be heated, not to exceed 110°C (230°F), as determined by a noncontact temperature device. Surfaces of the mechanical splitter that will come in contact with the HMA shall be lightly coated with an approved asphalt release agent to prevent a buildup and loss of asphalt binder and fines. The release agent shall not contain any solvents or petroleum-based products that could affect asphalt binder properties.</p>
8.2.5	<p>Revise with the following:</p> <p>Bring the HMA to the compaction temperature range by careful, uniform heating in an oven set at the specified compaction temperature immediately prior to molding.</p>
9.2	<p>Revise the first sentence as follows:</p> <p>Place the mixture into the mold in one lift using the mold-loading chute.</p>
9.4	<p>Revise as follows:</p> <p>Apply a $1.16 \pm 0.02^\circ$ (20.2 ± 0.35 mrad) average internal angle to the mold assembly and begin the gyratory compaction.</p>
A1.1	<p>Replace the first sentence in paragraph 3 with:</p> <p>The inside diameter of the molds may be measured using either a two-point bore gauge, a three-point bore gauge, or a Coordinate Measuring Machine (CMM).</p>
Note A1	<p>Replace with:</p> <p>Because CMMs are typically limited to manufacturers, it is considered best practice for a lab to also use the two-point or the three-point bore method as a check before putting a mold into service.</p>

Standard Method of Test
 For
**Preparing and Determining the Density of Asphalt Mixture Specimens
 by Means of the Superpave Gyratory Compactor**

Reference AASHTO T 312-19

AASHTO Section	Illinois Modification
A1.2 New Section	Each district shall own and operate an Internal Bore Gauge. A Three-Point gauge is recommended although a Two-Point gauge is allowed. Care must be exercised during operation to ensure accuracy and precision regardless which gauge is selected.
A2.1	Replace the first sentence with the following: Internal Bore Gauge – Minimum resolution shall be 0.0025 mm (0.0001 in).
A4.1	Replace with the following: <i>Standardize the bore gauge</i> – The bore gauge shall be standardized with the master ring prior to each use.
A4.1.2	Replace the fifth sentence with the following: When using the three-point gauge, while extending the gauge contacts, use a small circular motion at the top of the gauge to align the contact tips with the master ring bore.
A4.1.2	Add the following at the end: Do not use the small circular motion when using a two-point gauge. Instead, position the two probes in the calibration ring so that they are horizontal. Then, while remaining horizontal, slightly move one of the probes from side to side to ensure that the maximum inside diameter is measured.
Figure A4.1 Heading	Replace with the following: Techniques for using the Two-Point Gauge (left) and Three-Point Bore Gauge (right) with the Calibrated Master Ring
Note A4	Replace with the following: The circular motion depicted in Figure A4.1, applied to the top of the three-point gauge while tightening the contact tips against the bore surface, is necessary to eliminate errors from misalignment.

Standard Method of Test
 For
**Preparing and Determining the Density of Asphalt Mixture Specimens
 by Means of the Superpave Gyrotory Compactor**

Reference AASHTO T 312-19

AASHTO Section	Illinois Modification
A4.3	<p>Replace from the third sentence of the second paragraph to the end of the section with the following: At each elevation, measurements designated as “A” shall have one of the gauge contacts aligned with the mark made in A3.3, measurements designated as “B” shall have the contact rotated from the mark 90 degrees for a Three-Point gauge or 120 degrees for a Two-Point gauge, and measurements designated as “C” shall have the contact rotated from the mark 180 degrees for a Three-Point gauge or 240 degrees for a Two-Point gauge.</p> <p>For best accuracy and consistency, each bore measurement should use the same firmness and technique applied in Section A4.1.2 for gauge standardization.</p>
A4.3.2	<p>Replace the first sentence with the following: Release the gauge; rotate it 90 degrees (Three-Point gauge) or 120 degrees (Two-Point gauge) and obtain the measurement in this orientation.</p>
A4.3.3	<p>Replace the first sentence with the following: Release the gauge and for a Three-Point gauge rotate it an additional 90 degrees (180 degrees from “1A”) or for a Two-Point gauge rotate it an additional 120 degrees (240 degrees from “1A”) and obtain a third measurement at the same elevation.</p>
A4.3.3 Note A5	<p>Replace the first sentence with the following: Figure A4.2 shows the Three-Point gauge in the mold positioned for each measurement.</p>

This Page Reserved

Illinois Modified Test Procedure
Effective Date: [December 1, 2021](#)

Standard Method of testing
For
Water Content of Freshly Mixed Concrete Using Microwave Oven Drying

Reference AASHTO T 318-15 (2019)

AASHTO Section	Illinois Modification
2.1	<p>Revise as follows: AASHTO M 231 Weighing Devices Used in the Testing of Materials AASHTO T 84 (Illinois Modified) AASHTO T 85 (Illinois Modified) AASHTO T 255 (Illinois Modified) AASHTO T 121 (Illinois Modified) AASHTO R 60 (Illinois Modified)</p> <p>To maintain brevity in the text, the following will apply: Example: AASHTO T 121 (Illinois Modified) will be designated as “T 121.”</p>
2.2	<p>Add as follows: ASTM E 29 (Illinois Modified) Standard Practice for Using Significant Digits In Test Data to Determine Conformance with Specifications</p> <p>To maintain brevity in the text, the following will apply: Example: ASTM E 29 (Illinois Modified) will be designated as “ASTM E 29.”</p>
3.1	<p>Replace as follows: A test specimen of freshly mixed concrete is dried in a microwave oven using a minimum of three intervals. The water content of the test specimen is calculated based on loss in mass of the test specimen at completion of the test. Total drying time is usually less than 20 minutes.</p>
5.1	<p>Revise as follows: Delete the phrase: “a turntable”.</p>
5.2	<p>Replace as follows: Ceramic Tray – A 1.89 liter (2 quart) ceramic tray with a clean cloth to cover the specimen.</p>
5.5 & 6.1	<p>Delete these sections</p>
8.3	<p>Revise as follows: Replace “1500 g” with “1500 ± 100 g”.</p>
9.1	<p>Revise as follows: Replace “fiberglass cloth” with “clean cloth” and “1500 g” with “1500 ± 100 g”.</p>

Standard Method of testing
 For
Water Content of Freshly Mixed Concrete Using Microwave Oven Drying

(continued)
 Reference AASHTO T 318-15 (2019)

AASHTO Section	Illinois Modification
9.2	Replace as follows: Place the clean cloth on the heat-resistant ceramic tray with the cloth uniformly overhanging the outside edges of the tray.
9.3	Replace as follows: Determine the mass of the tray, and clean cloth together (WS). Make this mass determination, and all subsequent mass determinations to the nearest 0.1 gram.
9.4	Replace as follows: Leave the tray and clean cloth on the balance. Record the tare weight. Place the 1500 ± 100 gram test specimen in the ceramic tray, and cover with the clean cloth.
9.5	Replace as follows: Determine the mass of the tray, clean cloth, and freshly mixed concrete test specimen together (WF).
9.6	Replace as follows: Place the covered tray, with the test specimen, in the microwave oven. Dry the test specimen for a period of 5.0 ± 0.5 minutes, at the 900 W power setting.
9.7	Replace as follows: At the end of the first drying period, remove the tray, clean cloth, and test specimen from the microwave oven. Take off the clean cloth, and be careful of the hot steam. With the edge of the scraper, break the mass of concrete until the coarse aggregate is separated from the mortar.
9.8	Replace as follows: Place the covered tray, with the test specimen, in the microwave oven, and dry it for 5.0 ± 0.5 minutes at the 900 W power setting.
9.9	Replace as follows: At the end of the second drying period, remove the tray, clean cloth, and test specimen from the microwave oven. Take off the clean cloth, and be careful of the hot steam. Stir the test specimen with the scraper, and determine the mass of the tray, clean cloth, and specimen together.

Standard Method of testing
 For
Water Content of Freshly Mixed Concrete Using Microwave Oven Drying

(continued)
 Reference AASHTO T 318-15 (2019)

AASHTO Section	Illinois Modification
9.10	Replace as follows: Place the covered tray, with the test specimen, in the microwave oven, and dry it for 2.0 ± 0.5 minutes at the 900 W power setting.
9.11	Replace as follows: Remove the tray, clean cloth, and test specimen from the microwave oven. Determine the mass of the tray, clean cloth, and specimen together. If the change in mass is 1 g or more, repeat the 2 minute drying period until the change in mass is less than 1 g. Record the mass of the tray, clean cloth, and dry test specimen together (WD).
10.1.2	Revise as follows: Replace “cloth” with “clean cloth.”
10.4 New Section	<p>Water/Cement Ratio – Calculate the water cement ratio as follows:</p> $WCR = \frac{WT - \{[FA \times (FAA/100)] + [CA \times (CAA/100)]\}}{C}$ <p>Where:</p> <p>WCR = Water/Cement Ratio.</p> <p>WT = Total water content, kg/m³ (lb/yd³).</p> <p>FA = Fine aggregate [oven dry mass (weight)/volume], kg/m³ (lb/yd³), calculated from batch ticket or from mix design.</p> <p>CA = Coarse aggregate [oven dry mass (weight)/volume], kg/m³ (lb/yd³), calculated from batch ticket or from mix design.</p> <p>FAA = Fine aggregate absorption, percent.</p> <p>CAA = Coarse aggregate absorption, percent.</p> <p>C = Cement plus cementitious material, kg/m³ (lb/yd³), Calculated from batch ticket or from mix design.</p> <p>Note: The definition for water/cement ratio shall be according to the Standard Specifications for Road and Bridge Construction.</p>

Illinois Modified Test Procedure
Effective Date: December 1, 2021

Standard Method of testing
For
Water Content of Freshly Mixed Concrete Using Microwave Oven Drying

(continued)
Reference AASHTO T 318-15 (2019)

AASHTO Section	Illinois Modification
10.4 New Section (cont.)	<p>Procedure to Determine FA and CA from Batch Ticket:</p> <p><u>Example For Fine Aggregate</u></p> <p>Batch Size, From Ticket (A) = 6 m³ (8 yd³) Total Mass of FA Batched, From Ticket (B) = 4,390 kg (9,680 lbs) FA Total (free and absorbed) Moisture Content (C) = 5.4%</p> $FA = \frac{B/A}{1 + (C/100)} = \frac{4,390 \text{ kg}/6 \text{ m}^3}{1 + (5.4/100)} = 694 \text{ kg/m}^3 \text{ (metric)}$ $FA = \frac{B/A}{1 + (C/100)} = \frac{9,680 \text{ lbs}/8 \text{ yd}^3}{1 + (5.4/100)} = 1,148 \text{ lbs/yd}^3 \text{ (English)}$ <p><u>Example for Coarse Aggregate</u></p> <p>Batch Size, From Ticket (A) = 6 m³ (8 yd³) Total Mass of CA Batched, From Ticket (B) = 6,985 kg (15,400 lbs) CA Total (free and absorbed) Moisture Content (C) = 2.9%</p> $CA = \frac{B/A}{1 + (C/100)} = \frac{6,985 \text{ kg}/6 \text{ m}^3}{1 + (2.9/100)} = 1,131 \text{ kg/m}^3 \text{ (metric)}$ $CA = \frac{B/A}{1 + (C/100)} = \frac{15,400 \text{ lbs}/8 \text{ yd}^3}{1 + (2.9/100)} = 1,871 \text{ lbs/yd}^3 \text{ (English)}$
	<p>Procedure to Determine FA and CA from Mix Design:</p> <p><u>Example For Fine Aggregate</u></p> <p>Saturated Surface-Dry Mass per Volume for FA (A) = 673 kg/ m³ (1,134 lbs/yd³) FA Absorption (B) = 1.5%</p> $FA = \frac{A}{1 + (B/100)} = \frac{673 \text{ kg/m}^3}{1 + (1.5/100)} = 663 \text{ kg/m}^3 \text{ (metric)}$ $FA = \frac{A}{1 + (B/100)} = \frac{1,134 \text{ lbs/yd}^3}{1 + (1.5/100)} = 1,117 \text{ lbs/yd}^3 \text{ (English)}$ <p><u>Example For Coarse Aggregate</u></p> <p>Saturated Surface-Dry Mass per Volume for CA (A) = 1,140 kg/m³ (1,922 lbs/yd³) CA Absorption (B) = 1.2 %</p> $CA = \frac{A}{1 + (B/100)} = \frac{1,140 \text{ kg/m}^3}{1 + (1.2/100)} = 1,126 \text{ kg/m}^3 \text{ (metric)}$ $CA = \frac{A}{1 + (B/100)} = \frac{1,922 \text{ lbs/yd}^3}{1 + (1.2/100)} = 1,899 \text{ lbs/yd}^3 \text{ (English)}$

Illinois Modified Test Procedure
Effective Date: [December 1, 2021](#)

Standard Method of testing
For
Water Content of Freshly Mixed Concrete Using Microwave Oven Drying

(continued)
Reference AASHTO T 318-15 (2019)

AASHTO Section	Illinois Modification
10.5 New Section	All Rounding shall be according to ASTM E 29.
11.1.3	Replace as follows: Total water content, nearest 1 kg/m ³ (1 lb/yd ³).
11.1.4 New Section	Water/cement ratio, nearest 0.01.

This Page Reserved

Standard Method of Test
 for
Hamburg Wheel-Track Testing of Compacted Hot Mix Asphalt (HMA)

Reference AASHTO T 324-19

AASHTO Section	Illinois Modification
1.2	Revise the last sentence as follows: Alternatively, field cores with a diameter of 150 mm (5.91 in.), 255 mm (10 in.), 300 mm (12 in.), or saw-cut slab specimens may be tested.
2.1	Revise the individual AASHTO Standards with the appropriate Illinois modified AASHTO Standards: <ul style="list-style-type: none"> ▪ R 30, Mixture Conditioning of Hot Mix Asphalt (HMA) ▪ T 166, Bulk Specific Gravity of Compacted Hot Mix Asphalt (HMA) Using Saturated Surface-Dry Specimens ▪ T 209, Theoretical Maximum Specific Gravity (G_{mm}) and Density of Asphalt Mixtures ▪ T 312, Preparing and Determining the Density of Hot Mix Asphalt (HMA) Specimens by Means of the Superpave Gyrotory Compactor
2.1	Delete: T 168
2.1	Illinois Manual of Test Procedures: <ul style="list-style-type: none"> ▪ Appendix B6, Hot-Mix Asphalt QC/QA Initial Daily Plant and Random Samples ▪ Appendix B7, Hot-Mix Asphalt QC/QA Procedure for Determining Random Density Locations ▪ Appendix E3, PFP and QCP Random Density Procedure ▪ Appendix E4, PFP and QCP Hot Mix Asphalt Random Jobsite Sampling
4.1	Revise the second sentence as follows: The specimen is submerged in a temperature-controlled water bath at $50 \pm 1.0^{\circ}\text{C}$ ($122 \pm 1.8^{\circ}\text{F}$).
5.1	Delete the first sentence of the last paragraph:
Note 1	Revise as follows: Reference the NCHRP Report of available devices in the market meeting the relevant requirements as proposed in the NCHRP Report to verify the sinusoidal wave requirement of the Hamburg wheel tracking device.
5.2.1	Delete the second and third sentences:
Note 2	Delete

Illinois Modified Test Procedure
 Effective Date: June 1, 2012
 Revised Date: [December 1, 2021](#)

Standard Method of Test
 for
Hamburg Wheel-Track Testing of Compacted Hot Mix Asphalt (HMA)
 (continued)
 Reference AASHTO T 324-19

AASHTO Section	Illinois Modification
6.1	Replace Section 6.1 with the following: <i>Number of Test Specimens</i> – A single slab specimen, two 150 mm (5.91 in.) diameter gyratory compacted specimens, or field cores according to Section 6.4 will be tested under each wheel in the Hamburg Wheel Tester. A test is currently defined as HMA specimens being tested using two wheels. However, if the District has sufficient experience with how their mixtures perform in the Hamburg Wheel Tester, a test may be conducted using a single wheel, at the discretion of the District.
6.2.2	Replace with the following: The mixing temperature shall be according to IL Modified AASHTO T 312.
6.2.4	Replace with the following: Laboratory mixed test samples shall be conditioned at the appropriate compaction temperature according to the short-term conditioning procedure in IL Modified AASHTO R 30.
6.2.5	Replace with the following: The compaction temperature shall be according to IL Modified AASHTO T 312.
6.2.6.2	Replace with the following: <i>Compacting SGC Cylindrical Specimens</i> --Material shall be compacted into specimens using an SGC according to IL Modified AASHTO T 312. Compact three 160 mm tall gyratory cylinders to an air void level of 7.5 ± 0.5 %. If I-FIT long-term aging is conducted compact four 160 mm tall gyratory cylinders. Cut a 62 ± 2 mm disc from both the top and bottom of two of the 160 mm tall gyratory cylinders (for a total of four individual Hamburg Wheel test specimens). Position each of the test specimens so that the wheel is run on the as-compacted face. The I-FIT specimens are cut from the middle of the third and fourth gyratory cylinders. If the lab is not capable of compacting 160 mm tall gyratory cylinders, then compact two 115 mm tall gyratory cylinders instead of each 160 mm tall cylinder.
6.3.1	Replace with: Obtain field-mixed asphalt mixture sample in accordance with Appendix B.6 or E.4 of sufficient size to determine G_{mm} and make the 160 mm tall gyratory cylinders required in Section 6.2.6.2. Appendix B.6 shall be used in QC/QA applications and Appendix E.4 shall be used in QCP or PFP applications.

Illinois Modified Test Procedure
 Effective Date: June 1, 2012
 Revised Date: [December 1, 2021](#)

Standard Method of Test
 for
Hamburg Wheel-Track Testing of Compacted Hot Mix Asphalt (HMA)
 (continued)
 Reference AASHTO T 324-19

AASHTO Section	Illinois Modification
6.4.1	<p>Replace sentence one with the following: <i>Cutting Field Cores or Field Slab Specimens</i>—Field cores or field slab specimens may be taken from compacted HMA pavements according to Appendix B7 and Appendix E3. Appendix B.7 shall be used in QC/QA applications and Appendix E.3 shall be used in QCP or PFP applications.</p> <p>Replace sentence five with the following: The height of a field core specimen may need to be adjusted to fit the specimen mounting system.</p>
Note 3	<p>Renumber Note 3 to be Note 2, and Replace the second sentence with the following: In order for the total sample height to be 62±2 mm (2.4±0.1 in.), the sample must be trimmed with a wet saw if it is too tall. If the sample is too short then it must be shimmed up with Plaster of Paris (or equivalent).</p>
Note 4	Renumber Note 4 to be Note 3.
7.3	<p>Replace the second sentence with the following: Refer to Sections 6.2.6.2 and 6.3.1 for air void requirements for SCG compacted cylinders and prepared test specimens.</p>
Note 5	Renumber Note 5 to be Note 4.
8.6.1	<p>Replace with the following: <i>Test Temperature</i>—The test temperature shall be 50±1°C (122±1.8°F).</p>
8.6.2	<p>Replace with the following: <i>Maximum Rut Depth</i>—The maximum allowable rut depth shall be less than or equal to 12.5 mm (0.5 in.). When setting the machine up for testing, the maximum rut depth should be set at a value greater than 12.5 mm (16.0 mm suggested) to avoid a premature end of the test caused by temporary rut depth spikes.</p>

Standard Method of Test
 for
Hamburg Wheel-Track Testing of Compacted Hot Mix Asphalt (HMA)
 (continued)
 Reference AASHTO T 324-19

AASHTO Section	Illinois Modification
8.6.3	<p>Add the following:</p> <p><i>Selecting the Number of Wheel Passes</i>-The minimum number of wheel passes at the 0.5 in. (12.5 mm) rut depth criteria shall be selected based upon the PG Grade high temperature of the asphalt binder as specified in the mix requirements table of the plans.</p> <ul style="list-style-type: none"> • PG 58-xx or lower 5,000 wheel passes • PG 64-xx 7,500 wheel passes • PG 70-xx 15,000 wheel passes • PG 76-xx or higher 20,000 wheel passes <p>When IL 4.75 mm mixes are tested, the minimum number of wheel passes for PG 76-xx are 15,000 and the minimum number of wheel passes for PG 70-xx are 10,000.</p> <p>It may be useful to run every test for 20,000 wheel passes to collect additional data on moisture sensitivity.</p>
8.6.4	<p>Replace the first sentence with the following: Enter a start delay of 30 min to precondition the test specimens.</p>
Note 6	<p>Renumber Note 6 to be Note 5.</p>
Note 7	<p>Renumber Note 7 to be Note 6.</p>
Note 8	<p>Renumber Note 8 to be Note 7.</p>
8.8.4	<p>Replace with the following: Each wheel on the wheel-tracking device shall shut off independent of the other wheel. The end of a test for each wheel can occur when the specified number of wheel passes listed in Section 8.6.3 or the number of passes otherwise specified has occurred on that wheel. Further, each wheel on the device shall be set to lift independently when the LDT displacement is 16.0 mm (0.63 in.) for that wheel. The HWTD measures the rut depth at multiple points per pass across the specimen. The maximum rut depth is defined as the average rut depth of the point with the deepest rut depth and the rut depth of the two points physically closest to it. The testing device software automatically saves the test data file for each wheel.</p>

Illinois Modified Test Procedure
 Effective Date: June 1, 2012
 Revised Date: December 1, 2021

Standard Method of Test
 for
Hamburg Wheel-Track Testing of Compacted Hot Mix Asphalt (HMA)
 (continued)
 Reference AASHTO T 324-19

AASHTO Section	Illinois Modification
8.8.4.1 New Section	<p>Add the following: If the test was conducted using two wheels, the two wheels should have an average rut depth less than or equal to 12.5 mm at the prescribed number of passes in section 8.6.3. The test result is reported as the average of the two rut depths. A test is considered as failing if the average rut depth exceeds 12.5 mm at, or less than, the prescribed number of passes. If one wheel exceeds the 12.5 mm rut depth at, or less than, the prescribed number of passes, the maximum rut depth difference between the two wheels at failure shall be 6.25 mm. An additional test will be completed to replace the original if the maximum rut depth difference is exceeded.</p> <p>If the test was conducted using a single wheel, a passing test from that wheel shall have a rut depth less than or equal to 12.5 mm at the prescribed number of passes in section 8.6.3.</p>
Note 9	Renumber Note 9 to be Note 8.
8.9.2	Replace the first sentence with the following: Precondition the test specimens in the water bath for 30 min after the water has reached the selected test temperature.
8.9.3	Replace the first sentence with the following: Lower the wheels onto the specimens after the test specimens have preconditioned at the selected test temperature for 30 min.
9.1	Delete
9.2	Delete the first sentence.
9.2	Revise the last sentence in the first paragraph to read: From this plot, the following values may be obtained:
9.3	Revise the first sentence to read: The following test parameters may be calculated, all expressed in "Passes."

Illinois Modified Test Procedure
Effective Date: June 1, 2012
Revised Date: [December 1, 2021](#)

Standard Method of Test
for
Hamburg Wheel-Track Testing of Compacted Hot Mix Asphalt (HMA)
(continued)
Reference AASHTO T 324-19

AASHTO Section	Illinois Modification
Note 10	Delete
X1.1	Replace with the following: Follow the manufacturer's recommendations for lubrication and cleaning.
X2.5	Delete
X2.6	Delete
Table X1.1	Delete
Figure X1.1	Delete

Illinois Modified Test Procedure
Effective Date: [December 1, 2021](#)

Standard Method of Test
for
**Estimating the Strength of Concrete in
Transportation Construction by Maturity Tests**

Reference AASHTO T 325-04 (2020)

AASHTO Section	Illinois Modification
2.1	<p>Add as follows: AASHTO T 22 (Illinois Modified) AASHTO R 100 (Illinois Modified) (formerly AASHTO T 23) AASHTO T 177 (Illinois Modified)</p> <p>To maintain brevity in the text, the following will apply: Example: AASHTO T 22 (Illinois Modified) will be designated as “T 22.”</p>
2.2	<p>Revise as follows: ASTM C 1074 (Illinois Modified)</p> <p>To maintain brevity in the text, the following will apply: Example: ASTM C 1074 (Illinois Modified) will be designated as “ASTM C 1074.”</p>
4.1	<p>Replace as follows: This standard can be used to estimate the in-place strength of concrete pavement patches and bridge deck patches. These estimates provide guidance useful in making decisions concerning opening to traffic.</p>
5.1.2	<p>Revise as follows: Temperature sensors suitable for embedment within ± 0.5 in. (± 15 mm) of mid-depth and in the center of a concrete strength test specimen. Also required shall be a device suitable for monitoring and recording the temperature.</p>
Section 7.	<p>Replace the section with the following: <i>Pavement Patching or Bridge Deck Patching</i>— A lot shall be 167 m² (200 yd²), and one probe/sensor shall be installed in the last poured patch of a lot.</p>
9.1	<p>Revise as follows: Verify the calibration of systems used for monitoring the maturity of concrete per the manufacturer’s recommendation, but no longer than 10 calendar days when in use.</p>
9.2 New Section	<p><i>Validation of Strength-Maturity Relationship</i>—The strength-maturity relationship determined in Section 10.1 shall be validated monthly. Immediate validation of shall be required when 1) material sources change, 2) mix proportions change by more than ± 5 percent, 3) admixture dosage(s) change by more than ± 20 percent, 4) concrete temperature changes by more than ± 2 °C (± 3 °F), 5) water-cement ratio changes by more than ± 0.02, 4) batching and/or mixing procedure changes, and 6) significant equipment changes as determined by the Engineer.</p>

Illinois Modified Test Procedure
Effective Date: [December 1, 2021](#)

Standard Method of Test
for
**Estimating the Strength of Concrete in
Transportation Construction by Maturity Tests**
(continued)
Reference AASHTO T 325-04 (2020)

AASHTO Section	Illinois Modification
9.2 New Section continued	<p>Validation of the strength-maturity relationship shall be according to the following:</p> <ul style="list-style-type: none"> • A minimum of 2 strength test specimens and 1 test specimen for the probe/sensor shall be molded and cured according to T 23, except that specimens shall be cured for the first 24 hours in the same temperature conditions experienced in the field. Specimens shall be protected from disturbance, direct sunlight, and wind. • Once the desired maturity index is achieved, perform 2 strength tests according to T 22 or T 177. • Compare the average strength of the test specimens to that predicted by the strength-maturity relationship. If the average strength is within ± 10 percent or ± 200 psi (± 1380 kPa) compressive or ± 50 psi (± 550 kPa) flexural, whichever is smaller, of the predicted strength, the strength-maturity relationship shall be considered validated. • The Engineer reserves the right to verify the Contractor's strength tests. If the difference between the Engineer's and the Contractor's split sample strength test results does exceeds 6200 kPa (900 psi) compressive strength or 620 kPa (90 psi) flexural strength, the Contractor's test will be considered invalid, which will invalidate the strength-maturity relationship. • Strength specimens (beams or cylinders) shall be used during the interim if the maturity relationship is invalid and has to be re-established.
10.1	<p>Add as follows: The Arrhenius function shall be used, and the Contractor shall provide a current copy of ASTM C 1074 to the Engineer if requested.</p> <p>Delete Note 6.</p>
10.2.2	<p>Replace as follows: For pavement patching or bridge deck patching, place the probe/sensor 0.5 m (1.5 ft) from the edge of the repair and within ± 0.5 in. (± 15 mm) of mid-depth.</p>

Illinois Modified Test Procedure
Effective Date: December 1, 2019

Standard Method of Test
for
Evaluation of Asphalt Release Agents (ARAs)

Reference AASHTO T 383-18

AASHTO Section	Illinois Modification
1.1	Delete first sentence.
2.1.	Add the following: <ul style="list-style-type: none"> ▪ R 79, Vacuum Drying Compacted Asphalt Specimens (a.k.a. Core-Dry)
2.3.	Add the following: <ul style="list-style-type: none"> ▪ "Illinois Specification 101, Minimum Requirements for Electronic Balances ▪ AASHTO M 92 (Illinois Modified), Wire Cloth Sieves for Testing Purposes. ▪ ASTM E 29 (Illinois Modified), Standard Practice for Using Significant Digits in Test Data to Determine Conformance with Specifications ▪ Illinois Test Procedure 601, ATIR-FTIR Spectroscopy and Comparison Method."
3	Revise Section 3 as follows: <p>3.1. "In the Asphalt Stripping Test, evaluation of asphalt release agents is based on the percent mass loss or gain of a sample of hot-mix asphalt (HMA) after it has been immersed in undiluted release agent and agitated for 20 minutes in an ultrasonic cleaner, drained/rinsed with room temperature water and dried back to a constant mass. Constant mass shall be defined as the mass at which further drying at 52 ± 3 °C (125 ± 5 °F) for 2 hours, or at 110 ± 5 °C (230 ± 9 °F) for 1 hour, does not alter the mass more than 0.5 gram. All Rounding shall be according to ASTM E 29 (Illinois Modified)."</p> <p>3.1.1. Delete</p> <p>3.1.2. Delete</p> <p>3.1.3. Delete</p> <p>3.2. "Refer to Illinois Test Procedure 601, ATIR-FTIR Spectroscopy and Comparison Method."</p>
4	Revise Section 4 as follows: <p>4.1 Revise the second sentence to read: "The agent is evaluated in its concentrated, non-diluted form."</p> <p>4.2. Delete</p> <p>4.3. Delete</p> <p>4.5. Delete and replace with the following: "Refer to Illinois Test Procedure 601, ATIR-FTIR Spectroscopy and Comparison Method."</p>

Illinois Modified Test Procedure
Effective Date: December 1, 2019

Standard Method of Test
for
Evaluation of Asphalt Release Agents (ARAs)

Reference AASHTO T 383-18

AASHTO Section	Illinois Modification
5	<p>Replace Section 5 ASPHALT STRIPPING TEST with the following: “ASPHALT ULTRASONIC STRIP TEST</p> <p>5.1. <i>Equipment:</i></p> <p>5.1.1. Containers - three (3) 600 ml glass beakers;</p> <p>5.1.2. Ultrasonic Cleaner;</p> <p>5.1.3. Oven or Core-Dry. The oven shall be capable of maintaining 230 ± 9 °F (110 ± 5 °C) for 24 hours during testing;</p> <p>5.1.4. Sieve. No. 200 (μm 75) sieve of minimum diameter 12 in. (300 mm) manufactured according to M 92 and;</p> <p>5.1.5. Balance or Scale. The balance or scale shall conform to AASHTO M 231 and Illinois Specification 101. Refer to the requirements for coarse aggregate CA/CM 6 through 19.</p> <p>5.2. <i>Materials:</i></p> <p>5.2.1. Hot-Mix Asphalt (HMA). A 300 ± 5 g sample of HMA having nominal maximum aggregate size of 3/8 in. (9.5 mm).</p> <p>5.2.2. Asphalt Release Agent. A 1 gallon or (4 quarts) sample of concentrated asphalt release agent submitted per the Department’s Asphalt Release Agent Submittal for Testing and Approval.</p> <p>5.3. <i>Procedure:</i></p> <p>5.3.1. Heat HMA Sample in oven at 295 ± 5 °F (146 ± 3 °C) for 10 minutes.</p> <p>5.3.2. Place a heated HMA sample (300 ± 5 g) in each of the three (3) glass beakers, and record the mass of each to the nearest 0.1 g.</p> <p>5.3.3. Pour the sample of the concentrated asphalt release agent into each of the three (3) beakers completely immersing the HMA to the 400 ml mark on each beaker, place each beaker in an ultrasonic cleaner, and agitate for 20 minutes. Note any color change or darkening of the liquid, which would indicate stripping of the asphalt.</p>

Standard Method of Test
 for
Evaluation of Asphalt Release Agents (ARAs)

Reference AASHTO T 383-18

AASHTO Section	Illinois Modification
5 (cont'd)	<p>Replace Section 5 ASPHALT STRIPPING TEST with the following: “ASPHALT ULTRASONIC STRIP TEST</p> <p>5.3.4. Remove the beakers from the ultrasonic cleaner. Drain the release agent from the beakers, and with room temperature water, rinse each HMA sample thoroughly over a No. 200 (75 µm) sieve until all release agent is removed and clear water is present.</p> <p>5.3.5. Place the beakers containing the HMA sample in an oven at 230 ± 9 °F (110 ± 5 °C) for 24 hours until constant mass has been achieved or use the Core-Dry and dry HMA sample back to constant mass (ensure by running the samples one additional cycle once constant mass has been reached). Once constant mass has been achieved, record the mass of each sample to the nearest 0.1 g.</p> <p>5.4. <i>Calculations:</i></p> <p>5.4.1. Calculate the percent loss or gain of the initial sample mass for each of the three samples as follows:</p> $\Delta W = \left(\frac{W_i - W_f}{W_i} \right) \times 100$ <p>Where: ΔW is the percent change in the HMA sample mass in percent, W_i is the initial mass of the HMA sample to the nearest 0.1 g, and W_f is the final mass of the HMA sample after dry back to the nearest 0.1 g</p> <p>5.5. <i>Evaluation:</i></p> <p>5.5.1. Any change in color of liquid, visual stripping of asphalt, or mass loss/gain greater than 0.10 % shall be reason for rejection.</p> <p>5.5.2. After evaluation and approval, the asphalt release sample will be fingerprinted by infrared analysis using Fourier Transform Infrared (FTIR) spectroscopy. Refer to Illinois Test Procedure 601, ATIR-FTIR Spectroscopy and Comparison Method.”</p>

Illinois Modified Test Procedure
Effective Date: December 1, 2019

Standard Method of Test
for
Evaluation of Asphalt Release Agents (ARAs)

Reference AASHTO T 383-18

AASHTO Section	Illinois Modification
6	Delete: Section 6 MIXTURE SLIDE TEST
7	Delete: Section 7 ASPHALT PERFORMANCE TEST
8.1	Revise as follows: 8.1. Refer to Illinois Test Procedure 601, ATIR-FTIR Spectroscopy and Comparison Method.”
9	Revise Section 9 as follows: 9.1.1. Replace with the following: “Asphalt stripping observed for each sample and ΔW and percent change in weight for each sample tested from the Asphalt Ultrasonic Strip Test.” 9.1.2. Delete 9.1.3. Delete 9.1.4. Delete 9.1.5. Delete and replace with the following: Refer to Illinois Test Procedure 601, ATIR-FTIR Spectroscopy and Comparison Method. 9.1.6. Delete 9.1.7. Delete

Illinois Modified Test Procedure
 Effective Date: December 1, 2018
 Revised Date: [December 1, 2021](#)

Standard Method of Test
 for
Determining the Fracture Potential of Asphalt Mixtures Using the Illinois Flexibility Index Test (I-FIT)

Reference AASHTO T [393-21](#)

Note: Illinois Modified AASHTO T [393](#) replaces all references to [AASHTO TP 124](#).

AASHTO Section	Illinois Modification
2.1	Replace the individual AASHTO Standards with the appropriate Illinois modified AASHTO Standards:
2.1	Delete: R 67
2.1	Add reference to: <ul style="list-style-type: none"> ▪ Appendix B.7, Hot-Mix Asphalt QC/QA Procedure for Determining Random Density Locations ▪ Appendix E.3, PFP and QCP Random Density Procedure
9.1.1	Replace with the following: <i>SGC Specimens</i> —Prepare one laboratory SGC cylinder in the SGC according to T 312 with the compaction height of 160 mm ± 1 mm. Compact two 160 ± 1 mm tall SGC cylinders if long-term aging is to be conducted. Determine the bulk specific gravity (G_{mb}) and air voids of the SGC cylinder according to T 166 and T 269, respectively. The air voids of the 160 ± 1 mm tall SGC cylinders shall be 7.5 ± 0.5%. From the middle of each 160 mm ± 1 mm tall specimen, obtain two cylindrical 50 ± 1 mm thick discs with smooth, parallel faces by saw cutting each face (see Figure 4). Cut each disc into two dimensionally equivalent halves resulting in four individual I-FIT specimens from each 160 ± 1 mm tall SGC cylinder. A minimum of three individual test specimens are required for one I-FIT test.
Note 4	Replace with the following: The height of the gyratory compacted cylinders should be 160 ± 1 mm and contain 7.5 ± 0.5 percent air voids. If a lab does not have the capability to compact 160 ± 1 mm tall gyratory cylinders, then two 115 ± 1 mm tall gyratory cylinders with 7.5 ± 0.5 percent air voids may be compacted and used instead to replace each 160 ± 1 mm tall gyratory cylinder. A 50 ± 1 mm thick disc will be cut from the middle of each 115 mm tall gyratory cylinder, which will result in four individual I-FIT specimens (see Figure 4). Although the required air voids are determined from the SGC cylinders, it is also required to continue to determine the air voids on the individual semi-circular I-FIT test specimens to identify if 7.5 ± 0.5% air voids on the SGC cylinders is appropriate to produce individual semi-circular test specimens with 7.0 ± 1.0% air voids.

Illinois Modified Test Procedure
 Effective Date: December 1, 2018
 Revised Date: [December 1, 2021](#)

Standard Method of Test
 for
Determining the Fracture Potential of Asphalt Mixtures Using the Illinois Flexibility Index Test (I-FIT)

Reference AASHTO T [393-21](#)

Note: Illinois Modified AASHTO T [393](#) replaces all references to [AASHTO TP 124](#).

AASHTO Section	Illinois Modification
9.1.2	Replace the first sentence with the following: Obtain pavement cores in accordance with Appendix B.7 or Appendix E.3. Appendix B.7 shall be used in QC/QA applications and Appendix E.3 shall be used in QCP or PFP applications.
10.1	Replace with the following: Perform a long-term aging procedure on I-FIT specimens as defined in Section 7.3 of IL modified AASHTO R 30.
Note 6	Delete
12.1	Re-number Note 7 to be Note 6.
12.2	Re-number Note 8 to be Note 7.
12.7 New Section	When four individual I-FIT specimens that are within specification are tested, the Flexibility Index value that is farthest from the average of the four test specimens shall be discarded as an outlier to lower the variability of the average Flexibility Index value that is reported. The test specimen that is discarded as an outlier shall be removed from the calculations of average and COV for peak load, post-peak slope, fracture energy, and Flexibility Index.
12.8 New Section	When three individual I-FIT specimens are tested, all three specimens will be included in the average and COV for peak load, post-peak slope, fracture energy, and flexibility index.

Illinois Modified Test Procedure
 Effective Date: December 1, 2018
 Revised Date: [December 1, 2021](#)

Standard Method of Test
 for
Determining the Fracture Potential of Asphalt Mixtures Using the Illinois Flexibility Index Test (I-FIT)

Reference AASHTO T [393-21](#)

Note: Illinois Modified AASHTO T [393](#) replaces all references to [AASHTO TP 124](#).

AASHTO Section	Illinois Modification
14.1.7	Delete
14.1.8	Delete
14.1.9	Delete
Appendix X1.4.1.4.5	Replace Equation X1.10b with the following: $FI = \frac{G_f}{ m } \times A$
Appendix X2	Delete

This Page Reserved

Illinois Modified Test Procedure
 Effective Date: March 1, 2007
 Revised Date: [December 1, 2021](#)

Standard Specification
 for
Superpave Volumetric Mix Design

Reference AASHTO M 323-17 ([2021](#))¹

AASHTO Section	Illinois Modification
All Sections	Replace all references to AASHTO Standards with the appropriate Illinois Modified AASHTO Standard, except as noted below.
2.1	Delete reference to AASHTO T 176 and AASHTO T 304
2.2	Delete
3.4	Replace with the following: Dust to Binder Ratio ($P_{0.075} / P_b$)—By mass, the ratio between percent of aggregate passing the 75- μm (No. 200) sieve ($P_{0.075}$) and total asphalt content (P_b).
3.10	Replace with the following: Percent Asphalt Binder Replacement (ABR) – reclaimed asphalt binder that replaces virgin binder in asphalt mixtures
5.1	Replace with the following: The asphalt binder will be specified in the plans of each contract.
5.1.1	Delete
5.1.2	Delete
Note 2	Delete
5.1.3	Delete
5.2	Delete
Table 1 and all footnotes	Delete

Standard Specification
 for
Superpave Volumetric Mix Design

Reference AASHTO M 323-17 [\(2021\)](#)¹

AASHTO Section	Illinois Modification
Note 3	Delete
5.3	<p>Replace with the following: If RAP and / or recycled asphalt shingles (RAS) is to be used in the mixture, the amount shall be determined according to percent asphalt binder replacement (ABR). ABR is reclaimed asphalt binder that replaces virgin binder in asphalt mixtures. The percent ABR is determined by the ratio of reclaimed binder to the total binder in the mixture. The maximum allowable percent ABR is specified in Article 1031.06 of the BDE "Special Provision for Reclaimed Asphalt Pavement (RAP) and Reclaimed Asphalt Shingles (RAS)."</p> <p>If the RAP / RAS Asphalt Binder Replacement (ABR) exceeds 20 percent, the high and low virgin asphalt binder grades shall each be reduced by one grade (i.e. 25 percent ABR would require that a virgin asphalt binder grade of PG64-22 be reduced to a PG58-28).</p>
5.3.1	Delete
Note 4	Delete
Table 2	Delete
5.3.2	Delete
Table 3	Delete
Equation 1	Delete
6.1.1	<p>Replace with the following: Nominal Maximum Size—The combined aggregate shall have a nominal maximum aggregate size of 4.75 to 9.5 mm for level binder, 9.5 to 12.5 mm for surface course HMA and less than or equal to 25.0 mm for subsurface (base and binder) course HMA.</p>
Note 5	Delete

Illinois Modified Test Procedure
 Effective Date: March 1, 2007
 Revised Date: [December 1, 2021](#)

Standard Specification
 for
Superpave Volumetric Mix Design

Reference AASHTO M 323-17 ([2021](#))¹

AASHTO Section	Illinois Modification
6.1.2	Replace with the following: Mixture gradations shall be as specified in Article 1030.05(a) of the Illinois Department of Transportation Standard Specifications for Road and Bridge Construction.
6.1.2.1 New Section	Insert the following: Gradation Restricted Zones – It is recommended that the selected combined aggregate gradation does not pass through the restricted zone boundaries specified in Table 4.
New Table 4	Insert new Table 4 (below)

Table 4 –Restricted Zone Boundary										
Nominal Size										
Sieve, (mm)	37.5 mm		25 mm		19 mm		12.5 mm		9.5 mm	
	min	max	min	max	min	max	min	max	min	max
4.75	34.7	34.7	39.5	39.5						
2.36	23.3	27.3	26.8	30.8	34.6	34.6	39.1	39.1	47.2	47.2
1.18	15.5	21.5	18.1	24.1	22.3	28.3	25.6	31.6	31.6	37.6
0.600	11.7	15.7	13.6	17.6	16.7	20.7	19.1	23.1	23.5	27.5
0.300	10	10	11.4	11.4	13.7	13.7	15.5	15.5	18.7	18.7

Illinois Modified Test Procedure
 Effective Date: March 1, 2007
 Revised Date: [December 1, 2021](#)

Standard Specification
 for
Superpave Volumetric Mix Design

Reference AASHTO M 323-17 ([2021](#))¹

AASHTO Section	Illinois Modification
Figure 1	Delete
6.2	Delete
6.3	Delete
6.4	Delete
6.5	Delete
6.6	Replace with the following: When RAP is used in the mixture, the RAP aggregate shall be extracted from the RAP using a solvent extraction (T 164) or ignition oven (T 308) as specified by the agency. The RAP aggregate shall be included in determination of gradation.
Table 6	Delete
Note 6	Delete
7.2	Replace with the following: The asphalt mixture design, when compacted in accordance with T-312, shall meet the VMA, VFA and air void requirements specified in Article 1030.04(b) of the Illinois Department of Transportation Standard Specifications for Road and Bridge Construction.
Table 7	Delete
7.2.2 New Section	Insert the following: Dust to Binder Ratio: The ratio of material passing the 75 μ m (#200) sieve to total asphalt binder shall be as specified in Article 1030.04(a) of the Illinois Department of Transportation Standard Specifications for Road and Bridge Construction.
Note 7	Delete
7.3	Replace with the following: The asphalt mixture design, when compacted according to T 312 at 7.0 \pm 0.5 percent air voids and tested in accordance with T 283 shall have a minimum tensile strength ratio of 0.85.

Illinois Modified Test Procedure
Effective Date: March 1, 2007
Revised Date: [December 1, 2021](#)

Standard Specification
for
Superpave Volumetric Mix Design

Reference AASHTO M 323-17 ([2021](#))¹

AASHTO Section	<i>Illinois Modification</i>
Appendix X1	Delete
Appendix X2	Delete
Appendix X3	Delete

This Page Reserved

Illinois Modified Test Procedure
 Effective Date: January 1, 2002
 Revised Date: [December 1, 2021](#)

Standard Specification
 for
Stone Matrix Asphalt (SMA)

Reference AASHTO M325-08 ([2021](#))¹

AASHTO Section	Illinois Modification
Whole Document	This AASHTO Provisional document shall only be used in conjunction with a Special Provision that includes Illinois' SMA mix design and ingredient materials details.
2.1	Revise reference to the individual standards as follows: M 323 (Illinois Modified) R 46 (Illinois Modified) T 85 (Illinois Modified) T 283 (Illinois Modified) T 305 (Illinois Modified) T 312 (Illinois Modified) ASTM D 4791 (Illinois Modified) ASTM D 5821 (Illinois Modified)
8.1	Replace with the following after the second sentence: Cellulose shall conform to the properties outlined in Table 3. For mineral fibers, the dosage rate shall be approximately 0.4 percent by total mixture mass and sufficient to prevent draindown. Mineral fibers shall conform to the properties outlined in Table 4. The maximum draindown will be 0.3 percent by weight of the mix when held at the plant temperature for one hour.

Illinois Modified Test Procedure
 Effective Date: January 1, 2002
 Revised Date: December 1, 2021

Standard Specification
 for
Stone Matrix Asphalt (SMA)

Reference AASHTO M325-08 (2021)¹

AASHTO Section	Illinois Modification																												
8.1	<p>Insert after Note 3:</p> <p>Table 3 – Cellulose Fiber Quality Requirements</p> <table border="1" style="width: 100%; border-collapse: collapse;"> <thead> <tr> <th style="width: 60%;">Property</th> <th style="width: 40%;">Requirement</th> </tr> </thead> <tbody> <tr> <td colspan="2">Sieve Analysis</td> </tr> <tr> <td colspan="2">Method A – Alpine Sieve^a Analysis:</td> </tr> <tr> <td style="padding-left: 20px;">Fiber Length</td> <td>6 mm (0.25 in) maximum</td> </tr> <tr> <td style="padding-left: 20px;">Passing 0.150-mm (No. 100) sieve</td> <td>70 ± 10 percent</td> </tr> <tr> <td colspan="2">Method B – Mesh Screen^b Analysis:</td> </tr> <tr> <td style="padding-left: 20px;">Fiber Length</td> <td>6 mm (0.25 in) maximum</td> </tr> <tr> <td style="padding-left: 20px;">Passing 0.850-mm (No. 20) sieve</td> <td>85 ± 10 percent</td> </tr> <tr> <td style="padding-left: 40px;">0.425-mm (No. 40) sieve</td> <td>65 ± 10 percent</td> </tr> <tr> <td style="padding-left: 40px;">0.106-mm (No. 140) sieve</td> <td>30 ± 10 percent</td> </tr> <tr> <td>Ash Content^c</td> <td>18 ± 5 percent non-volatiles</td> </tr> <tr> <td>pH^d</td> <td>7.5 ± 1.0</td> </tr> <tr> <td>Oil Absorption^e</td> <td>5.0 ± 1.0 (times fiber mass)</td> </tr> <tr> <td>Moisture Content^f</td> <td>Less than 5 percent (by mass)</td> </tr> </tbody> </table> <p>^a This test is performed using an Alpine Air-Jet Sieve (Type 200 LS). A representative 5-g sample of fiber is sieved for 14 minutes at a controlled vacuum of 75 kPa (11 psi) of water. The portion remaining on the screen is weighed.</p> <p>^b This test is performed using standard 0.850-mm (No. 20), 0.425-mm (No. 40), 0.250-mm (No. 60), 0.180-mm (No. 80), 0.150-mm (No. 100), and 0.106-mm (No. 140) sieves, nylon brushes, and a shaker. A representative 10-g sample of fiber is sieved, using a shaker and two nylon brushes on each screen. The amount retained on each sieve is weighed and the percentage passing calculated. Repeatability on this method is suspect and needs to be verified.</p> <p>^c A representative 2- to 3-g sample of fiber is placed in a tared crucible and heated to between 595 and 650°C (1100 and 1200°F) for not less than two hours. The crucible and ash are cooled in a desiccator and weighed.</p> <p>^d Five grams of fiber are added to 100 mL of distilled water, stirred and allowed to sit for 30 minutes. The pH is determined with a probe calibrated with a pH buffer of 7.0.</p> <p>^e Five grams of fiber are accurately weighed and suspended in an excess of mineral spirits for not less than 5 minutes to ensure total saturation. It is then placed in a screen mesh strainer (approximately 0.5mm² opening size) and shaken on a wrist action shaker for 10 minutes (approximately 32-mm (1 ¼-in.) motion at 240 shakes per minute). The shaken mass is then transferred without touching to a tared container and weighed. Results are reported as the amount (number of times its own weight) the fibers are able to absorb.</p> <p>^f Ten grams of fiber are weighed and placed in a 121°C (250°F) forced-air oven for two hours. The sample is then reweighed immediately upon removal from the oven.</p>	Property	Requirement	Sieve Analysis		Method A – Alpine Sieve ^a Analysis:		Fiber Length	6 mm (0.25 in) maximum	Passing 0.150-mm (No. 100) sieve	70 ± 10 percent	Method B – Mesh Screen ^b Analysis:		Fiber Length	6 mm (0.25 in) maximum	Passing 0.850-mm (No. 20) sieve	85 ± 10 percent	0.425-mm (No. 40) sieve	65 ± 10 percent	0.106-mm (No. 140) sieve	30 ± 10 percent	Ash Content ^c	18 ± 5 percent non-volatiles	pH ^d	7.5 ± 1.0	Oil Absorption ^e	5.0 ± 1.0 (times fiber mass)	Moisture Content ^f	Less than 5 percent (by mass)
Property	Requirement																												
Sieve Analysis																													
Method A – Alpine Sieve ^a Analysis:																													
Fiber Length	6 mm (0.25 in) maximum																												
Passing 0.150-mm (No. 100) sieve	70 ± 10 percent																												
Method B – Mesh Screen ^b Analysis:																													
Fiber Length	6 mm (0.25 in) maximum																												
Passing 0.850-mm (No. 20) sieve	85 ± 10 percent																												
0.425-mm (No. 40) sieve	65 ± 10 percent																												
0.106-mm (No. 140) sieve	30 ± 10 percent																												
Ash Content ^c	18 ± 5 percent non-volatiles																												
pH ^d	7.5 ± 1.0																												
Oil Absorption ^e	5.0 ± 1.0 (times fiber mass)																												
Moisture Content ^f	Less than 5 percent (by mass)																												

Illinois Modified Test Procedure
 Effective Date: January 1, 2002
 Revised Date: [December 1, 2021](#)

Standard Specification
 for
Stone Matrix Asphalt (SMA)

Reference AASHTO M325-08 [\(2021\)](#)¹

AASHTO Section	Illinois Modification																						
8.1	Insert at end: Table 4 – Mineral Fiber Quality Requirements <table border="1" style="width: 100%; border-collapse: collapse;"> <thead> <tr> <th style="width: 60%; text-align: center;">Property</th> <th style="text-align: center;">Requirement</th> </tr> </thead> <tbody> <tr> <td colspan="2">Size Analysis:</td> </tr> <tr> <td style="padding-left: 20px;">Fiber Length^a</td> <td>6 mm (0.25 in) maximum mean test value</td> </tr> <tr> <td style="padding-left: 20px;">Thickness^b</td> <td>0.005 mm (0.0002 in.) maximum mean test value</td> </tr> <tr> <td colspan="2">Shot Content^c</td> </tr> <tr> <td style="padding-left: 20px;">Passing 0.250-mm (No. 60) sieve</td> <td>90 ± 5 percent</td> </tr> <tr> <td style="padding-left: 20px;">Passing 0.063-mm (No. 230) sieve</td> <td>70 ± 10 percent</td> </tr> <tr> <td colspan="2"><hr/></td> </tr> <tr> <td style="padding-left: 5px;">^a</td> <td>The fiber length is determined according to the Bauer McNett fractionation.</td> </tr> <tr> <td style="padding-left: 5px;">^b</td> <td>The fiber thickness, or diameter, is determined by measuring at least 200 fibers in a phase contrast microscope.</td> </tr> <tr> <td style="padding-left: 5px;">^c</td> <td>Shot content is a measure of non-fibrous material. The shot content is determined on vibrating sieves. Two sieves, the 0.250 mm (No. 60) and the 0.063 mm (No. 230), are typically utilized. For additional information, see C 612.</td> </tr> </tbody> </table>	Property	Requirement	Size Analysis:		Fiber Length ^a	6 mm (0.25 in) maximum mean test value	Thickness ^b	0.005 mm (0.0002 in.) maximum mean test value	Shot Content ^c		Passing 0.250-mm (No. 60) sieve	90 ± 5 percent	Passing 0.063-mm (No. 230) sieve	70 ± 10 percent	<hr/>		^a	The fiber length is determined according to the Bauer McNett fractionation.	^b	The fiber thickness, or diameter, is determined by measuring at least 200 fibers in a phase contrast microscope.	^c	Shot content is a measure of non-fibrous material. The shot content is determined on vibrating sieves. Two sieves, the 0.250 mm (No. 60) and the 0.063 mm (No. 230), are typically utilized. For additional information, see C 612.
Property	Requirement																						
Size Analysis:																							
Fiber Length ^a	6 mm (0.25 in) maximum mean test value																						
Thickness ^b	0.005 mm (0.0002 in.) maximum mean test value																						
Shot Content ^c																							
Passing 0.250-mm (No. 60) sieve	90 ± 5 percent																						
Passing 0.063-mm (No. 230) sieve	70 ± 10 percent																						
<hr/>																							
^a	The fiber length is determined according to the Bauer McNett fractionation.																						
^b	The fiber thickness, or diameter, is determined by measuring at least 200 fibers in a phase contrast microscope.																						
^c	Shot content is a measure of non-fibrous material. The shot content is determined on vibrating sieves. Two sieves, the 0.250 mm (No. 60) and the 0.063 mm (No. 230), are typically utilized. For additional information, see C 612.																						
9.1	Revise the first sentence to read: The combined aggregates shall conform to the gradation requirements of Table 5.																						
Table 3	Revise title to read: Table 5 – SMA Gradation Specification Bands																						
9.2	Revise to read: The designed SMA mixture shall meet the requirements of Table 6.																						
Table 4	Revise title to read: Table 6 – SMA Mixture Specifications for Superpave Gyratory Compactor																						
Table 4	Revise the TSR requirement to be 0.85 min.																						
9.3	Revise to read: The tensile strength ratio (TSR) of the SMA shall be at least 0.85, at 7.0 ± 1.0 percent air voids, when tested in accordance with T 283.																						

This Page Reserved

Standard Practice
 for
Mixture Conditioning of Hot Mix Asphalt (HMA)

Reference AASHTO R 30-02 (2019)

AASHTO Section	Illinois Modification
1.1	Replace with the following: This standard practice describes procedures for mixture conditioning of hot mix asphalt (HMA). Conditioning requirements for volumetric mixture design, short-term conditioning of specimens for Hamburg Wheel testing and I-FIT, specimens for strength and TSR testing, and long-term aging for I-FIT specimens are addressed.
2.1	Revise the individual AASHTO Standards with the appropriate Illinois Modified AASHTO Standards:
2.1	Delete reference to PP 3 and T 316. Add reference to: Illinois modified AASHTO T 393 , Determining the Fracture Potential of Asphalt Mixtures Using the Illinois Flexibility Index Test (I-FIT)
3.	Replace with the following: For mixture conditioning for volumetric mixture design, specimens for Hamburg Wheel testing, specimens for I-FIT, and specimens for strength and TSR testing, a mixture of aggregate and asphalt binder is conditioned in a forced-draft oven at the mixture's specified compaction temperature.
4.	Replace with the following: The properties and performance of HMA can be more accurately predicted by using conditioned test samples. The mixture conditioning for the volumetric mixture design procedure, for Hamburg Wheel test and I-FIT specimens and for specimens for strength and TSR testing is designed to allow for binder absorption.
7.1	Replace with the following: <i>Mixture Conditioning for Volumetric Mixture Design, for Hamburg Wheel Test and I-FIT Specimens, and for specimens for Strength and TSR Testing:</i>
7.1.1	Replace the first two sentences with the following: The mixture conditioning for the volumetric mixture design procedure, for short-term conditioning of Hamburg Wheel test and I-FIT specimens, and for specimens for strength and TSR testing applies to laboratory-prepared, loose mixture only. Mixture conditioning is only required when conducting quality control or quality assurance testing on plant-produced mixture, for I-FIT long-term aging specimens, and as specified for warm mix asphalt (WMA) mixtures.

Standard Practice
 for
Mixture Conditioning of Hot Mix Asphalt (HMA)

Reference AASHTO R 30-02 (2019)

AASHTO Section	Illinois Modification
7.1.1 Note 1	Delete
7.1.2	<p>Replace with the following: Place the mixture in a pan and spread the mixture to an even thickness ranging between 1 in. (25 mm) and 2 in. (50 mm).</p> <p>The aging may take place either:</p> <ol style="list-style-type: none"> a. Immediately after mixing but before compaction (without being cooled down), or b. After the mixture has been cooled down to room temperature. The mixture shall be placed in the oven, which has been pre-heated to compaction temperature, for the appropriate time specified below. <p>For testing of all mixtures with low-absorptive aggregate, place the mixture and pan in the conditioning oven pre-heated to the mixture's specified compaction temperature ± 5 °F (± 3 °C) for 1 hr. ± 5 min. prior to compaction. (1 hr. of oven time, not the time the mixture was held at compaction temperature, is used.)</p> <p>For testing of all mixtures with high-absorptive aggregate, place the mixture and pan in the conditioning oven pre-heated to the mixture's specified compaction temperature ± 5 °F (± 3 °C) for 2 hrs. ± 5 min. prior to compaction. (2 hrs. of oven time, not the time the mixture was held at compaction temperature, is used.)</p>
7.1.2 Note 2	Replace with the following: Note 2 – When SB/SBS/SBR polymer and GTR modified asphalt is used, the required compaction temperature is 305 ± 5 °F (152 ± 3 °C).
7.1.2 New Note	Note 2A – High-absorptive aggregate mixture is defined as aggregate with a combined absorption greater than 2.5% and all slags.
7.1.2 New Note	Note 2B – The compaction temperature for non-SB/SBS/SBR polymer and non-GTR modified asphalt is 295 ± 5 °F (146 ± 3 °C).

Standard Practice
 for
Mixture Conditioning of Hot Mix Asphalt (HMA)

Reference AASHTO R 30-02 (2019)

AASHTO Section	Illinois Modification																																			
7.1.2 New Note	Note 2C – Short-term conditioning is not permitted for testing plant-produced mixture, except as specified for WMA mixtures.																																			
7.1.2 New Note	Note 2D – Condition Hamburg Wheel specimens from WMA mixtures from both lab-produced mix and plant-produced mix for two hours in addition to the requirements for HMA.																																			
7.1.2.1 New Section	Add the following: Table 1 summarizes the various requirements for short-term conditioning of both HMA and WMA from lab-produced mix and plant-produced mix.																																			
7.1.2.1 New Table	Add the following: Table 1 <table border="1" style="margin-left: auto; margin-right: auto;"> <thead> <tr> <th colspan="7" style="text-align: center;">Short Term Conditioning (hours) ^{1/}</th> </tr> <tr> <th></th> <th colspan="3" style="text-align: center;">Lab-Produced Mix</th> <th colspan="3" style="text-align: center;">Plant-Produced Mix</th> </tr> <tr> <th></th> <th style="text-align: center;">Volumetric s</th> <th style="text-align: center;">T-283</th> <th style="text-align: center;">Hambur g/I-FIT</th> <th style="text-align: center;">Volumetric s</th> <th style="text-align: center;">T-283</th> <th style="text-align: center;">Hambur g/I-FIT</th> </tr> </thead> <tbody> <tr> <td style="text-align: center;">HMA</td> <td style="text-align: center;">1 or 2</td> <td style="text-align: center;">1 or 2</td> <td style="text-align: center;">1 or 2</td> <td style="text-align: center;">0</td> <td style="text-align: center;">0</td> <td style="text-align: center;">0</td> </tr> <tr> <td style="text-align: center;">WMA</td> <td style="text-align: center;">1 or 2</td> <td style="text-align: center;">1 or 2</td> <td style="text-align: center;">3 or 4</td> <td style="text-align: center;">0</td> <td style="text-align: center;">0</td> <td style="text-align: center;">2</td> </tr> </tbody> </table> <p>1/ When two different values are present within a single cell, the correct value is based on whether low or high absorptive aggregates are used.</p>	Short Term Conditioning (hours) ^{1/}								Lab-Produced Mix			Plant-Produced Mix				Volumetric s	T-283	Hambur g/I-FIT	Volumetric s	T-283	Hambur g/I-FIT	HMA	1 or 2	1 or 2	1 or 2	0	0	0	WMA	1 or 2	1 or 2	3 or 4	0	0	2
Short Term Conditioning (hours) ^{1/}																																				
	Lab-Produced Mix			Plant-Produced Mix																																
	Volumetric s	T-283	Hambur g/I-FIT	Volumetric s	T-283	Hambur g/I-FIT																														
HMA	1 or 2	1 or 2	1 or 2	0	0	0																														
WMA	1 or 2	1 or 2	3 or 4	0	0	2																														
7.1.4	Delete the first sentence.																																			
7.2	Delete all sections																																			
7.3	Delete all sections in Section 7.3 Replace Section 7.3 with the following: <i>I-FIT Long-Term Aging Procedure:</i>																																			
7.3.1	Replace with the following: Compact one laboratory SGC cylinder according to T 312 with the compaction height of 160 mm ± 1 mm. Determine the bulk specific gravity (G_{mb}) and air voids of the compacted cylinder according to T 166 and T 269, respectively. The air voids of the 160 ± 1 mm tall SGC cylinder shall be 7.5 ± 0.5%.																																			

Illinois Modified Test Procedure
 Effective Date: June 1, 2012
 Revised Date: [December 1, 2021](#)

Standard Practice
 for
Mixture Conditioning of Hot Mix Asphalt (HMA)

Reference AASHTO R 30-02 (2019)

AASHTO Section	Illinois Modification
7.3.2	Replace with the following: Cut four (4) individual semi-circular test specimens for each test.
7.3.3	Replace with the following: Cut the notch in each test specimen.
New Note	Note 3 - Although the required air voids are determined from the SGC cylinders, it is also required to determine the air voids on the individual semi-circular I-FIT test specimens to identify if $7.5 \pm 0.5\%$ air voids in the SGC cylinders is appropriate to produce individual semi-circular test specimens with $7.0 \pm 1.0\%$ air voids.
7.3.4	Replace with the following: Place the four (4) test specimens, notched-face down, on a tray (pan), with a "barrier" between the test specimens and the tray (parchment paper, a non-stick cooking mat, heavy duty aluminum foil, etc. are examples of a "barrier").
7.3.5	Replace with the following: Place the tray with the specimens in a pre-heated force-draft oven set at $95 \pm 3^{\circ}\text{C}$ ($203 \pm 5^{\circ}\text{F}$).
7.3.6	Leave the specimens (undisturbed) in the oven at this temperature for 72 hours \pm 1 hour.
7.3.7 New Section	Remove the entire tray from the oven and place in front of a cooling fan at room temperature for at least one hour.
New Note	Note 4: If the specimen is not cooled in front of a fan, allow the specimens to cool at room temperature overnight.

Illinois Modified Test Procedure
Effective Date: June 1, 2012
Revised Date: [December 1, 2021](#)

Standard Practice
for
Mixture Conditioning of Hot Mix Asphalt (HMA)

Reference AASHTO R 30-02 (2019)

AASHTO Section	Illinois Modification
7.3.8 New Section	Remove the specimen from the “barrier”.
7.3.9 New Section	After the specimens have cooled and the “barrier” has been removed, submerge them in a $25 \pm 0.5^{\circ}\text{C}$ ($77 \pm 1.0^{\circ}\text{F}$) water bath for 2 hours and test according to the IL-mod T 393 procedure.
8.3	Delete all sections
8.4	Delete all sections
9.1	Replace with the following: Conditioning; hot mix asphalt ; long-term aging

This Page Reserved

Illinois Modified Test Procedure
 Effective Date: May 1, 2007
 Revised Date: [December 1, 2021](#)

Standard Method of Test
 For
Superpave Volumetric Design for Asphalt Mixtures

Reference AASHTO R 35-17 [\(2021\)](#)¹

AASHTO Section	Illinois Modification
ALL Sections	<ul style="list-style-type: none"> • All references to calculations involving N_{ini} and N_{max} do not apply at this time. • Replace all references to AASHTO or ASTM standards with the appropriate Illinois-modified specification. • Replace all references to design air voids of 4.0% with the design air voids content specified in Illinois-modified M323.
3.9	Replace with the following: Dust-to-Binder Ratio ($P_{0.075}/P_b$)—By mass, the ratio between percent of aggregate passing the 75- μm (No. 200) sieve ($P_{0.075}$) and total asphalt content (P_b).
4.1 Note 3	Delete
6.1	Delete
6.2	Delete
6.5 New Note	Note 5a: Oven dry the mix design aggregates according to T 30.
6.5 New Note	Note 5b: The aggregate sample from each stockpile shall be sieved and separated into the specific size passing each appropriate sieve according to the Department’s Hot-Mix Asphalt Level III Technicians Manual.
6.6	Replace with the following: All aggregate specific gravity and absorption values used in mix design shall be obtained from the Department’s Central Bureau of Materials aggregate specific gravity/absorption listing.
6.6 New Note	Note 5c: The trial aggregate blends may be prepared from unwashed aggregates. If the trial aggregate blends are prepared from unwashed aggregates, then a dust correction factor shall be determined and applied to the blend chosen for the mix design according to the Department’s “HMA Mix Design Procedure for Dust Correction Factor Determination.”

Standard Method of Test
 For
Superpave Volumetric Design for Asphalt Mixtures

Reference AASHTO R 35-17 ([2021](#))¹

AASHTO Section	Illinois Modification																		
6.8	Replace with the following: Prepare a minimum of three trial aggregate blend gradations and confirm that each trial blend meets M 323 gradation controls. An example of three acceptable trial blends in the form of a gradation plot is given in Figure 1.																		
6.9	Delete																		
6.9 Note 6	Delete																		
8.1 New Note	Note 7a The design number of gyrations will be determined by the Department and specified in the plans.																		
Table 1 and all footnotes	Replace with new Table 1 (below) <table border="1" style="margin-left: auto; margin-right: auto;"> <thead> <tr> <th colspan="3" style="text-align: center;">Table 1 – N_{design} Table</th> </tr> <tr> <th style="text-align: center;">Design ESALs (millions) Based on 20-year design</th> <th style="text-align: center;">N_{des}</th> <th style="text-align: center;">Typical Roadway Application</th> </tr> </thead> <tbody> <tr> <td style="text-align: center;">< 0.3</td> <td style="text-align: center;">30</td> <td>Roadway with very light traffic volume such as local roads, county roads, and city streets where truck traffic is prohibited or at a very minimal level (considered local in nature; not regional, intrastate, or interstate). Special purpose roadways serving recreational sites or areas may also be applicable.</td> </tr> <tr> <td style="text-align: center;">0.3 to 3</td> <td style="text-align: center;">50</td> <td>Includes many collector roads or access streets. Medium-trafficked city streets and the majority of county roadways.</td> </tr> <tr> <td style="text-align: center;">3 to 10</td> <td style="text-align: center;">70</td> <td>Includes many two-lane, multi-lane, divided, and partially or completely controlled access roadways. Among these are medium-to-highly trafficked streets, many state routes, U.S. highways, and some rural interstates.</td> </tr> <tr> <td style="text-align: center;">≥ 10</td> <td style="text-align: center;">90</td> <td>May include the previous class of roadways which have a high amount of truck traffic. Includes U.S. Interstates, both urban and rural in nature. Special applications such as truck-weighing stations or truck-climbing lanes on two-lane roadways may also be applicable to this level.</td> </tr> </tbody> </table>	Table 1 – N_{design} Table			Design ESALs (millions) Based on 20-year design	N_{des}	Typical Roadway Application	< 0.3	30	Roadway with very light traffic volume such as local roads, county roads, and city streets where truck traffic is prohibited or at a very minimal level (considered local in nature; not regional, intrastate, or interstate). Special purpose roadways serving recreational sites or areas may also be applicable.	0.3 to 3	50	Includes many collector roads or access streets. Medium-trafficked city streets and the majority of county roadways.	3 to 10	70	Includes many two-lane, multi-lane, divided, and partially or completely controlled access roadways. Among these are medium-to-highly trafficked streets, many state routes, U.S. highways, and some rural interstates.	≥ 10	90	May include the previous class of roadways which have a high amount of truck traffic. Includes U.S. Interstates, both urban and rural in nature. Special applications such as truck-weighing stations or truck-climbing lanes on two-lane roadways may also be applicable to this level.
Table 1 – N_{design} Table																			
Design ESALs (millions) Based on 20-year design	N_{des}	Typical Roadway Application																	
< 0.3	30	Roadway with very light traffic volume such as local roads, county roads, and city streets where truck traffic is prohibited or at a very minimal level (considered local in nature; not regional, intrastate, or interstate). Special purpose roadways serving recreational sites or areas may also be applicable.																	
0.3 to 3	50	Includes many collector roads or access streets. Medium-trafficked city streets and the majority of county roadways.																	
3 to 10	70	Includes many two-lane, multi-lane, divided, and partially or completely controlled access roadways. Among these are medium-to-highly trafficked streets, many state routes, U.S. highways, and some rural interstates.																	
≥ 10	90	May include the previous class of roadways which have a high amount of truck traffic. Includes U.S. Interstates, both urban and rural in nature. Special applications such as truck-weighing stations or truck-climbing lanes on two-lane roadways may also be applicable to this level.																	

Illinois Modified Test Procedure
 Effective Date: May 1, 2007
 Revised Date: [December 1, 2021](#)

Standard Method of Test
 For
Superpave Volumetric Design for Asphalt Mixtures

Reference AASHTO R 35-17 [\(2021\)](#)¹

AASHTO Section	Illinois Modification
8.3 Note 9	Delete
8.3 Note 10	Delete
9.3.6	Replace with the following: Calculate the dust-to-binder ratio for each trial blend where: $\text{Dust to binder ratio} = \frac{P_{0.075}}{P_b}$ where: P_b = total asphalt content and $P_{0.075}$ = percent passing 75- μ m sieve.
10.5.2	Replace with the following: Calculate the dust-to-binder ratio where: $\text{Dust to binder ratio} = \frac{P_{0.075}}{P_b}$ where: P_b = total asphalt content and $P_{0.075}$ = percent passing 75- μ m sieve.
11.3	Replace with the following: If the tensile strength ratio is less than 85 percent, as required in M 323, remedial action, such as the use of anti-strip agents, is required to improve the moisture susceptibility of the mix. When remedial agents are used to modify the asphalt binder, the mixture shall be retested to assure compliance with the minimum requirement of 85 percent.
X2.3.1.1 Note X5	Replace the last sentence with the following: Appropriate mixing times for bucket mixers should be established by evaluating the coating of HMA mixtures prepared at the mixing temperatures specified in T 312.
X2.4.2	Replace with the following: Estimate the planned production and field compaction temperatures.

Illinois Modified Test Procedure
 Effective Date: May 1, 2007
 Revised Date: [December 1, 2021](#)

Standard Method of Test
 For
Superpave Volumetric Design for Asphalt Mixtures

Reference AASHTO R 35-17 [\(2021\)](#)¹

AASHTO Section	Illinois Modification
X2.5.1	Delete the last sentence
X2.6.3	Delete
Note X8	Delete
Table X2.1	Delete
X2.6.4	Delete
X2.6.4.1	Delete
X2.6.4.2	Delete
X2.6.4.3	Delete
X2.7.1.1.1 New Section	Dry the aggregates according to T 30.
Note X11	Delete the first sentence.
X2.7.3.2.5	Replace description of w_i with: w_i = oven-dry weight from X2.7.1.1.1, g; and
X2.7.4.6	Replace description of w_i with: w_i = oven-dry weight from X2.7.1.1.1, g; and
X2.7.5.2.5	Replace description of w_i with: w_i = oven-dry weight from X2.7.1.1.1, g; and
X2.7.6.8	Replace description of w_i with: w_i = oven-dry weight from X2.7.1.1.1, g; and
X2.10.1.10 New Section	Hamburg Wheel rut depth and number of wheel passes.

Illinois Modified Test Procedure
 Effective Date: [December 1, 2021](#)
 Standard Method of Test
 for

Making and Curing Concrete Test Specimens in the Laboratory

Reference AASHTO R 39-19
(formerly T 126)

AASHTO Section	Illinois Modification
2.1	<p>Revise as follows:</p> <p>AASHTO M 201 (Illinois Modified) AASHTO M 205 (Illinois Modified) AASHTO R 100 (Illinois Modified) (formerly AASHTO T 23) AASHTO T 27 (Illinois Modified) AASHTO T 84 (Illinois Modified) AASHTO T 85 (Illinois Modified) AASHTO T 119 (Illinois Modified) AASHTO T 121 (Illinois Modified) AASHTO R 60 (Illinois Modified) AASHTO T 152 (Illinois Modified) AASHTO T 196 (Illinois Modified) AASHTO T 231 (Illinois Modified) AASHTO T 255 (Illinois Modified) ASTM C 1064/C 1064M (Illinois Modified) replaces T 309 Illinois Test Procedure SCC-3 replaces T 345 Illinois Test Procedure SCC-2 replaces T 347 Illinois Test Procedure SCC-6 replaces T 351</p> <p>To maintain brevity in the text, the following will apply: Example: AASHTO T 119 (Illinois Modified) will be designated as “T 119.”</p>

This Page Reserved

Illinois Modified Test Procedure
 Effective Date: January 1, 2002
 Revised Date: [December 1, 2021](#)

Standard Practice
 for
Designing Stone Matrix Asphalt (SMA)

Reference AASHTO R46-08 ([2021](#))¹

AASHTO Section	Illinois Modification
Whole Document	This AASHTO document shall only be used in conjunction with a Special Provision that includes Illinois' SMA mix design and ingredient materials details.
2.1	Revise reference to the individual standards as follows: M 325 (Illinois Modified) R 30 (Illinois Modified) T 19 (Illinois Modified) T 27 (Illinois Modified) T 85 (Illinois Modified) T 166 (Illinois Modified) T 209 (Illinois Modified) T 283 (Illinois Modified) T 305 (Illinois Modified) T 312 (Illinois Modified)
4.4	Replace with: <i>Evaluating Moisture Susceptibility</i> – The moisture susceptibility of the mixture, designed and compacted in accordance with T 312 to a V_a content of 7.0 ± 1.0 percent, is evaluated in accordance with T 283.
5.3.1	Replace with the following: The mixing temperature shall be according to IL Modified AASHTO T 312.
5.3.2	Replace with the following: The compaction temperature shall be according to IL Modified AASHTO T 312.
Note 3	Delete
5.5	Revise to read: <i>Compaction of Specimens</i> – The compaction temperature is determined according to IL Modified AASHTO T 312. Laboratory samples of SMA are short-term conditioned according to IL Modified AASHTO R 30 and then compacted to either 50 or 80 gyrations according to the Standard Specifications, based on traffic level.
Note 5	Delete

Illinois Modified Test Procedure
Effective Date: January 1, 2002
Revised Date: [December 1, 2021](#)

Standard Practice
for
Designing Stone Matrix Asphalt (SMA)

Reference AASHTO R46-08 [\(2021\)](#)¹

AASHTO Section	Illinois Modification
11.1	Revise to read: Moisture susceptibility of the selected mixture is determined in accordance with T 283 using samples compacted in accordance with T 312 to a V_a content of 7.0 ± 1.0 percent. The retained tensile strength level of the SMA shall be as specified in T 325 at 7.0 ± 1.0 percent V_a .

Standard Method of Test
 For
Sampling Freshly Mixed Concrete

Reference AASHTO R 60-12 (2020)
 (formerly T 141)

AASHTO Section	Illinois Modification
5.2, 5.2.1, 5.2.2, 5.2.3, and 5.2.4	<p>Replace as follows:</p> <p style="text-align: center;">REPRESENTATIVE SAMPLE</p> <p>Do not obtain the sample from the first 0.1 m³ (4 ft³), or from the last 0.1 m³ (4 ft³) of discharged concrete.</p> <p style="text-align: center;">POINT OF SAMPLING</p> <p>The field sample shall be obtained at or near the point of discharge by the delivery equipment and prior to incorporation of the concrete into the work, except when concrete is placed by pump or conveyor.</p> <p>When concrete is placed by pump or conveyor, the field sample for strength tests shall be obtained at the discharge end of the pump or conveyor. Per specifications, a slump test (or applicable self-consolidating concrete tests), air content test, and temperature test shall be performed on the same sample obtained for strength tests.</p> <p>Additional sampling prior to and following transport by pump or conveyor is specified to determine a correction factor for air content according to the Check Sheet for "Quality Control/Quality Assurance of Concrete Mixtures" or Construction Memorandum 13-74 "Guidelines for Pumping of Bridge Deck Concrete."</p> <p>Note: Field samples for strength test are taken at the discharge end of the pump or conveyor because air content is likely to change during transport. Typically, if air content increases 1 percent, compressive strength will decrease approximately 2 to 6 percent and flexural strength will decrease approximately 2 to 4 percent. These sampling and testing procedures are mandatory for bridge deck concrete transported by pump or conveyor. For some construction items, it may not be feasible or practical to obtain a field sample at the discharge end of the pump or conveyor. These samples may be obtained prior to pumping or conveying at the discretion of the Engineer.</p> <p style="text-align: center;">SAMPLING FROM TRUCK MIXER, TRUCK AGITATOR, OR FRONT DISCHARGE CARRIER WHICH DEPOSIT CONCRETE WITH A CHUTE</p> <ol style="list-style-type: none"> 1. Collect the sample in a damp, non-absorbent container (a wheelbarrow or other large container).

Illinois Modified Test Procedure
Effective Date: December 1, 2020

Standard Method of Test
For
Sampling Freshly Mixed Concrete
(continued)
Reference AASHTO R 60-12 (2020)
(formerly T 141)

AASHTO Section	Illinois Modification
5.2, 5.2.1, 5.2.2, 5.2.3, and 5.2.4	<ol style="list-style-type: none"> 2. Repeatedly pass the sample container through the entire discharge stream, or completely divert the discharge stream in the sample container. 3. Protect the sample from contamination and if necessary, protect the sample from rapid evaporation by covering with a plastic sheet. 4. Transport the sample to the location of testing. 5. Remix the sample with a damp shovel. 6. Perform air content, slump, temperature, strength, and other tests as required. After completing a test, discard the concrete used. Never use any portion of the sample for more than one test. 7. Clean all test equipment with water and allow to drain, or wipe dry. Never assemble wet test equipment before storing. <p style="text-align: center;">SAMPLING FROM NONAGITATOR TRUCK OR OTHER DELIVERY EQUIPMENT WHICH DEPOSIT CONCRETE DIRECTLY ONTO GRADE</p> <ol style="list-style-type: none"> 1. Collect the sample in a damp, non-absorbent container (a wheelbarrow or other large container). 2. Use a damp shovel to obtain portions of the concrete from at least 5 locations of the pile, and composite into one test sample. 3. Be careful not to contaminate the sample by including underlying material. 4. Protect the sample from contamination and if necessary, protect the sample from rapid evaporation by covering with a plastic sheet. 5. Transport the sample to the location of testing. 6. Remix the sample with a damp shovel. 7. Perform air content, slump, temperature, strength, and other tests as required. After completing a test, discard the concrete used. Never use any portion of the sample for more than one test. 8. Clean all test equipment with water and allow to drain, or wipe dry. Never assemble wet test equipment before storing.

Standard Method of Test
 for
Developing a Family of Curves

Reference AASHTO R 75-16 (2020)

AASHTO Section	Illinois Modification
1.2	Revise as follows: The values stated in either SI units or inch-pound units are to be regarded separately as standard. The values stated in each system may not be exact equivalents in this standard. Combining values from the two systems may result in non-conformance with the standard, and diligence is advised when using unit conversions to combine the two systems. Results shall be reported in inch-pound units.
2.1	Revise as follows: AASHTO T 99 (Illinois Modified) AASHTO T 180 (Illinois Modified) AASHTO T 272 (Illinois Modified) To maintain brevity in the text, the following will apply: Example: AASHTO T 99 (Illinois Modified) will be designated as "T 99."
3.1.1	Add as follows: Discussion: Soils sampled from one source or geographic area typically have many different moisture-density curves, but if a group of these curves are plotted together, certain relationships usually become apparent.
4.4 New	The purpose of the family of curves is to represent the average moisture-density characteristics of the material. The family must, therefore, be based on moisture-density relationships that adequately represent the entire mass range and all types of material for which the family is to be used. It may be that particular soil types have moisture-density relationships that differ considerably and cannot be represented on one general family of curves; in this case, a separate family may be developed. Also, moisture-density relationships for material of widely varying geologic origins should be carefully examined to determine if separate families are required.
4.5 New	A family of curves is used in conjunction with T 272 for determining the maximum dry density and optimum moisture content of a soil in the field.
5.1	Add as follows: The family of curves shall consist of curves developed only from a single test type and method (e.g, T 99, Method C).

Illinois Modified Test Procedure
 Effective Date: December 1, 2018
 Revised Date: December 1, 2020

Standard Method of Test
 for
Developing a Family of Curves

Reference AASHTO R 75-16 (2020)

AASHTO Section	Illinois Modification
Note 2 New After Note 1	When a great number of moisture-density relationships are available, the above procedure can be modified by using average values. Tabulate the maximum density, optimum moisture content, and slope for all moisture-density relationships in each 1-kg (2-lb) increment of density. Average the maximum densities and optimum moisture contents for each increment and plot these values. As before, draw a smooth curve as close as possible to connect all the points. Determine the average slope for each increment, and at each 1-kg (2-lb) increment, draw a moisture-density curve using this average slope value. A computer may be used to accomplish this work.
Note 3 New After Note 2	The accuracy of a family of curves can be checked by comparing the maximum density and optimum moisture content from an individual moisture-density relationship with that obtained using the One-Point Method and family of curves. A point representing 80 percent of optimum moisture content is taken from the individual moisture-density relationship and used as described in the One-Point Method to determine the maximum density and optimum moisture content from the family of curves. These values are compared with the values from the individual moisture/density relationship. The difference represents the maximum variance expected when the One- Point Method and family of curves are used for material represented by that individual moisture-density relationship. This comparison should be made for all types of material over the mass range of the family. Based on these results, some adjustments may be necessary to the family, and/or it may be recognized that the family is not applicable to some types of material. Families based on relatively few moisture-density relationships will generally require the closest scrutiny, because it can be expected that a larger number of relationships will give better average conditions.
6.1	Add as following: compaction; one-point method; one-point Proctor; soil density; soil moisture

Standard Test Method
 for
Reducing Samples of Aggregate to Testing Size
 Reference AASHTO R76-16 (2020)

AASHTO Section	Illinois Modification
2	Replace Section 2 with the following: 2.1 Illinois Modified AASHTO Standards <ul style="list-style-type: none"> • R90, Sampling Aggregate Products • T11, Materials Finer Than No. 200 (75µm) Sieve in Mineral Aggregates by Washing 2.2 Illinois Specification: <ul style="list-style-type: none"> • Illinois Specification 201 Aggregate Gradation Sample Size Table. 2.3 ASTM Standard: <ul style="list-style-type: none"> • C125, Standard Terminology Relating to Concrete and Concrete Aggregates
5	Revise Section 5 with the following: 5.1 Replace with the following: Fine Aggregate – The preferred splitting method for fine aggregate shall be a fine aggregate mechanical splitter (Method A). However, quartering (Method B) and miniature stockpile sampling (Method C) may be used. 5.1.1 Replace Note 1 with the following: As a quick approximation of free moisture; if the fine aggregate will retain its shape when molded in the hand, it may be considered to be wetter than saturated surface-dry. 5.1.2 Replace “38 mm (1 ½ in.)” with “1 1/2in. (37.5mm)” in the second sentence of the paragraph 5.2 Replace with the following: Coarse Aggregate and Mixtures of Coarse and Fine Aggregate – The required splitting method for coarse aggregate and mixtures of coarse and fine aggregate shall be a coarse aggregate mechanical splitter (Method A). However, quartering (Method B) may be used for coarse aggregate moisture tests to proportion Portland cement concrete, cement aggregate mixture II, and controlled low-strength material mixtures. 5.3 Delete
6	Replace Section 6 with the following: 6.1 Field samples of aggregate shall be taken according to Illinois Modified AASHTO R90. The field sample size shall meet the minimum requirements in the Illinois Specifications 201.

Standard Test Method
 for
Reducing Samples of Aggregate to Testing Size
 Reference AASHTO R76-16 (2020)

AASHTO Section	Illinois Modification
7	<p>Replace Section 7 with the following: 7.1 Sample Splitter – Sample splitters shall have an even number of equal width chutes, but not less than a total of eight for coarse aggregate, or twelve for fine aggregate, which discharge alternatively to each side of the splitter. For coarse aggregate and mixed aggregate the minimum width of the individual chutes shall be approximately 50 percent larger than the largest particles in the sample to be split (Note 2). For dry fine aggregate in which the entire sample will pass the 3/8in. (9.5mm) sieve, the minimum width of the individual chutes shall be at least 50 percent larger than the largest particles in the sample and the maximum width shall be 3/4in. (19mm). The splitter shall be equipped with two receptacles to hold the two halves of the sample following splitting. It shall also be equipped with a hopper or straight-edged pan, which has a width equal to or slightly less than the overall width of the assembly of chutes, by which the sample may be fed at a controlled rate to the chutes. The splitter and accessory equipment shall be so designed that the sample will flow smoothly without restriction or loss of material (see Figure 1).</p> <p>Replace Note 3 with the following: Note 2 – Mechanical splitters are commonly available in sizes adequate for coarse aggregate having the largest particles not larger than 1 1/2in. (37.5mm).</p>
8	<p>Revise Section 8 with the following: 8.1 Replace 8.1 with the following: Place the original sample in the hopper or pan and uniformly distribute it from edge to edge, so that when it is introduced in the chutes, approximately equal amounts will flow through each chute. The rate at which the sample is introduced shall be such as to allow free flowing through the chutes into the receptacles below. Reintroduce the portion of the sample in one of the receptacles into the splitter as many times as necessary to reduce the sample to the size specified for the intended test. The portion of the material collected in the other receptacle may be reserved for reduction in size for other tests. Upon the final split, the mass of the two halves (after splitting) shall be within ± 10 percent of each other. This is determined by multiplying mass of the smaller split by (1.10 or 110%); the larger split cannot exceed this calculated mass. If it does, both split halves shall be recombined and split until the mass comparison requirement is met.</p>
9	<p>Revise Section 9 with the following: 9.1 Replace “2 by 2.5 m (6 by 8 ft.)” with “6 by 8ft (2 by 2.5m)”</p>

Standard Test Method
 for
Reducing Samples of Aggregate to Testing Size
 Reference AASHTO R76-16 (2020)

AASHTO Section	Illinois Modification
10	<p>Revise Section 10 with the following:</p> <p>10.1.1 Replace with the following: Mix the material thoroughly on a hard, clean, level surface by turning the entire sample over four times using a shovel. Each shovel full shall be deposited on top of the preceding one. This procedure shall be done three times, resulting in the formation of a small conical pile. Carefully flatten the conical pile to a uniform thickness and diameter by pressing down the apex with a shovel or trowel so that each quarter sector of the resulting pile will contain the material originally in it. The diameter should be approximately four to eight times the thickness. Divide the flattened mass into four equal quarters with a shovel or trowel. Remove two diagonally opposite quarters, including all fine material, and brush the cleared spaces clean. The two unused quarters may be set aside for later use and/or testing if desired. Successively mix and quarter the remaining material until the sample is reduced to the desired size (see Figure 2). Both halves of the final split shall meet the 10 percent comparison requirement of section 8.1 herein.</p> <p>10.1.2 Replace with the following: As an alternative to the procedure in Section 10.1.1, the field sample may be placed on a canvas blanket. Mixing may be accomplished by the shovel method listed in 10.1.1 herein or by alternately lifting each corner of the canvas and pulling over the sample diagonally toward the opposite corner. This causes the material to be rolled and mixed. The material shall then be flattened and divided as required in 10.1.1.</p> <p>(see Figure 3) Both halves of the final split shall meet the 10 percent comparison requirement of section 8.1 herein.</p>
12	<p>Revise Section 12 with the following:</p> <p>12.1 Mix the material thoroughly on a hard, clean, level surface as required in 10.1.1 or 10.1.2. The test sample shall be obtained by selecting at least five increments in a random "X" pattern over the resultant miniature sample pad using a sampling thief, small scoop, or spoon. A sufficient number of increments shall be obtained to provide a test sample slightly larger than the minimum test sample size when dried to a constant mass. For all samples from which a state monitor split will also be obtained, the number of increments shall be doubled to provide a sample twice the minimum required test size. This material shall then be dried to constant mass, as specified in Illinois Modified AASHTO T11, and split in a fine aggregate mechanical splitter according to Method A – Mechanical Splitter. Alternately, the material may also be quartered according to Method B – Quartering. Both halves of the final split shall meet the 10 percent comparison requirement of section 8.1 herein.</p>
13	Delete Section 13

This Page Reserved

Standard Test Method
for
Sampling Aggregate Products
Reference AASHTO R90-18

AASHTO Section	Illinois Modification
1	<p>Revise Section 1 with the following:</p> <p>1.3. Remove “of coarse, fine, or combinations” in the first paragraph. Remove “which the aggregate is furnished” and replace with “the AGCS Policy” in the first paragraph. Add “for the following purposes” to the end of the last sentence of the first paragraph.</p> <p>Replace 1.2 with the following:</p> <p>1.1.1 Preliminary investigation of the potential source of supply.</p> <p>1.1.2 Control of the product at the source of supply.</p> <p>1.1.3 Control of the operations at the site of use.</p> <p>1.1.4 Acceptance or rejection of the materials.</p> <p>Note 1 – Sampling plans and acceptance and control tests vary with the type of construction in which the material is used.</p> <p>1.2 The text of this standard references notes which provide explanatory material. These notes (excluding those in tables and figures) shall not be considered as requirements of the procedure.</p> <p>1.3 The values stated in either SI units or inch-pound units are to be regarded separately as standard. The values stated in each system may not be exact equivalents; therefore, each system shall be used independently of the other. Combining values from the two systems may result in non-conformance with the procedure.</p> <p>1.4 This standard does not purport to address all of the safety concerns, if any, associated with its use. It is the responsibility of the user of this procedure to establish appropriate safety and health practices and determine the applicability of regulatory limitations prior to use.</p> <p>Note 2 – The quality of the results produced by this procedure are dependent on the competence of the personnel performing the procedure and the capability, calibration, and maintenance of the equipment used.</p>
2	<p>Revise Section 2 with the following:</p> <p>2.1. Replace “AASHTO Standards” with “Illinois Modified AASHTO Standards”</p> <p>Replace 2.2 with the following:</p> <p>2.2 Illinois Specification:</p> <ul style="list-style-type: none"> • Illinois Specification 201 Aggregate Gradation Sample Size Table
3	<p>Replace Section 3 with the following:</p> <p>3 TERMINOLOGY</p> <p>3.1 Definitions:</p> <p>3.1.1 Maximum size of aggregate, n—in specifications for, or descriptions of aggregate—the smallest sieve opening through which the entire amount of aggregate is required to pass.</p> <p>3.1.2 Maximum aggregate size, (Superpave) n—in specifications for, or descriptions of aggregate—one size larger than the nominal maximum aggregate size.</p> <p>3.1.3 Nominal maximum aggregate size (of aggregate), n—in specifications for, or descriptions of aggregate—smallest sieve opening through which the entire amount of the aggregate is permitted to pass.</p> <p>3.1.4 Nominal maximum aggregate size (Superpave), n—in specifications for, or descriptions of aggregate—one size larger than the first sieve that retains more than 10% aggregate.</p> <p>3.1.4.1 Discussion – These definitions in 3.1.2 and 3.1.4 apply to hot mix asphalt (HMA) mixtures designed using the Superpave system only.</p> <p>3.1.4.2 Discussion – Specifications on aggregates usually stipulate a sieve opening through which all the aggregate may, but need not, pass so that a slated maximum portion of the aggregate may be retained on that sieve. A sieve opening so designated is the nominal maximum size.</p>
4	<p>Replace Section 4 with the following:</p> <p>4 SIGNIFICANCE AND USE</p> <p>4.1. Sampling is a critical step in determining the quality of the material being evaluated. Care shall be exercised to ensure that samples are representative of the material being evaluated.</p>

Standard Test Method
for
Sampling Aggregate Products
Reference AASHTO R90-18

AASHTO Section	Illinois Modification
	<p>4.2. This practice is intended to provide standard requirements and procedures for sampling coarse and fine aggregate products. The detailed requirements as to materials, interpretation of results, and precision and bias are described in specific test methods.</p> <p>4.3. For sampling of potential aggregate sources and preliminary site investigation, refer to Central Bureau of Materials AGCS Policy Memo.</p>
<p>5</p>	<p>Replace Section 5 with the following:</p> <p>5 APPARATUS</p> <p>5.1 Template – The template shall be designed with two end plates and shall be adjustable. The distance between the end plates may therefore be changed to gather more material from the belt for each increment. The end plates shall also be machined or cut to the approximate belt size and shape. A single template end plate may be used in the sampling method, if care is exercised.</p> <p>5.2 Sampling Device – The sample device used to cut the flow stream from the end of the belt or the bin discharge must be strong enough to handle the force of the flow stream. The device must also be large and deep enough to cut the entire flow stream and not overflow when passing through the stream. The device may be a bucket, a pan, or a manufactured sampling container. Note 3 – Shelby tubes are not allowed as sampling devices.</p> <p>5.3 Shovel – The shovel shall be square-nosed and of a size easily handled. It shall also have built-up sides and back (approximately 1 ½" [37.5mm]) to facilitate the retention of material on the shovel when sampling.</p> <p>5.4. Sampling Containers – Bags or other containers so constructed as to preclude loss or contamination of any part of the sample, or damage to the contents from mishandling during shipment. For moisture content samples, containers must prevent moisture loss.</p>
<p>6</p>	<p>Replace Section 6 with the following:</p> <p>6 PROCEDURE</p> <p>6.1 General – Samples to be tested for quality shall be obtained from the finished product. Samples from the finished product to be tested for abrasion loss shall not be subject to further crushing or manual reduction in particle size in preparation for the abrasion test unless the size of the finished product is such that it requires further reduction for the testing purposes.</p> <p>6.2 Inspection – The material shall be inspected to determine discernible variations. The seller shall provide suitable equipment needed for proper inspection and sampling.</p> <p>6.3 Sampling – Aggregate production sampling shall be accomplished by one of the following methods:</p> <ol style="list-style-type: none"> 1. belt-stream sampling 2. bin-discharge sampling (requires IDOT approval) 3. on-belt sampling 4. truck-dump or stockpile sampling <p>Note 4 – No other sampling methods will be permitted.</p> <p>6.3.1 Sampling from Belt-Stream Discharge or from Bins:</p> <p>Belt-Stream Sampling – The sample shall be taken by cutting the stream of aggregate as it leaves the end of the production belt. A sampling device is passed uniformly through the entire width and depth stream flow during normal production and belt load. Each sampling pass (increment) is combined with others to make up the field sample. A minimum of three increments shall be taken during a 10 to 15 minute sampling period. Enough increments shall be taken and combined to provide the correct field sample size. Extreme care shall be taken to make sure the sampling device passes completely and uniformly through the entire stream flow (from outside the stream on one side to outside the stream on the other side) and to ensure the device does not overflow.</p> <p>Bin Sampling – Bin discharge shall be sampled in a manner similar to belt-stream sampling. A sampling device is passed through the entire bin discharge stream. A minimum of three increments shall be taken during a 10 to 15-minute sampling period and combined to form the field sample. Before cutting the bin discharge stream, the bin must be emptied until such time that the stream of material entering the bin is the stream of material exiting the bin.</p>

Standard Test Method
 for
Sampling Aggregate Products
 Reference AASHTO R90-18

AASHTO Section	Illinois Modification
	<p>Sampling may take place at that time.</p> <p>Extreme care shall be taken to make sure the sampling device passes completely and uniformly through the entire stream flow (from outside the stream on one side to outside the stream on the other side) and to ensure the device does not overflow. Samples shall be taken only during normal plant operation and when the bin is being fed under normal load.</p> <p>The major problems associated with bin-discharge sampling involve segregated material clinging to the sides of the bin. This material can and does break loose, altering the bin-discharge stream gradation. The sampling method therefore shall be used only when approved by the District Engineer.</p> <p>6.3.2 On-Belt Sampling – The sample shall be taken by stopping the belt containing the finished product. A template shall be inserted into the material on the belt. All the material between the template shall be removed and shall represent one of the three increments (minimum) making up the field sample. Extreme care shall be taken, including the use of a brush, to remove all fines on the belt between the template for inclusion in the increment. The belt shall be stopped at least three times (three increments) during approximately 10 to 15 minutes of operation to obtain a field sample. If additional material is needed beyond three increments due to the amount of material on the belt, additional template cuts may be taken during the three belt stoppages. Automatic samplers may be used as long as the gradations compare to samples taken with the sample template. Contact the Central Bureau of Materials for further guidance.</p> <p>Samples shall be taken only during normal plant operation and when the belt is under normal load.</p> <p>6.3.3 Sampling from Truck-Dumps or from Stockpiles – Sampling from inside of transportation units is not permitted. The transportation unit shall be off-loaded and sampled by any of the sampling methods listed, herein.</p> <p>Truck-Dump Sampling – The sample shall be taken by placing one or two truck dumps together. This may occur during the building of a stockpile or feeding of a plant. The truck dump(s) shall be cut with an end loader and two or more bucket loads extracted. The bucket loads shall be dumped on one another to form a small pile. The small pile shall then be mixed from two directions perpendicular to each other. To mix the pile, the end loader shall cut into the pile along its base until approximately its midpoint. The loader bucket shall be lifted, the loader moved 1 to 2 feet forward, and the bucket dumped on the other half of the pile. Care shall be exercised to avoid cutting below the base of the truck dumps or small pile and contaminating the material to be sampled.</p> <p>After mixing twice, the end loader shall drop the angle of its bucket downward on one side of the pile and back drag the pile into a layer not less than 1 foot thick. The layer shall be sampled using a required shovel to take increments in a random “X” pattern over the layer. The shovel shall be forced vertically to its full depth when sampling each increment except that care shall be used to not dig completely through the layer. This would contaminate the sample being obtained. Care shall also be exercised to retain as much material on the shovel as possible when taking increments. Sufficient increments shall be taken to make up a correct field sample.</p> <p>CS01, CS02, RR1 and RR2 Sampling – The preparation of the sample pile shall be in accordance with section 6.3.3 on truck-dump sampling except after mixing twice, the end loader shall not back drag or strike off the top of the pile. The sample pile shall then be split in half by the end loader dragging away one half of the pile leaving a vertical slope. Spanning the breadth of the vertical face the sample shall be taken from higher and lower points in a “W” fashion. Sufficient increments shall be taken to obtain the correct field sample size.</p> <p>Stockpile Sampling – The sample shall be taken from the working face of the stockpile. The working face shall be perpendicular to the direction of flow used to build the stockpile. Stockpiles having no working face shall have one established prior to sampling. The working face shall have the interior of the pile exposed to permit proper re-blending of the pile to eliminate segregated aggregate. If necessary, material may be brought out of the main pile’s working face into the sub-stockpile for</p>

Standard Test Method
 for
Sampling Aggregate Products
 Reference AASHTO R90-18

AASHTO Section	Illinois Modification
	<p>sampling. The stockpile sampling method shall follow the truck-dump sampling method using an end loader. The end loader shall cut across the working face as detailed in "Truck-Dump Sampling." Any special mixing procedure used during loading shall be used when taking any samples. This is the only acceptable method for acquiring quality samples. 6.4 Masses of Field Samples: 6.4.1 Field Sample Sizes – The field sample size shall meet the minimum requirements as detailed in the Illinois Specification 201.</p>
<p>7</p>	<p>Replace Section 7 with the following: 7 SHIPPING SAMPLES 7.1 Transport aggregates in bags or other containers so constructed as to preclude loss or contamination of any part of the sample, or damage to the contents from mishandling during shipment. 7.2 Shipping containers for aggregate samples shall have a LM-5 envelope attached to the container. Written on the outside of the LM-5 shall be the following information: producer number, test id# (including suffix), material code, ledge description. The required information to be written on the outside of the LM-5 shall also be written on the outside of the sample container. Inside the LM-5 shall contain a fully completed LM-6 form. The LM-6 form shall be the most recent version of the Central Bureau of Materials online template. 7.3 Red Tag Samples – Used for Quality Samples only. 8.3.1 The Central Bureau of Materials has established a procedure which allows the producer the opportunity to deliver their quality samples directly to the Central Bureau of Materials in Springfield. The sample, taken by the District, will be sampled following the procedures outlined in 6.3.3. Upon completion of the sampling the District shall "Red Tag" the sample containers. During the tagging process the District shall write the "Red Tag" serial number on the LM-6 form. If the serial number is not indicated on the LM-6 form the samples will not be accepted. Once the sample containers are tagged and documentation has been completed the producer will then be allowed to deliver the samples to the Central Bureau of Materials.</p>

Standard Method of Test
 For
Making and Curing Concrete Test Specimens in the Field

Reference AASHTO [R 100-21](#)
 (formerly [AASHTO T 23](#))

AASHTO Section	Illinois Modification
2.1	Revise as follows: AASHTO M 201 (Illinois Modified) AASHTO M 205 (Illinois Modified) AASHTO R 39 (Illinois Modified) AASHTO T 119 (Illinois Modified) AASHTO T 121 (Illinois Modified) AASHTO R 60 (Illinois Modified) AASHTO T 152 (Illinois Modified) AASHTO T 196 (Illinois Modified) AASHTO T 231 (Illinois Modified)
	To maintain brevity in the text, the following will apply: Example: AASHTO T 119 (Illinois Modified) will be designated as “T 119.”
2.2	Add as follows: ASTM C1064/C1064M (Illinois Modified)
	To maintain brevity in the text, the following will apply: Example: ASTM C 1064/C 1064M (Illinois Modified) will be designated as “ASTM C 1064.”
4.3, 4.3.1, 4.3.2, 4.3.3, and 4.3.4	Replace as follows: Strength specimens shall be field cured with the construction item as follows: <i>Cast-in-Place Concrete</i> <ul style="list-style-type: none"> • Whenever the Contractor desires to open the pavement or shoulder to traffic prior to 14 days from time of concrete placement. • Whenever pavement patching or bridge deck patching is performed. • Whenever a sequential deck pour is involved, and the Contractor wants to pour the next portion of deck based on a previous deck pour strength of 650 psi (4,500 kPa) flexural or 3500 psi (24,000 kPa) compressive.

Standard Method of Test
 For
Making and Curing Concrete Test Specimens in the Field
 (continued)
 Reference AASHTO [R 100-21](#)
 ([formerly AASHTO T 23](#))

AASHTO Section	Illinois Modification
4.3, 4.3.1, 4.3.2, 4.3.3, and 4.3.4 continued	<ul style="list-style-type: none"> • As directed by the Engineer. The need to field cure strength specimens with the construction item is appropriate when the concrete curing temperature experienced in the field will be significantly different from the concrete curing temperature experienced in the laboratory. This will most often occur for concrete work done in the spring and fall. In this situation, it is not unusual for field air temperatures to be low, but not low enough to require cold weather concrete protection. As an example, a cement only concrete mix that is cured in the field at 13 °C (55 °F) will have significantly lower strengths at 3, 7, and 14 days than concrete cured in the laboratory at 23 ± 2 °C (73 ± 3 °F). However, by 28 days, the concrete cured in the field should have comparable strength to the concrete cured in the laboratory. <p>Therefore, it is important for the Engineer to consider daily high and low temperatures, concrete temperature of the delivered concrete, insulation benefit obtained from the forms and curing method, and the heat of hydration generated from the size of the pour. These factors will determine if field curing of strength specimens is warranted</p> <p>It should be noted that strength specimens cured in the field shall be in the same manner as the pavement or structure, which may include such thing as insulation if used</p> <p><i>Precast Concrete</i></p> <ul style="list-style-type: none"> • For precast concrete products, this shall be according to Article 1020.13 (Notes for Index Table of Curing and Protection of Concrete Construction) of the Standard Specifications for Road and Bridge Construction. <p><i>Precast Prestressed Concrete</i></p> <ul style="list-style-type: none"> • For precast prestressed concrete products, this shall be according to Section 1.2.4 “Quality Control Testing Requirements” of the Manual for Fabrication of Precast Prestressed Concrete Products.
5.1	Replace the first sentence as follows: Beam molds shall be made of steel or plastic, and cylinder molds shall be made of plastic. However, for precast products and precast prestressed products, metal cylinder molds may be used.

Standard Method of Test
 For
Making and Curing Concrete Test Specimens in the Field
 (continued)

Reference AASHTO R 100 -21
 (formerly AASHTO T 23)

AASHTO Section	Illinois Modification
5.3	Revise as follows: Delete the fourth and fifth sentences, and add after the third sentence: Beam molds with an interior radius at the bottom or top of the mold are unacceptable.
5.4	Revise as follows: The tamping rod shall be at least 584 mm (23 in.) in length for the 150 mm (6 in.) diameter cylinder or 150 mm (6 in.) wide beam and shall be 10 mm (3/8 in.) in diameter and at least 350 mm (14 in.) in length for the 100 mm (4 in.) diameter cylinder.
5.12	Revise as follows: The temperature measuring devices shall conform to the applicable requirements of ASTM C 1064.
6.2	Replace as follows: <i>Flexural Strength Specimens</i> —Flexural strength specimens shall be rectangular beams of concrete cast and hardened with long axes horizontal. The beam cross section shall be 152 by 152 mm (6 by 6 in.), and shall have a maximum tolerance of ± 6 mm ($\pm 1/4$ in.) in either direction. The beam length shall overhang a minimum of 23 mm (1 in.) at each end of the testing machine's span length. If two breaks are desired with one beam, the beam length shall be a minimum 756 mm (29-3/4 in.) and the machine's span length shall be a maximum of 406 mm (16 in.).
8.3	Revise as follows: Determine and record the temperature in accordance with ASTM C 1064.
10.1.2	Add as follows: A plastic cover with an absorbent pad saturated with water, is an acceptable method to cover beam molds. The plastic cover and absorbent pad shall be the preferred method to cover beam molds. A plastic cylinder lid shall be the preferred method to cover cylinder molds.
10.2, 10.2.1, and 10.2.2	Replace as follows: <i>Field Curing</i> —Store test specimens as near to the point of deposit of the concrete represented as possible. However, some instances may require a distinct and separate location. Therefore, carefully select the field location since the test specimens will generate minimal heat from hydration. The test specimens shall have the same curing method and shall be in the same field environment as the construction item. If form work is removed, remove test specimens from their molds. At the time of testing, guard against the drying of the test specimen if appropriate.

This Page Reserved

This Page Reserved

AASHTO TP 124 is discontinued. Please refer to AASHTO T 393.

This Page Reserved

AASHTO TP 124 is discontinued. Please refer to AASHTO T 393.

Illinois Modified Test Procedure
Effective Date: November 15, 2019

Standard Test Method
for
Emulsified Asphalt Content of Cold Recycled Mixture Designs

Reference AASHTO PP 86-17

AASHTO Section	Illinois Modification
5.1.1	Add the following sentence to the end of the first paragraph: “One sample per lane mile of planned CCPR shall be the minimum sampling frequency for mix design preparation.”
8.1.1.1	Replace the following in the second paragraph: “For Marshall stability testing from T 245, determine the amount of RAP material required to produce a 100-mm (4-in.) diameter...” With: “For Marshall stability testing from T 245, determine the amount of RAP material required to produce a 150 mm (6 in.) diameter...”
Note 8	Delete second sentence. “Compact at 75 blows per side if using a Marshall compaction apparatus.”
Note 9	Delete: “Choose only one strength or stability test.” Replace with the following: “Both indirect tensile strength and Marshall stability tests shall be performed.”
9.7	Change GRAP to $G_{se,RAP}$. Change calculation (2) to: $G_{mm} = \frac{100}{\frac{(100 - P_{br})}{G_{se,RAP}} + \left(\frac{P_{br}}{G_b}\right)}$ Add $G_{se,RAP}$ to where: $G_{se,RAP}$ = Effective specific gravity of RAP
10	Replace section 10 with the following: 10 RAVELING TEST 10.1. Mix specimens at the target optimum emulsified asphalt content established. Mix according to ASTM D7196, Method B. 10.2. Cure the specimens for 4 hours at 10±2°C (50±4°F), at specified humidity if required. 10.3. Abrade the specimens for 15 minutes according to ASTM D7196. 10.4. Record the percent mass loss according to ASTM D7196.

This Page Reserved

**Standard Test Method for Sampling, Determining Yield
and Air Content, and Making and Curing Strength Test
Specimens of Self-Consolidating Concrete**

I. SAMPLING OF FRESHLY MIXED CONCRETE

Sampling freshly mixed self-consolidating concrete (SCC) shall be performed according to Illinois Modified AASHTO R 60, except the elapsed time for obtaining the representative sample shall not exceed two minutes. The number of testing personnel shall be such that all tests shall start within five minutes of obtaining the representative sample.

II. YIELD AND AIR CONTENT OF FRESHLY MIXED CONCRETE

The yield test shall be according to Illinois Modified AASHTO T 121, except the measure shall be filled in one lift without vibration, rodding, or tapping. The air content test shall be according to Illinois Modified AASHTO T 152 or T 196, except the bowl shall be filled in one lift without vibration, rodding, or tapping.

III. MAKING AND CURING CONCRETE STRENGTH TEST SPECIMENS

Strength test specimens shall be made according to Illinois Modified AASHTO [R 100](#) or R 39, except for the following:

- a. The specimen molds shall be filled using a suitable container in one lift without vibration, rodding, or tapping.
- b. Strike off the surface of the concrete level with the top of the mold using the strike-off bar or tamping rod.
- c. The slump flow, VSI, air content, and temperature of each batch of concrete, from which specimens are made, shall be measured immediately after remixing.

This Page Reserved

Standard Test Method for Slump Flow and Stability of Self-Consolidating Concrete

Referenced Test Procedure(s):

1. Illinois Test Procedure SCC-1, Sampling, Determining Yield and Air Content, and Making and Curing Strength Test Specimens of Self-Consolidating Concrete
2. AASHTO T 119 (Illinois Modified), Slump of Hydraulic-Cement Concrete
3. ASTM E 29 (Illinois Modified), Standard Practice for Using Significant Digits in Test Data to Determine Conformance with Specifications

To maintain brevity in the text, the following will apply:

Example: Illinois Test Procedure SCC-1 will be designated as "Illinois Test SCC-1."
AASHTO T 119 (Illinois Modified) will be designated as "T 119."
ASTM E 29 (Illinois Modified) will be designated as "ASTM E 29."

1. GENERAL

This test method covers the determination of flowability and stability of fresh self-consolidating concrete (SCC). The average diameter of the slump flow is a measure of the filling ability (flowability) of SCC. The Visual Stability Index (VSI) is a measure of the dynamic segregation resistance (stability) of SCC.

All rounding shall be according to ASTM E 29.

2. EQUIPMENT

- a. Mold and Tamping Rod – The mold and tamping rod shall conform to that described in T 119.
- b. Strike-Off Bar – *Optional*. The strike-off bar shall be a flat straight bar at least 3 mm (0.125 in.) x 20 mm (0.75 in.) x 300 mm (12 in.).
- c. Base Plate – The base plate shall be of a smooth, rigid, and nonabsorbent poly methyl methacrylate (e.g. Plexiglas®, Lucite®, etc.) or high-density overlay (HDO) plywood material, and be of sufficient dimensions to accommodate the maximum slump flow. *Optional*: Centered on the testing surface of the base plate shall be a marked circle of diameter 500 mm (20 in.).
- d. Suitable container for filling inverted slump cone.
- e. Measuring Tape – The measuring tape shall have a minimum gradation of 10 mm (0.5 in.).
- f. Stopwatch – *Optional*. The stopwatch shall have a minimum reading of 0.2 seconds.

3. MATERIALS

The sample of SCC from which test specimens are made shall be obtained according to Section I of Illinois Test SCC-1.

4. PROCEDURE

- a. Dampen the slump cone and base plate. Ensure excess water is removed from the testing surface as too much water may influence the Visual Stability Index (VSI) rating.

- b. Place the base plate on level, stable ground. Center the mold on the base plate. The mold shall be placed inverted with the smaller diameter opening down.
- c. Fill the mold in one lift without vibration, rodding, or tapping.
- d. Strike off the surface of the concrete level with the top of the mold using the tamping rod or strike-off bar. Remove surplus concrete from around the base of the mold and base plate surface.
- e. Raise the mold vertically a distance of 225 ± 75 mm (9 ± 3 in.) in 3 ± 1 seconds without any lateral or torsional motion. Complete the test procedure from the start of filling through removal of the mold without interruption and within an elapsed time of 2.5 minutes.
- f. *Optional.* Measured from the time the mold is lifted, determine the time in seconds it takes for the concrete flow to reach a diameter of 500 mm (20 in.). This is the T_{50} time.

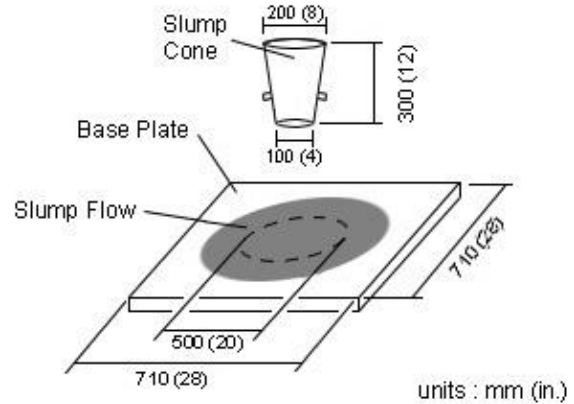

Figure 1. Slump Flow Test

- g. When the concrete has stopped flowing, measure the maximum diameter of the resulting slump flow and measure the diameter perpendicular to the maximum. Each measurement shall be to the nearest 10 mm (0.5 in.). If the two measurements differ by more than 50 mm (2 in.), verify base plate to be level, and test again.
- h. Calculate the average of the two measured diameters. This is the slump flow.
- i. By visual examination, rate the Visual Stability Index (VSI) of the SCC using the criteria in Table 1 and illustrated in Figures 2 – 9.

TABLE 1 – VISUAL STABILITY INDEX (VSI)

VSI	CRITERIA
0 stable	No evidence of segregation or bleeding in slump flow, mixer drum/pan, or sampling receptacle (e.g. wheelbarrow).
1 stable	No mortar halo or coarse aggregate heaping in the slump flow, but some slight bleeding and/or air popping is evident on the surface of the slump flow, or concrete in the mixer drum/pan or sampling receptacle (e.g. wheelbarrow).
2 unstable	Slight mortar halo, ≤ 10 mm (0.5 in.) wide, and/or coarse aggregate heaping in the slump flow, and highly noticeable bleeding in the mixer drum/pan or sampling receptacle (e.g. wheelbarrow).
3 unstable	Clearly segregated by evidence of a large mortar halo, > 10 mm (0.5 in.), and/or large coarse aggregate pile in the slump flow, and a thick layer of paste on the surface of the concrete sample in the mixer drum or sampling receptacle (e.g. wheelbarrow).

5. REPORT

- a. Report the slump flow (average of two measured diameters) to the nearest 5 mm (0.25 in.).
- b. Report the VSI.
- c. *Optional.* Report the T_{50} time to the nearest 0.2 second.



Figure 2. VSI = 0, stable



Figure 3. VSI = 0, stable



Figure 4. VSI = 1, stable



Figure 5. VSI = 1, stable



Figure 6. VSI = 2, unstable



Figure 7. VSI = 2, unstable



Figure 8. VSI = 3, unstable

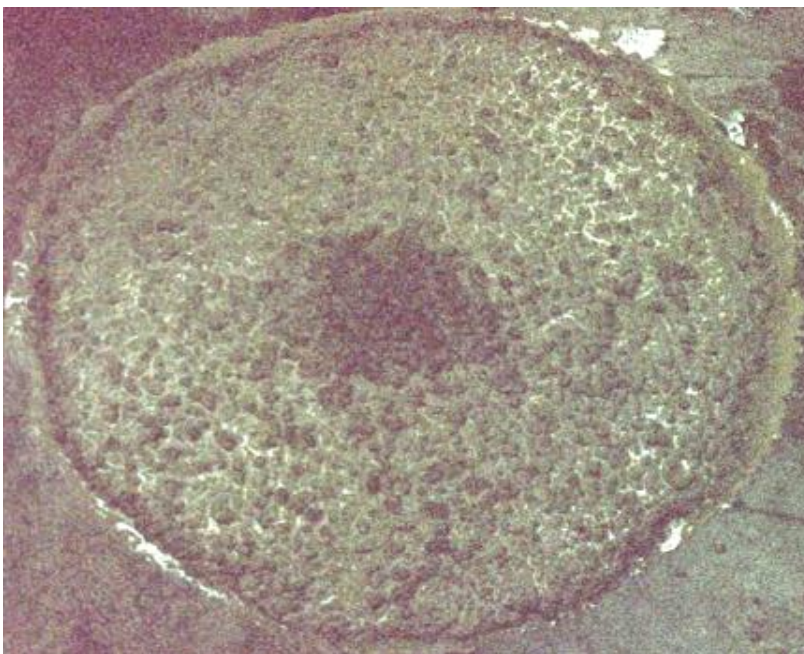

Figure 9. VSI = 3, unstable

Standard Test Method for Passing Ability of Self-Consolidating Concrete by J-Ring and Slump Cone

Referenced Test Procedure(s):

1. Illinois Test Procedure SCC-1, Sampling, Determining Yield and Air Content, and Making and Curing Strength Test Specimens of Self-Consolidating Concrete
2. Illinois Test Procedure SCC-2, Slump Flow and Stability of Self-Consolidating Concrete
3. AASHTO T 119 (Illinois Modified), Slump of Hydraulic-Cement Concrete
4. ASTM E 29 (Illinois Modified), Standard Practice for Using Significant Digits in Test Data to Determine Conformance with Specifications

To maintain brevity in the text, the following will apply:

Example: Illinois Test Procedure SCC-1 will be designated as "Illinois Test SCC-1."
AASHTO T 119 (Illinois Modified) will be designated as "T 119."
ASTM E 29 (Illinois Modified) will be designated as "ASTM E 29."

1. GENERAL

This test method covers the determination of the flowability and passing ability of self-consolidating concrete (SCC) using the J-Ring and Slump Cone. The diameter of the unobstructed slump flow versus the obstructed slump flow passing through the J-Ring is a measure of the passing ability of SCC.

All rounding shall be according to ASTM E 29.

2. EQUIPMENT

- a. J-Ring – See Figure 1. The J-Ring shall consist of sixteen evenly spaced smooth steel rods of 16 mm (5/8 in.) diameter and 100 mm (4 in.) length.
- b. Mold and Tamping Rod – The mold and tamping rod shall conform to that described in T 119.
- c. Strike-Off Bar – *Optional*. The strike-off bar shall be a flat straight bar minimum 3 x 20 x 300 mm (0.125 x 0.75 x 12 in.).
- d. Base Plate – The base plate shall be of a smooth, rigid, nonabsorbent poly methyl methacrylate (e.g. Plexiglas®, Lucite®, etc.) or high-density overlay (HDO) plywood material, and be of sufficient dimensions to accommodate the maximum slump flow.
- e. Suitable container for filling inverted slump cone.
- f. Measuring Tape – The measuring tape shall have a minimum gradation of 10 mm (0.5 in.).

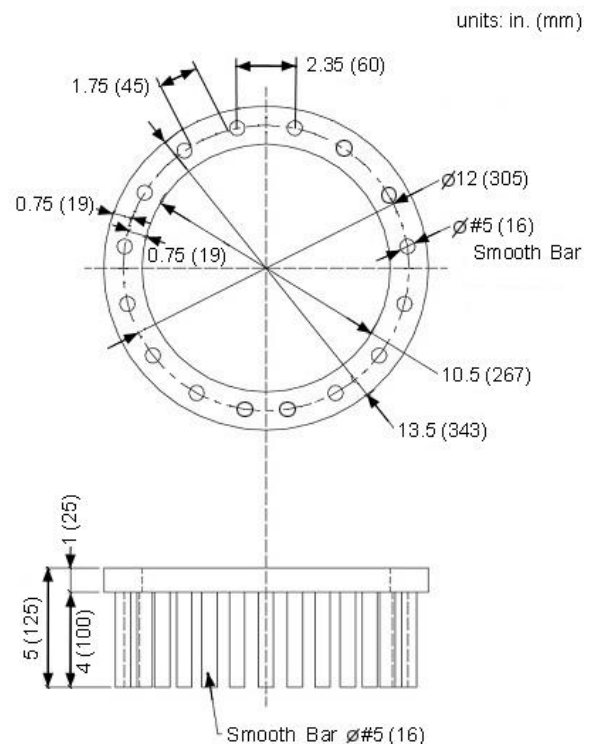

3. MATERIALS

The sample of SCC from which test specimens are made shall be obtained according to Section I of Illinois Test SCC-1.

4. PROCEDURE

- a. Dampen the J-Ring, slump cone, and base plate.
- b. Place the base plate on level, stable ground. Center the J-Ring on the base plate. The mold shall be centered within the J-Ring and inverted with the smaller diameter opening down.
- c. Fill the mold in one lift without vibration, rodding, or tapping.
- c. Strike off the surface of the concrete level with the top of the mold using the tamping rod or strike-off bar. Remove surplus concrete from around the base of the mold and base plate surface.
- e. Raise the mold vertically a distance of 225 ± 75 mm (9 ± 3 in.) in 3 ± 1 seconds without any lateral or torsional motion. Complete the test procedure from the start of filling through removal of the mold without interruption and within an elapsed time of 2.5 minutes.
- f. When the concrete has stopped flowing, measure the maximum diameter of the resulting slump flow and measure the diameter perpendicular to the maximum. Each measurement shall be the nearest 10 mm (0.5 in.). If the two measurements differ by more than 50 mm (2 in.), verify base plate to be level, and test again.

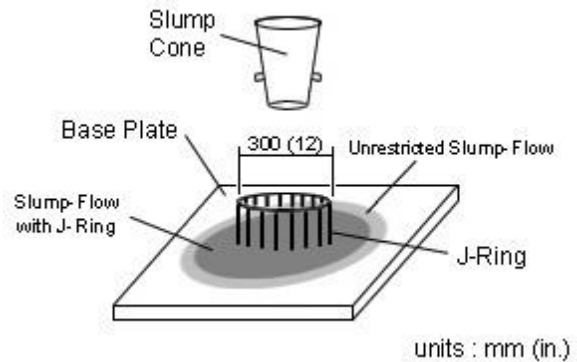

Figure 2. J-Ring Test

- a. Calculate the average of the two measured diameters. This is the J-Ring flow.
- b. Calculate the difference between the J-Ring flow and the unobstructed slump flow, as tested according to Illinois Test SCC-2, of the same representative sample. This is the J-Ring value. Rate the passing ability of SCC using the criteria in Table 1.

Table 1 – Passing Ability Rating

J-Ring Value, mm (in.)	Passing Ability Rating	Remarks
0 – 25 (0 – 1)	0	High passing ability
> 25 – 50 (> 1 – 2)	1	Moderate passing ability
> 50 (> 2)	2	Low passing ability

5. REPORT

- a. Report the unobstructed slump flow (average of two measured diameters) and J-Ring flow (average of two measured diameters) to the nearest 5 mm (0.25 in.).
- b. Report the J-Ring value and corresponding passing ability rating.

Standard Test Method for Passing Ability of Self-Consolidating Concrete by L-Box

Referenced Test Procedure(s):

1. Illinois Test Procedure SCC-1, Sampling, Determining Yield and Air Content, and Making and Curing Strength Test Specimens of Self-Consolidating Concrete
2. AASHTO T 119 (Illinois Modified), Slump of Hydraulic-Cement Concrete
3. ASTM E 29 (Illinois Modified), Standard Practice for Using Significant Digits in Test Data to Determine Conformance with Specifications

To maintain brevity in the text, the following will apply:

Example: Illinois Test Procedure SCC-1 will be designated as "Illinois Test SCC-1."
AASHTO T 119 (Illinois Modified) will be designated as "T 119."
ASTM E 29 (Illinois Modified) will be designated as "ASTM E 29."

1. GENERAL

This test method covers the determination of the flowability and passing ability of self-consolidating concrete (SCC) using the L-Box. The flow heights ratio is a measure of the passing ability of SCC. The flow times (T_{20} and T_{40}) are a measure of the flowability of SCC.

All rounding shall be according to ASTM E 29.

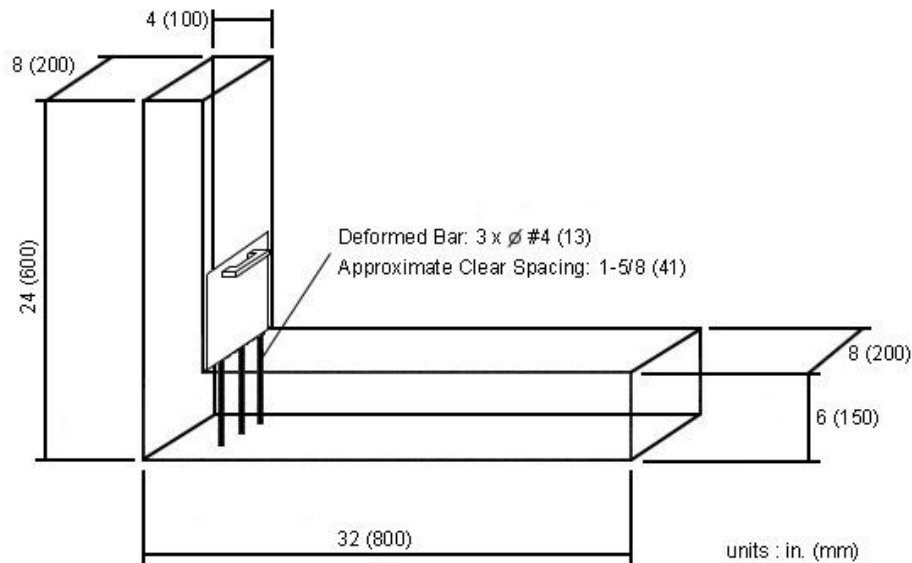

Figure 1. L-Box Apparatus

2. EQUIPMENT

- a. L-Box – See Figure 1. The inside surface of the L-Box walls shall be of a smooth, rigid, nonabsorbent material.
- b. Tamping Rod or Strike-Off Bar – The tamping rod shall conform to that described in T 119. The strike-off bar shall be a flat straight bar at least 0.125 x 0.75 x 12 in. (3 x 20 x 300 mm).
- c. Suitable container for filling L-Box.
- d. Measuring Tape – The measuring tape shall have a minimum gradation of 0.25 in. (5 mm).
- e. Stopwatch – *Optional*. The stopwatch shall have a minimum reading of 0.2 seconds.

3. MATERIALS

The sample of SCC from which test specimens are made shall be obtained according to Section I of Illinois Test SCC-1.

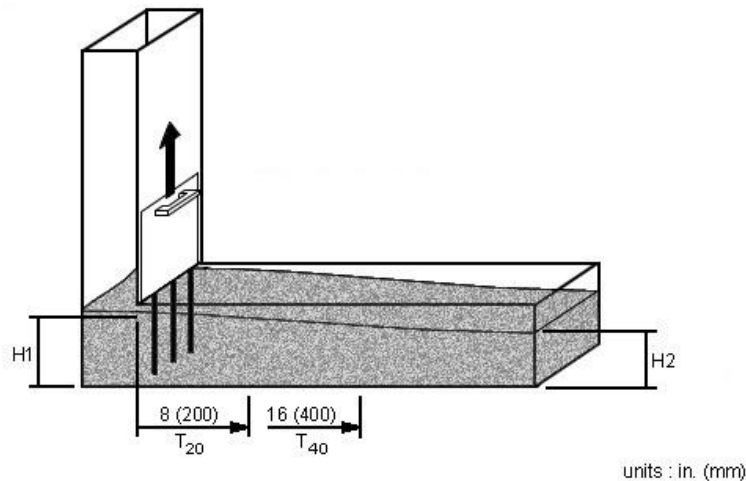

Figure 2. L-Box Test

4. PROCEDURE

- Dampen the L-Box.
- Place the L-Box on level, stable ground.
- Ensure the sliding gate is shut, and fill the vertical of the L-Box in one lift without vibration, rodding, or tapping.
- Strike off the surface of the concrete level with the top of the L-Box using the tamping rod or strike-off bar.
- Allow the test specimen to stand for 1 minute.
- Raise the sliding gate. Complete the test procedure from the start of filling through opening of the sliding gate without interruption and within 5 minutes.
- Optional.* Determine the time in seconds it takes for the concrete flow to travel 8 in. (200 mm) and 16 in. (400 mm), as measured from the time the sliding gate is lifted. These are the T_{20} and T_{40} times, respectively. Refer to Figure 2.
- When the concrete has stopped flowing, measure the height of the resulting flow at the sliding gate, H_1 , and at the end of the horizontal, H_2 , to the nearest 0.25 in. (5 mm). However, if a significant amount of coarse aggregate has not passed through the gate, then the test shall be considered failing and the blocking ratio disregarded.
- Calculate the blocking ratio as follows:

$$\text{Blocking Ratio} = \frac{H_2}{H_1} \times 100$$

5. REPORT

- Report the filling heights, H_1 and H_2 , to the nearest 0.25 in. (5 mm).
- Report the blocking ratio, H_2/H_1 , to the nearest 1 percent.
- Report observations of aggregate blockage, bleeding, and/or air popping of the concrete.
- Optional.* Report the T_{20} and T_{40} flow times to the nearest 0.2 second.

Standard Test Method for Static Segregation of Hardened Self-Consolidating Concrete Cylinders¹

Referenced Test Procedure(s):

1. Illinois Test Procedure SCC-1, Sampling, Determining Yield and Air Content, and Making and Curing Strength Test Specimens of Self-Consolidating Concrete
2. AASHTO T 22 (Illinois Modified), Compressive Strength of Cylindrical Concrete Specimens
3. AASHTO R 100 (Illinois Modified), Making and Curing Concrete Test Specimens in the Field
4. AASHTO T 24, Obtaining and Testing Drilled Cores and Sawed Beams of Concrete
5. AASHTO T 119 (Illinois Modified), Slump of Hydraulic-Cement Concrete
6. AASHTO R 39 (Illinois Modified), Making and Curing Concrete Test Specimens in the Laboratory

To maintain brevity in the text, the following will apply:

Example: Illinois Test Procedure SCC-1 will be designated as “Illinois Test SCC-1.”
AASHTO T 22 (Illinois Modified) will be designated as “T 22.”

1. GENERAL

This test method covers the determination of the static segregation resistance (stability) of self-consolidating concrete (SCC). The visual assessment, using a Hardened Visual Stability Index (HVS), of cast or cored hardened cylinders cut lengthwise in two is a measure of the stability of SCC.

2. EQUIPMENT

- a. Mold – The mold shall be a 6 x 12 in. (150 x 300 mm) cylinder mold and conform to R 100 or R 39.
- b. Tamping Rod or Strike-Off Bar – The tamping rod shall conform to that described in T 119. The strike-off bar shall be a flat straight bar at least 0.125 x 0.75 x 12 in. (3 x 20 x 300 mm).
- c. Suitable container for filling specimen molds.
- d. Saw – The saw shall have a diamond or silicon-carbide cutting edge and shall be capable of cutting specimens without excessive heating or shock.
- e. Core Drill – The core drill shall have diamond impregnated bits attached to a core barrel.

3. MATERIALS

The sample of SCC from which fresh test specimens are made shall be obtained according to Section I of Illinois Test SCC-1. Cored specimens from hardened concrete shall be obtained according to T 24 and have a minimum diameter of 50 mm (2 in.). When necessary as determined by the Engineer, the core may be taken so that its axis is perpendicular to the concrete as it was originally placed as long as the core diameter is sufficiently large enough to assess extent of static segregation.

¹Test method developed by the Illinois Department of Transportation (Original Effective Date: August 12, 2004). Test method submitted to AASHTO by Illinois Department of Transportation. The AASHTO version is similar and is known as AASHTO PP 58.

4. PROCEDURE

- a. A minimum of two fresh test specimens shall be made according to R 100 or R 39, except for the following:
 - i. The specimen molds shall be filled in one lift using a suitable container without vibration, rodding, or tapping.
 - ii. Strike off the surface of the concrete level with the top of the mold using the strike-off bar or tamping rod.
 - iii. The slump flow, VSI, air content, and temperature of each batch of concrete, from which specimens are made, shall be measured immediately after remixing.
- b. Immediately after being struck off, the specimens shall be capped with a plastic cylinder lid and moved to the storage place where they will remain undisturbed. The specimens shall be assigned an identification number, and the date of molding, location of concrete, and mix design number shall be recorded.
- c. Before being subjected to sawing, the specimens shall have had a minimum curing period of 24 hours at a minimum temperature of 16 °C (60 °F) **or** attained a minimum compressive strength of 6200 kPa (900 psi) according to T 22.
- d. The specimens shall be saw cut lengthwise down the center through its diameter. If the specimen cannot be satisfactorily sawed smooth from lack of curing, then the remaining specimen(s) shall remain undisturbed for an additional minimum curing period of 24 hours before being subjected to sawing.
- e. Make a visual assessment of the cut plane of the hardened concrete cylinder(s) using the criteria in Table 1 and illustrated in Figures 1 – 8. The cut plane shall be wetted to facilitate visual inspection.

Table 1 – Hardened Visual Stability Index (HVSİ)

HVSİ	CRITERIA
0 stable	No mortar layer at the top of the cut plane and no variance in size and percent area of coarse aggregate distribution from top to bottom.
1 stable	Slight mortar layer, less than or equal to 6 mm (1/4 in.) tall, at the top of the cut plane and slight variance in size and percent area of coarse aggregate distribution from top to bottom.
2 unstable	Mortar layer, less than or equal to 25 mm (1 in.) tall, at the top of the cut plane and distinct variance in size and percent area of coarse aggregate distribution from top to bottom.
3 unstable	Clearly segregated as evidenced by a mortar layer greater than 25 mm (1 in.) tall and considerable variance in size and percent area of coarse aggregate distribution from top to bottom.

5. REPORT

- a. Report the identification number and required information for each hardened specimen.
- b. Report the Hardened Visual Stability Index (HVSİ) for each hardened specimen.

¹Test method developed by the Illinois Department of Transportation (Original Effective Date: August 12, 2004). Test method submitted to AASHTO by Illinois Department of Transportation. The AASHTO version is similar and is known as AASHTO PP 58.

Single Coarse Aggregate Mixture

Uniformly Graded Coarse Aggregate Mixture

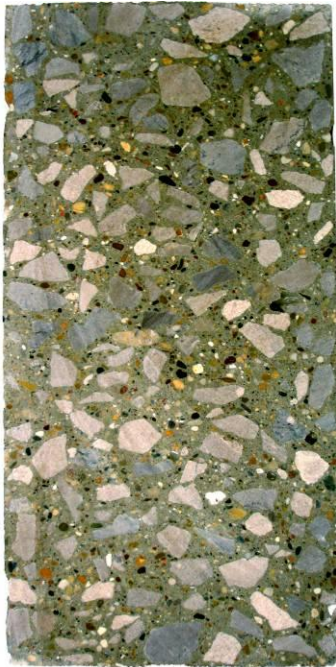

Figure 1. HVSI = 0, stable



Figure 2. HVSI = 0, stable

No mortar layer.
Uniform distribution
of coarse aggregate
from top to bottom.



Figure 3. HVSI = 1, stable

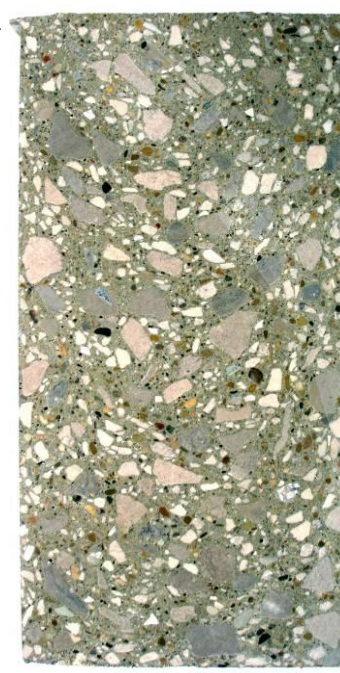

Figure 4. HVSI = 1, stable

Slight mortar layer,
 ≤ 6 mm (1/4 in.),
and slight variance
of coarse aggregate
distribution from top
to bottom.

¹Test method developed by the Illinois Department of Transportation (Original Effective Date: August 12, 2004). Test method submitted to AASHTO by Illinois Department of Transportation. The AASHTO version is similar and is known as AASHTO PP 58.

Single Coarse Aggregate Mixture

Uniformly Graded Coarse Aggregate Mixture



Figure 5. HVSI = 2, unstable

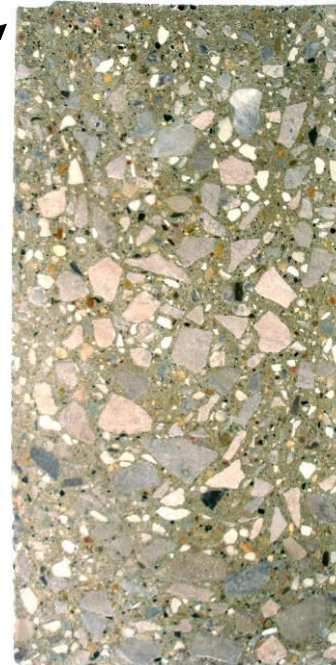

Figure 6. HVSI = 2, unstable

Visible mortar layer ≤ 1 in. (25 mm), and distinct variance of coarse aggregate distribution from top to bottom.



Figure 7. HVSI = 3, unstable



Figure 8. HVSI = 3, unstable

Visible Mortar layer > 1 in. (25 mm) and considerable variance of coarse aggregate distribution from top to bottom.

Note contrast at top. This is a layer of foam, which may be visible in any stable or unstable mix.

¹Test method developed by the Illinois Department of Transportation (Original Effective Date: August 12, 2004). Test method submitted to AASHTO by Illinois Department of Transportation. The AASHTO version is similar and is known as AASHTO PP 58.

Test Method for Assessment of Dynamic Segregation of Self-Consolidating Concrete During Placement¹

Referenced Test Procedure(s):

1. Illinois Test Procedure SCC-6, Standard Test Method for Static Segregation of Hardened Self-Consolidating Concrete Cylinders
2. Illinois Specification 101, Minimum Requirements for Electronic Balances
3. AASHTO M 92, Standard Specification for Wire Cloth Sieves for Testing Purposes
4. AASHTO R 100 (Illinois Modified), Making and Curing Concrete Test Specimens in the Field
5. AASHTO T 119 (Illinois Modified), Slump of Hydraulic-Cement Concrete
6. ASTM E 29 (Illinois Modified), Standard Practice for Using Significant Digits in Test Data to Determine Conformance with Specifications

To maintain brevity in the text, the following will apply:

Example: Illinois Test Procedure SCC-1 will be designated as "Illinois Test SCC-1."
AASHTO R 100 (Illinois Modified) will be designated as "R 100."
ASTM E 29 (Illinois Modified) will be designated as "ASTM E 29."

1. GENERAL

This test method covers the evaluation of the dynamic segregation resistance (stability) of self-consolidating concrete (SCC). The visual assessment using a Hardened Visual Stability Index (HVSI) or the coarse aggregate weight (mass) retained ratio are measures of the stability of SCC.

All rounding shall be according to ASTM E 29.

2. EQUIPMENT

- a. Specimen Mold – The mold shall be a 6 x 12 in. (150 x 300 mm) cylinder mold and conform to R 100.
- b. Tamping Rod or Strike-Off Bar – The tamping rod shall conform to that described in T 119. The strike-off bar shall be a flat straight bar at least 0.125 x 0.75 x 12 in. (3 x 20 x 300 mm).
- c. Suitable container for filling specimen molds.
- d. Saw – *Procedure Option A only*, The saw shall have a diamond or silicon-carbide cutting edge and shall be capable of cutting specimens without excessive heating or shock.
- e. Sieve – *Procedure Option C only*, The sieve shall be a No. 4 (4.75 mm) rectangular sieve of minimum dimensions 13 x 25 in. (330 x 635 mm) manufactured according to AASHTO M 92.
- f. Balance – *Procedure Option C only*, The balance shall be according to Illinois Specification 101 for portland cement concrete unit weight measurements.

3. MATERIALS

Test specimens shall be made from separate samples of SCC obtained at or near 1) the point of discharge by deliver equipment, and 2) the point of flow termination as approved by the Engineer.

¹Test method developed by the Illinois Department of Transportation (Original Effective Date: May 1, 2006).

4. PROCEDURE

Option A—For each of the two samples obtained (i.e., one at or near the point of discharge and another at point of flow termination), conduct testing according to Illinois Test SCC-6 for assessment of Hardened Visual Stability Index (HVSI).

Option B—Reserved.

Option C—Obtain two samples (i.e., one at or near the point of discharge and another at point of flow termination) and determine the Dynamic Segregation Index as follows:

- a. Fill the mold in one lift without vibration, rodding, or tapping.
- b. Strike off the surface of the concrete level with the top of the mold using the tamping rod or strike-off bar.
- c. Wet wash over the No. 4 (4.75 mm) sieve the sample collected at or near the point of discharge.
- d. Blot any free water from the retained coarse aggregate particles' surface with a towel to achieve a saturated surface dry (SSD) condition.
- e. Determine the weight (mass) of the coarse aggregate to the nearest 0.1 lb. (50 g).
- f. Repeat a. – e. for the sample collected at the point of flow termination.
- g. Calculate the Dynamic Segregation Index (DSI) as follows:

$$DSI = \frac{(CA_1 - CA_2)}{CA_1} \times 100$$

Where: CA_1 = weight (mass) of coarse aggregate collected at or near the point of discharge
 CA_2 = weight (mass) of coarse aggregate collected at the point of flow termination

5. REPORT

For all procedures,

- a. Report maximum length of flow and maximum and minimum width of flow path.
- b. Report approximate rate, feet per minute (meters per minute).
- c. Report reinforcement bar size(s) and typical longitudinal and lateral spacing.

Procedure Option A only,

- a. Report the Hardened Visual Stability Index (HVSI) rating for each hardened specimen.

Procedure Option B—Reserved.

Procedure Option C only,

- d. Report the SSD weight (mass) of coarse aggregate collected at or near the point of discharge and point of flow termination, CA_1 and CA_2 , respectively, to the nearest 0.1 lb. (50 g).
- e. Report the Dynamic Segregation Index (DSI) to the nearest 1 percent.

¹Test method developed by the Illinois Department of Transportation (Original Effective Date: May 1, 2006).

**Provisional Test Method for Dynamic Segregation
of Fresh Self-Consolidating Concrete by Flow Trough¹**

This is a provisional test method requiring field trials.

Referenced Test Procedure(s):

1. Illinois Test Procedure SCC-1, Sampling, Determining Yield and Air Content, and Making and Curing Strength Test Specimens of Self-Consolidating Concrete
2. Illinois Specification 101, Minimum Requirements for Electronic Balances
3. AASHTO M 92, Standard Specification for Wire Cloth Sieves for Testing Purposes
4. AASHTO R 100 (Illinois Modified), Making and Curing Concrete Test Specimens in the Field
5. AASHTO R 39 (Illinois Modified), Making and Curing Concrete Test Specimens in the Laboratory
6. ASTM E 29 (Illinois Modified), Standard Practice for Using Significant Digits in Test Data to Determine Conformance with Specifications

To maintain brevity in the text, the following will apply:

Example: Illinois Test Procedure SCC-1 will be designated as "Illinois Test SCC-1."
AASHTO R 100 (Illinois Modified) will be designated as "R 100."
ASTM E 29 (Illinois Modified) will be designated as "ASTM E 29."

1. GENERAL

This test method covers the determination of the dynamic segregation (stability) of self-consolidating concrete (SCC) using the flow trough. The Dynamic Segregation Index (DSI) is a measure of the dynamic segregation of SCC. A minimum slump flow of 24 in. (610 mm) is recommended to perform the test.

All rounding shall be according to ASTM E 29.

Trough Dimensions:

W x H x L = 6 x 6 x 72 in. (150 x 150 x 1830 mm)

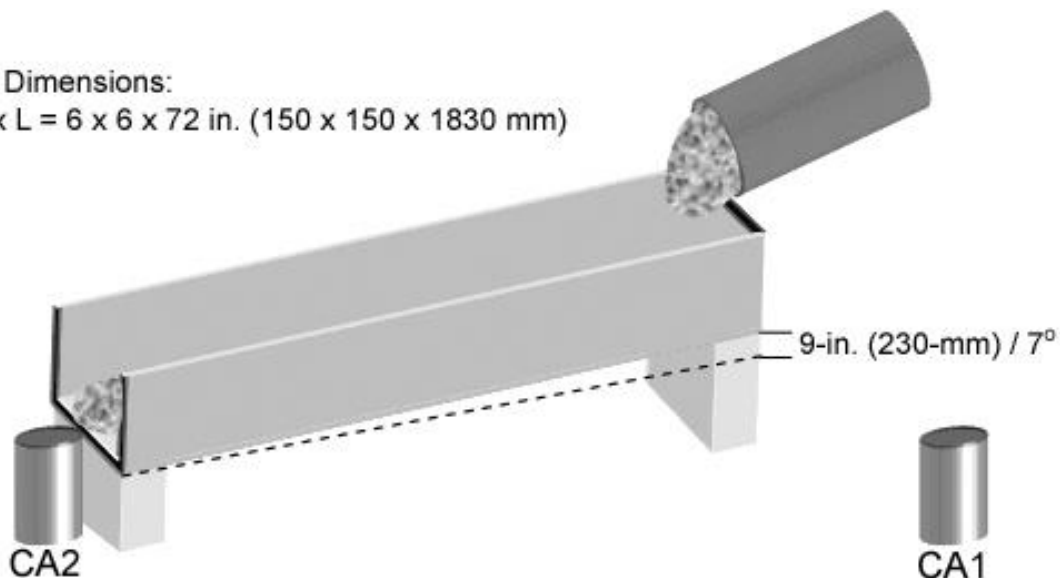

Figure 1. Flow Trough Apparatus

¹Test method developed by the Illinois Department of Transportation (Original Effective Date: August 1, 2007).

2. EQUIPMENT

- a. Flow trough – See Figure 1. The inside walls shall be of a smooth, rigid, nonabsorbent material.
- b. Molds (x4) – Two cylinder molds with dimensions 4 x 8 in. (100 x 200 mm) and two cylinder molds with dimensions 6 x 12 in. (150 x 300 mm), and conforming to R 100 or R 39.
- c. Tamping Rod or Strike-Off Bar – The tamping rod shall conform to that described in T 119. The strike-off bar shall be a flat straight bar at least 0.125 x 0.75 x 12 in. (3 x 20 x 300 mm).
- d. Sieve – No. 4 (4.75 mm) rectangular sieve of minimum dimensions 13 x 25 in. (330 x 635 mm) manufactured according to AASHTO M 92.
- e. Balance – The balance shall be according to Illinois Specification 101 for portland cement concrete unit weight measurements.

3. MATERIALS

The sample of SCC from which the test is performed shall be obtained according to Section I of Illinois Test SCC-1.

4. PROCEDURE

- a. Perform a slump flow test according to Illinois Test Procedure SCC-2.
- b. Dampen the flow trough.
- c. Place the flow trough on level, stable ground, ensuring the correct 7°-slope is maintained (height difference between the two ends is 9 in. (230 mm)).
- d. Fill a 4 x 8 in. (100 x 200 mm) mold in one lift without vibration, rodding, or tapping. Strike off the surface of the concrete level with the top of the mold using the tamping rod or strike-off bar, and set the filled mold to the side for the moment.
- e. Fill two 6 x 12 in. (150 x 300 mm) molds in one lift without vibration, rodding, or tapping.
- f. At the high end of the flow trough, pour the concrete from one of the 6 x 12 in. (150 x 300 mm) molds.
- g. After the concrete stops flowing, lift the high end of the flow trough vertically for 30 seconds, allowing the concrete to flow off the other end, leaving a priming layer of mortar on the trough surface.
- h. Return the flow trough to its initial position, and repeat Step e. using the concrete from the other 6 x 12 in. (150 x 300 mm) mold.
- i. Collect the concrete flow at the other end using an empty 4 x 8 in. (100 x 200 mm) mold.
- j. Strike off the surface of the concrete level with the top of the mold using the tamping rod or strike-off bar.
- k. Separately wet wash over the No. 4 (4.75 mm) sieve the samples from the two 4 x 8 in. (100 x 200 mm) molds (Steps c. and h.).
- l. Determine each sample's weight (mass) of retained coarse aggregate to the nearest 0.05 lb. (20 g).
- m. Calculate the Dynamic Segregation Index (DSI) as follows:

$$DSI = \frac{(CA_1 - CA_2)}{CA_1} \times 100$$

Where: CA_1 = weight (mass) of coarse aggregate in the first mold (Step c.)

CA_2 = weight (mass) of coarse aggregate collected in the second mold (Step h.)

5. REPORT

- f. Report the slump flow according to Illinois Test Procedure SCC-2.
- g. Report CA_1 and CA_2 to the nearest 0.05 lb. (20 g).
- h. Report the Dynamic Segregation Index (DSI) to the nearest 1 percent.

¹Test method developed by the Illinois Department of Transportation (Original Effective Date: May 1, 2006).

Standard Method of Test for

Determining Formwork Pressure of Fresh Self-Consolidating Concrete Using Pressure Transducers¹

1. SCOPE

- 1.1 This method covers the measurement of formwork pressure of fresh self-consolidating concrete (SCC) using pressure transducers attached to formwork.
- 1.2 This is a field test with the intention of measuring formwork pressure during placement of SCC.
- 1.3 The text of this standard references notes and footnotes that provide explanatory information. These notes shall not be considered as requirements for this standard.
- 1.4 The values stated in SI units are to be regarded as the standard.
- 1.5 *This standard may involve hazardous materials, operations, and equipment. This standard does not purport to address all of the safety concerns, if any, associated with its use. It is the responsibility of the user of this standard to establish appropriate safety and health practices and determine the applicability of regulatory limitations prior to use.*

2. REFERENCED DOCUMENTS

- 2.1 *ASTM Standards:*
- C 125, Standard Terminology Relating to Concrete and Concrete Aggregates

3. SIGNIFICANCE AND USE

- 3.1 This method is applicable when there is a concern about SCC form pressures that may exceed the rated strength of the formwork. SCC shall be defined by ASTM C 125.

Note 1— Formwork less than or equal to 3 m (10 ft) tall constructed of commercial forms rated at 57.5 kPa (1200 psf) or greater may be able to resist the SCC pressures encountered in the field. However, the engineer is still responsible for the formwork design.

¹Test method developed by the Illinois Department of Transportation (Original Effective Date: January 1, 2008). The test method provided is based on the version submitted to AASHTO by Illinois Department of Transportation. The AASHTO version is similar and is known as AASHTO T 352.

4. APPARATUS AND MATERIALS

4.1 *Pressure Transducer*— a suitable pressure transducer for measuring pressure from SCC.



Figure 1—Pressure Transducer

4.2 *Data Acquisition System*— a suitable data acquisition interface for obtaining pressure readings from pressure transducers.

4.3 *Bracket*— a bracket conforming to the pressure transducer and formwork geometry shall be used for attaching the pressure transducer to the formwork. Figures 2 and 3 show one such bracket system.

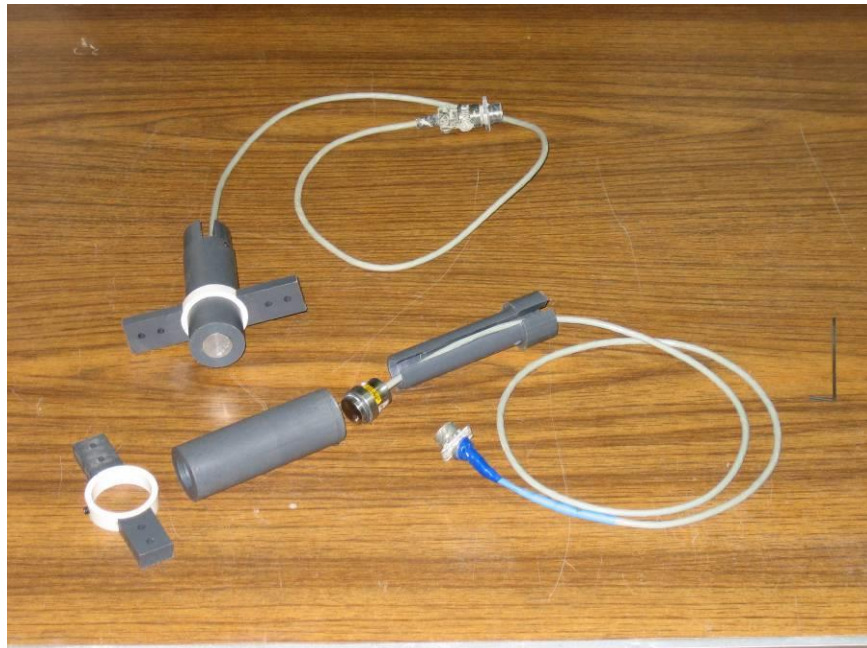

Figure 2—Bracket for Attaching Pressure Transducer to Formwork



Figure 3—Bracket with Pressure Transducer Attached to Formwork

- 4.4 *Portable Hand Drill and Bit*— a suitable drill and bit for drilling pressure transducer access holes.
- 4.5 *Baby Powder and Cellophane Wrap*— suitable materials for covering the pressure transducer face.

Note 2— A Vishay Model P3 Strain Indicator and Recorder with Honeywell Model AB/HP pressure transducers have been used for measuring pressures from SCC. The Vishay unit will accommodate four pressure transducers, and the required access hole for the Honeywell Model AB/HP pressure transducer is 35 mm (1 3/8 in.) in diameter.

5. PROCEDURE

5.1 *Prepare access hole for pressure transducer.*

- 5.1.1 Drill an appropriate size access hole through the formwork for the pressure transducer which will allow measurement of pressure.

5.2 *Mount pressure transducer:*

- 5.2.1 Mount the pressure transducer to the formwork using the bracket system. The pressure transducer face shall extend through a hole drilled in the formwork, and shall align flush with the inside form surface.
- 5.2.2 The face of the pressure transducer shall be protected with a light dusting of baby powder and a single layer of cellophane wrap on top.

Note 3—This technique prevents direct contact of the SCC with the pressure transducer face while ensuring measurement of pressure.

5.3 *Location of pressure transducers:*

- 5.3.1 Install a minimum of one pressure transducer at or near each point of SCC placement. The first pressure transducer below the point of SCC placement shall be approximately 300 mm (12 in.) above the base of the formwork. Additional pressure transducers shall be installed above the bottom transducer at the direction of the formwork design engineer.

Note 4— The reason a pressure transducer is installed at or near the point of SCC placement is due to the higher formwork pressure at this location.

5.4 *Recording pressure and form filling rate:*

5.4.1 The pressure shall be observed and recorded periodically to ensure that the pressure remains under the rated strength of the formwork during the pour. The calculation and recording of form filling rate during the pour should also be performed periodically to evaluate the pour rate influence.

Note 5— The measured pressure will rise as the formwork is filled with SCC, but will eventually slow down and start falling as the SCC begins to gel and stiffen.

Formwork pressure is also a function of the form filling rate. If the rate is low, the maximum pressure will be relatively low. If the rate is very high, the pressure may approach hydrostatic pressure. It is cautioned that if the form filling rate is significantly increased later in the day, formwork pressure above a pressure transducer location will likely be higher than the pressure at the transducer. In addition, stopping and subsequently starting a pour will cause the pressure to fluctuate. Therefore, it is important to maintain relatively constant pour rates through the day.

6. REPORT

6.1 The report shall include the following:

6.1.1 The formwork rating by the manufacturer,

6.1.2 The measured pressure at various times during the pour, and

6.1.3 The peak pressure.

6.2 The report should include the form filling rate.

7. KEYWORDS

7.1 Self-consolidating concrete (SCC); formwork pressure; pressure transducer; data acquisition system; bracket; form filling rate; measured pressure; hydrostatic pressure.

ILLINOIS TEST PROCEDURE ICC-1

SPECIFIC GRAVITY AND ABSORPTION OF LIGHTWEIGHT AGGREGATE FOR INTERNALLY CURING CONCRETE

Effective: January 1, 2016

1 SCOPE

- 1.1 This procedure covers the determination of surface (free) moisture, absorption, and bulk saturated surface-dry specific gravity of lightweight aggregates used for internally curing concrete.
- 1.2 *This standard does not purport to address all of the safety concerns, if any, associated with its use. It is the responsibility of the user of this procedure to establish appropriate safety and health practices and determine the applicability of regulatory limitations prior to use.*

2 REFERENCED DOCUMENTS

2.1 Illinois Test Procedures (ITP):

- ITP 2, Sampling of Aggregates
- ITP 84, Specific Gravity and Absorption of Fine Aggregate
- ITP 248, Reducing Samples of Aggregate to Testing Size

2.3 AASHTO Standards:

- M 231, Weighing Devices Used in the Testing of Materials

2.4 ASTM Standards:

- E 29 (Illinois Modified), Using Significant Digits in Test Data to Determine Conformance with Specifications

3 TERMINOLOGY

3.1 Definitions:

- 3.1.1 *Absorption* – the increase in the mass of aggregate due to water in the pores of the material, but not including water adhering to the outside surface of the particles, expressed as a percentage of the dry mass. The aggregate is considered “dry” when it has been maintained at an elevated temperature for sufficient time to remove all uncombined water by reaching a constant mass.
- 3.2.1 *Specific gravity* – the ratio of the mass (or weight in air) of a unit volume of a material to the mass of the same volume of gas-free distilled water at stated temperatures. Values are dimensionless.
- 3.2.1.1 *Bulk specific gravity (SSD)* – the ratio of the mass in air of a unit volume of aggregate, including the mass of water within the voids filled to the extent achieved by submerging in water at a stated temperature as directed herein, compared to the weight in air of an equal volume of gas-free distilled water at a stated temperature.

ILLINOIS TEST PROCEDURE ICC-1

SPECIFIC GRAVITY AND ABSORPTION OF LIGHTWEIGHT AGGREGATE FOR INTERNALLY CURING CONCRETE

Effective: January 1, 2016

4 SIGNIFICANCE AND USE

- 4.1 Bulk specific gravity is the characteristic generally used for calculation of the volume occupied by the aggregate in various mixtures containing aggregate including portland cement concrete. The laboratory design bulk saturated surface-dry specific gravity is based on submerging an oven-dry sample in water for 24 hours; on the other hand, the bulk saturated surface-dry specific gravity in the field is based on the sample's in situ absorbed moisture in the pre-wetted stockpile.
- 4.2 Absorption values are used to calculate the change in the mass of an aggregate due to water absorbed in the pore spaces within the constituent particles, compared to the dry condition, when it is deemed that the aggregate has been in contact with water long enough to satisfy most of the absorption potential. The laboratory standard for absorption of lightweight aggregate is that obtained after submerging oven-dry aggregate for approximately 24 hours in water.

5 APPARATUS

- 5.1 Balance – The balance shall have sufficient capacity, be readable to 0.1 percent of the sample mass, or better, and conform to the requirements of AASHTO M 231.
- 5.2 Sample Container – A solid, non-absorbent, sealable bag or tub with a capacity sufficient to hold approximately 2000 grams of lightweight aggregate. When running Slag products, the bucket shall be manufactured of copper.
- 5.3 Oven – A ventilated oven of sufficient size and capable of maintaining a uniform temperature of 230 ± 9 °F (110 ± 5 °C).
- 5.3.1 Alternative Heat Source – In the field, a gas burner, electric hot plate, electric heat lamp, or ventilated microwave oven may be used in place of an oven. Alternative heat sources should be operated on a low-as-needed heat to prevent popping, crackling, and/or sizzling noise from the aggregate during drying. If these noises occur, the heat must be turned down and/or the sample must be constantly stirred during drying to prevent potential aggregate particle breakdown.
- 5.4 Scoop, Shovel, or Large Spoon.
- 5.5 Sheet of non-absorbent cloth or polyethylene approximately 24 by 24 in. (600 by 600 mm).
- 5.6 Disposable Paper Towels – Commercial grade.
- 5.7 Oven Pans – Heat resistance pans with capacity sufficient to hold a minimum 600 grams of lightweight aggregate.
- 5.8 Pycnometer – A 0.946 L (1 qt.) glass jar, gasket, and conical pycnometer top. Typically, a canning jar is used.

ILLINOIS TEST PROCEDURE ICC-1

SPECIFIC GRAVITY AND ABSORPTION OF LIGHTWEIGHT AGGREGATE FOR INTERNALLY CURING CONCRETE

Effective: January 1, 2016

- 5.9 *Optional*, Centrifuge – A centrifuge according to AASHTO T 164, Method A, with controls for the time of operation and maximum speed.
- 5.9.1 *Optional*, Filter Ring – Felt or paper ring to fit the rim of the centrifuge bowl.

6 SAMPLING AND PREPARATION OF TEST SPECIMEN

- 6.1 Field samples of pre-wetted lightweight aggregate shall be taken according to ITP 2. Field sample size shall be minimum 25 lbs (11 kg).
- 6.2 Obtain a test sample of approximately 1500 grams from the field sample by procedures described in ITP 248.
- 6.3 Protect the sample from moisture loss; the sample shall not be allowed to dry except as directed herein.
- 6.4 Reduce the test sample into sub-samples of approximately 350 grams each.

7 FIELD PROCEDURE –ABSORBED MOISTURE (AM_{field}) & SURFACE MOISTURE (SM_{field})

- 7.1 Determine the initial mass (M_i) of one sub-sample to the nearest 0.1 gram.
- 7.1.1 Dry the sub-sample to a constant weight such that the weight loss between subsequent measurements at 15-minute intervals is not more than 0.1 % of the initial mass (M_i).

After the sub-sample has been dried to constant mass and allowed to cool to 120 °F (50 °C), determine the oven-dry mass (M_{OD}) to the nearest 0.1 gram.

- 7.1.2 Calculate the total moisture content (TM) content as follows:

$$\text{Total Moisture, } TM = \frac{M_i - M_{OD}}{M_{OD}} \times 100$$

- 7.2 Spread a second sub-sample on a flat, nonabsorbent surface exposed to a gentle current (e.g., a fan's lowest setting) of warm air, and stir frequently to assure uniform drying. No mechanical aids shall be used. Hand-stirring or lifting a nonabsorbent sheet corner-to-corner diagonally may be used. Care shall be exercised not to lose any of the sample. As the material begins to dry sufficiently, it may be necessary to work it with the hands in a rubbing motion to break up any conglomerations, lumps, or balls of material that develop. Continue this operation until the sample approaches a free-flowing condition.

To determine when the material has achieved a surface-dry condition, follow either method below:

- (a) Paper Towel Method. Using paper towels, surface dry the material until the point is just reached where the paper towel does not appear to be picking up moisture from the surfaces of the fine aggregate particles.

ILLINOIS TEST PROCEDURE ICC-1

SPECIFIC GRAVITY AND ABSORPTION OF LIGHTWEIGHT AGGREGATE FOR INTERNALLY CURING CONCRETE

Effective: January 1, 2016

- (b) Cone Method. Using a conical mold and tamper according to ITP 84, place the mold firmly on a smooth, nonabsorbent surface with the large diameter down. Place a portion of the partially dried material loosely in the mold by filling until overflow occurs. Hold the mold down tightly and lightly tamp the material into the mold with 25 drops of the tamper. Each drop should start about 0.2 in. (5mm) above the top surface of the material. Permit the tamper to fall freely under gravity on each drop. Adjust the starting height to the new surface elevation after each drop and distribute the drops evenly over the surface. After the 25th tamp, lift the mold vertically. If surface moisture is still present, the fine aggregate will retain the molded shape. For lightweight fine aggregate, surface-dry condition is reached when at least ¼ of the molded cone shape slumps off. If the first test indicates that surface moisture is not present, it has been dried past the saturated surface-dry condition. In this case, thoroughly remoisten the fine aggregate and permit the specimen to stand in a covered container for 30 minutes. Then resume the process of drying and testing at frequent intervals for the onset of the surface-dry condition.

Determine the saturated surface-dry mass (M_{SSD}) of the sub-sample to the nearest 0.1 gram.

- 7.2.1 Dry the saturated surface-dry sub-sample to a constant weight such that the weight loss between subsequent measurements at 15-minute intervals is not more than 0.1% of the saturated surface-dry mass (M_{SSD}).

After the sub-sample has been dried to constant mass and allowed to cool to 120 °F (50 °C), determine the oven-dry mass (M'_{OD}) to the nearest 0.1 gram.

- 7.2.2 Calculate the field absorbed moisture content (AM_{field}) content as follows:

$$\text{Absorbed Moisture, } AM_{field} = \frac{M_{SSD} - M'_{OD}}{M'_{OD}} \times 100$$

- 7.3 Determine the surface moisture content (SM) to the nearest 0.1% as follows:

$$\text{Surface Moisture, } SM_{field} = TM - AM$$

For example, $SM = TM - AM = 20.3\% - 16.4\% = 3.9\%$

8 LABORATORY PROCEDURE – SPECIFIC GRAVITY & ABSORBED MOISTURE CONTENT (AM_{lab})

- 8.1 Determine the mass of the pycnometer filled with water as follows:
- 8.1.1 Apply a light coat of grease to the gasket's side which will be in contact with the glass jar.
- 8.1.2 Screw the pycnometer top tightly on the glass jar. Place a mark on the pycnometer top and glass jar to indicate the tightened top's position. Always tighten the pycnometer top to this

ILLINOIS TEST PROCEDURE ICC-1

SPECIFIC GRAVITY AND ABSORPTION OF LIGHTWEIGHT AGGREGATE FOR INTERNALLY CURING CONCRETE

Effective: January 1, 2016

position. If the pycnometer top is ever able to be tightened beyond the mark on the glass jar, re-mark the jar's top.

- 8.1.3 Fill the glass jar nearly full of water and screw on the pycnometer top. Finish filling the pycnometer by pouring water until a bead of water appears above the top's opening.
- 8.1.4 Wipe off all exterior water on the pycnometer, and then weigh to the nearest 0.1 gram. Record the value as M_1 . Empty the pycnometer in preparation for 8.2
- 8.2 Determine the mass of the pycnometer filled with water and lightweight aggregate as follows:
 - 8.2.1 Dry one sub-sample in an oven at 230 ± 9 °F (110 ± 5 °C) for 24 ± 1 hours. After the sub-sample has been dried and allowed to cool to 120 °F (50 °C) or less, soak the sub-sample in water for 24 ± 1 hours at room temperature.
 - 8.2.2 Decant the water (avoid losing fine material), and according to the methods described in 7.2, determine the saturated surface-dry mass (M_{SSD}) of the sub-sample to the nearest 0.1 gram.
 - 8.2.3 Fill the empty pycnometer with approximately 2 in. (50 mm) of room temperature water.
 - 8.2.4 Introduce the saturated-surface dry sub-sample into the pycnometer via a funnel, and then fill the pycnometer nearly full with water. Place your thumb over the opening and gently roll and shake the pycnometer to remove any air entrapped in the sub-sample.
 - 8.2.5 Screw on the pycnometer top, and finish filling the pycnometer by pouring water until a bead of water appears above the top's opening.
 - 8.2.6 Wipe off all exterior water on the pycnometer, and then weigh to the nearest 0.1 gram. Record the value as M_2 .
- 8.3 Transfer the sub-sample from the pycnometer to an oven pan of known weight. Decant the excess water (avoid losing fine material), and dry the sub-sample in an oven at 230 ± 9 °F (110 ± 5 °C) to a constant weight such that the weight loss between subsequent measurements at 15-minute intervals is not more than 0.1% of the saturated surface-dry mass (M_{SSD}). After the sub-sample has been dried to constant mass, determine the oven-dry mass (M_{OD}) to the nearest 0.1 gram.

ILLINOIS TEST PROCEDURE ICC-1

SPECIFIC GRAVITY AND ABSORPTION OF LIGHTWEIGHT AGGREGATE FOR INTERNALLY CURING CONCRETE

Effective: January 1, 2016

- 8.4 Calculate the specific gravity, based on weight of saturated surface-dry aggregate, and laboratory absorbed moisture content as follows:

$$Sp\ Gr\ (Saturated\ Surface-Dry) = \frac{M_{SSD}}{M_{SSD} + M_1 - M_2}$$

$$AM_{lab} = \frac{M_{SSD} - M_{OD}}{M_{OD}} \times 100\%$$

where M_1 = mass of pycnometer filled with water only, g
 M_2 = mass of pycnometer filled with water and sub-sample, g
 M_{SSD} = mass of SSD lightweight fine aggregate sub-sample, g
 M_{OD} = mass of oven-dry lightweight fine aggregate sub-sample, g

9 OPTIONAL PROCEDURE – CENTRIFUGE METHOD FOR LABORATORY ABSORBED MOISTURE CONTENT (AM_{lab})

- 9.1 Determine the initial mass (M_i) of one sub-sample to the nearest 0.1 gram.
- 9.1.1 Dry the sub-sample according to 7.1.1. After the sub-sample has been dried to constant mass and allowed to cool to 120 °F (50 °C), determine the oven-dry mass (M_{OD}) to the nearest 0.1 gram.
- 9.2 Determine the mass (M_1) of a dry centrifuge bowl to the nearest 0.1 gram.
- 9.2.1 Evenly place the oven-dry sub-sample into the centrifuge bowl, and determine the combined mass (M_2) of the sub-sample and centrifuge bowl to the nearest 0.1 gram.
- 9.3 Cover the sub-sample with water and let soak for 24 hours at room temperature.
- 9.3.1 Decant the water (avoid losing fine material).
- 9.4 Place the filter ring around the centrifuge bowl's edge, and secure the cover in place.
- 9.4.1 Start the centrifuge revolving slowly, gradually increasing the speed to 2000 ± 20 rpm, at which point maintain that speed for 3 minutes before turning off the centrifuge.
- 9.4.2 Determine the combined mass (M_3) of the surface-dry sub-sample and centrifuge bowl to the nearest 0.1 gram.

ILLINOIS TEST PROCEDURE ICC-1

SPECIFIC GRAVITY AND ABSORPTION OF LIGHTWEIGHT AGGREGATE FOR INTERNALLY CURING CONCRETE

Effective: January 1, 2016

9.5 Calculate the laboratory absorbed moisture content as follows:

$$AM_{lab} = \frac{M_3 - M_2}{M_2 - M_1} \times 100\%$$

where M_1 = mass of empty centrifuge, g
 M_2 = mass of centrifuge and oven-dry sub-sample, g
 M_3 = mass of centrifuge and surface-dry sub-sample, g

10 OPTIONAL PROCEDURE – CENTRIFUGE METHOD FOR FIELD ABSORBED MOISTURE CONTENT (AM_{field}) & SURFACE MOISTURE (SM_{field})

10.1 Obtain a sub-sample representing the pre-wetted condition of the stockpile.

10.2 Determine the mass (M_1) of a dry centrifuge bowl to the nearest 0.1 gram.

10.2.1 Evenly distribute the sub-sample into the centrifuge bowl, and determine the combined mass (M_2) of the sub-sample and centrifuge bowl to the nearest 0.1 gram.

10.3 Place the filter ring around the centrifuge bowl's rim, and secure the cover in place.

10.3.1 Start the centrifuge revolving slowly, gradually increasing the speed to 2000 ± 20 rpm, at which point maintain that speed for 3 minutes, and then turn off the centrifuge.

10.3.2 Determine the combined mass (M_3) of the surface-dry sub-sample and centrifuge bowl to the nearest 0.1 gram.

10.4 Transfer the surface-dry sub-sample to a container of known mass (M_4), and determine the combined mass of the sub-sample and container (M_5).

10.4.1 Dry the sub-sample to a constant weight such that the weight loss between subsequent measurements at 15-minute intervals is not more than 0.1% of M_5 .

After the sub-sample has been dried to constant mass and allowed to cool to 120 °F (50 °C), determine the combined mass (M_6) of the oven-dry sub-sample and container to the nearest 0.1 gram.

ILLINOIS TEST PROCEDURE ICC-1

SPECIFIC GRAVITY AND ABSORPTION OF LIGHTWEIGHT AGGREGATE FOR INTERNALLY CURING CONCRETE

Effective: January 1, 2016

10.5 Calculate the field absorbed moisture content and surface moisture as follows:

$$AM_{field} = \frac{(M_3 - M_1) - (M_6 - M_4)}{M_6 - M_4} \times 100\%$$

$$SM_{field} = \frac{(M_2 - M_1) - (M_5 - M_4)}{M_5 - M_4} \times 100\%$$

where

- M_1 = mass of empty centrifuge, g
- M_2 = mass of centrifuge and field sub-sample, g
- M_3 = mass of centrifuge and surface-dry sub-sample, g
- M_4 = mass of container, g
- M_5 = mass of container and surface-dry sub-sample, g
- M_6 = mass of container and oven-dry sub-sample, g

11 REPORT

11.1 Report all masses to the nearest 0.1 gram, specific gravity results to the nearest 0.001 and all absorption results to the nearest 0.1 percent.

All rounding shall be according to ASTM E 29 (Illinois Modified).

This Page Reserved

AASHTO TP 124 (formerly ITP 405) has been replaced by AASHTO T 393 (Illinois Modified).

This Page Reserved

AASHTO TP 124 (formerly ITP 405) has been replaced by AASHTO T 393 (Illinois Modified).

ILLINOIS TEST PROCEDURE 601

ATR-FTIR Spectroscopy and Comparison Method

Effective Date: [September 1, 2021](#)

1.0 SCOPE

This test procedure covers the collection of infrared spectra using Attenuated Total Reflectance-Fourier Transform Infrared Spectroscopy (ATR-FTIR) including the parameters that shall be used to collect the spectra. The test procedure also covers the methodology to compare the IR spectra of two different samples. The degree of similarity between sample spectra can be measured by the correlation value which can be used for Quality Assurance by determining changes in the material composition.

- 1.1 The values stated in SI units are to be regarded as the standard.
- 1.2 *This standard does not purport to address the safety concerns, if any, associated with its use. It is the responsibility of the user of this procedure to establish appropriate safety and health practices and determine the applicability of regulatory limitations prior to use.*

2.0 METHOD FOR COLLECTING ATR-FTIR SPECTRA

This procedure outlines a general method for obtaining the characteristic infrared spectrum of a material. A sample can be analyzed as-is (as received) or as prepared below. The universal Smart iTR accessory is an attenuated total reflectance (ATR) accessory which has a diamond crystal upon which the sample is deposited. The infrared spectrum is a result of the absorption of infrared light by molecules in the sample. The absorption is specific to the chemical bonds or functional groups that are present in the molecular structure.

- 2.1 [Refer to the FTIR instrument manual for appropriate settings for maximum performance, and proper use.](#)
- 2.2 [For each material a minimum of 16 scans should be conducted to acquire the IR spectrum.](#)
- 2.3 Sample Preparation/Analysis
 - 2.3.1 For liquid samples, place enough sample to completely cover the diamond crystal of the ATR accessory.
 - 2.3.2 For paste samples, use a spatula to cover the diamond crystal with enough sample to cover the crystal. Tap lightly on the deposited sample to ensure complete contact between the sample and the crystal.
 - 2.3.3 For powder samples, finely grind the powder using a mortar and pestle or grinder. Attach a concave tip by screwing it to the pressure rod of the ATR apparatus. Use a spatula to put a small mound of the powder on top of the diamond crystal. Use the concave pressure tip to ensure complete contact between the powder and the crystal.
 - 2.3.4 For films, place enough film to cover the diamond crystal. Attach a flat tip by screwing it to the pressure rod of the ATR apparatus. Use the flat pressure tip to complete the contact between the film and the crystal.

ILLINOIS TEST PROCEDURE 601

ATR-FTIR Spectroscopy and Comparison Method

Effective Date: [September 1, 2021](#)

2.3.5 For asphalt, heat sample in a 135°C oven for approximately 30 minutes or until the sample is fluid enough to pour. Use a spatula to transfer enough sample to completely cover the diamond crystal. While acquiring the spectrum, use a spatula to apply gentle pressure to the asphalt sample to ensure optimum contact with the diamond crystal. Apply pressure throughout the collection of the IR spectrum. Enough pressure should be applied to acquire the transmittance or absorbance spectrum in accordance with Section 3.1.

2.4 Instrumentation and Materials

2.4.1 Nicolet FTIR spectrometer Model 6700 or any similar instrument capable of obtaining spectrum in the mid-IR region of 600-4000 cm^{-1} range.

2.4.2 OMNIC Software or any [compatible software that allows full operation of the FTIR spectrometer](#).

2.4.3 Instrument software shall either have a performance verification feature to demonstrate reliability and suitability or have a Spectrometer Performance Verification (SPV) tool.

2.4.4 Smart iTR [or equivalent ATR](#) accessory with diamond crystal

2.4.5 [Miscellaneous Laboratory Accessories](#): Spatula, mortar and pestle, [mixer/mill for grinding samples to fine particle size](#), disposable plastic transfer pipets, isopropyl alcohol, [mineral spirits](#), [oven](#) and Kim wipes.

3.0 SUMMARY OF SPECTRAL COMPARISON PROCEDURE

This procedure outlines a rapid and accurate quality verification of highway materials by comparing their ATR-FTIR spectra. The verification is accomplished by comparison of the IR spectra of a verification sample against that of a reference material or previously approved sample. This comparison method uses a basic algorithm to calculate a correlation value based on the IR peak positions and peak intensities of the spectra. This correlation value is a measure of the degree of similarity between two spectra. This procedure can identify samples, detect any formulation changes, and detect the presence of any contamination.

3.1 Obtain the IR spectrum of the verification or field sample. A satisfactory IR spectrum should have the major peaks at a transmittance between 5 – 35% or absorbance units between 0.5 – 1.0.

3.2 In the same collection window, retrieve and open the stored IR spectrum of the reference sample.

3.3 Both [the field sample and the reference sample](#) spectra should be obtained using the same IR analysis conditions.

3.4 Highlight both spectra and under the Analyze Menu of the OMNIC software, click on QCheck.

ILLINOIS TEST PROCEDURE 601

ATR-FTIR Spectroscopy and Comparison Method

Effective Date: [September 1, 2021](#)

- 3.5 Record the correlation value between the two spectra. Compare the correlation value to the allowed minimum correlation value to determine the PASS/FAIL status. Software can also be used to automatically report as PASS/FAIL if the specification or threshold is included in the analysis set up.
- 3.6 For aqueous solutions, the IR spectrum of water shall be subtracted using the OMNIC Subtraction Processing Feature.
 - 3.6.1 Highlight both the sample and water spectra and under the Process Menu, click on Subtract. (Check for the proper setting. The order of subtraction should be sample spectrum minus water spectrum). The OMNIC software will automatically determine the subtraction factor to best eliminate water peaks from the sample spectrum.
 - 3.6.2 The two main water peaks [are](#) at wavelengths 3300 cm⁻¹ and 1640 cm⁻¹.
 - 3.6.3 [Manual](#) adjustments can be made [to](#) the subtraction factor to eliminate as much of the water peaks as possible without subtracting important components from the sample spectrum.
 - 3.6.4 Repeat steps [3.4](#) and [3.5](#) to obtain the correlation value between the subtracted spectrum [of](#) the sample and the reference sample [spectrum](#).

4.0 PERFORMING A VERIFICATION CHECK ON FIELD SAMPLES

For the analysis of most materials, a correlation value ≥ 0.85 is acceptable. There are many variables that can affect this value though. For example, the signal strength of the sample's spectrum is very important. Very dilute samples will have a very weak signal, and this will greatly affect the correlation value.

5.0 SYSTEM PERFORMANCE VERIFICATION

Confirmation of the instrument performance for reliability and suitability of the analysis. Perform regular internal verification of the instrument.

This Page Reserved

ILLINOIS TEST PROCEDURE 701

RIDE QUALITY TESTING USING THE INTERNATIONAL ROUGHNESS INDEX

Effective Date: January 1, 2021

1 SCOPE

- 1.1 This procedure covers the determination of ride quality using the International Roughness Index (IRI) for both hot-mix asphalt (HMA) and Portland cement concrete (PCC) pavements.
- 1.2 The values stated are in U.S. Customary units and are to be regarded as the standard.
- 1.3 *This standard does not purport to address all of the safety concerns, if any, associated with its use. It is the responsibility of the user of this procedure to establish appropriate safety and health practices and determine the applicability of the regulatory limitations prior to use.*

2 REFERENCED DOCUMENTS

2.1 AASHTO Standards:

- M 328, Standard Specification for Inertial Profiler
- R 43, Standard Practice for Quantifying Roughness of Pavements
- R 54, Standard Practice for Accepting Pavement Ride Quality When Measured Using Inertial Profiling Systems
- R 56, Standard Practice for Certification of Inertial Profiling Systems
- R 57, Standard Practice for Operating Inertial Profiling Systems

2.2 ASTM Standard:

- E 2560, Standard Specification for Data Format for Pavement Profile

3 TERMINOLOGY

3.1 Definitions:

- 3.1.1 International Roughness Index (IRI). A statistic that summarizes the roughness qualities impacting vehicle response based on the Golden-Car vehicle model at a standard simulation speed of 49.7 mph (80 km/h).
- 3.1.2 Mean Roughness Index (MRI). A number calculated by averaging the IRI values from the two wheel path profiles.
- 3.1.3 Areas of Localized Roughness (ALR). Short sections of roadway that contribute disproportionately to the overall roughness index value.

4 SIGNIFICANCE AND USE

- 4.1 This test procedure outlines standard procedures for using inertial profilers to measure longitudinal profiles and calculate IRI for pavement surfaces to help produce consistent reporting of IRI for Quality Control / Quality Assurance (QC/QA) determinations.
- 4.2 This test procedure outlines standard procedures for using a 16 ft (5 m) straightedge to identify surface variations in the wheel tracks of new pavement surfaces that meet the criteria of miscellaneous pavement.

5 EQUIPMENT

- 5.1 *Inertial Profiling System* – The inertial profiling system (IPS) shall consist of a height sensor, an accelerometer, a distance sensor, and an operator according to AASHTO M 328.
 - 5.1.1 The IPS shall be verified on an annual basis at the Illinois Department of Transportation Profile Equipment Verification (PEV) Program. The IPS components shall display the decal to verify it has been tested. Documentation indicating the successful completion of the PEV Program can be found on the Department’s website at the following address: <http://www.idot.illinois.gov/transportation-system/research/index>. Any questions about the verification of an IPS can be directed to the Engineer of Pavement Technology in the Office of Planning and Programming, Bureau of Research.
 - 5.1.2 If any subsystem has been replaced/upgraded as detailed in AASHTO M 328, the IPS needs to be re-verified by the PEV Program.
- 5.2 16 ft (5 m) Straightedge – The 16 ft (5 m) straightedge shall consist of a metal I-beam mounted on two wheels spaced 16 ft (5 m) between the axles. Scratcher bolts, which can be easily and accurately adjusted, shall be set at the 1/4, 1/2, and 3/4 points between the axles. A handle suitable for pushing and guiding shall be attached to the straightedge.

6 CALIBRATION

- 6.1 *IPS:*
 - 6.1.1 The cold tire air pressure shall be checked daily and maintained according to manufacturer’s recommendations.
 - 6.1.2 The system shall be calibrated on a daily basis according to manufacturer’s recommendations and AASHTO R 57. At a minimum, the following calibration tests shall be completed: block test, distance factor calibration, accelerometer calibration, and the bounce test.

6.2 16 ft (5 m) straightedge:

6.2.1 The scratcher bolts shall be checked prior to testing each day to ensure that each bolt is set to the proper height.

7 PROCEDURE

7.1 *High-Speed and Low-Speed Pavements* – The following procedure shall be used for both high-speed and low-speed pavements.

7.1.1 The IPS shall make three passes in the direction of traffic in a manner that measures both the left and right wheel track of each lane according to AASHTO R 57.

7.1.2 The collection shall be coordinated with the Department's IPS to ensure that quality assurance testing is completed in a timely fashion and the same sections and lengths are tested.

7.2 *Miscellaneous Pavement* – The completed surface course shall be tested for smoothness in both wheel tracks with a 16 ft (5 m) straightedge. Surface variations of the miscellaneous pavement shall not exceed 5/16 in. (8 mm).

8 DATA PROCESSING

8.1 *High-Speed* – Data collected on high-speed pavements shall be processed according to the following.

8.1.1 *IRI* – The raw data from the collection of the longitudinal profile shall be processed for the IRI calculation according to AASHTO R 43.

8.1.2 *MRI* – The MRI for each subplot shall be calculated for analysis and comparison to the quality assurance testing completed by the Department. The three tests for each section shall be averaged for assessments and comparison to quality assurance testing. See Illinois Test Procedure 703 for the MRI Analysis procedures.

8.1.3 *ALR* – Each pass shall be analyzed for ALR, 150 in./mi. over 25 ft for high-speed mainline pavement and 200 in./mi. for low-speed mainline pavement. See Illinois Test Procedure 703 for processing data in ProVAL.

8.2 *Low-Speed Pavements* – Data collected shall be processed for a straightedge simulation according to Illinois Test Procedure 704.

8.3 *Miscellaneous Pavements* – No data analysis is required for testing conducted by the 16 ft (5 m) straightedge in accordance with Illinois Test Procedure 702.

9 ANALYSIS

- 9.1 *High-Speed Pavements* – Data and files for high-speed pavements shall be prepared according to the following.
- 9.1.1 The data shall be returned to the Department in an electronic format that can be used in ProVAL software. Acceptable file formats are as follows:
- *ERD file format*
 - *PPF file format*
- 9.1.2 A file shall be generated for each pass of the IPS. The file shall include the following information: contract number, date and time of testing, beginning and ending station, lane tested (e.g., driving, passing, etc.), wheel track tested (if operating a low-speed IPS with the ability to collect only one wheel track at a time), direction of testing, and the operator name(s).
- 9.1.3 All files shall be sent to Illinois Department of Transportation Bureau of Research for analysis and calculation of assessments by email within two days of testing being completed. DOT.BR.Smoothness.Testing@illinois.gov
- 9.1.4 A report with ALR will be returned to the Engineer and corrective work shall be coordinated.
- 9.2 *Low-Speed Pavements* – Data for low-speed pavements shall be prepared according to the following.
- 9.2.1 The results shall be returned to the Department in an electronic format that can be used in ProVAL software. Acceptable file formats are as follows:
- *ERD file format*
 - *PPF file format*
- 9.2.2 A file shall be generated for each pass of the IPS. The file shall include the following information: contract number, date and time of testing, beginning and ending station, lane tested (e.g., driving, passing, etc.), wheel track tested (if operating a low-speed IPS with the ability to collect only one wheel track at a time), direction of testing, and the operator name(s).
- 9.2.3 All files shall be sent to Illinois Department of Transportation Bureau of Research for analysis and calculation of assessments by email within two days of the testing being completed. DOT.BR.Smoothness.Testing@illinois.gov
- 9.2.4 Reports will be generated from Illinois Test Procedure 704 and surface variations will be marked by the Engineer.
- 9.3 *Miscellaneous Pavement* – Surface variations will be marked by the Engineer.

ILLINOIS TEST PROCEDURE 702

RIDE QUALITING TESTING USING A STRAIGHT EDGE

Effective Date: January 1, 2021

1 SCOPE

- 1.1 This procedure covers locating pavement surface deficiencies using a 16 ft (5 m) straightedge. This method is used on both hot-mix asphalt (HMA) and Portland cement concrete (PCC) surfaces.
- 1.2 The values stated are in U.S. Customary units and are to be regarded at the standard.
- 1.3 *This standard does not purport to address all of the safety concerns, if any, associated with its use. It is the responsibility of the user of this procedure to establish appropriate safety and health practices and determine the applicability of the regulatory limitations prior to use.*

2 REFERENCED DOCUMENTS

- 2.1 *AASHTO Standards:*
 - R 54, Accepting Pavement Ride Quality When Measured Using Inertial Profiling Systems

3 TERMINOLOGY

- 3.1 *Definitions:*
 - 3.1.1 *Miscellaneous Pavement* – pavement that cannot readily be tested by an inertial profiler or having conditions beyond the control of the contractor preclude the achievement of smoothness levels typically achievable with mainline pavement construction.

4 SIGNIFICANCE AND USE

- 4.1 This test procedure outlines standard procedures for using a 16 ft (5 m) straightedge to identify surface variations in the wheel paths of new pavement surfaces.

5 EQUIPMENT

- 5.1 16 ft (5 m) Straightedge – The 16 ft (5 m) straightedge shall consist of a metal beam mounted on two wheels spaced 16 ft (5 m) between the axles. Scratcher bolts, which can be easily and accurately adjusted, shall be set at the 1/4, 1/2, and 3/4 points between the axles. A handle suitable for pushing and guiding shall be attached to the straightedge.

6 CALIBRATION

- 6.1 The scratcher bolts shall be checked prior to testing each day to ensure that each bolt is set to the proper height.

7 PROCEDURE

- 7.1 The completed surface course shall be tested for smoothness in both wheel paths with a 16 ft (5 m) straightedge. Surface variations of the miscellaneous pavement shall not exceed 5/16 in. (8 mm). This testing shall be conducted in the presence of the Engineer.

8 REPORTING

- 8.1 Surface variations will be marked by the Engineer.

ILLINOIS TEST PROCEDURE 703

MEAN ROUGHNESS INDEX (MRI) ANALYSIS IN PROVAL

Effective Date: January 1, 2021

1. SCOPE

- 1.1. This test procedure covers the process to calculate the Mean Roughness Index of a pavement surface by applying the International Roughness Index algorithm to the collected pavement profiles.
- 1.2. The values stated in SI units are to be regarded as the standard.
- 1.3. *This standard does not purport to address all the safety concerns, if any, associated with its use. It is the responsibility of the user of this procedure to establish appropriate safety and health practices and determine the applicability of regulatory limitations prior to use.*

2. TERMINOLOGY

- 2.1. ProVAL: Profile Viewing and Analysis Software is free software that was created under the direction of FHWA and TPF-5(063). <https://www.roadprofile.com/>
- 2.2. International Roughness Index (IRI): A statistic that summarizes the roughness qualities impacting vehicle response based on the Golden-Car vehicle model at a standard simulation speed of 49.7 mph (80 km/h).
- 2.3. Mean Roughness Index (MRI): A number calculated by averaging the IRI values from the two wheelpath profiles.
- 2.4. Areas of Localized Roughness (ALR): Short sections of roadway that contribute disproportionately to the overall roughness index value.

3. SIGNIFICANCE AND USE

- 3.1. This procedure shall be used to determine the MRI of a pavement surface.

4. PROCEDURE

4.1. File Creation

- 4.1.1. Open ProVAL on your computer. Verify that you have the latest version installed.

4.1.2. Create a new project.

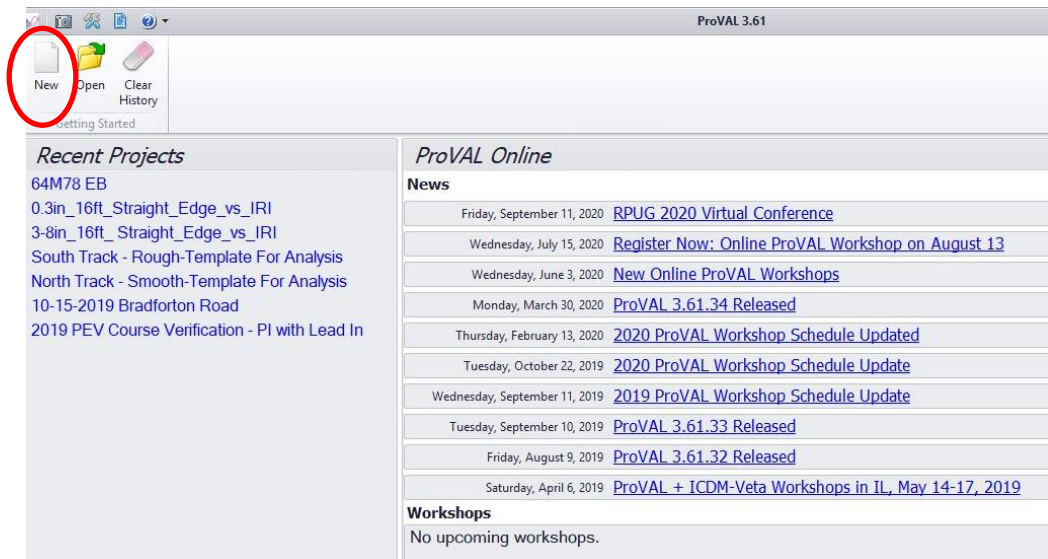

4.1.3. Save the project file with the following naming convention: XXXXX-DD-L

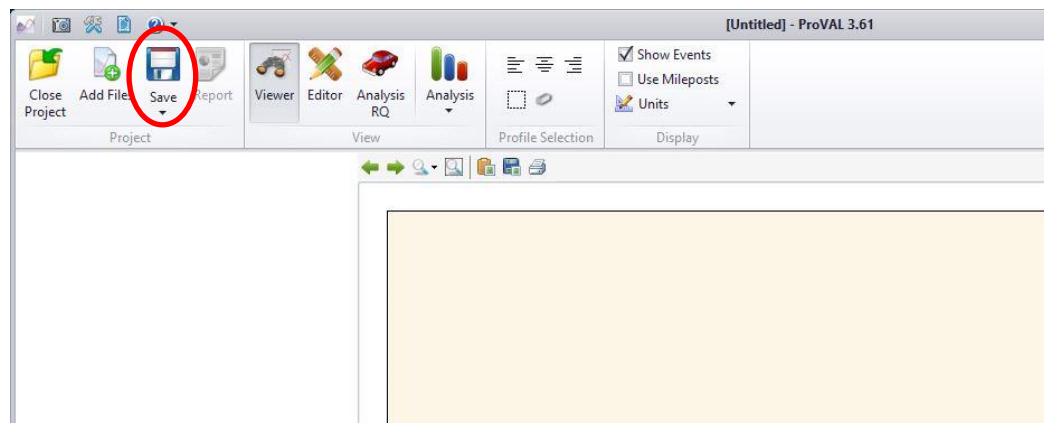

4.1.3.1. XXXXX – Contract Number

4.1.3.2. DD - Direction (EB, WB, NB, SB)

4.1.3.3. L - Lane Number (1 – outermost lane, 2, 3,...)

4.1.4. Add the files that are to be analyzed.

4.1.4.1. Click on “Add Files”.

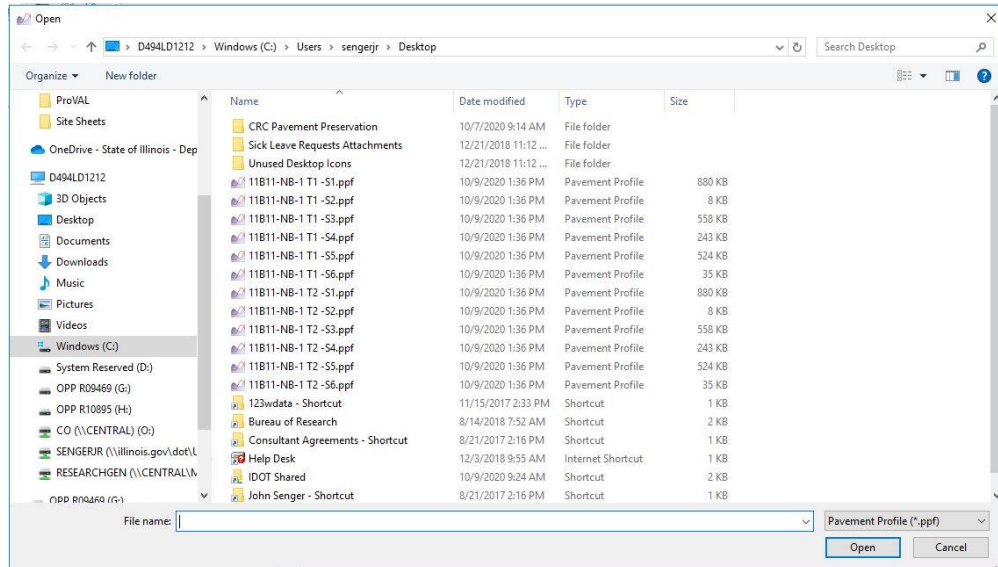

4.2. Project Information Verification

4.2.1. Verify the “Basic” project information under the “Editor” module.

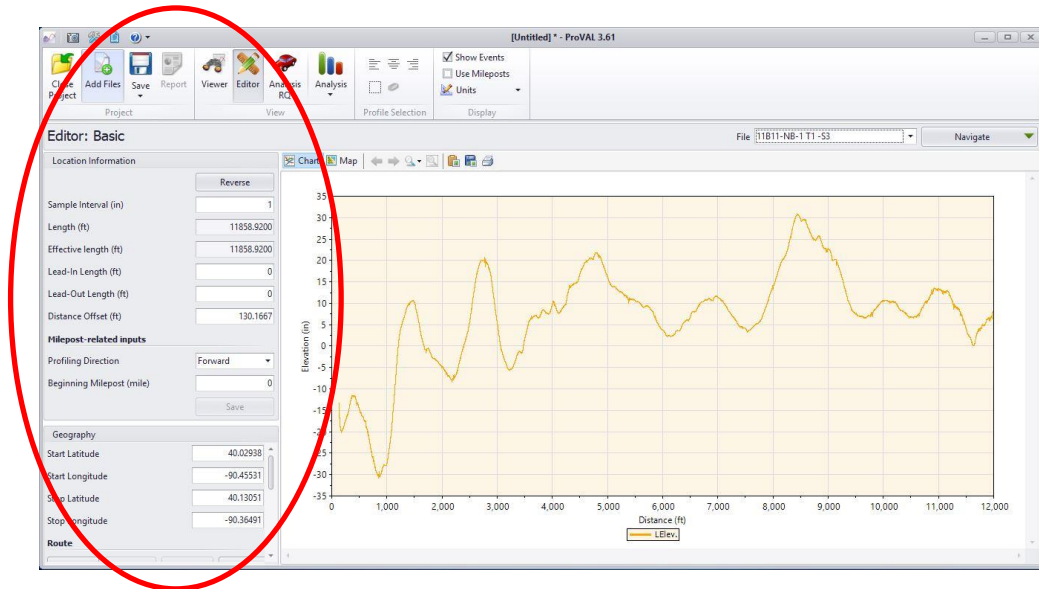

4.2.1.1. Verify the sample interval. (1-2 inches)

4.2.1.2. Verify the length. (Paved length, Contract Length,...)

4.2.1.3. Verify the trace appears in the correct location on the map.

4.2.2. Check and verify any events stored in the file.

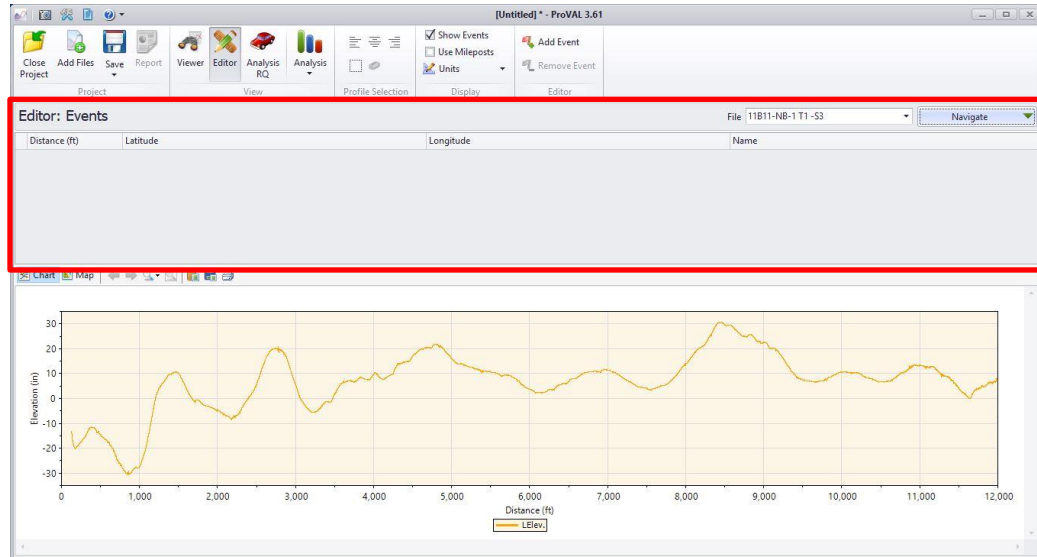

4.2.2.1. Add events if needed.

4.2.2.2. Remove events if needed.

4.2.3. Check and verify any sections.

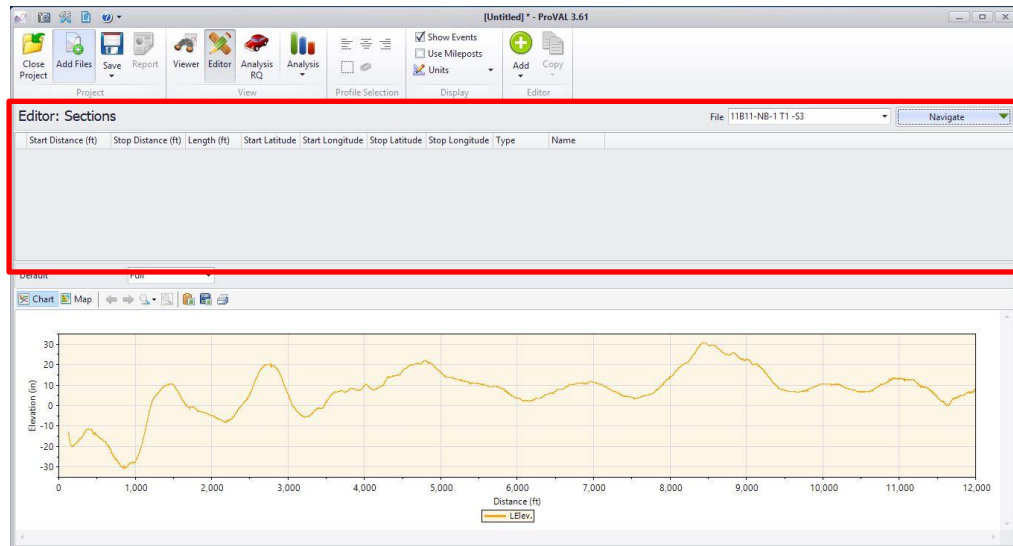

4.2.3.1. Add omissions to reduce file to only segments subject to MRI analysis, making sure the field "Type" is marked as "Leave-out" for each omission.

4.2.3.2. Edit omissions as necessary.

4.2.4. Verify the data in the “Information” section.

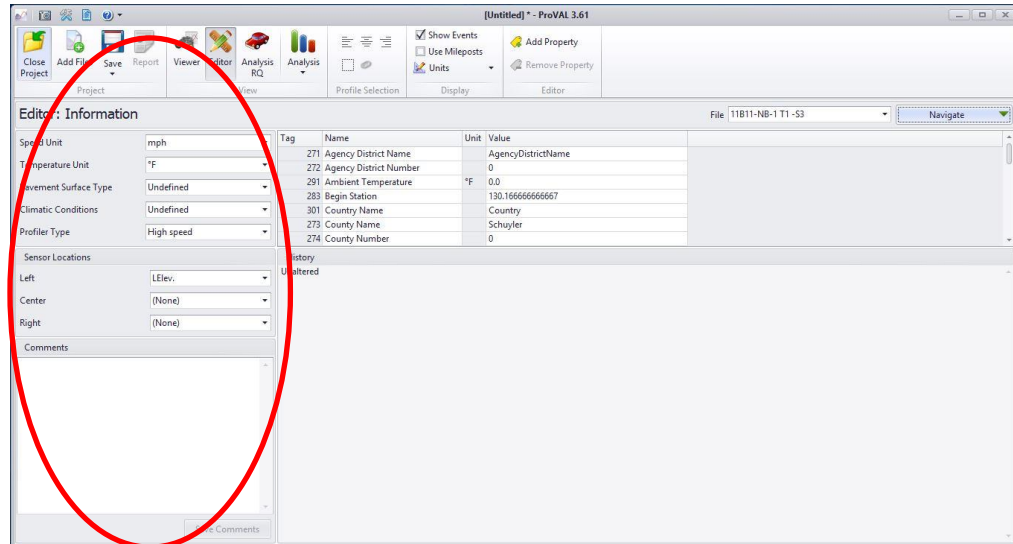

4.2.4.1. Speed Unit - mph

4.2.4.2. Temperature - F⁰

4.2.4.3. Pavement Surface Type – HMA or PCC

4.2.4.4. Climatic Conditions

4.2.4.5. Profiler Type – lightweight, high-speed, etc.

4.2.4.6. Sensor locations – left, center, right

4.2.5. Click the “Save” button.

4.3. Profile Synchronization.

4.3.1. Click on the “Analysis” button and select “Profile Synchronization”

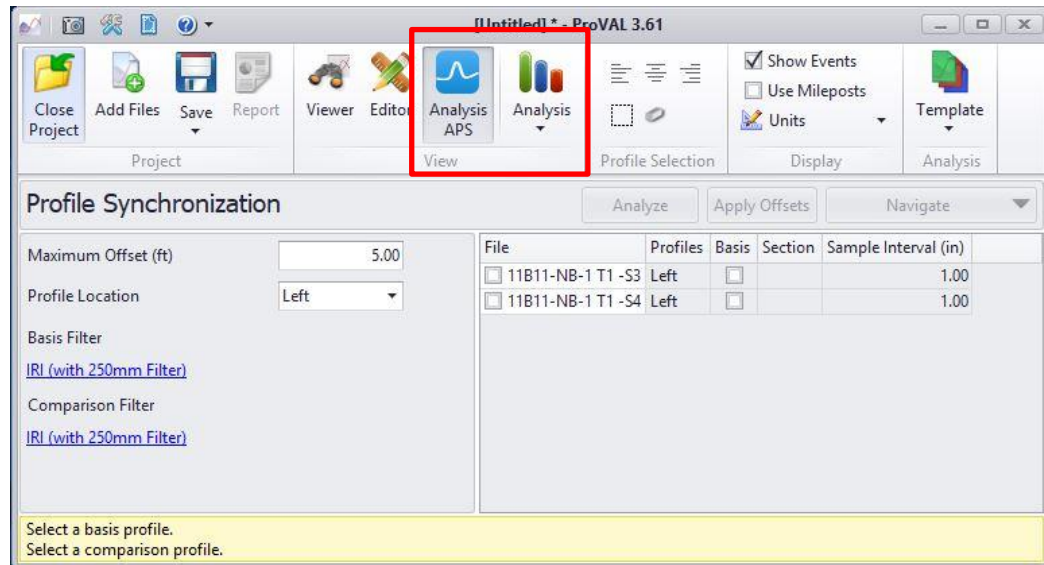

Note: After profile synchronization is selected the Analysis icon will change to look the screen above.

4.3.2. Select the files that are being compared.

4.3.3. Ensure that both are applying the IRI filter with the 250 mm filter.

4.3.4. Select the profile location (wheelpath) and the file for the basis of synchronization.

4.3.5. Click on Analyze.

4.3.6. Review the results, noting the correlation value.

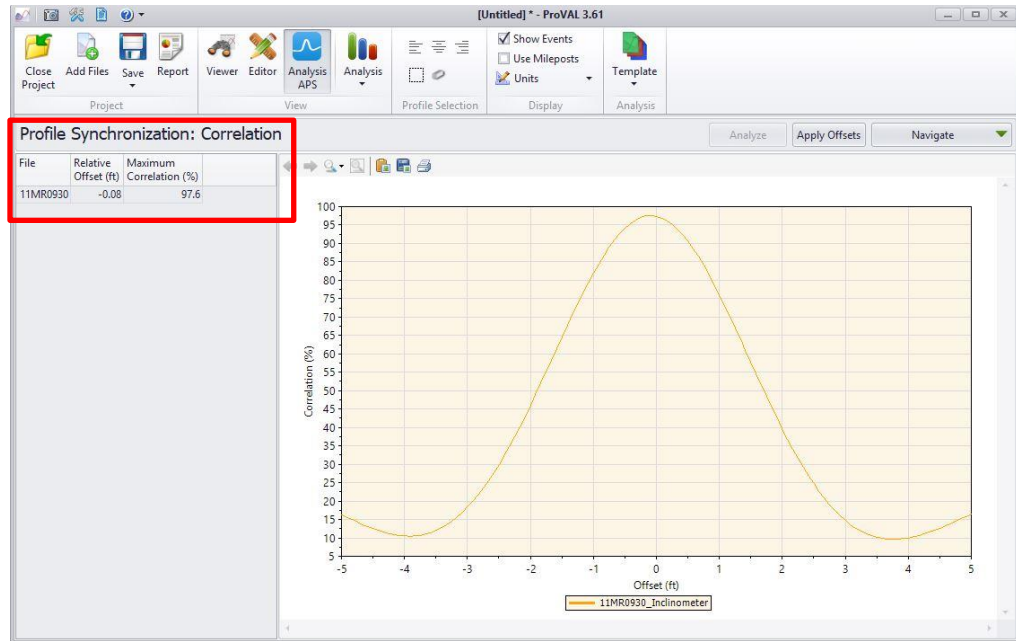

- 4.3.7. Repeat steps 4.6.3 through 4.6.5 for the opposite wheelpath and note the correlation.
- 4.3.8. If both wheelpath correlations are greater than 92%, click “Apply Offsets” for the larger of the two correlation values.
- 4.3.9. If the lowest wheelpath correlation is less than 92%, return to inputs and increase the maximum offset.
- 4.3.10. If the lowest wheelpath correlation is still less than 92% and the maximum offset is 25ft, collect the profile again, add the new files and start from step 4.2.
- 4.3.11. Click the “Save” button.
- 4.4. **Power Spectral Density Analysis**
- 4.4.1. Click the “Analysis” button and select “Power Spectral Density”.

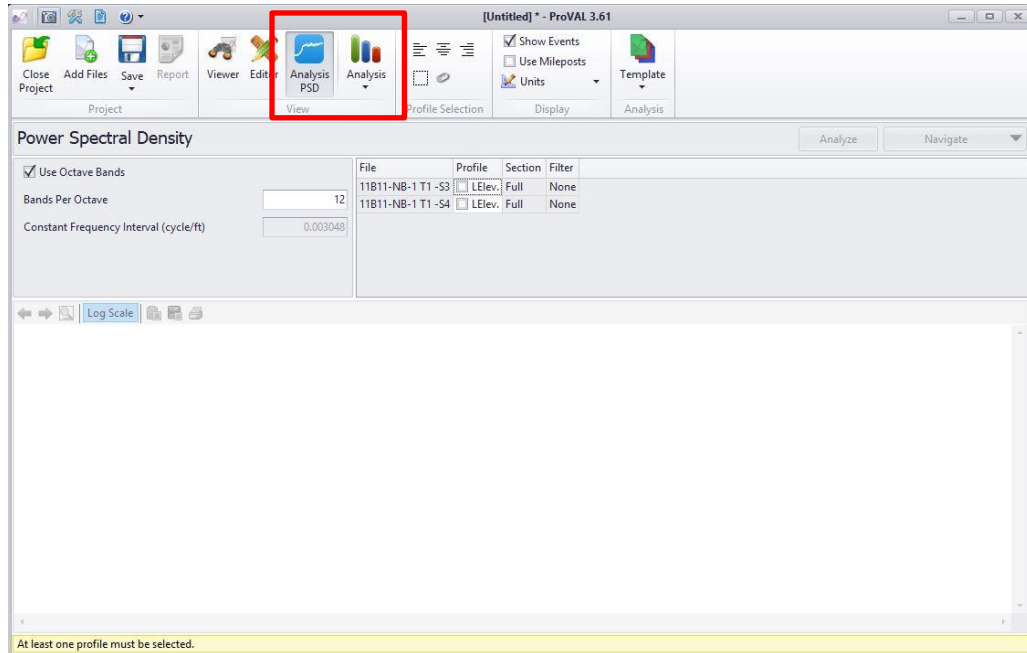

- 4.4.2. Change the “Bands per Octave” to 24.
- 4.4.3. Select the file(s) that you wish to analyze.
- 4.4.4. Filter setting will be “None”.
- 4.4.5. Click on “Analyze”.

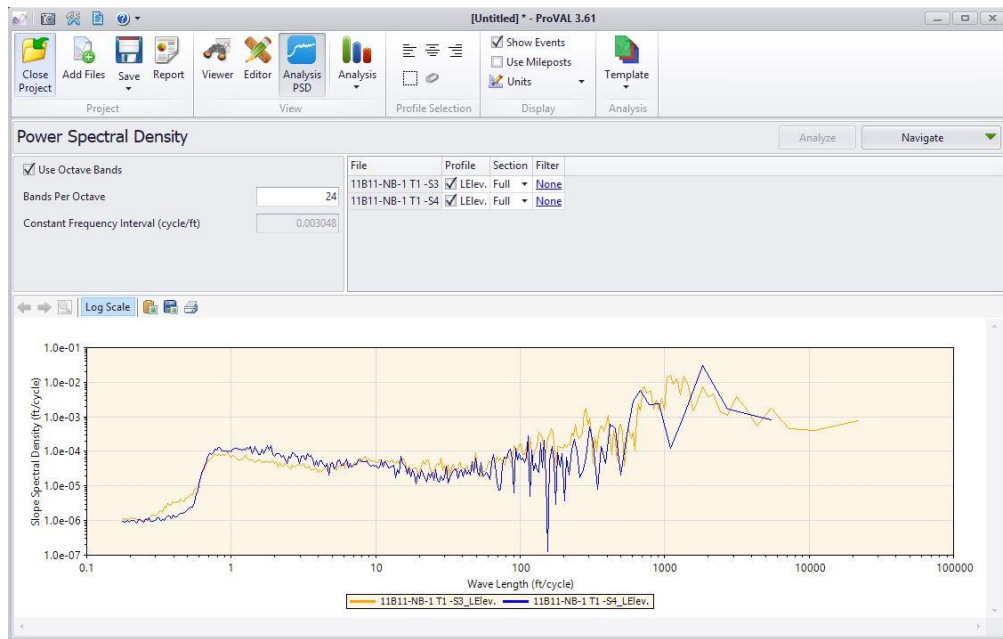

- 4.4.6. Click the “Save” button.

4.5. Mean Roughness Index Analysis.

4.5.1. Select “Ride Quality” of the “Analysis” menu.

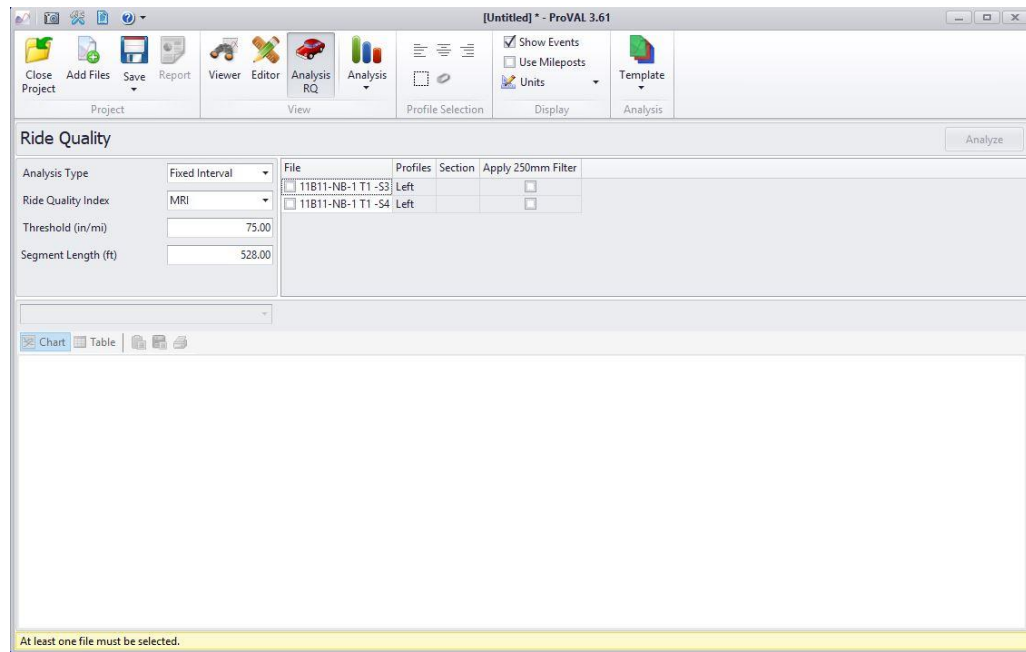

4.5.1.1. Change the “Analysis Type” to “Fixed Interval”.

4.5.1.2. Change the “Ride Quality Index” to “MRI”.

4.5.1.3. Change the Threshold to 75.0

4.5.1.4. “Segment Length” shall be equal to 528.0

4.5.1.5. Select the profiles to be analyzed.

4.5.1.6. Ensure that the “250mm Filter” is applied.

4.5.2. Click the “Analyze” button.

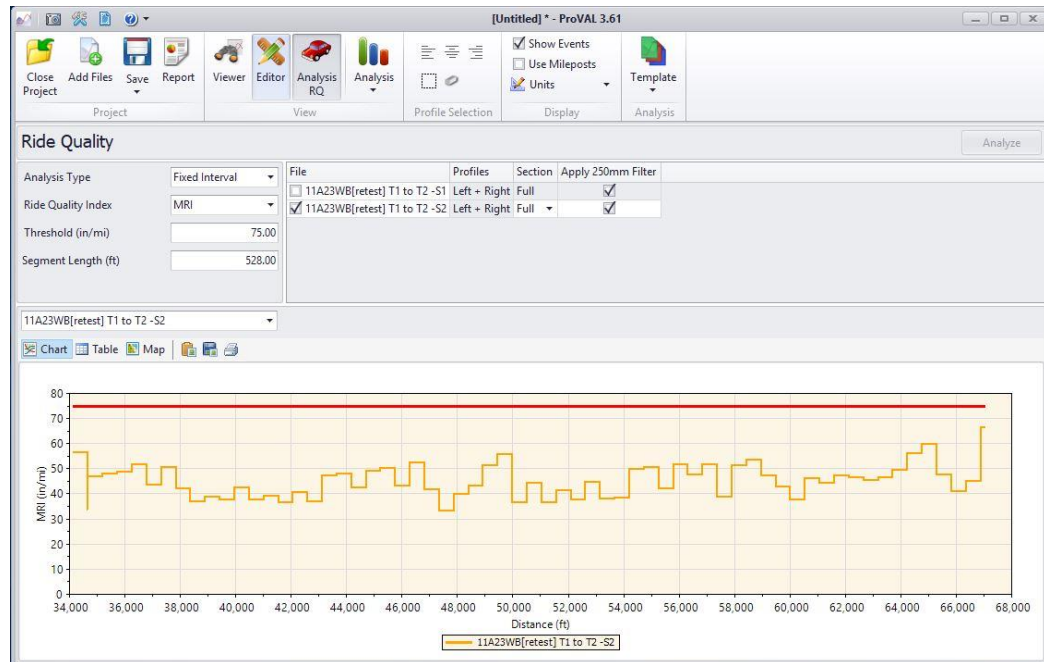

4.5.3. Review the results.

4.6. Areas of Localized Roughness Analysis

4.6.1. Determine the Areas of Localized Roughness

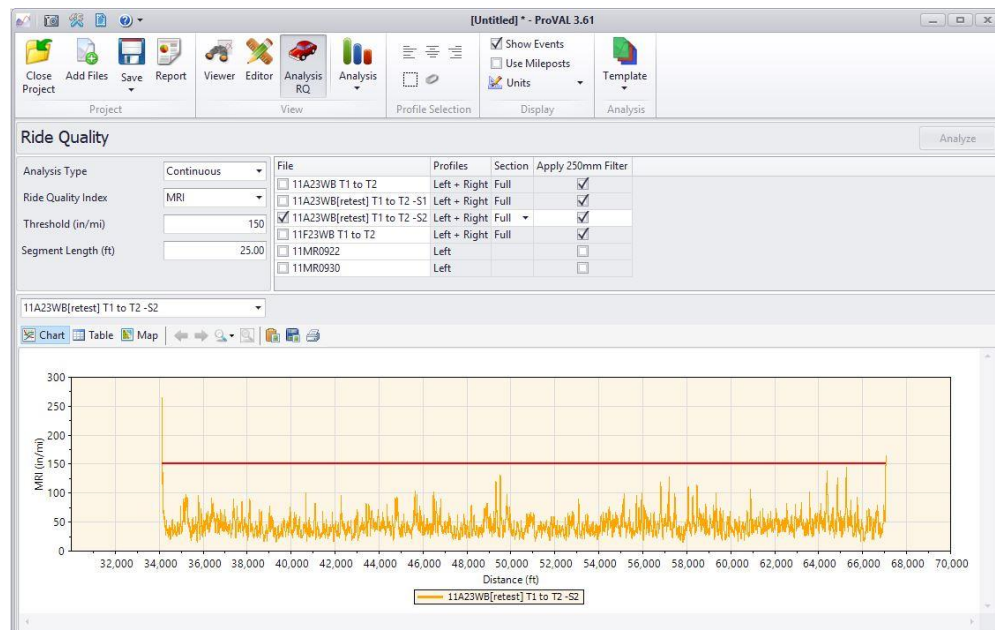

4.6.1.1. Change the “Analysis Type” to “Continuous”.

4.6.1.2. Change the “Ride Quality Index” to “MRI”.

- 4.6.1.2.1. Change the Threshold to 150.0
- 4.6.1.3. “Segment Length” shall be equal to 25.0
- 4.6.1.4. Select the profile(s) to be analyzed.
- 4.6.1.5. Ensure that the “250mm Filter” is applied.
- 4.6.2. Click the “Analyze” button.

5. REPORT

- 5.1. Click on the “Report” button.
- 5.2. Create a “Detailed Excel Report” for inclusion into the assessment worksheet.

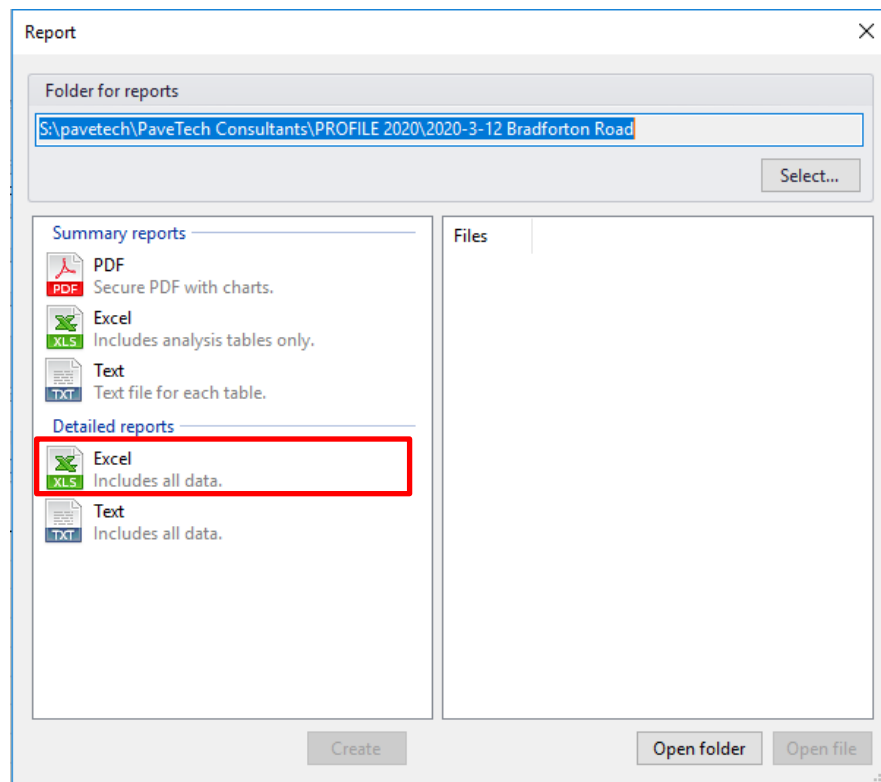

- 5.3. Save the file and close ProVAL.

This Page Reserved

ILLINOIS TEST PROCEDURE 704

Rolling Straightedge Simulation in ProVAL

Effective Date: January 1, 2021

1. SCOPE

- 1.1. This test procedure covers the process to bumps of a pavement surface by applying a computer simulation of a 16 ft (5 m) straightedge on the collected pavement profiles.
- 1.2. The values stated in US Customary units are to be regarded as the standard.
- 1.3. *This standard does not purport to address all the safety concerns, if any, associated with its use. It is the responsibility of the user of this procedure to establish appropriate safety and health practices and determine the applicability of regulatory limitations prior to use.*

2. TERMINOLOGY

- 2.1. ProVAL: Profile Viewing and Analysis Software is free software that was created under the direction of FHWA and TPF-5(063). <https://www.roadprofile.com/>

3. SIGNIFICANCE AND USE

- 3.1. This procedure will be used to determine bumps of a pavement surface.

4. PROCEDURE

4.1. File Creation

- 4.1.1. Open ProVAL on your computer. Verify that you have the latest version installed.

4.1.2. Create a new project.

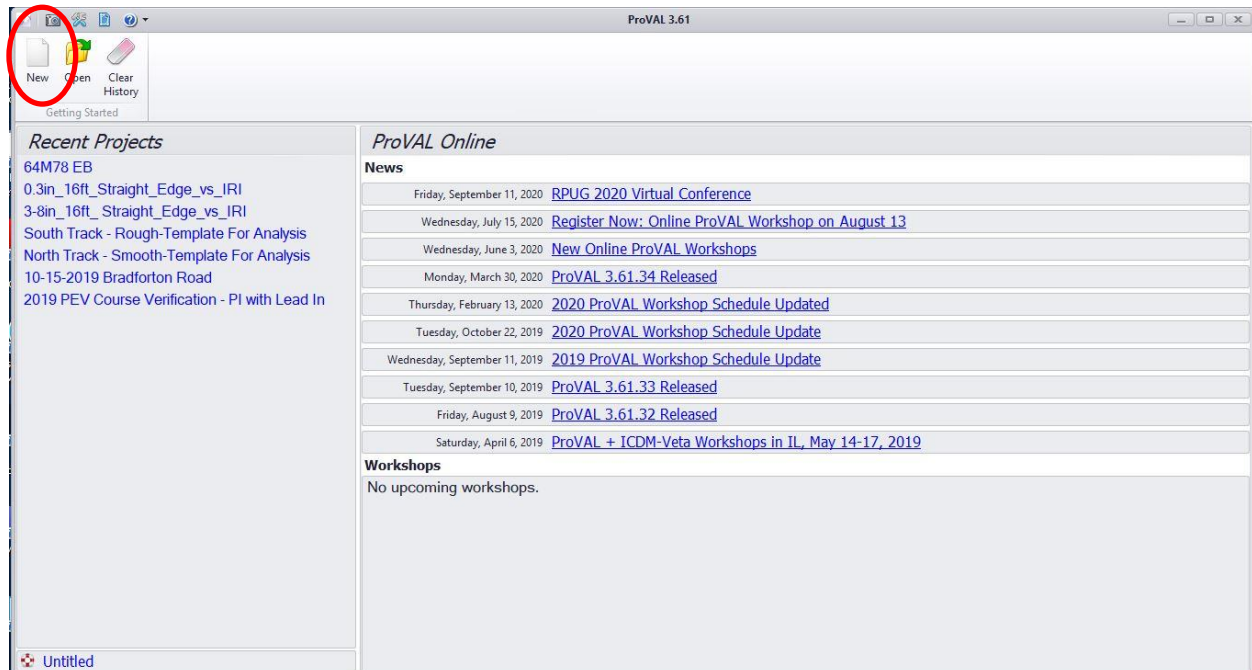

4.1.3. Save the project file with the following naming convention: XXXXX-DD-L

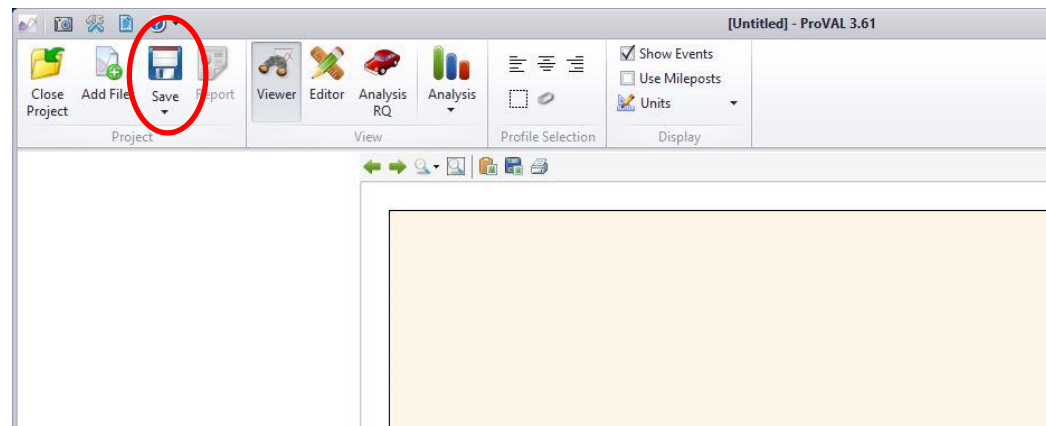

4.1.3.1. XXXXX - Contract Number

4.1.3.2. DD - Direction (EB, WB, NB, SB)

4.1.3.3. L - Lane Number (1 – outermost lane, 2, 3,...)

4.1.3.4. Add the files that are to be analyzed. Click on “Add Files”.

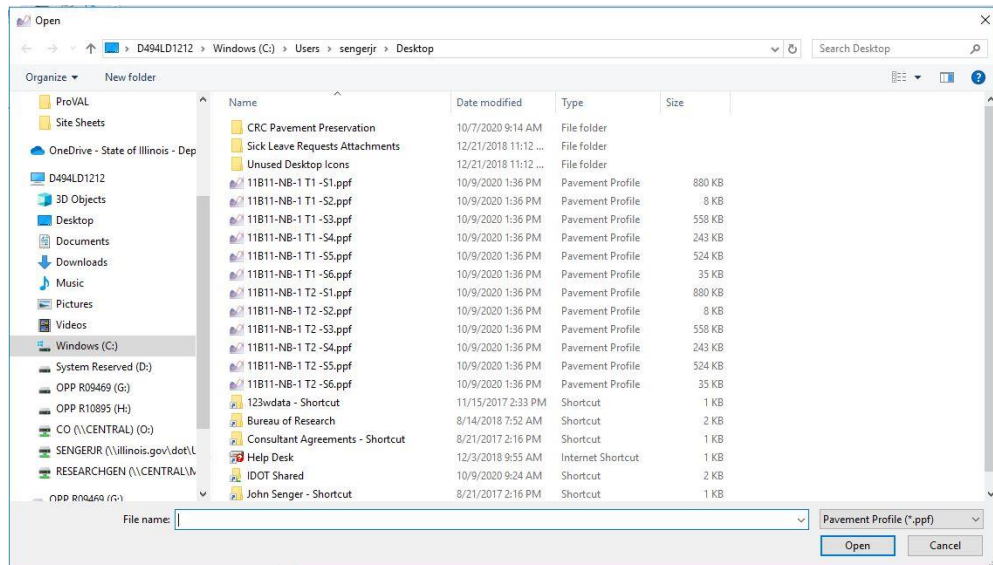

4.2. Project Information Verification

4.2.1. Verify the “Basic” project information under the “Editor” module.

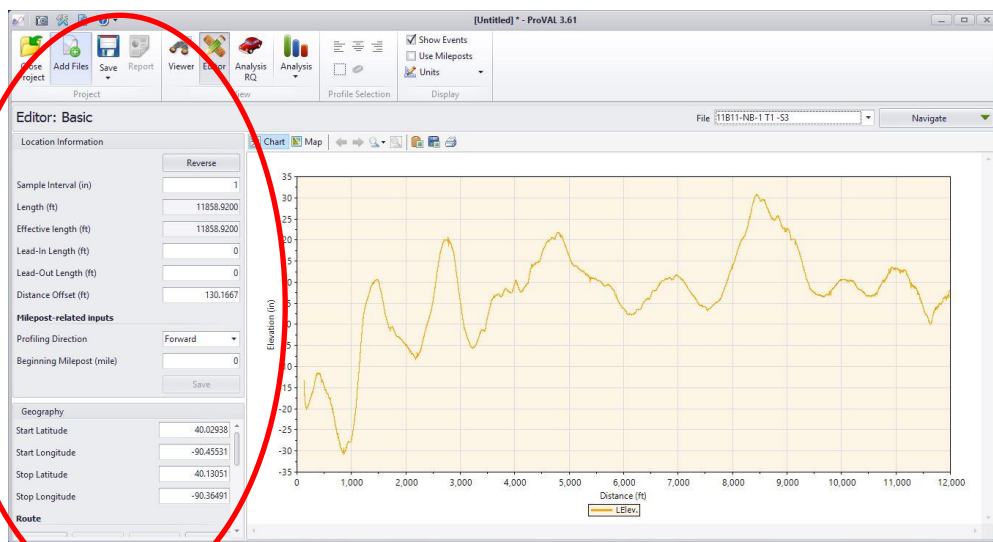

4.2.1.1. Verify the sample interval. (1-2 inches)

4.2.1.2. Verify the length. (Paved length, Contract Length....)

4.2.1.3. Verify the trace appears in the correct location on the map.

4.2.2. Check and verify any events stored in the file.

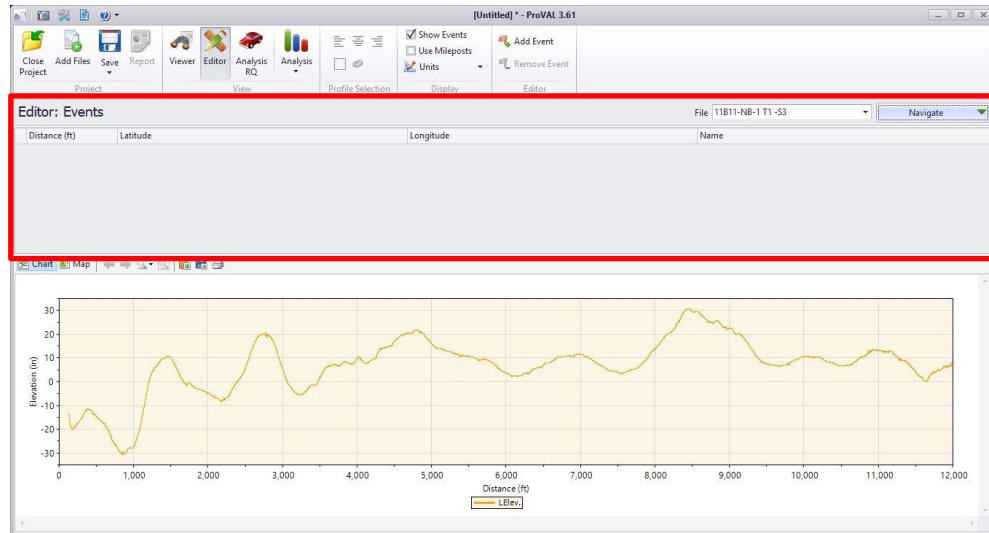

4.2.2.1. Add events if needed.

4.2.2.2. Remove events if needed.

4.2.3. Check and verify any sections.

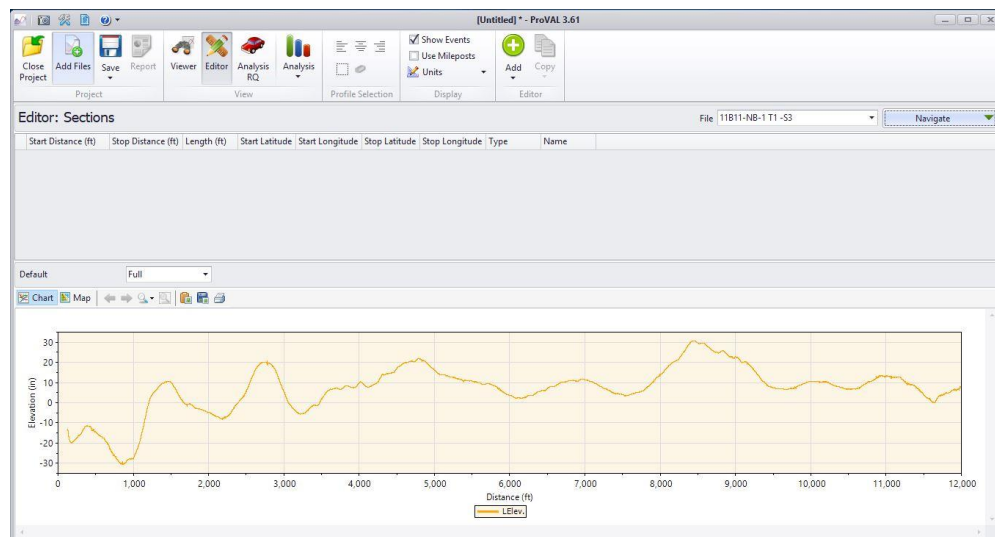

4.2.3.1. Add omissions to reduce file to include only segments subject to straight edge testing, making sure the field "Type" is marked as "Leave-out" for each omission.

4.2.3.2. Edit omissions as necessary.

4.2.4. Verify the data in the "Info" section.

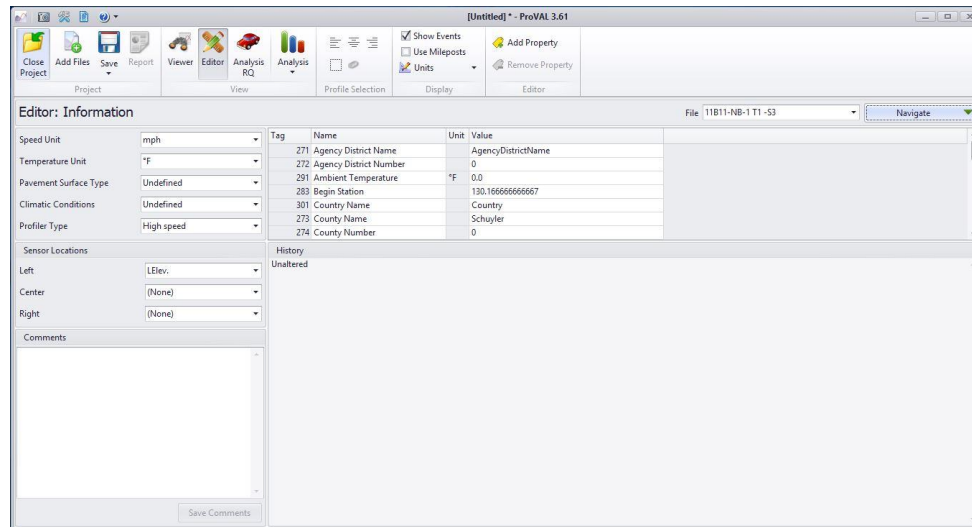

- 4.2.4.1. Speed Units - mph
- 4.2.4.2. Temperature Units - F°
- 4.2.4.3. Pavement Surface Tpye (HMA or PCC)
- 4.2.4.4. Climatic Conditions
- 4.2.4.5. Profiler Type (lightweight, high-speed, etc.)
- 4.2.4.6. Sensor locations (left, center, right)

4.3. Rolling Straightedge Analysis

4.3.1. Click on the “Analysis” button and select “Rolling Straightedge”.

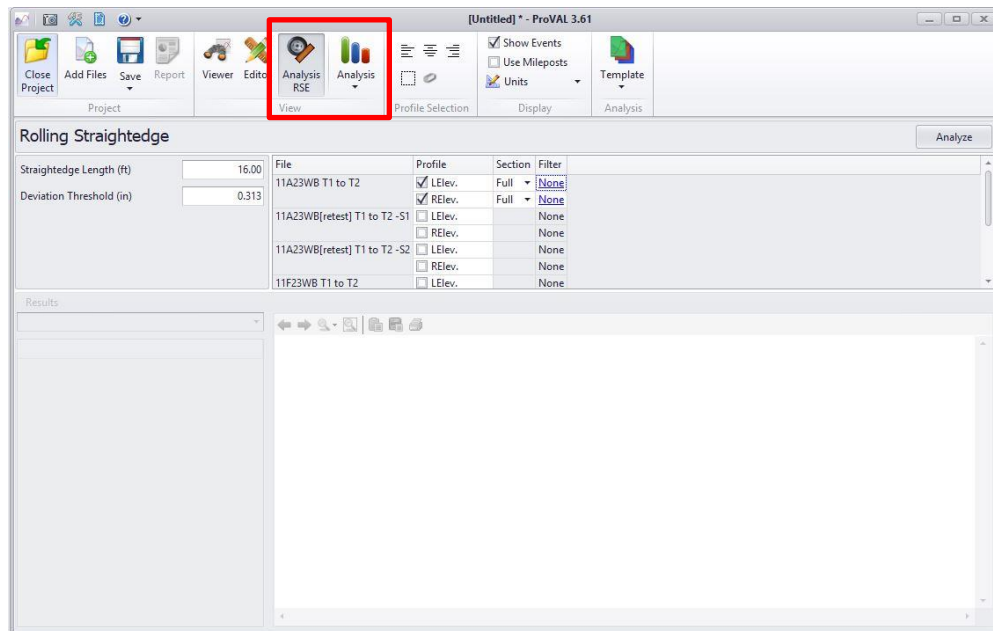

Note: After rolling straightedge is selected the Analysis icon will change to look the screen above.

4.3.2. Change the analysis to Rolling Straight Edge.

4.3.3. Change the Straightedge Length (ft) to 16.00.

4.3.4. Change the Deviation Threshold (in.) to 0.313 (5/16”).

4.3.5. Select the profiles that you want to analyze.

4.3.6. Change the filter to “None”

4.3.7. Click the “Analyze” button to perform the analysis.

4.3.8. Review the data (graphs and tables). Each wheelpath will be a separate drop down in the Results Table. The results table shows segments not conforming to the specification and will require additional corrections.

5. Report

5.1. Click on the “Report” button.

5.2. Select the PDF option and the folder to save the file.

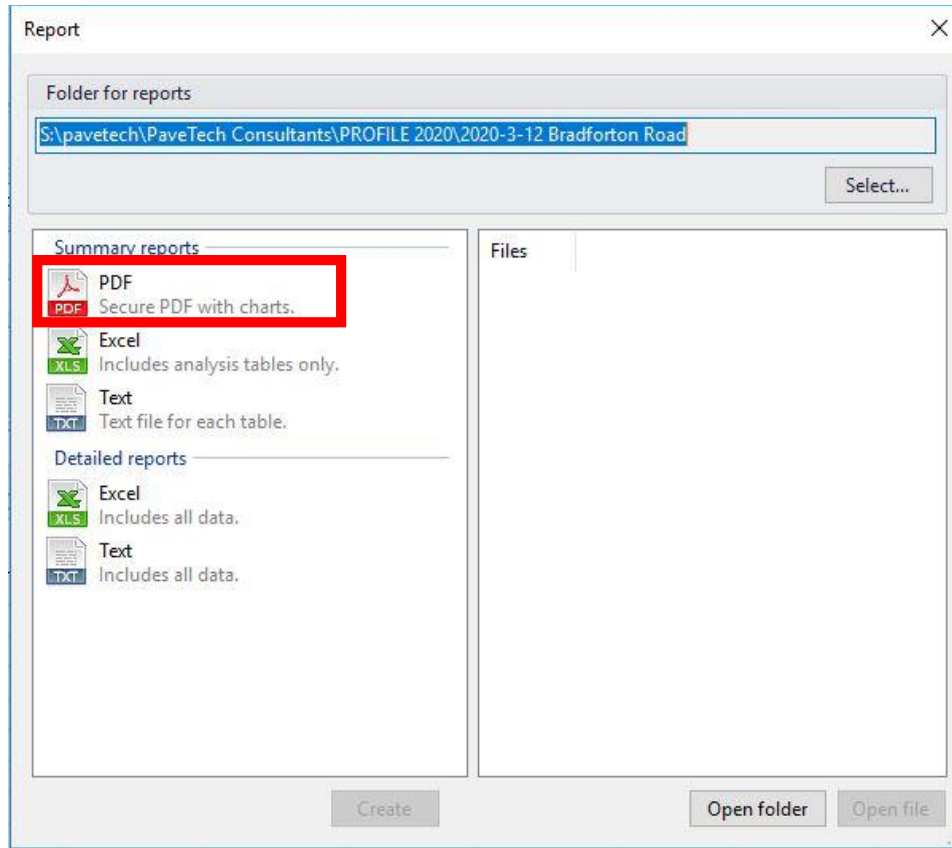

- 5.3. Click on the “Create” button.
- 5.4. Click on the “Open File” button to view the file (if necessary).
- 5.4.1. Close the PDF.
- 5.5. Click on the “Save” button to save the ProVAL file.
- 5.6. Close the program.

This Page Reserved

**Development of Gradation Bands on Incoming Aggregate at Hot-Mix Asphalt and
Portland Cement Concrete Plants**
Appendix A.1

Effective: January 1, 1994
Revised: December 1, 2021

A. Scope

Quality Control Plans for Hot-Mix Asphalt (HMA) and Portland Cement Concrete (PCC) contracts normally require incoming aggregate to be checked for gradation compliance before use in HMA and PCC plants. Aggregate is produced to tight gradation bands at the source but will degrade during handling and shipment.

B. Purpose

Establish a procedure to modify aggregate source gradation bands to develop mix plant gradation bands for use in checking gradation compliance on incoming aggregate at mix plants. The mix plant gradation bands will also be used in checking gradation compliance for required stockpile gradation tests at the mix plant.

C. Aggregate Source Gradation Bands

The Contractor shall obtain certified aggregate gradation bands (including master band, if required) from the aggregate source for all certified aggregates prior to any shipment of material to a mix plant. Natural sand gradation bands shall be obtained from the appropriate District Materials Engineer.

D. General Procedure

The Contractor may modify the aggregate source gradation bands according to the following procedures, if necessary, to check incoming aggregate for gradation compliance at the mix plant. If not modified, the aggregate source gradation bands shall be considered the mix plant gradation bands when checking incoming aggregate.

1. Coarse Aggregate—The Contractor may shift the aggregate source master band a maximum of three percent (3%) upwards to establish a Mix Plant Master Band for each coarse aggregate used. All other aggregate source gradation bands, except for the top sieve and bottom sieve bands in the gradation specification, may also be shifted upward a maximum of three percent (3%). The top sieve and bottom sieve bands shall not be changed, except as follows:

At PCC plants, the Contractor may increase the specification limit for the minus No. 200 (75- μ m) Illinois Modified AASHTO T 11 sieve material upwards one half percent (0.5%) if the No. 200 (75- μ m) material consists of dust from fracture, or degradation from abrasion and attrition, during

**Development of Gradation Bands on Incoming Aggregate at Hot-Mix Asphalt and
Portland Cement Concrete Plants**

Appendix A.1

(continued)

Effective: January 1, 1994

Revised: December 1, 2021

stockpiling and handling (reference Article 1004.01[b] of the Department's
Standard Specifications for Road and Bridge Construction).

2. **Manufactured Sand**—All aggregate source gradation bands, except the top sieve and bottom sieve bands in the gradation specification, for each certified manufactured sand may be shifted upwards a maximum of three percent (3%). The top sieve and bottom sieve bands shall not be changed.
3. **Natural Sand**—The gradation bands obtained from the Department for each natural sand shall not be changed.

E. Department Approval

All aggregate source gradation bands and mix plant gradation bands must be sent to the District Materials Engineer for approval prior to any shipment of aggregate to the mix plant. Once approved, the mix plant gradation bands shall not be changed without approval of the District Materials Engineer.

**Quality Control (QC) Manager / Aggregate Technician / AGCS Technician /
Mixture Aggregate Technician / IDOT Inspector / Gradation Technician
Responsibilities
(Chapter 7, Aggregate Technician Course Manual)
Appendix A.2**

Effective: November 1, 1995

Revised: [December 1, 2021](#)

**7.0 QUALITY CONTROL (QC) MANAGER / AGGREGATE TECHNICIAN /
AGCS TECHNICIAN / MIXTURE AGGREGATE TECHNICIAN /
IDOT INSPECTOR / GRADATION TECHNICIAN RESPONSIBILITIES**

The Quality Control (QC) Manager, Aggregate Technician, AGCS Technician, Mixture Aggregate Technician, IDOT Aggregate Inspector, and the Gradation Technician have specific responsibilities under the Aggregate Gradation Control System. Many of these responsibilities are similar, including gradation sampling/testing and visual inspection of production. Several are limited to the QC Manager, the Aggregate Technician, or the IDOT Aggregate Inspector. It should be noted that only the Aggregate Technician or the AGCS Technician may also be the QC Manager.

The following table denotes the responsibilities and the person responsible.

	QC Manager	Aggregate Tech.	AGCS Tech.	Mixture Agg. Tech.	IDOT Inspector	Gradation Tech.
▪ Knowledge of Specs	X	X	X		X	
▪ Quality Sampling					X	
▪ Visual Inspection	X	X	X		X	
▪ Gradation Sampling	X	X	X	X	X	
▪ Gradation Testing	X Note 2	X		X	X	X Note 1
▪ Plant Diary	X	X	X	X		
▪ Aggregate Certification	X					
▪ Safety	X	X	X	X	X	X

Note 1: Only under direct supervision of Aggregate Technician or Mixture Aggregate Technician

Note 2: Not allowed for AGCS Technician

Each responsibility is discussed below.

**Quality Control (QC) Manager / Aggregate Technician / AGCS Technician /
Mixture Aggregate Technician / IDOT Inspector / Gradation Technician
Responsibilities
(Chapter 7, Aggregate Technician Course Manual)
Appendix A.2**

Effective: November 1, 1995

Revised: December 1, 2021

7.1 **Knowledge of Current Specifications.** The QC Manager, the Aggregate Technician, the AGCS Technician, and the IDOT Aggregate Inspector must maintain up-to-date knowledge of the specifications that apply to the aggregate products currently being produced at the Source. The Aggregate Technician and the AGCS Technician shall have available at the Source a copy of the current Standard Specification, any applicable supplemental specifications, and the *Manual of Test Procedures for Materials*. All four individuals shall be aware of any special provisions which change current aggregate specifications. This applies to both quality and gradation specifications. A copy of the current Standard Specifications, Sections 1003 and 1004, and the supplemental specifications to Sections 1003 and 1004 are located in the Appendix.

7.2 **Quality Sampling / Testing.** IDOT will continue to sample and test all aggregates for quality. The IDOT Aggregate Inspector shall sample any certified stockpile at the frequency designated in the *Manual for Aggregate Inspection*. All quality samples are sent to the Central Bureau of Materials for testing. The tests run were discussed previously in Chapter 3.0 herein. Any certified stockpile must meet the designated quality before shipment. Willful shipment of out-of-specification material shall be handled according to Section 11.2 of the Department's current Policy Memorandum, "Aggregate Gradation Control System (AGCS)", in Chapter 8.0.

Although the Aggregate Technician/AGCS Technician will not be sampling or testing for quality, he will be notified when sampling occurs and may witness the sampling. The Aggregate Technician/AGCS Technician should obtain and maintain quality information on specific ledges, production methods, and the certified stockpiles. Shipment of approved material remains the responsibility of the Source.

A Consultant, hired by the Department to perform the duties of an Aggregate Inspector, shall not be allowed to take any quality or Freeze-Thaw samples at an aggregate source.

7.3 **Visual Inspection.** The responsibility of visually inspecting an aggregate Source's process on a frequent basis falls on the Aggregate Technician, the AGCS Technician, and the IDOT Aggregate Inspector. Visual inspection can be defined as observing the processing or production area, the stockpiling methods, and the loading/handling operation, as well as the condition of the aggregate in the flow stream or stockpiles.

7.3.1 For the Aggregate Technician/AGCS Technician, visual inspections shall be a daily occurrence—**several** (three or more) inspections spread uniformly through-out the production day—while producing certified aggregate. Visual inspections by the IDOT Aggregate Inspector may be at a reduced frequency. Most Aggregate/AGCS

**Quality Control (QC) Manager / Aggregate Technician / AGCS Technician /
Mixture Aggregate Technician / IDOT Inspector / Gradation Technician
Responsibilities
(Chapter 7, Aggregate Technician Course Manual)
Appendix A.2**

Effective: November 1, 1995

Revised: [December 1, 2021](#)

Technicians/Inspectors will establish an inspection route when they enter the Source. As an example, the inspection route will take them past the ledge face to verify from where the raw feed is coming. This also allows for visual examination of the face for contamination or the intrusion of poor quality material into the ledge.

The production plant, from the primary crusher to the final screening/logwashing, is visited next. This stop verifies that the correct production method is being used to produce the required quality and gradation. Problems with equipment, such as screen cloth, etc., can be observed and corrected.

Finally, the stockpiling/load-out area can be observed. Segregation, degradation, or contamination can be readily identified and proper steps taken to eliminate the problems.

- 7.3.2 This quick type of inspection helps the Aggregate Technician/AGCS Technician/Inspector “keep a handle on” the aggregate being produced. It does not take away from actual testing of the aggregate but enhances the inspection to ensure quality aggregate.

Remember, it is an Aggregate/AGCS Technician’s/Inspector’s responsibility to observe the overall aggregate operation to detect segregation, degradation, and contamination that is detrimental to the quality of the aggregate product. These observations should be communicated immediately to the QC Manager for corrective action if necessary.

- 7.4 **Gradation Sampling.** Quality or gradation sampling involves taking a small, representative portion of a finished product for quality/gradation control or compliance testing. The word “representative” is perhaps the most important word in that definition, especially in conjunction with gradation testing. It is imperative that the sample accurately represents the material being produced. Inaccurate samples can lead to acceptable material being rejected or to non-acceptable material being used. In either case, non-representative sampling often results in higher construction/maintenance costs.

- 7.4.1 Under the Aggregate Gradation Control System, the Aggregate Technician, the AGCS Technician, the Mixture Aggregate Technician, and the IDOT Aggregate Inspector must know how to correctly sample aggregate for gradation testing. The Aggregate Technician/AGCS Technician/Mixture Aggregate Technician will have to sample at a specified frequency from both production and stockpiles. They may choose one of the approved production sampling methods described in Illinois [Modified AASHTO R 90](#), (Chapter 5.0 of the AGCS). The stockpile sampling method noted in Chapter 5.0 is the only method allowed for sampling a stockpile.

**Quality Control (QC) Manager / Aggregate Technician / AGCS Technician /
Mixture Aggregate Technician / IDOT Inspector / Gradation Technician
Responsibilities
(Chapter 7, Aggregate Technician Course Manual)
Appendix A.2**

Effective: November 1, 1995

Revised: [December 1, 2021](#)

The IDOT Aggregate Inspector will sample on a very infrequent basis. Most of the IDOT monitor samples will be split samples taken and split by the Aggregate Technician/AGCS Technician/Mixture Aggregate Technician. However, the IDOT Aggregate Inspector may take a sample at any time under the program.

7.4.2 The frequency of sampling for the Aggregate Technician/AGCS Technician/Mixture Aggregate Technician, and the IDOT Aggregate Inspector is covered in the Department's current Policy Memorandum, "Aggregate Gradation Control System (AGCS)", in Chapter 8.0. The high number of samples required, especially by the Aggregate Technician/AGCS Technician/Mixture Aggregate Technician, makes it imperative that the technician/ inspector takes the time and has the knowledge to accurately sample for gradation testing. The overall program relies on accurate results to supply in-gradation aggregate to IDOT construction projects.

7.5 **Gradation Testing.** Illinois [Modified AASHTO T 11](#) / Illinois [Modified AASHTO T 27](#) (Chapter 6.0 of the AGCS) describes the correct and acceptable method to run a gradation test. As with gradation sampling, inaccurate results hurt both the aggregate producer as well as IDOT. It is therefore the responsibility of the Aggregate Technician, the Mixture Aggregate Technician, the Gradation Technician, and the IDOT Aggregate Inspector to correctly run the gradation test. The AGCS Technician is not allowed to split or run gradation tests under the AGCS.

7.6 **Plant Diary.** The Aggregate Technician/AGCS Technician is required to maintain a plant diary when producing under the program. This diary shall detail samples taken, pass/fail results, corrective action, plant/ledge changes, etc., [daily](#). The diary must be kept at the Source for periodic checking by the IDOT Aggregate Inspector. See Example on [following page (page 7-6 of Aggregate Technician Course Manual)].

The IDOT Aggregate Inspector is required to keep a personal diary on his daily inspection trips. Much of the same information required for the Aggregate Technician/AGCS Technician diary is noted by the IDOT Aggregate Inspector.

7.7 **Aggregate Certification.** The previous discussions on numerous individual responsibilities focus attention on the QC Manager's/Aggregate Technician's/AGCS Technician's/Inspector's overall responsibilities. The Source's QC Manager has the overall responsibility of certifying that material being placed on the certified stockpile is produced under and conforms to the Aggregate Gradation Control System. The production or quarry supervisor, if not the QC Manager, also assumes some of the responsibility for assuring that in-specification material is being made and shipped to IDOT projects.

**Quality Control (QC) Manager / Aggregate Technician / AGCS Technician /
Mixture Aggregate Technician / IDOT Inspector / Gradation Technician
Responsibilities
(Chapter 7, Aggregate Technician Course Manual)
Appendix A.2**

Effective: November 1, 1995

Revised: [December 1, 2021](#)

The IDOT Aggregate Inspector, through his monitoring activities (sampling/testing, visual inspection, etc.), must verify the continued compliance to the Aggregate Gradation Control System. Any lack of compliance, as noted by the IDOT Aggregate Inspector, will be grounds for Source decertification under the program and shall be communicated to the QC Manager as expeditiously as possible for correction.

- 7.8 **Safety.** It is the responsibility of the QC Manager, the Aggregate Technician, the AGCS Technician, the Mixture Aggregate Technician, the IDOT Aggregate Inspector, and the Gradation Technician to perform their respective duties in a safe manner. To assure that this condition is met, the QC Manager, the Aggregate Technician, the AGCS Technician, the Mixture Aggregate Technician, and the IDOT Aggregate Inspector should be familiar with any and all safety regulations in force. Great care should be taken when sampling around moving equipment, e.g., conveyor belts, screen decks, hopper grates, etc. Due to poor visibility and large truck/equipment traffic, caution should also be used when driving around the plants and stockpiles.

The QC Manager, the Aggregate Technician, the AGCS Technician, the Mixture Aggregate Technician, and the IDOT Aggregate Inspector must have a knowledge of applicable Mine Safety and Health Administration (MSHA) regulations. The IDOT Aggregate Inspector is also regulated by Departmental policies covered in the "Employee Safety Code" handbook.

Illinois Department of Transportation

**Quality Control (QC) Manager / Aggregate Technician / AGCS Technician /
Mixture Aggregate Technician / IDOT Inspector / Gradation Technician
Responsibilities
(Chapter 7, Aggregate Technician Course Manual)
Appendix A.2**

Effective: November 1, 1995

Revised: [December 1, 2021](#)

EXAMPLE

Company Name: _____

Aggregate / AGCS Technician Plant Diary

Date:	
Plant Name:	
Weather:	
Ledge Information:	
Material Being Produced:	

VISUAL INSPECTION:	1ST VISIT	2ND VISIT	3RD VISIT	ADDITIONAL VISITS
Time:				
Stockpile/Loadout:				
Degradation	YES/NO	YES/NO	YES/NO	YES/NO
Segregation	YES/NO	YES/NO	YES/NO	YES/NO
Contamination	YES/NO	YES/NO	YES/NO	YES/NO
Plant:				
Pit Area:				
Graph(s):				
Samples Taken:				
Production				
Loadout:				
Resample:				
SIGNATURE:				

Problems: (Init./Time)	
Action Taken: (Init./Time)	
Comments:	

**Aggregate Producer Control Chart Procedure
(Chapter 9, Aggregate Technician Course Manual)
Appendix A.3**

Effective: November 1, 1995

Revised: December 1, 2017

9.0 AGGREGATE PRODUCER CONTROL CHART PROCEDURE

Gradation control charts provide an effective way to monitor the aggregate production process and can present a graphical record of aggregate gradation during continuous production and stockpiling. Specific changes or gradual trends in a product's gradation can be readily identified before major trouble occurs. Other benefits that may also be realized by using control charts include but are not limited to:

- Decreased product variability
- Established production capabilities
- Permanent record of gradation quality
- Increased sense of "quality awareness" at the Source

For these reasons, an Aggregate Producer Control Chart Procedure is an important requirement in the Gradation Control Program at certified aggregate Sources in Illinois.

Under the Illinois Aggregate Producer Control Chart Procedure, all gradation test results (percent passing) for each required gradation/production point tested shall be recorded on a control chart within one working day of sampling. The control chart/s for any gradation in the program must therefore have each required sieve represented on the chart.

The gradation control charts are to be readily accessible at the source and/or approved laboratory and available for inspection upon request by the Aggregate Inspector or a representative of the Department. Computer-maintained charts shall be printed and displayed once per week or at the request of the Department. Control charts are the property of the Department and shall not be removed or altered in any manner. The Aggregate Inspector shall check the control charts on a regular basis.

The "Illinois Specification 201 Aggregate Gradation Sample Size Table & Quality Control Sieves" document from the "Manual of Test Procedures for Materials" designates the required sieves for coarse and fine aggregate gradations.

9.1 Definitions

9.1.1 **Average:** The sum of a series of test results or measurements divided by the number of values or measurements included in the sum, also, known as the arithmetic mean.

9.1.2 **Check Samples:** Samples taken for a specific purpose, other than required by Table 1. This information may be used to verify an observation or conclusion, or as a means of confirmation of corrective action, other than required by Table 1. Such samples are permitted under any circumstances except to replace samples required by Table 1.

**Aggregate Producer Control Chart Procedure
(Chapter 9, Aggregate Technician Course Manual)
Appendix A.3**

Effective: November 1, 1995

Revised: December 1, 2017

- 9.1.3 **Control Charts**: A visual representation of test results, observations, or measurements arranged in an orderly sequence in respect to time. Control charts provide the means of measuring the effectiveness of process control, detecting lack of control, directing a course of action to restore control, and increased sense of “quality awareness”.
- 9.1.4 **“Master Band” or Control Limits**: Mathematical limits placed on gradations, based on established Master Band limits, which when exceeded initiate action by those responsible for process control, and/or acceptance of aggregate products. These limits may be established on the basis of previous historical experience or by start of production results.
- 9.1.5 **Sample Testing Frequency**: As per Table 1.
- 9.1.6 **Table 1**: Table 1 of the current Central Bureau of Materials’ Policy Memorandum, “Aggregate Gradation Control System (AGCS)” found in Manual of Test Procedures for Materials
- 9.1.7 **Trend**: When two or more points move away from the mid-point target values in either direction (\pm), thus producing either a steep angled line or three points moving with a gradual angle. This is usually associated with the moving average points but can also be determined from individual test points. Trends are indications that a problem(s) are or will be present if corrective action is not taken.
- 9.1.8 **“Warning Band” or Moving Average**: The average of 5 consecutive values (sample results) obtained per Table 1 requirements, based on established Warning Band limits. Such values always represent the most recently obtained test results or measurements within the prescribed group of observations. These limits may be established on the basis of previous historical experience or by start of production results.
- 9.2 **Control Chart Paper / Size**. Control charts for the Gradation Control Program, when created by hand, must be placed on 10 x 10 cross-sectional graph paper measuring 420 mm x 280 mm (16-1/2" x 11") or 216 mm x 280 mm (8-1/2" x 11"). Graph paper, used for this purpose, can be ordered through office supply specialty stores, companies dealing in drafting materials or ordered thru the internet. An example of a control chart is found on the last page of this document.
- 9.3 **Chart Preparation**. At the top of the control chart, the aggregate product material code and the Master Band target (when known) will be noted.

Lines corresponding to the upper and lower percent-passing Standard Specification limits for each required sieve/gradation shall be drawn horizontally across the graph.

The vertical distance between these lines must accurately represent the difference between the upper and lower limits for each sieve using a vertical scale of one division (square) which will equal one percent (1%) passing on all sieves except the 75- μ m (No. 200), see Article 9.3.1.

**Aggregate Producer Control Chart Procedure
(Chapter 9, Aggregate Technician Course Manual)
Appendix A.3**

Effective: November 1, 1995

Revised: December 1, 2017

On the left side of the control chart, the upper and lower specification lines of each sieve shall be connected by a drawn vertical double arrow.

The specification limits for the each sieve, e.g., 45% for upper limit and 15% for lower limit, must be indicated at the top (for upper limit) and bottom (for lower limit) of the arrow. The sieve size, e.g., 4.75 mm (No. 4), shall also be indicated between the limits on the far left side of the chart.

The vertical scale [(1% = 1 division (square) or for 75µm (No. 200), 0.1% = 1 division (square)] shall be noted below each required sieve.

Each test value will be spaced horizontally every 1/2" or 5 horizontal divisions (squares).

- 9.3.1 The 75-µm (No. 200) sieve, when plotted, shall be plotted for washed tests only.
- 9.3.2 Master Bands and Warning Bands shall be drawn across the graph for the critical sieve, when required, as defined in Article 9.5.1 herein. Master Band limits, once known, shall be represented by a solid line and the Warning Band limits shall be represented by a broken line.
- 9.4 **Plotting of Test Values.** The Gradation Control Program allows the producer to run both washed and dry gradation tests. The percent passing results for each different kind of gradation test run shall be plotted on the control chart using specific symbols. All symbols must measure approximately 2.5 mm (1/10") on each side/diameter.
 - 9.4.1 The symbols to be used for each test type are as follows:

Type of Gradation Test	Symbol	
Washed Production	Open Circle	○
Dry Production	Circled X	⊗
Stockpile (can be plotted on separate chart)	Asterisk	*
Moving Average	Open Square	□

- 9.4.2 In addition to the required symbols, line-types are used to further facilitate proper interpretation of the plotted information. Washed production test results will be connected with a broken line while moving average results are to be connected with a solid line.
- 9.4.3 The moving average will be calculated and plotted on the last five consecutive washed production test values on each critical sieve and is only plotted when a new washed production test is ran.

**Aggregate Producer Control Chart Procedure
(Chapter 9, Aggregate Technician Course Manual)
Appendix A.3**

Effective: November 1, 1995

Revised: December 1, 2017

The moving average will be started by taking the fifth test value after the start of yearly production, or production restarted after a protracted shutdown, and averaging it with the four preceding test values. Once the moving average is established, the moving average will be calculated and plotted each time a new washed production test value is ran and plotted.

9.4.4 Each individual test result that is ran and plotted shall have the following information located at the bottom of the chart below the respective plotted test result.

- Date the sample was taken (e.g. 07/15/11)
- Time the sample was taken (e.g. 10:15 am)
- Every resample was taken. (An "R" shall be placed under the test result that it represents)
- Initials of the Aggregate technician plotting the test result(s)

9.4.5 Stockpile load out test results may be plotted or summarized on a separate control chart, graph, or table. The reporting format may be developed by the Source. The reporting format shall include the information required in this article (sample type, time, and date).

The control limits and deviation from the established Master Band shall be identified.

9.5 **Master Band/Warning Band.** During Start of Production, Master Bands/Warning Bands must be developed and placed on the control chart after five tests or within the first 9,100 metric tons (10,000 tons), whichever occurs first, for each product's critical sieve, when required. Any production or equipment change after development of a Master Band may necessitate the development of a new Master Band.

Historical data from washed production samples may also be used, at the Source's request, to establish Master Band targets. The average, rounded to the nearest whole number, used to establish the Master Band shall be based only on washed production critical sieve test results.

9.5.1 Master Bands/Warning Bands will be drawn plus/minus using the below-listed percentages from a rounded average for each listed coarse aggregate sieve/gradation.

If the critical sieve and the plus/minus percentages for coarse aggregates is not listed, this information will be assigned by the Central Bureau of Materials on an as-needed basis.

**Aggregate Producer Control Chart Procedure
(Chapter 9, Aggregate Technician Course Manual)
Appendix A.3**

Effective: November 1, 1995

Revised: December 1, 2017

Gradation	Sieve	Master Band (%)	Warning Band (%)
CA/CM 5	25 mm (1")	± 8	± 6
CA/CM 7	12.5 mm (1/2")	± 8	± 6
CA/CM 11	12.5 mm (1/2")	± 8	± 6
CA/CM 13	4.75 mm (No. 4)	± 8	± 6
CA/CM 14	9.5 mm (3/8")	± 8	± 6
CA/CM 16	4.75 mm (No. 4)	± 8	± 6

Sand producers - Refer to Illinois Specification 201 for gradation requirements.

9.5.2 When a production change is made, a vertical line shall be drawn through the Master Band. The change shall be noted on the chart and documented in the Source plant diary.

9.5.3 A Master Band, when established, shall take precedence over the Standard Specification limits set for that sieve/gradation.

9.6 **Test Values at Master Band/Warning Band Limits.** When an individual test value on a Master Band **exceeds** the Master Band limits, the producer must treat that test result as a failure. Article 6.5 of the current Department Policy Memorandum "Aggregate Gradation Control System" (AGCS) shall be enacted. Article 6.5 of the AGCS requires resamples/corrective action be taken in response to the initial failing test.

The situation of the moving average hitting or exceeding a Warning Band is different than a failing individual test and Master Bands. When the moving average **hits or exceeds** the Warning Bands, the Source must decide whether to take corrective action to bring the gradation back within the Warning Bands or to develop a new Master Band.

The Source must notify the District what action was taken.

If a new Master Band is developed, the material shall be stockpiled separately from the previous production.

The development of a new Master Band may necessitate new HMA or PCC mix designs.

032CM16 Master Band = 22%

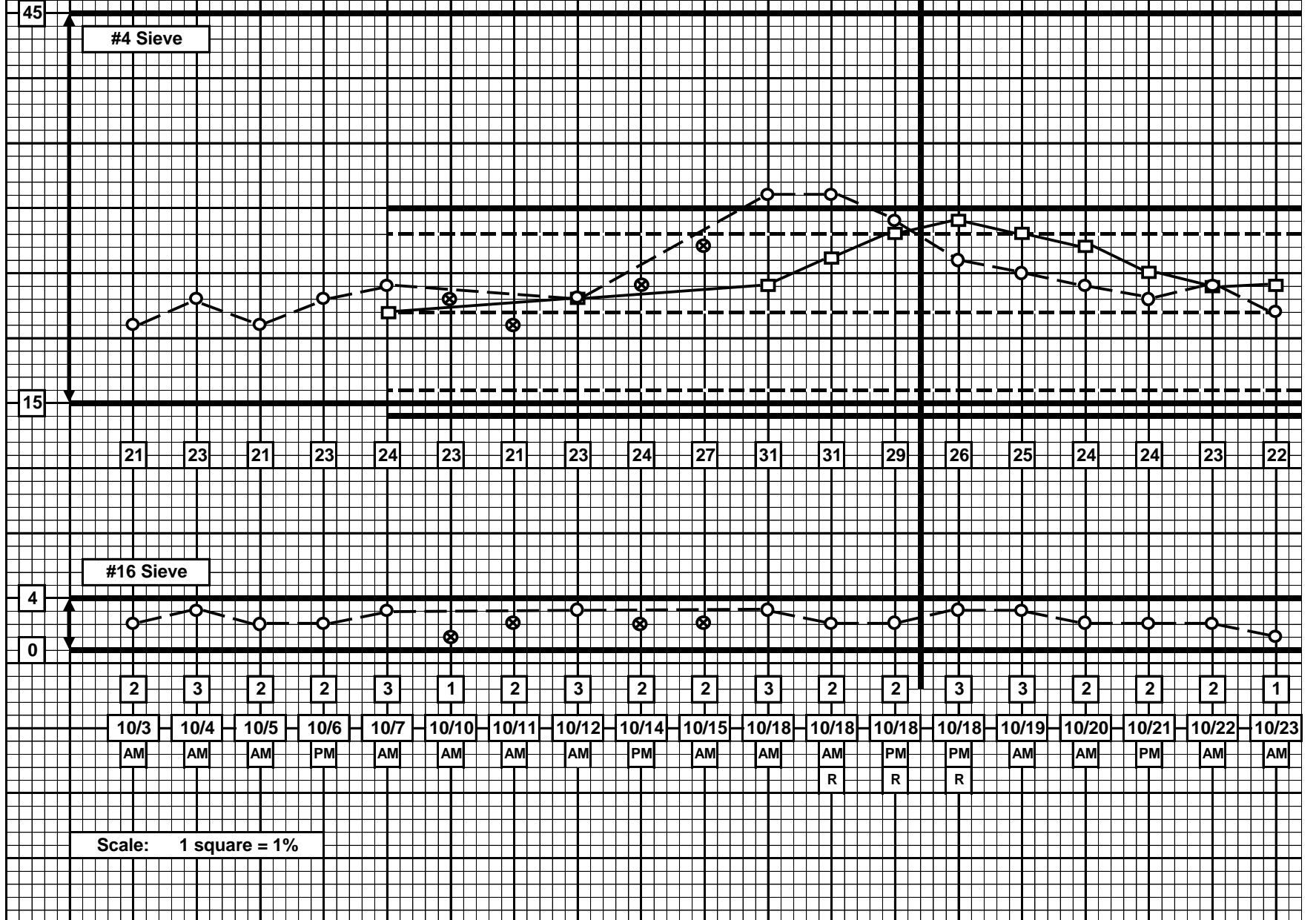

This Page Reserved

Stockpiling and Handling of Aggregate (Section 40.2, *Manual for Aggregate Inspection*) has moved to the current Central Bureau of Materials Policy Memorandum “Aggregate Gradation Control System” on the IDOT website.

This Page Reserved

Stockpiling and Handling of Aggregate (Section 40.2, *Manual for Aggregate Inspection*) has moved to the current Central Bureau of Materials Policy Memorandum “Aggregate Gradation Control System” on the IDOT website.

Illinois Department of Transportation
 QC/QA PROCEDURE
Procedure for Sample Comparison
Appendix A.5

Effective Date: November 10, 1997
 Revised Date: December 1, 2017

Precision Comparison Table*
State Monitor vs. Producer

	<i>Size Fraction Between Consecutive Sieves (%)†</i>	<i>Tolerance (%)</i>
<i>Coarse Aggregate:</i>	0 to 3.0	2
	3.1 to 10.0	3
	10.1 to 20.0	5
	20.1 to 30.0	6
	30.1 to 40.0	7
	40.1 to 50.0	9
<i>Fine Aggregate:</i>	0 to 3.0	1
	3.1 to 10.0	2
	10.1 to 20.0	3
	20.1 to 30.0	4
	30.1 to 40.0	4

* Split Samples only (reported values)

† The State Monitor Sample shall be used to pick tolerances.

Comparison Method

Calculate size fraction between consecutive sieves, including cutter sieves, for both the State Monitor and Producer test results (% Passing).

Show the fraction retained between consecutive sieves for both gradations, the fraction difference on each consecutive sieve grouping between the Monitor and Producer gradation, the applicable tolerance (if coarse aggregate, use coarse aggregate tolerances and, if fine aggregate, use fine aggregate tolerances- If size fraction between consecutive sieves exceeds largest fraction shown, use tolerance for largest size fraction), and whether they are in-tolerance or out-of-tolerance.

Illinois Department of Transportation
QC/QA PROCEDURE
Procedure for Sample Comparison
Appendix A.5

(continued)

Effective Date: November 10, 1997

Revised Date: June 1, 2012

If the comparison has no out-of-tolerance fractions, both sample results are considered valid. If an out-of-tolerance situation has been identified, both the producer certified technician and the State inspector shall immediately investigate the splitting procedure, test equipment, test method, and calculations for possible equipment failure or procedure errors. The State Monitor Sample shall always take precedence unless shown to be invalid during investigation.

Example:

CA11	25 mm (1")	19 mm (3/4")	16 mm (5/8")	12.5 mm (1/2")	9.5 mm (3/8")	6.3 mm (1/4")	4.75 mm (#4)	1.18 mm (#16)	75 μ m (#200)
Monitor, % Passing	100	87	67	36	13	4	2	1	0.7
Producer, % Passing	100	89	67	44	14	5	3	2	1.3

Comparison Data

Consecutive Sieve Sizes	Monitor Fraction	Producer Fraction	Fraction Difference	Applicable Tolerance	Disposition
25 mm and 19 mm (1" and 3/4")	13	11	2	5	OK
19 mm and 16 mm (3/4" and 5/8")	20	22	2	5	OK
16 mm and 12.5 mm (5/8" and 1/2")	31	23	8	7	Out
12.5 mm and 9.5 mm (1/2" and 3/8")	23	30	7	6	OUT
9.5 mm and 6.3 mm (3/8" and 1/4")	9	9	0	3	OK
6.3 mm and 4.75 mm (1/4" and #4)	2	2	0	2	OK
4.75 mm and 1.18 mm (#4 and #16)	1	1	0	2	OK
1.18 mm and 75 μ m (#16 and #200)	0.3	0.7	0.4	2	OK
75 μ m and Pan (#200 and Pan)	0.7	1.3	0.6	2	OK

**Model Annual Quality Control Plan for Hot-Mix Asphalt Production
Appendix B.1**

Effective Date: May 1, 1993
Revised Date: [December 1, 2021](#)

Producer Name: _____

Producer/Supplier No.*: _____

[Producer Main Office Mailing Address](#): _____

City/State/ZIP: _____

[Plant\(s\) City/State/ZIP](#): _____

*If the location includes more than one plant, this Annual Quality Control (QC) Plan may apply to the other facilities. Include relevant IDOT P/S Numbers under "Plant(s)".

A. [Producer Responsibilities](#)

The Producer is responsible for controlling the equipment, component materials, and production methods to ensure the specified product is obtained. All requirements of the Standard Specifications, the Manual of Test Procedures for Materials, contract-specific documents, Hot-Mix Asphalt (HMA) Level I and II Technician Manuals, and this Annual QC Plan will be adhered to. A Quality Control Addendum shall be completed for each contract and submitted prior to the preconstruction conference.

Where one Contractor is producing the mix and another is responsible for the laydown, the Quality Control Manager, from either party, who is ultimately responsible for the Quality Control should be identified in the Quality Control Addendum.

B. [Quality Control Personnel](#)

The QC Manager will assign duties in accordance with the "QC Personnel Responsibilities and Duties Checklist". The QC Manager will assure the listed duties are performed and documented. Additional duties, when necessary, will be assigned and monitored by the QC Manager. Sufficient QC personnel will be provided to comply with the QC Plan. Additional QC personnel will be added when necessary.

Quality Control Manager Name:
Phone Number:
e-mail Address:
Mailing Address (if different than above):

Backup Quality Control Manager Name:
Phone Number:
e-mail Address:

Illinois Department of Transportation

**Model Annual Quality Control (QC) Plan for Hot-Mix Asphalt (HMA) Production
Appendix B.1**

(continued)

Effective Date: May 1, 1993

Revised Date: [December 1, 2021](#)

Owner or Individual Supervising QC Personnel Listed Above:

Phone Number:

e-mail Address:

Additional contract-specific personnel will be included on the QC Addendum.

C. Plant(s)

IDOT Producer Number: _____

Manufacturer: _____

Model Number: _____

Serial Number: _____

Approved Batch Size or TPH as applicable: _____

Plant Survey Re/Approval Date: _____

(If more than one plant at location - Repeat for the additional plant)

D. Quality Control Laboratory

Quality Control Laboratory Location:

Quality Control Laboratory Approval Date:

Qualified for Method 2 Dispute Testing Complete (Y/N):

Use of Central Lab AC (Y/N):

Laboratory Manager:

Laboratory Phone Number:

Backup Quality Control Laboratory Location:

Backup Quality Control Laboratory Approval Date:

Qualified for Method 2 Dispute Testing Complete (Y/N):

Laboratory Manager:

Laboratory Phone Number:

Model Annual Quality Control (QC) Plan for Hot-Mix Asphalt (HMA) Production
Appendix B.1

(continued)

Effective Date: May 1, 1993

Revised Date: December 1, 2021

E. Materials

All materials proposed for use are from approved sources. Material sources are identified below for coarse aggregate, fine aggregate, mineral filler, RAP/FRAP/RAS, asphalt binder, tack coat, longitudinal joint sealant, anti-strip additive, and asphalt release agent.

1. Coarse Aggregates

Coarse aggregate materials are shown in the following table:

Material Code	Producer/Supplier Number	Producer Name	Location	Delivery Method ^{1/}

Note: 1/ Truck / Rail / On-Site Quarry

Coarse aggregate stockpile method: (Conveyor Cone, Conveyor Elongated Cone, Single Layer Truck, Multi-Layer Truck):

Procedures utilized to replenish and test stockpiles:

Procedures utilized to prevent intermingling of stockpiles:

List and attach any approved mix plant gradation adjustments according to Appendix A.1 of the Manual of Test Procedures.

2. Fine Aggregates

Fine aggregate materials are shown in the following table:

Material Code	Producer/Supplier Number	Producer Name	Location	Delivery Method ^{1/}

**Model Annual Quality Control (QC) Plan for Hot-Mix Asphalt (HMA) Production
Appendix B.1**

(continued)

Effective Date: May 1, 1993

Revised Date: December 1, 2021

Note: 1/ Truck / Rail / On-Site Quarry

Procedures utilized to replenish and test stockpiles:

Procedures utilized to prevent intermingling of stockpiles:

List and attach any approved mix plant gradation adjustments according to Appendix A.1 of the Manual of Test Procedures.

3. RAP/FRAP/RAS Materials

RAS materials incorporated into mixtures are shown in the following table:

Material Code	Producer Supplier Number	Producer Name	Producer Location

RAS stockpiling method

RAP/FRAP materials incorporated into mixtures will be described in the project QC Addendum.

RAP/FRAP Procedures:

- Delivery and stockpiling method:
- Method of Processing (Crushing / Screening / Fractionation method):
- Maintaining source and/or quality stockpile seal:

4. Liquid Asphalt

Liquid asphalt grades and sources are shown in the following table:

**Model Annual Quality Control (QC) Plan for Hot-Mix Asphalt (HMA) Production
Appendix B.1**

(continued)

Effective Date: May 1, 1993

Revised Date: December 1, 2021

PG Grade	Producer/Supplier Number	Producer Name	Producer Location

Procedures for preventing mixing liquid asphalt grades:

5. Mineral Filler, Anti-Strip, WMA and SMA Stabilizing Additives, Asphalt Release Agents, Longitudinal Joint Sealant & Tack Coat Materials

Material	Producer Supplier Number	Producer Name	Producer Location

F. Aggregate Stockpile Procedures

All aggregate stockpiles will be built using procedures that will minimize segregation and degradation.

G. Incoming Aggregate Gradation Samples

A washed gradation test will be performed for each 500 tons (450 metric tons) for the first 1,000 tons (900 metric tons) for each aggregate received. Additional gradation tests (every third test will be a washed gradation test) will be run on the frequency of one test per 2,000 tons (1,800 metric tons) for each aggregate received while the stockpiles are being built or aggregate is being shipped in. Gradation correction factors will be developed from washed gradation test results and applied to all dry gradation results. All aggregate (correction factors applied) will meet the mix plant gradation bands as developed according to the current Department policy, "Development of Gradation Bands on Incoming Aggregate at Mix Plants", before being used in mix production at the mix plant. All incoming aggregate gradation results shall be recorded in the plant diary. If a failing sample is encountered, the following resample procedure will be followed:

Model Annual Quality Control (QC) Plan for Hot-Mix Asphalt (HMA) Production
Appendix B.1

(continued)

Effective Date: May 1, 1993

Revised Date: [December 1, 2021](#)

1. Immediately resample the aggregate represented by the failing test.
2. If the first resample passes, the required frequency will be continued.
3. If the first resample fails, shipment of the aggregate will be halted, and corrective action will be taken. Corrective action may be rejection of the material, remixing or addition of material by feeder/conveyor system, or any other action approved by the Engineer. The aggregate producer will be notified of the problem. A second resample will be taken immediately after corrective action.
4. If the second resample passes, the aggregate represented will be used, and aggregate shipment into the plant will be resumed.
5. If the second resample fails, the aggregate represented will not be used in HMA mixtures. The material will be removed from the certified aggregate stockpile.

H. Required Gradation Sample

After mix production has started, all aggregate stockpiles will be checked with a required washed gradation sample on a weekly basis. This testing will be waived if the mixture is classified as a small tonnage item. The test results shall be compared to the mix plant gradation bands for compliance. These gradation results will be noted in the Plant Diary, and a copy will be provided to the Engineer.

If a weekly required stockpile sample fails, the following resample procedure will be followed:

1. Immediately resample and test the new stockpile sample.
2. If the first resample passes, mix production may continue. Several additional check samples will be taken to monitor the stockpile.
3. If the first resample fails, mix production will be halted, and corrective action will be taken on the stockpile. Corrective action may include rejection of the material, remixing or addition of material by feeder/conveyor system before use in the plant. The [Aggregate Producer](#) will be notified of the problem. A second resample will be obtained immediately after corrective action.
4. If the second resample passes, mix production will begin. Several additional check samples will be taken to monitor the stockpile.
5. If the second resample fails, the stockpile will not be used in HMA mixtures.

Illinois Department of Transportation

**Model Annual Quality Control (QC) Plan for Hot-Mix Asphalt (HMA) Production
Appendix B.1**

(continued)

Effective Date: May 1, 1993

Revised Date: [December 1, 2021](#)

Aggregate not meeting the mix plant gradation bands shall not be used in HMA mixtures.

I. Reporting of Test Results

All test results will be reported daily [either electronically using the Department QMP Package, or by submission of the following forms](#) to the Resident Engineer and other designated personnel as requested by the Department.

MI 504M	Field/Lab Gradations (stockpile gradations)
MI 305	Bituminous Daily Plant Report (front) Plant Settings and Scale Checks (back)
MI 303C	Bituminous Core Density Testing QC/QA
MI 303N	Nuclear Density Report QC/QA
MI 308	Asphalt Content and Volumetric Testing
LM-6	Sample Identification (for liquid asphalt)

The completed forms will be forwarded to the Engineer within three days of test completion.

J. Control Charts

In addition, [when control charts are required as part of the Quality Management Program they will either be posted at the laboratory or readily available electronically upon request](#) in accordance with the Department's current [document](#) "Hot-Mix Asphalt QC/QA Control Charts".

[Primary QC Manager](#) Signature _____ Date _____

(Please type or print name) _____ Title _____

This Page Reserved

**Model Quality Control (QC) Addendum for Hot-Mix Asphalt Production
Appendix B.2**

Effective Date: July 1, 1995
Revised Date: [December 1, 2021](#)

Contract No.: _____
 Marked Route: _____
 County: _____
 Prime Contractor: _____
 HMA Producer: _____
 Contractor Performing Laydown: _____

This Quality Control (QC) Addendum provides contract specific information to supplement the Hot-Mix Asphalt (HMA) Annual QC Plan. If multiple HMA producers will be utilized for specific items of work on a single contract (Example: one for mainline and another for shoulder), a separate QC Addendum shall be submitted for each producer.

A. HMA Production Location

	Producer Name	Location	IDOT P/S Number
Primary			
Backup			

B. Mix Designs

The following mix designs will be utilized:

Pay Item	Material Code	Lift (if applicable)	Mix Description	Department Mix Design Number	Annual Verification Completed (Y/N)

The table may include a primary and a secondary mixture for each item.

**Model Quality Control (QC) Addendum for Hot-Mix Asphalt Production
Appendix B.2**

(continued)

Effective Date: July 1, 1995

Revised Date: [December 1, 2021](#)

C. Reclaimed Asphalt Pavement (RAP/FRAP)

[RAP/FRAP material incorporated into mixtures originated from the following sources:](#)

Material Code	Material Description	Quality	Source (Marked Route, Location & Lift)	Mix Design # Utilizing the Material

D. Quality Control Personnel

[Overall \(Production & Laydown\) Project Quality Control Manager Name:](#)

[Company:](#)

[Phone Number:](#)

The QC personnel [are shown in the table below:](#)

Name	Task(s) Performed	Employed By	Training Level

E. Project Specific Issues:

[HMA Producer Signature:](#) _____

[Title:](#) _____

[\(Type or print name\):](#) _____ [Date:](#) _____

**Procedure for Correlating
Nuclear Gauge Densities with Core Densities for Hot-Mix Asphalt
Appendix B.3**

Effective Date: May 1, 2001

Revised Date: December 1, 2021

A. Scope

1. This method covers the proper procedures for correlating nuclear gauge densities to core densities.
2. The procedure shall be used on all projects containing 3000 tons (2750 metric tons) or more of any hot-mix asphalt mixture. It may also be used on any other project where feasible.

B. Applicable Documents

1. Illinois Department of Transportation Standard Test Methods

Illinois Modified AASHTO T 166, "Bulk Specific Gravity (G_{mb}) of Compacted Asphalt Mixtures Using Saturated Surface-Dry Specimens"

Illinois Modified AASHTO T 275, "Bulk Specific Gravity (G_{mb}) of Compacted Asphalt Mixtures Using Paraffin-Coated Specimens"
2. The density test procedure shall be in accordance with the Department's "Illinois Modified ASTM D2950, Density of Bituminous Concrete in Place by Nuclear Methods".

C. Definitions

Test Location: The station location for the density testing.

Test Site: Area where a single nuclear density and a core are collected. Five (5) test sites are positioned across the mat at each test location for the correlation process.

Nuclear Density: The average of two (2) or possibly three (3) nuclear density readings at a given test site.

Core Density: The core density result at a given test site.

**Procedure for Correlating
Nuclear Gauge Densities with Core Densities for Hot-Mix Asphalt
Appendix B.3**

(continued)

Effective Date: May 1, 2001

Revised Date: [December 1, 2021](#)

D. Significance and Use

1. Density results from a nuclear gauge are relative. If an approximation of core density results is [desired](#), a correlation must be developed to convert the nuclear density to core density.
2. A correlation developed in accordance with these procedures is applicable only to the specific gauge being correlated, the specific mixture, each specific thickness, and the specific project upon which it was correlated. A new correlation should be determined within a specific project if there is a significant change in the underlying materials.

E. Site Selection

1. The nuclear density tests and cores necessary for nuclear/core correlation shall be obtained during the [test strip](#) for each specific mixture for which a density specification is applicable.
2. Three [test](#) locations shall be selected. [One test location shall](#) be on [each of](#) the two growth curves from the first acceptable test strip. The third [test](#) location shall be chosen after an acceptable rolling pattern has been established and within the last 100 tons (90 metric tons) of material placed during [the test strip](#). The material from the third [test location](#) shall correspond to the same material from which the second [mixture](#) sample was taken.
3. If a [test strip](#) is not required, two of the three [test](#) locations shall be in an area containing a growth curve.

F. Procedures for Obtaining Nuclear Readings and Cores – [Backscatter Mode](#)

1. At each of the three [test](#) locations, five individual [test](#) sites shall be chosen and identified as shown in Figure 1.
2. Two nuclear readings shall [initially](#) be taken at each of the 15 individual [test](#) sites. (See Figure 1.) The gauge shall be rotated 180 degrees between readings at each [test](#) site. The two uncorrected readings taken at a specific individual [test](#) site shall be within 1.5 lb/ft³ (23 kg/m³). If the two readings do not meet this criterion, one additional reading shall be taken in [either](#) direction. The nuclear [readings](#) are to be recorded on the [Nuclear / Core Correlation Field Worksheet](#).
3. [All correlation locations should be cooled with ice, dry ice, or nitrogen so that cores can be taken as soon as possible.](#) One 4 in. diameter core in good condition shall be obtained from each of [the](#) 15 individual [test](#) sites (Figure 1). Care should be exercised that no additional compaction occurs between the nuclear testing and the coring [operation](#). The cores shall be tested for density in

**Procedure for Correlating
Nuclear Gauge Densities with Core Densities for Hot-Mix Asphalt
Appendix B.3**

(continued)

Effective Date: May 1, 2001

Revised Date: December 1, 2021

accordance with Illinois Modified AASHTO T 166 or T 275. The core densities are to be entered on the [Nuclear / Core Correlation Field Worksheet](#).

4. Extreme care shall be taken in identifying which [test location](#) and [test site](#) each of the density readings represents. The data points have to be paired accurately or the correlation process will be invalid.

G. Mathematical Correlation -- Linear Regression

1. The two (or possibly three) nuclear readings at each [test site](#) shall be entered on the [Nuclear / Core Correlation Field Worksheet](#) and then averaged. The core density [from](#) each [test site](#) shall be entered on the [worksheet](#). After the averaging, there will be 15 paired data points, each pair containing the average nuclear [reading](#) and core density for each of the 15 [test sites](#).
2. The paired [data points](#) shall be correlated using the Department's linear regression program from the Central Bureau of Materials [QMP Package](#) or an approved and equivalent calculating method.
3. For the purpose of this procedure, standard statistical methods for measuring the "best fit" of a line through a series of 15 paired data points consisting of core density and [corresponding average nuclear reading](#) shall be used.
4. It should be recognized that correlations obtained by this or similar procedures may or may not be valid; each attempt should be judged on its merit. In general, a correlation coefficient for each correlation linear regression should be calculated.
5. Correlation coefficients (r) may range from minus 1.0 to plus 1.0. [Only an r-value greater than 0.715 is considered acceptable.](#)
6. The correlation shall be stated and used in the form:

$$y = mx + b$$

where:

y	=	core density
x	=	average nuclear reading
b	=	intercept
m	=	slope of linear regression "best fit" line

**Procedure for Correlating
Nuclear Gauge Densities with Core Densities for Hot-Mix Asphalt**
Appendix B.3

(continued)

Effective Date: May 1, 2001

Revised Date: December 1, 2021

BACKSCATTER MODE

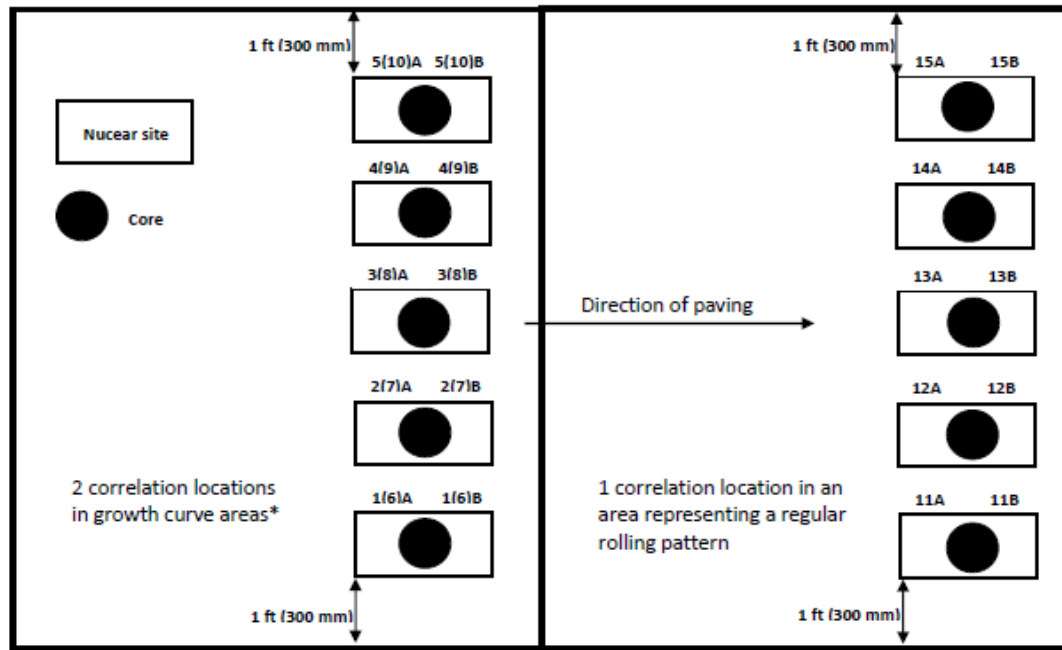

2 of 3 locations

1 of 3 locations

* First growth curve is between 225 and 250 tons (200 and 225 metric tons). The second growth curve is between 275 and 300 tons (250 and 275 metric tons).

NUCLEAR /CORE CORRELATION TEST LOCATION LAYOUT

Figure 1



Date: _____
 Contract: _____
 Job No.: _____
 Route: _____
 Base Material: Milled Binder Aggregate Other: _____
 Mix No.: _____
 Mix Code: _____
 Use: _____ (surface, 1st lift binder, etc.)

Gauge No.: _____
 Layer Thickness: _____
 Gmm: _____

Reading 1	Reading 2	1.5 lb/ft ³ (23.5 kgs/m ³) tol. Reading 3 (if applicable)	Average Nuc.	Core Density
-----------	-----------	--	--------------	--------------

STATION:

1A)	1B)	1A) 1B)	1)	1)
2A)	2B)	2A) 2B)	2)	2)
3A)	3B)	3A) 3B)	3)	3)
4A)	4B)	4A) 4B)	4)	4)
5A)	5B)	5A) 5B)	5)	5)

STATION:

6A)	6B)	6A) 6B)	6)	6)
7A)	7B)	7A) 7B)	7)	7)
8A)	8B)	8A) 8B)	8)	8)
9A)	9B)	9A) 9B)	9)	9)
10A)	10B)	10A) 10B)	10)	10)

STATION:

11A)	11B)	11A) 11B)	11)	11)
12A)	12B)	12A) 12B)	12)	12)
13A)	13B)	13A) 13B)	13)	13)
14A)	14B)	14A) 14B)	14)	14)
15A)	15B)	15A) 15B)	15)	15)

This Page Reserved

**Hot-Mix Asphalt Test Strip Procedures
Appendix B.4**

Effective Date: May 1, 1993
Revised Date: December 1, 2021

When the quantity of a mixture exceeds 3000 tons (2750 metric tons) on a contract, the Contractor and the Department shall make an evaluation of the mixture using a 300 ton (275 metric ton) test strip at the beginning of HMA production. The Contractor shall adhere to the following procedures for constructing a test strip.

A. Contractor/Department Test Strip Team

As the test strip is constructed, a team of both Contractor and Department personnel will evaluate the mix.

The test strip team may consist of the following:

1. Resident Engineer
2. District Construction Supervising Field Engineer, or representative
3. District Materials Mixtures Control Engineer, or representative
4. District Nuclear Density Gauge Tester
5. Contractor's QC Manager, required
6. Contractor's Paving Superintendent
7. Contractor's Density Tester

Optional:

8. Central Bureau of Construction representative
9. Central Bureau of Materials representative
10. Asphalt Binder Supplier representative

B. Communications

The Contractor shall advise the team members 48 hours in advance of the anticipated start date/time of production of the test strip mix. The QC Manager shall direct the activities of the test strip team. A Department appointed representative from the test strip team will act as spokesperson for the Department.

C. Test Strip Method

The mix design shall have been approved by the Department prior to the test strip. Target values shall be provided by the Contractor and will be approved by the Department prior to constructing the test strip.

The Contractor shall produce 300 tons (275 metric tons) of mix for the test strip.

Hot-Mix Asphalt Test Strip Procedures
Appendix B.4

(continued)

Effective Date: May 1, 1993

Revised Date: December 1, 2021

The procedures listed below shall be followed to construct a test strip.

1. Location of Test Strip - The test strip shall be located on a relatively flat portion of the roadway. Descending/ascending grades or ramps should be avoided.
2. Constructing the Test Strip - After the Contractor has produced and placed approximately 225 to 250 tons (200 to 225 metric tons) of mix, paving shall cease and a growth curve shall be constructed. After completion of the first growth curve, paving shall resume for the remaining 50 to 75 tons (45 to 70 metric tons), and the second growth curve shall be constructed within this area. The Contractor shall use normal rolling procedures for all portions of the test strip except for the growth curve areas which shall be compacted as directed by the QC Manager.
3. Mixture Sampling - Mixture samples shall be taken by the Contractor in the field at such a time as to represent the mixture in-between the two growth curves. The sampling procedure shall follow the method of field sampling described in the document "Hot-Mix Asphalt QC/QA Initial Daily Plant and Random Samples" Section D. Department Random Verification Mixture Sample Determination and Collection.

In addition to the quantity of mix the Contractor collects for their volumetric tests per Standard Specification Article 1030.09(a), the Contractor shall also collect a sufficient quantity of mix for Department tests. This shall include 50 lb (23 kg) for volumetric testing, a minimum of 150 lb (70 kg) for the Contractor to fabricate Hamburg Wheel and I-FIT gyratory cylinders, and if this test strip is the first of the year for the mix design, an additional 100 lb (45 kg) for the Contractor to fabricate gyratory cylinders for Tensile Strength and TSR testing.

D. Compaction Requirements

1. Compaction Equipment - The Contractor shall provide a roller meeting the requirements of Article 1101.01(g) for dense graded mixtures and 1101.01(e) for SMA and IL-4.75 mixtures. It shall be the responsibility of the QC manager to verify roller compliance before commencement of growth curve construction.
 - a. Dense Graded Mixtures – A vibratory roller shall be used with an appropriate amplitude determined based on the roller weight and mat thickness to achieve maximum density. The vibratory roller speed shall be balanced with frequency so as to provide compaction at a rate of not less than 10 impacts per 1 ft (300 mm).
 - b. SMA and IL-4.75 Mixtures – A static roller shall be used with the weight determined by the mixture composition, mat thickness, and ability to achieve maximum density.

Hot-Mix Asphalt Test Strip Procedures
Appendix B.4

(continued)

Effective Date: May 1, 1993

Revised Date: [December 1, 2021](#)

2. **Compaction Temperature** - In order to make an accurate analysis of the density potential of the mixture, the [initial compaction](#) temperature of the mixture on the pavement at the beginning of the growth curve shall [be no more than 10°F \(5°C\) lower than the minimum mixture placement temperature specified in Article 406.06](#).
3. **Compaction and Testing** - The Contractor shall direct the roller speed and number of passes required to obtain a completed growth curve. The nuclear gauge shall be placed near the center of the hot mat and the position marked for future reference. With the bottom of the nuclear gauge and source rod clean, a 1-minute nuclear reading (without mineral filler) shall be taken after each pass of the roller. Rolling shall continue until a growth curve can be plotted, the maximum density determined, and three consecutive passes show no appreciable increase in density or evident destruction of the mat.
4. **Final Testing** - A core shall be taken and will be secured by the Department from each growth curve to represent the density of the in-place mixture. Additional random cores may be required as determined by the Engineer.

E. [Evaluation of Growth Curves](#)

[Mixtures which exhibit density potential less than or greater than the density ranges specified in 1030.09\(c\) shall be considered to have a potential density problem which is sufficient cause for mix adjustment.](#)

[If an adjustment is made at the plant, the Engineer may require an additional test strip to be constructed and evaluated. This information shall then be compared to the AJMF and required design criteria for acceptance.](#)

F. Nuclear/Core Correlation

[When required, a correlation of core and nuclear gauge test results shall be performed on-site as defined in the document "Procedure for Correlating Nuclear Gauge Densities with Core Densities for Hot-Mix Asphalt". This correlation shall be completed by the Contractor prior to the next day's production. Smoothness of the test strip shall be to the satisfaction of the Engineer.](#)

G. Documentation

[All test strip volumetric test results, rolling pattern information \(including growth curves\), and nuclear readings and core test results for correlating the nuclear gauge shall be tabulated by the Contractor with a copy provided to each team member and the original retained in the project files.](#)

This Page Reserved

**Hot-Mix Asphalt QC/QA
QC Personnel Responsibilities and Duties Checklist
Appendix B.5**

Effective Date: May 1, 1993
Revised Date: [December 1, 2021](#)

The following checklists detail the required minimum duties of Contractor Quality Control (QC) personnel. The QC Manager has overall responsibility to ensure that the listed duties are performed and documented. The QC Manager shall not perform sampling and/or testing except in emergency situations or in any other situation approved by the Engineer. Additional [tasks or duties](#), as necessary, may be required to control the quality of production and placement of the Hot-Mix Asphalt (HMA) mixtures. An [HMA Level II Technician](#) may be used to perform any [HMA Level I Technician](#) duties.

Note: Testing frequency denoted as "P" = "Prior to [Test Strip](#)" and as "D" = "Daily".

A. [Level I Technician Checklist](#)

1. [Production/Placement Tasks](#)

- a. Perform incoming aggregate gradations before start-up time. (PD) _____
- b. Ensure lab equipment is on hand and in working order. (PD) _____
- c. Run moisture samples daily (drum only). (PD) _____
- d. Determine random sampling times one day in advance and inform the QC Manager and the Engineer of the sampling times. (D) _____
- e. Take required samples when required using proper procedures. (D) _____
- f. Run required tests as soon as possible using proper procedures. (D) _____
- g. Take resamples as required. (D) _____
- h. Plot all random and resample results on control charts as soon as test results are available. (D) _____
- i. Take check samples when necessary. (D) _____
- j. Contact QC Manager immediately when tests fail or any time problems occur. (D) _____
- k. Test cores for Nuclear/Core Correlation [when applicable](#) (After [Test Strip](#)). _____

2. [Required Tests](#). The minimum test frequency shall be according to Section 1030 of the Standard Specifications. However, additional tests may be required by the Engineer.

**Hot-Mix Asphalt QC/QA
QC Personnel Responsibilities and Duties Checklist
Appendix B.5**

(continued)

Effective Date: May 1, 1993

Revised Date: [December 1, 2021](#)

- a. Stockpiles
(washed gradations minimum one per week for each material used) _____
- b. Moisture samples (drum only) _____
- c. [Washed](#) Gradations _____
- d. Asphalt Content _____
- e. G_{mb} _____
- f. G_{mm} _____

B. QC Manager and/or Level II Technician Checklist

[Complete and submit Annual QC Plan prior to construction season.](#) _____

1. Preliminary Inspection Tasks

- a. Check for the approved sources of the materials:
 - (1) Aggregates — ensure it is from Certified Source _____
 - (2) Mineral filler _____
 - (3) Asphalt binder (See d. below.) _____
 - (4) Other additives _____
 - (5) [Truck Bed Release Agent](#) – ensure it is on the QPL _____
- b. Check the aggregate stockpiling and handling procedures:
 - (1) Observe stockpiling procedures to ensure they are built correctly. _____
 - (2) Discuss loadout and sampling procedures with endloader operator. _____
 - (3) Sample aggregate stockpiles, in conjunction with District inspectors, and submit for Mix Designs. _____
- c. Check the gradation of the aggregates:
 - (1) Obtain average gradation of each aggregate _____

**Hot-Mix Asphalt QC/QA
QC Personnel Responsibilities and Duties Checklist
Appendix B.5**

(continued)

Effective Date: May 1, 1993

Revised Date: [December 1, 2021](#)

- (including Master Bands) from the aggregate source. _____
- (2) Compare aggregate source information to stockpile samples at the mix plant and with the design gradation. _____
- (3) [Test the gradation of each aggregate stockpile.](#)
- d. Check asphalt binder:
 - (1) Source _____
 - (2) Grade _____
 - (3) Incoming temperatures _____
 - (4) Specific Gravity (drum only) _____
- e. Verify that the laboratory and laboratory equipment have been inspected and approved by the Department and are in good working order. _____
- f. [Review Hot-Mix Asphalt Level I and Level II Technician Course manuals.](#) _____
- 2. [Production/Placement Tasks](#)
 - a. [Complete and submit Quality Control Addendum \(P\)](#) _____
 - b. Check the mix plant for the following:
 - (1) Approval and calibration (P) _____
 - (2) Asphalt binder storage [temperature](#) (PD) _____
 - (3) Stockpiles (PD)
 - (a) [Correct](#) loadout _____
 - (b) [Place](#) in proper cold-feed bins
 - (4) Cold-feed bins or bulkheads and feeders (PD) _____
 - (5) Dust collecting systems (D) _____
 - (6) Screens and screening requirements (P) _____
 - (7) Hot-bin sampler (P) and hot-bin overflow (PD) _____
 - (8) Weigh belt 6-minute check (drum only) (D) _____
 - (9) Temperature recorders and thermometers (PD) _____

**Hot-Mix Asphalt QC/QA
QC Personnel Responsibilities and Duties Checklist
Appendix B.5**

(continued)

Effective Date: May 1, 1993

Revised Date: [December 1, 2021](#)

- (10) Mixing timers (batch plant only) (PD) _____
- (11) Surge and storage bins (PD) _____
- (12) Platform scales or suspended weigh hopper (PD) _____
- (13) [Additive system\(s\)](#) (when required) (PD) _____
- (14) Ticket printer (P) _____
- (15) Computer and control systems (PD) _____
- c. [RAP/FRAP/RAS from appropriate approved sealed stockpile](#) (PD) _____
- d. Check trucks for the following (QC Manager may assign these duties to a Level I Technician):
 - (1) Truck bed release agents (PD) _____
 - (2) Insulation (D) _____
 - (3) Tarps (D) _____
 - (4) Clean beds (D) _____
- e. Coordinate any [test strip](#) per Department guidelines (QC Manager only). _____
- f. Monitor sampling and testing procedures, density test, and laydown operations. (D) _____
- g. Check the mixtures for the following:
 - (1) Gradation test performed and bin percentages determined before start-up (P) _____
 - (2) Correct Job Mix Formula is being used (P) _____
 - (3) Moisture check (PD) _____
 - (4) Temperature (D) _____
 - (5) Coating and segregation (D) _____
 - (6) Additives (D) _____
 - (7) [Draindown](#) (D) _____
- h. Laydown operation (QC Manager only)

**Hot-Mix Asphalt QC/QA
QC Personnel Responsibilities and Duties Checklist
Appendix B.5**

(continued)

Effective Date: May 1, 1993

Revised Date: [December 1, 2021](#)

Monitor the following field checks:

- (1) Check for obvious defects in truck
(segregation, uncoated, temperature, etc.) (D) _____
- (2) Monitor paver operations (equipment, laydown procedures, etc) (PD) _____
- (3) Rollers and operations
(equipment, pattern, procedure, etc.) (PD) _____
- (4) Mix characteristics on road
(appearance, mat temperature, etc.) (D) _____
- (5) Monitor densities as required (D) _____
- i. Monitor all test results and make any adjustments necessary
(QC Manager only) (D). _____
- j. Perform scale checks (minimum one per week per scale).
Follow procedure in Construction Manual Documentation Section. _____
- k. Ensure following records are kept and reports are submitted
in a timely manner as required (QC Manager only):
 - (1) Daily plant output (D) _____
 - (2) Field gradation (D) _____
 - (3) Density (D) _____
 - (4) Control charts (D) _____
 - (5) Additives (D) _____
 - (6) Scale checks (D) _____
 - (7) Plant diary (D) _____

C. [HMA Level I Technician, HMA Level II Technician, and Quality Control Manager Duties](#)

1. Material Source

It is necessary to identify the source of the ingredients to ensure that they have been inspected and the correct quality of aggregate, grade of asphalt binder, and anti-strip additive are being used in the specified mix. Sources shall be verified.

2. Aggregate Quality

Hot-Mix Asphalt QC/QA
QC Personnel Responsibilities and Duties Checklist
Appendix B.5

(continued)

Effective Date: May 1, 1993

Revised Date: [December 1, 2021](#)

The [HMA](#) Level II Technician may confirm the quality of the aggregate by requesting current quality information from the District Materials office.

3. Stockpiling

Sites for stockpiles shall be grubbed and cleaned prior to storing the aggregates.

Separate stockpiles shall be provided for the various sources and kinds of aggregates. Stockpiles shall be separated to prevent intermingling at the base (width of endloader bucket). If partitions are used, they shall be of sufficient heights to prevent intermingling. Aggregates for HMA mixtures shall be handled, in and out of the stockpiles, in such a manner that will prevent contamination and degradation.

Coarse aggregate stockpiles shall be built in layers not exceeding 1.5 m (5 ft) in height and each layer shall be completely [in-place](#) before the next layer is started. A stockpile may be expanded by again starting the expansion from the ground and building layers as before. End-dumping over the sides will not be permitted. Use of steel track equipment on Class B Quality, Class C Quality and all blast furnace slag aggregate stockpiles shall not be permitted where degradation is detected. When loading out of stockpiles, vertical faces shall be limited to reasonable heights to eliminate segregation due to tumbling. Segregation or degradation due to improper stockpiling or loading out of stockpiles shall be just cause for rejecting the material.

[RAP/FRAP stockpiles shall be according to Article 1031.02\(a\).](#)

[RAS stockpiles shall be according to Article 1031.02\(b\).](#)

4. Gradations

The [HMA](#) Level II Technician shall obtain the average gradations as well as the Master Bands from the aggregate source. [The HMA Level II Technician](#) shall run the required gradation's test frequency on incoming aggregate as required in Section 1030 of the Standard Specifications.

5. Asphalt Binder

- a. Incoming Asphalt Binder: The [HMA](#) Level II Technician shall periodically check the grade and temperature of asphalt binder as received at the [plant](#). If the asphalt binder is shipped by truck, the driver should have in [their](#) possession a numbered ticket showing the name and location of the refinery, the name of the material, date shipped, loading temperature, quantity, specific gravity or weight/L (weight/gal), and the number of the tank from which the asphalt was loaded. It is the responsibility of the refinery to load trucks only from tanks that have been tested and

Hot-Mix Asphalt QC/QA
QC Personnel Responsibilities and Duties Checklist
Appendix B.5

(continued)

Effective Date: May 1, 1993

Revised Date: [December 1, 2021](#)

approved by the Department. If shipment is made by rail, a tag usually will be found on the top of the dome of the tank car indicating that it has been sampled at the refinery.

- b. Asphalt Binder Storage: The [HMA](#) Level II Technician shall check the temperature of the asphalt binder in storage. The temperatures shall be maintained in accordance with the Standard Specifications. The [HMA](#) Level II Technician should be aware of the grade of asphalt binder in each storage tank. Asphalt binders of different sources and grades shall not be intermixed in storage, and the tanks shall be identified.

6. Testing Equipment

Care of the laboratory testing equipment is the responsibility of the [HMA](#) Level I Technician. Equipment shall be furnished by the Contractor or Consultant, kept clean, and kept in good working condition. [The furnished equipment shall meet the minimum private laboratory requirements stated in the Central Bureau of Materials Policy Memorandum Number 6-08.4.](#) At the start of the project, the [HMA Level I](#) technician shall check that all equipment required to be furnished is available and in good condition. Acceptance and, ultimately, performance of a mixture may be dependent on the accuracy of the tests. Defective equipment could result in erroneous, as well as untimely, results.

7. Hot-Mix Asphalt Plant

- a. Plant Approval: Plant must be approved and calibrated prior to production each construction season. The QC Manager shall review this information. If it is not available or current, the District Hot-Mix Asphalt Supervisor shall be notified.
- b. Cold Aggregate Bins: The cold aggregate bins or bulkheads shall be checked for aggregate intermingling. Each bin or compartment in a bin shall contain only one source and type of aggregate. The bins should be checked each day to ensure the charging of the compartments remains the same as it was for previous operations for the same mix. The QC Manager shall notify the state inspector of changes in aggregate source and gradation and/or gate settings.
- c. [Batch Plant](#) Dust Collector: The Level II Technician shall check that the dust from the primary collector is returned to the boot of the hot elevator by a metering system as required by Article 1102.01(b)(3) of the Standard Specifications. This metering system should be such as to require a few adjustments in maintaining a uniform rate of collected dust returned to the hot elevator. The primary dust-feed shall occur only when aggregate is being discharged from the drier.

Hot-Mix Asphalt QC/QA
QC Personnel Responsibilities and Duties Checklist
Appendix B.5

(continued)

Effective Date: May 1, 1993

Revised Date: [December 1, 2021](#)

Plants having dry secondary collectors shall return this material to a storage silo or the mineral filler bin if it will meet the requirements of the mineral filler specifications (Section 1011 of the Standard Specifications).

- d. Screens: Samples from the hot-bins shall be inspected for contamination. An excess of coarse aggregate in the sand bin or sand in the coarse aggregate bins may indicate broken or clogged screens and/or a hole between the bins. The screens shall separate aggregate into sizes to produce a uniform gradation. If fluctuations in gradation occur, a change in screen size and/or aggregate flow rate may be required. Article 1102.01(b)(10) of the Standard Specifications shall be applied.
- e. Hot-Bins: The [HMA](#) Level II Technician is to ensure that each hot-bin overflow pipe is working to prevent back-up of material into other compartments or bins. An overflow or sudden shortage of material in a bin may indicate a broken or clogged screen, a change in feeding rate, or a change in gradation of the aggregate being used. Overflow pipes shall not be discharged into the hot elevator.
- f. Temperature Recording Device: The temperature recording devices shall be checked for compliance with Article 1102.01 of the Standard Specifications. A new chart shall be used each day.
- g. Timers: The timers used for recycling the wet and dry mixing times for a batch plant shall be checked and set at the required mixing times. The required times are in the appropriate articles of the Standard Specifications.
- h. Batching: The [HMA](#) Level II Technician shall observe the batching operation to ensure the approved batch weights are being met. Manually operated batch plants shall have markers on the scales to indicate the approved batch weight of each ingredient material. Automatic batching plants shall have posted near the scales the approved weights per bin. It is recommended that batch counters and/or ton counters be set at "zero" or initial and final readings be taken and recorded each day.
- i. Surge and Storage Bins: When a surge and storage bin are used, approval and scale calibration information should be available. They shall be inspected for compliance with Article 1102.01(a)(5) of the Standard Specifications. Trucks shall be loaded in such a manner as to minimize segregation.
- j. The platform and/or suspended weigh hopper scale shall be checked for proper zero. The scales shall be cleaned off before starting each day.
- k. The additive system(s) calibration shall be checked and the proper flow rate determined.

**Hot-Mix Asphalt QC/QA
QC Personnel Responsibilities and Duties Checklist
Appendix B.5**

(continued)

Effective Date: May 1, 1993

Revised Date: [December 1, 2021](#)

- l. The weigh ticket printer shall be checked for information required by the [appropriate articles of the Standard Specifications](#).
- m. The computer and/or control system shall be checked to see if the correct percentages of materials have been entered. The automatic printer for the computer of the drier drum should be turned on and working.

8. Trucks

A [HMA](#) Level I Technician, under the direct supervision of the QC Manager, or the [HMA](#) Level II Technician shall inspect the trucks used to transport the HMA mix. The technician shall see that each truck is provided with a cover and is properly insulated, if specified, before it is permitted to be used in the transportation of the mixture from the plant to the job. The truck bed shall be observed for foreign material before the bed is lubricated. [The HMA Level II Technician](#) shall observe the spraying of the inside of the trucks with a release agent and shall see that no pools of release agent remain in the truck beds before loading.

9. Mixture Inspection

The [HMA](#) Level II Technician shall inspect the mixture at the plant, which includes observing the weighing of the materials; checking the temperature of the mixture; and visually inspecting for coating of the aggregates, segregation, and moisture in the mixture. The [HMA](#) Level I Technician shall sample and determine the gradation of the hot-bins and/or cold-feeds and the proper amount of asphalt binder being used to ensure conformity to the mix formula. The [HMA](#) Level II Technician shall also verify and document the addition rates of the anti-strip additives.

In addition, the [HMA](#) Level I Technician shall perform the required core density tests and, when required, extraction tests at the field laboratory.

The QC Manager shall furnish the Contractor with the mixing formulas which have been established for a specific combination of sources of ingredients. The formulas shall state the percentage of aggregate for each sieve fraction and the percentage of asphalt binder. These formulas are to be used in proportioning the ingredient materials for HMA mixtures within the specified tolerances. Changes in the mix formulas are to be made only by the QC Manager.

It is important that the QC Manager observe the laying and compaction of the mixture.

Mixture variations are noticeable in the completed work, and variations that are not apparent in the mixture at the plant sometimes show up as defects in the texture and

Hot-Mix Asphalt QC/QA
QC Personnel Responsibilities and Duties Checklist
Appendix B.5

(continued)

Effective Date: May 1, 1993

Revised Date: [December 1, 2021](#)

uniformity of the surface. Flushing of the mixture is a defect that can be detected only on the road.

It is the duty of both the [HMA](#) Level I and [HMA](#) Level II Technicians to establish and maintain an open line of communications.

Timely and appropriate actions can be instituted by early detection of defects or mixture variations.

10. Scale Checks

When measurement of mixtures is on the basis of weights obtained from batch weights or [platform scales](#), occasional scale checks shall be made by weighing full truckloads of the mixture on an approved platform scale at the plant site or on a commercial scale approved by the Engineer. [The procedure is described in the Department's Documentation of Contract Quantities Manual.](#) The tests will be performed by the Level II Technician and reported on [form BIC 2367, as needed, and](#) the "Daily Plant Report".

11. Samples

The [HMA](#) Level I Technician shall take check samples of the mixture in addition to the required samples. Section 1030 of the Standard Specifications discusses sampling procedures and sampling frequency.

12. Reports

The Quality Control Manager is responsible for completion of a "Daily Plant Report" for each day of production for each type of mix. Other reports, when required, are "Sample Identification" (LM-6), and Scale Checks.

Hot-Mix Asphalt QC/QA Initial Daily Plant and Random Samples
Appendix B.6

Effective Date: May 1, 1993
Revised Date: [December 1, 2021](#)

Initial Daily Plant and Random Samples shall be obtained at the [frequencies](#) specified in [Standard Specifications Article 1030.09](#). The initial daily quality control (QC) mixture sample shall be taken at the plant and the second QC daily sample, if required, shall also be collected at the plant. The Department's verification mixture samples will be taken at the jobsite, except for mixtures used in patching and paving less than 3 ft (1 m) wide where it will be taken at the plant.

- A. The QC mixture sample shall be taken [from a truck at the plant](#). Two sampling platforms (one on each side of the truck) shall be provided for sampling of the mix. In order to obtain a representative sample of the entire truck, an equal amount of material shall be taken from each quarter point around the circumference of each pile in the truck to obtain a composite sample weighing approximately 100 lb (45 kg). All truck samples shall be obtained by using a "D"-handled, square-ended shovel with built-up sides and back (1 to 1½ in. [25 to 37.5 mm]). The composite sample shall be blended and split to lab sample size using an IDOT approved HMA splitter. The blending and splitting shall be according to HMA Level I procedures.
- B. Starting with the first day of production (excluding [a test strip](#)), the initial daily QC mixture sample shall be obtained between the first ½ to 1½ hours of daily production of a particular mixture [according to Article 1030.09\(a\)\(2\)](#).
- C. The second daily QC mixture sample, if required, shall be taken at a randomly selected time within the third quarter of the anticipated production day [as determined by the Contractor](#) using the "Random Numbers" table on the following page or the Department's [Quality Management Program \(QMP\) Package](#) software. The anticipated full production day shall be the time from ½ hour after production begins to ½ hour before production ends. The following procedure shall be used to calculate the second daily QC mixture sampling time.
 1. Multiply the quarter production day (in minutes) by a [three-digit](#) random number, expressed as a decimal, selected from the "Random Numbers" table or the Department's [QMP Package](#) software.
 2. The number obtained (rounded to a whole number) shall be added to the starting time of the third quarter. The time represented by this addition is the randomly selected sampling time.

If the plant is producing HMA mixtures intermittently, the samples shall be taken as close to the determined time as possible.

[The tests completed by the Contractor on the second daily QC mixture sample shall be according to Article 1030.09\(a\)\(2\)](#).

Hot-Mix Asphalt QC/QA Initial Daily Plant and Random Samples

Appendix B.6

(continued)

Effective Date: May 1, 1993

Revised Date: December 1, 2021

D. Department Random Verification Mixture Sample Determination and Collection.

The verification mixture sample will be collected at a randomly selected tonnage as specified in Article 1030.09(h). The Engineer will determine the location of the random verification mixture sample using the "Random Numbers" table as specified herein or the Department's QMP Package software. The plan quantities will be used for each mixture unless there is significant change during construction at which time the new quantity will be used in the calculation.

1. The Engineer will multiply the plan quantity by a three digit random number, expressed as a decimal, selected from the "Random Numbers" table or the Department's QMP Package software.
2. The number obtained (rounded to a whole number) is the randomly selected ton to be sampled.
3. This ton will be used to identify the truck containing the mixture to be sampled. For jobsite sampling, the Engineer will estimate the location this mixture will be placed to identify the location of plate sampling.

The values are to be considered confidential and are not to be disclosed to anyone outside of the Department until after the truck containing the random verification mixture has been produced.

Mixtures used for patching, paving applications less than 3 ft (1 m) wide, paving applications less than 1,320 ft (400 m) in length, and handwork shall be sampled from the truck at the plant by the Contractor following the same procedure used to collect QC mixture samples (section A). This process will be witnessed by the Engineer who will take custody of the verification sample.

For all other mixture applications, the Contractor may select either sampling behind the paver or sampling from the MTD discharge chute for jobsite sampling. The Contractor shall provide the necessary equipment and HMA Level I personnel to obtain the required samples, for whatever method is chosen, as specified herein.

1. Behind Paver Sampling.

This method covers the procedures for sampling HMA paving mixtures at the point of delivery immediately behind the paver and before initial compaction. This method is intended to provide a single composite sample that is representative of the mixture as produced (i.e. excludes paver effects).

Hot-Mix Asphalt QC/QA Initial Daily Plant and Random Samples

Appendix B.6

(continued)

Effective Date: May 1, 1993

Revised Date: [December 1, 2021](#)

a. Equipment

- 1) IDOT Approved Sampling Shovel (Fig. 1).
- 2) Sample Containers - four (4) each. Metal sample buckets with a minimum capacity of 3.5 gal (13 L).
- 3) IDOT Approved HMA Sample Splitter.
- 4) Plate/Shovel Sampling. The following additional equipment is needed when sampling HMA placed directly over a milled surface, rubblized concrete or an aggregate base.
 - i. Sampling Plates - four (4) each. The sampling plates shall be rectangular and have a minimum size of 14 x 28 in. (360 x 720 mm). Plates shall have a hole approximately 0.25 in. (6 mm) in diameter drilled through each of the four corners.
 - ii. Lifting Handles and Wire Lead. A 24 in. (600 mm) length of wire shall be attached to the two holes on one side of the plate to serve as lifting handle. An additional wire lead shall be attached to one of the lifting handles for locating the buried plate in the pavement. This wire shall extend to the edge of the pavement.
 - iii. Hammer and masonry nails for securing plates and wire lead.



Hot-Mix Asphalt QC/QA Initial Daily Plant and Random Samples

Appendix B.6

(continued)

Effective Date: May 1, 1993

Revised Date: [December 1, 2021](#)



Overall Length = 5 ft (1.5 m)
Shovel Width = 10 in. (255 mm)
Shovel Length = 12 in. (305 mm)
Shovel Sides = 4 in. (100 mm)

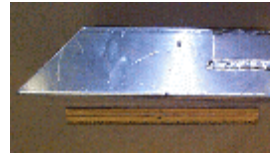

Figure 1. Aluminum Sampling Shovel & Dimensions

- b. Shovel Sample Sampling Procedure (Without Plates). This method shall be used when sampling over smooth HMA and concrete surfaces.
 - 1) The sampling shovel shall be used at each of the four offsets illustrated in Figure 2. to dig directly downward into the HMA behind the paver until it comes into contact with the previous pavement surface. When in contact, the shovel shall be pushed forward until it is full. The shovel shall be lifted up slowly. The mix shall be carefully placed into the sample container in order to prevent any loss of HMA.
- c. Shovel/Plate Sampling Procedure (With Plates). This method shall be used when sampling HMA directly over aggregate base, stabilized subbase, rubblized concrete, or a milled surface. This method may not be appropriate for a 3/4 in. (19 mm) binder lift over a milled surface. In the case of IL-4.75 or IL-9.5 FG mixtures, if approved by the Engineer, these mixtures may be shovel sampled from the auger area at the designated random location. Intentions of sampling IL-4.75 or IL-9.5 FG mixtures in this manner shall be listed in the approved QC Plan.
 - 1) Each plate with the wire lead attached to handles shall be placed at four locations at the designated random location ahead of the paver according to Figure 2. If conditions on the project require restricting movement of the plate, a nail shall be driven through one of the holes in the plate and into the pavement.

Hot-Mix Asphalt QC/QA Initial Daily Plant and Random Samples

Appendix B.6

(continued)

Effective Date: May 1, 1993

Revised Date: [December 1, 2021](#)

- 2) The wire lead shall be extended beyond the edge of the pavement. Trucks, pavers, and/or material transfer devices shall be allowed to cross over the plate and/or wire lead.
- 3) Immediately after the HMA is placed by the paver and before the initial roller compaction, the wire lead shall be used to locate the plate. Once located, the wire handles shall be lifted out of the pavement. This will locate the four corners of the plate.
- 4) Once the plate edges are defined, the shovel shall be used to dig downward through the thickness of the HMA behind the paver until it is in contact with the plate. The shovel shall be pushed forward until it is full. The shovel shall be lifted up slowly. The mix shall be carefully placed into the sample container in order to prevent any loss of HMA.
- 5) Remove the sampling plates from the pavement.

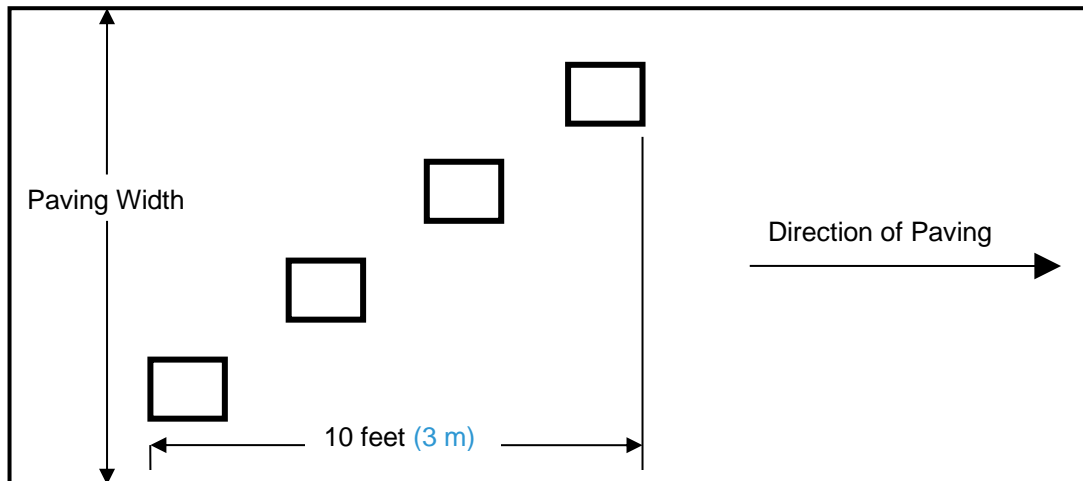

Figure 2. Behind the Paver Sampling Layout

d. Composite Sample.

- 1) The HMA samples in the containers shall be blended and split, using an IDOT approved HMA splitter, onsite by the Contractor and witnessed by the Engineer. One composite sample consists of four increments collected within 10 ft (3 m) longitudinally and diagonally across the width of the

Hot-Mix Asphalt QC/QA Initial Daily Plant and Random Samples

Appendix B.6

(continued)

Effective Date: May 1, 1993

Revised Date: December 1, 2021

paving operation (Fig. 2). The four increments shall be blended according to HMA Level I procedures to provide a single composite sample.

2) Composite/Lab Samples.

- i. A composite sample size shall be approximately 150 lb (70 kg) and a minimum of 100 lb (45 kg), allowing 50 lb (23 kg) for District testing, and 50 lb (23 kg) for Contractor testing.
- ii. The minimum lab sample size of 50 lb (23 kg) shall be obtained by splitting the composite samples into two equal lab samples using an IDOT approved HMA splitter. The Engineer will secure the Department lab sample for the Contractor to transport to the District Materials Laboratory.

e. Sample Site Repair.

- 1) HMA from the paver auger system shall be used to fill the voids left in the pavement from sampling. To reduce segregation and low density in the finished mat, buckets shall be used to fill the voids left by the samples.
 - i. HMA from the augers system shall be placed in clean metal buckets just prior to sampling the pavement.
 - ii. The metal buckets shall be filled with approximately 25% more HMA than will be removed for the composite sample.
- 2) The buckets shall be dumped directly over the void.
- 3) The filled void shall have a thickness greater than the surrounding HMA to allow compaction of the mix by the roller(s).
- 4) Unacceptable site repair shall be removed and replaced at the Contractor's expense.

2. MTD Sampling.

This method covers the procedures for sampling HMA paving mixtures at the point of delivery from a material transfer device (MTD).

a. Equipment.

- 1) MTD Sampling Device. A portable device mounted either in the bed of a pickup truck or on a trailer. The device shall be equipped with a funnel large

Hot-Mix Asphalt QC/QA Initial Daily Plant and Random Samples

Appendix B.6

(continued)

Effective Date: May 1, 1993

Revised Date: December 1, 2021

enough to capture the full stream of HMA from the MTD discharge chute without spillage and shall be capable of capturing a minimum composite sample. See Figures 3, 4 and 5 for illustrations of various MTD sampling device configurations.

- 2) Sample Containers – Metal containers each capable of holding a minimum of 50 lb (23 kg) of HMA.

b. MTD Sampling Procedure.

The Engineer will identify the truck containing the sample tonnage. Immediately after the truck containing the random HMA tonnage has finished unloading, the MTD shall pull forward away from the paver far enough to allow the sampling device to be positioned under the MTD discharge chute. The sampling device shall be positioned as level as possible in a safe location readily accessible by the MTD. The MTD shall discharge without spillage approximately 150 lb (70 kg) and a minimum of 100 lb (45 kg) into the funnel of the sampling device.

c. Composite Sample.

- 1) Composite Sample. HMA from all four sample containers of the sampling device shall be blended into one composite sample and split to lab sample size by the Contractor onsite using an IDOT approved HMA splitter. The blending and splitting shall be according to HMA Level I procedures and will be witnessed by the Engineer. A composite sample size shall be approximately 150 lb (70 kg) and a minimum of 100 lb (45 kg), allowing 50 lb (23 kg) for District testing, and 50 lb (23 kg) for Contractor testing.

The minimum lab sample size of 50 lb (23 kg) shall be obtained by splitting the composite samples into two equal lab samples using an IDOT approved HMA splitter. The Engineer will secure the Department lab sample for the Contractor to transport to the District Materials Laboratory.

d. Documentation.

After the sample has been obtained, the following information shall be written on each sample bag or box with a felt tip marker.

Hot-Mix Asphalt QC/QA Initial Daily Plant and Random Samples

Appendix B.6

(continued)

Effective Date: May 1, 1993

Revised Date: [December 1, 2021](#)

Contract #: _____
[Location](#) _____
Date: _____ Time: _____
Mix Type (binder, surface...): _____
Mix Design #: _____
Sampled By: _____

e. [Sample Security.](#)

Each sample bag with a Department verification mixture sample will be secured by the Engineer using a locking ID tag.

Sample boxes containing the Department's verification mixture sample will be sealed/taped using a security ID label.

f. [Sample Transportation.](#)

The Contractor shall deliver the secured Department verification mixture samples to the district laboratory, during regular working hours, within two days of sampling.

g. [Testing.](#)

The Contractor shall and the Department will complete testing on the split verification mixture samples as described in 1030.09(g) and 1030.09(h).

Hot-Mix Asphalt QC/QA Initial Daily Plant and Random Samples
Appendix B.6

(continued)

Effective Date: May 1, 1993

Revised Date: [December 1, 2021](#)



Figure 3. Example of MTD Sampling Device



Figure 4. Additional Examples of MTD Sampling Devices

Hot-Mix Asphalt QC/QA Initial Daily Plant and Random Samples
Appendix B.6

(continued)

Effective Date: May 1, 1993

Revised Date: [December 1, 2021](#)



[Figure 5. Additional Examples of MTD Sampling Devices](#)

Hot-Mix Asphalt QC/QA Initial Daily Plant and Random Samples
Appendix B.6

(continued)

Effective Date: May 1, 1993

Revised Date: [December 1, 2021](#)

RANDOM NUMBERS

0.576	0.730	0.430	0.754	0.271	0.870	0.732	0.721	0.998	0.239
0.892	0.948	0.858	0.025	0.935	0.114	0.153	0.508	0.749	0.291
0.669	0.726	0.501	0.402	0.231	0.505	0.009	0.420	0.517	0.858
0.609	0.482	0.809	0.140	0.396	0.025	0.937	0.301	0.253	0.761
0.971	0.824	0.902	0.470	0.997	0.392	0.892	0.957	0.040	0.463
0.053	0.899	0.554	0.627	0.427	0.760	0.470	0.040	0.904	0.993
0.810	0.159	0.225	0.163	0.549	0.405	0.285	0.542	0.231	0.919
0.081	0.277	0.035	0.039	0.860	0.507	0.081	0.538	0.986	0.501
0.982	0.468	0.334	0.921	0.690	0.806	0.879	0.414	0.106	0.031
0.095	0.801	0.576	0.417	0.251	0.884	0.522	0.235	0.389	0.222
0.509	0.025	0.794	0.850	0.917	0.887	0.751	0.608	0.698	0.683
0.371	0.059	0.164	0.838	0.289	0.169	0.569	0.977	0.796	0.996
0.165	0.996	0.356	0.375	0.654	0.979	0.815	0.592	0.348	0.743
0.477	0.535	0.137	0.155	0.767	0.187	0.579	0.787	0.358	0.595
0.788	0.101	0.434	0.638	0.021	0.894	0.324	0.871	0.698	0.539
0.566	0.815	0.622	0.548	0.947	0.169	0.817	0.472	0.864	0.466
0.901	0.342	0.873	0.964	0.942	0.985	0.123	0.086	0.335	0.212
0.470	0.682	0.412	0.064	0.150	0.962	0.925	0.355	0.909	0.019
0.068	0.242	0.777	0.356	0.195	0.313	0.396	0.460	0.740	0.247
0.874	0.420	0.127	0.284	0.448	0.215	0.833	0.652	0.701	0.326
0.897	0.877	0.209	0.862	0.428	0.117	0.100	0.259	0.425	0.284
0.876	0.969	0.109	0.843	0.759	0.239	0.890	0.317	0.428	0.802
0.190	0.696	0.757	0.283	0.777	0.491	0.523	0.665	0.919	0.146
0.341	0.688	0.587	0.908	0.865	0.333	0.928	0.404	0.892	0.696
0.846	0.355	0.831	0.281	0.945	0.364	0.673	0.305	0.195	0.887
0.882	0.227	0.552	0.077	0.454	0.731	0.716	0.265	0.058	0.075
0.464	0.658	0.629	0.269	0.069	0.998	0.917	0.217	0.220	0.659
0.123	0.791	0.503	0.447	0.659	0.463	0.994	0.307	0.631	0.422
0.116	0.120	0.721	0.137	0.263	0.176	0.798	0.879	0.432	0.391
0.836	0.206	0.914	0.574	0.870	0.390	0.104	0.755	0.082	0.939
0.636	0.195	0.614	0.486	0.629	0.663	0.619	0.007	0.296	0.456
0.630	0.673	0.665	0.666	0.399	0.592	0.441	0.649	0.270	0.612
0.804	0.112	0.331	0.606	0.551	0.928	0.830	0.841	0.702	0.183
0.360	0.193	0.181	0.399	0.564	0.772	0.890	0.062	0.919	0.875
0.183	0.651	0.157	0.150	0.800	0.875	0.205	0.446	0.648	0.685

Note: Always select a new set of numbers in a systematic manner, either horizontally or vertically. Once used, the set should be crossed out.

This Page Reserved

Hot-Mix Asphalt QC/QA Procedure for Determining Random Density Locations
Appendix B.7

Effective: May 1, 1993
Revised: December 1, 2021

Density [quality control and verification](#) tests shall be performed at random [test locations](#) based on the frequency specified in [Article 1030.09](#) of the Standard Specifications. The random test locations shall be determined as follows:

1. [By the Contractor for quality control using a nuclear density gauge at intervals as specified in 1030.09\(b\).](#)

- A) [The beginning station number shall be established daily and the estimated paving distance computed for the day's production. The total distance to be paved shall then be subdivided into density testing intervals. A minimum of one interval is required for each half day's production.](#)

[For patching, estimate the number of patches to be completed for each half of the day's production.](#)

- B) [The length of each paving interval shall be multiplied by the three digit random number expressed as a decimal from the "Random Numbers" table on the following page or from the Department's Quality Management Program \(QMP\) Package. The number obtained shall be added to the beginning station number for the interval to determine the longitudinal test location. This process shall be repeated for the subsequent intervals for the day's production using new random numbers to identify each test location.](#)

[The remaining partial length of paving at the end of each day shall be treated as an interval with the test location determined by multiplying the partial distance by the next random number.](#)

[For patching, multiply each of the estimated half day's production of patches by the three digit random number. If necessary, round these numbers up to the next whole number. The numbers obtained shall be the patches that shall be tested, starting the count over at each half day's production.](#)

- C) [Nuclear density test sites shall be equally positioned five \(5\) across all paved mat widths. The outer test sites shall be 4 in. \(100 mm\) from the edges of the mat. When LJS has been used, the outer test site shall be adjusted in 1 ft \(300 mm\).](#)

[For patching, only a single test site centered in the randomly selected patch shall be tested.](#)

- D) [The average of all nuclear density readings at each location shall be reported on the Department's MI 303N QC Nuclear Density Report form.](#)

2. [By the Engineer for verification testing using cores or a nuclear density gauge as specified in 1030.09\(h\). The test location will be the center of the core or nuclear density gauge.](#)

Hot-Mix Asphalt QC/QA Procedure for Determining Random Density Locations
Appendix B.7

Effective: May 1, 1993
Revised: December 1, 2021

- A) Prior to paving or patching, the random test locations for density will be determined by the Engineer using the random numbers. The values are to be considered confidential and are not to be disclosed to anyone outside of the Department until finish rolling is complete. Once random test locations are determined by the Engineer, it may be necessary to alter the random test locations due to quantity adjustments, sequencing changes, or other alterations made by the Department or Contractor. The Engineer will document any changes to the random test locations.
- B) For all paving, each test location will be randomly determined longitudinally. For paving less than 3 ft (1 m) wide, the transverse location will be centered in the paving width. For paving wider than or equal to 3 ft (1 m), each test location will also be randomly determined transversely within each density testing interval. Each test location will be determined with two random numbers. The first random number is used to determine the longitudinal distance to the nearest 1.0 ft (300 mm) into the density testing interval. The second random number is used to determine the transverse offset to the nearest 0.1 ft (30 mm) from the left edge of the paving. The direction of the paving lane will be the same as the direction of the traffic.
- 1) Longitudinal Location: Determine the random longitudinal location by multiplying the length of the prescribed density interval by the random number selected.
 - 2) Transverse Offset to Center of Core: For paving wider than or equal to 3 ft (1 m), determine the random transverse location by multiplying the width of the paving by the random number selected from the Random Numbers table or the Department's QMP Package. The effective lane width of the paving lane will be used in calculating the transverse offset. The effective lane width is determined by first subtracting 1.0 ft (300 mm) for each longitudinal joint with LJS from the entire lane width. The effective lane width is then reduced 4.0 in. (100 mm) for each joint that does not have LJS. The effective lane width is further reduced by 4.0 in. (100 mm) for the diameter of the core barrel.

Effective lane width of pavement = pavement lane width – 1.0 ft (300 mm) for each edge with LJS – 4.0 in. (100 mm) for each edge without LJS – 4.0 in. (100 mm) for core barrel

The transverse offset is determined by first multiplying the effective lane width by the selected random number. If the left edge is located immediately above LJS, 1.0 ft (300 mm) will be added to the calculated transverse offset measurement. If the left edge is confined but without LJS, 4.0 in. (100 mm) will be added to the calculated transverse offset measurement. An additional 2 in. (50 mm) will be added to the calculated transverse offset measurement to account for the distance from the edge of the core barrel to the center of core. The transverse offset is measured from the left physical edge of the paved lane to locate the center of the core on the pavement.

Hot-Mix Asphalt QC/QA Procedure for Determining Random Density Locations
Appendix B.7

Effective: May 1, 1993
Revised: December 1, 2021

Transverse Offset to Center of Core = effective lane width x random number + 1.0 ft (300 mm) if left edge has LJS + 4.0 in. (100 mm) if left edge does not have LJS + 2.0 in. (50 mm) for core barrel

Density taken within 1.0 ft (300 mm) from an unconfined edge without LJS will have 2.0% added.

For patching, the random density locations will be determined based on the number of patches estimated for the project multiplied by a random number. If necessary, round any calculated fraction up to the next whole number. The test location will be centered in the patch.

- C) The intervals used to determine the random locations for density verification are dependent on mixture use as specified in 1030.09(h).
- D) This process shall be repeated for all density intervals on a given project.
- E) Moving test locations.

There are two scenarios in which a random test location may be moved longitudinally using the same random transverse offset. The first scenario is to avoid only the obstacles listed in Case 1 below. The second scenario is to avoid pavement defects in the surface being overlaid as described in Case 2 below.

- 1) Case 1. In the event the random test location has an obstruction that will not allow the necessary compactive effort to be applied, the Engineer will adjust the longitudinal location of the density test in order to avoid the obstacle. Using the same random transverse offset, the test location will be moved longitudinally, ± 15 ft (5 m) to avoid the following obstacles only:
 - a) Structures or Bridge Decks
 - b) Detection loop or other pavement sensors
 - c) Manholes or other utility appurtenances
- 2) Case 2. In the event there are pavement defects in the surface being overlaid, the Contractor may place temporary markings on the shoulder to identify longitudinal locations where a defect is present. In the case of an asphalt scab (i.e. thin layer of less than 0.5 in. (12 mm) of asphalt pavement remaining after milling) the temporary markings shall show the extent or length of the defect. These pavement defect locations will be approved by the Engineer. If a random test location lands at the same longitudinal location as a temporary mark, the test location will be moved 5 ft (1.5 m) in the direction toward the paver at the same transverse offset.

Hot-Mix Asphalt QC/QA Procedure for Determining Random Density Locations
Appendix B.7

Effective: May 1, 1993
Revised: December 1, 2021

- F) Example Calculations for Identifying Density Verification Test Locations for QC/QA Paving and Patching Projects.

Example 1.

This example illustrates the determination of density verification test locations for a QC/QA overlay project.

Given: A mixture is to be paved as a 6.0 ft wide shoulder 3.5 in. thick for 1 mile with LJS placed at the pavement/shoulder joint.

This paving thickness will require a density testing interval of 0.2 miles. The shoulder consists of a 6.0 ft-wide mat with the left edge confined with LJS and the right edge unconfined without LJS. The random numbers selected for the longitudinal direction are: 0.904, 0.231, 0.517, 0.253, and 0.040. The random numbers for the transverse direction are: 0.003, 0.052, 0.998, 0.510 and 0.109.

The individual longitudinal density test interval distances can be converted to the cumulative random distance using the following equation:

$$CD_n = [D \times (n - 1)] + R_n$$

Where:

n = the density interval number

CD = cumulative distance

D = density testing interval length (typically 1056 ft (0.2 mile))

R = random distance within the given density testing interval

The longitudinal locations are determined by multiplying the longitudinal random numbers by 1056 ft (0.2 mile). The transverse offsets are determined by multiplying the transverse random number by the width of the paving minus 1.0 ft for the left edge confined with LJS (5.0 ft).

Determine the effective shoulder width by subtracting 1.0 ft for each edge with LJS and 4.0 in. (0.33 ft) for each edge without LJS from the 6.0 ft paved shoulder width. In this case the right edge of the shoulder is unconfined without LJS, so subtract 4.0 in. (0.33 ft), and the left edge is confined with LJS so subtract 1.0 ft. Then subtract 4.0 in. (0.33 ft) for the width of the core barrel.

$$\text{Effective Shoulder Width} = 6.0 \text{ ft} - 1.0 \text{ ft} - 0.33 \text{ ft} - 0.33 \text{ ft} = 4.34 \text{ ft}$$

The calculated transverse offset distances are determined by multiplying the effective shoulder width of 4.34 ft by the random numbers and adding 1.0 ft for the left confined edge with LJS plus 2.0 in. (0.17 ft) for the core barrel (1.0 ft + 0.17 ft = 1.17 ft). The random locations for the first mile measured

Hot-Mix Asphalt QC/QA Procedure for Determining Random Density Locations
Appendix B.7

Effective: May 1, 1993
 Revised: December 1, 2021

from the beginning of the lot and the left edge of the paved shoulder to the center of the core barrel are as follows:

Test Site #	Random Distance	Cumulative Distance	Center of Core Transverse Location ^{1/}
1	1056 x 0.904 = 955 ft	1056 x (1-1) + 955 = 955 ft	(4.34 x 0.003) + 1.17 = 1.2 ft
2	1056 x 0.231 = 244 ft	1056 x (2-1) + 244 = 1300 ft	(4.34 x 0.052) + 1.17 = 1.4 ft
3	1056 x 0.517 = 546 ft	1056 x (3-1) + 546 = 2658 ft	(4.34 x 0.998) + 1.17 = 5.5 ft
4	1056 x 0.253 = 267 ft	1056 x (4-1) + 267 = 3435 ft	(4.34 x 0.510) + 1.17 = 3.4 ft
5	1056 x 0.040 = 42 ft	1056 x (5-1) + 42 = 4266 ft	(4.34 x 0.109) + 1.17 = 1.6 ft

1/ Transverse location of the center of the core measured from the left physical edge of the shoulder.

Example 2.

This example illustrates the determination of density verification test locations for a QC/QA widening project.

Given: A mixture is to be paved as a 2.0 ft wide shoulder 1.5 in. thick for 4 miles.

This paving width will require a density testing interval of 1 mile. The shoulder consists of a 2.0 ft wide mat with the left edge confined and the right edge unconfined. No LJS was used. The random numbers for the longitudinal direction are: 0.821, 0.345, 0.623 and 0.140. As the paving is less than 3 ft, the transverse location will be centered.

The individual density test interval distances can be converted to the cumulative random distance using the following equation:

$$CD_n = [D \times (n - 1)] + R_n$$

Where:

- n* = the density interval number
- CD* = cumulative distance
- D* = density testing interval length (1 mile)
- R* = random distance within the given density testing interval

The longitudinal locations are determined by multiplying the longitudinal random numbers by 5,280 ft (1 mile). The transverse offsets are determined by dividing the width of the paving in half (by 2).

The random locations measured from the beginning of shoulder paving and the left (confined) edge of the paved mat to the center of the nuclear gauge are as follows:

Hot-Mix Asphalt QC/QA Procedure for Determining Random Density Locations
Appendix B.7

Effective: May 1, 1993
 Revised: December 1, 2021

Test Site #	Random Distance	Cumulative Distance	Transverse Location
1	5280 x 0.821 = 4,335 ft	5280 x (1-1) + 4,335 = 4,335 ft	2.0 / 2 = 1.0 ft
2	5280 x 0.345 = 1,822 ft	5280 x (2-1) + 1,882 = 7,162 ft	2.0 / 2 = 1.0 ft
3	5280 x 0.623 = 3,289 ft	5280 x (3-1) + 3,289 = 13,849 ft	2.0 / 2 = 1.0 ft
4	5280 x 0.140 = 739 ft	5280 x (4-1) + 739 = 16,579 ft	2.0 / 2 = 1.0 ft

Example 3.

This example illustrates the determination of density **verification test** locations for a QC/QA patching project.

Given: On an 8 mile full-depth patching project it is estimated that 140 patches will be constructed.

Patching projects require 1 nuclear density test for every 50 patches. The first random number is 0.289. The second is 0.760 and the third 0.444. The individual density test interval distance can be converted to the cumulative random patch using the following equation:

$$CP_n = [D \times (n - 1)] + P_n$$

Where:

- n = the density interval number
- CP = cumulative patch
- D = density testing interval (typically 50 patches)
- P = random patch within the given density testing interval

The longitudinal locations are determined by multiplying the longitudinal random numbers by 50 patches or when less than 50 patches remain, the number of remaining patches. **The test location is then centered in the identified patch.**

Nuclear #	Random Patch ¹	Cumulative Patch	Transverse Location
1	50 x 0.289 = 15	50 x (1-1) + 15 = 15	Center of patch
2	50 x 0.760 = 38	50 x (2-1) + 38 = 88	Center of patch
3	40 x 0.444 = 18	50 x (3-1) + 18 = 118	Center of patch

1/ If necessary, round any calculated fraction up to the next whole number.

Hot-Mix Asphalt QC/QA Procedure for Determining Random Density Locations
Appendix B.7

Effective: May 1, 1993
 Revised: December 1, 2021

RANDOM NUMBERS

0.576	0.730	0.430	0.754	0.271	0.870	0.732	0.721	0.998	0.239
0.892	0.948	0.858	0.025	0.935	0.114	0.153	0.508	0.749	0.291
0.669	0.726	0.501	0.402	0.231	0.505	0.009	0.420	0.517	0.858
0.609	0.482	0.809	0.140	0.396	0.025	0.937	0.301	0.253	0.761
0.971	0.824	0.902	0.470	0.997	0.392	0.892	0.957	0.040	0.463
0.053	0.899	0.554	0.627	0.427	0.760	0.470	0.040	0.904	0.993
0.810	0.159	0.225	0.163	0.549	0.405	0.285	0.542	0.231	0.919
0.081	0.277	0.035	0.039	0.860	0.507	0.081	0.538	0.986	0.501
0.982	0.468	0.334	0.921	0.690	0.806	0.879	0.414	0.106	0.031
0.095	0.801	0.576	0.417	0.251	0.884	0.522	0.235	0.389	0.222
0.509	0.025	0.794	0.850	0.917	0.887	0.751	0.608	0.698	0.683
0.371	0.059	0.164	0.838	0.289	0.169	0.569	0.977	0.796	0.996
0.165	0.996	0.356	0.375	0.654	0.979	0.815	0.592	0.348	0.743
0.477	0.535	0.137	0.155	0.767	0.187	0.579	0.787	0.358	0.595
0.788	0.101	0.434	0.638	0.021	0.894	0.324	0.871	0.698	0.539
0.566	0.815	0.622	0.548	0.947	0.169	0.817	0.472	0.864	0.466
0.901	0.342	0.873	0.964	0.942	0.985	0.123	0.086	0.335	0.212
0.470	0.682	0.412	0.064	0.150	0.962	0.925	0.355	0.909	0.019
0.068	0.242	0.777	0.356	0.195	0.313	0.396	0.460	0.740	0.247
0.874	0.420	0.127	0.284	0.448	0.215	0.833	0.652	0.701	0.326
0.897	0.877	0.209	0.862	0.428	0.117	0.100	0.259	0.425	0.284
0.876	0.969	0.109	0.843	0.759	0.239	0.890	0.317	0.428	0.802
0.190	0.696	0.757	0.283	0.777	0.491	0.523	0.665	0.919	0.146
0.341	0.688	0.587	0.908	0.865	0.333	0.928	0.404	0.892	0.696
0.846	0.355	0.831	0.281	0.945	0.364	0.673	0.305	0.195	0.887
0.882	0.227	0.552	0.077	0.454	0.731	0.716	0.265	0.058	0.075
0.464	0.658	0.629	0.269	0.069	0.998	0.917	0.217	0.220	0.659
0.123	0.791	0.503	0.447	0.659	0.463	0.994	0.307	0.631	0.422
0.116	0.120	0.721	0.137	0.263	0.176	0.798	0.879	0.432	0.391
0.836	0.206	0.914	0.574	0.870	0.390	0.104	0.755	0.082	0.939
0.636	0.195	0.614	0.486	0.629	0.663	0.619	0.007	0.296	0.456
0.630	0.673	0.665	0.666	0.399	0.592	0.441	0.649	0.270	0.612
0.804	0.112	0.331	0.606	0.551	0.928	0.830	0.841	0.702	0.183
0.360	0.193	0.181	0.399	0.564	0.772	0.890	0.062	0.919	0.875
0.183	0.651	0.157	0.150	0.800	0.875	0.205	0.446	0.648	0.685

Note: Always select a new set of numbers in a systematic manner, either horizontally or vertically. Once used, the set should be crossed out.

This Page Reserved

Hot-Mix Asphalt QC/QA Control Charts

Appendix B.8

Effective: May 1, 1993

Revised: December 1, 2021

A. Scope

1. All required Contractor test results, including resample tests, listed in Article 1030.09 shall be plotted on Control Charts. (No check tests shall be plotted on these Control Charts.)
2. Control Charts shall be maintained by the Contractor in the field laboratory. Contractor test results shall be recorded within 24 hours of sampling. The Engineer shall be provided access to the Control Charts at all times.
3. Rounded values shall follow the document "Hot-Mix Asphalt Rounding Test Values".

B. General Procedures

1. Control Charts shall be computer generated (10 divisions per 1 in. [25 mm]). The vertical scale used shall conform to the following requirements in respect to the rounded values of:

Gradation - 1% per 2.5 divisions (1 in. [25 mm] = 4.0%).

Air Voids, Field VMA, Minus No. 200 (75- μ m), Field Density - 0.1% per division (1 in. [25 mm] = 1.0%).

Asphalt Binder Content — 0.1% per 5 divisions (1 in. [25 mm] = 0.2%).

Specific Gravity (Bulk or Maximum Theoretical) - 0.001 per division (1 in. [25 mm] = 0.01).

2. The horizontal scale shall be arranged such that each randomly selected test value obtained is plotted at ½ in. (12.5-mm) intervals.

Note. When the QMP Package is used to generate Control Charts, 8.5" X 11.0" page format shall be used to produce the required divisions per 1 in.

C. Symbols and Control Limits

1. Individual test values shall be represented on Control Charts by open circles centered on the correct test value except that washed extraction gradations shall be denoted by a solid circle. Moving average values shall be represented by open squares centered on the correct value. State assurance test values

Hot-Mix Asphalt QC/QA Control Charts

Appendix B.8

Effective: May 1, 1993

Revised: December 1, 2021

shall be represented by solid triangles for washed **extraction** gradations and by open triangles for dry gradations. All symbols shall be 0.1 in. (2.5 mm) in their largest dimension.

2. Individual test values shall be connected by dashed lines. Moving average data points shall be connected by solid lines.
3. Target values shall be represented on Control Charts by horizontal solid lines. Appropriate control limits (solid lines) for each control parameter shall extend horizontally across the chart and be identified with an appropriate solid symbol corresponding to the type of test it represents, i.e., individual or moving average.

D. Individual Test Values and Moving Average

1. Moving averages are applicable to all values. The moving average is the average of four consecutive test values and is determined by starting with the fourth test value and averaging it with the three preceding test values. Plotting the average thereafter will be done in a similar manner starting with the test value just completed. Rounding procedures for the moving average are the same as used for the individual test values.

The moving average for minus **No. 200** (75 μm) for HMA production control shall include both washed **extraction** gradation and adjusted dry gradation individual results. When a given subplot includes both washed **extraction** and dry gradation test results for the minus **No. 200** (75 μm), only the washed **extraction gradation** shall be used in the moving average.

The moving average for G_{mm} of a new mixture shall be established initially with the results from the **first plant sample** and shall include more tests in the moving average as they occur until the moving average of four is established. Unless otherwise specified by the Engineer, the moving average for G_{mm} of a previously placed mixture shall begin with the most recent moving average of four and shall be averaged with subsequent test results.

Hot-Mix Asphalt QC/QA Control Charts

Appendix B.8

Effective: May 1, 1993

Revised: [December 1, 2021](#)

2. At the bottom of the chart under the line on which the individual test data is plotted, the following information shall be listed:
 - a. Date and specific time (include a.m. or p.m.) of sampling.
 - b. Lot Number.
 - c. Test Sequence.
 - d. Quantity of material represented (produced since previous test).
 - e. Initials of person performing the test.
 - f. Use "(rs)" to denote resample.

E. Test Strip Values

1. Test values obtained [from a test strip](#) shall be placed at the beginning of the Control Charts. Once all these tests have been completed and their values recorded, two vertical double black lines shall be drawn on the graph $\frac{1}{2}$ in. (12.5 mm) apart.
2. [After completion of an acceptable test strip](#), production under QC/QA shall be initiated with the agreed upon targets and appropriate limits being placed on the graph. Individual required [QC](#) plant test results shall be recorded from this point on with a moving average being established at the completion of the fourth test.

F. Adjusting Targets

1. If the adjustments in gradation or asphalt binder content are required in order to maintain proper voids, they shall be made according to [Article 1030.10](#) and shall be appropriately documented on the Control Charts.
2. When an adjustment to the Target value is made, two vertical double black lines shall be drawn on the graph $\frac{1}{2}$ in. (12.5 mm) apart. The new target value plus upper and lower control values will be placed on the chart. The moving average will continue as though the adjustment had not taken place.

Hot-Mix Asphalt QC/QA Control Charts

Appendix B.8

Effective: May 1, 1993

Revised: December 1, 2021

G. Resample Test Values

The Contractor resample tests shall be denoted by a circle (closed for washed gradations and open for all other tests) with its value placed on the vertical line, which corresponds to the time or lot from which the resample was taken. A circle shall be drawn around a failed test value and the corresponding resample test value. Both the failed test value and the resample test value shall be used as individual points in determining moving averages.

**Hot-Mix Asphalt Mixture Design Verification Procedure
Appendix B.9**

Effective Date: January 1, 2002
Revised Date: [December 1, 2021](#)

1.1 GENERAL

Contractors shall provide all hot-mix asphalt (HMA) mix designs for use on Department contracts. Mix designs must [result in mixtures](#) meeting Department criteria. The Department will provide current aggregate bulk specific gravities.

[Note. The values stated in SI units are to be regarded as the standard. The English units are shown in parentheses and may not be exact equivalents.](#)

2.1 PURPOSE

[To](#) establish a verification procedure to evaluate Contractor mix designs for use on Department contracts. This procedure also allows for comparison of test accuracy and precision between laboratories.

3.1 REQUIRED DESIGN DATA/MATERIAL SAMPLES

3.2 The Contractor shall provide a mix design prepared by a Hot-Mix Asphalt Level III Technician in accordance with the Department's "Hot-Mix Asphalt Design Procedure" in the current *Hot-Mix Asphalt Level III Technician Course* manual. All testing shall be performed by Hot-Mix Asphalt Level I, II, or III Technicians . [An approved mix design that will be used as WMA through the use of foaming technology alone \(without WMA additives\) will not require a new submittal.](#) Mix designs shall be submitted with the following design data:

- A. The average mix plant stockpile gradations and aggregate blend percentages used to design the mix. Each of the individual aggregate gradations used in the Contractor design shall be an average of a minimum of five stockpile gradations from existing stockpiles at the plant. Adjusted average aggregate source gradations (stockpile gradations preferred) may be substituted if aggregate has not been shipped to the mix plant. The adjustment shall be based on the amount of aggregate degradation [anticipated](#) during shipment to, and handling at, the mix plant. A design using gradation information not comparing to mix plant or aggregate source gradations shall be considered unacceptable.

Hot-Mix Asphalt Mixture Design Verification Procedure
Appendix B.9

(continued)

Effective Date: January 1, 2002

Revised Date: [December 1, 2021](#)

- B. The Contractor shall provide [the following information](#) utilizing a design package with the same output format as the [Department's Quality Management Program \(QMP\) Package software](#).
- (1) Design sheet. The design shall contain a minimum of four design points, two of which shall bracket the optimum design asphalt binder (AB) content by at least $\pm 0.5\%$. Under remarks include: short-term aging time, dust correction factor, compaction temperature, and mixing temperature.
 - (2) Design summary data sheet (in the [QMP Package](#) format).
 - (3) G_{mm} lab worksheets.
 - (4) Batching worksheet.
 - (5) Dust correction worksheet ([example shown in the *Hot-Mix Asphalt Technician Course Level III* manual](#)).
 - (6) Batching sources sheet.
 - (7) Mix design graphs (full page).
 - (a) Gradation ([0.45 power curve](#)).
 - (b) Asphalt Binder Content vs. G_{mb}/G_{mm} .
 - (c) Asphalt Binder Content vs. VMA.
 - (d) Asphalt Binder Content vs. Air Voids.
 - (8) Recalculations and/or retested points (e.g., recalculated G_{mm} 's using average G_{se}).
 - (9) TSR worksheet [including the mixture unconditioned tensile strength, conditioned tensile strength, TSR and, if anti-strip additive is used, the conditioned tensile strength of the mixture without the anti-strip additive](#).

Hot-Mix Asphalt Mixture Design Verification Procedure

Appendix B.9

(continued)

Effective Date: January 1, 2002

Revised Date: [December 1, 2021](#)

3.3 The Contractor shall [submit the following to the Department a minimum of 30 calendar days prior to production](#): samples of blended aggregate, asphalt binder, additives, and compacted gyratory [cylinders](#), at the optimum asphalt content according to Section 3.3.D as specified herein, which represent the materials in the mix design. These representative samples shall be identified and submitted as follows:

- A. Aggregate (including [the mineral filler or collected dust](#)) -- Dried, split into the individual sizes specified for the Batching Worksheet as stated in the current *Hot-Mix Asphalt Level III Technician Course* manual, and then blended to the chosen gradation. The amount submitted shall be two 10,000-gram samples of dry aggregate, with an additional 2,000 grams for gradation testing if requested by the District. All material shall be bagged in plastic bags or other airtight containers. Each container shall be identified with the source names, source locations, source Producer/Supplier Numbers, material codes, sample location, and sample date.
- B. Asphalt Binder -- A minimum of [four individual one quart cans with friction lids](#). [Each container shall be](#) identified with source name, source location, source Producer/Supplier Number, material code, sample location, and sample date.
- C. Additive(s) ([including anti-strip, WMA and fibers](#)) -- [Each container shall be](#) identified with the source name, source location, brand name or number, material code, sample location, sample date, [Safety Data Sheet \(SDS\)](#), the manufacturer's recommended dosage rate, and the [dosage](#) rate used in the design. **NOTE:** Prior to submitting the additive(s), the Contractor shall contact the District Materials Engineer for the required sample size.
- D. Compacted Gyratory [Cylinders](#) – The Contractor shall provide compacted 150 mm ([5.91 in.](#)) diameter gyratory [cylinders meeting the air void requirements of the respective tests shown in the following table](#). The number of gyratory [cylinders](#) and the height of the gyratory [cylinders](#) per test is [also](#) specified in the following table.

	TSR	Hamburg Wheel	I-FIT	I-FIT Long-Term Aging
IL Modified AASHTO Procedure	T 283	T 324	T 393	T 393
No. of Gyratory Cylinders*	6	2/4	1/2	1/2
Height of Gyratory Cylinders mm (in.)*	95 (3.74)	160/115 (6.30/4.53)	160/115 (6.30/4.53)	160/115 (6.30/4.53)

* If a Contractor does not possess the equipment to prepare 160 mm ([6.30 in.](#)) tall [gyratory cylinders](#), twice the number of 115 mm ([4.53 in.](#)) tall [gyratory cylinders](#) per test will be acceptable.

Hot-Mix Asphalt Mixture Design Verification Procedure

Appendix B.9

(continued)

Effective Date: January 1, 2002

Revised Date: [December 1, 2021](#)

3.4 All design data and material samples shall be submitted to the Department a minimum of 30 calendar days prior to production.

3.5 [By submitting a mix design and the constituent materials for verification](#), the Contractor [certifies that they](#) meet Department requirements and represent the materials to be used during mix production.

4.1 DEPARTMENT VERIFICATION

4.2 At the option of the Department, [new](#) mix designs [will](#) be verified using Method A or Method B listed below. [Previously approved](#) mix designs adjusted per Section 5.2.A will be verified using Method A or Method B. Mix designs adjusted per Sections 5.2.B, 5.2.C, 5.2.D, or Section 5.3 will be verified using Method C.

Method A (Contractor Four Point Mix Design). Department verification for mix designs will include review of all mix design data (including all aggregate field gradations) submitted by the Contractor, mixing the component materials submitted by the Contractor, and verification testing of the asphalt mixture. The verification testing; [which includes volumetric \(VMA, VFA, \$G_{mb}\$, \$G_{mm}\$, air voids\), tensile strength, TSR, Hamburg Wheel, and I-FIT; shall meet the mix design criteria at the optimum asphalt content.](#) A mixture made from the individual materials will be tested for volumetric properties. The Contractor shall provide compacted gyratory [cylinders](#) as per Section 3.3.D herein.

Method B (Contractor Four Point Mix Design). Department verification for mix designs will be based on 1) a review of all mix design data (including all aggregate field gradations) submitted by the Contractor and 2) Department verification testing for [tensile strength, TSR, Hamburg Wheel, and I-FIT.](#) The Contractor shall provide compacted gyratory [cylinders](#) as per Section 3.3.D herein. The mixture at the optimum design asphalt binder content shall meet the mix design criteria for the following: VMA, VFA, G_{mb} , G_{mm} , [air voids, tensile strength, TSR values, Hamburg Wheel, and I-FIT.](#)

Method C (Contractor One Point Mix Design). Department verification for mix designs will include review of all mix design data (including all aggregate field gradations) submitted by the Contractor, mixing the component materials submitted by the Contractor, and verification testing of the asphalt mixture. The verification testing; [which includes volumetric \(VMA, VFA, \$G_{mb}\$, \$G_{mm}\$, air voids\), tensile strength, TSR, Hamburg Wheel, and I-FIT; shall meet the mix design criteria at the optimum asphalt content.](#) A mixture made from the individual materials will be tested for volumetric properties. The Contractor shall provide compacted gyratory [cylinders](#) as per Section 3.3.D herein.

**Hot-Mix Asphalt Mixture Design Verification Procedure
Appendix B.9**

(continued)

Effective Date: January 1, 2002

Revised Date: December 1, 2021

Verification Method	Department Tests/Calculations Performed on ^{1/} :									
	Mixture Prepared by the Department					Gyratory Cylinders Prepared by Contractor				
	VMA	VFA	G _{mb}	G _{mm}	Air Voids	Unconditioned Tensile strength	Conditioned Tensile strength	Tensile strength Ratio	Hamburg Wheel	I-FIT
A ^{2/}	X	X	X	X	X	X	X	X	X	X
B ^{2/}						X	X	X	X	X
C ^{3/}	X	X	X	X	X	X	X	X	X	X

1/ At the optimum asphalt binder content using materials provided by the Contractor.

2/ Contractor Four Point Mix Design.

3/ Contractor One Point Mix Design at Optimum Asphalt Content.

In all cases the Department will review test data, including aggregate field gradations, provided by the Contractor for compliance with the specifications. All mixtures shall meet specifications at the optimum asphalt content for approval.

- 4.3 The Contractor mix design data and Department verification testing shall meet the mix design criteria in the Standard Specifications, any Special Provision in the Contract, and the following tolerances (where applicable):

Hot-Mix Asphalt Mixture Design Verification Procedure
Appendix B.9
 (continued)

Effective Date: January 1, 2002

Revised Date: [December 1, 2021](#)

Volumetric Testing	Tolerance
G _{se} (effective SG of combined aggregates)	± 0.014
G _{mb}	± 0.020
G _{mm}	± 0.014
Air Voids	± 0.5 %

Gradation	Tolerance
12.5 mm (1/2 in)	± 3.0
4.75 mm (No. 4)	± 2.0
2.36 mm (No. 8)	± 2.0
600 µm (No. 30)	± 1.0
75 µm (No. 200)	± 0.5
Pb (Asphalt Binder Content)	± 0.15

All aggregate field gradations submitted by the Contractor will be compared to previous mix plant and/or Aggregate Gradation Control System gradations for validity.

4.4 If a mix fails any of the Department's volumetric or verification tests, the Contractor shall make necessary changes to the mix and provide passing tensile strength, TSR, Hamburg Wheel, and I-FIT test results, as required, from a private lab before resubmittal. The Department will verify the passing results.

4.5 The Department will notify the Contractor in writing within 30 calendar days of receiving the design data/materials as to the acceptability of the submitted Contractor mix design. If the [mixture volumetrics](#) or verification tests fail, the 30-calendar-day time for the Department to notify the Contractor starts over.

5.1 MIX DESIGN APPROVAL STATUS

5.2 All mix designs verified as specified herein are approved indefinitely provided that the current contract documents have been met, [no changes are made to mixture ingredients](#) and the aggregate bulk specific gravities [are updated annually using the current Department published values](#). The following actions will occur to maintain verified mix designs due to changes at Aggregate Producers.

Hot-Mix Asphalt Mixture Design Verification Procedure

Appendix B.9

(continued)

Effective Date: January 1, 2002

Revised Date: [December 1, 2021](#)

- A. If the combined aggregate bulk specific gravity of the mix changes by more than ± 0.020 from the original mix design, the mix design shall be resubmitted for verification as per Section 4.2.
 - B. If the aggregate producer changes ledges prior to the construction season, the Department will require Method C verification [of a previously approved mix design](#) as per Section 4.2.
 - C. If the aggregate producer changes ledges during the construction season, the Department will require the Contractor to submit compacted gyratory [cylinders](#) of plant-produced mix as per Section 3.3.D herein to verify [tensile strength](#), TSR values, Hamburg Wheel, and I-FIT criteria. The Department will require Method C verification as per Section 4.2 after the current construction season is completed.
 - D. If the aggregate producer changes production practices (including, but not limited to changing crushers, stockpiling practices, or production rate), the Contractor [shall](#) submit material for Method C verification as per Section 4.2.
 - E. The Contractor may at any time resubmit [a](#) mix design for verification as per Section 4.1.
- 5.3 If a mix design adjustment is needed to meet current contract requirements and is outside of the adjustment limits stated in [Article 1030.10](#), the Department will require Method C verification as per Section 4.2.

This Page Reserved

This Page Reserved
Appendix B.10 is discontinued.

This Page Reserved
Appendix B.10 is discontinued.

**Calibration of Equipment for Asphalt Binder Content Determination
(Nuclear Asphalt Binder Content Gauge and Ignition Oven)
Appendix B.11**

Effective Date: January 1, 2002
Revised Date: December 1, 2021

A. Scope

The Contractor may be required to use a nuclear asphalt binder content gauge (Illinois Modified AASHTO T 287) or ignition oven (Illinois Modified AASHTO T 308) to determine the asphalt binder content of a Hot-Mix Asphalt (HMA) mixture. To ensure consistency, both the Contractor and the Department shall calibrate their device(s) in the same manner using the same mixture.

B. Purpose

This procedure was developed to provide consistent calibration between the Contractor's and Department's asphalt binder content determination equipment. The procedure also applies to any third-party gauges.

C. Nuclear Asphalt Binder Content Gauge

1. Department Verification of Sample Mixture

- a. All HMA mixture designs shall be verified in accordance with the Department's "Hot-Mix Asphalt Mixture Design Verification Procedure" before submitting materials for the nuclear asphalt binder content gauge calibration.
- b. The Contractor shall provide a mix design prepared by a Hot-Mix Asphalt Level III Technician in accordance with the Department's current Hot-Mix Asphalt Level III Technician Course manual. All testing shall be performed by Hot-Mix Asphalt Level I Technicians.

2. Department Calibration Process

- a. The Department calibration shall consist of the following process:

The Contractor shall submit the following to the District laboratory at least 2 weeks prior to production:

- 3 empty nuclear asphalt binder content pans
- 22 lb (10 kg) of the HMA mixture at the design optimum asphalt binder content
- 22 lb (10 kg) of the HMA mixture at 1% below the optimum asphalt binder content

**Calibration of Equipment for Asphalt Binder Content Determination
(Nuclear Asphalt Binder Content Gauge and Ignition Oven)
Appendix B.11
(continued)**

Effective Date: January 1, 2002
Revised Date: December 1, 2021

- 22 lb (10 kg) of the HMA mixture at 1% above the optimum asphalt binder content
- The actual blended aggregate, including the pan, used to determine the dry aggregate standard count

The Department may split out approximately 16.5 lb (7500 g) and/or 4.4 lb (2000 g) samples out of the 22 lb (10 kg) of mixture. Each of the three 16.5 lb (7500 g) samples will be placed in one of the empty calibration pans. The 4.4 lb (2000 g) samples may be used by the Department to run extractions on the samples for verification with the actual blended aggregate sample. The extraction results shall be within the following tolerances:

Sieve	Tolerance
12.5 mm (1/2 in.)	± 3.0
4.75 mm (# 4)	± 2.0
2.36 mm (# 8)	± 1.5
600 µm (# 30)	± 1.0
75 µm (# 200)	± 0.5
Asphalt Content	± 0.15

If the extraction results lie outside the above tolerances, the Contractor shall be required to resubmit all new material as outlined in C.2.

The Department will then calibrate its nuclear asphalt binder content gauges using the pans and mixtures the Contractor submitted. Once Department calibration is completed, the calibration pans will be covered with plastic bags (to prevent the introduction of moisture) and immediately sent back to the Contractor. This will be done for all 4 pans.

3. Contractor Calibration Process

- a. The Contractor shall calibrate their nuclear asphalt binder content gauges with the same calibrations pans and mixtures used by the Department within 24 hours of receiving the samples from the Department. The Contractor shall calibrate their nuclear asphalt

**Calibration of Equipment for Asphalt Binder Content Determination
(Nuclear Asphalt Binder Content Gauge and Ignition Oven)**

Appendix B.11

(continued)

Effective Date: January 1, 2002

Revised Date: December 1, 2021

binder content gauge only after the Department has verified the calibration samples as outlined above in Section C.1 and C.2.

- b. The Contractor shall retain the calibration pans. These pans shall be covered with plastic bags and stored in a dry, secure place.
- c. Calibration shall be done after a mixture is designed, an approved Job Mix Formula (JMF) is established, and the mixture has been verified by the Department. Calibration before the mixture is designed is not allowed since this would not necessarily allow for the proper range of asphalt binder content, and the job mix gradation would not be known. The calibration temperature for both the dry aggregate count and the HMA mixture count shall be within ± 10 °F (± 6 °C) of each other and be within the range of 180 to 290 °F (± 82 to 143 °C).

D. Ignition Oven

1. Department Verification of Sample Mixture

- a. All HMA mixture designs shall be verified in accordance with the Department's "Hot-Mix Asphalt Mixture Design Verification Procedure" before submitting materials for the ignition oven calibration.
- b. The Contractor shall provide a mix design prepared by a Hot-Mix Asphalt Level III Technician in accordance with the Department's current Hot-Mix Asphalt Level III Technician Course Manual. All testing shall be performed by Hot-Mix Asphalt Level I Technicians.

2. Department Calibration Process

- a. The Department calibration shall consist of the following process:

The Contractor shall submit the following to the District laboratory at least two weeks prior to production:

- Four individually batched, combined aggregate samples meeting the JMF. Each sample shall meet the minimum mass requirements listed in Section 6.4 of Illinois Modified AASHTO T 308.
- 1 L (1 qt.) asphalt binder

Illinois Department of Transportation

**Calibration of Equipment for Asphalt Binder Content Determination
(Nuclear Asphalt Binder Content Gauge and Ignition Oven)**

Appendix B.11

(continued)

Effective Date: January 1, 2002

Revised Date: December 1, 2021

The Department will mix the asphalt binder and the four individually batched, combined aggregate samples to produce four mixed samples. Two mixed samples will be used to calibrate the District's ignition oven. If the difference between the measured asphalt binder content of the two samples exceeds 0.15%, the tests will be repeated using the two remaining mixed samples.

**Hot-Mix Asphalt Mix Design
Procedure for Dust Correction Factor Determination
Appendix B.12**

Effective: January 1, 1998
Revised: December 1, 2017

A dust correction factor (DCF) shall be determined and applied to each new mix design using the procedure listed below. This procedure will be used to supplement the Hot-Mix Asphalt Level III Technician Course manual to account for additional minus No. 200 (minus 75- μ m) material present as a result of batching with unwashed aggregates.

It is important to note the Adjusted Blend Percentages are temporary percentages used during laboratory batching only. The original Blend Percentages on the "Design Summary Sheet" remain unchanged.

Note: When adjusting percentages to equal 100, the largest percentage should be adjusted accordingly.

A) Virgin Mix Design

1. Batch a combined aggregate sample matching the job mix formula (JMF). Test sample size shall be determined using Illinois Specification 201 and based on the nominal maximum size of the largest coarse aggregate.
2. Perform a washed test on the combined aggregate sample using Illinois Modified AASHTO T 11.
3. The DCF shall be the difference between the percent passing the No. 200 (75- μ m) sieve of the washed test and the JMF.
4. Determine the mineral filler reduction (MFR) by dividing the DCF by the percent (in decimal form) mineral filler gradation passing the No. 200 (75- μ m) sieve.
5. Subtract the MFR from the blend percentage of mineral filler.
6. Adjust the remaining blend percentages to sum to 100 by dividing each by the quantity (1 - MFR).

**Hot-Mix Asphalt Mix Design
Procedure for Dust Correction Factor Determination
Appendix B.12**

Effective: January 1, 1998
Revised: December 1, 2017

Example

Bituminous Mixture Design
Design Number: → 50BITEXPL
Lab preparing the design?(PP,PL,IL ect.) IDOT

Producer Name & Number → 1111-01 Example Company Inc Somewhere 1, IL
Material Code Number → 17552 BITCONC BCS 1 B TONS

Agg No. Size	#1	#2	#3	#4	#5	#6	ASPHALT
	032CMM11	032CMM16	038FAM20	037FAM01	004MFM01		10124M
Source (PROD#)	51972-02	51972-02	51230-06	51790-04	51052-04		
(NAME)	MAT SER	MAT SER	MIDWEST	CONICK	LIVINGSTON		2260-01
(LOC)							EMLSCOAT
Aggregate Blend	38.0	35.0	14.5	10.0	2.5	0.0	100.0

Agg No. Sieve Size	#1	#2	#3	#4	#5	#6	Blend
1	100.0	100.0	100.0	100.0	100.0	100.0	100.0
3/4	88.0	100.0	100.0	100.0	100.0	100.0	95.4
1/2	45.0	100.0	100.0	100.0	100.0	100.0	79.1
3/8	19.0	97.0	100.0	100.0	100.0	100.0	68.2
#4	6.0	29.0	97.0	97.0	100.0	100.0	38.7
#8	2.0	7.0	80.0	85.0	100.0	100.0	25.8
#16	2.0	4.0	50.0	65.0	100.0	100.0	18.4
#30	1.8	3.0	35.0	43.0	100.0	100.0	13.6
#50	1.7	3.0	19.0	16.0	100.0	100.0	8.6
#100	1.5	3.0	10.0	5.0	90.0	100.0	5.8
#200	1.3	1.3	4.0	2.5	88.0	100.0	4.0

- Step 1. Batch a combined aggregate sample meeting the JMF.** Illinois Specification 201 requires a 5000-gram sample when CM11 is present.
- Step 2. Run a washed test using AASHTO T 11.**
- Step 3. Determine the Dust Correction Factor (DCF).** The DCF is the difference in the percent passing the No. 200 (75-µm) sieve between the washed test and the JMF:

	<u>JMF</u>	<u>Washed Test</u>	<u>DCF</u>
No. 200 (75 µm)	4.0%	5.6%	1.6%

**Hot-Mix Asphalt Mix Design
Procedure for Dust Correction Factor Determination
Appendix B.12**

Effective: January 1, 1998
Revised: December 1, 2017

Step 4. Determine the Mineral Filler Reduction (MFR) by dividing the DCF (%) by the percent (in decimal form) mineral filler gradation passing the No. 200 (75-µm) sieve:

$$\text{MFR (\%)} = 1.6 / 0.88 = 1.8\%$$

Step 5. Determine the adjusted mineral filler blend percentage by subtracting the MFR (%) from the blend percentage of mineral filler:

$$2.5\% - 1.8\% = 0.7\%$$

Step 6. Adjust the remaining blend percentages to sum to 100 by dividing each by the quantity [1 - MFR (in decimal form)]:

	<u>Blend Percentage</u>	<u>Adjusted Blend Percentage¹</u>
032CMM11	38.0	38.7
032CMM16	35.0	35.6
038FAM20	14.5	14.8
037FAM01	10.0	10.2
004MFM01	<u>2.5</u>	<u>0.7</u>
	100.0	100.0

Note 1: It is important to note the Adjusted Blend Percentages are temporary percentages used during laboratory batching only. The original Blend Percentages on the “Design Summary Sheet” remain unchanged.

**Hot-Mix Asphalt Mix Design
Procedure for Dust Correction Factor Determination
Appendix B.12**

Effective: January 1, 1998
Revised: December 1, 2017

B) RAP Mix Design (Also Applicable to RAP/RAS Mix Designs)

1. Determine the Virgin Aggregate Fraction (VAF). The virgin aggregate fraction is the percentage of virgin aggregate
2. Adjust to the virgin blend percentages by dividing each virgin aggregate by the VAF.
3. Determine the RAP Adjusted JMF (RJMF)
4. Batch the virgin aggregates according to the adjusted blend percentages matching the RJMF. Test sample size shall be determined using Illinois Specification 201 and based on the nominal maximum size of the largest coarse aggregate.
5. Perform a washed test on the combined aggregate sample using Illinois Modified AASHTO T 11.
6. The DCF shall be the difference between the percent passing the No. 200 (75- μ m) sieve of the washed test and the RJMF.
7. Determine the mineral filler reduction (MFR_{RAP}) by dividing the DCF by the percent (in decimal form) mineral filler gradation passing the No. 200 (75- μ m) sieve.
8. Subtract the MFR_{RAP} from the blend percentage of mineral filler.
9. Adjust the remaining virgin aggregate blend percentages to sum to 100 by dividing each by the quantity $(1 - MFR_{RAP})$.
10. Determine the batching blend percentages with RAP by multiplying the adjusted virgin aggregate blend percentages by the VAF.

Illinois Department of Transportation

**Hot-Mix Asphalt Mix Design
Procedure for Dust Correction Factor Determination
Appendix B.12**

Effective: January 1, 1998
Revised: December 1, 2017

RAP Example

Design Number:----> 50BITWRAP

Lab preparing the design?(PP,PL,IL ect.) IDOT

Producer Name & Number> 1111-01 Example Company Inc Somewhere 1, IL

Material Code Number--> 19512R BITCONC BC N50 19.0R

Agg No.	Required!		FA20/21			RAP in #6		ASPHALT
	#1	#2	#3	#4	#5	#6		
Size (e.g. 032CAM16)	042CMM11	042CMM16	FINE AGG	037FMM01	004MF01	017CMM16	PG64-22	
Source (PROD#)	50572-01	50572-01		50530-02	51052-04	111-01	5627-02	
(NAME)	Prairie Materials	Prairie Materials		Prairie Materials	Livingston	Example Co	BPAMOCO	
(LOC)	Ashkum	Ashkum		Paxton	Pontiac	Somewhere	Whitting, Ind	
Aggregate Blend	38.3	23.0		13.0	2.0	23.7	100.0	
					RAP in Mix: 25			

Agg No.	#1	#2	#3	#4	#5	#6	Blend
Sieve Size							
1	100.0	100.0	100.0	100.0	100.0	100.0	100.0
3/4	79.0	100.0	100.0	100.0	100.0	100.0	92.0
1/2	34.0	100.0	100.0	100.0	100.0	100.0	74.7
3/8	9.0	99.0	100.0	100.0	100.0	97.8	64.4
#4	1.1	29.0	100.0	98.0	100.0	73.4	39.2
#8	1.1	3.0	100.0	89.0	100.0	49.0	26.3
#16	1.1	2.7	100.0	79.0	100.0	37.0	22.1
#30	1.1	2.5	100.0	63.0	100.0	28.0	17.8
#50	1.1	2.3	100.0	23.0	100.0	18.6	10.3
#100	1.1	1.8	100.0	2.0	90.0	12.6	5.9
#200	1.0	1.7	100.0	1.0	85.0	10.2	5.0

Step 1. Determine the virgin aggregate fraction (VAF).

$$VAF = \frac{(100 - RAP_{Agg} \%)}{100} \quad VAF = \frac{(100 - 23.7)}{100}$$

$$VAF = 0.763$$

Illinois Department of Transportation

**Hot-Mix Asphalt Mix Design
Procedure for Dust Correction Factor Determination
Appendix B.12**

Effective: January 1, 1998
Revised: December 1, 2017

Step 2. Adjust to the virgin aggregate percentages by dividing each virgin aggregate by the VAF.

	Initial		virgin agg %	
042CMM11	38.3	(÷0.763)	50.3	(added 0.1 sum = 100.0)
042CMM16	23.0	(÷0.763)	30.1	
037FMM01	13.0	(÷0.763)	17.0	
004MF01	2.0	(÷0.763)	2.6	
Sum	100.0		100.0	

Step 3. Determine the RAP adjusted JMF (RJMF). Combine gradation using the adjusted virgin aggregate blend percentages.

1	100.0
¾	89.4
½	66.8
3/8	53.9
#4	28.5
#8	19.2
#16	17.4
#30	14.6
#50	7.8
#100	3.8
#200	3.4

Step 4. Batch the virgin aggregates according to the adjusted blend percentages matching the RJMF. Illinois specification 201 requires a 5000-gram sample when CM11 is present.

Step 5. Run a washed test using AASHTO T11.

Step 6. Determine the dust correction factor (DCF). The DCF is the difference between the percent passing the No. 200 (75-µm) sieve of the washed test and the RJMF.

	Washed	RJMF	DCF
No. 200 (75-µm)	4.3	3.4	4.3-3.4= 0.9
	DCF = 0.9		

Illinois Department of Transportation

**Hot-Mix Asphalt Mix Design
Procedure for Dust Correction Factor Determination
Appendix B.12**

Effective: January 1, 1998
Revised: December 1, 2017

- Step 7. Determine the mineral filler reduction $(MFR)_{RAP}$. The $(MFR)_{RAP}$ is determined by dividing the DCF by the percent (in decimal form) mineral filler gradation passing the No. 200 (75- μ m) sieve.

$$MFR_{RAP} = \frac{0.9}{0.85} = 1.1\%$$

- Step 8. Determine the mineral filler blend percentage by subtracting the MFR_{RAP} from the blend percentage of mineral filler.

$$2.6 - 1.1 = 1.5\%$$

- Step 9. Adjust the remaining blend percentages to sum to 100% by dividing each by the quantity $[1 - MFR_{RAP}$ (in decimal form)]:

$$1 - MFR_{RAP} = 1 - 0.011 = 0.989$$

	Virgin %		Adj. Virgin Blend%
042CMM11	50.3	($\div 0.989$)	50.9
042CMM16	30.1	($\div 0.989$)	30.4
037FMM01	17.0	($\div 0.989$)	17.2
004MF01	2.6	(from step 8)	1.5
Sum	100.0		100.0

- Step 10. Determine the batching blend percentages with RAP by multiplying the adjusted virgin blend % by the VAF.

$$VAF = 0.763$$

	Adjusted Virgin %		Batching Blend%	
042CMM11	50.9	($\div 0.763$)	38.9	(added 0.1 sum = 100.0)
042CMM16	30.4	($\div 0.763$)	23.2	
037FMM01	17.2	($\div 0.763$)	13.1	
004MF01	1.5	($\div 0.763$)	1.1	
		RAP Agg	<u>23.7</u>	
		Sum	100.0	

This Page Reserved

**Calibration of the Ignition Oven for the Purpose of Characterizing
Reclaimed Asphalt Pavements (RAP)
Appendix B.13**

Effective Date: January 1, 2002
Revised Date: [December 1, 2021](#)

1.0 GENERAL

- 1.1 This method covers the calibration of the ignition oven for characterization of reclaimed asphalt pavement (RAP). Correction factors for both gradation and asphalt content are determined by conducting parallel ignition and extraction testing.

2.0 SIGNIFICANCE AND USE

- 2.1 The ignition oven may be used in place of solvent extractions at the frequency stated in Section 1031 of the Standard Specifications.
- 2.2 This method may be used only with the approval of the Engineer.
- 2.3 Each RAP stockpile shall require a separate ignition oven calibration.
- 2.4 All RAP stockpiles and sampling frequencies shall meet the requirements stated in Section 1031 of the Standard Specifications.

3.0 REFERENCED DOCUMENTS

- 3.1 AASHTO Standards (as modified by Illinois):
[R 76 Reducing Samples of Aggregate to Testing Size](#)
[R 90 Sampling Aggregates Products](#)
T 164 Quantitative Extraction of Asphalt Binder from Hot Mix Asphalt (HMA)
T 308 Determining the Asphalt Binder Content of [Asphalt Mixtures](#) by the Ignition Method

4.0 PROCEDURE

- 4.1 Sample the RAP according to AASHTO [R 90](#). Obtain an adequate amount of material to perform a minimum of two solvent extractions and four ignition oven burns. The minimum sample sizes shall be governed by the nominal maximum aggregate size of the mixture defined in Illinois Modified AASHTO T 164 and T 308. Reduce the samples to testing size according to Illinois Modified AASHTO [R 76](#).

**Calibration of the Ignition Oven for the Purpose of Characterizing
Reclaimed Asphalt Pavements (RAP)**

Appendix B.13

(continued)

Effective January 1, 2002

Revised Date: [December 1, 2021](#)

- 4.2 Perform a minimum of two solvent extractions and a minimum of four ignition oven burns according to [Illinois Modified AASHTO T 164](#) and [Illinois-Modified AASHTO T 308](#), respectively.

4.3 AB Binder Calibration

- 4.3.1 Calculate the average Asphalt Binder (AB) percentage of the two extractions, P_{ext} . Calculate the average AB percentage of the four ignition oven burns, P_{ign} . Assuming the average AB content from the extraction to be correct, subtract the average extraction AB percentage from the average ignition oven AB percentage to determine the asphalt correction factor, C_f .

$$C_f = P_{ign} - P_{ext}$$

Use the asphalt correction factor to adjust the ignition oven asphalt content on all subsequent testing of that stockpile.

4.4 Gradation Calibration

- 4.4.1 From the two extractions, calculate the average percent passing the applicable sieve, G_{ext} . Calculate the average percent passing each applicable sieve from the four ignition oven burns, G_{ign} . Subtract the extraction average percent passing each sieve from the ignition oven average of the corresponding sieve to determine a correction factor, GC_f , for gradation for each sieve.

$$GC_f = G_{ign} - G_{ext}$$

5.0 REPORT

- 5.1 Report the correction factors to the nearest 0.1%

6.0 PRECISION AND BIAS

- 6.1 The estimates of precision and bias shall be considered those that apply to the referenced documents.

**Calibration of the Ignition Oven for the Purpose of Characterizing
Reclaimed Asphalt Pavements (RAP)**

Appendix B.13

(continued)

Effective January 1, 2002

Revised Date: [December 1, 2021](#)

7.0 USE

- 7.1 Use the correction factor for percent passing the No. 200 (75- μ m) sieve to adjust the minus No. 200 (75- μ m) material from the ignition oven on all subsequent testing of that stockpile.
- 7.2 Use the asphalt correction factor to adjust the ignition oven asphalt content on all subsequent testing of that stockpile.
- 7.3 The ignition oven washed gradations may be used uncorrected for all sieves except for the No. 200 (75- μ m) sieve.

This Page Reserved

Hot-Mix Asphalt Composite Sample Blending and Splitting Diagrams

Appendix B.14

Effective Date: January 1, 2002

Revised Date: December 1, 2021

1. Plate Sample Blending

Minimum Total Weight Requirements

- 100 lb. (QC/QA Verification)
- 200 lb. (QCP/PFP)

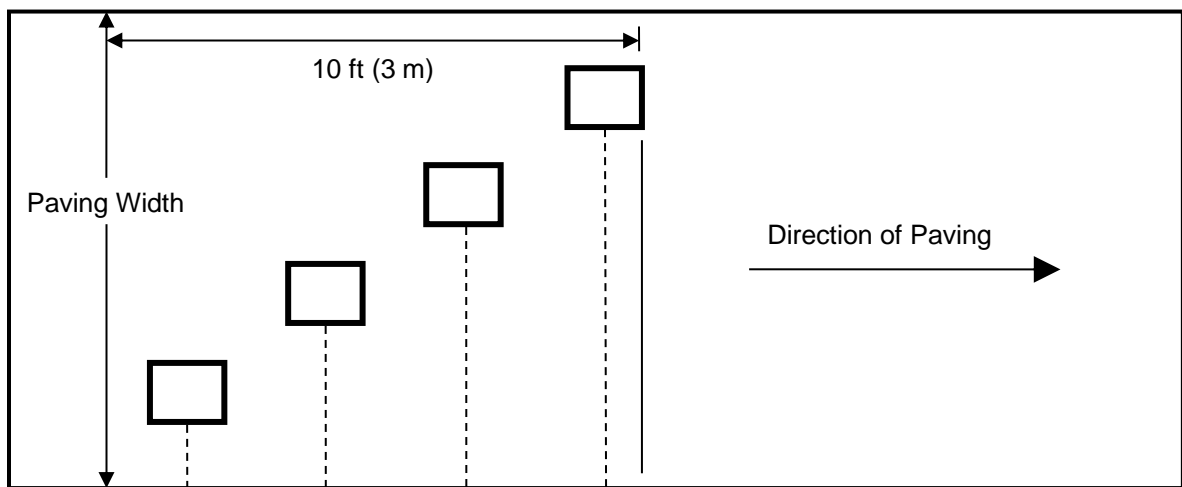

Blend the Plate Samples Together

**Proceed to Composite
Sample Splitting
Diagrams**

Hot-Mix Asphalt Composite Sample Blending and Splitting Diagrams

Appendix B.14

Effective Date: January 1, 2002

Revised Date: December 1, 2021

2. QC/QA Verification Composite Sample Splitting

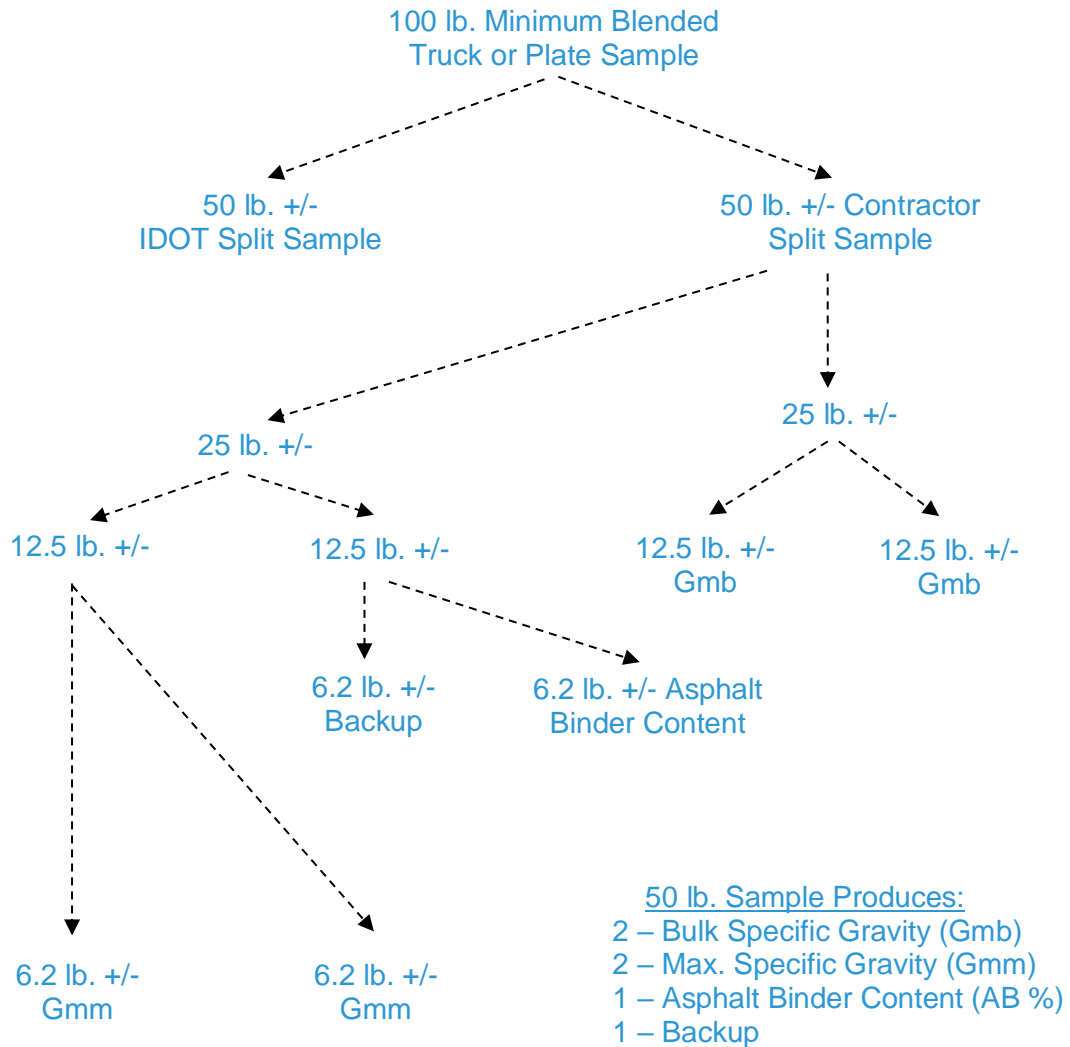

Hot-Mix Asphalt Composite Sample Blending and Splitting Diagrams

Appendix B.14

Effective Date: January 1, 2002

Revised Date: December 1, 2021

3. QCP/PFP Composite Sample Splitting

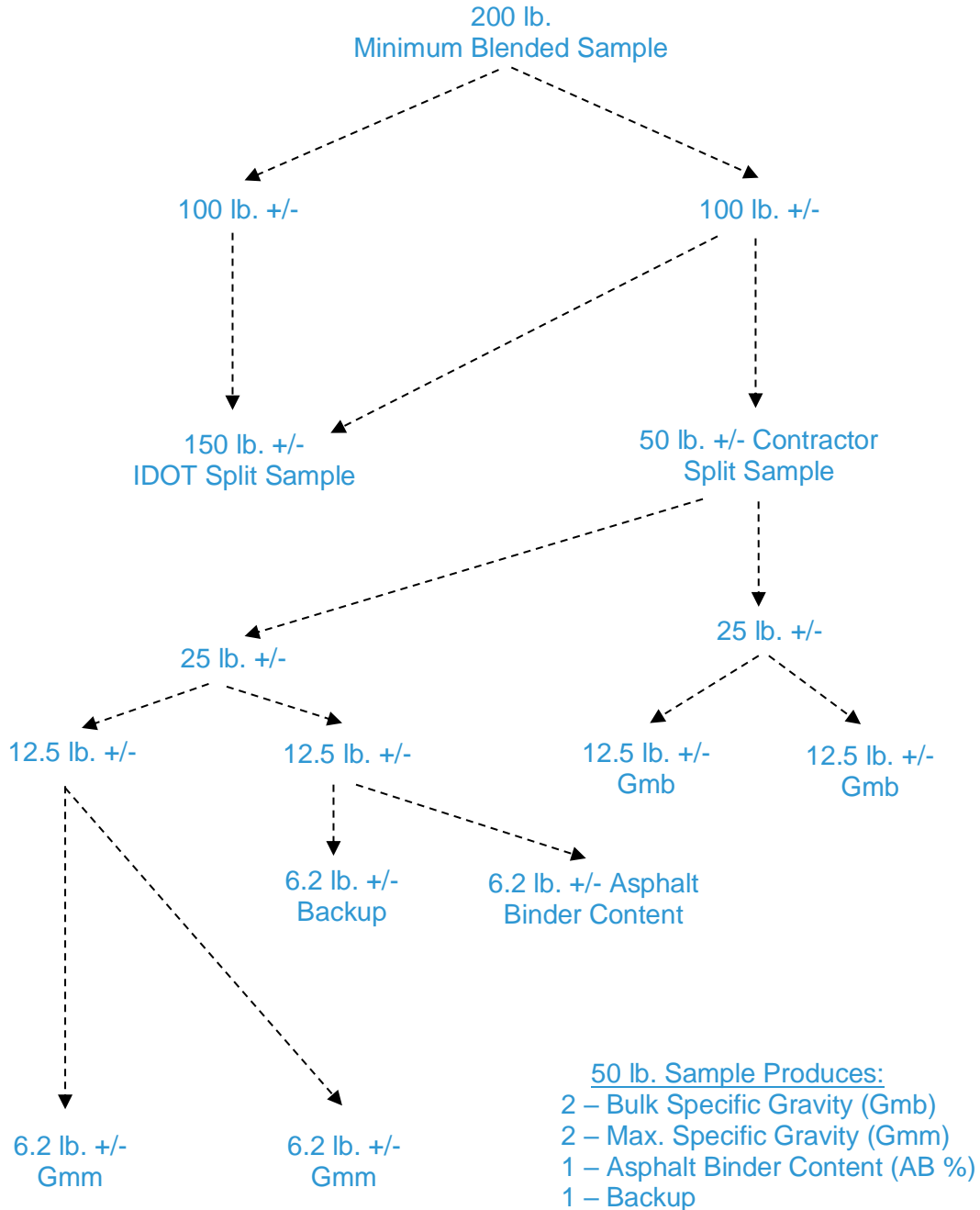

This Page Reserved

**Hot Mix Asphalt (HMA) Production Gradation Windage
Procedure for Minus #200 (minus 75µm) Material
Appendix B.15**

Effective: May 1, 2004

Revised: May 1, 2007

A. Scope

The Contractor will be required to provide production gradation test results for both washed ignition oven gradations (WIOG) and dry combined belt / hot bin gradations on the same control chart according to Section 1030 of the Standard Specifications. In order for this data to be meaningful, the dry combined belt / hot bin gradations shall be calibrated to the WIOG using the windage factor established below.

B. Purpose

A windage factor (WF) shall be determined and applied to dry gradation production test results in order to establish a WIOG equivalency. The WF accounts for the difference, in minus #200 (minus 75µm) material, between dry combined belt/hot bin gradations and WIOG due to the following:

- variability in the addition of Mineral Filler
- washed vs. dry gradation (cling-on dust)
- generation of dust through plant aggregate degradation

C. Procedure

The WF shall be determined during Start-up. During mix production, adjustments to the WF may be warranted. Therefore, a new WF may be established, according to the following procedure, anytime during the course of mix production.

1. Obtain two combined belt/hot bin aggregate samples and perform two dry gradation (DG) tests. The DG shall include the theoretical amount of mineral filler to be added. Average the two test results for the minus #200 (minus 75µm) material.

$$\text{Average DG-}\#200 = (\text{DG}\#1 + \text{DG}\#2) / 2$$

2. Obtain two samples of HMA representing, near as possible, material from step one. Perform WIOG testing on the HMA samples and average the two results for minus the #200 (minus 75µm) material.

$$\text{Average WIOG-}\#200 = (\text{WIOG}\#1 + \text{WIOG}\#2) / 2$$

3. Determine WF by subtracting Average DG-#200 in step 1 from Average WIOG-#200 in step 2.

$$\text{WF} = \text{Average WIOG-}\#200 - \text{Average DG-}\#200$$

**Hot Mix Asphalt (HMA) Production Gradation Windage
Procedure for Minus #200 (minus 75 μ m) Material
Appendix B.15**

(continued)

Effective: May 1, 2004

Revised: May 1, 2007

4. Add WF to all combined belt/hot bin gradation test results prior to plotting on the Minus #200 (minus 75 μ m) Control Chart. All, (including WIOG test results used to establish WF, are plotted directly on the Minus #200 (minus 75 μ m) Control Chart. When both the DG and WIOG test results represent the same material, the WIOG are the results to be included in the moving average.

Example:

Given:

- WIOG_{#1} (minus #200) = 4.8% (Truck sample taken between growth curves)
- WIOG_{#2} (minus #200) = 4.6% (Truck sample taken from outside Test Strip area during startup)
- DG_{#1} (minus #200) = 2.7% (Combined belt sample taken to correspond to material sampled for WIOG_{#1})
- DG_{#2} (minus #200) = 2.1% (Combined belt sample taken to correspond to material sampled for WIOG_{#2})

Step 1. Average the two DG test results for the minus #200 (minus 75 μ m) material.

$$\text{Average DG}_{\text{-#200}} = (2.7\% + 2.1\%) / 2 = 2.4\%$$

Step 2. Average the two WIOG test results for the minus #200 (minus 75 μ m) material.

$$\text{Average WIOG}_{\text{-#200}} = (4.8\% + 4.6\%) / 2 = 4.7\%$$

Step 3. Determine WF by subtracting Average DG_{-#200} in step 1 from Average WIOG_{-#200} in step 2.

$$\text{WF} = 4.7\% - 2.4\% = 2.3\%$$

Step 4. Add WF = 2.3% to all combined belt/hot bin gradation test results prior to plotting on the Minus #200 (minus 75 μ m) Control Chart.

**Stripping of Hot-Mix Asphalt Mixtures
Visual Identification and Classification
Appendix B.16**

Effective: November 20, 2003

Revised: January 1, 2014

The following instructions describe the method to be used for visually identifying and classifying the effect of moisture damage on the adhesion of asphalt binder to the aggregate in Hot-Mix Asphalt (HMA) mixtures. This procedure provides the means to rate this phenomenon in numerical terms. This procedure is applicable to both laboratory compacted specimens and pavement cores¹.

INSTRUCTIONS

1. This procedure shall only be applied to freshly split specimen faces, such as those obtained from split tensile testing. The observation of cored, sawed, or chiseled faces shall be avoided, as the true condition of the stripping will be obscured.
2. The rating shall be completed within 10 minutes of splitting for maximum clarity. When the specimens dry out, they may look considerably different. The aggregate surfaces shall be examined carefully to determine if the asphalt binder was stripped from the aggregate as a result of being “washed” by water before the specimen was split or if the asphalt binder was “ripped apart” near the asphalt/aggregate interface during the split tensile test. Also, aggregate surfaces with small, relatively isolated, globules of asphalt binder are quite likely not stripped.
3. Special attention shall be given to fractured and broken aggregates. Fractured aggregates are those that were cracked during compaction. These fractured aggregates will have a distinct face with a dull or discolored surface. Broken aggregates are those that were broken during the split tensile test. Broken aggregates often occur near the outside surface of the specimen where the compressive forces are greatest. These broken aggregates will also have a distinct broken face, but will have a bright, uncoated surface. The broken aggregates may be a continuation of a crack that was started during compaction. There is no evidence that a broken aggregate was broken entirely under the compressive force of the split tensile test.
4. Coarse aggregate particles shall be defined as those particles retained on the #8 sieve. Fine aggregate particles shall be defined as those particles that will pass through a #8 sieve.
5. When examining the split face, use the entire face area of all the fine particles separately from all the coarse particles on the split face to determine the percentage of the total area that is stripped. Do not use the percent of the area of each individual stone that is stripped to collectively determine the percentage of stripped aggregate particles on the entire split face of the specimen. Also, do not estimate the percentage of aggregate particles that are

¹ Pavement cores taken from the field shall be sealed in plastic bags immediately after coring in order to retain their in-situ moisture. Pavement cores shall be split and visually rated as soon as possible after coring to avoid any “healing” of the asphalt to the aggregate surfaces.

**Stripping of Hot-Mix Asphalt Mixtures
Visual Identification and Classification**

**Appendix B.16
(continued)**

Effective: November 20, 2003

Revised: January 1, 2014

stripped based on the total number of aggregate particles. (i.e., a small stripped aggregate particle does not affect the entire specimen the same as a large stripped aggregate particle.)

PROCEDURE

1. Obtain a freshly split face through the split tensile test.
2. Observe the coarse aggregate of the split face with the naked eye. Pay special attention to the coarse aggregate that is broken or fractured. These particles are not stripped.
3. Assign a strip rating to the coarse aggregate of the split face based on the following descriptions:
 - 1 - Less than 10% of the entire area of all the coarse aggregate particles is stripped (no stripping to slight stripping).
 - 2 - Between 10% and 40% of the entire area of all the coarse aggregate particles is stripped (moderate stripping).
 - 3 - More than 40% of the entire area of all the coarse aggregate particles is stripped (severe stripping).
4. Observe the fine aggregate particles and rate the particles for percent of the area showing moisture damage. A microscope or magnifying glass with a total magnification of 10X shall be used to aid in viewing the specimens. Observe the fine aggregate particles and mentally rate the particles present in the field of view. Move the specimen to a new field of view and rate the particles present. Repeat this process once more, ensuring a new field of view is chosen. Average the three observations.
5. Assign a strip rating to the fine aggregate of the split face based on the following descriptions:
 - 1 - Less than 10% of the entire area of all the fine aggregate particles viewed is stripped (no stripping to slight stripping).
 - 2 - Between 10% and 25% of the entire area of all the fine aggregate particles viewed is stripped (moderate stripping).
 - 3 - More than 25% of the entire area of all the fine aggregate particles viewed is stripped (severe stripping).
6. Report the individual strip ratings for both the coarse and fine aggregate on the strip rating form. Include any comments or special notes about the observations from that specimen.

**Stripping of Hot-Mix Asphalt Mixtures
Visual Identification and Classification**

**Appendix B.16
(continued)**

Effective: November 20, 2003

Revised: January 1, 2014

7. Average all the individual strip ratings for the conditioned specimens (typically 3) for a given test sample. Calculate a separate average for both coarse and fine aggregates. The average coarse and fine strip ratings for the unconditioned specimens (typically 3) may also be calculated for a given test sample. These average ratings give a quick overall appraisal of the moisture susceptibility of the sample. Note that the averaged ratings may not be simple whole numbers.

**Procedure for Introducing Additives to
Hot Mix Asphalt Mixtures and Testing in the Lab
Appendix B.17**

Effective Date: March 7, 2005

Revised: December 1, 2020

1.0 GENERAL

Moisture damage or stripping is considered to be one of the main reasons for an asphalt pavement (especially full depth asphalt pavement) not lasting indefinitely. Stripping is the weakening and loss of the adhesive bond between aggregates and asphalt binder, in the presence of moisture. Various additives can be used to help reduce the stripping potential of an aggregate. In Illinois, liquid anti-strip additives are used almost exclusively. However, other states use or require adding hydrated lime in HMA. Hydrated Lime is considered, by many, as a superior additive for moisture damage control and prevention. It typically is added to the aggregate and asphalt mixture by one of three methods, the dry, the wet, or the slurry method.

Different levels of conditioning can be used in lab-prepared specimens to simulate the effect of the actual moisture conditions in the field. Four levels are described in this document. The level of conditioning actually used will be as specified in contract documents or as determined in the workplan for research.

2.0 PURPOSE

- A. This procedure applies to using additives in hot mix asphalt (HMA) mixtures and testing those mixtures in the lab. This procedure includes the dry method of hydrated lime addition as well as the wet method and the slurry method. Also, this procedure includes specimens containing no additive, liquid anti-strip, polymer-modified asphalt, and polymer-modified asphalt with hydrated lime or liquid anti-strip.
- B. Four levels of conditioning are included in this procedure and are used when specified. These four levels are no conditioning (or control), submerging in a hot water bath, one cycle of freezing followed by submerging in the hot water bath, and five freeze and hot water bath cycles. The conditioned samples are all partially saturated with water before the freeze and hot water bath cycles begin.
- C. Illinois-modified AASHTO T-283 and T-324 are the standard specifications in Illinois that are required and used to test all HMA mixtures for moisture susceptibility. Only specimens with no conditioning and specimens conditioned in the hot water bath shall be tested according to Illinois-modified AASHTO T-283.

In addition to the conditioning and testing specified in Illinois-modified AASHTO T-283 and T-324, this procedure also contains guidelines for conditioning and testing specimens using freeze/thaw conditioning cycles. Freeze/thaw cycles shall be used if specified and also may be used for research projects. Utilizing five freeze/thaw cycles is harsher than the other conditioning methods in this

**Procedure for Introducing Additives to
Hot Mix Asphalt Mixtures and Testing in the Lab
Appendix B.17**

Effective Date: March 7, 2005

Revised: December 1, 2020

procedure and is considered to more effectively predict the long-term susceptibility to moisture damage of specific materials and mixtures.

- D. Tensile strengths are determined and the tensile strength ratio (TSR) is calculated. The tensile strength of the unconditioned specimens is compared with the tensile strength of the specimens from each of the applicable levels of conditioning to determine the TSR. The TSR is a measure of the relative effect that each additive type and conditioning method has on the moisture susceptibility of the samples. The results are used to compare the various additives and their effect on the stripping potential of each mix and to determine the best additive to be used for a specific mixture containing a specific blend of materials.

3.0 MATERIALS

- A. The hydrated lime shall conform to Section 1012.01 of the Standard Specifications for Road and Bridge Construction. Illinois Test Procedure 27 shall be used to determine the maximum percent of the hydrated lime retained on specified sieves.

The HMA Mix Design shall be performed using the hydrated lime addition method and / or the liquid anti-strip type that will be used during actual production in the field.

- B. The liquid anti-strip and / or hydrated lime method used must result in:
- 1) A conditioned tensile strength that is equal to, or greater than, the original conditioned tensile strength for the same mixture without the additive,
 - 2) A TSR value that is equal to, or greater than, 0.85 for 6-inch (150 mm) diameter specimens, and
 - 3) Hamburg Wheel test results for rut depth and number of wheel passes according to Illinois modified AASHTO T-324.

4.0 SAMPLE PREPARATION

- A. Dry Aggregates:

Dry the aggregate samples in a 230 ± 9 °F (110 ± 5 °C) oven so that the batch weights and additive amounts can be accurately determined.

- B. Split Aggregates:

The aggregate samples will then be split according to Illinois Test Procedure 248.

**Procedure for Introducing Additives to
Hot Mix Asphalt Mixtures and Testing in the Lab
Appendix B.17**

Effective Date: March 7, 2005

Revised: December 1, 2020

C. Blend Aggregates:

The aggregates will be blended into the correct batch size. Because of the large size of the gyratory specimens, each batch will contain enough material for two gyratory specimens (approximately 8000 - 8500 grams for tensile strength and TSR and approximately 5000 – 5500 grams for the Hamburg Wheel test). Several batches will need to be prepared to produce the required number of gyratory specimens (six for strength and TSR and four for Hamburg Wheel testing as well as pilot specimens). Also, include sufficient material in one of the batches for a maximum specific gravity (G_{mm}) test run according to Illinois-modified AASHTO T-209 (approximately 2000 grams).

D. Mix Samples:

1. With No Additive:

- a. Heat the asphalt binder and the dry aggregate blend to a mixing temperature of 295 ± 5 °F (146 ± 2.8 °C) for neat asphalt.
- b. Remove the blend from the oven and make a small crater in the top of the hot, dry aggregates.
- c. Add the correct amount of asphalt binder to the batch.
- d. Mix the aggregates and asphalt binder.

2. Hydrated Lime – Dry Method:

- a. List the hydrated lime in its own column on the Aggregate Blending Sheet and enter the percent passing each sieve in the corresponding line on the form.
- b. 1.0% hydrated lime is added to the mix. The 1.0% hydrated lime is based on the total dry weight of aggregate in the mix and is added in addition to the mineral filler specified in the mix design.

NOTE: Theoretically when hydrated lime is added by the dry method, it is assumed that half of the hydrated lime (0.5%) adheres to the aggregate and that the other half (0.5%) of the hydrated lime acts like mineral filler and becomes part of the asphalt binder in the HMA mix. However, for design purposes (and to adapt to existing design software), the hydrated lime is all considered as a separate aggregate, similar to mineral filler, and the gradation of all of the hydrated lime contributes to the overall blend gradation.

**Procedure for Introducing Additives to
Hot Mix Asphalt Mixtures and Testing in the Lab
Appendix B.17**

Effective Date: March 7, 2005

Revised: December 1, 2020

- c. When hydrated lime is used in a mix design, it is important to include sufficient added mineral filler in the design. During plant production some of this mineral filler may need to be removed to compensate for the fines that are generated during production.
- d. Calculate the dust correction factor (DCF) according to the "Hot-Mix Asphalt Mix Design Procedure for Dust Correction Factor Determination", on each mix design with hydrated lime added. Include the hydrated lime in both the job mix formula (JMF) gradation and the washed gradation on the aggregate combined blend. The DCF procedure is performed to account for additional minus 75- μm (minus No. 200) material present as a result of batching with unwashed aggregates. Refer to the attached sheet which shows an example calculation of the DCF.

Illinois Department of Transportation

**Procedure for Introducing Additives to
Hot Mix Asphalt Mixtures and Testing in the Lab
Appendix B.17**

Effective Date: March 7, 2005

Revised: December 1, 2020

DCF Example							
Bituminous Mixture Design							
Design Number						50BITEKPL	
Lab preparing the design?(PP, P, L, IL, etc.)						IDOT	
Producer, Name & Number		1111-01 Example Company Inc Somewhere 1, IL					
Material Code Number		17552 BITCONC BCS 1 B TONS					
Agg No.	#1	#2	#3	#4	#5	#6	ASPHALT
Size	032CMM11	032CMM16	038FAM20	037FAM01	004MFM01	003FA00	10124M
Source (PROD#)	51972-02	51972-02	51230-06	51790-04	51052-04	50315-07	2260-01
(NAME)	MAT SER	MAT SER	MIDWEST	CONICK	LIVINGSTON	MARBLEHD	EMLS COAT
(LOC)							
Aggregate Blend	37.5	35.0	14.0	10.0	2.5	1.0	100.0
Agg No	#1	#2	#3	#4	#5	#6	Blend
Sieve Size							
1	100.0	100.0	100.0	100.0	100.0	100.0	100.0
3/4	88.0	100.0	100.0	100.0	100.0	100.0	95.5
1/2	45.0	100.0	100.0	100.0	100.0	100.0	79.4
3/8	19.0	97.0	100.0	100.0	100.0	100.0	68.6
#4	6.0	29.0	97.0	97.0	100.0	100.0	39.2
#8	2.0	7.0	80.0	85.0	100.0	100.0	26.4
#16	2.0	4.0	50.0	65.0	100.0	100.0	19.2
#30	1.8	3.0	35.0	43.0	100.0	100.0	14.4
#50	1.7	3.0	19.0	16.0	100.0	99.0	9.4
#100	1.5	3.0	10.0	5.0	90.0	99.0	6.8
#200	1.3	1.3	4.0	2.5	88.0	96.3	4.9
Step 1.	Batch a combined aggregate sample meeting the JMF. Illinois Specification 201 requires a 5000-gram sample when CM-11 is present. Include the hydrated Lime in the Blend.						
Step 2.	Run a washed test using AA SHTO T-11						
Step 3.	Determine the Dust Correction Factor (DCF). The DCF is the difference in the percent passing the 75-µm (no. 200) sieve between the washed test and the JMF.						
			JMF	Washed Test	DCF		
	75-µm (no. 200)		4.9%	6.0%	1.1%		
Step 4.	Determine the Mineral Filler Reduction (MFR) by dividing the DCF (%) by the percent (in decimal form) mineral filler gradation passing the 75-µm (No. 200) sieve:						
	$MFR (\%) = 1.1 / 0.88 = 1.25\%$						
Step 5.	Determine the adjusted mineral filler blend percentage by subtracting the MFR (%) from the blend percentage of mineral filler.						
	$2.5\% - 1.25\% = 1.25\%$						
Step 6.	Adjust the remaining blend percentages of the coarse and fine aggregates to sum 100 by dividing each by the quantity $[1 - MFR]$ (in decimal form). Do not adjust the hydrated lime blend percentage of 1.0%						
		Blend Percentage	Adjusted Blend Percentage				
	032CMM11	37.5	38.0				
	032CMM16	35.0	35.4				
	038FAM20	14.0	14.2				
	037FAM01	10.0	10.1				
	004MFM01	2.5	1.3				
	003FA00	1.0	1.0				
		100.0	100.0				
Note:	It is important to note the Adjusted Blend Percentages are temporary percentages used during laboratory batching only. The original Blend Percentages on the "Design Summary Sheet" remain unchanged. Also, the Total Adjusted Blend Percentage may equal 100 as a result of rounding during calculation.						

**Procedure for Introducing Additives to
Hot Mix Asphalt Mixtures and Testing in the Lab
Appendix B.17**

Effective Date: March 7, 2005

Revised: December 1, 2020

- e. Heat the asphalt binder and the dry aggregates (not including mineral filler) to a mixing temperature of 295 ± 5 °F (146 ± 2.8 °C) for neat asphalt or 325 ± 5 °F (163 ± 2.8 °C) for polymer modified asphalt.
 - f. Make a small crater in the top of the hot, dry aggregates.
 - g. Add the correct amount of dry hydrated lime to the crater in the aggregates.
 - h. Mix the hydrated lime and aggregates until the aggregates are completely coated (approximately 10 to 15 seconds).
 - i. If the blend of aggregates and hydrated lime cools below the mixing temperature, place the blend back in the oven until the blend is returned to the mixing temperature (approximately 10 minutes).
 - j. Remove the blend from the oven and make a small crater in the top of the hot, dry aggregates and hydrated lime.
 - k. Add the correct amount of mineral filler, (if required in the mix design), to the crater in the aggregates.
 - l. Mix the mineral filler with the aggregates and hydrated lime until the mineral filler is uniformly dispersed in the blend (approximately 10 to 15 seconds).
 - m. If the blend of aggregates, hydrated lime, and mineral filler cools below the mixing temperature, place the blend back in the oven until the blend is returned to the mixing temperature (approximately 10 minutes).
 - n. Make a crater in the aggregates and add the correct amount of asphalt binder to aggregates, hydrated lime, and mineral filler.
 - o. Mix the asphalt binder with the blend of aggregates, hydrated lime, and mineral filler.
3. Hydrated Lime – Wet Method:
- a. List the hydrated lime in its own column on the Aggregate Blending Sheet and enter the percent passing each sieve in the corresponding line on the form.
 - b. 1.0% hydrated lime is added to the mix. The 1.0% hydrated lime is based on the total dry weight of aggregate in the mix and is added in addition to the mineral filler specified in the mix design.

NOTE: Theoretically when hydrated lime is added by the wet method, it is assumed that all of the hydrated lime (1.0%) adheres to the aggregate and does not function like mineral filler which becomes mixed with the asphalt binder in the HMA mix. Accordingly, the lime is added in addition to the mineral filler specified in the mix design. For design purposes (and to adapt to existing design software), the hydrated lime is all considered as a separate

**Procedure for Introducing Additives to
Hot Mix Asphalt Mixtures and Testing in the Lab
Appendix B.17**

Effective Date: March 7, 2005

Revised: December 1, 2020

aggregate, similar to mineral filler, and the gradation of all of the hydrated lime contributes to the overall blend gradation.

- c. When hydrated lime is used in a mix design, it is important to include sufficient added mineral filler in the design. During plant production some of this mineral filler may need to be removed to compensate for the fines that are generated during production.
- d. Calculate the dust correction factor (DCF) according to the “Hot-Mix Asphalt Mix Design Procedure for Dust Correction Factor Determination”, on each mix design with hydrated lime added to wet aggregates. Include the hydrated lime in both the job mix formula (JMF) gradation and the washed gradation on the aggregate combined blend. The DCF procedure is performed to account for additional minus 75- μm (minus No. 200) material present as a result of batching with unwashed aggregates. Perform the washed gradation on the combined aggregate blend containing the hydrated lime after it has been allowed to dry on the aggregates (step h.). Refer to the previously attached sheet which shows an example calculation of the DCF.
- e. Add the amount of water that is equal to the aggregate’s water absorption capacity to the cooled and blended, oven-dried aggregates. The aggregates should be in their saturated surface dry (SSD) condition.
- f. Add an additional three percent of water, based on the total dry weight of aggregates, to the aggregates in the SSD condition. Stir the aggregates and the additional water to ensure that the water is evenly mixed with the aggregates.
- g. Add one percent dry hydrated lime to the wet aggregates, based on the total dry weight of the aggregates. Stir and mix until the hydrated lime coats the aggregates and the aggregates and hydrated lime make up a homogeneous mixture.
- h. Dry the aggregates coated with the hydrated lime in a 230 ± 9 °F (110 ± 5 °C) oven to constant mass, as defined in Illinois-modified AASHTO T-166.
- i. Heat the hydrated lime-coated aggregates and the asphalt binder each to a mixing temperature of 295 ± 5 °F (146 ± 2.8 °C) for neat asphalt or 325 ± 5 °F (163 ± 2.8 °C) for polymer modified asphalt.
- j. Remove the blend from the oven and make a small crater in the top of the hot, dry, hydrated lime-covered aggregates.
- k. Add the correct amount of mineral filler, (if required in the mix design), to the crater in the aggregates.

**Procedure for Introducing Additives to
Hot Mix Asphalt Mixtures and Testing in the Lab
Appendix B.17**

Effective Date: March 7, 2005

Revised: December 1, 2020

- l. Mix the mineral filler with the hydrated lime-covered aggregates until the mineral filler is uniformly dispersed in the blend (approximately 10 to 15 seconds).
 - m. If the blend of hydrated lime-coated aggregates and mineral filler cools below the mixing temperature, place the blend back in the oven until the blend is returned to the mixing temperature (approximately 10 minutes).
 - n. Make a crater in the aggregates and add the correct amount of asphalt binder to the mixture of hydrated lime-covered aggregates and mineral filler.
 - o. Mix the hydrated lime-coated aggregates, mineral filler, and asphalt binder together until the aggregates are completely coated with the asphalt binder.
4. Hydrated Lime – Slurry Method:
- a. List the hydrated lime in its own column on the Aggregate Blending Sheet and enter the percent passing each sieve in the corresponding line on the form.
 - b. 1.0% hydrated lime is added to the mix. The 1.0% hydrated lime is based on the total dry weight of aggregate in the mix and is added in addition to the mineral filler specified in the mix design.

NOTE: Theoretically when hydrated lime is added by the slurry method, it is assumed that all of the hydrated lime (1.0%) adheres to the aggregate and does not function like mineral filler which becomes mixed with the asphalt binder in the HMA mix. Accordingly, the lime is added in addition to the mineral filler specified in the mix design. For design purposes (and to adapt to existing design software), the hydrated lime is all considered as a separate aggregate, similar to mineral filler, and the gradation of all of the hydrated lime contributes to the overall blend gradation.

- c. When hydrated lime is used in a mix design, it is important to include sufficient added mineral filler in the design. During plant production some of this mineral filler may need to be removed to compensate for the fines that are generated during production.
- d. Calculate the dust correction factor (DCF) according to the “Hot-Mix Asphalt Mix Design Procedure for Dust Correction Factor Determination”, on each mix design with hydrated lime slurry added. Include the hydrated lime in both the job mix formula (JMF) gradation and the washed gradation on the aggregate combined blend. The DCF procedure is performed to account for additional minus 75- μm (minus No. 200) material present as a result of batching with unwashed

**Procedure for Introducing Additives to
Hot Mix Asphalt Mixtures and Testing in the Lab
Appendix B.17**

Effective Date: March 7, 2005

Revised: December 1, 2020

aggregates. Perform the washed gradation on the combined aggregate blend containing the hydrated lime slurry after it has been allowed to dry on the aggregates (step h.). Refer to the previously attached sheet which shows an example calculation of the DCF.

- e. Add the amount of water that is equal to the aggregate's water absorption capacity to the cooled and blended, oven-dried aggregates. The aggregates should be in their saturated surface dry (SSD) condition.
- f. Mix one percent dry hydrated lime and three percent water together, each based on the total weight of aggregates, to form a slurry.
- g. Add the slurry to the aggregates. Stir and mix until the aggregates and hydrated lime slurry make up a homogeneous mixture.
- h. Dry the aggregates coated with the hydrated lime slurry in a 230 ± 9 °F (110 ± 5 °C) oven to constant mass, as defined in Illinois-modified AASHTO T-166.
- i. Heat the hydrated lime-coated aggregates and the asphalt binder each to a mixing temperature of 295 ± 5 °F (146 ± 2.8 °C) for neat asphalt or 325 ± 5 °F (163 ± 2.8 °C) for polymer modified asphalt.
- j. Remove the blend from the oven and make a small crater in the top of the hot, dry, hydrated lime-covered aggregates.
- k. Add the correct amount of mineral filler, (if required in the mix design), to the crater in the aggregates.
- l. Mix the mineral filler with the hydrated lime-covered aggregates until the mineral filler is uniformly dispersed in the blend (approximately 10 to 15 seconds).
- m. If the blend of hydrated lime-coated aggregates and mineral filler cools below the mixing temperature, place the blend back in the oven until the blend is returned to the mixing temperature (approximately 10 minutes).
- n. Make a crater in the aggregates and add the correct amount of asphalt binder to the mixture of hydrated lime-covered aggregates and mineral filler.
- o. Mix the hydrated lime-coated aggregates, mineral filler, and asphalt binder together until the aggregates are completely coated with the asphalt binder.

5. Liquid Anti-strip

- a. Add 0.5% of liquid anti-strip (by weight of asphalt) to the asphalt binder and mix together until the liquid anti-strip is distributed thoroughly in the asphalt binder.

**Procedure for Introducing Additives to
Hot Mix Asphalt Mixtures and Testing in the Lab
Appendix B.17**

Effective Date: March 7, 2005

Revised: December 1, 2020

- b. Heat the aggregates and asphalt binder each to a mixing temperature of 295 ± 5 °F (146 ± 2.8 °C) for neat asphalt or 325 ± 5 °F (163 ± 2.8 °C) for polymer modified asphalt.
 - c. Remove the aggregate blend from the oven and make a small crater in the top of the hot, dry aggregates.
 - d. Add the asphalt binder with liquid anti-strip to the dried aggregates.
 - e. Mix the aggregates and the asphalt binder.
6. Polymer
- a. Heat the aggregates and asphalt binder each to a mixing temperature of 325 ± 5 °F (163 ± 2.8 °C).
 - b. Remove the aggregate blend from the oven and make a small crater in the top of the hot, dry aggregates.
 - c. Add the correct amount of polymer-modified asphalt binder to aggregate blend.
 - d. Mix the aggregate blend and the polymer-modified asphalt binder.
7. Polymer with Hydrated Lime
- a. Heat the polymer-modified asphalt binder to a mixing temperature of 325 ± 5 °F (163 ± 2.8 °C).
 - b. Add the correct amount of hydrated lime to the dry aggregates. (1% based on the total weight of aggregates). Follow the instructions for adding hydrated lime dry method (section 2), hydrated lime wet method (section 3), or hydrated lime slurry method (section 4) above.
 - c. Heat the aggregates a mixing temperature of 325 ± 5 °F (163 ± 2.8 °C).
 - d. Remove the blend from the oven and make a small crater in the top of the hot, dry aggregates and hydrated lime.
 - e. Add the correct amount of mineral filler (if required in the mix design) to the crater in the aggregates.
 - f. Mix the mineral filler with the aggregates and hydrated lime until the mineral filler is uniformly dispersed in the blend (approximately 10 to 15 seconds).
 - g. If the blend of aggregates, hydrated lime, and mineral filler cools below the mixing temperature, place the blend back in the oven until the blend is returned to the mixing temperature (approximately 10 minutes).
 - h. Make a crater in the aggregates and add the correct amount of polymer-modified asphalt binder to aggregates, hydrated lime, and mineral filler.

**Procedure for Introducing Additives to
Hot Mix Asphalt Mixtures and Testing in the Lab
Appendix B.17**

Effective Date: March 7, 2005

Revised: December 1, 2020

- i. Mix the hydrated lime-coated aggregates and the polymer-modified asphalt binder.

E. Split Samples:

Split the batches into the correct sample size which will make a gyratory specimen 3 ¾ in. (95 mm) high (approximately 4200 grams).

F. Compact Samples:

1. Run a maximum specific gravity (G_{mm}) for each of the additive mix types being evaluated.
2. Heat the mixture to a compaction temperature of 295 ± 5 °F (146 ± 2.8°C) for neat asphalt or 305 ± 5 °F (152 ± 2.8°C) for polymer-modified asphalt.
3. Pilot bricks from the mixes for each type of additives being evaluated will be made to determine the correct compaction level to achieve 7.0 ± 1.0% air voids.
4. Run a bulk specific gravity (G_{mb}), according to Illinois-modified AASHTO T-166, for each pilot brick to determine the air void content.
5. Compact samples to 7.0 ± 1.0% air voids for each mix additive type using the number of gyrations determined above.
6. A total of 12 individual samples will be compacted for each additive mix type for each complete round of testing.
7. Run a G_{mb} on each sample to verify that the air voids are within the range of 7.0 ± 1.0%.

5.0 TESTING

Illinois Modified AASHTO T-283

For each set of samples for each additive type:

A. Control Sample Set – (Always use unless otherwise specified):

1. Three bricks will be tested with no conditioning.

**Procedure for Introducing Additives to
Hot Mix Asphalt Mixtures and Testing in the Lab
Appendix B.17**

Effective Date: March 7, 2005

Revised: December 1, 2020

2. The samples will be:
 - a. Placed in a 77°F (25°C) water bath for a minimum of two hours to bring the sample to room temperature.
 - b. Placed between the loading heads and loaded at 2 in. (50 mm) per minute until failure.
3. The corresponding load will be recorded.
4. The indirect tensile strength (ITS) will be calculated using the equation:

$$ITS = \frac{2 \times P}{\pi \times t \times d}$$

where:

P = Load (pounds)

π = 3.1416

t = Sample Thickness (inches)

d = Sample Diameter (inches)

5. Within 10 minutes after breaking the sample in the indirect tensile tester, the split samples will be inspected visually to evaluate the amount and degree of moisture damage. This will be done according to the IDOT procedure, "Stripping of Hot Mix Asphalt Mixtures - Visual Identification and Classification".
- B. Illinois-Modified AASHTO T-283 Sample Set – (Always use unless otherwise specified):
1. Three bricks will be tested according to IL-modified AASHTO T-283.
 2. The samples will be:
 - a. Vacuum saturated to 70 - 80%. Use a vacuum of approximately 0.8 to 1.0 in. (20 to 25 mm) of mercury (Hg) for one minute. Start with 0.8 in. (20 mm) Hg for one minute, and then weigh the specimen. Increase the vacuum until the saturation is 70 - 80%.
 - b. Soaked in a 140°F (60°C) water bath for 24 ± 1 hours, and
 - c. Tested as above in "Testing; A; 2, 3, 4, & 5."

**Procedure for Introducing Additives to
Hot Mix Asphalt Mixtures and Testing in the Lab
Appendix B.17**

Effective Date: March 7, 2005

Revised: December 1, 2020

- C. AASHTO T-283 Sample Set (with one freeze-thaw cycle) – (Only use when specified):
1. Three bricks will be tested according to AASHTO T-283.
 2. Each sample will be:
 - a. Vacuum saturated to 70 - 80%. Use a vacuum of approximately 0.8 to 1.0 in. (20 to 25 mm) of mercury (Hg) for one minute. Start with 0.8 in. (20 mm) Hg for one minute, and then weigh the specimen. Increase the vacuum until the saturation is 70 - 80%.
 - b. Wrapped in plastic wrap (Saran Wrap) placed in a plastic bag with 10 mL of water and sealed in a plastic bag.
 - c. Placed in a $0 \pm 5^{\circ}\text{F}$ ($-18 \pm 2.8^{\circ}\text{C}$) freezer for a minimum of 16 hours. (The exact time greater than 16 hours should be determined so that the testing can be done at approximately the same time each day).
 - d. After removal from the freezer, the samples will be placed in a 140°F (60°C) water bath and soaked for 24 ± 1 hours, with the plastic bag and plastic wrap removed as soon as possible after being placed in the bath.
 - e. After the freeze – thaw cycle is complete, follow the steps above in “Testing; A; 2, 3, 4, & 5.”
- D. AASHTO T-283 Sample Set (with five freeze-thaw cycles) – (Only use when specified):
1. Three bricks will be tested as in “Testing; C” above except that five complete freeze – thaw cycles will be completed instead of only one.
 2. The plastic bag and plastic wrap should stay on the sample throughout the test and should not be removed until the beginning of the final thaw cycle in the 140°F (60°C) bath. If the plastic bag tears or if the plastic wrap comes loose, replace them prior to the next freeze cycle and add 10 mL of water.
 3. After the final thaw cycle is complete, follow the steps above in “Testing; A; 2, 3, 4, & 5.”

Illinois Modified AASHTO T-324: Perform a Loaded Wheel test according to Illinois modified AASHTO T-324.

**Procedure for Introducing Additives to
Hot Mix Asphalt Mixtures and Testing in the Lab
Appendix B.17**

Effective Date: March 7, 2005

Revised: December 1, 2020

6.0 DATA COLLECTION AND EVALUATION

- A. All the data from testing will be collected and will/may include:
1. Gmm
 2. Gmb
 3. Voids
 4. Indirect Tensile Strength
 - a. Unconditioned
 - b. Conditioned
 - i. 140°F (60°C) water bath
 - ii. One freeze / thaw cycle
 - iii. Five freeze / thaw cycles
 5. The standard TSR, for each additive type (calculated with the unconditioned strength in the denominator and with the conditioned strength in the numerator). For each additive type the TSR is calculated separately for each level of conditioning.
 6. The combined TSR, which is similar to the standard TSR except that it is calculated by always using the unconditioned strength from samples with no additive in the denominator, regardless of the additive type used.
 7. Visual strip rating of each sample.
 8. Rut depth and number of wheel passes.
- B. Evaluate the strengths, TSRs, rut depths, and wheel passes for each additive type, for each aggregate type tested, to determine if:
1. An anti-strip additive is needed and improves the performance of the mix.
 2. One of the additive types consistently gives higher strengths, TSR ratings, rut depths, and wheel passes.

**Ignition Oven Aggregate Mass Loss Procedure
Appendix B.18**

Effective: May 1, 2005
Revised: May 1, 2007

A. Purpose

Dolomite aggregates that contain significant amounts of Magnesium Carbonate, when used in Hot-Mix Asphalt, have been found to undergo mass loss during ignition oven testing, which causes highly variable results in asphalt binder content. This procedure utilizes the ignition oven to identify these types of aggregates.

B. Procedure

1. Obtain a 3000 gram sample of the aggregate to be tested and oven dry to a constant mass in an oven set at $110^{\circ}\text{C} \pm 5^{\circ}$ ($230^{\circ}\text{F} \pm 9^{\circ}$). Constant mass is achieved by drying sample until further drying does not alter the mass by more than 0.5 g in one hour as stated in IL Modified AASHTO T-30.
2. Split sample into 3 separate 1000 gram samples.
3. Place one of the 1000 gram samples into the ignition oven catch pan.
4. Record the initial weight of the sample and catch pan at room temperature to the nearest 0.1 gram.
5. Place the sample and catch pan into an ignition oven preheated to 625°C . **Do not push the start button on the oven.** Allow sample to remain in ignition oven for one hour.
6. After one hour, remove the sample and catch pan, allow it to cool to room temperature and record the weight to the nearest 0.1 gram.
7. Repeat steps 3 through 10 for the two remaining 1000 gram samples.
8. Calculate the aggregate mass loss for each run according to the following:

$$\Delta W = \left(\frac{W_i - W_f}{W_i} \right) \times 100$$

Where: ΔW = Aggregate mass loss in percent

W_i = Initial weight of the aggregate sample in grams

W_f = Final weight of the aggregate sample in grams after exposure to 625°C

9. Calculate the average of the three mass loss results.
10. Aggregates exhibiting average mass loss in excess of 4% are likely to contain significant amounts of Magnesium Carbonate and will likely cause high variability in ignition oven test results for asphalt content.

This Page Reserved

Procedure for Internal Angle Calibration of Superpave Gyrotory Compactors (SGCs) using the Dynamic Angle Validator (DAV-2)

Internal Angle Testing with HMS

Nomenclature and DAV-2 orientation in the specimen mold

In the following sections, the terms “top” and “bottom” angles, “first position”, and “turned 90 degrees” will be used. This refers to the position where the DAV-2 will be collecting angle data. The following diagrams will display how the DAV-2 will be oriented in the gyrotory specimen mold and will help avoid confusion in the midst of testing:

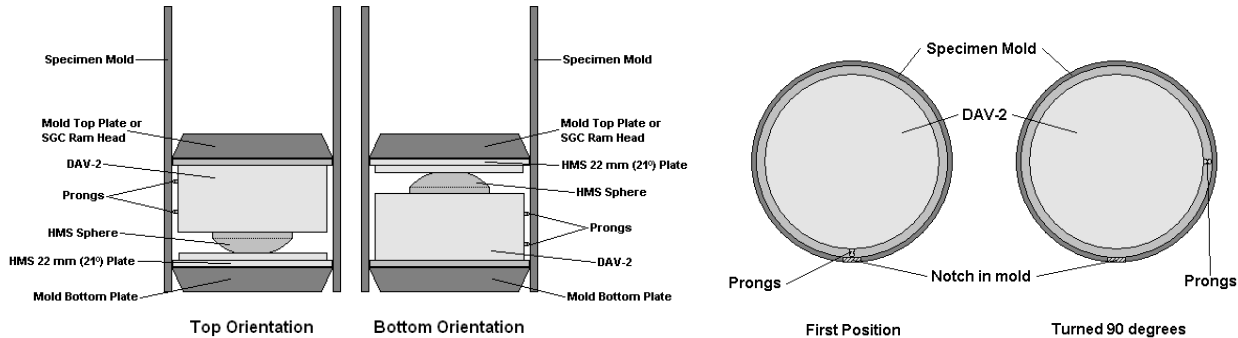

Basic method for all compactors (additional instructions included for early model Troxler 4140s)

1. Attach the HMS sphere to the top of the DAV-2 using the supplied bolt. Tighten the bolt enough so that the sphere will not turn, but do not over tighten as this could strip out the bolt. The HMS plates are referred to by their eccentricity, or how far (in mm) from the center of the sphere the load is applied. The 22 mm plate (the one labeled “21”, referring to the angle in degrees ground into the bottom of the plate) will be the only plate used in this calibration. Apply lubricant to the top of the sphere and to the angled surface on the bottom of the plate, as this will help to reduce wear from metal on metal contact. Petroleum jelly is the best lubricant to use with the DAV-2 and HMS.
2. Prior to testing, select two good, clean specimen molds to use for calibration. Make sure these molds are not too worn, are within specifications, and are used for production testing. The molds will be referred to as mold “A” and mold “B”. Place molds “A” and “B” into an oven set at 305° F / 154° C for a minimum of 30 minutes. Connect the DAV-2 to a CPU using the supplied interface cable. If the CPU doesn’t have a serial port, a serial to USB adapter may be used; these adapters, however, need software in order to function and this software must be installed before they will operate. There are three buttons in the Test Quip software that will be used. They are as follows:

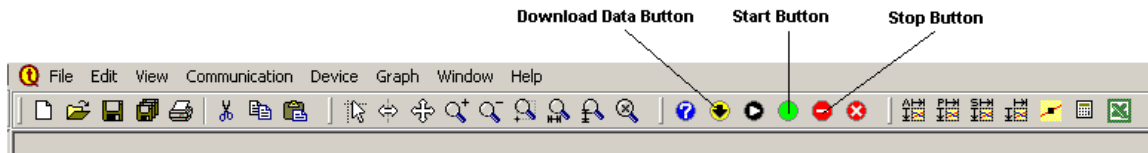

3. Open the Test Quip DAV-2 software and start data collection in the DAV-2 (“Start Button” in the illustration above). When data collection has been successfully initialized, disconnect the cable from the DAV-2. The DAV-2 has ~26 minutes of memory for data collection, so begin testing quickly so all test points will be collected within that time frame. Before placing the DAV-2 into a mold, apply lubricant to the bottom of the DAV-2. As the DAV-2 will spin during gyration, the lubricant will allow for free movement and help to reduce wear from metal on metal contact.

4. Take mold "A" out of the oven and begin testing. For the first bottom angle, place the DAV-2 and HMS plate into the mold, illustrated on the previous page as "bottom orientation". Choose a reference point on the mold (for example, the notch on the top of the Troxler 4140 molds makes a handy reference point) and line the DAV-2's prongs up with that point, as in the "first position" illustration on the previous page, before lowering it all the way into the mold. Place the mold in the SGC and gyrate for 25 gyrations. After this, extrude the DAV-2, flip the DAV-2 and HMS plate upside-down, and place the HMS plate and DAV-2 back into the mold, illustrated on the previous page as "top orientation". Gyrate the first top angle using the "first position", as was done with the first bottom angle, to line up the prongs. Extrude the DAV-2 and put mold "A" back in the oven to reheat for possible further testing.
5. Remove mold "B" from the oven. Repeat the same process as with mold "A" for the second bottom and top angles; but for both these angles, line the prongs up with a point 90 degrees counter-clockwise from the "first position", as in the "turned 90 degrees" illustration on the previous page. After running the second bottom and top angles, extrude the DAV-2 and put mold "B" back into the oven to reheat for possible further testing. These internal angles will yield a total of four test points for one "run".
6. Connect the DAV-2 to the CPU with the interface cable and stop the data collection in the DAV-2 ("Stop Button" in the illustration on the previous page). Download the data to the CPU ("Download Data Button" in the illustration on the previous page). Label the data sheet as needed and save it to a pre-labeled file that has been set up for internal angle data. The data will look something like this:

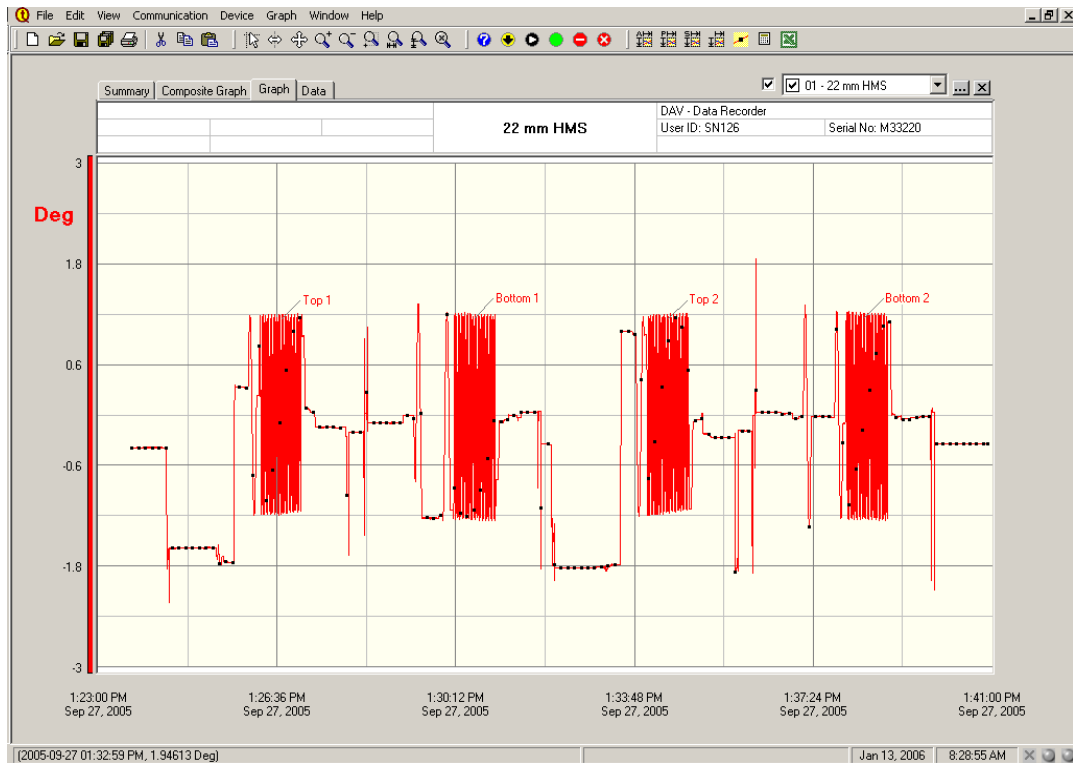

7. Open the DAV-2 Excel spreadsheet. Be sure to choose "Enable Macros" when prompted so the integrated buttons will function. A prompt should pop up asking to open a file. Choose the desired saved file and click "OK". If the prompt doesn't come up or an error occurs, simply click on the "Add Data" button. After the data imports to the spreadsheet, the initial page will look something like this:

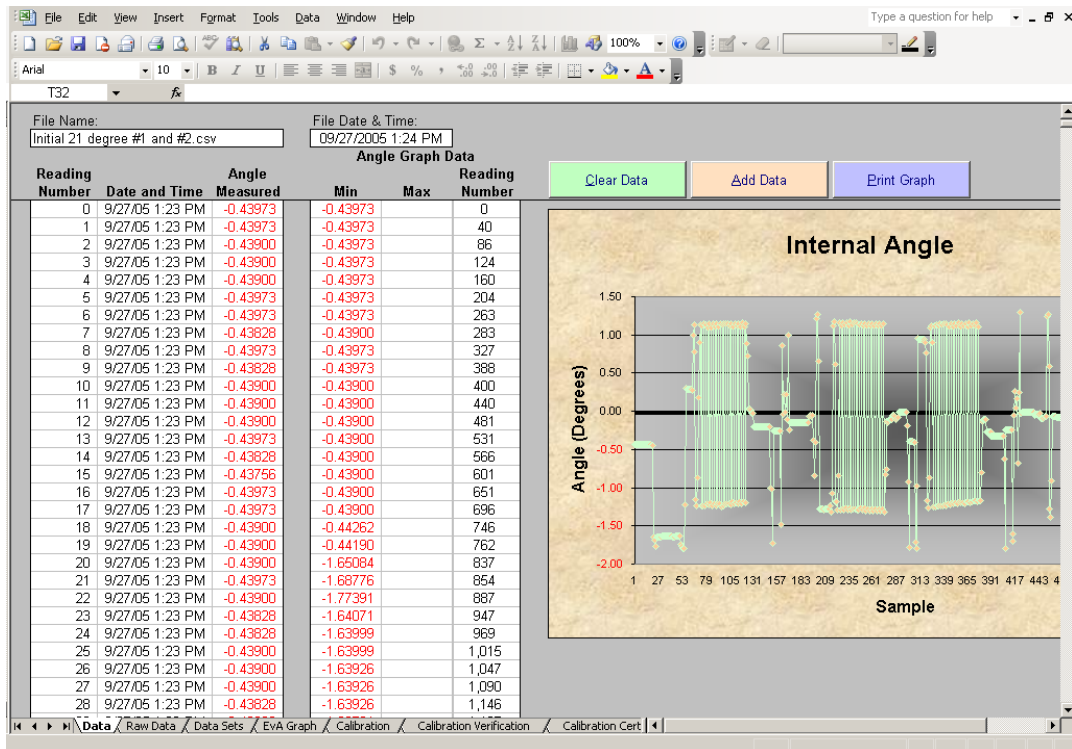

- Click on the "Data Sets" tab. In the "Data Sets" field, type in "4"; four individual angle measurements (or data sets) were run. In the "Gyrations" field, type in "24"; since the SGC and the DAV-2 may record the first gyration at different points, using a number one less than the number of gyrations entered into the SGC will ensure that the data will populate correctly. In the "Skip Gyrations" field, type in "2"; this is sufficient when running with the HMS. Click on the "Populate Data Sets" button and the internal angle data will be displayed in the blue boxes; the page will look something like this:

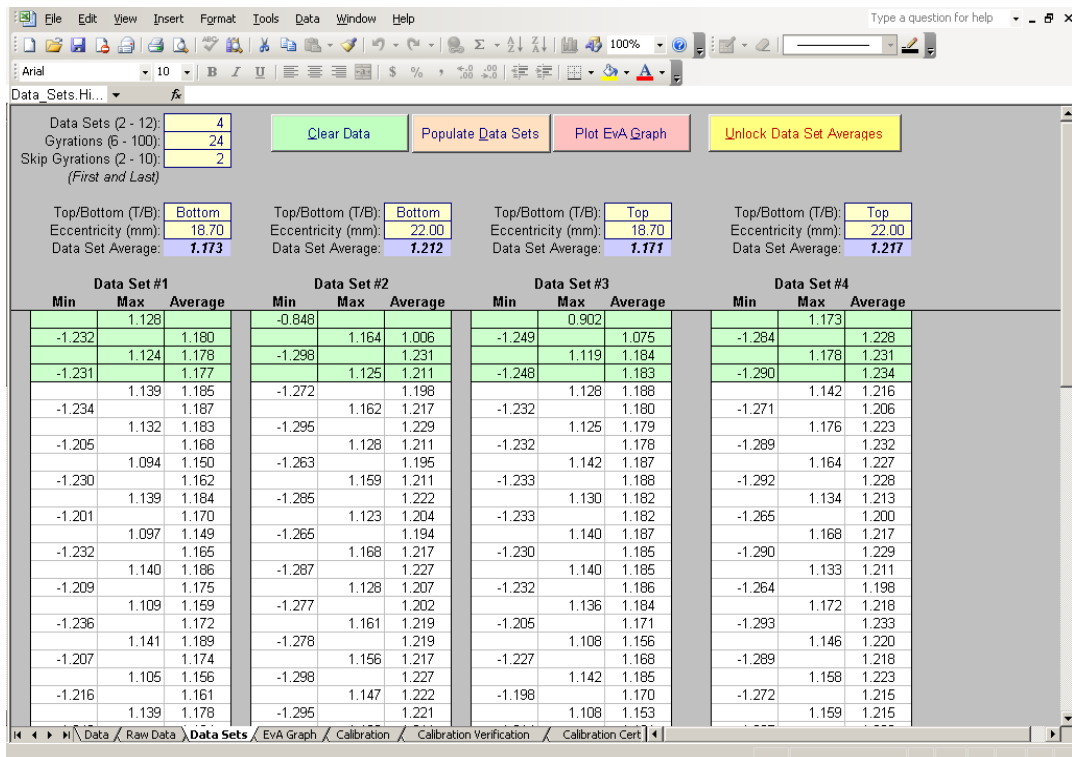

9. Manually calculate the average of the four internal angles. This average represents the current internal angle of the SGC. In the example above, the internal angle of this SGC is about 1.19° and is out of the specified range of $1.16^\circ \pm 0.02^\circ$.
10. If the average internal angle is not within the specified $1.16^\circ \pm 0.02^\circ$ range, the SGC's angle must be physically adjusted accordingly using the manufacturer's specified method. This adjustment often has to be done on a trial and error basis; some manufacturers have detailed documentation on changing the angle, so be sure to refer to that when possible. *State personnel **will not** perform the physical angle adjustment to contractor or consultant SGCs under any circumstances.*
11. When the angle is physically adjusted, repeat steps #2 – #10 after both molds have had a minimum of 30 minutes to reheat in the oven. This may take more than one additional attempt to get to the desired internal angle. Adjust the SGC's angle until the average of the four internal angles from the 22 mm HMS plate is at $1.16^\circ \pm 0.02^\circ$. The SGC is now within internal angle specifications.

Gyratory Angle Calibration Frequency

The DAV-2 and HMS must be used a minimum of once every 12 months for gyratory angle calibration. Routine monthly angle calibration verification of SGCs may be performed one of two ways:

1. Using the DAV-2 and HMS.
2. After the final angle is set and calibrated with the DAV-2 and HMS, an external angle verification procedure may be run according to the SGC manufacturer's specifications. If HMA is needed for this procedure, an N90 surface mix commonly used in the testing lab's area should be utilized. The external angle measurement from this procedure will become the reference angle for verification purposes. For example: the DAV-2 and HMS gives an internal angle of 1.16° and the external angle procedure gives an external angle of 1.23° . When verifying using the external angle from then on, the external angle should measure $1.23^\circ \pm 0.02^\circ$. This method addresses concerns of possible mold wear due to the use of the DAV-2 and HMS as well as giving labs that do not own a DAV-2 an accepted method of routine gyratory angle verification.



Additional Instructions for Early Model Troxler 4140 Compactors

When mixless testing was first introduced, intermittent problems with consistency and reproducibility were noted during testing with some older Troxler 4140 compactors. It was later
December 1, 2021 Manual of Test Procedures for Materials B.104

discovered that some early model 4140s (those with the sample chamber door that moves up and down) act in an unfriendly way when the DAV-2 and the HMS are used. It seems the load cell cannot react fast enough to reduce pressure when the ram head initially contacts the DAV-2 and HMS. This triggers an error in the load cell which essentially causes the compactor to apply excessive pressure; values as high as 1300 kPa have been recorded. This excessive pressure causes the internal angles drop significantly, often below 1.00°, making them unusable for calibration. Fortunately, this effect can be bypassed by using the alternate manual start procedure that follows:

1. Start data collection in the DAV-2. Load the DAV-2 and HMS into the mold, and place in the SGC sample chamber.
2. Hit the “MENU” button on the keypad. Hit “2” to adjust the maximum pressure setting. Type “200”, then hit the “ENTER” key to input the value. Hit the “ESC” key to exit the menu.
3. Hit the manual “RAM DOWN” key on the keypad.
4. When the ram reaches ~130 mm, hit the “ESC” key to stop the ram. Make sure the ram head and collar are seated squarely in the top of the mold, with the pin on the collar fully down into the notch on the top of the mold.
5. Hit the “ANGLE ON” key to induce the angle. Be sure that the angle stop block (inside the compactor) fully engages. Hit the “ESC” key after the tray stops rotating.
6. Hit the “RAM DOWN” key. The ram will travel down and contact the DAV-2 and HMS. Hit the “ESC” key when the ram has stopped completely.
7. Hit the “MENU” button on the keypad. Hit “2” to adjust maximum pressure setting. Type “600”, then hit the “ENTER” key to input the value. Hit the “ESC” key to exit the menu.
8. Hit the “START” button to use automatic compaction to complete the rest of the internal angle measurement.

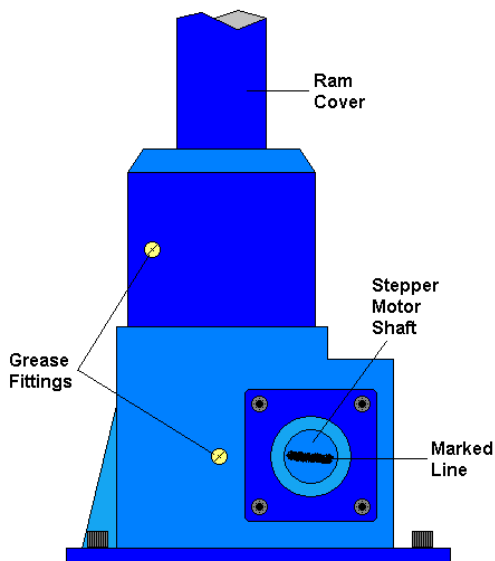

**Troxler 4140 External Ram Assembly
(On top of the sample chamber)**

9. Confirm that this procedure was effective by watching the end of the stepper motor shaft (illustration to the left) just above the sample chamber. When the compactor is gyrating, the end of the shaft should move clockwise and counterclockwise as much as one quarter of a turn as the pressure increases and decreases to adjust for the simulated loading that the HMS induces. Drawing a line on the end of the stepper motor shaft with a marker makes observing this motion easier. Enabling the pressure data collection feature on the compactor will also verify that the pressure is correct and will give a printout of pressure per gyration.

10. Repeat this procedure for each subsequent internal angle measurement.

Annual DAV-2 Calibration Verification

Calibration verification on the DAV-2 units will be performed by BMPR annually. The units are to be sent to the Central Bureau HMA Lab in the late fall or early winter after the construction season ends. The calibration verification will be performed and the units will be returned to the districts in time for winter mix design verifications and lab inspections.

Hints and Tips

1. Keep the DAV-2, the ram head, and the molds being used as clean as possible. Any debris on the bottom (or top) plate of the mold or on the ram head will have an effect on the angle when the bottom of the DAV-2 contacts it. A quick spray of WD-40 and a wipe down with a rag on the inside of the mold, the plate(s), and the ram head will ensure good angle data.
2. According to the DAV-2 manufacturer, mold temperature is important to collecting useful angle data. After two runs with the DAV-2 and HMS at 25 gyrations (i.e. one bottom and one top), the mold will have cooled enough that it could affect angle data. This is the reason for using two molds for calibration as outlined in previous pages.
3. While the standard hydraulic jack set up may be used for extruding the DAV-2 and other contents from the mold after testing, there is a more efficient way using Marshall molds. Start with a base plate, followed by a collar, then a mold, then another collar; then place your gyratory mold (with base plate) over the stack. This will give you enough height on most SGC molds to bring the gyratory mold base plate to the upper lip of the gyratory mold without coming out. Another Marshall base plate may be added to the top of the stack to give a little more height for taller gyratory molds (Troxler 4141, Pine compactors). This stack is also helpful in loading the DAV-2 into the mold without having to drop it down into the mold. Experiment to find the best setup to work with different models of SGCs.
4. Some early model Troxler 4140s have been noted to release the angle when the HMS is used. This is attributed to a worn main bearing in the compactor. This causes the angle stop block inside the compactor to start moving away from the fixed angle screw block that is supposed to be “pushing” it to keep the angle “on”. As the angle stop block moves farther away from the fixed angle screw block, the angle is reduced. This is seen mostly when using the 25.8 mm HMS plate or when the SGC exhibits excessive pressure. This issue shouldn’t be a problem when calibrating with the 22 mm HMS plate at 600 kPa (using the alternate manual start procedure), but it is good to be aware of the potential for this problem. A symptom of a worn main bearing can be observed during compaction of hot mix when the angle stop block inside the compactor “chatters” (causing a rapping noise) and can physically be seen moving a little bit during gyration. It seems to not be a problem when compacting hot mix as the angle will stay engaged despite the “chattering”, but this can pose a problem with HMS testing. While not recommended, the following technique has been used as a way to continue testing until the main bearing could be replaced. To physically keep the angle block engaged, a shop rag was first folded in half twice. When the compactor induced the angle, the protruding collar inside the compactor was gripped with the rag. Pressure was then applied in the opposite direction of gyration. This held the angle block in place and kept the angle “on”.
5. When calibrating the angle on a contractor or consultant’s SGC, be sure to let their personnel perform the physical angle adjustments when they are needed. This way the state is not held liable for any mechanical problems that may occur afterwards.

**Segregation Control of Hot-Mix Asphalt
Appendix B.20**

Effective Date: May 1, 2007

Revised Date: [December 1, 2021](#)

1.0 SCOPE

- 1.1 This work shall consist of the visual identification and corrective action to prevent and/or correct segregation of hot-mix asphalt.

2.0 DEFINITIONS

- 2.1 Segregation. Areas [With a](#) non-uniform distribution of coarse and fine aggregate particles in a hot-mix asphalt pavement.
- 2.2 End-of-Load Segregation. A systematic form of segregation typically identified by chevron-shaped areas [of segregation](#) at either side of a lane of pavement, corresponding with the beginning and end of truck loads.
- 2.3 Longitudinal Segregation. A linear pattern of segregation that usually corresponds to a specific area of the paver.
- 2.4 Severity of Segregation.
- 2.4.1 Low. A pattern of segregation where the mastic is in place between the aggregate particles; however, there is slightly more coarse aggregate in comparison with the surrounding acceptable mat.
- 2.4.2 Medium. A pattern of segregation that has significantly more coarse aggregate in comparison with the surrounding acceptable mat and which exhibits some lack of mastic.
- 2.4.3 High. A pattern of segregation [that](#) has significantly more coarse aggregate in comparison with the surrounding acceptable mat and which contains little mastic.

3.0 PROCEDURE

- 3.1 When medium or high segregation of the mixture is identified by the Contractor, the Engineer, or the daily evaluation, the following specific corrective actions shall be taken as soon as possible. The corrective actions shall be reported to the Engineer before the next day's paving proceeds.
- 3.1.1 End of Load Segregation. When medium or high end of load segregation is identified, the following actions as a minimum shall be taken.
- 3.1.1.1 Trucks transporting the mixture shall be loaded in multiple dumps. The first against the front wall of the truck bed and the second against the tailgate in

Segregation Control of Hot-Mix Asphalt
Appendix B.20
(continued)

Effective Date: May 1, 2007

Revised Date: [December 1, 2021](#)

a manner which prevents the coarse aggregate from migrating to those locations.

3.1.1.2 The paver shall be operated so the hopper is never below 30 percent capacity between truck exchanges.

3.1.1.3 The "Head of Material" in the auger area shall be controlled to keep a constant level, with a 1 inch (25 mm) tolerance.

3.1.2 Longitudinal Segregation. When medium or high longitudinal segregation is identified, the Contractor shall make the necessary adjustment to the slats, augers or screeds to eliminate the segregation.

3.2 When the corrective actions initiated by the Contractor are insufficient in controlling medium or high segregation, the Contractor and Engineer will investigate to determine the cause of the segregation.

When an investigation indicates additional corrective action is warranted, the Contractor shall implement operational changes necessary to correct the segregation problems.

Any verification testing necessary for the investigation will be performed by the Department according to the applicable project test procedures and specification limits.

3.3 The District Construction Engineer will represent the Department in any dispute regarding the application of this procedure.

**Determination of
Aggregate Bulk (Dry) Specific Gravity (G_{sb}) of Reclaimed Asphalt Pavement (RAP) and
Reclaimed Asphalt Shingles (RAS)
Appendix B.21**

Effective: May 1, 2007
Revised: December 1, 2019

A. Natural Aggregate RAP G_{sb}

If the RAP consists of natural aggregates only, the RAP G_{sb} shall be as follows:

District	RAP G_{sb}
1 & 2	2.660
3 - 9	2.630

B. Slag RAP G_{sb}

If the RAP contains slag aggregate the following procedure shall be used by an independent AASHTO accredited laboratory to determine the slag RAP G_{sb} .

1. Slag RAP G_{sb} Summary of Method

A representative slag RAP sample shall be thoroughly prepared prior to testing by reheating and remixing the reclaimed material. A solvent extraction, including washed gradation for Department comparison, and two maximum theoretical specific gravity (G_{mm}) tests are performed so that an effective specific gravity (G_{se}) can be calculated. The G_{se} value is used in the calculation to determine the bulk specific gravity (G_{sb}) of the RAP.

a. Slag RAP Sampling

The slag RAP stockpile, in its final usable form, shall be sampled by obtaining a minimum of five representative samples from the slag RAP stockpile. The samples shall be thoroughly blended and split into two- 20,000 gram samples. One of the samples shall be submitted to an independent AASHTO accredited IDOT approved laboratory for the subsequent preparation and testing as specified herein. The other sample shall be submitted to the Department for optional verification testing.

b. Slag RAP Testing Equipment

Equipment including oven balances, HMA sample splitter, vacuum setup and solvent extractor shall be according to the HMA QC/QA Laboratory Equipment document in the Manual of Test Procedures for Materials. In addition the following equipment will also be required:

- Sample pans - Large, flat and capable of holding 20,000 grams of RAP material.
- Chopping utensil – Blade trowel or other utensil used to separate the large conglomerations of a RAP sample into a loose-flowing condition.

**Determination of
Aggregate Bulk (Dry) Specific Gravity (G_{sb}) of Reclaimed Asphalt Pavement (RAP) and
Reclaimed Asphalt Shingles (RAS)
Appendix B.21
(continued)**

Effective: May 1, 2007
Revised: December 1, 2019

c. Slag RAP Sample Preparation

- 1) Transfer the entire 20,000 gram sample into a large flat pan(s).
- 2) Place sample into a preheated oven at $230 \pm 9^\circ \text{ F.}$ ($110 \pm 5^\circ \text{ C.}$) and heat for 30 to 45 minutes.
- 3) Remove the sample from the oven and begin breaking up the larger conglomerations of RAP with the chopping utensil.
- 4) As the material begins to soften, blend the heated RAP by mixing the freshly chopped material with the fines in the pan.
- 5) Return the RAP into the oven and continue heating for another 15 - 20 minutes.
- 6) Remove the RAP from the oven and repeat the chopping of the conglomerations and blending of the fines until the RAP sample is homogeneous and conglomerations of fine aggregate complies with Illinois Modified AASHTO T-209.
- 7) Place the loose RAP into a hopper or pan and uniformly pour it through a riffle splitter. Take each of the halves and re-pour through the splitter. Thoroughly blend the sample by repeating this process 2 - 3 times.

d. Slag RAP Testing

- 1) Percent Asphalt Binder P_b :
 - a) Split out a 1,500 - 2,000 gram prepared RAP sample.
 - b) Dry the RAP sample to a constant weight in an oven at $230 \pm 9^\circ \text{ F.}$ ($110 \pm 5^\circ \text{ C.}$).
 - c) Determine the P_b of the dried RAP sample according to Illinois Modified T 164. Record the P_b .
- 2) Maximum Specific Gravity determination, G_{mm} :
 - a) Split out one 3,000 gram prepared RAP sample.
 - b) Dry the sample to a constant weight in an oven at $230 \pm 9^\circ \text{ F.}$ ($110 \pm 5^\circ \text{ C.}$) While drying, chop and break up the sample as you would with a standard G_{mm} sample. Record as "dry RAP mass".
 - c) Place the sample in $295 \pm 5^\circ \text{ F.}$ ($146 \pm 3^\circ \text{ C.}$) oven for one hour.
 - d) Add 1.5 percent virgin asphalt binder (PG64-22 or PG58-22) at $295 \pm 5^\circ \text{ F.}$ ($146 \pm 3^\circ \text{ C.}$), based on the "dry RAP mass" from step 6.B.2, to the RAP and thoroughly mix at $295 \pm 5^\circ \text{ F.}$ ($146 \pm 3^\circ \text{ C.}$) to ensure uniform coating of all particles.
 - e) Split sample into two equal samples.
 - f) Determine the G_{mm} of the prepared RAP samples according to Illinois Modified AASHTO T209.

**Determination of
Aggregate Bulk (Dry) Specific Gravity (G_{sb}) of Reclaimed Asphalt Pavement (RAP) and
Reclaimed Asphalt Shingles (RAS)
Appendix B.21
(continued)**

Effective: May 1, 2007
Revised: December 1, 2019

- g) Calculate the individual G_{mm} values. The average result will be used in the calculation provided the individual results do not vary by more than 0.011. If the individual results vary more than 0.011, repeat steps in 6.B., discard the high and low values and average the remaining individual results provided they do not vary more than 0.011. If remaining individual results vary more than 0.011 repeat steps in 6.B. until individual results compare within 0.011.

e. Slag RAP Calculations:

- 1) Calculate the “adjusted P_b” of the RAP to account for the addition of the 1.5 percent virgin asphalt binder as follows:

a) Calculate “mass of RAP Asphalt Cement (AC)”:

b) $Mass\ of\ RAP\ AC = Dry\ RAP\ mass \times \frac{P_b}{100}$

c) Calculate “mass of virgin AC added”:

$$Mass\ of\ virgin\ AC\ added = 0.015 \times Dry\ RAP\ mass$$

d) Determine “New RAP mass”:

$$New\ RAP\ mass = Dry\ RAP\ mass + Mass\ of\ virgin\ AC\ added$$

e) Calculate “Adjusted P_b”:

$$Adjusted\ P_b = \frac{Mass\ of\ RAP\ AC + Mass\ of\ virgin\ AC\ added}{New\ RAP\ Mass} \times 100$$

- 2) Calculate the effective specific gravity (G_{se}) of the RAP:

$$G_{se}(RAP) = \frac{(100 - Adjusted\ P_b)}{\left(\frac{100}{G_{mm}} - \frac{Adjusted\ P_b}{1.040} \right)}$$

- 3) Calculate the stone bulk gravity (G_{sb}) of the RAP:

$$G_{sb}(RAP) = G_{se}(RAP) - 0.100$$

f. Example Slag RAP G_{sb} Calculation:

- Dry RAP mass = 3,000 g

**Determination of
Aggregate Bulk (Dry) Specific Gravity (G_{sb}) of Reclaimed Asphalt Pavement (RAP) and
Reclaimed Asphalt Shingles (RAS)
Appendix B.21
(continued)**

Effective: May 1, 2007
Revised: December 1, 2019

- P_b, (% AC) in RAP = 4.9%
- Determine “mass of RAP AC”:

$$\begin{aligned} \text{Mass of RAP AC} &= \text{Dry RAP mass} \times (P_b / 100) \\ &= 3,000 \times (4.9\% / 100) \\ &= 147 \text{ grams} \end{aligned}$$

- Add 1.5 percent virgin AC:
 - Determine “mass of virgin AC added”:

$$\begin{aligned} \text{Mass of virgin AC added} &= 0.015 \times \text{Dry RAP mass} \\ &= 0.015 \times 3,000 \text{ grams} \\ &= 45 \text{ grams} \end{aligned}$$

- Determine “New RAP mass”:

$$\begin{aligned} \text{New RAP mass} &= \text{Dry RAP mass} + \text{Mass of virgin AC added} \\ &= 3,000 + 45 \\ &= 3,045 \text{ grams} \end{aligned}$$

- Calculate “Adjusted P_b”:

$$\begin{aligned} \text{Adjusted } P_b &= \frac{\text{Mass of RAP AC} + \text{Mass of virgin AC added}}{\text{New RAP Mass}} \times 100 \\ &= \frac{147 \text{ grams} + 45 \text{ grams}}{3,045 \text{ grams}} \times 100 = 6.3\% \end{aligned}$$

- Calculate G_{se}:

$$G_{se} = \frac{100 - P_b}{\frac{100}{G_{mm}} - \frac{P_b}{1.04}} = \frac{100 - 6.3}{\frac{100}{2.505} - \frac{6.3}{1.04}} = \frac{93.7}{39.9 - 6.1} = 2.772$$

Adjusted P_b = 6.3%
Rice Test, G_{mm} = 2.505

- Calculate Slag RAP G_{sb}:

$$G_{sb} = G_{se} - 0.10 = 2.772 - 0.10 = 2.672$$

**Determination of
Aggregate Bulk (Dry) Specific Gravity (G_{sb}) of Reclaimed Asphalt Pavement (RAP) and
Reclaimed Asphalt Shingles (RAS)
Appendix B.21
(continued)**

Effective: May 1, 2007
Revised: December 1, 2019

C. RAS G_{sb}

The RAS G_{sb}, prior to adjustment using AASHTO PP78-14, is defined as 2.500. In accordance with AASHTO PP78-14 Note 6, the RAS asphalt binder availability factor is assumed equal to 0.85. The reduction in available RAS asphalt binder content equates to a reduction in G_{sb} of 0.200. This availability factor G_{sb} reduction is then applied to the RAS G_{sb} resulting in an adjusted G_{sb} of **2.300** which shall be used for all subsequent mix design and production mixture volumetric calculations.

D. G_{sb} for RAS Pre-blended with Fine Fractioned Reclaimed Asphalt Pavement (FRAP)

When RAS is mechanically pre-blended with fine FRAP, the G_{sb} for the final blended product shall be calculated as follows.

1. Calculate the weighted final blend RAS G_{sb} (G_{sb,blended}) using the following equations.
 - a. Determine the weighting factor for the percentage of combined aggregate (P_{agg}) using: the percentage of RAS in the combined blend (P_{RAS}), the percentage of RAP in the combined blend (P_{RAP}), the asphalt binder content of the RAS before adjustment using the availability factor of 0.85 (P_{b,RAS}), and the asphalt binder content of the RAP (P_{b,RAP}).

$$P_{agg} = \frac{P_{RAS} - P_{RAS} \left(\frac{P_{b,RAS}}{100} \right) + P_{RAP} - P_{RAP} \left(\frac{P_{b,RAP}}{100} \right)}{100}$$

- b. Determine the combined bulk specific gravity of the blended product (G_{sb,combined}) using: the RAS mix design G_{sb} equal to 2.300 (G_{sb,RAS,design}) and the RAP G_{sb}.

$$G_{sb,combined} = \frac{100}{\frac{P_{RAS} - P_{RAS} \left(\frac{P_{b,RAS}}{100} \right)}{P_{agg}} + \frac{P_{RAP} - P_{RAP} \left(\frac{P_{b,RAP}}{100} \right)}{P_{agg}}} \frac{P_{agg}}{G_{sb,RAS,design}} + \frac{P_{agg}}{G_{sb,RAP}}$$

E. Asphalt Binder Replacement Calculation (By Percent Weight of Aggregate)

The calculation of asphalt binder replacement (ABR) is completed in terms of percent weight of aggregate. It follows the percent weight of aggregate approach used in the Quality Management Program (QMP) available on the IDOT website.

**Determination of
Aggregate Bulk (Dry) Specific Gravity (Gsb) of Reclaimed Asphalt Pavement (RAP) and
Reclaimed Asphalt Shingles (RAS)
Appendix B.21
(continued)**

Effective: May 1, 2007
Revised: December 1, 2019

1. RAS Asphalt Binder Content

RAS available asphalt binder content ($P_{b,AV}$) is calculated using the AASHTO PP78-14 availability factor of 0.85. The value of $P_{b,AV}$ is used in calculations of ABR percentage in mix design. The following examples demonstrate the use of $P_{b,AV}$ with RAS and RAP/RAS mixtures.

a. RAS Asphalt Binder Content Calculations

- 1) Calculate the RAS and/or RAP aggregate percentages ($RAS_{Agg\%}$ and/or $RAP_{Agg\%}$).

$$CF = \frac{100 - P_b}{100}$$

$$RAP_{Agg\%} = \frac{RAP_{mix\%}}{CF} \times \frac{100 - P_{b,RAP}}{100}$$

$$RAS_{Agg\%} = \frac{RAS_{mix\%}}{CF} \times \frac{100 - P_{b,RAS}}{100}$$

- 2) Calculate the RAS Available Asphalt Binder Content ($P_{b,AV}$) given the Total RAS Asphalt Binder Content.

$$P_{b,AV} = P_{b,RAS} \times 0.85$$

- 3) Calculate the asphalt binder contributed ($AB_{rcy\%,mix}$) from the RAP ($AB_{RAP\%}$) and/or RAS ($AB_{RAS\%}$) given the aggregate percentages of RAP and/or RAS.

$$AB_{RAP\%} = 100 \times \left(\frac{RAP_{Agg\%}}{100 - P_{b,RAP}} \right) - RAP_{Agg\%}$$

$$AB_{RAS\%} = 100 \times \left(\frac{RAS_{Agg\%}}{100 - P_{b,AV}} \right) - RAS_{Agg\%}$$

$$AB_{rcy\%,mix} = CF (AB_{RAP\%} + AB_{RAS\%})$$

**Determination of
Aggregate Bulk (Dry) Specific Gravity (Gsb) of Reclaimed Asphalt Pavement (RAP) and
Reclaimed Asphalt Shingles (RAS)
Appendix B.21
(continued)**

Effective: May 1, 2007
Revised: December 1, 2019

- 4) Calculate the ABR for the mixture given the mixture total asphalt content (P_b).

$$ABR = 100 \times \left(\frac{AB_{rcy\%,mix}}{P_b} \right)$$

- b. Example Calculations for Increasing ABR to Compensate for the RAS Availability Factor Reduction of RAS asphalt binder content.

Example of Adjusting RAS for Additional ABR

- N70 Polymer Surface with RAS
 - P_b (%AC) in RAS = 25.0%
 - P_b (%AC) in Mixture = 6.0%
 - Maximum ABR = 10%
 - $RAS_{mix\%}$ Before Calculation of $P_{b,AV}$ = 2.4%

Step 1. Calculate the RAS and/or RAP aggregate percentages ($RAS_{Agg\%}$ and $RAP_{Agg\%}$). Note that $RAP_{Agg\%}$ is equal to 0.0% in this example.

$$CF = \frac{100 - P_b}{100} = \frac{100 - 6.0}{100} = 0.94$$

$$RAS_{Agg\%} = \frac{RAS_{mix\%}}{CF} \times \frac{100 - P_{b,RAS}}{100} = \frac{2.4}{0.94} \times \frac{100 - 25.0}{100} = 1.9\%$$

Step 2. Calculate the RAS Available Asphalt Binder Content ($P_{b,AV}$) given the Total RAS Asphalt Binder Content.

$$P_{b,AV} = 25.0\% \times 0.85 = 21.3\%$$

Step 3. Calculate the asphalt binder contributed ($AB_{rcy\%,mix}$) from the RAS ($AB_{RAS\%}$) given the aggregate percentage of RAS.

**Determination of
Aggregate Bulk (Dry) Specific Gravity (Gsb) of Reclaimed Asphalt Pavement (RAP) and
Reclaimed Asphalt Shingles (RAS)
Appendix B.21
(continued)**

Effective: May 1, 2007
Revised: December 1, 2019

$$AB_{RAS\%} = 100 \times \left(\frac{RAS_{Agg\%}}{100 - P_{b,AV}} \right) - RAS_{Agg\%} = 100 \times \left(\frac{1.9}{100 - 21.3} \right) - 1.9 = 0.5\%$$

$$AB_{rcy\%,mix} = CF(AB_{RAP\%} + AB_{RAS\%}) = 0.94(0.0 + 0.5) = 0.5\%$$

Step 4. Calculate the ABR for the mixture given the mixture total asphalt content (P_b).

$$ABR = 100 \times \left(\frac{AB_{rcy\%,mix}}{P_b} \right) = 100 \times \left(\frac{0.5}{6.0} \right) = 8.3\%$$

Step 5. If ABR is maximized, the blend percentage of RAS can be adjusted (assuming $RAS_{mix\%}$ is less than 5.0%). In this case, the RAS content will be adjusted. In order to modify the RAS content, the additional available ABR is calculated.

$$ABR_{added} = ABR_{max} - ABR_{current} = 10 - 8.3 = 1.7\%$$

Step 6. Calculate the additional percentage of recycled asphalt binder available in the mixture.

$$AB_{rcy\%,mix,added} = \frac{(ABR_{added})(P_b)}{100} = \frac{(1.7)(6.0)}{100} = 0.1\%$$

Step 7. Calculate the additional percentage of RAS asphalt binder available in aggregate percentage.

$$AB_{RAS\%,added} = \frac{AB_{rcy\%,mix,added}}{CF} = \frac{0.1}{0.94} = 0.1\%$$

Step 8. Calculate the additional percentage of RAS aggregate.

$$RAS_{Agg\%,added} = \frac{(AB_{RAS\%,added})(100 - P_{b,AV})}{P_{b,AV}} = \frac{0.1(100 - 21.3)}{21.3} = 0.4\%$$

Step 9. Calculate the additional percentage of RAS by weight of mixture.

**Determination of
Aggregate Bulk (Dry) Specific Gravity (Gsb) of Reclaimed Asphalt Pavement (RAP) and
Reclaimed Asphalt Shingles (RAS)
Appendix B.21
(continued)**

Effective: May 1, 2007
Revised: December 1, 2019

$$RAS_{mix\%,added} = \frac{100(CF)(RAS_{Agg\%,added})}{100 - P_{b,RAS}} = \frac{(100)(0.94)(0.4)}{100 - 25.0} = 0.5\%$$

In this case, the RAS blend percentage by weight of mixture increased from 2.4 to 2.9%. The RAS blend percentage by weight of aggregate increased from 2.0 (shown in Step 1) to 2.4% (additional 0.4% shown in Step 8).

Example of Adjusting RAP for Additional ABR

- N90 Surface Mixture
 - P_b (%AC) in RAS = 25.0%
 - P_b (%AC) in RAP = 5.5%
 - P_b (%AC) in Mixture = 6.0%
 - Maximum ABR = 30%
 - $RAS_{mix\%}$ Before Calculation of $P_{b,AV}$ = 5.0%
 - $RAP_{mix\%}$ Before Calculation of $P_{b,AV}$ = 10.3%

Step 1. Calculate the RAS and RAP aggregate percentages ($RAS_{Agg\%}$ and $RAP_{Agg\%}$).

$$CF = \frac{100 - P_b}{100} = \frac{100 - 6.0}{100} = 0.94$$

$$RAS_{Agg\%} = \frac{RAS_{mix\%}}{CF} \times \frac{100 - P_{b,RAS}}{100} = \frac{5.0}{0.94} \times \frac{100 - 25.0}{100} = 4.0\%$$

$$RAP_{Agg\%} = \frac{RAP_{mix\%}}{CF} \times \frac{100 - P_{b,RAP}}{100} = \frac{10.3}{0.94} \times \frac{100 - 5.5}{100} = 10.4\%$$

Step 2. Calculate the RAS Available Asphalt Binder Content ($P_{b,AV}$) given the Total RAS Asphalt Binder Content.

$$P_{b,AV} = 25.0\% \times 0.85 = 21.3\%$$

Step 3. Calculate the asphalt binder contributed ($AB_{rcy\%,mix}$) from the RAS ($AB_{RAS\%}$) and RAP ($AB_{RAP\%}$) given the aggregate percentages of RAS and RAP.

**Determination of
Aggregate Bulk (Dry) Specific Gravity (Gsb) of Reclaimed Asphalt Pavement (RAP) and
Reclaimed Asphalt Shingles (RAS)
Appendix B.21
(continued)**

Effective: May 1, 2007
Revised: December 1, 2019

$$AB_{RAS\%} = 100 \times \left(\frac{RAS_{Agg\%}}{100 - P_{b,AV}} \right) - RAS_{Agg\%} = 100 \times \left(\frac{4.0}{100 - 21.3} \right) - 4.0 = 1.1\%$$

$$AB_{RAP\%} = 100 \times \left(\frac{RAP_{Agg\%}}{100 - P_{b,RAP}} \right) - RAP_{Agg\%} = 100 \times \left(\frac{10.4}{100 - 5.5} \right) - 10.4 = 0.6\%$$

$$AB_{rcy\%,mix} = CF(AB_{RAP\%} + AB_{RAS\%}) = 0.94(0.6 + 1.1) = 1.6\%$$

Step 4. Calculate the ABR for the mixture given the mixture total asphalt content (P_b).

$$ABR = 100 \times \left(\frac{AB_{rcy\%,mix}}{P_b} \right) = 100 \times \left(\frac{1.6}{6.0} \right) = 26.7\%$$

Step 5. If ABR is maximized, the blend percentages of RAS and RAP can be adjusted (assuming $RAS_{mix\%}$ is less than 5.0%). In this case, the RAP content will be adjusted because the $RAS_{mix\%}$ is equal to 5.0%. In order to adjust the RAP content, the additional available ABR is calculated.

$$ABR_{added} = ABR_{max} - ABR_{current} = 30 - 26.7 = 3.3\%$$

Step 6. Calculate the additional percentage of recycled asphalt binder available in the mixture.

$$AB_{rcy\%,mix,added} = \frac{(ABR_{added})(P_b)}{100} = \frac{(3.3)(6.0)}{100} = 0.2\%$$

Step 7. Calculate the additional percentage of RAP asphalt binder available in aggregate percentage.

$$AB_{RAP\%,added} = \frac{AB_{rcy\%,mix,added}}{CF} = \frac{0.2}{0.94} = 0.2\%$$

Step 8. Calculate the additional percentage of RAP aggregate.

**Determination of
Aggregate Bulk (Dry) Specific Gravity (Gsb) of Reclaimed Asphalt Pavement (RAP) and
Reclaimed Asphalt Shingles (RAS)
Appendix B.21
(continued)**

Effective: May 1, 2007
Revised: December 1, 2019

$$RAP_{Agg\%,added} = \frac{(AB_{RAP\%,added})(100 - P_{b,RAP})}{P_{b,RAP}} = \frac{0.2(100 - 5.5)}{5.5} = 3.4\%$$

Step 9. Calculate the additional percentage of RAP by weight of mixture.

$$RAP_{mix\%,added} = \frac{100(CF)(RAP_{Agg\%,added})}{100 - P_{b,RAP}} = \frac{(100)(0.94)(3.4)}{100 - 5.5} = 3.4\%$$

In this case, the RAP blend percentage by weight of mixture increased from 10.3 to 13.7%. The RAP blend percentage by weight of aggregate increased from 10.4 (shown in Step 1) to 13.8% (additional 3.4% shown in Step 8).

Example of Adjusting RAP and RAS for Additional ABR

- N90 Surface Mixture
 - P_b (%AC) in RAS = 25.0%
 - P_b (%AC) in RAP = 5.5%
 - P_b (%AC) in Mixture = 6.0%
 - Maximum ABR = 30%
 - $RAS_{mix\%}$ Before Calculation of $P_{b,AV}$ = 4.0%
 - $RAP_{mix\%}$ Before Calculation of $P_{b,AV}$ = 14.5%

Step 1. Calculate the RAS and/or RAP aggregate percentages ($RAS_{Agg\%}$ and $RAP_{Agg\%}$).

$$CF = \frac{100 - P_b}{100} = \frac{100 - 6.0}{100} = 0.94$$

$$RAS_{Agg\%} = \frac{RAS_{mix\%}}{CF} \times \frac{100 - P_{b,RAS}}{100} = \frac{4.0}{0.94} \times \frac{100 - 25.0}{100} = 3.2\%$$

$$RAP_{Agg\%} = \frac{RAP_{mix\%}}{CF} \times \frac{100 - P_{b,RAP}}{100} = \frac{14.5}{0.94} \times \frac{100 - 5.5}{100} = 14.6\%$$

Step 2. Calculate the RAS Available Asphalt Binder Content ($P_{b,AV}$) given the Total RAS Asphalt Binder Content.

$$P_{b,AV} = 25.0\% \times 0.85 = 21.3\%$$

**Determination of
Aggregate Bulk (Dry) Specific Gravity (Gsb) of Reclaimed Asphalt Pavement (RAP) and
Reclaimed Asphalt Shingles (RAS)
Appendix B.21
(continued)**

Effective: May 1, 2007
Revised: December 1, 2019

Step 3. Calculate the asphalt binder contributed ($AB_{rcy\%,mix}$) from the RAS ($AB_{RAS\%}$) and RAP ($AB_{RAP\%}$) given the aggregate percentages of RAS and RAP.

$$AB_{RAS\%} = 100 \times \left(\frac{RAS_{Agg\%}}{100 - P_{b,AV}} \right) - RAS_{Agg\%} = 100 \times \left(\frac{3.2}{100 - 21.3} \right) - 3.2 = 0.9\%$$

$$AB_{RAP\%} = 100 \times \left(\frac{RAP_{Agg\%}}{100 - P_{b,RAP}} \right) - RAP_{Agg\%} = 100 \times \left(\frac{14.6}{100 - 5.5} \right) - 14.6 = 0.8\%$$

$$AB_{rcy\%,mix} = CF(AB_{RAP\%} + AB_{RAS\%}) = 0.94(0.8 + 0.9) = 1.6\%$$

Step 4. Calculate the ABR for the mixture given the mixture total asphalt content (P_b).

$$ABR = 100 \times \left(\frac{AB_{rcy\%,mix}}{P_b} \right) = 100 \times \left(\frac{1.6}{6.0} \right) = 26.7\%$$

Step 5. If ABR is maximized, the blend percentage of RAS can be adjusted (assuming $RAS_{mix\%}$ is less than 5.0%). In this example, the RAP content will be adjusted by 1.0% by weight of mixture to 15.5%. Then, this increase leads to an ABR of 28.3%. In order to adjust the RAS content, the additional available ABR is calculated.

$$ABR_{added} = ABR_{max} - ABR_{current} = 30 - 28.3 = 1.7\%$$

Step 6. Calculate the additional percentage of recycled asphalt binder available in the mixture.

$$AB_{rcy\%,mix,added} = \frac{(ABR_{added})(P_b)}{100} = \frac{(1.7)(6.0)}{100} = 0.1\%$$

Step 7. Calculate the additional percentage of RAS asphalt binder available in aggregate percentage.

$$AB_{RAS\%,added} = \frac{AB_{rcy\%,mix,added}}{CF} = \frac{0.1}{0.94} = 0.1\%$$

**Determination of
Aggregate Bulk (Dry) Specific Gravity (Gsb) of Reclaimed Asphalt Pavement (RAP) and
Reclaimed Asphalt Shingles (RAS)
Appendix B.21
(continued)**

Effective: May 1, 2007
Revised: December 1, 2019

Step 8. Calculate the additional percentage of RAS aggregate.

$$RAS_{Agg\%,added} = \frac{(AB_{RAS\%,added})(100 - P_{b,AV})}{P_{b,AV}} = \frac{0.1(100 - 21.3)}{21.3} = 0.4\%$$

Step 9. Calculate the additional percentage of RAS by weight of mixture.

$$RAS_{mix\%,added} = \frac{100(CF)(RAS_{Agg\%,added})}{100 - P_{b,RAS}} = \frac{(100)(0.94)(0.4)}{100 - 25.0} = 0.5\%$$

In this case, the RAP blend percentage by weight of mixture increased from 14.5 to 15.5%. The RAP blend percentage by weight of aggregate increased from 14.6 (shown in Step 1) to 15.6% (additional 1.0% shown in Step 8). The RAS blend percentage by weight of mixture increased from 4.0 to 4.5%. The RAS blend percentage by weight of aggregate increased from 3.3 (shown in Step 1) to 3.7% (additional 0.4% shown in Step 8).

This Page Reserved

**Use of Correction Factors for Adjusting the Gradation of Cores
to Estimate the Gradation of the In-Place Pavement**

Appendix B.22

Effective January 31, 2008

Revised December 1, 2019

GENERAL

When cores are removed from a pavement, and a solvent extraction or ignition oven burn is conducted on the cored material, the gradation of the resulting aggregate is finer than the original pavement because the perimeter of the core was cut by the core barrel. Also, breakdown may occur as a result of the aggregate being subjected to the high temperatures in the ignition oven. The following Core Correction Factors are used to estimate the gradation of the in-place pavement from the gradation of the core after a solvent extraction or an ignition oven burn has been conducted. The Core Correction Factors were determined from four-inch diameter cores cut from 150 mm gyratory compacted lab specimens. The six-inch Factors were estimated from the four-inch Factors.

APPLICABLE DOCUMENTS

- Illinois-modified AASHTO T 30, Mechanical Analysis of Extracted Aggregates
- Illinois-modified AASHTO T 164, Quantitative Extraction of Asphalt Binder from Hot Mix Asphalt (HMA)
- Illinois-modified AASHTO T 308, Determining the Asphalt Binder Content of Hot-Mix Asphalt (HMA) by the Ignition Method

FOUR-INCH AND SIX-INCH CORE CORRECTION FACTORS

Sieve	Percent Passing							
	EXTRACTION				IGNITION OVEN *			
	BINDER		SURFACE		BINDER		SURFACE	
	4-inch	6-inch	4-inch	6-inch	4-inch	6-inch	4-inch	6-inch
1" / 25.0mm	0.0	0.0	0.0	0.0	0.0	0.0	0.0	0.0
3/4" / 19.0mm	1.0	0.7	0.0	0.0	0.0	0.0	0.0	0.0
1/2" / 12.5mm	1.5	1.0	0.0	0.0	2.3	1.5	0.0	0.0
3/8" / 9.5mm	1.4	0.9	0.0	0.0	2.5	1.7	0.1	0.1
#4 / 4.75mm	0.9	0.6	2.2	1.5	1.9	1.3	2.1	1.4
#8 / 2.36mm	0.7	0.5	1.0	0.7	1.0	0.7	0.9	0.6
#16 / 1.18mm	0.6	0.4	0.6	0.4	0.7	0.5	0.6	0.4
#30 / 0.600mm	0.4	0.3	0.4	0.3	0.5	0.3	0.5	0.3
#50 / 0.300mm	0.4	0.3	0.4	0.3	0.4	0.3	0.3	0.2
#100 / 0.150mm	0.3	0.2	0.2	0.1	0.3	0.2	0.3	0.2
#200 / 0.075mm	0.17	0.11	0.16	0.11	0.20	0.13	0.20	0.13

The gradation of the aggregate from the extraction or ignition oven burn of the core is finer than the gradation of the original in-place pavement. Therefore, subtract the designated amount from the measured percent passing of the core to estimate the in-place gradation prior to coring.

* This testing was conducted on a limited number of aggregate sources. A larger amount of degradation in the ignition oven is possible from aggregates from other sources.

EXAMPLES

Given: 4-inch SURFACE mix cores where a SOLVENT EXTRACTION has been conducted.

Sieve	Percent Passing			
	EXTRACTION		Subtract Correction Factor from Extracted Gradation	Estimated In-place Pavement Gradation
	Extracted Gradation	Surface Correction Factor		
1" / 25.0mm	100.0	0.0	100.0 - 0.0	100.0
3/4" / 19.0mm	100.0	0.0	100.0 - 0.0	100.0
1/2" / 12.5mm	100.0	0.0	100.0 - 0.0	100.0
3/8" / 9.5mm	95.6	0.0	95.6 - 0.0	95.6
#4 / 4.75mm	60.6	2.2	60.6 - 2.2	58.4
#8 / 2.36mm	35.3	1.0	35.3 - 1.0	34.3
#16 / 1.18mm	23.8	0.6	23.8 - 0.6	23.2
#30 / 0.600mm	17.8	0.4	17.8 - 0.4	17.4
#50 / 0.300mm	12.8	0.4	12.8 - 0.4	12.4
#100 / 0.150mm	9.2	0.2	9.2 - 0.2	9.0
#200 / 0.075mm	7.10	0.16	7.10 - 0.16	6.94

Given: 4-inch BINDER mix cores where an IGNITION OVEN Burn has been conducted.

Sieve	Percent Passing			
	IGNITION OVEN		Subtract Correction Factor from Ignition Oven Gradation	Estimated In-place Pavement Gradation
	Ignition Oven Gradation	Binder Correction Factor		
1" / 25.0mm	100.0	0.0	100.0 - 0.0	100.0
3/4" / 19.0mm	97.9	0.0	97.9 - 0.0	97.9
1/2" / 12.5mm	77.2	2.3	77.2 - 2.3	74.9
3/8" / 9.5mm	63.6	2.5	63.6 - 2.5	61.1
#4 / 4.75mm	38.5	1.9	38.5 - 1.9	36.6
#8 / 2.36mm	25.0	1.0	25.0 - 1.0	24.0
#16 / 1.18mm	18.1	0.7	18.1 - 0.7	17.4
#30 / 0.600mm	14.0	0.5	14.0 - 0.5	13.5
#50 / 0.300mm	10.1	0.4	10.1 - 0.4	9.7
#100 / 0.150mm	6.9	0.3	6.9 - 0.3	6.6
#200 / 0.075mm	5.60	0.20	5.60 - 0.20	5.40

Given: 6-inch SURFACE mix cores where a SOLVENT EXTRACTION has been conducted.

Sieve	Percent Passing			
	EXTRACTION		Subtract Correction Factor from Extracted Gradation	Estimated In-place Pavement Gradation
	Extracted Gradation	Surface Correction Factor		
1" / 25.0mm	100.0	0.0	100.0 - 0.0	100.0
3/4" / 19.0mm	100.0	0.0	100.0 - 0.0	100.0
1/2" / 12.5mm	100.0	0.0	100.0 - 0.0	100.0
3/8" / 9.5mm	95.6	0.0	95.6 - 0.0	95.6
#4 / 4.75mm	60.6	1.5	60.6 - 1.5	59.1
#8 / 2.36mm	35.3	0.7	35.3 - 0.7	34.6
#16 / 1.18mm	23.8	0.4	23.8 - 0.4	23.4
#30 / 0.600mm	17.8	0.3	17.8 - 0.3	17.5
#50 / 0.300mm	12.8	0.3	12.8 - 0.3	12.5
#100 / 0.150mm	9.2	0.1	9.2 - 0.1	9.1
#200 / 0.075mm	7.10	0.11	7.10 - 0.11	6.99

**Off-Site Preliminary Test Strip and Modified Start-Up Procedures
Appendix B.23**

Effective Date: April 1, 2010
Revised Date: [December 1, 2021](#)

Effective Date: April 1, 2010
Revised Date: December 1, 2017

The purpose of an off-site preliminary test strip is to verify a plant can produce a new mixture within volumetric tolerances, to verify a mixture can be compacted within specification, and possibly to develop a rolling pattern on a similar pavement. If an off-site preliminary test strip is used in lieu of an on-site test strip, the process shall additionally follow the document "Hot-Mix Asphalt Test Strip Procedures".

A. Contractor/Department Off-Site Preliminary Test Strip Team Members

As the test strip is constructed, a team of both Contractor and Department personnel will evaluate the mix.

The test strip team may consist of the following:

1. Resident Engineer
2. District Construction Supervising Field Engineer, or representative
3. District Materials Mixtures Control Engineer, or representative
4. District Nuclear Density Gauge Tester
5. Contractor's QC Manager, [required](#)
6. [Contractor's Paving Superintendent](#)
7. [Contractor's Density Tester](#)

Optional:

8. [Central Bureau of Construction representative](#)
9. [Central Bureau of Materials representative](#)
10. Asphalt Binder Supplier representative

B. Communications

The Contractor shall advise the team members [48 hours in advance](#) of the anticipated start [date/time](#) of production of the off-site preliminary test strip [mix](#). The QC Manager shall direct the activities of the [test strip](#) team. A Department appointed representative from the [test strip](#) team will act as spokesperson for the Department.

C. Off-Site Preliminary Test Strip Method

The off-site preliminary test strip shall consist of [300 tons \(275 metric tons\)](#) of [mix](#). It shall contain two growth curves which shall be tested as outlined herein.

Off-Site Preliminary Test Strip and Modified Start-Up Procedures
Appendix B.23

Effective Date: April 1, 2010

Revised Date: December 1, 2021

1. **Location of Off-Site Preliminary Test Strip.** The off-site preliminary test strip shall be located on a pavement type similar to the contract pavement and acceptable to the Engineer. It shall be on a relatively flat portion of the roadway.
2. **Compaction Equipment.** It shall be the responsibility of the QC manager to verify roller compliance before commencement of growth curve construction.

All rolling equipment intended for use on a project shall be utilized on the off-site preliminary test strip.

3. **Compaction Temperature.** In order to make an accurate analysis of the density potential of the mixture, the initial compaction temperature of the mixture on the pavement at the beginning of the growth curve shall be no more than 10°F (5°C) lower than the minimum mixture placement temperature specified in Section 406.06. The mat temperature shall be monitored throughout the construction of each growth curve.
4. **Mixture Volumetric Samples.** The first and second sets of mixture volumetric samples shall be taken by the Contractor at such times as to represent the mixture of the two growth curves, respectively. All off-site preliminary test strip samples shall be processed by the Contractor for determination of mixture composition and air voids. This shall include washed extraction gradation and asphalt content test results. This information shall then be compared to the job mix formula (JMF) and required design criteria.
5. **Growth Curve.** The QC manager shall specify the roller(s) speed and number of passes required to obtain a completed growth curve. The nuclear gauge shall be placed near the center of the hot mat and the position marked for future reference. With the bottom of the nuclear gauge and the source rod clean, a one-minute nuclear reading (without mineral filler) shall be taken after each pass of the roller. Rolling shall continue until the maximum density is achieved and three consecutive passes show no appreciable increase in density or no evidence of destruction of the mat. The growth curve shall be plotted. No testing of initial passes shall be taken until the third roller pass is completed.
6. **Constructing the Off-Site Preliminary Test Strip.** After the Contractor has placed approximately 225 to 250 tons (200 to 225 metric tons) of mix, placement of the mix shall stop, and a growth curve shall be constructed. After completion of the first growth curve, paving shall resume for remaining 50 to 75 tons (45 to 70 metric tons) of mix, placement shall again stop, and the second growth curve shall be constructed within this area. Additional growth curves may be required if an adjustment/plant change is made during the off-site preliminary test strip. The Contractor shall use the specified rolling procedures for all portions of the test strip except for the growth curve areas which shall be compacted as directed by the QC Manager.

Off-Site Preliminary Test Strip and Modified Start-Up Procedures
Appendix B.23

Effective Date: April 1, 2010
Revised Date: December 1, 2021

If the off-site preliminary test strip is to be used as the final test strip, mixture sampling and testing as specified in the document "Hot-Mix Asphalt Test Strip Procedures" shall be followed.

7. **Evaluation of Growth Curves.** Mixtures which exhibit density potential outside of the specified density range shall be considered as sufficient cause for mix adjustment. If a mix adjustment is made, an additional test strip may be constructed, and associated tests shall be performed. This information shall then be compared to the adjusted job mix formula (AJMF) and required design criteria.

If the density potential of the mixture does not meet the minimum specified, the operation shall cease until adjustments are made to the AJMF or a new mix design is produced.

In addition, other aspects of the mixture, such as appearance, segregation, texture, or other evidence of mix problems, should be noted and corrective action taken at this time.

8. **Final Density Testing.** After the growth curve information is obtained, a final nuclear reading, using mineral filler to eliminate surface voids, shall be taken at the marked position. This reading is used to adjust the maximum density reading obtained during the growth curve.

D. Acceptance Criteria

If the off-site preliminary test strip is to be used as the final test strip, acceptance will be as specified in the document "Hot-Mix Asphalt Test Strip Procedures".

E. Documentation

All off-site preliminary test strip mixture volumetrics and rolling pattern information (including growth curves) will be tabulated by the QC manager with copies provided to each team member, and the original retained in the project files.

If the off-site preliminary test strip is to be used as the final test strip, documentation shall also include mixture tests, and nuclear readings and core test results if a nuclear gauge correlation was completed.

This Page Reserved

**Determination of Residual Asphalt in Prime and Tack Coat Materials
Appendix B.24**

Effective: March 1, 2013

A. Purpose

This procedure provides a means for determining the amount of asphalt binder remaining after a tack coat or prime coat cures. The remaining asphalt binder is termed residual asphalt. This procedure shall be used for verifying specification compliance when the tack coat or prime coat application rate is specified based on residual asphalt.

B. Procedure

1. Cut and label a 12.0 inch by 12.0 inch square piece of non-woven geotextile fabric or cardboard. Place the square in a 230 ± 9 °F (110 ± 5 °C) oven and dry to constant weight. Remove the square from the oven and record the weight W_i to the nearest 0.1 gram within 5 minutes after removal.

Notes:

- *Oven drying is necessary because cardboard especially can retain considerable moisture in humid conditions.*
 - *The fabric or cardboard used for squares needs to 1) have sufficient thickness to prevent loss of asphalt and 2) allow sufficient absorption to prevent spillage.*
 - *Constant weight is defined as the weight at which further drying does not alter the mass more than 0.5 gram in 1 hour.*
2. Place the pre-weighed square at a random transverse location prior to tack or prime coat application.
 3. After the prime or tack has been applied, remove the square from the pavement and protect from damage during transport. Place the square in a 230 ± 9 °F (110 ± 5 °C) oven and dry to a constant weight.
 4. Remove the square from the oven and record the final weight W_f to the nearest 0.1 gram within 5 minutes after removal from the oven.
 5. Subtract the initial weight W_i determined in step 1 from the final weight W_f determined in step 4. Divide this value by 454 to get the residual asphalt binder application rate in lbs/ ft².

$$\text{Residual Asphalt Application Rate} = (W_f - W_i) / 454$$

This Page Reserved

**Procedure for
Field Permeability Testing of Hot-Mix Asphalt Pavements**

Appendix B.25

Effective Date: January 1, 2016
Revised Date: [December 1, 2021](#)

1. Scope

- 1.1. This test method covers the in-place estimation of the water permeability of a compacted hot-mix asphalt (HMA) pavement. The estimate provides an indication of water permeability of a pavement location as compared to those of other pavement locations.
- 1.2. The values stated in metric (SI) units are regarded as standard. Values given in parenthesis are for information and reference purposes only.
- 1.3. This standard does not purport to address all the safety problems associated with its use. It is the responsibility of the user of this standard to establish appropriate safety and health practices and determine the applicability of regulatory limitations prior to use.

2. Summary of Test Method

- 2.1. [This test method is based on National Center for Asphalt Technology \(NCAT\) Report No. 99-1, Permeability of Superpave Mixtures – Evaluation of Field Permeameters by J. Allen Cooley, Jr.](#)
- 2.2. A falling head permeability test is used to estimate the rate at which water flows into a compacted HMA pavement. Water from a graduated standpipe is allowed to flow into a compacted HMA pavement and the interval of time taken to reach a known change in head loss is recorded. The coefficient of permeability of a compacted HMA pavement is then estimated based on Darcy's Law.

3. Significance and Use

- 3.1. This test method provides a means of estimating water permeability of compacted HMA pavements. The estimation of water permeability is based upon assumptions that the sample thickness is equal to the immediately underlying HMA pavement course thickness; the area of the tested sample is equal to the area of the permeameter from which water is allowed to penetrate the HMA pavement; one-dimensional flow; and laminar flow of the water. It is assumed that Darcy's law is valid.

4. Apparatus

- 4.1. *Hand Broom* – A broom of sufficient stiffness to sweep a test location free of debris.

**Procedure for
Field Permeability Testing of Hot-Mix Asphalt Pavements**

Appendix B.25

Effective Date: January 1, 2016

Revised Date: December 1, 2021

- 4.2. *Timing Device* – A stopwatch or other timing device graduated in divisions of at least 0.1 seconds.
- 4.3. *Sealant* – A silicone-rubber caulk to seal the permeameter to the pavement surface.
- 4.4. *Field Permeameter* – A field permeameter made to the determined dimensions and specifications.

5. Preparation of Pavement Surface

- 5.1. Prior to conducting the test, a broom should be used to remove all debris from the pavement surface. Debris left on the pavement surface can hinder the sealing of the permeameter to the pavement surface.

6. Test Procedure

6.1. Permeameter Setup

- 6.1.1. Ensure that both sides of the square rubber base and the bottom of the square plastic base plate of the permeameter are free of debris.
- 6.1.2. Apply sealant to one side of the square, rubber base.
- 6.1.3. Place the side of the square, rubber base containing the sealant onto the pavement surface. Evenly apply light hand pressure to the top of the square, rubber base to force the sealant into the surface voids.
- 6.1.4. Place the middle, medium sized standpipe and stopper into the bottom, large standpipe of the permeameter base and seat securely in the top of the large standpipe.
- 6.1.5. Place the base of the permeameter onto the square, rubber base ensuring that the hole within the square, plastic base plate of the permeameter lines up with the hole in the square, rubber base.
- 6.1.6. Carefully place the weight over the standpipes onto the square, plastic base plate of the permeameter.

6.2. Test

- 6.2.1. To start the test, pour water into the medium standpipe until the water level is well above the initial head (top marked line).
- 6.2.2. Notice how quickly the water level drops. When the water level is at the desired initial head, start the timing device. (See Note 1) Stop the timing device when the water level within the standpipe reaches the desired final head (bottom marked line) (See Note 2). Record the time interval between the initial and final head (top and bottom marked lines).

**Procedure for
Field Permeability Testing of Hot-Mix Asphalt Pavements**

Appendix B.25

Effective Date: January 1, 2016

Revised Date: December 1, 2021

Note 1: For relatively impermeable pavements, the water level will drop very slowly within the top tier standpipe. Therefore, the initial head should be taken within the top tier standpipe. For pavements of “medium” permeability, the water level will drop quickly through the top tier standpipe. Therefore, the initial head should be taken within the middle tier standpipe. For very permeable pavements the water level will drop very quickly through the top and middle tier standpipes but slow down when it reaches the bottom tier standpipe. Therefore, the initial head should be taken in the bottom tier standpipe.

Note 2: The initial and final head determinations should be made within the same standpipe tier.

Note 3: At some point, after several layers of silicone caulk have been allowed to build up on the square rubber base, removing the layers of silicone will be necessary. This is best done after the silicone has been allowed to “set up” somewhat but before the silicone layer becomes permanently attached to the square rubber base. This is normally around six layers.

7. Calculation

7.1. The coefficient of permeability, k , is estimated using the following equation:

$$k = \frac{aL}{At} \ln \left(\frac{h_1}{h_2} \right)$$

Where:

k = coefficient of permeability, cm/sec

a = inside cross-sectioned area of standpipe used for that test, sq cm

L = thickness of underlying HMA course, cm

A = cross-sectioned area of pavement through which water can penetrate, sq cm (generally the same area as the bottom tier standpipe and area of hole in the square rubber base)

t = elapsed time between h_1 and h_2 , sec

h_1 = initial head in the pavement location, cm

h_2 = final head on the pavement location, cm

7.2. Report the results for k to the nearest tenth of a unit x 10^{-5} cm/sec.

This Page Reserved

ILLINOIS TEST PROCEDURE 406

ASPHALT BINDER FILM THICKNESS OF ULTRATHIN BONDED WEARING COURSE (UBWC)

Appendix B.26

Effective Date: August 22, 2019

1. SCOPE

- 1.1 This test procedure covers the procedure to calculate the asphalt binder film thickness of an Ultrathin Bonded Wearing Course (UBWC) Hot Mix Asphalt (HMA) paving mixture by applying surface area factors to the design aggregate gradation.
- 1.2 The values stated in SI units are to be regarded as the standard.
- 1.3 *This standard does not purport to address all of the safety concerns, if any, associated with its use. It is the responsibility of the user of this procedure to establish appropriate safety and health practices and determine the applicability of regulatory limitations prior to use.*

2. TERMINOLOGY

- 2.1 Asphalt binder film thickness: The thickness, in mils (microns), of the total asphalt binder content minus the asphalt binder absorbed into the aggregate

3. SIGNIFICANCE AND USE

- 3.1 This procedure shall be used to determine the asphalt binder thickness of a UBWC HMA paving mixture.
- 3.2 The minimum binder content of the UBWC HMA paving mixture shall be determined by achieving the specified asphalt binder thickness.

4. PROCEDURE

- 4.1 Obtain the proposed UBWC aggregate blend sheet.
- 4.2 The surface area factors used for each sieve size are as follows:

Surface Area (SA) Factors	
Sieve Size (mm)	Units (ft ² /lb)
12.5	2
9.5	2
4.75	2
2.36	4
1.18	8
0.600	14
0.300	30
0.150	60
0.075	160

ILLINOIS TEST PROCEDURE 406

ASPHALT BINDER FILM THICKNESS OF ULTRATHIN BONDED WEARING COURSE (UBWC) Appendix B.26

Effective Date: August 22, 2019

The surface area for each sieve is obtained from the percent passing gradation data shown on the aggregate blend sheet. Determine and record the total aggregate surface area by summing the surface area for each sieve as follows:

$$SA_{\text{Total}} = 2 + \left[\sum_{\text{Sieves}} (\text{Percent Passing}/100 \times \text{SA Factor}) \right]$$

4.3 Determine and record the following from the UBWC mix design:

- 4.3.1 Total asphalt binder content, P_b
- 4.3.2 Total aggregate bulk specific gravity, G_{sb}
- 4.3.3 Asphalt binder specific gravity, G_b
- 4.3.4 Aggregate effective specific gravity, G_{se}

4.4 Determine and record the volume (in^3) of total asphalt binder as follows:

$$P_b \text{ Volume} = \frac{(M_T \times (P_b/100))}{G_b \times \gamma_w} \times (12 \text{ in/ft})^3$$

where:

- $P_b \text{ Volume}$ = volume of total asphalt binder
- M_T = total mass of mixture (assume 100 pounds)
- P_b = total asphalt binder content
- G_b = asphalt binder specific gravity (assume 1.030 if not known)
- γ_w = unit weight of water (62.416 lb/ft^3)

ILLINOIS TEST PROCEDURE 406

ASPHALT BINDER FILM THICKNESS OF ULTRATHIN BONDED WEARING COURSE (UBWC) Appendix B.26

Effective Date: August 22, 2019

4.5 Determine and record the absorbed asphalt binder percentage as follows:

$$P_{ba} = 100 \times ((G_{se} - G_{sb}) / (G_{se} \times G_{sb})) \times G_b$$

where:

P_{ba} = absorbed asphalt binder percentage

G_{se} = aggregate effective specific gravity

G_{sb} = total aggregate bulk specific gravity

G_b = asphalt binder specific gravity (assume 1.030 if not known)

4.6 Determine and record the weight (lbs) of absorbed asphalt binder as follows:

$$P_{ba \text{ Weight}} = M_T \times (P_{ba}/100) \times P_s$$

where:

$P_{ba \text{ Weight}}$ = weight of absorbed asphalt binder

M_T = total mass of mixture (assume 100 pounds)

P_{ba} = absorbed asphalt binder percentage

P_s = percentage of aggregate = 1 - (Pb/100)

4.7 Determine and record the volume (in³) of absorbed asphalt binder as follows:

$$P_{ba \text{ Volume}} = P_{ba \text{ Weight}} / (G_b \times \gamma_w) \times (12 \text{ in/ft})^3$$

where:

$P_{ba \text{ Volume}}$ = volume of absorbed asphalt binder

$P_{ba \text{ Weight}}$ = weight of absorbed asphalt binder

G_b = asphalt binder specific gravity (assume 1.030 if not known)

γ_w = unit weight of water (62.416 lb/ft³)

ILLINOIS TEST PROCEDURE 406

ASPHALT BINDER FILM THICKNESS OF ULTRATHIN BONDED WEARING COURSE (UBWC) Appendix B.26

Effective Date: August 22, 2019

- 4.8 Determine and record the volume (in³) of the effective asphalt binder percentage as follows:

$$P_{\text{be Volume}} = P_{\text{b Volume}} - P_{\text{ba Volume}}$$

where:

$P_{\text{be Volume}}$ = volume of effective asphalt binder

$P_{\text{b Volume}}$ = volume of total asphalt binder

$P_{\text{ba Volume}}$ = volume of absorbed asphalt binder

- 4.9 Determine and record the asphalt binder film thickness (in mils) as follows:

$$T_f = (P_{\text{be Volume}} / (SA_{\text{Total}} \times M_T \times P_s)) \times (1 \text{ ft}/12 \text{ in})^2 \times (1 \text{ mil}/0.001 \text{ in})$$

Where:

T_f = average asphalt binder film thickness

$P_{\text{be Volume}}$ = volume of effective asphalt binder

SA_{Total} = total aggregate surface area (ft²/lb)

M_T = total mass of mixture (assume 100 pounds)

P_s = percentage of aggregate = 1 - (Pb/100)

5. REPORT

- 5.1 The asphalt binder film thickness in mils shall be reported.

Hot-Mix Asphalt Production Inspection Checklist
Appendix B.27

Effective Date: December 1, 2019

Revised Date: [December 1, 2021](#)

A. Scope

This checklist is intended for use as a guide by Department materials inspectors engaged in reviewing hot-mix asphalt (HMA) plant and field operations.

B. Purpose

This checklist provides a standardized format for documenting HMA materials inspection activities.

C. General Information

This checklist is based upon the previous successful completion of all applicable plant surveys, truck certifications, scale (or volumetric mixer) calibrations, plant [Annual Quality Control \(QC\) Plan for Hot-Mix Asphalt Production](#), and QC laboratory inspections.

The inspector will familiarize themselves with Standard Specifications Sections 1030 and 1102, and applicable portions of the Manual of Test Procedures for Materials.

If applicable, the inspector will review the current Model Quality Control Plan and Quality Control Plan Addendum for the plant.

If applicable, the inspector will review project special provisions and plans relating to project specific HMA mixture property, sampling, and testing requirements.

The inspector will maintain a record of each visit to a production facility and typically include the following information:

- Date, arrival time, weather conditions, & departure time.
- Producer Name and Plant Location.
- Producer Number and Plant Description if more than one plant at location.
- Mix Design being produced.
- [Address for mixture delivery](#).
- Item mixture incorporated into.
- Plant QC personnel present.
- Results of any QC, QA, INV, or [Verification](#) testing performed.
- Component material samples taken.
- Substantive conversations with QC personnel relating to production or plant operations.
- Items described in the following sections that are not acceptable.

Note: The inspector is to inform plant personnel of any unacceptable items and document if they are corrected while present.

Hot-Mix Asphalt Production Inspection Checklist
Appendix B.27

Effective Date: December 1, 2019

Revised Date: [December 1, 2021](#)

D. Plant Operations

QC Laboratory and Equipment (if applicable)

Is testing equipment present and in good working order?

Does equipment calibration documentation indicate required calibration activities have been performed?

Aggregates

Are aggregate stockpiles clearly marked?

Are aggregate stockpiles separated with no adjacent stockpiles intermingling?

Are aggregate stockpiles free from clay or other contamination?

Are aggregate stockpiles free from segregation or degradation?

Is an Investigative Sample warranted for quality or gradation check?

Are aggregate stockpiles [constructed with](#) steel-track equipment?

Are stockpiles being handled properly?

Do aggregate shipping tickets clearly represent the material being stockpiled?

Does the aggregate source match the approved source from the Quality Control Plan or indicated on the approved mix design?

Is stockpile sampling being performed properly?

Are aggregate gradation results [up-to-date](#) and available?

If required, are aggregate split samples labeled and available?

Do QC and QA gradations compare?

[Are correct](#) RAP/RAS [stockpiles](#) being used and producer has RAP/RAS approval letter?

Perform Investigative gradation and quality sampling [as directed](#).

Hot-Mix Asphalt Production Inspection Checklist
Appendix B.27

Effective Date: December 1, 2019

Revised Date: [December 1, 2021](#)

Mineral Filler, Asphalt Binder, Additives

Do material delivery tickets indicate materials are on the qualified products list?

Do materials match those shown in the Quality Control Plan or indicated on the approved mix design?

Is an asphalt binder sample required?

Mixture Production

Is the mix design appropriate for the item?

Do the Batch Plant batch weights or Drum Plant cold feed percentages and component materials correlate to the mix design?

Are stockpile moistures being done daily for recycled materials, coarse, & fine aggregates?

Has the correct aggregate moisture been input?

At a drum plant, verify the 6-minute checks are being performed and information is within tolerance.

Is the moving average for critical gradation sieve within job mixture formula parameters?

Is the mixture temperature within specifications?

Does the mixture delivery ticket include the required information?

Is the truck loading [time](#)-stamp on the delivery ticket accurate?

E. Trucks

Are the truck beds clean?

Have the truck beds been sprayed with release agents? Is there a diesel fuel smell?

Does release agent delivery ticket indicate a product on the qualified product list?

Is a release agent sample required?

Are the truck tarps and insulation in place?

Hot-Mix Asphalt Production Inspection Checklist
Appendix B.27

Effective Date: December 1, 2019

Revised Date: [December 1, 2021](#)

F. Plant Mixture Testing

Are plant QC personnel documenting actions?

Do plant QC personnel performing testing match the approved QC Plan?

Is equipment utilized for plant testing calibrated and in good working condition?

Is sufficient QC testing being performed to control production?

Split samples [are](#) saved and labeled correctly?

Does QC testing comply with the approved QC Plan?

Are plant QC personnel performing tests according to proper procedures?

Are control charts available upon request?

Are all criteria with volumetrics moving averages being checked and calculated?

Are adjustments and re-testing results documented?

Do test results indicate mixture will arrive at the project site within specification limits?

Are Daily Plant Reports being completed?

Hot-Mix Asphalt Production Inspection Checklist
Appendix B.27

Effective Date: December 1, 2019

Revised Date: [December 1, 2021](#)

G. Project Site

Maintain a diary record of each visit to a project site where HMA is being placed. Include the following information.

- Date, arrival time, weather conditions, & departure time.
- Contract and project location.
- Producer Name and Plant Location.
- Producer Number and Plant Description if more than one plant at location.
- Mix Design being produced.
- The item the mixture is incorporated into.
- Jobsite QC personnel present. Jobsite QA personnel present if applicable.
- Document results of any QC, QA, INV, or [Verification](#) testing performed.
- Document any substantive conversations with contractor or IDOT field personnel relating to the mixture.
- Document any of the items described in the following section applicable to field operations that are not acceptable. Inform field personnel of any unacceptable items, and note if they are corrected while you are present.

[Do](#) jobsite QC personnel performing testing match the approved QC plan?

Do individuals performing testing on behalf of the agency have proper certification (HMA Level I or Nuclear Density)?

Is equipment utilized for jobsite testing calibrated and in good working condition?

Does testing frequency meet applicable requirements?

This Page Reserved

**Hot-Mix Asphalt Rounding Test Values
Appendix B.28**

Effective Date: [December 1, 2021](#)

A. Scope

The intent of rounding is to limit the number of digits in an observed or calculated value to those considered significant for the purpose of determining conformance with specification limits.

If improperly applied, rounding may contribute to loss of precision and result in increased risk to either the Department or Contractor.

B. Rounding Test Values

The following are the appropriate significant digits to which test values are to be rounded for parameters described in the Section 1030:

<u>Test</u>	<u>Significant Digits</u>
Gradation (% Passing);	Nearest whole percent (1%)
Field Density; Air Voids; Field VMA; Minus No. 200 (75- μ m); Asphalt Binder Content	Nearest one-tenth percent (0.1%)
Bulk Specific Gravity , G_{mb} ; Maximum Specific Gravity , G_{mm}	Nearest one-thousandth (0.001)

Rounding of test results shall be according to the document Illinois Modified ASTM E 29, "Using Significant Digits in Test Data to Determine Conformance with Specifications".

This Page Reserved

ILLINOIS DEPARTMENT OF TRANSPORTATION

MODEL QUALITY CONTROL PLAN FOR CONCRETE PRODUCTION

Effective: December 1, 1993

Revised: December 1, 2017

INSTRUCTIONS: The Contractor shall respond to all items addressed in this model. This is applicable to work performed by the Contractor or subcontractor(s). Examples are provided to assist the Contractor, and any innovations to the quality control process may be presented.

Part 1 is completed by the Contractor.

Part 2 is completed by the Contractor or Commercial Concrete Producer. For the Contractor, Part 2 is submitted annually, for the period which begins April 1st, and which expires the following year on March 31st. For a Commercial Concrete Producer, Part 2 shall remain in effect until the Producer submits an updated document or the District requests the Producer to update Part 2. (Note: A District may require Part 2 to be updated annually or at a longer interval.)

If Part 2 is approved by the Department's District office for a one year period, the Contractor shall either attach the approved Part 2 to each Quality Control Plan submitted, or shall state "The approved Part 2, for the period from mo/day/yr to mo/day/yr, is on file at the District office; the contents are fully and thoroughly understood, and the contents are a part of this Contract." When Part 2 has been completed by the Commercial Concrete Producer, the Contractor shall not make any revisions. However, the Contractor and Commercial Concrete Producer have the option to amend Part 2 for a specific project, and submit it to the Department's District office for approval.

QUALITY CONTROL PLAN CONCRETE

County: _____
Section: _____
Route: _____
District: _____
Contract No.: _____
Job No.: _____
Project: _____
Contractor: _____
P.O. Box: _____
Street Address: _____
City/State/Zip Code: _____
Telephone No.: _____
Fax No.: _____

CONTRACTOR RESPONSIBILITIES

This Quality Control plan explains how _____ proposes to control the equipment, materials, and production methods to ensure the specified product is obtained.

PART 1 - QUALITY CONTROL PLAN AT THE JOBSITE

I. FIELD OFFICE

Location: _____

Contact Person: _____

Telephone Number: _____

In the event of field equipment failure, _____ will provide back up equipment.

II. FIELD QUALITY CONTROL PERSONNEL

Individual's Name: _____

Department Training: _____

Company Name: _____

Telephone Number: _____

_____ Primary or _____ Back Up

The Level II PCC Technician who will be responsible for plant mixture control and adjustments is indicated in Part 2.

_____ is the Level I PCC Technician who will be responsible for jobsite mixture control and adjustments.

_____ is the Quality Control Manager who will be responsible for overall project quality control.

III. FIELD SAMPLING AND TESTING

INSTRUCTIONS: Indicate whether beams and/or cylinders will be cast, as well as how the specimens will be initially cured.

Note: In some instances, such as Articles 503.05 and 503.06, only a flexural strength is specified. An equivalent compressive strength may be used if approved by the Engineer.

Example:

Plastic cylinder molds [6 by 12 in. (152 by 305 mm)] will be used to cast strength specimens. The plastic cylinder mold will be covered with a plastic cylinder lid. A curing box will be used to maintain the specimens within 60 to 80° F (16 to 27° C). The specimens will be transported after 24 hours for standard curing.

INSTRUCTIONS: Indicate the final location for standard curing and testing of the strength specimens, and the method of curing.

Example:

The strength specimens will be transported to the consultant's lab for standard curing in a water storage tank, and testing.

IV. FAILING TESTS AND DEFECTIVE WORK

INSTRUCTIONS: Indicate the communication procedures between the Commercial Concrete Producer, the Contractor, and Department personnel in the event of failing tests or observation of defective work. This may also be in flow chart form.

Example:

In the event of failing tests or observation of defective work at the jobsite, the Level I PCC Technician will be responsible for notifying the Superintendent and the Quality Control Manager. The Superintendent will be responsible for notifying the Resident Engineer.

In the event of failing tests at the plant, the Level II PCC Technician will be responsible for notifying the Superintendent and the Quality Control Manager. The Superintendent will be responsible for notifying the Resident Engineer.

V. COMMUNICATION

INSTRUCTIONS: For concurrent pours, indicate how each Concrete Tester will be able to contact the Level I PCC Technician.

Indicate how jobsite personnel will be able to contact the Level II PCC Technician.

Example:

For concurrent pours, each Concrete Tester will be able to contact the Level I PCC Technician by two-way radio. Jobsite personnel will use two-way radio to contact the Level II PCC Technician, when he/she is at the plant. When the Level II PCC Technician is not at the plant, jobsite personnel and the Level II PCC Technician will use a cellular phone.

VI. FIELD DOCUMENTATION

INSTRUCTIONS: Indicate the forms, the bound hardback field books, and bound hardback diaries that will be used to maintain documentation at the jobsite.

Example:

A bound hardback field book will be used for all documentation at the jobsite.

VII. PRE-POUR MEETING

INSTRUCTIONS: Indicate when a bridge deck pre-pour meeting will be scheduled. Meetings for other important pours are encouraged.

Examples:

A meeting will be scheduled the day before the bridge deck pour to discuss mix, concrete delivery, pumped concrete, finishing equipment and requirements, labor, deficiencies, curing, weather conditions (i.e. temperature, humidity, wind), and other pertinent issues.

Or

A meeting will be scheduled two months, two weeks, and two days before the bridge deck pour. The meetings will discuss mix, concrete delivery, pumped concrete, finishing equipment and requirements, labor, deficiencies, curing, weather conditions (i.e. temperature, humidity, wind), and other pertinent issues.

PART 2 - QUALITY CONTROL PLAN AT THE CONCRETE PLANT

If applicable:

Department Producer/Supplier Number: _____

Commercial Concrete Producer: _____

P.O. Box: _____

Street Address: _____

City/State/Zip Code: _____

Telephone Number: _____

I. MATERIALS

INSTRUCTIONS: The wording for "A) Aggregates" is provided for the Contractor. Indicate the material sources for "B) Coarse Aggregates" and "C) Fine Aggregates". If applicable, attach proposed mix plant gradation bands in accordance with the Department's "Development of Gradation Bands on Incoming Aggregate at Mix Plants."

A) Aggregates

Certified aggregate gradation bands (including master band, if required) will be obtained from the aggregate source for all certified aggregates, prior to any shipment of material to the plant.

B) Coarse Aggregates

Material: (Example: CA 11 - Crushed Stone)

ASTM C 1260 Expansion: _____ (This is not required for limestone or dolomite aggregate.)

Department Producer/Supplier Number: _____

Company Name: _____

Company Address: _____

Contact Person: _____

Telephone Number: _____

C) Fine Aggregates

Material: (Example: FA 01 - Natural Sand)

ASTM C 1260 Expansion: _____ (This is not required for limestone or dolomite aggregate.)

Department Producer/Supplier Number: _____

Company Name: _____

Company Address: _____

Contact Person: _____

Telephone Number: _____

D) Aggregate Stockpiling and Handling

INSTRUCTIONS: Aggregates shall be stockpiled and handled in a manner which minimizes segregation and degradation, prevents contamination, and produces a uniform gradation, before placement in the plant bins. This is according to Articles 106.06, 106.07, 1003.01(e), 1004.01(e), 1004.02(d), and 1020.10. Indicate the specific methods to be used.

Example:

Coarse aggregates are shipped by rail to the plant, in a uniform gradation condition. Upon delivery of the coarse aggregate, it will be transferred to a stockpile by a movable conveyor system. The stockpile will be built according to Article 1004.01(e).

Fine aggregates are shipped by truck to the plant, in a uniform gradation condition. The fine aggregate will be truck dumped into a stockpile. The truck stockpile will be built according to Article 1003.01(e).

All stockpiles will be separated with concrete block walls, sufficient in width, length, and height to prevent contamination. The maximum height of the walls will be ___ ft (___ m).

E) Uniform Aggregate Moisture

INSTRUCTIONS: According to Article 1020.10, aggregates shall have a uniform moisture content before placement in the plant bins. Indicate the specific methods to be used.

Example:

Coarse and fine aggregates will be stockpiled and allowed to drain for 12 hours, before placement in the plant bins. However, during hot weather, the aggregate stockpiles will be periodically sprinkled with water.

F) Coarse Aggregate Moisture

INSTRUCTIONS: Indicate the frequency of coarse aggregate moisture testing to control production.

NOTE: Fine aggregate moisture testing is specified in the Special Provision for Quality Control/Quality Assurance of Concrete Mixtures.

G) Aggregate Gradation Samples

INSTRUCTIONS: Indicate how and where you will sample aggregates to assure they will meet current Department gradation specifications.

Example:

For aggregates arriving at the plant, truck-dump sampling will be performed for fine and coarse aggregate gradation tests.

For aggregates used during concrete production, on-belt sampling will be performed for fine and coarse aggregate gradation tests. The conveyor belt beneath the bin will be used.

H) Gradation Tests for Aggregates Arriving at the Plant

INSTRUCTIONS: Indicate the frequency of gradation testing for aggregates arriving at the plant, **to check the source**.

NOTE: The frequency of gradation testing **to check the production of concrete**, for aggregates stored at the plant in stockpiles or bins, is specified in the Special Provision for Quality Control/Quality Assurance of Concrete Mixtures.

II. PLANT AND DELIVERY TRUCKS

Plant Name: _____

Plant Location: _____

Producer No.: _____

NOTE: The plant and delivery trucks are to be approved according to the Central Bureau of Material's Policy Memorandum, "Approval of Concrete Plants and Delivery Trucks." Contact the Department's District office to obtain the required forms.

III. QUALITY CONTROL LABORATORY

Location: _____

Contact Person: _____

Telephone Number: _____

The quality control laboratory is ____ sq. ft. [The Department suggests 200 ft² (20 m²)].

The laboratory was approved on _____ by District _____.

In the event of lab equipment failure, _____ will provide back up equipment.

IV. PLANT QUALITY CONTROL PERSONNEL

Individual's Name: _____

Department Training: _____

Company Name: _____

Telephone Number: _____

_____ Primary or _____ Back Up

NOTE: Include personnel who have been trained by the Level II PCC Technician to sample and test aggregate for moisture.

_____ is the Level II PCC Technician who will be responsible for plant mixture control and adjustments.

The Level I PCC Technician who will be responsible for jobsite mixture control and adjustments is indicated in Part 1.

The Quality Control Manager who will be responsible for overall project quality control is indicated in Part 1.

V. MIX DESIGNS

INSTRUCTIONS: Provide mix design information as stated in 1.1 “Volumetric Mix Design and Mix Design Submittal” of the Portland Cement Concrete Level III Technician Course – Manual of Instructions for Design of Concrete Mixtures.

Otherwise state: “Only mix designs previously verified by the Department will be used”.

INSTRUCTIONS: Based on the ASTM C 1260 test information provided for the aggregates, indicate the mixture option selected for minimizing the risk of alkali-silica reaction. Refer to Article 1020.05(d).

VI. PLANT MIXTURE TESTING

INSTRUCTIONS: Indicate the plant start-up testing frequency, and the plant testing frequency thereafter, to control production. This is required for slump, air content, unit weight, yield, and temperature tests performed at the plant. Indicate any other tests that will be performed.

NOTE: Plant start-up situations are defined in the “Portland Cement Concrete Level II Technician Course” manual. Indicate if the manual’s plant start-up situations will be applicable, or if other start-up situations will apply.

VII. PLANT SUPERVISION

INSTRUCTIONS: If the Level II will supervise more than one plant, indicate his/her attendance at the various plants for large or critical pours.

VIII. COMMUNICATION

INSTRUCTIONS: Indicate how plant personnel will be able to contact the Level II PCC Technician, when he/she is not at the plant.

Example:

Plant personnel will use a land phone, to contact the Level II PCC Technician by cellular phone.

IX. PLANT DOCUMENTATION

INSTRUCTIONS: Indicate the forms, the bound hardback field books, and bound hardback diaries that will be used to maintain documentation at the plant, and at the laboratory.

Example:

A loose-leaf binder will be used to maintain any Department form which is required at the plant, or at the laboratory. A bound hardback field book will be used to record test results at the plant, and at the laboratory. A bound hardback diary will be used to document observations, inspections, adjustments to the mix design, and corrective actions at the plant.

INSTRUCTIONS:

To be completed by Contractor. Return with Quality Control Plan.

QUALITY CONTROL PLAN SIGNATURE SHEET

(IF AN INDIVIDUAL)

Firm Name _____
Print Name of Owner _____
Signature of Owner _____
Date: _____

(IF A CO-PARTNERSHIP)

Firm Name _____
Print Name of Partner _____
Signature of Partner _____
Date: _____

(IF A CORPORATION)

Corporate Name _____
Print Name of Authorized Representative _____
Signature of Authorized Representative _____
Date: _____

(ALL)

Business Address: _____
P.O. Box: _____
Street Address: _____
City/State/Zip Code: _____

INSTRUCTIONS: The Contractor shall complete this section for Addendums to a Quality Control Plan.

QUALITY CONTROL PLAN ADDENDUM
CONCRETE

County: _____

Section: _____

Route: _____

District: _____

Contract No.: _____

Job No.: _____

Project: _____

Contractor: _____

P.O. Box: _____

Street Address: _____

City/State/Zip Code: _____

Telephone No.: _____

Fax No.: _____

ADDENDUMS

INSTRUCTIONS: Indicate and/or attach addendums to Contractor Quality Control Plan.

INSTRUCTIONS:

To be completed by Contractor. Return with any amended Quality Control Plan.

QUALITY CONTROL PLAN ADDENDUM SIGNATURE SHEET

(IF AN INDIVIDUAL)

Firm Name _____

Print Name of Owner _____

Signature of Owner _____

Date: _____

(IF A CO-PARTNERSHIP)

Firm Name _____

Print Name of Partner _____

Signature of Partner _____

Date: _____

(IF A CORPORATION)

Corporate Name _____

Print Name of Authorized Representative _____

Signature of Authorized Representative _____

Date: _____

(ALL)

Business Address: _____

P.O. Box: _____

Street Address: _____

City/State/Zip Code: _____

ILLINOIS DEPARTMENT OF TRANSPORTATION

QUALIFICATIONS AND DUTIES OF CONCRETE QUALITY CONTROL PERSONNEL

Effective: December 1, 1993

Revised: January 1, 2014

This document summarizes the qualifications and duties of quality control personnel for Portland Cement Concrete (PCC) mixtures, Cement Aggregate Mixture II (CAM II), and Controlled Low-Strength Material (CLSM). Duties shall be performed daily, or as required, according to the QC/QA specifications and related documents.

QUALITY CONTROL MANAGER: An individual who has the experience, responsibility, and authority to make decisions regarding quality control of Portland Cement Concrete, Cement Aggregate Mixture II, and Controlled Low-Strength Material. This individual is required to have successfully completed the Department's Portland Cement Concrete Level I Technician Course, the Portland Cement Concrete Level II Technician Course, and either the 3-day Mixture Aggregate Technician Course or 5-day Aggregate Technician Course.

- Duties:**
1. Understand the specifications and related documents regarding QC/QA. Read the Quality Control Plan and any amendments to the Plan.
 2. Manage overall project quality control.
 3. Ensure the laboratory, concrete plant, and delivery trucks are approved by the Engineer.
 4. Ensure the test equipment is maintained and calibrated as required by the appropriate test procedure.
 5. Ensure the mixture meets the requirements of the specifications.
 6. Ensure good communication between the plant and jobsite to quickly resolve quality control problems. Failure to resolve quality control problems shall result in mixture production suspension.
 7. Ensure the Engineer is notified of any material supply problems.
 8. Ensure the Engineer is immediately notified of any failing tests and subsequent remedial action. Ensure passing tests are reported no later than the start of the next work day. Consult with the Engineer when questions arise concerning acceptance or rejection of materials.
 9. Ensure all observations, inspections, adjustments to the mix design, test results, retest results, and corrective actions are documented promptly, and in the specified format. Ensure form MI504M, form MI654, and form MI655 are submitted to the Engineer weekly, or as required by the Engineer.
 10. Supervise the Level III PCC Technician, Level II PCC Technician, Level I PCC Technician, Concrete Tester, Gradation Technician, Mixture Aggregate Technician, and Aggregate Technician.

11. Ensure sufficient personnel are provided to perform the required inspections, sampling, testing, and documentation. Ensure work is accurate and done in a timely manner.

LEVEL III PCC TECHNICIAN: An individual who has successfully completed the Department's Portland Cement Concrete Level I Technician Course, the Portland Cement Concrete Level II Technician Course, the Portland Cement Concrete Level III Technician Course, and either the 3-day Mixture Aggregate Technician Course or 5-day Aggregate Technician Course.

- Duties:
1. Understand the specifications and related documents regarding QC/QA. Read the Quality Control Plan and any amendments to the Plan.
 2. Read contract special provision(s) for project specific mix design information.
 3. Obtain component materials' specific gravities and absorptions (aggregates).
 4. Ensure coarse aggregate voids tests are performed when necessary to calculate mix design batch weights (mass). NOTE: The Level III PCC Technician may train anyone to sample and test coarse aggregate voids, provided the individual is monitored on a daily basis by the Level III PCC Technician. This is not applicable to aggregate sampling and testing for gradation, or to any other type of test.
 5. Determine the correct proportions of aggregates, cement, finely divided minerals, water, admixtures, and fiber reinforcement per cubic yard (meter).
 6. Evaluate results when a trial mixture is performed.
 7. Supervise a trial batch when requested by the Engineer.
 8. Ensure the mix design is verified by the Engineer.
 9. Ensure the mix design meets specification requirements during construction. If not, take appropriate action and re-submit to the Engineer.

LEVEL II PCC TECHNICIAN: An individual who has successfully completed the Department's Portland Cement Concrete Level I Technician Course, the Portland Cement Concrete Level II Technician Course, and either the 3-day Mixture Aggregate Technician Course or 5-day Aggregate Technician Course.

- Duties:
1. See Level I PCC Technician duties.
 2. Check the operation of the concrete plant and condition of the delivery trucks.
 3. Ensure only materials approved by the Department are used.
 4. Obtain and split aggregate samples.

5. Perform gradation test for coarse and fine aggregates. If test results are near specification limits or unsatisfactory, take appropriate action and retest when applicable.
6. Perform aggregate moisture tests to adjust mix design aggregate batch weights (mass). NOTE: The Level II PCC Technician may train anyone to sample and test aggregate for moisture, provided the individual is monitored on a daily basis by the Level II PCC Technician. This is not applicable to aggregate sampling and testing for gradation, or to any other type of test.
7. Verify the specified mix design is used, and the correct proportions of aggregates, cement, finely divided minerals, water, admixtures, and fiber reinforcement are batched.
8. Control water/cement ratio by determining the allowable quantity of water which can be added at the jobsite.
9. Maintain communications with jobsite personnel to control the mixture, for compliance with the specifications.
10. Supervise the Gradation Technician, or assign the task to the Mixture Aggregate Technician or Aggregate Technician.

LEVEL I PCC TECHNICIAN: An individual who has successfully completed the Department's Portland Cement Concrete Level I Technician Course.

- Duties:**
1. Understand the specifications and related documents regarding QC/QA. Read the Quality Control Plan and any amendments to the Plan.
 2. Maintain and calibrate test equipment as required by the appropriate test procedure.
 3. Sample the mixture.
 4. Perform temperature, slump, slump flow (self-consolidating concrete (SCC)), flow (CLSM), J-Ring (SCC), L-Box (SCC), hardened visual stability index (SCC), dynamic segregation index (SCC), and air content tests and compare with specifications. If test results are unsatisfactory or near specification limits, take appropriate action and retest when applicable.
 5. Perform unit weight test and determine yield.
 6. Make strength and static segregation (SCC) specimens. Transport strength specimens properly and ensure correct curing. Break strength specimens. NOTE: If an individual has the responsibility of breaking strength specimens only, such as at a consultant's laboratory, this individual is required to have the Level I PCC Technician training or the Concrete Strength Testing Technician certification by the American Concrete Institute (ACI).
 7. Monitor truck revolutions and haul time.

8. Determine the required quantity of water and admixtures for adjusting the mixture, to meet specifications and field conditions.
9. Observe the discharge of a mixture by the delivery truck, and take appropriate action if a problem is identified.
10. For a mixture which is not mixed on the jobsite, ensure the required information is recorded on the delivery truck ticket.
11. Document all observations, inspections, adjustments to the mix design, test results, retest results, and corrective actions promptly, and in the specified format.
12. Maintain communications with plant personnel to control the mixture, for compliance with the specifications.
13. Notify the Engineer of test results.
14. Report test results to the Quality Control Manager.
15. Supervise the Concrete Tester.

CONCRETE TESTER: An individual who has successfully completed the Department's Portland Cement Concrete Tester Course. The Concrete Tester shall be monitored on a daily basis by the Level I or the Level II PCC Technician when performing tests.

- Duties:**
1. Sample the mixture.
 2. Perform temperature, slump, slump flow (self-consolidating concrete (SCC)), flow (CLSM), J-Ring (SCC), L-Box (SCC), hardened visual stability index (SCC), dynamic segregation index (SCC), air content and unit weight tests.
 3. Make strength and static segregation (SCC) specimens.
 4. Monitor truck revolutions and haul time.
 5. Observe the mixture and notify the Level I or Level II PCC Technician of any problems.
 6. Assist the Level I or Level II PCC Technician with adjustments to a mixture, by adding water or an admixture.
 7. For a mixture which is not mixed on the jobsite, ensure the required information is recorded on the delivery ticket.
 8. Document all observations, inspections, adjustments to the mix design, test results, retest results, and corrective actions promptly, and in the specified format.

9. Report truck revolutions, haul time, and test results to the Level I or Level II PCC Technician. Immediate notification is required if truck revolutions, haul time, or test results are near specification limits or unsatisfactory.

GRADATION TECHNICIAN: An individual who has successfully completed the Department's Aggregate Gradation Testing Course and has demonstrated satisfactory field performance. The Gradation Technician shall be monitored on a daily basis by the Level II PCC Technician when performing tests. The Level II PCC Technician may have the Mixture Aggregate Technician, or Aggregate Technician responsible for supervising the Gradation Technician on a daily basis.

- Duties:
1. Split aggregate samples provided by others.
 2. Perform gradation test for coarse and fine aggregates.
 3. Document test results.
 4. Report test results to Level II PCC Technician. Immediate notification is required if test results are near specification limits or unsatisfactory.

MIXTURE AGGREGATE TECHNICIAN: An individual who has successfully completed the Department's 3-day Aggregate Training Course.

- Duties:
1. Obtain and split aggregate samples.
 2. Perform gradation test for coarse and fine aggregates.
 3. Document test results.
 4. Report test results to Level II PCC Technician. Immediate notification is required if test results are near specification limits or unsatisfactory.
 5. Supervise the Gradation Technician, when required by the Level II PCC Technician.

NOTE: The duties listed are for assisting the Level II PCC Technician, and are not to be confused with the "Aggregate Gradation Control System" program.

AGGREGATE TECHNICIAN: An individual who has successfully completed the Department's 5-day Aggregate Training Course.

- Duties:
1. Obtain and split aggregate samples.
 2. Perform gradation test for coarse and fine aggregates.
 3. Document test results.
 4. Report test results to Level II PCC Technician. Immediate notification is required if test results are near specification limits or unsatisfactory.
 5. Supervise the Gradation Technician, when required by the Level II PCC Technician.

NOTE: The duties listed are for assisting the Level II PCC Technician, and are not to be confused with the "Aggregate Gradation Control System" program.

Required Sampling and Testing Equipment for Concrete

Effective: December 1, 1993

Revised: [December 1, 2021](#)

This document applies to cast-in-place, precast, and precast prestressed operations. This document summarizes the minimum requirements for sampling and testing Portland Cement Concrete (PCC) mixtures, Cement Aggregate Mixture II (CAM II), and Controlled Low-Strength Material (CLSM). Refer to the *Manual of Test Procedures for Materials* for detailed equipment information.

AT THE PLANT OR LOCATION APPROVED BY THE ENGINEER:

Proportioning PCC, CAM II, CLSM

Aggregate Moisture Test Equipment, and Balance¹ or Scale¹
(¹ The weighing equipment does not have to be electronic. Check weights are recommended.)

Sampling Plastic PCC, CAM II, CLSM

Wheelbarrow or Similar Equipment

Shovel

Testing Plastic PCC, CAM II, CLSM

Slump Kit (PCC or CAM II)

Plastic Cylinder for Flow Test (CLSM)

Air Meter Kit and Calibration Equipment

Unit Weight Kit, Calibration Equipment, and Balance¹ or Scale¹
(¹ The weighing equipment does not have to be electronic. Check weights are recommended.)

Thermometer

Ruler

Hand Scoop or Trowel

Vibrator (if required)

Slump Flow Kit (Required only for self-consolidating concrete.)

J-Ring or L-Box Kit (Required only for self-consolidating concrete.)

Aggregate Sampling Equipment for High/Low Volume Operation

Template and brush, or sampling device, or shovel.

Aggregate Testing Equipment for High Volume Operation

Definition of High Volume Aggregate Testing Operation – The high volume aggregate testing equipment may be used for multiple concrete plants, if approved by the Engineer. The decision will be based on specification requirements for providing test results.

Electronic Balance²

(² Check weights are recommended.)

Sieve Shaker, 305 mm (12 in.) sieve capacity and sufficient inside height to accept typical sieve stock

Sample Splitter, coarse aggregate, two pans³

(³ Three pans are required if the sample splitter does not have a hopper to hold aggregate.)

Sample Splitter, fine aggregate, two pans³

(³ Three pans are required if the sample splitter does not have a hopper to hold aggregate.)

(or)

Shovel, hand scoop, brush and dust pan,

Canvas blanket (optional), trowel (optional),

Sampling thief or small scoop or large spoon (optional)

Sieves, 305 mm (12 in.) brass with brass or stainless cloth

2 in. nominal height⁴— 25 mm (1 in.), 19 mm (3/4 in.),
16 mm (5/8 in.), 12.5 mm (1/2 in.)

1 5/8 in. nominal height⁴— 9.5 mm (3/8 in.), 6.25 mm (1/4 in.),
4.75 mm (No. 4), 1.18 mm (No. 16) two required,
0.3 mm (No. 50), 0.15 mm (No. 100),
0.075 mm (No. 200) two required

⁴ Distance from the top of the frame to the sieve cloth surface

Two Pans

Lid

Electric Drying Oven 110 ± 5 °C (230 ± 9 °F)

(or)

Two Double Electric Hot Plates or Gas Burners

Sink, Faucet, and Water Supply

Four Drying Pans 330 x 230 x 50 mm (13 x 9 x 2 in.), typical

Four Holding Pans 305 mm (12 in.), minimum diameter

Accessories: Large spoon, soft bristle brass brush, paint brush or stencil brush, and putty knife or pointed dowel rod.

Aggregate Testing Equipment for Low Volume Operation

Definition of Low Volume Aggregate Testing Operation – The low volume aggregate testing equipment may be used only for a single concrete plant. If a reduced testing time is desired, the high volume aggregate testing equipment is recommended, since the low volume 200 mm (8 in.) sieves will normally require the coarse aggregate sample to be sieved in parts to prevent overloading.

Electronic Balance²

(² Check weights are recommended.)

Sieve Shaker, 200 mm (8 in.) sieve capacity and sufficient inside height to accept typical sieve stock

Sample Splitter, coarse aggregate, two pans³

(³ Three pans are required if the sample splitter does not have a hopper to hold aggregate.)

Sample Splitter, fine aggregate, two pans³

(³ Three pans are required if the sample splitter does not have a hopper to hold aggregate.)

(or)

Shovel, hand scoop, brush and dust pan,

Canvas blanket (optional), trowel (optional),

Sampling thief or small scoop or large spoon (optional)

Sieves, 200 mm (8 in.) brass with brass or stainless cloth

2 in. nominal height ⁴ —	25 mm (1 in.), 19 mm (3/4 in.), 16 mm (5/8 in.), 12.5 mm (1/2 in.), 9.5 mm (3/8 in.), 6.25 mm (1/4 in.), 4.75 mm (No. 4)
-------------------------------------	---

1 in. nominal height ⁴ —	1.18 mm (No. 16) two required, 0.3 mm (No. 50) 0.15 mm (No. 100), 0.075 mm (No. 200) two required
-------------------------------------	---

⁴ Distance from the top of the frame to the sieve cloth surface

Two Pans

Lid

Two Double Electric Hot Plates or Gas Burners

Sink, Faucet, and Water Supply

Two Drying Pans 330 x 230 x 50 mm (13 x 9 x 2 in.), typical

Three Holding Pans 305 mm (12 in.), minimum diameter

Accessories: Large spoon, soft bristle brass brush, paint brush or stencil brush, and putty knife or pointed dowel rod.

AT THE JOBSITE:

Sampling Plastic PCC, CAM II, CLSM

Wheelbarrow or Similar Equipment

Shovel

Testing Plastic PCC, CAM II, CLSM

Slump Kit (PCC or CAM II)

Plastic Cylinder for Flow Test (CLSM)

Air Meter Kit and Calibration Equipment

Thermometer

Ruler

Hand Scoop or Trowel

Vibrator (if required)

Slump Flow Kit (Required only for self-consolidating concrete.)

J-Ring or L-Box Kit (Required only for self-consolidating concrete.)

Making Strength Specimens (Cylinders or Beams)

Plastic Cylinder Molds, 150 x 300 mm (6 x 12 in.) or 100 x 200 mm (4 x 8 in.),

Plastic Cylinder Lids, 150 mm (6 in.), 100 mm (4 in.), or other material per Illinois Modified AASHTO [R 100](#)

-----OR-----

Steel or Plastic Beam Molds (typical length)

152 x 152 x 457 mm (6 x 6 x 18 in.),

152 x 152 x 483 mm (6 x 6 x 19 in.),

152 x 152 x 508 mm (6 x 6 x 20 in.),

152 x 152 x 533 mm (6 x 6 x 21 in.), or

152 x 152 x 762 mm (6 x 6 x 30 in.)

Plastic Cover with Absorbent Pad, or other material per Illinois Modified AASHTO [R 100](#)

-----AND-----

Tamping Rod or Vibrator (as appropriate)

Mallet

Hand Scoop (optional)

Trowel or Wood Float

AT THE JOBSITE OR LOCATION APPROVED BY THE ENGINEER:

Curing Strength Specimens

Moist Cabinet or Moist Room, with Air Temperature and
Relative Humidity Control Equipment

Recording Thermometer

Relative Humidity Measuring Device and Logbook, or
Relative Humidity Recording Device

-----OR-----

Water Storage Tank and Provisions for Water Temperature Control

Maximum/Minimum Thermometer and Logbook, or
Recording Thermometer

Testing Strength Specimens

Capping System for Compressive Strength

Mechanical Testing Machine for Compressive Strength

-----OR-----

Mechanical or Hand-Operated Testing Machine for
Flexural Strength (Using Simple Beam with Center-Point Loading)

Self-Consolidating Concrete

Saw to cut cylinders for hardened visual stability index.

PRECAST CONCRETE PLANTS (ADDITIONAL REQUIREMENTS):

For dry cast operations, the slump kit is optional and the air meter kit is not required.

Block/Brick Products – A compression test machine is required.

Pipe Products – A three-edge-bearing machine is required.

Applicable Products – When cores are used to determine compressive strength, the core drill shall have diamond impregnated bits attached to the core barrel.

Applicable Products – Absorption, permeability, hydrostatic, density, freeze/thaw, linear drying shrinkage, and abrasion resistance test equipment are required.

This Page Reserved

ILLINOIS DEPARTMENT OF TRANSPORTATION
METHOD FOR OBTAINING RANDOM SAMPLES FOR CONCRETE

Effective: December 1, 1993
 Revised: November 1, 2017

Point of Random Sampling and Testing Based on Production

Applicable Specification(s):

Special Provision for Quality Control/Quality Assurance of Concrete Mixtures

A random sample based on mixture production is to be determined as follows:

- a) Determine the total quantity to be placed.

Example: Total quantity of a substructure is 395 yd³ (302 m³).

- b) Divide the total quantity by the random sample testing frequency. Round up to the nearest whole number.

Example: Random sample testing frequency for slump and air is 50 yd³ (40 m³).

English: 395 yd³ / 50 yd³ = 7.9, or
Metric: 302 m³ / 40 m³ = 7.6

Obtain 8 random samples.

- c) Obtain a random number from a calculator, a computer, or the Department's random numbers table, and multiply this number by the random sample testing frequency. Round the result to the nearest whole number and document the random number used.

Example: First random sample to be obtained at:

English: 0.576 x 50 yd³ = 29 yd³ in the first 50 yd³, or*
Metric: 0.576 x 40 m³ = 23 m³ in the first 40 m³.*

** First sample random number =
0.576***

*** Random number is selected from the
Department's random numbers table as illustrated
in the figure.*

0.576	0.730	0.430	0.750
0.892	0.948	0.858	0.020
0.669	0.726	0.501	0.400
0.609	0.482	0.809	0.140
0.971	0.824	0.902	0.470
0.053	0.899	0.554	0.620
0.810	0.159	0.225	0.160

- d) Determine which truck is to be sampled by maintaining a cumulative total of the amount placed during the pour.

Example:

		<u>Cumulative Total</u>
1st truck	6.5 yd ³ (5.0 m ³)	6.5 yd ³ (5.0 m ³)
2nd truck	6.5 yd ³ (5.0 m ³)	13.0 yd ³ (10.0 m ³)
3rd truck	6.5 yd ³ (5.0 m ³)	19.5 yd ³ (15.0 m ³)
4th truck	6.5 yd ³ (5.0 m ³)	26.0 yd ³ (20.0 m ³)
**5th truck	6.5 yd ³ (5.0 m ³)	32.5 yd ³ (25.0 m ³)

** Sample this truck since the random sample calculation is 29 yd³ (23 m³). It is not necessary to sample exactly at 29 yd³ (23 m³). Therefore, the slump and air test may be performed upon arrival of the truck. Sampling is to be performed according to Illinois Modified AASHTO R 60.

- e) Continue the random sampling method for the next 50 yd³ (40 m³).

Example: Second sample to be obtained at:

English: 0.892* × 50 yd³ = 45 yd³ in the second 50 yd³, or

Metric: 0.892* × 40 m³ = 36 m³ in the second 40 m³.

That is, using the cumulative total you would sample at:

English: 50 yd³ + 45 yd³ = 95 yd³ (i.e., the 15th truck), or

Metric: 40 m³ + 36 m³ = 76 m³ (i.e., the 16th truck).

* Second sample random number =
0.892**

** Random number is selected from the Department's random numbers table as illustrated in the figure.

0.576	0.730	0.430	0.75
0.892	0.948	0.858	0.02
0.669	0.726	0.501	0.40
0.609	0.482	0.809	0.14
0.971	0.824	0.902	0.47
0.053	0.899	0.554	0.62
0.810	0.159	0.225	0.16

Third sample to be obtained at:

English: 0.669* × 50 yd³ = 33 yd³ in the third 50 yd³, or

Metric: 0.669* × 40 m³ = 27 m³ in the third 40 m³.

Again, using the cumulative total you would sample at:

English: 50 yd³ + 50 yd³ + 33 yd³ = 133 yd³ (i.e., the 21st truck), or

Metric: 40 m³ + 40 m³ + 27 m³ = 107 m³ (i.e., the 22nd truck).

* Third sample random number =
0.669**

** Random number is selected from the Department's random numbers table as illustrated in the figure.

0.576	0.730	0.430	0.75
0.892	0.948	0.858	0.02
0.669	0.726	0.501	0.40
0.609	0.482	0.809	0.14
0.971	0.824	0.902	0.47
0.053	0.899	0.554	0.62
0.810	0.159	0.225	0.16

- f) The last random sample shall be obtained by multiplying a random number by the fractional portion of the random sample testing frequency determined in part b).

Example: Obtain the last sample at:

English: $0.726^ \times (0.9 \times 50 \text{ yd}^3) = 33 \text{ yd}^3$ in the final 50 yd^3 , or*

Metric: $0.726^ \times (0.6 \times 40 \text{ m}^3) = 17 \text{ m}^3$ in the final 40 m^3 .*

Thus, your last random sample would be at 383 yd^3 or 297 m^3 (i.e., the 59th or 60th truck, respectively).

* Last sample random number = 0.726**

** Random number is selected from the Department's random numbers table as illustrated in the figure. Remember: select a new set of numbers systematically; that is, either horizontally, as shown here, or vertically.

0.576	0.730	0.430	0.75
0.892	0.948	0.858	0.02
0.669	0.726	0.501	0.40
0.609	0.482	0.809	0.14
0.971	0.824	0.902	0.47
0.053	0.899	0.554	0.62
0.810	0.159	0.225	0.16

Point of Random Sampling and Testing Based on Location

Applicable Specification(s): (Note: Specifically for pull-off tests.)

- Bridge Deck Microsilica Concrete Overlay
- Bridge Deck Latex Concrete Overlay
- Bridge Deck High-Reactivity Metakaolin (HRM) Concrete Overlay

A random sample based on a location within an area of pavement or bridge deck is to be determined according to the following procedure:

- a) Obtain the length and width of the lot or subplot.
- b) Obtain a random number from a calculator, a computer, or the Department's random numbers table, and multiply this number by the total length of the lot or subplot. Obtain another random number and multiply this number by the total width of the lot or subplot. For each result round to the nearest 0.1. Document the result and random number used.

Example: The lot or subplot is 500 ft (152 m) long by 12 ft (3.6 m) wide.

Length: $0.576^ \times 500 \text{ ft (152 m)} = 288.0 \text{ ft (87.6 m)}$*

Width: $0.892^ \times 12 \text{ ft (3.6 m)} = 10.7 \text{ ft (3.2 m)}$*

* Random number is from the Department's random numbers table.

Therefore, the random sample location shall be taken 288.0 ft (87.6 m) from the beginning of the lot or subplot, and 10.7 ft (3.2 m) from the designated right or left edge of the lot or subplot. The designated edge shall be determined by the Engineer, and shall not vary.

- c) For each random sample location, determine the corresponding station location and document.
- d) The process shall be repeated for additional test locations using new random numbers for each location.

*R*ANDOM *N*UMBERS

0.576	0.730	0.430	0.754	0.271	0.870	0.732	0.721	0.998	0.239
0.892	0.948	0.858	0.025	0.935	0.114	0.153	0.508	0.749	0.291
0.669	0.726	0.501	0.402	0.231	0.505	0.009	0.420	0.517	0.858
0.609	0.482	0.809	0.140	0.396	0.025	0.937	0.301	0.253	0.761
0.971	0.824	0.902	0.470	0.997	0.392	0.892	0.957	0.040	0.463
0.053	0.899	0.554	0.627	0.427	0.760	0.470	0.040	0.904	0.993
0.810	0.159	0.225	0.163	0.549	0.405	0.285	0.542	0.231	0.919
0.081	0.277	0.035	0.039	0.860	0.507	0.081	0.538	0.986	0.501
0.982	0.468	0.334	0.921	0.690	0.806	0.879	0.414	0.106	0.031
0.095	0.801	0.576	0.417	0.251	0.884	0.522	0.235	0.389	0.222
0.509	0.025	0.794	0.850	0.917	0.887	0.751	0.608	0.698	0.683
0.371	0.059	0.164	0.838	0.289	0.169	0.569	0.977	0.796	0.996
0.165	0.996	0.356	0.375	0.654	0.979	0.815	0.592	0.348	0.743
0.477	0.535	0.137	0.155	0.767	0.187	0.579	0.787	0.358	0.595
0.788	0.101	0.434	0.638	0.021	0.894	0.324	0.871	0.698	0.539
0.566	0.815	0.622	0.548	0.947	0.169	0.817	0.472	0.864	0.466
0.901	0.342	0.873	0.964	0.942	0.985	0.123	0.086	0.335	0.212
0.470	0.682	0.412	0.064	0.150	0.962	0.925	0.355	0.909	0.019
0.068	0.242	0.777	0.356	0.195	0.313	0.396	0.460	0.740	0.247
0.874	0.420	0.127	0.284	0.448	0.215	0.833	0.652	0.701	0.326
0.897	0.877	0.209	0.862	0.428	0.117	0.100	0.259	0.425	0.284
0.876	0.969	0.109	0.843	0.759	0.239	0.890	0.317	0.428	0.802
0.190	0.696	0.757	0.283	0.777	0.491	0.523	0.665	0.919	0.146
0.341	0.688	0.587	0.908	0.865	0.333	0.928	0.404	0.892	0.696
0.846	0.355	0.831	0.281	0.945	0.364	0.673	0.305	0.195	0.887
0.882	0.227	0.552	0.077	0.454	0.731	0.716	0.265	0.058	0.075
0.464	0.658	0.629	0.269	0.069	0.998	0.917	0.217	0.220	0.659
0.123	0.791	0.503	0.447	0.659	0.463	0.994	0.307	0.631	0.422
0.116	0.120	0.721	0.137	0.263	0.176	0.798	0.879	0.432	0.391
0.836	0.206	0.914	0.574	0.870	0.390	0.104	0.755	0.082	0.939
0.636	0.195	0.614	0.486	0.629	0.663	0.619	0.007	0.296	0.456
0.630	0.673	0.665	0.666	0.399	0.592	0.441	0.649	0.270	0.612
0.804	0.112	0.331	0.606	0.551	0.928	0.830	0.841	0.702	0.183
0.360	0.193	0.181	0.399	0.564	0.772	0.890	0.062	0.919	0.875
0.183	0.651	0.157	0.150	0.800	0.875	0.205	0.446	0.648	0.685

NOTE: Always select a new set of numbers in a systematic manner, either horizontally or vertically. Once used, the set should be crossed out.

IDOT Concrete Quality Control and Quality Assurance Documents

Effective Date: April 1, 2010

Revised Date: December 1, 2017

The following forms are located at <http://www.idot.illinois.gov/doing-business/material-approvals/concrete/index>.

Water/Cement Ratio Worksheet (BMPR PCCW01)
Field/Lab Gradations (MI504M)
Concrete Air, Slump and Quantity (BMPR MI654)
P.C. Concrete Strengths ((BMPR MI655)
Calibration of Concrete Test Equipment, Slump (BMPR PCCQ01)
Calibration of Concrete Test Equipment, Air Meter, Type "A" (BMPR PCCQ02)
Calibration of Concrete Test Equipment, Air Meter, Type "B" (BMPR PCCQ03)
Calibration of Concrete Test Equipment, Air Meter, Volumetric (BMPR PCCQ04)
Calibration of Concrete Test Equipment, Unit Weight (BMPR PCCQ05)
Calibration of Concrete Test Equipment, Cylinder Molds, Plastic or Metal, 6" x 12" (BMPR PCCQ06)
Calibration of Concrete Test Equipment, Beam Molds, Steel or Plastic (BMPR PCCQ07)
Calibration of Concrete Test Equipment, Metal Retainers & Neoprene Pads (BMPR PCCQ08)
Calibration of Concrete Test Equipment, Capping Cylindrical Strength Specimens (BMPR PCCQ09)
Calibration of Concrete Test Equipment, Cylinder Molds, Plastic, 4" x 8" (BMPR PCCQ10)

The following Manuals are located at <http://www.lakeland.cc.il.us/as/idt/manuals.cfm>.

Aggregate Technician Course or Mixture Aggregate Technician Course
Portland Cement Concrete Tester Course
Portland Cement Concrete Level I Technician Course - Manual of Instructions for Concrete Testing
Portland Cement Concrete Level II Technician Course - Manual of Instructions for Concrete Proportioning
Portland Cement Concrete Level III Technician Course - Manual of Instructions for Design of Concrete Mixtures

This Page Reserved

Illinois Department of Transportation

**PCC Production Inspection Checklist
Appendix C.6**

Effective: December 1, 2019

This checklist assumes any applicable plant surveys, truck certifications, scale (or volumetric mixer) calibrations, Plant QC Plans, and QC laboratory inspections have been reviewed and approved.

Be familiar with Standard Specifications Sections 1020 and 1103 and applicable portions of the Manual of Test Procedures for Materials. As applicable, be familiar with PPG Sampling Schedule 3 for Non-QC/QA Concrete, Recurring Special Provision for Quality Control of Concrete Mixtures at the Plant, and Recurring Special Provision for Quality Control/Quality Assurance of Concrete Mixtures.

If applicable, review the current plant Quality Control Plan and Field Quality Control Plan.

If applicable, review project special provisions and plans relating to concrete requirements.

Maintain a diary record of each visit to a production facility. Include the following information:

- Date, arrival time, weather conditions, & departure time.
- Producer Name and Plant Location
- Producer Number and Plant Description if more than one plant at location.
- Mix Design being produced
- Contract mixture delivered to.
- Item mixture incorporated into.
- Plant QC personnel present.
- Document results of any QC, QA, or INV testing performed.
- Document any component material samples taken.
- Document any substantive conversations with QC personnel relating to production or plant operations.
- Document any of the items described in the following section that are not acceptable. Inform plant personnel of any unacceptable items, and note if they are corrected while you are present. Take independent action to ensure the items are corrected or perform investigative sampling as authorized by supervisor.

PLANT OPERATIONS

QC Laboratory and Equipment (if applicable)

Is testing equipment present and in good working order?

Does equipment calibration documentation indicate required calibration activities have been performed?

Plant Operations (Continued)

Aggregates

Are aggregate stockpiles clearly marked?

Are aggregate stockpiles separated with no adjacent stockpiles intermingling?

Are the aggregate stockpiles free from clay or other contamination?

Are the aggregate stockpiles free from segregation or degradation?

Is an Investigative Sample warranted for quality or gradation check?

Are the aggregate stockpiles free from steel-track equipment use?

Are stockpiles being handled properly?

Do the aggregate shipping tickets clearly represent the material being stockpiled?

Does the aggregate source match the approved source from the Quality Control Plan or indicated on the approved mix design?

Is stockpile sampling being performed properly?

Are aggregate gradation results up to date and available?

If required, are aggregate split samples labeled and available?

Do QC and QA gradations compare?

Perform Investigative gradation and quality sampling occasionally.

(Space for Additional Questions Relevant to a Specific District)

Cement, Finely Divided Minerals, Admixtures, Fibers

Do material delivery tickets indicate materials are on the qualified products list?

Do materials match those shown in the Quality Control Plan or indicated on the approved mix design?

Are cement and/or finely divided mineral samples required?

Plant Operations (Continued)

Mixture Production

Is the mix design appropriate for the item?

Do the batch weights and component materials match the mix design?

Are aggregate stockpile moistures being done daily for coarse and fine aggregates?

If a moisture sensor is used for fine aggregates, is the probe accuracy checked weekly?

Does the aggregate scale re-zero properly?

Do applicable cement or finely divided mineral scales re-zero properly?

Are admixture dispensing units properly discharging?

Does the water scale re-zero or does the water meter work properly?

Have batch weights been adjusted for aggregate moisture?

Are actual batched weights within allowable tolerances of design weights?

Does the batching sequence meet mixture requirements?

When applicable, have preparations been made for maintaining concrete temperature within the required range?

Does the mixture delivery ticket include the required information?

Does the mixture delivery ticket or other attached document indicate the amount of water allowed to be added at the jobsite?

Is the batch time stamp on the delivery ticket accurate?

For central -mixed concrete, is the mixing time a minimum of 75 seconds or the minimum determined by mixer performance?

(Space for Additional Questions Relevant to a Specific District)

TRUCKS

Have trucks been certified by IDOT?

Is the revolution counter in proper working condition?

Is the water tank sight tube readable and in proper working condition?

Does the truck have the minimum revolutions required at mixing speed prior to leaving the plant?

Is wash water completely discharged from the drum prior to batching a new load?

(Space for Additional Questions Relevant to a Specific District)

PLANT MIXTURE TESTING

When applicable, are plant QC personnel documenting actions

When applicable, do plant QC personnel performing testing match the approved QC Plan?

Is equipment utilized for plant testing calibrated and in good working condition?

When applicable, is sufficient QC testing being performed to control production?

When applicable, does QC testing comply with the approved QC Plan?

When applicable, are plant QC personnel performing tests according to proper procedures?

Are plant test results written on the delivery tickets?

Are any adjustments and re-testing results documented?

Do test results indicate mixture will arrive at the project site within specification limits?

Perform Independent testing occasionally along with plant QC personnel.

(Space for Additional Questions Relevant to a Specific District)

PROJECT SITE

Before or after visiting a production facility during production, inspectors should visit the project site where mixture is being placed.

Maintain a diary record of each visit to a project site where concrete is being placed. Include the following information.

- Date, arrival time, weather conditions, & departure time.
- Contract and project location
- Producer Name and Plant Location
- Producer Number and Plant Description if more than one plant at location.
- Mix Design being produced
- The item the mixture is incorporated into.
- Jobsite QC personnel present. Jobsite QA personnel present if applicable.
- Document results of any QC, QA, or INV testing performed.
- Document any substantive conversations with contractor or IDOT field personnel relating to the mixture.
- Document any of the items described in the following section applicable to field operations that are not acceptable. Inform field personnel of any unacceptable items, and note if they are corrected while you are present.

When applicable, do jobsite QC personnel performing testing match the approved QC plan?

Do individuals performing testing on behalf of the agency have proper certification (PCC Level I, PCC Tester, or Local Agency QLAR)?

Is equipment utilized for jobsite testing calibrated and in good working condition?

Does testing frequency meet applicable requirements?

Is testing performed after the addition of any water or admixtures on the project site?

Are test results, mix adjustments, and re-testing results documented?

When applicable, are 40 additional revolutions being performed after jobsite adjustments?

Is the mixture well mixed and homogeneous?

Is the mixture consistent between loads?

Perform Independent or Investigative testing occasionally.

(Space for Additional Questions Relevant to a Specific District)

This Page Reserved

Illinois Department of Transportation

**Aggregate Laboratory Equipment
Appendix D.3**

Effective: October 1, 1995
Revised: December 1, 2020

All equipment listed is required unless noted otherwise. This list recommends 12" sieves and 12" shakers. Individual needs may vary for the specific products. Eight-inch sieves and other alternate equipment may be substituted provided they conform to Illinois Test Procedure or ASTM requirements and are approved by the Engineer.

Quantity	Description
1	Mechanical Sieve Shaker – 8" and 12" sieve capacity
1	Coarse Aggregate Sample Splitter (Illinois Test Procedure 248, Method A)
4	Splitter Pans, for coarse aggregate
1	Fine Aggregate Sample Splitter (as required)
4	Splitter Pans, for fine aggregate
1	Sink and clear Water Supply
1	Oven, electric drying, capable of maintaining a uniform temperature of 110 ± 5 °C (230 ± 9 °F), (optional – see Hot Plate)
2	Hot Plate, electric, or burner, gas – in lieu of Oven, if approved by the Engineer
1	Gloves, pair, insulated
1	Balance, electronic, see Illinois Specification 101 for capacity and readability requirements
15	Sample Pans, (constructed to minimize loss of material during testing)
2	Spoon, stainless steel, 15 in. minimum
1	Brush, stencil
1	Brush, brass
1	Knife, putty
1	Thermometers, -18 – 150 °C (0 – 300 °F), readable to 0.5 °C (1.0 °F), to verify Oven temperature
1	Set (11) Fine Aggregate Sieves, brass, 8 in. or 12 in. diameter, with brass or stainless cloth, 9.5 mm, 4.75 mm, 2.36 mm, *2.00 mm, 1.18 mm, 600 mm, 425 mm, 300 mm, 180 mm, 150 mm, 75 mm (3/8 in., No. 4, No. 8, *No. 10, No. 16, No. 30, No. 40, No. 50, No. 80, No. 100, No. 200), according to ASTM E 11. *The 2.00 mm (No. 10) sieve required as needed.
1	Lid for 8 in. and 12 in. sieve
1	Pan, catch, bottom, 8 in. and 12 in.
1	Set (11) Coarse Aggregate Sieves, brass, 12 in. diameter, with brass or stainless cloth, 37.5 mm, 25 mm, 19 mm, 16 mm, 12.5 mm, 9.5 mm, 6.3 mm, 4.75 mm, 2.36 mm, 1.18 mm, 75 mm (1 1/2 in., 1 in., 3/4 in., 5/8 in., 1/2 in., 3/8 in., No. 4, No. 8, No. 16, No. 200), according to ASTM E 11
1	Additional 12 in. brass sieves are required for testing larger coarse aggregate (e.g., a 1 3/4 in. sieve is required for CA 5 testing)
1	Wash Sieve, 12 in. diameter, No. 200, recommended 3 1/4 in. nominal height*
1	Wash Sieve, 12 in. diameter, No. 16, recommended 3 1/4 in. nominal height*

* Distance from the top of the frame to the sieve cloth surface

Illinois Department of Transportation

**Aggregate Laboratory Equipment
Appendix D.3**

(continued)

Effective: October 1, 1995

Revised: December 1, 2020

VENDOR LIST – For Information Only

Dual Manufacturing Co., Inc.
3522 Martens St.
Franklin Park, IL 60131
Phone: 847-260-5370
info@dualmfg.com

Gilson Company, Inc.
P.O. Box 200
Lewis Center, OH 43035-200
Phone: 800-444-1508
sales@gilson.com
www.globalgilson.com

Humboldt Scientific, Inc.
875 Tailgate Road
Elgin, IL 60123
Phone: 800-544-7220
708-468-6300
Fax: 708-456-0137
www.humboldtmg.com

Instro Tek, Inc.
1 Triangle Dr.
P.O. Box 13944
Research Triangle Park, NC 27709
Phone: 919-875-8371
Fax: 919-875-8328

McMaster-Carr
600 N. County Line Rd.
Elmhurst, IL 60126-2034
Phone: 630-833-0300
630-600-3600
www.mcmaster.com

Rainhart Company (An Instro Tek company)
P.O. Box 4533
Austin, Texas 78765
Phone: 800-628-0021
512-452-8848
www.rainhart@instrotek.com

VWR Scientific (Part of Avantor)
911 Commerce Ct.
Buffalo Grove, IL 60089
Phone: 847-229-0835
800-932-500

**Hot-Mix Asphalt Laboratory Equipment
Appendix D.4**

Effective Date: April 1, 1997
Revised Date: December 1, 2021

This document summarizes the minimum requirements for Hot-Mix Asphalt (HMA) quality control (QC), quality assurance (QA), and design laboratories. It is the Contractor's or Consultant's responsibility to ensure that all equipment complies with the applicable test specifications in the *Manual of Test Procedures for Materials*.

1. Quality Control Laboratory and Equipment

A. QC laboratories shall be 600 sq ft (55 sq m) or greater in size and be located at the mix production site. The laboratory shall have running water and controlled heating and air conditioning capable of maintaining a temperature between 68 – 86 °F (20 - 30 °C). The laboratory shall be properly maintained and contain the necessary equipment and supplies for performing the Quality Control testing. All testing shall be performed at the QC laboratory. All hazardous chemicals shall be properly stored and labeled to meet the associated regulations and standards.

B. Quality Control Equipment

1. Balance (1): As defined by Illinois Specification 101 **Minimum Requirements for Electronic Balances**. Balances used for Illinois Modified AASHTO T 166, Illinois modified AASHTO T 209 (weight in water method), and Illinois Modified AASHTO T 85 shall also include the following:
 - a. Suspension apparatus for weighing in water.
 - b. Wire or monofilament line, of smallest practical diameter, between the scale and water.
2. **Mixture Bulk Specific Gravity (G_{mb}) Water Bath (1)**: A water bath as defined by Illinois Modified AASHTO T 166 for immersing the specimen in water while suspended under the weighing device.
3. **Mixture Theoretical Maximum Specific Gravity (G_{mm}) Water Bath (1)**: A water bath as defined by Illinois Modified AASHTO T 209 for maintaining a constant water temperature, with the following additional requirements:
 - a. Commercial grade, built specifically for laboratory use.
 - b. Capable of maintaining 77 ± 1.8 °F (25 ± 1 °C).
 - c. Sufficient depth to immerse the pycnometer pot and capillary lid.
 - d. Having a perforated false bottom or equipped with a shelf at least 2 in. (50 mm) above the bottom of the bath.
4. **Saw or Freezer (1)**:

Hot-Mix Asphalt Laboratory Equipment

Appendix D.4

(continued)

Effective: April 1, 1997

Revised: [December 1, 2021](#)

- a. [A saw capable of producing an undamaged specimen.](#)
- b. [Or a freezer capable of storing twenty-five 4 in. \(100 mm\) cores.](#)

5. Metal Pot Pycnometer (2):

- a. Capable of containing a minimum sample weight of 1200 g, which will be completely submerged.
- b. Capillary lid.
- c. Small piece of fine wire mesh over the vacuum hose opening.

6. Manometer (1):

- a. Vacuum gauge or manometer capable of measuring residual pressure down to 30 mm of Hg or less (preferably zero). (Residual pressure is the pressure remaining in a container after a vacuum (negative pressure) is applied. The residual pressure is based on and measured with an absolute manometer.) The manometer or vacuum gauge shall be positioned at the end of the vacuum line and mounted according to the manufacturer's instructions.

7. Ovens (2) (Note 1):

- a. Aggregates (1): Capable of maintaining 230 ± 9 °F (110 ± 5 °C).
- b. [HMA Compaction Oven \(1\)](#): Capable of maintaining either 295 ± 5 °F (146 ± 3 °C) or 305 ± 5 °F (152 ± 3 °C) as required in IL Modified AASHTO T 312.

Note 1. In situations where large oven capacity is required, the Department recommends the use of two smaller ovens instead of one large oven. This is due to the problem of maintaining the required temperatures when the doors are frequently opened.

8. [Computer and Printer compatible with the Quality Management Program \(QMP\) Package](#)

9. Sample Splitters:

- a. Aggregate (1 each): As defined by Illinois [Modified AASHTO R 76](#).
- b. Hot-Mix Asphalt (1): As defined by Illinois [Modified AASHTO R 76](#) with the following additional requirements:

Hot-Mix Asphalt Laboratory Equipment

Appendix D.4

(continued)

Effective: April 1, 1997

Revised: [December 1, 2021](#)

- i. Length of discharge (catch) pan equals or exceeds total chute width.
- ii. Each chute separated by a vertical metal divider.

10. Sieve Shaker (Mary Ann type or equivalent) (1): Capable of holding 12 in. (305 mm) sieves.

11. Twelve-inch Sieves (2 sets), 2 in. in height ([Note 2](#)):

a. [For HMA Labs;](#)

1-1/2 in. (37.5mm)	3/8 in. (9.5mm)	No. 30 (600 μ m)
1 in. (25mm)	1/4 in. (6.3mm)	No. 50 (300 μ m)
3/4 in. (19mm)	No. 4 (4.75mm)	No. 100 (150 μ m)
5/8 in. (16 mm)	No. 8 (2.36mm)	No. 200 (75 μ m)
1/2 in. (12.5mm)	No. 16 (1.18mm)	bottom pan and lid

b. [For Aggregate Labs; all HMA Lab sieves and No. 40 and No. 80 sieves are required.](#)

c. Sieves below the 3/8 in. (9.5mm) may be 1 5/8 in. nominal height ([Note 2](#)).

d. Extra No. 8, 10 or 16 and No. 200 [sieves](#) required as wash sieves.

[Note 2](#). Distance from the top of the frame to the sieve cloth surface

12. Thermometers (4):

- a. Any Thermometric Device (1): As defined by Illinois Modified AASHTO T 209, with a suitable range to determine 77 ± 1.8 °F (25 ± 1 °C).
- b. Metal-stemmed (3): As defined by Illinois Modified AASHTO T 312 with a suitable range to determine 50 – 450 °F (10 – 232 °C).

13. Timer (1): Minimum 20-minute capability.

14. Vacuum Pump (1): Capable of removing entrapped air to a residual pressure of 30 mm Hg.

15. Gyratory Compactor (1) meeting the requirements of Illinois Modified AASHTO T 312.

Hot-Mix Asphalt Laboratory Equipment

Appendix D.4

(continued)

Effective: April 1, 1997

Revised: [December 1, 2021](#)

16. [Printer \(1\): As defined by Illinois Modified AASHTO T 312.](#)

17. Gyratory Mold-Loading Chute (1):

- a. Capable of holding a minimum of 130 cu in. (2120 cu cm).
- b. Minimum length of 22 in. (560 mm).
- c. Capable of loading entire gyratory sample in one motion without spillage or segregation.

18. Gyratory Specimen Molds (2): As defined by Illinois Modified AASHTO T 312.

19. Specimen Extruder (1):

- a. Does not allow free-fall of specimen.
- b. Diameter of extruding disk must not be less than 5.4 in. (138 mm).

20. Sampling Shovel with sides and back built up 1 – 1.5 in. (25 – 40 mm).

21. Nuclear Asphalt Density Gauge (1): As defined by Illinois Modified ASTM D 2950.

[22. Asphalt Content](#)

- a. [Ignition Oven \(1\) as defined by Illinois Modified AASHTO T 308 or,](#)
- b. [Solvent Extractions \(1\) as defined by Illinois Modified AASHTO T 164,](#)
 - i. [Reflux or,](#)
 - ii. [Centrifuge and High Speed Centrifuge for Mineral Matter Correction or,](#)
 - iii. [Automated extraction device or,](#)
- c. [Nuclear Asphalt Content Gauge \(1\) and Related Apparatus: As defined by Illinois Modified AASHTO T 287 “Asphalt Binder Content of Asphalt Mixtures by the Nuclear Method.”](#)

[23. Pan with approximate dimensions of 24 in. x 24 in. x 6 in. \(L x W x H\) for cleaning samples out of baskets after ignition burn \(Note 3\).](#)

Hot-Mix Asphalt Laboratory Equipment

Appendix D.4

(continued)

Effective: April 1, 1997

Revised: December 1, 2021

Note 3. Required if laboratory uses Illinois Modified AASHTO T 308 to determine asphalt content.

2. Mix Design Laboratory and Equipment

A. Required Items in Addition to the QC Laboratory Equipment

1. Balance (1): As defined by Illinois Specification 101 Minimum Requirements for Electronic Balances (additional minimum capacity requirements).
2. Extraction Apparatus (1): As defined by Illinois Modified AASHTO T 164, Test Methods A, B, and F.
 - a. Reflux or
 - b. Centrifuge and High Speed Centrifuge for Mineral Matter Correction or
 - c. Automated extraction device.
3. Tensile Strength Apparatus:
 - a. Loading Device (1): As defined by Illinois Modified AASHTO T 283.
 - b. Load-Measuring Device (1):
 - i. Sensitivity 10 lb (4.5 kg).
 - ii. Accuracy within 1.0%.
 - c. Loading Strips: One set for 6 in. (150 mm) specimens: As defined by Illinois Modified AASHTO T 283.
4. HMA Mixing Oven (1): Capable of maintaining either 295 ± 5 °F (146 ± 3 °C) or 325 ± 5 °F (163 ± 3 °C) as required according to IL Modified AASHTO T 312.
5. Water Bath (1): As defined by Illinois Modified AASHTO T 283 with the following additional requirements:
 - a. Depth at least 6 in. (150 mm).
 - b. Having a perforated false bottom or equipped with a shelf at least 2 in. (51 mm) above bottom of bath.

Hot-Mix Asphalt Laboratory Equipment

Appendix D.4

(continued)

Effective: April 1, 1997

Revised: [December 1, 2021](#)

- c. Thermostatically controlled.
 - d. Capable of maintaining 140 ± 1.8 °F (60 ± 1 °C).
6. Thermometer for Water Bath 140 °F (60 °C) (1):
- a. Minimum range of 131 – 149 °F (55 – 65 °C).
 - b. Graduated in increments less than or equal to 0.4 °F (0.2 °C).
7. Baking Pans (2): Each providing a minimum surface area of 140 sq in. (903 sq cm).
8. Mixing Apparatus (1): As defined by Illinois Modified AASHTO [R 35](#) with a minimum capacity of 12,000 g.
3. [QA Laboratory Equipment – in Addition to the Mix Design Laboratory Equipment](#)
- A. [No Additional Equipment Needed.](#)

**Illinois Specification 101
Minimum Requirements for Electronic Balances
Appendix D.5**

Effective Date: April 1, 1999
Revised Date: [December 1, 2021](#)

Electronic balances for materials testing laboratories shall be top-loading, direct-reading, with specified minimum capacity and readability per the table below. Underhooks are required for [hot-mix](#) asphalt laboratories.

Purchasers are advised to specify balances that are manufactured according to AASHTO M 231. Laboratories may, at their option, provide additional balances that comply with each individual test procedure.

[Note: Units](#)—The values stated in metric units are to be regarded as standard. Within the text, English units are shown when commonly used and may not be an exact equivalent.

Minimum Requirements for Laboratory Balances

LAB TYPE	MINIMUM CAPACITY	READABILITY
AGGREGATE (AGCS, HMA, PCC) Moisture, Gradation, Specific Gravity Fine Aggregate Coarse Aggregate CA/CM 6 through 20Coarse Aggregate CA/CM 1 through 5	8 kg 8 kg 12 kg	0.1 g 0.1 g 0.1 g
HOT- MIX ASPHALT ^{1/} Volumetric Analysis Mix Design Labs QC, QA Labs Asphalt Content (Nuclear AB Gauge, Approved Solvent Extraction , or Ignition Furnace)	15 kg 8 kg 12 kg	0.1 g 0.1 g 0.1 g
PORTLAND CEMENT CONCRETE ^{1/} Aggregate Moisture Content ^{2/} Unit Weight ^{2/} Cylinder Strength Specimens ^{3/}	8 kg ^{4/} ^{4/}	0.1 g ^{5/} 50 g

[1/ Also requires Aggregate Balances](#)

[2/](#) The weighing equipment may be a balance or scale, and it does not have to be electronic.

[3/](#) The weighing of the cylinder strength specimens prior to compressive strength testing is optional.

[4/](#) Sufficient capacity

[5/](#) A 20 g (0.05 lb) or smaller readability shall be required for unit weight measures and air meter measuring bowls which have a capacity less than 0.3 cu ft. A 50 g (0.1 lb) or smaller readability shall be required for unit weight measures which have a capacity greater than or equal to 0.3 cu ft.

This Page Reserved

**ASTM E 11
(formerly AASHTO M 92)**

Wire-Cloth Sieves for Testing Purposes

ASTM E 11 test method, Wire-Cloth Sieves for Testing Purposes, cannot be reproduced in this manual due to copyright. ASTM standards may be requested from the address below:

ASTM
100 Barr Harbor Drive, [P.O. Box C700](#)
West Conshohocken, PA 19428-2959
(610) 832-9500
www.astm.org

Contact:
Mark Axelman
ASTM International
Email: maxelman@astm.org

This Page Reserved

Illinois Modified Test Procedure
Effective Date: [December 1, 2021](#)

Standard Method of Test
for
**Mixing Rooms, Moist Cabinets, Moist Rooms, and Water Storage Tanks
Used in the Testing of Hydraulic Cements and Concretes**

Reference AASHTO M 201-[21](#)

AASHTO Section	Illinois Modification
6.1	Replace the fourth sentence as follows: All moist cabinets and moist rooms shall be equipped with either a relative humidity measuring device and logbook or relative humidity recording device.
7.1.1	Replace the first and second sentences as follows: Provisions shall be provided for water temperature control. Either a maximum/minimum thermometer and logbook or recording thermometer shall be required to monitor temperature. A maximum/minimum thermometer shall be checked for accuracy according to the same requirements as a recording thermometer.

This Page Reserved

Illinois Modified Test Procedure
Effective Date: December 1, 2021

Standard Method of Test
for
Molds for Forming Concrete Test Cylinders Vertically

Reference AASHTO M 205M/M 205-11 (2019)

AASHTO Section	Illinois Modification
2.1	Revise as follows: AASHTO R 100 (Illinois Modified) (formerly AASHTO T 23) AASHTO R 39 (Illinois Modified) To maintain brevity in the text, the following will apply: Example: AASHTO R 100 (Illinois Modified) will be designated as “AASHTO R 100.”

This Page Reserved

AASHTO R 18

Establishing and Implementing a Quality Management System for Construction Materials Testing Laboratories

AASHTO R 18 test method, Establishing and Implementing a Quality Management System for Construction Materials Testing Laboratories, cannot be reproduced in this manual due to copyright. AASHTO standards may be requested from the address below:

AASHTO
555 12th St., N. W.
Suite 1000
Washington, D.C. 20004
(202) 624-5800
www.transportation.org

This Page Reserved

Hot-Mix Asphalt PFP Pay Adjustments
Appendix E.1

Effective Date: December 12, 2003

Revised Date: December 1, 2021

This document explains the statistical analysis and procedures used to determine pay adjustments for a hot-mix asphalt (HMA) mixture and a HMA full-depth pavement when Pay for Performance (PFP) is specified as the Quality Management Program (QMP).

Pay parameters are evaluated using percent within limits (PWL) analyzed collectively and statistically by the Quality Level Analysis method to determine the total estimated percent of the lot that is within specification limits. Quality Level Analysis is a statistical procedure for estimating the percent compliance to a specification and is affected by shifts in the arithmetic mean and the sample standard deviation.

Additionally, for a full-depth pavement the adjusted pay and pay adjustment will be calculated using the combined composite pay factors for mixtures used in its construction.

Note: Monetary deductions will be applied separately for both dust/AB ratio using the Dust/AB Ratio Deduction Table and unconfined edge density using the Unconfined Edge Density Deduction Table found in the Standard Specifications Article 406.14.

(a) PAY ADJUSTMENT PROCEDURES

Items 1 through 8 of the following procedure will be repeated for each of the pay parameters (air voids, field VMA and core density) for each lot.

- (1) Determine the arithmetic mean (\bar{x}) of the test results:

$$\bar{x} = \frac{\sum x}{n}$$

Where:

\sum = summation of
 x = individual test value
 n = total number of test values

- (2) Calculate the sample standard deviation (s):

$$s = \sqrt{\frac{n \cdot \sum (x)^2 - (\sum x)^2}{n(n-1)}}$$

Where:

$\sum(x^2)$ = summation of the squares of individual test values

Hot-Mix Asphalt PFP Pay Adjustments

Appendix E.1

(continued)

Effective Date: December 12, 2003

Revised Date: December 1, 2021

$(\sum x)^2$ = summation of the individual test values squared

- (3) Calculate the upper quality index (Q_U):

$$Q_U = \frac{UL - \bar{x}}{s}$$

Where:

UL = upper specification limit (target value (TV) plus allowable deviation)

- (4) Calculate the lower quality index (Q_L):

$$Q_L = \frac{\bar{x} - LL}{s}$$

Where:

LL = lower specification limit (target value (TV) minus allowable deviation)

- (5) Determine P_U (percent within the upper specification limit which corresponds to a given Q_U) from Table 2. (Note: Round up to nearest Q_U in Table 2.)

Note: If a UL is not specified, P_U will be 100.

- (6) Determine P_L (percent within the lower specification limit which corresponds to a given Q_L) from Table 2. (Note: Round up to nearest Q_L in Table 2.)

Note: If a LL is not specified, P_L will be 100.

- (7) Determine the Quality Level or PWL (the total percent within specification limits).

$$PWL = (P_U + P_L) - 100$$

- (8) To determine the pay factor for each individual parameter lot:

$$\text{Pay Factor (PF)} = 55 + 0.5 (PWL)$$

- (9) Once the project is complete determine the Total Pay Factor (TPF) for each parameter by using a weighted lot average by tons (mix) or distance (density) of all lots for a given parameter.

$$TPF = W1PF_{lot1} + W2PF_{lot(n+1)} + etc.$$

Where:

$W1, W2, \dots$ = weighted percentage of material evaluated

PF = Pay factor for the various lots

TPF = Total pay factor for the given parameter

Hot-Mix Asphalt PFP Pay Adjustments

Appendix E.1

(continued)

Effective Date: December 12, 2003

Revised Date: December 1, 2021

- (10) Determine the Composite Pay Factor (*CPF*) for each mixture. The *CPF* shall be rounded to 3 decimal places.

$$CPF = [f_{\text{Voids}}(TPF_{\text{Voids}}) + f_{\text{VMA}}(TPF_{\text{VMA}}) + f_{\text{Density}}(TPF_{\text{Density}})] / 100$$

Substituting from Table 1:

$$CPF = [0.3(TPF_{\text{Voids}}) + 0.3(TPF_{\text{VMA}}) + 0.4(TPF_{\text{Density}})] / 100$$

Where:

f_{Voids} , f_{VMA} , and f_{Density} = Parameter Weights listed in Table 1

TPF_{Voids} , TPF_{VMA} , and TPF_{Density} = Total Pay Factor for the designated measured attribute from (9)

- (11) Determine the adjusted pay and pay adjustment for a given mixture.

$$\text{Plan Unit Pay} = \text{Mixture Unit Price} \times \text{Quantity}$$

$$\text{Adjusted Pay} = \text{Plan Unit Pay} \times \text{CPF}$$

$$\text{Pay Adjustment} = \text{Adjusted Pay} - \text{Plan Unit Pay}$$

- (12) To determine the adjusted pay and pay adjustment for a full-depth pavement, first combine the composite pay factors for all mixtures to arrive at the combined composite pay factor. Each mixture composite pay factor will be weighted equally. Mixtures placed having the same gradation values but with and without polymer will be treated as two separate mixtures. For example, one surface mix and one binder mix will be weighted 50/50 regardless of tonnage. Additionally, one surface mix, one polymer binder mix and one non-polymer binder mix will be treated as three equally (1/3) weighted mixtures even if the polymer binder is the only difference between binder lifts. The full-depth adjusted pay is determined by multiplying the plan unit pay by the combined composite pay factor. The pay adjustment is then determined by subtracting the plan unit pay from the adjusted pay.

Hot-Mix Asphalt PFP Pay Adjustments
Appendix E.1
 (continued)

Effective Date: December 12, 2003

Revised Date: December 1, 2021

Table 1

Pay Parameters, Parameter Weights "F" and Quality Levels				
Pay Parameter		Parameter Weight "F"	UL	LL
Air Voids		0.3	Design Voids + 1.35	Design Voids – 1.35
Field VMA		0.3	MDR ¹ + 3.0	MDR ¹ – 0.7
In-Place Density	IL-4.75	0.4	97.5	92.5
	IL-9.5, IL-9.5FG		97.5	91.5
	IL-19.0		97.5	92.2
	SMA		98.0	93.0

1. MDR = Minimum Design Requirement (VMA)

Illinois Department of Transportation

Hot-Mix Asphalt PFP Pay Adjustments
Appendix E.1
 (continued)

Effective Date: December 12, 2003
 Revised Date: December 1, 2021

TABLE 2: QUALITY LEVELS
QUALITY LEVEL ANALYSIS BY STANDARD DEVIATION METHOD

P _U OR P _L PERCENT WITHIN LIMITS FOR POSITIVE VALUES OF Q _U OR Q _L	UPPER QUALITY INDEX Q _U OR LOWER QUALITY INDEX Q _L														
	n=3	n=4	n=5	n=6	n=7	n=8	n=9	n=10 to n=11	n=12 to n=14	n=15 to n=18	n=19 to n=25	n=26 to n=37	n=38 to n=69	n=70 to n=200	n=201 to infinity
100	1.16	1.50	1.79	2.03	2.23	2.39	2.53	2.65	2.83	3.03	3.20	3.38	3.54	3.70	3.83
99		1.47	1.67	1.80	1.89	1.95	2.00	2.04	2.09	2.14	2.18	2.22	2.26	2.29	2.31
98	1.15	1.44	1.60	1.70	1.76	1.81	1.84	1.86	1.91	1.93	1.96	1.99	2.01	2.03	2.05
97		1.41	1.54	1.62	1.67	1.70	1.72	1.74	1.77	1.79	1.81	1.83	1.85	1.86	1.87
96	1.14	1.38	1.49	1.55	1.59	1.61	1.63	1.65	1.67	1.68	1.70	1.71	1.73	1.74	1.75
95		1.35	1.44	1.49	1.52	1.54	1.55	1.56	1.58	1.59	1.61	1.62	1.63	1.63	1.64
94	1.13	1.32	1.39	1.43	1.46	1.47	1.48	1.49	1.50	1.51	1.52	1.53	1.54	1.55	1.55
93		1.29	1.35	1.38	1.40	1.41	1.42	1.43	1.44	1.44	1.45	1.46	1.46	1.47	1.47
92	1.12	1.26	1.31	1.33	1.35	1.36	1.36	1.37	1.37	1.38	1.39	1.39	1.40	1.40	1.40
91	1.11	1.23	1.27	1.29	1.30	1.30	1.31	1.31	1.32	1.32	1.33	1.33	1.33	1.34	1.34
90	1.10	1.20	1.23	1.24	1.25	1.25	1.26	1.26	1.26	1.27	1.27	1.27	1.28	1.28	1.28
89	1.09	1.17	1.19	1.20	1.20	1.21	1.21	1.21	1.21	1.22	1.22	1.22	1.22	1.22	1.23
88	1.07	1.14	1.15	1.16	1.16	1.16	1.16	1.17	1.17	1.17	1.17	1.17	1.17	1.17	1.17
87	1.06	1.11	1.12	1.12	1.12	1.12	1.12	1.12	1.12	1.12	1.12	1.12	1.12	1.13	1.13
86	1.04	1.08	1.08	1.08	1.08	1.08	1.08	1.08	1.08	1.08	1.08	1.08	1.08	1.08	1.08
85	1.03	1.05	1.05	1.04	1.04	1.04	1.04	1.04	1.04	1.04	1.04	1.04	1.04	1.04	1.04
84	1.01	1.02	1.01	1.01	1.00	1.00	1.00	1.00	1.00	1.00	1.00	1.00	0.99	0.99	0.99
83	1.00	0.99	0.98	0.97	0.97	0.96	0.96	0.96	0.96	0.96	0.96	0.96	0.95	0.95	0.95
82	0.97	0.96	0.95	0.94	0.93	0.93	0.93	0.92	0.92	0.92	0.92	0.92	0.92	0.92	0.92
81	0.96	0.93	0.91	0.90	0.90	0.89	0.89	0.89	0.89	0.88	0.88	0.88	0.88	0.88	0.88
80	0.93	0.90	0.88	0.87	0.86	0.86	0.86	0.85	0.85	0.85	0.85	0.84	0.84	0.84	0.84
79	0.91	0.87	0.85	0.84	0.83	0.82	0.82	0.82	0.82	0.81	0.81	0.81	0.81	0.81	0.81
78	0.89	0.84	0.82	0.80	0.80	0.79	0.79	0.79	0.78	0.78	0.78	0.78	0.77	0.77	0.77
77	0.87	0.81	0.78	0.77	0.76	0.76	0.76	0.75	0.75	0.75	0.75	0.74	0.74	0.74	0.74
76	0.84	0.78	0.75	0.74	0.73	0.73	0.72	0.72	0.72	0.71	0.71	0.71	0.71	0.71	0.71
75	0.82	0.75	0.72	0.71	0.70	0.70	0.69	0.69	0.69	0.68	0.68	0.68	0.68	0.68	0.67
74	0.79	0.72	0.69	0.68	0.67	0.66	0.66	0.66	0.66	0.65	0.65	0.65	0.65	0.64	0.64
73	0.76	0.69	0.66	0.65	0.64	0.63	0.63	0.63	0.62	0.62	0.62	0.62	0.62	0.61	0.61
72	0.74	0.66	0.63	0.62	0.61	0.60	0.60	0.60	0.59	0.59	0.59	0.59	0.59	0.58	0.58

Illinois Department of Transportation

Hot-Mix Asphalt PFP Pay Adjustments
Appendix E.1
 (continued)

Effective Date: December 12, 2003

Revised Date: December 1, 2021

TABLE 2: QUALITY LEVELS (continued)
QUALITY LEVEL ANALYSIS BY STANDARD DEVIATION METHOD

P _U OR P _L PERCENT WITHIN LIMITS FOR POSITIVE VALUES OF Q _U OR Q _L	UPPER QUALITY INDEX Q _U OR LOWER QUALITY INDEX Q _L														
	n=3	n=4	n=5	n=6	n=7	n=8	n=9	n=10 to n=11	n=12 to n=14	n=15 to n=18	n=19 to n=25	n=26 to n=37	n=38 to n=69	n=70 to n=200	n=201 to infinity
71	0.71	0.63	0.60	0.59	0.58	0.57	0.57	0.57	0.57	0.56	0.56	0.56	0.56	0.55	0.55
70	0.68	0.60	0.57	0.56	0.55	0.55	0.54	0.54	0.54	0.53	0.53	0.53	0.53	0.53	0.53
69	0.65	0.57	0.54	0.53	0.52	0.52	0.51	0.51	0.51	0.50	0.50	0.50	0.50	0.50	0.50
68	0.62	0.54	0.51	0.50	0.49	0.49	0.48	0.48	0.48	0.48	0.47	0.47	0.47	0.47	0.47
67	0.59	0.51	0.47	0.47	0.46	0.46	0.46	0.45	0.45	0.45	0.45	0.44	0.44	0.44	0.44
66	0.56	0.48	0.45	0.44	0.44	0.43	0.43	0.43	0.42	0.42	0.42	0.42	0.41	0.41	0.41
65	0.52	0.45	0.43	0.41	0.41	0.40	0.40	0.40	0.40	0.39	0.39	0.39	0.39	0.39	0.39
64	0.49	0.42	0.40	0.39	0.38	0.38	0.37	0.37	0.37	0.37	0.36	0.36	0.36	0.36	0.36
63	0.46	0.39	0.37	0.36	0.35	0.35	0.35	0.34	0.34	0.34	0.34	0.34	0.33	0.33	0.33
62	0.43	0.36	0.34	0.33	0.32	0.32	0.32	0.32	0.31	0.31	0.31	0.31	0.31	0.31	0.31
61	0.39	0.33	0.31	0.30	0.30	0.29	0.29	0.29	0.29	0.29	0.28	0.28	0.28	0.28	0.28
60	0.36	0.30	0.28	0.27	0.27	0.27	0.26	0.26	0.26	0.26	0.26	0.26	0.26	0.25	0.25
59	0.32	0.27	0.25	0.25	0.24	0.24	0.24	0.24	0.23	0.23	0.23	0.23	0.23	0.23	0.23
58	0.29	0.24	0.23	0.22	0.21	0.21	0.21	0.21	0.21	0.21	0.20	0.20	0.20	0.20	0.20
57	0.25	0.21	0.20	0.19	0.19	0.19	0.18	0.18	0.18	0.18	0.18	0.18	0.18	0.18	0.18
56	0.22	0.18	0.17	0.16	0.16	0.16	0.16	0.16	0.16	0.15	0.15	0.15	0.15	0.15	0.15
55	0.18	0.15	0.14	0.14	0.13	0.13	0.13	0.13	0.13	0.13	0.13	0.13	0.13	0.13	0.13
54	0.14	0.12	0.11	0.11	0.11	0.11	0.10	0.10	0.10	0.10	0.10	0.10	0.10	0.10	0.10
53	0.11	0.09	0.08	0.08	0.08	0.08	0.08	0.08	0.08	0.08	0.08	0.08	0.08	0.08	0.08
52	0.07	0.06	0.06	0.05	0.05	0.05	0.05	0.05	0.05	0.05	0.05	0.05	0.05	0.05	0.05
51	0.04	0.03	0.03	0.03	0.03	0.03	0.03	0.03	0.03	0.03	0.03	0.03	0.03	0.03	0.03
50	0.00	0.00	0.00	0.00	0.00	0.00	0.00	0.00	0.00	0.00	0.00	0.00	0.00	0.00	0.00

Note: For negative values of Q_U or Q_L, P_U or P_L is equal to 100 minus the table P_U or P_L. If the value of Q_U or Q_L does not correspond exactly to a figure in the table, use the next higher value.

Hot-Mix Asphalt PFP Pay Adjustments
Appendix E.1
 (continued)

Effective Date: December 12, 2003

Revised Date: December 1, 2021

(b) Examples

Example 1 – One Lift Overlay:

Determine the **adjusted pay and pay adjustment** for the given lot of a N90 IL-9.5 HMA surface being placed at 1.5 inches thick as an overlay. The project consists of **27,840 tons** over **16.7 miles**.

Note that mix sample and density lots are independent of each other.

In this example the **first** mix sample lot represents 10,000 tons while the **first** density lot represents 6 miles (N=30). The project would have two additional **mix and density** lots following the same calculations as the first **mix and density** lots, **respectively**. All three lots are combined as per **step (9)**.

Mix sample: Each subplot represents 1000 tons

Lot #	Sublot #	Air Voids TV = 4.0	Field VMA Design Min. = 15.0
1	1	4.2	15.4
	2	4.5	15.7
	3	3.3	14.9
	4	5.0	15.0
	5	5.4	15.2
	6	2.5	15.5
	7	3.8	15.2
	8	4.1	15.3
	9	4.3	15.4
	10	4.5	15.6
Average:		4.16	15.32
Standard Deviation:		0.825	0.253

Density: Each density test interval represents 0.2 mile (**5 cores are taken per mile**) **along the 6 miles of paving resulting in an N=30**.

Hot-Mix Asphalt PFP Pay Adjustments
Appendix E.1
 (continued)

Effective Date: December 12, 2003

Revised Date: December 1, 2021

Lot #	Density Test Interval	Density	
1	1	91.5	
	2	93.0	
	3	92.9	
	4	93.5	
	5	93.0	
	6	94.0	
	7	92.8	
	8	93.5	
	9	91.0	
	⋮	⋮	
	30	92.7	
	Average:		92.79
	Standard Deviation:		0.910

Determine the pay factor for each parameter.

Air Voids:

Lot: Average = 4.16
 Standard Deviation = 0.825

$$Q_U = \frac{(4.0 + 1.35) - 4.16}{0.825} = 1.44$$

$$Q_L = \frac{4.16 - (4.0 - 1.35)}{0.825} = 1.83$$

$N = 10$ sublots (from Table 2)

$$P_U = 94$$

$$P_L = 98$$

$$PWL = (94 + 98) - 100$$

$$PWL = 92$$

$$PF = 55 + 0.5 (92)$$

$$PF = 101.0$$

Determine the pay factor for Air Voids.

$$PF_{Voids} = 101.0$$

Hot-Mix Asphalt PFP Pay Adjustments
Appendix E.1
(continued)

Effective Date: December 12, 2003

Revised Date: December 1, 2021

Field VMA:

Lot : Average = 15.32
Standard Deviation = 0.253

$$Q_U = \frac{(15.0+3.0)-15.32}{0.253} = 10.59$$

$$Q_L = \frac{15.32-(15.0-0.7)}{0.253} = 4.03$$

$N = 10$ sublots (from Table 2)

$$P_U = 100$$

$$P_L = 100$$

$$PWL = (100 + 100) - 100$$

$$PWL = 100$$

$$PF = 55 + 0.5 (100)$$

$$PF = 105.0$$

Determine the pay factor for Field VMA.

$$PF_{VMA} = 105.0$$

Hot-Mix Asphalt PFP Pay Adjustments

Appendix E.1

(continued)

Effective Date: December 12, 2003

Revised Date: December 1, 2021

Density:

Lot: Average = 92.79
Standard Deviation = 0.910

$$Q_U = \frac{97.0 - 92.79}{0.910} = 4.63$$

$$Q_L = \frac{92.79 - 91.5}{0.910} = 1.42$$

$N = 30$ Density measurements (from table)

$$P_U = 100$$

$$P_L = 93$$

$$PWL = (100 + 93) - 100$$

$$PWL = 93$$

$$PF = 55 + 0.5 (93)$$

$$PF = 100.5$$

Determine the pay factor for Density.

$$PF_{Density} = 101.5$$

Hot-Mix Asphalt PFP Pay Adjustments

Appendix E.1

(continued)

Effective Date: December 12, 2003

Revised Date: December 1, 2021

Determine the total pay factors for each parameter. In this example the Air Voids PF and Field VMA PF for the second and third lots are given to be equal to the Air Voids PF and Field VMA PF for the first lot, respectively. The total pay factor for density ($TPF_{Density}$) is calculated as shown below.

Lot #	Mix Tons	Air Voids PF	Field VMA PF	Density Distance	Density PF
1	10,000	101.0	105.0	31680 ft	101.5
2	10,000	101.0	105.0	31680 ft	101.4
3	7,840	101.0	105.0	24640 ft	97.3
Total	27,840			88000 ft	
TPF		101.0	105.0		100.3

$$TPF_{Density} = W1PF_{lot1} + W2PF_{lot2} + W3PF_{lot3}$$

$$TPF_{Density} = (31680/88000)(101.5) + (31680/88000)(101.4) + (24640/88000)(97.3)$$

$$TPF_{Density} = 100.3$$

Combine the three Total Pay Factors to determine the Composite Pay Factor for the mix.

$$CPF = [0.3(101.0) + 0.3(105.0) + 0.4(100.3)] / 100$$

$$CPF = 1.019$$

Determine the adjusted pay for the given mixture.

Given that the mixture bid price per ton = \$65.00 and 27,840 tons were placed.

$$\text{Plan Unit Pay} = \$65.00/\text{ton} \times 27,840 \text{ tons} = \$1,809,600.00$$

$$\text{Adjusted Pay} = \$65.00/\text{ton} \times 27,840 \text{ tons} \times 1.019 = \$1,843,982.40$$

The pay adjustment is the difference between the adjusted pay and the plan unit pay.

$$\text{Pay Adjustment} = \$1,843,982.40 - \$1,809,600.00 = \$34,382.40$$

If the difference is a positive value this will be the incentive paid. If the difference is a negative value this will be the disincentive applied. In this case a \$34,382.40 incentive would be paid as per Construction Memorandum #4.

Hot-Mix Asphalt PFP Pay Adjustments
Appendix E.1
(continued)

Effective Date: December 12, 2003

Revised Date: December 1, 2021

Example 2 – Full Depth:

Given: a 14,000 sq yd full-depth project bid at \$40/sq yd with two mixtures whose composite pay factors were determined to be 101.5% and 99.2%. The full-depth combined composite pay factor will be calculated as follows:

$$101.5(1/2) + 99.2(1/2) = 100.4\%$$

Determine the adjusted pay and pay adjustment for the full-depth pavement.

Given that the bid price per square yard = \$40.00 and 14,000 sq yd were placed.

$$\text{Plan Unit Pay} = \$40.00/\text{sq yd} \times 14,000 \text{ sq yd} = \$560,000$$

$$\text{Adjusted Pay} = \$40.00/\text{sq yd} \times 14,000 \text{ sq yd} \times 1.004 = \$562,240$$

$$\text{Pay Adjustment} = \$562,240 - \$560,000 = \$2,240 \text{ (Positive value = Incentive)}$$

Example 3 – Full Depth:

Given: a 43,000 sq yd full-depth project bid at \$40/sq yd with three mixtures whose composite pay factors were determined to be 98.9%, 101.5% and 99.2%. The full-depth combined composite pay factor will be calculated as follows:

$$98.9(1/3) + 101.5(1/3) + 99.2(1/3) = 99.9\%$$

Determine the adjusted pay and pay adjustment for the full-depth pavement.

Given that the bid price per square yard = \$40.00 and 43,000 sq yd were placed.

$$\text{Plan Unit Pay} = \$40.00/\text{sq yd} \times 43,000 \text{ sq yd} = \$1,720,000$$

$$\text{Adjusted Pay} = \$40.00/\text{sq yd} \times 43,000 \text{ sq yd} \times 0.999 = \$1,718,280$$

$$\text{Pay Adjustment} = \$1,718,280 - \$1,720,000 = -\$1,720 \text{ (Negative value = Disincentive)}$$

Hot-Mix Asphalt PFP and QCP Random Plant Samples
Appendix E.2

Effective Date: May 1, 2008

Revised Date: December 1, 2021

Samples shall be obtained at the frequencies specified in the Standard Specification Articles 1030.07 and 1030.08 for PFP and QCP, respectively.

- A. The samples shall be taken at the randomly selected tonnage within a subplot. The random tonnage will be determined by the Engineer using the "Random Numbers" table as specified herein or the Department's Quality Management Program (QMP) Package software. The tonnage shall be calculated according to the following:
1. Unless otherwise known, determine the random locations for a tonnage in excess of five percent over plan quantity by multiplying the plan quantity tonnage by 1.05 to determine an over-projected final quantity. If the over-projected final quantity is not achieved, disregard the additional random values.
 2. Determine the maximum number of sublots needed for the given mixture by dividing the over-projected tonnage calculated above by the subplot size in tons (metric tons) (typically 1,000 tons). Round this number to the next whole value. This will determine the maximum number of sublots for the given mixture.
 3. Multiply the subplot tonnage by a three-digit random number, expressed as a decimal. The number obtained (rounded to a whole number) shall be the random sampling tonnage within the given subplot.
 4. The individual subplot random tonnages shall then be converted to cumulative random tonnages. This is accomplished by using the following equation for each subplot.

$$CT_n = [(ST) \times (n - 1)] + RT_n$$

Where: n = the subplot number
CT = Cumulative tonnage
RT = Random tonnage as determined in #3 above
ST = Sublot tonnage

- B. If paving is completed for a particular mixture before the specified sampling tonnage for the last subplot is achieved, the last subplot shall be omitted.
- C. Samples shall be taken out of trucks at the plant. The truck containing the random tonnages will be determined by the Engineer following the procedure described herein. Two sampling platforms (one on each side of the truck) shall be provided for sampling of the mix. In order to obtain a representative sample of the entire truck load, an equal amount of material shall be taken from each quarter point around the circumference of each pile in the truck to obtain a composite sample weighing approximately 200lb (95 kg). All material shall be obtained by using a "D"-handled, square-ended shovel with built-up sides and back (1 to 1.5 in. [25 to 38 mm]). The sample tonnage will be disclosed no more than 30 minutes prior to sampling. Sampling shall be performed by the Contractor under the supervision of the Engineer.

Hot-Mix Asphalt PFP and QCP Random Plant Samples

Appendix E.2

(continued)

Effective Date: May 1, 2008

Revised Date: [December 1, 2021](#)

- D. The truck sample shall be divided into three approximately equal size (split) samples by the use of an approved mechanical sample splitter. The Engineer will witness all splitting. Two split samples for Department testing shall be placed in Department-approved sample containers provided by the Contractor and identified as per the Engineer's direction. The Engineer will gain immediate possession of both Department split samples. The Contractor may store, discard, or test the remaining split [sample](#) as described in Section 1030 of the Standard Specifications. However, the Contractor must test and provide the sample results in order to initiate the dispute resolution process as described in the Hot-Mix Asphalt Pay for Performance Special Provision.

Example:

Given: Plan quantity = 10,000 tons for a given mixture. Sublot = 1,000 tons.

1. Determine the over-projected final tonnage.

$$10,000 \text{ tons} \times 1.05 = 10,500 \text{ tons}$$

2. Determine the maximum number of sublots needed for the project based on the over-projected tonnage.

$$10,500 \text{ tons} / 1,000 \text{ tons} = 10.5 \text{ (Note: Always round up)}$$

Therefore, [a maximum of 11 sublots](#)

3. Obtain random numbers from the table and apply a different random number to each sublot.

$$1000 \times 0.546 = 546$$
$$1000 \times 0.123 = 123$$

Repeat for each sublot.

4. Convert **individual** tonnages to cumulative job tonnage.

$$[1,000 \times (1-1)] + 546 = 546$$
$$[1,000 \times (2-1)] + 123 = 1,123$$

Repeat for each sublot.

Hot-Mix Asphalt PFP and QCP Random Plant Samples
Appendix E.2

(continued)

Effective Date: May 1, 2008

Revised Date: December 1, 2021

The following contains a completed table for the 11 plant random samples:

Lot Number	Sublot Number	Random Number	Tonnage within Sublot	Cumulative Job Tonnage
1	1	0.546	$1000 \times 0.546 = 546$	$[1000 \times (1-1)] + 546 = 546$
	2	0.123	$1000 \times 0.123 = 123$	$[1000 \times (2-1)] + 123 = 1123$
	3	0.789	$1000 \times 0.789 = 789$	$[1000 \times (3-1)] + 789 = 2789$
	4	0.372	$1000 \times 0.372 = 372$	$[1000 \times (4-1)] + 372 = 3372$
	5	0.865	$1000 \times 0.865 = 865$	$[1000 \times (5-1)] + 865 = 4865$
	6	0.921	$1000 \times 0.921 = 921$	$[1000 \times (6-1)] + 921 = 5921$
	7	0.037	$1000 \times 0.037 = 37$	$[1000 \times (7-1)] + 37 = 6037$
	8	0.405	$1000 \times 0.405 = 405$	$[1000 \times (8-1)] + 405 = 7405$
	9	0.214	$1000 \times 0.214 = 214$	$[1000 \times (9-1)] + 214 = 8214$
	10	0.698	$1000 \times 0.698 = 698$	$[1000 \times (10-1)] + 698 = 9698$
	11	0.711	$1000 \times 0.711 = 711$	$[1000 \times (11-1)] + 711 = 10711$

If paving is completed prior to production of the 10,711 ton of mixture, the 11th sublot is omitted

Hot-Mix Asphalt **FPF** and **QCP** Random Plant Samples

Appendix E.2

(continued)

Effective Date: May 1, 2008

Revised Date: **December 1, 2021**

RANDOM NUMBERS

0.576	0.730	0.430	0.754	0.271	0.870	0.732	0.721	0.998	0.239
0.892	0.948	0.858	0.025	0.935	0.114	0.153	0.508	0.749	0.291
0.669	0.726	0.501	0.402	0.231	0.505	0.009	0.420	0.517	0.858
0.609	0.482	0.809	0.140	0.396	0.025	0.937	0.301	0.253	0.761
0.971	0.824	0.902	0.470	0.997	0.392	0.892	0.957	0.040	0.463
0.053	0.899	0.554	0.627	0.427	0.760	0.470	0.040	0.904	0.993
0.810	0.159	0.225	0.163	0.549	0.405	0.285	0.542	0.231	0.919
0.081	0.277	0.035	0.039	0.860	0.507	0.081	0.538	0.986	0.501
0.982	0.468	0.334	0.921	0.690	0.806	0.879	0.414	0.106	0.031
0.095	0.801	0.576	0.417	0.251	0.884	0.522	0.235	0.389	0.222
0.509	0.025	0.794	0.850	0.917	0.887	0.751	0.608	0.698	0.683
0.371	0.059	0.164	0.838	0.289	0.169	0.569	0.977	0.796	0.996
0.165	0.996	0.356	0.375	0.654	0.979	0.815	0.592	0.348	0.743
0.477	0.535	0.137	0.155	0.767	0.187	0.579	0.787	0.358	0.595
0.788	0.101	0.434	0.638	0.021	0.894	0.324	0.871	0.698	0.539
0.566	0.815	0.622	0.548	0.947	0.169	0.817	0.472	0.864	0.466
0.901	0.342	0.873	0.964	0.942	0.985	0.123	0.086	0.335	0.212
0.470	0.682	0.412	0.064	0.150	0.962	0.925	0.355	0.909	0.019
0.068	0.242	0.777	0.356	0.195	0.313	0.396	0.460	0.740	0.247
0.874	0.420	0.127	0.284	0.448	0.215	0.833	0.652	0.701	0.326
0.897	0.877	0.209	0.862	0.428	0.117	0.100	0.259	0.425	0.284
0.876	0.969	0.109	0.843	0.759	0.239	0.890	0.317	0.428	0.802
0.190	0.696	0.757	0.283	0.777	0.491	0.523	0.665	0.919	0.146
0.341	0.688	0.587	0.908	0.865	0.333	0.928	0.404	0.892	0.696
0.846	0.355	0.831	0.281	0.945	0.364	0.673	0.305	0.195	0.887
0.882	0.227	0.552	0.077	0.454	0.731	0.716	0.265	0.058	0.075
0.464	0.658	0.629	0.269	0.069	0.998	0.917	0.217	0.220	0.659
0.123	0.791	0.503	0.447	0.659	0.463	0.994	0.307	0.631	0.422
0.116	0.120	0.721	0.137	0.263	0.176	0.798	0.879	0.432	0.391
0.836	0.206	0.914	0.574	0.870	0.390	0.104	0.755	0.082	0.939
0.636	0.195	0.614	0.486	0.629	0.663	0.619	0.007	0.296	0.456
0.630	0.673	0.665	0.666	0.399	0.592	0.441	0.649	0.270	0.612
0.804	0.112	0.331	0.606	0.551	0.928	0.830	0.841	0.702	0.183
0.360	0.193	0.181	0.399	0.564	0.772	0.890	0.062	0.919	0.875
0.183	0.651	0.157	0.150	0.800	0.875	0.205	0.446	0.648	0.685

Note: Always select a new set of numbers in a systematic manner, either horizontally or vertically. Once used, the set should be crossed out.

Hot-Mix Asphalt PFP and QCP Procedure for Determining Random Density Locations
Appendix E.3

Effective Date: April 1, 2009

Revised Date: December 1, 2021

Random density test locations will be determined at the frequency specified in the Standard Specification Articles 1030.07 and 1030.08. Cores shall be collected by the Contractor at these locations and secured by the Department for testing. The test locations will be determined as follows:

- A) Prior to paving, the test locations will be determined by the Engineer using the “Random Numbers” table as specified herein or the Department’s Quality Management Program (QMP) Package software. The values are to be considered confidential and are not to be disclosed to anyone outside of the Department until finish rolling is complete. Disclosing the information prior to finish rolling would be in direct violation of federal regulations. Once random test locations are determined by the Engineer, it may be necessary to alter these locations due to quantity adjustments, sequencing changes, or other alterations made by the Department or Contractor. The Engineer will document any changes to the random test locations and provide documentation to the Contractor upon completion of the project.

Each test location will be randomly located both longitudinally and transversely within each density interval by using two random numbers. The first random number is used to determine the longitudinal distance to the nearest 1 ft (300 mm) into the density testing interval. The second random number is used to determine the transverse offset to the nearest 0.1 ft (30 mm) from the left edge of the paving lane. The direction of the paving lane will be the same as the direction of traffic.

Longitudinal Location: Determine the random longitudinal location by multiplying the length of the prescribed density interval by the random number selected from the Random Numbers table.

Transverse Offset to Center of Core: Determine the random transverse offset as follows:

1. PFP. The effective lane width of the paving lane will be used in calculating the transverse offset. The effective lane width is determined by first subtracting 1.0 ft (300 mm) for each unconfined edge from the entire paved lane width (i.e. If a 12.0 ft (3.7 m) wide paved lane has two unconfined edges, the effective lane width would be 10.0 ft (3.0 m).) The effective lane width is reduced by 1.0 ft (300 mm) for each confined longitudinal joint with longitudinal joint sealant (LJS) (i.e. If a 12.0 ft (3.7 m) wide paved lane has one unconfined edge without LJS and one confined edge with LJS, the effective lane width would be 10.0 ft (3.0 m).) The effective lane width is reduced by 4.0 in. (100 mm) for each confined edge without LJS. The effective lane width is further reduced 4.0 in. (100 mm) for the diameter of the core barrel.

Effective lane width of PFP pavement = pavement lane width – 1.0 ft (300 mm) for each unconfined/LJS edge – 4.0 in. (100 mm) for each confined non LJS edge – 4.0 in. (100 mm) for core barrel

The transverse offset is determined by first multiplying the effective lane width by the selected random number. If the left edge is unconfined or located immediately above LJS, 1.0 ft (300 mm) will be added to the calculated transverse offset measurement.

Hot-Mix Asphalt PFP and QCP Procedure for Determining Random Density Locations
Appendix E.3

Effective Date: April 1, 2009

Revised Date: December 1, 2021

If the left edge is confined but without LJS, 4.0 in. (100 mm) will be added to the calculated transverse offset measurement. An additional 2 in. (50 mm) will be added to the calculated transverse offset measurement to account for the distance from the edge of the core barrel to the center of core. The transverse offset is measured from the left physical edge of the paved lane to locate the center of the core on the pavement.

Transverse Offset to Center of Core = effective lane width x random number + 1.0 ft (300 mm) if left edge is unconfined/LJS edge + 4.0 in. (100 mm) if left edge is confined non LJS edge + 2.0 in. (50 mm) for core barrel

Areas outside the mainline pavement that are paved concurrently with the mainline pavement (i.e. 3 ft (1 m) wide shoulders, driveways, etc.) are not considered part of the paved mainline mat. See the PFP example calculation herein.

Additionally, the longitudinal joint density test locations of a paved lane with one or both unconfined edges without LJS will be determined by multiplying each subplot length for each unconfined, non-LJS edge by a random number. The transverse locations of the longitudinal joint density coring will be centered at a distance of 4.0 in. (150 mm) plus 2.0 in. (50 mm) (to account for the distance from the edge of the core barrel to the center of core) from each unconfined, non-LJS edge. See the PFP example calculation herein.

2. QCP. The effective lane width of the paving lane will be used in calculating the transverse offset. The effective lane width is determined by first subtracting 1.0 ft (300 mm) for each longitudinal joint with LJS from the entire lane width. The effective lane width is then reduced 4.0 in. (100 mm) for each joint that does not have LJS. The effective lane width is further reduced by 4.0 in. (100 mm) for the diameter of the core barrel.

Effective lane width of QCP pavement = pavement lane width – 1.0 ft (300 mm) for each edge with LJS – 4.0 in. (100 mm) for each edge without LJS – 4.0 in. (100 mm) for core barrel

The transverse offset is determined by first multiplying the effective lane width by the selected random number. If the left edge is located immediately above LJS, 1.0 ft (300 mm) will be added to the calculated transverse offset measurement. If the left edge is confined but without LJS, 4.0 in. (100 mm) will be added to the calculated transverse offset measurement. An additional 2 in. (50 mm) will be added to the calculated transverse offset measurement to account for the distance from the edge of the core barrel to the center of core. The transverse offset is measured from the left physical edge of the paved lane to locate the center of the core on the pavement.

Transverse Offset to Center of Core = effective lane width x random number + 1.0 ft (300 mm) if left edge has LJS + 4.0 in. (100 mm) if left edge does not have LJS + 2.0 in. (50 mm) for core barrel

Hot-Mix Asphalt PFP and QCP Procedure for Determining Random Density Locations
Appendix E.3

Effective Date: April 1, 2009

Revised Date: December 1, 2021

Cores taken within 1.0 ft (300 mm) of an unconfined edge without LJS will have 2.0% density added for pay adjustment calculation purposes. See the QCP example calculation herein.

B) This process will be repeated for all density intervals on a given project.

C) Moving Test Locations.

There are two scenarios in which random test locations may be moved longitudinally using the same random transverse offset. The first scenario is to avoid only the obstacles listed under Case 1 below. The second scenario is to avoid pavement defects in the surface being overlaid as described in Case 2 below.

1) Case 1. In the event the random test location will not allow the necessary compactive effort to be applied, the Engineer will adjust the longitudinal location of the test location in order to avoid the obstacle. Using the same random transverse offset, the test location will be moved longitudinally, ± 15 ft (4.6 m) to avoid the following obstacles only:

- a) Structures or Bridge Decks
- b) Detection loop or other pavement sensors
- c) Manholes or other utility appurtenances

2) Case 2. In the event there are pavement defects in the surface being overlaid, the Contractor may place temporary markings on the shoulder prior to paving to represent longitudinal locations where a defect is present. These pavement defect locations will be approved by the Engineer. If a random test location lands at the same longitudinal location as a temporary mark, the test location will be moved 5 ft (1.5 m) past the temporary mark in the direction toward the paver at the same transverse offset. In the case of an asphalt scab (i.e. thin layer of less than 0.5 in. (13 mm) of asphalt pavement remaining after milling) the temporary markings shall show the extent or length of the defect. The test location will then be moved to a longitudinal distance 5 ft (1.5 m) past the end of the defect toward the paver.

D) Example Calculations.

PFP Example.

This PFP example illustrates the determination of the random test locations within the first mile of a lot.

Given: The HMA pavement consists of a 13.0 ft wide mat 1.5 in. thick with the left edge confined without LJS and the right edge unconfined without LJS.

Hot-Mix Asphalt PFP and QCP Procedure for Determining Random Density Locations
Appendix E.3

Effective Date: April 1, 2009

Revised Date: December 1, 2021

This will require a density testing interval of 0.2 miles. The random numbers for the longitudinal direction are: 0.917, 0.289, 0.654, 0.347, and 0.777. The random numbers for the transverse direction are: 0.890, 0.317, 0.428, 0.998, and 0.003.

The individual longitudinal density test interval distances can be converted to the cumulative random distance using the following equation:

$$CD_n = [D \times (n - 1)] + R_n$$

Where:

n = the density interval number

CD = cumulative distance

D = density testing interval length (typically 1056 ft (0.2 mile))

R = random distance within the given density testing interval

The longitudinal test locations are determined by multiplying the longitudinal random numbers by 1056 ft (0.2 mile). The transverse core locations are determined by multiplying the transverse random number by the effective width of the paved mat.

Determine the effective lane width by subtracting 1.0 ft for each unconfined edge and 4.0 in. (0.33 ft) for each confined edge without LJS from the 13.0 ft paved lane width. In this case the right edge is unconfined, so subtract 1.0 ft (1.0 ft), and the left edge is confined without LJS so subtract 4.0 in. (0.33 ft). Then subtract 4.0 in. (0.33 ft) for the width of the core barrel.

$$\text{Effective Lane Width} = 13.0 \text{ ft} - 1.0 \text{ ft} - 0.33 \text{ ft} - 0.33 \text{ ft} = 11.34 \text{ ft}$$

The calculated transverse offset distances are determined by multiplying the effective lane width of 11.34 ft by the random numbers and adding 4.0 in. (0.33 ft) for the left confined edge plus 2.0 in. (0.17 ft) for the core barrel (0.33 ft + 0.17 ft = 0.5 ft). The random locations for the first mile measured from the beginning of the lot and the left (confined) edge of the paved mat to the center of the core barrel are as follows (See Figure 1):

Core #	Longitudinal Location	Cumulative Distance	Center of Core Transverse Location ^{1/}
1	1056 x 0.917 = 968 ft	1056 x (1-1) + 968 = 968 ft	(11.34 x 0.890) + 0.5 = 10.6 ft
2	1056 x 0.289 = 305 ft	1056 x (2-1) + 305 = 1361 ft	(11.34 x 0.317) + 0.5 = 4.1 ft
3	1056 x 0.654 = 691 ft	1056 x (3-1) + 691 = 2803 ft	(11.34 x 0.428) + 0.5 = 5.4 ft
4	1056 x 0.347 = 366 ft	1056 x (4-1) + 366 = 3534 ft	(11.34 x 0.998) + 0.5 = 11.8 ft
5	1056 x 0.777 = 821 ft	1056 x (5-1) + 821 = 5045 ft	(11.34 x 0.003) + 0.5 = 0.5 ft

1/ Transverse location of the center of the core measured from the left physical edge of the paved lane.

Hot-Mix Asphalt PFP and QCP Procedure for Determining Random Density Locations
Appendix E.3

Effective Date: April 1, 2009
 Revised Date: December 1, 2021

Additionally, there will be two longitudinal joint density sublots in the unconfined right edge within the mile section, each subplot 0.5 mile (2640 ft). The random numbers to determine the locations for coring are: 0.822 and 0.317.

Sublot #	Core #	Longitudinal Location	Cumulative Distance	Center of Core Transverse Location ^{1/}
1	1	2640 x 0.822 = 2170 ft	2640 x (1-1) + 2170 = 2170 ft	6.0 in.
2	2	2640 x 0.317 = 837 ft	2640 x (2-1) + 837 = 3477 ft	6.0 in.

1/ Transverse location of the center of the core measured from the right physical edge of the paved lane.

QCP Example.

This **QCP** example illustrates the determination of the core locations within the first mile of a project.

Given: The pavement consists of a 13.0 ft wide mat 1.5 in. thick with the left edge confined with LJS and the right edge unconfined without LJS.

This will require a density testing interval of 0.2 miles. The random numbers for the longitudinal direction are: 0.904, 0.231, 0.517, 0.253, and 0.040. The random numbers for the transverse direction are: 0.007, 0.059, 0.996, 0.515, and 0.101.

The individual density test interval distances can be converted to the cumulative random distance using the following equation:

$$CD_n = [D \times (n - 1)] + R_n$$

Where:

- n = the density interval number
- CD = cumulative distance
- D = density testing interval length (typically 1056 ft (0.2 mile))
- R = Random distance within the given density testing interval

The longitudinal core locations are determined by multiplying the longitudinal random numbers by 1056 ft (0.2 mile).

The transverse core locations are determined by multiplying the transverse random numbers by the effective lane width. The effective lane width is the width of the paved lane minus 1.0 ft for the left edge confined with LJS, 4.0 in (0.33 ft) for the right edge without LJS, and 4.0 in (0.33 ft) for the core barrel.

$$\text{Effective Lane Width} = 13.0 \text{ ft} - 1.0 \text{ ft} - 0.33 \text{ ft} - 0.33 \text{ ft} = 11.34 \text{ ft}$$

Hot-Mix Asphalt PFP and QCP Procedure for Determining Random Density Locations
Appendix E.3

Effective Date: April 1, 2009
 Revised Date: [December 1, 2021](#)

The calculated transverse offset distances are determined by multiplying the effective lane width by the random numbers and adding 1.0 ft for the left confined edge with LJS plus 2.0 in. (0.17 ft) for the core barrel (1.0 ft + 0.17 ft = 1.17 ft). The random locations for the first mile measured from the beginning of the lot and the left (confined) edge of the paved mat to the center of the core barrel are as follows:

Core #	Longitudinal Location	Cumulative Distance	Center of Core Transverse Location ^{1/}
1	$1056 \times 0.904 = 955 \text{ ft}$	$1056 \times (1-1) + 955 = 955 \text{ ft}$	$(11.34 \times 0.007) + 1.17 = 1.2 \text{ ft}$
2	$1056 \times 0.231 = 244 \text{ ft}$	$1056 \times (2-1) + 244 = 1300 \text{ ft}$	$(11.34 \times 0.059) + 1.17 = 1.8 \text{ ft}$
3	$1056 \times 0.517 = 546 \text{ ft}$	$1056 \times (3-1) + 546 = 2658 \text{ ft}$	$(11.34 \times 0.996) + 1.17 = 12.5 \text{ ft}$
4	$1056 \times 0.253 = 267 \text{ ft}$	$1056 \times (4-1) + 267 = 3435 \text{ ft}$	$(11.34 \times 0.515) + 1.17 = 7.0 \text{ ft}$
5	$1056 \times 0.040 = 42 \text{ ft}$	$1056 \times (5-1) + 42 = 4266 \text{ ft}$	$(11.34 \times 0.101) + 1.17 = 2.3 \text{ ft}$

1/ Transverse location of the center of the core measured from the left physical edge of the paved lane.

Hot-Mix Asphalt PFP and QCP Procedure for Determining Random Density Locations
Appendix E.3

Effective Date: April 1, 2009
Revised Date: December 1, 2021

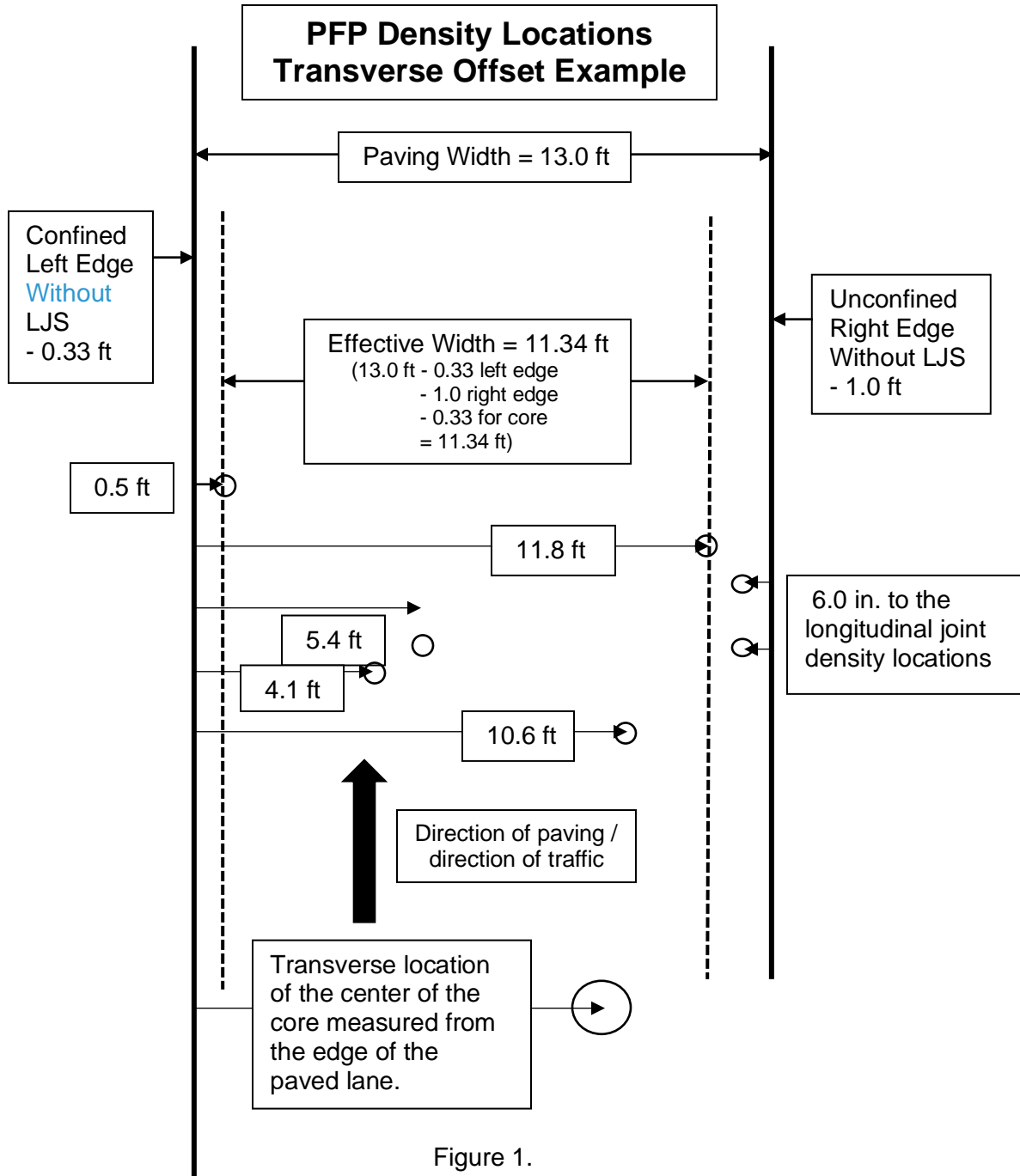

Figure 1.

RANDOM NUMBERS

0.576	0.730	0.430	0.754	0.271	0.870	0.732	0.721	0.998	0.239
0.892	0.948	0.858	0.025	0.935	0.114	0.153	0.508	0.749	0.291
0.669	0.726	0.501	0.402	0.231	0.505	0.009	0.420	0.517	0.858
0.609	0.482	0.809	0.140	0.396	0.025	0.937	0.301	0.253	0.761
0.971	0.824	0.902	0.470	0.997	0.392	0.892	0.957	0.040	0.463
0.053	0.899	0.554	0.627	0.427	0.760	0.470	0.040	0.904	0.993
0.810	0.159	0.225	0.163	0.549	0.405	0.285	0.542	0.231	0.919
0.081	0.277	0.035	0.039	0.860	0.507	0.081	0.538	0.986	0.501
0.982	0.468	0.334	0.921	0.690	0.806	0.879	0.414	0.106	0.031
0.095	0.801	0.576	0.417	0.251	0.884	0.522	0.235	0.389	0.222
0.509	0.025	0.794	0.850	0.917	0.887	0.751	0.608	0.698	0.683
0.371	0.059	0.164	0.838	0.289	0.169	0.569	0.977	0.796	0.996
0.165	0.996	0.356	0.375	0.654	0.979	0.815	0.592	0.348	0.743
0.477	0.535	0.137	0.155	0.767	0.187	0.579	0.787	0.358	0.595
0.788	0.101	0.434	0.638	0.021	0.894	0.324	0.871	0.698	0.539
0.566	0.815	0.622	0.548	0.947	0.169	0.817	0.472	0.864	0.466
0.901	0.342	0.873	0.964	0.942	0.985	0.123	0.086	0.335	0.212
0.470	0.682	0.412	0.064	0.150	0.962	0.925	0.355	0.909	0.019
0.068	0.242	0.777	0.356	0.195	0.313	0.396	0.460	0.740	0.247
0.874	0.420	0.127	0.284	0.448	0.215	0.833	0.652	0.701	0.326
0.897	0.877	0.209	0.862	0.428	0.117	0.100	0.259	0.425	0.284
0.876	0.969	0.109	0.843	0.759	0.239	0.890	0.317	0.428	0.802
0.190	0.696	0.757	0.283	0.777	0.491	0.523	0.665	0.919	0.146
0.341	0.688	0.587	0.908	0.865	0.333	0.928	0.404	0.892	0.696
0.846	0.355	0.831	0.281	0.945	0.364	0.673	0.305	0.195	0.887
0.882	0.227	0.552	0.077	0.454	0.731	0.716	0.265	0.058	0.075
0.464	0.658	0.629	0.269	0.069	0.998	0.917	0.217	0.220	0.659
0.123	0.791	0.503	0.447	0.659	0.463	0.994	0.307	0.631	0.422
0.116	0.120	0.721	0.137	0.263	0.176	0.798	0.879	0.432	0.391
0.836	0.206	0.914	0.574	0.870	0.390	0.104	0.755	0.082	0.939
0.636	0.195	0.614	0.486	0.629	0.663	0.619	0.007	0.296	0.456
0.630	0.673	0.665	0.666	0.399	0.592	0.441	0.649	0.270	0.612
0.804	0.112	0.331	0.606	0.551	0.928	0.830	0.841	0.702	0.183
0.360	0.193	0.181	0.399	0.564	0.772	0.890	0.062	0.919	0.875
0.183	0.651	0.157	0.150	0.800	0.875	0.205	0.446	0.648	0.685

Note: Always select a new set of numbers in a systematic manner, either horizontally or vertically. Once used, the set should be crossed out.

**Hot-Mix Asphalt PFP Hot Mix Asphalt Random Jobsite Sampling
Appendix E.4**

Effective Date: April 1, 2008
Revised Date: [December 1, 2021](#)

Hot-mix asphalt (HMA) samples shall be obtained at the frequency specified in [the Standard Specification Article 1030.07 for mixtures using Pay for Performance \(PFP\) criteria and 1030.08 for mixtures using Quality Control for Performance \(QCP\) criteria](#).

The jobsite mixture samples shall be taken at randomly selected test locations within [each](#) subplot. Prior to paving, the random test locations will be determined by the Engineer using the “Random Numbers” table as specified herein or the Department’s [Quality Management Program \(QMP\) Package software](#). The values are to be considered confidential and are not to be disclosed to anyone outside of the Department prior to the truck containing the random tonnage arriving at the jobsite. Disclosing the information would violate the intent of this procedure and federal regulations.

The sample location [will](#) be determined by calculating the longitudinal distance the truck [delivering the random sample tonnage](#) would travel to [discharge](#) the random sample tonnage. The starting station for the longitudinal distance measurement is the location of the paver where the truck begins to unload the mixture into the paver or Material Transfer Device (MTD). Computations are made to the nearest [1 ft \(300 mm\)](#) (see examples in [the appendix](#) herein). In the event the job site conditions pose a safety risk, the Engineer will adjust the random test location to the nearest safe location. Unsafe conditions include: intersections, narrow or restricted areas such as underpasses, on interchange ramps within [100 ft \(30 m\)](#) of an access controlled highway, or any other situation deemed unsafe.

If the paving is completed for a mixture before the specified sampling test location for the last mixture subplot is completed, a [sample](#) will not be taken and the tonnage will be added to the [previous](#) lot.

The Contractor may select either sampling behind the paver or sampling from the MTD discharge chute. The Contractor shall provide the necessary equipment and HMA Level I personnel to obtain the required samples, for whatever method is chosen, as specified herein.

A. Behind [the Paver](#) Sampling.

This method covers the procedures for sampling HMA mixtures at the point of delivery immediately behind the paver and before initial compaction. This method is intended to provide a single composite sample that is representative of the mixture as produced (i.e. excludes paver effects).

1. Equipment.

- a) IDOT Approved Sampling Shovel ([Figure 1](#)).
- b) Sample Containers (4 each). Metal sample buckets with a minimum capacity of 3.5 gal (13 L).
- c) IDOT Approved HMA Sample Splitter.
- d) Plate/Shovel Sampling. The following additional equipment is needed when sampling HMA placed directly over a milled surface, rubblized concrete or an aggregate base.
 - 1) Sampling Plates (4 each). The sampling plates shall be rectangular and have a minimum size of 14 x 28 in. (360 x 720 mm). Plates shall have a hole approximately 0.25 in. (6 mm) in diameter drilled through each of the four corners.

**Hot-Mix Asphalt PFP and QCP Random Jobsite Sampling
Appendix E.4**

Effective Date: April 1, 2008
Revised Date: December 1, 2021

- 2) Lifting Handles and Wire Lead. A 24 in. (600 mm) length of wire shall be attached to the two holes on one side of the plate to serve as a lifting handle. An additional wire lead shall be attached to one of the lifting handles for locating the buried plate in the pavement. This wire shall extend to the edge of the pavement.
- 3) Hammer and masonry nails for securing plates and wire lead.



Overall Length = 5 ft (1.5 m)
Shovel Width = 10 in. (255 mm)
Shovel Length = 12 in. (305 mm)
Shovel Sides = 4 in. (100 mm)

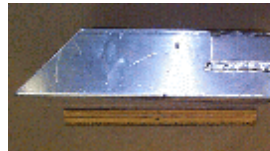

Figure 1. Aluminum Sampling Shovel & Dimensions

2. Shovel Sample Sampling Procedure (Without Plates). This method shall be used when sampling over smooth HMA and concrete surfaces.
 - a) The sampling shovel shall be used at each of the four offsets illustrated in Figure 2. to dig directly downward into the HMA behind the paver until it comes into contact with the previous pavement surface. When in contact, the shovel shall be pushed forward until it is full. The shovel shall be lifted up slowly. The mix shall be carefully placed into the sample container in order to prevent any loss of HMA.
3. Shovel/Plate Sampling Procedure (With Plates). This method shall be used when sampling HMA directly over aggregate base, stabilized subbase, rubblized concrete, or a milled surface. This method may not be appropriate for a 3/4 in. (19 mm) binder lift over a milled surface. In the case of IL-4.75 or IL-9.5 FG mixtures, if approved by the Engineer, these mixtures may be

Hot-Mix Asphalt PFP and QCP Random Jobsite Sampling
Appendix E.4

Effective Date: April 1, 2008

Revised Date: December 1, 2021

shovel sampled from the auger area at the designated random location. Intentions of sampling IL-4.75 or IL-9.5 FG mixtures in this manner shall be listed in the approved QC Plan.

- a) Each plate with the wire lead attached to the handle shall be placed at one of four positions at the designated location ahead of the paver according for Figure 2. If conditions on the project require restricting movement of the plate, a nail shall be driven through one of the holes in the plate and into the pavement.
- b) The wire lead shall be extended beyond the edge of the pavement. Trucks, pavers, and/or material transfer devices will be allowed to cross over the plate and/or wire lead.
- c) After the HMA is placed, the wire lead shall be used to locate the plate. Once located, the wire handles shall be lifted out of the pavement. This will locate the four corners of the plate.
- d) Once the plate edges are defined, the shovel shall be used to dig downward through the thickness of the HMA behind the paver until it is in contact with the plate. The shovel shall be pushed forward until it is full. The shovel shall be lifted up slowly. The mix shall be carefully placed into the sample container in order to prevent any loss of HMA.
- e) Remove the sampling plates from the pavement.

Hot-Mix Asphalt PFP and QCP Random Jobsite Sampling
Appendix E.4

Effective Date: April 1, 2008
Revised Date: **December 1, 2021**

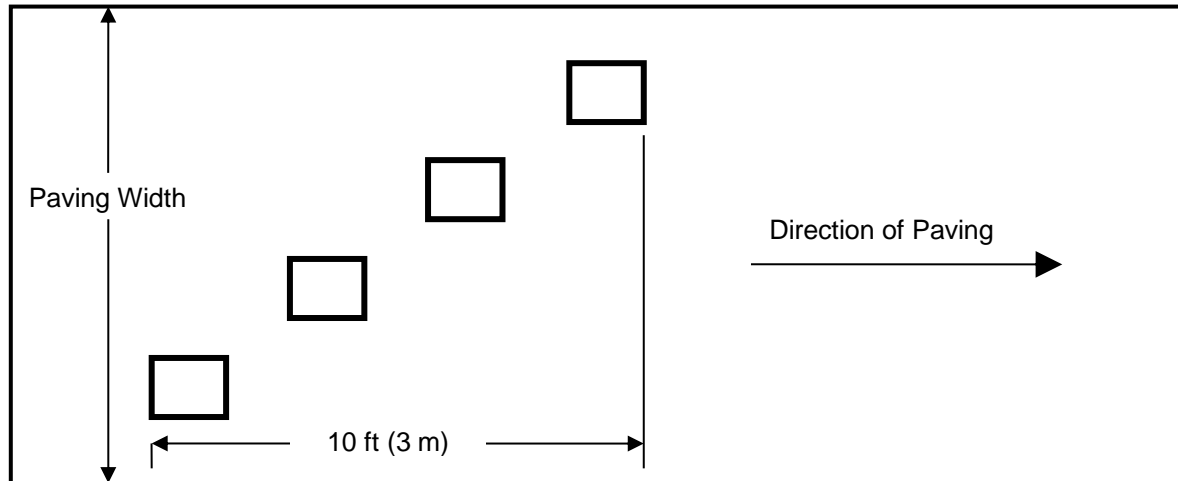

Figure 2. Behind the Paver Sampling Layout

4. Composite/Lab Samples.

a) HMA samples shall be taken, blended and split, using an IDOT approved HMA splitter, onsite by the Contractor and witnessed by the Engineer. The sample shall be taken immediately behind the paver and before initial roller compaction. One composite sample consists of four increments collected within 10 ft (3 m) longitudinally and diagonally across the width of the paving operation (Fig. 2). The four increments shall be blended according to HMA Level I procedures to provide a single composite sample.

b) Composite Sample.

PFP and QCP. A composite sample size shall be a minimum of 200 lb (90 kg).

c) Lab Sample.

PFP and QCP. The minimum lab sample size of 50 lb (23 kg) shall be obtained by splitting the composite samples into four equal lab samples using an IDOT approved HMA splitter. The Engineer will secure three Department lab samples for the Contractor to transport to the District Materials Laboratory.

5. Sample Site Repair.

a) HMA from the paver auger system shall be used to fill the voids left in the pavement from sampling. To reduce segregation and low density in the finished mat, buckets shall be used to fill the voids left by the samples.

Hot-Mix Asphalt PFP and QCP Random Jobsite Sampling
Appendix E.4

Effective Date: April 1, 2008
Revised Date: [December 1, 2021](#)

- 1) HMA from the augers system shall be placed in clean metal buckets just prior to sampling the pavement.
- 2) The metal buckets shall be filled with approximately 25% more HMA than will be removed from the voids.
- b) The buckets shall be dumped directly over the voids.
- c) The HMA shall be slightly leveled to provide a gradual hump over the filled voids to allow compression of the mix by the roller.
- d) Unacceptable site repair shall be removed and replaced at the Contractor's expense.

B. MTD Sampling.

This method covers the procedures for sampling HMA paving mixtures at the point of delivery from a material transfer device (MTD).

1. Equipment.

- a) **MTD Sampling Device.** A portable device mounted either in the bed of a pickup truck or on a trailer. The device shall be equipped with a funnel large enough to capture the full stream of HMA from the MTD discharge chute without spillage and shall be capable of capturing a minimum composite sample. See [Figures 3, 4, and 5](#) for illustrations of various MTD sampling device configurations.
- b) **Sample Containers –** Metal containers each capable of holding a minimum of 50 lb ([23 kg](#)) of HMA.

2. MTD Sampling Procedure.

The Engineer will identify the truck containing the sample tonnage immediately prior to sampling. Immediately after the truck containing the random HMA tonnage has finished unloading, the MTD shall pull forward away from the paver far enough to allow the sampling device to be positioned under the MTD discharge chute. The sampling device shall be positioned as level as possible in a safe location readily accessible by the MTD. The MTD shall discharge without spillage a minimum of 200 lb (90 kg) of HMA for PFP and QCP into the funnel of the sampling device.

3. Composite/Lab Sample.

- a) **Composite Sample.** HMA from all four sample containers of the sampling device shall be blended into one composite sample and split to lab sample size by the Contractor onsite using an IDOT approved HMA splitter. The blending and splitting shall be according to HMA Level I procedures and will be witnessed by the Engineer.
- b) **Lab Sample.**

PFP and QCP. The minimum lab sample size of 50 lb (23 kg) shall be obtained by splitting the composite samples into four equal lab samples using an IDOT approved HMA splitter.

Hot-Mix Asphalt PFP and QCP Random Jobsite Sampling
Appendix E.4

Effective Date: April 1, 2008
Revised Date: December 1, 2021

The Engineer will secure three Department lab samples for the Contractor to transport to the District Materials Laboratory.

- C. Documentation – After the sample has been obtained, the following information shall be written on each sample bag or box with a felt tip marker.

Contract #: _____
Lot #: _____ Sublot #: _____
Date: _____ Time: _____
Mix Type (binder, surface...): _____
Mix Design #: _____
Sampled By: _____

- D. Sample Security – Each sample bag will be secured by the Engineer using a locking ID tag. Sample boxes will be sealed/taped using a security ID label.
- E. Sample Transportation – The Contractor shall deliver the secured sample to the District Laboratory, during regular working hours, within two days of sampling.
- F. Examples:
1. Behind Paver Sampling. Determination of random sample locations for behind the paver sampling.

This example illustrates the determination of the random behind the paver test location within a subplot:

Given: A surface mix with a design G_{mb} of 2.400 is being placed 12 feet wide and 1.5 inches thick. The Engineer has determined all the undisclosed random tonnages prior to production. The plan quantity on the project was 10,000 tons and enough random values were determined to allow for a 5% overrun assuring enough random tonnages were generated. Discard any overrun random tonnages if the placed tonnage on the project is less than the calculated tonnage.

**Hot-Mix Asphalt PFP and QCP Random Jobsite Sampling
Appendix E.4**

Effective Date: April 1, 2008
Revised Date: December 1, 2021

Sublot Number	Random Number	Sublot Tonnage	Cumulative Job Tonnage
1	0.1669	167	167
2	0.5202	520	1520
3	0.3000	300	2300
4	0.6952	695	3695
5	0.4472	447	4447
6	0.2697	270	5270
7	0.5367	537	6537
8	0.7356	736	7736
9	0.4045	405	8405
10	0.3356	336	9336
11	0.0899	90	10090

The truck containing the mix representing the 167 ton shall be the first subplot tested. The truck in question contains 12 tons of mix, the 160 to 172 cumulative tons to be placed on the project. Determine the random location by dividing the value of the selected truck tonnage to determine the random distance value to 3 decimal places.

$$167 - 160 = 7 \text{ (where the random ton falls within the truck)}$$

$$7 / (172 - 160) = 7 / 12 = 0.583 \text{ (random distance value)}$$

Determine the distance using 58.3% of the distance the mix in the truck will pave out using the following formula:

$$\text{Longitudinal Distance} = \frac{384.6 \times \text{Tons} \times \text{RD}}{G_{mb} \times \text{width} \times \text{thickness}}$$

Where:

Longitudinal Distance = random distance from starting station (ft)

Tons = total tons within the sample truck

RD = random distance value as calculated above

G_{mb} = design G_{mb} for the mix being placed

Width = width of mat being paved (ft)

Thickness = thickness of mat being paved (in.)

$$\text{Longitudinal Distance} = \frac{384.6 \times 12 \times .583}{2.400 \times 12 \times 1.5}$$

$$\text{Longitudinal Distance} = 62.3 \text{ ft} = 62 \text{ ft}$$

**Hot-Mix Asphalt PFP and QCP Random Jobsite Sampling
Appendix E.4**

Effective Date: April 1, 2008
Revised Date: [December 1, 2021](#)

Measure the calculated longitudinal distance from the starting station where the truck began to unload. Determine and document the random sample station and obtain the random mix sample as outlined herein.

Starting Station = 105+00
Random Sample Location = 105+00 + 62 = 105+62

This process shall be repeated for the subsequent sublots.

2. Examples of MTD Sampling Devices.



Figure 3. Example of MTD Sampling Device

Hot-Mix Asphalt PFP and QCP Random Jobsite Sampling
Appendix E.4

Effective Date: April 1, 2008
Revised Date: December 1, 2021



Figure 4. Additional Examples of MTD Sampling Devices



Figure 5. Additional Examples of MTD Sampling Devices

**Hot-Mix Asphalt PFP and QCP Random Jobsite Sampling
Appendix E.4**

Effective Date: April 1, 2008
Revised Date: [December 1, 2021](#)



Figure 6. Additional Examples of MTD Sampling Devices

**Hot-Mix Asphalt PFP and QCP Random Jobsite Sampling
Appendix E.4**

Effective Date: April 1, 2008
Revised Date: [December 1, 2021](#)

RANDOM NUMBERS

0.576	0.730	0.430	0.754	0.271	0.870	0.732	0.721	0.998	0.239
0.892	0.948	0.858	0.025	0.935	0.114	0.153	0.508	0.749	0.291
0.669	0.726	0.501	0.402	0.231	0.505	0.009	0.420	0.517	0.858
0.609	0.482	0.809	0.140	0.396	0.025	0.937	0.301	0.253	0.761
0.971	0.824	0.902	0.470	0.997	0.392	0.892	0.957	0.040	0.463
0.053	0.899	0.554	0.627	0.427	0.760	0.470	0.040	0.904	0.993
0.810	0.159	0.225	0.163	0.549	0.405	0.285	0.542	0.231	0.919
0.081	0.277	0.035	0.039	0.860	0.507	0.081	0.538	0.986	0.501
0.982	0.468	0.334	0.921	0.690	0.806	0.879	0.414	0.106	0.031
0.095	0.801	0.576	0.417	0.251	0.884	0.522	0.235	0.389	0.222
0.509	0.025	0.794	0.850	0.917	0.887	0.751	0.608	0.698	0.683
0.371	0.059	0.164	0.838	0.289	0.169	0.569	0.977	0.796	0.996
0.165	0.996	0.356	0.375	0.654	0.979	0.815	0.592	0.348	0.743
0.477	0.535	0.137	0.155	0.767	0.187	0.579	0.787	0.358	0.595
0.788	0.101	0.434	0.638	0.021	0.894	0.324	0.871	0.698	0.539
0.566	0.815	0.622	0.548	0.947	0.169	0.817	0.472	0.864	0.466
0.901	0.342	0.873	0.964	0.942	0.985	0.123	0.086	0.335	0.212
0.470	0.682	0.412	0.064	0.150	0.962	0.925	0.355	0.909	0.019
0.068	0.242	0.777	0.356	0.195	0.313	0.396	0.460	0.740	0.247
0.874	0.420	0.127	0.284	0.448	0.215	0.833	0.652	0.701	0.326
0.897	0.877	0.209	0.862	0.428	0.117	0.100	0.259	0.425	0.284
0.876	0.969	0.109	0.843	0.759	0.239	0.890	0.317	0.428	0.802
0.190	0.696	0.757	0.283	0.777	0.491	0.523	0.665	0.919	0.146
0.341	0.688	0.587	0.908	0.865	0.333	0.928	0.404	0.892	0.696
0.846	0.355	0.831	0.281	0.945	0.364	0.673	0.305	0.195	0.887
0.882	0.227	0.552	0.077	0.454	0.731	0.716	0.265	0.058	0.075
0.464	0.658	0.629	0.269	0.069	0.998	0.917	0.217	0.220	0.659
0.123	0.791	0.503	0.447	0.659	0.463	0.994	0.307	0.631	0.422
0.116	0.120	0.721	0.137	0.263	0.176	0.798	0.879	0.432	0.391
0.836	0.206	0.914	0.574	0.870	0.390	0.104	0.755	0.082	0.939
0.636	0.195	0.614	0.486	0.629	0.663	0.619	0.007	0.296	0.456
0.630	0.673	0.665	0.666	0.399	0.592	0.441	0.649	0.270	0.612
0.804	0.112	0.331	0.606	0.551	0.928	0.830	0.841	0.702	0.183
0.360	0.193	0.181	0.399	0.564	0.772	0.890	0.062	0.919	0.875
0.183	0.651	0.157	0.150	0.800	0.875	0.205	0.446	0.648	0.685

Note: Always select a new set of numbers in a systematic manner, either horizontally or vertically. Once used, the set should be crossed out.

**Hot-Mix Asphalt PFP and QCP Random Jobsite Sampling
Appendix E.4**

Effective Date: April 1, 2008
Revised Date: December 1, 2021

PFP/QCP Jobsite Sampling Location Determination

Date: _____ Contract #: _____ Route: _____
 HMA Mix #: _____ HMA Mix Code: _____ HMA Desc.: _____
 Design G_{mb}: _____ Pvt width(w): _____ Pvt thickness(t): _____

Lot #:		Sublot #:		Sampling Tonnage (st):	
--------	--	-----------	--	------------------------	--

Begin Truck Tons (b):		Longitudinal Distance(d): $(d)=[384.6(q)(rd)] / [G_{mb}(w)(t)]$	
End Truck Tons (e):		Starting Station(ss):	
Tons in Truck (q): $(q)=(e)-(b)$		Random sample location(rl): $(rl)=(ss)+/-(d)$	
Random Truck distance(rd): $(rd)=[(st)-(b)]/(q)$		<i>{add or subtract if up/down sta.}</i>	

Lot #:		Sublot #:		Sampling Tonnage (st):	
--------	--	-----------	--	------------------------	--

Begin Truck Tons (b):		Longitudinal Distance(d): $(d)=[384.6(q)(rd)] / [G_{mb}(w)(t)]$	
End Truck Tons (e):		Starting Station(ss):	
Tons in Truck (q): $(q)=(e)-(b)$		Random sample location(rl): $(rl)=(ss)+/-(d)$	
Random Truck distance(rd): $(rd)=[(st)-(b)]/(q)$		<i>{add or subtract if up/down sta.}</i>	

Lot #:		Sublot #:		Sampling Tonnage (st):	
--------	--	-----------	--	------------------------	--

Begin Truck Tons (b):		Longitudinal Distance(d): $(d)=[384.6(q)(rd)] / [G_{mb}(w)(t)]$	
End Truck Tons (e):		Starting Station(ss):	
Tons in Truck (q): $(q)=(e)-(b)$		Random sample location(rl): $(rl)=(ss)+/-(d)$	
Random Truck distance(rd): $(rd)=[(st)-(b)]/(q)$		<i>{add or subtract if up/down sta.}</i>	

Lot #:		Sublot #:		Sampling Tonnage (st):	
--------	--	-----------	--	------------------------	--

Begin Truck Tons (b):		Longitudinal Distance(d): $(d)=[384.6(q)(rd)] / [G_{mb}(w)(t)]$	
End Truck Tons (e):		Starting Station(ss):	
Tons in Truck (q): $(q)=(e)-(b)$		Random sample location(rl): $(rl)=(ss)+/-(d)$	
Random Truck distance(rd): $(rd)=[(st)-(b)]/(q)$		<i>{add or subtract if up/down sta.}</i>	

**Hot-Mix Asphalt PFP Dispute Resolution
Appendix E.5**

Effective Date: April 1, 2010
Revised Date: [December 1, 2021](#)

A. Scope

This document describes the two methods for disputing [Pay for Performance \(PFP\)](#) test results and the requirements for each. It also provides cost information for dispute testing and instructions for submitting dispute resolution samples to the Central Bureau of Materials ([CBM](#)).

B. Dispute Resolution

Dispute resolution testing will be permitted when the Contractor submits their split sample test results prior to receiving Department split sample test results. Dispute resolution testing shall be according to Method 1 (pay parameter dispute) or Method 2 (individual parameter dispute). [When](#) dispute resolution is [chosen](#), the Contractor shall submit a request in writing within four working days of receipt of the [Department's](#) results of the [Quality Level Analysis](#) for the lot [in question](#). The Engineer will document receipt of the request. The request shall specify Method 1 or Method 2 [dispute resolution](#). The CBM laboratory will be used for dispute resolution testing.

1. Method 1:

Method 1 dispute resolution will be allowed when Contractor and Department split test results exceed the precision limits shown in Table 1. Dispute resolution test results for G_{mm} , G_{mb} , and asphalt binder content will replace the original Department G_{mm} , G_{mb} , and asphalt binder content test results. Method 1 shall be used in cases where Department test results are outside [the](#) acceptable limits shown in the [Standard Specifications Article 1030.07](#).

Table 1

Test Parameter	Limits of Precision
Voids	1.0 %
Field VMA	1.0 %
Dust/AB Ratio	0.2
Core Density	1.0 %

2. Method 2:

Method 2 dispute resolution will be allowed when [both](#): 1) the Contractor participates and complies with the AASHTO re:source Proficiency Sample Program testing protocol as specified herein and 2) the Contractor and Department [adjusted](#) split test results, as described herein, exceed the precision limits shown in Table 2. The dispute resolution test/s will only be performed for the parameter/s (G_{mm} , G_{mb} , or asphalt [binder](#) content) exceeding precision limits. Both solvent extraction and ignition oven procedures may be used for determining asphalt [binder](#) content. The dispute resolution test result(s) will replace the original Department result(s) for the disputed parameters.

**Hot-Mix Asphalt PFP Dispute Resolution
Appendix E.5**

Effective Date: April 1, 2010
Revised Date: [December 1, 2021](#)

Table 2

Test Parameter	Limits of Precision
G_{mm}	0.008
$G_{mb}^{1/}$	0.012
Asphalt Binder Content	0.2

1/ Both core G_{mb} and gyratory G_{mb} .

a. Proficiency Sample Testing

To qualify for dispute resolution using Method 2, a QC laboratory must participate in the AASHTO re:source's (formerly AMRL) Proficiency Sample Program (PSP). PSP samples are distributed annually to federal, state, independent, commercial, and research testing laboratories. AASHTO re:source scores proficiency test samples by fitting a standard normal distribution to the data from all laboratories (with outliers eliminated). Laboratories whose results fall within one standard normal deviation from the mean are assigned a numerical score of "5." Laboratories whose results fall between 1 and 1½ standard normal deviations from the mean are assigned a score of "4," and the ratings are further decreased one point for each half standard normal deviate thereafter. A positive sign (+) indicates the lab result is above the population mean, and a negative sign (-) indicates the lab result is below the population mean. This system can be depicted graphically, as follows:

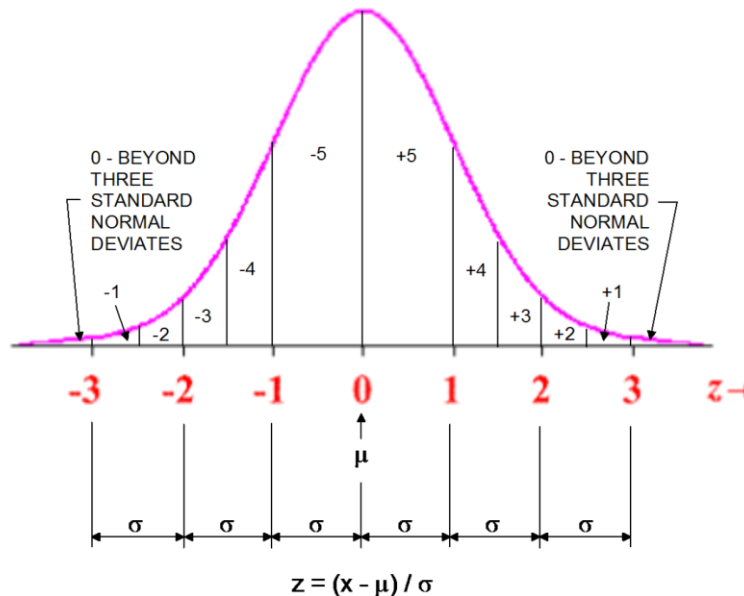

For the Contractor to dispute individual test results, G_{mm} , G_{mb} , and/or asphalt binder content, all of the following shall be met:

- 1) The Contractor's laboratory that conducts the Quality Control testing for the project in question participates annually in the appropriate AASHTO re:source PSP.

**Hot-Mix Asphalt PFP Dispute Resolution
Appendix E.5**

Effective Date: April 1, 2010
Revised Date: December 1, 2021

- 2) The Contractor has submitted the laboratory's proficiency sample report(s) to the Department within 30 calendar days of the date of issuance. The results will be evaluated as follows:
- a. If the Contractor's laboratory that conducts Quality Control testing received a proficiency score of 3 or better on all individual tests (G_{mm} , G_{mb} , and asphalt binder content), the Contractor will be approved for Method 2.
 - b. If the Contractor's laboratory that conducts Quality Control testing for the project in question received a proficiency score of 2 or lower on an individual test, the Contractor shall complete the following to remain on the Method 2 approved list:
 - i) Conduct an investigation and perform a root cause analysis to determine the possible reason(s) for the results;
 - ii) Correct any issues that are uncovered in the investigation;
 - iii) Document the investigation and corrective actions;
 - iv) Submit the AASHTO Accreditation Program (AAP) proficiency sample corrective action report to CBM; and
 - v) Purchase an extra proficiency sample from AASHTO re:source for retesting.

Note: Extra proficiency samples are surplus samples that were produced for a regularly scheduled round of testing and are available for purchase by contacting AASHTO re:source. The extra proficiency sample should be randomly selected by AASHTO re:source.

- vi) Submit the laboratory's proficiency sample report, for the extra proficiency sample for G_{mm} and G_{mb} , to the Department no later than December 31 and for asphalt content no later than June 7.
 - vii) Failure to achieve a score of 3 or better on all test parameters in the second attempt will result in removal from the Method 2 approved list until a score of 3 or better on all test parameters is achieved on a scheduled AASHTO re:source PSP.
- c. Use of Contractor Central Lab for asphalt binder content disputes:
- i) All labs shall conduct daily asphalt binder content testing for quality control.
 - ii) Any lab that participates in the PSP program and earns ratings of 3 or better on respective G_{mm} , G_{mb} , and asphalt binder content tests is eligible to dispute any of the three parameters according to Method 2.
 - iii) A Contractor's Lab that has earned PSP ratings of 3 or better in all three parameters can be used as a Central Lab to dispute asphalt binder content according to Method 2 for any of the labs operated by that Contractor. To be eligible to be a Central Lab, that specific lab must perform all the asphalt binder content testing that is reported to the Department for all of that Contractor's PFP projects for that calendar year including the asphalt binder content sample result that is being disputed. In addition, for any lab to use a Central Lab for asphalt binder content

**Hot-Mix Asphalt PFP Dispute Resolution
Appendix E.5**

Effective Date: April 1, 2010
Revised Date: December 1, 2021

disputes according to Method 2, the originating lab where daily quality control is conducted shall have earned ratings of 3 or better on both G_{mm} and G_{mb} testing.

- 3) The adjusted split test results, as defined below, for the individual test, G_{mm} , G_{mb} , or asphalt binder content, exceed the precision limits listed in Table 2. The adjusted split test results account for any offset between the Department and Contractor test results. The adjusted split test results will be determined for each lot by:
 - a) For each subplot, subtract the Department's result from the Contractor's result to determine the initial split;
 - b) For each lot, calculate the average initial split test result;
 - c) For each subplot, subtract the average initial split test result for the lot from the initial split result to determine the adjusted split subplot test result.
 - d) Compare the adjusted split with the precision limits listed in Table 2 to determine whether the sample qualifies for dispute testing (Example is shown in Table 3).

Table 3.

EXAMPLE ADJUSTED SPLIT RESULTS CALCULATION

G_{mm}				
Sublot	Contractor	IDOT	Initial Split	Adjusted Split
1-1	2.456	2.454	0.002	-0.001
1-2	2.458	2.455	0.003	0.000
1-3	2.462	2.466	-0.004	-0.007
1-4	2.471	2.463	0.008	0.005
1-5	2.459	2.461	-0.002	-0.005
1-6	2.474	2.462	0.012	0.009
1-7	2.463	2.465	-0.002	-0.005
1-8	2.463	2.461	0.002	-0.001
1-9	2.472	2.468	0.004	0.001
1-10	2.466	2.464	0.002	-0.001
Average Initial Split			0.003	

Density cores for dispute resolution testing shall be taken at the same time as the random density core. The density core for dispute resolution testing shall be taken within 1 ft (300 mm) longitudinally of the random density core and at the same transverse offset. Density dispute resolution will replace the original density test results. For density disputes, the Contractor shall use the Department's running average for G_{mm} when determining compliance with the limits of precision.

**Hot-Mix Asphalt PFP Dispute Resolution
Appendix E.5**

Effective Date: April 1, 2010
Revised Date: [December 1, 2021](#)

If three or more consecutive mixture sublots or G_{mm} results are contested, corresponding density results will be recalculated with the new G_{mm} .

C. Dispute Testing Pay Schedule

The lot pay factor for the lot under dispute resolution will be recalculated. If the recalculated lot pay factor is less than or equal to the original lot pay factor, laboratory costs listed below will be borne by the Contractor.

Table 4

Test	Cost
Method 1 Mix Testing	\$1000 / subplot
Core Density	\$300 / core
G_{mm}	\$200
G_{mb}	\$500
Asphalt Binder Content	\$500

D. Dispute Submittal Instructions

When submitting HMA mix and/or core samples to CBM for dispute testing, [the District will](#) include the following:

1. All District and Contractor split sample test results on [the](#) attached “PFP Dispute Resolution Form”,
2. [The](#) dispute resolution HMA mix split sample [with the contract number and subplot clearly marked on each sample bag](#),
3. Cores must be split or sawed by the Contractor to the appropriate lift thickness for testing,
4. [Quality Management Program \(QMP\)](#) Package template and [Daily Plant Reports sent electronically](#) for mix being tested.

Send sample and requested documentation to:

Illinois Department of Transportation
Central Bureau of Materials
Hot-Mix Asphalt Laboratory
126 E. Ash Street
Springfield, Illinois 62704-4766
Attention: [HMA](#) Lab Supervisor

Any sample sent to CBM without the above listed information will not be processed until all requested information is received.

Hot-Mix Asphalt QCP Pay Adjustments
Appendix E.6

Effective Date: January 1, 2012
Revised Date: December 1, 2021

This document explains the procedures used to determine the pay adjustment for a hot-mix asphalt (HMA) mixture and a hot-mix asphalt full-depth pavement when Quality Control for Performance (QCP) is specified as the Quality Management Program (QMP).

The following steps are used to determine the pay adjustment for a QCP mixture:

1. Determine subplot deviation from target for each pay parameter.
 - A. If intelligent compaction was successfully implemented, there will be no deviations from target for density.
 - B. A density subplot will either be based upon intelligent compaction or density tests using cores. The two methods will not be mixed.
2. Determine the subplot pay factor (PF) for each subplot using Table 1 and the deviation from target.
 - A. For mixtures, the 105% column only applies when the District conducts testing of all the sublots within a given lot and all the test results are within the Acceptable Limits.
 - B. For density, the 105% column also applies to density sublots where no individual density test is less than 90.0% or greater than 98.0% density.
 - C. If intelligent compaction was successfully implemented, the density pay factor will be 100%.
3. Determine the average subplot PF for each pay parameter. The average subplot PF for each pay parameter will be capped at 100.0%.
4. Calculate the composite pay factor (CPF) using the average subplot PFs and Equation 1.
5. Determine the plan unit pay, adjusted pay, and pay adjustment for the mixture using Equations 2, 3, and 4.

Additionally, for a full-depth pavement the adjusted pay and pay adjustment will be calculated using the combined composite pay factors for mixtures used in its construction. Each mixture composite pay factor will be weighted equally. Mixtures placed having the same gyration values but with and without polymer will be treated as two separate mixtures. For example, one surface mix and one binder mix will be weighted 50/50 regardless of tonnage. Additionally, one surface mix, one polymer binder mix and one non-polymer binder mix will be treated as three equally (1/3) weighted mixtures even if the polymer binder is the only difference between binder lifts. The full-depth adjusted pay is determined by multiplying the plan unit pay by the combined composite pay factor. The pay adjustment is then determined by subtracting the plan unit pay from the adjusted pay.

**Hot-Mix Asphalt QCP Pay Adjustments
Appendix E.6**

Effective Date: January 1, 2012
Revised Date: December 1, 2021

Note: Monetary deductions for dust/AB ratio will be applied separately using the Dust/AB Ratio Deduction Table found in the Standard Specifications Article 406.14.

Table 1

Pay Parameter		Pay Factor			
		105%	100%	95%	90%
Air Voids ^{1/2/3/}		± 0.5%	± 1.2%	± 1.6%	± 2.0%
Field VMA ^{1/2/}		0% to +1.0% above minimum specified	-0.5% to +2.0%	-0.7% to +2.5%	-1.0% to +3.0%
In-Place Density ^{4/5/}	SMA	94.0% to 95.0%	93.5% to 96.5%	92.5% to 97.0%	92.0% to 98.0%
	HMA	93.5% to 94.5%	92.5% to 96.5%	91.5% to 97.0%	90.0% to 98.0%

- 1/ Mixture targets specified in 1030.05(b).
- 2/ If mixture testing is waived for small tonnage, the Contractor will receive 100% for Air Voids and Field VMA pay factors in Equation 1.
- 3/ Ranges based on deviation from specified design percent Air Voids.
- 4/ If no density requirement applies, the Contractor will receive 100% for the Density pay factor in Equation 1.
- 5/ A density test where the core thickness is less than 0.75 in. will not be used in the Density pay factor calculation.

Equation 1: $CPF = 0.30(PF_{Voids}) + 0.30(PF_{VMA}) + 0.40(PF_{Density})$

Where:

CPF = Composite Pay Factor

PF_{Voids} , PF_{VMA} , and $PF_{Density}$ = Average subplot pay factors for the pay parameters

The pay adjustment for a given mixture is calculated by multiplying the Mixture Unit Price by the Quantity and the CPF, and then subtracting the Mixture Unit Price multiplied by the Unit Price according to Equations 2, 3, and 4 below.

Equation 2: $Plan\ Unit\ Pay = Mixture\ Unit\ Price \times Mixture\ Quantity$

Equation 3: $Adjusted\ Pay = (Mixture\ Unit\ Price \times Mixture\ Quantity \times CPF/100)$

Equation 4: $Pay\ Adjustment = Adjusted\ Pay - Plan\ Unit\ Pay$

**Hot-Mix Asphalt QCP Pay Adjustments
Appendix E.6**

Effective Date: January 1, 2012
Revised Date: December 1, 2021

Overlay Example:

Determine the adjusted pay and pay adjustment for a N70 HMA IL-9.5 surface mixture being placed at 1.5 inches thick as an overlay with QCP specified as the Quality Management Program. The project consists of 6,900 tons placed over a distance of 12 lane miles. From the mix requirements table in the contract plans and 1030.05(b) the target air voids are 4.0% and the target minimum field VMA is 15.0%, respectively.

Note: The mix sample lots and density lots are independent of one another.

In this example, the first mix lot represents 4,000 tons while the second lot represents 2,900 tons. There are 12 density sublots representing 12 lane-miles (N=12).

Mix samples: Each subplot represents 1,000 tons except for lot 2, subplot 3 which represents 900 tons. (Note: All sublots are weighted the same.)

Mixture Sample		Air Voids		Field VMA	
Lot	Sublot	Contractor	District	Contractor	District
1	1	4.1	3.2	14.9	14.6
	2	3.9		14.5	
	3	2.5		14.0	
	4	3.0		14.8	
2	1	2.3	2.5	14.3	14.5
	2	2.1	2.2	14.0	14.1
	3	3.8	3.6	14.7	14.6

Note: Bolded and italicized test results denote the subplot split that was randomly selected by the District for testing.

Density: Since this pavement is < 3 inches thick, cores are taken randomly every 0.2 miles which is 5 cores per mile (60 cores for the 12 lane-mile project). With each density subplot the average of 5 consecutive cores represents 1 mile of paving.

**Hot-Mix Asphalt QCP Pay Adjustments
Appendix E.6**

Effective Date: January 1, 2012
Revised Date: December 1, 2021

<u>Density Sublot</u>	<u>Density Intervals (cores)</u>				
	<u>1</u>	<u>2</u>	<u>3</u>	<u>4</u>	<u>5</u>
<u>1</u>	<u>90.4</u>	<u>90.8</u>	<u>91.6</u>	<u>92.4</u>	<u>92.1</u>
<u>2</u>	<u>93.8</u>	<u>94.1</u>	<u>92.3</u>	<u>92.1</u>	<u>92.6</u>
<u>3</u>	<u>91.8</u>	<u>93.5</u>	<u>93.9</u>	<u>92.8</u>	<u>92.5</u>
<u>4</u>	<u>93.7</u>	<u>94.2</u>	<u>93.5</u>	<u>93.3</u>	<u>92.8</u>
<u>5</u>	<u>92.1</u>	<u>94.1</u>	<u>92.6</u>	<u>93.8</u>	<u>92.3</u>
<u>6</u>	<u>94.1</u>	<u>94.3</u>	<u>93.2</u>	<u>94.5</u>	<u>93.9</u>
<u>7</u>	<u>93.6</u>	<u>93.3</u>	<u>92.5</u>	<u>91.9</u>	<u>92.7</u>
<u>8</u>	<u>92.8</u>	<u>93.3</u>	<u>94.2</u>	<u>93.5</u>	<u>93.7</u>
<u>9</u>	<u>91.5</u>	<u>91.2</u>	<u>91.9</u>	<u>91.8</u>	<u>90.9</u>
<u>10</u>	<u>93.0</u>	<u>92.6</u>	<u>92.1</u>	<u>92.3</u>	<u>94.1</u>
<u>11</u>	<u>92.3</u>	<u>93.0</u>	<u>93.8</u>	<u>92.6</u>	<u>94.1</u>
<u>12</u>	<u>91.5</u>	<u>93.5</u>	<u>92.7</u>	<u>93.8</u>	<u>92.1</u>

Determine the average subplot pay factor for each parameter:

Air Voids:

Since the District randomly selected and tested the split from Sublot 2 in Lot 1, and the Air Void results were 1) within the 100% pay factor tolerance **and** 2) within Precision Limits of the Contractor's results, the District does not need to test the remaining sublots in Lot 1 and the entire lot receives a pay factor of 100%.

For the second lot, the District randomly selected and tested the split from Sublot 1. Since the District Air Void results were not within the 100% pay factor tolerance, the District had to test all of the remaining subplot splits. (see completed table below):

Calculate the Air Void deviation from the target for each of the District subplot split results.

Lot 1:

Sublot 2: Deviation = 3.2% - 4.0% = -0.8%

Lot 2:

Sublot 1: Deviation = 2.5% - 4.0% = -1.5%

Sublot 2: Deviation = 2.2% - 4.0% = -1.8%

Sublot 3: Deviation = 3.6% - 4.0% = -0.4%

Using Table 1 and the deviation from the Target, determine the corresponding Air Voids subplot pay factor for each District test result.

**Hot-Mix Asphalt QCP Pay Adjustments
Appendix E.6**

Effective Date: January 1, 2012
Revised Date: **December 1, 2021**

- Lot 1:
Sublot 2: Pay Factor associated with -0.8% in Table 1 is 100%
- Lot 2:
Sublot 1: Pay Factor associated with -1.5% in Table 1 is 95%
Sublot 2: Pay Factor associated with -1.8% in Table 1 is 90%
Sublot 3: Pay Factor associated with -0.4% in Table 1 is 105%

Air Voids					
Lot	Sublot	Contractor	District	Deviation	Sublot PF
1	1	4.1	3.2	-0.8	100
	2	3.9			
	3	2.8			
	4	3.0			
2	1	2.3	2.5	-1.5	95
	2	2.1	2.2	-1.8	90
	3	3.8	3.6	-0.4	105

Note: Bolded and italicized test results denote the subplot split that was randomly selected by the District for testing.

Calculate the average subplot pay factor for Air Voids. (Note: The 100% in Lot 1 represents four sublots and therefore is multiplied by four.)

Average subplot Pay Factor (PF_{voids}) = ((100% x 4) + 95% + 90% + 105%) / 7 sublots = **98.6%**

Field VMA:

Since the District randomly selected and tested the split from Sublot 2 in Lot 1, and the Field VMA results were 1) within the 100% pay factor tolerance **and** 2) within Precision Limits of the Contractor's results, the District does not need to test the remaining sublots in Lot 1 and the entire lot receives a pay factor of 100%.

For the second lot, the District randomly selected and tested the split from Sublot 1. Since the District results were not within the 100% pay factor tolerance **for Air Voids**, the District had to test all of the remaining subplot splits. (see completed table below):

Calculate the Field VMA deviation from the target for each of the District subplot split results.

- Lot 1:
Sublot 2: Deviation = 14.6% - 15.0% = -0.4%

- Lot 2:
Sublot 1: Deviation = 14.5% - 15.0% = -0.5%
Sublot 2: Deviation = 14.1% - 15.0% = -0.9%
Sublot 3: Deviation = 14.6% - 15.0% = -0.4%

Hot-Mix Asphalt QCP Pay Adjustments
Appendix E.6

Effective Date: January 1, 2012
 Revised Date: December 1, 2021

Using Table 1 and the deviation from Target, determine the corresponding Field VMA subplot pay factor for each District test result.

Lot 1:

Sublot 2: Pay Factor associated with -0.4% in Table 1 is 100%

Lot 2:

Sublot 1: Pay Factor associated with -0.5% in Table 1 is 100%

Sublot 2: Pay Factor associated with -0.9% in Table 1 is 90%

Sublot 3: Pay Factor associated with -0.4% in Table 1 is 100%

Minimum Field VMA = 15.0%					
Lot	Sublot	Contractor	District	Deviation	Sublot PF
1	1	14.9	14.6	-0.4	100
	2	14.5			
	3	14.4			
	4	14.8			
2	1	14.3	14.5	-0.5	100
	2	14.0	14.1	-0.9	90
	3	14.7	14.6	-0.4	100

Note: Bolded and italicized test results denote the subplot split that was randomly selected by the District for testing.

Calculate the average subplot pay factor for Field VMA. (Note: The 100% in Lot 1 represents four sublots and therefore is multiplied by four)

Average subplot Pay Factor (PF_{VMA}) = ((100% x 4) + 100% + 90% + 100%) / 7 sublots = **98.6%**

Density:

Determine the average Density for each subplot.

Determine the subplot pay factor using the average subplot Density and Table 1 (see completed table below).

Determine the Density pay factor by averaging the subplot pay factors.

**Hot-Mix Asphalt QCP Pay Adjustments
Appendix E.6**

Effective Date: January 1, 2012
Revised Date: December 1, 2021

<u>Density Sublot</u>	<u>Density Intervals (cores)</u>						<u>Sublot Ave.</u>	<u>Sublot PF</u>
	<u>1</u>	<u>2</u>	<u>3</u>	<u>4</u>	<u>5</u>			
<u>1</u>	<u>90.4</u>	<u>90.8</u>	<u>91.6</u>	<u>92.4</u>	<u>92.1</u>	<u>91.5</u>	<u>95</u>	
<u>2</u>	<u>93.8</u>	<u>94.1</u>	<u>92.3</u>	<u>92.1</u>	<u>92.6</u>	<u>93.0</u>	<u>100</u>	
<u>3</u>	<u>91.8</u>	<u>93.5</u>	<u>93.9</u>	<u>92.8</u>	<u>92.5</u>	<u>92.9</u>	<u>100</u>	
<u>4</u>	<u>93.7</u>	<u>94.2</u>	<u>93.5</u>	<u>93.3</u>	<u>92.8</u>	<u>93.5</u>	<u>105</u>	
<u>5</u>	<u>92.1</u>	<u>94.1</u>	<u>92.6</u>	<u>93.8</u>	<u>92.3</u>	<u>93.0</u>	<u>100</u>	
<u>6</u>	<u>94.1</u>	<u>94.3</u>	<u>93.2</u>	<u>94.5</u>	<u>93.9</u>	<u>94.0</u>	<u>105</u>	
<u>7</u>	<u>93.6</u>	<u>93.3</u>	<u>92.5</u>	<u>91.9</u>	<u>92.7</u>	<u>92.8</u>	<u>100</u>	
<u>8</u>	<u>92.8</u>	<u>93.3</u>	<u>94.2</u>	<u>93.5</u>	<u>93.7</u>	<u>93.5</u>	<u>105</u>	
<u>9</u>	<u>91.5</u>	<u>91.2</u>	<u>91.9</u>	<u>91.8</u>	<u>90.9</u>	<u>91.5</u>	<u>95</u>	
<u>10</u>	<u>93.0</u>	<u>92.6</u>	<u>92.1</u>	<u>92.3</u>	<u>94.1</u>	<u>93.8</u>	<u>100</u>	
<u>11</u>	<u>92.3</u>	<u>93.0</u>	<u>93.8</u>	<u>92.6</u>	<u>94.1</u>	<u>92.1</u>	<u>100</u>	
<u>12</u>	<u>91.5</u>	<u>93.5</u>	<u>92.7</u>	<u>93.8</u>	<u>92.1</u>	<u>92.7</u>	<u>100</u>	
PF / 12 Sublots = 100.5								
Average Density Sublot PF = 100 (capped at 100)								

Composite Pay Factor:

Determine the Composite Pay Factor using Equation 1.

$$\begin{aligned} \text{CPF} &= 0.30(\text{PF}_{\text{Voids}}) + 0.30(\text{PF}_{\text{VMA}}) + 0.40(\text{PF}_{\text{Density}}) \\ &= 0.30(98.6) + 0.30(98.6) + 0.40(100.0) \\ \text{CPF} &= 99.2\% \end{aligned}$$

QCP Adjusted Pay and Pay Adjustment:

Determine the adjusted pay and pay adjustment for the given mixture using Equations 2, 3, and 4.

Where: Mixture Unit Price = \$65.00/ton

Mixture Quantity = 6,900 tons placed.

$$\text{Plan Unit Pay} = \$65.00/\text{ton} \times 6,900 \text{ tons} = \$448,500$$

$$\text{Adjusted Pay} = \$448,500 \times 99.2/100 = \$444,912$$

$$\begin{aligned} \text{Pay Adjustment} &= (\$65.00/\text{ton} \times 6,900 \text{ tons} \times 99.2 / 100) - (\$65.00/\text{ton} \times 6,900 \text{ tons}) \\ &= - \$3,588 \end{aligned}$$

Hot-Mix Asphalt QCP Pay Adjustments
Appendix E.6

Effective Date: January 1, 2012
Revised Date: December 1, 2021

In this case a \$3,588 disincentive would be applied as per Construction Memorandum #4.

Full Depth Example 1:

Given: a full-depth project with two mixtures whose composite pay factors were determined to be 100.0% and 98.2%. The bid price per square yard = \$40.00 and 1,400 sq yd were placed.

The full-depth combined composite pay factor will be calculated as follows:

$$100.0(1/2) + 98.2(1/2) = 99.1\%$$

Determine the full-depth adjusted pay and pay adjustment.

$$\text{Plan Unit Pay} = \$40.00/\text{sq yd} \times 1,400 \text{ sq yd} = \$56,000$$

$$\text{Adjusted Pay} = \$40.00/\text{sq yd} \times 1,400 \text{ sq yd} \times 0.991 = \$55,496$$

$$\text{Pay Adjustment} = \$55,496 - \$56,000 = - \$504$$

Full Depth Example 2:

Given: a full-depth project with three mixtures whose composite pay factors were determined to be 98.9%, 100.0% and 99.2%. The bid price per square yard = \$40.00 and 1,400 sq yd were placed.

The full-depth combined composite pay factor is calculated as follows:

$$98.9(1/3) + 100.0(1/3) + 99.2(1/3) = 99.4\%$$

Determine the full-depth adjusted pay and pay adjustment.

$$\text{Plan Unit Pay} = \$40.00/\text{sq yd} \times 1,400 \text{ sq yd} = \$56,000$$

$$\text{Adjusted Pay} = \$40.00/\text{sq yd} \times 1,400 \text{ sq yd} \times 0.994 = \$55,664$$

$$\text{Pay Adjustment} = \$55,664 - \$56,000 = - \$336$$

**Best Practices
for
Hot-Mix Asphalt PFP and QCP
Appendix E.7**

Effective Date: April 1, 2012
Revised Date: December 1, 2021

Purpose

This document is intended to aid District personnel in successfully supporting the Pay-For-Performance (PFP) and Quality Control for Performance (QCP) Quality Management Programs. Following these guidelines will lower risk to both the Department and Contractor, which should result in lower bid prices.

Lab

Since payment on PFP and QCP projects is based on Department test results, attention to laboratory equipment, qualified lab personnel and laboratory efficiency becomes paramount. Review of results from recent "Annual HMA Uniformity Studies" (aka Round Robins), dispute resolutions, and addressing any District lab issues resulting in poor comparisons will prove beneficial.

1) Equipment

It is imperative to inspect and calibrate all laboratory testing equipment according to frequencies listed in Policy Memorandum 21-08 "Minimum Department And Local Agency Laboratory Requirements For Construction Materials Testing Or Mix Design" at a minimum. Inspection and calibration immediately prior to PFP and QCP testing is highly recommended. Always use the same gyratory compactor for an individual PFP or QCP contract.

Assessment of existing and needed equipment should be performed to determine possible benefits of purchasing additional equipment to optimize productivity. Each district should also develop an action plan in the event key equipment breaks down.

2) Personnel

It is also imperative that all laboratory personnel intended to be involved in PFP and QCP testing be qualified with successful completion of HMA Level I as a minimum. It is also important to keep technician assignments as consistent as possible. It is highly recommended to conduct in-house round robins with the above-mentioned laboratory personnel to ensure repeatability.

3) Sample Treatment

Inconsistent treatment of samples prior to testing has been identified as the leading reason for differences in test results between the contractor and the state. It is recommended that samples, for all parties involved, be allowed to cool to room temperature immediately after blending and splitting. The samples should then be reheated and compacted as soon as the samples reach compaction temperature. In each subplot, it is recommended to maintain mixture bulk specific gravity (G_{mb}) specimen dry weights within 10 grams for HMA and 15 grams for SMA. This would entail the QC lab communicating the dry G_{mb} sample weight being used to the District Lab by writing it on the sample bag or some other means.

**Best Practices
for
Hot-Mix Asphalt PFP and QCP
Appendix E.7**

Effective Date: April 1, 2012

Revised Date: December 1, 2021

4) Laboratory Efficiency

The PFP and QCP QMP's are based heavily on Department testing which involves higher testing frequencies for the District laboratories when compared to the QC/QA QMP. Timely QA test completion has been proven to reduce risk for Contractors and, if done consistently, should reduce bid prices. An internal audit of your District laboratory for efficiency may help identify ways to improve productivity. This activity should be conducted by District materials staff that are not involved in day-to-day testing or CBM staff if requested.

While the PFP and QCP specifications allow a 10 day turnaround, the District should attempt to reduce the turnaround time as much as possible. Nationally recognized successful programs have test turnaround results within 5 days.

Project Personnel

Key components of PFP and QCP which provide the necessary compliance with the Code of Federal Regulations (CFR) are 1) undisclosed random mix and density sample locations, 2) samples witnessed by the Engineer, and 3) sample security. The CFR is intended to assure that samples are under control of the Engineer at all times to verify the quality of the product. Most Districts will need to rely on project staff to determine random mix sample and density core locations. It will be important for project personnel to understand their role in witnessing and securing the sample. District Materials and Construction staff should meet prior to the start of a PFP or QCP project to discuss:

1) Responsibilities

- a) Who will be responsible for generating random mix samples and random density locations according to the Manual of Test Procedures for Materials documents "Hot-Mix Asphalt PFP and QCP Random Jobsite Sampling" and "Hot-Mix Asphalt PFP and QCP Procedure for Determining Random Density Locations".
- b) Who will be responsible for identifying undisclosed sample locations and sample layout.
- c) How will samples be secured; discuss who will transport and / or store samples.
- d) Who will be responsible for entering data in QMP Package software, calculating pay and how communication regarding pay factors will occur.

2) Communication

- a) Random mix sample locations
 - i) Discuss when to disclose sampling locations.
 - ii) Discuss how to move mix sampling locations due to unsafe conditions according to the Manual of Test Procedures for Materials documents "Hot-Mix Asphalt PFP and QCP Random Jobsite Sampling".

**Best Practices
for
Hot-Mix Asphalt PFP and QCP
Appendix E.7**

Effective Date: April 1, 2012

Revised Date: December 1, 2021

- b) **Density Locations**
 - i) Discuss whether there will be obstacles that will warrant moving random core locations according to the Manual of Test Procedures for Materials document “**Hot-Mix Asphalt PFP and QCP Procedure for Determining Random Density Locations**”.
 - ii) Discuss how to handle coring locations that need to be opened immediately to traffic.

Also, it will be important to make sure Construction personnel have copies of all the necessary supporting documents.

This Page Reserved

Hot-Mix Asphalt PFP and QCP Calculations of Monetary Deductions

Appendix E.8

Effective Date: December 1, 2021

This document explains the procedures used to determine the unconfined edge density subplot **monetary** deduction for Pay for Performance (PFP), and the dust/AB **ratio** subplot deduction for hot-mix asphalt (HMA) mixtures and full-depth pavements when PFP or Quality Control for Performance (QCP) is selected as the Quality Management Program.

A. Determining and Applying an Unconfined Edge Density **Monetary** Deduction

The following steps are used to determine the unconfined edge density for a PFP mixture or full-depth pavement **and** calculate any **monetary** deductions. The Unconfined Edge Density Deduction Table in **Standard Specification Article** 406.14 will be used to determine the **monetary** deductions.

1. Test all sublots for unconfined edge density.
2. Determine the **monetary** deductions using the Unconfined Edge Density Deduction Table.
3. Total all unconfined edge density **monetary** deductions. For full-depth pavements, total all **monetary** deductions for all mixtures comprising the pavement.
4. If the total unconfined edge density **monetary** deductions are not \$0,
 - a) For full-depth pavements, apply the total **monetary** deductions to the adjusted full-depth pay.
 - b) For all other HMA mixtures, apply the total **monetary** deductions for the mixture to the adjusted mixture pay.

B. Determining and Applying a Dust/AB **Ratio** Deduction

The following steps are used to determine the dust/AB **ratio** for PFP and QCP mixtures or full-depth pavements **and to** determine any **monetary** deduction. The Dust/AB **Ratio** Deduction Table in 406.14 will be used to determine subplot **monetary** deductions for both PFP and QCP Quality Management Programs.

Note: The dust/AB **ratio monetary** deduction procedure is not applicable to Stone Matrix Asphalt (SMA) mixtures.

1. PFP:

- 5) Test all sublots for minus No. 200 (**75 µm**) (dust) content and asphalt binder (AB) content.
- 6) Determine the subplot deductions using the Dust/AB **Ratio** Deduction Table.
- 7) Total all dust/AB **ratio monetary** deductions. For full-depth pavements, total all **monetary** deductions for all mixtures comprising the pavement.

Hot-Mix Asphalt PFP and QCP Calculations of Monetary Deductions

Appendix E.8

Effective Date: [December 1, 2021](#)

- 8) If the total dust/AB [ratio monetary](#) deductions are not \$0,
 - 1) For full-depth pavements, apply the total [monetary](#) deductions to the adjusted full-depth pay.
 - 2) For all other HMA mixtures, apply the total [monetary](#) deductions for the mixture to the adjusted mixture pay.

2. QCP:

- a) Test for the subplot dust/AB [ratio](#) for the randomly selected subplot of each lot.
 - 1) If the air voids and field VMA meet the 100% pay factor limits of Table 1 of the document "Hot-Mix Asphalt QCP Pay Adjustments" and compare within the precision limits table of the 1030.08.
 - i. And the dust/AB [ratio](#) range is within the \$0 Deduct/Sublot using the Dust/AB [Ratio](#) Deduction Table, the entire lot will have a \$0 [monetary](#) deduction.
 - ii. If the dust/AB [ratio](#) range is within any [monetary](#) deduction other than \$0 Deduct/Sublot, all sublots will be tested for dust and AB and the dust/AB [ratio monetary](#) deduction [will be](#) calculated for each subplot.
 - 2) If the air voids or field VMA do not meet the 100% pay factor limits of Table 1 of the document "Hot-Mix Asphalt QCP Pay Adjustments" or do not compare within the precision limits table of the 1030.08.
 - i. All sublots will be tested for dust and AB and the dust/AB [ratio monetary](#) deduction [will be](#) calculated for each subplot.
- b) Total all dust/AB [ratio monetary](#) deductions. For full-depth pavements, total all [monetary](#) deductions for all mixtures comprising the pavement.
- c) If the total dust/AB [ratio monetary](#) deductions are not \$0,
 - 1) For full-depth pavements, apply the total [monetary](#) deductions to the adjusted full-depth pay.
 - 2) For all other HMA mixtures, apply the total [monetary](#) deductions for the mixture to the adjusted mixture pay.

Hot-Mix Asphalt PFP and QCP Calculations of Monetary Deductions

Appendix E.8

Effective Date: December 1, 2021

PFP Unconfined Edge Density Mixture Example

Given: The HMA pavement consists of a 13.0 ft wide mat 1.5 in. thick with the left edge confined without LJS and the right edge unconfined without LJS. Calculate the unconfined edge density subplot **monetary** deductions within the first mile.

There will be two unconfined edge density sublots along the right edge within the first mile.

Sublot #	Core #	Density	Deduct/Sublot ^{1/}
1	1	90.5%	\$0
2	2	89.3%	\$1,000
Total Monetary Deduction for Unconfined Edge Density = \$1,000			

1/ From the Unconfined Edge Density Deduction Table

In addition to any PFP pay adjustments calculated for the mixture; based upon the air voids, field VMA and density tests; and any dust/AB **ratio monetary** deductions, a **monetary** deduction for unconfined edge density of \$1,000 would be applied to this mixture.

Hot-Mix Asphalt PFP and QCP Calculations of Monetary Deductions

Appendix E.8

Effective Date: December 1, 2021

PFP Unconfined Edge Density Full-Depth Example

Given: A 75,000 sq yd full-depth pavement with a surface 24 ft wide is constructed with three mixtures. The contractor used two passes to achieve the width of the pavement. Each mixture was placed in one lift. The first pass of the first two mixtures had both edges unconfined. The second adjacent passes had one unconfined edge (centerline confined). The surface mixture was placed on LJS on all longitudinal joints. Calculate the unconfined edge density monetary deductions for the last 0.3 miles.

The first mix, first pass will have one random core taken in the last 0.3 miles from both unconfined edges. The second pass will have one random core taken in the last 0.3 miles from the unconfined edge. The second mix will be sampled the same way as the first mix. The third mix, the surface, will have no cores because LJS was used.

			Sublot #	Core #	Density	Deduct/Sublot ^{1/}
Mix 1	Pass 1	Left Edge	1	1	90.5%	\$0
		Right Edge	2	2	90.2%	\$0
	Pass 2	Left Edge	3	3	89.2%	\$1,000
		Right Edge		-	-	-
Mix 2	Pass 1	Left Edge	4	4	90.3%	\$0
		Right Edge	5	5	90.1%	\$0
	Pass 2	Left Edge	6	6	88.5%	\$3,000
		Right Edge		-	-	-
Mix 3	Pass 1	-		-	-	-
	Pass 2	-		-	-	-
Total Monetary Deduction for Unconfined Edge Density = \$4,000						

1/ From the Unconfined Edge Density Deduction Table

In addition to the PFP combined pay adjustments calculated from the three mixtures; based upon the air voids, field VMA and density tests; and any dust/AB ratio monetary deductions, a monetary deduction for unconfined edge density of \$4,000 would be applied to this full-depth pavement.

Hot-Mix Asphalt PFP and QCP Calculations of Monetary Deductions

Appendix E.8

Effective Date: December 1, 2021

PFP Dust/AB Ratio Example

Given: A N90 IL-9.5 HMA surface being placed at 1.5 inches thick as an overlay. The project consists of 10,000 tons over 16 miles.

Note: The mix sample and density lots are independent of each other.

In this example the mix sample lot represents 10,000 tons.

Note: All PFP sublots are tested for dust/AB ratio.

Lot #	Sublot #	Dust	AB	Dust/AB Ratio	Deduct/Sublot ^{1/}
1	1	5.1	6.0	0.8	\$0
	2	4.9	6.0	0.8	\$0
	3	4.8	5.9	0.8	\$0
	4	5.3	5.9	0.9	\$0
	5	5.8	5.8	1.0	\$0
	6	7.4	5.8	1.3	\$1,000
	7	7.3	5.7	1.3	\$1,000
	8	5.2	6.1	0.8	\$0
	9	5.3	5.9	0.9	\$0
	10	5.1	5.8	0.9	\$0
Total Monetary Deduction for Dust/AB Ratio = \$2,000					

1/ From the Dust/AB Deduction Table

In addition to any PFP pay adjustments calculated for the mixture; based upon the air voids, field VMA and density tests; and any unconfined edge monetary deductions, a monetary deduction for dust/AB ratio of \$2,000 would be applied to this mixture.

Hot-Mix Asphalt PFP and QCP Calculations of Monetary Deductions

Appendix E.8

Effective Date: December 1, 2021

QCP Dust/AB Ratio Example

Given: A N70 IL-9.5 HMA surface mixture being placed at 1.5 inches thick as an overlay with QCP specified as the Quality Management Program. The project consists of 6,900 tons placed over a distance of 12 lane miles. From the mix requirements table in the contract plans and 1030.04(b) the target air voids are 4.0% and the target minimum field VMA is 15.0%, respectively.

Note: The mix sample lots and density lots are independent of one another. In this example, the first mix lot represents 4,000 tons while the second lot represents 2,900 tons.

Mix samples: Each subplot represents 1,000 tons except for Lot 2, Sublot 3 which represents 900 tons. (Note: All sublots are weighted the same.)

Mixture Sample		Air Voids		Field VMA		District			Deduct/ Sublot ^{1/}
Lot	Sublot	Contractor	District	Contractor	District	Dust	AB	Dust/AB Ratio	
1	1	4.1	3.2	14.9	14.6				-
	2	3.9		14.5		4.8	5.9	0.8	\$0 ^{2/}
	3	2.5		14.0					-
	4	3.0		14.8					-
2	1	2.3	2.5	14.3	14.5	7.3	5.6	1.3	\$1,000
	2	2.1	2.2	14.0	14.1	7.4	5.5	1.3	\$1,000
	3	3.8	3.6	14.7	14.6	5.6	5.8	1.0	\$0
Total Monetary Deduction for Dust/AB Ratio = \$2,000									

Note: Bolded and italicized test results denote the subplot split that was randomly selected by the District for testing.

1/ From the Dust/AB Ratio Deduction Table

2/ If the tested mixture subplot is outside of the \$0 deduction range, the District will test the remaining sublots for dust/AB ratio monetary deductions. This in itself will not trigger testing the other sublots for air voids or field VMA.

Since the District randomly selected and tested the split from Sublot 2 in Lot 1, and the Air Void and Field VMA results were 1) within the 100% pay factor tolerance **and** 2) within Precision Limits of the Contractor's results, and the District Dust/AB Ratio test result is in the range of no monetary deduction, the District does not need to test the remaining sublots in Lot 1 for Dust/AB Ratio and the entire lot receives no Dust/AB Ratio monetary deduction.

For the second lot, the District randomly selected and tested the split from Sublot 1. Since the District Air Void results were not within the 100% pay factor tolerance, the District had to test all of the remaining sublots, including Dust/AB Ratio. The Dust/AB Ratio test results for Sublot 1

Hot-Mix Asphalt PFP and QCP Calculations of Monetary Deductions

Appendix E.8

Effective Date: [December 1, 2021](#)

and Sublot 2 were both in the range of a \$1,000/sublot [monetary](#) deduction. The Dust/AB [Ratio](#) test result for Sublot 3 is in the range of no [monetary](#) deduction.

In addition to any QCP pay adjustments calculated for the mixture; based upon the air voids, field VMA and density tests; a [monetary](#) deduction for [Dust/AB Ratio](#) of \$2,000 would be applied to this mixture.

This Page Reserved