



Bureau of Design and Environment Manual



Illinois Department of Transportation

Bureau of Design and Environment Manual

Prepared and Published by
Illinois Department of Transportation
Bureau of Design and Environment

Springfield, Illinois Published
September 2010
Revised January 2025

PREFACE

The *Bureau of Design and Environment (BDE) Manual* has been prepared to provide uniform practices for the Department and consultant personnel preparing Phase I studies and reports and contract plans for Department projects. The *BDE Manual* presents most of the information normally required in the development of a typical roadway project. The designer should attempt to meet all criteria and practices presented in the *BDE Manual*; however, the *BDE Manual* should not be considered a standard that must be met regardless of impacts. The designer should develop roadway designs that meet the Department's operational and safety requirements while preserving the environmental resources of an area. Designers must exercise good judgment on individual projects and, frequently, they must be innovative in their approach to roadway design. This may require, for example, additional research into the highway literature or use of other Department Manuals.

MANUAL FORMAT/UPDATE

The *Bureau of Design and Environment Manual* is available as a PDF document on the IDOT's website: It is intended to provide current design and environment policies and procedures for use in developing State highway projects. To ensure that the *BDE Manual* remains up to date and appropriately reflects changes in IDOT's needs and applicable requirements, its contents are updated on an ongoing basis. To aid users in keeping track of revisions and understanding their background, BDE Procedure Memoranda are posted to the *BDE Manual* website; however, the associated policy revisions are incorporated in the relevant chapter(s) of the *BDE Manual* itself.

BDE will be responsible for evaluating changes in the highway design and environmental literature (e.g., the issuance of new research publications, revisions to Federal regulations) and will ensure that those changes are appropriately addressed through the issuance of revisions to the manual. In addition, it is important that users of the *BDE Manual* inform BDE of any inconsistencies, errors, need for clarification, or new ideas to support the goal of providing the best and most up-to-date information practical. A form entitled BDE Manual Comments and/or Corrections (see page iii) has been provided for use in submitting any comments and/or suggestions.

TABLE OF CONTENTS

Preface

Manual Format/Updates

Manual Comments and/or Corrections

Table of Contents

PART I – ADMINISTRATION AND PROCEDURES

Chapter 1	Organization and Functions (Program Development)
Chapter 2	Project Development Network (New Alignment)
Chapter 3	Project Development Network (Existing Alignment)
Chapter 4	Coordination Responsibilities
Chapter 5	Local Agency Agreements
Chapter 6	Utility Coordination
Chapter 7	Railroad Coordination
Chapter 8	Consultant Developed and/or Designed Projects
Chapter 9	(Reserved)
Chapter 10	(Reserved)

PART II – PROJECT DEVELOPMENT

Chapter 11	Phase I Studies
Chapter 12	Phase I Engineering Reports
Chapter 13	Work Zone Transportation Management Plans
Chapter 14	Intersection Design Studies
Chapter 15	Interchange Type and Design Studies
Chapter 16	Rest Areas/Weigh Stations
Chapter 17	Bicycle and Pedestrian Accommodations
Chapter 18	Transportation Enhancements
Chapter 19	Public Involvement Guidelines
Chapter 20	Requirements for Major Projects
Chapter 21	(Reserved)

PART III – ENVIRONMENTAL PROCEDURES

Chapter 22	General Environmental Procedures
Chapter 23	Categorical Exclusions
Chapter 24	Environmental Assessments
Chapter 25	Environmental Impact Statements
Chapter 26	Special Environmental Analyses
Chapter 27	Environmental Surveys
Chapter 28	Environmental Permits/Certifications
Chapter 29	(Reserved)
Chapter 30	(Reserved)

Appendices

Appendix A	Regulations and Guidance
Appendix B	Acronyms/Glossary of Environmental Terms
Appendix C	Authority/Responsibilities
Appendix D	Guidance on EA/EIS Preparation

PART IV – ROADWAY DESIGN ELEMENTS

Chapter 31	Basic Design Controls
Chapter 32	Horizontal Alignment
Chapter 33	Vertical Alignment
Chapter 34	Cross Section Elements
Chapter 35	Access Control/Access Management
Chapter 36	Intersections
Chapter 37	Interchanges
Chapter 38	Roadside Safety
Chapter 39	Structure Planning/Geometrics
Chapter 40	General Drainage Procedures
Chapter 41	Construction Site Storm Water Pollution Control
Chapter 42	(Reserved)

PART V – DESIGN OF HIGHWAY TYPES

Chapter 43	Highway Systems
Chapter 44	Rural and Urban Freeways (New Construction/Reconstruction)
Chapter 45	Expressways (New Construction/Reconstruction)
Chapter 46	Strategic Regional Arterials (New Construction/Reconstruction)
Chapter 47	Rural Two-Lane/Multilane State Highways (New Construction/Reconstruction)
Chapter 48	Urban Highways and Streets (New Construction/Reconstruction)
Chapter 49	3R Guidelines for Rural and Urban Highways (Non-Freeways)
Chapter 50	3R Freeway Projects
Chapter 51	(Reserved)

PART VI – OTHER HIGHWAY DESIGN ELEMENTS

Chapter 52	(Reserved)
Chapter 53	Pavement Preservation and Rehabilitation Strategies
Chapter 54	Pavement Design
Chapter 55	Work Zone Traffic Control
Chapter 56	Highway Lighting
Chapter 57	Traffic Control Devices
Chapter 58	Special Design Elements
Chapter 59	Landscape Design
Chapter 60	Other Department Manuals
Chapter 61	(Reserved)
Chapter 62	(Reserved)

PART VII – PLANS AND CONTRACTS

Chapter 63	Plan Preparation
Chapter 64	Quantity Computations
Chapter 65	Cost Estimating
Chapter 66	Contract Processing

PART VIII – PROCEDURE MEMORANDA

Chapter One

ORGANIZATION AND FUNCTIONS (Program Development)

BUREAU OF DESIGN AND ENVIRONMENT MANUAL

Chapter One
ORGANIZATION AND FUNCTIONS
(Program Development)

Table of Contents

<u>Section</u>	<u>Page</u>
1-1	OFFICE OF PROGRAM DEVELOPMENT 1-1.1
1-2	BUREAU OF DESIGN AND ENVIRONMENT 1-2.1
1-2.01	Surveys, Mapping and Modeling Section..... 1-2.1
	1-2.01(a) Surveys Unit..... 1-2.1
	1-2.01(b) Product Compilation Unit 1-2.3
	1-2.01(c) Modeling and Support Unit 1-2.3
1-2.02	Project Coordination and Implementation Section..... 1-2.4
	1-2.02(a) Program Support Unit..... 1-2.4
	1-2.02(b) Project Management Unit 1-2.5
	1-2.02(c) Contracts Unit 1-2.5
1-2.03	Location and Environment Section 1-2.5
	1-2.03(a) Coordination Unit 1-2.6
	1-2.03(b) Natural Resources Unit 1-2.6
	1-2.03(c) Cultural Resources Unit..... 1-2.7
	1-2.03(d) Geologic and Waste Assessment Unit 1-2.8
	1-2.03(e) Project Development Unit..... 1-2.9
1-2.04	Preliminary Engineering Section 1-2.9
	1-2.04(a) Consultant Services Unit 1-2.10
	1-2.04(b) Agreements Unit 1-2.10
	1-2.04(c) Electrical and Mechanical Unit 1-2.11
1-2.05	Policy and Procedures Section 1-2.11
	1-2.05(a) Environmental Policy Unit 1-2.11
	1-2.05(b) Engineering Policy Unit 1-2.12
	1-2.05(c) Standards and Specifications Unit 1-2.13

Chapter 1

ORGANIZATION AND FUNCTIONS

(Program Development)

Chapter 1 provides a general organizational structure for the Illinois Department of Transportation (IDOT) Office of Program Development and brief discussion of the bureaus comprising the Office of Program Development. The Chapter also provides a detailed discussion of the work functions of the Units within each Section of the Bureau of Design & Environment (BDE). For a complete and updated organizational chart of the entire Department, see the IDOT internet site.

1-1 OFFICE OF PROGRAM DEVELOPMENT

The Office of Program Development (OPD) consists of five central bureaus responsible for developing policies, procedures, standards, and guidelines to accomplish the Department's highway system improvement program. Additionally, the five central bureaus under the Office of Program Development provide guidance to districts to ensure statewide uniformity of policy interpretation, program coordination with Federal, State, and local agencies, and compliance with Federal, State, and local laws and regulations. The five bureaus comprising the Office of Program Development include the Bureau of Bridges and Structures (BB&S), the Central Bureau of Land Acquisition (CBLA), the Central Bureau of Local Roads and Streets (CBLRS), the Bureau of Safety Programs and Engineering (BSPE), and the Bureau of Design and Environment (BDE).

1-2 BUREAU OF DESIGN AND ENVIRONMENT

The Bureau of Design and Environment (BDE) consists of five sections: Aerial Surveys, Location and Environment, Policy and Procedures, Preliminary Engineering, and Project Coordination and Implementation. BDE is responsible for developing highway standards, specifications, and policies for use on the state maintained Federal-aid highway system. Additionally, BDE is responsible for developing policies for the preparation, coordination, final review, and approval of project location studies and environmental documents; providing support services for district highway design programs; coordinating and preparing Federal-aid program documents; and processing plans and contract documents through the letting and contract award stage.

Figure 1-2.A presents the organization of BDE.

1-2.01 Surveys, Mapping and Modeling Section

The Surveys, Mapping and Modeling Section consists of three units: the Surveys Unit, Product Compilation Unit, and the Modeling and Support Unit.

1-2.01(a) Surveys Unit

The Surveys Unit, in combination with the district field survey crews, is responsible for the following:

- providing aerial photography and other survey services for the Department and other State agencies including scale changes for maps, plans, charts, and photographic plates used for reproduction and printing;
- maintaining survey datums and coordinate systems for a reference or base for all surveys in the State;
- providing technical assistance on surveying as needed to the districts and local jurisdictions;
- assisting with high-order geodetic surveys and field survey work necessary to provide horizontal and vertical control for photogrammetric mapping; and
- maintaining the IDOT *Survey Manual*.

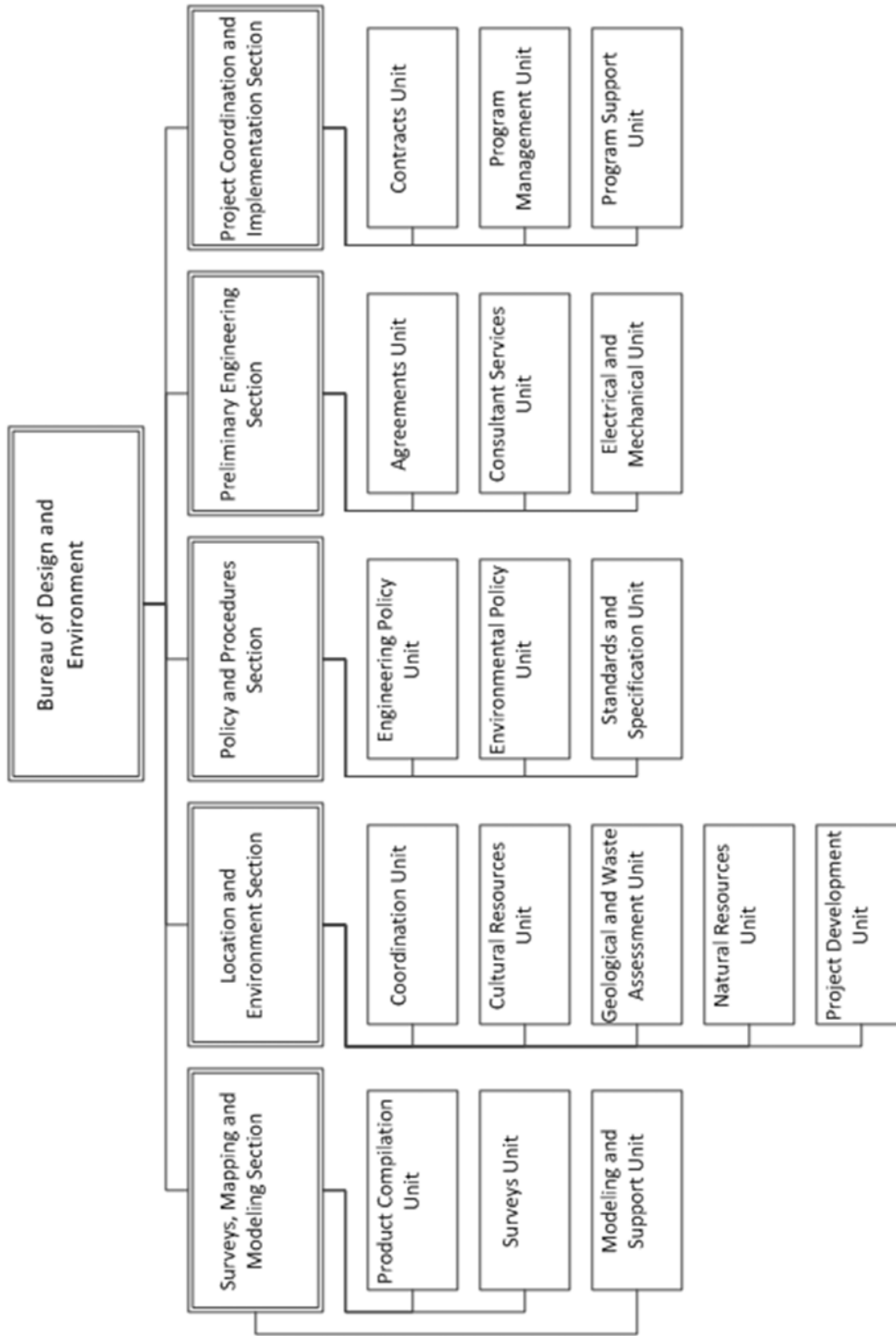

BUREAU OF DESIGN AND ENVIRONMENT

Figure 1-2.A

1-2.01(b) Product Compilation Unit

The Product Compilation Unit is responsible for the following:

- providing aerial photography and photographic services for the Department and other State agencies.
- maintaining the necessary records and filing systems for all Surveys, Mapping and Modeling Section projects;
- providing precise topographic maps in digital format for use with Computer Aided Design and Drafting (CADD) interactive graphic systems;
- providing digital imagery in raster format for use with CADD graphic systems; and
- preparing specifications and agreements for consultant mapping projects and monitoring compliance.

1-2.01(c) Modeling and Support Unit

The Modeling and Support Unit is responsible for the following:

- setting Computer Aided Design & Drafting (CADD) policy statewide;
- maintaining and updating the IDOT *Computer Aided Design, Drafting, Modeling and Deliverables Manual*;
- ensuring engineering policies are developed and fully integrated into CADD software and processes;
- providing liaison activities between bureaus, districts, consultants, and our CADD software vendor(s);
- maintaining the IDOT CADD workspace environment;
- maintaining 2-D and 3-D CADD cell libraries;
- maintaining 3-D civil cell libraries, including supporting and developing additional civil cells;
- supporting survey and design CADD and Geographic Information System (GIS) functions Department-wide;
- developing and maintaining CADD drawings for the IDOT *Highway Standards*;
- communicating CADD best practices and technological advances to district users;
- fostering communication between software application users and developers;

- providing research, development, and management of both CADD and GIS applications used in the scoping, programming, planning and design activities of roadway and structures improvements within the Department;
- providing necessary CADD and GIS training across the Department; and
- supporting innovative survey and design technologies within the Department.

1-2.02 Project Coordination and Implementation Section

The Project Coordination and Implementation Section consists of three units: the Contracts Unit, Program Management Unit, and Program Support Unit. In addition to these units, the Project Coordination group within the Section is responsible for the following:

- reviewing and checking project plans prepared by the districts and consultants for accuracy, completeness, and engineering validity;
- reviewing special provisions;
- facilitating plan coordination with districts, central office bureaus, and print shop; and
- facilitating changes, revisions, addendums, and updates in plans and special provisions.

1-2.02(a) Program Support Unit

The Program Support Unit is responsible for the following:

- determining project letting dates;
- clearing projects for advertising and awarding;
- processing Certification Acceptance (CA)/Project Status forms;
- determining the proper FHWA funding type and assigning project numbers;
- authorizing project funding;
- obtaining authorization from FHWA for all Federally funded projects;
- monitoring the availability of funds within State and Federal funding categories;
- obtaining approvals from the Governor's Office of Management and Budget for all projects under the State's jurisdiction; and
- ensuring that plans are prepared in accordance with agreements with local agencies or other State agencies.

1-2.02(b) Project Management Unit

The Project Management Unit is responsible for the following:

- determining the official engineer's estimate for all projects offered for letting by the Office of Program Development;
- analyzing bids received on lettings and presenting disposition recommendations to the awards committee;
- maintaining data on price trends;
- reviewing and processing plans during preparation of average unit prices used for cost estimates; and
- determining pay item numbers.

1-2.02(c) Contracts Unit

The Contracts Unit is responsible for the following:

- developing and publishing Invitation for Bid/Transportation Bulletin;
- issuing all electronic notifications;
- maintaining lists of bidders and non-bidders;
- conducting bid letting for Office of Program Development, Office of Highways Project Implementation, Bureau of Aeronautics, and Department of Natural Resources projects;
- reviewing identified low bids for responsiveness and responsibility;
- reviewing proposals and legal contract documents through the letting stage; and
- awarding and executing highway construction contracts.

1-2.03 Location and Environment Section

The Location and Environment Section consists of five units: the Coordination Unit, Cultural Resources Unit, Geological and Waste Assessment Unit, Natural Resources Unit, and Project Development Unit.

1-2.03(a) Coordination Unit

The Coordination Unit is responsible for the following:

- administering the central office review of environmental documents, reviewing and commenting on the disciplines assigned to the Unit, compiling comments from all units in the Location and Environment Section into a unified response and issuing State environmental approvals;
- providing expertise for the Department in the disciplines of socio-economics, agriculture, natural resources, air quality, and noise, including providing guidance on Departmental research in these disciplines;
- attending district coordination meetings and special project meetings to participate in project decisions and to guide project development;
- establishing environmental consultant prequalification criteria and reviewing consultants' Statements of Experience and Financial Condition to determine eligibility of firms requesting prequalification in environmental categories;
- reviewing and commenting on consultant advertisements, proposals, selection, and negotiations for projects involving complex environmental documents;
- providing training in environmental matters;
- providing technical advice to the Environmental Policy Unit in the Policy and Procedures Section;
- preparing specific studies and/or sections of text and participating in ad hoc teams to develop or manage environmental documents as requested; and
- providing liaison with other organization units in IDOT and other local, State, and Federal agencies regarding the disciplines assigned to the unit and regarding procedural matters relating to the environmental process.

1-2.03(b) Natural Resources Unit

The Natural Resources Unit is responsible for the following:

- operating and managing the environmental resource surveys for individual projects to identify impacts on biological and wetland resources;
- providing technical expertise on biological resource identification, impact evaluation, mitigation, protection, and management in project development, plan preparation, construction, and operations for such resources as threatened and endangered species, critical habitat for threatened and endangered species, other important ecosystems (e.g., prairies, savannahs, wetlands), and ecological resources in general;

- providing technical expertise and guidance on water resources including wetlands, water quality, flood plains, and Section 404 permits through the planning, design, construction, and operation phases;
- preparing and/or reviewing all or portions of environmental documents including:
 - Environmental Impact Statements,
 - Environmental Assessments,
 - Categorical Exclusions,
 - 4(f) Reports, and
 - 6(f) Reports;
- preparing and/or reviewing specialized environmental documents:
 - biological assessments,
 - wetland technical reports,
 - wetland banking prospectives,
 - conceptual and final wetland compensation plans,
 - wetland site assessment reports,
 - wetland monitoring reports, and
 - draft 404(b)1 guideline reports;
- providing liaison between the districts and the central office and with local, State, and Federal resource and regulatory agencies (e.g., USFWS, IDNR, USACE, USDOJ-NPS);
- disseminating technical environmental information regarding biological resources, water resources, wetlands, flood plains, and Section 404 permits;
- participating in the development of policies and guidance related to natural resources;
- providing technical training on biological resource identification, impact evaluation, development of mitigation, habitat and species protection, management of biological resources on Department-owned land, and incorporation of appropriate features into contract plans; and
- serving on IDOT's Storm Water Committee.

1-2.03(c) Cultural Resources Unit

The Cultural Resources Unit is responsible for the following:

- directing and managing the cultural resources portion of the Environmental Resource Surveys and Studies Program;
- providing technical expertise regarding prehistoric and historic archaeological sites, historic buildings and bridges, and historic districts to highway districts, Bureau of Local Roads and Streets and, at the direction of the Office of the Secretary and/or Director of

the Office of Program Development, to other divisions and offices and other State agencies. Investigations for possible cultural resources must be conducted for proposed project sites, all borrow pits, economic development sites (DCCA), and for any other site which will involve a State transaction;

- meeting with historic resource agencies at the State and Federal levels to resolve project issues and remaining abreast of regulatory changes;
- providing guidance to district and central offices by:
 - attending district coordination meetings,
 - participating in project field meetings or conducting independent field checks, and
 - providing technical training.
- reviewing environmental documents (EAs, EISs technical reports) prepared by the districts or consultants and preparing sections of environmental documents relating to specific cultural resources; and
- advising districts of appropriate responses including avoidance or preservation of significant resources or specific measures to mitigate negative impacts to cultural properties.

1-2.03(d) Geologic and Waste Assessment Unit

The Geologic and Waste Assessment Unit is responsible for the following:

- managing and directing Geologic and Special Waste Surveys on individual projects to identify potential impacts on special waste sites and geological resources (e.g., groundwater, sand, gravel) and potential impacts from geological hazards (e.g., landslides, mine subsidence, earthquakes);
- providing technical expertise and training on special waste problems and evaluations (e.g., underground storage tanks, public health concerns, asbestos, landfills) and expertise on geologic resources and hazards in Phase I and Phase II project development, construction, and operations;
- developing and promulgating Department criteria on the evaluation of special waste sites and geologic resources/hazards;
- developing and promulgating Department procedures for coordination activities with respect to special waste sites and geologic resources/hazards (e.g., Manual for Preparation of Preliminary Environmental Site Assessment, maintenance of waste site list, CERCLIS);

- managing and directing special waste and geological resource/hazard investigations on individual projects to identify the risk and liabilities of waste/geologic hazard sites and impacts to geological resources that cannot be avoided;
- establishing consultant prequalification criteria and reviewing consultant Statements of Experience and Financial Condition to determine their eligibility for prequalifications, developing Transportation Bulletin advertisements, reviewing statements of interest, and recommending selection priorities for the hazardous waste category; and
- providing liaison between the districts and central office with the appropriate resource and regulatory agencies (e.g., USEPA, IPEA, OSFM, IDNR).

1-2.03(e) Project Development Unit

The Project Development Unit is responsible for the following:

- monitoring, evaluating, and assisting in the development of Phase I engineering studies prepared by district offices and by other transportation modes to ensure uniformity of policy compliance and to assist on special location problems;
- preparing location studies for certain complex, critical, or environmentally sensitive projects;
- attending district coordination meetings to discuss engineering issues and the scope and status of projects;
- reviewing and approving requests for exceptions to design policies;
- assuring Phase I studies are developed and implemented using an interdisciplinary approach to resolve engineering and location problems; and
- reviewing and checking project plans prepared by district offices and consultants for accuracy, completeness, and engineering validity.

1-2.04 Preliminary Engineering Section

The Preliminary Engineering Section consists of three units: the Consultant Services Unit, Agreements Unit, and Electrical and Mechanical Unit.

1-2.04(a) Consultant Services Unit

The Consultant Services Unit is responsible for the following:

- prequalifying of architectural/engineering consultant firms;
- in conjunction with districts/bureaus/offices, compiling, coordinating, and preparing advertisements for publishing the Professional Transportation Bulletin;
- evaluating and preparing data for the selection of consultant firms;
- compiling consultant performance ratings;
- in conjunction with the Agreements Unit, establishing Department policies and procedures for consultant projects; and
- developing statewide policies for design, operations, and monitoring district compliance.

1-2.04(b) Agreements Unit

The Agreements Unit is divided into two sub-units: the Consultant Sub-Unit and the Project Support Sub-Unit.

The Consultant Sub-Unit is responsible for the following:

- developing policies and procedures for the administration of consultant agreements;
- obtaining necessary clearances to proceed with consultant agreements, such as procurements waivers, debt certification, and funding approvals;
- preparing consultant agreements based on the proposal package submitted by the districts, bureaus, and other other State agencies; and
- administering the consultant agreement process within the central office and attaining necessary signatures.

The Project Support Sub-Unit is responsible for the following:

- developing policies and procedures for the administration of the utility, railroad, and local agency agreements;
- reviewing, evaluating, and approving agreements with utility companies, railroad companies, local agencies, other State agencies, and other states submitted by the districts; and
- administering the agreement process within the central office and obtaining necessary signatures.

1-2.04(c) Electrical and Mechanical Unit

The Electrical and Mechanical Unit (E&MU) provides assistance on electrical, lighting, and pump station (EL&P) projects. Work performed by E&MU is for Districts 2 through 9, unless noted otherwise. More specifically, E&MU is responsible for the following:

- designing all in-house EL&P projects. This includes preparing all plans and contract documents as outlined in Section 56-4.04;
- reviewing all EL&P plans and documents for projects designed by consultants;
- reviewing all shop drawings for technical correctness and specification compliance for materials supplied to EL&P projects;
- developing and disseminating statewide design criteria, practices, and policies on EL&P;
- conducting final inspections and issuing approval recommendations to the Bureau of Construction on projects with EL&P work;
- assisting with updating EL&P portions of the Department documents such as the Standard Specifications, BDE Manual, BLRS Manual, Construction Manual, Operations Manual, and pay item list;
- reviewing and commenting on a proposed EL&P legislation and code changes impacting the Department; and
- interfacing with the districts, central office bureaus, suppliers, electrical contractors, and outside agencies on EL&P issues and assisting them in finding solutions to design, construction, maintenance, and operating problems.

1-2.05 Policy and Procedures Section

The Policy and Procedures Section consists of three units: the Environmental Policy Unit, Engineering Policy Unit, and Standards and Specifications Unit.

1-2.05(a) Environmental Policy Unit

The Environmental Policy Unit is responsible for the following:

- maintaining BDE Manual Part III, Environmental Procedures, and Chapter 19 Public Involvement Guidelines;
- remaining abreast of changes in environmental laws and regulations and determining their impact on Department policies and procedures;

- providing technical assistance to the Environment Section in the central office and to the districts on environmental and public involvement policy and procedural issues; and
- as necessary, publishing explanatory guidance (i.e., as Procedure Memoranda or Information Memoranda) on environmental and public involvement topics.

1-2.05(b) Engineering Policy Unit

The Engineering Policy Unit is responsible for the following:

- researching, preparing, and disseminating design policies and procedures for Phase I and Phase II engineering activities, including Phase I engineering studies, to the districts and central bureaus and providing interpretation of the policies and procedures for case-specific situations;
- developing policies and procedures for the geometric design of highways, intersections, and interchanges which includes alignment and profile guidelines, superelevation design, cross section elements, median types, and capacity analyses;
- remaining abreast of new research developments and incorporating this research, where applicable, into the design policies;
- developing and disseminating procedures for pavement design and rehabilitation;
- developing policies and procedures for 3R, 3P, and SMART projects;
- developing Department policies and criteria for access control on freeways and expressways and for access management on arterial highways;
- developing Department policies and criteria for roadside safety issues including barrier selection and layout, cost/benefit analyses, and clear zones;
- developing Department policies and procedures for special design elements including accessibility standards.
- developing and promulgating Department policy and guidance on the accommodation of bicyclists and pedestrians within the highway program;
- remaining abreast of State and national issues on bicyclist and pedestrian accommodation and determining their impact on Department practices;
- providing technical assistance to the districts on bicyclist and pedestrian issues; and
- ensuring that the Department complies with the regulations and policies governing the FHWA Transportation Enhancement Program.

1-2.05(c) Standards and Specifications Unit

The Standards and Specifications Unit is responsible for the following:

- developing and disseminating the *Highway Standards* used in contract plans to districts and central bureaus;
- developing new or revised roadway standards on the basis of internal needs, safety requirements, and new material or product development;
- initiating or reviewing requests for new or revised *Standard Specifications for Road and Bridge Construction* and evaluating their feasibility and impact;
- obtaining FHWA approval for new specifications;
- initiating or reviewing requests for new or revised special provisions and connected details for road and bridge construction and evaluating their applicability; and
- publishing the *Standard Specifications* and *Supplemental Specifications and Recurring Special Provisions* books as required.

Chapter Two

PROJECT DEVELOPMENT NETWORK (New Alignment)

BUREAU OF DESIGN AND ENVIRONMENT MANUAL

Chapter Two
PROJECT DEVELOPMENT NETWORK
(New Alignment)

Table of Contents

<u>Section</u>	<u>Page</u>
2-1 GENERAL	2-1.1
2-2 PHASE I STUDIES	2-2.1
Activity No. 1: Scope Project	2-2.5
Activity No. 2: Initiate/Program Project	2-2.6
Activity No. 3: Transfer/Assign to Project Study Group	2-2.7
Activity No. 4: Define Preliminary Purpose and Need	2-2.8
Activity No. 5: Identify Preliminary Corridors	2-2.9
Activity No. 6: Collect Data	2-2.10
Activity No. 7: Analyze Existing Conditions	2-2.12
Activity No. 8: Initiate Early Coordination/Scoping	2-2.13
Activity No. 9: Determine Reasonable Corridors	2-2.14
Activity No. 10: Conduct Public Involvement Activities	2-2.15
Activity No. 11: Conduct Further Analysis of Reasonable Corridors	2-2.16
Activity No. 12: Identify Recommended Corridor	2-2.17
Activity No. 13: Prepare Draft Corridor Report	2-2.18
Activity No. 14: Conduct Corridor Public Hearing	2-2.19
Activity No. 15: Identify Preferred Corridor	2-2.20
Activity No. 16: Prepare Final Corridor Report	2-2.21
Activity No. 17: Review/Approval of Corridor Report	2-2.22
Activity No. 18: Identify Preliminary Alignments within Selected Corridor	2-2.23
Activity No. 19: Initiate EIS Process	2-2.24
Activity No. 20: Begin External Coordination for EIS	2-2.25
Activity No. 21: Initiate Stakeholder Coordination	2-2.26
Activity No. 22: Conduct Purpose and Need Coordination	2-2.27
Activity No. 23: Collect Data	2-2.28
Activity No. 24: Conduct Environmental Survey (Field Phase)	2-2.29
Activity No. 25: Analyze Existing Conditions	2-2.30
Activity No. 26: Initiate Early Coordination	2-2.31
Activity No. 27: Determine Reasonable Alignments	2-2.32
Activity No. 28: Plot Existing/Proposed Topography, Typical Sections, Plan and Profile	2-2.33
Activity No. 29: Initiate Public Involvement	2-2.34
Activity No. 30: Conduct In-Depth Analysis of Reasonable Alignments	2-2.35
Activity No. 31: Identify Recommended Alignment	2-2.36
Activity No. 32: Prepare Drainage Report	2-2.37
Activity No. 33: Prepare Geotechnical Report	2-2.38
Activity No. 34: Prepare Bridge Drawings/Hydraulics Report	2-2.39
Activity No. 35: Conduct Preliminary Utility Review	2-2.40
Activity No. 36: Develop Transportation Management Plan	2-2.41
Activity No. 37: Obtain Detour Approval (if required)	2-2.42

Table of Contents
(Continued)

<u>Section</u>	<u>Page</u>
Activity No. 38: Initiate Local Agency Letters of Intent/Understanding	2-2.43
Activity No. 39: Set Pre-Final Geometry and Right-of-Way	2-2.44
Activity No. 40: Prepare and Circulate Draft EIS	2-2.45
Activity No. 41: Prepare Draft Design Report	2-2.46
Activity No. 42: Conduct Public Hearing	2-2.47
Activity No. 43: Select Preferred Alignment.....	2-2.48
Activity No. 44: Prepare/Circulate Final EIS (FEIS).....	2-2.49
Activity No. 45: Obtain Record of Decision	2-2.50
Activity No. 46: Prepare Final Design Report	2-2.51
Activity No. 47: Obtain Design Approval.....	2-2.52
2-3 PHASE II DESIGN	2-3.1
Activity No. 1: Approval of Phase I Report.....	2-3.4
Activity No. 2: Assign Project to Design Squad	2-3.5
Activity No. 3: Prepare Structures Report and TS&L Plans	2-3.6
Activity No. 4: Prepare Geotechnical Report	2-3.7
Activity No. 5: Initiate Land Acquisition Process and Plans	2-3.8
Activity No. 6: Process Railroad Agreements	2-3.9
Activity No. 7: Compile and/or Review Project Data	2-3.10
Activity No. 8: Conduct Field Survey (If Needed)	2-3.11
Activity No. 9: Perform Detailed Pavement Design and Selection.....	2-3.12
Activity No. 10: Process Local Agreements.....	2-3.13
Activity No. 11: Conduct Field Inspection	2-3.14
Activity No. 12: Coordinate Utility Plans	2-3.15
Activity No. 13: Refine Typical Sections, Plan and Profiles, Grades	2-3.16
Activity No. 14: Develop Detailed Bridge Plans	2-3.17
Activity No. 15: Develop Environmental Mitigation Plans	2-3.18
Activity No. 16: Set Right-of-Way Widths	2-3.19
Activity No. 17: Develop Detailed Plans	2-3.20
Activity No. 18: Develop Specialized Plans	2-3.21
Activity No. 19: Finalize Plotting on Cross Sections	2-3.22
Activity No. 20: Approve Erosion Control Plans.....	2-3.23
Activity No. 21: Assemble All Road Design Information	2-3.24
Activity No. 22: Secure All Permits	2-3.25
Activity No. 23: Process Utility Agreements or Adjustments.....	2-3.26
Activity No. 24: Implement Land Acquisition Process.....	2-3.27
Activity No. 25: Assemble All Information Prepared by Others.....	2-3.28
Activity No. 26: Conduct Plan-in-Hand Field Inspection	2-3.29
Activity No. 27: Prepare Schedules of Quantities	2-3.30
Activity No. 28: Prepare Combined Summary of Quantities	2-3.31
Activity No. 29: Prepare Final Plans and Specifications	2-3.32
Activity No. 30: Prepare Final Plan Submittal Estimate	2-3.33
Activity No. 31: Circulate Plans for District Review.....	2-3.34
Activity No. 32: Review all Project Commitments	2-3.35
Activity No. 33: Submit PS&E to BDE.....	2-3.36
Activity No. 34: Process Contract	2-3.37

Chapter Two

PROJECT DEVELOPMENT NETWORK (New Alignment)

Chapters 2 and 3 document the basic approach used by IDOT in its project development process. Chapter 2 presents Phase I and Phase II networks for projects on new alignment. Chapter 3 presents combined Phase I and Phase II networks for projects on existing alignment requiring major right-of-way purchases (e.g., converting a two-lane facility to an expressway), minor right-of-way purchases (e.g., 3R projects), and projects with no right-of-way acquisition (e.g., Interstate Resurfacing, SMART, 3P). Chapters 2 and 3 present networks that graphically illustrate the development of “typical” highway projects.

2-1 GENERAL

Figure 2-2.A presents a network which graphically illustrates the general process for Phase I of a new alignment project which requires separate corridor and design studies. Figure 2-3.A illustrates the Phase II project development. Following each figure is a brief description of each activity within the network. When using these figures, consider the following:

1. Precedence Activity Network. The networks or flowcharts are precedence activity networks. An “activity” occurs when a significant, discrete event occurs and/or when the responsibility for the project (activity) is transferred from one unit to another. The “precedence” nature of the network implies that an activity cannot occur until all activities preceding that one have been completed. However, the user must be aware that some flexibility is necessary to apply this network to project development, especially during Phase I. For example, identifying new information during the public involvement stage may require the project study group to return to a previous activity and gather additional data.
2. Project Application. These networks represent an approximate process for a complex project on new alignment requiring an Environmental Impact Statement (EIS). Not every activity will be applicable to every project and not all activities are shown. However, the user should find that projects that are developed according to this process have fewer management problems.

The illustrated network assumes a project designed in-house. The process for a consultant-designed project will be similar, except that communication lines exist between IDOT and the consultant for IDOT review and approval.

3. Lines of Communication. The rigid application of the network would lead to predetermined, precise points at which communication occurs between units. This is neither realistic nor desirable. Communication between units must be continuous. This will result in fewer problems and fewer “surprises” in project development.

4. Value Engineering. Refer to Section 11-7.03 for requirements and guidance on value engineering (VE) analyses. Where required, initiate the VE study no later than the time construction plans are 30% complete and allow for the implementation of the recommendations without delaying the project.
5. Project Approval. Districts are responsible for the review and approval of all projects except those projects involving major new alignments addressed by a Corridor Study, Feasibility Study, or Design Report. In these special circumstances, projects are approved by BDE. BDE may also review and approve projects where the Deputy Director/Regional Engineer has requested BDE assistance. See Section 12-5 for a discussion on the processing and approval of phase I reports.
6. Other Manual Chapters. The *BDE Manual* contains several other chapters that provide complementary information to Chapter 2. The designer should review these chapters for more information on the project development process. In particular, Chapter 2 should be used in combination with Chapter 4 “Project Coordination Responsibilities,” Chapter 11 “Phase I Studies,” Chapter 12 “Phase I Engineering Reports,” Chapter 19 “Public Involvement Guidelines,” and Chapter 25 “Environmental Impact Statements.”

2-2 PHASE I STUDIES

Figure 2-2.A illustrates a typical flowchart or network for a project on new alignment that will require both a corridor and a design study. Activities shown along the main axis of the chart represent items which are normally performed by the project study group. The other lines of the chart represent activities by other units or groups. For other project types, see the flowcharts in Chapter 3. Separate corridor studies are usually only prepared for new freeways, for new expressways where two or more existing routes are being considered for upgrading, or for a new two-lane highway proposed on new location. See Chapters 11 and 12. For projects deemed by FHWA as "Major Projects," see Chapter 20.

This network assumes that EIS will be required for a project on new alignment requiring a corridor and a design study. If a project on new alignment does not appear to involve significant environmental impacts, the procedures for development of an Environmental Assessment (Chapter 24) should be followed.

The FHWA's environmental regulations do not require a separate draft and final environmental document and record of decision at the corridor phase. The activity descriptions in this chapter reflect that corridor-phase environmental information will be incorporated in the corridor study report and will be coordinated with interested agencies and the public as a part of that document. Information from the corridor study will be summarized in the draft environmental document at the location-phase so that it will be covered under NEPA.

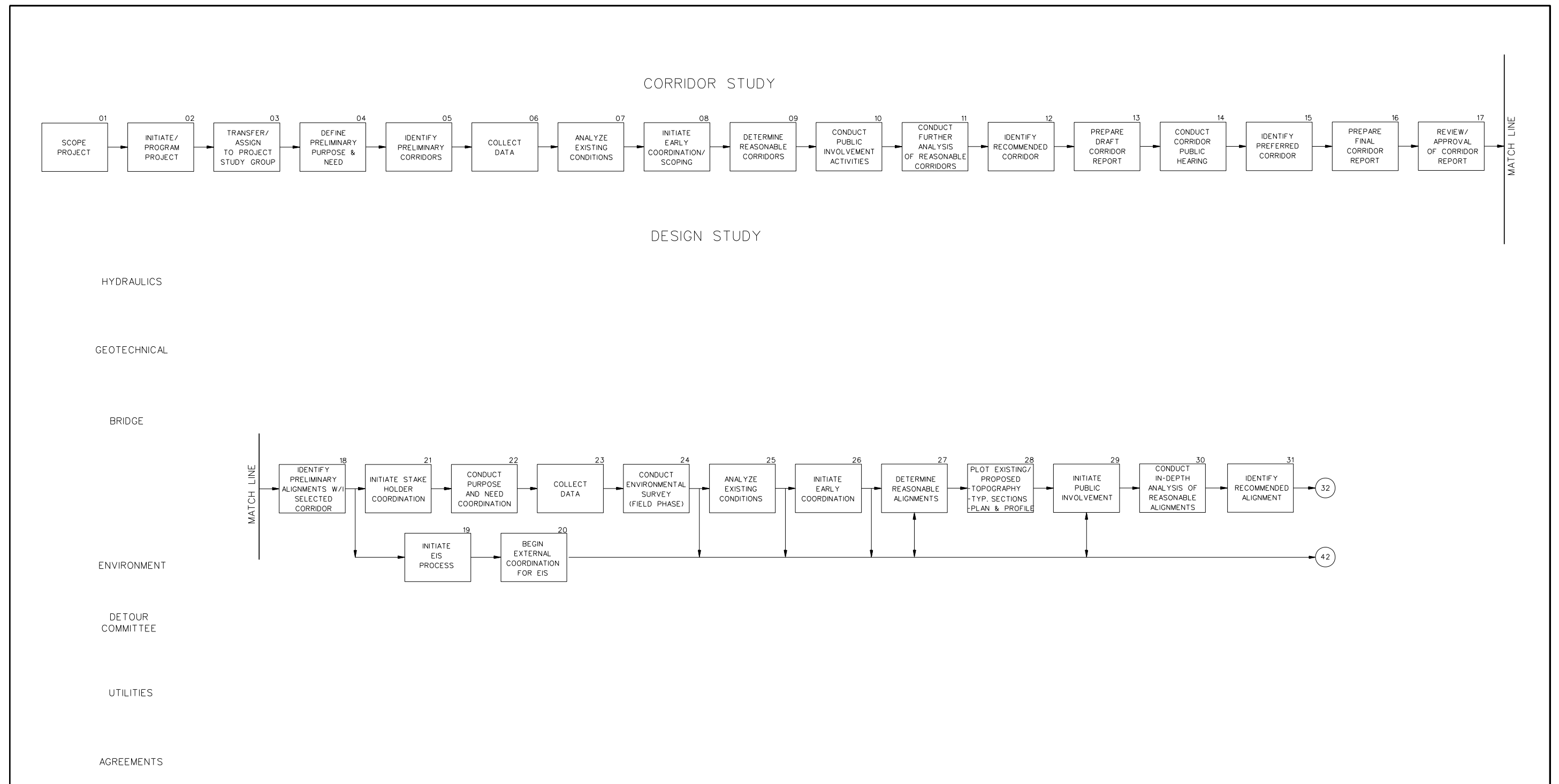

PHASE I PROJECT DEVELOPMENT NETWORK
(New Alignments)

Figure 2-2.A
(1 of 2)

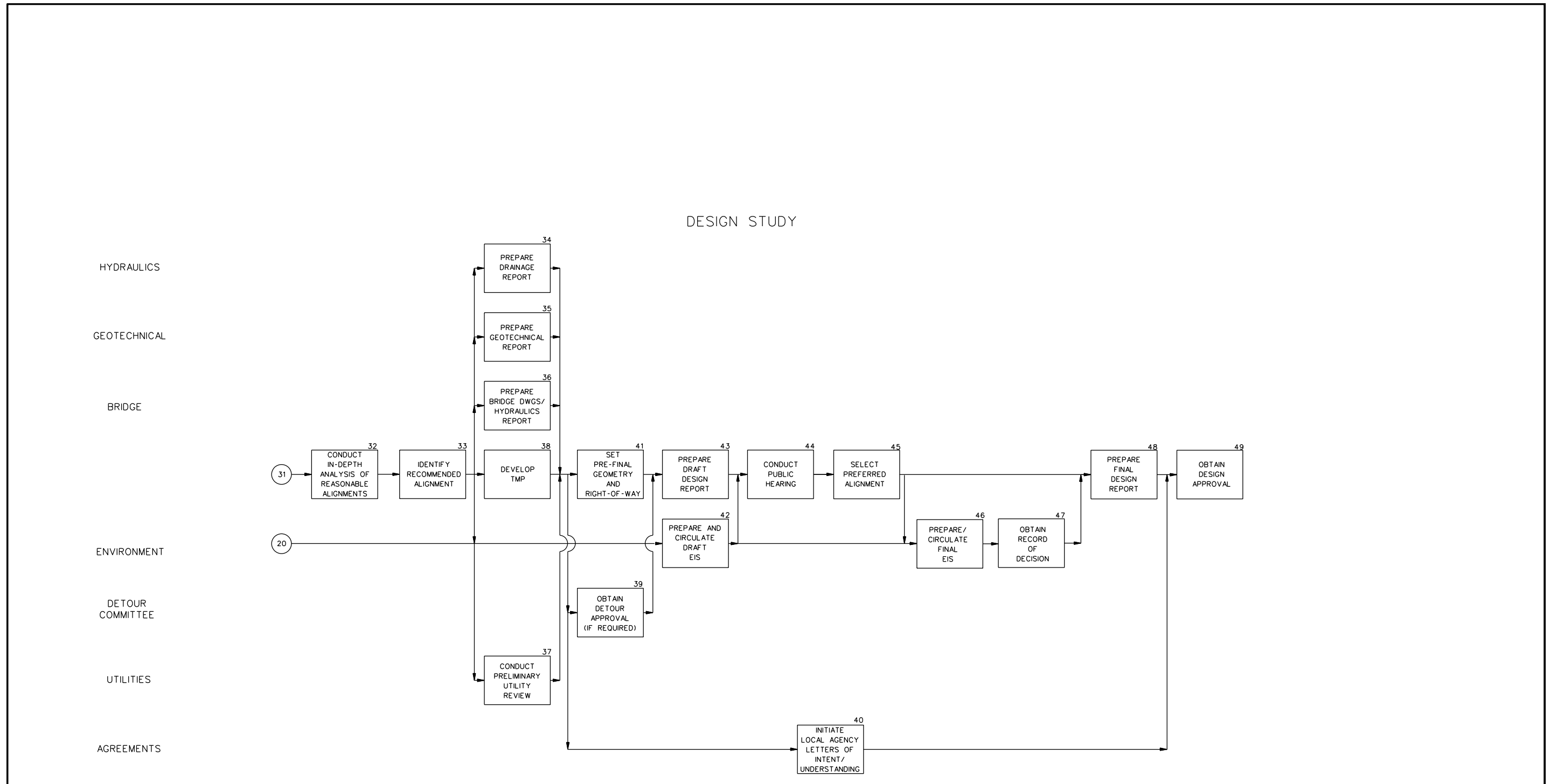

PHASE I PROJECT DEVELOPMENT NETWORK
(New Alignments)

Figure 2-2.A
(2 of 2)

PROJECT ACTIVITY (Phase I)

<u>Activity Title:</u>	Scope Project
<u>Activity No.:</u>	01
<u>Responsible Unit:</u>	District Bureau of Program Development

Activity Description:

A roadway project proposal can originate from a variety of sources, including local officials or metropolitan planning organizations (community-based need), directly from the IDOT districts (district-based need), from a bureau in the central office (Office of Planning and Programming, BDE, Operations, Bureau of Safety Programs and Engineering, etc.), and other sources targeting a special need or a Statewide need.

Before a project is entered onto the Department's Proposed Highway Improvement Program, the district Programming Section initially develops and documents the project concept. Developing the project concept will typically involve the following:

- establishing that there is, in fact, a need for the project;
- making a preliminary determination of the project scope of work;
- reviewing any available data and records;
- conducting an initial evaluation of right-of-way, utility, and environmental impacts and the likely level of environmental evaluation;
- developing a rough, preliminary cost estimate;
- determining a proposed schedule (note that, for projects with both corridor and design study phases, the completion schedule may be greater than that of the multi-year program); and
- developing a set of preliminary drawings/plans.

This information is forwarded for review and comment to district Program Development, district Operations, BDE, district Environmental Unit, the Bureau of Bridges and Structures, and other individuals, as appropriate. The district Programming will refine the scope based on the comments received.

Once the scope, cost, and schedule have been defined, district Programming will forward this information to the Office of Planning and Programming for incorporation into the Department's multi-year program (Activity 02).

PROJECT ACTIVITY (Phase I)

Activity Title: Initiate/Program Project
Activity No.: 02
Responsible Unit: Office of Planning and Programming

Activity Description:

Candidate projects are submitted by the districts as a request for project programming to the Office of Planning and Programming. Based on a statewide assessment of highway improvement needs and available funds, the Office of Planning and Programming will develop the Department's Proposed Highway Improvement Program. This will establish an individual project as an active project for further development.

The Office of Planning and Programming annually issues guidelines for multi-year programming criteria. This includes programming criteria for:

- improvement categories,
- pavement surface conditions,
- deficient bridges,
- safety improvements,
- Interstate rehabilitation,
- widening narrow and deteriorated pavements,
- improving intersections and reducing traffic bottlenecks,
- new construction/reconstruction of major facilities,
- transportation enhancement projects,
- Congestion Mitigation Air Quality (CMAQ) projects, and
- bicycle accommodation.

PROJECT ACTIVITY (Phase I)

Activity Title: Transfer/Assign to Project Study Group

Activity No.: 03

Responsible Unit: Studies and Plans Engineer

Activity Description:

At this point, the project will be assigned to a project study group within the district Bureau of Program Development to begin the corridor study. The Studies and Plans Engineer will have the overall day-to-day responsibility for advancing the project through the Phase I study process. The Studies and Plans Engineer, or designee, will:

- coordinate directly with other units within the Department;
- attend all internal meetings and field inspections;
- ensure that the project study meets all Department criteria and procedures;
- report directly to the District Program Development Engineer on all significant project activities, problems, and developments; and
- participate in the public involvement process.

The number and expertise of personnel initially assigned to the project study group will vary with the nature and scope of the proposed improvement. The personnel assigned will also vary over time relative to the priority for completion, the available lead time, and the activity in project development under study.

If the project is one which the Regional Engineer has determined will use the principles of Context Sensitive Solutions (CSS), the public involvement process should commence at this point. The project study group uses the Stakeholder Involvement Process (SIP) as outlined in Section 19-5.01 to conduct public involvement for CSS projects.

PROJECT ACTIVITY (Phase I)

<u>Activity Title:</u>	Define Preliminary Purpose and Need
<u>Activity No.:</u>	04
<u>Responsible Unit:</u>	Project Studies Group/BDE/FHWA/Office of Planning & Programming

Activity Description:

For a major transportation project, the project study group must first define the project purpose and need, which will direct the process for the identification of alternatives, in-depth analyses and, ultimately, selection of the preferred alternative. This will consist of reaffirming the need for the proposed improvement, establishing project goals and objectives, and establishing the study area and logical termini. The feasibility of a corridor depends on the social, economic, environmental, and engineering effects of the proposed highway improvement within each corridor. Previous studies and decisions should be reaffirmed and/or updated as necessary. Other factors that must be considered include:

- adequacy of the existing highway network,
- existing traffic volumes and capacity deficiencies,
- crash information,
- alignment and profile deficiencies,
- transportation demand,
- potential cost savings to the traveling public,
- enhanced economic development potential,
- improved access,
- programming guidelines,
- commitments to elected officials, and
- public input.

Further study may result in revisions to the preliminary purpose and need.

Prepare the purpose and need so that it can be transferred to the NEPA document. See Section 22-6.01 for more information on purpose and need.

PROJECT ACTIVITY (Phase I)

Activity Title: Identify Preliminary Corridors

Activity No.: 05

Responsible Unit: Project Study Group

Activity Description:

Based on the definition of the preliminary purpose and need (Activity 04) and the general design concept (Activity 01), the project study group should identify feasible corridors that could be used. Because this is an evolutionary process, the preliminary list will be narrowed during further evaluations. The evaluation of preliminary corridors should be sensitive to those environmental resources for which the analysis of alternatives for avoidance and minimization of adverse impacts is required (e.g., wetlands, flood plains, Section 4(f) properties, historic sites). All impractical corridors may be removed from the list with a brief description of why they were removed.

County or other area maps and USGS quadrangle topographic maps, combined with aerial photography, will furnish the locations of towns, streams, railroads, and other topographic features that will assist in defining the study area. Review these maps and locate feasible corridors with respect to local terrain, topographic features, and other controlling items.

The study area is determined through an office-based general overview of area maps and through field trips. Field trips may be facilitated by the prudent use of helicopter flights. The study area is defined as that part of the area of influence within which the facility will be investigated. The limits of the study area may not be the same as the area of influence. Lateral limits are dependent on the distance between the major termini, the function of the highway, and the character of the area traversed.

PROJECT ACTIVITY (Phase I)

Activity Title: Collect Data

Activity No.: 06

Responsible Unit: Project Study Group/Environmental Unit/BDE

Activity Description:

Once the preliminary corridors have been identified (Activity 05), the project study group must gather and inventory information and data on each corridor. All types of data, including social, economic, environmental, and engineering should be gathered simultaneously. The amount and type of information to be collected will vary with the nature and scope of the proposed improvement. Note that data collection is a continuous process throughout Phase I studies. As the process evolves, additional information must be collected.

Information can be obtained from the following sources:

- State, county, and city maps;
- ASCS photography or IDOT photography;
- USGS quadrangle topographic maps;
- traffic maps and data;
- functional classification maps;
- Federal agency plans (e.g., Army Corps of Engineers, Coast Guard, Department of Interior, Department of Housing and Urban Development, FEMA);
- special development plans (e.g., conservation, industrial, recreational, resource);
- population growth trends;
- utility maps;
- urban area transportation studies;
- other regional planning studies;
- road inventory data from the Illinois Road and Inventory System (IRIS);
- Illinois Department of Natural Resources;
- meetings with local officials;
- meetings with other IDOT units;
- local agency plans and reports (land use maps); and
- soil maps.

In addition, the project study group should review the additional sources listed in Section 11-4.02(b).

PROJECT ACTIVITY (Phase I)

Activity Title: Collect Data

Activity No.: 06 (*Continued*)

Responsible Unit: Project Study Group/Environmental Unit/BDE

Activity Description:

In gathering environmental inventory data for the corridor study phase, the district will primarily use existing sources of information on known resources in the study area. Environmental inventory data can be obtained using the on-line GIS database or by contacting BDE. These information sources may include the following:

- National Wetland Inventory maps;
- IDNR Natural Heritage database;
- NRCS wetland maps;
- ASCS county soils survey maps;
- flood plain maps;
- listing of Wild and Scenic Rivers;
- information on the locations of parks, recreation areas, and wildlife and waterfowl refuges;
- IEPA stream water quality data; and
- CERCLIS site listings.

This information will be supplemented by data provided by BDE in response to submittal of an environmental survey request form.

For additional guidance, see Chapter 27 "Environmental Surveys."

PROJECT ACTIVITY (Phase I)

Activity Title: Analyze Existing Conditions

Activity No.: 07

Responsible Unit: Project Study Group

Activity Description:

Using county or other area maps, USGS quadrangle topographic maps, aerial photography, and other data collected in Activity 06, review the existing conditions within the proposed corridors. Items that should be reviewed include:

- condition of the existing highway network;
- existing traffic volumes and capacity deficiencies;
- crash information;
- alignment and profile deficiencies;
- the locations of towns, streams, railroads, and other topographic features;
- existing and proposed land use from local governments, MPOs, fire districts, schools, etc.;
- environmental resources; and
- sensitive environmental areas (e.g., wetlands, floodplains, natural areas, nature preserves).

PROJECT ACTIVITY (Phase I)

Activity Title: Initiate Early Coordination/Scoping

Activity No.: 08

Responsible Unit: Project Study Group/BDE

Activity Description:

Coordination with other Department and governmental agencies, as appropriate, is an important aspect during the corridor study process. This coordination should begin as early as practical in project planning.

The project study group and BDE will initiate early coordination with individuals, organizations, and appropriate local, State, and Federal agencies that have an interest in the project or have information or expertise concerning any issues the project may involve. The purpose of this coordination will be to assist in the identification of reasonable corridors and in the gathering of information for evaluating the social, economic, and environmental impacts of the proposed project corridors and possible impact mitigation measures. Early coordination will also identify the cooperating agencies.

Scoping is an early and open process for determining the scope of issues to be addressed in the corridor study and for identifying the significant issues related to the proposed improvement. Scoping is intended to focus the study effort on issues that are truly significant and avoid the collection of needless detailed information on insignificant issues.

Although scoping may be accomplished by a formal meeting, it is more frequently accomplished through less formal meetings and exchanges of written and verbal communications. Scoping is typically not an individual step, but an ongoing process as part of the overall coordination and public involvement process.

PROJECT ACTIVITY (Phase I)

Activity Title: Determine Reasonable Corridors
Activity No.: 09
Responsible Unit: Project Study Group/Environmental Unit

Activity Description:

The determination of the reasonable corridors for further evaluation is an evolutionary process, which may be summarized as follows:

- identify preliminary corridors (Activity 05);
- perform a rough evaluation of the potential impacts of these preliminary corridors on the inventory of the affected environment to identify, for example, “fatal” flaws;
- incorporate input from agencies and/or the public (Activity 08) in the decision-making process;
- estimate the overall reasonableness of each corridor under consideration;
- ensure that each “reasonable” corridor will accommodate alternates that will satisfy the project purpose and need (Activity 04);
- ensure location of connections can be adequately developed (e.g., interchanges, frontage roads) (see Section 11-4.02(e)); and
- based on an appropriate level of re-evaluation and additional coordination, identify those selected reasonable corridors that are worthy of further evaluation considering:
 - + the need to identify potential avoidance and minimization alternatives for environmental reasons,
 - + that the cost of the studies for each corridor should be commensurate with its probability of implementation;
 - + that, collectively, the selected corridors should cover the full spectrum of alternatives; and
 - + that, collectively, the selected corridors should gain public acceptance that no reasonable corridor alternative has been omitted.

Typically, this process will yield two or three reasonable corridors for further evaluation. The “no-action” alternative also must be evaluated for presentation as part of the Corridor Study.

PROJECT ACTIVITY (Phase I)

Activity Title: Conduct Public Involvement Activities
Activity No.: 10
Responsible Unit: Project Study Group/Environmental Unit

Activity Description:

Once the reasonable corridors have been selected (Activity 09), the public should be provided an opportunity to become acquainted with the project and express its views. The public involvement program is first initiated by advising the public that a study is underway. As the project progresses, the district should offer opportunities for the public to receive updated information on the status of the project and provide input and comment. This will culminate in the corridor phase with Activity 14 "Conduct Corridor Public Hearing" when the public will be offered a formal opportunity to comment on the corridor alternatives under consideration. Public involvement should be an ongoing process as the project development evolves.

For projects which the Regional Engineer has determined will use the principles of CSS, the public involvement process should commence once the project is assigned to the project study group. The project study group uses SIP as outlined in Sections 19-5.01 to conduct public involvement for CSS projects.

For detailed information on public involvement activities, see Chapter 19.

PROJECT ACTIVITY (Phase I)

Activity Title: Conduct Further Analysis of Reasonable Corridors

Activity No.: 11

Responsible Unit: Project Study Group/Environmental Unit

Activity Description:

For each selected reasonable corridor (Activity 09), the project study group will identify and evaluate the socio-economic, environmental, and engineering issues, including those identified through agency coordination and public involvement that would be involved in the development of more detailed alternatives within the corridor. The evaluation of these issues must be presented at a comparable level of detail for each reasonable corridor and in a manner to facilitate comparison among the corridor alternatives. Some of the issues that should be evaluated include:

- land use;
- habitat;
- drainage impacts and construction in flood plains;
- projected ADTs;
- fire districts, mail routes, school districts, drainage districts, and taxing districts;
- recommendations from existing Geotechnical Reports;
- locations of major utility installations;
- other transportation facilities (e.g., commuter and freight railroads, airports, bus and trucking terminals);
- urban area transportation study reports and other data;
- regional planning agency reports;
- interagency comments (Activity 08);
- route planning considerations (see Section 11-3);
- estimated cost for each alternative (See Section 11-4.03(d));
- private and commercial property owner reports;
- location of cemeteries, 4(f) land, wetlands, threatened and endangered species/habitat, historic structures, archaeological sites, and special waste sites;
- water towers;
- coal mines; and
- other similar issues.

PROJECT ACTIVITY (Phase I)

Activity Title: Identify Recommended Corridor

Activity No.: 12

Responsible Unit: Project Study Group/Environmental Unit/BDE

Activity Description:

After conducting the analysis of each reasonable corridor (Activity 11), the project study group in conjunction with the district Environmental Unit will determine the recommended corridor alternative. In identifying a recommended corridor, give careful consideration to cost-effectiveness, potential socio-economic and environmental impacts, system connections, and potential for positive impact on affected communities as well as satisfying the purpose and need. The selected alternative corridor and description of why it was selected should be forwarded to BDE for review and approval prior to beginning the preparation of the draft Corridor Report (Activity 13) and before it is presented at the Corridor Public Hearing (Activity 14).

PROJECT ACTIVITY (Phase I)

Activity Title: Prepare Draft Corridor Report

Activity No.: 13

Responsible Unit: Project Study Group

Activity Description:

Once the analyses have been sufficiently conducted and the information and data gathered, the project study group will prepare the draft Corridor Report. Chapter 12 presents the format that should be used to prepare a Corridor Report. Because the corridor study should be essentially complete, it should be possible to prepare the draft Corridor Report in near-final format. The discovery of new, significant information during the Corridor Public Hearing (Activity 14) should be rare if the corridor study has been properly developed. With the exception of changes necessary to reflect input from the public hearing, a final Report should only need information concerning the public involvement and the final conclusion/recommendation section.

In general, the draft Corridor Report should be submitted to BDE for review prior to its availability to public viewing and inspection at the Corridor Public Hearing. Formal approval by BDE for release is not normally issued. Copies made available to the public should be marked as “draft” or “preliminary.”

The Corridor Report should include:

- a discussion on the purpose and need for the project;
- county maps in 11 in. x 17 in. sheets showing all corridors studied, all acceptable corridors, and existing and proposed land uses;
- USGS quadrangle maps showing topography and other details;
- existing and expected traffic data;
- discussion on prior studies;
- eliminated alternatives;
- advantages and disadvantages of the selected corridor alternative;
- environmental concerns;
- impacts on existing communities;
- results of public involvement and environmental coordination; and
- estimate of costs.

PROJECT ACTIVITY (Phase I)

<u>Activity Title:</u>	Conduct Corridor Public Hearing
<u>Activity No.:</u>	14
<u>Responsible Unit:</u>	Project Study Group/Environmental Unit

Activity Description:

The Corridor Public Hearing is conducted at this stage of the study to present to the public, and other interested organizations and agencies, the corridor alternative under final consideration, a summary of the analyses of alternatives, and the criteria used to select the recommended corridor.

The project study group and the district Environmental Unit will evaluate all comments from the Public Hearing and will prepare responses to these comments as appropriate. Possible responses include:

- modifying alternatives including the proposed action;
- developing and evaluating alternative corridors previously given serious consideration;
- supplementing, improving, or modifying analyses;
- making factual corrections; or
- explaining why the comments do not warrant further agency response, citing the sources, authorities, or reasons that support that position and, if possible, indicating those circumstances that would trigger reappraisal or further response.

Chapter 19 discusses the requirements for public hearings, public information meetings, and responding to comments received during the public hearing.

PROJECT ACTIVITY (Phase I)

Activity Title: Identify Preferred Corridor

Activity No.: 15

Responsible Unit: Project Study Group

Activity Description:

Based on the results of the Corridor Public Hearing (Activity 14) and previous study analyses, the project study group will select the preferred corridor for the project. The selected corridor, and its advantages and disadvantages, will be documented in the final Corridor Report (Activity 16).

PROJECT ACTIVITY (Phase I)

Activity Title: Prepare Final Corridor Report

Activity No.: 16

Responsible Unit: Project Study Group

Activity Description:

After analyzing the comments received from the public and other agencies, the project study group will determine if any changes are necessary in the draft Corridor Report and if any relevant issues have been overlooked. If an oversight has occurred, additional data and studies may be required to explain the resultant effects and to determine what changes, if any, are necessary.

After the review and analysis of comments is complete and the appropriate revisions incorporated, the final Corridor Report may be prepared. Activity 13 and Chapter 12 present the information and format that should appear in the Report.

PROJECT ACTIVITY (Phase I)

Activity Title: Review/Approval of Corridor Report

Activity No.: 17

Responsible Unit: BDE/Environmental Unit/FHWA

Activity Description:

Once the final Corridor Report has been completed, the project study group will forward the Corridor Report to BDE, the district Environmental Unit, and FHWA, if applicable, for review and approval. When approval is received for the Corridor Report, the corridor study portion of Phase I will be complete.

PROJECT ACTIVITY (Phase I)

Activity Title: Identify Preliminary Alignments within Selected Corridor

Activity No.: 18

Responsible Unit: Project Study Group

Activity Description:

This step initiates the design study portion of Phase I. Typically, some delay will occur between the corridor study and design study. Therefore, the project study group should review the Corridor Report and project files from the corridor study to become familiar with the decisions and determinations, commitments to local officials, and public input made during the corridor study. Also, the project study group will ensure that the corridor decisions are still valid. Throughout the design study process, reaffirm the approved corridor as contacts are made with planning agencies. Also, assess any changes in land use or development plans to determine if corridor modifications should be considered. This is especially important if several years have elapsed between the corridor and design studies or if new information is discovered during the more in-depth design analysis.

Using county maps, USGS quadrangle maps, and aerial photography, identify and lay out possible alignments within the corridor on base maps (see Chapter 11). Also include the no-action alternative in the design study. A possible alternative may include improving existing highways within the corridor. Set interchange locations and determine general horizontal alignment for each alignment. The selection of the preliminary alignments will define what information will be collected in Activity 23 and will initiate the EIS process in Activity 19.

At this stage, request project mapping based on the identified alignments. However, note that many times insufficient information will be available at the time mapping is requested and, therefore, some judgment must be used in deciding the width limits of mapping. Additional mapping can be requested later during the design study if needed for further alignment investigations.

PROJECT ACTIVITY (Phase I)

Activity Title: Initiate EIS Process

Activity No.: 19

Responsible Unit: BDE/Project Study Group/Environmental Unit/FHWA

Activity Description:

Once the information has been received on the preliminary alignments (Activity 18), the following actions are accomplished to initiate the process for preparing EIS. Actions 1 through 4 must be completed before Action 5, publication of a Notice of Intent:

1. The BDE sends a signed Project Initiation Letter to FHWA. FHWA and BDE encourage discussion of project initiation at coordination meetings.
2. The FHWA and IDOT develop negotiated timeframes for the project in accordance with the IDOT/FHWA 2005 Illinois Statewide Implementation Agreement for Establishment of Timeframes for Environmental Impact Statements and Environmental Assessments, giving consideration to input on the timeframes provided during development of the Stakeholder Involvement Plan (see Item 3).
3. The CSS project study group develops a draft plan for stakeholder involvement and coordination. The district contacts BDE for coordination plan examples. The project study group prepares one plan that addresses both requirements to promote a consistent and efficient process. This plan is called the Stakeholder Involvement Plan. FHWA and IDOT must agree on the content of the plan before it is distributed to external stakeholders. See Section 19-5.01(a) for further guidance.
4. The district Environmental Unit prepares a draft Notice of Intent and submits it to BDE for further action.
5. The BDE coordinates the draft Notice of Intent with FHWA for publication in the *Federal Register*. See Appendix B of FHWA Technical Advisory T6640.8A for more detailed information on the format, content, and processing of the Notice of Intent.

PROJECT ACTIVITY (Phase I)

Activity Title: Begin External Coordination for EIS

Activity No.: 20

Responsible Unit: Project Study Group/Environmental Unit/BDE/FHWA

Activity Description:

The project study group and district Environment Unit, in cooperation with BDE and FHWA, initiate the following external coordination actions:

1. The project study group, district Environmental Unit and BDE coordinate with FHWA to invite interested/affected Federal, State, and local agencies to be participating agencies or cooperating agencies. The invitation letters include a draft of the Stakeholder Involvement Plan and request input from the agencies contacted. IDOT and FHWA revisit the need for inviting additional agencies to be participating or cooperating agencies as new stakeholders are identified during project development.
2. The project study group and district Environmental Unit initiate identification of potential environmental resource issues, and may conduct one or more scoping meetings as a part of the identification effort.
3. The project study group and district Environmental Unit obtain input from participating agencies on the methodologies and level of detail planned for analysis of environmental issues for alternatives under study. Coordination with participating agencies on methodologies and level of detail for environmental analyses should be ongoing throughout development of the project. When new information warrants, the methodologies and level of detail may be revisited and modified.

The project study group and district Environmental Unit coordinate with BDE and FHWA to finalize the Stakeholder Involvement Plan after receiving and considering input from participating and cooperating agencies and the public.

PROJECT ACTIVITY (Phase I)

Activity Title: Initiate Stakeholder Coordination

Activity No.: 21

Responsible Unit: Project Study Group

Activity Description:

The project study group coordinates with stakeholders to complete a Context Audit.

The project study group also works with stakeholders to develop a clear statement of the transportation problem(s) the project will address. This problem statement is used in developing the project purpose and need.

See Section 19-5.01(b) for further guidance on Context Audits and development of project problem statements.

PROJECT ACTIVITY (Phase I)

Activity Title: Conduct Purpose and Need Coordination

Activity No.: 22

Responsible Unit: Project Study Group/FHWA

Activity Description:

The project study group, in cooperation with FHWA, accomplishes the following coordination regarding the statement of purpose and need for the project:

1. Provide participating agencies and the public opportunities to provide input for consideration in development of the statement of purpose and need for the project, in accordance with Section 6002 of SAFETEA-LU (23 U.S.C. 139).
2. Achieve consensus with CSS stakeholders on project purpose and need.
3. Obtain concurrence from NEPA/404 Merger Agreement signatories on project purpose and need.

PROJECT ACTIVITY (Phase I)

<u>Activity Title:</u>	Collect Data
<u>Activity No.:</u>	23
<u>Responsible Unit:</u>	Project Study Group

Activity Description:

In this Activity, the collection of data for each alignment identified in Activity 18 will begin. Note that data collection is an on-going process throughout the design study phase. Data gathering may begin with a review of information available in the district and central offices. Some of the information that is gathered includes:

- roadway, field, aerial, and stream surveys;
- existing roadway classifications and truck routes;
- crash rate maps and collision diagrams;
- pavement and bridge condition reports;
- ADT traffic maps and DHVs for current and design year traffic (all affected routes);
- inventory of posted speed limits;
- detailed transportation maps and plans with all modes of travel included;
- utility installations and detailed maps from utility companies;
- hydraulics survey, drainage survey, sewer atlas, and flooding information tables;
- fire districts, mail and school bus routes, location of churches, drainage districts, historic sites, and field-tile maps;
- commercial, agricultural, industrial, recreational, historic, and residential land use;
- conservation areas, archaeological sites, wetlands, special waste sites, etc.;
- local, State, and Federal agency coordination needs;
- maintenance information on existing routes;
- current topographic mapping at a scale of 1 in. = 50 ft (1:500 metric) in urban areas and 1 in. = 200 ft (1:2500 metric) in rural areas on new alignment or 1 in. = 50 ft (1:500 metric) in rural areas where existing alignment is studied;
- current aerial photographic mosaics at a scale of either 1 in. = 100 ft (1:1000 metric) or 1 in. = 200 ft (1:2500 metric) in urban areas and aerial photography at 1 in. = 400 ft (1:5000 metric) or 1 in. = 600 ft (1:7500 metric) in rural areas;
- geotechnical investigations;
- highway geometrics, development of access control plans, and right-of-way issues;
- joint development uses, scenic easements, and aesthetics of highway (see Chapter 33); and
- cost estimate (see Section 11-2.15) and road-user benefits (see Section 11-7.01).

See Chapters 11 and 12 for further guidance on the information that should be collected for a design study. Also see Section 25-2.

PROJECT ACTIVITY (Phase I)

Activity Title: Conduct Environmental Survey (Field Phase)

Activity No.: 24

Responsible Unit: Project Study Group/Environmental Unit /BDE

Activity Description:

During the corridor study phase, BDE will have conducted a preliminary environmental inventory (Activity 06). For Activity 24, the project study group in conjunction with BDE will determine if further field work is necessary to verify or further evaluate the location, nature, and extent of potential resource involvement. For this Activity, the district forwards a request to BDE to conduct an environmental survey.

Based on the preliminary alignments identified in Activity 18, BDE will determine whether any further work is necessary to delineate the limits of or otherwise evaluate sensitive resources the project may affect. If determined necessary, BDE will coordinate, as appropriate, with the responsible agencies and the project study group for the field survey(s). BDE will provide the results of the reconnaissance survey(s) and any related studies for resource delineation or evaluation to the district.

The district will consider the environmental resource information in further development of the project and, for resources within the project limits (e.g., wetlands, natural areas, archaeological and historical sites), evaluate options for avoiding and minimizing the project's effects on the resources. If adverse effects to environmental resources cannot be avoided, the project study group/Environmental Unit, in cooperation with BDE, will evaluate whether any further studies of the resources are necessary. If further studies are needed, BDE will initiate action to have the studies accomplished, considering program priority and project scheduling.

The BDE will provide information to the district regarding environmental study findings, results of coordination with outside agencies, and any recommendations for further coordination or action by the district. This information will also be used by the district Environmental Unit in preparing the draft EIS.

For additional guidance on field surveys, see Chapter 27.

PROJECT ACTIVITY (Phase I)

Activity Title: Analyze Existing Conditions

Activity No.: 25

Responsible Unit: Project Study Group

Activity Description:

Using county or other area maps, USGS quadrangle topographic maps, aerial photography, the Corridor Report (Activity 17), data collected in Activity 23, and the environmental survey (Activity 24), the project study group will review and identify the following existing conditions:

- the locations of towns, streams, railroads, and other topographic features;
- condition of the existing highway network within the corridor;
- existing traffic and capacity deficiencies;
- crash information;
- alignment and profile deficiencies;
- existing and planned land uses from local governments, MPOs, fire districts, schools, etc.;
- existing drainage patterns;
- sensitive noise receptors;
- wetlands and applicable 4(f), 6(f), and 106 sites, etc.;
- special waste sites; and
- tree and vegetation inventory.

Upon receipt of the topographic mapping, plot the property lines, property names, names of roads, and all other important cultural features. Make paper copies of the mapping sheets and tape together. This procedure allows the project study group to review long lengths of the alignment in one view and to see how lines may best fit together. Begin laying out all feasible alignments.

After an alignment is laid out, determine the State plane coordinates of all control points (POTs and PIs) from the project mapping. Input this information and the radii of horizontal curves into a computer file to mathematically describe each alternative. Once an alignment is mathematized and tied into digitized mapping files, the alignment can then be stationing from west to east or south to north and the information stored as a computer file for further design work.

Provide the results of this activity to the district Environmental Unit to allow them to prepare the draft EIS.

PROJECT ACTIVITY (Phase I)

Activity Title: Initiate Early Coordination

Activity No.: 26

Responsible Unit: Project Study Group

Activity Description:

Activity 08 discusses early coordination within the context of a corridor study; the project study group will engage in a similar early coordinated effort for the design study.

At this stage of the design study process, the project study group will begin early coordination with other Department Units or Bureaus and governmental agencies (e.g., FHWA, Land Acquisition, Construction, Operations, Bridges and Structures, Utilities, environmental resource agencies). The purpose of this coordination will be to assist in the identification of reasonable alignment alternatives and in gathering information to evaluate the social, economic, and environmental impacts of the proposed project and possible impact mitigation measures. This coordination should begin as early as practical.

Provide the results of this activity to the district Environmental Unit to allow them to prepare the draft EIS.

Also see Section 25-2.

PROJECT ACTIVITY (Phase I)

Activity Title: Determine Reasonable Alignments

Activity No.: 27

Responsible Unit: Project Study Group/Environmental Unit/FHWA

Activity Description:

The project study group and district Environmental Unit, in cooperation with FHWA, accomplish the following coordination regarding development of the range of alternatives for the project:

1. Provide participating agencies and the public opportunities to provide input for consideration in development of the range of alternatives for the project, in accordance with Section 6002 of SAFETEA-LU (23 U.S.C. 139).
2. Achieve consensus with CSS stakeholders on the range of alternatives for the project.
3. Obtain concurrence from NEPA/404 Merger Agreement signatories on the range of alternatives to be carried forward.

The project study group in conjunction with the district Environmental Unit considers the results of the coordination in reducing the number of alternatives to a reasonable number that are representative of the spectrum of possible alternatives that satisfy the project purpose and need. This will typically be two to three alternatives, including the no-action alternative. An in-depth analysis will be conducted on each of the remaining alternatives (Activity 30).

Using the base maps prepared in Activity 18, the information gathered in Activities 23 and 24, and the analyses conducted in Activity 25, the project study group and district Environmental Unit revise or eliminate any alternative alignments that are undesirable because of adverse engineering, environmental, economic, or social effects. An estimate of costs may be necessary to further determine which alternatives may warrant elimination. Document the reason(s) why an alignment has been discarded. Include this information in the final Design Report and EIS. Ensure that each of the remaining alternatives still meets the project's defined purpose and need.

Also see Section 25-2.

PROJECT ACTIVITY (Phase I)

Activity Title: Plot Existing/Proposed Topography, Typical Sections, Plan and Profile

Activity No.: 28

Responsible Unit: Project Study Group

Activity Description:

For each remaining alternative alignment identified in Activity 27, conduct the following:

- If not already done, plot the existing topography including property lines, property owner names, business names and type, names of roads, and all other important geographic and cultural features.
- Determine the proposed typical sections.
- Determine the detailed horizontal alignment, including radii, stationing, and State plane coordinates of all control points (e.g., POTs, PIs, PCs, PTs).
- Investigate alternative vertical profiles for each alignment. This may require designing two to three trial vertical profiles and performing several complete earthwork calculations; see Sections 11-2.05 and 11-5.04(d).
- Once the geometric elements have been set, determine the preliminary right-of-way limits for each alternative.
- Determine the rough quantities for each alternative and refine the cost estimate for each alternative. If no quantities are available, use a generalized cost (e.g., cost per mile (kilometer)); see Sections 12-4 and 65-1.02.

The IDOT uses the computer software program GEOPAK for laying out alignments, profiles, cross section designs, quantity calculations, and for determining construction limits. The GEOPAK also can be used to generate 3-D and perspective plots for any portion of the roadway. Use 3-D plots in the design process to assess potential safety problems and the aesthetics of each alternative.

PROJECT ACTIVITY (Phase I)

<u>Activity Title:</u>	Initiate Public Involvement
<u>Activity No.:</u>	29
<u>Responsible Unit:</u>	Project Study Group/Environmental Unit

Activity Description:

This Activity will allow the public an opportunity for input and comment on the alternatives selected in Activity 27. Typically, this will consist of informational letters, advertisements, and/or meetings with local government officials, fire districts, school districts, drainage districts, historic commissions, MPOs, residents, businesses, etc. These meetings or letters may include:

- advising local, State, and Federal officials that a project has been initiated;
- procedures for developing possible coordination and public service involvement;
- a discussion on the project scope;
- a request for information (e.g., MPO plans, drainage problems, transit needs);
- a discussion with businesses, railroads, and utility companies; and
- talking with individuals at public information meetings about individual concerns.

Public coordination must be continuous throughout the project development.

For projects which the Regional Engineer has determined will use the principles of CSS, the public involvement process should commence once the project is assigned to the project study group. The project study group uses the SIP as outlined in Sections 19-5.01 to conduct public involvement for CSS projects.

For guidance on public coordination, see Chapter 19.

PROJECT ACTIVITY (Phase I)

Activity Title: Conduct In-Depth Analysis of Reasonable Alignments

Activity No.: 30

Responsible Unit: Project Study Group

Activity Description:

During the initial development of alignment alternatives, some analyses will have been conducted as attempts to fit various options into the project location. After the reasonable alignments have been identified (Activity 27) and the information is plotted on the plan sheets (Activity 28), further analyses will be necessary to assess the capability of each alternative to accomplish the project goals cost effectively. Conduct an in-depth analysis of each of the proposed alignments considering the social, economic, environmental, and engineering factors discussed in Part II "Project Development" and Part III "Environmental Procedures."

The engineering and environmental analyses may include:

- intersection design studies,
- interchange type and design studies,
- capacity analysis,
- initial impact and mitigation alternatives,
- wetlands involvement,
- air and noise impacts,
- impacts on cultural resources,
- tree and vegetation evaluation,
- water quality and natural resources impacts, and
- soils evaluation.

After the results of these investigations have been analyzed, there may be legitimate reasons to eliminate one or more of the final alignment alternatives. Discuss the reason why these alignment(s) were not further considered in the Design Report and EIS. For instance, traffic estimates for the no-action alternative may overload existing routes creating unacceptable congestion and, thereby, eliminate this alternative.

The results of this and previous Activities will be submitted to the Hydraulics Unit, Geotechnical Unit, Bureau of Bridges and Structures, Environmental Unit, and Project Support Section to allow these Units to prepare their applicable reports for the Design Report.

Also see Section 25-2.

PROJECT ACTIVITY (Phase I)

Activity Title: Identify Recommended Alignment

Activity No.: 31

Responsible Unit: Project Study Group

Activity Description:

Considering the environmental, social, and economic impacts, engineering factors, and public input, the project study group will identify a preferred alignment through the corridor. If there are two or more alignments with essentially the same impact, the project study group still should select one recommended alignment. The final geometric and right-of-way design will be based on this recommended alignment. Also, this alignment should be presented as the recommended alignment at the public hearing (Activity 42).

PROJECT ACTIVITY (Phase I)

Activity Title: Prepare Drainage Report

Activity No.: 32

Responsible Unit: Hydraulics Unit

Activity Description:

Based on the information provided from the project study group (Activity 31), the Hydraulics Unit will perform the hydrology/hydraulics analysis, including the following:

- culvert sizing,
- longitudinal encroachments,
- storm drainage facilities,
- stormwater management, and
- pump stations.

Based on its evaluation, the Hydraulics Unit will prepare a Drainage Report. The project study group will use this information in making the final alignment determinations. It will also incorporate the Drainage Report into the final Design Report. See Chapter 40 and the *IDOT Drainage Manual* for more information on Drainage Reports.

PROJECT ACTIVITY (Phase I)

Activity Title: Prepare Geotechnical Report

Activity No.: 33

Responsible Unit: Geotechnical Unit

Activity Description:

Based on the information provided from the project study group (Activity 31), the Geotechnical Unit will prepare the Geotechnical Report. The analyses may include:

- basic soil properties (e.g., AASHTO soils classification);
- shrink/swell factors;
- properties of subsurface strata;
- potential for slides;
- slope stability at proposed cuts; and
- the development of a boring plan for any proposed bridges (e.g., location, spacing, and depth).

Based on its evaluation, the Geotechnical Unit will prepare a Geotechnical Report. The project study group will use this information in making the final alignment determinations. In addition, the Geotechnical Report will be incorporated into the final Design Report. See the *IDOT Geotechnical Manual* for more information.

PROJECT ACTIVITY (Phase I)

<u>Activity Title:</u>	Prepare Bridge Drawings/Hydraulics Report
<u>Activity No.:</u>	34
<u>Responsible Unit:</u>	Bureau of Bridges and Structures/Project Study Group

Activity Description:

Based on the information provided from the project study group (Activity 31), the Bureau of Bridges and Structures will prepare the Proposed Structure Sketch for major structures, which will illustrate:

- the type of structures,
- approximate horizontal and vertical alignment and skew,
- approximate pier locations, and
- typical bridge deck section.

The project study group will prepare this sketch for other than major structures.

See Chapter 39 for more information. The Bureau of Bridges and Structures will also prepare the Hydraulics Report for major structures. This will involve:

- the hydraulic analysis to determine the necessary dimensions of the waterway opening to pass the design flood, to meet the backwater allowances, and to satisfy any regulatory flood plain requirements;
- the hydraulic scour analysis to assist in determining the proper foundation design for the bridge; and
- a suggested freeboard elevation.

The project study group will prepare this report for other structures and the Bureau of Bridges and Structures will approve the report.

Incorporate the Structure Sketch and Hydraulics Report into the final Design Report.

PROJECT ACTIVITY (Phase I)

Activity Title: Conduct Preliminary Utility Review

Activity No.: 35

Responsible Unit: Project Support Section

Activity Description:

The project study group will provide the district Project Support Section with copies of the plan sheets for the recommended alignment. The Project Support Section will work with the applicable utility companies to identify project impacts on existing utilities and inform them of environmental issues that may affect their adjustments and relocations. The following items of work are typically performed:

1. Underground. The Project Support Section will coordinate with the district survey crew and will, if needed, request an underground survey to determine the depths and location of existing underground utilities within the project limits, especially fiber optic cables, water supply, and sanitary lines in urban areas.
2. Overhead. Determine if any major above-ground utilities that may be impacted by the project. The Project Support Section may prepare a cost estimate to determine if a special effort should be exercised to avoid certain utilities.
3. Impacts. The Project Support Section will notify any utility companies that will be potentially impacted by the upcoming project, and the Section will request that the Utility contact IDOT if it plans any work in the vicinity of the project.

The Project Support Section will document its findings in a report or memorandum and submit it to the project study group. The project study group will use the information in making the final alignment determinations and document its findings in the Design Report.

For additional guidance on utility coordination, see Chapter 6.

PROJECT ACTIVITY (Phase I)

Activity Title: Develop Transportation Management Plan

Activity No.: 36

Responsible Unit: Project Study Group

Activity Description:

The maintenance of traffic flow during construction of a State highway will involve traffic and worker safety, public relations, and capital costs to the Department. A well-planned method for maintaining traffic flow can minimize complaints from the traveling public and from residents and businesses along the affected route. Each construction site must be evaluated on its own merits as to the appropriate method for maintaining traffic. The Design Report should contain a Transportation Management Plan (TMP) indicating an overall strategy for accommodating traffic during construction. Chapter 13 presents the goals and objectives for a TMP. The TMP should address the preferred traffic control method, alternative traffic control applications, geometric design criteria, the impact traffic will have on other facilities, local concerns, cost effectiveness of various alternatives, etc. Chapter 55 and the *Highway Standards* provide the design criteria to use when designing a traffic control plan. In addition, consider the following:

- The TMP not only must address the alternatives confined to the project site, but it must also evaluate the impact traffic will have on the entire corridor.
- For large projects, a TMP team may be organized during Phase I to study the traffic control alternatives and their effect on the corridor. Section 13-1.08 provides guidance on the makeup and responsibilities of the TMP team.
- If improvements are required to other facilities (e.g., widening of detour routes), it is important that these improvements be implemented as soon as practical prior to construction of the mainline facility. Allow local agencies sufficient opportunity to complete their improvements before construction on the State route begins. Agreements or concurrence may be necessary between the State and local agencies to determine cost sharing arrangements and/or approval of a local road as a detour route (Activity 38).
- No formal public involvement activity (e.g., design hearing) should occur until the recommended alternative in the TMP Report has been approved by district Detour Committee. However, informal public involvement will be necessary during the analysis of alternatives.

PROJECT ACTIVITY (Phase I)

Activity Title: Obtain Detour Approval (if required)

Activity No.: 37

Responsible Unit: Project Study Group

Activity Description:

In general, TMP (Activity 36) will be approved as part of the Design Report. Exceptions to the approved TMP must be approved by the Bureau of Safety Programs and Engineering. For all marked and unmarked detours or for a road proposed to remain open by either stage construction or a runaround, TMP will be approved by the district Detour Committee. For a closed unmarked State highway, also coordinate with the local county officials prior to the submittal of the Design Report.

PROJECT ACTIVITY (Phase I)

Activity Title: Initiate Local Agency Letters of Intent/Understanding

Activity No.: 38

Responsible Unit: Project Support Section

Activity Description:

Based on the public involvement, decisions made in Activity 29, and the selection of the recommended alignment (Activity 31), the Project Support Section will initiate the preparation of any necessary letters of intent or letters of understanding with local officials. These may be prepared for:

- concurrence between the State and local agencies to determine cost sharing arrangements,
- approval of a local road as a detour route,
- determining maintenance responsibilities once the project is completed, and/or
- letters of support for the improvement.

For additional guidance, see Chapter 5.

PROJECT ACTIVITY (Phase I)

Activity Title: Set Pre-Final Geometry and Right-of-Way

Activity No.: 39

Responsible Unit: Project Study Group

Activity Description:

Based on the previous analyses for the recommended alignment (Activity 31) and information provided by others (Activities 32, 33, 34, and 35), the project study group will:

- make any necessary adjustments to the selected vertical and horizontal alignments;
- make any necessary adjustments to the typical sections;
- develop access control plans for freeways, expressways, and by-passes (see Section 11-5.04(f) and Chapter 35);
- set preliminary construction limits;
- set preliminary right-of-way limits;
- determine any easement requirements; and
- determine if any utility adjustments or displacements are necessary.

See Part IV "Roadway Design Elements" and Part V "Design of Highway Types" for detailed information on geometric design and the *IDOT Land Acquisition Manual* for guidance on right-of-way impacts.

PROJECT ACTIVITY (Phase I)

Activity Title: Prepare and Circulate Draft EIS

Activity No: 40

Responsible Unit: Environmental Unit/BDE/FHWA

Activity Description:

The district Environmental Unit, in cooperation with BDE and FHWA prepares the Draft EIS. To provide NEPA coverage of the corridor-phase study information, that information is summarized in the draft EIS.

When satisfied with the content, FHWA approves the Draft EIS for public availability. The district Environmental Unit coordinates with BDE and FHWA to have a Notice of Availability for the Draft EIS published in the *Federal Register*, which begins the minimum 45-day public comment period. See Chapter 25 for additional guidance on preparation of the Draft EIS, approval for public availability, and the *Federal Register* Notice of Availability.

PROJECT ACTIVITY (Phase I)

Activity Title: Prepare Draft Design Report

Activity No.: 41

Responsible Unit: Project Study Group

Activity Description:

Once the analyses have been conducted and the information gathered, the project study group will prepare the draft Design Report. Chapter 12 presents the format that should be used when preparing a Design Report. Because the design study should be essentially complete, it should be possible to prepare the draft Design Report in its near-final format. The discovery of new, significant information during the Public Hearing (Activity 42) should be rare if the design study has been properly developed. With the exception of changes necessary to reflect input from the public hearing (Activity 42), a final Design Report should only need information concerning the public involvement and the final conclusion/recommendation section.

In general, the draft Design Report for major new alignment projects should be submitted to BDE for review prior to its availability for public viewing and inspection at the Public Hearing. Formal approval by BDE for release is not normally issued. Copies made available to the public should be marked as “draft” or “preliminary.”

The Design Report should include:

- a summary of purpose and need of the project;
- a list and results of prior studies;
- a list of all alternative alignments eliminated earlier and the reasons for their elimination;
- a summary of major design features and policies;
- a discussion on the compatibility of the alternatives with existing streets and highways;
- a summary of the environmental factors considered;
- a discussion on the advantages and disadvantages of the reasonable alignments studied in-depth;
- the results of public involvement;
- the proposed maintenance and protection of traffic plan;
- a list of commitments made to the public;
- the reasons and determination for selecting the preferred alignment;
- plan and profile of the preferred alignment;
- the estimate of costs for each alternative;
- exhibits showing typical sections, aerial photography, mapping, etc.;
- copies of analyses; and
- documentation for approval of other reports conducted during the design study.

For further guidance on information to be included in the Design Report, see Chapter 12.

PROJECT ACTIVITY (Phase I)

<u>Activity Title:</u>	Conduct Public Hearing
<u>Activity No.:</u>	42
<u>Responsible Unit:</u>	Project Study Group/Environmental Unit

Activity Description:

No sooner than 15 days after publication of the Notice of Availability for the Draft EIS in the *Federal Register*, the project study group and district Environmental Unit conduct a Public Hearing. The purpose of the Public Hearing is to present to the public, and other interested organizations and agencies, the alignment alternatives under consideration and their anticipated social, economic, and environmental effects, a summary of the analyses for the various alternatives determined not to be feasible, and the criteria used to select the recommended alignment. Other Department Sections or Bureaus (e.g., Land Acquisition), as necessary, may attend the Public Hearing to answer specific questions relative to their expertise.

Corridor protection should also be addressed at the Public Hearing. Chapter 12 and the IDOT *Land Acquisition Manual* provide guidance on corridor protection.

The project study group and the district Environmental Unit evaluate all comments from the Public Hearing and prepare responses to these comments as appropriate. Possible responses include:

- modifying alternatives including the proposed action;
- developing and evaluating alternatives not previously given serious consideration;
- supplementing, improving, or modifying analyses;
- making factual corrections; or
- explaining why the comments do not warrant further agency response, citing the sources, authorities, or reasons that support that position and, if possible, indicating those circumstances that would trigger reappraisal or further response.

Chapter 19 discusses the requirements for public hearings, public information meetings, and responding to comments received during the public hearing.

Also see Section 25-2.

PROJECT ACTIVITY (Phase I)

Activity Title: Select Preferred Alignment

Activity No.: 43

Responsible Unit: Project Study Group/FHWA

Activity Description:

Based on the results of the public hearing, circulation of documents, and written and verbal comments received, the project study group will select the preferred alignment within the corridor. This may require additional analyses to resolve issues and questions raised during the Public Hearing.

The project study group, in cooperation with FHWA, conducts CSS coordination to achieve consensus with stakeholders on the preferred alignment and coordinates with NEPA/404 Merger Agreement signatories to obtain their concurrence on the preferred alignment.

The selected preferred alignment is used to prepare the final Design Report (Activity 46) and, consequently, for the detailed Phase II design.

PROJECT ACTIVITY (Phase I)

Activity Title: Prepare/Circulate Final EIS (FEIS)

Activity No.: 44

Responsible Unit: Environmental Unit

Activity Description:

The district Environmental Unit, in cooperation with BDE and FHWA, prepares the Final EIS. The FHWA conducts a legal sufficiency review and, when satisfied with the content, approves the Final EIS. The district Environmental Unit coordinates with BDE and FHWA to file the Final EIS with USEPA for publication of a Notice of Availability in the *Federal Register*.

The district Environmental Unit has the primary responsibility for circulating the FEIS which, basically, will be distributed to any entity which made substantive comments on the Draft EIS or requested a copy of the FEIS. See Chapter 25 for IDOT-specific information on circulating the FEIS and the procedures for processing the FEIS by FHWA and USEPA.

PROJECT ACTIVITY (Phase I)

Activity Title: Obtain Record of Decision

Activity No.: 45

Responsible Unit: Environmental Unit/FHWA

Activity Description:

The FHWA will complete and sign a Record of Decision no sooner than 30 days after publication of the Final EIS notice in the *Federal Register* or 90 days after publication of a notice for the Draft EIS, whichever is later. See Chapter 25 for further guidance on preparation and processing of the Record of Decision.

For projects with a high potential of litigation, FHWA in consultation with the Regional Engineer and Office of the Chief Counsel may publish a notice in the *Federal Register* regarding the 180-day Statute of Limitations (§139(I) notice), established in Section 6002 of SAFETEA-LU (23 U.S.C. 139), on claims against USDOT and other Federal agencies for certain environmental and other approval actions. A notice may be very useful in cases where there are no known potential litigants, but where there are complex or controversial issues or impacts that may generate opposition in the future, as the project moves into an implementation phase. A §139(I) notice will define the time period during which such “newly” interested parties must act on their views. If a project has no substantial known or likely opposition, then there may be little benefit from publication of a §139(I) notice.

PROJECT ACTIVITY (Phase I)

Activity Title: Prepare Final Design Report

Activity No.: 46

Responsible Unit: Project Study Group

Activity Description:

The comments received from the public and other agencies should be analyzed to determine if any changes are necessary in the draft Design Report and if any relevant issues have been overlooked. If an oversight has occurred, additional studies may be required to explain the resultant effects and determine what project design changes, if any, are necessary. After the review and analysis of comments is complete and appropriate revisions effected, the final Design Report may be prepared. Activity 41 and Chapters 11 and 12 list the appropriate format, reports, and discussions that should be included in the Design Report. The final Design Report will also include or reference a copy of the FEIS received from the district Environmental Unit.

After completing all public involvement and environmental requirements, the original scaled mapping is reduced for insertion into an appendix of the Design Report. Prepare the reduced mapping sheets and other engineering exhibits on 11 in x 17 in sheets and place them in an Appendix. In addition, place the aerial photography (access control plans) showing the alternatives advanced for environmental analysis and any other environmental exhibits on 11 in x 17 in sheets and place them in an Appendix. This Appendix can be used in conjunction with a draft and final EIS. Use the 11 in x 17 in format in all cases. This size format provides for ease of use of all final exhibits by Planning, Design, and Land Acquisition personnel.

PROJECT ACTIVITY (Phase I)

Activity Title: Obtain Design Approval

Activity No.: 47

Responsible Unit: Project Study Group

Activity Description:

The Regional Engineer reviews and approves most Phase I Engineering Reports. BDE reviews and approves Phase I Engineering Reports for those projects involving a major new alignment addressed by a Corridor Study, Feasibility Study, or Design Report, or where the Deputy Director/Regional Engineer has requested BDE assistance. See Section 12-5 for a discussion on the processing and approval of phase I reports.

Before submitting the final report for approval to the BDE/Regional Engineer, ensure that the following has been completed:

- the corridor has been approved;
- the applicable requirements in Part II “Project Development” and Part III Environmental Procedures” have been met;
- public involvement activities as described in Chapter 19 have been completed;
- the FEIS and Record of Decision have been approved by the appropriate agencies;
- if applicable, coordination with and approval from FHWA has been completed; and
- all design exceptions have been approved by BDE and, where necessary, FHWA.

Submit the following to the Regional Engineer or BDE:

- two copies of the Design Report and Appendices;
- the applicable number of copies of the FEIS as discussed in Figure 25-2.G;
- two copies of the Public Involvement Document;
- two copies of the Advisory Committee/Working Groups Document; and
- a memorandum describing the reasons for selecting the preferred alignment and design features, the items submitted, and the request for design approval.

For projects requiring the approval of the Bureau Chief of Design and Environment, approval will be granted with concurrence of the Director of the Office of Program Development. The Secretary of IDOT and the Director of the Office of Planning and Programming will also be contacted on their desire for a briefing meeting before design approval will be granted.

2-3 PHASE II DESIGN

Figure 2-3.A illustrates a typical Phase II flowchart or network for a complex project on new alignment. Following Figure 2-3.A are brief write-ups for each activity. For other project types, see the flowcharts in Chapter 3. Activities along the main axis are normally performed by the project design squad. The other lines of the chart represent activities performed by other units or groups.

Refer to Section 11-7.03 for requirements and guidance on value engineering (VE) analyses. Where required, initiate the VE study no later than the time construction plans are 30% complete and allow for the implementation of the recommendations without delaying the project. The designer should review any VE studies conducted during Phase I and update them as necessary.

For projects deemed by FHWA as “Major Projects,” see Chapter 20.

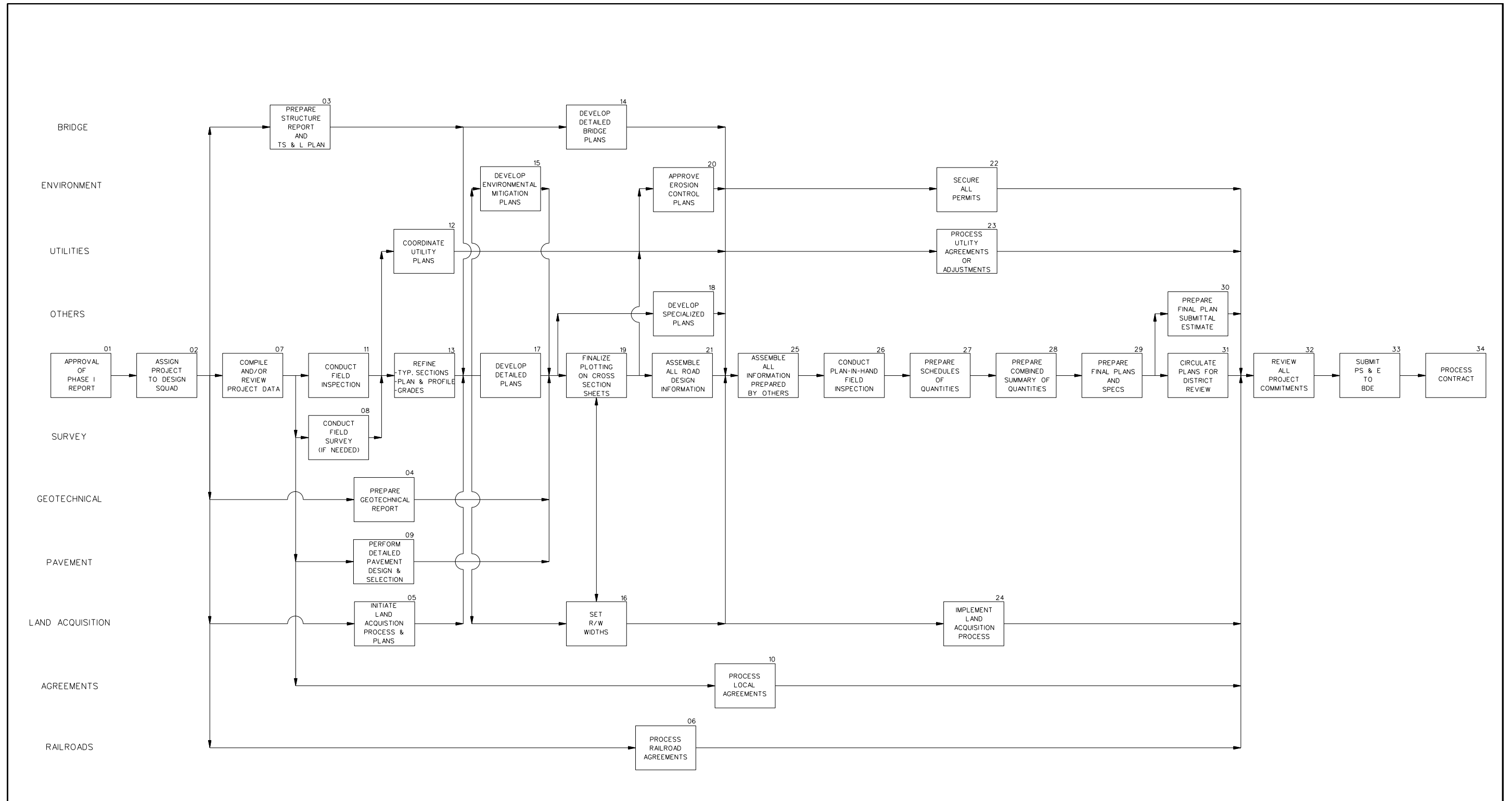

PHASE II PROJECT DEVELOPMENT NETWORK
(New Alignments)

Figure 2-3.A

PROJECT ACTIVITY (Phase II)

Activity Title: Approval of Phase I Report

Activity No.: 01

Responsible Unit: Regional Engineer (or BDE)

Activity Description:

Once the Phase I report has been approved, this will signify that Phase I is complete and that Phase II can begin. See Figure 2-2.A and the corresponding write-ups for Phase I work. For guidance on the approval of Phase I reports, see Section 12-5.

PROJECT ACTIVITY (Phase II)

Activity Title: Assign Project to Design Squad

Activity No.: 02

Responsible Unit: Studies and Plans Engineer

Activity Description:

This Activity begins Phase II of the project. At this point, the project will either be assigned to a design squad within the district Bureau of Program Development or to a consultant. The Studies and Plans Engineer will have the overall day-to-day responsibility for advancing the project through the Phase II project development process. The Studies and Plans Engineer, or designee, will:

- coordinate directly with other units or sections within the Department;
- attend all internal meetings and field inspections;
- be responsible for ensuring that the project meets all Department criteria and procedures;
- ensure the project is on schedule for the expected letting date;
- report directly to the Program Development Engineer on all significant project activities, problems, and developments; and
- participate in the public involvement process.

PROJECT ACTIVITY (Phase II)

<u>Activity Title:</u>	Prepare Structures Report and TS&L Plans
<u>Activity No.:</u>	03
<u>Responsible Unit:</u>	Bureau of Bridges and Structures/Design Squad

Activity Description:

Based on the approved Phase I report (Activity 01) and notification by the design squad that Phase II has begun (Activity 02), the district will prepare the Structures Report and the Bureau of Bridges and Structures will prepare the Type, Size, and Location (TS&L) Plans for any bridges within the project limits. TS&L Plans are detailed bridge configuration plans that are used to develop the detailed bridge construction plans. The TS&L Plans will present the following:

- plan and profile of the bridge showing the proposed type of superstructure and foundation, bridge end elevations, location of expansion and fixed ends, highway approaches, and existing contours at the bridge site;
- superstructure cross section showing pertinent structural details (e.g., number of beams, depth and width of bridge deck);
- bridge curb, sidewalk, and/or shoulders;
- design loadings, stresses, specifications, and other structural criteria;
- controlling horizontal and vertical clearances;
- hydraulic data, high and low water elevations, drift, ice, etc.; and
- a small-scale location map to identify the location of the proposed bridge.

The Structures Report and TS&L Plans will be used in developing the detailed roadway plans (Activity 17). See Chapter 39 for more information on TS&L Plans and bridge sizing/geometrics.

For Phase II plans prepared by a Consultant, these activities may be the responsibility of the Consultant and approved by the Bureau of Bridges and Structures.

PROJECT ACTIVITY (Phase II)

Activity Title: Prepare Geotechnical Report

Activity No.: 04

Responsible Unit: Geotechnical Unit

Activity Description:

After being assigned the project (Activity 02), the design squad will request the Geotechnical Unit to investigate the geotechnical characteristics within the project limits based on the information provided in the approved Phase I report (Activity 01). The nature and depth of the investigation will be determined on a project-by-project basis. One of the primary factors which will determine the scope of the investigation will be the anticipated amount of earthwork for the project. The geotechnical investigation may include:

- an in-depth subsurface investigation (e.g., to determine the hydrogeologic characteristics of the subsurface);
- an evaluation of the potential for slides;
- an investigation of any wetlands in the vicinity of the project;
- for proposed cuts, a determination of the slope stability characteristics and the need for any special treatments (e.g., benching);
- testing of materials from the site by Department laboratory tests;
- an evaluation of any erosion potential within the project limits; and
- an evaluation of foundations for bridges and long culverts.

The Geotechnical Unit will prepare a Geotechnical Report documenting the findings from its investigation. The Report will be submitted to the design squad for input into the final typical section design for the facility.

PROJECT ACTIVITY (Phase II)

Activity Title: Initiate Land Acquisition Process and Plans

Activity No.: 05

Responsible Unit: Land Acquisition Section

Activity Description:

Based on the approved Phase I report (Activity 01) and notification by the design squad that Phase II has begun (Activity 02), the Land Acquisition Section will initiate the land acquisition process and the preparation of the right-of-way plans. This includes obtaining the existing right-of-way plans and researching the existing right-of-way status within the project limits, including:

- right-of-way titles and deeds,
- permanent easements,
- property lines and owners, and
- existing limits of access.

The preparation of right-of-way plans will include:

- setting up the sheets and stationing for the right-of-way plans,
- recording the section corner information,
- recording property ownership information,
- plotting the existing right-of-way, and
- developing parcel plats.

The Land Acquisition Section will forward this information to the design squad for use in preparation of the detailed roadway plans (Activity 17).

PROJECT ACTIVITY (Phase II)

Activity Title: Process Railroad Agreements

Activity No.: 06

Responsible Unit: Project Support Section

Activity Description:

The district provides information to BDE for the preparation and negotiation of formal agreements between the Department and the Railroad. This includes both railroad grade separation and at-grade crossing projects on the State highway system. Based on the approved Phase I report, the design squad should submit the necessary crossing data with sufficient lead time to allow for negotiations. Typically, a year or more is required.

The Agreement will cover:

- division of work and expense involved between IDOT and the Railroad for the crossing improvement;
- responsibilities for the future maintenance of the improvement;
- establishment of the Railroad's share of the cost as determined under the provisions of any one of the several classifications provided in the *Federal-Aid Policy Guide* and Section 7-1.02;
- reference to the acquisition of property rights (see Section 7-1.06);
- reimbursement of the costs incurred by the Railroad according to the requirements of the *Federal-Aid Policy Guide*;
- coverage of liability during construction operations; and
- reference to or identification of plans and plan approval.

The Project Support Section will coordinate the transfer of information and plans between the design squad and the railroad companies. This will be a continuous process as the design plans are developed during the Phase II design. This process should be completed prior to the review of all project commitments (Activity 32).

For additional guidance on coordinating with railroads, see Chapter 7.

PROJECT ACTIVITY (Phase II)

Activity Title: Compile and/or Review Project Data

Activity No.: 07

Responsible Unit: Design Squad

Activity Description:

The design squad may or may not include the same personnel as the project study group for Phase I. Also, there typically will be some delay between the Phase I and the Phase II portions of a project. Therefore, the design squad should review the Phase I report(s) and project files to become familiar with the decisions and determinations made during Phase I. Some of the information and decisions that should be reviewed may include:

- any design variances,
- alignment and typical section plans developed during Phase I,
- any technical reports prepared for the Phase I study,
- crash and traffic data,
- aerial photographs,
- the commitment file,
- the proposed TMP,
- documentation on public hearings and/or private meetings,
- letters of understanding and/or letters of intent sent to local officials,
- any utility involvement,
- any railroad involvement, and
- existing conditions to assess any changes in land use or development plans.

Based on this review, the design squad should evaluate what additional information and coordination with other units may be required to complete the project. The design squad also should ensure that other units as appropriate have initiated their work (e.g., Bureau of Bridges and Structures (Activity 03), Land Acquisition Section (Activity 05)). At this stage of the project, the design squad should request:

- if necessary, the Surveys and Photo Services Unit to conduct additional surveys (Activity 08);
- the Pavement Design Section to begin the pavement design and type selection (Activity 09); and
- the Project Support Section to begin processing any necessary local agency agreements (Activity 10).

PROJECT ACTIVITY (Phase II)

Activity Title: Conduct Field Survey (If Needed)

Activity No.: 08

Responsible Unit: Surveys and Photo Services Unit

Activity Description:

In general, a survey should have been conducted during the development of the Phase I study. However, based on the review of the project data (Activity 07), the design squad may conclude that additional surveys are required. The needed survey information may include:

- existing field conditions (topography, vegetation, existing structures and road design features, etc.);
- drainage features (bodies of water, open channels, channel slopes and cross sections, existing drainage appurtenances, etc.);
- existing field landmarks;
- existing utilities (above and below ground);
- existing right-of-way markers and property lines; and
- alignment and cross section of any existing roads and driveways.

PROJECT ACTIVITY (Phase II)

Activity Title: Perform Detailed Pavement Design and Selection

Activity No.: 09

Responsible Unit: Pavement Design Section

Activity Description:

Based on the information provided by the design squad (Activity 07) and Phase I report (i.e., Geotechnical Report), the Pavement Design Section will perform the detailed pavement design analysis. For new or full-depth reconstruction, the objectives of the analysis will be to:

- select the design methodology, pavement type, and design criteria (see Chapter 54);
- determine the overall pavement thickness and thicknesses of individual layers; and
- determine any special surfacing design features (e.g., high-stress intersections, subdrainage design, use of geotextiles).

The objective of Activity 09 is to develop and compare pavement design options. See Chapter 54 for additional guidance on pavement design and approval.

PROJECT ACTIVITY (Phase II)

Activity Title: Process Local Agreements

Activity No.: 10

Responsible Unit: Project Support Section

Activity Description:

The district Project Support Section is responsible for the preparation and negotiation of formal agreements between the Department and local governments. These agreements may cover:

- division of work and expense involved between IDOT and the local agency in connection with the improvement,
- responsibilities for the future maintenance of the improvement,
- reference to the acquisition of property rights,
- reimbursement of the costs incurred by the local agency,
- coverage of liability during construction operations, and
- reference to or identification of plans and plan approval.

The Project Support Section also will be responsible for coordinating the transfer of information and plans between the design squad and the local agency. This will be a continuous process throughout the design phase as the design plans are developed. The district Project Support Section also will coordinate with BDE for review and approval of any agreements. This process should be completed prior to the review of all project commitments (Activity 32).

For additional guidance on coordinating with local agencies, see Chapter 5.

PROJECT ACTIVITY (Phase II)

Activity Title: Conduct Field Inspection

Activity No.: 11

Responsible Unit: Design Squad

Activity Description:

After completing the in-house review of the Phase I report and other project data, the design squad should conduct a field inspection of the project. The objective is to review major design features and project-related issues and to identify any potential problems. The design squad will arrange the field inspection and invite, as appropriate, individuals from the following units to the field inspection:

- district Bureau of Project Implementation,
- BDE,
- Bureau of Bridges and Structures,
- district Environmental Unit,
- district Bureau of Operations,
- Land Acquisition Section,
- FHWA,
- local officials, and
- others as deemed appropriate.

The design squad will document the findings and decisions in the minutes of the field inspection.

PROJECT ACTIVITY (Phase II)

Activity Title: Coordinate Utility Plans

Activity No.: 12

Responsible Unit: Project Support Section

Activity Description:

After conducting the field inspection (Activity 11) and any additional field surveys (Activity 08), the design squad will forward the preliminary construction plans with any known utilities plotted to the district Project Support Section. The design squad will also notify the Project Support Section of any unique issues (e.g., environmental, commitments). The Project Support Section will coordinate the transfer of information and plans between the design squad and the utility companies. The utility companies will review IDOT's plans, plot their facilities if not already shown, and prepare the necessary utility adjustment/relocation plans. As the design squad refines the construction plans, this information will be submitted to the Project Support Section to be forwarded to the utility companies.

For guidance on preparing utility plans and coordinating with utility companies, see Chapter 6.

PROJECT ACTIVITY (Phase II)

Activity Title: Refine Typical Sections, Plan and Profiles, Grades

Activity No.: 13

Responsible Unit: Design Squad

Activity Description:

Based on the review of the plans (Activity 07), the field inspection (Activity 11), the field survey (Activity 08), the Phase I report, and the project's commitment file, the design squad will refine and/or prepare the project's:

- cover sheet;
- general notes sheet;
- typical sections;
- the plan and profile sheets;
- alignment, ties, and benchmark sheet, and
- construction limits.

Section 63-4 provides guidance on the information that should be included on these plan sheets.

PROJECT ACTIVITY (Phase II)

Activity Title: Develop Detailed Bridge Plans

Activity No.: 14

Responsible Unit: Bureau of Bridges and Structures

Activity Description:

Based on the Phase I report (Activity 01), the Structure Report and TS&L Plans (Activity 03), and other information provided by the design squad, the Bureau of Bridges and Structures will perform the detailed structural design for any bridges and/or major structures on the project. The basic objective of the detailed design phase is to perform the in-depth structural analyses that are necessary to prepare a set of construction plans for any structures. The structural analyses, as applicable, may include the:

- superstructure design (e.g., framing details, deck slab, camber diagram);
- substructure design (e.g., piers, abutments);
- foundation design;
- approach slab design; and
- bridge rail design.

Once the structural plan sheets are completed, the Bureau of Bridges and Structures will submit the full set of bridge plan sheets and the quantities, pay items, and specifications to the design squad for direct insertion into the final project plans. Activity 14 must be completed before the assembly of information prepared by others (Activity 25).

For Phase II plans prepared by a Consultant, these activities may be the responsibility of the Consultant and approved by the Bureau of Bridges and Structures.

PROJECT ACTIVITY (Phase II)

Activity Title: Develop Environmental Mitigation Plans

Activity No.: 15

Responsible Unit: Environmental Unit

Activity Description:

Based on the approved Phase I report (Activity 01) and the typical sections and plan and profiles sheets (Activity 13), the district Environmental Unit, in consultation with BDE, as appropriate, will prepare the environmental mitigation plans, quantities, and specifications for direct insertion into the final construction plans. This may include wetlands compensation plans, Special Provisions for management and monitoring of special wastes, purchase of replacement lands, memorandums of agreements, etc. The Environmental Unit will ensure that the commitments made in Phase I of the project are incorporated into the plans.

See Section 25-2.

PROJECT ACTIVITY (Phase II)

Activity Title: Set Right-of-Way Widths

Activity No.: 16

Responsible Unit: Land Acquisition Section

Activity Description:

Based on the information gathered in developing the Right-of-Way Plan Sheets (Activity 05) and the submittal of the construction limits by the design squad (Activity 13), the Land Acquisition Section will determine the right-of-way widths for the project. The Land Acquisition Section will forward this information to the design squad, which will incorporate this information on the plan and profile sheets.

This information also will be used to initiate the land acquisition process (Activity 24).

PROJECT ACTIVITY (Phase II)

Activity Title: Develop Detailed Plans

Activity No.: 17

Responsible Unit: Design Squad

Activity Description:

Once the design squad has received the Structure Report and TS&L Plans from the Bureau of Bridges and Structures (Activity 03) and the right-of-way plans from the Land Acquisition Section (Activity 05), the design squad can prepare the detailed sheets which will be incorporated into the construction plans. This may include the following:

- stages of construction and temporary traffic control sheets;
- drainage sheets, including special drainage details;
- intersection details;
- interchange details;
- pavement marking details;
- grading plans;
- transition details;
- proposed cross sections, not including pavement template;
- special bikeway and trails plans;
- signing plans, if not prepared by the Bureau of Operations;
- environmental mitigation plans, if not prepared by others;
- highway lighting plans, if not prepared by others; and
- any other special details.

Section 63-4 presents guidance on what information should be included on each detail or plan sheet.

In addition, the design squad will:

- determine the appropriate level of access control for the facility;
- determine the need for construction permits, permanent right-of-way easements, and/or temporary easements;
- perform the detailed drainage design;
- perform a roadside safety analysis; and
- incorporate any special experimental features into the plans.

PROJECT ACTIVITY (Phase II)

Activity Title: Develop Specialized Plans

Activity No.: 18

Responsible Unit: Various Units

Activity Description:

Based on the typical sections, plan and profile sheets (Activity 13), and detailed plan sheets (Activity 17), various other units within IDOT will prepare their applicable plan sheets, quantities, and special provisions. This may include:

- district Bureau of Operations preparing the landscaping details;
- district Bureau of Operations preparing the signing plans, if included within the project;
- district Bureau of Operations (or Bureau of Electrical Operations in District 1) preparing the traffic signal plans;
- Bureau of Operations, BDE, and design squad developing rest area plans (see Section 16-1);
- Bureau of Operations, BDE, Bureau of Bridges and Structures, Capital Development Board, and the design squad developing weigh stations and weigh-in-motion plans; and/or
- BDE (or Bureau of Electrical Operations in District 1) preparing the highway lighting plans.

In addition, the following units may review the detailed plans prepared by the design squad (Activity 17):

- district Bureau of Operations will review the pavement marking details and stage construction and traffic control plans.
- district Bureau of Project Implementation will review the stage construction and traffic control plans.
- district Hydraulics Section will review the drainage plans and special drainage detail sheets.
- BDE will review bikeway and trail plans.
- district Environmental Unit will review the environmental mitigation plans, if prepared by the design squad.

PROJECT ACTIVITY (Phase II)

Activity Title: Finalize Plotting on Cross Sections

Activity No.: 19

Responsible Unit: Design Squad

Activity Description:

During Phase I, the cross sections may have been generated using GEOPAK to determine the earthwork quantities. Using the following information, update and plot the revised cross sections:

- the TS&L Plans from the Bureau of Bridges and Structures (Activity 03);
- the environmental mitigation plans from the district Environmental Unit (Activity 15);
- information received from the Project Support Section on utility plans (Activity 12);
- the refined typical sections and plan and profile sheets (Activity 13);
- the detailed plans (Activity 17);
- the Geotechnical Report from the Geotechnical Section (Activity 04);
- the final pavement design from the Pavement Design Section (Activity 09); and
- right-of-way information provided by the Land Acquisition Section (Activity 16).

Also during Activity 19, develop the erosion control plans and specifications according to the criteria in Chapter 41 and the information provided in the Phase I report. These plans and specifications will be submitted to the district Environmental Unit for review and approval (Activity 20).

PROJECT ACTIVITY (Phase II)

Activity Title: Approve Erosion Control Plans

Activity No.: 20

Responsible Unit: Environmental Unit

Activity Description:

The district Environmental Unit will review and approve the erosion control plans and specifications prepared by the design squad (Activity 19). Once approval has been granted, the erosion control plans will be incorporated into the construction plans (Activity 25). Also, once the erosion control plans have been approved, the Environmental Unit can initiate the process of securing the necessary project permits (Activity 22).

PROJECT ACTIVITY (Phase II)

Activity Title: Assemble All Road Design Information

Activity No.: 21

Responsible Unit: Design Squad

Activity Description:

Throughout the design process, the design squad will have prepared the various plan sheets separately. In Activity 21, conduct the following:

- plot a complete set of plans developed to date (e.g., cover sheet, typical plans, plan and profile sheets, detail plans, cross sections);
- assemble the sheets in the recommended order as noted in Chapter 63;
- review the plans and details to ensure that all necessary information has been included and that the plans and details are compatible with each other;
- calculate the quantities for roadway design elements according to the criteria in Chapter 64 of the *BDE Manual*, the *Coded Pay Items*, and the *Standard Specifications for Road and Bridge Construction* for pay items, units of measurement, rounding conventions, etc.; and
- prepare all required special provisions.

At this time, the Schedules of Quantities and the Summary of Quantities will not yet be prepared. For assembly purposes, blank Schedule of Quantities and Summary of Quantities may be included.

PROJECT ACTIVITY (Phase II)

Activity Title: Secure All Permits

Activity No.: 22

Responsible Unit: Environmental Unit

Activity Description:

After the cross sections have been finalized, the erosion control plans have been completed (Activity 19) and approved (Activity 20), the typical sections and plan and profiles sheets have been completed (Activity 13), and the detailed bridge plans have been completed (Activity 14), the district Environmental Unit will ensure all applicable permits and approvals required by the project are obtained. Depending upon the project-specific impacts, this may include any or all of the following:

- Section 401 water quality certification and 402 permits from the Illinois Environmental Protection Agency;
- U.S. Army Corps of Engineers, Section 404/Section 10 permit(s);
- U.S. Coast Guard, Section 9 permit; and
- permits issued by Illinois State agencies.

All permits, certifications, and approvals should be received by the Department prior to the review of all project commitments (Activity 32).

Chapter 28 provides a brief description of all Federal and State environmental permits and certifications.

PROJECT ACTIVITY (Phase II)

Activity Title: Process Utility Agreements or Adjustments

Activity No.: 23

Responsible Unit: Project Support Section

Activity Description:

Based on the roadway plans (Activities 13, 17, and 19), the detailed bridge plans (Activity 14), and the initial utility plans (Activity 12), the Project Support Section will work with the impacted utility companies and municipalities to implement the utility process. This process may include the following:

1. Plan Preparation. The utility companies are responsible for preparing all utility adjustment/relocation plans. The plans will be developed according to the criteria in Chapter 6.
2. Funding. Depending on the right-of-way ownership for existing and proposed utility locations, transportation funds may be eligible for utility adjustments/relocations required by the highway project; see Chapter 6. The Utilities pay for all betterments.
3. Agreements. The Project Support Section will prepare a Utility Agreement for each affected utility and will work with the utility companies to gain their input and approval. The Project Support Section will coordinate with BDE for review and approval of the agreements.

The Project Support Section will ensure that the utility process is completed before the review of all project commitments (Activity 32).

PROJECT ACTIVITY (Phase II)

Activity Title: Implement Land Acquisition Process

Activity No.: 24

Responsible Unit: Land Acquisition Section

Activity Description:

Based on the right-of-way plans (Activity 05), the final typical section and plan and profile sheets (Activity 13), and the right-of-way width determination (Activity 16), the Land Acquisition Section will implement the land acquisition procurement process. This will include the land acquisition functions of appraisal, negotiation, acquisition and, if necessary, condemnation. The Land Acquisition Section will also negotiate the terms of any construction permits, permanent easements, and/or temporary easements.

The Land Acquisition Section will ensure that the land acquisition procurement process is completed before the final review of all project commitments (Activity 32).

The Land Acquisition Section should coordinate with the design squad to ensure any negotiated considerations/commitments are included in the contract plans.

PROJECT ACTIVITY (Phase II)

Activity Title: Assemble All Information Prepared by Others

Activity No.: 25

Responsible Unit: Design Squad

Activity Description:

At this stage of project development, the design squad will have received the following completed plans, special provisions, pay items, and quantities from other IDOT units:

- the bridge/structure plans from the Bureau of Bridges and Structures (Activity 14);
- the landscaping details from the district Bureau of Operations (Activity 18);
- if included in the project, the signing plans from the district Bureau of Operations (Activity 18);
- the traffic signal plans from the district Bureau of Operations (or Bureau of Electrical Operations in District 1) (Activity 18);
- rest area plans from the Bureau of Operations and BDE (Activity 18);
- weigh stations and weigh-in-motion plans from the Bureau of Operations, BDE, Bureau of Bridges and Structures, and Capital Development Board (Activity 18); and
- the highway lighting plans from BDE (or Bureau of Electrical Operations in District 1) (Activity 18).

In addition, the design squad will have received approval of the erosion control plans from the district Environmental Unit (Activity 20) and right-of-way widths from the Land Acquisition Section (Activity 16).

The design squad will review these materials 1) to identify and incorporate any information which must be incorporated directly into the detailed road design plans and 2) to assemble those plan sheets prepared by others into the overall set of construction plans.

PROJECT ACTIVITY (Phase II)

Activity Title: Conduct Plan-in-Hand Field Inspection

Activity No.: 26

Responsible Unit: Design Squad

Activity Description:

At this stage of project development, all major design work has been completed, including roadway design, traffic items, structural elements, erosion control plans, right-of-way design, etc. The design squad is responsible for scheduling the Plan-in-Hand (PIH) review of the project. The PIH review is an in-depth office and on-site review of all project elements to ensure that all details and commitments have been satisfactorily incorporated into the construction plans and specifications, and that the project is nearly ready to advance to construction.

As applicable, the design squad will invite the following to conduct an office and PIH field inspection:

- district Bureau of Project Implementation,
- BDE,
- district Bureau of Operations,
- Bureau of Bridges and Structures,
- FHWA,
- local officials, and
- others as deemed appropriate.

Once the PIH office and field inspection has been completed, the design squad will prepare the PIH minutes to document all significant decisions made during the PIH review. After approval by the Program Development Engineer, distribute the PIH minutes to:

- all applicable Bureau Chiefs;
- Regional Engineer;
- all parties involved in the field review;
- FHWA, if applicable; and
- any other individuals or sections as deemed appropriate.

All parties receiving a copy of the PIH minutes are requested to provide comments on the minutes. Concurrence of the minutes will be assumed if no comments are received by the specified date.

PROJECT ACTIVITY (Phase II)

Activity Title: Prepare Schedules of Quantities

Activity No.: 27

Responsible Unit: Design Squad

Activity Description:

Based on any modifications due to the Plan-in-Hand field inspection (Activity 26), the design squad will refine the project quantities for the roadway design items developed during Activity 21. Using these quantities and those provided by other IDOT units (Activity 25), the design squad will prepare the Schedule of Quantities sheets according to the criteria presented in Chapter 64. These quantities will be incorporated onto the Summary of Quantities Sheet (Activity 28).

PROJECT ACTIVITY (Phase II)

Activity Title: Prepare Combined Summary of Quantities

Activity No.: 28

Responsible Unit: Design Squad

Activity Description:

Using the quantities developed in Activity 21, refined in Activity 27, and those provided by other IDOT units (Activity 25), the design squad will prepare the Summary of Quantities sheets, which will summarize all pay items necessary to construct the improvement. It also should include the applicable construction and safety code items, pay item code numbers, units of measurement, total quantities, and quantity breakdown for each section. One or more summary sheets typically will be included in each set of plans. Do not show other data on the summary sheets (e.g., general notes). When preparing the Summary of Quantities sheets, it is important that all quantities be calculated and segregated accordingly prior to completing the Summary of Quantities.

The Design Squad should coordinate with the Project Support Section to ensure that the percentages and cost breakdown in the Summary of Quantities and the Local Agency agreements are identical.

For additional guidance on preparing the Summary of Quantities, see Section 63-4.

PROJECT ACTIVITY (Phase II)

Activity Title: Prepare Final Plans and Specifications

Activity No.: 29

Responsible Unit: Design Squad/Others

Activity Description:

Based on the Plan-in-Hand Review and minutes (Activity 26), all bureaus and sections responsible for their respective project plans will make all necessary plan and specifications revisions. This will produce the final set of project plans ready for construction. Specifically for the design squad, the design squad will be responsible for revising the roadway plans and specifications. Once completed, the plans will be distributed for district review (Activity 31) and will allow the District Estimating Engineer to prepare the Final Plan Submittal Estimate.

Complete quality control/quality assurance (QC/QA) prior to the plans being circulated for district review.

PROJECT ACTIVITY (Phase II)

Activity Title: Prepare Final Plan Submittal Estimate

Activity No.: 30

Responsible Unit: District Estimating Engineer

Activity Description:

Based on the information from the final plans and specifications (Activity 29), the District Estimating Engineer will prepare the final district cost estimate. This may be a new estimate or an update of an earlier cost estimate prepared during Phase I or a revised cost estimate prepared during Phase II. This estimate will be submitted to the BDE Project Management Unit, which will use it to develop the Engineer's Estimate.

Chapter 65 provides guidance on the preparation of project cost estimates.

PROJECT ACTIVITY (Phase II)

Activity Title: Circulate Plans for District Review

Activity No.: 31

Responsible Unit: Design Squad

Activity Description:

Once all revisions from the Plan-in-Hand Review and minutes have been made to the plans and specifications, the design squad will submit a completed set of construction plans to the district units involved with the project for final review and comment. Typically, this review will consist of:

- reviewing the plans to ensure the reviewer's comments from previous reviews have been incorporated;
- ensuring that the changes do not conflict with the bureau's commitments; and
- ensuring that the plans conform to the Department's design criteria.

If changes are requested at this point which are desirable, but not mandatory, the Studies and Plans Engineer will determine if they should be incorporated. This will depend on other factors which may preclude the changes from being added to the plans. If another bureau determines the changes still should be incorporated, an appeal can be made to the Program Development Engineer for their incorporation.

PROJECT ACTIVITY (Phase II)

Activity Title: Review all Project Commitments

Activity No.: 32

Responsible Unit: Design Squad

Activity Description:

At this point in project development, the project design is essentially complete. The design squad must ensure that the following elements have been completed and/or have been incorporated into the plans:

- all environmental permits have been secured (Activity 22);
- all utility agreements and adjustments have been processed and signed (Activity 23);
- the final district cost estimate has been completed (Activity 30);
- the land acquisition process has been completed (Activity 24);
- all local agreements and letters of understanding have been processed and signed (Activity 10);
- all railroad agreements have been processed and signed (Activity 06); and
- all commitments made during the project development, including those made during Phases I and II, have been incorporated.

The design squad must carefully review all minutes of meetings, transcripts of public hearings, and the project study files to ensure that all commitments have been incorporated. If there are any questions, the design squad should contact the preparer of the Phase I report or the Unit making the commitment during Phase II.

If it is discovered during the plan development that a change is required to the approved Phase I report or a commitment cannot be met, the design squad must immediately notify BDE and all other applicable units so that the appropriate action can be taken. Failure to provide the appropriate notification and review may result in project delay.

PROJECT ACTIVITY (Phase II)

Activity Title: Submit PS&E to BDE

Activity No.: 33

Responsible Unit: Design Squad

Activity Description:

Once the plans are complete and the design squad has ensured all commitments, agreements, permits, etc., are complete or have been incorporated, the design squad will submit the following items to the BDE Program Support Unit:

- the Certification Acceptance/Project Status form, signed by the Regional Engineer;
- a cover sheet signed by the Regional Engineer indicating his/her approval of the plans;
- one complete set of full-size plans on reproducible paper, mylar, or vellum (see Chapter 63 for the Department's guidelines on preparing plan sheets);
- one copy of each special provision required for the project, including a copy of the electronic file in Microsoft Word format (see Section 66-1.04 for the procedures on developing special provisions);
- a completed Recurring Special Provision check sheet (see Chapter 66);
- the project quantities on Form BD-213 or BDE approved equal (see Chapter 64 for the procedures on determining plan quantities);
- the expected construction time for the project (see Section 66-2.03 for the Department's guidelines on determining the expected construction time); and
- copies or originals of all permits and agreements.

To place an improvement on any specific letting, it is imperative that the plans and supporting documents be submitted according to the schedules established in Section 66-2 which indicate the minimum number of weeks prior to the letting date for the submittal or completion of a particular phase of work.

PROJECT ACTIVITY (Phase II)

Activity Title: Process Contract

Activity No.: 34

Responsible Unit: BDE

Activity Description:

Once BDE has received the plans and other information from the district (Activity 33), it will conduct the following:

- prepare the Engineer's Estimate;
- verify that the plans are on the list of recommended projects;
- check the Certification Acceptance /Project Status Form;
- verify the project is programmed and the scope of work is correct;
- determine the final funding source;
- check all agreements to ensure they are consistent with the project;
- submit the plans, special provisions, quantities, etc., for review and comment;
- prepare the Transportation Bulletin and advertise the project;
- if necessary, submit the PS&E to FHWA for approval;
- prepare the contract proposal;
- submit the proposal and plans to bidders;
- implement the letting process;
- review all bids; and
- execute the contract.

For additional guidance on the contract process, see Chapter 66.

Chapter Three

PROJECT DEVELOPMENT NETWORK (Existing Alignment)

BUREAU OF DESIGN AND ENVIRONMENT MANUAL

Table of Contents
(Continued)

<u>Section</u>	<u>Page</u>
3-2.02 Phase II Design	3-2.34
Activity No. 1: Approval of Phase I Report.....	3-2.36
Activity No. 2: Assign Project to Design Squad	3-2.37
Activity No. 3: Prepare Structures Report and TS&L Plans	3-2.38
Activity No. 4: Prepare Geotechnical Report	3-2.39
Activity No. 5: Initiate Land Acquisition Process and Plans	3-2.40
Activity No. 6: Process Railroad Agreements	3-2.41
Activity No. 7: Compile and/or Review Project Data	3-2.42
Activity No. 8: Conduct Field Survey (If Needed)	3-2.43
Activity No. 9: Perform Detailed Pavement Design and Selection.....	3-2.44
Activity No. 10: Process Local Agreements.....	3-2.45
Activity No. 11: Conduct Field Inspection	3-2.46
Activity No. 12: Coordinate Utility Plans	3-2.47
Activity No. 13: Refine Typical Sections, Plan and Profiles, Grades	3-2.48
Activity No. 14: Develop Detailed Bridge Plans	3-2.49
Activity No. 15: Develop Environmental Mitigation Plans	3-2.50
Activity No. 16: Set Right-of-Way Widths	3-2.51
Activity No. 17: Develop Detailed Plans	3-2.52
Activity No. 18: Develop Specialized Plans	3-2.53
Activity No. 19: Finalize Plotting on Cross Sections	3-2.54
Activity No. 20: Approve Erosion Control Plans.....	3-2.55
Activity No. 21: Assemble All Road Design Information	3-2.56
Activity No. 22: Secure All Permits	3-2.57
Activity No. 23: Process Utility Agreements or Adjustments.....	3-2.58
Activity No. 24: Implement Land Acquisition Process.....	3-2.59
Activity No. 25: Assemble All Information Prepared by Others.....	3-2.60
Activity No. 26: Conduct Plan-in-Hand Field Inspection	3-2.61
Activity No. 27: Prepare Schedules of Quantities	3-2.62
Activity No. 28: Prepare Combined Summary of Quantities	3-2.63
Activity No. 29: Prepare Final Plans and Specifications	3-2.64
Activity No. 30: Prepare Final Plan Submittal Estimate	3-2.65
Activity No. 31: Circulate Plans for District Review.....	3-2.66
Activity No. 32: Review all Project Commitments	3-2.67
Activity No. 33: Submit PS&E to BDE.....	3-2.68
Activity No. 34: Process Contract	3-2.69
3-3 PROJECTS WITH MINOR RIGHT-OF-WAY ACQUISITIONS	3-3.1
3-3.01 Phase I Studies	3-3.1
Activity No. 1: Scope Project	3-3.4
Activity No. 2: Initiate/Program Project	3-3.5
Activity No. 3: Transfer/Assign to Project Study Group	3-3.6
Activity No. 4: Define Project Need.....	3-3.7

Table of Contents

(Continued)

<u>Section</u>		<u>Page</u>
Activity No. 5:	Collect Data	3-3.8
Activity No. 6:	Analyze Existing Conditions	3-3.9
Activity No. 7:	Initiate Early Coordination/Public Involvement	3-3.10
Activity No. 8:	Identify Candidate Improvements	3-3.11
Activity No. 9:	Plot Existing/Proposed Topography, Typical Sections, Plan and Profile	3-3.12
Activity No. 10:	Conduct In-Depth Analysis of Improvements	3-3.13
Activity No. 11:	Prepare Drainage Report (If Necessary)	3-3.14
Activity No. 12:	Prepare Geotechnical Report (If Necessary)	3-3.15
Activity No. 13:	Prepare Bridge Drawings/Reports	3-3.16
Activity No. 14:	Prepare Environmental Documentation	3-3.17
Activity No. 15:	Conduct Preliminary Utility Review	3-3.18
Activity No. 16:	Develop Transportation Management Plan	3-3.19
Activity No. 17:	Obtain Detour Approval (If Required)	3-3.20
Activity No. 18:	Set Pre-Final Geometry and Right-of-Way	3-3.21
Activity No. 19:	Prepare Draft Project Report	3-3.22
Activity No. 20:	Conduct Public Meeting	3-3.23
Activity No. 21:	Obtain Environmental Decision	3-3.24
Activity No. 22:	Prepare Final Project Report	3-3.25
Activity No. 23:	Obtain Design Approval	3-3.26
3-3.02	Phase II Design	3-3.27
3-4	PROJECT WITH NO RIGHT-OF-WAY ACQUISITIONS	3-4.1
Activity No. 1:	Scope Project	3-4.4
Activity No. 2:	Initiate/Program Project	3-4.5
Activity No. 3:	Transfer/Assign to Project Study Group/Design Squad	3-4.6
Activity No. 4:	Define Project Need	3-4.7
Activity No. 5:	Collect Data	3-4.8
Activity No. 6:	Conduct Preliminary Utility Review	3-4.9
Activity No. 7:	Analyze Existing Conditions	3-4.10
Activity No. 8:	Initiate Early Coordination	3-4.11
Activity No. 9:	Obtain CE	3-4.12
Activity No. 10:	Plot Existing/Proposed Topography, Typical Sections, Plan and Profile	3-4.13
Activity No. 11:	Prepare Final Report	3-4.14
Activity No. 12:	Obtain Design Approval	3-4.15
Activity No. 13:	Compile and/or Review Project Data	3-4.16
Activity No. 14:	Conduct Field Survey (If Needed)	3-4.17
Activity No. 15:	Process Local Agreements	3-4.18
Activity No. 16:	Conduct Field Inspection	3-4.19
Activity No. 17:	Review Utility Conflicts	3-4.20
Activity No. 18:	Refine Typical Sections, Plan and Profiles	3-4.21
Activity No. 19:	Develop Detailed Plans	3-4.22

Table of Contents

(Continued)

<u>Section</u>		<u>Page</u>
Activity No. 20:	Develop Specialized Plans	3-4.23
Activity No. 21:	Finalize Plotting on Cross Sections	3-4.24
Activity No. 22:	Approve Erosion Control Plans.....	3-4.25
Activity No. 23:	Secure All Permits	3-4.26
Activity No. 24:	Process Utility Agreements or Adjustments.....	3-4.27
Activity No. 25:	Assemble All Road Design Information	3-4.28
Activity No. 26:	Assemble All Information Prepared by Others.....	3-4.29
Activity No. 27:	Conduct Plan-in-Hand Field Inspection	3-4.30
Activity No. 28:	Prepare Schedules of Quantities	3-4.31
Activity No. 29:	Prepare Combined Summary of Quantities	3-4.32
Activity No. 30:	Prepare Final Plans and Specifications	3-4.33
Activity No. 31:	Prepare Final Plan Submittal Estimate	3-4.34
Activity No. 32:	Circulate Plans for District Review.....	3-4.35
Activity No. 33:	Review all Project Commitments	3-4.36
Activity No. 34:	Submit PS&E to BDE.....	3-4.37
Activity No. 35:	Process Contract	3-4.38

Chapter Three

PROJECT DEVELOPMENT NETWORK (Existing Alignment)

Chapters 2 and 3 document the basic approach used by IDOT in its project development process. Chapter 2 presents Phase I and Phase II networks for projects on new alignment. Chapter 3 presents Phase I and Phase II networks for projects on existing alignment requiring major right-of-way acquisitions (e.g., converting a two-lane facility to an expressway), minor right-of-way acquisitions (e.g., 3R projects), and projects with no right-of-way acquisition (e.g., Interstate Resurfacing, SMART, 3P). Chapters 2 and 3 present networks that graphically illustrate the development of “typical” highway projects.

3-1 GENERAL

The flowcharts in this chapter present networks that graphically illustrate the general process for Phase I and Phase II projects on existing alignments. Following each flowchart is a brief description of each activity within the network. When using these flowcharts, consider the following:

1. Precedence Activity Network. The networks or flowcharts are precedence activity networks. An “activity” occurs when a significant, discrete event occurs and/or when the responsibility for the project (activity) is transferred from one unit to another. The “precedence” nature of the network implies that an activity cannot occur until all activities preceding that one have been completed. However, the user must be aware that some flexibility is necessary to apply this network to project development, especially during Phase I. For example, identifying new information during the public involvement stage may require the project study group to return to a previous activity and gather additional data.
2. Project Application. These networks represent an approximate process for a complex project on existing alignment. Not every activity will be applicable to every project and not all activities are shown. However, the user should find that projects developed according to this process have fewer management problems.

The illustrated network assumes a project designed in-house. The process for a consultant-designed project will be similar, except that communication lines exist between IDOT and the consultant for IDOT review and approval.

3. Lines of Communication. The rigid application of the network would lead to predetermined, precise points at which communication occurs between units. This is neither realistic nor desirable. Communication between units must be continuous. This will result in fewer problems and fewer “surprises” in project development.

4. Value Engineering. Refer to Section 11-7.03 for requirements and guidance on value engineering (VE) analyses. Where required, initiate the VE study no later than the time construction plans are 30% complete and allow for the implementation of the recommendations without delaying the project.
5. Project Approval. Districts are responsible for the review and approval of all projects except those involving major new alignments addressed by a Corridor Study, Feasibility Study, or Design Report. In these special circumstances, projects are approved by BDE. BDE may also review and approve projects where the Deputy Director/Regional Engineer has requested BDE assistance. See Section 12-5 for a discussion on the processing and approval of phase I reports.
6. Other Manual Chapters. The *BDE Manual* contains several other chapters that provide complementary information to Chapter 3. The designer should review these chapters for more information on the project development process. In particular, Chapter 3 should be used in combination with Chapter 4 “Project Coordination Responsibilities,” Chapter 11 “Phase I Studies,” Chapter 12 “Phase I Engineering Reports,” Chapter 19 “Public Involvement Guidelines,” and Part III “Environmental Procedures.”

3-2 PROJECTS WITH MAJOR RIGHT-OF-WAY ACQUISITIONS

3-2.01 Phase I Studies

Figure 3-2.A illustrates a typical Phase I flowchart or network for a project on existing alignment that will require major ROW acquisitions and typically an Environmental Assessment. Those activities shown along the main axis of the chart represent those items that are normally performed by the project study group. The other lines of the chart represent activities by other units or groups. These projects typically will require a Design Report, Combined Design Report, or a State Improvement Report. For guidance on the preparation and format of these reports, see Chapters 11 and 12. For other project types, see the flowcharts in Chapter 2, Section 3-3, and Section 3-4. Following Figure 3-2.A are brief write-ups for each activity.

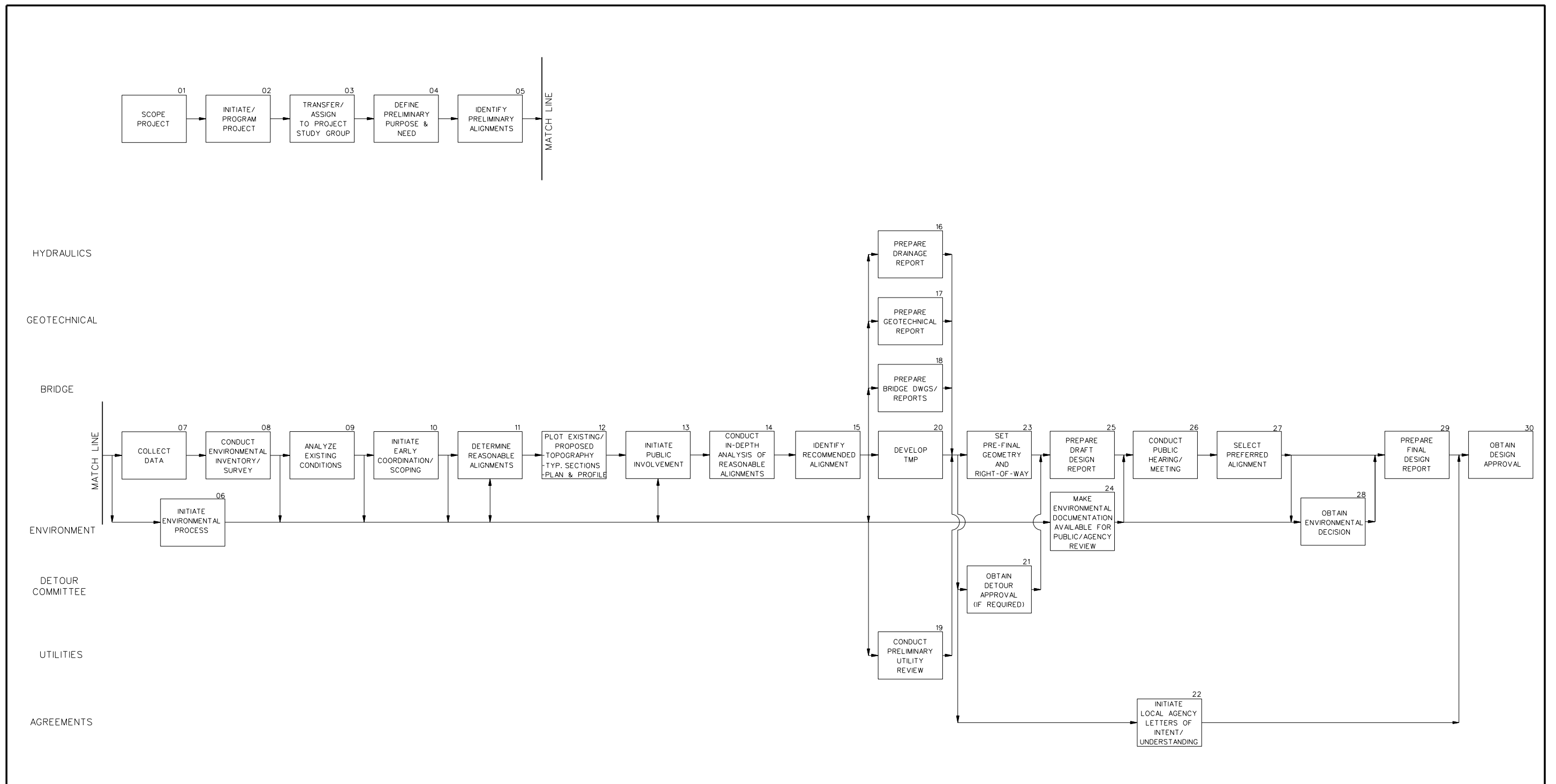

**PHASE I PROJECT DEVELOPMENT NETWORK
(Project on Existing Alignment with Major ROW Acquisitions)**

Figure 3-2.A

PROJECT ACTIVITY (Phase I)

<u>Activity Title:</u>	Scope Project
<u>Activity No.:</u>	01
<u>Responsible Unit:</u>	District Bureau of Program Development

Activity Description:

A roadway project proposal can originate from a variety of sources, including local officials or metropolitan planning organizations (community-based need), directly from the IDOT district (district-based need), from a Bureau in the central office (Office of Planning and Programming, BDE, Operations, Bureau of Safety Programs and Engineering, etc.), and other sources targeting a special need or statewide need.

Before a project is entered onto the Department's Proposed Highway Improvement Program, the district Programming Section initially develops and documents the project concept. Developing the project concept will typically involve the following:

- establishing that there is, in fact, a need for the project;
- making a preliminary determination of the project scope of work;
- reviewing any available data and records;
- conducting an initial evaluation of right-of-way, utility, and environmental impacts and the likely level of environmental evaluation;
- developing a rough, preliminary cost estimate;
- determining a proposed alignment; and
- developing a set of preliminary drawings/plans.

This information is forwarded for review and comment to Program Development, Operations, BDE, district Environmental Unit, Bridges and Structures, and other individuals, as appropriate. Programming will refine the scope based on the comments received.

Once the scope, cost, and schedule have been defined, district Programming will forward this information to the Office of Planning and Programming for incorporation into the Department's multi-year program (Activity 02).

PROJECT ACTIVITY (Phase I)

Activity Title: Initiate/Program Project

Activity No.: 02

Responsible Unit: Office of Planning and Programming

Activity Description:

Candidate projects are submitted by the districts as a request for project programming to the Office of Planning and Programming. Based on a Statewide assessment of highway improvement needs and available funds, the Office of Planning and Programming will develop the Department's Proposed Highway Improvement Program. This will establish an individual project as an active project for further development.

The Office of Planning and Programming annually issues guidelines for multi-year programming criteria. This includes programming criteria for:

- improvement categories,
- pavement surface conditions,
- deficient bridges,
- safety improvements,
- Interstate rehabilitation,
- widening narrow and deteriorated pavements,
- improving intersections and reducing traffic bottlenecks,
- new construction/reconstruction of major facilities,
- transportation enhancement projects,
- Congestion Mitigation Air Quality (CMAQ) projects, and
- bicycle accommodation.

PROJECT ACTIVITY (Phase I)

Activity Title: Transfer/Assign to Project Study Group

Activity No.: 03

Responsible Unit: Studies and Plans Engineer

Activity Description:

At this point the project will either be assigned to a project study group within the district Bureau of Program Development to begin the design study. The Studies and Plans Engineer will have the overall day-to-day responsibility for advancing the project through the Phase I study process. The Studies and Plans Engineer, or designee, will:

- coordinate directly with other units within the Department;
- attend all internal meetings and field inspections;
- ensure that the project study meets all Department criteria and procedures;
- report directly to the District Program Development Engineer on all significant project activities, problems, and developments; and
- participate in the public involvement process.

The number and expertise of personnel initially assigned to the project study group will vary with the nature and scope of the proposed improvement. The personnel assigned will also vary over time relative to the priority for completion, the available lead time, and the activity in project development under study.

If the project is one which the Regional Engineer has determined will use the principles of Context Sensitive Solutions (CSS), the public involvement process should commence at this point. The project study group uses the Stakeholder Involvement Process (SIP) as outlined in Sections 19-5.01 to conduct public involvement for CSS projects.

PROJECT ACTIVITY (Phase I)

Activity Title: Define Preliminary Purpose and Need

Activity No.: 04

Responsible Unit: Project Study Group/BDE/FHWA/Office of Planning & Programming

Activity Description:

For a major transportation project, the project study group must first define the project purpose and need, which will direct the process for the identification of alternatives, in-depth analyses and, ultimately, selection of the preferred alternative. This will consist of reaffirming the need for the proposed improvement, establishing project goals and objectives, and establishing the study area and logical termini. The feasibility of an alignment depends on the social, economic, environmental, and engineering effects of the proposed highway improvement. Previous studies and decisions should be reaffirmed and/or updated as necessary. Other factors that must be considered include:

- adequacy of the existing highway network;
- existing traffic volumes and capacity deficiencies;
- crash information;
- alignment and profile deficiencies;
- structural integrity of existing pavements, bridges, and culverts;
- transportation demand;
- potential cost savings to the traveling public;
- enhanced economic development potential;
- improved access;
- programming guidelines;
- commitments to elected officials; and
- public input.

The project study group will document the preliminary purpose and need so that it can be transferred to the NEPA document. Further study may result in revisions to the preliminary purpose and need.

See Section 22-6.01 for more information on purpose and need.

PROJECT ACTIVITY (Phase I)

Activity Title: Identify Preliminary Alignments

Activity No.: 05

Responsible Unit: Project Study Group

Activity Description:

Based on the definition of the preliminary purpose and need (Activity 04) and the general design concept (Activity 01), the project study group should identify feasible alignments that could be used. Because this is an evolutionary process, the preliminary list will be narrowed during further evaluations. The evaluation of preliminary alternatives should be sensitive to those environmental resources for which the analysis of alternatives for avoidance and minimization of adverse impacts is required (e.g., threatened and endangered species, natural areas, nature reserves, wetlands, flood plains, Section 4(f) properties, historic sites). All impractical alignments may be removed from the list with a brief description of why they were removed.

Using county maps, USGS quadrangle maps, and aerial photography, identify and lay out possible alignments on base maps (see Chapter 11). Also include the no-action alternative in the design study. General horizontal alignment should be determined for each alignment. The selection of the preliminary alignments will define what information will be collected in Activity 07 and the potential environmental impacts of the alignment will determine the type of environmental documentation that will be required on the project.

At this stage, request project mapping based on the identified alignments. However, note that many times insufficient information will be available at the time mapping is requested and, therefore, some judgment must be used in deciding the width limits of mapping. Additional mapping can be requested later during the design study if needed for further alignment investigations.

PROJECT ACTIVITY (Phase I)

Activity Title: Initiate Environmental Process

Activity No.: 06

Responsible Unit: Environmental Unit

Activity Description:

Once the preliminary alignments have been identified (Activity 05), the district Environmental Unit will initiate the environmental process. Depending on the project impact, this may involve either a:

- Categorical Exclusion (see Chapter 23),
- Environmental Assessment (see Chapter 24), or
- Environmental Impact Statement (see Chapter 25).

If the project will require an EIS, review the Phase I activities in Section 2-2 for guidance on processes for the Project Initiation Letter to FHWA, negotiated timeframes, Notice of Intent, invitation and involvement of participating agencies, stakeholder coordination, coordination on purpose and need and reasonable alignments, etc. As reflected in the Phase I activities in Section 2-2, these processes applicable to an EIS occur at key points throughout project development.

This Activity will include:

- discussing the project at a coordination meeting and obtaining verbal or written FHWA concurrence as to the type of environmental processing;
- assembling and analyzing the necessary information (see Part III “Environmental Procedures”);
- evaluating alternatives; and
- preparing the preliminary draft of the environmental documentation.

PROJECT ACTIVITY (Phase I)

<u>Activity Title:</u>	Collect Data
<u>Activity No.:</u>	07
<u>Responsible Unit:</u>	Project Study Group

Activity Description:

Once the preliminary alignments have been identified (Activity 05), the project study group must gather and inventory information and data on each alignment. All types of data, including social, economic, environmental, and engineering, should be gathered simultaneously. The amount and type of information to be collected will vary with the nature and scope of the proposed improvement. Some of the information that is gathered includes:

- roadway, field, aerial, and stream surveys;
- existing roadway classifications and truck routes;
- existing as-built plans and maintenance records;
- existing on-street parking;
- crash rate maps and collision diagrams;
- pavement and bridge condition reports;
- existing ROW information and any encroachments;
- ADT traffic maps and DHVs for current and design year traffic (all affected routes);
- inventory of posted speed limits;
- detailed transportation maps and plans with all modes of travel included;
- utility installations and detailed maps from utility companies;
- hydraulics survey, drainage survey, sewer atlas, and flooding information tables;
- fire districts, mail and school bus routes, location of churches, drainage districts, historic sites, and field-tile maps;
- commercial, agricultural, industrial, recreational, historic, and residential land use;
- conservation areas, archaeological sites, wetlands, special waste sites, etc.;
- local, State, and Federal agency coordination needs;
- current topographic mapping and aerial photographic mosaics;
- geotechnical investigations;
- highway geometrics, development of access control plans, and right-of-way issues;
- joint development uses, scenic easements, and aesthetics of highway (see Chapter 33);
- estimate of cost (see Section 11-2.15) and road-user benefits (see Section 11-7.01); and
- maintenance agreements with locals.

See Chapters 11 and 12 for further guidance on the information that should be collected for a Phase I study.

PROJECT ACTIVITY (Phase I)

Activity Title: Conduct Environmental Inventory/Survey

Activity No.: 08

Responsible Unit: Project Study Group/Environmental Unit/BDE

Activity Description:

The project study group will request BDE to conduct an environmental inventory by submitting an environmental survey request and Special Waste Assessment Screen/Survey Request Form, as appropriate, to BDE. Based on the preliminary alignments identified in Activity 05, BDE's review will include evaluating environmental databases, discussing the project at a district coordination meeting, and conducting field checks, as necessary. If determined necessary, BDE will coordinate, as appropriate, with the responsible agencies and the project study group for the field survey(s). BDE will provide the results of the reconnaissance survey(s) and any related studies for resource delineation or evaluation to the district.

After the inventory has been prepared, the project study group should perform a preliminary evaluation of the magnitude and importance of the potential environmental impacts precipitated by the proposed action. The project study group will consider the environmental resource information in further development of the project and, for resources within the project limits (e.g., wetlands, natural areas, archaeological and historical sites), the district will evaluate options for avoiding and minimizing the project's effects on the resources. This will assist in initiating the early coordination process (Activity 10) and establishing the significance of project impacts. When the district has determined the likely effects the project will have on resources, subject to requirements for Special Environmental Analyses (see Chapter 26), it notifies BDE.

If adverse effects to environmental resources cannot be avoided, BDE will evaluate whether any further studies of the resources are necessary. If further studies are needed, BDE will advise the district and will initiate action to have the studies accomplished, considering program priority and project scheduling.

BDE will provide information to the district regarding environmental study findings, results of coordination with outside agencies, and any recommendations for further coordination or action by the district. This information will also be used by the district Environmental Unit in preparing the environmental documentation.

For additional guidance, see Chapter 27 "Environmental Surveys."

PROJECT ACTIVITY (Phase I)

Activity Title: Analyze Existing Conditions

Activity No.: 09

Responsible Unit: Project Study Group

Activity Description:

Using county or other area maps, as-built plans, USGS quadrangle topographic maps, aerial and/or field surveys, previously prepared reports, data collected in Activity 07, and the environmental inventory/survey (Activity 08), the project study group will review and identify the following existing conditions:

- the locations of towns, streams, railroads, and other topographic features;
- condition of the existing highway network within the corridor;
- existing traffic and capacity deficiencies;
- pavement, bridge, and culvert structural integrity;
- crash information;
- alignment and profile deficiencies;
- existing lane and shoulder widths;
- existing ROW, ROW constraints, and encroachments;
- existing and planned land uses from local governments, MPOs, fire districts, schools, etc.;
- existing agreements with utilities, railroads, local agencies, etc.;
- existing drainage patterns and drainage systems;
- sensitive noise receptors;
- wetlands, applicable 4(f), 6(f), and 106 sites, etc.;
- special waste sites; and
- tree and vegetation inventory.

Upon receipt of the topographic mapping, plot the property lines, property names, names of roads, and all other important cultural features. Make paper copies of the mapping sheets and tape together. This procedure allows the project study group to review long lengths of the alignment in one view and to see how lines may best fit together. Begin laying out all feasible alignments.

After an alignment is laid out, determine the State plane coordinates of all control points (POTs and Pls) from the project mapping. Input this information and the radii of horizontal curves into a computer file to mathematically describe each alternative. Once an alignment is mathematized and tied into digitized mapping files, the alignment can then be stationed from west to east or south to north and the information stored as a computer file for further design work.

Provide the results of this activity to the district Environmental Unit for use in preparing the environmental documentation.

PROJECT ACTIVITY (Phase I)

Activity Title: Initiate Early Coordination/Scoping

Activity No.: 10

Responsible Unit: Project Study Group/BDE

Activity Description:

Coordination with other Department and governmental agencies, as appropriate, is an important aspect during the design study process. This coordination should begin as early as practical in project planning.

At this stage of the design study process, the project study group will initiate early coordination with other Department Units or Bureaus and governmental agencies (e.g., FHWA, Land Acquisition, Construction, Operations, Bridges and Structures, Utilities, environmental resource agencies) that have an interest in the project or have information or expertise concerning any issues the project may involve. The purpose of this coordination will be to assist in the identification of reasonable alignment alternatives and in gathering information to evaluate the social, economic, engineering, and environmental impacts of the proposed project and possible impact mitigation measures. This coordination should begin as early as practical. Early coordination will also identify the cooperating agencies. For projects involving preparation of an EIS, see Phase I Activities 20, 21 and 22 in Section 2-2 for guidance on participating agencies, stakeholder involvement, and purpose and need coordination.

Scoping is an early and open process for determining the scope of issues to be addressed in the design study and for identifying the significant issues related to the proposed improvement. Scoping is intended to focus the study effort on issues that are truly significant and avoid the collection of needless detailed information on insignificant issues. For these types of projects, a formal scoping process may or may not be necessary. This depends, in part, on the number and magnitude of issues potentially involved and the probability that the proposed improvement may involve significant issues.

Although scoping may be accomplished by a formal meeting, it is more frequently accomplished through less formal meetings and exchanges of written and verbal communications. Scoping is typically not an individual step but an ongoing process as part of the overall coordination and public involvement process.

The results of this activity should be forwarded to the district Environmental Unit so that it can be incorporated into the environmental documentation.

PROJECT ACTIVITY (Phase I)

<u>Activity Title:</u>	Determine Reasonable Alignments
<u>Activity No.:</u>	11
<u>Responsible Unit:</u>	Project Study Group/Environmental Unit

Activity Description:

The project study group, in conjunction with the district Environmental Unit, considers the results of the coordination in reducing the number of alternatives to a reasonable number that are representative of the spectrum of possible alternatives that satisfy the project purpose and need. This will typically be two or three alternatives, including the no-action alternative. An in-depth analysis will be conducted on each of the remaining alternatives (Activity 14). For projects involving preparation of an EIS, see Phase I Activity 27 in Section 2-2 for further guidance on development of the range of alternatives.

The determination of the reasonable alignments for in-depth evaluation, which is an evolutionary process, may be summarized as follows:

- identify preliminary alignments (Activity 05);
- achieve consensus with CSS stakeholders on the range of alternatives for the project;
- perform a rough evaluation of the potential impacts of these preliminary alignments on the inventory of the affected environment to identify, for example, “fatal” flaws;
- incorporate input from agencies and/or the public (Activities 07, 08, and 10) in the decision-making process;
- estimate the overall reasonableness of each alignment under consideration;
- ensure that each reasonable alignment can satisfy the project purpose and need (Activity 04);
- ensure location of connections can be adequately developed (e.g., interchanges, frontage roads; see Section 11-4.02(e)); and
- based on an appropriate level of re-evaluation and additional coordination, identify those selected reasonable alignments which are worthy of in-depth evaluation considering:
 - + the need to identify potential avoidance and minimization alternatives for environmental reasons;
 - + that the cost of the studies for each alignment should be commensurate with its probability of implementation;
 - + that, collectively, the selected alignment should cover the full spectrum of alternatives; and
 - + that, collectively, the selected alignment should gain public acceptance that no reasonable alternative has been omitted.

Document the reason(s) why an alignment has been discarded. Include this information in the final Design Report.

PROJECT ACTIVITY (Phase I)

Activity Title: Plot Existing/Proposed Topography, Typical Sections, Plan and Profile

Activity No.: 12

Responsible Unit: Project Study Group

Activity Description:

For each remaining alternative alignment identified in Activity 11, conduct the following:

- If not already done, plot the existing topography including property lines, property owner names, business names and type, names of roads, driveways/access roads, and all other important geographic and cultural features.
- Plot existing cross sections.
- Determine the proposed typical sections.
- Determine the detailed horizontal alignment, including radii, stationing, and State plane coordinates of all control points (e.g., POTs, PIs, PCs, PTs).
- Investigate alternative vertical profiles for each alignment. This may require designing two to three trial vertical profiles and performing several complete earthwork calculations; see Sections 11-2.05 and 11-5.04(d).
- Once the geometric elements have been set, determine the preliminary right-of-way limits for each alternative.
- Determine the rough quantities for each alternative and refine the cost estimate for each alternative. If no quantities are available, use a generalized cost (e.g., cost per mile (kilometer)); see Sections 12-4 and 65-1.02.

IDOT uses the computer software program GEOPAK for laying out alignments, profiles, cross section designs, quantity calculations, and for determining construction limits. GEOPAK also can be used to generate 3-D and perspective plots for any portion of the roadway. Use 3-D plots in the design process to assess potential safety problems and the aesthetics of each alternative.

PROJECT ACTIVITY (Phase I)

<u>Activity Title:</u>	Initiate Public Involvement
<u>Activity No.:</u>	13
<u>Responsible Unit:</u>	Project Study Group/Environmental Unit

Activity Description:

This Activity will allow the public an opportunity for input and comment on the alternatives selected in Activity 11. Typically, this will consist of informational letters, advertisements, and/or meetings with local government officials, fire districts, school districts, drainage districts, historic commissions, MPOs, residents, businesses, etc. These meetings or letters may include:

- advising local, State, and Federal officials that a project has been initiated and that a study is underway;
- procedures for developing possible coordination and public service involvement;
- a discussion on the project scope;
- a request for information (e.g., MPO plans, drainage problems, transit needs);
- a discussion with businesses, railroads, and utility companies; and
- talking with individuals at public information meetings about individual concerns.

Public coordination must be continuous throughout the project development. For guidance on public coordination, see Chapter 19.

For projects which the Regional Engineer has determined will use the principles of Context Sensitive Solutions (CSS), the public involvement process should commence once the project is assigned to the project study group. The project study group uses the Stakeholder Involvement Process (SIP) as outlined in Sections 19-5.01 to conduct public involvement for CSS projects.

PROJECT ACTIVITY (Phase I)

Activity Title: Conduct In-Depth Analysis of Reasonable Alignments

Activity No.: 14

Responsible Unit: Project Study Group

Activity Description:

During the initial development of alignment alternatives, some analyses will have been conducted as attempts are made to fit various options into the project location. After the reasonable alignments have been identified (Activity 11) and the information is plotted on the plan sheets (Activity 12), further analyses will be necessary to assess the capability of each alternative to accomplish the project goals cost-effectively. Conduct an in-depth analysis of each of the proposed alignments considering the social, economic, environmental, and engineering factors discussed in Part II "Project Development" and Part III "Environmental Procedures."

The engineering and environmental analyses may include:

- intersection design studies,
- interchange type and design studies,
- capacity analysis,
- initial impact and mitigation alternatives,
- wetlands involvement,
- air and noise impacts,
- impacts on cultural resources,
- tree and vegetation evaluation,
- water quality and natural resources impacts, and
- soils evaluation.

After the results of these investigations have been analyzed, there may be legitimate reasons to eliminate one or more of the final alignment alternatives. Discuss the reason why these alignment(s) were not further considered in the Design Report. For instance, traffic estimates for the no-action alternative may overload existing routes creating unacceptable congestion, thereby eliminating this alternative.

The results of this and previous Activities will be submitted to the Hydraulics Unit, Geotechnical Unit, Bureau of Bridges and Structures, district Environmental Unit, and Project Support Section to allow these Units to prepare their applicable reports for the Design Report.

PROJECT ACTIVITY (Phase I)

Activity Title: Identify Recommended Alignment

Activity No.: 15

Responsible Unit: Project Study Group

Activity Description:

After conducting the analysis of each reasonable alignment (Activity 14), considering the environmental, social, and economic impacts, engineering factors, and public input, the project study group will identify a recommended alignment through the corridor. If there are two or more alignments with essentially the same impact, the project study group still should select one recommended alignment. The final geometric and right-of-way design will be based on this recommended alignment. The selected alternative alignment and description of why it was selected should be forwarded to BDE for review prior to beginning the preparation of the draft Design Report (Activity 25) and before it is presented at the Public Hearing/Meeting (Activity 26).

PROJECT ACTIVITY (Phase I)

Activity Title: Prepare Drainage Report

Activity No.: 16

Responsible Unit: Hydraulics Unit

Activity Description:

Based on the information provided from the project study group (Activity 15), the Hydraulics Unit will perform the hydrology/hydraulics analysis, including the following:

- culvert sizing,
- longitudinal encroachments,
- existing and proposed storm drainage facilities,
- stormwater management, and
- pump stations.

Based on its evaluation, the Hydraulics Unit will prepare a Drainage Report. The project study group will use this information in making the final alignment determinations. It will also incorporate the Drainage Report into the final Design Report. See Chapter 40 and the *IDOT Drainage Manual* for more information on Drainage Reports.

PROJECT ACTIVITY (Phase I)

Activity Title: Prepare Geotechnical Report

Activity No.: 17

Responsible Unit: Geotechnical Unit

Activity Description:

Based on the information provided from the project study group (Activity 15), the Geotechnical Unit will prepare the Geotechnical Report. The analyses may include:

- basic soil properties (e.g., AASHTO soils classification);
- shrink/swell factors;
- properties of subsurface strata;
- potential for slides;
- slope stability at proposed cuts; and
- the development of a boring plan for any proposed bridges (e.g., location, spacing, and depth).

Based on its evaluation, the Geotechnical Unit will prepare a Geotechnical Report. The project study group will use this information in making the final alignment determinations. In addition, the Geotechnical Report will be incorporated into the final Design Report. See the *IDOT Geotechnical Manual* for more information.

PROJECT ACTIVITY (Phase I)

Activity Title: Prepare Bridge Drawings/Reports

Activity No.: 18

Responsible Unit: Bureau of Bridges and Structures/Project Study Group

Activity Description:

Based on the information provided from the project study group (Activity 15), the Bureau of Bridges and Structures (BB&S) will prepare the Proposed Structure Sketch for major structures, which will illustrate:

- the type of structures,
- approximate horizontal and vertical alignment and skew,
- approximate pier locations, and
- typical bridge deck section.

The project study group will prepare this sketch for other than major structures. In addition, prepare the Bridge Condition Report for existing bridges which will include:

- a description of the physical conditions and deficiencies that mandate repair or replacement,
- a verification of the apparent soundness of any structure elements recommended for reuse plus the economic advantage gained by their reuse,
- a statement of any geometric or hydraulic improvement requirements, and
- a recommendation for the scope of the proposed work.

For additional information on the Proposed Structure Sketch and Bridge Condition Reports, see Chapter 39. The BB&S will also prepare the Hydraulics Report for major structures which will involve:

- the hydraulic analysis to determine the necessary dimensions of the waterway opening to pass the design flood, to meet the backwater allowances, and to satisfy any regulatory flood plain requirements;
- the hydraulic scour analysis to assist in determining the proper foundation design for the bridge; and
- a suggested freeboard elevation.

The project study group will prepare this report for other structures and the BB&S will approve the report.

The Structure Sketch and Hydraulics Report will be incorporated into the final Design Report.

PROJECT ACTIVITY (Phase I)

Activity Title: Conduct Preliminary Utility Review

Activity No.: 19

Responsible Unit: Project Support Section

Activity Description:

The project study group will provide the district Project Support Section with copies of the plan sheets for the recommended alignment. The Project Support Section will work with the applicable utility companies to identify project impacts on existing utilities and inform them of environmental issues that may affect their adjustments and relocations. The following items of work are typically performed:

1. Underground. The Project Support Section will coordinate with the district survey crew and will, if needed, request an underground survey to determine the depths and location of existing underground utilities within the project limits, especially fiber optic cables, water supply, and sanitary lines in urban areas.
2. Overhead. Any major above-ground utilities that may be impacted by the project. The Project Support Section may prepare a cost estimate to determine if a special effort should be exercised to avoid certain utilities.
3. Impacts. The Project Support Section will notify any utility companies that will be potentially impacted by the upcoming project, and the Section will request that the Utility contact IDOT if it plans any work in the vicinity of the project.

The Project Support Section will document its findings in a report or memorandum and submit it to the project study group. The project study group will use the information in making the final alignment determinations and document its findings in the Design Report.

For additional guidance on utility coordination, see Chapter 6.

PROJECT ACTIVITY (Phase I)

Activity Title: Develop Transportation Management Plan

Activity No.: 20

Responsible Unit: Project Study Group

Activity Description:

The maintenance of traffic flow during construction of a State highway will involve traffic and worker safety, public relations, and capital costs to the Department. A well-planned method for maintaining traffic flow can minimize complaints from the traveling public and from residents and businesses along the affected route. Each construction site must be evaluated on its own merits as to the appropriate method for maintaining traffic. The Design Report should contain a Transportation Management Plan (TMP) indicating an overall strategy for accommodating traffic during construction. Chapter 13 presents the goals and objectives for a TMP. The TMP should address the preferred traffic control method, alternative traffic control applications, geometric design criteria, the impact traffic will have on other facilities, local concerns, cost effectiveness of various alternatives, etc. Chapter 55 and the *Highway Standards* provide the design criteria to use when designing a traffic control plan. In addition, consider the following:

- The TMP not only must address the alternatives confined to the project site, but it must also evaluate the impact traffic will have on the entire corridor.
- For large projects, a TMP team may be organized during Phase I to study the traffic control alternatives and their effect on the corridor. Section 13-1.08 provides guidance on the makeup and responsibilities of the TMP team.
- If improvements are required to other facilities (e.g., widening of detour routes), it is important that these improvements be implemented as soon as practical prior to construction of the mainline facility. Allow local agencies sufficient opportunity to complete their improvements before construction on the State route begins. Agreements or concurrence may be necessary between the State and local agencies to determine cost sharing arrangements and/or approval of a local road as a detour route (Activity 22).
- No formal public involvement activity (e.g., design hearing) should occur until the recommended alternative in the TMP Report has been approved by the district Detour Committee. However, informal public involvement will be necessary during the analysis of alternatives.

PROJECT ACTIVITY (Phase I)

Activity Title: Obtain Detour Approval (If Required)

Activity No.: 21

Responsible Unit: Project Study Group

Activity Description:

In general, the TMP (Activity 20) will be approved as part of the Design Report. For all marked and unmarked detours, or for a road proposed to remain open by either stage construction or a runaround, the TMP will be approved by the district Detour Committee. Exceptions to the TMP as discussed in Chapter 13 shall be through the Bureau of Safety Programs and Engineering. For a closed unmarked State highway, also coordinate with the local county officials prior to the submittal of the Design Report.

PROJECT ACTIVITY (Phase I)

Activity Title: Initiate Local Agency Letters of Intent/Understanding

Activity No.: 22

Responsible Unit: Project Support Section

Activity Description:

Based on the public involvement (Activity 13), analyses conducted (Activity 14), the selection of the recommended alignment (Activity 15), and the proposed traffic control (Activity 20), the Project Support Section will initiate the preparation of any necessary letters of intent or letters of understanding with local officials. These may be prepared for:

- concurrence between the State and local agencies to determine cost sharing arrangements,
- approval of a local road as a detour route,
- determining maintenance responsibilities once the project is completed, and/or
- letters of support for the improvement.

For additional guidance, see Chapter 5.

PROJECT ACTIVITY (Phase I)

Activity Title: Set Pre-Final Geometry and Right-of-Way

Activity No.: 23

Responsible Unit: Project Study Group

Activity Description:

Based on the previous analyses for the recommended alignment (Activity 15) and information provided by others (Activities 16, 17, 18, and 19), the project study group will:

- make any necessary adjustments to the selected vertical and horizontal alignments;
- obtain design exception approval (if needed) from BDE and, where necessary, FHWA;
- make any necessary adjustments to the typical sections;
- develop access control plans for freeways, expressways, and by-passes (see Section 11-5.04(f) and Chapter 35);
- set preliminary construction limits;
- set preliminary right-of-way limits;
- determine any easement requirements; and
- determine if any utility adjustments or displacements are necessary.

See Part IV “Roadway Design Elements” and Part V “Design of Highway Types” for detailed information on geometric design and the *IDOT Land Acquisition Manual* for guidance on right-of-way impacts.

PROJECT ACTIVITY (Phase I)

Activity Title: Make Environmental Documentation Available for Public/Agency Review

Activity No.: 24

Responsible Unit: Environmental Unit

Activity Description:

The applicable process presented in Chapters 23, 24, or 25, will apply to the preparation and processing of the environmental documentation for review.

PROJECT ACTIVITY (Phase I)

Activity Title: Prepare Draft Design Report

Activity No.: 25

Responsible Unit: Project Study Group

Activity Description:

Once the analyses have been conducted and the information gathered, the project study group will prepare the draft Design Report. Chapter 12 presents the format that should be used when preparing a Design Report. Because the design study should be essentially complete, it should be possible to prepare the draft Design Report in its near-final format. The discovery of new, significant information during the public hearing/meeting (Activity 26) should be rare if the design study has been properly developed. With the exception of changes necessary to reflect input from the public hearing/meeting (Activity 26), a final Design Report should only need information concerning the public involvement and the final conclusion/recommendation section.

In general, the draft Design Report should be submitted to BDE for review prior to its availability for public viewing and inspection at the public hearing/meeting. Formal approval by BDE for release is not normally issued. Copies made available to the public should be marked as "draft" or "preliminary."

The Design Report should include:

- a summary of purpose and need of the project;
- a list and results of prior studies;
- a list of all alternative alignments eliminated earlier and the reasons for their elimination;
- a summary of major design features and policies;
- a discussion on the compatibility of the alternatives with existing streets and highways;
- a summary of the environmental factors considered;
- a discussion on the advantages and disadvantages of the reasonable alignments studied in-depth;
- the results of public involvement;
- the proposed transportation management plan;
- a list of commitments made to the public;
- the reasons and determination for selecting the preferred alignment;
- plan and profile of the preferred alignment;
- the estimate of costs for each alternative;
- exhibits showing typical sections, aerial photography, mapping, etc.;
- copies of analyses; and
- documentation for approval of other reports conducted during the design study.

For further guidance on information to be included in the Design Report, see Chapter 12.

PROJECT ACTIVITY (Phase I)

<u>Activity Title:</u>	Conduct Public Hearing
<u>Activity No.:</u>	26
<u>Responsible Unit:</u>	Project Study Group/Environmental Unit

Activity Description:

As required by the project, a public hearing or public meeting will be held at this stage of the design study to present to the public, and other interested organizations and agencies, the alignment alternative under consideration, a summary of the analyses for the various alternatives determined not to be feasible, and the criteria used to select the recommended alignment. Other Department Sections or Bureaus (e.g., Land Acquisition), as necessary, may attend the public hearing/meeting to answer specific questions relative to their expertise.

For CSS projects, public meetings will occur throughout the Phase I process.

The project study group and the district Environmental Unit will evaluate all comments from the public hearing/meeting and will prepare responses to these comments as appropriate. Possible responses include:

- modifying alternatives including the proposed action;
- developing and evaluating alternatives not previously given serious consideration;
- supplementing, improving, or modifying analyses;
- making factual corrections; or
- explaining why the comments do not warrant further agency response, citing the sources, authorities, or reasons which support that position and, if possible, indicating those circumstances which would trigger reappraisal or further response.

Chapter 19 discusses the requirements for public hearings and public information meetings and for responding to comments received during the public hearing/meeting.

See the activity descriptions in Sections 23-2, 24-2, or 25-2, as appropriate, for additional information about public involvement in the environmental process.

PROJECT ACTIVITY (Phase I)

Activity Title: Select Preferred Alignment

Activity No.: 27

Responsible Unit: Project Study Group

Activity Description:

Based on the results of the public hearing/meeting, circulation of documents, and written and verbal comments received, the project study group will select the preferred alignment. This may require additional analyses to resolve issues and questions raised during the public hearing/meeting. The selected preferred alignment is used to prepare the final Design Report (Activity 29) and, consequently, the detailed Phase II design.

PROJECT ACTIVITY (Phase I)

Activity Title: Obtain Environmental Decision

Activity No.: 28

Responsible Unit: Environmental Unit

Activity Description:

Based on the environmental document for the project (e.g., EIS, FONSI, CE) (Activity 06), the district Environmental Unit will take the necessary actions to secure the final environmental decision. This will be one of the following:

1. CE Projects. The district Environmental Unit must obtain approval of the Federal Approved CE from FHWA; see Chapter 23. Districts are not required to seek BDE review of Federal Approved CEs unless BDE's expertise is desired.
2. EA Projects. For an EA project which does not uncover any significant environmental impacts, the district Environmental Unit must prepare and obtain approval of the Finding of No Significant Impact (FONSI); see Chapter 24. BDE will continue to review and approve all EAs and FONSI's prior to submittal to FHWA.
3. EIS Projects. The district Environmental Unit must obtain approval of the Record of Decision (ROD) from FHWA and/or BDE; see Chapter 25.

PROJECT ACTIVITY (Phase I)

Activity Title: Prepare Final Design Report

Activity No.: 29

Responsible Unit: Project Study Group

Activity Description:

The comments received from the public and other agencies should be analyzed to determine if any changes are necessary in the draft Design Report and if any relevant issues have been overlooked. If an oversight has occurred, additional studies may be required to explain the resultant effects and determine what project design changes, if any, are necessary. After the review and analysis of comments is complete and appropriate revisions made, the final Design Report may be prepared. Activity 25 and Chapters 11 and 12 list the appropriate format, reports, and discussions that should be included in the Design Report. The final Design Report will also include a copy or reference the final environmental documentation received from the district Environmental Unit.

After completing all public involvement and environmental requirements, the original scaled mapping is reduced for insertion into an appendix of the Design Report. Prepare the reduced mapping sheets and other engineering exhibits on 11 in x 17 in sheets and place them in an appendix. In addition, place the aerial photography (access control plans) showing the alternatives advanced for environmental analysis and any other environmental exhibits on 11 in x 17 in sheets and include them in an appendix. The 11 in x 17 in format provides for ease of use of all final exhibits by Planning, Design, and Land Acquisition personnel.

PROJECT ACTIVITY (Phase I)

Activity Title: Obtain Design Approval

Activity No.: 30

Responsible Unit: Project Study Group

Activity Description:

Section 12-5.05 provides information on whether the Regional Engineer, or BDE will approve the Project Report. Generally for these types of projects, the Regional Engineer will approve the Project Report. If the proposed improvement requires approval by BDE, submit two copies of the report to BDE for review and approval.

Before submitting the final Design Report for approval to the Regional Engineer or BDE ensure that the following has been completed:

- the alignment has been approved;
- the applicable requirements in Part II "Project Development" and Part III "Environmental Procedures" have been met;
- public involvement activities as described in Chapter 19 have been completed;
- the environmental documentation and environmental decision have been received with the appropriate approvals;
- if applicable, coordination with FHWA has been completed; and
- all design exceptions have been approved by BDE, and where necessary, FHWA.

Submit the following to the Regional Engineer:

- two copies of the Design Report and Appendices;
- the applicable number of copies of the environmental documentation as discussed in Part III;
- two copies of the Public Involvement Document;
- two copies of the Advisory Committee/Working Groups Document; and
- a memorandum describing the reasons for selecting the preferred alignment and design features, the items submitted, and the request for design approval.

3-2.02 Phase II Design

Figure 3-2.B illustrates a typical Phase II flowchart or network for a project on existing alignment that will require major ROW acquisitions. Following Figure 3-2.B are brief write-ups for each activity. For other project types, see the flowcharts in Chapter 2, Section 3-3, or Section 3-4. Activities along the main axis are normally performed by the design squad. The other lines of the chart represent activities by other units or groups.

Refer to Section 11-7.03 for requirements and guidance on value engineering (VE) analyses. Where required, initiate the VE study no later than the time construction plans are 30% complete and allow for the implementation of the recommendations without delaying the project. The designer should review any VE studies conducted during Phase I and update them as necessary.

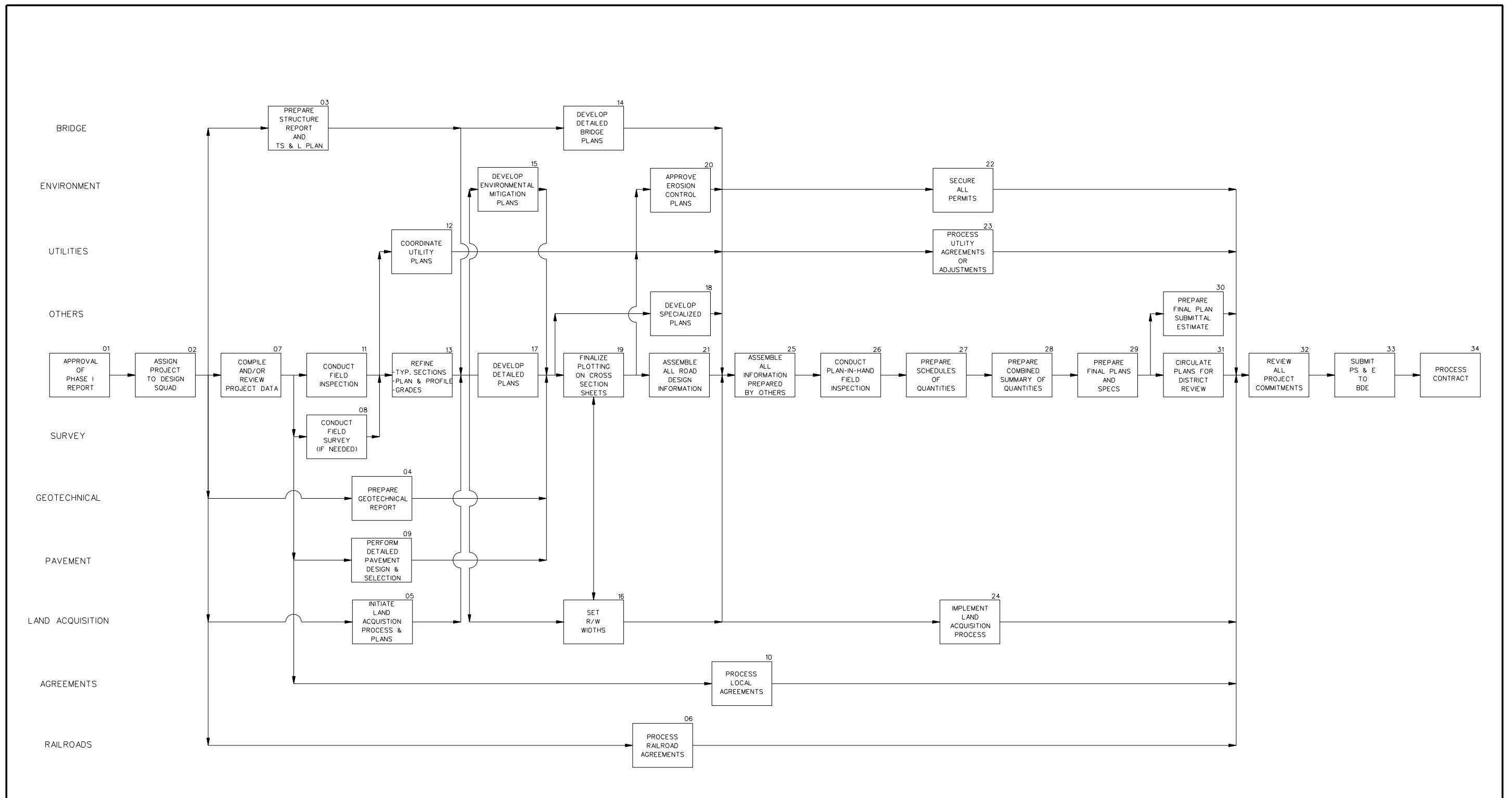

**PHASE II PROJECT DEVELOPMENT NETWORK
(Project on Existing Alignment with Major ROW Acquisitions)**

Figure 3-2.B

PROJECT ACTIVITY (Phase I)

Activity Title: Approval of Phase I Report

Activity No.: 01

Responsible Unit: Regional Engineer

Activity Description:

Once the Phase I report has been approved, this will signify that Phase I is complete and that Phase II can begin. See Figure 3-2.A and the corresponding write-ups for Phase I work. For guidance on the approval of Phase I reports, see Section 12-5.

PROJECT ACTIVITY (Phase II)

Activity Title: Assign Project to Design Squad

Activity No.: 02

Responsible Unit: Studies and Plans Engineer

Activity Description:

This Activity begins Phase II of the project. At this point, the project will either be assigned to a design squad within the district Bureau of Program Development or to a consultant. The Studies and Plans Engineer will have the overall day-to-day responsibility for advancing the project through the Phase II project development process. The Studies and Plans Engineer will:

- coordinate directly with other units or sections within the Department;
- attend all internal meetings and field inspections;
- be responsible for ensuring that the project meets all Department criteria and procedures;
- ensure the project is on schedule for the expected letting date;
- report directly to the Program Development Engineer on all significant project activities, problems, and developments; and
- participate in the public involvement process.

PROJECT ACTIVITY (Phase II)

<u>Activity Title:</u>	Prepare Structures Report and TS&L Plans
<u>Activity No.:</u>	03
<u>Responsible Unit:</u>	Bureau of Bridges and Structures/Design Squad

Activity Description:

Based on the approved Phase I report (Activity 01) and notification by the design squad that Phase II has begun (Activity 02), the district will prepare the Structures Report and the Bureau of Bridges and Structures will prepare the Type, Size, and Location (TS&L) Plans for any bridges within the project limits. TS&L Plans are detailed bridge configuration plans that are used to develop the detailed bridge construction plans. The TS&L Plans will present the following:

- plan and profile of the bridge showing the proposed type of superstructure and foundation, bridge end elevations, location of expansion and fixed ends, highway approaches, and existing contours at the bridge site;
- superstructure cross section showing pertinent structural details (e.g., number of beams, depth and width of bridge deck);
- bridge curb, sidewalk, and/or shoulders;
- design loadings, stresses, specifications, and other structural criteria;
- controlling horizontal and vertical clearances;
- hydraulic data, high and low water elevations, drift, ice, etc.; and
- a small scale location map to identify the location of the proposed bridge.

The Structures Report and TS&L Plans will be used in developing the detailed roadway plans (Activity 17). See Chapter 39 for more information on TS&L Plans and bridge sizing/geometrics.

For Phase II plans prepared by a Consultant, these activities may be the responsibility of the Consultant and approved by the Bureau of Bridges and Structures.

PROJECT ACTIVITY (Phase II)

Activity Title: Prepare Geotechnical Report

Activity No.: 04

Responsible Unit: Geotechnical Unit

Activity Description:

After being assigned the project (Activity 02), the design squad will request the Geotechnical Unit to investigate the geotechnical characteristics within the project limits based on the information provided in the approved Phase I report (Activity 01). The nature and depth of the investigation will be determined on a project-by-project basis. One of the primary factors that will determine the scope of the investigation will be the anticipated amount of earthwork for the project. The geotechnical investigation may include:

- an in-depth subsurface investigation (e.g., to determine the hydrogeologic characteristics of the subsurface);
- an evaluation of the potential for slides;
- an investigation of any wetlands in the vicinity of the project;
- for proposed cuts, a determination of the slope stability characteristics and the need for any special treatments (e.g., benching);
- testing of materials from the site by Department laboratory tests;
- an evaluation of any erosion potential within the project limits; and
- an evaluation of foundations for bridges and long culverts.

The Geotechnical Unit will prepare a Geotechnical Report documenting the findings from its investigation. The Report will be submitted to the design squad for input into the final typical section design for the facility.

PROJECT ACTIVITY (Phase II)

Activity Title: Initiate Land Acquisition Process and Plans

Activity No.: 05

Responsible Unit: Land Acquisition Section

Activity Description:

Based on the approved Phase I report (Activity 01) and notification by the design squad that Phase II has begun (Activity 02), the Land Acquisition Section will initiate the land acquisition process and the preparation of the right-of-way plans. This includes obtaining the existing right-of-way plans and researching the existing right-of-way status within the project limits, including:

- right-of-way titles and deeds,
- permanent easements,
- property lines and owners, and
- existing limits of access.

The preparation of right-of-way plans will include:

- setting up the sheets and stationing for the right-of-way plans,
- recording the section corner information,
- recording property ownership information,
- plotting the existing right-of-way, and
- developing parcel plats.

The Land Acquisition Section will forward this information to the design squad for use in preparation of the detailed roadway plans (Activity 17).

PROJECT ACTIVITY (Phase II)

Activity Title: Process Railroad Agreements

Activity No.: 06

Responsible Unit: Project Support Section

Activity Description:

The district provides information to BDE for the preparation and negotiation of formal agreements between the Department and the Railroad. This includes both railroad grade separation and at-grade crossing projects on the State highway system. Based on the approved Phase I report, the design squad should submit the necessary crossing data with sufficient lead time to allow for negotiations. Typically, a year or more is required.

The Agreement will cover:

- division of work and expense involved between IDOT and the Railroad for the crossing improvement;
- responsibilities for the future maintenance of the improvement;
- establishment of the Railroad's share of the cost as determined under the provisions of any one of the several classifications provided in the *Federal-Aid Policy Guide* and Section 7-1.02;
- reference to the acquisition of property rights (see Section 7-1.06);
- reimbursement of the costs incurred by the Railroad according to the requirements of the *Federal-Aid Policy Guide*;
- coverage of liability during construction operations; and
- reference to or identification of plans and plan approval.

The Project Support Section will coordinate the transfer of information and plans between the design squad and the railroad companies. This will be a continuous process as the design plans are developed during the Phase II design. This process should be completed prior to the review of all project commitments (Activity 32).

For additional guidance on coordinating with railroads, see Chapter 7.

PROJECT ACTIVITY (Phase II)

Activity Title: Compile and/or Review Project Data

Activity No.: 07

Responsible Unit: Design Squad

Activity Description:

The design squad may or may not include the same personnel as the project study group for Phase I. Also, there typically will be some delay between the Phase I and the Phase II portions of a project. Therefore, the design squad should review the Phase I report(s) and project files to become familiar with the decisions and determinations made during Phase I. Some of the information and decisions that should be reviewed may include:

- any design variances,
- alignment and typical section plans developed during Phase I,
- any technical reports prepared for the Phase I study,
- crash and traffic data,
- aerial photographs,
- the commitment file,
- the proposed TMP,
- documentation on public hearings and/or private meetings,
- letters of understanding and/or letters of intent sent to local officials,
- any utility involvement,
- any railroad involvement, and
- existing conditions to assess any changes in land use or development plans.

Based on this review, the design squad should evaluate what additional information and coordination with other units may be required to complete the project. The design squad also should ensure that other units as appropriate have initiated their work (e.g., Bureau of Bridges and Structures (Activity 03), Land Acquisition Section (Activity 05)). At this stage of the project, the design squad should request:

- if necessary, the Surveys and Photo Services Unit to conduct additional surveys (Activity 08);
- the Pavement Design Section to begin the pavement design and type selection (Activity 09); and
- the Project Support Section to begin processing any necessary local agency agreements (Activity 10).

PROJECT ACTIVITY (Phase II)

Activity Title: Conduct Field Survey (If Needed)

Activity No.: 08

Responsible Unit: Surveys and Photo Services Unit

Activity Description:

In general, a survey should have been conducted during the development of the Phase I study. However, based on the review of the project data (Activity 07), the design squad may conclude that additional surveys are required. The needed survey information may include:

- existing field conditions (topography, vegetation, existing structures and road design features, etc.);
- drainage features (bodies of water, open channels, channel slopes and cross sections, existing drainage appurtenances, etc.);
- existing field landmarks;
- existing utilities (above and below ground);
- existing right-of-way markers and property lines; and
- alignment and cross section of existing roads and driveways.

PROJECT ACTIVITY (Phase II)

Activity Title: Perform Detailed Pavement Design and Selection

Activity No.: 09

Responsible Unit: Pavement Design Section

Activity Description:

Based on the information provided by the design squad (Activity 07) and Phase I report (i.e., Geotechnical Report), the Pavement Design Section will perform the detailed pavement design analysis. For new or full-depth reconstruction, the objectives of the analysis will be to:

- select the design methodology, pavement type, and design criteria (see Chapter 54);
- determine the overall pavement thickness and thicknesses of individual layers; and
- determine any special surfacing design features (e.g., high-stress intersections, subdrainage design, use of geotextiles).

For existing pavements, the Pavement Design Section will develop a rehabilitation strategy. This may include, for example, determining pavement overlay thickness, patching needs, crack repair, joint repair, etc. See Chapter 53 for additional information.

The objective of Activity 09 is to develop and compare pavement design options. See Chapter 54 for additional guidance on pavement design and approval.

PROJECT ACTIVITY (Phase II)

Activity Title: Process Local Agreements

Activity No.: 10

Responsible Unit: Project Support Section

Activity Description:

The district Project Support Section is responsible for the preparation and negotiation of formal agreements between the Department and local governments. These agreements may cover:

- division of work and expense involved between IDOT and the local agency in connection with the improvement,
- responsibilities for the future maintenance of the improvement,
- reference to the acquisition of property rights,
- reimbursement of the costs incurred by the local agency,
- coverage of liability during construction operations, and
- reference to or identification of plans and plan approval.

The Project Support Section also will be responsible for coordinating the transfer of information and plans between the design squad and the local agency. This will be a continuous process throughout the design phase as the design plans are developed. The district Project Support Section also will coordinate with BDE for review and approval of any agreements. This process should be completed prior to the review of all project commitments (Activity 32).

For additional guidance on coordinating with local agencies, see Chapter 5.

PROJECT ACTIVITY (Phase II)

Activity Title: Conduct Field Inspection

Activity No.: 11

Responsible Unit: Design Squad

Activity Description:

After completing the in-house review of the Phase I report and other project data, the design squad should conduct a field inspection of the project. The objective is to review major design features and project-related issues and to identify any potential problems. The design squad will arrange the field inspection and invite, as appropriate, individuals from the following units to the field inspection:

- district Bureau of Project Implementation,
- BDE,
- Bureau of Bridges and Structures,
- district Environmental Unit,
- district Bureau of Operations,
- Land Acquisition Section,
- FHWA,
- local officials, and
- others as deemed appropriate.

The design squad will document the findings and decisions in the minutes of the field inspection.

PROJECT ACTIVITY (Phase II)

Activity Title: Coordinate Utility Plans

Activity No.: 12

Responsible Unit: Project Support Section

Activity Description:

After conducting the field inspection (Activity 11) and any additional field surveys (Activity 08), the design squad will forward the preliminary construction plans with any known utilities plotted to the district Project Support Section. The design squad will also notify the Project Support Section of any unique issues (e.g., environmental, commitments). The Project Support Section will coordinate the transfer of information and plans between the design squad and the utility companies. The utility companies will review IDOT's plans, plot their facilities, if not already shown, and prepare the necessary utility adjustment/relocation plans and specifications. As the design squad refines the construction plans, this information will be submitted to the Project Support Section to be forwarded to the utility companies.

For guidance on preparing utility plans and coordinating with utility companies, see Chapter 6.

PROJECT ACTIVITY (Phase II)

Activity Title: Refine Typical Sections, Plan and Profiles, Grades

Activity No.: 13

Responsible Unit: Design Squad

Activity Description:

Based on the review of the plans (Activity 07), the field inspection (Activity 11), the field survey (Activity 08), the Phase I report, and the project's commitment file, the design squad will refine and/or prepare the project's:

- cover sheet;
- general notes sheet;
- typical sections;
- the plan and profile sheets;
- alignment, ties, and benchmark sheet; and
- construction limits.

Section 63-4 provides guidance on the information that should be included on these plan sheets.

PROJECT ACTIVITY (Phase II)

Activity Title: Develop Detailed Bridge Plans

Activity No.: 14

Responsible Unit: Bureau of Bridges and Structures

Activity Description:

Based on the Phase I report (Activity 01), the Structure Report and TS&L Plans (Activity 03), and other information provided by the design squad, the Bureau of Bridges and Structures will perform the detailed structural design for any bridges and/or major structures on the project. The basic objective of the detailed design phase is to perform the in-depth structural analyses that are necessary to prepare a set of construction plans for any structures. The structural analyses, as applicable, may include the:

- superstructure design (e.g., framing details, deck slab, camber diagram);
- substructure design (e.g., piers, abutments);
- foundation design;
- approach slab design;
- bridge rail design; and
- existing physical conditions and deficiencies.

Once the structural plan sheets are completed, the Bureau of Bridges and Structures will submit the full set of bridge plan sheets and the quantities, pay items, and specifications to the design squad for direct insertion into the final project plans. Activity 14 must be completed before the assembly of information prepared by others (Activity 25).

For Phase II plans prepared by a Consultant, these activities may be the responsibility of the Consultant and approved by the Bureau of Bridges and Structures.

PROJECT ACTIVITY (Phase II)

Activity Title: Develop Environmental Mitigation Plans

Activity No.: 15

Responsible Unit: Environmental Unit

Activity Description:

Based on the approved Phase I report (Activity 01) and the typical sections and plan and profiles sheets (Activity 13), the district Environmental Unit, in consultation with BDE, as appropriate, will prepare the environmental mitigation plans, quantities, and specifications for direct insertion into the final construction plans. This may include wetlands compensation plans, Special Provisions for management and monitoring of special wastes, purchase of replacement lands, memorandums of agreements, etc. The district Environmental Unit will ensure that the commitments made in Phase I of the project are incorporated into the plans.

See Section 24-2 or Section 25-2, as appropriate.

PROJECT ACTIVITY (Phase II)

Activity Title: Set Right-of-Way Widths

Activity No.: 16

Responsible Unit: Land Acquisition Section

Activity Description:

Based on the information gathered in developing the Right-of-Way Plan Sheets (Activity 05) and the submittal of the construction limits by the design squad (Activity 13), the Land Acquisition Section will determine the right-of-way widths for the project. The Land Acquisition Section will forward this information to the design squad, which will incorporate this information on the plan and profile sheets.

This information also will be used to initiate the land acquisition process (Activity 24).

PROJECT ACTIVITY (Phase II)

Activity Title: Develop Detailed Plans

Activity No.: 17

Responsible Unit: Design Squad

Activity Description:

Once the design squad has received the Structure Report and TS&L Plans from the Bureau of Bridges and Structures (Activity 03) and the right-of-way plans from the Land Acquisition Section (Activity 05), the design squad can prepare the detailed sheets which will be incorporated into the construction plans. This may include the following:

- stages of construction and temporary traffic control sheets;
- drainage sheets, including special drainage details;
- intersection details;
- interchange details;
- pavement marking details;
- grading plans;
- transition details;
- proposed cross sections, not including pavement template;
- special bikeway and trails plans;
- signing plans, if not prepared by the district Bureau of Operations;
- environmental mitigation plans, if not prepared by others;
- highway lighting plans, if not prepared by others; and
- any other special details.

Section 63-4 presents guidance on what information should be included on each detail or plan sheet.

In addition, the design squad will:

- determine the appropriate level of access control for the facility;
- determine the need for construction permits, permanent right-of-way easements, and/or temporary easements;
- perform the detailed drainage design;
- perform a roadside safety analysis; and
- incorporate any special experimental features into the plans.

PROJECT ACTIVITY (Phase II)

Activity Title: Develop Specialized Plans

Activity No.: 18

Responsible Unit: Various Units

Activity Description:

Based on the typical sections, plan and profile sheets (Activity 13), and detailed plan sheets (Activity 17), various other units within IDOT will prepare their applicable plan sheets, quantities, and special provisions. This may include:

- district Bureau of Operations preparing the landscaping details;
- district Bureau of Operations preparing the signing plans, if included within the project;
- district Bureau of Operations (or Bureau of Electrical Operations in District 1) preparing the traffic signal plans;
- Bureau of Operations, BDE, and design squad developing rest area plans (see Section 16-1);
- Bureau of Operations, BDE, Bureau of Bridges and Structures, Capital Development Board, and the design squad developing weigh stations and weigh-in-motion plans; and/or
- BDE (or Bureau of Electrical Operations in District 1) preparing the highway lighting plans.

In addition, the following units may review the detailed plans prepared by the design squad (Activity 17):

- district Bureau of Operations will review the pavement marking details and stage construction and traffic control plans.
- district Bureau of Project Implementation will review the stage construction and traffic control plans.
- district Hydraulics Section will review the drainage plans and special drainage detail sheets.
- BDE will review bikeway and trail plans.
- district Environmental Unit will review the environmental mitigation plans, if prepared by the design squad.

PROJECT ACTIVITY (Phase II)

Activity Title: Finalize Plotting on Cross Sections

Activity No.: 19

Responsible Unit: Design Squad

Activity Description:

During Phase I, the cross sections may have been generated using GEOPAK to determine the earthwork quantities. Using the following information, update and plot the revised cross sections:

- the TS&L Plans from the Bureau of Bridges and Structures (Activity 03);
- the environmental mitigation plans from the district Environmental Unit (Activity 15);
- information received from the Project Support Section on utility plans (Activity 12);
- the refined typical sections and plan and profile sheets (Activity 13);
- the detailed plans (Activity 17);
- the Geotechnical Report from the Geotechnical Section (Activity 04);
- the final pavement design from the Pavement Design Section (Activity 09); and
- right-of-way information provided by the Land Acquisition Section (Activity 16).

Also during Activity 19, develop the erosion control plans and specifications according to the criteria in Chapter 41 and the information provided in the Phase I report. These plans and specifications will be submitted to the district Environmental Unit for review and approval (Activity 20).

PROJECT ACTIVITY (Phase II)

Activity Title: Approve Erosion Control Plans

Activity No.: 20

Responsible Unit: Environmental Unit

Activity Description:

The district Environmental Unit will review and approve the erosion control plans and specifications prepared by the design squad (Activity 19). Once approval has been granted, the erosion control plans will be incorporated into the construction plans (Activity 25). Also, once the erosion control plans have been approved, the Environmental Unit can initiate the process of securing the necessary project permits (Activity 22).

PROJECT ACTIVITY (Phase II)

Activity Title: Assemble All Road Design Information

Activity No.: 21

Responsible Unit: Design Squad

Activity Description:

Throughout the design process, the design squad will have prepared the various plan sheets separately. In Activity 21, conduct the following:

- plot a complete set of plans developed to date (e.g., cover sheet, typical plans, plan and profile sheets, detail plans, cross sections);
- assemble the sheets in the recommended order as noted in Chapter 63;
- review the plans and details to ensure that all necessary information has been included and that the plans and details are compatible with each other;
- calculate the quantities for roadway design elements according to the criteria in Chapter 64 of the *BDE Manual*, the *Coded Pay Items*, and the *Standard Specifications for Road and Bridge Construction* for pay items, units of measurement, rounding conventions, etc.; and
- prepare all required special provisions.

At this time the Schedules of Quantities and the Summary of Quantities will not yet be prepared. For assembly purposes, blank Schedule of Quantities and Summary of Quantities may be included.

PROJECT ACTIVITY (Phase II)

Activity Title: Secure All Permits

Activity No.: 22

Responsible Unit: Environmental Unit

Activity Description:

After the cross sections have been finalized, the erosion control plans have been completed (Activity 19) and approved (Activity 20), the typical sections and plan and profiles sheets have been completed (Activity 13), and the detailed bridge plans have been completed (Activity 14), the district Environmental Unit will ensure all applicable permits and approvals required by the project are obtained. Depending upon the project-specific impacts, this may include any or all of the following:

- Section 401 water quality certification and 402 permits from the Illinois Environmental Protection Agency;
- US Army Corps of Engineers, Section 404/Section 10 permit(s);
- US Coast Guard, Section 9 permit; and
- permits issued by Illinois State agencies.

All permits, certifications, and approvals should be received by the Department prior to the review of all project commitments (Activity 32).

Chapter 28 provides a brief description of all Federal and State environmental permits and certifications.

PROJECT ACTIVITY (Phase II)

Activity Title: Process Utility Agreements or Adjustments

Activity No.: 23

Responsible Unit: Project Support Section

Activity Description:

Based on the roadway plans (Activities 13, 17, and 19), the detailed bridge plans (Activity 14), and the initial utility plans (Activity 12), the Project Support Section will work with the impacted utility companies and municipalities to implement the utility process. This process may include the following:

1. Plan Preparation. The utility companies are responsible for preparing all utility adjustment/relocation plans. The plans will be developed according to the criteria in Chapter 6.
2. Funding. Depending on the right-of-way ownership for existing and proposed utility locations, transportation funds may be eligible for utility adjustments/relocations required by the highway project; see Chapter 6. The Utilities pay for all betterments.
3. Agreements. The Project Support Section will prepare a Utility Agreement for each affected utility and will work with the utility companies to gain their input and approval. The Project Support Section will coordinate with BDE for review and approval of the agreements.

The Project Support Section will ensure that the utility process is completed before the review of all project commitments (Activity 32).

PROJECT ACTIVITY (Phase II)

Activity Title: Implement Land Acquisition Process

Activity No.: 24

Responsible Unit: Land Acquisition Section

Activity Description:

Based on the right-of-way plans (Activity 05), the final typical section and plan and profile sheets (Activity 13), and the right-of-way width determination (Activity 16), the Land Acquisition Section will implement the land acquisition procurement process. This will include the land acquisition functions of appraisal, negotiation, acquisition and, if necessary, condemnation. The Land Acquisition Section will also negotiate the terms of any construction permits, permanent easements, and/or temporary easements.

The Land Acquisition Section will ensure that the land acquisition procurement process is completed before the final review of all project commitments (Activity 32).

The Land Acquisition Section should coordinate with the design squad to ensure any negotiated considerations/commitments are included in the contract plans.

PROJECT ACTIVITY (Phase II)

Activity Title: Assemble All Information Prepared by Others

Activity No.: 25

Responsible Unit: Design Squad

Activity Description:

At this stage of project development, the design squad will have received the following completed plans, special provisions, pay items, and quantities from other IDOT units:

- the bridge/structure plans from the Bureau of Bridges and Structures (Activity 14);
- the landscaping details from the district Bureau of Operations (Activity 18);
- if included in the project, the signing plans from the district Bureau of Operations (Activity 18);
- the traffic signal plans from the district Bureau of Operations (or Bureau of Electrical Operations in District 1) (Activity 18);
- rest area plans from the Bureau of Operations and BDE (Activity 18);
- weigh stations and weigh-in-motion plans from the Bureau of Operations, BDE, Bureau of Bridges and Structures, and Capital Development Board (Activity 18); and
- the highway lighting plans from BDE (or Bureau of Electrical Operations in District 1) (Activity 18).

In addition, the design squad will have received approval of the erosion control plans from the district Environmental Unit (Activity 20) and right-of-way widths from the Land Acquisition Section (Activity 16).

The design squad will review these materials 1) to identify and incorporate any information which must be incorporated directly into the detailed road design and 2) to assemble those plan sheets prepared by others into the overall set of construction plans.

PROJECT ACTIVITY (Phase II)

Activity Title: Conduct Plan-in-Hand Field Inspection

Activity No.: 26

Responsible Unit: Design Squad

Activity Description:

At this stage of project development, all major design work has been completed, including roadway design, traffic items, structural elements, erosion control plans, right-of-way design, etc. The design squad is responsible for scheduling the Plan-in-Hand (PIH) review of the project. The PIH review is an in-depth office and on-site review of all project elements to ensure that all details and commitments have been satisfactorily incorporated into the construction plans and specifications, and that the project is nearly ready to advance to construction.

As applicable, the design squad will invite the following to conduct an office and PIH field inspection:

- district Bureau of Project Implementation,
- BDE,
- district Bureau of Operations,
- Bureau of Bridges and Structures,
- FHWA,
- local officials, and
- others as deemed appropriate.

Once the PIH office and field inspection have been completed, the design squad will prepare the PIH minutes to document all significant decisions made during the PIH review. After approval by the Program Development Engineer, distribute the PIH minutes to:

- all applicable Bureau Chiefs;
- Regional Engineer;
- all parties involved in the field review;
- FHWA, if applicable; and
- any other individuals or sections as deemed appropriate.

All parties receiving a copy of the PIH minutes are requested to provide comments on the minutes. Concurrence of the minutes will be assumed if no comments are received by the specified date.

PROJECT ACTIVITY (Phase II)

Activity Title: Prepare Schedules of Quantities

Activity No.: 27

Responsible Unit: Design Squad

Activity Description:

Based on any modifications due to the Plan-in-Hand field inspection (Activity 26), the design squad will refine the project quantities for the roadway design items developed during Activity 21. Using these quantities and those provided by other IDOT units (Activity 25), the design squad will prepare the Schedule of Quantities sheets according to the criteria presented in Chapter 64. These quantities will be incorporated onto the Summary of Quantities Sheet (Activity 28).

PROJECT ACTIVITY (Phase II)

Activity Title: Prepare Combined Summary of Quantities

Activity No.: 28

Responsible Unit: Design Squad

Activity Description:

Using the quantities developed in Activity 21, refined in Activity 27, and those provided by other IDOT units (Activity 25), the design squad will prepare the Summary of Quantities sheets, which will summarize all pay items necessary to construct the improvement. It also should include the applicable construction and safety code items, pay item code numbers, units of measurement, total quantities, and quantity breakdown for each section. One or more summary sheets typically will be included in each set of plans. Do not show other data on the summary sheets (e.g., general notes). When preparing the Summary of Quantities sheets, it is important that all quantities be calculated and segregated accordingly prior to completing the Summary of Quantities.

The design squad should coordinate with the Project Support Section to ensure that the percentages and cost breakdown in the Summary of Quantities and the Local Agency agreements are identical.

For additional guidance on preparing the Summary of Quantities, see Section 63-4.

PROJECT ACTIVITY (Phase II)

Activity Title: Prepare Final Plans and Specifications

Activity No.: 29

Responsible Unit: Design Squad/Others

Activity Description:

Based on the Plan-in-Hand Review and minutes (Activity 26), all bureaus and sections responsible for their respective project plans will make all necessary plan and specifications revisions. This will produce the final set of project plans ready for construction. Specifically for the design squad, the design squad will be responsible for revising the roadway plans and specifications. Once completed, the plans will be distributed for district review (Activity 31) and will allow the District Estimating Engineer to prepare the Final Plan Submittal Estimate.

Complete quality control/quality assurance (QC/QA) prior to the plans being circulated for district review.

PROJECT ACTIVITY (Phase II)

Activity Title: Prepare Final Plan Submittal Estimate

Activity No.: 30

Responsible Unit: District Estimating Engineer

Activity Description:

Based on the information from the final plans and specifications (Activity 29), the District Estimating Engineer will prepare the final district cost estimate. This may be a new estimate or an update of an earlier cost estimate prepared during Phase I or a revised cost estimate prepared during Phase II. This estimate will be submitted to the BDE Project Management Unit, which will use it to develop the Engineer's Estimate.

Chapter 65 provides guidance on the preparation of project cost estimates.

PROJECT ACTIVITY (Phase II)

Activity Title: Circulate Plans for District Review

Activity No.: 31

Responsible Unit: Design Squad

Activity Description:

Once all revisions from the Plan-in-Hand Review and minutes have been made to the plans and specifications, the design squad will submit a completed set of construction plans to the district units involved with the project for final review and comment. Typically, this review will consist of:

- reviewing the plans to ensure the reviewer's comments from previous reviews have been incorporated;
- ensuring that the changes do not conflict with the bureau's commitments; and
- ensuring that the plans conform to the Department's design criteria.

If changes are requested at this point which are desirable, but not mandatory, the Studies and Plans Engineer will determine if they should be incorporated. This will depend on other factors that may preclude the changes from being added to the plans. If another bureau determines the changes still should be incorporated, an appeal can be made to the Program Development Engineer for their incorporation.

PROJECT ACTIVITY (Phase II)

Activity Title: Review all Project Commitments

Activity No.: 32

Responsible Unit: Design Squad

Activity Description:

At this point in project development, the project design is essentially complete. The design squad must ensure that the following elements have been completed and/or have been incorporated into the plans:

- all environmental permits have been secured (Activity 22);
- all utility agreements and adjustments have been processed and signed (Activity 23);
- the final district cost estimate has been completed (Activity 30);
- the land acquisition process has been completed (Activity 24);
- all local agreements and letters of understanding have been processed and signed (Activity 10);
- all railroad agreements have been processed and signed (Activity 06); and
- all commitments made during the project development, including those made during Phases I and II, have been incorporated.

The design squad must carefully review all minutes of meetings, transcripts of public hearings, and the project study files to ensure that all commitments have been incorporated. If there are any questions, the design squad should contact the preparer of the Phase I report or the Unit making the commitment during Phase II.

If it is discovered during the plan development that a change is required to the approved Phase I report or a commitment cannot be met, the design squad must immediately notify BDE and all other applicable units so that the appropriate action can be taken. Failure to provide the appropriate notification and review may result in project delay.

PROJECT ACTIVITY (Phase II)

Activity Title: Submit PS&E to BDE

Activity No.: 33

Responsible Unit: Design Squad

Activity Description:

Once the plans are complete and the design squad has ensured all commitments, agreements, permits, etc., are complete or have been incorporated, the design squad will submit the following items to the BDE Program Support Unit:

- the Certification Acceptance/Project Status Form, signed by the Regional Engineer;
- a cover sheet signed by the Regional Engineer indicating his/her approval of the plans;
- one complete set of full-size plans on reproducible paper, mylar, or vellum (see Chapter 63 for the Department's guidelines on preparing plan sheets);
- one copy of each special provision required for the project, including a copy of the electronic file in Microsoft Word format (see Section 66-1.04 for the procedures on developing special provisions);
- a completed Recurring Special Provision check sheet (see Chapter 66);
- the project quantities on Form BD-213 or BDE-approved equal (see Chapter 64 for the procedures on determining plan quantities);
- the expected construction time for the project (see Section 66-2.03 for the Department's guidelines on determining the expected construction time); and
- copies or originals of all permits and agreements.

To place an improvement on any specific letting, it is imperative that the plans and supporting documents be submitted according to the schedules established in Section 66-2 which indicate the minimum number of weeks prior to the letting date for the submittal or completion of a particular phase of work.

PROJECT ACTIVITY (Phase II)

Activity Title: Process Contract

Activity No.: 34

Responsible Unit: BDE

Activity Description:

Once BDE has received the plans and other information from the district (Activity 33), it will conduct the following:

- prepare the Engineer's Estimate;
- verify that the plans are on the list of recommended projects;
- check the Certification Acceptance /Project Status Form;
- verify the project is programmed and the scope of work is correct;
- determine the final funding source;
- check all agreements to ensure they are consistent with the project;
- submit the plans, special provisions, quantities, etc., for review and comment;
- prepare the Transportation Bulletin and advertise the project;
- if necessary, submit the PS&E to FHWA for approval;
- prepare the contract proposal;
- submit the proposal and plans to bidders;
- implement the letting process;
- review all bids; and
- execute the contract.

For additional guidance on the contract process, see Chapter 66.

3-3 PROJECTS WITH MINOR RIGHT-OF-WAY ACQUISITIONS

3-3.01 Phase I Studies

Figure 3-3.A illustrates a typical Phase I flowchart or network for a 3R or minor widening project on existing alignment that will require minimal or no ROW acquisitions. These projects typically are classified as Categorical Exclusions and require a Project Report. For guidance on the preparation and format of Project Reports, see Chapters 11 and 12. For other project types, see the flowcharts in Chapter 2, Section 3-2, and Section 3-4. Following Figure 3-3.A are brief write-ups for each activity.

Depending on the project, particularly those requiring structural work and/or right-of-way acquisitions, it may be desirable to begin the Phase II work prior to obtaining the approval of the Project Report. Typically, some Phase II activities can be started after the draft of the Project Report has been prepared.

Refer to Section 11-7.03 for requirements and guidance on value engineering (VE) analyses. Where required, initiate the VE study no later than the time construction plans are 30% complete and allow for the implementation of the recommendations without delaying the project.

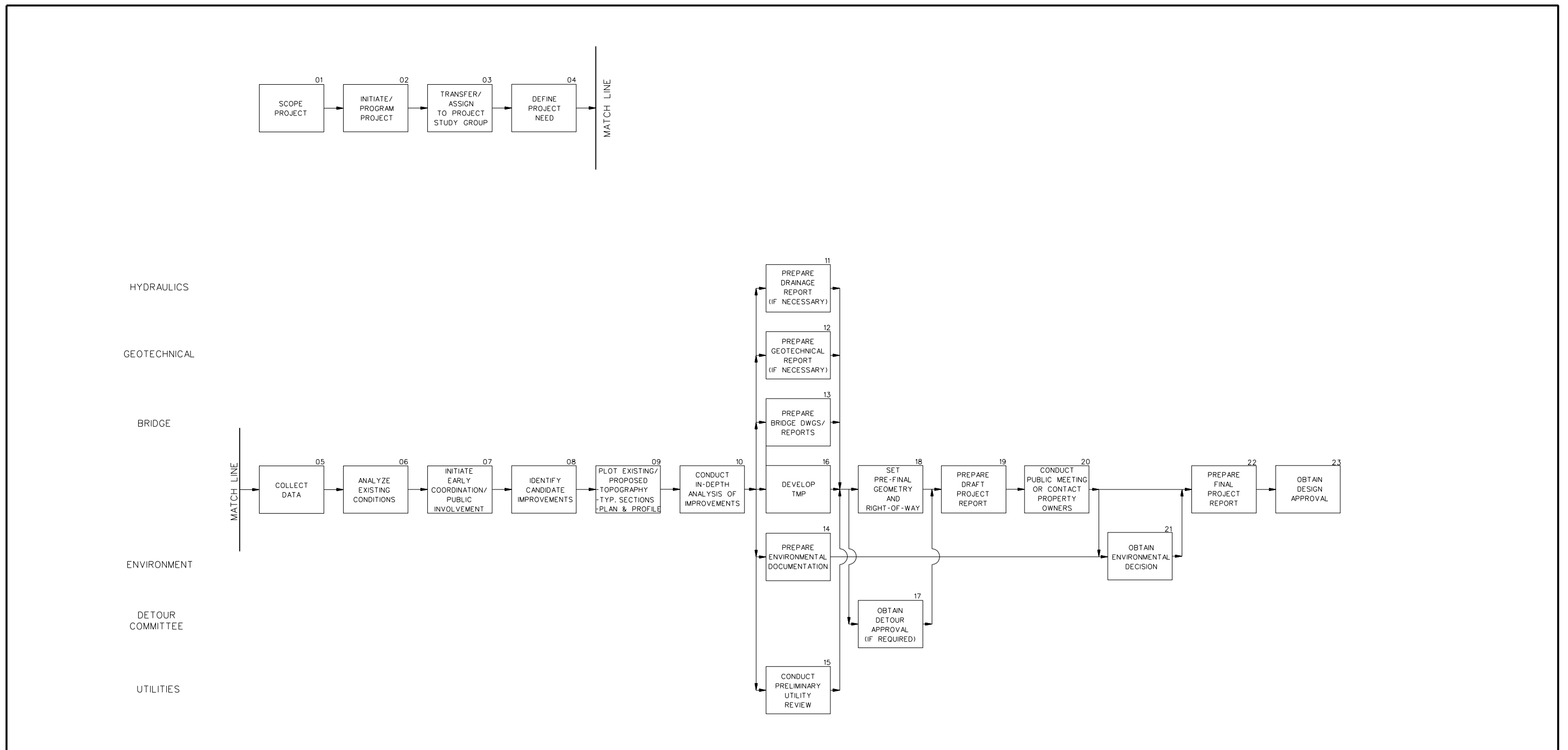

**PHASE I PROJECT DEVELOPMENT NETWORK
(3R or Minor Widening Project on Existing Alignment)**

Figure 3-3.A

PROJECT ACTIVITY (Phase I)

<u>Activity Title:</u>	Scope Project
<u>Activity No.:</u>	01
<u>Responsible Unit:</u>	District Bureau of Program Development

Activity Description:

A roadway project proposal can originate from a variety of sources, including local officials or metropolitan planning organizations (community-based need), directly from the IDOT district (district-based need), from a Bureau in the central office (Office of Planning and Programming, BDE, Operations, Bureau of Safety Engineering, etc.), or other sources targeting a special need or a Statewide need.

Before a project is entered onto the Department's Proposed Highway Improvement Program, the district Programming Section initially develops and documents the project concept. Developing the project concept will typically involve the following:

- establishing that there is, in fact, a need for the project;
- making a preliminary determination of the project scope of work;
- reviewing any available data and records;
- reviewing existing plans;
- conducting an initial evaluation of right-of-way, utility, and environmental impacts and the likely level of environmental evaluation;
- developing a rough, preliminary cost estimate; and
- developing a set of review plans.

This information is forwarded for review and comment to district Program Development, district Operations, BDE, district Environmental Unit, the Bureau of Bridges and Structures, and other individuals, as appropriate. District Programming will refine the scope based on the comments received.

Once the scope, cost, and schedule have been defined, district Programming will forward this information to the Office of Planning and Programming for incorporation into the Department's multi-year program (Activity 02).

PROJECT ACTIVITY (Phase II)

Activity Title: Initiate/Program Project

Activity No.: 02

Responsible Unit: Office of Planning and Programming

Activity Description:

Candidate projects are submitted by the districts as a request for project programming to the Office of Planning and Programming. Based on a Statewide assessment of highway improvement needs and available funds, the Office of Planning and Programming will develop the Department's Proposed Highway Improvement Program. This will establish an individual project as an active project for further development.

The Office of Planning and Programming annually issues guidelines for multi-year programming criteria. This includes programming criteria for:

- improvement categories,
- pavement surface conditions,
- deficient bridges,
- safety improvements,
- Interstate rehabilitation,
- widening narrow and deteriorated pavements,
- improving intersections and reducing traffic bottlenecks,
- new construction/reconstruction of major facilities,
- transportation enhancement projects,
- Congestion Mitigation Air Quality (CMAQ) projects, and
- bicycle accommodation.

PROJECT ACTIVITY (Phase I)

Activity Title: Transfer/Assign to Project Study Group

Activity No.: 03

Responsible Unit: Studies and Plans Engineer

Activity Description:

At this point the project will either be assigned to a project study group within the district Bureau of Program Development or to a consultant to begin the design study. The Studies and Plans Engineer will have the overall day-to-day responsibility for advancing the project through the Phase I study process. The Studies and Plans Engineer, or designee, will:

- coordinate directly with other units within the Department;
- attend all internal meetings and field inspections;
- ensure that the project study meets all Department criteria and procedures;
- report directly to the District Program Development Engineer on all significant project activities, problems, and developments; and
- participate in the public involvement process.

The number and expertise of personnel initially assigned to the project study group will vary with the nature and scope of the proposed improvement. The personnel assigned will also vary over time relative to the priority for completion, the available lead time, and the activity in project development under study.

If the project is one, which the Regional Engineer has determined will use the principles of Context Sensitive Solutions (CSS), the public involvement process should commence at this point. The project study group uses the Stakeholder Involvement Process (SIP) as outlined in Sections 19-5.01 to conduct public involvement for CSS projects.

PROJECT ACTIVITY (Phase I)

Activity Title: Define Project Need

Activity No.: 04

Responsible Unit: Project Study Group/BDE/FHWA/Office of Planning & Programming

Activity Description:

For a transportation project, the project study group must first define the project need, which will direct the process for the identification of design alternatives, in-depth analyses and, ultimately, selection of the preferred design. This will consist of reaffirming the need for the proposed improvement, establishing project goals and objectives, and establishing the study area and logical termini. The feasibility of a design depends on the social, economic, environmental, and engineering effects of the proposed highway improvement. Previous studies and decisions should be reaffirmed and/or updated as necessary. Other factors that must be considered include:

- existing traffic volumes and capacity deficiencies;
- crash information;
- alignment and profile deficiencies;
- structural integrity of bridges, pavements, and culverts;
- lane and shoulder widths;
- roadside safety;
- transportation demand;
- potential cost savings to the traveling public;
- enhanced economic development potential;
- programming guidelines;
- commitments to elected officials; and
- public input.

Further study may result in revisions to the preliminary need.

PROJECT ACTIVITY (Phase I)

<u>Activity Title:</u>	Collect Data
<u>Activity No.:</u>	05
<u>Responsible Unit:</u>	Project Study Group

Activity Description:

Once the project need has been identified (Activity 04), the project study group must gather and inventory information and data for the project. All types of data, including social, economic, environmental, and engineering, should be gathered simultaneously. The amount and type of information to be collected will vary with the nature and scope of the proposed improvement. Some of the information that is gathered includes:

- roadway, field, aerial, and stream surveys;
- existing roadway classifications and truck routes;
- existing as-built plans and maintenance records;
- existing highway geometrics;
- existing on-street parking;
- crash rate maps and collision diagrams;
- pavement and bridge condition reports;
- existing ROW information and any encroachments;
- ADT traffic maps and DHVs for current and design year traffic (all affected routes);
- inventory of posted speed limits;
- detailed transportation maps and plans with all modes of travel included;
- utility installations and detailed maps from utility companies;
- hydraulics survey, drainage survey, sewer atlas, and flooding information tables;
- fire districts, mail and school bus routes, location of churches, drainage districts, historic sites, and field-tile maps;
- commercial, agricultural, industrial, recreational, historic, and residential land use;
- conservation areas, archaeological sites, wetlands, special waste sites, etc.;
- local, State, and Federal agency coordination needs;
- current topographic mapping and aerial photographic mosaics;
- geotechnical investigations;
- joint development uses and scenic easements;
- estimate of cost (see Section 11-2.15) and road-user benefits (see Section 11-7.01); and
- maintenance agreements with locals.

See Chapters 11 and 12 for further guidance on the information that should be collected for a Phase I study. See Section 23-2 for further guidance on the collection of environmental information for the project.

PROJECT ACTIVITY (Phase I)

Activity Title: Analyze Existing Conditions

Activity No.: 06

Responsible Unit: Project Study Group

Activity Description:

Using as-built plans, aerial and/or field surveys, previously prepared reports, and data collected in Activity 05, the project study group will review and identify the following existing conditions:

- the locations of streams, railroads, and other topographic features;
- existing traffic and capacity deficiencies;
- pavement, bridge, and culvert structural integrity;
- crash information;
- alignment and profile deficiencies;
- existing lane and shoulder widths;
- existing ROW, ROW constraints, and encroachments;
- roadside safety concerns;
- existing and planned land uses from local governments, MPOs, fire districts, schools, etc.;
- existing agreements with utilities, railroads, local agencies, etc.;
- existing drainage patterns and drainage systems;
- sensitive noise receptors;
- wetlands, applicable 4(f), 6(f), and 106 sites, etc.;
- special waste sites; and
- tree and vegetation inventory.

If not already done, determine the State plane coordinates of all control points (POTs and PIs) from the project mapping/survey. Input this information and the radii of horizontal curves into a computer file to mathematically describe the alignment. Once an alignment is mathematized and tied into digitized mapping files, the alignment can then be stationed from west to east or south to north and the information stored as a computer file for further design work.

PROJECT ACTIVITY (Phase I)

Activity Title: Initiate Early Coordination/Public Involvement

Activity No.: 07

Responsible Unit: Project Study Group

Activity Description:

Coordination with other Department and governmental agencies, as appropriate, is an important aspect during the design study process. This coordination should begin as early as practical in project planning.

At this stage of the design study process, the project study group will initiate early coordination with other Department Units or Bureaus and governmental agencies (e.g., Environmental, FHWA, Land Acquisition, Construction, Operations, Bridges and Structures, Utilities) that have an interest in the project or have information or expertise concerning any issues the project may involve. The purpose of this coordination will be to assist in the identification of reasonable design alternatives and in gathering information to evaluate the social, economic, engineering, and environmental impacts of the proposed project and possible impact mitigation measures. This coordination should begin as early as practical. Early coordination will also identify the cooperating agencies.

Also, this Activity will allow the public an opportunity for input and comment on the project. Typically, this will consist of informational letters, advertisements, and/or meetings with local government officials, fire districts, school districts, drainage districts, historic commissions, MPOs, residents, businesses, etc. These meetings or letters may include:

- advising local, State, and Federal officials that a project has been initiated and that a study is underway;
- procedures for developing possible coordination and public service involvement;
- a discussion on the project scope;
- a request for information (e.g., MPO plans, drainage problems, transit needs);
- a discussion with businesses, railroads, and utility companies; and
- talking with individuals at public information meetings about individual concerns.

For projects which the Regional Engineer has determined will use the principles of CSS, the public involvement process should commence once the project is assigned to the project study group. The project study group uses the SIP as outlined in Sections 19-5.01 to conduct public involvement for CSS projects.

Public coordination must be ongoing throughout the project development. For guidance on public involvement, see Chapter 19.

PROJECT ACTIVITY (Phase I)

Activity Title: Identify Candidate Improvements

Activity No.: 08

Responsible Unit: Project Study Group

Activity Description:

Based on the information gathered (Activity 05) and analyzed (Activity 06), the project study group will review the types of improvements that meet the defined need for the project (Activity 04) and determine which designs are reasonable and cost effective. Some of the improvements that can be considered may include the following:

- increasing lane and shoulder widths;
- improving sight distance (e.g., stopping, decision, intersection);
- upgrading or realigning horizontal curves;
- improving superelevation rates and/or transition lengths;
- upgrading or realigning vertical curves;
- flattening grades;
- rehabilitating, reconstructing, or resurfacing the pavement;
- adding turn lanes or other improvements at intersections;
- upgrading, widening, or replacing structures;
- flattening side slopes;
- improving the clear zone;
- replacing and/or upgrading guardrail, impact attenuators, and end sections;
- replacing or upgrading signs, traffic signals, and lighting supports;
- adding or upgrading traffic signals;
- adding or upgrading highway lighting;
- upgrading pavement markings, including reflectorized pavement markings;
- upgrading culverts and/or other drainage systems;
- adding or removing curbs and gutters;
- adding mailbox turnouts;
- relocating utilities;
- upgrading railroad crossings and signals; and
- replacing or adding sidewalks, curb ramps, or bicycle facilities.

PROJECT ACTIVITY (Phase I)

Activity Title: Plot Existing/Proposed Topography, Typical Sections, Plan and Profile

Activity No.: 09

Responsible Unit: Project Study Group

Activity Description:

For this Activity, conduct the following:

- If not already done, plot the existing topography including property lines, property owner names, business names and type, names of roads, driveways/access roads, and all other important geographic and cultural features.
- Plot existing horizontal and vertical alignments and cross sections.
- Determine the proposed typical sections.
- Once the geometric elements have been set, determine the preliminary right-of-way limits.
- Determine the rough quantities for the proposed design and refine the cost estimate. If no quantities are available, use a generalized cost (e.g., cost per mile (kilometer)); see Sections 12-4 and 65-1.02.

IDOT uses the computer software program GEOPAK for laying out alignments, profiles, cross section designs, quantity calculations, and for determining construction limits. GEOPAK also can be used to generate 3-D and perspective plots for any portion of the roadway. Use 3-D plots in the design process to assess potential safety problems and the aesthetics of the design.

PROJECT ACTIVITY (Phase I)

Activity Title: Conduct In-Depth Analysis of Improvements

Activity No.: 10

Responsible Unit: Project Study Group

Activity Description:

For each of the candidate improvements identified in Activity 08, the project study group will conduct an analysis to determine if the improvement can be practically and cost effectively incorporated into the design. For example, the project study group will review the existing horizontal curvature against the criteria presented in Chapter 49 to determine if the existing curvature can be retained or should be upgraded. For each design improvement, the project study group should conduct a road user benefit analysis; see Section 11-7.01. Often, incorporating all the improvements found to be cost effective will exceed the proposed construction cost estimate for the project. Therefore, the project study group will need to prioritize the improvements to fit within the proposed construction funds or request additional funds to incorporate the changes. For CSS project, the project study group achieves consensus with CSS stakeholders on the range of improvements for the project.

The results of this and previous Activities will be submitted, as applicable, to the Hydraulics Unit, Geotechnical Unit, Bureau of Bridges and Structures, district Environmental Unit, and Project Support Section to allow these Units to prepare their applicable reports for the Project Report.

PROJECT ACTIVITY (Phase I)

Activity Title: Prepare Drainage Report (If Necessary)

Activity No.: 11

Responsible Unit: Hydraulics Unit

Activity Description:

Based on the information provided from the project study group (Activity 10), the Hydraulics Unit will perform the hydrology/hydraulics analysis, including the following:

- culvert sizing,
- longitudinal encroachments,
- existing and proposed storm drainage facilities,
- stormwater management, and
- pump stations.

Based on its evaluation, the Hydraulics Unit will prepare a Drainage Report. The project study group will use this information in making the final design determinations. It will also incorporate the Drainage Report into the final Project Report. See Chapter 40 and the *IDOT Drainage Manual* for more information on Drainage Reports.

PROJECT ACTIVITY (Phase I)

Activity Title: Prepare Geotechnical Report (If Necessary)

Activity No.: 12

Responsible Unit: Geotechnical Unit

Activity Description:

Based on the information provided from the project study group (Activity 10), the Geotechnical Unit will prepare the Geotechnical Report. The analyses may include:

- basic soil properties (e.g., AASHTO soils classification);
- shrink/swell factors;
- properties of subsurface strata;
- potential for slides; and
- slope stability at proposed cuts.

Based on its evaluation, the Geotechnical Unit will prepare a Geotechnical Report. The project study group will use this information in making the final design determinations. In addition, the Geotechnical Report will be incorporated into the final Project Report. See the *IDOT Geotechnical Manual* for more information.

PROJECT ACTIVITY (Phase I)

<u>Activity Title:</u>	Prepare Bridge Drawings/Reports
<u>Activity No.:</u>	13
<u>Responsible Unit:</u>	Bureau of Bridges and Structures/Project Study Group

Activity Description:

Based on the information provided from the project study group (Activity 10), the Bureau of Bridges and Structures (BB&S) will prepare the Proposed Structure Sketch for major structures, which will illustrate:

- the type of structures,
- approximate horizontal and vertical alignment and skew,
- approximate pier locations, and
- typical bridge deck section.

The project study group will prepare this sketch for other than major structures.

In addition, prepare the Bridge Condition Report for existing bridges which will include:

- a description of the physical conditions and deficiencies that mandate repair or replacement,
- a verification of the apparent soundness of any structure elements recommended for reuse plus the economic advantage gained by their reuse,
- a statement of any geometric or hydraulic improvement requirements, and
- a recommendation for the scope of the proposed work.

For additional information on the Proposed Structure Sketch and Bridge Condition Reports, see Chapter 39. The BB&S will also prepare the Hydraulics Report for major structures which will involve:

- the hydraulic analysis to determine the necessary dimensions of the waterway opening to pass the design flood, to meet the backwater allowances, and to satisfy any regulatory flood plain requirements;
- the hydraulic scour analysis to assist in determining the proper foundation design for the bridge; and
- a suggested freeboard elevation.

The project study group will prepare this report for other structures and the BB&S will approve the report.

The Structure Sketch and Hydraulics Report will be incorporated into the final Project Report.

PROJECT ACTIVITY (Phase I)

Activity Title: Prepare Environmental Documentation

Activity No.: 14

Responsible Unit: Environmental Unit

Activity Description:

Once the preliminary design improvements have been identified (Activity 08) and analyzed (Activity 10), the district Environmental Unit will initiate the environmental process. Typically, these projects will be classified as Categorical Exclusions (see Chapter 23).

This Activity will include:

- discussing the project at a coordination meeting, which may include obtaining FHWA concurrence in the appropriateness of the proposed environmental document processing type;
- assembling and analyzing the necessary information on environmental issues;
- determining and evaluating potential environmental impacts, mitigation measures, and applicable compliance requirements; and
- preparing the environmental documentation.

See Part III “Environmental Procedures” for further guidance on environmental documentation requirements and procedures.

PROJECT ACTIVITY (Phase I)

Activity Title: Conduct Preliminary Utility Review

Activity No.: 15

Responsible Unit: Project Support Section

Activity Description:

The project study group will provide the district Project Support Section with copies of the plan sheets for the proposed project. The Project Support Section will work with the applicable utility companies to identify project impacts on existing utilities and inform them of environmental issues that may affect their adjustments and relocations. The following items of work are typically performed:

1. Underground. The Project Support Section will coordinate with the district survey crew and will, if needed, request an underground survey to determine the depths and location of existing underground utilities within the project limits, especially fiber optic cables, water supply, and sanitary lines in urban areas.
2. Overhead. For any major above-ground utilities that may be impacted by the project, the Project Support Section may prepare a cost estimate to determine if a special effort should be exercised to avoid certain utilities.
3. Impacts. The Project Support Section will notify any utility companies that will be potentially impacted by the upcoming project, and the Section will request that the Utility contact IDOT if it plans any work in the vicinity of the project.

The Project Support Section will document its findings in a report or memorandum and submit it to the project study group. The project study group will use the information in making the final design determinations and document its findings in the Project Report.

For additional guidance on utility coordination, see Chapter 6.

PROJECT ACTIVITY (Phase I)

Activity Title: Develop Transportation Management Plan

Activity No.: 16

Responsible Unit: Project Study Group

Activity Description:

The maintenance of traffic flow during construction of a State highway will involve traffic and worker safety, public relations, and capital costs to the Department. A well-planned method for maintaining traffic flow can minimize complaints from the traveling public and from residents and businesses along the affected route. Each construction site must be evaluated on its own merits as to the appropriate method for maintaining traffic. The Project Report should contain a Transportation Management Plan (TMP) indicating an overall strategy for accommodating traffic during construction. Chapter 13 presents the goals and objectives for a TMP. The TMP should address the preferred traffic control method, alternative traffic control applications, geometric design criteria, the impact traffic will have on other facilities, local concerns, cost effectiveness of various alternatives, etc. Chapter 55 and the *Highway Standards* provide the design criteria to use when designing a traffic control plan. In addition, consider the following:

- The TMP not only must address the alternatives confined to the project site, but it must also evaluate the impact traffic will have on the entire corridor.
- No formal public involvement activity (e.g., design hearing) should occur until a recommended alternative has been decided upon based on the TMP Report. However, informal public involvement will be necessary during the analysis of alternatives.

PROJECT ACTIVITY (Phase I)

Activity Title: Obtain Detour Approval (If Required)

Activity No.: 17

Responsible Unit: Project Study Group

Activity Description:

In general, the TMP (Activity 16) will be approved as part of the Project Report. For all marked and unmarked detours, or for a road proposed to remain open by either stage construction or a runaround, the TMP will be approved by the district Detour Committee. Exceptions to the TMP, as discussed in Chapter 13, will be through the Bureau of Safety Programs and Engineer. For a closed unmarked State highway, also coordinate with the local county officials prior to the submittal of the Project Report.

PROJECT ACTIVITY (Phase I)

Activity Title: Set Pre-Final Geometry and Right-of-Way

Activity No.: 18

Responsible Unit: Project Study Group

Activity Description:

Based on the previous analyses for the recommended design improvements and information provided by others (Activities 10, 11, 12, 13, 14, and 15), the project study group will:

- make any necessary adjustments to the selected vertical and horizontal alignments;
- obtain approval of all design exceptions by BDE and, where necessary, FHWA.
- make any necessary adjustments to the typical sections;
- set preliminary construction limits;
- set preliminary right-of-way limits;
- determine any easement requirements; and
- determine if any utility adjustments or displacements are necessary.

See Part IV "Roadway Design Elements" and Part V "Design of Highway Types" for detailed information on geometric design and the *IDOT Land Acquisition Manual* for guidance on right-of-way impacts.

PROJECT ACTIVITY (Phase I)

Activity Title: Prepare Draft Project Report

Activity No.: 19

Responsible Unit: Project Study Group

Activity Description:

Once the analyses have been conducted and the information gathered, the project study group will prepare the draft Project Report. Chapter 12 presents the format that should be used when preparing a Project Report. Because the design study should be essentially complete, it should be possible to prepare the draft Project Report in its near-final format. The discovery of new, significant information during the public meeting (Activity 20) should be rare if the design study has been properly developed. The only changes necessary to prepare the final Project Report should be the addition of information concerning the public meeting (Activity 20), incorporation of revisions, if necessary, to respond to comments received at the public meeting, and inclusion of final conclusions/recommendations.

In general, the draft Project Report should be submitted to FHWA and BDE for review prior to its availability for public viewing and inspection at the public meeting. Formal approval by BDE for release is not normally issued. Copies made available to the public should be marked as “draft” or “preliminary.”

The Project Report should include:

- Project Report approval form;
- a summary of need and location of the project;
- description of the proposed improvements;
- a list of all design improvements eliminated and the reasons for their elimination;
- a summary of the environmental sign-offs obtained;
- the results of public involvement;
- the proposed temporary traffic plan;
- a list of commitments made to the public, Federal, and local agencies, etc.;
- the estimate of costs;
- an appendix showing typical sections, aerial photography, mapping, etc.; and
- reference to analyses and other reports conducted during the design study, including the environmental document, if applicable.

For further guidance on information to be included in the Project Report, see Chapter 12.

PROJECT ACTIVITY (Phase I)

Activity Title: Conduct Public Meeting

Activity No.: 20

Responsible Unit: Project Study Group

Activity Description:

As required by the project, a public meeting will be held at this stage of the project study to present to the public, and other interested organizations and agencies, the proposed design, a summary of the analyses for the various design improvements determined not to be feasible, and the criteria used to select the final design. Other Department Sections or Bureaus (e.g., Land Acquisition), as necessary, may attend the public meeting to answer specific questions relative to their expertise. When a project will require minimal amounts of land from a small number of property owners (e.g., 10 or fewer) and the project is not anticipated to be controversial, contacts with individual landowners may be sufficient to address public involvement needs. See Section 19-3.02 for further guidance on this option.

For CSS projects, public meetings will occur throughout the Phase I process.

The project study group will evaluate all comments from the public meeting and will prepare responses to these comments as appropriate. Possible responses include:

- modifying the design;
- developing and evaluating alternatives not previously given serious consideration;
- supplementing, improving, or modifying analyses;
- making factual corrections; or
- explaining why the comments do not warrant further agency response, citing the sources, authorities, or reasons which support that position and, if possible, indicating those circumstances that would trigger reappraisal or further response.

Chapter 19 discusses the requirements for public information meetings and for responding to comments received during the public meeting.

PROJECT ACTIVITY (Phase I)

Activity Title: Obtain Environmental Decision

Activity No.: 21

Responsible Unit: Environmental Unit

Activity Description:

As stated in Activity 14, most 3R projects are Categorical Exclusions (CE). For CE projects, the district Environmental Unit must obtain CE approval from FHWA unless the project qualifies as a State Approved CE; see Chapter 23.

PROJECT ACTIVITY (Phase I)

Activity Title: Prepare Final Project Report

Activity No.: 22

Responsible Unit: Project Study Group

Activity Description:

The comments received from the public and other agencies should be analyzed to determine if any changes are necessary in the draft Project Report and if any relevant issues have been overlooked. If an oversight has occurred, additional studies may be required to explain the resultant effects and determine what project design changes, if any, are necessary. After the review and analysis of comments is complete and appropriate revisions made, the final Project Report may be prepared. Activity 19 and Chapters 11 and 12 list the appropriate format, reports, and discussions that should be included in the Project Report. The final Project Report will also include or reference the final environmental documentation received from the district Environmental Unit.

After completing all public involvement and environmental requirements, the original scaled mapping is reduced for insertion into an appendix of the Project Report. Prepare the reduced mapping sheets and other engineering exhibits on 11 in. x 17 in. sheets and place them in an appendix. In addition, place the aerial photography (access control plans) showing the alternatives advanced for environmental analysis and any other environmental exhibits on 11 in. x 17 in. sheets and place them in an appendix. The 11 in. x 17 in. format provides for ease of use of all final exhibits by Planning, Design, and Land Acquisition personnel.

PROJECT ACTIVITY (Phase I)

Activity Title: Obtain Design Approval

Activity No.: 23

Responsible Unit: BDE

Activity Description:

Section 12-5.05 provides information on whether the Regional Engineer, or BDE will approve the Project Report. Generally for these types of projects, the Regional Engineer will approve the Project Report. If the proposed improvement requires approval by BDE submit two copies of the report to BDE for review and approval.

Before any reports can be finalized and submitted to BDE, the district must ensure:

- the applicable requirements in Part II "Project Development" and Part III "Environmental Procedures" have been met;
- public involvement activities as described in Chapter 19 have been completed;
- the environmental documentation and environmental decision have been received with the appropriate approvals;
- if applicable, coordination with FHWA has been completed; and
- all design exceptions have been approved by BDE, and, where necessary, FHWA.

3-3.02 Phase II Design

Figure 3-3.B illustrates a typical Phase II flowchart or network for a minor widening or 3R project on existing alignment. Because the design procedures are essentially the same as that for a project on existing alignment that will require major ROW acquisitions, the activity write-ups for Figure 3-2.B also apply to Figure 3-3.B and are not presented here; see Section 3-2.02. However, some judgment must be used when reviewing the activities in Section 3-2.02 as not all activities or all elements of an activity may apply. For example, if the proposed pavement resurfacing thickness matches the criteria in Section 53-4.02, it will not be necessary to request the Pavement Design Section to conduct a pavement design and selection (Activity 09). As another example, it will not be necessary to prepare access control plans for these types of projects (Activity 17). Note that, to expedite the design process, some activities may have already begun during Phase I (e.g., bridge replacement designs, land acquisition).

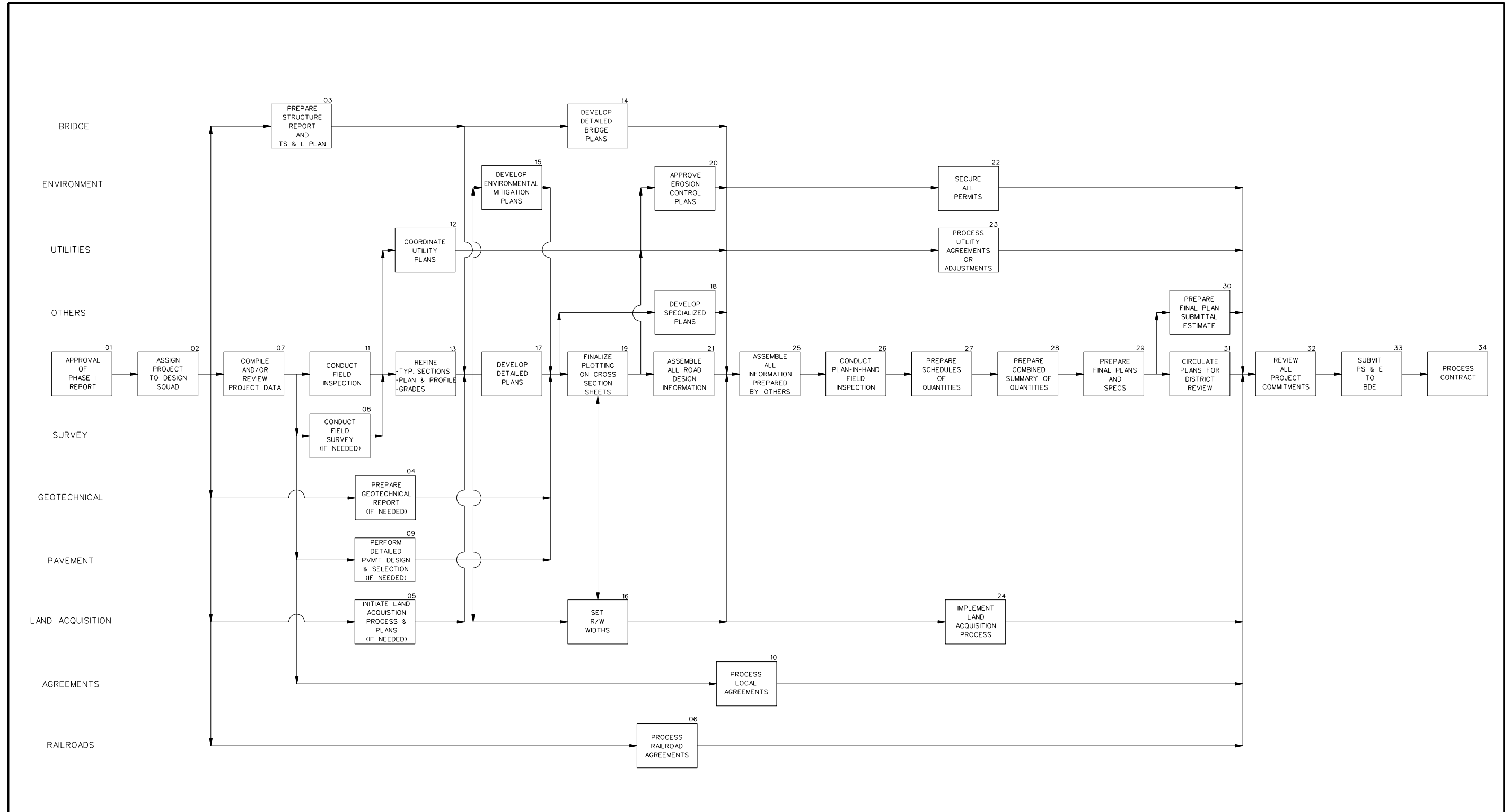

PHASE II PROJECT DEVELOPMENT NETWORK
(3R or Minor Widening Project on Existing Alignment)

Figure 3-3.B

3-4 PROJECT WITH NO RIGHT-OF-WAY ACQUISITIONS

Figure 3-4.A illustrates a combined Phase I and Phase II flowchart or network for SMART, 3P, or Interstate resurfacing projects on existing alignment not requiring additional right-of-way. These projects are classified as Categorical Exclusion projects and will require a Project Report, Abbreviated Project Report, 3P Report, or SMART Report. For guidance on the preparation and format of these reports, see Chapters 11 and 12. For other project types, see the flowcharts in Chapter 2, Section 3-2, and Section 3-3. See Chapter 52 for information on SMART projects. See Chapter 53 for information on 3P projects.

Following Figure 3-4.A are brief write-ups for each activity. Because of the variety of the project types that apply to this flowchart, some judgment must be used because not all activities or all elements of an activity may apply. Also note that, to expedite the design process, some activities may start prior to the completion of Phase I.

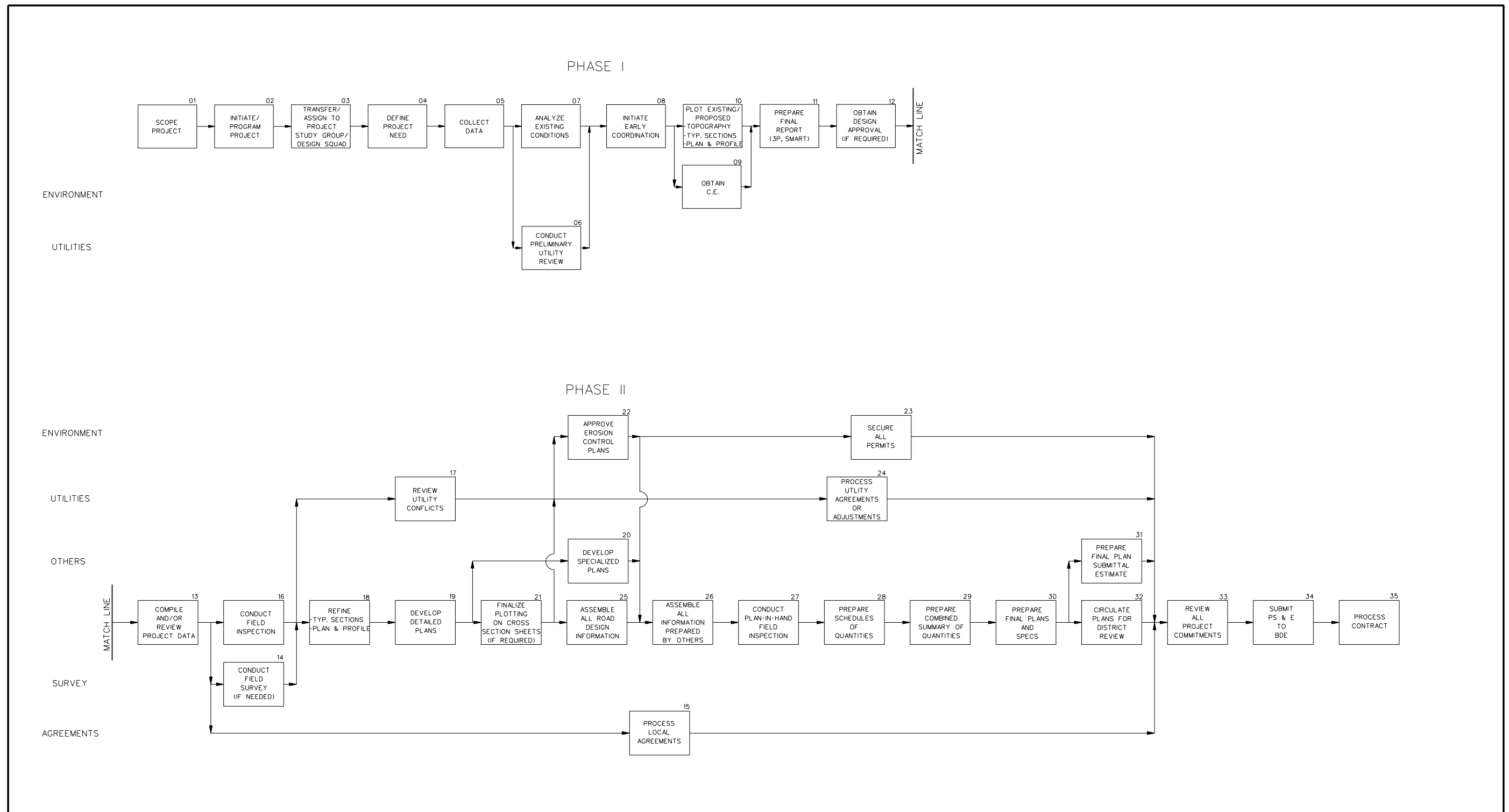

PHASE I & PHASE II PROJECT DEVELOPMENT NETWORK
(Projects Requiring No Right-of-Way)

Figure 3-4.A

PROJECT ACTIVITY (Phase I)

<u>Activity Title:</u>	Scope Project
<u>Activity No.:</u>	01
<u>Responsible Unit:</u>	District Bureau of Program Development

Activity Description:

A roadway project proposal can originate from a variety of sources, including local officials or metropolitan planning organizations (community-based need), directly from the IDOT district (district-based need), from a Bureau in the central office (Office of Planning and Programming, BDE, Operations, Bureau of Safety Programs and Engineering, etc.), or other sources targeting a special need or a statewide need.

Before a project is entered onto the Department's Proposed Highway Improvement Program, the district Programming Section initially develops and documents the project concept. Developing the project concept will typically involve the following:

- establishing that there is, in fact, a need for the project;
- making a preliminary determination of the project scope of work;
- reviewing any available data and records;
- reviewing existing plans;
- conducting an initial evaluation of right-of-way, utility, and environmental impacts; and
- developing a rough, preliminary cost estimate.

This information is forwarded for review and comment to district Program Development, district Operations, BDE, district Environmental Unit, the Bureau of Bridges and Structures, and other individuals, as appropriate. District Programming will refine the scope based on the comments received.

Once the scope, cost, and schedule have been defined, district Programming will forward this information to the Office of Planning and Programming for incorporation into the Department's multi-year program (Activity 02).

PROJECT ACTIVITY (Phase I)

Activity Title: Initiate/Program Project

Activity No.: 02

Responsible Unit: Office of Planning and Programming

Activity Description:

Candidate projects are submitted by the districts as a request for project programming to the Office of Planning and Programming. Based on a Statewide assessment of highway improvement needs and available funds, the Office of Planning and Programming will develop the Department's Proposed Highway Improvement Program. This will establish an individual project as an active project for further development.

The Office of Planning and Programming annually issues guidelines for multi-year programming criteria. This includes programming criteria for:

- improvement categories,
- pavement surface conditions,
- deficient bridges,
- safety improvements,
- Interstate rehabilitation,
- widening narrow and deteriorated pavements,
- improving intersections and reducing traffic bottlenecks,
- new construction/reconstruction of major facilities,
- transportation enhancement projects,
- Congestion Mitigation Air Quality (CMAQ) projects, and
- bicycle accommodation.

PROJECT ACTIVITY (Phase I)

Activity Title: Transfer/Assign to Project Study Group/Design Squad

Activity No.: 03

Responsible Unit: Studies and Plans Engineer

Activity Description:

At this point the project will either be assigned to a project study group/design squad within the district Bureau of Program Development or to a consultant to begin the design study. Because of the length and type of activity for these projects, typically the same unit which conducts the Phase I study will also perform the Phase II design. The Studies and Plans Engineer will have the overall day-to-day responsibility for advancing the project through plan submittal. The Studies and Plans Engineer, or designee, will:

- coordinate directly with other units within the Department;
- attend all internal meetings and field inspections;
- ensure that the project study meets all Department criteria and procedures;
- report directly to the District Program Development Engineer on all significant project activities, problems, and developments; and
- participate in the public involvement process.

The number and expertise of personnel initially assigned to the project will vary with the nature and scope of the proposed improvement. The personnel assigned will also vary over time relative to the priority for completion, the available lead time, and the activity in project development under study.

If the project is one which the Regional Engineer has determined will use the principles of Context Sensitive Solutions (CSS), the public involvement process should commence at this point. The project study group uses the Stakeholder Involvement Process (SIP) as outlined in Sections 19-5.01 to conduct public involvement for CSS projects.

PROJECT ACTIVITY (Phase I)

Activity Title: Define Project Need

Activity No.: 04

Responsible Unit: Project Studies Group/Design Squad

Activity Description:

For a transportation project, the project study group/design squad must first define the project need, which will direct the process for the identification of design alternatives, in-depth analyses and, ultimately, selection of the preferred design. This will consist of reaffirming the need for the proposed improvement, establishing project goals and objectives, and establishing the study area and logical termini. Previous studies and decisions should be reaffirmed and/or updated as necessary. Other factors that must be considered include:

- existing traffic volumes;
- crash information;
- alignment and profile deficiencies;
- structural integrity of bridges, pavements, and culverts;
- lane and shoulder widths;
- roadside safety;
- transportation demand;
- potential cost savings to the traveling public;
- programming guidelines;
- commitments to elected officials; and
- public input.

PROJECT ACTIVITY (Phase I)

<u>Activity Title:</u>	Collect Data
<u>Activity No.:</u>	05
<u>Responsible Unit:</u>	Project Study Group/Design Squad

Activity Description:

Once the project need has been identified (Activity 04), the project study group/design squad must gather and inventory information and data for the project. Environmental and engineering data, should be gathered simultaneously. The amount and type of information to be collected will vary with the nature and scope of the proposed improvement. Depending on the project type, information gathered may include:

- roadway, field, aerial, and stream surveys;
- existing roadway classifications and truck routes;
- existing as-built plans and maintenance records;
- existing highway geometrics;
- existing on-street parking;
- crash rate maps and collision diagrams;
- pavement and bridge condition reports;
- existing ROW information and any encroachments;
- ADT traffic maps and DHVs for current traffic (all affected routes);
- inventory of posted speed limits;
- detailed transportation maps and plans with all modes of travel included;
- utility installations and detailed maps from utility companies;
- hydraulics survey, drainage survey, sewer atlas, and flooding information tables;
- fire districts, mail and school bus routes, location of churches, drainage districts, historic sites, and field-tile maps;
- commercial, agricultural, industrial, recreational, historic, and residential land use;
- endangered and threatened species, wetlands in right-of-way, special waste sites, etc.;
- local, State, and Federal agency coordination needs;
- geotechnical investigations; and
- estimate of cost (see Section 11-2.15) and road-user benefits (see Section 11-7.01).

See Chapters 11 and 12 for further guidance on the information that should be collected for a Phase I study.

PROJECT ACTIVITY (Phase I)

Activity Title: Conduct Preliminary Utility Review

Activity No.: 06

Responsible Unit: Project Support Section

Activity Description:

The project study group/design squad will provide the district Project Support Section with information on the proposed project. The Project Support Section will work with the applicable utility companies to identify project impacts on existing utilities. The following items of work are typically performed:

1. Underground. The Project Support Section will coordinate with the district survey crew and will, if needed, request an underground survey to determine the depths and location of existing underground utilities within the project limits, especially fiber optic cables, water supply, and sanitary lines in urban areas.
2. Overhead. Any major above-ground utilities that may be impacted by the project. The Project Support Section may prepare a cost estimate to determine if a special effort should be exercised to avoid certain utilities.
3. Impacts. The Project Support Section will notify any utility companies that will be potentially impacted by the upcoming project, and the Section will request that the Utility contact IDOT if it plans any work in the vicinity of the project.

The Project Support Section will document its findings in a report or memorandum and submit it to the project study group/design squad. The project study group/design squad will use the information in making the final design determinations and document its findings in the final report.

For additional guidance on utility coordination, see Chapter 6.

PROJECT ACTIVITY (Phase I)

Activity Title: Analyze Existing Conditions

Activity No.: 07

Responsible Unit: Project Study Group/Design Squad

Activity Description:

Using as-built plans, aerial and/or field surveys, previously prepared reports, and data collected in Activity 05, the project study group/design squad will review and identify the following existing conditions:

- the locations of streams, railroads, and other topographic features;
- existing traffic and capacity deficiencies;
- pavement, bridge, and culvert structural integrity;
- crash information;
- alignment and profile deficiencies;
- existing lane and shoulder widths;
- existing ROW, ROW constraints, and encroachments;
- roadside safety concerns;
- existing and planned land uses from local governments, MPOs, fire districts, schools, etc.;
- existing agreements with utilities, railroads, local agencies, etc.;
- existing drainage patterns and drainage systems;
- sensitive noise receptors;
- wetlands in the right-of-way;
- special waste sites; and
- tree and vegetation inventory.

PROJECT ACTIVITY (Phase I)

Activity Title: Initiate Early Coordination

Activity No.: 08

Responsible Unit: Project Study Group/Design Squad

Activity Description:

Coordination with other Department and governmental agencies, as appropriate, is an important aspect during the design study process. This coordination should begin as early as practical in project planning.

At this stage of the design study process, the project study group/design squad will initiate early coordination with other Department Units or Bureaus (e.g., Environmental, Land Acquisition, Construction, Operations, Bridges and Structures, Utilities), CSS stakeholders, and governmental agencies (e.g., FHWA, MPOs) that have an interest in the project or have information or expertise concerning any issues the project may involve. The purpose of this coordination will be to assist in the identification of reasonable design alternatives and in gathering information to evaluate the engineering and environmental impacts of the proposed project and possible impact mitigation measures. This coordination should begin as early as practical. Early coordination will also identify the cooperating agencies.

Also, if applicable, this Activity should allow the public an opportunity for input and comment on the project. Typically, this will consist of informational letters, advertisements, and/or meetings with local government officials, fire districts, school districts, drainage districts, historic commissions, MPOs, residents, businesses, etc. These meetings or letters may include:

- advising local, State, and Federal officials that a project has been initiated and that a study is underway;
- procedures for developing possible coordination and public service involvement;
- a discussion on the project scope;
- a request for information (e.g., MPO plans, drainage problems, transit needs);
- a discussion with businesses, railroads, and utility companies; and
- talking with individuals about individual concerns.

For projects which the Regional Engineer has determined will use the principles of Context Sensitive Solutions (CSS), the public involvement process should commence once the project is assigned to the project study group. The project study group uses the Stakeholder Involvement Process (SIP) as outlined in Sections 19-5.01 to conduct public involvement for CSS projects.

Public coordination must be continuous throughout the project development. For guidance on public coordination, see Chapter 19.

PROJECT ACTIVITY (Phase I)

Activity Title: Obtain CE

Activity No.: 09

Responsible Unit: Environmental Unit

Activity Description:

Once the type of design improvements have been identified (Activity 04), analyzed (Activity 07), and the early coordination initiated (Activity 08), the district Environmental Unit will initiate the environmental process. Typically, these projects will be Categorical Exclusions (see Chapter 23).

This Activity will include:

- assigning a team to the project;
- discussing the project at a district coordination meeting, as appropriate, which may include obtaining FHWA concurrence, if necessary, in the appropriateness of the proposed environmental processing type;
- assembling and analyzing information on any potential environmental effects;
- determining and evaluating alternatives;
- preparing the appropriate environmental documentation;
- coordinating the environmental documentation for review, as appropriate; and
- obtaining/documenting the environmental decision.

PROJECT ACTIVITY (Phase I)

Activity Title: Plot Existing/Proposed Topography, Typical Sections, Plan and Profile

Activity No.: 10

Responsible Unit: Project Study Group/Design Squad

Activity Description:

For this Activity, conduct the following:

- If not already done, plot the existing topography including property lines, property owner's names, names of roads, driveways/access roads, and all other important geographic and cultural features.
- Plot existing horizontal and vertical alignments and cross sections.
- Determine the proposed typical sections.
- Determine the rough quantities for the proposed design and refine the cost estimate. If no quantities are available, use a generalized cost (e.g., cost per mile (kilometer)); see Sections 12-4 and 65-1.02.

PROJECT ACTIVITY (Phase I)

Activity Title: Prepare Final Report

Activity No.: 11

Responsible Unit: Project Study Group/Design Squad

Activity Description:

Once the analyses have been conducted and the information gathered, the project study group/design squad will prepare the final report. The type of report will depend on the project type; see Chapter 12, which also presents the format that should be used when preparing these reports.

The final report should include:

- approval form;
- a summary of need and location of the project;
- description of the proposed improvements;
- a summary of the environmental sign-offs obtained;
- the results of public involvement;
- a list of commitments made to the public, Federal and local agencies, etc.;
- the estimate of costs;
- exhibits showing typical sections, etc.; and
- copies of analyses and other reports conducted during the design study, including any environmental sign-offs, if applicable.

PROJECT ACTIVITY (Phase I)

Activity Title: Obtain Design Approval

Activity No.: 12

Responsible Unit: Project Study Group

Activity Description:

Generally for these types of projects, the Regional Engineer will approve the Report. If the proposed improvement requires approval by BDE, submit two copies of the Report to BDE for review and approval.

Before any reports can be finalized , the district must ensure:

- the applicable requirements in Part II “Project Development” and Part III “Environmental Procedures” have been met;
- if applicable, public involvement activities as described in Chapter 19 have been completed;
- the environmental documentation has been reviewed and the environmental decision obtained/documented;
- if applicable, coordination with FHWA has been completed; and
- all design exceptions have been approved by BDE, and, where necessary, FHWA.

PROJECT ACTIVITY (Phase II)

Activity Title: Compile and/or Review Project Data

Activity No.: 13

Responsible Unit: Design Squad/Project Study Group

Activity Description:

This Activity begins Phase II. The design squad/project study group should review the Phase I report and project files to become familiar with the decisions and determinations made during Phase I. Some of the information and decisions that should be reviewed may include:

- typical sections developed during Phase I,
- any technical reports prepared for the Phase I study,
- crash and traffic data,
- aerial/field surveys,
- the commitment file,
- any utility involvement, and
- any railroad involvement.

Based on this review, the design squad/project study group should evaluate what additional information and coordination with other units may be required to complete the project. At this stage of the project, the design squad/project study group should request:

- if necessary, the Surveys and Photo Services Unit to conduct additional surveys (Activity 14); and
- the Project Support Section to begin processing any necessary local agency agreements (Activity 15).

PROJECT ACTIVITY (Phase II)

Activity Title: Conduct Field Survey (If Needed)

Activity No.: 14

Responsible Unit: Surveys and Photo Services Unit

Activity Description:

In general, a survey should have been conducted during the development of the Phase I study. However, based on the review of the project data (Activity 13), the design squad/project study group may conclude that additional surveys are required. The needed survey information may include:

- existing field conditions (topography, vegetation, existing structures and road design features, etc.);
- drainage features (bodies of water, open channels, channel slopes and cross sections, existing drainage appurtenances, etc.);
- existing field landmarks;
- existing utilities (above and below ground);
- existing right-of-way markers and property lines; and
- alignment and cross section of existing roads and driveways.

PROJECT ACTIVITY (Phase II)

Activity Title: Process Local Agreements

Activity No.: 15

Responsible Unit: Project Support Section

Activity Description:

The district Project Support Section is responsible for the preparation and negotiation of formal agreements between the Department and local governments. These agreements may cover:

- division of work and expense involved between IDOT and the local agency in connection with the improvement,
- responsibilities for the future maintenance of the improvement,
- reimbursement of the costs incurred by the local agency,
- coverage of liability during construction operations, and
- reference to or identification of plans and plan approval.

The Project Support Section also will be responsible for coordinating the transfer of information and plans between the design squad/project study group and the local agency. This will be a continuous process throughout the design phase as the design plans are developed. The district Project Support Section also will coordinate with BDE for review and approval of any agreements. This process should be completed prior to the review of all project commitments (Activity 33).

For additional guidance on coordinating with local agencies, see Chapter 5.

PROJECT ACTIVITY (Phase II)

Activity Title: Conduct Field Inspection

Activity No.: 16

Responsible Unit: Design Squad/Project Study Group

Activity Description:

After completing the in-house review of the Phase I report and other project data, the design squad/project study group should conduct a field inspection of the project. The objective is to review major design features and project-related issues and to identify any potential problems. The design squad/project study group will arrange the field inspection and invite, as appropriate, individuals from the following units to the field inspection:

- district Bureau of Project Implementation,
- BDE,
- Bureau of Bridges and Structures,
- district Environmental Unit,
- district Bureau of Operations,
- district Geotechnical Unit,
- FHWA,
- local officials, and
- others as deemed appropriate.

The design squad/project study group will document the findings and decisions in the minutes of the field inspection.

PROJECT ACTIVITY (Phase II)

Activity Title: Review Utility Conflicts

Activity No.: 17

Responsible Unit: Project Support Section

Activity Description:

After conducting the field inspection (Activity 16) and any additional field surveys (Activity 14), the design squad/project study group will forward the preliminary construction plans with any known utilities plotted to the district Project Support Section. The Project Support Section will coordinate the transfer of information and plans between the design squad/project study group and the utility companies. The utility companies will review IDOT's plans, plot their facilities if not already shown, and determine any necessary utility adjustments/relocations. As the design squad/project study group refines the construction plans, this information will be submitted to the Project Support Section to be forwarded to the utility companies.

For guidance on preparing utility plans and coordinating with utility companies, see Chapter 6.

PROJECT ACTIVITY (Phase II)

Activity Title: Refine Typical Sections, Plan and Profiles

Activity No.: 18

Responsible Unit: Design Squad/Project Study Group

Activity Description:

Based on the review of the plans (Activity 13), the field inspection (Activity 16), the field survey (Activity 14), the Phase I report, and the project's commitment file, the design squad/project study group will refine and/or prepare the project's:

- cover sheet;
- general notes sheet;
- typical sections; and
- the plan and profile sheets.

Section 63-4 provides guidance on the information that should be included on these plan sheets.

PROJECT ACTIVITY (Phase II)

Activity Title: Develop Detailed Plans

Activity No.: 19

Responsible Unit: Design Squad/Project Study Group

Activity Description:

The design squad/project study group will prepare the detailed sheets that will be incorporated into the construction plans. This may include the following:

- temporary traffic control sheets;
- drainage sheets, including special drainage details;
- intersection details;
- pavement marking details;
- transition details;
- proposed cross sections, not including pavement template;
- signing plans, if not prepared by the district Bureau of Operations;
- highway lighting plans, if not prepared by others; and
- any other special details.

Section 63-4 presents guidance on what information should be included on each detail or plan sheet.

In addition, the design squad/project study group will:

- determine the proposed TMP for the project;
- determine the need for construction permits and/or temporary easements;
- perform a roadside safety analysis; and
- incorporate any special experimental features into the plans.

PROJECT ACTIVITY (Phase II)

Activity Title: Develop Specialized Plans

Activity No.: 20

Responsible Unit: Various Units

Activity Description:

Based on the typical sections, plan and profile sheets (Activity 18), and detailed plan sheets (Activity 19), various other units within IDOT will prepare their applicable plan sheets, quantities, and special provisions. This may include:

- district Bureau of Operations preparing the landscaping details;
- district Bureau of Operations preparing the signing plans, if included within the project;
- district Bureau of Operations (or Bureau of Electrical Operations in District 1) preparing the traffic signal plans; and/or
- BDE (or Bureau of Electrical Operations in District 1) preparing the highway lighting plans.

In addition, the following units may review the detailed plans prepared by the design squad/project study group (Activity 19):

- district Bureau of Operations will review the pavement marking details and temporary traffic control plans, and/or
- district Bureau of Project Implementation will review the temporary traffic control plans.

PROJECT ACTIVITY (Phase II)

Activity Title: Finalize Plotting on Cross Sections

Activity No.: 21

Responsible Unit: Design Squad/Project Study Group

Activity Description:

During Phase I, the cross sections may have been generated using GEOPAK to determine the initial quantities. Using the following information, update and plot the revised cross sections:

- information received from the Project Support Section on utility plans (Activity 06);
- the refined typical sections and plan and profile sheets (Activity 18); and
- the detailed plans (Activity 19).

Also during Activity 21, develop the erosion control plans and specifications according to the criteria in Chapter 41 and the information provided in the Phase I report. These plans and specifications will be submitted to the district Environmental Unit for review and approval (Activity 22).

PROJECT ACTIVITY (Phase II)

Activity Title: Approve Erosion Control Plans

Activity No.: 22

Responsible Unit: Environmental Unit

Activity Description:

The district Environmental Unit will review and approve the erosion control plans and specifications prepared by the design squad/project study group (Activity 21). Once approval has been granted, the erosion control plans will be incorporated into the construction plans (Activity 26). Also, once the erosion control plans have been approved, the Environmental Unit can initiate the process of securing the necessary project permits (Activity 23).

PROJECT ACTIVITY (Phase II)

Activity Title: Secure All Permits

Activity No.: 23

Responsible Unit: Environmental Unit

Activity Description:

After the cross sections have been finalized, the erosion control plans have been completed (Activity 21) and approved (Activity 22), and the typical sections and plan and profiles sheets have been completed (Activity 18), the district Environmental Unit will ensure all applicable permits and approvals required by the project are obtained. Depending upon the project-specific impacts, this may include any or all of the following:

- Section 401 water quality certification and Section 402 permit (NPDES) from the Illinois Environmental Protection Agency;
- U.S. Army Corps of Engineers, Section 404/Section 10 permit(s); and
- permits issued by Illinois State agencies.

All permits, certifications, and approvals should be received by the Department prior to the review of all project commitments (Activity 33).

Chapter 28 provides a brief description of all Federal and State environmental permits and certifications.

PROJECT ACTIVITY (Phase II)

Activity Title: Process Utility Agreements or Adjustments

Activity No.: 24

Responsible Unit: Project Support Section

Activity Description:

Based on the roadway plans (Activities 18, 19, and 21), the Project Support Section will work with the impacted utility companies and municipalities to implement the utility process. This process may include the following:

1. Plan Preparation. The utility companies are responsible for preparing all utility adjustment/relocation plans. The plans will be developed according to the criteria in Chapter 6.
2. Funding. Depending on the right-of-way ownership for existing and proposed utility locations, transportation funds may be eligible for utility adjustments/relocations required by the highway project; see Chapter 6. The Utilities pay for all betterments.
3. Agreements. The Project Support Section will prepare a Utility Agreement for each affected utility and will work with the utility companies to gain their input and approval. The Project Support Section will coordinate with BDE for review and approval of the agreements.

The Project Support Section will ensure that the utility process is completed before the review of all project commitments (Activity 33).

PROJECT ACTIVITY (Phase II)

Activity Title: Assemble All Road Design Information

Activity No.: 25

Responsible Unit: Design Squad/Project Study Group

Activity Description:

Throughout the design process, the design squad/project study group will have prepared the various plan sheets separately. In Activity 25, conduct the following:

- plot a complete set of plans developed to date (e.g., cover sheet, typical plans, plan and profile sheets, detail plans, cross sections);
- assemble the sheets in the recommended order as noted in Chapter 63;
- review the plans and details to ensure that all necessary information has been included and that the plans and details are compatible with each other;
- calculate the quantities for roadway design elements according to the criteria in Chapter 64 of the *BDE Manual*, the *Coded Pay Items*, and the *Standard Specifications for Road and Bridge Construction* for pay items, units of measurement, rounding conventions, etc.; and
- prepare all required special provisions.

At this time the Schedules of Quantities and the Summary of Quantities will not yet be prepared. For assembly purposes, blank Schedule of Quantities and Summary of Quantities may be included.

PROJECT ACTIVITY (Phase II)

Activity Title: Assemble All Information Prepared by Others

Activity No.: 26

Responsible Unit: Design Squad/Project Study Group

Activity Description:

Depending on the project, the design squad/project study group will have received the following completed plans, special provisions, pay items, and quantities from other IDOT units:

- the landscaping details from the district Bureau of Operations (Activity 20);
- the signing plans from the district Bureau of Operations (Activity 20);
- the traffic signal plans from the district Bureau of Operations (or Bureau of Electrical Operations in District 1) (Activity 20); and
- the highway lighting plans from BDE (or Bureau of Electrical Operations in District 1) (Activity 20).

In addition, the design squad/project study group will have received approval of the erosion control plans from the district Environmental Unit (Activity 22).

The design squad/project study group will review these materials 1) to identify and incorporate any information, which must be incorporated directly into the detailed road design plans, and 2) to assemble those plan sheets prepared by others into the overall set of construction plans.

PROJECT ACTIVITY (Phase II)

Activity Title: Conduct Plan-in-Hand Field Inspection

Activity No.: 27

Responsible Unit: Design Squad/Project Study Group

Activity Description:

At this stage of project development, all major design work has been completed, including roadway design, traffic items, erosion control plans, etc. The design squad/project study group is responsible for scheduling the Plan-in-Hand (PIH) review of the project. The PIH review is an in-depth office and on-site review of all project elements to ensure that all details and commitments have been satisfactorily incorporated into the construction plans and specifications, and that the project is nearly ready to advance to construction.

As applicable, the design squad/project study group will invite the following to conduct an office and PIH field inspection:

- district Bureau of Project Implementation,
- BDE,
- district Bureau of Operations,
- FHWA,
- local officials, and
- others as deemed appropriate.

Once the PIH office and field inspection have been completed, the design squad/project study group will prepare the PIH minutes to document all significant decisions made during the PIH review. After approval by the Program Development Engineer, distribute the PIH minutes to:

- all applicable Bureau Chiefs;
- Regional Engineer;
- all parties involved in the field review;
- FHWA, if applicable; and
- any other individuals or sections as deemed appropriate.

All parties receiving a copy of the PIH minutes are requested to provide comments on the minutes. Concurrence of the minutes will be assumed if no comments are received by the specified date.

PROJECT ACTIVITY (Phase II)

Activity Title: Prepare Schedules of Quantities

Activity No.: 28

Responsible Unit: Design Squad/Project Study Group

Activity Description:

Based on any modifications due to the Plan-in-Hand field inspection (Activity 27), the design squad/project study group will refine the project quantities for the roadway design items developed during Activity 25. Using these quantities and those provided by other IDOT units (Activity 26), the design squad/project study group will prepare the Schedule of Quantities sheets according to the criteria presented in Chapter 64. These quantities will be incorporated onto the Summary of Quantities Sheet (Activity 29).

PROJECT ACTIVITY (Phase II)

Activity Title: Prepare Combined Summary of Quantities

Activity No.: 29

Responsible Unit: Design Squad/Project Study Group

Activity Description:

Using the quantities developed in Activity 25, refined in Activity 28, and those provided by other IDOT units (Activity 26), the design squad/project study group will prepare the Summary of Quantities sheets, which will summarize all pay items necessary to construct the improvement. It also should include the applicable construction and safety code items, pay item code numbers, units of measurement, total quantities, and quantity breakdown for each section. One or more summary sheets typically will be included in each set of plans. Do not show other data on the summary sheets (e.g., general notes). When preparing the Summary of Quantities sheets, it is important that all quantities be calculated and segregated accordingly prior to completing the Summary of Quantities.

The design squad should coordinate with the Project Support Section to ensure that the percentages and cost breakdown in the Summary of Quantities and the Local Agency agreements are identical.

For additional guidance on preparing the Summary of Quantities, see Section 63-4.

PROJECT ACTIVITY (Phase II)

Activity Title: Prepare Final Plans and Specifications
Activity No.: 30
Responsible Unit: Design Squad/Project Study Group/Others

Activity Description:

Based on the Plan-in-Hand Review and minutes (Activity 27), all bureaus and sections responsible for their respective project plans will make all necessary plan and specifications revisions. This will produce the final set of project plans ready for construction. Specifically for the design squad/project study group, the design squad/project study group will be responsible for revising the roadway plans and specifications. Once completed, the plans will be distributed for district review (Activity 32) and will allow the District Estimating Engineer to prepare the Final Plan Submittal Estimate.

Complete quality control/quality assurance (QC/QA) prior to the plans being circulated for district review.

PROJECT ACTIVITY (Phase II)

Activity Title: Prepare Final Plan Submittal Estimate

Activity No.: 31

Responsible Unit: District Estimating Engineer

Activity Description:

Based on the information from the final plans and specifications (Activity 30), the District Estimating Engineer will prepare the final district cost estimate. This may be a new estimate or an update of an earlier cost estimate prepared during Phase I or a revised cost estimate prepared during Phase II. This estimate will be submitted to the BDE Project Management Unit, which will use it to develop the Engineer's Estimate.

Chapter 65 provides guidance on the preparation of project cost estimates.

PROJECT ACTIVITY (Phase II)

Activity Title: Circulate Plans for District Review

Activity No.: 32

Responsible Unit: Design Squad/Project Study Group

Activity Description:

Once all revisions from the Plan-in-Hand Review and minutes have been made to the plans and specifications (Activity 30), the design squad/project study group will submit a completed set of construction plans to the district units involved with the project for final review and comment. Typically, this review will consist of:

- reviewing the plans to ensure the reviewer's comments from previous reviews have been incorporated;
- ensuring that the changes do not conflict with the bureau's commitments; and
- ensuring that the plans conform to the Department's design criteria.

If changes are requested at this point which are desirable, but not mandatory, the Studies and Plans Engineer will determine if they should be incorporated. This will depend on other factors which may preclude the changes from being added to the plans. If another bureau determines the changes still should be incorporated, an appeal can be made to the Program Development Engineer for their incorporation.

PROJECT ACTIVITY (Phase II)

Activity Title: Review all Project Commitments

Activity No.: 33

Responsible Unit: Design Squad/Project Study Group

Activity Description:

At this point in project development, the project design is essentially complete. The design squad/project study group must ensure that the following elements have been completed and/or have been incorporated into the plans:

- all environmental permits have been secured (Activity 23);
- all utility agreements and adjustments have been processed and signed (Activity 24);
- the final district cost estimate has been completed (Activity 31);
- all local agreements and letters of understanding have been processed and signed (Activity 15); and
- all commitments made during the project development, including those made during Phases I and II, have been incorporated.

The design squad/project study group must carefully review all minutes of meetings and the project study files to ensure that all commitments have been incorporated. If there are any questions, the design squad/project study group should contact the preparer of the Phase I report or the Unit making the commitment during Phase II.

If it is discovered during the plan development that a change is required to the approved Phase I report or a commitment cannot be met, the design squad/project study group must immediately notify BDE and all other applicable units so that the appropriate action can be taken. Failure to provide the appropriate notification and review may result in project delay.

PROJECT ACTIVITY (Phase II)

<u>Activity Title:</u>	Submit PS&E to BDE
<u>Activity No.:</u>	34
<u>Responsible Unit:</u>	Design Squad/Project Study Group

Activity Description:

Once the plans are complete and the design squad/project study group has ensured all commitments, agreements, permits, etc., are complete or have been incorporated, the design squad/project study group will submit the following items to the BDE Program Support Unit:

- the Certification Acceptance/Project Status Form, signed by the Regional Engineer;
- a cover sheet signed by the Regional Engineer indicating his/her approval of the plans;
- one complete set of plans on reproducible paper, mylar, or vellum (see Chapter 63 for the Department's guidelines on preparing plan sheets);
- one copy of each special provision required for the project, including a copy of the electronic file in Microsoft Word format (see Section 66-1.04 for the procedures on developing special provisions);
- a completed Recurring Special Provision check sheet (see Chapter 66);
- the project quantities on Form BD-213 or BDE approved equal (see Chapter 64 for the procedures on determining plan quantities);
- the expected construction time for the project (see Section 66-2.03 for the Department's guidelines on determining the expected construction time); and
- copies or originals of all permits and agreements.

To place an improvement on any specific letting, it is imperative that the plans and supporting documents be submitted according to the schedules established in Section 66-2 which indicate the minimum number of weeks prior to the letting date for the submittal or completion of a particular phase of work.

PROJECT ACTIVITY (Phase II)

Activity Title: Process Contract

Activity No.: 35

Responsible Unit: BDE

Activity Description:

Once BDE has received the plans and other information from the district (Activity 34), it will conduct the following:

- prepare the Engineer's Estimate;
- verify that the plans are on the list of recommended projects;
- check the Certification Acceptance/Project Status Form;
- verify the project is programmed and the scope of work is correct;
- determine the final funding source;
- check all agreements to ensure they are consistent with the project;
- submit the plans, special provisions, quantities, etc., for review and comment;
- prepare the Transportation Bulletin and advertise the project;
- if necessary, submit the PS&E to FHWA for approval;
- prepare the contract proposal;
- submit the proposal and plans to bidders;
- implement the letting process;
- review all bids; and
- execute the contract.

For additional guidance on the contract process, see Chapter 66.

Chapter Four

COORDINATION RESPONSIBILITIES

BUREAU OF DESIGN AND ENVIRONMENT MANUAL

Chapter Four

COORDINATION RESPONSIBILITIES

BUREAU OF DESIGN AND ENVIRONMENT MANUAL

Chapter Four
COORDINATION RESPONSIBILITIES

Table of Contents

<u>Section</u>	<u>Page</u>
4-1 INTRODUCTION.....	4-1.1
4-2 FHWA OVERSIGHT AND INVOLVEMENT	4-2.1
4-2.01 Stewardship and Oversight Agreement.....	4-2.1
4-2.02 Projects of Division Interest (PoDI's).....	4-2.1
4-2.02(a) Projects Administered by Local Public Agencies	4-2.2
4-2.03 Oversight and Reporting Requirements	4-2.2
4-3 FUNCTIONAL RESPONSIBILITIES	4-3.1
4-3.01 Phase I Coordination	4-3.1
4-3.01(a) General	4-3.1
4-3.01(b) Environment.....	4-3.1
4-3.01(c) Public Involvement/Early Coordination	4-3.1
4-3.01(d) Governmental Coordination	4-3.2
4-3.01(e) Engineering Coordination	4-3.2
4-3.02 Agreements	4-3.2
4-3.03 Bridge Design	4-3.3
4-3.04 Bridge Deck Rehabilitation	4-3.3
4-3.05 Hydraulics.....	4-3.4
4-3.06 CADD Usage	4-3.4
4-3.07 Commitment File	4-3.4
4-3.08 Coordination with Bureau of Operations (Maintenance).....	4-3.5
4-3.09 Field Surveys.....	4-3.5
4-3.10 Roadway Drainage	4-3.5
4-3.11 Geotechnical Investigations and Reports	4-3.6
4-3.12 Patching Survey	4-3.7
4-3.13 Pavement Rehabilitation and Preservation	4-3.7
4-3.14 Pavement Design	4-3.7
4-3.15 Utilities Coordination.....	4-3.8
4-3.16 Railroad Involvement.....	4-3.8
4-3.17 Public Transportation Involvement	4-3.8
4-3.18 Rest Areas.....	4-3.9
4-3.19 Experimental Items	4-3.9
4-3.20 State and Federal Permits/Approvals.....	4-3.9
4-3.21 Traffic Engineering	4-3.10
4-3.22 Traffic Control Plans (TCP)	4-3.11
4-3.23 Plan-in-Hand Field Inspection	4-3.11
4-3.24 Special Waste.....	4-3.12

Table of Contents*(Continued)*

<u>Section</u>		<u>Page</u>
4-3.25	Coordination with Local Officials	4-3.12
4-3.26	Right-of-Way.....	4-3.13
4-3.27	NPDES/Erosion and Sediment Control	4-3.13
4-3.28	Landscaping	4-3.14
4-3.29	Coordination with BDE and FHWA.....	4-3.14
4-3.30	Project Cost Estimate	4-3.14
4-3.31	Comparison to Estimated Program Costs	4-3.15
4-3.32	Specifications and Special Provisions	4-3.15
4-3.33	Right-of-Way Purchased and All Permits Obtained.....	4-3.16
4-3.34	Construction Contract Items and Bid Letting	4-3.16
4-3.35	Pre-Construction Meeting.....	4-3.16

Chapter Four

COORDINATION RESPONSIBILITIES

4-1 INTRODUCTION

Chapter 4 discusses the FHWA/IDOT Stewardship and Oversight Agreement as it relates to the project coordination and approval process (Section 4-2), and the various coordination activities that occur during project development (Section 4-3).

Specifically, Section 4-3 presents a generic discussion of the approximate sequence of events that lead to the preparation of a set of construction plans, specifications, and cost estimate (PS&E), and has been prepared from the perspective of the district. The section identifies which functional unit within the Department is responsible for various project activities. Where applicable, it provides references to other *BDE Manual* chapters:

For the coordination discussion for Phase I (Section 4-3.01), the “project study group” is responsible for project development. For Phase II, the term “designer” is generic and refers to any project manager from the district; i.e., the designer is assumed to have responsibility for the indicated actions.

Several other *Manual* chapters discuss project coordination within different contexts. Refer to the chapters below for more information:

- Chapter 1 lists the organizational bureaus within IDOT’s Office of Program Development and the responsibilities of the functional units in the Bureau of Design and Environment.
- Chapters 2 and 3 present project development networks for several project types that describe, sequentially, the project activities.
- Chapters 5, 6, and 7 discuss coordination with local governments, utilities, and railroads.
- Chapters 11 – 15 discuss coordination for several studies that may be prepared during Phase I.
- Chapter 19 discusses coordination with the public on project input and district coordination meetings.
- Chapter 22 discusses coordination during implementation of the environmental process.
- Chapter 31 discusses the basic design criteria which control roadway design and the coordination process required when such criteria cannot be met (i.e., design exceptions).

4-2 FHWA OVERSIGHT AND INVOLVEMENT

4-2.01 Stewardship and Oversight Agreement

Section 106 of Title 23, U.S.C. (23 U.S.C. 106), requires that FHWA and the State enter into a Stewardship & Oversight (S&O) Agreement. The intent and purpose of the S&O Agreement is to document the roles and responsibilities of FHWA's Division Office and IDOT with respect to project approvals and related responsibilities, and to document the methods of oversight which will be used to efficiently and effectively deliver the Federal-aid Highway Program (FAHP).

The scope of FHWA responsibilities, and the legal authority for IDOT assumption of FHWA responsibilities, has developed over time. The most recent S&O Agreement between FHWA and IDOT was executed on May 27, 2015. The Agreement features a more targeted and "risk-based" approach rather than the traditional terminology of "full oversight." The notion of full oversight on Federal-aid projects by FHWA will no longer exist for all practical purposes, as Congress has recognized the need to give the States more authority to carry out project responsibilities traditionally handled by FHWA. The goal of the current risk based approach is to optimize the successful overall delivery of programs and projects and to help ensure compliance with federal requirements.

The current Stewardship and Oversight Agreement, including its Attachments A-D, is provided in *BDE Manual* Appendix A, "Regulations and Guidance", of Part III "Environmental Procedures."

Attachment A to the S&O Agreement contains a table entitled the "Project Action Responsibility Matrix", which outlines distinct typical project actions on or off the National Highway System (NHS), and whether those actions are to be carried out by FHWA or IDOT. Also Sections VI and VII of the S&O Agreement list specific permissible and non-permissible areas of IDOT assumption.

Attachment B to the S&O Agreement contains the "Program Responsibility Matrix" which specifies the program action responsibility, by activity, for FHWA and identifies both the FHWA and IDOT "responsible program office."

Attachment C to the S&O Agreement contains a list of all IDOT manuals and operating agreements through which the S&O Agreement is implemented.

Attachment D to the S&O Agreement and Section 4-2.02 below outline FHWA's selection and monitoring of Projects of Division Interest (PoDI's), a new FHWA oversight category which will be utilized along with project approval actions and the Compliance Assessment Program to ensure compliance with federal requirements.

4-2.02 Projects of Division Interest (PoDI's)

Approvals and related activities for which IDOT has assumed responsibilities as shown in Attachment A of the Stewardship and Oversight (S&O) Agreement will apply program wide, unless a specific project is listed by FHWA as a Project of Division Interest (PoDI). A PoDI is a project on which the responsibility for one or more of the actions indicated in Attachment A of the S&O Agreement as typically being assumed by IDOT will instead be retained by FHWA.

In coordination with IDOT, FHWA will annually select PoDI's and will finalize the list in June of each year. A PoDI plan will be developed by FHWA for each selected PoDI project. The PoDI plan will state the particular aspects of interest to FHWA and the specific actions for which FHWA will retain responsibility on the project.

Projects of Corporate Interest (PoCI's) are a subset of PoDI's. PoCI's are projects which have a national significance and may require FHWA resources beyond the Illinois Division. PoCI's will be included in the PoDI listing provided annually by FHWA, and will follow the guidelines for PoDI's.

The process by which PoDI's are coordinated between IDOT and FHWA is outlined in Attachment D of the S&O Agreement.

4-2.02(a) Projects Administered by Local Public Agencies

IDOT may permit Local Public Agencies (LPA's) to carry out IDOT's assumed responsibilities on locally administered projects. IDOT is responsible and accountable for LPA compliance with all applicable Federal laws and requirements.

4-2.03 Oversight and Reporting Requirements

FHWA and IDOT are responsible for ensuring financial integrity and compliance with applicable laws and regulations. The FHWA Division Office and IDOT may use techniques and processes such as program assessments, program reviews, certification reviews, periodic reviews such as the Compliance Assessment Program, or inspections of project elements or phases to ensure federal requirements are met. Oversight and reporting requirements will be in accordance with Sections X and XI of the S&O Agreement.

4-3 FUNCTIONAL RESPONSIBILITIES

Project development typically requires the completion of many functional work tasks. This Section briefly identifies which unit(s) is (are) responsible for the elements within each significant functional responsibility.

Section 4-3.01 summarizes the coordination responsibilities during the Phase I portion of project development. The remainder of Section 4-3 is primarily within the context of coordination responsibilities during the Phase II portion of project development.

4-3.01 Phase I Coordination

Reference: Chapters 2, 3, 11, 12, and 19, and Part III

4-3.01(a) General

The project study group or a consultant usually prepares Phase I reports. These reports are typically approved by the Regional Engineer. For large scale projects addressed by Corridor, Feasibility Study, and Combined Design Reports, the district requests design approval from the Project Development Unit in the Bureau of Design and Environment. Projects requiring a Phase I report that are proceeding to Phase II construction plans will be discussed at coordination meetings.

4-3.01(b) Environment

The project study group must coordinate closely with the district Environment Unit. For projects involving an EA or EIS, the district Environment Unit must coordinate closely with the Location and Environment Section within BDE throughout the development of the Phase I study to ensure that the project engineering analyses are consistent with the necessary project environmental analyses.

4-3.01(c) Public Involvement/Early Coordination

The project study group and district Environment Unit must coordinate during Phase I to fulfill the public involvement requirements and the early coordination requirements with other Department and governmental agencies. The Regional Engineer will determine if the project is to be developed using the principles of Context Sensitive Solutions (CSS), based on guidelines provided throughout the *BDE Manual*.

4-3.01(d) Governmental Coordination

The project study group must coordinate with the necessary Department, State, and Federal agencies to gather the necessary data for project evaluation (e.g., traffic, crashes, land-use plans, urban area transportation studies, bicycle plans).

4-3.01(e) Engineering Coordination

The project study group must coordinate with the applicable Department units to perform the engineering analyses necessary for a Phase I level of study, including:

- hydrology/hydraulics (district Hydraulics Unit and/or the Bureau of Bridges and Structures),
- intersection and interchange design studies (district Geometrics Unit)
- geotechnical and soils (district Geotechnical Unit),
- proposed structure sketches (Bureau of Bridges and Structures),
- utilities (district Project Support Section),
- detours (district Detour Committee),
- Highway Safety Improvement Program (HSIP) and crash trends (Bureau of Safety Programs and Engineering, district HSIP Coordinator and/or district Bureau of Operations),
- local agencies (district Project Support Section),
- aerial surveys (Surveys, Mapping and Modeling Section and district Surveys Unit), and
- bicycle/pedestrian impacts (district and BDE Bicycle and Pedestrian Coordinators).

4-3.02 Agreements

Reference: Chapters 5 through 7

1. The designer initiates action for the preparation of the following agreements:
 - a. Utility—Agreements Unit or Project Support Section
 - b. Railroads—Agreements Unit or Project Support Section
 - c. Local—Agreements Unit or Project Support Section
2. Because agreements often require considerable time to be prepared and processed, especially railroad agreements, work should be initiated as early as possible.

4-3.03 Bridge Design

Reference: Chapter 39

1. The bridge design process is initiated during the Phase I study, and the Phase I report will incorporate information from the Bridge Condition Report prepared by the district Bridge Engineer or by a consultant designated by the district and approved by the Bureau of Bridges and Structures.
2. The designer must determine if bridge hydraulics are required for bridge design and initiate action.
3. The designer requests that TS&L drawings be prepared in Phase II by the Bureau of Bridges and Structures or by a consultant designated by the district for any structures located within the project limits. Base information should be collected and summarized as early as practical.
4. The roadway and bridge designers coordinate the approach work, including guardrail-to-bridge-rail transitions; the bridge designer performs any structural design based on the approved TS&L plan.
5. The Bureau of Bridges and Structures (BBS) prepares all necessary PS&E elements for in-house designed structural items, including special provisions, quantities, and cost estimates. BBS will incorporate final structure plans and special provisions into the final contract once the plans are submitted to the Central Office for all in-house designed structural items. For structural projects not designed in-house, structural engineering consultants will complete all necessary PS&E elements and will submit final structure plans and special provisions to the district for forwarding to BBS.
6. Minor work on existing bridges is incorporated into the plans by the roadway designer (e.g., minor deck repairs, patching); however, work shall be submitted and approved by the Bureau of Bridges and Structures, ideally prior to PS&E.

4-3.04 Bridge Deck Rehabilitation

Reference: Chapter 39

1. Other than minor repairs, bridge deck rehabilitation work is performed by the district or a consultant designated by the district and submitted to the Bureau of Bridges and Structures for approval.
2. The designer must coordinate with the District Bridge Maintenance Engineer.

4-3.05 Hydraulics

Reference: Chapters 39 and 40

1. The designer must coordinate work with the district Hydraulics Engineer and/or the Bureau of Bridges and Structures in the Central Office.
2. The designer will request maintenance and flood records for the location through the district Hydraulics Engineer.
3. The designer and Hydraulic Engineer will decide the necessary surveying along the channel.

4-3.06 CADD Usage

Reference: Chapters 11 and 63

Except for very simple project designs, most projects will use Computer Aiding Design and Drafting (CADD). Refer to the IDOT *Computer Aided Design, Drafting, Modeling and Deliverables Manual* for information on preparation of roadway plans using CADD.

4-3.07 Commitment File

Reference: Chapters 11 and 12

1. This file is usually initiated during Phase I by the project study group and should be transferred to the designer when the designer receives the approved Phase I report.
2. This file may contain commitments to/for:
 - right-of-way;
 - cities, towns, villages, counties, or townships;
 - other agencies (e.g., State, Federal);
 - traffic operations;
 - driveways and entrances;
 - shared costs;
 - environmental issues; and
 - other issues requiring special attention.
3. The designer adds commitments to the file that were made during the project development.
4. The designer must document the transfer of this file to the district Bureau of Project Implementation.

4-3.08 Coordination with Bureau of Operations (Maintenance)

Reference: None

1. The project study group should contact the district Bureau of Operations early in the project development.
2. Operations should be involved in the development of the Phase I report (e.g., snow-drifting, drainage problems, pavement deterioration).
3. Operations should be invited to all patching surveys.
4. The designer should continuously coordinate with Operations during project study and design, especially for drainage facilities.
5. The designer should invite Operations to the Plan-in-Hand Field Inspection.

4-3.09 Field Surveys

Reference: IDOT *Survey Manual*

1. Surveying is located in the Bureau of Programming in District 1 and in the Bureau of Program Development in all other districts.
2. The survey typically is requested by the designer during the development of the Phase I report, or topographic data may be obtained from available mapping.
3. The designer may need to request additional surveys for bridge hydraulics, roadway drainage, erosion potential, entrance information, location of utilities, etc.
4. The designer may need to schedule additional field checks to determine surveying needs.

4-3.10 Roadway Drainage

Reference: Chapter 40

1. Large and/or complex structures are designed by the Bureau of Bridges and Structures or consultants.
2. For hydraulic design or procedural questions, the district Hydraulics Engineer should be contacted.
3. The designer determines designs for open channels (ditches) and closed systems (storm sewers). The project study group must have identified a drainage outlet in a Phase I report for closed drainage systems.

4. The designer is required to determine drainage areas, rainfall intensities, and culvert design and must design all closed drainage systems.
5. Drainage areas greater than 625 acres (250 ha) should have been identified by the project study group in the Phase I report. On large projects, a preliminary drainage report is prepared by the district Hydraulics Unit or engineering consultant and transferred to the designer.
6. The type and design of a pipe or box culvert will be determined by the designer or district Hydraulics Engineer using the IDOT *Culvert Manual*. Any drainage structure requiring a waterway opening greater than 7.5 ft² (0.7 m²) should be sized by the district Hydraulics Engineer. Multiple-box culverts, bridges, and three-sided structures will be designed by the Bureau of Bridges and Structures or structural engineering consultants.
7. Reference the Department's *Culvert Manual* and *Drainage Manual* for more information.

4-3.11 Geotechnical Investigations and Reports

Reference: None

1. The designer requests soil characteristics for pavement designs.
2. A Geotechnical Report should be completed in the planning stage; if not, the designer may need to request one from the district Geotechnical Unit.
3. Borings may be required for new pavements, bridges, box culverts, wingwalls, retaining walls, high-mast lighting, and deep storm sewers. Contact the district Geotechnical Unit to schedule borings.
4. The district Geotechnical Unit performs the following:
 - prepares the Soils Report (e.g., determines maximum fill and cut slopes, provides drainage recommendations for soils, determines the areas for removal of unsuitable materials);
 - performs simple pavement testing;
 - determines special materials to be used and provides assistance for special provisions;
 - determines when the Bureau of Bridges and Structures should be involved in the design of retaining walls and other types of walls; and
 - provides input on project schedules based on the expected availability of materials.
5. The Central Bureau of Materials (CBM):

- determines layer coefficients for special pavement designs,
 - performs complex pavement and soil tests, and
 - provides special assistance as needed.
6. See *Geotechnical Manual* for more information.

4-3.12 Patching Survey

Reference: Chapter 53

1. The designer will need to conduct a patching survey on pavement rehabilitation projects.
2. The designer should coordinate the survey with maintenance or off-peak construction personnel.
3. Usually, two patching surveys are conducted:
 - the first in Phase I to determine the preliminary scope of pavement work; and
 - the second near the end of the design phase to determine contract quantities.

4-3.13 Pavement Rehabilitation and Preservation

Reference: Chapters 52 and 53

1. These are established by IDOT policy.
2. The designer must adhere to policy. However, if the designer determines that policy is not applicable, the designer can request a variance from BDE. Design exceptions to policy shall be coordinated as applicable with the district Materials Section, BDE, CBM, and the Bureau of Research.

4-3.14 Pavement Design

Reference: Chapter 54

1. The designer submits the required pavement information to the district Pavement Design Engineer.
2. The district Pavement Design Engineer reviews and submits alternative designs to BDE.
3. The designer ensures that the approved pavement design is placed into the construction plans where appropriate (including on the typical sections, summary of quantities, schedules of quantities, and special provisions).

4-3.15 Utilities Coordination

Reference: Chapter 6

1. The designer coordinates work with the Project Support Section.
2. The designer contacts the Project Support Section to determine the potential involvement with utility companies.
3. The designer provides existing topography and/or preliminary plans, when available or necessary, to the Project Support Section, who then forwards these to the affected utility companies for markup and return to the designer.
4. The designer shows the location of all known utilities existing on the plans.
5. The designer identifies the possible locations of conflicts due to the proposed improvement.
6. The designer works with the Project Support Section to resolve any conflicts.

4-3.16 Railroad Involvement

Reference: Chapter 7

1. Any formal contact with railroad companies is accomplished through the Agreements Unit in BDE. Where a district Railroad Unit exists, informal contact can be made with a railroad to obtain preliminary information.
2. Railroad agreements usually require 18 to 24 months to process. Start this process early.
3. When work is performed by railroad forces, an Agreement is required. Some work included in the highway plans on railroad right-of-way and/or to railroad facilities may also require an agreement.
4. Where a contractor must work on or adjacent to the railroad right-of-way, railroad liability insurance is required. The designer must include a special provision and pay items with the plans that require this insurance.

4-3.17 Public Transportation Involvement

Reference: Chapters 55 and 58

1. A construction project may affect the location of public or school bus pickup/drop-off locations, bus turnouts or turnarounds or may involve commuter trains.

2. If a conflict appears unavoidable, the designer should coordinate with local public transportation agencies and school districts.
3. The designer must determine how the Traffic Control Plan will affect public transportation (e.g., detours), and convey this information to the appropriate public transportation agency so the agency can inform their ridership of revised routes.
4. Bicycle routes to public transportation facilities and bike storage facilities must be considered in project design.

4-3.18 Rest Areas

Reference: Chapter 16

1. Rest areas are usually included only on Interstate routes and other freeways.
2. The design of a rest area is developed by the district in coordination with BDE, the central Bureau of Operations, and the Rest Area Committee.
3. The design of the building, water supply, sanitary needs, and utilities is handled by the Capital Development Board (CDB), BDE, and district.
4. See Figure 16-1.A for details of which office is responsible for the various activities with rest areas.

4-3.19 Experimental Items

Reference: None

1. The designer coordinates their use with the Central Bureau of Materials (CBM).
2. The designer or CBM usually develops the specifications for experimental items.
3. Experimental items may also be initiated by BDE, which then prepares the specifications and work plan. The designer incorporates these into the final construction plans.
4. The designer coordinates work plans with CBM.
5. The CBM secures FHWA approval, if necessary.
6. The district may be requested to monitor the item in the field.

4-3.20 State and Federal Permits/Approvals

Reference: Chapter 28

1. The designer may need to coordinate with the US Army Corps of Engineers, US EPA, US Coast Guard, Illinois EPA, Illinois Division of Waterways, IDNR, the State Fire Marshall, etc.
2. The district Hydraulics Unit or district Environment Unit may become involved in any water-related permits.
3. Other permits or approvals on a project may include utility, driveway, and access permits.

4-3.21 Traffic Engineering

Reference: Chapters 56 and 57

1. The designer determines the placement of pavement markings. The district Bureau of Operations (District 1 Bureau of Traffic) reviews the plans.
2. The designer must consider the placement of signs in the design of a project.
3. Proposed traffic signing is typically part of the design plans, but may be prepared as a separate set of plans by the district Bureau of Operations (District 1 Bureau of Traffic). On Interstate or other freeway projects, signs are included in the roadway contract. Also, mast-arm mounted traffic signs are always included in the roadway contract.
4. For signal plans, the following applies:
 - Warrants for signals are usually requested by the project study group when an Intersection Design Study (IDS) is submitted.
 - Signals could also be added to a project at the request of the district Bureau of Operations (District 1 Bureau of Traffic). All locations require an IDS submittal, except standard designs for temporary traffic signals according to the *Highway Standards*.
 - Traffic signal plans are usually prepared by the district Bureau of Operations (District 1 Bureau of Traffic) and added to the plans by the designer.
5. For highway lighting, the following applies:
 - See Chapter 56 for warrants on highway lighting.
 - In all districts, except District 1, BDE prepares or reviews the plans and specifications for lighting.
 - In District 1, the lighting plans are prepared by the district Bureau of Electrical Operations.

- Where high-mast lighting is used, the designer must request soil borings.
6. For overhead signs, the following applies:
- When standard designs do not apply, the Bureau of Bridges and Structures is involved in the structural design.
 - The district Bureau of Operations (District 1 Bureau of Traffic) usually prepares the message for each sign and selects its location.
 - Cantilever and truss-mounted signs require soil borings.
7. The designer must incorporate the proper highway standards for signing, signals, and lighting into the final construction plans.

4-3.22 Traffic Control Plans (TCP)

Reference: Chapters 13 and 55

1. A work zone traffic management plan should be prepared and included as a part of an approved Phase I report, designated as a Transportation Management Plan (TMP). A TMP that does not meet the goals for queueing and delay must be reviewed and approved by the Bureau of Safety Programs and Engineering. All other TMPs may be approved by the Regional Engineer.
2. The designer prepares the Traffic Control Plan (TCP) from the approved TMP.
3. The designer coordinates the TCP with the district Bureau of Operations and the Bureau of Safety Programs and Engineering.
4. The TCP should be on separate plan sheets.
5. The designer must also include the appropriate traffic control standards in the final construction plans.

4-3.23 Plan-in-Hand Field Inspection

Reference: Chapters 2, 3, and 66

1. The Plan-in-hand field inspection (PIH) is usually scheduled for all projects.
2. Appropriate individuals should be invited to the PIH (e.g., FHWA, BDE, district Project Implementation, district Operations, district Land Acquisition Section, local agency representatives).
3. Interstate projects require coordination between BDE and FHWA.

4-3.24 Special Waste

Reference: Chapters 26 and 27

1. Initial investigations are accomplished by the district Environment Unit during the development of a Phase I study. Where special waste is determined to be present in property to be acquired, the results of these investigations should be provided to the district Land Acquisition Section so they may determine the appropriate rights or property interests to be acquired and the appropriate value of the land.
2. The designer incorporates any mitigation plans from the Phase I report, Environmental Assessment, or FEIS into the final construction plans.
3. The designer includes any necessary special provisions in the plans.
4. Specialized consultants are used to do sampling and testing and to develop specifications for disposal.
5. The designer should inform the project study group of any changes in the scope of work concerning special waste.

4-3.25 Coordination with Local Officials

Reference: Chapter 5

1. The designer coordinates agreements, letters of understanding, letters of intent, and plan reviews with the Project Support Section.
2. Early coordination is accomplished during Phase I by the project study group.
3. The designer must ensure that commitments are incorporated into the final construction plans from the Phase I report, Environmental Assessment, or FEIS.
4. The designer will need to identify and coordinate any local sidewalk maintenance or additions, ADA ramp improvements, or bicycle facilities of interest to potentially be included in the project.
5. The designer may be requested to incorporate items of local interest into the plans.
6. The designer ensures that details for the installation and/or improvement of city-owned utilities or traffic signals are coordinated as early as possible in the design process.
7. In urban areas, the designer should coordinate the traffic control plans with local officials.
8. The designer will need to obtain final plan review from local officials (e.g., traffic signals, drainage, landscaping), working through the Project Support Section.

9. The designer will need to identify and coordinate, with a city or town, encroachments from sign overhangs onto State right-of-way.
10. The designer may need to attend local meetings with city councils, school boards, drainage districts, or neighborhood groups.
11. The designer will address how emergency services will be accommodated during construction.
12. The designer will coordinate the pavement type selection and pavement design on non-State highways with the local government.
13. The designer will coordinate the type and selection of noise abatement with adjacent residents and the local government.

4-3.26 Right-of-Way

Reference: None

1. The project study group determines preliminary right-of-way (ROW) needs and limits during Phase I. The group also identifies any specific ROW issues that could significantly affect the alignment, cost, or timeline of the project. Examples of such ROW issues would be billboards, cell towers, railroads, mobile home parks, cemeteries, low-income properties, and hazardous/special waste within property to be acquired.
2. Once final construction limits are decided, the designer develops ROW limits and forwards the limits to the district Land Acquisition Section. The designer must also notify the district Land Acquisition Section when Phase I design approval has been granted so that acquisition may begin.
3. The district Land Acquisition Section or a consultant prepares final ROW plats.
4. The district Land Acquisition Section informs the designer when all ROW is cleared.

4-3.27 NPDES/Erosion and Sediment Control

Reference: Chapter 41

1. The designer evaluates the project for proper implementation of Erosion and Sediment control Best Management Practices (BMPs).
2. The designer develops a fully completed Storm Water Pollution Prevention Plan (SWPPP)–BDE 2342.
3. The designer coordinates with the district Erosion and Sediment Control coordinator as needed.

4. The designer may attend project field reviews to determine how best to prevent future Incidences of Noncompliance (IONs).

4-3.28 Landscaping

Reference: Chapter 59

1. The district Bureau of Operations (District 1 Bureau of Maintenance) is responsible for landscaping on all projects.
2. The designer provides a set of preliminary plans to the Bureau of Operations for recommendations.
3. The Bureau of Operations marks up the set of plans, indicates the types of plants required, and notes which specifications or special provisions will be used.
4. The designer is responsible for including the information on the plan sheets and incorporating the remainder of the information into the project documents.

4-3.29 Coordination with BDE and FHWA

Reference: Chapter 31

1. When major changes are proposed to an approved Phase I report, the designer must coordinate these changes with the project study group. If a proposed change affects an approved FONSI or FEIS, FHWA should be briefed at a monthly Coordination Meeting on the extent of the change.
2. FHWA periodically checks the Department's compliance with approved reports through annual process reviews of completed construction projects. Therefore, the designer should not make any major changes to the final construction plans without discussing the proposals with the project study group.
3. Proposed design exceptions, if any exist on the project, must be coordinated at a bi-monthly Coordination Meeting with BDE and/or FHWA (depending on the affected criteria).
4. The designer should invite BDE and FHWA to Plan-In-Hand Field Inspections on Interstate projects.

4-3.30 Project Cost Estimate

Reference: Chapter 65

1. The designer calculates quantities and prepares the summary of quantity sheets.

2. The district Estimator will input these quantities into the BDE Electronic Contract Management (ECM) system.
3. The district Estimator estimates unit prices, prepares all forms, and submits these to the Estimating Unit in BDE.
4. Usually, the designer is not involved with determining unit prices.

4-3.31 Comparison to Estimated Program Costs

Reference: Chapter 65

1. Estimated program costs are initially prepared by the district Bureau of Programming for the annual program.
2. A revised program cost is tabulated in the Phase I report.
3. The designer must be aware of how changes and additions can affect the cost of a project.
4. The project study group must be notified when there are major changes in the scope of approved work in the Phase I report. The designer must request additional funds for a project through a programming change order.
5. The BDE Project Development Unit and the Office of Planning and Programming must concur in and approve all major cost changes to a project.

4-3.32 Specifications and Special Provisions

Reference: Chapter 66

1. The designer develops special provisions for the roadway items not covered by the *Standard Specifications*.
2. The designer assembles all District Recurring Special Provisions.
3. The designer reviews the Statewide Recurring Special Provisions, current BDE Special provisions, and recurring district Special Provisions, and indicates the applicable ones on the Checklist.
4. This portion of the PS&E package is sent to the BDE Project Coordination and Implementation Section.

4-3.33 Right-of-Way Purchased and All Permits Obtained

Reference: Chapters 2 and 3

1. The designer must check that all right-of-way (ROW) has been purchased or is in quick-take proceedings.
2. All permits must be approved before a project can be placed on a bid letting.

4-3.34 Construction Contract Items and Bid Letting

Reference: Chapter 66

1. The designer uses a Checklist to ensure that all project items have been cleared.
2. The PS&E is submitted to BDE for final checking and processing of documents.
3. The Project Coordination and Implementation Section authorizes the project to be placed in a bid letting.
4. The bid letting is held and the bids are tabulated. The district and low bidder are notified.

4-3.35 Pre-Construction Meeting

Reference: None

1. The designer typically attends the Pre-Construction Meeting.
2. The designer discusses commitments made and any unusual aspects of the project with the district Bureau of Project Implementation and the contractor.

Chapter Five

LOCAL AGENCY AGREEMENTS

BUREAU OF DESIGN AND ENVIRONMENT MANUAL

Chapter Five
LOCAL AGENCY AGREEMENTS

Table of Contents

<u>Section</u>	<u>Page</u>
5-1 GENERAL	5-1.1
5-1.01 Need For Agreements	5-1.1
5-1.02 Signature Authority	5-1.1
5-1.03 Processing Guidelines and Procedures.....	5-1.1
5-1.03(a) Executed by the Regional Engineer	5-1.2
5-1.03(b) Executed by the Secretary of Transportation and Director of the Office of Highways Project Implementation (< \$250,000).....	5-1.2
5-1.03(c) Executed by the Secretary of Transportation, Chief Counsel, Director of Finance and Administration and the Office of Highways Project Implementation (≥ \$250,000).....	5-1.3
5-1.03(d) Processing Procedures	5-1.3
5-2 AGREEMENT FORMAT	5-2.1
5-2.01 Developed Format	5-2.1
5-2.02 Description of Improvement	5-2.1
5-2.03 Termination	5-2.1
5-3 MAINTENANCE OBLIGATIONS	5-3.1
5-3.01 Traffic Lanes Under Municipal Jurisdiction	5-3.1
5-3.02 Parking Under Municipal Jurisdiction.....	5-3.1
5-3.03 Parking or Municipal Traffic Lanes Assumed by State	5-3.1
5-3.04 Storm Sewers and Appurtenances	5-3.2
5-3.05 Traffic Signals.....	5-3.2
5-3.06 Lighting	5-3.2
5-3.07 Sidewalks	5-3.3
5-3.08 Right-of-Way Under Municipal Jurisdiction	5-3.3
5-3.09 Municipal Streets	5-3.3
5-3.10 Shared Use Paths	5-3.3
5-4 AGREEMENT ATTACHMENTS.....	5-4.1
5-4.01 Parking Restrictions.....	5-4.1
5-4.02 Sewer Restrictions.....	5-4.1
5-4.03 Encroachments.....	5-4.1
5-4.04 Approval of Plans.....	5-4.3
5-4.05 Funding Resolution.....	5-4.3

Table of Contents

(Continued)

<u>Section</u>		<u>Page</u>
5-5	DIVISION OF COST	5-5.1
5-5.01	State Responsibility	5-5.1
5-5.02	Municipality Responsibility	5-5.1
	5-5.02(a) Parking.....	5-5.1
	5-5.02(b) Sidewalks.....	5-5.3
	5-5.02(c) Highway Lighting Within a municipality.....	5-5.4
	5-5.02(d) Storm Sewers.....	5-5.5
	5-5.02(e) Traffic Signals.....	5-5.7
	5-5.02(f) Utility Adjustments.....	5-5.8
	5-5.02(g) Participation Cap	5-5.9
	5-5.02(h) Traffic Lanes Under Municipal Jurisdiction.....	5-5.9
	5-5.02(i) Pedestrian Overpass Structures.....	5-5.10
	5-5.02(j) Overpass Fencing.....	5-5.10
	5-5.02(k) RESERVED.....	5-5.10
	5-5.02(l) Engineering	5-5.10
	5-5.02(m) Right-of-Way.....	5-5.10
	5-5.02(n) Municipal Streets.....	5-5.10
	5-5.02(o) Bicycle Accommodations	5-5.11
	5-5.02(p) Bicycle and Pedestrian Accommodations on Structures	5-5.11
	5-5.02(q) Other Work	5-5.12
5-5.03	Basis of Payment	5-5.12
	5-5.03(a) Municipality Reimbursement.....	5-5.12
	5-5.03(b) State Reimbursement.....	5-5.13
5-5.04	Right-of-Way Acquisition	5-5.13
5-6	OTHER AGREEMENTS.....	5-6.1
5-6.01	Jurisdictional Transfers.....	5-6.1
5-6.02	Supplemental or Addendum Agreements	5-6.1
5-6.03	County and Township Agreements	5-6.1
5-6.04	Private Benefit Agreements	5-6.2
5-7	OTHER DOCUMENTS	5-7.1
5-7.01	Letters of Understanding	5-7.1
5-7.02	Informational Letters.....	5-7.1
5-8	EXAMPLES	5-8.1

Chapter Five

LOCAL AGENCY AGREEMENTS

Chapter 5 documents the Department's policies and procedures to use when processing local agency Agreements. The term "local agency," as used in this chapter, refers to municipalities, counties, townships, fire districts, and other public entities. The procedures in this chapter also apply to non-public entities.

5-1 GENERAL

5-1.01 Need For Agreements

The Department requires an Agreement with a local agency when the local agency participates in the improvement of a State route and/or when a transfer of jurisdictional responsibility is made. Participation may be a contribution of goods, services, or money (e.g., right-of-way, preliminary engineering, municipal funds). The Agreement also should resolve questions of maintenance, parking, storm sewer pollution, encroachments, approval of plans, and other similar items.

5-1.02 Signature Authority

The Regional Engineer, or assignee, may execute an Agreement with the local agency except under the following conditions:

- a Jurisdictional Transfer is involved;
- the Department is reimbursing or crediting the local agency;
- an Agreement with another State is involved; or

The Director of the Office of Highways Project Implementation will execute Agreements that cannot be executed by the Regional Engineer. The Secretary of Transportation will also execute Agreements when the Department is reimbursing the local agency or an Agreement with another State.

5-1.03 Processing Guidelines and Procedures

The district will prepare local agency Agreements in accordance with the applicable State laws and the Department's rules, regulations, and policies using the format discussed in Section 5-2. The following sections present the procedures and guidelines for processing local agency Agreements.

5-1.03(a) Executed by the Regional Engineer

The district is responsible for the Agreement from inception to execution. The project support engineer must submit a memorandum describing any element of an Agreement that deviates from IDOT policy to BDE for approval before the local agency signs the Agreement. Once fully executed, the district will send one original Agreement to the local agency and the other original Agreement, together with a copy of all waiver approvals, to BDE (to be retained, in perpetuity, as an official Department document). The district shall send copies of the Agreement to the affected central offices/bureaus and send one copy of the Agreement with the PS&E submittal.

5-1.03(b) Executed by the Secretary of Transportation and Director of the Office of Highways Project Implementation (< \$250,000)

If the agreement obligates an expenditure of less than \$250,000, the project support engineer will prepare the preliminary draft of the Agreement and send the preliminary draft to the appropriate district bureaus for review and approval of the Agreement prior to submitting drafts to each affected central office/bureau for review. To expedite the draft review process, note and explain in the transmittal memo to the bureaus any deviations from policy contained in the Agreement. If projects involve improvements to an unmarked State route and the Agreement does not provide for a transfer of jurisdictional responsibility, also note the following in the transmittal memorandum:

- whether the appropriate local agencies were contacted and their reasons for not accepting jurisdiction,
- whether the project could be deferred, or
- whether the project is the minimum required to prevent further deterioration of the existing pavement.

This information is necessary to obtain Executive Office approval to proceed with the project.

Following preliminary draft approval, the district will prepare the final draft in duplicate (i.e., presupposing a two-party Agreement) on letter-size paper and submit the two counterparts to the local agency for signature. The project support engineer will instruct the local agency to return the two signed counterparts. The project support engineer will then forward the signed counterparts to BDE for execution by the Director of the Office of the Highways Project Implementation and the Office of the Secretary. The BDE will file one original counterpart and send the remaining original counterpart to the district. The district will send the original counterpart to the local agency and forward one copy to each of the central offices/bureaus. For an improvement to be eligible for any particular letting, the Agreement, with attached ordinances, shall be fully executed and plan approval received prior to the PS&E dates indicated in the schedule for lettings that are published each year by BDE.

5-1.03(c) Executed by the Secretary of Transportation, Chief Counsel, Director of Finance and Administration and the Office of Highways Project Implementation (≥ \$250,000)

If the Agreement obligates an expenditure of \$250,000 or more payable to the local agency, the above signatures are required. The review process and all other aspects are the same as described in Section 5-1.03(b).

5-1.03(d) Processing Procedures

Figure 5-1.A illustrates the procedures to use when processing local agency Agreements. Adhering to these procedures will reduce confusion and provide consistency in implementing the process. For additional guidelines, contact BDE.

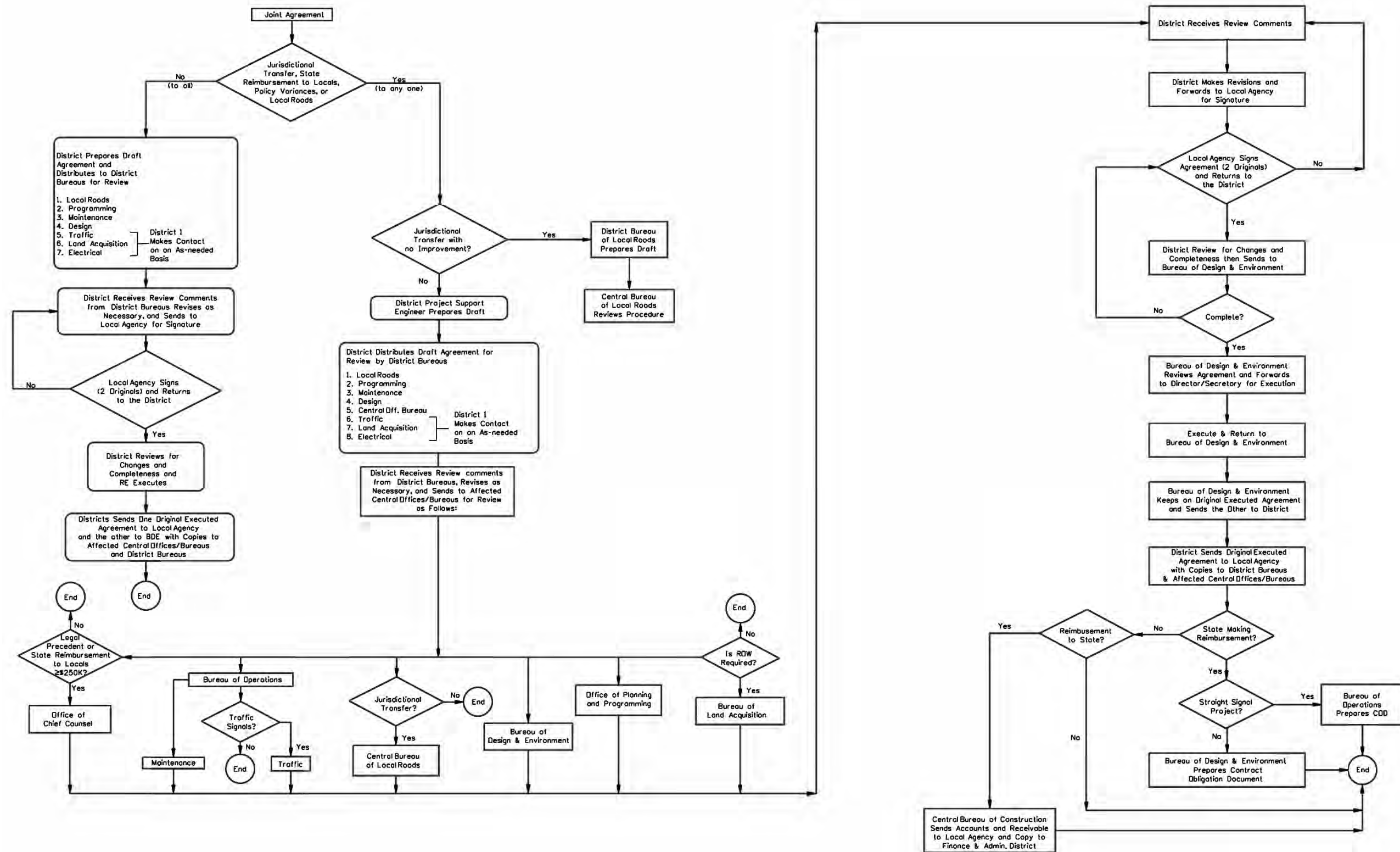

PROCESSING LOCAL AGENCY AGREEMENTS
Figure 5-1.A

5-2 AGREEMENT FORMAT

There is one format that is typically used for Agreements between the Department and a local agency. The following sections discuss the agreement format.

5-2.01 Developed Format

The district will use the Developed Format on all projects. See Section 5-8 for a sample of the Developed Format.

5-2.02 Description of Improvement

In the Agreement, include a brief description of the improvement to completely inform the local agency of the extent of the improvement. If the improvement extends beyond the limits of the local agency, also define the limits of local agency involvement. Provide the following in the description:

- the route designation and improvement limits, identified by official street names, as practical;
- the proposed number and width of traffic lanes;
- the width of any parking lanes;
- the width and type of median, if any;
- the type of curb and gutter construction;
- the type and limits of any pedestrian or bicycle accommodation being established;
- any storm sewer or incidental construction required; and
- any work requested by the local agency.

5-2.03 Termination

Include in the Agreement a mutually acceptable time of termination not to exceed three years if the contract is not awarded.

5-3 MAINTENANCE OBLIGATIONS

The Agreement should describe in detail the maintenance obligations of all parties to avoid potential misunderstandings upon completion of construction. Normally, on streets that are a part of the State highway system, the Department will maintain the following:

- the traffic lanes, including left- and right-turn lanes or bi-directional lanes, and the adjacent curb and gutter or ditch; and
- the median area, if provided.

The following sections provide additional information on maintenance obligations.

5-3.01 Traffic Lanes Under Municipal Jurisdiction

The municipality will maintain the traffic lanes and any adjacent curb and gutter under municipal jurisdiction.

5-3.02 Parking Under Municipal Jurisdiction

The Agreement should assign responsibility for parking maintenance according to the following criteria:

1. On-System Parking. If parking, including restricted parking, is included in the improvement, the municipality will maintain the parking lanes and the adjacent curb and gutter.
2. Off-System Parking Lanes. The municipality will accept complete jurisdiction of off-system parking facilities including, but not limited to, the following:
 - maintenance,
 - operation,
 - repair,
 - reconstruction,
 - striping, and
 - provision of electrical energy for lighting systems.

The municipality will hold the State harmless from any legal suits arising from the construction, operation, and maintenance of off-system parking facilities.

5-3.03 Parking or Municipal Traffic Lanes Assumed by State

If an IDOT traffic capacity analysis demonstrates a justification for additional traffic lanes, the Department may assume the additional full-time traffic and/or parking lanes under municipal

jurisdiction. Once assumed, the Department will maintain these facilities including any adjacent curb and gutter.

5-3.04 Storm Sewers and Appurtenances

The municipality normally will perform the routine maintenance of storm sewers and appurtenances constructed as part of the improvement, provided the storm sewer was designed to accommodate State highway drainage only. Routine maintenance is defined as those functions necessary to maintain the sewer in a serviceable condition including:

- cleaning sewer lines, inlets, manholes, and catch basins; and
- repairing and replacing inlet, manhole, and catch basin frames, grates, and lids.

The following provides additional guidance on the maintenance responsibilities of storm sewers and appurtenances:

1. Storm Sewers Constructed for State Highway Drainage Only. Beyond the level of routine maintenance, the Department will maintain, repair, and/or reconstruct storm sewers constructed for State highway drainage only.
2. Storm Sewers Constructed for Joint Municipal/State Use. If the storm sewer is oversized to accommodate a joint Municipal/State use, the Agreement shall proportion the cost for maintenance, repair, and/or reconstruction beyond the level of routine maintenance in the same manner as the initial construction cost was proportioned.

5-3.05 Traffic Signals

If traffic signals are included in the improvement and are within the municipality's corporate limits, the municipality and the Department normally will share maintenance responsibilities. The municipality is responsible for maintenance and energy costs as provided in Part 544 of the *Illinois Administrative Code* (92 Ill. Admin. Code 544) contact the Bureau of Operations for additional guidance).

5-3.06 Lighting

The following presents the maintenance obligations for lighting:

1. Separate Systems. The municipality is financially responsible for maintaining any separate lighting system installed by the Department at the request of the municipality. The municipality also will furnish and pay for the system's electrical energy.
2. Combined Systems. In addition to any obligations in Part 544 of the *Illinois Administrative Code* (92 Ill. Admin. Code) (contact the Bureau of Operations), the municipality is financially responsible for maintaining the luminaires, luminaire wiring, conduit, and control

devices and for providing the electrical energy for the combined systems the Department installs at the request of the municipality.

5-3.07 Sidewalks

The municipality will maintain any new or replacement sidewalks the Department provides in the improvement, excluding those constructed on structures.

5-3.08 Right-of-Way Under Municipal Jurisdiction

Use the following guidelines to determine maintenance responsibility for right-of-way under municipal jurisdiction:

1. Urban Cross Section. The municipality will maintain the entire right-of-way outside of that maintained by the Department. This includes, but is not limited to, municipal utilities, landscape plantings, parkways, guardrails, crosswalks, and stop line markings.
2. Rural Cross Section. The Department will maintain the entire right-of-way excluding the landscaping and utilities installed by others and the right-of-way under municipal responsibility as discussed in Sections 5-3.01 through 5-3.07.

5-3.09 Municipal Streets

If municipal streets are improved as part of the State highway project, the municipality is responsible for maintaining the municipal streets, except as provided in Section 3-500 "Construction/Reconstruction and Maintenance of Side Roads and Street Intersections with State Highways" of the Bureau of Operations "Maintenance Policy Manual."

5-3.10 Shared Use Paths

The municipality will maintain any bicycle paths associated with the State highway project other than that portion of the bicycle path carried on State structures. Incorporate the following paragraph in the Agreement:

The _____ agrees to assume responsibility for the administration, control, reconstruction, and maintenance of the shared use path not otherwise carried on State structures. The _____ further agrees to indemnify and hold harmless the State, its officers, employees, and agents from any and all claims, lawsuits, actions, costs, and fees (including reasonable attorney fees and expenses) of every nature and description arising from, growing out of, or connected with the construction and/or operation of the shared use path.

5-4 AGREEMENT ATTACHMENTS

5-4.01 Parking Restrictions

The district should ensure that any on-street parking included in the improvement is parallel and adjacent to the curb and, as practical, should eliminate any diagonal on-street parking from the project. Diagonal on-street parking shall be analyzed and approved by BDE before the Department will execute an Agreement for a joint municipal/State improvement; see Chapter 48. The municipality shall adopt and enforce an appropriate parking ordinance as part of the Agreement. If an appropriate parking ordinance is already in effect, obtain copies from the municipality. Attach the parking ordinance as an Exhibit to the Agreement prior to execution. Enforcement of the parking ordinance by the municipality is understood to include erection and maintenance of any necessary "NO PARKING" or "PARALLEL PARKING ONLY" signs. See Example 2 in Section 5-8 for a sample parking ordinance.

5-4.02 Sewer Restrictions

The municipality shall adopt and enforce an ordinance prohibiting the discharge of sanitary sewage or industrial waste into any storm sewer or drainage facility constructed by the Department as a part of the project. The district will attach the ordinance as an Exhibit to the Agreement prior to execution. See Example 3 in Section 5-8 for a sample storm sewer ordinance.

5-4.03 Encroachments

If a State highway improvement is within a municipality, the work generally is performed on right-of-way that is either acquired by or dedicated to the municipality. Occasionally, the Department performs work on new right-of-way, purchased either by the State or jointly with the municipality, under an Agreement with the municipality. As part of the Agreement, the municipality will provide for the disposition of any existing encroachments and adopt and enforce an ordinance prohibiting future encroachments on State highway right-of-way.

Encroachments on State highway right-of-way will not be permitted and shall be removed. Unless the encroachment is an existing violation, the State may compensate the owner during right-of-way negotiations. However, if the safe and free flow of vehicular and pedestrian traffic is maintained, the Department may allow the encroachment to remain. In such cases, the municipality will issue a revocable permit, approved by the Department, that provides for the future removal of the encroachment, if necessary.

The Department defines an encroachment as any building, fence, sign, billboard, or other structure or object (excluding certain items over sidewalks and most public and private utilities) that are placed, located, or maintained in, on, under, or over any portion of State highway right-of-way, except those structures and objects that:

- are informational signs,
- constitute a part of the highway,
- are a part of the highway facility's access control, or
- are in the public interest and do not impair highway operations or interfere with the safe and free flow of vehicular and pedestrian traffic.

Although not applicable to freeways, the last item includes awnings, marquees, signs advertising business activity, and similar building-supported structures that overhang a sidewalk on State highway right-of-way. If a building is set back from adjacent buildings that are flush with a sidewalk on State highway right-of-way, the Department may permit pole-mounted signs advertising the set-back enterprise to overhang the State highway right-of-way as it permits building-supported encroachments. In addition, if a public or private utility located in or near a sidewalk impedes the safe and free flow of pedestrian traffic, the Department considers the utility an encroachment. These utility encroachments are subject to a revocable permit. The Department should ensure that the placement of above-ground utilities does not restrict the clear width of the sidewalk to less than that allowed per Section 58-1. Clear width is the distance from the edge of the sidewalk to the near edge of the utility facility.

The Department and municipality jointly will establish a project right-of-way line within the limits of the platted street that will be encroachment free, except for revocable permits and the exempt structures and objects previously discussed. Representatives from both agencies will attend a field review to accomplish this task. As practical, establish the project right-of-way line to not less than 2 ft (600 mm) behind the face of the curb. After the field review, draw the project right-of-way line on the plans and designate the Municipal right-of-way area outside the project right-of-way line as a construction easement in which the Department will be permitted by Agreement to perform work. After construction, the municipality will control all areas outside the project right-of-way.

If an existing encroachment must remain on project right-of-way, the municipality will issue a revocable permit, approved by the Department, that provides for the future removal of the encroachment, if necessary. The district will coordinate a joint field review with the municipality to ensure that encroachments do not violate *Illinois Highway Code*, 605 ILCS 5/9-112.4. If during the field review it is determined that an encroachment impairs the safe and free flow of vehicular or pedestrian traffic, the municipality will revoke the permit. After the field review, the appropriate district personnel will certify that all encroachments have been properly disposed; see form BDE 488, Certification Acceptance/Project Status. Structures and objects over sidewalks on State highway right-of-way within the municipality that satisfy IDOT criteria may remain in place without a revocable permit. However, if alterations to a structure or object or to the highway itself subsequently cause the encroachment to impede the safe and free flow of traffic, the Department will require adjustment or removal of the encroachment.

In the Agreement, incorporate provisions for the disposition of existing encroachments and for the prohibition of future encroachments. Use the appropriate wording in the samples illustrated in Section 5-8. Regardless of the improvement's Federal-aid funding eligibility, the district will

incorporate the encroachment verbiage in the Agreement and obtain the necessary municipal encroachment ordinance. See Example 4 in Section 5-8 for a sample encroachment ordinance. This will ensure uniform treatment of encroachments for all improvements. As practical, attach and directly reference the encroachment ordinance as an Agreement Exhibit prior to executing the Agreement. However, cases such as municipal participation in preliminary engineering may preclude this suggested practice. In these cases, the district will arrange to execute the Agreement with the understanding that the municipality will provide the Department with certified copies of the encroachment ordinance prior to bid advertisement.

5-4.04 Approval of Plans

Regardless of which agency prepares the plans for the improvement, submit prints of the detailed plans to the municipality and obtain formal approval to ensure that the municipality is fully aware of the extent of the improvement. During construction, this will better position the Department to refuse unwarranted requests for additional improvements and revisions by abutting property owners. The district will obtain one copy of a municipal resolution or a formal letter from a municipal official responsible for approving the plans and forward it to BDE prior to PS&E submittal.

5-4.05 Funding Resolution

If the local agency is to reimburse the Department for work described in the Agreement, a funding resolution providing payment for the work must be attached to the Agreement.

5-5 DIVISION OF COST

The extension of a State highway into and through a municipality provides a multipurpose facility that accommodates vehicular, bicycle, and pedestrian traffic for both the State and municipality (i.e., the State highway becomes an integral part of the local street system). As such, under an Agreement with the municipality, the Department performs State-initiated highway improvements within municipal jurisdictions that proportionately benefit both parties. This section delineates the financial responsibilities of each party for State-initiated projects under State jurisdiction.

5-5.01 State Responsibility

The State is financially responsible for preliminary engineering, right-of-way, construction, and construction engineering for the traffic lanes on the State highway and the appurtenances related to the traffic lanes for which the State has jurisdiction. The State's financial responsibility for other items along the State highway are described below.

5-5.02 Municipality Responsibility

The municipality is financially responsible for preliminary engineering, right-of-way, construction, and construction engineering for the items specified in the following sections.

5-5.02(a) Parking

The Agreement will base the division of cost between the State and the municipality on the following criteria:

1. New On-System Parking. New on-system parking is defined as the construction of parallel parking either to replace existing parking assumed by the State for additional traffic lanes or to provide parking where legal parking did not previously exist. If the municipality includes new on-system parking in the improvement, proportion the cost as follows:
 - a. ADT > 5000. If the highway facility has an average daily traffic (ADT) greater than 5000, use the following criteria to proportion the cost:
 - If base and surface construction of new on-system parking is equivalent to the adjacent State-maintained traffic lane and the lane width for parking meets Department criteria, proportion the cost equally (i.e., 50%/50%) between the State and municipality.
 - The State is financially responsible for 100% of curb and gutter construction.
 - If the pavement composition of new on-system parking is less than the adjacent traffic lane's or if the lane width for parking does not meet Department criteria, the municipality is financially responsible for 100% of the cost.

- b. ADT ≤ 5000. Construct the new on-system parking with a base and surface composition that is compatible with its anticipated usage to a width acceptable to the Department at 100% Municipal expense. The State is financially responsible for 100% of curb and gutter construction

For either ADT range above, the municipality is 100% financially responsible for right-of-way that is acquired solely for the construction of new on-system parking where legal parking did not previously exist. The State will pay 100% for right-of-way that is acquired to replace existing parking assumed by the State for additional traffic lanes; or when additional right-of-way is required to construct the IDOT-proposed cross section.

2. Existing On-System Parking (Resurfacing, Repair and Reconstruction). If existing on-system parking is retained in an urban street resurfacing project, the State is financially responsible for resurfacing only the pavement area maintained by the Department including a full-width taper on the parking lane from the edge of the travel lane to gutter flag or face of curb where no gutter flag exists. Limit the maximum width of taper to that of the adjacent travel lane. If the municipality elects to have existing on-system parking resurfaced to a full thickness, the municipality is financially responsible as follows:

- 50% of milling and resurfacing costs for existing on-system parking having a width less than or equal to that of the adjacent travel lane;
- 100% of milling and resurfacing costs for that portion of existing on-system parking greater than the width of the adjacent travel lane;
- 100% of base repair costs for the entire width of existing on-system parking;
- in municipalities with less than 3000 population, the maximum Municipal participation toward milling and resurfacing costs for existing on-system parking is a cost equivalent to three years' Motor Fuel Tax allotment. The District shall verify locations of existing on-system parking for all joint State/Municipal improvements; and
- 100% of reconstruction costs for existing on-system parking and any adjacent curb and gutter.

3. Restricted On-System Parking. If an IDOT traffic capacity study establishes the need to restrict parking during peak hours to ensure the safe and free flow of traffic and the municipality enacts an ordinance implementing such parking restrictions, the State will pay 100% of full-thickness resurfacing costs, up to a maximum 12 ft (3.6 m) width including any needed base and curb repairs, for the restricted on-system parking.

4. Off-System Replacement Parking. If, for the benefit of State highway safety and capacity, the Department and municipality jointly determine it necessary to replace existing and legal on-system parking (not accommodated under Item 1) with off-system parking, the State may financially participate as follows:

- a. Alternative Off-System Replacement Facilities. The State will pay 100% of all engineering, right-of-way (except Municipal property), and construction costs to

replace existing on-system parking with alternative off-system parking. The maximum ratio for replacing parking spaces is one to one. Alternative off-system replacement parking may include improving adjacent local streets to accommodate new parking, constructing new off-street parking facilities, or a combination of the two. Construction costs will include those items IDOT deems reasonable and practical for a safe and convenient parking environment (e.g., paved surface, drainage, lighting, pedestrian walkways, fencing). The municipality will pay 100% of the construction costs associated with installing guard and toll collection facilities, metering devices, and parking spaces beyond the maximum one-to-one replacement ratio.

- b. Municipal Property. If the municipality owns the site selected for off-system replacement parking, the municipality will provide the property at no expense to the State.
- c. Clearing Municipal Property. As part of the State's financial responsibilities to construct replacement parking, the State will pay 100% of the cost to clear Municipal property if included in the IDOT construction contract for the improvement. See Example 5 in Section 5-8.

5-5.02(b) Sidewalks

For sidewalks, the Agreement will be based on the following to determine the division of cost between the State and Local Agency:

1. New Sidewalks. If the sidewalk criteria contained in Chapter 17 are met and the local agency agrees to maintain the sidewalks, the State will pay 100% for construction of new sidewalks within the project termini or for short distances outside the project termini as may be required to extend sidewalks to logical termini. The State will also pay 100% for right-of-way, reimbursable utility adjustments, pedestrian barriers, retaining walls, and other collateral items that are required for sidewalk construction. The local agency will pay 100% of the cost difference between decorative sidewalks and standard sidewalks.

If the local agency does not agree to maintain the sidewalk, the State will not construct it, even if it is warranted. However, the State will take reasonable actions to not preclude future additions of sidewalk at such locations.

2. Existing Deteriorated Sidewalks. If an existing deteriorated sidewalk is not affected by an IDOT project but is added at the request of the local agency, the local agency will pay 100% for its removal and the State will pay 100% for its replacement. The local agency will pay 100% of the cost difference between decorative sidewalks and standard sidewalks.
3. Adjustment or Removal and Replacement of Existing Sidewalks. If an existing sidewalk must be adjusted or removed and replaced due to an IDOT improvement, the State will pay 100% of the costs.

4. Curb Ramps. Cost sharing for curb ramps is treated the same as cost sharing of sidewalks.

All sidewalk construction can be considered for Federal-aid participation.

5-5.02(c) Highway Lighting Within a municipality

The Agreement will proportion the costs for highway lighting within a municipality according to the following:

1. New Lighting. If the municipality requests or includes street lighting in the improvement, the municipality is 100% financially responsible for lighting installation and energy costs.
2. Modernization of Existing Lighting. The municipality is 100% financially responsible for the modernization and betterment of any street lighting system the municipality installed or caused to be installed in the improvement.
3. Relocation of Existing Lighting. The Department considers the relocation of existing lighting as a utility adjustment which is subject to the cost proportioning discussed in Section 5-5.02(f).
4. Combination Traffic Signal and Lighting. If the poles will be replaced in new traffic signal installations or modernization projects, proportion the cost for combination lighting as follows:
 - Proportion the cost for poles and foundations (i.e., traffic signal appurtenances) in accordance with Section 5-5.02(e).
 - The municipality is 100% financially responsible for luminaires, luminaire wiring, conduit, and control devices.
5. Warrants for Highway Lighting. See Chapter 56 for criteria related to highway lighting.

5-5.02(d) Storm Sewers

For storm sewers, the division of cost between the State and municipality will be as follows:

1. Municipality Requests Extension or Use of IDOT Storm Sewer. If the municipality desires to extend or use the improvement's storm sewer facilities, the municipality is 100% financially responsible for any increase in system capacity over that required to drain the State highway improvement. An itemized division of cost between the State and municipality should be included in the preliminary draft Agreement.

If the municipality's cost share is minor, use Equation 5-5.1 (i.e., percent of actual storm sewer cost) to determine the municipality's share:

$$MC = (ASSC)(EF)[(ECC - ESOC) / ECC] \quad \text{Equation 5-5.1}$$

where:

MC	=	municipality's Cost
ECC	=	Estimated Combined Cost
ESOC	=	Estimated State-Only Cost
ASSC	=	Actual Storm Sewer Cost
EF	=	1.15 for Engineering

2. Municipal Storm or Combined Sewer System Rehabilitation or Adjustment. If the Department uses an existing Municipal storm or combined sewer system to drain the State highway, use the following guidelines to proportion any needed sewer adjustment or rehabilitation costs between the State and municipality:

- a. State Participation. If constructed for State highway drainage only, IDOT designs the highway storm sewer system to accommodate both the watershed runoff naturally reaching the highway site and the surface runoff across the highway right-of-way. If an improvement project uses an existing Municipal storm sewer system for State highway drainage, the State has no more or less financial responsibility for the storm sewer than any other property owner. The State will allocate straight State or Federal-aid funds for only the share of storm sewer costs that benefit the State. Unless a State highway improvement creates a need to increase the existing storm sewer system's capacity or the Department determines a need to improve the drainage of the State highway system, the State's financial participation will be limited to the cost of improving the storm sewer system within the limits of the State highway right-of-way. Use Equation 5-5.2 to determine the State's share of costs for rehabilitating and/or adjusting existing Municipal storm sewers:

$$SSOC = 100[2(HROWA)(C1)] / [(TASBSS)(C2)] \quad \text{Equation 5-5.2}$$

where:

SSOC =	State Share of Cost, percent (%)
HROWA =	Highway Right-of-Way Area, acres (ha)

C1 = Hydraulic Runoff Factor for HROWA
TASBSS = Total Area Served by Storm Sewer, acres (ha)
C2 = Hydraulic Runoff Factor for TASBSS

Note: The factor 2(HROWA) in Equation 5-5.2 is an administrative determination accounting for the various factors affecting surface drainage in urban areas. The runoff factors (e.g., C1 and C2 in Equation 5-5.2) normally are used in accepted hydraulic practice and reflect factors such as slopes, percent of area with different permeability rates, etc.

- b. Municipal Sewer System Adjustment. The State normally is 100% financially responsible for adjustments to Municipal sewer systems caused by State highway improvements unless it was originally installed on State right-of-way or within the limits of a highway under IDOT jurisdiction. However, if the Municipal sewer system will accommodate State highway drainage, the State may share the cost for adjusting the sewer on the basis of Equation 5-5.2. The State will not share in the cost of adjusting Municipal utilities that are not eligible for State participation. See Section 5-5.02(f) for additional information on utility adjustments.
- c. Municipal Sewer System Rehabilitation. The Department may participate in the rehabilitation of structurally deficient or functionally inadequate Municipal sewer systems to the extent such action will benefit State highway drainage. Use Equation 5-5.2 to determine the State's share of rehabilitation costs. If the rehabilitation need is due to structural inadequacy, the municipality will be responsible for performing the structural condition evaluation. The Department will review and approve the municipality's findings before committing to State financial participation. The State will share the cost for the structural condition evaluation in the same proportion it does for construction costs. If the project includes Municipal sewer rehabilitation predicated on a need to increase drainage capacity for a State highway facility, use Equation 5-5.2 to determine the State's share of rehabilitation costs. If the need to increase Municipal sewer capacity is necessitated by a combination of State highway and other needs, the State's financial participation will be negotiated on a case-by-case basis and Equation 5-5.2 will not apply.
- d. Combined Storm and Sanitary Sewer Systems. If the Municipal sewer carries both storm and sanitary flows, deduct the sanitary portion from the system's capacity before calculating the State's share of costs. In most areas, it is acceptable to assume 10% of system capacity is used for sanitary flow. However, in areas having significant sanitary flow (e.g., industrial parks, commercial business areas), evaluate the acceptability of using 10% and, if determined unacceptable, the Department will obtain mutual agreement with the municipality on a reasonable percentage to use in calculations.
- e. Separation of Combined Sewer Systems. If the improvement involves separating a Municipal sewer into storm and sanitary systems, the State is financially responsible for its share of the storm sewer system only. The Department will review the municipality's local storm sewer separation plan before the municipality

adopts the plan, which then becomes the basis for determining funding eligibility and the State's share of rehabilitation costs.

- f. Participation Outside an Active IDOT Project. If in the State's best interest, the State may financially participate in rehabilitating an existing Municipal sewer system even though no State highway improvement project is underway. In these cases, consider the impact State highway improvements planned for the area will have on the sewer system and use the applicable guidelines in Item 2 to determine the State's financial responsibility. In determining the State's share of costs, do not consider the affects of any planned non-State facilities.
3. Additional Repair or Reconstruction of Joint-Use Storm Sewers. Joint-use storm sewers constructed under the provisions of Items 1 and 2 that require repair or reconstruction beyond that covered in Section 5-3 will be performed at the joint expense of the State and municipality. Proportion the costs as proportioned in the Agreement for the sewers' initial construction.
4. Shoulder and Open Ditch Construction. If shoulder and open ditch construction is less costly and compatible with existing development, the Department may provide such a facility. If, instead, the municipality desires curb and gutter and storm sewer drainage, the Department may provide such a facility; however, the State will not pay for the additional cost.

5-5.02(e) Traffic Signals

The installation, modernization, relocation, electrical energy, and maintenance costs for traffic signals differ according to their application. All are governed by Department rules, regulations, or policy as follows:

1. Dedicated Streets. See Part 544 of the *Illinois Administrative Code* (92 Ill. Admin. Code 544) (contact the Bureau of Operations) for information on traffic signals and dedicated streets. Eighty percent (90% on Safety Projects) of the signal cost first will be deducted under Section 544.60 of the *Illinois Administrative Code*. The State will pay 80% (90% on Safety Projects) plus its proration as determined from Section 544.60. This applies only to State-initiated projects.
2. School and Commercial/Industrial Areas. See TRA-5 (contact the Bureau of Operations) for guidelines on traffic signals serving school and commercial/industrial areas.
3. Combinations of the Above Applications. Traffic signals serving both a high-volume, dedicated street opposite a high-volume, private benefit facility may require a hybrid proration of costs. Consult BDE for specific guidance.
4. Emergency Vehicle Preemption Equipment Installation, Modernization, and/or Relocation. The municipality is 100% financially responsible for emergency vehicle preemption

equipment installation, modernization, and/or relocation costs. Cost limitations shown in Item 1 or in Section 5-5.02(g) are not applicable.

5-5.02(f) Utility Adjustments

The Agreement will be based on the following to proportion costs for utility adjustments:

1. State-Initiated Municipal Utility Adjustments. If the proposed improvement is a State-initiated project on a State highway within the Municipal street system, the State will assume the total cost of adjusting Municipal lights, signs, utilities, etc., except that the municipality is financially responsible, other than in certain cases of Interstate or Freeway construction, for adjusting its facilities located within the municipality if they were installed:
 - on right-of-way acquired by the Department; or
 - within the defined limits of a street, subsequent to the date the Department accepted maintenance responsibility for the street.

If the utilities existed within the defined limits of the street prior to the Department's acceptance of maintenance responsibility for the street, the State will pay for the needed utility adjustments.

The municipality is financially responsible for adjusting its utility facilities if previously installed on State highway right-of-way outside the Municipal limits and subsequently incorporated within the municipality.

The Department will proportion the cost of adjusting any existing Municipal utility facility located outside Municipal limits the same as for any other utility facility (i.e., the State is financially responsible for the adjustment if the utility is located on private right-of-way and the municipality will pay for the adjustment if the utility is located on State highway right-of-way).

If financially responsible for utility adjustments, the municipality may elect to have the Department include the adjustments in the highway improvement plans. However, this does not relieve the municipality of its funding obligation. Include in the Agreement with the municipality the conditions for reimbursing the Department for utility adjustment costs.

For any improvement plans that include Municipal utility adjustments, the district will include a statement in the transmittal memorandum to the Central Office that describes the financial responsibilities of both the State and the municipality. If the municipality is obligated to pay for utility adjustments, also include in the memorandum the terms of reimbursement included in the Agreement.

Any utility adjustment included in the State's contract at State expense, as provided above, will be limited to adjustments in kind as practical. If the municipality desires a betterment or extension of the utility being adjusted, then the municipality is financially responsible for any increase in adjustment cost.

2. municipality-Requested Utility Adjustments. The municipality is 100% financially responsible for the cost of any utility adjustment it requests.
3. Other Utilities. The municipality will exercise its franchise rights to cause private utilities to be adjusted at no expense to the State. The principles set forth in Section 5-5.02(f) regarding utility adjustments for Municipalities will also apply to other legally constructed governmental facilities encountered along the improvement.
4. Permits and Assessment Fees. See Part 530 of Title 92 of the *Illinois Administrative Code* (contact the Bureau of Operations) for information on permits and assessment fees.

5-5.02(g) Participation Cap

For non-private benefit traffic signal installations and/or modernization (see Section 5-5.02(e), Item 1) and mandated utility adjustments (see Section 5-5.02(f), Item 1, adjustments in-kind not betterments) caused by a State-initiated improvement, include in the Agreement a cap or ceiling equal to 125% of the estimated cost to the municipality for these two items. The estimator will exercise judgment to ensure that the estimate is properly adjusted to reflect expected inflation between the time the estimate is prepared and the anticipated contract award date.

5-5.02(h) Traffic Lanes Under Municipal Jurisdiction

The State is not necessarily responsible for the maintenance, repair, or reconstruction of all traffic lanes along a State highway. Before preparing an Agreement with a municipality for a State highway improvement, the district will check IDOT records to determine the width of pavement over which the Department has jurisdiction. The Department is responsible for the jurisdiction of only those portions of streets that it constructed or those portions of local streets, that it has subsequently assumed. For through traffic lanes under Municipal jurisdiction, the cost proration is as follows:

- The State will assume the financial responsibility for patching, milling, and resurfacing all traffic lanes along State highways constructed in conjunction with a State-initiated project.
- Repair and/or replacement of curb and gutter or reconstruction of local traffic lanes will continue to be the municipality's financial responsibility in accordance with existing maintenance agreements.

5-5.02(i) Pedestrian Overpass Structures

The following presents the proration of construction costs and the warrants, liabilities, and maintenance responsibilities for pedestrian facilities:

1. State Highways Without Full Access Control. See Part 540 of *Illinois Administrative Code* (92 Ill. Admin. Code 540) (contact BDE).
2. State Highways with Full Access Control. For criteria on State highways with full access control (contact BDE).

5-5.02(j) Overpass Fencing

Part 510 of the *Illinois Administrative Code*, 92 Ill. Admin. Code 510 (contact BDE) presents the proration of construction costs and the warrants and maintenance responsibilities for overpass fencing.

5-5.02(k) RESERVED**5-5.02(l) Engineering**

The municipality will share in the cost of engineering provided by the State in direct proportion to its construction costs. Preliminary and construction engineering will be computed as 5% and 10% respectively of the Municipal share of construction costs.

5-5.02(m) Right-of-Way

If the municipality is financially responsible for all or a portion of right-of-way costs, its share will include the purchase price thereof and the cost of negotiators, appraisals, title evidence, relocation assistance and payments, property management, and such legal services as necessary to acquire the right-of-way. The acquiring agency, if participating in the cost of the right-of-way, will receive a credit for a proportionate amount of the proceeds of any sale or rental of improvements acquired within the right-of-way or as a direct result of the right-of-way acquisition.

5-5.02(n) Municipal Streets

Many State-initiated projects require improvements to intersecting Municipal streets to meet the geometric requirements for the design level of service. Generally, the State is financially responsible for all improvements required to achieve this goal. Any work beyond that deemed necessary by the State will be included in the State's contract only if the municipality agrees to pay its cost.

5-5.02(o) Bicycle Accommodations

The Agreement will base the cost for bicycle accommodations on the following criteria:

1. On-Road Bicycle Lanes. The State will pay 100% for the construction of new on-road bicycle lanes, including right-of-way, reimbursable utility adjustments, barriers, retaining walls, and other collateral items that are required for bike lane construction. The State will assume the maintenance of traditional and buffered bicycle lanes. The local agency will assume the maintenance of separated bicycle lane pavement and vertical separation elements.
2. Wide Outside Lanes and Widened Shoulders. The State will pay 100% of all costs for wide outside lanes or widened shoulders constructed for bicycle accommodation. The State will also assume the maintenance of these facilities.
3. Shared Use Paths. A shared use path can be selected as an accommodation, in place of the on-road accommodation type(s) identified in Figure 17-2.A, whenever it is determined to fit the project context. When the local agency agrees to maintain the path, assign the costs associated with the path as follows:
 - a. New Paths. The State will pay 100% of all costs for the construction of new paths within the project termini or for short distances outside the project termini as may be required to extend paths to logical termini. The State will also pay 100% for right-of-way, reimbursable utility adjustments, barriers, retaining walls, and other collateral items that are required for path construction.

If the Local Agency does not agree to maintain the path, the State will not construct it, even if it is warranted. However, the State will take reasonable actions to not preclude future additions of paths at such locations.
 - b. Existing Deteriorated Paths. If an existing deteriorated path is not affected by an IDOT project but is added at the request of the local agency, the local agency will pay 100% for its removal and the State will pay 100% for its replacement.
 - c. Adjustment or Removal and Replacement of Existing Paths. If an existing path must be adjusted, or removed and replaced, due to an IDOT improvement, the State will pay 100% of the costs.

All side path construction can be considered for Federal-aid participation.

5-5.02(p) Bicycle and Pedestrian Accommodations on Structures

If bicycle and/or pedestrian accommodations are warranted within the termini of a project, those accommodations should be carried over any structures within the project. See Chapter 17 for further guidance. If the project omits structure improvements, then bicycle and pedestrian improvements on those structures may also be omitted.

The State will pay 100% of all costs for bicycle and pedestrian accommodations on structures and approaches. The State will assume the maintenance of on-structure accommodations. The local agency will pay 100% of the cost difference of a requested separate bicycle and pedestrian structure if bicyclists and pedestrians could have been properly accommodated on the roadway structure, or a requested grade separation when at-grade crossings are considered adequate.

In determining cost shares, an approach is defined as the length of roadway necessary to transition the structure improvement into the existing highway system.

5-5.02(q) Other Work

Municipalities will bear all additional costs of improvements outside the traffic lanes including utility adjustments, curb or curb and gutter repair, drainage structure adjustments, traffic signal installation or modernization, and entrance reconstruction, except as otherwise noted in Section 5-5.02.

5-5.03 Basis of Payment

5-5.03(a) Municipality Reimbursement

For Agreements where the municipality is reimbursing the State, the Agreement or Funding Resolution must clearly delineate when and how the municipality will reimburse the State. The Central Office Bureau of Construction will bill the municipality directly after the award of the contract in accordance with the terms specified in the Agreement. Several alternative repayment methods are available as follows:

- Payment Upon Project Completion. Payment is made upon completion of the project provided the municipality's share does not exceed \$10,000.
- Payment Upon Contract Award. An 80% payment is made upon contract award with any balance paid upon completion.
- Equal Monthly Payments. Equal monthly payments are made based upon Equation 5-5.3 as follows:

$$\text{Monthly Payment} = \frac{0.80 (\text{Estimated Municipal Share})}{\text{Contract Duration in Months}} \quad \text{Equation 5-5.3}$$

The municipality will send its final payment upon project completion.

- Progress Payments. Progress payments are made based upon Equation 5-5.4 as follows:

$$\text{Progress Payment} = \frac{\text{Total Municipal Share}}{\text{Total Construction Cost}} (\text{Actual Progress Payment}) \quad \text{Equation 5-5.4}$$

- **Dual Payment.** A dual payment is based upon a 50% payment upon award with the remaining 50% paid upon completion. This payment alternative is limited to projects with a duration of 60 working days or less.

Example 6 in Section 5-8 illustrates a sample resolution.

5-5.03(b) State Reimbursement

It should be stated in the Agreement specifically when and how the State will reimburse the municipality. Once the Agreement is fully consummated, BDE will process the necessary Contract Obligation Documents (COD) for use in the processing of invoices. Any one of the five alternatives presented in Section 5-5.03(a) for municipality reimbursement can be applied similarly to State reimbursement. For an Agreement involving State reimbursement to be eligible for execution, the State's funding must be included in the current annual program or be approved as an exception by BDE and Statewide Program Planning. The Agreement must include specific language giving the State the right to approve the plans and specifications prior to advertisement for bids and to concur in the award of the contract.

5-5.04 Right-of-Way Acquisition

Under Section 605 ILCS 5/4-501 of the *Illinois Compiled Statutes*, the only governmental unit authorized to take title in its own name for a State highway improvement is the Department or any County, regardless of how the cost of the right-of-way is treated.

Accordingly, Agreements covering joint improvements with governmental units other than Counties shall provide that all right-of-way required for the improvement be acquired in the name of the State.

Although under the Statute a County can take title in its own name for land required for a State highway improvement, the Department will take this title in the name of the State for adequate control of the highway and more effective title approval.

5-6 OTHER AGREEMENTS

5-6.01 Jurisdictional Transfers

Improvement of an unmarked, State-maintained highway may involve a transfer of jurisdictional responsibility from the State to a local highway authority (i.e., a Jurisdictional Transfer). A marked route may also be transferred provided the marking is removed first. An Agreement using the developed format and executed by the Director of Highways Project Implementation is necessary for a Jurisdictional Transfer. See the Bureau of Local Roads and Streets publication *Jurisdictional Transfer Guidelines* for specific guidance. Example 7 in Section 5-8 illustrates a sample Jurisdictional Transfer Agreement.

5-6.02 Supplemental or Addendum Agreements

Use Supplemental Agreements to add provisions to the original Agreement. Use an Addendum Agreement to change rather than add to the original Agreement's provisions.

5-6.03 County and Township Agreements

County/township Agreements are most commonly required for improvements on unmarked routes involving a Jurisdictional Transfer or intersection improvement where one party is participating (as defined in Section 5-1.01) toward the second party's project.

The procedures for Agreements with municipalities generally apply to county/township Agreements, except as follows:

1. Agreement Format. Section 5-8 illustrates the Developed Format for county/township Agreements.
2. Maintenance Obligations. Use the following guidelines for maintenance obligations in County/Township Agreements:
 - The procedures presented in Sections 5-3.01, 5-3.02, 5-3.03, 5-3.08, and 5-3.09 are not applicable to county/township Agreements.
 - For storm sewers and appurtenances, the State will maintain all storm sewers it constructs outside a municipality except joint-use systems constructed at local request. Proportion the joint-use sewer's maintenance and/or reconstruction costs the same as the sewer's initial construction cost was proportioned.
 - For traffic signals and lighting, the State will maintain and pay the electrical energy for all traffic signals and lighting it deems necessary and constructs outside the corporate limits of a municipality.
3. Restrictions/Encroachments. The information presented in Sections 5-4.01, 5-4.02, and 5-4.03 are not applicable to county/township Agreements.

4. Division of Cost. The information in Sections 5-5.02(a), 5-5.02(c), and 5-5.02(h) are not applicable to county/township Agreements.

5-6.04 Private Benefit Agreements

Private Benefit Agreements generally are required where large traffic generators (e.g., shopping centers, factories) require special features (e.g., turn lanes, channelization, traffic signals) along a State highway to safely accommodate the increased traffic volume generated by the facility. Dedicated public roads which essentially provide access to developments (e.g., shopping centers, industrial, institutional, office sites) should be considered as private benefit roads in lieu of public roads. See Subchapter f, Part 550 of the *Illinois Administrative Code* (92 Ill. Admin. Code 550) and the Bureau of Operations publication TRA-5 for participation requirements.

The requisite Agreement should follow the procedures contained in Sections 5-1.01, 5-1.02, 5-1.03, 5-2.01, 5-2.02, 5-2.03, 5-4.04, 5-5.02(e) (Items 2 and 3), 5-5.02(j), and 5-5.02(k) and incorporate the following special considerations:

1. Letter of Credit. Except under extraordinary conditions approved by the Bureau Chief of BDE, all Private Benefit Agreements will include an irrevocable Letter of Credit. The Letter of Credit protects the State's interest by guaranteeing payment should the Private Benefit Organization (PBO) default.
2. Utility Adjustments. The PBO is financially responsible for all utility adjustments caused by highway improvements constructed for the PBO.
3. Right-of-Way. Any right-of-way required solely for PBO highway improvements will be provided at no expense to and as acceptable to the State. If the State must acquire the right-of-way, then the PBO will reimburse the State for its cost.

5-7 OTHER DOCUMENTS

5-7.01 Letters of Understanding

Improvements that do not involve local participation may at times be covered by Letters of Understanding. A Letter of Understanding may be used to delineate maintenance responsibilities (e.g., parking lanes, curbs and gutter flags, sidewalks, manholes, catch basins, storm sewers, traffic signals, utilities, appurtenances). Many of the provisions of an Agreement should be included in a Letter of Understanding (e.g., ordinances for sewer, parking, and encroachments; provisions for curb ramps and plan approval).

The district will prepare the Letter of Understanding. Include in the Letter of Understanding a brief description of the proposed project and describe the responsibilities of both parties. Also, include a description of any needed ordinances from the local agency. For convenience, the district will provide the local agency with sample ordinance forms.

The Letter of Understanding will be prepared by district in duplicate counterparts, signed by the Regional engineer, and transmitted to the local agency with the request that one of the counterparts with the Regional Engineer's signature and the local official's signature be returned to the district. As an option, where there is local agency reluctance to sign the document as presented, it may be advisable to request the local agency to sign the document first, thus avoiding the possibility of the local agency altering the fully executed Letter of Understanding in an unacceptable manner. The district shall file the counterpart with original signatures in the district and forward a copy to BDE. In addition, the report to BDE on projects available for letting should include a statement regarding the status of the Letters of Understanding. The district will secure copies of the required ordinances and plan approval from the local agency prior to advertising for letting and will notify BDE when all ordinances have been received for the improvement. The project support engineer or staff will file the ordinances in the district office.

5-7.02 Informational Letters

Informational Letters may be used on any project not requiring a formal Agreement where no changes in maintenance or other responsibilities from previously executed Agreements or Letters of Understanding will occur. The district will send the Informational Letter to the local official via certified or registered mail to verify receipt. For content, the document should advise the local agency of the improvement scope and anticipated letting and completion dates, and indicate that the covenants contained in previous Agreements or Letters of Understanding relating to jurisdiction, maintenance, electrical energy, enactment of ordinances, etc., will remain unchanged.

It will not be necessary to forward a copy of the document to BDE; however, the district should modify the Certification Acceptance sheet to designate that an Informational Letter rather than a Letter of Understanding will be used.

5-8 EXAMPLES

The following Examples present samples and guidelines for use when processing local agency Agreements:

Example 1 – Developed Agreement for Local Agencies

Example 2 – Parking Ordinance

Example 3 – Storm Sewer Ordinance

Example 4 – Encroachment Ordinance

Example 5 – Off-Street Replacement Parking Guidelines

Example 6 – Funding Resolution

Example 7 – Agreement for Jurisdictional Transfers

See IDOT Master Forms list for:

MFT Funding Resolution for Improvement by County (form BLR 09110)

MFT Funding Resolution for Improvement by municipality (form BLR 09111)

EXAMPLE 1 — Developed Agreement for Local Agencies

_____ Route _____

Section _____

(VILLAGE, CITY, COUNTY, TOWNSHIP) Section _____

County _____

Job No. _____

Agreement No. _____

Contract No. _____

AGREEMENT

This agreement entered into this ____ day of _____, A.D., 20____, by and between the STATE OF ILLINOIS, acting by and through its DEPARTMENT OF TRANSPORTATION hereinafter called the STATE, and the _____ of _____, of the State of Illinois, hereinafter called the (VILLAGE, CITY, COUNTY, or TOWNSHIP).

WITNESSETH:

WHEREAS, the STATE in order to facilitate the free flow of traffic and insure safety to the motoring public, is desirous of improving approximately ____ foot (____ lineal meters) of ____ Street, (FA/SBI Route ____ US/Illinois/CH Route ____, State Section ____, (VILLAGE, CITY, COUNTY, TOWNSHIP) Section ____ by (widening, milling, resurfacing, reconstructing) US/Illinois/CH Route ____ from ____ Street to ____ Street, providing ____ foot (____ meter) through traffic lanes in each direction, a ____ foot (____ meter) median with ____ foot (____ meter) and variable width left turn lanes at ____ and ____ Streets, (milling, resurfacing, constructing) ____ foot (____ meter) wide parking lanes on ____ side(s) of ____ Street between ____ Street and ____ Street, (modernizing, installing) traffic signals at the ____ Route ____ intersections with ____ and ____ Streets, installing a highway lighting system between ____ and ____ Streets, constructing new ____ foot (____ meter) wide PCC sidewalks from ____ Street to ____ Street, constructing curb and gutter and a storm sewer system for highway drainage and by performing all other work necessary to complete the improvement in accordance with the approved plans and specifications; and

WHEREAS, the (VILLAGE, CITY, COUNTY, TOWNSHIP) is desirous of said improvement in that same will be of immediate benefit to the (VILLAGE, CITY, COUNTY, TOWNSHIP) residents and permanent in nature;

NOW, THEREFORE, in consideration of the mutual covenants contained herein, the parties hereto agree as follows:

1. The STATE agrees to make the surveys, obtain all necessary rights of way, prepare plans and specifications, receive bids and award the contract, furnish engineering inspection during construction and cause the improvement to be built in accordance with the plans, specifications and contract.

2. The STATE agrees to pay for all right-of-way, construction and engineering costs, including the cost of railroad adjustments, subject to reimbursement by the (VILLAGE, CITY, COUNTY, TOWNSHIP) as hereinafter stipulated. The STATE will negotiate and/or coordinate with the Railroad for the adjustment of their railroad facilities.

3. It is mutually agreed by and between the parties hereto that the estimated cost and cost proration for this improvement is as follows:

Type of Work	State		Village, City, County, Township		Total
	Cost	%	Cost	%	
All construction costs excluding the following:	\$	100	NA	NA	\$
Mill and resurface parking lanes	\$	50	\$	50	\$
Patch parking lanes	NA	NA	\$	100	\$
Traffic signals at _____ Street	\$	90	\$	10	\$
New highway lighting	NA	NA	\$	100	\$
Relocate water main at _____ Street	NA	NA	\$	100	\$
Sub Total	\$		\$		\$
P&C Engineering 15%	\$		\$		\$
Total	\$		\$		\$

Participation and reimbursement shall be predicated by the percentages shown above for the specified work. Cost shall be determined by multiplying the final quantities times contract unit prices plus 15% for construction and preliminary engineering. Participation toward the traffic signals and watermain relocation shown above shall not exceed \$_____ which represents 125% of their estimated construction and engineering cost.

(If the local agency is to acquire right of way, at its own cost and expense or at the cost and expense of the state, in whole or in part, use the following paragraphs and make appropriate changes in paragraphs 1, 2, and 3).

4. The (VILLAGE, CITY, COUNTY, TOWNSHIP) agrees to obtain and pay for the cost of acquiring the necessary right of way in accordance with the following requirements:

A. Right of way shall be acquired in the name of the STATE on standard State forms which will be provided for that purpose in accordance with Land Acquisition Policies and Procedures of the STATE.

B. No award of a contract shall be made to cover construction of the project or any part thereof without first having been made a title approval by the Attorney General of Illinois on each individual parcel of right of way, the consideration for which exceeds \$10,000, including within such construction. A title approval shall be made by the STATE on each parcel of right of way acquired for the project where the consideration is \$10,000 or less. In the event acquisition of the right of way is by condemnation, then such action must be brought in the name of the State by the Attorney General and an Assistant Attorney General appointed by him.

C. Cost of the right of way shall include the purchase price thereof as well as the cost of negotiators, appraisals, title evidence, relocation assistance and payments, property management and such legal service as may be necessary to acquire said right of way. The acquiring agency, if participating in the cost of the right of way shall receive a credit for a proportionate amount of the proceeds of any sale or rental of improvements acquired within the right of way or as a direct result of the right of way acquisition.

D. All parties engaged in the acquisition of the right of way shall be approved in advance by the STATE.

E. Appraisals (use Item (1) or (2) as appropriate):

(1) Appraisals shall be reviewed and a negotiating figure approved by the STATE in advance of negotiations for the purchase of said right of way.

(2) The (VILLAGE, CITY, COUNTY, TOWNSHIP) shall provide a sufficient number of qualified reviewing appraisers approved by the STATE. The STATE shall approve the appraisal process in advance of negotiations for the purchase of said right of way.

F. Any phase of the STATE's Relocation Assistance Procedures to be performed by any qualified agency other than the STATE shall be covered by separate contractual agreement or agreements with the agency and are subject to prior approval of the Division Administrator of the Federal Highway Administration.

G. The STATE shall provide such guidance, assistance and supervision and monitor and perform audits to the extent necessary to assure compliance with the STATE's Land Acquisition Policies and Procedures.

(If the local agency is to acquire right of way off the State highway system and there are Federal funds being used for any portion of the project, not just land acquisition, use the following paragraph. Please note, on those occasions when more than one land acquisition condition exists, all appropriate provisions that apply must be included.)

4a. The _____ agrees to acquire in its name and at its own expense, subject to reimbursement as hereinafter provided, all right of way necessary for this project in accordance with the requirements of Titles II and III of the Uniform Relocation Assistance and Real Property Acquisition Policies Act of 1970, as amended. The requirements of Title II and Title III shall be carried out in accordance with established State Policies and Procedures, as now or hereafter revised or amended. Prior to the State's advertising for bids, the local agency shall certify to the STATE that all requirements of Titles II and III of said Uniform Act have been compiled with.

A. The STATE will advertise for bids for the construction of the proposed improvement after the local agency's certification as to compliance with Titles II and III requirements have been accepted by the STATE and subject to approval by the Division Administrator of the Federal Highway Administration.

B. The STATE shall provide such guidance, assistance and supervision and monitor and perform audits to the extent necessary to assure validity of the local agency's certification of compliance with Titles II and III requirements of the aforesaid Act.

5. The (VILLAGE, CITY, COUNTY, TOWNSHIP) has passed a resolution appropriating sufficient funds to pay its share of the cost for this improvement, a copy of which is attached hereto as "Exhibit ____" and made a part hereof.

(For Local's use of non-MFT funds for reimbursement, include one of the following.)

The (VILLAGE, CITY, COUNTY, TOWNSHIP) further agrees

a. ***(Payment upon Completion)*** that upon completion of the contract for this improvement, the _____ will pay to the DEPARTMENT OF TRANSPORTATION of the STATE OF ILLINOIS in a lump sum for any funds allotted to the _____ an amount equal to 100% of its obligation incurred under this AGREEMENT.

b. ***(80% Payment upon Award)*** that upon award of the contract for this improvement, the _____ will pay to the DEPARTMENT OF TRANSPORTATION of the STATE OF ILLINOIS in a lump sum from any funds allotted to the _____, an amount equal to 80% of its obligation incurred under this AGREEMENT, and will pay to the said DEPARTMENT the remainder of the obligation (including any non-participating costs on FA Projects) in a lump sum, upon completion of the project based upon final costs.

c. ***(Monthly Payments)*** that upon award of the contract for this improvement, the _____ will pay to the DEPARTMENT OF TRANSPORTATION of the STATE OF ILLINOIS from any funds allotted to the _____, the amount of \$_____ each month for a period of approximately _____ months or until 80% of the estimated obligation under the provisions of the AGREEMENT has been paid, and will pay to the said DEPARTMENT the remainder of its obligation (including

any non-participating costs on FA projects) in a lump sum upon completion of the project based upon final costs.

d. **(Progress Payments)** that upon receipt of the first and subsequent progress payments made to the CONTRACTOR, the _____ will pay to the DEPARTMENT OF TRANSPORTATION of the STATE OF ILLINOIS from any funds allotted to the _____ an amount equal to the _____ share, \$_____, divided by the estimated construction costs, \$_____, multiplied by the actual progress payment (appropriately adjusted for non-participating costs on FA projects) made to the CONTRACTOR until the entire obligation incurred under this AGREEMENT has been paid.

e. **(Dual Payment)** that upon award of the contract for this improvement, the _____ will pay to the DEPARTMENT OF TRANSPORTATION of the STATE OF ILLINOIS from any funds allotted to the _____, an amount equal to 50% of its obligation incurred under this AGREEMENT, and will pay to the said DEPARTMENT the remainder of the obligation (including any non-participating costs on FA projects) in a lump sum, upon completion of the project based upon final costs.

(Include in all Local reimbursement Agreements where non-MFT funds are used and traffic signals are not a sole reimbursable items):

The (VILLAGE, CITY, COUNTY, TOWNSHIP) further agrees to pass a supplemental resolution to provide necessary funds for its share of the cost of this improvement if the amount appropriated in "Exhibit_____" proves to be insufficient, to cover said cost.

6. The (VILLAGE, CITY) has adopted and will put into effect an appropriate ordinance, prior to the STATE's advertising for the proposed work to be performed hereunder, or shall continue to enforce an existing ordinance, requiring that parking be (parallel to the curbs) (prohibited) within the limits of this improvement, a copy of which is attached hereto as "Exhibit_____", and will in the future prohibit parking at such locations on or immediately adjacent to this improvement as may be determined necessary by the STATE from traffic capacity studies.

7. The (VILLAGE, CITY) has adopted and will put into effect an appropriate ordinance, prior to the STATE's advertising for the proposed work to be performed hereunder, or shall continue to

enforce an existing ordinance, prohibiting the discharge of sanitary sewage and industrial waste water into any storm sewers constructed as a part of this improvement, a copy of which is attached hereto as "Exhibit _____".

8. Prior to the STATE advertising for the work proposed hereunder, the disposition of encroachments will be cooperatively resolved with representatives from the (VILLAGE, CITY) and the STATE.

The (VILLAGE, CITY) has adopted and will put into effect an appropriate ordinance, prior to the STATE's advertising for the proposed work to be performed hereunder, or shall continue to enforce an existing ordinance, relative to the disposition of encroachments and prohibiting, in the future, any new encroachments within the limits of the improvements, a copy of which is attached as "Exhibit _____".

(If the local agency is to perform any part of the work and/or engineering involved in the improvement, and the STATE is paying for or allowing credit for the work and/or engineering both of the following paragraphs (10 and 11) should be included):

9. The (VILLAGE, CITY, COUNTY, TOWNSHIP) shall maintain, for a minimum of (3,5) years after the completion of the Project, adequate books, records, and supporting documents to verify the amounts, recipients, and uses of all disbursements of funds passing in conjunction with this Agreement. All books, records, and supporting documents related to the Project shall be available for review and audit by the Auditor General and other State auditors and the (VILLAGE, CITY, COUNTY, TOWNSHIP) agrees to cooperate fully with an audit conducted by the Auditor General and other State Auditors and to provide full access to all relevant materials. Failure to maintain the books, records, and supporting documents required by this paragraph shall establish a presumption in favor of the STATE for the recovery of any funds paid by the STATE under this Agreement for which adequate books, records, and supporting documentation are not available to support their purported disbursement.

10. The (VILLAGE, CITY, COUNTY, TOWNSHIP) agrees to comply with all applicable Executive Orders and Federal Highway Acts pursuant to the Equal Employment Opportunity and non-discrimination regulations required by the U.S. Department of Transportation. (Non-Federal-aid projects use Illinois Department of Transportation in lieu of U.S.)

11. The (VILLAGE, CITY, COUNTY, TOWNSHIP) agrees not to permit driveway entrance openings to be made in the curb, as constructed, or the construction of additional entrances, private or commercial, along _____ Route _____ without the consent of the STATE.

12. The (VILLAGE, CITY, COUNTY, TOWNSHIP) shall exercise its franchise rights to cause private utilities to be relocated, if required, at no expense to the STATE.

13. The (VILLAGE, CITY, COUNTY, TOWNSHIP) agrees to cause its utilities installed on right of way after said right of way was acquired by the STATE or installed within the limits of a roadway after the said roadway's jurisdiction was assumed by the STATE, to be relocated and/or adjusted, if required, at no expense to the STATE.

(If the State contract includes the relocation or adjustment of a municipally owned utility, include the following paragraph):

14. All (VILLAGE, CITY) owned utilities, on STATE right of way within the limits of this improvement, which are to be relocated/adjusted under the terms of this Agreement, will be relocated/adjusted in accordance with the applicable portions of the "Accommodation of Utilities of Right of Way of the Illinois State Highway System." (92 Ill. Adm. Code 530).

15. The (VILLAGE/CITY) agrees to obtain from the STATE an approved permit for the facility, and to abide by all conditions set forth therein.

16. Upon final field inspection of the improvement and so long as (Street Name) _____ is used as a State Highway, the STATE agrees to maintain or cause to be maintained the median, the _____ through traffic lanes lying _____ on either side of the (median), (centerline) and the left-turn and right-turn lanes, each lane being _____ feet (_____ meters) and variable in width, and the curb and gutter or stabilized shoulders and ditches adjacent to those traffic lanes and turn lanes to be maintained by the STATE.

17. Upon final field inspection of the improvement, the (VILLAGE, CITY, COUNTY, TOWNSHIP) agrees to maintain or cause to be maintained those portions of the improvement which are not maintained by the STATE, including parking lanes and their adjacent curb and gutter, sidewalks,

parkways, guardrails, crosswalk and stopline markings, (VILLAGE, CITY, COUNTY, TOWNSHIP) owned utilities including appurtenances thereto, highway lighting including furnishing the electrical energy therefore and shall maintain the storm sewers and appurtenances by:

NOTE: INSERT A OR B AS APPROPRIATE.

(A) Applicable when storm sewer system constructed for State highway drainage only:

performing those functions necessary to keep the sewer in a serviceable condition including cleaning sewer lines, inlets, manholes, and catch basins along with the repair or replacement of inlet, manhole and catch basins' frames, grates or lids. The maintenance, repair and/or reconstruction of storm sewers constructed as part of this improvement beyond the aforescribed responsibilities shall be that of the STATE.

(B) Applicable when storm sewer system constructed as a joint LA and State use facility:

performing those functions necessary to keep the sewer in a serviceable condition including cleaning sewer lines, inlets, manholes and catch basins along with the repair or replacement of inlet, manholes and catch basins' frames, grates or lids. The STATE shall share cost of the maintenance, except as aforescribed, repair and/or reconstruction of the joint use sewer(s) to the same proportioning as the sewers initial construction costs.

The (VILLAGE, CITY, COUNTY, TOWNSHIP) further agrees to continue its existing maintenance responsibilities on all side road approaches under its jurisdiction, including all left and right turn lanes on said side road approaches, up to the through edge of pavement of US/Illinois/CH Route _____. Drainage facilities, if any, at the aforementioned side roads located within the STATE right-of-way shall be the joint maintenance responsibility of the STATE and the (VILLAGE, CITY, COUNTY, TOWNSHIP) unless there is an agreement specifying different responsibilities.

FOR TRAFFIC SIGNALS - USE 18a, 18b, 18c WHERE APPROPRIATE.

(Verbiage For Installation And/Or Modernization Projects Where No Master Agreement Exists.)

18a. Upon acceptance by the STATE of the traffic signal work included herein, the financial responsibility for the maintenance and electrical energy charges for the operation of the traffic signal(s) shall be proportioned as follows:

Intersection	Maintenance	Electrical Energy
_____ Route _____		
@ _____ Street		
STATE Share	()%	()%
CITY or VILLAGE Share	()%	()%

(Share percentages are determined from Appendix C.)

It is mutually agreed that the actual traffic signal maintenance will be performed by the (STATE, CITY or VILLAGE), either with its own forces or through an ongoing contractual agreement. It is further mutually agreed that the traffic signals shall be maintained to the standard described in the 2000 Edition of the Illinois Manual of Uniform Traffic Control Devices, Part 4, Section 4D.02 a copy of which is attached hereto as "Exhibit _____" and made a part hereof.

(The following paragraph is needed only when a City or Village maintains the signals.)

It is also understood that if, in the judgment of the STATE, the (CITY or VILLAGE) has not provided adequate maintenance for those traffic signals which it has been assigned to maintain, the STATE will, upon giving 30 days written notice, arrange for the appropriate maintenance efforts and bill the (VILLAGE or CITY) for its share of the costs.

The (STATE, VILLAGE or CITY) agrees to bill the (STATE, VILLAGE, or CITY) for its proportionate share of the traffic signal maintenance costs on a three-month basis. The amount billed shall be the actual costs incurred less any third party damage claims received during the billing period for repair of traffic signals that are the responsibility of the billed party.

Any proposed expenditure in excess of \$5,000 for repair of damage to any single traffic signal installation must be approved by the billed party before the expenditure is made. The STATE reserves the right to examine the records of the (VILLAGE or CITY) to determine that costs billed are fully documented.

The STATE agrees to make arrangements with the local power company to furnish the electrical energy for the operation of the traffic signals. The (STATE, CITY or VILLAGE) agrees to pay their proportionate share of this cost as billed by the local power company.

The STATE retains the right to control the sequence and timing of the traffic signals.

Payment by the STATE of any or all of its share of maintenance and energy costs is contingent upon the STATE receiving adequate funds in its annual appropriation.

The parties hereto agree that the traffic signal maintenance and energy provisions of this Agreement shall remain in effect for a period of twenty (20) years from the date of its execution or so long as the traffic signals covered by the terms of this Agreement or any amendment hereto remain in place either in their current or some modified configuration, whichever, is the shorter period of time. Such an effective term shall apply unless otherwise agreed in writing by the parties hereto.

(Verbiage for Modernization Project Where Master Agreement Exists.)

18b. Upon acceptance by the STATE of the traffic signal work included herein the responsibility for maintenance and energy shall continue to be as outlined in the Master Agreement executed by the STATE and the (CITY/VILLAGE) on _____ 20 _____.

(Verbiage for Installation Project Where Master Agreement Exists.)

18c. Upon acceptance by the STATE of the new traffic signal installation(s), the financial responsibility for maintenance and electrical energy for the operation of the traffic signals shall be proportioned as follows:

Intersection	Maintenance	Electrical Energy
_____ Route _____		
@ _____ Street		
STATE Share	()%	()%
CITY or VILLAGE Share	()%	()%

(Share percentages are determined from Part 544 of Title 92, Illinois Administrative Code.)

It is mutually agreed that the actual traffic signal maintenance will be performed by the (STATE, CITY or VILLAGE), either with its own forces or through an ongoing contractual agreement.

It is further agreed that the traffic signal shall be maintained to at least the Levels of Maintenance shown in the Illinois Manual of Uniform Traffic Control Devices, Part 4, Section 4D.02, a copy of which is attached hereto as "Exhibit _____" and made a part hereof.

Upon acceptance by the STATE of the new traffic signal installation(s) included herein, the responsibility for maintenance and energy outlined above shall become a part of the Master Agreement executed by the State and the (CITY/VILLAGE) on _____ 20 _____.

(The following paragraph should be included when an agreement involves both new signal installations, as above, and the modernization or modifications of existing signals.)

19. Upon acceptance by the STATE of the work proposed herein on existing signals, the responsibility for maintenance and energy shall continue to be as outlined in the aforementioned Master Agreement.

20. The STATE agrees to make arrangements with the local power company to furnish the electrical energy for the operation of the traffic signals. The (STATE, CITY or VILLAGE) agrees to pay their proportionate share of this cost as billed by the local power company.

(If the local agency is To Provide Engineering, Materials, And/Or Let The Contract On A Federal-aid Project, Then The Following Covenant Must Be Included.)

21. The (VILLAGE, CITY, COUNTY, TOWNSHIP), subrecipient or subcontractor shall not discriminate on the basis of race, color, national origin, or sex in the performance of this contract. The (VILLAGE, CITY, COUNTY, TOWNSHIP) shall carry out applicable requirements of 49 CFR part 26 in the award and administration of STATE-assisted contracts. Failure by the (VILLAGE, CITY, COUNTY, TOWNSHIP) to carry out these requirements is a material breach of this contract, which may result in the termination of this contract or such other remedy as the STATE deems appropriate.

22. The (VILLAGE, CITY, COUNTY, TOWNSHIP) agrees to provide written approval of that portion of the plans and specifications relative to the (VILLAGE, CITY, COUNTY, TOWNSHIP) financial and maintenance obligations described herein, prior to the STATE's advertising for the aforescribed proposed improvement.

23. Obligations of the STATE and (VILLAGE, CITY, COUNTY, TOWNSHIP) will cease immediately without penalty or further payment being required if, in any fiscal year, the Illinois General Assembly or Federal funding source fails to appropriate or otherwise make available funds for this contract.

24. This AGREEMENT and the covenants contained herein shall be null and void in the event the contract covering the construction work contemplated herein is not awarded within the three years subsequent to execution of the agreement.

This agreement shall be binding upon and to the benefit of the parties hereto, their successors and assigns.

NOTE: THIS SIGNATURE FORMAT IS TO BE USED IF THE LOCAL AGENCY REIMBURSES THE STATE LESS THAN \$250,000.

Attest:

Clerk
(SEAL)

Name of Local Agency

By: _____
Name

Date: _____

STATE OF ILLINOIS
DEPARTMENT OF TRANSPORTATION

By: _____
Name
Regional Engineer

Date: _____

NOTE: THIS SIGNATURE FORMAT IS TO BE USED IF THE STATE REIMBURSES THE LOCAL AGENCY \$250,000 OR MORE.

Attest: _____
Clerk

(SEAL)

Name of Local Agency

By: _____
(Printed Name)

TITLE: _____

Date: _____

STATE OF ILLINOIS
DEPARTMENT OF TRANSPORTATION

By: _____
Secretary

Date: _____

By: _____
Director - Office of Highways
Project Implementation

Date: _____

By: _____
Office of Finance & Administration

Date: _____

By: _____
Chief Counsel

Date: _____

NOTE: THIS SIGNATURE FORMAT IS TO BE USED IF THE STATE REIMBURSES THE LOCAL AGENCY LESS THAN \$250,000.

Attest: _____
Clerk

(SEAL)

Name of Local Agency

By: _____

TITLE: _____

Date: _____

STATE OF ILLINOIS
DEPARTMENT OF TRANSPORTATION

By: _____
Secretary

By: _____
Director - Office of Highways
Project Implementation

Date: _____

Date: _____

EXAMPLE 2 — Parking Ordinance

Route _____
State Section _____

“Exhibit _____”
AN ORDINANCE IN RELATION TO
MOTOR VEHICLE PARKING

BE IT ORDAINED BY THE _____ OF _____ OF THE COUNTY OF _____ ILLINOIS THAT:

Section 1: It shall be unlawful for any person, firm or corporation to park any motor vehicle within the area of _____ Street from _____ to _____.

Section 2: Any person, firm or corporation violating the provisions of this Ordinance shall be fined not less than \$ _____ nor more than \$ _____ for each offense.

Section 3: This ordinance shall take effect and be in full force _____ days after its passage, approval and legal publication as required by law, and the _____ Clerk is hereby directed to cause this Ordinance to be published immediately after its due passage and approval.

Passed this _____ day of _____, 20__

(Title)

Attest

Clerk

PASSED: _____

SIGNED: _____

PUBLISHED: _____

EXAMPLE 3 — Storm Sewer Ordinance

“Exhibit _____”

AN ORDINANCE PROHIBITING THE DISCHARGE
OF SANITARY SEWAGE AND INDUSTRIAL WASTE WATER
INTO THE STORM SEWERS OR DRAINAGE FACILITY CONSTRUCTED IN CONJUNCTION
WITH THE IMPROVEMENT OF _____ ROUTE _____
IN THE _____ OF _____, _____ COUNTY, ILLINOIS

WHEREAS, the State of Illinois, through its Department of Transportation and the _____ of _____ a municipal corporation, have entered into an AGREEMENT for the improvement of _____ known as State Section _____ and

WHEREAS, this improvement includes the construction of storm sewers and/or appurtenances for highway drainage;

NOW, THEREFORE, BE IT ORDAINED BY THE _____ OF _____, ILLINOIS:

Section 1: It shall be unlawful for any person, firm or corporation to connect or cause to be connected any drain carrying or to carry any toilet, sink, basement, septic tank, cesspool, industrial waste or any fixture or device discharging polluting substances into any storm sewers constructed as part of this improvement.

Section 2: Any person, firm or corporation violating this ordinance shall be fined not less than \$ _____ nor more than \$ _____ for each offense and separate offense shall deem to be committed each and every day during which a violation continues or exists.

Section 3: This Ordinance shall be in effect from and after its passage, approval, and publication as provided by law.

BE IT FURTHER ORDAINED, that the _____ of _____ does hereby authorize and empower the _____ to execute this Ordinance on behalf of the _____ of _____, and

BE IT FURTHER ORDAINED, that the _____ Clerk is hereby directed to transmit three (3) certified copies of this Ordinance to the Illinois Department of Transportation through the Regional Engineer’s office in _____, Illinois.

ATTEST

PASSED: _____

SIGNED: _____

PUBLISHED: _____

STATE OF ILLINOIS)

)

COUNTY OF _____)

I, _____, _____ Clerk in and for the _____ of _____, hereby certify the foregoing to be a true perfect and complete copy of the resolution adopted by the _____ at a meeting on _____, 20__.

IN TESTIMONY WHEREOF, I have hereunto set my hand seal this _____ day of _____ AD, 20_____.

_____ Clerk

EXAMPLE 4 — Encroachment Ordinance

“Exhibit _____”

AN ORDINANCE REGULATING ENCROACHMENT
ON PUBLIC RIGHT OF WAY IN THE _____ OF _____
_____ COUNTY, ILLINOIS

WHEREAS, the _____ of _____ hereinafter known as _____, and the State of Illinois, acting by and through its Department of Transportation, have entered into an agreement relative to the improvement of _____ Street (_____ Route _____, State Section _____, _____ Section _____) From _____ to _____; and

WHEREAS, in order to facilitate said improvement, it is necessary for the _____ to adopt an ordinance regulating encroachments on the right of way for said improvement in accordance with the following definitions:

1. Roadway Right of way is defined as those areas existing or acquired by dedication or by fee simple for highway purposes; also, the areas acquired by temporary easement during the time the easement is in effect:
2. Project Right of way is defined as those areas within the project right-of-way lines established jointly by the _____ and the STATE which will be free of encroachments except as hereinafter defined;
3. Encroachment is defined as any building, fence, sign (excluding certain signs located over sidewalks) or any other public structure or object of any kind (with the exception of utilities and public road signs) which is placed, located, maintained, in, on, under or over any portion of the project right of way or the roadway right of way where no project right of way line has been established;
4. Permissible encroachment is defined as any existing awning, marquee or sign advertising activity on the property or similar overhanging structure supported from a building immediately adjacent to the limits of the platted street where there is sidewalk extending to the building line and which does not impair the free and safe flow of pedestrian traffic or traffic

on the highway. The permissive retention of overhanging signs is not to be construed as being applicable to those signs supported from poles constructed outside the project right of way line and not confined by adjacent buildings.

- 5. Construction easement Area is defined as the area lying between the project right of way limits and the platted street limits within which the _____, by concurrence with the establishment of the project right of way lines, will permit the STATE to enter to perform all necessary construction activities; and

WHEREAS, representatives of the _____ And the STATE have, by visual inspection, cooperatively established project right of way lines and have mutually determined the disposition of encroachments;

NOW, THEREFORE, BE IT ORDAINED, by the _____ of _____, County, Illinois:

Section 1: It shall be unlawful for any person, firm or corporation to erect, cause to be erected, to retain or cause to be retained any ENCROACHMENT (herein above defined), except as provided in Section 3, within the project right-of-way or roadway right of way where no project right-of-way lines have been established.

Section 2: Project right-of-way lines have been established at the following locations
Along the _____ side of _____ Street _____ feet (_____ meter) _____ the centerline of the proposed improvement from _____ to _____.

(No project right-of-way lines have been established.)

Section 3: Revocable permits have been issued by the _____ for the temporary retention of the following PERMISSIBLE ENCROACHMENT (hereinabove defined):

(No temporary permits have been issued.)

Section 4: This ordinance is intended to and shall be in addition to all other ordinances, rules and regulations concerning encroachments and shall not be construed as repealing or rescinding any other ordinance or part of any ordinance unless in direct conflict therewith.

Section 5: Any person, firm or corporation violating the provisions of this Ordinance shall be fined not less than \$ _____ nor more than \$ _____ for each offense, a separate offense shall be deemed committed for each and every day during which the violation continues or exists.

Section 6: This ordinance shall be published _____ time(s) within _____ days after its passage in the newspaper having a general circulation in the _____ of _____, Illinois, and shall be in full force and effect after its passage, publication and approval as provided by law.

Passed and approved this _____ day of _____, 20____.

(Title)

ATTEST

Clerk

EXAMPLE 5 — Off-Street Replacement Parking Guidelines

Illinois Department of Transportation

Memorandum

To: All District Engineers
From: Ralph C. Wehner
Subject: Replacement Parking Guidelines
Date: September 10, 1991

The following set of guidelines were developed to allow the Department to participate in the construction of replacement urban parking facilities as part of an improvement which requires removal of on-street parking.

I. PURPOSE

To enable the District Engineer, at his discretion, to cooperate with a municipality to replace existing legal on-State system parking in useable segments with off-site parking spaces for the benefit of State highway capacity and safety.

II. ASSUMPTIONS

These guidelines assume that existing on-street parking cannot be accommodated by widening the existing parking lanes or by constructing new replacement parking adjacent to through traffic lanes. These conditions are covered in Section 1-400 of the Design Manual and require municipal financial participation. This incentive/disincentive should work to discourage on-street parking thus reducing the hazard and capacity problems associated with on street parking.

III. IMPLEMENTATION

Early involvement coordination with the affected municipality shall be accomplished in order to determine any significant social, economic, and environmental effects from both parking removal and replacement. Discussion of existing parking patterns should be made to determine replacement requirements based on actual needs rather than the existing number of available spaces. This information should be included in the appropriate location and environmental studies and reports together with estimated costs for parking replacement. Replacement off-street parking may be let as part of the roadway improvement or as a separate municipal contract.

All District Engineers
Page 2
September 10, 1991

IV. PARTICIPATION

The State will provide 100% of all engineering, right of way (except where replacement parking is constructed on municipally-owned property), and construction costs required to construct alternate (off-State system) parking on a maximum ratio of 1 to 1. Alternate parking can consist of improving adjacent local streets to provide parallel parking, the construction of off-street parking facilities, or combinations thereof. Construction costs shall include those items the State deems reasonable to provide parking facilities having a safe and convenient environment as is practical, including a paved surface, drainage, lighting, pedestrian walkways, and fencing. The construction and installation of guard and toll collection facilities, metering devices, and parking capacity beyond the maximum replacement ratio shall be totally the local agency's responsibility.

V. MAINTENANCE

The municipality shall enter into an Agreement with the State accepting complete jurisdiction of the parking facility(ies) including but not limited to its maintenance, operation, repair, reconstruction, and provision of electrical energy for lighting systems and striping. The municipality shall hold the State harmless from any suits arising from construction, operation, and maintenance of these parking facilities.

VI. RIGHT OF WAY

The municipality shall acquire or have acquired all rights of way and easements in its own name and shall provide the State with certification that it holds good and sufficient title to such property(ies).

Prior to the municipality acquiring the right of way:

- A. The State shall, at its own expense, conduct a survey for potential hazardous wastes and shall notify the municipality of its acceptance or rejection of said site.
- B. The municipality shall follow the procedures contained in the State's Land Acquisition Manual and provide the State with an estimate of right-of-way costs, including its purchase price plus fees associated with negotiators, appraisals, title evidence, and legal services for each potential parcel. The State shall be given an opportunity to accept or reject the parcel(s).

All District Engineers
Page 3
September 10, 1991

- C. If the municipality owns the site selected for replacement parking, it shall provide same at no expense to the State. Clearing of municipally-owned property included in the State's construction contract shall be considered as part of the replacement parking construction cost and thus shall be at the expense of the State.

VII. ENFORCEMENT

The municipality shall agree to enact and enforce ordinances prohibiting parking at all locations where on-street parking is removed.

The municipality shall, unless approved by the State in writing, retain in public trust for a period of 20 years, all parking facilities constructed at State expense. The State shall not unreasonably withhold such approval, but will require prorata compensation for its initial expense in constructing the parking facilities as a condition of its approval.

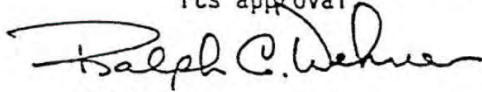

RDM/jmb/2109M

cc: Allan Abbott
M. J. Macchio

EXAMPLE 6 — Funding Resolution

“Exhibit _____”

FUNDING RESOLUTION

WHEREAS, the _____ of _____ has entered into an AGREEMENT with the STATE OF ILLINOIS for the improvement of _____, known as State Section; _____ and

WHEREAS in compliance with the aforementioned AGREEMENT, it is necessary for the _____ to appropriate sufficient funds to pay its share of the cost of said improvement.

NOW, THEREFORE, BE IT RESOLVED, that there is hereby appropriated the sum of _____ dollars (\$ _____) or so much thereof as may be necessary, from any money now or hereinafter allotted to the _____ to pay its share of the cost of this improvement as provided in the AGREEMENT; and

BE IT FURTHER RESOLVED, that upon completion of the contract for this improvement, the _____ will pay the DEPARTMENT OF TRANSPORTATION, in lump sum from any funds allotted to the _____ an amount equal to 100% of its obligation incurred under this AGREEMENT.

BE IT FURTHER RESOLVED, that upon award of the contract for this improvement, the _____ will pay to the DEPARTMENT OF TRANSPORTATION of the STATE OF ILLINOIS in a lump sum from any funds allotted to the _____, an amount equal to 80% of its obligation incurred under this AGREEMENT, and will pay to the said DEPARTMENT the remainder of the obligation in a lump sum, upon completion of the projected based on final costs.

BE IT FURTHER RESOLVED, that upon award of the contract for this improvement, the _____ will pay to the DEPARTMENT OF TRANSPORTATION of the STATE OF ILLINOIS from any funds allotted to the _____, the amount of \$ _____ each month for a period of approximately _____ months or until 80% of its estimated obligation under the provisions of this AGREEMENT has been paid, and will pay

to the said DEPARTMENT the remainder of the obligation in a lump sum, upon completion of the projected based on final costs.

BE IT FURTHER RESOLVED, that upon receipt of the first and subsequent progress payments made to the CONTRACTOR, the _____ will pay to the DEPARTMENT OF TRANSPORTATION of the STATE OF ILLINOIS from any funds allotted to the _____, an amount equal to the _____ share \$ _____ divided by the estimated construction costs, \$ _____, multiplied by the actual progress payment made to the CONTRACTOR until the entire obligation incurred under this AGREEMENT has been paid.

BE IT FURTHER RESOLVED, that upon award of the contract for this improvement, the _____ will pay to the DEPARTMENT OF TRANSPORTATION of the STATE OF ILLINOIS in a lump sum from any funds allotted to the _____, an amount equal to 50% of its obligation incurred under this AGREEMENT, and will pay to the said DEPARTMENT the remainder of the obligation in a lump sum, upon completion of the projected based on final costs.

BE IT FURTHER RESOLVED, that the _____ agrees to pass a supplemental resolution to provide any necessary funds for its share of the cost of this improvement if the amount appropriated herein proves to be insufficient, to cover said cost.

STATE OF ILLINOIS)
COUNTY OF _____)

I, _____, _____ Clerk in and for the _____ of _____, hereby certify the foregoing to be a true perfect and complete copy of the resolution adopted by the _____ at a meeting on _____, 20_____.

IN TESTIMONY WHEREOF, I have hereunto set my hand seal this _____ day of _____ AD, 20_____.

(SEAL) _____ Clerk

EXAMPLE 7 — Agreement for Jurisdictional Transfer

_____ Route _____

Section _____

(VILLAGE, CITY, COUNTY, TOWNSHIP) Section _____

County _____

Job No. _____

Agreement No. _____

Contract No. _____

AGREEMENT

This agreement entered into this ____ day of _____, A.D., 20____, by and between the STATE OF ILLINOIS, acting by and through its DEPARTMENT OF TRANSPORTATION hereinafter called the STATE, and the _____ of _____, of the State of Illinois, hereinafter called the (VILLAGE, CITY, COUNTY, or TOWNSHIP).

WITNESSETH:

WHEREAS, the STATE in order to facilitate the free flow of traffic and insure safety to the motoring public, is desirous of improving approximately ____ foot (____ lineal meters) of _____ Street, (FA/SBI Route _____ US/Illinois/CH Route _____, State Section _____, (VILLAGE, CITY,COUNTY, TOWNSHIP) Section _____ by (widening, milling, resurfacing. reconstructing) US/Illinois/CH Route _____ from _____ Street to _____ Street, providing _____ foot (____ meter) through traffic lanes in each direction, a _____ foot (____ meter) median with _____ foot (____ meter) and variable width left turn lanes at _____ and _____ Streets, (milling, resurfacing, constructing) _____ foot (____ meter) wide parking lanes on _____ side(s) of _____ Street between _____ Street and _____ Street, (modernizing, installing) traffic signals at the _____ Route _____ intersections with _____ and _____ Streets, installing a highway lighting system between _____ and _____ Streets, constructing new ____ foot (____ meter) wide PCC sidewalks from _____ Street to _____ Street, constructing curb and gutter and a storm sewer system for highway drainage and by performing all other work necessary to complete the improvement in accordance with the approved plans and specifications; and

WHEREAS, the (VILLAGE, CITY, COUNTY, TOWNSHIP) is desirous of said improvement in that same will be of immediate benefit to the (VILLAGE, CITY, COUNTY, TOWNSHIP) residents and permanent in nature;

NOW, THEREFORE, in consideration of the mutual covenants contained herein, the parties hereto agree as follows:

1. The STATE agrees to make the surveys, obtain all necessary rights of way, prepare plans and specifications, receive bids and award the contract, furnish engineering inspection during construction and cause the improvement to be built in accordance with the plans, specifications and contract.

2. The STATE agrees to pay for all right-of-way, construction and engineering costs, including the cost of railroad adjustments, subject to reimbursement by the (VILLAGE, CITY, COUNTY, TOWNSHIP) as hereinafter stipulated. The STATE will negotiate and/or coordinate with the Railroad for the adjustment of their railroad facilities.

3. It is mutually agreed by and between the parties hereto that the estimated cost and cost proration for this improvement is as follows:

Type of Work	State		Village, City, County, Township		Total
	Cost	%	Cost	%	
All construction costs excluding the following:	\$	100	NA	NA	\$
Mill and resurface parking lanes	\$	50	\$	50	\$
Patch parking lanes	NA	NA	\$	100	\$
Traffic signals at _____ Street	\$	90	\$	10	\$
New highway lighting	NA	NA	\$	100	\$
Relocate water main at _____ Street	NA	NA	\$	100	\$
Sub Total	\$		\$		\$
P&C Engineering 15%	\$		\$		\$
Total	\$		\$		\$

Participation and reimbursement shall be predicated by the percentages shown above for the specified work. Cost shall be determined by multiplying the final quantities times contract unit

prices plus 15% for construction and preliminary engineering. Participation toward the traffic signals and watermain relocation shown above shall not exceed \$_____ which represents 125% of their estimated construction and engineering cost.

(If the agreement addresses a jurisdictional transfer, insert the following paragraph.)

4. The (VILLAGE, CITY, COUNTY, TOWNSHIP) and the State have agreed to the jurisdictional transfer of the portion of highway described in the local agency – State Agreement for Jurisdictional Transfer (BLR 05210), attached hereto as “Exhibit_____” and made a part hereof.

(If the local agency is to acquire right of way, at its own cost and expense or at the cost and expense of the state, in whole or in part, use the following paragraphs and make appropriate changes in paragraphs 1, 2, and 3.)

5. The (VILLAGE, CITY, COUNTY, TOWNSHIP) agrees to obtain and pay for the cost of acquiring the necessary right of way in accordance with the following requirements:

A. Right of way shall be acquired in the name of the STATE on standard State forms which will be provided for that purpose in accordance with Land Acquisition Policies and Procedures of the STATE.

B. No award of a contract shall be made to cover construction of the project or any part thereof without first having been made a title approval by the Attorney General of Illinois on each individual parcel of right of way, the consideration for which exceeds \$10,000, including within such construction. A title approval shall be made by the STATE on each parcel of right of way acquired for the project where the consideration is \$10,000 or less. In the event acquisition of the right of way is by condemnation, then such action must be brought in the name of the State by the Attorney General and an Assistant Attorney General appointed by him.

C. Cost of the right of way shall include the purchase price thereof as well as the cost of negotiators, appraisals, title evidence, relocation assistance and payments, property management and such legal service as may be necessary to acquire said right of way. The acquiring agency, if participating in the cost of the right of way shall receive a credit for a proportionate amount of the proceeds of any sale or rental of improvements acquired within the right of way or as a direct result of the right of way acquisition.

D. All parties engaged in the acquisition of the right of way shall be approved in advance by the STATE.

E. Appraisals (use Item (1) or (2) as appropriate):

(1) Appraisals shall be reviewed and a negotiating figure approved by the STATE in advance of negotiations for the purchase of said right of way.

(2) The (VILLAGE, CITY, COUNTY, TOWNSHIP) shall provide a sufficient number of qualified reviewing appraisers approved by the STATE. The STATE shall approve the appraisal process in advance of negotiations for the purchase of said right of way.

F. Any phase of the STATE's Relocation Assistance Procedures to be performed by any qualified agency other than the STATE shall be covered by separate contractual agreement or agreements with the agency and are subject to prior approval of the Division Administrator of the Federal Highway Administration.

G. The STATE shall provide such guidance, assistance and supervision and monitor and perform audits to the extent necessary to assure compliance with the STATE's Land Acquisition Policies and Procedures.

(If the local agency is to acquire right of way off the State highway system and there are Federal funds being used for any portion of the project, not just land acquisition, use the following paragraph. Please note, on those occasions when more than one land acquisition condition exists, all appropriate provisions that apply must be included.)

5a. The _____ agrees to acquire in its name and at its own expense, subject to reimbursement as hereinafter provided, all right of way necessary for this project in accordance with the requirements of Titles II and III of the Uniform Relocation Assistance and Real Property Acquisition Policies Act of 1970, as amended. The requirements of Title II and Title III shall be carried out in accordance with established State Policies and Procedures, as now or hereafter revised or amended. Prior to the State's advertising for bids, the local agency shall certify to the STATE that all requirements of Titles II and III of said Uniform Act have been compiled with.

A. The STATE will advertise for bids for the construction of the proposed improvement after the local agency's certification as to compliance with Titles II and III requirements have been accepted by the STATE and subject to approval by the Division Administrator of the Federal Highway Administration.

B. The STATE shall provide such guidance, assistance and supervision and monitor and perform audits to the extent necessary to assure validity of the local agency's certification of compliance with Titles II and III requirements of the aforesaid Act.

6. The (VILLAGE, CITY, COUNTY, TOWNSHIP) has passed a resolution appropriating sufficient funds to pay its share of the cost for this improvement, a copy of which is attached hereto as "Exhibit ____" and made a part hereof.

(For Local's use of non-MFT funds for reimbursement, include one of the following.)

The (VILLAGE, CITY, COUNTY, TOWNSHIP) further agrees

a. ***(Payment upon Completion)*** that upon completion of the contract for this improvement, the _____ will pay to the DEPARTMENT OF TRANSPORTATION of the STATE OF ILLINOIS in a lump sum for any funds allotted to the _____ an amount equal to 100% of its obligation incurred under this AGREEMENT.

b. ***(80% Payment upon Award)*** that upon award of the contract for this improvement, the _____ will pay to the DEPARTMENT OF TRANSPORTATION of the STATE OF ILLINOIS in a lump sum from any funds allotted to the _____, an amount equal to 80% of its obligation incurred under this AGREEMENT, and will pay to the said DEPARTMENT the remainder of the obligation (including any non-participating costs on FA Projects) in a lump sum, upon completion of the project based upon final costs.

c. ***(Monthly Payments)*** that upon award of the contract for this improvement, the _____ will pay to the DEPARTMENT OF TRANSPORTATION of the STATE OF ILLINOIS from any funds allotted to the _____, the amount of \$_____ each month for a period of approximately _____ months or until 80% of the estimated obligation under the provisions of the AGREEMENT has been paid, and will pay to the said DEPARTMENT the remainder of its obligation (including

any non-participating costs on FA projects) in a lump sum upon completion of the project based upon final costs.

d. **(Progress Payments)** that upon receipt of the first and subsequent progress payments made to the CONTRACTOR, the _____ will pay to the DEPARTMENT OF TRANSPORTATION of the STATE OF ILLINOIS from any funds allotted to the _____ an amount equal to the _____ share, \$ _____, divided by the estimated construction costs, \$ _____, multiplied by the actual progress payment (appropriately adjusted for non-participating costs on FA projects) made to the CONTRACTOR until the entire obligation incurred under this AGREEMENT has been paid.

e. **(Dual Payment)** that upon award of the contract for this improvement, the _____ will pay to the DEPARTMENT OF TRANSPORTATION of the STATE OF ILLINOIS from any funds allotted to the _____, an amount equal to 50% of its obligation incurred under this AGREEMENT, and will pay to the said DEPARTMENT the remainder of the obligation (including any non-participating costs on FA projects) in a lump sum, upon completion of the project based upon final costs.

(Include in all Local reimbursement Agreements where non-MFT funds are used and traffic signals are not a sole reimbursable items):

The (VILLAGE, CITY, COUNTY, TOWNSHIP) further agrees to pass a supplemental resolution to provide necessary funds for its share of the cost of this improvement if the amount appropriated in "Exhibit _____" proves to be insufficient, to cover said cost.

7. The (VILLAGE, CITY) has adopted and will put into effect an appropriate ordinance, prior to the STATE's advertising for the proposed work to be performed hereunder, or shall continue to enforce an existing ordinance, requiring that parking be (parallel to the curbs) (prohibited) within the limits of this improvement, a copy of which is attached hereto as "Exhibit _____", and will in the future prohibit parking at such locations on or immediately adjacent to this improvement as may be determined necessary by the STATE from traffic capacity studies.

8. The (VILLAGE, CITY) has adopted and will put into effect an appropriate ordinance, prior to the STATE's advertising for the proposed work to be performed hereunder, or shall continue to

enforce an existing ordinance, prohibiting the discharge of sanitary sewage and industrial waste water into any storm sewers constructed as a part of this improvement, a copy of which is attached hereto as "Exhibit _____".

9. Prior to the STATE advertising for the work proposed hereunder, the disposition of encroachments will be cooperatively resolved with representatives from the (VILLAGE, CITY) and the STATE.

The (VILLAGE, CITY) has adopted and will put into effect an appropriate ordinance, prior to the STATE's advertising for the proposed work to be performed hereunder, or shall continue to enforce an existing ordinance, relative to the disposition of encroachments and prohibiting, in the future, any new encroachments within the limits of the improvements, a copy of which is attached as "Exhibit _____".

(If the Local Agency is to perform any part of the work and/or engineering involved in the improvement, and the STATE is paying for or allowing credit for the work and/or engineering both of the following paragraphs (10 and 11) should be included):

10. The (VILLAGE, CITY, COUNTY, TOWNSHIP) shall maintain, for a minimum of (3,5) years after the completion of the Project, adequate books, records, and supporting documents to verify the amounts, recipients, and uses of all disbursements of funds passing in conjunction with this Agreement. All books, records, and supporting documents related to the Project shall be available for review and audit by the Auditor General and other State auditors and the (VILLAGE, CITY, COUNTY, TOWNSHIP) agrees to cooperate fully with an audit conducted by the Auditor General and other State Auditors and to provide full access to all relevant materials. Failure to maintain the books, records, and supporting documents required by this paragraph shall establish a presumption in favor of the STATE for the recovery of any funds paid by the STATE under this Agreement for which adequate books, records, and supporting documentation are not available to support their purported disbursement.

11. The (VILLAGE, CITY, COUNTY, TOWNSHIP) agrees to comply with all applicable Executive Orders and Federal Highway Acts pursuant to the Equal Employment Opportunity and non-discrimination regulations required by the U.S. Department of Transportation. (Non-Federal-aid projects use Illinois Department of Transportation in lieu of U.S.)

12. The (VILLAGE, CITY, COUNTY, TOWNSHIP) agrees not to permit driveway entrance openings to be made in the curb, as constructed, or the construction of additional entrances, private or commercial, along _____ Route _____ without the consent of the STATE.

13. The (VILLAGE, CITY, COUNTY, TOWNSHIP) shall exercise its franchise rights to cause private utilities to be relocated, if required, at no expense to the STATE.

14. The (VILLAGE, CITY, COUNTY, TOWNSHIP) agrees to cause its utilities installed on right of way after said right of way was acquired by the STATE or installed within the limits of a roadway after the said roadway's jurisdiction was assumed by the STATE, to be relocated and/or adjusted, if required, at no expense to the STATE.

(If the State contract includes the relocation or adjustment of a municipally owned utility, include the following paragraph):

15. All (VILLAGE, CITY) owned utilities, on STATE right of way within the limits of this improvement, which are to be relocated/adjusted under the terms of this Agreement, will be relocated/adjusted in accordance with the applicable portions of the "Accommodation of Utilities of Right of Way of the Illinois State Highway System." (92 Ill. Adm. Code 530).

16. The (VILLAGE/CITY) agrees to obtain from the STATE an approved permit for the facility, and to abide by all conditions set forth therein.

17. Upon final field inspection of the improvement and so long as (Street Name) _____ is used as a State Highway, the STATE agrees to maintain or cause to be maintained the median, the _____ through traffic lanes lying _____ on either side of the (median), (centerline) and the left-turn and right-turn lanes, each lane being _____ feet (_____ meters) and variable in width, and the curb and gutter or stabilized shoulders and ditches adjacent to those traffic lanes and turn lanes to be maintained by the STATE.

18. Upon final field inspection of the improvement, the (VILLAGE, CITY, COUNTY, TOWNSHIP) agrees to maintain or cause to be maintained those portions of the improvement which are not maintained by the STATE, including parking lanes and their adjacent curb and gutter, sidewalks,

parkways, guardrails, crosswalk and stopline markings, (VILLAGE, CITY, COUNTY, TOWNSHIP) owned utilities including appurtenances thereto, highway lighting including furnishing the electrical energy therefore and shall maintain the storm sewers and appurtenances by:

NOTE: INSERT A OR B AS APPROPRIATE.

(A) Applicable when storm sewer system constructed for State highway drainage only:

performing those functions necessary to keep the sewer in a serviceable condition including cleaning sewer lines, inlets, manholes, and catch basins along with the repair or replacement of inlet, manhole and catch basins' frames, grates or lids. The maintenance, repair and/or reconstruction of storm sewers constructed as part of this improvement beyond the aforescribed responsibilities shall be that of the STATE.

(B) Applicable when storm sewer system constructed as a joint LA and State use facility:

performing those functions necessary to keep the sewer in a serviceable condition including cleaning sewer lines, inlets, manholes and catch basins along with the repair or replacement of inlet, manholes and catch basins' frames, grates or lids. The STATE shall share cost of the maintenance, except as aforescribed, repair and/or reconstruction of the joint use sewer(s) to the same proportioning as the sewers initial construction costs.

The (VILLAGE, CITY, COUNTY, TOWNSHIP) further agrees to continue its existing maintenance responsibilities on all side road approaches under its jurisdiction, including all left and right turn lanes on said side road approaches, up to the through edge of pavement of US/Illinois/CH Route _____. Drainage facilities, if any, at the aforementioned side roads located within the STATE right-of-way shall be the joint maintenance responsibility of the STATE and the (VILLAGE, CITY, COUNTY, TOWNSHIP) unless there is an agreement specifying different responsibilities.

FOR TRAFFIC SIGNALS – USE 19A, 19B, 19C WHERE APPROPRIATE.

(Verbiage For Installation And/Or Modernization Projects Where No Master Agreement Exists.)

19a. Upon acceptance by the STATE of the traffic signal work included herein, the financial responsibility for the maintenance and electrical energy charges for the operation of the traffic signal(s) shall be proportioned as follows:

Intersection	Maintenance	Electrical Energy
_____ Route _____		
@ _____ Street		
STATE Share	()%	()%
CITY or VILLAGE Share	()%	()%

(Share percentages are determined from Appendix C.)

It is mutually agreed that the actual traffic signal maintenance will be performed by the (STATE, CITY or VILLAGE), either with its own forces or through an ongoing contractual agreement. It is further mutually agreed that the traffic signals shall be maintained to the standard described in the 2000 Edition of the Illinois Manual of Uniform Traffic Control Devices, Part 4, Section 4D.02 a copy of which is attached hereto as "Exhibit _____" and made a part hereof.

(The following paragraph is needed only when a City or Village maintains the signals.)

It is also understood that if, in the judgment of the STATE, the (CITY or VILLAGE) has not provided adequate maintenance for those traffic signals which it has been assigned to maintain, the STATE will, upon giving 30 days written notice, arrange for the appropriate maintenance efforts and bill the (VILLAGE or CITY) for its share of the costs.

The (STATE, VILLAGE or CITY) agrees to bill the (STATE, VILLAGE, or CITY) for its proportionate share of the traffic signal maintenance costs on a three-month basis. The amount billed shall be the actual costs incurred less any third party damage claims received during the billing period for repair of traffic signals that are the responsibility of the billed party. Any proposed expenditure in excess of \$5,000 for repair of damage to any single traffic signal installation must be approved by the billed party before the expenditure is made. The STATE reserves the right to examine the records of the (VILLAGE or CITY) to determine that costs billed are fully documented.

The STATE agrees to make arrangements with the local power company to furnish the electrical energy for the operation of the traffic signals. The (STATE, CITY or VILLAGE) agrees to pay their proportionate share of this cost as billed by the local power company.

The STATE retains the right to control the sequence and timing of the traffic signals. Payment by the STATE of any or all of its' share of maintenance and energy costs is contingent upon the STATE receiving adequate funds in its annual appropriation.

The parties hereto agree that the traffic signal maintenance and energy provisions of this Agreement shall remain in effect for a period of twenty (20) years from the date of its execution or so long as the traffic signals covered by the terms of this Agreement or any amendment hereto remain in place either in their current or some modified configuration, whichever, is the shorter period of time. Such an effective term shall apply unless otherwise agreed in writing by the parties hereto.

(Verbiage for Modernization Project Where Master Agreement Exists.)

19b. Upon acceptance by the STATE of the traffic signal work included herein the responsibility for maintenance and energy shall continue to be as outlined in the Master Agreement executed by the STATE and the (CITY/VILLAGE) on _____ 20 _____.

(Verbiage for Installation Project Where Master Agreement Exists.)

19c. Upon acceptance by the STATE of the new traffic signal installation(s), the financial responsibility for maintenance and electrical energy for the operation of the traffic signals shall be proportioned as follows:

Intersection	Maintenance	<u>Electrical Energy</u>
_____ Route _____		
@ _____ Street		
STATE Share	()%	()%
CITY or VILLAGE Share	()%	()%

(Share percentages are determined from Appendix C.)

It is mutually agreed that the actual traffic signal maintenance will be performed by the (STATE, CITY or VILLAGE), either with its own forces or through an ongoing contractual agreement.

It is further agreed that the traffic signal shall be maintained to at least the Levels of Maintenance shown in the Illinois Manual of Uniform Traffic Control Devices, Part 4, Section 4D.02, a copy of which is attached hereto as "Exhibit _____" and made a part hereof.

Upon acceptance by the STATE of the new traffic signal installation(s) included herein, the responsibility for maintenance and energy outlined above shall become a part of the Master Agreement executed by the State and the (CITY/VILLAGE) on _____ 20 _____.

(The following paragraph should be included when an agreement involves both new signal installations, as above, and the modernization or modifications of existing signals.)

20. Upon acceptance by the STATE of the work proposed herein on existing signals, the responsibility for maintenance and energy shall continue to be as outlined in the aforementioned Master Agreement.

21. The STATE agrees to make arrangements with the local power company to furnish the electrical energy for the operation of the traffic signals. The (STATE, CITY or VILLAGE) agrees to pay their proportionate share of this cost as billed by the local power company.

(If the Local Agency Is To Provide Engineering, Materials, And/Or Let The Contract On A Federal-aid Project, Then The Following Covenant Must Be Included.)

22. The (VILLAGE, CITY, COUNTY, TOWNSHIP), subrecipient or subcontractor shall not discriminate on the basis of race, color, national origin, or sex in the performance of this contract.

The (VILLAGE, CITY, COUNTY, TOWNSHIP) shall carry out applicable requirements of 49 CFR part 26 in the award and administration of STATE-assisted contracts. Failure by the (VILLAGE, CITY, COUNTY, TOWNSHIP) to carry out these requirements is a material breach of this contract, which may result in the termination of this contract or such other remedy as the STATE deems appropriate.

23. The (VILLAGE, CITY, COUNTY, TOWNSHIP) and the State have agreed to a jurisdictional transfer for a portion of Highway described in this Agreement. A copy of the jurisdictional transfer document is attached hereto as "Exhibit _____", and made a part hereof.

24. The (VILLAGE, CITY, COUNTY, TOWNSHIP) agrees to provide written approval of that portion of the plans and specifications relative to the (VILLAGE, CITY, COUNTY, TOWNSHIP) financial and maintenance obligations described herein, prior to the STATE's advertising for the aforescribed proposed improvement.

25. Obligations of the STATE and (VILLAGE, CITY, COUNTY, TOWNSHIP) will cease immediately without penalty or further payment being required if, in any fiscal year, the Illinois General Assembly or Federal funding source fails to appropriate or otherwise make available funds for this contract.

26. This AGREEMENT and the covenants contained herein shall be null and void in the event the contract covering the construction work contemplated herein is not awarded within the three years subsequent to execution of the agreement.

This agreement shall be binding upon and to the benefit of the parties hereto, their successors and assigns.

NOTE: THIS SIGNATURE FORMAT IS TO BE USED FOR JURISDICTIONAL TRANSFERS WITH NO REIMBURSEMENT BY EITHER PARTY.

Attest: _____ of _____

 Clerk

 (SEAL)

By: _____
 (Printed Name)
 TITLE: _____
 Date: _____

STATE OF ILLINOIS
DEPARTMENT OF TRANSPORTATION

By: _____
Director – Office of Program Development
Date: _____

NOTE: THIS SIGNATURE FORMAT IS TO BE USED IF THE STATE REIMBURSES THE LOCAL AGENCY \$250,000 OR MORE AND JURISDICTIONAL TRANSFER.

Attest: _____ of _____

 Clerk

 (SEAL)

By: _____
 (Printed Name)
 TITLE: _____
 Date: _____

STATE OF ILLINOIS
DEPARTMENT OF TRANSPORTATION

By: _____
Secretary

Date: _____

By: _____
Director – Office of Highways
Project Implementation

Date: _____

By: _____
Director – Finance & Administration

Date: _____

By: _____
Chief Counsel

Date: _____

NOTE: THIS SIGNATURE FORMAT IS TO BE USED IF THE STATE REIMBURSES THE LOCAL AGENCY LESS THAN \$250,000 AND JURISDICTIONAL TRANSFER.

Attest: _____ of _____

 Clerk
 (SEAL)

By: _____
 Printed Name
 TITLE: _____
 Date: _____

STATE OF ILLINOIS
DEPARTMENT OF TRANSPORTATION

By: _____
 Secretary

By: _____
 Director – Office of Highways
 Project Implementation

Date: _____ Date: _____

Chapter Six
UTILITY COORDINATION

BUREAU OF DESIGN AND ENVIRONMENT MANUAL

Chapter Six
UTILITY COORDINATION

Table of Contents

<u>Section</u>	<u>Page</u>
6-1 GENERAL GUIDELINES.....	6-1.1
6-1.01 Definitions	6-1.1
6-1.02 Applicable Publications	6-1.1
6-1.03 Reimbursement of Utility Adjustments.....	6-1.2
6-1.03(a) General Policy for Reimbursable Utility Adjustments.....	6-1.2
6-1.03(b) Non-Freeway Facilities.....	6-1.3
6-1.03(c) Freeway and Expressway Facilities	6-1.3
6-1.04 Programming Utility Adjustments	6-1.3
6-2 PROCEDURES	6-2.1
6-2.01 General	6-2.1
6-2.02 Utility Agreement/Adjustment Process (Utility/State Agreements)	6-2.1
6-2.03 Process for City of Chicago Force Account	6-2.1
6-2.04 Municipally Owned Utilities.....	6-2.1
6-3 PREPARATION OF UTILITY PLANS	6-3.1
6-3.01 General	6-3.1
6-3.02 Plan Preparation for Department Projects	6-3.1
6-3.02(a) General	6-3.1
6-3.02(b) Topographic Plans	6-3.2
6-3.02(c) Preliminary Plans	6-3.2
6-3.02(d) Pre-Final Plans	6-3.3
6-3.02(e) Final Plans	6-3.3
6-3.02(f) Transmittal Letters	6-3.4
6-3.02(g) Utility Plans	6-3.4
6-4 605 ILCS 5/9 – 113 AND UTILITY COORDINATION.....	6-4.1
6-5 ESTIMATES	6-5.1
6-5.01 General	6-5.1
6-5.02 Preparation of Estimates	6-5.1
6-5.03 Review of Estimates.....	6-5.2

Table of Contents
(Continued)

<u>Section</u>	<u>Page</u>
6-6	AGREEMENT PROCESSING (UTILITY/STATE AGREEMENTS)..... 6-6.1
6-6.01	Review and Approval by District..... 6-6.1
6-6.02	Utility Agreement Preparation..... 6-6.1
6-6.03	Emergency Agreements..... 6-6.2
6-6.04	Approval of Bids..... 6-6.2
6-7	ADJUSTMENT PROCEDURES 6-7.1
6-7.01	Change Orders 6-7.1
6-7.02	Final Billing..... 6-7.1

Chapter Six

UTILITY COORDINATION

A utility adjustment is performed by a utility company (i.e., Utility), under a binding Agreement between the Utility and the State or under the terms of a utility permit, to relocate or remove a utility facility that cannot otherwise be avoided during highway construction. The procedures for processing these adjustments for IDOT's Federally funded projects are based primarily on the requirements of the Federal Highway Administration. For uniformity, IDOT also applies these requirements to its non-Federally funded projects. Chapter 6 documents the policies and procedures that should be employed when processing utility adjustments for the Department's highway improvement projects.

6-1 GENERAL GUIDELINES

6-1.01 Definitions

The following definitions apply to the accommodation of utilities on highway projects:

1. Utility. A privately, publicly, or cooperatively owned line, facility, or system for producing, transmitting, or distributing communications, cable television, power, electricity, light, heat, gas, oil, crude products, water, steam, waste, storm water not connected with highway drainage, or any other similar commodity, including any fire or police signal system or street lighting system, which directly or indirectly serves the public. The term Utility shall also mean the utility company inclusive of any wholly owned or controlled subsidiary. The term utility includes those facilities used solely by the Utility that are a part of its operating plant.
2. Utility Adjustment. A utility adjustment includes all activities necessary to relocate or remove an existing utility facility that interferes with a highway improvement project.
3. Utility Agreement. A utility Agreement is a legally binding document between the Utility and the State that defines the scope, reimbursement, and schedule parameters of the work to be performed by the Utility to complete the utility adjustment.

6-1.02 Applicable Publications

The policies, procedures, and guidelines that govern utility accommodation and adjustments are documented primarily in Items 1 through 4 in the following list of publications. Other references in the following list provide additional information on utility accommodation:

1. *Accommodation of Utilities on Right-of-Way*, 92 Ill. Admin. Code 530.
2. *A Guide for Accommodating Utilities within Highway Right-of-Way*, AASHTO.

3. *Federal-Aid Policy Guide*, 23 CFR 645 Subparts A and B.
4. *Buy America Requirements*, 23 CFR 635.410.
5. *The Illinois Underground Utility Facilities Damage Prevention Act*, 220 ILCS 50/1 et seq.
6. 49 CFR 21 and 23.
7. Program Guide: Utility Relocation and Accommodation of Federal-aid Highway Projects, FHWA.
8. *Standard Specifications for Road and Bridge Construction*, IDOT.
9. *A Policy on the Accommodation of Utilities within Freeway Right-of-Way*, AASHTO.
10. *Transportation of Natural and Other Gas by Pipeline; Annual Report; Incident Reports, and Safety Related Condition Reports*, 49 C.F.R. 191.
11. *Transportation of Natural and Other Gas by Pipeline: Minimum Federal Safety Standards*, 49 CFR 192.
12. *National Bridge Inspection Standards*, 23 CFR 650, Subpart C.
13. *National Electrical Safety Code*, ANSI C2, IEEE.
14. Gas Transmission and Distribution Piping Systems, ASME B31.8, ASME.
15. Pipeline Transportation Systems for Liquid Hydrocarbons and Other Liquids, ASME B31.4, the American Society of Mechanical Engineers (ASME).
16. *Standard Specifications for Water and Sewer Main Construction in Illinois*, AGCE, ISPE, IML, UCA.
17. *Valuation of Landscape Trees, Shrubs and Other Plants: A Guide to the Methods and Procedures for Appraising Amenity Plants*, ISA.

6-1.03 Reimbursement of Utility Adjustments

6-1.03(a) General Policy for Reimbursable Utility Adjustments

When the State is obligated to reimburse a Utility for the removal or alteration of its facility, all parties should understand that the adjustment will be undertaken in the most economical manner consistent with good engineering practice and in compliance with applicable codes and permit regulations. It should also be understood that Buy America requirements (23 CFR 635.410) shall apply to all reimbursable costs.

The State only will reimburse the Utility for comparable facilities. If the Utility elects to improve its facility during the adjustment (i.e., a utility betterment), the State will only reimburse the

company for the cost of a comparable facility. Non-reimbursable adjustments of utilities located on public right-of-way should be conducted in accordance with the requirements outlined in the *Accommodation of Utilities on Right-of-Way*. Additionally, pursuant to the same administrative regulations, a utility permit shall be obtained by the utility for all utilities to be located on State right-of-way.

6-1.03(b) Non-Freeway Facilities

Where utility adjustments are required for the construction of a non-freeway highway improvement project, the expense of these adjustments is generally borne as follows:

1. Public Right-of-Way. If a utility facility is located on publicly owned right-of-way, whether by permit or otherwise, the adjustment is at the expense of the Utility.
2. Private Right-of-Way or Easement Rights. If a Utility presents legal evidence that its facility is located on privately owned right-of-way or easement rights, the cost of the adjustment is eligible for reimbursement by the State.
3. Municipally Owned Utilities. When a Joint Agreement with a Municipality is required, the cost of adjusting a municipally owned facility is determined in accordance with the policies and procedures referenced in this section and in Section 5-5.
4. Prior Rights. If a utility was located on public right-of-way prior to the marking of a State-maintained route or if any utility is located on or adjacent to an easement previously subordinated to the State, the adjustments are eligible for reimbursement by the State. The burden of proof regarding prior rights falls upon the Utility. In absence of such proof, the Department considers the cost of the relocation to be non-reimbursable.

6-1.03(c) Freeway and Expressway Facilities

In accordance with 605 ILCS 5/3-107, the State may participate in the cost to reimburse the Utility for adjusting a facility on public right-of-way when such adjustment is necessitated by the construction or reconstruction of the freeway facility. The amount of reimbursement will be for a comparable facility; facility improvements (betterments) are not reimbursable. If the adjustment is in conjunction with highway reconstruction and the facility was adjusted during the highway's initial construction, the State will reimburse the Utility for the adjustment excluding any betterments or subsequent installations. Additional utility installations made after initial construction of an Interstate or other freeway facility are not eligible for reimbursement.

6-1.04 Programming Utility Adjustments

The district initiates, plans, and coordinates the programming and preliminary engineering activities of utility adjustments as documented in the *Federal-Aid Policy Guide* and Section 65-1. Consider the following guidelines when programming utility adjustments:

1. Programming. The adjustments may be programmed as:
 - a separate project,
 - a part of the right-of-way acquisition, or
 - an item that is included in the construction phase.

2. Required Programming Information. Include the following programming information:
 - list of all utility adjustments,
 - a general description of the necessary adjustment activities, and
 - the best available estimate for the total costs involved.

6-2 PROCEDURES

6-2.01 General

Locating and avoiding existing utility installations during the planning phase of any highway improvement is the first step for highways and utilities to co-exist in the same environment. If it is not practical to avoid an existing utility installation during construction, it will be necessary to adjust the utility. However, a considerable amount of time and money may be saved by modifying the design to avoid utility adjustments.

For Utility/State Agreements, City of Chicago Force Accounts, or Municipality/State Agreements, the cost estimates, design plan sheets, and Agreements should be reviewed, approved, and processed to meet scheduling of highway construction activities. The district must initiate, plan, and coordinate utility adjustment work so highway construction activities can proceed without unnecessary delay or expense. Completing the planning and negotiations for utility adjustments is as essential for clearing right-of-way as is acquiring property.

6-2.02 Utility Agreement/Adjustment Process (Utility/State Agreements)

Figures 6-2.A and 6-2.B illustrate, respectively, the process flowchart and timeline for utility adjustments on a typical highway improvement project.

6-2.03 Process for City of Chicago Force Account

If the State is obligated to reimburse the City of Chicago for adjusting utility facilities that interfere with highway construction, the following guidelines apply:

1. Plan and Estimate Review. The district reviews and approves the plan and estimate and forwards two copies of a Letter of Understanding to the City of Chicago for signature. Upon execution by the City, the district forwards the two copies of the Letter of Understanding to the Agreements Unit for final execution.
2. Authorization to Proceed. Upon final execution of the Letter of Understanding, the Agreements Unit returns one original to the district, which then authorizes the City to begin the relocation work.
3. Contract Obligation Document (COD). The Agreements Unit uses the Letter of Understanding to prepare and submit COD.

6-2.04 Municipally Owned Utilities

If it is necessary to adjust a municipally owned utility, use one of the following two processing methods:

1. Joint Agreement Required. If a Joint Agreement is required between the State and local agency because of local participation in the project, the costs of any municipally owned utility adjustments may be included in the Joint Agreement. Follow the processing procedures for Joint Agreements outlined in Section 5-1.03.
2. Joint Agreement Not Required. If a Joint Agreement is not required or if the municipally owned utility operates as a separate entity, process the Agreement in the same manner as for Utility/State Agreements (see Section 6-2.02).

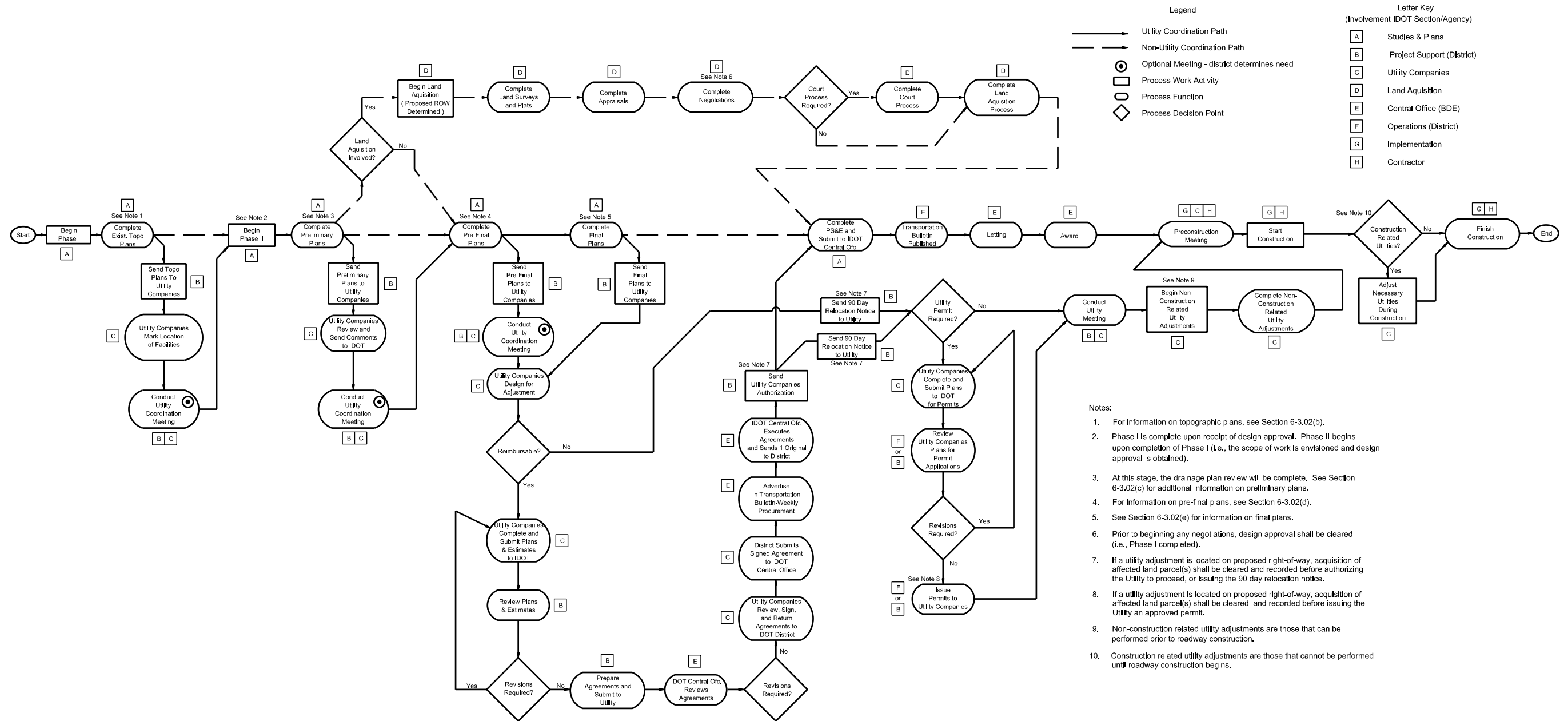

- Notes:
1. For information on topographic plans, see Section 6-3.02(b).
 2. Phase I is complete upon receipt of design approval. Phase II begins upon completion of Phase I (i.e., the scope of work is envisioned and design approval is obtained).
 3. At this stage, the drainage plan review will be complete. See Section 6-3.02(c) for additional information on preliminary plans.
 4. For information on pre-final plans, see Section 6-3.02(d).
 5. See Section 6-3.02(e) for information on final plans.
 6. Prior to beginning any negotiations, design approval shall be cleared (i.e., Phase I completed).
 7. If a utility adjustment is located on proposed right-of-way, acquisition of affected land parcel(s) shall be cleared and recorded before authorizing the Utility to proceed, or issuing the 90 day relocation notice.
 8. If a utility adjustment is located on proposed right-of-way, acquisition of affected land parcel(s) shall be cleared and recorded before issuing the Utility an approved permit.
 9. Non-construction related utility adjustments are those that can be performed prior to roadway construction.
 10. Construction related utility adjustments are those that cannot be performed until roadway construction begins.

**UTILITY ADJUSTMENT PROCESS FLOWCHART
(Typical Highway Improvement Project)**

Figure 6-2.A

6-3 PREPARATION OF UTILITY PLANS

6-3.01 General

Coordination with Utilities begins as early as practical during project development (e.g., planning, preliminary engineering). The Department typically sends plans at various stages of completion to each affected Utility for review and comment. It is the responsibility of each Utility to verify and/or provide the following information on its utility facilities:

- type,
- size,
- vertical and horizontal location, and
- information on retired facilities.

If a utility installation will be located or relocated on or across public right-of-way that is under the Department's jurisdiction, the Utility shall submit an application for a utility permit to the district for review and approval in accordance with the policies and procedures in the *Accommodation of Utilities on Right-of-Way*.

For any contract that requires work below the existing pavement structure or ground surface, including those where posts will be driven into existing ground, the designer will identify all known utility facilities within the limits of the right-of-way by appropriate symbol on the final construction plans. Show vertical and horizontal dimensions of both existing and proposed utility facilities to the precision provided by the Utility regardless of whether the facility will be adjusted or remain in place.

For each utility adjustment that will be reimbursed by the State, the district reviews the adjustment type, method, plans, and cost estimate and provides recommendations for final approval by BDE.

6-3.02 Plan Preparation for Department Projects

6-3.02(a) General

See Chapter 63 for criteria on plan preparation for Department projects (e.g., drafting guidelines, individual plan sheet content and format, construction codes). Plans typically are sent at various stages of completion to each affected Utility to assist in determining whether or not an adjustment is needed. IDOT may prepare separate plan sheets with utility information and insert these sheets into the final contract plan assembly at the proper location (see Section 63-3.04). The district is responsible for clearly showing the locations of all known utility facilities on the project plans and how they will be affected. Each Utility is responsible for identifying the location of their respective facilities (e.g., horizontal and vertical dimensions) on the plan sheets and documenting the work for any needed adjustments.

6-3.02(b) Topographic Plans

The district submits the following information to the Utilities so they can identify their respective facilities within the improvement area:

- a cover sheet that includes a location map showing the limits of the improvement, and
- a set of plan sheets that contain complete topography and existing right-of-way limits.

Prior to surveying a project, the Project Support Section will contact JULIE and schedule a Design Phase Locate Meeting with the Utilities to explain the limits and scope of the improvement and the approximate date and location that IDOT surveyors will begin work. So that IDOT surveyors can record the necessary utility information, the Utilities should be given sufficient time to locate and mark their facilities in the field prior to the IDOT survey. Incorporate the utility information gathered in the field on the topographic plans and submit the plans to each affected Utility for review and verification. If a Utility does not mark its facilities in the field prior to the IDOT survey, the Utility will need to manually plot its facilities on the topographic plans based on office records and previously filed location data and return the markups to the Department.

6-3.02(c) Preliminary Plans

Preliminary plans are considered to be 60% to 70% complete and ready for a district plan and field review. The district prepares preliminary plans in sufficient detail to conduct the preliminary plan and field review (see Section 63-1.02(b)) which will include the following:

1. Cover Sheet. Provide a cover sheet that includes a location map showing the limits of the improvement.
2. Plan Sheets. Include the following information on the plan sheets:
 - existing utility locations,
 - all proposed improvements,
 - existing and proposed right-of-way and easement lines, and
 - known environmental issues.
3. Cross Section Sheets. Include the following information on the cross section sheets:
 - proposed improvements,
 - limits of earthwork, and
 - drainage improvements.

During the development of the preliminary plans, it may be necessary for the Utilities to survey or probe the site to locate their facilities. Obtain and include this information on the preliminary plans.

The Project Support Section is responsible for determining the type and nature of all utility facilities located within the limits of both existing and proposed right-of-way and for identifying

each facility owner and its address. Through field surveys, verify all utility facilities within the limits of the improvement and determine potential conflicts. Notify the Project Support Section of any additional utility facilities located but not previously identified. Use the following guidelines when preparing the preliminary plans:

1. Utility Facility Plan Symbols. Identify the utility facilities using the appropriate plan symbols as documented in the *Highway Standards* and the *Computer Aided Design, Drafting, Modeling and Deliverables Manual*.
2. Dimensional Precision in Locating Facilities. Show the vertical and horizontal locations of the utility facilities to the dimensional precision provided by the Utility.
3. Use of Dimensional Ranges. If the location of the utility facility provided by the Utility is expressed as a dimensional range (e.g., 6.0 ft to 6.5 ft (2.0 m to 2.5 m)), show the same range on the preliminary plans.

Submit the preliminary plans to the Utilities for review and verification and inform them of the schedule for placing the highway improvement under contract. Periodically contact all affected Utilities to maintain a mutual understanding of the project schedule and to facilitate a timely completion of the needed adjustments. For complex or utility-sensitive projects, hold coordination meetings with all affected Utilities to discuss and/or clarify the following:

- relevant details of the overall project scope,
- potential conflict areas,
- design alternatives,
- coordination of adjustments,
- timing and scheduling of work,
- deadlines for permit applications,
- deadlines for completing adjustments; and
- budgeting for future adjustments.

6-3.02(d) Pre-Final Plans

Pre-final plans are considered to be 90% to 95% complete, including all necessary details, pay items, quantities, and special provisions, and ready for district review and signatures. Send pre-final plans to the affected Utilities so they can identify conflicts, determine the extent of needed adjustments, complete adjustment designs, order materials, prepare contracts, and schedule work crews.

6-3.02(e) Final Plans

Final plans are 100% complete and ready for PS&E submittal and letting by the central office. Upon completing the final plans, the district immediately forwards the plan set to each Utility (this applies to both municipally owned and privately owned utilities). Include the following information in the transmittal letter:

1. Date of Transmittal. The date of transmittal is the date the transmittal letter is prepared.
2. Letting Date. The letting date is the anticipated date of letting by the central office.
3. Response Date. Request the Utility to respond with information by a specific date. The response date will be, at a maximum, 30 days from the Utility's receipt of the final plans.
4. Date(s) of Previous Plan Submittals. Include the date(s) that previous plans were forwarded, if applicable.
5. Verification of Accuracy. Include a short statement requesting the Utility to review the plans and verify the accuracy of its facility locations as shown on the plans.
6. Notification of Plan Changes. Inform the Utility of any revisions to its utility adjustment(s) that were made after the pre-final plan stage.
7. Other Information. Include other relevant information as appropriate.

Send the transmittal letter and final plan set to each Utility via certified mail and request that a delivery receipt be returned. Other methods of transmittal (e.g., e-mail, electronic transfer) are acceptable provided that a delivery receipt indicating the package was received by the Utility is returned.

6-3.02(f) Transmittal Letters

Examples of transmittal letters for topographic plans, preliminary plans, pre-final plans, and final plans are illustrated, respectively, in Figures 6-3.A, 6-3.B, 6-3.C, and 6-3.D.

6-3.02(g) Utility Plans

The Utility is responsible for preparing plans for adjustments to its facilities and for ensuring that the plans conform to the requirements of the following documents:

- *Federal-Aid Policy Guide,*
- *A Policy on the Accommodation of Utilities Within Freeway Right-of-Way,* and
- *Accommodation of Utilities on Right-of-Way.*

Clearly and accurately show the existing conditions, proposed utility adjustments, and any needed relocations relative to the final roadway construction. Include the following items on the utility plans:



Illinois Department of Transportation

CERTIFIED MAIL

UTILITY ADJUSTMENT

Route _____
Section _____
_____ County

Dear _____:

We are transmitting two sets of existing topography plans for the subject improvement which has been included in our multi-year program.

The contemplated scope of work consists of _____

Please incorporate and/or identify your existing utility facilities on the enclosed plans, provide dimensions for any underground facilities, and return one set of the plans to this office by _____. Information you provide will be incorporated in the project plans as they are developed. If a reimbursable agreement is required, please be aware that Buy America requirements, as specified in 23 CFR 635.410 shall apply to all reimbursable costs.

Should you have any questions regarding this improvement, contact _____ at _____.

Sincerely,

Regional Engineer

Program Development Engineer

bcc: Project Engineer

**SAMPLE TRANSMITTAL LETTER TO UTILITIES
(Topographic Plans)**

Figure 6-3.A

CERTIFIED MAIL

UTILITY ADJUSTMENT

Route _____

Section _____

_____ County

Job No. _____

Contract No. _____

Dear _____:

Enclosed are preliminary plans for the above noted improvement, which is tentatively scheduled for the _____ construction letting.

The improvement will consist of _____

_____.

In order for us to complete our construction plans, it will be necessary for us to know the locations of all utilities on or along our right of way as well as possible utility conflicts.

We are enclosing two sets of plans, one of which you may keep for your files. On the second set of plans, please confirm the location of your facilities (if shown) and draw on the prints any facilities not shown. Accurate horizontal and vertical locations as well as sizes of facilities are needed. Also, please outline the areas of possible conflicts with your facilities.

Please return the marked set to this office by _____.

We will include your utility locations on our detailed plans and provide you with such plans when they are available.

Since we are acquiring additional right of way, a portion of your adjustments may be reimbursable. If adjustments are required to that portion of your facilities located on easement and/or private property, then plans, estimates, and an agreement to cover reimbursement will be necessary. If a reimbursable agreement is required, please be aware that Buy America requirements, as specified in 23 CFR 635.410 shall apply to all reimbursable costs. (SEE NOTE)

In the above regard, you should advise us as soon as possible whether any portion of your adjustments is reimbursable and the approximate cost of such reimbursable adjustments. This letter is your authorization to proceed with the preliminary engineering for the adjustment of your facilities that are reimbursable. (SEE NOTE)

**SAMPLE TRANSMITTAL LETTER TO UTILITIES
(Preliminary Plans)**

**Figure 6-3.B
(1 of 2)**

Page 2

If additional information is needed in determining your involvement, please make any early request to _____ at _____ office by _____. You should return the marked set of plans to this construction plans.

Sincerely,

Regional Engineer

Program Development Engineer

bcc: Project Engineer

NOTE: PARAGRAPHS IN BOLD AND ITALICS ARE OPTIONAL

**SAMPLE TRANSMITTAL LETTER TO UTILITIES
(Preliminary Plans)**

**Figure 6-3.B
(2 of 2)**

CERTIFIED MAIL

UTILITY ADJUSTMENT

Route _____
Section _____ County _____
Job No. _____
Contract No. _____

Dear _____:

Enclosed is one set of pre-final plans for subject improvement which is tentatively scheduled for the _____ construction letting. These plans should permit you to determine the extent of adjustments to your facilities. Preliminary plans for this improvement were previously provided your office on _____.

Please review these plans as to the location of your utility facilities. Should you find any additions and/or corrections, you must notify the Project Support Section by _____. Failure to comply with this notification could result in damage to your facilities and delays during the construction of this project.

We request you proceed with the preparation of plans for the necessary adjustment at the earliest possible time. If the cost of the adjustments is reimbursable, please submit four copies of the plans and estimates to this office along with documentation of easement rights.

Any adjustment work necessary in eliminating a conflict shall be done in accordance with the manual "Accommodation of Utilities on Rights of Way of the Illinois State Highway System" and an approved utility permit. Application for a permit shall be made through the Permit Section Chief. No adjustments may be performed until a permit has been issued by this office.

Should you have any questions regarding this improvement, contact _____.

Sincerely,

Regional Engineer

Engineer of Program Development

bcc: Project Engineer

**SAMPLE TRANSMITTAL LETTER TO UTILITIES
(Pre-Final Plans)**

Figure 6-3.C

CERTIFIED MAIL

UTILITY ADJUSTMENT

Route _____
Section _____

_____ County

Job No. _____

Contract No. _____

Dear _____:

Enclosed is one set of final plans for subject improvement which is scheduled for the _____ letting. Pre-final plans for this improvement were previously provided your office on _____.

Please review these plans as to the location of your utility facilities. Should you find any additions and/or corrections, you must notify the Project Support Section by _____. Failure to comply with this notification could result in damage to your facilities and delays during the construction of this project.

You are hereby requested to proceed promptly with the adjustment of your facilities required by this improvement and notify this office as to the status of this work. Any adjustment work necessary in eliminating a conflict shall be done in accordance with the manual "Accommodation of Utilities on Rights of Way of the Illinois State Highway System" and an approved utility permit. Application for a permit shall be made through the Permit Section Chief. No adjustments may be performed until a permit has been issued by this office.

Should you have any questions regarding this improvement, contact _____ at _____. Arrangements will be made for you to be invited to the preconstruction conference.

Sincerely,

Regional Engineer

Engineer of Program Development

bcc: Project Engineer

**SAMPLE TRANSMITTAL LETTER TO UTILITIES
(Final Plans)**

Figure 6-3.D

- existing and proposed right-of-way lines;
- access control lines;
- existing utility facility;
- temporary work, if required;
- final utility facility;
- cross section and elevation drawings for all buried and overhead utilities;
- plan scale;
- roadway stationing; and
- notes for construction sequencing, as appropriate.

In addition to these requirements, consider the following additional guidelines when developing the utility plans:

1. Overhead Lines. Ensure that the vertical clearance of overhead power or communication lines crossing any highway meets or exceeds the vertical clearance criteria in the *National Electric Safety Code (NESC)*.
2. Underground Facilities. For underground facilities permitted to cross fully access-controlled or conventional highways, meet or exceed the minimum cover requirements of the applicable ANSI Standard.
3. Plan Detail. Provide a legend that clearly defines all plan symbols. Locate the plan scale in a discernible location and clearly show the roadway stationing. If the sequence of construction is not readily apparent from the plans, provide detailed notes for clarification.
4. Clear Width of Sidewalks. When placing above ground utilities in or near sidewalks, do not encroach the clear width of the sidewalk. See Section 58-1 for information on sidewalk clear width and other ADA design criteria.
5. Other Guidelines. See the publications in Section 6-1.02 for additional provisions, guidelines, and requirements.

If the utility adjustment is programmed and let by the State as a separate project, prepare a cover sheet in the same manner as for other highway projects. See Section 63-4.02 for information that should be included on the cover sheet. List each utility adjustment on the cover sheet and indicate the utility company name, type of adjustment, and its location with respect to roadway stationing. When adjustments are made under a State contract in conjunction with a roadway project, submit the plans and estimates according to the procedures in Section 66-3.

6-4 605 ILCS 5/9 – 113 AND UTILITY COORDINATION

For further statutory requirements on Utility coordination please refer to 605 ILCS 5/9-113 or contact BDE for additional guidance.

6-5 ESTIMATES

6-5.01 General

The affected Utilities are responsible for preparing and submitting to the district cost estimates for each of their respective reimbursable adjustments. Each cost estimate will be prepared in accordance with the requirements of the *Federal-Aid Policy Guide*, 23 CFR 645 Subpart A and shall meet Buy America requirements, 23 CFR 635.410.

6-5.02 Preparation of Estimates

Ensure that each cost estimate contains, at a minimum, the following details:

- labor type, hours, and hourly rate;
- equipment types and rates;
- material quantities and costs; and
- engineering costs.

Consider the following guidelines when requesting cost estimates for utility adjustments:

1. Multiple Locations of Adjustments. Request the Utility to submit a separate cost estimate for each reimbursable adjustment location within the limits of the project.
2. Multiple Sources of Funding. When a utility adjustment is necessary on a project financed with multiple funding sources, the district will indicate the limits for each participating source on the final utility plan sheets. The district will instruct the Utility on the division of the adjustment among the funding sources, and indicate the number of separate cost estimates required. For information on funding splits, see Chapter 65.
3. Utility Facility Improvements (Betterments). Improvements (betterments) to utility facilities are not reimbursable. If a Utility elects to improve, change, rearrange, or otherwise enhance its facilities beyond that which currently exists, obtain separate estimates to identify the cost difference between the preferred adjustment and the adjustment that is comparable to the existing facility.
4. Temporary Work. When temporary work (e.g., temporary pole, temporary line) is necessary to accomplish the final adjustment, separately estimate the costs attributable to the temporary portion. Document cost estimates for temporary work in the same detail as that required for permanent work.
5. Preliminary Engineering Estimates. Document preliminary engineering costs separately from construction costs.
6. Overheads and Additives. Include construction overheads and labor additives in the cost estimate as described in the *Federal-Aid Policy Guide*.

7. Credits. Credit for accrued depreciation and salvaged materials will be provided in the adjustment estimate.
8. Buy America. Buy America applies to any reimbursable utility relocation that is accomplished as a result of a federal-aid highway project. When a utility company is eligible for reimbursement for a utility adjustment they must comply with federal Buy America requirements to furnish and install only domestically manufactured iron and steel products from the United States. If the utility relocation is not eligible for reimbursement then Buy America does not apply to the utility relocation work.

6-5.03 Review of Estimates

The district will review each Utility's cost estimate for reasonableness and accuracy. Verify material costs through material suppliers or through a comparison to similar items on previous adjustments. Also verify material quantities. Compare engineering costs either to those previously approved or to those recommended by the Illinois Society of Professional Engineers. Document that all estimates have received the necessary level of technical evaluation.

6-6 AGREEMENT PROCESSING (Utility/State Agreements)

6-6.01 Review and Approval by District

The district has the primary responsibility for reviewing submittals prepared by Utilities. Thoroughly review each Agreement Package for the following:

- proper preparation and submission,
- discrepancies between the Utility's submittal and the project plans and schedule,
- reasonableness and accuracy of cost estimates,
- items that are not reimbursable by the State, and
- the identification and segregation of any proposed utility betterments.

If discrepancies are found, immediately return the plans and estimate, with appropriate comments, to the Utility. Resolve all discrepancies with the Utility prior to submitting the adjustment plans and estimate to BDE.

6-6.02 Utility Agreement Preparation

The district prepares the necessary Utility Agreements for any reimbursable relocations that have been determined. The Utility Agreement will contain the following:

- a district assigned Agreement Number (i.e., UTxxxxxx);
- all pertinent State project information;
- the full legal name of the Utility Company;
- a general description of the highway project including general location and the type of improvement, and also a detailed description of the utility relocation including type, size, number of poles, lengths, diameters, stationing, or any other special items that thoroughly describe the extent of the relocation;
- a detailed estimate of the cost and a reasoning for any cost divisions and/or betterments;
- an estimated number of working days;
- the correct signature blocks for over/under \$ 250,000; and
- a general plan of the proposed utility relocation.

The following process will apply:

1. The district prepares the Utility Agreement containing the information above and forwards two originals to the Utility for review and execution.

2. After execution, the Utility returns both originals to the district where they are forwarded to BDE to be advertised in the Transportation Bulletin-Weekly Procurement and then executed by the Director of the Office of Highways Project Implementation along with the Secretary of Transportation. Agreements over \$250,000 will also require signatures by the Director of Finance and Administration and the Chief Counsel.
3. When the Agreements are fully executed, one original Agreement is returned to the district and the remaining original Agreement is placed in the BDE file.
4. The district returns the original agreement to the Utility with a letter authorizing the Utility to proceed with the adjustment(s). The district also provides copies of the executed agreement to BDE (Project Coordination and Implementation Section) and the Project Control Section within the Office of Planning and Programming (OP&P).
5. The district prepares COD for the Utility Agreement using the Appropriation provided by BDE.

6-6.03 Emergency Agreements

If it is determined that a reimbursable utility adjustment is required after highway construction has begun, the district will immediately notify the BDE of the necessity and required adjustment and provide an Agreement to the Utility (see Section 6-6.02). The BDE will expedite Agreement upon receipt from the district.

In extreme cases when the adjustment has considerable impact on the progression of highway construction, the district, with concurrence from the BDE, may authorize the Utility to begin its adjustment(s) prior to completion of the Agreement. Inform the Utility that no reimbursement can be made until the Agreement is completed and executed. This type of emergency agreement will contain additional language stating the emergency authorization date and emergency authorization letter.

6-6.04 Approval of Bids

When a Utility is authorized to proceed with all or a portion of an adjustment via contract with an outside contractor rather than its own personnel, the Utility will furnish the district with a list of qualified contractors to whom invitations for bids will be sent prior to solicitation. The list of bidders is for informational purposes only and does not require approval by the State; however, the State is to be notified of the selected bidder.

6-7 ADJUSTMENT PROCEDURES

6-7.01 Change Orders

If the scope, nature, and/or cost of the adjustment has changed significantly, an amendment to the Agreement may be necessary. If it is deemed that an amendment is required, the district will submit the amendment to the Utility for signature and then to BDE for processing. See Section 6-6.02.

For minor modifications in scope, nature, and/or cost, the district should complete BDE 804A or BDE 804B and set forth the following information:

- the extent of the change,
- an estimate of the additional costs,
- the justification for the change, and
- a request for authorization of the change.

6-7.02 Final Billing

The following applies to processing the final bill for utility adjustments:

1. Preparation of Final Billing. Ensure that the final bill complies with all requirements of the *Federal-Aid Policy Guide*, Part 645 A and B.
2. Review of Final Billing. The district will review the final bill to determine whether or not the final bill reflects the labor, equipment, and materials used in the adjustment. A Buy America certificate of compliance shall be submitted with the final invoice.
3. Billing Discrepancies. If the final bill exceeds the estimated amount of the adjustment and BDE 804A or BDE 804B were not submitted in the interim, explain the increase and submit appropriate recommendations on BDE 804A or BDE 804B.

Submission of Final Billing. Submit final bills and recommendations to the Bureau of Business Services within the Office of Finance and Administration.

Chapter Seven

RAILROAD COORDINATION

BUREAU OF DESIGN AND ENVIRONMENT MANUAL

Chapter Seven
RAILROAD COORDINATION

Table of Contents

<u>Section</u>	<u>Page</u>
7-1 ADMINISTRATIVE FUNCTIONS	7-1.1
7-1.01 Selection of Projects.....	7-1.1
7-1.02 Financial Participation	7-1.2
7-1.02(a) Grade-Separation Improvements.....	7-1.2
7-1.02(b) Grade-Separation Maintenance.....	7-1.3
7-1.02(c) Grade Crossing Participation	7-1.6
7-1.02(d) Grade Crossing and Warning Device Maintenance	7-1.7
7-1.02(e) Grade Crossing Warning Device Improvements.....	7-1.7
7-1.02(f) Grade Crossing Modification on a Permit Crossing.....	7-1.8
7-1.03 Preliminary Engineering.....	7-1.8
7-1.03(a) General.....	7-1.8
7-1.03(b) Reimbursement.....	7-1.8
7-1.03(c) Railroad Structures Designed By or For the Railroad	7-1.8
7-1.03(d) Preliminary Engineering Portion of Railroad Force Account Work	7-1.9
7-1.03(e) Programming.....	7-1.9
7-1.04 Commerce Commission Hearings	7-1.9
7-1.04(a) Commerce Commission Jurisdiction.....	7-1.9
7-1.04(b) Procedure Before the Commission	7-1.9
7-1.05 Procedure for Removing Abandoned Railroad Structures and Grade Crossings	7-1.10
7-1.06 Acquisition of Railroad Property	7-1.11
7-1.06(a) Acquisition of Railroad Nonoperating Property.....	7-1.11
7-1.06(b) Acquisition of Railroad Operating Property	7-1.11
7-2 AGREEMENTS.....	7-2.1
7-2.01 General	7-2.1
7-2.02 District Data	7-2.1
7-2.03 Negotiation Procedure.....	7-2.3

Table of Contents

(Continued)

<u>Section</u>		<u>Page</u>
7-2.04	Authorization Procedure	7-2.3
7-2.05	Adjustment Procedures	7-2.4
	7-2.05(a) Change Orders	7-2.4
	7-2.05(b) Final Billing.....	7-2.5
7-2.06	Railroad Agreement Process	7-2.5
7-3	DESIGN FUNCTIONS	7-3.1
7-3.01	General	7-3.1
7-3.02	At-Grade Crossings	7-3.1
	7-3.02(a) Selection Guidelines for Warning Devices	7-3.1
	7-3.02(b) Example for Warning Device Selection	7-3.5
	7-3.02(c) Circuitry Devices	7-3.5
	7-3.02(d) Barrier Systems.....	7-3.6
	7-3.02(e) Approaches.....	7-3.7
	7-3.02(f) Design Considerations	7-3.7
	7-3.02(g) Signalized Intersections	7-3.12
7-3.03	Grade-Separated Structures.....	7-3.12
	7-3.03(a) Warrants	7-3.12
	7-3.03(b) Design Considerations	7-3.12
7-3.04	Other Agency References.....	7-3.13

Chapter Seven

RAILROAD COORDINATION

7-1 ADMINISTRATIVE FUNCTIONS

7-1.01 Selection of Projects

The *Federal Highway Safety Act* authorizes funds for the improvement of highway-railroad safety by installing or upgrading warning devices.

The available program funds are allocated as a specific dollar amount between the Bureaus of Design and Environment and Local Roads and Streets with recommendations for distribution among the various types of projects (e.g., warning devices, abandoned crossings) for each bureau's program.

The BDE allocates funds to each district according to a weighted average of a district's share of the total track-lanes of crossings in the State, modified by demonstrated need. Each district prepares a list of candidate projects and proposed types of improvement for inclusion in the upcoming year's program, based on the following criteria:

- the expected crashes (see Section 7-3.02 to determine if existing warning devices are sufficient for the expected crashes);
- crash history;
- public complaints;
- individual observations made during the annual grade crossing inspection (the credibility of the existing warning devices should be carefully checked); and
- Railroad Company's request for improvements.

For additional guidance on the selection of projects, review the FHWA *Railroad-Highway Grade Crossing Handbook*. Consider the following when determining project selection:

- removal of non-complying guardrail around warning device bases; and
- removal of abandoned at-grade crossings.

Make every attempt to coordinate any proposed warning device projects on crossings of State-maintained highways where track circuitry overlaps those of adjacent local crossings. Exchange this information with the Bureau of Local Roads and Streets to coordinate the work and programming.

The BDE, working with the Bureau of Safety Programs and Engineering, Office of Planning and Programming, and Illinois Commerce Commission, may identify a list of high-crash locations not

included in the district's lists. The BDE will convene a "Diagnostic Team" to investigate each crossing on the list. BDE will document any deficiencies discovered and solutions proposed.

The priority lists are finalized and published as the "FY 20__ Highway Safety Improvement Program." This publication becomes the official program of the Department. The selected projects are then sent to FHWA by BDE with a request for authorization as soon as the Federal funds become available. The projects are then administered as Federal-aid projects under the FHWA/IDOT Stewardship and Oversight Agreement.

7-1.02 Financial Participation

7-1.02(a) Grade-Separation Improvements

The following financial arrangements will apply:

1. New Structure — Department Project. Where a new grade-separation structure will be constructed as a result of a project initiated by the Department, 100% of the cost will be borne by the Department except for the following:
 - a. Active Warning Devices. Where the principal grade crossing or crossings, at which active warning devices are in place or ordered to be installed by the Illinois Commerce Commission, will be closed after completion of the project, the Railroad will be required to bear 5% of the cost of the structure and approaches.

Where the number of traffic lanes will increase, the Railroad's share will be based on the estimated cost of the theoretical structure and approaches required to separate the grade for the existing number of traffic lanes.
 - b. Additional Track(s). Where the Railroad has no definite plan for the installation of additional future tracks within a reasonable time, the Railroad will be responsible for 100% of the increased costs due to providing space for the additional future track(s).
2. New Structure — Railroad Project. Where a new grade-separation structure will be constructed as a result of a Railroad-initiated project, the Railroad will be responsible for 100% of the cost.
3. Existing Structure — Department Project. Where an existing grade-separation structure on a State highway will be reconstructed as a result of a project initiated by the Department, 100% of the cost will be borne by the Department; however, this policy will not abrogate the covenants of any existing agreement that remains in effect containing provisions for maintenance or reconstruction of the structure.
4. Existing Structure — Railroad Project. Where an existing grade-separation structure (maintained by the Railroad) on a State highway is determined by the Department to be unsafe due to physical damage or deterioration and must be reconstructed, the Railroad

will be responsible for 100% of the estimated cost of the theoretical structure required to reconstruct the existing structure to its original design loading or 100% of the estimated cost to repair the existing structure to its original design loading.

7-1.02(b) Grade-Separation Maintenance

The Department will maintain new grade-separation structures on Department initiated construction. Any structures constructed as a Railroad initiated project will be maintained by the Railroad. In all cases, the Railroad will maintain the track, track bed, and railroad appurtenances.

When the Department is responsible for the maintenance of an existing structure, either by the terms of an agreement or by an Illinois Commerce Commission Order, maintenance of the Department initiated reconstructed structure will remain the responsibility of the Department.

When the Railroad is responsible for the maintenance of an existing structure, either by the terms of an agreement or by an Illinois Commerce Commission Order, maintenance of the reconstructed structure will remain the responsibility of the Railroad unless an exception is granted.

When it is in the best public interest, the Department may relieve a railroad of its maintenance obligations for a structure in return for a lump-sum payment based on the capitalized cost for perpetuation of the structure. This capitalized cost will be determined according to the following:

1. **Service Life.** For calculations, assume that no routine maintenance is performed and that each of the structural components will be replaced at the end of its service life in perpetuity. For most structures, the service life of the substructure will be assumed to be 100 years and, for the superstructure, 50 years. Calculate the costs for replacing the existing structural components at current prices.
2. **Interest Rate.** Determine the interest rate by calculating the average annual rate of return to the nearest 0.25% increment using the current fiscal year and the two preceding fiscal years. The annual rate of return for each fiscal year can be obtained from the State Treasurer's Office.
3. **Capital Cost.** The capitalized cost should be derived using the equation shown in Figure 7-1.A.

$$C = y \left[\frac{1}{(1+i)^n} \right] + x \left[\frac{1}{(1+i)^m} \right] + \left[\frac{\left(y \left[\frac{i}{(1+i)^{50} - 1} \right] \right)}{i} \right] \left[\frac{1}{(1+i)^n} \right] + \left[\frac{\left(x \left[\frac{i}{(1+i)^{100} - 1} \right] \right)}{i} \right] \left[\frac{1}{(1+i)^m} \right]$$

Where:

- C = capitalized cost
 x = cost of replacing substructure, in kind, at current prices
 y = cost of replacing superstructure, in kind, at current prices
 m = remaining life of substructure, years
 n = remaining life of superstructure, years
 100 = service life of substructure, years

50 = service life of superstructure, years
i = interest rate, decimal

$\left[\frac{1}{(1+i)^m} \right]$ = single payment present worth factor for *m* years

$\left[\frac{1}{(1+i)^n} \right]$ = single payment present worth factor for *n* years

$\left[\frac{i}{(1+i)^{100}-1} \right]$ = sinking fund factor for 100 years

$\left[\frac{i}{(1+i)^{50}-1} \right]$ = sinking fund factor for 50 years

$x \left[\frac{1}{(1+i)^m} \right]$ = present cost which expresses the cost of replacing the substructure *m* years from the present

$y \left[\frac{1}{(1+i)^n} \right]$ = present cost which expresses the cost of replacing the superstructure *n* years from the present

$\left[\frac{\left(x \left[\frac{i}{(1+i)^{100}-1} \right] \right)}{i} \right] \left[\frac{1}{(1+i)^m} \right]$ = present cost which expresses the cost of replacing the substructure at 100-year intervals in perpetuity beginning at a point in time *m* years from the present

$\left[\frac{\left(y \left[\frac{i}{(1+i)^{50}-1} \right] \right)}{i} \right] \left[\frac{1}{(1+i)^n} \right]$ = present cost which expresses the cost of replacing the superstructure at 50-year intervals in perpetuity beginning at a point in time *n* years from the present

CAPITAL COST DETERMINATIONS

Figure 7-1.A

Example 7-1.1

Given: An original highway-railroad grade structure was built in 1940. In 1963, the original superstructure was removed and replaced. Maintenance of the structure has been borne equally by the Railroad and the Department by Illinois Commerce Commission Order.

- x = \$52,003 – Cost to replace the substructure
- y = \$56,956 – Cost to replace superstructure
- m = 42 years – Remaining life of substructure
- n = 15 years – Remaining life of superstructure
- i = 6% – Interest rate

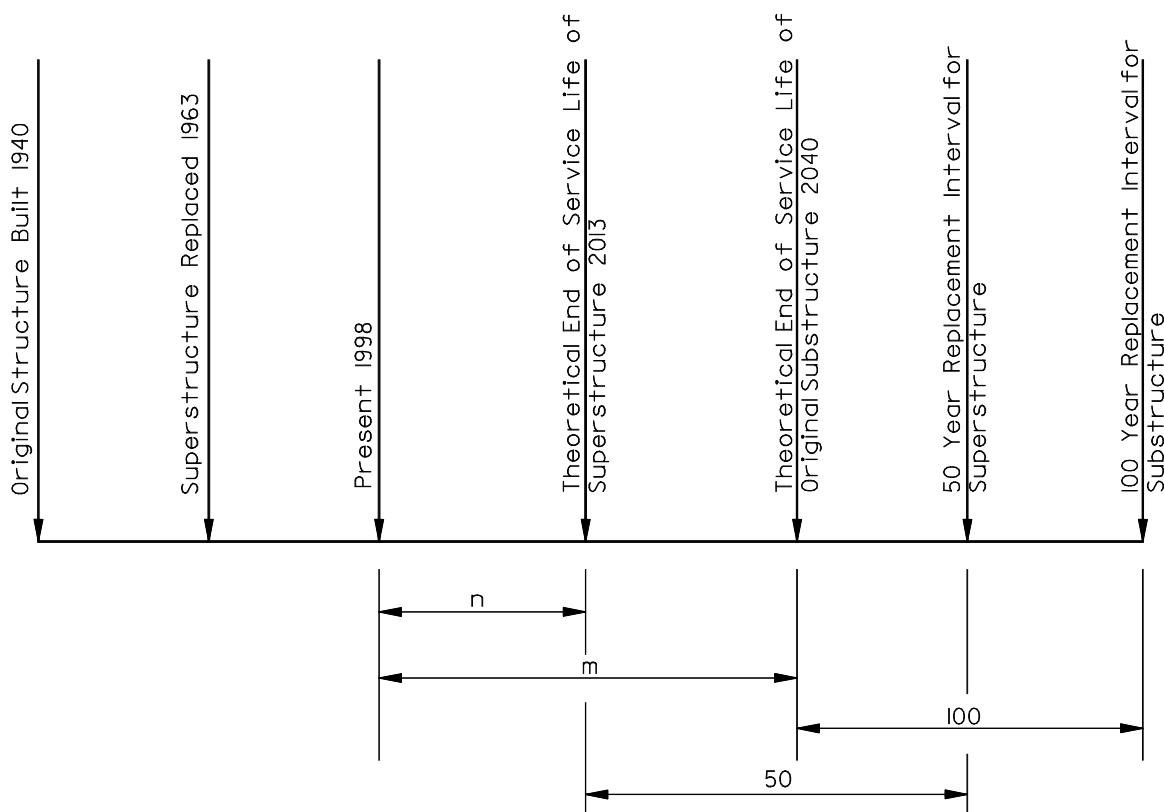

Problem: A Railroad has indicated its interest in being relieved of its maintenance obligation for a highway-railroad grade-separation structure in return for a lump-sum payment to the Department in a sum equivalent to the capitalized cost for perpetuation of the structure.

Solution:

$$x \left[\frac{1}{(1+i)^m} \right] = 52,003(0.0865) = \$4498.26$$

$$y \left[\frac{1}{(1+i)^n} \right] = 56,956(0.4173) = \$23,767.74$$

$$\left[\frac{\left(x \left[\frac{i}{(1+i)^{100} - 1} \right] \right)}{i} \right] \left[\frac{1}{(1+i)^m} \right] = \left[\frac{(52,003[0.00018])}{0.06} \right] [0.0865] = \$13.49$$

$$\left[\frac{\left(y \left[\frac{i}{(1+i)^{50} - 1} \right] \right)}{i} \right] \left[\frac{1}{(1+i)^n} \right] = \left[\frac{(56,956[0.00344])}{0.06} \right] [0.4173] = \$1362.69$$

Capitalized Cost = \$29,642.18

Railroad share (50%) = 0.5 (29,642.18) = \$14,821.09

7-1.02(c) Grade Crossing Participation

The Department opposes any new at-grade crossing when such crossing involves a railroad line used for passenger train operations, regardless of the operator or frequency of the trains or the location of the crossing.

Where a new grade crossing of a freight rail line is established or an existing grade crossing will be reconstructed on a State highway as a result of a highway improvement project initiated by the Department, the Department will be responsible for 100% of the cost for constructing the crossing.

Where a new grade crossing is established or an existing grade crossing will be reconstructed on a State highway as a result of a railroad reconstruction, rehabilitation, or maintenance program initiated by the Railroad, the Railroad will be responsible for 100% of the cost of constructing or reconstructing the crossing.

When the Department determines that an existing grade crossing on a State highway is at the end of its service life and in need of reconstruction or when the Department determines that conditions warrant reconstruction, the Department may participate toward the cost of the new construction or reconstructing the crossing.

If an existing grade crossing on a State highway will be reconstructed or rehabilitated as a result of a project initiated by other than the Department or the Railroad and the Department has determined that the installation is necessary and in the best public interest, the Department may participate in the cost in proportion to the benefits to the motoring public.

Where all or any portion of the cost of new construction, reconstruction, or rehabilitation of a crossing will be provided by the Department, participation by the Department will be limited to the materials, labor, and equipment required to construct, reconstruct, or rehabilitate the crossing.

7-1.02(d) Grade Crossing and Warning Device Maintenance

The Railroad, or the track owner, is responsible for maintenance of the grade crossing and the warning devices, actuating devices, and circuitry.

7-1.02(e) Grade Crossing Warning Device Improvements

The Department requires the installation of appropriate warning signs and devices at all highway-railroad grade crossings. The Department's participation in the cost of these devices is contingent upon Department concurrence in the type of device required, the degree of sophistication necessary in the activating equipment, and the degree of contribution to highway capacity and safety.

Funding for all Department-initiated projects will be determined on a priority basis based on vehicular traffic, railroad traffic, highway classification, and the availability of funds.

The Department, the Railroad, or agencies other than the Department may propose changes in either the type of warning devices or in the method of actuation at existing crossings. Where the Department has determined that these changes will result in mutual benefits to all parties involved, the Department may participate in the costs in proportion to the benefits to the motoring public.

The Department will generally bear 100% of the cost of the improvements for the following conditions:

- Where the project includes the installation of warning devices at new grade crossings, the relocation of existing warning devices, or the installation of additional devices at existing crossings that are required as the result of highway improvement projects initiated by the Department.
- Where the Department has determined that the warning devices in place at an existing grade crossing are no longer adequate to provide for the safety of the motoring public and that additional or supplemental warning devices are deemed necessary.

- Where the Department has determined that a change is necessary in the method of actuation of automatic warning devices at existing crossings for the improvement of vehicular operations.

The Railroad will be responsible for 100% of the cost of the improvements where changes to an existing grade crossing or the construction of a new grade crossing are necessitated as the result of improvement or maintenance programs initiated by the Railroad or changes in rail operations (e.g., number of movements, speeds).

7-1.02(f) Grade Crossing Modification on a Permit Crossing

Where a railroad grade crossing has been created as the result of a permit issued by the Department, the Railroad or track owner shall take prompt action to adjust, reconstruct, or otherwise modify the crossing and/or warning devices as required by any highway improvements upon receiving a request from the Department. The Railroad or track owner will be responsible for 100% of the costs of such improvements. See *Accommodation of Utilities on Right-of-Way, 92 Ill. Admin. Code 530*.

7-1.03 Preliminary Engineering

7-1.03(a) General

In most instances, the Department prepares the plans for new construction, modernization, or reconstruction of highway structures, drainage facilities, and the approaches. Occasionally, the Railroad will prepare plans for a structure carrying the railroad over a highway.

All plans, specifications, and special provisions prepared by either the Department or the Railroad are subject to approval by the other party, and no changes will be allowed by either party without the consent in writing of the other party.

7-1.03(b) Reimbursement

Preliminary engineering performed by Railroad forces or by consultants employed either by the Railroad or by IDOT on highway-railroad grade separations is reimbursable with Federal or State funds.

7-1.03(c) Railroad Structures Designed By or For the Railroad

This section applies to a railroad structure over a State highway. When the Railroad elects not to perform the structure design with its own forces and the Department does not have the forces available to perform the design within the required schedule, a consultant may be employed to perform the design. Ordinarily, the Department will select a suitable consultant from a list of consultants approved by the Railroad. The design work is then performed by agreement between the Department and the consultant with the Railroad's approval.

In certain cases, where justified, the Railroad will select a consultant to design the structure and enter into an agreement with the consultant for the design. The selection of the consultant and the terms, including the fee, is subject to IDOT approval.

In those projects where Federal-aid funds are anticipated for reimbursing the Railroad's consultant for the cost of preparing the plans for a structure, the preliminary engineering cost must be programmed before IDOT can authorize the preparation of such plans.

7-1.03(d) Preliminary Engineering Portion of Railroad Force Account Work

The Railroad will generally perform the preliminary engineering with its own forces for the railroad force account work covered by construction agreements between the Department and the Railroad.

In special instances (particularly warning device system design), the Railroad may use the services of a consultant retained by the Railroad to perform the preliminary engineering.

7-1.03(e) Programming

When the method of treating a railroad crossing has been determined, it is essential that the district plan, initiate, and coordinate the programming and preliminary engineering portion of the proposed construction.

7-1.04 Commerce Commission Hearings

7-1.04(a) Commerce Commission Jurisdiction

Rail carriers (Railroads) are corporations engaged in the transportation of passengers and/or goods for hire in the State of Illinois, as defined in the *Illinois Commercial Transportation Law, 625 ILCS 5/18c-1101 et seq.*, and come under the jurisdiction of the Illinois Commerce Commission. The *Code* states, in part:

No public road, highway, or street shall hereafter be constructed across the track of any rail carrier at grade, nor shall the track of any rail carrier be constructed across a public road, highway, or street at grade, without having first secured the permission of the Commission;

The Commission's rules, regulations, and requirements cover the construction, maintenance, division of cost, marking, and signaling of highway and railroad crossings in the State.

7-1.04(b) Procedure Before the Commission

The Preliminary Engineering Section will work with the Office of Chief Counsel to prepare petitions to the Commission requesting issuance of an Order relative to the crossing of a railroad by a proposed highway improvement when the improvement requiring the crossing was initiated by the Department.

If a hearing is required, the Department must be represented at the hearing to present the evidence through an expert witness who is familiar with the project.

After the case is heard by a duly authorized examiner of the Commission, an Order will be entered either denying or granting the request of the petitioner.

When a Railroad desires to establish a new crossing with a highway, it will file a petition with the Commission and present its case at a hearing which will be attended by representatives from the Office of Chief Counsel, the Preliminary Engineering Section, and the district involved when the Department is a respondent. This action is followed by the decision of the Commission as outlined in its Order. The Railroad must also acquire a permit from the district according to the Department's *Accommodation of Utilities on Right-of-Way*.

7-1.05 Procedure for Removing Abandoned Railroad Structures and Grade Crossings

Many highway-railroad grade-separation structures, at-grade crossings, and related track materials of rail lines that have been abandoned remain in place on intersecting public highways. These structures constitute obstructions and encroachments on these highways and should be removed.

Before a Railroad company's right to operate on a particular line has been terminated (i.e., the rail line is abandoned), the Railroad company had authority from the Illinois Commerce Commission to obstruct the highway with the structure in question. After the right to operate is terminated, there remains no authority to obstruct the highway. Therefore, the Railroad company may be treated as any other person obstructing the highway.

The *Illinois Highway Code, 605 ILCS 5/9-117* establishes the procedure for identifying and removing obstructions from public highways. This procedure may be used if it is clear that the highway authority has absolutely no responsibility. Because sole responsibility by a Railroad is uncommon, it is unlikely that this procedure for removing obstructions will be used often. The Office of Chief Counsel may be consulted to help determine whether this procedure is appropriate in a particular situation.

The *Illinois Commercial Transportation Law, 625 ILCS 5/18c-7401* provides an additional statutory means for removing railroad structures from public highways. Under this law, the Illinois Commerce Commission, after notice and hearing, has the authority to order the removal of abandoned tracks and overhead railroad structures crossing highways, waterways, or other railroads. The Commission may equitably apportion the costs between the parties. This may be based on the assignment of original construction costs and/or the present maintenance responsibility.

Therefore, after determining that the abandonment is final, as per notice from the Bureau of Rail in the Office of Intermodal Project Implementation, and that the facility can be removed and after the district determines that the Railroad refuses or delays the removal, a request should be made to BDE for the removal. BDE will ensure the abandonment is final and request the Office of Chief

Counsel to file a Petition for an Order requiring the removal of the facility. The district should be aware that the Commission may order the Department to bear part or all of the cost of removal.

If the Department determines that it should pay the entire cost of structure removal or that the structure presents an immediate danger to the traveling public, the Department may remove the structure without the permission of the Railroad, its successor in interest, or the Illinois Commerce Commission.

Remember that only the Railroad's right to operate is being abandoned. The Railroad may wish to sell its structures or may wish to use the structure at another location. If the Department agrees that the Railroad owns the structure on the highway right-of-way, the Railroad should be allowed to remove it. If the Department removes a structure owned by the Railroad or its assignee, the removed materials should be made available to the rightful owner.

7-1.06 Acquisition of Railroad Property

When the Department requires property interest from a Railroad to complete a highway improvement, sufficient lead time to acquire these interests is essential. It is critical that once it is determined that a project will require the acquisition of property owned or under the control of a Railroad that the Department's Land Acquisition personnel be informed.

7-1.06(a) Acquisition of Railroad Non-operating Property

The acquisition of non-operating Railroad property is accomplished according to the criteria outlined in the *Land Acquisition Policies and Procedures Manual*, and the *Federal-Aid Policy Guide*.

7-1.06(b) Acquisition of Railroad Operating Property

Where a proposed highway improvement will cross or longitudinally use a Railroad's operating property, the Department generally will acquire a permanent easement to construct and maintain the improvement. There will be instances when a highway project will require only the temporary use of Railroad property. When this situation occurs, permission to do work of a temporary nature on Railroad right-of-way will be included in the construction and maintenance agreements between the Department and the Railroad. When there is no agreement, permission to do work of a temporary nature will be obtained by the district Land Acquisition staff.

Occasions where payment for such acquisition may be established and paid are as follows:

1. Land Owned in Fee. When a value is indicated and the Railroad company owning the fee title to its operating right-of-way can continue to operate its facilities either in, above, below, or adjacent to the highway, the Department of Transportation will compensate the Railroad for the right-of-way needed according to the Department's *Land Acquisition Policies and Procedures Manual*. No compensation of any kind will be provided for the acquisition of right-of-way to construct a grade-separation facility where an existing highway grade crossing is eliminated.

2. Land Owned as an Easement. If a Railroad has only an easement for its operating right-of-way and can continue to operate its facilities either in, above, below, or adjacent to the highway, there will be no compensation paid to cross or longitudinally use any part of the right-of-way.

The Railroad shall execute the necessary documents to cover the rights or interests required for the highway project according to the criteria in the *Land Acquisition Policies and Procedures Manual*, regardless of whether or not it owns the fee title or easement. The *Land Acquisition Policies and Procedures Manual* provides the procedure to be used if condemnation is necessary. However, note that permission of the Illinois Commerce Commission is a prerequisite to the filing of the complaint for condemnation and motion for the right of immediate possession and the time required must be considered when scheduling the project.

7-2 AGREEMENTS

7-2.01 General

The Preliminary Engineering Section within BDE is responsible for the preparation and negotiation of formal Agreements between the Department and the Railroad. This includes railroad grade separation projects, grade crossing projects, or projects involving the installation of State facilities (e.g., pipe culverts, storm sewers, underground electrical wiring on Railroad property) or any other work on Railroad property for improvements to the State highway system. The district should submit the necessary crossing data with sufficient lead time allowed for these negotiations. Typically, a year or more is required.

The Agreement will cover:

- division of work and expense involved between IDOT and the Railroad in connection with the crossing improvement;
- responsibilities for the future maintenance of the improvement;
- establishment of the Railroad's share of the cost as determined under the provisions of any one of the several classifications provided in the *Federal-Aid Policy Guide* and Section 7-1.02;
- reference to the acquisition of property rights, (see Section 7-1.06);
- reimbursement of the costs incurred by the Railroad according to the requirements of the *Federal-Aid Policy Guide*;
- coverage of liability during construction operations; and
- reference to or identification of plans and plan approval.
- Buy America requirements, as specified in 23 CFR 635.410

7-2.02 District Data

When Federal-aid funds are proposed, the district will be required to submit the necessary data for programming the project together with the necessary data for negotiations with the Railroad.

The district should submit a report to BDE containing reproducible drawings of the crossing plan prepared in sufficient detail showing the following:

1. Grade Separations. Include the following in the report:
 - existing conditions in the crossing area;

- a plan and profile of the track or tracks and of the proposed highway improvement for 500 ft (150 m) in each direction from the intersection of the highway and railroad centerlines;
 - typical highway and track cross sections;
 - railroad and highway right-of-way limits;
 - distance to a railroad reference marker (i.e., mile post);
 - railroad communication lines including the location of poles and height of wires;
 - existing and proposed drainage ditches, structures, and the direction of flow affecting the railroad;
 - construction details of existing and/or proposed grade crossings in the vicinity; note the type and location of warning devices;
 - details of any track adjustments or runaround tracks proposed, including staging;
 - details for detour road crossings and proposed temporary warning devices, including a plat and description of temporary easement if required;
 - number and speeds of passenger and freight trains using the track or tracks daily;
 - plat and description of the temporary easement as required by Section 7-3.03 for the possible location of the contractor's temporary grade crossing; and
 - all other data pertinent to the project.
2. Grade Crossings. For this report, full-size plan sheets will not be required. Include the following in the report:
- a. Existing Grade Crossing. At existing grade crossings, provide the following:
 - number of mainline and subsidiary tracks;
 - type, width, and condition of the existing crossing(s);
 - type and locations of the existing warning devices at the crossing;
 - number and speeds of passenger and freight trains using the crossing daily; and
 - current and ten-year ADT of the highway.
 - b. Proposed Grade Crossing. For new grade crossings, provide the following:

- number of tracks;
 - type and width of crossing(s);
 - types and locations of the proposed warning devices;
 - anticipated date of construction; and
 - any unusual conditions bearing on the proposed work.
- c. Alternative Methods of Accommodating Traffic. For most projects, include a recommended method for accommodating traffic in the report. Methods are discussed in Chapter 13 and Departmental Policy TRA-3, Handling Traffic During the Reconstruction and Repair of Railroad Grade Crossings.

7-2.03 Negotiation Procedure

The Railroad Agreement is normally prepared by the Preliminary Engineering Section, Agreements Unit, and sent to the Railroad for review. A copy is also furnished to the district for its review.

When the Railroad receives the Agreement, the Railroad will begin preparation of the plans and cost estimates for the railroad force account work involved. Upon completion, the Railroad will submit the plans and cost estimates to the Department for review.

After the plans and cost estimates have been approved by the Department and the Agreement has been executed by the Railroad, the Agreement is returned to BDE for execution by the Department.

Upon full execution of the Agreement by the Railroad and the Department, one original copy is retained for the BDE file and the Agreement Unit distributes copies of the Agreement to the following:

- Railroad (1 original copy);
- Illinois Commerce Commission (1 copy);
- district (1 copy);
- Bureau of Accounting and Auditing (1 copy at the time the contract obligation document is established); and
- Project Control (1 copy).

7-2.04 Authorization Procedure

When a contract is awarded for a highway improvement which includes work in the area of a highway-railroad grade crossing, and when the affected Railroad is required to adjust its facilities

as a part of the improvement, construction delays may be encountered. Generally, the Railroad is authorized to assemble its materials and perform its construction work at the time the contract has been scheduled for letting or at the time the contract is awarded. Because time is required by the Railroad to order materials and schedule work crews, it is not uncommon for the highway contractor to be unable to proceed with its work in the area of the crossing. Although the delay may not create problems for the highway contractor or for the Department, it does represent a hardship to the motoring public.

To avoid delays and to facilitate construction, the district is allowed to review each project individually to determine if the contractor's operations will be facilitated by authorizing the Railroad to proceed prior to the letting advertisement or award of the highway contract. The district will authorize the Railroad to proceed with the force account work according to the executed railroad Agreement. The authorization should be issued to the same Railroad official to whom BDE sent the executed Agreement.

Before an early authorization is given, a most probable highway letting date should have been established so that any necessary coordination between the Railroad and the contractor can be undertaken. Proper timing can also reduce any interim roadway maintenance.

If Federal-aid funds are used, the crossing work also must be programmed and authorized before the advance Railroad work is authorized. The district must request and obtain approval for early authorization from BDE's Project Coordination and Implementation Section, Program Support Unit and send a copy of the district authorization letter to the Railroad to BDE.

BDE will authorize the railroad work for individual safety crossings not related to highway contracts.

7-2.05 Adjustment Procedures

7-2.05(a) Change Orders

If a plan or estimate change becomes necessary after the Agreement has been executed, the district initiates the change. Extensively review all change orders or amendments to Agreements. Fully explain any deviations between the actual cost or the revised estimate and the original estimate. Submit supporting documentation (e.g., reason for change, copies of revised estimate, statements of actual cost) with the request for the change order or amendment to the Agreement. Changes will not be deemed accepted until approved by BDE.

If the scope, nature, and/or cost of the adjustment has changed significantly, an amendment to the Agreement may be necessary. If it is deemed that such an amendment is needed, submit an Agreement report for the amendment to BDE for processing. See Section 7-2.02.

For minor modifications in scope, nature, and/or cost, the district should complete BDE 804A or BDE 804B and set forth the following information:

- the extent of the change,

- an estimate of the additional costs,
- the justification for the change, and
- a request for authorization of the change.

BDE 804A, Request for Authorization for Costs Involving Utility, Railroad or Local Agency Agreement under \$250,000 and BDE 804B, Request for Authorization for Costs Involving Utility, Railroad or Local Agency Agreement \$250,000 and above may be located on the IDOT official website.

7-2.05(b) Final Billing

The following applies to processing the final bill for railroad adjustments:

1. Preparation of Final Billing. Ensure that the final bill complies with all requirements of the *Federal-Aid Policy Guide*, Part 140, Subpart I.
2. Review of Final Billing. The district will review the final bill to determine whether or not the final bill reflects the labor, equipment, and materials used in the adjustment. Buy America certificate of Compliance shall be submitted with the Final Invoice.
3. Submission of Final Billing. Submit final bills and recommendations to the Bureau of Accounting and Auditing for audit.
4. Billing Discrepancies. If the final cost as approved by audit exceeds the estimated amount of the adjustment and BDE 804A or BDE 804B were not submitted in the interim, explain the increase and submit appropriate recommendations on BDE 804A and BDE 804B.

7-2.06 Railroad Agreement Process

Figures 7-2.A, 7-2.B, and 7-2.C illustrate flowcharts for the agreement negotiation processes for the following projects:

- Figure 7-2.A—grade separation structure projects,
- Figure 7-2.B—grade crossings/non-safety projects, and
- Figure 7-2.C—grade crossings/safety projects.

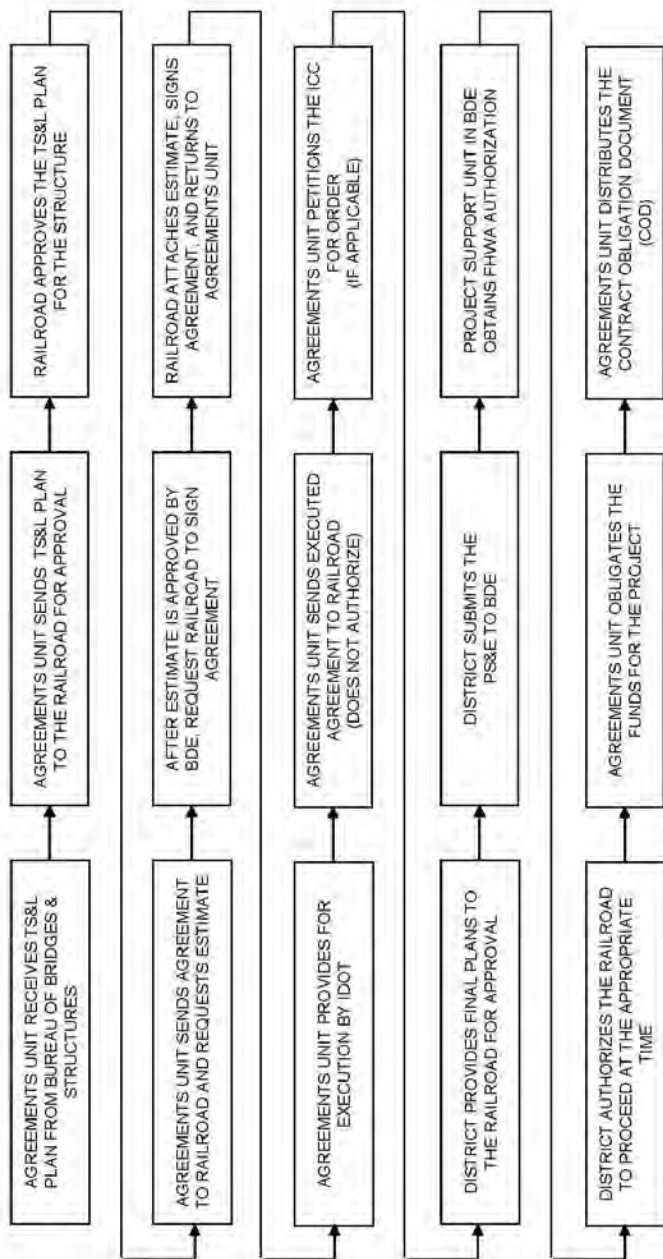

RAILROAD AGREEMENT PROCESS
(Grade Separation Structure Projects)
Figure 7-2.A

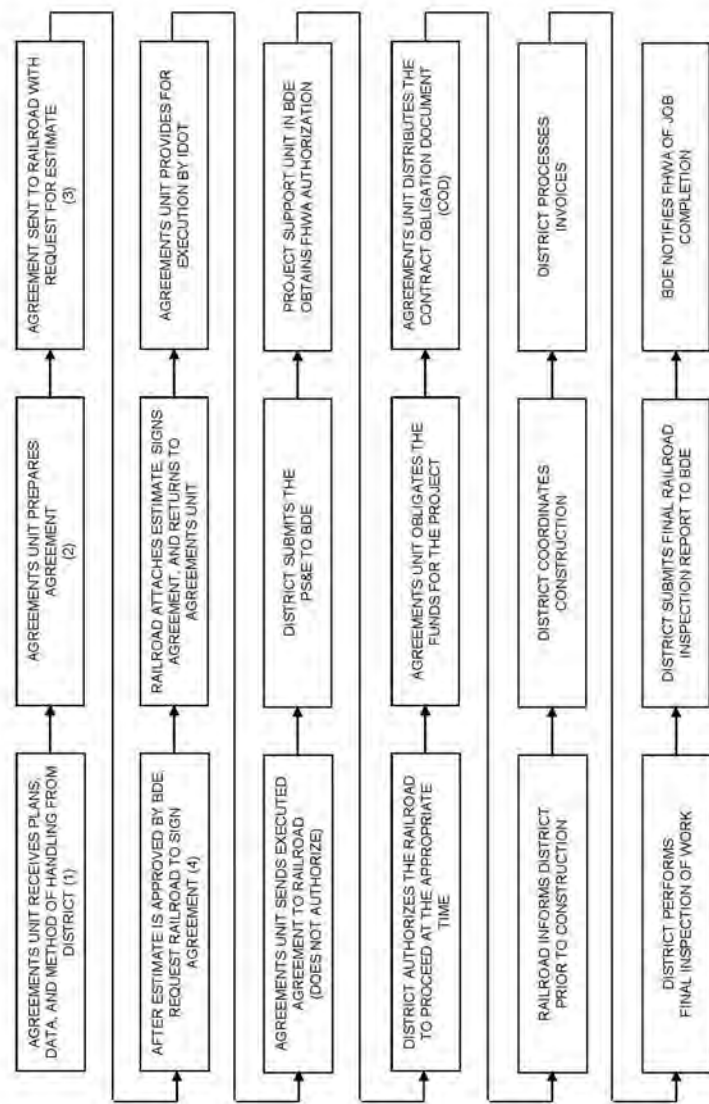

(1) District submittal should indicate whether an interconnection is needed, including any timing requirements for the railroad control circuitry. Interconnection plans and requirements will be approved by the Central Bureau of Operations prior to submittal to the Railroad.

(2) When signal improvements are involved, the typical agreement states the following:

The COMPANY will petition the Illinois Commerce Commission in accordance with 92 Illinois Administrative Code 1535 to take jurisdiction in this matter and to enter such orders as may be necessary.

(3) The transmittal to the Railroad should indicate any interconnection requirements.

(4) The Railroad's interconnection plans will be approved by the Central Bureau of Operations prior to the approval of the estimate.

**RAILROAD AGREEMENT PROCESS
(Grade Crossing/Non-Safety Projects)**

Figure 7-2.B

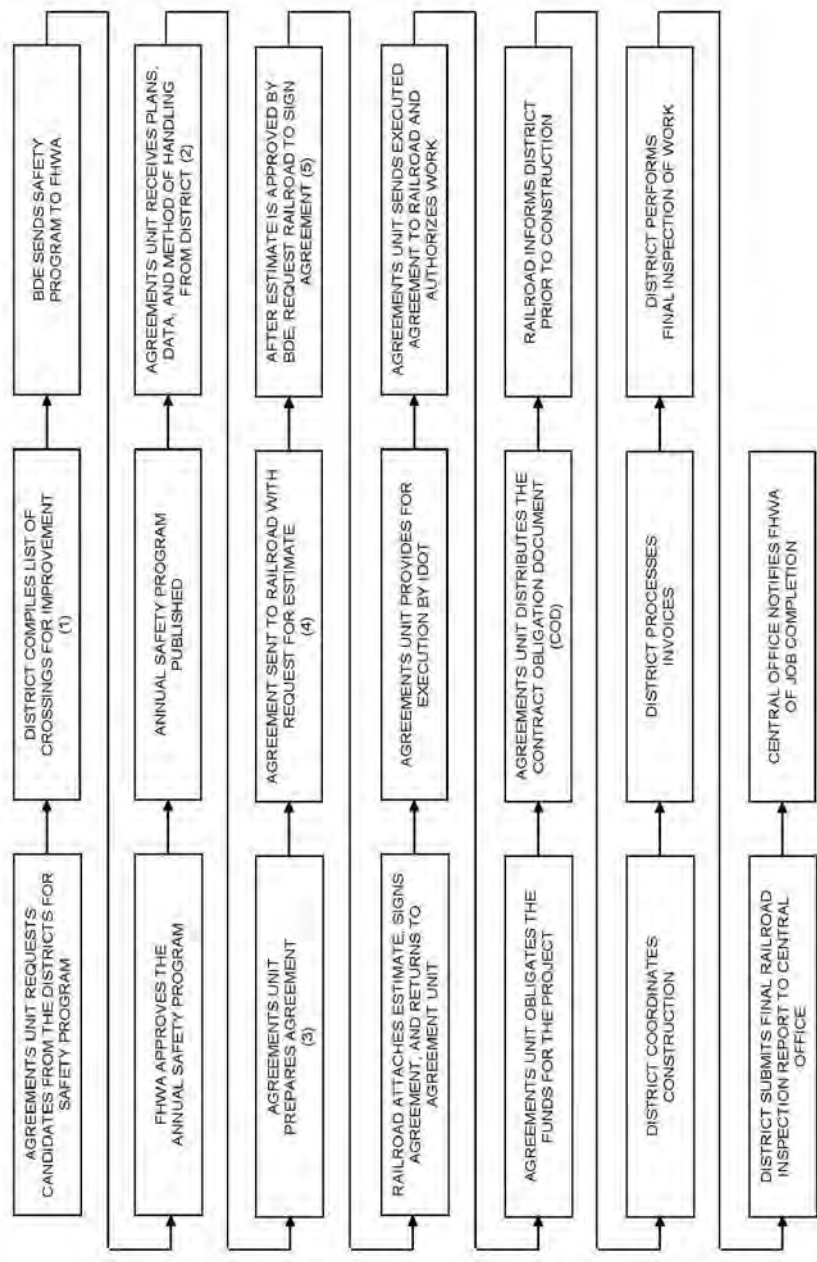

- (1) List based on annual inspections, expected crashes, and complaints.
- (2) District submittal should indicate whether an interconnection is needed, including any timing requirements for the railroad control circuitry. Interconnection plans and requirements will be approved by the Central Bureau of Operations prior to submittal to the Railroad.
- (3) When signal improvements are involved, the typical agreement states the following:
The COMPANY will petition the Illinois Commerce Commission in accordance with 92 Illinois Administrative Code 1535 to take jurisdiction in this matter and to enter such orders as may be necessary.
- (4) The transmittal to the Railroad should indicate any interconnection and requirements.
- (5) The Railroad's interconnection plans will be approved by the Central Bureau of Operations prior to the approval of the estimate.

**RAILROAD AGREEMENT PROCESS
(Grade Crossing/Safety Projects)**

Figure 7-2.C

7-3 DESIGN FUNCTIONS

7-3.01 General

As State highways and railroads are expanded or modernized, it is inevitable that new highway-railroad crossings will need to be established and that existing crossings will need to be modernized, reconstructed, or eliminated. Basically, there are two methods of accomplishing these crossings:

1. At-Grade Crossing. This method is where the highway and railroad intersect at the same elevation requiring proper warning to reduce the inherent hazard of collisions between trains and highway vehicles.
2. Grade Separation Crossing. This method is where the inherent collision hazard is eliminated by the construction of a structure that carries the highway over or under the railroad.

7-3.02 At-Grade Crossings

7-3.02(a) Selection Guidelines for Warning Devices

Warning devices will be warranted at all highway-railroad crossings where grades are not separated. Select the type of warning device according to the following:

1. General. At a minimum, provide reflectorized crossbucks, pavement markings, and advance warning signs as indicated in the *Illinois Manual on Uniform Traffic Control Devices* at all crossings.
2. Flashing Signals. Install flashing signals at crossings where the warrants for gates are not met and where the expected crash frequency equals or exceeds 0.02. Use Equation 7-3.1 and the factors in Figure 7-3.A to determine the expected crash frequency.

$$ECF = A \times B \times T$$

Equation 7-3.1

Where:

ECF	=	Expected Crash Frequency
A	=	Traffic factor, see Figure 7-3.A
B	=	Component factor, see Figure 7-3.A
T	=	Current number of trains per day

3. Cantilevered Flashing Signals. Use cantilevered flashing signals, in addition to other warning devices, on multilane highways that qualify for active warning devices and where there is the possibility of a truck blocking the view of the roadside signals. Also, consider providing cantilever signals at high-frequency crash locations that possibly could be improved by more visible signals.

A Factors

VEHICLES PER DAY (10-YR. ADT)	FACTOR
250	0.000347
500	0.000694
1000	0.001377
2000	0.002627
3000	0.003981
4000	0.005208
5000	0.006516
6000	0.007720
7000	0.009005
8000	0.010278
9000	0.011435
10000	0.012674
12000	0.015012
14000	0.017315
16000	0.019549
18000	0.021736
20000	0.023877
25000	0.029051
30000	0.034757

B Factors — Basic Values for Existing Devices

Components	Basic Value Adjustments
Crossbucks, traffic volume less than 500 vehicles per day	3.89
Crossbucks, urban	3.06
Crossbucks, rural	3.08
Stop signs, traffic volume less than 500 vehicles per day	4.51
Stop signs	1.15
Wigwags	0.61
Flashing lights, urban	0.23
Flashing lights, rural	0.93
Gates, urban	0.08
Gates, rural	0.19

**CRASH FREQUENCY FACTORS
(Highway-Railroad Grade Crossings)**

Figure 7-3.A

4. Gates and Flashing Signals. Provide flashing signals and gates where one or more of the following conditions are met:
- multiple mainline railroad tracks;
 - multiple tracks at or in the vicinity of the crossing which may be occupied by a train or locomotive, so as to obscure from view the movement of another train approaching the crossing;
 - high-speed train operation combined with limited sight distance at either single or multiple track crossings;
 - a combination of high speeds and moderately high volumes of highway and railroad traffic;
 - either a high volume of vehicular traffic, high number of train movements, substantial numbers of school buses or trucks carrying hazardous materials, unusually restricted sight distance, continuing crash occurrences, or any combination of these conditions;
 - the expected crash frequency for flashing lights exceeds 0.02 and the benefit-cost ratio equals or exceeds 1.0 (the method for determining the benefit-cost ratio is shown in Figure 7-3.B); and/or
 - a diagnostic team recommends them.

In individual cases where a diagnostic team justifies that gates are not appropriate, gates will not be required.

5. High-Type Device. Provide a higher type of warning device which may not be justified under any of the preceding warrants based on continuing or potential crash occurrence due to:
- unusual track or roadway geometrics;
 - restricted sight distance; and/or
 - other unusual conditions, such as where there exist exceptional crash consequences to a large number of people as rail or highway passengers or as the result of a crash involving hazardous materials.

In other instances, a lower level device may be justified if concurred with by a diagnostic team.

- Definitions: ECF = Expected Crash Frequency = $A \times B \times T$ Equation 7-3.1
- Z = Cost of crash = ratio of deaths and injuries per crash (average for latest 3 years in Illinois) x cost per crash (National Safety Council crash cost data which is documented and periodically updated by BDE)
- U = Cost of flashing lights divided by expected life = _____
- V = Yearly maintenance cost of flashing lights = _____
- Y = Cost of gates divided by expected life = _____
- W = Additional annual cost to maintain = _____
gates instead of flashing lights
- L = Cost of grade separation divided by expected life = _____
- M = Additional annual cost to maintain grade = _____
separation instead of gates

(Expected life can be assumed as 20 to 30 years.)

Step 1: ECF for present installation = $A \times B \times T$ = _____

Step 2: ECF for proposed installation = $A \times B \times T$ = _____

Step 3: Savings in ECF per year = Step 1 - Step 2 = _____

Step 4: Benefit = $Z \times$ Step 3 = \$ _____

Step 5: Cost of proposed installation = $Y + W$, or $U + V$, or $L + M$ = \$ _____

Step 6: Benefit-Cost Ratio = Step 4 divided by Step 5 = _____

**BENEFIT-COST RATIO ANALYSIS
(Highway-Railroad Crossings)**

Figure 7-3.B

Where the distance measured along the centerline of the highway between two regularly used adjacent tracks is less than 100 ft (30 m), consider the crossing as a multiple track crossing and install warning devices accordingly. Where the distance is 100 ft (30 m) or more, consider each crossing as individual crossings and signalize each according to the preceding warrants.

7-3.02(b) Example for Warning Device Selection

* * * * *

Example 7-3.1

Given: Urban Area
Crossbuck Protection
10-year ADT = 5000 Vehicles Per Day
Current Train Traffic = 5 Trains Per Day

Problem: Determine the appropriate warning devices that should be used at this crossing.

Solution: First determine the expected crash frequency of the existing crossbuck protection.

Expected Crash Frequency:

$$ECF = 0.006516 \times 3.06 \times 5$$

$$ECF = 0.10$$

ECF = 1 crash every ten years

Crash frequency is greater than 0.02 indicating the need for higher type device.

Try flashing lights:

$$"B" = 0.23$$

$$ECF = 0.006516 \times 0.23 \times 5$$

$$ECF = 0.01$$

Therefore, flashing lights are warranted.

* * * * *

7-3.02(c) Circuitry Devices

Refinements to activation circuitry should be recommended where the credibility of the warning devices could be beneficially increased. This includes shortening the signal "starts" to reflect reduced train speeds, or installing motion detectors or constant warning time devices (predictors). Consider the following:

1. Grade Crossing Predictors. Install grade crossing predictors (GCP/constant warning time) circuitry at crossings with ADT of at least 1000 vehicles and an average daily train traffic of at least 5 trains per day, or where there are concentrations of train or vehicular traffic during “rush hours” and where:
 - there are switching moves on the approach circuits,
 - at least 25% of the average daily trains operate at 25 mph (40 km/h) slower than the fastest train on the line, or
 - there is an unusual track and crossing geometry.
2. Motion Detectors.
 - a. Gates. Where gates are present, provide motion detectors where there:
 - is stopping or other lengthy occupancy of the approach circuits,
 - are new gate installations,
 - is upgrading of crossings with flashing signals to gate installations, or
 - are major control circuitry changes required at existing installations.
 - b. Flashing Signals. For flashing signals, provide motion detectors where there:
 - is stopping or other lengthy occupancy of the approach circuits,
 - are new flashing signal installations with ADT of 1000 vehicles or more and 5 or more trains per day, or
 - are major control circuit changes required by changes in or additions to flashing signals at crossings with ADT of 1000 vehicles or more and 5 or more trains per day.

Note that the cost differential between grade crossing predictors (GCP/constant warning time) and motion detector circuitry is minor in comparison to the total installation cost. In addition, grade crossing predictor (GCP/constant warning time) circuitry can be adjusted to a wider, more variable set of train traffic conditions. When contemplating circuitry improvements, it is best to contact the railroad to make an accurate assessment of train traffic and a more informed decision on circuitry improvements.

7-3.02(d) Barrier Systems

The following will apply to barrier systems around warning devices:

1. General. Do not provide barrier systems (e.g., guardrail, impact attenuators) at railroad grade crossings except in extraordinary circumstances. In most cases, the roadside barrier presents more of a hazard than the railroad warning device it shields. Also, it may

block a lateral escape route in advance of the signal. Extraordinary circumstances which may justify the use of a roadside barrier in the vicinity of a railroad crossing warning device include:

- locations where the approach roadway is on a fill with side slopes steeper than 1V:3H and greater than 10 ft (3.0 m) in height,
 - locations with a high-crash history involving warning device where a cost-effective analysis demonstrates a roadside barrier is warranted, and
 - locations where there will be a temporary delay in moving warning devices for widening of a highway.
2. Installation. See Chapter 38 and the *Highway Standards* for the installation of guardrail at crossings.
 3. Special Conditions. In industrial or other areas involving low-speed highway traffic and where warning devices are vulnerable to damage by turning truck traffic, ring-type guardrail may be installed to provide protection for warning devices. Ring-type guardrail should conform to Figures 7-3.C and 7-3.D. Substitute shielding devices (e.g., concrete, railroad ties, railroad rails) are not permitted.
 4. Signals. Do not use breakaway or frangible bases for cantilever signal supports.
 5. Maintenance of Barriers. The Department will maintain all longitudinal guardrail and impact attenuators. The Railroad will be responsible for maintaining the ring-type guardrail.
 6. Approval. Approval for the erection of any roadside barrier by the Railroad must be obtained in writing from BDE.

7-3.02(e) Approaches

When a grade crossing improvement is undertaken, that portion of the roadway lying within or adjacent to the crossing should, if necessary, be improved to provide a smooth approach to the crossing so that the driver's attention will not be diverted from warning devices or oncoming trains by rough approaches. Also, consider removing or relocating any obstructions to a motorist's view of warning devices within the roadway. This includes utility poles, shrubs, trees, signs, etc.

7-3.02(f) Design Considerations

When it has been determined that an at-grade crossing is appropriate at a highway-railroad intersection, the district will prepare a plan and profile sheet for the highway showing complete

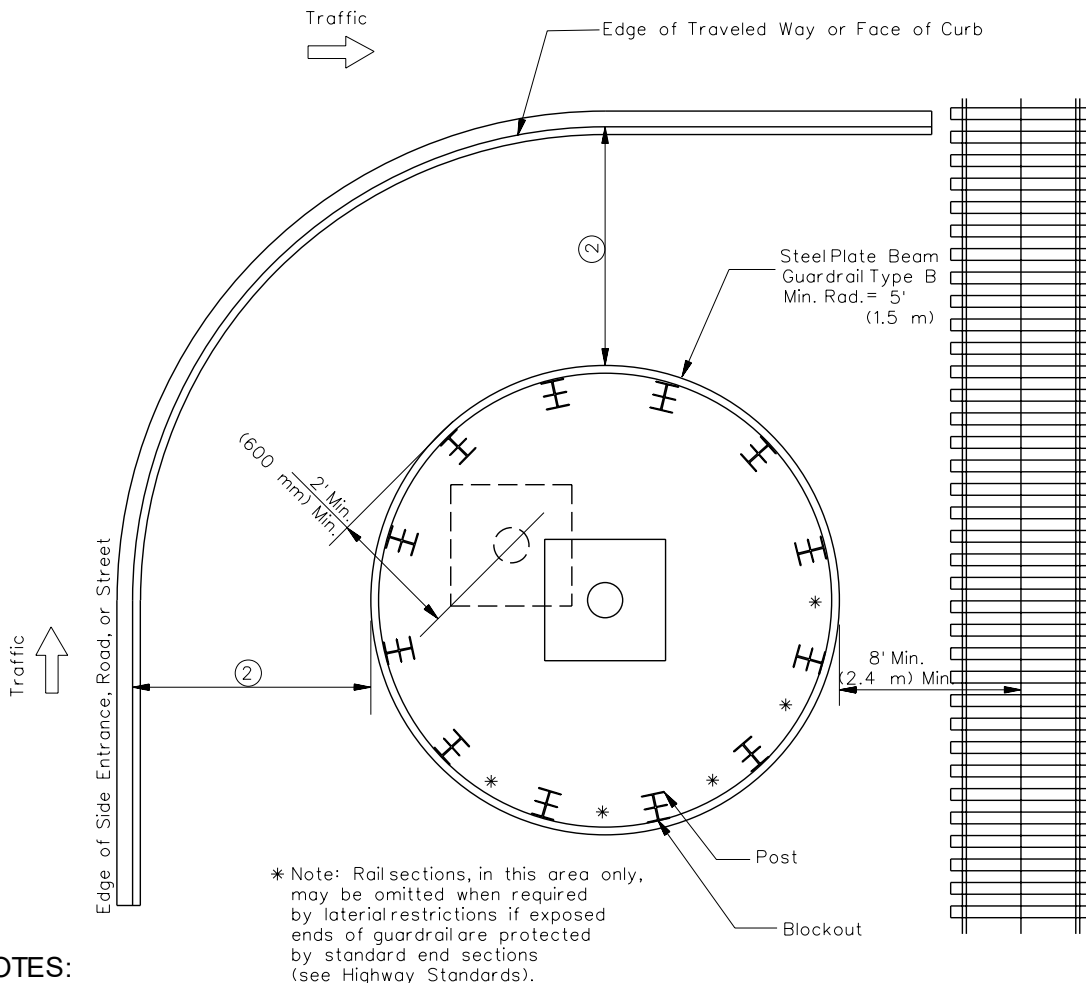

NOTES:

1. All construction and material should conform to the latest editions of the IDOT *Highway Standards* and IDOT *Standard Specifications*.
2. Minimum offset determined by general conditions with 6 ft (1.8 m) and 2 ft (600 mm) desirable for rural and urban sections respectively. Offset the guardrail a minimum of 6 ft (1.8 m) where the roadway cross sections include flush shoulders. In no case shall guardrail encroach upon the shoulder.
3. Guard ring may be off center of warning device when required by lateral restrictions.
4. If either the size or the number of warning device foundations will preclude the use of a circular ring as shown, an appropriate amount of tangent guardrail may be included.
5. If, due to geometrics of the warning device location, it is not practical to provide a 5-ft (1.5-m) minimum radius guard ring, with minimum clearance, the alternative structural plate ring should be considered; see Figure 7-3.D.

**RAILROAD WARNING DEVICE GUARDRAIL
(For Roadways Up to 45 mph (70 km/h))**

Figure 7-3.C

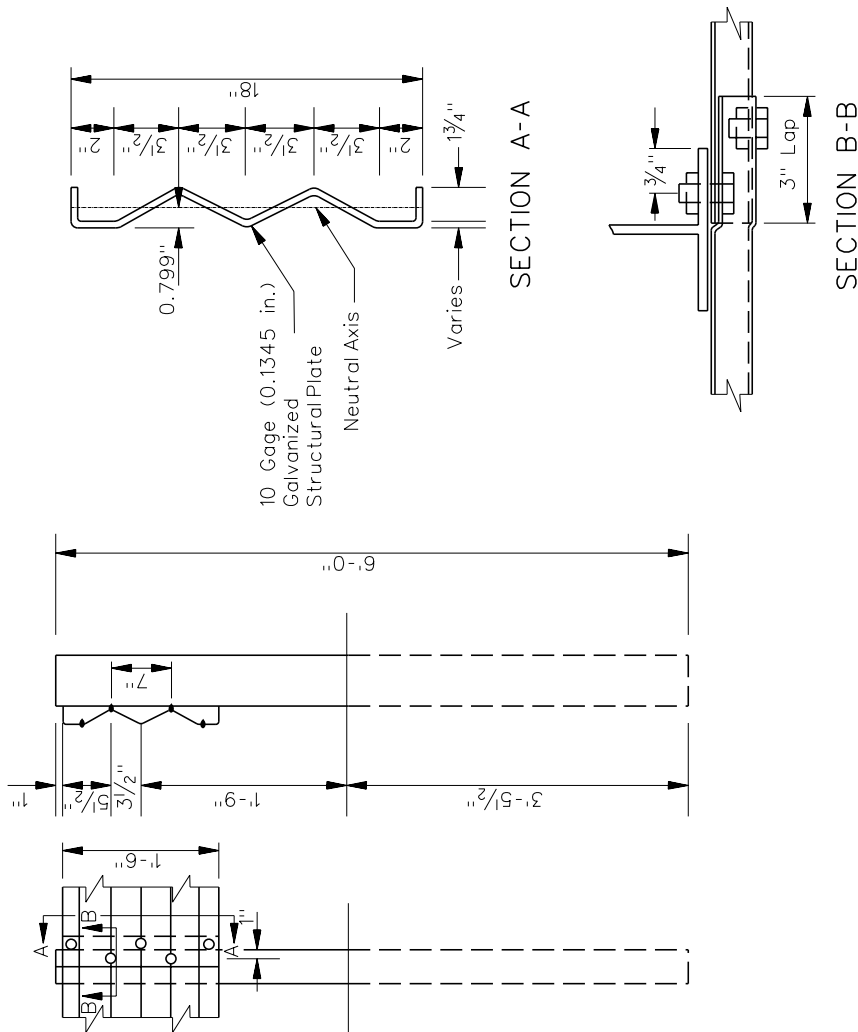

General Notes:

1. All bolts have a 5/8" diameter and length as required.
2. Galvanize all bolts and nuts according to the requirements of AASHTO M232.
3. All holes in posts are 3/4" diameter.
4. The rail elements should conform to the material requirements and be galvanized according to AASHTO M180.
5. Structural Plate Guard Ring and posts will conform to the applicable portions of the IDOT Standard Specifications and Highway Standards.
6. The inch-pound units have been retained for use by Railroads.

**(For Radius, 5 ft (1.5 m))
Figure 7-3.D**

information for existing and proposed railroad facilities; see Section 7-2.02. These plans will be used by BDE for negotiating with the Railroad involved. When designing grade crossings, consider the following:

1. Grade Crossing Proper.
 - a. Surface Material. Where the roadway traffic equals or exceeds 1000 ADT, use prefabricated rubber or concrete surface materials. For ADT less than 1000, timber and/or asphalt crossings may be used.
 - b. Medians. Where median-mounted warning devices will be installed and other than an earth median is adjacent to a grade crossing, the median should have a minimum median width of 8.5 ft (2.6 m) (10 ft (3.0 m) desirable) back-to-back of curb. Depress all medians and curbs on approaches to the crossing to the level of the pavement edge or gutter flag within the track clearance line which is parallel to and 8 ft (2.4 m) from the centerline of the nearest track; see Figure 7-3.E.
 - c. Location. Where no barrier curbs extend along the pavement, the crossing proper and islands between tracks should extend to parallel lines which are 8 ft (2.4 m) outside of the pavement edges or to edge of stabilized shoulder, whichever is greater. Where barrier curbs along the pavement are present, the crossing proper and islands should extend to the back of the curb except where the opening along the curb exceeds 55 ft (16.8 m), in which case the crossing should extend 3 ft (900 mm) outside the curb face.
 - d. Sidewalks. Where sidewalks are present, also include a sidewalk crossing. Where sidewalks abut or are in close proximity to the back of curb, the district may elect to extend the prefabricated crossing materials to the outer limits of the sidewalk.
 - e. Pavement. Construct the approaches to grade crossings and the islands between the tracks according to the *IDOT Highway Standards*. This also applies where a Railroad constructs a crossing through an existing pavement.
 - f. Grades. Design the grades on approaches to grade crossings, as a minimum, according to the criteria in the *92 Ill. Admin. Code*, 1535.204.
2. Grade Crossing Warning Devices. Ensure the design, installation, and operation of grade crossing warning devices conforms to the *Illinois Manual on Uniform Traffic Control Devices (ILMUTCD)* and *92 Ill. Admin. Code*, 1535 as applicable.

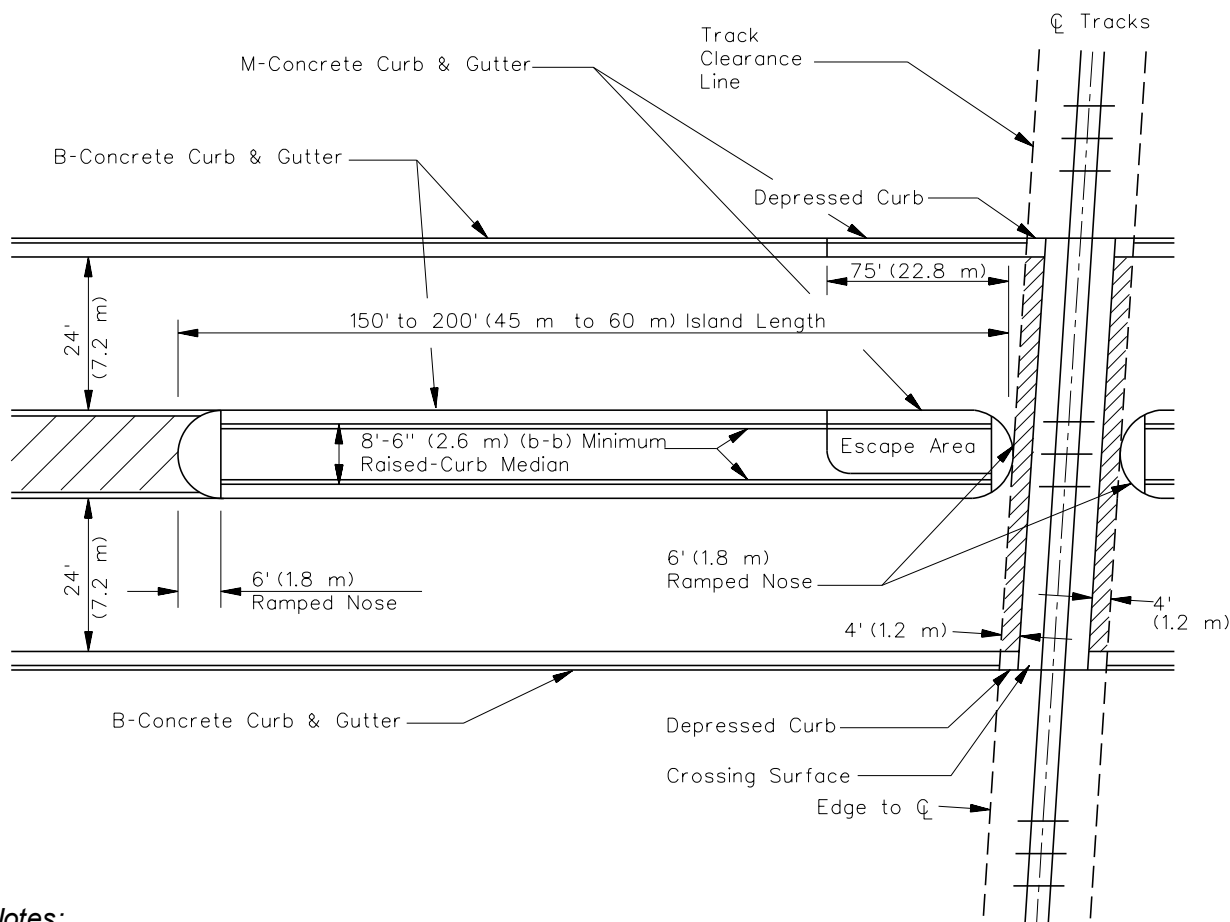

Notes:

1. Where a raised-curb, flush, or traversable type median is used on the roadway, provide B-6 or B-9 (B-15 or B-22) raised-curb median on crossing approaches and provide M-2 or M-4 (M-5 or M-10) raised-curb median on crossing departures adjacent to each side of the railroad track(s); see Section 34-2.04.
2. In addition to deterring vehicular movements over the track(s) in the median area, the raised-curb median provides a space for mounting railroad warning device units, if required. Also, see Section 36-8.
3. If the railroad tracks are located close to a cross street and lie within the left-turn lane of the intersection, this situation will require a special design and the use of barrier type curb along the median adjacent to the turn lane.
4. The median should have a minimum width of 8.5 ft (2.6 m) (10 ft (3.0 m) desirable) back-to-back of curb.

**TYPICAL MID-BLOCK MEDIAN TREATMENT ADJACENT TO RAILROAD CROSSINGS
(Multilane Urban and Suburban Highways)**

Figure 7-3.E

Locate warning device units a minimum of 12 ft (3.6 m) from the centerline of near track and 4 ft-3 in. (1.3 m) back of the face of curb or outside the edge of paved shoulder or 8 ft-3 in. (2.5 m) outside the edge of traveled way. The 4 ft-3 in. (1.3 m) and 8 ft.3 in. (2.5 m) dimensions allow the clearances noted in the *ILMUTCD* in the event the railroad installs lamp units equipped with large backgrounds.

3. Sight Distance. The AASHTO *A Policy on Geometric Design of Highways and Streets* presents criteria to determine the applicable sight triangle at a highway-railroad crossing.

7-3.02(g) Signalized Intersections

Where a signalized highway intersection is located near a railroad grade crossing, ensure that there is sufficient storage distance between the highway intersection and railroad grade crossing to allow for the storage of stopped vehicles at the intersection. Where this is not practical, coordinate the traffic signal system with the railroad's approach circuitry to allow stopped traffic on or near the grade crossing to clear the crossing upon the approach of a train. Where the railroad crossing is signalized, interconnect the two signal systems. For guidance on the design and coordination of traffic signals near grade crossings, review the *ILMUTCD*, the ITE publication *Preemption of Traffic Signals At or Near Railroad Grade Crossings with Active Warning Devices*, Section 36-8, and Chapter 57.

All grade crossings requiring an interconnection must be coordinated with the Bureau of Operations. See the flowcharts in Figures 7-2.A, 7-2.B, and 7-2.C for a general outline of the coordination process.

7-3.03 Grade-Separated Structures

7-3.03(a) Warrants

A grade separation should be provided where a highway is constructed or reconstructed across a railroad when the crash frequency for gates exceeds 0.02 and the benefit-cost ratio equals or exceeds 1.0.

A grade separation should be provided where an expressway in a rural area is constructed or reconstructed across the railroad.

7-3.03(b) Design Considerations

Where grade separation is warranted as determined by the criteria contained in Section 7-3.03(a), BDE will be responsible for the negotiations with the railroad involved to determine who will design the structure; see Section 7-2. Plans prepared by or for the Department must be approved by the Railroad and should show:

- the structural design features;
- the vertical clearance from top of rail to under clearance of superstructure;

- the distance between track centers for multiple-track crossing;
- the lateral clearance from track center to face of adjacent pier (or abutment);
- the distance to a designated railroad reference marker (i.e., mile post) from centerline of bridge;
- the flow line and cross section of existing and proposed drainage features, including drainage structures;
- the location and stationing of railroad right-of-way lines;
- the wire lines and utility facilities located on railroad right-of-way; and
- other pertinent features affecting the Railroad's interests.

For details of the geometric design, see the *Bureau of Bridges and Structures Manual*.

Section 7-1.06 addresses acquisition of the necessary railroad property for the structure. The contractor shall be responsible for temporary railroad crossings for use by the Contractor in accordance with Article 107.10 of the *Standard Specifications*.

7-3.04 Other Agency References

For uniformity, use the applicable Federal regulations on both Federally and non-Federally funded projects. Clearance and public safety aspects of all projects shall conform to the regulations of the Illinois Commerce Commission. Applicable publications of these agencies are provided in Figure 7-3.F.

PUBLICATION	SUBJECT
* <i>FPG</i> , Chapter 1, Subchapter B, Part 140, Subpart I	Reimbursement for Railroad Work
* <i>FPG</i> , Chapter 1, Subchapter G, Part 646, Subpart B	Railroad-Highway Projects
* <i>FPG</i> , Chapter 1, Subchapter G, Part 646, Subpart A	Railroad-Highway Insurance Protection
92 <i>Illinois Administrative Code</i> , Chapter III, Subchapter C, Part 1500	Minimum Clearances Applicable to Tracks, Structures, Fixtures, and Other Appurtenances of Railroads
92 <i>Illinois Administrative Code</i> , Chapter III, Subchapter C, Part 1535	Crossings of Rail Carriers and Highways
<i>Illinois Supplement to the Manual on Uniform Traffic Control Devices</i>	
<i>Title 23 Code of Federal Regulations, 23 CFR 635.410</i>	Buy America Requirements

**FPG* = FHWA *Federal-Aid Policy Guide*.

PERTINENT PUBLICATIONS OF OTHER AGENCIES

Figure 7-3.F

Chapter Eight

CONSULTANT DEVELOPED AND/OR DESIGNED PROJECTS

BUREAU OF DESIGN AND ENVIRONMENT MANUAL

Chapter Eight
CONSULTANT DEVELOPED AND/OR DESIGNED PROJECTS

Table of Contents

<u>Section</u>	<u>Page</u>
8-1	DEFINITIONS AND PROCEDURES..... 8-1.1
8-1.01	Definitions..... 8-1.1
8-1.02	Acronyms..... 8-1.2
8-2	PREQUALIFICATION AND SELECTION 8-2.1
8-2.01	Use of Consulting Engineering Firms 8-2.1
8-2.02	Prequalification of Consultants 8-2.1
8-2.03	Request for Consultant Services 8-2.3
8-2.04	Advertisement of Need 8-2.5
	8-2.04(a) Statements of Interest (SOI) 8-2.5
	8-2.04(b) Confirmation of Eligibility..... 8-2.6
	8-2.04(c) Preliminary Review and Ranking 8-2.6
8-2.05	Consultant Selection..... 8-2.7
	8-2.05(a) Consultant Selection Committee 8-2.7
	8-2.05(b) Selection Procedures 8-2.8
8-3	AGREEMENT NEGOTIATION AND PROCESSING 8-3.1
8-3.01	General..... 8-3.1
8-3.02	Scope 8-3.1
	8-3.02(a) Scope of Services Meeting 8-3.1
	8-3.02(b) Scope of Work 8-3.2
8-3.03	Methods of Compensation..... 8-3.3
	8-3.03(a) Cost Plus Fixed Fee (CPFF)..... 8-3.3
	8-3.03(b) Unit of Work 8-3.4
8-3.04	Negotiations..... 8-3.4
8-3.05	Cost Proposal Packages 8-3.5
8-3.06	Agreement Processing 8-3.7
8-3.07	Funding Approvals and Federal Authorizations..... 8-3.7
8-3.08	Cost Approvals 8-3.8
8-3.09	Signature Authority 8-3.8
8-3.10	Authority to Proceed 8-3.9
	8-3.10(a) Letter of Authorization..... 8-3.9

Table of Contents

<u>Section</u>		<u>Page</u>
	8-3.10(b) Risk Management	8-3.9
8-3.11	Early Authorization To Proceed	8-3.9
	8-3.11(a) Start-Up Agreement	8-3.9
8-3.12	Contract Administration	8-3.10
8-3.13	Subcontracts by Consulting Engineering Firms.....	8-3.11
8-3.14	Supplemental Agreements	8-3.11
	8-3.14(a) General	8-3.11
	8-3.14(b) Early Authorization to Proceed-Prior Approval	8-3.13
8-3.15	Monitoring Consultant's Work.....	8-3.14
	8-3.15(a) Agreement Schedule	8-3.14
	8-3.15(b) Completion Dates	8-3.15
	8-3.15(c) Documentation.....	8-3.15
	8-3.15(d) Consultant Invoices.....	8-3.15
	8-3.15(e) Federal Funding.....	8-3.15
8-3.16	Evaluation of Consultant's Performance	8-3.16
	8-3.16(a) General	8-3.16
	8-3.16(b) Interim Evaluations	8-3.19
	8-3.16(c) Final Evaluations.....	8-3.20
	8-3.16(d) Phase I Studies and Environmental Document Evaluations	8-3.20
	8-3.16(e) Structure Plan Evaluations.....	8-3.20
	8-3.16(f) Other Evaluations to be Completed by the IDOT Project Managers.....	8-3.20
	8-3.16(g) Final Project Evaluations	8-3.20
	8-3.16(h) Consultant Selection Committee.....	8-3.20
	8-3.16(i) Below Satisfactory Interim Evaluations.....	8-3.21
	8-3.16(j) Below Satisfactory Final Evaluations	8-3.21
	8-3.16(k) Final Plan Adequacy Evaluations	8-3.22
	8-3.16(l) Consultant Appeal Process of Final Evaluation	8-3.22
8-3.17	Completion and Termination Procedures	8-3.22
	8-3.17(a) Completion.....	8-3.22
	8-3.17(b) Termination	8-3.23
8-3.18	Reassignment of Vested Interest in an Agreement to Another Consultant.....	8-3.23
8-4	CLAIMS.....	8-4.1

Table of Contents

<u>Section</u>	<u>Page</u>
8-4.01	Damage Due to Consultant Errors and/or Omissions 8-4.1
8-4.01(a)	Errors By Phase I Consultant Discovered During Phase II 8-4.1
8-4.01(b)	Errors By Phase II or Phase III Consultant Discovered During Construction 8-4.1
8-4.01(c)	Notifying Consultant of the Cost of the Errors or Omissions 8-4.2
8-4.01(d)	Errors and Omissions Threshold (EOT)..... 8-4.2
8-4.01(e)	Dispute Resolution..... 8-4.3
8-4.01(f)	Obtaining Reimbursement for Consultant Errors or Omissions 8-4.4
8-5	QUALITY ASSURANCE QUALITY/CONTROL (QA/QC) GUIDELINES FOR WORK BY CONSULTING ENGINEERS 8-5.1
8-5.01	Definitions..... 8-5.1
8-5.02	Elements of a QA/QC 8-5.3
8-5.02(a)	Project Team..... 8-5.3
8-5.02(b)	Written Project Plan 8-5.3
8-5.02(c)	Project Control 8-5.5
8-5.03	Compliance Statements 8-5.7
8-5.04	Verification Process..... 8-5.7

Chapter Eight

CONSULTANT DEVELOPED AND/OR DESIGNED PROJECTS

Chapter 8 documents the Department's policies and procedures to use when processing consultant developed and/or designed projects.

8-1 DEFINITIONS AND PROCEDURES

8-1.01 Definitions

The following definitions apply to Chapter 8:

1. Additional Services. Any service or action required of the consultant not identified in the Agreement or any Supplemental Agreement.
2. Agreement/Contract. The legal instrument or negotiated contract defining the obligations and considerations of the signatory parties. The term "Agreement" or "Contract" includes all Supplemental Agreements.
3. Bureau Chief. The Department's officer named in the Agreement who shall approve any change or additional work authorization.
4. Consultant. The firm providing professional services as a party to the Agreement.
5. Department or IDOT. The Department of Transportation of the State of Illinois.
6. Department or IDOT Internet Site. <http://www.dot.il.gov>.
7. Director. The director of the office of the Department who is in charge of the services under the Agreement.
8. EPAS: Engineering Prequalification and Agreement System.
9. Fixed Fee. A specified dollar amount to cover profit and certain business expenses based on the assigned complexity factor of the project.
10. Liaison Managers. The duly authorized representatives of the Department and the Consultant charged with day-to-day administration of the terms of the Agreement.
11. Prequalification. A condition that shall be met before consideration is given.

12. Project Schedule. A comprehensive description of all significant services required of the Consultant and of all actions required of the Department and approving parties by the obligations of the Agreement, together with the durations and/or dates for performing these services and actions.
13. Regional Engineer. The engineer in charge of the region that has jurisdiction over the services.
14. Scope of Services (Advertised). All services and actions required of the Consultant as advertised in the Professional Transportation Bulletin (PTB).
15. Scope of Services (Negotiated). All services and actions required of the Consultant by the obligations of the Agreement.
16. Subconsultant. Any independent professional firm, person, or organization who, with the approval of the Department, performs a part of the services for the Consultant.
17. Supplemental Agreement. An additional agreement modifying the original signed Agreement.
18. Service. All engineering and related services and the furnishing of all equipment, supplies, and materials required to achieve the broad purpose and general objectives of the Agreement.

8-1.02 Acronyms

The following are common terms used with consultant developed and/or designed projects:

1. AA Affirmative Action.
2. A/E Architectural-Engineering.
3. AFC Annual Fee Capacity.
4. AU Agreements Unit.
5. BBFM IDOT Bureau of Budget and Fiscal Management.
6. BIC IDOT Bureau of Investigations and Compliance.
7. BoBS IDOT Bureau of Business Services.
8. BDE IDOT Bureau of Design and Environment.
9. CA Certification Acceptance.
10. CAAS Consultant Agreement Approval Sheet.
11. CECS Cost Estimate of Consultant Services.

12. CEUF Consultant's Employee Utilization Form.
13. CFR Code of Federal Regulations.
14. COD Contract Obligation Document.
15. CPO Chief Procurement Officer.
16. CPFF Cost Plus Fixed Fee.
17. CSC Consultant Selection Committee.
18. CU Consultant Unit.
19. DBE Disadvantaged Business Enterprise.
20. DLM Direct Labor Multiple.
21. EEO Equal Employment Opportunity.
22. EPAS Engineering Prequalification and Agreement System.
23. FHWA Federal Highway Administration.
24. OMB The White House Office of Management and Budget.
25. OP&P IDOT Office of Planning and Programming.
26. PPB Procurement Policy Board.
27. PSU Project Support Unit.
28. PTB Professional Transportation Bulletin.
29. QA/QC Quality Assurance/Quality Control.
30. SAPCS Standard Agreement Provisions for Consultant Services.
31. SEFC Statement of Experience and Financial Condition.
32. SOI Statement of Interest.
33. TS&L Type, Size, and Location Plan.

8-2 PREQUALIFICATION AND SELECTION

8-2.01 Use of Consulting Engineering Firms

Extensive engineering activity is required to complete the Transportation Improvement Program (e.g., performing necessary studies, preparing construction plans and specifications for advertising construction projects, inspecting construction activities). To accomplish the Program without appreciably increasing the number of IDOT personnel or performing services for which the Department does not have specialized expertise, the Department uses outside consulting engineering firms. Engineering and Land Surveying consulting firms' services are procured under the Architectural, Engineering, and Land Surveying Qualifications Based Selection Act; 30 ILCS 535-1 et seq., the Selection of Architectural, Engineering and Land Surveying Services, 44 Ill. Admin. Code 625, and Departmental Order 6-2.

8-2.02 Prequalification of Consultants

All Architectural-Engineering (A/E) Consultants desiring to provide services to the Department, whether as Prime or Subconsultant, are prequalified before any consideration is given to their respective Statements of Interest; see Section 8-2.04(a). Prequalification must be obtained no later than the final date established for the receipt of Statements of Interest for any particular work. However, a Consultant that is prequalified for one or more types of work on the final date established for the receipt of Statements of Interest may submit supplemental information as necessary to establish prequalification for additional types of work. This supplemental information must be approved no later than three working days prior to the Consultant Selection Committee meeting; see Section 8-2.05(a). The following items discuss the prequalification procedures:

1. SEFC Filing. A properly completed Statement of Experience and Financial Condition (SEFC) with required attachments are filed through an on-line application called EPAS; see IDOT's website. Because of varying workloads, the Department cannot guarantee a SEFC will be processed by a particular date. Therefore, any Consultant desiring prequalification for a particular project should complete this process as early as possible.
2. Prequalification Notification. The BDE analyzes SEFC and attachments and notifies the Consultant of the size and types of services it is qualified to perform. When this notice is given, the Consultant is prequalified. The size of service that a Consultant is qualified to perform is based on its annual fee capacity.
3. Annual Fee Capacity. A Consultant's annual fee capacity is an evaluation of its technical and professional staff's ability to generate an annual volume of work. To estimate the maximum annual fee capacity of a Consultant to perform transportation or architectural work, the larger of the fees computed by the following two methods is used:
 - the fee produced by multiplying the total number of technical staff by \$200,000, or,
 - the fee produced by multiplying the total number of professional staff by \$800,000.

To determine the annual fee capacity of Consultants performing aerial mapping services only, the figure of \$700,000 per plotter/operator is considered appropriate or the fee produced by multiplying the total number of technical staff by \$200,000. The following presents general application guidelines:

- a. Determining Performance Ability. To determine a Consultant's ability to perform a project, the total uncompleted volume of transportation-related work is subtracted from the annual fee capacity, as determined above, to arrive at an unobligated fee capacity. Appropriate consideration is given to instances where a Consultant's uncompleted work is expected to extend over a period of more than one year. To be eligible for consideration, such unobligated fee capacity shall equal or exceed the estimated annual fee of the project for which the Consultant is seeking to perform.
 - b. Determining Staff Sufficiency. To determine whether a Consultant is sufficiently staffed to do a construction supervision project, the estimated overall fee for the project is reduced by one-half for the comparison to account for the seasonal hiring by the Consultant for this type of work.
4. Period of Effectiveness. The prequalification notice provided in Item 2 above is effective, unless otherwise changed by the Department, from the time notice is given until six months after the end of the Consultant's current fiscal year. At that time, the prequalification automatically expires and the Consultant's Statement of Interest cannot be considered until prequalification is re-established. To avoid expiration of prequalification, a Consultant renews and submits the Corporate and Financial Information section of SEFC as early as practical after the end of each fiscal year. In addition, Consultants submit a new SEFC (i.e., the Experience and Staffing) every three years. The due date for the new SEFC is noted in the firm's last prequalification letter. The schedule for new SEFC's is also located in the EPAS manual.
 5. Changes within the Consulting Firm. Each Consultant notifies the Department within 15 working days of key personnel changes.
 6. Evaluation and Prequalification Status. A Consultant is removed from the list of prequalified firms for a category when a final evaluation of Poor or Substandard is given by the Department. For specific information on consultant evaluations, see Section 8-4.05.
 7. Prequalification Inquiries. All inquiries regarding the procedures or information required for prequalification are referred to in the EPAS instructional manual on the Department's website.
 8. Confidentiality of Information. The Department maintains and treats all information required under this section as confidential for use only by the Department or other governmental agencies entitled by law or agreement.

9. Categories of Service. The Department prequalifies A/E Consultants in the categories of service. A description of the work involved in each category and the minimum requirements are available on Department's website.
10. Professional Licensing and Registration. A Full-time employee who has acted in a leadership role on relevant projects is required when the prequalification category requires Illinois licensing or registration. Consultants, committing or pledging individuals, or persons on retainer are not considered to meet the minimum requirements for prequalification, except as noted for Environmental Reports. See "Description and Minimum Requirements for Prequalification" on the Department's website. The experience of the licensee or registered must be relevant to the category of transportation work and performed within the time frames specified in "Description and Minimum Requirements for Prequalification" available on the Department's website.
11. Support Staff Experience and Training. Prequalification also requires a support staff of engineers and/or technicians with relevant experience or training. The lack of relevant experience or training of the support staff may result in denial of prequalification.
12. Required Documentation. Consultants requesting prequalification, upload documentation through EPAS of their previous work outlining:
 - firm and key employee pertinent experience, and
 - capabilities of current staff.

The Department may, at its discretion, make on-site visits to the Consultant's office to verify the information set forth in SEFC is submitted.

8-2.03 Request for Consultant Services

Use the following general guidelines when requesting consultant services:

1. Project Selection Proceedings. The Consultant Unit (CU) requests offices, districts, and bureaus submit candidate projects approximately 6-8 weeks prior to publishing a Professional Transportation Bulletin (PTB). Actual dates are shown on the Schedule for Professional Transportation Bulletins available on BDE's internal SharePoint site.
2. Preparation of Form A/A-1. Information is entered into A/A-1 section in EPAS; see District EPAS manual available on BDE's internal SharePoint site.

To request engineering services use the following guidelines:

- a. Cost Estimate. A detailed cost estimate (not required for work order projects) is prepared by the submitting IPM ensuring adequate funds are programmed for the advertised project. Where insufficient funds are programmed, IPM works with OP&P to secure the necessary funds. The detailed cost estimate is retained in the originating office's file for use during negotiations. The total required dollars are

entered into EPAS; see district EPAS manual available on BDE's internal SharePoint site.

- b. Proposed Project Advertisements. In conjunction the information contained on the A/A-1 page, the requesting IPM submits a proposed advertisement for PTB. The project is advertised after approval by the originating area's division or office director. The advertisement is prepared in EPAS for review, coordination, final preparation, and issuance. Use the PTB guidelines (see BDE's internal SharePoint site) and previous advertisements when preparing project advertisements.
 - c. Urgent Consultant Need. When the selection of a Consultant is urgent and special advertisement is required, submit the request with justification to BDE. BDE requests concurrence from the Secretary of Transportation through the Director of Program Development to either hold a special bulletin/selection or to use a Secretary Selection according to the appropriate laws and rules.
3. Dissemination of Materials. After all divisions and IPMs have completed the information on A/A-1 and advertisement in EPAS, the information is distributed to the following individuals for comment:
- Director of the Office of Program Development, and
 - Director of the Office of Planning and Programming.
4. Presentations for Advertisements. Presentations may be required as part of a Consultants SOI and the request for presentations is included in the advertisement. Presentations may be required if:
- Estimated engineering fee is greater than \$10,000,000,
 - Extremely complex project,
 - High visibility, and
 - Specialized Services.

Review and final determination of the need for presentations is determined by the requesting bureau/office and the Director of Highways Project Implementation or Director of Program Development on a project by project basis. The presentation process is overseen by CU.

Short Listing: The requesting Bureau/Office is responsible for determining criteria for the review of submitting firm's Statements of Interest. Criteria are required before Statements of Interest are submitted. The Bureau submits documents with the criteria for the specific job for CU file. This is specific for the projects but in general criteria consists of:

- Firm's capability and project team experience,
- Understanding the scope and goals of the project,
- Demonstrated successful past performance on Project Management Team oversight, and

- Independence and innovation.
5. The SOI's are reviewed by the requesting office and the top scoring firms are requested by letter and e-mail to do presentations. Typically, the top four firms are chosen. Firms are also notified if they are not being requested to do a presentation.
 6. PTB Advertisement. After incorporation of any comments from the Director of Program Development the advertisements are completed for publication in the next PTB. When projects are dropped from the list to be advertised, appropriate Directors, Regional Engineers, or Bureau Chiefs are informed of the reason(s) for not advertising the projects.

8-2.04 Advertisement of Need

Official notice of the need for architectural or engineering services by the Department is published in an IDOT Professional Transportation Bulletin (PTB). The PTB schedule is available on the Department's website and the Notice of the PTB publication is sent through the IDOT's subscription service. Each advertisement describes the requirements of the project as they apply to:

- the project's scope of work,
- the time for completion,
- the necessary professional and technical expertise, and
- the required proximity of the Consultant to IPM in charge of the work, if applicable.

8-2.04(a) Statements of Interest (SOI)

Consultants desiring consideration as a Prime Consultant for a project submit, through EPAS, a Statement of Interest by the date and time specified in PTB. The PTB also specifies the types of information required in the Statement of Interest. See SOI Entry in the EPAS Instruction Manual located on the Department's website. This information includes:

- a staffing plan that designates key personnel and shows the number and classification of personnel assigned to the project, along with their current office location, and any work that the Consultant proposes to subcontract;
- estimated time requirements for completion using the proposed staff,
- the known work load of the Consultant's transportation staff,
- the existing office where the majority of the work will be performed,
- a completed disclosure form,

- a completed Delinquent Debt Certification, and
- a completed Disclosure of Business Operation in Iran.

8-2.04(b) Confirmation of Eligibility

The Department determines the eligibility of each Consultant responding to a project advertisement. A Consultant is considered ineligible from the selection process for any of the following reasons:

- the Statement of Interest was not completed and/or not received by the deadline,
- the firm is not prequalified for the type(s) or volume of services required,
- the firm does not have sufficient expertise or work force for the particular job,
- the firm does not have a sufficient financial rating or accounting system for the type of contract contemplated, or
- the owning Railroad determines that the particular Consultant is unacceptable on projects when the Consultant is retained to prepare construction plans for a facility, which will carry railroad traffic.

Any Consultant determined to be ineligible under this section is notified of such determination and the reason(s) therefore.

8-2.04(c) Preliminary Review and Ranking

Following the confirmation of each Consultant's eligibility, each Statement of Interest is reviewed for: firm's experience data, staffing, and any evaluations of previous work for the Department. Based upon this review, each candidate firm is ranked in order of apparent ability to perform the work. This review and ranking takes into consideration at least the following factors:

- previous experience in the type(s) of service required,
- the staffing plan and specific expertise of key employees,
- the plan for accomplishing the objectives, if applicable, as stated in the requirements of the PTB,
- the Department's evaluations of prior contractual services with IDOT, if any; and
- comments furnished by the requesting division or office.

Depending upon the type of project, the following factors also may be important in selecting a Consultant:

- the location of the Consultant's office in which the majority of the work on the project will be performed, and
- the Consultant's proposed utilization of Disadvantaged Business Enterprise subconsultants.

The Consultant Selection Committee (CSC) reviews information including the ranking of each Consultant and the additional information described above. The information also indicates those Consultants determined to be disadvantaged business enterprises in accordance with the Department's eligibility criteria.

The CSC determines which projects, by their nature and the corresponding qualifications of the proposing minority-owned firms are suitable for implementing in an applicable affirmative action program. Any unresolved differences between the reviewers will be brought to the attention of CSC.

All information developed or provided under this section is advisory only and has no binding effect upon CSC. The Department maintains and treats all such information as confidential for use only by the Department or other governmental agency entitled by law or agreement.

8-2.05 Consultant Selection

8-2.05(a) Consultant Selection Committee

The Consultant Selection Committee (CSC) consists of the following members:

1. Chairperson. The Deputy Secretary of Transportation for Project Implementation, or his/her designee, serves as member and chairperson of up to nine-member CSC.
2. Department Members. Three of the remaining seven members of CSC are from the Department. Specifically, they are:
 - The Director of the requesting office, or that Director's designee (currently the Director of Finance and Administration is the designee),
 - the Regional Engineer, or designee, or the central office Bureau Chief, or designee, from the same division or office, as designated by the Director, and
 - the Director of the Office of Planning and Programming, or designee.

In the event that the office requesting the services is the Office of Planning and Programming, CSC meets and operates as normal except the Director of Planning and Programming has only one vote and CSC has only seven members and seven votes.

3. Public Members. The other four members of CSC are from the public and have professional experience in either transportation or engineering. Two are appointed by the Secretary of Transportation and the other two by the Illinois Society of Professional

Engineers (ISPE). Each public member is appointed for a term of two years. If a public member does not complete the term, another member is appointed by the Secretary or ISPE, in accordance with the original appointment, to serve the remainder of the uncompleted term.

4. **Diversity.** It is the goal of the Department that membership of CSC reflects the ethnic and cultural diversity of the population of Illinois. In furtherance of such, the Department has a goal that two or more of the members of CSC are females or minorities. Additionally, the Department has a goal for CSC membership to reflect the geographic diversity of the population of Illinois.
5. Pursuant to the Illinois Procurement Code, 30 ILCS 500 *et seq.*, Public Officer Prohibited Activities Act, 50 ILCS 105 *et seq.*, Selection of Architectural, Engineering and Land Surveying Services, 44 Ill. Admin. Code 625, and Department Personnel Policies Manual (PPM) all CSC members are required to sign a Compliance, Conflict of Interest, and Confidentiality statements before selection. The CSC members sign the statement attesting to an understanding of the confidentiality, compliance, and conflict of interest policies established by the State of Illinois. This document is updated on a two year cycle or as needed by the Office of Chief Counsel and signed/re-signed by the CSC members. The CU retains these documents.

The CSC meets when called by its Chairperson. This meeting is usually scheduled approximately 7 to 8 weeks after the Consultant Statement of Interests are due. The selection date is stipulated in the Professional Transportation Bulletin and on the Schedule for Professional Transportation Bulletins located on the Department's website.

To conduct business, CSC shall have a quorum. A quorum consists of at least four members; at least one of who is a public member.

Where another governmental body, or bodies, is contributing to the funding of a particular contract, CSC may, at its discretion, take either of the following two actions:

- Permit such governmental body, or bodies, to provide one or more representatives to serve as member(s) of CSC with a total of one vote, or such fractional vote as may be prescribed by the Department. In some instances, this option may result in a total CSC membership of more than eight and a total number of votes in excess of eight, with respect to the affected services.
- Select a number of Consultants, typically three, in the typical manner, in no order of preference; the Department then may permit the governmental body, or bodies, to select one Consultant from that group selected by CSC.

8-2.05(b) Selection Procedures

The following procedures are used when selecting the Consultant. Political affiliation of the Consultant shall not be considered during the selection process.

1. Preliminary Vote. The CSC members review the rankings for the Consultants, as well as any of the additional information described in Section 8-2.04(c) and, by voice/electronic vote, reduce the number of Consultants under consideration to three, or fewer where fewer than three have submitted acceptable Statements of Interest.
2. Written/Electronic Ballot. First, second, and third choices are determined by a plurality vote of those CSC members in attendance. This second round of voting is by written/electronic ballot.
3. Policy Against Multiple Awards. Selection of a single Consultant as first choice for more than one project is not made in a single session unless such selection is determined necessary. The reasons therefore are recorded in the CSC's records, and a majority of the committee members approve, by written ballot, such reasons. For purposes of this part, "single session" means and includes one or more meetings necessary for CSC to make all selections from a single Professional Transportation Bulletin.
4. Identity of Firms. The identity of the second and third ranked firms is maintained and treated by the Department as confidential for use only by the Department or other governmental agencies entitled by law or agreement. However, if negotiations fail with the first ranked firm, the identity of the second ranked firm then is considered public information. Similarly, if negotiations fail with the second ranked firm, the identity of the third ranked firm is considered public information.
5. Notification of Selection. The first ranked firms are notified of the following information:
 - PTB and item number of selection,
 - date and time of the negotiation meeting, and
 - request for current payroll by employee, classification, hourly rate, and raise schedule for their firm and any proposed Subconsultants.

A list of the top ranked consultants and corresponding projects is available on the Department's website. All prequalified firms on the subscription server are e-mailed when the list is available.

8-3 AGREEMENT NEGOTIATION AND PROCESSING

8-3.01 General

The Department's project manager initiates negotiations with the top ranked firm. If a successful conclusion cannot be obtained, negotiations are formally terminated. Negotiations with the second ranked firm are then initiated. Similarly, if negotiations fail with the second ranked firm, negotiations with the third firm are initiated. Prior to the second and/or third ranked firms being contacted, the director's concurrence is required.

The term "negotiation" includes all of the steps necessary, following the selection of a Consultant, to arrive at a signed Agreement and to authorize the work. This includes negotiation meetings to reach agreement on:

- scope of work,
- man-hours,
- schedule of completion,
- subconsulted work, and
- non-salary direct costs.

Negotiations also include:

- reaching agreement on the acceptable average payroll rates for the project;
- approving the detailed fee estimate and proposal from the Consultant firm and obtaining authorization from the Federal Highway Administration (when Federal participation is anticipated),
- obtaining signatures to the Agreement, and
- authorizing the work.

8-3.02 Scope

8-3.02(a) Scope of Services Meeting

The scope of services meeting is the first step in the process leading to the execution of an Agreement and authorization to proceed with the work. For simple and typical projects, the scope of services can be determined in one meeting whereas more complex jobs may require multiple meetings to delineate the scope of work. The initial scope of services meeting date is specified in the project advertisement in the Professional Transportation Bulletin.

The Department's project manager chairs the meeting, records attendance, distributes data, and informs the Consultant to keep minutes of the meeting and to furnish the minutes to those in

attendance. The chairperson discusses with the Consultant and Subconsultants the following items:

- Standard Agreement Provisions for Consultant Services (SAPCS), (see Department's Website),
- Architectural and Engineering Report and Negotiation Guidelines for Engineering Agreements and Supplements, see BDE Procedure Memorandum 17-09 (see the Forms Master List for the latest BDE 17-09 form), and
- Quality Assurance/Quality Control Guidelines; see Section 8-6.

The Department personnel answer questions about SAPCS and discuss Equal Employment Opportunity and Affirmative Action Plan requirements. The Consultant is asked to review the Architectural and Engineering Report and Negotiation Guidelines for Engineering Agreements and Supplements and to be prepared to answer the questions in the report.

Final scope details may be completed in subsequent negotiation meetings.

The method of reimbursement is explained and the firm informed when a Start-Up Agreement is anticipated. The Consultant reviews all the material furnished and prepares man-hours, average hourly rates, and direct non-salary costs for the project. Subsequently, the Consultant submits, on the applicable forms, the Cost Estimate of Consultant Services (CECS), Average Hourly Payroll Rates, and Direct Cost all on IDOT forms found on the Department's website. The Consultant and Subconsultant(s) are reminded to submit electronically their payroll rates and direct costs, to facilitate the Agreement process. The Consultant also includes in its submittal CECS and Direct Costs for all Subconsultants working on the project.

8-3.02(b) Scope of Work

A well-defined scope of services facilitates the negotiation process. The better the understanding of the scope of services between the Consultant and the Department, the easier it is to develop a fee that is acceptable and reasonable to both parties. It is vital that all parties become familiar with the project. To this end, the Department's project manager sends a preliminary engineering information package containing all the pertinent project information to the selected Consultant immediately after selection notification, allowing the Consultant and the Subconsultants to be active participants during the first meeting. The final negotiated scope, by law, must fall within the advertised scope for the project. However, the negotiated scope does not need to be as all-inclusive as the advertised scope.

The overall scope of work is described and the schedule of completion is discussed, on which general agreement is reached. The Consultant is reminded of the Department's policy concerning Quality Assurance/Quality Control (QA/QC), and is asked to submit a project specific QA/QC plan for review and approval, including specific hours for QA/QC in his/her proposal.

On Phase II projects, the Consultant includes specified hours for consultation during Phase III of the project. The Consultant is furnished preliminary information pertinent to the work, such as:

- Phase I study reports,
- environmental documents,
- aerial photography,
- mapping studies,
- traffic data,
- survey data,
- old plans, and
- samples of final product format.

8-3.03 Methods of Compensation

The following are the methods of compensation used by the Department:

- cost plus fixed fee (CPFF),
- unit of work; and
- specific hourly rates.

The Contract specifies a maximum amount payable for direct labor, for direct costs, and a total contract amount, none of which is exceeded unless adjusted by a Supplemental Agreement. The method of compensation for work by a Subconsultant is the same as the Prime Consultant's method of compensation.

8-3.03(a) Cost Plus Fixed Fee (CPFF)

This method of payment compensates the Consultant for actual payroll, overhead & fringe benefits, and direct costs plus a fixed fee. Use this method of compensation for work involving aerial mapping, geotechnical engineering, special waste, or asbestos abatement; Federally funded projects; and on all project specific Agreements.

R = Complexity Factor: 0.00, 0.035 or 0.07

Compensation = DL + DC + OH + FF

DL = Direct Labor

DC = Direct Cost

OH = Overhead & Fringe Benefits Rate

SubDL = Subconsultant Direct Labor

Prime Consultant Fixed Fee formula: $(0.37 + R) DL + \%SubDL$

%SubDL is: 1 to 2 Subconsultants = 10% of direct labor of Subconsultants

%SubDL is: 2 to 4 Subconsultants = 12% of direct labor of Subconsultant

%SubDL is: 5 or more Subconsultants = 15% of direct labor of Subconsultants

Subconsultant Fixed Fee formula: $(0.37 + R)SubDL$

When firms combine forces to create a Team, neither firm shall be considered a Subconsultant for the purposes of calculating the subconsultant direct labor.

8-3.03(b) Unit of Work

Unit of work involves compensating the Consultant in units such as “each” or “feet.” Rates are established in the Agreement and include all costs including profit. The unit of work method of payment often is used for geotechnical, thermographic, ground penetrating radar, subsurface utility and special waste contracts.

8-3.04 Negotiations

The negotiation meeting is one of the most important steps to the success of the project. It is vital that all parties become familiar with the project and come prepared to participate in the meeting. The project team for both the Department and the Consultant, including Subconsultants, should be active participants in this process.

The end result of the negotiations is a well thought out and clearly documented understanding of the anticipated project scope and level of effort. The Department and the Consultant's representatives (i.e., individuals with the authority to modify original man-hour estimates) negotiate to clarify the extent of the effort involved in completing various work tasks.

For a successful negotiation immediately after selection, provide the consultant the following:

- any pertinent project information, (i.e. schedules, reports, survey data, etc.),
- the “Consultant Scoping and Negotiation Check Sheets” for the project, and
- a detailed list of tasks for which hours will be negotiated. The list of tasks is taken from the independent man-hour estimate completed prior to advertising the project. Also you this estimate in evaluating the number of hours the Consultant proposes for each task to establish the final project upper limit.

The negotiations should culminate with agreement on the following items:

- scope of work,
- project schedule,
- man-hours required,
- direct costs,
- QA/QC plan,
- QA/QC hours specified,
- Phase III hours in Phase II projects, and
- All of the above items for each Subconsultant.

The Department's project manager and the Consultant also reach agreement on the procedure for the work progression and the line items of work to be shown on the monthly progress report. It is imperative that the Department's project manager ensures that the appropriate Department personnel and the Consultant are thoroughly familiar with the Agreement and the SAPCS, particularly with Sections 2.24, 2.32, 2.37, and 2.4, because improper procedures under these sections of the SAPCS may preclude payment to the Consultant.

8-3.05 Cost Proposal Packages

After negotiations have been completed, the Consultant submits a proposal package to the IPM. Instructions and forms for preparing the proposal are available on the Department's Consultant Services SharePoint site. The IPM verifies the proposal is consistent with negotiations and all the proper forms are completed and submitted with the required IDOT approvals through the BDE SharePoint site for further processing. The proposal package contains the following items for the appropriate type of project:

1. Prime Agreement Proposal Package.^{*} Consists of the following:
 - draft Scope of Work^{*} with schedule,
 - BDE Procedure Memorandum 17-9,
 - Negotiation Meeting Minutes,
 - Cost Estimate Of Consulting Services (CECS), including QA/QC and Phase III hours/costs broken out,
 - Consultant Employee Utilization form (BDE 2350),
 - EEO/AA/Title VI Section form (EEO 1981),
 - Direct Costs (BDE 436), and
 - CAAS^{*}- – for costs that exceed 10% of the estimate given to CSC.

* Uploaded to the BDE SharePoint site.

2. Subconsultant Agreement Package.** Consists of the following:

- Cost Estimate Of Consulting Services (CECS),
- Consultant Employee Utilization form (BDE 2350),
- EEO/AA/Title VI Section form (EEO 1981), and
- Direct Costs (BDE 436).

** The Prime Consultant posts all Subconsultant Agreements on the Vendor Documents site with the Subconsultant disclosure forms prior to the Prime Consultants' authorization to proceed.

3. Various/Various Prime Agreement Package. Consists of the following:

- draft Scope of Work,*
- Architectural & Engineering Report & Negotiation Guidelines for Engineering Agreements & Supplements (BDE 17-09),
- Negotiation Meeting Minutes,
- Consultant Employee Utilization form (BDE 2350),
- EEO/AA/Title VI Section form (EEO 1981), and
- Direct Costs (BDE 436).

4. The IPM's approvals included in the proposal package. The IDOT's project manager (IPM) includes in the proposal package affirmation of the following:

- IPM's review and approval of all consultant prepared forms,
- an independent check of the man-hour estimate is on file in the IPM,
- the negotiated scope is within the scope of the advertisement,
- IPM's approval of all the submitted direct cost and labor costs,
- IPM's approval of the QC/QA plan included in the IPM project file,
- IPM approval of the minutes of the scoping and negotiation meetings, and
- the negotiated DBE percent participation meets or exceeds the advertised goal.

For Prime Agreements that exceed the estimated fee by more than 10%, a Consultant Agreement Approval Sheet (CAAS) stating reasons for the cost overrun with costs and man-hours for each reason is uploaded to the BDE SharePoint site.

8-3.06 Agreement Processing

Upon receipt of the proposal package from the IPM, BDE conducts the following steps:

- verifies the program numbers and dollar amounts through the Office of Planning and Programming (OP&P),
- requests Federal authorization from the BDE Program Support Unit for projects Federally funded,
- prepares independent check of extensions and escalations and all costs can be supported,
- ensures the negotiated scope is within the advertised scope,
- ensures QA/QC hours of all projects and Phase III hours in a Phase II Contract are included,
- ensures the Consultant disclosure information are current, complete, and approved,
- checks on the status of the Consultant insurance, and
- secures the procurement waiver or ensures project information is posted for at least 30 days.

The Agreements Unit resolves any findings. This may involve discussions with IPM and Consultant. After all issues have been mutually resolved, the Agreement is sent to the Consultant for signature. The Consultant reviews the Agreement, signs it, dates the signature but does not date the Agreement, and returns all copies to BDE. BDE obtains the appropriate signature(s) (including the date each signature is written) on behalf of the Department. Once the Agreement is fully executed, the Consultant and IPM are notified to proceed with the work. A fully executed copy is sent to the Consultant and uploaded into EPAS. An original copy is placed on file in BDE. The IPM will receive a copy of the approved Contract Obligation Document (COD). Work done prior to Department authorization date is not eligible for reimbursement.

8-3.07 Funding Approvals and Federal Authorizations

Upon receipt of a proposal package from the IPM, the Agreements Unit requests verification of the program code number and the type & amount of funds (State or Federal) from OP&P. Once the information is received from OP&P, the agreement manager initials and includes the funding sheet in the project file.

When Federal funds are to be used, the Agreement Manager requests Federal authorization through the BDE Program Support Unit (PSU). The PSU requests FHWA's authority to proceed with the work. Once authorization is received, a copy of this request and the FHWA authorization furnished by PSU is included in the project file. Work done prior to FHWA authorization date is not eligible for Federal participation.

Compliance with all aspects of 23 CFR 172 and OMB Circular No. A-102 is required and shall be documented. Lead-time of three weeks is estimated for obtaining FHWA authority to proceed, provided IPM has submitted prerequisite programming material (OMB Standard Form 424).

8-3.08 Cost Approvals

When the first ranked firm is notified after selection, current payroll by employee and classification, hourly rates, and raise schedule are also requested emailed to BDE in the correct form.

The BDE completes an independent CECS for each firm on the project once a complete proposal package is received. The Agreement Manager reviews the independent CECS and discusses any differences with Consultant, and IPM, until consensus is reached. The disposition of the differences is kept in the project file.

Delays in sending wage rates and direct costs (with appropriate back-up information) to BDE results in a delay in processing the Agreement.

After the Agreement is executed, a COD form is prepared by the Agreements Unit and along with a copy of the executed agreement is submitted to the BoBS for approval. Funds, by law, are obligated and the Agreement filed with the State Comptroller within 30 days of the date of the Agreement.

If the 30-day deadline is not met, a late filing affidavit is required.

On projects using bond funds, the funds are released by BBFM. A request memorandum is prepared by PSU listing such projects. The PSU then notifies the Agreements Unit when the bond funds are released.

The Bureau of Investigations and Compliance is also responsible for performing a final audit on completed projects. The administering IPM should request that the appropriate audit be made at the time the Consultant's final invoice is submitted for payment.

8-3.09 Signature Authority

Every Contract must contain the Secretary's signature. A card must be on file with the Comptroller for the IDOT personnel with the Secretary's signature authority. The Secretary of Transportation has delegated signatures for Consultant Agreements; see Departmental Order 2-2. Each Agreement contains a line for the Secretary of Transportation's signature (signed by the delegated authority) followed by a line for the delegated authority's own signature.

8-3.10 Authority to Proceed

8-3.10(a) Letter of Authorization

A Letter of Authorization is sent to the Consultant with a “blue-backed” original of the fully executed Agreement. Copies of the Letter of Authorization are electronically transmitted to the administering IPM. The following items are distributed as indicated:

- the Agreement-original in BDE’s project file and electronic copy in EPAS,
- an approved COD form- emailed to IPM and copy in BDE’s project file, and
- the FHWA authorization, if Federal funds are utilized- copy in BDE project file.

The Department’s project manager verifies in EPAS the firm’s insurance is up to date before approving payments made to the Consultant.

Prior to issuance of the Letter of Authorization, the Agreements Unit reviews the entire file and ensures all required clearances/approvals for authorization (e.g., by the FHWA, BBFM (bond funds), procurement waiver/advertisement, design approval or risk management approval) have been obtained.

8-3.10(b) Risk Management

Authorization to proceed for Phase II projects is possible without design approval if risk management is approved. Only projects with completed public involvement, a draft Phase I report reviewed by BDE, and funded with STATE only funds are considered for risk management. The Department’s project manager requests risk management from BDE. Authorization request for a Start-Up Agreement does not include risk management approval.

8-3.11 Early Authorization To Proceed

8-3.11(a) Start-Up Agreement

At the option of the Regional Engineer/Bureau Chief or agency head, the Regional Engineer/Bureau Chief/ Agency Head may authorize the Consultant to begin work by obtaining approval through BDE and signing a Start-Up Agreement.

Immediately after the final negotiation meeting, the IDOT project manager (IPM) completes and uploads to BDE’s SharePoint site, a Start-Up Agreement request memorandum. The IPM is sent approval or denial of the Start-Up Agreement. The IPM works with the Office of Planning and Programming to resolve any funding issues with the Start-Up Agreement.

The Start-Up Agreement request is granted when the disclosures for the Prime Consultant are clear and a procurement waiver granted. Approval of the request for a Start-Up Agreement does not include approval of risk management. A separate risk management request is submitted to BDE.

The IPM, upon receiving a complete proposal package from the Consultant, and approval for the Start-Up Agreement, enters into a Start-Up Agreement with the Consultant using the Start-Up Agreement template. The Agreement amount may be for no more than 40% of the Prime Agreement negotiated amount. Non-Federally funded Start-up Agreements for \$249,999 or less can be executed by the Regional Engineer or corresponding Office Director for Central Bureaus. Federally funded Start-up Agreements and Start-up Agreements of \$250,000 or more shall be executed by the Central Office and the necessary signatures shall be coordinated by BDE. The District or Central Bureau may authorize the consultant to begin work after the Start-Up Agreement is authorized. The Consultant may then work up to the Start-Up Agreement dollar amount. The Start-Up Agreement should not exceed the contract term length or two years, whichever is less.

The IPM e-mails copy of the fully executed Start-Up Agreement to the Preliminary Engineering Section within 1 week of signing the Start-Up Agreement authorization. Failure to do so might result in a late filing affidavit by IPM and delay processing the proposal package. The Preliminary Engineering Section develops COD for the Start-Up Agreement.

Once the Prime Agreement is executed, it supersedes and includes costs stated in the Start-Up Agreement. The Consultant may start, complete, and invoice for the work as specified in the Start-Up Agreement prior to the authorization of the Prime Agreement. No other work may be started until the Prime Agreement has been executed, and the Consultant authorized.

No supplements are written on the Start-Up Agreement. The Consultant may not invoice for work until COD is approved. The Preliminary Engineering Section tracks the Start-Up Agreement through EPAS. Once approved and executed, a PDF version of the executed Agreement and the approved request are found in EPAS. Copies of the Start-Up Agreement template and request memorandum template for the Start-Up Agreement are on BDE's SharePoint site.

8-3.12 Contract Administration

Administration of the project agreement is the responsibility of the agency (IPM) requesting use of a Consultant. The IPM is responsible for monitoring the execution and progress of the work.

The Department's project manager is the Department's contact with the Consultant. A Department's project manager is assigned and all work, and all project correspondence are channeled through the Department's project manager. Invoices and progress reports are received and reviewed by the Department's project manager.

The Department's project manager ensures any changes are negotiated in accordance with the terms of the Agreement and the files are properly documented for all verbal instructions. The Department's project manager is also responsible for documenting the Consultant's performance throughout the project and provides the Consultant Performance Evaluation.

8-3.13 Subcontracts by Consulting Engineering Firms

The SAPCS provides that the Department can utilize prequalified Subconsultants upon approval. The SOI submitted by the successful consultant, lists all the Subconsultants the Prime proposes to utilize on the project. After the scoping and negotiation meetings and the proposal package is sent uploaded to BDE, a copy of the fully executed subcontract is uploaded to the Vendor Doc site by the Prime Consultant before any Subconsultant work is authorized. The Subconsultant Agreement and Supplemental Subconsultant Agreement templates located on the Department's Website contain the clauses required by law and the clearly defined scope of work, the schedule of completion, and the payment basis are included by the Prime. Any Subconsultant Agreement not using the Department's template requires review and approval by the Office of the Chief Council (through BDE) prior to authorizing the Subconsultant's work. The following items provide additional guidance on subcontracts by Consultants:

1. Individual Professionals and Nonprofessional Work. All subcontracted work by professional Consultants requires negotiation of a subcontract. This does not apply to individual professionals that are on a retainer basis to the Prime Consultant; nor does it apply to nonprofessional work, obtained by competitive bidding.
2. Supplemental Agreements and Profit. If the scope of work in the Prime Agreement does not include the proposed subcontract work deemed necessary by the Department, the Prime compensation and scope of the Prime Agreement is modified by a Supplemental Agreement to include the subcontract work. If the Prime Agreement has a fixed fee for profit that includes profit on items later proposed to be subcontracted, the Prime Agreement shall be modified to exclude profit to the Prime Consultant on subcontracted items (i.e., no double profit).
3. Fee Estimates. The Subconsultant's proposal for work shall contain direct payroll, direct costs, man-hours or units of work, and supported by back-up data as required for a Prime Agreement. The proposed man-hours and direct costs are approved by the administering IPM based upon its estimate of cost and submitted to BDE. Payroll additive percentages used in the fee estimate are approved by Bureau of Investigations and Compliance.
4. Payment. The Consultant may bill the Department for the Subconsultant's work as the work progresses. If the method of reimbursement is lump sum or unit of work, payment is based upon the percentage of work completed as indicated on the Progress Schedule. If the method of reimbursement is CPFF, payment is based upon the number of man-hours completed. The Subconsultant contract provides that the final payment is not made to the Subconsultant by the Prime Consultant until an Affidavit of Completion is submitted.

8-3.14 Supplemental Agreements

8-3.14(a) General

During the course of a Consultant's work on a project, occasions arise where changes in the negotiated work items are identified. All changes in the schedule, negotiated scope of work, or

fee require the Department's written authorization to the Consultant prior to implementation. The Consultant, per the Agreement, forfeits its right to claim additional compensation for added work done prior to receiving written authorization from the Department. It is the Department's project manager's responsibility to ensure that any changes are negotiated, agreed to, and authorized in full accordance with SAPCS and the terms of the Agreement. When the Consultant is notified of changes the Department finds necessary, the notice should clearly state that it is not an authorization to proceed with the changes and advise of the steps necessary to negotiate the change. When in doubt, the Department's project manager contacts BDE for procedural advice.

Increases in the negotiated work are accomplished through Supplemental Agreements that include the additional scope of work to be accomplished, any necessary changes to the project schedule, and the manner of payment with a stated Upper Limit of Compensation.

Most Supplemental Agreements are applicable in the following situations:

- extension of time,
- corrections in Contract language,
- deletion of work,
- addition of direct costs not previously in agreement,
- transfer of work between Prime and Subconsultant,
- transfer of funds between labor and direct costs,
- work advertised but not previously negotiated nor included in contract scope, and
- additional level of effort of previously negotiated items.

All Supplemental Agreements must have a Consultant Agreement Approval Sheet (CAAS) approved prior to execution. The CAAS states reasons for the additional cost and the associated man-hours. The CAAS also includes the work items involved, why it is being added, the cost for each, and why the Consultant is entitled to additional compensation. When the supplemental cost has been negotiated, the Consultant Agreement Approval Sheet (CAAS) is prepared by Department's project manager and approved by the Bureau Chief of Design and Environment.

All Supplemental Agreements are authorized and paid for in accordance with the terms of the Agreement. The appropriate Departmental signatures, in accordance with Departmental Order 2-2, are required to authorize Supplemental Agreements. Note, if a Supplemental Agreement increases the value of the Contract equal to or greater than \$250,000 in a fiscal year (total of all supplements in a fiscal year), the Agreement requires the signatures necessary to authorize an Agreement of \$250,000 or greater. All procedures for estimates, review, and approval that apply to Prime Agreements also apply to Supplemental Agreements. The Department's project manager negotiates the scope of work, man-hours and direct costs for the Supplemental Agreement. The following information is then uploaded to the SharePoint site:

- cover memo/transmittal memo,
- draft Scope of Work with schedule (bar chart),
- BDE 17-09 (if applicable),
- negotiation meeting minutes,
- Cost Estimate Of Consulting Services (CECS(if applicable)),

- revised QC/QA Plan, if applicable,
- direct costs if applicable, and
- CAAS.

The BDE obtains fee approval, finalizes the Supplemental Agreement, and obtains FHWA approval, if required, executes the agreement, and notifies IPM, that the consultant may be authorized to begin work.

8-3.14(b) Early Authorization to Proceed-Prior Approval

The Consultant may be authorized to work on items outside of the negotiated scope once that work is identified and agreed to by all parties through a Prior Approval. A written Prior Approval allows the Consultant to begin the additional work; however, the Consultant may not invoice for the increased work until the Supplemental Agreement has been authorized.

Once the need and extent of the additional work is identified and within the advertised scope of the project by the Department, and negotiations with the Consultant begin, the appropriate Department personnel authorizes, by Prior Approval Authorization Letter, and the Consultant to proceed with the work up to a specific dollar amount. This Prior Approval Letter outlines the additional work being authorized and the amount being authorized. A signed copy of the letter is sent to BDE. Prior Approval is intended to keep the work going to meet the project's schedule. Supplemental Agreement negotiations should be finalized quickly.

The Prior Approval authorization process only establishes limits for continued work while the Supplemental Agreement is negotiated and processed. Any additional funding required for the supplemental work must be secured by IPM through OP&P. Once the negotiations for the supplemental agreement are complete and CAAS is approved, a second letter called, **CAAS Approved Letter**, may raise the authorized amount. (Send a copy to BDE.) See the following chart for authorization limits. At all times, the amount authorized prior to the execution of a supplemental agreement may not exceed 40% of the anticipated supplemental agreement amount.

Only a single set of Prior Approval authorizations (initial letter and CAAS approved letter) may be issued per Supplemental Agreement. A subsequent set of Prior Approval authorizations cannot be issued until the previous Supplemental Agreement has been authorized. Prior Approval authorizations cannot be issued adding a Subconsultant.

Signature Required	Prior Approval Amount
Prior Approval Authorization Letter signed by Regional Engineer (maximum of 40% of the estimated supplement amount)	Up to \$50,000
CAAS Approved Letter (2 nd Letter) signed by Regional Engineer (maximum of 40% of the estimated supplement amount)	\$50,000 to \$249,999
CAAS Approved Letter after CAAS is approved, Secretary (maximum of 40% of the estimated supplement amount)	Over \$249,999

PRIOR APPROVAL AUTHORIZATION SIGNATURE AUTHORITY

Figure 8-3.A

8-3.15 Monitoring Consultant's Work

8-3.15(a) Agreement Schedule

After the work under the Agreement has been authorized, IPM meets with the Consultant. They agree on detailed procedures and progress report percentages for elements of work. They also indicate on the appropriate progress report the calendar days to complete each of the various work elements, which should agree with the calendar days indicated in the Agreement Project Schedule. The date due is indicated on the Progress Report for each work element after authority to proceed with that work element is given. All report forms and invoice forms are available to the Consultant on IDOT's website.

As work progresses and work elements are approved, the date due for other work elements should be indicated on the Progress Report. These dates should be revised, as needed, if the Consultant's work is stopped or placed on hold by the Department. The "Remarks" column may be used to indicate the date on which the work element was submitted.

The IPM, or other appropriate official, indicates on the Progress Report if the project is on schedule or behind schedule. If behind schedule, the reason for the delay is stated on the Progress Report; the reverse side of the form may be used if needed.

If it is determined that the work is behind schedule due to factors under the Consultant's control, this is reflected on the Consultant's Performance Evaluation Form.

If work is lagging due to no fault of the Consultant, IPM should make every effort to expedite the work because the Agreement provides for fee renegotiations if completion is delayed beyond the time limits set in the Agreement. If the completion schedule is to be revised, IPM has the Consultant request approval of the revised schedule. A copy of the approved schedule change is then furnished to BDE. If the work is behind schedule due to factors under the Consultant's control, IPM issues written remedial instructions to a principal of the firm. If this fails to correct the problem, it may be necessary for the using agency to recommend termination of the Agreement

to BDE. The IPM may recommend that the Agreement be terminated for other reasons in the best interest of the Department such as unsatisfactory work or change in Department priorities shifting construction time too far into the future.

8-3.15(b) Completion Dates

The IPM should be aware of the completion dates in the Agreement. There is a work schedule completion date and a completion date for billing purposes. If the Contract extends past the billing completion date any submitted invoices will be rejected by the Comptroller's office. The IPM should request a time extension from BDE prior to the schedule and/or billing dates in the Agreement. If the completion dates are passed, IPM obtains a general affidavit signed by the Consultant and completes one, signed by the Regional Engineer, and submits these to BDE with the extension request.

8-3.15(c) Documentation

The project manager maintains a complete log in the files of what was decided during all phone calls, meetings, visits, and inspections. Copies are furnished to the Consultant for purposes of FHWA audit and/or of documenting performance.

8-3.15(d) Consultant Invoices

Process consultant invoices for payment only when the reported percentage of completion is approved. The IPM promptly notifies the Consultant if the percent of work complete does not correspond to the percent of work accomplished. Total costs in excess of the approved percentage of completion are not approved for partial or final payments. When such higher costs are billed, IPM determines if this is due to Consultant inefficiency and, if so, takes appropriate steps to correct the problem. If overruns are due to underestimation of the negotiated scope by the Department, IPM takes steps to have the limits adjusted; see Section 8-4.03. The IPM promptly requests BBFM make payment on invoices found reasonable, or corrected to reasonable, and in accordance with the terms of the Agreement.

The "Invoicing Procedure Guide for Project Managers" is available for IDOT employees on the Engineering Consultant information SharePoint site.

8-3.15(e) Federal Funding

When Federal funds are involved in the Agreement, IPM keeps the FHWA representative apprised of the Consultant's work and, if FHWA requests, arrange to conduct joint reviews of the work.

8-3.16 Evaluation of Consultant's Performance

8-3.16(a) General

The Department formally evaluates all work performed by Consultants. During the life of a project, IPM informally evaluates a Consultant by keeping lines of communication open, and keeping the Consultant aware of any problems or concerns the Department has with its performance. Among the areas evaluated are:

- timeliness,
- completeness,
- quality & assurance,
- public / agency / coordination,
- cooperation management,
- budget / supplement / invoicing,
- additional comments.

There are some Consultant errors that the Department views as significant and substantial causing the project to be in jeopardy. These are "Fatal Flaws" and where these Consultant errors occur, the highest final rating the project may receive is a "Satisfactory," providing the Consultant makes corrections and improves their quality control. These errors result in an interim rating of "Substandard" or "Poor." If a Consultant demonstrates any of the fatal flaws below, their evaluation should reflect these errors and justification must be documented in the comments section:

Fatal Flaws are defined as:

- errors involving significant structural deficiencies or safety on bridges/structures,
- errors resulting in the Consultant failing to identify significant environmental impacts,
- errors involving substandard geometrics for the specified design criteria,
- inaccurate survey information impacting the project's constructability,
- inappropriate behavior by the Consultant when working with the public,
- false information used by the Consultant in the report documentation, and
- adjustment of letting date or design approval due to late Consultant submittals.

The evaluation process, by nature, is a subjective process. Although an "Excellent" project is a goal, in practice, very few projects are truly "Excellent." An Excellent project has the following characteristics:

- the submittals contained no major errors and very few minor errors.
- the Consultant during the life of the project was self-managed (e.g., responsive to requests, minimal calls/requests on standard procedures, took lead of project).

- the Consultant was innovative (e.g., focused special resources on issues, perceived and managed problems early and effectively, innovatively used resources/technology, and/or posed solutions which saved the Department significant funds).
- submissions were not only early, but allowed the Department to advance a letting or advertisement to an earlier date. Consideration will be given for an accelerated Department dictated timetable.
- the project was cost effective, safe, and considered a context-sensitive design.
- quality presentation of products was acceptable (e.g. spelling, grammar, labeling, links).
- the Consultant maintained a consistent high-quality level of personnel throughout the life of the project.
- complied with all Department manuals, policies, procedures, or explained exceptions with minimal prompting by the Department.
- consistently promoted a positive Department image and minimized controversy during public involvement.

The evaluations are available through the Engineering Prequalification and Agreement System (EPAS) database. The following are areas generally evaluated under each prequalification category. Consider the following guidelines when evaluating Consultants:

1. Timeliness.

- Exceeds – Consultant submits key items of work consistently early affording the Department the opportunity to advertise the next phase of work on an earlier bulletin.
- Meets – Consultant submits key items of work consistently on or about the time agreed to by both parties.
- Substandard – Consultant submits key items of work consistently past the time agreed to by both parties.

2. Completeness.

- Meets – Consultant includes, consistently on key items of work, all items in a submittal as specified in Department manuals, policies, procedures, and the Contract documents.
- Substandard – On key items of work, the Consultant consistently fails to include all items in a submittal as specified in Department manuals, policies, procedures, and the Contract documents.
-

3. Quality & Assurance.

- Exceeds – The Consultant submittals contain no major errors and very few minor errors. Minimal hours are expended by Department staff in review of submittals. Presentation of material is clear, concise, and of high quality (e.g., spelling, grammar, labeling, links). The next phase of work experienced little or no major problems/questions attributable to the Consultant. The project thoroughly analyzed the major elements of the project. Maintained a high quality of work with a Department-accelerated schedule.
- Meets – The Consultant submissions contain no major errors and some minor errors. Presentation of material is clear, concise, and adequate (e.g., spelling, grammar, labeling, links). The next phase of work experienced the expected problems/questions attributable to the Consultant.
- Substandard – The Consultant submissions contain major and minor errors. The Consultant demonstrated low quality presentation of products (e.g., spelling, grammar, labeling, links, etc.). The next phase of work experienced problems/questions attributable to the Consultant. The Consultant showed poor understanding of the work type.

4. Public / Agency / Coordination.

- Exceeds – The Consultant independently developed proactive and creative public/agency involvement techniques that both identified and effectively responded in a timely manner to minimize highly controversial issues. The Consultant managed and implemented the public relations program and presented accurate and pertinent project information to the public, news media, and coordinating agencies, which resulted in project acceptance and a positive Department image.
- Meets – The Consultant followed Departmental guidelines in performing project coordination with the public, news media, and agencies in such a manner that fulfilled all requirements and resulted in project acceptance and design approval.
- Substandard – The Consultant responses were misleading, incorrect, or inflammatory at public/agency involvement meetings. Presentation material (e.g., aerial exhibits, details, tables, data, etc.) contained incorrect or conflicting information which reflected negatively on the Department or the public's acceptance of the project design features. The Consultants public/agency involvement program required an over-reliance on Department staff to correct, revise, and present project improvement/mitigation.

5. Cooperation Management.

- Exceeds – Consultant was consistently available and responsive to and ahead of problems and concerns. The Consultant initiated open and timely communications with the Department. Consultant was consistently self-managed.
- Meets – Consultant was available and generally responsive to problems and concerns. The Consultant initiated open and timely communications with the Department. Consultant was self-managed at times.
- Substandard – Consultant was generally neither available nor responsive to problems and concerns. The Consultant communications with the Department were rarely timely. Consultant continually asked the Department for clarification on standard procedures.

6. Budget / Supplement / Invoicing

- Exceeds – Submittals are accurate with little to no send backs, invoices and work orders are submitted in a timely fashion.
- Meets – Consultant were able to stay within the projected budget, invoices were submitted in a timely and complete accurate manner.
- Substandard – Consultant has numerous errors in invoice/work order submittals resulting in a multiple send backs, late invoice submittals, submit charges that are above/outside the agreement, lack of backup documentation or missing information on forms.

8-3.16(b) Interim Evaluations

Evaluations are made for both Prime Consultants and Subconsultants at interim and final stages. Interim evaluations may be completed at any time. Scheduled interim evaluations are determined by each IPM. Interim evaluations are typically done on an annual basis or at deliverables dates determined at negotiations. The structural work, however, requires two interims, one at TS&L and one at prints of the final plan stage, and then final overall evaluation. An interim evaluation accompanies a submittal when returned to the Consultant due to excessive errors/corrections.

All interim evaluations are sent to Consultants at the same time they are transmitted to BDE. The evaluations are a very important tool for both the Consultant and Department. They provide timely feedback to the Consultant concerning its performance on an active project. The interim evaluation allows the Consultant to correct any deficiencies during the life of the project, in some cases turning what would otherwise have been a bad experience for all involved, into a good one. The responsibilities for completing Consultant evaluations are documented in the following sections.

It is important to conduct interim evaluations so as not to delay processing any possible Supplemental Agreements.

8-3.16(c) Final Evaluations

After the Consultant completes the work covered in an Agreement, final evaluations are prepared by IPM for the Consultant and Subconsultant in the appropriate categories. The Department's project manager and his/her supervisor concur and sign the final evaluation. The final evaluation is sent to the Regional Engineer or Bureau Chief for concurrence and signature. The final evaluation is then sent to the Consultant and transmitted electronically to the BDE Consultant Unit using the EPAS database.

8-3.16(d) Structure Plan Evaluations

The performance evaluations of Consultants or Subconsultants preparing structure plans are completed by the Bureau of Bridges and Structures. An interim evaluation is completed if the overall work is "poor" or "needs improvement", if work is "satisfactory" or greater no interim evaluation is performed. The final overall evaluation is made after the completed drawings are submitted for letting and takes into account the two interim ratings.

In the case where the completed final plans are not placed on an immediate letting, IPM forwards a reduced set of bridge plans (prints) to the Bureau of Bridges and Structures (BB&S). This procedure allows BB&S to complete its final overall evaluation of the Consultant in a timely manner.

8-3.16(e) Other Evaluations to be Completed by the IDOT Project Managers

The interim and final performance evaluations of Consultants preparing construction plans, performing specialized studies, surveys, geotechnical engineering, construction engineering, preparing photogrammetric mapping, and other services are completed by the appropriate IDOT personnel. These evaluators may access the EPAS database.

8-3.16(f) Final Project Evaluations

Upon completion of all the final evaluations by IPM and/or bureau, a final project evaluation is prepared. The final project evaluation is prepared after PE II for PE I work and after construction is complete for PE II and PE III. If the next phase is delayed more than one year, the final project evaluation is prepared immediately after completion of the contract work.

Where the project is evaluated by more than one department evaluating entity (e.g., BB&S, Environment), the final evaluations are transmitted to BDE by the Regional Engineer and/or Bureau Chief with the ratings incorporated from the applicable entity.

8-3.16(g) Consultant Selection Committee

Performance evaluations are provided to the Consultant Selection Committee as part of the preliminary review and rating information. A five-year average of performance evaluations on

similar types of projects is used for this purpose. The Selection Committee is also apprised of all appeals.

A listing of all evaluations, other than Satisfactory, is forwarded to the Consultant Selection Committee. In addition, a listing of all evaluations of Good or Excellent (final) are forwarded to the Consultant Selection Committee. The Consultant Selection Committee considers this information when deliberating at the selection meetings.

8-3.16(h) Below Satisfactory Interim Evaluations

Where a below satisfactory rating is received on an interim evaluation: A Substandard or Poor rating can be removed based on any of the following conditions:

- Five years has elapsed since the interim evaluation of Substandard in a particular category.
- A subsequent interim evaluation on the same project in the same category is satisfactory or better.
- The Consultant meets with IPM that made the Substandard or Poor evaluation and the evaluation for the project is upgraded to satisfactory. This condition involves situations where there has been a misunderstanding between the Department's evaluator and the Consultant.
- The Consultant demonstrates to IPM the corrective measures have been taken to correct the less than satisfactory performance. Under this condition, the evaluations will not be removed but marked with an asterisk to indicate that corrective measures have been implemented by the Consultant to the satisfaction of IPM.

8-3.16(i) Below Satisfactory Final Evaluations

A final evaluation of Poor results in suspension from submitting a Statement of Interest in the evaluated category and any higher level category in the same work type for a period of the next eight PTB's or two years, whichever is greater, as a Prime or Subconsultant. At the end of this period, the Consultant must request reinstatement to the suspended category. This will require documentation of the efforts and success in correcting the issues which led to the Poor evaluation.

If a second final evaluation of Poor occurs in the same category within five years, it will result in loss of prequalification in that category for five years. At the end of this period, the Consultant must request reinstatement of prequalification in that category. This will require documentation that the issues which led to the subject evaluations have been rectified.

A final evaluation of Substandard results in suspension from submitting a Statement of Interest in the evaluated category and any higher level category in the same work type for a period of the next two PTB's or six months, whichever is greater, as a Prime or Subconsultant. At the end of this period, the Consultant must request reinstatement to the suspended category. This will

require documentation of the efforts and success in correcting the issues which led to the Substandard evaluation.

If a second final evaluation of Substandard occurs in the same category within five years, it will result in loss of prequalification in that category for one year. At the end of this period, the Consultant must request reinstatement of prequalification in that category. This will require documentation that the issues which led to the subject evaluations have been rectified.

8-3.16(j) Consultant Appeal Process of Final Evaluation

After receipt of the final evaluation, the Consultant has 30 days in which to appeal a Substandard or Poor evaluation. The appeal is submitted in writing to the Department entity that prepared the final evaluation (e.g., Regional Engineer, Bureau of Design and Environment, Bureaus of Bridges and Structures). The appeal will clearly state the basis for the appeal and any supporting documentation shall be attached.

If the Consultant is not satisfied with the results of the appeal, the Consultant may request in writing, within 14 days, a review by either the Director of Highways Project Implementation or Director of Program Development. Either Director will review the documentation file, the evaluation, and meet with the Consultant and the departmental entities involved.

If the Consultant is not satisfied with the results, after meeting with the either Director of Highways Project Implementation or Director of Program Development, the Consultant may file a written appeal with the Deputy Secretary for Project Implementation or Deputy Secretary for Program Development within 14 days of final action by the either Director. The appeal shall state specifically the basis of the appeal and the reason(s) the Consultant disagrees with Director's decision. No new issues may be raised. The appropriate Deputy Secretary will review the information submitted in the appeal. The appropriate Deputy Secretary may request a meeting with the Consultant. The Consultant will be notified in writing of the Deputy Secretary's decision which will be final.

8-3.17 Completion and Termination Procedures

8-3.17(a) Completion

When any Consultant Agreement is ended, whether by completion of the work or by termination procedures stipulated in the Agreement, copies of the final voucher request, request for audit, Affidavit of Completion, and the final invoice with all its attached documentation is submitted by the administering agency to BDE. Also, include the final Consultant Performance Evaluations; (see Section 8-4.05, for the Prime Consultant and all Subconsultants working in prequalification categories).

Upon receipt of a final audit, IPM prepares a Contract Obligation Document (COD) deobligating excess funds for jobs that have reduced costs. The COD is submitted to the Bureau of Investigations and Compliance with a copy to the Agreements Unit. This completes the closeout

procedures for projects, which are not programmed for Federal fund participation. If the final audit recommends increasing the Agreement amount, a COD is prepared by BDE.

The IPM must submit the following additional documentation to BBFM for all programmed Federal-aid projects when completed (after final costs are confirmed by the BBFM audit):

- the date all work was completed or the Agreement was terminated;
- a list of all authorization dates from FHWA, for work authorized on the project, to verify that it is participating;
- a list of all construction sections under the specific preliminary engineering Agreement. In the event the Agreement is for work other than construction plans, the type of work should be listed and its acceptance verified (e.g., “the report was approved by _____ (*name*) on (_____ (*date*) _____),” or “the Soils Committee approved the soils report on (_____ (*date*) _____”); and
- method of payment stipulated in the Agreement. Note all the methods and areas of application if several methods of payment are used.

8-3.17(b) Termination

If an administering IPM desires to terminate an Agreement, a memorandum recommending termination will be submitted to BDE. The memorandum will include:

- the reasons for recommending termination,
- the percentage of work completed,
- the percentage of fee expended, and
- an estimate of the cost and time required to complete the work, if applicable.

The BDE will send the termination request to the Secretary. Upon notification by BDE that the Secretary has concurred with termination, the administering IPM will notify the Consultant in writing.

8-3.18 Reassignment of Vested Interest in an Agreement to Another Consultant

Occasionally, it is necessary to assign an existing Agreement to another Consultant because of an ownership or organizational change (e.g., dissolution of the firm, death of a principal, absorption of the firm by corporate expansion, a partnership change). The existing Agreement is kept in force by an Assignment to the new legal entity.

The Assignment Agreement is a legal document that transfers all rights, obligations, and interests in the Agreement from the original Consultant (the assignor) to the new Consultant (the assignee). It must be properly executed in triplicate by the assignor and the assignee and then submitted to IDOT for acceptance and signature. A copy of the Assignment is returned to the assignor and

assignee when fully executed. Form BDE 2364 may be used as a guide in determining whether the Assignment contains the essential elements.

If there is no ownership or management change and the change is only related to name, address, absorbing another firm, or adding personnel to the firm which is party to the Agreement, a notice of the Assignment, authorization to make payment to the new Consultant, and release of obligation executed by the assignor is sufficient to continue the Agreement work and payments.

The Agreements Unit makes distribution of information on the reassignment of a Consultant to the affected areas within the Department.

8-4 CLAIMS

8-4.01 Damage Due to Consultant Errors and/or Omissions

By Contract, a Consultant is responsible for damages incurred by the Department as a result of the Consultant's errors and/or omissions. However, when the Department believes a fair and equitable price for an omission is obtained from the Contractor and the cost would have normally been incurred by the nature of the contract; the Consultant typically is not charged damages for their omissions.

8-4.01(a) Errors by Phase I Consultant Discovered During Phase II

The IPM will notify the Agreements Unit if errors in the Phase I work have occurred that will result in additional cost in subsequent phases of the project. The notification should describe the situation, the corrective measures that result, and the amount of the Consultant's liability. If IPM deems it practical, the Consultant responsible for the error may be given the opportunity to assist in making the corrections to reduce his/her financial liability.

8-4.01(b) Errors by Phase II or Phase III Consultant Discovered During Construction

When an error or omission is found resulting in damages to the Department and is believed to be caused by the Consultant, the district's Bureau of Project Implementation or the Bureau Chief responsible for the phase of work where the error was discovered first determines if time is critical and then:

1. Where Time is Not Critical. Notify the Program Development Engineer or the appropriate Department office immediately. The Department's Consultant Manager notifies the Consultant of the error or omission either by e-mail, fax, or mail. The Consultant is given an opportunity to be involved in the resolution of the error or omission along with the timetable involved. After the investigation, if the error or omission is determined not to be the Consultant's responsibility, the firm may submit an invoice for the hours used during the investigation. The fact that the Consultant provided assistance in the resolution of the error or omission will not be construed as either absolving the Consultant of the firm's portion of the damages or implying the Consultant's responsibility for the damages.
2. Where Time is Critical. Notify the Program Development Engineer or the appropriate Department office of the error and also identify the steps that were taken to remedy the error. If the Department determines the error is the Consultant firm's responsibility, the Department's Consultant Manager notifies the Consultant firm of the error and the remedy by e-mail, fax, or mail.

The initial notification to the Consultant firm includes: (1) the nature of the error or omission, (2) the action sought from the Consultant, if any, and (3) the time constraints required for the response or the solution recommended for implementation. The extent of liability for the error may be determined at a later time and is not included in the initial notification. A copy of the notification is sent to BDE.

The district's Bureau of Project Implementation submits an Authorization of Contract Changes (form BC-22), necessitated by the plan error or omission, to the Central Bureau of Construction and resolves the error accordingly. The BC 22 should provide detailed information on the cost to correct the error or omission. The BC 22 should also include a copy of the district's Bureau of Project Implementation notification to the Program Development Engineer (or appropriate Department office) specified above.

Upon approval of BC 22, the district's Bureau of Project Implementation forwards a copy of the approved BC 22 to the Program Development Engineer or the appropriate Department office. If the Consultant is found responsible for damages, the Program Development Engineer or the appropriate Department office will forward a copy of the approved BC 22, all applicable documentation, and the extent of the consultant's liability to BDE.

8-4.01(c) Notifying Consultant of the Cost of the Errors or Omissions

The Agreements Unit in BDE notifies the Consultant of the amount and extent of liability of the Consultant resulting from the errors and/or omissions. The Consultant has 30 days to respond to the notification indicating either agreement that they are responsible for the claim or intent to appeal the claim. A Consultant may request an extension of those 30 days for more complex situations to allow sufficient time to investigate the matter. If the Consultant agrees they are responsible for the claim, an invoice is sent to the firm as set forth in Section 8-4.01(f). If the Consultant does not agree they are responsible either totally or partially, the dispute resolution process in Section 8-5.01(e) is followed.

8-4.01(d) Errors and Omissions Threshold (EOT)

In recognition that the Department is not seeking a level of effort required to produce a perfect product and in order to reduce the time and expense for the Department and the Consultant in processing claims for minor dollar amounts, an Errors and Omissions Threshold (EOT) is used. Claims for damages involving errors and/or omissions are not billed to the Consultant unless the damages exceed the EOT Amounts shown in Figure 8-5. Errors and omissions are defined in the Standard Agreement Provisions for Consultant Services along with the EOT amounts.

Construction Contract Award Amount	EOT Amount
\$2,000,000 or less	\$20,000
Over \$2,000,000 to \$10,000,000	1% of Contract
Over \$10,000,000	\$100,000

Error and Omissions Threshold (EOT)

Figure 8-4.A

Where a Consultant designed multiple projects under one Contract, use a separate EOT for each project (e.g., one Phase I report for multiple Phase II projects, one Phase II Contract for multiple construction contracts).

8-4.01(e) Dispute Resolution

The Department and the Consultant agree to work together on a basis of good faith and fair dealings. When a dispute arises concerning damages caused by errors or omissions, the Consultant may choose to appeal according to the following requirements. The Consultant providing assistance in the resolution of the problem is not construed as absolving the Consultant of his/her portion of the damages.

If the appeal, after consideration by the Department, is found to have merit, an equitable adjustment is made. If the Department finds the appeal to be without merit, no adjustment to the damages due by the Consultant is made.

All appeals are submitted in writing no later than six months after notification of the damages by the Department.

All appeals are first submitted to the Regional Engineer. The Consultant may request an opportunity to present the appeal verbally at each of the following levels if the appeal is not satisfactorily resolved at the previous level:

- (1) Regional Engineer
- (2) Director of Highways Project Implementation/Chief Engineer
- (3) Deputy Secretary for Project Implementation

The Department has the option of considering other methods to resolve the dispute (e.g. Alternative Dispute Resolution).

If the Consultant and the Department cannot agree on the extent of the liability, the matter will be referred to the Bureau of Claims in the Office of Chief Council for further proceedings. Damage claims arising subsequent to construction will be referred to the Office of Chief Council for proper resolution.

The written response of the Deputy Secretary for Project Implementation shall be deemed a final action of the Department.

Once the appeal process has been exhausted, IPM notifies BDE, clearing the way for an invoice to be sent to the Consultant. The Department notifies the firm when the Consultant is considered delinquent if the invoice is not paid within 30 days.

8-4.01(f) Obtaining Reimbursement for Consultant Errors or Omissions

When the Consultant takes responsibility for the errors or omissions or the dispute resolution process has been completed with a finding of Consultant responsibility, BDE sends an invoice to the Consultant. Procedures for processing invoices and accounts receivables are contained in the *Revenue Accounting Manual*. The "Payment Due Date" on the invoice is 30-45 days from the date of the invoice. If payment is not received by the due date, use the collection procedures described in Chapter 4 of the *Revenue Accounting Manual*. If those procedures fail, refer the matter in writing to the Bureau of Claims in the Office of the Chief Counsel. The referral to the Bureau of Claims should include all correspondence from the appeal and collection processes.

8-5 QUALITY ASSURANCE QUALITY/CONTROL (QA/QC) GUIDELINES FOR WORK BY CONSULTING ENGINEERS

8-5.01 Definitions

1. Calculations. Written documentation of assumptions, analysis, and conclusions for design of an element of a project.
2. Checklist. A list of things, names, etc., to be checked off or referred to for verifying, comparing, ordering, etc.
3. Communication. Giving or exchanging of information, signals, or message as by talk, gestures, or writing. Communication is required throughout the process, is the responsibility of everyone, and must be open.
4. Compliance. The act of following the stated quality assurance plan. An act of complying with a requirement, directive, etc.
5. Computations. Written documentation of the figuring of quantities for a project.
6. Computer Program Verification. Assurance that a computer program correctly performs the operations specified in a numerical model. Usually accomplished by comparing program results to:
 - a hand calculation,
 - an analytical solution or approximation,
 - a verified program designed to perform the same type of analysis, or
 - a comparison with a test case provided by the vendor of the program.
7. Consultant. The firm providing professional services as a party to a Standard Agreement. An expert who is called on for professional or technical advice or opinions.
8. Corrective Action. Measures taken to rectify conditions adverse to quality and, where necessary, to preclude repetition.
9. Department. The Department of Transportation of the State of Illinois.
10. Design Control. Requirement providing assurance that a design is defined, controlled, and verified.
11. Documentation. Any written or pictorial information describing, defining, specifying, reporting, or certifying activities, requirements, procedures, or results.
12. Final Documents. Approved documents and approved changes thereto.
13. Performance. The act of carrying out the stated objectives on a project.
14. Planning. Those activities needed to ensure that the correct people are performing the correct tasks using the correct tools in the correct sequence. The end product should be

- identified and kept in mind when performing planning activities to ensure that the end product contains the required quality.
15. Project Budget. A comprehensive description of the costs associated with all the services required of the consultant, including labor costs, direct expenses, overhead costs, and profit.
 16. Project Team. The Department's and the Consultant's staff assigned to the project with specified duties and responsibilities, participating together in a cooperative manner.
 17. Project Resources. All things available to the project team to complete the project, including people, tools, information, equipment, etc.
 18. Project Manager. The individual assigned by the Consultant to act as the liaison between the consultant and the Department in matters relating to the achievement of project requirements, including budget control, schedules, milestones, and quality objectives.
 19. Project Schedule. A comprehensive description of all significant services required of the Consultant and of all actions required of the Department and approving parties by the obligations of the Agreement, together with the durations and/or dates for performing these services and actions.
 20. Quality. Meeting valid requirements so that the product produced is suitable for its intended use (quality in fact). Providing what is expected (quality in perception).
 21. Quality Assurance. All those planned and systematic actions necessary to provide adequate confidence that a structure, system, or component will perform satisfactorily in service.
 22. Quality Assurance Manager. The individual assigned by the Consultant to have full authority and responsibility for generating, updating, monitoring, and maintaining the quality assurance program, and responsibility for verifying conformance to the QA requirements as set forth by the Department and applicable codes and standards.
 23. Quality Assurance Plan. A document describing the implementation of the Quality Assurance Program on a specific project, including organizational responsibilities, applicable procedures, and other information required to address client (contractual) quality requirements. The plan may also address any unique contractual requirements or modifications.
 24. Quality Assurance Procedures. A quality assurance document that outlines a planned and systematic action for various quality affecting activities requiring quality control.
 25. Quality Control. A system for maintaining desired standards in a product or process, especially by inspecting samples of the product.

26. QA Records. A completed document that furnishes evidence of the quality of items or activities affecting quality. A record is an authentic, official copy (or original) of a document retained to attest to past decisions, actions, or events.
27. Scope of Services. All the actions required of the Consultant to complete the obligations for the project.
28. Training. In-depth instruction provided to personnel to develop and demonstrate initial proficiency in the application of selected requirements, methods, and procedures, and to adapt to changes in technology, methods, or job responsibilities.
29. Valid Requirements. Requirements established resulting in the product satisfying the customer's expectations on schedule and within planned resources.
30. Verification. The act of reviewing, inspecting, testing, checking, auditing, or otherwise determining (and documenting) whether items, processes, services, or documents conform to specified requirements. Ensuring that the project team is doing the right thing and that the work being performed, or that has been performed, is performed correctly.

8-5.02 Elements of a QA/QC

The following sections identify the key elements addressed in the QA/QC plan.

8-5.02(a) Project Team

This section should include a list of key personnel from in-house staff, outside consultants, and client liaison and includes a brief description of the key members' responsibilities. A typical project team should include:

- Project Manager,
- Client Liaison,
- Technical Support Staff,
- Subconsultants and other Consultants, and
- QA/QC reviewer.

8-5.02(b) Written Project Plan

A. PROJECT SCOPE

This section includes a brief description and the purpose and need for the project. Consider and address the matter of possible future expansion of the facilities. Identify if the project is to be done in U.S. customary or metric units. Note if the project includes more than one contract (i.e., two or more sections). Also note in this section anything significantly different for this project.

B. SUBCONSULTANT'S ROLE

List and identify all Subconsultants. Delineate the scope of work and responsibilities for each Subconsultant. Provide the Subconsultant's key project personnel and telephone numbers. Identify all deliverables with expected time frames. These deliverables can be from the Subconsultant to the consultant and, in certain instances, vice versa.

C. STANDARDS AND GUIDELINES

List all appropriate manuals and memorandums applicable to the project.

D. TIME SCHEDULE

The schedule includes the estimated Agreement date, any meeting dates, and periodic milestones. The number of milestones varies considerably depending on the size and type of project.

Establish deliverables with dates for submittals to various parties to the Agreement. Provide reasonable float and review times in the overall schedule.

Ensure in-house quality assurance reviews are scheduled in accordance with the various milestones and deliverables. Schedule the reviews several times during the project rather than as a final, comprehensive check.

Identify and schedule report phase milestones and the preliminary submittal date. Provide the beginning date for preliminary design along with milestones and submittal date to IDOT. Identify the starting date for final design along with any overlap with the preliminary design. Provide a list of periodic milestones during this stage.

Periodic meetings with IDOT are required, up-front, and coordinated with the various deliverables and their review.

The success of the project can often hinge on the time schedule. The entire time schedule is a dynamic schedule and may be reviewed and adjusted periodically.

E. PERSON-HOUR BUDGET

Prepare a person-hour budget by classification and by work tasks. Estimate the percent of total budget expected to be expended at various milestones. This assists in monitoring progress and assists in providing early alerts to a problem with the budget.

F. RESOURCE MATERIAL

This section consists of a listing of pertinent information available for the project including:

- existing drawings,
- previous reports,
- soil borings,

- TS&L,
- boundary surveys, and
- easements.

G. ESTIMATED CONSTRUCTION BUDGET

This section notes the anticipated total construction cost. Keep in mind, cost and budget during the course of design. When the consultant believes the costs will be exceeded, the Consultant notifies IDOT. The goal is to avoid unpleasant surprises further down the road.

Identify and list cost limitations by segment, where applicable.

H. SPECIAL CONDITIONS

If the project has any special requirements and/or special construction materials requirements for a project, note them in this section.

8-5.02(c) Project Control

A. PROCEDURES

Procedures for quality control are often in the form of check lists. The procedures are intended to assure completeness of the function and conformance of the project.

1. Engineering and Environmental Studies/Plan Preparation.

- a. **Scoping/Field Checks.** This procedure itemizes basic elements to be reviewed and evaluated during the initial field inspection of a project. The basic elements include, but are not limited to:

- inspection of pavement condition,
- logical termini,
- drainage problems,
- hazards,
- existing guardrail condition,
- accessibility,
- evidence of wells,
- gas pumps or storage tanks, and
- other environmental considerations.

- b. **Contents of Submittals.** This procedure provides a consistent definition of the content of the following key submittals:

- preliminary reports,
- prefinal reports,
- final reports,
- preliminary plans,

- prefinal plans, and
 - final plans.
- c. **Special Provision Preparation.** This procedure defines the proper preparation of a contract special provision and provides a procedural method to ensure a clearinghouse for unnecessary special provisions.
2. **Design Calculations.** Identify the procedures to be used to develop quantity calculations and proposed methods for checking the calculations.
3. **Computer Inputs/Outputs.** This procedure defines the software applications and the process for verifying results.
4. **Documentation of Directives.** This procedure provides guidelines for consistent documentation of project decisions and directives (e.g., meeting minutes, telephone communications).
5. **Dissemination of Correspondence and Documents.** This procedure provides guidelines for consistent dissemination of project decisions and directives.

B. PROJECT RECORDS

This section specifies the requirements for the preparation and maintenance of project records generated by the Project Team. The following are key features of these requirements:

- legible, identifiable, and retrievable records;
- records protected from damage or loss; and
- defined responsibilities for routing, maintaining, accessing, transferring, and long-term storage.

Project records generated during project work activities may include, but are not limited to:

- informational records,
- field records,
- data compilation and testing records,
- data interpretation records,
- calculation and computer records,
- telephone messages,
- e-mails, and
- draft and final reports.

The Department requires quality records be maintained to demonstrate achievement of the required quality and the QA/QC plan is followed. Pertinent Subconsultant quality records are an element of these records.

Where agreed contractually, ensure quality records are available for review by the Department for an agreed period.

8-5.03 Compliance Statements

All Agreements contain language requiring “statements of compliance” with the QA/QC plan prepared by the Consultant and approved by the Department. Statements of compliance are required on an interim basis and at the conclusion of the work. The interim statements of compliance are required throughout the project at each major milestone. For example, a statement of compliance is made for a typical contract plans project at the preliminary plans, pre-final plans, and final documents stages. The interim statements of compliance satisfies with a sentence added to the Consultant’s letter of transmittal stating the plans were prepared in compliance with the approved QA/QC plan.

The final statement of compliance is on the Department’s form.

8-5.04 Verification Process

The Department reviews selected projects to verify the Consultant’s plan, approved by the Department, was followed. Selection of jobs to be reviewed considers type of work, size of project, IPM, and level of performance ensuring the results of the review are meaningful.

The review is conducted at the Consultant’s office. Participants include, but are not limited to, the Consultant’s project manager, Consultant’s QA/QC manager, IPM, and representatives from the Department’s central bureaus. Generally, the review is one-half day and occurs prior to completing the work. The firm is furnished questions and/or statements to assist in preparation for the review meeting. The review meeting begins with a brief overview of the QA/QC plan by the Consultant. The Department’s review team proceeds through the questions/statements previously furnished to the Consultant. A copy of the report prepared by the review team is furnished to the consultant.

The purpose of the verification process is to determine if the QA/QC plan is being followed, identify innovative ideas that can be shared with others, and to identify areas needing improvement.

The IPMs may conduct their own verifications in addition to the formalized process described above.

In the event of non-compliance with the QA/QC plan, certain actions by the Department may occur. It is essential the Consultant demonstrate to the Department corrective action was taken to ensure future compliance. The Agreements state non-compliance could result in termination of the Contract and/or have an effect on the firm’s prequalification status. Non-compliance leading to less than satisfactory performance is considered in the selection of firms for future work.

Chapter Nine

RESERVED

Chapter Nine
RESERVED

Chapter Ten

RESERVED

BUREAU OF DESIGN AND ENVIRONMENT MANUAL

Chapter Ten
RESERVED

Chapter Eleven

PHASE I STUDIES

BUREAU OF DESIGN AND ENVIRONMENT MANUAL

Chapter Eleven
PHASE I STUDIES

Table of Contents

<u>Section</u>	<u>Page</u>
11-1 GENERAL	11-1.1
11-1.01 Phase I Studies	11-1.1
11-1.01(a) Scope	11-1.1
11-1.01(b) Purpose	11-1.1
11-1.01(c) Types of Phase I Studies	11-1.2
11-1.02 Social, Economic, and Environmental Considerations	11-1.4
11-1.03 Project File	11-1.4
11-2 DESIGN AND ENGINEERING CONSIDERATIONS	11-2.1
11-2.01 General	11-2.1
11-2.01(a) Scope	11-2.1
11-2.01(b) Design Policies and Guidelines	11-2.1
11-2.01(c) Phase I Study Procedures	11-2.3
11-2.02 Need for Highway Improvements	11-2.3
11-2.02(a) Functional Classification	11-2.3
11-2.02(b) Multi-Year Program	11-2.3
11-2.02(c) Highway Data Bank	11-2.4
11-2.02(d) Urban Transportation Planning	11-2.4
11-2.02(e) Traffic-Carrying Capacity	11-2.5
11-2.02(f) Crash and Skid Reduction Analyses	11-2.5
11-2.02(g) Pavement Condition	11-2.7
11-2.02(h) Bridge Condition Information	11-2.7
11-2.03 Access Control/Access Management	11-2.8
11-2.03(a) Overall Policy	11-2.8
11-2.03(b) Highway Type	11-2.8
11-2.03(c) Median Crossovers and Openings	11-2.8
11-2.03(d) Frontage Roads/Service Drives	11-2.9
11-2.03(e) Driveways	11-2.9
11-2.03(f) Changes in Access	11-2.9
11-2.03(g) Signing Policies	11-2.9

Table of Contents
(Continued)

<u>Section</u>		<u>Page</u>
11-2.04	Geometric Design Criteria	11-2.9
	11-2.04(a) Basic Design Controls	11-2.9
	11-2.04(b) Horizontal Alignment	11-2.10
	11-2.04(c) Vertical Alignment	11-2.11
	11-2.04(d) Cross Section Elements	11-2.12
	11-2.04(e) Intersections.....	11-2.12
	11-2.04(f) Interchanges	11-2.13
	11-2.04(g) Roadside Safety.....	11-2.13
	11-2.04(h) Design of New Construction/Reconstruction Projects....	11-2.13
	11-2.04(i) Design of 3R Projects	11-2.14
	11-2.04(j) Design of 3P and SMART Projects	11-2.15
11-2.05	Hydraulics (Drainage).....	11-2.15
11-2.06	Traffic Engineering	11-2.16
11-2.07	Structures.....	11-2.16
11-2.08	Miscellaneous Highway Features.....	11-2.17
	11-2.08(a) Utilities	11-2.17
	11-2.08(b) Railroads.....	11-2.17
	11-2.08(c) Weigh Stations and Rest Areas.....	11-2.17
	11-2.08(d) Lighting	11-2.17
	11-2.08(e) Sidewalks and Pedestrians	11-2.17
	11-2.08(f) ADA	11-2.18
	11-2.08(g) Landscaping/Stormwater Pollution Control.....	11-2.18
	11-2.08(h) Existing Public Educational Facility Entrances	11-2.18
11-2.09	Maintenance Considerations	11-2.19
11-2.10	Geotechnical Considerations.....	11-2.19
11-2.11	Agreements.....	11-2.20
	11-2.11(a) Local Agency Agreements	11-2.20
	11-2.11(b) Utility Agreements.....	11-2.20
	11-2.11(c) Railroad Agreements	11-2.21
11-2.12	Right-of-Way Issues.....	11-2.21
11-2.13	Coordination with Airports	11-2.21
11-2.14	Traffic Control During Construction	11-2.22
11-2.15	Estimate of Costs	11-2.22
11-3	ROUTE PLANNING.....	11-3.1
	11-3.01 Scope.....	11-3.1
	11-3.02 Logical Termini.....	11-3.1
	11-3.03 General Considerations.....	11-3.2
	11-3.04 Overall Procedures	11-3.3

Table of Contents
(Continued)

<u>Section</u>	<u>Page</u>
11-4 CORRIDOR STUDIES	11-4.1
11-4.01 Purpose	11-4.1
11-4.02 Reconnaissance During Corridor Study	11-4.1
11-4.02(a) Objectives	11-4.1
11-4.02(b) Sources of Information	11-4.1
11-4.02(c) Coordination.....	11-4.2
11-4.02(d) Study Area	11-4.3
11-4.02(e) Corridor Location	11-4.3
11-4.03 Analysis of Acceptable Corridors.....	11-4.4
11-4.03(a) Objectives	11-4.4
11-4.03(b) Final Corridor Exhibits	11-4.5
11-4.03(c) Final Field Inspections	11-4.5
11-4.03(d) Estimate of Costs.....	11-4.5
11-4.03(e) Public Involvement.....	11-4.5
11-4.03(f) Selection of Final Corridor.....	11-4.5
11-5 DESIGN STUDIES	11-5.1
11-5.01 Objective	11-5.1
11-5.02 Products and Services from Surveys, Mapping and Modeling	11-5.1
11-5.03 Alignment Investigations	11-5.2
11-5.03(a) Review of Corridor Selection.....	11-5.2
11-5.03(b) Preliminary Alignments	11-5.2
11-5.03(c) Mapping Requests	11-5.3
11-5.04 Study of Design Alternatives	11-5.4
11-5.04(a) Objectives	11-5.4
11-5.04(b) Sources of Information	11-5.4
11-5.04(c) Locating Alignments.....	11-5.5
11-5.04(d) Establishing Gradelines (Procedures)	11-5.6
11-5.04(e) Evaluation of Alternatives.....	11-5.8
11-5.04(f) Access Control Plans	11-5.8
11-5.04(g) Exhibits	11-5.8
11-5.04(h) Technical Reports	11-5.9
11-5.04(i) Selection of Preferred Alternative.....	11-5.9
11-6 COMBINED DESIGN STUDIES	11-6.1
11-7 OTHER PHASE I STUDY CONSIDERATIONS	11-7.1
11-7.01 Road User Benefit Analysis.....	11-7.1

Table of Contents

(Continued)

<u>Section</u>		<u>Page</u>
	11-7.01(a) Scope.....	11-7.1
	11-7.01(b) Procedures	11-7.1
11-7.02	Road Closures	11-7.2
	11-7.02(a) General	11-7.2
	11-7.02(b) Road Closures for Freeways (Full Access Control)	11-7.4
	11-7.02(c) Road Closures for Expressways (Partial Access Control)	11-7.5
	11-7.02(d) Road Closures for Highways Other Than Freeways or Expressways.....	11-7.5
11-7.03	Value Engineering.....	11-7.6
	11-7.03(a) Procedures	11-7.7
	11-7.03(b) Constructability Reviews	11-7.10
11-7.04	Planning and Environmental Linkage	11-7.12
	11-7.04(a) PEL Considerations	11-7.12
	11-7.04(b) PEL Process	11-7.13
	11-7.04(c) PEL to Class of Action Determination or NEPA Scoping	11-7.14
11-8	ENGINEERING COMPUTER PROGRAMS	11-8.1
	11-8.01 General	11-8.1
	11-8.02 Roadway Design Software	11-8.1
	11-8.03 Bridge Design Software.....	11-8.1
	11-8.04 3D Models.....	11-8.1
	11-8.05 CADD Support	11-8.2
11-9	DISTRICT GEOMETRIC APPROVAL QUALIFICATION REQUIREMENTS	11-9.1
	11-9.01(a) General.....	11-9.1
	11-9.01(b) Items Exempt from Qualification.....	11-9.2
	11-9.01(c) Removal of Qualification	11-9.2
	11-9.01(d) Qualification Requirements	11-9.2
	11-9.01(e) Qualification Process	11-9.2
11-10	REFERENCES.....	11-10.1

Chapter Eleven

PHASE I STUDIES

Chapter 11 discusses the goals and objectives of Phase I studies for projects administered by the Department. Phase I studies include both engineering and environmental studies, each requiring a separate decision-making process. Chapter 12 discusses the applicability of the various Phase I engineering report types, as well as their content, format, processing, and approval.

For the engineering and environmental analyses and any public involvement conducted in a Phase I study, Chapter 11 references the applicable chapters in the *BDE Manual* and other applicable documents (e.g., other Department manuals, FHWA publications).

11-1 GENERAL

11-1.01 Phase I Studies

11-1.01(a) Scope

Phase I work can vary from a very minor type study to an in-depth investigation of corridors, alternative alignments and cross sections, different highway types, and other design features with consideration of social, economic, environmental, and engineering factors. In addition, safety, serviceability, and economy must be considered during project development. The Phase I study should clearly describe the need for the improvement and how to implement the improvement in a logical and organized manner.

To effectively analyze a proposed improvement, coordinate and develop Phase I studies concurrently with public involvement activities and any required environmental analyses. The Phase I study will culminate in the completion of a Phase I report that documents the findings of the study. Chapter 12 describes the recommended content and format of, in addition to the submittal and approval processes for, the different types of Phase I engineering reports.

Job limits shall be extended to include intersections within 500 ft of paving and other improvement project termini for the inclusion of pedestrian and bicycle features. Pedestrian and bicycle features included in this work are detailed in Section 17-1.02. Normal project termini for pavement work should remain in place.

11-1.01(b) Purpose

Phase I studies are developed to ensure that, as practical, highway locations and proposed designs are consistent with Federal, State, and local goals and objectives. Consider the following when performing a Phase I study:

1. Design Uniformity. When conducting Phase I studies, ensure that proposed improvements will satisfy a need, are designed and constructed according to IDOT policies and criteria, and that uniform designs are used statewide. Designers must seek, however, to use all of the flexibility inherent in the policies included herein to craft the best possible solutions to identified transportation problems.
2. Public Involvement. Develop the final design in conformance with the public involvement requirements of Chapter 19.
3. Public Interest Considerations. Make final project decisions in the best overall public interest. A Phase I study should fully consider the need for safe and efficient transportation, public services, and the costs of eliminating or minimizing adverse impacts to the social and natural environment.
4. Adverse Effects of Project. Ensure that the potential adverse economic, social, and environmental effects of any proposed action have been fully considered. See Part III, Environmental Procedures.

11-1.01(c) Types of Phase I Studies

For complex projects, a separate corridor and design study may be required to determine the location and design of a proposed improvement. However, for minor type improvements only a separate Phase I engineering study is required. Depending upon the complexity and potential impact of a proposed improvement, the following types of Phase I studies are prepared:

1. Corridor Study. A corridor study is required for a complex highway project on new location of significant length and where alternative corridors are available. A corridor study will determine, in part, the selection of a specific corridor for the proposed highway. Alternative alignments should be developed within a general corridor location during the corridor study to determine the suitability of that corridor. These improvements typically will have a substantial social, economic, and environmental effect, or they will essentially change the layout or function of connecting roads and streets. The impacts of a complex highway project, such as a freeway on new location, will also require the preparation of a separate environmental document (normally an environmental impact statement (EIS)) to address the environmental issues of both the corridor and subsequent Phase I design studies.
2. Major Design Study. For complex highway projects requiring a separate corridor study, a Phase I design study is prepared after the corridor location has been selected and approved. The design study determines, in part, the specific alignments, profiles, and the major design features (e.g., typical sections, location and type of interchanges, road closures) of the proposed highway improvement. Because a separate environmental report is required with this category of work, environmental investigations are initiated during the corridor phase and are completed concurrently along with the design study.
3. Combined Design Study (Combined Corridor and Design Study). A combined design study is conducted for a proposed highway project within a predetermined highway

corridor or location. The acceptability of the corridor or location usually results from a decision to use the existing highway alignment due to constraints imposed by land use and development, or due to the results of prior engineering studies (e.g., a transportation systems plan). For example, the reconstruction of an urban arterial highway requiring additional right-of-way and some business or residential relocations will normally be a suitable project for a combined design study. Other examples include upgrading an existing two-lane rural highway to a four-lane expressway, the addition of an interchange, or a change in type for an existing interchange. For these types of projects, an environmental assessment (Chapter 24) is usually required. However, if significant impacts are known in advance, an EIS (Chapter 25) will be required.

4. Minor Design Study. For categorical exclusion type projects, conduct and document any necessary engineering and environmental analyses to substantiate the categorical exclusion determination; see Chapter 23. As discussed in Chapter 12, a Project Report, Abbreviated Project Report, 3P Report, or SMART Report will be prepared for this type of project. Examples of highway improvement types normally addressed include:

- bridge rehabilitation or replacement projects,
- intersection improvements,
- most 3R projects, and
- resurfacing of the existing traveled way with no other improvements.

5. Feasibility Study. A feasibility study is typically initiated to assess whether or not a proposed highway improvement warrants further study or whether additional Phase I engineering studies are needed. Feasibility studies typically are conducted to address the following types of questions:

- Will a new four-lane highway or major river bridge promote economic development in a certain region of the State and create more benefits than costs, or would upgrading existing two-lane highways be a better solution for promoting economic development?
- Is a missing link of a four-lane highway causing traffic operational problems, which, in turn, are creating a high number of crashes? Would a new four-lane highway or bypass alleviate the problem, or would some other type of improvements be more cost effective?
- Would it be possible and cost effective to build a new four-lane highway on new alignment through rugged terrain in comparison to upgrading the existing alignment? Also, what would be the projected benefits?
- Will a new four-lane highway (typically an expressway) promote economic development in a certain region of the State and create more benefits than costs? With this scenario, there may be two closely spaced corridors (10 to 12 miles (15 to 20 km) apart) that tie into the same termini at each end. Both corridors are worthy of consideration for upgrading to a new four-lane highway and a determination is needed as to which corridor would provide more benefits. The feasibility study provides this answer and the need as to whether to proceed with

location/design study type work in one corridor. However, to proceed with only one corridor, sufficient corridor environmental investigations must be completed, documented, and then carried forth into the location/design study phase.

- Other similar situations where additional information is needed before making a decision to proceed with more detailed engineering studies (e.g., major drainage alternatives, alternate locations for a proposed interchange).

A feasibility study can be similar to a corridor study.

11-1.02 Social, Economic, and Environmental Considerations

Part III, Environmental Procedures, discusses in detail the procedures for evaluating the social, economic, and environmental impacts of proposed actions. Consider the following items when developing a highway improvement:

- effects on regional and community growth;
- conservation and preservation of natural resources;
- public facilities, services, and recreational areas;
- community cohesion;
- displacement of people, businesses, and farms;
- air, noise, and water pollution; and
- aesthetic values.

The depth of environmental analysis will vary depending upon the scope and nature of the project, the location, the stage of project development, and the magnitude of any adverse impacts. For complex projects, the district will prepare a separate environmental document (i.e., an environmental impact statement or an environmental assessment). For categorical exclusion projects, the project report will document the environmental analysis.

11-1.03 Project File

Each Phase I study requires establishment and maintenance of a project file. This file shall be the responsibility of the associated district office under the terms of the pertinent document retention policy. The Phase I file shall be considered the collection of record for any legal or other inquiries pertaining to the Phase I portion of the project.

To assist in successful compilation of the file, the district shall utilize BDE 1101 Phase I Project File Checklist. Upon final file completion, district staff will sign and date the form – including supervisory review - and append the form to the file.

Annual reviews will be performed on a sample of project files by BDE in each district to provide central management oversight and assure compliance with requirements.

11-2 DESIGN AND ENGINEERING CONSIDERATIONS

11-2.01 General

11-2.01(a) **Scope**

Phase I studies are used to identify the following:

- need for highway improvement,
- capacity deficiencies,
- need to improve safety,
- level of service,
- project termini,
- specific locations,
- design criteria,
- cross section elements,
- horizontal and vertical alignments,
- need for right-of-way,
- hydraulic design (drainage),
- need for intersection design/interchange designs,
- access control features or access management guidelines,
- location of bridge and traffic structures, and
- project costs.

The scope and depth of engineering analyses for Phase I studies will vary depending on the project scope of work. These studies may be less than that required for final plans, but they should be sufficiently accurate to preclude significant design or major cost estimate revisions during final construction plan preparation. When determining the scope, extent, and accuracy needed for a specific engineering study, the effects on adjacent property owners are often a good indicator.

11-2.01(b) **Design Policies and Guidelines**

One objective of a Phase I engineering study is to compare existing highway features (or topography and land use for possible new highway locations) to current design policies and criteria and then to determine the needed improvements that are cost and safety effective. This requires resourcefulness and engineering judgment in the development of alternatives and the preparation of project designs.

Location/design study personnel must ensure that major design decisions are finalized during the Phase I engineering studies. This minimizes the time and effort needed to prepare design details during final plan preparation in Phase II. Examine and document any design exceptions from current policies and explain the reasons for the variance; see Chapter 31. A few of the most frequently referenced policies and guidelines are as follows:

1. New Construction/Reconstruction. Part IV, Roadway Design Elements and Part V, Design of Highway Types provide cross section and alignment criteria for new construction projects on new location and for reconstruction projects.
2. Rehabilitation, Restoration, and Resurfacing (3R). Chapter 49 presents the Department 3R criteria for non-freeways, and Chapter 50 presents the Department 3R criteria for freeways.
3. Intersections/Interchanges. Chapters 36 and 37 provide design guidance for intersections and interchanges.
4. Access Control/Access Management. Chapter 35 presents Department policies and guidelines for the control of access on freeways and expressways and access management principles.
5. Bikeways/Pedestrians. Chapters 17, 48, and 58 present Department policies for the accommodation of bicyclists and pedestrians within the highway right-of-way.
6. Roadside Safety. Chapter 38 discusses the selection and layout of roadside safety appurtenances. The design policies for protective barriers (e.g., median barriers, longitudinal barriers, impact attenuators) included in Chapter 38 are for new construction/reconstruction projects. For 3R improvements, Chapters 49 and 50 present roadside safety design policies.
7. Structures. For the structural design and rehabilitation of existing bridges, the Bureau of Bridges and Structures maintains several manuals for design. For structure geometrics, Chapter 39 documents bridge width and vertical clearance criteria for new construction/reconstruction improvements. Chapters 49 and 50 present geometric design criteria for bridges within the limits of 3R projects.
8. Pavements. Chapters 53, and 54 present information for determining pavement preservation, pavement rehabilitation, and pavement design, respectively.
9. Other Department Manuals/Publications. The Illinois Department of Transportation publishes and maintains a wide variety of engineering documents in addition to the *BDE Manual*. These address other aspects of roadway projects, including standards and specifications, policies for local roads and streets projects, land acquisition, surveying, CADD, traffic engineering, structural design, hydraulics, materials, and construction. Chapter 60 of the *BDE Manual* briefly describes these publications. As needed, the Phase I designer should review other Department manuals/publications for use in project evaluation.

To properly conduct engineering analyses and to develop a functional design, diverse sources of information must be used. This includes contact with Central Office and district bureaus. The designer must be familiar with data available from outside sources and needs to understand how to use the data. In addition, the designer must ensure that the scope, extent, and accuracy of the

data requested from other sources are commensurate with the intended use of the engineering analysis being performed.

11-2.01(c) Phase I Study Procedures

The successful implementation of a Phase I study will depend upon timely coordination among all parties involved in the process. Chapters 2 and 3 present Phase I Project Development Networks that illustrate the proper interrelationships among the IDOT central office bureaus, the district, resource agencies, and the public for different types of projects. Depending on the scope of the project and design policies used, the Phase I designer should, as practical, use one of these networks.

11-2.02 Need for Highway Improvements

Engineering investigations in a Phase I study must determine if the proposed highway improvement satisfies the need for safe, economical, and efficient transportation and provides other relevant benefits (e.g., traffic benefits, public services, reduction of crashes, pedestrian facilities, and transit considerations). Having a clear and provable need will help the project avoid pitfalls later on. The following informational sources are important in establishing the need for the highway improvement.

11-2.02(a) Functional Classification

The Office of Planning and Programming has departmental responsibilities for functionally classifying all State highways. For information on functional classification, see the FHWA's document entitled, *Highway Functional Classification Concepts, Criteria and Procedures*, 2013 Edition, available on the FHWA website and IDOT's *Five Year Classification Maps*, available on the IDOT website. Section 43-1 discusses the application of the functional classification system in Illinois for geometric design applications. All highway improvements must be compatible with the functional classification of the highway under design. A highway's functional classification and highway type are important factors in determining which design policies and criteria to use and for establishing programming priorities for new construction, reconstruction, or 3R type improvements.

11-2.02(b) Multi-Year Program

The Office of Planning and Programming annually issues the IDOT publication "Statewide Program Planning – Programming Guidelines." This usually occurs in the autumn of each year. This publication includes programming criteria for:

- improvement categories,
- pavement surface conditions,
- deficient bridges,

- safety improvements,
- Interstate rehabilitation,
- widening narrow and rough pavements,
- improving intersections and reducing traffic bottlenecks,
- new construction/reconstruction of major facilities,
- enhancement projects,
- Congestion Mitigation Air Quality (CMAQ) projects, and
- bicycle accommodation.

The publication also contains criteria for district selection of projects for inclusion in the annual and multi-year programs, such as bridge deficiencies for improvement eligibility when based upon highway classification and average daily traffic.

11-2.02(c) Highway Data Bank

The Office of Planning and Programming, Planning Systems Section, is responsible for maintaining and updating the Illinois Roadway Information System (IRIS,) and corresponding *Illinois Highway Information System Roadway Information and Procedure Manual*, in addition to the Illinois Structure Inventory System (ISIS) and corresponding *Illinois Highway Information System Structure Information and Procedure Manual*. Maintaining IRIS and ISIS is accomplished through the district data collection and highway field inventory operations. The Planning Systems Section can provide computer-generated route log listings for State routes, local roads, and municipal streets. The available data is dependent on the highway system. A key route number designates each roadway. IRIS contains information on roadway administrative classification, physical dimensions, characteristics, traffic data, pavement cross sections, pavement surface type, shoulder and median type, and historical construction information. ISIS contains detailed inspection and appraisal data, in addition to existing physical characteristics and historical construction information, on bridges and large culverts.

11-2.02(d) Urban Transportation Planning

The urban transportation planning process produces information on local governmental functions in urbanized areas of over 50,000 inhabitants. The Metropolitan Planning Organizations (MPOs) administer a continuing, cooperative, comprehensive transportation planning process that results in transportation improvement plans and programs consistent with the planned development of the urbanized areas. This process determines the transportation modal choice. In urbanized areas, Phase I reports should discuss the consistency of proposed improvements with local transportation planning agencies. Major urban freeway improvements shall meet joint FHWA/FTA regulations for major highway improvements in urban areas. The urban transportation planning process also can provide other social-economic-environmental-engineering information for Phase I studies.

11-2.02(e) Traffic-Carrying Capacity

A facility's current and future traffic-carrying capacity is one of the most critical elements for establishing the need for a highway improvement. Two elements impact this analysis:

1. Current and Projected Traffic Volumes. Under the general guidance of the Office of Planning and Programming (OP&P), the districts count and classify existing traffic volumes on the State highway system. OP&P also maintains data used to project future traffic volumes (i.e., annual traffic growth factors). The following data are available from the districts:

- current hourly and daily traffic volumes,
- current turning movement volumes,
- traffic projections and assignments for new facilities, and
- traffic projections for future design years on existing facilities.

Similar data, developed in conjunction with the Urban Transportation Planning Process, also may be obtained from a local MPO. OP&P maintains a list of MPOs on the Department's webpage. Phase I reports should document current year average daily traffic (ADT), design year ADT, and design year 30th highest hourly traffic volumes (DHV). Also, provide the directional distribution factor and the percent of trucks for the proposed highway and for other affected facilities. Because the design of a project is so greatly dependent upon the projected design hourly volumes, these figures must be carefully examined and questioned before using for design purposes. Improper traffic projections can result in the assumption of unnecessary highway improvements.

2. Highway Capacity Studies. The desired level of service (LOS) (i.e., mobility and freedom from delay and congestion) for a State highway is determined by its functional classification and urban/rural location. The tables of geometric design criteria in Part V, Design of Highway Types present the Department's LOS criteria for each functional class. The *Highway Capacity Manual* provides the analytical techniques to determine the level of service for all highway elements (e.g., for basic segments, intersections, interchanges) for a given set of traffic and roadway conditions. For a major highway segment, for example, the capacity analysis will determine if an existing roadway will accommodate future traffic demands at the desired LOS or if roadway improvements are necessary (e.g., the addition of travel lanes). Section 31-4 discusses highway capacity analyses for Department projects in more detail.

11-2.02(f) Crash and Skid Reduction Analyses

The districts are able to access crash data through the use of GIS applications and the Safety DataMart, which are linked to the Bureau of Safety Programs and Engineering Crash Information System (CIS). The Bureau of Safety Programs and Engineering may also furnish the district with traffic crash information upon request. The following is a partial listing of available crash information for Phase I studies:

- State highway Five-Percent Report and computer-generated listings that report supplemental data for high-crash spots and roadway sections;
- county crash summaries;
- municipal crash summaries;
- reports which can be generated for individual locations, selected geometric feature, or type of crash:
 - + Five-Percent Report,
 - + Intersection Profile,
 - + Segment Profile,
 - + Location Summary,
 - + Crash—One-Line Listing,
 - + Intersection Summary,
 - + Cross Tab—Time of Day by Severity,
 - + Cross Tab—Crash Type by Severity,
 - + Cross Tab—Conditions by Severity,
 - + Cross Tab—Time of Day by Day of Week,
 - + Roadway Description,
 - + Roadway Summary, and
 - + Deer/Vehicle Collisions.
- Statewide average crash rates (distributed annually for comparison with existing project crash rates for proposed improvement justification);
- collision diagram printouts for requested project locations, including intersections. Coding sheets are available for interpreting collision diagram printouts of vehicle maneuvers and involvements. Collision diagram summary sheets document percentages of collision types (on or off the roadway), weather conditions, and light conditions. Crash rates also may be requested for specific locations. Sufficient information is included to assist in manually drawing a collision diagram. Collision diagram computer plots also may be requested for intersections;
- individual crash reports at specific locations (upon request from a microfilm or imaging retrieval system);
- summaries of Motor Vehicle Traffic Crashes and Class of Trafficway (statewide average percentages) by type of collision, light condition, and road surface (these percentages may be compared with project percentages from collision diagram summary sheets to help identify over-represented crash patterns).

The Phase I study should include, as appropriate, the following crash analyses to assist in demonstrating the need for a highway improvement:

1. Spot Map. Provide a crash spot map as basic crash information in the Phase I report. As applicable, also include a comparison of the calculated project crash rates with the statewide average crash rates for the same class of highway. Collision diagram summary sheet percentages also may be compared with statewide averages.

2. High-Crash/Crash Pattern Analyses. In the Phase I study, identify Five-Percent Report locations, rates, and all crash patterns (e.g., fixed objects, sideswipes, rear-ends, overturns, wet-weather, night-time, etc.) at various sites throughout the project. Also, include schematic collision diagrams, results of field checks, crash analyses, and recommended countermeasures for these items, or provide a statement that no high-crash locations or other crash patterns exist along the proposed improvement.

For projects with a high percentage of wet-weather crashes, include friction numbers, if available, in the analysis of critical wet-pavement crash locations. Also include existing and projected traffic volumes, existing geometric features, and countermeasure alternative(s) such as grooving, reprofiling, and/or high-friction resurfacing. Specify a high-friction resurfacing type and mix design during Phase II.

3. Time Period. Analyze the traffic crash data available for the most recent five years and update the data accordingly. Notify BDE of any resultant changes to project design elements, if appropriate.
4. IDOT Procedures. See Chapter 12 for a discussion on processing Phase I reports for the “Highway Safety Improvement Program” at isolated Five-Percent Report locations identified and selected for the Illinois Safety Improvement Program. Include project/program sheets in the Phase I report, with benefit/cost ratio calculations and district safety committee signatures.
5. Other Publications. For additional information on analyzing crash patterns, see the Institute of Transportation Engineers (ITE) publications *Manual of Transportation Engineering Studies* and *Traffic Engineering Handbook*, the FHWA publication *Highway Safety Engineering Studies Procedural Guide*, or the *Highway Safety Manual (HSM)*.

11-2.02(g) Pavement Condition

The Condition Rating Survey (CRS) is performed biennially by the districts in cooperation with the Office of Planning and Programming. This information is most often used to determine the extent of pavement rehabilitation for a 3R project, or eligibility for potential SMART or 3P resurfacing projects. All State highway pavements are rated on a scale from 1.0 (poorest) to 9.0 (best) that measures pavement serviceability based upon cracking, patching, potholes, rutting, deterioration, maintenance, and visual physical condition. Resurfacing and rehabilitation needs may be determined from the surface condition rating in combination with the functional classification criteria and the traffic volume/crash criteria presented in the multi-year program. Include the most recent CRS values for pavement improvement eligibility in the Phase I report. See Chapter 53 for more information on pavement condition surveys and pavement rehabilitation strategies.

11-2.02(h) Bridge Condition Information

For existing bridges within the limits of a proposed project, coordinate with bridge maintenance engineer to obtain information on the bridge condition and to prepare a Bridge Condition Report;

see Section 39-3. Identify any deficiencies in a bridge's physical condition and load-carrying capacity. Also, contact the Bureau of Bridges and Structures for inventory and operating load ratings and the results of physical inspection ratings for the substructure and superstructure. Determine any bridge improvement needs from this information and the multi-year program.

11-2.03 Access Control/Access Management

Access control features are dependent upon a variety of factors (e.g., type of highway, either freeway or expressway, urban/rural location) and will affect traffic benefits, access to adjacent properties, and right-of-way costs. Proposed access control features for freeways or expressways must be determined for public presentation and discussion because of their effects on adjacent properties. The *BDE Manual* discusses access control elements and access management concepts in several locations. These are summarized as follows:

11-2.03(a) Overall Policy

Chapter 35 presents the overall Departmental policies and guidelines for access control and access management on the State highway system. This includes:

- definitions of access control terms,
- access control at interchange crossroads,
- access control along expressways and at sideroads,
- the development of access control plans, and
- access management concepts and techniques.

11-2.03(b) Highway Type

The tables of geometric design criteria in Chapters 44 through 48 interrelate access control or access management with highway functional classification (i.e., principal and minor arterials, and collectors). Section 43-1 discusses, in general, the relationship between access, mobility, and functional classification.

11-2.03(c) Median Crossovers and Openings

These are discussed in various locations in the *BDE Manual* as follows:

- Section 44-2.04 discusses median crossovers on freeways.
- Chapter 45 discusses median crossovers on expressways.
- Chapter 46 discusses median openings on Strategic Regional Arterials.
- Chapters 34 and 36 discuss median openings on all other facilities.

11-2.03(d) Frontage Roads/Service Drives

Frontage roads and service drives and how they relate to access control are discussed in Sections 44-2.05 (freeways) and 45-2 (expressways).

11-2.03(e) Driveways

Locate driveways to provide good service to users while simultaneously minimizing interference to highway traffic. The *Policy on Permits for Access Driveways to State Highways* (92 Ill. Admin. Code 550) provides guidance for driveway design in conjunction with the permit process and may be used as a starting point for developing access management studies.

11-2.03(f) Changes in Access

For new or revised points of access to an existing freeway, see Section 37-1. For changes in access control along an expressway, see Section 45-2.04.

11-2.03(g) Signing Policies

For the current IDOT policies on signing of access controlled highways, see the Bureau of Operations *Traffic Policies and Procedures Manual*.

11-2.04 Geometric Design Criteria

Part IV, Roadway Design Elements and Part V, Design of Highway Types of the *BDE Manual* present the Department's geometric design criteria for the different types of highways. This is an important element for all Phase I studies. The following sections briefly summarize the information in Parts IV and V.

11-2.04(a) Basic Design Controls

Chapter 31 discusses the design controls that have an overall impact on the geometric design of a highway facility; therefore, this is an important chapter for Phase I studies. As discussed in Chapter 31 and as appropriate, the designer should evaluate the following:

1. Project Scope of Work. Section 31-6 defines the following project scopes of work:
 - new construction,
 - reconstruction,
 - 3R (non-freeways), and
 - 3R (freeways).

The project scope of work will be determined before the initiation of a Phase I study. The definitions in Section 31-6 indicate the conceptual objective of the project under study.

2. Design Speed. This is a critical highway design element and is selected before initiating any studies. Section 31-2 discusses the overall philosophy in design speed selection. Chapters 44 through 50 present specific numerical criteria for project design speed based on functional classification, highway type, urban/rural location, and project scope of work.
3. Traffic Volume Analysis. Section 31-4 provides definitions of highway capacity terms and selection of the design year and design hourly volume for highway capacity analyses. It references the *Highway Capacity Manual* for detailed highway capacity techniques.
4. Sight Distances. Stopping sight distance (SSD) is a determining factor in an acceptable highway design, especially for vertical alignment. Section 31-3 presents Department criteria for SSD based on design speed. Other sight distances which may be applicable are:
 - decision sight distance,
 - intersection sight distance, and
 - passing sight distance.
5. Design Exceptions. Section 31-7 describes the Department's process for justifying and approving design exceptions to geometric design criteria on its roadway projects. There are two categories of design exceptions:
 - a. Level One. Level One design exceptions involve the controlling design criteria established by FHWA, but only on the interstate system, pursuant to the FHWA/IDOT Stewardship and Oversight Agreement. When not met, Level One design exceptions require documentation and justification by the district, concurrence by BDE, and formal approval by FHWA.
 - b. Level Two. Level Two design exceptions involve two distinct sub-sets. In addition to the 13 FHWA controlling design criteria for projects off the interstate system, Level Two design criteria are also design criteria identified by IDOT, on both interstate and non-interstate projects. When not met, Level Two design exceptions require documentation and justification by the district and formal approval by BDE only.

11-2.04(b) Horizontal Alignment

Chapter 32 discusses horizontal alignment for new construction/reconstruction projects in general. A significant portion of this chapter applies to the Phase II detailed design (e.g., superelevation development, mathematical details for horizontal curves). However, during Phase I studies, the designer should review and evaluate the following based on Chapter 32 and Section 48-5:

1. General Design Controls. The overall horizontal alignment of a highway facility impacts the safe and efficient flow of traffic and the aesthetic appeal of the facility. Section 32-5 presents several general design controls for horizontal alignment that will enhance the performance of the highway (e.g., avoidance of alignment reversals and broken-back curvature). The designer should ensure that alignment development is consistent with these goals.
2. Minimum Radii. Section 32-2 presents minimum radii for horizontal curves assuming open-roadway conditions, which applies to high-speed urban facilities and all rural facilities. When developing and evaluating alternative alignments in Phase I, the designer should, as practical, avoid the use of minimum radii. Section 48-5.03 discusses design criteria for horizontal curves for low-speed conditions ($V \leq 45$ mph (70 km/h)).
3. Coordination with Vertical Alignment. See Section 11-2.04(c) and Chapter 33.

11-2.04(c) Vertical Alignment

Chapter 33 discusses vertical alignment for new construction/reconstruction projects. A portion of this chapter applies to the Phase II detailed design (e.g., mathematical details for vertical curves). However, the majority of Chapter 33 applies to the decision-making during Phase I studies. This reflects the significant impact that vertical alignment has on a highway's safety, aesthetics, operations, and costs. Therefore, the Phase I designer must carefully review the following from Chapter 33 before proceeding with alignment development:

1. General Design Controls/Coordination with Horizontal Alignment. Sections 33-6.01 and 33-6.02 present several general design controls for vertical alignment (e.g., avoidance of roller-coaster profile) and in coordination with horizontal alignment (e.g., balance between horizontal and vertical curvature). Using these controls will enhance the overall design of the highway. The designer should ensure that profile development is consistent with these goals.
2. Aesthetics. The combined effect of horizontal and vertical alignment on highway aesthetics is considered to be very important. A highway alignment should fit gracefully into its surroundings and become an integrated component of the natural landscape. The guidance in Section 33-6.03 describes how to accomplish this objective.
3. Maximum/Minimum Grades. Section 33-2 discusses, in general, the use of maximum and minimum grades. These values determine the limits of vertical profiles studied in Phase I. Avoid the use of maximum grades, as practical. Chapters 44 through 48 present specific criteria for maximum and minimum grades based on highway types, design speed, and urban/rural location.
4. Minimum Vertical Curvature. Section 33-4 presents K-values for minimum curvature at crest and sag vertical curves, which are based on minimum stopping sight distances. When developing and evaluating alternative profiles for new construction and

reconstruction projects, the designer should, as practical, avoid the use of minimum vertical curvature.

5. Truck-Climbing Lanes. Section 33-3 presents the warrants and design of truck-climbing lanes. If truck-climbing lanes are warranted, the designer should determine the critical design elements (e.g., starting and ending points, width).
6. Vertical Clearances. Section 33-5 discusses vertical clearances in general, and Chapters 39 and 44 through 50 present specific clearance criteria based on highway type, urban/rural location, highway feature crossed (e.g., highway bridges, railroads, traffic signals), and the type of proposed improvement. Profiles must meet the vertical clearance criteria listed in these chapters.
7. Gradelines. In addition to previously discussed elements, the proper selection of the gradeline in Phase I will depend on many other factors (e.g., geotechnical, right-of-way impacts, snow drifting, drainage, earthwork balance). Section 33-6.04 discusses the evaluation of these factors in selecting a profile gradeline.

11-2.04(d) Cross Section Elements

Chapter 34 presents the Department's general criteria for cross section elements, and Chapters 44 through 48 present specific numerical criteria for cross sections based on highway type, design speed, traffic volumes, and urban/rural location. The designer must review the cross section criteria in these chapters and determine the most appropriate design for the given conditions. The selected roadway cross section will determine the type of operations, maximum allowable design speed, safety, costs, and right-of-way needs of a highway facility. The proposed typical section must identify:

- the number and width of travel lanes;
- the selection of an urban (curbed) or rural section;
- the shoulder width, if applicable;
- cross slopes;
- the type and width of median;
- parking lanes, if applicable;
- sidewalks and bike lanes/paths, if applicable;
- side slope configuration (i.e., fill slopes, cut slopes, roadside ditches);
- right-of-way width; and
- type and thickness of pavement.

11-2.04(e) Intersections

Chapter 36 presents the Department's criteria for the design of intersections. Chapter 14 specifically discusses the warrants and the criteria for the preparation of an Intersection Design Study (IDS). If IDSs are required with a project, the IDSs shall reflect the latest design alternative if displayed at a public hearing. The IDSs must be labeled as a draft version if it is not approved.

An IDS is not required when the scope of work for a project is limited to only installing pedestrian and/or bicycle accommodations unless their installations is done in conjunction with a change in the vehicular lane configuration of an intersection.

11-2.04(f) Interchanges

Chapter 37 presents the Department's criteria for the design and layout of interchanges. In some cases, type approval may be required before proceeding with detailed design. Chapter 15 discusses the warrants for an interchange and the criteria for the preparation of an Interchange Design Study (IDS). If IDSs are required with a project report, the IDSs shall reflect the latest design alternative if displayed at a public hearing. The IDSs must be labeled as a draft if it is not approved.

11-2.04(g) Roadside Safety

Chapter 38 presents the Department's criteria for roadside safety, including clear zones, barrier warrants, barrier design and layout, impact attenuators, and glare screens. Most of the information in Chapter 38 is applicable to the detailed design completed in Phase II. During a Phase I study, however, the designer should evaluate and establish the following:

1. Clear Zones. Section 38-3 presents the Department's clear zone criteria for new construction/ reconstruction projects. The applicable clear zone should be identified in Phase I. This will determine, in part, right-of-way needs and utility impacts.
2. Median Barrier Warrants. Section 38-7 discusses the Department's warrants for median barriers based on the median width and traffic volumes. The Phase I study should identify whether or not a median barrier is warranted.
3. Roadside Barrier Warrants. Section 38-4 discusses roadside barrier warrants. In general, the preferred design is to provide a roadside configuration and clearance that eliminates the need for roadside barriers. The typical section and alignment decisions made during Phase I must include the determination of the need for roadside barriers. Also, during Phase I a determination of the roadside barrier length may be included. Therefore, the Phase I study should, as practical, seek to find the balance between providing a safe roadside (which tends to increase project costs) and limiting construction, right-of-way, and environmental impacts (which tends to decrease roadside safety). Review Section 38-4.03, which discusses the Department's policies on roadside barrier warrants and cost-effective analyses.

11-2.04(h) Design of New Construction/Reconstruction Projects

In the Phase I study, use the appropriate chapter in Part V that corresponds to the type of facility under design.

Part V Highway Systems presents the following chapters based on functional classification and highway type for new construction or reconstruction type projects:

- Chapter 44, Rural and Urban Freeways,
- Chapter 45, Expressways,
- Chapter 46, Strategic Regional Arterials,
- Chapter 47, Rural Two-Lane/Multilane State Highways, and
- Chapter 48, Urban Highways and Streets.

These chapters are structured to present specific numerical criteria for each highway type and reference the chapters in Part IV, Roadway Design Elements for detailed information on specific geometric design elements (e.g., horizontal alignment). Chapters 44 through 48 also discuss geometric design features that are unique to a certain type of facility. For example, Chapter 44 discusses frontage roads adjacent to freeways, and Chapter 48 discusses urban design features (e.g., parking lanes, sidewalks, horizontal alignment on low-speed urban streets).

11-2.04(i) Design of 3R Projects

The applicable chapters in Part IV, “Roadway Design Elements” and Part V, “Highway Systems” present the Department’s design criteria that apply to new construction/reconstruction projects. For these projects, the designer often has the liberty of designing the highway to meet the most desirable criteria. However, available finances do not always permit the reconstruction of existing highways to this level.

Therefore, the geometric design of projects on existing highways must be viewed from a different perspective. These projects are often initiated for reasons other than geometric design deficiencies (e.g., pavement deterioration, crashes), and they often must be designed within existing right-of-way, with financial limitations, and environmental constraints. As a result, the design criteria for new construction and reconstruction are often not attainable without major cost and, frequently, adverse impacts. At the same time, however, the Department must make cost-effective and practical improvements to existing highways and streets.

For these reasons, the Department has adopted separate geometric design guidelines for 3R projects on existing highways. Chapter 49 presents guidelines for 3R projects on rural and urban highways, and Chapter 50 presents guidelines for 3R freeway projects. These guidelines are intended to find a balance among many competing and conflicting objectives. These include the objective of improving the riding surface; minimizing adverse impacts of highway construction on adjacent lands; targeting improvements where ADT is higher or safety performance is lacking, and improving the greatest number of miles (kilometers) with available funding.

Phase I studies for 3R projects will be based on the guidelines discussed in Chapters 49 and 50.

11-2.04(j) Design of 3P and SMART Projects

Chapter 53 presents the guidelines for SMART projects, as well as other pavement preservation strategies, which are intended to extend the service life of the pavement without significantly increasing its structural capacity. Chapter 53 presents the guidelines for 3P projects, as well as other methods of pavement rehabilitation, which are intended to address specific pavement deficiencies. The scope of SMART and 3P Projects do not normally include geometric improvements. Job limits shall be extended to include intersections within 500 ft of project termini for the inclusion of bicycle and pedestrian features. Pedestrian and bicycle features included in this work are detailed in Section 17-1.02. Normal project termini should remain in place.

11-2.05 Hydraulics (Drainage)

For the hydraulic evaluations in conjunction with a Phase I study, use the following references:

1. IDOT Drainage Manual. The Bureau of Bridges and Structures is responsible for the *Drainage Manual*. The Manual is a compilation of Department policies and criteria on drainage and hydraulics for road and bridge projects. The *Drainage Manual* discusses:
 - division of responsibility for drainage;
 - legal requirements;
 - drainage policies;
 - permits;
 - preparation of drainage studies and hydraulic reports;
 - floodplain encroachments (hydraulic analysis);
 - hydrology;
 - open channel flow;
 - culvert hydraulics;
 - bridge hydraulics;
 - storm sewers;
 - encroachment onto traveled way adjacent to curb and gutter;
 - inlet spacing;
 - roadside ditches;
 - erosion and sediment control;
 - scour;
 - detention storage;
 - pumping stations; and
 - rules for construction in rivers, lakes, and streams.
2. Drainage Procedures. Chapter 40 of the *BDE Manual* discusses those procedures related to the evaluation of drainage design in a Phase I study. This includes the division of responsibility between the districts and Central Office, scope of the Drainage Study, and general drainage considerations in the design of highway projects.

3. Floodplain Finding. The *IDOT Drainage Manual* provides the hydrological requirements for a floodplain study. Section 26-7 of the *BDE Manual* provides guidance for the environmental documentation required for projects that will involve a significant floodplain encroachment.
4. Hydraulic-Related Permits. These include permits for Section 404, Section 9, Section 401, Section 402 (NPDES) and IDNR Construction in Floodways. Chapter 28 of the *BDE Manual* briefly discusses each of these permits.

11-2.06 Traffic Engineering

The Bureau of Operations has the primary responsibility for traffic engineering analyses on State highway projects. These responsibilities include:

- warrants and phasing for traffic signals;
- warrants, design, and placement for highway signs and pavement markings; and
- traffic engineering investigations (e.g., speed studies, school zone studies).

Many traffic engineering elements are addressed during detailed design in Phase II (e.g., selection and location of traffic signs and pavement markings). However, as appropriate for the project scope of work and a Phase I study, the designer will evaluate those traffic engineering factors which will impact the decision-making in Phase I (e.g., traffic signal warrants, preliminary signing plans for freeways and expressways). Chapter 57 of the *BDE Manual* provides guidance on traffic engineering issues important to highway design, and it references documents published by the Bureau of Operations for more detailed information.

11-2.07 Structures

The Bureau of Bridges and Structures is responsible for the design of highway structures (e.g., bridges, culverts, retaining walls). As appropriate for the project scope of work and a Phase I study, the designer will evaluate those structural factors that are appropriate for these studies. Section 39-3 of the *BDE Manual* discusses the bridge planning process, which documents:

- the necessary coordination between parties to identify needed bridge improvements,
- the preparation of a Bridge Condition Report and proposed Bridge Drawing,
- preliminary bridge investigations, and
- the preparation of Type, Size, and Location Plans for Phase II work.

The proper implementation of the bridge planning process will ensure that appropriate structural considerations are reflected in a Phase I study. This includes geotechnical, hydraulic, environmental, right-of-way, costs, and aesthetic factors. In addition, Section 39-4 presents the Department's criteria for bridge geometrics (e.g., widths, clearance).

11-2.08 Miscellaneous Highway Features

The Phase I study should reflect, as appropriate, other highway features as follows:

11-2.08(a) Utilities

The Illinois Administrative Code (92 Ill. Admin. Code 530) sets forth the requirements for the accommodation of utilities on the right-of-way of the Illinois highway system. The Bureau of Operations should be contacted for policies on the location of utilities (e.g., with respect to the roadside clear zone). Consider provisions for utilities when determining approximate project right-of-way requirements during the Phase I study. See Chapter 6 for utility adjustments required for highway improvements. Describe all utility locations and any proposed modifications, changes, or multiple uses of right-of-way, including a division of the estimated adjustment costs.

11-2.08(b) Railroads

The Phase I study must identify all railroad crossings within the proposed project limits, and it must determine if each crossing will be at-grade or grade separated. This will be a collaborative effort between the Department, the affected railroad, and the Illinois Commerce Commission. For existing crossings, the Phase I report should document the number of trains/day, the existing warning devices, the crash history, and the geometrics at the crossing. In most cases for at-grade crossings, it will be appropriate in Phase I to specifically determine the type of warning devices at the crossing (e.g., automatic gates, flashing signals). Section 7-3 provides additional information on the design of highway/railroad crossings.

11-2.08(c) Weigh Stations and Rest Areas

See Chapter 16 for guidance when a proposed project involves a weigh station or rest area. Analyze access and other design considerations (including effects on highway alignment and grade) where weigh stations, rest areas, or rest stops are proposed.

11-2.08(d) Lighting

Consult Chapter 56 for warrants for highway lighting and illumination. Describe existing and proposed illumination levels including uniformity ratios and glare levels. Provide descriptions of crash rates, night/day crash ratios, and illumination of adjacent highway sections, as necessary, to demonstrate the need for proposed lighting improvements.

11-2.08(e) Sidewalks and Pedestrians

See Chapter 17 for information on pedestrian accommodations and Chapter 48 for warrants and the design of sidewalks within the roadway cross section. Also, see Chapter 39 for sidewalks or bikeways on bridges. Describe the reasons for providing, or not providing, sidewalks and the

coordination needed with local governmental units. See Chapter 58 for additional discussion on sidewalks and ADA compliance. The Phase I report must discuss any requests and the justification for deviations from the participation policies for sidewalks as discussed in Chapter 5 on Local Agency Agreements.

11-2.08(f) ADA

Chapter 58 discusses the Department's implementation of the Americans with Disabilities Act (ADA). The Phase I report must contain a discussion on satisfying ADA requirements including, if applicable, coordination with local officials. Any Intersection Design Study (see Chapter 14) prepared in Phase I must indicate the location of the curb cuts/ramps or other accommodations to be provided. The Phase I report also must discuss any request for a design exception from Department policies on accommodating individuals with disabilities and the justification for the request; see Section 31-7.04(c).

11-2.08(g) Landscaping/Stormwater Pollution Control

Consult the District Landscape Architect for tree removal/replacement, revegetation/erosion control, and other landscaping features and document the recommendations in the Phase I report. To avoid duplication, information contained in environmental documents that has been developed according to Section 26-17 and Sections 24-3.02(e) and 25-3.08(r) (e.g., environmental commitments and mitigation) should be referenced. Also, review Chapter 59 for guidance on landscaping and Chapter 41 for stormwater pollution control.

11-2.08(h) Existing Public Educational Facility Entrances

1. Background. Public Act 95-0271 amended the Department of Transportation Law of the Civil Administrative Code of Illinois by adding Section 2705-580 (20 ILCS 2705/2705-580) as follows:

“As part of State highway construction projects, the Department shall evaluate, fund, and repair, within the right-of-way, the entrances to public educational facilities that border State highways.”

2. Procedures. The following procedures apply to all State highway projects with a public educational facility entrance onto a state highway. For the purpose of this policy the word “evaluate” shall mean to examine the existing public educational facility entrance and to determine any deficiencies and repairs needed as part of the roadway project. The intent is to improve the condition of such existing entrances, if unsatisfactory, as part of an improvement of the roadway onto which the entrances abut, consistent with the scope of the mainline improvement. For instance, it would not be appropriate to improve the unsatisfactory roadway surface condition of an entrance if the mainline project scope is only installation or modification of traffic signals.

- a. Phase I Studies and Reports. The Phase I study and engineering report shall evaluate and document any entrance for a public educational facility that enters onto the project roadway.
- b. New Construction/Reconstruction Projects. For these types of projects, the procedures for designing entrances and side roads as outlined in the *BDE Manual* and the *Handbook for the Policy on Permits for Access Driveways to State Highways* would apply. The entrance should be evaluated and a design provided based on operational needs, turning radii, left and right turn movements, safety, drop-off/pick-up zones, and accessibility for pedestrians, bicyclists, and persons with disabilities.

Reconstruction types of projects are not limited to the existing right-of-way, but the entrance construction should not be the main reason for the right-of-way acquisition. If the reconstruction project could be done without any reconstruction or other upgrade to an existing public education facility entrance, such entrances should still be evaluated and repaired as necessary within the existing right-of-way, as described above.

- c. 3R Projects. Use the same procedures as that for New Construction/Reconstruction Projects.
- d. Pavement Rehabilitation and Preservation Projects. For pavement rehabilitation and preservation projects that are generally considered to be resurfacing only, such as 3P or SMART, the entrance to the public educational facility should be evaluated and any repairs/resurfacing should be extended to the right-of-way limits. The work shall be consistent with the work allowed by this type of project and in most cases match the existing grade and surface of the entrance.

11-2.09 Maintenance Considerations

See the FHWA publication *Integration of Maintenance Needs into Preconstruction Procedures*, Report No. FHWA-TS-78-216, for information on highway maintenance as it pertains to highway design. The section of this publication entitled "Maintainability Considerations in Highway Planning" provides guidelines for highway maintenance considerations related to highway location, right-of-way, and geometrics. Also, see NCHRP Report 349, *Incorporation of Maintenance Considerations in Highway Design*. In addition, develop Phase I studies in cooperation with bridge and highway maintenance personnel who are responsible for the highway section under design.

11-2.10 Geotechnical Considerations

See the IDOT *Geotechnical Manual* for information on geotechnical considerations. The Central Bureau of Materials (CBM) maintains the *Geotechnical Manual*. The following applies:

1. Chapter 1, Geotechnical Investigations and Chapter 3, Geotechnical Analysis. These chapters provide guidelines to adequately assess the subsurface conditions on highway projects and to identify the soil and foundation concerns that need to be evaluated for structural support. This information facilitates preliminary highway location or design and can assist in determining the economies of various alignments considering soils and geology. Upon determining the general alignment, the data also assists in selecting the proposed gradeline.
2. Chapter 4, "Design Recommendations". This chapter describes design recommendations and reflects the conclusion of field and laboratory investigations and any office work. The conclusions are documented in a Geotechnical Report. The Soils Committee reviews district- or consultant-prepared Geotechnical Reports for proposed highway improvements. The district initiates the requests for reviews.

Conduct Phase I studies in cooperation with soils specialists and geologists when these disciplines influence the location and/or design of a proposed improvement. Also, the location of foundations for structures or high embankments may be an important item in the highway location.

11-2.11 Agreements

Consult with the Agreements Unit in BDE during the preparation of Phase I studies to determine if any agreements will be necessary. Depending upon the nature of the project, one or more of the following agreements may be necessary:

11-2.11(a) Local Agency Agreements

In general, agreements will be required with a local agency whenever it will participate in the improvement of a State route within its boundaries. Local agency participation may be a contribution of materials, services, or money (e.g., right-of-way, preliminary engineering, local funds). Although the Agreements Unit has the primary responsibility for processing local agency agreements after design approval, some agreements may depend in part upon decisions reached during the Phase I study. See Chapter 5 for information on local agency agreements. The agreement, or Letter of Understanding, will also define the division of costs between the State and local agency and the respective responsibilities for a variety of project elements and any maintenance or jurisdictional transfers.

11-2.11(b) Utility Agreements

A Utility Agreement will be necessary on all State highway projects that require an adjustment of a public or private utility. Chapter 6 documents the policies and procedures that apply to utility adjustments on Department projects. This chapter discusses Department reimbursement policies, procedures for agreement processing, the preparation of utility plans, and the preparation of cost estimates for utility adjustments.

11-2.11(c) Railroad Agreements

A Railroad Agreement will be necessary on all State highway projects that impact railroad right-of-way, either at a highway-railroad grade crossing or a grade-separation between a highway and railroad. Chapter 7 documents the policies and procedures for work that impacts railroad right-of-way. This chapter also discusses division of costs between the Department and Railroad, procedures for processing the agreement, and other activities related to railroads (e.g., removing abandoned highway-railroad crossings, preliminary engineering for design, and acquisition of railroad property).

The Phase I report should document the reasons for any deviations from current Department policies for these agreements, and it should describe the necessary coordination with the district and other affected entities. In addition, discuss the coordination with local officials, utility companies, and railroads that might affect the preparation of any agreements. Develop cost estimates for the Phase I study consistent with the division of costs between the State and other entities involved in the work. Also, describe any commitments made with the local agency, utility companies, or railroad.

11-2.12 Right-of-Way Issues

The district Land Acquisition Section develops preliminary right-of-way cost estimates and relocation assistance plans as necessary and in accordance with the *Land Acquisition Policies and Procedures Manual*.

Right-of-way costs are determined on a per acre (hectare) basis or on a parcel-by-parcel basis and include costs for displaced persons as a result of a proposed highway improvement. For projects where relocations are anticipated, it is a good practice to estimate the cost of each relocation when finalizing the overall right-of-way project cost estimate. The steps in the land acquisition process are shown in the *Land Acquisition Policies and Procedures Manual*.

When publicly owned facilities will be acquired, a decision should be made at the completion of the Phase I study to either pay the market value for the property or to functionally replace it. The guidance on this issue is in the *Land Acquisition Policies and Procedures Manual*.

See Section 34-5 when laying out highway alignments. This section provides guidance on right-of-way issues that could avoid adverse property severance, undesirable access features, unnecessary damages, and odd-shaped takings. Also, consider existing property lines and the value of property to avoid excessive right-of-way costs. Often, alternative locations and designs can be selected with lower right-of-way costs.

11-2.13 Coordination with Airports

Highway and bridge improvements within 2 miles (3.2 km) of publicly owned airports, within 1 mile (1.6 km) of privately owned airports open to the public, and within 0.5 miles (0.8 km) of restricted-landing areas will require coordination with Aeronautics. These coordination requirements concerning distance to an airport are in conjunction with height obstructions of 15 ft (4.6 m) or

more above the roadway. In addition, the district must coordinate with Aeronautics for all realignments and construction improvements on new location regardless of the height of obstruction.

Airport clearance requirements could affect the controlling elevations and locations of pavements and structures. Discuss the necessary construction equipment (e.g., cranes, pile drivers), highway appurtenances (e.g., signs, lighting, traffic signals, utility poles), and environmental mitigation that might affect airspace clearances. During preparation of the Phase I study, also contact the local airport authorities to ascertain that any proposed airport expansion plans will not cause the highway improvement to conflict with future airspace clearances.

For those airports that are publicly owned, coordination with the Federal Aviation Administration (FAA) is required. Contact Aeronautics prior to communicating with FAA.

The Phase I report must include a discussion as to whether or not any airports exist within the distance requirements set forth above and if any obstructions will exist due to highway improvements. Any required vertical clearance permits must be obtained prior to PS&E approval. Airspace clearances are defined in the Illinois Administrative Code (Aviation Safety, 92 Ill. Admin. Code 14).

11-2.14 Traffic Control During Construction

The Phase I study must include a discussion on or development of a conceptual plan to accommodate traffic during construction. The following references are applicable:

1. Work Zone Traffic Management Studies. Chapter 13 documents the goals and objectives for developing a Transportation Management Plan (TMP) report. Each Phase I report should contain TMP indicating an overall strategy for accommodating traffic during construction. The TMP usually will be approved as part of a Phase I report and the decisions made in TMP will be used to prepare the detailed Traffic Control Plan (TCP) during Phase II work.
2. Work Zone Traffic Control. Chapter 55 presents detailed design criteria for accommodating traffic in a work zone (e.g., geometric design, roadside safety). During the Phase I study, the designer will need to review Chapters 13 and 55 to determine the appropriate design features for different methods of accommodating traffic during construction.

11-2.15 Estimate of Costs

At the completion of a Phase I study, prepare a cost estimate for the project. This cost estimate is used during the programming process at both the district and central office levels to determine a realistic annual construction budget. To accomplish this for complex projects requiring more than one construction season, provide cost estimates for individual usable segments. The multi-

year highway improvement program can then be developed using the individual segment costs rather than an estimated proportional cost of the total project.

Sections 12-4 and 65-1.02 discuss the information needed to document project costs. Typical cost estimate sheets for minor complexity and major complexity Phase I projects are shown in Section 12-4. To provide statewide uniformity of items used in estimating costs, the designer should use these typical cost estimate sheets in Phase I reports.

11-3 ROUTE PLANNING

11-3.01 Scope

Route planning is the general term used for locating and selecting a design for a major highway facility on new alignment or, in some cases, along an existing highway. Route planning is typically accomplished by the Office of Planning and Programming and is conducted 10 to 15 years prior to a corridor study analysis. Typical examples where route planning would apply are with freeways, expressways, and bypasses. It involves the consideration of engineering, sociological, environmental, and economic elements. Proper planning will determine the traffic needs and the type of facility required to satisfy those needs. After this determination has been made, a study area and area of influence can be selected, and corridors within the study area can be proposed and investigated.

After selection and approval of a corridor, a Phase I study may be initiated and alternative alignments within the corridor may be developed to determine the optimum project design. During detailed project development, consider the requirements in Chapter 19 (public involvement) and Part III, Environmental Procedures.

11-3.02 Logical Termini

Phase I studies for route planning projects as listed above should span a route length that extends to logical termini. Also, ensure that the study addresses the social, economic, and environmental impacts of the ultimate improvement and provides for a uniform set of design criteria between logical termini.

Logical termini generally consist of population centers, major traffic generators, major crossroads, and other features that serve as a destination, either intermediate or final, for a significant portion of the traffic likely to use the route being considered for improvement. Consider the following when determining logical termini:

1. Population Centers. Population centers, typically considered as logical termini, will vary considerably in size. They may be defined, however, as those cities, towns, or villages that serve as trade or business centers in the geographical area where the improvement is located.
2. Major Traffic Generators. Major traffic generators are those shopping districts, factories, employment centers, recreational facilities, and other developments that serve as a destination for a significant portion of the traffic likely to use the facility being considered for improvement.
3. Major Crossroads. Major crossroads are those crossroads that have a functional classification equal to or higher than the route being proposed for improvement.

Section 22-6 discusses logical termini in more detail with respect to the selection of project alternatives.

11-3.03 General Considerations

Prior to developing a Phase I study in detail, reaffirm the location of logical termini for consistency with the project goals, objectives, and NEPA requirements. Logical termini usually have been predetermined by other methods (e.g., need studies, comprehensive transportation studies). Also, reaffirm the recommendations of any previous studies.

Upon reaffirming the recommendations of previous studies and selecting the major logical termini, consider the following factors in route planning for freeways, expressways, or bypasses:

- functional classification;
- directness;
- preliminary intersection or interchange locations;
- provision of good access to communities;
- effect on developed areas;
- route markings;
- plans of adjacent States for routes at State lines;
- location of major structures;
- flood hazards and longitudinal floodplain encroachments;
- displacement of businesses, families, and farms;
- property values and prime farmlands;
- public utilities;
- fire protection;
- traffic operations;
- operation and use of existing highway facilities and other transportation facilities during construction and after completion of project; and
- general environmental impacts including those on archaeological sites, historic sites, wetlands, special waste sites, and public lands (see Part III).

In the route planning process, it is necessary to use the knowledge and expertise from various disciplines and to obtain information from various sources. The following is a partial list of sources, information, and disciplines that are available in the route planning processes:

- photography;
- bridge condition reports, crash reports, and pavement condition ratings;
- natural resource and conservation agencies;
- local agencies;
- economists;
- geotechnical engineers;
- airport agencies;
- railroad agencies;
- sociologists;
- road designers;
- urban and regional transportation planning agencies;
- other resource, recreational, planning, and public agencies;
- utility companies; and
- special flood hazard area maps.

11-3.04 Overall Procedures

Once the route planning process is completed and a general route location is selected, the next step in the highway development process is to investigate and select a corridor location. Once the corridor location is selected, Phase I studies are initiated and the final alignment and design features are chosen.

For an overview of the Study Development Process for these types of projects, see Chapter 2, Figures 2-2.A and 2-3.A. Each of these stages is discussed elsewhere in this chapter, Chapter 19, and Part III, Environmental Procedures.

11-4 CORRIDOR STUDIES

As applicable, a corridor study must reflect general engineering evaluations as discussed in Section 11-2 and the environmental analyses in Part III, Environmental Procedures. Section 11-4 presents additional information that applies specifically to a corridor study. Section 12-3.01 discusses the content and format of a Corridor Report.

11-4.01 Purpose

The purpose of a corridor study is to investigate all feasible corridors within a regional area as determined by the route planning process. In some cases, such a study could be considered a Feasibility Study. The feasibility of a corridor depends on the social, economic, environmental, and engineering effects of the proposed highway improvement within each corridor. Corridor studies usually are prepared only for new freeways, for new expressways where two or more existing routes are being considered for upgrading, or for a new two-lane highway proposed on new location.

A separate corridor study usually is necessary for lengthy projects on new location where alternative corridors are available for a proposed action. This analysis will indicate that alternative corridors can cause substantially different social, economic, or environmental effects or will essentially change the layout or function of connecting streets or roads. Because alternative corridors may be able to provide similar functions, a corridor study provides the means to select the most appropriate corridor for detailed studies of a highway facility. Coordinate and fulfill the appropriate requirements of Chapter 19 and Part III concurrently with the corridor study. Chapter 2, Figure 2-2.A illustrates corridor study coordination on a highway with environmental studies and public involvement activities.

11-4.02 Reconnaissance During Corridor Study

11-4.02(a) Objectives

The objectives of the reconnaissance stage of the corridor study are to:

- reaffirm the need for the proposed improvement,
- establish goals and objectives,
- establish the study area and logical termini,
- identify preliminary corridors,
- analyze each of the preliminary corridors, and
- eliminate corridors not feasible for further study.

11-4.02(b) Sources of Information

Use the following sources of information during the reconnaissance stage:

- State, county, and city maps;
- ASCS photography or IDOT photography;
- USGS quadrangle topographic maps;
- National Wetland Inventory maps;
- Advanced Identification of Wetland maps (District 1 only);
- traffic maps and data;
- functional classification maps;
- Federal agency plans (e.g., U.S. Army Corps of Engineers, Coast Guard, Department of Interior, Department of Housing and Urban Development);
- special development plans (e.g., conservation, industrial, recreational, resource);
- population growth trends;
- utility maps;
- urban area transportation studies;
- other regional planning studies;
- road inventory data from the Illinois Road and Inventory System (IRIS);
- Illinois Department of Natural Resources (IDNR), including:
 - + Office of Water Resources for regulatory floodway maps;
 - + Office of Mines and Minerals for mined-out area maps; and
 - + Office of Realty & Environmental Assessment for consultation, coordination, and Impact Assessment;
 - + Office of Resource Conservation for endangered species, nature preserves, wildlife action plan, fishery data, and biological stream ratings;
- USDA, Natural Resources Conservation Services for county soils surveys and wetland maps;
- Federal Emergency Management Agency (FEMA) for flood hazard boundary maps and flood insurance rate maps;
- IEPA Illinois Integrated Water Quality Report and Section 303(d) List;
- USEPA/IEPA for a listing of special waste sites (e.g., LUST, USTS, CERCLIS sites); and
- IHPA for historic site location information.

This list is not all-inclusive, and the designer should consult all available sources prior to proceeding with the development of the corridor study.

11-4.02(c) Coordination

In accordance with Chapter 19 and Part III, Environmental Procedures, contact the following agencies during the reconnaissance phase:

- planning agencies;
- airport authorities;
- local agencies (e.g., counties, municipalities, townships);
- conservation, drainage districts, historical, recreational, and archaeological agencies; and
- other appropriate individuals or agencies.

Contacting these agencies will avoid conflicting improvements. See Section 22-5 for more information on coordination.

11-4.02(d) Study Area

Determining the need for a highway facility is a function of the Office of Planning and Programming and/or local urbanized area transportation agencies. Because the type of highway is selected during route planning, this identifies the geometric design requirements of the facility and the area of influence. Once the area of influence is determined, this allows an estimate of potential land development and, in turn, traffic growth within the corridor.

County or other area maps and USGS quadrangle topographic maps, combined with aerial photography, will furnish the locations of towns, streams, railroads, and other topographic features that will assist in defining the limits of the study area. Plot special flood-hazard areas, wetlands, and public lands on those maps for reference and analysis. Review these maps and locate feasible corridors upon the area maps with respect to local terrain, topographic features, and other controlling items. Use the area maps showing all feasible corridors as the basis to study and investigate different corridor locations.

The study area is determined through a general overview of area maps in the office and field trips. Field trips may be facilitated by prudent use of helicopter flights. The study area is that part of the area of influence within which the facility will be investigated. The limits of the study area may not be the same as the area of influence. Lateral limits are dependent on the distance between the major termini, the function of the highway, and the character of the area traversed.

11-4.02(e) Corridor Location

In general, locate new highway facilities as close as practical to major municipalities to maximize road-user and local-interest benefits and to contribute to the orderly growth of communities. Traffic volumes, combined with origin-destination studies and major transportation plans, reflect the need and extent of intersection or interchange connections to other highway facilities within the corridor. Determine whether these connections can be adequately developed (e.g., size of interchanges, length of access control on crossroads, profiles). It may be necessary to revise tentative corridors to accomplish this goal.

During this stage, determine the approximate location of major intersections and/or interchanges, major drainage structures, and the approximate number of proposed grade separations, if applicable. This information will be used for cost estimating. At this time, determine the need for frontage roads, service drives, and other related features, and their practicality. This will aid in the determination of corridor widths. Also, consider establishing an approximate gradeline for certain segments if:

- an abnormal amount of earthwork is anticipated,
- there is a major difference in the grading requirements of alternative corridors, or
- major drainage structures require that a gradeline be established.

In planning the location of a highway, avoid corridors that create longitudinal encroachments into floodplains. Transverse encroachments of a floodplain are unavoidable and, fortunately, create much less of an impact on floodways compared to longitudinal encroachments. However, transverse encroachments must still be investigated to establish the significance of floodway impacts.

Also, at this stage, a general geologic survey should be made to determine whether the study area contains any adverse soil conditions that could have a major impact on the suitability of a potential corridor. The district initiates the request for a Corridor Geotechnical Report by contacting the Soils and Foundations Unit in the Bureau of Bridges and Structures. If they are unable to conduct the study, the Soils and Foundations Unit will recommend hiring a consultant to complete the work.

Analyze the reconnaissance information and eliminate the unacceptable corridors. In the Corridor Report, note the reason(s) for the elimination of any corridors (e.g., environmental consequences, route planning considerations).

11-4.03 Analysis of Acceptable Corridors

11-4.03(a) Objectives

After completing the reconnaissance stage and eliminating unacceptable corridors, analyze the remaining corridor alternatives. The objective of this stage of analysis is to perform a detailed study of acceptable corridors. The following additional information will be useful during this stage:

- land use;
- habitat (e.g., forested, prairie, wetlands);
- drainage impacts and construction in floodplains;
- projected ADT's;
- fire districts, mail routes, school districts, drainage districts, and taxing districts shown on maps;
- recommendations from Geotechnical Reports;
- locations of major utility installations;
- other transportation facilities (e.g., commuter and freight railroads, airports, bus and trucking terminals);
- urban area transportation study reports and other data;
- regional planning agency reports;
- interagency coordination in accordance with Chapter 19 (public involvement) and Part III (environment);
- route planning considerations (see Section 11-3);
- private and commercial property owner reports; and
- location of cemeteries, public lands, wetlands, threatened and endangered species/habitat, nature preserves, natural areas, biological stream ratings, TMDLs, historic structures, archaeological sites, and special waste sites.

11-4.03(b) Final Corridor Exhibits

For rural areas, sketch corridors on aerial photography (screened half-tone positives) at a scale of 1 in = 600 ft (1:7500 metric). If recent aerial photography for rural areas is not available, county maps may be used initially until new photography is obtained. In highly urbanized areas, use aerial mosaics at a scale of 1 in = 100 ft (1:1000 metric). Sketch sensitive areas (e.g., parks, wetlands, nature preserves, historic sites) and other controlling features on the base maps of aerial photography. As practical, avoid any of these controlling features and sensitive areas.

In addition to the use of aerial photography, sketch the final corridors on USGS quadrangle maps. Using the quad maps, consider the characteristics of the land including flood-prone areas and the need for major drainage structures. Evaluate soils maps in conjunction with aerial photography and locate any areas of unstable or unsuitable materials that must be avoided or replaced. These areas may cause stability problems for embankments or may not be suitable for excavated material to be used in embankments.

See Section 11-5.02 for the services and products available from the Surveys, Mapping and Modeling Section in BDE.

11-4.03(c) Final Field Inspections

During the final analysis of acceptable corridors, conduct a field inspection of each corridor. This inspection should consider any features previously noted and observations should be made of any new local developments. Also, investigate other major features in the corridors and make decisions on the suitability of each corridor.

11-4.03(d) Estimate of Costs

Prepare a generalized cost estimate for all acceptable corridors; see Sections 12-4 and 65-1.02. This estimate, by necessity, will be an approximation because only major design features will have been determined. Therefore, a road user benefit analysis comparing alternative corridors will not be required.

11-4.03(e) Public Involvement

Public involvement for corridor studies entails a series of meetings with different agencies, interest groups, municipalities, and general public; see Chapter 19. The results of these meetings help determine the most suitable corridor or corridors for detailed design studies.

11-4.03(f) Selection of Final Corridor

When selecting the final corridor, consider the public involvement comments (see Chapter 19), environmental effects (see Part III), and engineering factors (see Section 11-2). The final selection of a corridor is documented in a Corridor Report; see Section 12-3.

11-5 DESIGN STUDIES

As applicable, a design study reflects the engineering evaluations discussed in Section 11-2 and the environmental analyses in Part III, Environmental Procedures. Section 11-5 presents information that applies specifically to a design study for a complex project (e.g., freeway, expressway, bypass) as defined in Section 11-1. Section 12-3.03 discusses the content and format of a Design Report for a complex project.

11-5.01 Objective

Develop the purpose and need for the study of a complex project and then investigate all plausible alignments within an approved corridor by using topographic mapping and aerial photography. In developing the design study, address the following features or items:

- design criteria;
- typical sections;
- intersection/interchange designs;
- access control features;
- horizontal alignment and vertical profile;
- right-of-way limits;
- number of traffic lanes; and
- the rationale for the location of bridges, interchanges, intersections, and other structures.

In addition, public involvement activities (see Chapter 19) and environmental studies (see Part III) shall be conducted concurrently with the design study. The Project Development Network for complex projects shown in Chapter 2 illustrates the coordination needed in conjunction with public involvement activities and environmental studies.

11-5.02 Products and Services from Surveys, Mapping and Modeling

Extensive products or services are available from the Surveys, Mapping and Modeling Section for use in performing design studies and other types of work. Some of the more common products or services are:

- uncontrolled aerial photography (black and white or color);
- high-altitude statewide photography;
- aerial photographic mosaics (i.e., aerial photographs that are pieced together to eliminate most of the distortion and then re-photographed);
- contact prints;
- CADD-generated mapping at a scale of either 1 in = 50 ft (1:500 metric) or 1 in = 200 ft (1:2500 metric);
- digital terrain models;
- screened positives of aerial photographs (paper prints can be produced from this product);
- oblique photography for use at informational and/or public hearings;
- enlargements or reductions of exhibits and mapping;

- a complete USGS quadrangle file for use by the Department;
- plotting of centerline on mylar sheets;
- photo plan and profile sheets;
- orthophoto maps (controlled aerial photography with contour lines superimposed on photography); and
- reading of cross sections from mapping.

To determine more details on the use of the above products and services, contact the Surveys, Mapping and Modeling Section.

11-5.03 Alignment Investigations

11-5.03(a) Review of Corridor Selection

Review the Corridor Report in detail before proceeding with the design study and ensure that the corridor decisions are still valid. Throughout the design study process, reaffirm the approved corridor as contacts are made with planning agencies. Also, assess any changes in land use or development plans to determine if corridor modifications should be considered. This is especially important if several years have elapsed between the corridor and design studies or if new information is discovered during a more in-depth design analysis.

11-5.03(b) Preliminary Alignments

The objectives of the first phase of a design study for a complex project are to:

- Identify the preliminary alignments for study, including an analysis of the no-action alternative, and if applicable, analyze the alternative for improving existing highways. The no-action alternative is used as a base condition to determine the consequences of not proceeding with the project.
- Analyze the preliminary alignments identified in the previous step.
- Determine preliminary social, economic, environmental, and engineering factors that will affect the suitability of each preliminary alignment.
- Eliminate the preliminary alignments deemed unacceptable for detailed study.

Use county maps and USGS quad maps in the preparation of base maps for the remaining preliminary alignments. Indicate the following on these base maps:

- existing and projected land use;
- school districts;
- school bus routes;
- fire districts;
- neighborhood boundaries;
- parks and historic sites and districts;
- nature preserves; and

- other elements listed in Part III, Environmental Procedures that may affect the location of the alignments studied (e.g., flood-plain encroachments, natural areas, wetlands, special waste sites, cultural resources, public lands identified as 4(f) by FHWA).

Once the base maps have been prepared, determine and layout preliminary alignments from the following other known influences within the area:

- locations of municipalities,
- recreational areas,
- other highways,
- topography,
- property lines,
- acceptable locations of intersections or interchanges,
- industries, and
- the feasible locations of bridges (over railroads and waterways) and grade separations.

Once the preliminary alignments are identified on these base maps, eliminate the unacceptable alternatives. For the next step of alternative development, transfer plausible alignments to aerial photography. This is accomplished by requesting current aerial photography, scaled at either 1 in = 600 ft (1:7500 metric) or 1 in = 400 ft (1:5000 metric) for rural areas, and aerial photographic mosaics, scaled at either 1 in = 100 ft (1:1000 metric) or 1 in = 200 ft (1:2500 metric) for urban areas. The photographic exhibits are prepared as screened positives. This medium allows paper prints to be produced from the aerial photography. Depict the main influences and any other secondary influences on aerial photography. To proceed further with this phase of the design study, contact all affected agencies and planning commissions within the corridor again to obtain their comments and opinions. These agencies may be affected either directly or indirectly by the proposed improvement. This is part of the scoping process.

Analyze the results of these contacts. Revise or eliminate any of the alignments that are undesirable because of adverse engineering, environmental, economic, or social effects. Document the reason(s) any alignments have been discarded. Also, determine and discuss the impacts of the “no-action” alternative.

11-5.03(c) Mapping Requests

Long lead times are usually required to obtain mapping (one to two years) and, therefore, mapping requests must be made early so that delays do not occur in proceeding with a study. However, it must be noted that many times insufficient information may be available at the time mapping is requested and, therefore, some judgment must be used in deciding on the width limits of the mapping. Additional mapping always can be requested during the design study if needed for further alignment investigations.

In rural areas, the Department typically uses a 1 in = 200 ft (1:2500 metric) scale for topographic mapping where a freeway or expressway is proposed on new alignment. This mapping is commonly referred to as location mapping. However, if a freeway or expressway alternative is

being considered along and adjacent to an existing rural highway, use a larger topographic map scale [i.e., 1 in = 50 ft (1:500 metric)]. This larger scale enables the location study staff to make informed, accurate decisions on the feasibility and impacts of using the existing alignment and it also can be used for the preparation of construction plans at a later time.

In urban areas, where a new freeway is being proposed or where an existing expressway is proposed for upgrading, or where the extension of an arterial route into an urban area is being proposed for reconstruction, use a 1 in = 50 ft (1:500 metric) scale topographic mapping for the design study. This larger scale mapping in urban areas provides the necessary detail to determine impacts, displacements, and right-of-way limits.

Submit all mapping requests to the Surveys, Mapping and Modeling Section. This Section will make the determination on whether the in-house staff can provide mapping or if there is a need to hire a mapping consultant. Also, requests for photography for the preparation of aerial photographic mosaics or digital imagery should be made at the same time as mapping requests. This procedure helps to ensure that the minimum number of flights is made to the project area.

11-5.04 Study of Design Alternatives

11-5.04(a) Objectives

After the set of plausible alternatives has been reduced to a set of feasible alignments, perform a detailed analysis to compare the remaining alternatives. Topographic mapping and aerial photography are the primary media used for this phase of the design study. The objectives of this phase are:

- to study and analyze the feasible alignments for a freeway, expressway, bypass, etc.;
- to identify acceptable design alternatives; and
- to choose and recommend a final preferred alternative for construction.

11-5.04(b) Sources of Information

The following are sources of information available, items to use, and items to consider for this phase of the design study:

- crash rate maps and collision diagrams (see Section 11-2.02);
- pavement and bridge condition reports (see Section 11-2.02);
- ADT traffic maps and DHVs for current and design year traffic (all affected routes) (see Section 11-2.02);
- detailed transportation maps and plans with all modes of travel included;
- utility installations and detailed maps from utility companies;
- fire, school, mail, and school bus routes; location of churches, drainage districts, and historic sites; and field-tile maps;
- commercial, agricultural, industrial, recreational, historic, and residential land use (see Part III);

- parks and conservation areas, archaeological sites, floodplains, wetlands, endangered and threatened species, nature preserves, special waste sites, biological stream ratings, etc. (see Part III);
- local, State, and Federal agency coordination (see Section 22-5);
- maintenance information on existing routes (see Section 11-2.09);
- current topographic mapping at a scale of 1 in = 50 ft (1:500 metric) in urban areas and 1 in = 200 ft (1:2500 metric) in rural areas on new alignment or 1 in = 50 ft (1:500 metric) in rural areas where existing alignment is studied;
- current aerial photographic mosaics at a scale of either 1 in = 100 ft (1:1000 metric) or 1 in = 200 ft (1:2500 metric) in urban areas and aerial photography at 1 in = 400 ft (1:5000 metric) or 1 in = 600 ft (1:7500 metric) in rural areas;
- geotechnical investigations (see Section 11-2.10);
- highway geometrics (see Section 11-2.04), development of access control plans (see Section 11-2.03), and right-of-way issues (see Section 11-2.12);
- joint development uses, scenic easements, and aesthetics of highway design (see Chapter 33); and
- cost estimate (see Section 11-2.15) and road-user benefits (see Section 11-7.01).

11-5.04(c) Locating Alignments

Upon receipt of the topographic mapping, plot property lines, property names, names of roads, and all other important cultural features on the original mylar sheets. Make paper copies of the mapping sheets and tape together. This procedure allows the designer to review long lengths of the alignment in one view and to see how lines may best fit together. Begin laying out feasible alignments. With freeways and expressways, the major controlling items in locating the highway alignment are as follows:

- the proper location of interchanges and major intersections;
- topography;
- waterway crossings;
- property lines;
- avoidance of cultural features, if practical; and
- avoidance of regulatory environmental constraints (e.g., wetlands, Section 4(f) lands, longitudinal floodplain encroachments).

In some cases, the placement of grade separations or major bridges may dictate the location of the highway and may require a revision to an initial proposed alignment.

After an alignment is laid out, determine the state plane coordinates of all control points (POTs and PIs) from the project mapping. This information, along with radii of horizontal curves, is then input into a computer file to mathematically describe each alternative. Once an alignment is mathematized and tied into digitizing mapping files, the alignment can then be stationing from west to east or south to north and the information stored as a computer file for further design work.

11-5.04(d) Establishing Gradelines (Procedures)

Once an alignment is judged to be a probable final alternative, the design of the profile may then be investigated in detail. This may require designing two to three trial vertical profiles and performing several complete earthwork calculations. However, before profile work can be completed, preliminary drainage investigations (see Section 11-2.05), using stream gauging data, USGS quadrangle maps, or topographic mapping, must be completed to set design high waters. Use computer programs to determine high waters and other drainage information. IDOT uses GEOPAK software for alignment, profile, and cross section designs. Once the overall design is finalized, compute earthwork using the GEOPAK software. This software allows the designer to quickly investigate trial profile designs, to determine quantities, and to determine construction limits. GEOPAK can also be used to generate perspective plots for any portion of the roadway. Use 3-D plots in the design process to assess potential safety problems and the aesthetic value of each final alternative.

The following procedures apply to the development of gradelines for construction and reconstruction projects:

1. Control Factors. Develop each feasible highway alignment on mapping sheets based on the following factors:
 - location of intersections or interchanges,
 - property lines,
 - topography, and
 - waterway crossings.

These factors will be the main alignment design controls if environmental issues are not a significant factor.
2. Centerline Elevations. For each feasible alignment, develop a tabulation of groundline elevations along the centerline of the alignments at the selected station intervals. This may be done manually and plotted on a continuous roll of cross section paper or elevations may be read from digitized mapping and plotted using computer programs. The method of obtaining centerline elevations will be dependent on the length and complexity of the proposed project.
3. Controlling Features. Locate controlling features by station and elevation along the centerline profile, including:
 - railroad crossings or separations,
 - streams,
 - highway crossings or separations,
 - location and elevation of transverse utility crossings,
 - rock outcrops, and
 - known locations of unsuitable soils.

4. Trial Profile Gradelines. Once the groundline at the centerline of an alignment has been plotted, either manually or by using computer plots, and other controlling features such as PCs and PTs noted, the designer may then proceed to lay out the first trial profile gradeline. This procedure allows the designer to begin selecting VPI locations and elevations and to visualize how a profile might fit together over long distances. The selected VPIs are connected together by using a long, straight edge and drawing in the profile lines.
5. Vertical Profile. Examine the preliminary profile design considering the controls for vertical alignment discussed in Chapter 33. Make adjustments to ensure safety and to promote aesthetics. A good vertical alignment design should not be sacrificed only to achieve a balance in earthwork or solely to create a less expensive design.
6. Computations. Compile VPI elevations and stations and compute the gradient between VPIs. Determine the minimum length of vertical curves to be used at each VPI. Crest vertical curve lengths are set by using desirable K-values for the selected design speed or longer to emphasize aesthetic values. Sag vertical curve lengths have a more pronounced effect on the view of the road than crest vertical curves. Therefore, use longer lengths than the minimums wherever practical to provide a more pleasing profile.

Upon completing the first trial profile gradeline, use either of the following two methods to obtain cross sections from topographic mapping and to compute earthwork:

1. Method #1. Manually scale distances and groundline elevations from CADD-generated mapping sheets and compile data. Enter the data into a suitable earthwork program (available with either GEOPAK or equivalent software). Run the program using typical sections, special cross sections, superelevation runoff lengths, and the proposed profile.
2. Method #2. Provide state plan coordinate data for all POTs, PIs, horizontal curves, and beginning stationing. District staff then can submit this information to the Surveys, Mapping and Modeling Section for direct reading of cross sections from CADD-generated mapping. Enter the cross section data into a suitable earthwork program (available with either GEOPAK or equivalent software). Run the program using typical sections, special cross sections, superelevation runoff lengths, and the proposed profile.

Using either method, obtain a computer-generated mass-haul diagram and graphically investigate the earthwork balances. To assess the aesthetics of key roadway segments, use computer-generated perspective plots to critique the facility from a driver's-eye view. Examine the results of the first trial profile and develop additional profiles as needed. Usually, two to three trial profiles are developed before a final profile gradeline is selected.

Upon selecting the final profile, request a computer-generated slope-stake table to determine right-of-way limits. Also, see Section 34-5 for guidance on setting right-of-way limits. Then save the final preliminary earthwork file and use this file to develop final cross sections during the Phase II design.

11-5.04(e) Evaluation of Alternatives

Analyze each of the proposed final alignments considering the social, economic, and environmental factors discussed in Part III “Environmental Procedures.” To properly analyze these effects, it may be necessary to meet again with affected agencies that had been previously contacted. See Chapter 19 for public involvement activities on complex projects and Section 22-5 for guidance on coordination.

After the results of further investigations have been analyzed, there may be legitimate reasons to eliminate one or more final alignments. Discuss the reasons these alignments were not given further consideration in the Design Report. For instance, traffic estimates for the no-action alternative may overload existing routes creating unacceptable congestion and, thereby, eliminating this alternative.

11-5.04(f) Access Control Plans

Once the design study has eliminated all but two or three major alternatives for the proposed project, prepare an access control plan for each freeway, expressway, or bypass alternative; see Chapter 35. Prepare the plan on aerial photographic exhibits (i.e., screened positives) at a scale defined in Section 11-5.03(b). The access control plan will consist of all interchange, intersection, frontage road, service drive, and entrance locations. Also, show all grade separations, major drainage structures, and any cattle underpasses or machinery underpasses that may be required. See Chapter 35 for the access control symbols.

Before an access control plan can be finalized, all intersection or interchange designs shall be developed and approved in sufficient detail to indicate all entrances and access control limits. Show all current property owners, property lines, and developments. In addition, indicate the approximate right-of-way limits for each alternative. If alternatives overlap or are closely spaced, it may be desirable to prepare separate sets of access control plans.

11-5.04(g) Exhibits

After completing all public involvement and environmental requirements, the original scaled mapping is reduced for insertion into an appendix to the Design Report. Prepare the reduced mapping sheets and other engineering exhibits on 11 in x 17 in sheets and place them in an appendix. In addition, place the aerial photography (access control plans) showing the alternatives advanced for environmental analysis and any other environmental exhibits on 11 in x 17 in sheets and place them in an appendix. The appendix can then be used in conjunction with a draft and final EIS or with an environmental assessment. Use the 11 in x 17 in format in all cases. This size format provides for ease of use of all final exhibits by planning, design, and land acquisition personnel.

11-5.04(h) Technical Reports

In completing a design study for an expressway, freeway, or bypass, it is usually necessary to prepare a number of technical reports. The following is a list of technical reports that may be required:

- Preliminary Drainage Report,
- Frontage Road/Service Drive and Access Road Justifications,
- Grade Separation/Road Closure Analysis,
- Crash Analysis Report Along Existing Route,
- Transportation Management Plan (TMP) Report,
- Preliminary Pavement Design Report,
- Agricultural Report,
- Noise and Air Quality Report,
- Water Quality Technical Report,
- Wetlands Technical Report,
- Tree Assessment Report,
- Biological Assessment or Detailed Action Report, and
- Geotechnical (Soils) Report.

Reference these technical reports in the Design Report and EIS, as appropriate. It is also recommended that each report be assigned a letter description (e.g., Technical Report A, Technical Report B).

11-5.04(i) Selection of Preferred Alternative

Resolve all public involvement comments (see Chapter 19) and consider all environmental impacts (see Part III) and engineering factors (Section 11-2) before recommending a preferred alternative. See Chapter 12 for processing and approval of reports, Corridor Protection, Route Location Decisions, and for the Order Establishing a Freeway.

11-6 COMBINED DESIGN STUDIES

Sections 11-4 and 11-5 address projects that require a separate corridor study and design study, respectively.

Many proposed projects (e.g., reconstruction of an existing urban arterial, adding a new interchange to a freeway, creating a one-way urban street couple, upgrading an existing two-lane highway to an expressway design) using predominantly the existing alignment are categories of improvements where the corridor or location is predetermined due to the design of the project and, therefore, a separate corridor study is not needed nor required.

For these types of projects, the investigation of how to design the project is designated as a “combined corridor and design study.” To shorten the title of the engineering investigations, the Department has designated these studies as “combined design studies.” Projects in this category of improvement are major in nature, use most or all of the existing alignment and right-of-way, and usually involve the purchase of additional right-of-way adjacent and contiguous to existing right-of-way.

The items covered in Section 11-2 apply to studies in this category of improvement types and, in some instances, the information in Section 11-5 “Design Studies” applies to the engineering investigations. Review both of these sections before proceeding with the scope of a combined design study.

Projects designated as combined design studies are set up to follow Federal environmental and public involvement procedures to be eligible for Federal-aid construction funding and may or may not involve separate environmental documentation. If the proposed project qualifies as a categorical exclusion type project, environmental documentation will be included in the Combined Design Report as a separate section. If not, a separate environmental report (EA or EIS) is prepared.

11-7 OTHER PHASE I STUDY CONSIDERATIONS

Section 11-7 discusses other analyses and procedures that might apply to Phase I studies.

11-7.01 Road User Benefit Analysis

11-7.01(a) Scope

To optimize the use of available highway funds, the Department's objective is to provide motorists with the safest and most economically efficient highway practical. Highway economy is not limited to the initial cost of construction. It also includes the cost of maintenance and operating costs to motorists. Any proposed improvement should be cost effective. It may be necessary to determine the comparative worth of likely alternative improvements where other considerations (e.g., highway location) do not clearly indicate a preferred alternative.

An aid in making these determinations is a road user benefit analysis. This analysis compares road user operating costs to highway construction and maintenance costs. Note, however, that the road user benefit analysis is not a complete economic analysis. It does not consider the solvency of the highway system or the economic impacts on adjacent land and communities. The road user benefit analysis, therefore, aids in making a selection between alternatives. It should not be used as the sole indication of engineering practicality.

Road user benefit analyses may be used, in conjunction with other considerations, for the following:

- comparing alternative alignments,
- determining the location of interchanges and grade separations, and
- determining the cost-effectiveness of providing freeway frontage or access roads.

Use the guidelines contained in the AASHTO publication *User and Non-User Benefit Analysis of Highways* in conjunction with this section when performing road user benefit analyses. Also, consult NCHRP Report 133 *Procedures for Estimating Highway User Costs, Air Pollution, and Noise Effects*.

11-7.01(b) Procedures

When it is determined that other social-economic-environmental-engineering considerations do not control a specific location or design element, a road user benefit analysis may be conducted. For each proposed alternative, determine the annual road user costs and the annual cost of improving, maintaining, and operating that section of highway over a selected period of time. Then, arithmetically compare the alternatives to express a benefit ratio or quotient of a cost difference.

In the simplest form of the analysis, one alternative will be the proposed improvement and the other will be the base condition, normally the no-action alternative. For two or more alternatives,

calculate a benefit ratio for each alternative and compare the results to that of the base condition. The ratio indicates the relative merit of each alternative considering road user benefits.

The annual road user cost is the total of the computed vehicular operating costs, travel time costs, and traffic crash costs. The highway improvement is divided into as many sections as there are significant variations among the major elements of analysis. Summation of the sectional road user costs provides the annual road user cost for that specific alternative. Road user costs include the costs of all traffic directly involved or indirectly affected by the improvement. For example, an analysis may include the road user costs both for vehicles operating on the new or improved route and for those vehicles continuing to operate on parallel or connecting routes on which traffic flow is affected by the improvement.

The road user analysis should cover the entire design period, normally 20 years. Figure 11-7.A provides the average life expectancy, or period of amortization, for individual items comprising the highway cost.

Ensure that the alternative improvements are equivalent for those items not included in the road user benefit analysis. These items are primarily the degree of access control and the design features affecting operational safety. First, determine and analyze the provision of access control and the retention of substandard features only for similar alternatives, or consider qualitative factors for these differences in the final analysis.

11-7.02 Road Closures

11-7.02(a) General

During the project development process, it may be necessary to assess the practicality of eliminating at-grade crossings that are within the limits of the proposed improvement. The primary reasons for eliminating crossings are to promote the safety and convenience of highway traffic and to best serve the public interest. If at-grade crossings will be eliminated, perform a study of the existing road system and traffic patterns to determine the most effective method of elimination (e.g., relocation, grade separation, closure).

With the design of freeways, it is necessary to eliminate at-grade crossings for traffic safety. The Department has the legal authority to either close, relocate, or to grade separate at-grade crossings with proposed freeways. This includes any highway, road, street, alley, or other public way. When cost effective, the Department may choose to eliminate at-grade crossings by proposing grade separations and, thereby, continuing the public way over or under the freeway. Because relocations and grade separations provide for the continuation of through traffic, road closure proceedings are not required.

ITEM	PERIOD OF SERVICE LIFE
Right-of-Way	100 Years
Major Substructures	100 Years
Structures: Superstructures	50 Years
Concrete Pipe & Box Culverts & Heavy Grading	40 Years
Portland Cement Concrete Pavement	40 Years
High-Type Flexible Pavement	40 Years
Continuously Reinforced PCC Overlay	20 Years
Metal Culvert Pipe	20 Years
Bituminous Concrete Resurfacing of PCC Base (Depending upon thickness, base, and traffic)	5 to 15 Years
Low-Type Flexible Pavement	12 Years
Gravel or Crushed Stone Surface	10 Years
Bituminous Surface Treatment of Gravel or Crushed Stone	5 Years

- Notes:
- 1. The cost of light grading shall have the same service life period as the proposed surfacing or resurfacing.*
 - 2. For service lives to be used for Highway Safety Improvement Program projects, see the benefit/cost methodology presented in the IDOT publications, Systemic Safety Improvements: Analysis, Guidelines and Procedures and Users Manual Benefit-Cost Tool, located on the IDOT website..*

PERIOD OF SERVICE LIFE FOR HIGHWAY COSTS

Figure 11-7.A

Expressways (partial access control) are more likely to require relocations of at-grade crossings or to remain in place than either grade separations or road closures. Complete closures of at-grade crossings primarily occur on freeways (full access control) where it is neither practical nor cost effective to provide a grade separation at each local road or street and where relocation may not involve such extensive adverse travel as to cause a serious disruption to local travel patterns.

During the design study, determine which at-grade crossings should be eliminated and document this information in a technical report to the Design Report or Combined Design Report. See Chapter 44 for a detailed analysis of whether or not to close a road. For appropriate signing guidelines on road closures, review the Bureau of Operations *Traffic Policies and Procedures Manual*.

Applicable sections of the Illinois Compiled Statutes discuss the authority to relocate or close roads and the means of implementation. Because closure procedures vary according to the type of improvement and jurisdiction, this subject will be treated in three sections:

- road closures for freeways (full access control),
- road closures for expressways (partial access control), or
- road closures for highways other than freeways or expressways.

The procedures described in the following sections are applicable to improvements on new location and improvements to existing facilities.

11-7.02(b) Road Closures for Freeways (Full Access Control)

The Department may close any intersecting road, street, alley, or other public way at its intersection with a freeway but only after holding a public hearing in the county in which the crossing is located. The hearing will consider the needs of local traffic and the effect of the closing on other highways in the locality. The authority for such closures is granted to the Department under 605 ILCS 5/8-106(b)(2).

Road closure hearings are discussed in Chapter 19. Specific requirements for road closure hearings are included where appropriate. If no specific requirements are mentioned, the general public involvement procedures will apply. When road closure hearings are advertised and integrated with design or combined design hearings, the project record submitted for design approval normally will contain the required information as described in Chapter 19 and shall include hearing transcripts, road closure comments, copies of notices, and handouts.

If the road closure hearing for each county is held as a separate hearing before design approval is requested, the road closure transcript, copies of notices, and handouts shall be included with the project record that is submitted for design approval.

When the requirements of a road closure public hearing are satisfied prior to receiving design approval or when a road closure public hearing is held subsequent to receiving design approval but before construction plans are completed, an "Order Closing a Public Way" shall be prepared.

11-7.02(c) Road Closures for Expressways (Partial Access Control)

Road closures on expressways usually are accomplished through agreements with appropriate local officials according to the *Illinois Highway Code*, 605 ILCS 5/8-106(b)(1). When using this procedure, the district shall secure an agreement with each local agency having jurisdiction over roads to be closed.

The district will prepare and present the agreement to the local officials together with a written request for their cooperation. In addition, the district will make available a written or verbal explanation of the need to close the roads in question to those entities expected to act on the agreements. Agreements need not be executed prior to design approval; however, the Design Report or Combined Design Report should include evidence of coordination with local officials.

In addition to the use of Section 605 ILCS 5/8-106(b)(1), Section 605 ILCS 5/8-106(b)(2) may also be used to propose the closing of any existing public road at its intersection with the expressway. In this case, the district will advertise and hold a road closure hearing.

Provide a statement in the Design Report or Combined Design Report that construction of the recommended expressway design will not be initiated until critical road closures, applicable to the operations and safety of the expressway, have been completed.

11-7.02(d) Road Closures for Highways Other Than Freeways or Expressways

In the rehabilitation, relocation, or construction of State routes that are not freeways or expressways, it may be necessary to relocate or eliminate intersections with local roads, city streets, alleys, or other thoroughfares, usually for the safety and convenience of the traveling public. The following describes two options available to the Department for this procedure:

1. Traffic Control. IDOT has the authority to eliminate an intersection using a traffic control measure or device as authorized under the *Illinois Vehicle Code*, 625 ILCS 5/11-302(c). This can occur if IDOT determines that a local road intersection may be a hazard to State highway traffic.

See the *Illinois Manual of Uniform Traffic Control Devices* for the full range of traffic control devices available to protect and give preference to State highway traffic. The Prohibition of Left Turns, Right Turn Only, and No Outlet are traffic control measures that may be considered at an intersection. However, note that the restriction or prohibition of access to a State route from an intersecting highway is not the same as a road closure or, to be more definitive, as vacating the local highway.

In addressing the isolated elimination of crossings for non-freeways, IDOT also considers the interest of all affected highway authorities based on the intent of the *Illinois Highway Code*. Section 605 ILCS 5/1-102 of the *Illinois Highway Code* declares legislative intent and indicates the need for an integrated system of highways based on cooperation between various highway agencies. Therefore, when applying the *Illinois Vehicle Code*,

625 ILCS 5/11-302(c), consult with the local highway authority as a means of addressing any local concerns.

2. Road Closure and Relocation. The Department has the option to eliminate traffic at an intersection with a State route through a relocation or closing of the local highway. In this case, the local agency having jurisdiction over the intersecting roads or streets must authorize the relocation or closing. Municipalities, townships, and counties must meet different statutory requirements when asked to close roads under their jurisdiction. Counties and municipalities require action by their governing bodies, and township highway commissioners follow a specified procedure that allows for public input.

Perform the following tasks when it is determined that a county or municipal road, street, or alley should be closed:

- contact the appropriate local official;
- explain the need to close the road, street, or alley;
- provide adequate descriptions and information for the preparation of required legal documents; and
- request that the local agency take the necessary action to accomplish the closing.

Then, secure a reproducible copy of the passed resolution or ordinance on vacating the road and forward it to BDE for proper distribution. See the *Illinois Highway Code*, 605 ILCS 5/5-109 for counties and the *Illinois Municipal Code*, 65 ILCS 5/11-91-1 for municipalities.

If a township or district road closure is proposed, prepare and sign a certificate describing the roads affected and the need for altering or vacating such roads. Ensure that the certificate and its processing conform to the requirements of the *Illinois Highway Code*, 605 ILCS 5/6-303 and 605 ILCS 5/6-305.

Although it is not necessary to close local roads prior to design approval, include evidence of the coordination with the local agency having jurisdiction over such roads in the Phase I report. Also, state in the report that construction of the recommended design will not be initiated until critical road closures, applicable to the operation and safety of the improvement, have been completed.

11-7.03 Value Engineering

Value Engineering is the systematic application of recognized techniques by a multi-disciplinary team not directly involved with the planning and development phase of a project to identify the function of a product or service, establish a worth for that function, generate alternatives through the use of creative thinking, and provide the needed functions to accomplish the original purpose of the project, reliably and at the lowest life-cycle cost, without sacrificing safety, necessary quality, and environmental attributes of the project.

23 U.S.C. 106 and 23 C.F.R. 627 establishes value engineering (VE) requirements for Federal-aid projects developed and administered by the Department. These requirements include establishing a VE Program, conducting a VE analysis, providing VE program oversight, and reporting performance results annually. The preferred timing to conduct a VE study is during Phase I for complex projects.

A VE analysis is required for the following types of projects:

1. Each project located on the National Highway System (NHS) (as specified in 23 U.S.C. 103) with an estimated total project cost of \$50 million or more that utilizes Federal-aid highway program (FAHP) funding (see Section 11-7.03(a), item 2, for definition of total project cost);
2. Each bridge project located on the NHS with an estimated total project cost of \$40 million or more that utilizes FAHP funding;
3. Any Major Project (as defined in Chapter 20) located on or off of the NHS that utilizes FAHP funding in any contract or phase of the project;
4. Any project where a VE analysis has not been conducted and a change is made to the project's scope or design between the final design and the construction letting which results in an increase in the project's total cost exceeding the thresholds as identified in 23 USC 106 and 23 CFR 627; and
5. Any other project FHWA determines to be appropriate that utilizes FAHP funding.

The following links provide more information regarding Value Engineering:

FHWA VE Policy (<https://www.fhwa.dot.gov/ve/>)

Society of American Value Engineers (<http://value-eng.org>)

11-7.03(a) Procedures

1. Project Selection. Each district identifies applicable projects during the preparation of the multi-year program. However, other projects not meeting the definition may be selected for this program. Due to the complexity and scope of large projects, more than one VE study may be desirable.
2. Total Project Cost. Costs associated with environmental studies, preliminary engineering, final design, land acquisition, and construction should be used in determining the selected project cost. The project cost includes State, local agency, and Federal-aid highway funds.

3. VE Analysis.

- a. Initiation of VE Analysis. Schedule the VE analysis in a manner so as not to cause delay of the project. For a Phase I report with multiple construction contracts, develop a plan for conducting the VE analysis based on the Phase I considerations and the nature and complexity of the work type, (e.g., one VE study may cover alike construction projects). A single VE analysis should cover as many construction contracts under the single Phase I report as practicable and beneficial. Initiate the VE analysis no later than the time the construction plans are 30% complete and to allow for the implementation of the recommendations without delaying the project.
- b. Team Makeup. The VE team, selected by the district, consists of individuals not personally involved in the design of the project. The team leader should have attended the NHI course on Value Engineering or have equivalent experience in the preparation of VE studies. When making up the team, take into account the following:
 - draw team members from either the district or central office;
 - consider individuals from specialty areas depending on the project scope;
 - assign personnel from construction, maintenance, and studies and plans (as applicable);
 - include representatives from environment, operations, and land acquisition as necessary; and
 - include individuals from the public and other agencies when in the public interest.

Qualified consultants may be retained to conduct VE studies provided the consultant has not worked on the subject project.

- c. Conducting VE analysis. To accomplish the goals of VE, the district should follow the following seven phases when completing the VE Analysis. Figure 11-7.B shows the flow diagram of the Value Engineering Process.
 1. Information Phase: Gather specific project information, including purpose and needs of all the owners/users/stakeholders, project commitments and constraints. The following list of information is usually assembled:
 - All project reports (Location Drainage Studies, Hydraulic Report, Bridge Condition Report, etc.)
 - Design Criteria
 - Plans and Specifications
 - Programmed Cost and Detailed Cost Estimate
 - Project Schedule (design approval and target letting)
 2. Function Analysis Phase: Analyze the project to understand the required functions. The purpose of function analysis is to thoroughly familiarize all

members of the VE Team with the functional aspects of the project, to ensure that all relevant issues are addressed, and to highlight any imbalances between cost and worth of functions.

3. Creative Phase: Generate ideas on ways to accomplish the required functions that improve project performance, enhance quality, and lower project costs.
 4. Evaluation Phase: The VE Team evaluates and selects feasible ideas for development.
 5. Development Phase: The VE Team develops the selected alternatives into fully supported recommendations (long-term as well as interim solutions).
 6. Presentation Phase: The VE Team presents the recommendations to the project stakeholders. The team leader develops a report that documents the VE study.
 7. Resolution Phase: District Office evaluates, resolves, and implements all approved recommendations.
- d. Final VE Analysis Report. Each Study concludes with a formal VE analysis report, which outlines the decisions and recommendations and is presented to the Deputy Director/Regional Engineer or representative. The FHWA shall be invited to all VE closeout meetings. The district establishes a procedure for prompt review and implementation of the approved recommendations. When any recommendation is a major change to an approved Design Report or is a design exception to policy, the recommended change is coordinated through the appropriate central bureau.

Furthermore, district VE coordinators should ensure that the following eight required items are included in the VE report:

1. Project information;
2. Identification of the VE analysis team;
3. Background and supporting documentation, such as information obtained from other analyses conducted on the project (e.g., environmental, safety, traffic operation, constructability);
4. Documentation of the stages of the VE Job Plan, which would include documentation of the life-cycle costs that were analyzed;
5. Summarization of the analysis conducted;
6. Documentation of the proposed recommendations and approval received at the time the report is finalized;

7. Documentation of the proposed and approved recommendations, and related information to support the Department's and FHWA's VE program monitoring and reporting;
 8. The formal written report shall be retained for at least 3 years after the completion of the project (as specified in 49 CFR 18.42).
- e. Monitoring. Each district appoints a VE coordinator who is knowledgeable in VE studies and trained in VE procedures. Coordinator's responsibilities include monitoring each VE study from initiation through the final report, reviewing the report, and assisting in the implementation of the findings. During the month of October, each year, the district VE coordinator sends the BDE VE coordinator a list, which itemizes the total number of VE studies conducted over the past year and the estimated cost savings for each study. BDE will summarize the information and forward it to the FHWA.

11-7.03(b) Constructability Reviews

Constructability reviews are useful tools for complex or unusual projects and are encouraged as a cost or time saving measure. These reviews may include the use of IDOT personnel unassociated with the project or consultant/contractor teams that would not be bidding on the project. These reviews would not typically be making complex design change recommendations as would be expected in a full VE study. The constructability review would focus upon staging issues, work staging areas, field expedient procedures or methods, and similar activities focused upon accelerating or enhancing the proposed design.

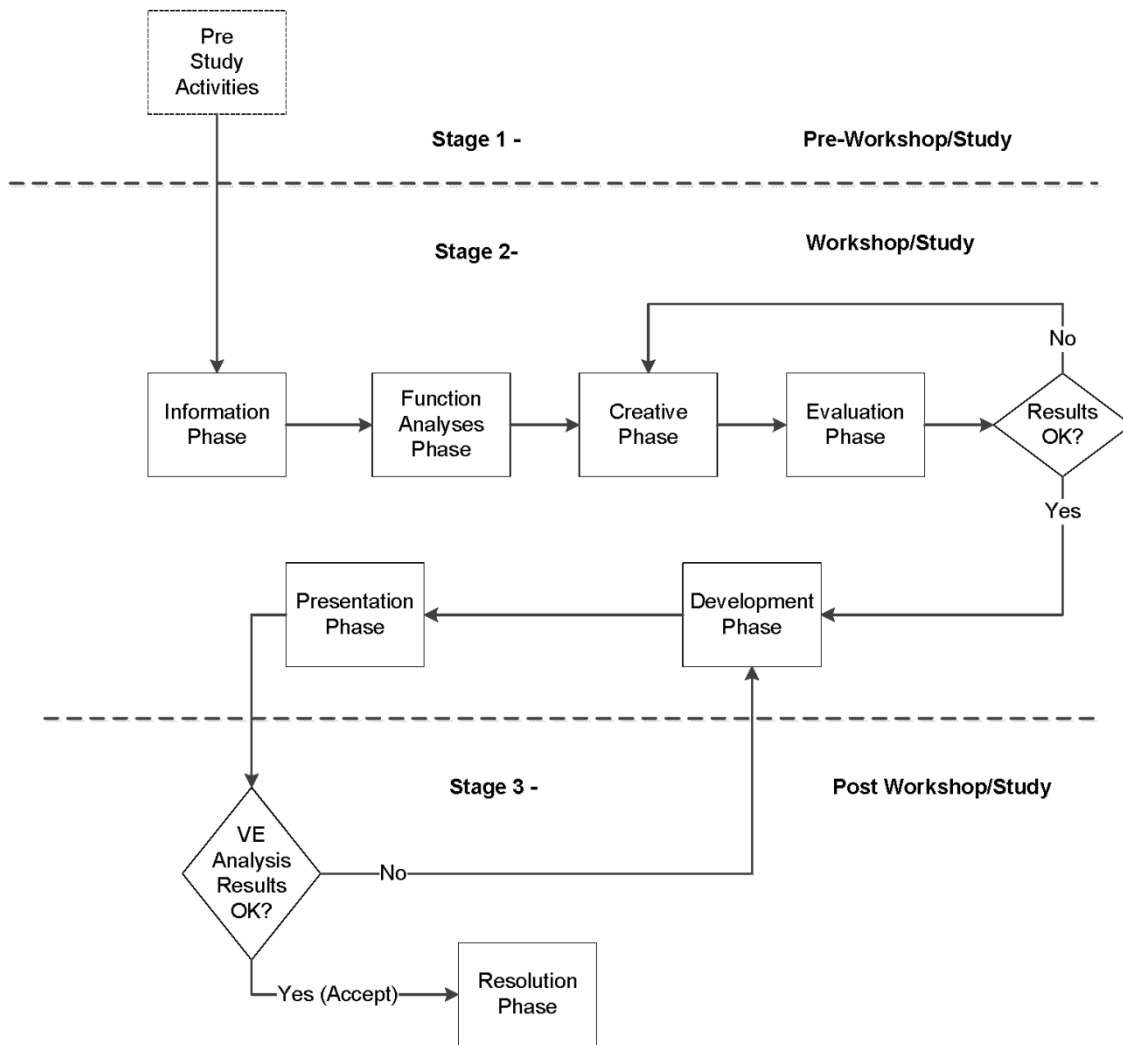

Value Engineering Flow Diagram

Figure 11-7.B

11-7.04 Planning and Environmental Linkage

Per the *Integration of Planning and NEPA Processes Memorandum*, dated February 22, 2005, and Federal Acts authorizing funds for Federal-Aid highway projects (i.e., SAFETEA-LU, MAP-21, and FAST ACT), the planning process and NEPA can be designed to work in conjunction so that the results of the planning process can directly flow into NEPA. However, planning studies such as Corridor Studies and Feasibility Studies, as discussed in Section 11-1, are not traditionally written to produce a NEPA product such as Purpose and Need and Alternatives to be Carried Forward.

The purpose of this section is to provide guidance on when Planning and Environmental Linkage (PEL) is appropriate and what elements to include when drafting a PEL document with the goal of producing a document that seamlessly flows into the CE, EA or EIS Phase I process. A major component of meeting this goal is drafting a NEPA-ready Purpose and Need and Alternatives to Be Carried Forward so that an outcome of this process will be a shorter time frame from project initiation to the FONSI or ROD.

11-7.04(a) PEL Considerations

There are three considerations for why PEL is appropriate for CE (usually of the more complex nature), EA or EIS project. It can:

- assist a subsequent Phase I project in meeting FHWA time constraints for EAs and EISs;
- advance a project that does not have Phase II funding; and
- assist in gauging public support for a project.

Note: Planning products generated from PEL (i.e., Purpose and Need and Alternatives to be Carried Forward) must meet the conditions specified in 23 U.S.C. 168 in order to be incorporated into NEPA. If more than five years have passed between the PEL study and incorporated by reference into a NEPA product, the project sponsor shall determine that, “there is no new significant information or new circumstances that have a reasonable likelihood of affecting the continued validity or appropriateness of the planning product.”

11-7.04(b) PEL Process

The steps below describe the PEL process: The project sponsor shall:

1. Notify FHWA and BDE that a project will be processed as PEL.
2. Introduce the PEL study and coordinate the need for the study and logical termini with BDE and FHWA at regularly scheduled district coordination meeting.
3. Determine the level of public involvement. For projects using the principles of Context Sensitive Solutions, see Section 19-5 for applicable procedures (i.e., Section 19-5.01(a) to Section 19-5.01(c)).
4. Develop a timeframe agreement for the PEL study (see Section 24-2.01(d)).
5. Submit an Environmental Survey Request (see Section 24-2.03) to BDE for database information and evaluation. This is to help ensure an informed decision is made for potential environmental impacts.
6. Develop a NEPA-ready Purpose and Need in accordance with Section 24-2.07 and Part 1 of Chapter 1 in Appendix D, to be coordinated with Federal and state resource agencies through the NEPA/404 Merger Process, as applicable for EAs and EISs. In addition, coordination with the tribes shall be initiated by the district, in consultation with the cultural resource unit, via letter (See Figure 11-7.C for letter example).
7. Develop NEPA-ready Alternatives to be Carried Forward in accordance with Section 24-2.08 and Part 1 of Chapter 2 in Appendix D, to be coordinated with Federal and state resource agencies through the NEPA/404 Merger Process, as applicable for EAs and EISs. In addition, coordination with the tribes shall be done by the district, in consultation with the cultural unit, via letter (See Figure 11-7.D for letter example).

Note: The Purpose and Need plus Alternatives to be Carried Forward will be called “coordination points” during the PEL process. For projects that will be processed as an EA or EIS under NEPA, and when the project moves from PEL to NEPA, then FHWA will request the resource agencies to concur on the Purpose and Need and Alternatives to be Carried Forward that were considered “coordination points” during PEL. The request for concurrence may occur via email from FHWA to the resource agencies.

8. A PEL document, after coordination with FHWA and BDE, may include:
 - a. the Purpose and Need for the project,
 - b. discussion of Alternatives to Be Carried Forward, and
 - c. summary of public involvement.

11-7.04(c) PEL to Class of Action Determination or NEPA Scoping

A project initiated through the use of a PEL can advance to:

- a CE and incorporate the PEL study by reference into the Phase I document;
- NEPA scoping (if the project may be processed as an EA or EIS) by sending out the cooperating agency and Section 106 consulting party letters (see Section 24-2.02). The PEL study should be incorporated by reference in the EA or EIS. NEPA Scoping is discussed in Chapter 24; or,
- a stand-alone PEL planning document.

[Date]
[Address Title] [First Name] [Initial] [Last Name]
[Agency]
[Address]
[City], [State] [Zip Code]
Subject: [name of study] invitation for Section 106 consulting party status
Dear [Address Title] [Last Name]:

The Illinois Department of Transportation (IDOT) is notifying your Tribe that a Planning and Environment Linkage (PEL) study is being developed for [name of study].. Your Tribe is being notified based on your interest in the county(ies) where the project is located.

What is a PEL?

PEL studies are a collaborative and integrated approach to transportation decision-making that 1) considers environmental, community, and economic goals early in the transportation planning process, and 2) uses the information, analysis, and products developed during planning to inform the environmental review process. The PEL study will include an evaluation of transportation system needs across the entire study area. [list primary technical tools used to identify transportation system needs and potential environmental impacts during the PEL, e.g. GIS, transportation demand models, field studies.]

Upon conclusion of the study, IDOT intends to carry forward the decisions made into the National Environmental Policy Act (NEPA) decision-making process and additional coordination with your Tribe will occur during the NEPA process.

THE PROJECT

The study area is located in [project location including local agencies and counties]. See enclosed map. The study area covers approximately [area in square miles] and is located [description of study area]. It contains environmentally sensitive resources, including [list primary resources/locations potentially affected].

Please notify us if there are any resources of concern in the project area that should be avoided. **No field archaeological investigations will occur during the PEL study.**

We are submitting for your review and comment on the attached Purpose and Need for the project. The next step in the PEL process will be the determination of Alternatives to be Carried Forward at which time a separate notification letter will be sent to you. The selection of a preferred alternative will not occur until after initiation of the NEPA process.

If you have any questions, would like to discuss the study in more detail or have questions regarding our agencies' respective roles and responsibilities during the preparation of this study, please contact [IDOT POC].

Thank you for your cooperation and interest in this project.

Sincerely,

[IDOT Signature]

Example Purpose and Need PEL letter to Tribes

Figure 11-7.C

[Date]
[Address Title] [First Name] [Initial] [Last Name]
[Agency]
[Address]
[City], [State] [Zip Code]
Subject: [name of study] invitation for Section 106 consulting party status
Dear [Address Title] [Last Name]:

The Illinois Department of Transportation (IDOT) is notifying your Tribe that a Planning and Environment Linkages (PEL) study is ongoing for [name of study]. As discussed in the previous letter sent to you regarding this project on [date], your Tribe is being notified based on your interest in the county(ies) where the project is located. IDOT will continue to coordinate with your Tribe throughout the study.

THE PROJECT

The study area is located in [project location including local agencies and counties]. See enclosed map. The study area covers approximately [area in square miles] and is located [description of study area]. It contains environmentally sensitive resources, including [list primary resources/locations potentially affected].

Please notify us if there are any resources of concern in the project area that should be avoided. **No field archaeological investigations will occur during the PEL study.**

We are submitting for your review and comment the attached Alternatives to be Carried Forward under consideration. As stated previously, the selection of a preferred alternative will not occur until after initiation of the NEPA process.

If you have any questions, would like to discuss the study in more detail, or have questions regarding our agencies' respective roles and responsibilities during the preparation of this study, please contact [IDOT POC].

Thank you for your cooperation and interest in this project.

Sincerely,
[IDOT Signature]

Enclosure

Example Alternatives to be Carried Forward PEL Letter to the Tribes

Figure 11-7.D

11-8 ENGINEERING COMPUTER PROGRAMS

11-8.01 General

IDOT uses various engineering programs for Phase I and Phase II work (e.g., hydraulic programs, traffic operations, highway capacity programs). These programs greatly increase the efficiency of providing solutions to the Department's engineering needs and should be used whenever possible. Discuss with the appropriate district bureau, section, or unit the use of computer software for project development.

The remainder of this section focuses on the use of MicroStation and GEOPAK Computer Aided Drafting and Design (CADD) software used in project development.

11-8.02 Roadway Design Software

The GEOPAK Engineering Suite is a comprehensive, proprietary design software package from Bentley Systems, Inc. that works as an interactive program within MicroStation. The Department presently uses this engineering program for its roadway design work. GEOPAK is used to provide engineering solutions in Phase I work and to develop detailed plans in Phase II. All final roadway plans are produced using MicroStation.

Detailed workflows and required deliverables for all aspects of roadway design using MicroStation and the GEOPAK suite of tools are included in the IDOT *Survey Manual* and the *Computer Aided Design, Drafting, Modeling and Deliverables Manual*.

11-8.03 Bridge Design Software

The Bureau of Bridges and Structures uses a variety of software packages for analytical design. The software provides a full suite of structural design capabilities for concrete and steel structures and bridges. While a variety of different software can be used for analytical design on bridge and structures projects, all final plans are produced using MicroStation.

Detailed workflows and required deliverables for all aspects of bridge and structures design are included in the *Computer Aided Design, Drafting, Modeling and Deliverables Manual*.

11-8.04 3D Models

For many projects during and at completion of Phase II design, a three-dimensional (3D) model of roadways, bridges, or structures is the desired end product. The workflows defined in the *Computer Aided Design, Drafting, Modeling and Deliverables Manual* have been developed in order to produce these 3D models in a standard and consistent format when the nature of the project makes 3D models desirable.

Many projects, such as SMART and PPP projects, do not greatly benefit from 3D models. For these projects the workflows for a traditional two-dimensional (2D) design are also accommodated in the *Computer Aided Design, Drafting, Modeling and Deliverables Manual*.

11-8.05 CADD Support

Detailed information on the uses of MicroStation and GEOPAK is available in the *Computer Aided Design, Drafting, Modeling and Deliverables Manual*, as well as MicroStation and GEOPAK user reference materials provided to each district, and tutorial information available on-line through the Bentley Systems Learn website.

The Bureau of Information Processing (BIP) is responsible for the following:

- Computer hardware configuration and support,
- Software installation, maintenance and support,
- Inter-agency coordination, and.
- Management of software licensing.

Please see Section 1-2.01(c) for a list of support duties provided by the BDE Modeling and Support Unit.

Also in each district, the CADD Manager or an Engineering Support Specialist may be available to provide assistance on the use of MicroStation and GEOPAK software.

11-9 DISTRICT GEOMETRIC APPROVAL QUALIFICATION REQUIREMENTS

Geometric designs such as Intersection Design Studies and Interchange Design Studies represent some of the most critical parts of Phase I Engineering Reports with respect to the safety and operational quality of the highway facilities. These designs are some of the most complex and technically rigorous portions of the preliminary engineering process. Proficiency in geometric design takes years of experience, training, and hands-on work to achieve. Great care must be taken in choosing those individuals responsible for the development and approval of such designs, and the end products must be closely monitored for quality compliance. As such, only qualified individuals shall approve geometric designs for phase I of the project, or for any geometric modifications proposed in phase II or phase III of the project after initial phase I design approval. This section details the requirements and process necessary for the District Geometrics Engineer to approve geometric designs on federally funded roadway projects.

11-9.01(a) General

Districts are eligible to become qualified to approve all geometric designs they produce. The process involves the Regional Engineer of the appropriate district seeking district approval authority from the Central Office Bureau of Design and Environment (BDE). The prerequisite requirements for the District Geometrics Engineer, and hence the district, to be qualified for approval of geometric designs, are listed below in Section 11-9.01(d). Once qualified, districts can approve all geometric designs they produce. However, design exceptions included in any geometric design must be approved through the central office as outlined in Chapter 31.

As an ultimate goal, districts would fill the Geometrics Engineer position with able and experienced personnel. With budget constraints and staff turnover, it is understood that this process will be an evolving one, where responsibilities will shift periodically between the district offices and the central office. District coordination meetings and annual quality reviews will ensure proper and consistent application of policy and quality compliance.

The geometric designs of districts not qualified for geometric approval will be reviewed and approved by BDE. This would occur for districts where the Regional Engineer has not requested anyone to be qualified, where staffing changes have left the Geometric Engineer position vacant, as well as for those districts for which qualification has been rescinded. Although BDE review and approval are not required for qualified districts, these districts may request BDE assistance in the processing of any geometric design. The Regional Engineer is also responsible for requesting assistance from BDE should the district staff experience be insufficient for the required work.

The BDE is not precluded from reviewing any portion of the Phase I process at any time, especially when unique features or unusual circumstances are involved. If an annual quality review determines that a qualified district's geometric designs are unsatisfactory, the Regional Engineer and the Director of the Office of Program Development will be notified immediately of the deficiencies, and corrective action up to and including rescission of the qualification may be pursued.

11-9.01(b) Items Exempt from Qualification

Design exceptions included in any geometric design must still be approved through the central office as outlined in Chapter 31. Access Justification Reports (AJR) and access control changes on interstates will continue to be coordinated with BDE. This is due to the complex nature of the designs and issues involved, and the need for statewide consistency. BDE will review and approve the AJR and access control changes for transmittal to the Federal Highway Administration (FHWA) for federal approval.

11-9.01(c) Removal of Qualification

Once approved, the District Geometrics Engineer is qualified to approve all geometric designs. The District Geometrics Engineer is the only position in the districts eligible to have geometric design approval authority.

Approval authority of the Geometrics Engineer can be withdrawn by the Bureau Chief of BDE in the event of failure to exhibit the requisite professional ability. Removal of approval authority would be based on unsatisfactory results of process reviews or other similar evidence.

Staffing changes within the Geometrics Unit may also nullify the district's approval authority. To continue to maintain approval authority, the Regional Engineer shall submit a list of staffing changes within the Geometrics Unit, including revised qualifications, to the Bureau Chief of BDE for approval. See Section 11-9.01(e).

11-9.01(d) Qualification Requirements

1. The candidate must have a degree in Civil Engineering, possess a Civil Engineer V technical classification or higher within the department (State of Illinois Professional Engineer License implied), and be the District Geometrics Engineer.
2. The candidate must have demonstrated the professional ability to produce designs which reflect genuine expertise in the field of geometrics as recognized by the Regional Engineer.
3. The candidate must have attended the following IDOT approved capacity and geometrics training classes:
 - a. Basic Highway Capacity
 - b. Advanced Highway Capacity
 - c. Fundamentals of Geometric Design
 - d. Advanced Geometric Design

11-9.01(e) Qualification Process

1. Upon fulfillment of the above requirements, the Regional Engineer will assess the capabilities of the Geometrics Engineer and, if deemed qualified, submit the candidate to the Bureau Chief of the Bureau of Design and Environment for district approval

authority. The submittal to BDE should include a cover memo requesting district qualification and a resume which details the professional experience of the candidate and lists the significant projects the candidate has previously worked on.

2. The Bureau Chief of the Bureau of Design and Environment will verify the qualifications of the candidate and determine whether the candidate Geometrics Engineer is qualified for approval authority.
3. The Bureau Chief of BDE is responsible for approving or denying the Geometrics Engineer as qualified for approval authority. The Bureau Chief of the Bureau of Design and Environment will notify the Regional Engineer via memo of the approval or denial of the request for geometric qualification.

11-10 REFERENCES

1. NCHRP Report 399, *Multimodal Corridor and Capacity Analysis Manual*, Transportation Research Board, 1998.
2. NCHRP Report 418, *Research on the Relationship Between Economic Development and Transportation Investment*, Transportation Research Board, 1998.

Chapter Twelve

PHASE I
ENGINEERING REPORTS

BUREAU OF DESIGN AND ENVIRONMENT MANUAL

Chapter Twelve
PHASE I ENGINEERING REPORTS

Table of Contents

<u>Section</u>	<u>Page</u>
12-1 GENERAL	12-1.1
12-1.01 Purpose of Phase I Engineering Reports.....	12-1.1
12-1.02 Applicability of Report Types.....	12-1.1
12-1.03 Functions	12-1.6
12-1.04 Objectives	12-1.7
12-1.05 Content	12-1.7
12-2 REPORT FORMAT FOR MAJOR STUDIES.....	12-2.1
12-3 SPECIFIC PHASE I REPORTS.....	12-3.1
12-3.01 Corridor Reports.....	12-3.1
12-3.02 Feasibility Study Reports	12-3.3
12-3.03 Design Reports.....	12-3.4
12-3.04 Combined Design Reports	12-3.7
12-3.05 State Improvement Reports	12-3.9
12-3.06 Project Reports.....	12-3.11
12-3.07 Abbreviated Project Reports	12-3.21
12-3.08 3P and PAVEMENT PRESERVATION (High/Low) Projects.....	12-3.31
12-3.08(a) Report Format and Content.....	12-3.31
12-3.08(b) Safety Needs Analysis.....	12-3.31
12-3.09 Phase I Checklist	12-3.32
12-3.10 Phase I Report Exemptions.....	12-3.32
12-4 ESTIMATE OF COST FORMATS	12-4.1
12-4.01 Corridor or Feasibility Studies	12-4.1
12-4.02 Design Reports, Combined Design Reports, and State Improvement Reports	12-4.1
12-4.03 Project Reports and Other Reports	12-4.1
12-5 PROCESSING AND APPROVAL OF PHASE I REPORTS	12-5.1
12-5.01 Corridor and Feasibility Study Reports	12-5.1
12-5.02 Design Reports.....	12-5.1
12-5.03 Combined Design Reports.....	12-5.3
12-5.04 State Improvement Reports	12-5.4
12-5.05 Other Types of Reports	12-5.4
12-5.06 Regional Engineer Delegation of Approval Authority.....	12-5.6
12-5.07 Reports for Local Public Agency Projects.....	12-5.6

Table of Contents
(Continued)

<u>Section</u>	<u>Page</u>
12-5.07(a) Local Public Agency Lead Projects on the State Highway System	12-5.6
12-5.07(b) Local Public Agency Projects on Combined Systems	12-5.7
12-5.07(c) Local Public Agency Projects on the Local Highway System.....	12-5.7
12-5.07(d) Modified Procedures.....	12-5.7
12-5.08 Project Reports for the Highway Safety Improvement Program	12-5.7
12-6 CORRIDOR PROTECTION	12-6.1
12-6.01 Authority and Purpose	12-6.1
12-6.02 Need	12-6.1
12-6.03 Timing and Procedures.....	12-6.1
12-7 ROUTE LOCATION DECISIONS	12-7.1
12-7.01 Purpose.....	12-7.1
12-7.02 Applicability.....	12-7.1
12-7.03 Content	12-7.1
12-7.04 Preparation and Processing.....	12-7.1
12-7.05 Execution	12-7.4
12-8 ORDER ESTABLISHING A FREEWAY	12-8.1
12-8.01 Freeways and Expressways.....	12-8.1
12-8.02 Procedures.....	12-8.1

Chapter Twelve

PHASE I ENGINEERING REPORTS

Chapter 11 discusses the goals and objectives of Phase I studies for projects administered by the Department. Chapter 12 discusses the applicability of the various Phase I engineering report types, as well as their content, format, processing, and approval.

12-1 GENERAL

12-1.01 Purpose of Phase I Engineering Reports

The purpose of preparing reports for the projects in the annual and multi-year programs is to document the coordinated efforts of each district on why the Department is proposing an improvement, and how the improvement will be designed to satisfy a need. Depending on the complexity and type of improvement proposed, the size of a Phase I engineering report and appropriate exhibits can vary from a two-page form for a pavement preservation project, to 25-50 pages for a pavement rehabilitation/replacement project on an existing road, or to a few hundred pages for a complex new construction or reconstruction project.

These reports are more than just a paperwork requirement and have been created to ensure that a proposed improvement has been carefully evaluated, that appropriate policies and criteria are being used, that the design reflects an assessment of environmental concerns, and, if required, that public involvement has occurred. These reports should be able to stand on their own and document all major design decisions and exceptions to the policy.

12-1.02 Applicability of Report Types

Each type of Phase I study requires a corresponding report to document the findings of the investigation. The type of Phase I engineering report used depends upon the scope of the study and sometimes the funding source as described below:

1. Corridor Report. The funding and scope of engineering (e.g., a large scale Federally funded project on new alignment) will determine when to prepare a Corridor Report. The following will apply to a Corridor Report:
 - a. Funding. These projects involve Federal funding for construction or the desire to obtain future Federal reimbursement of construction costs.
 - b. Engineering. Typically, these projects involve significant lengths of highway on new location with alternative corridors available for the proposed improvement.

- c. Typical Projects. Typical projects include new freeways, alternative bypasses around an urban area, or expressway designs with a considerable length of proposed highway on new locations.
 - d. Environment. Because these projects are complex and Federally funded, environmental aspects are addressed in a separate section of the Corridor Report or in a separate EA or EIS type document.
 - e. Review. The BDE Location and Environment Section reviews and provides concurrence on engineering information contained in the Corridor Report, as well as environmental information either contained in the Corridor Report or provided separately through the EIS or EA.
2. Feasibility Study Report. A Feasibility Study, which is similar in scope and purpose to a Corridor Study, is typically prepared to assess whether or not a proposed highway improvement warrants further study or additional funding for Phase I engineering costs. The following other types of investigations are applicable:
- study of major drainage alternatives,
 - comparison of proposed interchange types at different locations, and
 - HOV studies versus other transportation alternatives.

The Feasibility Study Report documents the findings and recommendations of the study and, in many cases, may be used as a substitute for a Corridor Report. Reviews are essentially the same as for a Corridor Report and concurrence in the recommendations is by the Bureau Chief of Design and Environment.

3. Design Report. The funding and scope of engineering (e.g., a large scale Federally funded project on new alignment) will determine when to prepare a Design Report. The following will apply to a Design Report:
- a. Funding. These projects involve Federal funding for construction or the desire to obtain future Federal reimbursement of construction costs.
 - b. Engineering. Typically, these projects involve significant lengths of highway on new location and include an analysis of potential alternative locations and a detailed design of each alternative.
 - c. Typical Projects. Typical projects include new freeways, new bypasses around an urban area within a selected corridor, or expressway designs with considerable length of proposed highway on new locations.
 - d. Environment. Because these projects are complex and Federally funded, environmental aspects are addressed in a separate document (i.e., EA or EIS).
 - e. Review. The BDE Location and Environment Section reviews and provides concurrence on engineering information contained in the Design Report, as well as environmental information provided separately through the EIS or EA.

4. Combined Design Report. The funding and scope of engineering (e.g., a large scale Federally funded project on existing alignment) will determine when to prepare a Combined Design Report. The following will apply to a Combined Design Report:
 - a. Funding. These projects involve Federal funding for construction or the desire to obtain future Federal reimbursement of construction costs.
 - b. Engineering. Typically, these projects are complex projects using most or all of an existing highway alignment and right-of-way.
 - c. Typical Projects. The corridor or location is predetermined due to the design of the proposed project. Typical projects include:
 - proposed expressway designs using much of the existing highway alignment;
 - the upgrading of existing urban arterial or collector highways to add through lanes and/or the addition of a median or a change in median type;
 - the creation of a one-way couple;
 - the addition of an interchange;
 - a change in type for an existing interchange;
 - the reconstruction of an existing rural highway with a considerable number of changes to the alignment, profile, and front slopes and back slopes; or
 - the reconstruction of an existing freeway or expressway to increase capacity by adding lanes and/or to increase safety.
 - d. Environment. Depending upon the anticipated environmental issues involved, the project could be a CE, EA, or EIS. If the proposed improvement qualifies as a Federally Approved CE project, the environmental documentation will be included in the Combined Design Report as a separate section. If not, a separate environmental report (EA or EIS) is prepared.
 - e. Review. Environmental information (EA or special analyses and studies that may be necessary to address environmental compliance requirements for specific types of resources or potential for unusual circumstances) and comments are passed on to the BDE Regional Field Engineer and forwarded to the district for inclusion in the Combined Design Report. The district is responsible for compliance with engineering policies. However, if design exceptions are proposed, the project should be presented at a district coordination meeting.
5. Project Report. Only the scope of engineering (e.g., pavement or bridge replacement, pavement rehabilitation with geometric, roadside, or drainage improvements, etc.) will determine when to prepare a Project Report. The following will apply to the Project Report:

- a. Funding. These projects involve Federal or State funding for construction. The design of the project would allow it to be programmed for Federal funding.
 - b. Engineering. Typically, these projects use the existing highway alignment but some may involve curve corrections or minor relocations.
 - c. Typical Projects. Typical projects may include:
 - widening and resurfacing or resurfacing only of existing lanes,
 - bridge rehabilitation or total bridge replacements,
 - pavement replacement,
 - reconstruction of an intersection with minor right-of-way impacts, or
 - other projects on existing roads which may involve an occasional curve relocation or profile changes.
 - d. Environment. These projects typically qualify as a CE and, therefore, the environmental documentation is included in the Project Report.
 - e. Review. Environmental information (EA or special analyses and studies that may be necessary to address environmental compliance requirements for specific types of resources or “potential for unusual circumstances”) and comments are passed on to the BDE Regional Field Engineer and forwarded to the district for inclusion in the Project Report. The district is responsible for compliance with engineering policies. However, if design exceptions are proposed, the project should be presented at a district coordination meeting.
6. State Improvement Report. The funding and scope of engineering (e.g., a large scale State-funded project) will determine when to prepare a State Improvement Report (SIR). The following will apply to a State Improvement Report:
- a. Funding. A decision has been made that no Federal funds will be used for planning, right-of-way, or construction of the project.
 - b. Engineering. Typically, these projects involve a major construction project that may or may not use an existing highway alignment or street.
 - c. Typical Projects. Typical projects will include:
 - upgrading of existing urban arterial or collector highways to add through lanes and/or the addition of a median or change in median type;
 - creation of a one-way couple;
 - addition of an interchange;
 - change in type for an existing interchange; or

- reconstruction of an existing intersection with significant right-of-way impacts.
- d. Environment. Because Federal funding is not being used, these projects typically only require environmental documentation to comply with State regulations and Federal permits as identified in Chapters 26 and 28. Include any documentation of public involvement coordination in the State Improvement Report (SIR).
- e. Review. Environmental information (EIS, EA, or special analyses and studies that may be necessary to address environmental compliance requirements for specific types of resources or “potential for unusual circumstances”) and comments are passed on to the BDE Regional Field Engineer and forwarded to the district for inclusion in the State Improvement Report. The district is responsible for compliance with engineering policies. However, if design exceptions are proposed, the project should be presented at a district coordination meeting.
7. Pavement Preservation Policy (3P) Report. The scope of engineering will determine when to prepare a 3P Report and the following will apply:
- a. Funding. These projects may or may not involve Federal funding for construction.
- b. Engineering. These projects rehabilitate existing paved roadways to prevent further pavement deterioration by repairing and resurfacing existing pavements. Avoid projects with significant safety needs where an improvement with a larger scope would be more appropriate.
- c. Typical Projects. The emphasis of this program is to improve State highway pavements with few or no non-pavement items. Focus is on rural marked routes, but urban marked routes and high-volume unmarked routes may be acceptable on a priority basis. Rural projects should be at least 1 mile (1.6 km) in length. No geometric revisions or pavement widening are permitted, and acquisition of right-of-way is not allowed except when required to implement a countermeasure to mitigate Five Percent Report locations. However, 1 ft (300 mm) wide shoulder strips are required for rural cross-sections if no paved shoulders exist. Structurally deficient or functionally obsolete bridges should be gapped and addressed through other programs.
- d. Environment. These projects will usually qualify as a categorical exclusion.
- e. Review. Engineering information will be developed by the district using the standard 3P Report, form BDE 1202 (fill in the blanks, check off items, and attachments). Occasionally, a special analysis may be required to address environmental compliance requirements. The district is responsible for compliance with engineering policies. However, if design exceptions are proposed, the project should be presented at a district coordination meeting.

8. Pavement Preservation (High/Low) Report. This simple report is required for projects categorized as High Pavement Preservation or Low Pavement Preservation. No report is required for preservation projects categorized as Proactive Maintenance. The following applies to High/Low Pavement Preservation Reports:
 - a. Funding. These projects may or may not involve Federal funding for construction.
 - b. Engineering. These projects are primarily intended to preserve pavements in good condition using “low cost” treatments. However, if safety improvements are identified as part of the project’s needs and can be accomplished for 15% or less of the total project cost, said safety improvements shall be made part of the project.

When the identified safety need is beyond the scope of high/low preservation, or would represent more than 15% of the total project cost, the roadway is not eligible for preservation and a higher project scope must be selected to address the need.
 - c. Typical Projects. The emphasis of this program is to improve State highway pavements with few or no non-pavement items. Structurally deficient or functionally obsolete bridges should be gapped and addressed through other programs. Avoid projects with significant safety needs where a project on an existing road with a larger scope would be more appropriate.
 - d. Environment. These projects almost always qualify as a categorical exclusion.
 - e. Review. The district will develop engineering information using BDE 1203 Pavement Preservation (High/Low) Report form (fill in the blanks, check off items, and attachments). Occasionally, a special analysis may be required to address environmental compliance requirements. The district is responsible for compliance with engineering policies. However, if design exceptions are proposed, or there are issues related to the project’s scope that would benefit from discussion, the project should be presented at a district coordination meeting.

12-1.03 Functions

Phase I reports provide a systematic methodology for identifying and evaluating location, design, and environmental issues. The report provides a medium for documenting the decision-making process and communicating the reasoning for the proposed improvement need. In this capacity, the report fulfills many functions, including:

1. Project Summary. Phase I reports summarize the coordinated efforts of both the district and Central Offices in determining the need for a project and how it will be designed.
2. Public Involvement. Phase I reports provide an organized document that can be used by the district to discuss improvements with the public and to ensure that the proposed project has been planned consistent with safety and cost-effective objectives.
3. Plan Preparation Guide. A Phase I report provides a reference guide for preparing construction plans and ensures that certain prerequisite design and environmental

requirements have been met. This aids and expedites plan preparation, scheduling, environmental coordination, and construction.

12-1.04 Objectives

All Phase I engineering reports should meet the following general objectives:

- Present the study findings in clear, unambiguous language. As practical, the writing should be understandable to the general public.
- Do not duplicate information documented in other reports (e.g., environmental documents, Transportation Management Plan, Geotechnical Report, Preliminary Drainage Report, Bridge Condition Report). The Phase I Engineering Report should reference or summarize these other documents.
- Ensure all relevant information is included or referenced in the report so that the reader can understand the reasons for the design decisions.
- Ensure the level of detail in the report is commensurate with the conceptual objective of a Phase I study; i.e., limit the information to that needed to make major decisions.

12-1.05 Content

A Phase I engineering report should document the following, as applicable:

1. Prior Studies. List and analyze any prior studies relevant to the undertaking.
2. Project Need. Include all the necessary information, technical reports, and other materials to clearly demonstrate the study has adequately demonstrated the need for safe, fast, and efficient transportation. In addition, document the construction cost, traffic benefits, and public services provided by the highway improvement.
3. Local Conditions and Improvements. Briefly describe the highway/pavement conditions adjacent to the proposed action and any plans for future improvements. Coordinate these items between districts for route continuity when district boundary lines fall between logical termini.
4. Improvement Alternatives. Describe the alternatives considered and discuss the anticipated social, economic, and environmental effects of the alternatives, emphasizing the significant differences and the supporting reasons for the proposed location or design. In addition, analyze the relative consistency of each alternative with the goals and objectives of any adopted local or regional urban plan. Depending on the type of study, also include the following information:
 - a. Corridor Studies. For Corridor Studies (see Section 11-4), describe the termini, the general type of facility, the nature of the service that the highway is intended to provide, and other major features of the alternatives.

- b. Design Studies. For Design Studies (see Section 11-5), describe the critical elements such as safety and crash patterns on the existing route, applicable design criteria (e.g., new construction, reconstruction, projects on existing roads), traffic volumes, number of traffic lanes, other cross-section elements, access control/access management features, method of locating horizontal alignment, vertical profile considerations, right-of-way requirements, bicycle/pedestrian considerations, intersection designs, interchange designs, hydraulic information, bridges, and other structures.
5. Environmental Issues. Summarize or reference the discussion in the environmental document on the anticipated social, economic, and environmental effects as discussed in Part III "Environmental Procedures." Identify the adverse effects, develop appropriate measures to avoid, minimize, or mitigate these effects, and estimate the associated costs.
6. Policy and Design Exceptions. List any major design exceptions from IDOT policies and design criteria (e.g., engineering, environmental) together with supporting reasons, pertinent minutes of district coordination meetings, and relevant documentation of BDE coordination with FHWA, if appropriate. For geometric design exceptions, see Chapter 31.
7. Maps and Drawings. Include the appropriate maps or drawings of the location or design for which approval is requested.
8. Summary of Public Involvement. Provide a summary and analysis of the comments received from the public involvement process (see Chapter 19) and from the environmental analyses (see Part III, Environmental Procedures) based on:
- coordination with the State's resource, recreational, planning, and historic agencies; and
 - those Federal and local public agencies, public officials, and public advisory groups that IDOT knows or believes are interested in and/or affected by the proposed action.
9. Costs and Schedules. Estimate costs and tentative schedules for right-of-way acquisition and construction. For complex projects requiring more than one construction season, provide cost estimates for individual usable segments for construction staging. The multi-year highway improvement program can then be developed using the individual segment costs rather than an estimated proportional cost of the total project.

If cost breakdowns for individual segments or improvement alternatives are necessary, use multiple columns on the cost-estimate sheet or provide multiple cost estimate sheets. For all cost estimates, indicate the base year and separate all construction, right-of-way, utility adjustment, and consultant PE costs to facilitate the programming of these items.

See Section 12-4 for more information on cost estimates.

12-2 REPORT FORMAT FOR MAJOR STUDIES

Section 12-2 presents the detailed outline format that can be used for a Corridor Report, Design Report, Combined Design Report, or State Improvement Report. Section 12-3 discusses specific requirements for report content of major and minor studies. Use the following format, as applicable, when developing reports for major studies:

I. INTRODUCTION

- A. Description and Location of Project
- B. History of Project
- C. Discussion of Design Criteria Used (e.g., new construction, reconstruction) and Highway Types Considered

II. PURPOSE AND NEED FOR THE IMPROVEMENT

- A. Conditions on Existing Highway Network
 - 1. Typical sections
 - 2. Extent of access control/access management
- B. Existing Traffic and Capacity Deficiencies
- C. Existing Safety Performance/Crash Analysis
- D. Alignment and Profile Deficiencies
- E. Corridor Studies

III. EXISTING SETTINGS OR CONDITIONS

- A. Description of Project Area
- B. Project Limits (logical termini)
- C. Land Use (fire districts, school bus, and mail routes)
- D. Existing Bicycle/Pedestrian Generators
- E. Environmental Resources
- F. Sensitive Environmental Areas
 - 1. Parks and recreational areas (Section 4(f) properties)
 - 2. Floodplains and waterways
 - 3. Wetlands
 - 4. Historical sites
 - 5. Special waste sites
 - 6. Endangered species locations
 - 7. Natural areas
 - 8. Biologically significant streams

IV. ALTERNATIVES CONSIDERED

- A. Transportation Demand Strategies
- B. Mass Transit (if applicable)
- C. Proposed Highway Design Guidelines
 - 1. Typical sections
 - 2. Design speed
 - a. Horizontal alignment
 - b. Vertical profile
 - 3. To remain in place criteria
 - 4. Proposed access control or access management
- D. No Action (continued maintenance)
- E. Widen Existing Roadway or Major Reconstruction of Existing Roadway
 - 1. Urban arterial improvement
 - 2. Expressway design
- F. Construction on New or Existing Locations
 - 1. Freeway design
 - 2. Expressway design
 - 3. Bypass around towns
 - 4. New rural two-lane highway
- G. Description of Intersections or Interchanges
 - 1. Locations and types
 - 2. Design features
 - 3. Level of service achieved
 - 4. Signal progression (if applicable)
 - 5. Uniformity of types
- H. Description of Bicycle and Pedestrian Facilities

V. DESCRIPTION AND ANALYSIS OF ALTERNATIVES STUDIED IN DETAIL

- A. Attainment of Purpose and Need
- B. Traffic Service to Region
- C. Engineering Considerations Including Aesthetics (e.g., combining horizontal and vertical alignments)
- D. Important Social, Economic, and Environmental (SEE) Effects (mainly reference)
- E. Utility Involvements/Drainage Considerations

- F. Possible Mitigation Measures
 - G. Discussion of Costs and Benefits
 - H. Priority of Implementation
- VI. COORDINATION ACTIVITIES
- A. Local Governments/Metropolitan Planning Organizations
 - B. State and Federal Agencies
 - C. Property Owner Considerations
- VII. PUBLIC INVOLVEMENT ACTIVITIES
- A. Advisory Committee and Working Groups (if desirable)
 - 1. Public interest groups
 - 2. Agricultural groups
 - 3. Growth and development groups
 - 4. Public officials' groups
 - B. Informational Meetings/Property Owner Contacts
 - C. Design Public Hearing (open house meeting)
 - D. Analysis of Correspondence
 - E. Commitments
- VIII. CONCLUSIONS/RECOMMENDATIONS
- A. Recommended Design Alternative
 - B. Supporting Reasons for Alignment Recommendation and/or Design Features (be specific)
 - C. Discussion of Design Exceptions
 - D. Identification of Criteria for Implementing Next Step/Phase of Study
 - E. Proposed Interim Improvements or Stage Construction (if applicable)
- IX. APPENDICES (Usually produced in an 11 in. x 17 in. format)
- A. Quad Maps and County Maps
 - B. Proposed Typical Sections
 - C. Schematic Drawings Showing Traffic Data
 - D. Aerial Mosaics Showing Alternatives and Important Cultural Features
 - E. Environmental Survey Data Shown on Aerial Mosaics, As Needed
 - F. Topographic Mapping, As Needed, Showing Alternatives

- G. Oblique Photographs and Photomontages (perspective view of a proposed highway)
- H. Schematics of Interchange Designs and Approved Interchange/Intersection Design Studies (IDSs)

For more complex projects, prepare the appendix as a separate document using 11 in. x 17 in. sheets. In this case, a separate appendix improves the readability of the Report, allows design information to be examined more easily, and simplifies the conveyance of information to the design and land acquisition personnel.

12-3 SPECIFIC PHASE I REPORTS

Major studies should follow the detailed outline format described in Section 12-2. Section 12-3 presents information specific to the content of individual Phase I engineering reports.

12-3.01 Corridor Reports

A corridor study is developed according to the guidance in Section 11-4. In addition to the information listed in Section 12-2, also include the following in the Corridor Report:

1. Structure of Report. Lay out the Corridor Report in the format as shown in Section 12-2. In addition, consider the following:
 - a. Table of Contents. Provide a table of contents for the report that should list each separate report section, the figures and tables, and appendices.
 - b. Page Numbers. Consecutively number the pages in the report including all exhibits and figures (i.e., do not renumber each major section).
 - c. Exhibits. Show all exhibits as figures with figure numbering for easy referencing. Place figures, small maps, and tables at the back of the report and reference them in the text. Place large figures (11 in. x 17 in. format) in an appendix to the report. Removing the figures and tables from the text allows for easier reading and review of the report, quicker access to a desired page number, and more effective positioning and access of materials that are used to support the text.
 - d. Cross References. Provide cross-references to information provided elsewhere in the report (e.g., other sections, figures, appendices).
2. County Maps. Use 11 in. x 17 in. sheets and a scale of either 1 in. = 1 mile (1:60,000 metric) or 1 in. = 2 miles (1:120,000 metric). Indicate the following on these maps:
 - all corridors studied;
 - all acceptable corridors; and
 - existing and proposed land use including:
 - + flood plains/floodways,
 - + school districts,
 - + fire protection districts,
 - + recreational areas and lakes (existing and proposed),
 - + airports,
 - + historic sites,
 - + cemeteries,
 - + archaeological sites (only show on internal use maps),
 - + Special Waste Sites (CERCLIS, RCRA and Brownfield sites, etc.),
 - + wetland sites/natural resources, and
 - + other pertinent information.

3. USGS Quadrangle Maps. Use 11 in. x 17 in. sheets and a scale of 1 in. = 2000 ft (1:24,000 metric). This larger scale is used to provide more detail on the project and to show topography.
4. Traffic Data. Determine design year ADT volumes for all acceptable corridors. This data is used during the corridor selection stage. Prepare ADT volume data for other highways within the area of influence and determine the impacts the improvement will have on the entire system of highways in the area.
5. Corridor Report Discussion. Discuss the following items:
 - a. General Description. Describe the following for each alternative:
 - purpose and need of the project,
 - logical termini,
 - general type of facility,
 - nature of service which the highway is intended to provide, and
 - other major features.
 - b. Prior Studies. Discuss any prior studies relevant to the undertaking (e.g., feasibility studies) and a reaffirmation of the need for the improvement.
 - c. Eliminated Alternatives. Discuss the alternative corridors considered but not studied further and describe the reason(s) the alternatives were discounted. Identify and discuss the environmental factors, as discussed in Part III, Environmental Procedures, that were considered in the preliminary investigation but were not considered significant determinants among the alternatives.
 - d. Compatibility with Highway System. Discuss the compatibility of the alternatives studied with the existing street and highway plans or related comprehensive plans. Where these plans do not exist, discuss the extent of coordination with local officials concerning highway needs.
 - e. Compatibility with Other Plans. Discuss the compatibility of the alternatives studied with the plans and objectives of all agencies affected by the improvement.
 - f. Advantages and Disadvantages of Final Alternatives. Discuss the advantages and disadvantages of the final acceptable corridors, including the no-action alternative. Discuss the issues of primary concern to the Department such as construction costs, right-of-way acquisition, highway maintenance, traffic operations, type of access control, and any other pertinent engineering aspects (see Section 11-4) of the improvement. Also, when applicable, discuss other transportation facilities in the corridor.
 - g. Environmental Considerations. Discuss the socio-economic and environmental advantages and disadvantages of the final acceptable corridors, including the no-action improvement alternative. Discuss the environmental considerations as they

relate to each alternative; see Part III, Environmental Procedures. Identify the adverse effects, appropriate measures to avoid, minimize or mitigate the adverse effects, and the costs to do so.

- h. Impacts on Existing Communities. In addition to the general factors mentioned above, discuss the impacts on existing communities where a corridor passes near or through an urban area. Include the following in the discussion:
- change in travel patterns;
 - the estimated number of people, dwelling units, and business establishments being displaced and the economic effects on the communities;
 - the potential for land use change and the likelihood of joint development; and
 - the relative consistency of the alternatives with the goals and objectives of any urban plan adopted by the community concerned.

These factors will often significantly impact the selection of the corridor location in densely populated areas. Ensure that the proposed corridor adequately reflects the urban transportation planning process.

- i. Public Involvement and Environmental Coordination. Include a summary and analysis of the views received as a result of public involvement activities and environmental coordination.
- j. Recommended Corridor. Identify the recommended corridor and provide a synopsis of the determinants used in making the final selection.
6. Estimate of Cost. Include a general estimate of right-of-way and construction costs for those corridors that have not been eliminated. The estimate should reflect the effects the proposed improvement will have on the existing transportation system in conjunction with other needed proposed improvements in the corridor.
7. Map Exhibits. In the discussion, reference all exhibits used in the study. As needed, develop map exhibits and other exhibits on 11 in. x 17 in. sheets. If many exhibits are planned for the report, prepare a separate Appendix for the report. A separate Appendix provides a more useful format.

12-3.02 Feasibility Study Reports

A feasibility study is very similar to the details described for a corridor study and, in many cases, the feasibility study is documented in a similar format as a Corridor Report. See Sections 11-1.01(c) and 12-1.02 for typical situations where a feasibility study is initiated.

12-3.03 Design Reports

A design study is developed according to the guidance in Section 11-5. In addition to the information listed in Section 12-2, consider the following items in the preparation of the Design Report:

1. Structure of Report. Lay out the Design Report in the format as shown in Section 12-2. In addition, consider the following:
 - a. Table of Contents. Provide a table of contents for the report that should list each separate report section, the figures and tables, appendices, and other reports included with the Design Report.
 - b. Page Numbers. Consecutively number the pages in the report including all exhibits and figures (i.e., do not renumber each major section).
 - c. Exhibits. Show all exhibits as figures with figure numbering for easy referencing. Place figures, small maps, and tables at the back of the report and reference them in the text. Place large figures (11 in. x 17 in. format) in either Appendix A or B. Removing the figures and tables from the text allows for easier reading and review of the report, quicker access to a desired page number, and more effective positioning and access of materials that are used to support the text.
 - d. Technical Reports. Provide a summary or reference the information provided in the technical reports.
 - e. Cross References. Provide cross-references to information provided elsewhere in the report (e.g., other sections, figures, appendices).
 - f. Checklist. Section 12-3.09 provides a checklist that may be used to ensure all applicable project information, certifications, coordination, and other requirements are covered in the Design Report.
2. Design Report Discussions. Include the following discussions in the Design Report:
 - a. Summary of Need and Location. Provide a summary of the need for the improvement and reasons supporting the general location of the highway as described in the Corridor Report.
 - b. Prior Studies. Include an analysis and listing of prior studies relevant to the improvement.
 - c. Plausible Alternatives. Discuss the plausible alternatives considered but not studied in depth; and provide a detailed explanation of why these alternatives were eliminated. Also, address the “no-action” alternative.
 - d. Major Design Features. Provide a detailed explanation of how major control points (e.g., interchange locations, river crossings, topography) were selected for the

- location of alignments on mapping; how the alignment best satisfies the geometric needs of an intersection or interchange; selected median types; and how the profile relates to the intersections and interchanges so that driver decision points are not hidden or cause visual obstructions. Also, provide a detailed explanation of aesthetic considerations for combining alignment and profiles; see Chapter 33.
- e. Compatibility with Highway System. Discuss the compatibility of the alternatives studied with existing street and highway plans including any necessary detours. Also, discuss the compatibility of alternatives with comprehensive urbanized plans or, where these plans do not exist, the extent of coordination with local officials concerning their highway needs.
 - f. Environmental Considerations. Present the social, economic, and environmental advantages and disadvantages of the final alternatives studied, including the “no-action” alternative. Part III “Environmental Procedures” discusses environmental considerations.
 - g. Final Alternatives. Discuss the advantages and disadvantages of the final alternatives studied with respect to:
 - purpose and need;
 - traffic service, safety and operations;
 - construction and maintenance considerations and costs; and
 - other pertinent aspects (e.g., those revealed by engineering analyses); see Section 11-2.
 - h. Public Involvement and Environmental Coordination. Provide a summary and an analysis of comments and concerns received as a result of public involvement activities and environmental coordination.
 - i. Temporary Traffic Control. If applicable, discuss the management of existing traffic during construction; see Chapter 13.
 - j. Commitments. Provide a list of commitments made during the public involvement process and interagency coordination. This list should eventually be discussed with the Phase II design squad and then transmitted to construction personnel.
 - k. Recommended Alternative. Identify the recommended design alternative and present a synopsis of the determinants for its selection. Demonstrate that the recommended alternative best meets the purpose and need of the project with consideration of its social and environmental impacts.
3. Estimate of Costs. Prepare a cost estimate for all final alternatives developed by usable segments. A usable segment is suitable for traffic operations and construction phasing. The estimate format should follow that shown in Section 12-4 and Chapter 65.

4. Typical Sections. Provide typical sections for all proposed and affected roadways. Include pavement cross sections from approved pavement designs.
5. Base Maps. Use county maps or USGS Quadrangle Maps as a base map to show all alternatives considered initially, the final alternatives advanced for detailed study, and the termini of the design study.
6. Aerial Photography. Use uncontrolled photography in rural areas and controlled aerial photography in urban areas. Indicate the access control limits and sensitive environmental features for the alternatives advanced for detailed study. Prepare these exhibits on 11 in. x 17 in. sheets and place them in a separate Appendix A. This Appendix is used in conjunction with an EIS or EA and for the overall design study. Section 11-2.03 and Chapter 35 discuss access control features. Include in the Design Report a discussion on the specific access control features of the project. The Report should analyze and justify road closures and access features on expressways and freeways; see Sections 11-7.02 and Chapter 44.
7. Mapping Exhibits. Reduce original mylar sheets of mapping at 1 in. = 50 ft (1:500 metric) or 1 in. = 200 ft (1:2500 metric) scales by 50% to 1 in. = 100 ft (1:1000 metric) and 1 in. = 400 ft (1:5000 metric), respectively. Prepare mapping exhibits as plan and profile sheets for reduction on 11 in. x 17 in. sheets. Show the following on the mapping sheets:
 - State plane coordinates for all control points,
 - right-of-way limits,
 - preliminary design data,
 - structure locations,
 - horizontal alignment,
 - proposed frontage roads and service drives, and
 - current ADTs for all intersected or affected roadways.

Use a vertical scale of 1 in. = 20 ft (1:250 metric) with 1 in. = 200 ft (1:2500 metric) mapping and a vertical scale of 1 in. = 5 ft (1:50 metric) with 1 in. = 50 ft (1:500 metric) mapping. Combine the complete design of the highway as shown on the mapping sheets with the profile to make the final plan and profile sheets. Place these final reduced sheets into a separate Appendix B.
8. Intersection/Interchange Design Studies. Include approved IDSs for all interchanges and major intersections for each studied alignment carried to a public hearing. Prepare Intersection Design Studies in accordance with Chapter 14 and Interchange Type and Design Studies in accordance with Chapter 15. Include reduced-size copies of approved IDSs in Appendix B.
9. Public Involvement Document. On large complex projects, a considerable volume of letters is received from the public and different agencies concerning the need for the project and the possible impacts. For guidance on responses, refer to Section 19-4.08(c), Section 24-2, and Section 25-2. To organize this information and to make it more useful for future reference in case of litigation or questions concerning environmental issues, the letters and their responses are included together in a separate volume. When a large number of similar

comments are received, it may be advantageous to prepare a newsletter and mail to public meeting participants.

12-3.04 Combined Design Reports

The Combined Design Report is prepared where the corridor or location is predetermined due to the design of the proposed project. See Section 12-1.02 for a listing of typical projects in this category. At a minimum, the Combined Design Report should include the items listed in Section 12-2 and the following:

1. **Structure of Report**. Lay out the Combined Design Report in the format as shown in Section 12-2. In addition, consider the following:
 - a. **Table of Contents**. Provide a table of contents for the report that should list each separate report section, the figures and tables, appendices, and other reports included with the Combined Design Report.
 - b. **Page Numbers**. Consecutively number the pages in the report including all exhibits and figures (i.e., do not renumber each major section).
 - c. **Exhibits**. Show all exhibits as figures with figure numbering for easy referencing. Place figures, small maps, and tables at the back of the report and reference them in the text. Place large figures (11 in. x 17 in. format) in either Appendix A or B. Removing the figures and tables from the text allows for easier reading and review of the report, quicker access to a desired page number, and more effective positioning and access of materials that are used to support the text.
 - d. **Technical Reports**. Provide a summary or reference the information provided in the technical reports.
 - e. **Cross References**. Provide cross references to information provided elsewhere in the report (e.g., other sections, figures, appendices).
 - f. **Checklist**. Section 12-3.09 provides a checklist that may be used to ensure all applicable project information, certifications, coordination, and other requirements are covered in the Combined Design Report.
2. **Functional Classification**. Identify the functional classification of the highway proposed for improvement and for all affected roadways.
3. **Typical Sections**. Provide typical sections for the proposed improvement and all side roads. Include pavement cross sections from the approved pavement design.
4. **Traffic Volumes**. Include the current and design year traffic volumes for the proposed facility and for all crossroads; see Section 11-2.02.
5. **Area Map**. Provide an area map that indicates the general location of the improvement.

6. Existing Conditions and Alternative Features. Present the existing conditions and features along the proposed improvement. This information may be shown on a county map, city map, or photographic aerial mosaic, as needed, to adequately illustrate differences and termini. Prepare these exhibits on 11 in. x 17 in. sheets.
7. Major Design Features. Indicate the criteria used (e.g., new construction, reconstruction) and present, on appropriate exhibits such as topographic mapping, the proposed design for the project. Include horizontal and vertical alignment revisions, intersections, entrances, any grade separations, drainage structures, and other major design features. The original mylar sheets of mapping with proposed design features are reduced 50% and prepared on 11 in. x 17 in. sheets for the report. If an extensive number of exhibits are necessary, place them in an Appendix to the report. Also, include the appropriate information from any engineering analyses; see Section 11-2.
8. Right-of-Way Requirements. Provide an indication of the right-of-way to be acquired in sufficient detail to inform an individual of the effect on his or her property. This is usually shown on topographic mapping for the project. Also, discuss the resolution of any encroachment or utility adjustment problems.
9. Intersection/Interchange Design Studies. Include approved Intersection Design Studies (Chapter 14) or Interchange Type and Design Studies (Chapter 15) for all major intersections. Use an 11 in. x 17 in. reduced size sheet format.
10. Estimate of Costs. Provide cost estimates by usable segments, if applicable, or for an isolated project in accordance with the format in Section 12-4 and Chapter 65.
11. Combined Design Report Discussion. Discuss the following items:
 - a. General Description. Describe the need for the improvement, the general type of facility, the nature of service which the highway is intended to provide, and the adjacent highway sections including any plans for improvements on adjacent sections.
 - b. Corridor Feasibility. Discuss the reasons that no other corridor or location is feasible.
 - c. Alternatives and Environmental Considerations. Discuss any plausible alternatives considered and the reasons why these alternatives were eliminated. Use the EA checklist to identify the social, economic, and environmental considerations. For large complex projects, an EA or EIS may be required; see Part III, Environmental Procedures.
 - d. Compatibility with Highway System. Discuss the compatibility of the alternatives studied with existing street and highway plans including related comprehensive urban plans and pedestrian facilities. Where these plans do not exist, discuss the extent of coordination with local officials on highway needs.
 - e. Final Alternatives. Discuss the advantages and disadvantages of the alignment or cross section alternatives studied with respect to the following:

- purpose and need;
 - traffic service, safety, and operations;
 - maintenance and protection of traffic during construction;
 - the need for bridge improvements;
 - the need for traffic signals and progression;
 - access control or access management considerations;
 - construction costs and right-of-way impacts; and
 - other pertinent aspects (e.g., those revealed by an engineering analysis); see Section 11-2.
- f. Recommended Improvement. Provide a summary of facts leading to the recommended improvement, including the consideration of the “no-action” alternative and an analysis of all comments received as a result of public involvement (see Chapter 19) and environmental coordination (see Part III, Environmental Procedures).
- g. Commitments. Provide a list of commitments made during the public involvement process and interagency coordination. This list should eventually be discussed with the Phase II design squad and then transmitted to construction personnel.
12. Public Involvement Document. On large complex projects, a considerable volume of letters is received from the public and different agencies concerning the need for the project and the possible impacts. For guidance on responses, refer to Section 19-4.08(c), Section 24- 2, and Section 25-2. To organize this information and to make it more useful for future reference in case of litigation or questions concerning environmental issues, the letters and their responses are included together in a separate volume. When a large number of similar comments are received, it may be advantageous to prepare a newsletter and mail to public meeting participants.

12-3.05 State Improvement Reports

A State Improvement Report is a combined engineering/environmental document prepared for a State-only or State and locally funded project. This report is used when the scope of the project is major in nature and a programming decision is made that no Federal funds will be used for planning, right-of-way, or construction of the project. See Section 12-1.02 for a description of typical projects. Environmental information, agency coordination, and public involvement coordination are included in the report. Consider the following when preparing State Improvement Reports:

1. Format. The format of a State Improvement Report generally will be similar to that of a Combined Design Report; see Section 12-3.04.
2. Structure of Report. Lay out the State Improvement Report in the format as shown in Section 12-2. In addition, consider the following:

- a. Table of Contents. Provide a table of contents for the report that should list each separate report section, the figures and tables, appendices, and other reports included with the State Improvement Report.
 - b. Page Numbers. Consecutively number the pages in the report including all exhibits and figures (i.e., do not renumber each major section).
 - c. Exhibits. Show all exhibits as figures with figure numbering for easy referencing. Place figures, small maps, and tables at the back of the report and reference them in the text. Place large figures (11 in. x 17 in. format) in either Appendix A or B. Removing the figures and tables from the text allows for easier reading and review of the report, quicker access to a desired page number, and more effective positioning and access of materials that are used to support the text.
 - d. Technical Reports. Provide a summary or reference the information provided in the technical reports.
 - e. Cross References. Provide cross-references to information provided elsewhere in the report (e.g., other sections, figures, appendices).
 - f. Checklist. Section 12-3.09 provides a checklist that may be used to ensure all applicable project information, certifications, coordination, and other requirements are covered in the State Improvement Report.
3. Functional Classification. Identify the functional classification of the highway proposed for improvement and for all affected roadways.
 4. Typical Sections. Provide typical sections for the proposed improvement and all side roads. Include pavement cross sections from the approved pavement design.
 5. Traffic Volumes. Include the current and design year traffic volumes for the proposed facility and for all crossroads; see Section 11-2.02.
 6. Area Map. Provide an area map that indicates the general location of the improvement.
 7. Existing Conditions and Alternative Features. Present the existing conditions and features along the proposed improvement. This information may be shown on a county map, city map, or photographic aerial mosaic, as needed, to adequately illustrate differences and termini. Prepare these exhibits on 11 in. x 17 in. sheets.
 8. Right-of-Way Requirements. Provide an indication of the right-of-way to be acquired in sufficient detail to inform an individual of the effect on his or her property. This is usually shown on topographic mapping for the project. Also, discuss the resolution of any encroachment or utility adjustment problems.
 9. Intersection/Interchange Design Studies. Include approved Intersection Design Studies (Chapter 14) or Interchange Type and Design Studies (Chapter 15) for all major intersections. Use an 11 in. x 17 in. reduced size sheet format.

10. Content. The content of a State Improvement Report will be based on project complexity:
 - a. Design Features. These projects are major reconstruction or new construction type of improvements that may or may not involve an existing highway alignment or street. List and discuss the design guidelines used for the proposed improvement.
 - b. Environmental Information. Use the Abbreviated Environmental Assessment, BDE Template 2401 to determine the potential project impacts. Most projects will be the Categorical Exclusion type or occasionally will require an Environmental Assessment type analysis. Include a summary and analysis of the environmental impacts.
 - c. Public Involvement. Include a summary and analysis of the comments and concerns received as a result of public involvement. One or two informational meetings should be held and an offer to hold a public hearing should be made.
 - d. Estimate of Costs. Provide cost estimates by usable segments, if applicable, or for an isolated project in accordance with the format in Section 12-4 and Chapter 65.

12-3.06 Project Reports

A Project Report typically documents a construction project which uses an existing alignment but curve corrections or minor relocations may also be involved. It could be prepared for a Federal or State-only funded project. These types of projects typically qualify as Categorical Exclusions and, therefore, the environmental documentation is included in the Project Report. Also, see Section 12-1.02. When preparing a Project Report, consider the following:

1. Format. The Project Report should have the following generalized format:
 - table of contents;
 - BDE 1201 Phase I Report Approval;
 - text of report; and
 - exhibits (e.g., plan and profile sheets, aerial photograph, maps) located in the back of the report on 11 in. x 17 in. sheets. Designate each different exhibit as a "Figure" and, if figures are depicting the same information but at different locations, label each exhibit as Sheet ____ (No.) of ____ (No.) ____.
2. Page Numbering. Provide consecutively numbered pages for the report. Also, provide page numbers for all figures in the exhibit sections.
3. Cross References. Make cross-references between related areas and to figures contained in the exhibit section of the report.

4. Content. Information placed in a Project Report should reflect appropriate engineering and environmental investigations and should indicate compatibility with current Department criteria. The project study should meet the requirements for public involvement (Chapter 19), environmental analyses (Part III, Environmental Procedures), and engineering analyses (Section 11-2). Figure 12-3.A provides an outline of the information, as applicable, that should be included in a Project Report. Also, review the items listed on the Fact Sheets for an Abbreviated Project Report as shown in Section 12-3.07.
5. Checklist. Form BDE 1210 provides a checklist that may be used to ensure all applicable project information, certifications, coordination, and other requirements are covered in the Project Report.

**TABLE OF CONTENTS
FOR PROJECT REPORT**

	Page
Title Sheet	
Table of Contents	
Phase I Report Approval form (BDE 1201)	
I. NEED FOR IMPROVEMENT	
A. Project Location and Termini	
1. Functional classifications and local name(s)	
2. Regional location — Note the project/route location with respect to other major routes, municipalities, and geographical markers	
3. Limits, county, municipality, maintenance jurisdictions (who owns road)	
4. Separate classifications (e.g., SRA, truck routes, NHS)	
B. Description of Existing Conditions	
1. Land use (along route and in project vicinity)	
a. Residential, commercial, industrial	
b. Historical sites	
c. Schools, parks, forest preserves, etc.	
2. Existing Cross Section	
a. Number of lanes, parking, shoulders and/or curb and gutter, sidewalk, median (type), and right-of-way (see Item VII.B. Typical Cross Sections); typical sections should also include pavement composition	
b. Existing drainage (brief description of open/closed system and record of flooding)	
C. Operational and Safety Analyses	
1. Why project was initiated (need)	
a. Safety analysis/concerns: include crash summary (e.g., number of crashes, predominant crashes and causes, Five Percent Report)	
b. Pavement condition	
c. Operational concerns/capacity	
d. Existing geometry and profile	
e. Structural deficiencies	
f. Local interest	
2. Relationship to other projects (past, current, future)	
D. Project Purpose/Identified Deficiencies (general statement)	

Note: Table of Contents may be modified as necessary depending on the proposed improvement.

TYPICAL TABLE OF CONTENTS FOR PROJECT REPORT

Figure 12-3.A
(1 of 8)

TABLE OF CONTENTS
(Continued)

	Page
<hr/>	
II. DESCRIPTION OF PROPOSED IMPROVEMENT (only include items relevant to project)	
A. Introduction	
This section is not intended to be lengthy, but should include the following:	
1. General scope of work	
2. Relationship to the purpose and need for improvement	
B. Design Criteria Utilized	
Note design criteria (e.g., projects on existing roads, reconstruction) used in developing improvement.	
C. Geometric Improvements	
Include reasons for each of the following:	
1. Typical roadway template (proposed cross section)	
2. Intersections	
3. Vertical alignment — lower or raise the profile (safety and drainage)	
4. Horizontal alignment — correct sight distance problem/deficient curves, revise superelevation, correct broken back alignments, etc.	
5. Unique considerations	
D. Approved Pavement Design/Rehabilitation	
1. Need for Geotechnical Survey	
2. Documentation for pavement design or rehabilitation of pavement	
3. Statement if cold milling is proposed	
E. Pavement Drainage	
1. Describe existing system and any proposed improvements	
2. Reference Preliminary Drainage Study or Hydraulic Report, as applicable	
F. Design Exceptions	
Include all design exceptions/waivers as approved by BDE and/or FHWA. Typically, these are discussed, and concurrence is received at district coordination meetings.	
G. Right-of-Way	
1. Acquisition required	
a. Total parcels	
b. Land use summary	
c. Total area	

TYPICAL TABLE OF CONTENTS FOR PROJECT REPORT

Figure 12-3.A
(2 of 8)

TABLE OF CONTENTS
(Continued)

	Page
<ul style="list-style-type: none"> 2. Permanent easements required <ul style="list-style-type: none"> a. Total parcels b. Land use summary c. Total area 3. Temporary easements required <ul style="list-style-type: none"> a. Total parcels b. Land use summary c. Total area 4. Residential/business displacement; see Plan Sheets and Part III, Environmental Procedures for discussion 5. If no ROW acquisition is required, then include a statement to this effect. 	
<p>H. Structures</p> <p>This section is to be more detailed than Section I, Need for Improvement, and will function as a “quick-look” reference area; see Bridge Condition Report (BCR) and information listed in Abbreviated Project Reports:</p> <ul style="list-style-type: none"> 1. Feature carried 2. Feature crossed and adjacent land use 3. Structure number 4. Existing structural deficiencies 5. Proposed scope of work and cross section (e.g., deck replacement, superstructure replacement, bridge removal/replacement, in-stream work, widening) 6. Vertical clearances — deficient or the need for restrictions on resurfacing projects 7. Indicate whether foundation borings requested and/or completed. If completed, include in Project Report (supplement) 8. Include memo from Bureau of Bridges and Structures approving BCR 9. Reference coordination meeting with BDE for cross section concurrence 	
<p>I. Traffic Signal Modernization/Installation</p> <ul style="list-style-type: none"> 1. Location(s) 2. Description of work (e.g., modernizing, interconnect, pre-emption, railroad crossing, installation) 3. Reference signal warrants(s) met 4. Local participation (e.g., construction costs, maintenance responsibility, maintenance costs, energy costs) 	
<p>J. Lighting</p> <ul style="list-style-type: none"> 1. Existing conditions (Lighting Survey) 2. Maintenance responsibility 	

TYPICAL TABLE OF CONTENTS FOR PROJECT REPORT

Figure 12-3.A
(3 of 8)

TABLE OF CONTENTS

(Continued)

	Page	
3.	Proposed improvement	
4.	Funding responsibility	
K.	On-Street Parking	
1.	Existing conditions (e.g., parallel/diagonal, peak-hour restrictions, metered), include limits, municipality, and parking use (e.g., residential, commercial)	
2.	Proposed improvement — Describe whether parking lanes are removed, replaced, resurfaced, reconstructed, or relocated	
3.	Local participation	
L.	Sidewalks/ADA Requirements	
1.	Existing conditions (e.g., width, continuous, location)	
2.	Proposed improvement (e.g., new, repair, width, location, local coordination, accessible for persons with disabilities)	
3.	Local participation	
4.	If no sidewalks exist and/or no new sidewalks requested, include statements to this effect	
M.	Bikeways/Trails	
1.	Note if route is a recommended road bicycle route or if there is another recommended (alternative) route in the proximity of the improvement	
2.	Existing trails in the proximity of the improvement	
3.	Bicycle generators in the area	
4.	Local coordination to determine any planned facilities	
5.	How project addresses bicycle usage (include specific improvements such as wider lanes, separate path, etc.)	
6.	If the improvement does not accommodate bicycle use, then complete the Bicycle Checklist as discussed in Chapter 17	
N.	Pedestrian Overpass/Subways/Other Facilities	
1.	Existing — Describe pedestrian generators, crashes, and other features that would necessitate a grade separated pedestrian facility	
2.	Proposed — Discuss proposed work and how it will accommodate pedestrians and provide benefits (e.g., safe access to parks/schools/public facilities/ commuter stations/bus stops, aesthetics, safety)	
O.	Mass Transportation	
1.	Existing services (e.g., bus, train, shuttle (include route numbers))	
2.	Describe existing facilities (e.g., pedestrian accessible, park and ride lots, kiss and ride locations, commuter stations, bus stops (near side/far side))	

TYPICAL TABLE OF CONTENTS FOR PROJECT REPORT**Figure 12-3.A**

(4 of 8)

TABLE OF CONTENTS
(Continued)

	Page
<ul style="list-style-type: none"> 3. Will project improve access to mass transportation (e.g., bus turnouts, bus pads, shelters, signal work) 	
<ul style="list-style-type: none"> P. Utility Conflicts <ul style="list-style-type: none"> 1. Identify utilities that were contacted and those that responded to having facilities within the project limits 2. Describe conflicts with these utilities due to the proposed improvement (e.g., changes in horizontal and vertical alignment, widening, replacement of bridge deck or superstructure, trenching, boring for conduits, storm sewer) 	
<ul style="list-style-type: none"> Q. Encroachments <ul style="list-style-type: none"> 1. Existing (e.g., illegal parking, ROW infringements) 2. Proposed remediation of encroachments 3. Reference letters sent to property owner about encroachments 	
<ul style="list-style-type: none"> R. Mail Delivery <ul style="list-style-type: none"> 1. Type of drop-off (e.g., locations, door-to-door, streetside) 2. Hazardous mailbox supports (reference letters sent to property owners); see Chapter 58 3. Improvement's impact on mail delivery (need to contact local postmaster) 4. Mailbox turnouts (shoulder section versus curb and gutter); see Chapter 58 	
<ul style="list-style-type: none"> S. Landscape/Roadside Development <ul style="list-style-type: none"> 1. Note all areas disturbed by construction to be restored to turf cover 2. Note all tree and other plants removed for construction and which will be replaced; see Chapter 59 3. Summarize the results of the vegetation assessment survey 	
<ul style="list-style-type: none"> T. Construction Site Stormwater Pollution Control If soil is exposed to displacement, include construction site stormwater pollution control documentation; see Chapter 41 	
<ul style="list-style-type: none"> U. At-Grade Railroad Crossings <ul style="list-style-type: none"> 1. Location and rail line (e.g., Union Pacific, Wisconsin Central, CTA "L"). 2. Existing conditions <ul style="list-style-type: none"> a. railroad crossing flashers, gates, and pedestrian gates b. proximity of train stations or stops c. number of tracks and alignment of crossing d. crash history at crossing 	

TYPICAL TABLE OF CONTENTS FOR PROJECT REPORT

Figure 12-3.A
(5 of 8)

TABLE OF CONTENTS
(Continued)

		Page
	3. Proposed improvement — In addition to roadway work, include the results of the coordination with the Railroad Unit to determine proposed improvements (e.g., rail replacement, rehabilitation, changes in gate/flasher (preemption) timing).	
	4. Train interruptions/detour routes.	
	5. Proximity of traffic signals and preemption. Include results of discussions with the district Bureau of Operations to identify signal sequence and preemption at the crossing. Describe existing (or the need for) near side traffic signals that stop traffic in advance of the crossing; see Section 36-8.	
	6. Coordination with Illinois Commerce Commission.	
V.	Surveillance	
	1. Existing surveillance within or in the proximity of the proposed improvement (e.g., changeable message signs, detector loops, volume/speed loops, video detection/monitors).	
	2. Proposed surveillance for the improvement.	
	3. Results of coordination with the district Bureau of Operations (Bureau of Traffic, District 1), where necessary.	
W.	Pump Stations	
	The electrical requirements associated with pump stations are determined and designed by the Bureau of Electrical Operations (District 1) and Bureau of Operations in other districts. The roadway collection system, pump capacity, pump discharge, storm water storage, and outlet evaluation are detailed in the Hydraulics Report prepared by the Hydraulics Unit in the district. For this section of the Project Report, provide the following general information, while referencing the Hydraulics Report for the more detailed, technical information:	
	<ul style="list-style-type: none"> • pump station number and location, • roadway limits that are drained by the pump station, • outfall location, and • proposed improvements as directed by Hydraulics Unit. 	
X.	Retaining Walls	
	a. Existing retaining walls within and/or affected by the improvement.	
	b. Proposed retaining walls that are required as a result of improvement (e.g., profile adjustments, regrading near bridge abutments, sidewalk separations). Walls over 10 ft (3 m) high are either designed by Bureau of Bridges and Structures or the design is reviewed by Bureau of Bridges and Structures.	

TYPICAL TABLE OF CONTENTS FOR PROJECT REPORT

Figure 12-3.A
(6 of 8)

TABLE OF CONTENTS

(Continued)

Page

c.	Provide information on length and height (exposed) so that the design squad can determine need for consultant services.	
d.	Indicate whether foundation borings requested/completed. If completed, include as supplement.	
Y.	Public Educational Facility Entrances; see Section 11-2.08(h)	
a.	Existing entrances to route	
b.	Existing conditions	
c.	Proposed improvement, if any	
III.	ENVIRONMENTAL RESOURCE SUMMARIES	
	For documentation requirements in the Project Report, see Section 12-3.09.	
IV.	TRANSPORTATION MANAGEMENT PLAN AND RECOMMENDATIONS	
	See Chapters 13 and 55 to determine type and cost of traffic management for proposed improvement.	
V.	ESTIMATE OF COSTS	
	See Section 12-4 and Chapter 65 for details on cost estimates for Project Reports.	
VI.	COMMITMENTS	
A.	Environmental (e.g., permits, restricted areas, tree cutting, mitigation)	
B.	Property owner/local/forest preserve/transit company	
C.	Other agencies (e.g., IDNR, Agriculture, U.S. Army Corps of Engineers)	
	These commitments require review by the Project and Environmental Studies Section Chief and by the Environmental Unit Head in District 1 and by the Project Engineer and Environment Studies Supervisor in other districts. Discuss these commitments with Phase II design squad and with construction personnel.	
VII.	EXHIBITS	
A.	Location Maps	
B.	Typical Cross Sections	
C.	Traffic Diagrams of Overall Street Network	
D.	Existing Conditions (Aerial Photography)	
E.	Proposed Conditions (Plan and Profile Sheets in 11 in. x 17 in. format)	

TYPICAL TABLE OF CONTENTS FOR PROJECT REPORT

Figure 12-3.A
(7 of 8)

TABLE OF CONTENTS
(Continued)

	Page
F. Approved Intersection Design Studies (Reduce to 11 in. x 17 in. format)	
G. Overall Schematic of Horizontal Control and Curve Data	
H. Vertical Curve Data	
VIII. COORDINATION/DOCUMENTATION	
Provide copies of correspondence, coordination, minutes of meetings, and a summary of public involvement needed and completed.	
A. Environmental Correspondence/Permits	
B. District Coordination Meeting Minutes	
C. Coordination	
1. Municipalities/counties	
2. Parks and forest preserves	
3. Mass transit agencies	
4. Other agencies (utilities, railroads, etc.)	
D. Public Involvement	
1. Property owner letters or contacts	
2. Other correspondence	
3. Summary of Informational Meetings/Public Hearings	
E. Pavement design approval memorandum	
IX. TECHNICAL REPORTS	
A. Air Quality	
B. Noise/Construction Noise	
C. Crash Analysis	
D. Vegetation Assessment/Survey	
E. Bridge Condition Report	
F. Geotechnical Survey	
G. Transportation Management Plan (TMP)	
H. Pavement Design Analysis	
I. Other	
X. PRELIMINARY DRAINAGE STUDY	
If needed, prepare as a separate technical report.	

TYPICAL TABLE OF CONTENTS FOR PROJECT REPORT

Figure 12-3.A
(8 of 8)

12-3.07 Abbreviated Project Reports

For some pavement rehabilitation or pavement replacement projects, an Abbreviated Project Report format may be used to document the results of a Phase I engineering study. This format eliminates considerable writing and provides an easy-to-follow checklist, fill-in-the-blanks, and attachments type report.

Only use an Abbreviated Project Report when the environmental and engineering impacts of a project can be adequately described by completing the Fact Sheet and by use of attachments. However, if the project information as described in Part III, Environmental Procedures requires the preparation of a narrative type report for adequate coverage, then use the Project Report format described in Section 12-3.06.

The recommended format of an Abbreviated Project Report can be found in the following figures as applicable:

- Figure 12-3.B, Fact Sheet (Roadway Improvement); and
- Figure 12-3.C, Fact Sheet (Total Structure or Superstructure Replacement).

As an exhibit, include a copy of the applicable district coordination meeting minutes. This documentation describes the proposed improvement and lists the decisions made at those meetings. A typical example of these meeting minutes is shown in Figure 12-3.D.

ABBREVIATED PROJECT REPORT

ILLINOIS DEPARTMENT OF TRANSPORTATION

1. PPS (Project Planning System) No.: _____
2. Contract No.: _____
3. State Job No.: _____
4. Highway Functional Classification: _____
5. Truck Route Classification: _____
6. Type of Improvement: _____ W & RS or _____ RS
If other type of improvements, attach description: _____
7. Proposed Project Funding (Must be compatible with selected design guidelines.): _____
8. Current ADT: _____ % Trucks in ADT: _____
9. Surrounding Land Use: _____
10. Existing Right-of-Way Width: _____ Proposed: _____
11. Existing No. of Lanes: _____ Proposed: _____
12. Existing Roadway Width: _____ Proposed: _____
13. Existing Traveled Way Width: _____ Proposed: _____
14. Pavement Surface Condition (CRS): _____ (Year): _____
15. Existing Shoulder or Curb Type: _____ Proposed: _____
16. Existing Clear Zone Width: _____ Proposed: _____
17. Describe existing conditions or proposed highway improvements adjacent to project limits:

18. Are there any bridges in this construction section? ____ Yes ____ No. Can they all remain in place? ____ Yes ____ No. Give description of what must be done to each bridge in this segment and when work will be accomplished; see Figure 12-3.C: ____

19. What has the field check indicated for culvert extensions, side road culvert improvements, and other safety work: _____

**FACT SHEET
(Roadway Improvement)**

**Figure 12-3.B
(1 of 4)**

Use a straight-line diagram or schematic plan to indicate proposed work including culvert extensions, guardrail, etc.

20. Will ditch cleaning be necessary with this improvement? _____ Yes _____ No

21. What has a review of crash data shown? _____

22. Existing Rural Posted Speed: _____ Urban Posted Speed: _____

23. Proposed Rural Design Speed: _____

Proposed Urban Design Speed: _____

24. Check design policy used:

_____ Projects on Existing Roads, pavement replacement; see Chapter 49

_____ Projects on Existing Roads, pavement rehabilitation; see Chapter 49

_____ Projects on Existing Roads, unmarked routes; see Chapter 49

_____ Other (list): _____

25. List and indicate reasons for any design exceptions: _____

Does existing highway geometry meet IDOT criteria?

Horizontal: _____ Yes _____ No

Vertical: _____ Yes _____ No

If "No" is checked, discuss what will be done: _____

Is resurfacing thickness in accordance with policy; see Chapter 53?

_____ Yes _____ No; Reason(s) _____

**FACT SHEET
(Roadway Improvement)**

Figure 12-3.B
(2 of 4)

26. How will traffic be maintained during construction? _____
27. RR Data: Trains/Day _____ # Tracks _____ Speed of Trains _____
28. RR Crossing Protection: Existing: _____ Changes Proposed: ___ Yes ___ No
29. Type of proposed improvements at RR crossing: _____
30. Sidewalks: Existing: _____ Proposed: _____
31. Parking: Existing: _____ Proposed: _____
32. Will signals be installed or modernized? _____
33. Lighting: _____
34. Utilities/Encroachments: _____
35. Drainage (flood plain, detention, flooding over the roads, etc.): _____
36. Any Section 4(f) sites on Federal-aid projects? _____ Yes ___ No
37. Is an environmental survey request required by Department policy? ___ Yes ___ No
38. If applicable, Metropolitan Planning Organization approval date: _____
39. Permit Status (Sections 404, 402, and 10 Permits, 401 Certification, etc.): _____
40. Have any special erosion control or tree retention commitments been made?
___ Yes ___ No
- If yes, has the district Landscape Architect/Specialist reviewed the commitments?
___ Yes ___ No
41. If soil is exposed to displacement, include construction site stormwater pollution control documentation; see Chapter 41.
42. Are there any existing public educational facility entrances onto the route?
See Section 11: 2.08(h)
___ Yes ___ No

**FACT SHEET
(Roadway Improvement)**

**Figure 12-3.B
(3 of 4)**

43. Roadway Exhibits:	<u>Page No.</u>
• Completed Estimate of Costs; see Figure 12-4.B:.....	_____
• Concurrence Letter for Funding Participation:	_____
• IDOT TIP Sheet:	_____
• Location Map and Aerial Photography (use 11 in. x 17 in. format): .	_____
• Profile Gradelines of Existing Alignment, Any Corrections, and Topographic Mapping for Alignment and Profile Changes:	_____
• List of Existing Horizontal Curvature from Road Plans and Superelevation Rates from Field Check (if applicable):	_____
• Typical Roadway Cross Sections (existing and proposed):.....	_____
• BDE Approval Memorandum on Resurfacing Thickness Deviation (if applicable):	_____
• Crash Analysis and Schematic Drawing of Crashes (Collision Diagram) for Previous Three Years:	_____
• Wet-Weather Skid Crash Analysis:.....	_____
• Resolution of Any Encroachments on ROW:.....	_____
• Archaeological/Biological Sign-off (where applicable) or Evidence of the Results of Surveys and Related Coordination:	_____
• Noise Statement for Projects with Alignment Changes or Noise Abatement:	_____
• Coordination and US Army Corps of Engineer, Section 404 Permit Status If Bridges are Involved:.....	_____
• Route Improvement Plans for Adjacent Districts:	_____
• Agency Coordination Letters:	_____
• Utility Coordination:.....	_____
• District Coordination Meeting Minutes; see Figure 12-3.D:.....	_____
• Public Involvement Comments and Responses (if applicable):.....	_____
• Discussion of Mailbox Supports:.....	_____
• List Commitments with Discussion of Each:.....	_____
• Airport Clearance Coordination (if applicable):.....	_____
• Drainage/Hydraulic Reports (summary):.....	_____
• Approved Intersection Design Studies:.....	_____
• Transportation Management Plan (TMP) and Approval Memorandum:	_____

**FACT SHEET
(Roadway Improvement)**

**Figure 12-3.B
(4 of 4)**

ABBREVIATED PROJECT REPORT
ILLINOIS DEPARTMENT OF TRANSPORTATION

1. PPS (Project Planning System) No.: _____
2. Contract No.: _____
3. State Job No.: _____
4. Highway Functional Classification: _____
5. Truck Route Classification: _____
6. Is project eligible for HBP funds? _____ Yes _____ No
7. Current ADT: _____ % Trucks in ADT: _____
8. Name of Stream or Crossing: _____
9. Surrounding Land Use: _____
10. Existing Approach Roadway Width: _____ Proposed: _____
11. Existing Traveled Way Width: _____ Proposed: _____
12. Existing Shoulder Type: _____ Proposed: _____
13. Existing Shoulder Width: _____ Proposed: _____
14. Existing Clear Roadway Bridge Width: _____ f-f Proposed: _____ f-f
15. Are sidewalks warranted? _____ Yes _____ No
16. Existing Posted Speed: _____
17. Proposed Rural Design Speed: _____ Proposed Urban Design Speed: _____
18. Check Design Policy Used:
 - _____ Projects on Existing Roads, bridge replacement; see Chapter 49
 - _____ Projects on Existing Roads, superstructure replacement; see Chapter 49
 - _____ Projects on Existing Roads, bridges on unmarked routes; see Chapter 49
 - _____ Other (List): _____
19. Does existing highway geometry meet IDOT criteria?
 - Horizontal: _____ Yes _____ No (discuss): _____
 - Vertical: _____ Yes _____ No (discuss): _____

FACT SHEET
(Total Structure or Superstructure Replacement)

Figure 12-3.C
(1 of 4)

20. List and indicate reasons for any design exceptions: _____

21. Are proposed clear roadway bridge width and alignment compatible with existing and proposed bridge widths within adjacent roadway sections assuming logical segments?
_____ Yes _____ No, Discuss: _____
22. Any crash problems on or adjacent to bridge: _____ Yes _____ No, Discuss: _____

23. Is channel work required? _____ Yes _____ No
24. Hydraulic Information or Attach Waterway Table (where applicable).
- a. Drainage Area: _____ acres (hectares)
 - b. Existing Opening: _____ sq ft (m²)
 - c. Required Opening: _____ sq ft (m²)
 - d. Proposed Opening: _____ sq ft (m²)
 - e. Q (): _____ cu ft/s (m³/s)
- Discuss Results: _____
25. Has Bureau of Bridges and Structures concurred in Proposed Bridge Drawings and Bridge Condition Report? _____ Yes _____ No
26. Has district Bridge Engineer made a recent field inspection of abutments and piers?
_____ Yes _____ No
27. Comments on Field Check: _____
28. Is an environmental survey request required by Department policy? _____ Yes _____ No
- a. Any Wetlands Involved in Reconstruction: _____ Not Applicable: _____
 - b. 4(f)/106 Involved on Federal-aid Projects: _____ Not Applicable: _____

FACT SHEET
(Total Structure or Superstructure Replacement)

Figure 12-3.C
(2 of 4)

c. Illinois Department of Natural Resources, Office of Water Resources:

Status of Flood Plain Permit: _____ Not Applicable: _____

29. Are Sections 404, 402, and 10 Permits and Section 401 Certification required for channel work, runaround detours, etc.? _____ Yes _____ No Status of Permit: _____

30. Status of Other Permits (see Chapter 28): _____

31. Is this a historic bridge? _____ Yes _____ No If yes, discuss: _____

32. If applicable, Metropolitan Planning Organization approval date: _____

33. What method will be used to detour or maintain traffic during construction (Transportation Management Plan)? _____

34. Have any special erosion control or tree retention commitments been made?

_____ Yes _____ No

If yes, has the district landscape architect/specialist reviewed the commitments?

_____ Yes _____ No

If soil is exposed to displacement, include construction site stormwater pollution control documentation (see Chapter 41).

35. Structure or Superstructure Replacement Exhibits: Page No.

- Completed Estimate of Costs; see Figure 12-4.B: _____
- Concurrence Letter for Funding Participation: _____
- IDOT TIP Sheet: _____
- Location Map & Aerial Photography (use 11 in. x 17 in. format): ... _____
- Profile Gradeline of Existing Alignment, Any Corrections and Topographic Mapping for Alignment and Profile Changes: _____
- List Existing Horizontal Curvature from Road Plans and Super-elevation Rates from Field Check (if applicable): _____
- Proposed Bridge Drawings and Memorandum Approving Each Bridge Condition Report(s): _____
- Color Photographs of Existing Bridge(s): _____
- Other Items for Approach Roadway (if applicable): _____

**FACT SHEET
(Total Structure or Superstructure Replacement)**

**Figure 12-3.C
(3 of 4)**

- Crash Analysis Schematic Drawing of Crashes
(Collision Diagram) 0.5 miles (800 m) on Each Side of Bridge: _____
- Wet-Weather Skid Crash Analysis: _____
- Resolution of Any Encroachments On ROW: _____
- Archaeological/Biological Sign Off (where applicable), or
Evidence of the Results of Surveys and Related Coordination: _____
- Noise Statement for Projects with Alignment Changes or Noise
Abatement: _____
- Coordination with US Army Corps of Engineer, Section 404
Permit Status: _____
- Agency Coordination Letters: _____
- Utility Coordination: _____
- District Coordination Meeting Minutes, see Figure 12-3.D: _____
- Public Involvement Comments and Responses (if applicable): _____
- List Commitments with Discussion of Each: _____
- Airport Clearance Coordination (if applicable): _____
- Transportation Management Plan (TMP) and Approval
Memorandum: _____
- Drainage/Hydraulic Reports (summary): _____

36. Are there any existing public education facilities entrances onto the route?
See Section 11: 2.08(h)

_____ Yes _____ No

If yes, will they be improved? _____ Yes _____ No

FACT SHEET
(Total Structure or Superstructure Replacement)

Figure 12-3.C
(4 of 4)

ILLINOIS DEPARTMENT OF TRANSPORTATION

COORDINATION MEETING MINUTES		TOPIC NO. 9	
DISTRICT 3 CONFERENCE ROOM			
DATE OF MEETING:	January 29, 2019	FUNDING SOURCE:	STBG
ROUTE:	FAP 41		
MARKED ROUTE:	Illinois 17	DESIGN GUIDELINES USED: Existing Roads (Chapter 49)	
LOCAL NAME:	N/A	FUNCTIONAL CLASSIFICATION: East of CH 6 - Urban Other Principal Arterial West of CH 6 - Rural Minor Arterial	
SECTION:	(11, 12) RS-3	DESIGN SPEED:	60 mph
COUNTY:	Kankakee	POSTED SPEED:	55 mph
ADT:	Herscher Rd. to Warner Bridge Road - 3,850/2018/10.4 Warner Bridge Road to Kankakee City Limits - 9,400/2018/5.4		

- LIMITS OF PROJECT:** The project begins approximately 0.75 miles east of Herscher Road and extends east approximately 9.13 miles to the west Kankakee city limits.
- PREVIOUS DATES OF DISCUSSION:** None
- PROJECT DESCRIPTION:** The length of roadway to be improved is approximately 9.13 miles. It was originally constructed in 1924 to a width of 18 ft with a pavement design of 9 in.-6 in.-9 in. portland cement concrete and earth shoulders.

In 1961, the roadway was widened to 24 ft with 9 in. portland cement concrete and overlaid with 3.25 in. of HMA. In 1975, HMA shoulders 9 in. at a width of 1.5 ft were added to each side and the entire roadway given an HMA overlay of 3 in. and aggregate shoulders. In 1986, the shoulders were widened an additional 1.5 ft with 6 in. of HMA to allow for a bituminous shoulder of 3 ft. Turn lanes of 12 ft were also constructed at Lehigh and Limestone Roads with 9 in. of HMA base course. The existing roadway was cold milled 0.625 in. and the entire roadway was given an HMA overlay of 2 in. Aggregate shoulders 5 ft were also added.

Pavement rehabilitation is the only need established for this project so the proposed improvement includes a 2.25 in. HMA overlay consisting of 0.75 in. IL-4.75 binder and 1.5 in. IL-9.5FG surface course. A 5 ft aggregate wedge will also be placed. Mr. John Doe of the Bureau of Design and Environment concurred with the scope of work and with the project being processed as a State Approved Categorical Exclusion.

- TRAFFIC CONTROL:** This project will be constructed using applicable traffic control standards with one lane open to traffic at all times during construction.
- REVIEW OF CRASH DATA:** A total of 102 crashes have occurred on this segment of Illinois Route 17 from January 1993 to December 1995. The highest crash pattern was in clear and dry conditions (69 percent). The most common type was animal related (28 percent). No Five Percent Report locations were noted in the project limits.
- EXPLANATION OF DESIGN EXCEPTIONS:** No exceptions required.
- ENVIRONMENTAL ACTIONS DESIRED:**
 - NATIONWIDE 404 PERMITS:** N/A
 - ENVIRONMENTAL SURVEY REQUEST:** N/A
 - CATEGORICAL EXCLUSION:** State Approved CE Concurred 1-29-2019
- ADDITIONAL RIGHT-OF-WAY NEEDED:** N/A
- ATTACHMENTS:** Location Map(s) attached.

**EXAMPLE OF DISTRICT MINUTES
(Coordination Meeting Minutes)**

Figure 12-3.D

12-3.08 3P and PAVEMENT PRESERVATION (High/Low) Projects

12-3.08(a) Report Format and Content

The report format for documenting 3P projects and pavement preservation projects in the “high” or “low” categories (see Chapter 53) are contained in forms BDE 1202 and BDE 1203, respectively. At the discretion of the district, 3P and pavement preservation projects may be presented at coordination meetings. These meetings provide the means to discuss design exceptions and how other project needs, especially safety and ADA compliance, will be addressed. However, 3P or pavement preservation projects are only required to be presented at coordination meetings when any of the following conditions apply:

- design exceptions are being requested by the district; see Section 31-7,
- the proposed project will have a location(s) not fully compliant with current ADA standards, requiring completion of form BDE 3101 ADA Statement of Maximum Extent Practicable; see Section 31-7.03(c),
- the project is (or will be presented to be) classified as a Federally Approved Categorical Exclusion, or
- there are issues related to the project’s scope that would benefit from discussion.

See Section 12-1.02 for further information on these reports and Chapter 53 for further design details on pavement rehabilitation and preservation strategies.

12-3.08(b) Safety Needs Analysis

The need to address safety must be determined during scoping. This is done by analyzing the existing crash data to determine: 1) the relative safety performance of the roadway as compared to similar roadways in the district; and 2) if specific crash types, severities, locations, or conditions are over-represented in the data.

When safety improvements are identified as part of the project’s needs and can be accomplished for 15% or less of the total project cost, said safety improvements shall be made part of the project. When the needed improvements are beyond the scope of 3P or high/low preservation or would represent more than 15% of the total project cost, a higher project scope must be selected to address the safety need.

12-3.09 Phase I Checklist

A checklist for Phase I Reports, BDE 1210 Phase I Checklist, is available on the Forms Master List. This form is optional for inclusion in Phase I Engineering Reports.

12-3.10 Phase I Report Exemptions

There are certain projects that are not complex from an engineering standpoint. Additionally, they do not cause sufficient impacts to require the preparation of a Phase I report. In this case, the district prepares a set of documents designated as the Plans, Specifications, and Estimates (PS&E).

However, even though Phase I documentation is not needed, projects that are federally funded still require NEPA documentation. This documentation may be achieved by either using BDE 488 Certification Acceptance/Project Status or BDE 2301 Categorical Exclusion Determination and Approval, whichever is most convenient for the district.

The following project types (and combinations thereof) are intended to have the above-mentioned expedited processing and design approval prior to implementation:

1. traffic signal modifications and installations of new signals;
2. signing;
3. pavement markings not affecting the number of through traffic lanes;
4. anti-skid treatments and pavement reprofiling;
5. pavement preservation projects in the "proactive maintenance" subcategory;
6. curb and/or gutter repairs and construction of curb ramps for persons with disabilities;
7. bridge repairs, which do not require traffic detours or runarounds, including:
 - a. bridge rail replacement;
 - b. bridge deck overlay and waterproofing;
 - c. expansion joint replacement;
 - d. bearing replacement;
 - e. repairs to deck, partial or full depth;
 - f. repairs to damaged rails, corroded or damaged structural steel members, and deteriorated areas of concrete elements including sidewalks, curbs, water tables, girders, and portions of the substructure above ground or water;
 - g. painting of structural steel;
 - h. bridge washing, and
 - i. individual stringer replacement for a portion of a superstructure;

**Note: All items under Number 7 require coordination with the Bureau of Bridges and Structures prior to preparation of final plans. Additionally, Item 6a requires TSL plan approval and Item 6e requires approval of a "Bridge Deck Condition Report."*

8. the following lighting and electrical work:
 - a. continuous and tower lighting,
 - b. tunnel lighting,
 - c. temporary lighting,
 - d. bridge lighting,
 - e. pedestrian lighting,
 - f. pumping station,
 - g. highway advisory radio,
 - h. control systems for changeable lanes,
 - i. traffic monitoring systems, and
 - j. changeable message signing;
9. landscaping;
10. the following stormwater control within existing right-of-way:
 - a. slope repair,
 - b. ditch and/or culvert cleaning, and
 - c. miscellaneous storm sewer work to eliminate ditch (which does not reduce necessary urban runoff storage/retention);
11. impact attenuator and glare screen installations;
12. the following isolated highway-railroad grade crossing improvements:
 - a. repair/rehabilitation of crossing proper,
 - b. rehabilitation of immediate roadway approaches to crossing, and
 - c. upgrading of crossing protection;
13. the following restoration projects:
 - a. retaining wall repair (coordinate with Bureau of Bridges and Structures),
 - b. fencing,
 - c. guardrail repair,
 - d. pavement and shoulder patching/sealing,
 - e. intermittent resurfacing, and
 - f. repairs to drainage structures not requiring traffic detours or runarounds;
14. installation of turning lanes within an existing median;
15. junkyard screenings;
16. upgrading safety features (e.g., signing, striping, guardrail end terminals);
17. approval of utility installations along or across a transportation facility, excluding longitudinal installations within the access control lines of Interstate and freeway rights-of-way;
18. activities included in the highway safety plan developed pursuant to *23 U.S.C. 402*;
19. alterations to existing buildings to provide for noise reduction and/or the installation of noise abatement barriers;

20. emergency repairs under 23 *U.S.C. 125* that do not substantially change the design of the facility and are commenced during or immediately after the occurrence of a declared national disaster;
21. acquisition of scenic easements;
22. minor improvements to existing rest areas and truck weigh stations that do not require changes to the geometrics or to the number of parking stalls;
23. installation of noise barriers;
24. approval of air space agreements; and
25. disposal of excess right-of-way.

12-4 ESTIMATE OF COST FORMATS

12-4.01 Corridor or Feasibility Studies

These studies are general in nature and are usually comparing alternative corridors or locations. Therefore, the cost estimate is generalized and is made on a per-mile (per-kilometer) basis or by assigning lump-sum dollar amounts to major items.

The format of the cost estimate sheet should only cover major items plus a contingency figure. As a guide in preparing generalized estimates, see Chapter 65 or the latest instructional manual for preparing an Interstate Cost Estimate.

12-4.02 Design Reports, Combined Design Reports, and State Improvement Reports

Figure 12-4.A presents the cost items normally used for complex projects. See Section 12-1.02 for a description of typical projects in this category. Items may be added or further divided as necessary to properly identify costs on specific projects. Individual cost estimate sheets are usually necessary for each construction segment, which then make up the total cost of each alternative. This segment type format allows the project to be easily programmed for multi-year construction and to provide for usable highway segments. Individual major elements such as interchanges or bridges are listed separately to identify their location and costs. For additional guidance, see Chapter 65.

12-4.03 Project Reports and Other Reports

Figure 12-4.B presents a sample cost estimate form with work classification elements considered appropriate for a Project Report or Abbreviated Project Report. This form may be copied and inserted directly into reports or may be modified to fit a specific improvement.

For other reports (e.g., 3P Reports, Pavement Preservation (High/Low) Reports), the cost estimate is completed on work sheets and the total cost for the project is listed in the report; see forms BDE 1202 and BDE 1203. For improvements not requiring a report (i.e., Phase I Report Exemptions, see Section 12-3.10), the cost estimate is prepared at the same time as the PS&E package and itemized by pay items.

COST ESTIMATE

Date: _____
 Route: _____
 Section: _____

Designer: _____
 City/County: _____
 Base Year: _____

WORK CLASSIFICATION	Estimated Costs in \$1000's					
	Segments					
	1	2	3	4	5	Totals
1. Clear and Grub (Minor removal items and demolition)						
2. Earthwork						
a. Mainline grading and drainage (minor structures).						
b. Frontage road grading and drainage (minor structures).						
3. Pavement						
a. Mainline subbase, base, surface, and shoulder						
b. Frontage road, subbase, base, surface, and shoulder						
4. Grade Separations						
a. Railroads						
b. Highway grade separations, including earthwork and pavement (without ramps). List each separately.						
c. Structure removal						
5. Interchanges (structure, crossroad and ramp earthwork, and crossroad and ramp pavements). List each separately. (Do not include mainline grading or pavement.)						
6. Structures						
a. Drainage (major structures)						
b. Walls (retaining or reinforced earth)						
7. Miscellaneous Items						
a. Guardrail, fencing, and lighting						
b. Traffic control						
c. Traffic signals (modernization or new)						
d. Signing						

**COST ESTIMATE FORMAT
 (Complex Projects)**

Figure 12-4.A
 (1 of 2)

e. Railroad Crossing Improvements						
f. Field Office and Laboratory						
8. Other Items						
a. Construction Site Stormwater Pollution Control						
b. Landscaping						
c. Rest areas or other amenities						
d. Environmental mitigation						
9. Transportation Management Plan Costs						
a. Crossovers						
b. Temporary roadways						
c. Detours						
10. Subtotal (Categories 1 - 9)						
11. Contingencies (____% of Line 10). (Should not exceed 20%).						
12. Total Construction Cost (Lines 10 and 11)						
13. Right-of-Way						
a. Residential property and relocations						
b. Farm and business property and relocations						
14. Utility Adjustments						
15. *Preliminary Engineering (____% of Line 12).						
16. *Construction Engineering (____% of Line 12)						
17. Total Project Cost (Lines 12 - 16)						
18. Local Participation						

*Note: *If consultant work is anticipated for preliminary engineering or construction engineering, these items should be listed separately in submission of costs for programming purposes.*

**COST ESTIMATE FORMAT
(Complex Projects)**

**Figure 12-4.A
(2 of 2)**

COST ESTIMATE

Date: _____
 Route: _____
 Section: _____

Designer: _____
 City/County: _____
 Base Year: _____

WORK CLASSIFICATION	Estimated Costs in \$1000's
1. Clearing; Minor Removal Items	
2. Earthwork	
3. Construction Site Stormwater Pollution Control	
4. Drainage	
5. Subbase, Base, Surface, Shoulders	
6. Guardrail, Roadside Safety	
7. Traffic Signals (Modernization or New)	
8. Detours, Temporary Traffic Control - Roadway	
9. Railroad Crossing Improvements	
10. Field Office and Laboratory	
11. Environmental Mitigation/Incidental Items	
12. Roadway Subtotal (Categories 1-11)	
13. Structure Removal	
14. Major Culverts	
15. Bridges	
16. Structures for Detours and Temporary Traffic Control	
17. Structure Subtotal (Categories 13 - 16)	
18. Roadway and Structure Subtotal (Lines 12 and 17)	
19. Contingencies (___% of Line 18) (should not exceed 15%)	
20. Total Construction Cost (Lines 18 and 19)	
21. Utility Adjustments	
22. Land Acquisition and Relocations	
23. *Preliminary Engineering (___% of Line 20)	
24. *Construction Engineering (___% of Line 20)	
25. Total Project Cost (Lines 20 - 24)	

*Note: *If consultant work is anticipated for preliminary engineering or construction engineering, these items should be listed separately in submission of costs for programming purposes.*

**COST ESTIMATE FORMAT
 (Project Reports)
 Figure 12-4.B**

12-5 PROCESSING AND APPROVAL OF PHASE I REPORTS

12-5.01 Corridor and Feasibility Study Reports

For Corridor and Feasibility Study Reports, the following will apply:

1. Submittal of Reports. Before the report is submitted for approval, the Secretary of IDOT and the Director of the Office of Planning and Programming should be contacted on their desire for a briefing meeting. The designer will submit the Corridor and Feasibility Study Reports to BDE for approval. BDE will approve a highway corridor only after the following has occurred:
 - The requirements of Chapter 11 and other applicable laws and regulations (e.g., Part III, Environmental Procedures) have been met.
 - The public involvement activities as required by Chapter 19 have been fulfilled.
 - Coordination and involvement with BDE and FHWA have been completed. This is usually accomplished at district coordination meetings or at special district meetings. Include the minutes of these meetings in the report.
 - The district has submitted three copies of a Corridor Study Report or Feasibility Study Report and any separate appendices to the Report to BDE.
 - The district has written a detailed memorandum to BDE describing the reasons for selecting the recommended corridor, the items submitted, and requesting corridor approval.
2. Corridor Study and Feasibility Study Approval. The Bureau Chief of Design and Environment will grant corridor approval and feasibility approval (for feasibility studies which involve a corridor) with concurrence of the Director of Highways Project Implementation.
3. Feasibility Study Approval not Involving a Corridor. For feasibility studies which do not involve a corridor, concurrence of the recommendations will be by the Bureau Chief of Design and Environment.

12-5.02 Design Reports

For Design Reports, the following will apply:

1. Submittal of Reports. Before the report is submitted for approval, the Secretary of IDOT and the Director of the Office of Planning and Programming should be contacted on their desire for a briefing meeting. The designer will submit the Design Report to the Regional Engineer for approval, except those involving major new alignment, which should be submitted to the BDE Location and Environment Section for approval.

The Regional Engineer (or BDE) will approve a Design Report only after the following has occurred:

- The corridor has been approved.
 - The applicable requirements of Chapter 11 and other applicable laws and regulations (e.g., Part III, Environmental Procedures) have been met.
 - The Record of Decision (ROD) for projects requiring an Environmental Impact Study (EIS) has been signed; the Finding of no Significant Impacts (FONSI) for projects requiring an Environmental Assessment (EA) has been approved; or the Categorical Exclusion (CE) has been approved for projects qualifying as being exempt from the requirement to prepare and EIS or an EA.
 - The district has submitted two copies of the Design Report and appendices including copies of any technical reports (see the partial list in Section 11-5.04(h)), if applicable, to BDE when the project involves a major new alignment.
 - The Bureau of Design and Environment's Bicycle and Pedestrian Policy Engineer has been notified. See Chapter 17 for Bicycle and Pedestrian Accommodation.
 - The public involvement activities as required by Chapter 19 have been fulfilled.
 - Coordination and involvement with BDE and the FHWA have been completed. Projects requiring Federal Actions such as EIS/ROD approval, EA/FONSI approval, and Federal Approved CE are required to be discussed at district coordination meetings. Actions qualifying as a State Approved CE are not required to be discussed at district coordination meetings (see Section 22-5.03), unless there are issues related to the project's scope, design exceptions, or meeting ADA standards to the maximum extent practicable. The district may choose, however, to present at the coordination meeting additional projects qualifying as a State Approved CE at their discretion. Include the minutes of these meetings in the report.
 - BDE and/or FHWA has concurred with and approved any design exceptions to the project as discussed in Chapter 31.
 - The district has written a memorandum to the Regional Engineer (or BDE if applicable) describing the reasons for selecting the recommended alignment and design features, the items submitted, and requesting design approval.
2. Design Approval. The Regional Engineer or the Bureau Chief of Design and Environment, (for large-scale projects on new alignment) with concurrence of the Director of Highways Project Implementation, will grant design approval for Design Reports. The district will retain the final approved report. When the Regional Engineer approves the report, a copy of form BDE 1201 is submitted to the BDE Location and Environment Section upon report approval. A sample design approval sign-off sheet is shown in Figure 12-5.A.

12-5.03 Combined Design Reports

For Combined Design Reports, the following will apply:

1. **Submittal of Reports.** Before controversial projects are submitted for approval, the Bureau Chief of Design and Environment and the Director of Highways Project Implementation should be contacted on their desire for a briefing meeting before design approval is granted. The designer will submit the Combined Design Report to the Regional Engineer for approval. The Regional Engineer may approve a proposed improvement in a Combined Design Report only after the following has occurred:
 - The applicable requirements of Chapter 11 and other applicable laws and regulations (e.g., Part III, Environmental Procedures) have been met.
 - The Record of Decision (ROD) for projects requiring an Environmental Impact Study (EIS) has been signed; the Finding of no Significant Impacts (FONSI) for projects requiring an Environmental Assessment (EA) has been approved; or the Categorical Exclusion (CE) has been approved for projects qualifying as being exempt from the requirement to prepare an EIS or an EA.
 - The public involvement activities as required by Chapter 19 have been fulfilled.
 - Coordination and involvement with BDE and the FHWA have been completed. Projects requiring Federal Actions such as EIS/ROD approval, EA/FONSI approval, and Federal Approved CE are required to be discussed at district coordination meetings. Actions qualifying as a State Approved CE are not required to be discussed at district coordination meetings (see Section 22-5.03), unless there are issues related to the project's scope, design exceptions, or meeting ADA standards to the maximum extent practicable. The district may choose, however, to present at the coordination meeting additional projects qualifying as a State Approved CE at their discretion. Include the minutes of these meetings in the report.
 - BDE and/or FHWA has concurred with and approved any design exceptions to the project as discussed in Chapter 31.
 - The district has written a memorandum to the Regional Engineer describing the reasons for selecting the recommended alignment and design features, the items submitted, and requesting design approval.
2. **Design Approval.** On most projects involving a Combined Design Report, design approval will be granted by the Regional Engineer. The district may request concurrence from BDE if project complexities warrant BDE involvement. The district will retain the final approved report. Submit form BDE 1201 to the BDE Location and Environment Section upon report approval.

12-5.04 State Improvement Reports

For State Improvement Reports, the following will apply:

1. Submittal of Reports. Projects in this category are similar to those covered in a Combined Design Report (major improvements) except that a decision was made during the programming process not to use Federal funds on the project. For controversial projects, the Bureau Chief of Design and Environment and the Director of Highways Project Implementation should be contacted on their desire for a briefing meeting before design approval is sought.
2. The Regional Engineer approves projects in this category after the following has occurred:
 - The applicable requirements of Chapter 11 and other applicable laws and regulations (e.g., Part III “Environmental Procedures”) have been met.
 - The public involvement activities as required by Chapter 19 have been fulfilled.
 - Environmental information and documentation have been completed. Use the EA record forms as a checklist to determine potential project impacts. Include a summary and analysis of impacts as a separate section in the report.
 - BDE has concurred with and approved any design exceptions to the project. However, regardless of the funding, if the project involves the Interstate, FHWA must approve any Level One design exceptions.
 - The district has written a memorandum to the Regional Engineer describing the reasons for selecting the recommended design alternative, the items submitted, and requesting design approval.
3. Design Approval. Design approval for State Improvement Reports will be granted by the Regional Engineer. The district will retain the final approved report. Submit form BDE 1201 to the BDE Location and Environment Section upon report approval.

12-5.05 Other Types of Reports

The Regional Engineer gives design approval for Project Reports, Abbreviated Project Reports, 3P Reports, and Pavement Preservation (High/Low) Reports. For all of these report types, submit form BDE 1201 to the BDE Location and Environment Section upon report approval.

Before any reports can be finalized, the district and the BDE Regional Field Engineers must determine if any design exceptions on the project are required and, if so, concurrence of the exception must be approved by the BDE Regional Field Engineer, or, if necessary, FHWA, through discussions at a district coordination meeting. See Chapter 31 for guidelines on design exceptions.

**FEDERAL AID PRIMARY ROUTE 413
FROM INTERSTATE ROUTE 270 AND INTERSTATE
ROUTE 255 INTERCHANGE IN MADISON COUNTY
TO ILLINOIS ROUTE 267 NORTH OF ALTON, ILLINOIS
IN MADISON COUNTY**

FINAL DESIGN REPORT

Prepared by
the Illinois Department of Transportation

August 1998

The proposed action is the construction of approximately 21 miles (34 km) of four-lane, fully access-controlled, divided highway. The proposed highway extends from the directional interchange of I-270 and I-255 west of Glen Carbon to Illinois Route 267 north of Alton.

This Design Report addresses the no-action alternative and the option of improving existing highways in the study area. Detailed studies for five build alternatives are also presented in this document.

An Environmental Impact Statement has been prepared and the Record of Decision signed in conjunction with this Design Report and assesses the potential social, economic, and environmental effects of the various alternatives. The recommended alternative for construction is Alternative C.

Design Approval _____
Regional Engineer or Bureau of Design & Environment Date

**EXAMPLE OF DESIGN APPROVAL SHEET
(Major Type Project)**

Figure 12-5.A

12-5.06 Regional Engineer Delegation of Approval Authority

The Regional Engineer may only delegate project approval authority to the district Program Development Engineer.

12-5.07 Reports for Local Public Agency Projects

When a local public agency has a project on the State highway system, or on a local highway system that affects a state highway, the following sections, as well as the *Bureau of Local Roads and Streets Manual*, will apply. Note: Projects that qualify as a State Approved CE would be approved by the district BLRS.

12-5.07(a) Local Public Agency Lead Projects on the State Highway System

For Federal-aid projects, generally use the procedures outlined in Section 12-5-05 and Section 12-3.10. In addition, consider the following:

1. Projects Not Involving a Jurisdictional Transfer (JT). The following applies to all State routes, marked or unmarked:
 - a. District Coordination Meetings. Discuss all projects at district coordination meetings before finalizing and submitting any reports.
 - b. Geometric Review. If a local public agency or their consultant is preparing the report for any marked or unmarked State highway, the district Geometric Engineer will review the highway geometrics and cross-section design during the development of preliminary alternatives stage. Once the geometrics and cross-section designs are approved, the district BLRS will forward the report to central office Bureau of Local Roads and Street (CBLRS).
 - c. Submittal of Reports. Reports prepared by the district (or their consultant) or the local public agency (or their consultant) should be submitted to CBLRS for information, review, and/or approval, in conformance with the CBLRS policies. When the need for design exceptions is determined on routes under State jurisdiction, CBLRS will coordinate and discuss the design exceptions with BDE prior to approval action.
2. Projects Resulting in a Jurisdictional Transfer (JT) to a Local Public Agency (not including Present Worth Value (PWV) JT's). The following will apply:
 - a. Federal Funds. Regardless of which agency initiates a project, submit the project report to CBLRS for review and approval. When the State is providing matching funds, CBLRS will coordinate the design requirements with BDE prior to approval.
 - b. State-Only Funds. The preparation of a project report will usually be required. Submit the report to CBLRS for review and approval. The local public agency should

coordinate the proposed design with the district BLRS before submitting the report to CBLRS.

- c. District Coordination Meetings. For jurisdictional transfers using either Federal funds or State-only funds, it is imperative that these projects be discussed at the district coordination meetings. This will allow BDE and CBLRS to become aware of proposed design features and costs and to determine if the project scope is appropriate.
- d. Agreements. Ensure all joint projects conform with the Department's participation policies for joint agreements; see Chapter 5.
- e. Review of Agreements. After joint agreements are finalized by the district and submitted to CBLRS, CBLRS will forward agreements to BDE for their review and concurrence. In addition to the normal review by the BDE Preliminary Engineering Section, the BDE Regional Field Engineers will also review the agreement for proper design content.

12-5.07(b) Local Public Agency Projects on Combined Systems

For local public agency projects that have substantial work on both highway systems or for systems under joint jurisdiction with the State, process the project report through the district to CBLRS. CBLRS will coordinate design requirements with BDE.

12-5.07(c) Local Public Agency Projects on the Local Highway System

See the *Bureau of Local Roads and Streets Manual* for procedural requirements.

12-5.07(d) Modified Procedures

Where special or unusual situations arise during project development, modified review and processing procedures may be necessary. In these cases, the district, CBLRS, and BDE should agree on the modified procedures to use.

12-5.08 Project Reports for the Highway Safety Improvement Program

The Highway Safety Improvement Program (HSIP) is intended to make moderate cost improvements, addressing specific site-related crashes, and eliminating over-represented crash patterns. These projects will typically require an Abbreviated Project Report or may be exempt from the preparation of a report; see Section 12-3.10.

In many cases, the improvements may be short-term until major reconstruction can be undertaken. Any additional work not directly related to the specific crash problem is not eligible for HSIP funding,

unless it can be justified as being appropriate or necessary due to its relationship with the basic crash history.

In addition to the guidelines in Section 12-3.07, Project Reports for safety improvements will include the Regional Engineer's concurrence of the project in the Highway Safety Improvement Program. Project Reports should include the following information:

- project priority numbers for the annual district HSIP;
- project locations showing county, route, and limits of construction;
- descriptions of work as determined by the district Highway Safety Committee;
- estimated costs and benefit/cost ratios; and
- district Highway Safety Committee member titles, their bureaus, and signatures together with the Regional Engineer's concurrence.

When any significant revisions to the scope of work, estimated cost, or benefit/cost ratio are proposed for the annual district HSIP, the district Safety Coordinator must coordinate the revision through the Bureau of Safety Programs and Engineering.

Design approval procedures and the preparation of a project report for safety projects will continue to be in accordance with Section 12-5.05 or Section 12-3.10.

12-6 CORRIDOR PROTECTION

12-6.01 Authority and Purpose

The *Illinois Highway Code*, 605 ILCS 5/4-510 provides the Department the authority to “establish presently the approximate locations and widths of rights of way for future additions to the State highway system to inform the public and prevent costly and conflicting development of the land involved”. The law then provides once corridor protection is established by the Department, “no one shall incur development costs or place improvements in, upon, or under the land involved nor rebuild, alter or add to any existing structure” without first giving notice to the Department.

Corridor protection can be applied to either new construction projects or to additions/widening of the existing highway system under the reconstruction category (legal opinion, Chief Counsel, November 19, 1991).

12-6.02 Need

Prior to establishing corridor protection, the proposed improvement must be analyzed to determine the potential for costly development within the future rights of way. For example, a proposed highway located in or near a rapidly developing urban area might benefit from corridor protection provided the Department is willing to acquire properties upon notification from the owners of their intent to make costly improvements; whereas a proposed highway in a rural area might not benefit from corridor protection if there is little likelihood of immediate or costly development.

12-6.03 Timing and Procedures

Since corridor protection is related to the approximate locations and widths of future rights of way, it is usually established during the Phase I process based upon the specific details and schedule of the project at hand. However, there are a few important milestones that are typically achieved before the decision is made:

1. The preferred corridor has been identified,
2. The NEPA process has progressed far enough to assure the corridor contains no fatal flaws, and
3. The public involvement process has progressed far enough to satisfy the legal requirements contained in 605 ILCS 5/4-510.

Note: Corridor protection is separate from, and does not have to be tied to, either a route location decision or an order establishing freeway; see Sections 12-7 and 12-8 respectively.

Chapter 19 of the BDE Manual describes the public involvement process. The *Land Acquisition Policies and Procedures Manual* describes the detailed procedures and exhibits needed to establish corridor protection.

Once corridor protection is established, the Department must be cognizant of the length of time the protection is maintained. Pursuant to 605 ILCS 5/4-510: Not more than ten years after a protected corridor is established, and not later than the expiration of each succeeding ten-year period, the Department shall hold public hearings to discuss the viability and feasibility of the protected corridor. The Department shall retain the discretion to maintain any protected corridor but shall give due consideration to the information obtained at the public hearing. If the Department in its discretion determines that the construction of the roadway is no longer feasible, the Department shall abolish the protected corridor. The *Land Acquisition Policies and Procedures Manual* describes the detailed procedures and exhibits needed to abolish corridor protection.

12-7 ROUTE LOCATION DECISIONS

12-7.01 Purpose

A Route Location Decision is a legal declaration made by the Illinois Department of Transportation, establishing the location of a proposed State highway or revising the location of an existing State route, as required by the *Illinois Highway Code*, 605 ILCS 5/4-204.

12-7.02 Applicability

Prepare a Route Location Decision where the following occurs on a State highway:

- a route will be developed on a new location;
- there is a change in the termini of an existing route;
- a portion of an existing route will be relocated for a length of 1 mile (1.6 km) or more;
- a portion of an existing route will be relocated a lateral distance of 0.5 miles (0.80 km) or more from the former location;
- a loop or spur will be added to an existing route;
- an existing route will be relocated due to the expansion of airport facilities; and/or
- in conjunction with an Order Establishing a Freeway, the freeway or expressway will be developed on a new location. Where a portion of an existing route will be declared a freeway, a Route Location Decision is not required.

12-7.03 Content

The Route Location Decision consists of a detailed legal description referenced to section corners, townships, ranges, and a map upon which the selected route location is shown.

Approximate scale values may be used in the description where field survey data is not available. A county map having a scale 1 in. = 1 mile (1:60,000 metric) typically is used to show the route location.

A sample Route Location Decision is shown in Figure 12-7.A.

12-7.04 Preparation and Processing

After the review of comments received at a public hearing or informational meeting and the disposition of comments, and after design approval of the location is given by BDE, prepare a Route Location Decision and forward it, in duplicate, to BDE. The Preliminary Engineering Section will review the location decision for form and content and will process it for execution.

STATE OF ILLINOIS
DEPARTMENT OF TRANSPORTATION
ROUTE LOCATION DECISION

Along Federal-aid Route 155 from Henry Street in Alton, one block east of the Clark Bridge, in a generally southeasterly direction to a point near the intersection with FA Route 4 near Wood River in Madison County.

WHEREAS, the Department of Transportation of the State of Illinois has proceeded to select, lay out, and survey a part of Federal-aid Route 155 along a line as shown on the map attached hereto and made a part hereof, and on a location more particularly described as follows:

Commencing from a stone set at the northwest corner of Front Street and Henry Street, as said streets are now laid out on the plats of the City of Alton, thence South 84 degrees 19 minutes East along an easterly prolongation of the north line of Front Street for a distance of 99.00 feet (30.175 meters) to a point in the east line of Henry Street; thence South 6 degrees 12 minutes West along the east line of Henry Street for a distance of 864.60 feet (263.530 meters) to a point, said point being the POINT OF BEGINNING; thence South 80 degrees 48 minutes East along the centerline of FA Route 155 for a distance of 585.73 feet (178.531 meters) to a point of curve,

(continuation of detailed legal description referenced to section corners, townships, and ranges)

...for a distance of 266.82 feet (81.327 meters) to an intersection with the centerline of FA Route 4 (Business US 67); said point of intersection being the END OF ROUTE LOCATION DECISION; and being approximately 1000 feet (305 meters) South 68 degrees 17 minutes West from the east Line of NW 1/4 of Section 28, T5N, R9W of Third Principal Meridian, Madison County.

WHEREAS, the location of Federal-aid Route 155 within the above limits having been fully examined and observed and the width of right-of-way needed for developing and improving said route having been considered and determined; and

WHEREAS, it is required that a detailed description of the location of that part of Federal-aid Route 155 described above, and the width of right-of-way needed for development and improvement be entered of record in the Department of Transportation of the State of Illinois;

IT IS THEREFORE ORDERED, that that part of Federal-aid Route 155 extending from a point on Henry Street in Alton, one block east of the Clark Bridge, in a generally southeasterly direction to a point near the intersection with FA Route 4 near Wood River in Madison County be and is hereby located as described herein, and that the said location as described be and is hereby selected as the location of part of Federal-aid Route 155 and also, that there shall be acquired for this part of Federal-aid Route 155 a general right-of-way width of 200 feet (60.960 meters), except that such additional widths may be acquired as may be required for backslopes in cuts, downslopes in fills, frontage roads to serve built-up areas, and additional areas as may be required at intersecting streets or highways for providing traffic flow, safe-sight distances, and control of access to Federal-aid Route 155.

SAMPLE ROUTE LOCATION DECISION

Figure 12-7.A
(1 of 2)

IT IS FURTHER ORDERED that this map and order be filed as a part of the records of the Department of Transportation of the State of Illinois.

ENTERED THIS _____ day of _____ 20____.

Secretary of Transportation

SAMPLE ROUTE LOCATION DECISION

Figure 12-.7A
(2 of 2)

12-7.05 Execution

Upon execution of the Route Location Decision by the appropriate Department officials, an original copy of the document is returned to the district for recording in the Office of the County Clerk of each county in which the highway is located. Once the recording is complete, the Route Location Decision is returned to BDE for filing.

12-8 ORDER ESTABLISHING A FREEWAY

12-8.01 Freeways and Expressways

1. New Locations. According to the *Illinois Highway Code*, 605 ILCS 5/8-101, once it has been decided to control access on a State route, it is necessary to designate and establish the facility as an access-controlled highway. This action is initiated after design approval is obtained for the freeway/expressway. The Order Establishing a Freeway (Freeway Order) is a legal declaration made by the Department designating a highway as an access-controlled facility and delineating the extent of the freeway/expressway.
2. Revisions to Existing Orders. This situation is identical to “new locations” except that an existing Freeway Order is revised to describe a change in the originally approved access control limits; see Section 37-1.03 and Chapter 35.

12-8.02 Procedures

The Freeway Order must include the access limits along the mainline and the specific limits on all crossroads kept open to traffic. The Freeway Order contains a legal description of the freeway/expressway referenced to section corners, townships, and ranges. The Freeway Order is approved and signed by the Illinois Secretary of Transportation. An original copy of the fully executed Freeway Order is returned to the district for recording in the Office of the County Clerk of each county in which the freeway/expressway is located. Once the recording is completed, the Freeway Order is returned to BDE for filing. Figure 12-8.A illustrates a sample Freeway Order.

STATE OF ILLINOIS
DEPARTMENT OF TRANSPORTATION
ORDER ESTABLISHING A FREEWAY

Along Federal-aid Route 155 from Henry Street in Alton, one block east of the Clark Bridge, in a generally southeasterly direction to a point near the intersection with FA Route 4 near Wood River in Madison County.

The Department of Transportation of the State of Illinois acting under authority conferred on it by "An Act authorizing the Department of Transportation, the County Board of any County, or the corporate authorities of any City, Village, or Incorporated Town to designate and establish existing and proposed highways under their respective jurisdiction and control as freeways, and to limit access thereto" designated as Chapter 605 ILCS 5/8-101, as amended, and the Department being of the opinion that the safety and convenience of highway traffic will be promoted and the public interest subserved thereby, does hereby designate and establish a FREEWAY along the general location of those portions of Federal-aid Route 155 described below, and does declare its intention of proceeding to improvement and develop said portions of Federal-aid Route 155 in a manner which will permit access between said FREEWAY and abutting lands only at entrances provided for that purpose, in accordance with the provisions of said Act:

Commencing from a stone set at the northwest corner of Front Street and Henry Street, as said streets are now laid out on the plats of the City of Alton, thence South 84 degrees 19 minutes East along an easterly prolongation of the north line of Front Street for a distance of 99.00 feet (30.175 meters) to a point in the east line of Henry Street; thence South 6 degrees 12 minutes West along the east line of Henry Street for a distance of 864.60 feet (263.530 meters) to a point, said point being the POINT OF BEGINNING; thence South 80 degrees 48 minutes East along the centerline of FA Route 155 for a distance of 585.73 feet (178.531 meters) to a point of curve, thence along a curve to the right, having a radius of 2864.79 feet (873.188 meters), for a distance of 1879.17 feet (572.771 meters) to a point of tangency; thence South 43 degrees 13 minutes East for a distance of 589.97 feet (179.823 meters) to a point of curve; thence along a curve to the left, having a radius of 3819.72 feet (1164.251 meters), for a distance of 1433.33 feet (436.879 meters) to a point of tangency; thence South 64 degrees 43 minutes East for a distance of 259.62 feet (79.132 meters) to a point of curve; thence along a curve to the right, having a radius of 5729.58 feet (1746.376 meters), for a distance of 2206.67 feet (672.593 meters) to a point of tangency; thence South 42 degrees 39 minutes East for a distance of 1241.69 feet (378.467 meters) to a point of curve; thence along a curve to the left, having a radius of 2864.79 feet (873.188 meters), for a distance of 970.00 feet (295.656 meters) to a point of tangency; thence South 62 degrees 3 minutes East for a distance of 2529.42 feet (770.967 meters) to a point on the westerly edge of east-half of Fractional Section 19, T5N, R9W, 3rd PM; said point being South 0 degrees 51 minutes East a distance of 498.40 feet (151.912 meters) from the center of said Section 19, thence South 62 degrees 3 minutes East for a distance of 791.51 feet (241.252 meters) to a point of curve; thence along a curve to the right, having a radius of 3819.72 feet (1164.251 meters), for a distance of 1631.11 feet (497.162 meters) to a point of tangency; thence South 37 degrees 35 minutes East for a distance of 319.90 feet (97.506 meters) to a point of curve; thence along a curve to the left, having a radius of 2864.79 feet (873.188

SAMPLE ORDER ESTABLISHING A FREEWAY/EXPRESSWAY

Figure 12-8.A
(1 of 2)

meters), for a distance of 1718.34 feet (523.750 meters), to a point of tangency; thence South 71 degrees 57 minutes East for a distance of 1111.06 feet (338.651 meters) to a point of curve; thence along a curve to the right, having a radius of 7473.04 feet (2277.783 meters), (for a distance of 1021.69 feet (311.411 meters) to a point of tangency; thence South 64 degrees 7 minutes East for a distance of 1256.64 feet (383.024 meters) to a point of curve; thence along a curve to the left, having a radius of 3819.72 feet (1164.251 meters), for a distance of 3173.33 feet (967.231 meters) to a point of tangency, thence North 68 degrees 17 minutes East for a distance of 266.82 feet (81.327 meters) to an intersection with the centerline of FA Route 4 (Business US 67); thence continuing North 68 degrees 17 minutes East along the centerline of SBI Route 3, being also the centerline of Ferguson Avenue, for a distance of 598.70 feet (182.483 meters) to a point, said point being approximately 40 feet (122 meters) South 68 degrees 17 minutes West from the east line of the NW 1/4 of Section 28, T5N, R9W of the Third Principal Meridian, Madison County, and the END OF THIS FREEWAY ORDER.

Notice is hereby given that, in accordance with the provisions of the Act referred to above, no owner of or persons having an interest in land abutting those portions of Federal-aid Route 155 hereby designated and established as a FREEWAY shall lay out, provide, or construct any new means or enlarge or extend any existing means of ingress to or egress from said abutting land from or to such FREEWAY except upon written consent of the Department of Transportation.

Notice is further given that, in accordance with the provisions of the Act referred to above, no new highway, road, street, alley, or other public way shall be opened into or connected with or be carried over or under those portions of Federal-aid Route 155 hereby designated and established as a FREEWAY except upon written consent of the Department of Transportation.

By Order of
The Department of Transportation

Secretary of Transportation

Date

SAMPLE ORDER ESTABLISHING A FREEWAY/EXPRESSWAY

Figure 12-8.A
(2 of 2)

Chapter Thirteen

WORK ZONE TRANSPORTATION MANAGEMENT PLANS

BUREAU OF DESIGN AND ENVIRONMENT MANUAL

Chapter Thirteen
WORK ZONE TRANSPORTATION MANAGEMENT PLANS

Table of Contents

<u>Section</u>	<u>Page</u>
13-1 GENERAL	13-1.1
13-1.01 Goals	13-1.1
13-1.02 Definitions.....	13-1.1
13-1.03 Guideline for Work Zone Mobility Strategies	13-1.3
13-1.03(a) Non-Significant Projects.....	13-1.3
13-1.03(b) Significant Projects – Short Term	13-1.3
13-1.03(c) Significant Projects – Long Term	13-1.4
13-1.04 Impact Meet Goals – TMP Approval.....	13-1.5
13-1.05 Impacts Do Not Meet Goals – Exception to Compliance.....	13-1.7
13-1.06 Implementation	13-1.7
13-1.07 TMP Corridor Considerations	13-1.7
13-1.08 TMP Team.....	13-1.8
13-2 TRAFFIC CONTROL MANAGEMENT	13-2.1
13-2.01 Terminology.....	13-2.1
13-2.02 Work Zone Type	13-2.1
13-2.03 Work Zone Strategies.....	13-2.8
13-2.03(a) Relocating Traffic Flow	13-2.8
13-2.03(b) Selection of Traffic Control Strategy	13-2.9
13-3 TRAFFIC CONTROL PLAN STRATEGIES	13-3.1
13-3.01 Construction Phases	13-3.1
13-3.01(a) Reconstruction by Halves (Sides).....	13-3.1
13-3.01(b) Parallel/Adjacent Reconstruction	13-3.1
13-3.01(c) Serial/Segmental Reconstruction.....	13-3.2
13-3.01(d) Complete Closure (Detour).....	13-3.2
13-3.01(e) Combinations	13-3.3
13-3.02 On-Site Strategies	13-3.3
13-3.02(a) Traffic Control Devices.....	13-3.3
13-3.02(b) Capacity	13-3.4
13-3.02(c) Queue Analysis.....	13-3.5
13-3.02(d) Miscellaneous Strategies	13-3.6
13-3.03 Off-Site Strategies	13-3.7
13-3.04 Scheduling.....	13-3.8

Table of Contents*(Continued)*

<u>Section</u>	<u>Page</u>
13-4 PUBLIC INFORMATION PLAN (PIP).....	13-4.1
13-5 TRANSPORTATION OPERATIONS PLAN (TOP)	13-5.1
13-5.01 Demand Management.....	13-5.1
13-5.02 Corridor/Network Management	13-5.1
13-5.03 Work Zone Safety Management.....	13-5.2
13-5.04 Traffic and Incident Management.....	13-5.2
13-5.05 Enforcement	13-5.2
13-6 COST-EFFECTIVE ANALYSES	13-6.1
13-6.01 General.....	13-6.1
13-6.02 Cost Evaluations.....	13-6.1
13-6.02(a) On-Site	13-6.1
13-6.02(b) Detours	13-6.1
13-6.02(c) Detour User Costs	13-6.2
13-6.02(d) Example Cost Evaluation.....	13-6.3
13-7 EXAMPLE TMP FOR SMALL PROJECTS ON SIGNIFICANT ROUTES	13-7.1

Chapter Thirteen

WORK ZONE TRANSPORTATION MANAGEMENT PLANS

Chapter 13 discusses the goals and objectives of a Transportation Management Plan (TMP). The Bureau of Safety Programs and Engineering policies, Chapter 13, Chapter 55, the *Standard Specifications for Road and Bridge Construction*, and the *Highway Standards* provide the criteria to be used when developing TMP.

13-1 GENERAL

13-1.01 Goals

The goal of TMP is to address the following safety and mobility issues early in project development:

1. Safety.

- Zero worker fatalities for traffic-related work zone crashes.
- Reduce the number of motorist fatalities in traffic-related work zone crashes by 10% each year with the eventual goal of eliminating all of these fatalities.
- Eliminate crashes and resulting fatalities and serious injuries caused by queuing.
- Reduce the number of work zone crashes by 5% from each prior year.

2. Mobility.

- Delays caused by work zones should not exceed more than 5 minutes per mile (3 minutes per km) of project length with a maximum of 30 minutes above the normal recurring traffic delay.
- Queues caused by work zones should be no more than 1.5 miles (2.4 km) beyond pre-existing queues.

13-1.02 Definitions

1. Impact Analysis. An analysis of the safety and mobility impacts of a road construction or maintenance project.

2. Mobility. Moving road users efficiently through or around a work zone area (site specific or regionally) with a minimum of delay compared to baseline travel when no work zone is present, while not compromising safety.
3. Non-Significant Route. Work on a roadway that is not considered a significant route and that impacts the traveling public to a small degree due to low traffic volume, low public interest, and short to moderate duration.
4. PIP (Public Information Plan). A plan that consists of strategies to inform those affected road users, including the surrounding community, of the expected impact of a project, of changing conditions, and available travel options.
5. PLCM (Permitted Lane Closure Map) List. Developed by the district, PLCM defines the allowable times a lane(s) may be closed on Significant Routes within each district. The PLCM is based upon district knowledge and should be updated as traffic conditions warrant. The intent of PLCM is to allow minor short-term work to be completed with as little impact to the motorist as possible and to aid the district in complying with mobility requirements.
6. Safety. For work zones, safety refers to minimizing potential hazards to travelers and highway workers in the vicinity of a work zone.
7. Significant Project – Long Term. Roadway segments identified on the Significant Route Location Maps involving work greater than three days duration are considered as Significant Projects – Long Term. A Significant Project – Long Term requires an Impact Analysis be performed and requires TMP.
8. Significant Project – Short Term. (Operations, Permit, Utility, and other short-term work.) Roadway segments identified on the Significant Route Location Maps involving work of three days or less.
9. Significant Route. Roadway segments where a lane closure on the roadway is expected to cause sustained work zone impacts that are not considered tolerable based on work zone mobility goals or public opinion.
10. TCP (Traffic Control Plan). A plan to safely guide traffic through a construction project through the use of traffic control devices and project coordination. The TCP focuses on the mobility and protection of traffic within the construction zone.
11. TMP (Transportation Management Plan). An integrated strategy to manage work zone impacts of a project. The possible components of TMP are TCP, TOP, and PIP.
12. TOP (Transportation Operations Plan). A plan that consists of strategies which mitigate work zone impacts through the use of improved transportation operations and management of the transportation system.
13. Work Zone Impacts. Deviation from normal mobility and safety of the roadway due to the presence of a work zone.

13-1.03 Guideline for Work Zone Mobility Strategies

A well-planned method for maintaining traffic flow is critical for meeting the Department's mobility goals, minimizing complaints from the traveling public, residents, and businesses, and reducing unnecessary capital costs. Each Phase I report should contain a Transportation Management Plan indicating an overall strategy for work zone safety and mobility during construction.

For projects not requiring a Phase I report (e.g., 3P, traffic signals) and for projects where the application of the *Highway Standards* and *Standard Specifications* will provide the TCP, TMP is not required except for projects on significant routes. The goals of the Work Zone Safety and Mobility Rule for queuing and delay should be addressed. If the goals can be met, the district may approve TMP. If the goals cannot be met, then submit a Request for Exception to Compliance with the Work Zone Safety and Mobility Rule" form to the Bureau of Safety Programs and Engineering; see Section 13-1.05.

Figure 13.1-A presents the Work Zone Safety and Mobility Process Flow Chart to determine the level of significance of a project. Significant Route Location Maps (see Bureau of Safety Engineering's Programs and Policies website for maps) are statewide and district maps that show those State routes where a lane closure on the roadway is expected to cause sustained work zone impacts that are not considered tolerable based on the goals and objectives of this policy or public opinion. Roadways marked in red are considered as Significant Routes. Roadways marked in yellow are approaching Significant Route designation and should be evaluated for potential impacts. These maps will be revised as additional information becomes available through process reviews and district feedback.

Use the Significant Route Location Maps and the Work Zone Safety and Mobility Process Flow Chart to determine if a project is considered Non-Significant, Significant–Short Term (Less Than Three Days), or Significant–Long Term.

13-1.03(a) Non-Significant Projects

If the proposed project is on a roadway that is not considered a Significant Route, then it is a Non-Significant Project. Work is considered to impact the traveling public to a small degree. Traffic volumes are low, public interest is low, and duration is short to moderate. For Non-Significant Projects, an Impact Analysis is not required. The final design may proceed with TMP that consists of only TCP. However, appropriate TOP and PIP strategies are encouraged to be considered as well.

13-1.03(b) Significant Projects – Short Term

Roadway segments identified on the Significant Route Location Maps involving work of three days or less are considered Significant Projects–Short Term. A Permitted Lane Closure Map/List (PLCM) is to be developed by the district, based on the Significant Route Location Maps and district knowledge. The PLCM should be updated as traffic conditions warrant.

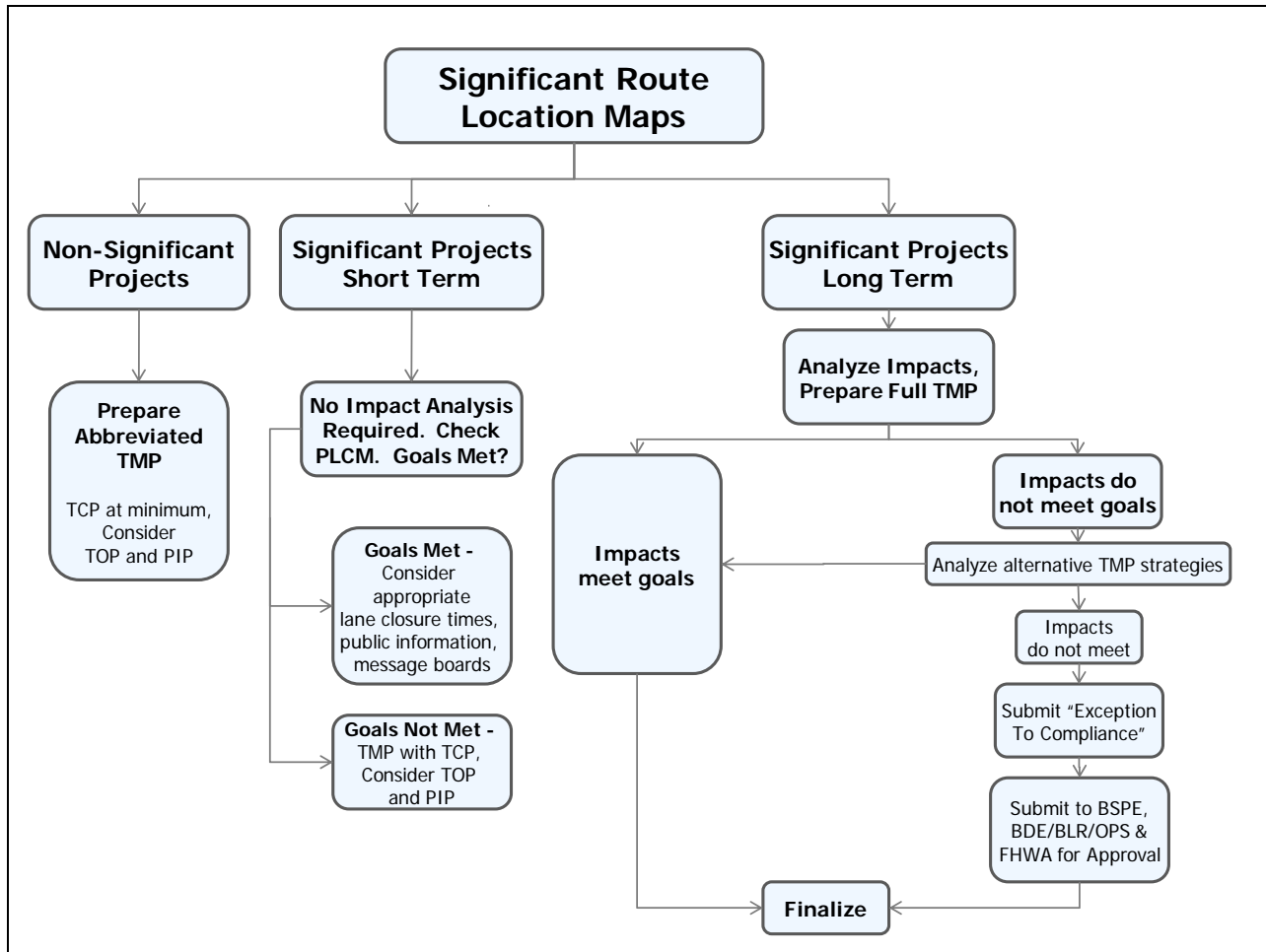

WORK ZONE SAFETY AND MOBILITY PROCESS FLOW CHART

Figure 13-1.A

The PLCM map defines the allowable times a lane (or lanes) may be closed on Significant Routes within each district to assist in meeting mobility goals. It allows minor short time work to be accomplished with as little impact to the motorist as possible. If mobility goals cannot be met, plan the work in advance to minimize impacts. However, emergency repairs/work is allowed. The project may proceed with TMP that consists of only TCP. However, consider appropriate TOP and PIP strategies to ensure the project achieves the Department’s stated safety and mobility goals.

13-1.03(c) Significant Projects – Long Term

Routes identified on the Significant Route Location Maps involving work greater than three days are considered Significant Projects–Long Term. Because of their duration, work zones for these projects have a much greater impact on motorists. Consider every reasonable effort to mitigate

these impacts. Identify Significant Projects as early as possible in the development process to help allocate resources more effectively to projects that are likely to have greater impacts. A Significant Project–Long Term requires an Impact Analysis. The Impact Analysis is the process of understanding the safety and mobility impacts of a road construction/ maintenance project.

During the planning and design phase of a Significant Project–Long Term, consider various TMP strategies and the resulting impacts to delays and queuing should be analyzed to determine which are acceptable or unacceptable based upon safety and mobility goals.

Developing TMP is a process that involves identifying applicable strategies to manage the impacts of the work zone, and budgeting costs to ensure that funding is available. A full TMP is required for Significant Projects–Long Term. The TMP should lay out a set of coordinated transportation management strategies and describe how they will be used to manage the work zone impacts of a road project. As the project evolves, it is important to reassess TMP, including the transportation management strategies, to ensure the work zone impacts are mitigated and the necessary budget for the project is available. Incident management and emergency services should also be considered.

A full TMP includes TCP, TOP, and PIP. A relatively small project on a significant route may follow the outline in Section 13-8 for a simple full TMP. Larger projects will require a more extensive examination. See Figure 13-1.B for the components of large project TMP.

13-1.04 Impact Meet Goals – TMP Approval

If the prepared TMP meets the mobility and/or queueing goals, present the project as follows:

1. Federal Funds. Present at the periodic joint FHWA/IDOT coordination meeting.
2. No Federal Funds. Present at the district project coordination meeting.

The TMP may be approved by the appropriate bureau (Bureau of Design and Environment, Bureau of Local Roads, or Bureau of Operations). Once TMP is approved, include TMP in the Phase I report and incorporate it into plan development.

Note that delays or time lapse from Phase I to Phase II in project development or changes made during the preparation of TCP may affect the overall TMP. For example, a lane closure that precipitates unavoidable large queues on a freeway may cause traffic to divert to a nearby urban arterial. This may require signal coordination, lane widening, turn restrictions, etc., on the arterial to improve its capacity. Review TMP from Phase I to Phase II to ensure that it is still applicable.

<u>TMP Component</u>		<u>Complete</u>
1.	Executive Summary	_____
2.	Request for Exception to Compliance (If Needed)	_____
3.	Project Description:	_____
	a. Background	_____
	b. Project Description	_____
	c. Location Map	_____
	d. Construction Staging/Phasing	_____
	e. Construction Schedule/Timeline	_____
	f. Interaction with other projects	_____
4.	Existing Conditions	_____
	a. Existing traffic data, counts and queues	_____
	b. Incident, crash data and analysis	_____
	c. Local community and business concerns	_____
	d. Traffic growth rates (anticipate future construction dates)	_____
5.	TCP (Traffic Control Plan) Strategies	_____
	a. Describe Traffic Control Plan (and alternatives, if considered)	_____
	i. Safety impacts of TCP alternatives	_____
	ii. Mobility – Predicted queues and delays, method used	_____
	iii. Costs associated with TCP alternatives	_____
	b. Evaluation and Selection of TCP alternative	_____
	c. Traffic Control Plan Sheets for selected alternative	_____
6.	PIP (Public Information Plan)	_____
	a. Strategies to inform the public of construction activities	_____
	b. Strategies to inform motorists on and around the project	_____
	c. Promotion of alternative transportation nodes	_____
7.	TOP (Transportation Operations Plan)	_____
	a. Work zone safety management strategies	_____
	b. Traffic and incident management, enforcement strategies	_____
8.	TMP Implementation and Monitoring	_____
	a. Monitoring plan	_____
	b. Contingency plans for incidents, excessive queue or delay	_____

**TRANSPORTATION MANAGEMENT PLAN COMPONENTS CHECKLIST
(For Large Projects)**

Figure 13-1.B

13-1.05 Impacts Do Not Meet Goals – Exception to Compliance

Once all reasonable and cost-effective TMP strategies have been evaluated and incorporated into the project and mobility and/or queue goals still cannot be met, the district prepares an exception to compliance form BSPE WZ 2. All strategies, including those in the full TMP, an explanation of why it is not feasible to meet the goals of this policy, and the proposed strategies to mitigate work zone impacts are submitted with the exception to compliance.

Submit the request to the Bureau of Safety Programs and Engineering for review, and routing for additional reviews to the appropriate bureau (i.e., Bureau of Design and Environment, Bureau of Local Roads, or Bureau of Operations) and FHWA for approval. Upon approval, final development of TMP may proceed. Include the final TMP in the Phase I report and incorporate it into plan development.

13-1.06 Implementation

During Phase II, it will be the designer's responsibility to implement the recommendations from the approved TMP into a detailed Traffic Control Plan, which is included in the construction plans and special provisions. Design standards, special provisions, traffic volume or movement, etc., may have changed if there is a significant time lapse between Phase I and Phase II. The designer may be required to collect additional data and conduct additional analyses. Coordination with the Phase I author is recommended when possible.

Any significant changes to TMP proposed by Construction or the contractor should be reviewed with the TMP author or team prior to implementation. For larger projects, a public relations campaign as documented in PIP may be required prior to construction. If an approved marked detour route must be altered, it must be coordinated with the District Detour Committee for approval of the new detour route. During construction, TMP performance will be assessed as per Safety Engineering Policy 3-07.

13-1.07 TMP Corridor Considerations

The TMP should not only address traffic mobility alternatives confined to the project site, but it should also evaluate the impact traffic will have on the entire corridor. Conduct an evaluation of the entire corridor on projects that have one or more of the following characteristics:

- where the project scope of work consists of major reconstruction or new construction;
- where there are high traffic volumes;
- where there may be significant detrimental impacts on mobility for either through or local trips in the corridor;
- where the facility's capacity will be significantly reduced (e.g., lane, ramp, or interchange closures);

- where alternative routing will be necessary (e.g., detour routing for hazardous materials, wide loads);
- where there will be significant impacts on local communities and businesses (e.g., emergency vehicles, school buses, postal service);
- where timing (e.g., special events) and seasonal impacts may be significant;
- where there will be significant grade changes; and/or
- where no alternative routes are available.

Where a series of proposed projects are along the same corridor or along corridors of close proximity, consider coordinating individual TMPs into a Unified TMP for the corridor. The Unified TMP is authored by a TMP Team, a group organized during Phase I to study the traffic control alternatives and their effect on the corridor. The TMP Team and selection is discussed in Section 13-1.08.

13-1.08 TMP Team

A TMP Team may be created for a project that is large in scope or impact. It may be beneficial to write a Unified TMP for a series of TMPs created for several projects along the same corridor, or along corridors of close proximity. A TMP Team allows the designer to bring in stakeholders to aid in “buy-in” of the project and may avoid changes to plans in Phase II and Phase III.

For projects that the Regional Engineer has determined will use the principles of Context Sensitive Solutions (CSS), the public should be involved with the TMP Team. See Section 19-5 for more information on CSS.

If it has been determined that a TMP team is required for the project, the district will initially recommend the TMP Team representatives. This determination will be based on the purpose, goals, and constraints of the TMP. A well-balanced TMP Team is an important ingredient for a successful project. The variety of disciplines represented presents an effective liaison group to meet the various needs of TMP. Depending on the project logistics, the team composition will vary from project to project. The TMP Team may include representatives from:

- Design;
- Operations;
- Construction;
- Local Roads and Streets;
- Safety Engineering;
- Maintenance Operations;
- Traffic Operations;
- Planning and Programming;
- Public Transportation;
- FHWA;

- local government (county and/or city);
- State or local enforcement;
- major employers (e.g., factories, shopping malls); and/or
- others as deemed necessary (e.g., emergency responders, hospitals).

The anticipated work zone impacts will dictate the extent and nature of the TMP team's responsibilities. This is especially true for those projects on significant routes. These may include all or part of the following functions:

- collecting data (e.g., traffic counts, crash history, roadway geometrics, proposed developments, operating speeds);
- conducting analyses (e.g., capacity analyses, traffic impact studies, safety studies, queuing analysis, geometric adequacy);
- addressing safety (see the most current Bureau of Safety Programs and Engineering's Policy Memorandum BSE-04):
 - + Positive Protection Devices,
 - + Design Policy to Minimize Drop-off Exposure, and
 - + Law Enforcement in Work Zones;
- reviewing design alternatives;
- reviewing traffic control alternatives;
- reviewing the adequacy of alternative routes (e.g., geometrics, capacity, safety, structural, roadway widths);
- reviewing on-site and off-site traffic operational improvements (e.g., signal improvements, parking restrictions, radius improvements);
- reviewing construction phasing and scheduling alternatives;
- determining the cost of various options and improvements;
- determining which options are the most cost effective;
- coordinating with local officials and businesses;
- researching local traffic demand for effects of seasonal and special events;
- coordinating funding and timing with other projects within the corridor;
- coordinating the design with other TMP plans in the region that may be under construction before, during, and after the project(s);
- planning for emergency responses (incident management);

- planning rideshare and transit strategies;
- providing recommendations for the Phase I report;
- reviewing design and TMP changes made by the designer to ensure they meet the TMP objectives;
- reviewing proposed changes made by the contractor or resident engineer during construction; and
- where necessary, developing a final report on the successes and problems of TMP.

13-2 TRAFFIC CONTROL MANAGEMENT

13-2.01 Terminology

The following definitions are used to define the time length for work zones:

1. Long-Term Stationary Work Zone. A construction, maintenance, or utility work site that requires traffic control in the same location and where the activity requires longer than three days.
2. Intermediate-Term Stationary Work Zone. A construction, maintenance, or utility work site that requires traffic control in the same location and occupies a location from overnight to three days.
3. Short-Term Stationary Work Zone. A construction, maintenance, or utility work site that requires traffic control in the same location and where the activity takes from one to twelve hours.
4. Short-Duration Work Zone. A construction, maintenance, or utility work site that occupies a location up to one hour.
5. Mobile Work Zone. A construction, maintenance, or utility work site that is continuously moving during the period when work is actively in progress.

13-2.02 Work Zone Type

There are several basic work zone types that may be considered in TMP. The main function of these work types is to “relocate traffic flow” so that the construction work can proceed with minimum interruption and hazard to the workers and to the motorists. The most common projects where relocating traffic flow may be a factor include:

- bridge reconstruction, rehabilitation, or replacement;
- major pavement rehabilitation of existing highways;
- pavement removal and replacement;
- horizontal alignment change; and
- vertical alignment change.

The following presents a description for several work zone applications:

1. Lane Constriction. This work zone type is configured by reducing the width of one or more lanes to retain the number of lanes normally available to traffic. An example of lane constriction is shown in Figure 13-2.A. This application is the least disruptive of all work zone types, but it is generally only appropriate if the work area is mostly outside the normal traffic lanes. Note that narrow lane widths may reduce the facility’s capacity, especially where there is significant truck traffic. The use of shoulders as part of the lane width helps reduce the amount of lane width reduction that may be required; however, check the structural adequacy of the shoulders. Where this application is

applied to long-term work zones, it will require the removal of the current lane markings to avoid motorist confusion. Chapter 55 discusses the minimum lane widths that must be provided.

2. Lane Closure. This work zone type closes off one or more normal traffic lanes. A lane closure example is shown in Figure 13-2.B. Capacity and delay analyses may be required to determine whether serious congestion will result from lane closures. In some cases, use of the shoulder or median area as a temporary lane will help mitigate the problems arising from the loss in capacity. Upgrading or replacement of existing pavement or shoulder, or placement of temporary pavement may be necessary.
3. One-Lane, Two-Way Operation. This work zone type involves utilizing one lane for both directions of traffic. Figure 13-2.C illustrates a one-lane, two-way operation work zone. This work zone type is typically only used on bridges or small, short-term projects. Flagger or traffic signals are normally used to coordinate the two directions of traffic.
4. Runaround. This work zone involves the total closure of the roadway (one or both directions) where work is being performed and the traffic is rerouted to a temporary roadway constructed within the highway right-of-way. A runaround example is shown in Figure 13-2.D. This application may require the acquisition of a temporary easement and usually requires extensive preparation of the temporary roadway. Generally, temporary runarounds are designed for a posted speed reduction of no more than 5 mph to 15 mph below the existing posted speed of the route. Chapter 55 discusses the minimum geometric design criteria for runarounds.
5. Intermittent Closure. This work zone type involves stopping all traffic in one or both directions for a relatively short period to allow the work to proceed. This application is illustrated in Figure 13-2.E. After a specific time, depending on traffic volumes, the roadway is re-opened and all vehicles can travel through the area. This application is normally only appropriate on low-volume roadways or during periods where there are very low volumes (e.g., Sunday morning, nighttime).
6. Use of Shoulder or Median. This work zone type involves using the shoulder or the median as a temporary traffic lane. Figure 13-2.F illustrates an example of using the shoulder and median. To use this technique for more than a short period, it will be necessary to evaluate the shoulder and subgrade to see if it is adequate to support the anticipated traffic loads. This technique may be used in combination with other work zone types or as a separate technique.
7. Two-Way Traffic on Median Divided Facility with Crossover. This work zone type involves routing one direction of the traffic stream across the median to the opposite traffic lanes. This application might also incorporate the use of shoulders and/or lane constrictions to maintain the same number of lanes. Figure 13-2.G illustrates examples of crossovers. Due to the inherent high traffic volumes and, in most cases, higher speeds, it will be necessary to consider higher geometric criteria due to the higher motorist expectations.

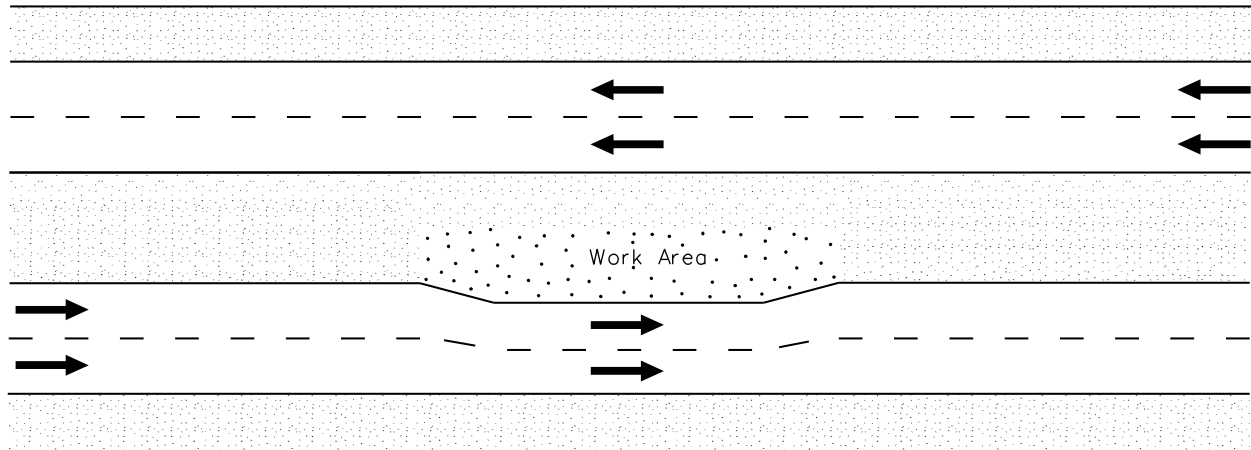

Four-Lane Divided Highway

LANE CONSTRICTION WORK ZONE

Figure 13-2.A

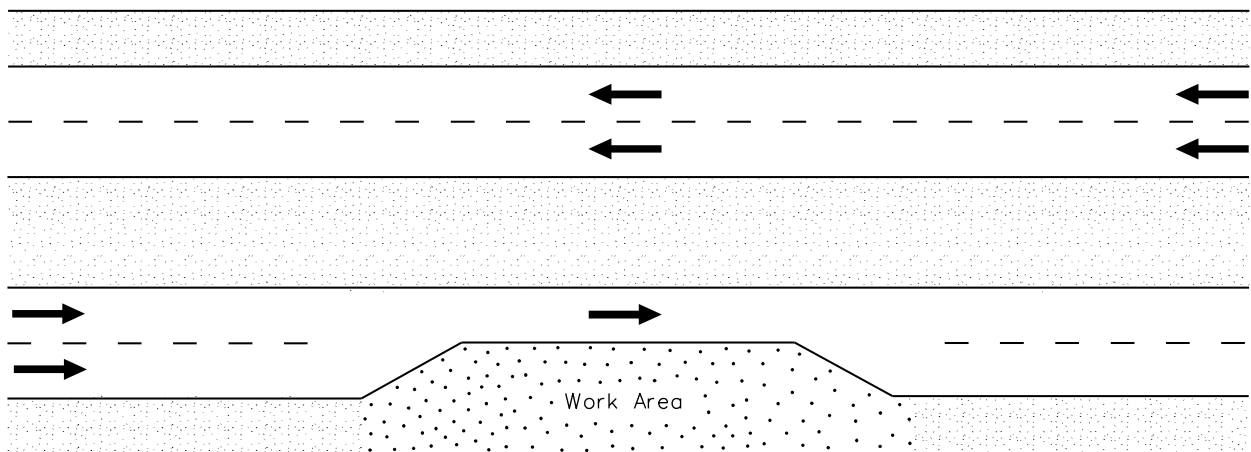

Four-Lane Divided Highway

LANE CLOSURE WORK ZONE

Figure 13-2.B

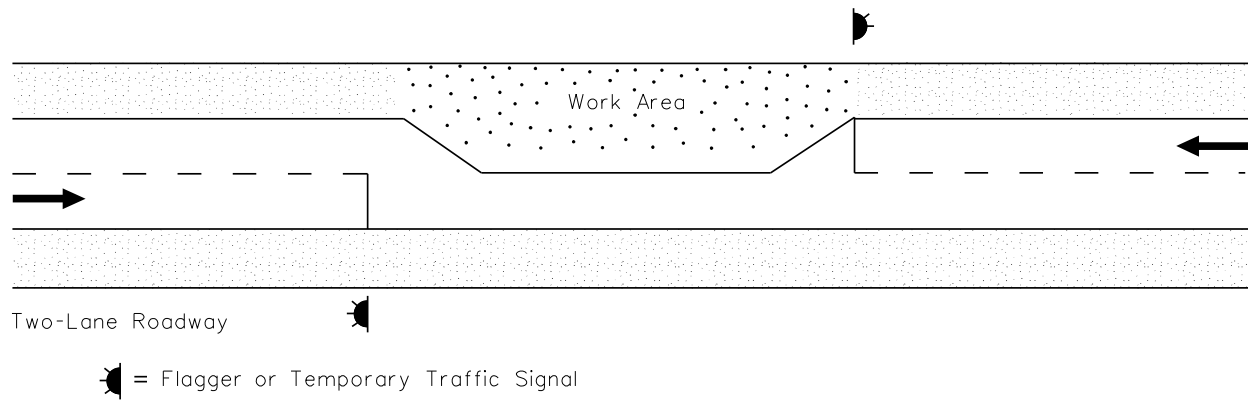

ONE-LANE, TWO-WAY OPERATION WORK ZONE

Figure 13-2.C

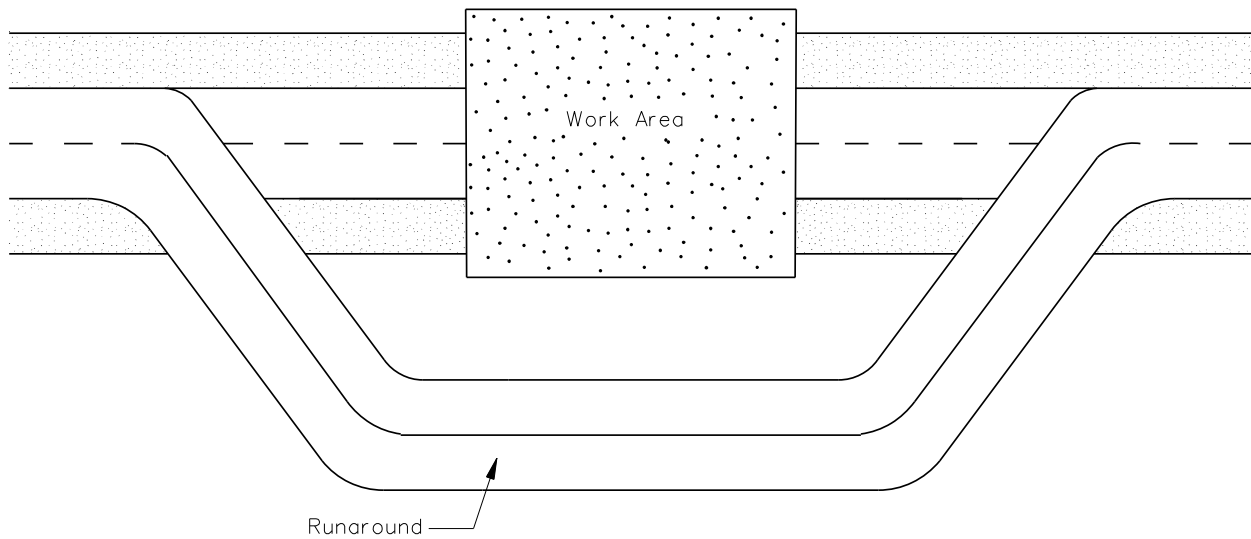

RUNAROUND WORK ZONES

Figure 13-2.D

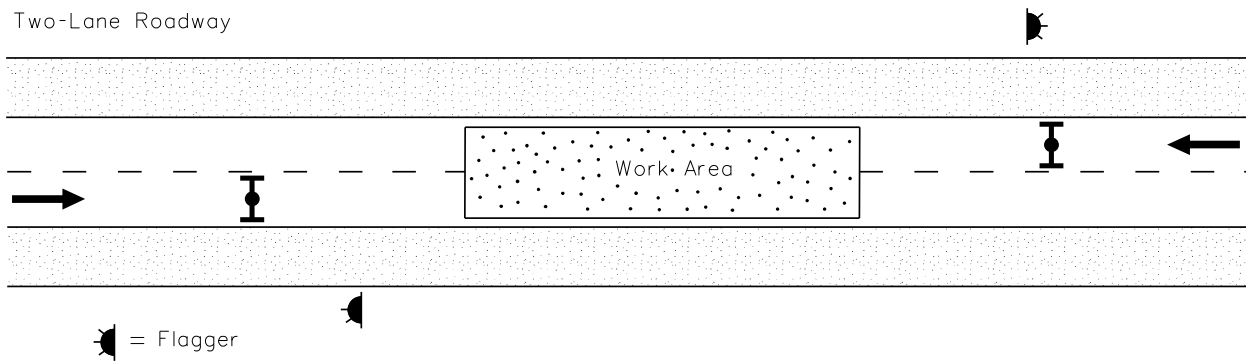

INTERMITTENT CLOSURE

Figure 13-2.E

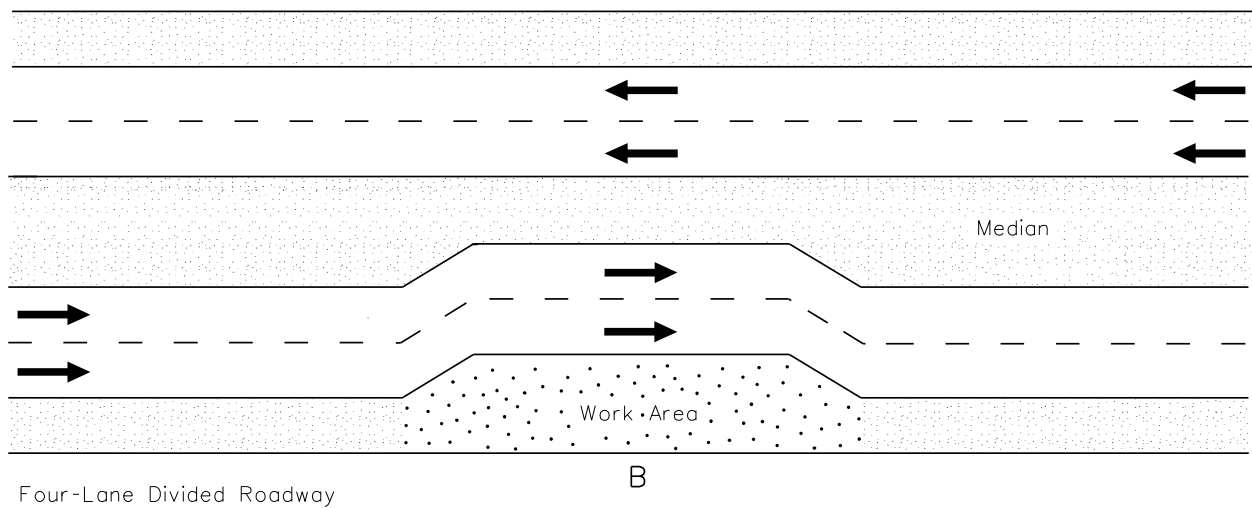
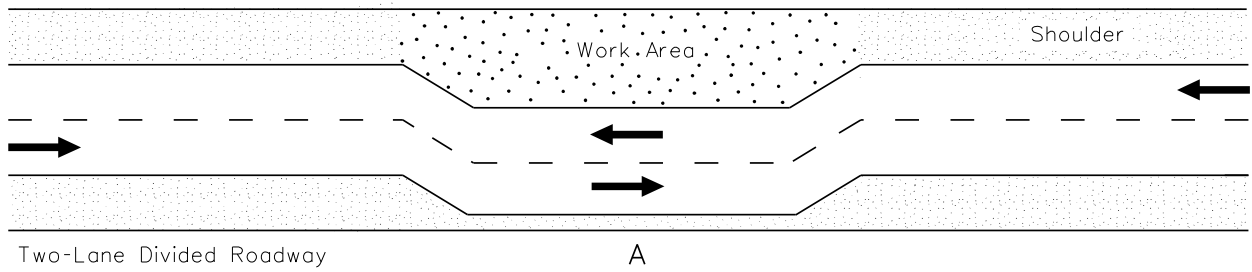

SHOULDER OR MEDIAN USE WORK ZONES

Figure 13-2.F

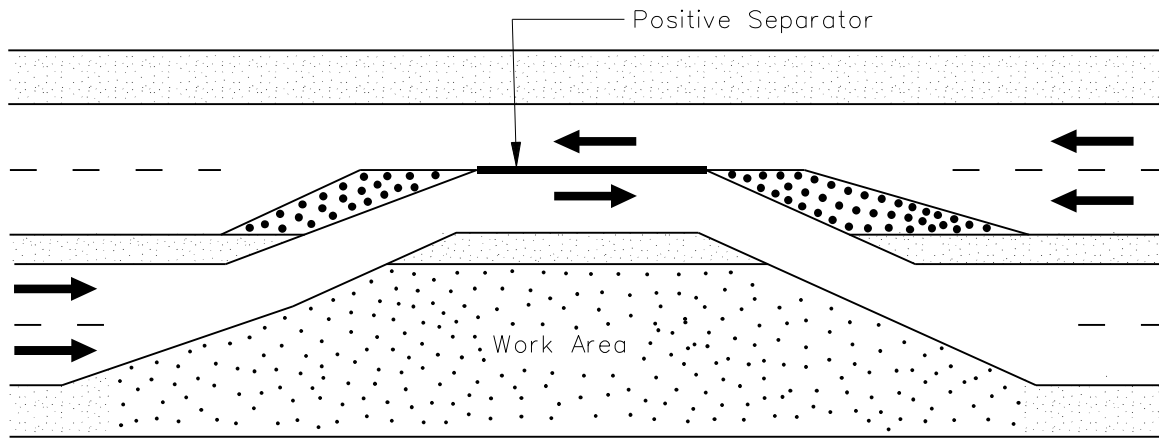

Four-Lane Divided Roadway

A

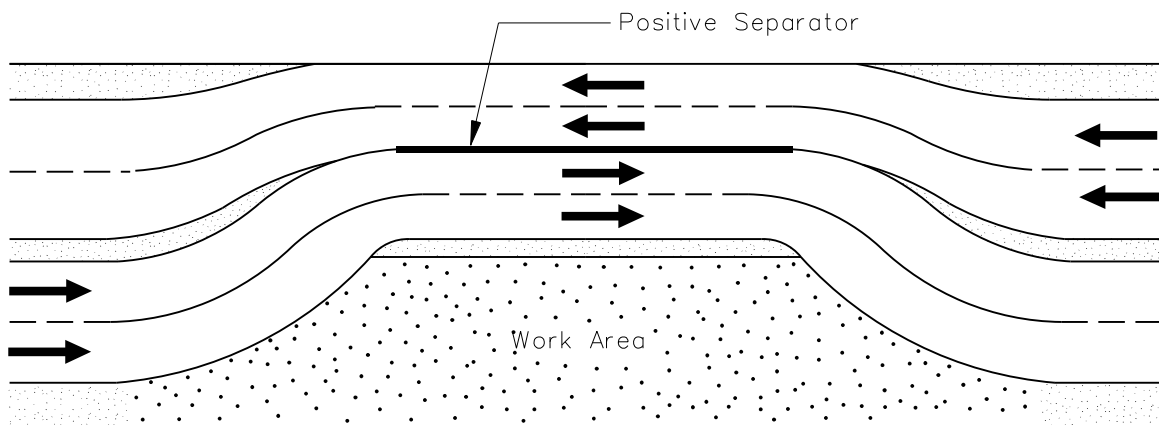

Four-Lane Divided Roadway

B

CROSSOVER WORK ZONES

Figure 13-2.G

The use of this application is encouraged under the following conditions:

- all safety issues can reasonably be addressed,
- construction time can be reduced,
- pavement and shoulder structures can be reasonably upgraded, and
- roadway geometrics allow crossover construction.

Chapter 55 and the *Highway Standards* discuss the design issues relative to designing two-way applications and crossovers (e.g., maximum length, pavement widths, pavement design, speed reductions). If this application is used, separate opposing traffic on high-speed facilities (i.e., posted speeds of 45 mph or greater) with positive barriers throughout the length of the two-way operation. Drums, cones, or vertical panels may be substituted for positive barriers in low-speed urban situations. The *Highway Standards* also depict the channelization devices that may be used with this layout. Consider also the option of reconstructing the shoulder to allow it to be used as a travel lane.

8. Detour. This work zone type involves total closure of the roadway, one or both directions, when work is being performed and rerouting the traffic to existing alternative facilities. This application is particularly desirable when there is unused capacity on roads running parallel to the closed roadway. When considering detours, evaluate the following:
 - a. Local Route Detours. Local route detours are generally used in conjunction with the rehabilitation or reconstruction of two-lane, two-way State-maintained highways having ADT less than 5000 vpd. However, a local route (e.g., county highway, township road, municipal street) may require upgrading (structurally and/or geometrically) or extraordinary maintenance to carry the anticipated temporary increase in traffic and to restore it subsequent to the detour. When investigating the practical use of a local road as a detour route, note that the detour route only will be temporarily serving the through traffic. If the local route detour will be an economically reasonable alternative, make every effort to use the existing roadway width, the existing right-of-way, and to minimize any contemplated utility adjustments. Also, investigate the local route to determine the safe detour speed. Where the posted speed of the detour route is less than that of the detoured route, additional speed signs and warning devices may be required. Contact officials having jurisdiction over the local route and obtain their concurrence prior to using the route for a temporary detour.
 - b. Marked State Routes. For marked State routes with ADTs greater than 5000 vpd, locate the detour along other marked State routes. Note that the adverse effects listed below and those for local detour routes also may apply to these detour routes.

- c. Location. The beginning and end of all detours should coincide as near as possible with the beginning and end of the construction project. Where practical, avoid long detours that will bypass entire communities.
 - d. Pedestrians. Evaluate pedestrian traffic concerns and methods of eliminating or minimizing any other adverse effects when closing a road. Adverse effects could include inadequate access to buildings, private property, or businesses along the closed road.
 - e. Railroad Crossings. Examine railroad crossings to see if existing protective devices, sight distances, geometrics, and crossing surfaces are adequate for the proposed traffic.
 - f. Wide Load Restrictions. Determine if there will be a need to post advance signs to prohibit wide loads from using the detour.
 - g. Split Detours. In some cases, it may be advantageous to provide two detours routes — a marked State route detour and a local route detour. Through traffic and heavy-truck traffic is detoured onto State-marked, high-type surface highways. The local route detour is for local traffic and vehicles weighing less than 25,000 pounds (11,000 kg). This limit will allow school buses to use the local route detour.
 - h. Benefits. Note that improvements to local routes provide a permanent benefit for the public, whereas runarounds provide only temporary benefits that cease when the construction project is completed.
9. Roadway Shifts. This work zone type shifts the proposed roadway alignment laterally, (e.g., 50 ft (15 m), 100 ft (30 m)) so that the existing roadway or bridge can be used as the means to maintain traffic flow at the work site. This is an option that is usually only appropriate at horizontal curve locations, or bridge sites where the roadway profile gradeline must be raised for hydraulic purposes. Note that additional right-of-way or easements will often be necessary for this work zone type.
 10. Work During Non-Peak Hours. When high-volume projects do not have good alternatives for 3R type work, consider requiring work during non-peak hours and/or night work.

13-2.03 Work Zone Strategies

13-2.03(a) Relocating Traffic Flow

The desired objectives to consider in relocating traffic flow are:

- Meet safety and mobility goals (see Section 13-1.01) to reduce fatal and serious injury crashes, and to avoid unreasonable adverse travel and public inconvenience.

- Plan for incidents and emergency vehicle access. Ensure that emergency vehicles can move through the work zone with minimal delay.
- Maintain reasonable access for local interests (residents, businesses, agriculture, etc.).
- Maintain marked route continuity to avoid motorist confusion and to enhance safe travel.

13-2.03(b) Selection of Traffic Control Strategy

Selection of the appropriate work zone type represents one of the most significant elements of a control strategy. Other elements of a control strategy that should be considered include length of the work zone, time of work, number of lanes, width of lanes, traffic speeds, and right-of-way. Considering these and other factors, reasonable alternatives can be narrowed to a selected few for further review. Typically, only a small number of reasonable work zone alternatives will emerge for a particular project. Identification of these alternatives at an early stage in the planning process can reduce significantly the necessary analysis effort.

Figure 13-2.H provides guidelines for identifying practical work zone alternatives based on roadway type, lane closure requirements, shoulder width, traffic volume, and the availability of right-of-way and detour routes. However, every work zone location will have a wide variation of conditions and an all-inclusive selection matrix is not practical. Other issues to consider include the following:

1. Local Regulations. Many jurisdictions have adopted safety regulations and public convenience policies as safeguards against the unacceptable impacts of work zones. These regulations and policies may impose additional constraints regarding the types of control strategies that can be implemented. Knowing these constraints can help eliminate impractical alternatives from consideration. The public convenience policies or local regulations may specify peak-hour restrictions, access requirements, noise level limitations, material storage and handling, excavation procedures, work zone lengths, and number of traffic lanes that must remain open.
2. Multilane Facilities. Traffic on multilane facilities is usually maintained through the use of lane constrictions, lane closures, or median crossovers. Maintaining traffic flow on multilane facilities generally will require higher criteria than those used on the rural two-lane highway system because of the higher speeds and traffic volumes. See the *Highway Standards* and Chapter 55 for recommended design guidelines.

3. Bridges. Traffic maintenance for bridges may consist of crossovers, stage construction (partial closure), detours, runarounds, or split detours. Coordinate all proposed designs with the Bureau of Bridges and Structures early in Phase I to determine possible structural solutions and related costs before writing TMP. In addition, consider the following:
- a. Crossovers (Full Closure). Consider using crossovers with bridge and superstructure replacements and deck replacements on multilane median divided facilities.
 - b. Stage Construction (Partial Closure). Stage construction for bridges will generally consist of lane constrictions, lane closures, or one-lane, one-way operations. However, stage construction may increase unit costs, increase the difficulty of reconstructing the bridge, have inherent hazards due to close proximity of traffic to the construction operations, and generally involves a restricted lateral clearance for vehicles, wide loads, and farm equipment. With lateral restrictions, it is important that these restrictions be adequately marked in advance of the work site. Consider the following factors when determining the feasibility of stage construction for bridges:
 - type, length, and width of present and new structure;
 - beam spacing and location in relation to the desirable staging limits;
 - lane and shoulder widths required during stage operations; this may require using the shoulder as part of the lane;
 - the use of temporary traffic signals; and
 - cost attributable to staging.

Deck repairs can usually be staged for all structure types. Superstructure and deck replacement, however, is sensitive to the type of structure involved. Existing multi-beam superstructures (e.g., steel I-beams, concrete I-beams) and culverts can usually be adapted to construction staging techniques. Other types of structures (e.g., pony trusses, relatively short-span structures utilizing low trusses without cross bracing) may be staged, but with greater difficulty and expense. Some structures (e.g., through trusses, through girders) cannot practically be staged.
 - c. Runarounds. At locations where a through truss, pony truss, or steel through girder is being replaced, consider moving the truss or girder laterally to temporary abutments and using the structure as a part of the runaround.
 - d. Split Detours. If significant through traffic is using the road, it may be advantageous to provide a marked detour route around the work site and build a low-water runaround across a stream for local access. This option is usually

applicable only on low-volume unmarked rural highways with less than 400 vehicles per day. See the *Bureau of Local Roads and Streets Manual* for design considerations and Section 404 permit requirements.

4. Additional Guidance. For additional guidance in analyzing and preparing a scheme to maintain traffic flow at work sites, see the *Highway Standards, Illinois Manual on Uniform Traffic Control Devices*, and *Standard Specifications*.

13-3 TRAFFIC CONTROL PLAN STRATEGIES

The following sections provide brief summaries of the various Traffic Control Plan (TCP) strategies that may be considered during the development of TCP. These strategies must be reviewed and adjusted to meet each project location and situation. Note that the strategies discussed in these sections are not all inclusive and that other options may be applicable for the location under consideration. Specific work zone traffic control recommendations are discussed in Chapter 55.

13-3.01 Construction Phases

How a project is constructed can greatly impact the traffic flow through the work area. The following sections discuss some of the basic construction phases for freeways.

13-3.01(a) **Reconstruction by Halves (Sides)**

This approach involves the reconstruction of all lanes in one direction while the opposing lanes share the same roadway with traffic in the other direction. This basic concept is the two-way traffic on a divided facility discussed in Section 13-2.02. For high-volume, four-lane facilities, both shoulders may be rebuilt to provide four reduced-width lanes. For six-lane facilities, traffic is generally restricted to two lanes in each direction. This may require using the shoulders, reducing the lane widths, and/or providing minor widening. Under certain circumstances, depending on the median width and shoulder configuration, the inner lane of the two-way operation may not be readily accessible in the event of emergencies. Providing for emergency turnouts and/or emergency vehicle access at appropriate intervals on the segment under construction may be considered. Some advantages and disadvantages of this strategy include:

Advantages

- It provides an effective work area.
- Generally, workers are well separated from the traffic stream.
- Work site access can be arranged with minimal interference from the general traffic flow.

Disadvantages

- Crossovers are typically required.
- Positive separation of the traffic streams is required.
- There are potential emergency access problems throughout the project.
- There may be special problems at interchanges with traffic crossing the work zone.
- Reduced capacity.

13-3.01(b) **Parallel/Adjacent Reconstruction**

This approach usually involves a variety of lane constriction and lane closure sequences discussed in Section 13-2.02. A typical sequence of this approach is as follows:

1. Phase A. First, the existing shoulders are widened and strengthened if necessary.

2. Phase B. Traffic is shifted to the shoulders to allow construction of the inner lanes and any median reconstruction.
3. Phase C. Traffic is then shifted to the newly constructed inner lanes to allow reconstruction of the outer lanes.
4. Completion. After construction is completed, traffic is returned to the original travel lanes.

A key advantage of this strategy is that traffic is not required to cross over the median and does not operate in a two-way operation. Some of the disadvantages include:

- Typically, it provides a more constrained work area for the contractor.
- Work crews are generally closer to moving traffic.
- Access to the construction zone typically involves entry and exit from the travel lanes.

For six-lane facilities, the facility is generally reduced to two-lanes in each direction and the above sequence is used. When closing the middle lane, it is preferable to keep the two through lanes on the same side of the construction zone (e.g., by using the shoulder) versus splitting the two lanes on either side of the construction zone.

13-3.01(c) Serial/Segmental Reconstruction

This strategy consists of permitting only short segments of the facility to be under construction at one time. This also requires one or more of the other concepts for traffic accommodation. An example of this application may include a shallow culvert replacement where each half can be constructed, backfilled, and opened to traffic within a 12-hour time period.

The advantages of this approach include relatively short work zones and few, if any, interchanges are impacted at any one time. One of the more serious disadvantages of this strategy is that the overall time period that the facility is under construction may be lengthened considerably because the construction for each segment will proceed independently. Therefore, the exposure to the potentially hazardous conditions of a work zone for both the traveling public and the work force may be substantially greater than could be the case with one of the other strategies.

13-3.01(d) Complete Closure (Detour)

In some circumstances, complete closure of the facility or closure of one direction of travel and detouring the traffic onto an alternative route may be an effective strategy. This strategy may also be effective for only certain hours of the day (e.g., 8 p.m. to 6 a.m. on weekdays and from 8 p.m. to 8 a.m. on weekends). Section 13-2.02 discusses other issues relative to detours. Some of the advantages and disadvantages of this strategy include:

Advantages

- Increases the safety for construction workers.
- May provide cost and time savings.

- Reduces the overall travel impacts to the public due to reduced construction time.

Disadvantages

- Potentially significant short-term travel impacts to the public.
- Potential increase in traffic congestion on other routes.
- May need to construct a detour/runaround.
- Potential adverse impact on businesses due to trip suppression (not enough traffic).
- Potential adverse impact to businesses on alternative routes (too much traffic).

13-3.01(e) Combinations

Often, a combination of construction sequences is the best strategy. For example, reconstructing existing shoulders prior to initiating parallel construction activities. The following sequence of construction could be used:

1. Phase A. Reconstruct shoulders as appropriate to allow one side of the roadway to accommodate four lanes.
2. Phase B. Shift traffic to the four available lanes on one side of the roadway.
3. Phase C. Shift traffic to the newly constructed side of the roadway using the additional reconstructed shoulder lane.

Other combination-type construction sequences involve the reconstruction of interchanges where both sequential and parallel activities may occur simultaneously.

13-3.02 On-Site Strategies

13-3.02(a) Traffic Control Devices

Consider the application of the following traffic control devices when developing TCP:

1. Portable Changeable Message Signs (PCMS). These devices may be used where static sign messages are not sufficient to accommodate the changing conditions of a work zone (e.g., lane closures, ramp closures, to advise motorists of conditions for which they will need to possibly react). These devices are also used to inform the traveling public of road construction activities on site prior to construction. Where numerous PCMS are used on a project, there should be a plan for their use to ensure a consistent and cohesive message. See Section 55-5.01(d) and *MUTCD* for further guidance.
2. Additional Informational Panel Signs. These signs may be used to give the motorists additional information about a work zone. Ensure the message on these signs is pertinent to the likely conditions the motorist will encounter.

3. Signal Interconnect. Interconnect traffic signals where the benefit of moving traffic through a work zone more efficiently will be enhanced by adding interconnection between the traffic signals on the system.
4. Signal Timing. Revise the timing of traffic signals within a work zone to increase the capacity. Adding or deleting of signal phases may be required for changes in travel patterns.
5. Highway Advisory Radio. Use highway advisory radio where changing work zone conditions make it important to give the motorist a longer, more accurate message than could be obtained through the use of signs or other means. This option requires additional information and signing to alert motorists.
6. Temporary Work Zone Speed Limits. A reduced regulatory speed limit may be warranted where work activity may constitute a hazard to traffic or workers. Direction on alteration of work zone speed limits may be found in the Bureau of Operations Policy on Establishing and Posting Speed Limits on the State Highway System.
7. Arrow Boards. In construction areas, arrow boards are used to supplement conventional traffic control devices. They typically are warranted where additional warning and directional information is required to assist in merging and controlling traffic through and around the work activity. The *Highway Standards* provide additional guidance on the placement and use of arrow boards in construction zones.
8. Intelligent Information Systems. Investigate new and emerging technology to provide better travel information to the public. Current systems provide real time travel information to the public through PCMS. Other systems that have been used include: variable speed limit signs, early merge and late merge strategies for lane closures, and electronic speed monitoring devices.

13-3.02(b) Capacity

Each construction site will affect the capacity of the existing facility. The extent the roadway is occupied for work and safety purposes will determine the number of strategies required to compensate for the loss of capacity. As well as, a reduction in capacity affects mobility (see Section 13-3.02(c)). Consider the following capacity strategies when developing TCP:

1. Temporary Parking Restrictions. One option to increase capacity is to restrict on-street parking that can then be used to add an additional lane or to reduce traffic conflicts. These restrictions can be during peak periods or for 24 hours/day. However, ensure that the concerns of on-street parking for local businesses have been addressed. Use of parking lanes for traffic lanes also may require geometric revisions at intersections.
2. Restriction of Trucks. Restriction of trucks may increase the facility's capacity. However, consider local and/or State ordinances and the availability and suitability of alternative routes that the restricted trucks will be required to take.

3. Turn Restrictions. Eliminate or restrict turns at intersections and/or driveways may increase capacity and reduce crashes. Turn restrictions can be during peak periods or for 24 hours/day.
4. Reversible or Contra-Flow Lanes. Reversible or contra-flow lanes may be considered where a large percentage of the traffic moves in one direction during peak periods, and the existing facilities are adaptable. Candidates for reversible flow lanes lack center medians and have continuity in the route and the width of the street. The optimum distribution may be found by dividing the number of lanes operated in the primary direction by the total number of lanes (e.g., 4 lanes primary direction divided by 6 lanes total yields a 67% optimum percent traffic in the primary direction).

The advantage of reversible lanes is the ability to increase the capacity of the existing facility. However, there are many disadvantages:

- High cost of reversing direction twice a day.
 - Consider need for positive separation between lanes, which requires movable barrier and the associated equipment.
 - Public information campaign required to educate the traveling public.
 - Resistance from business owners, schools, traffic generators, and emergency service providers.
 - Where applicable:
 - + Parking must be time restricted or eliminated.
 - + Left turns must be restricted or eliminated.
 - + Bus service may cause mobility problems in secondary direction.
 - Incident management may be needed, as a stalled vehicle or crash will severely restrict or stop flow for the secondary direction.
5. Ramp Metering. Consider using or revising ramp metering where it is necessary to control the volume of traffic entering a freeway for capacity and safety reasons. Ramp metering may be used during peak periods or for 24 hours/day. Also, consider the impact ramp metering will have on the intersecting street (e.g., traffic backup).

13-3.02(c) Queue Analysis

Queue analysis is critical not only to meeting mobility goals, but to improving safety for the motorist. The largest category of crashes in work zones is rear end collisions. At highway speeds, the number of rear end collisions increases to nearly 30% of all work zone crashes. These crashes are largely due to the highway not meeting the motorist's expectations – the motorist does not expect a queue, even in a work zone.

Analysis of the peak queue allows the designer to place warning signs (e.g., road construction ahead, static PCMS, dynamic message boards) in advance of possible queues. This practice not only improves the safety of the work zone, but it aids the designer in the placement of signage for suggested alternative routes well ahead of the queue.

Queue analysis methodology should be appropriate to the type of work zone and may include one or more of the following:

- Permitted Lane Closure Maps;
- hourly volume maps;
- district knowledge and experience;
- site reviews;
- highway capacity analysis converted into a predicted queue; and
- computer simulation programs (e.g., QUEWZ, TSIS – CORSIM, Quickzone).

Experience with similar construction projects and the effectiveness of the traffic control strategies employed is critical to provide a reality check to any analysis.

Where queues are normally present without lane closures, compare existing queues to expected queues. Discuss how the main and alternative strategies may reduce the impact lane closures, construction, or other work have on the project.

13-3.02(d) Miscellaneous Strategies

In addition to the above sections, consider the following miscellaneous on-site strategies when developing TCP:

1. Ramp Closures. The following will apply to ramp closures:
 - a. Short/Intermediate Term. Short- or intermediate-term ramp closures may be necessary for construction purposes. If closures are required, additional signage will be necessary to forewarn the motorist. It is recommended to post signs on the affected ramp two weeks in advance to advise motorists of the closure date(s) and/or periods of the day the ramp will be closed.
 - b. Long Term. Long-term ramp closures may be necessary to construct or to improve traffic flow on the mainline road. Consider the effect the ramp closure will have on emergency services, local access, and businesses before deciding on a long-term ramp closure. Also evaluate the user costs for a detour route and the capacity and safety impact of the detour route. Do not close two adjacent ramps at the same time unless necessary for safety reasons.
2. Incident Management. Consider the use of on-site tow trucks for freeway work zones with limited or no shoulders available. They should also be considered where a crash or break-down will seriously impact the roadway and cause significant backups and delays. Consider providing turnarounds for access through temporary concrete barrier and for tow trucks and State Police to park.

3. Special Materials. Examine the use of high early strength concrete, precast items or other special materials where traffic restrictions must be minimized (e.g., ramps, intersections, high-volume roadways). Time and overall cost savings may offset the potentially higher material costs.
4. Police Enforcement. For projects that include complex work zones with high speeds, high traffic volumes, or that would benefit from the presence of enforcement over an extended period of time, consider using planned enforcement. Designers should indicate this need as part of the Phase I and Phase II process in developing the project Transportation Management Plan. Designers should coordinate with Construction, Operations, and Programming Engineers to include this cost as an additional project expense in the highway program, as opposed to using annual allocation of hire-back hours, if it is warranted in order to ensure that dedicated law enforcement is provided in the work zone.
5. Photo Speed Enforcement. Photo Speed Enforcement is another work zone enforcement option allowed by Illinois law. This program is funded by the Transportation Safety Highway Hire-back Fund. The locations of these patrols are coordinated through IDOT and Illinois State Police districts with the guidance of the Bureau of Safety Programs and Engineering.
6. Pedestrians. In urban or suburban areas where pedestrian activity is likely, pedestrian access must also be provided during construction. This may require positive guidance, providing temporary sidewalks, protection from drop offs, adjustment to traffic signals, etc. ADA accessibility requirements shall be applicable to construction zones in urban areas where accessibility is provided by the existing facility. Consult *MUTCD* and *ADA Standards for Accessible Design* to ensure devices meet accessibility requirements.

13-3.03 Off-Site Strategies

Where construction will significantly impact the traffic flow away from the work zone, consider the following off-site strategies in TCP:

1. Advance Informational Signs. These signs may be used to give the motorists additional information about a work zone that is ahead or on a different route. Provide these signs where it is advantageous to give this information to a large number of motorists or where it is necessary to inform motorists of an alternative route to avoid a congested work zone.
2. Portable Changeable Message Signs (PCMS). These devices can be used to give the motorists information required to prepare them for upcoming changing conditions or information about how to avoid a condition. These devices may be used to provide more information than feasible on an informational panel sign. See Section 55-5.01(d) for more information.

3. Signal Interconnect. Evaluate interconnecting traffic signals where moving traffic through an alternative route corridor more efficiently is enhanced by adding interconnection between traffic signals on the alternative route system.
4. Signal Timing. Evaluate traffic signal timing changes and/or additional phases for traffic signals on an alternative route because of the added traffic expected to use the route.
5. Capacity Improvements. Additional improvements on the alternative route may be necessary for capacity reasons to accommodate the expected diversion of traffic. Examples of capacity improvements include additional pavement width, adding turn lanes, removal of parking, turn restrictions, and truck restrictions.
6. Trailblazing to Attractions and Points of Interest. Trailblazing may be necessary to guide motorists to attractions and points of interest in those circumstances where the normal route is closed or seriously restricted, or where an alternative route to the attraction or points of interest will assist traffic through the work zone.

13-3.04 Scheduling

Construction time has a direct effect on the cost of the project. A short schedule to minimize construction activities and disruption to traffic may be required if motorist user costs are expected to be high. A schedule that minimizes construction time also limits the exposure for workers and the traveling public to the hazards of the work zone. However, short schedules may increase the cost of the project. A longer schedule of construction activities may be cost effective if it does not significantly increase the adverse impact to motorists. The contractor may bid a lower price for a longer schedule. When determining a construction schedule, consider the following:

1. Strategies for Reducing Construction Time. Incentives/Disincentives and A+B contracts may be used to minimize the time a facility is affected by construction. Contact BDE for information. See Section 66-2.03 for guidance on estimating the expected construction time for the project.
2. Lane Rental. Lane rental is a contracting technique whereby either the contractor bids the number of days of work requiring lane closures as part of the contract, or the Department sets the number of days for which such closures are allowed. If the contractor finishes early, an incentive is paid. If the contractor exceeds the number of days allowed, a disincentive payment is deducted from the contract for each day the limit is exceeded. This type of contract forces the contractor to schedule resources and perform work in a more timely manner.

Consider contracts using a lane rental specification on all high-volume, multi-lane projects (e.g., Interstates, expressways). Complete a traffic capacity analysis for these projects to determine the level-of-service to be anticipated during construction. In addition, conduct a queuing analysis to determine the anticipated traffic backups at different times during the day and week. Once a traffic capacity analysis and queuing

analysis are complete, a decision may be made on whether or not to use a lane rental specification. If a lane rental specification is used, this information will aid in determining the average road user benefit cost.

For all Interstate and expressway projects that involve patching, include the lane rental specifications. The lane rental specification must apply to the patching operation and may be applied to the whole project. Prepare a traffic capacity analysis and queuing analysis to determine the anticipated back-ups at different times during the day and week. This information is then used in determining the average road user benefit cost for purposes of developing the lane rental specification.

3. Letting Dates. Projects that can be completed in one construction season should be let and scheduled to be completed prior to winter shutdown. For those projects requiring more than one season, the major phases of construction need to be planned to recommend an appropriate letting date and provide a schedule for winter shutdown. Delays and impacts to the traveling public and adjacent property owners should be minimized. A schedule that minimizes construction time also limits the exposure for workers and the traveling public to the hazards of the work zone. See Chapter 66 for further information for selecting contract letting dates.
4. Time of Day/Day of Week Restrictions. These types of restrictions may be necessary if the work zone capacity will not accommodate the expected demand during the peak periods and other measures are not as cost effective. For example, night work may be required to allow longer work hours than can be provided between morning and afternoon peaks. Night work may also be used to decrease the excessive traffic delays or congestion associated with lane closures during the daytime.
5. Project Phasing. Project phasing or completing smaller portions of a construction project one portion at a time may be necessary to limit disruption to traffic. However, construction activity in the same area over several seasons should be discouraged.
6. Combining with Other Work. Projects within a corridor may be combined or scheduled at the same time where practical, pending available funding, to minimize impacts to the motoring public.
7. Timing. Control the timing of road closures for a certain time of the year by either setting the letting date or by placing restrictions in the special provisions. Also, when closing or restricting widths on rural highways, time the closure to occur after spring planting operations have been completed and ensure that the highway is open to traffic by harvest time.
8. Sequence of Construction. Consider the sequence of construction to reduce any stages of construction when possible. For example, requiring a shoulder and pavement lane to be milled and resurfaced in the same operation would eliminate a second traffic control setup for resurfacing the shoulder. The reduction in traffic control cost, overall reduction in time, the bituminous plant change over from one mix to another, and cost reduction due to increased volume of one mix may offset the additional cost for the increased

material cost on the shoulder material, especially in the binder stage. Examine the overall effects of staging and sequence of construction to reduce the exposure time of workers and the traveling public to the hazards of the construction zone.

9. Prohibit Weekend Lane Closures. On roadways with ADT of 25,000 or more, keep all lanes open to traffic from 3:00 P.M. Friday to 12:00 midnight Sunday except where structure construction or major rehabilitation makes it impractical. Where patching and resurfacing are performed on these routes, lane closures are often in place and cause extensive backups. By restricting the work on weekends, all traffic lanes are available to accommodate the higher weekend volumes of traffic.

Where ADT exceeds 25,000, provide ADT on the cover sheet of the construction plans. A traffic capacity analysis and a queuing analysis should still be completed. On some routes ADTs may be lower on weekends and it would be beneficial to allow or require work on weekends. In these cases, contracts should contain specifications to allow this work.

For projects with less than 25,000 ADT on which traffic volumes are still relatively high, especially Interstates, conduct a traffic capacity analysis and a queuing analysis to evaluate the possible benefit of prohibiting weekend lane closures.

10. Night/Non-Peak Hour Construction. On high-volume roadways, the Traffic Management Analysis (TMA) should consider limiting construction to non-peak or nighttime hours. For all TMAs prepared for roadways with greater than 25,000 ADT, include a traffic capacity analysis and a queuing analysis. Where the one-way VPH exceeds 1700 or the level of service drops to E or F, excessive back-ups will occur. Under these situations, restrict work to other times of the day.

Once the traffic peaks and expected queues have been reviewed, TCP can be developed. Under the above situations, construction should not be permitted during certain time periods for each direction of travel. This provides the contractor with some flexibility in scheduling work.

Under certain conditions it may be beneficial to require work be done only at night. This decision should be made after close examination of the traffic capacity analysis and queuing analysis. In cases where the traffic volumes remain high throughout the day but drop significantly during the night, where traffic delays would be continuous throughout the day, or to provide longer continuous work periods, consider using night construction.

Before requiring night construction, consider the following factors:

- noise level ordinances that may prohibit certain construction activities at certain times,
- noise and light impacts on the surrounding community,
- neighborhood traffic impacts due to detours or alternative routes,
- impacts to businesses, and

- community resistance.

When night construction is required by the contract, include the following:

- a lighting specification detailing the minimum lighting requirements,
- additional signing and increased use of PCMS to alert traffic,
- increased public relations efforts to notify the surrounding community, and
- restrictions to limit work hours to 7:00 P.M. to 6:00 A.M. Hours may be adjusted according to the traffic analysis.

13-4 PUBLIC INFORMATION PLAN (PIP)

Work zones, particularly those deemed to have a sustained impact on safety and mobility should include a Public Information Plan (PIP) in the Transportation Management Plan. Significant projects are required to have PIP.

Successful work zone public information and outreach campaigns incorporate three essential messages:

- Safety First,
- Plan ahead to minimize delay, and
- We care.

It is important that the public be informed initially and remains informed in a timely manner. Consider the following steps to create PIP:

1. Scope. The PIP should consist of a plan to inform and reach out to the public. For smaller projects, PIP may be limited to contacting local EMS and schools, press releases of project scope and duration, and the IDOT website. Larger, more disruptive projects may warrant a more extensive campaign.
2. Identify Resources.
 - Use free media coverage through press releases to local news media (newspapers, radio, television) and the IDOT website.
 - Examine use of existing resources (e.g., highway advisory radio, dynamic message signs).
 - Use town meetings and project hearings to describe the project and gather public support.
 - Coordinate with public officials and law enforcement to help with gaining favorable public opinion.
 - Consider low cost options (e.g., creating brochures to be given to motorists at key locations and for posting at rest areas and welcome centers).
 - Coordinate with other transportation agencies (e.g., local agencies) to identify their construction and maintenance activities and to minimize motorist delays near the project.
 - Major employers and service providers may assist in informing the public. For example, these entities may be willing to incorporate messages in newsletters, web sites, or flyers to employees and customers at no cost to the Department.

- Business and neighborhood associations have a vested interest in the road network. Buy-in from these groups may result in strategies to offset traveling hours or delivery times and increase the use of local routes by local drivers.

Larger projects may require public information and outreach spending as a part of the project budget.

3. Identify Partners. Identify other affected State and local agencies, major employers, schools, businesses, and neighborhood associations.
4. Identify Target Audience. Examine the project and identify which motorists are most affected by the project. Focus efforts on this audience.
5. Develop the Message.
 - Inform the motoring public that the Department cares about safety and delay in the work zone. For example:
 - + Emphasize that safe passage through the work zone is critical.
 - + Show that minimizing delay is important to the Department.
 - Indicate which alternate routes are available. Do not simply say “use alternative routes,” be specific as to which route should be taken.
 - Clearly communicate the project start date and plan to update the public throughout the project.
 - Where applicable, communicate hours of work (e.g., 7:00 pm to 5:00 am Monday through Saturday). Encourage travel during off-peak times.
 - Advertise alternative modes of transportation (e.g., carpool, share-a-ride, mass transit).

For larger projects, consider a unified message that revolves around a slogan or mascot (e.g., Jack Hammer (mascot) for the upgrade 74 (slogan) project in Peoria, Illinois, 2002). A unified approach may aid in gathering positive public support for extensive projects.

6. Determine Communication Strategies and Timing. Develop a plan for how and when to get the word out. For large projects, consider including a thank-you campaign to publicize completion and enhance the Department’s image as focused on the motorist.
7. Evaluate. The TCP author or team should evaluate the effectiveness of PIP as part of the Department’s long-term efforts to improve safety and mobility in and around work zones.

See the FHWA publication *Work Zone Public Information and Outreach Strategies*, November 2005, for more information.

13-5 TRANSPORTATION OPERATIONS PLAN (TOP)

Work zones, particularly those deemed to have a sustained impact on safety and mobility should include a Transportation Operations Plan (TOP) in the Transportation Management Plan. Significant projects are required to have TOP.

A TOP is a plan that consists of strategies that mitigate work zone impacts through the use of improved transportation operations and management of the transportation system. The TOP may consist of strategies for:

- demand management,
- corridor/network management,
- work zone safety management,
- traffic and Incident management, and
- enforcement.

13-5.01 Demand Management

Demand management strategies include techniques intended to reduce the volume of traffic traveling through the work zone. These techniques include, but are not limited to:

- mass transit service improvements and incentives,
- shuttle services,
- carpooling incentives,
- park and ride promotion,
- ramp metering, and
- working with local business to promote variable work hours and/or telecommuting.

13-5.02 Corridor/Network Management

Corridor or network management strategies optimize traffic flow through the work zone corridor and adjacent roadways. Strategies include, but are not limited to:

- signal timing and coordination improvements,
- street and intersection improvements on mainline and adjacent roadways,
- bus turnouts,
- truck lanes or truck restrictions,
- turn restrictions,
- parking restrictions, and
- coordination with adjacent construction projects.

13-5.03 Work Zone Safety Management

Work zone safety management strategies address worker and traffic safety. Strategies include, but are not limited to:

- variable work zone speed limits based on traffic volume and/or type of work,
- temporary traffic signals,
- temporary longitudinal traffic barrier and movable barrier systems,
- trailer or truck mounted attenuator systems,
- temporary rumble strips,
- safety awards/incentives,
- construction safety supervisor/inspectors,
- TMP monitoring/inspection team, and
- work zone safety assessments.

13-5.04 Traffic and Incident Management

Traffic and incident management strategies monitor traffic conditions and make adjustments based on these changing conditions. Strategies include, but are not limited to:

- Intelligent Transportation Systems (ITS) may be used to:
 - + detect traffic flow, and automatically relay “real time” travel time to motorists via PCMS, websites, or other outlets; and
 - + detect queues, and automatically actuate warning systems.
- gawk screens to reduce driver distraction;
- milepost markers to aid the motorist in locating themselves in an incident;
- tow/service patrol; and
- incident/emergency management plans.

13-5.05 Enforcement

Enforcement is a critical and unique portion of work zone transportation operations planning. The presence of law enforcement, appropriately deployed, has proven effective in gaining compliance with work zone speed limits to enhance work zone safety. See Section 55-6 for more information.

13-6 COST-EFFECTIVE ANALYSES

13-6.01 General

Along with not obtaining mobility goals, failure to maintain traffic flow during construction can cause driver aggravation, add substantial operating cost to motorists or businesses, and cause unfavorable public relations for the Department. However, these considerations must be balanced against the capital costs to the Department, because limited funds are available.

Capital costs include the building and removal of a temporary runaround, using a local route detour and structurally upgrading its roadway, paying for accelerated construction progress, night work, or providing stage construction that may result in increased unit costs. These options can add considerable costs to the overall project.

For many projects, there may be more than one option that will address the problem of traffic during construction. To determine the most appropriate option, the designer or TMP team must compare the benefits and costs of each to determine the most appropriate option.

13-6.02 Cost Evaluations

13-6.02(a) On-Site

When determining the cost for on-site options (e.g., runarounds, lane closures, crossovers, shoulder use), the designer should consider the following:

- right-of-way costs (temporary and permanent);
- additional construction costs;
- environmental effects;
- vehicular delay;
- user costs (including detour user costs; see Section 13-6.02(c)); and
- crash potential.

When determining the effect of each on-site option, the designer may also consider the effect the selected option will have on unofficial detours (i.e., detours which drivers select on their own to avoid the construction area).

13-6.02(b) Detours

For detours, the designer must determine the total cost of the detour. This includes:

- detour user costs; see Section 13-6.02(c);
- the cost for any improvements needed to the detour route (e.g., repaving, pavement widening, signal improvements);
- the effect the detour will have on the community and local businesses; and

- the effect on the local street network.

13-6.02(c) Detour User Costs

Adverse travel is the additional distance that motorists must travel to complete their trips around the work site while a detour is in use. To reduce project construction costs to the Department and to enable these savings to be used for other needed improvements, it is considered in the best interests of the public for road users to directly share in the costs of road and bridge improvements. Road users will bear some of the costs of reasonable adverse travel. Accordingly, this should be reflected during preparation of TMP. Multiply the computed adverse travel costs by 0.5 before making any comparisons to the costs of other alternative methods of maintaining traffic flow.

Breakout the cost according to the following:

1. Cars, Pickups, and Vans. When computing operating costs for cars, pickups, and vans, *Your Driving Costs* published by the American Automobile Association and available on their website, may be used as a guide to determine the per mile (km) costs.

Only the operating costs need to be considered in computing per mile (km) costs that include:

- gasoline and oil (note the gasoline price used for calculation by the publication);
- maintenance, accessories, parts, and tires; and
- State and Federal taxes on the above.

Fixed costs (e.g., insurance, depreciation, license fees, finance charges) need not be considered because they are incurred whether or not a vehicle is driven extra miles (km).

2. Trucks. For truck operation costs, only the operating costs need to be considered in computing per mile (km) costs for trucks. These costs include:

- diesel fuel for tractor-trailer units and gasoline or diesel fuel for single-unit trucks (note the fuel cost used for calculations by the publication);
- tires;
- maintenance (oil, grease, repairs);
- driver's wages and fringes; and
- operating depreciation.

Fixed costs (e.g., tractor or trailer replacement costs, Federal highway use tax, license fees, insurance, finance charges) need not be considered because they are incurred whether or not the vehicle is driven extra miles (km).

These costs may be estimated by multiplying the average car, truck, and van operating costs by 4.5 for SU and 5.5 for MU.

For any additional information on adverse travel costs or on the above listed publications, contact BDE.

13-6.02(d) Example Cost Evaluation

Project – Three Span Bridge, Full Structure Replacement

Option 1 – Detour			
Project Costs	1	Widening and Intersection Improvements	\$
	2	Signal Improvements	\$
	3	Repairs/Improvements of Local Routes	\$
	4	Motorist delay/cost in detour	\$
Total Project Cost			\$
User Costs	1	Effect on Local Businesses	\$
	2	Adverse Travel, Cars	\$
	3	Adverse Travel, Trucks, 8% SU, 5% MU	\$
Total User Costs			\$
Option 2 – Temporary Runaround			
Project Costs	1	Right-of-Way	\$
	2	Construction and Removal of Runaround	\$
	3	Temporary Bridge	\$
Total Project Cost			\$
User Costs	1	Motorist delay in work zone	\$
Total User Cost			\$
Option 3 – Stage Construction			
Project Costs	1	Temporary Longitudinal Traffic Barrier	\$
	2	Temporary Traffic Signals	\$
	3	Increased Structure Cost due to Staging	\$
Total Project Cost			\$
User Costs	1	Motorist delay in work zone	\$
	2	Longer construction time	\$
Total User Cost			\$

13-7 EXAMPLE TMP FOR SMALL PROJECTS ON SIGNIFICANT ROUTES

A small project on a significant route may follow this full TMP template:

District X Transportation Management Plan

1. Project Description:

This project consists of ...

This project is located ...

This project is on (or approaching) a significant route.

2. Work Zone Impacts:

The impacts to the work zone were evaluated by ...

Based on this evaluation and previous experience with similar work in this area, the project is expected to meet safety and mobility goals of less than X mile queue and less than X minute delay.

3. Selected Work Zone Impact Management Strategies:

A. Traffic Control Plan: A traffic control plan was developed using Standard Specifications, Special Provisions, and Highway Standards. A copy of the Traffic Control Plan is attached.

B. Public Information Plan: Project information will be communicated to the public at the beginning of work by use of portable changeable message boards (PCMS) two weeks in advance of construction activities. Media outlets will be informed with a press release two weeks in advance. Both static message boards and PCMS will be used to convey real time information to the public.

C. Transportation Operations Plan: The scope of this project does not warrant extensive transportation operations strategies. Strategies to be utilized include: Limited work hours, etc.

4. TMP Monitoring:

The TMP will be monitored during the project for queue length and user delay. Monitoring of TMP will be completed by district personnel as required throughout the duration of the project. Evaluations will be completed daily during work zone activity. Evaluations will be discussed during 50% design reviews with design personnel.

The Resident Engineer overseeing the project will be responsible for evaluating the need to revise traffic control strategies, and will coordinate these revisions with the Supervising Field Engineer. Contingency plans may be developed with the input of the contractor, Bureau of Construction, and the Bureau of Operations.

Chapter Fourteen

**INTERSECTION DESIGN
STUDIES**

BUREAU OF DESIGN AND ENVIRONMENT MANUAL

Chapter Fourteen
INTERSECTION DESIGN STUDIES

Table of Contents

<u>Section</u>	<u>Page</u>
14-1 WARRANTS FOR THE PREPARATION OF INTERSECTION DESIGN STUDIES	14-1.1
14-2 PREPARATION OF INTERSECTION DESIGN STUDIES	14-2.1
14-2.01 Signalized, Two-way Stop-controlled, and All-way Stop-controlled Intersection.....	14-2.1
14-2.02 Roundabout Intersections	14-2.2
14-3 DATA REQUIRED FOR INTERSECTION DESIGN STUDIES.....	14-3.1
14-4 INTERSECTION DESIGN STUDY PROCESSING	14-4.1

Chapter Fourteen

INTERSECTION DESIGN STUDIES

An Intersection Design Study (IDS) is a graphic representation of a proposed treatment for the development or improvement of an intersection facility. It is based on an analysis of traffic needs and an evaluation of physical and economic elements at the intersection site. Chapter 14 presents the Department's criteria for the preparation of an IDS. Chapter 36 presents the detailed design criteria for intersections.

The primary purpose of an IDS is to provide a review medium for use by the district, BDE, and the general public. The IDS also provides a file reference that documents all pertinent data and information controlling the design of the intersection improvement.

14-1 WARRANTS FOR THE PREPARATION OF INTERSECTION DESIGN STUDIES

Prepare an IDS for intersections if any of the following conditions apply:

- The study location is an intersection of two marked routes.
- The improvement is intersected by either:
 - + a rural highway that has an existing 30th maximum hourly volume greater than 300 vehicles or additional lanes and/or channelization is proposed on one or both routes; or
 - + an urban highway that has an existing 30th maximum hourly volume greater than 400 vehicles or additional lanes and/or channelization is proposed on one or both routes.
- Where complex conditions exist at the intersection (e.g., high crash rate, adverse terrain features, geometric features that will be difficult to correct due to the extent of cultural development).
- Where a roundabout is proposed.
- When requested by the district or BDE in accordance with the engineering study and advance engineering data requirements in the ILMUTCD.

14-2 PREPARATION OF INTERSECTION DESIGN STUDIES

14-2.01 Signalized, Two-way Stop controlled, and All-way Stop-controlled Intersections

Prepare IDS plan sheets on CADD. For guidance on the preparation of plan or profile sheets, see Section 63-4.01. A sample intersection design study for a signalized intersection is illustrated in Figure 14-2.A. To facilitate uniformity, use the following sheet formats:

1. Cover Sheet. The cover sheet layout for two-way stop-controlled and all-way stop-controlled intersections is generally similar, with different Capacity Design Analysis, Elements Controlling Design, and General Notes blocks. In urban areas, the intersection layout is usually drawn at a scale ratio of 1 in = 50 ft (1:500 metric) and in rural areas 1 in = 100 ft (1:1000 metric) or 1 in = 50 ft (1:500 metric). The cover sheet contains the following items:
 - scaled plan view layout of the intersection (including traffic signal locations, if proposed, and striping plan),
 - Capacity Design Analysis table,
 - DHV turning movement diagram,
 - graphic bar scale,
 - Traffic Data table,
 - north arrow,
 - phasing diagram,
 - location map box,
 - existing and proposed right-of-way,
 - Elements Controlling Design data block,
 - General Notes data block,
 - property lines, natural features, and manmade cultural developments, and
 - signature and title block in the lower right-hand corner.
2. Intersection Detail Sheet(s). These sheets are supplemental sheets for intersection details. They may not be necessary (for simple intersections), be a single page or be multiple pages. The need to show special details or cross sections depends on the complexity and size of the intersection. These sheets contain improvements to the approach legs, beyond the intersection proper, when they cannot fit on the cover sheet. In urban areas, the scale ratio is usually 1 in = 20 ft (1:250 metric) and in rural areas 1 in = 50 ft (1:500 metric). Also include the following items on each sheet:
 - graphic bar scale,
 - title block in the lower right-hand corner, and
 - sheet index block in the upper right-hand corner indicating the route, section, county, and sheet numbers.
3. Profile Sheets. Typical grid sheets are used for showing profiles, if profiles are necessary. Use the format illustrated in Figure 14-2.B. Also include the following items on the sheet:

- title block in the lower right-hand corner; and
 - sheet index block in the upper right-hand corner indicating the route, section, county, and sheet numbers.
4. Design Vehicle Turning Path Sheets. Include the design vehicle turning paths if generated by computer software.

14-2.02 Roundabout Intersections

1. Cover and Intersection Detail Sheets. Information on these sheets of a roundabout IDS is similar as that described above for signalized intersections
2. Other Sheets.
 - Include the baselines of the approach roadways and the central island. The baselines of the approach roadways should follow the median edges of the approaches and be defined by tangents and curve data. Both edges of the median should have a baseline as the alignment of the approaches and departures are independent. Once the baselines reach the outside edge of the circulatory roadway, it should break directly toward the center of the central island. Include a station equation at the center of the central island where the other baselines intersect. The baseline of the central island should be along the outside of the truck apron.
 - Include the profiles of the approach roadways along the baselines up to the intersection of the baseline of the central island. Include the profile of the central island along the baseline of the central island. Include the stations equations and elevations at the intersection of the profile of the approach baselines and the profile of the central island.
 - Include the design vehicle turning paths for all movements from all approaches.
 - Include the fastest paths. Include the radii of the curves and the design speed.
 - Include the sight lines for the approaches to show there is adequate intersection sight distance for drivers to perceive and react to the presence of conflicting vehicles, pedestrians, and bicyclists. Evidence suggests that it is advantageous to provide no more than the minimum required sight distance on each approach. Excessive intersection sight distance can lead to higher vehicle speeds that reduce the safety of the intersection for all users.
 - Include the phi (Φ) angle. Defined in Section 36-9.04(h), the phi angle should range between 20° and 40°.
 - Show the existing and proposed right-of-way, if not shown on Sheet No. 1.

All of the above sheets should have the title block in the lower right-hand corner and sheet index block in the upper right-hand corner indicating the route, section, county, and sheet numbers.

SIGNALIZED CAPACITY DESIGN ANALYSIS													
PROGRAM USED:		HCS 2010		VERSION:		6.70		SIGNAL TYPE:		ACTUATED		AREA TYPE:	NON-CBD
NUMBER OF PHASES:		(A.M.) 4 (P.M.) 4		CYCLE LENGTH:		(A.M.) 120 SEC. (P.M.) 120 SEC.		PEAK HOUR FACTOR:		0.95			
INTERSECTION DELAY/LEVEL-OF-SERVICE:		A.M. 18.1 SECONDS LOS B		P.M. 27.9 SECONDS LOS C									
APPROACH	EASTBOUND (C)			WESTBOUND (D)			NORTHBOUND (B)			SOUTHBOUND (A)			
LANE GROUP	L	T	TR	L	T	R	LT	R		LT	R		
NUMBER OF LANES	1	1	1	1	2	1	1	1		1	1		
2034 30TH MAX. HOUR TRAFFIC (veh/h)	A.M. 19	719	718	118	1118	7	18	58		43	61		
	P.M. 68	815	815	90	1377	18	42	115		23	24		
BASE SATURATION FLOW RATE (veh/h)	1900	2000	1900	1900	2000	1900	1900	1900		1900	1900		
LANE WIDTH (FT)	12	12	12	12	12	12	12	12		12	12		
VOLUME OF RIGHT TURN ON RED (veh/h)	A.M. 0	P.M. 0	A.M. 1	P.M. 2	A.M. 6	P.M. 12	A.M. 6	P.M. 12		A.M. 3	P.M. 2		
PEDESTRIANS/HOUR (ped/h)	A.M. 10	P.M. 5	A.M. 7	P.M. 3	A.M. 11	P.M. 10	A.M. 3	P.M. 4		A.M. 3	P.M. 4		
ARRIVAL TYPE	4			4			3			3			
LANE UTILIZATION ADJ. FACTOR	1.000	1.000	1.000	1.000	0.952	1.000	1.000	1.000		1.000	1.000		
GREEN TIME (SECONDS)	A.M. 74	63	63	74	63	77	14	21		14	27		
	P.M. 74	62	62	74	62	77	13	21		15	29		
GREEN RATIO (G/C)	A.M. 0.58	0.52	0.52	0.58	0.52	0.52	0.12	0.18		0.12	0.18		
	P.M. 0.58	0.52	0.52	0.58	0.52	0.52	0.11	0.18		0.12	0.19		
CAPACITY (c)	A.M. 291	936	932	222	1764	756	195	242		195	252		
	P.M. 230	912	909	186	1736	744	183	244		208	276		
v/c RATIO (x)	A.M. 0.069	0.809	0.810	0.558	0.667	0.008	0.097	0.227		0.233	0.229		
	P.M. 0.311	0.942	0.943	0.509	0.835	0.024	0.242	0.470		0.116	0.069		
STORAGE QUEUE (FEET OR VEHICLES)	A.M. 13'	582'	582'	41'	456'	6'	13'	41'		32'	83'		
	P.M. 48'	665'	665'	32'	562'	14'	31'	80'		17'	32'		
LANE GROUP DELAY (SECONDS/VEHICLE)	A.M. 13.2	18.9	18.9	22.2	12.9	8.6	47.4	42.7		48.3	42.7		
	P.M. 19.1	34.2	34.6	26.7	18.4	9.1	49.2	45.1		46.7	39.8		
LANE GROUP LEVEL-OF-SERVICE	A.M. B	B	B	C	B	A	D	D		D	D		
	P.M. B	C	C	C	B	A	D	D		D	D		
APPROACH DELAY (SECONDS/VEHICLE)	A.M.	18.8			13.8			43.9			45.2		
	P.M.	33.8			18.8			46.2			43.7		
APPROACH LEVEL-OF-SERVICE	A.M.	B			B			D			D		
	P.M.	C			B			D			D		

PHASE	1	2	3	4	CYCLE LENGTH							
GREEN TIME IN SECONDS	A.M. 7	4	0	63	4	14	4	2	14	4	2	120 SEC.
	P.M. 8	4	0	62	4	13	4	2	15	4	2	120 SEC.

ELEMENTS CONTROLLING DESIGN

PREFERRED ROUTE:
 F.A. ROUTE NUMBER: FAP 312, MARKED ROUTE NUMBER: IL 217
 STREET NAME: MAIN ST. SRA ROUTE: NO
 FUNCTIONAL CLASSIFICATION: OTHER PRINCIPAL ARTERIAL, OSOW DESIGN NO
 EXISTING ADT: 25,600 VPD, DESIGN YEAR ADT: 32,300 VPD,
 PROPOSED DESIGN SPEED: 45 MPH, PROPOSED POSTED SPEED: 40 MPH.

SECONDARY ROUTES:
 ROUTE NUMBER: FAS 618, MARKED ROUTE NUMBER: N/A.
 STREET NAME: ILLINOIS ST. SRA ROUTE: NO
 FUNCTIONAL CLASSIFICATION: URBAN STREET, OSOW DESIGN NO
 EXISTING ADT: 900 VPD, DESIGN YEAR ADT: 1,100 VPD,
 PROPOSED DESIGN SPEED: 30 MPH, PROPOSED POSTED SPEED: 25 MPH.

GENERAL NOTES:
 IMPROVEMENT TYPE: HSIP & 3P RESURFACING, ANTICIPATED YEAR OF CONSTRUCTION: FY 2014.
 EXISTING METHOD OF TRAFFIC CONTROL: TRAFFIC SIGNALS, PROPOSED METHOD: TRAFFIC SIGNALS.
 SIGNAL WARRANT: EXISTING SIGNALS.
 DESIGN VEHICLE: WB-50 DESIGN VEHICLE WAS UTILIZED AT THIS INTERSECTION.
 DESIGN YEAR: 2034 WHICH IS A 20 YEAR DESIGN.
 TRUCK ROUTE DESIGNATION: PREFERRED ROADWAY: IL 217/MAIN ST.
 SECONDARY ROADWAY: ILLINOIS ST.
 DESIGN CRITERIA: URBAN 3R.

EXIST. CURVE C100
 PI STA. = 13+05.71
 $\Delta = 24^\circ 36' 16''$ (LT)
 $D = 27^\circ 04' 05''$
 $R = 211.67'$
 $T = 46.16'$
 $E = 90.90'$
 $L = 4.97'$
 $\theta = N.C.$
 $T.R. = N/A$
 $S.E. RUN = N/A$
 $P.C. STA. = 12+59.55$
 $P.T. STA. = 13+50.45$

PUT DATE
 FILE NAME
 USER NAME

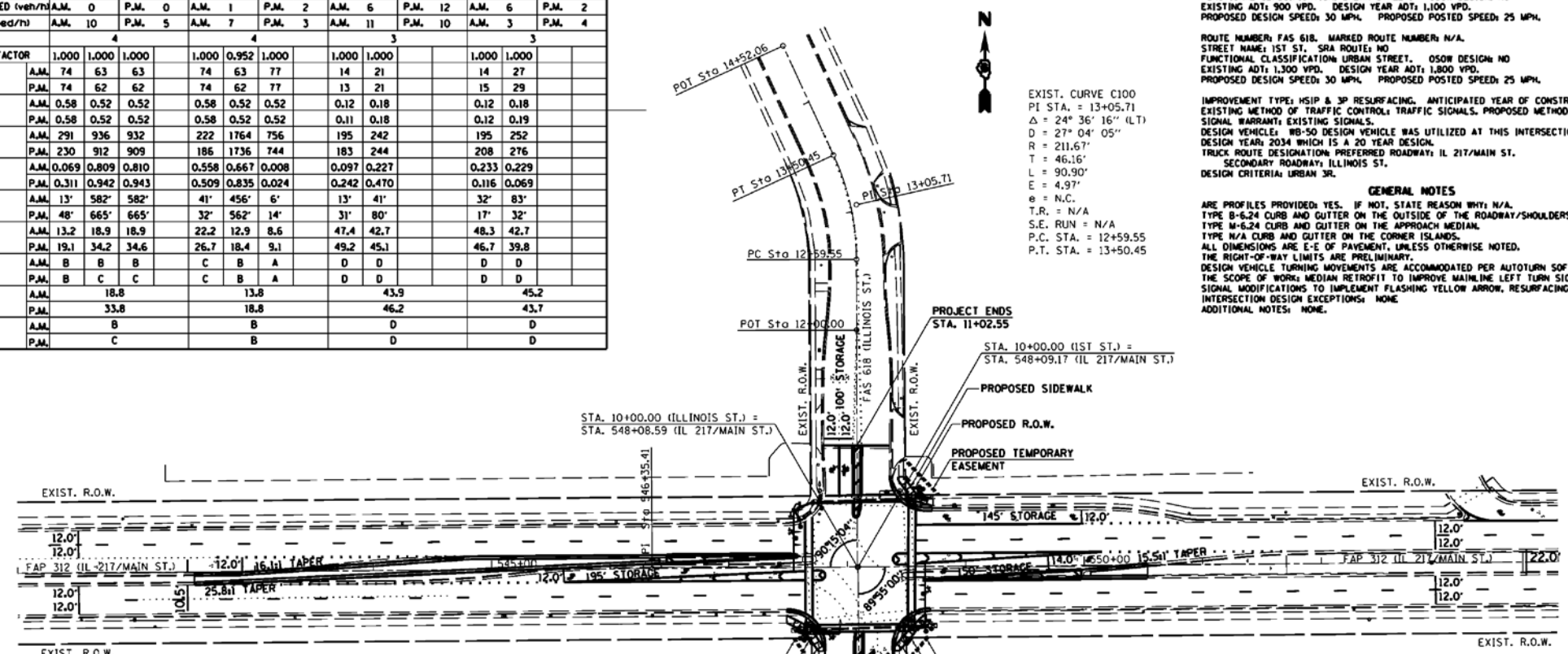

MOVEMENT	YEAR 2014 30TH MAXIMUM HOUR TRAFFIC		PERCENT TRUCK TRAFFIC IN 30TH MAX. HOUR		ESTIMATED PERCENT INCREASE BY	YEAR 2034 30TH MAXIMUM HOUR TRAFFIC		ESTIMATED PERCENT INCREASE BY	YEAR 2034 30TH MAXIMUM HOUR TRAFFIC	
	A.M.	P.M.	A.M.	P.M.		A.M.	P.M.		A.M.	P.M.
AD (L)	18	11	0	0					22	13
AB (T)	17	9	0	0					21	10
AC (R)	49	20	0	0					61	24
BC (L)	7	10	0	0					8	11
BA (T)	8	26	0	0					10	31
BD (R)	40	79	3	2					58	115
CA (L)	16	56	0	0					19	68
CD (T)	1,137	1,293	1	2					1,422	1,617
CB (R)	13	11	3	2					15	13
DB (L)	81	62	0	0					118	90
DC (T)	894	1,101	2	2					1,118	1,377
DA (R)	6	15	0	0					7	18
TOTAL A	114	137							140	164
TOTAL B	166	197							230	270
TOTAL C	2,166	2,491							2,643	3,110
TOTAL D	2,176	2,561							2,745	3,230

T = THROUGH, L = LEFT, R = RIGHT

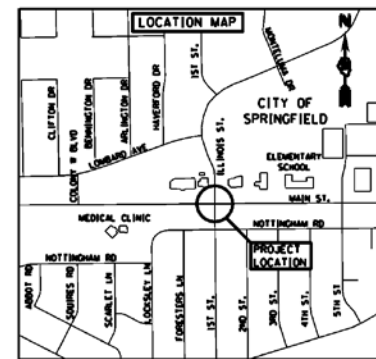
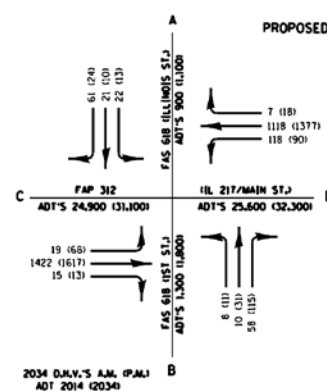

INTERSECTION DESIGN STUDY
 FAP ROUTE 312 WITH IL 127/MAIN ST.
 NORTH LEG: FAS 618 (ILLINOIS ST.)
 SOUTH LEG: FAS 618 (1ST ST.)
 SEC. NO. (27RS-2,15-1) PROJ. NO. D670123
 SCALE 1"=50' COUNTY SANGAMON
 S.N. D-96-997-12 REV. NO. _____
 DESIGNED BY _____ DATE _____
 SATISFACTORY _____ DISTRICT GEOMETRICS ENGINEER DATE _____
 SATISFACTORY _____ DISTRICT PROGRAM DEVELOPMENT ENGINEER DATE _____
 SATISFACTORY _____ DISTRICT OPERATIONS ENGINEER DATE _____
 APPROVED _____ DEPUTY DIRECTOR OF HIGHWAYS, REGION ENGINEER DATE _____
 CAD FILE NAME: I 1 I.D.S. SHEET 1 OF 5

SIGNALIZED INTERSECTION DESIGN STUDY

Figure 14-2.A

SIGNALIZED INTERSECTION DESIGN STUDY

Figure 14-2.B
(Continued)

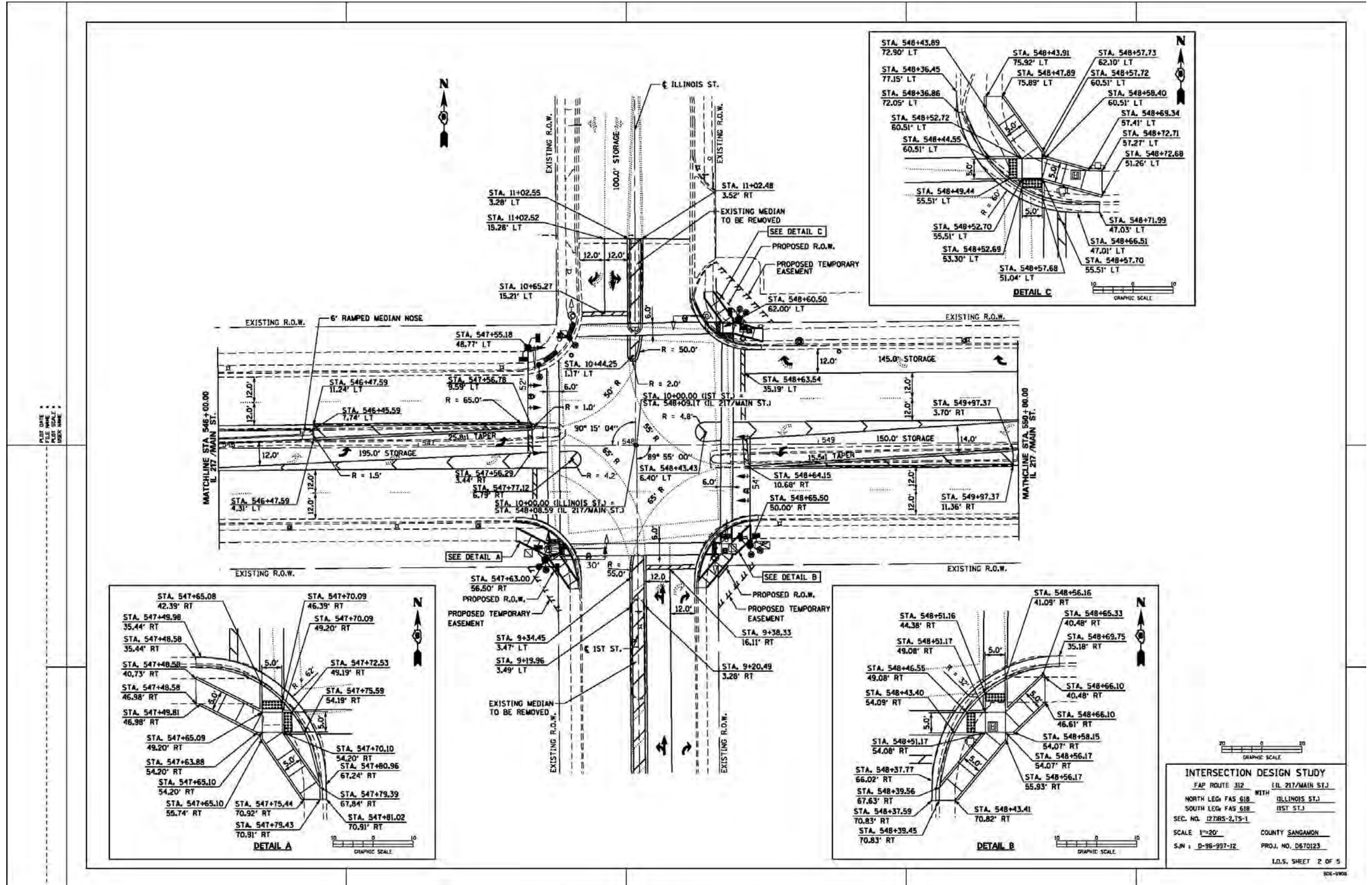

SIGNALIZED INTERSECTION DESIGN STUDY

Figure 14-2.D (Continued)

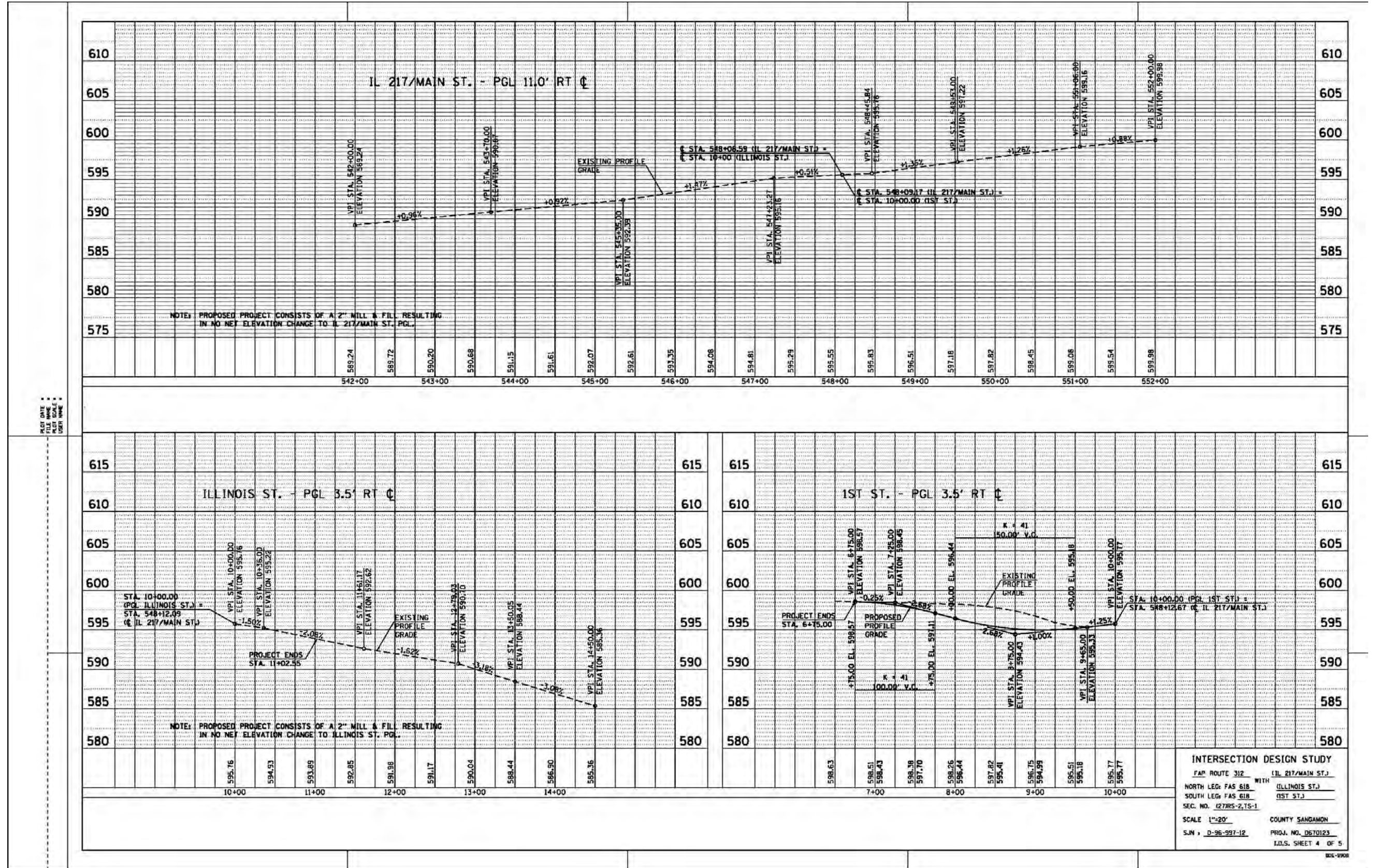

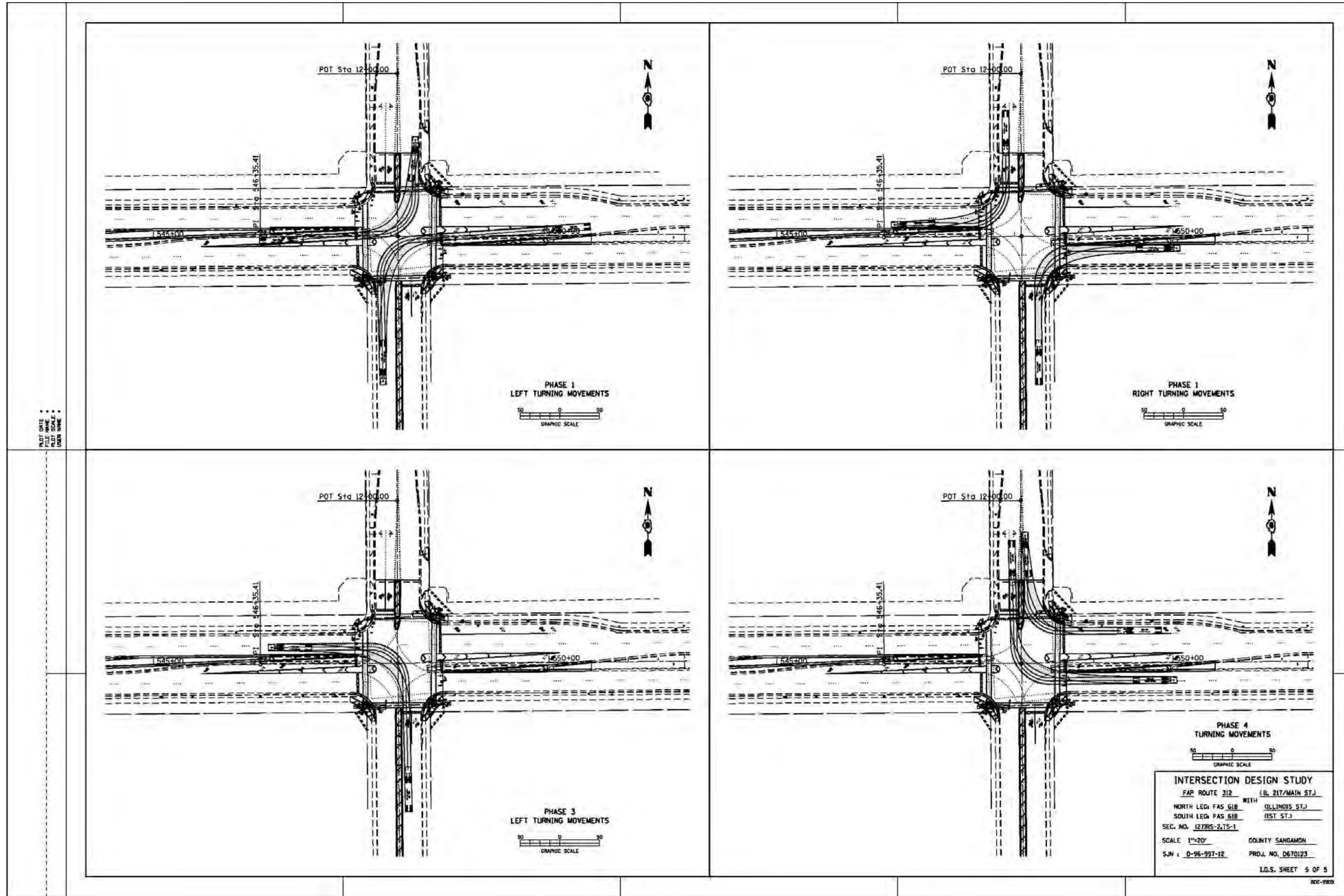

SIGNALIZED INTERSECTION DESIGN STUDY

Figure 14-2.E
(Continued)

14-3 DATA REQUIRED FOR INTERSECTION DESIGN STUDIES

Document the following data in the IDS:

1. Elements Controlling Design. Chapter 36 presents the design criteria for intersections. On the cover sheet, list all pertinent elements affecting the design of the intersection including:
 - the route designation including highway functional classification for both intersecting routes, where applicable,
 - SRA Route designation, if appropriate,
 - existing and design traffic (ADT) for both intersecting routes;
 - the preferential route;
 - design year and the number of years for which the project is designed,
 - the anticipated year of construction;
 - the type of existing and proposed traffic control including:
 - + a statement indicating whether signals will be installed or adjusted;
 - + the signal warrant (only one is necessary) from the *ILMUTCD* justifying the use of signal control, or whether new signal installations are a special request; and
 - + use of a roundabout;
 - design criteria;
 - Improvement Type. List the type of improvement (e.g., new construction, reconstruction, 3R, safety).
 - design vehicle;
 - truck route designation and whether the routes are to be designed for oversize/overweight vehicles (OSOW), and
 - existing and proposed posted and design speeds on all intersection approaches.
2. General Notes. Include the following information in the general notes on the cover sheet:
 - a. Grades. Where all existing grades to remain are greater than 1% or in all cases with any new or altered grades, include a statement that profiles are shown for both intersecting roads and show them on a subsequent sheet. If existing grades

- are to remain and are all less than 1%, including profiles is optional. Indicate this fact if profiles are not included for these reasons.
- b. Curb and Gutter. Indicate the type of curb and gutter to be used on the outer edges of the traveled way, shoulders, channelizing islands, and corner islands.
 - c. Dimensions. Indicate the type of dimensioning used (e.g., edge-to-edge of pavement, edge-to-edge of traveled way).
 - d. Design Exceptions. List design exceptions that affect the intersection from design criteria and typical traffic control practice (e.g., large truck turning encroachments, lane widths less than Department criteria, less than desirable level of service, less than desirable storage length for queued vehicles). Include the justification for the design exceptions in the Phase I report.
 - e. Verification. Note the software or method used to verify sufficiency of the intersection to accommodate turning movements of the design vehicle.
 - f. Right-of-Way. Indicate if proposed right-of-way limits for the intersection are preliminary.
 - g. Other. A cell is available for additional information not listed elsewhere that will add information relevant to the operation of the intersection, address unique policies or regulations, and/or aid in the review of the IDS.
3. Capacity Analysis. Perform and document the capacity analysis of the IDS according to the following guidelines:
- a. Source Document. Use the *Highway Capacity Manual* and the *Highway Capacity Software* (distributed by the McTrans Center for Microcomputers in Transportation) for the capacity analyses. The use of any other capacity techniques and software must be first approved by BDE; see Section 36-1.07.
 - b. Signal Phasing. For signalized intersection, illustrate the proposed signal phasing for the level of service determined from the capacity analysis in diagrammatic form. Orient the signal phasing diagram to be consistent with the plan view of the intersection and any other pertinent diagrams.
 - c. Results. Document the data and results of the capacity analysis for each leg of the intersection. Use Figure 14-3.A for a signalized intersection, Figure 14-3.B for a roundabout intersection, Figure 14-3.C for an all-way stop-controlled intersection, and Figure 14-3.D for a two-way stop-controlled intersection.
4. Traffic Data. Provide the following traffic data on using the format illustrated in Figure 14-3.E:
- a. Traffic Movements. Provide a tabular listing of all movements to and from each leg of the intersection during the a.m. and p.m. 30th maximum hour for the

- existing and design years. . Also, prepare a traffic diagram for the design year showing all 30th maximum hour movements within the intersection. Orient the traffic diagram to be consistent with the plan view of the intersection and any other pertinent diagrams.
- b. Percent Truck Traffic in 30th Maximum Hour. Provide the percentage of vehicles with more than 4 wheels touching the pavement..
 - c. Estimated Percent Increase. Include the percent of traffic increase between the existing year's traffic and the design year's traffic.
5. Intersection Layout and Design. Provide the following intersection layout and design information on the cover sheet and, if necessary on subsequent sheets:
- a. Centerline. Show the centerline information for all proposed and existing curves within the immediate area of the intersection. Include superelevation rates and transition stations. Label the station equation for all intersecting side roads.
 - b. Angle. Note the angle of intersection between the two intersecting roadways and between the roadways and side roads.
 - c. Location Map. Provide a small scale location map, covering a sufficient area to properly identify the location of the improvement. It should portray the existing street or local road network and any municipalities adjacent to the improvement. Layout the map with North in the same direction as shown on the intersection layout.
 - d. Auxiliary Lane Lengths. Indicate lengths for all auxiliary lanes.
 - e. Widths and Dimensions. Include lane, median, driveway, and sidewalk widths. Include the radii for all curb returns and offsets for two and three center curb returns.
 - f. Tapers. Indicate all taper lengths and rates.
 - g. Scales. Provide a bar scale on each sheet.
 - h. Topographic Features. Indicate all limiting topographic features or cultural developments including:
 - existing and proposed access driveways;
 - existing and proposed right-of-way lines and any access control limits;
 - property lines;
 - property identification numbers, business names, land uses, and buildings;
 - sidewalks, curb ramps, and other accessibility requirements, see Chapter 58; and

- other factors controlling the intersection design (e.g., retaining walls, utilities, gasoline pumps, other appurtenances).
- i. Signals. Show the proposed signal and controller locations and signal phasing diagram. Prepare these according to the criteria and guidelines presented in Chapter 57. This information will ensure compatibility with other design elements, right-of-way, and traffic flow (progression).
 - j. Signs. For complex intersections, show the proper placement of signs and traffic control devices. Because signing distance and legend requirements could influence the design of complex facilities, include a preliminary signing plan with the IDS for all complex intersection designs.
 - k. Striping. Include the proposed striping details on the IDS as well as on Phase I plan sheets.
 - l. Control Points. Provide the station and offset of all control points, including all island noses, radius return points of curvature and tangency, and centerline or baseline control points.
6. Title Block. Only the individual personally responsible for the intersection design will occupy the “Designed By” line in the title block.

SIGNALIZED CAPACITY DESIGN ANALYSIS											
Program used: _____ version: _____ Signal type: _____ Area type: _____ Number of phases: (a.m.) _____ (p.m.) _____ cycle length: (a.m.) _____ (p.m.) _____ Peak hour factor: _____ Intersection delay/level-of-service a.m. _____ sec. LOS _____ p.m. _____ sec. LOS _____											
APPROACH											
Lane group											
Number of lanes											
20 th 30 th max. hour traffic (veh/h) a.m. _____ p.m. _____											
Base saturation flow rate (veh/h)											
Lane width (ft)											
Volume of right turn on red (veh/h) am pm am pm am pm am pm											
Pedestrians/hour (ped/h) Count or estimate am pm am pm am pm am pm											
Arrival type											
Lane utilization adj. factor											
Green time (seconds) a.m. _____ p.m. _____											
Green ratio (g/C) a.m. _____ p.m. _____											
Capacity (c) a.m. _____ p.m. _____											
v/c ratio (X) a.m. _____ p.m. _____											
Storage queue (feet or vehicles) a.m. _____ p.m. _____											
Lane group delay (seconds) a.m. _____ p.m. _____											
Lane group level-of-service a.m. _____ p.m. _____											
Approach delay (seconds/vehicle) a.m. _____ p.m. _____											
Approach Level-of-service a.m. _____ p.m. _____											

SIGNALIZED CAPACITY DESIGN ANALYSIS

Figure 14-3.A

Roundabout Capacity Design Analysis									
Program used:		Version:		Area:		Peak hour factor:			
Intersection control delay:		a.m. _____ seconds		p.m. _____ seconds					
Intersection level of service:		a.m. _____		p.m. _____					
Approach									
Lane group									
20 - 30 th max. hour traffic		a.m. _____		p.m. _____					
Entry flow rate $v_i, pc/h$		a.m. _____		p.m. _____					
Ped/hour crossing the approach		a.m. _____		p.m. _____					
Lane movements									
Entry flow rate v_i (vph)		a.m. _____		p.m. _____					
Lane capacity c_i (vph)		a.m. _____		p.m. _____					
x_i (v_i/c_i ratio)		a.m. _____		p.m. _____					
Storage queue length (feet or vehicles)		a.m. _____		p.m. _____					
Lane delay, d (sec)		a.m. _____		p.m. _____					
Lane level of service		a.m. _____		p.m. _____					
Approach control delay, d (sec)		a.m. _____		p.m. _____					
Approach level of service		a.m. _____		p.m. _____					

ROUNDABOUT CAPACITY DESIGN ANALYSIS

Figure 14-3.B

ALL-WAY STOP-CONTROLLED CAPACITY DESIGN ANALYSIS											
Program used: _____, version: _____											
Peak hour factor: _____											
Intersection control delay: a.m. _____ p.m. _____ (sec.) Intersection level-of-service: a.m. _____ p.m. _____											
APPROACH											
Major or minor leg?											
Lane group											
Number of lanes											
20____30 th											
max. hour traffic (V _i) (veh/h)											
v/c ratio (v _i /c _{p,x})											
a.m.											
p.m.											
Storage queue (feet or vehicles)											
a.m.											
p.m.											
Lane control delay (seconds)											
a.m.											
p.m.											
Lane level-of-service											
a.m.											
p.m.											
App. control delay (seconds)											
a.m.											
p.m.											
Approach level-of-service											
a.m.											
p.m.											

ALL-WAY STOP-CONTROLLED CAPACITY DESIGN ANALYSIS

Figure 14-3.C

TWO-WAY STOP-CONTROLLED CAPACITY DESIGN ANALYSIS	
Program used: _____, version: _____ Peak hour factor: _____ Signalized intersection(s) within 0.25 miles of intersection along major route? (yes/no) _____ Flared approach for minor street right-turning vehicle (yes/no): _____ on the _____ approach, _____ on the _____ approach. Single or two-stage gap acceptance? _____	
APPROACH	
Major or minor leg?	
Lane group	
Number of lanes	
20 _____ 30 th _____	
max. hour traffic (V _i) (veh/h)	a.m. _____ p.m. _____
Pedestrians/hour (ped/h) count or estimate?	a.m. _____ p.m. _____
Capacity (c _{p,x} or c _r) (veh/h)	a.m. _____ p.m. _____
v/c ratio (v _i /c _{p,x})	a.m. _____ p.m. _____
Storage queue (no. of vehicles)	a.m. _____ p.m. _____
Control delay (seconds)	a.m. _____ p.m. _____
Lane group level-of-service	a.m. _____ p.m. _____
Approach delay (seconds)	a.m. _____ p.m. _____
Approach level-of-service	a.m. _____ p.m. _____

TWO-WAY STOP-CONTROLLED CAPACITY DESIGN ANALYSIS

Figure 14-3.D

TRAFFIC DATA									
Movement	Year 20__ 30th Maximum Hour Traffic		% Truck Traffic in 30 th Max. Hr.	Est. % Increase by 20__	Year 20__ 30th Maximum Hour Traffic		Est. % Increase by 20__	Year 20__ 30th Maximum Hour Traffic	
	A.M.	P.M.			A.M.	P.M.		A.M.	P.M.
AD (L)									
AB (T)									
AC (R)									
BC (L)									
BA (T)									
BD (R)									
CA (L)									
CD (T)									
CB (R)									
DB (L)									
DC (T)									
DA (R)									
TOTAL A									
TOTAL B									
TOTAL C									
TOTAL D									

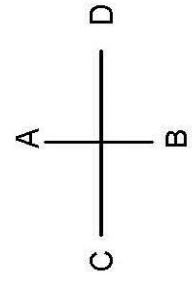

T = Through, L = Left, R = Right

TRAFFIC DATA SUMMARY

Figure 14-3.E

14-4 INTERSECTION DESIGN STUDY PROCESSING

Intersection design studies (IDS) are normally prepared under the direction of and approved by the District Geometrics Engineer. Upon completion of the IDS, it is approved by the district as illustrated in the signature block in Figure 14-2.A and included in the Phase I report. BDE will review and approve IDS's if requested by the district or if the district does not have a qualified Geometrics Engineer. The procedure to qualify a District Geometrics Engineer is discussed in Section 11-9.

When projects require an IDS, the district should not conduct public involvement activities without a completed IDS which reflects the most recent design alternatives. When an IDS is prepared by a qualified Geometrics Engineer, reviewed according to current geometric design policies, and approved by the District Geometrics Engineer, it may be included as part of the Phase I report. Upon approval of the IDS, the district will submit a completed BDE 2602 template to BDE for status information of the IDS.

Final approval of an IDS is given with the design approval of the final Phase I report. This ensures the consideration of social, economic, and environmental factors and public comments that could affect the design elements of an intersection. In addition, a crash analysis and relevant collision diagrams may be reviewed concurrently with the IDS.

If intersection conditions are complex, the district, at its option, may forward the IDS to BDE for early review. In this case, the IDS is reviewed with particular emphasis on compliance with accepted design practices, methods of managing or controlling access, intersection capacity, signal phasing, operational safety, efficiency, and any needed design exceptions. BDE may recommend changes to the IDS. If changes are recommended, the comments are forwarded to the district for revision. After the revised IDS is reviewed and considered satisfactory, it is then approved by the District Geometrics Engineer or BDE for inclusion in the Phase I report.

Chapter Fifteen

INTERCHANGE TYPE AND DESIGN STUDIES

BUREAU OF DESIGN AND ENVIRONMENT MANUAL

Chapter Fifteen
INTERCHANGE TYPE AND DESIGN STUDIES

Table of Contents

<u>Section</u>	<u>Page</u>
15-1 INTERCHANGE TYPE STUDIES AND ADDITIONS.....	15-1.1
15-1.01 Purpose of Interchange Type Studies (ITS)	15-1.1
15-1.02 Guidelines for Preparing Interchange Type Studies.....	15-1.2
15-1.03 Processing Interchange Type Studies.....	15-1.3
15-2 INTERCHANGE DESIGN STUDIES.....	15-2.1
15-2.01 Guidelines for Preparing Interchange Design Studies.....	15-2.1
15-2.02 Processing Interchange Design Studies.....	15-2.2

Chapter Fifteen

INTERCHANGE TYPE AND DESIGN STUDIES

Chapter 37 presents criteria for determining the warrants, application, and selection of various interchange types.

15-1 INTERCHANGE TYPE STUDIES AND ADDITIONS

The functional classification of the crossroad has a significant impact on whether an interchange is warranted and the type of interchange selected. In addition, traffic operations (e.g., freeway ramp terminal spacing, mainline weaving, level of service, signing) may affect the interchange type and spacing, especially in urban areas. The following sections present guidelines on the preparation and processing of Interchange Type Studies.

15-1.01 Purpose of Interchange Type Studies (ITS)

Interchange Type Studies (ITS) are prepared to determine the preferred type, to aid in developing the design of the selected type, and to minimize the number of man-hours used before detailed design studies are initiated. When a corridor/design study is initiated for a new freeway or expressway, the Phase I project study group prepares a brief report that includes proposed interchange locations and describes the proposed interchange type at each location.

An existing freeway may require an additional interchange due to urban development or due to lack of proper access to an area, or an expressway may require the upgrading of an existing intersection to an interchange. In all cases, the proposal to provide an interchange must be justified and documented and may require an Interchange Type Study. Section 37-1 provides the guidelines for justification of need, and the results of the entire Study are documented in a report entitled *Request for Additional (Modified) Interstate (Freeway or Expressway) Access*.

As part of the access report, include the necessary information as discussed in Chapter 19 and in Part III, Environmental Procedures, that demonstrates the public benefits and need for an interchange (i.e., the “Purpose and Need”). See Chapter 35 for details on access control along the crossroad.

If the district determines that a conventional diamond or parclo Type C interchange is the most appropriate type of interchange at a particular location, an Interchange Type Study is not required. However, the district may prepare and submit an Interchange Type Study to BDE for review if assistance would be beneficial.

For complex interchanges, BDE involvement in type studies is recommended because of the larger number of alternatives requiring analysis and the typically higher costs. Complex interchange designs usually require more supporting information, such as:

- crossroad, ramp, and mainline profiles;
- access restrictions;
- weaving analyses;
- capacity analyses of entrance and exit terminals;
- lane balance;
- route continuity coordination;
- preliminary signing plans;
- topography;
- existing cultural developments; and
- cost estimates.

15-1.02 **Guidelines for Preparing Interchange Type Studies**

Use the following guidelines to prepare the Interchange Type Study:

1. **Base Exhibits.** Prepare a schematic drawing of the interchange layout on a print of an aerial mosaic or aerial mapping using a scale of 1 in = 400 ft (1:5000 metric) or 1 in = 600 ft (1:7500 metric). For complex interchanges, use a scale of 1 in = 200 ft (1:2500 metric) for rural areas and either a 1 in = 100 ft (1:1000 metric) or 1 in = 50 ft (1:500 metric) scale for urban areas. Figure 15-1.A illustrates a typical schematic drawing of an interchange layout. In addition, it is desirable to include a county map and a 0°7'30" quadrangle map as exhibits with the ITS. In urban areas, also include a city map showing the proposed interchange location(s).
2. **Alternatives.** When interchange type selection is controversial, prepare alternative schematics on separate aerial mosaics. Indicate which alternative is preferred and the rationale used in the selection.
3. **Content.** Schematic drawings may be prepared in the form of a single-line diagram. Show the layout of the mainline, crossroad, and ramps. Include the following information:
 - traffic flow diagram for projected DHV (e.g., typically based on 20 years);
 - functional classification, design speed, and design traffic volumes of both routes;
 - angle of intersection between mainline and crossroad;
 - angle of intersection between ramps and crossroad;
 - typical cross sections, including shoulder widths;
 - all existing and proposed radii of ramps and roadways;
 - lengths of left-turn lanes and taper rates;
 - limits of access control along the crossroad;
 - limits of ramps on the mainline and crossroad;

- any proposed structures;
 - any proposed local road relocation and frontage roads or service drives;
 - property lines and names of land owners; and
 - any relevant photographs of the area.
4. Special Conditions. List any special conditions (e.g., wetlands, historic site, archeological site) that support the development of an unusual interchange type, and include all necessary elements that control the design. Provide a statement regarding satisfactory alignments and profiles in conjunction with the design. If the development of preliminary profiles are necessary, include them with ITS.

15-1.03 Processing Interchange Type Studies

The district is responsible for preparing the Interchange Type Study (ITS). Districts with a qualified Geometrics Engineer can approve the ITS.

Access Justification Reports (AJRs) and access control changes on Interstates require coordination with headquarters. This is due to the complex nature of the designs and issues involved, and the need for statewide consistency. BDE will review and approve the documents for transmittal to FHWA for final Federal approval. If ITS is a part of access control modification and/or access justification report, the district should submit the report to BDE for review and approval.

Once the type study, interchange addition, or proposed change in access has been approved and, where necessary approved by FHWA, the district may initiate the preparation of the Interchange Design Study, as discussed in Section 15-2.

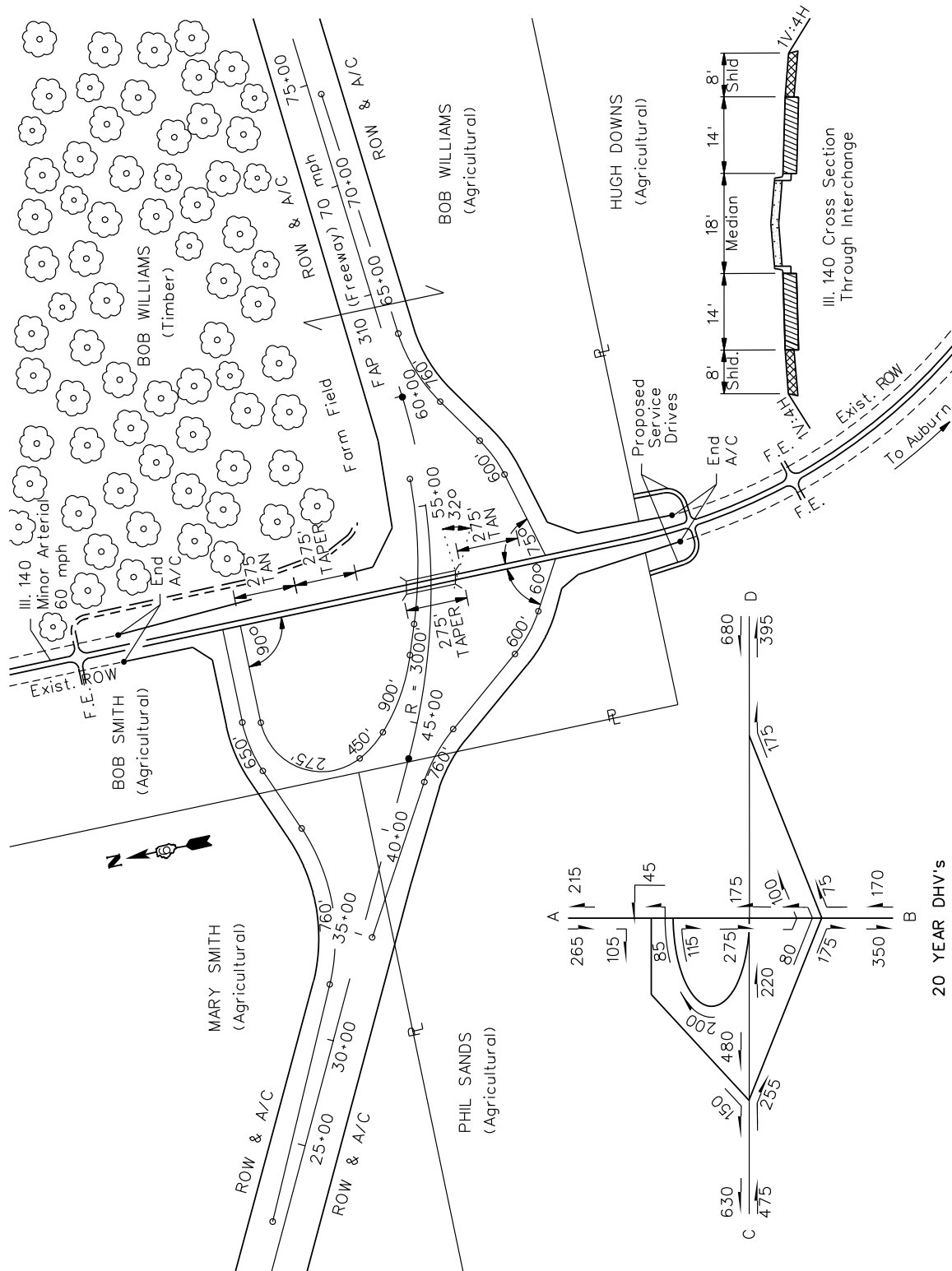

TYPICAL SCHEMATIC OF AN INTERCHANGE TYPE STUDY
(US Customary)

Figure 15-1.A

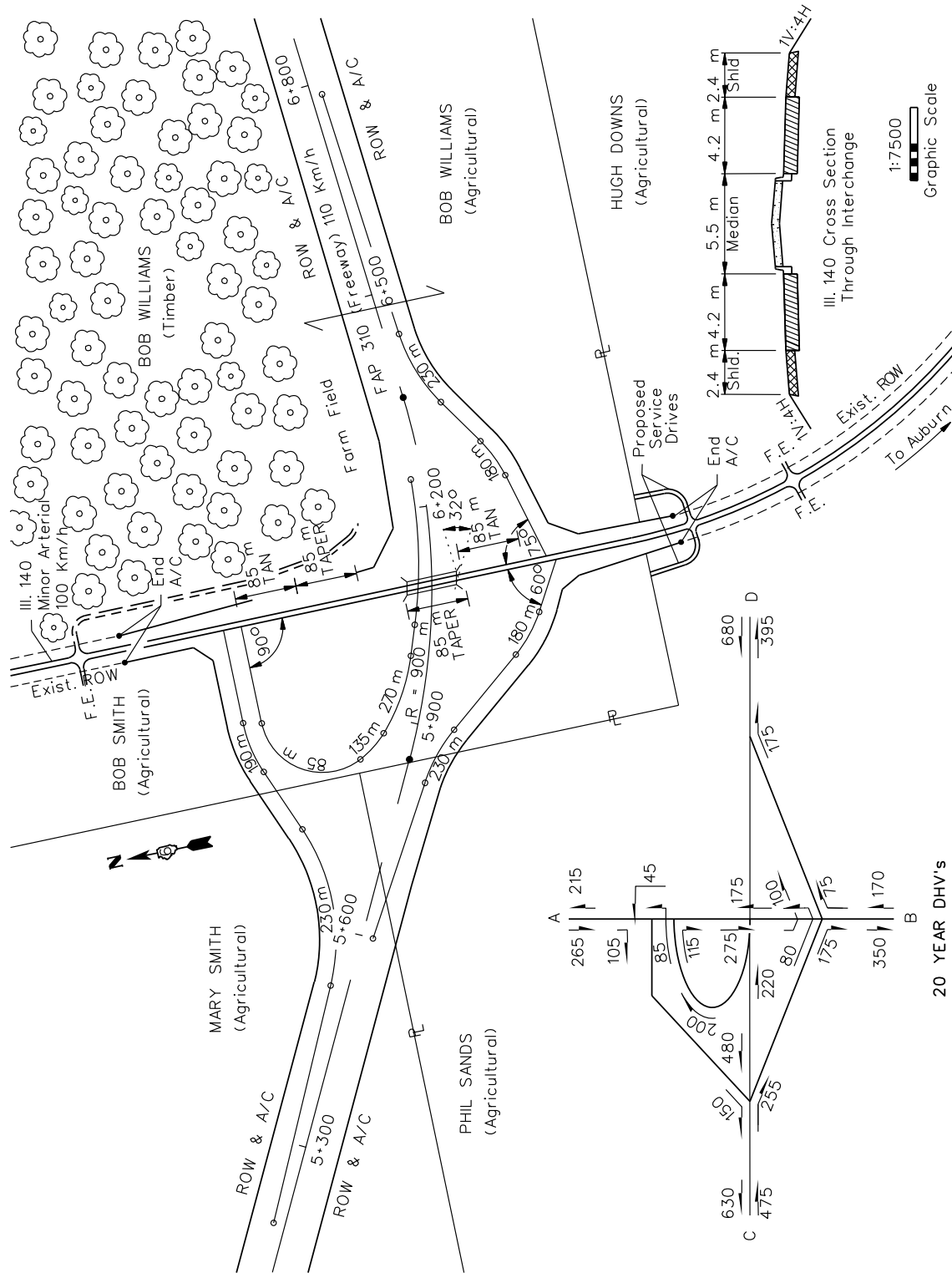

TYPICAL SCHEMATIC OF AN INTERCHANGE TYPE STUDY (Metric)

Figure 15-1.B

15-2 INTERCHANGE DESIGN STUDIES

Interchange Design Studies (IDS) are required for all interchange facilities. After the interchange type has been approved, preparation of IDS can be initiated. However, before design work is started, a field review should be made to each interchange location. The following sections discuss the guidelines and procedures for preparing IDS.

15-2.01 Guidelines for Preparing Interchange Design Studies

The IDS base sheets are standardized and available in the IDOT CADD cell library. These standardized sheet sizes along with formatting details are used in developing IDS. In general, prepare IDS in the same manner as an intersection design study; see Chapter 14 for format details. Figures 15-2.A, 15-2.B, 15-2.C, 15-2.D, and 15-2.E illustrate the typical format that should be used for uniformity on IDS plans. In addition, consider the following guidelines:

1. General.
 - a. Drafting. The entire IDS is prepared on CADD. A controlled-scale aerial mosaic or aerial mapping usually is the base for development of IDS. This base is the visual description of the existing topography. Photographic inserts may be added for additional clarification.
 - b. Scales. For interchange designs on new alignment, use topographic mapping at 1 in. = 200 ft (1:2500 metric) for the interchange layout. This scale allows the entire interchange to be shown on one sheet without match lines and also allows all property lines and roads to be shown around the interchange. If the interchange is being developed as a result of a planned upgrade of an existing route, usually an expressway design, use a scale ratio of either 1 in. = 100 ft (1:1000 metric) or 1 in. = 50 ft (1:500 metric). Also, for interchange designs in urban areas, the same scale ratios of either 1 in. = 100 ft (1:1000 metric) or 1 in. = 50 ft (1:500 metric) may be used. Larger scales aid in the decision-making process, especially where cultural land development or elevation restrictions are an issue.
2. First Sheet. Include the following information on the first sheet:
 - a. Topography/Cultural Features. Include all houses, businesses, major utilities, roads and streets, right-of-way, access control lines, and structures on the topographic mapping. If contour lines are desired, plot them as light lines so they do not detract from the line work of the proposed interchange.
 - b. General Notes. Include references to design exceptions, crash data, cultural development, terrain, improvement type, etc. See Section 14-3 for additional information.

- c. Elements Controlling Design. Chapter 37 presents the design criteria for interchanges. On Sheet No. 1, list all pertinent elements affecting the design of the interchange.
 - d. Interchange Layout. Include horizontal alignment details, stationing, and proposed structures.
 - e. Capacity Analysis Table. For ramp/crossroad intersections, include the capacity analysis table in the upper left-hand corner. This table summarizes the results of the capacity analysis. See Chapter 14 for an example of the format.
3. Second Sheet. Show the details for each ramp/crossroad intersection, any specially designed free-flow terminals, and how the crossroad turn lanes are designed. If more space is needed, use an additional sheet for details. See Figure 15-2.B. Select a scale that will allow the details to be clearly shown. Include the capacity table for free-flow ramp terminals; see Figure 15-2.F. If weaving areas are proposed, also include a weaving analysis table as illustrated in Figure 15-2.G. This table should include a summary of the ramp capacity analysis and the number of lanes required.
 4. Profiles. After the crossroad details, show the profiles for the mainline and crossroad through the interchange; see Figure 15-2.C. Next, include the profiles for each ramp; see Figure 15-2.D. Where necessary, include detailed profiles for each turning roadway at the ramp crossroad intersections.
 5. Cross Sections. After the profile sheets, show all the necessary controlling cross sections adjacent to the mainline, a cross section for the mainline, if applicable, and a typical section of the ramp proper; see Figure 15-2.E. Figures in Chapter 37 indicate the locations where controlling ramp cross sections should be taken.
 6. Interchange Models. For very complex interchanges, it may be desirable or necessary to prepare a model for evaluating alternative interchange design features. This can be accomplished using a computer software package (i.e., GEOPAK) or by preparing a simple, three-dimensional model. The model may be developed by mounting the plan layout onto thin cardboard and then pasting the mainline, crossroad, and ramp profiles onto the plan sheet of the roadway alignment.

15-2.02 Processing Interchange Design Studies

The Interchange Design Study (IDS) is prepared under the direction of and approved by the District Geometrics Engineer or BDE. Upon approval of IDS, the district will submit a completed BDE 2602 template to BDE for status information of IDS. The BDE will review and approve IDS if requested by the district or if the district does not have a qualified geometrics engineer. The procedure to qualify a District Geometrics Engineer is discussed in Section 11-9.

IDS on the Interstate system will require FHWA approval. IDS's used at public involvement activities should reflect the most recent design alternatives. Final approval of IDS is given with

design approval of the Phase I report. This final approval ensures that the social, economic, and environmental factors have been properly considered. Once the Phase I report has been approved, the IDS can then be used in the preparation of the detailed construction plans.

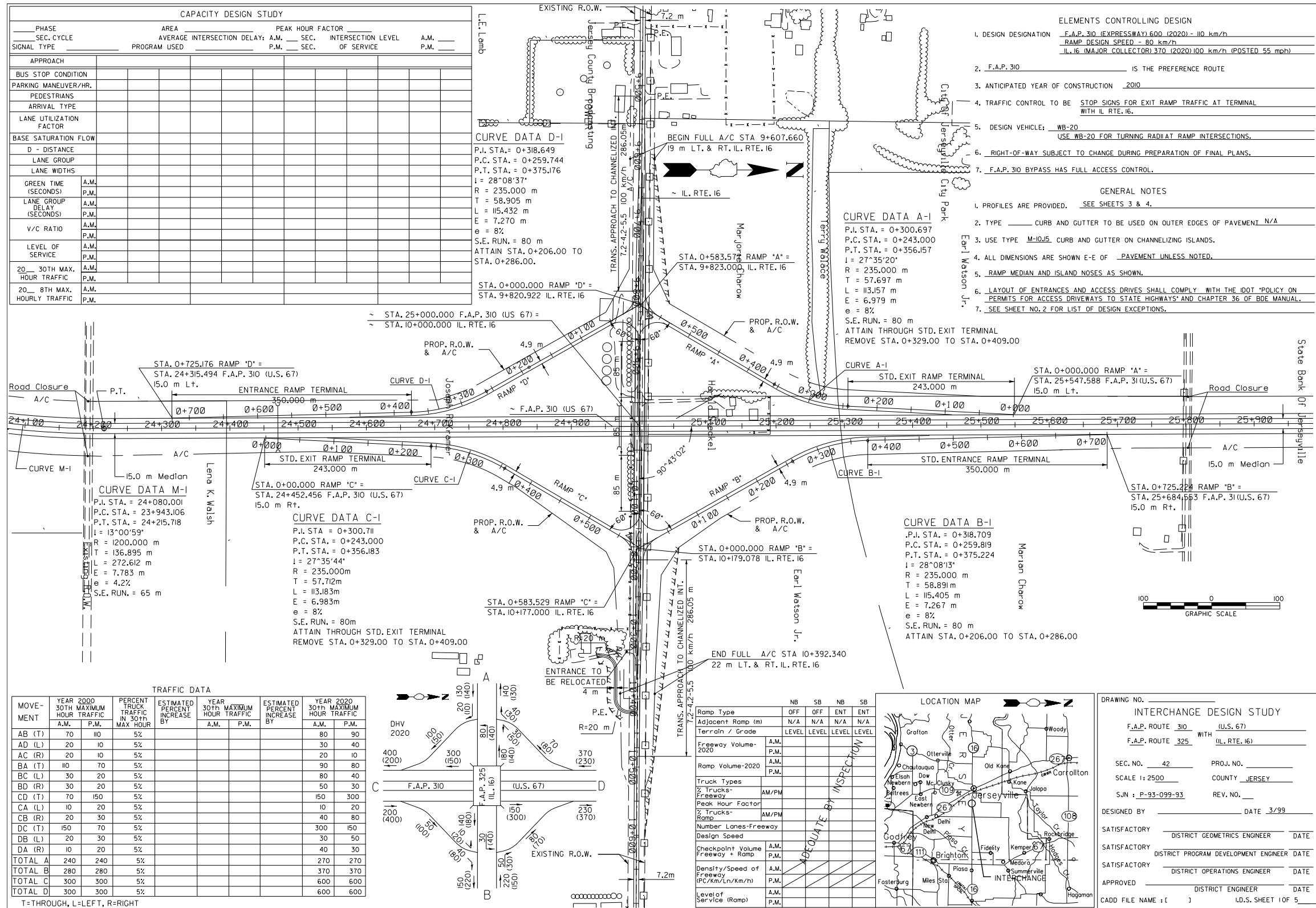

EXAMPLE IDS SHEET
(General Layout — First Sheet)
Figure 15-2.A

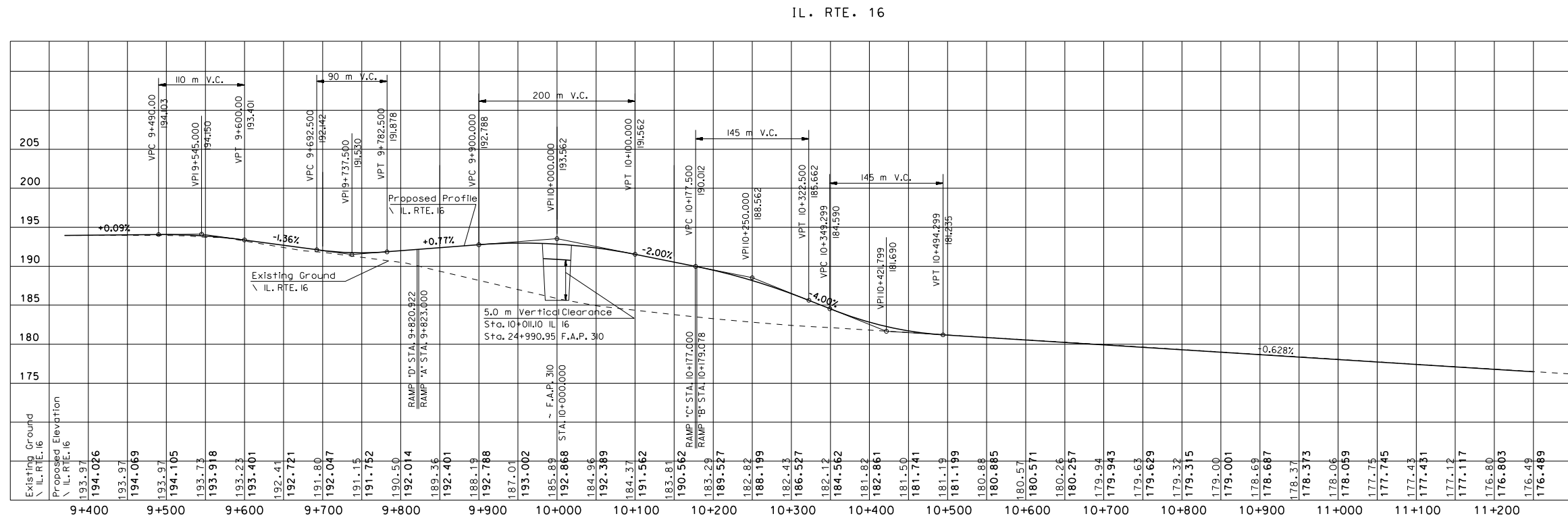

F.A.P. 310 MAINLINE PROFILE

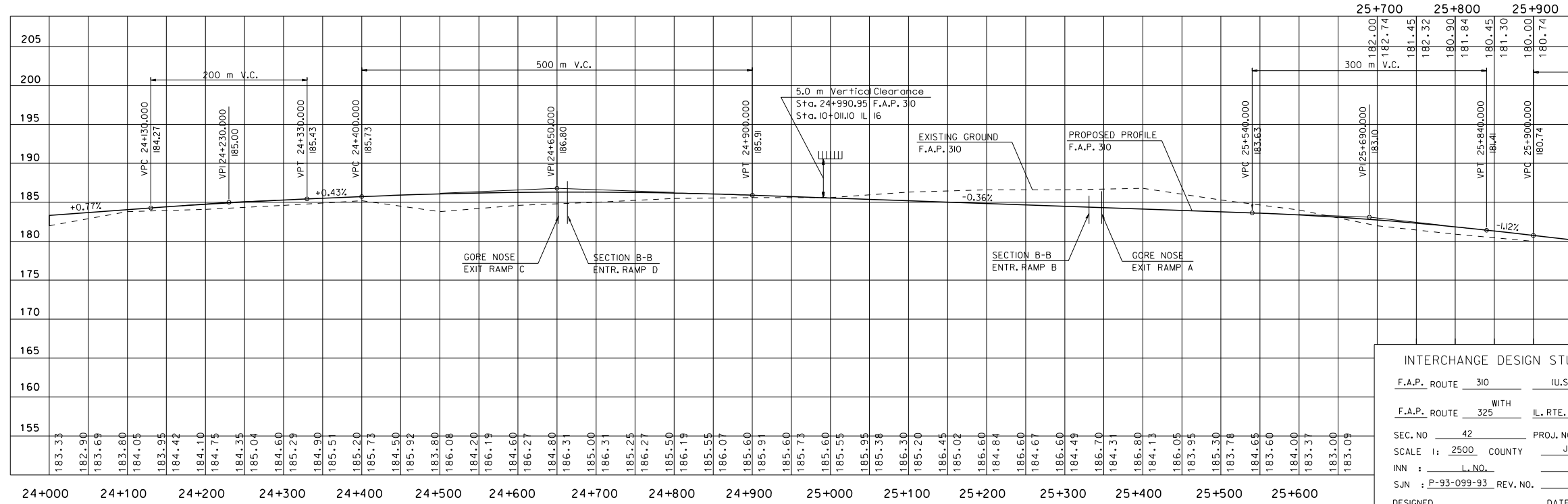

INTERCHANGE DESIGN STUDY

F.A.P. ROUTE 310 (U.S. 67)

WITH F.A.P. ROUTE 325 IL. RTE. 16

SEC. NO 42 PROJ. NO

SCALE 1: 2500 COUNTY JERSEY

INN : L. NO.

SJN : P-93-099-93 REV. NO.

DESIGNED DATE 3/99 SHEET 3 OF 5

EXAMPLE IDS SHEET (Mainline and Crossroad Profiles) Figure 15-2.C

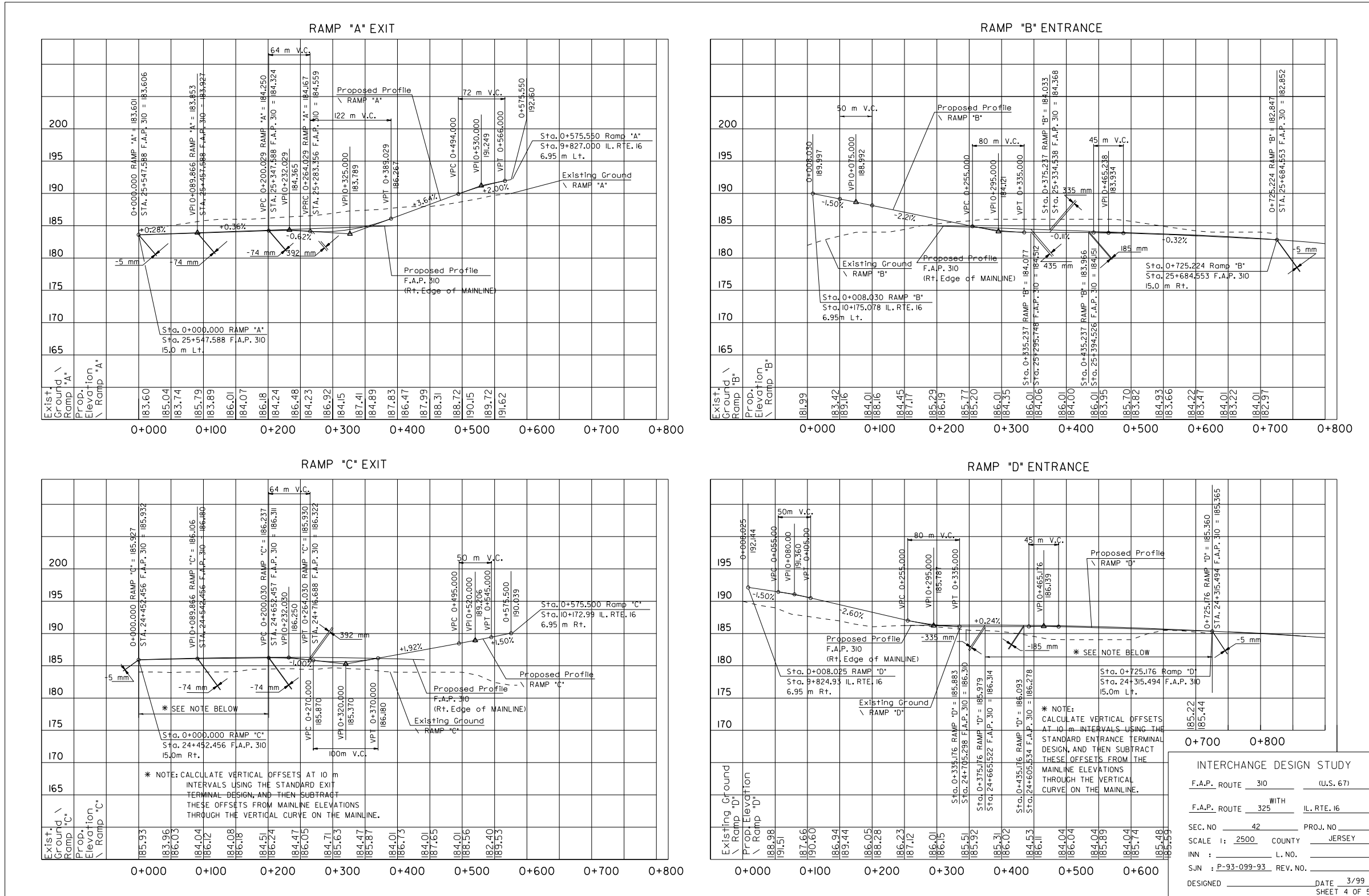

EXAMPLE IDS SHEET
 (Ramp Profiles)
 Figure 15-2.D

CROSS SECTION DETAILS AT RAMP TERMINALS

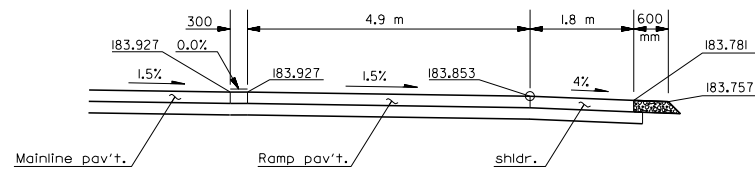

SECTION B-B
STA. 0+089.87

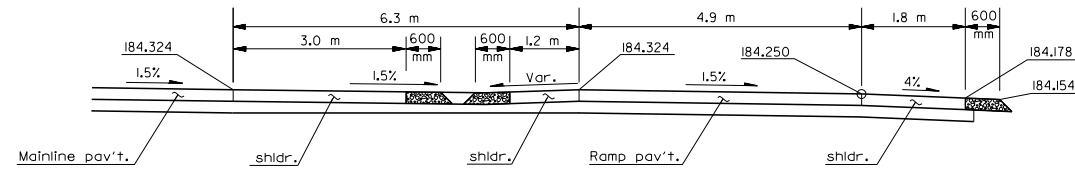

SECTION C-C (Ahead)
STA. 0+200.02

RAMP "A"
EXIT TERMINAL

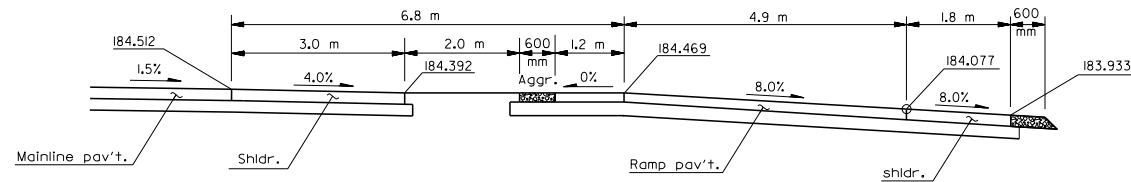

SECTION A-A
STA. 0+335.24

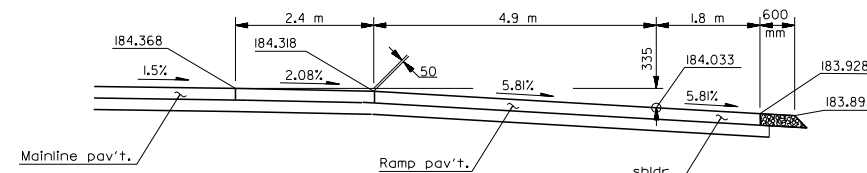

SECTION B-B
STA. 0+375.24

RAMP "B"
ENTRANCE TERMINAL

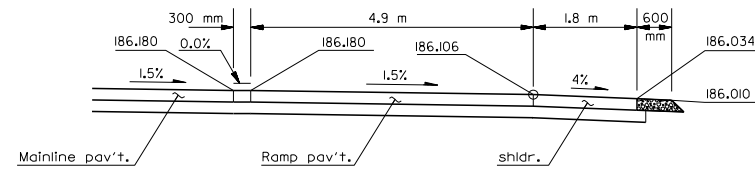

SECTION B-B
STA. 0+089.87

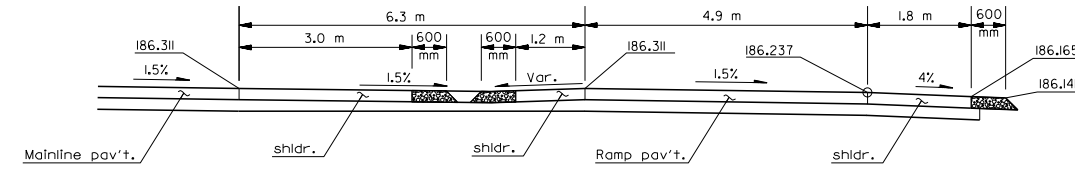

SECTION C-C (Ahead)
STA. 0+200.02

RAMP "C"
EXIT TERMINAL

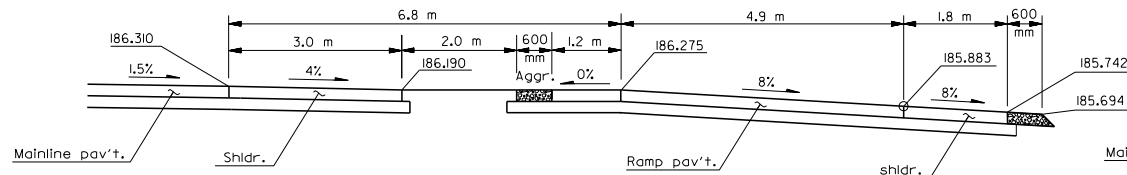

SECTION A-A
STA. 0+335.18

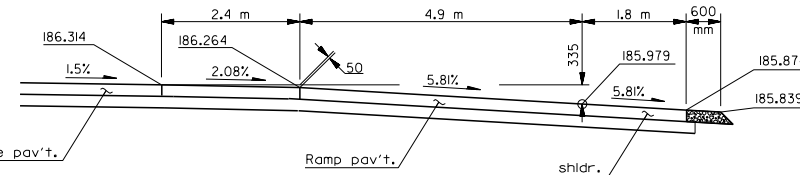

SECTION B-B
STA. 0+375.18

RAMP "D"
ENTRANCE TERMINAL

INTERCHANGE DESIGN STUDY			
F.A.P. ROUTE	310	(U.S. 67)	
	WITH		
F.A.P. ROUTE	325	IL. RTE. 16	
SEC. NO	42	PROJ. NO	
SCALE 1:	500	COUNTY	JERSEY
INN	L. NO.		
SJN	P-93-099-93	REV. NO.	
DESIGNED		DATE	3/99
		SHEET	5 OF 5

EXAMPLE IDS SHEET
(Cross Sections Sheet)
Figure 15-2.E

Ramp Type					
Peak-Hour Factor (PHF)					
% of Trucks on Freeway					
% Trucks on Ramp					
Number of Lanes on Freeway					
Number of Lanes on Ramp					
Design Speed of Freeway/Ramp					
Type/Distance to Adjacent Upstream Ramp (ft (m))					
Type/Distance to Adjacent Downstream Ramp (ft (m))					
Unadjusted Freeway Volume (vph) (V_F)	A.M.				
	P.M.				
Unadjusted Ramp Volume (vph) (V_R)	A.M.				
	P.M.				
Density (pc/mi/ln) (D)	A.M.				
	P.M.				
Level of Service (LOS)	A.M.				
	P.M.				

ENTRANCE AND EXIT RAMP TERMINAL CAPACITY TABLE

Figure 15-2.F

Weaving Section Location					
Peak Hour Factor (PHF)					
% Trucks					
v/c ratio					
One-sided or two-sided weave					
Maximum Weaving Length (ft (m)) (L_{MAX})					
Proposed Weaving Length (ft (m)) (L_S)					
Unadjusted Freeway Volume (vph) (V_{FF})	A.M.				
	P.M.				
Unadjusted Freeway to Ramp Volume (vph) (V_{FR})	A.M.				
	P.M.				
Unadjusted Ramp to Freeway Volume (vph) (V_{RF})	A.M.				
	P.M.				
Unadjusted Ramp to Ramp Volume (vph) (V_{RR})	A.M.				
	P.M.				
Average Weaving Speed (mph(km/h)) (S_W)	A.M.				
	P.M.				
Average Non-Weaving Speed (mph (km/h)) (S_{NW})	A.M.				
	P.M.				
Density (pc/mi/ln) (D)	A.M.				
	P.M.				
Level of Service (LOS)	A.M.				
	P.M.				

TABLE FOR WEAVING ANALYSIS

Figure 15-2.G

Chapter Sixteen

REST AREAS/WEIGH STATIONS

BUREAU OF DESIGN AND ENVIRONMENT MANUAL

Chapter Sixteen
REST AREAS/WEIGH STATIONS

Table of Contents

<u>Section</u>	<u>Page</u>
16-1 REST AREAS	16-1.1
16-1.01 General	16-1.1
16-1.02 Rest Area Committee	16-1.1
16-1.03 Departmental Responsibilities	16-1.2
16-1.04 Interstate Rest Area Design Components	16-1.2
16-1.04(a) Spacing	16-1.2
16-1.04(b) Site Selection	16-1.2
16-1.04(c) Vehicle Capture Rates/Parking and Usage Requirements	16-1.6
16-1.04(d) Other Design Elements	16-1.10
16-1.04(e) Entrance and Exit Ramp Terminals	16-1.10
16-1.04(f) Parking Area and Internal Roadway Requirements	16-1.10
16-1.04(g) Pavement/Shoulder Design	16-1.11
16-1.04(h) Comfort Station	16-1.16
16-1.04(i) Other Amenities	16-1.20
16-1.04(j) Accessibility Requirements	16-1.21
16-1.04(k) Utilities	16-1.21
16-1.04(l) Outdoor Electrical and Mechanical Equipment	16-1.22
16-1.04(m) Landscaping	16-1.22
16-2 REST STOPS	16-2.1
16-2.01 General	16-2.1
16-2.01(a) Site Selection	16-2.1
16-2.01(b) Design Guides	16-2.1
16-2.01(c) Access Control/Right-of-Way	16-2.2
16-3 WEIGH STATIONS	16-3.1
16-3.01 General	16-3.1
16-3.02 Weigh Station Committee	16-3.1
16-3.03 Interstate Weigh Stations	16-3.2
16-3.03(a) Site Selection Criteria	16-3.2
16-3.03(b) Planning	16-3.3
16-3.04 Interstate Design Criteria	16-3.4
16-3.04(a) General	16-3.4
16-3.04(b) Weigh-in-Motion	16-3.4

Table of Contents*(Continued)*

<u>Section</u>		<u>Page</u>
	16-3.04(c) Storage Requirements	16-3.5
	16-3.04(d) Entrance and Exit Terminals	16-3.11
	16-3.04(e) Detention Parking Requirements	16-3.11
	16-3.04(f) Scale House Parking Requirements	16-3.11
	16-3.04(g) Pavement Design	16-3.11
	16-3.04(h) Vehicle Inspection Pit	16-3.11
	16-3.04(i) Conversion of Static Scale Facility to Weigh-in-Motion	16-3.13
	16-3.04(j) Intelligent Transportation Systems (ITS)	16-3.13
16-3.05	Arterial Weigh Stations	16-3.13
	16-3.05(a) General	16-3.13
	16-3.05(b) Site Selection	16-3.14
	16-3.05(c) Design Guides	16-3.14
16-4	CONTRACT PLANNING AND COORDINATION	16-4.1
	16-4.01 General	16-4.1
	16-4.02 Scope	16-4.1
	16-4.02(a) Division of Work	16-4.1
	16-4.02(b) Coordination of Scope	16-4.2
16-5	REFERENCES	16-5.1

Chapter Sixteen

REST AREAS/WEIGH STATIONS

16-1 REST AREAS

16-1.01 General

Rest areas are an essential element of the complete highway system. They are provided for the safety and convenience of the traveling public. A rest area provides an oasis for weary travelers to relax and refresh from the rigors of highway travel. A comfort station is provided to accommodate the basic needs of the traveling public. Multi-use land is also provided for picnic tables and limited recreational activities. Rest stops for two-lane highways are discussed in Section 16-1.06.

Welcome centers are rest areas located at port-of-entry routes that also provide a full range of amenities. Welcome centers are staffed to provide assistance to travelers regarding directions, lodging arrangements, automotive services, food services, and many other activities. Welcome centers also promote local tourist attractions. Tourist information centers are rest areas that provide amenities similar to welcome centers but are located on interior routes and generally serve a specific tourist area.

16-1.02 Rest Area Committee

The Rest Area Committee (RAC) is comprised of members of the Office of Program Development and the Office of Highways Project Implementation and directs the rest area program to ensure that the Department's objectives are met. The Committee is co-chaired by the Directors of the Offices of Program Development and Highways Project Implementation. The responsibilities and Committee objectives are as follows:

1. Central Bureau of Operations. This Bureau is responsible for maintaining the rest areas, comfort stations, signing, and traffic operations.
2. Bureau of Design and Environment. The BDE will have one representative on the Committee.
3. District. One representative from the district will serve on the Committee, and the district is responsible for providing the environmental survey of the site and the geometric design of the rest area.

4. Committee. The Committee's responsibilities include:
 - reviewing and evaluating all applicable guidelines, policies, and procedures for the location and design of a rest area facility;
 - establishing priority projects and coordinating the construction program; and
 - recommending corrective rehabilitation treatments as appropriate.

16-1.03 Departmental Responsibilities

The recommended actions of the RAC are carried out by the districts, BDE, and Bureau of Operations. Their responsibilities are noted in Figure 16-1.A.

16-1.04 Interstate Rest Area Design Components

16-1.04(a) Spacing

Select and acquire the site for the rest area concurrently with the acquisition of the freeway right-of-way. Use a one-hour driving time to determine the average spacing between rest areas. However, many factors influence the final location of the site.

16-1.04(b) Site Selection

Rest areas should be developed as part of a comprehensive program that considers:

- the attractiveness of the location,
- the site's topography,
- the distance from other rest areas,
- the distance between interchanges, and
- the availability of water and utilities.

Consider the following additional information during the site selection process:

1. Needs Assessment. The RAC, in cooperation with the district, will make the determination that a rest area is to be constructed within certain limits of a freeway corridor.
2. Site Investigation and Prioritization. Representatives of the Committee and the district will investigate potential sites and prioritize the sites using the form illustrated in Figure 16-1.B. Site selection basically considers the scenic quality of the area, access to the area, and the site's adaptability to development including available utilities.
3. Residential and Industrial Areas. Desirably, do not locate rest areas near residential or industrial areas due to noise and fumes. New rest areas or improvements to an existing rest area may be considered a Type I project for noise and consequently require a noise

analysis. Traffic noise analyses shall be conducted in accordance with Section 26-6 “Noise Analyses” of this BDE Manual. The *IDOT Highway Traffic Noise Assessment Manual* has been prepared to provide guidance on how to implement the policy for IDOT projects or *projects being reviewed by IDOT*. The guidance manual provides information to be included in the environmental documentation.

4. Airports and Lighting Zones. Desirably, do not locate rest areas near airports, air fields or heliports, which have airspace restrictions prohibiting highmast light towers. Also avoid observatories and areas having lighting ordinances which discourage the type of site lighting necessary for rest areas.
5. Water and Sewer Needs. As practical, use a municipal service for the facility’s water and sewer system. Recommend using municipal services to reduce operating costs. If access to a municipal system is unavailable, provide well water and an on-site waste disposal system. Contact the Illinois State Geological Survey for assistance in evaluating the water conditions of a proposed site. Also, contact local well driller/contractors for local history of water depths.
6. Right-of-Way Needs. Approximately 25 acres (10 ha) of right-of-way are necessary to accommodate each site.
7. Locations Near Interchanges. Where a rest area is located near a freeway interchange, provide a minimum distance of 3000 ft (1000 m) between the ramp gores of the rest area and the interchange. Provide a greater distance where a rest area ramp is near a major convergence or divergence.
8. Juxtaposition of Rest Areas. Locate rest areas on a freeway so that the rest area approaching on the right precedes the rest area on the opposite side of the freeway and separate them by at least 0.25 miles (400 m). Where rest areas are located closer than the desired distance, consider providing a fence or other physical barrier in the median to restrict crossover pedestrian traffic. Locate rest areas near median crossovers to allow maintenance operations to easily access both locations.
9. Entrance and Exit Ramps. Design rest area entrance and exit ramp terminals according to the typical design criteria used for interchange ramps. See Section 16-1.04(e).

Once a site has been selected, presented to the RAC, and inspected by representatives of the FHWA for preliminary approval, prepare a Phase I report and submit it to the BDE for obtaining FHWA approval.

Bureau of Design and Environment	
<ul style="list-style-type: none"> • Establish Building/Grounds Policy • Propose Site Locations • Select Rest Area Names • Consultant Selection Rating • Coordinate with District on Building Design • Review and Comment on Construction Plans • Participate in District/Consultant Meetings • Develop Site Lighting Plan 	
District	
<ul style="list-style-type: none"> • Review Site Locations • Approve Rest Area Names • Develop Conceptual Layouts/Review • Prepare Environmental and Design Reports • Request Environmental Surveys • Early Coordination with Outside Agencies • Review Conceptual Layouts • Develop Rest Area Geometrics • Preliminary Design Approval • Hold Public Informational Meetings • Early Coordination with Outside Agencies • Apply for NPDES Permit • Prepare Roadway and Parking Lot Plans • Consultant Selection Rating • Coordinate Consultants on Building Design • Approve Final Design Plans 	<ul style="list-style-type: none"> • Coordinate with Capital Development Board for Building Plans • Coordinate with BDE for Lighting Plans • Coordinate with Department of Commerce and Economic Opportunity (DCEO) • Coordinate with the Department of Rehabilitation Services • Prepare Landscape Plans Including Appurtenances • Review and Approve Landscape Plans • Oversee Construction of Project • Coordinate with Bureau of Operations on Maintenance Contracts • Assure Maintenance Compliance to Department Standards • Administer Maintenance Contracts • Monitor Vending and Tourism Operations • Perform or Contract for Repairs
Bureau of Operations	
<ul style="list-style-type: none"> • Establish Building/Grounds Policy • Review Site Locations • Review and Comment on Geometric Designs • Review Roadway and Parking Lot Design • Develop Sign and Striping Policies • Coordinate with District on Signing and Striping Plan • Review and comment on Lighting Plans on site • Consultant Selection Rating • Coordinate with District on Building Design • Participate in District/Consultant Meetings & DCCA • Coordinate with Department of Rehabilitative Services on Vending Facilities • Review and Approve Construction Plans • Review and Approve Landscape Plans • Provide Policies and Procedures for Maintenance Operations & Standards • Coordinate with District on Maintenance Contracts • Provide for Testing of Water Plant Sewage Effluents when necessary • Provide for Repairs at Facilities • Conduct Annual Rest Area Evaluation Report 	

REST AREA COMMITTEE PARTICIPANT RESPONSIBILITIES

Figure 16-1.A

Criteria	Alternatives				
	#1	#2	#3	#4	#5
A. Aesthetics					
1. Fits Topography					
2. View From Interstate					
3. View From Rest Area					
4. Landscaping Potential/Screening					
5. Natural Site Features/Existing Tree Cover					
B. Geometrics					
1. Adequacy Truck/R.V. Parking					
2. Adequacy Car Parking					
3. Expansion Potential					
4. Accessibility					
C. Use Areas					
1. R.V. Picnic Area					
2. Picnic Areas					
3. Sidewalks					
4. Playground					
5. Pet Walks					
6. Security					
D. Land Use Compatibility					
1. Adjacent Farmsteads/Subdivisions					
E. Environmental Control					
1. Hazmat					
2. Water Quality/Wetland					
3. Endangered Species					
4. Archaeology					
5. Air					
6. Noise					
7. Right-of-Way					
F. Distance From Commercial Enterprise					
1. Truck Stops					
G. Utilities					
1. Sewage					
2. Water					
3. Gas					
4. Electric					
H. Cost					
Totals					

Rank 1 -5
 1 - Lowest
 5 - Highest
 N/A - Indicates Not Applicable

**EVALUATION CRITERIA FOR SITE SELECTION, LAYOUT,
 AND DESIGN OF INTERSTATE REST AREAS**

Figure 16-1.B

16-1.04(c) Vehicle Capture Rates/Parking and Usage Requirements

National studies indicate that approximately 10% of the total Average Daily Traffic (ADT) will enter a rest area. A study conducted by the Department concluded that 9% of passenger cars and 15% of trucks in the approaching traffic stream will enter a rest area. Based on ADT, the criteria for estimating the number of vehicle parking stalls (per type), picnic tables, and litter receptacles required at a rest area are illustrated in Figure 16-1.C.

The annual growth of traffic on the Interstate highway system has created the demand to increase vehicle parking requirements for new and rehabilitated rest areas. The RAC has established that a facility should be maximized at 50 passenger car stalls and 40 truck stalls. Where site conditions restrict full compliance of the maximum requirements, apply the values obtained from Figure 16-1.C.

The criteria for determining the number of persons projected to use the rest area, the anticipated demand for water, and the type of rest room facilities that should be provided are illustrated in Figure 16-1.D.

Route _____ Rest Area _____ NSEW-Bound _____
 County _____ Analyst _____ Date _____

Two-Way ADT _____ (Current/Projected) Year _____

x 0.60 Directional Distribution (1 Way ADT) _____
 x 0.11 Design Hourly Volume (30th Max. Hr.) DHV

Parking Requirements	
Trucks	Passenger Cars
% Trucks _____ x DHV = _____ x 0.15 Entering Veh. = _____ x 0.50 Dwell Time/Turnover <input type="text"/> Min. Required Truck Stalls (One Side Only)	% P. Cars _____ x DHV = _____ x 0.09 Entering Veh. = _____ x 0.34 Dwell Time/Turnover <input type="text"/> Min. Required P. Car Stalls (One Side Only)*

Notes:

- *1. Passenger car stall requirements should be increased 25% for welcome centers.
2. Provide one (1) accessible stall per 25 passenger cars in the passenger car parking area.
3. Provide one (1) accessible stall per 25 trucks in the truck parking area.
4. See Section 16-1.05(d) for maximum number of vehicle parking stalls.

Picnic Tables	Litter Receptacles
DHV x 0.008 = <input type="text"/> (Generally, 33% are sheltered.)	DHV x 0.0008 = <input type="text"/>

Determination of Design Guidelines for Rest Area Parking Requirements

- Enter with two-way **ADT** for current or projected year.
- **Directional Distribution** — A 60/40 distribution is a typical split on the Interstate highway system.
- **Design Hourly Volume** — The DHV represents the 30th maximum hourly volume of the year (30 HV). In this case, it represents the vehicles on the mainline that approach a rest area in one hour. Typical conversion of ADT to DHV on the Illinois Interstate system is 11% as indicated in *Traffic Characteristics on Illinois Highways — Bi-Annual Report OPP*.
- **Trucks/Cars as % of Traffic** — Enter actual truck and passenger car percentages of the appropriate highway section and multiply by the DHV.
- **Percent of Entering Vehicles** — Typically, 15% of the trucks and 9% of the passenger cars enter the rest area.
- **Dwell Time** — Assume a dwell time of 15 minutes for trucks and 10 minutes for passenger cars. A factor of 2 is used to convert to 30 minutes (0.50 hour) for trucks and 20 minutes (0.34 hour) for passenger cars.

DESIGN GUIDELINES FOR INTERSTATE REST AREA PARKING REQUIREMENTS

Figure 16-1.C

Route _____ Rest Area _____ Date _____

County _____ Analyst _____

Two-Way ADT (Current/Projected) Year _____

- x 0.60 Directional Distribution (One-Way ADT) _____
- x 0.11 Design Hour Volume (30th Max. Hr.) _____
- x 0.10 Vehicles Entering Rest Area Per Hr. _____
- x 2.0 Average Vehicle Occupancy _____
- x 0.85 Persons/Rest Room Usage = **P/RU** _____
- ÷ 60 Persons Per Minute _____
- * x 2.5 Gallons (9.5L) Per Person = **GPM (LPM)**
- x 60 Gallons (Liters) Per Hour = **GPH (LPH)**
- x 12 Gallons (Liters) Per Day = **GPH (LPD)**
(One Side Only)

Notes:

- *1. Ensure that the momentary peak flow rate (GPM (LPM)) is twice the design flow rate or the total toilets and urinals times 5 GPM (19 LPM), whichever is less for a period of two hours.
2. Check water supply systems to determine the impact of momentary peaks.
3. Provide design usage at a pressure of 40 psi (275 kPa).

Rest Room Amenities							
P/RU	Men				Women		
	Urinals	Toilets	W. Basins	H. Dryers	Toilets	W. Basins	H. Dryers
<250	4	2	2	2	6	2	2
>250	4	4	4	4	8	4	4
>500	6	4	4	6	10	4	6

Note: Values may be adjusted for site-specific percentages.

DESIGN GUIDELINES FOR INTERSTATE REST AREA USAGE AND WATER NEEDS

Figure 16-1.D
(1 of 2)

- Enter with **Two-Way ADT** for current or projected year.
- **Directional Distribution** — Use a 60/40 distribution, which is a typical split on the Interstate highway system.
- **Design Hourly Volume** — The DHV represents the 30th highest hourly volume of the year (30 HV). In this case, it represents the vehicles on the mainline that approach a rest area in one hour. Typical conversion of ADT to DHV on the Illinois Interstate system is 11% as indicated in *Traffic Characteristics on Illinois Highways — Bi-Annual Report OPP*.
- **Vehicles Entering Rest Area** — Typically, 15% of the trucks and 9% of the passenger cars will enter the rest area. Using a typical Interstate truck percentage of 28% and 72% for passenger cars, the capture rate of passing vehicles is a weighted average of 10%. On Interstate routes where the truck percentage is 45%, the weighted average is 16%. Various truck percentages can be interpolated to determine the weighted average.
- **Vehicle Occupancy** — Vehicle occupancy is determined to be 1.83 persons per vehicle; however, the weekend rate is 2.3. Use a weighted average of 2.0 for these calculations.
- **Persons/Rest Room Usage** — Of the people entering a rest area, 85% will utilize the rest rooms. A slightly higher percentage of men use the rest rooms than women, but the difference is not significant to warrant any difference in rest room conveniences.
- **Water Usage** — Use a value of 2.5 gallons (9.5 L) per person to determine the peak gallons (L) per minute rate (based on low-volume flush toilets and urinals). Provide for enough on-site water storage to handle peak traffic volumes.
- **Water Usage Per Day** — The multiplier of 12 is based on GPH (gallon per hour) (LPH, liters per hour) rate for two hours per day, 80% of GPH occurring for eight hours and 25% of GPH occurring for 14 hours. Hence, $GPD = (GPH)(2) + (0.8 GPH)(8) + (0.25 GPH)(14) = 11.9$ round to 12.
- Use the **P/RU** value in the table to determine the desirable rest room amenities.

DESIGN GUIDELINES FOR INTERSTATE REST AREA USAGE AND WATER NEEDS

Figure 16-1.D
(2 of 2)

16-1.04(d) Other Design Elements

Consider the following guidelines during the design of rest areas:

1. **Buffer Zone.** To enhance patron safety, locate the facility a minimum distance of 100 ft (30 m) away from the freeway to create a buffer zone to the nearest use area.
2. **Parking.** See Section 16-1.05(d) for information on vehicle parking requirements.
3. **Internal Roadways.** Design internal rest area roadways for a minimum speed of 20 mph (30 km/hr) and a desirable speed of 25 mph (40 km/hr).
4. **Curbing.** Curbing may be used on internal roadways to restrict illegal parking on the shoulder and to minimize vehicular encroachment.
5. **Fencing.** Fence the rest area right-of-way to prevent access to or from adjacent properties.

16-1.04(e) Entrance and Exit Ramp Terminals

Provide access to and from rest areas according to the typical ramp terminal designs presented in Chapter 37 and the *Highway Standards*. Also consider the following additional information on entrance and exit ramp terminals:

1. **Exit Ramps.** Design initial ramp curves for 50 mph (80 km/hr) and limit superelevation to 6% maximum. Provide decision sight distance for the exit maneuver. Provide a deceleration distance of 600 ft (180 m) from the gore of the exit ramp to the car/truck divergence gore. See Section 37-6.01 for additional guidance.
2. **Entrance Ramps.** Provide a minimum distance of 1200 ft (350 m) from the truck parking area to the gore nose on the entrance ramp. This distance typically will allow a truck to accelerate to an acceptable speed before entering the freeway. Adjust the acceleration distance where the ramp terminal is on a grade greater than 3% or where the freeway level of service is adversely affected by the truck's merging speed. See Section 37-6.02 for additional guidance.

16-1.04(f) Parking Area and Internal Roadway Requirements

Typically, truck parking areas are located to the rear of a site. An exception to this would be if the terrain or a scenic vista would be better served if passenger cars were located at the rear of a site. The truck parking area should typically provide a center aisle 30 ft (9.2 m) wide with 45-degree diagonal parking on both sides; however, 35-degree may be used in confined areas.

Design exit aisles to be 28 ft (8.6 m) in width, minimum, with an adjacent B-9.18 (B-22.45) curb and gutter. Desirably, place an island in the truck parking area near the center walkway to the comfort station. This island may contain a telephone kiosk and picnic tables. Design ramp

widths and roadway geometry to accommodate a WB-67 (WB-20) design vehicle assuming the Case I condition. Ramp widths are normally 16 ft (4.9 m) wide; however, increase this width to accommodate truck off-tracking when providing a curved alignment. See Section 36-2.03 for turning roadway widths that are also applicable to rest areas. Chapter 37 provides additional criteria regarding entrance/exit ramp design.

Within the car parking area, the through roadway width of 20 ft (6.0 m) is desired with diagonal parking generally on both sides of the roadway. Provide B-6.18 (B-15.45) curb and gutter within the vehicle parking area.

For typical details for rest area parking, including typical accessible parking stall locations, typical accessible parking striping layout, the required number of accessible parking spaces, and a typical ramp cross-section, see Figures 16-1.E through 16-1.H. Note that accessible parking spaces and accessible passenger loading zones shall be the spaces or zones closest to the nearest accessible entrance of the comfort station. Further, an accessible route must be provided from the accessible spaces or zones to the comfort station entrance. See Chapter 58 for additional guidance.

16-1.04(g) Pavement/Shoulder Design

Design the rest area exit and entrance ramps, roadways, shoulders, and parking areas according to Section 54-1.07. The concentration of heavy trucks braking on the ramps and inner roadways and the sharp turning maneuvers to enter parking stalls requires these facilities to be considered “high stress” locations. See Chapter 54 for guidelines on “high stress” pavement designs. Design ramps to handle overflow truck parking on shoulders (40,000 lbs (16,000 kg) plus for each truck).

Figure 16-1.H illustrates a typical ramp cross section with 1V:4H side slopes and pipe underdrains. In areas where curbing is desired to restrict trucks from parking on the shoulder, use a B-9.24 (B-22.60) curb and gutter. For truck parking areas, use a B-6.18 (B-22.45) curb and gutter with a 1 ft (300 mm) wide curb top. For car parking areas, use a B-6.18 (B-15.45) curb and gutter. Ramp all island noses for safety and ease of maintenance.

Because of the likelihood of vehicle off-tracking onto ramp shoulders, provide fully paved 8 ft (2.4 m) wide shoulders on the right and fully paved 4 ft (1.2 m) wide shoulders on the left. The transition (i.e., intersection of paved shoulders) between the rest area shoulder design and the freeway shoulder design will occur near the 1 ft (300 mm) stub of the ramp tapers.

Design ramp elements (e.g., superelevation, superelevation transitions, crossover crown) as indicated in Chapter 37.

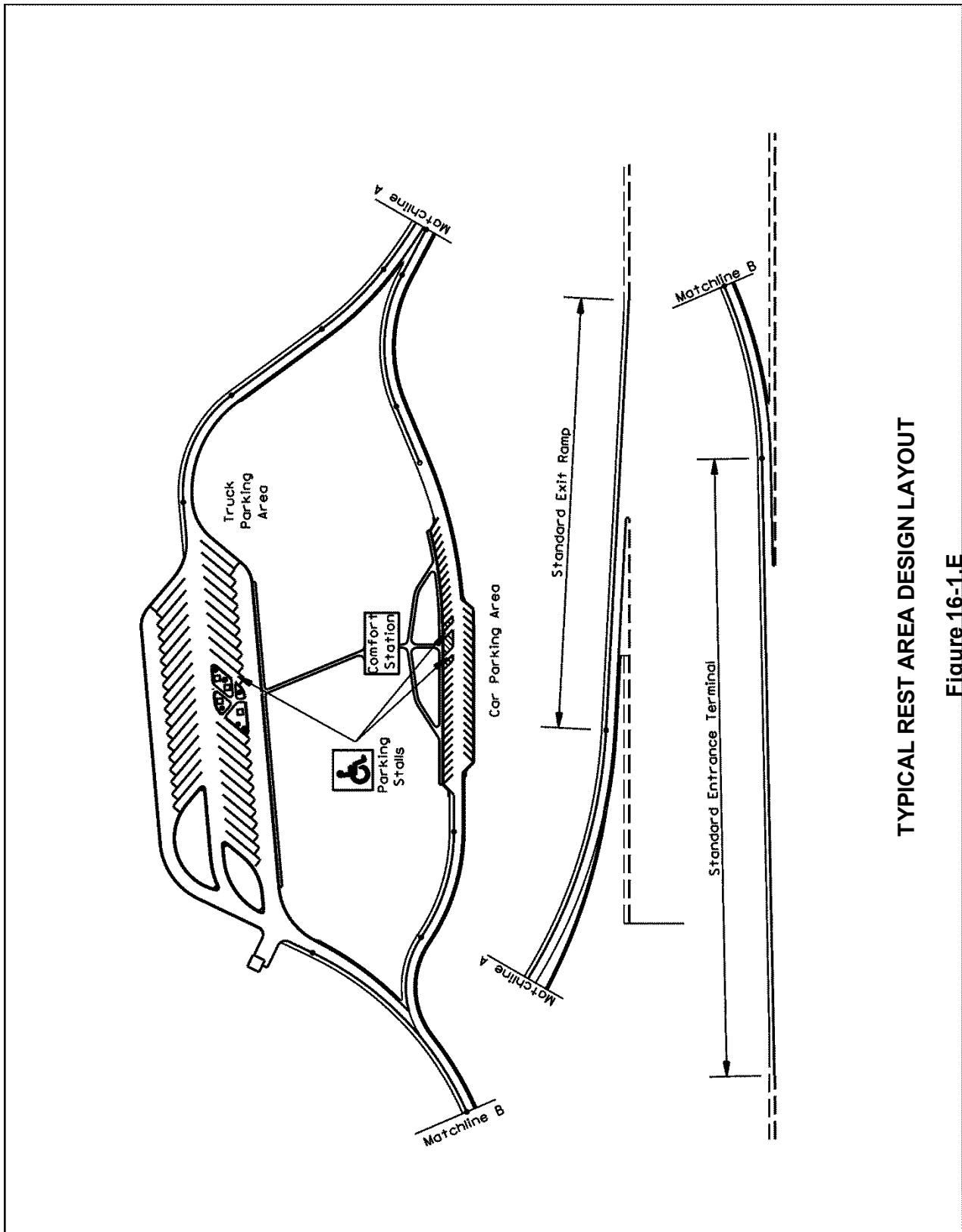

TYPICAL REST AREA DESIGN LAYOUT

Figure 16-1.E

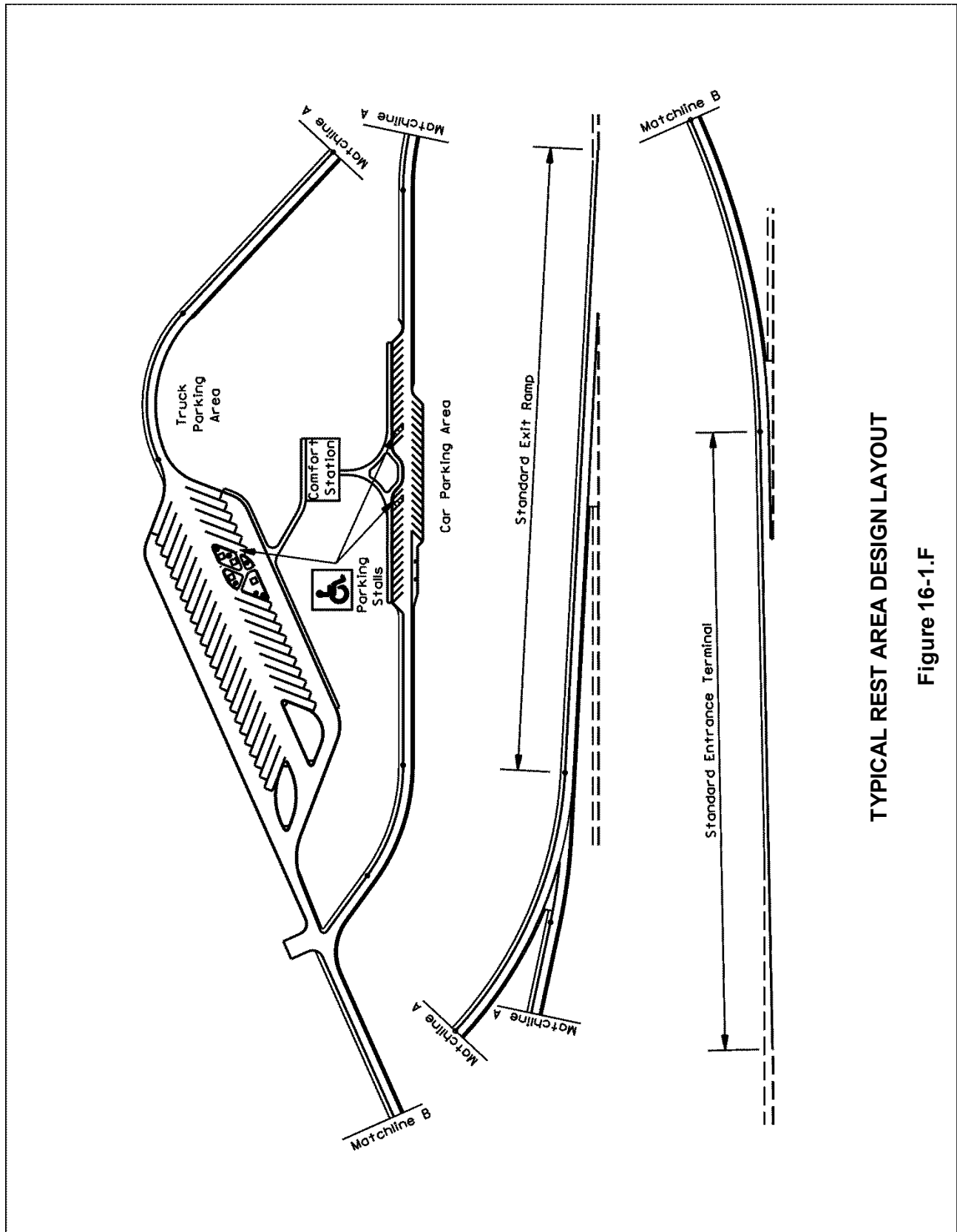

TYPICAL REST AREA DESIGN LAYOUT

Figure 16-1.F

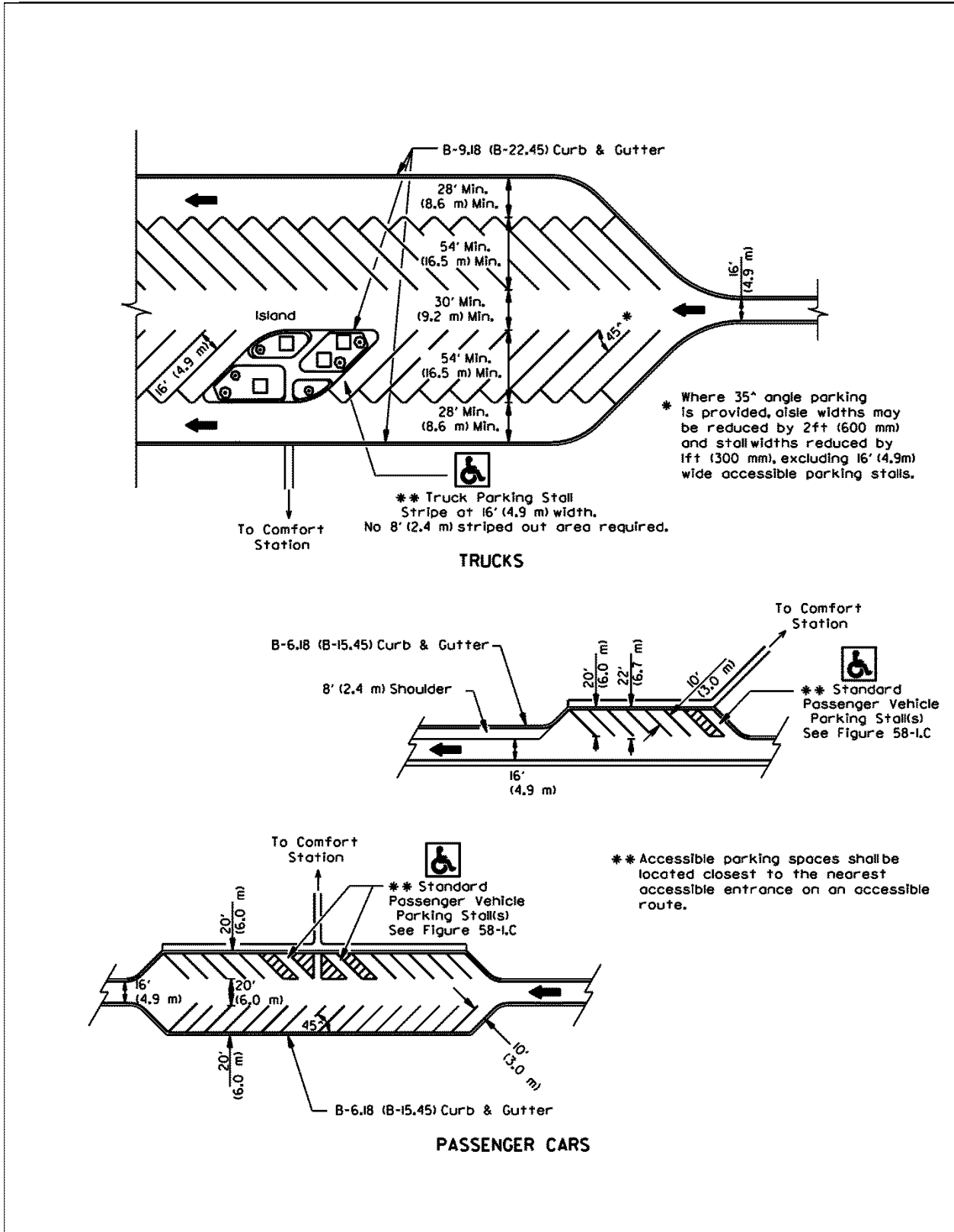

TYPICAL PARKING CONFIGURATION

Figure 16-1.G

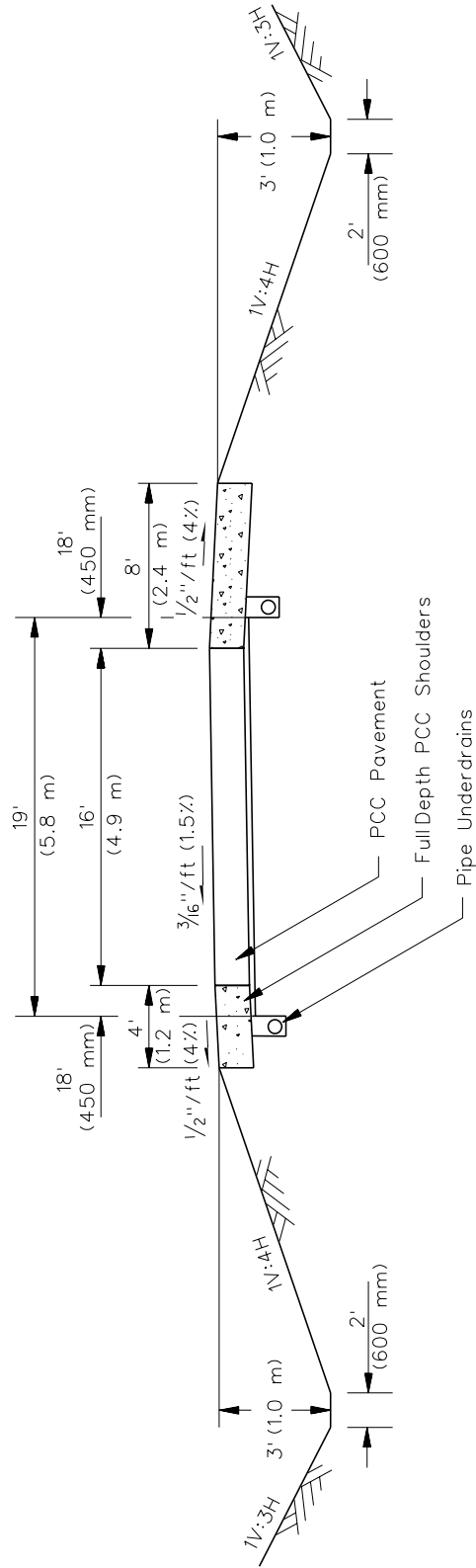

**RAMP CROSS SECTION
(Rest Areas)**

Figure 16-1.H

16-1.04(h) Comfort Station

Entranceways to comfort stations should provide an unobstructed, ADA compliant, walkway to the facility per criteria presented in Chapter 58, as well as a clear view into the lobby area. Elevated planters, walls, shrubs, and bushes should not obscure the view of the approaching patron. The open view also allows the State Police to scan the lobby in drive-by and recording video surveillance. In general, a comfort station requires approximately 3000 ft² (280 m²) of floor space to accommodate the necessary conveniences to meet the needs of the traveling public. The following provides additional information on the design of comfort stations:

1. **Vestibule.** The entryway should be a glass enclosure that provides an unobstructed view into the lobby. Use double air-lock doors with high-quality latches and closure hardware to withstand high use.
2. **Lobby.** The lobby area should provide 800 ft² to 1000 ft² (75 m² to 93 m²) of floor space with a generous amount of windows to maximize natural light. Windows will be provided with safety glass and sectioned in 4 ft (1.2 m) increments or less for ease of repair and maintenance. Protect full-length windows on the inside by placement of handrails and/or bench seating. Locate water fountains away from the windows to prevent splashing. Recessed lighting with vandal-proof flush lenses is desirable. Design emergency lighting to be flush with the ceiling.
3. **Vending Area.** Locate the vending area to the side of the lobby and provide space for a minimum of six machines. Bench seating is desirable in this area. A security camera should be installed to monitor the vending area. Also, provide a cold-water (softened water) hose bib for the vending machines.
4. **Wall Space for Information Boards.** All rest area facilities will display a large 4 ft x 6 ft (1.2 m x 1.8 m) State map in a prominent location on either a wall or a center kiosk. Additional wall space of approximately 30 ft² (3 m²) is necessary for information services and notices. Welcome/tourist information centers require additional space for brochures to promote Statewide and local attractions.
5. **Telephones.** Provide a minimum of one telephone in the comfort station lobby for public use, one of which meets accessibility requirements. TTY telephones (i.e., teletypewriters for persons with hearing and speech impairments) may be provided in selected facilities in coordination with Central Management Services (CMS). Additionally, one phone is required in the mechanical room and, where a welcome center is provided. One phone is required for the Department of Commerce and Community Affairs (DCCA) attendants. Provide remote ringers in the lobby and outdoors for the mechanical room phone.
6. **Vending Storage Room.** The vending storage room should be located near the vending area with internal and external access doors. The room should be approximately 225 ft² (21 m²). Provide a 5 lb (2.26 kg) ABC fire extinguisher in the storage room. Also, provide double duplex receptacles and telephone outlet at the proposed location of a desk. Provide hose bibs in the storage area.

7. Rest Rooms. Rest rooms should be a “split” design with open doorways (see Figure 16-1.I). Rest rooms with eight fixtures should be approximately 700 ft² (65 m²). Determine the number of urinals and toilets using Figure 16-1.D. Design the rest room entry to prohibit direct sight lines into rest rooms from the lobby. The split design allows one-half of the rest room to be closed for cleaning, repairs, and off-season low usage. Also, install a diaper changing station in both the men’s and women’s rest rooms. Plumbing and electrical systems should be valved and switched, respectively, to allow repair work in one-half of each rest room. The following provides additional information on rest rooms:
- Standardization of components such as faucets, valves, fixtures, washers, lighting, and locks are essential for ease of replacement. High-quality, heavy-duty vandal proof components are required.
 - Rest room walls should be tiled with a neutral color for ease of maintenance.
 - Construct toilet stall partitions with minimum 4-in (100-mm), glazed-tile concrete blocks.
 - Recessed toilet paper holders are desirable. Consider large volume type multi-roll dispensers (vandal proof).
 - Provide three-quarter length stainless steel stall doors with heavy-duty hinges and latches.
 - Toilet stools will be of high-quality, “institutional type,” floor-mounted, rear-discharge fixtures. Consider using stainless steel or cast iron.
 - Specify use of water-saving, automatic-flushing devices with an override.
 - Install wash basins (i.e., lavatories), other than accessible wash basins, with heavy-duty, twist-type, self-closing faucets with cam ball-bearing pressure plates or automatic controls (ADA compliance).
 - Specify access doors below basins to be manufactured of stainless steel material made to prison standards.
 - Provide an infrared sensory device at accessible wash basins.
 - Include a small plate glass mirror over wash basins. Include a lower facing mirror for ADA compliance.
 - Specify and locate heavy-duty hand dryers near the lavatories to minimize a slippery floor condition.
 - Provide heavy-duty soap dispensers that will not drip onto floor.

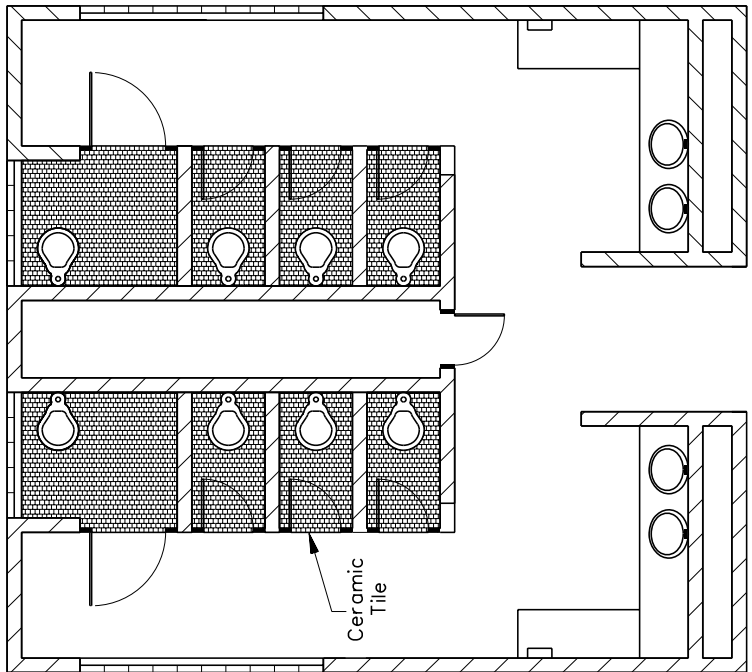

WOMEN'S RESTROOM

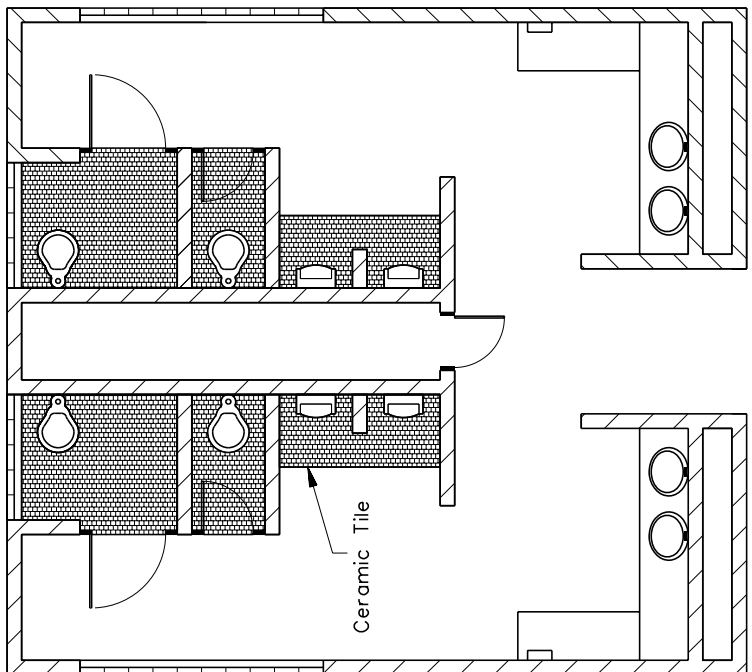

MEN'S RESTROOM

**TYPICAL REST ROOM LAYOUT
(Rest Rooms with Stalls for the Persons with Disabilities)**

Figure 16-1.1

8. Lighting. The lighting of a rest area is accomplished by a combination of high-mast lighting and pole lights. Lighting shall be provided to illuminate entrance and exit ramps, parking areas, internal roads, sidewalks, and pedestrian areas. The high-mast lighting is normally applicable to parking and multi-use areas with poles approximately 100 ft (30 m) in height. Flagpole lighting shall be mounted above ground in inconspicuous locations. Lighting on the sides of buildings shall be recessed with screen covers to prevent bird nesting. Lighting plans shall be prepared by BDE according to the criteria in Section 56-4. Design all light poles to be of a non-breakaway design; see Section 38-4.11.
9. Flooring. Provide terrazzo flooring in the lobby and rest rooms except for the tile flooring under urinals and stalls. Terrazzo flooring will be curved upward at the edges (i.e., where it meets the wall) to enhance the cleaning process. Consider using uric acid resistant material under urinals.
10. Sidewalks. Place sidewalks adjacent to all curb parking areas and design them to comply with accessibility requirements (ADA). Entrance walks to the comfort station should provide direct access from the parking area and should not be obstructed by signing, bench seating, or planting areas. Accessories (e.g., drinking fountains, signing, newspaper containers, recycling receptacles) should be positioned adjacent to the sidewalk and anchored to concrete pads. Provide a specific location for newspaper dispensers.

Other than the main entrance to the comfort station, sidewalks should be 5 ft (1.5 m) wide and constructed of concrete with a slip-resistant surface. Do not include wood slats at expansion construction joints. Other recreational walkways may be constructed with loose gravel, shredded bark, or similar loose material, to allow extended walks to other natural areas of the facility. Consider ADA compliance requirements. Provide nature trails where site conditions warrant such amenities.
11. Unisex Rest Room. This room serves a person with disabilities who needs assistance. It should be located off the lobby and is generally 60 ft² (6 m²) in which one toilet and one lavatory are provided with inside locking door.
12. Mechanical/Storage Room. This room will house all of the mechanical equipment necessary to serve the facility. Approximately 350 ft² (32 m²) is required with access doors to both the interior lobby and the exterior. Provide a 5 lb (2.26 kg) ABC fire extinguisher in this room. Also include a desk, telephone, and an area for security system computer and monitors in the room. Storage space is required with shelving for toiletry items, cleaning liquids, appliances, and electronic equipment for the security system.
13. Code Blue Emergency Phones. If these are provided, install a minimum of one wall-mounted phone in the interior of the lobby area, and one post-mounted in the exterior of the building located in the car parking area and truck parking area. Install additional units as deemed necessary. Code Blue Emergency Phones must be located along an accessible route and within allowable reach ranges from an ADA clear space.

14. Welcome Centers/Visitors Center. A welcome/visitors center generally requires an additional 300 ft² (28 m²) of flooring for a service counter and storage room. Provide a minimum 8 ft (2.4 m) counter for the distribution of brochures and/or information services. Also provide a gate to secure the counter area and a storage room of approximately 250 ft² (23 m²).

16-1.04(i) Other Amenities

The multi-use area provides a restful environment for the traveler and allows some limited recreational activities. Many facilities offer a scenic vista to the adjacent landscape as well as access to lakes, creeks, and wooded areas. Use the following guidelines to provide the most desirable elements of a rest area facility:

1. Picnic Tables. Use Figure 16-1.C to determine the desired number of picnic tables. Generally, ensure that 33% of the tables are sheltered with an appropriate number being wheelchair accessible. Sheltered tables are not required where an adequate number of trees would provide some shade for picnic tables. Sidewalks should interconnect approximately 50% of the picnic tables, particularly those tables that are wheelchair accessible.

The design of the shelters should be compatible with the design of the comfort station. Ensure the shelter design takes in consideration to exclude birds and insects from gathering in the rafters. Generally, lighting in the shelters is not required, but certain locations may warrant some illumination. Anchor picnic tables to concrete pads to prevent vandalism. Where appropriate, place tables on parking lot islands or on the backside of truck parking areas.

2. Playground. Provide a children's playground in a convenient location that attracts its use, but does not impede access to the comfort station. Locate the playground area as near to the car parking area as practical, but a sufficient distance away to enhance the safety of playing children. A general size of 30 ft x 40 ft (9 m x 12 m) provides an acceptable area to install a variety of playground equipment.

The area should have a fixed border to retain the surface material. Consider using rubberized surface on top of concrete base for ease of maintenance and longevity of surface. Ensure that the playground meets accessibility requirements (ADA) and includes a sufficient number of play equipment to accommodate the needs of children with disabilities. The following ASTM Standards can be used as guides for the construction of playgrounds:

- ASTM F1487 – 07ae1 “Standard Consumer Safety Performance Specifications for Playground Equipment for Public Use,” and
- ASTM F1292 – 04 “Standard Specification for Impact Attenuation of Surfacing Materials within the Use Zone of Playground Equipment.”

3. Pet Walk. Provide a mowed pet walk area at all rest area facilities. The location should be a designated area that is well signed and well-lit at night. Also, the area should be away from the parking lot, picnic tables, and playground.

16-1.04(j) Accessibility Requirements

Design all elements of the rest area facility to properly accommodate persons with disabilities according to the criteria presented in Chapter 58, *ADA Accessibility Guidelines for Buildings and Facilities*, and the *Illinois Accessibility Code*.

16-1.04(k) Utilities

Generally, rest areas are located in rural areas where utility services are not readily available. Water, electric, gas, and sewer services are necessary for a rest area facility. The following provides information on these rest area utilities:

1. Water. It is highly desirable to obtain water service from an adjacent municipal system. If this option is not available, then use a well-water system. If a well system is used, provide for a secure storage area for water treatment chemicals and softener salt. Also, use a back-up well and water storage (3000 gallon (11,350 L) plus) to maintain adequate supply and pressure during peak periods. Determine water demand from Figure 16-1.D. Evaluate all water systems, well or municipal, for quality and, if deemed necessary, treat to remove objectionable minerals and/or gases. Hard water also should be treated to avoid early deterioration of fixtures.
2. Electricity. Obtain electrical service from the local utility company. Provide a high-efficiency, commercial-grade cooling unit in the facility to cool all areas of the building. Where a feasible, include an emergency generator to operate enough lighting and machinery to function.
3. Gas. Consider natural gas where readily available to provide for the heat source. The use of propane gas is not desirable because of the potential for vandalism. Perform life-cycle cost analyses of energy sources, for heat and cooling requirements. Provide a high-efficiency, commercial-grade heating unit in the facility to heat all areas of the building and locate controlled access thermostats inside the mechanical room.

Consider using geothermal, solar, and/or wind power to augment traditional heating/cooling systems. However, alternative energy systems should be carefully investigated and considered and, where practical and financially feasible, incorporated into the design of the comfort station.

4. Sewer. It is highly desirable to connect sewer systems to a local municipal system. Where this is not practical, consider the construction of sewage lagoons with aeration capability. Consider installation of an inline mechanical grinder to reduce the need to sewer rod a clogged line. Other sewage systems that may be considered include:

- purification mounds (Wisconsin mound),
- recirculating sand-filter systems, and
- self-contained systems of reusable chemicals.

Perform life-cycle cost analyses to determine the appropriate system for the facility. Size sanitary sewer lines and lift stations in accordance with the *Illinois Plumbing Code*. Design lift-station pressure switches for specific requirements and pumping demands. Provide a malfunction or power-outage warning signal in the building for wells and lift stations. Provide for sewer gas escapement. Built-up sewer gases combining with moisture will create sulfuric acid that will greatly reduce the life of untreated metal and concrete components.

16-1.04(l) Outdoor Electrical and Mechanical Equipment

Where practical, locate heating and air conditioning equipment indoors or on the building rooftop. If the only reasonable outdoor location is at ground level, then provide a security fence around the equipment that is architecturally compatible with the building design.

Locate electrical transformers and exterior electrical cabinets on an inconspicuous side of the building away from the view of entering patrons. If necessary, screen these items from view with plantings or architecturally compatible fencing. Coordinate with the utility company for required equipment access clearances.

16-1.04(m) Landscaping

When cost effective, preserve existing shade trees and other natural features to increase the aesthetic value of the site. Develop the facility with minimal disturbance to natural terrain and existing plant growth. Supplement existing vegetation with landscape treatments to achieve an environment conducive to rest and relaxation. Where applicable, give consideration to the acquisition of adjacent right-of-way or easement where a scenic view or natural attraction can be correlated with shorelines, ridgetops, woods, and/or other natural features.

Promote the use of low-maintenance features in a facility's landscape plans. Consider providing earth mounding to screen features such as sewage lagoons and to enhance the visual effect of plantings. See Chapter 59 for additional information on landscaping and plant material.

16-2 REST STOPS

16-2.01 General

Rest stops are facilities constructed on State highways other than freeways or expressways. These facilities are generally located on one side of the highway and serve both directions of travel. The need for a rest stop is initiated by the district and submitted to the Rest Area Committee for concurrence. Also included are scenic overlooks and roadside tables. Scenic overlooks also may provide rest room facilities, enlarged parking facilities, and picnic tables. New rest stops or improvements to an existing rest stop may be considered a Type I project for noise and consequently require a noise analysis. Traffic noise analyses shall be conducted in accordance with Section 26-6 "Noise Analyses" of this BDE Manual. The *IDOT Highway Traffic Noise Assessment Manual* has been prepared to provide guidance on how to implement the policy for IDOT projects or projects being reviewed by IDOT. The guidance manual provides information to be included in the environmental documentation.

16-2.01(a) Site Selection

When it is determined that a State highway should be considered for rest stops, representatives of the RAC and the district will investigate and prioritize potential sites. Most of the site selection guidelines presented in 16-1.04(b) are also applicable to rest stops. Locate rest stops at sites with natural settings and shade. To avoid its misuse as a local park, do not locate rest stops close to urban areas.

Rest stops usually have rest rooms, limited parking spaces, and several picnic tables. Generally, running water and flush toilets are provided unless the availability of water is not practical for a particular site, in which case a vault type is used. A minimum designed facility requires approximately 4 acres (1.6 ha).

16-2.01(b) Design Guides

A typical rest stop configuration is illustrated in Figure 16-1.J. Entrances to the facility and the inner roadway should accommodate the movement of two-way traffic. Provide minimum intersection sight distance as discussed in Section 36-6. Entrance radii are typically simple curves, and the roadway surface beyond the limits of the shoulder should be an aggregate material.

Base the estimated vehicle parking spaces on 20-year, two-way ADT. Provide for one passenger car stall for every 500 vehicles passing the facility and one truck stall for every four passenger car stalls. A minimum number of four car stalls and one truck stall is necessary to warrant the consideration of such a facility. Parking stalls, although not striped, should be provided for passenger cars at 10 ft x 20 ft (3 m x 6 m) and for trucks at 12 ft x 60 ft (3.6 m x 18 m). Use a WB-55 (WB-17) design vehicle for turning roadway criteria, see Chapter 36.

16-2.01(c) Access Control/Right-of-Way

A rest stop facility shall be provided with access control to enhance the site and to preclude the future development of adjacent commercial properties. This will prevent the rest stop from being used as customer parking. Figure 16-1.J also illustrates the extent of access control that should be acquired to ensure the intended functions of the facility. Exercise engineering judgment in acquiring access rights because more or less distance may be required depending upon the exact locations of property lines.

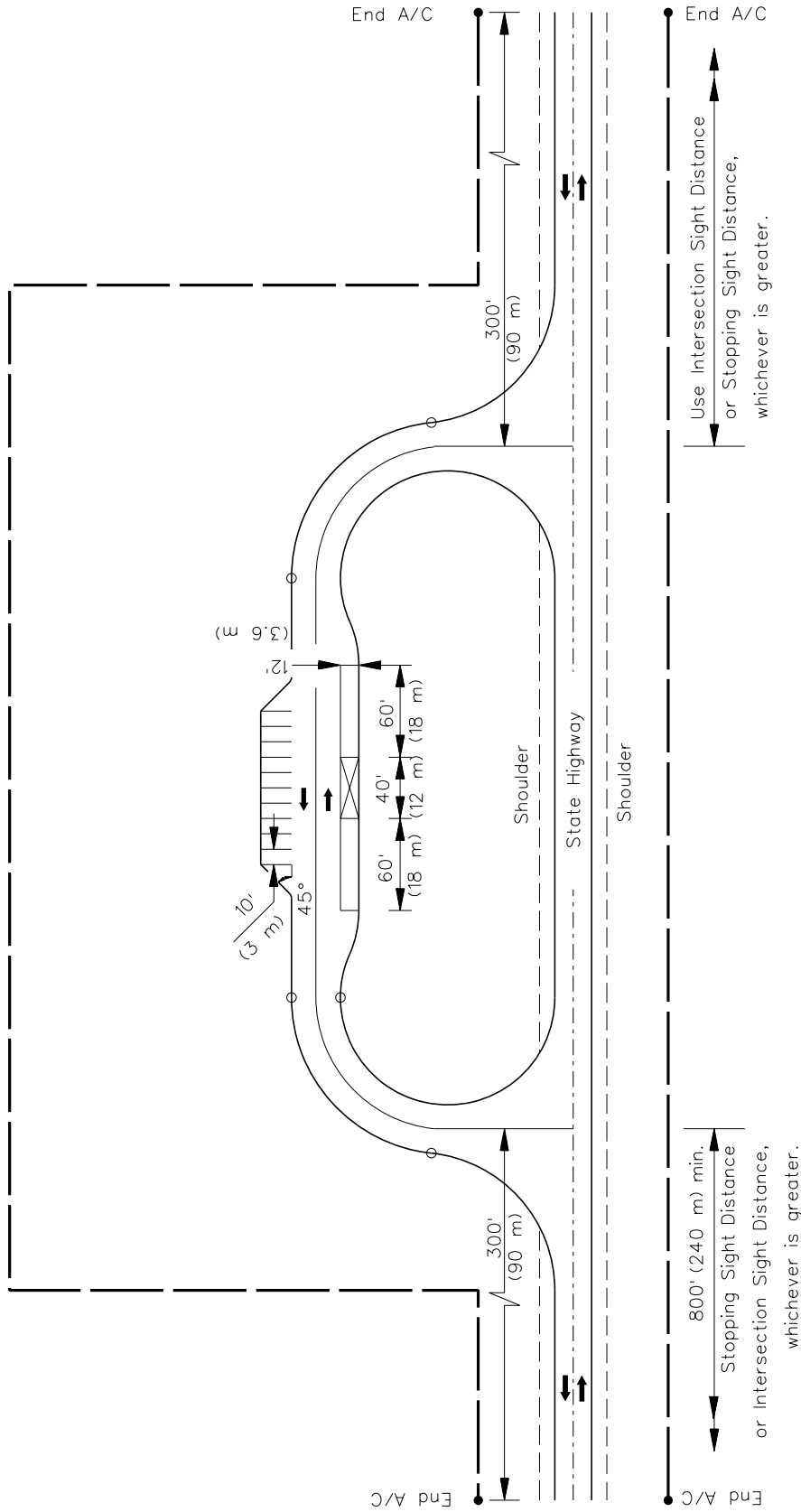

Note: Design all radii and roadway widths consistent with Designated State Truck Route System classification.

TYPICAL REST STOP
Figure 16-2.A

16-3 WEIGH STATIONS

16-3.01 General

Truck weighing facilities are necessary to:

- collect data for pavement research,
- monitor single axle loads (ESAL's),
- inspect trucks for safety violations, and
- remove illegal trucks from the Illinois highway system.

Other agencies (e.g., State Police, Department of Agriculture, Interstate Commerce Commission) also use weigh stations for inspection purposes. A weigh station provides a means to monitor vehicles for compliance with Federal Regulations and State statutes. Interstate weigh stations are discussed in Section 16-2.03. Arterial weigh station facilities are discussed in Section 16-2.05.

16-3.02 Weigh Station Committee

To ensure a level of consistency in all matters concerning weigh stations, the Department has established a Weigh Station Committee. The Committee directs and monitors the truck weight program. It also provides coordination with the districts, the Illinois State Police, and the Department of Agriculture. In addition to serving as a technical liaison with these agencies, the Committee is responsible for providing long-range planning and developing policies for design, construction, operation, and maintenance. The Weight Enforcement Engineer of the Bureau of Operations chairs the Committee. The Committee is comprised of representatives from IDOT and other agencies as follows:

1. IDOT Office of Program Development:
 - a. Bureau of Design and Environment. This bureau is responsible for providing the environmental survey of the site, designing all outdoor site lighting, and letting all construction contracts except those concerning the scale house. New weigh stations or improvements to an existing weigh station may be considered a Type I project for noise and consequently require a noise analysis. Traffic noise analyses shall be conducted in accordance with Section 26-6 "Noise Analyses" of this BDE Manual. The *IDOT Highway Traffic Noise Assessment Manual* has been prepared to provide guidance on how to implement the policy for IDOT projects or projects being reviewed by IDOT. The guidance manual provides information to be included in the environmental documentation.
 - b. Bureau of Bridges and Structures. This bureau prepares the scale pit and inspection pit designs.

2. IDOT Office of Highways Project Implementation:
 - a. Central Bureau of Operations. This bureau is charged with maintaining the weigh station facilities, maintenance of the electronic scales, signing, and traffic operations.
 - b. District. The district is responsible for the geometric design of the weigh station layout and for preparing the detailed plans for roadway construction of the weigh station. The district will also provide survey data, as needed by the Capital Development Board, for the design of the scale house.
3. IDOT Office of Planning and Programming. This office is responsible for collecting and analyzing data concerning truck weights and dimensions.
4. Capital Development Board (CDB). This agency is responsible for the preparation of construction drawings and contract specifications for the scale house and appurtenances. It will also let the contract for the construction of the scale house and provide construction supervision.
5. Illinois State Police (ISP). This agency is responsible for the enforcement of State statutes regarding weight and dimension limitations.

16-3.03 Interstate Weigh Stations

16-3.03(a) Site Selection Criteria

Weigh stations on the Interstate system generally should be located near State lines to serve inbound traffic. Other sites within the State should be considered on high truck volume routes. Site selection for weigh station facilities should attempt to restrict by-pass opportunities via convenient alternate routes. The Weigh Station Committee will determine the need to construct a facility within a specific corridor. Representatives of the Weigh Station Committee and the district will select the site and submit the proposal to the Committee for concurrence. Consider the following criteria when selecting a site for a weigh station:

1. Utilities. Ensure that utilities are available to adequately serve the scale house.
2. Spacing. Provide a distance of approximately 4000 ft (1200 m) between the weigh station entrance or exit ramp gore and any adjacent interchange ramp gore.
3. Sight Distance. Provide decision sight distance to the weigh station exit ramp gore.
4. Airports and Lighting Zones Desirably, do not locate weigh stations near airports, air fields or heliports, which have airspace restrictions prohibiting highmast light towers. Also avoid observatories and areas having lighting ordinances which discourage the type of site lighting necessary for weigh stations.

16-3.03(b) Planning

The following procedures are established to provide the proper coordination of various agencies involved in the planning of weigh stations:

1. Determine Location. Representatives of the district and the Weigh Station Committee will determine a suitable location.
2. Preliminary Layout. Prepare and submit a preliminary layout in the form of an aerial mosaic or scale drawing showing the following information:
 - the scale house location and limits of entrance and exit terminals;
 - the distance from the exit or entrance ramp gore to the ramp gore of the nearest interchange or to the nearest intersection, and
 - the availability of telephone, electrical power, heating fuel, water, and sewer services.
3. Field Inspection. Conduct a field inspection of the site and ensure that all agencies involved are invited to attend.
4. Road Plan Preparation. Upon approval of the site by the Weigh Station Committee, prepare the road plans and submit them to the BDE. Appropriate low-maintenance landscaping should be included in the roadway plans or as a separate contract.
5. Preparation of Lighting Plans. All weigh stations should be illuminated. See Sections 56-2.05 and 56-4 for the data to be submitted for preparing lighting plans.
6. Scale Pit Design. The district shall submit the following data for the scale pit design:
 - soil borings and blow counts at each end and in the center of the proposed scale pit to determine the size and type of footings and whether pilings are necessary,
 - location and details of the pit drainage, and
 - estimated quantities for the pavement and the median section adjacent to the scale and for the approach pavement.

Upon receipt of the above information and a set of roadway plans, the Bureau of Bridges and Structures will prepare the scale pit plans.

Figure 16-3.A provides the required information for the design of weigh stations.

16-3.04 Interstate Design Criteria

16-3.04(a) General

A typical Interstate weigh station facility with weigh-in-motion (WIM) capabilities is illustrated in Figure 16-3.B. A WIM facility virtually eliminates the delay legal trucks experience from stopping at weigh stations. When a truck enters a facility, the dynamic scale in the ramp pavement will sort the vehicle into one of two lanes. The by-pass lane allows a legal weight vehicle to return to the freeway without any further delay. The static scale lane directs the vehicle to the static scales for a more precise weighing. The static lane vehicles then are either returned to the freeway or directed to the detention parking area.

There are five basic operational elements of a WIM facility as follows:

- the deceleration distance,
- the signal zone,
- the storage requirements,
- the acceleration distance, and
- the detention parking area.

Design the weigh station to accommodate the operational characteristics of a WB-67 (WB-20) design vehicle. Provide advanced signing in accordance with the *ILMUTCD*. Coordinate signing with the Bureau of Operations.

16-3.04(b) Weigh-in-Motion

The dynamic scale is placed in the exit ramp at the end of the required deceleration length. The WIM electronic processor can determine:

- vehicular speed,
- length of wheelbase,
- gross weight,
- axle weight,
- axle spacing,
- vehicle length, and
- classification of 13 different vehicle types.

A vehicle that is within 3% of its maximum legal weight limit or exceeds its legal limit will be directed to the static scale for a precise weighing. Vehicles that are determined to be within the legal weight limit are directed to a bypass lane and returned to the freeway. As a vehicle passes over the dynamic scale, the vehicle will be directed to the static scale if the driver:

- exceeds the posted speed limit,
- does not maintain a 100 ft (30 m) distance from the rear of the forward vehicle, or
- fails to properly align the vehicle on the dynamic scale.

Pneumatic tubes or electronic sensors are placed on the outer edges of the dynamic scale to detect off-scale occurrences and to override the system to direct the vehicle into the static scale lane.

The “signal zone” is illustrated in Figure 16-2.C which describes critical lengths of the WIM system. Trucks exit the freeway and decelerate to the posted speed of 30 mph (50 km/hr) before passing over the dynamic scale. A WIM facility may be designed for a higher speed; however, extend the signal zone accordingly to provide approximately six seconds of signal viewing time.

16-3.04(c) Storage Requirements

At a facility where only a static scale is provided, all trucks will stop and be weighed. Delays at such facilities are frequent and queuing often occurs on the deceleration ramp. Research has determined that approximately 12% of the trucks that enter a weigh facility are near their legal limit and require a more precise weighing on a static scale. Storage length requirements for static scale and WIM facilities are illustrated in Figure 16-3.D. It is imperative that the signal zone of a WIM facility is free of stored vehicles. Consequently, use a safety factor of two in the storage equation that increases the 12% trucks-entering value to 25%. Provide the calculated storage length between the secondary signal and the static scale. Generally, a concrete barrier wall is desired in the median adjacent to the storage lane with a length equal in distance to the storage length requirements.

1.	Property:
	(a) Location and orientation of the site and legal description
	(b) Property lines and dimensions
	(c) Elevations and/or contours, including at least one bench mark
	(d) Layout of proposed approach, weighing platform and scale house and exit.
	(e) Proximity to airports, airfields, and heliports.
	(f) Location of nearby observatories.
2.	Test Soil Borings
	(a) To be made in area of proposed new buildings when required
	(b) Type of soil and bearing capacity in pounds per square foot (kN/m ²)
3.	Availability of water supply:
	(a) City water supply available
	Location
	Distance from site
	Size of main
	Water pressure
	Easements required
	(b) Well to be provided
	Information on wells in vicinity
	Depth
	Size
	Yield in cubic feet per second (m ³ /s)
	Location
	Water characteristics
	Test holes drilled
4.	Availability of sewers
	(a) Sanitary district or city sewers
	Location
	Distance from site
	Size at proposed connection
	Invert elevation
	Easements required
	(b) Septic tank required
	Absorption tests
5.	Availability of natural gas for heating (Input 55 ft ³ (1.6 m ³) per hour per building):
	(a) Natural gas available
	Name of utility company
	Location of service connection
	Distance from site
	Specific gravity pressure
	Size of main at connection
	Easement required
6.	Availability of electrical service (17 kW per building, ramp lighting additional)
	Name of utility company
	Service available Volts Phase
	Location of service
	Distance from site
	Telephone Service:
	Name of company
	Location of service
	Distance from site

**DATA AND SURVEY INFORMATION FOR PROPOSED
INTERSTATE WEIGH STATION**

Figure 3.A

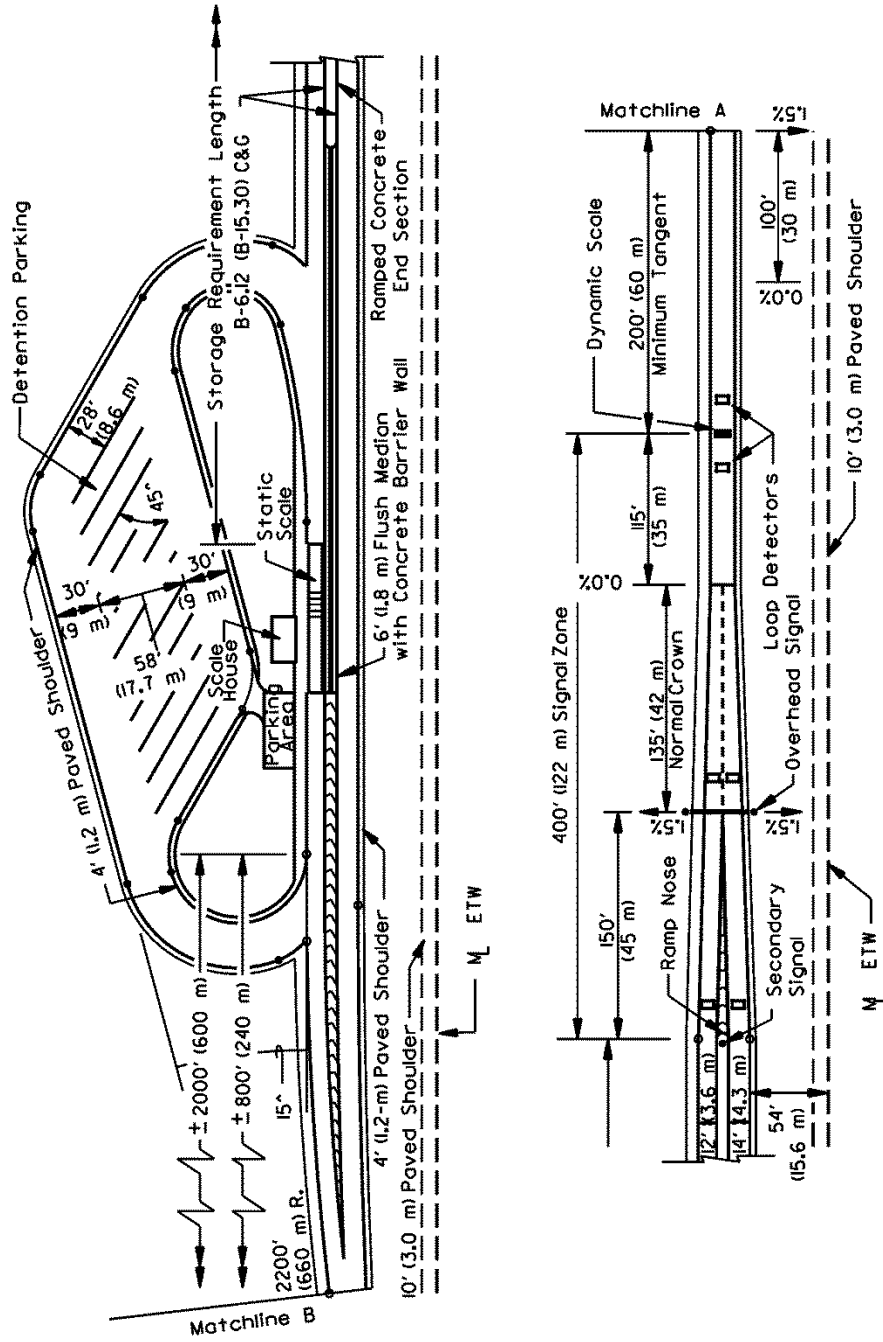

TYPICAL INTERSTATE WEIGH STATION WITH WEIGH-IN-MOTION

Figure 16-3.B

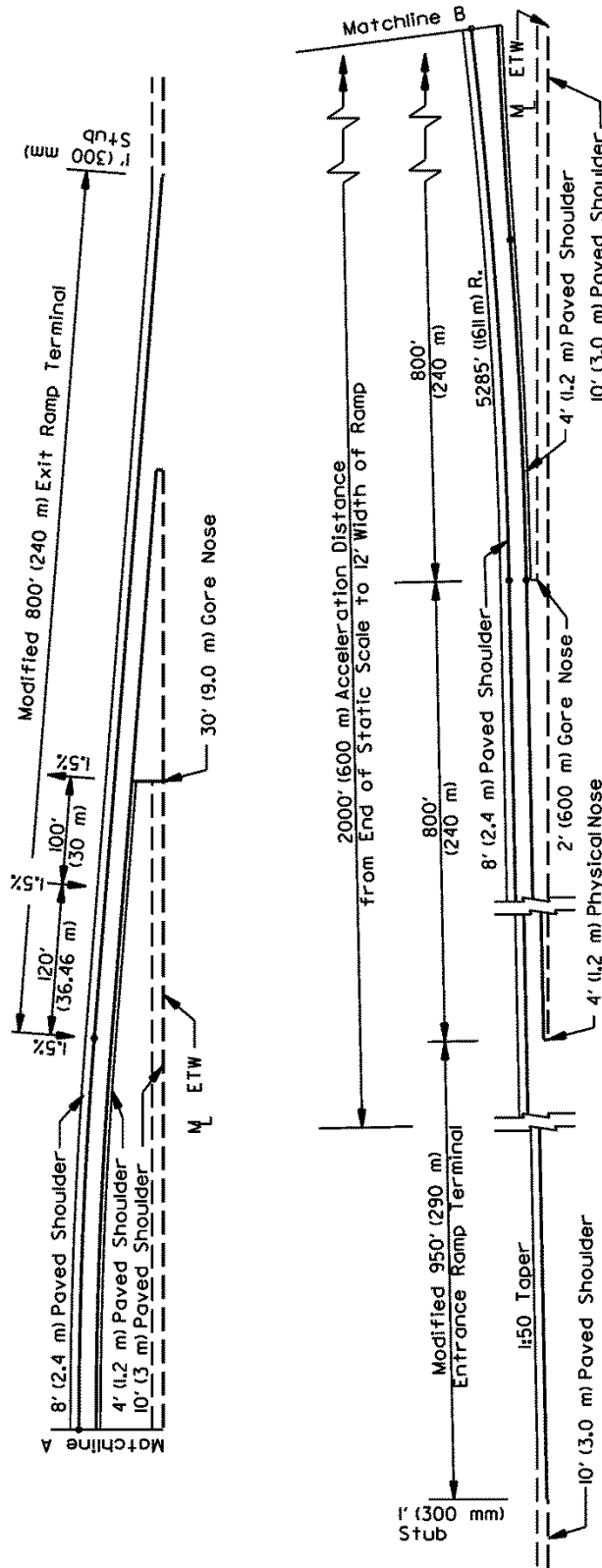

TYPICAL INTERSTATE WEIGH STATION WITH WEIGH-IN-MOTION

Figure 16-3.B
(Continued)

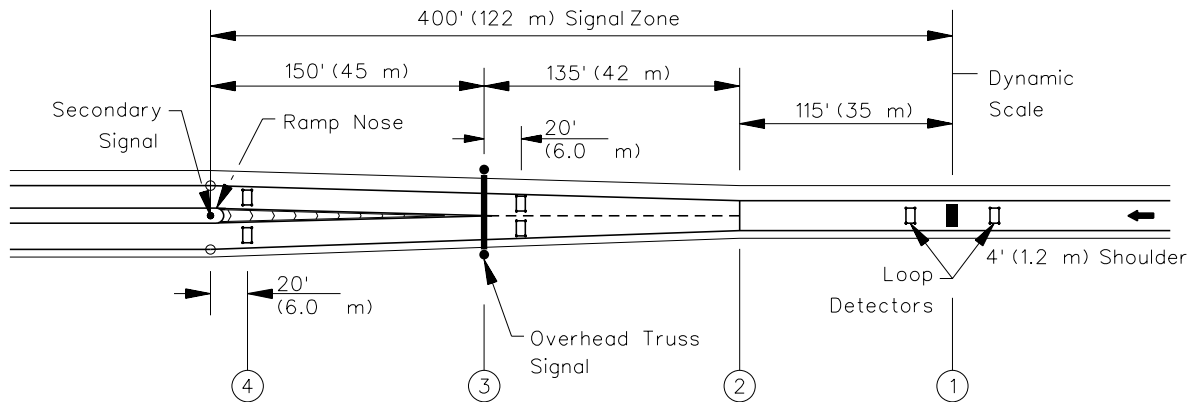

- ① Vehicle approaches the dynamic scale at a posted speed of 30 mph (50 km/hr). Loop detectors adjacent to the dynamic scale will determine vehicular speed.
- ② The distance of 115 ft (35 m) past the dynamic scale is based on the length of a large truck (i.e., 75 ft (22.5 m)) plus one second travel time at 30 mph (50 km/hr) (i.e., 40 ft (13 m)). At this position, an overhead signal arrow will direct the driver to the proper lane. The remaining distance to the overhead signal is 135 ft (42 m) which allows nearly three seconds of viewing time. Loop detectors located in front of the overhead signal truss will deactivate the overhead signal and simultaneously activate the secondary signal allowing a continued lane arrow assignment.
- ③ The overhead signal truss displays a lane arrow for proper lane assignment. The truss signal is deactivated when the vehicle passes over the loop detector preceding the truss. The secondary signal is simultaneously activated as a vehicle passes over the loop detector. This provides a continuation of the lane arrow assignment for an additional three seconds.
- ④ When a vehicle passes over the loop detector preceding the secondary signal, it deactivates the secondary signal and detects a vehicle that violates the proper lane assignment. When a violation occurs, a warning alarm is activated in the scale house and the violator is intercepted and directed to the detection parking area.

WEIGH-IN-MOTION (WIM) SIGNAL ZONE

Figure 16-3.C

Design Year Two-Way ADT _____

One-Way ADT x 60% _____

x % Commercial Vehicles _____ = _____

% Multiple Units (MU) _____ = _____ MU

% Single Units (SU) _____ = _____ SU

MUPH x 0.06 = _____ MUPH

SUPH x 0.09 = _____ SUPH

$\frac{MUPH \times 75}{8.2}$ = _____ MU Storage Length (ft) US Customary

$\frac{MUPH \times 22.5}{8.2}$ = _____ MU Storage Length (m) Metric

$\frac{SUPH \times 30}{8.2}$ = _____ SU Storage Length (ft) US Customary

$\frac{SUPH \times 9.0}{8.2}$ = _____ SU Storage Length (m) Metric

Add SU + MU = _____ Static Scale Required
Storage Storage Length (ft) (m)

Weigh-in-Motion (WIM) Storage Calculations:

Total Required Storage Length _____ x 25% = _____ ft (m)
(Static Scale) WIM Required Storage Length

REQUIRED STORAGE LENGTHS

Figure 16-3.D

16-3.04(d) Entrance and Exit Terminals

The exit and entrance terminal designs are modified versions of the typical designs. The exit ramp terminal design provides a 4°30' divergence angle from the freeway which normally will allow the design of a single horizontal curve to be used in advance of the dynamic scale. Provide a minimum distance of 800 ft (240 m) from the ramp gore to the dynamic scale to accommodate vehicular deceleration, allows drivers to maintain a steady speed, and achieve proper vehicular spacing. The approach tangent preceding the dynamic scale should desirably be level and smooth for 200 ft (60 m) to enhance scale performance. The ramp downstream from the dynamic scale also should be level for 100 ft (30 m).

For trucks to achieve an acceptable speed before entering the freeway, provide an acceleration distance of approximately 2000 ft (600 m) from the static scale to a point coinciding with the 12 foot (3.6 m) width of ramp. Adjust the acceleration distance where the ramp terminal is on a grade greater than 3% or where the freeway level of service is adversely affected by the truck's merging speed. See Section 37-6.02 for additional guidance.

16-3.04(e) Detention Parking Requirements

Design the detention parking area to accommodate a minimum of 10 trucks that may be held for overweight violations or vehicle inspections. The turning roadways to and from the parking area should have a 50 ft (15 m) inside radius and are generally 30 ft (9 m) wide. Adjust the parking angle for specific site conditions. Provide a 4 ft (1.2 m) concrete shoulder on the turning roadways and parking area. See Figure 16-3.B. Provide an accessible route from the detention parking area to the scale house. See Section 58-1.05 for more information.

16-3.04(f) Scale House Parking Requirements

Provide sufficient parking for scale house staffing and maintenance needs, including the appropriate number of accessible parking spaces as shown in Figure 58-1.B.

16-3.04(g) Pavement Design

Design the weigh station ramps and detention parking area according to Section 54-1.08. Truck weighing stations are considered "high stress" locations. See Chapter 54 for pavement and shoulder design guides.

16-3.04(h) Vehicle Inspection Pit

A vehicle inspection pit may be provided to enhance the safety inspection of trucks or other special vehicles. Locate the pit adjacent to the detention parking area to provide joint parking opportunities. A schematic design is shown in Figure 16-3.E.

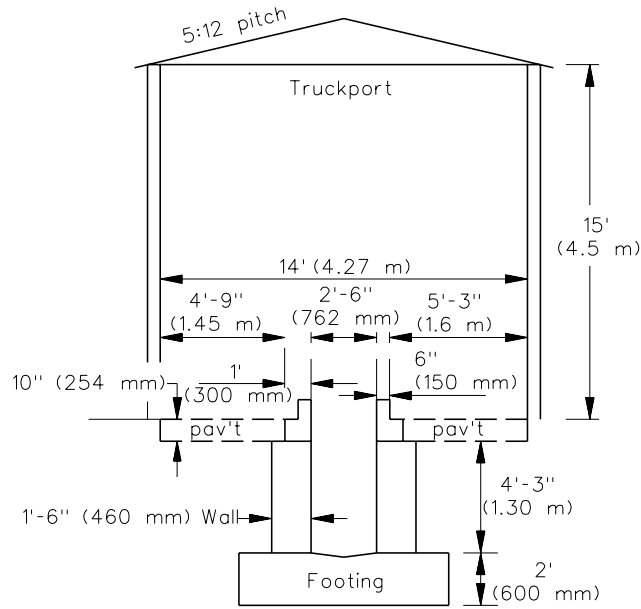

TYPICAL CROSS SECTION OF INSPECTION PIT

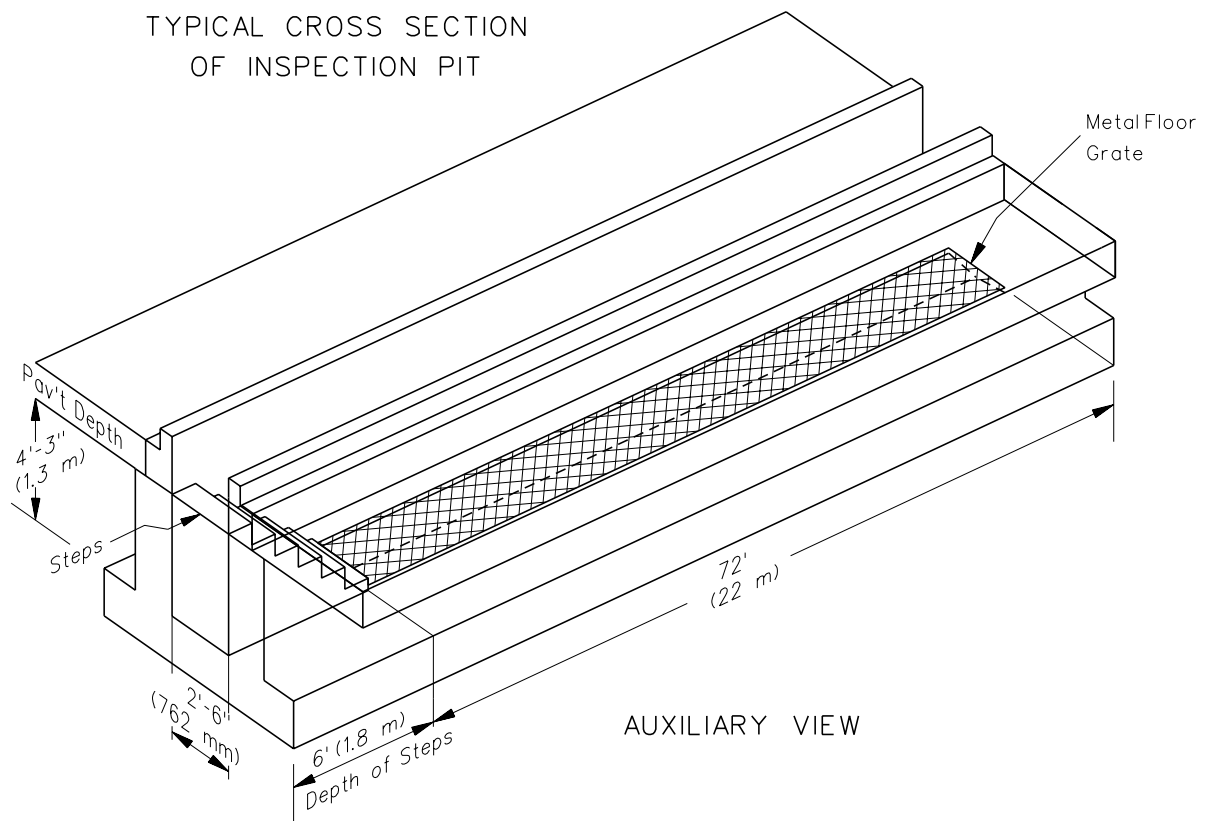

TYPICAL INSPECTION PIT DESIGN

Figure 16-3.E

16-3.04(i) Conversion of Static Scale Facility to Weigh-in-Motion

Most existing static scale weigh stations can be converted to weigh-in-motion facilities within the existing right-of-way limits. Reconstruction will be required of the exit ramp terminal, ramp proper, and detention parking area. The remaining elements of the weigh station (i.e., scale house, static scale, by-pass lane, storage lane, and acceleration ramp) only will need replacement if in deteriorated condition.

Design the exit ramp terminal as illustrated in Figure 16-3.B. With the conversion of existing facilities, the ramp should be aligned with the existing by-pass lane. Extend the existing 6 ft (1.8 m) median upstream a distance equivalent to the required storage length. Typically, a concrete barrier wall should be constructed between the by-pass and static lanes.

Widen the turning roadways to and from the detention parking area to accommodate the WB-67 (WB-20) design vehicle criteria. Design the detention parking area in a diagonal pattern according to Figure 16-3.B. The existing scale house should adequately accommodate the new WIM equipment without expansion.

16-3.04(j) Intelligent Transportation Systems (ITS)

Weigh station facilities may be provided with electronic systems that can monitor passing trucks equipped with transponders. A dynamic scale is located in the mainline pavement preceding the exit ramp to the weigh station. A roadside reader connected to the scale house computer system emits a signal to an approaching truck that is equipped with a transponder. The roadside reader relays the signal to the scale house computer, identifying the particular vehicle, while the dynamic scale computer analyzes the vehicle's weight. A record is created by merging the weight of the vehicle with the transponder information. Using the merged record, a signal is transmitted back to the transponder. A green light indicates approval to by-pass the weigh station and a red light indicates that the vehicle must exit into the weigh station for the normal weighing process.

These electronic systems can be expanded to include additional features (e.g., tracking hazardous materials, identifying mechanical malfunctions) and may be interconnected to other State systems.

16-3.05 Arterial Weigh Stations**16-3.05(a) General**

Arterial weigh stations are constructed on State highways other than freeways. This facility is typically located on one side of the highway and serves both directions of travel. The Weigh Station Committee determines the need for an arterial weigh station. A 12 ft (3.6 m) wide static scale is provided for single and dual-axle weighing.

16-3.05(b) Site Selection

Arterial weigh stations are generally located at ports-of-entry on high-volume arterial State routes. Other intra-State facilities may be located at high-volume truck routes as deemed necessary.

Where it is determined that a specific corridor of a State highway should be considered for an arterial scale facility, representatives of the district and the Weigh Station Committee will investigate feasible locations and determine a suitable site. Criteria for site selection primarily are based on availability of right-of-way, minimizing by-pass opportunities, and availability of utilities to support the scale house.

16-3.05(c) Design Guides

The geometric design of an arterial weigh station is illustrated in Figure 16-3.F and should accommodate the appropriate design vehicle for the highway classification. A facility is designed to store two or four vehicles from both directions of travel. If additional storage is required, construct auxiliary lanes on the mainline. For example, if opposing volumes restricts left-turn entry, consider providing a flush left-turn lane on the State highway.

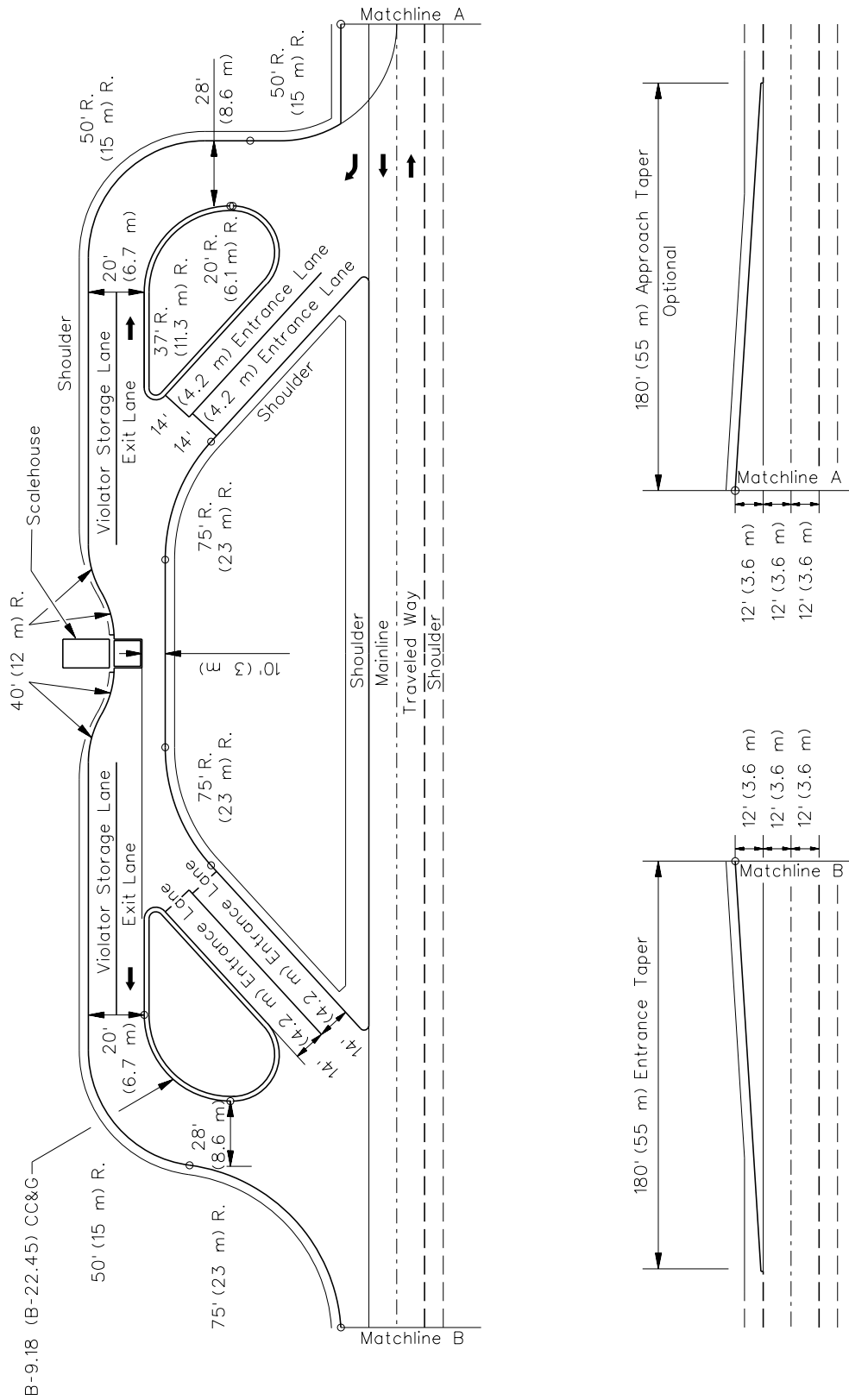

TYPICAL ARTERIAL WEIGH STATION

Figure 16-3.F

16-4 CONTRACT PLANNING AND COORDINATION

16-4.01 General

All rest area type facilities and weigh stations are inherently complex to build because they can involve as many as seven separate construction contracts to complete each project. Therefore, it is important to clearly define the scope of each contract relative to the others. Doing this can prevent overlapping scopes of work or omitting necessary work tasks. Both situations ultimately lead to expensive contractual problems in the field.

16-4.02 Scope

All rest area type facilities and weigh stations generally will be built through a combination of contracts. The following presents the recommended sequence of contract award:

1. Grading and Paving. Grading and paving, a unit-price contract, will be awarded first.
2. Outdoor Lighting. The second award will be for outdoor lighting, a unit-price contract.
3. General. The general work typically is awarded as four lump-sum contracts as follows:
 - general,
 - plumbing,
 - HVAC, and
 - electrical.

The general contractor is named as the prime contractor who coordinates the work of the other three assigned contractors.

4. Landscaping. The landscaping award, a unit-price contract, typically is the last contract to be awarded.

16-4.02(a) **Division of Work**

It is relatively simple to determine the scope of work for each contract. However, certain aspects of the work in each contract clearly affect subsequent contracts. Consider the following design elements to better avoid conflicts and omissions of scope:

1. Grading and Paving Contracts. Grading and paving contracts include the following items:
 - earthwork,
 - pavement and shoulders,
 - curbs,
 - storm sewers,
 - right-of-way fencing,

- roadway signing,
 - pavement striping, and
 - seeding.
2. Outdoor Lighting Contracts. Lighting contracts generally include the following items:
- light poles,
 - light towers,
 - sign lighting,
 - unit duct and wiring, and
 - controller.
3. General and Assigned Contracts. General and assigned contracts include the following items:
- complete buildings,
 - utility connections,
 - water system,
 - sanitary sewer system,
 - site furnishings, and
 - sidewalks.
4. Landscaping Contracts. Include the following items for landscaping contracts:
- sodding and final seeding,
 - trees and bushes, and
 - flower plantings.
5. Security/Surveillance/Code Blue. For security and surveillance concerns, consider the following:
- site placement and installation of equipment,
 - maintenance, and
 - training.

16-4.02(b) Coordination of Scope

Experience has shown that the following suggestions simplify the construction process and ultimately reduce costs:

1. Grading and Paving Contracts. Consider the following for grading and paving contracts:
- a. Topsoil. Rather than placing topsoil where buildings and sidewalks will be located, stockpile the topsoil for placement after all other general contract work is complete. This will promote better turf growth.

- b. Temporary Seeding. Specify temporary seeding for areas that will be disturbed under future contracts.
 - c. Curb Slipforming. Prohibit slipforming of portland cement concrete (PCC) curbs where they will abut PCC sidewalks. Formed PCC curbs will provide a better appearance adjacent to sidewalks.
 - d. Earthwork. Design earthwork grades in sidewalk areas to ensure compliance with accessibility requirements. Design earthwork carefully to minimize excavation during the general contract.
2. Lighting Contracts. Consider the following when preparing lighting contracts:
- a. Unit Ducts. Coordinate unit duct routing with building utilities to avoid conflicts.
 - b. Lighting Controller. Allow space in the mechanical room for the lighting controller.
3. General and Assigned Contracts. Consider the following for general and assigned contracts:
- a. Plan Limits. Establish plan limits of areas to be seeded under the landscaping contract. Beyond these limits, require restoration by the general contractor.
 - b. Topsoil Spreading. After sidewalk and building work is complete, specify the spreading of topsoil that was stockpiled during the grading and paving contract.
 - c. Topsoil Grading. Specify that topsoil remain in a rough-graded condition for the landscaping contract.
4. Landscaping Contracts. The following should be considered when preparing landscape contracts:
- a. Grading and Seeding. Specify fine grading and seeding of all areas that remained in a rough-graded condition under the general contract.
 - b. Number of Contractors. Experience has shown that only one contractor should be responsible for all landscaping work within a clearly defined area. Otherwise, unneeded conflicts will arise.

16-5 REFERENCES

1. NCHRP Report 324, *Evaluation of Safety Roadside Rest Areas*, Transportation Research Board, 1989.
2. *Traffic Characteristics on Illinois Highways — Bi-Annual Report OPP*.
3. *A Policy on Geometric Design of Highways and Streets*, AASHTO, 2011.
4. *2010 ADA Standards for Accessible Design*, United States Department of Justice, September 15, 2010.
5. *Illinois Accessibility Code*, Capital Development Board, April 24, 1997.

Chapter Seventeen

**BICYCLE AND PEDESTRIAN
ACCOMMODATIONS**

BUREAU OF DESIGN AND ENVIRONMENT MANUAL

Chapter Seventeen
BICYCLE AND PEDESTRIAN ACCOMMODATIONS

Table of Contents

<u>Section</u>	<u>Page</u>
17-1 BICYCLE ACCOMMODATIONS: POLICIES AND PROCEDURES	17-1.1
17-1.01 Definitions	17-1.1
17-1.02 Policies	17-1.4
17-1.02(a) Exceptions to Consideration of Accommodations – Access Controlled Facilities	17-1.5
17-1.02(b) Consideration of Accommodations on Resurfacing Projects	17-1.5
17-1.03 Bikeway Warrants - Needs Assessment.....	17-1.6
17-1.04 Documenting Bicycle Travel Accommodation Warrants	17-1.7
17-1.05 Maintenance	17-1.8
17-1.06 Right-of-Way	17-1.8
17-1.07 Funding	17-1.8
17-2 DESIGN GUIDANCE AND CRITERIA FOR BICYCLE FACILITIES.....	17-2.1
17-2.01 Documentation Requirements and Procedures	17-2.1
17-2.02 On-Road Accommodations	17-2.4
17-2.02(a) Paved Shoulders on Rural Roadways	17-2.6
17-2.02(b) Shared Roadways and Shared Lanes	17-2.6
17-2.02(c) Conventional and Buffered Bicycle Lanes	17-2.9
17-2.02(d) Separated Bicycle Lanes on Urban and Suburban Roadways.....	17-2.15
17-2.02(e) Intersection and Interchange Treatments	17-2.17
17-2.02(f) Accommodations on Highway Structures	17-2.28
17-2.02(g) Road Diets and Lane Width Reductions.....	17-2.32
17-2.02(h) Other Design Considerations	17-2.35
17-2.02(i) Bicycle Routes	17-2.37
17-2.02(j) Signing, Marking, and Traffic Control	17-2.38
17-2.03 Off-Road Accommodations (Shared-Use Paths).....	17-2.41
17-2.03(a) Consideration of All Users.....	17-2.42
17-2.03(b) Width and Clearance.....	17-2.44
17-2.03(c) Side Path Separation from Traffic	17-2.46
17-2.03(d) Additional Safety Considerations.....	17-2.49
17-2.03(e) Design Speed	17-2.49
17-2.03(f) Horizontal Alignment and Superelevation.....	17-2.50
17-2.03(g) Drainage	17-2.53
17-2.03(h) Grade.....	17-2.54
17-2.03(i) Accessible Width.....	17-2.54
17-2.03(j) Sight Distance.....	17-2.54

Table of Contents

(Continued)

<u>Section</u>		<u>Page</u>
	17-2.03(k) Path Intersections	17-2.54
	17-2.03(l) Independent Path Structures.....	17-2.61
	17-2.03(m) Paths on Highway Structures	17-2.66
	17-2.03(n) Paths Through Interchanges	17-2.69
	17-2.03(o) Signing and Marking	17-2.69
	17-2.03(p) Lighting	17-2.70
	17-2.03(q) Restriction of Motor Vehicle Traffic.....	17-2.70
	17-2.03(r) Pavement Structure	17-2.71
17-2.04	Accommodations Through a Roundabout	17-2.76
	17-2.04(a) Traversing Roundabouts like Motorized Vehicles.....	17-2.76
	17-2.04(b) Traversing Roundabouts like Pedestrians	17-2.77
17-3	BICYCLE OPERATING CHARACTERISTICS.....	17-3.1
17-4	PEDESTRIAN ACCOMMODATIONS.....	17-4.1
	17-4.01 General	17-4.1
	17-4.02 Pedestrian Warrants – Needs Assessment	17-4.1
	17-4.03 Sidewalk Design Considerations	17-4.2
	17-4.04 Sidewalks on Highway Structures	17-4.3
	17-4.05 Intersection Crosswalks	17-4.6
	17-4.06 Midblock Crosswalks.....	17-4.7
	17-4.07 Safety Rails and Handrails	17-4.10
	17-4.08 Documentation.....	17-4.12
	17-4.09 Pedestrian Accommodations During Construction.....	17-4.12
17-5	REFERENCES.....	17-5.1
17-6	BICYCLE CHECKLISTS AS INCLUDED ON BTA FORM (BDE 1702)	17-6.1
17-7	PROPOSED RESOLUTION LANGUAGE FOR MUNICIPALITIES IN OPPOSITION	17-7.1

Chapter Seventeen

BICYCLE AND PEDESTRIAN ACCOMMODATIONS

When planning transportation improvements, the Department considers the travel needs of all users of a transportation corridor including bicyclists and pedestrians. Bicycle and pedestrian travel demand in the vicinity of a project is to be determined in the scoping and early project planning phases. When sufficient demand is indicated the Department will provide the appropriate accommodations by applying guidelines presented in Chapter 17.

Chapter 1 of the *AASHTO Green Book* identifies five context classifications that integrally affect the design of a transportation facility. These contexts – rural, rural town, suburban, urban, and urban core – were originally presented in NCHRP Report 855, *An Expanded Functional Classification System for Highways and Streets*. Primary factors that lead to the designation of a context classification include development density, land uses, building setbacks, and population density. The character of development along a corridor may vary such that a single project may include more than one context classification. Simply applying geometric criteria without regard to context and roadway user needs will not adequately meet the expectations of the traveling public and local community. This chapter acknowledges the *AASHTO Green Book* context classifications in making pedestrian and bicyclist accommodation decisions, and references context throughout.

Policies relating to accessibility, including curb ramps, crossing controls, and overpasses and underpasses are addressed in Chapter 58. Financial and maintenance responsibilities for bicycle and pedestrian accommodations are addressed in Chapter 5.

17-1 BICYCLE ACCOMMODATIONS: POLICIES AND PROCEDURES

17-1.01 Definitions

The following terms and definitions apply to Chapter 17:

1. Bicycle and Pedestrian Policy Engineer (BPPE). The engineer within the Bureau of Design and Environment, who is accountable for the development and interpretation of the engineering policies that govern the design of bicycle and pedestrian facilities.
2. Bicycle Box or Bike Box. A designated area on an approach to a signalized intersection, typically between an advance motorist stop line and the crosswalk, intended to provide bicyclists with a visible place to wait in front of stopped vehicles during the red signal phase.

3. Bicycle Facilities. A broad term which includes bikeways, shared roadways, shoulders (which may be used by bicyclists), shared-use paths, traffic control devices, shelters, and parking facilities for bicycles.
4. Bicycle Lane or Bike Lane. That portion of the traveled way that is designated for bicyclist use by pavement marking/symbols and optional signing. The bicycle lane width includes any buffer areas. Without buffers these lanes may be called conventional bike lanes.
5. Bicycle Level-of-Service (BLOS). A measure of on-road bicycle service quality along road segments that is based on studies of bicyclist perception of safety and comfort. The BLOS model considers a variety of factors influencing bicycle service quality and computes a numerical base score that is translated into a level of service ranging from A (best) to F (worst). Intersections are not considered. The *Highway Capacity Manual* describes BLOS computations in detail.
6. Bicycle Travel Assessment (BTA). The standard evaluation performed to determine whether bikeway warrants are met and bicycle accommodations should be included as part of a project. A BTA form BDE 1702 is used to document the results of the evaluation and describe the accommodations to be provided.
7. Bikeway. A generic term for any road, street, path, or way which is specifically designated for bicycle travel and provides space reserved for bicyclists distinct from motor vehicle traffic.
8. Buffered Bicycle Lane. A bicycle lane that includes a primary riding area and additional width to increase separation of bicyclists from vehicular traffic. The buffer area comprises a pattern of standard longitudinal markings and added chevron or diagonal markings for larger buffer widths.
9. Excessive Cost. In documenting whether pedestrian and bicycle facilities must be included in projects according to the *Illinois Highway Code*, excessive cost typically involves adding at least 20% to the total cost of a project not providing accommodation.
10. Leading Pedestrian Interval (LPI). The practice of displaying the walk symbol to pedestrians several seconds ahead of parallel vehicular traffic receiving a green signal allowing pedestrians a 'head start' to occupy the crosswalk and increase their visibility to both right-turning and left-turning drivers.
11. Municipality. A city, village, or incorporated town in the State of Illinois (65 ILCS 5/1-1-2).
12. Rural Roadway. To guide the process of bicycle facility selection and design, rural roadways are discussed in this chapter as those generally in undeveloped and low-density development areas, with shoulders along the edges of the traveled way. These roadways are most generally present in the AASHTO rural *town* and *rural* contexts and may have posted speeds of 30 mph (in town) to 55 mph.
13. Separated Bicycle Lane (SBL). A portion of the roadway that is designated for use by bicyclists and is physically separated from the vehicle traveled way by horizontal distance

and vertical elements such as flexible delineators, longitudinal raised curb islands, or parking lanes. SBLs are usually designed for one-way bicycle travel in the same direction as the adjacent lane, but may be designed for two-way bicycle travel when operationally justified. SBLs are also sometimes called protected bicycle lanes.

14. Shared Lane. A travel lane where motor vehicles and bicyclists share operating space. For projects on state routes shared lanes will typically be widened to a minimum of 14 ft (4.2 m) to provide adequate space for drivers to pass bicyclists while staying in the lane and providing the “three feet clear” distance required by state law.
15. Shared Roadway. Any roadway upon which a bicycle lane is not designated and which may be legally used by bicyclists, regardless of whether such facility is specifically identified as a bikeway.
16. Shared-Use Path/Side Path. A facility within public right-of-way but physically separated from the roadway, intended for bicycle and other non-motorized transportation (e.g., pedestrians, in-line skaters). A “side path” is typically located parallel within the road right-of-way. The terms “shared-use path” and “path” are used interchangeably throughout this chapter in discussing these facilities. “Trails” are considered recreational facilities, are often unpaved, and are not covered by this policy.
17. Suburban Roadway. To guide the process of bicycle facility selection and design, suburban roadways are discussed in this chapter as those in outlying portions of urban areas, with low-to moderate development densities, off-street parking, and posted speeds of 40 to 45 mph. Suburban roadways may incorporate either curb and gutter or shoulders along the edges of the traveled way and are generally found within the AASHTO *suburban* context.
18. Two-Stage Bicycle Turn Box. An area set aside for bicyclists, outside of the travel paths of motor vehicles and pedestrians, to queue to turn at a signalized intersection, and avoid having to merge across traffic ahead of the turn.
19. Urban Roadway. To guide the process of bicycle facility selection and design, urban roadways are discussed in this chapter as those generally in high-density development areas and generally incorporating curb and gutter along the edges of the traveled way, and quite often parking. With posted speeds of 40 mph and lower, these roadways are most generally found in the AASHTO *urban core* and *urban* contexts but occasionally also in the *rural town* context.

17-1.02 Policies

The *Illinois Highway Code*, 605 ILCS 5/4-220, states (*in part*):

1. Bicycle and pedestrian ways shall be given full consideration in the planning and development of transportation facilities, including the incorporation of such ways into State plans and programs.
2. In or within one mile of a municipality with a population of over 1,000 people, (...*redacted*...), the Department shall establish and solely fund bicycle and pedestrian ways in conjunction with the construction, reconstruction, or other change of any State transportation facility except:
 - a. in pavement resurfacing projects that do not widen the existing traveled way or do not provide stabilized shoulders.
 - b. where approved by the Secretary of Transportation based upon documented safety issues, excessive cost, or absence of need; or
 - c. where the municipality passes a resolution stating that a bicycle or pedestrian way does not fit within its development plan.
3. Bicycle and pedestrian ways may be included in pavement resurfacing projects when local support is evident or the bicycling and walking accommodations can be added within the overall scope of the original roadwork.
4. The Department shall establish design and construction standards for bicycle and pedestrian ways.

Providing for the needs of pedestrians and bicyclists is a key goal of this policy. Therefore, an assessment of non-motorized transportation needs and appropriate accommodation is central to the fulfillment of the policy. The location of a project in either areas covered in the *Illinois Highway Code* above or other areas is in and of itself insufficient to make accommodation decisions. On each project it is necessary to:

- Where bicyclists and pedestrians are legally allowed to use the roadway, evaluate and document safety issues and warrants specific to the project.
- If warrants are not met, document the absence of need in the Phase I engineering report.
- If warrants are met, assess the appropriate type(s) of accommodation and coordinate with the local agency.
- Where warrants are met and the local agency is supportive, the Secretary must specifically approve omission of accommodations in areas covered in the law on the basis of documented safety issues, excessive cost, or absence of need. BDE 1701 shall be used to request such an omission. The BPPE concurrence should be sought for any omissions in other areas of the State. As safety issues and costs will vary greatly depending on the

characteristics of the project, there will not be simple and absolute guidelines. A cost analysis would include all costs specifically attributable to the accommodation, including construction costs, environmental mitigation, and right-of-way, as applicable. However, needs will be based on whether warrants have been met as defined in Section 17-1.03.

Exceptions to the provision of bicycle accommodations cannot be considered simply because a roadway is identified in the Illinois Official Bicycle Maps as unsuitable for bicycling. Current usability or comfort to cyclists does not preclude a roadway project from bicycle consideration or this policy.

Furthermore, the Illinois Highway Code, 20 ILCS 2705/2705-625 states (in part):

Every state route project within municipal boundaries, regardless of scope, shall make improvements to bicycle and pedestrian safety within 500 ft beyond the limits of the scoped project. The intent of the 500 ft intersection rule is to provide continuity for bicycle improvements and accelerate the implementation of bicycle and pedestrian safety features. These features shall be in alignment and complement the scope of the project.

Improvements are limited to those that follow the design guidance within Chapters 17 and 58 and current Operations policies. Examples include but are not limited to signs, pavement markings including crosswalks and bicycle pavement markings, beacons, signal improvements such as APS and ADA pushbuttons, countdown heads or leading pedestrian interval timing, bus stop accommodations, and lighting improvements.

17-1.02(a) Exceptions to Consideration of Accommodations – Access Controlled Facilities

Projects on interstate highways, or other roadways where bicycles and pedestrians are prohibited, can be excluded from consideration of accommodations. As such, no warrant analyses or needs assessments are required. In rare circumstances, incorporation of separated accommodations along access-controlled facility right-of-way may be possible in coordination with the Secretary and FHWA.

However, consideration for bicycle and pedestrian accommodations on roads/bridges crossing such roadways are typically appropriate. Especially in urban and suburban contexts, strive to reserve sufficient space along crossing roadway approaches and bridges for pedestrian and bicycle facilities which may be added in the future.

17-1.02(b) Consideration of Accommodations on Resurfacing Projects

On pavement resurfacing projects that do not widen the existing traveled way nor provide stabilized shoulders bicycle accommodation is not mandated by 605 ILCS 5/4-220. However, the need for and feasibility of providing an accommodation should still be assessed in the scoping phase based on the statutory provisions on local support and accommodation within the overall scope of each project. Chapter 1 of the *AASHTO Green Book* encourages designers to consider all potential road users and apply flexibility for “projects on existing roads”. The potential for

reallocation of available roadway space is a fundamental decision that must be made on all resurfacing projects except those in rural contexts. On some state routes there may be excess capacity that encourages faster speeds and discourages use by pedestrians and bicyclists. Such locations are particularly well-suited for reallocation of space on resurfacing projects since slower travel speeds and improved safety may result in conjunction with appropriately reduced motor vehicle capacity.

On rural route resurfacing projects, the presence of a bicycle warrant may affect paved shoulder rumble strip considerations; these issues are discussed in Chapter 34. Adding paved shoulder width will typically be constrained by scope considerations.

If sufficient width is available, bike lanes or shared lanes can be created in a resurfacing project by adjusting the pavement markings at very little cost. In other cases, reducing the number of through travel lanes through a Road Diet or eliminating parking may provide sufficient space for adding an accommodation. Evaluate trade-offs in terms of vehicle capacity, vehicle travel times, bicycle and pedestrian facility widths, potential levels of bicycle use, on-street parking, potential vehicle speed reduction, and overall user safety. For certain project locations and contexts, a decision could be made during scoping that accommodations are infeasible; for most resurfacing projects assessments should be performed and decisions documented. Refer to the FHWA *Road Diet Informational Guide* and Section 17-2.02(g) for more information on these types of projects.

17-1.03 Bikeway Warrants - Needs Assessment

The Department shall provide on-road or off-road accommodations for bicycle travel in highway projects when any of the following warrant conditions exist:

1. The highway or street is designated as a bikeway or recommended bike route in a regionally or locally adopted bike plan or map. Note that regional or local maps should not be confused with the Illinois Official Bicycle Maps, which depict current bicycling conditions and should not affect decisions on accommodations.
2. The projected two-way bicycle traffic volume (see Section 17-1.04) will approximate 25 ADT or more during the peak three months of the bicycling season five years after completion of the project.
3. The route provides access to a park, recreational area, school, or other destination expected to attract bicycle traffic.
4. The route provides access across a natural or man-made barrier (e.g., bridges over rivers, bridges over railroad tracks/yards, bridges over freeways or expressways, highways through a national forest). Bicyclists shall be accommodated on the bridge, unless bicycles are otherwise prohibited to operate on the roadway approaches. See Sections 17-2.02(f) and 17-2.03(m) for bridge deck replacement or rehabilitation projects or for culvert replacement projects. For projects that meet no other warrants, a minimum shoulder width of 4 ft (1.2 m) with standard height parapet or bridge rail shall satisfy this warrant. For projects that meet this and other warrants, use the guidance provided in the Bicycle Facility Selection Table (Figure 17-2.A) and incorporate bridge railings appropriate for bicyclists.

5. The highway project will negatively affect the recreational or transportation utility of an independent bikeway or trail. Highway projects will negatively affect at-grade paths and trails when they are severed, when the projected roadway traffic volumes increase to a level that prohibits safe crossings at-grade, or when the widening of the roadway prohibits sufficient time for safe crossing. If certified by the State or local agency having jurisdiction as being programmed for construction no later than five years beyond the anticipated completion of the highway project, treat proposed or planned bikeways that cross or parallel a roadway as an existing facility. Specific improvements to address such facilities can potentially be included in projects.

Multilane arterial roads can create substantial barriers to bicycling and walking, if not properly planned and designed. A connected network is necessary for bicycling or walking to be practical and feasible, and this policy seeks to expand connected networks. Development centers along state routes should be conveniently accessible by foot and by bike. State routes can provide regional connections that encourage greater numbers of people to bike and walk. Not all residents and workers may have access to private vehicles, so there is also an equity aspect to consider in designing IDOT facilities.

Problems can arise when accommodations start and stop such that users do not have clearly defined ways to proceed safely from the end of a bikeway accommodation. When looking at bicycle warrants and the need for accommodation as part of a project, designers are therefore encouraged to examine the overall network available to bicyclists. Connected and integrated networks provide transportation options to likely destinations and consider reasonable termini. Corridors should be considered for accommodation as part of a longer-term plan to provide for continuous bicycle travel and for connection to contiguous routes. As an example, an intersection improvement could include bike lanes in anticipation that adjacent areas could have bike lanes added in the future. Project limits may be extended beyond highway improvements for reasonable distances to connect to bicycling facilities at nearby intersections or to avoid short accommodation gaps. Reflect such extensions in the Phase I report. Documentation requirements and procedures are covered in Sections 17-1.04 and 17-2.01.

17-1.04 Documenting Bicycle Travel Accommodation Warrants

Assess bicycle travel demand in the project scoping phase or early in the project planning stage. The concepts of identifying cycling origins and destinations, and thus travel demand, are discussed in the FHWA publication *Selecting Roadway Design Treatments to Accommodate Bicycles*. Like motorists, many bicycle riders seek direct routes and require access to destinations immediately along arterial and collector roadways. Demand can therefore seldom be assumed to be satisfied by the presence of an alternate route. Because of the potential for bicycle travel, accommodation will likely be warranted in all urban core and in most urban and suburban areas. In all contexts, consider commercial, recreational, or other development near or along highways that may generate bicycling activity.

The first use of BTA form BDE 1702 on projects is to assess and document bicycle travel needs and accommodation decisions. The BTA is to be used on all projects other than those excluded

under the *Illinois Highway Code* or where accommodations are clearly infeasible, including some resurfacing projects as described in Section 17-1.02(b). Bicycle origins and destinations should be reviewed. A map to illustrate travel generators and travel paths, a checklist for organization and public coordination, an overall assessment of bike warrants and travel in the project area, and a record of local coordination are to be included in the BTA. The completed sections of the form should be reviewed by the district bicycle coordinator, as it provides the basis for evaluating whether or not a travel demand warrant for bicycle accommodation has been met. The process used in subsequent accommodation decisions is described in 17-2.01.

17-1.05 Maintenance

Normally, responsibility for ongoing maintenance of bikeway facilities on the roadway surface and not separated from other traffic is assumed to be an integral part of the roadway. The state will assume maintenance of these facilities, although local agency maintenance agreements are sometimes developed by the districts for the restriping of bike lane and crosswalks. Responsibility for maintenance of bikeway and pedestrian facilities separated from motorized traffic should be delegated by agreement with local jurisdictions or others early in the project planning process. For example, separated bike lanes will become part of local maintenance responsibilities; refer to Chapter 5.

17-1.06 Right-of-Way

Acquire right-of-way for bikeway and pedestrian facilities in accordance with existing IDOT land acquisition policies and procedures. Additional right-of-way required for bikeway and pedestrian purposes should be purchased in conjunction with the right-of-way for the overall roadway improvement.

17-1.07 Funding

Bicycle and pedestrian facilities are considered an integral part of a highway project for funding purposes and thus are eligible for federal cost participation as discussed in Chapter 5.

17-2 DESIGN GUIDANCE AND CRITERIA FOR BICYCLE FACILITIES

The Department utilizes the *Guide for the Development of Bicycle Facilities (AASHTO Bike Guide)* as the primary basis for design. The guide provides information on the physical infrastructure needed to support bicycling. The Bicycle Facility Selection Table, Figure 17-2.A, is based on the most recent AASHTO guidance and includes BLOS evaluations. Only on-road accommodations are listed; side paths are considered independently.

The FHWA issues guidance on the design and implementation of bicycle and pedestrian accommodations. FHWA websites and publications, including those listed at the end of this chapter, can be reviewed for additional design guidance and ideas. The *National Association of City Transportation Officials Urban Bikeway Design Guide (NACTO Bikeway Guide)* includes many bicycle design features which have been proven effective in locations including larger cities in the United States. Use of the *NACTO Bikeway Guide* is endorsed by FHWA and is often appropriate to enhance the safety and mobility of bicyclists. Design features in FHWA publications, the *NACTO Bikeway Guide*, or other recognized guidance documents may be proposed as long as they are fully compliant with the *ILMUTCD* and discussion in this chapter. Additional guidance and information on accommodation measures for bicyclists and pedestrians is included in the department's *Bicycle and Pedestrian Accommodations Study (2019)*. In all cases coordinate bicycle facility design with the cross section criteria presented in Part IV "Roadway Design Elements" and Part V "Highway Systems."

17-2.01 Documentation Requirements and Procedures

The incorporation of context in design decisions allows for appropriate assessment of the needs of all transportation modes within a corridor, especially pedestrians and bicyclists. Urban and urban core areas, higher-density suburban areas and rural towns often have land uses that generate higher rates of bicycling and walking and a greater variety of users, including many who are less confident and therefore adequately comfortable only on separated facilities. User profiles are considered in the Bicycle Facility Selection Table and discussed in the following section, On-Road Accommodations. Reducing the comfort level of a bike facility will generally reduce the numbers and types of bicyclists using the facility.

When one or more of the warrants presented in Section 17-1.03 are met accommodation is required. Preliminary design should be guided by the Bicycle Facility Selection Table, considering options where listed. These are the base accommodation options. Local coordination and site conditions may sometimes constrain the accommodation and necessitate an adjusted design. Providing the highest-and-best bikeway facility that conditions and context dictate is better than providing no bike accommodation.

Roadway Characteristics ^{8/}	Type and Width of Bicycle Accommodation ^{1/, 2/}			
	Paved Shoulder	Wider Outside Lane	Bicycle Lane including Buffers ^{3/}	One-way Separated Bicycle Lane ^{4/, 5/}
Rural Roadway Two-Lane, ≤ 40 mph				
Design Year ADT < 2,900	3 ft (0.9 m) ^{6/}	14 ft (4.2 m) ^{7/}		
Design Year ADT 2,900 - 8,000	4 ft (1.2 m)			
Design Year ADT > 8,000	5 ft (1.8 m)			
Rural Roadway Two-Lane, ≥ 45 mph				
Design Year ADT < 2,750	3 ft (0.9 m) ^{6/}			
Design Year ADT 2,750 - 5,000	4 ft (1.2 m)			
Design Year ADT 5,001 - 10,000	5 ft (1.5 m)			
Design Year ADT > 10,000	6 ft (1.8 m)			
Rural Roadway Multilane, All Speeds				
Design Year ADT < 12,000	6 ft (1.8 m)			
Design Year ADT ≥ 12,000	8 ft (2.4 m)			
Urban Roadway Two-Lane, <30 mph				
Design Year ADT < 2,900		14 ft (4.3 m) ^{7/}	5 ft (1.5 m)	
Design Year ADT 2,900 - 4,000			5 ft (1.5 m)	
Design Year ADT > 4,000			6 ft (1.8 m)	
Urban Roadway Two-Lane, 30-35 mph				
Design Year ADT < 2,900			5 ft (1.5 m)	
Design Year ADT 2,900 - 4,000			6 ft (1.8 m)	7 ft (2.1 m)
Design Year ADT 4,001 – 9,500			7 ft (2.1 m)	7 ft (2.1 m)
Design Year ADT > 9,500			8 ft (2.4 m)	7 ft (2.1 m)
Urban Roadway Two-Lane, 40 mph				
Design Year ADT < 3,500			6 ft (1.8 m)	7 ft (2.1 m)
Design Year ADT 3,500 – 7,700			7 ft (2.1 m)	7 ft (2.1 m)
Design Year ADT > 7,700			8 ft (2.4 m)	7 ft (2.1 m)
Suburban Roadway Two-Lane, 40-45 mph				
Design Year ADT < 6,500	6 ft (1.8 m)			7 ft (2.1 m)
Design Year ADT ≥ 6,500	8 ft (2.4 m)			7 ft (2.1 m)
Urban Roadway Four-Lane, <30 mph				
Design Year ADT < 5,800		14 ft (4.3 m) ^{7/}	5 ft (1.5 m)	
Design Year ADT 5,800 - 8,000			5 ft (1.5 m)	
Design Year ADT > 8,000			6 ft (1.8 m)	
Urban Roadway Four-Lane, 30-35 mph				
Design Year ADT < 5,800			5 ft (1.5 m)	
Design Year ADT 5,801 – 8,000			6 ft (1.8 m)	7 ft (2.1 m)
Design Year ADT 8,001 – 19,000			7 ft (2.1 m)	7 ft (2.1 m)
Design Year ADT > 19,000			8 ft (2.4 m)	7 ft (2.1 m)
Urban Roadway Four-Lane, 40 mph				
Design Year ADT < 7,000			6 ft (1.8 m)	7 ft (2.1 m)
Design Year ADT 7,000 – 15,400			7 ft (2.1 m)	7 ft (2.1 m)
Design Year ADT > 15,400			8 ft (2.4 m)	7 ft (2.1 m)
Suburban Roadway Four-Lane, 40-45 mph				
Design Year ADT < 13,000	6 ft (1.8 m)			7 ft (2.1 m)
Design Year ADT ≥ 13,000	8 ft (2.4 m)			7 ft (2.1 m)

BICYCLE FACILITY SELECTION TABLE

FIGURE 17-2.A (1 of 2)

Notes:

- 1/ A shared use path adjacent to the roadway (i.e., a side path) is an option that fulfills accommodation requirements in most situations. A side path can be selected whenever it is locally supported and the locals agree to maintain it. Two-way side paths shall be a minimum of 10 ft (3.0 m) wide.
- 2/ All widths shown are considered minimums for typical design situations. Wider facilities can be provided. Project-level assessments of highest-and-best facilities may also affect widths provided.
- 3/ Bicycle lane widths are measured from the outside lane line to the face of curb or edge of parking lane. Bicycle lane widths of 5 to 6 ft *may* be buffered; widths greater than 6 ft *must* be buffered. Buffer striping is included in the bicycle lane widths shown.
- 4/ One-way separated bicycle lane width shown is the minimum clear width between vertical features and allows bicycle passing. Additional width is needed for vertical elements such as raised curbs, tubular markers with striped buffer, or parking lanes. Each jurisdiction may identify larger minimum clear width restrictions based on maintenance requirements.
- 5/ As an alternate to a one-way SBL, a two-way SBL of a minimum 8 ft (2.4 m) clear width can be provided on one side of the roadway. Additional width is needed for vertical elements.
- 6/ This value assumes no rumble strips are present. If rumble strips will be installed, utilize Standard 642006 and increase the paved shoulder width to 4 ft (1.2 m) to maintain the required 3 ft (0.9 m) clear width for bicycles.
- 7/ Truck (Single Unit + Multi-Unit) volumes should be less than 3% of ADT in order to select a Wider Outside Lane accommodation. Refer to Figure 17-2.C for measurement of the Wider Outside Lane.
- 8/ Refer to Section 17-2.03. Determine Project Context in the Scoping Phase. Speeds listed refer to posted speed limits and are assumed consistent with the 85th percentile speed.

BICYCLE FACILITY SELECTION TABLE**Figure 17-2.A (2 of 2)**

There are situations in which the principles of Context Sensitive Solutions (CSS) and Complete Streets conflict. Refer to Chapter 19 and 605 ILCS 5/4-219 for CSS principles and requirements. In instances where the requirements of the Complete Streets Law run counter to the consensus view of project stakeholders, the Regional Engineer will determine the accommodation solution, or lack thereof, typically in consultation with BPPE. After need has been established and the required accommodation has been identified using the Bicycle Facility Selection Table, it is the responsibility of the district to convey this information to the appropriate local agency. If the local agency believes the accommodation will not fit with their development plan for the area, the Department will request the local agency pass a resolution indicating as such and a copy will be included in the Phase I report. Proposed resolution language is included in Section 17-7. With the passage of a resolution the Department is no longer compelled by law to establish the accommodation; however, the Department may consider options to incorporate the next highest-and-best accommodation in consideration of project context and constraints.

If it is determined that the accommodation(s) in the Facility Selection Table cannot be built without excessive cost or disruptive ROW considerations, then the next highest-and-best accommodation shall be considered in order to achieve the highest comfort/safety for the user in light of the project's cost, local development plans, and ROW considerations. An example of a next highest-and-best accommodation is provision of a paved shoulder width (rural contexts) or bicycle lane width (urban contexts) less than those shown in the Bicycle Facility Selection Table. In such cases BLOS would be checked as described in Section 17-2.02. Selection of next highest-and-best accommodations shall be determined on a case-by-case basis by the district, as many variables will need to be considered. This may become an iterative process when considering all project variables. The lowest level of accommodation that may meet the intent of this policy is a shelf of sufficient width to allow for future path construction within right-of-way. In rare cases, another example could be to identify a parallel route adjacent to the state highway as the highest-and-best accommodation, but only when direct accommodation on the state route is determined infeasible and the parallel route would fill a critical gap in the bikeway network. Once all analyses and decisions are complete the BTA form should be signed by the district bicycle coordinator and included in the Phase I report.

17-2.02 On-Road Accommodations

On-road bicycle accommodations include paved shoulders, wider outside lanes, bicycle lanes, and separated bicycle lanes. Choice of accommodation is dependent on project context, roadway type, traffic volumes and speed; the base on-road accommodations are presented in the Bicycle Facility Selection Table. Whenever on-road accommodations are selected it is advisable to perform project-specific BLOS analysis prior to moving forward with local coordination. BLOS provides an estimate of bicyclist perceived safety and comfort – considering lane width, motor vehicle volumes, percent trucks (SU + MU), posted speed limit, and pavement condition. A better BLOS may result in more bicyclists using a facility.

Several bicyclist design user profiles have been developed through national research. There are “somewhat confident” and “highly confident” groups that makes up ten to fifteen percent of the total population. A much larger group is identified as “interested but concerned.” They comprise

just over fifty percent of the population and may not be comfortable in certain bike lanes, usually preferring separated facilities. Note that children were not considered in this research. In order to properly address the varying confidence levels of potential users, this policy introduces an assessment of BLOS as a part of design decision making. IDOT considers it appropriate to target BLOS C in the urban core, urban, and rural town contexts where a high number of bicyclists may desire to commute or otherwise travel on-road. This level of accommodation could encourage a substantial portion of the “interested but concerned” population segment to utilize facilities, making the accommodation provision cost effective in these contexts. In the rural context (higher speed roadways) most potential users would be in the highly confident group and a lower level of service, approximated by BLOS D, is considered acceptable. In the suburban context an intermediate BLOS C/D is the appropriate target.

The accommodations listed in the Bicycle Facility Selection Table have been checked for a reasonable range of variables and will typically provide the target minimum BLOS. When trucks (SU + MU) exceed 4 percent the results of BLOS analysis are less reliable due to data limitations of the model; coordinate the analysis with BPPE in those cases and work to provide a higher level accommodation.

Use one of the two worksheets provided in form BDE 1703 to calculate BLOS. The assessment applies to paved shoulders, bicycle lanes and shared lanes (e.g. wider outside lanes). Input needed for the calculation includes lane and shoulder widths, vehicle traffic volume, traffic speed (typically use posted speed), truck percentage, and pavement surface condition (CRS). For traffic volume typically use design year ADT. Since the pavement surface condition will deteriorate over time it is appropriate to use a “fair” condition (CRS 5 to 6) to approximate the conditions that will be near the end of the project design life. The presence of intermittent on-street parking along a paved shoulder accommodation can negatively affect BLOS. A Shoulder Accommodation worksheet is available that allows consideration of the effects of such parking, which may sometimes be present in a rural town context. Such parking effects would not be seen in other rural contexts. The Bike Lane Accommodation worksheet does not allow consideration of parking encroachment; bike lanes cannot legally be blocked by parked or standing vehicles.

When the calculation shows an accommodation would likely not provide the target minimum BLOS (C through D depending on context), consider adjusting the design width (e.g. widen for a buffered bike lane) or instead incorporating a side path. A path fulfills accommodation requirements in most situations. Local coordination would then move forward with the adjusted accommodation. Additional information on BLOS is available in Chapter 15 of the *Highway Capacity Manual*.

On-road accommodations often place cyclists and motor vehicles in close proximity to one another, especially when motor vehicles are passing (i.e. overtaking) a cyclist. Illinois law (625 ILCS 5/11-703) requires motorists to give at least 3 feet of clearance to cyclists when passing but this law is not always followed. Using engineering judgement, “Bicycle Passing Signs” (R4-I102) may be installed to increase awareness and compliance with this requirement. Refer to the Bureau of Operations’ policy OPS-T-10.

17-2.02(a) Paved Shoulders on Rural Roadways

On-road bicycle accommodation on rural roadways typically consists of providing a paved shoulder. Paved shoulders can accommodate bicycle travel efficiently and offer many other benefits (e.g., added safety, reduced maintenance, rural mail delivery). The typical bicyclist in rural contexts is the recreational (i.e., highly confident) bicyclist. Other users do not feel comfortable on high-speed roadway shoulders, but there are usually no reasonable alternatives on rural roadways. Use the Bicycle Facility Selection Table to determine the appropriate width. The table specifies widths that will generally provide a BLOS D, which is considered sufficient for travel by the recreational bicyclist. When rumble strips are installed in a paved shoulder which serves as a bicycle accommodation and the width of the paved shoulder is 6 ft (1.8 m) or less the 8 in (200 mm) rumble strip design should be used to minimize the impact to the accommodation.

Where the shoulder widths shown in the Table cannot be provided, a narrower shoulder might still be considered an adequate bicycle accommodation. A 3 ft (0.9 m) minimum clear width beyond a rumble strip is required to qualify as an accommodation. If rumble strips *will or may* be installed on a paved shoulder where bicycle warrants are met, always provide a minimum 4 ft (1.2 m) paved width to maintain the required 3 ft (0.9 m) clear width for bicyclists. Edge line rumble strips may also be considered in accordance with the Chapter 34 procedures in order to minimize impacts to bicyclists. Paved shoulders *may* include word or symbol markings along with arrow markings to designate preferential bicycle use (i.e., a bike lane) only where the paved width is 5 ft (1.5 m) or more and the posted speed limit is 45 mph or less.

Transitions from rural cross sections into urban cross sections (e.g., frequent entrances, intersections) should accommodate bicyclists through movements by providing additional width in the curb and gutter section. For example, Figure 17-2.B illustrates an acceptable approach where the urban accommodation would be a wider outside lane. A consistent cross section and consistent bikeway width is preferred in addressing rider comfort and safety.

17-2.02(b) Shared Roadways and Shared Lanes

On a shared roadway facility, bicyclists and motorists share the same travel lanes without a striped separation. The *AASHTO Bike Guide* identifies a minimum outside lane width of 14 ft (4.2 m) as adequate for accommodating bicyclists in a shared lane. At this width motorists can provide the required 3 ft (0.9 m) buffer to pass bikes without encroaching into an adjacent lane. As shown in the Bicycle Facility Selection Table, a wider outside lane of 14 ft (4.2 m) or more can be considered to provide bicycle accommodation for lower-speed and lower-volume roadways. Typical cross sections are shown in Figure 17-2.C. Measure the width of the lane from the lane/centerline stripe to the joint between the pavement and the gutter. If no joint exists, as with monolithic pavement, measure width to the face of the curb. Where parking is marked or allowed along the roadway additional width for a bicycle use area is required as shown in the figure. In shared lane situations where bus traffic is common, bicycles and buses may share an outside lane with a minimum width of 16.5 ft (5.0 m) to the curb face.

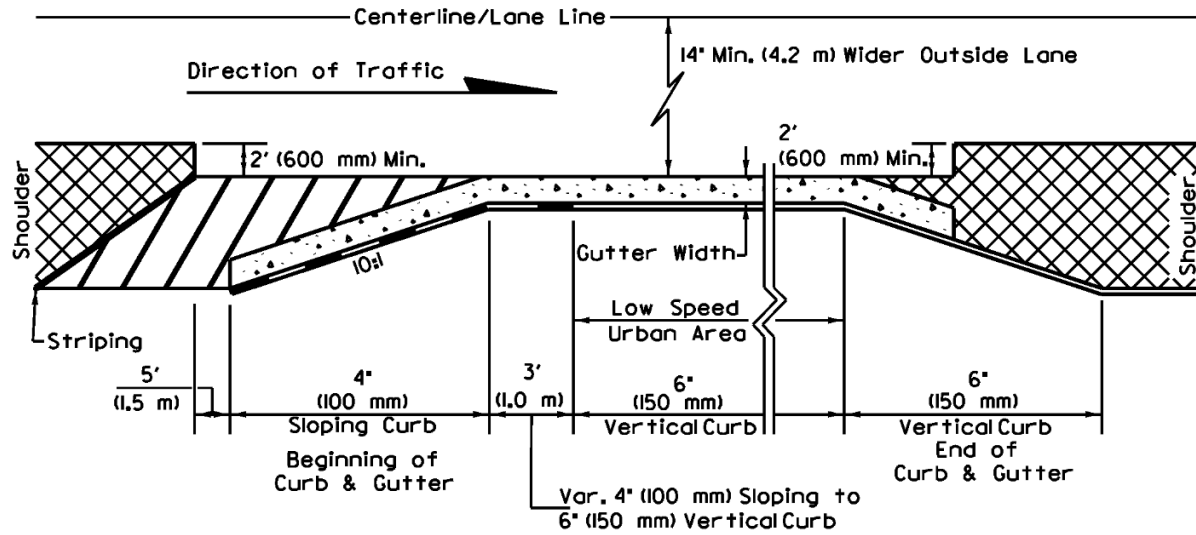

PAVED SHOULDER TRANSITION INTO CURB AND GUTTER

Figure 17-2.B

Shared roadways can also sometimes be identified as a next highest-and-best accommodation where posted speed limits will be up to 35 mph (55 km/h) in restricted locations, BLOS is checked, and any issues are discussed with BPPE. Shared lane markings, typically called “sharrows,” should not be used on roadways with posted speed limits above 30 mph (50 km/h), and should be considered only where traffic volumes are fairly low. Signing options for shared urban roadways are presented in the *AASHTO Bike Guide* and include the W11-1 and R4-11 signs. Other *ILMUTCD*-compliant bicycle signing may be proposed as well.

TWO-LANE SECTIONS WITH WIDER OUTSIDE LANES

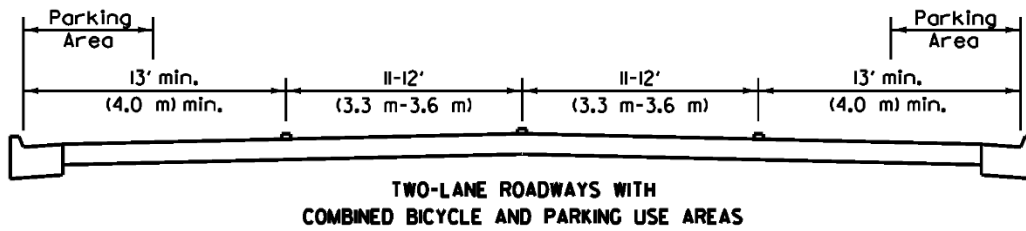
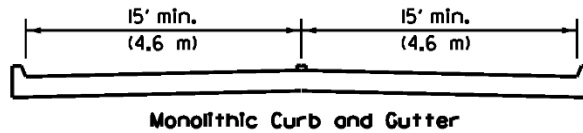
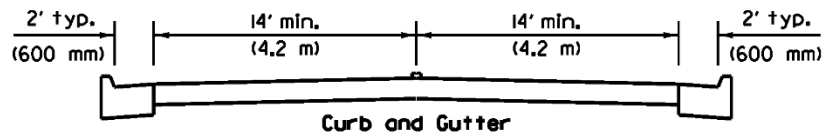

FOUR-LANE SECTIONS WITH WIDER OUTSIDE LANES

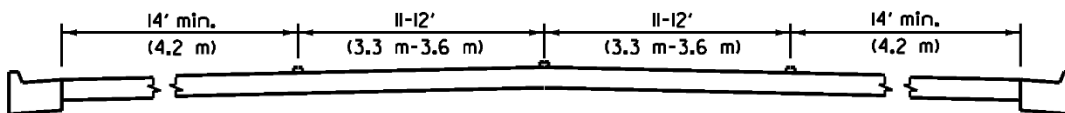

FIVE-LANE SECTIONS WITH WIDER OUTSIDE LANES

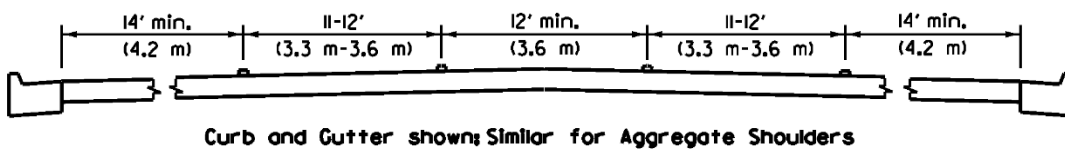

**TYPICAL CROSS SECTIONS FOR DESIGN OF SHARED ROADWAYS
FIGURE 17-2.C**

17-2.02(c) Conventional and Buffered Bicycle Lanes

On-road bicycle accommodations on urban roadways typically consist of providing bicycle lanes. Two variations in the design of bicycle lanes can be applied based on the specific conditions of a project: conventional bike lanes and buffered bike lanes. The width of a bicycle lane is measured from the edge of the adjacent vehicular lane stripe to the face of curb or parking lane line as shown in Figures 17-2.D and 17-2.E. Use the Bicycle Facility Selection Table to determine the appropriate width. Five ft (1.5 m) is the minimum width of a bike lane (stripe-to-stripe or stripe-to-curb face). Gutter pans are sometimes not acceptable for bicycle travel due to the presence of debris or broken pavement, and the pavement/ gutter joint can sometimes become vertically uneven or separated from the gutter and affect bicycles with narrow tires. However, clear distance to the curb face is increased by the presence of a gutter. Widths shown in the Bicycle Facility Selection Table and used in the calculation of BLOS include the gutter pan.

Bicycle lane word or symbol markings (e.g., the helmeted bicyclist) along with arrow markings are required to designate a bicycle lane. Markings inform all users of the restricted nature of the bicycle lane. A five in. (130 mm) minimum normal line width is appropriate between a through traffic lane and a bicycle lane. Refer to *ILMUTCD* Section 9C for discussion of marking requirements. The *AASHTO Bike Guide* provides further details on bicycle lane markings.

Green pavement markings may be used as a traffic control device to clarify for all users the locations where bicyclists are expected to operate. These markings are supplemental to the other pavement markings that are required for the designation of a bicycle lane. Green pavement marking can be installed under an MUTCD Interim Approval and therefore locations are tracked and performance reported. Green pavement markings should be used only within intersections and on intersection approaches where bicyclists and other roadway traffic would have potentially conflicting weaving or crossing movements; refer to Section 17-2.02(e) for further discussion.

Signing is optional when designating a bicycle lane. Use *ILMUTCD* Section 9B and apply engineering judgment to develop a signing plan that provides relevant information to adequately address safety for all users.

For conventional bicycle lanes the following are typical cross section requirements:

- On curbed streets without parking, locate the bicycle lane next to the gutter, as shown in Figure 17-2.D.
- Where parking is permitted, locate the bicycle lane between the parking lane and the through traffic lanes, as shown in Figure 17-2.E. Consider providing additional parking/bike lane width, above the required minimum, to reduce the likelihood of car door/bicyclist conflicts (a.k.a. dooring crashes) under the following conditions:
 - + where there is frequent parking turnover,
 - + where parked vehicles are mostly commercial vehicles, or
 - + where the posted motor vehicle speed limit is above 35 mph.

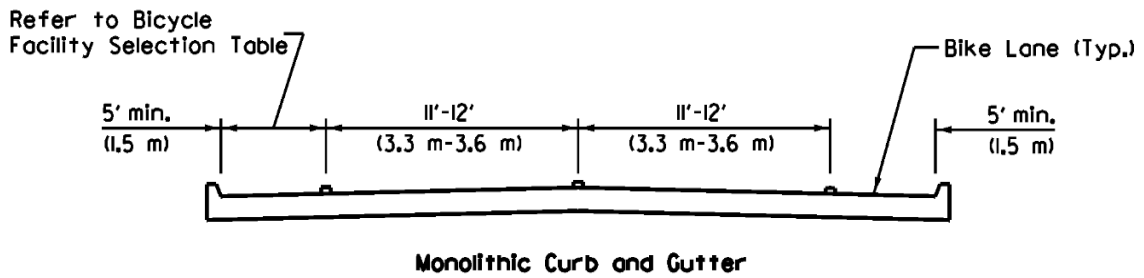
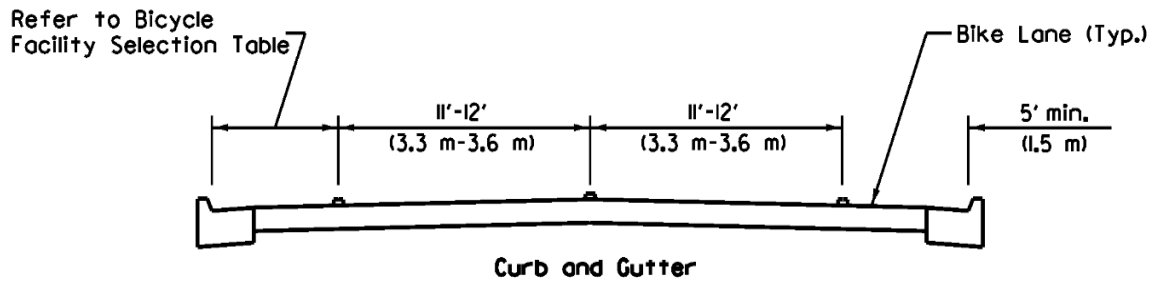

Note: Bike lanes should include buffer area(s) per Section 17-2.02(c)

TYPICAL CROSS SECTIONS WITH BIKE LANES AND NO PARKING

Figure 17-2.D

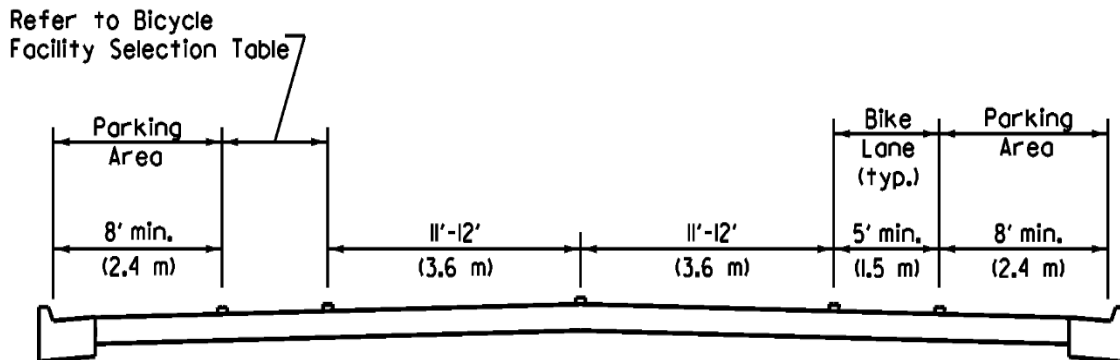

Note: Bike lanes should include buffer area(s) per Section 17-2.02(c)

TYPICAL CROSS SECTION WITH BIKE LANES AND WITH PARKING

Figure 17-2.E

Design bicycle lanes as one-way facilities that carry bicycle traffic in the same direction as adjacent motor vehicle traffic. Two-way bicycle lanes on one side of the roadway (without physical separation) and contra-flow bike lanes are unacceptable because riding against the flow of motor vehicle traffic introduces safety concerns. Wrong-way riding is a major cause of bicycle crashes nationally and violates the *Illinois Vehicle Code*, 625 ILCS 5/11-1505. Locate one-way bicycle lanes that are on one-way streets on the right side of the street, except in areas where placing the bicycle lane on the left will decrease the number of conflicts (e.g., those caused by heavy bus traffic). Place bicycle lanes that are adjacent to dedicated bus lanes between the vehicular traffic lane and the bus lane as shown in Figure 17-2.F.

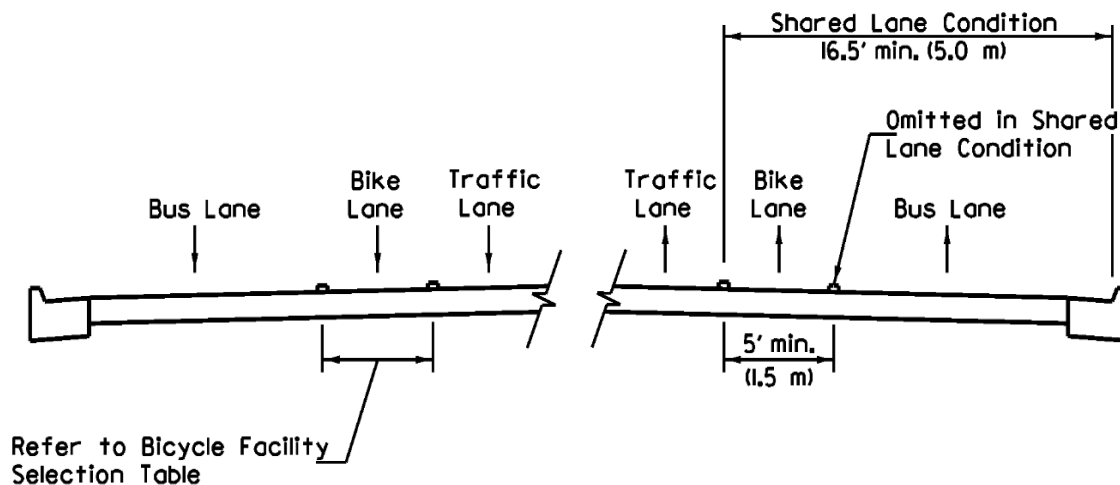

Note: Bike lanes should include buffer area(s) per Section 17-2.02(c)

BICYCLE LANES ADJACENT TO BUS LANES

Figure 17-2.F

Buffered bike lanes add a delineated buffer space to a conventional bicycle lane for the purpose of widening the bicycle travel space and providing a better level of comfort, as described by BLOS. The buffer areas can be placed on one or both sides of the primary riding area. The buffer area width(s) are included in the specified bike lane width; refer to Figures 17-2.G(1) and 17-2.G(2). Buffer areas are marked with two solid white lines (a 5 in. (130 mm) minimum line width is required on the vehicle traffic side) at least 12 in. (300 mm) apart. Where the buffer total width is 18 in. (460 mm) or more, diagonal (Case 1) or chevron (Case 2) markings are recommended for clarity. Placing a 2 ft 6 in. (760 mm) minimum buffer immediately adjacent to a parking lane can be effective in reducing dooring crashes. Buffered bike lanes should be transitioned to conventional skip-dash lines on intersection approaches and the width may be reduced where width constraints dictate. Note that the primary riding area must be a minimum of 3 ft 6 in. (1070 mm) to allow for placement of the bike lane pavement marking symbol. Bike lane widths of 7 ft (2.1 m) or more will accommodate bicycle passing within the limits of the bike lane.

Adding bike lanes to an existing roadway cross section is a way to utilize existing infrastructure to achieve multimodal goals efficiently at low cost; refer to Section 17-2.02(g). Figure 17-2.G(3) illustrates options for accommodating bikes within a specific roadway width. Project constraints will often dictate whether conventional, buffered or separated bike lanes can be provided as part of a road diet or lane diet project. Existing drainage grates should be assessed and may need to be changed to provide properly oriented openings to ensure that narrow bicycle tires do not fall into or become wedged within large parallel openings. Refer to Section 17-2.02(h); the BPPE can suggest appropriate grate options for conventional, buffered and separated bike lanes.

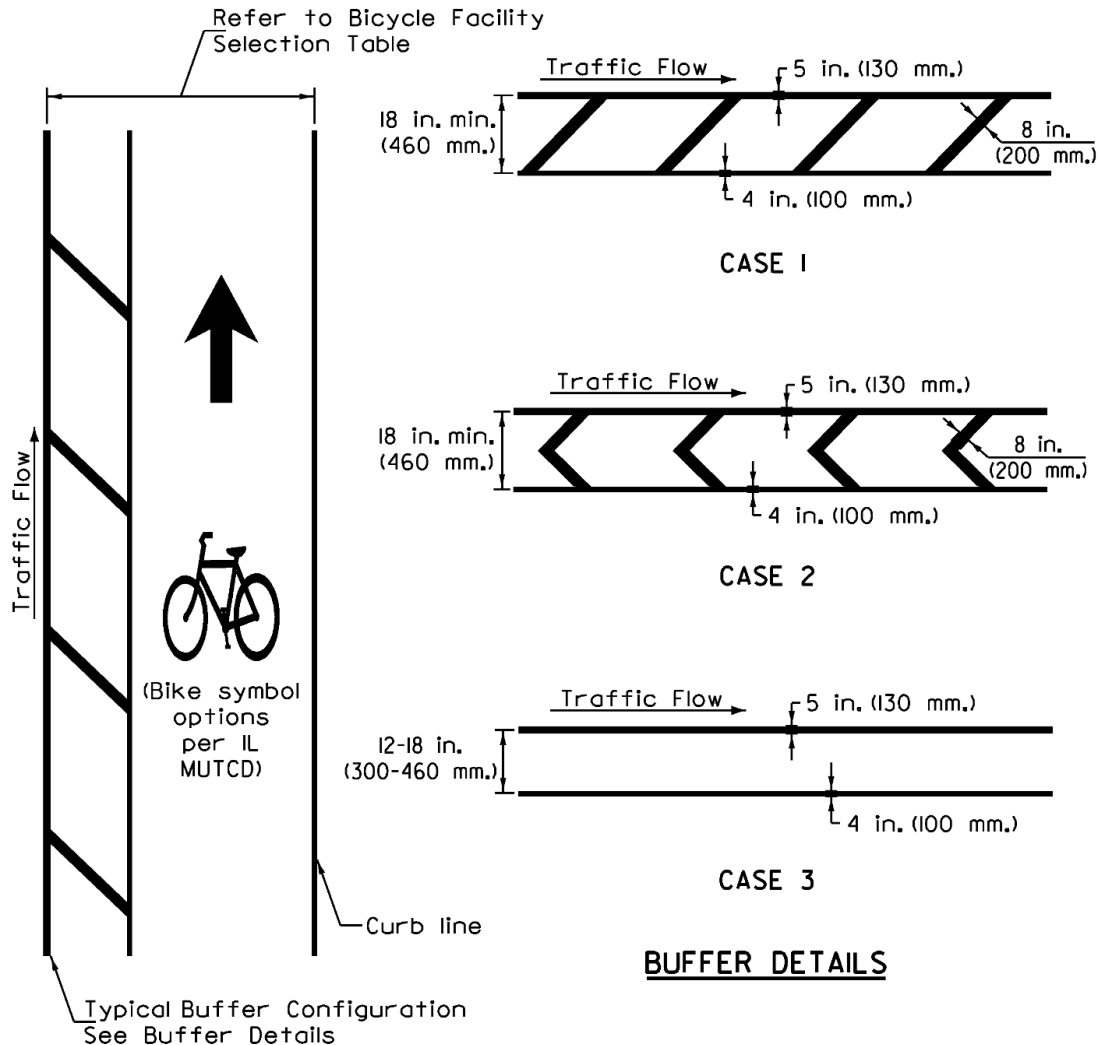

Note: Separation may also be provided between bike lane striping and the parking boundary to reduce door zone conflicts, as shown on the following page.

BICYCLE LANES WITH BUFFER AREAS

Figure 17-2.G
(1 of 3)

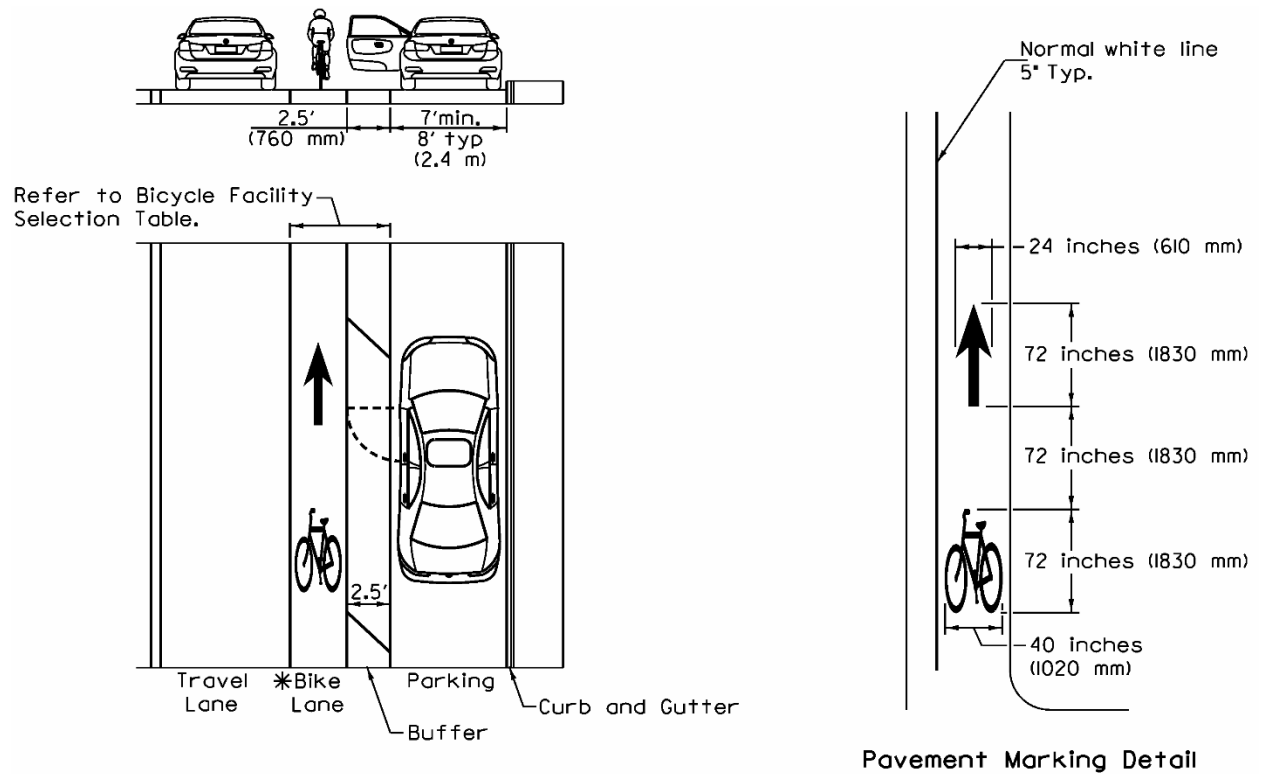

*Bike lane primary riding area may be a minimum of 3.5' (1070 mm) if located adjacent to a buffer.

BICYCLE LANES WITH BUFFER AREAS

**Figure 17-2.G
(2 of 3)**

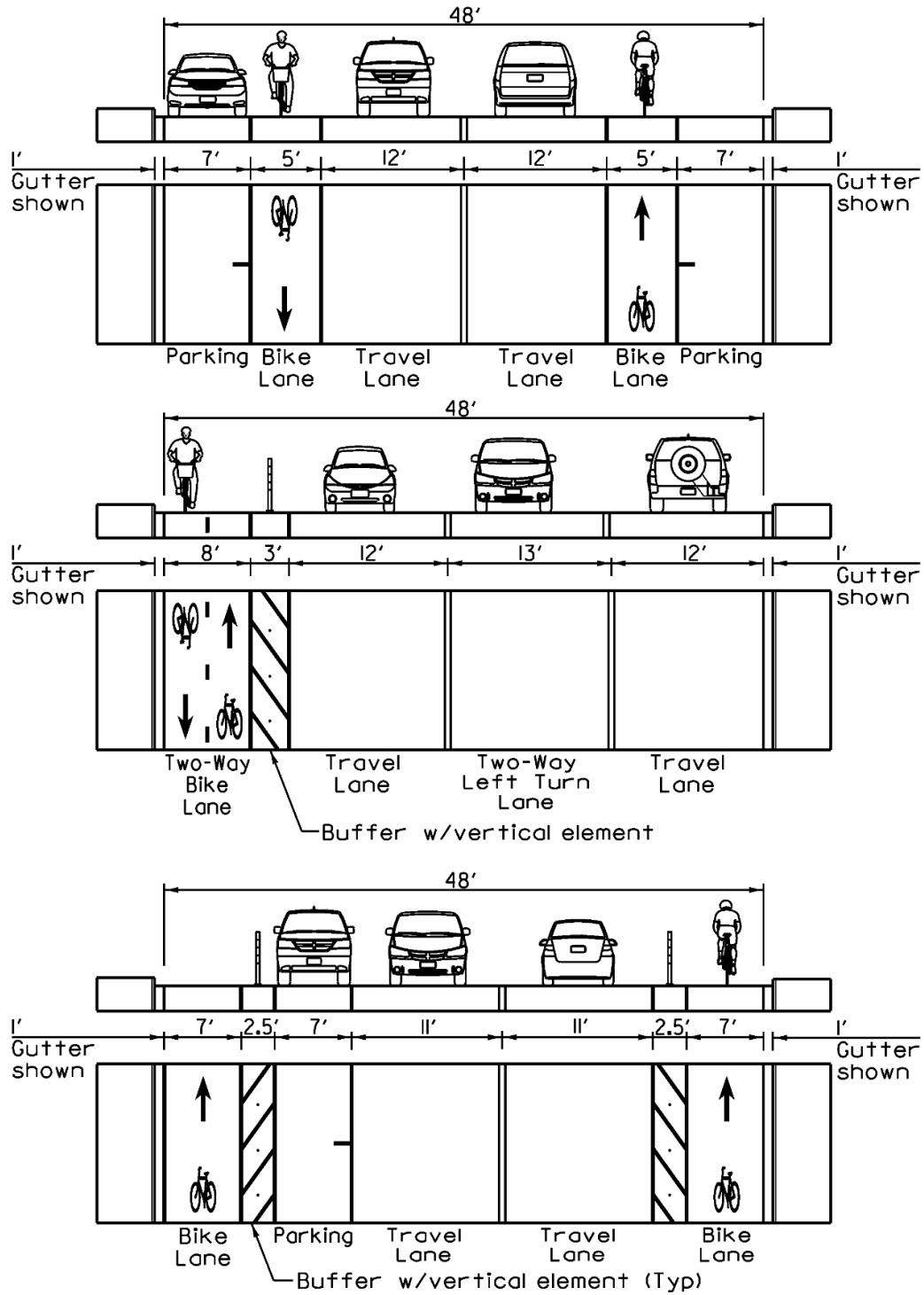

Note: Available options are shown for a 50' f/f two-way roadway with bike accomodation and both parking and no-parking scenarios. This is for illustration purposes. A range of available options should typically be considered.

BICYCLE LANES WITH BUFFER AREAS

Figure 17-2.G
(3 of 3)

17-2.02(d) Separated Bicycle Lanes on Urban and Suburban Roadways

Separated Bicycle Lanes (SBLs) in their most common application are one-way, bike-only facilities located on both sides of two-way roadways or one side of one-way roads. Separation is provided by incorporating continuous or intermittent vertical elements within a street-side buffer that is at least 2 ft 6 in. (760 mm) wide. Compared to conventional bike lanes SBLs provide an enhanced level of perceived comfort and safety that may attract a greater range of users and better fulfill the goal of serving more potential bicyclists. Some contexts and operational conditions are appropriate for two-way separated bike lanes. Refer to Figure 17-2.G(3) for example cross sectional views of the two types of SBLs within a specific roadway width. SBLs are appropriate in many contexts as an alternative to side paths; both are separated sufficiently from traffic such that a BLOS evaluation is not required or appropriate.

For one-way accommodation, design separated bicycle lanes to carry bicycle traffic in the same direction as adjacent motor vehicle traffic for the reasons stated in Section 17-2.02(c). Since bicyclists in one-way SBLs better follow the expectations of drivers, there is potential safety advantage at crossings in comparison to two-way side paths. SBLs also provide a dedicated bikeway space as opposed to the shared-use space along a path. Two-way separated bicycle lanes on one side of the roadway (and contra-flow separated bike lanes) are not-preferred where riding against the flow of motor vehicle traffic will introduce specific safety concerns. Locate one-way SBLs that are on one-way streets on the right side of the street, except in areas where placing the SBL on the left will decrease the number of conflicts (e.g., those caused by heavy bus traffic). Refer to the *Illinois Vehicle Code*, 625 ILCS 5/11-1505.

SBLs are typically located at street level and separated from the traffic by vertical elements, such as raised curb islands, tubular markers (flexible posts) with a striped buffer, or a parking lane. A detail of a typical tubular marker is shown on Figure 17-2.I(3) in Section 17-2.02(e). Reasons for a street level configuration include control of pedestrian encroachment, provision of a detectable edge for low vision individuals, and (in retrofit projects) the possibility of using existing drainage systems with minimal modification. Raised SBLs may be considered under certain conditions and are addressed later in this section.

The street-level buffer should provide adequate separation from motor vehicles and control other curbside activities (e.g., loading). The following are considerations in the selection and design of separation elements.

Raised curb islands:

- May add considerable cost,
- Typically construct as cast-in-place features; precast options may provide less integrity,
- Provide a continuous island; with gaps primarily to facilitate necessary drainage,
- Discontinue on intersection approaches to allow for operational mixing,
- May be used in conjunction with parking where space and cost considerations allow,
- Widths typically range from 3 ft (0.9 m) to 6 ft (1.8 m); wider islands can allow additional features (e.g., low-growing vegetation) with a 6 ft (1.8 m) minimum face-to-face width also providing for pedestrian refuge at crosswalks where applicable.

Tubular markers:

- Typically add relatively minor cost beyond that of a buffered bike lane,
- Buffer widths as narrow as 2 ft 6 in. (760 mm) may be used, and these may partially overlap the usable riding area,
- Must meet minimum ILMUTCD requirements for color (the same as the pavement marking they supplement) and retro-reflectivity,
- Must be identified specifically as a local maintenance item in an agreement,
- Shall be removable to facilitate maintenance, which is typically frequent,
- Must not be bolted into place on bridge decks (epoxy pad fastening is available),
- May be considered less attractive and will require replacement when damaged. The need for regular ongoing maintenance must be committed to by the local agency.

Parking Lanes:

- Ten ft (3.0 m) is the preferred minimum separation distance to allow for parking and separation elements; curbed noses can be used to introduce the parking lane on the approach end,
- Opening of car doors (on the passenger side along two-way roads) creates the potential for dooring crashes; a striped buffer of minimum 2 ft 6 in. (750 mm) width is highly recommended for any bike lane running along the edge of a parking lane,
- Parked vehicles can restrict sight lines between motor vehicles and bicyclists; it is necessary to prohibit parking near intersections to maintain sight lines.

Measure SBL clear width between curb face and edge of tubular markers or face of curbed island. The minimum width of a one-way SBL is typically 7 ft (2.1 m) to allow for bicycle passing and the use of local maintenance equipment (e.g. for snow removal). This minimum clear width is specified in the Bicycle Facility Selection Table since passing is typically important. In constrained conditions a one-way SBL width could possibly be reduced, but only if a local agency confirms maintenance would be practical. However, the SBL should also be wide enough to accommodate anticipated bicycle volumes, noting that completion/extension of a bicycling network could increase bicycle use.

A two-way SBL of minimum clear width 8 ft (2.4 m) can be provided on one side of a roadway where operational issues and all safety concerns can be effectively mitigated. This minimum clear width cannot be reduced for two-way SBL as passing will be necessary and usually frequent. An additional 3 ft (910 mm) minimum buffer width for raised curb, or 2.5 ft (760 mm) minimum for tubular markers, is also needed. Two-way SBL provide user separation and a low-stress bicycling experience. One potential concern is that drivers may not expect the counter-flow direction of bicycle travel. Careful attention must be paid to the design of crossings of driveways and intersections to maximize bicyclist visibility. The design to accommodate counterflow bicycle traffic movements may require additional traffic signals (often bicycle signal heads) and related infrastructure. On the other hand, maintenance costs may be less for a two-way facility based on the much shorter SBL length required. Selecting the appropriate configuration for separated bike lanes, one-way versus two-way, will include location-specific consideration of safety, connectivity, ease of access, public feedback, available right-of-way, termini transitions, traffic signal controls, and maintenance. Either design option could provide good accommodation solutions. Carefully assess the constraints and circumstance that will be present along project segments and intersections and design accordingly.

Raised bicycle lanes (RBLs), also known as cycle tracks, provide for one-way bicycle accommodation elevated above the road surface beyond the curb line. Typically RBLs are at sidewalk elevation but may be at an intermediate height, 4 inches above the roadway surface. Raised bicycle lanes are considered separated from motorized traffic based on the curb height differential. A horizontal separation is also possible with a parking lane or other measure. Bicycle pavement marking symbols and arrows shall be placed at the beginning of an RBL block length (near intersections) and provided periodically along block segments. Although not intended for pedestrian use raised bicycle lanes shall be constructed within ADA tolerances since such use could occur. Where a transit stop is located along an RBL, the draft PROWAG's boarding and alighting zone may overlap with the RBL; advanced signage and pavement markings shall be provided for bicyclist awareness.

Stormwater drainage must be examined for adequate positive flow to structures with grates that do not compromise bicycle or pedestrian travel. RBLs that are proposed on bridge decks shall be coordinated with the Bureau of Structures and the BPPE.

17-2.02(e) Intersection and Interchange Treatments

Accommodations for on-road bicycle travel through conventional intersections are covered in the ILMUTCD, Part 9, including striping and signing requirements for bicycle lanes. Specific situations are further discussed and illustrated in this section. Safety and usability for bicyclists through roundabouts depend on details of the roundabout design including provisions unique for cyclists; these issues are covered in Section 17-2.04.

Local legs approaching signalized intersections may have various accommodation types, often including shared lanes or paved shoulders of widths different than those required for state route accommodations. When redesigning an intersection, maintain accommodation widths on local approaches and through the intersection so that restricted-width bottlenecks are not created, and comfortable bicyclist travel is provided on those legs. As an example, avoid reducing through lane widths when adding turn lanes on the local approaches. Considering and accommodating all bike movements during intersection design will often affect the scope of work along local legs. Where bicycle lanes are not provided, typically continue an approaching wider outside lane through intersections to accommodate bicycle through movements. Since bicyclists may be on-road even if a side path is provided, avoid outside lane width reductions through intersections in any case.

Figure 17-2.H(1) provides an example of pavement markings and signing at a signalized intersection where bike lanes are present along the routes. Typical movements for signalized intersections with bike lanes are shown in Figure 17-2.H(2). Left-turning bicyclists may follow the optional paths shown. Some bicyclists will move to the left in advance of an intersection and turn from the left turn lane, utilizing an optional bicycle box where provided on the approach. Most bicyclists will proceed straight through the intersection staying to the right on the far side, then either crossing like a pedestrian or using a two-stage bicycle turn box where provided. Either a bicycle box or the two-stage bicycle turn box may be included under an MUTCD Interim Approval; there are specific marking, signing, signalization, and reporting requirements involved, administered through the central Bureau of Operations as discussed below. Consultation with BPPE is recommended where these features will be incorporated into the design in order to discuss design details. Refer to the *AASHTO Bike Guide* and the *ILMUTCD* for additional design

considerations. Dotted line extensions of bike lanes through intersections may be used consistent with *ILMUTCD* Section 3B.08. This extension marking is recommended only when guidance is appropriate related to an accommodation type, such as where a two-way separated bicycle lane transitions across an intersection to a one-way system on both sides as shown in Figure 17-2.1 (3 of 3).

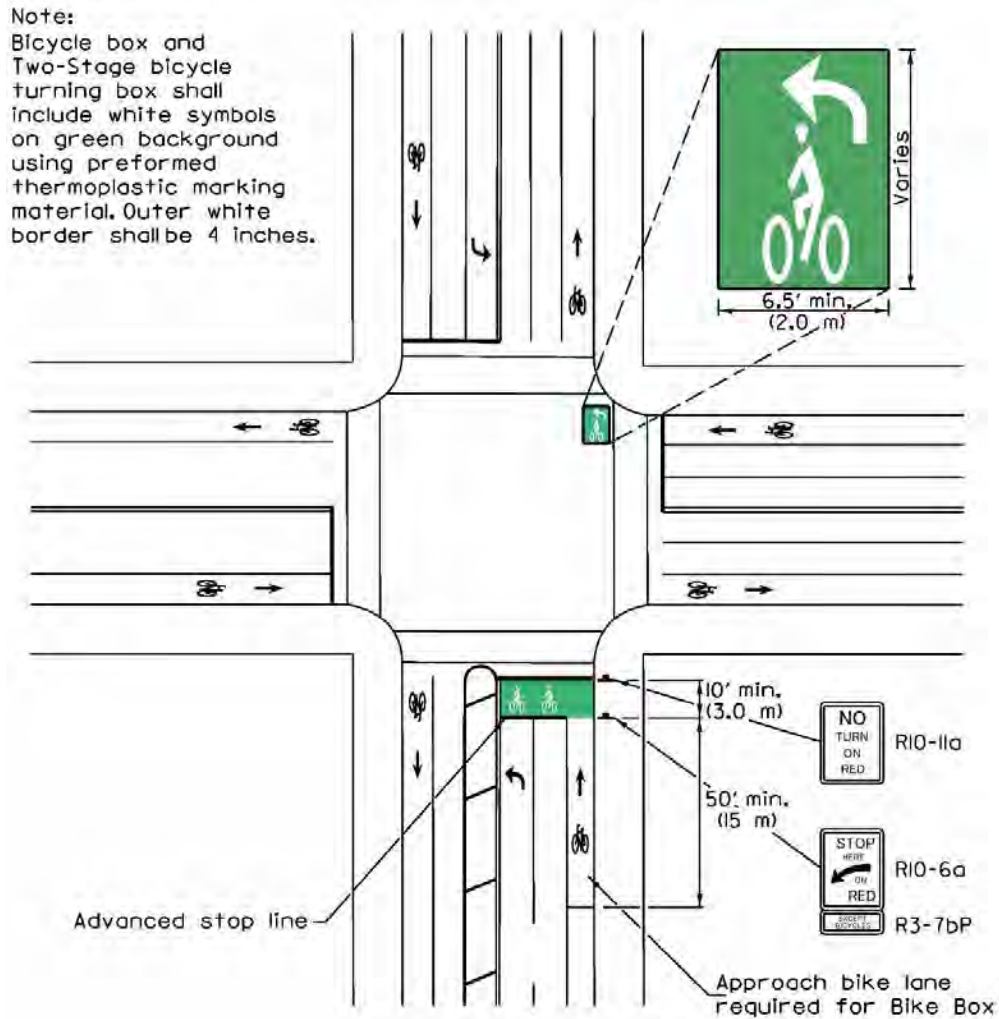

Note: Consider and accommodate all bike movements on all legs.

Note: Consider and accommodate all bicycle movements on all legs.

TYPICAL STRIPING AND BICYCLE MOVEMENTS AT INTERSECTIONS FOR STREETS WITH BICYCLE LANES

Figure 17-2.H
(1 of 2)

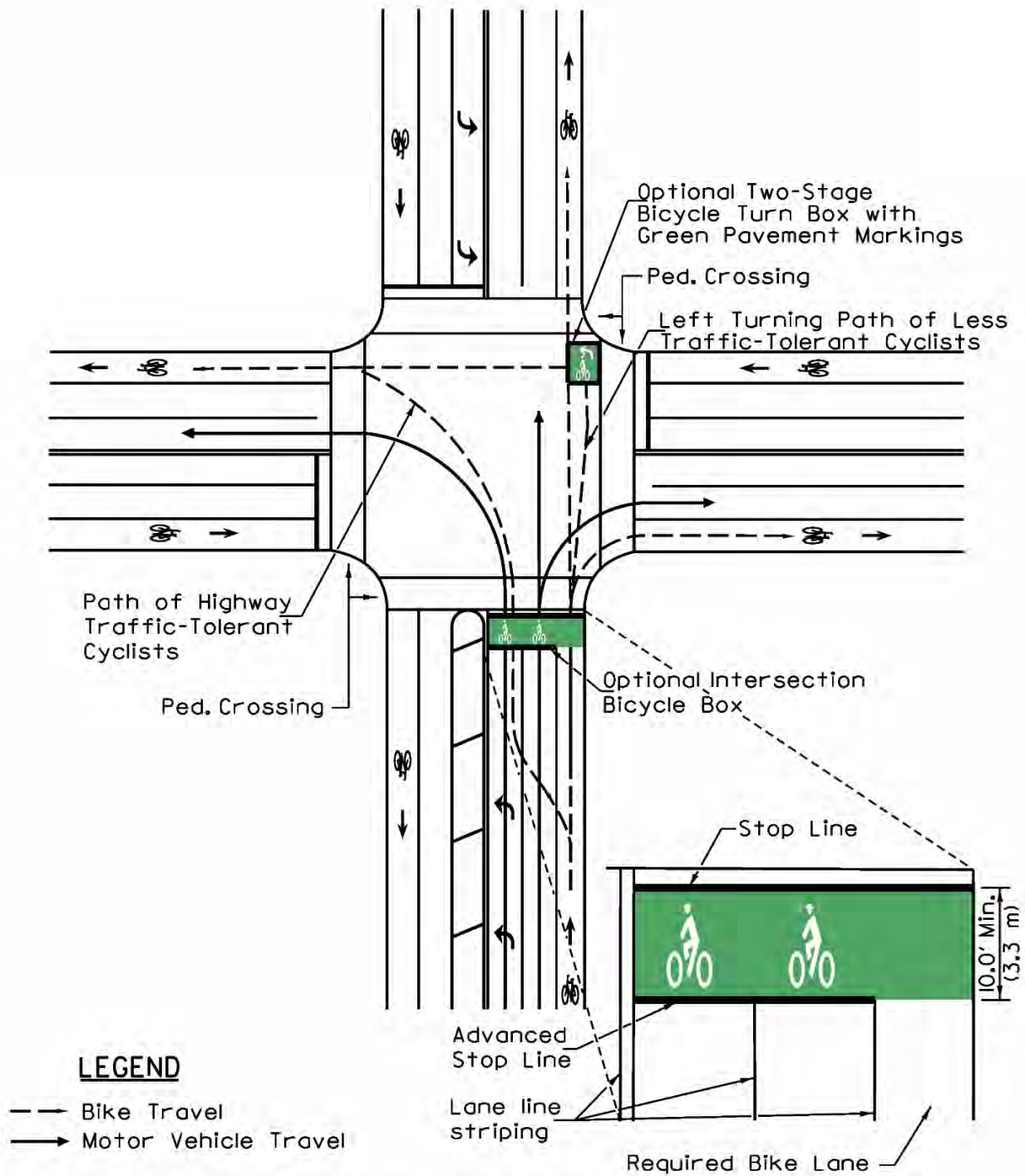

TYPICAL STRIPING AND BICYCLE MOVEMENTS AT INTERSECTIONS FOR STREETS WITH BICYCLE LANES

Figure 17-2.H
(2 of 2)

The *AASHTO Bike Guide* includes a discussion of the requirements for on-road bicycle accommodations on intersection approaches and at intersections, and the *ILMUTCD* provides examples of required pavement markings; see Figures 9C-1, 9C-4, 9C-5, and 9C-6. Additional striping considerations and details for general guidance at these locations are illustrated in Figure 17-2.1. Figure 17-2.1(1) shows the general striping required for bicycle lanes on approaches to intersections. Through bike lanes should be located to the right of the right-hand through lane and to the left of an auxiliary right turn lane for both urban or rural roadways. This placement greatly reduces the potential for last-moment conflicts with right-turning vehicles. A 5 ft (1.5 m) minimum width bike lane adjacent to the right turn lane typically provides comfortable bicyclist operating space. Where an auxiliary right turn lane is introduced, two dotted lines are used through the right turn lane tapers to designate the priority of bicyclist operations. For rural roadways these may be the only marked bike lane accommodations provided when the accommodation is located along a paved shoulder. Consider Begin Right Turn Lane Yield to Bikes (R4-4) signs to add clarity for drivers. In a situation with bike lanes where a through travel lane is dropped into a right-turn-only lane, bicyclists not motorists are the users who must yield. In such a situation the bike lane should not be striped diagonally across the travel lane, as shown in Figure 17-2.1(1).

Examples of striping and signing for bike lanes at and between intersections are shown in Figure 17-2.1(2). A possible layout for transitioning two one-way separated bike lanes to a two-way separated bike lane at an intersection is shown in Figure 17-2.1(3). In all cases strive to maintain good visibility among all roadway users and provide channelization for proper positioning of all traffic. For conventional, buffered, and separated bike lanes clearly mark intersection approaches and through movements. Checking visibility and line-of-sight between motor vehicles and bicyclists is especially important at intersections with SBLs, and the separation elements must be discontinued to provide for all crossing and merging movements.

Consider access to/from links in the bicycle network and to/from adjacent properties and side streets. When considering bicycle safety, geometry that reduces vehicle speeds for turns is encouraged since vehicle turns involve potential conflicts with bicyclists. Well-designed corner islands, possibly including mountable aprons, can accommodate large vehicle turning movements while also providing bicycle/pedestrian refuge areas and appropriately reducing the turning speeds of vehicles.

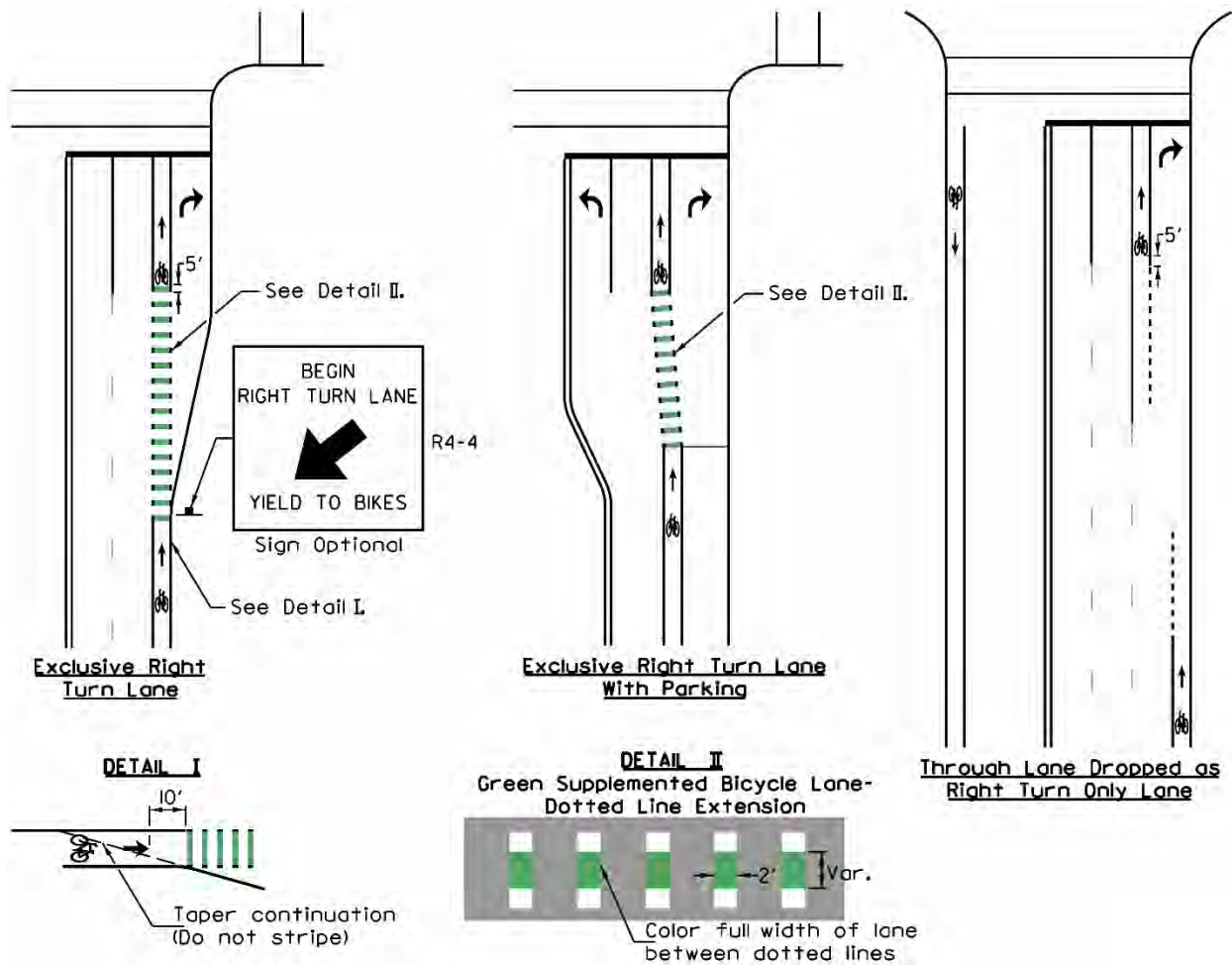

TYPICAL TREATMENTS ON APPROACHES AND AT INTERSECTIONS FOR STREETS WITH TRADITIONAL AND SEPARATED BICYCLE LANES

Figure 17-2.I
(1 of 3)

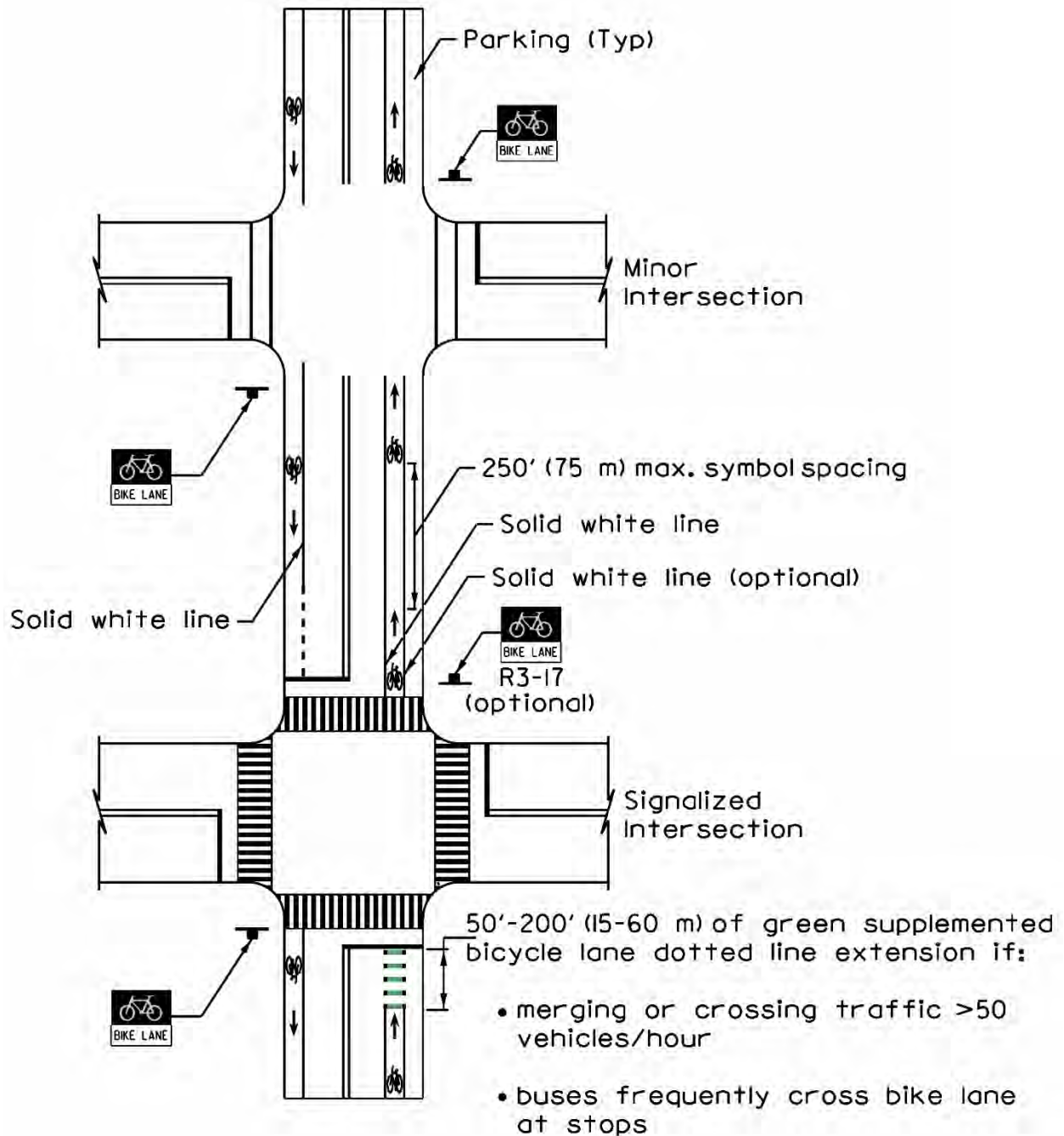

TYPICAL TREATMENTS ON APPROACHES AND AT INTERSECTIONS FOR STREETS WITH TRADITIONAL AND SEPARATED BICYCLE LANES

**Figure 17-2.1
(2 of 3)**

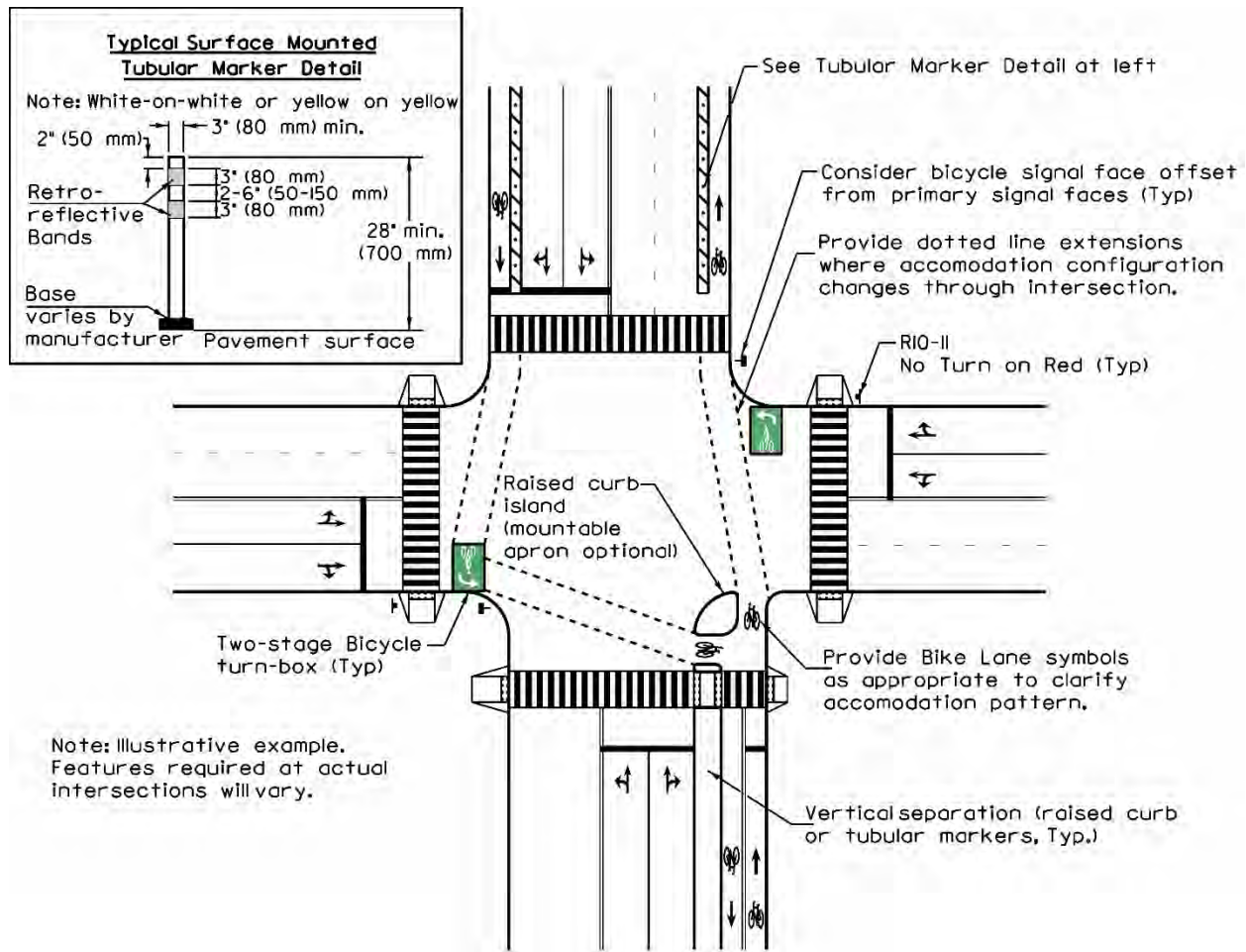

TYPICAL TREATMENTS ON APPROACHES AND AT INTERSECTIONS FOR STREETS WITH TRADITIONAL AND SEPARATED BICYCLE LANES

**Figure 17-2.1
(3 of 3)**

IDOT is administering statewide Interim Approvals (I.A.) for bicycle boxes, two-stage bicycle turn boxes, and green colored pavement markings. Bicycle signal faces may also be considered to facilitate accommodations, and would be handled with an individual I.A. To comply with the terms of a statewide Interim Approval, any jurisdiction that utilizes these devices must report the location to IDOT, which will maintain an inventory of all installation locations. Installations must be in accordance with the terms of the Interim Approval, and the requirements and guidance on use of these devices as listed below. Contact the central Bureau of Operations to identify locations and have them added to a statewide inventory.

17-2.02(e)1 *Bicycle Boxes (I.A.-18 for Optional Use of an Intersection Bicycle Box)*

In conjunction with bike lanes, a bicycle box is a designated area on the approach to a signalized intersection consisting of an advanced stop line and bicycle symbol markings. The box is provided as a space for bicyclists to wait in front of stopped motor vehicles during the red signal phase, so they are more visible to motorists at the start of the green phase. Bike boxes can serve to mitigate conflicts between through bicyclists and right-turning motorists by allowing bicyclists to proceed first. Bicycle boxes may be installed across only one through lane. They may also be installed across a right turn lane. Turns on red should be prohibited using a NO TURN ON RED sign on an approach where a bike box is placed in front of traffic that otherwise has the potential to turn on red.

Bicycle boxes may be installed across a left turn lane at T-intersections or if a high left turning bike volume is anticipated. In other situations, bicyclists will tend not to utilize bike boxes for left turns, and the preferred treatment is to include a two-stage bicycle turn box, as described below, for left-turning bicyclists. Bike boxes shall be at least 10 ft (3.0 m) in depth, include a bicycle symbol within the box, and connect directly to a bike lane on the approach. At least 50 ft (15.2 m) of bike lane should be provided on the approach to a bike box. Green colored pavement marking shall be used within the bike box. The stop bar for motorists should coincide with the beginning of the bike box. A STOP HERE ON RED sign (R10- 6 or R10-6a) should be placed even with this stop bar, along with an EXCEPT BICYCLES (R3-7bP) plaque. This must be modified where stop bars for through lanes and turn lanes will be at staggered locations.

17-2.02(e)2 *Two-stage Bicycle Turn Boxes (I.A.-20 for Optional Use of Two-Stage Bicycle Turn Boxes)*

The two-stage bicycle turn box designates an area at an intersection for bicyclists to wait for traffic to clear before proceeding in a different direction. These boxes are used to facilitate left-turning bicycle traffic at signalized intersections. They are a preferred treatment along high-volume multi-lane roadways where bicyclists would otherwise have to make lane changes, weave across traffic on an approach to turn left at a signal. Operationally, bicyclists traverse the intersection (e.g. along an extension of the through bike lane), stop within the turn box, reorient the bike to the cross street, and wait for the green phase to proceed. The following requirements apply to two- stage bicycle turn boxes:

- Locate where visible and outside the path of potentially conflicting through and turning vehicle traffic. Where the paths of other vehicles turning on a red signal would travel through the two-stage bicycle turn box, these turns shall be prohibited using a NO TURN ON RED sign;
- Locate so bicycles will not queue into the path of moving traffic;
- Locate downstream of the cross-street crosswalk and stop bar;
- Include a bike symbol oriented in the direction of entry of the box and an arrow showing the direction of turn;

- Outline the box in solid white lines using a 6.5 ft (1.9 m) minimum length to accommodate the queued bike and include green colored pavement marking to increase conspicuity;
- Passive detection of bicycles shall be provided in the two-stage bicycle turn box, if detection is required to actuate the signal for the cross street.

17-2.02(e)3 *Bicycle Signal Faces (I.A.-16 for Optional Use of a Bicycle Signal Face)*

A bicycle signal face incorporates bicycle symbols on the lenses of the signal head. In one-way contra-flow situations these may be the only signal faces visible to users; in other cases, these signal faces are placed at an offset location from the primary signal faces on the intersection approach. When these devices are present, bicyclist are not to follow pedestrian signals or standard traffic signal heads, as they do at other signalized locations. The current Interim Approval allows these devices only where there will be no conflicting motor vehicle movements concurrent with the bike green phase. The most common applications are for bike lanes that must be placed to the right of right turn lanes and in conjunction with both contra-flow and two-way separated bike lanes. They are not allowed at PHB locations. Early coordination with the local municipality regarding these devices is highly recommended; local jurisdictions may affect device placement and direct vehicle travel paths, pursuant to 625 ILCS 5/11-1510.

When operating on shared use paths, bicyclists must follow pedestrian signal heads and use the crosswalk, unless a bicycle signal face is also present. When operating in a separated bike lane, bicyclists will typically use the vehicle signal heads. However, if these are obscured in certain geometric situations, or if bikes have a directional movement separate from vehicle movements, bicycle signal faces may be utilized. The BIKE SIGNAL sign (R10-10b) sign must supplement these signals. Where appropriate, the BIKES USE PED SIGNAL sign (R9-5) may be mounted adjacent to the pedestrian signal heads; however, studies have indicated that compliance rates are low for bicyclists directed to follow pedestrian signals. This will be an important consideration at intersections with long crossings or unique signal phasing.

17-2.02(e)4 *Green Colored Pavement Markings (I.A.-14 for Optional Use of Green Colored Pavement for Bike Lanes)*

Green colored pavement marking applications on state routes must be limited to strategic locations to achieve positive operational effects on bicyclist positioning, improved comfort for bicyclists, and increased awareness for drivers of the potential for bicyclist interactions. The primary application for green colored pavement markings will be for increased conspicuity on approaches to intersections (e.g. between dashes in taper areas), within bicycle boxes, and within two-stage bicycle turn boxes. Use of green colored pavement markings in bike lanes outside approach and transition areas is not recommended due to application and maintenance costs. There is likely little benefit in conspicuity away from signalized intersections. See Interim Approval 14 for restrictions on the use of green colored pavement markings at locations other than those specifically mentioned above.

Green colored pavement markings have specific requirements related to marking material, green color limits, and retro-reflectivity; refer to the IDOT Standard Specifications.

Intersection improvement projects are sometimes undertaken separate from adjacent roadway segment improvements. For such projects a bicycle warrant analysis must be completed, and if warrants are met the intersection geometrics should be designed to accommodate bicyclists along the intersection legs. Such accommodation may include, for example, width for bicycle lanes and offset corner islands and signal poles. Pavement areas can be hatched with diagonal lines to maintain consistency with the existing adjacent lane widths through an interim period. The ultimate design must be understood, and interim measures designed in the appropriate form and width so that subsequent roadway improvements may require only restriping at the intersection, thereby minimizing costs for the overall improvements.

Bike lanes may be dropped at logical locations beyond intersections (for example to a shared lane, shoulder, or side-path facility), if necessary due to width constraints near a project improvement limit. Refer to the discussion of network considerations in Section 17-1.03. The goal is to provide the on-road bicyclist with a safe path to continue travel. At roundabouts bike lanes can be transitioned off of the pavement using angled ramps; see Section 17-2.04 for more information regarding bicycle accommodation through roundabouts. An example application of signing is the BIKE LANE ENDS sign (R3-17 and R3-17bP) to give warning to bicyclists that the on-road accommodation is ending.

Accommodating bicyclists through an interchange with free-flow ramps requires design considerations to address safety of bicyclists. Where on-road accommodation is necessary, the design shown in Figure 17-2.J reflects an acceptable approach to directing bicyclists through interchanges (shoulder accommodation is illustrated; bicycle lanes similar). Each specific interchange design requires individual consideration to meet accommodation and geometric design requirements. A diverging diamond interchange accommodates left-turning movements at signalized intersections while eliminating the need for left turn phasing. Single Point Urban interchanges involve larger open pavement areas. On-road accommodations can continue along the right side of the arterial route travelled way in each direction through these interchange types.

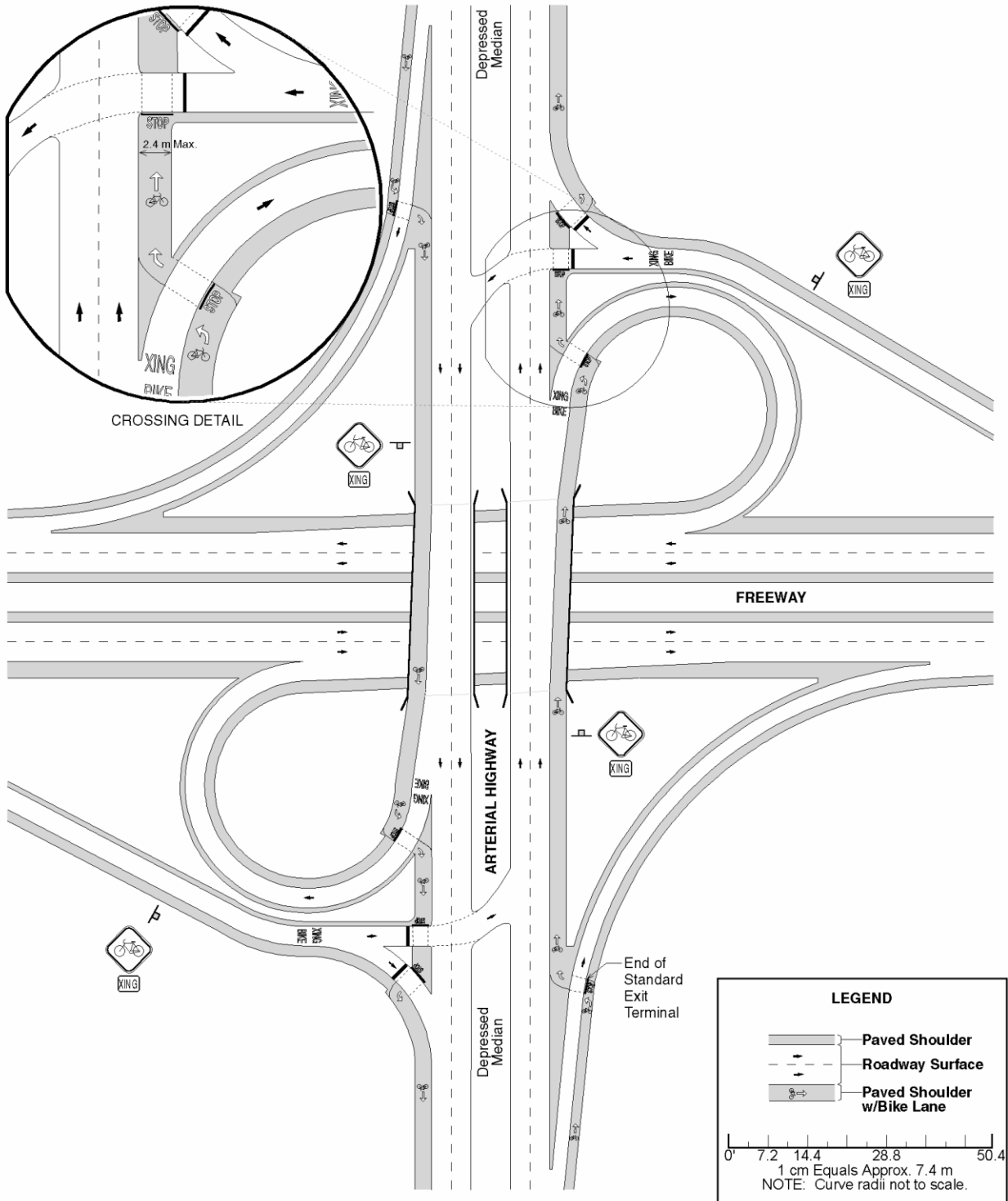

SHOULDER ACCOMMODATION THROUGH HIGHER SPEED INTERCHANGES

Figure 17-2.J

17-2.02(f) Accommodations on Highway Structures

Bicycle accommodations on approach roadways, either on-road or as shared-use side paths, should be carried across structures in the same form. Side path crossings are discussed in Section 17-2.03. The width of new highway structures should, at a minimum, equal the width of the traveled way plus the width of approaching bicycle lanes and/or paved shoulders. Minimum cross sections for roadways and structures will vary significantly depending on the type of bicycle facility being accommodated. Several examples of minimum cross sections for shared wider outside lanes, bicycle lanes, and separated bicycle lanes are shown in Figures 17-2.K, 17-2.L, and 17-2.M respectively.

A minimum 4 ft (1.2 m) outside railing height shall be provided on roadway structures accommodating bicycles. This railing height is necessary to provide for bicyclist safety on any structure where bicycle warrants are met or where a bike route will be specifically designated. Bicycles are considered a design vehicle in these situations. When no warrant is met, only a standard parapet is required. Details available on the Bureau of Bridges and Structures base sheets may exceed this height and have been developed in consideration of AASHTO and FHWA crashworthiness requirements, as well as future bridge overlays.

Coordinate SBL design with the Bureau of Bridges and Structures and BPPE regarding any SBL on a bridge deck. Flexible posts are typically anchored into the pavement, so their use on bridges is discouraged given the need to avoid any deck reinforcement damage, which could also cause deck deterioration. Epoxy pads are usually the best alternative fastening method on bridge decks. Retrofitting raised curbs on bridge decks would require structural analysis by the Bureau of Bridges and Structures.

Bridge deck replacement or rehabilitation projects are not typically intended to widen the traveled way but rather to improve the roadway surface and integrity of the structure. Bridge width is limited by the existing superstructure components, with very limited opportunity for widening, and as such, may not allow for the bicycle accommodations called for in the Bicycle Facility Selection Table. If an existing structure cannot provide the accommodation widths provided along the roadway, appropriately sign the facility to warn users of width restrictions. However, such restrictions (e.g., narrowing a shoulder or bike lane) should still provide an accommodation. If only a shared lane can be provided, signing for drivers and bicyclists on the approaches is especially critical. For example, the BIKES MAY USE FULL LANE sign may be appropriate in such situations.

For any corridor improvement that includes existing culverts where warrants are met, the culverts should provide for the appropriate bicycle accommodation. Assess bicycle warrants as part of spot culvert projects and provide width for the appropriate future accommodation. Hydraulic analysis is typically required in conjunction with culvert extensions.

When a project has a bridge omission and accommodations are included along the roadway, bikeway facilities will be added within the project limits in order to allow for compatible future accommodations on the omitted structures; signing may be appropriate as noted above. Funding splits shall be as outlined in Chapter 5 (5-5.02 and 5-5.05).

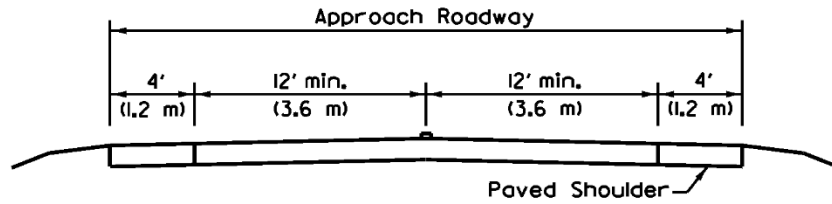

TWO-LANE ROADWAY WITH PAVED SHOULDERS

Note: Illustrative example. Paved shoulder width should be provided as indicated in Figure 17-2A.

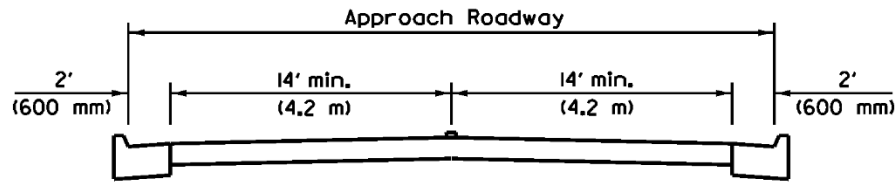

TWO-LANE URBAN ROADWAY WITH WIDER OUTSIDE LANES

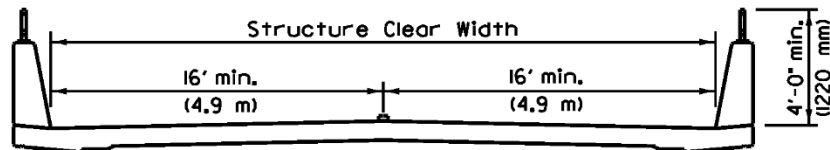

WIDE LANES/SHOULDERS CONTINUED ACROSS STRUCTURE

**TYPICAL CROSS SECTIONS FOR TWO-LANE SHARED ROADWAYS AND STRUCTURES
(Without Marked Bicycle Lanes)**

Figure 17-2.K

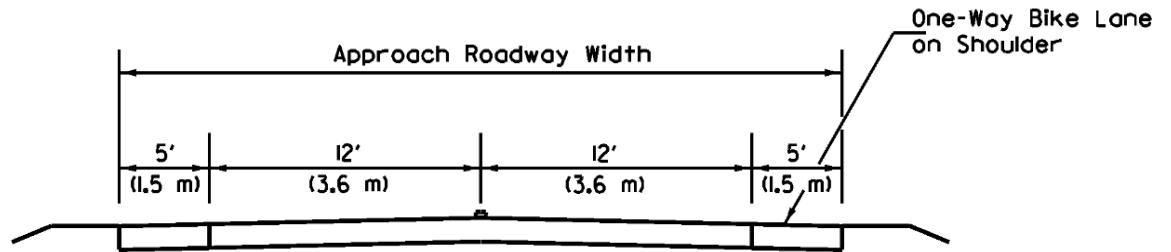

BIKE LANES ON RURAL ROADWAY SHOULDERS

Note: Illustrative example. Paved shoulder width should be provided as indicated in Figure 17-2.A.

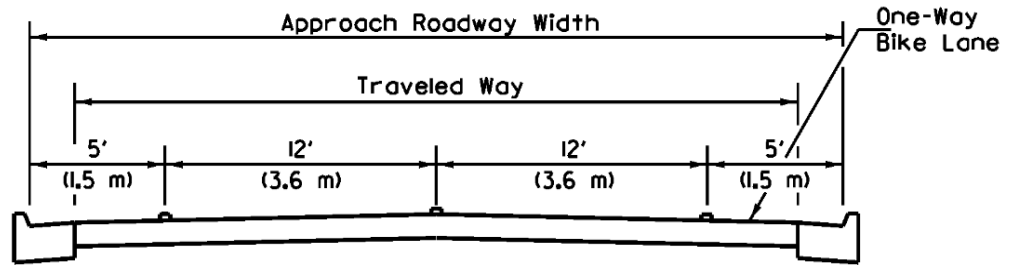

BIKE LANES ON URBAN ROADWAY

Note: Bike lane width should be provided as indicated in Figure 17-2.A.

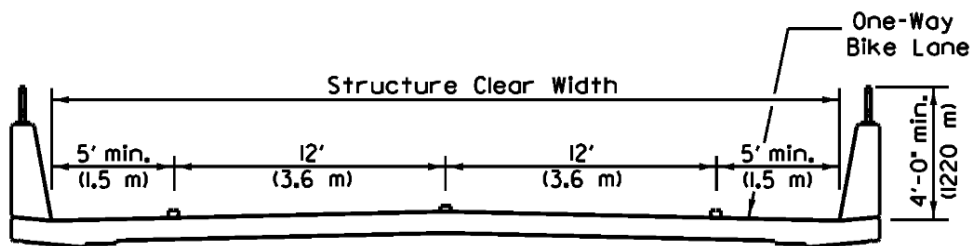

BIKE LANES ACROSS STRUCTURE

TYPICAL CROSS SECTIONS FOR MARKED BIKE LANES ON TWO-LANE ROADWAYS AND STRUCTURES

Figure 17-2.L

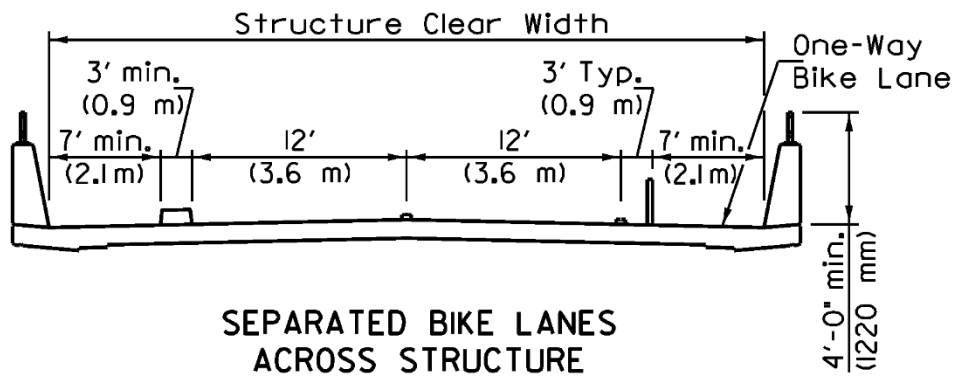
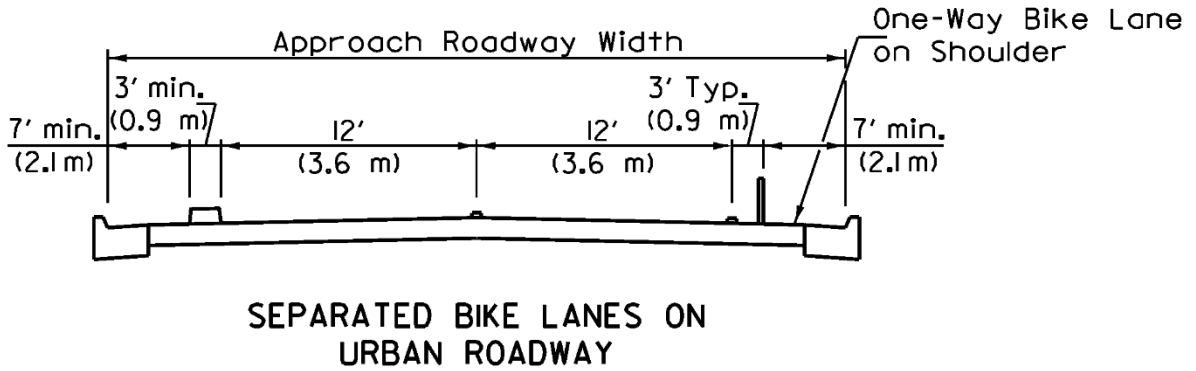
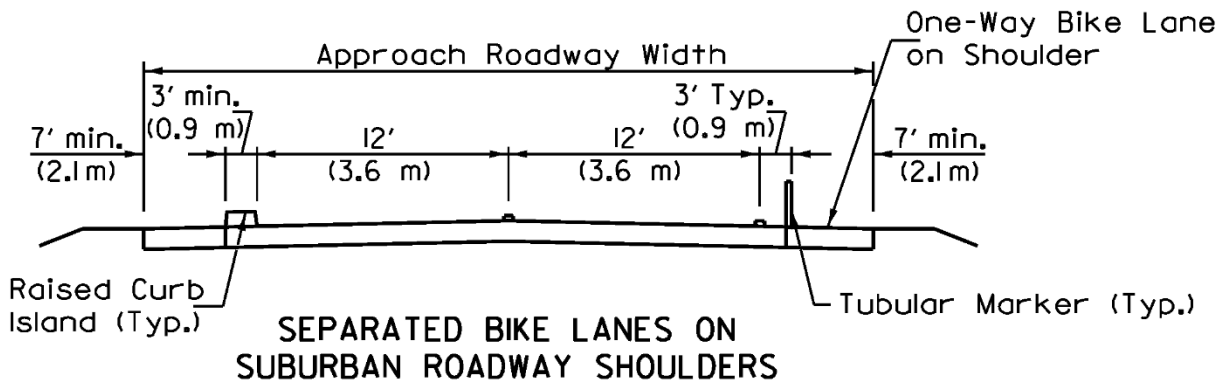

TYPICAL CROSS SECTIONS FOR SEPARATED BIKE LANES ON TWO LANE ROADWAYS AND STRUCTURES

FIGURE 17-2.M

17-2.02(g) Road Diets and Lane Width Reductions

Bicycles also can be accommodated on a roadway by marking or re-marking the pavement to increase the width of the curb lane or to add bike lanes. For example, it may be feasible to:

- reduce the width of traffic lanes in accordance with IDOT and AASHTO criteria;
- change the median width, create raised curb medians if pedestrian refuge is needed, or remove portions of a two-way center turn lane;
- remove parking, possibly in conjunction with providing off-street parking; or
- reduce the number of through traffic lanes, subject to analysis of capacity, safety, and operational needs.

Reducing the number of through traffic lanes, when accompanied by the addition of bicycle and/or pedestrian improvements, is referred to as a road diet. Figure 17-2.N depicts example plan and cross section views of an existing 4-lane roadway and two options for a 3-lane road diet improvement within the same face-to-face roadway dimension. Districts should review the range of issues involved on the specific corridor when deciding whether to pursue a road diet. Districts may also consider and determine whether to study locally suggested road diets and can require local study on a case-by-case basis. Specific dimensions applied would be unique for each project. The following guidance applies when road diets are considered.

Safety. Studies indicate that properly designed road diets can result in both speed reduction and safety benefits. Refer to the HSM and the Crash Modification Factor Clearinghouse for details on safety analysis for these projects. Both improved BLOS and the potential reduction in severe crash frequency should be investigated and reported.

Operations. Traffic studies must be performed to evaluate future capacity and vehicle level of service. Signal system modifications are generally needed for any signalized intersections that are within the project limits. It is likely that timing and phasing changes will be required that will affect operations along cross streets. The lane reduction upstream of a road diet should be accomplished in accordance with the requirements of Chapter 36. Early coordination with both district and central office Operations staff is necessary.

Local coordination. Review and consider local complete streets policies, whenever a community has adopted them. If a road diet is an option, begin local coordination early in Phase I, applying CSS procedures as appropriate. If a road diet is selected through the local coordination process, the district should request and receive a formal resolution stating that a municipality supports a road diet. At a minimum, a public meeting that includes invitations to area residents/business owners and roadway users is typically necessary and should be completed early in the process, before a design alternative has been selected.

Similar to other project types, if the accommodation identified in the Bicycle Facility Selection Table will not fit within the constraints of the roadway width, consider next highest-and-best options in order to provide an accommodation. Appropriate accommodations can sometimes be developed by narrowing through lanes (e.g., to a minimum 10 ft (3.0 m) width), commonly referred to as a “lane diet.” Use form BDE 1703 to calculate BLOS for the accommodation width available,

targeting BLOS C or C/D, and move forward to local coordination identifying the next highest- and- best accommodations. Raised median and corner islands are a key consideration for the safety of non-motorized users and can be established in conjunction with existing or new crosswalks as part of road diet projects. Additional discussion of road diets is provided in the *AASHTO Bike Guide* and FHWA's *Road Diet Informational Guide*.

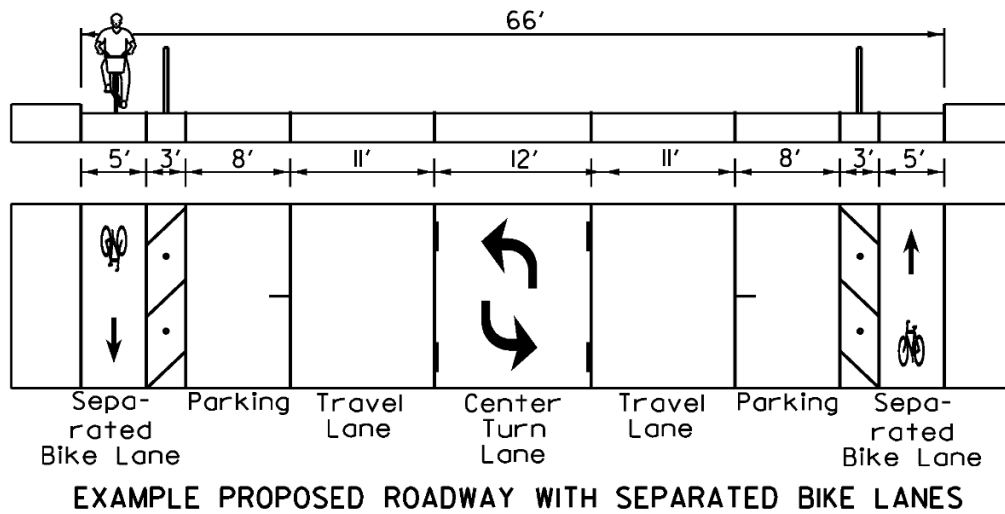
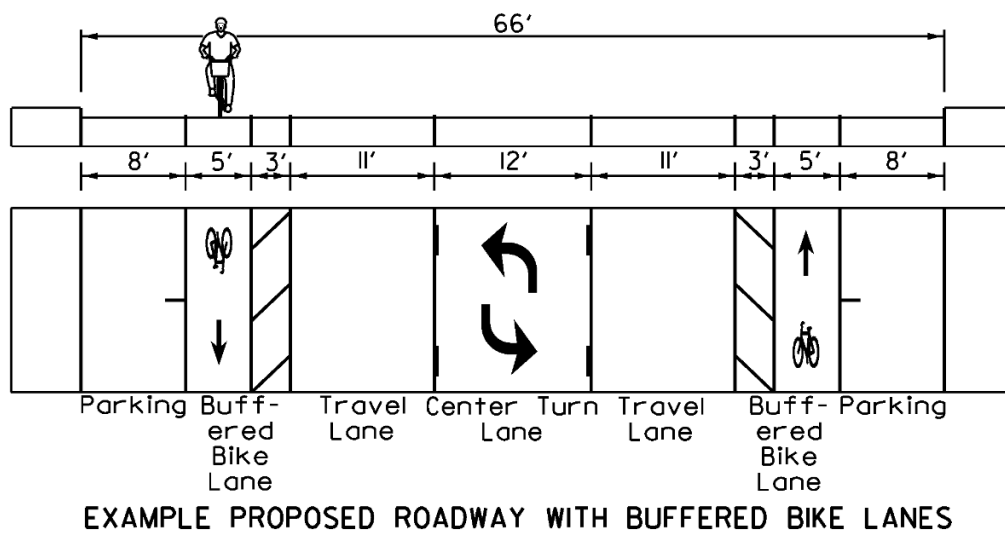
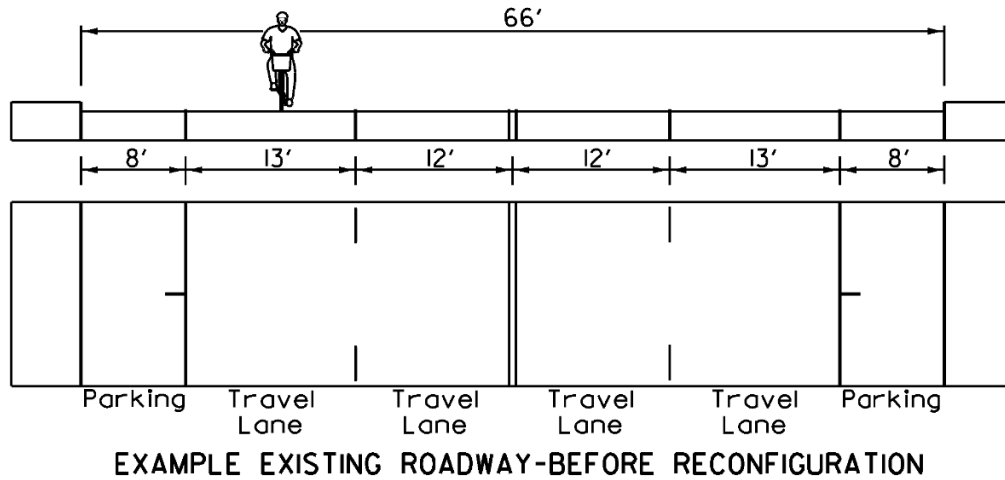

ROAD DIET EXAMPLES ADDING BUFFERED OR SEPARATED BIKE LANES

Figure 17-2.N

17-2.02(h) Other Design Considerations

Regardless of the type of on-road bicycle accommodation improvement being developed, always consider the following items:

Drainage Grates. Drainage grates and utility covers on roads, bridge approaches, and bridges can be hazardous to bicyclists. Bicycles often have narrow tires and no shock absorbent systems, and therefore are more sensitive to older elongated-slot style drainage inlets and irregularities on the pavement surface. Current IDOT drainage grate designs suitable for bicycle travel include Types 1, 3, 3V, 4, 5, 9, 10, 11, 11V, 23, and 24. Specify that grate openings run perpendicular to bicycle travel. Types 20, 21, and 22 are conditionally acceptable if the vane length is perpendicular to bicycle travel. Other grates are acceptable for bicycles, if the opening slots do not exceed 6¼" L x 1½" W (159 mm L x 38 mm W). With pavement overlay projects, replace utility covers and non-conforming drainage grates and adjust them flush with the new surface.

Railroad Crossings. Bicyclists should be able to cross railroad tracks at or near a right angle to minimize the potential for a bicycle's front wheel to become trapped in the flangeway, which would cause loss of steering control. The potential for a bicyclist's front wheel to be trapped in the rail flangeway increases when the angle of approach deviates greatly (20° or more) from 90°. When the crossing angle is less than 45°, consider widening the outside lane, shoulder, or bicycle lane to improve the angle of approach; see Figure 17-2.O(a). Where this is not practical, consider using commercially available compressible flangeway fillers, such as that shown in Figure 17-2.O(b), to provide a smooth transition over the rails. Coordination with the railroad owner is required. Design the bicycle portion of the pavement surface so that it is the same elevation as the rails and consistent with the vehicular crossing surface. Remove abandoned tracks, if practical, to eliminate the hazard.

Pavement Joints and Surfaces. Consider the following factors related to pavement structures:

- a. Joints and Drop-Offs. In new construction, pavement surface irregularities can cause a bicyclist to lose control and crash. Because bicycle tires may be as narrow as 1 in. (25 mm), gaps between pavement slabs and gutters or drop-offs at overlays, especially parallel to the direction of travel, can trap a bicycle wheel and result in loss of control. This loss of control can cause a bicyclist to fall or swerve into the path of motor vehicle traffic. To the extent practical, pavement surfaces should be free of irregularities and the edge of the pavement should be uniform in width. To assure pavement suitability, overlay projects should consider options to scarify the old pavement up to the gutter edge.

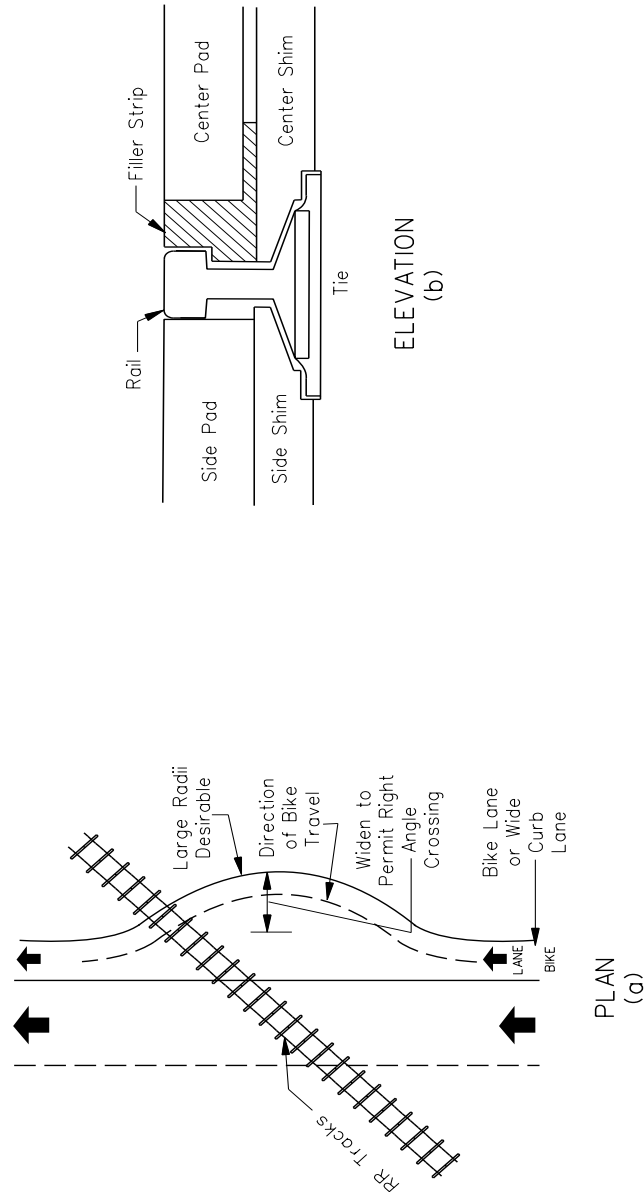

BIKE LANE CROSSING WITH RAILROAD

Figure 17-2.0

- b. Rumble Strips. Where rumble strips are placed across the traffic lane in rural areas to warn motorists of upcoming traffic controls, provide a minimum 3 ft (900 mm) clear paved area on the paved portion of the shoulder to allow a bicyclist an opportunity to avoid the rumble strips.

When rumble strips are installed in a paved shoulder which serves as a bicycle accommodation and the width of the paved shoulder is 6 ft (1.8 m) or less, the 8 in. (200 mm) rumble strip design should be used to minimize the impact to the accommodation. The minimum width of a paved shoulder accommodation with rumble strips is 4 ft (1.2 m). This width maintains a minimum paved width of 3 ft (0.9 m) beyond the edge of the rumble strip for bicyclist use.

- c. Surface Type. Many rural roadways, because of their low traffic volumes, are very conducive to bicycling. When selecting the surface type and maintenance methods, consider the impacts on bicycle use. Particularly with oil and chip (A2/A3) surfaces, the aggregate specified should be a coarse aggregate, and care should be exercised to ensure that the surface is properly rolled and swept. Any loose stones and debris allowed to accumulate on the outer edges of the roadway or shoulder can present safety concerns for bicyclists.

17-2.02(i) Bicycle Routes

It may be advantageous to sign some roadways as bicycle routes, particularly if certain roadways provide preferred alternatives to heavily traveled highways. When providing continuity to other bicycle facilities, a bicycle route can be relatively short; however, a bicycle touring route can be quite long.

Base the decision whether to provide a bicycle route on the advisability of encouraging bicycle use on a particular road instead of on parallel and adjacent highways. Consider the roadway width, BLOS, and other factors (e.g., volume, speed, type of traffic, parking conditions, grade, sight distance) when identifying appropriate bicycle routes.

Generally, bicycle traffic cannot be diverted to a less direct alternative route, unless the favorable factors outweigh the inconvenience to the bicyclist. Roadway conditions such as adequate pavement width, traversable drainage grates, railroad crossings, pavement smoothness, peak traffic volumes and times, and signal responsiveness to bicycles always should be considered before a roadway is identified as a bicycle route. Local agency support is required.

Bicycle route signing should not end at a location where bike travel conditions suddenly downgrade. Rather, provide information signing to direct the bicyclist to a relatively safe route to continue travel. Further guidance on signing bicycle routes is provided in the *ILMUTCD*.

17-2.02(j) Signing, Marking, and Traffic Control

Signing, pavement markings, and traffic control for bicycle facilities will be in accordance with the criteria presented in the *ILMUTCD* and applicable local ordinances. Signing and pavement markings are especially important at the approaches to intersections and at bike lane termini. Where a bike lane ends, bicyclists may be required to merge with motor vehicle traffic. Bicyclists should be encouraged with the appropriate signing and pavement markings to make appropriate lane changes in advance of an intersection.

Not all bicycle accommodations or bikeways need to be or should be marked as bike routes. Generally, only low-volume roads, bike lanes, and bicycle paths should be marked as designated bicycle routes. The following are some examples of what should not be marked:

- wide curb lanes that provide intermittent access to businesses along the route, but provide no connection to another part of a bike route; and
- any facility that does not meet minimum design criteria throughout its length.

At signalized intersections where frequent bicyclists need access to a green signal phase, a number of acceptable alternative methods are available including timed signals (where a cyclist must wait for the signal to change), traffic-actuated detectors (usually recommended for bike lanes or shoulders), and push-button actuation (more common for side paths). This opportunity (to access a green signal) should be provided where a marked bikeway runs along a project corridor or crosses a project corridor. Other crossing locations to consider include those in the vicinity of potential bicycle travel from schools, parks, or other significant destinations described in Sections 17-1.03 and 17-1.04.

Traffic-actuated detection should be sensitive to bicycles and should be located in the bicyclist's expected path, including left turn lanes, if necessary. Figure 17-2.P(a) shows recommended loop types for bicycle detection, each with particular advantages. Figure 17-2.P(b) also shows a pavement-marking stencil used to designate where a bicyclist should stand to activate the detector loop. The following information on bicycle detection should be considered:

1. Quadrupole Loop Detectors. The quadrupole loop detector functions best in a bicycle path or lane situation. In such a situation, the expected position of a bicyclist can be easily predicted. This loop is less sensitive over its outer wire than over its center wires and is also relatively insensitive to motor vehicle traffic in neighboring lanes.
2. Diagonal Quadrupole Loop Detector. The diagonal quadrupole loop detector functions best in shared-roadway situations where the position of a bicycle cannot be easily predicted. This detector is equally sensitive over its entire width and is relatively insensitive to motor vehicle traffic in neighboring lanes.

Signal phasing lengths may need to be increased to allow adequate time for bicycle crossing. The AASHTO publication *Guide for the Development of Bicycle Facilities* recommends calculating clearance intervals with a bicyclist's speed of 10 mph (16 km/hr) and a perception, reaction, braking time of 2.5 seconds. Figure 17-2.Q illustrates the approximate times for bicycles to cross intersections. A conservative approach to timing is recommended to avoid having bicyclists being caught in the middle of wider intersections. At very wide intersections consider providing a median refuge area that is at least 6 ft (1.8 m) wide if signal timing would prohibit adequate crossing time. Providing for two-stage crossings is a good approach for many larger intersections and requires median pushbuttons and/or detection areas.

QUADRUPOLE LOOP

- Detects most strongly in center.
- Sharp cut-off of sensitivity.
- Used in bike lanes.

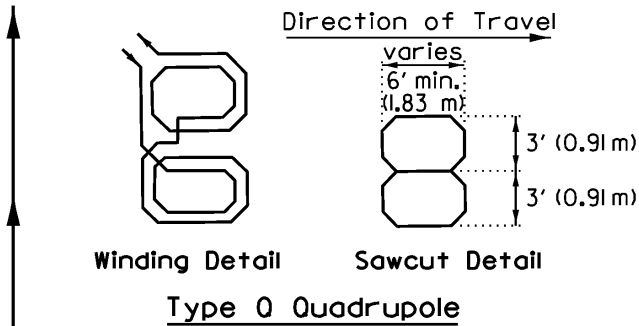

Note:
Video detection technology is available at comparable costs. Pavement Marking detail used for loop or video detection.

DIAGONAL QUADRUPOLE LOOP

- Sensitive over whole area.
- Sharp cut-off of sensitivity.
- Used in shared lanes.

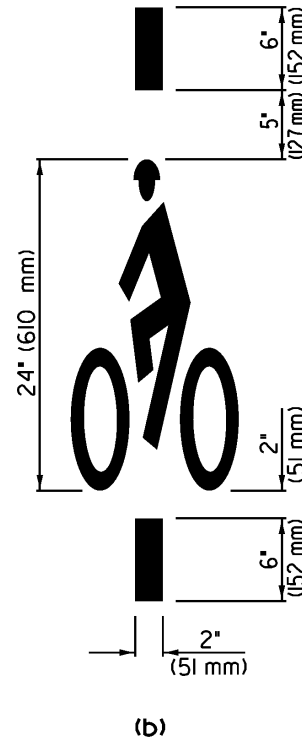
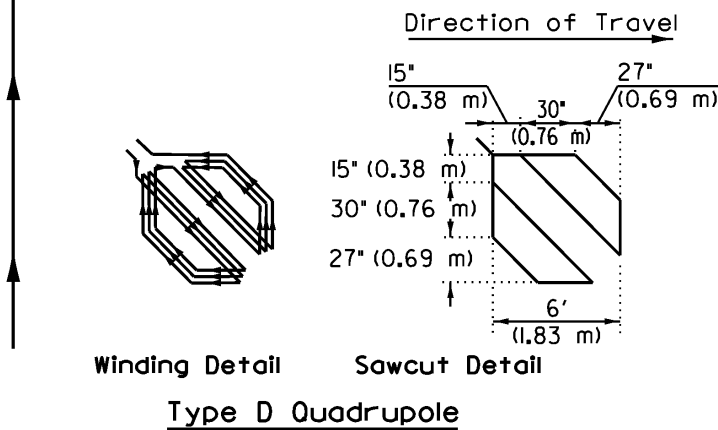

**RECOMMENDED LOOP TYPES AND PAVEMENT MARKINGS
FOR BICYCLE DETECTION LOOPS**

Figure 17-2.P

Number of Lanes*	2	3	4	5	6	7	8	9
Approximate Time to Cross Intersection	4.2 sec	5.0 sec	5.8 sec	6.6 sec	7.4 sec	8.2 sec	9.0 sec	9.9 sec

*Assumes average of 12 ft (3.6 m) lane widths and no median. Consider median refuge where possible and calculate crossing time manually if median is present and no refuge is possible.

APPROXIMATE BICYCLE TRAVEL TIMES THROUGH INTERSECTIONS

Figure 17-2.Q

17-2.03 Off-Road Accommodations (Shared-Use Paths)

Off-road bicycle accommodations are provided on shared-use paths where bicyclists, pedestrians, and some other motorized (e.g., e-bikes and e-scooters) and non-motorized users share space. Paths fulfill a primary transportation purpose by providing an opportunity for relatively safe and separated travel for both pedestrians and bicyclists. Shared-use paths comprise both facilities along roadway corridors (side paths) and those along independent rights-of-way that have minimal cross flow of motor vehicles.

As noted in the Bicycle Facility Selection Table, side paths are an option that fulfills accommodation requirements, and they are effective in many project contexts. In an urban core or urban context, side path effectiveness can be diminished due to ROW constraints, operational inefficiencies (e.g., mixing of bicyclists and high pedestrian volumes), or the presence of closely-spaced commercial driveways. The suburban and rural town contexts can very often be conducive to side paths. A side path can be selected for an accommodation whenever it is locally supported in accordance with Chapter 5 cost sharing and maintenance requirements. Note that many communities have ordinances that disallow bicycles on sidewalks, often with exceptions for children. AASHTO and NACTO, among others, identify issues that make cycling on sidewalks generally inappropriate. The unique features of paths, including design speed and their minimum 10 ft (3.0 m) width, differentiate side paths from sidewalks and allow for effective bike accommodation.

Shared-use paths can also be located along abandoned railroad rights-of-way, on former canal towpaths, river banks, and other similar areas. Paths sometimes can provide access to areas that are otherwise only served by limited-access highways that are closed to bicycles. Appropriate locations for paths can be identified during the planning process.

Shared-use paths will serve both transportation/utilitarian and recreational purposes and must be fully accessible to people with disabilities in accordance with the American with Disabilities Act (ADA). Refer to Section 58-1.01(a) for accessibility standards and Sections 58-1.05 through 58-1.12 for accessibility requirements. Chapter 58 guidance is generally based on information presented in the *2010 ADA Standards for Accessible Design* and the *Illinois Accessibility Code*. However, for situations in the public right-of-way that are not specifically or adequately addressed by either of the above standards, the guidance is taken from information presented in the *Draft*

Public Rights-of-Way Accessibility Guidelines (draft PROWAG). An accessible pedestrian access route (PAR) fully compliant with ADA shall be provided for the full width of any shared-use path, with maximum cross slopes limited to 2% at all points. Paths must be firm, stable, and slip-resistant. Hard, all-weather pavement surfaces are required since unpaved surfaces are more likely to result in bicyclists losing traction, can restrict some users, and will require more maintenance. Both asphalt and PCC can provide good all-weather pavement structures.

Paths should be considered extensions of the highway system that are intended for the preferential use of bicycles and pedestrians. As such, design criteria for paths are based on both bicycle use (e.g., for curvature, sight distance) and pedestrian use (e.g., for accessibility). Design considerations include horizontal alignment, sight distance requirements, drainage, signing and markings, horizontal and vertical clearance requirements, grades, and pavement structure. Section 17-3 provides bicycle clearances and operating characteristics. During design, always be cognizant of the operating characteristics of bicycles and how they influence the design of paths. Electric-assist bikes (e-bikes) are a growing segment of overall bicycle use and may increase the number of people bicycling, as well as average bicycling speeds. E-bikes include a motor, typically electric, that can either assist rider pedaling efforts or provide self-propelled operations. Any conventional bicycle may be converted to an e-bike. In general, the behavior of people riding e-bikes is very consistent with traditional bicyclist behavior on a national level (e.g. related to compliance with traffic control devices and risky behavior). In addition to e-bikes, electric assist pedestrian mobility (personal mobility) devices such as e-scooters may be used on shared-use paths. These devices are generally not allowed to operate on sidewalks, although local ordinances vary. The acceleration and braking characteristics of e-bikes and pedestrian mobility devices may vary somewhat from traditional bicycles. The design guidance provided in this chapter is based on traditional riders and is appropriate to cover the mix of users expected to use paths. The following sections provide guidance for designing safe and functional paths. Several issues that are unique to side paths are covered in Section 17-2.03(c).

17-2.03(a) Consideration of All Users

Potential users of shared-use paths include bicyclists, pedestrians, joggers, in-line skaters, and individuals with disabilities in either motorized or un-motorized wheelchairs. In most local jurisdictions in Illinois, bicycles on paths may be motorized (e-bikes) as long as operated at reasonable speeds. All potential users should be considered in the design of the facility. Where practical and where use levels are high, provide separate areas to minimize the conflicts arising from the different user speeds. If this is not feasible and usage is expected to be high, consider providing additional width, signing, and pavement markings. Figure 17-2.R shows an option for accommodating diverse users, minimizing conflicts, and delineating rights-of-way.

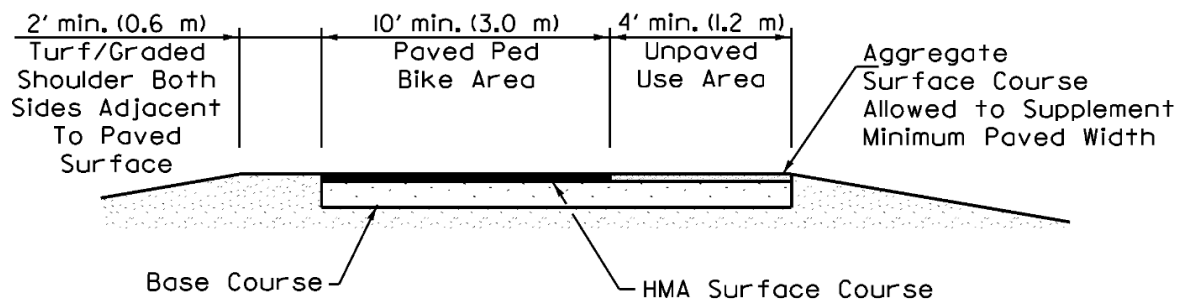

SHARED USE PATH CROSS SECTION WITH ADDED UNPAVED AREA

Figure 17-2.R

Using a path for both bicycles and horses is not a recommended practice. However, when circumstances dictate that horses share the same corridor as bicyclists, provide a minimum unpaved width of 4 ft (1.2 m) and provide signs to warn users of shared use (see Figure 17-2.S) and to restrict equestrians to the side area. Further guidance on equestrian trails is provided in the publication *Trails for the Twenty-First Century*.

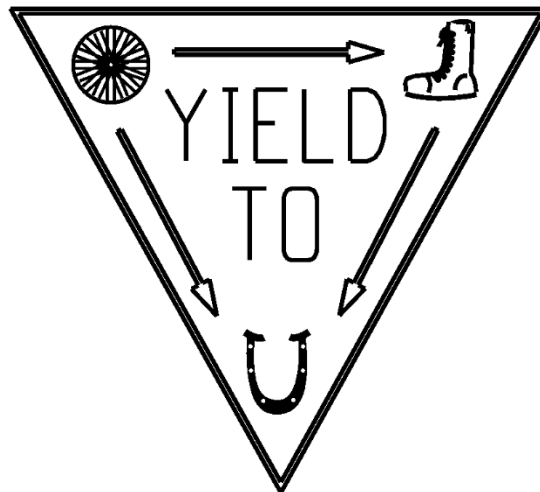

SHARED-USED PATH ETIQUETTE SIGN

Figure 17-2.S

17-2.03(b) Width and Clearance

Widths for shared-use paths will vary in accordance with the use level, as illustrated in Figure 17-2.T. Most locations will have use levels under 300 users per peak hour. Figure 17-2.U illustrates the minimum cross sections for two-way, shared-use paths. The 10 ft (3.0 m) minimum paved width shall be used for two-way paths. Wider paved paths should be considered in areas where very high use is expected. Widths less than 10 ft (3.0 m) do not allow for appropriate operation even with low use volumes. Normal social behavior, the need for passing, and the normal mix of users and operating speeds necessitates this width to address safety concerns for all users. However, where is a substantial physical constraint or an environmental feature to be avoided, reductions to an 8 ft (2.4 m) width for short distances may be allowed. Provide signing to notify path users of narrowed path conditions.

A minimum 2 ft (600 mm) wide graded turf or gravel area should be maintained adjacent to both sides of the path pavement. Three ft (0.9 m) or more is desirable to provide clearance from trees, poles, walls, fences, guardrails, and other lateral obstructions.

As shown in Figure 17-2.T, a paved width of 7 ft (2.1 m) may be considered as a one-way bicycle accommodation where such bike travel is allowed by local ordinances and pedestrian use is low. Paths are needed on both sides of the roadway where one-way facilities are selected.

Anticipated Volume	One-Way	Two-Way
< 300 Users per Peak Hour	7 ft (1.8 m)	10 ft (3.0 m)
> 300 Users per Peak Hour	10 ft (2.1 m)	12 ft (3.6 m) ⁽¹⁾

Notes:

1. *With very high use, separating bicycle and pedestrian travel should be considered, as shown in Figure 17-2.U.*

SHARED-USE PATH WIDTHS**Figure 17-2.T**

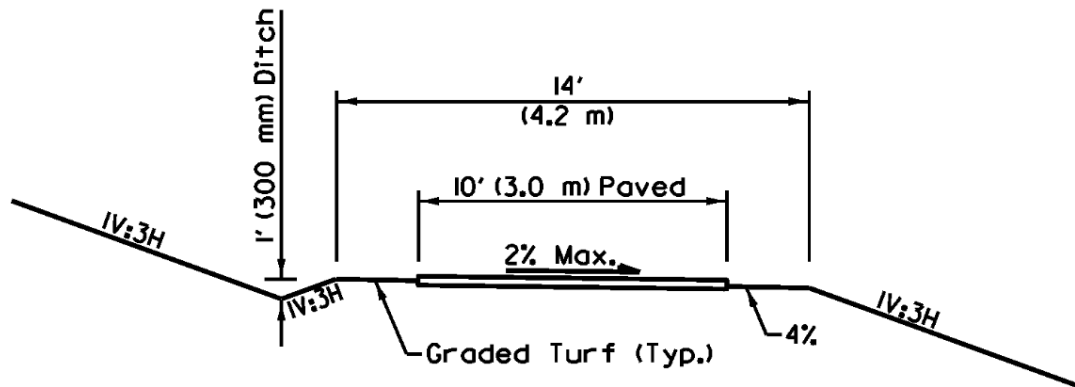

TYPICAL SHARED-USE PATH FOR LOWER USE

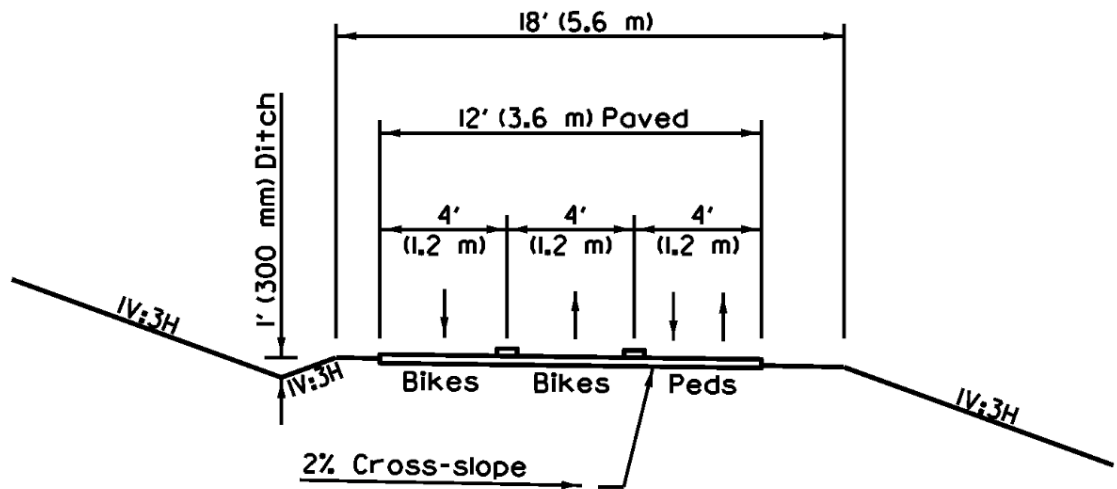

**TYPICAL SHARED-USE PATH FOR HIGHER USE
(Optional Striping Shown)**

TYPICAL CROSS SECTIONS FOR TWO-WAY SHARED-USE PATHS

Figure 17-2.U

17-2.03(c) Side Path Separation from Traffic

Side paths must be sufficiently offset or otherwise separated from motorized traffic so that operational and safety needs are met. Separation should be as wide as practical while allowing bicyclists to be visible to motorists at intersections and driveways; refer to Figure 17-2.V. Along urban roadways, a path could be located much like a sidewalk, with the edge of the path located at least 5 ft (1.5 m) from the curb face and 7 ft (2.1 m) from the traveled way. In rural sections, it is desirable for a two-way shared use path to be located on the top of the back slope at least 30 ft (9.1 m) away from the edge of the traveled way. At a minimum in a high-speed rural section the path edge should be 10 ft (3.0 m) from the outside edge of the shoulder. Turf areas will typically provide an adequately delineated boundary between the roadway and the path. Maintaining minimum offsets will reinforce that the bicycle path is an independent facility and will discourage bicyclists from making unexpected and undesirable movements between the path and the traveled way. Existing side paths closer than the offset distances described should be addressed as part of a project. Where safety issues are identified for such side paths consider retrofit options that either shift the path or insert appropriate barrier separation. Concrete barrier used for this purpose should be a minimum of 3 ft (910 mm) high; standard guardrail also provides adequate separation at a slightly lower height. Refer to Section 17-2.03(m) for further discussion.

All vertical surfaces within a 2 ft (600 mm) clear distance adjacent to the bicyclists' path should be smooth to avoid snagging of clothing or incurring abrasive injuries from contact with the surface. A primary concern in this regard is protection of the sharp edges of the backside of guardrail located within 2 ft (600 mm) of the edge of a path by smooth planking or a rub rail as shown in Figure 17- 2.W. No modifications shall be made within the length of Type 1 guardrail terminals. Highway Standard 630116 provides further details. Approved crash testing for elements attached to guardrail should be investigated by the designer.

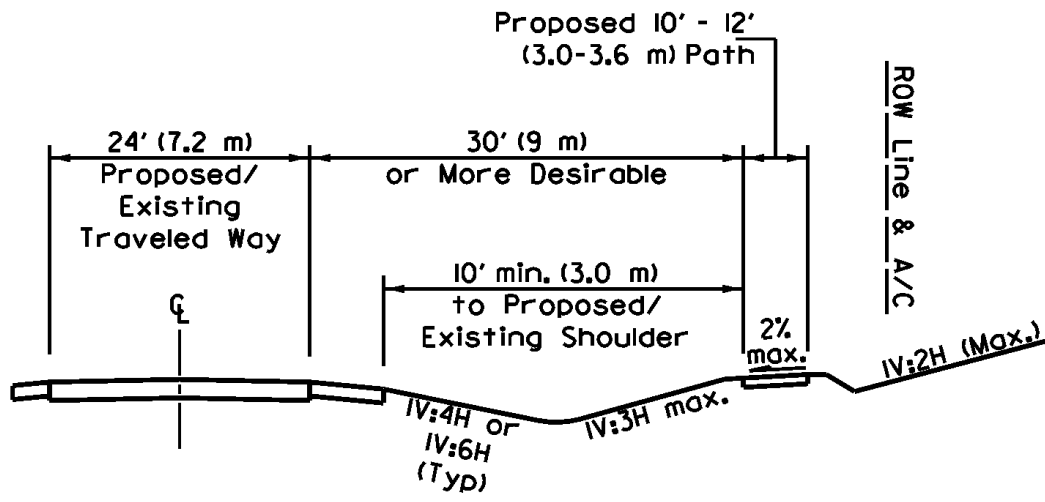
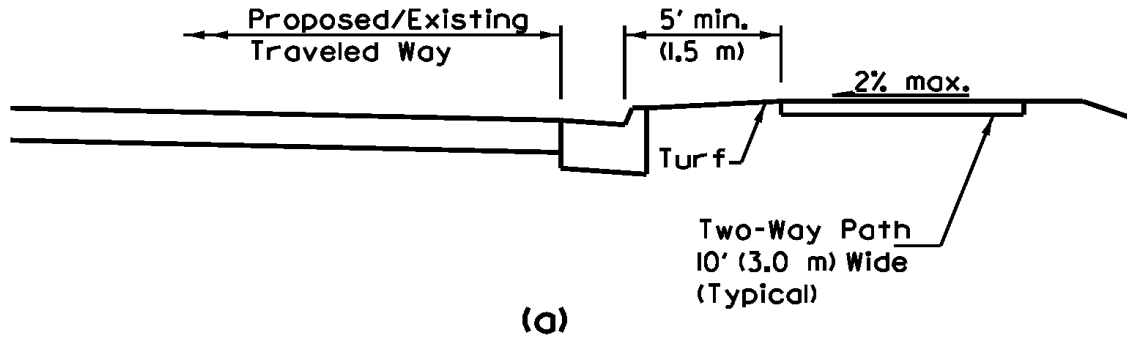

TYPICAL SIDE PATH SEPARATION FROM ROADWAY

Figure 17-2.V

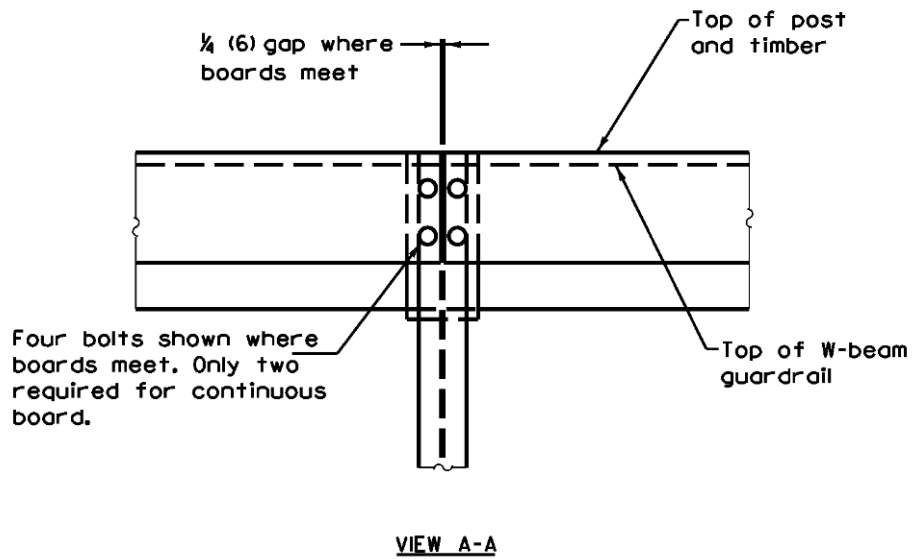
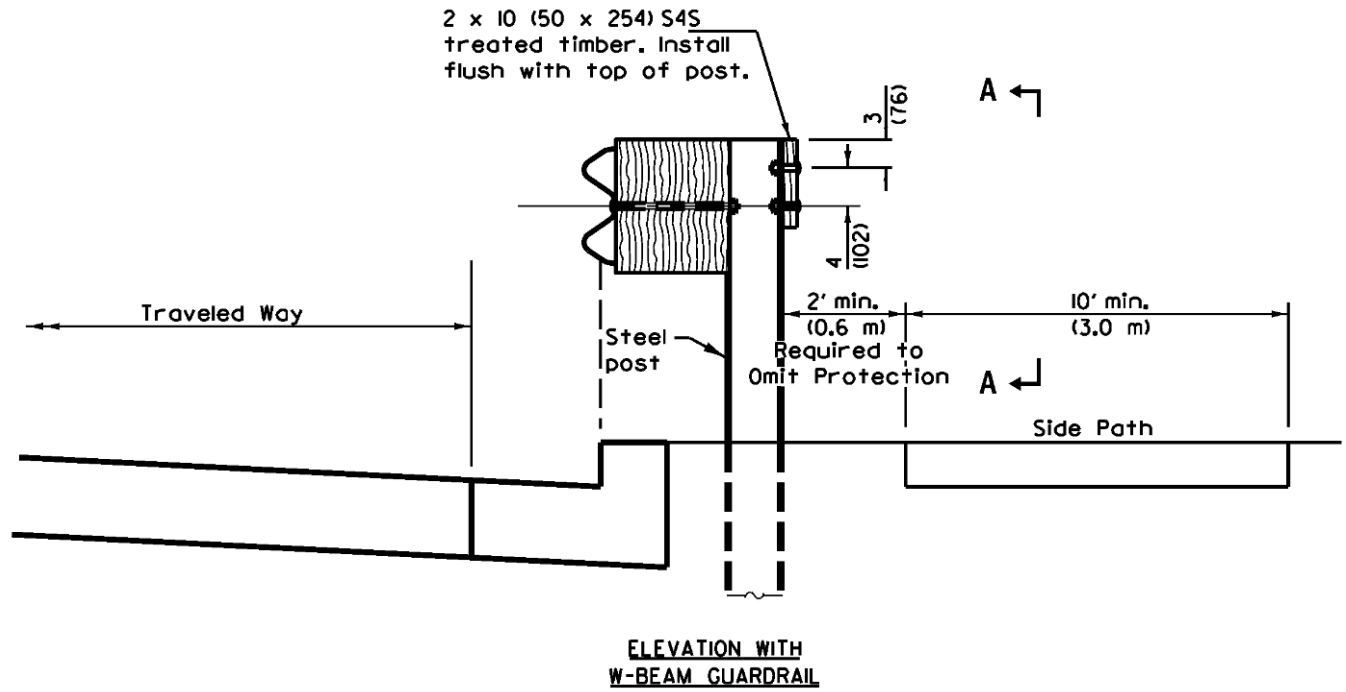

Note: Refer to Highway Standards 6300I and 630II6.

PROTECTION OF BACKSIDE OF GUARDRAIL

Figure 17-2.W

17-2.03(d) Additional Safety Considerations

Safety rails should be considered alongside paths with front slopes steeper than 1:3. Refer to Section 17-4.07 for situations where safety rails should be considered and to Figure 17-4.D for guidance on railing placement and height. The minimum height for a bicycle safety rail is 4 ft (1.2 m). Generally, if the consequences of striking a fixed object hazard or running off the path are believed to be more serious than hitting the railing, then the barrier may be warranted. In addition, the cost effectiveness and probability of encroachment also should be considered. For example, along a lengthy tangent section of path on an elevated railroad section, the cost effectiveness of installing safety rail along the entire distance would be questionable; however, the placement of rail at clearly hazardous locations (e.g., river crossing approaches, less than minimum widths and curves, potential points of conflict) may be prudent. Select the treatment that is judged to be the most practical and cost-effective for the site. The range of treatments includes:

- eliminating the hazard (e.g., flatten embankment, remove rock outcroppings);
- relocating the hazard;
- shielding the hazard with safety railing; or
- doing nothing.

The determination of the separation distance between a path and an active railroad is dependent on the speed and frequency of the rail service, the amount of access available to the railroad from the surrounding area, and the requirements of the railroad company. For low speed and low frequency service, the separation may be as little as 10 ft – 15 ft (3.0 m – 4.6 m), with no physical barrier (e.g., fencing, landscaping). As railroad speeds and frequencies increase, the requirements for increased separation and a physical barrier increase as well. An 8 ft (2.4 m) high chain link fence or other barrier type may be required to satisfy the railroad company that path users will be adequately separated from the hazards of the trains.

The vertical clearance to obstructions should be an absolute minimum of 8 ft (2.4 m). However, vertical clearance may need to be greater to permit passage of maintenance vehicles, rescue vehicles, and ambulances. Rescue vehicles typically can exceed 9 ft (2.7 m) in height and 9 ft (2.7 m) in width. In undercrossings and tunnels, a vertical clearance of 10 ft (3.0 m) is desirable. The geographical location of the vertical obstructions, as well as alternate access points, are primary considerations for determining clearance. It is imperative that adequate clearance be provided where the path offers the primary access to a remote location. Any overhead restrictions with less than a 10 ft (3.0 m) clearance should be marked on the structure according to the *ILMUTCD*.

17-2.03(e) Design Speed

Paths should be designed for a selected speed that is at least as high as the preferred speed of the faster bicyclists. In general, use a minimum design speed of 20 mph (30 km/hr). However, where the grade exceeds 4% or where strong prevailing tail winds exist, (e.g., along a lake or river), a design speed of 30 mph (50 km/hr) is advisable. On approaches to intersections, bicyclists can be expected to slow since the path will typically cross the side street in a crosswalk fashion and caution is required. A 10 mph (15 km/hr) design speed may be applied to the curves that provide for alignment into crosswalks.

17-2.03(f) Horizontal Alignment and Superelevation

Unlike an automobile, a bicycle must be leaned while cornering to prevent it from falling outward due to centrifugal force. The horizontal curvature should not require a bicyclist to use a lean angle greater than 15° nor need more than 2% superelevation. The minimum radius is calculated by the following equation:

$$R_{\min} = 0.067 V^2 / \tan \theta \quad (\text{U.S. Customary}) \text{ Equation 17-2.1}$$

$$R_{\min} = 0.0079 V^2 / \tan \theta \quad (\text{Metric}) \text{ Equation 17-2.1}$$

where: R_{\min} = minimum radius of curvature, ft (m)
 V = design speed, mph (km/hr)
 θ = lean angle from vertical, degrees

Figure 17-2.X presents minimum radii for horizontal curves using a 15° lean angle. Paths should be superelevated so that the 1% to 2% cross slope is partially counteracting the inward friction force on a bicycle as it traverses the horizontal curve, but the radius values shown in the figure are acceptable for adverse cross slopes of up to 2%.

Design Speed (V)		Lean Angle (θ) (degrees)	Minimum Radius (R_{\min})	
mph	km/hr		ft	m
10	16	15	25	8
20	30	15	100	27
25	40	15	155	47
30	50	15	225	74

DESIRABLE MINIMUM RADIUS FOR PAVED PATHS BASED ON 2% SUPERELEVATION RATE AND 15° LEAN ANGLE

Figure 17-2.X

In restricted conditions a lean of up to 20° can be tolerated. The same formula is applied. Figure 17-2.Y presents minimum radii for horizontal curves where lean angles up to 20° can be tolerated. For either lean angle the radii assume a maximum superelevation rate of 2% so that ADA requirements for accommodation of users with disabilities are fully met. A minimum 1% cross slope should be maintained to facilitate drainage of the path. Where transitioning from a 1% to a 2% cross slope on tangent to a 2% superelevation rate on the high side of the curve or where reversing curvature, use a minimum transition length of 15 ft (4.6 m).

Figure 17-2.Y presents minimum radii for horizontal curves where lean angles up to 20° can be tolerated and the path is not paved. Use of unpaved paths (or portions of paths) would be very rare; additional detail is available in the *AASHTO Bike Guide*.

Design Speed (V)		Side-Friction Factor (f) (Paved Surface)	Minimum Radius (R _{min})	
mph	km/hr		ft	m
10	16	0.31	20	6
20	30	0.28	74	22
25	40	0.25	115	35
30	50	0.21	166	50

**MINIMUM RADII FOR PAVED PATHS BASED ON
2% SUPERELEVATION RATE AND 20° LEAN ANGLE**

Figure 17-2.Y

When a lean angle of 20° is used, the bicyclist taking the curve will occupy more horizontal space and more width needs to be provided. In these cases, the path width should be increased as noted in Figure 17-2.Z and a centerline located in the middle of the curve.

When curve radii smaller than those shown in Figure 17-2.X must be used because of limited right-of-way, topographical features, or other considerations, standard curve warning signs and supplemental pavement markings should be installed according to the *ILMUTCD*. The negative effects of sharper curves can also be partially offset by widening the pavement through the curves as shown in Figure 17-2.Z.

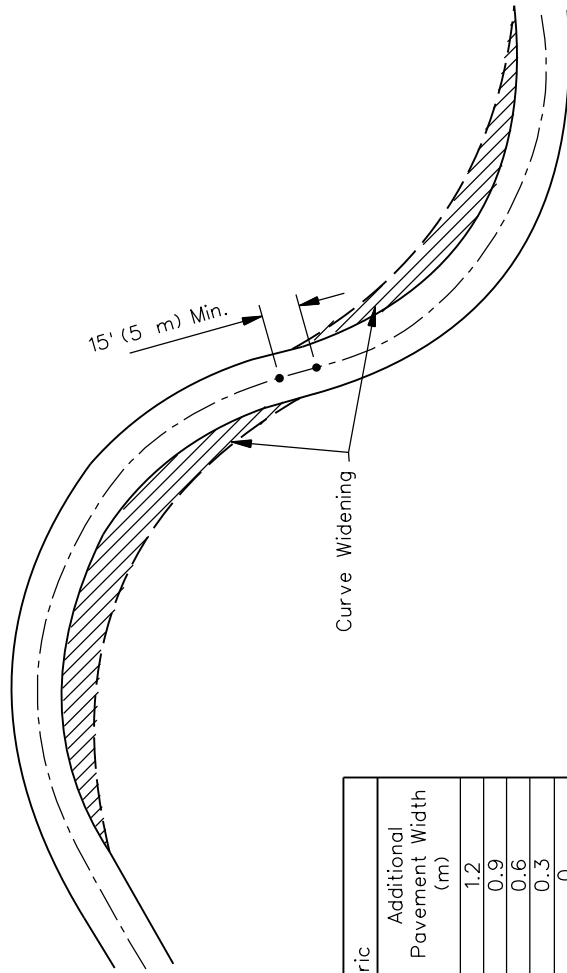

US Customary		Metric	
Curve Radius (ft)	Additional Pavement Width (ft)	Curve Radius (m)	Additional Pavement Width (m)
0-25	4	0-7.5	1.2
25-50	3	7.5-15	0.9
50-75	2	15-22.5	0.6
75-100	1	22.5-30	0.3
100+	0	30+	0

Note: Only use additional pavement width where curve radii are less than design speed of bike path or where a 20° lean angle is assumed.

BIKEWAY CURVE WIDENING FOR VARIOUS CURVE RADII

Figure 17-2.Z

17-2.03(g) Drainage

Typically design paths with cross slopes of 1% to 1.5% for drainage; ensure that a 2% maximum cross slope is not exceeded. Sloping in one direction instead of crowning is preferred and usually simplifies the drainage and surface construction. A smooth surface is essential to prevent water ponding and ice formation. Shoulders should provide further positive drainage by sloping away at 2% to 4%.

Where a path is constructed on a hillside a ditch of suitable dimensions should be provided on the uphill side to intercept the hillside drainage. Design these ditches so as not to present an obstacle to bicyclists. Figure 17-2.AA shows the dimensions of a minimum swale/ditch to redirect runoff. Where necessary, provide catch basins with drains to carry intercepted water under the path. Locate drainage grates and manhole covers outside the traveled way of bicyclists. To assist in draining the area adjacent to the path, consider preserving the natural ground cover. Include seeding, mulching, and sodding of adjacent slopes, swales, and other erodible areas in the design plans.

Side paths should pass over waterways at elevations consistent with the adjacent roadway, and path flooding would not be a concern. However, concerns related to path overtopping may be relevant for some paths along independent alignments, such as for roadway underpasses or for locations along waterways. Path usability at such locations is a pertinent issue, and studies of the potential for path flooding will be important to understand the reliability of the path system. Refer to the *IDOT Drainage Manual* for further information.

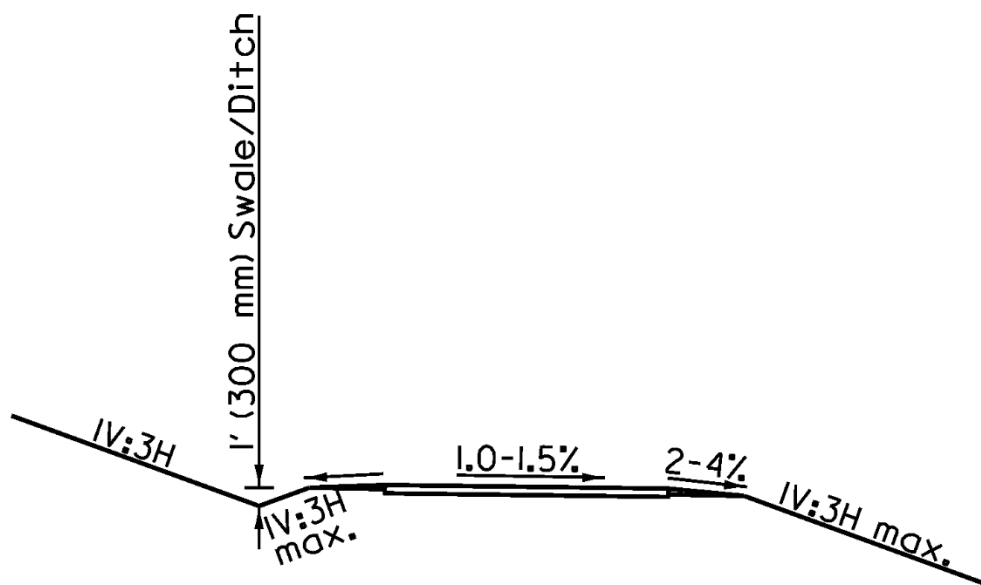

TYPICAL PATH DRAINAGE

Figure 17-2.AA

17-2.03(h) Grade

Grades on paths shall not exceed 5%, except along a roadway with a grade that exceeds 5%, in which case the path grade may match but not exceed the roadway grade. Long grades of over 2% on shared-use paths should be avoided to the extent possible. Some users, especially individuals with disabilities, may have difficulty negotiating high grades over 300 ft (90 m) in length. Consider incorporating intermediate flatter and wider landings when this distance would be exceeded.

17-2.03(i) Accessible Width

Because the intent is to create a facility to accommodate pedestrians, shared-use paths must meet accessibility requirements across the full width. Vertical discontinuities must be less than ¼ in. (6 mm) untreated or ½ in. (13 mm) beveled per ADA guidelines to accommodate individuals in wheelchairs. Additionally, grates and utility covers located in the expected paths of bicyclists or pedestrians should be flush with the pavement. Refer to Section 58-1 for accessibility standards and the criteria to be met in the design of paths.

17-2.03(j) Sight Distance

To provide bicyclists with an opportunity to see and react to the unexpected, a shared-use path should be designed with adequate stopping sight distance and intersection sight distance. The distance required to bring a bicycle to a full controlled stop is a function of:

- the bicyclist's perception and brake reaction time,
- the initial speed of the bicycle,
- the coefficient of friction between the tires and the pavement, and
- the braking characteristics of the bicycle.

See the *AASHTO Bike Guide* for information on determining adequate sight distance.

Bicyclists frequently ride abreast of each other on paths, and on narrow paths bicyclists tend to ride near the middle of the path. For these reasons, and because of the serious consequences of a head-on bicycle crash, calculate lateral clearances on horizontal curves based on the sum of the stopping sight distances for bicyclists traveling in opposite directions around the curve. Where this is not feasible, consider widening the path through the curve, installing a yellow center stripe, installing turn or curve signs (W1-1 or W1-2) as appropriate, or a "KEEP RIGHT" (R4-7b) sign, or some combination of these alternatives.

17-2.03(k) Path Intersections

Shared use paths usually cross various transportation elements. These intersections can be roadways, railroads, or other paths; all present potential conflicts and must be thoroughly analyzed to consider their impacts on the path users as well as the users of the other intersecting legs. Figure 17-2.BB illustrates how a bikeway could interact with crossing roads and railroads. All paths intersecting with roads and railroads require the installation of detectable warnings immediately adjacent to the crossing. Unauthorized access is sometimes a concern. Although

rigid bollards have been used to restrict motor vehicle access to paths the hazards they create for bicyclists, and in some cases for motor vehicles, often outweigh access concerns. Refer to Section 2.03(p) for further guidance on this issue.

Where a side path crosses a street, by definition near an intersection, the path should cross in a typical crosswalk fashion, as in Figure 17-2.CC. AASHTO notes that paths should be located in close proximity to the parallel roadway at intersections so that motorists turning off the roadway can better detect the path users. Locating the crosswalk close to the parallel through edge of pavement may also lead motorists to better obey the single stop bar location. Consider including right-turn corner islands for path crossings to provide refuge areas for all vulnerable users. Regardless of location, crosswalks width must equal or exceed the full width of the path.

For paths on independent rights-of-way, according to AASHTO, it is preferable that any crossing of the path and a highway be at a location away from the influence of intersections with other highways. Crosswalks width must equal or exceed the full width of the path; refer to Figure 17-2.DD. Assign right-of-way and provide adequate sight distance to minimize the potential for conflicts. For further discussion of mid-block crossings see Section 17-4, Operations Policy TRA-23 (*IDOT Guidelines for Pedestrian Crossings at Uncontrolled Locations*), and the *AASHTO Bike Guide*.

Design crossings as close to a right angle as possible for safety reasons. Controlling vehicular movements at mid-block intersections is more easily and safely accomplished through the application of standard traffic control devices and normal rules of the road. Use engineering judgement in determining appropriate crossing measures such as markings, post-mounted signs, overhead signs, flashing beacons, traffic signals, or a grade separation. At crossings with high-volume, multi-lane arterial highways where a signal or a grade separation is not practicable, consider providing a median refuge area for bicyclists and pedestrians. IDOT Bureau of Operations Policy TRA-23 provides design guidelines for uncontrolled pedestrian crossing locations and includes recommended signing, striping, refuge areas and beacon treatments based on vehicle speeds, traffic volumes, and roadway cross section. These guidelines apply to roadway crossings involving either paths or sidewalks. At all roadway crossings, appropriate curb ramps and detectable warnings shall be included on the paths as discussed in Section 58-1.09.

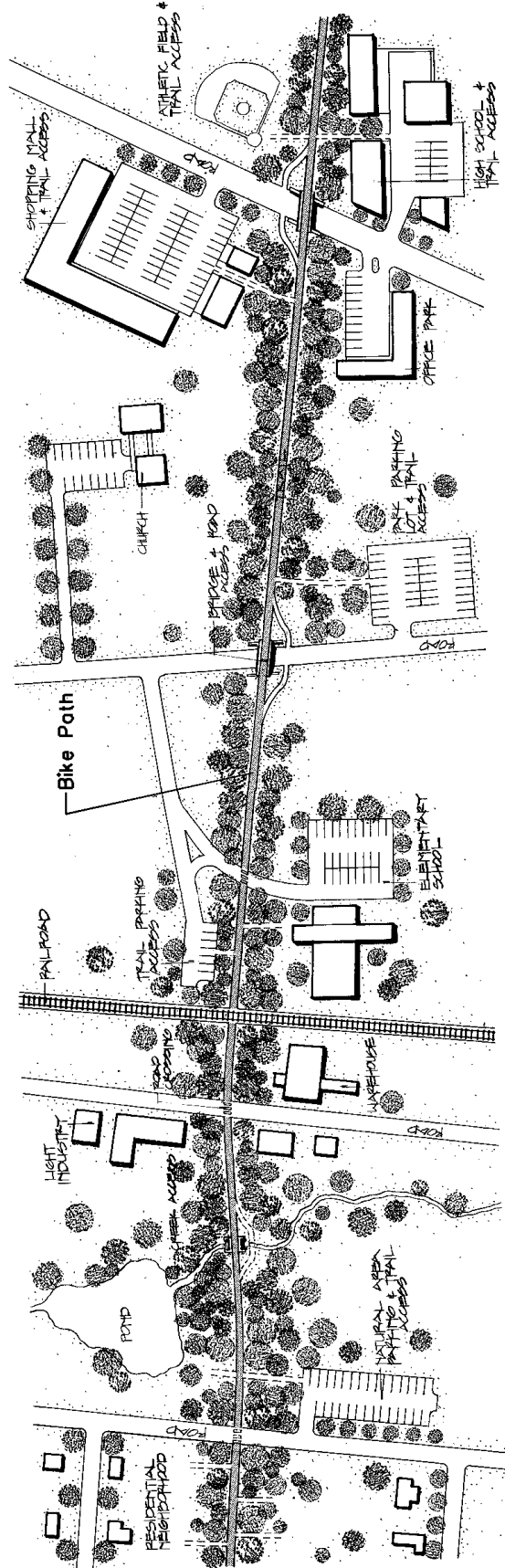

BIKE PATH/TRAIL INTERACTION WITH VARIOUS INTERSECTIONS

Figure 17-2.BB

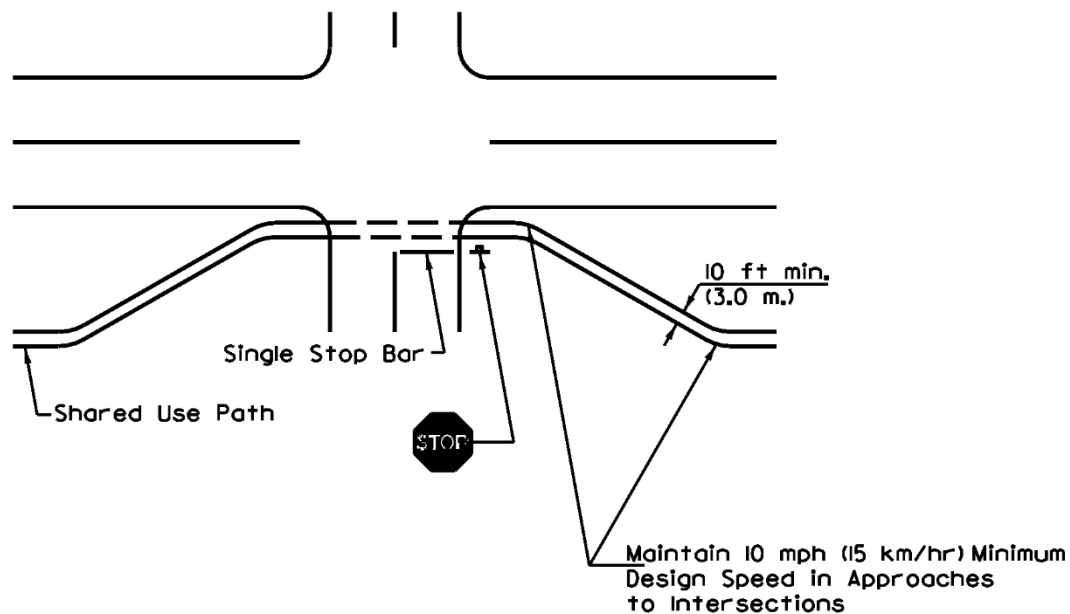

SHARED BICYCLE/PEDESTRIAN CROSSING

Figure 17-2.CC

Where paths terminate, integrate the path into the adjacent road network. Transition traffic into a safe merging or diverging situation, considering all users. Provide appropriate signing to warn and direct both bicyclists and motorists regarding these transition areas. Ensure that signs are located so that they clearly direct each user group. Do not merge a shared-use path into a bicycle lane or paved shoulder without providing an alternative connection for pedestrians away from vehicular traffic to the existing sidewalk network.

Path intersection approaches should have relatively flat grades. Check stopping sight distances at each intersection and provide adequate warning to allow bicyclists to safely stop before the intersection, considering downgrades where present.

Flare the ramps for curb cuts at intersections to allow bicycle movements from the roadway to the path. A minimum radius or flare of 5 ft (1.5 m), as shown in Figure 17-2.DD, will allow bicycles, including tandem bicycles (i.e., two-person bicycles) and bicycles with trailers, sufficient opportunity to negotiate turns. If maintenance vehicles are expected to access the path at these points, provide a 15 ft (4.5 m) flare to reduce edge rutting and turf disturbance.

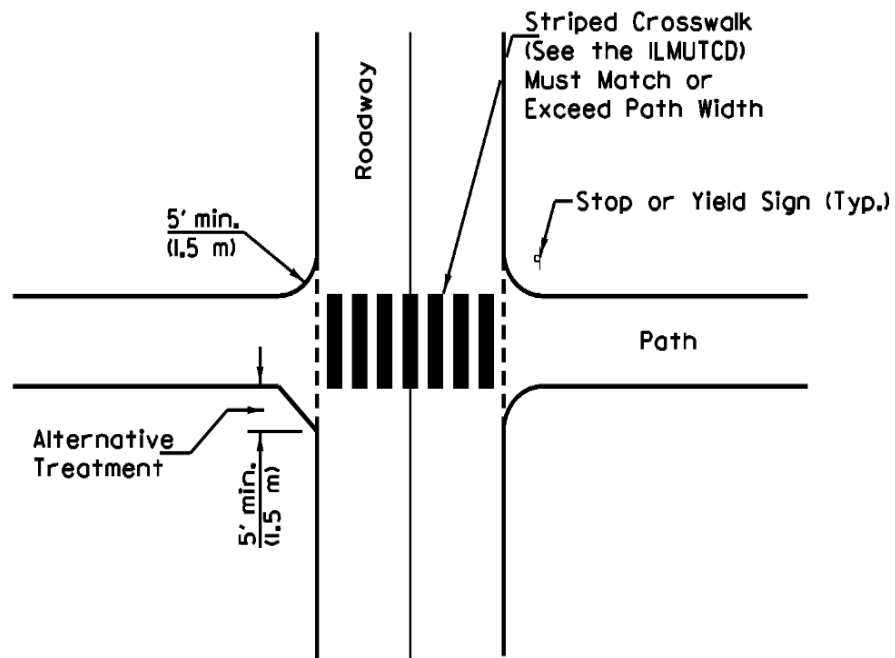

Note: Consider warning signs and other treatments per Bureau of Operations TRA-23 Policy.

TYPICAL CURB FLARES AND STRIPING AT PATH/ROADWAY INTERSECTIONS

Figure 17-2.DD

Path/Railroad Crossings

Where independent paths intersect with railroads, locate the crossing as close to a right angle as practical for safety reasons, as shown in Figure 17-2.EE. Considerations noted in Section 17-2.02(h) apply. Signing and pavement markings shall be in accordance with the *ILMUTCD*. Crossbuck signs and pavement markings are minimum advanced warning requirements. In addition, ensure that adequate sight distance is provided so bicyclists can see approaching trains. Existing and planned railroad operations always should be factored into the design elements of the crossing. As train speeds and frequencies increase, the level of crossing protection should increase. It may be necessary to provide train activated crossing gates and signals, along with fencing, to ensure the safety of bicyclists and to satisfy the requirements of the railroad company. In extreme situations, rerouting the path to an adjacent roadway crossing or installing an underpass or overpass may provide the best crossing solution.

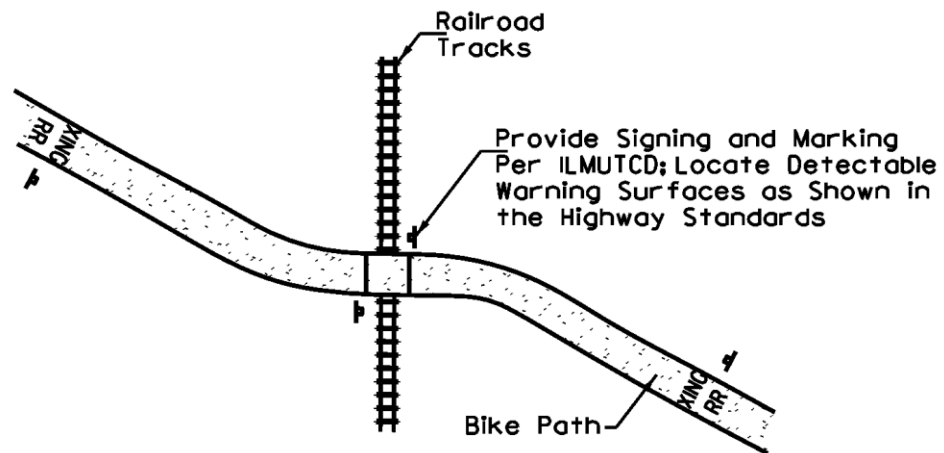

Note: Path should intersect rails at right angle where practical.

TYPICAL PATH/RAILROAD INTERSECTIONS

Figure 17-2.EE

Path/Path Crossings

Where paths intersect with other paths, the minimum return radius provided should be 15 ft (4.5 m), as shown in Figure 17-2.FF, to accommodate tandem bicycles, bicycles with trailers, and occasional vehicular movements without running off the pathway. These movements are likely to be negotiated at higher speeds and thus the larger radii are necessary. The figure also shows a circular intersection option that can be applied to slow riders where there are operational and safety concerns.

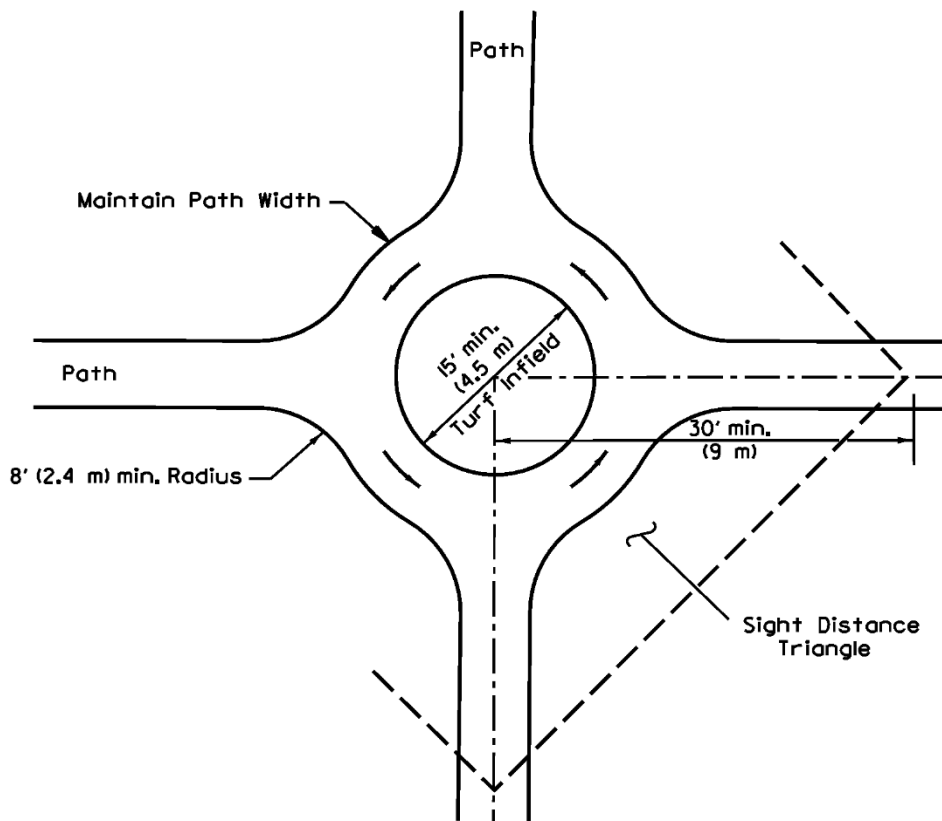
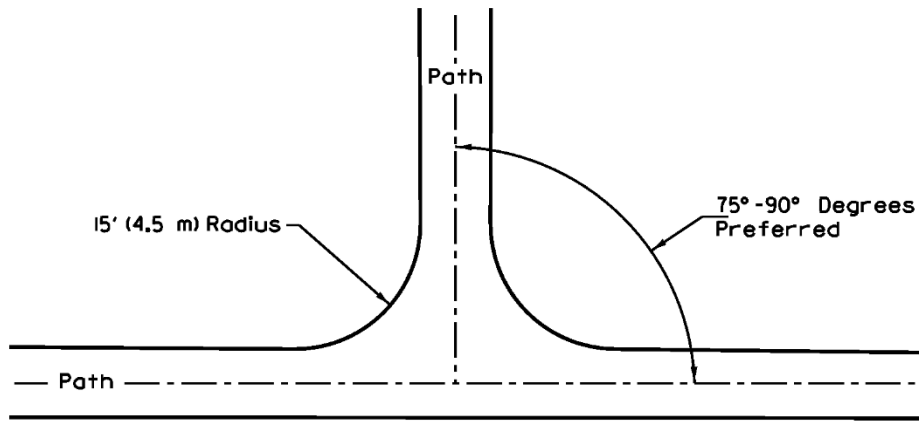

Note: Consider "KEEP RIGHT" signs.

PATH INTERSECTIONS

Figure 17-2.FF

17-2.03(I) Independent Path Structures

An overpass, underpass, bridge, or drainage facility may be necessary to provide continuity to a path. Modification of existing facilities are sometimes necessary to construct a side path under an existing bridge, most commonly along expressways. One method for retrofitting paths under bridges is illustrated in Figure 17-2.GG. Slopewall modifications typically involve full removal and reconstruction of the walls. Consult with the Bureau of Bridges and Structures in developing the structural plans.

With new shared-use path structures, the minimum clear width should be the same as the path's paved approach, and the desirable clear width should include 2 ft (600 mm) minimum shoulders on each side; see Figure 17-2.HH. Carrying the clear width across a bicycle path structure has two advantages. First, it reduces concerns about horizontal shy distance from the railing or barrier; and second, it provides needed maneuvering space to avoid conflicts with pedestrians and other bicyclists who are stopped on the bridge. Additional width would be warranted on structures over rivers where users would likely stop to enjoy the view. Users would be less likely to stop on bridges over railroads or highways or in tunnels.

Bridges designed exclusively for bicycle and pedestrian traffic should be designed for live loadings in accordance with the AASHTO publication, *Guide Specifications for Design of Pedestrian Bridges*. Bridges that must provide access for ambulances or rescue vehicles shall support specific minimum design loads.

On all bridge decks, ensure that bicycle-safe expansion joints are used. Where wood planking is used for flooring, it should be placed 45° to 90° from the direction of travel, as shown in Figure 17- 2.HH. Bridge railings on paths should be a minimum of 4 ft (1.2 m) tall. Bridge approaches should provide a safety railing as shown in Figure 17-2.HH to protect users from hazardous conditions.

Other types of bikeway structures will be necessitated by the various ways that paths can interface with roadways, rivers, or railroads. Paths can utilize the underside of a highway or railroad bridge and can cross under roadways or railroads in various ways, as illustrated in Figures 17-2.II and 17-2.JJ. Where bikeways are routed under highway bridges, drainage from the bridge above should be routed to drain away from the path surface.

Design of bikeway underpasses should proceed with recognition of the types of traffic that need to be accommodated (e.g., emergency vehicles). Minimum vertical clearance should be 10 ft (3.0 m) and the minimum width should be 10 ft (3.0 m). With tunnels or box culverts exceeding 100 ft (30 m) in length, the users' sense of security is enhanced with larger openings (e.g., 12 ft (3.6 m) high and 14 ft (4.2 m) wide). The alignment of the approaching path should provide a clear view through the structure where practical. On long structures (e.g., under multi-lane highways) a shaft opening at the median can provide natural light and ventilation. Lighting should be considered in areas where security is a concern.

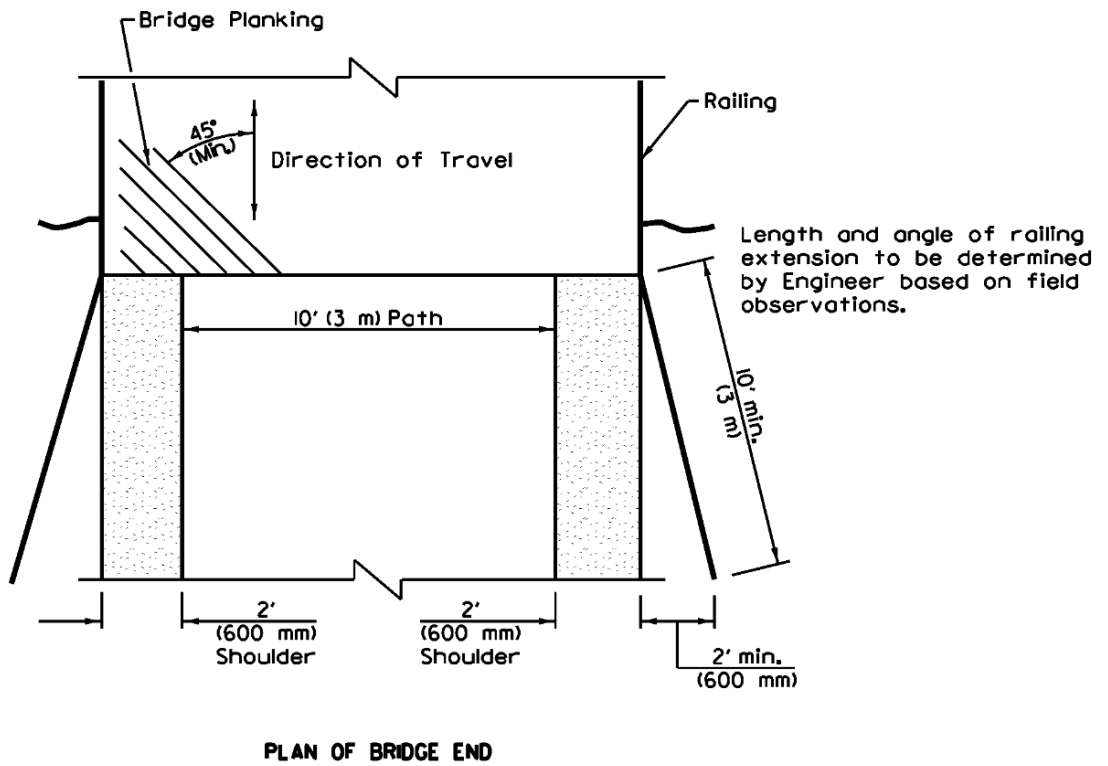
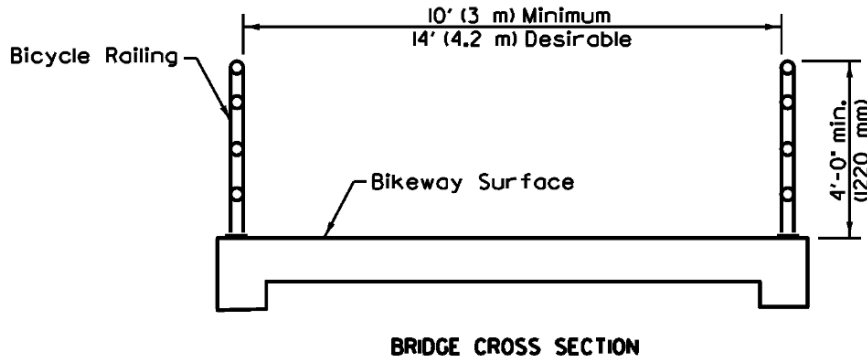

PLAN AND CROSS SECTION OF SHARED USE PATH BRIDGE WITH RAILING

FIGURE 17-2.HH



BOX CULVERT FOR BIKEWAY

Figure 17-2.11



BIKE PATH DEPRESSED TO GAIN ADEQUATE VERTICAL CLEARANCE

Figure 17-2.JJ

17-2.03(m) Paths on Highway Structures

Side paths should be accommodated on new and rehabilitated structures in accordance with the dimensions shown in Figure 17-2.KK. Appropriate railings must be provided. Bridge railings along shared-use paths must provide a minimum 4 ft (1.2 m) rail-height on the outside edge. The required barrier or separation element between the path and the adjacent traffic lane must be a minimum of 3 ft (910 mm) high, with the lesser height in recognition of the need for both path user safety and the need for visibility between path users and motorists. Consider the potential for sight line impediments at adjacent intersections created by barriers. Adjacent signalized intersections may need to include right-turn-on-red (RTOR) restrictions if intersection sight distance is substantially limited by a barrier adjacent to the traveled way.

Several examples of barriers and railings used for path applications on bridges are shown in Figure 17-2.LL. Specific configurations depend on the roadway speed limit, roadway classification and the facility being crossed. Barrier and railing selection can be determined in consultation with BPPE and the Bureau of Bridges and Structures.

When a project has a bridge omission with side path accommodations along the roadway, fully compatible future accommodations should be planned for the omitted structure. Where it is necessary to accommodate a shared-use path across an existing highway bridge as an interim condition, consider alternatives in light of what the geometrics of the bridge will allow. Carrying the path across the bridge is a primary goal where the bridge facility will connect to a shared-use path at both ends. Sufficient width may be provided on one side of the bridge by shifting, narrowing or restriping lanes, or by reducing median width. Consider a reduced path width if necessary. In all cases separate bicycle traffic from motor vehicle traffic by means of a crashworthy barrier. Identifying existing sidewalks as one-way shared-use facilities is not typically acceptable, since bicyclists do not have good options for crossing a roadway twice to access a path on the opposite side of the roadway. Raised sidewalks without a separation barrier do not provide for two-way bicycle accommodation adjacent to traffic lanes. Consult with BPPE and Bureau of Bridges and Structures for retrofit options. Adding a separation barrier on the deck could sometimes be an option, as illustrated in Figure 17-2.KK.

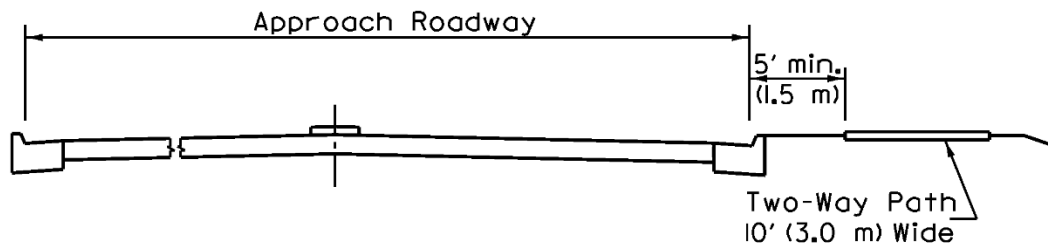

APPROACHING ROADWAY SECTION WITH ADJACENT TWO-WAY PATH

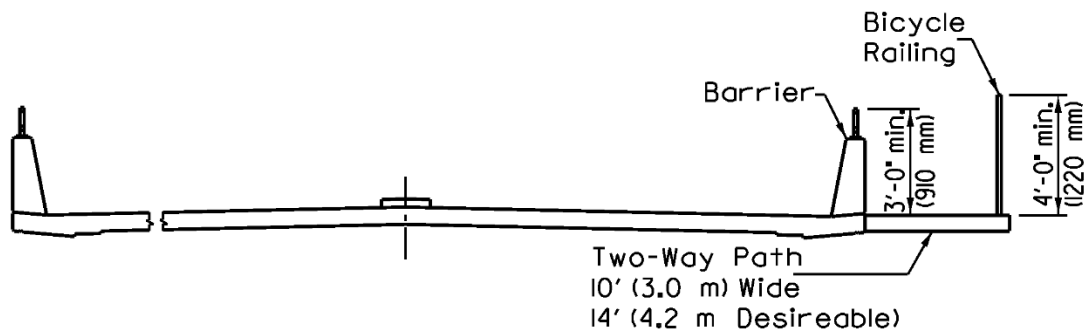

ROADWAY SECTION CONTINUED ACROSS BRIDGE WITH INTEGRAL PATH

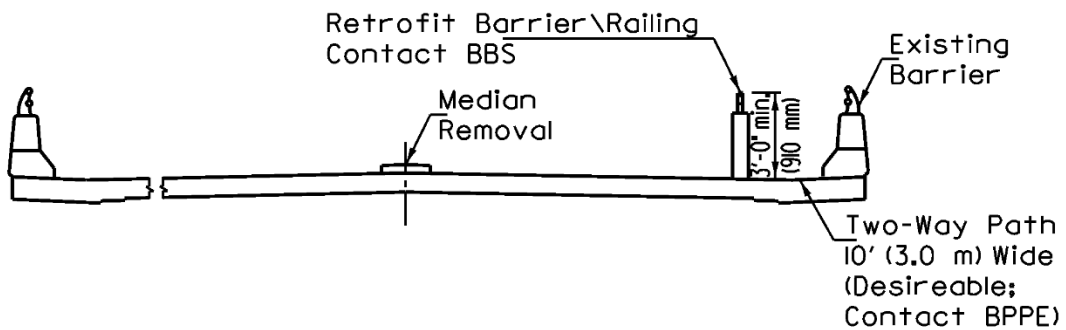

ROADWAY SECTION ACROSS BRIDGE WITH RETROFIT PATH

TYPICAL CROSS SECTIONS FOR PATHS ON HIGHWAY STRUCTURES

Figure 17-2.KK

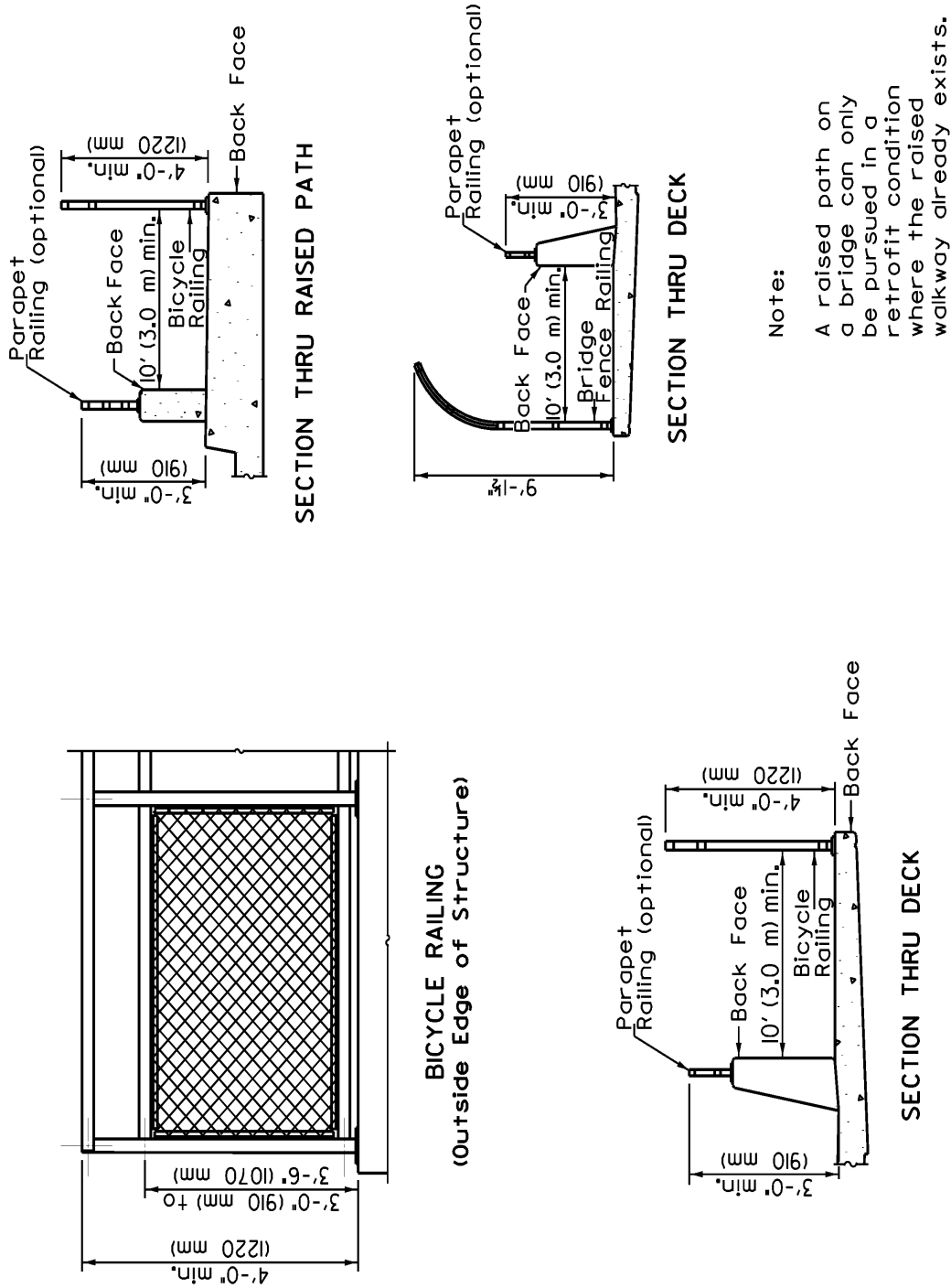

BICYCLE RAILING APPLICATIONS

Figure 17-2.LL

17-2.03(n) Paths Through Interchanges

Design of a path along an arterial roadway, as it passes through an interchange with free-flow ramps, requires design considerations to address safety of bicyclists. Providing a separate structure for bicyclists and pedestrians will maximize safety but can be cost-prohibitive. A side path can be accommodated at ramp crossings in a similar pattern to that shown for on-road accommodations, as discussed in Section 17-2.02(e) and shown in Figure 17-2.J. All interchange ramp crossings require individual consideration to meet accommodation, sight distance, and geometric design requirements.

A diverging diamond interchange (DDI) accommodates left-turning movements at signalized intersections while eliminating the need for left-turn phasing. DDIs will typically feature paths within the center of the arterial roadway to provide improved sight lines further from the bridge parapet walls, to place path crosswalk at signalized intersections, and to allow free-flow left turns onto entrance ramps without the potential for conflicts. These paths typically would be protected from traffic by barrier wall for the full length between the two intersections. A single-point urban interchange (SPUI) provides a convergence of all through and left-turning movements into a single large signalized intersection area. There are significantly wider pavement areas for path users to cross at SPUIs. The addition of path crosswalks may create greater delays in traffic when compared to the conventional diamond since SPUI signal phasing does not typically provide a red phase where crosswalks would be protected. Unique operational and safety design considerations will apply at SPUI interchanges.

17-2.03(o) Signing and Marking

Adequate signing and marking are essential on paths and the adjacent roadway, to alert bicyclists and pedestrians to potential conflicts and to convey regulatory messages to motorists and other users at highway intersections. Provide warning signs to identify conflict points and for design elements that are less than minimum criteria (e.g., less than minimum curve radii, vertical or horizontal clearances, speeds dictated by grades) to warn the user of these conditions. Additionally, use guide signing, (e.g., directions, destinations, distances, route numbers, names of crossing streets) in the same manner as they are used on highways. In general, uniform application of traffic control devices, as described in the *ILMUTCD*, will tend to encourage proper bicyclist and motorist behaviors.

A solid yellow centerline may be appropriate on path approaches to an intersection to discourage passing and help increase bicyclist awareness of the intersection. Consider a broken yellow centerline stripe (3 ft (0.9 m) stripe with 9 ft (2.7 m) gap) to separate opposite directions of travel on path segment under the following circumstances:

- for heavy volumes of bicycles,
- on curves with restricted sight distance, and
- on unlighted paths where nighttime riding is expected.

White edge lines also can be beneficial where nighttime bicycle traffic is expected. Marking should be considered for shared-use paths that are 12 ft (3.6 m) or wider to delineate lanes for bicyclists and pedestrians.

Investigate friction qualities of pavement marking materials. Some marking materials become slippery when wet. Marking materials with reflective elements typically offer better friction properties, especially in wet conditions.

17-2.03(p) Lighting

Fixed-source lighting reduces the potential for crashes and conflicts along paths and at intersections. Additionally, lighting allows the bicyclist to see the bicycle path direction, surface conditions, and obstacles. Lighting should be considered where substantial riding at night is expected (e.g., bicycle paths serving college students or commuters, highway intersections). Lighting is important through underpasses or tunnels and when nighttime security could be an issue; see Chapter 56. Depending on the location, average maintained horizontal illumination levels of 5 lux to 22 lux should be considered. Where special security problems exist, higher illumination levels may be considered. Light standards (poles) should meet the recommended horizontal and vertical clearances. Luminaires and standards should be at a scale appropriate for a path and should be designed to deter vandalism.

17-2.03(q) Restriction of Motor Vehicle Traffic

Restriction of path use by motor vehicles may be reinforced by signing at roadway intersections. In certain situations, a physical barrier may be appropriate to prevent unauthorized motor vehicles from using the facility. Rigid bollards have often been used to restrict motor vehicle access to paths and can be an acceptable solution. However, the hazards they create for bicyclists, and in some cases motorists, can be significant. Barriers to path entry need not be proposed where unauthorized access is considered unlikely.

An alternate method of physically discouraging entry of motor vehicles is to split the entry way into two 5 ft (1.5 m) minimum sections separated by very low landscaping (e.g. groundcover, grass) as shown in Figure 17-2.MM. Motorists can thereby identify the path as a restricted feature while emergency vehicles can enter, if necessary, by straddling the landscaping.

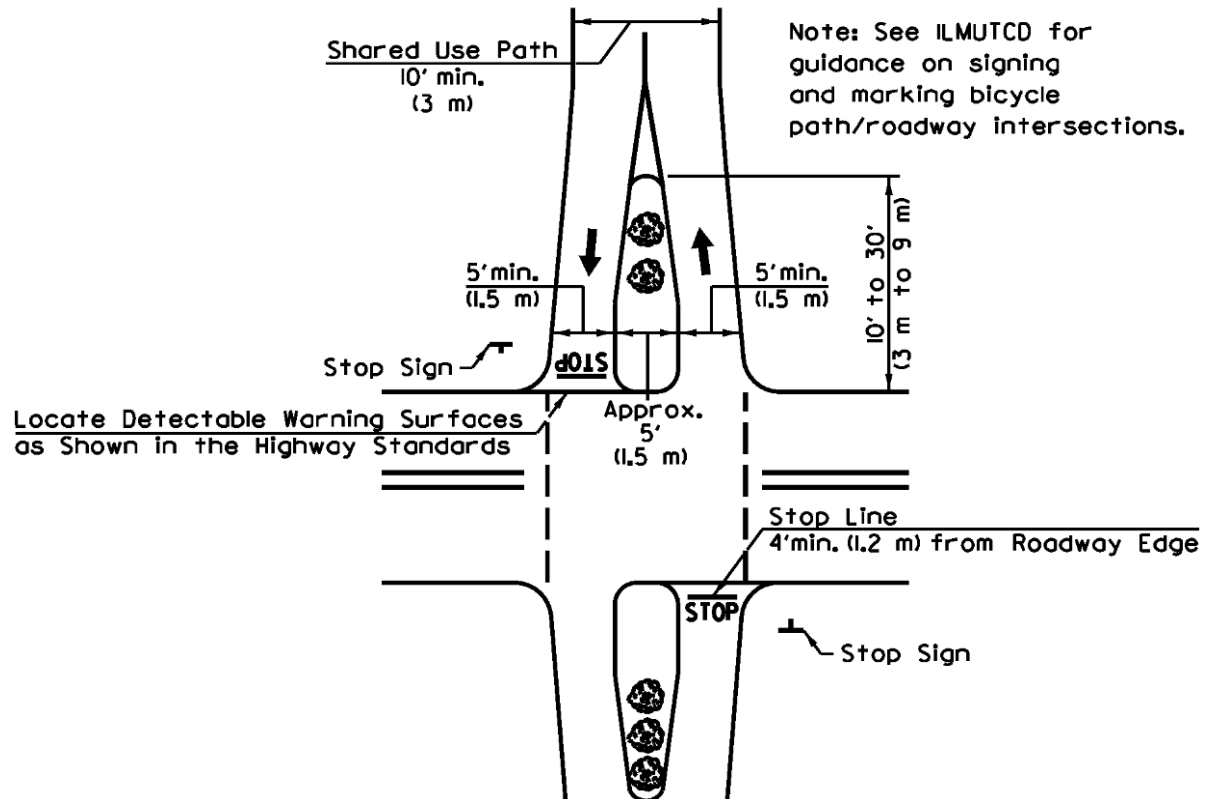

LANDSCAPING DIVIDER FOR PATHS

Figure 17-2. MM

17-2.03(r) Pavement Structure

Designing and selecting pavement sections for bicycle paths are in many ways similar to designing and selecting highway pavement sections. A soils investigation should be conducted to determine the load carrying capabilities of the native soil and the need for any special provisions. The investigation need not be elaborate, but should be performed by, or under the supervision of, a qualified engineer. Additionally, while loads on bicycle paths will be substantially less than highway loads, design bicycle paths to sustain, without damage, the wheel loads of occasional emergency, patrol, maintenance, and other motor vehicles that are expected to use or cross the path.

Give particular consideration to the location of motor vehicle wheel loads on the path. Where motor vehicles are driven on paths, especially if less than 10 ft (3.0 m) wide, their wheels usually will be

at or very near the edges of the path. Because this can cause edge damage that will, in turn, reduce the effective operating width of the path, adequate edge support should be provided. Edge support can be either in the form of stabilized shoulders (e.g., use of geotextile fabric underlay) or in constructing additional pavement width.

Paths built along streams and in wooded areas can present unique problems. The roots of shrubs and trees can pierce through the path surfacing and cause it to bubble up and break apart in a short period of time. Preventative methods include: removal of vegetation, realignment of the path away from trees, and placement of root barriers (e.g., a 1 ft (300 mm) deep plastic shield) along the edge of the path as shown in Figure 17-2.NN.

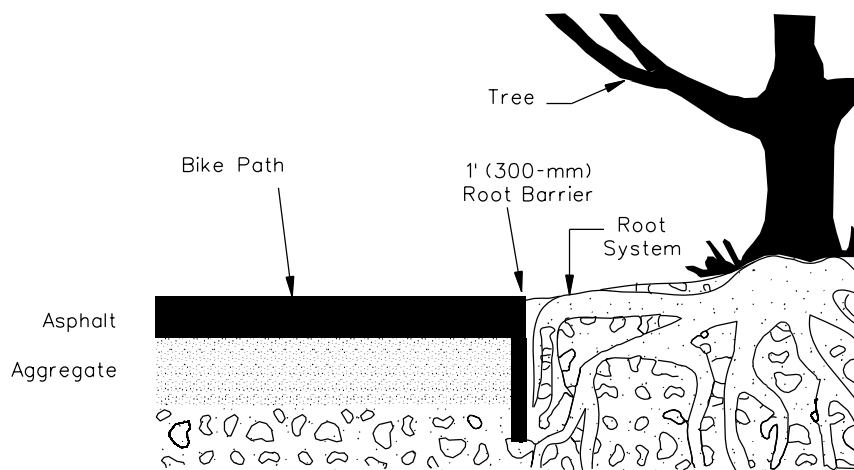

SHARED-USE PATH ADJACENT TO TREES

Figure 17-2.NN

At unpaved highway or driveway crossings of shared-use paths, pave the highway or driveway a minimum of 10 ft (3.0 m) on each side of the crossing to reduce the amount of gravel being scattered along the path by motor vehicles. Design the pavement structure at the crossing to adequately sustain the expected loading at that location.

Bituminous (HMA) or PCC pavement surfaces are required for side paths in state right of way. Aggregate materials provide a much lower level of service and require substantially more maintenance over the life of a project. PCC may offer advantages in wet soil conditions or in areas that may periodically flood. As guidance, Figure 17-2.OO provides examples of several acceptable pavement cross sections (an aggregate surface is also shown for reference). Consider using geotextile fabric in all areas. Fabric offers advantages that include extended pavement life, weed control, and lower maintenance.

In some situations, an HMA surface treatment (A1/A2/A3) may be adequate for paths, considering the limitations of the surface (e.g., bleeding oil on hot summer days). The proper application of this type of surface is very important. Specify a CA 16 aggregate size or smaller. The surface should be rolled, and the excess stone should be swept away, preventing accumulation at the outside edges of the path. Negotiating loose gravel on a bicycle can be very hazardous.

Figure 17-2.PP provides information regarding the advantages and disadvantages of various path surfaces.

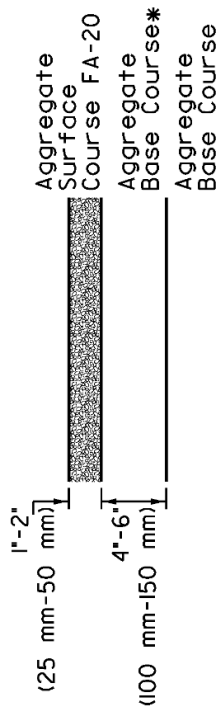
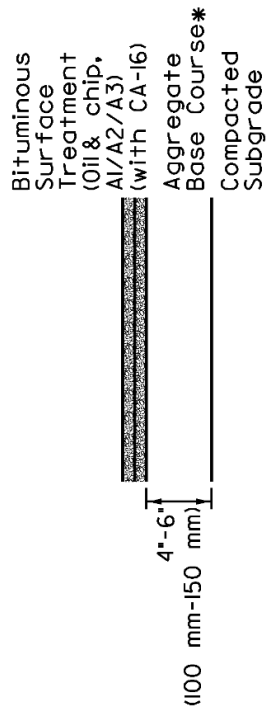

UNPAVED PATH CROSS SECTIONS

*CA-6 or CA-10

Note: Unpaved path surfaces are not directly covered in this policy and all paths constructed in state right of way must be paved. Refer to Bureau of Local Roads guidance for unpaved paths.

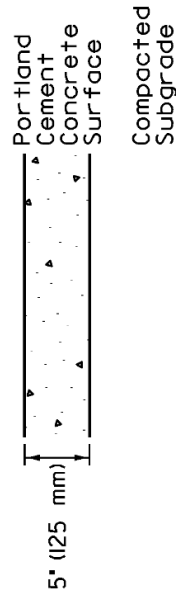
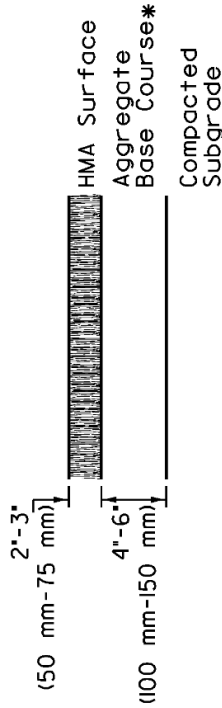

PAVED PATH CROSS SECTIONS

SHARED-USE PATH CROSS SECTIONS

Figure 17-2.00

Surface Material	Advantages	Disadvantages
Crushed Aggregate	Soft but firm surface; natural material; moderate cost; rough surface; accommodates some multi-use.	Surface can rut or erode from heavy rainfall; surface softens when set - bike tires, horses will damage surface; regular maintenance to keep consistent surface; replenishing aggregate may be a long-term expense; not for slopes >3%.
Bituminous Surface Treatment (also called Oil & Chip, Chip Seal)	Inexpensive to apply; more stable surface, durable.	Potential for oil bleeding to surface in hot weather, application methods important to minimize loose gravel.
Asphalt	Hard surface; supports most types of use; all weather; does not erode; accommodates most users simultaneously; low maintenance.	Higher installation costs; more costly to repair; not a natural surface; freeze/thaw can crack surface; heavy construction vehicles need access.
Concrete	Hardest surface; easy to form to site conditions; supports multiple use; lowest maintenance; resists freeze/thaw; best cold weather surface; best for wet conditions.	High installation cost; costly to repair; not a natural looking surface; construction vehicles will need access to the trail corridor.

SHARED-USE PATH/TRAIL SURFACE SYNOPSIS

Figure 17-2.PP

17-2.04 Accommodations Through a Roundabout

Safety and usability for bicyclists through roundabouts depend on the details of the roundabout design and provisions unique for bicyclists. When approaching a roundabout using an on-road bike accommodation, some cyclists may choose to travel like other vehicles, through the circulatory roadway, while others may choose to travel like pedestrians, along the sidewalks. Roundabouts can be designed to accommodate either choice.

Since typical on-road bicycle travel speeds are between 12 mph and 20 mph (20 km/hr to 30 km/hr), roundabouts that are designed to constrain the speeds of motor vehicles below 30 mph (50 km/hr) thereby improve safety and usability for cyclists. As described in Section 36-9.04(a), roundabouts designed for urban conditions should have a recommended maximum entry speed of 20 mph to 25 mph (30 km/hr to 40 km/hr) based on theoretical fastest path. These speeds are generally compatible with bicycle travel. Note that side paths at a roundabout are treated similarly to more typical intersection types, but clear opportunities for bicyclists to join the path from the sideroad approaches need to be provided in all such cases.

17-2.04(a) Traversing Roundabouts like Motorized Vehicles

In general, cyclists who have the knowledge and skills to ride effectively and safely on collector roadways can navigate low-speed, single-lane roundabouts without much difficulty. Cyclists and motorists will travel at approximately the same speed, making it easier for bicyclists to merge with other vehicular traffic and take the lane within the roundabout itself; these are necessary actions for safe bicycling in a roundabout. Even at multilane roundabouts, many cyclists will be comfortable traveling through like other vehicles.

Where bicycle lanes or shoulders are used on approach roadways, they should be terminated in advance of roundabouts. The full-width bicycle lane should normally end at least 100 ft (30 m) before the edge of the circulatory roadway. Terminating the bike lane helps remind cyclists that they need to merge. An appropriate taper should be provided to narrow the sum of the travel lane and bike lane widths down to the appropriate width necessary to achieve desired motor vehicle speeds on the roundabout approach.

The taper should end prior to the crosswalk at the roundabout to achieve the shortest possible pedestrian crossing distance. A taper rate of 7:1 is recommended to accommodate a design speed of 20 mph (30 km/hr), which is appropriate for bicyclists and motor vehicles approaching the roundabout. To taper a 5 ft to 6 ft (1.4 m to 1.8 m) wide bicycle lane, a 40 ft (12 m) taper is recommended. The bicycle lane line should be dotted for 50 ft to 200 ft (15 m to 60 m) prior to the beginning of the taper and dropped entirely through the taper itself. A longer dotted line gives advance notice to cyclists that they need to merge, providing more room for them to achieve this maneuver and find an appropriate gap in traffic; see Figure 17-2.QQ.

Bicycle lanes should not be located within the circulatory roadway of roundabouts. This would suggest that bicyclists should ride at the outer edge of the circulatory roadway, which can increase crashes resulting from exiting motorists who cut off circulating bicyclists and from entering motorists who fail to yield to circulating bicyclists.

At roundabout exits, an appropriate taper should begin after the crosswalk, with a dotted line for the bike lane through the taper. The solid bike lane line should resume as soon as the normal bicycle lane width is available.

17-2.04(b) Traversing Roundabouts like Pedestrians

Because some cyclists may not feel comfortable traversing roundabouts in the same manner as other vehicles, bicycle ramps can be provided to allow access to the sidewalk or a shared use path at the roundabout. Bicycle ramps at roundabouts have the potential to be identified as pedestrian ramps, particularly by pedestrians who are blind or who have low vision, unless properly designed.

Bicycle ramps may always be used. At some roundabouts traffic speeds or other conditions (e.g., a right turn bypass lane) make circulating like other vehicles more challenging for less confident riders than is typically the case. Multilane roundabouts are more challenging for all cyclists, and bicycle ramps should always be provided along with widened sidewalk or path connections. Where bicycle ramps are provided, provide a shared-use path or a widened sidewalk of 7 ft (2.1 m) between the ramps along all edges of the roundabout. A minimum 10 ft (3.0 m) width is recommended, and appropriate shared-use path design details should be applied.

In some jurisdictions, local laws may prohibit cyclists from riding on sidewalks and local coordination is encouraged to address this. In these areas, the following options could be considered:

- Signs could be posted to remind cyclists that they must walk their bicycles on the sidewalk.
- An exception could be made to allow cyclists to ride on the sidewalks at the roundabout; with appropriate regulatory signs posted.
- The sidewalk could be designed and designated as a shared use path.

Appropriate bicycle ramps are critical to provide choice to cyclists, ensure usability by cyclists, and reduce the potential for confusion of pedestrians, particularly those who are blind or who have low vision. Bicycle ramps should be placed at the end of the full-width bicycle lane where the taper for the bicycle lane begins. Cyclists approaching the taper and bike ramp will thus be provided the choice of merging left into the travel lane or moving right onto the sidewalk/path.

Bike ramps should not be placed directly in line with the bike lane or otherwise placed in a manner that appears to cyclists that the bike ramp and the sidewalk is the recommended path of travel through the roundabout. This encourages more sidewalk use by bicyclists, which can have a negative effect on pedestrians at the roundabout and may be less safe for bicyclists as well. Bicycle ramps should be placed at least 50 ft (15 m) prior to the crosswalk along the entry approach to the roundabout.

Wherever possible, bicycle ramps should be placed entirely within the planting strip between the sidewalk and the roadway. In these locations, the bicycle ramps should be placed at a 35° to 45°

angle to the roadway and the sidewalk to enable cyclists to use the ramp even if pulling a trailer, but to discourage them from entering the sidewalk at high speed. The bike ramp can be fairly steep, with a slope potentially as high as 20%. If placed within the sidewalk area itself, the ramp slope must be built in a manner so that it is not a tripping hazard. Figure 17-2.QQ illustrates several possible designs of bike ramps, depending on whether a planting strip is available and the available sidewalk width.

Detectable warnings are shown at the top of the bicycle ramps in Figure 17-2.QQ. These ramps are not intended for pedestrians. This detectable warning position indicates that the ramp itself is part of the vehicular area for which the detectable warning is used. If the ramp is in the sidewalk itself the detectable warning should be placed at the bottom of the ramp. Other aspects that can help keep pedestrians from misconstruing the bike ramp as a pedestrian crossing location include the angle of the ramp, the possible steeper slope of the ramp, and location of the ramp relatively far from the roundabout and crosswalk.

Bicycle ramps at roundabout exits should be built with similar geometry and placement as the ramps at roundabout entries. On exits, the angle between the bike ramp and the roadway can be as small as 20° since it is not necessary to encourage bicyclists to slow down as they reenter the roadway, but some angle is necessary so that visually-impaired pedestrians do not inadvertently travel down the ramp. Bike ramps should be placed at least 50 ft (15 m) after the crosswalk at the roundabout exit.

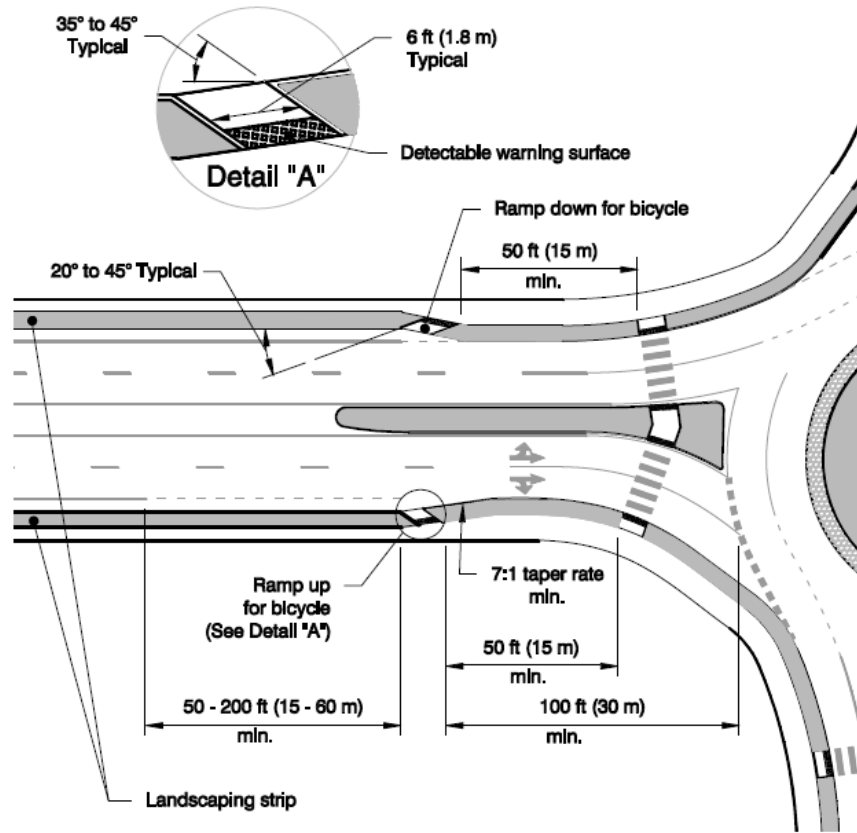

<p>Landscape buffer provided on approach to roundabout</p>	
<p>Wide curb-tight sidewalk on approach to roundabout</p>	
<p>Narrow curb-tight sidewalk on approach to roundabout</p>	

POSSIBLE TREATMENTS AND RAMP OPTIONS FOR BICYCLES

Figure 17-2.QQ

17-3 BICYCLE OPERATING CHARACTERISTICS

Bicycle operating characteristics, rider dimensions, and rider clearances are important considerations in design. There are many different types and sizes of bicycles, ranging from children's bicycles to tandem units for two riders, as well as buggy carts for transporting children and belongings. Typical bicycle dimensions and clearances are shown in Figures 17-3.A and 17-3.B, respectively. Figure 17-3.C illustrates the rider envelopes that are a primary basis for the minimum widths for paths, buffered bike lanes, and one-way and two-way SBLs. Minimum operating space is 3.5 ft (1.1m) for each rider. Passing between bicyclists will occur regularly along SBLs; the addition of pedestrians along paths, and considering social walking behavior, is a primary basis for the minimum 10 ft (3.0 m) width of paved paths. Providing the shy space envelopes shown in Figure 17-3.C is desirable and will further improve bicyclists comfort.

Characteristics	Dimensions*
Width (physical space)	30 in. (760 mm)
Length	6 ft (1.8 m)
Height	7 ft (2.2 m)
Vertical Pedal Clearance	6 in. (150 mm)

**Note: If bike trailers are likely, the characteristic width becomes 3 ft – 3.5 ft (0.9 m - 1.0 m) wide and 9 ft (2.7 m) long. The indicated height of an adult bicyclist takes into consideration that the rider may be standing up while riding. Adult bicyclists sit between 5 ft (1.5 m) and 6 ft (1.8 m) above the riding surface while sitting on the saddle.*

TYPICAL BICYCLE AND RIDER DIMENSIONS

Figure 17-3.A

Lateral Clearances		Preferred Vertical Clearance	
Bike to Parked Car	2 ft (600 mm)	Bike Rider to Overhead Obstruction	3 ft (900 mm)
Bike to Curb Drop-Off	2 ft (600 mm)	Maneuvering Clearances	
Bike to Utility Poles, Trees, Hydrants	2 ft (600 mm)	Bike to Vehicle	3 ft (900 mm)
Bike to Soft Shoulder	1.5 ft (450 mm)	Bike to Other Bike	2.0 ft (600 mm)
Bike to Sloped Drop-Off	1 ft (300 mm)	Bike to Pedestrian	2.5 ft (750 mm)
Bike to Raised Curb	1 ft (300 mm)	Turning Radius	5 ft (1.5 m) (min)

Note: Because turning radius, sight distance, and braking of bicycles differ significantly from that of motor vehicles, design of bicycle facilities should take a conservative approach. This conservative approach should accommodate differing aspects of bikes, including the fact that riders are of different skill levels.

BICYCLE OPERATIONAL CLEARANCES

Figure 17-3.B

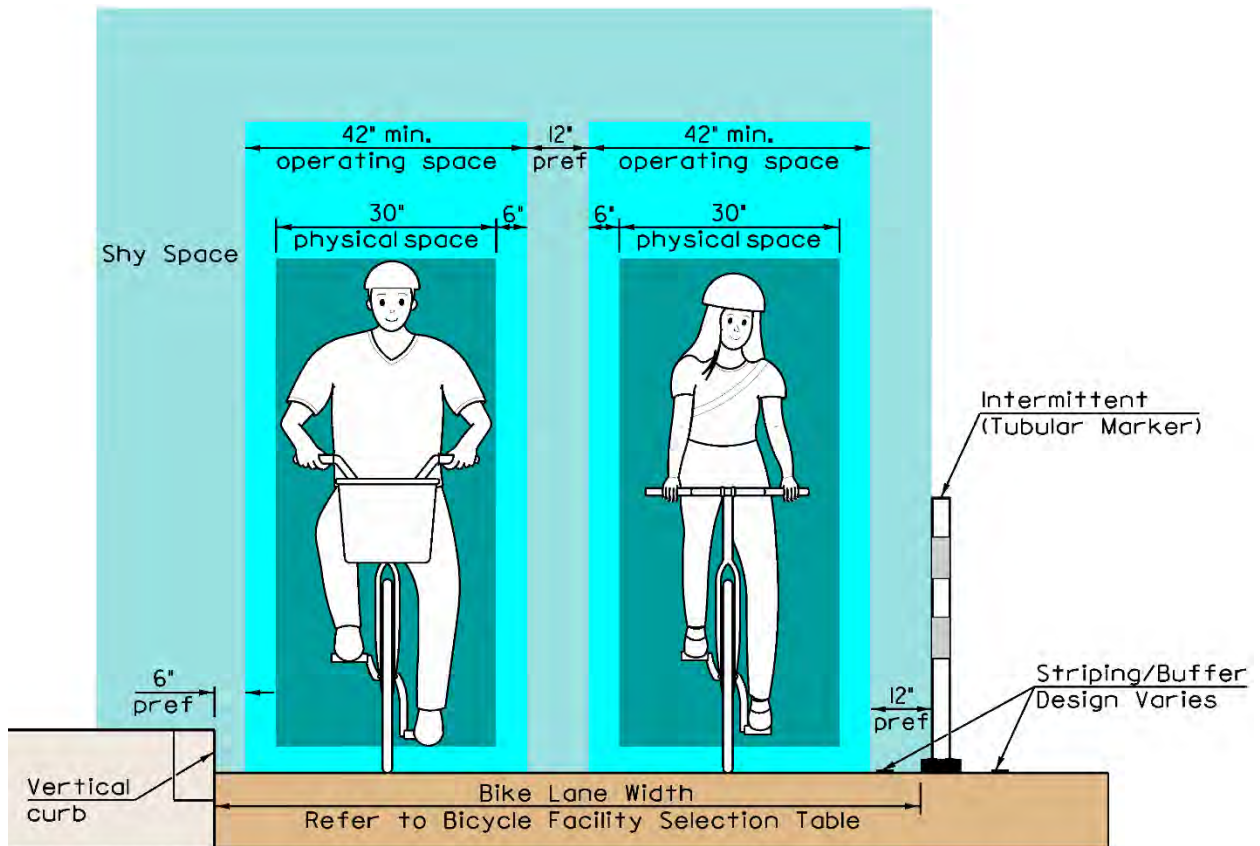

Note: A 7 ft (2.1m) minimum width is required to accommodate the operating space requirements of either side-by-side or two-way bicyclist operations.

BICYCLE RIDER ENVELOPES FOR DESIGN

Figure 17-3.C

17-4 PEDESTRIAN ACCOMMODATIONS

17-4.01 General

Pedestrian accommodations are an integral part of urban and suburban transportation corridors. They facilitate pedestrian travel and access to public transportation, thereby contributing to alleviation of urban traffic congestion. The most pressing need for accommodation is at points of community development that result in pedestrian concentrations near or along the highway, such as at schools, public transportation stations and stops, local businesses, industrial plants, hospitals, churches, shopping centers, parking lanes, etc. Moreover, pedestrians should be included as design users at all intersections where they are expected to cross. Accommodations can include sidewalks, elevated walkways, grade-separated structures, curb ramps, crosswalks, traffic signals, and other traffic control devices.

The Department utilizes the recommended practice of the Institute of Transportation Engineers, entitled *Designing Walkable Urban Thoroughfares: A Context Sensitive Approach* and the *AASHTO Guide for the Planning, Design, and Operation of Pedestrian Facilities* in the development of pedestrian facilities.

The legal basis for bicycle and pedestrian policy is discussed in Section 17-1.02.

17-4.02 Pedestrian Warrants – Needs Assessment

The Department seeks to accommodate pedestrians within all project contexts with the exception of rural. Exceptions to the provision of accessible sidewalks on both sides, and logical crosswalks, will be quite rare within the urban and urban core project contexts. Suburban and rural town contexts will also typically include pedestrian accommodations, although in these contexts there may be more situations where constraints dictate that sidewalk be provided only along one side of a roadway. Consistent with this philosophy, there is no mechanism for tracking lack of need, excessive cost, or user safety issues to potentially justify sidewalk omissions, as there is with the BTA form for bicycle travel.

Pedestrian accommodations are specifically warranted, including provision of logical new state route crossing opportunities if they are absent, if any of the following conditions exist:

- there is current evidence of frequent pedestrian activity;
- there is a history of pedestrian-related crashes;
- the roadway improvement will create a safety impediment to existing or anticipated pedestrian travel (e.g., adding lanes so that the improvement itself acts as a barrier to pedestrian traffic);
- there is urban or suburban development that would attract pedestrian travel along or immediately adjacent to the route to be improved;

- pedestrian-attracting development is expected along the route within five years of project completion, either as documented in a local plan or anticipated as a factor of similar development history; and/or
- the roadway provides access to a park, recreation area or other significant destination, or across a natural or man-made barrier, within contexts other than rural.

If the local agency believes the accommodation will not fit with their development plan for the area, the Department will request the local agency pass a resolution indicating as such and a copy will be included in the Phase I report. Proposed resolution language is included in Section 17-7.

Overpasses and underpasses involve substantial cost and accessibility challenges and will be evaluated on a case-by-case basis considering the level of pedestrian travel, travel generators (e.g., schools, factories, stadiums, parks, transit terminals, shopping districts), the amount of other non-motorized traffic, and the potential safety impacts of not providing the accommodations. Anticipated pedestrian trip length to generators should be 1 mile (1.6 km) or less and the adverse travel distance alleviated by construction of the overpass/underpass should be greater than 0.5 miles (800 m). Refer to Section 58-1.12 for more information on grade separations.

17-4.03 Sidewalk Design Considerations

Where pedestrian accommodations are provided they must be accessible to all users. Refer to Section 58-1 for accessibility standards and the criteria to be met in the design of sidewalks and crosswalks. The typical ROW challenges associated with adding sidewalks to existing roadways underscore the importance of providing adequate sidewalks during new construction and reconstruction projects. Refer to 17-2.02(g) on road diets and lane diets for a discussion of redistribution of space within the right of way; pedestrian accommodations can be added by similar means into urban roadway projects where no (or substandard) facilities exist. Amenities along sidewalks to increase pedestrian safety and comfort levels may include sidewalk buffers, plantings, bump-outs, and street furniture. Note that on projects that will not move curb lines (e.g., resurfacing) scope constraints will typically restrict construction work beyond the curb lines.

Sidewalks are typically 5 ft (1.5 m) wide along state routes. Where conditions do not allow for a width of 5 ft (1.5 m), a minimum clear sidewalk width 4 ft (1.2 m) is permissible as long as 5 ft by 5 ft (1.5 m by 1.5 m) passing spaces are provided at least every 200 ft (60 m). Sidewalks wider than 5 ft (1.5 m) should be considered if more compatible with the local sidewalk network or if intended to accommodate a high volume of pedestrians or a wider range of users. If located directly behind a curb, sidewalks should be a minimum 7 ft. (2.1 m) wide. Preferably and especially where utilities will be present, include a 3 ft (900 mm) minimum turf sidewalk buffer, considering that an area is typically required for signs and other small appurtenances. The object free operational offset must be met and encroachments on the sidewalk PAR width must be avoided. Consider applying the enhanced lateral offset (see Section 38-9.02) for any locally-desired features being evaluated for placement within a corridor with sidewalk. Typical sections for

sidewalks along urban roadways are presented in Section 48-2.03; incorporation of sidewalks on urban roadways is covered in Section 48-2.04.

Along high-speed rural roadways, sidewalks should be located as far as practical from the roadway. At a minimum along lower speed rural roadways (e.g., rural town context), the sidewalk edge should be at least 5 ft (3.0 m) from the outside edge of the shoulder. While pedestrians are not prohibited by law from traveling on roadway shoulders they should not be designed for pedestrian use or designated as pedestrian facilities.

Project limits may be extended beyond highway improvements for reasonable distances to include necessary pedestrian facilities at nearby intersections, to provide access to public transportation facilities, or to avoid short sidewalks gaps either on one side or both sides of the primary route. Any such extensions should be documented to show justification and reflected in the Phase I report.

17-4.04 Sidewalks on Highway Structures

Raised sidewalks are the typical pedestrian accommodation provided on roadway bridges. Chapter 39 includes additional design considerations. Provide a 5 ft (1.5 m) minimum clear width for pedestrians on a structure. If not separated from traffic by a barrier, a sidewalk is raised 8 in. (200 mm) above the bridge deck to provide a level of separation and comfort for pedestrians. A vertical barrier is required between the travelled way and the sidewalk when speed limits exceed 40 mph, and the raised surface is optional in those cases. At lower speeds the vertical barrier should still be considered where there are high pedestrian volumes, concentration of school children, or safety concerns. Regardless of speed limit, bicycles are accommodated in the traffic lane, on the shoulder or in a bicycle lane adjacent to the traffic lane. If bicyclists are to be separated from the traveled way, provide a side path as described in Section 17-2.03(m).

Sidewalks should be provided on new and rehabilitated structures in accordance with the dimensions shown in Figure 17-4.A. Required bridge railings along sidewalks must provide a minimum 3 ft 6 in (1070 mm) rail height along the structure edge, and 3 ft (910 mm) between the sidewalk and adjacent traffic lanes. Consider the potential for sight line impediments created by barriers and/or railings for drivers at adjacent intersections. Adjacent signalized intersections may need to include right-turn-on-red (RTOR) restrictions if intersection sight distance is restricted by a pedestrian railing. Several examples of barriers and railings used for sidewalk applications on bridges are shown in Figure 17-4.B. Specific configurations depend on the roadway speed limit, the roadway classification, and the facility being crossed. Refer to Chapters 39 and 58 for requirements of protective fencing.

When a project has a bridge omission with sidewalk accommodations along the roadway, fully compatible future accommodations should be planned for the omitted structure. Where it is necessary to accommodate pedestrians on an existing highway bridge as an interim condition, consider alternatives in light of what the geometrics of the bridge will allow. If it is necessary to accommodate pedestrians directly on the bridge deck, separate pedestrians from motor vehicle traffic with a barrier. When questions arise consult with BPPE and Bureau of Bridges and Structures for retrofit options and/or barrier and railing selection.

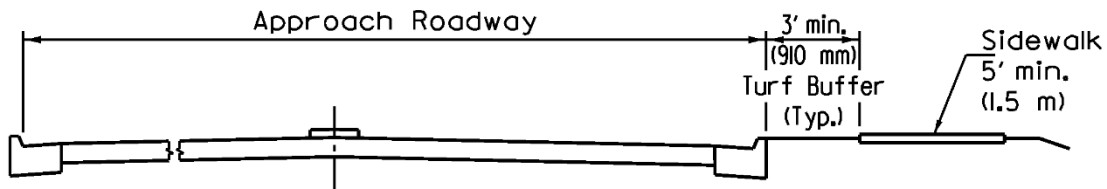

APPROACHING ROADWAY SECTION WITH ADJACENT SIDEWALK



ROADWAY SECTION CONTINUED ACROSS BRIDGE WITH INTEGRAL SIDEWALK

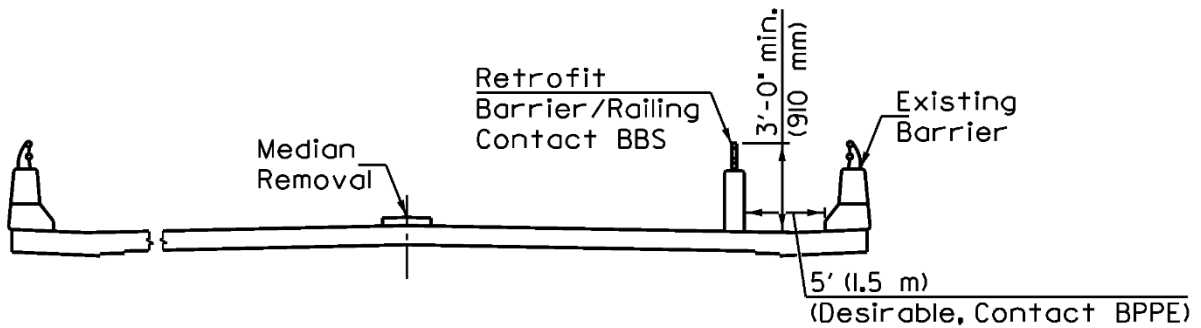

ROADWAY SECTION ACROSS BRIDGE WITH RETROFIT SIDEWALK

TYPICAL CROSS SECTIONS FOR SIDEWALKS ON HIGHWAY STRUCTURES

Figure 17-4.A

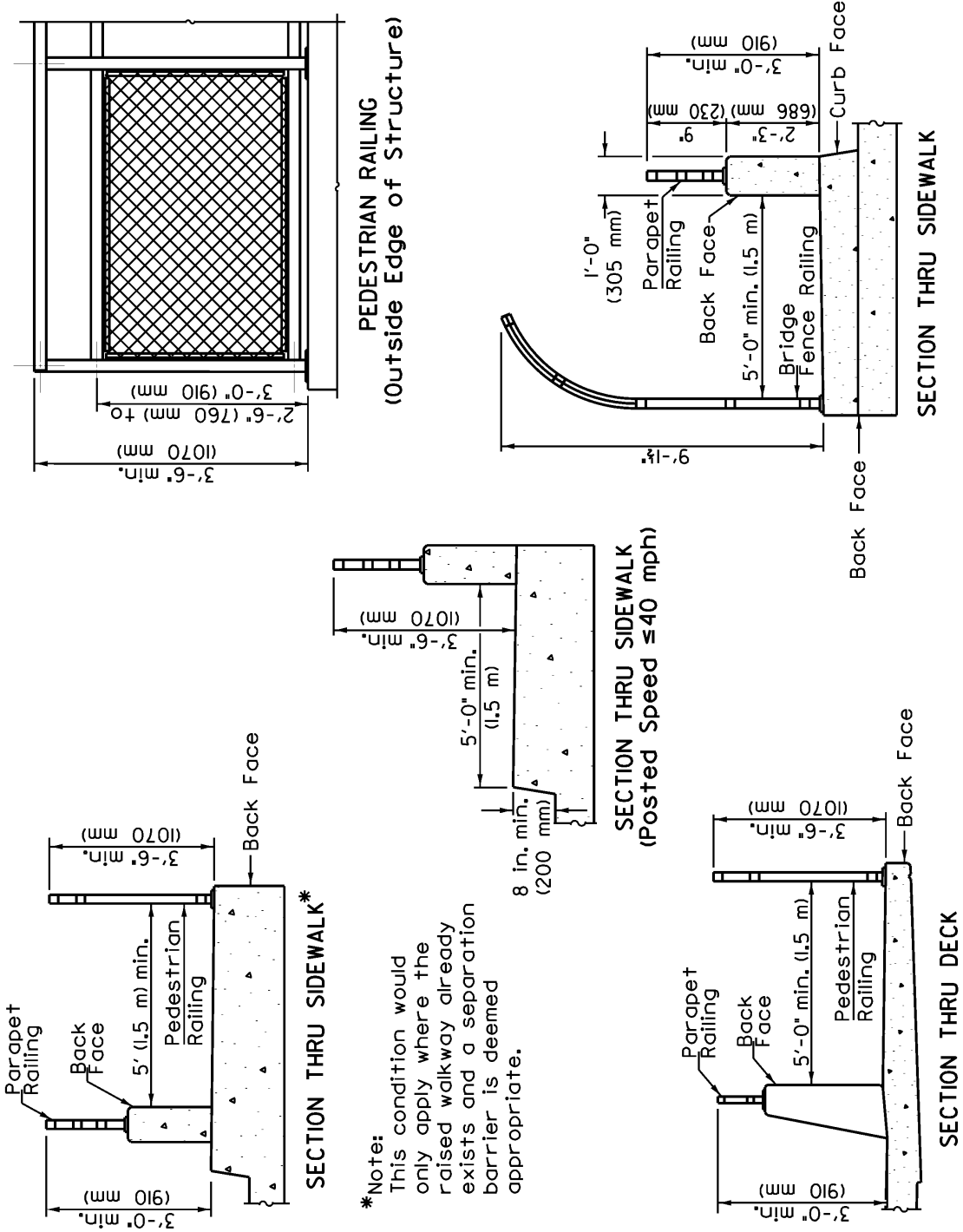

PEDESTRIAN RAILINGS ON HIGHWAY STRUCTURES

Figure 17-4.B

17-4.05 Intersection Crosswalks

Wherever pedestrians use an intersection, crosswalks are a primary geometric design element and should be considered in the initial steps of the intersection design process that is governed by Chapter 36. Signalized intersections are often the most direct and best places for pedestrians to cross a major roadway. Consider roadway width, traffic volumes, traffic speeds, and lines-of-sight when designing crossings. Assess the overall pedestrian network. Consider that the *Illinois Vehicle Code* includes in the definition of a crosswalk the prolongation or connections of the lateral lines of a sidewalk or shoulder across the intersection regardless of whether a crossing is marked or not, pursuant to 625 ILCS 5/1-113.

Pedestrian safety at intersections is typically improved with slowed turning traffic and good sight lines. Minimizing curb return radii within the constraints of operational needs can improve accommodations. Tighter radii can increase visibility of pedestrians, slow vehicle turning speeds, and reduce crossing distances.

Longer crossing distances increase pedestrian exposure to traffic and the potential for vehicle–pedestrian conflicts. Providing for multi-stage crossings can decrease overall traffic delay. Intermediate pedestrian refuge areas within raised medians and corner islands can reduce exposure and enhance pedestrian safety by providing multi-stage crossing opportunities. Refuge areas must provide 6 ft (1.8 m) minimum face-to-face width measured along the pedestrian travel path. Well- designed channelizing raised corner islands can help separate the individual conflicts between motor vehicles and pedestrians or bicyclists. They can be especially effective in conjunction with right-turn lanes and where intersection returns must accommodate larger design vehicles. Painted islands with crosswalks provide neither refuge for pedestrians nor directional guidance for persons with vision impairment. At actuated signalized intersections where raised medians provide refuge, pedestrian signal heads and pushbuttons/detectors must be installed within the median. Where corner islands are used in conjunction with dual right-turn lanes, the same requirement applies. Countdown pedestrian signal heads are required.

Leading pedestrian intervals (LPI) at signalized intersections are a low-cost pedestrian safety countermeasure that may be considered for use at urban and suburban locations. LPI consists of displaying the walk symbol to pedestrians several seconds ahead of parallel vehicular traffic receiving a green signal allowing pedestrians a ‘head start’ to occupy the crosswalk and increase their visibility to both right-turning and left-turning drivers. One downside to LPI is that it potentially creates increased vehicular delay and queues at the intersection. Accessible Pedestrian Signals (APS) is used in conjunction with LPI. The Bureau of Operations has developed guidelines using intersection factors to identify when LPI should be considered as an appropriate safety countermeasure; contact Operations to discuss the latest Operations Policy on LPI.

To the extent possible, minimize intersection skews and place crosswalks at right angles to traffic movements where they best meet both driver and pedestrian expectations. Skewed crossings tend to increase pedestrian exposure to traffic and may reduce sight distance for some users. Design return radii to minimize crossing distances considering that design turning vehicles may utilize all available roadway width in the direction of travel rather than turning into the near lane.

The *ILMUTCD* provides standards for marked crosswalks. All crosswalk markings must be white. For simplicity of maintenance, two transverse crosswalk lines are typically used for marking crosswalks on stop-controlled and signalized approaches. Two transverse crosswalk lines provide for good channelization and guidance and are adequately visible in conjunction with stop bars. However, longitudinal crosswalk markings (e.g. Continental style) should be considered at locations where (a) physical or level-of-use conditions are such that added visibility of the crosswalk is desired; or (b) a pedestrian crosswalk might not be expected by drivers. Studies show that crosswalks marked longitudinally can be detected much further away than crosswalks with only transverse lines. IDOT Bureau of Operations Policy TRA-23 provides design guidance for crosswalk striping that can apply to intersection markings.

17-4.06 Midblock Crosswalks

In areas of considerable pedestrian activity, midblock crosswalks reduce distances pedestrians must travel and focus crossing interactions where pedestrian safety can be maximized. Pavement markings legally establish a crosswalk at any non-intersection location. Designated midblock crossings must meet the same accessibility requirements as pedestrian crossings at intersections. Where safety concerns are identified at midblock crosswalks, first consider potential methods for upgrading the design, rather than simply working to remove them.

Because drivers may be less expectant of pedestrians crossing at non-intersection locations, these crossings should include enhanced visual cues and/or geometric features to increase driver awareness of the crossing and improve safe behavior by all users. IDOT Bureau of Operations Policy TRA-23 provides guidelines for establishing pedestrian crossings at midblock locations, including recommended signing, striping, and beacon treatments based on vehicle speeds, traffic volumes, and roadway cross section. A general illustration of a midblock crosswalk for a multi-use path is shown in Figure 17-4.C(1). The location and design of midblock crossings should consider pedestrian volumes, vehicle mix, desired paths for pedestrians, and adjacent land uses. Longitudinal crosswalk markings (e.g., Continental or ladder style) should typically be specified. Especially for areas where there has been a history of nighttime pedestrian crashes, crosswalk lighting should be considered. Guidance on crosswalk lighting can be found in Chapter 56 as well as FHWA's *Informational Report on Lighting Design for Midblock Crosswalks*.

Providing shorter directional crossings can maximize pedestrian safety. Raised medians that are a minimum 6 ft (1.8 m) wide face-to-face with cut-throughs provide an area of refuge for both pedestrians and bicyclists. For guidance on the use of medians to divide traffic, refer to Chapters 31 and 36 as well as the *AASHTO Green Book*. Raised medians with cut-throughs also call attention to a crossing, reduce pedestrian exposure, and allow pedestrians to address one direction of conflict at a time. Designers can sometimes provide adequate space for a raised median refuge by reducing lane or shoulder widths. Cut-throughs within raised medians may be angled to better align pedestrians toward oncoming traffic, increasing their awareness of traffic. Refer to Figure 17-4.C(2) for an example. Another measure to enhance safety is a curb bump-out. These geometric features can greatly improve sight lines at crosswalks, especially where parking or other sight line constraints will exist. It is critical that operational and maintenance issues are considered when curb bump-outs are to be included in the roadway design.

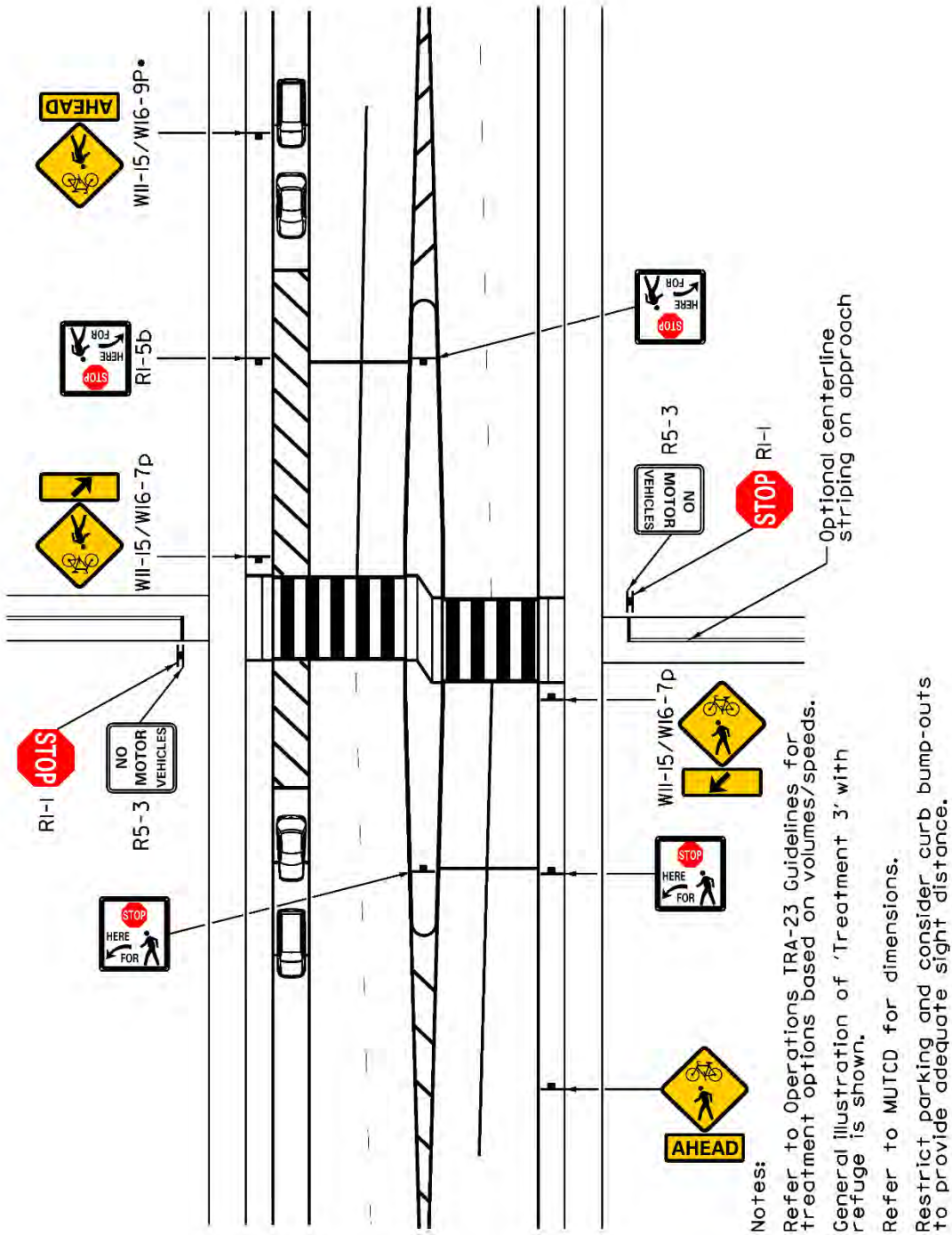

Notes:
 Refer to Operations TRA-23 Guidelines for treatment options based on volumes/speeds.
 General illustration of 'Treatment 3' with refuge is shown.
 Refer to MUTCD for dimensions.
 Restrict parking and consider curb bump-outs to provide adequate sight distance.

EXAMPLE MIDBLOCK CROSSWALK WITH REFUGE FOR SHARED-USE PATH

Figure 17-4.C
(1 of 2)

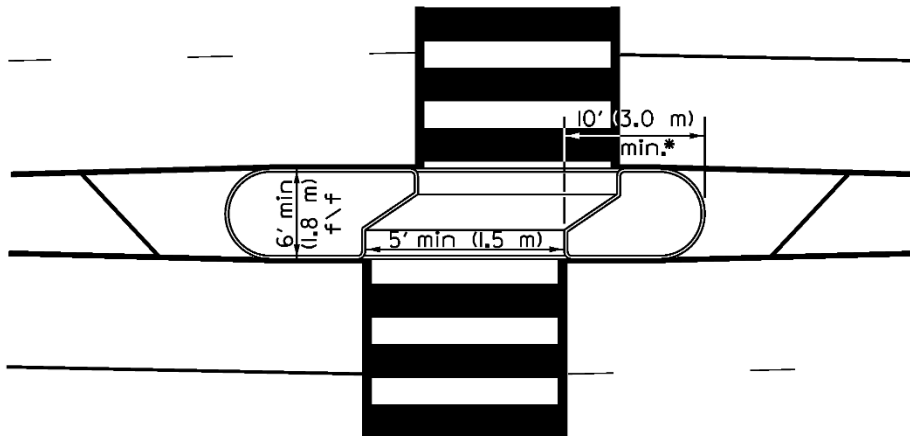
Detail

*Extend raised curb 50 feet ahead of the crossing on each approach where possible based on location constraints.

EXAMPLE MIDBLOCK CROSSWALK WITH REFUGE FOR SHARED-USE PATH

Figure 17-4.C
(2 of 2)

Pedestrian Hybrid Beacons (PHBs) are a type of traffic control device used to warn and control motorists at marked unsignalized midblock crosswalks and assist pedestrians in crossing. PHBs are typically not to be considered at locations where conventional signal warrants are met. The *ILMUTCD* provides guidance regarding the volume of pedestrians crossing a roadway that would merit the consideration of PHBs as well as the location and design requirements. The *ILMUTCD* also identifies specific restrictions on the locations of PHBs near intersections or entrances. The primary location for consideration of PHBs is at midblock crosswalks along multi-lane urban and suburban roadways, as covered in Operations Policy TRA-23.

Another example of a supplemental device to increase driver awareness of pedestrian presence at a midblock crosswalk is the Rectangular Rapid Flashing Beacon (RRFB). RRFBs can be utilized under an Interim Approval statewide (IA-21.38). Specific technical conditions are established by FHWA for their use. Pedestrian actuation and supplemental signs and pavement markings are required with both PHBs and RRFBs. Compliance by pedestrians and motorists can be maximized by providing a relatively “hot response” (fast activation) for pedestrians pressing a button. For PHBs, this type of activation may adversely affect progression along arterial roadways.

Consider whether the potential safety benefit of a system that reduces non-compliance by all users (e.g. improves motorist stopping behavior) warrants some disruption to vehicle traffic flow. Coordinate these issues with the Bureau of Operations.

17-4.07 Safety Rails and Handrails

Safety rails are placed along paths or sidewalks to protect pedestrians and bicyclists from hazards such as vertical drop-offs or steep slopes. Refer to Figure 17-4.D for guidance on railing placement and height. Consider the range of non-motorized users expected in applying this guidance to sidewalks and paths. Situations that should be considered for the inclusion of safety rails include areas where there are:

- Slopes steeper than 1:3 (for drops of 6 ft (1.8 m) or greater) or 1:2 (for drops of 4 ft (1.2 m) or greater immediately adjacent to the path,
- Drop-offs of more than one ft (300 mm) and steeper than 1:1 immediately adjacent to the path,
- Slope surfaces consisting of rough materials, such as revetment or rip-rap, immediately adjacent to the path, or
- Bodies of water at the bottom of a slope adjacent to the path.

Safety rails adjacent to pedestrian-only areas (e.g., sidewalks) should be a minimum of 3 ft 6in. (1070 mm) high. A typical design for a safety rail includes two to four horizontal elements with vertical elements equally spaced. On bridges or other locations with high vertical drops there are important opening restrictions. Opening sizes in the lower 27 in. (700 mm) should be small enough so that a 6 in. (150 mm) sphere cannot pass between them. Above 27 in. (700 mm) openings should restrict passage of an 8 in. (200 mm) sphere.

Related to accessibility, handrails are required in the following situations in accordance with ADA requirements:

- On both sides of stairways, with appropriate extensions at the top and bottom,
- On both sides of ramps, not curb ramps, where the rise of the ramp run is more than 6 in. (150 mm).

However, it is not the intent to typically provide handrails along state highways as they likely could pose a hazard to vehicle traffic. Handrails may have applications perpendicular to traffic, and when outside of the clear zone. Also note that matching the grade along a side road usually does not create a condition where a handrail is required.

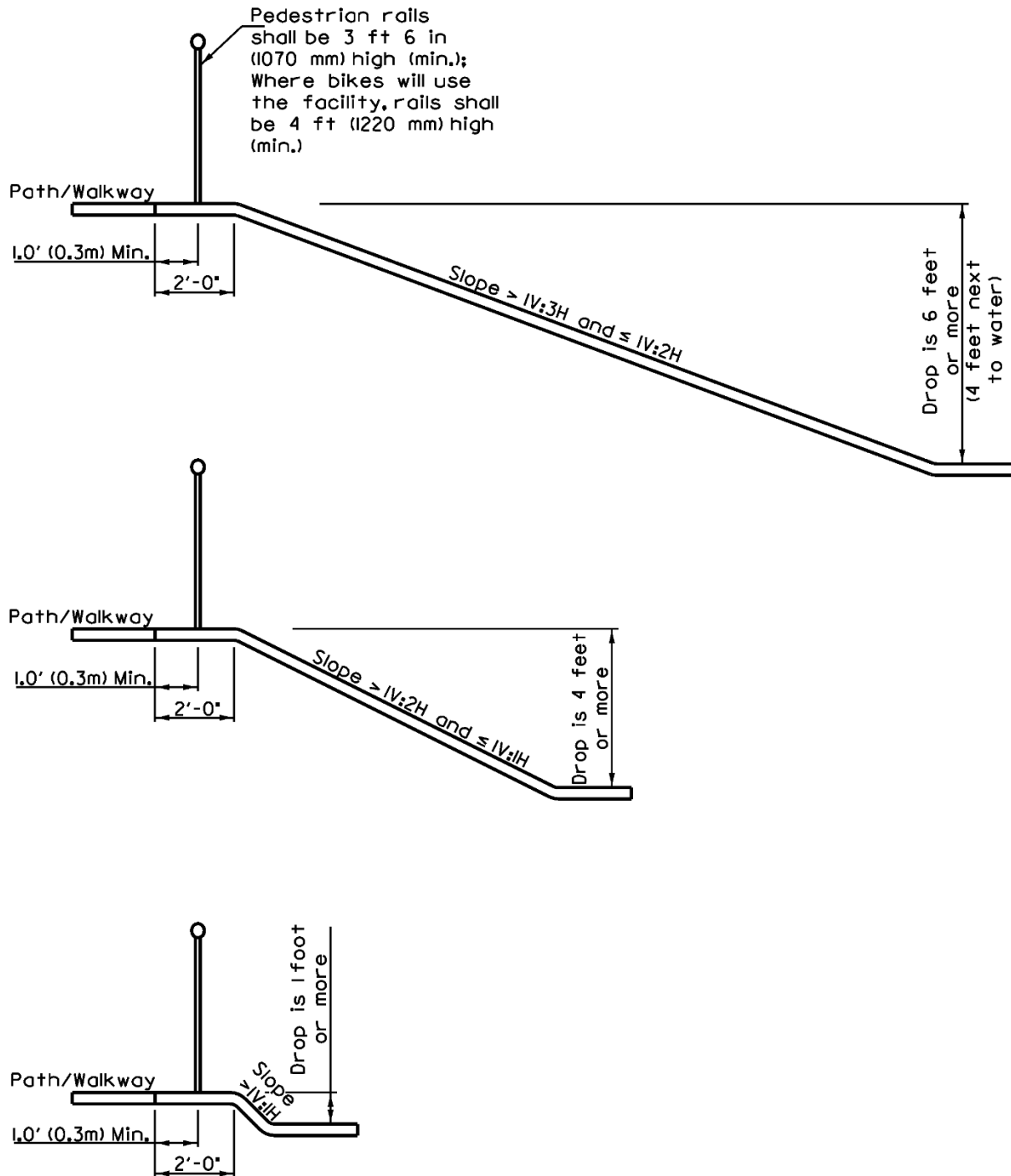

SAFETY RAILS FOR WALKWAYS AND SHARED-USE PATH

Figure 17-4.D

17-4.08 Documentation

When one or more of the warrants presented in Section 17-4.02 are met, appropriate and accessible pedestrian sidewalk accommodations are required. When pedestrian accommodations will be included in the project, include documentation of the decision in the Phase I report. When urban core, urban or suburban context projects do not meet warrants, send an electronic copy of the assessment of the warrants to BPPE to obtain concurrence. Exceptions to these design treatments, either on the basis of cost or user safety, require concurrence by BPPE and will be granted at coordination meetings after a sufficient review period. Total omissions based on documented safety issues, excessive cost or lack of need on projects within 1 mile (1.6 km) of a municipality with more than 1,000 people will require concurrence of the Secretary. Signed documentation of the Secretary's concurrence on a BDE 1701 shall be included in the Phase I report.

17-4.09 Pedestrian Accommodations During Construction

The *ILMUTCD* requires that alternate pedestrian access routes (APAR) be provided whenever existing pedestrian accommodations are affected by construction; refer to *ILMUTCD* Section 6D. Accessibility must be maintained consistent with the features present in the existing facility. See Section 55-2.01(d) and the *Highway Standards* for guidance. Lengthy pedestrian detours should be avoided. In rare circumstances, provision of an APAR or a reasonable pedestrian detour may not be feasible along a roadway or across a structure. In such cases alternative accommodations such as a shuttle service may be provided.

17-5 REFERENCES

The following are applicable references for bicycle travel assessments and facility design and pedestrian accommodation evaluation and design:

1. *Guide for the Development of Bicycle Facilities*, AASHTO, 2012. (Update expected in 2020 under NCHRP 15-60).
2. *Guide for the Planning, Design, and Operation of Pedestrian Facilities, 1st Edition*, AASHTO, 2004. (Update expected in 2020 under NCHRP 15-45).
3. *Selecting Roadway Design Treatments to Accommodate Bicycles*, FHWA, 1994.
4. *Accommodating Bicycle and Pedestrian Travel: A Recommended Approach*, FHWA, 2017. http://www.fhwa.dot.gov/environment/bicycle_pedestrian/guidance/design.cfm
5. *Bikeway Selection Guide*, FHWA, 2019.
6. *Urban Bikeway Design Guide*, NACTO, 2014.
7. *Urban Streets Design Guide*, NACTO, 2013.
8. *Designing Walkable Urban Thoroughfares: A Context Sensitive Approach*, Institute of Transportation Engineers, 2010.
9. *Achieving Multimodal Networks: Applying Design Flexibility and Reducing Conflicts*, Federal Highway Administration (FHWA-HEP-16-055), 2016.
10. *Separated Bike Lane Planning and Design Guide*, FHWA (FHWA-HEP-15-025), 2015.
11. *Incorporating On-Road Bicycle Networks into Resurfacing Projects*, FHWA (FHWA-HEP-16-025), 2016.
12. *Guidebook for Developing Pedestrian & Bicycle Performance Measures*, FHWA (FHWA-HEP-16-037), 2016.
13. *Small Town and Rural Multimodal Networks*, FHWA (FHWA-HEP-17-024), 2016.
14. *Road Diet Informational Guide*, Federal Highway Administration Safety Program (FHWA-SA-14-028), 2014. http://safety.fhwa.dot.gov/road_diets/info_guide/
15. *Establishing Procedures and Guidelines for Pedestrian Treatments at Uncontrolled Locations*, Illinois Center for Transportation, 2017.
16. *Illinois Manual on Uniform Traffic Control Devices (ILMUTCD)*, IDOT.
17. *Standard Specifications for Road and Bridge Construction*, IDOT.

18. *Warrants for Pedestrian Over and Underpasses*, FHWA, 1984, Report # FHWA-RD-84/082.
19. *Revisiting the Four Types of Cyclists*, *Transportation Research Record 2587*, TRB, National Research Council, Washington, DC, 2016.
20. *Informational Report on Lighting Design for Midblock Crosswalks*, FHWA (FHWA-HRT-08-053), 2008.
21. *Leading Pedestrian Interval (LPI) Proven Safety Countermeasures*, Federal Highway Administration Safety Program (FHWA-SA-17-063), 2020.
https://safety.fhwa.dot.gov/provencountermeasures/lead_ped_int/

All projects involving bicycle and pedestrian accommodation for the Department will be in accordance with Reference Publications 1 and 2 above. For projects involving separate bikeways, guidance beyond the AASHTO *Guide* (i.e., Reference Publication 1) is available in Reference Publication 3. The following FHWA-endorsed webpages can also be referenced for additional guidance and information on specific design features:

1. http://safety.fhwa.dot.gov/ped_bike/
2. http://safety.fhwa.dot.gov/road_diets/info_guide/

17-6 BICYCLE CHECKLISTS AS INCLUDED ON BTA FORM (BDE 1702)**CHECKLIST FOR BICYCLE TRAVEL GENERATORS IN PROJECT VICINITY**

Generators	Yes	NA	Generators	Yes	NA
Residential Areas	<input type="checkbox"/>	<input type="checkbox"/>	Shopping Centers	<input type="checkbox"/>	<input type="checkbox"/>
Parks	<input type="checkbox"/>	<input type="checkbox"/>	Hospitals	<input type="checkbox"/>	<input type="checkbox"/>
Recreation Areas	<input type="checkbox"/>	<input type="checkbox"/>	Employment Center	<input type="checkbox"/>	<input type="checkbox"/>
Churches	<input type="checkbox"/>	<input type="checkbox"/>	Government Offices	<input type="checkbox"/>	<input type="checkbox"/>
Schools	<input type="checkbox"/>	<input type="checkbox"/>	Local Businesses	<input type="checkbox"/>	<input type="checkbox"/>
Libraries	<input type="checkbox"/>	<input type="checkbox"/>	Industrial Plants	<input type="checkbox"/>	<input type="checkbox"/>
Existing Bicycle Trails	<input type="checkbox"/>	<input type="checkbox"/>	Public Transportation Facilities	<input type="checkbox"/>	<input type="checkbox"/>
Planned Bicycle Trails	<input type="checkbox"/>	<input type="checkbox"/>	Other ()	<input type="checkbox"/>	<input type="checkbox"/>

CHECKLIST FOR ORGANIZATIONS AND PUBLIC COORDINATION

Organization	Yes	NA	Organizations	Yes	NA
Metropolitan Planning Organization (if applicable)	<input type="checkbox"/>	<input type="checkbox"/>	Ride Illinois	<input type="checkbox"/>	<input type="checkbox"/>
Local Municipalities	<input type="checkbox"/>	<input type="checkbox"/>	Illinois Department of Natural Resources	<input type="checkbox"/>	<input type="checkbox"/>
Park or Forest Preserve Districts	<input type="checkbox"/>	<input type="checkbox"/>		<input type="checkbox"/>	<input type="checkbox"/>
Sub-Regional Planning Council (as appropriate)	<input type="checkbox"/>	<input type="checkbox"/>	Active Transportation Alliance (District 1 only)	<input type="checkbox"/>	<input type="checkbox"/>
Local Bicycle Clubs, Advocacy Groups	<input type="checkbox"/>	<input type="checkbox"/>	Other		

Organizations and Public Coordination addresses:

- Ride Illinois, 815 Leicester Rd #314, Elk Grove, IL 60007. (info@rideillinois.org)
- Illinois Department of Natural Resources, Office of Realty and Environmental Planning, One Natural Resources Way, Springfield, IL 62702-1271.
- Active Transportation Alliance, 35 East Wacker Drive, Suite 1782, Chicago, IL, 60601. (info@activetrans.org)

EXAMPLE OF MAP TO ACCOMPANY CHECKLIST FOR BICYCLE TRAVEL

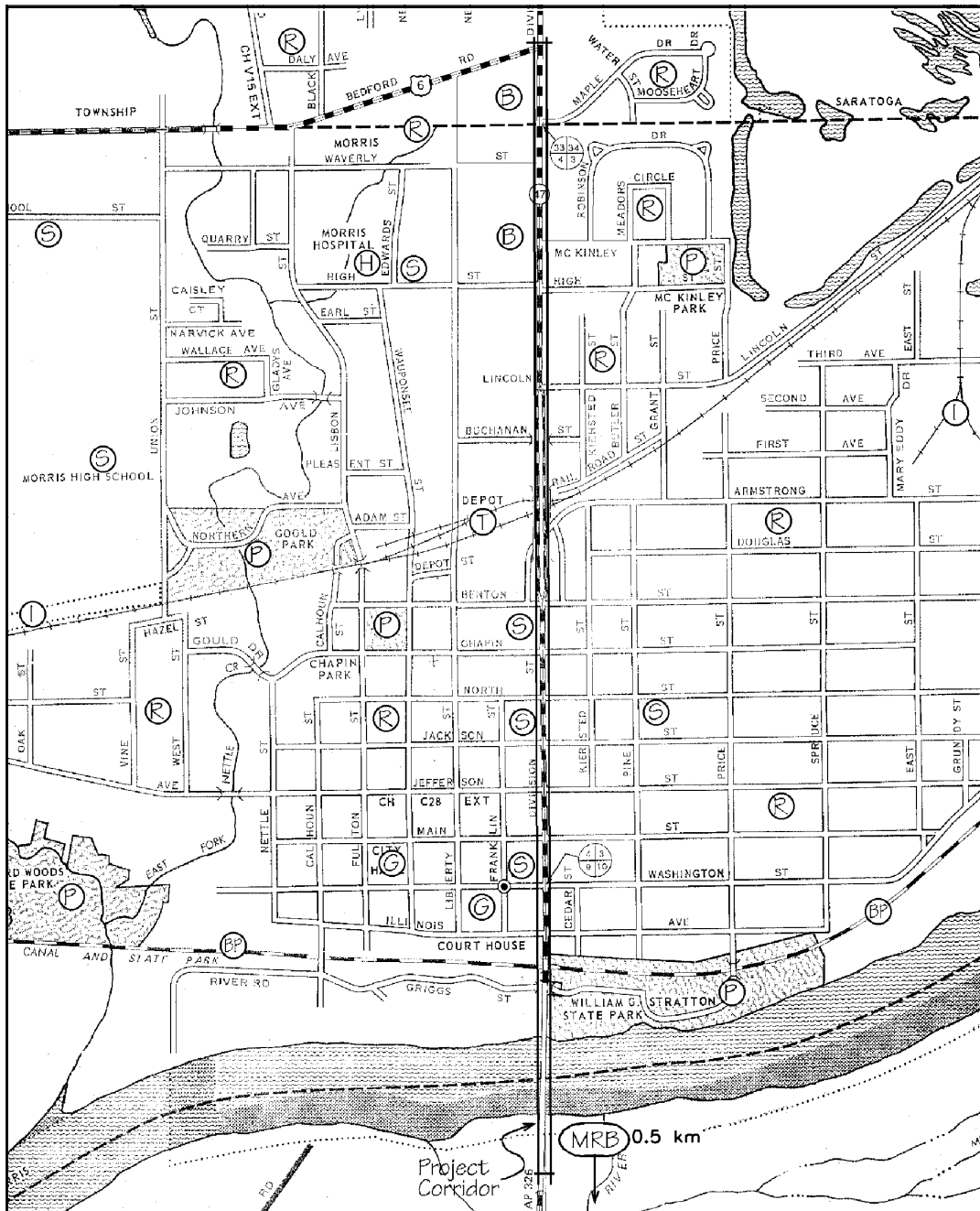

R	Residential Areas	BP	Existing Bicycle Trails	G	Government Offices
P	Parks	PBP	Planned Bicycle Trails	B	Local Businesses
P	Recreational Areas	M	Shopping Centers	I	Industrial Plants
C	Churches	H	Hospitals	T	Public Transit Facilities
S	Schools	E	Employment Centers	O	Other

QUESTIONS ON BICYCLE TRAVEL ASSESSMENT

Route _____

Section _____

County _____

Warrants Met

Warrant 1: Is the highway or street designated as a bikeway or recommended bike route in a regionally or locally adopted bike plan or shown in a regionally or locally adopted map as a recommended bike route?

Describe the designation

Warrant 2: Will the projected two-way bicycle traffic volume approximate 25 ADT or more during the peak three months of the bicycling season five years after completion of the project?

Describe estimating method

Warrant 3: Does the route provide access to a park, recreational area, school, or other significant destination?

List destinations

Warrant 4: Does the project provide access across a river, railroad, highway, corridor, or other natural or man-made barrier?

Note barriers

Warrant 5: Will the highway project negatively affect the recreational or transportation utility or an independent bikeway or trail? Highway projects will negatively affect at-grade paths or trails when they are severed, when the projected roadway traffic volumes increase to a level that prohibits safe crossing at-grade, or where the widening of the roadway prohibits sufficient time for safe crossing.

List bikeway(s) affected

If any of the five warrants above are met, the Department shall provide on-road or off-road accommodations for bicycle travel. Roadway improvement corridors should also be assessed with respect to adjacent/contiguous routes. Items to be addressed in the reporting include:

- The following bicycle network considerations apply
- Key connections to be provided with this project
- Accommodations type identified as "required" or "optional" in the Bicycle Facility Selection Table
- Accommodations proposed
- Reasons for lesser accommodations (highest/best or none)
- Bicycle LOS information (urban on-road facilities only; attach BDE 1703)

17-7 PROPOSED RESOLUTION LANGUAGE FOR MUNICIPALITIES IN OPPOSITION

WHEREAS, The Illinois Department of Transportation (IDOT) has the power to approve and determine the final plans, specifications and estimates for all State highways; and

WHEREAS, IDOT's projects must adequately meet the State's transportation needs, exist in harmony with their surroundings, and add lasting value to the communities they serve; and

WHEREAS, IDOT must embrace principles of context sensitive design and context sensitive solutions in its policies and procedures for the planning, design, construction, and operation of its projects for new construction, reconstruction, or major expansion of existing transportation facilities by engaging in early and ongoing collaboration with affected citizens, elected officials, interest groups, and other stakeholders to ensure that the values and needs of the affected communities are identified and carefully considered in the development of transportation projects; and

WHEREAS, Bicycle and pedestrian ways must be given full consideration in the planning and development of transportation facilities, including the incorporation of such ways into State plans and programs; and

WHEREAS, Illinois statute (605 ILCS 5/4-220) requires IDOT to establish and solely fund bicycle and pedestrian ways in or within one mile of a municipality with a population of over 1,000 people in conjunction with the construction, reconstruction, or other change of any State transportation facility except: 1) in pavement resurfacing projects that do not widen the existing traveled way or do not provide stabilized shoulders; 2) where approved by the Secretary of Transportation based upon documented safety issues, excessive cost, or absence of need; or 3) where the municipality passes a resolution stating that a bicycle or pedestrian way does not fit within its development plan; and

WHEREAS, During the development of highway projects throughout the State, IDOT gives consideration to accommodating bicyclists and pedestrians on a need-basis; and

WHEREAS, IDOT has presented the (*local authority*), for its consideration, a bicycle and/or pedestrian improvement consisting of (*describe improvement*), solely funded by IDOT with maintenance to be provided by (*IDOT/unit of local government*);

THEREFORE, be it

RESOLVED, That the (*local authority*) has determined the improvement as proposed by IDOT does not fit within its development plan; and be it further

RESOLVED, That a suitable copy of this resolution be presented to the IDOT district office associated with the proposal.

Chapter Eighteen

RESERVED

BUREAU OF DESIGN AND ENVIRONMENT MANUAL

Chapter Eighteen
RESERVED

Chapter Nineteen

**PUBLIC INVOLVEMENT
GUIDELINES**

BUREAU OF DESIGN AND ENVIRONMENT MANUAL

Chapter Nineteen
PUBLIC INVOLVEMENT GUIDELINES

Table of Contents

<u>Section</u>	<u>Page</u>
19-1 GENERAL GUIDELINES.....	19-1.1
19-1.01 Definitions	19-1.1
19-1.02 Acronyms.....	19-1.2
19-2 LEGAL REQUIREMENTS FOR PUBLIC INVOLVEMENT.....	19-2.1
19-2.01 Federal Requirements.....	19-2.1
19-2.02 State Requirements	19-2.1
19-2.02(a) Road Closures	19-2.1
19-2.02(b) Corridor Protection	19-2.2
19-2.02(c) Context Sensitivity.....	19-2.2
19-2.02(d) Projects not Involving Federal Funds	19-2.3
19-3 LEVELS OF PUBLIC INVOLVEMENT.....	19-3.1
19-3.01 General	19-3.1
19-3.02 Property Owner Contact.....	19-3.1
19-3.02(a) General	19-3.1
19-3.02(b) Procedures	19-3.1
19-3.03 Public Meetings.....	19-3.6
19-3.03(a) General	19-3.6
19-3.03(b) Public Meeting Notice	19-3.6
19-3.03(c) Public Meeting Formats	19-3.6
19-3.04 Public Hearings.....	19-3.15
19-3.04(a) General	19-3.15
19-3.04(b) Procedures	19-3.15
19-3.04(c) Public Hearing requirements	19-3.16
19-3.04(d) Offer of Public Hearing	19-3.16
19-3.04(e) Public Hearing Notice.....	19-3.17
19-3.04(f) Public Hearing Formats.....	19-3.18
19-3.04(g) Transcripts	19-3.22
19-3.04(h) Certification	19-3.23
19-3.05 Public Engagement.....	19-3.26

Table of Contents
(Continued)

<u>Section</u>	<u>Page</u>
19-4 PLANNING AND IMPLEMENTING THE PUBLIC INVOLVEMENT ACTIVITY.....	19-4.1
19-4.01 Stakeholder Engagement.....	19-4.1
19-4.01(a) Stakeholder Identification.....	19-4.1
19-4.01(b) Notification of Involvement Activities.....	19-4.1
19-4.01(c) Public Notice Content.....	19-4.3
19-4.01(d) Public Notice Publishing Frequency.....	19-4.5
19-4.01(e) Public Notice Examples.....	19-4.6
19-4.02 Location and Facility Selection.....	19-4.10
19-4.02(a) Number of Locations.....	19-4.10
19-4.02(b) Selection of Facility.....	19-4.10
19-4.02(c) Examples of Suitable Locations.....	19-4.11
19-4.02(d) Inspecting the Site.....	19-4.12
19-4.02(e) Preparing the Meeting Site.....	19-4.12
19-4.03 Preparations at the District.....	19-4.12
19-4.04 The Presentation.....	19-4.13
19-4.04(a) General Considerations.....	19-4.13
19-4.04(b) Presentation Content.....	19-4.14
19-4.04(c) Audio-Visual Aids.....	19-4.16
19-4.05 Post-Activity Follow-Up.....	19-4.19
19-4.06 Mailing Lists.....	19-4.19
19-4.07 General Releases of Information.....	19-4.20
19-4.08 Records and Reports.....	19-4.20
19-4.08(a) Public Comments.....	19-4.20
19-4.08(b) Reports.....	19-4.21
19-4.08(c) Responses.....	19-4.21
19-5 CONTEXT SENSITIVE SOLUTIONS.....	19-5.1
19-5.01 The Stakeholder Involvement Process.....	19-5.1
19-5.01(a) Stakeholder Identification and Development of the Stakeholder Involvement Plan (SIP) (Step 1).....	19-5.4
19-5.01(b) Developing Project Problem Statement (Step 2).....	19-5.10
19-5.01(c) Defining Alternatives (Step 3).....	19-5.18
19-5.01(d) Preferred Alternative (Step 4).....	19-5.20
19-5.02 Implementing the Stakeholder Involvement Process.....	19-5.21

Table of Contents
(Continued)

<u>Section</u>		<u>Page</u>
19-5.02(a)	Choosing an Approach.....	19-5.21
19-5.02(b)	Follow-up.	19-5.22
19-5.02(c)	Working Towards Stakeholder Understanding.	19-5.22

Chapter Nineteen

PUBLIC INVOLVEMENT GUIDELINES

Pursuant to 23 CFR 771.111, each State must have procedures approved by the FHWA to carry out a public involvement/public hearing program pursuant to 23 U.S.C. 128 and 139, and Council on Environmental Quality (CEQ) regulations. Chapter 19 outlines IDOT's public involvement/public hearing procedures and fulfills this requirement.

The public involvement process provides for free and open discussions with individuals, organizations, agencies, and other interested parties to encourage early resolution of controversial and non-controversial issues related to the project. The process also ensures that potential adverse economic, social, and environmental effects are fully considered in project development. This should result in final decisions that reflect the best overall public interest in providing a safe, economic, and efficient transportation system with minimal adverse effects.

19-1 GENERAL GUIDELINES

19-1.01 Definitions

The following definitions apply to Chapter 19:

1. Context Sensitive Design. Context Sensitive Design is a model for transportation project development. Proposed transportation projects must be planned not only for their physical aspects as a facility serving specific transportation objectives, but also for their effects on the aesthetic, social, economic and environmental values, needs, constraints and opportunities in a larger community setting.
2. Context Sensitive Solutions. Context Sensitive Solutions (CSS) is an Illinois law which provides for a collaborative, interdisciplinary, and holistic approach to public involvement for the development of transportation projects. It is both a process and product, characterized by a number of attributes. It involves all stakeholders, including community members, elected officials, interest groups, and affected local, State, and Federal agencies. It puts project needs and both agency and community values on a level playing field and considers all trade-offs in decision making. Often associated with Context Sensitive Design, Context Sensitive Solutions should be a part of all phases of program delivery including long range planning, programming, environmental studies, design, construction, operations, and maintenance.
3. National Environmental Policy Act Process. Signed into law January 1, 1970, National Environmental Policy Act (NEPA) requires federal agencies to assess the environmental effects of their proposed actions, provides for public input, and requires that agencies make well-informed decisions. The NEPA process includes development of purpose and need, analysis of alternatives to address the purpose and need, public involvement, interagency coordination, and well-informed decisionmaking in determining the preferred

alternative. NEPA is completed with approval of a Categorical Exclusion (CE), Finding of No Significant Impact (FONSI), or Record of Decision (ROD).

4. **Public Hearing**. A type of public involvement activity referenced in public law where the public's comments are recorded, transcribed, and sent to the lead agency. A public hearing is a formal opportunity for the public to review proposed plans for transportation projects and provide comments for decision makers to consider in reaching a final decision. Federal regulations include specific requirements for what must occur prior to, during, and after a public hearing is held. Typically, public hearings are held toward the end of Phase I after a preferred alternative has been identified.
5. **Public Involvement Activity**. A public involvement activity is any effort by the Department to engage the public in discussion about a proposed project, for the purpose of providing information to the public and receiving information from the public. Public Involvement activities include, but are not limited to, property owner contact letters, public meetings, and public hearings.
6. **Public Meeting**. A type of public involvement activity where the public can comment or inquire about the nature of the project and its potential impacts. Federal regulations do not include specific requirements for public meetings, such as a transcript of the proceedings. Public meetings are therefore a more flexible public involvement activity than a public hearing.

19-1.02 Acronyms

<u>3P</u>	Pavement Preservation Project
<u>3R</u>	Project Resurfacing, Restoration, Rehabilitation
<u>CAG</u>	Community Advisory Group
<u>CE</u>	Categorical Exclusion
<u>CEQ</u>	Council on Environmental Quality
<u>CFR</u>	Code of Federal Regulation
<u>CSS</u>	Context Sensitive Solutions
<u>EA</u>	Environmental Assessment
<u>EIS</u>	Environmental Impact Statement
<u>FONSI</u>	Finding of No Significant Impact
<u>FHWA</u>	Federal Highway Administration
<u>ILCS</u>	Illinois Compiled Statutes
<u>NEPA</u>	National Environmental Policy Act
<u>ROD</u>	Record of Decision
<u>PSG</u>	Project Study Group
<u>SIP</u>	Stakeholder Involvement Plan
<u>SIR</u>	State Improvement Report
<u>SMART</u>	Surface Maintenance at the Right Time
<u>U.S.C.</u>	United States Code

19-2 LEGAL REQUIREMENTS FOR PUBLIC INVOLVEMENT

19-2.01 Federal Requirements

Pursuant to 23 CFR 771.111, State public involvement/public hearing procedures must provide for one or more public hearings, or the opportunity for hearing(s), to be held by the State highway agency for any Federal-aid project which:

- involves the bypassing of, or going through, any city, town, or village, either incorporated or unincorporated; or
- requires significant amounts of right-of-way; or
- substantially changes the layout or functions of connecting roadways or of the facility being improved; or
- has a substantial adverse impact on abutting property; or
- has a significant social, economic, environmental or other effect; or
- FHWA determines that a public hearing is in the public interest.

The public hearing must be held at a convenient time and place, include reasonable notice to the public, indicate the availability of explanatory information, and provide information required to comply with public involvement requirements of other laws, Executive Orders, and regulations. Federal requirements describing what must be explained at the public hearing are in Section 19-3.04.

The Department must submit to FHWA a transcript (Section 19-3.04(g)) of each public hearing and a certification (Section 19-3.04(h)) that a required hearing was held, or that a hearing opportunity was offered. The transcript must be accompanied by copies of all written comments from the public, both submitted at the public hearing or during an announced period after the public hearing.

19-2.02 State Requirements

In addition to Federal requirements, the State also requires a public hearing for road closures and corridor protection. The State also has requirements for when Context Sensitive Solutions must be implemented on highway projects.

19-2.02(a) Road Closures

When the Department proposes to permanently close a road to eliminate an at-grade crossing or junction with an Interstate highway or a highway where the authority to control access has been exercised to permit access only at certain public roads, 605 ILCS 5/8-106 requires that a public hearing be held to consider the road closure. Such road closure hearing must be held in the

county where the closure will occur, and must consider local traffic needs and the effect of the closing on other highways in the locality. The preparation of final construction plans shall not begin until road closure hearings have been held. See Chapter 11 for more information on road closures.

Road closure hearings may be held in conjunction with other required hearings. If the discussion of road closures extends the length of the presentation beyond the time limits discussed in this Section, separate hearings may be necessary. Because road closures should be discussed in environmental reports, the district should schedule road closure hearings prior to the preparation of the final report if not combined with other hearings. Changes in proposed road closures may be sufficient grounds for preparing revised or supplemental environmental reports. Public Hearing announcements should be in conformance with Section 19-4.01(c).

19-2.02(b) Corridor Protection

The Illinois Highway Code, 605 ILCS 5/4-510 provides means of protecting the right-of-way for future additions to State highways from future developments through the preparation and filing of a map showing the location and approximate widths of the rights-of-way needed for future additions; see Section 12-6. When the Department intends to invoke this provision, it must hold a public hearing in or near the county or counties where the land to be used is located and must publish notice of the hearing in a newspaper or newspapers of general circulation in the county or counties involved. If a public hearing is held in conjunction with the location and design studies for a project, it can also serve as the hearing required for corridor protection under 605 ILCS 5/4-510. As an alternative, the Department may hold a separate hearing specifically to receive testimony regarding the corridor protection map. For any hearing intended to fulfill the requirements of 605 ILCS 5/4-510, the notice(s) announcing the hearing should indicate that intent; see Section 19-4.01(c).

Not more than ten years after a protected corridor is established and not later than the expiration of each succeeding ten year period, the Department shall hold public hearings to discuss the viability and feasibility of the protected corridor. The Department shall retain the discretion to maintain any protected corridor but shall give due consideration to the information obtained at the public hearing. If the Department in its discretion determines that the construction of the roadway is no longer feasible, the Department shall abolish the protected corridor.

The Land Acquisition Manual describes the procedures and exhibits needed to file a Corridor Protection Map.

19-2.02(c) Context Sensitivity

Pursuant to 605 ILCS 5/4-219, the Department shall embrace the principles of context sensitive design and context sensitive solutions in the policies and procedures for the planning, design, construction, and operation of its project for new construction, reconstruction, or major expansion of existing transportation facilities.

Departmental policy D&E-21 provides guidelines for defining the Context Sensitive Solutions (CSS) process and its uses. Section 19-5 discusses procedures for implementing CSS for Department projects.

19-2.02(d) Projects not Involving Federal Funds

For projects not involving the use of Federal funds, the Regional Engineer will generally follow the same public involvement process as that for projects using Federal-aid funds. When State-only funded projects are subject to restricted time constraints, the Regional Engineer may elect to implement the following procedures as appropriate:

1. Where no additional right-of-way will be acquired, make releases of information to one or more news media announcing the initiation of studies and/or plans and the awarding of contracts.
2. Where minor amounts of right-of-way will be acquired, initiate property owner contact from whom right-of-way will be acquired and provide an opportunity to comment on the improvement. A representative of the Regional Engineer will record and document these comments and address them in the Phase I report. In addition, release information to one or more news media on the initiation of studies and/or plans and the award of contracts.
3. Where significant amounts of right-of-way will be acquired or the scope of the project is major in nature, the Regional Engineer will schedule one or two public meetings and an offer to hold a public hearing should be made. Comments received from these public involvement activities will be included in the State Improvement Report (SIR). In addition, release information to one or more news media on the initiation of studies and/or plans and the award of contracts.

19-3 LEVELS OF PUBLIC INVOLVEMENT

19-3.01 General

This Section describes the types of public involvement activities that may be implemented for a project and the procedures for implementing them. Public involvement activities may include property owner contact, public meeting(s), or a public hearing.

An early activity of the project team will be to design and schedule the public involvement activity(ies) for the project. The public involvement should be dynamic and flexible and may include one or more public involvement activities described in this Section, depending on the project size, impacts, complexity, or class of action. The public involvement team should be especially cognizant of any opposition to the project and should develop strategies to address conflict issues early to help minimize disruptions at the meetings/hearings. Strategies may include:

- meeting with opposition groups early to hear and try to alleviate their concerns;
- include those opposed to the project in the advisory group if CSS is being used; and
- use of conflict resolution specialists.

Once completed, each public involvement activity should be documented and included in the project file. For projects using CSS, the Stakeholder Involvement Plan (SIP) provides this documentation.

The following provides a description of the typical levels of public involvement and procedures for each (e.g. property owner contact, public meeting, or public hearing).

19-3.02 Property Owner Contact

19-3.02(a) General

Property owners are generally contacted to notify them of the project and the potential impact to their property. Property owner contact is generally suitable when the project involves acquisition of a minimal amount of right-of-way from a small number of property owners (e.g., 10 or fewer, depending on context) for projects such as:

1. 3P projects requiring involving right-of-way or easements.
2. 3R projects requiring minor amounts of right-of-way or easements.

19-3.02(b) Procedures

The district will contact each property owner from whom property will be acquired and provide them with an opportunity to comment on the project. A district representative can make contact

in-person or via certified mail. The district should document in-person contacts by including a summary of the conversation in a memorandum to the file. If certified mail is used, the letter (Figure 19-3.A) should describe/include:

- reason for the contact,
- scope and schedule of the project,
- reason for the proposed right-of-way,
- exhibit map showing the property affected,
- acquisition procedures,
- policy on public involvement,
- a comment form, Figure 19-3B,
- self-addressed, stamped return envelope,
- other options for submitting comments, and
- where to get more information.

Make a record of any comments from the property owner, whether contacted in person or via certified mail, and inform the owner of any actions taken to resolve any objections or suggested changes. When public involvement requirements are satisfied by this option, the Regional Engineer shall determine what information regarding the project should be released to the media.

When property owners are not readily available (e.g., when the property is the subject to a trust agreement) send a written notice or make an in-person visit to the trust officer or manager of record to request him/her to inform the actual owner of a possible need for the property. Attempt to ascertain the name and address of the owner or power of attorney for comments. Include a time limit of not less than 21 days for response in the request. If response is not received in that time, assume the owner or legal representative is not available or interested in commenting on the project.

For larger projects with many property owners affected, it may be more practical to hold a public meeting rather than to contact owners separately; see Section 19-3.03.

(UNDERLINED PORTIONS VARY WITH PROJECT)

Location Studies

Illinois Route 2 to Illinois Route 3

Job No.: P-91-000-00

Some County

RE: Property Tax Number 12-34-567-890

Month Day, 20xx

Mr. John Doe

123 S. 4th Street

Some Town, IL 60000

Dear Property Owner:

Reason for Contact	The purpose of this letter is to notify you that the Illinois Department of Transportation is presently in the preliminary engineering phase of a study for the improvement of <u>Illinois Route 1 from Illinois Route 2 to Illinois Route 3 and to seek your input on the project.</u>
Scheduling	This project is one of the projects tentatively included in our Fiscal Year <u>XXXX</u> Program, subject to the availability of funds.
Policy	It is the policy of the Illinois Department of Transportation to allow interested or affected persons an opportunity to comment on this project during the early stages of project development. Depending on the impacts generated from this project, other types of public involvement may result when warranted, such as a public meeting or a public hearing. Notices for these types of public involvement will be made available to the public.
Identify Property Affected	Based upon a review of the <u>XXXX</u> tax records of <u>Some County</u> , you are indicated to be the <u>owner of the property located in the northeast corner of Illinois Route 1 and Illinois Route 2</u> as shown on the enclosed aerial photograph.
Describe Project	The proposed improvement generally consists of <u>widening, resurfacing, rehabilitation, restoration, intersection channelization and traffic signal modernization.</u> The intersection at Illinois Route 2 will be channelized to provide <u>separate left-turn lanes and the traffic signal will be modernized.</u> The roadway <u>will be widened 4 ft (1.2 m) on both sides and curb and gutter provided.</u> The proposed right-of-way that is to be acquired from your property for this improvement is indicated on the enclosed aerial preliminary plan sheet.

SAMPLE PROPERTY OWNER CONTACT LETTER

Figure 19-3.A

(1 of 2)

Reason for acquisition:	This right-of-way acquisition is needed to <u>improve the corner turning radius at Illinois Route 2.</u>
How to Comment:	Included in the packet is a response form to indicate your comments, if any. You may also request further discussions with us, either via the telephone or in an in person meeting. Please indicate the appropriate response and return one copy to us in the enclosed, self-addressed, stamped envelope. We would appreciate receiving any comments you may have by <u> (date) </u> .
Acquisition Procedures:	Upon completion of our study, we will proceed with the plan preparation and land acquisition phase. In that phase, a representative of the Department will contact you regarding any necessary acquisition. Please note that your response, or lack thereof, will in no way influence the amount of compensation you will receive for your property if acquired as part of the project.
How to Get More Information:	If, after reviewing this letter, you have any questions or wish to arrange a meeting to discuss this improvement in more detail, please contact <u>(Contact Person as assigned by district)</u> at 312/884-4100. Very truly yours, Regional Engineer or District Program Development Engineer
Exhibit & Self-Addressed Stamped Envelope	Enclosure

SAMPLE PROPERTY OWNER CONTACT LETTER

Figure 19-3.A
(2 of 2)

(UNDERLINED PORTIONS VARY WITH PROJECT)

Location Studies

Illinois Route 2 to Illinois Route 3

Job No.: P-91-000-00

Some County

RE: Property Tax Number 12-34-567-890

Month Day, 20xx

Mr. John Doe

123 S. 4th Street

Some Town, IL 60000

Comment Form

Check the appropriate response:

_____ I have no comments at this time.

_____ I have noted my comments on the back of this page.

_____ I would like to discuss this further in a telephone conversation.

_____ I will call you.

_____ Please call me at _____ (Telephone Number)
(Indicate preferred day and time)

_____ I would like to have a personal meeting to discuss this project.
(Please call (Contact Person) to arrange date, time and location.)

Signature
Blank for
Owner

Print Name of Owner

Signature of Owner

Date

Sample Property Owner Contact Comment Form

Figure 19-3.B

19-3.03 Public Meetings**19-3.03(a) General**

Public meetings are suitable for, but not limited to, more complex projects such as Federal Approved Categorical Exclusions (CE), projects following CSS, projects requiring a public hearing, or an EA/EIS project. These types of projects may be:

1. A small 3R project in an urban area but with several displacements;
2. A large 3R widening and resurfacing project on highway, or a major bridge replacement in a rural area;
3. A 3R project with several unusual circumstances;
4. An add lanes project (i.e., 2 to 4 lanes);
5. A bridge relocation on new alignment;
6. A road diet project being supported by the local agency(ies) through early project coordination (see Section 17-2.02(g));
7. A new intersection; or
8. Several small projects in localized area but proposed for a single construction season.

Public meetings provide an opportunity to assemble a large group at one time to discuss the purpose and status of the project, design, project impacts, alternatives (if any), and critical remaining decisions.

The meeting should be prepared for and conducted following the guidelines in Section 19-4.

19-3.03(b) Public Meeting Notice

Prior to the public meeting being held, regardless of format, a notice should be published in a newspaper near where the meeting is to be held, and other announcements should be made on social media, radio, television, and/or websites to encourage as much attendance as possible.

For content to include in the notice; see Section 19-4.01(c)

19-3.03(c) Public Meeting Formats

The following are different public meeting formats that may be used depending on the desired goal. Some of the formats may be used in the CSS process as well; see Section 19-5.

19-3.03(c)1 *Group Briefings*

Group briefings are informal meetings with special interest stakeholders and can be an effective means of both circulating information on a proposed project and gaining valuable input. If a group or organization invites district staff to attend a meeting to make a presentation or participate in discussions, the district is not subject to compliance with the *Open Meetings Act* for its involvement in the meeting. However, if the district initiates arrangements for meeting with a specific group(s) to discuss project issues, it may need to provide notice of the meeting in accordance with the *Open Meetings Act*. If the district makes staff available for presentations to some groups or organizations, it should be prepared to accept invitations from other groups or organizations if they desire a similar opportunity.

These meetings generally begin with a brief presentation by a member of the project team giving the background and goals of the proposed project, a summary of the work and decisions made to date, and a brief synopsis of the proposed schedule for completing the improvement. After this presentation, the meetings should be “open” for a question-and-answer period.

The following is a list of such stakeholders:

- Service clubs (e.g., Kiwanis, Rotary);
- Units of local government (e.g. city councils and/or county boards);
- Chambers of Commerce;
- Homeowners associations;
- League of women voters;
- Local and regional planning agencies;
- State elected officials in whose district the project is located;
- Environmental organizations;
- Minority organizations;
- Organizations representing persons with a disability; and
- Non-motorized users.

Where there may not be an existing organized group, a neighborhood leader may need to be identified, or meeting arranged by the district. For example, in neighborhoods without homeowners associations, a particular homeowner may agree to act as a leader and arrange for meetings and attendees to discuss the project with representatives of the Department. If this option is not available, the district may arrange a meeting in the neighborhood or community and invite homeowners, business owners, community leaders, etc., in small groups at different times to discuss the project.

This format has been used very effectively to gather data and ascertain community attitudes and values towards transportation projects, acquisition of properties, rerouting of traffic, interruption of services during construction, preservation of archaeological and historic properties, and the

extent of concern for certain types of environmental and social impacts. Where a certain interest group may be impacted more severely than others by a project, a special meeting at a mutually acceptable time and place may be effective in gaining its understanding of the complexities of the issues, ascertaining the nature of possible resistance, and determining mitigation procedures which might resolve certain objections. Meetings of this type tend to diffuse organized opposition, especially when the opposition is based on non-factual data.

As a part of the group briefing format, use small displays and/or handouts to supplement the presentation as they may be used in facilities with limited space. Handouts containing basic project information will be useful for orientation and for future reference by attendees.

19-3.03(c)2 *Open House*

An open house offers the public an opportunity to meet with representatives of the district at a time and place that is reasonably convenient to discuss a proposed project. An open house may use any space that is readily available to the public and in the immediate area of the proposed improvement. Throughout the open house session, appropriate members of the district staff will be available to discuss the project with the public and answer questions.

An open house allows a large group of people to be able to learn about a project and ask questions in a short time. Also, the public can ask questions on a one on one basis, such as determining if there are any impacts to their property.

Section 19-4.02 discusses criteria for location and facilities suitable for an open house.

19-3.03(c)3 *Workshops*

Workshops are meetings where participants are given basic transportation requirements, economic and design constraints, and anticipated social, economic, and environmental impacts all related to a proposed project or project problem, and are then asked to study the problem and suggest a solution. In a workshop format participants are requested to analyze the provided information, identify impacts that may have been overlooked, work with others with whom they may agree or disagree, and offer solutions and explanations on their suggestions.

Workshops provide an opportunity for the public to fully understand the complexities and problems that confront Department personnel during project development. This enhances public understanding and appreciation of Department efforts. Because the public will be analyzing pertinent information, suggesting solutions to problems, and indicating preferences among impacts and tradeoffs, a sense of existing local values and preferred mitigation measures can be gained.

When workshops are announced in the news media, the announcements must clearly explain that those attending the meeting will be expected to participate in study groups. The announcement should also explain that formal comments or testimony will not be taken, but that other opportunities will be offered for that purpose. At the beginning of the meeting, the same information must again be clearly explained to those present.

Although not always controllable, workshop formats are generally more effective if the participants are limited to a number that can be divided into smaller groups of four to eight participants per group, and the number of groups is consistent with available space and manpower.

Because those attending workshops will be expected to participate for two to three hours, they must be scheduled at a time when attendees will have the time available. Weekday evenings or daytimes during weekends are the most effective. Workshop meeting places should have tables and chairs, good lighting, and other facilities appropriate for the work groups. School cafeterias are usually excellent facilities for workshops.

At the beginning of a workshop, the moderator should explain the goals and objectives of the session. If other activities have been scheduled subsequent to the workshop, those should also be announced so the participants will be aware of subsequent opportunities to comment on the project. The moderator should explain the project background to the workshop attendees. This includes an explanation of the project need, the basic constraints under which the project will be designed (economics and design criteria), the impacts that have been recognized to date, and any other information that may be pertinent to the scope of the workshop. This presentation must be concise because most of the available time should be allotted to problem solving and solution development. The opening presentation should generally be thirty minutes or less. Divide the participants into groups of four to eight people. Provide each group with the data and exhibits needed for its work and assign each group a resource person or group leader to answer questions and provide general guidance to the group. The leader may also exercise informal group control, act as group recorder, and report group conclusions. Each group will be expected to provide a recommendation and an explanation.

For workshops or other public involvement activities involving the formation of small working groups, certain practices can be applied to optimize the effectiveness of the working group process:

1. When explaining the purpose and role of the working group, emphasize that the group should function as a “horizontal” organization (i.e., members of equal standing) rather than a hierarchical organization. A horizontal organization will enhance the productivity, creativity, participation, and commitment among the group members.
2. The group must recognize and understand that, to be effective, it must have a common focus and agreement on *what* will be discussed and *how* the discussion will progress. Designation of a group facilitator is essential to accomplishing this objective. (Facilitators may be paid personnel hired by the Department or the project consultant.) The facilitator will serve as a neutral agent in the process who will function to keep the participants focused and on track in working toward agreement on specific issues, rather than allowing the group participants to attempt to address multiple issues simultaneously. He/she will direct the flow of discussion to promote open and balanced participation and will protect individuals and their ideas from personal attacks that can stifle participation. At the outset of the group’s formation, the roles and responsibilities of the facilitator and group members must be made clear so all understand how the group will function.

3. Designate a recorder for the group. Like the facilitator, the recorder will act as a neutral agent and will not judge the comments or suggestions offered by group members. The recorder will write down the main points and ideas expressed by the group in a format that can be viewed by all group members as discussions proceed (e.g., large sheets of paper on which the ideas and comments can be written). The recording of discussion points in full view of the group serves to focus attention and ensures complete and accurate documentation of the ideas and comments expressed. This “group memory” is important both for the efficiency of group meetings (e.g., it eliminates the need for group members to be preoccupied with the process of recording) and for reporting on the actions of the group.

The seating arrangement can affect small work group functioning. The recommended arrangement has the group members seated in a semicircle facing the facilitator and recorder. This helps to focus the attention of the group on the facilitator and the written record of comments and ideas. It also avoids placing any of the group members in perceived positions of authority (e.g., at the head of a table) relative to other members.

19-3.03(c)4 *Information Exchange (Citizen Working Groups/Advisory Committee)*

The districts may consider establishing an Information Exchange, see Figure Figure 19-3.D, to assist in identifying and focusing concerns and comments from a diverse array of interests. The Information Exchange involves the formation of Citizen Working Groups to analyze and react to project alternatives, impacts, and other project-related issues, and an Advisory Committee to serve as the focal point for receiving comments and recommendations from the Working Groups and to pass them to the Department.

Note: Information Exchanges are commonly used in CSS but are usually referred to as a Community Advisory Group (CAG) instead of a Working Group and Project Study Group (PSG) instead of Advisory Committee; see Section 19-5.

In using this approach, the district should discuss the expectations and rules of the exchanges and should state that this approach is not intended to make any final project decisions. Rather, the exchange will provide a forum for discussion and comment on various project-related issues. The following discussion presents an overview of the key elements of the Information Exchange process:

- Working Groups. In the Information Exchange process, Working Groups form the key mechanism for eliciting discussion and comment on the proposed project. These Groups are formed on the basis of common interests or stakeholders (e.g., public officials, resource and regulatory agencies, public interests, agricultural interests, development interests) and have the following primary objectives:
 - + evaluating alternatives presented by the Department and discussing and commenting on impacts, analysis factors, and evaluation methods;

- + assessing the relative merits of the alternatives, identifying advantages and disadvantages of the alternatives, and suggesting ways to make the alternatives more acceptable; and
- + informing the Advisory Committee of the Working Groups' evaluations, assessments, concerns, and suggestions.

The issues and interests on a specific project will affect the nature and number of Working Groups that may be appropriate. As the initial step in establishing Working Groups, organizations and other interests likely to see themselves as potentially affected by the project should be identified and contacted to determine their interest in participating. The district may solicit interest through any of the various methods used for public involvement. For public officials or organizations representing specific interests, letters of invitation to those entities may be appropriate. For the public at-large, public meetings may be a more effective method of alerting potentially affected parties and determining interest.

At the organizational meeting for the Working Groups, the Information Exchange process and the objectives of the Working Groups and Advisory Committee can be further explained. In addition, the district can determine the membership in each Working Group, present and adopt Constitutions and Bylaws, and initiate selection of a Group chairperson and vice chairperson to represent the group on the Advisory Committee. Following the initial organizational meeting, the adoption of Constitutions and Bylaws, and the designation of chairpersons, the Working Groups can proceed with their activities and exchange information concerning Working Group and Advisory Committee meetings, project details and schedules, etc., through their representation on the Advisory Committee.

- Advisory Committee. The Advisory Committee may include two representatives from each of the Working Groups (the chairperson and vice chairperson of each Group), the Department of Transportation, the Federal Highway Administration, the project consultant, and others, as appropriate. The functions of the Advisory Committee include integrating the interests and values of the Working Groups into the planning process and advancing the objectives of the Information Exchange. The objectives of the Advisory Committee include the following:
 - + providing policy direction for the Information Exchange;
 - + evaluating alternatives for the project based on information provided by, but not limited to, public meetings/hearings; deliberations of Working Groups; consultant reports, as appropriate; and FHWA and IDOT inputs;
 - + recommending alternatives for the project; and
 - + If warranted, preparing a report to the Secretary of IDOT detailing the work of the Committee, including its recommendations and conclusions.

Tasks performed by the Advisory Committee in accomplishing its objectives will include actions such as:

- + evaluating the need for the project;
- + evaluating the social, economic, and environmental impacts of project alternatives;
- + serving as a communication link to the Working Groups and bringing their concerns to the decision makers (i.e., IDOT, FHWA, and public officials);
- + helping to resolve conflicts among various interests;
- + reviewing and making recommendations on the decision making process; and
- + assisting in educating the public about the proposed action and the decision making process.

See AASHTO Practitioner's Handbook 05 *Utilizing Community Advisory Committees for NEPA Studies*, December 2006, for additional guidance concerning the role of Community Advisory Committees.

19-3.03(c)5 *Virtual Public Meetings*

The Department may elect to hold virtual public meetings instead of in person meetings. If the project area or persons affected by the project lack reliable access to technology or internet service, then a virtual public meeting may not be feasible.

At minimum, a virtual public meeting must include the following:

- a public meeting notice that meets Section 19-4.01(c). The location of the meeting would be stated as virtual and include the website address.
- a method for the public to submit comments electronically for the project.
- the notice shall also contain a starting date and ending date of when official comments may be made a part of the public record (a minimum timeframe should be seven calendar days). Typically, it is assumed the starting time of the meeting is the starting date of when official comments can be received.
- persons with limited internet access and/or require special accommodations under ADA should contact <insert contact name>, phone number and email address for further assistance.
- see Section 19-4.04(b) for information that should be included in the virtual public meeting.

The following considerations may assist the districts in implementing a successful virtual public meeting.

- publish public meeting notices on several social media sites (e.g. facebook, linkedin, twitter, etc.) as well as tradition newspapers. Ads on radio and television may be another option to get the public's attention. The meeting should be coordinated with the Office of Communication for use of social media sites during this process (See Order 14-8).
- host a virtual presentation of the project. The presentation should be available for streaming later if a live presentation was used for the virtual public meeting.
- a longer timeframe for the virtual public meeting (i.e. more than seven days) is recommended for larger and more complex projects.
- develop a brochure/pamphlet to be distributed that includes project information, project website, and it is suggested to have a pre-paid mailer included as part of the brochure/pamphlet for the public to submit comments.
- in addition to the above considerations, the district should be mindful that these methods be accessible to ADA stakeholders included in the virtual public meeting process

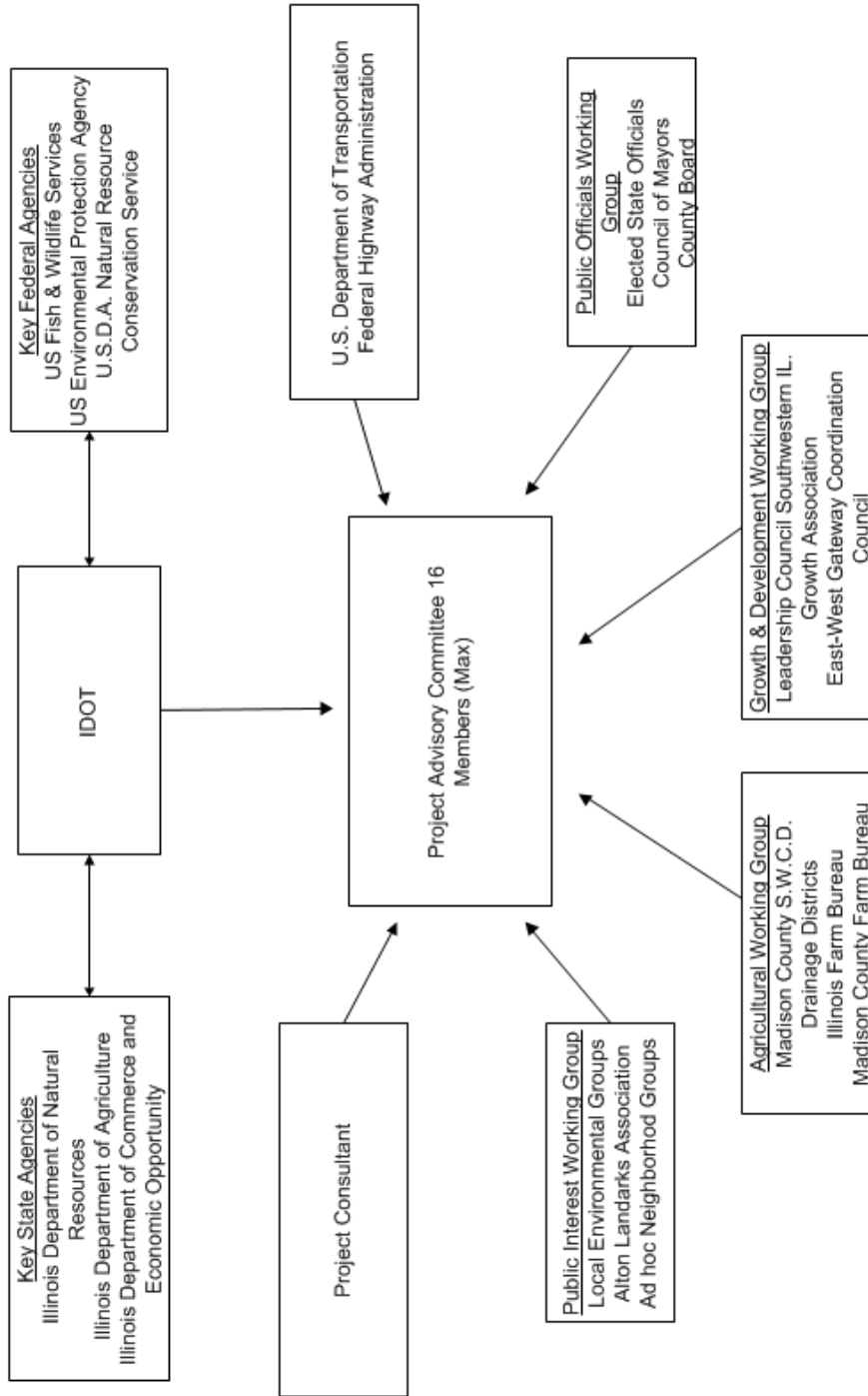

EXAMPLE OF INFORMATION EXCHANGE PROCESS

Figure 19-3.D

19-3.04 Public Hearings

19-3.04(a) General

Federal requirements for public hearings are broadly defined in Federal regulations; see Section 19-2.01. State requirements are more specific; see Section 19-2.02. In order to have a consistent public hearing process, the Department has developed procedures for when a public hearing is warranted under Federal or State law. The procedures consider the category of action and how it intersects with public hearing requirements.

19-3.04(b) Procedures

19-3.04(b)1 *Environmental Impact Statement (EISs)*

A public hearing is required for all EISs. The timing is discussed in Section 25-2.19.

19-3.04(b)2 *Environmental Assessment (EAs)*

A public hearing is required for all EAs. The timing is discussed in Section 24-2.16.

19-3.04(b)3 *Categorical Exclusions (CEs)*

1. Federal Approved CEs. Projects that have one or more potential for unusual circumstances, see Section 23-1.04(b), may approach the threshold of requiring a public hearing. In general, these will be 3R projects where a major amount of right-of-way is required or the function of the highway is altered. Examples of these project actions may include but are not limited to:

- the relocation of an existing marked route from one street to another which did not previously carry marked route traffic, with or without additional right-of-way.
- the changing of a route to a one-way couple which will use a street that did not previously carry marked route traffic, with or without additional right-of-way.
- the reconstruction of an existing marked route with additional through traffic lanes, included because a reasonable alternative would be a bypass or one-way couple.

If the district is unsure about whether or not a Federal approved CE may warrant a public hearing, the district should discuss with FHWA at a district coordination meeting.

2. State Approved CEs. Pursuant to CE Agreement, projects on the 23 CFR 771.77(c) and 23 CFR 771.117(d) list may not have potential for unusual circumstances and the likelihood of a State approved CE involving a Federal requirement discussed in Section 19-2.01 is extremely small, especially for SMART or 3P projects.

If the district is unsure about whether or not a State approved CE may warrant a public hearing, the district should discuss with FHWA at the district coordination meeting.

19-3.04(c) Public Hearing requirements

FHWA regulations in 23 CFR 771.111(h)(2)(iii) require the Department to provide a public hearing(s), or the opportunity for hearing(s), for Federal-aid projects as discussed in Section 19-2.01.

The district may either offer to hold a public hearing and determine if there is sufficient interest based on the response, or may hold a public hearing.

When a public hearing will be offered, the offer of the public hearing must be done with proper timing and shall include the language required by Federal regulation; see Section 19-3.04(d).

When a public hearing was offered but not held, certification of the offer shall be submitted to FHWA.

When a public hearing will be held, the following shall be met:

1. The public hearing notice shall include applicable language in Section 19-3.04(e).
2. The format of the public hearing should be appropriate for the project; see Section 19-3.04(f).
3. The items in 23 CFR 771.111(h)(2)(v) shall be explained at the hearing, as appropriate.
4. A transcript and a certification that a public hearing was held shall be submitted to FHWA; see Sections 19-3.04(g) and 19-3.04(h).

19-3.04(d) Offer of Public Hearing**19-3.04(d)1 *Timing***

When the district, in consultation with FHWA, determines that an offer for hearing(s) will be afforded for a project, the requirements shall be satisfied by publishing an offer notice in a local newspaper.

The offer of a public hearing need *not* be announced by a legal notice in the legal notice section of newspapers. Public hearing offers can be announced by use of paid advertisements in newspapers and may be supplemented by radio and TV announcements, posters, the project website, social media, or other means. Legal notices may be used if it is the only means to ensure verbatim publication and specified timing. The size of paid advertisements should be sufficient to attract attention and to contain the information that is necessary.

The district should publish the offer notice at least twice, approximately one week apart. More than two notices may be published if it is considered necessary to provide adequate coverage of those affected by the project. Publish the notice of the offer in at least one newspaper of general circulation in the vicinity of the project. If a notable segment of the local population is non-English

speaking and there is a foreign language paper serving the area, it should also be used to carry the notice. The deadline for requesting a public hearing shall be at least 21 days after the notice first appears in a newspaper.

19-3.04(d)2 *Content*

See Section 19-4.01(c) for content to include in the public hearing offer.

Figure 19-4.B presents an example of a typical offer of a public hearing.

19-3.04(d)3 *Determination of Sufficient Interest*

If there is a request, or requests, to hold a public hearing, then the Regional Engineer will determine if there is sufficient interest to hold a public hearing. If a public hearing is determined to be necessary, follow Section 19.3.04(f) requirements.

If the Regional Engineer determines there is not sufficient interest, then the district shall contact each requestor by certified mail with return receipt and inform them of the lack of sufficient interest in the public hearing and advise the requestor that comments are welcome. If a personal contact is made, the district shall record comments during the contact. If the contact is by certified mail, the district shall include a stamped, self-addressed envelope and a name, telephone number, email, fax number, and telecommunications device for persons with hearing and speech impairments (TTY) number for returning comments. Use the fax number for the Regional Engineer's office and the district's TTY number.

19-3.04(e) Public Hearing Notice

When a public hearing is to be held, the district shall publish a notice in a local newspaper, on Department websites, and on other social media.

19-3.04(e)1 *Publishing Frequency*

See Section 19-4.01(d) for publishing public notice frequency.

19-3.04(e)2 *Content*

See Section 19-4.01(c) for content to include in the public hearing notice.

An example of a public hearing notice is shown on Figure 19-4.C.

19-3.04(f) Public Hearing Formats19-3.04(f)1 *General*

Public hearings often involve a larger gathering compared to other public involvement activities. When an exceptionally large attendance is expected, it may be desirable to conduct several activities concurrently. If separate rooms are available at the hearing facility, a special room may be used for receiving testimony from persons having prepared statements for the record and who are not interested in attending the entire hearing. After the presentation is complete, comments can be recorded in the main hearing room also making two recorders available for statements. If such a process is used, it should be announced both prior to and at the public hearing and indicate that both recordings will become an official part of the record. Although some duplication of comments may occur, the shortening of the time involved at the public hearing may make the duplication acceptable.

Many of the comments expressed at public hearings concern right-of-way acquisition. The district may address these concerns by establishing a separate room or discussion center staffed with Land Acquisition personnel to dispense general information and to discuss property acquisition procedures, relocation assistance programs, and effects on individual properties. By satisfying property-related questions prior to or during the presentation, this may minimize the number of comments raised during the public hearing. Because Land Acquisition personnel should generally be available throughout the hearing, the separate, integrated use of such personnel is both effective and efficient.

The choice of the public hearing format should fit the project. The three types of format discussed below are the formal public hearing, open house public hearing, and hybrid public hearing.

Regardless of the type of format used and in accordance with 23 CFR 771.111(h)(2)(v), when a public hearing is held, the following information should be explained:

- the project's purpose, need, and consistency with the goals and objectives of any local urban planning;
- the project's alternatives and major design features;
- the social, economic, environmental, and other impacts of the project;
- the relocation assistance program and the right-of-way acquisition process; and
- the Department's procedures for receiving both oral and written statements from the public.

Public hearings generally require considerable time for preparation of displays and electronic presentations. The need for a video presentation and the possible need for outside media services for the development of electronic presentations may require additional lead time. The displays for the individual discussions do not necessarily need to be large because they will generally be viewed from relatively short distances. The hearing may include aerial photography

with superimposed design and location features, but preliminary plan and profile sheets may also be suitable. Where visual impacts are a major concern, the district may wish to also provide exhibits produced through video imaging, computer imaging, or photomontage, which depict how alternatives will look in the project setting.

19-3.04(f)2 *Formal Public Hearing*

A formal public hearing is where a speaker(s) directly addresses the audience via a presentation and a court reporter is present to transcribe the hearing. After the presentation, members of the audience have an opportunity to address the speaker(s) publicly; see Figure 19-3.E.

This type of format can discourage participation by certain persons or groups that are intimidated by the formality and size or make-up of the audience. Conversely, formal public hearings may attract individuals that are seeking a forum, which often includes press coverage, to present their views on transportation matters or a variety of other topics. As such, the moderator may need to caution attendees occasionally to restrict their comments and statements to the project and may need to suggest a time limit for each commenter to discourage individuals from attempting to monopolize the comment period. Whatever timeframe is utilized (e.g. 5 minutes, 3 minutes, 2 minutes) the moderator must clearly state such timeframe at the beginning of the hearing and impose the same timeframe for each commenter. The notice should also include any time constraints for public testimony during the comment period.

The presentation opening the formal public hearing should normally not exceed 30 minutes and in no case should it exceed 45 minutes. The district staff should carefully develop the discussion and highlight important points because time is limited. See Section 19-4.04 for further information on the development of presentations.

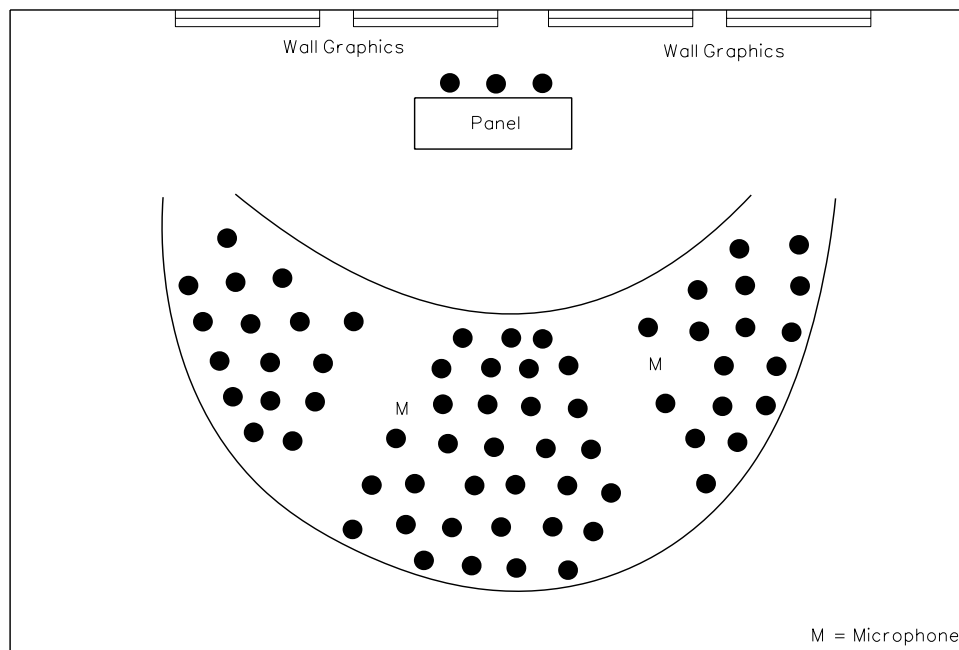
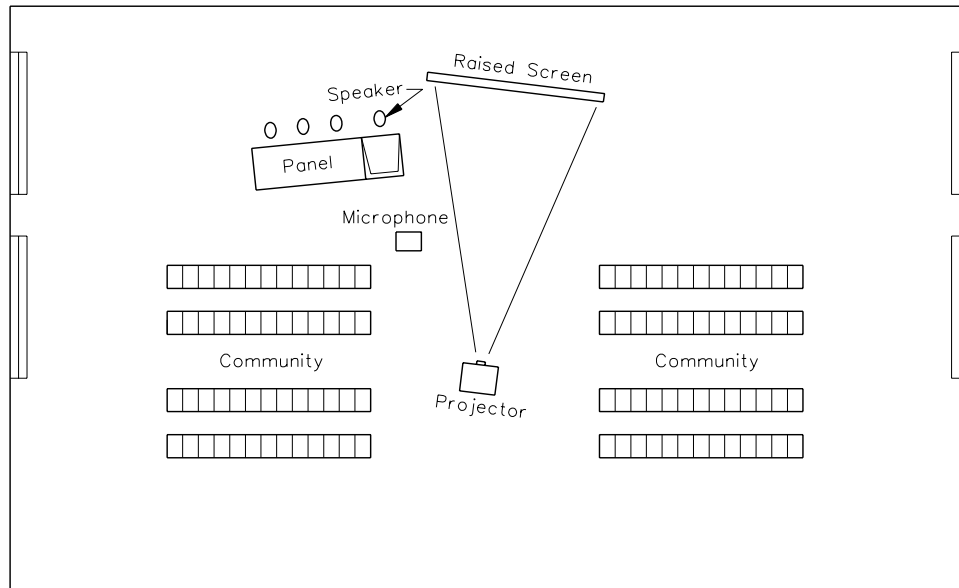

FORMAL PUBLIC HEARING FORMAT

Figure 19-3.G

19-3.04(f)3 *Open House Public Hearings*

The open house public hearing format is an alternative to the formal public hearing format and may also be used wherever a public hearing is required or appropriate. It remains necessary, however, to have appropriate Department representatives present, to provide explanatory project information, to provide for the receipt of oral and written statements, and to prepare a transcript of the proceedings.

The open house public hearing format provides for a continuous flow of visitors over a period of hours in contrast to a formal public hearing that attracts a large crowd at a fixed time. The smaller number of visitors present at any given time at an open house public hearing allows personalized service through authorized IDOT staff and their consultants. The open house hearing format is less intimidating to participants and offers a more workable option for conducting hearings for large audiences.

Open house public hearings generally involve four separate activities:

1. The first is the greeting station. Here, staff members greet the public, advise them about hearing procedures, distribute handouts, obtain names and addresses, and note the opportunity to submit oral and written statements. The handout may include forms for submitting written comments during or after the meeting. While it is encouraged to ask names and addresses and have a sign-in sheet, it is not required.
2. Next, the visitors are directed to a presentation of general information about the project to orient them on the purpose of the project, alternatives under consideration, and the potential impacts. This is best accomplished by electronic means such as a video that can be repeated without variance.
3. The district staff directs the visitors to an area with displays and staff experts for small group or individual discussions on specific questions or concerns. A variety of disciplines should be represented so virtually any question can be addressed. Members of the public are free to remain in this area as long as necessary to obtain the information they desire. Staff members should remind visitors of the opportunity to submit comments at the conclusion of discussions.
4. The final activity is an opportunity to give oral comments to recorders or prepare and submit written comments. After completing their comments, visitors are free to leave. A typical setup for an open house public hearing is shown in Figure 19-3.F.

19-3.04(f)4 *Hybrid Public Hearing*

The hybrid public hearing format combines elements of the open house public hearing format with a formal public hearing format. The hybrid public hearing format should be used to the maximum extent practical.

The advantages of the hybrid public hearing format include the ability to engage the public through the open house format while offering a formal opportunity for individuals to express their views in

a public forum and also hear the views of their fellow citizens. Additionally, the hybrid format may protect the project from legal challenges related to the use of the open house format alone.

There are a several methods that the districts may use to allow the public to express their views publicly. The following are some examples for the districts to consider and are encouraged to explore other methods for accomplishing the goal of giving the public a forum to express and hear views from their fellow citizens at a specified time:

- asking questions – The public is given an opportunity to ask questions and the project team gives the answers. One option is for the district to allow the public to ask the questions directly to the project staff, who immediately responds in the public forum. Another option is to collect questions from the public on written cards and have the project staff read the questions and answer them. This allows the project staff to collate similar comments and remove some of the emotion from the question and answer process.
- formal comment with time limit – The public is given an opportunity to express their views publicly. The project team may limit the amount of time each speaker is given if there is a large quantity of speakers. The project team should decide ahead of time and make it clear to the public how comments will be responded to. For example, the project team may choose to respond to each comment after it is made in public, or they may choose to address comments later in writing as part of the comment/response period.
- conversation tables – A variety of tables are setup with each table having a different topic for conversation, with at least one project team member available at each table. For example, topics could include property acquisition, historic properties, natural resources, community resources, etc. Members of the public can sit at the table with a topic they are interested in and engage in conversations with other members of the public and the project team members.

A separate room is also desirable for the formal opportunity for the public to express their views.

19-3.04(g) Transcripts

A court reporter is the preferred means to meet the requirement of having a transcript from the public hearing. If a court reporter is not available, the public hearing shall be recorded using a digital recorder. A transcript shall be made from the digital recording.

To ensure coverage, some districts have used both electronic recorders and court reporters. If a digital recorder is used, a backup recorder should be available in case of malfunction. If an activity is scheduled that may last an extensive period of time, it may be necessary to arrange for more than one court reporter so they may operate in alternating shifts to maintain alertness.

For any public hearings, the transcript will consist of a copy of the handout, the attendance list, all written comments received, a written copy of the narrative from the general information presentation, and a written copy of the verbal comments recorded by the court reporter.

19-3.04(h) Certification

In accordance with 23 CFR 771.111(h)(2)(vi), IDOT must certify in writing to FHWA that a public hearing was offered or held. This certification shall include the following, as applicable:

- A letter certifying that a public hearing was held or that a public hearing was offered (but not held).
- If a public hearing was held, include the transcript of the public hearing, along with copies of all written statements received during the hearing and during the public comment period.

Figure 19-3.H is an example letter that may be used to satisfy this requirement. The letter should address the bullet points as appropriate.

FHWA Illinois Division
3250 Executive Park Drive
Springfield, Illinois 62703

<insert project Information>

Public Hearing Certification

This letter certifies the following to be true:

The opportunity for a public hearing was offered and the offer was published on <insert date> in the <insert newspaper's name>. Based on the public's response there was/was not sufficient interest in the public hearing (*remove previous paragraph if there was no offer*).

OR

The public hearing notice was published on <insert 1st publication date> and <insert 2nd publication date> > in the <insert newspaper's name>.

A public hearing was held on <insert date.> at <insert location>.

Transcripts of the public hearing and a copy of all written statement from the public hearing and public comment period are attached per 23 CFR 771.111(h)(2)(vi) for FHWA review.

<insert District contact information>

<insert date>

Public Hearing Transcript Certification Letter Example

Figure 19-3.H

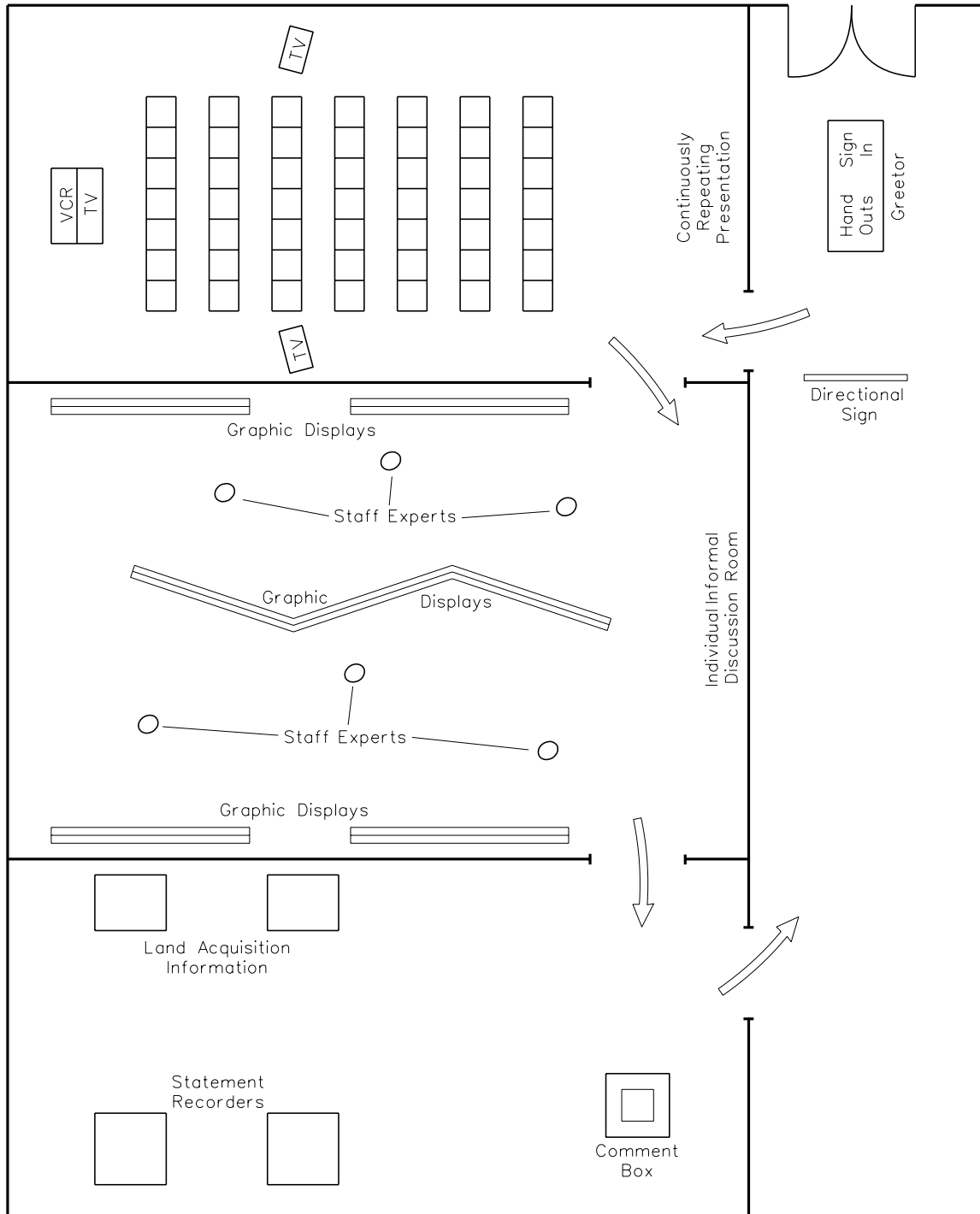

OPEN HOUSE PUBLIC HEARING FORMAT

Figure 19-3.I

19-3.05 Public Engagement

The following activities may be useful for gathering additional input from the public, or providing information to the public, but do not involve face-to-face interactions like public meetings or hearings. These activities are not intended to replace other public involvement activities but may be used to increase public awareness of projects and upcoming meetings/hearings. This section presents a list of ideas that may be utilized. The district can best determine what types of public engagement works for their stakeholders:

- social media (facebook, twitter, etc.);
- newsletters, brochures, and handouts;
- television and radio ads;
- electronic signs; or
- internet sites.

19-4 PLANNING AND IMPLEMENTING THE PUBLIC INVOLVEMENT ACTIVITY

This section discusses the overall process for planning and implementing the public involvement activity, whether it is a public meeting or a public hearing. The district must carefully prepare and develop the public involvement activity not only to attract and hold the public's attention but also to create a comfortable atmosphere for discussion of highway projects.

19-4.01 Stakeholder Engagement

After the type of public involvement activity has been determined, the district must decide to whom (stakeholders), when, and how the information will be transmitted to the public to make sure interested individuals and organizations are aware of the opportunity to provide input on the project.

19-4.01(a) Stakeholder Identification

The district must determine which groups or sectors will be contacted and what means or media are most appropriate. When identifying groups to be notified, consider several general categories:

- those who live in the geographic area of the project.
- groups who are known to be or are likely to be affected by property acquisition.
- potential users of the facility.
- commuters who will likely be concerned with the effect of alternative routing both during and after project construction.
- owners of businesses along a route who may be concerned about ingress/egress.
- resource and regulatory agencies that may have an action or authority over the proposed project.

Other groups may be singled out for attention because of special communication needs. This sector could include ethnic neighborhoods, low-income neighborhoods, elderly people, non-English speaking individuals, and persons with disabilities.

19-4.01(b) Notification of Involvement Activities

Once the proper recipients of project information and interaction have been identified, the next action is to determine the most appropriate means of announcing the involvement activity. It is not necessary to publish legal notices of upcoming activities, although it is the most defensible method for documenting public notice, particularly when it is a public hearing. Paid advertisements in newspapers and on radio and television are acceptable and frequently more effective. Where local news media are reluctant to carry such advertisements, a legal notice may

be one means of ensuring verbatim publication and specified timing. For an announcement in a newspaper to be effective, it must be strategically located and of sufficient size to attract attention. It may also be necessary to advertise notices in more than one newspaper or on more than one radio or TV station to provide adequate coverage.

In predominantly ethnic or non-English speaking neighborhoods, it may be appropriate to publish a notice in a foreign language newspaper. Newsletters of various clubs and organizations may also provide an effective means of notifying specific groups. A local chapter of a State or national association, a church, the Chamber of Commerce, or a service club may publish periodic newsletters and may be agreeable to including announcements of upcoming public involvement activities free of charge. Translations of notices and project documents should be made available when large numbers of non-English speaking residents will be affected by the project.

It may be appropriate to place posters or to distribute handouts or pamphlets on street corners in neighborhoods that are likely to be affected. Announcements of upcoming activities may be mailed to anyone on established mailing lists or to anyone who has shown an interest in the project or in highway projects in general. If low-income and/or minority populations will be affected by the proposed project, special efforts to announce public involvement activities may be necessary. In accordance with the Executive Order 12898 "Federal Actions to Address Environmental Justice in Minority Populations and Low-Income Populations," and the the public involvement process must be thorough and fully inclusive. It may be necessary to distribute pamphlets or project notices door to door for residents or place notices in churches or other community centers.

Appearances on radio and TV talk shows are also effective in many communities. Copies of all notices announcing upcoming public involvement activities shall be kept in the project file. A copy should also be forwarded to the Department's Office of Communications for their use.

Public involvement activities should be advertised via the news media, posters, mailing lists, or other media as needed. General announcements are not normally required with presentations to specific groups and other activities which the general public is not expected to attend; instead, a group requesting a presentation will arrange for attendance. When the district initiates the presentation, it will arrange for attendance through appropriate invitations. There may be occasions where the group involved will release the results of these meetings to the media. Clubs or other special interest groups may have a standard practice of issuing a news release summarizing the activities and programs that occur at their meetings. Occasionally, the district may announce the results of certain non-public activities. For example, the results of opinion polls or questionnaires may be of interest to the general public and appropriate for general release.

However, pursuant to 23 CFR 771.111(h)(iv) notices for public hearings have specific requirements addressed in the following section.

19-4.01(c) Public Notice Content19-4.01(c)1 *General Content*

In general, the notice should:

- discuss the date, time and location of the meeting/hearing,
- discuss the purpose of the meeting/hearing and the format to be used,
 - + if an open house format will be used, the notice should specifically state this and mention both the features of the open house and that all information and presentations will be available throughout the time period specified.
 - + if a hybrid format will be used, the notice should state this and specifically describe that all information and presentations will be available throughout the time period specified and that a formal opportunity will be offered to publicly express views at a specific time.
 - + if a formal format will be used, the notice should specifically state this and give the time that the formal presentation will be made and that an opportunity to provide comments on the project will occur following the presentation.
 - + If a virtual format will be used, the notice (Figure 19-4.A) should include a website instead of a physical address where a project information and or presentation can be viewed.
- include a description of the proposed improvement,
- state that all interested persons (i.e., stakeholders) are invited to attend and participate and should also state that district personnel will be present to receive input, provide information, and answer questions,
- include project website, if available (this should be standard practice for virtual public involvement activities),
- the time limit available to submit a request,
- information concerning the preparation and availability of EIS, EA, or CE, if applicable,
- include a map showing the location of the improvement, if feasible,
- discuss applicable laws, regulations, or executive orders for specific issues that may be involved with the project; see Section 19-4.01(c)2,
- for in-person meetings explain that the location is accessible to person with disabilities; however individuals in need of special accommodations or assistance should contact the department at least 5 days before the meeting,

- include contact information:
 - + fax, email, phone (including TTY) for the Regional Engineer in the body of the notice.
 - + a contact person and telephone number from the Office of Communications in the upper right-hand corner.

19-4.01(c)2 *Public Notice Legal Content*

Whether it is an offer of a public hearing, or a notice of a public meeting/hearing, pursuant to 23 CFR 771.111(h)(2)(iv) the notice will indicate the availability of explanatory information and provide information required to comply with public involvement requirements of other laws, Executive Orders, and regulations. Example legal language for some specific issues which may be involved in the project is included below:

- EA/EIS:

This offer/hearing will provide an opportunity for the public to provide comments on the proposed EA/EIS and provide comments regarding potential impacts to the resources discussed below. IDOT is requesting these comments to assist in the project decision making and consultation with resource agencies.

- + Corridor Protection (if applicable, see Section 19-2.02(b)):

This hearing will afford an opportunity to provide input on the location and approximate widths of right-of-way needed for certain future additions to the highway system in accordance with the Illinois Highway Code, 605 ILCS 5/4 510..

- + Relocations:

When individuals or businesses will be relocated due to a Federally funded project, state that right-of-way acquisition and relocation assistance information will be available as required by the Uniform Relocation Assistance and Real Property Acquisition Regulations for Federal and Federally-Assisted Programs, 49 CFR 24.

- + Section 106:

List known historic resources that may be affected by the proposed project and the historic resources protection process, pursuant to Section 106 of the National Historic Preservation Act of 1966.

- + Parks, Recreation Areas, and Refuges (Section 4(f) de minimis impact):

The proposed project would involve use of land from the city park. Approximately two out of forty acres included in the park would be converted for highway use. The two acres would be taken from the northeast edge and would not affect the park's activities, features, or attributes that make the property eligible for Section 4(f) protection. Through

publication of this notice, the Department is requesting the public's views on the proposed use of parkland, and on FHWA's intent to make a Section 4(f) de minimus determination.

+ Floodplains (Executive Order 11988 Floodplain Management):

In accordance with the Executive Order 11988, Floodplain Management, the environmental document (EA or EIS) describes impacts to the floodplain. The comment period on the environmental document (EA or EIS) is the opportunity for early public review of the proposal for action in the floodplains. The proposed project will impact X acres of floodplain (describe floodplain and location). Accordingly, IDOT is providing the public an opportunity to comment on the potential floodplain impacts.

A statement concerning permits for construction in a regulated floodway is required for District One projects that are outside of Chicago. The Illinois Department of Natural Resources – Division of Water Resources Management (IDNR-DWRM) has delegated authority to IDOT to issue permits under the IDNR- DWRM (17 Ill. Admin.. Code 3708) rules for floodway construction in Northeastern Illinois for certain projects like bridge and culvert replacements. Example, *One alternative under consideration involves a potentially significant encroachment on the Salt Creek flood plain. The Department will process a Permit for Construction in a Regulated Floodway for the replacement of the bridge over Salt Creek.*

+ Project Level Conformity Analysis (Pariculate Matter (PM)_{2.5} Hot Spot):

Pursuant to 40 CFR 93.105(e), IDOT and FHWA are seeking public comments on the project level hot spot analysis for PM_{2.5}. In compliance with air quality conformity requirements, a quantitative hot spot analysis has been prepared for this project and is included in the environmental document (EA/EIS) and is available for public review and comment.

19-4.01(d) Public Notice Publishing Frequency

19-4.01(d)1 Public Notice Publishing Frequency for Public Hearings

The public hearing shall be subject to a minimum of two notices to the public. More than two notices may be published if a special effort is needed to ensure an adequate public response or if there is considerable public interest in the project. However, the number of days prior to a public hearing are different for EISs versus EAs and CEs.

- The first notice of a public hearing on a project requiring an EA or a CE shall be published at least 15 days in advance of the public hearing.
- The first notice of a public hearing on a project requiring an EIS shall be published at least 30 days in advance of the hearing.

- In all cases, the second notice shall be published 3 to 7 days before the activity. If notices in addition to the two required notices are beneficial, they may be scheduled up to 2 months ahead or during the week preceding the involvement activity.

The unique circumstances surrounding a particular project may affect the timing of notices. If a project requiring an EA or a CE is known to be controversial or the subject of organized opposition, the district should consider extending the minimum 15-day public hearing notice timing.

19-4.01(d)2 *Public Notice Publishing Frequency for Public Meetings*

While there are no formal legal requirements for when and where public notices for public meetings should be published, the publishing frequency of the notice should occur in advance of the public meeting and should be frequent enough to engage the public.

19-4.01(e) Public Notice Examples

The following page has an example for each of the following:

- Public Meeting Notice, Figure 19-4.A
- Public Hearing Offer, Figure 19-4.B
- Public Hearing Notice, Figure 19-4.C

*<insert contact name(s) and number(s)
for the Office of Communications>*

Public Meeting

Scheduled by

Illinois Department of Transportation

For Improvement of US Route 52 near Central City

The Illinois Department of Transportation (IDOT) announced today a public meeting has been scheduled for September 22, 2017 from 7:00 P.M. to 9:00 P.M. in the Central City High School Gymnasium for the purpose of discussing the improvement of US Route 52 from its intersection with Main Street east to the corporate limits of Central City. All persons interested in this project are invited to attend the meeting.

The meeting will be conducted on an informal basis with project displays and other information available for viewing. IDOT representatives will also be available to explain the project, answer individual questions and record comments offered by those in attendance.

One alternative under consideration involves a potentially significant encroachment on the Salt Creek flood plain. Preliminary reports, including an environmental assessment and an engineering analysis with drawings, maps, and aerial photography, will be available for inspection and viewing during the entire time the IDOT representatives are present. This same material currently is available for review and inspection at the district office.

This meeting will also serve to involve and obtain the views of the public about potential project impacts to: (see Section 19-3.04(e) & insert as appropriate).

The location of the meeting is accessible to persons with disabilities. If special accommodations or assistance are needed, please contact the individual listed below by September 17, 2017.

For more information, contact George Robertson, Regional Engineer, 1200 East Main Street, Richland, Illinois 62673, telephone 416/343-6420, fax 416/343-6414, TTY 217/524-4875.

PUBLIC MEETING NOTICE EXAMPLE

Figure 19-4.A

*<insert contact name(s) and number(s)
for the Office of Communications>*

Public Hearing Offer
by
Illinois Department of Transportation
concerning
Improvement of US Route 52 near Central City

The Illinois Department of Transportation (IDOT) is proposing to improve US Route 52 from its intersection with Illinois Route 1 to its intersection with Main Street in Central City. The project will consist of reconstructing the existing two-lane pavement to provide four lanes, two in each direction, separated by a 14-foot painted median. The project will include the signalization of the intersections of US Route 52 and Illinois Route 1 and US Route 52 and Main Street. Curb and gutter and underground drainage will be provided as a part of this project. Alternatives under consideration have potentially significant impacts to Moore's Slough, approximately 0.5 miles east of Illinois Route 1. IDOT has prepared an Environmental Impact Statement (EIS) for the project in accordance with the National Environmental Policy Act of 1969 and this public hearing is being held to address requirements of 23 U.S.C. 128 and 139, and the Council on Environmental Quality regulations.

This meeting will also serve to involve and obtain the views of the public about potential project impacts to: (see Section 19-4.01(c)(2)).

Any interested person who believes a public hearing should be held for this project may request that a hearing be held by contacting George Robertson, Regional Engineer, 1200 East Main Street, Richland, Illinois 62673, telephone 416/343-6420, fax 416/343-6414, TTY 217/524-4875. To be considered, requests must be received by September 23, 2017. A hearing will be held if the public demonstrates sufficient interest.

Maps, drawings, aerial photography, the Environmental Assessment and other information are available for viewing and inspection by the general public in the district office at the above address. If additional information is desired, contact the Regional Engineer.

PUBLIC HEARING OFFER EXAMPLE

Figure 19-4.B

*<insert contact name(s) and number(s)
for the Office of Communications>*

Public Hearing

Scheduled by Illinois Department of Transportation
For Improvement of US Route 52 near Central City

The Illinois Department of Transportation (IDOT) announced today an open house public hearing has been scheduled for 7:00 P.M. on September 22, 2017 in the Central City High School Gymnasium Central City, Illinois for the purpose of discussing the improvement of US Route 52. The project limits are from the intersection with Main Street east to the corporate limits of Central City. The project will consist of reconstructing the existing two-lane pavement to provide four lanes, two in each direction, separated by a 14-foot painted median. The project will include the signalization of the intersections of US Route 52 and Illinois Route 1 and US Route 52 and Main Street. Curb and gutter and underground drainage will be provided as a part of this project. IDOT has prepared an Environmental Impact Statement (EIS) for the project in accordance with the National Environmental Policy Act of 1969 and this public hearing is being held to address requirements of 23 U.S.C. 128 and 139, and the Council on Environmental Quality regulations.

All persons interested in this project are invited to attend the meeting to express their views and comment on the project. This hearing will also serve to involve and obtain the views of the public about potential project impacts to: (see Section 19-4.01(c)(2)).

Beginning at 7:00 P.M. a brief presentation on the status of the project, the proposals under consideration, and the decisions to be made. Representatives of the IDOT will be available from 6:00 P.M. until the presentation and also after the presentation to discuss the project. An opportunity will be made available for participants to comment on the project and these verbatim comments will be made part of the public record. The presentation will address topics such as the need for the project, the design alternatives under consideration, right-of-way acquisition and relocation assistance, and the tentative construction schedule.

Project documents, including an environmental impact statement and an engineering analysis with drawings, maps, and aerial photography, will be available for inspection and viewing during the entire time the IDOT representatives are present. This same material currently is available for review and inspection at the district office at Richland.

The location of the hearing is accessible to persons with disabilities. If special accommodations or assistance are needed, please contact the individual listed below by September 17, 2017.

For more information, contact George Robertson, Regional Engineer, 1200 East Main Street, Richland, Illinois 62673, telephone 416/343-6420, fax 416/343-6414, TTY 217/524-4875.

PUBLIC HEARING NOTICE EXAMPLE

FIGURE 19-4.C

19-4.02 Location and Facility Selection

A critical aspect of planning the public involvement activity is the selection of an appropriate location(s) and facility(ies). Several criteria must be considered.

19-4.02(a) Number of Locations

The number of locations should be based on the geographic area affected by the project, the availability of adequate transportation for those affected, and reasonable travel distances for the public expected to attend the involvement activities. In rural areas, it may be necessary to hold public involvement activity in each county traversed by the project.

In urban areas, the determination of needs is more difficult. In low-income neighborhoods, many persons depend upon public transportation. Accordingly, it may be a burden for these individuals to attend involvement activities outside of their immediate neighborhood. Residents of racial minority or ethnic neighborhoods may be reluctant to travel outside their neighborhood, especially to another racial or ethnic neighborhood. Where minority or ethnic neighborhoods are of considerable size, it may be appropriate to hold individual involvement activities in each affected neighborhood. Where neighborhoods are relatively small and without apparent mobility problems, it is usually appropriate to hold one involvement activity for multiple neighborhoods.

19-4.02(b) Selection of Facility

When selecting the facility(ies) where public involvement activities will occur, consider the following:

- During their normal activities, do residents of the area affected by the project normally travel the distances that will be required to attend the public involvement activity?
- Is transportation available to those interested for travel to the facility during the time the involvement activity is scheduled?
- Are there any social impediments that could affect travel to the area or neighborhood scheduled for the involvement activity?

Other criteria that should be considered when selecting a facility for a public involvement activity are listed below. Most are self-explanatory; however, the discussion of individual formats in Section 19-3 offers some insight into the application of these criteria:

- size and capacity,
- availability of the facility and/or equipment,
- comfort,
- cost,
- parking,
- accessibility for persons with disabilities, and
- acceptability to all segments of the public.

Title II of the Americans with Disabilities Act (ADA) requires all of the programs and services provided by the Department be accessible to all individuals. As a result, potential public involvement sites must be reviewed to ensure they meet accessibility standards.

19-4.02(c) Examples of Suitable Locations

Presentations for Groups:

- organization's regular meeting place,
- community or civic center,
- schools,
- churches,
- restaurant,
- motel or hotel meeting rooms,
- private company meeting rooms or offices, and
- district office.

Open House:

- school gymnasium or cafeteria,
- hotel/motel conference room,
- church meeting room
- storefront building,
- courthouse rotunda,
- central area of shopping mall,
- civic center,
- Chamber of Commerce meeting room,
- City Council chambers,
- judicial courtroom, and
- district office.

Workshops:

- school cafeteria or classroom,
- church meeting room,
- hotel or motel meeting rooms,
- restaurant (during off-peak hours),
- civic center, and
- service club meeting hall.

Public Meetings and Public Hearings:

- schools (gymnasium, auditorium, cafeteria, or classroom);
- church meeting room;
- civic center;

- City Council chambers;
- judicial courtroom;
- service club or other social club meeting hall; and
- any meeting hall generally used by the public.

19-4.02(d) Inspecting the Site

Before district personnel begin the preparation of exhibits and presentations, inspect the selected meeting site. A rough drawing of the shape of the room(s), noting the approximate dimensions may be helpful. Note other features such as stage location, projection room, light switches, electrical plug-ins, public address (PA) equipment (mixing console, microphones, microphone jacks, cables, and speakers), entrances, and emergency exits. The person(s) conducting the inspection of the meeting site should also note whether there are other rooms available for possible use for recording public statements or in answering individuals' questions concerning right-of-way, relocation, acquisition, etc.

The person(s) conducting the inspection should examine any equipment that the facility will provide to ensure that it is in good working order and that district personnel are familiar with its operation. PA equipment and projectors should be provided special attention. At the time of the site visit, if practical, discuss with the facility manager arrangements for setting up tables and chairs and for bringing equipment to the meeting room on the day(s) of the involvement activity.

When conducting the site inspection, the district representative(s) also should evaluate whether signs will be needed outside or inside the meeting facility to direct participants to the involvement activity.

19-4.02(e) Preparing the Meeting Site

When all personnel have reached the site and have set up the equipment supplied by the district, make a final check to ensure that all equipment, especially any furnished at the site, is operational (such as the PA equipment for the sound quality and function). Set up a table at each entrance that will be used for access into the meeting room. The table(s) should be used for registering attendees and for distributing printed materials. Assign personnel to each table to handle the registration and to direct attention to the available handout materials. Entrances not used for the meeting should be locked and signed (but be mindful of emergency evacuation procedures). Place other signing, as determined necessary, at the meeting location. Set up displays as previously planned and orient them with North in the same direction in each. As applicable, the district may have security personnel at the meeting site, before, during, and after the meeting.

19-4.03 Preparations at the District

During the course of developing a public involvement program, the district generally will have gained some insights on the profile of the potential audience. The knowledge of which sectors of

the public are likely to attend, what they are likely to expect, and their likely positions may be helpful in selecting a format for the involvement activity that will be most effective.

The notices of upcoming public involvement activities will instruct persons with a disability needing special accommodations to contact the district by telephone, in writing/e-mail, fax, or by TTY to advise of their anticipated attendance and any special needs. If interpreters for hearing-impaired persons or materials for visually impaired individuals have been requested, make every effort to provide the requested services. The district may prepare recordings of printed materials when Braille materials are not available or not acceptable.

If the involvement activity will include a period for questions or informal discussion, the district staff responsible for providing information at the activity should be prepared to respond to anticipated questions. Informal “brainstorming” sessions in advance of the activity may be helpful in generating possible questions that may be asked.

When developing handout materials, in many cases some material from previous involvement activities or previous projects may be usable. For example, information regarding right-of-way and relocation assistance will remain essentially the same. For new materials that will be developed, schedule appropriate lead time for preparation of displays and written materials and for printing handouts. Allow sufficient lead time for printing and other preparation activities whether the work will be performed commercially or by the Surveys, Mapping and Modeling Section or the Print Shop in the central office. Review any activities requiring action outside the district to determine the proper lead time for completion.

The district may prepare the photo-ready copy for notices of public involvement activities. After the notices have been sent to the newspapers, the district should ensure that the notices appear in the papers at the specified time.

All personnel who will be expected to participate in the involvement activity should be familiar with the format, schedule, objectives, and any applicable time constraints for their participation. This includes the moderator, if one will be used, who may or may not be an IDOT employee.

A checklist is an excellent tool for ensuring that final preparations do not overlook required equipment and supplies such as nametags, laser pointers, projectors, laptops, displays, display stands, and handouts or reminders to involved personnel. Spare equipment and parts such as extra bulbs for projectors, a spare slide screen, extension cords, charging cables, and other equipment can be extremely valuable in keeping the meeting on schedule in the event of equipment failure.

19-4.04 The Presentation

19-4.04(a) General Considerations

Public participation and attitudes may depend upon how well the personnel conducting the activity understand and react to the public’s viewpoints and reasons for participation. With the proper approach, both the public and the Department can use the involvement activity to benefit its

interests. A frequently overlooked element that is important to the overall success of the involvement activity is the time required for completion. Normally, an audience will tolerate a two-hour meeting. With this time frame, limiting the presentation portion to 30 minutes (40 minutes on complex projects) provides sufficient time to discuss the basic features of the proposed improvement while recognizing the participants' desire to have questions answered with as little delay as possible.

To conform to the time allotted, carefully prepare and review the presentation to ensure that only necessary information is included. Practice sessions or "dry-runs" are helpful for allowing the presenter to fit the presentation to the scheduled time limits. When more than one person will be involved in the presentation, complete a practice session(s) with all of the presenters prior to the actual presentation at the involvement activity.

Most of the people attending a public involvement activity will not be familiar with the technical language associated with highway projects. Those making presentations should minimize the use of technical terms in their presentations and in their responses to questions. The personnel presenting should convey an attitude of friendliness, understanding, respect, and cooperation to promote a positive atmosphere. If non-English speaking persons are expected, it may be appropriate to provide oral and written information in more than one language. If visually impaired persons will be attending the activity, it may be appropriate to have the information from the handout materials available in Braille or on a recording.

19-4.04(b) Presentation Content

The following paragraphs discuss the general topics that should be addressed in a presentation and provide some insight on the manner in which the topics should be approached.

19-4.04(b)1 Introduction

The opening speaker or moderator should first welcome those in attendance and explain the purpose of the activity. The opening remarks are extremely important for they may set the tone for the entire activity. Those in attendance should understand from the explanation of the purpose whether they are providing input into the basic data gathering effort or whether they are involved in providing input on alternatives, environmental impacts, the preferred alternative, etc. The opening speaker should also explain the format to be used. The speaker should describe what is involved in a workshop, a public meeting, or a public hearing, and the method that will be used to record comments.

The moderator should introduce all staff participants and district representatives and describe their role in the program. The public must be made aware that those with the expertise required to address their questions are present. If staff participants will be available for informal questioning after the presentation and formal comment period (if one is being held), the speaker may also indicate where the various experts will be located during the informal discussion period. At this time in the program, remind the audience of handouts, if available, and briefly describe the contents of the handout. If exhibits used in the presentation correspond with information in the handouts, attendees may use the handouts to their benefit as a presentation supplement.

19-4.04(b)2 *Main Portion*

At this point, the presentation should describe the project and include the following (as appropriate):

- the project's purpose, need, and consistency with the goals and objectives of any local urban planning;
- the project's alternatives, and major design features;
- the social, economic, environmental and other impacts of the project;
- the relocation assistance program and the right-of-way acquisition process; and
- IDOT's procedures for receiving both oral and written statements from the public.

If the purpose of the meeting is to collect data, the description should briefly outline the work that is proposed and then describe the type of information that is desired from the participants. If the project is further advanced and the participants are expected to offer information concerning the development of alternatives, the description should include a discussion of some of the work completed to date. If the involvement activity occurs when the project is in an advanced stage and the purpose is to provide information that will facilitate a choice among alternatives, provide more information to indicate the status of the improvement and the scope of the options or alternatives that remain. It should include descriptions of design features and beneficial and adverse impacts.

Often when describing a project to the participants, it is helpful to use examples of similar design in the immediate area of the proposed project. For example, in describing the type of medians that are under consideration, the speaker should emphasize that the median types being considered are similar to the flush painted median as now exists on Main Street, or a curbed-barrier median as now exists on Broadway. The participants can thereby relate directly to an operational situation with which they are already familiar.

Another topic that should be addressed during the meeting presentation is the tentative schedule for the remaining steps in the project. The public should be apprised of future opportunities to participate in the project's development, when the NEPA process will be completed, when construction will be initiated, and when construction should be completed.

19-4.04(b)3 *Special Considerations*

If noise abatement measures are proposed for the project, they should be briefly discussed. Also, briefly discuss the acquisition of right-of-way and the availability of relocation assistance. If the purpose of the activity is to offer an opportunity to provide input on alternatives that are being considered, then information should also be available which would indicate the approximate right-of-way acquisition and the properties affected. Advise interested property owners of whether they will be affected and to what extent. Explain that individual questions concerning the land acquisition process will be answered by land acquisition personnel during the informal period. Indicate where the land acquisition personnel will be located during the informal period.

If the project involves use of land subject to Section 4(f), the presentation should describe the nature and extent of the proposed use (e.g., name, location and size of the facility affected,

amount of land proposed for use, impacts to the functions of the facility) and proposed measures to minimize harm to the facility resulting from the intended use. The presentation should also seek input regarding the proposed use, its anticipated impacts and the measures for minimizing harm, including the intent of FHWA to make a de minimis determination, if applicable.

If a public hearing is held to satisfy the requirements for a road closure hearing, the discussion should include a statement of need for road closings, the needs of local traffic, and the effect of the closing on other highways in the locality. The discussion should further address access to schools, churches, markets, and trade or community centers. Discuss all anticipated impacts and benefits of various closing options.

19-4.04(b)4 *Closing the Presentation*

The last portion of the presentation should address the procedure that will be used during the formal comment period if included in the meeting. If there are time limitations on speakers or other procedures to be used, the participants should be aware. Remind the audience that Department personnel will be available at discussion centers to answer individual questions after the formal part of the presentation is complete. If any activities are occurring in a separate room, the participants should be reminded of them. Before closing, announce the length of time (e.g., 10 days) that written comments will be included as a part of the hearing transcript or meeting records; however, comments are welcomed at any time during the development of the project. Present the name and address of the person to whom comments should be submitted.

The information described in the preceding paragraphs should be developed to answer as many questions as possible for the participants.

19-4.04(c) Audio-Visual Aids

19-4.04(c)1 *General*

A major problem in developing public involvement activities is how to convey a large amount of technical data to the public in a manner and language that they can understand and in a relatively short time. The majority of those who attend public hearings are unable to understand the technical language and engineering drawings that are typically used by project team personnel in their studies of a particular project. Audio-visual aids are capable of significantly increasing the ability of the public to understand the information being presented.

Use the following audio-visual aids for public involvement activities as appropriate:

- projector,
- video/DVD,
- audiotape/digital recording,
- large writing pad and tripod,
- fixed exhibits,
- models,
- demonstrations, and

- markerboard.

Several of these aids may be combined for an even more effective presentation. A coordinated video and exhibit show is a good example of an effective combination.

Exhibits should remain as simple as practical, omitting contour lines, curve data, and other technical information that may not have meaning to the majority of those attending the activity. Label the exhibits to indicate the project stage such as preliminary, proposed, or draft and, if applicable, to contain a title such as Alternative 1 of 3. Identification of local landmarks shown on exhibits can be helpful in orienting viewers. Common landmarks include major street intersections, rivers, parks, large buildings, etc. They should be identified with large bold letters and should be readable from a considerable distance.

In the preparation of visual exhibits, the use of colors to depict different alternatives or features of the proposal can be important. If one alternative is shown in a particular color on one exhibit, it should be shown in the same color on all exhibits. This is also preferable when examples such as bar graphs are used for quantitative comparisons. If quantitative comparisons are appropriate, a bar graph is one means of demonstrating such comparisons quickly and simply. In general, all exhibits should be simple and as easy to understand as possible.

Another effective means of communicating with the public is the use of examples of similar existing facilities near the project area. In many cases, such examples will be helpful to the public in visualizing the scope of the project and its effects on them individually or as a community. For instance, instead of using a typical section of a proposed arterial street, an example of a local facility that is familiar to the attendees may be more effective. The familiarity of the attendees with the example facility should lead to a better understanding of how the proposed project will affect access to homes and businesses, the amount of right-of-way that might be required, and the vehicular and pedestrian characteristics of the facility. Usually, examples of this nature are superior to technical drawings in conveying a message to the public.

19-4.04(c)2 *Fixed Exhibits*

Fixed exhibits are defined as large-size drawings, maps, aerial mosaics, etc., that are prepared for use at public involvement activities to display proposed designs and alignments that are under consideration. Fixed exhibits can be very helpful during public involvement activities because some design concepts and alignments are difficult to visualize from a verbal description alone. Some fixed exhibits may serve a dual purpose in that large-scale maps or aerial mosaics are often prepared for normal use by a project team during the course of its study. Although fixed exhibits are often prepared for a specific purpose and used only once, their use may be increased by photographically reproducing them or using plastic overlays so that alternatives can be drawn on the exhibit or overlays during workshop sessions. Smaller exhibits may be enlarged photographically for use as a fixed exhibit at a public hearing.

Fixed exhibits may also be used effectively in combination with other audio-visual aids at public involvement activities. Because slide presentations have a relatively short duration and require a darkened room, fixed exhibits that duplicate slides can be used for discussion following the presentation. Handouts may also contain reduced photocopies of fixed exhibits. Some fixed

exhibits may be retained for future use if they display a standard design or feature that might be a consideration in another project. Districts can establish a library of reusable exhibits so that standard design exhibits will not need to be prepared for each involvement activity.

Although fixed exhibits are useful and flexible visual aids, they have some disadvantages when compared to audio-visual aids. They require considerable space for displaying, storing, and transporting. Another limitation is the time and expense often required to prepare a large drawing or display.

19-4.04(c)3 *Presentation Software*

Presentation software (e.g. PowerPoint) may be effective because a large amount of information can be disseminated in a controlled time and repeated as needed.

19-4.04(c)4 *Video*

Video can be a practical alternative for public involvement activity presentations. Such presentations are very effective for repetitive showings of the same information to small groups. Projected videos can be used with an audience size limited only by the size of the facility and screen and the audio capability. This need might commonly occur at open houses and at briefings of small groups such as homeowners or civic organizations. Technical videos may be integrated with other audio-visual aids to demonstrate certain design techniques that may be new or not available in the project area for local familiarity. An example of this is demonstrating the effectiveness of a concrete median barrier compared to a guardrail median barrier via actual crash tests. The district may obtain technical films demonstrating the effectiveness of specific design features from a variety of sources including FHWA and TRB.

19-4.04(c)5 *Miscellaneous Audio-Visual Aids*

There are other audio-visual aids that are not as common as those which have been described. Many of these are more applicable to serving special needs that do not commonly occur. The use of models, for example, may not be appropriate on most projects; however, they may be appropriate to demonstrate complicated interchanges or complex urban joint development projects. Demonstrations for use at a public involvement activity are also generally reserved for a special situation. The district may use a demonstration to explain the effectiveness of a specific design feature such as a noise barrier.

Another visual-aid technique is the use of a large writing pad mounted on an easel and drawn on with felt tip markers. The usefulness of this technique is limited by the ability of the speaker or an aide to draw and sketch as the presentation is being made.

A large writing pad and felt tip markers may be used to record spoken comments. This is in addition to recording comments by a court reporter or electronic recorder (e.g., tape, digital). This ensures the speaker that his comment is received and interpreted correctly. Large writing pads are also effective at workshop sessions to record comments, interests, suggested alternatives, etc. The working groups usually prioritize these, and they can become a significant source of input for district decision making.

Audiotape and other electronic recording media are another aid that may be used to present information to the public and control precisely the length and content of a talk. These media are useful in the preparation of standard presentations that are repeated, such as those concerning right-of-way acquisition and relocation assistance and the Federal-State relationship.

19-4.05 Post-Activity Follow-Up

Those who attend a public involvement activity are normally interested in the results of the input provided. This includes the follow-up to questions for which answers were not available at the time of the activity. The public may determine the success or failure of a public involvement activity based on the actions taken after the activity. Therefore, follow-up is a significant action to minimize opposition and create a positive relationship with the public.

The appropriate type of follow-up will partially depend on the public's attitude at the public involvement activity. If the public has been generally supportive of the proposed project, it is probably not necessary to initiate a large-scale follow-up. It may suffice to write individual letters to those who asked questions which were not answered and to release information to the news media on any changes that were made as a result of the input.

If the public attending the activity was generally opposed to the project, a more extensive follow-up is appropriate. In this case, write those individuals who had questions that were not answered and provide the information requested or explain the results of the investigation. Issue a news release that notes some of the major comments made at the activity and the Department's reaction to these comments. The release should also include a discussion on any changes resulting from the activity. For projects of major scope where a mailing list has been developed and where public involvement activities may span a long period of time, a newsletter might be developed and mailed to those on the mailing list and to those who attended the activity. Local radio and TV talk shows may also be used to disseminate information following a public involvement activity of major scope and impact.

Project revisions are often made after public involvement activities. If project revisions are substantial, the project shall be discussed with BDE and FHWA to determine if additional public involvement activities are needed.

19-4.06 Mailing Lists

Each district should develop and maintain mailing lists for distributing information. A general mailing list should include agencies, organizations, and appropriate individuals that are generally interested in being advised of all highway projects scheduled within the district. The general list consists primarily of Federal, State, and local agencies usually interfacing with the Department on highway projects; entities such as major industries, environmental groups, and local transportation operators; and individuals, including elected officials, who have requested and have a need for project information. To serve the intended purposes, those included in the general list should be sent copies of announcements of public involvement activities and other

general information as appropriate. Confirm names and addresses periodically to keep lists current and to determine whether the parties are still interested in receiving project information.

In addition to a general mailing list, the district should develop specific lists for individual projects. These project-specific lists include the general mailing list and any additional persons or groups that are interested in specific highway projects. Individuals and organizations may be added to the list when requests are received for information on a specific project or on the basis of attendance lists that are maintained as part of involvement activities. These lists may be used to distribute information on the resolution of certain problems discovered during involvement activities. The project-specific mailing lists may be retained for use with other planned projects in a particular area, or they may be discarded following completion of the project for which they were developed.

19-4.07 General Releases of Information

Releases of information to the news media can be a very effective tool for minimizing adverse public reaction during both the daily operations of the Department and the development of proposals and final plans for specific projects. Maximize effectiveness by writing the release in layman's terms and avoid using jargon and technical terms as much as possible. Releases of information involving the routine operations of the district may be at the discretion of the Regional Engineer. Releases of information on activities which are controversial or in which the Secretary has shown an interest, such as major freeway projects, should be coordinated with the Office of Communications. That Office also may initiate releases of information in response to inquiries from the news media or to address a demonstrated public interest. It may also release information concerning involvement activities for projects of statewide interest when advised of their scheduling. All releases of information should include, in the upper right-hand corner, a fax number, a TTY number, and the name and telephone number of the person the media may call for additional information.

19-4.08 Records and Reports

19-4.08(a) Public Comments

The district must record all comments received by the Department on a given highway improvement and enter these in the project file. Encourage all commentators to put their comments in writing and include their name and address. This relieves Department personnel from the responsibility of interpreting the meaning of the commentator's spoken word in recording their input. Consider providing a Comment Form that commenters may complete and return. Include on the form the date by which the form should be returned.

Record comments when they are received, whether or not they were received as a part of an involvement activity. For example, if an individual visits or calls the district and comments on a project, record that comment and include it in the project files. All comments received should be addressed.

For public hearings, all public comments shall be documented either by a court reporter or, if a court reporter is not available, a digital recording that is transcribed and a transcript produced; see Section 19-3.04(g).

19-4.08(b) Reports

All comments must become a part of the project files and the Phase I report or NEPA document. For a public hearing, the transcript from the hearing is sent to FHWA; see Section 19-3.04(g). In either case, the report/document should also contain a response to each of the comments included in the summary or the transcript. If a comment is addressed in the body of the report, it is not necessary to repeat that information under "Responses." Refer to the applicable page number of the report.

19-4.08(c) Responses

The district should acknowledge in writing all written comments received from the public, including individuals, private organizations, or government agencies. The acknowledgment should thank them for their input and provide a response to their questions or comments. If an answer will not be available for some time, acknowledge receipt of the comment with an indication that a final response will be forwarded at a later date. Verbal comments should also be acknowledged and responded to when the name and address of the commenter is available.

To reduce the workload of responding to comments after a scheduled public involvement activity, consider forwarding copies of the summary of comments and responses prepared for inclusion in the Phase I report, along with a letter thanking them for their participation, to all who attended the activity. Separate responses need not be prepared. This summary of comments and responses could also be incorporated into a newsletter.

The district should acknowledge and respond to comments received from other governmental agencies. These responses are likely to eliminate the repetition of those comments in subsequent formal contacts, such as through the circulation of environmental documents. For local agencies, the formal responses serve as resolution documentation, which can also aid in the transition by new local administrations.

19-5 CONTEXT SENSITIVE SOLUTIONS

19-5.01 The Stakeholder Involvement Process

Once a project has been scoped and included in the Department's Proposed Highway Improvement Program, the Regional Engineer will determine if it is to be developed using the principles of Context Sensitive Solutions (CSS). This decision shall be based on the preliminary scope of the project and if it falls under the types of projects 605 ILCS 5/4-219 specifies to embrace CSS, which includes new construction, reconstruction, or major expansion of existing transportation facilities.

For projects that meet CSS criteria, the districts shall confirm the decision to use CSS, or the decision not to use CSS, by a memorandum to that effect signed by the Regional Engineer. The signed memorandum shall be placed in the project file. This will document compliance of the project with the terms of 605 ILCS 5/4-219. Further, any decision regarding the CSS status for a project shall be discussed at a district coordination meeting and documented.

All CSS projects must use the stakeholder involvement process for public involvement; see Figure 19-5.A. At the discretion of the Regional Engineer, this process and the CSS approach may also be used for any State highway improvement.

The stakeholder involvement process will facilitate effective identification and understanding of the concerns and values of all stakeholders (i.e., persons and entities that have a stake in the outcome of a highway project, see Figure 19-5.B, as an integral part of the project development process. It includes a formal written plan, the Stakeholder Involvement Plan (SIP), see Figure 19-5.C, which explains how stakeholder input and comments will be obtained. Public hearings may be required, depending on the project.

The purpose of the stakeholder involvement process is to promote a proactive and responsive CSS approach that seeks the input of the full range of concerned stakeholders early and often and provides for appropriate consideration of stakeholder input at key points in the project decision making process (e.g., project purpose, range of alternatives, selection of a preferred alternative).

The involvement and coordination activities associated with the environmental process are an integral part of the stakeholder involvement process. The district should schedule stakeholder involvement process activities to coordinate with and accommodate the key milestones in the environmental process and, as applicable, the concurrence points for the NEPA/404 merger process; described in Section 22-4. For projects subject to the NEPA/404 merger process, consideration of the outcomes of the concurrence point meetings with the environmental regulatory and resource agencies should be a part of the iterative processes for achieving stakeholder consensus on project purpose and need, range of alternatives, and the preferred alternative.

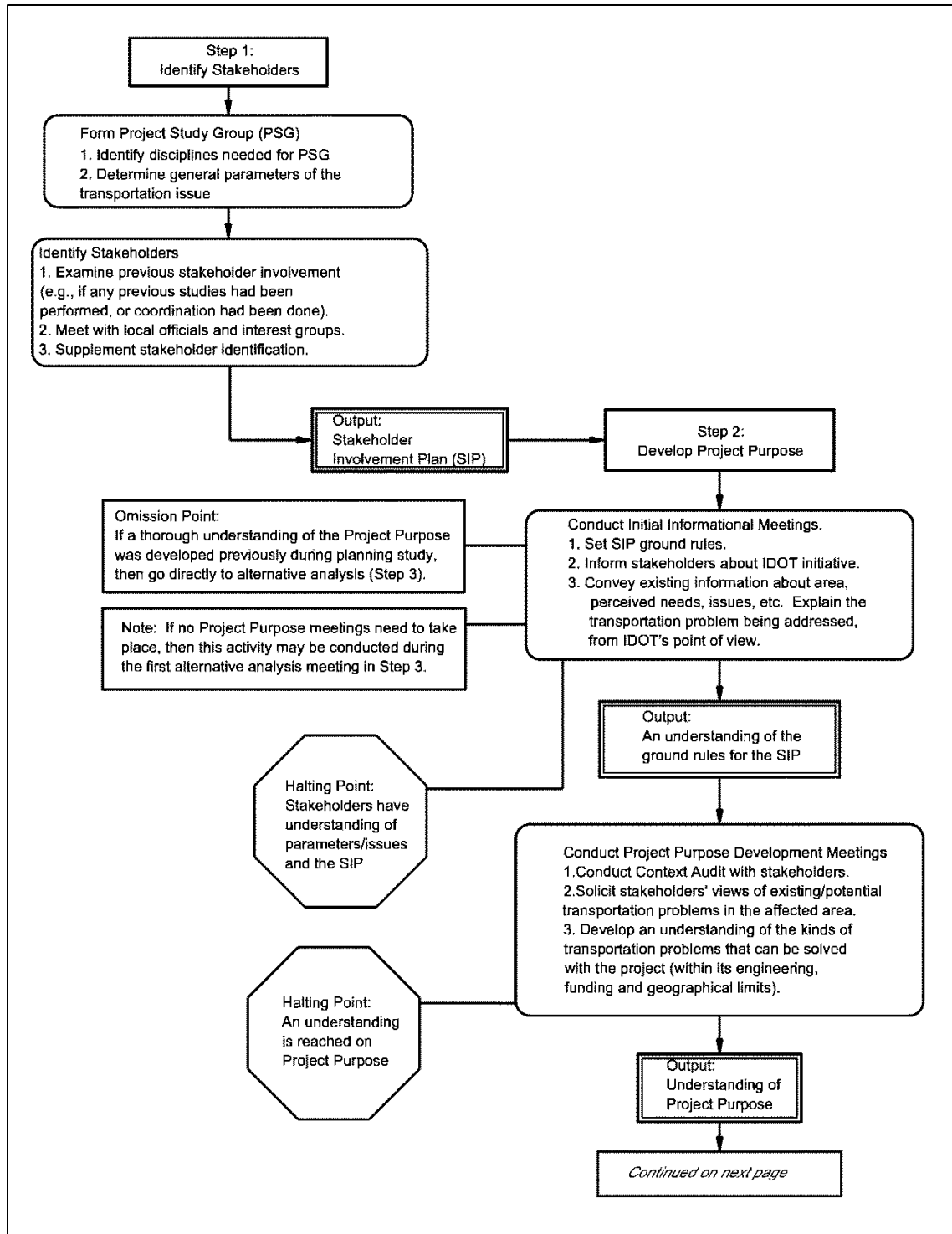

STAKEHOLDER INVOLVEMENT PROCESS

Figure 19-5.A
(1 of 2)

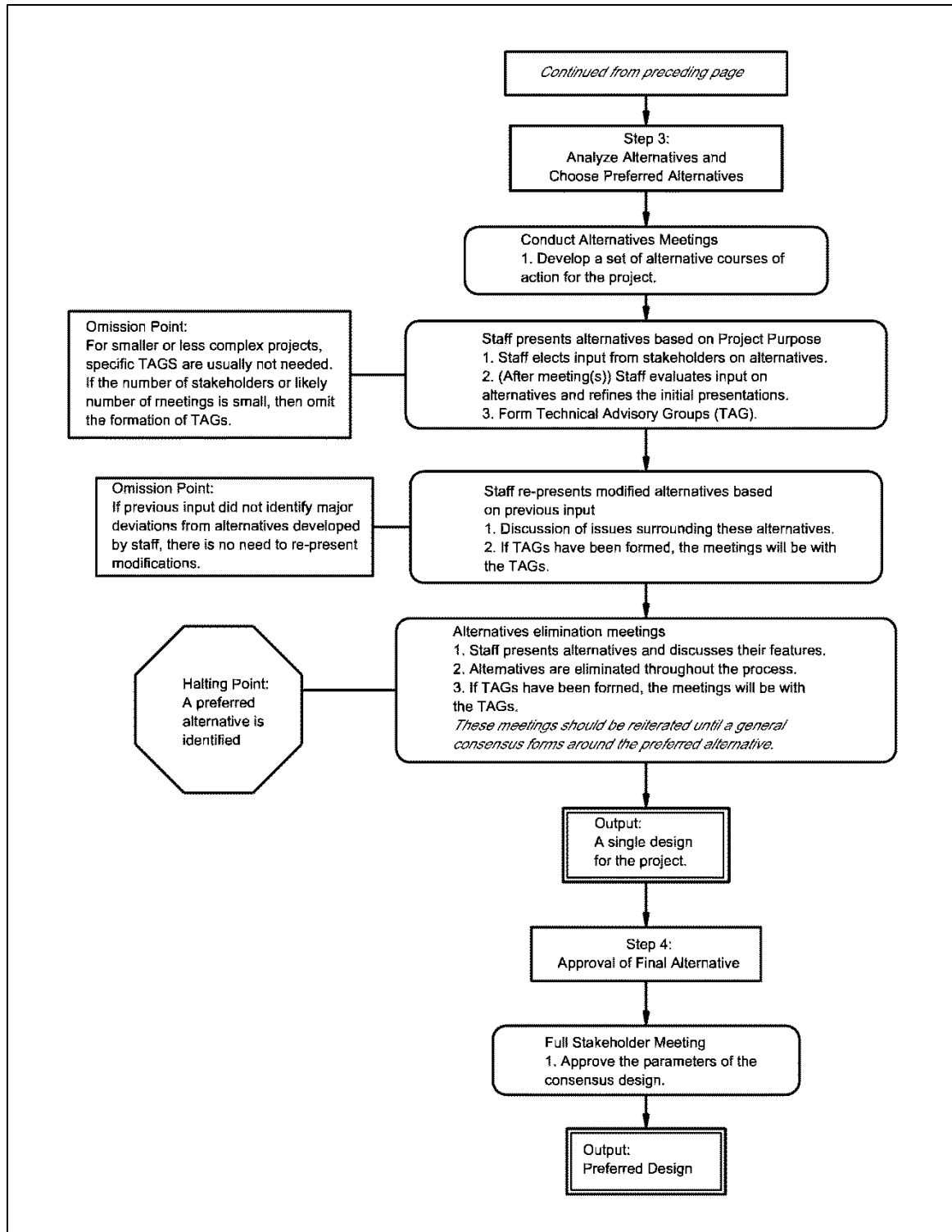

STAKEHOLDER INVOLVEMENT PROCESS

Figure 19-5.A
(2 of 2)

The most serviceable definition of consensus is when a majority of the stakeholders agree on a particular issue, while the dissenting remainder of stakeholders agrees its input has been heard and duly considered and that the process as a whole was fair.

The stakeholder involvement process is flexible and modular and should be designed to fit the size and complexity of each project. The stakeholder involvement process includes the complementary concepts of “omission points” and “halting points.” The “omission points” show where and why certain activities may be omitted from the process for a particular project. The “halting points” show under what conditions certain activities can be considered completed. Decisions made for each of these points may be found in a particular SIP, where certain activities are excluded as being unnecessary while others are continued until a result is reached. The Project Study Group should tailor the stakeholder involvement process to meet the needs of a particular project and its stakeholders.

19-5.01(a) Stakeholder Identification and Development of the Stakeholder Involvement Plan (SIP) (Step 1)

19-5.01(a)1 Project Study Group

Once a project is designated for CSS, a Project Study Group (PSG) should be formed. In addition to appropriate district and consultant staff, the group may include representatives from other offices/entities, including, but not limited to, the following:

- FHWA,
- Office of Planning and Programming (OP&P),
- Bureau of Design and Environment (BDE), and
- Metropolitan Planning Organizations (MPOs).

If the project is likely to involve bicycle and pedestrian issues, the district’s bicycle and pedestrian coordinator also should be a part of the PSG.

Once the preliminary engineering study is started, other disciplines can be added to the PSG, or consulted as necessary to respond to issues involved with the project and to promote identification and evaluation of the full range of possible project options. The disciplines to be included or consulted should be determined early in the process and should be reflected in the SIP.

The PSG should research correspondence and other information leading to the initiation of the project and start making a list of stakeholders (e.g., individuals, organizations, agencies, that are on record as supporting or opposing a proposed transportation improvement project or issue). This initial stakeholder list should expand as the preliminary engineering study proceeds, and can grow into a contacts list for specific issues or projects; see Section 19-4.06.

For EIS projects, the PSG will identify entities to be invited to become Participating Agencies in accordance with 23 U.S.C. 139. For EIS and EA projects, the PSG should identify Cooperating

Agencies and Section 106 consulting parties. The PSG should coordinate with FHWA to identify the appropriate Tribal governments to include in project coordination.

Each district should maintain such a contacts list of concerned citizens, public officials, organizations, agencies, and others who want to be involved or informed on transportation issues in their areas. The district should determine from this list the possible stakeholders that may desire to be involved in helping the Department proceed with a preliminary engineering study on the transportation issue and should add those names to the list of stakeholders for the project. The stakeholder list will be expanded as information is gathered from contacts or meetings with local officials, chambers of commerce, planning commissions, affected property owners, environmental resource agencies, the motoring public, special interest groups, etc.

19-5.01(a)2 *Community Advisory Group (CAG)*

Unless previous records or contact lists already exist, the best way to identify many of the stakeholders for a particular project is to meet with the elected officials and agency representatives for the project area. The PSG can ask these officials and representatives about the groups and types of people likely to be interested and/or affected, and ask them to identify any organizations through which these stakeholders can be contacted. For larger and more complex projects, it is suggested that other sources of stakeholder information (e.g., neighborhood and business organizations, environmental and preservation interest groups, transportation and growth management groups) be consulted to supplement the information received from elected officials and agency representatives.

Figure 19-5.B lists various types of stakeholders. Not all of these types will necessarily be affected on any specific project, and a particular group of stakeholders may belong in more than one category. This listing is intended to aid the PSG in formulating potential stakeholder contact lists. It is not meant to be an exhaustive checklist that must be followed in strict order.

Although State and Federal Resource Agencies may be identified as stakeholders on any project, if it is known that the project will be subject to the NEPA/404 Merger Process (see Section 22-4), the Resource Agencies shall be considered stakeholders and involved in the process early on. Once the stakeholders are identified a CAG can be formed. The CAG will served to provide input to PSG on the content of the SIP.

19-5.01(a)3 *Development of the Stakeholder Involvement Plan*

After a preliminary list of stakeholders is compiled, the PSG will develop a Stakeholder Involvement Plan (SIP), see Figure 19-5.C, that identifies who the stakeholders are, how they are going to be reached, and a tentative schedule of meetings. The SIP does not need to be extremely detailed and can be modified as the process develops. The plan does not need to be time or date driven, but could be linked to milestones or decision points that occur throughout the course of a study. The SIP should also contain the tentative ground rules under which the stakeholder involvement process will be conducted. An example outline of a SIP is included for reference.

For projects subject to 23 U.S.C. 139, primarily EISs, the CSS study group must develop a draft Coordination Plan for working with Participating Agencies in development of the environmental document. The district should contact BDE for examples of the Coordination Plan. The CSS study group should integrate the Coordination Plan requirements within the SIP to provide a single document that addresses both the SIP and Coordination Plan requirements. FHWA and the Department, as joint lead agencies, must agree upon the content of this plan before it is distributed to external stakeholders, including participating agencies.

After FHWA publishes a Notice of Intent in the Federal Register, see Section 25-2.01(e), the Department and FHWA initiate external coordination activities. FHWA invites appropriate Federal agencies to be Participating Agencies or Cooperating Agencies. FHWA invites Tribal governments to become Participating Agencies and Section 106 consulting parties. FHWA also invites State agencies that have jurisdiction by law or special expertise to be Cooperating Agencies. The Department invites State and local agencies to be Participating Agencies, as applicable. The Department sends invitations to potential Section 106 consulting parties asking them to participate in the process. See Chapter 25 for sample agency invitation letters. The invitations to Federal, State, and local agencies will include a copy of the draft SIP and will request comments. The request for comments on the SIP will be revisited as new stakeholders are identified throughout project development.

Geographic Interests	Transportation Professionals
<ul style="list-style-type: none"> • Adjacent property owners + Residential + Commercial + Industrial + Institutional: education, religious, government, non-profit • Adjacent property renters + Residential + Commercial + Industrial + Institutional • Transportation Service Providers + Public Transportation Agencies + Airports + Marine Ports • Neighborhood Organizations + Homeowners Associations + Local Interest Groups 	<ul style="list-style-type: none"> • Regional Transportation Professionals + Metropolitan Planning Organization + transportation planners + Council of Government Planners + Transportation Management Associations
Project Area Public Service Providers	<ul style="list-style-type: none"> • State Transportation Professionals + State DOT Highway designers + Traffic Engineers + Environmental Planners • Federal Transportation Professionals + Federal Highway Administration + Federal Transit Administration
<ul style="list-style-type: none"> • Post Offices • Emergency Services • Schools • Drainage Districts • Utility Companies 	Interest Groups
Local and Regional Officials	<ul style="list-style-type: none"> • Facility users + Commuters + Truckers + Business Customers + Major Regional Employers + Tourists • Transportation Interest Groups + Highway/Transit + Bicycle/Pedestrian • Business Organizations + Local and Regional Chambers of Commerce + Economic Development Agencies
<ul style="list-style-type: none"> • Local jurisdiction elected and appointed officials + Mayors + Aldermen/City Council + County Board Members + County Commissioners + Township Boards + Planning Commissions • Local jurisdiction transportation or technical professionals + Public Safety Officials + Public Works Directors + Traffic Engineers + Planning Directors • Permitting Agencies + Corps of Engineers + US Environmental Protection Agency + Ill. Environmental Protection Agency + Coast Guard + US Fish and Wildlife Service + Ill. Department of Natural Resources 	<ul style="list-style-type: none"> + Industry Associations • Environmental Interest Groups • Cultural • Historic Preservation and Scenic + Conservation Groups • Growth Management Interest Groups + Local advocates for underserved communities + Low income facility users + racial and ethnic minority advocacy groups + Local advocacy groups for people with disabilities

STAKEHOLDER TYPES

Figure19-5.B

Typical Stakeholder Involvement Plan (SIP) Content Outline

A. Cover Page

This typically has a graphic, project name, and who prepared the SIP.

B. Table of Contents

C. Introduction

This section discusses the project background, project limits, and other relevant introductory language.

D. Goals and Objectives

This section discusses the goals and objectives of the SIP. Example goals are as follows:

- Identify all stakeholders of the project, and ensure their opportunity for meaningful input into the project's development from beginning to end.
- Determine project context, with stakeholder input and concurrence.
- Identify transportation problems that can and should be solved by the project, with stakeholder input and concurrence.
- Identify reasonable alternative solutions to solve identified transportation problems, with stakeholder input and concurrence.
- Choose a preferred alternative solution to identified transportation problems for the project, with stakeholder input and concurrence.
- Treat all involved parties with respect and dignity, in a transparent manner and in a way that ensures their input was duly heard and considered.

E. Project Study Group (PSG) and Community Advisory Group (CAG)

This section describes who was included in the PSG and should list the CAG (person's name and the group they represent), Cooperating Agencies (CAs), Participating Agencies (PAs), and Section 106 consulting parties.

F. Public Involvement Plan Activities

This section will include a summary of all the public involvement activities for the project (i.e. workshops, informational meetings, public hearings, etc.)

G. Tentative Schedule

This section described the tentative schedule. The following is an example schedule:

- The first meeting with all stakeholders will include gaining stakeholder consensus on the ground rules of the SIP including descriptions of roles, a description of the IDOT project development process and an introduction to the stakeholders of the preliminary project concept. Further, the project study group must explain the role the requirements of the

SIP Content Outline

Figure 19-5.C

(1 of 2)

National Environmental Policy Act (NEPA) will play in the development of the project. Finally, the PSG will conduct a context audit with the stakeholders to determine characteristics contributing to the project's context. The format for this meeting, like all stakeholder meetings for this SIP, will be in a workshop format to facilitate collaboration. It should precede definition of preliminary purpose & need, and its target date will tentatively be August 2018.

- The second stakeholder meeting will draw upon the completed context audit, and will have as its goal the development of a comprehensive statement of the transportation problem to be solved by the project. The statement must be realistic under the constraints placed by engineering considerations, available funding and geographic limitations. The statement must also represent a consensus view. This meeting should also precede definition of preliminary purpose & need, and its target date is January 2019.
- The third meeting with all stakeholders is to define several possible alternatives for further consideration, and is complete once consensus is reached. It should take place after preliminary purpose & need and determination of reasonable alternatives. Its target date is June 2019.
- The fourth stakeholder meeting has the goal of attaining consensus on a preferred alternative for the project. It should be held after in-depth analysis of reasonable alternatives and before a recommended alignment is chosen. Its target date is January 2020.
- The fifth and final stakeholder meeting is intended to formally approve the final preferred alternative, and should precede official design approval. There should be a formal and comprehensive statement outlining the purpose of the project, its scope specific design elements of the final alternative. The target date for this meeting is June 2020.

H. Appendices

The appendices typically include the Project Study Group (e.g. table showing the names, affiliated organization, and contact information), a list of stakeholders, revision dates to the SIP, etc.

19-5.01(b) Developing Project Problem Statement (Step 2)

The first general contact with stakeholders serves to introduce the transportation issues to be resolved to the public, exchange information, and identify concerns. This contact starts the process of coordinating with the public so they can begin to understand that their involvement is vital to the development of the project.

The contact should commence with an initial public meeting of the PSG with the stakeholders to explain the ground rules under which the SIP will be conducted. The following questions must be addressed by explicit ground rules, and agreed upon by the stakeholders:

- what is the code of conduct for the group?
- what are the purpose and goals of the process?
- what will be the method of decision making?
- what are the accountabilities of the participants?
- how is consensus defined?
- how will transparency of the process be ensured?

Once SIP ground rules are established and accepted by the stakeholders, the PSG should present its vision of the transportation problem or problems to be solved and the preliminary proposed solutions resulting from the scoping process. It is also helpful at that time to explain departmental procedures for choosing and developing projects to stakeholders.

For projects subject to 23 U.S.C. 139, primarily EISs, the Department and FHWA collaborate with Participating Agencies on the methodologies and level of detail planned for analyzing environmental effects of project alternatives. (FHWA and the Department may agree to revisit methodologies and level of detail when new information warrants doing so. If this occurs, FHWA and the Department will re-coordinate with Participating Agencies for their input.) FHWA and the Department will finalize the SIP after receiving input from Participating and Cooperating Agencies and the public.

Halting Point: This activity is finished when the stakeholders understand and agree with the stakeholder involvement process ground rules and understand the Department's preliminary definition of the transportation problems and solutions for the project.

Next, the PSG should undertake an effort to complete a Community Context Audit Form, see Figure 19-5.D, for the project in concert with the stakeholders. These audits are intended to help identify various characteristics that define the context of each project. This will aid in defining the project purpose or the transportation problem to be addressed. The audit is designed to consider not only the area's history and heritage, but environmental conditions and community goals.



**Illinois Department
of Transportation**

Community Context Audit Form

Purpose:

The Community Context Audit form is intended to be a guide to identify various community characteristics that make each transportation project location unique to its residents, its businesses and the public in general. This information will help to define the purpose and need of the proposed transportation improvements based upon community goals and local plans for future development. The audit is designed to take into account the community's history or heritage, present conditions and anticipated conditions. As you complete this audit, please consider the interaction of persons and groups within your community when considering factors such as mobility and access (vehicular, non-vehicular and transit modes), safety, local and regional economics, aesthetics and overall quality of life.

PROJECT INFORMATION		
Key Route:	PPS No.:	
F.A. Route:	Marked Route:	County:
Section:	Project Length:	
Job Number:	Contract No.:	Program No.:
Limits:		
Municipalities:		
General Description of Existing Facility:		
Need for Proposed Improvement:		
Design Policies Used: <input type="checkbox"/> New Construction <input type="checkbox"/> Reconstruction <input type="checkbox"/> 3R <input type="checkbox"/> Other		
General Description of Proposed Improvement:		
Estimated Program Cost:	(in FY Dollars)	Fund Type:
Construction Cost:	ROW Cost:	
Utility Relocation Cost:	Consultant P.E. Cost:	

Contact Person: _____

Telephone #: _____

Individual Completing Context Audit Form: _____

Date: _____

COMMUNITY CONTEXT AUDIT FORM

Figure 19-5.D
(1 of 6)



**Illinois Department
of Transportation**

Community Context Audit Form

Section 1: Community Characteristics/ Land Use

Please conduct a visual assessment in the field and attach a project location map. If appropriate, include a photo index for the project area. If appropriate gather public opinions and concerns about the proposed project. Consider community needs as the basis for this assessment. Assess the community characteristics and indicate the community's perception of importance for each characteristic currently and based upon known / planned future conditions.

Community Characteristics	Presence		Importance		
	Yes	No	High	Med.	Low
Is this place an established city center?	<input type="checkbox"/>	<input type="checkbox"/>	<input type="checkbox"/>	<input type="checkbox"/>	<input type="checkbox"/>
Is this place a multi-modal transportation center?	<input type="checkbox"/>	<input type="checkbox"/>	<input type="checkbox"/>	<input type="checkbox"/>	<input type="checkbox"/>
Is this place a commercial center?	<input type="checkbox"/>	<input type="checkbox"/>	<input type="checkbox"/>	<input type="checkbox"/>	<input type="checkbox"/>
Is this place a residential center?	<input type="checkbox"/>	<input type="checkbox"/>	<input type="checkbox"/>	<input type="checkbox"/>	<input type="checkbox"/>
Is this place a mixed residential /commercial center?	<input type="checkbox"/>	<input type="checkbox"/>	<input type="checkbox"/>	<input type="checkbox"/>	<input type="checkbox"/>
Is this place an industrial center?	<input type="checkbox"/>	<input type="checkbox"/>	<input type="checkbox"/>	<input type="checkbox"/>	<input type="checkbox"/>
Is this place a rural/agricultural area? Comments	<input type="checkbox"/>	<input type="checkbox"/>	<input type="checkbox"/>	<input type="checkbox"/>	<input type="checkbox"/>
Are there important cultural features or identifiers which convey information about the community within the project area? If yes, list:	<input type="checkbox"/>	<input type="checkbox"/>	<input type="checkbox"/>	<input type="checkbox"/>	<input type="checkbox"/>
Are there social/community features or identifiers within the project area? If yes, list:	<input type="checkbox"/>	<input type="checkbox"/>	<input type="checkbox"/>	<input type="checkbox"/>	<input type="checkbox"/>
Are there important architectural features within the project area? If yes, list:	<input type="checkbox"/>	<input type="checkbox"/>	<input type="checkbox"/>	<input type="checkbox"/>	<input type="checkbox"/>
Are there important natural features within the project area? If yes, list:	<input type="checkbox"/>	<input type="checkbox"/>	<input type="checkbox"/>	<input type="checkbox"/>	<input type="checkbox"/>
Is this place of historical significance to the community? If yes, list:	<input type="checkbox"/>	<input type="checkbox"/>	<input type="checkbox"/>	<input type="checkbox"/>	<input type="checkbox"/>
Overall assessment of community characteristics and setting:					
<input type="checkbox"/> Urban .. <input type="checkbox"/> Suburban .. <input type="checkbox"/> Rural (Please note, this is not the identification of a functional classification. This is an assessment of the community based upon physical characteristics noted above.)					

COMMUNITY CONTEXT AUDIT FORM

Figure 19-5.D
(2 of 6)



**Illinois Department
of Transportation**

Community Context Audit Form

Section 2: Infrastructure Assessment

Assess the project or study area for the presence and adequacy of the following infrastructure items. If present (a yes response) and in poor condition, please make notation and provide any other relevant comments in space provided for each item. If not present (a no response), indicate in the comment section if the item needs further evaluation. Indicate the level of importance each item may have to the community currently and based upon known / planned future conditions.

Infrastructure	Presence		Importance		
	Yes	No	High	Med.	Low
Sidewalks Comments:	<input type="checkbox"/>	<input type="checkbox"/>	<input type="checkbox"/>	<input type="checkbox"/>	<input type="checkbox"/>
ADA Compliance Comments:	<input type="checkbox"/>	<input type="checkbox"/>	<input type="checkbox"/>	<input type="checkbox"/>	<input type="checkbox"/>
Bicycle Lanes/Paths/Facilities Comments:	<input type="checkbox"/>	<input type="checkbox"/>	<input type="checkbox"/>	<input type="checkbox"/>	<input type="checkbox"/>
On-street Parking Comments:	<input type="checkbox"/>	<input type="checkbox"/>	<input type="checkbox"/>	<input type="checkbox"/>	<input type="checkbox"/>
Transit Connections Comments:	<input type="checkbox"/>	<input type="checkbox"/>	<input type="checkbox"/>	<input type="checkbox"/>	<input type="checkbox"/>
Transit Shelters Comments:	<input type="checkbox"/>	<input type="checkbox"/>	<input type="checkbox"/>	<input type="checkbox"/>	<input type="checkbox"/>
Street Lighting Comments:	<input type="checkbox"/>	<input type="checkbox"/>	<input type="checkbox"/>	<input type="checkbox"/>	<input type="checkbox"/>
Pedestrian Lighting Comments:	<input type="checkbox"/>	<input type="checkbox"/>	<input type="checkbox"/>	<input type="checkbox"/>	<input type="checkbox"/>
Pedestrian Crossings Comments:	<input type="checkbox"/>	<input type="checkbox"/>	<input type="checkbox"/>	<input type="checkbox"/>	<input type="checkbox"/>
Signals (Traffic, Directional & Pedestrian) Comments:	<input type="checkbox"/>	<input type="checkbox"/>	<input type="checkbox"/>	<input type="checkbox"/>	<input type="checkbox"/>
Crosswalks Comments:	<input type="checkbox"/>	<input type="checkbox"/>	<input type="checkbox"/>	<input type="checkbox"/>	<input type="checkbox"/>

Other Comments:

COMMUNITY CONTEXT AUDIT FORM

Figure 19-5.D
(3 of 6)



**Illinois Department
of Transportation**

Community Context Audit Form

Section 3: Neighborhood Culture, Aesthetics and Street Amenities

Assess the study area for the following amenities and cultural, aesthetic and comfort factors. If present (a yes response) and items are in poor condition, please make notation and provide any other relevant comments in the space provided for each item. If not present (a no response), indicate in the comment section if the item requires further evaluation. Indicate the level of importance each item may have to the neighborhood currently and based upon known / planned future conditions.

Resource	Presence		Importance		
	Yes	No	High	Med.	Low
Neighborhood Parks /Open Space /Civic Areas Comments:	<input type="checkbox"/>	<input type="checkbox"/>	<input type="checkbox"/>	<input type="checkbox"/>	<input type="checkbox"/>
Benches Comments:	<input type="checkbox"/>	<input type="checkbox"/>	<input type="checkbox"/>	<input type="checkbox"/>	<input type="checkbox"/>
Trash Containers Comments:	<input type="checkbox"/>	<input type="checkbox"/>	<input type="checkbox"/>	<input type="checkbox"/>	<input type="checkbox"/>
Street Trees Comments:	<input type="checkbox"/>	<input type="checkbox"/>	<input type="checkbox"/>	<input type="checkbox"/>	<input type="checkbox"/>
Landscaping Comments:	<input type="checkbox"/>	<input type="checkbox"/>	<input type="checkbox"/>	<input type="checkbox"/>	<input type="checkbox"/>
Wayfinding Signage Comments:	<input type="checkbox"/>	<input type="checkbox"/>	<input type="checkbox"/>	<input type="checkbox"/>	<input type="checkbox"/>
Community Safety Issues Comments:	<input type="checkbox"/>	<input type="checkbox"/>	<input type="checkbox"/>	<input type="checkbox"/>	<input type="checkbox"/>
Traffic Safety Comments:	<input type="checkbox"/>	<input type="checkbox"/>	<input type="checkbox"/>	<input type="checkbox"/>	<input type="checkbox"/>

Please list any seasonal events affected by proposed improvements at this location.

Overall Comments:

COMMUNITY CONTEXT AUDIT FORM

Figure 19-5.D
(4 of 6)

	Illinois Department of Transportation	Community Context Audit Form			
<p>Section 4: Economic Development</p> <p>Assess the project or study area for the following community development indicators. Indicate the level of importance for each indicator currently and based upon known / planned future conditions.</p>					
Resource	Presence		Importance		
	Yes	No	High	Med.	Low
Has this area been identified for new development? If yes, describe the proposed or planned development.	<input type="checkbox"/>	<input type="checkbox"/>	<input type="checkbox"/>	<input type="checkbox"/>	<input type="checkbox"/>
Are visitors attracted to this area? If yes, indicate why?	<input type="checkbox"/>	<input type="checkbox"/>	<input type="checkbox"/>	<input type="checkbox"/>	<input type="checkbox"/>
Is the local economy supported by historic, natural, cultural and entertainment resources?	<input type="checkbox"/>	<input type="checkbox"/>	<input type="checkbox"/>	<input type="checkbox"/>	<input type="checkbox"/>
Does the roadway serve as a commuter corridor?	<input type="checkbox"/>	<input type="checkbox"/>	<input type="checkbox"/>	<input type="checkbox"/>	<input type="checkbox"/>
Does the roadway serve as a gateway?	<input type="checkbox"/>	<input type="checkbox"/>	<input type="checkbox"/>	<input type="checkbox"/>	<input type="checkbox"/>
Do stakeholders include business or other advocacy groups? (in addition to public agencies and residential associations)	<input type="checkbox"/>	<input type="checkbox"/>	<input type="checkbox"/>	<input type="checkbox"/>	<input type="checkbox"/>
Is limiting sprawl a regional concern applicable to this place?	<input type="checkbox"/>	<input type="checkbox"/>	<input type="checkbox"/>	<input type="checkbox"/>	<input type="checkbox"/>
Is redevelopment underway or planned for this place? If yes, how does the proposed transportation project impact redevelopment?	<input type="checkbox"/>	<input type="checkbox"/>	<input type="checkbox"/>	<input type="checkbox"/>	<input type="checkbox"/>
<p>Other Comments:</p> <p>-----</p> <p>-----</p> <p>-----</p>					

COMMUNITY CONTEXT AUDIT FORM

Figure 19-5.D
(5 of 6)

	Illinois Department of Transportation	Community Context Audit Form
---	--	-------------------------------------

Section 5: Community Planning

Assess the proposed project in context to local planning initiatives. Please provide the following information and documentation related to the project or study area.

	Yes	No
Does the municipality, county or regional planning authority have a comprehensive plan? If yes, indicate the date of the plan.	<input type="checkbox"/>	<input type="checkbox"/>
Is this project generally consistent with the municipality's comprehensive plan? If yes, indicate how.	<input type="checkbox"/>	<input type="checkbox"/>
Are there any special studies associated with this project? If yes, please indicate the name of study or studies and attach copies.	<input type="checkbox"/>	<input type="checkbox"/>
Has the municipality adopted a growth management plan or designated growth area? If yes, is this project located within the designated growth area.	<input type="checkbox"/>	<input type="checkbox"/>
Does this project have regional significance? If so, explain.	<input type="checkbox"/>	<input type="checkbox"/>
Are there other scheduled or planned projects that may tie into this project or impact this project? If yes, please indicate the project name(s) and type of project(s).	<input type="checkbox"/>	<input type="checkbox"/>
Identify planning and project development partners for this project:	<input type="checkbox"/>	<input type="checkbox"/>
	<input type="checkbox"/>	<input type="checkbox"/>

Other Comments:

COMMUNITY CONTEXT AUDIT FORM

Figure 19-5.D
(6 of 6)

Context audit meetings can be large and include all stakeholders or can be conducted as multiple smaller meetings if the project is large in scale and affects a great many stakeholders of varied interests or affects many communities. It is often helpful to conduct these smaller meetings with groups of stakeholders that have common interests, for example, based on geography or specific issues. The smaller meetings should be informal in nature, designed to learn about each group's issues. At the end of a multi-meeting process, it is recommended that a full public meeting be held to compile and complete the overarching context audit for the project.

This audit process should be simple and should deal with broad, problem-defining issues. Staffing at the meetings should be adequate for stakeholders to have their questions answered in a timely fashion. For larger projects, communications consultants may be involved in this type of outreach instead of, or in addition to, Department staff.

After the context audit is completed, the PSG should meet with the stakeholders to develop a clear statement of the transportation problem(s) to be solved by the project. This can occur at a context audit meeting, or may require a meeting or meetings subsequent to the context audit meeting on projects with a more complex context. The PSG should seek input on current transportation problems in the area the stakeholders believe need to be solved, and how the project, as preliminarily proposed, might help alleviate them. If stakeholder solutions are suggested that are technically or financially infeasible, the PSG should determine the underlying problems the suggestions were attempting to solve, and whether or not there is a feasible way to address them within the project's anticipated scope.

Translate the input into a clear problem statement, which should, and can be, solved by the project. The PSG should ensure the stakeholders understand that this statement is of perceived transportation problems, not of the preferred project scope of work. Care must be taken to make the statement realistic within the limits imposed by engineering considerations, available funding, and the logical termini, see Section 11-3.02, of the project. Once a clear problem statement is completed, it must be accepted by consensus of the stakeholders.

IDOT and FHWA develop the Purpose and Need based on many factors and relevant planning/transportation data. The PSG should ensure that the stakeholders understand that the problem statement is a *contributing factor* to the Purpose and Need. Further, Federal and State Resource Agencies (e.g., US Environmental Protection Agency, US Army Corps of Engineers) must concur in the Purpose and Need for projects subject to the NEPA/404 Merger process. For EIS projects, Participating Agencies and the public must be afforded an opportunity for involvement in defining the Purpose and Need.

Omission Point: The PSG should ensure that the stakeholders understand that these issues will be revisited on projects during formal development of Purpose and Need under the NEPA process, if applicable. Further, Federal Resource Agencies (e.g., US Environmental Protection Agency, US Army Corps of Engineers) must concur in the Purpose and Need for projects subject to the NEPA/404 Merger process. For EIS projects, Participating Agencies and the public must be afforded an opportunity for involvement in defining the Purpose and Need. Purpose and Need also should be revisited for EIS projects subject to 23

U.S.C. 139 that requires that Participating Agencies and the public be afforded an opportunity for involvement in defining the Purpose and Need. It would be prudent to hold a meeting to verify that all stakeholders agree with the revised Purpose and Need.

Halting Point: This Step is finished when both the Department and the stakeholders arrive at an understanding as to the purpose of the project. If the project is subject to the NEPA/404 Merger Process, this will include concurrence on the Purpose and Need from the Resource Agencies. For projects subject to 23 U.S.C. 139, this will include having afforded Participating Agencies and the public an opportunity for involvement in defining the Purpose and Need. This step can also be concluded if the consensus is to not proceed with the project.

Developing the project purpose is the first, fundamental step in the overall project development process. Central to this concept is the understanding by all stakeholders that a transportation problem has been identified, and the Department is committing resources to address that problem. At the onset, outreach focuses on understanding community viewpoints on the nature of transportation issues associated with the identified problem. Outreach should also focus on finding out the specific values associated with the local context.

The point of this outreach is to assure congruence between the Department's assessment of the problem(s) to be addressed and those recognized by the community. If these views are different, it can become very difficult for stakeholders to agree to make trade-offs during the planning and design process. The absence of general endorsement of the problem's definition at this point is a strong indication that the process is not ready to proceed to the next step. A clear understanding between stakeholders and the Department regarding a transportation need, including what transportation issues and problems are to be addressed, is needed for progress toward solving the transportation problem.

19-5.01(c) Defining Alternatives (Step 3)

The intent of this step is to develop project alternatives or options and to ask for input into the development process for the preliminary study alternatives. The Purpose and Need that was developed in Step 2 for the project and the concerns identified from Step 2, are the driving force for the identification of the alternatives or options, and should be considered during this process. For EIS projects, Participating Agencies and the public must be afforded an opportunity for involvement in defining the range of alternatives.

On larger and more complex projects (e.g., new construction, major reconstruction), this is usually the appropriate time to form one or more "technical advisory groups" (TAGs). These groups are composed of stakeholders who volunteer to be in ongoing contact with the PSG, over and above the full public meetings that take place, and will work on analyzing alternatives generated. Several groups could be created and could each be responsible for analyzing the alternatives according to a particular subject matter (e.g., economic development, aesthetics). In some situations, consultant staff may assume these responsibilities, overseen by the PSG.

For smaller and less complex projects, a single group that handles all relevant subjects could be convened instead.

Omission Point: For smaller and/or less complex projects on which the number of stakeholders or the likely number of meetings is small, the formation of TAGs can be omitted.

Staff should approach stakeholder suggestions from the standpoint of determining what problems and issues are being addressed. If suggested proposals are either technically or financially infeasible (or both), explain this plainly and respectfully. Staff should work with stakeholders to determine the underlying issues and should try to identify alternative solutions that would address the concerns within the engineering and budgetary constraints. Input obtained from these meetings generally will result in revisions to the alternatives being considered at this time. Ideally, the range of alternatives retained for further study will be narrowed at this point in the process, based on the comments received, the results of preliminary surveys, and the design analyses conducted to date.

Halting Point: Once a reasonable range of alternatives have been developed and all issues that are reasonably related to the project have been identified, the process can move on to the environmental documentation and review stage. The alternatives and their respective environmental impacts will be made available for public and agency review through the environmental process.

Omission Point: The process can proceed directly to the environmental documentation and review stage if, at the initial meeting(s), stakeholders did not identify any significant differences or issues omitted from previously developed alternatives.

For all but the smallest or least complex projects, several meetings for analyzing alternatives are likely to be necessary. The purpose of follow-up “alternative analysis” meetings is to present the refined alternatives generated from the first round of meetings and to begin to reduce the number of alternatives carried forward. Concerns from previous meetings, along with any current conflict resolution results, are discussed. If concerns cannot be incorporated, staff must indicate why and attempt to offer solutions that address the issues underlying these concerns.

TAGs, if formed, would continue their analysis and help make the presentation at the full meeting(s). In fact, subsequent alternative analysis meetings are best conducted with the TAGs themselves. This saves time, space, budget, and is consistent with the purpose for which the TAGs were created. At this stage, full public meetings should only happen if a new issue emerges, or an issue not previously considered relevant becomes important.

For large or complex projects, there may be a need for several rounds of meetings for refining and reducing the number of alternatives; whereas, if the project is simple, elimination of alternatives can occur in one meeting. On larger projects, consultant staff can assume these responsibilities, under the supervision of the PSG.

Halting Point: Meetings are reiterated until a preferred alternative is reached. If a preferred alternative is being identified during a corridor or feasibility study, and the project is later subject to NEPA compliance, the preferred alternative identification process will be revisited if or when the NEPA process is initiated for the project. Further, Federal Resource Agencies (e.g., US Environmental Protection Agency, US Army Corps of Engineers) must concur in the alternatives to be carried forward for further analysis and the preferred alternative on projects subject to the NEPA/404 Merger process. For EIS projects, Participating Agencies and the public must be afforded an opportunity for involvement in defining the range of alternatives.

19-5.01(d) Preferred Alternative (Step 4)

This is the last stakeholder involvement activity during initial design/NEPA and its intent is to reach consensus with the public. In order to reach this point, all reasonable concerns should have been addressed and all conflicts resolved.

The purpose of this activity is to formalize the agreed-upon consensus for the project scope. The watchwords should be “no outstanding issues” and “no surprises.” Staff should carefully determine whether issues remain unresolved or unidentified. If so, more rounds of alternative definition, analysis, and selection should be conducted before a public hearing.

A good goal to work toward throughout the entire SIP is the creation of a consensus document outlining the following:

- the purpose of the project,
- project scope, and
- design elements that each stakeholder group and the Department feel comfortable approving at this end-point.

If staff does not feel that the process has reached such a point, address all outstanding issues before scheduling the final meeting. If a corridor study is conducted and a corridor is chosen, the preferred alternative within that corridor will be selected through the NEPA process, if applicable. The decisions made in the corridor study process will be carried forward into the NEPA document to explain why the corridor was selected and others were eliminated. Resource Agencies (e.g., US Environmental Protection Agency, US Army Corps of Engineers) must concur in the preferred alternative on projects subject to the NEPA/404 Merger process.

19-5.01(d)1 *Documentation of the Stakeholder Involvement Process for CSS Projects*

A critical element to the success of the CSS stakeholder involvement process is documentation. The PSG should clearly note and explain all major decisions made during the stakeholder involvement process. This includes all choices made from the selection of stakeholders, the definition of stakeholder involvement process ground rules, other parameters of the stakeholder

involvement process (e.g., type and frequency of meetings), the selection of alternatives to be studied, and the selection of the preferred alternative. Any exceptions to established departmental design criteria must be clearly and completely justified. Any design features requiring special treatment during Phase II, construction, or maintenance during the project's design life should be noted and passed on to the entities responsible for those. Include this documentation in the project file for future reference.

19-5.01(d)2 *Stakeholder Involvement in Phase II and beyond*

There may be instances where changes to design features are proposed subsequent to Phase I Engineering and the stakeholder involvement process as outlined above. The changes can occur during Phase II Project Development, construction, or operation of the project. In the case where the change represents a major departure from the design resulting from the stakeholder involvement process, the PSG is required to meet again with the stakeholders to discuss and obtain consensus on the changes to be made. Any original design features, as well as any other commitments made during Phase I, will be contained in the project's commitment file; see Section 4-3.07.

There may also be occasions where the PSG will be required to approach the stakeholders on new issues that arise during Phase II Engineering, construction, or operation of the project. The issues will generally relate to decisions including, but not limited to, architectural design features, landscaping, aesthetics, management of traffic, maintenance of access, or public health. Stakeholder consensus must be obtained on such issues before any such feature is included in the project.

19-5.02 Implementing the Stakeholder Involvement Process

The activities outlined above should lead to greater integration of stakeholder ideas and opinions into project development. These activities should be aimed at providing stakeholders, most of whom are not going to be transportation or engineering professionals, with a good understanding of the issues, limitations, and purpose of the project being considered. Districts should not feel that the process outlined above is a rigid checklist of activities that must be followed to the letter; rather, they should use their judgment in applying the steps in the framework to determine how best to contact and engage stakeholders.

The following are additional considerations that can guide the planning of a constructive stakeholder involvement process:

19-5.02(a) Choosing an Approach

For most of the stakeholder involvement activities detailed above, the "open house" format of meeting is generally considered to be the most conducive towards public understanding and input. However, specific involvement activities may utilize a number of other formats in providing information to and receiving input from stakeholders. Section 19-3.03 discusses other type of Public Meeting formats that may be utilized.

19-5.02(b) Follow-up

There are many types of meetings and activities that can be used to help plan for or follow-up on large-scale stakeholder meetings. It is important to reach a wide variety of stakeholders during the planning and design process and to create an atmosphere that encourages the free and open exchange of information. Section 19-4.05 provides further details on several of these techniques.

For the meeting activities described in the preceding section, prompt and open follow-up on issues raised during these meetings is necessary. The appropriate type of follow-up will partially depend on public or stakeholder attitudes at the public involvement activity. If the public has been generally supportive of the material presented at the meeting, it is probably not necessary to initiate a large-scale follow-up. It may suffice to write individual letters to those who asked questions that were not answered and to release information to the news media, via project newsletters, or through updates on the project website for any changes that were made as a result of stakeholder input.

A greater amount of follow-up is required when a particular meeting has not resolved the issues to a reasonable degree. If there was opposition or a lack of understanding regarding what the Department is trying to accomplish with the project, a more extensive follow-up program is appropriate. In this case, additional follow-up stakeholder meetings are an effective means of achieving better stakeholder understanding of issues at hand. These meetings can range from large-scale community briefings to one-on-one discussions with a particular stakeholder.

19-5.02(c) Working Towards Stakeholder Understanding.

“Project Purpose” discussions involving the community should focus on providing the community with background on known traffic safety problems or congestion/operational problems, traffic forecasts, and their anticipated effect on future traffic conditions. These help explain the Department’s perspective on problems and needs, and set the stage for discussions about potential solutions. District staff should take advantage of any and all methods and opportunities to interact with the local citizens, public officials, and any other identified stakeholders. Efforts should focus on gathering data, developing a rapport and good working relationship with the local community, and obtaining a sense of what solutions to the identified transportation needs are in the context of the involved community.

19-5.02(c)1 Consensus Building Efforts

It should be noted that more than one of the meeting types listed above may need to be used and may require repetition, depending on the following:

- the number of stakeholders or stakeholder groups involved,
- the scope of the problems and issues discussed, and
- the positions and views of the stakeholders on the various issues.

Keep in mind the “halting points” outlined in the SIP flowchart, Figure 19-5.A, if a consensus resolution of these issues has not been achieved, then further meetings are probably necessary.

Department staff and elected officials involved in project development may find this frustrating or time consuming. However, problems and issues raised by stakeholders do not go away if left unaddressed. Often, relatively minor problems can become major impediments to progress if ignored or left unattended.

Throughout the SIP, project development staff should seek out activists and other participants with differing viewpoints from the team members, and engage in good faith discussions with them. An important component of conflict resolution is full disclosure of all information and discussions needed to manage and resolve conflicting values of stakeholders. When parties disagree, it is sometimes due to a misunderstanding or lack of information. It is important that both sides disclose relevant information to resolve or at least manage conflict between competing values.

An essential component of the stakeholder involvement process is the concept of “consensus.” The stakeholder involvement process seeks consensus on all decisions driving the project development process, and allows for multiple iterations of each step in order to achieve it. However, there may be occasions when consensus on one or more issues is impossible. Further, there may be occasions when the consensus decision of stakeholders is infeasible on engineering, environmental, funding, operational, safety, or other grounds.

If consensus is impossible or infeasible, the PSG must take the issue back to the Regional Engineer, and confer with FHWA, as necessary, to determine how to proceed with the project. Ultimately, the Department, acting in accordance with applicable State and Federal requirements, is responsible for project development decisions on State highway improvement projects.

19-5.02(c)2 *Stakeholder Understanding of the Alternative Solutions.*

The Context Sensitive Solutions approach varies as to how the Department handles this step. In one approach, the district can develop a range of alternatives that meet identified needs and that consider identified concerns. These alternatives are then reviewed in a public outreach process. New alternatives or variations on the original alternatives can be suggested by the stakeholders and should be analyzed and addressed by the district.

In a different approach, alternatives can be developed during the various stakeholder meetings and activities. Alternatives developed in this manner are refined and analyzed by district staff and presented broadly for public review and comment. This approach often fits best in situations involving a new facility, a significant change in the nature of a facility, or where a variety of configurations are possible for the project.

The PSG considers the issues involved, along with the time and resources available, in order to make a choice about the proper approach to use.

Stakeholders can be involved in the screening and evaluation of alternatives in many ways. The results of the district’s analyses are shared broadly with the stakeholders for review and comment. Stakeholders can also be involved in conducting screening and evaluation. For example, stakeholders can be asked to conduct an exercise where they rate project criteria and then weigh alternatives. Technological tools are available for conducting this kind of interactive analysis.

Using such tools can give both the PSG and the stakeholders a much clearer view of everyone's preferences.

One of the issues in soliciting stakeholder input as it pertains to technical issues is how to convey a large amount of technical data to the public in a manner and language they can understand, and in a relatively short period of time. The majority of citizens involved in these processes do not have the time to become conversant in the technical language and engineering concepts that are typically used by team personnel in studies of particular issues. Visualization aids, especially newer computer-assisted visual renderings, can significantly improve public understanding, enabling stakeholders to quickly analyze the information being presented. As a result, the use of effective visualization techniques can be a major asset to the successful implementation of public involvement activities.

19-5.02(c)3 *Stakeholder Understanding of the Recommendation.*

If clear communication with stakeholders has occurred during the alternatives analysis stage, stakeholder understanding of the benefits and impacts of various transportation solutions should clear the way to a consensus option. Results of effective stakeholder involvement may include agreement that further study is needed, support for a solution or approach, revision of design right-of-way or construction details, or even the delay, postponement, or cancellation of the project. A true measure of the success of a SIP, regardless of the solution implemented, is the degree the community at large, and each stakeholder, can feel a sense of involvement and ownership of the recommended solution.

Chapter Twenty

**REQUIREMENTS FOR
MAJOR PROJECTS**

BUREAU OF DESIGN AND ENVIRONMENT MANUAL

Chapter Twenty
REQUIREMENTS FOR MAJOR PROJECTS

Table of Contents

<u>Section</u>	<u>Page</u>
20-1 MAJOR PROJECT DETERMINATIONS.....	20-1.2
20-1.01 Operationally Independent Non-Concurrent Construction Projects.....	20-1.2
20-1.02 Construction Phasing.....	20-1.2
20-2 PROJECT MANAGEMENT PLAN	20-2.1
20-2.01 Purpose.....	20-2.1
20-2.02 Submittal Process and Approval.....	20-2.1
20-2.03 Contents.....	20-2.2
20-3 FINANCIAL PLAN.....	20-3.1
20-3.01 General	20-3.1
20-3.02 Purpose.....	20-3.1
20-3.03 Timing	20-3.1
20-3.04 Methodology	20-3.2
20-3.05 IDOT Certification.....	20-3.2
20-3.06 FHWA Review and Approval.....	20-3.2
20-3.07 Content	20-3.3
20-3.08 Annual Updates	20-3.7
20-4 REQUIREMENTS FOR OTHER THAN MAJOR PROJECTS.....	20-4.1

Chapter Twenty

REQUIREMENTS FOR MAJOR PROJECTS

Subsection (h) of 23 U.S.C. 106, "Project approval and oversight," sets forth specific requirements that apply to "Major Projects." As defined in Subsection (h) and associated guidance issued by FHWA, "Major Projects" include those with a total estimated cost of \$500 million or more that are receiving Federal financial assistance, or for such other projects as may be identified by FHWA. FHWA may choose to apply this designation in situations that include, but are not limited to, where FHWA determines a project requires a substantial portion of a State Transportation Agency's program resources, has a high level of public or congressional interest, is an unusually complex project, or is likely to exceed \$500 million in total cost during the life of the project.

The requirements described in Subsection (h) for Major Projects include preparation and submittal of the following plans and updates:

1. Project Management Plan. This plan will document the procedures and processes that are in effect to provide timely information to the project decision-makers to effectively manage the scope, costs, schedules, and quality of, and the Federal requirements applicable to, the project and the role of the agency leadership and management in the delivery of the project.
2. Financial Plan. This plan will be based on detailed estimates of the cost to complete the project and will provide for the annual submission of updates that are based on reasonable assumptions of future increases in the cost to complete the project.

Pursuant to 23 U.S.C. 106 (i), "Other Projects" having an estimated total cost between \$100 million and \$500 million, when not classified as Major Projects, are required to have a financial plan. However, these plans do not require FHWA approval and the project estimates do not need to be validated through a formal Cost Estimate Review. See Section 20-4 for requirements for Other Projects.

The Transportation Infrastructure Finance and Innovation Act (TIFIA) program is a Federal financial assistance program that provides Federal credit assistance in the form of direct loans, loan guarantees, and standby lines of credit to finance surface transportation projects of national and regional significance. Regardless of total project cost, TIFIA loan proceeds require the borrower to submit annual financial plan updates throughout the life of the loan, which can extend beyond completion of construction for the project. If TIFIA or other programs are used, one financial plan may be submitted to meet both TIFIA and Major Project requirements.

The following sections provide guidance for implementing the above requirements on IDOT projects that meet the \$500 million total estimated cost threshold or that FHWA otherwise designates as Major Projects.

See the appropriate Chapter in Part III, Environmental Procedures, regarding environmental coordination guidelines for Major Projects.

20-1 MAJOR PROJECT DETERMINATIONS

All costs associated with the project from the NEPA phase through final construction must be included in determining the total estimated project cost, regardless of the source of funding. The scope of the Major Project is defined in the NEPA decision document - whether a Record of Decision (ROD), Finding of No Significant Impact (FONSI) or Categorical Exclusion (CE) and includes all work associated with implementing the undertaking.

20-1.01 Operationally Independent Non-Concurrent Construction Projects

For purposes of the Major Project requirements, the scope of work can be reduced to component projects where the overall project will be built over a long period of time. To be applicable, the “operationally independent non-concurrent construction projects” need to be separated by at least five years between the completion of one project and the start of the other. There also must be work that is not expected to begin construction for at least 20 years after initial construction commences. In addition, the completed non-concurrent project, once opened, needs to effectively operate even if the rest of the work described in the environmental document is never built.

The operationally independent non-concurrent construction projects need to be identified so they can be incorporated into the Final Environmental Impact Statement (FEIS) or Environmental Assessment (EA). Approval of the FHWA Division Office is needed for this approach, and the Division must consult with and obtain concurrence from the FHWA Headquarters Project Delivery Team in the Office of Innovative Program Delivery (OIPD), before making its determination.

This determination by FHWA is solely for the purposes of applying Major Project requirements, and specifically Financial Plan and Project Management Plan requirements, and has no effect on project planning or NEPA review. Once the determination has been made concurring with the operational independence of non-concurrent construction projects, Major Project requirements will apply to the initial portion of the project rather than the overall project. If the initial portion of the project is still deemed a Major Project on its own merits, the required Project Management and Financial Plans for the operationally independent and non-concurrent project should only cover the scope for that portion of the project.

20-1.02 Construction Phasing

Construction phasing is another option to be addressed within the Major Project requirements when the project will be implemented over a long period of time, so that incremental funding and building phases of the overall project are logically planned and completed.

In the event there are insufficient financial resources immediately available to complete the entire project as defined in the NEPA decision document, Financial Plans may identify fundable

incremental improvements or phases (a “phasing plan”) that will address the purpose and need of the overall project in the short term (23 U.S.C. 106(h)(3)(C)). For projects with Financial Plans that include phasing plans, the total cost of the overall project, not the cost of any fundable incremental improvement or phase, is still used to determine whether the project meets the \$500 million threshold (23 U.S.C. 106(h)(1)).

In general, the inclusion of a phasing plan does not alter the contents of the Financial Plan as described in this guidance, but does have an impact on how the overall project can meet fiscal constraint requirements under 23 U.S.C. 134 and 135. If a phasing plan is included in an approved Major Project Financial Plan, and fiscal constraint requirements are met for the funded phase, then pursuant to 23 U.S.C. 106(h)(3)(C), the overall project is deemed to meet fiscal constraint requirements under 23 U.S.C. 134 and 135.

Fundable incremental improvements or phases do not need to meet the operationally independent and non-concurrent construction project criteria, but should be segments that can be opened to the public and effectively operated without the completion of subsequent segments or other additional transportation investments. The decision to adopt a phasing plan for a Major Project needs to be closely coordinated with FHWA, as this decision does not relieve or waive any of the other regular planning or NEPA requirements, and could require re-evaluation of fiscal constraint and/or NEPA reviews. Ideally, the phasing plan would be identified so it could be incorporated into the Final Environmental Impact Statement (FEIS) or Environmental Assessment (EA). Approval of the FHWA Division Office is needed for this approach, and the Division must consult with the FHWA Headquarters, Project Delivery Team in the Office of Innovative Program Delivery, before making its determination.

Fundable incremental improvements or phases should be presented as one individual funded phase in the Financial Plan. As additional fundable incremental improvements or phases are identified, they should be added to the single funded phase in the Financial Plan, including what was previously financed and constructed. Additionally, the Financial Plan should document the entire project’s scope, cost, and schedule as defined by the NEPA decision document approving the project, and be updated annually. A Project Management Plan is still required even if the first phase is less than what would be considered as a Major Project.

The decision to adopt a phasing plan for a Major Project needs to be closely coordinated with FHWA.

Section 20-2 follows which provides Project Management Plan guidance. See Section 20-3 regarding additional Financial Plan requirements.

20-2 PROJECT MANAGEMENT PLAN

References: FHWA *Major Project Guidance Memorandum*, January 19, 2007
FHWA *Project Management Plan Guidance*, May 22, 2017

20-2.01 Purpose

The Project Management Plan is the guide for implementing a Major Project. It documents assumptions and decisions regarding communication, management processes, execution, and overall project control. The ultimate purpose of the Project Management Plan is to clearly define the roles, responsibilities, procedures, and processes that will result in the Major Project being managed so that it is completed:

- on-time;
- within budget;
- with the highest degree of quality;
- in a safe manner for both the individuals working on the project and for the traveling public; and
- in a manner that will maintain the public trust, support, and confidence in the project.

The Project Management Plan addresses all phases of the Major Project's life cycle and ensures the project will be managed holistically and as a continuum; not incrementally as the project progresses. The Project Management Plan establishes the metrics by which the success of the project is defined.

When a Major Project has multiple project sponsors, a single Project Management Plan should be prepared.

20-2.02 Submittal Process and Approval

The responsible district will prepare Project Management Plans for IDOT Major Projects. The district will obtain a written endorsement of the Project Management Plan from the IDOT executive leadership confirming the commitment of achieving the project objectives and officially initiating the use of the requirements set forth in the Project Management Plan. The executive endorsement signature page should include language noting that the effectiveness of the Project Management Plan will be continuously evaluated and revised, as appropriate, as the project progresses in order to provide for the most effective management of the project in meeting its defined objectives. Once the executive leadership endorsement is obtained, a draft Project Management Plan shall be submitted to the FHWA for review at least 60 days prior to approval of the NEPA decision document. The FHWA will provide comments and the district shall submit a final Project Management Plan for approval within 90 days of the date of the signed NEPA decision document (CE, FONSI or ROD).

The FHWA Division Office will coordinate with FHWA Major Projects Team in the Office of Infrastructure to review the Project Management Plan and any plan updates that require FHWA

review. FHWA will respond whether the plan conforms to applicable requirements no later than 60 days after the document is received by the FHWA Major Projects Team. The FHWA approval of the Project Management Plan and updates rests with the FHWA Division Office; however, the Division Office must receive a concurrence email from the FHWA Major Projects Team. For all Major Projects, the Project Management Plan should be submitted and approved by FHWA prior to the approval of the Initial Financial Plan.

The Project Management Plan is a living document which may be revised throughout the course of the project. Updates may be issued to ensure that the documented procedures, processes, and roles are current. Project Management Plan updates with significant changes to the project should be submitted to FHWA for review and approval. Other plan updates should be submitted for recordkeeping purposes.

Significant changes that will necessitate submittal of the updated Project Management Plan to FHWA for review and approval include organizational structure changes to the project management team or changes to the project management procedures or processes.

The Project Management Plan should be approved prior to authorization of Federal-aid funds for right-of-way acquisition and prior to authorization of Federal-aid funds for construction.

20-2.03 Contents

The following topics form the basic contents for the Project Management Plan. The intent of the following paragraphs is not to establish a prescriptive format, but to provide a general framework in which modifications can be made to produce a Project Management Plan that will most effectively serve IDOT and FHWA throughout the project.

1. Project Purpose, Goals, Objectives, and Metrics. A well-defined project purpose is instrumental to project success. The Project Management Plan should document the project purpose consistent with the NEPA purpose and need statement. The plan should also list goals and objectives of the overall project, and how those goals and objectives will be measured and quantified. Project goals and objectives explain what needs to be achieved by the project. While project goals broadly define the long-term vision for the project, the project objectives define strategies or implementation steps to attain such goals. Objectives are specific, measurable, short-term actions that set the framework for establishing quantitative and qualitative metrics for the project and define what is considered a successful project. For example, one commitment may be to complete the project within a certain budget. The extent to which this commitment will be met is a quality measure. Completing the project at 10% under budget would be a possible outcome and would be a more favorable outcome than completing the project at 1% under budget. Metrics included in the plan should cover schedule, budget (including cost containment), quality, safety, scope control, public trust and confidence, and Federal requirements.

The quality requirements for the project should be stated up-front, so that all involved and concerned parties can understand the basic management philosophies that will be

incorporated to meet these requirements. The Project Management Plan should be clear and specific on how quality will be measured and should include appropriate targets and tolerances.

2. Project Description and Scope of Work. The Project Management Plan should document the complete description of the project, along with the history of its development and important project decisions. It should contain a clearly defined project scope as defined in the NEPA decision document. A clearly defined scope of work will document design, construction, environmental, railroad/utilities, and right of way activities and outline which items of work have been dedicated in the baseline cost budget and will assist in controlling and minimizing future potential scope increases. A map of the defined project can be included for added clarity.
3. Project Organizational Management. The project management team should be organized, from a managerial, technical, oversight, and decision-making perspective, to achieve all of the stated project goals and objectives. The Project Management Plan should include an organizational chart for clarity, with a brief description of roles and responsibilities for each individual or organizational team. Normally, an executive oversight committee (or steering committee) will be shown at the top of the chart to provide overall project direction. The executive oversight committee would be primarily composed of executive level FHWA, IDOT, and local officials and should meet on a periodic basis. The day-to-day project management team is normally led by a project manager who would report to and support the executive oversight committee.

This section of the plan should define the relationships between public and private stakeholders and their organizational structures. Also, if the Major Project is in multiple states, describe each state's roles and responsibilities.

In addition to technical and functional support teams for right-of-way, utilities, design, construction, project controls (e.g., scheduling, cost, document control), QA/QC, etc., consideration should be given to creating separate teams for media and public information, civil rights, environmental monitoring and review, safety, and security.

The project team must have experienced key personnel dedicated to the success of the Major Project, with the requisite technical, managerial, leadership, and communication skills needed to proficiently perform the required tasks. Project teams that integrate consultants and Department personnel in the project management and functional/support teams can be successful, but the use of consultants must be carefully structured and reviewed to ensure proper oversight. At least one Department manager should be directly responsible and accountable for the project management team and each functional/support team.

4. Project Phases and Phasing. The planning and project development portion of the project can include many stages and a range of potential alternatives. The Project Management Plan should include a description of the procedures and processes for a Major Project to facilitate effective management of day-to-day project activities and to

promote understanding by the project management team of the broader context of the project timelines and potential influences on the project.

Additionally, project sponsors often fund and/or construct portions of the project incrementally. If the overall project scope is being delivered as part of several smaller, incremental projects as discussed in Section 20-1.02, the Project Management Plan should document and describe all operationally independent and non-concurrent construction phases approved for the project.

5. Procurement and Contract Administration. Document and formalize how procurement and contract administration activities are to be conducted to comply with all applicable federal, State, and local laws, regulations, rules, and mandates. This section should discuss how procurement decisions are to be made, including selection of consultants, contractors, and contracting methods. Consideration should be given to the size and length of contracts as they relate to bonding capacity, the number of likely bids, and other market conditions. It is also important to note that the strategy of using multiple contracts may introduce additional coordination and interface issues among separate contracts.

This section should address how the contract will be administered and the requirements for performance reporting, payments, claims administration, and records management will be monitored and documented. In addition, it should document the process for contract closeout, including analysis of the results of the contract.

6. Cost, Budget and Schedule. Cost and schedule data are included in the Financial Plan and annual updates (see Section 20-3) required for all Major Projects. The initial Financial Plan is required prior to the first federal authorization for construction funds. The Project Management Plan should specifically reference the Financial Plan and Annual Updates as an integral part of the Project Management Plan and should discuss the process and frequency for validation of cost estimates and schedules. The Project Management Plan should include the current cost and schedule information, broken down into major cost elements and significant schedule milestones. The initial financial arrangements for the project, including any proposed loans and/or bonds also should be discussed. The financing for Major Projects must be consistent with any fiscally constrained plans, Statewide Transportation Improvement Programs (STIPs), Transportation Improvement Programs (TIPs), etc. The Financial Plan Annual Updates will document any subsequent budget and financing revisions.

Prior to preparation of the Initial Financial Plan, the Project Management Plan should have a mechanism in place for providing an annual report updating the project cost estimate.

Independent validations of the cost and schedule at key milestones are important to avoid unexpected cost overruns and project delays. The Project Management Plan should provide for independent validations by an unbiased team that does not have a stake in the outcome of the validation. FHWA will conduct its own independent validations of the cost estimate as appropriate at key milestones throughout the project

continuum (e.g., prior to approval of the FEIS or EA and again during preparation of the Initial Financial Plan, which will precede the initial FHWA construction authorization). FHWA may also review project cost estimates any time the Financial Plan Annual Update shows a significant cost increase, delay, or scope change from the previous Annual Update. Independent validations conducted by IDOT should be coordinated with FHWA for verification.

7. Project Documentation, Reporting and Tracking. The Project Management Plan should include discussion on how project records will be managed, including definition of the project document control, reporting and tracking system. The project document control, reporting and tracking system will be a key element in ensuring the consistency of the project with the budget and schedule to the maximum extent practical, that the project will be completed with the highest degree of quality, and that compliance will be established with all applicable Federal regulations.

The project document control, reporting and tracking system should provide for collecting, assessing and maintaining timely, independent, and accurate project status information and data. It should provide current information on project progress, changes, and issues for use in identifying trends, forecasting project performance, and proactively addressing potential problems.

The need for continuously and accurately reporting cost increases, schedule changes, items of deficient quality and the causes, impacts, and measures to mitigate these issues is paramount for effectively administering the project and protecting the public investment in the project. Any apparent reporting deficiencies or questionable data should be promptly addressed and resolved. IDOT and FHWA must have timely and complete information on the project status to be able to take appropriate action to effectively address any problems, if necessary.

FHWA recommends monthly reports on project cost, schedule and status and monthly status meetings with the project management team, IDOT and FHWA representatives and representatives of other agencies, as appropriate. The monthly status meetings should include discussion of project costs, schedule, quality issues, compliance with Federal requirements, and other status items in sufficient detail to make all involved parties aware of any significant status issues and actions planned to address any adverse effects.

The following is a sample format for a monthly status report. It is provided as an example and is not intended to be prescriptive. (Refer to the FHWA *Project Management Plan Guidance* for additional detail on the content of each section of the report.)

- a. Executive Summary. The executive summary should provide a clear and concise description of the current project status, including any major issues that impact the project scope, budget, schedule, quality, safety, etc.

- b. Project Activities and Deliverables. The purpose of this section is to highlight (1) project activities and deliverables for the current reporting period (i.e., the previous month) and (2) activities and deliverables planned for the next two reporting periods.
 - c. Action Items/Outstanding Issues. This section should identify and track the progress in resolving highly significant or sensitive issues that require action and direction to address.
 - d. Project Schedule. This section should include an updated master project schedule reflecting the current status of project activities.
 - e. Project Cost. This section should include an updated cost spreadsheet reflecting the current projected cost, compared with the approved budget and the baseline budget.
 - f. Project Quality. The purpose of this section is to (1) summarize the QA/QC activities during the reporting period and (2) highlight any significant items of deficient quality identified.
 - g. Other Status Reports. IDOT and FHWA may agree that other reports may be beneficial for ensuring project status issues are fully and openly communicated. Examples include reports on contractor safety performance, wrap-up insurance payments and reserves, and/or actual DBE use compared to DBE-use goals.
8. Project Management Controls (Scope, Cost, Schedule, Claims, etc.). A project controls team normally helps to manage the scope, total cost, and overall master schedule for the project. The team also assists the project management team to meet the projects schedule and budget objectives. The project controls team also produces project reports that include quantification of delays and cost increases and initiatives being analyzed to address the delays and cost increases. The following are project management controls that should be used on most Major Projects and that should be documented, as appropriate, in the Project Management Plan (Refer to the FHWA *Project Management Plan Guidance* for additional details.):
- a. Risk Management Plan. This plan documents a systematic process to identify, analyze, and respond to project risk throughout all phases of the project.
 - b. Scope Management Plan. This plan documents the philosophy regarding scope management, the process for approving scope changes, and for verifying the planned scope of work is actually completed.
 - c. Scheduling Software. This item describes the scheduling software to be used for the project and the frequency and detailed process for reviewing and validating schedules.

- d. Cost Tracking Software. This item describes the software to be used to track and report costs for the project and the frequency and detailed process for reviewing and validating cost estimates.
 - e. Project Metrics. This item describes the metrics by which the success of the project is measured (e.g., cost, schedule, public opinion).
 - f. New and Innovative Contracting Strategies. This item discusses management processes for new and innovative procurement strategies to be incorporated in the project (e.g., Design-Build, Public-Private-Partnerships, cost-plus-time bidding, lane rental, bid options).
 - g. Value Engineering Analysis. Refer to Section 11-7.03 for requirements and guidance on value engineering analyses.
 - h. Partnering. This item documents a formalized partnering process to enhance working relationships between the project delivery team and contractors. It should describe the level of organizational involvement and professional facilitation required, including any partnership development and team-building workshops.
 - i. Contractor Outreach Meetings. If contractors are to be consulted during the early design process, this item discusses the level of involvement by contractors and any procurement restrictions on contractors involved in outreach meetings.
 - j. Change Order and Extra Work Order Procedures. These are procedures for addressing change orders and extra work orders during project construction that will ensure appropriate review, efficient processing, and consistency with project objectives.
 - k. Claims Management Procedure. This item describes the claims review and management process to be followed in cases of contractor claims. It should document the roles and responsibilities of those reviewing and approving the claims, including legal reviews.
 - l. Other Programs. This item describes how other unique programs (e.g., Owner Controlled Insurance Programs (OCIPs), Transportation Infrastructure Finance and Innovation Act (TIFIA) loan program) are to be managed.
9. Design Quality Assurance/Quality Control (QA/QC). The Project Management Plan should set the general requirements for QA/QC to be used during the design phase. A reference to standard design QA/QC documents may be appropriate, plus any enhanced QA/QC procedures to be incorporated due to the complexity and visibility of the Major Project. FHWA guidance suggests that, at a minimum, the design QA/QC procedures include the following:
- an overall Design QA/QC Plan;

- design criteria to be adhered to;
- design criteria specific to the individual project;
- procedures for preparing and checking individual plans, specifications, estimates, calculations, and other items;
- procedures for preparing and checking any unique or highly specialized designs;
- procedures for coordinating work performed by different persons for related tasks to ensure that conflicts, omissions, or errors do not occur between drawings or between drawings and other design documents;
- procedures for coordinating and obtaining permits from permitting agencies, utility companies, and railroad companies. This should include procedures for ensuring that all permitting, utility, and railroad requirements are incorporated into the design of the project and procedures for coordinating submittals and agency reviews so that the overall project schedule is not delayed;
- level, frequency, and methods of review of the adequacy of the total project design and methods by which:
 - + all final design documents will be independently reviewed;
 - + verified for constructability, completeness, clarity and accuracy; and
 - + back-checked;
- level and frequency of audit and oversight design reviews (concerning QA/QC and validity of consultant payments) to be performed by IDOT, FHWA, independent consultants, and/or other agencies;
- procedures for reviewing and checking design drawings and documents required during construction;
- qualifications for all key design personnel; and
- documentation and submission procedures to ensure the established design QA/QC procedures have been followed.

10. Construction Quality Assurance/Quality Control (QA/QC). The Project Management Plan should also set the general requirements for QA/QC to be used during the construction phase. A reference to standard construction QA/QC documents may be appropriate, plus any enhanced QA/QC procedures to be incorporated due to the complexity and visibility of the Major Project. FHWA guidance suggests that, at a minimum, the construction QA/QC procedures include the following:

- an overall Construction QA/QC Plan;
- guidance on:

- + construction standards to be adhered to for performing construction inspection;
 - + documents to be used that will define materials to be certified, materials to be tested, sampling procedures, and testing procedures; and
 - + recordkeeping and reporting procedures and nonconformance plan;
 - agency or party responsible for QA/QC (i.e., responsibilities of the contractor versus IDOT for sampling, testing, monitoring, and reporting test results);
 - frequency and agency involvement for construction coordination (progress) and/or partnering meetings;
 - procedures for coordinating with permitting agencies, utility companies and railroad companies during construction to ensure all requirements are incorporated into the project so that the overall project schedule is not delayed;
 - level and frequency of inspections to identify and correct any deficiencies in the project construction that do not meet the requirements of the plans, specifications, and other binding documents;
 - level and frequency of audit and oversight construction reviews (concerning QA/QC and validity of contractor payments) to be performed by IDOT, FHWA, independent consultants, and/or other agencies;
 - qualifications for all key construction personnel; and
 - documentation and submission procedures to ensure the established construction QA/QC procedures have been followed.
11. Environmental Monitoring. The final NEPA decision document and other agreements can define the required mitigation for the Major Project. In addition, environmental permits may be obtained during project design that will specify additional requirements to be adhered to during construction. The Project Management Plan should establish the general requirements for ensuring all environmental commitments are included in the design and construction of the project, and that a proactive approach is used for overseeing and inspecting environmental work during construction to help guard against cost overruns and project delays. In addition, many Records of Decision include requirements for environmental compliance actions on an ongoing basis after a facility is open to traffic (e.g., storm water management, wetlands performance). FHWA guidance suggests that for a Major Project with a substantial amount of sensitive environmental issues, environmental monitoring procedures should include some or all of the following:
- an overall Environmental Monitoring Plan to verify that environmental commitments from the NEPA document, environmental permits and other

environmental approvals are implemented in accordance with the scope as described;

- roles and responsibilities of the environmental monitoring staff;
 - any strategic stationing or positioning of staff members to maintain ongoing contact with resource agencies and a working knowledge of the project's environmental issues to ensure follow-through on all commitments from the FEIS and environmental permits;
 - any planned proactive coordination with resource agencies during project design and construction to ensure early and ongoing communication of environmental issues and requirements;
 - any fluctuating work schedules among environmental monitoring staff to ensure continuous coverage of key contractor schedules and activities that may involve environmental effects;
 - coordination of environmental monitoring staff's daily activities with the project management and construction management teams to monitor and observe critical contractor activities;
 - recordkeeping and reporting procedures;
 - procedures for addressing noncompliance and violations;
 - permit modification procedures related to construction activities, including strategies for guarding against cost overruns and project delays while still ensuring good environmental stewardship; and
 - post-construction environmental performance for wetlands, storm water, vegetation, wildlife crossings, endangered species, etc.
12. Right-of-Way. This discussion should address policies and processes for appraisals, acquisitions, relocations, demolitions, construction/utility easements, scheduling, and reporting.
13. Safety and Security. This section should define the requirements to be incorporated to ensure the project is conducted in a safe and secure environment for all individuals working on the project. Accident prevention during execution of a Major Project should be a primary concern of all participants and should be a responsibility of all management levels for the project. Safety should be considered an integral part of an efficient and quality project and should never be compromised for the sake of production. FHWA guidance suggests that safety and security procedures include the following:
- safety and health standards;
 - roles and responsibilities of the safety/security staff;

- requirement for contractors (i.e., prime contractors, subcontractors) to have a Safety Director and an approved safety manual or plan available to all employees;
- requirement for contractors to hold periodic on-site safety meetings;
- requirement for contractors to conduct periodic on-site safety inspections;
- requirement for contractors to provide safety training for all new employees and refresher training for all employees;
- requirement for contractors to conduct drug screening for all new hires;
- requirement for contractors to publish daily housekeeping and clean-up procedures;
- provisions for possible employee sharing of savings from accident prevention;
- provisions for having first-aid and medical kits readily available;
- provisions for having a site-security plan, possibly including such items as restricted parking near vulnerable structures, physical barriers (e.g., fences, barricades), coordinated efforts with local law enforcement officials during heightened threat levels, video surveillance, alarm systems, emergency telephones, etc.;
- provisions for having an emergency preparedness and incident management plan including roles and responsibilities, emergency evacuation procedures, communications, first responder awareness training, and field drills;
- provisions for establishing an employee identification (ID) system;
- provisions for level and frequency of audit and oversight safety/security reviews to be performed by IDOT, FHWA, independent consultants, and/or other agencies; and
- provisions for periodic reporting (normally monthly) on safety and security matters.

In addition, appropriate threat and vulnerability assessments should be made and taken into consideration throughout the project's life cycle, recognizing that transportation elements of a Major Project could have a significant impact on regional safety and security plans.

14. Traffic Management. This section of the Project Management Plan should define the requirements for providing monitoring and oversight of the contractor's day-to-day maintenance of traffic operations, to ensure the project is conducted in the safest and

most efficient manner for the traveling public. FHWA guidance suggests traffic management procedures include the following:

- maintenance of traffic standards;
- roles and responsibilities of traffic management staff;
- provisions for reviewing maintenance of traffic plans and proposals at various design reviews for conformance with approved standards and familiarity with traffic phasing, traffic shifts, and lane closures proposed during construction;
- provisions for coordinating with local agencies during design and construction regarding placement of temporary signing and traffic control devices within their jurisdictions;
- provisions for coordinating with local agencies during design and construction regarding traffic restrictions and management for special events;
- provisions for coordinating with all local emergency agencies during design and construction to ensure adequate passage for emergency vehicles through construction zones;
- provisions for coordinating traffic maintenance with multiple contractors to integrate temporary signing and traffic control devices among various contracts;
- provisions for coordinating with contractors concerning specific language to be used on variable message signs during construction;
- provisions for conducting periodic reviews during construction (including nighttime inspections) for conformance with plans, specifications, and approved standards and to ensure all traffic control devices are functioning properly;
- provisions for having an incident management plan for crashes occurring within the project limits, including crash prevention strategies, emergency procedures, reporting requirements and mitigation strategies;
- provisions for coordinating with and assisting the media and public information team and local new media concerning traffic pattern changes, periods of lane closures, traffic delays, availability of alternative routes, work zone crashes, etc.;
- provisions for level and frequency of audit and oversight traffic management reviews to be performed by IDOT, FHWA, independent consultants, and/or other agencies; and
- provisions for periodic (normally monthly) traffic management reporting.

15. Project Communications Management. The Project Management Plan should document all external communications planned for the Major Project. A critical objective for all

Major Projects is to maintain the trust, support, and confidence of the media and the public throughout the life of the project. A Media and Public Information Plan, that will promote proactive, effective, and responsive project communications, is a key component in meeting this objective. FHWA guidance suggests examples of key strategies that should be incorporated into the plan, including the following:

- establish a public information team or office to be responsible for all media and public information efforts for the project;
- proactively convey current project status information to the media and the public, including scheduled milestone completion dates; major contracts advertised, awarded or completed, and total cost projections;
- proactively convey updated commuter and traffic information, including traffic pattern changes, periods of lane closures, traffic delays, work zone crashes, availability of alternative routes, and alternative forms of transportation (including benefits and possible subsidies);
- proactively convey, to the greatest extent possible, construction impacts to local residents and businesses and measures to be implemented for mitigation of the impacts;
- provide timely responses to questions and requests for project information from the media and the public; and
- provide information to increase awareness and understanding of the benefits of the project to encourage a sense of ownership and pride in the project for the affected community and other stakeholders.

In addition to external project communications, reporting and tracking, internal communications and communications with stakeholders should be addressed as an integral part to a successful project. The Project Management Plan should include a discussion addressing communications between project team members and stakeholders that covers how informal and formal communications will be conducted and managed.

16. Civil Rights Program. IDOT and FHWA should make a commitment to provide a strong civil rights program for the Major Project. This section of the Project Management Plan should outline the specific goals and requirements related to Disadvantaged Business Enterprises (DBE), Small Business Enterprises (SBE), Equal Employment Opportunity (EEO), and other civil rights programs for contractors, consultants, and the project delivery team. A separate civil rights team or office may be created that would be responsible for administration and oversight of the civil rights program for the project.

Procedures and requirements should be established for periodic (normally monthly) reporting on the civil rights program and for review and audit of the program.

Procedures should be defined for prompt handling of negative findings and complaints regarding the program, including the use of appropriate sanctions, if necessary.

The civil rights team/office should interface with the public information team/office to ensure that disadvantaged communities are included in public outreach programs. Consideration should be given to conducting DBE outreach sessions that bring DBEs and prime contractors together in “one-on-one” meetings to discuss large, upcoming contracts. These types of sessions have shown positive results in helping to meet or exceed DBE goals.

17. Closeout Plan. The Project Management Plan should include a Closeout Plan that discusses the requirements for providing a coordinated transition from construction to operations and the roles and responsibilities of various agencies and offices in accomplishing the transition.
18. Other Possible Sections. The Project Management Plan could also include sections on:
 - human resources management, including management of project teams and their roles and responsibilities, project team performance assessment and other human resource issues; and
 - any other project functions IDOT or FHWA believe would be beneficial to help in meeting the goals and objectives for the Major Project.
19. Appendices. Appendices to the Project Management Plan could include any prior interagency agreements or other applicable documents that would aid users of the plan in understanding prior commitments and previously established roles.

20-3 FINANCIAL PLAN

References: FHWA *Major Project Guidance Memorandum*, January 19, 2007
FHWA *Major Project Financial Plan Guidance*, December 18, 2014
FHWA *Major Project Program Cost Estimating Guidance*, January 2007

20-3.01 General

These Financial Plan requirements apply to Major Projects as described in 23 U.S.C. 106 (h).

Section 20-3.06 describes the review and approval process for Major Projects. Section 20-4 describes the financial plan requirements for Other than Major Projects under 23 U.S.C. 106 (i).

The Initial Financial Plan will provide information on the immediate and long-term financial implications resulting from project initiation. The Annual Updates of the Financial Plan should provide information on actual cost, expenditure, and revenue performance in comparison to initial estimates and updated estimates of future years' obligations and expenditures. The annual updates will provide information on cost and revenue trends, current and potential funding shortfalls, and the financial adjustments necessary to ensure completion of the project. The projected uses of funding for the project must meet the fiscal constraint requirements for the IDOT planning process.

20-3.02 Purpose

A Financial Plan is a comprehensive document that reflects the project's cost estimate and revenue structure and provides reasonable assurance that there will be sufficient financial resources available to implement and complete the project as planned. A Financial Plan provides a description of how a project will be implemented over time by identifying project costs and the financial resources to be used in meeting those costs. The plan should clearly explain the assumptions about cost and revenue upon which the plan is based. Additionally, the Annual Updates to the plan will enable decision makers to track the financial progress of the project over time by highlighting significant deviations from the Initial Financial Plan and subsequent Annual Updates explaining the mitigation actions taken to adjust for those deviations. In essence, the Financial Plan process is a subset of the overall Project Management Plan that is required for each Major Project.

20-3.03 Timing

The Initial Financial Plan should be prepared as early in the Major Project development process as practical. The cost estimate developed during the environmental process is used to determine if the action is subject to the Major Project requirements. If the estimated cost is over \$500 million, a cost estimate review is completed no later than FEIS. Accordingly, a Financial Plan could be submitted to the FHWA Division Office at the time of issuance of the Record of Decision if all other elements of the Financial Plan have been completed. The Initial Financial Plan for a Major Project could also be submitted and approved by FHWA prior to right-of-way

acquisition but, in all cases, should be submitted and approved by FHWA before the first authorization of Federal-aid funding for construction. On a design-build project, the Initial Financial Plan should be approved prior to FHWA concurrence in the award of the design-build contract. The FHWA Division Office will approve all Financial Plan documents, even when the FHWA Headquarters Project Delivery Team is involved in the review and concurrence process. In these cases, the FHWA Office of Innovative Program Delivery (OIPD) will provide formal concurrence to the Division Office.

Financial Plans must be updated annually. The Initial Financial Plan should indicate the reporting date for Annual Updates to the plan. IDOT has the option of determining the effective date of the Annual Update submission and may choose a date one year after approval of the Initial Financial Plan or, more commonly, at the end of the IDOT fiscal year or end of the federal fiscal year. The Annual Updates must reflect changes in total and remaining project cost and/or available funding. The annual updates shall be submitted to FHWA for approval no more than 90 days after the effective date established in the Initial Financial Plan.

The scope of the Annual Updates should be sufficient to identify and resolve any cost and/or funding (including cash flow) changes that have occurred since submission of the previous plan or update. This would include any changes in project scope that impact the cost estimate and/or completion schedule for the project. In the event of major changes in cost or funding, the updates may need to revise the cost and funding figures for future years in addition to those for the current year.

20-3.04 Methodology

The Initial Financial Plan and Annual Updates should be prepared in accordance with the guidelines provided in this Chapter and recognized financial reporting standards (e.g., *Guide for Prospective Financial Information* of the American Institute of Public Accountants included as Attachment A in the FHWA *Financial Plans Guidance*). In unique or unusual circumstances, alternative formats may be acceptable with prior concurrence of the FHWA Division Office and the FHWA Project Delivery Team.

20-3.05 IDOT Certification

The Initial Financial Plan and each Annual Update should include a certification, signed by the IDOT Secretary, indicating that the content is “accurate and reasonable to the best of my knowledge and belief.” The Secretary may specifically delegate in writing the signature authority for major project financial plans. (See Attachment A of the FHWA *Financial Plans Guidance* for a sample Letter of Certification.)

20-3.06 FHWA Review and Approval

The Initial Financial Plan and Annual Updates shall be submitted to the FHWA Division Office for review and approval. The FHWA Division Office and FHWA Projects Delivery Team will coordinate the review and approval of the Initial Financial Plan and all Annual Updates. The

review will evaluate such items as the reasonableness of the cost projections, the viability of the identified funding sources, including whether they are contained in the fiscally constrained STIP/TIP/Long Range Plan, and the likelihood the funding commitments will provide sufficient resources to complete the project as planned. The FHWA review and determination of acceptability should be completed within 30 to 60 days from the date the FHWA Project Delivery Team receives the document. A concurrence memorandum from the Director of OIPD will be sent to the Division Office prior to approval of the Initial Financial Plan. A concurrence e-mail from the FHWA Project Delivery Team will be sent to the Division Office prior to the approval of Annual Updates. After project construction is completed, the FHWA Project Delivery Team will send a concurrence e-mail which will include the statement that all major project requirements have been met. In all cases during the construction period, the approval of the Initial Financial Plan and Annual Updates will be by the FHWA Division Office.

20-3.07 Content

The Initial Financial Plan should consist of at least eight main sections:

- Project Description,
- P3 (Public-Private Partnership) Assessment
- Cost Estimate,
- Implementation Plan,
- Financing and Revenues,
- Cash Flow,
- Risk Identification and Mitigation Factors, and
- Annual Update Cycle

The following paragraphs provide a detailed explanation of the content for each of the required sections:

1. Project Description. The purpose of this section is to describe the scope of the project. Since the scope of the overall project is established by the environmental document, it must outline the environmental process and indicate the date of the NEPA decision document to ensure that the entire project is contained in the financial plan. Additionally, it is recommended to include a graphic depicting the project location.

If a phasing plan is presented, a detailed description of the scope of the funded phase is required. It should document that the funded phase can be opened to the public and operated without the remaining construction being completed.

2. P3 Assessment. This section should describe the process used to determine the appropriateness of P3 to deliver the project. The discussion should include the existence or absence of legislative authority allowing P3 type procurement; the plan to manage P3; and the comparison of benefits and challenges of procuring the project as P3 compared to traditional procurement methods, including innovation, project delivery schedule, cost and schedule impacts, quality, operations and maintenance efficiencies, and increased likelihood of project delivery. Additionally, the narrative should include the

risk allocation analysis comparing P3 with traditional delivery methods and relative access to and cost of capital.

3. Cost Estimate. The purpose of this section is to present the current estimate of the total cost of the project and the remaining cost-to-complete. This should include all costs and the value of all resources necessary to perform the preliminary engineering, including the cost of NEPA and other environmental documentation, right-of-way, environmental mitigation, construction, project management, Transportation Demand Management and Transportation System Management, public outreach, and costs associated with external third party work (e.g., utility adjustments, railroad relocations.) All costs should be calculated in accordance with standard accounting methods and generally do not include the costs of acquiring revenue (taxation, mortgage interest payments, etc.). For further information on estimating costs for Major Projects *Major Project Program Cost Estimating Guidance* is available on the FHWA Major Projects website. The total cost of the project should be presented as the sum of the costs for each major segment and element of the project. This section should include a narrative describing the assumptions used in developing the cost estimates. All costs should be presented in “year of expenditure” dollars (i.e., dollars that are adjusted for inflation) because it is important for the Financial Plan to be consistent in presenting both costs and revenues in comparable dollars.

At least one FHWA Cost Estimate Review (CER) should have been conducted for the entire project within 12 months prior the submission of the Initial Financial Plan. The FHWA and the project sponsor should participate during the entire CER. Alternatives to CER process may be considered with prior FHWA consultation.

4. Implementation Plan. This portion of the Initial Financial Plan should present the schedule for completing the project. Completion is usually established as the date (month and year) when the project sponsor expects to accept all of the construction work; but it should not include warranty periods. The Implementation Plan should describe the methodology used to develop the schedule and include discussion of assumptions for future inflation, cost escalation, etc. These factors are key considerations in developing the schedule because estimated expenditures for project implementation must be covered by projected revenues. This section should discuss the likelihood of occurrence, and the possible impacts on the implementation schedule, for a wide array of potential changes in costs and/or revenues. For example, cost increases might result from unforeseen environmental and subsurface conditions, inflation, litigation, technological innovations, contractor problems, overtime costs needed to meet the project schedule, changes in government rules and regulations affecting the project, value engineering savings, etc. Changes in revenues could result from lower than expected toll or tax collections, or a diversion of project funds to other projects.
5. Financing and Revenues. The plan should describe all funding sources for the project and should clearly describe these funds either as committed or as anticipated amounts, with an evaluation of the likelihood of the anticipated amounts actually being realized. The discussion should note where the funding sources are identified in the fiscally constrained IDOT STIP/TIP/Metropolitan Long Range Transportation Plan. Funds that

are identified in a Statewide Long Range plan are not fiscally constrained and will not automatically be considered committed. As a result, such funds must be evaluated for future commitment and availability.

Federal funds should be described by funding category under existing legislation and as potential amounts under future legislation. Projected expenditures of Federal-aid funds should be constrained by anticipated annual limitations on Federal-aid fund obligations.

If special funding techniques (e.g., advance construction) are to be used, the plan should include estimated annual conversion amounts.

Any portions of the project that are likely to be funded with other than Federal-aid funds should be discussed. The amount and sources of revenue for the non-Federal share should be clearly identified. If the availability of these funds is limited to certain parts or phases of the project, those limits should be explained. The Financial Plan should never assume there will be future Federal or non-Federal discretionary allocation made for the Major Project. If and when such discretionary allocations are enacted, they may be included in the project revenue in the next annual update.

The plan should address the potential for unanticipated changes in expected revenue and the impact on the project. Changes might include delays or decreases in receipt of project funding, reductions in user fees earmarked for the project, changes in government rules affecting the project, etc.

The cost of financing for the project should be estimated separately from the total project cost. It should include the issuance costs, interest costs and other aspects of borrowing funds, and each financing facility (e.g. bonds, loans etc.) should be shown separately as estimates in the Initial Financial Plan and Annual Updates.

6. Cash Flow. The key objective of this section is to demonstrate that revenue will be available to permit annual project fund obligations and expenditures as presented in the Implementation Plan, consistent with the STIP/TIP/Metropolitan Long Range Transportation Plan.

The plan should include an annual schedule of cash needs versus available cash to meet those needs. This will demonstrate that the project schedule for payments to construction contractors and others can be met. The cash flow analysis should extend through the point at which all project expenditures have been met and all Advance Construction conversions have been completed.

Annual Updates should include the original projected cash flow, actual expenditures and revised estimates for future construction. Significant deviations from the Initial Financial Plan should be explained. If phasing plan is presented, cash flow should only be provided for the funded phase.

7. Risk Identification and Mitigation Factors. This section should discuss the risk analysis for the project. It should identify risks to project completion and revenue sufficiency and

describe potential mitigation measures for addressing those risks. The following are examples of issues that should be addressed:

- a. Capital Program Impacts. Major Projects will significantly impact the IDOT transportation project capital program, thus the Financial Plan for these projects should be coordinated with the Statewide Long Range Transportation Plan and the Statewide Transportation Improvement Program. This coordination will evaluate the impact to the transportation capital program during the period of analysis covered by the Financial Plan.
- b. Cost Containment. This section should describe all special project cost containment strategies being used or planned for later use. These might include design-to-estimated cost for individual project elements (i.e., limit design so as not to exceed a target construction cost), design-build, use of cost control teams, management cost control strategies, vendor participation via warranties or guarantees, value engineering, incentive and disincentive clauses, etc.
- c. Responsibilities. The plan should describe the major responsibilities, financial and otherwise, of the various parties involved in the project and should contain evidence of agreements or commitments.
- d. Special/Unique Arrangements. The plan should describe any special or unique agreements, laws, rules, or regulations in addition to NEPA and Title 23 that apply to the Major Project. These could include Federal or State project-enabling legislation, financial agreements and covenants, accounting system reports and audits, etc.
- e. Cost Monitoring. If pertinent, the plan should discuss the liability for subsequent operation and maintenance costs as project segments come on-line. On some Major Projects, the opening of certain segments to traffic could require significant operational resources (e.g., a tunnel or complex traffic management system) while other elements of the project are not complete and still require significant construction expenditures.

When Financial Plans call for funding mechanisms other than existing revenue streams to meet the non-Federal revenue needs or to meet cash flow demands, the likelihood of the mechanisms being implemented must be thoroughly analyzed. This would apply to mechanisms such as new taxes, future toll increases not currently authorized, contributions from third parties, and short-term or long-term borrowing. The analysis must address whether authority exists to pursue the mechanisms or must be granted through legislation or other means. In evaluating this portion of the Financial Plan, the Federal focus will be on the likelihood of realizing the non-Federal revenues, not on the choice of mechanism.

8. Annual Update Cycle. The Initial Financial Plan will identify the schedule for the future Annual Updates. It may be advantageous to time the submittal of the Annual Updates to coincide with the beginning of either the State fiscal year or the Federal fiscal year,

rather than the anniversary of the approval of the Initial Financial Plan. If the annual updates are submitted on a schedule that does not correspond to the beginning of the Federal fiscal year, it still will be permissible to display Federal-aid obligations and expenditures on a Federal fiscal year basis.

20-3.08 Annual Updates

Each Annual Update of the Financial Plan should be presented in both total cost (actual cost to date) and cost-to-complete estimates (shown in year-of-expenditure dollars). These updates should use the same project elements of segment breakpoints as used in the Initial Financial Plan to present the costs and revenues. Any significant change in the total project cost or revenue since the last estimate should be clearly presented and should include a discussion of the major reasons for the significant changes.

In the Annual Updates, each of the eight main sections from the Initial Financial Plan should be updated to reflect any changes that have occurred since approval of the initial plan. The following subjects should be addressed and incorporated in the appropriate sections of the annual updates:

1. Cost and Revenue History. The presentation should clearly summarize significant cost and/or revenue changes from the Initial Financial Plan estimates and discuss the reason(s) for the changes. Any identified or potential funding shortfall should be discussed in detail, along with the steps that have been taken, or that will be available, if needed, to address the shortfall(s). As appropriate, the annual updates should discuss mitigating measures that increase project funding and/or reduce project costs, including changes in project scope and design undertaken specifically in response to revenue shortfall. Significant changes in project scope also should be discussed and their impact on project costs, both to date and in the future, should be explained. Where appropriate, Annual Updates should track project milestones and compare initial cost and revenue estimates to the actual costs and revenues at the milestone points.
2. Cost and Revenue Trends. This discussion should clearly identify the trends that have impacted project costs and revenues in the past year(s) and the probable reasons for these trends. This may be as simple as identifying a change in the anticipated rate of inflation, the availability of materials, the cost of supplies, or the wages paid to project personnel; or as complicated as assessing changes in the competitive arena that have impacted construction bid prices. For each of the trends identified, the Annual Updates should discuss the implications of the trends for the remainder of the project and should explain any adjustments in the Financial Plan necessary to respond to those trends.
3. Summary of Significant Cost Reductions. If any changes in the project have reduced the cost by at least \$10 million, the changes should be discussed individually. The discussion should include the original cost estimate, the reduced actual or projected cost, and a brief explanation of how and/or why the reduction was achieved. These changes should be grouped by element and include any scope changes made to the project.

4. Summary of Significant Cost Increases. If any items have increased the cost of the project by at least \$10 million, the items should be discussed individually. The discussion should include the original cost estimate, the increased actual or projected cost, and a brief explanation of why the increase was necessary. Those increases in cost should be grouped by element and/or changes to the project scope.
5. Summary of Schedule Changes and Trends. This discussion should identify the changes that have affected the project completion date and/or funded phase since the Initial Financial Plan or the last Annual Update. The discussion should clearly identify the primary reason(s) and trends that have impacted the schedule change.

20-4 REQUIREMENTS FOR OTHER THAN MAJOR PROJECTS

References: FHWA *Major Project Financial Plan Guidance*, December 18, 2014

Subsection (i) of 23 U.S.C. 106, "Project approval and oversight," sets forth requirements for preparation of an annual Financial Plan for "Other Projects," which are projects not otherwise selected as Major Projects, and have an estimated total cost of \$100 million up to \$500 million. Phasing and Operationally Independent Non-Concurrent Construction Projects can also be applied to these projects in order to address projects implemented over extended periods of time.

In accordance with FHWA guidance implementing Subsection (i), the responsible district must prepare an Initial Financial Plan and Annual Updates for projects with an estimated total cost of \$100 million up to \$500 million. The estimated total cost will be based on the full scope of the project for the limits defined by the environmental process or for the limits that are considered an operationally independent non-concurrent construction project.

These Other Projects with an estimated total cost exceeding \$100 million, but not designated by FHWA as Major Projects, must have an Initial Financial Plan and Annual Updates to be available to FHWA for review upon request.

The content of the Initial Financial Plan and Annual Updates should address the same sections as those for Major Projects and should be consistent with the guidance in Section 20-3. It is anticipated that the level of detail will be more straightforward for these plans. Also, optional reporting formats for presenting information on multiple IDOT projects of this type will be considered on a case-by-case basis. FHWA will not approve these Initial Financial Plans, but they will be subject to FHWA review to ensure they were completed in accordance with Title 23 requirements for content and timeliness.

For these projects, the Initial Financial Plan may be developed and completed at the earliest feasible point in the project development process. However, it must be finalized prior to construction contract authorization and obligation of Federal funds for construction under the design/bid/build process and prior to contract award for design/build projects.

Chapter Twenty-one

RESERVED

BUREAU OF DESIGN AND ENVIRONMENT MANUAL

Chapter Twenty-one
RESERVED

Chapter Twenty-two

GENERAL ENVIRONMENTAL PROCEDURES

BUREAU OF DESIGN AND ENVIRONMENT MANUAL

Chapter Twenty-two
GENERAL ENVIRONMENTAL PROCEDURES

Table of Contents

<u>Section</u>	<u>Page</u>
22-1 COORDINATION BETWEEN BDE MANUAL AND KEY ENVIRONMENTAL DIRECTIVES AND GUIDANCE	22-1.1
22-2 ENVIRONMENTAL DOCUMENTATION AND PROCESS FOR FEDERAL ACTIONS	22-2.1
22-2.01 Introduction	22-2.1
22-2.02 Policy	22-2.1
22-2.03 Environmental Documentation for Federal Projects.....	22-2.2
22-2.04 Environmental Process for Federal Projects.....	22-2.2
22-2.05 Environmental Process and Documentation for Non-Federal Project ...	22-2.2
22-3 GENERAL NEPA REQUIREMENTS	22-3.5
22-3.01 Purpose/Policy	22-3.5
22-3.02 Application	22-3.5
22-3.03 Integration of NEPA and Planning.....	22-3.6
22-3.04 Lead/Cooperating/Participating Agencies.....	22-3.7
22-3.05 Proposed Action.....	22-3.8
22-3.06 Environmental Studies	22-3.8
22-3.07 Significance of Environmental Impacts.....	22-3.9
22-3.08 Evaluation of Alternatives and Selection of Preferred Alternative	22-3.10
22-3.09 Public Access to Preliminary Environmental Documents.....	22-3.10
22-3.10 Cooperating Agency access to Preliminary Environmental Documents	22-3.11
22-3.11 Time Limits.....	22-3.12
22-3.12 Limitations on Actions	22-3.12
22-3.13 Other Agency Adoption	22-3.13
22-3.14 Re-evaluations of CE, FONSI, or ROD.....	22-3.13
22-3.14(a) General.....	22-3.13
22-3.14(b) Definitions	22-3.13
22-3.14(c) Re-evaluation Factors	22-3.15
22-3.14(d) Re-evaluation Document Elements.....	22-3.15
22-3.14(e) Re-evaluation Format.....	22-3.16
22-4 CONCURRENT NEPA/404 PROCESSES	22-4.1
22-4.01 Background.....	22-4.1
22-4.02 Applicability	22-4.1
22-4.03 Procedures.....	22-4.1

Table of Contents

(Continued)

<u>Section</u>	<u>Page</u>
22-4.03(a) General.....	22-4.1
22-4.03(b) Concurrence Point Meetings.....	22-4.2
22-4.03(c) Concurrence Point Information.....	22-4.3
22-4.03(d) Special Concurrence Point Meetings	22-4.3
22-4.03(e) Prevention, Minimization, and Mitigation of Adverse Effects to Aquatic Resources	22-4.3
22-4.04 Section 404(b)(1) Compliance Information Outline	22-4.4
22-4.04(a) Discussion of Alternatives	22-4.4
22-4.04(b) Items for 404(b)(1) Compliance Evaluation	22-4.4
22-5 COORDINATION	22-5.1
22-5.01 General	22-5.1
22-5.01(a) Policy	22-5.1
22-5.01(b) Procedures	22-5.2
22-5.01(c) Lines of Communication.....	22-5.2
22-5.02 Coordination with Federal and State Regulatory and Resource Agencies	22-5.3
22-5.02(a) Federal Agencies.....	22-5.4
22-5.02(b) State Agencies.....	22-5.8
22-5.03 District Coordination Meetings.....	22-5.10
22-5.03(a) Scheduling Coordination Meetings.....	22-5.11
22-5.03(b) Appropriate Representation	22-5.11
22-5.03(c) Topics for Discussion.....	22-5.11
22-5.03(d) Information Presented.....	22-5.12
22-5.03(e) Documentation.....	22-5.12
22-5.03(f) Recommended Practices	22-5.13
22-5.03(g) Commitments.....	22-5.15
22-6 GUIDANCE ON SPECIAL TOPICS	22-6.1
22-6.01 Purpose and Need	22-6.1
22-6.01(a) Introduction	22-6.1
22-6.01(b) Safety Considerations.....	22-6.2
22-6.01(c) Consideration of Alternatives	22-6.3
22-6.01(d) Basic Ingredients of Purpose and Need	22-6.4
22-6.01(e) Using Purpose and Need in Decision Making	22-6.5
22-6.01(f) Key Points to Remember	22-6.6
22-6.01(g) Additional Information	22-6.6

Table of Contents
(Continued)

<u>Section</u>	<u>Page</u>
22-6.02 Indirect and Cumulative Environmental Impacts.....	22-6.6
22-6.02(a) Background.....	22-6.7
22-6.02(b) Applicability.....	22-6.7
22-6.02(c) Definitions.....	22-6.7
22-6.02(d) Identifying and Disclosing Reasonably Foreseeable Indirect and Cumulative Environmental Impacts.....	22-6.8
22-6.02(e) Compatibility with Comprehensive Resource Plans.....	22-6.9
22-6.02(f) Mitigation.....	22-6.9
22-6.02(g) Format for Documentation in Environmental Reports.....	22-6.10
22-6.03 Logical Termini.....	22-6.10
22-6.03(a) Introduction.....	22-6.10
22-6.03(b) A Definition of Logical Termini.....	22-6.11
22-6.03(c) Sample Project Concepts and Discussion.....	22-6.12
22-6.03(d) Conclusions.....	22-6.16
22-6.04 Congestion Management Process (CMP) Alternatives.....	22-6.16
22-7 ENVIRONMENTAL DOCUMENTATION AND PROCESS FOR NON-FEDERAL PROJECTS.....	22-7.19
22-7.01 Environmental Documentation for Non-Federal Projects.....	22-7.19
22-7.01(a) “Categorical Exclusion” Projects.....	22-7.19
22-7.01(b) Non “Categorical Exclusion” Projects.....	22-7.19
22-7.02 Environmental Process for Non-Federal Projects.....	22-7.19
22-7.02(a) Inventory and Evaluate Preliminary Alternatives.....	22-7.19
22-7.02(b) Perform Environmental Surveys.....	22-7.22
22-7.02(c) Initiate Early Coordination.....	22-7.22
22-7.02(d) Determine Reasonable Alternatives and Evaluate In-Depth.....	22-7.22
22-7.02(e) Prepare/Distribute Special Technical Reports.....	22-7.23
22-7.02(f) Prepare Environmental Documentation.....	22-7.23
22-7.02(g) Coordinate with Public/Affected Agencies.....	22-7.23
22-7.02(h) Revise Environmental Documentation.....	22-7.24
22-7.02(i) Secure Design Approval.....	22-7.24
22-7.02(j) Implement Mitigation Measures.....	22-7.24
22-8 REFERENCES.....	22-8.1
22-8.01 National.....	22-8.1

Table of Contents
(Continued)

<u>Section</u>	<u>Page</u>
22-8.02 State	22-8.4
22-8.02(a) Manuals	22-8.4
22-8.02(b) BDE Memoranda and Policies	22-8.4

Chapter Twenty-two

GENERAL ENVIRONMENTAL PROCEDURES

All projects administered by IDOT must meet applicable Federal and State laws and regulations requiring identification and evaluation of the project's environmental impacts. In aggregate, Part III of the BDE Manual describes the applicable environmental procedures for State highway projects. Chapter 22 presents information which has a general application to all IDOT projects. This includes environmental documentation, coordination, and general NEPA compliance procedures. The subsequent chapters in Part III discuss more specific applications of the environmental procedures (e.g., preparation of an EIS).

The appendices in Part III accomplish the following:

- Appendix A presents duplicated regulation and guidance to support the environmental procedures.
- Appendix B presents acronyms and definitions which apply to environmental procedures.
- Appendix C presents descriptions of legal authorities for key environmental requirements and descriptions of functional responsibilities of governmental agencies responsible for implementing environmental requirements.
- Appendix D presents guidance on the preparation of an EA/EIS.

22-1 COORDINATION BETWEEN BDE MANUAL AND KEY ENVIRONMENTAL DIRECTIVES AND GUIDANCE

The literature on environmental procedures is too voluminous to reproduce in its entirety. Therefore, Appendix A duplicates selected environmental documents.

IDOT has developed criteria and information for its specific application of the environmental procedures which supplements the national documents duplicated in Appendix A. The IDOT-specific information is presented in *Part III, "Environmental Procedures"*. Where applicable, a reference is provided to allow the user of the BDE Manual to coordinate the IDOT specific information with the duplicated documents in Appendix A.

The *Council on Environmental Quality (CEQ) Regulations* are intended to apply to Federal agencies. For Federally funded or regulated IDOT projects, the provisions of the regulations constitute policy guidance for IDOT and should be viewed accordingly.

22-2 ENVIRONMENTAL DOCUMENTATION AND PROCESS FOR FEDERAL ACTIONS

References: 23 U.S.C. 139 “Efficient Environmental Reviews for Project Decision Making”
40 CFR 1500-1508 “CEQ Regulations for Implementing NEPA”
23 CFR 771 “Environmental Impact and Related Procedures”
FHWA Technical Advisory T 6640.8A “Guidance for Preparing and Processing Environmental and Section 4(f) Documents”
FHWA *SAFETEA-LU Environmental Review Process Final Guidance*

22-2.01 Introduction

The primary purpose of environmental documentation is to ensure that the policies and goals defined in NEPA (See Section 22-4) are incorporated into the ongoing programs and actions of the Department. Environmental documentation is intended to accomplish more than mere disclosure; it will be used in conjunction with other relevant material to plan actions and to make decisions.

Environmental documentation is also required to reflect compliance with other applicable Federal and State laws, regulations, and Executive Orders (e.g., addressing protection of threatened and endangered species, farmland protection, historic preservation, protection of bald eagles and golden eagles, environmental justice, protection of flood plains and protection of wetlands).

22-2.02 Policy

References: 40 CFR 1502.1 “Early application of NEPA”
CEQ Q&A, Question 17 “Consultants and Conflict of Interest”
CEQ Q&A, Question 27a “Identifying Consultants in List of Preparers”

All environmental documentation shall provide full and fair discussion of environmental impacts and shall inform decision-makers and the public of the reasonable alternatives that would avoid or minimize adverse impacts or enhance the quality of the human environment. Preparers of environmental documentation shall focus on the significant environmental issues and alternatives and shall reduce paperwork and the accumulation of extraneous background data. Documentation shall be concise, clear, and to the point and shall be supported by evidence that the necessary environmental analyses have been performed. Use of metric values in environmental documents is optional. Where dual units are used, they may be shown in either order provided the selected approach is consistently applied in the documents for a particular project. The preferred method will be to show US Customary values first with metric values in parentheses.

Consultants may be employed to prepare all types of environmental documentation; however, the responsibility for all conclusions and determinations involved in environmental decisions remains with IDOT and FHWA. Environmental work by consultants leading to a project decision

shall be carefully reviewed to ensure that complete and objective consideration has been provided to all relevant project impacts and alternatives.

22-2.03 Environmental Documentation for Federal Projects

Reference: 23 CFR 771.115 “Classes of Action”

The term “environmental documentation”, as used in this Manual, refers to the information prepared to analyze the potential environmental impacts of project alternatives. Depending upon the specific circumstances involved, the environmental documentation for a project will be one of the following three types:

- documentation included in Phase I Report (Categorical Exclusions (CEs) (Chapter 23),
- Environmental Assessment (EA) Document (Chapter 24), or
- Environmental Impact Statement (EIS) Document (Chapter 25).

The selection of the appropriate type of environmental documentation for a project is based upon the following two factors:

- the project’s potential for significant environmental impacts, and
- the involvement of Federal funding participation or Federal approvals.

Figure 22-2.A illustrates the decision-making process for selecting the appropriate environmental documentation format. The determinations in the selection process must be supported by the appropriate environmental studies.

22-2.04 Environmental Process for Federal Projects

The environmental process for Federal Projects is discussed throughout Part III of the BDE Manual.

22-2.05 Environmental Process and Documentation for Non-Federal Project

For a discussion on this topic, please see Section 22-7.

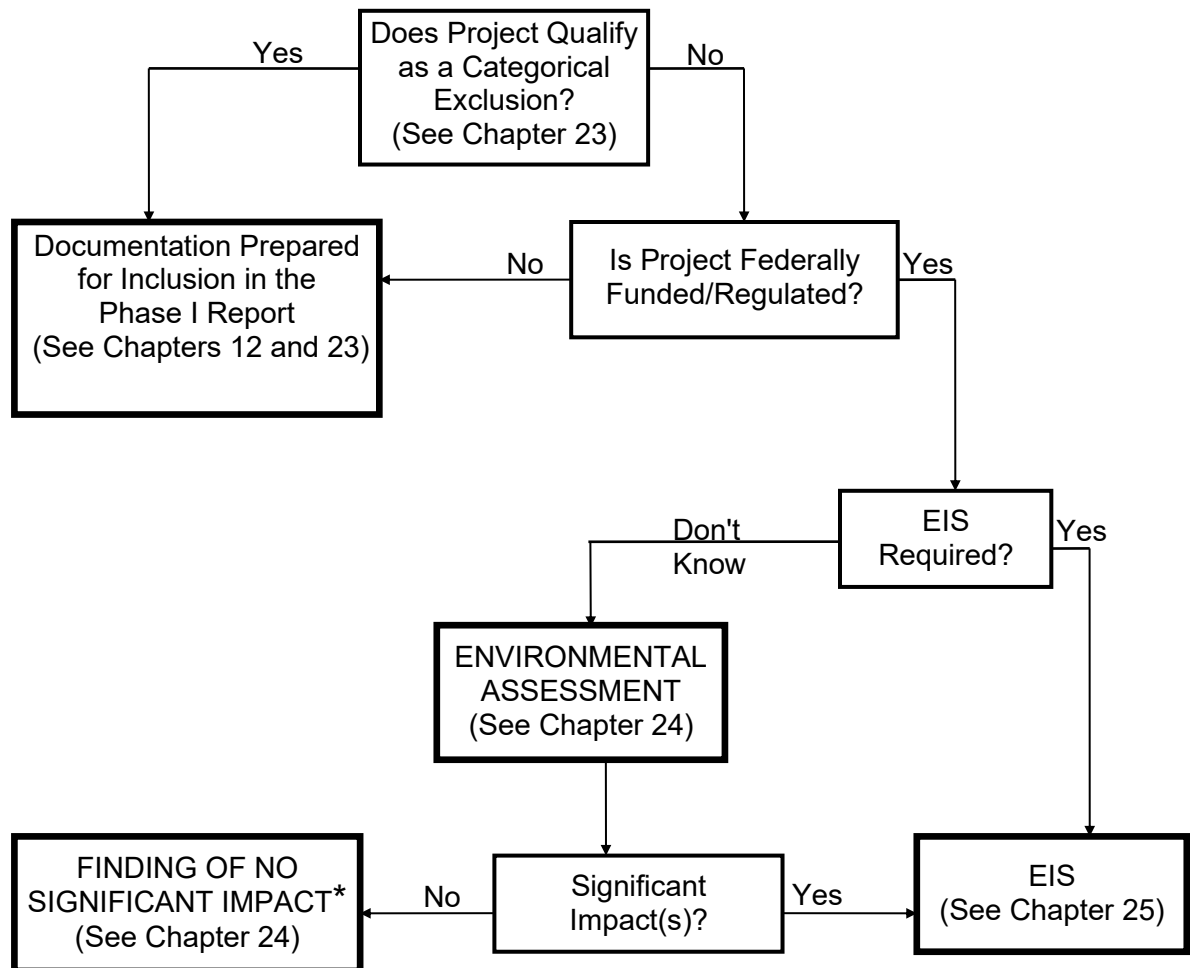

* A Finding of No Significant Impact (FONSI) is a separate document from the EA. It summarizes the basis for FHWA's determination that a project will not cause significant impacts that would require preparation of an EIS.

SELECTION OF ENVIRONMENTAL DOCUMENTATION TYPE

Figure 22-2.A

22-3 GENERAL NEPA REQUIREMENTS

This section discusses general requirements which IDOT projects must follow to satisfy NEPA, if the project is Federally funded or regulated.

22-3.01 Purpose/Policy

References: 40 CFR 1500.1 "Purpose of NEPA"
40 CFR 1500.2 "NEPA Policy"

40 CFR 1500.1 defines the purpose of the *National Environmental Policy Act* of 1969. The following excerpts highlight some of its key provisions:

- *NEPA establishes policy, sets goals, and provides means for carrying out the policy.*
- *NEPA procedures must insure that environmental information is available to public officials and citizens before decisions are made and before actions are taken.*
- *NEPA documents must concentrate on the issues that are truly significant to the action in question, rather than amassing needless detail.*
- *The NEPA process is intended to help public officials make decisions that are based on understanding of environmental consequences, and take actions that protect, restore, and enhance the environment.*

40 CFR 1500.2 sets forth the policy for compliance with NEPA. The policy provides that Federal agencies shall to the fullest extent possible:

- *Implement procedures to make the NEPA process more useful to decision makers and the public; to reduce paperwork and the accumulation of extraneous background data; and to emphasize real environmental issues and alternatives.*
- *Use the NEPA process to identify and assess the reasonable alternatives to proposed actions that will avoid or minimize adverse effects of these actions upon the quality of the human environment.*
- *Encourage and facilitate public involvement in decisions which affect the quality of the human environment.*
- *Use all practicable means to restore and enhance the quality of the human environment and avoid or minimize any possible adverse effects of their actions upon the quality of the human environment.*

22-3.02 Application

References: 40 CFR 1500.1(a) "Application of NEPA"
23 CFR 771.109(a) "Application of 23 CFR 771"

The NEPA procedures apply to all Federally regulated and Federally funded projects; e.g., a State-only funded project which requires an individual Section 404 permit also might require an Environmental Impact Statement to comply with NEPA for the Federal action (granting the permit). In this example, the Federal Highway Administration may not be involved in the project; therefore, the flow of information and activities will be modified to suit the lead Federal agency involved (i.e., the US Army Corps of Engineers).

Section 22-7 presents the environmental process for non-Federal projects.

22-3.03 Integration of NEPA and Planning

References: 23 USC 134 “Metropolitan Transportation Planning”
23 USC 135 “Statewide Transportation Planning”
23 CFR 450.212 “Transportation Planning Studies and Project Development (Statewide Transportation Planning and Programming)”
23 CFR 450.318 “Transportation Planning Studies and Project Development (Metropolitan Transportation Planning and Programming)”
Appendix A to Part 450 “Linking the Transportation Planning and NEPA Processes”
40 CFR 1501 “NEPA *and Agency Planning*”
Chapter 2 “Project Development Network (New Alignment)”
Part II, Project Development

The *CEQ Regulations* issued to implement the *National Environmental Policy Act* (NEPA) include provisions that address the relationship between NEPA and planning. 40 CFR 1501.2 states, in part, that:

Agencies shall integrate the NEPA process with other planning at the earliest possible time to ensure that planning and decisions reflect environmental values, to avoid delays later in the process, and to head off potential conflicts.

The *Safe, Accountable, Flexible, Efficient Transportation Equity Act: A Legacy for Users* (SAFETEA-LU) implemented several changes in parts 134 and 135 of the United States Code intended to enhance consideration of environmental issues and impacts within the transportation planning process and encourage the use of the products from planning in the NEPA process.

In 23 U.S.C. 134(h) “Scope of Planning Process,” paragraph (1)(E) requires the metropolitan planning process to provide for consideration of projects and strategies that will “...protect and enhance the environment...” The same requirement is included in paragraph (1)(E) of 23 U.S.C. 135(d) “Scope of Planning Process” for statewide planning.

In 23 U.S.C. 134(i) “Development of Transportation Plan,” paragraph (4)(A) requires metropolitan planning organizations “...to consult, as appropriate, with State and local agencies responsible for land use management, natural resources, environmental protection, conservation, and historic preservation concerning the development of a long-range

transportation plan.” The same requirement is included in paragraph (2)(D)(i) of 23 U.S.C. 135(f) “Long Range Statewide Transportation Plan.”

Also in 23 U.S.C. 135(f), paragraph (4) “Mitigation Activities” includes a provision requiring long-range transportation plans to “...include discussion of potential environmental mitigation activities and potential areas to carry out these activities, including activities that may have the greatest potential to restore and maintain the environmental functions affected by the plan.” This paragraph also includes a requirement that the discussion of mitigation activities “...be developed in consultation with Federal, State, and tribal wildlife, land management, and regulatory agencies.”

The changes in the referenced sections of the U.S.C. are reflected in the provisions of the current planning regulations in 23 CFR 450.212 and 450.318. Appendix A to Part 450 provides additional information to explain the linkage between the transportation planning and project development/National Environmental Policy Act (NEPA) processes.

Chapter 2 and *Part II, “Project Development”* of the BDE Manual, referenced above, include discussion of IDOT procedures for integrating the NEPA process with other Department planning activities.

22-3.04 Lead/Cooperating/Participating Agencies

References: 23 U.S.C. 139 “Efficient Environmental Reviews for Project Decision Making”
40 CFR 1501.5 “Responsibilities of, and Procedures for, Determining Lead Agencies”
40 CFR 1501.6 “Cooperating Agency’s Responsibilities”
40 CFR 1508.5 “Definition of Cooperating Agency”
40 CFR 1508.16 “Definition of Lead Agency”
23 CFR 771.109(c) “Role of Federal Funding Applicant; Local Public Agencies as Cooperating Agencies”
23 CFR 771.111(d) “Requesting Involvement of Cooperating Agencies”
CEQ Q&A, Question 14 “Coordination Between Lead and Cooperating Agencies”
CEQ Q&A, Question 22 “State and Federal Agencies as Joint Lead Agencies”
FHWA SAETEA-LU Final Guidance, Questions 14-20 “Lead Agencies”
FHWA SAETEA-LU Final Guidance, Questions 21-29 “Participating Agencies”
FHWA SAETEA-LU Final Guidance, Questions 30 and 31 “Cooperating Agencies”

FHWA will be the Federal lead agency for most IDOT projects subject to the NEPA process, although FHWA and IDOT typically act as joint lead agencies; see 23 CFR 771.109(c)(2). The cited references from 40 CFR 1500 discuss the responsibilities of the lead agency and cooperating agencies. The cited questions from the FHWA *SAFETEA-LU Environmental Review Process Final Guidance* provide additional guidance regarding lead and cooperating agencies and discuss procedural requirements, roles, and responsibilities associated with participating agencies.

Section 24-2 describes the role of Cooperating Agencies in the preparation of an EA.

Section 25-2 describes the role of Cooperating and Participatory Agencies in the preparation of an EIS.

22-3.05 Proposed Action

References: 40 CFR 1502.4(a) "Scope of Proposal(s) Covered in Environmental Document"
40 CFR 1508.23 "Definition of Proposal"
23 CFR 771.107(b) "Definition of Action"
23 CFR 771.111(f) "Logical Termini, Independent Utility, Effect on Other Projects"
Section 22-6.04 "Logical Termini"

IDOT must properly define the proposed action to ensure a meaningful evaluation of alternatives and to avoid commitments to transportation improvements before they are fully evaluated. This should occur as part of the planning process for the development of the Department's annual, multi-year, and long-range programs of projects. For reference, 23 CFR 771.107(b) defines "action" as:

A highway or transit project proposed for FHWA or UMTA funding. It also includes activities such as joint and multiple-use permits, changes in access control, etc., which may or may not involve a commitment of Federal funds.

Section 22-6.04 discusses the determination of logical project termini for the proposed action.

The proposed action may include completed and/or incomplete portions of a highway section and one or more future highway projects. Avoid piecemealing a proposed improvement in separate environmental reports. The proposed action should include the total length of highway between logical termini, even if only a short length is proposed for construction within the multi-year and long-range program. The environmental report should clearly identify the length of the proposed action and furnish any available information on long-range possibilities of future improvements for the proposed action.

22-3.06 Environmental Studies

References: 23 U.S.C. 139 "Efficient Environmental Reviews for Project Decision Making"
40 CFR Part 1502.24 "Methodology and Scientific Accuracy"
23 CFR 771.107(a) "Definition of Environmental Studies"
Chapter 26 "Special Environmental Analyses"
Chapter 27 "Environmental Surveys"
FHWA SAFETEA-LU Final Guidance, Question 38 "Developing the Methodologies for the Analysis of Alternatives"

Environmental studies provide the technical data and information necessary to identify and evaluate the nature and extent of environmental impacts of a proposed action (and associated mitigation measures that may be appropriate). Chapters 26 and 27 and the IDOT environmental

technical manuals discuss the procedural and technical aspects of the environmental studies. These include, for example, air quality analyses, water quality analyses, Section 4(f), noise analyses, cultural impact analyses, wetland technical reports, and biological assessments. 40 CFR 1502.24 identifies the basic objective of the environmental studies:

Agencies shall insure the professional integrity, including scientific integrity, of the discussions...

The environmental studies typically will be conducted in conjunction with actions for which an EIS will be prepared. They also will be performed for actions processed as an EA or a Categorical Exclusion, if necessary, to address specific substantive issues. To maximize benefits, the district should initiate these studies as early as practical and continue the studies throughout project development. Some studies will be initiated by BDE upon receipt of an Environmental Survey Request from the district (e.g., wetlands, biological, cultural resources) and others will be prepared by the district (e.g., socio-economic, agriculture, water quality). The evolution of the environmental studies should be commensurate with the decisions which are being made during project development. The environmental studies will be used:

- to determine the type of environmental processing (i.e., EIS, EA, CE) for a specific project (including determination of the presence of unusual circumstances for proposed CE projects);
- as the basis for scoping decisions;
- to determine the significance of project impacts; and
- as the basis for discussions in reports.

The discussions of the study results should indicate whether resources are present that could be affected, how those resources would be affected, what attempts were made to avoid or minimize the impact, and what mitigation measures are proposed to address the unavoidable impacts. Generic descriptions of impacts that “may” occur as a result of highway projects (e.g., highway projects may result in the conversion of farmland) should be avoided in favor of descriptions of the specific effects anticipated to result from the project alternatives under study.

22-3.07 Significance of Environmental Impacts

Reference: 40 CFR 1508.27 “Definition of ‘Significantly’ (Affecting) as Used in NEPA”

In evaluating the significance of impacts, the district shall consider the nature of the changes which may be caused by the action and the magnitude and importance of those changes. It is important to contact agencies which have special expertise or jurisdiction by law and individuals and organizations directly affected by the proposal to fully assess project impacts. Documentation of such contacts and those concerning the resolution of identified problems shall be included in the appropriate environmental document.

22-3.08 Evaluation of Alternatives and Selection of Preferred Alternative

References: 23 U.S.C. 139 “Efficient Environmental Reviews for Project Decision Making”
40 CFR 1502.14 “Alternatives Including the Proposed Action”
23 CFR 771.125(a)(1) “Identification of Preferred Alternative in FEIS”
Paragraph II.C of FHWA Technical Advisory T6640.8A “Alternatives Discussion in EAs”
Paragraph V.E of FHWA Technical Advisory T6640.8A “Alternatives Discussion in EISs”
FHWA SAFETEA-LU Final Guidance, Questions 36-38 “Alternatives Analysis”
FHWA SAFETEA-LU Final Guidance, Questions 39-46 “Preferred Alternative”
CEQ Q&A, Questions 1 through 3 “Evaluation of Alternatives”
CEQ Q&A, Questions 4 through 6 “Identification of Preferred Alternative and Environmentally Preferable Alternative”

When a proposed project may adversely affect resources, such as wetlands, floodplains, Section 4(f) properties, or threatened and endangered species, districts must ensure that the evaluation of alternatives appropriately addresses avoidance, minimization, and mitigation options as required by regulations applicable to these resources. In addition, if the preferred alternative will affect such resources, districts must ensure that adequate justification is provided to explain why avoidance alternatives were not selected, in accordance with the regulations applicable to the resource(s) involved.

In selecting the preferred alternative for implementation, all of the social, economic, environmental, and engineering factors involved must be carefully weighed. Input from environmental agencies with relevant expertise and from the public should be sought at each step when narrowing the choices among alternatives to ensure, to the maximum extent practical, that the decision-making process fully and fairly considers all relevant information.

All alternatives considered in the selection process, the alternative(s) considered to be environmentally preferable, and the preferred alternative shall be identified in the decision statement for the action.

22-3.09 Public Access to Preliminary Environmental Documents

Federal environmental directives, including NEPA and 23 CFR 771, encourage an open process which fully involves the public. In addition, the Federal Freedom of Information Act (FOIA) directs that information be made available to the public to the greatest extent practical. However, although public involvement is strongly encouraged, there is a need to ensure that no segment of the public obtains an unfair advantage through premature access to project information.

This principle applies to preliminary environmental documents, which the general public should not have access to these documents. Such access not only provides individuals or groups involved with an unfair advantage over the remaining public, it also may promote attempts by such entities to influence decision making at inappropriate times in project development.

The FOIA and the implementing regulation of the U.S. Department of Transportation (49 CFR 7.71) provide an exemption to address these cases. These directives provide that, where material is intended for public release at a specified time in the future and premature disclosure would be detrimental to the orderly processing of a Federal project, this material can be withheld during the development of the environmental document. Such material must be released after the environmental action is taken.

22-3.10 Cooperating Agency access to Preliminary Environmental Documents

This procedure is applicable to all State highway projects involving Federal funding, authorization, or approvals for which an Environmental Impact Statement or Environmental Assessment is being prepared. The Department may provide a preliminary environmental document (EIS or EA) to a cooperating agency as discussed in Section 24-2.13 and Section 25-2.16. In these instances, the letter of transmittal shall be sent and include a statement such as the following:

The Federal Highway Administration has determined that this preliminary document is an intergovernmental exchange that may be withheld under the Freedom of Information Act. Premature release of this material to any segment of the public could give some sectors an unfair advantage and would have a detrimental effect on intergovernmental coordination and the success of the cooperating agency concept. For these reasons, we respectfully request that the public not be given access to this preliminary document.

22-3.11 Time Limits

References: 23 U.S.C. 139 “Efficient Environmental Reviews for Project Decision Making”
40 CFR 1501.8 “Time Limits”
CEQ Q&A, Question 35 “Time Required for NEPA Process”
23 CFR 771.119(d), (e), and (h) “Time Limits in EA/FONSI Processing”
23 CFR 771.123(h) and (i) “Time Limits in DEIS Processing”
23 CFR 771.127(a) “Time Limits for Record of Decision”
FHWA SAFETEA-LU Final Guidance, Questions 47-57 “Coordination and Schedule”
FHWA/IDOT Statewide Implementation Agreement for Establishment of Timeframes for Environmental Impact Statements and Environmental Assessments

The *CEQ Regulations* include provisions for establishing time limits on various steps in the NEPA process. These time limit provisions are not mandatory. Section 1309 of the *Transportation Equity Act for the 21st Century (TEA-21)* mandated “Environmental Streamlining” for transportation projects and imposed requirements for cooperatively determining time frames for development of EISs and EAs. IDOT and FHWA have executed a Statewide Implementation Agreement (SIA) for establishing time frames for EISs and EAs for IDOT projects. This SIA is included in Appendix A. It applies to all EIS and EA documents initiated after October 1, 2003. Pursuant to the SIA, time frame negotiations should typically occur in conjunction with FHWA/IDOT coordination meetings. The meeting minutes will document the approval of the time frame for the project by the appropriate FHWA and IDOT district personnel. FHWA will monitor all milestone dates. FHWA and IDOT will provide a copy of the time frames to the involved environmental review and permitting agencies.

For EIS projects, 23 U.S.C. 139 requires development of a coordination plan for public and agency participation and imposes deadlines on certain aspects of the environmental process. Provisions in 23 U.S.C. 139(g) encourage, but do not require lead agencies to include a schedule in the coordination plan. Questions 47 through 57 in the FHWA *SAFETEA-LU Environmental Review Process Final Guidance* provide direction on these topics.

22-3.12 Limitations on Actions

References: 23 U.S.C. 139 “Efficient Environmental Reviews for Project Decision Making”
40 CFR 1506.1 “Limitations on Actions During NEPA Process”
23 CFR 771.113 “Timing of Administration Activities”
CEQ Q&A, Question 10 Limitations on Actions

The cited references for 40 CFR 1506, 23 CFR 771 and the CEQ Questions and Answers discuss limitations on actions that IDOT and FHWA can take during the NEPA process.

22-3.13 Other Agency Adoption

References: 40 CFR 1506.3 “Adoption of EIS
CEQ Q&A, Question 30 “Adoption of EIS by Cooperating Agency”

As discussed in the cited references, agencies other than FHWA and IDOT may adopt environmental documents prepared by IDOT.

22-3.14 Re-evaluations of CE, FONSI, or ROD

References: 23 CFR 771.129 “Re-evaluations of Environmental Documents”
Section XI of FHWA Technical Advisory T6640.8A “Re-evaluations
CEQ Q&A, Question 32 EIS Validity”

22-3.14(a) General

The National Environmental Policy Act (NEPA) requires Federal and state agencies to consider and disclose the environmental impacts of their proposed actions as part of their decisionmaking. Prior to FHWA authorizing a project to go to final design, right-of-way acquisition or construction, the environmental approval must be analyzed to determine if the approval remains valid. Sometimes there are changes to the proposed action, new information or circumstances, or there is a lapse of time between preparation of the environmental document and implementation of the action. These circumstances may trigger the need to re-evaluate and document those changes to verify the NEPA determination remains valid.

The following sections discuss this process in further detail.

22-3.14(b) Definitions

1. **Project Scoping** – A project development activity that involves determining and documenting project goals and objectives, tasks, deliverables, schedule, cost and delivery method.
2. **Re-evaluation.** A re-evaluation is a review of any proposed changes in an action, affected environment, anticipated impact, applicable requirements or mitigation measure as they relate to the environmental document or decision. The re-evaluation is a document, e-mail, and/or meeting minutes prepared by the Department that evaluate any new or updated information that affects the project's impacts or significance and documents whether the NEPA determination should remain the same or change.
3. **Significance.** Significance as used in NEPA requires considerations of both context and intensity:

Context. This means that the significance of an action must be analyzed in several contexts such as society as a whole (human, national), the affected region, the affected interests, and the

locality. Significance varies with the setting of the proposed action. For instance, in the case of a site-specific action, significance would usually depend upon the effects in the locale rather than in the world as a whole. Both short- and long-term effects are relevant.

Intensity. This refers to the severity of impact. Responsible officials must bear in mind that more than one agency may make decisions about partial aspects of a major action. The following should be considered in evaluating intensity:

- Impacts that may be both beneficial and adverse. A significant effect may exist even if the Federal agency believes that on balance the effect will be beneficial.
- The degree to which the proposed action affects public health or safety.
- Unique characteristics of the geographic area such as proximity to historic or cultural resources, park lands, prime farmlands, wetlands, wild and scenic rivers, or ecologically critical areas.
- The degree to which the effects on the quality of the human environment are likely to be highly controversial.
- The degree to which the possible effects on the human environment are highly uncertain or involve unique or unknown risks.
- The degree to which the action may establish a precedent for future actions with significant effects or represents a decision in principle about a future consideration.
- Whether the action is related to other actions with individually insignificant but cumulatively significant impacts. Significance exists if it is reasonable to anticipate a cumulatively significant impact on the environment. Significance cannot be avoided by terming an action temporary or by breaking it down into small component parts.
- The degree to which the action may adversely affect districts, sites, highways, structures, or objects listed in or eligible for listing in the National Register of Historic Places or may cause loss or destruction of significant scientific, cultural, or historical resources.
- The degree to which the action may adversely affect an endangered or threatened species or its habitat that has been determined to be critical under the Endangered Species Act of 1973.
- Whether the action threatens a violation of Federal, State, or local law or requirements imposed for the protection of the environment.

22-3.14(c) Re-evaluation Factors

Several factors should be considered to determine when a documented re-evaluation is necessary. If one or more of the following factors exist, then a documented re-evaluation should be prepared.

- Changes to any laws or regulations, such as newly listed threatened or endangered species; after the environmental process was completed.
- Changes in project scope or new design refinements that result in the identification of new impacts, additional right of way, or will require additional study of environmental factors before construction authorization;
- Phase II postponed/stalled for several years and now there are plans to advance to Phase III;
- Requesting Federal authorization in Phase II (final design and land acquisition) or Phase III; or
- Several years have passed since the original environmental decision date (CE, FONSI, or ROD) and project is now advancing to Phase II; or
- Project is partially constructed, and has gone inactive/dormant for several years and now will complete Phase III;

22-3.14(d) Re-evaluation Document Elements

The intent of a re-evaluation is to document any changes that have occurred compared to what was documented in the CE, EA and FONSI, or EIS and ROD so that a determination can be made if the original environmental approval remains valid. Elements to be contained in the re-evaluation document should include:

- new logical termini, if applicable;
- additional study area(s), if applicable;
- any changes to impacts and mitigation;
- any changes to laws or regulations;
- the following statement: "*This re-evaluation was prepared in accordance with the requirements of the Federal Highway Administration Rules and Regulations set forth in 23 CFR 771.129.*" ;
- a determination on whether the original environmental decision (CE, FONSI, or ROD) is still valid or whether the project now requires a higher level of processing; and

- The date the original CE, FONSI, or ROD was signed and dates of subsequent re-evaluation(s).

22-3.14(e) Re-evaluation Format

The format of the re-evaluation will most likely be dependent on the NEPA Category of Action. And should be commensurate with the changes that have occurred with the project. The following sections of the BDE Manual discuss re-evaluations for each type of NEPA document and will contain more appropriate information on the suggested format:

- Re-evaluation of Categorical Exclusion (CE), see Section 23-1.06
- Re-evaluation of Finding of No Significant Impact (FONSI), see Section 24-2.23
- Re-evaluation of Record of Decision (ROD), see Section 25-1.03

22-4 CONCURRENT NEPA/404 PROCESSES

22-4.01 Background

A Statewide Implementation Agreement (SIA) (see Appendix A) is in effect that provides for concurrent *National Environmental Policy Act* (NEPA) and Section 404 processes on Federal-aid highway projects in Illinois. The purpose of the SIA is to ensure appropriate consideration of the concerns of the US Army Corps of Engineers (Corps), the US Environmental Protection Agency (USEPA), the US Coast Guard (USCG), and the US Fish and Wildlife Service (USFWS), especially regarding compliance with the Section 404(b)(1) Guidelines, as early as practical in highway project development. The USCG is involved in the SIA for those projects over navigable waters.

The intent is also to involve the State agencies, including the Illinois Environmental Protection Agency (IEPA), Illinois Historic Preservation Agency (IHPA), Illinois Department of Agriculture (IDOA), and Illinois Department of Natural Resources (IDNR), at key decision points early in the process to minimize the potential for unforeseen issues during the Section 404 permit review.

22-4.02 Applicability

All State highway projects needing Federal Highway Administration (FHWA) action under NEPA and an individual permit from the Corps under Section 404 of the *Clean Water Act* are eligible for processing under the NEPA/404 SIA. Decisions on whether to process specific eligible projects under the concurrent NEPA/404 procedures will be made in accordance with Part III of the SIA. The procedures that follow shall apply to all projects processed under the concurrent NEPA/404 process described in the SIA.

22-4.03 Procedures

22-4.03(a) General

As reflected in the executed SIA, Section 404 permit issues (i.e., relating to possible discharges of dredge and fill material into waters of the United States, including wetlands) should be considered throughout the highway planning and development process. Careful consideration should be given to comments provided by the Corps and the natural resource agencies relative to Section 404 issues, whether received during the systems planning phase, the scoping and NEPA compliance activities for individual projects, or the design-phase Section 404 permit application process.

The normal scoping and environmental coordination with the Corps, USEPA, USCG, and USFWS will continue for applicable projects, as reflected in the executed SIA. In addition, concurrence will be specifically requested from these agencies regarding the Purpose and Need, Alternatives To Be Carried Forward, and the Selected Alternative for applicable projects as described in the executed SIA and the following subsections of these procedures.

22-4.03(b) Concurrence Point Meetings

The SIA provides that the concurrence reviews for Purpose and Need, Alternatives To Be Carried Forward, and the Preferred Alternative normally will be addressed at joint meetings of the SIA signatories and the State agencies. The intent is to promote efficient use of staff resources and time by consolidating reviews of a number of projects at these periodic meetings. The number and location of projects to be addressed will be key considerations in determining where meetings will occur.

The FHWA/BDE will develop schedules and agendas for these meetings in consultation with the IDOT districts. BDE will contact each district to request information concerning projects that have been developed sufficiently to enable preparation of the information necessary to support a request for concurrence on one or more of the three points specified. These contacts by BDE will be accomplished two to three months prior to the tentative range of dates being considered for the joint meeting(s). This should allow the districts sufficient time to prepare information for the regulatory and natural resource agencies regarding the projects and concurrence points to be addressed. It also should afford time for review of the information by BDE and FHWA and for incorporation of any necessary changes. In addition, it will accommodate the 30-day period that the regulatory and natural resource agencies will have to review the information in advance of the meetings, as provided in the SIA.

After receiving information from the districts on the number and locations of projects for discussion, BDE will confer with the FHWA on arrangements for the meetings. FHWA will transmit to BDE and to other involved Federal and State agency offices a final meeting schedule, indicating the date(s), time(s), and location(s) of the meetings plus a list of projects to be discussed. FHWA also will disseminate the written project concurrence point information to the regulatory and natural resource agencies after it has been reviewed and revised as necessary.

At the concurrence point meetings, each district will be responsible for presenting its projects to the outside agencies. The presentation should be less than 30 minutes and should summarize the key points from the information package for the project. Each district also will be responsible for keeping minutes of the proceedings at the meeting pertaining to its projects (e.g., key issues raised, responses to issues, and action on concurrence point requests). Written information and exhibits prepared to describe the projects presented at the meeting should be attached to and incorporated into the minutes by reference to eliminate the need for repeating the information. Meeting minutes should be concise and should cover only what occurred at the meeting. They should not include actions, discussions, or decisions that were not covered in the meeting. Where issues are raised that cannot be resolved at the concurrence point meeting (e.g., because additional information is needed), the minutes should note the issue(s) and indicate how the matter will be addressed. Either the minutes of a subsequent meeting or an exchange of correspondence should document the follow-up on the issue(s). FHWA will consolidate and distribute the various project-specific minutes as a package for each concurrence point meeting.

If a regulatory or natural resource agency does not concur regarding one or more of the concurrence points, the district and BDE will jointly determine the appropriate course of action to

respond to the dispute after discussion as necessary with the regulatory or natural resource agency involved and FHWA.

22-4.03(c) Concurrence Point Information

The advance information package for each project should include general project identification information (route designation(s), location/termini, city or county(ies)) and the information for the specific concurrence point(s) to be addressed. The concurrence point information should present essentially the same content as will be in the section of the project environmental documentation corresponding to the concurrence point(s) (i.e., the “Purpose and Need” concurrence point information should be similar to the information which will be in the “Purpose and Need” section of the environmental document). To the fullest extent practical, the information should address the items necessary for determining compliance with the Section 404(b)(1) “Guidelines for Specification of Disposal Sites For Dredged or Fill Material” (see Section 22-4.05). If districts wish to obtain preliminary comments from the regulatory and natural resource agencies, BDE, and FHWA regarding information being developed to support concurrence point requests, it is recommended this be accomplished through the district’s regularly scheduled coordination meetings, where possible. As a project proceeds through the three concurrence points, the information package should be cumulative (i.e., the information prepared for the first point should be a part of the package for the second, and the information for the first two should be in the submittal for the third).

22-4.03(d) Special Concurrence Point Meetings

In most instances, concurrence points should be addressed at the regularly scheduled meetings. If a district cannot attend a regularly scheduled meeting, for major or complex actions, or those on expedited schedules, separate NEPA/404 concurrence meetings may be scheduled in lieu of the regularly scheduled concurrence meetings. FHWA and IDOT may also request signatory agency concurrence via e-mail. As with the other joint concurrence point meetings, the district will be responsible for preparing the necessary concurrence point information and making it available in advance of the anticipated meeting date for necessary reviews by BDE, FHWA, and the regulatory and natural resource agencies, as described above.

22-4.03(e) Prevention, Minimization, and Mitigation of Adverse Effects to Aquatic Resources

Options for preventing, minimizing, and mitigating adverse effects to aquatic and wetland resources should be considered as an integral part of the merger process. As project details are refined, the potential for adverse impacts on the aquatic resources must be discussed with the regulatory and resource agencies. The discussions should focus on identification and evaluation of practicable alternatives for preventing, minimizing, and mitigating the adverse effects. These considerations generally will be addressed as a part of the concurrence point discussions on Alternatives to be Carried Forward and the Preferred Alternative.

22-4.04 Section 404(b)(1) Compliance Information Outline

This subsection presents an outline that should be used for determining the appropriate level of information needed for compliance with the 404(b)(1) "Guidelines for Specification of Disposal Sites for Dredged or Fill Material" in the Section 404 permit process.

22-4.04(a) Discussion of Alternatives

The 404(b)(1) "Guidelines for Specification of Disposal Sites for Dredged or Fill Material" (40 CFR 230) provide that "...no discharge of dredged or fill material shall be permitted if there is a practicable alternative to the proposed discharge which would have less adverse impact on the aquatic ecosystem, so long as the alternative does not have other significant adverse environmental consequences." Furthermore, the Guidelines provide that "Where the activity associated with a discharge which is proposed for a special aquatic site...[sanctuaries and refuges, wetlands, mud flats, vegetated shallows, riffle and pool complexes]...does not require access or proximity to or siting within the special aquatic site in question to fulfill its basic purpose (i.e., is not 'water dependent'), practicable alternatives that do not involve special aquatic sites are presumed to be available, unless clearly demonstrated otherwise. In addition, where a discharge is proposed for a special aquatic site, all practicable alternatives to the proposed discharge which do not involve a discharge into a special aquatic site are presumed to have less adverse impact on the aquatic ecosystem, unless clearly demonstrated otherwise."

When the recommended or selected project alternative will involve a discharge of dredged or fill material into waters of the United States, the environmental documentation must include exhibits delineating aquatic habitat and any special aquatic sites in the project area. In addition, sufficient information must be provided to demonstrate why alternatives that would have less impact on the aquatic ecosystem either are not practicable or that such alternatives would have other significant adverse environmental consequences. Furthermore, when the recommended or selected project alternative will involve a discharge of dredged or fill material into a special aquatic site, information must be provided to clearly explain why practicable alternatives that do not involve special aquatic sites are not available.

22-4.04(b) Items for 404(b)(1) Compliance Evaluation

To the fullest extent practicable, project environmental studies for projects anticipated to require an individual Section 404 permit should address the information the Corps and the USEPA will need for evaluating compliance with the Section 404(b)(1) Guidelines. The following is an outline of the information evaluated under the 404(b)(1) Guidelines. Districts should contact the BDE Location and Environment Section, as necessary, for guidance on responding to these items:

1. Information for determining that the activity will not violate applicable State water quality standards or effluent standards prohibited under Section 307 of the CWA or jeopardize the existence of Federally listed endangered or threatened species or their habitat.

-
2. Information to establish that the activity will not cause or contribute to significant degradation of waters of the United States, including adverse effects on human health, life stages of organisms dependent upon aquatic ecosystems, ecosystem diversity, productivity and stability and recreational, aesthetic, and economic values.
 3. Information to demonstrate that appropriate and practicable steps have been taken to avoid and minimize potential adverse impacts of the discharge on the aquatic ecosystem (i.e., description of measures considered and measures to be implemented), including the following, as applicable:
 - actions concerning the location of the discharge,
 - actions concerning the material to be discharged,
 - actions controlling the material after discharge,
 - actions affecting the method of dispersion,
 - actions related to technology,
 - actions affecting plant and animal populations, and
 - actions affecting human use.
 4. Information addressing the potential of the proposed discharge to cause short-term or long-term environmental effects related to any of the following:
 - physical substrate;
 - water circulation and fluctuation:
 - + alteration of current patterns of water circulation, and
 - + alteration of normal water fluctuations/hydroperiod;
 - suspended particulates/turbidity;
 - contaminant availability;
 - aquatic ecosystem structure and function (including both secondary and cumulative impacts);
 - water column impacts;
 - alteration of salinity gradients;
 - Federally listed threatened or endangered species and their habitat;
 - other wildlife (e.g., mammals, birds, reptiles, amphibians);
 - special aquatic sites:
 - + sanctuaries and refuges,
 - + wetlands,
 - + mud flats,

- + vegetated shallows, and
 - + riffle and pool complexes;
- municipal and private water supplies;
 - recreational and commercial fisheries;
 - water-related recreation;
 - aesthetics; and
 - parks, national and historical monuments, wilderness areas, research sites, and similar preserves.
5. Information to support determination that the proposed dredged or fill material is not a carrier of contaminants or that levels of contaminants are substantively similar at extraction and disposal sites and not likely to result in degradation of the disposal site. Factors to consider include the following:
- physical characteristics of material;
 - hydrography in relation to known or anticipated sources of contaminants;
 - results from previous testing of the material or similar material in the vicinity of the project;
 - known significant sources of persistent pesticides from land runoff or percolation;
 - spill records for petroleum products or designated hazardous substances;
 - other public records of significant introduction of contaminants from industries, municipalities, or other sources; and
 - known existence of substantial material deposits of substances which could be released in harmful quantities to the aquatic environment by the proposed discharge activities.
6. Information regarding the following factors for the proposed dredged or fill material disposal site:
- depth of water at disposal site;
 - current velocity, direction, and variability at disposal site;
 - degree of turbulence;
 - water column stratification;
 - discharge vessel speed and direction;

- rate of discharge;
- dredged material characteristics (constituents, amount and type of material, settling velocities);
- number of discharges per unit of time; and
- other factors affecting rates and patterns of mixing.

See Section 26-19 "Surface Water Resources and Aquatic Habitat" for guidance on obtaining and analyzing the information on aquatic resources in the project's area of potential effect.

22-5 COORDINATION

References: 23 U.S.C. 139 “Efficient Environmental Reviews for Project Decision Making”
40 CFR 1500.2(d) “Policy Encouraging Public Involvement”
40 CFR 1500.5(b) “Interagency Cooperation”
40 CFR 1501.1(b) “Early Coordination”
40 CFR 1501.6 “Cooperating Agencies”
40 CFR 1503.4 “Response to Comments”
40 CFR 1506.6 “Public Involvement”
23 CFR 771.111 “Early Coordination and Public Involvement”
23 CFR 771.119(b) “Early Coordination in Development of EA”
CEQ Q&A, Question 9 “Coordination of NEPA with Other Applicable Requirements”
FHWA SAFETEA-LU Final Guidance, Questions 21-29 “Participating Agencies”
FHWA SAFETEA-LU Final Guidance, Questions 30 and 31 “Cooperating Agencies”
Chapter 19 “Public Involvement Guidelines”
Chapter 26 “Special Environmental Analyses”

The primary objective of coordination is to emphasize cooperative consultations among staff, other organizations, and state and federal agencies before the final environmental report (e.g. FEIS) is prepared. This is intended to avoid the submission of adverse comments on a completed document. This section discusses policies and practices on coordination for all State highway projects. The necessary coordination for a specific environmental process (e.g., an EIS) is discussed in the applicable chapter (e.g., Chapter 25 for an EIS).

22-5.01 General

During the development of a proposed highway project, the Department often must coordinate with a variety of agencies to address compliance issues pursuant to Federal and State requirements. Other coordination may be informal and intended to discuss certain aspects of upcoming highway projects such as potential effects of the project on specific resources or cost participation by local agencies for improvements associated with or necessitated by a State highway project that affects local-system facilities. (Cost participation issues should be addressed with the affected local agencies as early as practical in project development; see Chapter 5.) Some agencies also have opportunities to review packages of information that are circulated for comment as described in Section 22-4. In addition, notices of upcoming public involvement activities afford another mechanism for agencies to obtain information on proposed projects. All of these actions contribute to interagency coordination.

22-5.01(a) Policy

Every reasonable effort shall be made in project development to inform and solicit the aid of agencies, organizations, and persons who have an interest in the project or who have information or expertise on environmental factors relevant to the project. Special efforts shall be made to begin such coordination as early as practicable in project development and to use

procedures which will encourage and allow public participation in constructing the value judgments necessary to select wisely among project alternatives.

22-5.01(b) Procedures

To achieve proper coordination, IDOT has adopted the following procedures which collectively apply to all highway projects:

1. The Integrated Survey Process.

Section 27-1 describes this process, which determines the need and necessity of environmental surveys and coordination for projects that may adversely affect the environment.

2. Applicability of Programmatic Agreements, Programmatic Evaluations, and Memorandums of Understandings.

Appendix A discusses these documents which basically describes sets of circumstances that require the Department to coordinate a project or where the Department may act on a regulatory agencies behalf. For example, under the "CE Agreement" the Department may approve certain types of projects on behalf of the FHWA.

3. NEPA Procedures.

These procedures discuss the processing of Categorical Exclusions (Chapter 23), Environmental Assessments (Chapter 24), and Environmental Impact Statements (Chapter 25).

4. Public Involvement Procedures.

These procedures are discussed in Chapter 19

5. Special Environmental Analyses.

Depending on the resource impact, certain coordination will be required and is further discussed in Chapter 26.

22-5.01(c) Lines of Communication

The IDOT districts are typically the primary points of contact for coordination with the public, project consultants, and contractors. The following applies to the means of communication:

1. District Meetings. IDOT districts should encourage agencies, organizations, and persons who have special expertise or jurisdiction by law for any environmental impact of a proposed project to attend the regularly scheduled coordination meetings held by the districts. This will allow these entities to receive early notification and firsthand

information on undertakings and to provide firsthand knowledge on environmental issues relevant to these undertakings. Other coordination-type meetings should be scheduled and undertaken, as needed, to resolve potential environmental problems as early as practical in project development. Information provided and received at all such meetings should be documented for potential use in decision making and in environmental reports or Phase I Reports.

2. Scoping Meetings. If practical, the regularly scheduled district meetings discussed in Item #1 should also serve as scoping meetings, where appropriate. Formal scoping meetings may be appropriate for complex projects that involve several Federal agencies. Where scoping occurs, either at the regular district coordination meetings or in a specially convened meeting, these should be especially well documented, including who participated, what information was provided and received, what decisions were made, and who agreed and who dissented with specific determinations.
3. Public Involvement. Chapter 19 discusses this in detail.
4. Correspondence. Correspondence is a key element in coordination activities. Correspondence received on an environmental issue should be acknowledged. If the correspondence responds to a request for comments on a public involvement activity or an environmental document, the correspondence should be acknowledged as described in the procedures for public involvement (see Chapter 19) or as described in 40 CFR 1503.4. For other correspondence on environmental matters, the appropriate form of written acknowledgment may be an individual response letter. Substantive comments should be addressed in sufficient detail to allow the commenter to obtain a clear understanding of the status of the issue and its disposition.

22-5.02 Coordination with Federal and State Regulatory and Resource Agencies

Coordination with Federal and State regulatory and natural resource agencies is dependent on the nature and severity of project impacts. Specific coordination requirements are identified in Chapter 26 "Special Environmental Analyses." The following sections provide an overview of agency involvement and their areas of interest.

Section 22-5.01 discusses policy and procedures for accomplishing effective coordination on all State highway projects. A key component of the coordination process is the interactions with agencies that have jurisdiction or expertise regarding resources and/or issues a proposed project may affect. These agencies may be requested to serve as cooperating agencies and/or, for projects involving an EIS, may be invited to serve as participating agencies in accordance with 23 U.S.C. 139; see Chapter 25.

When it is determined an agency should be a cooperating agency for a specific project, the request to the agency should be made as early as practical in project development and should include the best available information on the proposed undertaking (e.g., project scope, alternatives, pertinent issues that have been identified).

To facilitate early identification and coordination with appropriate agencies based on the resources and issues associated with particular projects, the following sections provide brief descriptions of the respective areas of jurisdiction and/or expertise for key Federal and State agencies that are most often involved with proposed IDOT projects. Refer to the websites for the respective agencies for information on programs and responsibilities, regulations, resources, and contacts.

The lists provided are not intended to cover all potential agency involvements; only those that occur most often. Districts must be alert to the potential for project issues that may require involvement of additional agencies not addressed in the following sections.

22-5.02(a) Federal Agencies

Agency	Jurisdiction/Expertise
U.S. Department of the Interior (USDO I)	<ul style="list-style-type: none"> <li data-bbox="597 810 1305 873">• <u>Distribution of Environmental Documents to USDO I Agencies for Formal Comment</u> When transmitting draft and final Environmental Impact Statements (EIS) to DOI during formal comment periods direct the transmittals to the following office: Natural Resources Management Team Office of Environmental Policy and Compliance Office of the Secretary U.S. Department of the Interior MS-2462-MIB 1849 C Street Washington DC, NW 20240 Provide ___ copies for a draft EIS and ___ copies for a final EIS; see Chapter 25. <li data-bbox="597 1310 1421 1457">• <u>Individual Section 4(f) Evaluations</u> In accordance with 23 CFR 774.5(a), prior to Section 4(f) approval, all individual Section 4(f) Evaluations must be provided to USDO I for coordination and comment.
U.S. Fish and Wildlife Service (USFWS), USDO I	<ul style="list-style-type: none"> <li data-bbox="597 1512 1421 1692">• <u>Endangered Species Act</u> Projects that may affect Federally-listed threatened or endangered species or designated critical habitat and/or that require an “incidental take” permit for impacts to listed species; see Section 26-9. <li data-bbox="597 1713 1421 1858">• <u>Bald and Golden Eagle Protection Act</u> Projects that may affect eagle nesting sites and/or winter night roost sites and/or if an “eagle permit” or migratory bird permit is required (e.g., for destruction/”take” of an active

Agency	Jurisdiction/Expertise
	<p>nest); see Section 26-15.</p> <ul style="list-style-type: none"> • <u><i>Migratory Bird Treaty Act</i></u> Projects that may affect migratory birds during their nesting season and/or if a migratory bird permit is required (e.g., for destruction/"take" of an active nest); see Section 26-15. • <u><i>Fish and Wildlife Coordination Act</i></u> Projects involving modification of a water body (e.g., stream channelization); see Section 26-19. • <u><i>Wild and Scenic Rivers Act</i></u> Projects that may affect a designated Wild and Scenic River segment under the jurisdiction of USFWS. • <u>Concurrent NEPA/404 Processes</u> Projects subject to the Statewide Implementation Agreement for "Concurrent NEPA/404 Processes for Transportation Projects in Illinois" in Appendix A; see Section 22-4. • <u>Project Effects on Federal Wildlife and Waterfowl Refuges</u> Projects that may affect Federally owned/managed wildlife and waterfowl refuges; see Section 26-2. • <u>Project Effects on Federal Lands</u> Projects involving use of any Federal lands (e.g., Shawnee National Forest). • <u>Wetland Impacts Requiring an Individual 404 Permit</u> Projects involving wetland impacts that are sufficient to trigger the requirement for an individual Section 404 permit.
National Park Service (NPS), USDOI	<ul style="list-style-type: none"> • <u><i>Wild and Scenic Rivers Act</i></u> Projects that may affect a designated Wild and Scenic River segment under the jurisdiction of NPS or a river included in the Nationwide Rivers Inventory; see Section 26-19. • <u><i>Land and Water Conservation Fund Act (LAWCON)</i></u> Projects involving conversion of land acquired or improved with LAWCON funds to other than public outdoor recreation use; see Section 26-3.
U.S. Army Corps of Engineers	<ul style="list-style-type: none"> • <u>Concurrent NEPA/404 Processes</u> Projects subject to the Statewide Implementation

Agency	Jurisdiction/Expertise
	<p>Agreement for “Concurrent NEPA/404 Processes for Transportation Projects in Illinois” in Appendix A; see Section 22-4.</p> <ul style="list-style-type: none"> • <u>Rivers and Harbors Act - Section 10 Permits</u> Projects involving structures or work (other than bridges and causeways) affecting the navigable waters of the United States; see Section 28-2.
U.S. Environmental Protection Agency (USEPA)	<ul style="list-style-type: none"> • <u>Concurrent NEPA/404 Processes</u> Projects subject to the Statewide Implementation Agreement for “Concurrent NEPA/404 Processes for Transportation Projects in Illinois” in Appendix A; see Section 22-4. • <u>National Environmental Policy Act</u> USEPA has developed a set of criteria for rating draft EISs. The rating system provides a basis upon which USEPA makes recommendations to the lead agency for improving the draft EIS. • <u>Clean Air Act, Section 309</u> This Section authorizes USEPA to review other Federal-agency projects requiring an EIS and to make those reviews public. It also provides that if the agency responsible for the project does not make sufficient revisions in response to the review, and the project remains environmentally unsatisfactory, USEPA may refer the matter to the Council on Environmental Quality for mediation. • <u>Clean Air Act</u> USEPA administers implementation of the provisions of this Act for regulating air emissions from stationary and mobile sources. The agency establishes National Ambient Air Quality Standards (NAAQS) to protect public health and public welfare and to regulate emissions of hazardous air pollutants. It also administers regulations for achieving conformity with the NAAQS; see Sections 26-11, 26-12 and 26-13. • <u>Clean Water Act, Section 401</u> USEPA administers the regulations for implementing the Section 401 Water Quality Certification provisions. For any Federal permit or license to conduct any activity which may result in any discharge into waters of the US, the

Agency	Jurisdiction/Expertise
	<p>regulations require certification or a waiver of certification that the activity will not cause a violation of applicable water quality standards.</p> <p>For actions in Illinois, Illinois Environmental Protection Agency is the certifying agency for Section 401; see Sections 22-5.02(b) and 28-2.</p> <ul style="list-style-type: none"> • <u>Clean Water Act, Section 404(b)(1) Analysis</u> <p>Projects involving discharge of dredged or fill material requiring an individual Section 404 permit and compliance with the Section 404(b)(1) "Guidelines for Specification of Disposal Sites for Dredged or Fill Material"; see Section 28-2.</p> <ul style="list-style-type: none"> • <u>Comprehensive Environmental Response, Compensation and Liability Act (CERCLA)/Resource Conservation and Recovery Act (RCRA)</u> <p>USEPA administers Federal regulations and programs for addressing the control and management of hazardous waste and other regulated substance contamination.</p> <p>Illinois Environmental Protection Agency administers State regulations under the Illinois <i>Environmental Protection Act</i> that apply in lieu of the Federal regulations for actions in this State; see Section 22-5.02(b).</p>
U.S. Forest Service (USFS), U.S. Department of Agriculture (USDA)	<ul style="list-style-type: none"> • <u>Wild and Scenic Rivers Act</u> <p>Projects that may affect a designated Wild and Scenic River segment under the jurisdiction of USFS.</p> <ul style="list-style-type: none"> • <u>National Forest</u> <p>Projects that affect the Shawnee National Forest.</p>
Natural Resources Conservation Service, USDA	<ul style="list-style-type: none"> • <u>Farmland Preservation Policy Act</u> <p>Projects requiring additional right-of-way outside any corporate limits, subject to certain specified exemptions; see Section 26-10.04.</p>
Federal Emergency Management Agency, Department of Homeland Security (DHS)	<ul style="list-style-type: none"> • <u>National Flood Insurance Act</u> <p>Projects involving encroachments in floodways; see Section 26-7.</p>
U.S. Coast Guard, DHS	<ul style="list-style-type: none"> • <u>Concurrent NEPA/404 Processes</u> <p>Projects subject to the Statewide Implementation</p>

Agency	Jurisdiction/Expertise
	<p>Agreement for “Concurrent NEPA/404 Processes for Transportation Projects in Illinois” in Appendix A; see Section 22-4.</p> <ul style="list-style-type: none"> • <u>Rivers and Harbors Act - Section 9 Permits</u> Projects involving construction of bridges or causeways over navigable waters of the US; see Section 28-2.
U.S. Department of Housing and Urban Development (HUD)	<ul style="list-style-type: none"> • <u>Housing and Community Development Act</u> Projects involving use of land acquired with HUD Open Space Lands funds; see Section 26-4.
Advisory Council on Historic Preservation	<ul style="list-style-type: none"> • <u>National Historic Preservation Act</u> Projects having an adverse effect on a property included on, or eligible for inclusion on, the National Register of Historic Places; see Section 26-5.04.

22-5.02(b) State Agencies

Agency	Jurisdiction/Expertise
Illinois Department of Natural Resources (IDNR)	<ul style="list-style-type: none"> • <u>Illinois Endangered Species Protection Act</u> Projects determined to be in the vicinity of a State-listed threatened or endangered species, in accordance with the “Memorandum of Understanding By and Between IDNR and IDOT” in Appendix A; see Section 26-9. • <u>Interagency Wetland Policy Act of 1989</u> Projects involving unavoidable adverse wetland impacts, in accordance with the IDOT Wetlands Action Plan and the “Memorandum of Understanding By and Between IDNR and IDOT” in Appendix A; see Section 26-8. • <u>Illinois Natural Area Inventory (INAI) Sites</u> Projects determined to be in the vicinity of a site listed on the INAI, including Illinois Natural Area Inventory sites, dedicated Illinois Nature Preserves and registered Land and Water Reserves, in accordance with the IDOT Wetlands Action Plan and the “Memorandum of Understanding By and Between IDNR and IDOT” in Appendix A; see Section 26-9.

Agency	Jurisdiction/Expertise
	<ul style="list-style-type: none"> • <u>Impacts to Natural Resources</u> Projects that could adversely affect streams, forest/trees, prairie/savanna areas, or properties owned, leased or managed by IDNR, in accordance with the “Memorandum of Understanding By and between IDNR and IDOT” in Appendix A; see Section 27-1. • <u>Land and Water Conservation Fund Act (LAWCON)</u> Projects involving conversion of land acquired or improved with LAWCON funds to other than public outdoor recreation use; see Section 26-3. • <u>Open Space Lands Acquisition and Development Act (OSLAD)</u> Projects involving conversion of land acquired or improved with OSLAD funds to other than public outdoor recreation use; see Section 26-4. • <u>Rivers, Lakes and Streams Act</u> Projects involving: <ul style="list-style-type: none"> + construction in floodways of rivers, lakes and streams under the jurisdiction of the IDNR Office of Water Resources (OWR); + construction in those rivers, lakes, streams, and waterways considered “public waters”; or + new construction within the regulatory floodways of rivers, lakes, and streams in Cook, DuPage, Kane, Lake, McHenry, and Will counties excluding the City of Chicago. <p>See Section 28-3.</p>
Illinois Environmental Protection Agency	<ul style="list-style-type: none"> • <u>Clean Water Act, 401 Water Quality Certification</u> Projects involving work that may result in any discharge into waters of the US and that is subject to a Federal permit requiring an individual 401 water quality certification (i.e., for which IEPA has neither waived certification nor issued blanket certification); see Section 28-2. • <u>Clean Water Act, 303(d) Impaired Waters</u> Projects that may affect a water resource included in the IEPA list of “impaired” waters; see Section 26-21. • <u>Clean Water Act, National Pollutant Discharge Elimination System (NPDES) Permits</u>

Agency	Jurisdiction/Expertise
	<p>Projects that:</p> <ul style="list-style-type: none"> + will require a point-source NPDES permit; + will involve clearing, grading, and/or excavation activities disturbing one acre (4047 m²) or more of land area; or + occur in an area covered by an NPDES Metropolitan Separate Storm Sewer System (MS4) permit. <p>See Chapter 41.</p> <ul style="list-style-type: none"> • <u>Illinois Environmental Protection Act</u> Projects determined, through the IDOT special waste screening process, to have potential for involvement with special wastes or other regulated substance contamination; see Section 27-3.
Illinois Department of Agriculture	<ul style="list-style-type: none"> • <u>Illinois Farmland Preservation Act</u> Projects requiring additional right-of-way, subject to certain specified exemptions, as defined in the IDOT Agricultural Land Preservation Policy Statement and Cooperative Working Agreement in Appendix A; see Section 26-10.05.
Illinois Historic Preservation Agency	<ul style="list-style-type: none"> • <u>National Historic Preservation Act</u> Projects involving Federal funding, approvals, permits or licenses that have the potential to cause effects on properties included on, or eligible for inclusion on, the National Register of Historic Places; see Section 26-5.04. • <u>Illinois Historic Preservation Act</u> Projects that do not involve Federal funding, approvals, permits or licenses, do not otherwise comply with the National Historic Preservation Act and have the potential to cause effects on properties included on, or eligible for inclusion on the Illinois Register of Historic Places; see Section 26-5.06.

22-5.03 District Coordination Meetings

The district conducts periodic coordination meetings, which involve personnel from the central offices, FHWA, and other agencies, as appropriate. These meetings provide a forum for discussing various project-related issues (e.g., scope of the project, exceptions to design

criteria, meeting ADA standards to the maximum extent practicable, Federal funding participation, progress of environmental clearances, and level of environmental processing).

22-5.03(a) Scheduling Coordination Meetings

BDE will develop an annual coordination meeting schedule in cooperation with districts and FHWA to eliminate meeting conflicts among districts and to allow appropriate central office personnel to be available. The district should distribute a tentative agenda and associated project information, draft reports, exhibits, etc., approximately two weeks in advance of each meeting.

22-5.03(b) Appropriate Representation

Invite persons to the meetings who have a role in project development and decision making, such as central office environmental specialists, district specialists and, if applicable, the consultant's project manager, environment leads, and specialists.

If projects to be discussed significantly affect other agencies or require special expertise or coordination, the district should invite the applicable agencies to the coordination meeting. Highlight in the invitations and agendas the projects and issues requiring the expertise of the other agencies. State agencies (e.g., Illinois Department of Natural Resources, Illinois Historic Preservation Agency, Illinois Department of Agriculture, Illinois Environmental Protection Agency) and Federal agencies (e.g., Department of the Interior, Army Corps of Engineers) may be involved frequently. Consultant environmental staff should attend coordination meetings if environmental issues on their projects are an agenda topic.

22-5.03(c) Topics for Discussion

Coordination meetings should address such topics as the need for and adequacy of environmental reports, need for special reports, typical sections, intersection design studies, design exceptions, meeting ADA standards to the maximum extent practicable, etc. The scoping of environmental reports (see 40 CFR 1501.7, 23 CFR 771.119(b) and 771.123(b)) is also an appropriate topic for coordination meetings. When other agencies are present, the coordination meeting may serve as the scoping meeting as discussed in Section 25-2.04.

Submit an agenda to the intended participants at least two weeks prior to the meeting. Include the following items in the agenda for each project to be discussed:

- a short description of the project, its location, and the desired action or reason for including the project on the agenda, including environmental issues, as appropriate;
- the route designation and transportation system (e.g., NHS), funding, and anticipated construction year;
- design policy to be used;

- status of environmental surveys;
- measures for minimizing and mitigating adverse socio-economic and environmental impacts; and
- district contact person for the project and, as appropriate, the project consultant.

Also indicate on the agenda projects to be advertised in the Professional Transportation Bulletin and include in the agenda any topics of general concern intended for discussion. Include documentation with the agenda, as necessary, to support the desired action for specific projects.

22-5.03(d) Information Presented

The information presented at a coordination meeting usually depends on:

- the project development stage,
- coverage at previous coordination meetings, and
- the scope of the project.

A complex project on new alignment may involve many topics and presentations at numerous meetings over the duration of the study. If a minor project requires discussion, a brief presentation may be sufficient.

Because several projects may be discussed at each coordination meeting, information that has been previously presented and discussed need not be repeated. However, the meeting should include a brief summary of important points previously discussed and any decisions reached on each project.

If design exceptions, or maximum extent practicable (MEP) determinations for ADA will be requested, the district must provide supporting documentation/ justification. The supporting documentation/justification for design exceptions and MEP's ultimately will be included in the Phase I report.

The district should also make available appropriate information on the mitigation of impacts, effects on sensitive areas, detours, and stream crossings. Explain any channel work proposed in stream crossings so that the degree of impact can be determined.

22-5.03(e) Documentation

At all coordination meetings, the district must maintain a record on who attended and what transpired. Although a verbatim transcript is not necessary for coordination meetings, a recording may be useful to the district if questions arise on the accuracy of typed minutes. Prepare minutes promptly and send to each agency that was represented at the meeting. The transmittal letter should describe the process for correction of the minutes and set a time limit for submitting any corrections.

The suggested format for the minutes is shown in Figure 22-5.A. Identify each project discussed in the minutes, and provide special attention to any scoping actions because documentation may be required later. Each project should be covered on a separate page(s).

22-5.03(f) Recommended Practices

The following practices are recommended for coordination meetings to improve their effectiveness:

- Use video-teleconference, where practical.
- Schedule meetings for projects eligible for field approval prior to or after the regular meeting. Indicate the schedule for these meetings in the agenda and provide appropriate information for action in advance of the meeting.
- Schedule separate meetings for large or complex project issues, including the review of report comments.
- Avoid getting bogged down on minor issues that can be resolved over the phone or within the district.
- Keep the discussion focused on the desired action.
- Use slides, photographs, aerial photos, and other visual exhibits to clarify issues.
- Provide appropriate handouts such as location maps, ADT/DHV schematics, typical section drawings, crash history information, synopsis of environmental issues, and critical path items.
- Submit completed forms for Nationwide Section 404 Permit 23 to BDE prior to the coordination meeting.
- Provide meeting minutes to participants within two weeks following the meeting.

MINUTES OF COORDINATION MEETING

DISTRICT 1

May 9, 2009

ATTENDANCE

- Federal Agencies
- State Agencies
- Local Agencies

- FHWA
- IDOT Central Office
- District

PROJECT #1

- Project location, identification information
- Description of existing conditions, traffic data, and any high-crash locations
- Description of proposed work and status of development
- Information presented (e.g., on environmental surveys, impacts, mitigation)
- Comments and input received, including scoping actions/information (see Section 22-5.01(c))
- Design exceptions presented and action taken
- Environmental report concurrence

MINUTES OF COORDINATION MEETING FORMAT

Figure 22-5.A

22-5.03(g) Commitments

References: 40 CFR 1505.3 "Responsibility for Implementing Mitigation"
23 CFR 771.109(b) "Responsibility for Implementing Mitigation"
CEQ Q&A, Question 34d "Enforceability of ROD"
CEQ Q&A Question 39 "Imposing Enforceable Mitigation for EA and FONSI"
IDOT Departmental Policy D&E-19 "Follow-Through on Project Commitments"

Often the end result of coordination activities is IDOT commitments to provide measures to mitigate the adverse impact of a project. No other single factor is as significant in IDOT's ability to interact effectively with other entities as the Department's record and credibility for fulfilling its past commitments. It is important that commitments be honored, for the follow through on one project may affect negotiations, approvals, and processing for many other projects.

It is sometimes difficult to ensure that a commitment made at the planning stage of project development will be implemented at a later stage (e.g., design, construction, or maintenance). To ensure that a commitment is not neglected, special efforts should be made to identify and emphasize commitments in environmental reports or Phase I Reports. Commitments must be identified in the decision statement and/or a special subsection of each report. Decision statements could serve as an appropriate mechanism for transmitting important information among bureaus within the IDOT district offices.

22-6 GUIDANCE ON SPECIAL TOPICS

22-6.01 Purpose and Need

References: 23 USC 139 "Efficient Environmental Reviews for Project Decision Making"
40 CFR 1502.13 "Purpose and Need"
Paragraph II.B of FHWA Technical Advisory T6640.8A "Purpose and Need for EAs"
Paragraph V.D. of FHWA Technical Advisory T6640.8A "Purpose and Need for EISs"
FHWA SAFETEA-LU Final Guidance, Questions 32-35 "Purpose and Need"
July 23, 2003 Memorandum from Federal Highway Administrator, Guidance on "Purpose and Need"

This discussion provides guidance for the "Purpose and Need" section of environmental documents. This guidance was prepared by the Federal Highway Administration's Washington Office of Environmental Policy and issued on September 18, 1990. It has been edited to be consistent with the format of the BDE Manual. The guidance emphasizes the importance of the "Purpose and Need" discussion in establishing a sound basis for evaluating alternatives and environmental impacts. Although the FHWA guidance is within the context of an EIS, the information also applies to an EA as appropriate for the project.

For guidance on writing a Purpose and Need for an EA or EIS, see Appendix D.

22-6.01(a) Introduction

The Purpose and Need section is in many ways the most important chapter of an environmental impact statement (EIS). It establishes why the agency is proposing to spend large amounts of taxpayers' money while at the same time precipitating significant environmental impacts. A clear, well-justified Purpose and Need section explains to the public and decision makers that the expenditure of funds is necessary and worthwhile and that the priority the project is receiving relative to other needed highway projects is warranted. In addition, although significant environmental impacts are expected to result from the project, the Purpose and Need section should justify why impacts are acceptable based on the project's importance.

As importantly, the project purpose and need drives the process for consideration of alternatives, in-depth analyses, and ultimate selection. The *Council on Environmental Quality (CEQ) Regulations* require that the EIS address the "no-action" alternative and "rigorously explore and objectively evaluate all reasonable alternatives." Furthermore, a well-justified purpose and need is vital to meeting the requirements of Section 4(f) (49 USC 303) and the Executive Orders on Wetlands (E.O. 11990) and Floodplains (E.O. 11988) and the Section 404(b)(1) Guidelines. Without a well-defined, well-established, and well-justified purpose and need, it will be difficult to determine which alternatives are reasonable, prudent, and practical, and it may be impossible to dismiss the no-action alternative.

The transportation planning process, which includes regional, subarea, and corridor planning, can serve as the primary source of information for establishing purpose and need as well as evaluating alternatives. Information and forecasts of vehicular miles of travel, travel demand, highway and travel speeds, traffic diversion, time of day characteristics, and traffic crash rates can be provided by the planning process. This information can be used to evaluate congestion, air quality, safety, and other environmental issues for various transportation alternatives including the no-action alternative. Planning can also estimate the benefits and costs associated with highway and transit projects that can be used in the development of project Purpose and Need.

22-6.01(b) Safety Considerations

As mentioned previously, a clear, well-written Purpose and Need section in an EA or EIS explains why the expenditure of funds is necessary and worthwhile and why the project is warranted. In addition, the Purpose and Need section should justify why expected environmental impacts are acceptable based on the project's importance. The Purpose and Need drives consideration of alternatives and is vital to meeting the requirements of Section 4(f) (49 USC 303), Executive Orders on Wetlands (E.O. 11990) and Floodplains (E.O. 11988), and the Section 404(b)(1) Guidelines in determining which alternatives are reasonable, prudent, and practical.

If safety problems are recognized as one of the reasons for proposing a project then an identification of these issues is a key consideration in developing a well-defined, well-established, and well-justified Purpose and Need. Safety issues will be a factor in the development of alternatives to be considered and in the determination of which alternatives are reasonable, prudent, and practical.

Each Phase I Study is required to contain a safety analysis of the section of the facility on which the improvement is being proposed. This safety analysis is a very important tool which will help to identify the level of safety issues/problems that are involved in the project and to what extent safety is an element of the project Purpose and Need. As such, a safety analysis is required to be completed for all EAs and EISs prior to finalization of the project Purpose and Need.

The safety analysis should be summarized in the Purpose and Need Section of all EAs and EISs. The summary should provide sufficient data and information to justify all conclusions derived from the safety analysis. The types of data and information used in the safety analysis will vary based on the complexity and characteristics of the project. However, examples of typical types of data and information that might be included in the summary are as follows:

- the number, type, location and severity of crashes through tables and maps;
- locations of 5% Selected Sections;
- identification of trends;
- identification of the safety problems;

- identification of possible low costs countermeasures that can be implemented immediately; and
- identification of the proposed project's potential to address identified safety problems and to eliminate 5% Sections.

22-6.01(c) Consideration of Alternatives

In urbanized areas, the urban transportation planning process required by Section 134 of Title 23 should result in plans and programs that are consistent with the comprehensively planned development of an area and that integrate transportation, land use, and environmental considerations. Comprehensive planning, which includes transportation, should establish the basic purpose and need for specific projects and the system-wide consequences of operational improvements and the no-action alternative. For example, the planning process should identify the need for a transportation improvement between points "x" and "y" at some future date. Further, in a high percentage of cases, a decision on the appropriate mode (highway or transit) and the basic project concept (e.g., freeway on new location, upgrade of existing facility, light rail transit, bus/high occupancy vehicle lanes, approximate travel demand) can be determined. In other cases, it may not be possible to resolve these issues until the conclusion of the project development process. Scoping meetings early in the environmental process are an excellent means to reach agreement with the participants on the basic purpose and need for the project, the consequences of the no-action alternative, operational improvements and, where possible, the mode and project concept.

After the basic purpose and need for the project are established, a number of lines can theoretically still be drawn to connect points "x" and "y." If the project's purpose and need are so vague as to only stipulate that a transportation improvement between "x" and "y" is needed, then reasonable alternatives would cover a wide range and must be evaluated to comply with the *CEQ Regulations*. As the project's purpose and need are refined, a number of alternatives will drop out, thereby permitting a more focused analysis of those alternatives that truly address the problem to be solved. As alternatives are eliminated from consideration, it is recommended that the concurrence of those cooperating agencies with jurisdiction by law be sought in that decision.

Similarly, the type of improvement to be considered, even after the planning process, may be wide ranging — from upgrading an existing facility to a multilane freeway on new location. The traffic demands, safety concerns, system continuity considerations, etc., will help define reasonable alternatives, and products from the transportation planning process should serve as a primary source for this information.

Beyond the *CEQ Regulations'* requirement of evaluating all alternatives (or a reasonable number representative of the full spectrum of reasonable alternatives), there are other more action-limiting requirements for alternatives under Section 4(f), the Executive Orders on Wetlands and Floodplains, and the Section 404(b)(1) guidelines. To address these requirements and conclusively demonstrate that some alternatives are not prudent or practical, a well-justified purpose and need are vital.

The use of land from a Section 4(f) protected property (i.e., significant publicly owned public park, recreational area, or wildlife and waterfowl refuge, or any significant historic site) may not be approved unless a determination is made that there is no feasible and prudent alternative to such use or FHWA determines the impact qualifies as *de minimis*. There are numerous factors that could render an alternative “not prudent” because of unique problems, including cost and environmental impacts. If an alternative does not meet the project’s purpose or satisfy the needs, then the alternative is not prudent provided the Purpose and Need section can substantiate that unique problems will result by not building the project.

If a proposed action is to be located in a wetland or if it entails a floodplain encroachment with significant impacts, a finding must be made that there is no practicable alternative to the wetland taking or floodplain encroachment. Any alternative which does not meet the need for the project is not practicable. If the project’s purpose and need are not adequately addressed, specifically delineated, and properly justified, resource agencies, interest groups, the public, or others will be able to generate one or possibly several alternatives which avoid or limit the impact and “appear” practicable. Sometimes long, protracted negotiations or additional analyses are needed to demonstrate that an alternative is not practicable, whereas a well-described justification of the project’s purpose and need would have clearly established that finding.

If an alternative does not satisfy the purpose and need for the project, as a rule, it should not be included in the analysis as an apparent reasonable alternative. There are times when an alternative that is not reasonable is included based on the request of another agency or due to public expectation. In such cases, it should be clearly explained why the alternative is not reasonable (or prudent or practicable), why it is being analyzed in detail and, that because it is not reasonable, it will not be selected.

22-6.01(d) Basic Ingredients of Purpose and Need

The purpose and need should be as comprehensive and specific as possible. For example, rather than simply stating that additional capacity is needed between two points, information on the adequacy of current facilities to handle the present and projected traffic (e.g., what capacity is needed and the level of service for the existing and proposed facilities) should be discussed. Other information on factors (e.g., safety, system linkage, social demands, economic development, and modal interrelationships) that the proposed project will attempt to address, should be described as fully as possible. This will assist in pinpointing and refining the alternatives that should be analyzed. If the purpose of and need for the proposed project are rigorously defined, the number of “solutions” that will satisfy the conditions can be more readily identified and narrowly limited.

The Purpose and Need section of the project may, and probably should, evolve as information is developed and more is learned about the project and the corridor. For example, assume that the only known information regarding purpose and need is that additional capacity is needed between points “x” and “y.” At the outset, it may appear that commuter traffic to a downtown area is the problem, and only this traffic needs to be served. A wide range of alternatives may meet this need. As the studies progress, it may be learned that a shopping center, university,

major suburban employer, and other traffic generators contribute substantially to the problem and require transportation service. In this case, the need is further refined so that not only commuter trips but also student, shopping, and other trips will be accommodated. These refinements would clearly reduce and limit the number of alternatives that could satisfy the project's purpose and need, thereby reducing the number and range of reasonable, prudent, and practical alternatives. If an alternative is suggested that does not serve the university or other traffic generator, and such service is a vital element of the project, the alternative may be eliminated from future study because it does not meet the need for the project.

In the example above, it should be noted that products of the urban transportation planning process should identify many of the elements which contribute to the transportation problems. To the extent that the planning process develops these products and these products are used in project development, it may not be necessary to prepare additional studies.

Some of the elements that may assist in explaining a project's purpose and need (e.g., capacity, safety, system linkage), are described on page 14 of FHWA Technical Advisory T6640.8A "Guidance for Preparing and Processing Environmental and Section 4(f) Documents." (See Appendix A of Part III of the BDE Manual.) This discussion is included here as additional information. All of the elements which are relevant should be as fully developed as possible and utilize as specific data as possible to compare the present, future no-action, and future build conditions. Data should be presented on such factors as reduction in vehicular hours of travel; improvements in travel speeds on the system; reduction in traffic crashes; injuries and fatalities; savings in cost to the traveling public; enhanced economic development potential; increased tax base; improved access to public facilities; etc. It is not sufficient to state that the project is needed to provide increased capacity and improve safety. Supporting data must be provided.

22-6.01(e) Using Purpose and Need in Decision Making

As noted above, the purpose and need define what can be considered reasonable, prudent, and practical alternatives. The decision-making process should first consider those alternatives that meet the purpose and need for the project at an acceptable cost and level of environmental impact relative to the benefits which will be derived from the project.

At times, it is possible that no alternative meets all aspects of the project's purpose and need. In such a case, it must be determined if the alternatives are acceptable and worth pursuing considering the cost, environmental impact, and less than optimal transportation solution. To properly assess this, it is important to determine the elements of the purpose and need that are critical to the project, as opposed to those that may be desirable or simply support it. The critical elements are those that, if not met at least to some minimal level, would lead to a "no-action" decision. Determining critical needs could include policy decisions as well as technical considerations.

Other times, the cost or level of environmental impact are not acceptable and an alternative that only partially meets the purpose and need or the no-action alternative must be considered. If the costs are justified relative to the transportation benefits, then a less than full-build alternative may be acceptable.

In the vast majority of cases, however, at least one alternative will fully meet the purpose and need at an acceptable cost and level of impact. In cases where more than one alternative fully meets the purpose and need, a number of factors including cost, traffic service, safety, public support, environmental impact, etc., will be considerations in reaching the decision on which is the preferred alternative. The requirements of Section 4(f), the Wetland and Floodplain Executive Orders, and the Section 404(b)(1) Guidelines, of course, play an important role in this process.

22-6.01(f) Key Points to Remember

In summary, the Purpose and Need section in an environmental document presents why the proposed action, with its inherent costs and environmental impacts, is being pursued. If properly described, it also limits the range of alternatives that may be considered reasonable, prudent, and practicable in compliance with the *CEQ Regulations*, Section 4(f), the Executive Orders on Wetlands and Floodplains, and the Section 404(b)(1) guidelines. Further, it demonstrates the problems that will result if the project is not implemented.

There are three key points to remember on the Purpose and Need section of environmental documents. The section should be:

- a justification of why the improvement must be implemented,
- as comprehensive and specific as possible, and
- re-examined and updated as appropriate throughout the project development process.

22-6.01(g) Additional Information

Reference: Paragraph V.D. of FHWA Technical Advisory T6640.8A "Purpose of and Need for Action"

The cited reference provides additional information which applies to defining the purpose and need for the proposed action.

22-6.02 Indirect and Cumulative Environmental Impacts

References: 40 CFR 1502.16(b) "Discussion within Environment Consequences Section"
40 CFR 1508.7 "Definition of Cumulative Impact"
40 CFR 1508.8 "Definition of Direct and Indirect Effects"
CEQ Q&A, Question 18 "Uncertainties on Indirect Effects"
Considering Cumulative Effects under the National Environmental Policy Act (NEPA), CEQ, January 1997
FHWA Interim Guidance: Indirect and Cumulative Impacts in NEPA

22-6.02(a) Background

Indirect and cumulative environmental impacts will be considered and addressed as a normal component of environmental analyses for highway projects. The primary focus of the IDOT approach will be to ensure that the Department is conducting a good-faith effort to identify and disclose potential indirect and cumulative impacts that may occur. This will be demonstrated if the environmental document discloses all information of which the Department could reasonably have been expected to have knowledge.

22-6.02(b) Applicability

The procedures in this section are applicable to the following types of highway projects initiated by the Department:

- constructing highways on new alignment,
- adding lanes to an existing highway, and
- constructing a new interchange on an existing freeway or adding ramps to an existing interchange that will increase access to an area.

22-6.02(c) Definitions

The following definitions apply:

1. Reasonably Foreseeable. Deemed likely to occur in the future based on the best available planning information for the project area (e.g., formal planning documents, information from community officials, local land-use/zoning/permitting processes). The term is not intended to imply that district project development personnel or local officials are expected or encouraged to speculate on anticipated development in lieu of or beyond the scope of formal planning processes. To the extent that community officials are willing to provide their views on anticipated development in their locale, the information should be summarized in the project environmental document and appropriately analyzed and discussed according to these procedures. The sources of the information also should be cited in the environmental document.
2. Indirect Impacts. Those environmental impacts, such as conversion of agricultural land or habitat, that will result from reasonably foreseeable non-highway actions (e.g., land-use changes such as residential or business development) that will accompany or occur after completion of a highway project and that are assumed to be induced by the highway project.
3. Cumulative Impacts. The total impacts on specific environmental resources anticipated to result from the proposed highway project and other highway and non-highway development in the project area. In determining cumulative impacts, the district should

consider both development that the project will induce and development that is unrelated to the project but which will affect the same resources.

22-6.02(d) Identifying and Disclosing Reasonably Foreseeable Indirect and Cumulative Environmental Impacts

In evaluating cumulative impacts, districts should apply the guidance in the CEQ publication *Considering Cumulative Effects Under the National Environmental Policy Act*. The publication is available on the CEQ website and also can be accessed through the FHWA website. In the early planning phase of project development, districts should contact local community officials and planning and zoning authorities to determine the existence of land-use plans, planning information, and permitting processes that will identify anticipated development in the project area. These contacts also should explore the extent to which the development has been determined to be, or is perceived to be, related to or induced by the highway project. Districts should advise local officials that the information they provide will be incorporated in the project environmental documentation as part of the discussion of indirect and cumulative impacts. Where development has preceded the proposed highway project, the district should nonetheless evaluate whether planning information for the area indicates the highway may prompt further development. The influence of the development in “inducing” the highway project should be reflected in the discussion of the improvement’s purpose and need.

The spatial extent of analysis for potential indirect and cumulative impacts generally should correspond to the area over which the highway project is anticipated to affect traffic patterns and volumes based on traffic forecasts for the highway system with and without the improvement. The temporal extent of such analyses should correspond to the time frame reflected in current planning documents for the area or, in their absence, the time frame for which local officials will project planning information. The following provides specific direction on how indirect and cumulative impacts should be addressed for different levels and types of planning information available for the project area:

1. No Formal Planning Process Nor Current Planning Document for Project Area. If there is no local or regional planning process for the project area or if there is such a process but no current planning document, the district should contact community officials to determine if they will provide information regarding anticipated development in the project area. If local officials do not provide such information, disclose in the coordination section of the environmental document that there is no formal local planning process nor current planning document, as appropriate, and that contacts with local officials did not elicit information on anticipated development for the project area. The district should evaluate whether the current approved highway program includes any other current or anticipated improvements which could result in cumulative impacts when combined with the project under development. Any such cumulative impacts should be discussed in the environmental consequences section of the environmental document. Indirect and cumulative impacts need not be discussed further except to respond to comments or concerns of review agencies and the public.

If local officials do provide information regarding anticipated development in the project area, summarize the information in the coordination section of the environmental document. Also note the source of the information and that there is no formal planning process nor current planning document available for the area. Analyze the information to identify development which the highway project could induce (i.e., for which the highway project would be a necessary condition) or which would involve cumulative impacts on resources which the highway project would affect. Discuss the anticipated indirect and cumulative impacts of the development in the environmental consequences section of the environmental document and any cumulative impacts that would result from other highway projects indicated in the current approved IDOT highway program.

2. Current Planning Document in Place for Project Area. If there is a current planning document in place for the project area, disclose the existence of the document in the coordination section of the project environmental document. Analyze the information to identify development which the highway project could induce (i.e., for which the highway project would be a necessary condition) or which would involve cumulative impacts on resources which the highway project would affect. Discuss the anticipated indirect and cumulative impacts of the development in the environmental consequences section of the environmental document and any cumulative impacts that would result from other highway projects indicated in the current approved IDOT highway program.

If the district determines that the information in the current planning document is not consistent with actual land-use decisions in the area, this finding should be disclosed in the coordination section of the environmental document. The district should consider and discuss in the environmental consequences section potential indirect and cumulative impacts relative to the development projected in the planning document and relative to the patterns of development that actually are occurring.

22-6.02(e) Compatibility with Comprehensive Resource Plans

The district should confirm whether comprehensive resource plans (e.g., watershed or basin plans) have been prepared for the project area. Where such plans exist, the district should determine and disclose in the environmental document the compatibility of the reasonably foreseeable indirect and cumulative impacts relating to the project with the basic assumptions and objectives of the resource plan(s). The district also should determine and discuss in the environmental document, the compatibility of the reasonably foreseeable indirect and cumulative impacts relating to the project with statewide comprehensive resource plans (e.g., Illinois Wildlife Action Plan, Illinois Statewide Comprehensive Outdoor Recreation Plan).

22-6.02(f) Mitigation

The district must disclose indirect and cumulative environmental impacts in the environmental documents for highway projects subject to these procedures. However, the document must not necessarily include a discussion of mitigation for indirect or cumulative non-highway impacts. The document should include information describing any mitigation proposed for the direct

impacts of the highway project. In addition, when the district has knowledge of mitigation proposals or commitments by others (e.g., developers or resource agencies) relating to indirect or cumulative impacts associated with a proposed highway project, the environmental document for the highway project should disclose this information.

The district also should confirm and disclose in the environmental document whether local governments with jurisdiction in the project area have ordinances in place for protection of environmental resources, particularly those affected by the anticipated indirect and cumulative impacts associated with the project.

22-6.02(g) Format for Documentation in Environmental Reports

There is no prescribed format for discussing indirect and cumulative impacts in project environmental documents. These impacts may be incorporated, as appropriate, in the discussion of each environmental resource issue area or consolidated in a separate “indirect and cumulative impacts” topic in the environmental consequences section. BDE recommends use of the first option in most cases. It allows reviewers to more conveniently identify the total anticipated impacts for each environmental issue area, which may be desirable for review agencies interested in selected areas. The second option may be preferred where concerns have been expressed regarding indirect and cumulative impacts. In these instances, it may be helpful to consolidate the discussion of indirect and cumulative impacts in a separate section to clearly demonstrate that they have been addressed.

22-6.03 Logical Termini

References: 23 CFR 771.111(f) “Logical Termini, Independent Utility, Effect on Other Projects”
Section 22-3.06 “Proposed Action”

This discussion provides guidance in determining logical project termini for proposed actions. This guidance was prepared by the FHWA’s Office of Environment and Planning and issued on November 5, 1993. It has been edited to be consistent with the format of the BDE Manual. This guidance provides several working examples to illustrate the factors involved in choosing termini. These factors are then applied to issues such as project purpose and need, environmental impacts, and avoidance of segmentation.

22-6.03(a) Introduction

In developing a project concept which can be advanced through the stages of planning, environment, design, and construction, the project sponsor must consider a “whole” or integrated project. This project should satisfy an identified need, such as safety, rehabilitation, economic development, or capacity improvements, and should be considered in the context of the local area socioeconomics and topography, the future travel demand, and other infrastructure improvements in the area. Without framing a project in this way, proposed improvements may miss the mark by only peripherally satisfying the need or by causing

unexpected side effects which require additional corrective action. A problem of “segmentation” may also occur where a transportation need extends throughout an entire corridor, but environmental issues and transportation need are inappropriately discussed for only a segment of the corridor.

The Federal Highway Administration (FHWA) regulations outline three general principles in 23 CFR 771.111(f) that are used to frame a highway project:

In order to ensure meaningful evaluation of alternatives and to avoid commitments to transportation improvements before they are fully evaluated, the action evaluated in each Environmental Impact Statement (EIS) or finding of no significant impact (FONSI) shall:

- (1) Connect logical termini and be of sufficient length to address environmental matters on a broad scope;*
- (2) Have independent utility or independent significance, i.e., be usable and be a reasonable expenditure even if no additional transportation improvements in the area are made; and*
- (3) Not restrict consideration of alternatives for other reasonably foreseeable transportation improvements.*

The aim of this guidance is to discuss criteria that can be used to select logical termini (project limits) for development of a project. The primary discussion will be on the first of the three factors mentioned above. However, all three are interrelated and necessary to the development of an integrated project.

The remainder of this guidance is divided into three sections. Section 22-6.03(b) defines logical termini. Section 22-6.03(c) discusses several case studies covering factors that are relevant in choosing termini, and Section 22-6.03(d) offers some conclusions.

22-6.03(b) A Definition of Logical Termini

Logical termini for project development are defined as (1) rational end points for a transportation improvement, and (2) rational end points for a review of the environmental impacts. The environmental impact review frequently covers a broader geographic area than the strict limits of the transportation improvements. In the past, the most common termini have been points of major traffic generation, especially intersecting roadways. This is due to the fact that in most cases traffic generators determine the size and type of facility being proposed. However, there are also cases where the project improvement is not primarily related to congestion due to traffic generators, and the choice of termini based on these generators may not be appropriate. The next section will show some examples where this is the case.

Choosing a corridor of sufficient length to look at all impacts need not preclude staged construction. Therefore, related improvements within a transportation facility should be evaluated as one project, rather than selecting termini based on what is programmed as short

range improvements. Construction may then be “staged” or programmed for shorter sections or discrete construction elements as funding permits.

22-6.03(c) Sample Project Concepts and Discussion

Case #1

Identified Need:
Correct Existing Safety Hazards

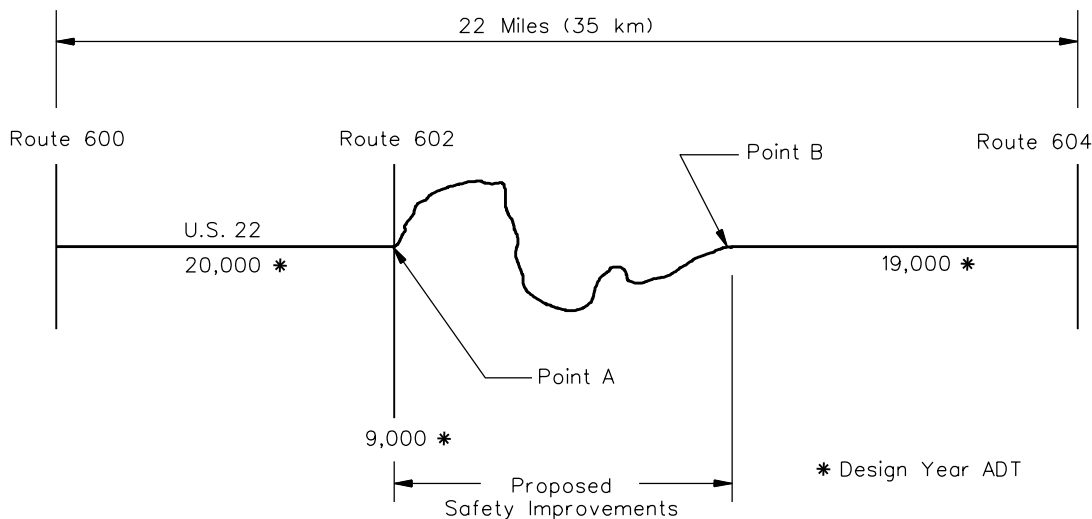

CASE #1

Figure 22-6.A

US 22 is a rural two-lane facility without access control. A number of crashes have been identified, and the need for the project is to correct site-specific geometric deficiencies between Point A (Route 602) and Point B (no intersecting roadway).

Discussion: In this Case, the selection of A and B as termini is reasonable, given the scope of the project. In fact, for projects involving safety improvements, almost any termini (e.g., political jurisdictions, geographical features) can be chosen to correspond to those sections where safety improvements are most needed. The first criterion, that the project connect logical termini and be of sufficient length to address matters on a broad scope, is largely irrelevant due to the limited scope of most safety improvements. Furthermore, even if other safety improvements are needed beyond those in segment A-B, the project termini need not be expanded to include these other improvements. The other two criteria still need to be met to choose A and B as termini: The safety improvements have independent utility (i.e., they can function as stand-alone improvements without forcing other improvements which may have impacts), and these improvements do not restrict consideration of other reasonably foreseeable transportation improvements (such as major safety improvements in an adjoining section; e.g., Point B to Route 604, which could involve changes in alignment of the segment currently under review).

Also, all environmental requirements must still be met. For instance, straightening of a curve through park land cannot take place without completing the necessary Section 4(f) analysis.

Case #2

Identified Need:
Correct Existing Safety Hazards

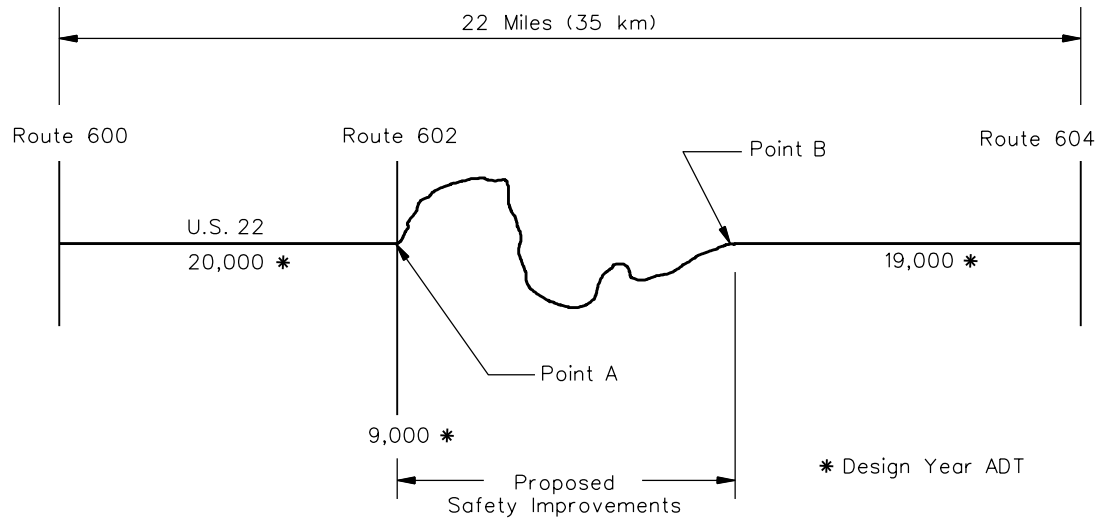

CASE #2

Figure 22-6.B

US 26 is on the eastern fringe of a rapidly growing urban area. Over the next 20 years, traffic growth and congestion are predicted for the section of roadway closest to the urban area, between Route 100 and Route 200. Because US 26 also serves as a through facility to points east, congestion will increase on the other sections also. It is proposed to deal with the worst of the congestion problems by widening the road to four lanes between Point A (Route 100) and Point B (Route 200).

Discussion: Widening between Point A and Point B could be implemented as a reasonable project with a logical termini, but several conditions would have to be met.

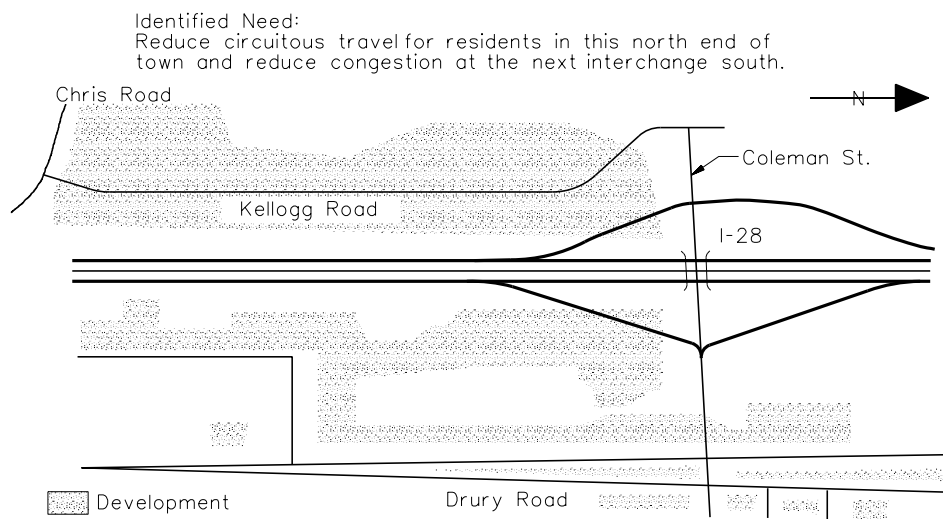
Case #3**CASE #3****Figure 22-6.C**

The proposed project is a new interchange with I-28 at the north edge of a growing urban area with options to upgrade an existing north-south feeder/collector route, Kellogg Road, on a new location. The next interchange south is at capacity now due to (1) new housing in the north end of town, and (2) a rapidly expanding commercial area at the existing interchange. The identified purposes of this project are to reduce circuitous travel for north end residents and to reduce congestion at the next interchange south.

Discussion: At first glance, the logical termini for analysis are the points where the new interchange ties in with existing facilities (Kellogg Road and Drury Road). Would this action force other project improvements? In this example, Kellogg Road and Drury Road may be overloaded by interchange traffic. If this is considered now, there may be design options to address this without substantial change or disruption. If this is dealt with later, the options may be more limited. If the only remaining option in the future is to widen Kellogg Road and Drury Road, there may be considerable disruption, relocations, etc., which could possibly have been avoided. For this particular project, the eastern project terminus was the intersection of Coleman Street and Drury Road, because there was adequate capacity on Drury road to absorb the traffic and no additional improvements would be forced. The western project terminus was further away from the intersection, because Kellogg Road did not have sufficient capacity to accommodate the traffic from the interchange. The terminus in this case was where Kellogg Road intersected with Chris Road. It was demonstrated that Chris Road had the capacity to handle the additional traffic and that no additional improvements would be forced. Options for upgrading Kellogg Road included widening of the existing Kellogg Road or a north-south feeder road on new alignment. Even if the project sponsor had decided not to upgrade Kellogg Road,

the environmental document should have covered the environmental impacts resulting from the congestion of this route (e.g., community disruption, possible air quality violations).

Case #4

Identified Need:
Satisfy travel demand in a new corridor
to and from points east on the existing facility.

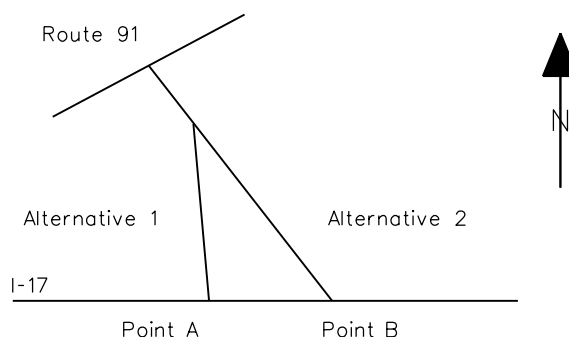

CASE #4

Figure 22-6.D

This proposed facility is on new alignment, connecting Route 91 with I-17. Alternative 1 is shorter, connecting to I-17 at Point A, and Alternative 2 would tie in further east, at Point B. The primary travel on this new facility is to and from points east on I-17. I-17 is four lanes west of Point B and six lanes east of Point B. Alternative 2 has been designated as the preferred option by the project sponsor. Alternative 1 was proposed by a citizen's group to reduce the number of relocations and community disruption. Cost estimates are \$50 million for Alternative 1 (to tie in at Point A) and \$63 million for Alternative 2 (to tie in at Point B).

Discussion: It is likely that an incomplete picture of the costs and impacts of Alternative 1 is being provided by only carrying the analysis as far as Point A. For both alternatives, consideration of impacts should continue to Point B or east of B if there are likely to be any weaving or merging problems which will force changes in the facility beyond B. In this example, the four-lane section between A and B, if overloaded by Alternative 1, would force further improvements on I-17 which would likely have additional impacts.

Failure to take this into account would underestimate the cost and overall impacts of Alternative 1 and skew decision making. As a result of these factors, if Alternative 1 is considered a reasonable alternative, the discussion of impacts should extend to impacts occurring at Point B. If I-17 will be able to accommodate the increased traffic from Alternative 1 without widening, then the discussion could simply be a demonstration of that fact.

22-6.03(d) Conclusions

The aim of this guidance has not been to present all possible ways of determining logical project termini but, rather, to present a thought process that can be used to make these determinations on a case-by-case basis. For the vast majority of highway projects, the choice of logical termini will be obvious and non-controversial. For those few complex projects where other considerations are important, the termini chosen must be such that:

- environmental issues can be treated on a sufficiently broad scope to ensure that the project will function properly without requiring additional improvements elsewhere, and
- the project will not restrict consideration of alternatives for other reasonably foreseeable transportation improvements.

By following this guidance, proposed highway projects will be more defensible against litigation claims of project segmentation, and decision makers and the public will have a clearer picture of the transportation requirements in the project area and a better understanding of the project purpose and need.

22-6.04 Congestion Management Process (CMP) Alternatives

CMP requirements apply to the following Transportation Management Areas (TMAs) in Illinois, regardless of air quality attainment status: Chicago (Chicago Metropolitan Agency for Planning jurisdiction), St. Louis (East-West Gateway Council of Governments jurisdiction), Peoria (Tri-County Regional Planning Commission jurisdiction), the Quad Cities (Bi-state Regional Commission jurisdiction), and Rockford (Rockford Metropolitan Agency for Planning jurisdiction). These areas must address congestion management through a cooperatively developed and implemented process for new and existing transportation facilities that incorporates use of travel demand reduction and operational management strategies. The CMP must include methods to:

- monitor and evaluate the performance of the multimodal transportation system (i.e., performance indicators),
- identify the causes of recurring and non-recurring congestion,
- identify and evaluate alternative strategies,
- provide information supporting the implementation of actions, and
- evaluate the effectiveness of implemented actions.

Each TMA must also develop appropriate performance measures as part of the CMP to assess the extent of congestion and support the evaluation of the effectiveness of transportation improvements in reducing congestion within the TMA. The TMA may also establish thresholds for congestion reduction that must be met for a project to be considered for Federal funding. In TMAs where performance measures have been established, the district will need to coordinate

with Metropolitan Planning Organization staff to ensure that a proposed project's effectiveness in reducing congestion has been evaluated through the CMP. In cases where thresholds have also been developed, the district must coordinate to ensure the project meets those thresholds. The results of coordination for the CMP will be reflected in the congestion management strategies incorporated in the project scope and alternatives, as appropriate.

In areas designated as nonattainment for carbon monoxide or ozone, additional requirements apply for analysis of CMP alternatives. When projects within these areas would significantly increase capacity for single-occupancy vehicles (i.e., by adding lanes to an existing highway or constructing a new highway), the alternatives section must include information on CMP alternatives. Lane additions for safety improvements or for elimination of bottlenecks are not considered to be projects that significantly increase capacity for single-occupancy vehicles. The following paragraphs provide recommended wording for use in addressing this requirement:

Congestion Management Process Alternatives

The provisions of 23 CFR 450.320 place restrictions on the use of Federal funds for projects in Transportation Management Areas (TMAs) designated as nonattainment for carbon monoxide and/or ozone. In these areas, Federal funds may not be programmed for any project that will significantly increase capacity for single-occupancy vehicles (SOVs) unless the project is addressed through a Congestion Management Process (CMP). The CMP is required to provide an appropriate analysis of alternatives to the proposal for adding SOV capacity, including all reasonable congestion management strategies. If the analysis demonstrates that other alternatives and/or congestion management strategies cannot fully satisfy the need for additional capacity and that, therefore, the additional SOV capacity is warranted, the CMP must identify all reasonable strategies that will maintain the functional integrity of the additional lanes. All identified reasonable strategies must be incorporated into the project. The CMP for each affected TMA is addressed in materials available from the Metropolitan Planning Organization responsible for the area.

[The following paragraphs provide recommended text to use for projects in the Chicago metro area. This text should be modified as appropriate (e.g., regarding references to the affected planning area, the responsible Metropolitan Planning Organization, the documents referenced for the CMP) for projects in other TMAs.]

Individual projects involving addition of SOV capacity were evaluated, selected, and prioritized in the course of developing the Fiscal Year *[insert appropriate years]* Transportation Improvement Program (TIP) and the long-range *[insert appropriate year]* Regional Transportation Plan (RTP) for Northeastern Illinois. The Northeastern Illinois CMP is documented via various materials that are available through the Chicago Metropolitan Agency for Planning (CMAP). The following are examples:

- Congestion Mitigation Handbook, September 1998
- Congestion Management System for Northeastern Illinois, *[insert appropriate year]* Annual Status Report

- [Date of most recent] Regional Transportation Plan for Northeastern Illinois
- Arterials and Streets Infrastructure and Operations for Mobility, Access, and Community in Metropolitan Chicago, January 2009
- Travel Demand Management, Strategy Paper, March 2009
- Congestion Reduction Demonstration for Northeastern Illinois A Proposal for Direct Highway Pricing, Transit, Technology, and Supporting Strategies, December 31, 2007

The development process for the TIP and Regional Transportation Plan constitutes the CMP for Northeastern Illinois. This process documents warranted projects for adding SOV capacity and, as applicable, also documents that regional and/or project-specific alternatives (e.g., Transportation Demand Management measures, High-Occupancy Vehicle measures, Transit Capital Improvements, Congestion Pricing, Growth Management, Incident Management) would not obviate the need for adding SOV capacity. Planned projects resulting from the CMP are documented in the annual CMP status report referenced above. *[Include the following sentence, when applicable.]* For this project, it has been determined that stand-alone CMP alternatives will not satisfy the project purpose and need and, therefore, this undertaking is a warranted project for adding SOV capacity.

Reasonable project-specific CMP strategies, including Traffic Operational Improvements, Transit Operational Improvements, Non-motorized modes/measures (Pedestrian/Bicycle), Intelligent Transportation System (ITS), and Access Management, have been incorporated into this project to the extent practical. Specific strategies incorporated include *[list the strategies (as described in the Congestion Management Handbook) such as adding turning lanes, modernizing signals, signal interconnect, ITS (adding dynamic message signs, highway advisory radio, fiber optic, etc.), sidewalk/bicycle accommodations, access consolidation, and/or barrier median to control access, etc.]*. *[Add the following, if applicable:]* With respect to Transit Operational Improvements, coordination occurred with [PACE/Metra/CTA]. Based on this coordination the following transit improvements were included in the project: *[briefly describe any included transit projects and reference pertinent correspondence]*.

As documented in the above information, this project results from the CMP for Northeastern Illinois as a warranted project for adding SOV capacity and all reasonable congestion management strategies have been incorporated into the project to sustain its effectiveness.

22-7 ENVIRONMENTAL DOCUMENTATION AND PROCESS FOR NON-FEDERAL PROJECTS

22-7.01 Environmental Documentation for Non-Federal Projects

22-7.01(a) “Categorical Exclusion” Projects

For actions that do not involve Federal funding or approvals and which qualify as “Categorical Exclusions” as discussed in Section 23-1.03, the environmental documentation for the project shall be a part of the Phase I Report (See Section 12-3.06).

22-7.01(b) Non “Categorical Exclusion” Projects

For projects that do not involve Federal funding or approvals and which do not qualify as “Categorical Exclusions” as discussed in Section 23-1.03, the environmental documentation shall be a part of the State Improvement Report; see Section 12-1.02 for the types of projects and Section 12-3.05 for the content.

The process for addressing environmental issues on non-Federal projects will depend upon whether the projects qualify as Categorical Exclusions (CEs) as described in Section 23-1.03. Non-Federal actions that qualify as CEs will follow the environmental process as described in Section 23-2, except that FHWA will not be involved. For non-Federal actions that do not qualify as CEs, the environmental process described in this section will apply, as presented in Figure 22-7.A. This is followed by a brief description of each step within the network.

22-7.02 Environmental Process for Non-Federal Projects

22-7.02(a) Inventory and Evaluate Preliminary Alternatives

If the project is one which the Regional Engineer has determined will use the principles of Context Sensitive Solutions (CSS), the public involvement process should commence once the project is assigned to the project study group. The project study group shall use the Stakeholder Involvement Process (SIP) as outlined in Section 19-5.01 to conduct public involvement for CSS projects.

After the district office determines the preliminary project purpose and need, it will initiate activities to inventory and evaluate the affected environment and to develop and evaluate preliminary project alternatives. The compilation of environmental inventories should be pursued only to the extent necessary to provide high-quality information on the environmental impacts of the proposed action and to facilitate decision making. By limiting inventory work to an optimum level, the amassing of needless detail can be avoided, thus reducing paperwork.

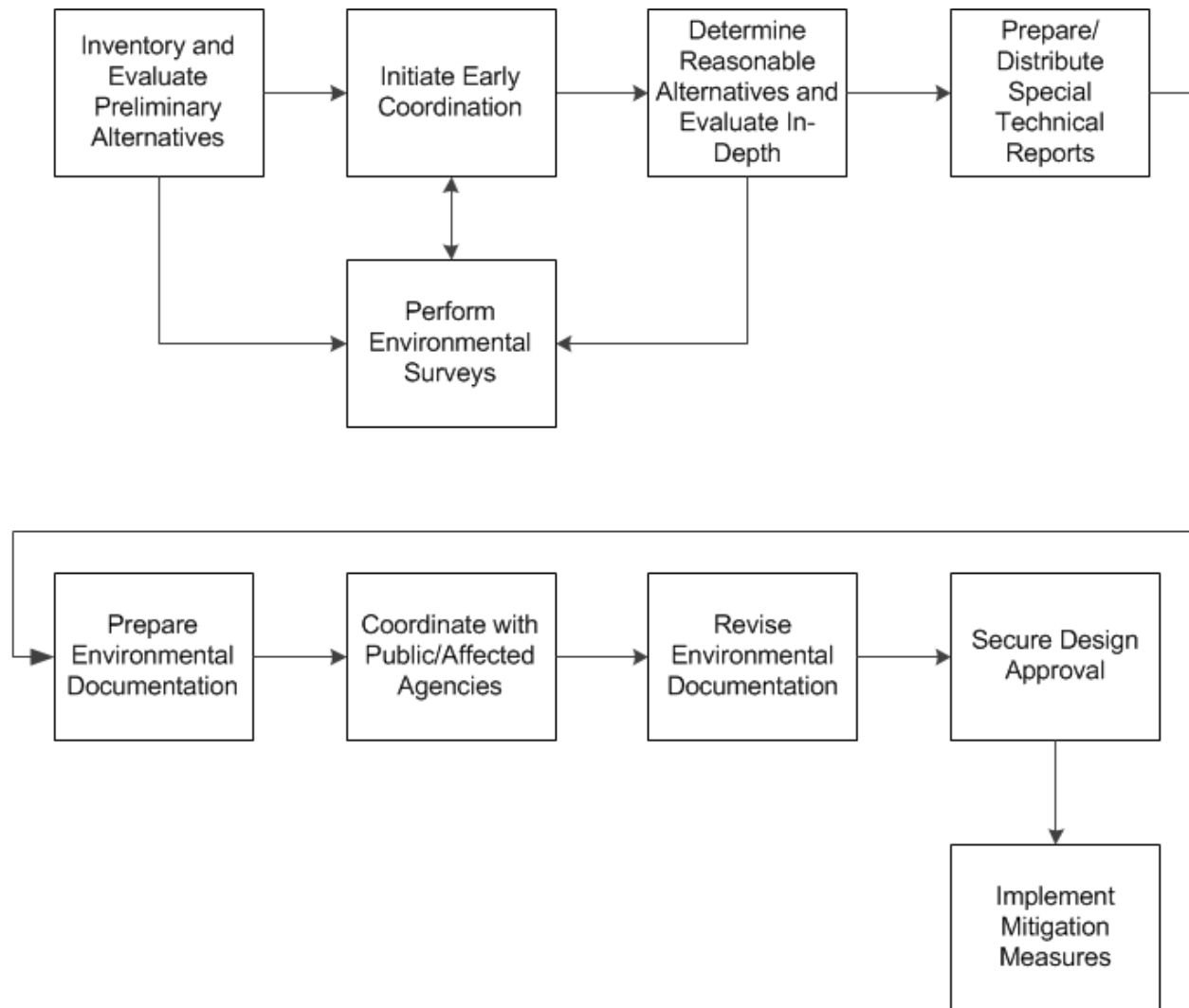

PROCESS FOR NON-FEDERAL PROJECTS

Figure 22-7.A

The district should identify the range of the environmental inventory by evaluating environmental databases and submitting an environmental survey request, as appropriate, to BDE. Environmental concerns involved may include:

- Section 6(f) or OSLAD properties;
- archaeological and historical properties;
- floodplains;
- sensitive noise receptors;
- prime farmland;
- wetlands;
- threatened or endangered species habitat, nature preserves, and natural areas;
- wild and scenic rivers;
- status of air quality attainment;
- water quality of streams or lakes;
- special waste sites;
- social/economic characteristics of the affected population;
- visual quality/aesthetics;
- well-head protection areas;
- groundwater recharge areas; and
- other biological areas.

After the inventory has been prepared, the district should perform a preliminary evaluation of the magnitude and importance of the potential environmental impacts of the alternatives under study. This will assist in initiating the early coordination process and in further refining the alternatives. The evaluation of preliminary alternatives should be sensitive to those environmental resources for which analysis of alternatives for avoidance and minimization of adverse impacts is required (e.g., wetlands floodplains, historic sites, and threatened and endangered species). In addition, districts should recognize that avoidance of environmental resources requiring special compliance procedures for impacts should be the preferred course of action. Avoidance of such resources will help to shorten project development time by avoiding the reporting and coordination necessary for compliance.

Reference: AASHTO Practitioner's Handbook 11 Complying with Section 4(f) of the US DOT Act, May 2009

22-7.02(b) Perform Environmental Surveys

Based on the environmental survey request and Special Waste Assessment Screen/Survey Request form, as appropriate, BDE will perform a record survey to assess published information and determine the need for further investigation of the following:

- wetlands,
- archaeological and historical resources,
- Federal and State threatened and endangered species or their critical/essential habitat,
- well-head protection zones and regulated recharge areas, and
- special waste sites.

As determined necessary on the basis of the records survey or special waste assessment screening process, BDE will coordinate, as appropriate, with the responsible agencies and the district for further field surveys. BDE will provide the environmental survey information to the district as it becomes available to assist in the evaluation of project alternatives.

Reference: Chapter 27 "Environmental Surveys"

22-7.02(c) Initiate Early Coordination

Coordination with governmental agencies and the public is an important aspect of the project development process and should begin as early as practical in project planning. This coordination facilitates obtaining information from other entities and individuals which may assist in the inventorying of the affected environment and in the evaluation of alternatives.

If the project is one which the Regional Engineer has determined will use the principles of Context Sensitive Solutions (CSS), the public involvement process should commence once the project is assigned to the project study group. The project study group shall use the Stakeholder Involvement Process (SIP) as outlined in Section 19-5.01 to conduct public involvement for CSS projects.

References: Section 22-5 "Coordination"
Chapter 19 "Public Involvement Guidelines"

22-7.02(d) Determine Reasonable Alternatives and Evaluate In-Depth

The district should evaluate the potential impacts of the preliminary alternatives on the inventory of environmental resource concerns and should consider the information and comments

provided by other agencies and the public in determining the scope of issues of importance and, ultimately, the reasonable alternatives worthy of in-depth evaluation. The cost and level of effort for preliminary environmental evaluations of an alternative should be commensurate with its likelihood of being implemented. Collectively, the alternatives selected for in-depth study should be representative of the full range of alternatives and should gain public acceptance that no reasonable alternative has been omitted.

The district must evaluate in detail the environmental impacts of each selected reasonable alternative in accordance with the scope determined through the environmental inventory process and early coordination with other agencies and the public. The district, in cooperation with BDE, will initiate those detailed studies and associated coordination with other agencies and the public necessary to further evaluate the environmental impacts of the proposed project alternatives

References: Section 22-5 "Coordination"
Chapter 19 "Public Involvement Guidelines"

22-7.02(e) Prepare/Distribute Special Technical Reports

For environmental concerns requiring in-depth analysis (e.g., wetlands, noise), it may be appropriate to prepare "technical reports" discussing the analyses and findings for the issues involved. BDE will determine "technical report" requirements. As appropriate to respond to requests identified during early coordination, these "technical reports" will be coordinated with agencies and other interested entities. Technical reports should be reviewed by BDE prior to making them available to other parties. The key conclusions from these reports will be summarized in the environmental documentation for the Phase I Report.

Reference: Chapter 26 "Special Environmental Analyses"

22-7.02(f) Prepare Environmental Documentation

At this stage of project development, the district will have received input from appropriate agencies and the public, will have evaluated the selected reasonable alternatives in depth, and will have received input on any special technical reports. The environmental information resulting from these activities should be summarized in the Phase I Report as described in Section 22-2.05(b).

References: Chapter 26 "Special Environmental Analyses"
Section 22-2.05 "Environmental Documentation for Non-Federal Actions"

22-7.02(g) Coordinate with Public/Affected Agencies

In Section 22-7.03, the district will have made a preliminary identification of those agencies which may have an interest in the project. The district will coordinate the information regarding

the project alternatives and the evaluation of their environmental impacts with the public and appropriate agencies prior to submitting the project for design approval.

If the project is one which the Regional Engineer has determined will use the principles of Context Sensitive Solutions (CSS), the public involvement process should commence once the project is assigned to the project study group. The project study group shall use the Stakeholder Involvement Process (SIP) as outlined in Section 19-5.01 to conduct public involvement for CSS projects.

Reference: Chapter 19 "Public Involvement Guidelines"

22-7.02(h) Revise Environmental Documentation

The district will evaluate any comments received as a result of coordinating the environmental information for the project with the public and appropriate agencies and will incorporate additional information or changes in information as necessary to respond to the comments.

22-7.02(i) Secure Design Approval

The district will submit the Phase I Report, including appropriate environmental documentation, to BDE for projects requiring central office Design Approval. BDE will review the environmental documentation and will advise the district of any changes or additional information needed prior to approval.

22-7.02(j) Implement Mitigation Measures

Those involved in preparing and processing the environmental documentation for the project should assist those involved in subsequent aspects of project development and implementation in facilitating the fulfillment of any environmental commitments for the project. The district must ensure that its procedures for follow-through on commitments provide for including information on mitigation measures and other commitments (e.g., for wetlands compensation plans, erosion control plans, special provision for management and monitoring of special waste) in the project plans, as necessary, and for implementing and monitoring the measures during construction and maintenance, as appropriate.

22-8 REFERENCES

In addition to Part III and the duplicated information in Appendix A, many other references are available in the literature to assist in the preparation of environmental documents. Section 22-8 briefly discusses selected references. This list is not comprehensive and is intended only to provide an overview of selected information that may be of interest.

22-8.01 National

The following briefly discusses national publications which may provide useful resource information to the preparers of environmental documents:

1. AASHTO Practitioner's Handbook 01 *Maintaining a Project File and Preparing an Administrative Record for a NEPA Study*, July 2006. Preparing the administrative record for a complex project can be a major challenge. This handbook provides a starting point for undertaking this important task. It includes key issues for consideration during NEPA and when litigation is imminent or under way.
2. AASHTO Practitioner's Handbook 02 *Responding to Comments on an Environmental Impact Statement*, July 2006. This guidance provides information for developing responses to comments on both a Draft EIS and Final EIS, and covers the issues associated with responding to comments on an Environmental Assessment.
3. AASHTO Practitioner's Handbook 03 *Managing the NEPA Process for Toll Lanes and Toll Roads*, July 2006. Conducting NEPA studies for projects involving toll lanes and toll roads involves many sensitive issues and complex considerations. This handbook covers issues associated with the NEPA process and related issues.
4. AASHTO Practitioner's Handbook 04 *Tracking Compliance with Environmental Commitments/Use of Environmental Monitors*, November 2006. This handbook provides recommendations for tracking compliance with environmental commitments from the environmental review phase through design, construction, operations, and maintenance phases of a transportation project.
5. AASHTO Practitioner's Handbook 05 *Utilizing Community Advisory Committees for NEPA Studies*, December 2006. A Community Advisory Committee (CAC) is a public participation technique that can be employed to gain stakeholder feedback, identify and resolve local concerns, and build community support during the NEPA process. Although not required, a CAC can be an effective means of addressing specific issues and hearing a variety of stakeholder views.
6. AASHTO Practitioner's Handbook 06 *Consulting under Section 106 of the National Historic Preservation Act*, February 2007. This handbook clarifies and provides information on the successful integration of Section 106 and NEPA with a specific focus on Section 106 as it applies to transportation projects for which the project applicant is a State Department of Transportation (DOT).

7. AASHTO Practitioner's Handbook 07 *Defining the Purpose and Need and Determining the Range of Alternatives for Transportation Projects*, August 2007. One of the most important tasks in any NEPA study is the definition of the project's purpose and need. This handbook provides recommendations for defining the purpose and need, and determining the range of alternatives in Environmental Impact Statements and Environmental Assessments for transportation projects in accordance with NEPA.
8. AASHTO Practitioner's Handbook 08 *Developing and Implementing an Environmental Management System in a State Department of Transportation (DOT)*, September 2007. DOTs face ever-mounting pressure to enhance environmental and business performance and to demonstrate their commitment to environmental stewardship. This handbook provides recommendations for developing and implementing an Environmental Management System (EMS) to help meet these goals and expectations.
9. AASHTO Practitioner's Handbook 09 *Using the SAFETEA-LU Environmental Review Process (23 USC 139)*, January 2008. Section 6002 of SAFETEA-LU established an environmental review process for highway and transit projects that involve preparation of an Environmental Impact Statement (EIS). This handbook provides assistance to practitioners in complying with the Section 6002 requirements, while also using this process to achieve better, faster, and more efficient environmental reviews.
10. AASHTO Practitioner's Handbook 10 *Using the Transportation Planning Process to Support the NEPA Process*, February 2008. Thoughtful consideration of environmental needs during the planning process can shorten the environmental review process. This handbook is intended to help transportation planners and NEPA practitioners improve linkages between the planning and NEPA processes, while also complying with recent legislative changes that require increased consideration of environmental issues in the planning process.
11. AASHTO Practitioner's Handbook 11 *Complying with Section 4(f) of the US DOT Act, May 2009*. This Handbook provides guidance to assist practitioners in managing all aspects of compliance with Section 4(f). It is intended to help practitioners take advantage of the flexibility afforded by recent changes to Section 4(f) while ensuring that all requirements are met. It addresses the full range of Section 4(f) compliance options, including individual Section 4(f) evaluations, *de minimis* impact determinations and programmatic Section 4(f) evaluations.
12. *Aesthetics in Transportation — Guidelines for Incorporating Design, Art, and Architecture into Transportation Facilities*, 1980. Although the aesthetic design of transportation facilities is important in the open countryside, it is especially critical in urban areas. This publication contains examples of aesthetic applications in various situations.
13. *A Design Guide for Wildlife Protection and Conservation for Transportation Facilities*, AASHTO, 1976. This publication is a guide for the consideration of wildlife and habitat impacts when transportation system facilities are being planned, designed, constructed, operated, and/or maintained.

14. *Aligning National Environmental Policy Act Processes with Environmental Management Systems, A Guide for NEPA and EMS Practitioners, Council on Environmental Quality (CEQ), April 2007.* An Environmental Management System (EMS) is a structure of procedures and policies used to systematically identify, evaluate, and manage environmental impacts of ongoing activities, products, and services. CEQ prepared this guide to assist Federal agencies in aligning the statement of policy in Section 101 of NEPA and the analysis and decision processes of Section 102 with the elements of an EMS when establishing, implementing, and maintaining their EMS.
15. *Collaboration in NEPA – A Handbook for NEPA Practitioners, CEQ, October 2007.* This handbook is intended to assist Federal agency personnel responsible for conducting environmental reviews in expanding the effective use of collaboration, with other governmental entities and affected and interested parties as part of the NEPA process.
16. *Considering Cumulative Effects under the National Environmental Policy Act (NEPA), CEQ, January 1997.* This handbook introduces the NEPA practitioner and other interested parties to the complex issue of cumulative effects, outlines general principles, presents useful steps and provides information on methods of cumulative effects analysis and data sources.
17. *Environmental Guidebook, FHWA.* This is a collection of FHWA position papers, interpretation of regulations, and agreements with other agencies on the implementation of NEPA.
18. *Environmental Policy Statement, 1994, FHWA.* This statement provides a formal expression of the FHWA's commitment to the protection and enhancement of the environment and the incorporation of environmental stewardship in all of its programs and policies.
19. *Guide for Transportation Landscape and Environmental Design, AASHTO, 1991.* The *Guide* addresses all modes of transportation and the interaction of landscape considerations with transportation improvements. It places a special emphasis on supplying technical information that will assist the planner, designer, project engineer, landscape architect, supervisor, and/or transportation manager in providing landscape features which integrate into the transportation system, producing an environmentally pleasing facility.
20. *A Guide to Wetland Functional Design, FHWA, 1990.* This document was developed as a conceptual guide to replacing wetland functions identified by WET II.
21. *Guidelines on Citizen Participation in Transportation Planning, AASHTO, 1978.* This publication focuses on the needs of agency administrators and professionals in the planning process and public participation programs in State agencies, but it is also relevant at regional and local levels for all transportation modes.
22. *Hazardous Waste Guide for Project Development, AASHTO, 1990.* This *Guide* is for those projects where it is unknown whether or not a hazardous waste potential exists.

The *Guide* provides steps to determine if there is hazardous waste present and what tasks are involved if there is one present.

23. *Improving the Quality of Environmental Documents, AASHTO/ACEC, 2006*. This reports documents an initiative by transportation practitioners nationwide to improve the quality of EISs and EAs to comply with NEPA.
24. *Incorporating Biodiversity Considerations into Environmental Impact Analysis under NEPA, CEQ, 1993*. This Report is intended to provide background on the emerging, complex subject of biodiversity; outline some general concepts that underlie biological diversity analysis and management; describe how the issue is currently addressed in the NEPA process; and provide options for agencies undertaking NEPA analyses that consider biodiversity.
25. *Interim Guidelines for Hazardous Waste, 1988, FHWA*. This guidance provides an overview of the legal and policy/procedure issues important in the consideration of hazardous waste sites. It is intended to provide a framework for states to use in developing effective processes for addressing such sites in highway project development.
26. *NHI Course #142005 Manual NEPA and Transportation Decisionmaking*. This course considers FHWA's policies and procedures for applying the *National Environmental Policy Act* for the project development processes related to transportation facilities.

22-8.02 State

22-8.02(a) Manuals

The Bureau of Design and Environment has published or is developing a series of environmental technical manuals which contain information on methods to use for technical investigations and analyses that support highway project environmental impact studies and documents. These manuals plus the environmental memoranda issued by BDE provide guidance on technical study methods, pertinent environmental data, and other background information. References to these manuals are important; in many cases, they refer to specific technical procedures which are required in specific circumstances. Whereas Part III stipulates what must be done, where, and when, the technical manuals address how.

22-8.02(b) BDE Memoranda and Policies

The BDE periodically distributes memoranda which address environmental issues. These are segregated as follows:

1. Procedure Memoranda (PM). These are the most important to the application of environmental policies and procedures. Procedure Memoranda summarize and give background for updates to the environmental chapters where the full update is

automatically incorporated in the BDE Manual. Active PMs are shown on the BDE Procedure Memorandums internet site.

2. Departmental Policies. These policies should be referenced as needed in the preparation of environmental documents.
3. Technical Environmental Memoranda (TEM). As a way of disseminating information to the districts related to environmental regulations, laws, permits, and best practices, BDE will at times issue a TEM. The content of a TEM is considered “guidance” instead of “policy” so the TEM’s are not incorporated in the BDE Manual. When a TEM is issued, it will be posted on BDE’s Environmental Policy Unit’s SharePoint site (accessible via InsideIDOT >Sites>Design and Environment>Policy>Environmental Policy Unit) and also emailed to the Environmental Coordinators in each District. Also maintained on the SharePoint site is a disposition of past TEMs that have been retired.

Chapter Twenty-three
CATEGORICAL EXCLUSIONS

BUREAU OF DESIGN AND ENVIRONMENT MANUAL

Chapter Twenty-three
CATEGORICAL EXCLUSIONS

Table of Contents

<u>Section</u>	<u>Page</u>
23-1 GENERAL	23-1.1
23-1.01 Definition	23-1.1
23-1.02 Applicability to Federal Actions.....	23-1.2
23-1.03 Applicability to Non Federal Actions	23-1.2
23-1.04 CE Classifications.....	23-1.2
23-1.04(a) State Approved Categorical Exclusions	23-1.2
23-1.04(b) Federal Approved Categorical Exclusions.....	23-1.3
23-1.05 Compliance with Other Requirements.....	23-1.5
23-1.06 Re-evaluation of CE Designation.....	23-1.5
23-1.06(a) For state-approved CE:	23-1.5
23-1.06(b) For Federally approved CE:.....	23-1.5
23-2 THE CE PROCESS.....	23-2.1
23-2.01 Initiate CE Process	23-2.1
23-2.02 Plans, Specifications, and Estimates (PSE) Projects.....	23-2.2
23-2.03 Inventory Project Area	23-2.2
23-2.04 Initiate Early Coordination	23-2.3
23-2.05 Evaluate Project Alternatives and Project's Potential for Unusual Circumstance	23-2.3
23-2.06 CE Determination	23-2.4
23-2.07 CE Approval	23-2.4
23-2.08 Documentation of Environmental Commitments	23-2.5
23-2.09 Documentation of the CE Determination and Approval.....	23-2.5
23-2.09(a) Documentation for Federal Actions.....	23-2.5
23-2.09(b) Documentation for Non-Federal Actions	23-2.6

Chapter Twenty-three

CATEGORICAL EXCLUSIONS

Chapter 23 discusses IDOT procedures for those projects classified as Categorical Exclusions. IDOT and FHWA are both committed to addressing environmental requirements under the *National Environmental Policy Act* (NEPA) and doing so in a streamlined and efficient manner.

23-1 GENERAL

23-1.01 Definition

FHWA environmental regulations (23 CFR 771.115) define Categorical Exclusions (CEs) as “Class II” actions that meet the definition as described in 40 CFR 1508.4, and based on past experience with similar actions are actions that:

- do not induce significant impacts to planned growth or land use for the area;
- do not require the relocation of significant numbers of people or businesses;
- do not have a significant impact on any natural, cultural, recreational, historic, or other resource;
- do not involve significant air, noise, or water quality impacts;
- do not have significant impacts on travel patterns; and
- do not otherwise, either individually or cumulatively, have any significant environmental impacts.

Therefore, these actions are excluded from the requirement to prepare an Environmental Assessment (EA) (see Chapter 24) or Environmental Impact Statement (EIS) (see Chapter 25). The FHWA has listed examples of Class II actions in 23 CFR 771.117. Most projects developed by IDOT do not have significant environmental impacts and therefore qualify as CEs.

Per 23 CFR 771.117, FHWA and IDOT have approved a Programmatic Agreement between Federal Highway Administration and the Illinois Department of Transportation regarding the Processing of Actions Classified as Categorical Exclusions for Federal-Aid Highway Projects (See Appendix A).

The Programmatic Agreement, herein referred to as “CE Agreement,” has been developed to address the development and approval of CEs in a streamlined and efficient manner.

References:

40 CFR 1508.4 - Categorical Exclusion
Subsection 23 CFR 771.115(b) of 23 CFR 771.115 - Classes of Actions
Section I of FHWA Technical Advisory T6640.8A - Categorical Exclusion (CE)

23-1.02 Applicability to Federal Actions

These procedures apply to any Federal “action”, defined in 23 CFR 771.107(b) as follows:

A highway or transit project proposed for FHWA or FTA funding. It also includes activities such as joint and multiple use permits, changes in access control, etc., which may or may not involve a commitment of Federal funds.

For example, a project may require an Interstate access justification approval by FHWA, and the entire project would therefore be subject to all Federal requirements regardless if Federal funding was involved or not. Another example would be a project that requires a Section 404 Clean Water Act permit.

References:

Subsection 23 CFR 771.117(a) of 23 CFR 771.117 - FHWA categorical exclusions
Subsection 23 CFR 771.107(b) of 23 CFR 771.107 - Definitions
Paragraph I.A. of FHWA Technical Advisory T6640.8A - Documentation of Applicability

23-1.03 Applicability to Non Federal Actions

Although Categorical Exclusion (CE) is a Federal concept, these procedures are also generally applied to State-only or State/locally funded projects that are not otherwise considered a Federal “action” (see definition of Federal “action” above) to: 1) provide a consistent method of documenting the lack of any significant environmental impacts of CE-type projects; and 2) ensure compliance with State environmental laws and regulations.

23-1.04 CE Classifications

The CE Agreement establishes two categories of CEs, those that may be approved by IDOT on behalf of FHWA (State Approved CEs) and those that require FHWA approval (Federal Approved CEs).

23-1.04(a) State Approved Categorical Exclusions

Actions qualifying as a CE, as listed in Appendix A and Appendix B of the CE Agreement; and that do not involve the potential for unusual circumstances (see Section 23-1.04(b) or Section V

of the CE Agreement), may be approved by IDOT on behalf of the FHWA. No separate review or approval of such "State Approved CEs" by FHWA is required.

Actions qualifying as a State Approved CE are not required to be discussed at district coordination meetings (see Section 22-5.03) unless there are issues related to the project's scope, design exceptions, or meeting ADA standards to the maximum extent practicable.

The district will use Chapter 26 for any special environmental analyses needed.

References:

Subsections (c) and (d) of 23 CFR 771.117 - FHWA Categorical Exclusions
Paragraph I.A. of FHWA Technical Advisory T6640.8A - Documentation of Applicability
for CE projects

23-1.04(b) Federal Approved Categorical Exclusions

Actions qualifying as a CE, as listed in Appendix A and Appendix B of the CE Agreement; but that do exceed one or more of the impact thresholds, results, or requirements as discussed in the potential for unusual circumstances listed below (also listed in Section V of the CE Agreement), must be approved by FHWA. The list of potential for unusual circumstances is as follows:

- 1) Requires one or more residential or business relocations and/or the acquisition of more than 10 acres (4 ha) total for a non-linear improvement (spot improvement, e.g. bridge, intersection) or the acquisition of more than 3 acres per mile (0.75 ha per kilometer); or
- 2) The project is defined as a "Type I project" per 23 CFR 772.5 and therefore requires a noise analysis; or
- 3) Results in an "adverse effect" finding to a historic property, as defined in 36 CFR 800.16(l); or
- 4) Requires the use of properties as defined and protected by Section 4(f) of the Department of Transportation Act (49 U.S.C. 303) that cannot be documented with either an FHWA de minimis determination or a programmatic Section 4(f) evaluation; or
- 5) Involves impacts that would require an Individual Section 404 Permit from the U.S. Army Corps of Engineers; or
- 6) Through Section 7 of the Endangered Species Act consultation, results in a finding of "may affect, likely to adversely affect" a federally listed or candidate species, or proposed or designated critical habitat; or
- 7) Requires substantial changes in access, access control, or travel patterns. IDOT will present such information to FHWA to determine if changes are substantial; or

- 8) Requires the use of a temporary road, detour or ramp closure, unless the use of such facilities satisfies the following conditions:
 - a) Provisions are made for access by local traffic and so posted,
 - b) Businesses dependent on through-traffic will not be adversely affected,
 - c) To the extent possible, there is no interference with any local special event or festival,
 - d) There is no substantial change to the environmental consequences of the action, and
 - e) There is no substantial controversy associated with such facilities.
- 9) Involves State designated Nature Preserves; or
- 10) Exceeds the IDNR threshold for an increase in 100-year flood water surface elevations, or has potential for a "significant encroachment" to floodplains, as defined in Executive Order 11988; or
- 11) Requires a permit from U.S. Coast Guard under Section 9 of the Rivers and Harbors Act of 1899; or
- 12) Requires the acquisition of lands under the protection of Section 6(f) of the Land and Water Conservation Act of 1965 or other unique areas or special lands that were acquired in fee or easement with public-use money and have deed restrictions or covenants on the property; or
- 13) Involve impacts to a stream listed on the National Park Service's National Rivers Inventory site and would adversely affect the listings Outstandingly Remarkable Value; or
- 14) Has potential for controversy on environmental grounds as determined by FHWA, or Inconsistency with Federal, State, or local requirements relating to the environment or planning.

Through the planning, screening, and coordination process, the district will determine if the potential for unusual circumstances result from the project. Further studies may be warranted, and the type and depth of additional studies will vary with the facts and circumstances of each situation and will help determine if the CE classification is appropriate.

The district will use Chapter 26 for any special environmental analyses needed.

Actions qualifying as a Federal Approved CE must be discussed at a District Coordination Meeting.

References:

Subsections (c) and (d) of 23 CFR 771.117 - FHWA Categorical Exclusions
Paragraph I.B. of FHWA Technical Advisory T6640.8A - Consideration
of Unusual Circumstances

23-1.05 Compliance with Other Requirements

CEs still require compliance with other applicable State and Federal environmental requirements (e.g., Section 4(f), Section 106, *Endangered Species Act*, Executive Order 11990 - Wetlands, Executive Order 11988 - Floodplain Management, *Comprehensive Environmental Response, Compensation, and Liability Act* (CERCLA)). CE approval may only be granted after all applicable requirements are satisfied.

References:

Chapter 26 Special Environmental Analyses

23-1.06 Re-evaluation of CE Designation

Per 23 CFR 771.129, after approval of a CE and prior to requesting further Federal approval, the Department will re-evaluate the project to determine if the project still qualifies to be classified as a CE (i.e., the project will have no significant impacts as defined by NEPA). The process for reevaluating state and Federally approved CEs is discussed below.

23-1.06(a) For state-approved CE:

BDE 488 (The Certification of Acceptance/Project Status) can be used to document the re-evaluation. If the district determines that an unusual circumstance is now present, then the district must coordinate this change with FHWA and request the project to be changed to a Federally approved CE. If the district determines that no unusual circumstances are present, then BDE 488 suffices as the re-evaluation documentation.

23-1.06(b) For Federally approved CE:

An email shall be sent to the FHWA Transportation Engineer prior to request for Federal authorization that details any changes to the project since the original CE determination (documented in the Phase I report) was signed which includes, but is not limited to the following:

- Substantial design changes,
- Substantial changes in the scope of the project,
- Changes to state or Federal environmental rules, environmental requirements, or environmental legislation that will affect changes to or within the environment in which the project will be located,
- Increase in the amount of right of way, permanent or temporary,
- Increase in the number of relocations or displacements of residences or businesses,
- Addition to, or the identification of new, unusual circumstances, or
- Updated natural resource and cultural resource clearances.

The email shall also include a statement on whether the district initially determines that the project still has no significant impacts or whether the project shall now be processed as an EA or EIS.

The FHWA will make an official final determination on whether the CE remains valid or an EA or EIS must be prepared.

References:

23 CFR 771.129 “Re-evaluations of Environmental Documents”
Re-evaluations of CE, FONSI, or ROD, Section 22-3.14

23-2 THE CE PROCESS

This section discusses and describes each step in the CE process. During each step, the following should also be considered:

- Lines of Communication. The rigid application of the process would lead to predetermined, precise points and is neither realistic nor desirable. Communication between units must be continuous. This will result in fewer problems and fewer “surprises” in the process.
- Lead Agency. It is assumed that the Federal Highway Administration is the lead agency for FHWA-funded projects. If another Federal agency is the lead agency, other procedures may be required.
- Application. This section applies to all CE projects involving State highway projects regardless of the source of funding.

23-2.01 Initiate CE Process

For actions that will be processed as a CE, this is often known at the time of project initiation. The district will initiate the CE by assigning a team and assemble project information which may include:

- planning reports or studies,
- record plans (as-builts),
- letters/correspondence on the project,
- traffic data,
- documentation on any public or private meetings,
- original surveys,
- aerial photos,
- statistical data documenting need for improvement,
- scoping data providing recommended improvement,
- Maintenance Management Information System (MMIS) data,
- appropriate information from engineering and Department databases,
- verification that the project is included in the applicable Transportation Improvement Program/State Transportation Improvement Program,
- existing right-of-way,
- information and decisions from the programming process, and
- results of the preliminary field check of project location.

The district can, if necessary, conduct an on-site field review early in the project development to identify current environmental or engineering factors that the project may involve. For Federal Approved CEs, the district will notify FHWA of any scheduled field reviews so FHWA can attend, if appropriate.

If the district intends to use the Professional Transportation Bulletin to hire a consultant, the district must determine what level of environmental prequalification will be required for the project based on anticipated impacts.

References:

Subsection 40 CFR 1500.1(b) of 40 CFR 1500.1 - Purpose

40 CFR 1501.2 - Early Application of NEPA

Subsection 23 CFR 771.115 of 23 CFR 771.115(b) - Definition of Class II (CE) Action

Section 22-3.06 Proposed Action

23-2.02 Plans, Specifications, and Estimates (PSE) Projects

Per Section 12-3.10, there are certain types of projects that occur within existing right-of-way, will not require an Environmental Survey Request (ESR) (See Section 27-1) and, therefore, will not generate a Phase I document. These projects only require Plans, Specifications, and Estimates (PSE). However, NEPA compliance is still required when federal funds are used. BDE 488 (Certification Acceptance/Project Status) or BDE 2301 (Categorical Exclusion Determination and Approval) may be used to document NEPA compliance.

23-2.03 Inventory Project Area

Based on the project scope, the district office with technical assistance from BDE will inventory the affected environment. The district should identify the full range of the environmental resources by evaluating environmental databases, and, if required, submit an ESR.

Resources involved may include:

- Section 4(f) and/or 6(f) properties;
- archaeological and historical properties;
- floodplains;
- sensitive noise receptors;
- prime farmland;
- wetlands;
- threatened or endangered species habitat, nature preserves, and natural areas;
- wild and scenic rivers;
- status of air quality attainment;
- water quality of streams and lakes;
- special waste;
- social/economic characteristics of the population;
- visual quality factors;
- wellhead protection areas;
- groundwater recharge areas; and
- other biological resources (biodiversity, riparian habitat, etc.).

References:

FHWA Technical Advisory T6640.8A - Background
Chapter 27 Environmental Surveys

23-2.04 Initiate Early Coordination

The ESR process involves coordination with State and Federal agencies and the public (see Chapter 19), as appropriate, and the level of coordination is generally dependent on the complexity of the project. Potential reasons for public coordination by the district could include road closures, Section 4(f) impacts (*de minimis* impacts), Section 106, historic bridge advertisements, and addressing controversy. The district will coordinate with the IDNR if the project involves property purchased with LAWCON or OSLAD funds (see Chapter 26).

If the district conducts public involvement, it should occur before requesting CE determination so that the results of public involvement activities can be considered in determining the appropriateness of the CE classification. Minutes of the meeting or a memorandum to the file, as appropriate, shall document the discussions. Public Involvement activity should also be documented on BDE Form 1201 Phase I Approval and included in the Project Report.

References:

23 CFR 771.111 - Early Coordination, Public Involvement and Project Development

Subsection 40 CFR 1500.2(d) of 40 CFR 1550.2 - Policy

40 CFR 1500.5(b) of 40 CFR 1500.5 - Reducing Delay

40 CFR 1501.1(b) of 40 CFR 1501.1 - Purpose

40 CFR 1501.6 - Cooperating Agencies

Forty Most Common Questions concerning CEQ's NEPA Regulations Memorandum -
Question 9. "Approvals from Other Agencies"

Chapter 19 Public Involvement Guidelines

Section 22-5 Coordination

Chapter 26 Special Environmental Analysis

Chapter 27 Environmental Surveys

23-2.05 Evaluate Project Alternatives and Project's Potential for Unusual Circumstance

The district should develop alternatives based on the Purpose and Need for the project and be sensitive to environmental resources for which avoidance and minimization of adverse impacts is necessary (e.g., wetlands, floodplains, Section 4(f) properties/historic sites, threatened and endangered species). In addition, the district should recognize that avoidance of protected environmental resources (some of which are potentials for unusual circumstances) through project design will help shorten project development time by eliminating the need for the reporting and coordination necessary for compliance.

Once avoidance and minimization of adverse impacts has been completed, the district shall review the project for the potential for unusual circumstances. The list of unusual circumstances is in Section 23-1.04(b) and in Section V of the CE Agreement. If the project has one or more potential for unusual circumstances, then the project must be discussed with FHWA at a district coordination meeting to determine if the project may proceed as a Federal Approved CE or if an EA or EIS is required.

References:

Subsection 23 CFR 771.113(a) of 23 CFR 771.113 - Timing of Administration Activities

23-2.06 CE Determination

Once the above steps have been completed, a determination that the project qualifies as a CE; as well as the appropriate classification (State Approved or Federal Approved) under which it should be processed, can be made.

Projects which are determined to qualify as a State Approved CE do not need concurrence by the FHWA and are not required to be discussed at a coordination meeting unless there are issues related to the project's scope, design exceptions, or meeting ADA standards to the maximum extent practicable.

Projects which are determined to qualify as a Federal Approved CE must be presented at a coordination meeting. During the meeting, the district will present its recommendation for a Federal Approved CE determination, explain the basis for the recommendation, and discuss any potential(s) for unusual circumstances. The FHWA may then concur in the determination, request additional information for review (e.g. written reports or technical documents), or request additional studies, analyses, and coordination activities regarding the project's environmental impacts. As the district completes additional studies, analyses, and coordination activities regarding the project's environmental impacts, these results should be discussed with FHWA at subsequent coordination meetings. The district may discuss these results as each study is completed or wait to consolidate the discussion of several studies. Once FHWA concurrence is given, it should be documented in the minutes of the coordination meeting.

Note: A CE determination, or concurrence thereof by the FHWA, is a preliminary step which helps to ensure a project is being processed appropriately and it should not be confused with CE Approval.

References:

Subsection 23 CFR 771.117(b) of 23 CFR 771.117 - Categorical Exclusions

23 CFR 774 - Parks, Recreation Areas, Wildlife and Waterfowl Refuges, and Historic Sites (Section 4(f)) Section 22-5 Coordination

23-2.07 CE Approval

Once a CE determination has been made, and once all environmental clearances have been obtained, the CE can be approved.

State Approved CEs are approved by the Regional Engineer or their designee, as discussed in the CE Agreement.

Federal Approved CEs are approved by the FHWA. This approval is typically obtained at a coordination meeting or via emailed correspondence.

23-2.08 Documentation of Environmental Commitments

If there are commitments made during the CE process, they should be documented in the Phase I report and the district commitment file.

References:

D&E-19 Follow-through on Project Commitments

23-2.09 Documentation of the CE Determination and Approval

The level of documentation required is dependent upon whether the project is a Federal action or not (see Section 23-1.02).

23-2.09(a) Documentation for Federal Actions

For Federal actions, the following items are to be included in the Phase I Engineering report when a report is required or otherwise in the project files:

1. Environmental Surveys and Special Reports. The environmental surveys and special reports required to support a CE determination must summarize the results of any necessary environmental screening, surveys, coordination, and special reports for natural resources, cultural resources, air, noise, and special waste.
2. Coordination. Coordination required to support a CE determination must be summarized in the Phase I Engineering Report. For example, where coordination with the Natural Resources Conservation Service and/or the Illinois Department of Agriculture is required, the Phase I Engineering Report should include a brief summary of the results of the coordination (a copy of Form NRCS-CPA-106, when required, and/ or a synopsis of comments received and the related responses).
3. Permits. The report must indicate those permits (e.g., Section 404, Section 402 National Pollutant Discharge Elimination System (NPDES), Section 10, IDNR Office of Water Resources) that will be required for the project.
4. CE Certification Paragraph. The purpose of the certification paragraph is to document that the project scope and impacts fall within the thresholds of a CE.

For State Approved CEs, the certification paragraph reads as follows:

IDOT has addressed all environmental requirements for this project and determined that it has met the following requirements for a State Approved CE in the CE

Programmatic Agreement (approved 10/14/15): (1) the scope is consistent with the project scope listed in [[Appendix (A or B), Item (include number)]] and (2) none of the circumstances in Section V exist. Therefore, on behalf of FHWA, IDOT hereby approves this project as a State Approved CE.

For Federal Approved CEs, the certification paragraph reads as follows:

After reviewing the project information provided, FHWA has determined that this project will not have any significant impacts on the human environment and approves its designation as a Federal Approved CE.

Each of the above paragraphs is contained on form BDE 2301 (Categorical Exclusion Determination and Approval) which shall be completed, signed as appropriate, and included in the project report or project file.

5. Wetland Finding. If the CE involves wetland impacts, the report shall also include the following paragraph:

The FHWA issued a programmatic Wetland Finding for CEs on October 14, 2015 in compliance with Executive Order 11990, Protection of Wetlands. The Programmatic Wetland Finding is contained in the CE Agreement, available online in the BDE Manual (Appendix A).

This paragraph is also contained on form BDE 2301 (Categorical Exclusion Determination and Approval) and the “yes” or “no” box must be checked as appropriate to document the involvement of wetland impacts.

23-2.09(b) Documentation for Non-Federal Actions

For non-Federal actions, the following items are to be including in the Phase I Engineering report, when a report is required, or otherwise in the project files:

1. Environmental Surveys and Special Reports. The environmental surveys and special reports must summarize the results of any necessary environmental screening, surveys, coordination, and special reports for natural resources, cultural resources, air, noise, and special waste.
2. Coordination. Coordination must be summarized in the Phase I Engineering Report.
3. Permits. The Phase I Engineering Report must indicate any state-issued permits needed for the project.

Chapter Twenty-four
NEPA SCOPING TO CE/EA/EIS

BUREAU OF DESIGN AND ENVIRONMENT MANUAL

Chapter Twenty-four
NEPA SCOPING TO CE/EA/EIS

Table of Contents

<u>Section</u>	<u>Page</u>
24-1 GENERAL	24-1.1
24-1.01 Definitions	24-1.1
24-1.02 Applicability	24-1.2
24-1.02(a) NEPA Scoping	24-1.2
24-2 THE NEPA SCOPING TO NEPA CLASS OF ACTION DETERMINATION (CE, EA, OR EIS) AND EA PROCESS.....	24-2.1
24-2.01 NEPA Scoping Activities	24-2.1
24-2.01(a) Satisfying Planning Requirements.....	24-2.2
24-2.01(b) Context Sensitive Solutions.....	24-2.2
24-2.01(c) Develop Draft Stakeholder Involvement Plan (SIP)	24-2.3
24-2.01(d) Establishment of Timeframes	24-2.3
24-2.02 Begin External Coordination Activities	24-2.4
24-2.03 Perform Environmental Survey (Records Phase)	24-2.18
24-2.04 Finalize Context Sensitive Solutions Stakeholder Involvement Plan....	24-2.18
24-2.05 Conduct Context Audit	24-2.19
24-2.06 Develop Problem Statement.....	24-2.19
24-2.07 Conduct Purpose and Need Coordination	24-2.19
24-2.08 Conduct Alternative to be Carried Forward Coordination.....	24-2.20
24-2.09 Perform Environmental Survey (Field Phase).....	24-2.21
24-2.10 Evaluate Alternatives In Depth	24-2.21
24-2.11 Conduct Preferred Alternative Coordination	24-2.22
24-2.12 Class of Action Determination	24-2.23
24-2.13 Department Review of the Preliminary EA (Review #1).....	24-2.23
24-2.14 Preliminary EA Review (Review #2).....	24-2.23
24-2.15 Signature Ready EA.....	24-2.24
24-2.16 Make EA Available to the Public.....	24-2.25
24-2.17 Public Hearing.....	24-2.28
24-2.18 Evaluate for Major Project Requirements	24-2.28
24-2.19 Planning Requirement Prior to NEPA Approval	24-2.28
24-2.20 Prepare EA Errata and Recommend FONSI	24-2.29
24-2.21 Draft Project Management Plan for Major Projects	24-2.30
24-2.22 Issue FONSI or Proceed to EIS.....	24-2.30
24-2.23 Re-evaluation of a Finding of No Significant Impact (FONSI)	24-2.31
24-2.24 Determine Applicability of Limitation on Claims (Statute of Limitations).....	24-2.32
24-2.25 Finalize Project Management Plan for Major Projects	24-2.32
24-2.26 Implement Mitigation Measures.....	24-2.32

Chapter Twenty-four

NEPA SCOPING TO CE/EA/EIS

Chapter 24 discusses procedures for conducting NEPA scoping and NEPA Class of Action Determination (CE, EA, or EIS).

24-1 GENERAL

NEPA scoping includes data compilation for project development before a class of action (CE, EA, or EIS) determination is made. NEPA scoping can be any length of time that is necessary to gather and evaluate information prior to making a class of action determination. Once data has been fully compiled during the NEPA scoping phase, consultation with FHWA will provide a determination if the project will be processed as a CE, EA, or EIS.

If the project is determined to require processing as an EA or EIS, then the required processing timeframes are 12 months for an EA and 24 months for an EIS.

References:

Time Limits, 40 CFR 1501.10

24-1.01 Definitions

1. Categorical Exclusion – See Chapter 23.
2. Environmental Assessment - The Council on Environmental Quality (CEQ) regulations in 40 CFR 1508.9 state that an Environmental Assessment (EA) is a concise public document that serves to briefly provide sufficient evidence and analysis for determining whether to prepare an Environmental Impact Statement (EIS) or a Finding of No Significant Impact (FONSI).
3. FONSI - A FONSI is a Federal agency decision document that presents the reasons why an action will not have a significant effect on the human and natural environment and for which an EIS will not be prepared (CEQ regulations in 40 CFR 1508.13).
4. Environmental Impact Statement – See Chapter 25.

References:

Classes of Action, 23 CFR 771.115(a)
Definition of Class III (EA) Action, 23 CFR 771.115(c)
Definitions, 40 CFR 1508.9
Finding of No Significant Impact, 40 CFR 1508.13

24-1.02 Applicability

24-1.02(a) NEPA Scoping

NEPA scoping is utilized when the class of action (CE, EA, or EIS) is undetermined or when the project will likely be processed as an EA or EIS and revolves around two factors:

- whether or not the district is confident the project will get Phase II funding; and
- whether or not the district is confident the project will be constructed.

If the district is not confident, the district may utilize the Planning and Environment Link (PEL) Process (See Section 11-7.04).

24-1.02(a)1 *Environmental Assessment*

The decision to prepare an EA is project-specific and should be based on a number of factors including, but not limited to, the context and intensity of anticipated environmental impacts and the level of public interest or potential controversy in the project.

References:

When to Prepare an Environmental Assessment, 40 CFR 1501.3

Whether to Prepare an Environmental Impact Statement, 40 CFR 1501.4(b)

When to Prepare an Environmental Assessment, 23 CFR 771.119(a)

Forty Most Common Questions Concerning CEQ's NEPA Regulations Memorandum -
Question 40 "Mitigation of Significant Impacts – Appropriateness of EA"

24-1.02(a)2 *Finding of No Significant Impact (FONSI)*

A FONSI will be a brief summary document as noted in 40 CFR 1508.13 and shall be prepared for a proposed action:

- that is not categorically excluded, or;
- for which an EIS will not be prepared.

References:

When to Prepare a FONSI, 40 CFR 1501.4(e)

Environmental Assessments, 23 CFR 771.119(g)

Findings of No Significant Impact, 23 CFR 771.121(a)

24-2 THE NEPA SCOPING TO NEPA CLASS OF ACTION DETERMINATION (CE, EA, OR EIS) AND EA PROCESS

This section discusses the general process for a project processed using NEPA Scoping and determining the NEPA Class of Action (CE, EA, or EIS) and how an EA is processed. This is followed by a description of each activity. The district shall consider the following:

1. Lines of Communication. Communication among the district, BDE, and FHWA should be ongoing throughout the development of the EA. The districts will provide updates to BDE and FHWA at coordination meetings on the project status, activities, and decisions that are being made. This will avoid problems that may otherwise arise late in the process, causing needless delays.
2. Lead Agency. FHWA is the lead agency for FHWA-funded projects. If another Federal agency is the lead agency, other procedures may be required.
3. Application. This section applies to all EA projects involving State highways regardless of the source of funding.
4. References. Some of the references in the process are to 40 CFR 1500 excerpts that are specifically applicable to projects processed with an EIS. Although not explicit in the Federal regulations, these references also are applicable to EAs.
5. EIS. If at any stage of the EA process the potential for significant impacts is identified, it will be necessary to prepare an EIS; see Chapter 25.

24-2.01 NEPA Scoping Activities

The district will determine the preliminary scope and general location of the proposed project and present the proposed project at a coordination meeting.

The district will begin to determine the types of information that will be used in accomplishing the environmental process, which may include:

- statistical data documenting need for improvement;
- planning reports or studies;
- traffic data;
- engineering and Department databases;
- information and decisions from the planning/programming process;
- existing right-of-way information;
- documentation on any public or private meetings;
- letters/correspondence on the project;
- preliminary field check of the project location;
- biological, cultural, and regulated substances field surveys (BDE);
- State and Federal environmental databases and reports; and

- verification that the project is included in the applicable Transportation Improvement Program/State Transportation Improvement Program.

References:

Apply NEPA Early in the Process, 40 CFR 1501.2

Proposed Action Section 22-3.06

Special Environmental Analyses, Chapter 26

Environmental Surveys, Chapter 27

AASHTO Practitioner's Handbook 01 – Maintaining a Project File and Preparing an Administrative Record for a NEPA Study, August 2016

24-2.01(a) Satisfying Planning Requirements

Early in the process, the district should determine what planning requirements will need to be satisfied prior to completing the NEPA process:

- in an urbanized area
 - + the project must be included in the conformed fiscally constrained portion of the Metropolitan Transportation Plan, and;
 - + a subsequent phase of project development (e.g., final design, acquire right-of-way, utility relocations, or construction) must be included in the Metropolitan Planning Organization's (MPO's) Transportation Improvement Program (TIP).
- in a non-urbanized area
 - + the project must be consistent with the Long Range Transportation Plan, and
 - + a subsequent phase of the project development (e.g., final design, acquire right-of-way, utility relocations, or construction) must be included in the Statewide Transportation Improvement Program (STIP).

Due to the amount of time it takes to include the project in the appropriate planning documents, the district should work with the appropriate planning organizations to initiate the process. The district also should coordinate with FHWA to ensure that the subsequent phase is included in the TIP or STIP and that it adequately demonstrates commitment to advance the project. FHWA cannot sign the CE, FONSI, or ROD until this has occurred.

24-2.01(b) Context Sensitive Solutions

For projects that the Regional Engineer has determined the principles of Context Sensitive Solutions (CSS) will be used, the district shall form a CSS Project Study Group (PSG) in accordance with the procedures described in Section 19-5. Public involvement commences once the project is assigned to the PSG.

For projects that the Regional Engineer has determined the principles of CSS will not be used, the district will write a memorandum to the project file that is signed by the Regional Engineer documenting compliance of the project with the terms of 605 ILCS 5/4-219.

References:

Context Sensitive Solutions, Section 19-5

24-2.01(c) Develop Draft Stakeholder Involvement Plan (SIP)

For projects using the principles of CSS, the PSG develops a draft Stakeholder Involvement Plan (SIP) to document stakeholder involvement activities. As part of the SIP development, the district, FHWA, and BDE will coordinate to identify governmental entities that should be invited to serve as cooperating agencies in the NEPA process for the proposed project and Tribes and consulting parties to satisfy Section 106 requirements for historic properties.

FHWA and the Department, as joint lead agencies, should agree upon the content of the draft plan before it is distributed to external stakeholders.

References:

Collaboration in NEPA – A Handbook for NEPA Practitioners, Council on Environmental Quality, October 2007

AASHTO Practitioner's Handbook 05 – Utilizing Community Advisory Committees for NEPA Studies, December 2006

24-2.01(d) Establishment of Timeframes

The district will develop a draft timeframe agreement establishing milestones and responsibilities for major activities through the NEPA process and submit it to BDE for review. Subsequently, FHWA, the district, and BDE will reach consensus on the timeframe agreement. The purpose of the timeframe on projects is to provide a tool for managing document review, preparation, coordination, and approval steps.

FHWA and the Department will ensure that involved environmental resource and permitting agencies receive a copy of the timeframe agreement. For projects following CSS, the timeframe is a part of SIP.

The timeframes may be revised, if necessary, as a result of input from cooperating agencies or if new issues arise or priorities change. Revisions to the timeframes will be addressed in accordance with the terms of the Statewide Implementation Agreement, and updated timeframes will be provided to BDE and FHWA.

In coordination with FHWA, the district will monitor all milestone dates for the negotiated timeframes.

References:

Illinois Statewide Implementation Agreement between the Federal Highway Administration and the Illinois Department of Transportation for Establishment of Timeframes for Environmental Impact Statements and Environmental Assessments.

24-2.02 Begin External Coordination Activities

IDOT and FHWA will send letters to entities inviting them to be Cooperating Agencies (CAs) and Section 106 consulting parties. For projects using the principles of CSS, these agencies are outlined in SIP. The district will draft letters discussed below and submit them to BDE and FHWA, along with a map of the study area, the Area of Potential Affect (if different than the study area), and a list of Section 106 consulting parties. After any necessary revisions, FHWA and the district will send out their respective letters as follows:

FHWA sends letters to:

- Cooperating Agencies
 - + Federal agencies (Figure 24-2.A)
 - + State agencies (Figure 24-2.B)
- Section 106 Consulting Parties
 - + Tribes (Figure 24.2.C)
 - + State Historic Preservation Officer (Figure 24-2.D)

The district sends letters to:

- Section 106 Consulting Parties
 - + Non-Governmental Local Interest Groups (Figure 24-2.E)
 - + State and Local Government entities

The district will also develop a spreadsheet showing all Cooperating agencies, Section 106 consulting parties, and status of coordination and responses; see Figure 24.2.F.

After the response deadline, which is usually 30 days, the district will collect all responses and update the SIP based on responses, or lack thereof, to the invitation letters. The following reflects the status of the responses:

- Federal and non-Federal agencies invited as CAs must accept invitation in writing. If they do not respond they are not a CA.
- Any entity, except SHPO and local government agencies, invited to be a Section 106 consulting party must accept in writing to be a consulting party. The SHPO and local government agencies are 106 consulting parties even if they do not respond.

Thirty days after the coordination letters are sent, the district will send a copy of the draft SIP to all agencies who accepted the invitation to be a CA or consulting party. As new stakeholders are identified throughout the environmental review process, the SIP will be reviewed and revised, if necessary.

References:

Purpose, 40 CFR 1500.1(b)

Policy, 40 CFR 1500.2(d)

Reducing, Delay, 40 CFR 1500.5(b)

Purpose, 40 CFR 1501.1(b)

Cooperating Agencies, 40 CFR 1501.6

Early Coordination, Public Involvement, and Project Development, 23 CFR 771.111

FHWA *SAFETEA-LU Environmental Review Process Final Guidance*, Questions 30 and 31
“Cooperating Agencies”

Coordination, Section 22-5

Public Involvement Guidelines, Chapter 19

Collaboration in NEPA – A Handbook for NEPA Practitioners, Council on Environmental Quality,
October 2007

AASHTO Practitioner’s Handbook 05 – Utilizing Community Advisory Committees for NEPA Studies, December 2006

AASHTO Practitioner’s Handbook 09 – Using the SAFETEA-LU Environmental Review Process (23 USC 139), January 2008

Date]

[Address Title] [First Name] [Initial] [Last Name]

[Agency]

[Address]

[City], [State] [Zip Code]

Subject: [name of study] invitation for cooperating agency status

Dear [Address Title] [Last Name]:

The Federal Highway Administration (FHWA) is requesting your agency to become a cooperating agency for the [name of study]. Please respond to our office at the above listed address in writing, with an acceptance or denial of this invitation to be a cooperating agency prior to [30 day Response Deadline Date].

THE PROJECT

The FHWA, in cooperation with the Illinois Department of Transportation (IDOT), is starting the National Environmental Policy Act (NEPA) scoping process for the [name of study]. The NEPA class of action will be determined when more information is collected. The study area is located in [project location including local agencies and counties]; see enclosed map.

The study area covers approximately [area in square miles] and is located [description of study area]. It contains environmentally sensitive resources, including [list primary resources/locations potentially affected].

The project will include an evaluation of transportation system needs across the entire study area. [list primary technical tools used to identify transportation system needs and potential environmental impacts, e.g. GIS, transportation demand models, field studies.]

FHWA LETTER TO FEDERAL COOPERATING AGENCIES

Figure 24-2.A

(1 of 2)

COOPERATING AGENCY

In accordance with 40 CFR 1501.6 of the Council on Environmental Quality's regulations for implementing the procedural provisions of NEPA, FHWA is required to invite agencies with jurisdiction by law or with special expertise with respect to environmental issues to be cooperating agencies.

We propose that your agency's role in the development of the above project should include the following as they relate to your area of expertise or jurisdiction by law:

- provide meaningful and early input on defining the purpose and need, determining the range of alternatives to be carried forward, and the methodologies and level of detail required in the alternatives analysis; and
- participate in coordination meetings and joint field reviews, as appropriate.

To consider your agency as a cooperating agency, FHWA and IDOT must receive a written response from your agency within the stated deadline agreeing to engage in the project in this role. If your agency declines to be a cooperating agency, please indicate the reason for declining this request and provide a copy to CEQ pursuant to 40 CFR 1501.6(c).

If you have any questions or would like to discuss in more detail the study or our agencies' respective roles and responsibilities, please contact [FHWA and BDE/BLRS contact names, emails and phone numbers].

Thank you for your cooperation and interest in this project.

Sincerely,

[FHWA signature]

Enclosure

cc: IDOT Bureau Chief of Design and Environment
Regional Engineer

id: Field Engineering Supervisor, PPD Manager, Engineering Team Leader, Transportation Engineer, PER Team Leader, environmental protection specialists.

FHWA LETTER TO FEDERAL COOPERATING AGENCIES

Figure 24-2.A
(2 of 2)

Date]

[Address Title] [First Name] [Initial] [Last Name]
[Agency]
[Address]
[City], [State] [Zip Code]

Subject: [name of study] invitation for cooperating agency status

Dear [Address Title] [Last Name]:

The Federal Highway Administration (FHWA) is requesting your agency to become a cooperating agency for the [name of study]. Please respond to our office at the above listed address in writing, with an acceptance or denial of this invitation to be a cooperating agency prior to [30-day Response Deadline Date].

THE PROJECT

The FHWA, in cooperation with the Illinois Department of Transportation (IDOT), is starting the National Environmental Policy Act (NEPA) scoping process for the [name of study]. The NEPA class of action will be determined when more information is collected. The study area is located in [project location including local agencies and counties]; see enclosed map.

The study area covers approximately [area in square miles] and is located [description of study area]. It contains environmentally sensitive resources, including [list primary resources/locations potentially affected].

The project will include an evaluation of transportation system needs across the entire study area. [list primary technical tools used to identify transportation system needs and potential environmental impacts, e.g. GIS, transportation demand models, field studies.]

COOPERATING AGENCY

In accordance with 40 CFR 1501.6 of the Council on Environmental Quality's regulations for implementing the procedural provisions of NEPA, FHWA is required to invite agencies with jurisdiction by law or with special expertise with respect to environmental issues to be cooperating agencies.

FHWA LETTER TO STATE COOPERATING AGENCIES

Figure 24-2.B
(1 of 2)

We propose that your agency's role in the development of the above project should include the following as they relate to your area of expertise or jurisdiction by law:

- provide meaningful and early input on defining the purpose and need, determining the range of alternatives to be carried forward, and the methodologies and level of detail required in the alternatives analysis; and
- participate in coordination meetings and joint field reviews, as appropriate.

To consider your agency as a cooperating agency, FHWA and IDOT must receive a response from your agency within the stated deadline agreeing to engage in the project in this role. If your agency declines to be a cooperating agency, please indicate the reason for declining this request and provide a copy to CEQ pursuant to 40 CFR 1501.6(c).

If you have any questions or would like to discuss in more detail the study or our agencies' respective roles and responsibilities, please contact [FHWA and BDE/BLRS contact names, emails, and phone numbers].

Thank you for your cooperation and interest in this project.

Sincerely,

[FHWA signature]

Enclosure

cc: IDOT Bureau Chief of Design and Environment
Regional Engineer

id: Field Engineering Supervisor, PPD Manager, Engineering Team Leader, Transportation Engineer, PER Team Leader, Environmental Programs Engineer, Environmental Engineer.

FHWA LETTER TO STATE COOPERATING AGENCIES

Figure 24-2.B
(2 of 2)

[Date]

[Address Title] [First Name] [Initial] [Last Name]

[Agency]

[Address]

[City], [State] [Zip Code]

Subject: [name of study] invitation for Section 106 consulting party status

Dear [Address Title] [Last Name]:

The Federal Highway Administration (FHWA) is inviting your Tribe to become a Section 106 consulting party for the [name of project]. If you wish to engage in this role, please send FHWA a response prior to [30-day Response Deadline Date].

THE PROJECT

The FHWA, in cooperation with the Illinois Department of Transportation (IDOT), is starting the National Environmental Policy Act (NEPA) scoping process for the [name of study]. The NEPA class of action will be determined when more information is collected. The study area is located in [project location including local agencies and counties]; see enclosed map.

The study area covers approximately [area in square miles] and is located [description of study area]. It contains environmentally sensitive resources, including [list primary resources/locations potentially affected].

The project will include an evaluation of transportation system needs across the entire study area. [list primary technical tools used to identify transportation system needs and potential environmental impacts, e.g. GIS, transportation demand models, field studies.]

SECTION 106 CONSULTING PARTY

Section 106 of the National Historic Preservation Act requires Federal agencies to (1) take into account the effect of their undertakings on historic properties and (2) afford the Advisory Council on Historic Preservation (ACHP) a reasonable opportunity to comment. The Section 106 process is outlined in 36 CFR Part 800.

These regulations require Federal agencies to identify parties entitled to be consulting parties and invite them to participate as such in the Section 106 process. Since your Tribe has expressed an interest in the county(ies) that the project is located in, we are inviting you to be a consulting party. Consulting parties may be asked to provide information on historic properties in the project area, identify issues relating to the project's potential effects on historic properties, and if applicable, consult to resolve adverse effects to historic properties.

FHWA LETTER TO TRIBES

Figure 24-2.C

(1 of 2)

If you would like to be a Section 106 consulting party, please send FHWA a response within the stated deadline to engage in the project in this role.

If you have any questions or would like to discuss in more detail the study or our agencies' respective roles and responsibilities, please contact [FHWA Environmental Engineer name, email, and phone number].

Thank you for your cooperation and interest in this project.

Sincerely,

[FHWA DA signature]

Enclosure

cc: IDOT Bureau Chief of Design and Environment
Regional Engineer

idl: Field Engineering Supervisor, PPD Manager, Engineering Team Leader, Transportation Engineer, PER Team Leader, Environmental Programs Engineer, Environmental Engineer.

FHWA LETTER TO TRIBES

Figure 24-2.C
(2 of 2)

[Date]

[Address Title] [First Name] [Initial] [Last Name]

[Agency]

[Address]

[City], [State] [Zip Code]

Subject: [name of study] invitation for consulting party status

Dear [Address Title] [Last Name]:

The Illinois Department of Transportation (IDOT) is requesting you to become a Section 106 consulting party for the [name of EA]. If you wish to engage in this role, please send IDOT a response prior to [30-day Response Deadline Date].

THE PROJECT

The Federal Highway Administration (FHWA), in cooperation with IDOT, is initiating an National Environmental Policy Act (NEPA) scoping process for the [name of study]. The NEPA class of action will be determined when more information is collected. The study area is located in [project location including local agencies and counties]; see enclosed map.

The study area covers approximately [area in square miles] and is located [description of study area]. It contains environmentally sensitive resources, including [list primary resources/locations potentially affected].

The project will include an evaluation of transportation system needs across the entire study area. [list primary technical tools used to identify transportation system needs and potential environmental impacts during the EA, e.g., GIS, transportation demand models, field studies.]

SECTION 106 CONSULTING PARTY

Section 106 of the National Historic Preservation Act requires Federal agencies to (1) take into account the effect of their undertakings on historic properties and (2) afford the Advisory Council on Historic Preservation (ACHP) a reasonable opportunity to comment. The Section 106 process is outlined in 36 CFR Part 800.

FHWA LETTER TO STATE HISTORIC PRESERVATION OFFICER

Figure 24-2.D
(1 of 2)

Federal agencies may invite individuals or organizations to become a Section 106 consulting party, if they have a demonstrated interest in the project or if they have concerns with the project's effects on historic properties. Consulting parties may be asked to provide information on historic properties in the project area, identify issues relating to the project's potential effects on historic properties, and if applicable, consult to resolve adverse effects to historic properties. IDOT and FHWA have identified you as a potential interested party and are therefore inviting you to be a Section 106 consulting party.

If you would like to be a consulting party, please send IDOT a response within the stated deadline to engage in the project in this role.

If you have any questions or would like to discuss in more detail the study or our agencies' respective roles and responsibilities, please contact [BDE/BLRS contact names, emails and phone numbers].

Thank you for your cooperation and interest in this project.

Sincerely,

[IDOT signature]

Enclosure

cc:

FHWA LETTER TO STATE HISTORIC PRESERVATION OFFICER

Figure 24-2.D
(2 of 2)

HARD COPIES UNCONTROLLED

24-2.13

Date]

[Address Title] [First Name] [Initial] [Last Name]

[Agency]

[Address]

[City], [State] [Zip Code]

Subject: [name of study] invitation for consulting party status

Dear [Address Title] [Last Name]:

The Illinois Department of Transportation (IDOT) is requesting you to become a Section 106 consulting party for the [name of the study]. If you wish to engage in this role, please send IDOT a response prior to [30-day Response Deadline Date].

THE PROJECT

The Federal Highway Administration (FHWA), in cooperation with IDOT, is initiating an National Environmental Policy Act (NEPA) scoping process for the [name of study]. The NEPA class of action will be determined when more information is collected. The study area is located in [project location including local agencies and counties]; see enclosed map.

The study area covers approximately [area in square miles] and is located [description of study area]. It contains environmentally sensitive resources, including [list primary resources/locations potentially affected].

The project will include an evaluation of transportation system needs across the entire study area. [list primary technical tools used to identify transportation system needs and potential environmental impacts, e.g., GIS, transportation demand models, field studies.]

SECTION 106 CONSULTING PARTY

Section 106 of the National Historic Preservation Act requires Federal agencies to (1) take into account the effect of their undertakings on historic properties and (2) afford the Advisory Council on Historic Preservation (ACHP) a reasonable opportunity to comment. The Section 106 process is outlined in 36 CFR Part 800.

IDOT LETTER TO SECTION 106 CONSULTING PARTY

Figure 24-2.E

(1 of 2)

Federal agencies may invite individuals or organizations to become a Section 106 consulting party, if they have a demonstrated interest in the project or if they have concerns with the project's effects on historic properties. Consulting parties may be asked to provide information on historic properties in the project area, identify issues relating to the project's potential effects on historic properties, and if applicable, consult to resolve adverse effects to historic properties. IDOT and FHWA have identified you as a potential interested party and are therefore inviting you to be a Section 106 consulting party.

If you would like to be a consulting party, please send IDOT a response within the stated deadline to engage in the project in this role.

If you have any questions or would like to discuss in more detail the study or our agencies' respective roles and responsibilities, please contact [BDE/BLRS contact names, emails and phone numbers].

Thank you for your cooperation and interest in this project.

Sincerely,

[IDOT signature]

Enclosure

cc:

IDOT LETTER TO SECTION 106 CONSULTING PARTY

Figure 24-2.E
(2 of 2)

FHWA sends	IDOT sends													
CA-Federal Agencies	CA-State Agencies	106-Tribes	106-SHPO	106 consulting parties	First Name	Last Name	Affiliation	Address	City	State	Zip	Phone	Email	Notes
** Combine all contacts for each letter type. For example group all CA Federal agencies together before listing CA state agencies.														

COORDINATION ACTIVITY SPREADSHEET

Figure 24-2.F

24-2.03 Perform Environmental Survey (Records Phase)

The district shall submit an Environmental Survey Request (see Section 27-1) in order for BDE to perform a record search to access published information and determine the need for further investigation of the following:

- wetlands;
- archaeological resources, historic standing structures and bridges;
- Federal/State threatened or endangered species or their designated critical habitat;
- Illinois Natural Areas Inventory Sites;
- Nature Preserves; and
- Regulated substances.

BDE provides this information to the district as it becomes available to assist in the progression of activities in the NEPA scoping process.

Concurrent with the survey work by BDE, the district conducts activities (e.g., researching environmental databases, contacting environmental resource agencies) to support an inventory of the project's affected environment for resources and issues of concern. Examples of resources/issues of concern, in addition to those being addressed by BDE, include:

- Section 4(f) and/or Section 6(f) properties,
- Wild and Scenic Rivers,
- noise analysis,
- project specific air quality analyses,
- social/economic characteristics,
- visual quality,
- floodplains,
- water quality of surface waters,
- prime farmland,
- upland plant communities,
- groundwater recharge areas,
- wellhead protection areas, and
- wildlife resources (biodiversity, riparian habitat, etc.).

References:

Purpose, 40 CFR 1500(b)

24-2.04 Finalize Context Sensitive Solutions Stakeholder Involvement Plan

For projects following the principles of Context Sensitive Solutions, the Project Study Group (PSG) coordinates with FHWA and BDE to finalize the SIP. The SIP should be posted on the project website and may need to be updated as the project progresses.

References:

Collaboration in NEPA – A Handbook for NEPA Practitioners, Council on Environmental Quality, October 2007

AASHTO Practitioner's Handbook 05 – Utilizing Community Advisory Committees for NEPA Studies, December 2006

24-2.05 Conduct Context Audit

Following development of the SIP, the CSS project study group initiates contacts with stakeholders to conduct a context audit. The purpose of the context audit is to help identify various characteristics that define the context for the project. The CSS project study group applies the context audit procedures.

References:

AASHTO Practitioner's Handbook 05 – Utilizing Community Advisory Committees for NEPA Studies, December 2006

24-2.06 Develop Problem Statement

After the context audit is completed, the CSS project study group meets with stakeholders to develop a clear problem statement. The CSS project study group seeks stakeholder input on current transportation problems in the area and how the proposed project might help alleviate them.

The CSS project study group translates the stakeholder input into a clear statement of the transportation problems that should be, and can be, solved by the project. Once a clear problem statement is completed, it must be accepted by consensus of the stakeholders.

IDOT and FHWA will consider the accepted problem statement when developing the project purpose and need. The problem statement is stakeholder driven and is one consideration in developing the Purpose and Need.

References:

AASHTO Practitioner's Handbook 05 – Utilizing Community Advisory Committees for NEPA Studies, December 2006

AASHTO Practitioner's Handbook 07 – Defining the Purpose and Need and Determining the Range of Alternatives for Transportation Projects, August 2007

24-2.07 Conduct Purpose and Need Coordination

The district will:

- use technical analyses to develop a draft Purpose and Need,
- consider the accepted CSS problem statement while developing a draft Purpose and Need, and
- submit the draft purpose and need to BDE for coordination with FHWA.

After BDE and FHWA agree the draft Purpose and Need is sufficient for distribution, then the district will coordinate with the Community Advisory Group for their input.

Next, the district may coordinate with the general public for their input in the form of public workshops or meetings, solicitations of verbal or written input, postings on websites, distribution of printed materials, or other involvement techniques or media.

If the Purpose and Need changes after input from the stakeholders, the district will coordinate the revised Purpose and Need with FHWA and BDE.

For projects subject to the NEPA/404 Merger Process, see Section 22-4, the district, FHWA, and BDE seek concurrence on the Purpose and Need at the NEPA/404 Merger meeting. The decision will be documented through the meeting minutes, which will be provided by the district and distributed by FHWA to the Merger Agreement signatory agencies, and all other participants in the meeting.

After the purpose and need is complete, the district will update the timeframes agreement and send it to BDE and FHWA.

References:

Concurrent NEPA/404 Processes, Section 22-4

24-2.08 Conduct Alternative to be Carried Forward Coordination

For projects using the principles of CSS, the objective of the CSS Community Advisory Group (CAG) is to reach consensus acceptance of the range of alternatives.

The district will consider input from the CAG, technical analyses of travel performance, potential impacts to environmental resources, etc., to develop the Alternatives to be Carried Forward, which means those alternatives that are to be studied in detail, including the “no build.” A Preferred Alternative will be selected from the Alternatives to be Carried Forward.

For projects subject to the NEPA/404 Merger Process, the district will submit the Alternatives to be Carried Forward concurrence package to BDE and FHWA. The district, FHWA, and BDE seek concurrence on the Alternatives to be Carried Forward at the NEPA/404 Merger meeting. The decision will be documented through the meeting minutes which will be provided by the district and distributed by FHWA to the Merger Agreement signatory agencies, and all other participants in the meeting.

After the Alternatives to be Carried Forward is complete, the district will update the timeframes agreement and send it to BDE and FHWA.

References:

Concurrent NEPA/404 Processes, Section 22-4

AASHTO Practitioner's Handbook 05 – Utilizing Community Advisory Committees for NEPA Studies, December 2006

AASHTO Practitioner's Handbook 07 – Defining the Purpose and Need and Determining the Range of Alternatives for Transportation Projects, August 2016

24-2.09 Perform Environmental Survey (Field Phase)

In this step, the district will submit an Environmental Survey Request (ESR) addendum to BDE for the alternatives to be carried forward. BDE determines if field work is necessary to verify or further evaluate the location, nature, and extent of potential resource involvement. If determined necessary, BDE coordinates with the responsible agencies and the district for the field survey(s). BDE provides the district documentation of the survey results and recommendations on resources identified.

The Field Survey phase is performed in coordination with other activities and can take a minimum of twelve months to receive results due to required time of year to conduct field surveys. This should be accounted for in the timeframe agreement.

BDE will coordinate with the resource agencies regarding the requirements for analysis methodologies to be used in the field surveys.

24-2.10 Evaluate Alternatives In Depth

For each Alternative to be Carried Forward, the district must identify and evaluate in detail those environmental impacts that will likely be caused by the construction and operation of the proposed action. This includes:

- coordination with affected local, State, and Federal agencies and the public; and
- an evaluation of the potential environmental impacts that may involve:
 - + social/economic (including environmental justice);
 - + floodplains and hydrologic assessment;
 - + agricultural;
 - + wetlands;
 - + historic/archaeological;
 - + endangered and threatened species;
 - + project specific air quality analyses;
 - + wildlife resources;
 - + aesthetics;
 - + upland plant communities;
 - + noise analysis;

- + regulated substances;
- + Section 4(f)/6(f);
- + surface water resources;
- + aquatic resources;
- + groundwater resources;
- + water quality; and
- + other issues as applicable (e.g., Wild and Scenic Rivers, Wellhead Protection Zones, regulated ground-water recharge areas).

References:

Environmental Consequences, 40 CFR 1502.16
Forty Most Common Questions concerning CEQ's NEPA Regulations Memorandum - Questions 1, 2, and 3 "Identification and Evaluation of Alternatives"
Paragraph V.E. of FHWA Technical Advisory T6640.8A - Alternatives Selection of Preferred Alternative, Section 22-3.08
Logical Termini, Section 22-6.04

24-2.11 Conduct Preferred Alternative Coordination

For projects using the principles of CSS, the objective of the CSS Community Advisory Group (CAG) is to reach consensus acceptance of the Preferred Alternative.

The district will consider input from the CAG, technical analyses of travel performance, potential impacts to environmental resources, etc., to select a Preferred Alternative.

For projects subject to the NEPA/404 Merger Process, the district will submit the Preferred Alternative concurrence package to BDE and FHWA. The district, FHWA, and BDE seek concurrence on the Preferred Alternative at the NEPA/404 Merger meeting. The decision will be documented through the meeting minutes which will be provided by the district and distributed by FHWA to the Merger Agreement signatory agencies, and all other participants in the meeting.

After the Preferred Alternative identification is complete, the district will update the timeframes agreement and send it to BDE and FHWA.

References:

Concurrent NEPA/404 Processes, Section 22-4
Collaboration in NEPA – A Handbook for NEPA Practitioners, Council on Environmental Quality, October 2007
AASHTO Practitioner's Handbook 05 – Utilizing Community Advisory Committees for NEPA Studies, December 2006

24-2.12 Class of Action Determination

Based on the preferred alternative impacts, the district, in consultation with BDE and FHWA, determines whether the project will be processed as a CE, EA, or EIS. Documentation of the decision should be done via email or at a coordination meeting and shall be included in the project file. If the project is determined to be processed as a:

- CE, determine if the project will be processed as a Federally-approved CE or a state-approved CE (See Section 23-2.06).
- EA, continue to the next section of this Chapter.
- EIS, proceed with the Notice of Intent (see Section 25-2.02).

24-2.13 Department Review of the Preliminary EA (Review #1)

The “preliminary EA” is considered any version of the EA that is not ready and complete for public review and comment. Using information gathered from prior activities, the district prepares the preliminary EA. The preliminary EA will be reviewed by the district and BDE using the following process:

- The district submits the preliminary EA to BDE in MS Word format.
- BDE has 60 days to review and evaluate the preliminary EA and notifies the district of any revisions before proceeding with further reviews.
- The district will address all comments and prepare a disposition of comments.

At this time, FHWA does not receive a copy or review of the preliminary EA unless there is a demonstrated need and requested in writing by the Regional Engineer.

References:

Synthesis of Data Needs for EA and EIS Documentation – A Blueprint for NEPA Document Content, prepared at the request of AASHTO, January 2005

Improving the Quality of Environmental Documents, Joint AASHTO/ACEC Committee in Cooperation with FHWA, May 2006

24-2.14 Preliminary EA Review (Review #2)

The district will submit to BDE a revised preliminary EA and disposition of comments with BDE’s comments addressed in MS Word format.

- BDE will submit the preliminary EA to FHWA, and disposition of comments if applicable, for review. BDE and FHWA will have 30 days to complete the review.
- Concurrently:

- + BDE submits the preliminary EA to the IDOT Office of Chief Counsel for legal sufficiency review. Office of Chief Counsel has 28 days to provide comments to BDE.
- + For projects with Environmental Justice concerns, BDE submits the preliminary EA to IDOT Civil Rights Officer for review in compliance with the Community Impact Assessment Manual.
- BDE sends its comments and FHWA's comments to the district. BDE may transmit the comments together, depending on when they are available.
- The district will address all comments, prepare a disposition of comments, and send both to BDE.
- This review process will continue with BDE and FHWA until the preliminary EA is deemed to be signature ready. The EA is considered "signature ready" when IDOT and FHWA both agree it contains all appropriate information to make the EA available for public review and comment.
- After all comments on the preliminary EA are addressed, the district provides the preliminary EA to any cooperating agencies that requested a copy for their review and comment.

References:

Synthesis of Data Needs for EA and EIS Documentation – A Blueprint for NEPA Document Content, prepared at the request of AASHTO, January 2005
Improving the Quality of Environmental Documents, Joint AASHTO/ACEC Committee in Cooperation with FHWA, May 2006

24-2.15 Signature Ready EA

At this stage, the district will have received input from BDE, the Office of Chief Counsel, FHWA, and cooperating agencies, as applicable, on the preliminary EA. The document is considered a "signature ready EA" when both IDOT and FHWA agree that the document is acceptable for making available to the public for review. The following process applies to the preparation and processing of the signature ready EA for approval to make available to the public:

- The district submits to BDE an electronic copy of the signature ready EA, which include the cover sheet, containing the signature block; see Figure 2 in Appendix D.
- The Engineer of Design and Environment signs the cover sheet for the Department.
- BDE submits the EA to the FHWA Division Office.
- The FHWA Division Office signs the cover sheet of the EA. This signature approves the EA for public review.
- BDE then returns the signed cover sheet to the district.

24-2.16 Make EA Available to the Public

The district is responsible for notifying the cooperating agencies, Section 106 consulting parties, and the public that the signed EA is available for review and providing a link to the document. If the project utilizes CSS, these stakeholders will be identified in the Stakeholder Involvement Plan (SIP). See Figure 24-2.H for a list of resource agencies.

The minimum 30-day time period of availability for comment begins on the date the public is notified of its availability (through newspaper, website, letters, etc.). The notice of availability of the EA shall briefly describe the project and its impacts (particularly any impacts involving wetlands, floodplains, Section 4(f) resources, and business/residential relocations), in accordance with 23 CFR 771.119.

The district shall make the EA available for review by the public on the Department website, the district office and other areas, as appropriate.

Figure 24-2.G provides a Sample EA Notice of Availability for publication in newspapers, etc. Prior to submitting the Notice of Availability, the Office of Communication should be contacted so that the notice can be published on social media and other sites as required.

References:

Environmental Assessments, 23 CFR 771.119 (c, d, e, f, and h)

Forty Most Common Questions concerning CEQ's NEPA Regulations Memorandum - Question 38 "Public Availability of EA"

Concurrent NEPA/404 Processes, Section 22-4
Section 4(f) Evaluations, Section 26-2

Notice of Availability

**Environmental Assessment
for the proposed
four-lane improvement
of Illinois Route 29 from
Illinois Route 6 to Interstate 180**

Peoria, Marshall, Putnam, and Bureau counties

**The Illinois Department of Transportation has
placed copies of the IL 29 EA in the following
area(s) for public review:**

**<Insert district information and other areas as
appropriate>**

The EA also can be reviewed on the web at:

<insert URL here>

Comments on the EA can be mailed to:

**[Name], P.E.
Region Three Engineer
Illinois Department of Transportation
401 Main Street
Peoria, IL 61602**

**Comments on the document are due by
[Date]**

Notice of Availability

Figure 24-2.G

District Distribution (as applicable)¹
District to Federal Agencies
Environmental Protection Agency, Region V, Office of Environmental Review (Chicago)
US Army Corps of Engineers (if 404 permit potentially needed)
Chicago District
Rock Island District
St. Louis District
Louisville District
Memphis District
US Coast Guard (if USCG. Permit required)
US Fish and Wildlife Service
Chicago
Rock Island
Marion
District to State Agencies
Department of Agriculture
IDNR, Office of Realty and Environmental Planning
IDNR, Office of Water Resources
Environmental Protection Agency
IDNR, Illinois Historic Preservation Division
District to Other Entities
Local Agencies (list)
Organizations and Institutions (list)
Persons (list)

1. Distribution of the EA occurs when an agency has jurisdiction over an involved resource due to regulation (e.g. individual 4(f), listed species, cultural) or permit, coordinate as applicable.

Distribution of EA

Figure 24-2.H

24-2.17 Public Hearing

Section 19-2 discuss the state and Federal requirements for public involvement. Section 19-3.04(b) stipulates that a public hearing is required for EAs.

References:

Public Hearings, 23 USC 128

Early coordination, public involvement, and project development, 23 CFR 771.111

Public Involvement, 40 CFR 1506.6

Public Hearings, Section 19-3.04

Collaboration in NEPA – A Handbook for NEPA Practitioners, Council on Environmental Quality, October 2007

AASHTO Practitioner's Handbook 05 – Utilizing Community Advisory Committees for NEPA Studies, December 2006

24-2.18 Evaluate for Major Project Requirements

After identification of the Preferred Alternative, if the project cost exceeds \$500 million, FHWA has Major Project requirements that must be satisfied prior to completing the NEPA process (i.e., before FHWA can issue a FONSI). These requirements may include an independent cost estimate review by FHWA, preparation of a financial plan, and completion of a project management plan. Chapter 20 contains detailed information on meeting these requirements.

References:

Requirements for Major Projects, Chapter 20

24-2.19 Planning Requirement Prior to NEPA Approval

Before FHWA can approve a FONSI the appropriate planning requirements must be satisfied:

- in an urbanized area
 - + the project must be included in the conformed fiscally constrained portion of the Metropolitan Transportation Plan, and;
 - + a subsequent phase of project development (e.g., final design, acquire right-of-way, utility relocations, or construction) must be included in the Metropolitan Planning Organization's (MPOs) Transportation Improvement Program (TIP).
- in a non-urbanized area
 - + the project must be consistent with the long range Statewide Transportation Plan, and;

- + a subsequent phase of the project development (e.g., final design, acquire right-of-way, utility relocations, or construction) must be included in the Statewide Transportation Improvement Program (STIP).

At this time, the district should coordinate with the appropriate planning entities to verify the planning requirements have been satisfied so that the FONSI can be signed.

24-2.20 Prepare EA Errata and Recommend FONSI

Following the public availability period and public hearing or offer of public hearing, the district will prepare an Errata to the EA to:

- reflect changes in the proposed action or mitigation measures resulting from comments received on the EA or at the public hearing, if one is held, and the effect of the changes;
- include any necessary findings, agreements, or determinations (e.g., for compliance with wetlands requirements, Section 106, Section 4(f)); and
- incorporate pertinent comments received on the EA and the responses to those comments.
- Include public hearing transcripts, if applicable;
- Include certification that a public hearing was held, or an offer for a public hearing was made.

If the district determines the Preferred Alternative will have no significant impacts, the district will prepare a draft FONSI. A FONSI is a Federal agency decision document that presents the reasons why an action will not have a significant effect on the human and natural environment and for which an EIS will not be prepared (CEQ regulations in 40 CFR 1508.13). The following process will apply to the EA Errata and draft FONSI:

1. The district will submit the EA Errata and draft FONSI to BDE.
2. BDE will review and evaluate the two documents and will notify the district of any required revisions.
3. After the district has incorporated any necessary changes, the EA Errata and draft FONSI will be submitted to FHWA through BDE.
4. The FHWA comments on the EA Errata and draft FONSI and those comments will be transmitted to the district through BDE.
5. After all BDE and FHWA comments have been addressed by the district, BDE will send the following to FHWA:
 - a. letter recommending a FONSI;
 - b. FONSI; and
 - c. EA Errata (including public hearing transcript (if applicable) and certification that a public hearing was held, or an offer for a public hearing was made).

Part II of Appendix D provides guidance on how to write an Errata and Finding of No Significant Impact (FONSI).

References:

When to Prepare a FONSI, 40 CFR 1501.4(e)
Environmental Assessments, 23 CFR 771.119(g)
Findings of No Significant Impact, 23 CFR 771.121(a)

PART II: How To Write A Finding Of No Significant Impact (FONSI) And Errata, Appendix D
Environmental Assessments, 23 CFR 771.119(g)
Paragraph II.H. of FHWA Technical Advisory T6640.8A - EA Revisions
Section III of FHWA Technical Advisory T6640.8A – Finding of No Significant Impact (FONSI)
Forty Most Common Questions concerning CEQ's NEPA Regulations Memorandum -
Question 37a "Level of Detail in FONSI"

24-2.21 Draft Project Management Plan for Major Projects

For projects subject to the Major Project requirements, prior to signing of the FONSI. the district prepares a draft Project Management Plan in accordance with the guidance in Section 20-2.

The district coordinates the draft Project Management Plan with BDE for submittal to FHWA. The FHWA will coordinate with FHWA Office of Innovative Program Delivery (IPD) Project Delivery Team as appropriate, review, and provide comments to BDE.

References:

Requirements for Major Projects, Chapter 20

24-2.22 Issue FONSI or Proceed to EIS

If FHWA determines that the project will have no significant impacts, the FHWA will sign the FONSI. The district will send a notice of availability of the FONSI to Federal, State, and local government agencies that asked to be informed, provided comments on the EA, or that otherwise would have an interest in the undertaking. IDOT will post the FONSI on the IDOT website.

Note: If the EA involves an individual Section 4(f) Evaluation, the district also must also send the EA Errata and final Section 4(f) Evaluation to the USDOT (consistent with USDOT policy).

If it is determined the project involves one or more significant impacts, FHWA will not approve the FONSI. In this case, the district coordinates with BDE and FHWA to initiate the process for preparing an Environmental Impact Statement (EIS); see Chapter 25.

References:

Timing of Administration Activities, 23 CFR 771.113(a)
Findings of No Significant Impact, 23 CFR 771.121(a, b, and c)
Section III of FHWA Technical Advisory T6640.8A – Finding of No Significant Impact (FONSI)
Paragraph IV.B. of FHWA Technical Advisory T6640.8A - Distribution of FONSI

Forty Most Common Questions Concerning CEQ's NEPA Regulations Memorandum -
Questions 37b and 38 "Public Availability of FONSI"
Collaboration in NEPA – A Handbook for NEPA Practitioners, Council on Environmental Quality,
October 2007

24-2.23 Re-evaluation of a Finding of No Significant Impact (FONSI)

The district is responsible for determining if there have been any changes compared to what is disclosed in the FONSI for the following items:

- Substantial design changes,
- Substantial changes in the scope of the project,
- Changes to state or Federal environmental rules, environmental requirements, or environmental legislation that will affect changes to or within the environment in which the project will be located,
- Increase in the amount of right of way, permanent or temporary,
- Increase in the number of relocations or displacements of residences or businesses,
- the anticipated impacts, and
- proposed mitigation measures.

The re-evaluation shall also include a statement on whether the district initially determines that the FONSI is still valid or whether the project shall now be processed as an EIS. FHWA will make an official final determination on whether or not the FONSI is still valid or an EIS is required.

Making this determination is called a re-evaluation and must occur any time after a FONSI is issued and before major approvals (i.e., final design, land acquisition, construction, etc.) are requested and authorized. However, before undertaking any re-evaluation, the district should discuss the project and its history with BDE and FHWA to determine the type of documentation that will be required and if additional public involvement, see Chapter 19, is necessary. The re-evaluation can then be documented via an email, memorandum to the file, or a new EA. The documentation should be commensurate with the changes in the project impacts.

Note: BDE has prepared a re-evaluation template that can assist the district in preparing a re-evaluation. Please contact BDE Project Coordination Unit for a copy of this document.

The district will submit the re-evaluation via e-mail to the FHWA Transportation Engineer requesting concurrence with the conclusions in the re-evaluation. If there are substantial changes since the FONSI was issued, FHWA will use the re-evaluation to determine if the FONSI remains valid or if an EIS is required.

References:

Re-evaluations, 23 CFR 771.129

Re-evaluations of CE, FONSI, or ROD, Section 22-3.14

Section XI of FHWA Technical Advisory T6640.8A - Re-evaluations

24-2.24 Determine Applicability of Limitation on Claims (Statute of Limitations)

23 U.S.C. 139 establishes a 150-day statute of limitations on claims against US Department of Transportation and other Federal agencies for certain environmental and other approval actions, provided a notice is published in the Federal Register announcing the permit, license, or approval is final pursuant to the law under which the agency action is taken. The statute of limitations provision is intended to expedite the resolution of issues affecting transportation projects.

Before the completion of the FONSI, IDOT will consult with FHWA to determine if a limitation on claims is appropriate for the project. If so, IDOT will submit a draft limitation on claims notice in MS Word format to FHWA at the same time the draft FONSI is submitted; see Figure 25-2.N for a sample notice.

References:

FHWA *SAFETEA-LU Environmental Review Process Final Guidance*, Section 3 “Statute of Limitations”

AASHTO Practitioner’s Handbook 09 – Using the SAFETEA-LU Environmental Review Process (23 USC 139), January 2008

24-2.25 Finalize Project Management Plan for Major Projects

For projects subject to the Major Project requirements, the district revises the draft Project Management Plan to respond to FHWA comments. The district coordinates the final Project Management Plan with BDE for submittal to FHWA within 90 days of the date the FONSI is signed.

References:

Requirements for Major Projects, Chapter 20

24-2.26 Implement Mitigation Measures

Those involved in preparing and processing the EA should assist those involved in subsequent aspects of project development and implementation in facilitating the fulfillment of commitments made as a part of the NEPA process. In accordance with Departmental Policy D&E-19, each district must ensure that its procedures for follow-through on commitments provide for including information on mitigation measures and other commitments (e.g., Wetlands Compensation Plan, Erosion Control Plan, Special Provisions for management and monitoring of regulated

substances) in the project plans, as necessary, and for implementing and monitoring the measures during construction and maintenance, as appropriate.

After FONSI approval, if there are changes to the project scope, or portion of the design changes in a way that commitments will change or there is a substantial change in ROW acquisition, it is the district's responsibility to coordinate with the appropriate district project development and land acquisition staff, BDE, and FHWA.

References:

Implementing the Decision, 40 CFR 1505.3

Applicabilities and Responsibilities, 23 CFR 771.109 (b)

Forty Most Common Questions concerning CEQ's NEPA Regulations Memorandum - Question 34d "What is the enforceability of a Record of Decision?"

AASHTO Practitioner's Handbook 04 – Tracking Compliance with Environmental Commitments/Use of Environmental Monitors, November 2006

Departmental Policy D&E-19 Follow-Through on Project Commitments

Chapter Twenty-five

**ENVIRONMENTAL IMPACT
STATEMENTS**

BUREAU OF DESIGN AND ENVIRONMENT MANUAL

Chapter Twenty-five
ENVIRONMENTAL IMPACT STATEMENTS

Table of Contents

<u>Section</u>	<u>Page</u>
25-1 GENERAL	25-1.1
25-1.01 Definitions	25-1.1
25-1.02 Applicability.....	25-1.1
25-1.02(a) Environmental Impact Statement (EIS).....	25-1.1
25-1.02(b) Supplemental EIS.....	25-1.2
25-1.02(c) Tiering	25-1.2
25-1.03 Record of Decision (ROD) Re-evaluation(s).....	25-1.2
25-2 THE EIS PROCESS.....	25-2.4
25-2.01 Class of Action Determination.....	25-2.4
25-2.02 Publish Notice of Intent.....	25-2.4
25-2.03 Department Review of the Preliminary DEIS.....	25-2.6
25-2.04 Preliminary DEIS Review	25-2.6
25-2.05 Signature Ready DEIS	25-2.7
25-2.06 Circulate approved DEIS.....	25-2.8
25-2.07 Implement Public Hearing Process.....	25-2.11
25-2.08 Evaluate and Respond to Substantive Comments on DEIS	25-2.13
25-2.09 Evaluate for Major Project Requirements	25-2.14
25-2.10 Planning Requirement Prior to NEPA Approval.....	25-2.15
25-2.11 Determination of Combined Final EIS/Record of Decision (FEIS/ROD) or Separate FEIS & ROD.....	25-2.15
25-2.12 Procedures for Combined FEIS/ROD or Separate FEIS and ROD.....	25-2.16
25-2.12(a) Procedures for Combined FEIS/ROD	25-2.16
25-2.12(b) Procedures for Separate FEIS and ROD.....	25-2.19
25-2.13 Draft Project Management Plan for Major Projects	25-2.24
25-2.14 Finalize Project Management Plan for Major Projects	25-2.24
25-2.15 Implement Mitigation Measures.....	25-2.28

Chapter Twenty-five

ENVIRONMENTAL IMPACT STATEMENTS

Chapter 25 discusses procedures for preparing and processing Environmental Impact Statements. These procedures shall be used if an EIS is determined to be the appropriate class of action following the procedures as described in Section 24-2.01 through Section 24-2.12 .

25-1 GENERAL

25-1.01 Definitions

1. Environmental Impact Statement (EIS). A detailed written statement prepared for major Federal actions significantly affecting the quality of the human environment, which discusses the environmental impact of the proposed action; any adverse environmental effects which cannot be avoided should the proposal be implemented; alternatives to the proposed action; the relationship between local short-term uses of the human environment and the maintenance and enhancement of long-term productivity; and any irreversible and irretrievable commitments of resources which would be involved in the proposed action should it be implemented.
2. Supplemental Environmental Impact Statement (SEIS). A detailed written statement on changes in the proposed action and/or on the identification and analysis of new circumstances or information not addressed in the Draft or Final EIS, which would introduce new or changed environmental effects of significance on the quality of the human environment.
3. Tiering. "Tiering" means covering broad or more general matters in a Tier I EIS with a Tier II EIS addressing narrower, more specific matters. Tiering is intended to be an aid in focusing on issues that are ready for decision and excluding issues already decided or not yet ready; see 40 CFR 1508.28, 23 CFR 771.111(g).

25-1.02 Applicability

25-1.02(a) Environmental Impact Statement (EIS)

An EIS is required for all Federally-funded highway projects (or other Federally-regulated highway activities) determined to be likely to cause significant impacts on the environment. 23 CFR 771.115(a) lists project types that normally will require the preparation of an EIS.

References:

Statutory Requirements for Statements, 40 CFR 1502.3

Major Federal Action Requiring the Preparation of Environmental Impact Statements, 40 CFR 1502.4

Class of Actions, 23 CFR 771.115(a)

25-1.02(b) Supplemental EIS

The cited references describe those circumstances where a Supplemental EIS may be appropriate.

References:

Draft, Final, and Supplemental Statements, 40 CFR 1502.9(c)
Supplemental Environmental Impact Statements, 23 CFR 771.130
Supplemental EISs, Section XII of FHWA Technical Advisory T6640.8A

25-1.02(c) Tiering

Tiering of EISs should be used when it will improve or simplify the environmental processing of proposed IDOT actions. Preparation of tiered EISs should be considered for complex transportation proposals (e.g., major urban transportation investments). The first tier EIS would focus on broad issues such as mode choice, general location, area wide air quality, and land use implications of the transportation improvement alternatives being considered. The first tier EIS(s) should use information from appropriate corridor planning and other planning studies. A subsequent site-specific environmental document will be required to focus on more detailed project impacts and mitigation measures (e.g., addressing details of route location, highway interchange configurations, etc.). If tiered EISs are used, the subsequent document(s) shall state where the preceding document is available.

References:

Tiering, 40 CFR 1502.20
Early Coordination, Public Involvement, and Project Development, 23 CFR 771.111(g)

25-1.03 Record of Decision (ROD) Re-evaluation(s)

The district is responsible for determining if there have been any changes compared to what is disclosed in the ROD for the following items:

- Substantial design changes,
- Substantial changes in the scope of the project,
- Changes to state or Federal environmental rules, environmental requirements, or environmental legislation that will affect changes to or within the environment in which the project will be located,
- Increase in the amount of right of way, permanent or temporary,

- Increase in the number of relocations or displacements of residences or businesses,
- the anticipated impacts, and
- proposed mitigation measures.

The re-evaluation shall also include a statement on whether the district initially determines that the ROD is still valid or whether a Supplemental EIS is now required. FHWA will make an official final determination on whether or not the ROD is still valid or a Supplemental EIS is required.

Making this determination is called a re-evaluation and must occur any time after a ROD is issued and before major Federal approvals (i.e., final design, land acquisition, construction, etc.) are authorized. However, before undertaking any re-evaluation, the district should discuss the project and its history with BDE and FHWA to determine the type of documentation that will be required (e.g., email, memorandum to the file, or new EA) and if additional public involvement (see Chapter 19) is necessary. The district will submit the re-evaluation to the FHWA Transportation Engineer requesting concurrence with the conclusion in the re-evaluation. If there are substantial changes since the ROD was issued, FHWA will use the re-evaluation to determine if the ROD remains valid or if a Supplemental EIS is required.

Note: BDE has prepared a re-evaluation template that can assist the district in preparing a re-evaluation. Please contact BDE Project Coordination Unit for a copy of this document.

References:

Re-evaluations, 23 CFR 771.129

Re-evaluations of CE, FONSI, or ROD, Section 22-3.14

Re-evaluations, Section XI of FHWA Technical Advisory T6640.8A

25-2 THE EIS PROCESS

The following section discusses the general process for an action processed as an Environmental Impact Statement (EIS). This is followed by a description of each activity. The user also should consider the following:

1. Lines of Communication. The rigid application of the process would lead to predetermined, precise points at which communication occurs between units. This is neither realistic nor desirable. Communication between units must be continuous. This will result in fewer problems and fewer surprises in the process.
2. Lead Federal Agency. It is assumed that the Federal Highway Administration (FHWA) is the lead Federal agency for FHWA-funded projects. If a different agency is the lead Federal agency, other procedures may be required.
3. Application. This section applies to all EIS projects involving State highways regardless of the source of funding.

25-2.01 Class of Action Determination

Based on Section 24-2.01 through 24-2.12, if a significant impact or significant public controversy is identified, an EIS is required. Follow the procedures below after the decision that an EIS is required.

25-2.02 Publish Notice of Intent

The district prepares a draft Notice of Intent (NOI) and submits the draft NOI to BDE who will coordinate with FHWA on acceptable format and content. BDE bureau chief will sign a letter requesting FHWA to publish NOI and FHWA will ensure NOI is published in the *Federal Register*. The date the NOI is published starts the 2-year timeframe for the project.

FHWA Technical Advisory T6640.8A discusses the format, content, and processing of the NOI in more detail (See Appendix A in the BDE Manual). Figure 25-2.A presents the required format for the NOI and includes information necessary for project initiation. The NOI format is available from BDE as an electronic document.

References:

Scoping, 40 CFR 1501.7

Notice of Intent, 40 CFR 1508.22

Draft Environmental impact Statements, 23 CFR 771.123(a)

Appendix B of FHWA Technical Advisory T6640.8A-Preparation and Processing of NOI

Section 1305 of MAP-21-Efficient Environmental Reviews for Project Decisionmaking,
23 U.S.C. 139

DEPARTMENT OF TRANSPORTATION

Federal Highway Administration

Environmental Impact Statement: *[County or City]*, Illinois

AGENCY: Federal Highway Administration (FHWA), DOT

ACTION: Notice of Intent

SUMMARY: The FHWA is issuing this notice to advise the public that an environmental impact statement will be prepared for *[project name and description]*...FOR FURTHER INFORMATION CONTACT: *[Name]*, Division Administrator, Federal Highway Administration, 3250 Executive Park Drive, Springfield, Illinois 62703, Phone: *[Office Phone Number]*. *[Name]*, Deputy Director of Highways, Region *[Number]* Engineer, Illinois Department of Transportation, *[Office Address]*, Phone: *[Office Phone Number]*.SUPPLEMENTARY INFORMATION: The FHWA, in cooperation with the Illinois Department of Transportation (IDOT), will prepare an environmental impact statement (EIS) for ... *[In this section, provide (1) a brief narrative description of the proposed action (e.g., location of the action, type of construction, length of the project, needs to be addressed by the action); (2) a brief description of possible alternatives (e.g., upgrade existing facility, construction on new alignment, no action (should always be listed), multi-modal design); (3) any other federal approvals anticipated, such as 404 permits; and (4) a brief description of the proposed scoping and public involvement process for the particular action, including whether, when, and where any scoping meeting(s) or public hearing(s) will be held.]*

(Catalog of Federal Domestic Assistance Program Number 20.205, Highway Research, Planning and Construction. The regulations implementing Executive Order 12372 regarding intergovernmental consultation on Federal programs and activities apply to this program.)

Issued on: *[FHWA will enter the date.]*

[Name]
Division Administrator
Springfield, Illinois

*[Note: Left margin should be 1.5 inches (40 mm) minimum and all others 1 inch (25 mm).]**All typing must be double spaced except for the information identifying the person signing the document.]***REQUIRED FORMAT FOR NOTICE OF INTENT****Figure 25-2.A**

25-2.03 Department Review of the Preliminary DEIS

At this stage of project development, the district will have received input from the appropriate agencies and the public, will have evaluated in depth the alternatives carried forward, identified a Preferred Alternative. An internal review of the preliminary version of the DEIS will be reviewed by the Department prior to submitting to FHWA. The following process applies to the review of the preliminary DEIS:

- The district reviews the preliminary DEIS and ensures its comments are addressed.
- The district submits the preliminary DEIS to BDE in MS Word format.
- BDE has 60 calendar days to review and evaluate the preliminary DEIS and notifies the district of any revisions before proceeding with further reviews.
- The district will address all comments and prepare a disposition of comments.

At this time, FHWA does not receive a copy or review of the preliminary DEIS unless there is a demonstrated need and requested in writing by the Regional Engineer.

References:

Environmental Impact Statement, 40 CFR 1502

Draft environmental impact statements, 23 CFR 771.123(c) and (d)

Section V of FHWA Technical Advisory T6640.8A - Format and Content of EIS

Synthesis of Data Needs for EA and EIS Documentation—A Blueprint for NEPA Document Content, prepared at the request of AASHTO, January 2005

Improving the Quality of Environmental Documents, Joint AASHTO/ACEC Committee in Cooperation with FHWA, May 2006

25-2.04 Preliminary DEIS Review

The district will submit to BDE a revised DEIS with BDE's comments addressed in MS Word format.

- BDE will submit the DEIS to FHWA for review. BDE and FHWA will have 30 days to complete the review.
- Concurrently, BDE submits the preliminary DEIS to the IDOT Office of Chief Counsel for legal sufficiency review. Office of Chief Counsel has 30 days to provide comments to BDE.
- BDE sends its comments and FHWA's comments to the district. BDE may transmit the comments together, depending on when they are available.
- This review process will continue with BDE and FHWA until the DEIS is deemed to be signature ready.
- After all comments are addressed, the district provides the preliminary DEIS to any cooperating agencies that requested a copy during the scoping process.

References:

Environmental Impact Statement, 40 CFR 1502
Draft Environmental Impact Statements, 23 CFR 771.123(c) and (d)
Section V of FHWA Technical Advisory T6640.8A EIS–Format and Content
Synthesis of Data Needs for EA and EIS Documentation–A Blueprint for NEPA Document Content,
prepared at the request of AASHTO, January 2005
Improving the Quality of Environmental Documents, Joint AASHTO/ACEC Committee in
Cooperation with FHWA, May 2006

25-2.05 Signature Ready DEIS

At this stage, the district will have received input from BDE, the office of Chief Counsel, FHWA, and cooperating agencies, as applicable, on the preliminary DEIS. The following process applies to the preparation and processing of the signature ready DEIS for approval to circulate:

- The district submits to BDE an electronic copy of the signature ready DEIS, which include the cover sheet, which contains the signature block; see Figure 3 of Appendix D. The calendar date for return of comments shall be shown on the DEIS cover sheet. The minimum 45-day time period of availability for comment is calculated based on the date of publication of the Notice of Availability in the *Federal Register*. The maximum number of days for the comment period is 60 days, unless FHWA and participating agencies agree to a longer period.
- The Engineer of Design and Environment signs the cover sheet for the Department.
- BDE submits the cover sheet for the DEIS to the FHWA Division Office.
- The FHWA Division Office signs the cover sheet of the DEIS. This signature approves the DEIS for circulation.
- BDE then returns the signed cover sheet to the district.
- The district will prepare and submit to FHWA a copy of the approved DEIS in the format that meets USEPA requirements outlined in *e-NEPA: Electronic Submittal of Environmental Impact Statements to EPA*.

References:

Draft Environmental *Impact Statements*, 23 CFR 771.123(e)
Synthesis of Data Needs for EA and EIS Documentation–A Blueprint for NEPA Document Content,
prepared at the request of AASHTO, January 2005
Improving the Quality of Environmental Documents, Joint AASHTO/ACEC Committee in
Cooperation with FHWA, May 2006

25-2.06 Circulate approved DEIS

The district has the responsibility for notifying appropriate governmental agencies, public officials, interest groups, and the public of the availability of the DEIS (See Figure 25-2.B) and providing a link to the document. If the project utilizes CSS, these stakeholders will be identified in SIP. The district should ensure the entities discussed previously receive notification of the DEIS no later than the date of the Notice of Availability (NOA) in the Federal Register.

The following describes the distribution of the DEIS:

- FHWA will upload the DEIS to USEPA's electronic filing system for publication of the NOA in the Federal Register. FHWA will notify BDE when the DEIS has been successfully uploaded to the USEPA site. The NOA will be published on Friday of the week following that in which USEPA received the electronic submittal of the DEIS from FHWA.
- The district will prepare letters to transmit the DEIS to identified stakeholders. The transmittal letter shall state: (1) the calendar date comments are due, (2) where to send comments, and (3) that the FEIS will be furnished to those who make substantive comments on the DEIS or request a copy.
- The district shall make the DEIS available to the public for review on the Department's website and a hardcopy available at the district.

Figure 25-2.C provides a Sample DEIS Availability Notice, for publication in newspapers, etc. Prior to submitting the Availability Notice, the Office of Communication should be contacted so that the notice can be published on social media and other sites as required.

References:

Draft Environmental Impact Statements, 23 CFR 771.123(e), (f), (g), (h), and (i)
Commenting, 40 CFR 1503

District Distribution (as applicable) ¹
District to Federal Agencies
Environmental Protection Agency, Region V, Office of Environmental Review (Chicago)
US Army Corps of Engineers (if 404 permit potentially needed)
Chicago District
Rock Island District
St. Louis District
Louisville District
Memphis District
US Coast Guard (if USCG permit potentially needed)
US Fish and Wildlife Service
Chicago
Rock Island
Marion
District to State Agencies
Department of Agriculture ⁴
IDNR, Office of Realty and Environmental Planning
IDNR, Office of Water Resources
Environmental Protection Agency
IDNR, Historic Preservation Division
District to Other Entities
Local Agencies (list)
Organizations and Institutions (list)
Persons (list)

Footnotes:

1. Distribution of the EIS occurs when an agency has jurisdiction over an involved resource due to regulation (e.g. individual 4(f), listed species, cultural) or permit, coordinate as applicable.

District Distribution of Approved DEIS, FEIS, FEIS/ROD

Figure 25-2.B

Notice of Availability

**Draft Environmental Impact
Statement (DEIS)
for the proposed
four-lane improvement
of Illinois Route 29 from
Illinois Route 6 to Interstate 180**

Peoria, Marshall, Putnam, and Bureau counties

**The Illinois Department of Transportation has
placed copies of the IL 29 DEIS in the
following area(s) for public review:**

**<insert district information and others areas as
appropriate>**

The DEIS also can be reviewed on the web at:

<insert URL here>

Comments on the DEIS can be mailed to:

**[Name], P.E.
Region Three Engineer
Illinois Department of Transportation
401 Main Street
Peoria, IL 61602**

**Comments on the document are due by
[Date]**

SAMPLE DEIS AVAILABILITY NOTICE

Figure 25-2.C

25-2.07 Implement Public Hearing Process

Public involvement is a critical element of the EIS process. Chapter 19 and the cited references discuss public involvement requirements for public hearings and public information meetings. Figure 25-2.D provides a Sample DEIS Public Hearing Notice. FHWA regulations require that the draft EIS must be available at the public hearing and a minimum of 15-days in advance of the public hearing. The Department has additional public notice requirements that must be met. The initial public notice must be published 30 days in advance of the public hearing and a second public notice shall be published 3 to 7 days prior to the public hearing.

In accordance with 23 CFR 771.111(h)(2)(vi), anytime a public hearing is held, the Department must submit to FHWA a transcript of the public hearing and a certification that a required hearing or hearing opportunity was offered. For more information, please see Section 19-3.04(g) and Section 19-3.04(h).

References:

Policy, 40 CFR 1500.2(d)

Public Involvement Requirements, 40 CFR 1506.6

Early Coordination, Public Involvement, and Project Development. 23 CFR 771.111(h)

Draft Environmental Impact Statements, 23 CFR 771.123(h)

Public Involvement Guidelines, Chapter 19

Collaboration in NEPA—A Handbook for NEPA Practitioners, Council on Environmental Quality, October 2007

AASHTO Practitioner's Handbook 05—Utilizing Community Advisory Committees for NEPA Studies, December 2006

<insert Office of Communications contact name (s) and numbers(s)>
PUBLIC HEARING
 for
ILLINOIS ROUTE 29
DRAFT ENVIRONMENTAL IMPACT STATEMENT

The Illinois Department of Transportation (IDOT) will hold an open house public hearing to seek public comment on the Draft Environmental Impact Statement (DEIS) for the IL Route 29 project and proposed road closures of a proposed four-lane facility from IL Route 6 near Peoria, IL to I-180 in Bureau County.

When?

June 14, 2006
 4:00 pm to 7:00 pm
 June 15, 2006
 4:00 pm to 7:00 pm

Where?

Three Sisters Park Pavilion
 17201 North State Route 29, Chillicothe, IL
 Henry Senachwine High School Gymnasium
 1023 College Street, Henry, IL

IDOT will hold two open-house public hearings to present the [[see 23 CFR 771.111(h)(2)(v), suggest listing those items here]]. All interested parties are invited to attend and participate in the public hearings. You may attend any time between 4:00 pm and 7:00 pm. NO FORMAL PRESENTATION WILL BE GIVEN. IDOT personnel and representatives from their consultant team will be on hand to answer questions and receive comments about the proposed project. A court reporter will be available at the hearings to take oral testimony. The public also may submit written comments. All comments received by June 25th will be included in the official hearing record. Property acquisition and relocation assistance information will be available. Exhibits and maps of the proposals developed in the study will be available for review during the entire time as will copies of the Draft Environmental Impact Statement (DEIS).

This hearing will provide an opportunity for the public to provide comments about potential impacts to cultural resources, in compliance with Section 106 of the National Historic Preservation Act of 1966, as amended and to assist in consultation with the Illinois State Historic Preservation Officer. [**include a list of other findings from EOs, other laws, as applicable; for example, hot spot analysis, floodplain **].

The DEIS also is available for public review and comment at IDOT's website ([insert url here](#)) and at the area(s) listed below. The document discusses the alternatives that were evaluated, including IDOT's preferred alternative, and the project's potential impacts on the natural and man-made environment in the study area. Comments on the DEIS can be sent to [Name of Regional Engineer], P.E. at the address listed at the bottom of this ad any time before June 25, 2006.

<Insert area(s) name & address>

The hearing locations are accessible to persons with disabilities. Persons with disabilities needing special accommodations or additional information should contact the person listed below at least 5 days prior to the public hearing.

[Name of District Office Contact], P.E.
 Illinois Department of Transportation
 401 Main Street
 Peoria, Illinois 61602
 Phone: (309) 671-3333, TDD: (309) 671-3450
 Fax: (309) 671-3498

Sample DEIS Public Hearing Notice

Figure 25-2.D

25-2.08 Evaluate and Respond to Substantive Comments on DEIS

The district evaluates all comments (from the public, resource agencies, and other stakeholders) on the DEIS and/or Section 4(f) Evaluation, where applicable, and prepares responses to these comments as appropriate. Possible responses include:

- modifying alternatives including the proposed action;
- developing and evaluating alternatives not previously given serious consideration;
- supplementing, improving, or modifying analyses;
- making factual corrections; or
- explaining why the comments do not warrant further agency response, citing the sources, authorities, or reasons supporting that position and, if possible, indicating those circumstances that would trigger reappraisal or further response.

It is important for the Department and/or FHWA to resolve any interagency disagreements before the preparation of the Final EIS (FEIS).

Copies of all comments must be included in the FEIS per requirements of 40 CFR 1503.4. The responses to comments must be included in the FEIS in table format. The copies of comments and comment–response table shall be included as an appendix.

Comments that are received after the formal comment period, but before the FEIS is signed by FHWA, shall be incorporated into the FEIS, where practical. When the comments are received after the FEIS has been submitted to FHWA but before signature, the comments shall be forwarded to FHWA. The transmittal of the comments to FHWA shall include an explanation that the comments were received late, and it shall indicate the response to the comments.

The comments and responses to comments shall be reviewed by BDE and FHWA during the review of the preliminary FEIS.

References:

Response to Comments, 40 CFR 1503.4

Final Environmental Impact Statements, 23 CFR 771.125(a)

Forty Most Common Questions concerning CEQ's NEPA Regulations Memorandum-Question 14d "Lead Agency Response to Cooperating Agency's Comments" and Question 29 "Responses to Comments"

Responses, Section 19-4.08(c)

Collaboration in NEPA—A Handbook for NEPA Practitioners, Council on Environmental Quality, October 2007

AASHTO Practitioner's Handbook 02—Responding to Comments on an Environmental Impact Statement, August 2016

25-2.09 Evaluate for Major Project Requirements

Once the Preferred Alternative is chosen, the district, in cooperation with FHWA and BDE, determines if the total estimated project cost (construction, right-of-way, and engineering) is greater than \$500 million. If the cost exceeds \$500 million, the project is subject to the Major Project requirements, see Chapter 20, which include: Cost Estimate Review, Financial Plan, and Project Management Plan. If the cost is greater than \$100 million and less than \$500 million, only a Financial Plan is required, unless otherwise designated as a Major Project at the discretion of FHWA. The FHWA Division Office will coordinate review of Major Project components with the FHWA Major Project Team.

If the project is a Major Project, the district determines if it can be divided into operationally independent phases of work. There are three approaches to addressing such projects; maintain the project as one undertaking, develop a phasing plan for various phases over an extended time frame, or define operationally independent non-concurrent construction projects.

When applicable, the district prepares documentation of the basis for either of the second two options and submits it to BDE for coordination with FHWA for FHWA IPD Project Delivery Team approval. The benefits of a phasing plan are explained in Chapter 20. Operationally independent non-concurrent construction projects, which have a total estimated cost less than \$500 million, are only subject to the Major Projects requirements when they are designated by FHWA as a Major Project. If the operationally independent non-concurrent construction projects exceed \$100 million, the district must still address the financial plan requirement, but those financial plans are approved by IDOT.

The required Major Projects components and their timing are:

- A Cost Estimate Review, which should be completed prior to the ROD, normally about 30 days prior to ROD approval.
- An Initial Financial Plan, which should be submitted after the Cost Estimate Review is completed and must be submitted prior to the first authorization of Federal-aid funding for construction. A draft Project Management Plan, which should be submitted 60 days before the ROD approval and the Final Project Management Plan within 90 days of ROD approval. A draft Project Management Plan must be submitted before a ROD can be issued.

If the total estimated project cost is not greater than \$500 million, and FHWA does not otherwise designate the action as a Major Project, the district shall:

- document that the project is not subject to Major Project requirements,
- when applicable, complete a financial plan which will be approved by the Department (see Chapter 20 for financial plan requirements), and
- proceed to the next activity.

References:

Requirements for Major Projects, Chapter 20

25-2.10 Planning Requirement Prior to NEPA Approval

Before FHWA can approve a Record of Decision (ROD) the appropriate planning requirements must be satisfied:

- in an urbanized area
 - + the project must be included in the conformed fiscally constrained portion of the Metropolitan Transportation Plan, and;
 - + a subsequent phase of project development (e.g., final design, acquire right-of-way, utility relocations, or construction) must be included in the Metropolitan Planning Organization's (MPOs) Transportation Improvement Program (TIP).
- in a non-urbanized area
 - + the project must be consistent with the long range Statewide Transportation Plan, and
 - + a subsequent phase of the project development (e.g., final design, acquire right-of-way, utility relocations, or construction) must be included in the Statewide Transportation Improvement Program (STIP).

Early in project development (Section 25-2.01(a)), the district should have initiated coordination with the appropriate planning agencies to ensure that these requirements will be met prior to approval of the ROD. At this time, the district should coordinate with the appropriate planning entities to verify the planning requirements have been satisfied so that the ROD can be signed.

25-2.11 Determination of Combined Final EIS/Record of Decision (FEIS/ROD) or Separate FEIS & ROD

MAP-21, Section 1319(b), directs FHWA, to the maximum extent practicable, to develop a single document that combines the FEIS and ROD, unless certain conditions exist:

- The FEIS makes substantial changes to the proposed action that are relevant to environmental or safety concerns; or
- There are significant new circumstances or information relevant to environmental concerns and that bear on the proposed action or the impacts of the proposed action.

The district and BDE should seek FHWA's determination if the project can be issued as a combined FEIS/ROD. FHWA will then consult with their Headquarters' staff and legal counsel to determine

whether a combined FEIS/ROD is practicable. If a combined FEIS/ROD is determined to be practicable, proceed to Section 25-2.24. If the FEIS and ROD will be separate, proceed to 25-2.27.

25-2.12 Procedures for Combined FEIS/ROD or Separate FEIS and ROD

25-2.12(a) Procedures for Combined FEIS/ROD

25-2.12(a)1 Opportunity for Discussion of Resource Agency Comments

The district will collate all resource agency comments and prepare a draft response for FHWA and BDE review. Once FHWA and BDE and the district concur on adequate responses, FHWA will offer to meet with resource agencies to discuss the draft responses. This meeting may occur in person or by phone call. In consultation with FHWA and BDE, the district will revise the responses as necessary. It may be necessary to revise the FEIS document to address the agencies' comments.

25-2.12(a)2 Determine Applicability of Limitation on Claims (Statute of Limitations)

23 U.S.C. 139 establishes a 150-day statute of limitations on claims against US Department of Transportation and other Federal agencies for certain environmental and other approval actions, provided a notice is published in the Federal Register announcing the permit, license, or approval is final pursuant to the law under which the agency action is taken. The statute of limitations provision is intended to expedite the resolution of issues affecting transportation projects.

Before the completion of the combined FEIS/ROD, IDOT will consult with FHWA to determine if a limitation on claims is appropriate for the project. If so, IDOT will submit a draft limitation on claims notice in MS Word format to FHWA at the same time the draft combined FEIS/ROD is submitted; see Figure 25-2.D for a sample notice.

References:

Efficient Environmental Reviews for Project Decision-making, 23 U.S.C. 139(l)

FHWA *SAFETEA-LU Environmental Review Process Final Guidance*, Section 3 "Statute of Limitations"

AASHTO Practitioner's Handbook 09—Using the SAFETEA-LU Environmental Review Process (23 U.S.C. 139), January 2008

25-2.12(a)3 Prepare/Review Preliminary Combined FEIS/ROD

Before the final preparation and distribution of the combined FEIS/ROD, a preliminary version must be reviewed by the Department and FHWA to evaluate its adequacy for distribution. If the project is a Major Project, see Section 25-2.21, the preliminary FEIS/ROD should summarize any operationally independent phases of work identified and the results of a cost estimate review. The following process applies to the review of the preliminary FEIS/ROD:

- The district submits the preliminary FEIS/ROD and the table of response to comments to the DEIS to BDE in MS Word format.

- BDE reviews and evaluates the preliminary FEIS/ROD and response to comments and notifies the district within 30 days of any required revisions.
- After the district has incorporated any necessary changes, the preliminary FEIS/ROD and response to comments are submitted to BDE for review. The district prepares a disposition of all comments received from FHWA and BDE. The disposition will be included with subsequent submittals of the FEIS/ROD. BDE will submit to FHWA for a 30 day concurrent review and evaluation. Repeat this step as necessary.
- After BDE and FHWA deem the preliminary FEIS/ROD and response to comments acceptable, FHWA submits the document to FHWA legal counsel for a legal sufficiency review. Any comments from the legal sufficiency review will be communicated to IDOT BDE, who will coordinate the comments to the district. The district incorporates changes as necessary to address comments received as part of FHWA's legal sufficiency review.
- For projects meeting the criteria described in 23 CFR 771.125(c), the FHWA Division Office coordinates the FEIS/ROD with FHWA Headquarters for prior concurrence.

Once FHWA and BDE comments have been addressed, the district will prepare the FEIS/ROD for approval.

NOTE: Prior to approving a ROD, a subsequent phase of the project must be included in the fiscally constrained portion of the STIP or TIP (See Section 25-2.01(a) and Section 25-2.22).

References:

Draft, Final, and Supplemental Statements, 40 CFR 1502.9(b)

Final Environmental Impact Statements, 23 CFR 771.125

Documentation, 23 CFR 774.7

Section VI of FHWA Technical Advisory T6640.8A-Options for Preparing FEIS

Concurrent NEPA/404 Processes, Section 22-4

Section 4(f) Evaluations and Determinations, Section 26-2

Synthesis of Data Needs for EA and EIS Documentation—A Blueprint for NEPA Document Content, prepared at the request of AASHTO, January 2005

Improving the Quality of Environmental Documents, Joint AASHTO/ACEC Committee in Cooperation with FHWA, May 2006

25-2.12(a)4 *Obtain Approval of Combined FEIS/ROD*

- The following process applies for obtaining approval of the FEIS/ROD:
- The district submits to BDE a minimum of 3 hard copies of the signature ready FEIS/ROD, which include the cover sheet bound in the documents. The district also shall submit 1 unbound cover sheet.
- The district also submits to BDE a transcript of each public hearing held and a certification that a public hearing was held. With the hearing transcript(s), the district provides copies of

all written statements from the public, both submitted at the public hearing(s) or during an announced period after the hearing(s).

- The Engineer of Design and Environment signs the FEIS cover sheet (Figure 5 of Appendix D) for the Department. BDE forwards all copies of the FEIS/ROD and the unbound cover sheet to the FHWA Division Office along with the public hearing information.
- The FHWA Division Administrator signs all copies of the FEIS/ROD and the unbound cover sheet.

Please note that the district must provide a signed version of the FEIS/ROD to FHWA Division Office in PDF format which meets the USEPA requirements outlined in *e-NEPA: Electronic Submittal of Environmental Impact Statements to EPA*. There is no public review or comment period when a combined FEIS/ROD is issued.

References:

Timing of Administrative Activities, 23 CFR 771.113(a)(2)

Final Environmental Impact Statements, 23 CFR 771.125(c) and (e).

Timing, 23 CFR 774.9.

Section VIII of FHWA Technical Advisory T6640.8A-Format and Content of ROD

Forty Most Common Questions concerning CEQ's NEPA Regulations Memorandum-Question 6

“Environmentally Preferable Alternative,” Question 34b “Use of FEIS Summary as ROD,” and Question 34c “ROD and Mitigation/Monitoring”

Section 4(f) Evaluations and Determinations, Section 26-2

25-2.12(a)5 *Circulation of Combined FEIS/ROD*

The district has the primary responsibility for circulating the FEIS/ROD.

The following describes the distribution of the FEIS/ROD:

- District will submit the FEIS/ROD in PDF format to FHWA Division Office (See USEPA's website on filing format-<http://www.epa.gov/compliance/nepa/submiteis/index.html>).
- The FHWA Division Office electronically submits the FEIS/ROD to the USEPA, Office of Federal Activities in Washington, D.C. for publication of the Notice of Availability in the Federal Register.
- FHWA Division Office provides the transmittal memo to the district who forwards the FEIS/ROD to FHWA Headquarters and the FHWA legal counsel for information purposes.
- USEPA will publish in the *Federal Register* the Notice of Availability for the FEIS/ROD. The Notice will be published on Friday of the week following that in which USEPA received the FEIS/ROD.
- Figure 25-2.B identifies the recipients to receive the FEIS/ROD. The district shall also distribute the FEIS/ROD to any entity that made substantive comments on the DEIS and is

not included in Figure 25-2.B, or requested a copy of the FEIS/ROD; the district also shall make the FEIS/ROD available for public review on the Department website and at the district office.

- The district shall provide copies of the FEIS/ROD free of charge unless the IDOT Regional Engineer concludes that a fee, which is not more than the actual printing cost, should be charged. IDOT shall inform the FHWA of requests for FEIS/RODs that it is unable to fill with free copies. IDOT will direct the party to the IDOT website or the nearest location where they may review the FEIS/ROD. If FHWA receives a specific request for a copy of the FEIS/ROD, FHWA will ask the Department to fulfill the request.
- Where the FEIS/ROD is voluminous and the number of comments on a DEIS is large, the district, BDE, and FHWA may jointly decide on alternative arrangements for distribution of the FEIS/ROD (e.g., CDs, DVDs).
- If FHWA receives a request from the public for a copy of the FEIS/ROD, FHWA will ask the Department to fulfill the request.

A FEIS/ROD that has been signed by FHWA shall (1) be posted on the IDOT website to make it available publicly; (2) be included with copies of the FEIS/ROD that are used as a reference for further development and implementation of the project by Department units; (3) be included in the project files; and (4) otherwise be made available to those Department units involved in subsequent project development and implementation.

25-2.12(b) Procedures for Separate FEIS and ROD

25-2.12(b)1 *Prepare/Review Preliminary FEIS (Separate FEIS and ROD)*

Before the final preparation and distribution of the FEIS, a preliminary version of the FEIS and response to comments must be reviewed by the Department and FHWA to evaluate its adequacy for approval and release for public review. For Major Projects, see Section 25-2.21, the preliminary FEIS should summarize any operationally independent phases of work identified and the results of a cost estimate review. The following process applies to the review of the preliminary FEIS:

- The district submits the preliminary FEIS and response to comments to BDE in MS Word format.
- BDE reviews and evaluates the preliminary FEIS and response to comments and notifies the district within 30 days of any required revisions.
- After the district has incorporated any necessary changes, the preliminary FEIS and response to comments are submitted to BDE for review. The district prepares a disposition of all comments received from BDE. BDE will submit to FHWA for a 30 day concurrent review and evaluation. The district will include a disposition of BDE and FHWA comments will all subsequent submittals of the FEIS. Repeat this step as necessary.

- After BDE and FHWA agree the preliminary FEIS and response to comments are acceptable, FHWA submits the document to FHWA legal counsel for a legal sufficiency review. Any comments from the legal sufficiency review will be communicated to IDOT BDE, who will coordinate the comments to the district. The district incorporates changes as necessary to address comments received as part of FHWA's legal sufficiency review.
- For projects meeting the criteria described in 23 CFR 771.125(c), the FHWA Division Office coordinates the FEIS with FHWA Headquarters for prior concurrence.

Once FHWA and BDE comments have been addressed, the district will prepare the FEIS for approval.

NOTE: Prior to approving a ROD, a subsequent phase of the project must be included in the fiscally constrained portion of the STIP or TIP; see Section 25-2.01(a) and 25-2.22.

References:

Draft, Final, and Supplemental Statements, 40 CFR 1502.9(b)
Final Environmental Impact Statements, 23 CFR 771.125
Documentation, 23 CFR 774.7
Section VI of FHWA Technical Advisory T6640.8A-Options for Preparing FEIS
Concurrent NEPA/404 Processes, Section 22-4
Section 4(f) Evaluations and Determinations, Section 26-2
Synthesis of Data Needs for EA and EIS Documentation—A Blueprint for NEPA Document Content,
prepared at the request of AASHTO, January 2005
Improving the Quality of Environmental Documents, Joint AASHTO/ACEC Committee in
Cooperation with FHWA, May 2006

25-2.12(b)2 *Prepare/Process FEIS for Approval (Separate FEIS and ROD)*

The following process applies for obtaining approval of the FEIS:

- The district submits to BDE a minimum of 3 hard copies of the signature ready FEIS, which include the signature page bound in the documents. The district also shall submit one unbound signature page.
- The district also submits to BDE a transcript of each public hearing held and a certification that a public hearing was held. With the hearing transcript(s), the district provides copies of all written statements from the public, both submitted at the public hearing(s) or during an announced period after the hearing(s).
- The Engineer of Design and Environment signs the FEIS cover sheet (Figure 6 of Appendix D) for the Department. BDE forwards the FEIS (all copies and the separate signature sheets) to the FHWA Division Office along with the public hearing information.
- The FHWA signs the FEIS.

Please note that the district must provide a signature version of the FEIS to FHWA Division Office in PDF format which meets the USEPA requirements outlined in *e-NEPA: Electronic Submittal of Environmental Impact Statements to EPA*.

References:

Timing of Administrative Activities, 23 CFR 771.113(a)(2).

Final Environmental Impact Statement, 23 CFR 771.125(c) and (e).

Timing, 23 CFR 774.9.

Section VIII of FHWA Technical Advisory T6640.8A-Format and Content of ROD

Forty Most Common Questions concerning CEQ's NEPA Regulations Memorandum-Question 6 "Environmentally Preferable Alternative," Question 34b "Use of FEIS Summary as ROD," and Question 34c "ROD and Mitigation/Monitoring"

Section 4(f) Evaluations and Determinations, Section 26-2

25-2.12(b)3 *Circulate FEIS (Separate FEIS and ROD)*

The district has the primary responsibility for circulating the FEIS.

The following describes the distribution of the FEIS:

- District will submit the FEIS in PDF format to FHWA Division Office (See USEPA's website on filing format-<http://www.epa.gov/compliance/nepa/submiteis/index.html>).
- The FHWA Division Office electronically submits the FEIS to the USEPA, Office of Federal Activities in Washington, D.C. for publication of the Notice of Availability in the Federal Register.
- FHWA Division Office provides the transmittal memo to the district who forwards the FEIS to FHWA Headquarters and the FHWA legal counsel for information purposes.
- USEPA will publish in the *Federal Register* the Notice of Availability for the FEIS. The Notice will be published on Friday of the week following that in which USEPA received the FEIS.
- The district shall distribute the FEIS to any entity that made substantive comments on the DEIS, or requested a copy of the FEIS; the district also shall make the FEIS available for public review on the Department website and at the district office.
- The district shall provide copies of the FEIS free of charge unless the IDOT Regional Engineer concludes that a fee, which is not more than the actual printing cost, should be charged. IDOT shall inform the FHWA of requests for FEISs that it is unable to fill with free copies. IDOT will direct the party to the IDOT website or the nearest location where they may review the FEIS. If FHWA receives a specific request for a copy of the FEIS, FHWA will ask the Department to fulfill the request.
- Where the FEIS is voluminous and the number of comments on a DEIS is large, the district, BDE, and FHWA may jointly decide on alternative arrangements for distribution of the FEIS (e.g., CDs, DVDs).

- If FHWA receives a request from the public for a copy of the FEIS, FHWA will ask the Department to fulfill the request.
- There is a minimum 30-day waiting period after the Notice of Availability for the FEIS is published before FHWA can issue the ROD. If FHWA receives substantive comments during this waiting period, then FHWA will respond to the comments in the ROD.

References:

Circulation of the Environmental Impact Statement, 40 CFR 1502.19

Circulation of the Environmental Impact Statement, 40 CFR 1502.19(d)

Filing Requirements, 40 CFR 1506.9

Timing of Agency Action, 40 CFR 1506.10

Final Environmental Impact Statement, 23 CFR 771.125(c), (f), and (g)

Paragraph VII. A. and Paragraph VI.C. of FHWA Technical Advisory T6640.8A-Cover Sheet and Table of Contents

25-2.12(b)4 *Evaluate and Respond to Substantive Comments on FEIS (Separate FEIS and ROD)*

The district evaluates all comments on the FEIS and prepares a draft Record of Decision (ROD). The district identifies and responds in the draft ROD to those comments that are substantive. The district summarizes and responds to comments on the FEIS as appropriate.

The district will ensure that a subsequent phase (e.g., final design, acquire right-of-way, utility relocations, or construction) of the project is incorporated into the fiscally-constrained portion of either the Metropolitan Planning Organization's (MPO's) Transportation Improvement Program (TIP) or in the Statewide Transportation Improvement Program (STIP). (See 25-2.01(a) and 25-2.22).

The district submits the draft ROD to BDE in MSWord format. BDE forwards it to FHWA. BDE and FHWA will concurrently review the ROD. The district will revise the ROD to address FHWA and BDE comments, as necessary. Once all IDOT and BDE comments on the ROD are sufficiently addressed, the ROD is ready for signature.

References:

Paragraph VIII.F. of FHWA Technical Advisory T6640.8A-Comments on Final EIS

Collaboration in NEPA—A Handbook for NEPA Practitioners, Council on Environmental Quality, October 2007

AASHTO Practitioner's Handbook 02—Responding to Comments on an Environmental Impact Statement, July 2006

25-2.12(b)5 *Determine Applicability of Limitation on Claims (Statute of Limitations)*

The Efficient Environmental Reviews for Project Decision-making, 23 U.S.C. 139 establishes a 150-day statute of limitations on claims against US Department of Transportation and other Federal agencies for certain environmental and other approval actions, provided a notice is

published in the Federal Register announcing the permit, license, or approval is final pursuant to the law under which the agency action is taken. The statute of limitations provision is intended to expedite the resolution of issues affecting transportation projects.

Before the completion of the ROD, IDOT will consult with FHWA to determine if a limitation on claims is appropriate for the project. If so, IDOT will submit a draft limitation on claims notice in MS Word format to FHWA at the same time the draft ROD is submitted; see Figure 25-2.D for a sample notice.

References:

Efficient Environmental Reviews for Project Decision-making, 23 U.S.C. 139(I).

FHWA *SAFETEA-LU Environmental Review Process Final Guidance*, Section 3 “Statute of Limitations”

AASHTO Practitioner’s Handbook 09–Using the SAFETEA-LU Environmental Review Process (23 U.S.C. 139), January 2008

25-2.12(b)6 *Approval of ROD (Separate FEIS and ROD)*

After all comments on the ROD are satisfactorily resolved, the ROD will be processed and approved as follows:

- BDE will submit the ROD, with a cover letter signed by the Engineer of Bureau of Design and Environment, requesting FHWA’s signature.
- The FHWA Division Administrator may sign the ROD no sooner than 30 days after the *Federal Register* public availability notice for the FEIS, or 90 days after such notice for the DEIS, whichever is later.

A ROD that has been signed by FHWA shall (1) be posted on the IDOT website to make it available publicly; (2) be included with copies of the EIS that are used as a reference for further development and implementation of the project by Department units; (3) be included in the project files; and (4) otherwise be made available to those Department units involved in subsequent project development and implementation.

References:

Record of Decision in cases requiring Environmental Impact Statements, 40 CFR 1505.2

Record of Decision, 23 CFR 771.127

Re-evaluations, 23 CFR 771.129

Timing, 23 CFR 774.9

Forty Most Common Questions concerning CEQ’s NEPA Regulations Memorandum-Question 33b “May a referral be made after this issuance of a Record of Decision?” and Question 34a “Records of Decision. Must Records of Decision (RODs) be made public? How should they be made available?”

Ensuring Validity of Environmental and Design Documents, Section 22-3.1

25-2.13 Draft Project Management Plan for Major Projects

For projects subject to the Major Project requirements, prior to approval of the Record of Decision, the district prepares a draft Project Management Plan in accordance with the guidance in Section 20-2, addressing the following topics, at a minimum:

- Project Description and Scope of Work;
- Goals and Objectives;
- Project Organizational Chart, Roles, and Responsibilities;
- Project Phases;
- Procurement and Contract Management;
- Cost, Budget and Schedule;
- Project Reporting and Tracking;
- Internal and Stakeholder Communications;
- Project Management Controls;
- Design Quality Assurance/Quality Control;
- Construction Quality Assurance/Quality Control;
- Environmental Monitoring;
- Right-of-Way;
- Safety and Security;
- Traffic Management;
- Project Communications (Media and Public Information);
- Civil Rights Program;
- Closeout Plan;
- Project Documentation; and
- Appendices.

The district coordinates the draft Project Management Plan with BDE for submittal to FHWA. The FHWA will coordinate with FHWA Office of Innovative Program Delivery (IPD) Project Delivery Team as appropriate, review, and provide comments to BDE.

References:

Requirements for Major Projects, Chapter 20

25-2.14 Finalize Project Management Plan for Major Projects

For projects subject to the Major Project requirements, the district revises the draft Project Management Plan to respond to FHWA comments. The district coordinates the final Project Management Plan with BDE for submittal to FHWA within 90 days of the date the ROD is signed.

References:

Requirements for Major Projects, Chapter 20

4910-22
DEPARTMENT OF TRANSPORTATION

Federal Highway Administration

Notice of Final Federal Agency Action on Proposed Highway in Illinois

AGENCY: Federal Highway Administration (FHWA), DOT

ACTION: Notice of limitation on claims for judicial review of actions by FHWA and other Federal agencies

SUMMARY: This notice announces actions taken by the FHWA and other Federal agencies that are final within the meaning of 23 U.S.C. 139(l)(1). The actions relate to the proposed Illinois Route 29 (IL 29) highway project, for construction of an access-controlled, four-lane freeway on new right-of-way between the existing IL 6 interchange near Mossville and the proposed Chillicothe interchange north of Chillicothe in Peoria County, and the widening of IL 29 to four-lanes, largely on existing right-of-way, from north of Chillicothe to Interstate 180 (I-180) in Peoria, Marshall, Putnam, and Bureau Counties, Illinois. Those actions grant licenses, permits and approvals for the project.

DATES: By this notice, the FHWA is advising the public of final agency actions subject to 23 U.S.C. 139(l)(1). A claim seeking judicial review of the Federal agency actions of the highway project will be barred unless the claim is filed on or before *[insert date 150 days after publication in the Federal Register]*. If the Federal law that authorizes judicial review of a claim provides a time period of less than 150 days for filing such claim, then that shorter time period still applies.

FOR FURTHER INFORMATION CONTACT: *[Name]*, P.E., Division Administrator, Federal Highway Administration, 3250 Executive Park Drive, Springfield, Illinois 62703, Phone: (217) 492-4600, E-mail address: *[First_Name.Last_Name]*@ dot.gov. The FHWA Illinois Division Office's normal business hours are 7:30 a.m. to 4:15 p.m.

SAMPLE STATUTE OF LIMITATIONS NOTICE

Figure 25-2.D
(1 of 3)

You also may contact [*Name of Regional Engineer*], P.E., Illinois Department of Transportation, Deputy Director of Highways, Region Three Engineer, 401 Main Street, Peoria, Illinois 61602, Phone: (309) 671-3333. The Illinois Department of Transportation Region Three's normal business hours are 8:00 a.m. to 4:30 p.m.

SUPPLEMENTARY INFORMATION: Notice is hereby given that the FHWA and other Federal agencies have taken final agency actions by issuing licenses, permits and approvals for the following highway project in the State of Illinois: construction of an approximately 10-mile, access-controlled, four-lane freeway on new right-of-way between the existing IL 6 interchange near Mossville and the proposed Chillicothe interchange north of Chillicothe, and the approximately 25-mile widening to a four-lane expressway of IL 29, largely on existing right-of-way, from north of Chillicothe to I-180. The actions by the Federal agencies, and the laws under which such actions were taken, are described in the Final Environmental Impact Statement (FEIS) for the project approved on April 23, 2009; and the Record of Decision (ROD) issued on January 19, 2010; and other documents in the FHWA administrative record. The FEIS, ROD and other documents in the FHWA administrative record are available by contacting FHWA or the Illinois Department of Transportation at the addresses above. Project information can be viewed and downloaded from the project website <http://www.dot.il.gov/il29/default.aspx>. The FEIS also can be downloaded from <http://www.dot.il.gov/desenv/env.html>, or hard copies of the FEIS and the ROD are available upon request.

This notice applies to all Federal agency decisions as of the issuance date of this notice and all laws under which such actions were taken, including, but not limited to:

1. General: National Environmental Policy Act (NEPA), 42 U.S.C. 4321-4351 and Federal-Aid Highway Act, 23 U.S.C. 109.
2. Air: Clean Air Act, 42 U.S.C. 7401-7671(q).
3. Land: Section 4(f) of the Department of Transportation Act of 1966, 49 U.S.C. 303.
4. Wildlife: Endangered Species Act, 16 U.S.C. 1531-1544 and 1536; Migratory Bird Treaty Act, 16 U.S.C. 703-712.
5. Historic and Cultural Resources: Section 106 of the National Historic Preservation Act of 1966, 16 U.S.C. 470(f) et seq. (as amended); Archaeological and Historic Preservation Act (AHPA), 16 U.S.C. 469-469(c).

SAMPLE STATUTE OF LIMITATIONS NOTICE

Figure 25-2.D
(2 of 3)

6. Social and Economic: Civil Rights Act of 1964, 42 U.S.C. 2000(d)-2000(d)(1); Farmland Protection Policy Act (FPPA), 7 U.S.C. 4201-4209.
7. Wetlands and Water Resources: Clean Water Act, 33 U.S.C. 1251-1377 (Section 401 and 404); Wild and Scenic Rivers Act, 16 U.S.C. 1271-1287.
8. Executive Orders: E.O. No. 11990 Protection of Wetlands; E.O. No. 11988 Floodplain Management; E.O. No. 12898 Federal Actions to Address Environmental Justice in Minority Populations and Low Income Populations.

(Catalog of Federal Domestic Assistance Program Number 20.205, Highway Research, Planning and Construction. The regulations implementing Executive Order No. 12372 regarding intergovernmental consultation on Federal programs and activities apply to this program).

Authority: 23 U.S.C. §139(l)(1)

Issued on: January 26, 2010

[Name], Division Administrator
Springfield, Illinois

SAMPLE STATUTE OF LIMITATIONS NOTICE

Figure 25-2.D
(3 of 3)

25-2.15 Implement Mitigation Measures

Those involved in preparing and processing the EIS should assist those involved in subsequent aspects of project development and implementation in facilitating the fulfillment of commitments made as a part of the NEPA process. In accordance with Departmental Policy D&E-19, each district must ensure that its procedures for follow-through on commitments provide for including information on mitigation measures and other commitments (e.g., Wetlands Compensation Plan, Erosion Control Plan, Special Provisions for management and monitoring of special wastes) in the project plans, and for implementing and monitoring the measures during construction and maintenance, as appropriate.

References:

Implementing the decision, 40 CFR 1505.3

Applicability and responsibility, 23 CFR 771.109 (b)

Forty Most Common Questions concerning CEQ's NEPA Regulations Memorandum-Question 34d
"What is the enforceability of a Record of Decision?"

AASHTO Practitioner's Handbook 04—Tracking Compliance with Environmental Commitments/Use of Environmental Monitors, November 2006

Follow-Through on Project Commitments, Departmental Policy D&E-19

Chapter 26

**SPECIAL ENVIRONMENTAL
ANALYSES**

BUREAU OF DESIGN AND ENVIRONMENT MANUAL

Table of Contents

(Continued)

<u>Section</u>		<u>Page</u>
26-5.04	Federal Requirements	26-5.2
	26-5.04(a) Definitions	26-5.2
	26-5.04(b) Applicability	26-5.3
	26-5.04(c) Procedures	26-5.3
	26-5.04(d) Unanticipated Discovery During Construction	26-5.27
	26-5.04(e) Coordination with the National Environmental Policy Act	26-5.27
	26-5.04(f) National Register Criteria for Evaluation	26-5.28
26-5.05	State of Illinois Requirements	26-5.29
26-6	NOISE ANALYSES	26-6.1
26-6.01	Introduction	26-6.1
26-6.02	Complementary Technical Manual	26-6.1
26-6.03	Legal Authority	26-6.1
26-6.04	Policy.....	26-6.1
26-6.05	Procedures.....	26-6.2
	26-6.05(a) Definitions.....	26-6.2
	26-6.05(b) Applicability	26-6.5
	26-6.05(c) Traffic Noise Analysis	26-6.5
	26-6.05(d) Noise Abatement.....	26-6.10
26-6.06	Noise Abatement Wall Materials.....	26-6.15
	26-6.06(a) Physical Requirements.....	26-6.15
	26-6.06(b) Acoustical Specifications	26-6.15
	26-6.06(c) Aesthetic Considerations	26-6.16
	26-6.06(d) Absorptive Material Considerations	26-6.16
	26-6.06(e) Noise Abatement Wall Maintenance	26-6.17
26-6.07	Coordination	26-6.18
26-6.08	Construction Noise	26-6.18
26-6.09	NEPA Documentation	26-6.19
	26-6.09(a) Type III projects	26-6.20
	26-6.09(b) Type I projects.....	26-6.20
26-6.10	Validity of Noise Assessments	26-6.21
26-7	FLOODPLAIN ENCROACHMENTS/ENCROACHMENTS.....	26-7.1
26-7.01	Introduction	26-7.1
26-7.02	Complementary Technical Manual	26-7.1
26-7.03	Legal Authority	26-7.1

Table of Contents
(Continued)

<u>Section</u>	<u>Page</u>
26-7.04 Policy.....	26-7.1
26-7.05 Procedures.....	26-7.2
26-7.05(a) Definitions.....	26-7.2
26-7.05(b) Applicability	26-7.4
26-7.05(c) Floodplain Studies	26-7.4
26-7.05(d) Environmental Documentation for Floodplain Encroachments	26-7.6
26-7.05(e) FEMA Buyout Properties Floodplain	26-7.6
26-7.05(f) Mitigation	26-7.7
26-7.05(g) Public Involvement.....	26-7.8
26-7.05(h) Coordination	26-7.8
26-8 WETLANDS.....	26-8.1
26-8.01 Introduction	26-8.1
26-8.02 Legal Authority	26-8.1
26-8.03 Policy.....	26-8.1
26-8.04 Procedures.....	26-8.2
26-8.04(a) Definitions.....	26-8.2
26-8.04(b) Applicability	26-8.4
26-8.04(c) Analysis and Documentation	26-8.4
26-8.04(d) Public Involvement/Coordination	26-8.15
26-8.04(e) Wetlands Finding	26-8.15
26-8.04(f) Development of IDOT Wetland Banks.....	26-8.16
26-9 THREATENED AND ENDANGERED SPECIES/NATURAL AREA IMPACT ASSESSMENTS.....	26-9.1
26-9.01 Introduction	26-9.1
26-9.02 Complementary Technical Manual	26-9.1
26-9.03 Legal Authority	26-9.1
26-9.04 Policy.....	26-9.1
26-9.05 Federal Requirements.....	26-9.2
26-9.05(a) Definitions.....	26-9.2
26-9.05(b) Applicability	26-9.4
26-9.05(c) Determination of Need for a Biological Assessment	26-9.5
26-9.05(d) Preparation of the Biological Assessment	26-9.6
26-9.05(e) Processing of the Biological Assessment.....	26-9.7
26-9.06 State Requirements.....	26-9.8
26-9.06(a) Definitions.....	26-9.8
26-9.06(b) Applicability	26-9.9
26-9.06(c) Determination of Need for Detailed Action Report	26-9.9

Table of Contents

(Continued)

<u>Section</u>	<u>Page</u>
26-9.06(d) Preparation of the Detailed Action Report	26-9.10
26-9.06(e) Processing of the Detailed Action Report	26-9.10
26-9.06(f) Special Circumstances	26-9.11
26-9.06(g) Incidental Taking Authorization	26-9.12
26-9.07 Coordination of Federal/State Requirements.....	26-9.17
26-10 EVALUATIONS OF FARMLAND CONVERSION IMPACTS.....	26-10.1
26-10.01 Introduction	26-10.1
26-10.02 Legal Authority	26-10.1
26-10.03 Policy.....	26-10.1
26-10.04 Federal Requirements.....	26-10.2
26-10.04(a) Definitions.....	26-10.2
26-10.04(b) Applicability	26-10.2
26-10.04(c) Procedures	26-10.3
26-10.04(d) Form NRCS-CPA-106.....	26-10.4
26-10.04(e) Siting Requirements.....	26-10.4
26-10.04(f) Notification of Selected Alternative	26-10.5
26-10.05 State Requirements.....	26-10.5
26-10.05(a) Definitions.....	26-10.5
26-10.05(b) Applicability	26-10.6
26-10.05(c) Procedures	26-10.6
26-10.05(d) Coordination	26-10.9
26-10.06 Relationship of Federal and State Requirements.....	26-10.9
26-11 TRANSPORTATION AIR QUALITY CONFORMITY REQUIREMENTS AND DOCUMENTATION.....	26-11.1
26-11.01 Introduction	26-11.1
26-11.02 Applicability.....	26-11.2
26-11.03 Procedures.....	26-11.2
26-11.03(a) Determining Project Involvement in Designated Nonattainment or Maintenance Areas.....	26-11.2
26-11.03(b) Determining Whether Project is Exempt from Conformity Requirements	26-11.2
26-11.03(c) Determining Highway Project Conformity.....	26-11.4
26-11.03(d) Information for NEPA Documents or Project Reports ..	26-11.5

Table of Contents

(Continued)

<u>Section</u>	<u>Page</u>
26-12 TRANSPORTATION CONFORMITY PROJECT-LEVEL QUALITATIVE HOT-SPOT ANALYSIS IN PM _{2.5} AND PM ₁₀ NONATTAINMENT AND MAINTENANCE AREAS ...	26-12.1
26-12.01 Introduction	26-12.1
26-12.02 Applicability.....	26-12.2
26-12.03 Procedures.....	26-12.2
26-12.03(a) Exempt Projects.....	26-12.2
26-12.03(b) Non-Exempt Projects That Are Not an Air Quality Concern.....	26-12.2
26-12.03(c) Nonexempt Projects That Are an Air Quality Concern ..	26-12.3
26-12.03(d) Hot-Spot Analysis Procedures	26-12.5
26-13 MOBILE SOURCE AIR TOXICS	26-13.1
26-13.01 Introduction	26-13.1
26-13.02 Applicability.....	26-13.1
26-13.03 Procedures.....	26-13.1
26-13.03(a) Projects with No Meaningful Potential MSAT Effects or Exempt Projects.....	26-13.1
26-13.03(b) Projects with Low Potential MSAT Effects	26-13.2
26-13.03(c) Projects with Higher Potential MSAT Effects	26-13.9
26-13.03(d) Prototype Language for Compliance with 40 CFR 1502.22	26-13.11
26-14 MICROSCALE ANALYSIS.....	26-14.1
26-14.01 Introduction	26-14.1
26-14.02 Applicability.....	26-14.1
26-14.03 Procedures.....	26-14.1
26-14.03(a) Exempt Projects.....	26-14.2
26-14.03(b) Projects Not Suitable for Use of COSIM 4.0	26-14.2
26-14.03(c) COSIM Pre-Screen Documentation	26-14.3
26-14.03(d) Projects Subject to COSIM Screening Analysis.....	26-14.3
26-14.03(e) Projects Subject to Detailed Project-Level CO Analysis.....	26-14.3
26-15 MIGRATORY BIRDS	26-14.1
26-15.01 Introduction	26-14.1
26-15.02 Legal Authority	26-14.1
26-15.03 Policy.....	26-14.1
26-15.04 Procedures.....	26-14.1
26-15.04(a) Definitions.....	26-14.1

Table of Contents

(Continued)

<u>Section</u>	<u>Page</u>
26-15.04(b) Applicability	26-14.2
26-15.04(c) Analysis and Documentation	26-14.2
26-15.04(d) Coordination	26-14.4
26-16 WILDLIFE RESOURCES	26-14.1
26-16.01 Introduction	26-14.1
26-16.02 Legal Authority/Guidance	26-14.1
26-16.03 Policy.....	26-14.1
26-16.04 Procedures.....	26-14.1
26-16.04(a) Definitions.....	26-14.1
26-16.04(b) Applicability	26-14.2
26-16.04(c) Analysis and Documentation	26-14.2
26-16.04(d) Coordination	26-14.5
26-17 TREE/VEGETATION ASSESSMENTS	26-14.1
26-17.01 Introduction	26-14.1
26-17.02 Legal Authority	26-14.1
26-17.03 Policy.....	26-14.1
26-17.04 Procedures.....	26-14.1
26-17.04(a) Definitions.....	26-14.1
26-17.05 Applicability.....	26-14.2
26-17.06 Analysis and Documentation	26-14.2
26-17.06(a) Tree Surveys	26-14.2
26-17.06(b) Cover Type and Vegetation Surveys.....	26-14.4
26-17.07 Coordination.....	26-14.6
26-18 INVASIVE SPECIES AND NOXIOUS WEEDS	26-14.1
26-18.01 Introduction	26-14.1
26-18.02 Legal Authority	26-14.1
26-18.03 Policy.....	26-14.1
26-18.04 Procedures.....	26-14.2
26-18.04(a) Definitions.....	26-14.2
26-18.04(b) Applicability	26-14.3
26-18.05 Analysis and Documentation	26-14.3
26-18.06 IDOT List of Species Under Management	26-14.3
26-19 SURFACE WATER RESOURCES AND AQUATIC HABITAT	26-14.1

Table of Contents

(Continued)

<u>Section</u>	<u>Page</u>
26-19.01 Introduction	26-14.1
26-19.02 Complementary Technical Manuals	26-14.1
26-19.03 Legal Authority	26-14.1
26-19.04 Policy.....	26-14.2
26-19.05 Procedures.....	26-14.2
26-19.05(a) Definitions.....	26-14.2
26-19.05(b) Applicability	26-14.4
26-19.05(c) Analysis and Documentation	26-14.4
26-19.06 Antidegradation Assessment	26-14.12
26-19.06(a) Existing Uses	26-14.12
26-19.06(b) Outstanding Resource Waters	26-14.12
26-19.06(c) High Quality Waters.....	26-19.13
26-19.06(d) Information Requirements.....	26-19.13
26-19.07 Coordination.....	26-14.13
26-20 NATIONWIDE RIVERS INVENTORY.....	26-14.1
26-20.01 Introduction	26-14.1
26-20.02 Legal Authority	26-14.1
26-20.03 Policy.....	26-14.1
26-20.04 Procedures.....	26-14.1
26-20.04(a) Definitions.....	26-14.2
26-20.04(b) Applicability	26-14.2
26-20.04(c) Analysis and Documentation	26-14.2
26-20.04(d) Coordination	26-14.3
26-21 IMPAIRED WATERS/TMDLS	26-14.1
26-21.01 Introduction	26-14.1
26-21.02 Legal Authority	26-14.1
26-21.03 Policy.....	26-14.1
26-21.04 Procedures.....	26-14.1
26-21.05 Definitions	26-14.2
26-21.06 Applicability.....	26-14.2
26-21.06(a) Analysis and Documentation	26-14.2
26-21.06(b) Coordination	26-14.3
26-22 GROUNDWATER.....	26-14.1
26-22.01 Introduction	26-14.1
26-22.02 Legal Authority	26-14.1

Table of Contents
(Continued)

<u>Section</u>		<u>Page</u>
26-22.03	Policy.....	26-14.1
26-22.04	Procedures.....	26-14.1
26-22.04(a)	Definitions.....	26-14.2
26-22.04(b)	Analysis and Documentation	26-14.3

Chapter Twenty-six

SPECIAL ENVIRONMENTAL ANALYSES

26-1 GENERAL

26-1.01 Introduction

Although the *National Environmental Policy Act* (NEPA) is the major mandate for environmental considerations, there are other laws, executive orders, regulations, agreements, etc., which require special studies, analyses, coordination, and documentation on specific environmental issues. Chapter 26 addresses these other special requirements.

26-1.02 Policy

As practical, impact analyses and related surveys, studies, and coordination made necessary by environmental laws and requirements other than NEPA shall be integrated with the development of environmental information for inclusion in environmental reports or Phase I Engineering Reports.

26-1.03 Topics

Special analyses discussed in this Chapter addresses the following topics:

- Section 4(f) Evaluations and Determinations,
- Section 6(f) Land Conversion Request,
- OSLAD Land Conversion Request,
- Historic Act Compliance,
- Noise Analyses,
- Floodplain Encroachments,
- Wetlands,
- Threatened and Endangered Species/Natural Areas Impact Assessments,
- Evaluations of Farmland Conversion Impacts,
- Transportation Air Quality Conformity Requirements and Documentation,
- Transportation Conformity Project-Level Qualitative Hot-Spot Analysis in PM_{2.5} and PM₁₀ Nonattainment and Maintenance Areas,

- Mobile Source Air Toxics,
- Microscale Analysis,
- Migratory Birds,
- Wildlife Resources,
- Tree/Vegetation Assessments,
- Invasive Species and Noxious Weeds,
- Surface Water Resources and Aquatic Habitat,
- Nationwide Rivers Inventory,
- Impaired Waters/TMDLs, and
- Groundwater.

26-1.04 Applicability

Many of the special environmental analyses discussed in this Chapter are the result of Federal requirements. Although the Federally required analyses primarily affect Federally funded or regulated projects, some may apply to State-only (or State and local) funded projects where the projects affect resources covered by the Federal requirements. In addition, several of the special analyses discussed are the result of State requirements. These State requirements are often more stringent than those at the Federal level, and they may potentially affect any State project if the project involves the specific types of resources the State requirements address. Carefully review the Applicability discussion for each topic within Chapter 26 to determine the need for compliance with both Federal and State requirements on specific projects.

Information from special analyses should be (or, in some cases, is required to be) included in a project's environmental report (EIS or EA) or Phase I engineering report.

26-2 SECTION 4(F) EVALUATIONS AND DETERMINATIONS

26-2.01 Introduction

When a project involving approvals or funding from an agency of the US Department of Transportation proposes use of publicly owned land from a public park, recreational area, wildlife and waterfowl refuge, or any land from a historic property, special analyses are required for compliance with Section 4(f) of the Department of Transportation Act of 1966.

This Section provides guidance for identifying resources subject to Section 4(f), determining uses requiring Section 4(f) approval and exceptions to the approval requirement, conducting the required analyses, and documenting concurrences and approvals and discusses the applicability and requirements for Section 4(f) compliance.

26-2.02 Legal Authority

Section 4(f) of the Department of Transportation Act of 1966 (49 U.S.C. 303) provides that the Secretary of the U.S. Department of Transportation may approve a transportation program or project requiring the use of publicly owned land of a public park, recreation area, or wildlife and waterfowl refuge, or land of an historic site of national, State, or local significance (as determined by the Federal, State, or local officials having jurisdiction over the park, recreation area, refuge, or site) only if:

- There is no prudent and feasible alternative to using that land; and
- The program or project includes all possible planning to minimize harm to the park, recreation area, wildlife and waterfowl refuge, or historic site resulting from the use.

Or

- The use, including any measures to minimize harm (such as any avoidance, minimization, mitigation, or enhancement measures), will have a *de minimis* impact on the property.

26-2.03 Procedures

26-2.03(a) Definitions

1. All Possible Planning. All reasonable measures identified in the Section 4(f) evaluation to minimize harm or mitigate for adverse impacts and effects must be included in the project:
 - a. With regard to public parks, recreation areas, and wildlife and waterfowl refuges, the measures may include, but are not limited to, design modifications or design goals, replacement of land or facilities of comparable value and function, or monetary compensation to enhance the remaining property or to mitigate the adverse impacts of the project in other ways.
 - b. With regard to historic sites, the measures normally serve to preserve the historic activities, features, or attributes of the site as agreed by FHWA and the official(s) with jurisdiction over the Section 4(f) resource in accordance with the consultation process under 36 CFR 800 (see Section 26-5 Historic Act Compliance).

- c. In evaluating the reasonableness of measures to minimize harm, FHWA will consider the preservation purpose of the statute and:
- The views of the official(s) with jurisdiction over the Section 4(f) property,
 - Whether the cost of the measures is a reasonable public expenditure in light of the adverse impacts of the Section 4(f) property and the benefits of the measure to the property, and
 - Any impacts of benefits of the measures to communities or environmental resources outside of the Section 4(f) property.
- d. All possible planning does not require analysis of feasible and prudent avoidance alternatives, since such analysis will have already occurred in the context of searching for alternatives that avoid Section 4(f) properties altogether or is not necessary as in the case of a *de minimis* impact determination.
- e. A de minimis impact determination subsumes the requirement for all possible planning to minimize harm by reducing the impacts on the Section 4(f) property to a *de minimis* level.
2. Constructive Use. Occurs when the transportation project does not incorporate land from a Section 4(f) property, but the project's proximity impacts on an adjacent or near-by Section 4(f) property, after incorporation of impact mitigation, are so severe that the activities, features, or attributes that qualify the property for protection under Section 4(f) are substantially impaired.
3. De minimis Impact.
- a. For historic sites, *de minimis* impact means FHWA has determined, in accordance with 36 CFR 800, that no historic property is affected by the project or that the project will have "no adverse effect" on the historic property in question.
 - b. For parks, recreation areas, and wildlife and waterfowl refuges, a *de minimis* impact is one that will not adversely affect the features, attributes, or activities qualifying the property for protection under Section 4(f).
4. Feasible and Prudent Avoidance Alternative.
- a. A feasible and prudent avoidance alternative avoids using Section 4(f) property and does not cause other severe problems of a magnitude that substantially outweighs the importance of protecting the Section 4(f) property. In assessing the importance of protecting the Section 4(f) property, it is appropriate to consider the relative value of the resource to the preservation purpose of the statute.
 - b. An alternative is not feasible if it cannot be built as a matter of sound engineering judgment.

- c. An alternative is not prudent if:
- It compromises the project to a degree that it is unreasonable to proceed with the project in light of its stated purpose and need;
 - It results in unacceptable safety or operational problems;
 - After reasonable mitigation, it still causes:
 - + severe social, economic, or environmental impacts;
 - + Severe disruption to established communities;
 - + Severe disproportionate impacts to minority or low income populations; or
 - + Severe impacts to environmental resources protected under other Federal statutes;
 - It results in additional construction, maintenance, or operational costs of an extraordinary magnitude;
 - It causes other unique problems or unusual factors; or
 - It involves multiple factors prudence, defined above, that while individually minor, cumulatively cause unique problems or impacts of extraordinary magnitude.
5. Historic Site. For purposes of 23 CFR 774, the term “historic site” includes any prehistoric or historic district, site, building, structure, or object included in, or eligible for inclusion in, the National Register. The term includes properties of traditional religious and cultural importance to an Indian Tribe that are included in, or are eligible for inclusion in, the National Register.
6. Individual Section 4(f) Evaluation. Documentation prepared when a project requires the use of a Section 4(f) property that is greater than *de minimis* and a Programmatic Section 4(f) Evaluation cannot be applied to the situation.
7. Official(s) with Jurisdiction (OWJ).
- a. In the case of historic properties, the OWJ is the State Historic Preservation Officer (SHPO) for the State wherein the property is located. When the Advisory Council on Historic Preservation (ACHP) is involved in a consultation concerning a property under Section 106 of the National Historic Preservation Act (NHPA), the ACHP is also an OWJ over that resource for purposes of 23 CFR 774. When the Section 4(f) property is a National Historic Landmark, the National Park Service is also an OWJ over that resource for purposes of 23 CFR 774.

- b. In the case of public parks, recreation areas, and wildlife and waterfowl refuges, the OWJ(s) is the official(s) of the agency or agencies that own or administer the property in question and who is empowered to represent the agency on matters related to the property.
- c. In the case of portions of Wild and Scenic Rivers to which Section 4(f) applies, the OWJ(s) is the official(s) of the Federal agency or agencies that own or administer the affected portion of the river corridor in question. For state administered, Federally designated rivers, the OWJ includes both the state agency designated by the respective Governor and the Secretary of the Interior.

Note: As of June 2022, Illinois has only one designated Wild and Scenic River, which is a 17.1-mile stretch of the Middle Fork Vermilion River in Vermilion County.

8. Programmatic Section 4(f) Evaluation. A time-saving procedural option for preparing an individual Section 4(f) evaluation for certain minor uses of Section 4(f) property. FHWA has approved five programmatic evaluations for use nationwide. Through applying a specific set of criteria, the evaluation of avoidance alternatives is standardized and simplified.
9. Section 4(f) Property or Resource. Publicly owned land of a public park, recreation area, or wildlife and waterfowl refuge of national, State, or local significance, or land of an historic site (regardless of ownership) of national, State, or local significance.
10. Significant. For the purposes of Section 4(f), the term “significant” means comparing the availability and function of the park, recreation area, or wildlife and waterfowl refuge, with the park, recreation or refuge objectives of the agency, community or authority, the property in question plays an important role in meeting those objectives.
11. Use. Except as set forth in 23 CFR 774.11 (Applicability) and 23 CFR 774.13 (Exceptions), a “use” of Section 4(f) property occurs when:
 - Land is permanently incorporated into a transportation facility;
 - There is a temporary occupancy of land that is adverse in terms of the statute’s preservation purposes as determined by the criteria in 23 CFR 774.13(d); or
 - There is a constructive use of a Section 4(f) property as determined by the criteria in 23 CFR 774.15.

Permanent Use. Occurs when land from a Section 4(f) priority is either purchased outright as a transportation right-of-way or when the applicant for Federal-aid funds has acquired a property interest that allows permanent access onto the property such as a permanent easement.

Temporary Use. A temporary occupancy of land that does not meet the exception criteria set forth in 23 CFR 774.15(d). The property is not permanently incorporated into a

transportation facility, but the activity is considered to be adverse in terms of the preservation purpose of Section 4(f).

26-2.03(b) Applicability and Exceptions

References:

Applicability, 23 CFR 774.11

Exceptions, 23 CFR 774.13

FHWA Section 4(f) Policy Paper, July 20, 2012

Section 4(f) applies only to agencies within the US Department of Transportation (U.S. DOT) (e.g., Federal Highway Administration (FHWA), Federal Transit Administration, Federal Aviation Administration, Federal Railroad Administration) and only to projects that involve a U.S. DOT action, such as Federal-aid funding, Interstate Access approval, or NEPA approval. Where such funding approvals are involved for highway projects initiated by the Department, FHWA will determine applicability of Section 4(f).

The Interstate System is not considered to be a historic site subject to Section 4(f), with the exception of those individual elements formally identified by FHWA for Section 4(f) protection on the basis of national or exceptional historic significance.

26-2.03(c) Steps to Determine Section 4(f) Applicability and Evaluation

26-2.03(c)1 *The following are five steps to determine if Section 4(f) is applicable to a property in the project area. More detail is given below for each step.(Step 1) Gather Information*

Multiple factors contribute to determining whether a property is afforded protection as a Section 4(f) resource and, if so, which evaluation is appropriate for the resource. The following items may need to be obtained to determine appropriate applicability of Section 4(f) for a project:

- US DOT involvement (e.g., Federal-aid funding, Interstate Access approval, NEPA approval)
 - + If there is no US DOT involvement, Section 4(f) does not apply.
- Official designations (i.e., by a Federal, state, or local agency) as a park, recreation area, or refuge
- OWJ(s) of resources and potential resources (e.g., school playgrounds, golf course)
- Property ownership, including leasing arrangements
- Property boundaries
- Public accessibility
- Existing and planned comprehensive and management plans
- Proposed project scope (e.g., roadway or non-roadway)
- Proposed project duration
- Proposed ROW needs (i.e., acquisition, permanent easement, temporary easement)
- Anticipated NEPA processing (i.e., CE, EA, EIS)

This list is not comprehensive, and additional information may be needed throughout the remaining steps.

26-2.03(c)2 *(Step 2) Identify Parks, Recreations Areas, Wildlife and Waterfowl refuges, and Historic Sites*

Parks, Recreation Areas, Wildlife and Waterfowl Refuges

In order for a park, recreation area, and wildlife and waterfowl refuge to be a Section 4(f) resource all four criteria must be true:

1. Criterion 1 – Publicly Owned

Owned or leased by a unit of public government (e.g., Federal, state, city, village, county, township, or local parks authority) and designated as a park, recreation area, or wildlife and waterfowl refuge;

“Publicly owned” includes situations where the facility/land is privately owned, but a public agency has a long-term interest (lease, permit) as determined by FHWA.

2. Criterion 2 – Open to the General Public

The general public is permitted access at any time when the property is open;

Publicly owned wildlife and waterfowl refuges are considered open to the public to the extent that public access does not interfere with the primary purpose of the refuge (e.g., public access may be restricted to preserve or protect wildlife and waterfowl during certain seasons or at certain locations within the refuge).

3. Criterion 3 – Major Purpose

Clearly established, used, and managed as a park, recreation area, or wildlife and waterfowl refuge;

Incidental, secondary, and occasional uses or dispersed park, recreational, or refuge activities do not constitute a major purpose;

The OWJ determined/designated its major purpose a park, recreation area, or wildlife and waterfowl refuge.

4. Criterion 4 – Significant

A public park, recreation area, or wildlife and waterfowl refuge must be a significant property. For the purposes of Section 4(f), the term significant means that in comparing the availability and function of the park, recreation area or wildlife and waterfowl refuge, with the park, recreation or refuge objectives of the agency, community or authority, the property in question plays an important role in meeting those objectives. Except for certain multiple-use land holdings, significance determinations are applicable to the entire property and not just to the portion of the property proposed for use by a project.

Significance determinations are made by OWJ(s) over the property, and the meaning significance should be explained if the OWJ(s) is not familiar with Section 4(f). Management plans or other official forms of documentation are important when determining significance.

If a determination from the OWJ(s) cannot be obtained, and a management plan that addresses significance is not available, the property will be presumed to be significant. All significance determinations are subject to review by FHWA.

EXAMPLES: All park- and recreation-type properties need to be assessed against the four criteria to determine Section 4(f) applicability. The following example properties can be unclear. Additional research and consideration may be required to determine if the four criteria are true and accurately determine applicability.

- School playgrounds – While the primary purpose of a public school playgrounds is generally for structured physical education classes and recreation for students, these properties may also serve significant public recreational purposes. When a public school playground serves only school activities and functions, the playground is not considered a Section 4(f) resource. When a public school playground is open to the public and serves either organized or substantial walk-on recreational purposes that are determined to be significant (Criterion 4), it is considered Section 4(f) resource.

The term playground refers to the area of the school property developed and/or used for public park or recreation purposes, such as baseball diamonds, soccer fields, tennis courts, track and field facilities, and other features such as jungle gyms or swing sets. This can also include open space or practice fields if those areas serve primarily as a park or recreation function. Section 4(f) would apply only to the playground areas and not to the entire campus, unless the campus is also a significant historic site.

- Shared use paths and trails – Certain trail types are excepted from the requirement for Section 4(f) approval.
- Public golf courses – Golf courses that are owned, operated and managed by a public agency for the primary purpose of public recreation and are determined to be significant are Section 4(f) resources. Section 4(f) does not apply to privately owned and operated golf courses, even when they are open to the general public. Golf courses that are owned by a public agency, but managed and operated by a private entity, may still be Section 4(f) resources depending on the structure of the management agreement.

The fact that green fees or reservations (tee times) may be required by a facility does not alter the Section 4(f) resource identification, as long as the standards of public ownership (Criterion 1), public access (Criterion 2), and significance (Criterion 4) are met.

If a golf course is on or eligible for listing in the NRHP, then the requirements for public ownership (Criterion 1) and public access (Criterion 2) do not apply because a historic site afforded Section 4(f) protections may be privately or publicly owned.

- Museums, Aquariums, and Zoos – Publicly owned museums, aquariums, and zoos generally are not considered parks, recreational areas, or wildlife and waterfowl refuges and are therefore not Section 4(f) resources, unless they are significant historic sites. If the facility offers additional park or recreational opportunities, it will need to be evaluated on a case-by-case basis to determine the primary purpose of the resource.
- Fairgrounds – Publicly owned fairgrounds that function primarily for commercial purposes (e.g., stock car races, horse racing, county or state fairs), rather than as park or recreation areas, are not Section 4(f) resources. When fairgrounds are open to the public and function primarily for public recreation other than an annual fair, Section 4(f) applies only to those portions of land determined significant for park or recreational purposes, unless they are significant historic sites.
- Cemeteries – Cemeteries would only be considered Section 4(f) resources if they are determined to be on or eligible for the NRHP as historic sites deriving significance from association with historic events, from age, from the presence of graves of persons of transcendent importance, or from distinctive design features.
- Planned Section 4(f) Resources – Section 4(f) applies when the public agency that owns the property has formally determined and designated its future function to be significant for park, recreation area, or wildlife and waterfowl refuge purposes. Evidence of formal designation would be the inclusion of the publicly owned land and its function as a Section 4(f) property into a city or county Master Plan, for example. A mere expression of interest or desire is not sufficient.

When privately owned properties of this type are formally designated into a Master Plan for future park development, Section 4(f) is not applicable because the property is not publicly owned (Criterion 1).

When a planned facility is presently publicly owned (Criterion 1), presently formally-designated for future Section 4(f) purposes, and presently significant (Criterion 4), it is considered a Section 4(f) resource.

Historic Sites.

In order for a historic site to be a Section 4(f) resource, all of the following must be true:

- Publicly or privately owned regardless of whether it is open to the public;
- Significant nationally, to a state, locally, or to a community;

- Individually eligible for or listed in the National Register of Historic Places (NRHP) in accordance with the Section 106 process; however, a historic site of local historical significance ineligible for or on the NHRP may be a Section 4(f) resource. FHWA makes the determination based on information formally provided by an official indicating its local significance;
- If the historic site is an archeological site, then the site must warrant preservation in place, including sites discovered during construction.

Note: FHWA has the final determination regarding Section 4(f) applicability of all sites and should be consulted with questions and for confirmation regarding the identification of Section 4(f) resources.

26-2.03(c)3 *(Step 3) Determine “Use”*

If a Section 4(f) resource was identified, determine if there will be a “use” or if the “use” qualifies as an exception.

“Use” of a Section 4(f) property occurs when:

- Land is permanently incorporated into a transportation facility;
- There is a temporary occupancy of land that is adverse in terms of the statute’s preservation purposes (23 CFR 774.13(d)), or;
- There is a constructive use of a Section 4(f) property (23 CFR 774.15).

Note: FHWA has the final determination regarding Section 4(f) applicability and should be consulted with questions and for confirmation regarding the identification of Section 4(f) uses.

26-2.03(c)4 *(Step 4) Screen for Applicability of Exceptions*

Seven exceptions to the requirement of Section 4(f) approval have been identified by the FHWA. Specific criteria for meeting and documenting each exception are identified in 23 CFR 774.13 (a)-(g) and must be adhered to:

(a) Use of historic transportation facilities in certain circumstances (23 CFR 774.13(a));

- (1) Common post-1945 concrete or steel bridges and culverts that are exempt from individual review under Section 106;
- (2) Improvement of railroad or rail transit lines that are in use or were historically used for the transportation goods or passengers, except for: 1-stations, 2-Abandoned bridges or tunnels on railroad lines, and 3-Historic sites unrelated to the railroad or rail transit lines; and
- (3) Maintenance, preservation, rehabilitation, operation, modernization, reconstruction, or replacement if FHWA concludes the work will not adversely affect the historic qualities of the facility and the OWJ does not object to the conclusion.

- (b) Archeological sites that are on or eligible for the National Register when the FHWA concludes the resource is important chiefly because of what can be learned by data recovery and preservation in place has minimal value and the OWJ does not object with the conclusion (23 CFR 774.13(b));
- (c) Designations of park and recreation lands, wildlife and waterfowl refuges, and historic sites that are made, or determinations of significance that are changed, late in the development of a proposed action (23 CFR 774.13(c));
- (d) Temporary occupancies of land are so minimal as to not constitute a use within the meaning of Section 4(f) (23 CFR 774.13(d)). The following five conditions must be satisfied:
 - (1) Duration must be temporary (i.e., less than the time needed for construction of the project) and there should be no change in ownership of the land;
 - (2) Scope of the work must be minor (i.e., both the nature and the magnitude of the changes to the Section 4(f) property are minimal);
 - (3) There are no anticipated permanent adverse physical impacts, nor will there be interference with the protected activities, features, or attributes of the property, on either a temporary or permanent basis;
 - (4) The land being used must be fully restored (i.e., the property must be returned to a condition which is at least as good as that which existed prior to the project); and
 - (5) There must be documented agreement of the OWJ(s) over the Section 4(f) resource regarding the above conditions.
- (e) Projects for the Federal lands transportation facilities described in 23 U.S.C. 101(a)(8) (23 CFR 774.13(e));
- (f) Certain trails, paths, bikeways, and sidewalks, in the following circumstances (23 CFR 774.13(f)):
 - (1) Trail-related projects funded under the Recreational Trails Program, 23 U.S.C. 206(h)(2);
 - (2) National Historic Trails and the Continental Divide National Scenic Trail;
 - (3) Trails, paths, bikeways, and sidewalks that occupy a transportation facility right-of-way without limitation to any specific location within that right-of-way, so long as the continuity of the trail, path, bikeway, or sidewalk is maintained;
 - (4) Trails, paths, bikeways, and sidewalks that are part of the local transportation system and which function primarily for transportation;

- a. During early consultation, it should be determined whether or not a management plan exists that addresses the primary purpose of the facility in question;
- (g) Transportation enhancement activities, transportation alternatives projects, and mitigation activities, where (23 CFR 774.13(g)):
 - (1) The use of the Section 4(f) property is solely for the purpose of preserving or enhancing an activity, feature, or attribute that qualifies the property for Section 4(f) protection; and
 - (2) The OWJ(s) over the Section 4(f) resource agrees in writing to paragraph (g)(1) of this section.

If an exception is not applicable, screen the use of the Section 4(f) resource for *de minimis* applicability.

26-2.03(c)5 (Step 5) Screen for *de minimis* applicability

In cooperation with FHWA, the district considers any avoidance, minimization, and mitigation or enhancement measures incorporated into the project and evaluates whether the impact to the Section 4(f) resource, resulting from the proposed use, may be considered *de minimis*.

If it is determined that the impact is *de minimis*, no further alternatives analysis is required for FHWA to approve use of the Section 4(f) resource.

De minimis impact determinations must be made for each Section 4(f) property and not for a project in its entirety. The impacts and impact avoidance, minimization, and mitigation or enhancement measures must be considered on an individual resource basis. When there are multiple resources for which *de minimis* impact determinations are appropriate, however, the procedural requirements of Section 4(f) can and should be completed in a single process, document and circulation, so long as it is clear that distinct determinations are being made. Also in these cases, the written concurrence of the OWJ(s) may be provided for the project as a whole, so as long as the *de minimis* impacts determinations have been made on an individual resource basis.

If *de minimis* is not applicable, screen the use of the Section 4(f) resource for applicability of a Nationwide Section 4(f) Programmatic Evaluation.

i. *De minimis* impact processing

The district and FHWA evaluate applicability of a *de minimis* impact determination. If applicable, the district obtains FHWA concurrence to pursue a *de minimis* impact determination at a district coordination meeting, via e-mail or phone.

The district initiates coordination with the OWJ(s). For historic properties, the State Historic Preservation Officer (SHPO) is the OWJ. For parks, recreation areas, or wildlife and waterfowl refuges, the OWJ is the agency/agencies that own or manage the property.

ii. *De minimis* impact coordination requirements

The *de minimis* impact coordination requirements for historic properties differ slightly from those for parks, recreation areas, and wildlife and waterfowl refuges (23 CFE 774.5(b)).

For historic sites, the following coordination requirements must be met:

- FHWA considers the views of any consulting parties participating in the National Historic Preservation Act Section 106 consultation (see Chapter 26-5);
- The Section 106 process results in a determination of either "no adverse effect" or "no historic properties affected"; the notification letter from IDOT of the Section 106 effect determination includes notice that FHWA will make a *de minimis* impact determination based on SHPO's concurrence; and the SHPO concurs with the Section 106 effect finding in writing.

For publicly owned public parks, recreation areas, or wildlife and waterfowl refuges, the following criteria must be met:

- FHWA informs the OWJ(s) of its intent to make a *de minimis* impact determination;
- The public is afforded notice and opportunity to review and comment concerning the project's effects on the protected activities, features, or attributes of the Section 4(f) resource;
 - + This requirement can be satisfied in conjunction with other public involvement procedures for the project (e.g., a public hearing, public meeting) and/or through other sufficient activities specifically to seek Section 4(f) public involvement (e.g., website, social media, and newspaper notices seeking comments). A formal meeting is not required;
- Following the public comment period, the OWJ(s) concurs in writing that the project will not adversely affect the activities, features, or attributes that make the resource eligible for Section 4(f) protection.

If the OWJ(s) does not agree with the assessment of impacts, the district is encouraged to work with the OWJ(s) to seek ways to reduce the impacts Section 4(f) resource so the OWJ(s) can concur with a *de minimis* impact determination.

If any of the coordination requirements cannot be met, *de minimis* is not applicable, and the 4(f) use needs to be screened for applicability of a Nationwide Section 4(f) Programmatic Evaluation.

If the coordination requirements are met, the district coordinates with FHWA and formally documents the *de minimis* impact determination .

iii. *De minimis* impact determination documentation

A *de minimis* impact determination shall include sufficient supporting documentation to demonstrate that the impacts, after avoidance, minimization, mitigation, or enhancement

measures are taken into account, are *de minimis*. Accordingly, the district must prepare documentation in accordance with the checklist format below to ensure FHWA has sufficient information to make a *de minimis* determination on a proposed use of a Section 4(f) resource.

Format of *de minimis* Documentation:

1. Project Description.
 - Project number (e.g., State, Federal, Section number);
 - Official project name;
 - Project location (e.g., roadway designations, termini);
 - Project type (e.g., new alignment, widening, safety improvement);
 - Project size (e.g., total project length in miles);
 - NEPA Class of Action (i.e., Categorical Exclusion, Environmental Assessment, or Environmental Impact Statement);
 - Purpose and Need Summary; and
 - Project status.
2. Section 4(f) Resource.
 - Resource type (e.g., historic property, park, recreation area, wildlife/waterfowl refuge);
 - Resource name;
 - Official(s) with jurisdiction (OWJ) name; and
 - Description of role/significance in the community.
3. Description of Intended Section 4(f) Resource Use.
 - Acres (ha) to be taken and/or impacted (used);
 - Type of impact (e.g., right-of-way acquisition, permanent incorporation/change in ownership, perpetual easement);
 - Existing function of impacted areas;
 - Relationship of impacted areas to Section 4(f) function and significance to resource; and
 - Resulting function of impacted areas.
4. Description of Efforts to Avoid, Minimize, and Mitigate or Enhance Resource.
 - Avoidance and minimization efforts made and benefits to the resource; and
 - Commitments for mitigation or enhancement.
5. Evidence of Opportunity for Public Review and Comment.
 - Type of public availability (e.g., internet posting, public meeting, mailers);
 - + The notice of the opportunity for public involvement must include at a minimum a description of the project and Section 4(f) resource, and language to the effect that “this is an opportunity for the public

to review and comment on the effects of the project on the activities, features, and attributes that qualify (**Name of Section 4(f) Resource**) for protection under Section 4(f).

- Date of action;
 - Summary of comments; and
 - Notification to OWJ of public availability and summary of comments.
6. Evidence of Coordination with OWJ.
- Meeting minutes and agendas;
 - Correspondence; and
 - OWJ written concurrence with a “No Adverse Effect” determination.
 - + Written concurrence must explicitly state “concur with a determination that there will be no adverse effect” to the resource. The concurrence cannot predate the completion of public involvement for the *de minimis* impact determination.
7. Supporting Documentation.
- Map of project area indicating relationship of project to resource; and
 - Supporting photographs of resource.
8. Written Request for FHWA to Make a *De Minimis* Impact Determination.
- Formal statement that IDOT has determined there will be no adverse effect and that the OWJ(s) concurs with this determination; and
 - Format requested for FHWA determination .

iv. *De minimis* impact determination and environmental class of action

While the general process for FHWA to make a *de minimis* impact determination will be consistent, the steps may vary depending on the environmental Class of Action (i.e., Categorical Exclusion, Environmental Assessment, or Environmental Impact Statement). Steps for the three classes are as follows:

1. Categorical Exclusions (CE). The district will submit to the appropriate FHWA Transportation Engineer the completed *de minimis* impact determination for review. The FHWA Transportation Engineer will review within 30 days and coordinate with the Department to obtain additional documentation or information if required. If the *de minimis* impact determination documentation is sufficient and FHWA concludes that the *de minimis* impact determination is appropriate, then the FHWA Transportation Engineer may formally make the *de minimis* impact determination and document via e-mail with the following statement:

*(**Name of Project**) will result in the use of (**Name of Resource**), a Section 4(f) resource. FHWA hereby makes a de minimis impact determination for this use as it will not adversely affect this resource’s activities, features, and attributes. The de minimis impact determination*

*is based on the impact avoidance, minimization, and mitigation or enhancement measures detailed in the documentation submitted on (**Date**).*

The *de minimis* impact determination documentation shall a part of the project report.

2. Environmental Assessment (EA)/Finding of No Significant Impact (FONSI). Documentation supporting a *de minimis* impact determination will be included in the EA under the Section 4(f) discussion. If all required *de minimis* impact coordination and public involvement is complete prior to approval of the EA, evidence of this will be included in the appendix of the EA. If any required *de minimis* impact coordination and public involvement occurs after the EA is approved, include evidence of this coordination and/or public involvement and any additional commitments with the FONSI request.

The FHWA Transportation Engineer, in consultation with the BDE Location and Environment Section, will evaluate the documentation during the review of the EA or FONSI. The FHWA Transportation Engineer will coordinate with the strict office to obtain additional documentation or information if required. If the *de minimis* impact determination documentation is sufficient and FHWA concludes that the *de minimis* impact determination is appropriate, then the FHWA Transportation Engineer may formally make the *de minimis* impact determination will be documented in the FONSI with the following statement:

*(**Name of Project**) will result in the use of (**Name of Resource**), a Section 4(f) resource. FHWA hereby makes a de minimis impact determination for this use as it will not adversely affect this resource's activities, features, and attributes. The de minimis impact determination is based upon the impact avoidance, minimization, and mitigation or enhancement measures detailed in the attached Environmental Assessment.*

3. Environmental Impact Statement (EIS)/Record of Decision (ROD). Documentation supporting a *de minimis* impact determination will be included in the FEIS under the Section 4(f) discussion. The complete *de minimis* impact determination documentation, including evidence of the opportunity for public involvement, will be included in the appendix of the FEIS. The *de minimis* impact determination will be made in the ROD. If coordination and additional commitments occur after FHWA approves the FEIS, evidence of the coordination and commitments will be sent to FHWA with the draft ROD. The FHWA Transportation Engineer, in consultation with the BDE Location and Environment Section, will evaluate the documentation during the review of the FEIS or ROD. The FHWA Transportation Engineer will coordinate with the district office to obtain additional documentation or information if required. If the *de minimis* impact determination documentation is sufficient and FHWA concludes that the *de minimis* impact determination is appropriate, the *de minimis* impact determination will be documented in the ROD with the following statement:

*(**Name of Project**) will result in the use of (**Name of Resource**), a Section 4(f) resource. FHWA hereby makes a de minimis impact determination for this use as it will not adversely affect this resource's activities, features, and attributes. The de minimis impact determination is based upon the impact avoidance, minimization, and mitigation or enhancement measures detailed in the Environmental Impact Statement*

26-2.03(c)6 Screen for Nationwide Section 4(f) Programmatic Evaluation applicability

The conditions for applicability of the programmatic Section 4(f) evaluations relate to the type of project, severity of impacts to Section 4(f) resource, evaluation of alternatives, establishment of a procedure for minimizing harm to the Section 4(f) resource, adequate coordination with appropriate entities, and NEPA class of action. There are five approved Nationwide Section 4(f) Programmatic Evaluations:

1. "Programmatic Section 4(f) Evaluation and Approval for FHWA Projects that Necessitate the Use of Historic Bridges."
2. "Final Nationwide Section 4(f) Evaluation and Approval for Federally-Aided Highway Projects with Minor Involvements with Public Parks, Recreation Lands, and Wildlife and Waterfowl Refuges."
3. "Final Nationwide Section 4(f) Evaluation and Approval for Federally-Aided Highway Projects with Minor Involvements with Historic Sites."
4. "Section 4(f) Statement and Determination for Independent Bikeway or Walkway Construction Projects."
5. "Section 4(f) Evaluation and Approval for Transportation Projects That Have a Net Benefit to a Section 4(f) Property."

Procedures for documentation and approval are outlined in each Nationwide Section 4(f) Programmatic Evaluation in Appendix A.

Note: If a Nationwide Section 4(f) Programmatic Evaluation is not applicable, an Individual Section 4(f) Evaluation must be prepared.

26-2.03(c)7 Prepare an Individual Section 4(f) Evaluation

The Section 4(f) evaluation documentation shall include:

- description of the proposed action, including a concise statement of the project purpose and need (When a Section 4(f) evaluation is being done as part of an Environmental Impact Statement (EIS) or Environmental Assessment (EA), the corresponding section of the NEPA document can be referenced);
- description of the Section 4(f) resource;
- description of the alternatives, including avoidance alternatives;

- description of impacts;
- discussion of mitigation measures;
- discussion of coordination activities; and
- documentation of coordination with the OWJ(s).

The following paragraphs describe the preparation and processing of individual Section 4(f) evaluations.

For Parks, Recreation Areas and Wildlife/Waterfowl Refuges:

1. The district prepares a draft Section 4(f) evaluation and coordinates it with FHWA and BDE for review and comment. After addressing FHWA and BDE comments, the district electronically submits a copy of the signature-ready draft evaluation to FHWA.
2. FHWA electronically signs the cover sheet of the draft Section 4(f) evaluations and returns to BDE. BDE coordinates the signed draft with the district. The district provides an electronic copy of the draft evaluation to FHWA. FHWA distributes the draft evaluation to the US Department of the Interior, the US Department of Agriculture, and the US Department of Housing and Urban Development, as applicable, for review and comment. The district provides the draft evaluation for review and comment to the owner(s) of the Section 4(f) resource and, if applicable, other State/local OWJ(s). The recipients of the draft evaluation have 45 days to comment.
3. The district and FHWA coordinate to evaluate the comments received and incorporate appropriate revisions in the final Section 4(f) evaluation. The district submits a preliminary final evaluation to FHWA and BDE for review and comment.
4. The district addresses FHWA and BDE comments and submits an electronic copy of the signature-ready final evaluation to FHWA.
5. FHWA submits the signature-ready final evaluation to FHWA legal counsel for a 30-day legal sufficiency review. FHWA provides comments from the legal sufficiency review to BDE for coordination with the district. The district incorporates changes as necessary to address the comments and submits an electronic copy of the final evaluation to FHWA for signature.
6. FHWA signs the cover sheet of the final evaluation and returns a copy to BDE. BDE coordinates the signed final evaluation with the district. The district provides FHWA with an electronic link of the signed final evaluation for distribution to Federal agencies. The district provides the signed final evaluation to the owner(s) of the Section 4(f) resource and, as applicable, to other State/local OWJ(s).

For Historic Properties:

The Section 4(f) process for historic properties is essentially the same as that for parks, recreation areas, and wildlife and waterfowl refuges; except that a Section 106 Memorandum of Agreement (MOA) must be completed before the final evaluation is approved. The MOA, signed by all parties involved in the Section 106 process, must be included in the final Section 4(f) evaluation. It also may be included in the draft evaluation if it has been signed at that time.

Note that BDE review of Section 4(f) evaluations for Federal Approved CE projects is not required ~~except when the 4(f) evaluation is included in combined Section 106/4(f) documentation.~~ Provide

Section 4(f) evaluations to BDE for review when they are associated with EA or EIS projects and/or when they are combined with Section 106 compliance documentation.

26-2.04 References

1. Parks, Recreation Areas, Wildlife and Waterfowl Refuges, and Historic Sites (Section 4(f)), 23 CFR 774
2. FHWA Technical Advisory T6640.8A "Guidance for Preparing and Processing Environmental and Section 4(f) Documents", October 30, 1987
3. FHWA Section 4(f) Policy Paper, July 20, 2012
4. Programmatic Section 4(f) Evaluations:
 - Programmatic Section 4(f) Evaluation and Approval for FHWA Projects that Necessitate the Use of Historic Bridges
 - Final Nationwide Section 4(f) Evaluation and Approval for Federally-Aided Highway Projects With Minor Involvements With Public Parks, Recreation Lands, and Wildlife and Waterfowl Refuges
 - Final Nationwide Section 4(f) Evaluation and Approval for Federally-Aided Highway Projects With Minor Involvements With Historic Sites
 - Section 4(f) Evaluation and Approval for Transportation Projects That Have a Net Benefit to a Section 4(f) Property
 - Programmatic Section 4(f) Statement for Independent Bikeway or Walkway Construction Projects

26-3 SECTION 6(F) LAND CONVERSION REQUEST

26-3.01 Introduction

Special procedures are required when lands that have Land and Water Conservation (LAWCON) funds involved in their purchase or development, will be used for highway purposes. This Section discusses these procedures. Similar procedures may be required where lands are involved that have been improved or developed with funds under Section 1010 of the *Urban Park and Recreation Recovery Act* of 1978. There are few such sites in the State. Specific procedural requirements will be addressed on a case-by-case basis.

26-3.02 Legal Authority

16 U.S.C. 4601-8(f)(3), commonly known as Section 6(f) of the *Land and Water Conservation Fund Act* of 1965 (Public Law 88-578), requires that:

...No property acquired or developed with assistance under this section shall, without the approval of the Secretary, be converted to other than public outdoor recreation uses. The Secretary shall approve such conversion only if he finds it to be in accord with the then existing comprehensive Statewide outdoor recreation plan and only upon such conditions as he deems necessary to assure the substitution of other recreation properties of at least equal fair market value and of reasonably equivalent usefulness and location.

“Secretary” refers to the Secretary of the US Department of Interior. The authority to approve Section 6(f) land conversions has been delegated to the Regional Directors of the National Park Service (NPS).

The Illinois Department of Natural Resources (IDNR) publishes the Statewide Comprehensive Outdoor Recreation Plan (SCORP) for Illinois. The most recent plan is available on the IDNR website or may be requested from the IDNR Planning Division.

26-3.03 Policy

Special efforts will be made in the development of a project to identify and preserve public outdoor recreational areas and facilities.

26-3.04 Procedures

26-3.04(a) Applicability

Section 6(f) procedures will be followed for all projects initiated by the Department, regardless of project type or funding source.

26-3.04(b) Coordination

Early and ongoing coordination with the official having jurisdiction over the Section 6(f) land, the IDNR and the NPS Regional Director should be diligently pursued.

26-3.04(c) Report Requirements

When a project proposes use of land in which LAWCON funds have been involved in its purchase or development, Section 6(f) requires the approval of the Secretary of the Interior for the conversion of the land to other than public outdoor recreational use. Section 6(f) does not otherwise require a special report. Discuss involvement with the Section 6(f) land in the environmental documentation for the project and in any documentation for compliance with Section 4(f) (see Section 26-2) when the project involves the use of Section 6(f) land from a significant publicly owned public park, recreational area, or wildlife and waterfowl refuge.

For a State-only funded highway project involving Section 6(f) lands, information on the Section 6(f) involvement should be incorporated in the action's Phase I engineering report.

26-3.04(d) Conversion Request

Requests to convert LAWCON-assisted properties in whole or in part to other than public outdoor recreational uses must be submitted, in writing, through the IDNR to the appropriate NPS Field Director. NPS will consider the conversion request if the entity proposing the conversion (i.e., IDOT) has met the prerequisites described below. As applicable, districts should submit a request for Section 6(f) land conversion approval the IDNR Division of Grant Administration for submittal to the appropriate NPS Field Director. The district should submit the request after CE/FONSI/ROD approval and prior to design approval. Formal review periods for conversion requests are not specified in the regulation. IDNR has advised that the typical time frame for NPS response to conversion requests is 60 to 90 days.

The conversion request should include information to address each of the following points (i.e., based on information extracted from NPS regulations on compliance responsibilities for LAWCON-assisted properties; 36 CFR 59.3 "Conversion Requirements"):

1. Alternatives. All practical alternatives to the proposed conversion have been evaluated.
2. Value. The fair market value of the property to be converted has been established and the property proposed for substitution is of at least equal fair market value as established by an approved appraisal (i.e., prepared according to Uniform Federal Appraisal Standards), excluding the value of structures or facilities that will not serve a recreational purpose.
3. Replacement Property. The property proposed for replacement is of reasonably equivalent usefulness and location as that being converted. Depending upon the situation and at the discretion of the NPS Field Director, the replacement property does not need to provide identical recreational experiences or be located at the same site, provided it is

in a reasonably equivalent location. Generally, the replacement property should be administered by the same political jurisdiction as the converted property. Equivalent usefulness and location will be determined based on the following criteria:

- Property to be converted must be evaluated to determine what recreational needs are being fulfilled by the facilities, which exist, and the types of outdoor recreational resources and opportunities available. The property being proposed for substitution must then be evaluated in a similar manner to determine if it will meet the recreational needs that are at least similar in magnitude and impact to the user community as the converted site. This criterion is applicable in the consideration of all conversion requests with the exception of those where wetlands are proposed as replacement property. Wetland areas and interests therein which have been identified in the wetlands provisions of the Statewide Comprehensive Outdoor Recreation Plan shall be considered to be of reasonably equivalent usefulness with the property proposed for conversion regardless of the nature of the property proposed for conversion.
 - Replacement property need not necessarily be directly adjacent to or close to the converted site. This policy provides the administrative flexibility to determine a location recognizing that the property should meet existing public outdoor recreational needs. Although, generally, this will involve the selection of a site serving the same community(ies) or area as the converted site, there may be exceptions. For example, if property being converted is in an area undergoing major demographic change and the area has no existing or anticipated future need for outdoor recreation, then the district should seek to locate the substitute area in another location within the jurisdiction.
 - The acquisition of one parcel of land may be used in satisfaction of several approved conversions.
4. Eligibility Requirements. The property proposed for substitution must meet the eligibility requirements for LAWCON-assisted acquisition. The replacement property must constitute or be part of a viable recreational area. Unless *each* of the following additional conditions is met, land currently in public ownership, including that owned by another public agency, may not be used as replacement land for land acquired as part of a LAWCON project:
- The land was not acquired by IDOT or the selling agency for recreation.
 - The land has not been dedicated or managed for recreational purposes while in public ownership.
 - No Federal assistance was provided in the original acquisition unless the assistance was provided under a program expressly authorized to match or supplement LAWCON assistance.
 - Where IDOT acquires the land from another public agency, the selling agency must be required by law to receive payment for the land so acquired.

In the case of development projects for which the State match was not derived from the cost of the purchase or value of a donation of the land to be converted but from the value of the development itself, public land that has not been dedicated or managed for recreational/conservation use may be used as replacement land, even if this land is transferred from one public agency to another without cost.

5. Partial Conversion—Effect on Remainder. In the case of assisted sites that are partially rather than wholly converted, the impact of the converted portion on the remainder shall be considered. If such a conversion is approved, the unconverted area must remain recreationally viable or be replaced as well.
6. Coordination. All necessary coordination with other Federal agencies has been satisfactorily accomplished including, for example, compliance with Section 4(f) and NEPA.
7. Environmental Review. The guidelines for environmental evaluation have been satisfactorily completed and considered by NPS during its review of the proposed Section 6(f) action. Where the proposed conversion arises from another Federal action, final review of the State's proposal shall not occur until the NPS Regional Office is assured that all environmental review requirements including NEPA related to that other action have been met.
8. SCORP. The proposed conversion and substitution are consistent with the Statewide Comprehensive Outdoor Recreation Plan (SCORP) and/or equivalent recreational plans.

26-4 OSLAD LAND CONVERSION REQUEST

26-4.01 Introduction

Special procedures, similar to those applicable under Section 6(f), are required when lands that have Open Space Land Acquisition and Development (OSLAD) grant program funds involved in their purchase or development will be converted to other than public outdoor recreational uses.

26-4.02 Legal Authority

The OSLAD program is a State-funded grant program authorized by the *Open Space Lands Acquisition and Development Act*, 525 ILCS 35/1, *et seq.* The Illinois Administrative Code provisions for the OSLAD grant program (17 Ill. Adm. Code 3025) incorporate by reference essentially the same compliance procedures as required for the Land and Water Conservation Fund (LAWCON) Section 6(f) grant program; see Section 26-3. However, because the OSLAD program is State-funded, concurrence of the National Park Service is not required for proposed conversion of OSLAD-assisted lands to other than public outdoor recreational use.

26-4.03 Policy

Special effort shall be made in the development of a project to identify public outdoor recreational areas and to comply with applicable requirements when projects propose the conversion of such areas to other than public outdoor recreational use.

26-4.04 Procedures

The following procedures will apply:

1. Applicability. Compliance procedures for proposed conversion of OSLAD-assisted lands are applicable to all projects proposing such conversion, regardless of project type or funding source.
2. Coordination. Early and ongoing coordination with the official having jurisdiction over the OSLAD-assisted land and IDNR should be diligently pursued.
3. Report Requirements. When a project proposes the use of land in which OSLAD funds have been involved in its purchase or development, the IDNR Division of Grant Administration, in the Office of Architecture, Engineering and Grants, must approve conversion of the land to other than public outdoor recreational use; however, a special report is not required. Discuss involvement with the OSLAD-assisted land in the environmental documentation for the project and in any documentation for compliance with Section 4(f) (see Section 26-2) when the project would involve use of OSLAD-assisted land from a significant publicly owned park, recreational area, or wildlife and waterfowl refuge.

For a State-only funded highway project involving OSLAD-assisted lands, information on the involvement should be incorporated in the Phase I engineering report.

4. Conversion Request. Requests to convert OSLAD-assisted properties in whole or in part to other than public outdoor recreational uses must be submitted to the IDNR in writing. IDNR will approve conversions only upon the substitution of replacement property having equal fair market value and comparable outdoor recreational usefulness, quality, and location. As applicable, districts should submit a request for OSLAD land conversion approval to the IDNR Division of Grant Administration for review and approval. The district should submit the request prior to design approval. Formal review periods for conversion requests are not specified in the OSLAD regulation.

IDNR regulations do not specify information requirements for conversion requests; however, the information specified in the Section 6(f) requirements to support fair market value and comparable outdoor recreational usefulness, quality, and location (see Section 26-3.04(d)) should serve as a guide for the items to address in preparing OSLAD conversion requests.

26-5 HISTORIC ACT COMPLIANCE

26-5.01 Introduction

In the development of State highway projects, it is necessary to consider the effects of the undertaking on properties included in or eligible for inclusion in the *National Register of Historic Places* (NRHP) or included in the *Illinois Register of Historic Places* (IRHP). This Section describes the procedures for identifying historic resources, evaluating their significance, and assessing and addressing effects on those resources that meet the eligibility criteria for the NRHP or that are included in the IRHP.

26-5.02 Legal Authority

The following legal authority regulates or influences the policies and procedures for historic act compliance:

- 16 U.S.C. 470f, Section 106 of the *National Historic Preservation Act* of 1966, as amended,
- 16 U.S.C. 470h-2, Section 110(f) of the *National Historic Preservation Act* of 1966, as amended,
- Exec. Order No. 11593, Protection and Enhancement of the Cultural Environment (1971),
- 23 U.S.C. 138 and 49 U.S.C. 303, Section 4(f) of the *Department of Transportation Act* of 196,
- Protection of Historic Properties, 36 CFR 800,
- *The Illinois State Agency Historic Resources Preservation Act*, 20 ILCS 3420/1 *et seq.*,
- *The Illinois Historic Preservation Act*, 20 ILCS 3410/1 *et seq.*, and
- Rules for Review of State Agency Undertakings, 17 Ill. Admin. Code 4180.

Appendix C provides brief descriptions of each of the directives in the preceding list.

26-5.03 Policy

In the development of a proposed State highway project, appropriate measures shall be taken to evaluate the undertaking's effect on properties included in or eligible for inclusion in the NRHP and properties included in the IRHP. Where such properties will be affected, coordination will be initiated with consulting parties, as appropriate, including the Advisory Council on Historic Preservation (ACHP), in accordance with applicable Federal and State historic preservation directives. Special efforts will be made to minimize harm to any national historic landmark that may be directly and adversely affected by a proposed Federally funded/ regulated undertaking.

Throughout project development, avoidance of historic properties should be a priority.

26-5.04 Federal Requirements**26-5.04(a) Definitions**

1. Area of Potential Effects. The geographic area or areas within which an undertaking may directly or indirectly cause alterations in the character or use of historic properties, if any such properties exist. The area of potential effects is influenced by the scale and nature of an undertaking and may be different for different kinds of effects caused by the undertaking.
2. Comment. The findings and recommendations of the Council formally provided in writing to the head of a Federal agency under Section 106.
3. Consultation. The process of seeking, discussing, and considering the views of other participants and, where feasible, seeking agreement with them regarding matters arising in the Section 106 process.
4. Council. The ACHP or a Council member or employee designated to act for the Council.
5. Day or Days. Refers to calendar days.
6. Effect. Alteration to the characteristics of a historic property qualifying it for inclusion in or eligibility for the NRHP.
7. Historic Property. Any prehistoric or historic district, site, building, structure, or object included in or eligible for inclusion in the NRHP maintained by the Secretary of the Interior. This term includes artifacts, records, and remains that are related to and located within such properties. The term includes properties of traditional, religious, and cultural importance to an Indian Tribe and that meet the NRHP criteria. The term "eligible for inclusion in the National Register" includes both properties formally determined as such in accordance with regulations of the Secretary of the Interior and all other properties that meet the NRHP criteria.
8. Illinois State Archaeological Survey (ISAS). The entity that conducts all archaeological investigations for IDOT projects, in accordance with an intergovernmental agreement between IDOT and the University of Illinois at Urbana-Champaign.
9. Indian Tribe. An Indian Tribe, band, nation, or other organized group or community that is officially recognized by the US government.
10. Local Government. A city, county, parish, township, municipality, borough, or other general purpose political subdivision of a State.
11. Memorandum of Agreement. The document that records the terms and conditions agreed upon to resolve the adverse effects of an undertaking upon historic properties.
12. National Historic Landmark. A historic property that the Secretary of the Interior has designated a national historic landmark.

13. National Register. The NRHP maintained by the Secretary of the Interior.
14. National Register Criteria. The criteria established by the Secretary of the Interior for use in evaluating the eligibility of properties for the NRHP (36 CFR 60.4).
15. Programmatic Agreement. A document that records the terms and conditions agreed upon to resolve the potential adverse effects of a Federal agency program, complex undertaking, or multiple undertakings.
16. Senior Policy Official. The senior policy level official designated by the head of the lead Federal agency pursuant to Section 3(e) of Executive Order No. 13287.
17. State Historic Preservation Officer (SHPO). The official appointed or designated pursuant to Section 101(b)(1) of the *National Historic Preservation Act* to administer the State historic preservation program or a representative designated to act for the SHPO. The SHPO for Illinois is the Director of the State Historic Preservation Agency.
18. Undertaking. A project, activity, or program funded in whole or in part under the direct or indirect jurisdiction of a Federal agency, including those carried out by or on behalf of a Federal agency; those carried out with Federal financial assistance, and those requiring a Federal permit, license or approval.

26-5.04(b) Applicability

These procedures apply to all Federally funded/regulated highway project initiated by the Department that have the potential to cause effects on historic properties. See Chapter 20 of the *Bureau of Local Roads and Streets Manual* for historic act compliance procedures applicable to local highway projects.

26-5.04(c) Procedures

The following guidance reflects the assumption that FHWA, in most cases, will be the lead Federal agency for a project subject to the Section 106 requirements. If a different Federal agency is the lead (e.g., Corps of Engineers for a State-only funded project requiring a Section 404 permit), that agency would fulfill the functions indicated for FHWA. See the *AASHTO Practitioner's Handbook 06-- Consulting Under Section 106 of the National Historic Preservation Act*, February 2007, for additional guidance on the Section 106 process.

The steps in the Section 106 process will be coordinated, as appropriate, with the overall planning schedule for each project and with any reviews required under other authorities (e.g., the *National Environmental Policy Act* (NEPA), the *Native American Graves Protection and Repatriation Act*, the *Archaeological Resources Protection Act*, Section 4(f)). Where it is consistent with the Section 106 procedures, information developed for other reviews (e.g., NEPA) may be used to meet the requirements of Section 106.

Figure 26-5.A presents a flowchart that graphically illustrates the process for compliance with the Section 106 requirements. Following Figure 26-5.A are descriptions of the activities referenced within the flowchart.

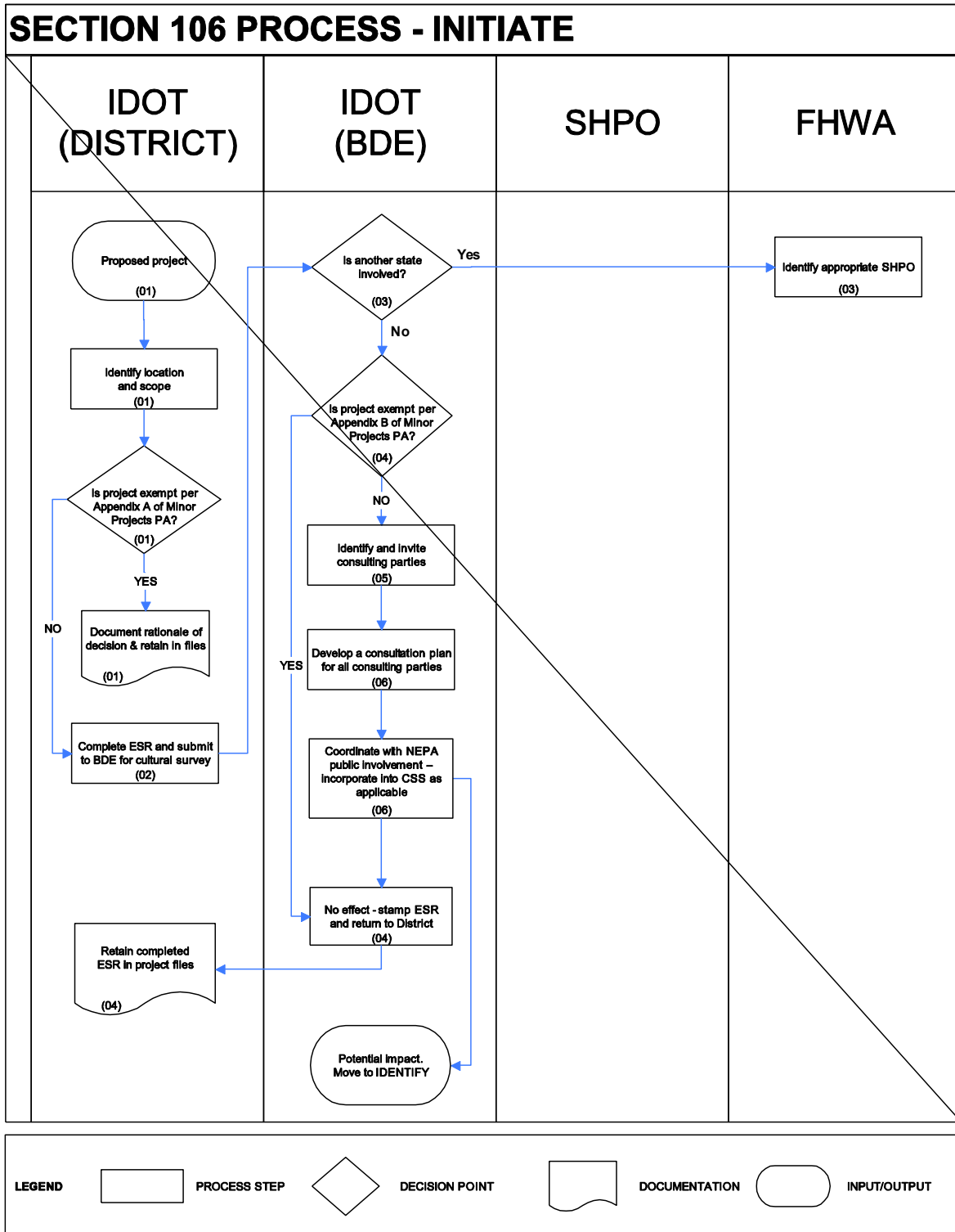

SECTION 106 PROCESS

Figure 26-5.A
(1 of 4)

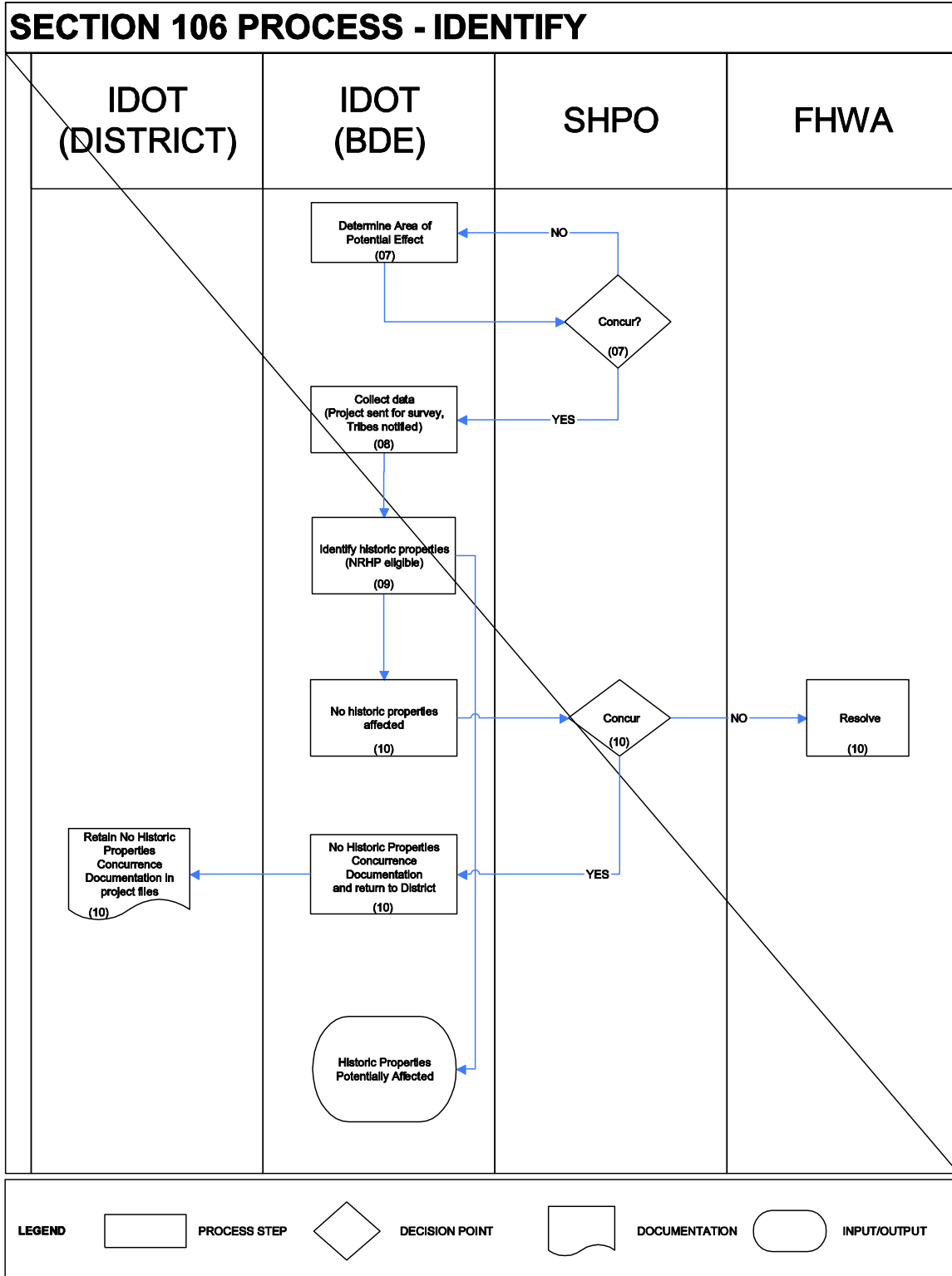

SECTION 106 PROCESS

Figure 26-5.A
(2 of 4)

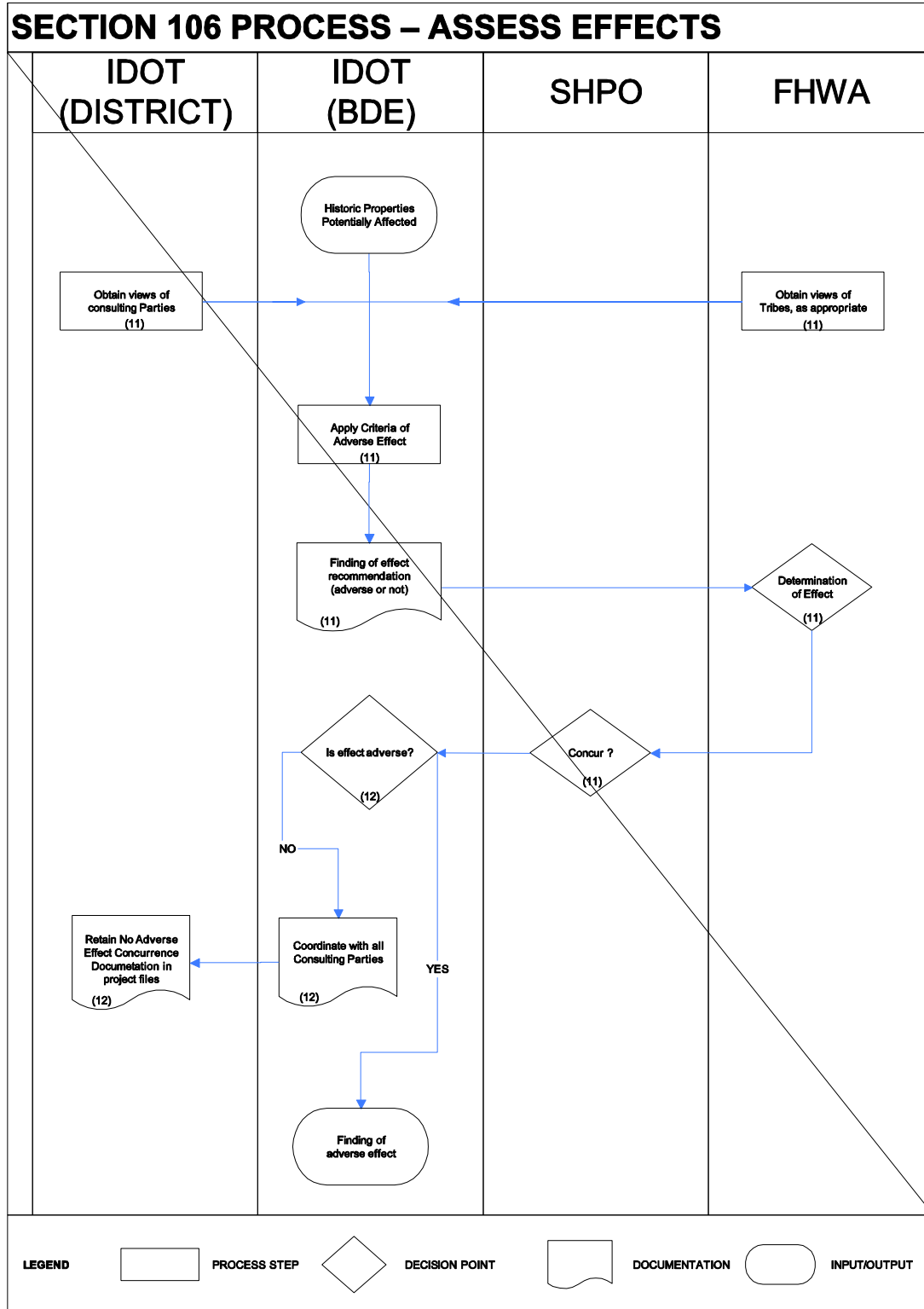

SECTION 106 PROCESS

Figure 26-5.A
(3 of 4)

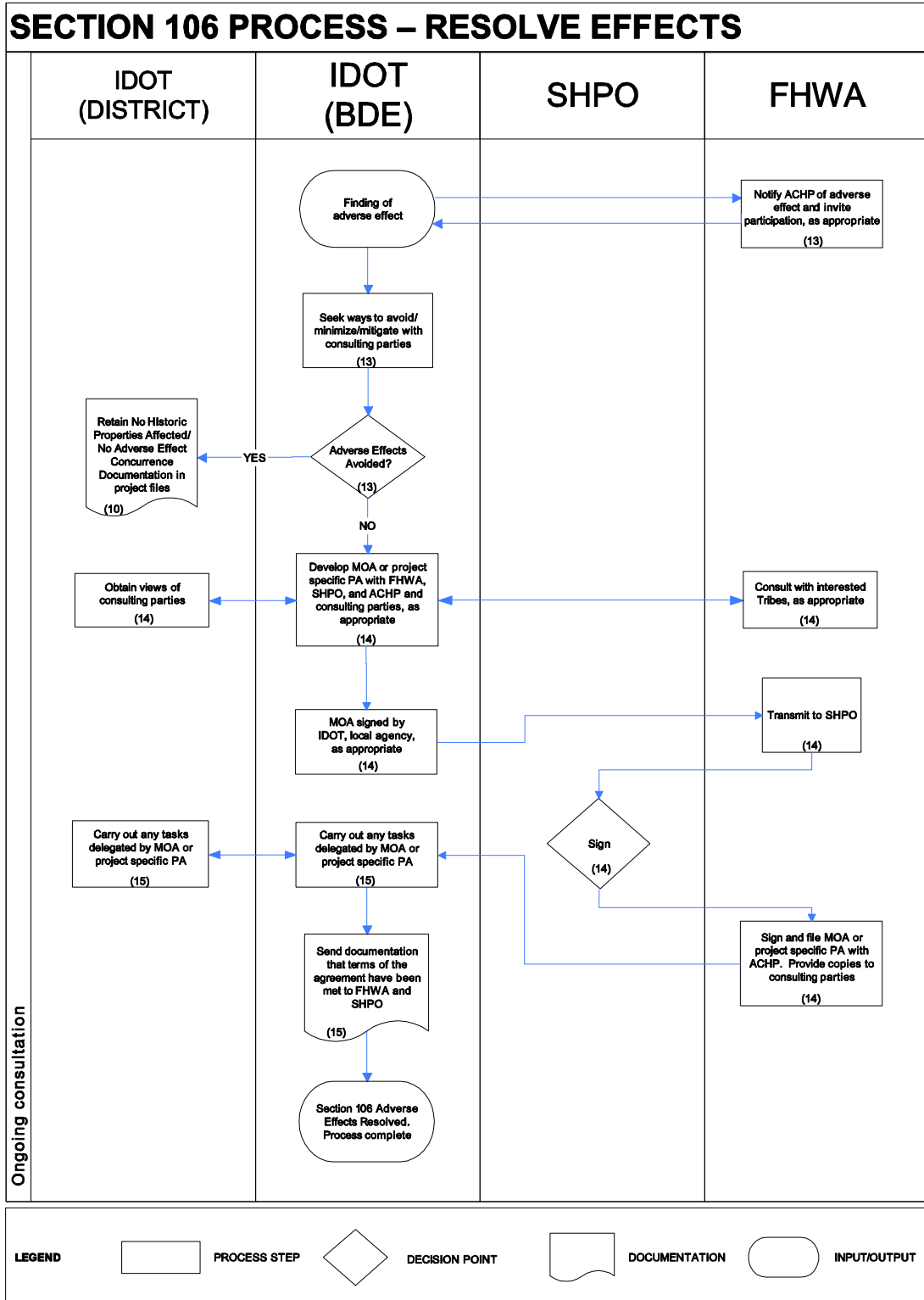

SECTION 106 PROCESS

Figure 26-5.A
(4 of 4)

PROJECT ACTIVITY

Activity Title: Identify Proposed Projects Potentially Subject to Section 106

Activity No.: 01

Responsible Unit: District

Activity Description:

For Categorical Exclusion (CE) projects, the district checks the exempt project list in Appendix A of the "Minor Projects Delegation Programmatic Agreement" (see Part III Appendix A) to determine if the project type is exempt from submittal to BDE. If the project is on the exempt list, the district documents, in the project file, that the project is on the exempt list and notes which number qualifies it as exempt, and no further action is required. If the district determines the project meets the criteria for Category A (Minor Projects Requiring No Review by IDOT Cultural Resources Staff) in the Programmatic Agreement for Minor Projects Delegation (see Part III Appendix A), the district documents the basis for determining that the action is exempt from further review by BDE and the SHPO. The district retains the documentation in project files.

For an Environmental Assessment (EA) project or an Environmental Impact Statement (EIS) project, or for a CE project that does not meet the criteria in Appendix A of the Programmatic Agreement for Minor Projects Delegation, the district proceeds to Activity 02.

References:

Effect, 36 CFR 800.16(i)
Historic Property, 36 CFR 800.16(l)
Programmatic Agreement for Minor Projects, Appendix A

PROJECT ACTIVITY

Activity Title: Submit ESR to BDE

Activity No.: 02

Responsible Unit: District

Activity Description:

The district prepares an Environmental Survey Request (ESR) for the proposed project using the form and instructions available on the Department website. The district submits the completed form and applicable supporting information to BDE.

References:

Environmental Surveys, Chapter 27

PROJECT ACTIVITY

Activity Title: Determine Involvement of Other States

Activity No.: 03

Responsible Unit: BDE

Activity Description:

BDE evaluates the information in the ESR to determine if any other States are involved in the project. If another State is involved, BDE advises the FHWA Division Office. The FHWA Division Office, as the lead Federal agency, coordinates with the involved SHPOs to determine their respective roles (i.e., whether they may agree to designate a lead SHPO). The FHWA Division Office advises BDE of the results of coordination with the SHPOs. BDE then proceeds to Activity 04.

If another State is not involved, BDE proceeds directly to Activity 04.

References:

Undertakings Involving More than One State, 36 CFR 800.3(c)(2)

PROJECT ACTIVITY

Activity Title: Evaluate Project per Category B Criteria

Activity No.: 04

Responsible Unit: BDE

Activity Description:

For CE projects, BDE evaluates the proposed project to determine if it is a type included in Category B (Minor Projects Requiring Review by IDOT Cultural Resource Staff to Determine if Field Survey is Required) in the Programmatic Agreement for Minor Projects Delegation.

If BDE determines the project is a type included in Category B, it evaluates the project to determine the need for field survey and coordination with the SHPO. If BDE determines that the field survey is not warranted, it applies a stamp to the ESR indicating the finding is "no historic properties affected." BDE returns the ESR with the finding to the district. The district retains the ESR in project files.

If BDE determines either that the proposed project does not qualify as a Category B action or that it involves circumstances requiring field survey and coordination with the SHPO, it proceeds to Activity 05.

For EA projects and EIS projects, BDE proceeds to Activity 05.

References:

Programmatic Agreement for Minor Projects, Appendix A

PROJECT ACTIVITY

Activity Title: Identify and Invite Consulting Parties

Activity No.: 05

Responsible Unit: BDE

Activity Description:

BDE, in consultation with FHWA, identifies entities that should be invited to participate as consulting parties in the Section 106 process, including the following, as appropriate:

- SHPO,
- Indian Tribes,
- representatives of local governments, and
- individuals and organizations with a demonstrated interest in the project.

Interested Tribes are provided initial notification through ISAS Project Notification System (PNS) when BDE requests an archaeological survey. The notification includes a request for information the Tribes may have that could assist in identifying properties of religious and cultural significance.

For EA and EIS projects, FHWA contacts all Tribes early in project development (possibly prior to the PNS notification) and works with BDE/districts and the Illinois SHPO to identify other parties to contact. The district contacts each of the identified parties (e.g., by letter or e-mail) to formally invite their participation and seek their input on historic properties in the project area and potential impacts to those properties. The district compiles a list of all consulting parties and shares any information provided by the parties with BDE and FHWA. The district retains in the project files a list of who was contacted.

References:

Consulting Parties, 36 CFR 800.2(c)

PROJECT ACTIVITY

Activity Title: Develop Involvement Plan for Consulting Parties and the Public

Activity No.: 06

Responsible Unit: BDE

Activity Description:

The district develops a plan that identifies the points for involving consulting parties and the public in the Section 106 process. The plan identifies the appropriate points for seeking the consulting party, public input, and for notifying the public of proposed actions associated with the Section 106 process. The level of involvement documented in the plan reflects the nature and complexity of the project. The plan addresses public involvement for the Section 106 process in the context of other public involvement activities for compliance with NEPA. Use public involvement opportunities that are scheduled as part of the normal project development process to inform the public of ongoing Section 106 activities and seek the public's input. Key Section 106 issues to include during public involvement events are:

1. notification that the Section 106 process is under way, and public input on potential historic properties and effects to historic properties is being sought;
2. communicating the results of efforts to identify historic properties;
3. communicating the results of the effect findings; and
4. seeking input on measures to resolve adverse effects to historic properties.

On projects the Regional Engineer has determined will use the principles of Context Sensitive Solutions (CSS), the district coordinates with the CSS Project Study Group (PSG) to ensure the Stakeholder Involvement Plan (SIP), as outlined in Section 19-5, addresses considerations associated with the Section 106 process. The district coordinates the SIP with BDE and FHWA and retains the SIP and other CSS documentation in the project file.

For most EA projects and all EIS projects, the district consults with BDE and FHWA to develop the plan.

References:

Initiation of the Section 106 Process, 36 CFR 800.3
Public Involvement Guidelines, Chapter 19

PROJECT ACTIVITY

Activity Title: Determine Area of Potential Effects

Activity No.: 07

Responsible Unit: BDE

Activity Description:

For CE projects, BDE coordinates with the SHPO as needed to determine and document the area of potential effects (APE) for the proposed project. This may be an iterative process, as necessary to obtain SHPO concurrence. See Section 26-5.04(a) for the definition of the term "area of potential effects" from 36 CFR 800.16.

For EA and EIS projects, BDE, SHPO, and FHWA consult to develop the APE. The district coordinates the APE with consulting parties and the public as described in the involvement plan developed in Activity 06.

References:

Determine Scope of Identification Efforts, 36 CFR 800.4(a)
Area of Potential Effects, 36 CFR 800.16(d)

PROJECT ACTIVITY

Activity Title: Collect Data

Activity No.: 08

Responsible Unit: BDE

Activity Description:

BDE forwards the ESR to the ISAS for survey. At this point, the PNS generates the email notification to interested Tribes.

ISAS reviews existing information on historic properties, including any data concerning possible historic properties not yet identified, and conducts field surveys, as appropriate.

For EA and EIS projects, the district is responsible for providing BDE a project photo log of standing structures over 50 years old. The district also sends BDE any information received from consulting parties and the public regarding potential historic properties.

References:

Determine Scope of Identification Efforts, 36 CFR 800.4(a)
Environmental Surveys, Chapter 27

PROJECT ACTIVITY

Activity Title: Identify Historic Properties

Activity No.: 09

Responsible Unit: BDE

Activity Description:

For CE projects, in consultation with the SHPO and interested Tribes, BDE uses the information gathered in Activity 08 and takes the steps necessary to identify historic properties within the APE.

BDE makes a reasonable and good faith effort to carry out appropriate identification efforts, which may include background research, consultation, oral history interviews, sample field investigation, and field survey.

In consultation with the SHPO and interested Tribes and guided by the Secretary of the Interior's standards and guidelines for evaluation, BDE applies the NRHP criteria (36 CFR 60.4, see Section 26-5.04(f)) to properties identified within the APE.

If BDE determines any of the NRHP criteria are met and the SHPO concurs, the property is considered eligible for the NRHP for Section 106 purposes. If BDE determines the criteria are not met and the SHPO concurs, the property is considered not eligible. If BDE and SHPO do not concur, BDE coordinates with FHWA to resolve the determination. If resolution cannot be reached, FHWA obtains a determination of eligibility from the Keeper of the National Register (Department of the Interior) in accordance with 36 CFR 63.

For EA projects and EIS projects, BDE prepares eligibility recommendations and submits them to FHWA. FHWA consults with the SHPO by letter to seek concurrence with the determination. The SHPO may stamp the FHWA letter "Concur," write a letter of concurrence, or write a letter disagreeing with the determination. If the SHPO disagrees with the determination, FHWA obtains a determination of eligibility from the Keeper of the National Register in accordance with 36 CFR 63. FHWA submits the eligibility documentation to BDE. BDE forwards a copy of the documentation to the district to include in the EA or EIS. The district coordinates the determination in accordance with the involvement plan developed in Activity 06.

If historic properties are in the APE, BDE consults with the district to determine if there are feasible and prudent alternatives for avoiding the site(s).

Regulations and Guidance

Identify Historic Properties, 36 CFR 800.4(b)

Evaluate Historic Significance, 36 CFR 800.4(c)

Criteria for Evaluation, 36 CFR 60.4

Determinations of Eligibility for Inclusion in the National Register of Historic Places, 36 CFR 63.

Secretary of the Interior's Standards and Guidelines for Archeology and Historic Preservation

PROJECT ACTIVITY

Activity Title: Determine if Historic Properties May Be Affected

Activity No.: 10

Responsible Unit: BDE

Activity Description:

BDE evaluates the project scope and the information obtained in Activity 09 to determine whether the project may affect historic properties.

For CE projects, if BDE determines that there are no historic properties present or that there are historic properties present but the project will have no effect on them as defined in 36 CFR 800.16(i), BDE provides documentation of this finding to the SHPO. In accordance with 36 CFR 800.11(d), the documentation includes the following:

- a description of the project, specifying the Federal involvement, and its area of potential effects, including photographs, maps, drawings, as necessary;
- a description of the steps taken to identify historic properties, including, as appropriate, efforts to seek information from consulting parties, Indian Tribes, etc.; and
- the basis for determining no historic properties are present or affected.

If the SHPO concurs or does not object within 30 days of receipt of an adequately documented finding, responsibilities under Section 106 are fulfilled. BDE documents the determination that no historic properties will be affected and provides the documentation to the district. The district retains the documentation in project files.

If the SHPO objects within 30 days of receipt of an adequately documented finding, BDE coordinates with FHWA and the SHPO to resolve the disagreement. If the disagreement is resolved, responsibilities under Section 106 are fulfilled. BDE documents the determination that no historic properties will be affected and provides the documentation to the district. The district retains the documentation in project files.

If the SHPO disagrees with the finding, FHWA follows the process in 36 CFR 800.4(d)(1)(ii).

The district notifies all consulting parties, including Indian Tribes, in accordance with the involvement plan developed in Activity 06 and makes the documentation available for public inspection.

PROJECT ACTIVITY

Activity Title: Determine if Historic Properties May Be Affected

Activity No.: 10 (*Continued*)

Responsible Unit: BDE

Activity Description:

For EA and EIS projects, BDE submits documentation of findings that there are no historic properties present or that historic properties are present, but the project will have no “effect” on them as defined in 36 CFR 800.16(i) (see Section 26-5.04(a)). FHWA considers the recommendation and, if in agreement, seeks concurrence from the SHPO. If the SHPO concurs or does not object within 30 days of receipt of an adequately documented finding, responsibilities under Section 106 are fulfilled. The SHPO may stamp the FHWA letter “Concur,” write a letter of concurrence, or write a letter disagreeing with the finding. If the SHPO disagrees with the finding, FHWA follows the process in 36 CFR 800.4(d)(1)(ii).

FHWA provides the documentation of coordination with the SHPO to BDE. BDE forwards the documentation to the district and the district includes it in the EA or EIS.

References:

Finding of No Historic Properties Affected, 36 CFR 800.11(d)

PROJECT ACTIVITY

Activity Title: Apply Criteria of Adverse Effect

Activity No.: 11

Responsible Unit: BDE

Activity Description:

In consultation with the SHPO and BDE, FHWA applies the criteria of adverse effect to historic properties within the APE.

The criteria of adverse effect provide that an adverse effect is found when a project may alter, directly or indirectly, any of the characteristics of a historic property that qualify it for inclusion in the NRHP, in a manner that would diminish the integrity of the property's location, design, setting, materials, workmanship, feeling, or association.

Examples of adverse effects on historic properties include, but are not limited to:

- physical destruction of or damage to all or part of the property;
- alteration of a property, including restoration, rehabilitation, repair, maintenance, stabilization, hazardous material remediation, and provision of handicapped access, that is not consistent with the Secretary of the Interior's standards for the treatment of historic properties and applicable guidelines;
- removal of the property from its historic location;
- change of the character of the property's use or of physical features within the property's setting that contribute to its historic significance;
- introduction of visual, atmospheric, or audible elements that diminish the integrity of the property's significant historic features;
- neglect of a property that causes its deterioration, except where such neglect and deterioration are recognized qualities of a property of religious and cultural significance to an Indian Tribe; and
- transfer, lease, or sale of property out of Federal ownership or control without adequate and legally enforceable restrictions or conditions to ensure long-term preservation of the property's historic significance.

FHWA considers any views provided by consulting parties, the public, and Tribes, as appropriate, regarding the project's effects on historic properties. BDE submits documentation of its preliminary findings regarding the results of application of the criteria of adverse effect to FHWA. The documentation includes:

PROJECT ACTIVITY

Activity Title: Apply Criteria of Adverse Effect

Activity No.: 11 (*Continued*)

Responsible Unit: BDE

Activity Description:

- a description of the project, specifying the Federal involvement, and its area of potential effects including photographs, maps, and drawings, as necessary;
- a description of the steps taken to identify historic properties;
- a description of the affected historic properties, including information on the characteristics that qualify them for the NRHP;
- a description of the project's effects on historic properties;
- an explanation of why the criteria of adverse effect were found applicable or inapplicable, including any conditions or future actions to avoid, minimize, or mitigate adverse effects; and
- copies or summaries of any views provided by consulting parties and the public.

For projects that have an adverse effect, a Section 4(f) evaluation may also be required. The Section 4(f) evaluation may be combined with the Section 106 documentation to streamline and condense the processes. The district should consult with BDE and FHWA to discuss how the Section 106 documentation and Section 4(f) evaluation may be combined.

FHWA considers the recommendation and, if in agreement, seeks concurrence from the SHPO. If the SHPO concurs with FHWA's findings or does not object within 30 days of receipt of adequately documented findings, BDE proceeds directly to Activity 12. If the SHPO disagrees with the findings, FHWA follows the process in 36 CFR 800.5(c)(2).

For CE projects, BDE may make a "no adverse effect" finding in consultation with the SHPO. If the finding is "adverse effect," then FHWA must make the finding in consultation with the SHPO.

For EA projects and EIS projects, FHWA makes either a "no adverse effect" or "adverse effect" finding in consultation with the SHPO and BDE.

PROJECT ACTIVITY

Activity Title: Apply Criteria of Adverse Effect

Activity No.: 11 (*Continued*)

Responsible Unit: BDE

References

Assessment of Adverse Effects, 36 CFR 800.5
The Secretary of the Interior's Standards for the Treatment of Historic Properties, 36 CFR 68

PROJECT ACTIVITY

Activity Title: Coordinate with Consulting Parties and the Public

Activity No.: 12

Responsible Unit: BDE

Activity Description:

BDE provides documentation, as described in Activity 11, of the effect findings to the district. The district provides the documentation to consulting parties and the public in accordance with the involvement plan developed in Activity 06.

FHWA sends the documentation to interested Tribes who have requested to be consulting parties in the Section 106 process. Information concerning the location of archaeological properties and properties of religious or cultural significance will not be included in documents to be made available for public inspection, in accordance with 36 CFR 800.11(c)(1).

If the SHPO concurs with the finding of no adverse effect, the Section 106 process is complete. The district retains the documentation in the project files and includes it in the NEPA document.

If there is a finding of adverse effect, proceed to Activity 13.

References:

Consulting Party Review, 36 CFR 800.5(c)
Finding of No Adverse Effect or Adverse Effect, 36 CFR 800.11(e)

PROJECT ACTIVITY

Activity Title: Consult to Resolve Adverse Effect

Activity No.: 13

Responsible Unit: BDE

Activity Description:

BDE sends a request to FHWA to notify the ACHP of the adverse effect finding.

BDE provides two copies of documentation described in Activity 11 to FHWA for submittal to the ACHP with the notice.

The ACHP advises FHWA whether it will participate within 15 days of receipt of the notice. FHWA notifies the SHPO and BDE by e-mail if no response has been received within 15 days or sends the SHPO and BDE a copy of the ACHP response letter, if one is received. BDE forwards a copy of the FHWA e-mail/ACHP letter to the district for inclusion in the project file and NEPA document.

FHWA consults with BDE, the district, the SHPO, and other consulting parties, including Indian Tribes, as appropriate, to develop and evaluate alternatives or modifications to the project that could avoid, minimize, or mitigate adverse effects on historic properties.

References:

Continued Consultation, 36 CFR 800.6(a)
Confidentiality, 36 CFR 800.11(c)
Programmatic Agreements, 36 CFR 800.14(b)
Public Involvement Guidelines, Chapter 19

PROJECT ACTIVITY

Activity Title: Develop and Execute MOA or PA

Activity No.: 14

Responsible Unit: BDE/District

Activity Description:

BDE and FHWA consult with the SHPO, the ACHP, and other consulting parties, including Indian Tribes, to seek ways to avoid, minimize, or mitigate the project's adverse effects. If BDE, district, FHWA, SHPO, and ACHP (if they are participating in the consultation) agree on how the project's adverse effects will be resolved, they will enter into a Memorandum of Agreement (MOA) or project-specific Programmatic Agreement (PA) to document the terms and conditions agreed upon for resolving the adverse effects. After FHWA and BDE are satisfied with the terms of the MOA/PA, BDE coordinates ratification by IDOT and local agencies, as appropriate, and sends those signed copies to FHWA. There will be one original copy of the MOA/PA for each ratifying party. FHWA sends the document with signatures to the SHPO for ratification. Upon receipt of the document with the SHPO's signature, FHWA signs the MOA/PA and, if the ACHP is participating, sends it to the ACHP for signature. The MOA/PA is considered effective upon the date of FHWA signature, or signature by the ACHP, if they are participating in the consultation.

FHWA obtains signatures of Tribes and other concurring parties, as applicable. After FHWA receives all required signatures on the MOA/PA, they send a copy of the executed agreement to all signatories and consulting parties. FHWA submits a copy of the executed agreement to the ACHP, along with documentation of the following:

- any substantive revisions or additions to the documentation provided to the ACHP in Activity 13,
- an evaluation of any measures considered to avoid or minimize the project's adverse effects, and
- a summary of the views of consulting parties and the public.

After submittal of the executed MOA/PA to the ACHP, BDE proceeds to Activity 15. If the SHPO does not agree to the terms of an MOA or PA for resolving the project's adverse effects, FHWA follows the process in 36 CFR 800.6(b)(v).

After distribution of the executed MOA or PA, BDE proceeds to Activity 15. A copy of the MOA or PA is included in the project file and in the EA or EIS.

PROJECT ACTIVITY

Activity Title: Develop and Execute MOA or PA

Activity No.: 14 (*Continued*)

Responsible Unit: BDE/District

References:

Resolve Adverse Effects, 36 CFR 800.6(b)
Memorandum of Agreement, 36 CFR 800.6(c)

PROJECT ACTIVITY

Activity Title: Implement MOA or PA

Activity No.: 15

Responsible Unit: BDE/District

Activity Description:

After execution of an MOA or PA, BDE and district carry out any assigned tasks in accordance with the provisions of the MOA or PA.

When all provisions of the MOA or PA have been fulfilled, BDE prepares documentation to confirm that all provisions have been satisfied. BDE provides copies of the documentation to FHWA, the SHPO, the district, and the Illinois Historic Preservation Agency (IHPA) and Illinois State Museum. The district retains the documentation in the project files. For archaeological resource information, the IHPA and State Museum retain the documentation in the Statewide Archaeological Files.

26-5.04(d) Unanticipated Discovery During Construction

If any unanticipated discoveries of historic properties, sites, artifacts, or objects occur during the implementation of any project, the district will coordinate with BDE and BDE will coordinate with FHWA to comply with 36 CFR 800.13 and the Illinois *Human Skeletal Remains Protection Act*, 20 ILCS 3440/0.01 *et seq.*, as appropriate. This will involve stopping work in the immediate area and informing the SHPO and County Coroner of the unanticipated discoveries or effects within two business days. BDE will coordinate with ISAS to ensure that any necessary archaeological investigations are conducted according to the provisions of the Illinois *Human Skeletal Remains Protection Act*.

If any unanticipated effects on historic properties are found to be occurring during the implementation of any project, the district will coordinate with BDE and BDE will coordinate with FHWA to comply with 36 CFR 800.13 and inform the SHPO immediately.

If any human remains are encountered during the implementation of any project exempted under the provisions of the Minor Projects Delegation Programmatic Agreement, the district will cease work in the immediate area, notify BDE, and ensure the human remains are left undisturbed. Where there is a discovery of human remains or burials on Federal lands, BDE will coordinate with FHWA to ensure compliance with the *Native American Graves Protection and Repatriation Act* (NAGPRA), (25 U.S.C. 3001.). In the event of an inadvertent discovery of human remains or burials on non-Federal lands during transportation construction activities, the district will cease work in the area of the discovery and notify BDE. BDE will ensure compliance with the Illinois *Human Skeletal Remains Protection Act* and will notify FHWA of the discovery. FHWA will notify the Federally recognized Indian Tribes with an interest in that county.

Work on the portion of the site where human remains are found cannot resume until a plan for the treatment of the human remains is developed and approved in consultation with the SHPO and any appropriate consulting parties. BDE will coordinate with FHWA to ensure the plan complies with the Illinois *Human Skeletal Remains Protection Act*, and all other appropriate Federal and State guidelines, statutes, rules, and regulations.

26-5.04(e) Coordination with the National Environmental Policy Act

The regulations in 36 CFR 800 encourage agencies to coordinate Section 106 compliance with steps taken to meet the requirements of the *National Environmental Policy Act* (NEPA). Consider Section 106 responsibilities as early as possible in the NEPA process and public participation, analysis, and plan review so that they can meet the purposes of both statutes in a timely and efficient manner. The determination of whether an undertaking is a “major Federal action significantly affecting the quality of the human environment” and, therefore, requires preparation of an EIS should include consideration of the undertaking’s likely effects on historic properties. A finding of adverse effect on a historic property does not necessarily require an EIS under NEPA.

If a project, activity, or program is categorically excluded from NEPA review, the undertaking still must be evaluated to determine if it qualifies as an undertaking that requires review under Section 106.

Section 106 documentation will be included in the CE project file, EA, or EIS. Documentation should include correspondence among all agencies and consulting parties, and the project MOA/PA, as applicable. The NEPA document will contain a summary of any Section 106 commitments.

26-5.04(f) National Register Criteria for Evaluation

The quality of significance in American history, architecture, archaeology, engineering, and culture is present in districts, sites, buildings, structures, and objects that possess integrity of location, design, setting, materials, workmanship, feeling, and association and that:

- are associated with events that have made a significant contribution to the broad patterns of our history;
- are associated with the lives of persons significant in our past;
- embody the distinctive characteristics of a type, period, or method of construction, or that represent the work of a master, that possess high artistic values, or that represent a significant and distinguishable entity whose components may lack individual distinction; and
- have yielded, or may be likely to yield, information important in prehistory or history.

Ordinarily cemeteries, birthplaces, or graves of historical figures, properties owned by religious institutions or used for religious purposes, structures that have been moved from their original locations, reconstructed historic buildings, properties primarily commemorative in nature, and properties that have achieved significance within the past 50 years shall not be considered eligible for the National Register. However, such properties will qualify if they are integral parts of districts that do meet the criteria or if they fall within the following categories:

- a religious property deriving primary significance from architectural or artistic distinction or historical importance;
- a building or structure removed from its original location, but which is significant primarily for architectural value, or which is the surviving structure most importantly associated with a historic person or event;
- a birthplace or grave of a historical figure of outstanding importance if there is no appropriate site or building directly associated with his/her productive life;
- a cemetery that derives its primary significance from graves of persons of transcendent importance, from age, from distinctive design features, or from association with historic events;
- a reconstructed building when accurately executed in a suitable environment and presented in a dignified manner as part of a restoration master plan, and where no other building or structure with the same association has survived;

- a property primarily commemorative in intent if design, age, tradition, or symbolic value has invested it with its own exceptional significance; and
- a property achieving significance within the past 50 years if it is of exceptional importance.

26-5.05 State of Illinois Requirements

In addition to the Federal requirements for historic preservation, the *Illinois State Agency Historic Resources Preservation Act*, 20 ILCS 3420/1, *et seq.* and the *Rules for Review of State Agency Undertakings*, 17 Ill. Admin. Code 4180, *et seq.* establish State-level historic preservation requirements applicable to State agency undertakings. Section 4(g) of the *Illinois State Agency Historic Resources Preservation Act* provides that:

(g) When an undertaking is being reviewed pursuant to Section 106 of the National Historic Preservation Act of 1966, the procedures of this law shall not apply and any review or comment by the Director on such undertaking shall be within the framework or procedures of the federal law.

IDOT highway projects typically are developed in accordance with Federal requirements, including Section 106 of the *National Historic Preservation Act*, so that they may be eligible for Federal funding participation. Accordingly, for the vast majority of IDOT highway projects, the above-referenced provision applies, and the projects are not subject to the State historic preservation requirements. In the event that a project is subject to the State requirements, the *Rules for Review of State Agency Undertakings* will be used to determine the actions necessary for compliance.

26-6 NOISE ANALYSES

26-6.01 Introduction

In the development of a project, it may be necessary to undertake special technical analyses to identify and evaluate any potential traffic noise impacts related to the project. The following information includes:

- criteria and procedures for these analyses,
- noise abatement measures and related coordination, and
- the noise abatement criteria prescribed by Federal regulations.

26-6.02 Complementary Technical Manual

The *IDOT Highway Traffic Noise Assessment Manual* (Manual) provides technical information and technical procedures associated with the provisions of this topic. The Manual contents will comply with the procedures described herein.

26-6.03 Legal Authority

The following legal authority regulates or influences the policies and procedures for noise analyses:

- 42 U.S.C. 4901-4918, popularly known as the *Noise Control Act of 1972* (Public Law 92-574),
- 23 U.S.C. 109(h) and (i), which are amendments to the *Federal-Aid Highway Act of 1970* (Public Laws 93-87 and 91-605),
- 42 U.S.C. 4331 and 4332, which are portions of the *National Environmental Policy Act of 1969* (Public Law 91-190),
- Procedures for Abatement of Highway Traffic Noise and Construction Noise, 23 CFR 772, and
- “Highway Traffic Noise: Analysis and Abatement Guidance” by the U.S. Department of Transportation, Federal Highway Administration June 2010, as revised December 2011.

26-6.04 Policy

Special efforts shall be made in the development of a project to comply with Federal and State requirements for noise control; to consult with the affected community regarding local noise requirements, noise impacts, and abatement measures; and to mitigate highway-related noise impacts, where feasible and reasonable. The reasonableness evaluation for noise abatement will include the solicitation of viewpoints from benefited receptors if necessary.

26-6.05 Procedures**26-6.05(a) Definitions**

1. Auxiliary Lane. The American Association of State Highway Transportation Officials (AASHTO) defines an auxiliary lane as the portion of the roadway adjoining the traveled way for speed change, turning, weaving, truck climbing maneuvering of entering and leaving traffic, and other purposes supplementary to through-traffic movement (AASHTO, 2001).

The Department will take a broad approach to defining auxiliary lanes with respect to defining a Type I project for noise analysis. FHWA states that auxiliary lanes 2,500 ft (762 m) or longer should be considered a Type I project. For auxiliary lanes shorter than 2,500 ft (762 m) in length, consideration for auxiliary lanes should be limited to those that could be used as a through lane (including bus or truck lanes) rather than lanes used for parking, speed change, turning or storage for weaving. For interstates, auxiliary lanes considered to be Type 1 projects are those that are:

- a. more than 2,500 ft (762 m), and;
- b. between two closely spaced interchanges or carried through one or more interchanges.

The final determination regarding Type I project classification will be left to the IDOT district and the Bureau of Design and Environment, on a case-by-case basis.

2. Benefited Receptor. The recipient of an abatement measure that receives a noise reduction of 5 dB(A) or greater. A benefited receptor does not need to be an impacted receptor.
3. Common Noise Environment. A group of receptors within the same Activity Category in Figure 26-6.A that are exposed to similar noise sources and levels; traffic volumes, traffic mix, and speed; and topographic features. Generally, common noise environments occur between two secondary noise sources, such as interchanges, intersections, and cross-roads.
4. Date of Public Knowledge. The date of environmental approval of the Categorical Exclusion (CE), the Finding of No Significant Impact (FONSI) for an Environmental Assessment (EA), or the Record of Decision (ROD) for an Environmental Impact Statement (EIS), as defined in 23 CFR 771.
5. Department. The Illinois Department of Transportation (IDOT).
6. Design Year. The future year used to estimate the probable traffic volume for which a highway is designed. For NEPA, IDOT uses the latest approved traffic projections from the appropriate Metropolitan Planning Organization (MPO) for all projects within the planning area of an MPO. For locations outside the planning area of an MPO, except for 3R projects, the design year traffic volumes shall be consistent

with the traffic projections used for design. For the purpose of a noise analysis, 3R projects shall use a design year of 20 years after the anticipated year of completion.

7. Existing Noise Levels. The worst hourly noise level resulting from the combination of natural and mechanical sources and human activity usually present in a particular area at the time the noise analysis is performed.
8. Facility or Existing Highway. Any of the freeways, expressways, or various classes of roads and streets that make up the highway system under the jurisdiction of the Department.
9. Feasibility. The combination of acoustical and engineering factors considered in the evaluation of a noise abatement measure. The acoustical criterion for feasibility requires a minimum 5 dB(A) traffic noise reduction at a minimum of two impacted receptor locations.
10. Impacted Receptor. The recipient that has a traffic noise impact.
11. Leq. The equivalent steady-state sound level, which in a stated period of time, contains the same acoustic energy as the time-varying sound level during the same time period, with $L_{eq}(h)$ being the hourly value of L_{eq} .
12. Multifamily Dwelling. A residential structure containing more than one residence. Each residence in a multifamily dwelling shall be counted as one receptor when determining impacted and benefited receptors.
13. Noise Abatement Criteria. Noise impact thresholds for considering noise abatement for various land uses. Defined in 23 C.F.R. Part 772.
14. Noise Barrier. A physical obstruction (i.e., standalone noise walls, noise berms (earth or other material), and combination berm/wall systems) that is constructed between the highway noise source and the noise sensitive receptor(s) that lowers the noise level at the receptor location.
15. Noise Reduction Design Goal. The optimum desired dB(A) noise reduction determined from calculating the difference between future build noise levels with abatement, to future build noise levels without abatement. The noise reduction goal is at least 8 dB(A) for at least one benefited receptor location.
16. Permitted. A definite commitment to develop land with an approved specific design of land use activities as evidenced by the issuance of a building permit.
17. Property Owner. An individual or group of individuals who hold(s) a title, deed, or other legal documentation of ownership of a property or a residence.
18. Reasonableness. The combination of social, economic, and environmental factors considered in the evaluation of a noise abatement measure.

19. Receptor. A discrete or representative location of a common noise environment(s), for any of the land uses listed in Figure 26-6.A.
20. Residence. A dwelling unit. Either a single-family residence or each dwelling unit in a multifamily dwelling.
21. Statement of Likelihood. A statement provided in the NEPA environmental document based on the feasibility and reasonableness analysis completed at the time the NEPA document is being approved.
22. Substantial Construction. The granting of a building permit by the local governing entity with permitting authority, prior to right-of-way acquisition or construction approval for the highway.
23. Substantial Noise Increase. One of two types of highway traffic noise impacts. For a Department project, this is defined as an increase in noise levels of greater than 15 dB(A) or greater in the design year over the existing noise level.
24. Traffic Noise Impacts. Design year build condition noise levels that approach or exceed the noise abatement criteria (NAC) listed in Figure 26-6.A for the future build condition; or design year build condition noise levels that create a substantial noise increase over existing noise levels. For purposes of this policy, approach is defined as within 1 dB(A) of the NAC. Substantial increase is considered to be at least 15 dB(A).
25. Type I Project.

The FHWA definition of a Type I Project includes the following:

- The construction of a highway on new location; or,
- The physical alteration of an existing highway where there is either:
 - + Substantial Horizontal Alteration. A project that halves the distance between the traffic noise source and the closest receptor between the existing condition to the future build condition; or,
 - + Substantial Vertical Alteration. A project that removes shielding and therefore exposes the line-of-sight between the receptor and the traffic noise source. This is done by either altering the vertical alignment of the highway or by altering the topography between the highway traffic noise source and the receptor; or,
- The addition of a through-traffic lane(s). This includes the addition of a through-traffic lane that functions as a High Occupancy Vehicle (HOV) lane, High-Occupancy Toll (HOT) lane, bus lane, or truck climbing lane; or

- The addition of an auxiliary lane, except for when the auxiliary lane is a turn lane; or,
- The addition or relocation of interchange lanes or ramps added to a quadrant to complete an existing partial interchange; or
- Restriping existing pavement for the purpose of adding a through-traffic lane or an auxiliary lane; or
- The addition of a new or substantial alteration of a weigh station, rest stop, ride-share lot or toll plaza.

If any part of a project is determined to be a Type I project under this definition, then the entire project area as defined in the NEPA environmental document is a Type I project.

26. Type II Project. A Federal or Federal-aid highway project for noise abatement on an existing highway. IDOT does not maintain a Type II program.
27. Type III Project. A Federal or Federal-aid highway project that does not meet the classifications of a Type I or Type II project. Type III projects do not require a noise analysis.
28. Undeveloped Lands. Those tracts of land or portions thereof that do not contain improvements or activities devoted to frequent human habitation or use (including low-density recreational use) and for which no such improvements or activities are permitted.
29. Worst Hourly Traffic Noise. The noise level resulting from the highest hourly volume a facility can handle while maintaining stable flow. This traffic volume will be either the design hourly volume or the maximum volume that can be accommodated under level of service C (i.e., where high traffic volumes begin to restrict speed and drivers' maneuverability).

26-6.05(b) Applicability

The noise analysis and abatement procedures described in this section shall apply to all Type I projects initiated by the Department, whether Federally funded or State-only funded (or State and local-funded, as appropriate), or requires FHWA approval regardless of funding sources.

26-6.05(c) Traffic Noise Analysis

In the development of proposed projects, expected traffic noise impacts shall be determined and analyzed, and the overall benefits that can be achieved by noise abatement measures to mitigate these impacts shall be determined, giving weight to any adverse social, economic, and environmental effects.

The traffic noise analysis shall be conducted in the following manner:

- Identify existing activities, developed areas, and undeveloped lands that may be affected by noise from the highway. Land uses shall be characterized based on the activity categories and descriptions listed in Figure 26-6.A. Undeveloped lands permitted for development by the date of public knowledge shall be evaluated for traffic noise impacts and noise abatement (if impacts are identified) based on the permitted land use description.
- Predict the traffic noise levels for each reasonable alternative carried forward under detailed study (including the “no-action” alternative) using the most current version of the FHWA-approved Traffic Noise Model (TNM) which is described in “FHWA Traffic Noise Model” Report No. FHWA-PD-96-010, or any other model determined by the FHWA to be consistent with the methodology of the FHWA TNM. The pavement type in TNM shall be the average pavement type unless a different pavement type has been approved by FHWA.
- When determining traffic noise impacts, primary consideration shall be given to exterior areas where frequent human use occurs *for Activity Categories A, B, C and E*. Traffic noise impacts for land uses within Activity Category D shall be predicted for interior areas only if no exterior use areas are identified. See the *IDOT Highway Traffic Noise Assessment Manual* for additional guidance.
- Determine the existing noise levels using field measurements, modeling, or both, using the most current version of the FHWA-approved TNM or any other model determined by the FHWA to be consistent with the methodology of the FHWA TNM. Modeling of existing conditions may not be appropriate when the project involves construction of a new roadway in a new location where there is no existing traffic noise contribution. Predicted noise levels shall be validated through comparison between measured and predicted noise levels at selected representative receptors. The $L_{eq}(h)$ noise metric shall be used to quantify the measurements of both existing and predicted noise levels.

Activity Category	$L_{eq}(h)$	Evaluation Location	Activity Description
A	57	Exterior	Lands on which serenity and quiet are of extraordinary significance and serve an important public need and where the preservation of those qualities is essential if the area is to continue to serve its intended purpose.
B	67	Exterior	Residential.
C	67	Exterior	Active sport areas, amphitheatres, auditoriums, campgrounds, cemeteries, day care centers, hospitals, libraries, medical facilities, parks, picnic areas, places of worship, playgrounds, public meeting rooms, public or nonprofit institutional structures, radio studios, recording studios, recreation areas, Section 4(f) sites, schools, television studios, trails and trail crossings.
D	52	Interior	Auditoriums, day care centers, hospitals, libraries, medical facilities, places of worship, public meeting rooms, public or nonprofit institutional structures, radio studios, recording studios, schools, and television studios.
E	72	Exterior	Hotels, motels, offices, restaurants/bars, and other developed lands, properties or activities not included in A-D or F.
F	---	---	Agriculture, airports, bus yards, emergency services, industrial, logging, maintenance facilities, manufacturing, mining, rail yards, retail facilities, shipyards, utilities (water resources, water treatment, electrical), and warehousing.
G	---	---	Undeveloped lands that are not permitted.

*Note: The Noise Abatement Criteria are noise impact thresholds for considering abatement. Abatement must be considered when predicted traffic noise levels for the design year approach (i.e., within 1 decibel of) or exceed the noise abatement criteria, or when the predicted traffic noise levels are substantially higher (i.e., more than 15 decibels or greater) than the existing noise level. The Noise Abatement Criteria are **not** attenuation design criteria or targets. The goal of noise abatement measures is to achieve the feasibility noise reduction criteria and the noise reduction design goal. The reductions may or may not result in design year noise levels at or below the Noise Abatement Criteria.*

Figure 26-6.A Noise Abatement Criteria

[Hourly A-Weighted Sound Level-decibels (dB(A))]

- Compare the predicted design year build traffic noise levels based on traffic characteristics that yield the worst traffic noise impact for the preferred alternative, or for each alternative under detailed study, with the existing noise levels and with the noise abatement criteria (see Figure 26-6A). This comparison shall also include predicted traffic noise levels for the “no-action” alternative in the design year. Such information shall be used primarily to describe the noise levels of proposed highway improvements in contrast with noise levels likely to be reached in the same area if no highway improvement is undertaken. Noise impacts are defined when the predicted traffic noise levels for the design build year approach (defined by the Department as “within 1 decibel of”) or exceed the Noise Abatement Criteria provided in Figure 26-6.A, or when the predicted traffic noise levels for the design year are substantially higher (defined by the Department as “15 decibels

greater”) than the existing noise levels. The results of the impacts analysis must be disclosed and shall be summarized in the NPEA document (see Section 26-6.09).

- Examine and evaluate noise abatement measures (see Section 26.05(d)) for existing activities, developed lands, and undeveloped lands for which development is permitted where traffic noise impacts have been identified.
- Design year build noise levels shall be predicted for undeveloped lands for which there will be no development permitted by the date of public knowledge. The results shall be documented in the NEPA environmental documents and noise analysis documents. The information presented may include a prediction of noise contours or a prediction of distances from the highway for which impacts would likely occur so that local jurisdictions may use information for site planning if the undeveloped land would be developed in the future. A noise abatement evaluation is not warranted for these undeveloped lands provided that development is not permitted by the date of public knowledge. See Section 26-6.05(e) for additional information to be provided to local officials for undeveloped lands.

The following figure (Figure 26-6.B) identifies potential sensitive land uses and the potential locations to be considered as benefited receptors within that land use. See the IDOT Highway Traffic Noise Assessment Manual for additional guidance.

Receptor Type	FHWA Activity Category	Receptor Unit(s)
Single-family Residence	B	Each residential unit with exterior use area (i.e., patio, yard, deck, etc.)
Multi-family Residence	B	Each residential unit with access to the exterior common area (i.e., pool, benches, or building entrance) or with exterior use areas (i.e., patio or balcony)
Nursing Home	C	Each residential unit with access to an exterior common area (i.e., benches or main entrance) or with exterior use areas (i.e., patio or balcony)
School	C	Each classroom with access to an exterior use area (i.e., benches, playground, main entrance)
Hospital or In-patient Medical Facility	C	Each hospital room with a bed(s) with access to an exterior use area (i.e., benches or main entrance)
Cemetery	C	Each exterior area of anticipated gathering (i.e., benches, information board)
Auditoriums	C	Each exterior area of anticipated gathering (i.e., bench or main entrance)
Day Care Center	C	Each exterior area of anticipated gathering (i.e., playground or main entrance)
Campground	C	Each campsite within the noise study area.
Sports Fields	C	Each exterior area of anticipated gathering (i.e., dugout, bleachers, field)
Places of Worship	C	Each exterior area of anticipated gathering (i.e., benches, patio, gazebo, or main entrance)
Golf Courses	C	One receptor per hole in the worst-case noise location (tee box, fairway, green), in addition to other exterior use areas (i.e., benches, putting green)
Parks / Recreational Area	C	Each exterior use area (i.e., gazebo, picnic tables, play equipment)
Trails and Trail Heads	C	Each exterior area of anticipated gathering (i.e., bench, information board)
Libraries*	C	Each exterior area of anticipated gathering (i.e., bench, patio, gazebo)
Office*	E	Each business with an exterior use area (i.e., bench or picnic tables)
Hotel/Motel*	E	Each hotel/motel room with access to an exterior use area
Restaurants/Bars*	E	Each exterior area of anticipated gathering (i.e., group of tables)
Medical Office or Out-patient Medical Office*	E	Each exterior area of anticipated gathering (i.e., bench or tables)
Undeveloped Lands	G	Uses with an NAC and a building permit that have access to a planned exterior use area

Figure 26-6.B
Potential Benefited Receptor Units

26-6.05(d) Noise Abatement

26-6.05(d)1 General Considerations

When traffic noise impacts are identified, noise abatement shall be considered and evaluated for feasibility and reasonableness. The assessment of noise abatement should give weight to the benefits and costs of abatement and the overall social, economic, and environmental effects by using feasible and reasonable noise abatement measures presented herein.

In determining and abating traffic noise impacts, primary consideration is given to exterior areas. Abatement may be recommended only where outdoor frequent human use occurs and abatement would provide a noise reduction benefit. If a noise impact is identified, the abatement measures evaluation shall be conducted as discussed below.

Abatement measures that are feasible and reasonable shall be recommended to be incorporated into the project plans and specifications. The FHWA will not approve NEPA environmental documents or plans and specifications for Federally funded projects unless such measures are identified and incorporated to mitigate the identified noise impacts.

26-6.05(d)2 Noise Abatement Measures

The information in this subsection is written primarily for Type I projects that are Federally funded or require Federal approval; however, the provisions regarding conditions for providing abatement measures and information on types of measures also applies to appropriate State-only funded Type I projects. All noise assessments and noise abatement evaluations for State-only funded projects should be submitted to BDE for review and concurrence.

The following are noise abatement measures that may be incorporated into Federally funded Type I projects to reduce highway-generated noise impacts when the abatement measure has been determined to be feasible and reasonable pursuant to this section. At a minimum, noise abatement in the form of noise barriers shall be considered. The remaining noise abatement measures can be considered as an alternative abatement measure(s) for the Department but are not required to be evaluated. The costs of such measures may be included in Federal-aid participating project costs with the Federal share being the same as that for the system on which the project is located:

- construction of noise barriers, including acquisition of property rights, either within or outside the highway right-of-way. Landscaping is not a viable noise abatement measure;
- traffic management measures (e.g., traffic control devices and signing for prohibition of certain vehicle types, time use restrictions for certain vehicle types, modified speed limits and exclusive lane designations);
- alteration of horizontal and vertical alignments;
- acquisition of real property or interests therein (predominantly unimproved property) to serve as a buffer zone to preempt development that would be adversely impacted by traffic noise; or,

- noise insulation of Activity Category D land use facilities listed in Figure 26-6.A. [noise insulation for public use or nonprofit institutional structures (e.g., places of worship, schools, hospitals, libraries, etc.). Public use or nonprofit institutional structures means the facility is open for public use, owned by the public or that a nonprofit organization owns the facility; post-installation maintenance and operational costs for noise insulation are not eligible for Federal-aid funding or State funding.]

For Federally funded projects, Federal funds may be used for noise abatement measures when a traffic noise impact has been identified (see Section 26-6.05(c)) and the noise abatement measure is determined to be feasible and reasonable based on the following evaluations.

26-6.05(d)3 Feasibility Evaluation

A noise abatement measure is determined to be feasible by achieving IDOT's highway traffic noise reduction feasibility criterion of at least 5 dB(A) at impacted receptors. The noise reduction shall be achieved for at least two impacted receptors.

The noise abatement measure also needs to be determined to be possible to design and construct to be considered feasible. Factors including but not limited to safety, barrier height, topography, drainage, utilities, maintenance, and access issues should be considered. See the *IDOT Highway Traffic Noise Assessment Manual* for additional guidance.

26-6.05(d)4 Reasonableness Evaluation

A noise abatement measure is determined to be reasonable when all three of the following reasonableness evaluation factors are met:

- cost effectiveness of the highway traffic noise abatement measure;
- achievement of IDOT's noise reduction design goal; and,
- consideration of the viewpoints of the benefited receptors (property owners and residents).

Each of these three reasonableness evaluation factors is further described below.

Reasonableness Criterion 1: Noise Reduction Design Goal

The first component of reasonableness is achieving the noise reduction design goal for highway noise abatement measures. The noise reduction design goal is to achieve a traffic noise reduction of at least 8 dB(A) for at least one benefited receptor. The noise reduction goal should be achieved for as many receptors as possible while still achieving the cost effectiveness.

Reasonableness Criterion 2: Cost-Effectiveness

The second component of reasonableness is cost effectiveness. The estimated build cost of each noise abatement measure may not exceed the allowable noise abatement cost based on a cost per benefited receptor comparison. The base value for the allowable noise abatement cost shall be \$30,000 per benefited receptor. Benefited receptors are those that would have at least a 5 dB(A) traffic noise reduction (regardless of whether the receptor was impacted).

The estimated build cost for noise barriers should be determined using the current standard unit cost approved by IDOT. The current unit cost used by IDOT to determine the estimated build

cost for noise barriers is \$30 per square foot. This unit cost is based on actual IDOT Phase III construction costs (materials and installation) and engineering design. This unit cost and the allowable cost will be evaluated every five years by IDOT and will be based on actual construction costs. Estimated build costs for other noise abatement measures being evaluated should be based on estimated Phase I costs.

Receptor Type	Potential Benefited Receptor Unit(s)
Single-family Residence	Each residential unit
Multi-family Residence	Each residential unit with access to the exterior common area or with exterior use areas, such as a patio or balcony
Nursing Home	Each residential unit with access to the exterior common area
School	Each classroom
Hospital	Each hospital room with a bed(s)
Hotel/Motel	Each hotel/motel room
Cemetery	Each point of anticipated gathering (i.e., bench, information board)
Places of Worship	Each point of anticipated gathering (i.e., bench, patio, gazebo)
Parks	Each gazebo, group of picnic tables, playground
Trails and Trail Heads	Each point of anticipated gathering (i.e., bench, information board)
Libraries	Each point of anticipated gathering (i.e., bench, patio, gazebo)
Business	Each business unit
Undeveloped Lands	Each unit with a building permit

Figure 26-6.B – Potential Benefited Receptor Units*

* To be considered benefited, each receptor unit location must receive at least a 5 dB(A) traffic noise reduction to be considered as part of the cost-effective evaluation.

Cost Effectiveness Determination

Other cost effectiveness determination factors shall be considered to potentially adjust the allowable noise abatement base value cost of \$30,000 per benefited receptor to account for project-specific factors. Consideration of the following three reasonableness factors can be used to adjust the allowable noise abatement base cost of \$30,000 per benefited receptor. These other reasonableness factors include:

- the absolute noise level of the benefited receptors in the design year build scenario before noise abatement;
- the incremental increase in noise level between the existing noise level at the benefited receptor and the predicted build noise level before noise abatement; and
- the date of development compared to the construction date of the highway.

The base value of \$30,000 per benefited receptor will be adjusted considering these three factors and based on Figure 26-6.C. Only one value from each of the three factors may be used for each

receptor, resulting in a potential maximum allowable noise abatement cost of \$45,000 per benefited receptor. If the estimated build cost of noise abatement per benefited receptor is less than the adjusted allowable noise abatement cost per benefited receptor, then the noise abatement measure achieves the cost-effective reasonableness criterion. For additional guidance on the use of optional reasonableness factors, see the *IDOT Highway Traffic Noise Assessment Manual*.

Absolute Noise Level Consideration

Predicted Build Noise Level Before Noise Abatement	Dollars Added to Base Value Cost per Benefited Receptor
Less than 70 dB(A)	\$0
70-74 dB(A)	\$1,000
75-79 dB(A)	\$2,500
80 dB(A) or greater	\$5,000

Increase in Noise Level Consideration

Incremental Increase in Noise Level Between the Existing Noise Level and the Predicted Build Noise Level Before Noise Abatement	Dollars Added to Base Value Cost per Benefited Receptor
Less than 5 dB(A)	\$0
5-9 dB(A)	\$1,000
10-14 dB(A)	\$2,50
15 dB(A) or greater	\$5,000

New Alignment / Construction Date Consideration

Project is on new alignment OR the receptor existed prior to the original construction of the highway	Dollars Added to Base Value Cost per Benefited Receptor
No for both	\$0
Yes for either	\$5,000

Note: No single optional reasonableness factor shall be used to determine that a noise abatement measure is unreasonable.

Figure 26-6.C

FACTORS FOR ADJUSTING THE ALLOWABLE NOISE ABATEMENT COST PER BENEFITED RECEPTOR BASE VALUE OF \$30,000 USING OTHER REASONABLENESS FACTORS

Cost Averaging

Cost averaging of noise abatement among common noise environments may be used when conducting the reasonableness evaluation. For a single noise abatement measure to be considered as part of a cost averaging evaluation, the estimated build cost of noise abatement per benefited receptor may not exceed two times the adjusted allowable noise abatement cost per benefited receptor. Noise abatement measures achieve the cost reasonableness criterion if

the common noise environment collective average estimated build cost of noise abatement per benefited receptor is less than the collective average adjusted allowable cost per benefited receptor. See the *IDOT Highway Traffic Noise Assessment Manual* for further guidance and an example cost-averaging evaluation.

Third Party Funding

Third party funding is not allowed on a Federal or Federal-aid project if the noise abatement measure would require the additional funding from the third party to be considered feasible and/or reasonable. Third party funding is acceptable on Federal or Federal-aid highway project to make functional enhancements to a noise abatement measure already determined feasible and reasonable.

Assessing Feasibility and Reasonableness of Modifying Existing Noise Barriers.

In order to represent the existing noise environment, the noise model for the existing condition must include any existing solid barrier of considerable mass designed specifically to abate noise; therefore, existing modeled noise levels must include any existing barriers in the model. The noise analysis for a new Type I project should consider the effectiveness of existing noise barriers and consider whether they require retrofit or modification based on the new Build conditions. See the *IDOT Highway Traffic Noise Assessment Manual* for procedures for assessing feasibility and reasonableness of existing noise barriers.

Reasonableness Criterion 3: Benefited Receptor Viewpoints

The third component of reasonableness is obtaining the viewpoints of benefited receptors, either during Phase I Preliminary Engineering and Environmental Studies or in Phase II Design. The timing of viewpoints solicitation is at the discretion of IDOT and FHWA. See the *IDOT Highway Traffic Noise Assessment Manual* for additional guidance.

The viewpoints of benefited receptors shall be solicited for noise abatement measures (e.g., noise barriers) determined to be feasible to achieve the noise reduction design goal and to be, cost-effective. The viewpoints of benefited receptors shall be solicited to determine the desire for implementation of the noise abatement measure. A benefited receptor includes property owners (including non-residential properties) and renters/lessees residing on the benefited property.

A common method employed for viewpoints solicitation is using voting packets mailed to each benefited receptor that may include a cover letter explaining the project and the voting process, a plan view of the proposed barrier, and a voting form with space for additional public comments. For more information regarding viewpoints solicitation methods, see the *IDOT Highway Traffic Noise Assessment Manual*.

Regardless of when the viewpoints solicitation occurs in the project development process or the method of how votes are solicited, the desire is to obtain as many vote responses as possible. The goal is to obtain responses from at least one-third of the potential number of votes for each noise abatement measure (i.e., for each noise barrier being considered). If responses from one-third of the potential votes cast for a given barrier are not received after the first attempt, a second

attempt shall be made. The voting result can be determined after viewpoints from at least one-third of the potential votes have been received or after two attempts have been made to obtain the responses. If after the second attempt, there are still less than one-third of the potential votes received, the voting result will be determined based on the responses received.

Once the responses have been collected, the viewpoints must be tallied. In order for a proposed noise abatement measure to be implemented, greater than 50% of the received votes must be in favor of the proposed abatement measure. If no votes are received, the barrier will not be recommended for construction. Viewpoints will be tallied for each individual abatement measure (i.e., for each noise barrier being considered).

A response from front row benefited receptors (receptors or properties adjacent to a proposed barrier; see the IDOT *Highway Traffic Noise Assessment Manual*) will be counted and weighted as four votes. Benefited receptors not in the front row will count as two votes. In the case of front row rental properties each the tenant responding shall count as two votes and the owner shall count as two votes per unit. Non-front row rental properties' tenants shall receive one vote per unit and the owner shall count as one vote per unit. See the *IDOT Highway Traffic Noise Assessment Manual* for additional guidance and an example viewpoints evaluation.

The proposed abatement measures will be presented as likely to be implemented (provided they are deemed feasible and reasonable for noise reduction and cost-effectiveness) as part of the public involvement process.

The IDOT Highway Traffic Noise Assessment Manual includes a letter template that districts may use as the first attempt to obtain the viewpoints from benefited receptors. If a second attempt is required due to insufficient responses from the first attempt, a modification of this letter can accomplish that effort.

26-6.06 Noise Abatement Wall Materials

26-6.06(a) Physical Requirements

When the noise analysis, as described in Section 26-6.05(c), determines that a noise abatement evaluation is warranted and a noise wall is determined to be feasible and reasonable as described in Section 26-6.05(d), it will be constructed with a design life of 35 or more years. In addition, it will be aesthetically pleasing, consistent with any neighboring design themes, easily maintained, and replaceable, if damaged. The noise abatement wall material must be suitable for safe recycling.

26-6.06(b) Acoustical Specifications

The noise wall material must achieve a sound Transmission Loss (TL) (i.e., a reduction in sound transmitted through the material) equal to or greater than 20 dB in all one-third octave bands from 100 hertz to 5,000 hertz, inclusive. Testing for TL shall be in accordance with ASTM E90 "Standard Test Method for Laboratory Measurement of Airborne Sound Transmission Loss of Building Partitions." Specialty items and materials that are not covered by ASTM, AASHTO, or other Department specifications must have the prior approval of the Illinois Highway Development

Council (IHDC). Contact the Engineer of Technical and Product Studies at the Bureau of Materials and Physical Research for additional information on the IHDC process.

26-6.06(c) Aesthetic Considerations

Funding for aesthetics is assessed per individual project and may require local (municipal or county) funding, based on FHWA and IDOT discretion.

The Department generally uses standard surface textures and colors for noise abatement walls constructed for Department projects. The standard textures include brick, stone, or wood patterns. The standard colors include earth tones in shades of browns and grays.

The Regional Engineer or their designee will recommend one of the standard patterns and colors for a proposed noise abatement project unless, after evaluating existing or proposed design themes for the project area or the architectural style of the neighborhood, a different pattern or color is deemed appropriate.

The recommendation of the Regional Engineer, or their designee, may be presented at public involvement meetings. If the affected residents desire a different pattern or color, or a noise wall material that does not fully conform to this policy, the following options will apply:

- any of the other “standard” patterns or any color on their side of the wall may be accommodated without any monetary commitment from local agencies beyond that normally required for a “standard pattern” noise abatement project, as appropriate;
- any non-standard pattern or color on the side of the wall away from the highway may be accommodated upon agreement by the local agency(ies) to compensate the Department for 100 percent of the cost beyond that of a “standard pattern” for a “non-standard pattern”, as appropriate; or
- proposals for construction of noise abatement walls from materials that meet the 20 dB TL requirement but that otherwise do not fully conform to this policy may be evaluated and approved by the Department on a case-by-case basis. The local agency funding participation required for engineering, construction, and maintenance costs associated with the wall also will be determined on a case-by-case basis.

For additional aesthetic considerations see the IDOT *Highway Traffic Noise Assessment Manual*.

26-6.06(d) Absorptive Material Considerations

Under the following circumstances, consider an absorptive surface³ for noise abatement walls to be constructed pursuant to this policy:

³ For purposes of this policy, a noise abatement wall surface will qualify as “absorptive” provided that it achieves a composite Noise Reduction Coefficient (NRC) of at least 0.80 if on the roadway side of the wall, and a composite NRC of at least 0.65 if on the side of the wall away from the roadway. The composite NRC shall be calculated based on the individual NRC values for each of the components of the total noise abatement wall system, as determined

- An absorptive surface should be considered for the *roadway* side of a noise abatement wall when:
 - + walls (including noise abatement walls, retaining walls, or abutments) paralleling or approximately paralleling the proposed noise abatement wall are also located, or proposed for construction, on the opposite side of the roadway and the ratio of the “canyon” width (between the noise abatement wall and the opposing wall) to the height of the walls is 10:1 or less; or
 - + the noise abatement wall is proposed to close a gap in a noise abatement barrier that has an absorptive surface on the roadway side.
- An absorptive surface should be considered for the side of the noise abatement wall *away* from the roadway when:
 - + residences or other noise-sensitive receptors would be affected by reflected noise from industrial, commercial, or transportation sources on the side of the wall away from the roadway or noise from the roadway reflected off structures along the roadway, and it has been determined the reflected noise reduces the noise wall effectiveness below the feasibility criterion (i.e. at least 5 dB(A) for impacted receptors) or the noise reduction design goal (i.e., at least 8 dB(A) for benefited receptors); or
 - + the noise abatement wall must be gapped for an access road to the residences or other noise-sensitive receptors the wall is intended to benefit; or
 - + the noise abatement wall is proposed to close a gap in a noise abatement barrier that has an absorptive surface on the side away from the roadway.

Absorptive surfaces also should be considered where walls paralleling or approximately paralleling the proposed noise abatement wall are located or proposed for construction, on the opposite side of the roadway and the “canyon” width to wall height ratio is greater than 10:1 but less than 20:1. Conduct a parallel barrier analysis to determine the degradation in noise wall performance where the width to wall heights ratio is less than 20:1. If the multiple reflections created by parallel barriers reduce the noise wall effectiveness below the feasibility criterion (i.e. at least 5 dB(A) for impacted receptors) or the noise reduction design goal (i.e., at least 8 dB(A) for benefited receptors), the feasible and reasonable evaluation should be presented using both an absorptive surface and a reflective noise wall surface.

26-6.06(e) Noise Abatement Wall Maintenance

The Department will maintain the roadway side of the noise abatement wall. Where the wall is located in such close proximity to the right-of-way line that the other side of the wall cannot be maintained from the State’s right-of-way, a maintenance agreement with the appropriate local

using ASTM C423 “Standard Test Method for Sound Absorption Coefficients by the Reverberation Room Method.” For purposes of this testing, the materials must be placed in accordance with Type A Mounting as described in ASTM E795 “Standard Practices for Mounting Test Specimens During Sound Absorption Tests”.

agency will be pursued. If such an agreement is not reached, additional right-of-way or easements may be acquired to provide access for maintenance.

26-6.07 Coordination

The Districts shall furnish local officials (e.g., county or municipal officials) within whose jurisdiction the highway project is located the following information pertaining to undeveloped lands within the project limits:

- approximate generalized design year traffic noise levels (for various distances from the highway improvement) for currently undeveloped lands or properties in the immediate vicinity of the project, and
- information that may be useful to local communities to protect future land development from becoming incompatible with anticipated highway noise levels.

Design year build noise levels shall be provided to inform local officials of the possibility of traffic noise impacts should the land be developed. Distances from the edge of the nearest travel lane of the highway improvement shall be provided where the noise levels approach the exterior noise abatement criteria in Figure 26-6A. Noise contours may be used to depict the build noise levels for the design year. This information shall be included in the traffic noise analysis documentation and NEPA environmental documentation. See the *IDOT Highway Traffic Noise Assessment Manual* for further guidance.

During the NEPA environmental studies, likely abatement measures should be discussed at public meetings and hearings, regardless of when viewpoints solicitation occurs. Information to be presented shall include the preliminary form of barrier, location, height, length, cost, and predicted noise reduction. Illustrations or drawings of likely abatement can be provided, if available. Published notices advertising these meetings will identify that noise abatement measures are being investigated for potential installation and that the viewpoints of benefited receptors will be solicited either during Phase I or Phase II as a part of the proposed project. Results of the viewpoints solicitation (regardless if solicitation occurs in Phase I or Phase II) and final recommendations for proposed noise abatement will be made available to the public.

26-6.08 Construction Noise

The following general steps for addressing construction noise shall be performed for Type I projects, as appropriate:

- Identify land uses or activities affected by noise from construction of the project. This identification should be considered during the NEPA environmental studies.
- Determine the measures recommended for inclusion in the contract plans and specifications to minimize or eliminate adverse construction noise impacts on the community. This determination shall include a weighing of the benefits to be achieved and the overall adverse social, economic, and environmental effects and the costs of the abatement measures.

- Incorporate the needed abatement measures in the plans and specifications.

A construction noise evaluation should determine the following:

- if there is sufficient basis (i.e., needs or benefits) for recommending early construction of proposed noise barriers, so that they might also abate construction noise; and
- if provisions for any of the following (or other) abatement measures should be incorporated into project construction contract documents:
 - + requiring special construction measures (e.g., work hour limits, equipment muffler requirements, location of haul roads, elimination of “tail gate banging,” reduction of backing up for equipment with alarms, use of “sound curtains” on certain equipment such as pavement breakers, placing materials stockpiles to form temporary noise barriers, positioning equipment as far as practical from sensitive areas);
 - + limiting the duration of the contract period (calendar date of completion); or
 - + imposing limits on all construction during special events (e.g., outdoor concerts, athletic events).

FHWA has released the FHWA Roadway Construction Noise Model (FHWA RCNM). Use of this model is not required on Federal-aid projects; however, it is a screening tool that can be used during NEPA environmental studies for the prediction of construction noise when construction noise has been identified as a potential concern.

Construction noise should be addressed in NEPA documents and Phase I engineering reports. The following paragraph should be included:

Trucks and machinery used for construction produce noise that may affect some land uses and activities during the construction period. Residents along the alignment will, at some time, experience perceptible construction noise from implementation of the project. To minimize or eliminate the effect of construction noise on these receptors, mitigation measures have been incorporated into the Illinois Department of Transportation Standard Specifications for Road and Bridge Construction as Article 107.35.

When additional abatement measures are proposed to mitigate construction noise, a brief description of the specific measures should also be included. See the *IDOT Highway Traffic Noise Assessment Manual* for additional guidance.

26-6.09 NEPA Documentation

Language to be included in the NEPA document will depend on the project type (Type I or Type III - the Department does not maintain a Type II program) the results of the noise study, and the feasibility and reasonableness determination.

26-6.09(a) Type III projects

Projects classified as Type III do not require a noise analysis and should be addressed in NEPA environmental documents or Phase I engineering reports, as appropriate. The following paragraph should be included:

“The types of projects that do not require a noise analysis are stated in 23 CFR Part 772. This project meets those criteria and does not require a traffic noise analysis, noise barrier, or other noise abatement measures.”

26-6.09(b) Type I projects

For those types of projects that are considered a Type I project, it is important that appropriate information from the noise study as described in the *Highway Traffic Noise Assessment Manual* be made a part of the NEPA documentation. Therefore, careful planning should be undertaken to ensure that the technical study reaches appropriate milestones in time to incorporate summaries of the noise analysis results into the NEPA documentation for circulation and comments, as appropriate.

If the result of the noise study is that there are no traffic noise impacts, state:

“Future noise levels for the receptors would not approach, meet, or exceed the noise abatement criteria, or substantially exceed existing noise levels.”

If there are traffic noise impacts, a statement of likelihood shall be included in the NEPA document and will typically fall into one of the three following scenarios:

1. If abatement measures are NOT feasible and reasonable, document why and state the following:

“The proposed project is anticipated to have traffic noise impacts, but the noise barriers studied and identified in Table (reference table in NEPA documentation) do not meet IDOT’s feasibility and reasonableness criteria. Due to this, traffic noise abatement measures are not likely to be implemented based on preliminary design. If the project’s final design is different from the preliminary design, IDOT will determine if revisions to the traffic noise analysis are necessary. A final decision on noise abatement will not be made until the project’s final design is approved and the public involvement processes is complete.”

2. If noise abatement measures are determined to be feasible and reasonable, and viewpoints solicitation is completed during Phase I, then state the following:

“The noise barriers were determined to meet the feasibility and reasonableness criteria. If the project’s final design characteristics is different from the preliminary design, IDOT will determine if revisions to the traffic noise analysis are necessary. A final decision on noise abatement will not be made until the project’s final design is approved and the public involvement processes is complete.”

3. If abatement measures are determined to be feasible, meets the IDOT Noise Reduction Design Goal, and are cost effective, but the solicitation of viewpoints from benefitted receptors will be deferred until Phase II Design then state the following:

“The noise barriers were determined to meet the feasibility criteria, the noise reduction design goal, and the cost effectiveness criteria as identified in Table (reference table in NEPA documentation). In order to determine if noise barrier(s) will be implemented, viewpoints solicitation still needs to occur. Viewpoints solicitation will occur after the project’s final design is approved. If the project’s final design is different from the preliminary design, IDOT will determine if revisions to the traffic noise analysis are necessary. A final decision on noise abatement will not be made until the project’s final design is approved and the public involvement processes is complete.”

For projects with Phase II viewpoints solicitation, a supplemental memorandum should be completed in Phase II summarizing the results of the viewpoints solicitation and clearly identifying the locations and top-of-wall elevations of the “likely to be implemented” noise barriers. This memorandum will be made available to the public so they are aware of the final barriers recommended for construction. IDOT will determine the best method to make this information available in Phase II on a project-by-project basis.

26-6.10 Validity of Noise Assessments

After approval of any Record of Decision, Finding of No Significant Impact, or Categorical Exclusion approvals, and before the districts request any subsequent approvals (e.g., approval to acquire right-of-way, final design and construction funding) from FHWA, the districts should consult with FHWA and BDE to determine if the NEPA decision, documentation, and approvals remain valid or if any additional or updated noise analysis is required.

26-7 FLOODPLAIN ENCROACHMENTS ENCROACHMENTS

26-7.01 Introduction

Projects involving Federal and/or State funds will include an evaluation of all encroachments into 100-year floodplains. The results of the evaluation will be documented in the reports prepared for corridor and/or design approval and must be summarized in the projects' environmental documentation. This Section provides guidance regarding information on floodplain encroachments to include in project environmental documents.

26-7.02 Complementary Technical Manual

The *IDOT Drainage Manual* discusses hydraulic analyses for floodplain encroachments.

26-7.03 Legal Authority

The following legal authority regulates or influences the policies and procedures for floodplains:

- Exec. Order No. 11988, Floodplain Management (1977),
- U.S. Water Resources Council's Floodplain Management Guidelines for Implementing Exec. Order No. 11988,
- U.S. Department of Transportation Order 5650.2, "Floodplain Management and Protection Floodplain,"
- Federal Highway Administration regulations on "Location and Hydraulic Design of Encroachments on Floodplains" (23 CFR 650, Subpart A),
- 17 Ill. Admin. Code 3708, implementing Sections 23, 29, and 30 of the *Rivers, Lakes, and Streams Act*, 615 ILCS 5/23, 29a and 30,
- Hazard Mitigation Grant Program, 44 CFR 206.430, and
- Illinois Exec. Order No. 2006-05, "Construction Activities in Special Flood Hazard Areas."

26-7.04 Policy

In the development of Federal and/or State-funded projects, special efforts shall be made to:

- encourage a broad and unified effort to prevent uneconomic, hazardous, or incompatible use and development of floodplains;
- avoid longitudinal encroachments, where practical;
- avoid significant encroachments, where practical;

- minimize impacts of actions that adversely affect base floodplains;
- restore and preserve the natural and beneficial floodplain values that are adversely impacted by IDOT actions;
- avoid support of incompatible floodplain development; and
- be consistent with the intent of the Standards and Criteria of the National Flood Insurance Program, where appropriate.

26-7.05 Procedures

26-7.05(a) Definitions

The following definitions are included to provide *BDE Manual* users a broad understanding of terminology associated with analysis and documentation of project-related floodplain encroachments. A number of these terms are not specifically used in the text of this Section but may arise in coordination efforts with the Federal Emergency Management Agency (FEMA), Illinois Department of Natural Resources, Office of Water Resources (IDNR-OWR), and public concerning floodplain encroachments.

1. Action. Any highway project construction, reconstruction, rehabilitation, repair, or improvement.
2. Base Flood. The flood or tide having a 1-percent chance of being exceeded in any given year (i.e., the 100-year flood).
3. Base Flood Elevation (BFE). The water surface elevation of the base flood.
4. Base Floodplain. The area subject to flooding by the base flood (100-year flood).
5. Design Flood. The peak discharge (volume, if appropriate) stage or wave crest elevation of the flood associated with the probability of exceedance selected for the design of a highway encroachment. By definition, the highway will not be inundated from the stage of the design flood.
6. Encroachment. An action within the limits of the base floodplain.
7. Flood Fringe. That portion of the floodplain outside of the floodway (often referred to as "floodway fringe").
8. Floodplain. The lowland and relatively flat areas adjoining waters, including, at a minimum, that area subject to a 1% or greater chance of flooding in any given year.
9. Freeboard. The vertical clearance of the lowest structural member of a bridge superstructure above the water surface elevation of the overtopping flood. It is a factor of safety usually expressed in ft (m) above a flood level for purposes of floodplain

- management. Freeboard tends to compensate for the many unknown factors that could contribute to flood heights greater than the height calculated for a flood frequency and floodway conditions (e.g., wave action, floating debris under bridge openings).
10. Longitudinal Encroachment. An encroachment on the floodplain that is parallel to the direction of flow.
 11. Minimize. To reduce to the smallest practicable amount or degree.
 12. Natural and Beneficial Floodplain Values. These include but are not limited to fish, wildlife, plants, open space, natural beauty, scientific study, outdoor recreation, agriculture, aquaculture, forestry, natural moderation of floods, water quality maintenance, and groundwater recharge.
 13. Practicable. Capable of being done within reasonable natural, social, or economic constraints.
 14. Preserve. To avoid modification to the functions of the natural floodplain environment or to maintain it as closely as practicable in its natural state.
 15. Regulatory Floodway. The floodplain area that is reserved in an open manner by Federal, State, or local requirements (i.e., unconfined or unobstructed either horizontally or vertically) to provide for the discharge of the base flood so that the cumulative increase in water surface elevation is no more than a designated amount (not to exceed 1 ft (300 mm)) as established by FEMA for Administering the National Flood Insurance Program (NFIP).
 16. Restore. To reestablish a setting or environment in which the functions of the natural and beneficial floodplain values adversely impacted by the highway agency action can again operate.
 17. Risk. The consequences associated with the probability of flooding attributable to an encroachment. It shall include the potential for property loss and hazard to life during the service life of the highway.
 18. Significant Encroachment. A highway encroachment and any direct support of likely base floodplain development that would involve one or more of the following construction or flood-related impacts:
 - a significant potential for interruption or termination of a transportation facility that is needed for emergency vehicles or provides a community's only evacuation route,
 - a significant risk, or
 - a significant adverse impact on natural and beneficial floodplain values.
 19. Special Flood Hazard Areas (SFHAs). The areas delineated on a NFIP map as being subject to inundation by the base (100-year) flood.
-

20. Support Base Floodplain Development. To encourage, allow, serve, or otherwise facilitate additional base floodplain development. Direct support results from an encroachment; indirect support results from an action out of the base floodplain.
21. Transverse Encroachment. An encroachment on the floodplain that is perpendicular to the direction of flow.

26-7.05(b) Applicability

These procedures shall apply to all Federal and/or State-funded projects initiated by the Department, that will entail encroachment, or which otherwise will affect base floodplains, except for repairs made with emergency funds during or immediately following a disaster. The assessment of floodplain encroachments should be incorporated into the development and analysis of corridor and design alternatives so that floodplain impacts will not be considered in isolation from other social, economic, environmental, and engineering considerations.

26-7.05(c) Floodplain Studies

For studies for evaluating proposed highway location alternatives, use the following steps for evaluating and documenting floodplain impacts:

1. Determine whether the proposed action will encroach upon the base (100-year) floodplain. Identify the geographic area of the floodplain. NFIP maps must be used if available. If NFIP maps are not available, information developed by IDOT and/or local, State, and Federal water resources and floodplain management agencies should be used for determining an encroachment.

There are several types of NFIP maps available. The Flood Insurance Rate Map (FIRM) is the most common map and most communities have this type of map. The FIRM depicts flood hazard zones and their boundaries and may show floodways and BFEs. Use the FIRM, if available, to identify the floodplain boundaries.

Several other NFIP maps are in circulation. The Flood Boundary and Floodway Map (FBFM) shows only the floodway and flood boundaries. The FBFM is no longer produced and is in the process of being phased out. The Flood Hazard Boundary Map (FHBM) is an older version of a flood map and is based on approximate data. Digital FIRMs (DFIRM) are being produced for Illinois. Maps are available on the Illinois Floodplain Maps website maintained by the Map Modernization Project in the Illinois State Water Survey. Use these maps if they are available for the county or counties where the project is located.

2. Determine if the project has transverse or longitudinal encroachments or both.
3. Address the following items for transverse encroachments:
 - Is there a significant potential for interruption of the roadway that is needed for emergency vehicles or provides a community's only evacuation route?

- Are there significant impacts on natural and beneficial floodplain values?
 - Is there a significant increase in the risk of flooding?
 - Will the project support and/or result in incompatible floodplain development?
4. Address the following items for longitudinal encroachments:
- Can the longitudinal encroachment be avoided? If the answer is yes, revise the project to avoid the longitudinal encroachment.
 - If the longitudinal encroachment cannot be practicably avoided; document the reasons why.
5. Determine if the project involves any significant encroachments. If an encroachment is significant, an "Only Practicable Alternative Finding" is required. A proposed action that includes a significant encroachment will not be approved unless FHWA finds that the proposed significant encroachment is the only practicable alternative.
6. Document the following in the location study report, in accordance with 23 CFR 650.111(e):
- The determination of whether or not the project alternatives involve floodplain encroachments.
 - Evaluation and discussion of the practicability of alternatives to any longitudinal encroachments.
 - Discussion of the following items, commensurate with the significance of the risk or environmental impact, for all alternatives containing encroachments and for those actions that would support base floodplain development:
 - + the risks (e.g., flooding risk) associated with implementation of the action;
 - + the impacts on natural and beneficial floodplain values;
 - + the support of probable incompatible floodplain development;
 - + the measures to minimize floodplain impacts associated with the action; and
 - + the measures to restore and preserve the natural and beneficial floodplain values impacted by the action.
 - Evaluation and discussion of the practicability of alternatives to any significant encroachments or any support of incompatible floodplain development.

Summarize the results of the floodplain studies in the project's Environmental Impact Statement (EIS) or Environmental Assessment (EA).

Section 26-7.05(d) provides guidance on the appropriate documentation to be incorporated in project environmental documents.

26-7.05(d) Environmental Documentation for Floodplain Encroachments

The environmental document should briefly summarize the results of the location hydraulic studies. The summary should identify the number of encroachments and any support of incompatible floodplain developments and their potential impacts. Where an encroachment or support of incompatible floodplain development results in substantial impacts, the environmental document should provide more detailed information on the location, impacts, and appropriate mitigation measures. In addition, if any alternative (1) results in a floodplain encroachment or supports incompatible floodplain development having significant impacts, or (2) requires a commitment to a particular structure size or type, the environmental document needs to include an evaluation and discussion of practicable alternatives to the structure or to the significant encroachment. The environmental document should include exhibits that display the alternatives, the base floodplains, and, where applicable, the regulatory floodways.

If the preferred alternative includes a significant floodplain encroachment, the final environmental document (final EIS or FONSI) must include a finding that it is the only practicable alternative, as required by 23 CFR 650.113. The finding should refer to Executive Order No. 11988 and 23 CFR 650, Subpart A. Include it in a separate subsection entitled “Only Practicable Alternative Finding” and must be supported by the following information:

- the reasons why the proposed action must be located in the floodplain,
- the alternatives considered and why they were not practicable, and
- a statement indicating whether the action conforms to applicable State or local floodplain protection standards.

For each alternative encroaching on a designated or proposed regulatory floodway, the environmental document should provide a preliminary indication of whether the encroachment would be consistent with or require a revision to the regulatory floodway. Engineering and environmental analyses should be undertaken, commensurate with level of encroachment, to permit the consistency evaluation and identify impacts. Coordination with FEMA and appropriate State and local government agencies should be undertaken for each floodway encroachment. If the preferred alternative encroaches on a regulatory floodway, the final environmental document should discuss the consistency of the action with the regulatory floodway. If a floodway revision is necessary, the environmental document should include evidence from FEMA and local or State agency indicating that such revision would be acceptable.

26-7.05(e) FEMA Buyout Properties Floodplain

The Federal government, through FEMA, administers the Hazard Mitigation Grant Program (HMGP) under the Hazard Mitigation, 42 U.S.C.42 5170c to purchase flood prone properties,

rather than repeatedly providing disaster relief after each flooding episode. The Illinois Emergency Management Agency (IEMA) administers the HMGP and makes grants available to State and local governments, and eligible private, non-profit organizations to implement cost-effective and long-term mitigation measures following major disaster declarations.

There are over 3,000 flood buyout parcels throughout the State that are located in flood prone areas. These parcels are owned by the local community or a private, non-profit organization. Deed restrictions are in place so that no structures or improvements, including placement of fill material or bridge piers, may be placed or erected on these properties. These sites are restricted to open space, recreation, or wetlands in perpetuity and must be avoided. Contact the BDE or the IEMA Hazard Mitigation Specialist for the location of buyout properties.

26-7.05(f) Mitigation

In general, flood damages outside the project right-of-way are not to be increased due to increased flood heights. Absent contrary evidence, this requirement is considered met for urban bridge crossings if, for all events up to and including the 100-year event, the water surface profile increase would not exceed 0.5 ft (150 mm) at the structure, nor 0.1 ft (30 mm) at a point 1,000 ft (300 m) upstream of the structure or would be constrained within flood easements. For rural bridge crossings, the limits are 1.0 ft (300 mm) at the structure and 0.5 ft (150 mm) 1,000 ft (300 m) upstream of the structure. For other types of development (e.g., longitudinal encroachments), absent contrary evidence, this requirement is considered met if, considering cumulative effects, the water surface profile increase would not exceed 0.1 ft (30 mm) (urban); 0.5 ft (150 mm) (rural) or would be contained within flood easements.

If there are existing buildings or other uses in the 100-year floodplain that would be damaged by higher flood stages than would occur under existing conditions, this would constitute "contrary evidence" and the normally allowed water surface increases are not applicable unless all impacted property owners are compensated for the additional flood damages attributed to the project. If compensation is provided (by the purchase of the properties or flood easements), the project may be designed so that the maximum overall water surface profile increase, considering both the project alone and the combined effects of equal floodplain encroachments on other properties, would be limited to 0.5 ft (150 mm) (urban)/1.0 ft (300 mm) (rural) at the bridge and 0.1 ft (30 mm) (urban) / 0.5 ft (150 mm) (rural) 1,000 ft (300 m) upstream of the bridge and throughout the remaining impacted reach.

Also, compensatory flood storage volume would need to be provided to compensate for any floodway storage losses resulting from the project. To minimize flood easement and flood storage compensation costs, consider the following:

- purchase of adjoining flood fringe properties to compensate for lost floodway conveyance and storage. A non-construction covenant would have to be put on the property to ensure preservation of the conveyance and storage provided; and
- removal of existing floodway encroachments or construction of conveyance/storage areas to compensate for the restrictions created by the project.

26-7.05(g) Public Involvement

Executive Order No. 11988 provides that when the only practicable alternative cannot avoid encroachment into the floodplain, the public must be given the opportunity for early review and comment. A reference to encroachments on the 100-year floodplain must be included in public involvement notices and any encroachments must be identified at public meetings.

26-7.05(h) Coordination

IDOT will coordinate with the entity having land use jurisdiction, whether it is a city, county, or the State. The local community has the responsibility for enforcing NFIP regulations in that community if the community is participating in the NFIP. Most NFIP communities have established a permit requirement for all development within the base (100-year) floodplain. Consistency with NFIP standards is a requirement for Federal-aid highway actions involving regulatory floodways. The community, by necessity, is the entity that must submit proposals to FEMA for amendments to NFIP ordinances and maps in that community if it becomes necessary.

IDOT coordination with FEMA should occur in situations where administrative determinations are needed involving a regulated floodway or where flood risks in NFIP communities are significantly impacted. The circumstances that would ordinarily require coordination with FEMA include:

- a proposed crossing encroaches on a regulatory floodway and, consequently, would require an amendment to the floodway map;
- a proposed crossing encroaches on a floodplain where a detailed study has been performed, but no floodway designated, and the maximum 1-ft (300 mm) increase in the base flood elevation would be exceeded; and
- a local community is expected to enter into a regulatory program within a reasonable period and detailed floodplain studies are under way.

The IDNR-OWR is authorized to administer a permit program regulating construction within public bodies of water and within floodways of rivers, lakes, and streams. The program's jurisdiction is tied to the size of the drainage area, the project scope of work, and the level of floodplain development at the project site. An IDNR-OWR permit is not required for projects within urban or urbanizing watersheds under 1 square mile (2.6 km²) or for rural locations draining less than 10 square miles (26 km²).

The Bureau of Bridges and Structures (BBS) is responsible for obtaining all IDNR-OWR permits on projects that require approval of the Hydraulic Report by the BBS.

Special permits are required for actions involving construction within the regulatory (100-year) floodways, as designated by the IDNR-OWR, in Cook, DuPage, Kane, Lake, McHenry, and Will counties, except for those areas that are within the City of Chicago.

26-8 WETLANDS

26-8.01 Introduction

The Executive Order No. 11990 applies special requirements for addressing the impacts of Federal projects on wetlands. Wetlands also are subject to regulation under the Federal *Clean Water Act* as a part of the Section 404 permit process and the Section 401 Water Quality Certification requirements. In addition, the Illinois *Interagency Wetland Policy Act of 1989* and the implementing rules for the *Act* address State policy for wetlands, which is reflected in the IDOT “Wetlands Action Plan” for compliance with the *Act* and rules. This Section provides guidance and procedures for complying with applicable requirements when proposed State highway projects would impact wetlands.

26-8.02 Legal Authority

The following legal authority regulates or influences the policies and procedures for wetlands:

- Exec. Order No. 11990, 42 Fed. Reg. 26961 (May 24, 1977),
- U.S. Department of Transportation Order 5660.1A, Preservation of the Nation’s Wetlands,
- Certification, 33 U.S.C. 1341 (*Clean Water Act* Section 401),
- Permits for Dredged or Fill Material, 33 U.S.C. 1344 (*Clean Water Act* Section 404),
- Regulatory Program of the Corps of Engineers, 33 CFR 320 through 331,
- Compensatory Mitigation for Losses of Aquatic Resources, 33 CFR 332,
- Section 404(b)(1) Guidelines for Specification of Disposal Sites for Dredged or Fill Material, 40 CFR 230,
- Mitigation of Impacts to Wetlands and Natural Habitat. 23 CFR 777,
- The *Interagency Wetland Policy Act of 1989*, 20 ILCS 830/1-1 *et seq.*,
- Implementation Procedures for the *Interagency Wetland Policy Act of 1989*, 17 Ill. Admin. Code 1090, and
- Illinois Department of Transportation Wetlands Action Plan.

26-8.03 Policy

In the development of proposed State highway projects, avoid impacts to wetlands unless there is no practicable alternative, and the proposed action includes all practicable measures to minimize harm to the wetlands. Further, in accordance with the *Interagency Wetland Policy Act*

of 1989, the Department shall preserve, enhance, and create wetlands where necessary in order to increase the quality and quantity of the State's wetland resource base.

26-8.04 Procedures

26-8.04(a) Definitions

1. Adverse Wetland Impact. Any land management and construction or related project activity that directly or indirectly reduces the size of a wetland or impairs a wetland's functional value or the hydraulic and hydrologic characteristics of a wetland. Throughout this Section, the term "wetland impact" refers to an adverse impact.
2. Coefficient of Conservatism (C). An integer from 0 to 10 assigned to each plant species in the Illinois flora that is used to calculate the Floristic Quality Index. Each value reflects an estimate of a plant species' tendency to be restricted to "natural areas." Native species most successful in badly damaged habitats are given C values of 0. Species virtually restricted to natural areas receive values of 10. Non-native species or those not identified to the species level are not treated in the calculations of FQI. The C is identified on the Illinois Natural History Survey (INHS) wetland delineations provided through the Environmental Survey Process.
3. Floristic Quality Index (FQI). An index derived from floristic inventory data that is considered in determining mitigation ratios for wetland compensation in accordance with the provisions of 17 Ill. Adm. Code 1090. The FQI is calculated and identified on the INHS wetland delineations. In general, an index score below 10 suggests a site of low natural quality; below 5, a highly disturbed site. An FQI value of 20 or more suggests that a site has evidence of native character and may be considered an environmental asset.
4. Hydrologic Unit. An 8-digit number (Cataloging Unit) depicted on the Hydrologic Unit Map-1974 State of Illinois. Each of the 52 Unit Codes represents a specific watershed (drainage basin).
5. Mitigation Bank. A site where wetlands and/or natural habitats are restored, created, enhanced, or preserved, expressly for the purpose of providing compensatory mitigation in advance of authorized impacts to similar type resources.
6. National Wetlands Inventory. A mapping program administered by the US Fish and Wildlife Service (USFWS) for identifying the locations of wetlands and deepwater habitats. Quadrangle-based maps are available for Illinois that include Riverine (streams), Lacustrine (lakes), and Palustrine (wetland) systems.
7. Off-Site. Where a wetland compensation site is located within the same Hydrologic Unit boundary but more than one mile (1.6 km) from the project for which wetland compensation is required.

8. On-Site. When a wetland compensation site is located within the same Hydrologic Unit boundary and is within one mile (1.6 km) of the project for which wetland compensation is required.
9. Out-of-Basin. When a wetland compensation area is located outside the Hydrologic Unit boundary that includes the site of the proposed project for which wetland compensation is required.
10. Percent Adventive. The determination of the percentage of non-native species at a wetland site determined by dividing the number of non-native plant species by the total number of plant species in a wetland. The percentage is calculated from the Species List information included with INHS wetland delineations. A high percentage of adventive (invasive) plants indicates a high level of disturbance.
11. Practicable. Available and capable of being done after taking into consideration cost, existing technology, and logistics in light of the overall project purposes.
12. Wetlands. Those areas that are inundated or saturated by surface or groundwater at a frequency and duration to support, and that under normal circumstances do support, a prevalence of vegetation typically adapted for life in saturated soil conditions. For purposes of the *Interagency Wetland Policy Act of 1989*, the term includes areas that are restored or created as the result of mitigation or planned construction projects and that function as a wetland even when all three wetland parameters (i.e., hydric soils, inundation or saturation by surface or groundwater, and prevalence of hydrophytic vegetation) are not present.
13. Wetland Classification. A system for designating wetlands and deepwater habitats as to type, based on vegetation and other pertinent characteristics. The Cowardin classification of wetlands and deepwater habitats is used on the National Wetland Inventory maps. Sites depicted as palustrine on these maps may be jurisdictional wetlands. On-site wetland determinations are required to confirm the jurisdictional status of the site. Classes of palustrine wetlands include emergent, scrub-shrub, and forested.
14. Wetland Compensation Plan. A plan developed for each individual construction project affecting wetlands that details how compensation will be provided for unavoidable adverse wetland impacts.
15. Wetland Functions. Benefits that wetlands provide because of their physical, chemical, and biological properties and processes. Examples of these functions include surface and subsurface water storage, nutrient cycling, particulate removal, maintenance of plant and animal communities, and groundwater discharge and recharge.
16. Wetland Impact Evaluation (WIE) Form. An IDOT form that identifies the amount and type of wetland impact, the measures considered to avoid and minimize the impacts, the applicable mitigation ratio, and the amount of compensation required for each wetland impacted by a project.

17. Wetland Technical Report. A report in the form of a brief Environmental Assessment (EA) used to determine the significance of wetland impacts. The significance determination is based on the analysis of wetland impacts in the Report and the results of coordination of the Report with the Corps, USFWS, US Environmental Protection Agency, FHWA, and IDNR.

26-8.04(b) Applicability

The procedures in this Section apply to all highway projects initiated by the Department that:

- involve acquisition of additional right-of-way or easements (temporary or permanent);
- require a drainage structure runaround or any in-stream work;⁴
- potentially affect a recognized natural area/nature preserve or a location where a State-listed or Federal-listed species is known to occur; or
- potentially affect a wetland within existing right-of-way, as identified through National Wetland Inventory (NWI) maps or other wetlands information source that the district possesses.

26-8.04(c) Analysis and Documentation

The following procedures address identification and description of wetlands (e.g., plant communities), avoidance and minimization of wetland impacts, identification and description of unavoidable wetland impacts, mitigation of unavoidable wetland impacts, and public involvement and agency coordination for wetland involvement.

26-8.04(c)1 Wetland Identification

The identification and characterization of wetland resources is accomplished through the Environmental Survey Process (Chapter 27). In response to the submittal of an Environmental Survey Request (ESR), BDE uses available information (e.g., National Wetland Inventory maps, aerial photos, soils maps) to determine whether wetlands are, or may be, present in the area potentially affected by the project. If the information clearly indicates that no wetlands are present in or near the project vicinity, BDE provides the district a sign-off indicating that further action under the wetland requirements will not be necessary, unless the scope or location of the project changes and it would potentially affect locations beyond the area previously reviewed for wetlands. For projects processed as a Categorical Exclusion (CE), include the BDE sign-off in

⁴ Note: For contractor-furnished borrow, waste, and use areas and for contractor-proposed drainage structure runarounds affecting areas beyond the limits of Phase I environmental surveys conducted for the project, BDE performs initial screening for wetlands as described below. For any wetlands potentially affected by these contractor-furnished facilities, the contractor is responsible for obtaining delineations of the wetlands in accordance with the current Federal Wetlands Delineation Manual. The contractor also is responsible for complying with applicable permitting and compensation requirements for any unavoidable adverse wetland impacts resulting from these contractor-furnished facilities. The procedures in this Section are not intended to cover compliance actions for contractor-furnished facilities.

the Phase I engineering report. For projects processed with an Environmental Assessment (EA) or Environmental Impact Statement (EIS), include a statement in the environmental document indicating that the project area was reviewed for wetlands, and none were identified. Retain the BDE sign-off in the project file.

If the review indicates there are, or may be, wetlands in or near the project vicinity, BDE submits the project to the INHS for wetland delineation. The turnaround time for providing wetland delineations is six months to one year from the date the ESR is received. If the INHS delineations indicate that the sites are not wetlands, BDE provides the survey results to the district with a sign-off as described above. For CE projects, include the BDE sign-off and the INHS delineations in the Phase I engineering report. During Phase II, if the project requires a Section 404 permit from the Corps for other reasons (e.g., streams, impoundments), include the INHS delineations as a part of the permit submittal to document the absence of wetlands. For EA or EIS projects, include a statement in the environmental document indicating that the project area was reviewed and surveyed for wetland resources, and none were identified. If the surveyed locations involve wooded areas, identify and describe these areas in the upland plant community section of the environmental document or, if in a riparian corridor, in the surface water resources/aquatic habitat section of the document.

If the INHS survey results identify wetlands within the project vicinity, BDE provides the district the wetland delineations and a wetland survey report. BDE includes a request that a Wetland Impact Evaluation (WIE) Form be filled out and submitted to BDE once the extent of any unavoidable wetland impacts is determined. For CE projects, include in the Phase I engineering report a copy of the wetland delineations, the wetland survey report, the completed WIE Form, and the BDE reply to the WIE Form, if needed. For EA or EIS projects, include in the environmental document descriptions of each delineated wetland within the project vicinity. Place the descriptions in a table with the following headings:

- Wetland Site Number,
- Wetland Type (plant community/cover type),
- Wetland Size (acres (ha)),
- NWI Code (if any),
- Dominant Plant Species,
- Soil Type,
- FQI,
- Percent Adventive, and
- Wetland Functions.

This information can be obtained from the wetland delineations and the INHS wetland survey report.

26-8.04(c)2 Evaluation of Wetland Importance

Although wetlands in general are subject to protection under Federal and State directives, wetlands with a higher level of importance warrant proportionately greater efforts for avoidance of adverse impacts. In evaluating the importance of wetlands, consider factors such as uniqueness, natural quality, special designations, and habitat functions.

Unique wetland types include bog, fen, flatwoods, sedge meadow, wet prairie, seep, and forested wetland containing oak, hickory, birch, beech, black gum, eastern arborvitae, bald cypress, or black ash. These types of wetland plant communities are not common because of the unique geological and topographic conditions necessary to support their existence. Accordingly, the potential for creating or restoring wetlands of these types is extremely limited or non-existent. These types of wetlands deserve the utmost consideration for avoidance of adverse impacts.

Natural quality is a measure of the extent to which a wetland has avoided disturbance (e.g., of its wetland plant communities). A relative lack of disturbance is considered to confer high quality or Illinois Natural Area status to an area. Wetlands with unpolluted water, unaltered to slightly altered water level, and intact vegetation structure with a diversity of native plant species are considered to be of high natural quality.

Wetlands with special designations include those designated as Advanced Identification (ADID) sites and Illinois Natural Areas. These designations are made by U.S. Environmental Protection Agency (USEPA), the Corps for ADID sites, and IDNR for Illinois Natural Areas. The designations are applied based on the high quality of the resource.

Where wetlands provide habitat for Federal and/or State listed threatened and endangered species and/or contain designated critical/essential habitat for listed species, these wetlands have a high level of importance based on their habitat functions.

26-8.04(c)3 Analysis of Impact Avoidance and Minimization Alternatives

Where a project may affect wetlands, the district must consider location and design alternatives to avoid and minimize adverse wetland impacts to the extent practical. This includes consideration of the “no action” alternative, alternative alignments, and other design aspects (e.g., steepening slopes, reducing median and lane widths, overland bridges) to minimize encroachment into wetlands.

In the environmental documentation for the project, include information on any measures taken to avoid and minimize adverse wetland impacts (e.g., discussion and comparison of alternatives that avoid and minimize impacts to wetland resources). Show location alternatives on maps or other drawings that depict the wetland areas. If avoidance alternatives are not practicable, include in the environmental documentation an explanation of the reasons why (e.g., cost, impacts on highway performance, socio-economic, other environmental impacts).

26-8.04(c)4 Wetland Impact Evaluation Form

For all projects that are surveyed for wetlands and determined to have wetlands within the project vicinity, complete a WIE Form and submit it to BDE. Submit the WIE Form after completing the analysis of avoidance and minimization alternatives and determining the likely extent of unavoidable wetland impacts. The information in the WIE Form indicates whether or not the project involves unavoidable adverse wetland impacts and provides the basis for determining whether it qualifies as a Programmatic Review Action or Standard Review Action, in accordance with the IDOT Wetlands Action Plan (see Part III, Appendix A).

If the project will not impact wetlands, indicate that determination on the WIE Form and send the completed form to BDE. BDE will respond, indicating that coordination under the wetland requirements is complete. For CE projects, include a copy of the completed WIE Form in the Phase I engineering report. For EA or EIS projects, include a statement in the environmental document indicating that the project will not impact wetland resources.

If the project has wetland impacts, fill out the WIE Form and submit it to BDE for review. For Programmatic Review Actions, BDE responds to the WIE submittal to confirm the processing category and confers with the district on options for providing the necessary compensation for unavoidable adverse wetland impacts. For Standard Review Actions, BDE coordinates the WIE Form, delineations, and wetlands survey report with IDNR, as required by the IDOT Wetlands Action Plan and 17 Ill. Adm. Code 1090.50(a)(1). Upon completion of IDNR's review, BDE provides the district a copy of IDNR's response and confers with the district on options for providing the necessary compensation for unavoidable adverse wetland impacts. For CE projects, include in the Phase I engineering report the completed WIE and results of coordination with BDE and, if applicable, with IDNR, for Standard Review Actions. For EA or EIS projects, include the following information in the environmental document for each alternative that would affect wetlands:

- a brief description of the work within wetlands;
- wetland impacts, summarized in a table containing the wetland site number, its aerial exhibit sheet number, wetland type, total size of the wetland (acres(ha)), area of impact (acres(ha)), FQI, percent Adventive, and function(s) impacted;
- as applicable, identification and description of impacts to wetlands identified as important; and
- description of impacts on wetland functions (e.g., wildlife habitat, flood storage, groundwater discharge).

For Standard Review Actions, also include the results of coordination with IDNR in the environmental document.

26-8.04(c)5 Compensation Plan Development

After the processing category and amount of anticipated unavoidable adverse wetland impacts have been established for a project, the compensation process can begin. Compensation for unavoidable adverse wetland impacts will be in accordance with the "Policy on Wetlands Impacts and Compensation" in Section V of the IDOT Wetlands Action Plan (recognizing that the size of wetland impacts eligible for accumulation is now 0.1 acre (400 m²), rather than 0.3 acre (1200 m²) as indicated in the Wetlands Action Plan). For projects requiring compensation under a Section 404 permit, the Corps may, at its discretion, require different ratios on a case-by-case basis. The project will need to comply with the more stringent of the State or Federal compensation requirements.

If the district and BDE decide to accumulate impacts smaller than 0.1 acre (400 m²), BDE documents the decision and records the impact amount for tracking against the maximum

thresholds for total amounts that can be accumulated as set forth in Section V of the IDOT Wetlands Action Plan. For Standard Review Actions, BDE informs IDNR of the decision to accumulate the impacts when the project is coordinated for IDNR review. This decision also should be reflected in the environmental documentation for the project.

If compensation for impacts smaller than 0.1 acre (400 m²) will be provided on-site or from an existing source of wetlands credits, preparation and processing of a compensation plan will be necessary, as described below.

The Department's preferred method of wetland compensation involves the use of pre-existing wetland credits from a commercial or Department-owned wetland mitigation bank site. This preference may be met when the project is within the service area of a bank site. Information on Department-owned wetland mitigation bank sites and service areas may be accessed at the Department's Environment webpage. For projects that are not within the service area of a mitigation bank, compensation will be provided through wetlands restoration, enhancement, and/or creation, as described below.

26-8.04(c)6 Compensation through Use of Pre-Existing Wetland Credits

Credits generated at approved commercial and Department bank sites may be used to satisfy compensation requirements for Section 404 of the *Clean Water Act* and the *Interagency Wetland Policy Act of 1989*.

If compensation will be provided from a wetland bank or other approved source of wetlands credits, a compensation plan is prepared in accordance with Section VII A. of the IDOT Wetlands Action Plan. BDE coordinates the plan in accordance with Section VI of the IDOT Wetlands Action Plan. Summarize the information from the compensation plan in the environmental documentation for the project and include evidence of IDNR concurrence in the plan for projects classified as Standard Review Actions.

For proposals to draw credits from a Department bank, BDE forwards a copy of the WIE to the District Environmental Coordinator and District Programming Engineer. Debits are considered pending until the project is awarded. Current district bank site ledger information can be obtained by contacting BDE.

Districts receive priority consideration for use of credits from their own bank(s) and BDE will only approve credit withdrawals for other districts if the bank has sufficient credits available to meet the foreseeable needs of the district that owns the bank. Each district has the option to object to an incoming WIE, in writing, within 20 working days of receipt of the WIE. The reason for the objection must be included in the written documentation.

BDE serves as the principal point of contact with wetland regulatory agencies for resolving issues regarding the use of bank credits on specific projects and for any required reporting to those agencies associated with the bank sites (e.g., concerning credit balances, credits used).

A district may want to purchase a block or surplus of credits from a commercial or Department-owned bank site. These credits would be purchased in advance of any known impacts and used to compensate for small losses (i.e., less than 0.5 acre (0.2 hectare)) from several projects. When

a district purchases a block of credits, the district creates and maintains a ledger for tracking debits from that block. When coordinating with BDE, the district submits a copy of the ledger associated with the block purchase with the WIE.

A district that proposes to draw credits from a commercial bank must commit program funds to cover the purchase of credits. Where credits from a Department-owned bank are used by another district, that district must reimburse the district that owns the bank. The Office of Planning and Programming (OPP) accomplish billing and reimbursement through the re-appropriation of district program funds. Re-appropriations will occur once each year based on information provided by BDE. Each district should submit their cost for bank site development to OPP to ensure the district is adequately compensated during the re-appropriation process. Cost should be the sum of land acquisition, construction, and maintenance for each acre (ha).

26-8.04(c)7 Compensation through Wetlands Restoration, Enhancement, and/or Preservation

If compensation is provided through wetlands restoration, enhancement, and/or preservation, the district will take the lead in locating a suitable compensation site(s) and giving appropriate consideration to the effect of the applicable compensation ratios on the amount of compensation needed. The district should consider wetland resource needs within the watershed and the practicability of accomplishing ecologically self-sustaining on-site wetland restoration, enhancement, and/or preservation (i.e., at the site of the proposed project). In selecting potential sites for wetland restoration, the district should consider the need for using sites that contain a majority of hydric soils.

After the district has identified one or more potential compensation sites, it submits information to BDE to request a more detailed assessment of the suitability of the sites for wetland compensation purposes. The information provided to BDE includes a map (7.5' topographic map or plat map) that shows the location and boundary of the site(s) and indicates their size and current ownership. In response to this submittal, BDE makes a preliminary site suitability evaluation, based on soils information. If BDE has concerns about the suitability of the site based on this preliminary evaluation, it will confer with the district before proceeding with any further studies or evaluations of the site. If BDE does not identify any immediate site suitability concerns, or if its concerns are resolved, it will forward the information to the INHS and the Illinois State Geological Survey (ISGS), as appropriate. INHS and ISGS will conduct further investigations of the hydrology, soils, vegetation, and adjacent land use for the proposed site. As necessary, BDE contacts the district to confirm that landowner permission has been obtained or that written notification has been provided to the landowner prior to having the INHS/ISGS initiate the on-site investigations. BDE forwards the results of the site assessments to the district with recommendations on the suitability of the site for wetland restoration or creation.

For sites the district wishes to continue to pursue, it submits an ESR to BDE to initiate evaluations of the site for cultural resources, and endangered and threatened species, or Illinois Natural Area Inventory sites. The district also screens the site for special waste in accordance with the procedures in Section 27-3.02. For sites on agricultural land, the district coordinates with the Natural Resources Conservation Service (NRCS) of the US Department of Agriculture to obtain

certification on the status of wetlands on the site (e.g., prior-converted wetlands, farmed wetlands).

After completion of site evaluations and any necessary coordination for cultural resources, endangered species/natural areas, or special wastes, the district and BDE confer regarding the suitability of the site for use prior to preparing the conceptual compensation plan or initiating property negotiations with the landowner.

1. Conceptual Compensation Plan. After conferring with BDE and deciding to proceed with proposing use of a particular site for compensation, the district prepares a conceptual compensation plan in accordance with the outline in Section VII B. of the IDOT Wetlands Action Plan and the following:

- In the description of the proposed wetland compensation site(s), include an indication of its current vegetation characteristics.
- Include in the conceptual compensation plan a description of the monitoring plan that will be used to evaluate the success of the compensation, including the use of measures to correct identified deficiencies or problems. Monitoring of restored or created wetlands should commence the growing season after completion of the work for the restoration/creation. Compensation projects larger than one acre (0.4 ha) are monitored for five years. Compensation projects of one acre (0.4 ha) or less are monitored for three years. All monitoring is conducted by the INHS, through BDE. BDE accomplishes any required coordination of monitoring reports with IDNR and the Corps.
- Include in the conceptual compensation plan a description of the operation, management, and maintenance plan for the site. Include procedures to restrict further adverse impacts to the site (e.g., use of buffer areas, restricting highway project, other incompatible construction within the wetland compensation area).

The district submits one copy of the conceptual plan to BDE for review. As a part of the initial review, BDE may confer with the Corps or the USFWS, or both, on a case-by-case basis to obtain a preliminary reaction to the conceptual plan prior to proceeding with further reviews. Any concerns or comments from these agencies will be relayed to the district. After BDE review of the conceptual compensation plan and resolution of any concerns identified, BDE provides the plan to IDNR for concurrence in accordance with Section VI of the IDOT Wetlands Action Plan.

Summarize the details of the conceptual compensation plan as concurred in by IDNR in the environmental documentation for the project. On EIS projects, include a summary of the conceptual compensation plan information in the draft and final statement. If an EA is prepared, ensure that the summary conceptual compensation plan information is in the document when it is available for public and agency review. If the project qualifies as a CE, include a summary of the conceptual compensation plan information in the Phase I engineering report prior to Design Approval. Include a table presenting a summary of the wetland mitigation. In the table, provide the wetland site number, wetland type, impact

area (acres (h)), ratio category (e.g., on-site, off-site, FQI, T&E species, natural area, essential habitat), ratio (State mitigation ratio), and compensation required (acres (ha)).

2. Compensation Design Plan. After the conceptual compensation plan has received the necessary concurrence from IDNR, include appropriate information and details for the approved compensation plan in the project design plans. Continue to analyze and incorporate, as practical, ways to avoid and minimize adverse wetland impacts as plan preparation progresses. As a part of the design-phase compensation plan work, proceed with development of any necessary agreement with the entity or entities that will assume responsibility for long-term management of the compensation wetlands. Submit the agreement to BDE as far in advance of the target letting date for the project as practical. As appropriate, include in the design documents the following details for compensation to be provided through wetland restoration, enhancement, and/or creation:
 - a. Earthwork. Provide a grading plan with contours of final grading elevations, staging and method of grading, and topsoil stockpile site(s), unless at contractor's discretion.
 - b. Planting Plan and Specifications. Provide species list, quantities, sizes, form (e.g., container-grown, bare root, cutting, sprig), spacing, grouping, staking requirements, timing of planting, weed control, etc.
 - c. Hydrology. Indicate inflow and outflow points and water control structures.
 - d. Work Schedule. Reflect the timing of each construction phase for the wetland compensation site in the plans and specifications to ensure the successful establishment of wetland hydrology, plant materials, etc. The wetlands compensation work should commence prior to or concurrent with the highway project construction work that causes the adverse wetlands impacts requiring the compensation (i.e., compensation for wetland impacts that would occur under the first contract of a project should commence prior to or concurrent with the work under that contract and should not be put off to be addressed under a subsequent contract).
 - e. Special Measures. Include a description in the special provisions or plan notes for any special measures that will be implemented during construction of the wetland compensation site to avoid or minimize unnecessary construction-stage impacts to existing wetlands (e.g., designation of "no-work" areas, restrictions on utility relocation/accommodation that could affect wetlands, placement of geotextile fabric to prevent permanent compaction of wetland soils), and to correct temporary impacts that may occur (e.g., restoration of preconstruction contours, replanting or reseeding of areas in which wetlands vegetation is disturbed or destroyed). Include notations in the plans to ensure that the wetland compensation site will not be used as a construction staging area, concrete recycling site, temporary stockpile site for spoil soils or topsoil, or other such construction-related uses.
 - f. Notification to BDE. Include provisions in the plans for notifying BDE to facilitate monitoring and reporting on progress in accordance with the approved conceptual

compensation plan. This must include notification when the wetlands compensation site construction work begins and when it is completed. In addition, the plans must provide for contacting the BDE Natural Resources Unit regarding any field changes that would affect the approved wetlands compensation plan so the changes can be coordinated with IDNR, as necessary, prior to implementation.

Describe the information concerning hydrology in the plan notes and show the information on the plan sheets for grading work. Show planting information on plan sheets for the planting work and in appropriate specifications. Show estimates of quantities in the same way as those for highway construction to provide guidance to contractors bidding on the work. District personnel responsible for plan preparation should work closely with district personnel and others involved in the development of the wetlands compensation plan to ensure that the components of the compensation work are completely and accurately reflected in the plans.

Submit plan information for the wetlands compensation work to BDE for review at 50% completion and at 100% completion. The district should address these submittals to the attention of the BDE Natural Resources Unit or should notify the BDE Natural Resources Unit by phone or e-mail when these submittals are being sent. In one of these submittals, include an indication of the scheduled letting date for the contract that will include the compensation site work. If the scheduled letting date subsequently changes, notify the BDE Natural Resources Unit. For project tracking purposes, the district should also notify the BDE Natural Resources Unit when the contract involving the wetland compensation site work is awarded and advise that Unit of the anticipated date that construction work for the compensation site will begin.

When BDE receives the wetlands compensation plan information for review at 100% completion, it coordinates the plan with IDNR for approval in accordance with Section VI of the IDOT Wetlands Action Plan. Approval may also be required from the Corps. The Corps may want to provide the plan to the USFWS for review and comment prior to making its decision. BDE coordinates the compensation design plan to obtain all necessary approvals.

When the necessary approvals are received from IDNR and, as appropriate, the Corps, BDE provides the district documentation of the approvals. The validity period for IDNR's approval of the compensation plan will be as stipulated in Section VI.B of the IDOT Wetlands Action Plan. If the district does not commence implementation of the compensation plan (i.e., acquire the mitigation site and/or begin the earthwork, planting, or other work necessary for the wetland restoration, enhancement, and/or creation) within three years of IDNR's approval, contact BDE to request a reevaluation of site conditions. BDE will reinitiate evaluations of the site by the INHS and/or ISGS, as necessary, and confer with the district on any changes needed in the compensation plan. BDE will re-coordinate the plan with IDNR, and, as necessary, with the Corps, before implementation of the compensation plan may commence.

For projects involving wetland compensation work, it may be beneficial to provide for a pre-bid conference to afford an opportunity to answer any questions regarding the compensation plan.

26-8.04(c)8 Compensation Plan Implementation

Once the compensation plan has received any needed approvals from IDNR and the Corps, the district proceeds with actions necessary to implement the plan. Projects involving adverse

wetlands impacts should not proceed to letting until the wetland compensation plan has been approved.

26-8.04(c)9 Compensation Plan for Use of Preexisting Wetland Credits

When the approved plan calls for use of credits from an IDOT bank site, the district and BDE coordinate to accomplish the necessary accounting in the bank site ledger for the application of credits on the project. When the approved plan calls for acquiring credits from a commercial bank or other outside source, the district shall proceed with the actions necessary to secure the credits for the project. Piecemeal acquisition of compensation credits for a project is discouraged. To the fullest extent practical, provide all of the compensation credits required for a project or acquired concurrently. Provide and secure the credits before the associated adverse wetland impacts occur. Once the credits are secured, provide written confirmation to BDE to verify compliance with the terms of the approved compensation plan. For purchase of credits from commercial banks, include in the written confirmation documentation from the bank owner/manager indicating that the credits have been purchased. BDE coordinates written confirmation with IDNR and the Corps, as necessary.

26-8.04(c)10 Compensation Plan for Wetlands Restoration, Enhancement, and/or Creation

When compensation is provided through wetlands restoration, enhancement, and/or creation, careful oversight will be required to ensure that the compensation plan is implemented as approved, including any long-term monitoring and reporting required. (Implementation of the wetlands compensation site construction work should commence prior to or concurrent with the contract for the highway project construction work that causes the adverse wetlands impacts requiring the compensation.) This oversight responsibility applies throughout construction of the compensation site and beyond, until successful criteria have been met and the compensation site is transferred for long-term management. Address the considerations described below as implementation of the compensation plan proceeds (e.g., through district procedures for tracking and follow-through on commitments, or other suitable means). BDE will have ongoing involvement in the oversight for monitoring activities and in the coordination of the results of those activities with IDNR and the Corps, as appropriate.

1. Land Acquisition Phase.

- a. Acquire parcels necessary for accomplishing the wetlands compensation work in a timely manner to facilitate conducting the wetlands work at the proper time in the project construction schedule.
- b. If the property is transferred to an entity other than IDNR, include suitable deed restrictions, conservation easements, or other enforceable legal mechanisms in the documents for transfer of compensation wetlands to prevent future activities at the site(s) that would be incompatible or potentially harmful to the wetlands.

2. Construction Phase.

- a. It may be beneficial for the preconstruction conference on the project to include discussion of logistics and other issues relating to the wetland compensation plan to promote understanding of the objectives of the plan and to respond to any questions or concerns. Depending upon the complexity of the compensation plan, consider inviting BDE and district staff involved in the development of the compensation plan, and the planting contractor or other special subconsultants that will be involved in the wetlands work. The following topics may be appropriate for discussion:
 - scheduling in relation to other project construction work;
 - no-work areas (e.g., existing wetlands, other areas to be avoided);
 - topsoil stockpile sites; and
 - utility relocation/accommodation issues.
 - b. Notify BDE at key points (e.g., site work begins, when it is completed) in implementation of the wetland compensation plan to facilitate appropriate monitoring and reporting on progress in accordance with the provisions in the approved compensation plan. Notify BDE within 30 days of completion, and prior to closing out the contract, to afford time for a final check of the site and to allow for accomplishing any associated corrective measures that may be necessary. In response to this notification, BDE will provide a compensation site post-construction evaluation report to IDNR, as required by the IDOT Wetlands Action Plan and the implementing rules for the *Interagency Wetland Policy Act*.
 - c. Any proposed field changes that would affect components of the wetland compensation as approved by IDNR and the Corps must be coordinated with the BDE Natural Resources Unit prior to proceeding. As necessary, BDE will confer with IDNR and the Corps regarding the effect of the proposed changes on the approved wetland compensation plan.
3. Operations Phase.
- a. When BDE receives notification from the district that activities for construction of the wetland compensation site have been completed, it will task the INHS and ISGS to begin monitoring the site in accordance with the monitoring plan component of the compensation plan approved by IDNR and the Corps. BDE will review the monitoring reports and transmit them to the district, with copies to IDNR and the Corps, as appropriate. The transmittals and monitoring reports will identify any needed management or maintenance measures for the wetland site and will include an assessment of the progress toward attainment of the site performance standards. The district will be responsible for accomplishing any identified management and/or maintenance measures in accordance with the site management component of the approved wetland compensation plan. BDE will be available to provide guidance as needed.
 - b. Districts must ensure that maintenance personnel are aware of the location and limits of wetland compensation sites that could be affected by maintenance

operations. Wetland compensation sites adjacent to highway rights-of-way must be protected from mowing, weed spraying, or other operations activities where those activities would adversely affect the wetlands.

- c. When the monitoring reports indicate that site performance standards have been attained, BDE will include a request for final approval of the compensation site in the transmittal of the monitoring information to IDNR and the Corps. The request will offer the option for either agency to request an on-site meeting to inspect the compensation area prior to giving approval. BDE will coordinate with the district on arrangements for on-site meetings, if requested. After IDNR and the Corps have approved the compensation site, monitoring will be terminated, and the district may begin the process of transferring the site for long-term management. District and central Land Acquisition Bureaus must ensure that transfer of wetlands compensation sites for long-term management complies with Section XI of the IDOT Wetland Action Plan and the provisions of any agreements executed with the entity that is to receive the site.

26-8.04(d) Public Involvement/Coordination

For projects being processed with an environmental document, a public notice must be given if wetlands would be affected (see Chapter 19). Include documentation of coordination with State and Federal agencies in the Appendix. The addendum for an EA or the FEIS will address any comments received from the public or State and Federal agencies concerning the wetland involvement. The response to comments may include acceptance of recommendations for practicable measures that would decrease wetland impacts.

26-8.04(e) Wetlands Finding

If the preferred alternative is located in wetlands, include in the environmental documentation the finding required by Executive Order No. 11990 that there are no practicable alternatives to construction in wetlands.

26-8.04(e)1 Categorical Exclusion

The FHWA has approved a wetland finding on a program-wide basis for transportation improvement projects classified as a categorical exclusion (CE). It satisfies the requirements of Executive Order No. 11990 and U.S. Department of Transportation Order 5660.1A. No individual wetland finding needs to be prepared for CE projects.

26-8.04(e)2 Environmental Assessment/Environmental Impact Statement

For Finding of No Significant Impact (FONSI) or Final Environmental Impact Statement, provide a separate subsection under Wetlands entitled "Only Practicable Alternative Finding." Include the following support information:

- a reference to Executive Order No. 11990;

- an explanation why there are no practicable alternatives to the proposed action;
- an explanation why the proposed action includes all practicable measures to minimize harm to wetlands; and
- a concluding statement:

Based upon the above considerations, it is determined that there is no practicable alternative to the proposed construction in wetlands and that the proposed action includes all practicable measures to minimize harm to wetlands that may result from such use.

26-8.04(f) Development of IDOT Wetland Banks

Districts may propose development of IDOT wetland banks for use in providing compensation credits for offsetting unavoidable adverse wetland impacts resulting from highway projects. The procedures in the following Sections will apply.

If the proposed IDOT wetland bank is within an area covered by an area-specific Federal or State interagency agreement or directive governing wetland banking activities (e.g., the “Interagency Coordination Agreement on Wetland Mitigation Banking Within the Regulatory Boundaries of Chicago District, Corps of Engineers”), the provisions of that agreement or directive will govern to the extent that its requirements are different from the details in this Section. BDE will be available to provide assistance as necessary for complying with applicable alternative requirements and still should be involved in review of information prepared for evaluation of potential banking sites and information for development of the bank prospectus and banking instrument/charter. In addition, BDE still should be involved in coordinating information regarding development of the prospectus and banking instrument with Mitigation Bank Review Team (MBRT) agencies as discussed in these procedures.

26-8.04(f)1 Site Identification and Evaluation

The district takes the lead in identifying proposed sites for IDOT wetland bank development. The Corps district offices and the local offices of the USFWS, NRCS, and IDNR may be able to provide useful information on potential bank sites in their area of jurisdiction. Districts should be aware that some Corps district offices may stipulate minimum sizes for banks that will be used to provide compensation credits under the Section 404 permit requirements. Districts should confer with the Corps district office(s) that have jurisdiction to determine the nature and applicability of any constraints.

After the district has identified a site it wishes to pursue for use as a wetland bank, it submits information to BDE to request a more detailed assessment of the suitability of the site for wetland compensation purposes. The information provided to BDE includes a map (7.5' topographic map or plat map) that shows the location and boundary of the site and its size and ownership. In response to this submittal, BDE makes a preliminary site suitability evaluation based on soils information. If BDE has concerns about the suitability of the site based on this preliminary evaluation, it confers with the district before proceeding with any further studies or evaluations of

the site. If BDE does not identify any immediate site suitability concerns or if concerns are resolved, it forwards the information to the INHS and ISGS, as appropriate. INHS and IGS conduct further investigations of the hydrology, soils, vegetation, and adjacent land use for the proposed site. As necessary, BDE contacts the district to confirm that landowner permission has been obtained or that written notification has been provided prior to having the INHS/ISGS initiate the on-site investigations. BDE forwards the results of the site assessments to the district with recommendations on the suitability of the site for wetland banking purposes.

For sites that the district wishes to continue to pursue, it submits an Environmental Survey Request form to BDE to initiate evaluations of the site for cultural resources, and endangered and threatened species, or Illinois Natural Area Inventory sites. The district also evaluates the site for special waste in accordance with the procedures in Section 27-3.02. For sites on agricultural land, the district coordinates with the NRCS to obtain certification on the status of wetlands on the site (e.g., prior converted wetlands, farmed wetlands).

26-8.04(f)2 Mitigation Bank Prospectus

To initiate the planning and review process with outside agencies for a proposed bank site, the district is responsible for preparing a Mitigation Bank Prospectus. Preparation of the prospectus should not begin until site evaluations and any necessary coordination for cultural resources, endangered species/natural areas, or special wastes have been completed, and the district and BDE have conferred regarding suitability of the site for banking purposes. After the district and BDE confer and decide to proceed with proposing use of a site for wetland banking purposes, BDE contacts the appropriate Corps district(s) and IDNR to obtain their preliminary views on the proposal. BDE provides the district any information or views provided by the Corps and IDNR for consideration in preparing the prospectus. BDE provides assistance, as needed.

The prospectus provides information that IDNR and the Corps will use to evaluate the need for, and technical feasibility of, a proposed mitigation bank. The prospectus should contain the following information:

- the site location, size, and legal description;
- a delineation of any wetlands or other jurisdictional areas that may exist at the proposed bank location;
- the type of real estate interest proposed for the bank site;
- the type of bank proposed (e.g., government agency bank for use in offsetting unavoidable adverse wetland impacts of highway projects);
- the method of credit production (e.g., restoration, creation, enhancement, preservation), the number of credits to be produced by each method, and the rationale for crediting;
- a general site plan showing the location of all existing and proposed wetland and upland habitats, roads, trails, structures, utilities, and any other existing or proposed site improvements;

- a preliminary bank site construction plan and schedule of completion, preliminary planting plan, and preliminary administrative, management, and monitoring plans; and
- an outline of management and maintenance responsibilities.

For bank site proposals within the Chicago Corps District, the prospectus also must include a statement regarding compliance with the “Interagency Coordination Agreement on Wetland Mitigation Banking within the Regulatory Boundaries of Chicago District, Corps of Engineers.”

The district submits one copy of the prospectus to BDE for review. After BDE review of the prospectus and resolution of any concerns identified, BDE coordinates the prospectus with the Corps and IDNR. After the Corps and IDNR have responded to the prospectus, the district and BDE confer on whether to continue to pursue acquisition and development of the proposed bank site. When decision is made that a site will be acquired and established as a bank, the district will proceed with preparation of a Mitigation Banking Instrument.

26-8.04(f)3 Mitigation Banking Instrument

All mitigation banks must have mitigation banking instruments to document concurrence of all the responsible State and Federal agencies in the objectives and administration of the banks. This includes IDOT, IDNR, the Corps, the USEPA, and the USFWS. The banking instrument documents, in detail, the physical and legal characteristics of the bank and how the bank will be established and operated. The district is responsible for preparing the Mitigation Banking Instrument. BDE provides assistance, as needed.

The mitigation banking instrument should address the following items:

- bank goals and objectives;
- ownership of bank lands;
- bank size and classes of wetlands and/or other aquatic resources proposed for inclusion in the bank, including a site plan and specifications;
- description of baseline conditions at the bank site;
- geographic service area;
- wetland classes or other aquatic resource impacts suitable for compensation from the bank;
- methods for determining credits and debits;
- accounting procedures;
- performance standards for determining credit availability and bank success;
- reporting protocols and monitoring plan;

- contingency and remedial actions and responsibilities (if performance standards are not being met);
- compensation ratios; and
- provisions for long-term management and maintenance.

The district submits one copy of the Mitigation Banking Instrument to BDE for review. After BDE review of the Mitigation Banking Instrument and resolution of any concerns identified, BDE coordinates the document with the Corps, IDNR, USEPA, and USFWS. These agencies generally constitute the MBRT for mitigation banking proposals in Illinois. After review by the MBRT and resolution of any concerns identified, BDE coordinates the Mitigation Banking Instrument for final execution. The Secretary of IDOT and a representative of each of the agencies on the MBRT sign the Mitigation Banking Instrument. BDE provides the district a copy of the executed Mitigation Banking Instrument and advises that implementation of the steps to establish the bank may proceed.

26-8.04(f)4 Mitigation Bank Implementation

After approval to proceed with implementation of the mitigation bank proposal, the district may initiate property negotiations for acquiring the site and may proceed with arrangements for any site work necessary to establish wetlands credits. Careful oversight is required to ensure that the provisions of the Mitigation Banking Instrument are implemented as approved, including any long-term monitoring and reporting required. As implementation proceeds, the district involves BDE, as necessary, to accomplish monitoring, ensure consistency with the approved bank plan, and evaluate progress toward establishment of mitigation credits. BDE is also involved in reporting to the MBRT on implementation of the mitigation bank, in accordance with the reporting protocols in the Mitigation Banking Instrument.

26-9 THREATENED AND ENDANGERED SPECIES/NATURAL AREA IMPACT ASSESSMENTS

26-9.01 Introduction

In the development of a project, special studies and coordination are required when the action may affect Federally listed threatened or endangered species. Studies and coordination also are required for actions that may adversely impact State-listed species or an area included on, or published as a candidate for inclusion on, the Illinois Natural Areas Inventory. This Section addresses the reporting and processing requirements for such actions.

26-9.02 Complementary Technical Manual

Currently, there is not a complementary IDOT Technical Manual for this subject area.

26-9.03 Legal Authority

The following legal authority regulates or influences the policies and procedures for Threatened and Endangered Species/Natural Area Impact assessments:

- *Federal Endangered Species Act of 1973, 16 U.S.C. 1536(a)(d),*
- *Procedures for Interagency Cooperation - Endangered Species Act of 1973, 50 CFR 402,*
- *The Illinois Endangered Species Protection Act, 520 ILCS 10/1 et seq.,*
- *The Illinois Natural Areas Preservation Act, 525 ILCS 30/1 et seq.,*
- *Consultation Procedures for Assessing Impacts of Agency Actions on Endangered and Threatened Species and Natural Areas, 17 Ill. Admin. Code 1075,*
- *Incidental Taking of Endangered or Threatened Species, 17 Ill. Admin. Code 1080,“*
- *Memorandum of Understanding by and between the Illinois Department of Natural Resources and the Illinois Department of Transportation, 2007.*

See Appendix C for more information.

26-9.04 Policy

In the development of a project, an assessment shall be made of the likely impacts on species of plants or animals listed at the Federal and/or State level as threatened or endangered and on State-designated Natural Areas. Every effort shall be made to minimize the likelihood of jeopardizing the continued existence of listed threatened or endangered species, the destruction or adverse modification of a Natural Area, or an area of habitat that has been designated as critical habitat or essential habitat.

26-9.05 Federal Requirements**26-9.05(a) Definitions**

26-9.05(a)1 From 50 CFR 402.04

1. Action Area. All areas to be affected directly or indirectly by the proposed action and not merely the immediate area involved in the action.
2. Biological Assessment. Information on listed and proposed species and designated and proposed critical habitat that may be present in the action area, and the evaluation of potential effects of the action on such species and habitat.
3. Biological Opinion. The document that states the opinion of the U.S. Fish and Wildlife Service (USFWS) as to whether an action is likely to jeopardize the continued existence of listed species or result in the destruction or adverse modification of critical habitat.
4. Conference. A process that involves informal discussions with USFWS regarding the impact of an action on proposed species or proposed critical habitat and recommendations to minimize or avoid the adverse effects.
5. Conservation Recommendations. Suggestions of the USFWS regarding discretionary measures to minimize or avoid adverse effects of a proposed action on listed species or critical habitat or regarding the development of information.
6. Critical Habitat. An area designated by USFWS as critical habitat.
7. Destruction or Adverse Modification. A direct or indirect alteration that appreciably diminishes the value of critical habitat for both the survival and recovery of listed species. Such alterations include, but are not limited to, alterations adversely modifying any of those physical or biological features that were the basis for determining the habitat to be critical.
8. Formal Consultation. A process between USFWS and the Federal agency responsible for a proposed action that commences with the Federal agency's written request for consultation and concludes with USFWS issuance of a biological opinion.
9. Informal Consultation. An optional process that includes all discussions, correspondence, etc., with USFWS prior to formal consultation, if required.
10. Jeopardize the Continued Existence. To engage in an action that reasonably would be expected, directly or indirectly, to reduce appreciably the likelihood of both the survival and recovery of a listed species in the wild by reducing the reproduction, numbers, or distribution of that species.
11. Listed Species. Any species of fish, wildlife, or plant that has been determined to be endangered or threatened pursuant to the *Federal Endangered Species Act*.

12. Major Construction Activity. A construction project (or other undertaking having similar physical impacts) that is a major Federal action significantly affecting the quality of the human environment as referred to in the *National Environmental Policy Act* (NEPA).
13. Proposed Critical Habitat. Habitat proposed in the *Federal Register* to be designated or revised as critical habitat for any listed or proposed species.
14. Proposed Species. Any species of fish, wildlife, or plant that is proposed to be listed under Section 4 of the *Federal Endangered Species Act*.

26-9.05(a)2 From the Endangered Species Act Consultation Handbook

1. Biological Assessment. Information prepared to determine whether a proposed action is likely to: (a) adversely affect listed species or designated critical habitat; (b) jeopardize the continued existence of species that are proposed for listing; or (c) adversely modify proposed critical habitat. Biological assessments must be prepared for "major construction activities." The outcome of the biological assessment determines whether formal consultation or a conference is necessary.
2. Conference. A process of early interagency cooperation involving informal or formal discussions with USFWS regarding the likely impact of an action on proposed species or proposed critical habitat. Conferences are: (a) required for proposed Federal actions likely to jeopardize proposed species or destroy or adversely modify proposed critical habitat; (b) designed to help identify and resolve potential conflicts between an action and species conservation early in a project's planning; and (c) designed to develop recommendations to minimize or avoid adverse effects to proposed species or proposed critical habitat.
3. Conservation Measures. Actions to benefit or promote the recovery of listed species that are included as an integral part of a proposed project. These actions will serve to minimize or compensate for project effects on the species under review. These may include actions taken prior to the initiation of consultation, or actions committed to in a biological assessment or similar document.
4. Conservation Recommendations. Non-binding suggestions from the USFWS resulting from formal or informal consultation that: (a) identify discretionary measures a Federal agency can take to minimize or avoid the adverse effects of a proposed action on listed or proposed species, or designated or proposed critical habitat; (b) identify studies, monitoring, or research to develop new information on listed or proposed species, or designated or proposed critical habitat; and (c) include suggestions on how an action agency can assist species conservation as part of their action.
5. Formal Consultation. A process between the Services and a Federal agency or applicant that: (a) determines whether a proposed Federal action is likely to jeopardize the continued existence of listed species or destroy or adversely modify designated critical habitat; (b) begins with a Federal agency's written request and submittal of a complete initiation package; and (3) concludes with the issuance of a biological opinion and incidental take statement by USFWS. If a proposed Federal action may affect a listed species or designated critical habitat, formal consultation is required; except when

- USFWS concurs, in writing, that a proposed action “is not likely to adversely affect” listed species or designated critical habitat.
6. Incidental Take. Refers to takings that result from, but are not the purpose of, carrying out an otherwise lawful activity.
 7. Is Likely to Adversely Affect. The appropriate finding in a biological assessment (or conclusion during informal consultation) if any adverse effect to listed species may occur as a direct or indirect result of the proposed action or its interrelated or interdependent actions, and the effect is not: discountable, insignificant, or beneficial (see definition of “not likely to adversely affect”). In the event the overall effect of the proposed action is beneficial to the listed species, but is also likely to cause some adverse effects, then the proposed action “is likely to adversely affect” the listed species. If incidental take is anticipated to occur as a result of the proposed action, an “is likely to adversely affect” determination should be made. An “is likely to adversely affect” determination requires the initiation of formal consultation.
 8. Is Not Likely to Adversely Affect. The appropriate conclusion when effects on listed species are expected to be discountable, insignificant, or completely beneficial. Beneficial effects are contemporaneous positive effects without any adverse effects to the species. Insignificant effects relate to the size of the impact and should never reach the scale where take occurs. Discountable effects are those extremely unlikely to occur. Based on best judgment, a person would not: (a) be able to meaningfully measure, detect, or evaluate insignificant effects; or (b) expect discountable effects to occur.
 9. May Affect. The appropriate conclusion when a proposed action may pose any effects on listed species or designated critical habitat. When the Federal agency proposing the action determines that a “may affect” situation exists, they must either initiate formal consultation or seek written concurrence from the Services that the action “is not likely to adversely affect” listed species.
 10. No Effect. The appropriate conclusion when the action agency determines its proposed action will not affect a listed species or designated critical habitat.
 11. Take. To harass, harm, pursue, hunt, shoot, wound, kill, trap, capture, or collect, or to attempt to engage in any such conduct; may include significant habitat modification or degradation if it kills or injures wildlife by significantly impairing essential behavioral patterns including breeding, feeding, or sheltering.

26-9.05(b) Applicability

The procedures in this Section apply to all projects initiated by the Department that involve funding or approvals from FHWA or another Federal agency.

The preparation of a Biological Assessment is required for any Federally funded/regulated “major construction activity” where listed species or critical habitat may be present in the action area. A Biological Assessment also may be appropriate for other actions where listed species or critical

habitat may be present and it is unclear whether they may be affected. If they may be adversely affected, formal consultation is required.

For additional guidance on the Federal requirements, see the following:

- USFWS *Endangered Species Consultation Handbook*, March 1998.
- February 20, 2002, FHWA Memorandum: Management of the Endangered Species Act (ESA) Environmental Analysis and Consultation Process, February 20, 2002”; and
- February 18, 2005, FHWA Memorandum: Joint Agency Agreement on ESA’s Formal Consultation Process, February 18, 2005.”

26-9.05(c) Determination of Need for a Biological Assessment

To initiate the process for compliance with the Federal *Endangered Species Act* requirements, obtain information from USFWS concerning any listed or proposed species or designated or proposed critical habitat that may be present in the action area. Either request the information from USFWS during project scoping/early coordination or gather the information from websites maintained by the USFWS Rock Island and Chicago field offices.

In response to a request for information, USFWS will:

- provide information regarding listed or proposed species, or designated or proposed critical habitat that may be present in the action area, and a list of candidate species that may be present in the action area⁵; or
- advise whether, based on the best scientific and commercial data available, any listed or proposed species or designated or proposed critical habitat may be present in the action area.

If, as a result of the coordination with USFWS, a determination is made that no listed species or critical habitat may be present, a Biological Assessment is not required. In such cases, a “no effect” determination applies and further consultation with USFWS on listed species or critical habitat is not required. If it is determined that only proposed species or proposed critical habitat may be present, a Biological Assessment will not be required unless the proposed listing and/or designation become final before the action is completed.

If the coordination with USFWS results in a determination that listed species or critical habitat may be present, prepare a Biological Assessment. Where proposed species or proposed critical habitat also may be present, they should be addressed in the Biological Assessment.

⁵ *Candidate species refers to any species being considered by USFWS for listing as endangered or threatened but not yet formally proposed or listed. Candidate species are accorded no protection under the Endangered Species Act. Notification concerning each species is intended to alert agencies of potential proposals or listings. These species should be identified in the environmental report for a proposed undertaking. Also, close contact should be maintained with BBE on the disposition of the candidate species during the environmental processing of a project.*

26-9.05(d) Preparation of the Biological Assessment

Biological Assessments will be prepared by or under the direction of BDE and in consultation with the IDOT district(s) responsible for the action involved. If the proposed action may involve impacts to Critical Habitat, consider the guidance provided in BLE IM 1-78 "*Endangered Species Act of 1973, Mitigation of Critical Habitat.*" Any required associated specialized environmental field studies will also be conducted by or under the direction of BDE. The Biological Assessment for an action must be completed before Phase I completed.

There is no prescribed format for a Biological Assessment prepared pursuant to Federal requirements; however, the following items typically will be included:

- a description of the proposed undertaking; its location (including a map) and purpose; and, if available, anticipated dates for beginning and completing construction;
- the results of an on-site inspection of the action area to determine if listed or proposed species are present or occur seasonally;
- the views of recognized experts on the species at issue;
- a review of the literature and other information concerning species potentially involved with the action;
- an analysis of the effects of the action on the species (in terms of individuals and populations) and habitat required for its survival and propagation, including consideration of cumulative effects and the results of any related studies; and
- an analysis of alternatives considered for the proposed action.

The Biological Assessment must be completed within 180 days of its initiation unless a different time period is agreed upon in consultation with USFWS.

If preparation of the Biological Assessment for an action is not initiated within 90 days of the response from USFWS (indicating that listed species or critical habitat may be present), verification of the current accuracy of the species/habitat information must be accomplished with USFWS at the time the preparation of the Biological Assessment is initiated. BDE will make the necessary contacts for this verification, if required.

If a proposed action requiring a Biological Assessment is identical, or very similar, to a previous action for which a Biological Assessment was prepared, a separate Biological Assessment need not be prepared for the current action. The earlier Biological Assessment, plus any supporting data from other documents pertinent to the consultation, may be incorporated by reference into a written certification to USFWS indicating that:

- the proposed action involves similar impacts to the same species in the same geographic area;
- no new species have been listed or proposed or no new critical habitat designated or proposed for the action area; and

- the Biological Assessment has been supplemented with any relevant changes in information.

26-9.05(e) Processing of the Biological Assessment

The complete Biological Assessment will be coordinated with FHWA and transmitted by BDE to USFWS for review. USFWS will respond in writing within 30 days on whether it concurs with the findings of the Biological Assessment.

If the Biological Assessment indicates the action is not likely to jeopardize the continued existence of proposed species or result in the destruction or adverse modification of proposed critical habitat and USFWS concurs, then a conference is not required. If it is determined the action is likely to jeopardize the continued existence of proposed species or result in the destruction or modification of proposed critical habitat, a conference is required.

If the Biological Assessment indicates that listed species or critical habitat are not likely to be adversely affected by the action and USFWS concurs, a formal consultation will not be required.

If it is determined that listed species or critical habitat are likely to be adversely affected by the action, a formal consultation will be required. In this case, BDE will coordinate with FHWA and FHWA will submit a written request to USFWS to initiate formal consultation. This request will include:

- a description of the proposed action;
- a description of the specific area that may be affected by the action;
- a description of any listed species or critical habitat that may be affected by the action;
- a description of the manner in which the action may affect any listed species or critical habitat and an analysis of any cumulative effects;
- relevant reports including any Environmental Impact Statement, Environmental Assessment, or Biological Assessment prepared; and
- any other relevant available information on the action, the affected listed species, or critical habitat.

Formal consultation will be directed toward further analysis of the species and/or critical habitat involved and alternatives to the proposed action. The purpose of these analyses is to allow USFWS to develop its opinion concerning whether the action is likely to jeopardize the continued existence of listed species or result in the destruction or adverse modification of critical habitat.

Formal consultation will be concluded within 90 days after its initiation unless a longer period is mutually agreed to. Within 45 days after concluding formal consultation, USFWS will provide its Biological Opinion concluding that:

- the action is likely to jeopardize the continued existence of a listed species or result in the destruction or adverse modification of critical habitat (a “jeopardy” biological opinion); or
- the action is not likely to jeopardize the continued existence of a listed species or result in the destruction or adverse modification of critical habitat (a “no-jeopardy” biological opinion).

If a “jeopardy” biological opinion is issued, USFWS must be notified of the final decision on the action (i.e., whether the action will be modified and, if so, how).

If the final decision on the action will involve a likelihood of jeopardizing the continued existence of a listed species or resulting in the destruction or adverse modification of critical habitat, the action may not proceed (under Federal approvals or with Federal funds) unless, and until, an exemption from the requirements of Section 7(a)(2) of the *Endangered Species Act* (which directs Federal agencies to “ensure” that their actions are not likely to “jeopardize” listed species or destroy or adversely modify critical habitat) is obtained.

The results of coordination regarding Federal endangered and threatened species and/or critical habitat must be summarized in the environmental report or Phase I engineering report for the action.

26-9.06 State Requirements

26-9.06(a) Definitions

1. **Action**. Construction, land management, or other activities that are authorized, funded, or performed in whole or in part by agencies of State and local governments, and that will result in a change to the existing environmental conditions or may affect listed threatened or endangered species or their essential habitat or Natural Areas.
2. **Adverse Impact**. A direct or indirect alteration of the physical or biological features of the air, land, or water that may affect the survival, reproduction, or recovery of a listed species or that may diminish the viability of a Natural Area.
3. **Biological Opinion**. The component of the Detailed Action Report prepared by the Illinois Department of Natural Resources (IDNR) when a valid record of an occurrence for a threatened or endangered species or Natural Area exists within the vicinity of a proposed action. This opinion will conclude whether the action will jeopardize the listed species present, destroy or adversely modify their essential habitat, or adversely modify a Natural Area.
4. **Cumulative Effects**. Direct and indirect effects of a proposed action(s), together with the identifiable effects of actions that are interrelated or interdependent with the action. Indirect effects are those that are caused by the action but are later in time or farther in distance. Interrelated actions are those that are a part of a larger action. Interdependent actions are those that have independent utility apart from the action.

5. Detailed Action Report. A written report that is prepared by an agency when a threatened or endangered species or Natural Area has been identified within the vicinity of a proposed action. This report shall contain sufficient information to make a judgment regarding the potential adverse impacts to a listed species, its essential habitat, or a Natural Area.
6. Essential Habitat. The physical and biological environment that is required to maintain viable populations of a listed species to ensure the survival and recovery of that species.
7. Jeopardize. To engage in an action that would reduce the likelihood of the survival or recovery of a listed species, result in the destruction or adverse modification of the essential habitat of such a species, or result in the destruction or adverse modification of a Natural Area.
8. Listed Species. Any species of plant or animal that has been listed as threatened or endangered by the Illinois Endangered Species Protection Board or the USFWS.
9. Natural Area. Any area of land in public or private ownership that is registered under the Illinois *Natural Areas Preservation Act*, 525 ILCS 30/1 *et seq.* or is identified in the Illinois Natural Areas Inventory.
10. Vicinity. The area surrounding the action, as determined by the life history requirements of the species of concern or proximity to a Natural Area.

26-9.06(b) Applicability

The following procedures are applicable to all projects requiring submittal of an Environmental Survey Request (ESR) pursuant to the criteria in Section 27-1.03(d).

26-9.06(c) Determination of Need for Detailed Action Report

The district will consider information on threatened and endangered species/Natural Areas in evaluating potential environmental effects as development of the proposed project proceeds. The evaluation of effects on threatened and endangered species/Natural Areas should determine whether any of the following findings apply to the project:

- a listed species or Natural Area may be adversely affected within the right-of-way (existing or proposed), easements, or borrow/use areas the project will involve;
- construction activities within the right-of-way will adversely affect wetland areas outside the right-of-way and listed species are known to occur in the wetlands; or
- noise, air quality, or water quality aspects of a project may adversely affect a listed species or Natural Area outside the right-of-way, easements, or borrow/use areas for the action.

If any of the preceding findings are applicable, a Detailed Action Report is required unless a programmatic agreement with the IDNR is in force for the resource(s) involved that addresses measures for avoidance and mitigation of adverse impacts. An example would be the restrictions

on the months in which Indiana Bat nesting trees may be cut. If the resource involved is covered by a programmatic agreement and the project will comply with the agreed terms, no further coordination with IDNR is necessary for that resource.

If the district and BDE determine that the project will not adversely affect listed species or Natural Areas, a Detailed Action Report is not required.

26-9.06(d) Preparation of the Detailed Action Report

When a Detailed Action Report is required, it will be prepared by, or under the direction of BDE in consultation with the district responsible for the action involved. Any needed associated specialized environmental studies will also be conducted by or under the direction of BDE. The Detailed Action Report typically will include the following components:

- the name and address of the contact person in BDE;
- a description of the proposed action, its location (including a map) and purpose and, if available, anticipated dates for beginning and completing construction;
- an analysis of the effects of the action on any Natural Area(s) present and on listed species (in terms of individuals and populations) and habitat required for their survival and propagation, including consideration of cumulative effects; and
- a discussion of any alternatives considered for the proposed action.

The Detailed Action Report may include the following additional components, when necessary to respond to specific issues or concerns regarding listed species:

- results of an on-site inspection of the area affected by the action to determine if listed or proposed species are present or occur seasonally;
- the views of recognized experts on species involved; and
- a review of literature and other pertinent information on species potentially involved with the action.

26-9.06(e) Processing of the Detailed Action Report

BDE will transmit the completed Detailed Action Report to the IDNR for formulation of a Biological Opinion. The Biological Opinion will address whether the action, taken with its cumulative effects, will jeopardize the listed species present, have an adverse impact on its essential habitat, or cause adverse modification of a Natural Area.

Within 90 days of the date, it receives the Detailed Action Report (unless an extension is mutually agreed to by IDOT and IDNR), IDNR will provide its Biological Opinion to the BDE. The Biological Opinion will result in one of the following findings:

- the action may promote the conservation of a listed species or its essential habitat or enhance the protection of a Natural Area, in which case the consultation process for endangered species/Natural Areas is concluded;
- the action is not likely to jeopardize a listed species or its essential habitat or cause adverse modification of a Natural Area, in which case the consultation process for endangered species/Natural Areas is concluded; or
- the proposed action is likely to jeopardize a listed species or its essential habitat or cause adverse modification of a Natural Area, in which case the consultation process will continue. In this case, IDNR generally will include recommendations in the Biological Opinion on how the impacts to the listed species/Natural Area could be avoided or minimized.

If the Biological Opinion concludes that an action is likely to jeopardize a listed species or its essential habitat or cause the adverse modification of a Natural Area, IDOT and IDNR will have 45 days, commencing on the date IDOT receives the Biological Opinion, to attempt to satisfactorily resolve the adverse effects on the listed species/Natural Area. If satisfactory resolution is reached within the 45-day period, IDNR will provide a sign-off indicating compliance with the requirements of the *Illinois Endangered Species Protection Act* and the *Illinois Natural Areas Preservation Act*. If a resolution is not reached within the 45-day period, one of the following will occur:

- the consultation process will end and will be classified as having failed or partially failed to protect the resource(s) involved;
- IDOT and IDNR may decide to elevate the matter within each agency,⁶ or
- upon mutual agreement by both parties, negotiations may continue.

When agreement is reached on the satisfactory resolution of adverse impacts to listed species or Natural Areas, IDNR will provide a sign-off to IDOT indicating compliance with threatened and endangered species/Natural Area requirements. The IDNR sign-off for threatened and endangered species/Natural Area requirements is valid for three years from the date of issuance. If the project involves other resource concerns requiring further IDNR review, the IDNR will re-screen the project against the Natural Heritage Database prior to any final action confirming satisfactory disposition of the other resource issues. In such cases, the validity period will be reset to extend for three years from the date of resolution of the other issues, provided no Special Circumstances, as described in Section 26-9.06(g), apply.

26-9.06(f) Special Circumstances

⁶ *It is desirable that disagreements which arise be resolved quickly and at the lowest possible level of agency involvement. For most actions, disagreements should be resolved by middle- or upper-level management of IDNR and IDOT. However, where there is failure to reach agreement, it may be necessary to refer the matter to the IDNR Director and IDOT Secretary for resolution.*

Consultation will be initiated, or a terminated consultation process will be reopened, if any of the following circumstances apply:

- new information reveals effects of the proposed action that may adversely affect a listed species or its essential habitat or a Natural Area in a manner not previously considered;
- the proposed action is subsequently modified such that it may adversely affect a listed species or its essential habitat or a Natural Area in a manner that was not considered in the consultation process; or
- additional listed species or their essential habitat or Natural Areas are identified within the vicinity of the action.

26-9.06(g) Incidental Taking Authorization

Section 11 of the *Illinois Endangered Species Protection Act*, (520 ILCS 10/11) states that where a State or local agency evaluates its actions through the *Endangered Species Act* consultation process with the IDNR, the agency shall be deemed to have complied with its obligations under the *Act*, provided the agency action shall not result in the killing or injuring of any Illinois-listed animal species, or provided that authorization for taking a listed species has been issued in accordance with Sections 4, 5, or 5.5 of the *Act*. Based on this language, the endangered species consultation process can be used to establish compliance with the *Act* for all impacts of agency actions on Illinois-listed plant species. The consultation process also can establish compliance for effects of agency actions on Illinois-listed animal species, provided the action will not result in killing or injuring of any of the species. However, if the agency action will result in killing or injuring of a listed animal species, the only way compliance with the *Act* can be established for that aspect of the action is by obtaining an authorization for “taking.” (Section 2 of the *Act* defines “take” to mean, in reference to animals, “...to harm, hunt, shoot, pursue, lure, wound, kill, destroy, harass, gig, spear, ensnare, trap, capture, collect, or to attempt to engage in such conduct.” This definition covers killing or injuring of listed animal species.)

Section 5.5 of the *Act* sets forth “incidental taking” provisions whereby IDNR may authorize a taking that is incidental to, and not the purpose of, carrying out of an otherwise lawful activity. IDNR has promulgated detailed procedures for the incidental taking authorization process in 17 Ill. Adm. Code 1080.

The requirements for obtaining an incidental taking authorization will apply to any project that will result in killing or injuring of Illinois-listed animal species. The need for requesting an incidental taking authorization will be based on a thorough evaluation of the likelihood that the project will result in the killing or injuring of any Illinois-listed animal species. This evaluation will consider available data and/or the results of field studies regarding the actual occurrence of Illinois-listed animal species, not just the existence of suitable habitat, within the specific area that will be affected by the project. It will also consider the potential for the undertaking to actually impact the species such that they may be killed or injured.

Recommendations for obtaining an incidental taking authorization may be included in IDNR’s coordination responses (e.g., for a Biological Resource Review or Detailed Action Report).

Another possibility is that the district and/or BDE may determine that an incidental taking authorization is needed, based on the results of field studies or other available information. If an incidental taking authorization is determined to be necessary, initiate the application process as soon as possible after the need for the authorization is confirmed. The *Endangered Species Protection Act* and the implementing rules on incidental taking provide that the authorization for incidental taking must be in place before a taking occurs. To ensure appropriate compliance with this requirement on highway projects, the incidental taking authorization must be in place prior to awarding the contract for the work that will cause the incidental taking, unless the potential incidental taking issue is not identified until after the contract has been awarded. If the potential incidental taking is identified after award, the authorization still must be in place before proceeding with the work that would result in a taking.

It is recommended that coordination with IDNR for a potential incidental taking be initiated as early as practical to afford maximum flexibility for considering and accommodating alternatives to avoid, minimize, and mitigate the taking. The avoidance alternatives and minimization and/or mitigation measures will ultimately be reflected in the conservation plan, which will provide the information IDNR will use in making its decision on approval or denial of the authorization request. Although there currently is no requirement for having the incidental taking authorization prior to design approval, coordination with IDNR on the incidental taking issues should occur prior to that point to ensure that project plans reflect decisions (e.g., regarding minimization and mitigation measures for the proposed incidental taking) that are acceptable to IDNR for purposes of approving the incidental taking authorization. Failure to do so may result in potentially costly project/plan changes and delays later in project development or implementation (e.g., if IDNR does not accept the minimization and mitigation measures as planned or it stipulates additional measures as a condition for approving the incidental taking authorization).

When the need for an incidental taking authorization is identified during Phase I, coordinate the public notice procedures required for the incidental taking authorization to coincide with other public involvement activities for the project to the extent practical.

If the district receives a recommendation from IDNR or BDE to obtain an incidental taking authorization and subsequently determines that the incidental taking authorization will not be pursued (e.g., because changes in the project have eliminated the need), the district must provide written notification of the decision to the BDE. Provide notification as soon as possible after the determination is made and include an explanation of the reason(s) for not seeking the incidental taking authorization.

When authorization for incidental taking is determined necessary, the following procedures will apply, unless the IDNR has approved special “programmatic” procedures for the category of action and species involved. In such case, the approved alternate procedures will govern:

- a) The district will be responsible for preparing the required Conservation Plan⁷ and newspaper notice for compliance with the incidental taking authorization rules

⁷ The State implementing rules for the incidental taking requirements provide that a Habitat Conservation Plan approved by the US Fish and Wildlife Service pursuant to Section 10 of the Endangered Species Act of 1973 may be submitted in lieu of a Conservation Plan as otherwise required under the State rules. The rules also provide that

(17 Ill. Adm. Code 1080, distributed via BDE Information Memorandum 01-35). BDE will provide information and technical assistance, as needed, to help the district in preparing the plan and notice. This may include, for example, biological data on the affected species, recommendations for mitigation measures, data and information regarding the effect of the proposed taking on the likelihood of the survival of the listed species, and information identifying participants that will be involved in implementing portions of the Conservation Plan.

- a. Conservation Plan. At a minimum, ensure the Conservation Plan contains the following:
- A description of the impact likely to result from the proposed taking of the listed animal species that would be covered by the authorization, including, but not limited to:
 - + legal description, if available, or detailed description including street address and map of the area to be affected by the proposed action and information indicating the ownership or control of the affected property;
 - + biological data on the affected species;
 - + description of the activities that will result in taking (e.g., killing, injuring) of the endangered or threatened animal species; and
 - + explanation of the anticipated adverse effects on the listed species.
 - Measures that will be taken to minimize and mitigate the impact on the listed animal species and the funding that will be available to undertake those measures, including, but not limited to:
 - + plans to minimize the area affected by the proposed action, the estimated number of individuals of the endangered or threatened species that will be taken, and the amount of habitat affected;
 - + plans for management of the area affected by the proposed action that will enable continued use of the area by endangered or threatened species;
 - + description of all measures to be implemented to minimize or mitigate the effects of the proposed action on the endangered or threatened species;

an authorization to take an endangered or threatened species under the terms of biological opinion issued by the US Fish and Wildlife Service pursuant to Section 7 of the Endangered Species Protection Act of 1973 may be submitted in lieu of a Conservation Plan.

-
- + plans for monitoring the effects of measures implemented to minimize or mitigate the effects of the proposed action on the endangered or threatened species;
 - + adaptive management practices that will be used to deal with changed or unforeseen circumstances that affect the effectiveness of measures instituted to minimize or mitigate the effects of the proposed action on the endangered or threatened species; and
 - + verification that adequate funding exists to support and implement all mitigation activities described in the Conservation Plan.
- A description of alternative actions considered that would not result in take of an Illinois-listed animal species and the reasons that each of those alternatives was not selected. A “no action” alternative shall be included in this description of alternatives.
 - Data and information to indicate that the proposed taking will not reduce the likelihood of the survival of the endangered or threatened animal species in the wild within the State of Illinois, the biotic community that the species is a part, or the habitat essential to the species’ existence in Illinois.
- b) An implementing agreement, which includes, but is not limited to:
- the names and signatures of all participants in the execution of the Conservation Plan;
 - the obligations and responsibilities of each of the identified participants with schedules and deadlines for completion of activities included in the Conservation Plan and a schedule for preparation of progress reports to be provided to the IDNR;
 - certification that each participant in the execution of the Conservation Plan has the legal authority to carry out their respective obligations and responsibilities under the Conservation Plan;
 - assurance of compliance with all other Federal, State and local regulations pertinent to the proposed action and to execution of the Conservation Plan; and
 - copies of any final Federal authorizations already issued for the proposed taking, if any.
- c. Newspaper Notice. At a minimum, the notice for publication in the newspaper, as described later, includes the following:
- the name of the district contact person and the district mailing address;

- a map or description that clearly shows or describes the precise location and boundaries of both the area to be affected by the proposed project and any areas to be affected by provisions of the Conservation Plan and is sufficient to enable local residents to readily identify the subject areas. It must include towns, bodies of water, local landmarks, or any other information that would identify the subject areas. If a map is used, indicate the north direction;
 - a summary of the incidental taking for which authorization is being requested;
 - a summary of the measures that will be instituted to minimize and mitigate the effects of the proposed incidental taking;
 - the location where a copy of the Conservation Plan is available for inspection;
 - the street and e-mail address of the IDNR office to which comments on the Conservation Plan may be submitted; and
 - the closing date for receipt of written comments on the Conservation Plan. The closing date must allow at least 30 days from the last date the notice will be published in the newspaper as discussed in Item #5, below.
- 1) After the district, in consultation with BDE, as necessary, has prepared the Conservation Plan and proposed newspaper notice, it will submit two copies of each to BDE.
 - 2) BDE will complete a final review of the Conservation Plan and notice. After resolving any comments with the district, BDE will forward the Conservation Plan and notice to IDNR.
 - 3) Within 30 days of receipt of the Conservation Plan and notice, IDNR will either respond that the Conservation Plan is complete, and the newspaper notice is satisfactory or will provide an indication of any deficiencies identified in the Conservation Plan or notice.
 - 4) If IDNR identifies deficiencies in the Conservation Plan or notice, BDE will coordinate with the district and IDNR as necessary to resolve the deficiencies. When IDNR advises that the Conservation Plan is complete and the notice is satisfactory, the district will proceed with publication of the notice. It must be placed in a newspaper of general circulation in the locality of the proposed action at least once a week for three consecutive weeks. At least 14 days must elapse between the first and last publication of the notice. Concurrent with the first publication in a local newspaper, the notice also must be published one time in the official State newspaper. Prior to, or concurrent with, publication of the first newspaper notice, the district must make one or more copies of the complete Conservation Plan available for review at the nearest public library in the county or counties in which the proposed action will occur. The district also must provide a copy of the complete Conservation Plan to the Executive Director of the Illinois Endangered Species Protection Board at IDNR headquarters.

- 5) The Incidental Taking rules in 17 Ill. Adm. Code 1080.30 provide that comments on the Conservation Plan may be submitted to IDNR for up to 30 days following the last publication of the newspaper notice. The rules also indicate that "...IDNR shall, upon receipt of written comments, transmit a copy of the comments to the applicant." As comments submitted on the Conservation Plan are received from IDNR, BDE will forward them to the district. The district, in consultation with BDE, will prepare a written summary in accordance with the requirements in the Incidental Taking rules. The summary will include a list of all persons or organizations making comments, a list of the criticisms, suggestions, and issues raised, and an analysis of each comment, including a description of any revisions to the Conservation Plan made in response to public comment. Complete the written summary of comments as quickly as possible so that it can be submitted to the IDNR Office of Resource Conservation within 10 days after the close of the public comment period, as required by Section 1080.30 of the Incidental Taking rules.
- 6) The IDNR Office of Resource Conservation must complete its review of the Conservation Plan and issue its decision on the incidental taking authorization request within 120 days after the date of the first publication of the notice in the newspaper. IDNR may authorize the incidental taking if it finds that the taking will meet all requirements as stipulated in 17 Ill. Adm. Code 1080.40(a). If IDNR finds that the Conservation Plan does not meet all of the stipulated requirements, it may require additional terms and conditions to ensure the requirements will be met. BDE will coordinate with the district and IDNR to resolve any identified deficiencies in the Conservation Plan and to respond to any additional terms and conditions proposed by IDNR. Upon receipt of the written notice from IDNR concerning its decision on the incidental taking application, BDE will forward the notice to the district. Work that would cause the killing or injuring of an Illinois-listed animal species must not be commenced until IDNR has issued an incidental taking authorization for the work.

BDE will be available to provide technical assistance to the district, as necessary, in implementing the approved Conservation Plan and any additional terms and conditions required.

26-9.07 Coordination of Federal/State Requirements

Where a species involved with an action is listed at both the Federal and State level, the Biological Assessment (Federal) and Detailed Action Report (State) prepared for the action will be processed concurrently with USFWS and IDNR as practical. Although processing may be concurrent and the results of consultation with either agency may be considered by the other, the Federal and State requirements are independent; both must be satisfied when species are on both the Federal and State lists.

26-10 EVALUATIONS OF FARMLAND CONVERSION IMPACTS

26-10.01 Introduction

In the development of a project, consideration must be given to the impacts that the action will cause in the conversion of farmland to non-farm uses. Under certain circumstances, coordination must be initiated with the U.S. Department of Agriculture, Natural Resources Conservation Service (NRCS), and/or the Illinois Department of Agriculture (IDOA) to evaluate the impacts on farmland and obtain the views of those agencies on alternatives to the proposed action. This Section discusses the criteria and procedures for accomplishing the necessary coordination with NRCS and IDOA.

26-10.02 Legal Authority

The following legal authority regulates or influences the policies and procedures on farmland conversions:

- *Farmland Protection Policy Act* of 1981, 7 U.S.C. 4201-4209,
- *Farmland Protection Policy Act*, 7 CFR 658,
- *The Farmland Preservation Act*, 505 ILCS 75/1 *et seq.*,
- State Exec. Order No. 4 (1980), Preservation of Illinois Farmland,
- Illinois Department of Transportation, Agriculture Land Preservation Policy,
- Cooperative Working Agreement between the Illinois Department of Agriculture and the Illinois Department of Transportation on Farmland Preservation, and
- *Farmland Preservation Act*, 8 Ill. Admin. Code 700.

See Appendix C for more information.

26-10.03 Policy

In the development of a project, evaluate the action's effects on conversion of farmland to non-farm use. Undertake coordination with NRCS and/or IDOA, as appropriate, to obtain their views on any anticipated farmland conversion. This evaluation and coordination with NRCS and IDOA is to be accomplished in conformance with Federal and State statutes, regulations, executive orders, and IDOT agreements concerning farmland. Consider alternatives that could lessen adverse impacts to farmland. As practical, ensure proposed actions are developed to be compatible with State, local government, and private programs and policies to protect farmland.

26-10.04 Federal Requirements

26-10.04(a) Definitions

1. **Farmland.** Prime or unique farmlands, as defined in Section 1540(c)(1) of the *Farmland Protection Policy Act*, or farmland that is determined by the appropriate State or unit of local government agency or agencies with concurrence of the Secretary of Agriculture to be farmland of Statewide or local importance. Farmland does not include land already in or committed to urban development or water storage. Farmland “already in” urban development or water storage includes all such land with a density of 30 structures per 40 acre (16 ha) area. Farmland already in urban development also includes lands identified as urbanized area (UA) on the Census Bureau Map, as urban area mapped with a tint overprint on the USGS topographical maps, or as urban-built-up on the USDA Important Farmland Maps. Areas shown as white on the USDA Important Farmland maps are not farmland and, therefore, are not subject to the Act. Farmland committed to urban development or water storage includes all such land that receives a combined score of 160 points or less from the land evaluation and site assessment criteria.
2. **Site.** The location(s) that would be converted by the proposed action(s).

26-10.04(b) Applicability

A project that requires additional right-of-way outside any corporate limits must be coordinated with NRCS unless any one of the following applies:

1. There are no Federal funds involved in the project.
2. None of the acquired land is prime farmland or farmland of Statewide or local importance.
3. The land to be acquired is in urban development (i.e., has a minimum current density of 30 structures (permanently affixed to the ground) per 40 acre (16 ha) tract).
4. The project is exclusively for widening and resurfacing, and does not involve borrow areas, mitigation sites, or new alignment in which the right-of-way diverges from and is not contiguous to the existing right-of-way.
5. The project is nonlinear (e.g., bridge, intersection improvements) and requires acquisition of no more than 10 acres (4 ha) of land. This threshold applies to nonlinear projects other than new rest areas and new truck weigh stations. All new rest area and truck weigh station projects must be coordinated with NRCS, regardless of the amount of acquisition involved. Where the area of right-of-way for the project approaches the 10 acre (4 ha) threshold for coordination and the project will likely involve additional acquisition for borrow or mitigation, coordinate the project with NRCS. Anticipated sites for borrow and mitigation should be indicated if known.
6. The project is linear; requires acquisition of no more than 3 acres of land per project mile (0.75 ha of land per project kilometer) (area of acquisition divided by project length); and does not involve alternative alignment(s) in which the right-of-way diverges from, and is

not contiguous to, the existing right-of-way. Where the amount of right-of-way to be acquired approaches the 3 acres per project mile (0.75 ha per project kilometer) threshold for coordination and the project will likely involve additional acquisition for borrow or mitigation, coordinate the project with NRCS. Anticipated sites for borrow and mitigation should be indicated if known.

The categories of projects addressed by these items have been programmatically addressed in consultations with NRCS, and a general Form NRCS-CPA-106 (see Section 26-10.04(d)) has been prepared for these actions. The general form is available in the IDOT district offices or may be obtained from BDE. Further project-specific review by NRCS on these projects ordinarily will not be necessary. See Section 26-10.04(c) for further discussion of requirements for these types of actions.

If there is a question on whether any of the above conditions are met, contact BDE for a determination of applicability.

26-10.04(c) Procedures

The following will apply:

1. NRCS Coordination. For all projects requiring coordination with NRCS according to the criteria in Section 26-10.04(b), contact NRCS as early in the project development process as practical. Make the initial contact with the State Office of the NRCS in Champaign. Forward Form NRCS-CPA-106 to the NRCS Office as part of the coordination process as soon as sufficient information is available. Coordination may be initiated prior to completion of the forms, as appropriate.
2. Minor Impacts. Where a project appears to be covered by Item #'s 5 and 6 in Section 26-10.04(b), care should be taken to ensure that the project does not involve more than minor impacts on farmland and that there are no unusual circumstances that would make the criteria described inapplicable to the project. If more than minor impacts on farmland are involved or if unusual circumstances are present, initiate coordination with NRCS as discussed in Item #1 above.

If such impacts/circumstances are not involved, documentation should be included in the project file indicating the applicability of the criterion in Section 26-10.04(b) as the basis for not coordinating with NRCS. Also, include a copy of the general Form NRCS-CPA-106 for these projects in the file. A paragraph such as the following should be included in the Phase I engineering report or environmental report, as appropriate:

The impact of this project on farmland conversion has been evaluated in accordance with the requirements of the U.S. Natural Resources Conservation Service (NRCS). The project will convert 3 acres or less of farmland per mile (0.75 hectares or less of farmland per kilometer) and the conversion will not result in more than minor impacts. Accordingly, the project conforms to the general Form NRCS-CPA-106 prepared by NRCS.

Therefore, further coordination with NRCS on this project will not be necessary.

26-10.04(d) Form NRCS-CPA-106

The following will apply:

1. Districts should complete Parts I and III of Form NRCS-CPA-106 and submit it to the State NRCS office when information is submitted to IDOA in accordance with State farmland protection requirements (see Section 26-10.05(c)). NRCS will complete Parts II, IV, and V and will then send the Form to IDOA for completion of the Site Assessment portions of the Form. When completed, IDOA will return the Form to the district.
- 7) Form NRCS-CPA-106 is the primary means of coordination with NRCS. It may, however, be supplemented with other information. It is recommended that a copy of the information sent to IDOA (see Section 26-10.05(c)) be sent to NRCS with Form NRCS-CPA-106. The additional information will help to expedite the review and minimize turnaround time. Provide an informational copy of the completed NRCS-CPA-106 form to IDOA when it is submitted to NRCS.
- 8) On new construction and reconstruction projects, early contacts with the local field offices and the statewide office of NRCS are recommended. This will notify NRCS of the project and allow early comments while maximum flexibility still exists. Form NRCS-CPA-106 can follow later as project development permits. In this manner, substantive comments are discovered early and the potential for major changes in the later stages of project development will be reduced.
- 9) Copies of and instructions for completing Form NRCS-CPA-106 are available in the IDOT district offices and may be obtained from BDE. See Section 26-10.04(f) for an example of a completed form.

Do not send NRCS-CPA-106 forms for single-county projects to NRCS county field offices. Send NRCS-CPA-106 forms for single and multi-county projects to the State NRCS office at the following address:

United States Department of Agriculture
Natural Resources Conservation Service
Attention: State Soil Scientist
2118 West Park Court
Champaign, Illinois 61821

See the NRCS website for additional contact information.

26-10.04(e) Siting Requirements

Sites or alternatives with the highest combined scores (determined on Form NRCS-CPA-106) should be regarded as most suitable for protection from conversion to non-farm use, and sites/alternatives with the lowest scores as least suitable for such protection. Sites or alternatives receiving total scores of 175 or fewer points require only minimal consideration for protection from conversion, and no additional sites/alternatives need be evaluated. Sites or alternatives with scores of 176 to 225 points are in the moderate range for consideration of protection from conversion. For such projects, consider at least one build alternative that would involve lesser amounts of farmland conversion. Sites or alternatives receiving scores over 225 points should receive the highest priority for protection from conversion to non-farm uses. For such sites or alternatives, consider other alternatives such as rehabilitation of existing facilities and alignments that use lesser amounts of farmland.

Alternatives that adversely affect agriculture may be recommended, but only after full consideration of adverse effects and less damaging alternatives. The coordination with NRCS will ensure the adequacy of that consideration.

Summarize the results of coordination with NRCS in the environmental report or Phase I engineering report for the action.

26-10.04(f) Notification of Selected Alternative

NRCS requires that, when a Federally funded project has one or more alternatives that require acquisition of farmland subject to the FPPA and is not otherwise exempted from the requirement to submit Form NRCS-CPA-106, the project agency should provide NRCS a copy of the Form NRCS-CPA-106 indicating the project alternative selected for implementation. Upon receiving design approval for such projects, the district shall inform the State NRCS office which alternative was selected for implementation. The district should use a copy of the previously coordinated Form NRCS-CPA-106 for providing this notification. The district should complete the parts of the Form entitled "Site Selected" (enter appropriate site identification letter from the NRCS-CPA-106) and "Date of Selection" and should then send one copy to the State NRCS office at the address provided in Section 26-10.04(d). To aid NRCS in its record keeping, note on the top of the Form that it is a "Final Decision Notification."

26-10.05 State Requirements

26-10.05(a) Definitions

1. Agricultural Land or Farmland. All land in farms including cropland, hayland, pastureland, forestland, corrals, gardens, and orchards; land used for farmsteads, buildings, barns, and machinery sheds; adjacent yards or corrals, pens, waste lagoons, feedlots, farmstead or feedlot windbreaks, grain bins, lanes for farm residences and fields, field windbreaks, ponds, commercial feedlots, greenhouses, nurseries, broiler facilities, and farm landing strips.
2. Agricultural Land Conversion. The taking of land directly out of agricultural production or displacing it by another use and not returning it to production.

3. Land Class. One of eight classes of land in the Land Capability Classification System (Handbook 210, issued September 1961, and approved for reprinting January 1973) as developed by the Soil Conservation Service, United States Department of Agriculture. Incorporation by reference does not include any future editions or amendments. The land capability classification shows, in a general way, the suitability of soils for most kinds of field crops. The soils are grouped according to their limitations for field crops, the risk of damage to the soil if they are used for crops, and the way they respond to management.
4. Modern Soil Survey. A document published after 1965 by SCS or NRCS containing a description of a county's soils, maps showing their distribution, and discussions concerning their behavior and adaptability.

26-10.05(b) Applicability

Coordination with the IDOA is required for State highway and bridge projects funded in whole or in part with State funds and which require additional right-of-way, unless any of the following apply:

1. The project is located within the boundaries of an incorporated municipality.
2. The project is nonlinear (e.g., bridge, intersection improvements) and requires acquisition of no more than 10 acres (4 ha) of land. When the area of right-of-way for the project approaches the 10 acre (4 ha) threshold for coordination and the project will likely involve additional acquisition for borrow or mitigation, coordinate the project with IDOA. If known, indicate anticipated sites for borrow and mitigation.
3. The project is linear; requires acquisition of no more than 3 acres of land per project mile (0.75 ha per project kilometer) (area acquisition divided by project length); and does not involve alternative alignment(s) in which the right-of-way diverges from, and is not contiguous to, the existing right-of-way. When the amount of right-of-way for the project approaches the threshold for coordination and the project will likely involve additional acquisition for borrow or mitigation, coordinate the project with the IDOA. If known, indicate anticipated sites for borrow and mitigation.

26-10.05(c) Procedures

26-10.05(c)1 General

The IDOA is especially interested in projects that consider more than one alignment, each of which has different agricultural impacts and different amounts of farmland conversion. Projects with multiple alignments can be as localized as those developed to eliminate offset intersections, or as widespread as those for a new freeway connecting distant cities. In all cases, however, only that information that is likely to influence a choice among alternatives should be gathered and considered. For 3R/spot improvements with multiple alignments, include soils information when modern soil surveys are available. If modern soil surveys are not available, forward the remaining coordination information to IDOA. If it is determined that soils information is necessary,

IDOA will normally acquire such information. Studies of alternative freeway alignments between distant points should consider a multitude of factors and soil class/type should be among them because the scope of the project alternatives will likely encounter soils of varying qualities. On new construction/reconstruction projects, IDOT will acquire all soils information.

Where a proposed project will convert farmland to non-farm use, consider measures that could mitigate the scope and impacts of the conversion. In cases where coordination with IDOA is required, this coordination will assist in the identification and evaluation of possible mitigation measures. In all other instances, the IDOT district should ensure that measures to minimize farmland conversion impacts are appropriately identified and considered.

Project information being furnished to the IDOA for review should be addressed as follows:

Illinois Department of Agriculture
Bureau of Land and Water Resources
P. O. Box 19281
State Fairgrounds
Springfield, Illinois 62794-9281

When IDOA has completed its review, it will respond in writing to the agency that submitted the information. Early and complete submittals will generally result in a timely response. Should the IDOA response contain substantive comments or raise controversial issues, such comments and issues should be addressed to the extent that the information is available, and a response forwarded expeditiously to IDOA. Remaining comments should then be addressed as soon as the necessary information becomes available. Additional follow-up coordination may be required to determine if mutually satisfactory solutions exist prior to assuming a Departmental position at a hearing or in draft and final environmental documents.

Summarize the results of the evaluations of farmland conversion impacts, mitigation measures, and associated coordination with IDOA in the project's environmental report or Phase I engineering report, as appropriate.

The discussions below identify specific procedures for projects involving construction or reconstruction and for 3R projects. If coordination with IDOA is necessary and it is unclear whether the project is 3R or reconstruction, provide the information required for a 3R project to IDOA as early in project development as practical. When offered an early opportunity to review project information, IDOA can make an initial determination of its degree of interest and request follow-up information, if appropriate, without delaying the project unduly.

26-10.05(c)2 New Construction or Reconstruction Projects

When coordination with IDOA is required, the timing of the coordination and the information provided is important. When new construction or reconstruction is involved, it is appropriate, shortly after location and/or environmental studies have been initiated, to notify IDOA that a project is being studied and that more detailed information will follow as it is developed. On such major projects, it is desirable to maintain contact with IDOA so that potential problems can be identified early to minimize any delays. This may be accomplished through IDOA attendance at scheduled district coordination meetings, NEPA/404 Merger meetings and/or recurring written

communications providing information contained in the list below. It is also appropriate to include IDOA on the recipient list for public hearing/meeting notices.

On new construction and reconstruction projects, the description, purpose, and scope of each proposed project shall be provided to IDOA, together with the following information for each alternative:

1. The location, including proposed right-of-way lines if scale permits, on all the following maps:
 - a general county highway map,
 - a plat map, and
 - a modern soil survey map (if available).
2. Total land area in acres (hectares) required for additional right-of-way (includes frontage and access roads).
3. The number of acres (hectares) of each USDA Land Capability Classification (Land Classes I-VIII) and Soil Type (including index number) proposed for acquisition, if applicable.
4. Identification of all soil types occurring within the proposed right-of-way and the number of acres (hectares) of each soil type, if applicable. *Note: Land class and soil type are obtainable from a county's modern soil survey that may be obtained from a local NRCS field office.*
5. Identification of the following impacts that may be associated with the implementation of the project, as applicable:
 - number of farm units and owners affected;
 - number of farm parcels severed;
 - number of farm unit operations severed;
 - number of landlocked parcels created;
 - miles (kilometers) of adverse travel created for each affected farm unit;
 - effects of the proposal upon existing farm drainage systems (surface and subsurface);
 - acres (hectares) of farmland required for borrow and location of the borrow site (depicted on a soil survey and plat map), if available; and
 - erosion control techniques to be utilized on the disturbed area during and after project construction.

6. A brief discussion of all measures included to mitigate any adverse impacts identified in Item #'s 1 through 55.
7. Indication that farmland conversion has been minimized and other appropriate mitigation included for the selected alternative consistent with the operational and safety requirements applicable to the project.

26-10.05(c)3 3R Projects

When coordination is necessary and the proposed improvement primarily involves 3R work on existing alignment, it is appropriate, shortly after location and/or environmental studies have been initiated, to notify IDOA that a project is being studied and to provide the following information:

1. Description, purpose, and scope of the proposed project.
2. Map depicting the location of the project. A county highway map is acceptable.
3. Total land area in acres (hectares) required for additional right-of-way and a brief description of its nature; for example, a 10 ft (3 m) strip on north side or a 3 acre (1 ha) parcel to flatten curve at location noted on map.
4. Indication that farmland conversion has been minimized and other appropriate mitigation included for the selected alternative consistent with the operational and safety requirements applicable to the project.

Summarize the results of coordination with IDOA in the environmental report or Phase I engineering report for the action.

26-10.05(d) Coordination

IDOA should be invited to all district coordination meetings. The invitation should include the meeting notice and agenda. IDOA also may participate in NEPA/404 Merger meetings hosted by FHWA.

26-10.06 Relationship of Federal and State Requirements

Requirements for coordination with the NRCS, although similar to those for the IDOA, are separate and distinct. Coordination with IDOA does not preclude the need to coordinate with NRCS. Projects that require coordination with NRCS will normally also require coordination with IDOA.

26-11 TRANSPORTATION AIR QUALITY CONFORMITY REQUIREMENTS AND DOCUMENTATION

26-11.01 Introduction

Section 176(c) of the *Clean Air Act* as amended in 1990 requires that transportation plans, programs, and projects that are funded or approved under Title 23 U.S.C. must be determined to conform to State or Federal air implementation plans. Such implementation plans describe how air quality standards will be achieved in those areas of a State in which standards are being exceeded. Areas where monitored air quality exceeds established National Ambient Air Quality Standards (NAAQS) are termed nonattainment areas. Areas that were once classified as nonattainment but have been re-designated as being in compliance with the NAAQS are termed maintenance areas. Conformity to an implementation plan is defined in the *Clean Air Act* as conformity to an implementation plan's purpose of eliminating or reducing the severity and number of violations of the NAAQS and achieving expeditious attainment of such standards. Federal activities may not cause or contribute to new violations of air quality standards, exacerbate existing violations, or interfere with the timely reduction of emissions as reflected in the State Implementation Plan (SIP). The implementing regulations for determining conformity of transportation projects (Determining Conformity of Federal Actions to State or Federal Implementation Plans, 40 CFR 93") also impose requirements upon "regionally significant projects" in nonattainment or maintenance areas regardless of whether those projects involve Federal funding or approvals. Regionally significant projects are transportation projects (other than projects exempt from the conformity requirements) that are on facilities which serve regional transportation needs (e.g., access to and from the area outside of the region, major activity centers in the region, major planned developments, transportation terminals) and would normally be included in the modeling of a metropolitan area's transportation network including, at a minimum, all principal arterial highways and all fixed guideway transit facilities that offer an alternative to regional highway travel.

The US Environmental Protection Agency (USEPA) has established NAAQS for six criteria pollutants including carbon monoxide (CO), ozone (O₃), lead (Pb), sulfur dioxide (SO₂), nitrogen dioxide (NO₂), and particulate matter (PM). The PM pollutant includes both PM₁₀, which are particles with an aerodynamic diameter less than or equal to a nominal 10 microns, and PM_{2.5}, which are particles with an aerodynamic diameter less than or equal to a nominal 2.5 microns. Transportation-related criteria pollutants include ozone, carbon monoxide, nitrogen dioxide, and both PM_{2.5} and PM₁₀. Precursors of these pollutants also are considered for regulatory purposes and in regional air quality analyses for nonattainment and maintenance areas. These precursors include volatile organic compounds (VOC) and oxides of nitrogen (NO_x) in ozone areas and NO_x in PM_{2.5} areas. Illinois includes areas in which standards are being exceeded for one or more of the criteria pollutants and also includes areas that have been re-designated from nonattainment to maintenance for the PM₁₀ NAAQS.

BDE disseminates information to all districts regarding the location, boundaries, and applicable criteria pollutant(s) for nonattainment and maintenance areas in Illinois. Updates to this information will be issued as changes are published in the *Federal Register*. This information also is available on the USEPA website.

26-11.02 Applicability

The following procedures are applicable to all highway projects initiated by the Department that are funded or approved by the Federal Highway Administration (FHWA) under Title 23 U.S.C. and to “regionally significant projects” in nonattainment or maintenance areas, regardless of whether such projects are Federally funded or approved under Title 23.

26-11.03 Procedures**26-11.03(a) Determining Project Involvement in Designated Nonattainment or Maintenance Areas**

In the preparation of environmental documentation for projects subject to these procedures, districts should review the most recent information from BDE regarding those areas of Illinois that have been designated as nonattainment or maintenance for one or more of the criteria pollutants. If the proposed improvement is partially or completely within a designated nonattainment or maintenance area it will be subject to the conformity requirements unless the type of work involved is exempted (see the following section). *The USEPA rules do not require conformity determinations for projects outside of nonattainment or maintenance areas (i.e., within attainment areas).*

26-11.03(b) Determining Whether Project is Exempt from Conformity Requirements

The USEPA conformity rules for transportation projects exempt the project types listed below from the requirement for a conformity determination. The determination of whether a particular action is exempt from the conformity requirement, in most cases, is made during the development of the Transportation Improvement Program (TIP) by a Metropolitan Planning Organization (MPO) prior to the initiation of, or in conjunction with, Phase I planning. Note that a particular project of a type listed is not exempt if the MPO, in consultation with USEPA and FHWA, concurs that it has potentially adverse emissions impacts for any reason. The following are exempt projects:

1. Safety. The following safety projects are exempt:
 - railroad/highway crossing;
 - hazard elimination program;
 - safer non-Federal-aid system roads;
 - shoulder improvements;
 - increasing sight distance;
 - safety improvement program;
 - traffic control devices and operating assistance other than signalization projects;

- railroad/highway crossing warning devices;
 - guardrails, median barriers, crash cushions;
 - pavement resurfacing and/or rehabilitation;
 - pavement marking demonstration;
 - emergency relief (23 U.S.C. USC 125);
 - fencing;
 - skid treatments;
 - safety roadside rest areas;
 - adding medians;
 - truck climbing lanes outside the urbanized area;
 - lighting improvements;
 - widening narrow pavements or reconstructing bridges (no additional travel lanes); and
 - emergency truck pullovers.
2. Air Quality. Exempt projects include:
- continuation of ride-sharing and van-pooling promotion activities at current levels, and
 - bicycle and pedestrian facilities.
3. Other. Other exempt projects include:
- specific activities that do not involve or lead directly to construction, such as:
 - + planning and technical studies,
 - + grants for training and research programs,
 - + Federal-aid systems revisions, and
 - + planning activities conducted pursuant to Titles 23 and 49 of the United States Code;
 - engineering to assess social, economic, and environmental effects of a proposed action or alternatives to that action;
 - noise attenuation;

- emergency or hardship advance land acquisitions (23 CFR712.204(d));
 - acquisition of scenic easements;
 - plantings, landscaping, etc.;
 - sign removal;
 - directional and informational signs;
 - transportation enhancement activities (except rehabilitation and operation of historic transportation buildings, structures, or facilities); and
 - repair of damage caused by natural disasters, civil unrest, or terrorist acts, except projects involving substantial changes in function, location, or capacity.
4. Exempt from Regional Emissions Analyses. The following projects are exempt:
- intersection channelization projects,
 - intersection signalization projects at individual intersections,
 - interchange reconfiguration projects,
 - changes in vertical and horizontal alignments, and
 - truck size and weight inspection stations.

26-11.03(c) Determining Highway Project Conformity

To determine conformity of non-exempt projects within designated nonattainment or maintenance areas, the district must ascertain whether the project is from a conforming transportation plan and a conforming TIP and satisfies other applicable conditions as specified in the conformity rules. As used in this procedure, the term transportation plan refers to the official intermodal metropolitan transportation plan that is developed through the metropolitan planning process for the metropolitan planning area pursuant to 23 CFR 450. TIP refers to the staged, multi-year, intermodal program of transportation projects covering a metropolitan planning area that is consistent with the metropolitan transportation plan and is developed pursuant to 23 CFR 450. The district should contact their Area Programmer or their MPO if confirmation or clarification is needed regarding whether a specific project was in a conforming plan and the latest conforming TIP.

The project conforms with the requirements of the *Clean Air Act* if the district confirms that the following statements are applicable to the action:

- The project was included in the latest conforming transportation plan and TIP in the fiscally constrained portion of the plan.
- The project design concept and scope have not changed significantly from what was reflected in the conformity analysis for the plan and TIP.

- The project will comply with PM_{2.5} and/or PM₁₀ control measures in the SIP.
- Hot-spot analysis requirements are satisfied.

Other criteria and procedures will apply for determining conformity of projects within CO, PM_{2.5}, or PM₁₀ nonattainment or maintenance areas (e.g., Transportation Conformity Hot-Spot Analysis). See Section 26-12.

To determine conformity for projects in nonattainment areas or maintenance areas outside of locations served by Metropolitan Planning Organizations, the district should contact BDE. BDE will discuss and coordinate with the Office of Planning and Programming to initiate a regional emissions analysis. The purpose of this analysis is to demonstrate that the proposed project will not cause nor contribute to any new localized violations nor increase the frequency or severity of any existing violations of the NAAQS for the criteria pollutant(s) that caused the area to be designated as nonattainment. The project will be determined to conform to the requirements of the 1990 *Clean Air Act* amendments upon the concurrence of FHWA in the regional emissions analysis supporting this finding.

Projects must be found to conform before they are adopted, accepted, approved, or funded. Conformity must be re-determined if none of the following major steps has occurred within three years of the conformity determination—NEPA process completion; start of final design; acquisition of a significant portion of the right-of-way; or approval of the plans, specifications, and estimates. A new conformity determination also will be required if there is a significant change in project design concept and scope or if a supplemental environmental document for air quality purposes is initiated.

Regionally significant projects that do not involve Federal approvals or funding from FHWA do not require conformity determinations. However, under the conformity rules, IDOT may not approve these projects unless there is a currently conforming transportation plan and TIP for the area in which the project is located, and the project satisfies specific conditions regarding its potential effect on regional air quality. The district should contact BDE relative to regionally significant non-Federal projects in nonattainment and maintenance areas for guidance regarding these specific conditions.

26-11.03(d) Information for NEPA Documents or Project Reports

The environmental documentation for all projects subject to these procedures must include a statement regarding the status of the project with regard to the *Clean Air Act* conformity regulations (i.e., indicating that the project is outside of any designated nonattainment or maintenance area, that the project is of a type exempted from conformity requirements, or that the project has been determined to satisfy the conformity regulations). The following paragraphs indicate the different statements that should be used for this documentation:

Note: For those statements that include references to dates (e.g., for TIPs and plans), the district should enter the dates in effect at the time of the latest conformity determination. BDE should be contacted for guidance if questions arise regarding particular projects.

1. Projects Outside of Nonattainment or Maintenance Areas. For projects that the district determines are completely outside of any designated nonattainment or maintenance areas, the following statement should be included in the project environmental documentation:

No portion of this project is within a designated nonattainment or maintenance area for any of the air pollutants for which the USEPA has established standards. Accordingly, a conformity determination under 40 CFR Part 93 (“Determining Conformity of Federal Actions to State or Federal Implementation Plans”) is not required.

- a. Exempt Projects. For projects that the district determines are located within a designated nonattainment or maintenance area but have been identified by their MPO as an exempt project type as identified in Section 26-11.03(b) (which includes project types exempt from conformity and those exempt from regional emissions analyses), include the following statement in the project environmental documentation:

This project is located within a designated nonattainment or maintenance area but is a project type, which the U.S. Environmental Protection Agency (USEPA) has designated as exempt from regional emissions analyses of transportation plans and Transportation Improvement Programs for purposes of determining conformity with the State Implementation Plan (SIP). This designation is based on USEPA’s determination that the nature of the project is such that it would not affect the outcome of a regional emissions analysis.

3. For project-types discussed in the following sections (i.e., projects that are within a nonattainment or maintenance area and are not exempt projects), include the following introductory paragraphs before the applicable paragraphs documenting the conformity finding for the project-type involved:

The National Ambient Air Quality Standards (NAAQS), established by the US Environmental Protection Agency, set maximum allowable concentration limits for six criteria air pollutants. Areas in which air pollution levels persistently exceed the NAAQS may be designated as “nonattainment.” States where a nonattainment area is located must develop and implement a State Implementation Plan (SIP) containing policies and regulations that will bring about attainment of the NAAQS. Areas that had been designated as nonattainment, but that have attained the NAAQS for the criteria pollutant(s) associated with the nonattainment designation, will be designated as maintenance areas.

All areas of Illinois currently are in attainment of the standards for five of the six criteria pollutants: particulate matter, carbon monoxide, nitrogen dioxide, sulfur dioxide, and lead.

For the eight-hour ozone, Cook, DuPage, Kane, Lake, McHenry, and Will Counties, as well as Aux Sable and Goose Lake Townships in Grundy

County and Oswego Township in Kendall County, have been designated as marginal nonattainment areas. Jersey, Madison, Monroe, and St. Clair Counties in the St. Louis area also have been designated as marginal nonattainment areas for the eight-hour ozone standard.

- a. Projects Within a Portion of a Nonattainment or Maintenance Area Where the Chicago Metropolitan Agency for Planning (CMAP) is the MPO. In addition to the introductory paragraphs above, the following paragraphs should be used to document the necessary findings for conformity of projects within a nonattainment or maintenance area for which CMAP is the MPO:

This project is included in the FY [indicate years] Transportation Improvement Program (TIP) endorsed by the Metropolitan Planning Organization Policy Committee of the Chicago Metropolitan Agency for Planning (CMAP) for the region in which the project is located. Projects in the TIP are considered to be consistent with the [indicate year] regional transportation plan endorsed by CMAP. The project is within the fiscally constrained portion of the plan.

On [indicate date], the Federal Highway Administration (FHWA) and the Federal Transit Administration (FTA) determined that the [indicate year] regional transportation plan conforms with the State Implementation Plan (SIP) and the transportation-related requirements of the 1990 Clean Air Act Amendments. On [indicate date], the FHWA and the FTA determined that the TIP also conforms with the SIP and the Clean Air Act Amendments. These findings were in accordance with Determining Conformity of Federal Actions to State or Federal Implementation Plans 40 CFR Part 93.

The project's design concept and scope are consistent with the project information used for the TIP conformity analysis. Therefore, this project conforms to the existing State Implementation Plan and the transportation-related requirements of the 1990 Clean Air Act Amendments.

The TIP number for this project is _____.

- b. Projects Within a Nonattainment or Maintenance Area Served by an MPO other than CMAP. In addition to the introductory paragraphs above, use the following paragraphs to document the necessary findings for conformity of projects within a nonattainment or maintenance area served by a MPO other than CMAP:

This project is included in the [indicate date] Long-Range Transportation Plan and in the [indicate years] Transportation Improvement Program (TIP) endorsed by [indicate name of MPO], the Metropolitan Planning Organization (MPO) for the region in which the project is located. The project is within the fiscally constrained portion of the plan.

On [indicate date] the Federal Highway Administration (FHWA) and the Federal Transit Administration (FTA) determined that the Long-Range

Transportation Plan conforms with the transportation-related provisions of the Clean Air Act Amendments of 1990. The FHWA and the FTA determined on [indicate date] that the TIP conforms with the Clean Air Act Amendments. These findings were in accordance with Determining Conformity of Federal Actions to State or Federal Implementation Plans, 40 CFR Part 93.

The project's design concept and scope are consistent with the project information used for the TIP conformity analysis. Therefore, this project conforms to the existing State Implementation Plan and the transportation-related requirements of the 1990 Clean Air Act Amendments.

The TIP number for this project is _____.

- c. Projects Within a Nonattainment or Maintenance Area Not Served by an MPO. For projects that the district determines will be located within a nonattainment or maintenance area outside an area served by an MPO, in addition to the introductory paragraphs above, use the following paragraphs to document the necessary analysis and finding by FHWA for conformity:

This project is located within an area that the US Environmental Protection Agency (USEPA) has designated as nonattainment or maintenance in relation to the national ambient air quality standards for [insert name(s) of applicable criteria pollutant(s)]. The project is outside of an area served by a Metropolitan Planning Organization (MPO).

The Federal Highway Administration (FHWA) has reviewed the results of a regional emissions analysis prepared by the Illinois Department of Transportation that includes the proposed project. Based on the results of this analysis, the FHWA has determined that the project will not cause or contribute to any new localized violations of the standard[s] for [insert name(s) of applicable criteria pollutant(s)] nor increase the frequency or severity of any existing violations of the [insert name(s) of applicable criteria pollutant(s)] standard[s]. Therefore, this project conforms to the transportation-related requirements of the 1990 Clean Air Act Amendments.

- d. "Regionally Significant" Non-Federal Projects Within a Nonattainment or Maintenance Area. For "regionally significant" projects located in nonattainment or maintenance areas that do not involve funding or approvals from FHWA, in addition to the introductory paragraphs above, use the following paragraphs to document compliance with the conformity regulations:

This project is located within an area that the US Environmental Protection Agency (USEPA) has designated as nonattainment or maintenance in relation to the national ambient air quality standards for [insert name(s) of applicable criteria pollutant(s)]. The project does not involve approvals or

funding from the Federal Highway Administration but has been determined to be “regionally significant” under the Determining Conformity of Federal Actions to State or Federal Implementation Plans, 40 CFR Part 93.

The Illinois Department of Transportation has confirmed that there is a currently conforming transportation plan and transportation improvement program and has determined that the plan, transportation improvement program, and project are consistent with the 121 Requirements for adoption or approval of projects by other recipients of funds designated under Title 23 USC or the Federal Transit Act, 40 CFR 93.121.

26-12 TRANSPORTATION CONFORMITY PROJECT-LEVEL QUALITATIVE HOT-SPOT ANALYSIS IN PM_{2.5} AND PM₁₀ NONATTAINMENT AND MAINTENANCE AREAS

26-12.01 Introduction

*Please note that on December 27, 2018, the USEPA approved Illinois's May 8, 2018 request to revise the state's designation for PM_{2.5} from unclassifiable to unclassifiable/attainment. (see [83 FR 66631](#)) Based on this final rule, transportation conformity project-level qualitative Hot-Spot analysis for PM_{2.5} is not required. Illinois is also in attainment for the PM₁₀ 1987 standard.

The provisions of 40 CFR 93.116 and 40 CFR 93.123 establish the transportation conformity criteria and procedures for determining which transportation projects in Particulate Matter (e.g., PM_{2.5}, PM₁₀), nonattainment, and maintenance areas require a transportation conformity project-level Hot-Spot analysis.

Transportation conformity is required under the *Clean Air Act*, Section 176(c) (42 U.S.C. 7506(c)) to ensure that Federally supported highway and transit project activities are consistent with the purpose of the State air-quality implementation plan (SIP). Conformity to the purpose of the SIP means that transportation activities will not cause new air quality violations, worsen existing violations, or delay timely attainment of the relevant National Ambient Air Quality Standards (NAAQS). The US Environmental Protection Agency (USEPA) transportation conformity rule (e.g., 40 CFR 51.390, 40 CFR 93) establishes the criteria and procedures for determining whether transportation activities conform to the SIP.

A Hot-Spot analysis is defined in 40 CFR 93.101 as an estimation of likely future localized PM_{2.5} or PM₁₀ pollutant concentrations, and a comparison of those concentrations to the relevant air quality standards. A Hot-Spot analysis assesses the air quality impacts on a scale smaller than an entire nonattainment or maintenance area. The analysis is a means of demonstrating that a transportation project meets *Clean Air Act* conformity requirements to support State and local air quality goals with respect to potential localized air quality impacts. On March 29, 2006, USEPA and FHWA issued joint guidance, *Transportation Conformity Guidance for Qualitative Hot-Spot Analysis in PM_{2.5} and PM₁₀ Nonattainment and Maintenance Areas*, on how to perform a qualitative Hot-Spot analysis. See FHWA's website for further guidance or the district can contact BDE for a copy of the document.

When a Hot-Spot analysis is required, it is included within the project-level conformity determination that is made by FHWA or the Federal Transit Administration.

The Chicago Metropolitan Agency for Planning, Tier 2 Consultation Team has a PM Hot-Spot analysis procedure for all transportation projects, regardless of mode. This Section describes how the IDOT will comply with the Hot-Spot analysis requirements for FHWA-Funded projects Statewide and how the IDOT process fits into the Tier 2 Consultation Team procedure. In addition to the Hot-Spot analysis, other requirements of the transportation conformity regulations (40 CFR 93) must be met prior to NEPA approval; see Section 26-11.

26-12.02 Applicability

The following procedures are applicable to all Federally funded/approved highway projects in PM_{2.5} and PM₁₀ nonattainment and maintenance areas. Currently, Illinois is in attainment for both PM_{2.5} and PM₁₀. Therefore, no project will require a Hot-Spot analysis. It is possible for this designation to change so the procedure will remain in the BDE Manual.

26-12.03 Procedures

26-12.03(a) Exempt Projects

See Section 26-11.03(b) for a list of project-types (from the Exempt projects, 40 CFR 93.126) that are exempt from Hot-Spot analysis requirements and project-level conformity determinations. Further coordination with FHWA and BDE is not required for these project-types provided requirements in 40 CFR 93.126 are met (i.e., a particular action listed under 40 CFR 93.126 is not exempt if the MPO in consultation with other agencies, the USEPA, and FHWA concur that it has potentially adverse emissions impacts for any reason).

In addition to the project types listed in Section 26-11.03, in accordance with 40 CFR 93.128, traffic signal synchronization projects may be approved, funded, and implemented without satisfying conformity requirements.

For projects that are exempt, insert the following language into the NEPA document or project report:

This project is considered exempt from the requirements of conformity per 40 CFR 93.126 or 40 CFR 93.128, as applicable. USEPA has determined that such projects meet the Clean Air Act's requirements without any further Hot-Spot analysis.

26-12.03(b) Non-Exempt Projects That Are Not an Air Quality Concern

Non-exempt projects that are not an air quality concern do not require a Hot-Spot analysis but should be discussed at the district coordination meeting and still require a project-level conformity determination that meets the remaining applicable provisions of the conformity rule.

The following are examples of non-exempt projects that are not an air quality concern under 40 CFR 93.123(b)(1)(i) and (ii):

- Projects that do not meet the criteria under 40 CFR 93.123(b)(1) (i.e., they are not new or expanded highway projects that have a significant number of, or a significant increase in, diesel vehicles, and are not projects affecting intersections that are at Level-of-Service D, E, or F with a significant number of diesel vehicles, or those that will change to Level-of-Service D, E, or F because of increased traffic volumes from a significant number of diesel vehicles related to the project).
- An intersection channelization project or interchange configuration project that involves turn lanes or slots, lanes, or movements that are physically separated. These kinds of

projects improve freeway operations by smoothing traffic flow and vehicle speeds by improving weave and merge operations, which would not be expected to create or worsen PM_{2.5} or PM₁₀ violations.

- Intersection channelization projects, traffic circles or roundabouts, intersection signalization projects at individual intersections, and interchange reconfiguration projects that are designed to improve traffic flow and vehicle speeds and do not involve any increases in idling.

For non-exempt projects that are not an air quality concern, insert the following language into the NEPA document or project report:

This project is not an air quality concern under 40 CFR 93.123(b)(1). Due to [state reason(s)], it has been determined that the project will not cause or contribute to any new localized PM_{2.5} or PM₁₀ violations or increase the frequency or severity of any PM_{2.5} or PM₁₀ violations. USEPA has determined that such projects meet the Clean Air Act's requirements without any further Hot-Spot analysis.

26-12.03(c) Nonexempt Projects That Are an Air Quality Concern

USEPA specifies in 40 CFR 93.123(b)(1) that projects that are an air quality concern include highway and transit projects that involve significant levels of diesel vehicle traffic, or any other project that is identified in the PM_{2.5} SIP as a localized concern. The following are projects of air quality concern that require a Hot-Spot analysis:

- new or expanded highway projects that have a significant number of or significant increase in diesel vehicles;
- projects affecting intersections that are at Level-of-Service D, E, or F with a significant number of diesel vehicles, or those that will change to Level-of-Service D, E, or F because of increased traffic volumes from a significant number of diesel vehicles related to the project;
- new bus and rail terminals and transfer points that have a significant number of diesel vehicles congregating at a single location;
- expanded bus and rail terminals and transfer points that significantly increase the number of diesel vehicles congregating at a single location; and
- projects in or affecting locations, areas, or categories of sites that are identified in the PM_{2.5} or PM₁₀ applicable implementation plan or implementation plan submission, as appropriate, as sites of violation or possible violation.

Some examples of projects of air quality concern that would be covered by 40 CFR 93.123(b)(1)(i) and (ii) include, but are not limited to:

- a project on a new highway or expressway that serves a significant volume of diesel truck traffic (e.g., facilities with greater than 125,000 annual average daily traffic (AADT) and 8% or more of such AADT is diesel truck traffic);
- new exit ramps and other highway facility improvements to connect a highway or expressway to a major freight, bus, or intermodal terminal;
- expansion of an existing highway or other facility that affects a congested intersection (operated at Level-of-Service D, E, or F) that has a significant increase in the number of diesel trucks; and
- similar highway projects that involve a significant increase in the number of diesel transit buses and diesel trucks.

Discuss all projects located in the PM_{2.5} nonattainment and PM₁₀ maintenance areas at district coordination meetings so BDE and FHWA can jointly determine if the project is an air quality concern. The district may also involve the air quality Tier 2 Consultation Team if FHWA and IDOT cannot conclude the project is not an air quality concern. The district should provide the following information associated with the project in a table format:

- AADT in current year, time of completion, and design year;
- diesel truck percentage (e.g., total of all categories), and diesel truck AADT, in current year, time of completion and design year;
- anticipated change of diesel truck traffic due to the project; and
- level-of-service (for intersections) in existing year, time of completion, and design year.

If a project does not clearly fit any of the examples of projects that are not an air quality concern, BDE and FHWA may recommend the district contact their Metropolitan Planning Organization (MPO) so that the project may be discussed at an interagency consultation meeting to determine if a project is an air quality concern as described in 40 CFR 93.123(b)(1).

If it is determined that the project is not an air quality concern, the basis for the determination should be included in the district coordination meeting minutes (e.g., low AADT, low percentage of diesel vehicles). Include the following paragraph in the environmental consequences section of the NEPA document or project report.

This project is not an air quality concern under 40 CFR 93.123(b)(1). Due to [state reason(s)], it has been determined that the project will not cause or contribute to any new localized PM₁₀ violations or increase the frequency or severity of any PM₁₀ violations. USEPA has determined that such projects meet the Clean Air Act's requirements without any further Hot-Spot analysis.

If the project is determined to be an air quality concern, a qualitative Hot-Spot analysis will be required and the steps in Section 26-12.03(d) should be followed.

26-12.03(d) Hot-Spot Analysis Procedures

1. Obtain Regional Emissions PM Analysis Table. The district should contact BDE to obtain the Regional Emissions Analysis Table provided by the MPO for their region. This table will become a component of the Hot-Spot Analysis Report.
2. Draft Hot-Spot Analysis Report. BDE will provide the district with an example Hot-Spot Analysis Report. The district should use this example in conjunction with the joint guidance issued by FHWA and USEPA to complete a Hot-Spot Analysis report. The title of this guidance is *Transportation Conformity Guidance for Qualitative Hot-Spot Analysis in PM_{2.5} and PM₁₀ Nonattainment and Maintenance Areas*. Districts should also use the "Final PM Qualitative Guidance Clarification," issued by FHWA June 12, 2009.

One of the two qualitative methods described below should be used until USEPA releases a quantitative model:

- d. Comparison to Another Location with Similar Characteristics. This method involves reviewing existing highway or transit facilities constructed in the past and built in locations similar to the proposed project and, whenever possible, near an air quality monitor (a surrogate) to allow a comparison of PM₁₀ air quality concentrations.

The district, in consultation with BDE, should identify proposed project(s) and air quality monitor(s) to be used for the surrogate and coordinate this with the Tier 2 Consultation Team through the appropriate MPO. The district will document in the project-level conformity determination the reasons for picking a surrogate project and air quality monitor, including similarities to and differences between the surrogate and proposed project and location, and summarize the coordination that took place with the Tier 2 Consultation Team.

- e. Air Quality Studies for the Proposed Project Location. Air quality information from many sources may be available for the proposed project's location. The State Implementation Plan (SIP) can be an important tool to be referenced when conducting qualitative Hot-Spot analysis, especially for PM₁₀ maintenance areas that already have SIPs in place. The Illinois Environmental Protection Agency would be able to supply data from air quality monitors that may be useful in a given Hot-Spot analysis.

In some cases, the USEPA or a university may have also performed an air quality study near the location of a proposed project. In addition, other scientific studies may be appropriate to understand the potential air quality impact from certain projects.

The interagency coordination process with the appropriate MPO can be used to determine what air quality information from a SIP or other air quality study is appropriate for assessing the air quality impacts of the proposed project. The district should contact BDE for further guidance. The district would then document

within the project-level conformity determination the air quality information used and why it is appropriate.

The following documentation should be included in the Hot-Spot Analysis Report:

- description of project (e.g., location, design and scope; date project is expected to be open, what part of 40 CFR 93.123(b)(1) applies);
- description of type of emissions considered in the analysis (e.g., road dust, construction emissions);
- contributing factors;
- air quality;
- transportation and traffic conditions;
- built and natural environment;
- meteorology, climate, and seasonal data;
- adopted emissions control measures;
- consideration of full timeframe of area's Long-Range Transportation Plan;
- description of existing conditions;
- description of changes resulting from project;
- description of analysis method chosen;
- description of analysis years;
- examination of year or years in which emissions are expected to peak;
- discussion of why project will not cause violation of either the annual or 24-hour standard;
- discussion of professional judgment on impact;
- discussion of any mitigation measures;
- written commitments for mitigation; and
- conclusion on how project meets 40 CFR 93.116 and 93.123.

Upon completion of the draft Hot-Spot Analysis Report, the district will provide a copy of the report to BDE. BDE will coordinate the report, as appropriate, with FHWA for comments on the draft report. BDE will provide the comments from BDE and FHWA to the district for the district to address. Once all BDE and FHWA comments have been

addressed, the Hot-Spot Analysis Report will be summarized in the NEPA document, and the full version included in the NEPA document appendix. If the project is a CE, a copy of the report will be retained in the project files.

11. Public Involvement. The documents and information supporting the project level conformity determination, including the qualitative Hot-Spot analysis must be made available to the public for comment prior to a project-level conformity determination being issued by FHWA. The public involvement process typically used by the districts to satisfy NEPA requirements can be used to satisfy the public involvement requirements for the project-level conformity determination, because project-level conformity determinations are usually conducted as part of the NEPA process. Therefore, the Hot-Spot analysis, and documentation for other project-level conformity requirements should be summarized in the Draft EIS or in the EA.

However, if a CE project requires a qualitative Hot-Spot analysis, and the CE does not require public involvement, then the analysis must be made publicly available prior to determining project-level conformity and concluding the NEPA process. The district should coordinate with BDE/FHWA to determine the appropriate public involvement activity.

For projects of air quality concern that completed the NEPA process before April 5, 2006, and an FHWA approval is still required, a Hot-Spot analysis must be completed. A public comment opportunity must be provided prior to FHWA issuing a project-level conformity determination if the NEPA public involvement process cannot be used to coordinate the Hot-Spot analysis with the public.

This may be accomplished by posting an advertisement in the local newspaper, posting the notice on the MPO's or IDOT's website, and having a copy of the announcement placed at a library or libraries closest to the project corridor.

The following language is suggested for the advertisement/notice:

The Illinois Department of Transportation (IDOT) is currently proposing improvements from _____ to _____. The project scope includes _____. On March 10, 2006, the US Environmental Protection Agency issued new regulations on Particulate Matter (PM₁₀) Hot-Spot Analysis in Project-Level Transportation Conformity Determinations. A Hot-Spot analysis is defined in 40 CFR 93.101 as an estimation of likely future localized PM₁₀ concentrations and a comparison of those concentrations to the relevant air quality standards.

The proposed project has been identified as a project of air quality concern requiring a Hot-Spot analysis as part of the project level conformity determination. IDOT has completed a Hot-Spot analysis for the proposed improvement that is available for public comment. The Hot-Spot analysis is available for review on _____ or at _____. A hard copy of this

analysis can be obtained by contacting _____ at _____.
Comments should be received no later than _____. (Thirty days is
recommended. For shorter time-periods consult BDE and FHWA.) Written
correspondence related to this Hot-Spot analysis should be addressed to
_____.

12. Final Approval. The district should provide BDE and FHWA a summary of any public comments received and the district's response to those comments. If necessary, the district may need to revise the Hot-Spot Analysis Report based on comments received from the public involvement process. The district will provide BDE with the revised report who will then coordinate it with FHWA. FHWA and BDE will review the revised report and provide the district with comments, if any, through BDE.

If the qualitative analysis demonstrates the project does not create or increase the existing PM₁₀ violations, include the following statement in the NEPA document:

The qualitative analysis demonstrates the project will not create new local PM₁₀ violations. Furthermore, the analysis demonstrates the project will not increase the severity or number of existing PM₁₀ violations. The FHWA has, therefore, determined that the project satisfies the Clean Air Act project-level conformity requirements for PM₁₀.

If mitigation measures are necessary to demonstrate conformity, include the mitigation measures in the NEPA document, along with enforceable written Environmental Commitments to implement them. The following statement must be included in the NEPA document:

The qualitative analysis demonstrates the project may create new local PM₁₀ violations or it may increase the severity or number of existing PM₁₀ violations. Implementation of the following air quality mitigation measures will allow this project to meet the conformity Hot-Spot requirements [list mitigation measure(s) here]. The FHWA has, therefore, determined that the project satisfies the Clean Air Act project-level conformity requirements for PM₁₀.

Final approval of the conformity determination is made upon approval of the NEPA document (FONSI, ROD or CE determination).

26-13 MOBILE SOURCE AIR TOXICS

26-13.01 Introduction

On January 18, 2023, the US Department of Transportation and FHWA issued an updated interim guidance on when and how to analyze Mobile Source Air Toxics (MSAT) in the NEPA process for highway project (See *Memorandum: Updated Interim Guidance Update on Mobile Source on Air Toxic Analysis in NEPA Documents* for additional guidance). This guidance and a document of Frequently Asked Questions (FAQ) is available by the following link:

http://www.fhwa.dot.gov/environment/air_quality/air_toxics/policy_and_guidance/msat/index.cfm

The *Clean Air Act Amendments (CAAA) of 1990* identified 188 air toxics, also known as hazardous air pollutants. The US Environmental Protection Agency (USEPA) has assessed this expansive list of toxics and identified a group of 93 compounds emitted from mobile sources, listed in the USEPA Integrated Risk Information System (IRIS). From this list, USEPA also identified a subset of nine compounds that are of greatest priority due to associated health risks. These nine “priority” MSATs are 1,3-butadiene, acetaldehyde, acrolein, benzene, diesel particulate matter (diesel PM), ethylbenzene, formaldehyde, naphthalene, and polycyclic organic matter. While FHWA considered these to be the priority MSATs, USEPA stresses that the list is subject to change and may be revised in future rules.

FHWA developed a tiered approach for analyzing MSATs in NEPA documents, depending on the specific project circumstances. FHWA has identified three levels of analysis:

- no analysis for projects with no potential for meaningful MSAT effects,
- qualitative analysis for projects with low potential MSAT effects, or
- quantitative analysis to differentiate alternatives for projects with higher potential MSAT effects.

For projects warranting MSAT analysis, all nine priority MSATs should be analyzed. Project sponsors who are uncertain about which level of analysis is appropriate for a particular project should consult the BDE Project Coordination Unit staff for additional guidance.

26-13.02 Applicability

The following procedures apply to all proposed highway projects initiated by the Department.

26-13.03 Procedures

26-13.03(a) **Projects with No Meaningful Potential MSAT Effects or Exempt Projects**

The types of projects in this category include:

- Projects qualifying as a categorical exclusion under 23 CFR 771.117;

- Projects exempt under the *Clean Air Act* conformity rule in 40 CFR 93.126 (see Section 26-11.03(b) (Items #1-#3) for a complete list of exempt project types); or
- Other projects with no meaningful impacts on traffic volumes or vehicle mix.

For project types qualifying as a categorical exclusion or for projects that are exempt under the *Clean Air Act* conformity rule under 40 CFR 93.126, no analysis or discussion of MSATs is necessary. Documentation that the project qualifies as a categorical exclusion and/or exempt project is sufficient.

For other projects with no meaningful impacts on traffic volumes or vehicle mix, regardless of the class of NEPA environmental document, no MSAT analysis is recommended. A list of project types that may meet these criteria can be found in Section 26-11.03(b), Item #4.

The project record should document the basis for determination of no meaningful potential impacts with a brief description of the factors considered. Include the following text in the Phase I engineering report and, as applicable, the associated environmental document:

Mobile Source Air Toxics

The purpose of this project is to [insert major deficiency that the project is meant to address] by constructing [insert major elements of the project]. This project has been determined to generate minimal air quality impacts for Clean Air Act criteria pollutants and has not been linked with any special Mobile Source Air Toxic (MSAT) concerns. As such, this project will not result in changes in traffic volumes, vehicle mix, basic project location, or any other factor that would cause an increase in MSAT impacts of the project from that of the no-build alternative.

Moreover, USEPA regulations for vehicle engines and fuels will cause overall MSATs emissions to decline significantly over the next several decades. Based on regulations now in effect, an analysis of national trends with USEPA's MOVES3 model forecasts a combined reduction of more than 76 percent in the total annual emission rate for the priority MSAT from 2020 to 2060 while vehicle-miles of travel are projected to increase by 31 percent (Updated Interim Guidance on Mobile Source Air Toxic Analysis in NEPA Documents, Federal Highway Administration, January 18, 2023). This will both reduce the background level of MSAT as well as the possibility of even minor MSAT emissions from this project.

26-13.03(b) Projects with Low Potential MSAT Effects

The types of projects included in this category are those that serve to improve operations of highway, transit, or freight without adding substantial new capacity or without creating a facility that is likely to meaningfully increase MSAT emissions. This category covers a broad range of projects.

Any projects not meeting the criteria in Sections 26-13.03(a) or 26-13.03(c), should be included in this category. Examples of these types of projects are minor widening projects; new

interchanges, replacing a signalized intersection on a surface street; or projects where design year traffic is projected to be less than 140,000 to 150,000 annual average daily traffic (AADT).

For project types that have a low potential for MSAT effects, conduct a qualitative assessment of emissions projections. This qualitative assessment should compare, in narrative form, the expected effect of the project on traffic volumes, vehicle mix, or routing of traffic and the associated changes in MSAT for the project alternatives, including no-build, based on VMT, vehicle mix, and speed. It should also discuss national trend data projecting substantial overall reductions in emissions due to stricter engine and fuel regulations issued by EPA. Because the emission effects of these projects typically are low, it is expected that there would be no appreciable difference in overall MSAT emissions among the various alternatives.

To aid project sponsors and promote uniformity in NEPA documents, example project documentation is offered for four commonly encountered project types:

1. a minor widening project,
2. a new interchange connecting an existing roadway with a new roadway,
3. a new interchange connecting new roadways, and
4. minor improvements or expansions to intermodal centers or other projects that affect truck traffic.

In addition to the qualitative assessment, the NEPA document for this category of projects must include a discussion of information that is incomplete or unavailable for a project specific assessment of MSAT impacts, in compliance with Council on Environmental Quality (CEQ) regulations 40 CFR 1502.21(b). This discussion should explain how current scientific techniques, tools, and data are not sufficient to accurately estimate human health impacts that could result from a transportation project in a way that would be useful to decision-makers. Recommended prototype language for this discussion is included in Section 26-13.03(e).

Following are some examples of qualitative MSAT analyses for different types of projects. Each project is different, and some projects may contain elements covered in more than one of the examples below. Project sponsors can use the example language as a starting point but should tailor it to reflect the unique circumstances of the project being considered. Consider the following factors when crafting a qualitative analysis:

- For projects on an existing alignment, MSATs are expected to decline due to the effect of new USEPA engine and fuel standards.
- Projects that result in increased travel speeds will reduce MSAT emissions per vehicle miles traveled (VMT) basis. MOVES3 provides an estimation of speed changes on diesel particulate matter and should be accounted for accordingly. This speed benefit may be offset somewhat by increased VMT if the more efficient facility attracts additional vehicle trips.
- Projects that facilitate new development may generate additional MSAT emissions from new trips, truck deliveries, and parked vehicles (due to evaporative emissions). However,

these may also be activities that are attracted from elsewhere in the metro region ; thus, on a regional scale there may be no net change in emissions.

- Projects that create new travel lanes, relocate lanes, or relocate economic activity closer to homes, schools, businesses, and other populated areas may increase concentrations of MSAT at those locations relative to No Build. Other elements related to a qualitative analysis are a discussion of information that is incomplete or unavailable for a project-specific assessment of MSAT impacts and a discussion of any MSAT mitigation measures that may be associated with the project.

A qualitative analysis provides a basis for identifying and comparing the potential differences among MSAT emissions, if any, from the various alternatives. The qualitative assessment presented below is derived in part from a study conducted by FHWA entitled “A Methodology for Evaluating Mobile Source Air Toxic Emissions Among Transportation Project Alternatives.” The study is available through the FHWA website at the following link.

https://www.fhwa.dot.gov/environment/air_quality/air_toxics/research_and_analysis/mobile_source_air_toxics/msatemissions.cfm

Consider the following introduction language for qualitative assessments:

1. Minor Widening Project. For purposes of this scenario, minor highway widening projects are those in which the design year traffic level is predicted to be less than 150,000 AADT. Widening projects that surpass these criteria are subject to a quantitative analysis.

For minor widening projects, include wording similar to the following:

For each build alternative carried forward in this [identify NEPA document], the amount of mobile source air toxics (MSAT) emitted would be proportional to the vehicle miles traveled, or VMT, assuming that other variables (e.g., fleet mix) are the same for each alternative. The VMT estimated for each of the Build Alternatives carried forward is slightly higher than that for the No Build Alternative, because the additional capacity increases the efficiency of the roadway and attracts rerouted trips from elsewhere in the transportation network. [as applicable, Refer to Table XX for more details.] This increase in VMT would lead to higher MSAT emissions for the preferred action alternative along the highway corridor, along with a corresponding decrease in MSAT emissions along the parallel routes. The emissions increase is offset somewhat by lower MSAT emission rates due to increased speeds; according to USEPA’s MOVES3 model, emissions of all of the priority MSAT decrease as speed increases.

Because the estimated VMT under each of the Build Alternatives carried forward are nearly the same, varying by less than [specify] percent, it is expected there would be no appreciable difference in overall MSAT emissions among the various alternatives. Also, regardless of the alternative chosen, emissions will likely be lower than present levels in the design year as a result of USEPA’s national control programs that are

projected to reduce annual MSAT emissions by more than 76 percent between 2020 and 2060 (Updated Interim Guidance on Mobile Source Air Toxic Analysis in NEPA Documents, Federal Highway Administration, January 18, 2023). Local conditions may differ from these national projections in terms of fleet mix and turnover, VMT growth rates, and local control measures. However, the magnitude of the USEPA-projected reductions is so great, even after accounting for VMT growth, that MSAT emissions in the study area are likely to be lower in the future in nearly all cases.

If the project includes plans to construct travel lanes closer to populated areas, include this paragraph:

The additional travel lanes contemplated as part of the project alternatives will have the effect of moving some traffic closer to nearby homes, schools and businesses; therefore, under each Build Alternative carried forward there may be localized areas where ambient concentrations of MSAT could be higher under certain Build Alternatives than the No Build Alternative. The localized increases in MSAT concentrations would likely be most pronounced along the expanded roadway sections that would be built at [specify location], under Alternatives [specify], and along [specify route] under Alternatives [specify alternatives]. However, the magnitude and the duration of these potential increases compared to the No-build alternative cannot be reliably quantified due to incomplete or unavailable information in forecasting project-specific MSAT health impacts.

Conclude with this summary:

In summary, where a highway is widened, the localized level of MSAT emissions for the Build Alternative carried forward could be higher relative to the No Build Alternative, but this could be offset due to increases in speeds and reductions in congestion, which are associated with lower MSAT emissions. Also, MSAT will be lower in other locations when traffic shifts away from them. However, on a regional basis, USEPA's vehicle and fuel regulations, coupled with fleet turnover, will over time cause substantial reductions that, in almost all cases, will cause region-wide MSAT levels to be significantly lower than today.

2. New Interchange Connecting an Existing Roadway with a New Roadway. This example is oriented toward projects where a new roadway section connects to an existing limited access highway. The purpose of the roadway is primarily to meet regional travel needs (e.g., by providing a more direct route between locations). Include wording similar to the following:

For each build alternative carried forward in this [identify NEPA document type], the amount of mobile source air toxics (MSAT) emitted would be proportional to the vehicle miles traveled, or VMT, assuming that other variables (e.g., fleet mix) are the same for each alternative. Because the

VMT estimated for the No Build Alternative is higher than for any of the Build Alternatives carried forward, higher levels of regional MSAT are not expected from any of the Build Alternatives carried forward compared to the No Build Alternative. [as applicable, Refer to Table XX for more details.] In addition, because the estimated VMT under each of the Build Alternatives carried forward are nearly the same, varying by less than [specify] percent, it is expected there would be no appreciable difference in overall MSAT emissions among the various alternatives. Also, regardless of the alternative chosen, emissions will likely be lower than present levels in the design year as a result of USEPA's national control programs that are projected to reduce annual MSAT emissions by more than 76 percent between 2020 and 2060 (Updated Interim Guidance on Mobile Source Air Toxic Analysis in NEPA Documents, Federal Highway Administration, January 18, 2023). . Local conditions may differ from these national projections in terms of fleet mix and turnover, VMT growth rates, and local control measures. However, the magnitude of the USEPA-projected reductions is so great, even after accounting for VMT growth, that MSAT emissions in the study area are likely to be lower in the future in virtually all locations.

Under each alternative carried forward, there may be localized areas where VMT would increase, and other areas where VMT would decrease. Therefore, it is possible that localized increases and decreases in MSAT emissions may occur. The localized increases in MSAT emissions would likely be most pronounced along the new roadway sections that would be built at [specify location], under Alternatives [specify alternatives], and along [specify route] under Alternatives [specify]. However, even if these increases do occur, they too will be substantially reduced in the future due to implementation of USEPA's vehicle and fuel regulations.

In summary, under all Build Alternatives carried forward in the design year it is expected there would be reduced MSAT emissions in the immediate area of the project, relative to the No Build Alternative, due to the reduced VMT associated with more direct routing, and due to USEPA's MSAT reduction programs.

3. New Interchange Connecting New Roadways. This example is oriented toward interchange projects developed in response to or in anticipation of economic development (e.g., a new interchange to serve a new shopping/residential development). Projects from the previous example may also have economic development associated with them, so some of this language may also apply. Include wording similar to the following:

For each build alternative carried forward in this [identify NEPA document type], the amount of mobile source air toxics (MSAT) emitted would be proportional to the vehicle miles traveled, or VMT, assuming that other variables (e.g., fleet mix) are the same for each alternative. The VMT estimated for each of the Build Alternatives carried forward is slightly higher than that for the No Build Alternative, because the interchange facilitates

new development that attracts trips that would not otherwise occur in the area. [as applicable, Refer to Table XX for more details.] This increase in VMT means MSAT under the Build Alternatives carried forward would probably be higher than the No Build Alternative in the study area. There could also be localized differences in MSAT from indirect effects of the project such as associated access traffic, emissions of evaporative MSAT (e.g., benzene) from parked cars, and emissions of diesel particulate matter from delivery trucks [modify depending on the type and extent of the associated development]. Travel to other destinations would be reduced with subsequent decreases in emissions at those locations.

Because the estimated VMT under each of the Build Alternatives carried forward are nearly the same, varying by less than [specify] percent, it is expected there would be no appreciable difference in overall MSAT emissions among the various Build Alternatives. For all Alternatives carried forward, emissions are virtually certain to be lower than present levels in the design year as a result of USEPA's national control programs that are projected to reduce annual MSAT emissions by more than 76 percent between 2020 and 2060 (Updated Interim Guidance on Mobile Source Air Toxic Analysis in NEPA Documents, Federal Highway Administration, January 18, 2023). Local conditions may differ from these national projections in terms of fleet mix and turnover, VMT growth rates, and local control measures. However, the magnitude of the USEPA-projected reductions is so great, even after accounting for VMT growth, that MSAT emissions in the study area are likely to be lower in the future than they are today.

Use the following discussion for new interchanges in areas already developed to some degree. For new construction in anticipation of economic development in rural or largely undeveloped areas, this discussion would be applicable only to populated areas (e.g., residences, schools, or businesses).

The travel lanes contemplated as part of the project alternatives carried forward will have the effect of moving some traffic closer to nearby homes, schools and businesses; therefore, under each alternative carried forward there may be localized areas where ambient concentrations of mobile source air toxics (MSAT) would be higher under certain Alternatives than others. The localized differences in MSAT concentrations would likely be most pronounced along the new/expanded roadway sections that would be built at [specify location], under Alternatives [specify alternatives], and along [specify route] under Alternatives [specify]. However, the magnitude and the duration of these potential increases cannot be reliably quantified due to incomplete or unavailable information in forecasting project-specific MSAT health impacts. Further, under all Alternatives carried forward, overall future MSAT are expected to be substantially lower than today due to implementation of USEPA's vehicle and fuel regulations.

Then include this summary:

In summary, under all Build Alternatives carried forward in the design year, it is expected there would be slightly higher MSAT emissions in the study area, relative to the No Build Alternative, due to increased VMT. There also could be increases in MSAT levels in a few localized areas where VMT increases. However, USEPA's vehicle and fuel regulations will bring about significantly lower MSAT levels for the area in the future than today.

4. Minor Improvements or Expansions to Intermodal Centers or Other Projects that Affect Truck Traffic. The description for these types of projects depends on the nature of the project. The key factor from an MSAT standpoint is the change in truck and rail activity and the resulting change in MSAT emissions patterns. Include wording similar to the following:

For each build alternative carried forward in this [identify NEPA document type], the amount of mobile source air toxics (MSAT) emitted would be proportional to the amount of truck vehicle miles traveled (VMT) and rail activity, assuming that other variables (e.g., travel not associated with the intermodal center) are the same for each alternative. The truck VMT and rail activity estimated for each of the Build Alternatives carried forward are higher than that for the No Build Alternative, because of the additional activity associated with the expanded intermodal center. [as applicable, Refer to Table XX for more details.] This increase in truck VMT and rail activity associated with the Build Alternatives carried forward would lead to higher MSAT emissions (particularly diesel particulate matter) in the vicinity of the intermodal center. The higher emissions could be offset somewhat by two factors: 1) the decrease in regional truck traffic due to increased use of rail for inbound and outbound freight; and 2) increased speeds on area highways due to the decrease in truck traffic. The extent to which these emissions decreases will offset intermodal center-related emissions increases is not known.

Because the estimated truck VMT and rail activity under each of the Build Alternatives carried forward are nearly the same, varying by less than [specify] percent, it is expected there would be no appreciable difference in overall MSAT emissions among the various alternatives. Also, regardless of the alternative chosen, emissions will likely be lower than present levels in the design year as a result of USEPA's national control programs that are projected to reduce annual MSAT emissions by more than 76 percent between 2020 and 2060 (Updated Interim Guidance on Mobile Source Air Toxic Analysis in NEPA Documents, Federal Highway Administration, January 18, 2023). . . Local conditions may differ from these national projections in terms of fleet mix and turnover, VMT growth rates, and local control measures. However, the USEPA-projected reductions are so significant, even after accounting for VMT growth, that MSAT emissions in the study area are likely to be lower in the future as well.

The following discussion may apply if the intermodal center is close to other development:

The additional freight activity contemplated as part of the project alternatives carried forward will have the effect of increasing diesel emissions in the vicinity of nearby homes, schools and businesses; therefore, under each alternative carried forward there may be localized areas where ambient concentrations of MSAT would be higher than under the No Build alternative. The localized differences in MSAT concentrations would likely be most pronounced under Alternatives [specify]. However, the magnitude and the duration of these potential differences cannot be reliably quantified due to incomplete or unavailable information in forecasting project-specific health impacts. Even though there may be differences among the Alternatives carried forward, on a region-wide basis, USEPA's vehicle and fuel regulations, coupled with fleet turnover, will cause substantial reductions over time so that in almost all cases, the MSAT levels in the future will be significantly lower than today.

[Insert a description of any emissions-reduction activities that are associated with the project (e.g., truck and train idling limitations or technologies, auxiliary power units, alternative fuels, engine retrofits for container-handling equipment)].

In summary, all Build Alternatives carried forward in the design year are expected to be associated with higher levels of MSAT emissions in the study area, relative to the No Build Alternative, along with some benefit from improvements in speeds and reductions in region-wide truck traffic. There also could be slightly higher differences in MSAT levels among Alternatives carried forward in a few localized areas where freight activity occurs closer to homes, schools and businesses. Under all alternatives carried forward, MSAT levels are likely to decrease over time due to nationally mandated cleaner vehicles and fuel.

26-13.03(c) Projects with Higher Potential MSAT Effects

This category includes projects that have the potential for meaningful differences in MSAT emissions among project alternatives. A two-prong test is used to determine if projects fall into this category. Projects included in this category must be proposed to be located in proximity to populated areas, and either:

- create or significantly alter a major intermodal freight facility that has the potential to concentrate high levels of diesel particulate matter in a single location, involving a significant number of diesel vehicles for new projects or accommodating with a significant increase in the number of diesel vehicles for expansion projects; or
- create or add significant capacity to urban highways (e.g., Interstates, urban arterials, urban collector-distributor routes) with traffic volumes where the AADT is projected to be in the range of 140,000 to 150,000 or greater by the design year.

Projects meeting the criteria for higher potential MSAT effects will be more rigorously assessed for impacts. It is possible that some projects do not meet the criteria listed above but may still have the potential to substantially increase future MSAT emissions. In this case, project sponsors should contact the BDE Project Coordination Unit staff to determine the appropriate course of action for the subject project.

For any project with higher potential MSAT effects, the specific approach for assessing impacts will be developed by the project sponsor in conjunction with the BDE Project Coordination Unit staff, in consultation with the FHWA Illinois Division Office. Assistance may also be sought from the Office of Natural Environment (HEPN) and the Office of Project Development and Environmental Review (HEPE) in FHWA Headquarters as warranted.

At a minimum, impact assessment for projects in this category shall include a quantitative analysis to forecast local-specific emissions trends of the priority MSAT for each build alternative carried forward, to use as a basis of comparison. This analysis also may address the potential for cumulative impacts, where appropriate, based on local conditions. Consider how and when cumulative impacts would be addressed as part of FHWA assistance outlined above. The NEPA document should also include relevant language on unavailable information as outlined below. Project sponsors should consult with the BDE Project Coordination Unit staff on documenting this information in NEPA documents.

If the analysis for a project in this category indicates meaningful differences in levels of MSAT emissions, mitigation options as outlined below should be identified and considered.

26-13.03(d) MSAT Mitigation Strategies

Lessening the effects of mobile source air toxics should be considered for projects with substantial construction-related MSAT emissions that are likely to occur over an extended building period, and for post-construction scenarios where the NEPA analysis indicates potentially meaningful MSAT levels. Such mitigation efforts should be evaluated based on the circumstances associated with individual projects, and they may not be appropriate in all cases. There are a number of available mitigation strategies and solutions for countering the effects of MSAT emissions.

Mitigating for Construction MSAT Emissions. Construction activity may generate a temporary increase in MSAT emissions. Project-level assessments that render a decision to pursue construction emission mitigation will benefit from a number of technologies and operational practices that should help lower short-term MSAT. In addition, the FHWA has supported a host of diesel retrofit technologies in the Congestion Mitigation and Air Quality (CMAQ) Improvement Program provisions – technologies that may lessen a number of MSAT emissions.

Construction mitigation includes strategies that reduce engine activity or reduce emissions per unit of operating time (e.g., reducing the numbers of trips and decreased idling). Operational agreements that reduce or redirect work or shift times to avoid community exposures can have positive benefits when sites are near populated areas. For example, agreements that stress work activity outside normal hours of an adjacent school campus would be operations-oriented mitigation. Verified emissions control technology retrofits or fleet modernization of engines for construction equipment could be appropriate mitigation

strategies. Technology retrofits could include particulate matter traps, oxidation catalysts, and other devices that provide an after-treatment of exhaust emissions. Implementing maintenance programs per manufacturers' specifications to ensure engines perform at USEPA certification levels, as applicable, and to ensure retrofit technologies perform at verified standards could also be deemed appropriate. The use of clean fuels (e.g., ultra-low sulfur diesel, biodiesel, natural gas) can be a very cost-beneficial strategy.

USEPA has listed a number of approved diesel retrofit technologies. Many of these can be deployed as emissions mitigation measures for equipment used in construction. The following USEPA website contains more information about these technologies:

<https://www.epa.gov/verified-diesel-tech/clean-diesel-technology>

Post-Construction Mitigation for Projects with Potentially Significant MSAT Levels. Travel demand management strategies and techniques that reduce overall vehicle-mile of travel (vehicle-km of travel); reduce a particular type of travel (e.g., long-haul freight, commuter travel) or improve the transportation systems' efficiency will mitigate MSAT emissions. Examples of such strategies include congestion pricing, commuter incentive programs, and increases in truck weight or length limits. Operational strategies that focus on speed limit enforcement or traffic management policies may help reduce MSAT emissions even beyond the benefits of fleet turnover. Well-traveled highways with high proportions of heavy-duty diesel truck activity may benefit from active Intelligent Transportation System programs (e.g., traffic management centers or incident management systems). Similarly, anti-idling strategies (e.g., truck-stop electrification) can complement projects that focus on new or increased freight activity.

Planners also may want to consider the benefits of establishing buffer zones between new or expanded highway alignments and populated areas. Modifications of local zoning or the development of guidelines that are more protective may also be useful in separating emissions and receptors.

The initial decision to pursue MSAT emissions mitigation strategies should be made in consultation with BDE Project Coordination Unit staff. It is desirable for project sponsors to identify potential options for MSAT mitigation at the earliest juncture to ensure sufficient time for interagency coordination if warranted.

26-13.03(e) Prototype Language for Compliance with 40 CFR 1502.21

For projects that require a quantitative or a qualitative analysis, include wording similar to the following for compliance with 40 CFR 1502.21. This language should precede the specific qualitative or quantitative analysis in the environmental document.

*INCOMPLETE OR UNAVAILABLE INFORMATION FOR PROJECT-SPECIFIC
MSAT HEALTH IMPACTS ANALYSIS*

In FHWA's view, information is incomplete or unavailable to credibly predict the project-specific health impacts due to changes in mobile source air toxics (MSAT) emissions associated with a proposed set of highway alternatives. The outcome

of such an assessment, adverse or not, would be influenced more by the uncertainty introduced into the process through assumption and speculation rather than any genuine insight into the actual health impacts directly attributable to MSAT exposure associated with a proposed action.

USEPA Role

The US Environmental Protection Agency (USEPA) is responsible for protecting the public health and welfare from any known or anticipated effect of an air pollutant. They are the lead authority for administering the Clean Air Act and its amendments and have specific statutory obligations with respect to hazardous air pollutants and MSAT. USEPA is in the continual process of assessing human health effects, exposures, and risks posed by air pollutants. They maintain the Integrated Risk Information System (IRIS), which is “a compilation of electronic reports on specific substances found in the environment and their potential to cause human health effects.” IRIS can be accessed through the USEPA website (<https://www.epa.gov/iris>). Each report contains assessments of non-cancerous and cancerous effects for individual compounds and quantitative estimates of risk levels from lifetime oral and inhalation exposures with uncertainty spanning perhaps an order of magnitude.

Role of Other Organizations

Other organizations are also active in the research and analyses of the human health effects of MSAT, including the Health Effects Institute (HEI). Several HEI studies are summarized in Appendix D of FHWA’s Interim Guidance Update on Mobile Source Air Toxic Analysis in NEPA Documents, the link to which is provided at the beginning of this section. Among the adverse health effects linked to MSAT compounds at high exposures are cancer in humans in occupational settings; cancer in animals; and irritation to the respiratory tract, including the exacerbation of asthma. Less obvious is the adverse human health effects of MSAT compounds at current environmental concentrations or in the future as vehicle emissions substantially decrease.

Problems with Modeling Methodologies

The methodologies for forecasting health impacts include emissions modeling, dispersion modeling, exposure modeling, and then final determination of health impacts; each step in the process building on the model predictions obtained in the previous step. All are encumbered by technical shortcomings or uncertain science that prevents a more complete differentiation of the MSAT health impacts among a set of project alternatives. These difficulties are magnified for lifetime (i.e., 70 year) assessments, particularly because unsupportable assumptions would have to be made regarding changes in travel patterns and vehicle technology, which affects emissions rates over that time frame, because such information is unavailable.

It is particularly difficult to reliably forecast 70-year lifetime MSAT concentrations and exposures near roadways; to determine the portion of time that people are actually exposed at a specific location; and to establish the extent attributable to a proposed action, especially given that some of the information needed is unavailable.

MSAT Toxicity Estimates

There are considerable uncertainties associated with the existing estimates of toxicity of the various MSAT, because of factors such as low-dose extrapolation and translation of occupational exposure data to the general population, a concern expressed by HEI. As a result, there is no national consensus on air dose-response values assumed to protect the public health and welfare for MSAT compounds, and in particular for diesel PM.

Level of Risk

There is also the lack of a national consensus on an acceptable level of risk. The current context is the process used by USEPA, as provided by the Clean Air Act, to determine whether more stringent controls are required in order to provide an ample margin of safety to protect public health or to prevent an adverse environmental effect for industrial sources subject to the maximum achievable control technology standards (e.g., benzene emissions from refineries). The decision framework is a two-step process. The first step requires USEPA to determine an “acceptable” level of risk due to emissions from a source, which is generally no greater than approximately 100 in a million. Additional factors are considered in the second step, the goal of which is to maximize the number of people with risks less than 1 in a million due to emissions from a source. The results of this statutory two-step process do not guarantee that cancer risks from exposure to air toxics are less than 1 in a million; in some cases, the residual risk determination could result in maximum individual cancer risks that are as high as approximately 100 in a million. In a June 2008 decision, the US Court of Appeals for the District of Columbia Circuit upheld USEPA’s approach to addressing risk in its two-step decision framework. Information is incomplete or unavailable to establish that even the largest of highway projects would result in levels of risk greater than safe or acceptable.

Conclusions

Because of the limitations in the methodologies for forecasting health impacts described, any predicted difference in health impacts between alternatives is likely to be much smaller than the uncertainties associated with predicting the impacts. Consequently, the results of such assessments would not be useful to decision makers, who would need to weigh this information against project benefits (e.g., reducing traffic congestion, crash rates, and fatalities plus improved access for emergency response) that are better suited for quantitative analysis.

26-14 MICROSCALE ANALYSIS

26-14.01 Introduction

The Clean Air Act requires the USEPA to set National Ambient Air Quality Standards (NAAQS, see 40 CFR Part 50) for six principal pollutants considered harmful to public health and the environment, one of these pollutants is Carbon Monoxide (CO). Additionally, the FHWA issued Technical Advisory T 6640.8A which recognizes that carbon monoxide (CO) is a highway project-related concern and should be evaluated as a part of the environmental analyses for proposed projects and as such should be based on the 1- and 8-hour NAAQS.

IDOT and Illinois Environmental Protection Agency (IEPA) have executed an agreement on Microscale Air Quality Assessments for Department projects (Illinois Department of Transportation and Illinois Environmental Protection Agency Agreement on Microscale Air Quality Assessment for Illinois Department of Transportation-Sponsored Transportation Projects, See Appendix A). This agreement establishes requirements for determining when a microscale analysis is necessary and the methodology to be used for accomplishing the analysis. BDE has developed a *Carbon Monoxide Screen for Intersection Modeling (COSIM) Air Quality Manual* (referred to as *Air Quality Manual* henceforth) that discusses procedures for implementing the IDOT-IEPA agreement. The procedures in this Section provide guidance on documenting microscale analysis results in accordance with the IDOT-IEPA agreement and the *Air Quality Manual*.

26-14.02 Applicability

The following procedures apply to all proposed highway projects initiated by the Department.

26-14.03 Procedures

26-14.03(a) Exempt Projects

Under the terms of the IDOT-IEPA Agreement, projects that are exempt under the Clean Air Act conformity rule in 40 CFR 93.126 are also exempt from a CO microscale analysis. A complete list of exempt project types can be found in Section 26-11.03(b) (Items #1-#3) of this manual. For projects that are a project type identified in 40 CFR Part 93.126, project sponsors should include the following text in the environmental document or project report:

In accordance with the IDOT-IEPA "Agreement on Microscale Air Quality Assessments for IDOT Sponsored Transportation Projects," this project is exempt from a project-level carbon monoxide air quality analysis because it is a project type identified in 40 CFR Part 93.126.

The IDOT-IEPA Agreement requires that all IDOT-sponsored intersection projects that increase capacity and are in the vicinity of a sensitive receptor be subject to a CO microscale analysis, if such projects are not otherwise exempt under 40 CFR 93.126. Examples of projects that increase capacity include the addition of through lanes, auxiliary turn lanes, or installation of traffic signals at an intersection.

There are three additional exemptions included in the IDOT -IEPA Agreement which are described below.

1) Minimum Volume Threshold: An intersection project is exempt from a CO microscale analysis if the highest design-year approach-volume on the busiest leg of the intersection is less than 5,000 vph or 62,500 ADT, even if sensitive receptors are nearby. For such projects, project sponsors should include the following text in the environmental document or project report:

In accordance with the IDOT-IEPA "Agreement on Microscale Air Quality Assessments for IDOT Sponsored Transportation Projects," this project is exempt from a project-level carbon monoxide air quality analysis because the highest design-year approach volume on the busiest leg of the intersection is less than 5,000 vph or 62,500 ADT. [Insert reference to section of project report that describes design-year approach volumes, if desired.]

2) No Sensitive Receptors: Intersection projects which include one or more legs that exceed the minimum volume threshold described above may still be exempt from a CO microscale analysis if there are no sensitive receptors within 1,000 feet of the project location. Sensitive receptors are defined as any building or location (e.g., residence, school, or nursing home) where the general public may be expected to remain for longer than eight consecutive hours. For such projects, project sponsors should include the following text in the environmental document or project report:

In accordance with the IDOT-IEPA "Agreement on Microscale Air Quality Assessments for IDOT Sponsored Transportation Projects," this project is exempt from a project-level carbon monoxide air quality analysis because there are no sensitive receptors within the project area.

3) Modern Roundabout: An intersection project that consists of the installation of a modern roundabout is exempt from a CO microscale analysis. For modern roundabout projects, project sponsors should include the following text in the environmental document or project report:

In accordance with the IDOT-IEPA "Agreement on Microscale Air Quality Assessments for IDOT Sponsored Transportation Projects," this project is exempt from a project-level carbon monoxide air quality analysis because the project consists of the installation of a modern roundabout.

If a project does not meet the criteria for exemption, a CO microscale analysis must be performed as described in the following sections. Project sponsors should consult with the BDE Project Coordination Unit staff to clarify the appropriate analysis and documentation requirements for non-exempt projects.

26-14.03(b) Projects Not Suitable for Use of COSIM 4.0

The COSIM software program is not suitable for projects where the vehicle fleet mix at the project intersection differs greatly from the default fleet mix used by IDOT (e.g., modeling an intersection near a truck stop) or if nearby receptors are located in or near a tunnel or other enclosed area. COSIM is also not suitable for projects that will add through lanes or auxiliary turning lanes and have sensitive receptors, but no intersection work. In such cases, project sponsors should contact the BDE Project Coordination Unit staff regarding CO microscale analysis and environmental documentation requirements.

26-14.03(c) COSIM Pre-Screen Documentation

The COSIM Pre-Screen feature may be used by project sponsors to provide documentation that a project is exempt from a project-level CO air quality analysis. The COSIM Pre-Screen output is not required but may be included in the environmental document or project report at the discretion of the project sponsor.

26-14.03(d) Projects Subject to COSIM Screening Analysis

Non-exempt projects will be subject to a complete COSIM analysis. The COSIM analysis will indicate whether further detailed air quality analysis is needed. If the COSIM analysis indicates that the project “passes” (i.e., does not have the potential for causing a violation of the NAAQS for CO for any affected receptors), additional detailed air quality analysis is not required. Complete and include the following in the environmental document:

The air quality effects of the proposed project were analyzed using the Illinois Carbon Monoxide Screen for Intersection Modeling (COSIM). The “worst case” analysis provided by the COSIM model indicated that the proposed undertaking does not have the potential for contributing to a violation of the National Ambient Air Quality Standards for CO. CO concentrations for the worst case receptor (i.e., residence) located [_____] (see Exhibit [____]) were as follows:

Existing ([year]) - ____ ppm; Build – Time of Completion (TOC) ([year]) - ____ ppm, TOC + 10 years ([year]) - ____ ppm, and Design Year ([year]) - ____ ppm; No Action - ____ ppm in [TOC year], ____ ppm in [TOC + 10 year], and ____ ppm in [design year].

26-14.03(e) Projects Subject to Detailed Project-Level CO Analysis

If the COSIM screening analysis indicates the project “fails” (i.e., it has potential for contributing to a violation of the NAAQS for CO) or if the project does not fit the assumptions for use of the COSIM screening analysis, perform and document a detailed project-level CO analysis. Districts should use the latest US Environmental Protection Agency (USEPA) emission factors and air quality dispersion models; contact BDE for guidance on the latest inputs and modeling information.

Analysis results greater than the eight-hour CO NAAQS will indicate impacts that will require discussion of mitigation measures with FHWA, USEPA, and IEPA. Describe any such mitigation measures in the Environmental Resources, Impacts, and Mitigation discussion.

26-15 MIGRATORY BIRDS

26-15.01 Introduction

The *Migratory Bird Treaty Act* affords protection to migratory bird species native to the United States or its territories and makes it unlawful (unless and except as permitted by regulation) at any time, by any means or in any manner to pursue, hunt, take, capture, kill, attempt to take, capture or kill, possess, sell, import or export any migratory bird, any part, nest, or eggs of any such bird or any product that includes any such bird or any part, nest, or egg thereof. The *Act* prohibits the direct take of birds and their young, eggs, and nests. A take does not include habitat destruction or alteration, as long as there are no birds, nests, or eggs occupying the habitat being removed or altered.

Bald and golden eagles are migratory birds that are also protected under the *Bald and Golden Eagle Protection Act*. Special conditions apply when projects intrude on eagle nesting and winter roosting areas.

In the development of a proposed highway project, an environmental screening must be done to identify and evaluate the potential for impacts to migratory birds, their nests, eggs, and young. This Section prescribes procedures for these analyses, related coordination, mitigation, and documentation.

26-15.02 Legal Authority

The following legal authorities influence policies and procedures for migratory birds:

- Migratory Bird Treaty Act, 16 U.S.C. 703-712,
- *Bald and Golden Eagle Protection Act*, 16 U.S.C. 668a through 668d,
- Exec. Order No. 13186, 66 Fed. Reg. 3853 (January 17, 2001), Responsibilities of Federal Agencies to Protect Migratory Birds, and
- U.S. Fish and Wildlife Service (USFWS), "National Bald Eagle Management Guidelines," May 2007.

26-15.03 Policy

Make special effort to avoid construction-related impacts to migratory birds, their nests, eggs, and young.

26-15.04 Procedures

26-15.04(a) Definitions

2. Area-Sensitive Birds. Species of birds requiring a relatively large forest or grassland patch within which to reproduce successfully.

3. Disturb. To agitate or bother a bald eagle or golden eagle to a degree that causes, or is likely to cause, based on the best scientific information available, injury to an eagle; a decrease in its productivity by substantially interfering with normal breeding, feeding, or sheltering behavior; or nest abandonment, by substantially interfering with normal breeding, feeding, or sheltering behavior.
4. Fragmentation. The degree to which forested or grassland areas are being broken into smaller patches and interspersed with habitat areas of different vegetative composition.
5. Forest-Interior Birds. Neotropical migrants that nest in large, contiguous forest areas and are affected by fragmentation.
6. Migratory Bird. Any bird species listed in 50 CFR 10.13 "List of Migratory Birds."
7. Neotropical Migrant. Birds that nest in the United States and Canada and spend the winter months in tropical Mexico, Central and South America, and the Caribbean.
8. Take. To pursue, hunt, shoot, wound, kill, trap, capture or collect, or attempt to carry out any of these activities. Take does not include habitat destruction or alteration, as long as there are no birds, nests, or eggs occupying the habitat being removed or altered.

26-15.04(b) Applicability

The following procedures apply to proposed projects initiated by the Department involving tree removal or destruction of grassland habitat.

26-15.04(c) Analysis and Documentation

To assess the presence of nesting migratory birds within a project area, a determination of breeding birds within the project area to be disturbed by construction will need to be made. Information on Illinois birds can be obtained from the USFWS *Breeding Bird Survey* (BBS), which is available on the USFWS, Division of Migratory Bird Management *Bird Monitoring* website. The BBS is a roadside survey designed to monitor population trends of land birds. A total of 103 routes are run annually throughout Illinois. Each BBS route includes species presence, abundance, and land cover data. Though most projects will not involve BBS routes, the BBS data can be applied to most project areas by extrapolation. Match a BBS route close to the project area that contains land cover types similar to those within the project area. If appropriate information cannot be obtained from these sources, initiate an individual breeding bird survey. Projects reviewed through the Environmental Survey Process (see Chapter 27) will be evaluated for the presence of migratory birds. Results of the evaluation will be sent to the district for evaluation of the project's impact on migratory birds.

Projects processed with an EA or EIS should identify the species potentially present within the project area, the habitat(s) they occupy, their abundance in the region, the likely mechanisms of take (e.g., vegetation removal, habitat loss, fragmentation), and mitigation measures to avoid a take (e.g., restricting tree removal during the breeding season).

Identify the fragmentation of a forested parcel or woody riparian corridor larger than 20 acres (8 ha) and discuss the potential for impacts to forest interior species. For those neotropical migrants that could be affected by the project, include a table within the EA or EIS identifying the species, the species' habitat, and the nesting season dates. This information can be obtained from *The Illinois Breeding Bird Atlas* and *The Birds of Illinois*. *The Illinois Breeding Bird Atlas* (Kleen, Cordle, and Montgomery, 2004) provides information on distribution, abundance, breeding habitats, and fledgling times. *The Birds of Illinois* (Bohlen and Zimmerman, 1989) provides arrival and departure dates on a geographical basis. Discuss the mitigation measures and the actions to avoid a take.

Projects Involving Bald Eagles

Projects involving bald eagles will follow the USFWS *National Bald Eagle Management Guidelines*, available on the USFWS, Division of Migratory Bird Management *Bald and Golden Eagle* website. The EA or EIS will document the results of application of the USFWS guidelines.

In Illinois, bald eagle habitat consists of wintering habitat, winter night roosts, and nesting habitat. During the winter (October through March) migrating bald eagles (and some golden eagles) are present along the Mississippi and Illinois Rivers, and adjacent lakes and sloughs. They also occur around large impoundments. Winter night roosts generally consist of wooded ravines along the bluffs of the Mississippi and Illinois Rivers. These ravines are used annually and offer protection from cold winds and seclusion from human disturbance. The locations of winter night roosts can be obtained through coordination with the Illinois Department of Natural Resources (IDNR). Eagles build large nests in the upper branches of the tallest trees, usually cottonwoods. Edges and openings in forests, fencerows, and other type areas are used for nesting. Impact analysis for nesting and winter night roosts follows the USFWS guidelines. A circle with a radius of 1,320 ft (400 m) is established around a nest/winter night roost. The circle is broken into three zones, as follows:

- The first zone extends out from the nest/winter night roost 330 ft (100 m). No human use is allowed year-round within this zone.
- The second zone extends from 330 ft to 660 ft (100 m to 200 m). Land-use activities involving clear cutting, land clearing, or major construction are prohibited within this zone.
- The third zone extends from 660 ft to 1,320 ft (200 m to 400 m) and is the least restrictive. Most activities are permissible within this zone except during the nesting period (generally late February to mid- July).

Projects processed as CEs should receive either a biological signoff or a Biological Resource Review (BRR) Memorandum. A biological signoff indicates the likelihood of migratory bird impacts is remote. If potential migratory bird habitat and/or impacts are present, the BRR Memorandum will contain the results of the migratory bird evaluation. Projects involving bald eagles will follow the USFWS guidelines as described above. Include this documentation in the Phase I engineering report.

26-15.04(d) Coordination

Coordination with the USFWS is required for all actions that are likely to take a migratory bird(s). In general, EIS projects will be coordinated with the USFWS, IDNR, and US Environmental Protection Agency through the circulation of the Draft and Final EIS. EA and CE projects will be coordinated with the IDNR and USFWS (if appropriate) through the Environmental Survey Process. Agency comments, if any, should be addressed by the district with a copy to the BDE. Construction plans must include identification of sensitive areas and measures to be used to avoid a take of a migratory bird or its nest, eggs, or young.

The construction contractor should be made aware through the use of a General Note in the project plans if the action is likely to take a migratory bird(s). The construction contractor is personally liable for violations of the *Migratory Bird Treaty Act*. Mitigation options include avoiding impacts to migratory birds, their nest, eggs, or young; performing tree removal outside the critical stage for the species involved; or performing a specific bird survey to confirm that migratory birds are not using the area.

26-16 WILDLIFE RESOURCES

26-16.01 Introduction

Wildlife resources are of ecological, educational, aesthetic, cultural, recreational, economic, and scientific value to Illinois. In the development of projects, it may be necessary to undertake special technical analyses, coordination, and mitigation to reduce and minimize impacts to wildlife species and their habitats.

26-16.02 Legal Authority/Guidance

- Fish and Wildlife Coordination Act, 16 U.S.C. 661-667e,
- Mitigation of Impacts to Wetlands and Natural Habitats, 23 CFR 777,
- Environmental Mitigation, 23 CFR 710.513,
- Section 404(b)(1) Guidelines for Specification of Disposal Sites for Dredged or Fill Material, 40 CFR 230,
- Memorandum of Understanding to Foster the Ecosystem Approach between all Federal Agencies, December 15, 1995,
- Illinois Comprehensive Wildlife Conservation Plan and Strategy (Illinois Wildlife Action Plan), 2005,
- Eco-Logical: An Ecosystem Approach to Developing Infrastructure Projects, 2006,
- *Critter Crossings: Linking Habitats and Reducing Roadkill* (FHWA-EP-004) (available on FHWA website), and
- *Wildlife Vehicle Collision Reduction Study: Best Practices Manual* (FHWA-HEP-09-022), 2008 (available on FHWA website).

26-16.03 Policy

In the development of major highway projects, project impacts to wildlife resources will be identified and evaluated and consideration will be given to implementing practical measures for avoiding, minimizing, and mitigating adverse impacts to those resources.

26-16.04 Procedures

26-16.04(a) Definitions

9. Cover Types. This term refers to the plant communities (predominant vegetation types) for a particular area of land. The cover types used in evaluating proposed highway

projects are derived from the Natural Areas Inventory and US Fish and Wildlife Service (USFWS) Habitat Evaluation Procedure, and have been modified to fit the Department's need for consistent field survey results. Cover types include forest, cropland, urban/built-up lands, and other plant community types. These cover types are further described in Section 26-17.06(b).

10. Important Use Areas. Specific areas (e.g., pond, marsh, or similar features) containing amphibians and reptiles having a high species diversity relative to other areas in the region.
11. Species in Greatest Need of Conservation in Illinois. This term refers to those species of fish and wildlife listed in Appendix I of the Illinois Wildlife Action Plan.
12. Wildlife Action Plan. This is a statewide plan for Illinois that addresses conservation of a broad range of wildlife species by identifying their associated habitats and the actions needed to protect and restore the viability of those habitats. The strategies for habitat protection and restoration focus on the species in greatest need of conservation while also addressing the needs of the full array of wildlife in the State.
13. Wildlife Resources. In the context of this Section, this term refers to terrestrial insects, amphibians, reptiles, birds, mammals and their habitats.
14. Wildlife Habitat. This term refers to areas of land that provide food, water, cover, and space required to meet the biological needs of one or more wildlife species.

26-16.04(b) Applicability

The following procedures are applicable to highway projects initiated by the Department that are being processed as an EA or EIS where the project would result in destruction or modification of forested, grassland, including pasture and hayland, and/or wetland (marsh) wildlife habitat.

26-16.04(c) Analysis and Documentation

In response to submittal of an Environmental Survey Request, BDE will determine the need for and the type of wildlife studies for the proposed project. In making this determination, BDE will consider the environmental class of action, the scope of the project, the potential wildlife resources in the project area, and the potential for adverse impacts to wildlife and their habitats. If biological surveys are determined necessary for gathering information on wildlife resources, BDE will task the Illinois Natural History Survey (INHS) to perform the surveys. BDE will provide a scope of work for the survey work to the INHS and the district. The biological surveys generally are conducted over a yearlong period that covers the spring, summer, and fall seasons. Surveys that do not start at the beginning of a year may take 15 months or more to complete. BDE will provide the results of the biological surveys conducted for the project to the district and to Federal, State, and local agencies and the public, as appropriate.

The district will summarize the information on wildlife resources in the project area from the INHS biological survey report and from the appropriate sections of the Illinois Wildlife Action Plan. This summary will include the identification and brief characterization of the Illinois Natural Division, major habitat types, wildlife species and groups of species and their habitats, wildlife impacts, and a discussion of measures to minimize and mitigate adverse impacts to wildlife species and their habitats.

Identify the Natural Division(s) and characterize the features relevant to the project area based on information in the Wildlife Action Plan.

Characterize wildlife habitats in the project areas as wooded, non-wooded, or transitional areas between the two primary habitat divisions. Provide a brief summary regarding the distribution of habitats in the project area and the general wildlife species that occupy these habitats and transitional areas.

Identify species with the greatest need of conservation that are known to occur within or adjacent to a project area and characterize their habitats. The discussion also should address the distribution and abundance of these habitat-types in the project area.

Identify wildlife species or groups of wildlife species that require more specialized habitats and characterize their habitats (e.g., important use areas for amphibians, reptiles). Identify the population size for these species and describe linkages between their habitats.

Many groups of avian species are subject to national plans and are of ecological or economic importance. These groups include neotropical migrants, shorebirds, raptors, wading birds, waterfowl, and upland game bird species. Their importance for consideration in project development varies by season and their habitat preferences. If these types of avian species groups do not use and/or are not present in the project area, they do not need to be discussed in the environmental document.

Neotropical migrants occupy a variety of habitat types and breed from late March to mid-July, depending upon the location within the State. Breeding habitat and species' susceptibility to habitat fragmentation should be identified and characterized. Shorebirds (e.g., yellowlegs, sandpipers) are long-distance migrants that pass through Illinois during the spring or fall migration. These birds often migrate through in large numbers and use lake shorelines, river floodplains, and flooded agricultural fields. Shorebird species, their numbers, and the habitats used during the spring migration should be identified and characterized. Important migration routes for raptors (e.g., hawks, falcons, eagles, vultures, owls) are along the bluffs of major river systems. Raptors generally breed from February to mid-July and use wooded habitats for breeding. The location of a raptor's breeding area and/or the presence of migration routes should be identified and characterized. See Section 26-15 for additional guidance regarding migratory birds.

Wading birds include bitterns, herons, egrets, and cranes. Some wading birds are communal species (e.g., herons, egrets). They nest together in a cluster called a rookery. These colonies can be made up of a single species of bird or may include two or more species. The species forage outward for miles (km) from these rookeries. Identify the location, species, and population size of the rookery and the major foraging areas within the project area.

Waterfowl (e.g., ducks, geese) are of economic importance. Major habitats for these species include lakes, ponds, streams, and open water wetlands. Identify the species that are known to breed in the project area, location of important habitat areas, and economic importance of these species within the project area.

Upland game bird species include both native (e.g., American crow, mourning dove) and introduced (e.g., wild turkey, ring-necked pheasant) species. These species would be considered recreationally important on public lands and some private lands. Where a project will affect these types of lands on which upland game bird species are recreationally important, identify the lands and species.

Identify the areas of high deer/vehicle collisions based on information obtained from the IDOT Division of Traffic Safety. If the project traverses large areas of public and private lands under wildlife management and wildlife mortality is a concern, the district should conduct a roadkill survey. This survey is meant to supplement the deer/vehicle collision data with information on small and medium size mammals, birds, amphibians, and reptiles. The purpose of the survey is to identify areas where wildlife mortality is high and where such features as overpasses, underpasses, or culvert/bridge modifications may be appropriate to reduce the incidence of wildlife/vehicle collisions. Discuss the study protocols for specific roadkill surveys with BDE and the INHS. Generally, the following protocols will apply:

- Drive the survey route during the morning on the first working day of each week from March through September.
- Identify each individual specimen by species and location (e.g., stationing, mile marker, or other identifier). Species identification can be accomplished by photographing the specimen and sending the photo to the INHS for identification.

The environmental documentation should identify and characterize the project impacts on wildlife (e.g., habitat loss, impacts to species in greatest need of conservation, impacts to wildlife species or groups of species). In addition to habitat loss, other impacts to wildlife include construction mortality, barriers to movement, habitat fragmentation, and operational mortality. Identify and evaluate measures to minimize and mitigate adverse wildlife impacts. Possible impact minimization measures include reducing the roadway footprint, fencing, preserving wildlife habitat, restricting vegetation removal during critical times in the life cycle of a potentially impacted affected species, and incorporating wildlife underpasses or overpasses into the project. Possible mitigation measures include habitat banking; restoration of degraded forest, prairie or savanna areas; planting trees to fill gaps within forested areas on public land or restoring woody vegetation along stream banks within and adjacent to highway rights-of-way. Some of these alternatives may require the purchase of conservation easements. For areas involving high incidence of vehicle/deer collisions, consider alternative locations, design modifications, and/or habitat modifications for reducing the likelihood of these collisions.

In evaluating potential mitigation measures and strategies for addressing wildlife impacts, consider the needs identified in the Illinois Wildlife Action Plan for the Natural Division(s) where the project is located. Coordination should be initiated with IDNR and BDE to evaluate proposals

for addressing the identified needs. All proposed mitigation measures for wildlife impacts should be coordinated with BDE.

26-16.04(d) Coordination

For projects processed as EAs or CEs, coordination regarding wildlife resources is done through the ESR process. Coordinate the biological survey reports with the IDNR and the USFWS, as appropriate. Coordination with the public will be done when the EA is made available at the public meeting. Address comments received in the FONSI.

For projects processed as an EIS, coordination with IDNR and USFWS will occur through the NEPA/404 Merger Process; see Section 22-4. The biological survey reports will be made available on the IDOT website and the link to the documents will be provided to IDNR, USFWS, and other agencies involved in the Merger Process. Discuss the potential project impacts on wildlife resources and measures to minimize and mitigate these impacts at NEPA/404 Concurrence Point meetings and include a summary of these discussions in the draft EIS.

For projects the Regional Engineer determines will use the principles of Context Sensitive Solutions (CSS), the link to the biological survey documents also will be made available to the community resource council and/or appropriate Technical Advisory Group(s) (TAG), as applicable; see Section 19-5. The district will consider any comments submitted by the TAG(s) regarding wildlife resource issues in preparing the draft EIS or EA.

26-17 TREE/VEGETATION ASSESSMENTS

26-17.01 Introduction

As reflected in Departmental Policy D&E-18, the Department acknowledges the beneficial functions that trees can perform and the importance of considering effects on these functions in project development. Project effects on functions performed by other types of vegetation also should be considered as a part of the project development process. Tree and vegetation assessments provide information for determining overall quality of the vegetation in the project area, for identifying important plant communities (e.g., that provide wildlife habitat) and for inventorying and evaluating trees in the area the project may affect (e.g., type, size, health, functions).

This Section provides policy and procedures for conducting and documenting tree and vegetation assessments for proposed projects.

26-17.02 Legal Authority

- *The Illinois Highway Code*, 605 ILCS 5/2-220, Forestation of Department Controlled Property,
- D&E-18, Preservation and Replacement of Trees,
- Federal Participation for Use of Native Wildflowers, 23 CFR 752.11(b),
- *Context Sensitivity*, 605 ILCS 5/4-219, and
- Memorandum of Understanding by and between the Illinois Department of Natural Resources and the Illinois Department of Transportation, 2007.

26-17.03 Policy

Tree/vegetation assessments will be conducted as necessary to ensure full compliance with Departmental Policy D&E-18 and to support the identification and appropriate consideration of project effects on other types of vegetation and their respective functions.

26-17.04 Procedures

26-17.04(a) Definitions

15. District Tree Evaluation Team. A team within each district that is responsible for conducting evaluations in accordance with Departmental Policy D&E-18 for trees being considered for removal. The team must include expertise in roadside safety, landscape architecture, and environmental impact analysis.

16. Diameter at Breast Height (DBH). The diameter of a tree measured (in inches (mm)) at a point 4.5 ft (1.35 m) above ground level.
17. Specimen Tree. A notable and valued tree, based on consideration of species, size, condition, age, longevity, visual quality, and genetic attributes, as determined by the public and/or resource agencies and the district.
18. Tree. For purposes of the Department's *Standard Specifications for Road and Bridge Construction*, a tree is a woody perennial plant having a single main stem (trunk), the diameter of which is 6 in. (150 mm) or more at a point 4.5 ft (1.35 m) above the highest ground level at the base of the tree. The term "tree" also includes woody perennial plants having a single trunk of less than 6 in. (150 mm) in diameter where such plants have been intentionally planted for landscaping, environmental mitigation, or habitat preservation/enhancement. For purposes of biological surveys conducted for proposed projects, the criteria for identifying "trees" are essentially the same as in the first sentence above, except that the diameter used is 4 in. (100 mm) or more at a point 4.5 ft (1.35 m) above the highest ground level at the base of the plant.
19. Trees with Special Functions. Woody vegetation that is a buffer between a highway and a State-listed Natural Area, Nature Preserve, or Land and Water Reserve are considered trees with special functions.
20. Vegetation. The plants of an area.

26-17.05 Applicability

These procedures apply to all proposed highway projects initiated by the Department.

26-17.06 Analysis and Documentation

26-17.06(a) Tree Surveys

For most projects needing tree surveys, the district Tree Evaluation Team accomplishes the surveys. On some projects in rural areas being processed with an Environmental Assessment (EA) or an Environmental Impact Statement (EIS), the Illinois Natural History Survey (INHS) accomplishes the surveys. The purpose of the tree surveys is to obtain information on the health and diversity of trees and shrubs in a project area. Tree surveys are recommended for projects that involve:

- residential areas containing numerous trees of various sizes, particularly if the project is one on which CSS principles are being applied or if the community has an established urban tree program;
- removal of trees from public land;
- rest area construction in wooded locations;

- new interchange construction in wooded locations;
- impacts to wooded areas 20 acres (8 ha) or larger in agricultural locations;
- wooded areas along scenic routes and/or in existing and potential scenic easement areas;
- need to establish an inventory of trees and their condition on existing highway rights-of-way for management purposes;
- need to identify targeted woody species in USDA Quarantine areas (see Section 26-18); and
- wooded areas along streams with special designations (see Section 26-19) or streams for which the Corps could request mitigation for impacts to the riparian corridor.

Tree surveys should be initiated for projects in urban areas that will involve the removal of trees along streets and/or removal of associated landscape elements from residential areas, public lands, and open lands including fence rows. Before doing a tree survey in a community that has an established urban tree program, contact the community's urban forester or other appropriate official to discuss the information to be collected and its relationship to the community's program, as appropriate. Likewise, contact the appropriate official(s) responsible for public lands prior to initiating tree surveys on those lands. Provide the results of the surveys to a community's urban forester or other designated official and to the appropriate official(s) responsible for public lands, as applicable. If a project is one on which principles of Context Sensitive Solutions (CSS) are being applied, provide the survey results to the project study group and the appropriate Technical Advisory Group(s).

The methods for conducting tree surveys involve either direct counting or sampling. The particular method used is determined by the distribution of trees within the project area and the purpose of the survey.

26-17.06(a)1 *Direct Counting Method*

Tree surveys in residential areas, on public lands, in scenic areas, along stream corridors, or for projects that will affect a relatively small area (e.g., interchanges, rest areas) are accomplished using the direct counting method. In this method, each individual tree within the project limits is inventoried. For each tree, information is collected on its species, size (DBH), station, offset, health, structure, and impact status. Collected field data is incorporated into the project files. If coordination with the public and/or agencies will be undertaken, prepare a tree survey report. The data should be in table format and the table headings should include tree species, size (DBH), station, offset, health, structure, impact status, and suitability for preservation.

The report should categorize "health" and "structure" as good, fair, poor, or dead. The report should explain that ratings for "health" are based on the extent to which a tree is reasonably free of signs and symptoms of disease, and ratings for "structure" are based on the extent to which a tree has structure and form typical of the species.

The report should categorize “suitability for preservation” as good, fair, or poor. Suitability for preservation considers the health, age, and structural condition of the tree and its potential to remain an asset into the future. A rating of good applies to trees with good health and structural stability that have the potential for longevity at the site. A rating of fair applies to trees with somewhat declining health and/or structural defects that can be abated with treatment. These trees will require more intense management and monitoring and may have a shorter life span. A rating of poor applies to trees in poor health or with significant structural defects that cannot be mitigated. They should be removed.

The information on impact status and suitability for preservation will be coordinated with project designers in making final decisions on whether specific trees along the project should be removed or preserved and protected (e.g., trees outside project right-of-way that are given suitability for preservation ratings of poor due to significant structural defects and which, therefore, pose a hazard, should be identified for removal).

Coordinate the tree survey report with the community’s urban forester or other designated official, as applicable and affected landowner(s), as appropriate. During Phase II, coordinate tree trimming or removal with the landowner and offer replacement trees and/or shrubs.

26-17.06(a)2 *Sampling Method*

Tree surveys can be done in spot locations or for projects on new alignments. Instead of inventorying each tree, quantitative or qualitative sampling can be employed. The ecological literature has a number of methods for the quantitative sampling of trees. Two of these are the circular plot and point-center quarter methods. When using either of these survey methods, document the quality, disturbance, and presence of specimen trees, or other noteworthy features within the area being sampled.

Either method yields information on density (number of trees per acre (ha)), size (basal area per acre (ha)), and distribution within the stand (frequency of occurrence for each species sampled). Using these results, generate a table for inclusion in the tree survey report summarizing the information for the wooded stands that were sampled. The table should include headings for the stand location, species composition, structure (density, basal area, and frequency of occurrence) and potential project impact (acreage (ha) or number of trees lost). The tree report also should include a discussion of specimen trees, trees with special functions and other features of the stand, as well as mitigation options for the project’s anticipated impacts to trees. If the project is being processed as an Environmental Assessment (EA) or Environmental Impact Statement (EIS), include a summary of the report into the environmental document. If the project is a CE, the report and the results of coordination with Illinois Department of Natural Resources (IDNR) should be in the appendix of the Phase I engineering report.

26-17.06(b) *Cover Type and Vegetation Surveys*

Cover type surveys are done for some EA projects and most EIS projects. BDE tasks the Illinois Natural History Survey (INHS) to survey the project area for the purpose of classifying plant communities according to cover type and characterizing the vegetation in the area. Cover type

surveys are done to determine the distribution and composition of plant communities (e.g., vegetation/habitat types) within a project area. The survey is usually based on the review of aerial photography and topographic maps with field checks to determine the adequacy of the cover typing and to identify the species composition, quality, and disturbance history of the delineated plant communities. Cover type surveys are usually done for projects on new alignments or in areas where the project will affect a diverse number of plant communities.

The vegetation cover types used for INHS cover type mapping are derived from the Natural Areas Inventory and the USFWS Habitat Evaluation Procedure and have been modified to fit IDOT projects. The definitions of the vegetation cover types used by the INHS are provided below:

21. Forbland. Abandoned pastures and successional fields dominated by disturbance adapted and disturbance tolerant forbs. Shrub or tree cover should not exceed 25% of the overall cover.
22. Pasture and Hayland. Dominated by perennial grasses or forbs, native or introduced, that are planted primarily for livestock grazing or are mowed at least once a year. Both pasture and hayland should have no more than 5 percent areal cover from woody vegetation.
23. Cropland. Agricultural field planted to annual crops of grains, vegetables, or silage.
24. Urban/Built-Up Lands. Includes any land that has been modified or has structures built on it. Examples include residential, commercial, and industrial areas, vacant urban lots, farm buildings, feedlots, parking lots, roadways, and cemeteries.
25. Shrubland. Abandoned pastures, successional fields, railroad and highway rights-of-way dominated by dense to open stands of shrubs and young trees, with at least 25% shrub cover.
26. Grassland (Prairie). Native grasses dominated communities found as remnant communities along roadsides, in pastures, abandoned rights-of-way, and cemeteries. Also includes prairie restoration areas.
27. Non-Native Grassland. Open land dominated by exotic cool-season grasses, especially brome, blue grass, and fescue. The areas are periodically mowed. This cover type includes mowed roadsides and grass ways within cropland.
28. Upland Forest. Forests that normally are not flooded by stream overflow.
29. Floodplain Forest. Forests that occur on the 100-year floodplain. These forests may or may not meet the regulatory requirements of a wetland. When they do, they also qualify as forested wetland.
30. Forested Wetland. Forests that meet the regulatory requirements of a wetland.
31. Wet Shrubland. Includes areas dominated by woody vegetation (e.g., greater than 25% areal cover) less than 20 ft (6 m) in height.

32. Marsh. Includes areas dominated by tall graminoid plants and that have water near or above the surface for most of the year.
33. Sedge Meadow. Includes areas dominated by sedges on peat, muck, or wet sand.
34. Wet Meadow. Includes areas dominated by grasses, where the soils are hydric.
35. Pond. Natural or man-made impoundments that support wetland vegetation around the periphery of the pond (regulated wetland) or maintained ponds that are actively used farm ponds, sewage lagoons, ornamental ponds, active quarry ponds, or retention/detention facilities not containing hydrophytic vegetation (non-wetland areas).
36. Lacustrine. Deepwater habitats that are situated in a topographic depression or dammed river channel. Their total area exceeds 20 acres (8 ha).
37. Riverine. Includes habitats contained within a channel. Refers to a stream, creek, or river.
38. Barren Land. Land having less than 1% total vegetation cover. Includes rock outcrops, recently mined areas, and recently scraped areas.

Vegetation surveys are done by the district to characterize existing conditions in potential mitigation sites and managed roadside areas. The results of these surveys are depicted on maps. Proposed modifications in the vegetation can be overlaid on these maps to delineate the nature and extent of the changes.

26-17.07 Coordination

Coordinate tree surveys done in an urban area with the community's urban forester, if applicable, and the appropriate property owners. Coordinate tree surveys in other venues with the IDNR. For project processed with an EIS, summarize tree and vegetation surveys in the draft EIS and coordinated through the circulation of the document. Coordinate tree and vegetation survey reports on EA processed projects with the IDNR. Summarize these reports and the results of coordination with IDNR in the EA.

Vegetation surveys accomplished by the district for mitigation purposes will be coordinated with BDE and IDNR.

26-18 INVASIVE SPECIES AND NOXIOUS WEEDS

26-18.01 Introduction

Non-native flora and fauna can cause significant changes to ecosystems, upset the ecological balance, and cause economic harm to the agricultural and recreational sectors. Transportation systems can facilitate the spread of plant and animal species outside their natural range. Those species that are likely to harm the environment, human health, or economy, including species designated as noxious weeds, are of particular concern.

Highway corridors provide opportunities for the movement of invasive species and noxious weeds through the landscape. Invasive plants can be moved from site to site during spraying and mowing operations. Weed seed can be inadvertently introduced into the corridor during construction, on equipment, and through the use of mulch, imported soil or gravel, and sod. Some invasive plant species might be deliberately planted in erosion control, landscape, or wildflower projects. Highway rights-of-way traverse public and private lands and many of these adjacent lands have weed problems. The highway rights-of-way provide corridors for further spread of the weeds.

Federal and State requirements are in place for controlling and/or eliminating noxious weeds and invasive species. The procedures in this Section provide guidance for evaluating and documenting invasive species and noxious weed issues in the environmental documentation for proposed highway projects.

26-18.02 Legal Authority

- Exec. Order No.13112, 64 Fed. Reg. 6183, February 8, 1999, Invasive Species,
- Management of Undesirable Plants on Federal Lands, 7 U.S.C. 2814,
- Definitions, 7 U.S.C. 7702,
- Noxious Weed Regulations, 7 CFR 360,
- FHWA Guidance on Invasive Species, August 10, 1999,
- Illinois Noxious Weed Law, 8 Ill. Admin, Code 220, ,
- The Illinois Noxious Weed Law, 505 ILCS 100/1 *et seq.*,
- The Illinois Exotic Weed Act, 525 ILCS 10/1 *et seq.*, and
- The Insect Pest and Plant Disease Act, 505 ILCS 90/1 *et seq.*

26-18.03 Policy

The environmental analyses and documentation for proposed highway projects initiated by the Department will include determinations of the likelihood of introducing or spreading invasive species and/or noxious weeds. When invasive species and/or noxious weed are identified as a potential concern, include in the environmental documentation a description of measures to be taken to avoid introducing or spreading the species and to minimize their potential for causing harm.

26-18.04 Procedures

For projects being processed with an Environmental Impact Statement, the Environmental Survey Process will include identification of invasive species and/or noxious weeds in the area the project potentially may affect. Biological survey reports and wetland determinations produced by the Illinois Natural History Survey for these projects will include information on these species. For projects processed as Categorical Exclusions or with an Environmental Assessment, obtain information on invasive species and/or noxious weeds the project may involve from the Illinois Department of Agriculture website.

26-18.04(a) Definitions

39. Alien Species. Any species with respect to a particular ecosystem including its seeds, eggs, spores, or other biological material capable of propagating that species that is not native to that ecosystem.
40. Control. As appropriate, eradicating, suppressing, reducing, or managing invasive species populations, preventing spread of invasive species from areas where they are present, and taking steps such as restoration of native species and habitats to reduce the effects of invasive species and to prevent further invasions. Control as applied to weed control, means to prevent weeds from spreading or being spread by dissemination of seed or other propagating parts.
41. Ecosystem. The complex of a community of organisms and its environment.
42. Eradicate. The complete killing or destruction of weeds, seeds, or other propagating parts of weeds by the use of cutting, chemicals, tillage, cropping systems, pasturing, livestock or crops, or any one or all of these in effective combination.
43. Exotic Weeds. Plants not native to North America, which, when planted, either spread vegetatively or naturalize and degrade natural communities, reduce the value of fish and wildlife habitat, or threaten an Illinois endangered or threatened species.
44. Introduction. The intentional or unintentional escape, release, dissemination, or placement of a species into an ecosystem as a result of human activity.
45. Invasive Species. An alien species whose introduction does or is likely to cause economic or environmental harm or harm to human health.
46. Native Species. With respect to a particular ecosystem, a species that, other than a result of an introduction, historically occurred or currently occurs in that ecosystem.
47. Noxious Weed. For Federal requirements, any plant or plant product that can directly or indirectly injure or cause damage to crops, including nursery stock or plant products, livestock, poultry, or other interests of agriculture, irrigation, navigation, natural resources of the United States, public health, or environment. For the State of Illinois requirements,

this means an annual, biennial, or perennial plant propagated by seed or vegetative parts that is designated in 8 Ill. Admin. Code 220.60 as being a noxious weed, in accordance with Section 2(5) and Section 4 of the *Illinois Noxious Weed Act*.

26-18.04(b) Applicability

These procedures apply to all proposed highway projects initiated by the Department.

26-18.05 Analysis and Documentation

During early coordination and/or scoping, discussions with agencies and stakeholders should identify the potential for the introduction and/or spread of invasive species and/or noxious weeds and should address possible prevention and control measures.

The project environmental documentation should identify and quantify any existing plant and animal invasive species populations and/or noxious weeds occurring within the project area. In addition, if a project is in the vicinity of a designated US Department of Agriculture quarantine zone for an invasive species and/or noxious weed, identify and briefly discuss the quarantine zone. Information regarding these quarantine zones is available through the Illinois Department of Agriculture website.

The environmental documentation should discuss the potential of the project to promote or inhibit the spread of invasive species and/or noxious weeds that were identified in the project area.

The environmental documentation also should include a discussion of any preventative measures or eradication measures that will be taken on the project. Examples include the inspection and cleaning of construction equipment, commitments to ensure the use of invasive-free mulches, top soils and seed mixes, and eradication strategies.

The discussion should indicate that landscaping and erosion control included in the project will not use species listed as noxious weeds. It also should state that in sensitive areas (e.g., Natural Areas, Nature Preserves, parks), if noxious weeds and/or invasive species are found in or adjacent to construction areas, precautions will be taken to ensure the project does not result in noxious weed and/or invasive species impacts to the sensitive areas.

If it is anticipated that noxious weeds and/or invasive species will be a problem during construction, the discussion should acknowledge that concern. It should also identify and assess potential impacts associated with clearing and grading operations, borrow/fill areas, disposal sites, and in-stream work, as appropriate, and measures for avoiding and/or minimizing those impacts.

26-18.06 IDOT List of Species Under Management

This list represents the primary plant and animal species that IDOT targets for eradication. It is based on Departmental experience with trying to control exotic species on highway rights-of-way

or that are associated with other resource issue areas (e.g., wetlands, incidental take authorizations). Individual districts may have targeted other plant and animal species for eradication in addition to those in the following list.

Plants:

Purple Loosestrife (<i>Lythrum salicaria</i>)	Wetlands, roadside ditches
Canada Thistle (<i>Cirsium arvense</i>)	Open areas, roadsides
Teasel (<i>Dipsacus</i> spp.)	Open areas, roadsides
Johnson Grass (<i>Sorghum halepense</i>)	Open areas, roadsides
Musk Thistle (<i>Carduus nutans</i>)	Open areas, roadsides

Animals:

Zebra Mussel (<i>Dreissena polymorpha</i>)	Large rivers
Emerald Ash Borer (<i>Agrilus planipennis</i>)	Ash trees

26-19 SURFACE WATER RESOURCES AND AQUATIC HABITAT

26-19.01 Introduction

Surface water resources are of ecological, economic, educational, aesthetic, cultural, recreational, and scientific value to Illinois. In the development of highway projects, it may be necessary to undertake biological surveys, special technical analyses, and coordination to comply with Federal, State, and local laws and regulations applicable to surface water resources and aquatic habitat. This Section provides guidance and procedures regarding these surveys, analyses, and related coordination. The surface water resources that highway projects most commonly encounter are streams (including rivers and creeks). Where other types of surface waters (e.g., drainage ditches, lakes, ponds) are involved, identify and analyze in a manner similar to streams.

In addition to this Section, Section 26-9, Section 26-20, Section 26-21, Chapter 28, Chapter 40, and Chapter 41 also contain guidance and procedures applicable to surface water resources/aquatic habitat.

26-19.02 Complementary Technical Manuals

The *IDOT Drainage Manual* provides additional information to assist in fulfilling the requirements of this Section.

26-19.03 Legal Authority

- Fish and Wildlife Coordination Act, 16 U.S.C. 661-667e,
- Mitigation of Impacts to Wetlands and Natural Habitat, 23 CFR 777,
- Environmental Mitigation, 23 CFR 710.513,
- FHWA (2005) Memorandum: Federal-aid Eligibility of Wetland and Natural Habitat Mitigation,
- Section 404(b)(1), Guidelines for Specification of Disposal Sites for Dredged or Fill Material, 40 CFR 230,
- Exec. Order No. 11990, 42 Fed. Reg. 26961, May 24, 1977, Protection of Wetlands,
- Exec. Order No. 11988, 42 Fed. Reg. 26951, May 24, 1977, Floodplain Management,
- Statewide Implementation Agreement for the *National Environmental Policy Act* and *Clean Water Act* Section 404 Concurrent NEPA/404 Process for Transportation Projects in Illinois,
- Memorandum of Understanding by and between the Illinois Department of Natural Resources and the Illinois Department of Transportation, 2007, and

- Antidegradation, 35 Ill. Admin. Code 302.105.

26-19.04 Policy

In the development of proposed State highway projects, potential project impacts to surface water resources and aquatic habitat will be identified and evaluated. Consideration will be given to implementing practical measures for avoiding, minimizing, and mitigating adverse project impacts to those resources.

26-19.05 Procedures

Surface water resources within a project's area of potential effects are identified through the Environmental Survey Process; see Chapter 27. BDE determines the need for aquatic habitat surveys and/or agency coordination based on consideration of the following:

- results of preliminary coordination with Illinois Department of Natural Resources (IDNR);
- presence of listed threatened or endangered aquatic species (see Section 26-9) or natural areas;
- presence of a stream included in the Nationwide Rivers Inventory (see Section 26-20);
- presence of a stream that is involved in an Advanced Identification (ADID) study (i.e., for identifying high quality aquatic resources that should be protected);
- presence of a biologically significant stream;
- presence of a stream with a Biological Stream Rating of "A" or "B" for diversity or integrity;
- project scope of work; and
- environmental Class of Action (i.e., Categorical Exclusion (CE), Environmental Assessment (EA), or Environmental Impact Statement (EIS)).

For major actions (i.e., EIS projects and some EA projects), BDE requests the Illinois Natural History Survey (INHS) to provide an assessment of biological resources. The resulting report contains information on the existing aquatic habitat in the project area. Summarize this information in the environmental document. The following Section provides guidance on the various physical, biological, and chemical parameters evaluated for surface water resources and aquatic habitat.

26-19.05(a) Definitions

48. Aquatic Habitat. Places where aquatic plants and animals interact with the physical and chemical components of their environment.
49. Biologically Significant Stream. A stream that has a Biological Stream Rating System score of "A" either for Diversity or Integrity based on data from at least two taxonomic

- groups. These streams are unique resources in the State and are considered to be the highest quality streams.
50. Biological Stream Rating System (BSRS). A system administered by the IDNR that identifies Illinois stream segments possessing exceptional quality, based on data concerning the populations of fish, mussels, macroinvertebrates, crayfish, and threatened and endangered species they support. The system provides a stream segment rating for three areas: integrity, diversity, and biological significance. Ratings for each area range from “A” (excellent) to “E” (very poor). BSRS ratings are available only for small to medium size streams. They are not available for rivers.
 51. Diversity. The variety of taxa from several important aquatic groups (e.g., mussels, fish, macroinvertebrates, crayfish) present within a stream segment.
 52. Dominant Fish Species. Those species of fish that make up 20% or more of the total catch at a sampling site.
 53. Ephemeral Stream. A stream that has flowing water only during, and for a short duration after, precipitation events in a typical year. Ephemeral streambeds are located above the water table year-round. Groundwater is not a source of water for the stream. Runoff from rainfall is the primary source of water for stream flow.
 54. EPT Richness. The total number of different kinds of aquatic organisms in a collection belonging to the insect groups Ephemeroptera (mayflies), Plecoptera (stoneflies), and Trichoptera (caddis flies).
 55. In-Stream Work. Any work or other activity within the stream banks that modifies or otherwise affects the streambed or stream banks (e.g., cofferdams, riprap, construction haul roads, work pads, abutment construction, pier removal and construction, bank clearing and excavation, channel excavation, channel change, weir construction).
 56. Integrity. The wholeness of a stream system and its ability to support organisms and processes comparable to the natural habitat of the region, based on BSRS data.
 57. Intermittent Stream. A stream that has flowing waters during certain times of the year, where groundwater provides water for stream flow. During dry periods, intermittent streams may not have flowing water. Runoff from rainfall is a supplemental source of water for stream flow.
 58. Intolerant Species. Species of fish sensitive to various environmental perturbations as identified by the IDNR or Illinois Environmental Protection Agency (IEPA).
 59. Mean Habitat Score. An index used to rate the habitat structure of a stream segment based on the physical aspects of the stream. A score greater than 130 indicates excellent habitat characteristics. A score below 80 indicates poor habitat characteristics.
 60. Perennial Stream. A stream that has flowing water year-round during a typical year. The water table is located above the streambed for most of the year. Groundwater is the

primary source of water for stream flow. Runoff from rainfall is a supplemental source of water for stream flow.

61. Pollutant. For surface water resources and aquatic habitat, this is any substance that, due to its characteristics and/or quantity, if introduced into the aquatic environment has a degrading effect that impairs the usefulness of the aquatic environment or renders it offensive.
62. Substrate. The mineral and organic material that forms the bed of the stream on which aquatic organisms live. Mineral materials may include sand, gravel, cobble, silt, bedrock, etc. Organic material may include algae, macrophytes, dead leaves, woody debris, etc.
63. Tolerant Species. Species of fish tolerant of various environmental perturbations as identified by the IDNR/IEPA.
64. Woody Riparian Habitat. An area predominantly covered by trees and/or shrubs located adjacent to and up-gradient from streams and lakes.

26-19.05(b) Applicability

These procedures apply to all proposed highway projects initiated by the Department that may have an effect on surface water resources.

26-19.05(c) Analysis and Documentation

The analysis and documentation required for addressing surface water resources and aquatic habitat will vary according to the scope of work and environmental class of action for a proposed project and the presence of streams with special designations. Bridge replacement projects often involve minor in-stream work that requires minimal analysis and documentation (see BDE 1210 Phase I Checklist). Projects that involve more extensive in-stream work and/or that occur within or adjacent to a stream with a special designation will require more analysis, documentation, and coordination. Projects requiring an EIS generally will require extensive analysis and coordination. The coordination typically is accomplished through the NEPA/404 Merger Process; see Section 22-4.

The following guidance discusses the various factors that may need to be considered in analyzing project effects on surface water resources and aquatic habitat. For projects processed with an EIS, all of the factors generally will apply. For other projects, evaluate the range of factors and address those that are determined applicable.

For EIS projects, BDE provides the district information for analysis of effects on surface water resources and aquatic habitat in an Assessment of Biological Resources Report prepared by the INHS. The Report also contains additional information that may be useful in preparing the environmental document (e.g., information that describes and characterizes potentially affected resources and that provides a basis for discussing potential project impacts). As needed, the district should contact BDE for assistance in determining which items of additional information may be relevant for inclusion in the EIS.

65. Clean Water Act Section 404(b)(1). The alternative analysis for NEPA and the *Clean Water Act* differs substantially. During project development for projects that will require an individual Section 404 permit, it is essential that these differences are understood and are reflected in the environmental documentation. NEPA requires that all reasonable alternatives be evaluated in detail. Section 404(b)(1) of the *Clean Water Act*, and the associated implementing guidelines in 40 CFR 230, provide that the US Army Corps of Engineers (Corps) can approve only the Least Environmentally Damaging Practicable Alternative (LEDPA). The guidelines are binding regulations that the Corps uses in determining a project's impact on aquatic resources from discharges of dredged and/or fill material. The LEDPA requirement means that no discharge of dredged or fill material will be permitted if there is a practicable alternative to the proposed discharge that would have less adverse impact on the aquatic ecosystem, so long as the alternative does not have other significant adverse environmental consequences. Noncompliance with this requirement is a sufficient basis for the Corps to deny a permit. If the project does comply with the guidelines, the Corps still may deny the permit if it is determined to be contrary to the public interest.

The following guidance is based on the requirements of the Section 404(b)(1) "Guidelines for Specification of Disposal Sites for Dredged or Fill Material, 40 CFR 230. The guidance is applicable to all projects that will involve in-stream work or anticipated impacts from operation and maintenance of the roadway. For EA and EIS projects, include the information prepared in accordance with this guidance in the environmental document. For CE projects, incorporate the information in the Phase I engineering report and associated appendices.

66. Physical Parameters. Identify the physical attributes that characterize streams. Examples of these attributes include upstream drainage area, flow regime, substrate, stream width and depth, mean habitat quality, woody riparian habitat, highly erodible soils, and watershed cover types. List the attributes for each stream. For projects with a number of stream crossings, present the information in a table to allow for comparisons between streams and/or stream reaches. Identify attributes the project may affect and include discussion of the nature and extent of the potential effects in the text of the document. Physical parameters are further described below:

- Upstream drainage area is one of the measures of stream size and provides an indication of the size of a stream's watershed. The district determines upstream drainage area.
- Illinois streams have either a perennial, intermittent, or ephemeral flow regime. Perennial and intermittent flow regimes are depicted on US Geological Survey (USGS) topographic quadrangles (7.5 minutes). Ephemeral flow regimes can be identified from aerial photography and/or field observations. A perennial flow regime is required to support fish and mussels. An intermittent flow regime may support a limited assemblage of fish species during seasonal high water periods. Flow regimes identified in INHS reports are based on field observations.

- Stream width is another measure of stream size. Stream depth refers to the depth of water in a stream when measured during biological surveys. It does not necessarily correlate with the stream flow regime as depicted on USGS topographic maps.
- Substrates in Illinois streams consist of varying percentages of cobble, gravel, sand, silt, or bedrock. Excessive sand and silt in the stream substrate can diminish habitat quality for fish and aquatic macroinvertebrates. Other substrate types (e.g., gravel, cobble, detritus) can contribute to a diverse fish and aquatic macroinvertebrate assemblage. In-stream work can result in varying degrees of change in the physical, biological, and chemical characteristics of the substrate. In addition, discharge of sediment from the adjacent construction site can affect bottom-dwelling organisms at the site by smothering immobile forms and by changing the habitat.
- Mean habitat quality scores are based on a modification of a standard US Environmental Protection Agency (USEPA) method. They are used by the INHS to rate the habitat structure of a stream reach and to identify need for more accurate assessment methods (e.g., aquatic resource surveys for fishes, mussels, aquatic macroinvertebrates). The scores are derived from 12 physical characteristics (e.g., channel structure, flow, bank vegetation, substrate) of a stream. Two people complete the evaluation and numerical values are given to each characteristic and are averaged and summed. The sum of the values is called the mean habitat score. A score greater than 130 receives a rating of “excellent,” a score of 129.9 to 110 is considered “good,” a score of 109.9 to 80 is “fair,” and a score below 80 is “poor.” These scores indicate the presence of degraded habitat and/or the presence of pollutants.
- Woody riparian habitat provides cover for fish and other wildlife, keeps streams cool, slows erosion and stream flow, and adds organic material to the aquatic food chain. Woody riparian habitat is a key requirement for healthy streams and aquatic communities. Where a project will remove woody riparian habitat, describe the composition, length, and width of this habitat, along each bank, in the environmental documentation. Mitigation for the loss of this habitat may be required. Consider replacing the habitat on-site and working with landowners to extend it to adjacent areas that do not currently have that habitat-type.
- Highly erodible soils have slopes of 4% or greater. The district should identify these soils from appropriate County Soil Maps. These soil types are usually associated with changes in topography and can occur along streams. When these soils are cleared of vegetation during construction, they become a source of sediment pollution for the adjacent stream.
- Watershed cover types are those that dominate the area through which a stream flows. In Illinois, these would mainly be residential/urban areas, agricultural, upland and bottomland forests/woodlands, and non-native grasslands. These cover types are discussed further in Section 26-17. Drainage from these cover types has a bearing on the potential sediment and chemical makeup of the stream.

- Other factors to be considered include the identification of upstream dischargers of pollutants (e.g., industrial facilities, wastewater treatment plants) and the downstream receivers (e.g., water supply intakes). Districts should obtain this information, based on their knowledge of the project area. Information on the locations of pollutant discharge sources also can be found on Illinois State Water Survey maps (7-Day 10-Year Flow Maps). Locations of water supply intake structures can be obtained through coordination with IEPA or the IDNR Natural Heritage Database.

67. Biological Parameters. Biological parameters include fish, mussels, and aquatic macroinvertebrates. Fish are important and dominant organisms in streams and have ecological, economic, and recreational values. Several parameters of the fish population should be characterized (e.g., dominant species, total number of species sampled, number of tolerant and intolerant species, percentage of tolerant and intolerant individuals). This information is best depicted in a table.

Identify the presence of species listed as endangered and threatened and discuss the species in the part of the environmental documentation that addresses that subject.

In the environmental documentation, identify and discuss potential project impacts on the fish populations and habitat in the stream from construction, operation, and maintenance of the roadway. Address the following items, as appropriate:

- If species of fish identified in the *Illinois Wildlife Action Plan* as Species in Greatest Need of Conservation are found in the area a project will affect, include discussion of the species, their habitat requirements, and possible measures to minimize impacts and provide improved habitat conditions for the species.
- If a project involves a river that supports recreational and/or commercial fishing and other water-related recreation, identify and discuss the nature and extent of these activities in the project area. IDNR can provide this type of information. Also, discuss potential project impacts on these activities and measures to minimize the impacts.

Mussels occur in most permanent flow streams. Their occurrence in beds (e.g., dense, natural aggregations of mussels, which can support a diverse variety of benthic fauna) is generally restricted to large rivers and high quality streams. IDNR has designated some of these beds as Natural Areas. The environmental document should indicate the number of live individuals per species at a particular site. This material can be presented in a table that also includes fish data.

Aquatic macroinvertebrates are useful in determining the health of a water resource with regard to the presence of organic pollution. Indices that can be used are the mean Family-Level Biotic Index and EPT Richness. This information can also be presented in a table, along with fish and mussel data.

The Biological Stream Ratings (BSR) process includes data from 1997 through 2007. It is anticipated that the ratings will be updated on a regular basis; see the IDNR website for

more information. The Ratings score the streams on three parameters: Diversity, Integrity, and Biologically Significant Streams. Letter ratings of A to E are used for the Diversity and Integrity Ratings. The following biotic resource quality descriptors apply to these Letter Ratings: A (excellent), B (good), C (fair), D (poor), and E (very poor). The Biologically Significant Streams are unique (high quality) stream resources. The biological communities present in these streams must be protected at the stream reach and at the upstream reach. Identify and discuss streams that have been rated.

68. Chemical Parameters (Water Quality). For EIS projects, water quality sampling is done in the spring, summer, and fall by the INHS and tabulated results are included as appendices to their reports. The INHS does not include a water quality analysis in the reports. The district is responsible for conducting this analysis. The tabulated results include many different parameters. For most projects, only a select group of the parameters needs to be analyzed. These parameters include the following:

- air and water temperature;
- dissolved oxygen;
- pH;
- sulfate;
- total potassium;
- chloride;
- total dissolved solids;
- hardness; and
- dissolved copper, lead, and zinc.

Present the information on these parameters in a table in the EIS, labeled “Measured Levels of Water Quality Constituents vs. the Numeric Water Quality Standards within the Project Area.” The values in the table are the average of the three seasonal values for each parameter. For those parameters that have a water quality standard, compare the summarized values and the individual values from the INHS Report to the numeric Illinois water quality standard from the most recent issue of the *Integrated Water Quality Report and Section 303(d) List*, available on the IEPA website. Use the individual values to determine whether there is an exceedance of the standards. If a value exceeds the applicable standard, include information in the environmental document identifying the parameter, its concentration as sampled, and the date of the sample. Also, include discussion of the possible reason(s) for the exceedance of the water quality standard.

In areas where the use of road salt (sodium chloride) for winter maintenance is an issue, conduct an analysis to determine chloride concentrations in highway storm water runoff. Use the methodology from the FHWA publication “Evaluation and Management of Highway Runoff Water Quality” to predict the chloride concentrations. Compare the predicted chloride concentrations with the existing chloride levels indicated in the INHS Report. Summarize the results of the analysis, including existing and predicted chloride levels, in the environmental document. If the sum of the predicted chloride value and the existing chloride value exceeds the 500 ppm water quality standard for chloride, measures must be implemented to reduce the use of road salt in the area of the potential violation of the standard.

In addition to numeric water quality standards, the *Integrated Water Quality Report and Section 303(d) List* contains narrative water quality standards. These are based on designated use methodology. Under the State's general use water quality standards, designated uses have been identified for many Illinois streams. These designated uses include aquatic life, fish consumption, primary contact, secondary contact, and aesthetic quality. Streams are either in full support or nonsupport of their designated uses. Streams that are in nonsupport of the designated use are considered impaired; see Section 26-21. Include information in the environmental document identifying designated uses for each stream in the area of a project.

Another way to judge a stream's water quality is by using Hilsenhoff's Family-Level Biotic Index. This Index is based on the sensitivity of aquatic macroinvertebrates to organic pollution. Scores range from 0 to 10, where 0.00 to 3.75 = Excellent; 3.76 to 4.25 = Very good; 4.26 to 5.00 = Good; 5.01 to 5.75 = Fair; 5.76 to 6.5 = Fairly poor; 6.51 to 7.25 = Poor; and 7.26 to 10.00 = Very poor. Low scores indicate good water quality with negligible organic pollution; high scores indicate bad water quality with serious organic pollution. This information can be obtained from INHS Reports and should be incorporated in the environmental document.

69. Special Designations. Identify streams in the area of a proposed project that have a special designation. The special designation may impose additional requirements that must be addressed (e.g., impact analysis, coordination with specific Federal, State, local agencies). The following discuss various special designations that may apply:
- a. Navigable Waters. The *IDOT Drainage Manual* and includes a listing of navigable streams in Illinois. In addition to being subject to other surface water permit requirements (e.g., Section 404 of the *Clean Water Act*), navigable streams are subject to specific permit requirements under Section 9 and Section 10 of the *Rivers and Harbors Act of 1899*. Section 9 requires a permit from the US Coast Guard (USCG) for construction of bridges or causeways over or in a navigable stream. Section 10 requires a permit from the Corps for construction of any structure other than a bridge or causeway in or over a navigable stream, for the excavation/dredging or deposition of material in a navigable stream, or for any obstruction or alteration in a navigable stream. When a project requires a Section 9 or a Section 10 permit, include discussion in the environmental document concerning need for the permit(s) and the project's effects on navigational use of the stream. Identify the presence of barge terminals and the number of commercial and recreational vessels passing through the project area. Also, identify and discuss any existing navigational deficiencies in and adjacent to the navigational channel. Incorporate this discussion in the environmental document in a subsection on Navigation in the part of the document that addresses land use. Include a summary of coordination with USCG and/or the Corps. Discuss the physical, biological, and chemical aspects of the stream in the Water Resources and Aquatic Habitat section of the environmental document.

The USCG and Corps are signatories to the agreement for the "Concurrent NEPA/404 Process for Transportation Projects in Illinois." For EIS and EA projects

requiring a Section 9 permit and/or a Section 10 permit, invite the USCG and the Corps to be Cooperating Agencies (and Participating Agencies for EIS projects, pursuant to 23 U.S.C. 139 “Efficient environmental reviews for project decision-making”).

For CE projects, identify the Section 9 permit and/or Section 10 permit involvement(s) in the Phase I engineering report and include copies of correspondence with USCG and/or the Corps in an appendix to the report.

See Chapter 28 for additional guidance concerning Section 9 and Section 10 permits.

- b. Nationwide Rivers Inventory. The list of streams included in the Inventory is available on the National Park Service “Conservation and Outdoor Recreation” website. Potential involvement with streams on the Inventory is identified as a part of the Environmental Survey Process when an Environmental Survey Request (ESR) form is submitted for a project. Potential involvement with a stream included in the Inventory may require coordination with the National Park Service. See Section 26-20 for further guidance on the Nationwide Rivers Inventory.
- c. Illinois Natural Area. Approximately 110 stream segments in Illinois are listed by IDNR as aquatic Natural Areas. When an ESR form is submitted for a proposed project, the Environmental Survey Process identifies potential involvements with streams designated as Illinois Natural Areas. Information on these stream segments also is available from IDNR. For EA and EIS projects, identify these potential involvements in the part of the environmental document that addresses surface water resources and aquatic habitat. Include detailed discussion of the involvements, including results of coordination with IDNR, in the part of the document that deals with State-designated lands. For CE projects, document the involvement and results of coordination with IDNR in the BDE 1210 Phase I Checklist. See Section 26-9 for guidance on the requirements associated with designated Illinois Natural Areas.
- d. Advanced Identification of Water Resources (ADID) Streams. These are streams that the USEPA and Corps have determined contain high quality aquatic habitat that is generally unsuitable for discharges of dredged or fill material. Under the ADID process, identification of a stream as generally unsuitable for discharges of dredged or fill material is an advisory designation. It alerts potential permit applicants that a discharge into the stream is not likely to be consistent with the Section 404(b)(1) “Guidelines for Specification of Disposal Sites for Dredged or Fill Material” and that the USEPA could request denial of the permit. These streams may also be subject to local ordinances based on the ADID study that identified the area as containing high quality aquatic habitat. When an ESR form is submitted for a proposed project, the Environmental Survey Process identifies potential involvements with ADID streams. Information on these streams also is available on site maps for those counties that have completed ADID studies. The site maps are accessible via the Internet.

Where a proposed project may affect an ADID stream, include information in the environmental documentation identifying the stream and describing its physical, biological, and chemical attributes. Determine and document potential impacts on stream functions (e.g., aquatic habitat value, shoreline/stream bank stabilization, hydrologic stabilization) and summarize the results of coordination with the USEPA and U.S. Fish and Wildlife Service. If a stream is subject to local requirements, identify the requirements and the actions necessary for compliance.

- e. BSRS High Quality Streams. These include stream segments designated as Biologically Significant Streams and stream segments rated as “A” or “B” for Diversity or Integrity. When an ESR request is submitted for a proposed project, the Environmental Survey Process identifies high quality stream segments.

For Biologically Significant Streams, the biological communities present must be protected at the stream reach (i.e., project site) and in-stream work in these areas should be prohibited. In addition, the scientific literature documents findings that the physical and chemical properties of water at a stream site reflect upstream influences. Accordingly, consider the potential effects of work in the upstream reach of Biologically Significant Streams and coordinate projects affecting the upstream reach with IDNR.

For potential project involvements with stream segments rated as “A” or “B” for Diversity or Integrity, identify and evaluate the potential project impacts on the features of the stream that were the basis for the “A” or “B” ratings.

Include information on potential involvements with high quality stream segments in the part of the environmental documentation that addresses surface water resources and aquatic habitat. Include discussion of potential project impacts, measures for reducing or mitigating the impacts, and the results of coordination with IDNR regarding the potential impacts and mitigation measures.

- f. Impaired Streams. These are streams that are included on the *Clean Water Act* Section 303(d) list of impaired waters in Illinois. The list is included in the *Integrated Water Quality Report and Section 303(d) List*, available on the IEPA website. The “impaired” designation is based on a determination that the streams are sufficiently polluted that they are unable to support their designated uses (e.g., aquatic life, indigenous aquatic life, primary contact (swimming), public and food processing water supply (drinking water), secondary contact, aesthetic quality, fish consumption). Streams on the Section 303(d) may be subject to Total Maximum Daily Load (TMDL) restrictions that limit the quantity of specific pollutants that may be introduced into the streams.

For projects involved with a stream on the Section 303(d) list, identify the pollutant(s) causing the impairment and determine if the project may contribute to the impairment. If the project may contribute pollutants causing the impairment, evaluate measures to reduce the contribution to an acceptable level, consistent with TMDL requirements, if applicable. Identify the impaired stream(s) and summarize the results of the analysis of impacts and mitigation measures in the part of the environmental documentation that

addresses surface water resources and aquatic habitat. For CE projects, place the documentation of the analyses in an appendix to the Phase I engineering report. See Section 26-21 for additional guidance on Impaired Waters/TMDLs.

26-19.06 Antidegradation Assessment

In accordance with the requirements set forth in 35 Ill. Adm. Code 302.105, the IEPA must conduct an antidegradation assessment for any proposed action involving an increase in pollutant loading that necessitates the issuance of a new, renewed, or modified National Pollutant Discharge Elimination System (NPDES) permit or a Section 401 water quality certification. The purpose of the antidegradation requirements is to protect existing uses of all waters of the State of Illinois, maintain the quality of these waters with a quality that is better than the water quality standards, and to prevent the unnecessary deterioration of waters of the State.

In conducting antidegradation assessments, IEPA must consider the following provisions of 35 Ill. Adm. Code 302.105 regarding existing uses, outstanding resource waters, and high quality waters.

26-19.06(a) Existing Uses

Existing uses actually attained in a surface water body or water body segment, whether or not they are included in the water quality standards, must be maintained and protected. Examples of degradation of existing uses of the waters of the State include:

- an action that would result in the deterioration of the existing aquatic community (e.g., a shift from a community of predominantly pollutant-sensitive species to pollutant tolerant species or a loss of species diversity);
- an action that would result in a loss of a resident or indigenous species whose presence is necessary to sustain commercial or recreational activities; or
- an action that would preclude continued use of a surface water body or water body segment for a public water supply or for recreational or commercial fishing, swimming, paddling, or boating.

26-19.06(b) Outstanding Resource Waters

A surface water body or water body segment that is of exceptional ecological or recreational significance as designated by the Illinois Pollution Control Board (i.e., an Outstanding Resource Water (ORW)) must not be lowered in quality except as provided below:

- activities that result in short-term, temporary (e.g., weeks, months) lowering of water quality in an ORW; or
- existing site storm water discharges that comply with applicable Federal and State storm water management regulations and do not result in a violation of any water quality standards.

As of the date of publication of this edition of the *BDE Manual*, the Pollution Control Board had not designated any Illinois waters as Outstanding Resource Waters. However, the Biologically Significant Streams discussed in Section 26-19.07 would qualify as exceptional ecological resources.

26-19.06(c) High Quality Waters

High quality waters are waters of the State whose existing quality is better than any of the established standards. These waters must be maintained in their present high quality, unless the lowering of water quality is necessary to accommodate important economic or social development.

26-19.06(d) Information Requirements

To ensure that IEPA has the information needed for conducting antidegradation assessments, when required, include the following information in submittals for NPDES permits, individual Section 404 permits, and nationwide permits that require an individual 401 water quality certification (e.g., nationwide permit 23 for approved categorical exclusions):

- Identification and characterization of the water body affected by the proposed load increase or proposed activity and the existing water body's uses. Characterization must address physical, biological, and chemical conditions of the water body.
- Identification and quantification of the proposed load increases for the applicable parameters and of the potential impacts of the proposed activity on the affected waters.
- The purpose and anticipated benefits of the proposed activity.
- Assessments of alternatives to proposed increases in pollutant loading or activities subject to IEPA certification pursuant to Section 401 that result in less of a load increase, no load increase, or minimal environmental degradation.
- Any additional information IEPA may request.
- Proof that a copy of the application has been provided to the IDNR.

26-19.07 Coordination

The EIS projects will be coordinated with the Corps, USEPA, USFWS, and IDNR through the circulation of the draft EIS and some or all of these agencies may serve as Cooperating Agencies. Where the project is being processed under the NEPA/404 Merger Process, BDE and the district must provide the agencies the information and analysis required under the Section 404(b)(1) guidelines. Coordination with the Corps, USEPA, and USFWS will be through the Merger Process. EA and CE projects will be coordinated with the USFWS and IDNR through the Environmental Survey Process. Address any agency comments, including any concerning consideration of measures for minimization and mitigation of impacts.

26-20 NATIONWIDE RIVERS INVENTORY

26-20.01 Introduction

The Nationwide Rivers Inventory (NRI) is managed by the National Park Service Rivers, Trails, and Conservation Assistance Program. It is a compilation of rivers and river segments that appear to have one or more qualities that could qualify them for inclusion in the National Wild and Scenic Rivers System. The NRI contains a number of Illinois streams or stream segments. The list of Illinois NRI streams is maintained on the National Park Service NRI website. The list includes the river name, county or counties of occurrence, reach, length (miles), year listed/updated, potential classification, Outstandingly Remarkable Values (ORVs), and description. In accordance with a 1979 Presidential Directive and associated Council on Environmental Quality procedures, Federal agencies, as part of their normal planning and environmental review process, must take care to avoid or mitigate adverse effects on rivers included in the NRI. This Section provides guidance and procedures for complying with these requirements and for documenting compliance in project environmental documentation.

26-20.02 Legal Authority

- Wild and Scenic Rivers, 16 U.S.C. 1271-1287,
- Presidential Memorandum for the Heads of Departments and Agencies, dated August 2, 1979, requiring each Federal agency, as part of its normal planning and environmental review process, to take care to avoid or mitigate adverse effects on rivers identified in the Nationwide Rivers Inventory,
- Council on Environmental Quality, "Interagency Consultation to Avoid or Mitigate Adverse Effects on Rivers in the Nationwide Inventory", August 10, 1980, and
- FHWA, "Policy Guidance for Wild and Scenic Rivers", dated October 3, 1980, transmitting the Council on Environmental Quality procedures for Interagency Consultation to Avoid or Mitigate Adverse Effects on Rivers in the Nationwide Inventory.

26-20.03 Policy

In the development of Federally funded or regulated State highway projects, take care to avoid or mitigate adverse effects on rivers identified in the NRI. The evaluation of potential project impacts on these streams or stream segments will be coordinated with the NPS prior to taking actions that could effectively foreclose wild, scenic, or recreational river status for rivers in the Inventory.

26-20.04 Procedures

The identification of NRI streams within the project area will be done through the Environmental Survey Process. BDE will determine the need for coordination with the NPS based on the

project's scope of work. See Section 26-20.05(d) for information on coordination requirements and procedures.

26-20.04(a) Definitions

70. Adverse Effect. An impact to a listed stream or stream segment that alters the free-flowing characteristics, causes the deterioration of water quality, or has the potential to impair the ORV(s) that qualified the stream for listing in the NRI.
71. Nationwide Rivers Inventory (NRI). A registry of streams compiled and maintained by the National Park Service consisting of stream and stream segments that potentially qualify as national wild, scenic, or recreational river areas.
72. Outstandingly Remarkable Value (ORV). A characteristic that a river must possess, in addition to being free-flowing, to be listed on the NRI. ORVs include scenery, recreation, fish, wildlife, geology, prehistory, history, cultural, and other similar values.

26-20.04(b) Applicability

These procedures apply to all Federally funded/regulated projects that have the potential for an adverse effect on a NRI stream or stream segment.

26-20.04(c) Analysis and Documentation

For projects that affect a stream listed on the NRI, the analysis of potential impacts to the stream's free-flowing characteristics, water quality, and ORV(s) that qualified it for listing, should be sufficient to determine whether the impacts would be adverse. Adverse effects should be avoided or mitigated, in accordance with the Presidential directive and Council on Environmental Quality procedures regarding the NRI.

As applicable, incorporation documentation of project impacts on NRI streams, and NPS recommendations regarding those impacts into Phase I engineering reports, Environmental Assessments (EAs), and Environmental Impact Statements (EISs) discussed in the following Sections.

26-20.04(c)1 Categorical Exclusion (CE) Projects

A project being processed as a CE that affects an NRI stream is considered to have potential for "unusual circumstances" and, therefore, requires FHWA approval of the CE classification; see Section 23-1.04(bb). In accordance with the CEQ procedures for "Interagency Consultation to Avoid or Mitigate Adverse Effects on Rivers in the Nationwide Inventory," an adverse effect on a listed stream will require processing the project as an EA or EIS.

For NRI streams that BDE has determined will not be affected, the Phase I engineering report should contain documentation of the BDE determination.

For NRI streams that BDE has determined will be affected, the Phase I engineering report should contain documentation of the BDE determination and the NPS response regarding the effect(s), the results of any further coordination with the NPS, and the response to NPS recommendations for addressing the effects.

26-20.04(c)2 EA/EIS Projects

Because the NRI consists of streams, include the main discussion of this topic in a subsection of the Surface Water Resources and Aquatic Habitat Section entitled "Nationwide Rivers Inventory". However, include the data on the physical, biological, and water quality aspects of the NRI stream in the physical, biological, and water quality subsections of the Surface Water Resources and Aquatic Habitat Section.

The environmental document should identify the stream and include the ORV(s) and stream description from the NRI website. Describe the stream's free-flow nature and water quality. The document should identify the potential impacts caused by each construction activity and briefly discuss the effects on the stream's ORV(s), free flowing characteristics, and water quality.

A determination of the magnitude of the impact on water quality, free-flow, and each listed ORV should be made and documented. The coordination response from the NPS should help in determining the magnitude of the impacts.

Include a summary of the coordination effort with the NPS and describe impact avoidance, minimization, and mitigation measures, as appropriate. The discussion of these measures should center on the listed ORV(s).

The appendix of the EA or EIS must contain the results of the coordination with the NPS. The FONSI (EA) or the ROD (EIS) will summarize the coordination, list the measures to minimize harm and proposed mitigation, as appropriate, and include a commitment to ensure the stream's eligibility for the NRI and/or the Wild and Scenic Rivers System is not diminished.

If the ORV of a listed stream is scenery, the Visual Resources Section of the environmental document should identify the stream and refer to the discussions in the Nationwide Rivers Inventory subsection of the Surface Water Resources and Aquatic Habitat Section.

26-20.04(d) Coordination

Coordination with the NPS is required for projects that may affect NRI streams. BDE will initiate early coordination with the NPS, when required, through the Environmental Survey Process and will provide the district the results of the coordination. Additional coordination, if required, will be the responsibility of the district, with input from BDE.

26-21 IMPAIRED WATERS/TMDLS

26-21.01 Introduction

Pursuant to Section 303(d) of the *Clean Water Act*, the Illinois Environmental Protection Agency (IEPA) identifies and prioritizes waters in the State that do not meet the applicable water quality standards or do not fully support their designated uses. These waters are referred to as impaired waters. Section 303(d) also requires that a Total Maximum Daily Load (TMDL) be established for each pollutant of an impaired water body. The TMDL is then used to allocate pollutant loads among the identified pollution sources in a watershed, including highway facilities, thereby supporting attainment of applicable water quality standards and designated uses.

Information on impaired waters can be obtained from the “Illinois Integrated Water Quality Report and Section 303(d) List” available on the IEPA website. This Report is revised and updated every two years.

Information on TMDLs can be obtained from the “TMDL Watersheds Map,” “TMDL Report Status,” and “TMDL Implementation Projects” web pages on the IEPA website. TMDL Reports will identify the waters affected and the source(s) and cause(s) of the impairment(s). The Final TMDL Report will provide Implementation Actions and Management Measures for each identified pollutant.

26-21.02 Legal Authority

- Identification of areas with insufficient controls; maximum daily load; certain effluent limitations revision, 33 U.S.C. 1313(d) (*Clean Water Act*, Section 303(d)), and
- Water Quality Planning and Management, 40 CFR 130.

26-21.03 Policy

In the development of proposed State highway projects, impaired waters, and waters subject to TMDLs will be identified within the areas the projects may affect. Where projects have potential to increase levels of a pollutant that is a cause of impairment, measures will be implemented to reduce the discharge of that pollutant from the project to ensure it does not contribute to the impairment and is consistent with any applicable TMDL.

26-21.04 Procedures

The district will check the most recent “Integrated Illinois Water Quality Report and Section 303(d) List” to determine if a proposed project may affect an impaired water resource. Appendices B-2 (Specific Assessment Information for Streams) and B-3 (Specific Assessment Information for Inland Lakes) contain the information required for Phase I engineering reports and environmental documents. Larger streams (e.g., Illinois, Rock, Fox, and Sangamon Rivers) are divided into assessment units. To determine the applicable assessment unit, use the Illinois Water Quality

Mapping Tool on the IEPA website. The project's contribution to the cause of the impairment should be determined and discussed, as appropriate.

For involvements with water bodies involving a draft or final TMDL, the district should determine if construction, operation, or maintenance of the transportation facility would contribute to an increase in the pollutant(s) of concern addressed in the TMDL. If a project contributes to an increase in the pollutant(s) of concern, the district will evaluate practicable measures to reduce or eliminate that contribution.

26-21.05 Definitions

5. Impaired Waters. Waters listed on the IEPA Section 303(d) List due to nonattainment of applicable water quality standards and/or designated uses.
6. Total Maximum Daily Load (TMDL). The greatest amount of a given pollutant that a water body can receive without violating water quality standards and designated uses.

TMDLs set pollution reduction goals that are necessary to improve the quality of impaired waters. A TMDL takes a watershed approach in determining the pollutant load that can be allowed in a given lake or stream. By taking a watershed approach, a TMDL considers all potential sources of pollutants, both point and non-point sources. It also takes into account a margin of safety, which reflects scientific uncertainty and future growth. The effects of seasonal variation are also included.

26-21.06 Applicability

These procedures apply to all proposed highway projects initiated by the Department that may affect a water resource listed by IEPA as impaired and/or that is subject to a TMDL.

26-21.06(a) Analysis and Documentation

For projects that may affect a water resource listed as impaired and/or subject to a TMDL, the Phase I engineering report (for projects processed as CEs) or environmental document (EA or EIS) should contain the following impaired waters information:

73. Section 303(d) Impaired Waters List. If the proposed project may affect a listed water body or water body segment, include the following information from the list for each affected water body or segment:
 - a. Water Body Identification. Indicate the Name and Assessment Unit ID of the water body as shown on the list.
 - b. Use Attainment. Identify designated use(s) classified as non-supporting.

- c. Causes. Identify the cause(s) of the impairment listed for the water body (use the word descriptors rather than the numeric codes) on the Section 303(d) List.
 - d. Sources. Identify the source(s) of the impairment listed for the water body (use the word descriptors rather than the numeric codes) on the Section 303(d) List.
74. Total Maximum Daily Load. For each affected water body or segment on the Section 303(d) list, also indicate whether a TMDL is under development or has been finalized.
75. Analysis and Discussion. The analysis and discussion of the project's effects on waters listed as impaired should address how those effects relate to the "Causes" that resulted in the impaired waters designation. Indicate whether the project may contribute to an increase or decrease in any of the constituent(s) causing the impairment. If the project would potentially contribute to an increase in those constituent(s), identify the specific constituent(s), describe the anticipated increase, and discuss practicable mitigation measures that can be implemented to reduce or eliminate that contribution. If none of the listed constituent(s) causing the impairment are generated by the project, document that finding and how it was determined.
76. Pollutant Load. If a project contributes to the pollutant load identified in a final TMDL, identify and discuss those aspects that would apply to the construction, operation, or maintenance of the highway project and discuss how the project will respond to the TMDL provisions.

26-21.06(b) Coordination

Coordination with IEPA for impaired waters is not required. However, for projects that have potential to contribute to an increase in a pollutant identified in a final TMDL, coordination with IEPA is recommended. The coordination should address the potential pollutant contribution from the project and the measures proposed for implementation to reduce or eliminate the contribution to the pollutant load. The district should initiate the coordination with guidance from the BDE.

IEPA considers impaired waters as a component of antidegradation assessments; see Section 26-19.06.

26-22 GROUNDWATER

26-22.01 Introduction

The *Illinois Environmental Protection Act*, the *Illinois Groundwater Protection Act*, and parts of the *Illinois Administrative Code* impose requirements for protection of the State's groundwater resources to ensure their availability for beneficial purposes. This Section provides guidance and procedures for considering and addressing these requirements as part of the environmental impact evaluation process for proposed State highway projects. The topics covered in this Section include potable water supply wells, special resource groundwaters, karst topography, groundwater discharge areas (seeps), and sole source aquifers.

26-22.02 Legal Authority

- *The Illinois Environmental Protection Act*, 415 ILCS 5/1 *et seq.*,
- *The Illinois Groundwater Protection Act*, 415 ILCS 55/1 *et seq.*,
- Existing Activities in a Setback Zone or Regulated Recharge Area, 35 Ill. Admin. Code 615, ,
- New Activities in a Setback Zone or Regulated Recharge Area, 35 Ill. Admin. Code 616,
- Regulated Recharge Areas, 35 Ill. Admin. Code 617,
- Maximum Setback Zones, 35 Ill. Admin. Code 618,
- Groundwater Quality, 35 Ill. Admin. Code 620, and
- Sole Source Aquifers, 40 CFR 149.

26-22.03 Policy

In the development of proposed highway projects initiated by the Department, potential impacts to groundwater resources will be identified and consideration will be given to implementing practical measures for avoiding, minimizing, and mitigating adverse project impacts to those resources.

26-22.04 Procedures

The information and requirements for evaluating groundwater resources in the vicinity of the project area, and for identifying and addressing potential adverse environmental impacts of project alternatives on these resources are described below. In general, proposed projects must be designed to avoid adverse impacts to groundwater resources, to the fullest extent practical and to mitigate any unavoidable adverse impacts (e.g., through use of Best Management Practices (BMPs)).

26-22.04(a) Definitions

7. Aquifer. Saturated (with groundwater) soils and geologic materials that are sufficiently permeable to readily yield economically useful quantities of water to wells, springs, or streams under ordinary hydraulic gradients.
8. Groundwater. Underground water that occurs within the saturated zone and geologic materials where the fluid pressure in the pore space is equal to or greater than atmospheric pressure.
9. Potable. Generally fit for human consumption in accordance with accepted water supply principles and practices.
10. Potential Primary Source. Any unit at a facility or site not currently subject to a removal or remedial action that:
 - is used for the treatment, storage, or disposal of any hazardous or special waste not generated at the site;
 - is used for the disposal of municipal waste not generated at the site, other than landscape waste, and construction and demolition debris;
 - is used for the landfilling, land treating, surface impounding, or piling of any hazardous or special waste that is generated on the site or at other sites owned, controlled, or operated by the same person; or
 - stores or accumulates at any time more than 75,000 lbs (3400 kg) above ground, or more than 7,500 lbs (3400 kg) below ground, of any hazardous substances.
11. Potential Route. Abandoned and improperly plugged wells of all kinds, drainage wells, all injection wells, including closed loop heat pump wells, and any excavation for the discovery, development, or production of stone, sand, or gravel.
12. Potential Secondary Source. Any unit at a facility or a site not currently subject to a removal or remedial action, other than a potential primary source, that:
 - is used for the landfilling, land treating, or surface impounding of waste that is generated on the site or at other sites owned, controlled, or operated by the same person, other than livestock and landscape waste, and construction and demolition debris;
 - stores or accumulates at any time more than 25,000 lbs (11.4 Mg) but not more than 75,000 lbs (34 Mg) above ground, or more than 2,500 lbs (11.4 Mg) but not more than 7,500 lbs (34 Mg) below ground, of any hazardous substance;
 - stores or accumulates at any time more than 25,000 gallons (94 ML) above ground, or more than 500 gallons (2 ML) below ground, of petroleum, including

- crude oil or any fraction thereof that is not otherwise specifically listed or designated as a hazardous substance;
- stores or accumulates pesticides, fertilizers, or road oils for purposes of commercial application or for distribution to retail sales outlets;
 - stores or accumulates at any time more than 50,000 lbs (22.8 Mg) of any de-icing agent; or
 - is used for handling livestock waste or for treating domestic wastewaters other than private sewage disposal systems as defined in the *Private Sewage Disposal Licensing Act*.
13. Regulated Recharge Area. A compact geographic area, as determined by the Pollution Control Board, the geology of which renders a potable resource groundwater particularly susceptible to contamination.
14. Resource Groundwater. Groundwater that is presently being, or in the future is capable of being, put to beneficial use by reason of being of suitable quality.
15. Setback Zone. A designated geographic area containing a potable water supply well or a potential source or potential route having a continuous boundary, and within which certain prohibitions or regulations are applicable in order to protect groundwaters.
16. Sole Source Aquifer. An underground water supply designated by the US Environmental Protection Agency as the sole or principal source of drinking water for an area.
17. Special Resource Groundwater. Groundwater that is determined by the Illinois Pollution Control Board to be 1) demonstrably unique (e.g., irreplaceable sources of groundwater) and suitable for application of a water quality standard more stringent than the otherwise applicable water quality standard, or 2) vital for a particularly sensitive ecological system; or groundwater that contributes to a dedicated Nature Preserve listed by the Illinois Environmental Protection Agency (IEPA) in accordance with 35 Ill. Admin. Code 620.230(b).
18. Wellhead Protection Area. The surface and subsurface recharge area surrounding a community water supply well or well field, delineated outside of any applicable setback zones pursuant to Illinois' Wellhead Protection Program, through which contaminants are reasonably likely to move toward such well or well field.

26-22.04(b) Analysis and Documentation

Nearly all surface water features (e.g., streams, lakes, wetlands) interact with groundwater resources to some extent. Consequently, pollution of surface waters can cause degradation of groundwater quality and vice versa. It is important to recognize and consider these interactions in analyzing and documenting the full extent of a proposed project's potential effects on

groundwater resources. The following Sections provide guidance for addressing groundwater-related issues in project environmental documentation.

26-22.04(b)1 Groundwater Resource Identification

In areas where groundwater is determined to be the primary source of potable water, identify and characterize wellhead and groundwater protection areas, potable water supply wells, groundwater recharge zones, special resource groundwater, areas of karst topography, and the potential for contamination of shallow aquifers. If a Preliminary Environmental Site Assessment (PESA) is conducted for the project, the PESA report will identify these items. If a PESA is not conducted, the district should obtain this information through coordination with the IEPA and from Illinois State Geological Survey maps (e.g., potential for aquifer recharge and for contamination of shallow aquifers).

In areas where groundwater supports specialized biotic communities (e.g., seeps, bogs, fens, sedge meadows, spring runs, obligate cave inhabitants) the Environmental Survey Process will identify these features.

Karst topography is a landscape characterized by sinkholes, depressions, caves, and underground drainage, generally underlain by soluble rocks (e.g., limestone, dolomite). Most karst topography is restricted to northwestern Illinois (Jo Daviess and Carroll Counties), western Illinois (Adams, Pike, and Calhoun Counties), and southwestern Illinois (Madison, St. Clair, Monroe, and Randolph Counties). Projects occurring within these counties should be surveyed for karst features.

For groundwater resources identified in the area a project may affect, apply the guidance in the following sections to evaluate and document potential project impacts and measures for avoiding, minimizing, and mitigating adverse impacts.

26-22.04(b)2 Potable Water Supply Wells

If the project is in the vicinity of a potable water supply well, the district must determine whether or not the project will create any new potential routes for groundwater pollution (e.g., dry wells, borrow pits) or any new potential sources of groundwater pollution (e.g., storage facilities for bulk road oil or de-icing salt). If the project will not create any new potential routes for groundwater pollution or any new potential sources of groundwater pollution, include the following statement in the project environmental documentation:

This project will not create any new potential "routes" for groundwater pollution or any new potential "sources" of groundwater pollution as defined in the Illinois Environmental Protection Act, 415 ILCS 5/1 et seq.). Accordingly, the project is not subject to compliance with the minimum setback requirements for community water supply wells or other potable water supply wells as set forth in the Act.

If the project will create a new potential route or source for groundwater pollution, describe the nature of the route or source and indicate whether it will be within a setback zone (minimum or maximum) for a potable water supply well. Indicate the type of well (i.e., community water supply or private water supply) and discuss any permits or mitigation measures that may be needed for the route or source to protect groundwater resources. For new community water supply wells,

indicate if the new route or source of groundwater pollution will be within a wellhead protection area. The minimum setback distance for a potable water supply well is 200 ft (60 m) or 400 ft (130 m) for a community water supply well with high to moderate geologic susceptibility. Maximum setback zones for community water supply wells may be up to 1000 ft (300 m) from the wellhead or, in rare cases, up to 2500 ft (760 m). Indicate whether the project is within a regulated recharge area established through Illinois Pollution Control Board rulemaking and describe the extent of the regulated area.

26-22.04(b)3 Groundwater Quality

IEPA monitors groundwater quality from community water supplies in the State. This information is available in the IEPA "Integrated Water Quality Report and Section 303(d) List." For wells in the project area, identify the name of the facility, groundwater pollutant(s) and their concentrations, type of aquifer, and level of use support. Use support levels include the following:

77. Full Support. Water quality is Good. This rating indicates that no detections occurred in organic chemical monitoring data and inorganic constituents assessed were at or below background levels for the groundwater source being used.
78. Nonsupport.
 - a. Water Quality is Fair. This rating indicates that organic chemicals were detected and, therefore, exceed the non-degradation standard. However, measured levels are less than the numerical Class I Groundwater Quality Standard and inorganic constituents assessed were above background level (non-degradation standard), but less than the numerical Class I Groundwater Quality Standard.
 - b. Water Quality is Poor. This rating indicates that organic chemical monitoring data detections were greater than the Class I Groundwater Quality Standard and inorganic chemicals assessed were greater than both the background concentration and Class I Groundwater Quality Standard.

26-22.04(b)4 Special Resource Groundwater

These resources will be identified through the Environmental Survey Process. Projects within the groundwater recharge area of a designated Special Resource Groundwater must be coordinated with the IDNR.

The Phase I engineering report, EA, or EIS will contain a map showing the recharge area in relation to the project. The project environmental documentation will also identify and describe the potential project impacts, describe the proposed mitigation measures and document the associated coordination with the IDNR and the Nature Preserves Commission.

26-22.04(b)5 Karst Topography

Karst areas are highly vulnerable to groundwater contamination. For projects that are processed as CEs, the Phase I engineering report should indicate if karst surface features (e.g., sinkholes, depressions) are within or adjacent to the highway right-of-way. If these features are present,

construction BMPs for storm water pollution prevention should be strictly adhered to. Also, identify the features on the NPDES construction permit, as applicable.

For projects that are processed as environmental documents, the Groundwater Section should identify and depict the karst features (e.g., caves, sinkholes, springs) on an environmental inventory map. The sensitivity of the aquifer should be briefly discussed.

During the alternative analysis, consider the potential for hitting karst features in the underlying carbonate rocks. These potential impacts include instability from the increased loading on existing rock cavities or the removal of structurally sound overburden and rock cover over existing cavities. In addition, construction-related changes in the water table can induce subsidence and undermine the highway.

The environmental document should identify and discuss project impacts to karst features and the potential for groundwater contamination. Avoidance of the karst features and the use of storm water pollution prevention BMPs during construction and operation of the roadway should be discussed.

Karst areas may be protected under the Class III groundwater standards, may contain Federal and/or State listed endangered and threatened species, or may be listed as special lands (e.g., Natural Areas, Nature Preserves, Land and Water Reserves). If any of these attributes apply they should be identified in this Section. Further description and assessment of impacts to these features will occur under the appropriate resource headings of the environmental document.

26-22.04(b)6 Seeps

Seeps are areas found in sloping terrain where the groundwater is discharged to the surface. The groundwater typically flows year-round and has a relatively constant temperature. Seeps are essentially groundwater discharge wetlands. As wetlands, discuss in the wetlands section of an environmental document. Seeps are generally small in size, but may contain a high diversity of species including those that are endangered and/or threatened. Seeps are also habitats of preference for amphibians.

Generally, the discharge area (seep) can be avoided; however, construction and operation of the roadway may intersect the groundwater flow causing a decrease of water to the seep surface. In addition, operation of the roadway may allow surface runoff containing pollutants (including de-icing salts) to contaminate the discharge water. Analyzed and discuss the potential for these types of impacts in the environmental documentation, along with alternatives for avoiding, minimizing, and mitigating the impacts.

26-22.04(b)7 Sole Source Aquifers

On March 11, 2015 the U.S. Environmental Protection Agency (USEPA) designated a portion of the Mahomet Aquifer system as a sole source aquifer (SSA) for Illinois. The Safe Drinking Water Act of 1974 gives the USEPA authority to designate all or part of an aquifer as a "sole source" if contamination of the aquifer would create a significant hazard to public health and there are no physically available or economically feasible alternative sources of drinking water to serve the population that relies on the aquifer. A significant hazard to public health is defined as the level

of contaminants in an aquifer would exceed National Primary Drinking Water Standards or exceed Federal, Tribal or state public health advisory levels for currently unregulated contaminants, or violate the intent of EO 12088, "Federal Compliance with Pollution Control Standards." This designation authorizes USEPA review of federally funded projects to assess potential for contamination of the aquifer system. A memorandum of understanding (MOU) (See Appendix A) between the Department, FHWA and USEPA was developed which discusses which categories of proposed projects are exempt or nonexempt and must therefore be evaluated for impacts to the Mahomet SSA.

Exempt Projects

Categorical Exclusions are considered to not pose a significant hazard to public health when they occur in the project review area (Figure 26-22.A) as they do not typically require excavation greater than 10 feet or use chemicals listed in the National Primary Drinking Water Regulations (40 CFR 141). However, per the MOU, "*the USEPA reserves the right to review an exempt project upon written notice to FHWA and IDOT should new information lead it to conclude the project may contaminate an SSA so as to create a significant hazard to public health.*"

For EAs or EISs that do not occur in the project review area, state the following in the *Groundwater* section:

There are no Sole Source Aquifers, as designated under Section 1424(e) of the Safe Drinking Water Act, within the project area."

Nonexempt Projects

For EAs or EISs that occur in the Mahomet SSA project review area, these projects will need to be evaluated for impacts according to the following evaluation criteria by determining if the project involves:

- substantial excavation (greater than 10 feet in depth);
- addition of drainage wells, or stormwater infiltration facilities that do not meet IDOT treatment requirements ;
- adding Pollution Generating Impervious Surface (PGIS) of more than 5,000 square feet without applying pollution prevention BMPs;
- opening of new material sources that could result in potential contamination;
- replacement of drywells or other injection wells that do not meet IDOT treatment requirements or Underground Injection Control regulations;
- drilled shafts or pile-driving, for bridge or other foundations that penetrate, or come close to penetrating the SSA;
- installation, repair, or abandonment of a public or private water supply well that accesses the SSA;
- construction or upgrading of sewage disposal stations at rest areas, weigh stations, scenic overlooks, or other locations;
- use of pesticides, herbicides, and fertilizers that contain any of the chemicals listed in the National Primary Drinking Water Regulations, 40 CFR Part 141;

- project located within the boundaries of a site listed on the USEPA National Priorities List (i.e., a Superfund site); or
- removal of underground storage tanks that are known to have leaked (i.e., a Leaking Underground Storage Tank as listed in the Office of the Illinois State Fire Marshal (OSFM) website.

If the project does not involve any of the evaluation criteria discussed above and will not cause a significant hazard to public health, state the following in the EA or EIS:

“On March 11, 2015 the U.S. Environmental Protection Agency (USEPA) designated a portion of the Mahomet Aquifer system as a sole source aquifer (SSA) under Section 1424(e) of the Safe Drinking Water Act, as shown in the attached map. The Safe Drinking Water Act gives USEPA authority to designate all or part of an aquifer as a "sole source" if contamination of the aquifer would create a significant hazard to public health and there are no physically available or economically feasible alternative sources of drinking water to serve the population that relies on the aquifer. The designation authorizes USEPA review of projects that receive Federal financial assistance to assess potential for contamination of the aquifer system that would create a significant hazard to public health.

Since the project is within the review area of the Mahomet SSA, the Department and FHWA evaluated impacts to the Mahomet SSA as established by the Memorandum of Understanding (MOU) between IDOT, FHWA, and USEPA Region 5. The MOU is based upon procedures that ensure compliances with requirements of Section 1424(e) of the Safe Drinking Water Act.

Based upon the evaluation criteria set forth in the in the Mahomet SSA Memorandum of Understanding, the proposed project will not cause any risks to the Mahomet Aquifer that could create a significant hazard to public health.”

If the project does involve the evaluation criteria discussed earlier, state the following along with a summary of impacts.

“On March 11, 2015 the U.S. Environmental Protection Agency (USEPA) designated a portion of the Mahomet Aquifer system as a sole source aquifer (SSA) under Section 1424(e) of the Safe Drinking Water Act, as shown in the attached map. The Safe Drinking Water Act gives USEPA authority to designate all or part of an aquifer as a "sole source" if contamination of the aquifer would create a significant hazard to public health and there are no physically available or economically feasible alternative sources of drinking water to serve the population that relies on the aquifer. The designation authorizes USEPA review of projects that receive Federal financial assistance to assess potential for contamination of the aquifer system that would create a significant hazard to public health.

This project is within the review area of the Mahomet SSA. The potential to impact the SSA and create a significant hazard to public health has been evaluated as established by the Memorandum of Understanding (MOU) between IDOT, FHWA, and USEPA Region 5. The MOU is based upon procedures that ensure compliances with requirements of Section 1424(e) of the Safe Drinking Water Act.”

<insert summary here>

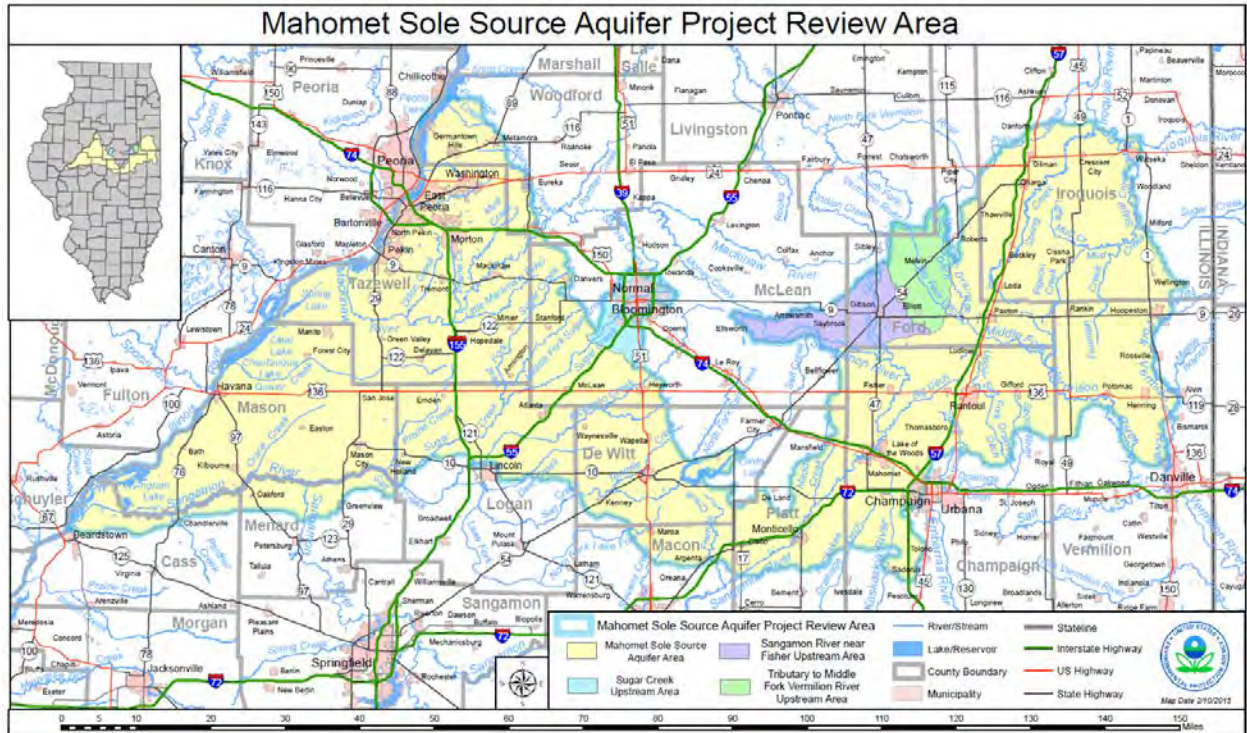

Mahomet Sole Source Aquifer Project Review Area

Figure 26-22.A

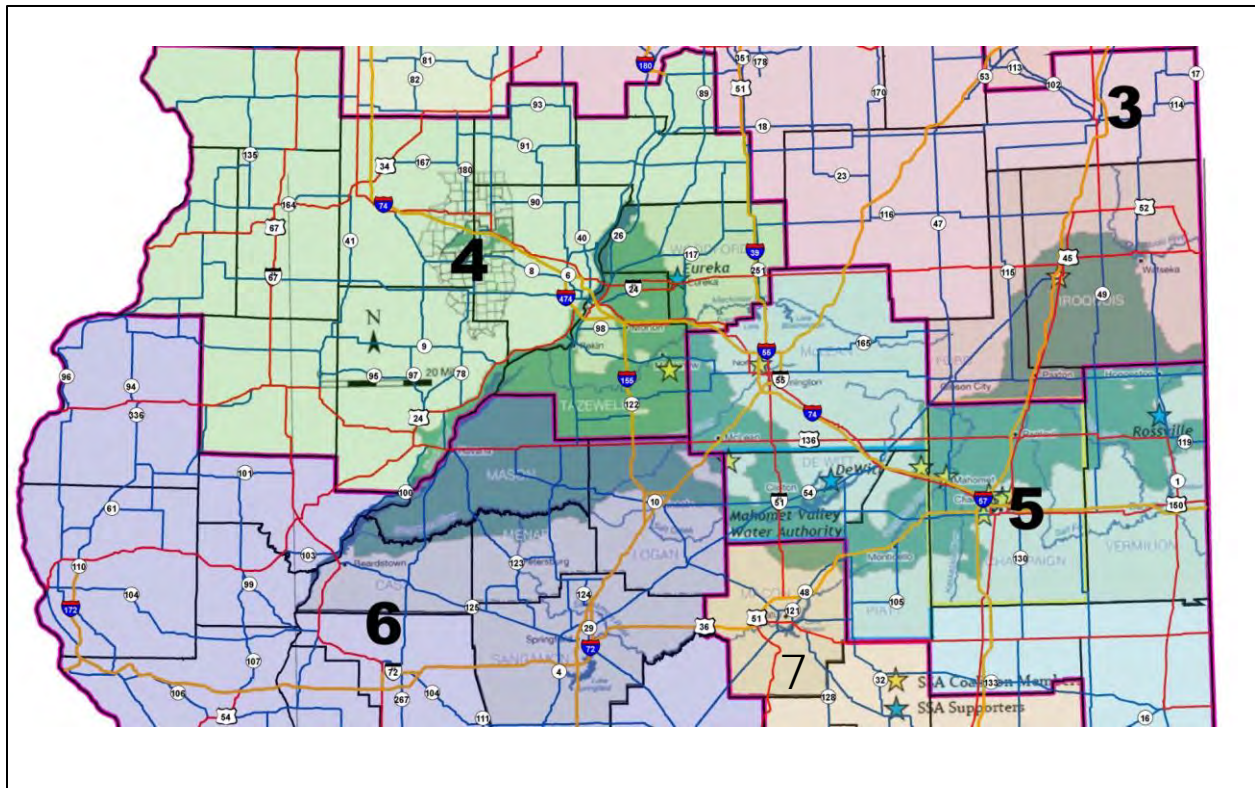

Table Notes

District 3	District 4	District 5	District 6	District 7
Ford	Peoria	Champaign	Cass	Macon
Iroquois	Tazewell	DeWitt	Logan	
Livingston *	Woodford	McLean	Mason	
	Fulton *	Piatt	Menard	
	Marshall *	Vermilion	Schuyler *	
		Douglas*		

- Counties identified with * = the Mahomet Aquifer is not directly present in this county, however, portions of the county may be included in the “Project Review Area” because it contains a stream flow source area.
- Stream flow source area: The surrounding land surface that drains onto the aquifer.

Map and Table of Districts in Mahomet Sole Source Aquifer Project Review Area

Figure 26-22.B

Chapter Twenty-Seven
ENVIRONMENTAL SURVEYS

BUREAU OF DESIGN AND ENVIRONMENT MANUAL

Chapter Twenty-Seven
ENVIRONMENTAL SURVEYS

Table of Contents

<u>Section</u>	<u>Page</u>
27-1	INTEGRATED SURVEY PROCESS FOR HIGHWAY PROJECTS27-1.1
27-1.01	Background.....27-1.1
27-1.02	Definitions.....27-1.1
27-1.03	Regulatory Framework.....27-1.1
27-1.04	Department Actions27-1.2
27-1.05	Procedures.....27-1.3
27-1.05(a)	District Environmental Screening Process27-1.3
27-1.05(b)	Local Roads Environmental Screening Process27-1.8
27-1.06	Submittal of Environmental Survey Request (ESR).....27-1.10
27-1.07	BDE Response to Environmental Survey Request.....27-1.11
27-1.07(a)	Review of Natural Resources27-1.11
27-1.07(b)	Natural Resource Review (NRR)27-1.11
27-1.07(c)	Environmental Survey Request Addenda27-1.13
27-1.08	Application of Findings.....27-1.14
27-1.09	Reporting Requirements27-1.14
27-2	SURVEY PROCESS FOR CONTRACTOR SUPPLIED BORROW, USE, AND WASTE SITES.....27-2.1
27-2.01	Background.....27-2.1
27-2.02	Applicability.....27-2.1
27-2.03	Procedures.....27-2.1
27-2.03(a)	Definitions.....27-2.1
27-2.03(b)	Contractor’s Site Request.....27-2.2
27-2.03(c)	Site Review Process.....27-2.2
27-2.03(d)	Close-Out Photos.....27-2.4
27-2.03(e)	Site Response Letter27-2.4
27-3	REGULATED SUBSTANCES EVALUATION PROCEDURES27-3.1
27-3.01	Definitions.....27-3.1
27-3.02	Regulated Substances Evaluation27-3.10
27-3.02(a)	Level 1 Screening.....27-3.16
27-3.02(b)	Level 2 Screening.....27-3.16
27-3.02(c)	Level 3 Screening.....27-3.20
27-3.03	Preliminary Environmental Site Assessment.....27-3.23
27-3.03(a)	PESA Requested Through BDE27-3.23
27-3.03(b)	Regulated Substances Evaluation for EA, EIS, and Other Special Projects.....27-3.23

Table of Contents

(Continued)

<u>Section</u>	<u>Page</u>
27-3.03(c) PESA Findings and Response.....	27-3.24
27-3.03(d) PSI Work Order Request.....	27-3.25
27-3.04 All Appropriate Inquiries (AAI).....	27-3.25
27-3.05 Site Investigations.....	27-3.26
27-3.05(a) Preliminary Site Investigation (PSI).....	27-3.26
27-3.05(b) Remedial Investigation/Feasibility Study and Risk Assessment.....	27-3.27
27-3.06 Relationship of Regulated Substances Evaluation Process Results to Design Approval.....	27-3.28
27-3.07 Relationship of Regulated Substances Evaluation Process Results to Land Acquisition.....	27-3.30
27-3.07(a) Acquisitions	27-3.30
27-3.07(b) Donations to the Department and Divestitures by the Department.....	27-3.30
27-3.07(c) Underground Storage (UST) Parcels	27-3.31
27-3.08 Relationship of Regulated Substances Evaluation Process Results to Contract Letting	27-3.31
27-3.09 Validity of Regulated Substances Evaluation Assessment Results	27-3.32
27-3.10 Phase III Construction Requirements.....	27-3.33
27-3.10(a) Regulated Substances Pre-Construction Plan	27-3.33
27-3.10(b) Pre-Construction Meeting	27-3.34
27-3.10(c) Regulated Substances Monitoring	27-3.34
27-3.10(d) Regulated Substances Management and Disposal.....	27-3.34
27-3.10(e) Temporary Staging	27-3.34
27-3.10(f) Unexpected Regulated Substances.....	27-3.34
27-3.10(g) USTs Encountered During Construction	27-3.35
27-3.10(h) Regulated Substances Final Construction Report (BDE 2733).....	27-3.36
27-3.11 Recovery of Costs	27-3.37
27-3.12 Responding to FOIA Requests for Special Waste Information	27-3.37
27-3.13 Responding to General Information Requests	27-3.37
27-4 ASBESTOS REQUIREMENTS FOR HIGHWAY BRIDGES	27-4.1
27-4.01 Background	27-4.1
27-4.02 Applicability	27-4.1
27-4.02(a) Procedures.....	27-4.2
27-4.02(b) Bridges on Approved No Asbestos (Waiver) List	27-4.2
27-4.02(c) Bridges on Confirmed/Unconfirmed List	27-4.2
27-4.02(d) Evaluation Based on Available Information.....	27-4.2

Table of Contents
(Continued)

Section

Page

27-4.02(e)	Evaluation Based on Sampling and Testing.....	27-4.3
27-4.02(f)	Asbestos Involvement Confirmed	27-4.5
27-4.02(g)	Removal of All Asbestos Containing Bridges from the State ..	27-4.6

Chapter Twenty-seven

ENVIRONMENTAL SURVEYS

27-1 INTEGRATED SURVEY PROCESS FOR HIGHWAY PROJECTS

27-1.01 Background

Section 27-1 provides procedures for the Department's integrated survey process to determine the need for screening, environmental surveys, and coordination for state and Federally-funded highway projects that may involve the following:

- cultural resources (e.g., archaeological, historical, or architectural resources);
- natural resources (e.g., threatened or endangered species, Illinois Natural Areas Inventory sites, Nature Preserves, streams, wetlands, and floodplains); and
- presence of regulated substances (i.e., special and non-special waste).

27-1.02 Definitions

1. Actions. Actions are activities the Department undertakes that can potentially affect the environment.
2. Environmental Survey Limits. The outermost limits of an area that have the potential to be included in the associated Department actions.
3. Excavation. See definition as listed under Section 27-3.01.
4. Facility. A facility is a Department-owned or operated building in addition to other roadway infrastructure.
5. In-stream work. Work or activity within the stream banks that modifies or otherwise affects the stream bed or stream banks. This includes the need for a drainage structure runaround. In-stream work includes but is not limited to drainage ditches which may be classified as Waters of the US (WOTUS) and would require permitting for disturbance below the Ordinary High-Water Mark (OHWM).
6. Resources. Resources mean listed species, protected or regulated site(s), property(ies), or area(s), etc., and require the Department to develop measures to avoid, minimize, or mitigate impacts or manage these resources.
7. Structure. A structure is defined as bridge, culvert or building.

27-1.03 Regulatory Framework

Due to an agreement with a Federal or state agency, potential involvement with a Federal or state regulation or law (and potential permit), the Department is required to screen actions for the presence of resources and may require surveys to determine the extent and nature of these resources that include the following:

- a historic district or historic property listed on, eligible for listing on, or potentially eligible for listing on the National Register of Historic Places;

- a state of Federally listed threatened and endangered species;
- Illinois Natural Area Inventory (INAI) site or dedicated Nature Preserve (NP);
- floodplain;
- prairie(s);and/or
- wetland(s) and/or stream(s).

In addition to the above resources, the Department must review projects which have the potential to affect property containing regulated substances. This includes existing Department right-of-way as well as properties under consideration for state highway project use.

27-1.04 Department Actions

Certain types of Department actions have the potential to impact the resources or properties containing regulated substances described above and include the following:

- acquisition of additional right-of-way or easement(s) (temporary or permanent)
- excavation or subsurface utility relocation
- construction and maintenance activities such as:
 - + demolition of an existing structure;
 - + building a new highway system, bridge or culvert and associated in-stream work (when applicable);
 - + removal and replacement of existing sidewalks and ramps to Americans with Disabilities Act (ADA) standards;
 - + removal and replacement of an existing bridge or culvert and associated in-stream work;
 - + widening of an existing highway system;
 - + new facility construction or reconstruction (e.g., district offices, facility yards, rest areas, and Department- owned utilities);
 - + tree clearing;
 - + land disturbance greater than 1 acre;
 - + installation of scour protection;
 - + repairs to bridge and culverts; and/or
 - + vegetation management

27-1.05 Procedures

If project associated actions do apply, initiate the screening process as follows:

1. For the district environmental screening process, see Section 27-1.05(a):
 - a. natural resources, see Section 27-1.05(a)1
 - b. cultural resources, see Section 27-1.05(a)2
 - c. regulated substances, see Section 27-1.05(a)3
2. For the local roads environmental screening process. See Section 27-1.05(b)
 - a. natural resources, see Section 27-1.05(b)1
 - b. cultural resources, see Section 27-1.05(b)2
 - c. regulated substances, see Section 27-1.05(b)3

27-1.05(a) District Environmental Screening Process**27-1.05(a)1 Natural Resource Screening (BDE 2710)**

The District Natural Resource Screening consists of a Level 1 and Level 2 screening utilizing BDE 2710.

Note: For projects where a Section 404 permit is anticipated, BDE 2710 is not sufficient to satisfy Section 7 of the Endangered Species Act for the Corps; therefore, an ESR shall be submitted (See Section 27-1.06).

Part I of BDE 2710 (Level 1 District Natural Resource Screening)

A Level 1 Natural Resources Screening is required for all projects for those actions described in Section 27-1.04.

Part I.A of BDE 2710 has five questions about project activities, which are:

1. Require any acquisition of additional right-of-way or easements (temporary or permanent), other rights of access, OR has new alignment even if no new right-of-way is necessary (new alignment includes trails/sidewalks)?

If temporary or permanent construction easements are unknown, it should be assumed that any widening, ditching, or utility work will result in at least a minimal amount of temporary access. Temporary access includes construction staging areas. In order to select “no”, the district should be fully confident all work can be contained within the existing right-of-way.

2. Require a drainage structure runaround or any in-stream work (i.e., any work or other activity within the stream banks that modifies or otherwise affects the stream bed or stream banks)?

Please see the definition for In-stream work in Section 27-1.02. If the district is unclear whether a waterway/ditch impacted would be classified as WOTUS, “unknown” should be selected.

3. Require tree removal (if yes or unknown selected, the project description must identify whether the project has the potential to remove trees at a distance greater than 100 feet from the existing edge of road pavement or railroad surface)?

Note: this is commonly unknown at the start of a project. Also, the district should avoid selecting "No" unless confident trees will not be removed.

4. Require an ILR10 NPDES permit (i.e., will the project disturb greater than one acre of land within existing ROW)?
5. Require bridge deck or culvert surface work will occur either from the underside or from above the deck surface and bore down to the underside (this includes any activities that could impact expansion joints, deck removal on bridges, or structure demolition for bridges, culverts, and/or other structures)?

This includes the following:

- any activities that could impact expansion joints, deck removal on bridges, or structure demolition for bridges, culverts, and/or other structures.
- Drainage structures include bridges and culverts with openings taller than four feet.
- work is defined as any activity that could cause disturbance to bat species using the underside of the structure. This may include activities occurring from the deck surface such as boring.
- A project may include work on multiple structures. "Yes" must be selected if the disturbance activities occur to any of the structures.

If "Yes" or "Unknown" is selected, the district must complete Part I-B Bridge Deck and Culvert Activities.

Part I.B of BDE 2710 is only related to question #5 of Part 1.A (above) and is only applicable when there is work below the bridge deck or culvert surface. This section asks the following two questions.

1. Is there suitable bat habitat within 1,000 feet of a bridge or culvert within the project limits?

The district must evaluate the area surrounding each structure potentially disturbed (within 1,000 ft radius) for suitable bat habitat. Suitable habitat is considered woodland corridors surrounding tributaries or open water bodies. If suitable habitat is present within the surrounding area of any structure, "Yes" must be selected.

2. Did any of the Bridge/Structures Bat assessments find evidence of bats?

For each structure with suitable habitat present, a Bridge/Structure Bat Assessment must be completed. Based on the outcome of the assessment(s), it must be identified whether any of the assessments identified evidence of bat use: "Yes" or "No".

Note: Copies of the Bridge/Structure Bat Assessment form are available from BDE.

If the project passes the Level 1 screening, the district representative shall sign BDE 2710 and place it in the project file or report for documentation of clearance for natural resources.

If the project fails the Level 1 screening, a Level 2 screen must be conducted as described below.

Part II of BDE 2710 (Level 2 District Natural Resource Screening)

To complete a Level 2 screening, the district will conduct a review using the Transportation Review for Ecological Compliance (TREC) tool for the following resources.

- State or Federally listed threatened or endangered species
- Illinois Natural Area Inventory Sites (INAI)
- Nature Preserves
- Prairies
- Rusty Patched Bumblebee High Potential Zone
- National Wetland Inventory
- Hydric Soils
- Within 0.5 miles from a Northern Long-eared bat or Indiana bat hibernaculum
- National River Inventory

Note: In the TREC Report, Nature Preserves, Natural Heritage Landmarks, and Land and Water Reserves are included under the same title of "Nature Preserve".

If the TREC Report indicates none of the above resources are present, the project passes the Level 1 Natural Resource Screening and the district environmental coordinator shall sign BDE 2710. Include both the TREC Report and the form in the project file/ report for documentation of clearance for natural resources. Include this documentation with any permit application.

If the TREC report indicates any of the above resources are present, then the project will fail the Level 2 screening and the project will be submitted as an ESR requiring Natural Resource Unit review. Include both the TREC Report and BDE 2710 with the ESR submittal.

27-1.05(a)2 *Cultural Resource Screening*

Per the Programmatic Agreement (PA) among the FHWA, IDOT, SHPO, and the Advisory Council on Historic Preservation Regarding Section 106 Implementation for Federal-Aid Transportation Projects in Illinois (see Appendix A), district staff who are considered trained staff, may screen and approve projects as discussed in the PA., otherwise an ESR should be submitted (See Section 27-1.06).

Screening for projects within existing ROW that require an ILR10 NPDES permit

For projects that disturb greater than one acre of land and occur within existing ROW, an ILR10 NPDES Permit is required. With the deployment of the IEPA's online Notice of Intent portal (NeT system), documentation of Section 106 compliance is required. Many types of work within existing ROW can be addressed in the Programmatic Agreement referenced above.

Per BDE Cultural Unit, Figure 27-1.A can be used as a template and uploaded into the NeT system to satisfy the Section 106 determination requirement.



Illinois Department of Transportation

To: _____ Attn: _____
From: _____
Subject: Cultural Clearance
Date: _____

<Insert Project Information here>

The above reference project has been reviewed by the District's Environmental Studies Unit. This project is excluded from further review for cultural resources under the FHWA/SHPO/IDOT Section 106 Programmatic Agreement because the scope of work falls under Activity (X) as described below.

The following activities have no potential to affect historic properties, whether there may be historic properties in the area of the undertaking.

- (1) Activities which do not involve or lead directly to construction, such as planning and research activities; grants for training; engineering to define the elements of a proposed action or alternatives so that social, economic, and environmental effects can be assessed.
- (2) General highway maintenance and repair, including but not limited to filling potholes, crack sealing, joint grinding, milling, resurfacing in kind, shoulder reconstruction, erosion control, ditch cleaning, storm sewer repair, and debris removal.
- (3) Removal and replacement of existing sidewalks and ADA ramps with in-kind materials.
- (4) Repair and replacement of highway signs or other traffic control devices.
- (5) General pavement marking activities that include, but are not limited to, installation of raised pavement markers, striping, or installation of sensors in existing pavements.
- (6) Repair and replacement of appurtenances such as glare screens, median barriers, fencing, guardrails, safety barriers, crash attenuators, safety cable, or lighting.
- (7) Repair, rehabilitation, or removal of railroad grade crossings, separations or grade crossing protection.

Figure 27-1.A

Section 106 Documentation for ILR10

- (8) Roadway surface treatments such as pavement repair, median repair, seal coating, and pavement grinding.
- (9) Improvements and repairs to Interstate Highway System including bridges, weigh and inspection stations, toll facilities, and rest areas.
- (10) Establishment, replacement, or removal of landscaping or other vegetation on the interstate.
- (11) Installation of interstate surveillance, changeable message signs, ramp metering equipment, appurtenances such as glare screens, median barriers, fencing, guardrails, safety barriers, crash attenuators, safety cable, or lighting.

Figure 27-1.A(cont'd)

Section 106 Documentation for ILR10

27-1.05(a)3 *Regulated Substances Screening*

See section 27-3.02.

27-1.05(b) Local Roads Environmental Screening Process

Local Roads Natural Resource Screening form BDE 2715 is applicable for most projects that use Federal, state, or Motor Fuel Tax (MFT) funds, and any locally funded project that require Department review and approval.

However, for projects that do not meet the above requirement, compliance with Federal and state environmental laws and regulations still apply. In addition, for projects where a Section 404 permit is anticipated, BDE 2715 is not sufficient to satisfy Section 7 of the Endangered Species Act for the Corps; therefore, an ESR shall be submitted (See Section 27-1.06).

27-1.05(b)1 *Natural Resource Screening (BDE 2715)***Level 1 Natural Resource Screening**

The Local Public Agency (LPA) portion of the screening form will contain the following five questions with the options to answer Yes/No/Unknown in Part I.A. Does the project:

1. Require any acquisition of additional right-of-way or easements (temporary or permanent), other rights of access, OR has new alignment even if no new right-of-way is necessary (new alignment includes trails/sidewalks)?

If temporary or permanent construction easements are unknown, it should be assumed that any widening, ditching, or utility work will result in at least a minimal amount of temporary access. Temporary access includes construction staging areas. In order to select “no”, the LPA should be fully confident all work can be contained within the existing right-of-way. Moreover, new alignment includes trails and sidewalks in addition to roadways.

2. Require a drainage structure runaround or any in-stream work (i.e., any work or other activity within the stream banks that modifies or otherwise affects the stream bed or stream banks?

Please see the definition for In-stream work in Section 27-1.02. If the LPA is unclear whether a waterway/ditch impacted would be classified as WOTUS, “unknown” should be selected.

3. Require tree removal (if yes or unknown selected, the project description must identify whether the project has the potential to remove trees at a distance greater than 100 feet from the existing edge of road pavement or railroad surface)?

Note: this is commonly unknown at the start of a project. Also, the LPA should avoid selecting “No” unless confident trees will not be removed.

4. Require an ILR10 NPDES Permit ((i.e., will the project disturb greater than one acre of land within existing ROW)?

Note: LPAs that are covered under the ILR40 MS4 permit are exempt from this requirement, see Section 41-1.04(b) for more information.

5. Require bridge deck or culvert surface work will occur either from the underside or from above the deck surface and bore down to the underside?

This includes the following:

- any activities that could impact expansion joints, deck removal on bridges, or structure demolition for bridges, culverts, and/or other structures.
- drainage structures include bridges and culverts with openings taller than four feet.
- work is defined as any activity that could cause disturbance to bat species using the underside of the structure. This may include activities occurring from the deck surface such as boring.
- a project may include work on multiple structures. "Yes" must be selected if the disturbance activities occur to any of the structures.

Part I.B of BDE 2715 is only related to question #5 of Part 1.A (above) and is only applicable when there is work below the bridge deck or culvert surface. This section asks the following two questions.

1. Is there suitable bat habitat within 1,000 feet of a bridge or culvert within the project limits?

The district must evaluate the area surrounding each structure potentially disturbed (within 1,000 ft radius) for suitable bat habitat. Suitable habitat is considered woodland corridors surrounding tributaries or open water bodies. If suitable habitat is present within the surrounding area of any structure, "Yes" must be selected.

2. Did any of the Bridge/Structures Bat assessments find evidence of bats?

+For each structure with suitable habitat present, a Bridge/Structure Bat Assessment must be completed. Based on the outcome of the assessment(s), it must be identified whether any of the assessments identified evidence of bat use: "Yes" or "No".

Note: Copies of the Bridge/Structure Bat Assessment form are available from BDE.

The district representative will review and then certify the Level 1 Natural Resource Screening. Projects that fail the Level 1 Natural Resource Screening shall be subject to a Level 2 Natural Resource Screening which will be conducted by the Central Bureau of Local Roads.

Level 2 Natural Resource Screening

To complete a Level 2 screening, CBLRS will conduct a review using the Transportation Review for

Ecological Compliance (TREC) tool for the following resources.

- State or Federally listed threatened or endangered species
- Illinois Natural Area Inventory Sites (INAI)
- Nature Preserves
- Prairies
- Rusty Patched Bumblebee High Potential Zone
- National Wetland Inventory
- Hydric Soils
- Within 0.5 miles from a Northern Long-eared bat or Indiana bat hibernaculum
- National River Inventory

If the TREC report indicates no resources are present, then the project will pass the Level 2 screening and CBLRS will certify the results, submit the documentation to the project file, and notify the LPA.

This documentation shall be included with any permit application. If the TREC report indicates any of the above resources are present, then the project will fail the Level 2 screening and the project will be submitted as ESR requiring Natural Resource Unit review. Include both the TREC Report and BDE 2715 with the ESR submittal.

27-1.05(b)2 ***Cultural Resource Screening***

In accordance with the Programmatic Agreement (PA) among the FHWA, IDOT, SHPO, and the Advisory Council on Historic Preservation Regarding Section 106 Implementation for Federal-Aid Transportation Projects in Illinois (see Appendix A), certain types of activities are exempt from an ESR submittal (these activities are listed in the Appendix of the PA) when reviewed by Trained Staff.

27-1.05(b)3 ***Regulated Substance***

See Section 27-3 for the types of LPA projects that must be screened for regulated substance.

27-1.06 **Submittal of Environmental Survey Request (ESR)**

When a project fails a Level 2 screening or a Section 404 permit is required, an ESR shall be submitted to the appropriate BDE unit. The ESR forms to be used in conjunction with the procedures described herein are electronic documents. For all survey request submittals, use the electronic forms and associated instructions in effect at the time of the submittal.

The Environmental Survey Request (ESR) form may be accessed through the Project Monitoring Application (PMA) by district staff that has obtained rights to use the application. Page 2 of the ESR form is used for regulated substances screening formerly referred to as special waste screening. Instructions for using these forms may be found under the “Help” menu in PMA. Consultants and Local Public Agencies should use the web version of the forms and instructions found at:

<http://apps.dot.illinois.gov/environment/envsvyrqst.asp>

Note: Submittal of the ESR initiates the Phase I environmental survey process, which takes a minimum of 6 months to complete. Results of the environmental surveys and consultation with appropriate resource agencies must be completed in advance of the desired design approval and/or construction letting, as appropriate.

27-1.07 BDE Response to Environmental Survey Request

27-1.07(a) Review of Natural Resources

BDE will review the ESR based upon regulatory requirements of the Department to determine if the project could have an adverse effect or other impacts that require avoidance, minimization, or mitigation. BDE will review the ESR and may task the Illinois Natural History Survey (INHS) to perform biological and/or wetland surveys, as necessary, to gather additional information on natural resources.

For all proposed projects that BDE determines to have the potential for an adverse effect on a T/E species or impact to nature preserves, wetlands, or other natural resources, BDE will coordinate as necessary with the appropriate resource agencies and will coordinate the information with the district for evaluation of alternatives for avoiding or minimizing adverse impacts to the identified resources.

27-1.07(b) Natural Resource Review (NRR)

The result of the ESR will be the preparation of an NRR that will discuss any applicable survey results and required commitments as part of environmental clearance for natural resources. The NRR will be included in the project report for documentation of clearance for natural resources. All commitments contained within the NRR shall be incorporated into the project at the appropriate project phase (e.g., in the design plans, activities during construction, or post-construction monitoring). Clearance for natural resources will be valid for two years unless:

- new information becomes available that was not previously considered;
- the proposed project is modified; or
- additional species, essential habitat, Natural Areas, or wetlands are identified in the project area.

An updated/validated NRR must be requested prior to construction letting. Documentation must be

included for those projects with commitments occurring between design approval and construction letting (e.g., completion of an ITA, wetland mitigation and revised wetland impacts, etc.).

27-1.07(b)1 ***Biological Review Validation***

Pursuant to 17 Ill. Admin. Code 1075, IDNR approval of the proposed project is valid for a period of two years. Districts are responsible for ensuring valid compliance documentation is in effect prior to when the project is advertised for bid letting.

District validation

This can be accomplished by the completion of an updated Level 1 and 2 natural resource screening. The results of that screening shall be included in the project file. If any resources appear that are not present during the initial screening, then submit for BDE validation.

BDE validation:

This can be accomplished through a validation request to BDE. Submittal of the biological review validation takes a minimum of 3 months to complete, provided no additional coordination or surveys are required.

27-1.07(b)2 ***Review of Cultural Resources***

Projects Exempt from an ESR

In accordance with the Programmatic Agreement (PA) among the FHWA, IDOT, SHPO, and the Advisory Council on Historic Preservation Regarding Section 106 Implementation for Federal-Aid Transportation Projects in Illinois (see Appendix A), certain types of activities are exempt from an ESR submittal (these activities are listed in the Appendix of PA).

However, to fully implement all types of activities district Environmental Coordinator will have to be considered Trained Staff as defined in PA. This aspect has yet to be completed statewide. While this training component is ongoing, FHWA has agreed that the removal and replacement of existing sidewalks and ADA ramps with in-kind material will not require an ESR as long as in-kind materials are used, and the project is not completely or partially located within the limits of a National Historic Landmark (NHL).

In-kind material is defined as the same type of material that currently exists, such as replacing brick with brick, stone with stone, asphalt with asphalt, and concrete with concrete. Please contact BDE Qualified Cultural Resources staff for guidance.

Projects Requiring an ESR

The BDE Qualified Cultural Resources staff will review the information provided with each ESR to determine if field reconnaissance surveys or detailed studies are needed for identification or evaluation of cultural resources. Qualified Cultural Resources staff will consider a variety of factors in making this determination, including but not limited to the project setting, results of previous field investigations, likelihood of prior ground disturbance, integrity, and likely age of potentially affected structures (buildings and bridge) based on photographs (photo log) submitted with the ESR.

If Qualified Cultural Resources staff determines additional studies are not warranted, it will use the information submitted with the ESR to make a preliminary assessment of whether there are potentially significant cultural resources in the area that the project may potentially affect. In evaluating buildings and bridges, BDE uses the photo log submitted with the ESR to make a preliminary determination of their eligibility for the NRHP. Qualified Cultural Resources staff may request additional information not included in the ESR to help in their determination.

In certain cases, projects can be cleared for cultural resources by Qualified Cultural Resources staff provided the projects meet criteria outlined in the Programmatic Agreement Among the FHWA, IDOT, the SHPO, and the Advisory Council on Historic Preservation Regarding Section 106 Implementation for Federal Aid Transportation Projects in Illinois. In other cases, Qualified Cultural Resources staff will coordinate determinations with the Illinois State Historic Preservation Officer (SHPO). If SHPO agrees with determination whether the cultural resources are or are not eligible for the NRHP, Qualified Cultural Resources staff will provide the information to the district.

If Qualified Cultural Resources staff determines reconnaissance surveys or other studies are warranted, or if coordination with SHPO identifies a need for surveys or studies, through an Intergovernmental Agreement, the Qualified Cultural Resources staff will initiate arrangements with the Illinois State Archaeological Survey (ISAS) for archaeological and/or architectural studies, if needed, and with other qualified entities for surveys and/or studies regarding historic buildings and bridges. Qualified Cultural Resources staff will review the survey and/or study results and coordinate the information with SHPO. Qualified Cultural Resources staff will provide these results and the results of coordination with SHPO to the district.

The district considers the cultural resource information in further development of the project and, for archaeological sites and historical buildings and bridges eligible for NRHP, the district, in coordination with Qualified Cultural Resources staff, evaluates options for avoiding and minimizing the project's effects on the resources.

If adverse effects to the resources eligible for the NRHP cannot be avoided, Qualified Cultural Resources staff will evaluate whether any further studies of the resources are necessary. If further studies are needed, Qualified Cultural Resources staff will advise the district and will initiate action to accomplish the studies, considering program priority and project scheduling.

Qualified Cultural Resources staff will coordinate the results of any further studies and the determination of the project's anticipated impacts with SHPO. Qualified Cultural Resources staff will provide information to the district regarding study findings, results of coordination with SHPO, and any recommendations for further coordination or actions by the district, as outlined in Chapter 26.

27-1.03(b)3 *Review of Regulated Substances*

Please refer to the regulated substances procedures discussed in Section 27-3.

27-1.07(c) Environmental Survey Request Addenda

When providing the results of reconnaissance surveys conducted on a project, BDE will include information to indicate the extent of the area that was surveyed. Submittal of a survey request addendum will only be necessary when changes in the project will affect areas outside the limits

of the surveyed areas or when a change in the scope of work for the project would invoke a different criterion in Section 27-1.02 than shown in the original survey request. If questions arise on the need for submitting addenda to survey requests for specific projects, contact the BDE Project Coordinator for the district involved.

The Addendum Environmental Survey Request (AESR) form may be accessed through PMA by IDOT staff that has obtained rights to use the application. Form instructions may be found under the "Help" menu in PMA. Consultants should use the web version of the form, and instructions can be found at <http://apps.dot.illinois.gov/environment/envsrvyrgstaddm.asp>.

27-1.08 Application of Findings

The district will ensure that the results and recommendations it receives in response to the ESR are fully integrated into the development and implementation of the project or action. The documentation of the Phase I environmental investigations, associated coordination, and any commitments made will become part of the environmental information included in or with the Environmental Impact Statement, Environmental Assessment, or Phase I Engineering Report, as appropriate.

27-1.09 Reporting Requirements

If a project passes the Level 1 or 2 Natural Resource screening but must still be submitted to another unit in BDE for an ESR review, please include the Level 1 and 2 screening documentation (BDE 2710/BDE 2715 and associated TREC Report) in the ESR submittal. The Natural Resource Unit will keep a record of these Level 1 and 2 signoffs to be included in an annual report required by the Department's MOU with IDNR.

If a project passes the Level 1 or 2 Natural Resource Screening but does not require an ESR submittal to another unit in BDE, a record shall be kept at the district or Bureau of Local Roads level. An annual report shall be provided to the Natural Resource Unit by January 10th of these additional Level 1 and 2 signoffs conducted and documented at the district or Local level for the previous calendar year to be included with the above-mentioned report.

27-2 SURVEY PROCESS FOR CONTRACTOR SUPPLIED BORROW, USE, AND WASTE SITES

27-2.01 Background

Article 107.22 of the *Standard Specifications for Road and Bridge Construction* requires contractors to seek the Department's approval of borrow, use and waste sites prior to their use in a construction project. The following procedures are intended to establish the appropriate amount of documentation for review and approval of such sites.

27-2.02 Applicability

The procedures that follow apply to contractor-proposed borrow, use, and waste sites located within the State of Illinois for all projects on which IDOT is the awarding authority.

27-2.03 Procedures

27-2.03(a) Definitions

1. BDE 2289. "Borrow Site Review" form, BDE 2289, including map(s) and necessary drawings indicating the exact location of the proposed site and ground level photographs. This form includes the Landowner Agreement, which must be filled out and signed by appropriate landowner(s).
2. BDE 2290. "Waste/Use Site Review" form, BDE 2290, including map(s) and necessary drawings indicating the exact location of the proposed site and ground level photographs. This form includes the Landowner Agreement, which must be filled out and signed by appropriate landowner(s).
3. Borrow Site. A borrow site includes any source of items paid as borrow excavation or furnished excavation, as well as any source of excavated materials not paid for separately but included in the costs of other items of work.
4. Contractor Letter. A signed letter on the contractor's letterhead indicating intended use of the proposed site.
5. IEPA Permit or List. For sites accepting clean construction and demolition debris (CCDD) under the Illinois Environmental Protection Agency (IEPA) Interim Authorization list or IEPA CCDD Fill Operation Permit and commercial landfills permitted to accept anticipated materials, the site must be on the IEPA approved CCDD or Solid Waste sites list or possess the appropriate permit prior to its use.
6. Quarry/Mines. Quarry or mines include current and former mines and quarries operating in accordance with the Illinois Environmental Protection Act (the Act).
7. Use Site. A use site is any disturbed location outside of the limits of construction where the contractor intends to receive, stage, or temporarily store material, equipment, or personnel necessary for the satisfactory completion of the project or subsequent disposition at another location.

8. Waste Site. A waste site is any location where excess material from the project is taken without the expressed intent of returning the material either to the project from where it was generated, or to the economic mainstream (recycled). As used by the Department, the term “waste site” is not the same as “waste” defined by the Illinois Environmental Protection Act, 415 ILCS 5.

27-2.03(b) Contractor’s Site Request

The contractor’s site request (BDE 2289 and BDE 2290) for borrow, use and waste sites will be submitted to the Resident Engineer/Technician (Resident) who will fill out the appropriate information and then forward it to the district environmental staff . The request shall include sufficient documentation for the Department to determine if the site can be approved for the intended use.

If a site has been previously approved by the Department, the request shall include documentation indicating the previous use, limits and approvals.

See Figure 27-2.A for a list of required documentation and which form is required based on the type of work.

27-2.03(c) Site Review Process

27-2.03(c)1 *No Site Review Needed*

For the following types of sites, a natural resource and cultural review is not required:

- a. currently permitted CCDD facilities;
- b. currently permitted commercial land fill operations; and
- c. commercial operations intended to return excess material to the economic mainstream such as recycling facilities.

For other types of sites, the review process is discussed below:

27-2.03(c)2 *Cultural Resources Review of a Site*

1. New Borrow Sites and New Use Sites Where the Depth of Disturbance is greater than six Inches.

These sites must be reviewed by the BDE Cultural Unit as they have the potential to affect cultural resources. The district shall ensure the appropriate form is completed before forwarding the request to BDE, who will then conduct a review and respond back to the district.

2. New Waste Sites and New Use Sites Where the Depth of Disturbance is less than six inches;

These sites do not require a cultural review as the level of disturbance is not deep enough to affect cultural resources.

3. Previously Approved Borrow, Waste, and Use Sites.

For previously approved borrow, waste, and use sites, the district may determine further cultural reviews are not required where it is documented that the contractor will restrict activities to areas that were previously approved for such use, the contingencies of the previous approval continue to be met, and the site was cleared by BDE Cultural Unit within the past 5 years.

27-2.03(c)3 ***Natural Resources Review of Site***

Note: these procedures apply to locations within existing ROW and outside existing ROW.

1. New Borrow, Waste, and Use Sites (without tree removal).

The district shall review the site for natural resources impacts (i.e., threatened and endangered species, wetlands, floodplains, etc.) utilizing Part II of BDE 2710. Sites where resources occur may be approved when the site meets the Situational Site Exemptions (See #4) or receive a response letter from BDE indicating the site has been approved.

2. Previously Approved Borrow, Waste, and Use Sites (without tree removal)

For previously approved borrow, waste, and use sites, the district may determine further natural resource reviews are not required where it is documented that the contractor will restrict activities to areas that were previously approved for such use. If the site is to be expanded or material deposited in a different location on the property, then a new natural resource review is required.

If the Level II Natural Resource screening indicated no resources of concern present, sign and complete Part II of BDE 2710, the site is now cleared for natural resources for two years.

If the Level II Natural Resource Screening indicated resources are present but meets the criteria for a Situational Site Exemption, sign and complete Part II of BDE 2710. The site is now clear for natural resources for two years.

If the Level II Natural Resource Screening indicated resources area present but does not meet the criteria for a Situational Site Exemption, the district has two options:

a) reject the site; or;

b) submit the site to BDE for further review (See #5 below)

Per Section 27-1.05(e), natural resource clearances are valid for two years. Sites in use more than two years must be re-evaluated for natural resources screening by completing Part II of BDE 2710.

3. New and Previously Approved Borrow, Waste, and Use Sites (with tree removal).

For sites where tree removal is required, it is preferable to select an alternate site where tree removal is not required. If tree removal cannot be avoided, submit the site to BDE along with Part II of BDE 2710.

4. Situational Site Exemptions:

The following may be approved by the district following a review under Part II of BDE 2710 and include the following situations:

- a) Sites where the land use is marked Row Crops or Pasture and the only resource is hydric soils.
- b) Sites where there is no tree removal, but the Level II screening identified listed bats in the site vicinity and no other resources are present.
- c) Sites where the Level II screening identified listed fish and/or mussels in the site vicinity, there are no additional resources present, and there is no stream on or adjacent to the site/property.

5. Sites reviewed by BDE

If the site does not pass the Level II screening or does not meet the Situational Site Exemptions (#4), the district may submit the site to BDE for further review. The following shall be submitted:

- Part II of BDE 2710 (including TREC Report), and;
- BDE 2289/BDE 2290

Once these forms are received by BDE. A determination will be made on whether site can be approved or denied. BDE will send approval//denial response letter to the district

27-2.03(d) Close-Out Photos.

Close-out photos of waste/use sites should be sent to the district. Close-out photos of borrow and discussed use sites are not needed.

27-2.03(e) Site Response Letter

The district will give written notice to the Resident if the site has been approved or if the site has been rejected and include the reason(s) why. The Resident will be responsible for ensuring the written notice is forwarded to the contractor. The district is responsible for retaining information concerning the site review on file.

	Site Documentation						Required Reviews / Review Authority			
	Contractor's Letter	IEPA Permit or List	BDE 2289	BDE 2290	Landowner Agreement	Part II of BDE 2710	T & E Species / district	Cultural / BDE	Wetlands / district	Floodplains / district
New Borrow Sites	X		X		X	X	X	X	X	X
New Waste Sites	X			X	X	X	X		X	X
Permitted Disposal Sites										
Quarry or Mine	X	X								
Commercial Landfill	X	X								
New Use Sites										
Disturbing ≤ 6" (150 mm)				X	X	X	X		X	X
Disturbing > 6" (150 mm)				X	X	X	X	X	X	X
Sites Intended to Return Materials to the Economic Mainstream	X									
Previously Approved Sites - Still Valid	X									

REVIEW OF CONTRACTOR PROPOSED BORROW, USE, AND WASTE SITES

Figure 27-2.A

27-3 REGULATED SUBSTANCES EVALUATION PROCEDURES

The procedures in Section 27-3 are applicable to all of the following types of projects regardless of funding source:

1. State highway projects;
2. local project or portion of the project affecting right-of-way or a road under Department jurisdiction;
3. Local project or portion of the project acquiring right-of-way in the name of the State for Department transportation purposes;
4. Local project or portion of the project involving temporary or permanent easement in the name of the state for Department transportation purposes; and,
5. Other transportation projects (e.g., railroad or aeronautics projects) affecting right-of-way or roads under Department jurisdiction.

This section is designed to supplement Departmental Policy D&E-11, "Identifying and Responding to Regulated Substances in Highway Project Development, Implementation and Operations."

27-3.01 Definitions

1. Adjoining Property. Any property or properties of which the border is contiguous with that of the subject property (project limits), or that would be contiguous with that of the property but for a street, road, or other public thoroughfare separating them.
2. Agriculture Property. Any real property for which the present or post-remediation use is growing agricultural crops for food or feed, either as harvested crops, cover crops, or as pasture. This definition includes but is not limited to, properties used for confinement or grazing of livestock or poultry and for forestry operations. Excluded from this definition are farm residences, farm outbuildings, and agrochemical facilities.
3. All Appropriate Inquiries (AAI). AAI refers to the requirements for assessing the environmental conditions of a property prior to its acquisition. The US Environmental Protection Agency (EPA) published a final rule setting Federal standards for the conduct of AAI. The final rule became effective November 1, 2006. As of November 1, 2006, parties must comply with the requirements of the AAI Final Rule or follow the standards set forth in the American Society for Testing and Materials (ASTM) E1527 Phase I Environmental Site Assessment Process, to satisfy the statutory requirements for conducting AAI. The AAI must be conducted in compliance with either of these standards to obtain protection from potential liability under the *Comprehensive Environmental Response, Compensation, and Liability Act* (CERCLA) as an innocent landowner, a contiguous property owner, or a bona fide prospective purchaser.
4. Area Background. Area background refers to concentrations of regulated substances that are consistently present in the environment near a site and are the result of natural conditions or human activities, and not the result solely of releases at the site (415 ILCS 5/58.2).

5. Bona Fide Prospective Purchaser. The 2002 Brownfield Amendments to the Superfund Law (CERCLA) provide a Superfund liability defense for property owners who qualify as “Bona Fide Prospective Purchasers (BFPP)” of known contaminated property, if the property transaction occurred after January 11, 2002. If able to obtain BFPP status, EPA’s recourse for unrecovered response cost is limited to a lien on property for the lesser of the unrecovered response costs or increase in fair market value attributable to EPA’s response action. A BFPP may purchase property with knowledge of contamination after performing AAI, provided the property owner meets or complies with all of the other statutory requirements set forth in CERCLA Section 101(40).
6. CERCLA. CERCLA stands for the *Comprehensive Environmental Response, Compensation, and Liability Act*.
7. Conservation Property. Any real property for which the present or post-remediation use is primarily for wildlife habitat.
8. Contaminant of Concern. See Regulated Substance of Concern.
9. Contamination. The presence of any regulated substance on the land or in the waters of the State in quantities that are, or may be, harmful or injurious to human health or welfare, or animal or plant life.
10. Contiguous Property Owner. The 2002 Brownfield Amendments to the Superfund Law (CERCLA) provide a Superfund liability defense for property owners who qualify as a “Contiguous Property Owner” and excludes from the definition of “owner” or “operator” under CERCLA Section 107(a)(1) and (2) a person who owns property that is “contiguous to, or otherwise similarly situated with respect to, and that is or may be contaminated by a release or threatened release of a hazardous substance from” property owned by someone else. To qualify as a contiguous property owner, a landowner must have no knowledge or reason to know the contamination at the time of acquisition, have conducted AAI, and meet all criteria set forth in CERCLA Section 107(q)(1)(A).
11. Design Approval. An environmental approval by the department and the FHWA of the design recommended as a result of a Phase I design study and a design public hearing. Phase I design approval is a necessary step for a project to move to Phase II.
12. District Environmental Studies Unit (DESU). The district personnel primarily responsible for screening projects for the possible presence of regulated substances and administering responsibilities as described in this chapter.
13. Engineered Barrier. A barrier designed or verified using engineering practices that limits exposure to or controls migration of the contaminants of concern.
14. Excavation. For the purposes of this chapter, excavation is the digging or grading of any soil sediment or fill material, including underground utility works such as installation of fiber optic cabling, and in-stream work or underwater work, except for aggregate fills, subbase or pavement, which are not considered a soil or fill material of concern for the purpose of transportation projects and regulated substances evaluation.

15. Exposure Route. The transportation mechanism whereby a contaminant of concern reaches or may reach a receptor.
16. Hazard. A set of inherent properties known to be dangerous to the environment.
17. Hazardous Substance. Hazardous substance means:
 - a. any substance designated pursuant to Section 311(b)(2)(A) of the *Clean Water Act of 1972*, 33 U.S.C. 1321 *et seq.*, (P.L. 92-500), as amended;
 - b. any element, compound, mixture, solution, or substance designated pursuant to Section 102 of the *Comprehensive Environmental Response, Compensation, and Liability Act of 1980*, 42 U.S.C. 9601 *et seq.*, (P.L. 96-510), as amended;
 - c. any hazardous waste;
 - d. any toxic pollutant listed under Section 307(a) of the *Clean Water Act*, 33 U.S.C. 1321 *et seq.*, (P.L. 92-500), as amended;
 - e. any hazardous air pollutant listed under Section 112 of the *Clean Air Act*, 42 U.S.C. 7401 *et seq.*, (P.L. 95- 95), as amended; and
 - f. any imminently hazardous chemical substance or mixture with respect to which the Administrator of the EPA has taken action pursuant to Section 7 of the *Toxic Substances Control Act*, 15 U.S.C. 2601 *et seq.*, (P.L. 94-469), as amended.

The term does not include petroleum, including crude oil or any fraction thereof, that is not otherwise specifically listed or designated as a hazardous substance under the criteria described above, and the term does not include natural gas, natural gas liquids, liquefied natural gas, or synthetic gas usable for fuel or mixtures of natural gas and such synthetic gas; see 415 ILCS 5/3.215.

18. Hazardous Waste. A waste, or combination of wastes, that because of its quantity, concentration, or physical, chemical, or infectious characteristics may cause or significantly contribute to an increase in mortality or an increase in serious, irreversible, or incapacitating reversible, illness; or pose a substantial present or potential hazard to human health or the environment when improperly treated, stored, transported, or disposed of, or otherwise managed, and has been identified by characteristics or listing, as hazardous pursuant to Section 3001 of the *Resource Conservation and Recovery Act of 1976*, 42 U.S.C. 6901 *et seq.*, the Environmental Protection Act, 415 ILCS 5/22.4, or pursuant to the Pollution Control Board regulations, 35 Ill. Admin. Code 721.103. Potentially infectious medical waste is not a hazardous waste, except for those potentially infectious medical wastes identified by characteristics or listing as hazardous under Section 3001 of the *Resource Conservation and Recovery Act of 1976*, the Environmental Protection Act, 415 ILCS 5/3.220, or pursuant to the Pollution Control Board regulations, 35 Ill. Admin. Code 229.102.
19. Industrial/Commercial Property. Any real property not meeting the definition of residential property, conservation property, or agriculture property. For the purposes of regulated substances evaluation, the term also includes real property used historically or previously for industrial, manufacturing, commercial, or retail purposes.
20. Industrial Process Waste. Any liquid, solid, semi-solid, or gaseous waste generated as a direct or indirect result of the manufacture of a product or the performance of a service.

Any such waste that would pose a present or potential threat to human health or the environment or with inherent properties that make the disposal of such waste in a landfill difficult to manage by normal means is an industrial process waste. Industrial process waste includes, but is not limited to:

- a. spent pickling liquors,
- b. cutting oils,
- c. chemical catalysts,
- d. distillation bottoms,
- e. etching acids,
- f. equipment cleanings,
- g. paint sludge,
- h. incinerator ashes (including but not limited to ash resulting from the incineration of potentially infectious medical waste),
- i. core sands,
- j. metallic dust sweepings,
- k. asbestos dust, and
- l. off-specification, contaminated, or recalled wholesale or retail products.

Specifically excluded are:

- a. uncontaminated packaging materials,
- b. uncontaminated machinery components,
- c. general household waste,
- d. landscape waste, and
- e. construction or demolition debris; see 415 ILCS 5/3.235.

21. Innocent Landowner. The 1986 *Superfund Amendments and Reauthorization Act* (SARA) provides a Superfund liability defense for property owners who qualify as an "Innocent Landowner." To qualify, the landowner must show "that they did not know and had no reason to know" that prior to the purchase of a property there was a release or threatened release of any hazardous substances. To qualify as an innocent landowner, a person must conduct AAI and meet all statutory requirements.
22. Institutional Control. A legal mechanism for imposing a restriction on land use.
23. ISATS (IDOT Site Assessment Tracking System). A secure webpage maintained by the Bureau of Design and Environment containing environmental survey documents prepared for and by the Location and Environment Section of BDE for use by district Environmental Studies Unit personnel and other interested parties. ISATS was also commonly referred to as "the extranet" or "frostycap," and the terms are interchangeable for purposes of this chapter.
24. Leaking Underground Storage Tank (LUST). An underground storage tank where the contents have leaked into the environment.

25. Maximum Allowable Concentration (MAC). Maximum allowable concentrations of chemical constituents in uncontaminated soil used as fill material at regulated fill operations, as determined by 35 Ill. Admin. Code 1100.Subpart F.
26. Municipal Waste. Garbage, general household and commercial waste, industrial lunchroom or office waste, landscape waste, and construction or demolition debris.
27. No Further Remediation (NFR) Letter. A letter issued by the IEPA acknowledging that a person is released from further responsibility under the *Illinois Environmental Protection Act* at a site. An NFR letter may have conditions attached to it, including institutional controls.
28. Non-Hazardous Special Waste. Special waste found not to be hazardous (e.g., industrial process waste, pollution control waste).
29. PESA Response form. A form in PMA completed by the District Environmental Studies Unit (DESU) indicating the district's desired response to the PESA.
30. PESA Response/Work Order (PR/WO) form. A form completed by the District Environmental Studies Unit (DESU) indicating the district's request to complete a Preliminary Site Investigation (PSI). The basic information for the PR/WO form is populated in PMA and prepared using BDE 2735, PESA Response/PSI Work Order Request.
31. PESA Validation. The re-evaluation of the project area to check for the possibility of new reported releases or incidents and determine if land uses have changed within the project area.
32. Pollution Control Waste. Any liquid, solid, semi-solid, or gaseous waste generated as a direct or indirect result of the removal of contaminants from the air, water, or land, and poses a present or potential threat to human health or to the environment or with inherent properties that make the disposal of such waste in a landfill difficult to manage by normal means. Pollution control waste includes, but is not limited to, water and wastewater treatment plant sludge, bag house dusts, landfill waste, scrubber sludge, and chemical spill cleanings; see 415 ILCS 5/3.335.
33. Preliminary Environmental Site Assessment (PESA). A detailed evaluation of available records dealing with site history, including site reconnaissance to visually inspect and investigate conditions.
34. Preliminary Site Investigation (PSI). A preliminary investigation of the site, including sampling, testing, and analysis of soil or groundwater, as necessary, and an estimate of the cost of cleanup by parcel, if possible, for the Department's project.
35. Project Monitoring Application (PMA). The electronic database used by BDE to manage Environmental Survey Requests (ESR). Each project in PMA is assigned a unique BDE sequence number and is also referenced to a construction job number and contract number, when available. The database is accessible to designated IDOT central office personnel and district environmental personnel.
36. Property. The buildings, fixtures, and improvements within existing or proposed right-of-way that are subject to the site reconnaissance.

37. Property Owner. The individual or legal entity holding the fee title to a parcel or parcels that the Department is seeking to acquire or from whom the Department has acquired title. In the case of multiple individuals or entities jointly holding title, the term will apply to all holders collectively.
38. Recognized Environmental Condition (REC). The presence or likely presence of any regulated substances on a property under conditions that indicate an existing release, a past release, or a material threat of a release of any regulated substances into structures on the property or into the ground, groundwater, or surface water of the property. The term includes regulated substances even under conditions in compliance with laws. The term is not intended to include *de minimis* conditions that generally do not present a material risk of harm to public health or the environment, and that generally would not be the subject of an enforcement action if brought to the attention of appropriate governmental agencies.
39. Regulated Substances. Any hazardous substances, as defined by the *Comprehensive, Environmental Response, Compensation, and Liability Act* of 1980, 42 U.S.C. 9601, and petroleum products including crude oil or any fraction thereof, natural gas, natural gas liquids, liquefied natural gas, or synthetic gas usable for fuel or mixtures or natural gas and such synthetic gas, as defined by the Environmental Protection Act, 415 ILCS 5/58.2.
40. Regulated Substance of Concern. Any contaminant that is expected to be present at the site based upon past and current land uses and associated releases that are known to the person conducting remediation based upon reasonable inquiry; see 415 ILCS 5/58.2.
41. Remedial Investigation/Feasibility Study (RI/FS). An investigation/study to assess site conditions and evaluate alternatives to the extent necessary to select a remedy. The RI is designed to assess the nature and extent of releases of regulated substances and determine those areas of a site where releases have created damage or the threat of damage to public health or the environment. The FS develops a range of remedies for the site, considering the findings of the RI.
42. Remedial Action. Action consistent with permanent remedy taken instead of or in addition to removal actions in the event of a release or threatened release of a regulated substance into the environment to prevent or minimize the release of regulated substances so that they do not migrate to cause substantial danger to present or future public health or welfare or the environment. The term includes off-site transport of regulated substances, or the storage, treatment, destruction, or secure disposition off-site of such regulated substances or contaminated material.
43. Removal. The cleanup or removal of released regulated substances from the environment. It includes:
- a. actions that may be necessary in the event of the threat of release of regulated substances into the environment;
 - b. actions that may be necessary to monitor, assess, and evaluate the release or threat of release of regulated substances;
 - c. the disposal of removed material; and

- d. other actions as may be necessary to prevent, minimize, or mitigate damage to the public health or welfare or the environment, that may otherwise result from a release or threat of release.
44. Residential Property. Any real property used for habitation by individuals, or where children have the opportunity for exposure to contaminants through soil ingestion or inhalation at educational facilities, health care facilities, childcare facilities, or outdoor recreational areas.
45. Resource Conservation and Recovery Act (RCRA). The RCRA governs the management of hazardous wastes. The process for identifying a hazardous waste involves many steps. There is no single, comprehensive list of hazardous wastes that is regularly updated. To be considered a hazardous waste, a material first must be classified as a solid waste (40 CFR 261.2 "Definition of Solid Waste"). The EPA defines solid waste as garbage, refuse, sludge, or other discarded material (including solids, semisolids, liquids and contained gaseous materials). If a waste is considered solid waste, it must then be evaluated to determine if it is a hazardous waste (40 CFR 262.11 "Hazardous Waste Determination"). The EPA defines wastes as hazardous, if they are specifically named on one of four lists of hazardous wastes included in Subpart D of 40 CFR 261 "Lists of Hazardous Wastes" (see 40 CFR 261.30 through 261.35), or if they exhibit any of the four characteristics discussed in Subpart C of 40 CFR 261 "Characteristics of Hazardous Waste"; see 40 CFR 261.20 through 261.24.
46. Right-of-Way (ROW). Land, or interests therein, acquired for or devoted to highways, waterways, railroads, bicycle paths, and other public or private transportation purposes.
47. Risk Assessment. A determination of the kind and degree of hazard posed by regulated substances, the extent to which a particular group of people has been or may be exposed to the contamination and the health risk that exists due to the contamination.
48. Risk Managed Project (RMP). A project that impacts a property with REC for which PSI is not conducted. The BDE will provide the district with a special provision for monitoring and/or managing potentially any contaminated soil and/or groundwater that is expected to be encountered during construction. The use of RMP approach in lieu of PSI is determined on a case-by-case basis and at the discretion of BDE's staff based on the results of the PESA and other technical facts about the project.
49. Site. Any single location, place, tract of land or parcel of property, or portion thereof, including contiguous property separated by a public or private right-of-way; see 415 ILCS 5/58.2.
50. Site Reconnaissance. A visit to the project site and adjoining properties during which observations are made. The objective of site reconnaissance is to obtain information indicating the possible presence of environmental conditions within the minimum search distances listed in Figure 27-3.B. Environmental conditions include current or historical situations that may negatively affect the property including the presence of, for example, railroad crossings, illegal dumping, unknown containers and vessels, waste associated with 'crack' and methamphetamine houses (e.g., discarded hazardous material on the outside of a property), battery piles, paint spills, abandoned transformers, surface staining, and vegetative damage. This level of inspection generally does not require the investigator to enter onto a property and may be done from the existing ROW. During the site

reconnaissance, observations are documented, and photographic evidence is obtained to assist in completing the Environmental Survey Request (ESR).

51. Special Provision for the Removal and Disposal of Regulated Substances. A special provision written by the Geologic and Waste Assessment Unit within BDE and issued to the district for inclusion in the contract documents. In the case of RMP, the special provision requires the contractor to hire an environmental firm for monitoring a specified area for soil and groundwater contamination and worker protection. In the case of a project where a PSI was conducted, the special provision requires the contractor to conduct regulated substances monitoring in specified areas for soil and groundwater contamination, and worker protection and management of the affected area for site disposal.
52. Special Waste. Special waste means any of the following:
- a. potentially infectious medical waste;
 - b. hazardous waste, as determined in conformance with RCRA hazardous waste determination requirements set forth in 35 Ill. Admin. Code 722.111, including a residue from burning or processing hazardous waste in a boiler or industrial furnace unless the residue has been tested in accordance with 35 Ill. Admin. Code 726.212 and proven to be non-hazardous;
 - c. industrial process waste or pollution control waste, except:
 - I. any such waste certified by its generator, pursuant to Section 22.48 of the *Illinois Environmental Protection Act*, not to be any of the following:
 - i. a liquid, as determined using the paint filter test set forth in subdivision (3)(A) of subsection (m) of 35 Ill. Admin. Code 811.107;
 - ii. regulated asbestos-containing waste materials, as defined in 40 CFR61.141, under the National Emission Standards for Hazardous Air Pollutants;
 - iii. polychlorinated biphenyls (PCBs) regulated pursuant to 40 CFR 761;
 - iv. an industrial process waste or pollution control waste subject to the waste analysis and recordkeeping requirements of 35 Ill. Admin. Code 728.107 under the land disposal restrictions of 35 Ill. Admin. Code 728; and
 - v. a waste material generated by processing recyclable metals by shredding and required to be managed as a special waste under Section 22.29 of the *Illinois Environmental Protection Act*.
 - II. any empty portable device or container, including but not limited to a drum where a special waste has been stored, transported, treated, disposed of, or otherwise handled, provided that the generator has certified that the device or container is empty and does not contain a liquid, as determined using the

paint filter test set forth in subdivision (3)(A) of subsection (m) of 35 Ill. Admin. Code 811.107. For purposes of this definition, "empty portable device or container" means a device or container where removal of special waste, except for a residue not to exceed one inch (25 mm) in thickness, has been accomplished by a practice commonly employed to remove materials of that type. An inner liner used to prevent contact between the special waste and the container shall be removed and managed as a special waste; or

- III. as may otherwise be determined under Section 2.9 of the *Illinois Environmental Protection Act*.

Special waste does not mean fluorescent and high-intensity discharge lamps as defined in subsection (a) of Section 22.23a of the *Illinois Environmental Protection Act*, waste that is managed in accordance with the universal waste requirements set forth in 35 Ill. Admin. Code 733, or waste that is subject to rules adopted pursuant to subsection (c)(2) of Section 22.23a of the *Illinois Environmental Protection Act*, 415 ILCS 5/3.475.

53. Survey Target Date. The date established by the district by which the completed survey report (e.g., the PESA) is desired. This target date is used by BDE for internal scheduling purposes for all the requested environmental surveys and does not necessarily represent the completion date of the respective survey(s). The size, length, and complexity of the proposed project, along with seasonal field conditions and minimum timing required by policy, should be considered when establishing the date.
54. Tiered Approach to Corrective Action Objectives (TACO). A method for developing remediation objectives for contaminated soil and groundwater in accordance with 35 Ill. Adm. Code 742. These remediation objectives protect human health and consider site conditions and land use. Remediation objectives generated by TACO are risk based and site specific, and can be based on area background, the use of engineered barriers, and elimination of exposure routes.
55. Underground Storage Tank (UST). Any single tank or combination of tanks (including underground pipes connected to the tank(s) used to contain an accumulation of regulated substances, and that has 10% or more of its volume (including the volume of associated underground pipes) beneath the surface of the ground. The term does not include any of the following facilities or associated pipes:
- a. farm or residential tank with a capacity of 1100 gallons or less, used for storing motor fuel for noncommercial purposes;
 - b. septic tank;
 - c. pipeline facility (including gathering lines) regulated under the *Natural Gas Pipeline Safety Act* of 1968 or the *Hazardous Liquid Pipeline Safety Act* of 1979 (both codified in 49 U.S.C. 60101, *et seq.*), or that is an intrastate pipeline facility regulated under State laws as provided in either of the aforementioned statutes, and that is determined by the Secretary of Energy to be connected to a pipeline or to be operated or intended to be capable of operating at pipeline pressure or as an integral part of a pipeline;
 - d. surface impoundment, pit, pond, or lagoon;

- e. storm water or waste water collection system;
- f. flow-through process tank;
- g. liquid trap or associated gathering lines directly related to oil or gas production and gathering operations; or
- h. storage tank situated in an underground area (e.g., basement, cellar, mine working, drift, shaft, tunnel) if the storage tank is situated upon or above the surface of the floor.

The term also means an underground storage tank used exclusively to store heating oil for consumptive use on the premises where stored and that serves other than a farm or residential unit; see 415 ILCS 5/57.2.

27-3.02 Regulated Substances Evaluation

Taking title (or lesser interest) to property containing regulated substances or moving soil impacted with regulated substances exposes the Department to potential liability for associated investigation and cleanup costs. To limit such liability, projects must be evaluated/assessed for the potential presence of special waste or other regulated substances, as described in the following sections, and as flowcharted in Figures 27-3.A through 27-3.D. Successfully following the screening process and documenting the results limit the Department's potential environmental liability, protects our workers and the public, and demonstrates adherence to Departmental Policy D&E-11, "Identifying and Responding to Regulated Substances in Highway Project Development, Implementation and Operations." D&E-11 policy states, among other items, that "due care shall be exercised to determine whether regulated substances may be present on or located adjacent to property being considered for use for state highway project purposes and supporting highway operations and maintenance. Acquisition of an interest in a property determined to contain regulated substances shall be avoided unless the risks and liabilities of such acquisition can be justified, documented, and appropriately managed."

To determine whether regulated substances may be present on property under state control for state highway project purposes, properties on and adjoining the project area shall be evaluated using the processes outlined in Section 27-3. A regulated substances evaluation must be conducted on every applicable project. A Preliminary Environmental Site Assessment (PESA) is the Department's fundamental method of demonstrating "due care." Thus, PESA is required on every applicable project, as listed in the opening paragraph of Section 27-3. Nevertheless, there are some select circumstances where the need for PESA can be avoided and due care demonstrated based on successful performance and documentation by the project developer of a Level 1, 2, or 3 screening or similar due diligence evaluation. The screening criteria have been carefully crafted and apply in project situations where they pose minimal risk and potential liability to the project developer entity, environment, and the public and road workers. It is the project developer's responsibility to properly conduct the screening, document the results, and submit the documented results for concurrence to BDE. The project shall be submitted to BDE for completion of PESA, if the project developer chooses not to conduct a Level 1, 2, or 3 screening.

Screening of projects for regulated substances in Phase I and Phase II should be conducted by the DESU for project types listed at the beginning of Section 27-3. The DESU is responsible for, for example, coordinating and preparing the Environmental Survey Request (ESR) and the PESA

Response/PSI Work Order (PR/WO) form. Additional responsibilities include participating in pre-construction meetings, reviewing and documenting pre-construction plans and post-construction environmental reports, and interacting with resident engineers before, during and after construction to coordinate and document management of contaminated soils, including unexpected situations concerning regulate substances and underground storage tanks.

Environmental Assessment (EA), Environmental Impact Statement (EIS), or large Categorical Exclusion (CE) projects may require special handling due to size, complexity, and/or long project development periods and should be discussed with BDE staff. Refer to Section 27-3.03(b) of this Manual for additional information on the regulated substances evaluation process for these types of projects. Included in this list of projects requiring special handling are river crossing projects requiring sediment management.

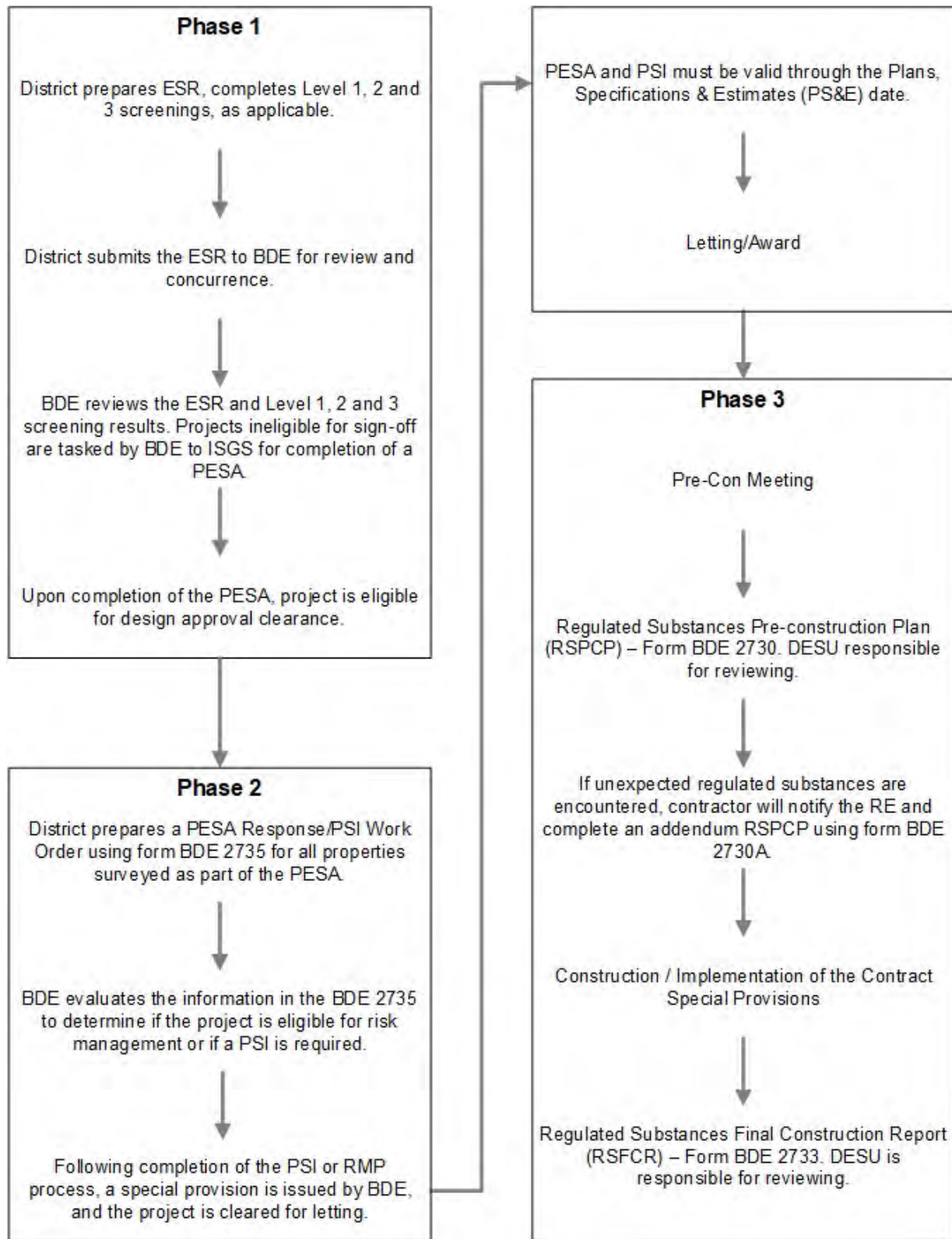

SPECIAL WASTE ASSESSMENT PROCESS

FIGURE 27-3.A

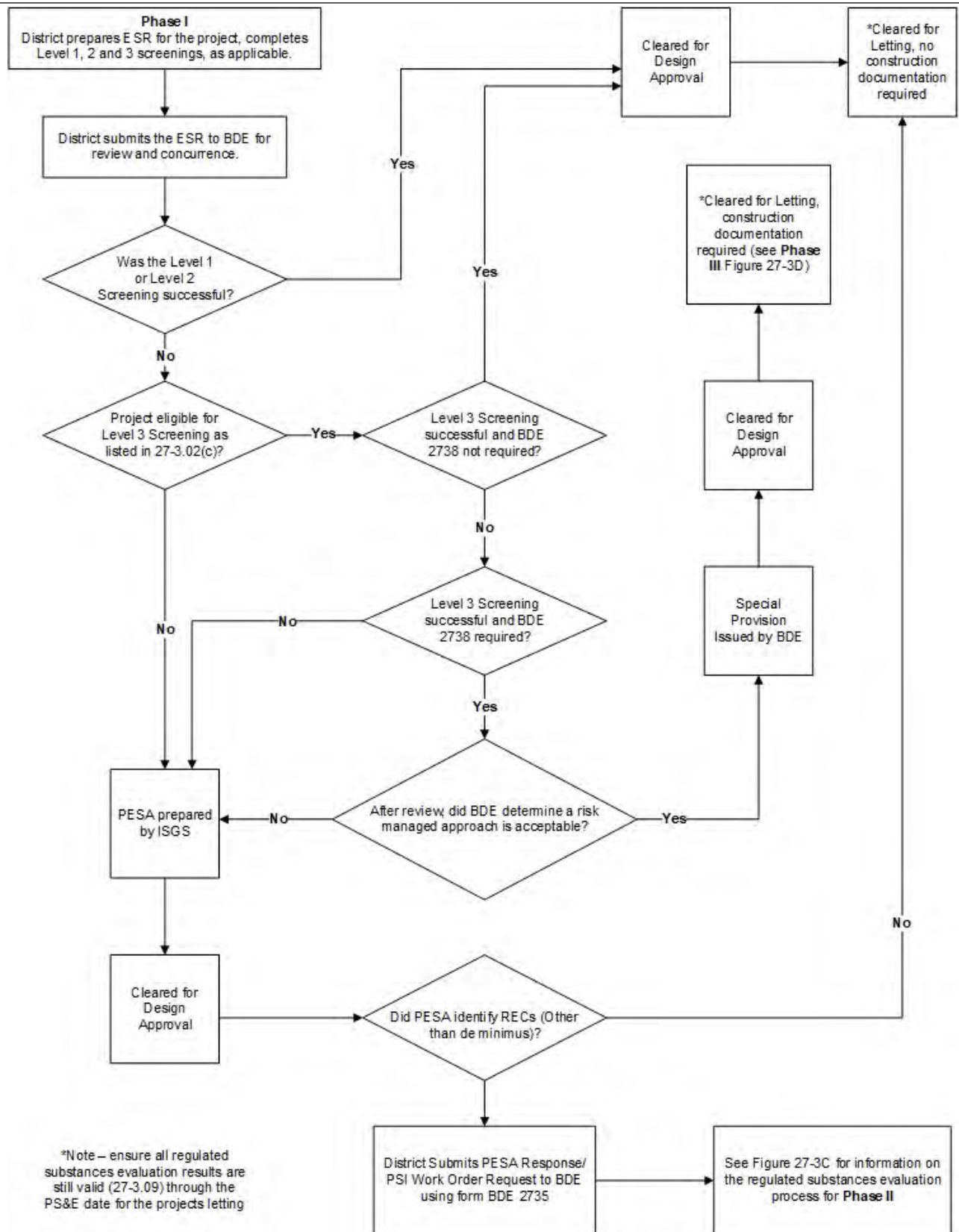

REGULATED SUBSTANCES EVALUATION PROCESS – PHASE I

FIGURE 27-3.B

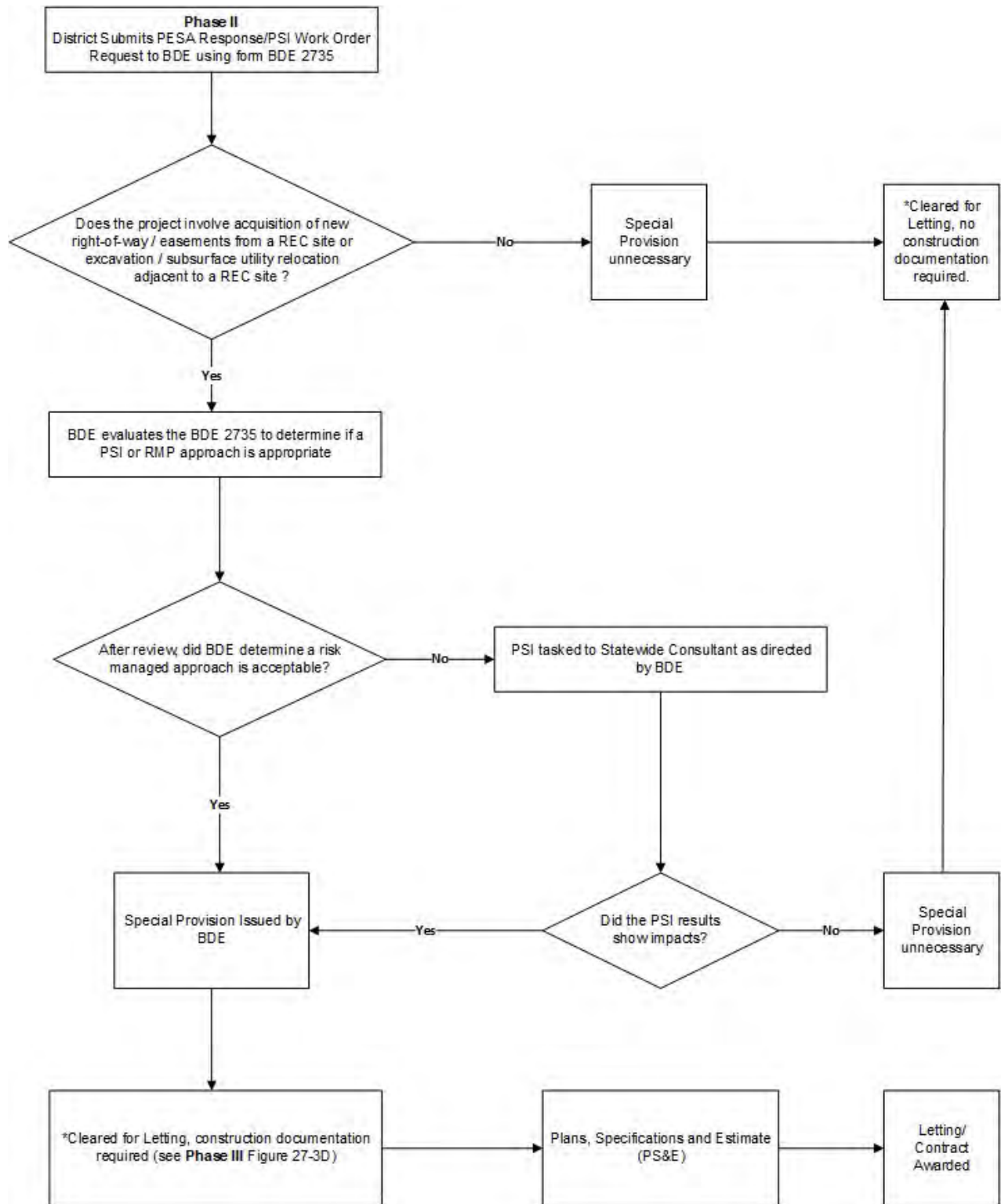

*Note – ensure all regulated substances evaluation results are still valid (27-3.09) through the PS&E date for the projects letting

REGULATED SUBSTANCES EVALUATION PROCESS – PHASE II

FIGURE 27-3.C

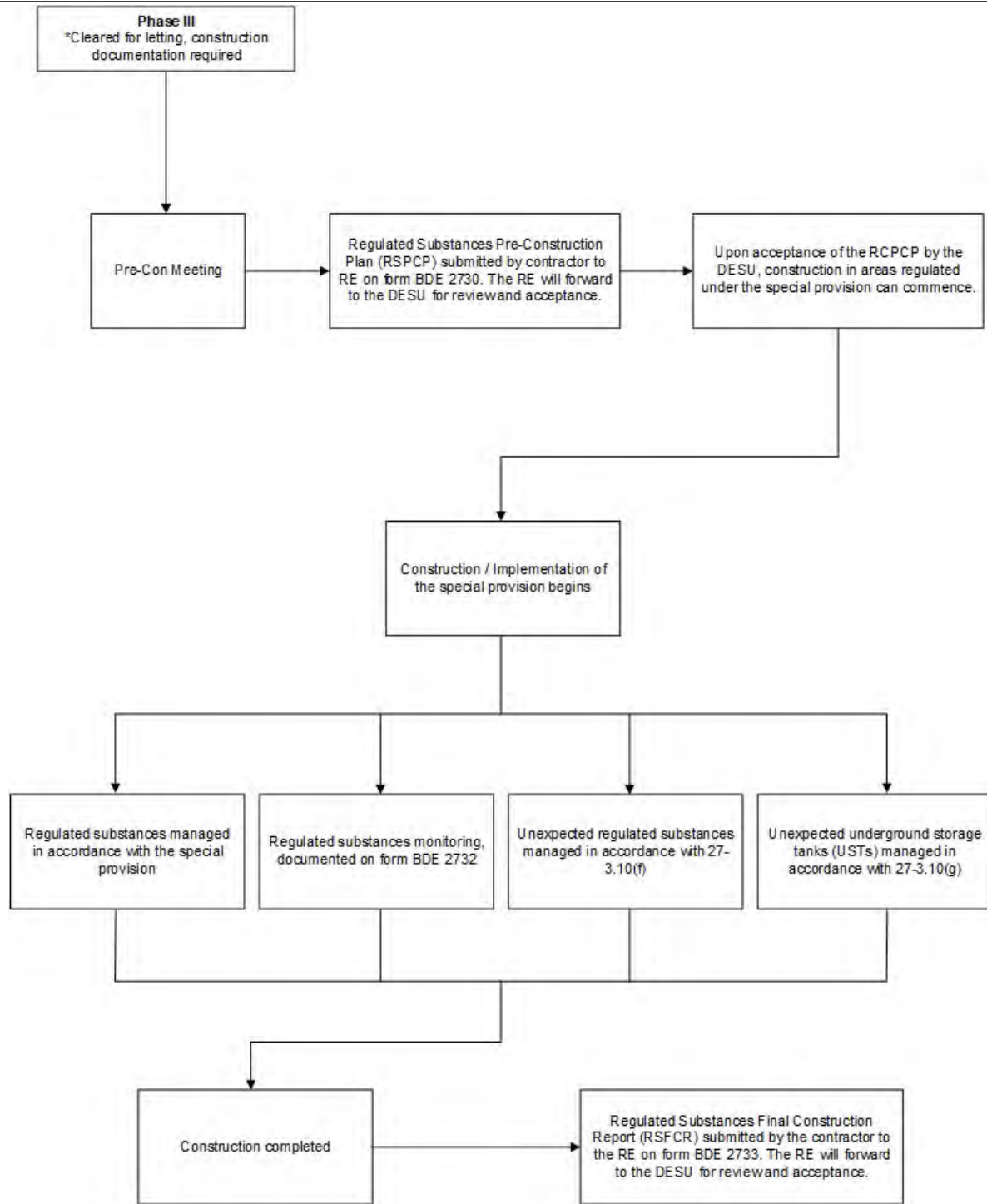

*Note – ensure all regulated substances evaluation results are still valid (27-3.09) through the PS&E date for the projects letting

REGULATED SUBSTANCES EVALUATION PROCESS – PHASE III

FIGURE 27-3.D

27-3.02(a) Level 1 Screening

The District Environmental Studies Unit (DESU) may sign-off the project and not undertake further action to identify and assess regulated substances, if the project does not involve either:

1. acquisition of additional right-of-way or easements (temporary or permanent) in the name of the State for IDOT transportation purposes; or
2. excavation (see definition of excavation) or subsurface utility relocation on State right-of-way.

The DESU shall complete the applicable portion of the ESR form and BDE 2737, Regulated Substances Screening form, sign and date them, and send the results to BDE. After BDE receives the ESR and concurs, the design approval and letting clearance dates can be entered into PMA. The district shall retain the fully completed Level 1 screening form and BDE 2737 in the district project file and shall include them in the project's environmental documentation for the project to support the finding that proper due diligence was performed, and further investigations are unwarranted.

27-3.02(b) Level 2 Screening

Projects failing Level 1 screening can be further screened by the DESU using Level 2 criteria to determine if the project may be eligible for a district sign-off or can be submitted for initiation of PESA. To be eligible for the Level 2 sign-off, the following conditions must be met:

1. there are no conditions or database occurrence within the minimum search distances shown in Figure 27-3.E;
2. a site reconnaissance was conducted, and no concerns were identified, and
3. the ESR form and BDE 2737 were thoroughly completed and processed through BDE.

Environmental Condition	Minimum Search Distance (miles)	Database (See form BDE 2737 for web hyperlink to each database)
Industrial / commercial property	0.25	Identified during Site Reconnaissance
Other Environmental Conditions ¹	Property & Adjoining Property	See footnote below
Crosses or otherwise involves railroad ROW ²	Property & Adjoining Property	See footnote below
State UST	Property & Adjoining Property	The Office of State Fire Marshall UST database
State LUST	0.5	IEPA Bureau of Land, LUST Incident Tracking database
State Voluntary Cleanup	0.5	IEPA Bureau of Land, Site Remediation Program database (includes Voluntary Cleanup sites)
State Brownfield	0.5	IEPA Bureau of Land, Office of Brownfields database
State Landfills	0.5	IEPA Bureau of Land Inventory database (landfills are included but not flagged separately)
Federal NPL site	1.0	U.S. EPA CERCLIS database (includes NPL, Active, and Delisted sites)
Federal NPL site - Delisted	0.5	
Federal	0.5	

¹ Other environmental conditions are identified through in-person site reconnaissance and any other research method not otherwise listed in the table above. The DESU shall evaluate any situations where a sign-off may be inappropriate because of scenarios of concern for which they may be aware.

² Crosses or otherwise involves railroad ROW, other than a single rail rural ROW with no maintenance facilities.

CERCLIS site		
Federal CERCLIS – NFRAP site	0.5	

ENVIRONMENTAL CONDITIONS AND MINIMUM SEARCH DISTANCE TABLE FIGURE**27-3.E**

Environmental Condition	Minimum Search Distance (miles)	Database (See form BDE 2737 for web hyperlink to each database)
Federal RCRA CORRACTS facilities list	1.0	U.S. EPA RCRA database (includes CORRACTS, TSD RCRA, and other RCRA)
Federal RCRA non- CORRACTS TSD facilities list	0.5	
Federal RCRA generators list	Property & Adjoining Property	
Federal Brownfield sites	0.5	U.S. EPA Federal Brownfields & Land Revitalization database
Federal ERNS System	Property	The Right-To-Know Network, Spills and Accidents database (covers the years 1982-2008) (U.S. Coast Guard, National Response Center, covers the years 1990-Present)

Acronyms

1. CERCLA = Comprehensive Environmental Response, Compensation and Liability Act
2. CERCLIS = Comprehensive Environmental Response, Compensation, and Liability Information System
3. CORRACTS = Corrective Action Activity
4. ERNS = Emergency Response Notification System
5. LUST = Leaking Underground Storage Tank
6. NFRAP = No Further Remediation Action Planned
7. Non-CORRACTS = Non-Corrective Action Activity
8. NPL = National Priorities List
9. RCRA = Resource Conservation and Recovery Act
10. RCRIS = Resource Conservation and Recovery Information System
TSD = Treatment Storage & Disposal
UST = Underground Storage Tank
11. TSDF = Treatment and Disposal Facility
12. UST = Underground Storage Tank
13. SEMS = Superfund Enterprise Management System³

ENVIRONMENTAL CONDITIONS AND MINIMUM SEARCH DISTANCE TABLE

FIGURE 27-3.E
(Continued)

³ The CERCLIS Public Access Database, which contained a selected set of publicly releasable Superfund program data was retired in 2015. The USEPA has transitioned to the Superfund Enterprise Management System (SEMS), which includes the same data fields and contents as the former CERCLIS database

For purposes of the screening process, the project and project area shall include the area encompassing the current right of way or easements (temporary or permanent) plus the outer most limits of the proposed right of way or easements. Furthermore, the minimum search distance when conducting the screening is measured from the outermost edges of the project area.

For a successful Level 2 screening, the DESU shall complete the entire ESR form and BDE 2737, sign and date the forms, and send the results to BDE. After BDE receives the ESR and concurs, the design approval and letting clearance dates can be entered into PMA. The district shall retain the fully completed Level 2 screening form and BDE 2737 in the district project file and include them in the environmental documentation for the project to support the finding that proper due diligence was conducted, and further investigations are unwarranted.

If the Level 2 screening fails, PESA for the entire project shall be requested by the district, unless the project is eligible for and the district chooses to perform a Level 3 screening.

27-3.02(c) Level 3 Screening

Projects failing Level 1 and Level 2 screenings may be submitted for PESA or may be further screened by the DESU using the criteria listed below to determine the project's eligibility for a Level 3 sign-off. To be eligible for a Level 3 sign-off, the following conditions must be met.

1. If the project involves excavation for only the following types of work, proceed to step 2 to conduct the screening. Otherwise, a PESA for the entire project is required.
 - a. Sidewalks/bike paths;
 - b. Sidewalk ramps;
 - c. Curb & gutter;
 - d. Mast arm/light pole installation;
 - e. Sign post/truss installation;
 - f. Traffic signal foundation work/hand holes;
 - g. Ditch cleaning;
 - h. Guardrails/median cables; or
 - i. A project type specifically listed on form BDE 2737 under Level 3 screening criteria.
2. If there are no conditions or database occurrence(s) shown in Figure 27-3.F on or adjoining the project area, proceed to step 3. Otherwise, PESA for the entire project is required.

Environmental Condition	Minimum Search Distance	Database and Search Site (see form BDE 2737 for web hyperlink to each database)
State Landfills	Property & Adjoining Property	IEPA Bureau of Land Inventory database (landfills are included but not flagged separately)
Federal NPL site	Property & Adjoining Property	U.S. EPA SEMS database (includes NPL, Active, and Delisted sites)
Federal NPL site - Delisted	Property & Adjoining Property	
Federal SEMS site	Property & Adjoining Property	
Federal SEMS site -NFRAP site	Property & Adjoining Property	
Federal RCRA CORRACTS facilities list	Property & Adjoining Property	U.S. EPA RCRA database (includes CORRACTS, TSD RCRA, and other RCRA)
Federal RCRA non-CORRACTS TSD facilities list	Property & Adjoining Property	
State Brownfield	Property & Adjoining Property	IEPA Bureau of Land, Office of Brownfields database
Federal Brownfield sites	Property & Adjoining Property	U.S. EPA Federal Brownfields & Land Revitalization database
Other Environmental Conditions	Property & Adjoining Property	Other environmental conditions identified through in-person site reconnaissance and any other research method not otherwise listed in the table above.
Full Take Property Acquisition	On project	Full take properties by the Department must be evaluated via the PESA process and are ineligible for a Level 3 screening.

ENVIRONMENTAL CONDITIONS AND MINIMUM SEARCH DISTANCE TABLE

FIGURE 27-3.F

3. If there are no database occurrences shown in Figure 27-3.G on or adjoining the project area, proceed to step 4 to document the screening results. If there are database occurrences shown in Figure 27-3.G on or adjoining the project area, BDE 2738 Regulated Substances Level 3 Screening should be completed for the property(ies) on which the below database occurrences were identified. Then proceed to step 4.

Environmental Condition	Minimum Search Distance	Database and Search Site
State Voluntary Cleanup	Property & Adjoining Property	IEPA Bureau of Land, Site Remediation Program database (includes Voluntary Cleanup sites)
State LUST	Property & Adjoining Property	IEPA Bureau of Land, LUST Incident Tracking database
State UST	Property & Adjoining Property	The Office of State Fire Marshall UST database

ENVIRONMENTAL CONDITIONS AND MINIMUM SEARCH DISTANCE TABLE

FIGURE 27-3.G

4. The ESR form and Level 3 screening documentation must be thoroughly completed and submitted to BDE for review and concurrence.

For purposes of the screening process, the project and project area shall include the area encompassing the current right of way or easements (temporary or permanent) plus properties along the outer most limits of the proposed right of way or easements.

For a successful Level 3 screening not requiring BDE 2738, the DESU shall complete the entire ESR form and BDE 2737, sign and date the forms, and send the results to BDE. After BDE receives the ESR and concurs, the design approval and letting clearance dates can be entered into PMA. The district shall ensure the forms are retained in the district project file and included in the environmental documentation for the project to support the finding that proper due diligence was performed, and further investigations are unwarranted.

If BDE 2738 was required as part of step 3 above, the DESU shall complete the entire ESR form, BDE 2737, and BDE 2738, sign and date the forms, and send the results to BDE. BDE will review to determine the necessary course of action. This may include completion of PESA for the project, or issuance of a special provision without requiring PESA.

27-3.03 Preliminary Environmental Site Assessment

27-3.03(a) PESA Requested Through BDE

To request a PESA, the DESU completes the ESR form in PMA and forwards it to BDE along with plan sheets, a location map, and other pertinent project details. BDE then tasks the Illinois State Geological Survey (ISGS) with completion of a PESA or similar environmental due diligence, as appropriate, using information provided in the ESR and associated supporting documents. Districts with more than one PESA under way should advise BDE of their priorities.

It is critical for efficient execution of the PESA for the district to carefully choose a Survey Target Date considering project complexity, seasonal field conditions, and the minimum time frame for completion of the PESA stated in this section.

After receiving a PESA tasking from BDE, ISGS will review file information and conduct appropriate investigations to determine if recognized environmental conditions exist or assess the potential of the project area for involving other natural hazards and concerns. The target⁴ for completion of the PESA report for most projects will be within six months from the date ISGS receives the survey request from BDE. The target for completion of the PESA report for spot projects, considered to be a single parcel, will generally be within three months from the date ISGS receives the survey request.

The ISGS will send the final report to BDE and also upload the document to the Illinois Site Assessment Tracking System (ISATS) for use by the DESU and other interested parties. The BDE will forward the report to the district, to IEPA, and to the Office of State Fire Marshal, as appropriate. The transmittal memorandum from BDE will specify conditions for complying with Departmental Policy D&E-11, "Identifying and Responding to Regulated Substances in Highway Project Development, Implementation, and Operations."

27-3.03(b) Regulated Substances Evaluation for EA, EIS, and Other Special Projects

For EA and EIS projects with large geographic footprints or long project development periods, it can often be time consuming and inefficient to conduct a full PESA on the initial study area. In these cases, and in coordination with the district, BDE will consider completing a more pertinent due diligence assessment for the project. For example, a Site Assessment Letter Report (SALR) is an evaluation that includes a site reconnaissance over the entire project area (which usually includes several corridor alternatives and a large footprint), associated database searches, and an extended hydrogeology discussion. The SALR will usually not contain individual property historical research or FOIA requests and thus, can be done more efficiently while still providing the necessary minimal information needed to prepare the NEPA document. SALR results should be used by the project

⁴ The target time frames are the anticipated minimums. Factors contributing to longer time frames could include size, length and complexity of the project, the number and complexity of other project studies in progress, and the number of calls for emergency investigations, which compete for the attention of the regulated substances survey staff. For larger or more complex projects, ISGS will inform BDE of the estimated target time for the final report when it receives the survey request.

developer through the Phase 1 completion cycle. It is unnecessary for the district to request a new regulated substances survey at each milestone of the NEPA 404 Merger process (i.e., Purpose and Need, Alternatives to be Carried Forward, Preferred Alternative). Once the district initiates Phase II (which may or may not happen for several years after Phase I), the district should then request a full PESA on the selected alternative or alignment (typically a significantly smaller and focused geographic footprint than the original study area). The full PESA document will subsequently be used to prepare the PSI and eventually the special provision for letting, which is typical for the department's Phase II and III processes.

Projects involving river crossings and management of sediment require additional coordination between the DESU and BDE due to complications and additional costs associated with management of sediment. In these cases, BDE may desire to conduct river sediment sampling in conjunction with the planned geotechnical sampling completed by the district, which typically occurs early in project development and much earlier than the DESU would normally submit an ESR. When the DESU becomes aware of a project which has the potential to involve river sediments, an ESR should be prepared, and BDE should be alerted as soon as possible in the project cycle to coordinate this sampling effort with the district geotechnical staff or the district Phase 1 consultant.

27-3.03(c) PESA Findings and Response

The following procedures will apply:

1. No "Recognized Environmental Condition" (REC) Finding. If the PESA report indicates that the property(ies) investigated within the project limits have no RECs (other than de minimis), the district shall document this finding in the environmental documentation for the project. The documentation should be a copy of the memorandum from BDE transmitting the PESA report. The PESA report should not be included. The district need not take any further action regarding property(ies) that do not contain any REC unless a re-evaluation for regulated substances becomes necessary (see Section 27-3.09) or a previously unidentified property is encountered. If such a property is encountered, work affecting the property should immediately cease until the district, in consultation with BDE, the Central Bureau of Construction, and the Office of Chief Counsel, has assessed the situation and determined an appropriate course of action.
2. "Recognized Environmental Condition" (REC) Finding. If the PESA report indicates that the property(ies) investigated within the project limits has a REC, BDE will consult with the Office of Chief Counsel in developing conditions for non-routine situations. BDE will forward the property(ies) with a REC to the district Bureau of Program Development/Environmental Unit via a PESA review Transmittal Memorandum and will send a copy of the correspondence to the district Land Acquisition Engineer, the Central Bureau of Land Acquisition, if requested, BDE Project Control and Implementation Section, and the Office of Chief Counsel for their respective action.

The district shall prepare and submit to BDE a PESA Response with supporting documentation indicating the project will or will not avoid the property(ies) with a REC or the project will not avoid the property(ies) with a REC. The PESA Response shall be sent to BDE after the PESA is reviewed by the district; it does not necessarily have to include the PSI Work Order request, for example, if avoidance is possible.

- a. Avoidance Possible. If the district determines the project can avoid the purchase of additional right-of-way/easement from any property containing a REC and any excavation or subsurface utility relocation adjacent to property containing a REC, it shall indicate this on the PESA Response form and send it to BDE. The district also shall provide a copy of the completed PESA Response form to the Central Bureau of Land Acquisition. The district shall retain a copy of the PESA Response form in the project file and includes it in the environmental documentation for the project. The district should not take any further action regarding properties containing a REC that were avoided unless a validation of the regulated substances results becomes necessary; see Section 27-3.09.
- b. Avoidance Not Possible. If the district cannot avoid the purchase of additional right-of-way/easement from any property containing a REC or avoid any excavation or subsurface utility relocation adjacent to property containing a REC, it shall indicate this on BDE 3735 PESA Response / PSI Work Order form and send it to BDE. This process requests BDE to initiate the services of the Statewide Regulated Substances Investigation Consultant to perform a PSI to determine the nature and extent of contamination (i.e., above or below the cleanup objectives). Additionally, the district shall provide a copy of BDE 2735 to the Central Bureau of Land Acquisition, if requested.

27-3.03(d) PSI Work Order Request

To submit a PSI request, the district completes both the top half (PESA Response) and the bottom half (Work Order) of the PMA form and associated form BDE 2735 at which time the PSI will be tasked by BDE to a pre-qualified regulated substances environmental consultant. The district shall include supporting documentation including plan sheets for the REC sites involving any of the situations listed in Section 27-3.02(a) or subsurface utility relation adjacent to a property with a REC, in other words, the sites that are deemed to require a PSI. The plan sheet should show the specific location and stationing of planned soil excavation and acquisition or easements in the name of the State. The district should also identify, for each location referenced in Table 1 of the PESA, the REC identification number, maximum excavation depth per site location, the type of excavation per site investigated, and the soil excavation volume per site, and other pertinent information such as possible presence of underground storage tanks (USTs) and whether it is anticipated the project will be a net importer or exporter of soils. This information is prepared using BDE 2735. Additionally, cross-section figures are also helpful to determine the depth of the proposed construction elements.

For properties containing a REC classified as a hazardous substance (non-petroleum), BDE and the Office of the Chief Counsel will determine if acquisition of the property requires additional liability protection under CERCLA. If additional liability protection is necessary, BDE will task ISGS to conduct an "All Appropriate Inquiry" (AAI) on those properties.

27-3.04 All Appropriate Inquiries (AAI)

In some cases, proposed land acquisition at, or excavation adjacent to property(ies) with potential significant contamination may require the PESA to be re-conducted under the "All Appropriate Inquiry"

(AAI) standard to provide the Department the appropriate CERCLA liability protection. A Preliminary Site Investigation (PSI) may also be necessary, depending upon the results of the PESA and/or AAI. Moreover, BDE will determine the need for AAI in consultation with the Office of Chief Counsel.

On November 1, 2006, 40 CFR 312 became effective; this rule defined AAI on what is required for due diligence to avoid Comprehensive Environmental Response, Compensation and Liability Act (CERCLA) liability (Superfund liability). The AAI rule implements the 2002 Small Business Liability Relief and Brownfields Revitalization Act (2002 Brownfield Act), which aimed to clarify and expand the potential defenses to strict liability under CERCLA. To qualify for CERCLA's defenses to strict liability (i.e., as an innocent purchaser, a bona fide prospective purchaser, or a contiguous property owner), a defendant must show it conducted AAI prior to taking title to the property. Following the AAI procedures affords IDOT CERCLA liability protection as an innocent purchaser, bona fide prospective purchaser, or a contiguous property landowner.

27-3.05 Site Investigations

27-3.05(a) Preliminary Site Investigation (PSI)

BDE uses the information provided in the PESA Response / Work Order (concerning the volume and cost of material for excavation) and information from the PESA to determine whether the REC can be addressed during construction without a PSI. In these cases, if BDE determines, through this "risk management" evaluation procedure, a PSI is not warranted, it will notify the district the project is eligible to be a Risk Managed Project (RMP). Projects involving acquisition of parcels with REC that are full takes or have potential uneconomic remnants are ineligible for "risk management." For a project deemed eligible by BDE to be an RMP, BDE will provide the district with a regulated substances special provision consistent with Section 669 of the Standard Specifications for Road and Bridge Construction for inclusion in the construction documents.

For actions that do not qualify as RMPs, BDE will contact the Statewide Regulated Substances Investigation Consultant and request an investigatory work plan and estimated budget for the PSI. BDE will review the work plan and budget and provide the district with an opportunity for review prior to approval.

PSI budgets of up to \$100,000 generally will be paid from funds for the pre-qualified regulated substances investigation consultant agreement. If the estimated cost is more than \$100,000, BDE will discuss funding options with the district. If the estimated budget is more than \$200,000, the district will be required to fund the PSI. Upon receiving approval of the work plan and budget, the statewide consultant will proceed with the investigations of the property(ies).

After completing the investigations, the consultant will provide a draft PSI report to BDE. BDE, in consultation with the Office of Chief Counsel, as appropriate, will review the report for adequacy and provide it to the district for review. Generally, the draft PSI report will be completed within 75 calendar days from authorization of the PSI work plan, unless completion is delayed to meet target letting dates for other projects. After all comments on the draft PSI report have been addressed, BDE issues a revised final PSI report. At various milestones in the PSI process, the DESU will be alerted of the anticipated cost, schedule, technical details and results. The DESU can and should

actively participate in the process by providing comments about the proposed actions and communicate this information as necessary with others, for example, district land acquisition.

BDE forwards to the district a final PSI report with the appropriate special provision for management and monitoring of the contaminated areas. BDE also forwards a copy of the report to the Central Bureau of Land Acquisition, if requested, the Office of Chief Counsel (to consider if any legal actions may be necessary), the Illinois State Geological Survey, and the appropriate State agencies (e.g., Office of State Fire Marshal, IEPA), as appropriate. If the district accepts BDE recommendations, it so advises BDE. If the recommendations are accepted prior to design approval, the district should summarize the proposal for management and monitoring of the property(ies) in the environmental documentation for the project. Estimated cleanup costs should be included in project environmental documents and must be included when the costs of property involvement vary for different alternatives under study.

The target for completion of the final PSI report for most projects will be within six months of the district's request to conduct the PSI, unless completion is delayed to meet target letting dates for other projects. The PSI report will identify areas impacted by special waste or regulated substances, recommend actions to be taken, and provide estimated costs for excavating, transporting, and disposing of materials exceeding IEPAs:

1. Tiered Approach to Corrective Action Objectives (TACO) Tier 1 Soil Remediation Objectives for Residential Properties (35 Ill. Admin. Code 742), and/or
2. Most stringent maximum allowable concentration (MAC) for chemical constituents in uncontaminated soil established pursuant to the proposed Subpart F of 35 Ill. Admin. Code 1100.605.
3. Other regulatory thresholds applicable and appropriate to the scope of the investigations.

The cost information will include a soil management estimate for each proposed right-of-way/temporary easement parcel based upon proposed construction excavation. In some cases, a second estimate is included for land acquisition and full take situations based on cleanup of the parcel to be obtained without regard to the proposed construction excavation. The district will review the cost estimates for excavation, transportation, and disposal of the material containing regulated substances and advise whether they are acceptable. If the district determines the costs are unacceptable, the district will further investigate alternatives to avoid involvement with the impacted property(ies).

Following completion of the PSI, BDE will provide the district with a regulated substances special provision consistent with Section 669 of the Standard Specifications for Road and Bridge Construction for inclusion in the construction documents.

27-3.05(b) Remedial Investigation/Feasibility Study and Risk Assessment

Following completion of the IDOT internal reviews of the draft PSI and prior to incorporation of any necessary revisions in the PSI report, BDE, in consultation with the Office of Chief Counsel as appropriate and the Statewide Regulated Substances Investigation Consultant, will evaluate whether sufficient information is available to determine the total extent of special waste/regulated substance contamination for which the Department would be liable relative to the project and the

estimated cost and method for cleanup or whether a Remedial Investigation/Feasibility Study (RI/FS) is needed.

If BDE, in consultation with the Office of Chief Counsel as appropriate, determines additional information is needed for determining the extent of contamination and method(s) and cost for cleanup of the property(ies), it will advise the district. The district will be required to fund the additional studies. Accordingly, BDE will not proceed with arrangements until the district has confirmed it will provide the necessary funding. If the district re-examines the project and identifies a strategy to avoid the property(ies), the need for the additional studies may be eliminated. Upon receiving confirmation from the district for funding the additional studies, BDE will initiate a request to the Statewide Regulated Substances Consultant for a RI/FS and, if appropriate, a Risk Assessment. The purpose of the RI will be to precisely determine the extent of the soil and/or groundwater contamination exceeding IEPA's TACO Tier 1 Soil Remediation Objectives for Residential Properties (35 Ill. Admin. Code 742). The purpose of an FS will be to identify options for addressing the property(ies) and the estimated costs of each. The purpose of a Risk Assessment will be to determine the potential of the contamination for coming into contact with people (e.g., directly or through water supplies), or otherwise posing a threat during or after construction, if left in place. A Risk Assessment will be prepared only when the Statewide Regulated Substances Investigation Consultant determines in the FS that the levels of contamination and their location are such that leaving the waste in place may be an option.

Upon its completion, BDE reviews the results of the RI/FS. After incorporation of any necessary changes, BDE forwards the results to the district with a request for the district to advise which option for addressing the property(ies) it wishes to select (normally based on cost). Upon receipt of the district's response, BDE forwards the recommendation to IEPA for acceptance of the selected Remedial Action Plan (in the case of a cleanup option) or Risk Assessment (in the case of a proposal to leave the contamination in place). If IEPA accepts the recommended course of action, BDE will advise the district. BDE and the Statewide Regulated Substances Investigation Consultant, as necessary, will continue to be involved to assist the district in the preparation of plans and specifications for implementing the Remedial Action Plan. Also, if IEPA objects to the proposed course of action, BDE will continue to be involved in coordination to assist the district in responding to the objections. As practical, the selected method of addressing the property(ies) and the results of coordination with IEPA should be discussed in project environmental documents.

Note: For properties on the National Priorities List, the nationwide list of hazardous waste sites maintained by the USEPA for purposes of assigning priorities for cleanup (National Priorities List sites are identified in the SEMS list), the public must be afforded an opportunity to comment on the analysis of alternatives for addressing the property(ies). As practical, the district should address this requirement as a part of the normal public involvement activities for the project. Estimated costs for addressing the sites should be indicated, particularly when the costs of site involvement vary for different alternatives under study.

27-3.06 Relationship of Regulated Substances Evaluation Process Results to Design Approval

Since regulated substances evaluation is required for every applicable project, design approval clearance for regulated substances is obtained, when results of the evaluation support one of the following scenarios:

27-3.28

1. The project clears a Level 1 screening as described in Section 27-3.02(a). The request for design approval clearance must include a copy of the fully completed Level 1 Screening form and BDE 2737.
2. The project clears a Level 2 screening as described in Section 27-3.02(b). The request for design approval clearance must include a copy of the fully completed Level 2 Screening form and BDE 2737.
3. The project clears a Level 3 screening, as described in Section 27-3.02(c). The request for design approval clearance must include a copy of the fully completed Level 3 screening form, BDE 2737 and BDE 2738, if required.
4. The PESA indicates that the project has no property(ies) with a REC (other than de minimis). The request for design approval clearance must include a copy of the BDE PESA Review memorandum confirming the no REC determination.
5. The PESA indicates that the project has property(ies) containing a REC(s) and the district has determined that the property(ies) can be avoided. The request for design approval clearance must include a copy of the memorandum from BDE transmitting the PESA report and the district's avoidance determination, documented on the PESA Response form. The information regarding the avoidance determination must be included in the commitment file for the project to ensure follow-through in subsequent stages of project development and implementation.
6. The PESA indicates that the project has property(ies) containing a REC(s) and the district has determined the property(ies) cannot be avoided. The request for design approval must include a copy of the memorandum from BDE transmitting the PESA report. Design approval can be given subject to the condition that subsequent studies (e.g., PSI), if needed, will be completed before the district may acquire any additional ROW/easements or underground storage tanks from any property containing a REC and before the PS&E date associated with a project letting.

The following documentation, if required for the project, must be included in the district project file and the Phase I Engineering Report:

1. BDE 2737 showing the results of the Level 1, 2 and 3 screenings, and
2. PESA (or equivalent ISGS report) Review Memo from BDE.

The district must reflect in the commitment file for the project the requirement for completing the PSI and other related studies, if needed, prior to completing acquisition of any contaminated parcel and/or the project letting date and must ensure follow-through on the commitment. If the district intends to request the PSI, it should initiate arrangements with BDE well in advance (a minimum of six months) before the projected date(s) for acquisition of the affected property(ies) and the PS&E letting milestone to allow sufficient time for completion of the PSI and inclusion of the special provision into the plans and letting documents.

27-3.07 Relationship of Regulated Substances Evaluation Process Results to Land Acquisition

The Bureau of Design and Environment (BDE) recommends an environmental review of any property, including donated land, prior to taking ownership or relinquishing ownership. The goal is to proactively obtain environmental information about a property(ies) so that a reasoned decision can be made whether or not to proceed with the property transfer, determine what type of contract language may be appropriate, and thereby minimize the potential environmental liability to the Department, in adherence to Departmental Policy D&E-11, "Identifying and Responding to Regulated Substances in Project Development, Implementation and Operations." The D&E-11 policy states, among other items, that "Due care shall be exercised to determine whether regulated substances may be present on property being considered for use for state highway project purposes and supporting highway operations and maintenance. Acquisition of an interest in a property determined to contain regulated substances shall be avoided unless the risks and liabilities of such acquisition can be justified, documented, and appropriately managed." As such, and in accordance with the Section 10.1.2 of the Land Acquisition Policies and Procedures Manual, the regulated substance evaluations (PESA and PSI) must be completed, and the results must be considered by district Land Acquisition, prior to completing acquisition of a property.

The following sections provide additional information for situations involving property acquisition, donation of land to the Department, divestiture of excess land by the Department, and acquisition of parcels with existing underground storage tanks (USTs).

27-3.07(a) Acquisitions

For property acquisitions associated with projects to which the opening paragraph of Section 27-3 does not apply (i.e., maintenance yard expansions), the district shall follow Chapter 10 of the Land Acquisition Policies and Procedures Manual and coordinate the proposed acquisition with the District Environmental Studies Unit (DESU). Prior to acquiring a new property, the DESU should submit an Environmental Survey Request (ESR) for the proposed subject parcel. The BDE will review the information and will typically task ISGS to complete an All Appropriate Inquiries (AAI) on the subject property. This report type includes a more detailed evaluation of the property than a typical PESA and provides liability protection under CERCLA. The AAI is typically tasked to ISGS with a 3-month desired turnaround time.

Based on the results of the AAI, BDE may need to complete additional work (e.g., PSI, geophysical survey) to determine environmental site conditions prior to acquisition. Once the evaluation process is completed by BDE, the results will be forwarded to the district via the DESU.

27-3.07(b) Donations to the Department and Divestitures by the Department

For information on property donations to the Department or divestitures by the Department, refer to the Land Acquisition Manual Section 3.6.14, Valuation of Contaminated Property and Chapter 10, Special Waste.

27-3.07(c) Underground Storage (UST) Parcels

Land acquisition of properties with a UST or LUST containing petroleum or other chemicals poses additional hazards and potential significant liability to the department requiring careful evaluation and coordination. The acquisition of such properties shall not be completed until the Phase I and Phase II regulated substances evaluation process is complete, thus allowing land acquisition proceedings to consider and incorporate results of the regulated substances assessment.

When considering land acquisition at a property with potential or known UST(s), the district shall follow Chapter 10 of the Land Acquisition Manual titled Special Waste, specifically, Section 10.1.3. The acquisition of a property shall be pursued in a manner that will not cause the department to be classified as an “owner/operator” as defined in the Leaking Underground Storage Tank Program (415 ILCS 5/57.2), unless due care has been conducted to assess and measure the presence of regulated substances in the environment caused by the target property, and sufficient district resources have been allocated by the district to fulfill subsequent assessment and remediation costs associated with environmental corrective action.

27-3.08 Relationship of Regulated Substances Evaluation Process Results to Contract Letting

The district should ensure a PSI is completed, when applicable, and to ensure all commitments in the environmental document regarding the monitoring and management of regulated substances are included in the contract prior to letting. The district will provide BDE with written notification (i.e., Certification Acceptance/Project Status form) that all required regulated substances studies have been completed and are current (valid).

Regulated Substances clearance for letting is achieved when results of the regulated substances process support one of the following:

1. The project clears a Level 1 screening as described in Section 27-3.02(a);
2. The project clears a Level 2 screening as described in Section 27-3.02(b);
3. The project clears a Level 3 screening as described in Section 27-3.02(c). If BDE 2738 is required as part of the successful Level 3 screening, a regulated substances special provision is prepared by BDE for inclusion in the contract;
4. The PESA indicates that the project has no property(ies) with a REC (other than de minimis)
5. The PESA indicates that the project has properties with a REC and the district has determined the property(ies) can be avoided and the district will not need right-of-way from the REC property, if applicable; or
6. A regulated substance special provision is prepared by BDE for inclusion in the contract resulting from successful completion of a PSI or an RMP.

27-3.09 Validity of Regulated Substances Evaluation Assessment Results

Standards issued by the American Society for Testing and Materials (ASTM) and AAI indicate property assessments for special waste/regulated substance contamination shall only be considered valid for a period of six months. This reflects the realization that special wastes and other regulated substance contamination often may be introduced (through illegal disposal, off-site migration, spills, or generation from new or different land uses) into areas previously evaluated for contamination. Before proceeding with arrangements for a PSI, Remedial Investigation/Feasibility Study (RI/FS), and/or before completing land acquisition or receiving NEPA approval, the DESU should re-evaluate the project area to check for new reported releases and determine if land uses have changed within the project area, including site reconnaissance, a process called "validation." The DESU will also demonstrate the PESA will be current through the anticipated PS&E date associated with the desired letting.

Validation should be conducted in the following scenarios:

1. For projects that were signed-off under a Level 2 screening, if six months or more have elapsed since the last Level 2 screening of the project area, the DESU should validate the project area using the Level 2 regulated substances waste screening criteria methodology.
2. For projects that were signed-off under a Level 3 screening, if six months or more have elapsed since the last Level 3 screening of the project area, the DESU should validate the project area using the Level 3 regulated substances screening criteria methodology.
3. For projects that a PESA was conducted:
 - a. if six months or more have elapsed since the PESA report was completed for the project area (identified by the date of the PESA report), the DESU should validate the project area using the Level II special waste screening criteria methodology. If land use changes or new releases are identified, the entire project should be re-evaluated as a new PESA prior to proceeding with arrangements for further special waste/regulated substances investigations or before finalizing land acquisition. If no land use changes or new releases are identified as a result of the validation process, the district DESU can sign-off the project by checking and dating the "Validation – Level 2" screen in PMA and maintain documentation for the project file.
 - b. If three years or more have elapsed since the last PESA report was prepared (identified by the date on the PESA report), then the entire project should be evaluated as a new project and, if necessary, a new PESA should be requested.
4. Projects for which a Site Assessment Letter Report (SALR) for an EA/EIS was conducted, a full PESA should be initiated in Phase II once the district chooses to move toward construction with the preferred alternative. At this point, the PESA and PSI process is similar to a CE project.
5. If a PSI was conducted for a project and five years or more have elapsed since it was completed, the entire project should be evaluated for land-uses with a REC and a new PESA must be conducted prior to proceeding with the aforementioned project actions.

When re-evaluation of a PESA or PSI is necessary to verify its validity, the re-evaluation should consider any changes in the proposed action, the affected environment, anticipated special waste/regulated substance involvement, and proposed measures for addressing the special waste(s)/regulated substance(s). Sufficient detail must be provided to support a decision on whether a PESA or PSI addendum is necessary.

27-3.10 Phase III Construction Requirements

During Phase III construction, the DESU and BDE have various responsibilities for demonstrating proper management of regulated substances. Section 669 of the Standard Specifications for Road and Bridge Construction and the regulated substances special provision outline these requirements. BDE provides supplementary information below on the following Phase III construction topics:

1. Regulated Substances Pre-Construction Plan
2. Pre-Construction Meeting
3. Regulated Substances Monitoring
4. Regulated Substances Management and Disposal
5. Temporary Staging
6. Unexpected Regulated Substances
7. Underground Storage Tanks Encountered During Construction
8. Regulated Substances Final Construction Report

27-3.10(a) Regulated Substances Pre-Construction Plan

Prior to commencement of construction activities in areas regulated under the special provision, i.e., the contract specific work areas, the contractor will submit BDE 2730, Regulated Substances Pre-Construction Plan (RSPCP) to the Resident Engineer (RE) no later than 21 calendar days prior to commencement of construction activities. The RE will delegate review of the form to the DESU, which will have 10 calendar days to review and return the form to the RE. BDE 2731 serves as a checklist to assist the DESU in review of BDE 2730. This checklist includes all required information the DESU must verify as part of their review of the RSPCP.

If information on BDE 2730 is missing or insufficient, the DESU will reject the form and provide a thorough explanation on BDE 2731 why the RSPCP was rejected. The DESU will sign BDE 2730, and provide BDE 2730 and BDE 2731 to RE. The RE will sign both forms and will send them back to the contractor for revisions. Once a revised BDE 2730 is provided to the RE, additional 21 calendar days will be required for review by IDOT prior to commencement of construction activities.

Upon approval of BDE 2730, the DESU signs the form, provides BDE 2730 and BDE 2731 to the RE, and the RE will accept the form on behalf of the district. Only after the form is approved by the DESU and accepted by the RE can the contractor begin construction activities in areas regulated under the special provision.

27-3.10(b) Pre-Construction Meeting

The DESU should attend the Bureau of Construction pre-construction (pre-con) meetings to review the RCPSP requirements and answer questions regarding regulated substances management. The pre-con meetings provide an opportunity to discuss issues or questions prior to the commencement of construction activities when they can be more easily addressed.

27-3.10(c) Regulated Substances Monitoring

Regulated substances monitoring entails a systematic approach to observing, responding to, and documenting conditions in the environment (e.g., construction site). It is required during regulated substances management activities at the contract specific work areas. These work areas are identified in the regulated substances special provision for the contract. The Construction Manual and Sections 669.03 and 669.04 of the Standard Specifications for Road and Bridge Construction provide more details about this topic.

27-3.10(d) Regulated Substances Management and Disposal

A regulated substances special provision identifies contaminated soil, sediment, and groundwater restrictions for an IDOT project and dictates proper management of that material during construction. The Construction Manual and Section 669.05 of the Standard Specifications for Road and Bridge Construction provide more information for the various methods of managing regulated substances encountered during construction.

27-3.10(e) Temporary Staging

If circumstances require the contractor to use temporary staging for soil, groundwater, or material other than those specified above, the contractor will request written approval from the Resident Engineer in consultation with the DESU and BDE. The Construction Manual and Section 669.07 of the Standard Specifications for Road and Bridge Construction list the general requirements for temporarily staged material containing known or suspected regulated substances.

27-3.10(f) Unexpected Regulated Substances

When unexpected regulated substances are encountered during construction, the contractor shall follow Sections 107.19 and 669.04 of the Standard Specifications for Road and Bridge Construction, and work in the affected area will immediately stop. The contractor will notify the Resident Engineer (RE) who will consult with the DESU, as necessary.

The contractor will prepare an amended RSPCP (BDE 2730A) and additional information including:

1. A description of the circumstances and type of unexpected conditions encountered;
2. An estimate of the extent of regulated substances within the work area;

3. The sampling methods and parameters to be used based on contaminants of concern and property's land use history and the encountered abnormality;
4. The sample preservation and chain-of-custody methods; and
5. A cost estimate of materials, labor, equipment, etc. necessary for the DESU to determine how potential regulated substance(s) shall be managed. The cost estimate should be listed in terms of applicable construction pay items.

The contractor will submit BDE 2730A to the RE who will then delegate review of the form to the DESU. The DESU shall review BDE 2730A as described above in Section 27-3.10(a). Once the DESU approves BDE 2730A, they will submit it to the RE for acceptance. Only after BDE 2730A is approved by the DESU and accepted by the RE shall work resume in the affected area. The contractor will follow requirements of BDE 2730A, and all activities completed to address the unexpected regulated substances will be documented in the Regulated Substances Final Construction Report (RSFCR) in accordance with Section 669.09.

Examples of unexpected regulated substances occurrences include encountering:

1. Railroad ties. In such cases, Technical Environmental Memorandum TEM I-6-94 (Waste Classification of Railroad Ties) shall be followed.
2. Underground storage tanks (USTs). In such cases, refer to Section 27-3.10(g) for information on handling unexpected USTs.

27-3.10(g) USTs Encountered During Construction

Once the department becomes aware of the presence of an undocumented/orphan UST on highway right-of-way (ROW) under the department's jurisdiction, the tanks system shall be removed or abandoned in-place as necessary in accordance with D&E-15, Removal of Orphan Underground Storage Tanks procedures and the Office of the Illinois State Fire Marshall (OSFM) regulations, whether or not will be affected by planned construction activities.

UST removal activities must be completed in conformance with Section 669.08 of the Standard Specifications for Road and Bridge Construction. The UST removal activities, including moving or opening UST, shall not begin until a completed OSFM UST removal permit has been obtained. Upon discovery of an undocumented/orphan UST, the DESU shall be responsible for coordinating the following process between the contractor, RE and BDE:

1. The contractor will notify the Resident Engineer (RE). The RE will notify the DESU who will coordinate with BDE.
2. Activities must be completed by a licensed UST removal contractor meeting the qualifications for regulated substances and UST work as detailed in Section 669.03 of the Standard Specifications for Road and Bridge Construction.
3. The removal contractor must complete an online draft UST removal application on the OSFM website. The removal contractor must check the box indicating that the removal is related to an IDOT project. The draft application must include supporting documentation, such as a site plan with the UST location, aerial images of the site and surrounding area, a description of

the work, etc. These documents must be uploaded to the OSFM website with the permit application. Although the UST may be an orphan tank, the IDOT district office shall be listed as the owner of the UST on the permit application and the district environmental studies unit chief shall be listed as the contact person. Once the draft permit is submitted online, BDE will be automatically alerted via email by the OSFM tank permit system. Paper applications are not acceptable. Online applications are required so BDE can modify them, as necessary.

4. The BDE will review and edit the online draft application and compose a cover letter stating the UST is an orphan tank, and IDOT has never been the owner or operator of that UST. If the UST is deemed to be pre-1974, it will be addressed in the cover letter.
5. The BDE will submit the draft application to the IDOT Office of Chief Council (OCC). Following OCC approval, BDE will approve the OSFM online draft application.
6. The OSFM will review the application and, after approval, will issue a UST removal permit to the licensed contractor. The BDE and the tank removal contractor will be alerted via email, and the removal contractor can download the permit from the OSFM website.
7. The removal contractor and District Environmental Studies Unit will schedule the UST removal with the OSFM and inform BDE of the proposed removal date.
8. Once the UST has been removed, the licensed removal contractor's environmental consultant must conduct a Site Assessment in accordance with 41 Ill. Admin. Code 176.360(a) consisting of soil sample collection from the excavation floor and sidewalls. A ground water sample shall also be collected if water is encountered. A Site Assessment is always required; it is not dependent on a release being confirmed or not by the OSFM on-site inspector.
9. In accordance with 41 Ill. Admin. Code 176.330, a Site Assessment Report must be completed by the removal contractor within 45 days of the UST removal, regardless of whether or not a release is reported for the site. The report is uploaded to the OSFM website by the removal contractor.

27-3.10(h) Regulated Substances Final Construction Report (BDE 2733)

Following completion of construction activities, the contractor will submit BDE 2733, Regulated Substances Final Construction Report (RSFCR) to the Resident Engineer (RE) in conformance with Section 669.09 of the Standard Specifications for Road and Bridge Construction. Information provided in the document details the regulated substances activities conducted during the project and describes the methods and manners in which materials were managed to document compliance with Section 669 and the regulated substances special provision.

The contractor will prepare BDE 2733 no later than 90 calendar days after the completion of construction activities as follows:

1. One hard copy and one electronic copy must be submitted to the RE;
2. One hard copy and one electronic copy must be submitted to the DESU; and

3. One electronic copy must be submitted to BDE.

The DESU shall review the form within 60 calendar days of receiving it from the contractor. BDE 2734 is a checklist to assist the DESU in review of BDE 2733 and includes all required information the DESU must verify as part of their review of the RSFCR.

If information on BDE 2733 is missing or insufficient, the DESU will reject the form and provide a thorough explanation on BDE 2734 why the RSFCR was rejected. The DESU will sign BDE 2733, and both BDE 2733 and 2734 will be sent to the RE. The RE will sign both forms and will send them back to the contractor for revisions. Once a revised BDE 2733 is provided to the RE, an additional 60 calendar days will be required for review by IDOT.

Upon approval of BDE 2733, the DESU shall sign the form indicating it has been approved. The DESU will provide BDE 2733 and 2734 to the RE, and the RE will accept the form on behalf of the district. Upon approval by the DESU and acceptance by the RE, the RSFCR pay item can be processed.

27-3.11 Recovery of Costs

For property(ies) involving transportation and disposal costs for regulated substances, the Department may pursue cost recovery from responsible parties. For all property(ies), BDE will provide a special provision regarding proper record-keeping for the costs associated with the property(ies). Compliance with the special provision will ensure that appropriate expenditure records are available for any cost-recovery action. When the Department pursues cost recovery for property(ies) involving hazardous substances, the Office of Chief Counsel will advise if the public must be afforded an opportunity to comment on the analysis of alternatives for addressing the property(ies).

When the opportunity for public comment must be afforded, the district should address this requirement, as practical, as a part of the normal public involvement activities for the project. An opportunity to comment may be announced through public notice(s) or can be addressed by making information regarding the alternatives for addressing the hazardous substance property(ies) available at public meetings/hearings.

27-3.12 Responding to FOIA Requests for Special Waste Information

If a Freedom of Information Act (FOIA) request is received by the district to obtain information concerning regulated substances investigations (e.g., PESA and PSI) conducted for IDOT projects, the request and any responsive records shall be immediately forwarded to the Department's FOIA Officer at DOT.FOIAOfficer@illinois.gov. The FOIA Officer and Office of Chief Counsel will conduct a review to determine if any information within the responsive records should be withheld under one or more of FOIA statutory exemptions. The district shall provide assistance to the FOIA Officer in order to prepare an appropriate response to the request.

27-3.13 Responding to General Information Requests

An outside entity (e.g., local public agency or their consultant) working on a road project involving

roadway under IDOT jurisdiction may request a copy of IDOT environmental assessments completed in the affected area. In these specific situations, it is appropriate to provide the entity with a copy of the IDOT PESA(s) or other similar Phase I due diligence assessments associated with the road project. Because the information presented in these documents is readily accessible via public sources, the Phase I assessments can be provided to the entity without a FOIA request.

Phase II assessments (e.g., PSI) should not be released in the manner described above. Rather, if the entity desires to obtain a copy of IDOT PSIs or other similar intrusive environmental assessments, they should be directed to submit a FOIA request. The PSI and supporting documents are available to “authorized bidders” through the Department’s standard bidding process (i.e., the Integrated Contractor’s Exchange or ICX).

All other situations involving requests for regulated substances assessments completed by IDOT shall be handled through the Department’s FOIA process.

27-4 ASBESTOS REQUIREMENTS FOR HIGHWAY BRIDGES

27-4.01 Background

In an October 19, 2001 letter, the Region 5 Office of the U.S. Environmental Protection Agency (USEPA) approved a Department request for a waiver from the asbestos notification requirements under 40 CFR 61.145 for highway bridges, as defined in 23 CFR 650.403(a), determined not to involve asbestos in the bridge deck wearing surface or waterproofing membrane. The initial group of bridges covered by the waiver was included in a list sent to each district. The USEPA Region 5 also approved the Department's proposed approach for addressing bridges in which involvement of asbestos in the bridge deck wearing surface or waterproofing membrane is unconfirmed. Application of this approved approach will allow for exempting other bridges from the asbestos notification requirements upon confirmation that the bridge deck wearing surface and waterproofing membrane, if one is present, do not contain asbestos.

These procedures do not address the evaluation of asbestos in structures such as tender houses associated with bridges. Work affecting such structures should be coordinated with the Asbestos Abatement Unit in the central Bureau of Administrative and Facility Services for compliance with applicable inspection and notification requirements. This coordination should be initiated sufficiently in advance of the commencement of work that would affect the structures to allow time for accomplishing any necessary investigations and paperwork.

Additionally, these procedures do not address the evaluation of and response to asbestos in pipes, conduits, or other such utilities associated with bridges. The owners of the pipes, conduits, etc. shall be responsible for determining whether they involve asbestos and for ensuring compliance with applicable requirements for any work that could disturb regulated asbestos that the pipes, conduits, etc. may contain. If unexpected pipes or conduits are encountered (e.g., embedded in the concrete bridge components), work affecting the pipes or conduits shall be suspended until ownership has been determined and any necessary inspection, testing, and notification has been completed.

The following sections describe the procedures for documenting application of the notification waiver for bridges in the initial group and for applying and documenting the approved approach for addressing bridges with unconfirmed asbestos involvement. They also describe the notification procedures and special provision to be followed for bridges involving bituminous overlays and waterproofing membranes that are confirmed to contain asbestos.

Bridge lists coordinated with IEPA for purposes of the asbestos notification waiver request were prepared in cooperation with the Bureau of Urban Program Planning, Planning Services Section based on information provided by the districts. If errors or omissions are found in the lists, they should be brought to the attention of the Planning Services Section in Urban Program Planning and the Bridge Planning Section in the Bureau of Bridges and Structures.

27-4.02 Applicability

The procedures in this memorandum are applicable to all highway bridges under State jurisdiction.

27-4.02(a) Procedures

For all projects that will involve bridge demolition (removal or wrecking of any load-supporting structural member), reconstruction, rehabilitation, or deck repair, the district must determine and document applicability of the asbestos notification requirements. The district will be responsible for complying with the asbestos notification requirements for any work that will disturb a bridge deck wearing surface or waterproofing membrane that contains asbestos. (See Section 27-4.01 regarding structures such as tender houses and pipes or conduits associated with a bridge that may contain asbestos). The asbestos notification determination should be completed as far in advance as practical of the anticipated date for beginning construction work to allow enough time for compliance with notification requirements, if applicable. The asbestos notification determination and documentation for highway bridges shall be accomplished in accordance with the following procedures.

For purposes of documenting the asbestos determination finding, BBS 2536, Asbestos Determination Certification form can be used to cover multiple structures when the same asbestos determination finding applies. BBS 2536 would then be submitted to the Bridge Planning Section of the Bureau of Bridges and Structures, and a copy included in the district files and Phase I Engineering Report for each project involving one of the covered structures, as described in these procedures. The following discusses five potential determination outcomes, as described on the form.

27-4.02(b) Bridges on Approved No Asbestos (Waiver) List

Each district has been provided a list of bridges covered by the notification waiver as of October 19, 2001, the date of USEPA approval of the waiver. This list is labeled "State Owned Bridges - No Asbestos." For bridges included in this list, the district should complete the "Structure Identification" and "Certification" sections of BBS 2536 and check box number 1. A copy of the completed form should be included in the district files and in the Phase I Engineering Report when a project is proposed involving demolition, reconstruction, or rehabilitation of the bridge, or repair of the deck on the bridge. This will document the basis for determining that the bridge does not contain asbestos in the bridge deck wearing surface or waterproofing membrane and is exempt from the asbestos notification requirements.

27-4.02(c) Bridges on Confirmed/Unconfirmed List

Each district has also been provided a second list of bridges that either are known to contain asbestos or for which the presence or absence of asbestos is unconfirmed. This list is labeled "State Owned Bridges Under Investigation for Asbestos." For bridges listed as having known asbestos involvement refer to the procedures in the section below on "Asbestos Involvement Confirmed." For unconfirmed cases, proceed with the following steps for evaluation.

27-4.02(d) Evaluation Based on Available Information

In accordance with the approach approved by USEPA, if a bridge is included in the list of bridges under investigation for asbestos and is unconfirmed for asbestos involvement, the district should

first examine available information (e.g., file information, bridge plans) to attempt to verify whether asbestos is present in the bridge deck wearing surface or waterproofing membrane. If the district confirms based on its information that asbestos is involved, refer to Section 27-4.03(e).

If the district confirms based on its information that asbestos is not involved, it should complete the "Structure Identification" and "Certification" sections of BBS 2536 and check box number 2. The district shall submit a copy of the completed form to the Bridge Planning Section of the Bureau of Bridges and Structures at the time the asbestos determination is made. Bridges covered by a signed BBS 2536 indicating that no asbestos is present will be exempt from the EPA asbestos notification requirements upon submittal of the signed certification form to the Bureau of Bridges and Structures. These bridges will be re-coded as "Asbestos Investigation Status: Complete" and "Bridge Contains Asbestos: N" on the list of bridges under investigation for asbestos. The Bureau of Bridges and Structures will provide the affected district(s) and IEPA (which administers the asbestos requirements in Illinois on behalf of USEPA) updates to the bridge list for any month in which changes occur. A copy of the completed BBS 2536 should be included in the district files and in the Phase I Engineering Report when a project is proposed involving demolition, reconstruction, or rehabilitation of the bridge, or repair of the deck on the bridge.

27-4.02(e) Evaluation Based on Sampling and Testing

If information available to the district is not enough to confirm whether or not a bridge involves asbestos, the following sampling and testing procedures shall be applied. Asbestos determination for applicable bridges must be completed prior to commencing any work that would disturb the wearing surface or waterproofing membrane. The determination must be made sufficiently in advance of the commencement of construction or demolition work to allow compliance with the notification requirements of the asbestos national emissions standards; see 40 CFR 61.

27-4.02(e)1

Sampling

The purpose of this sampling procedure is to obtain one or more representative samples of the bituminous wearing surface and/or waterproofing membrane, if one is present, for asbestos determination. At least one sample must be taken from each representative portion of the suspect bridge deck overlay material. If portions of a bridge deck involve overlay materials installed at different times, each such area must be sampled. If there is any reason to suspect that overlay materials might be different, even though they appear uniform, they should be sampled separately. Use of a licensed asbestos inspector for conducting the sampling is not required provided the protocol described below is followed.

Before initiating sampling, prepare a plan-view diagram of the bridge deck indicating the approximate dimensions, the area(s) of the deck surface to be sampled, and the sample location(s). If more than one sample will be taken, number the sample locations on the diagram and use the corresponding numbers when labeling each sample. The sampling diagram should be retained in the project files at least until testing of the samples has been completed and any areas of the bridge deck requiring application of the special provision for "Asbestos Waterproofing Membrane and Asbestos Bituminous Concrete Surface Removal (BDE)" have been identified.

Samples shall be removed with a minimum 2-inch diameter core drill. The depth of each sample shall be sufficient to include the full thickness of both the bituminous wearing surface and the

waterproofing membrane, if one is present. For each sampling operation, sufficient water shall be applied before and during the core drilling to prevent generation of airborne dust as a result of the drilling and removal of the sample. Upon removal of the core sample, it shall immediately be placed in a resealable plastic sample bag. Each sample bag shall be labeled with the structure number (000-0000); route identification; county; water body or facility crossed; name and employer, if other than IDOT, of the person removing the sample, and sample number keyed to the diagram of the bridge deck showing the sample location(s).

27-4.02(e)2 **Testing**

The samples of the bituminous bridge deck wearing surface and/or bituminous waterproofing membrane shall be tested for the presence of asbestos using the Polarized Light Microscopy (PLM) method specified in Section 1 of Appendix E, Subpart E, 40 CFR 763. The testing shall be performed by a laboratory that has National Voluntary Laboratory Accreditation Program (NVLAP) or National Environmental Laboratory Accreditation Program (NELAP) accreditation for asbestos fiber analysis using the PLM method and is equipped for performing analysis of non-friable organically bound asbestos using Gravimetric Reduction.* If a bituminous waterproofing membrane layer is present, testing shall be conducted on portions of the sample from both the waterproofing membrane layer and the wearing surface layer. Materials which are determined, through application of the specified testing method, to contain more than one percent asbestos are classified as Category II non-friable Asbestos Containing Materials (ACM). Work that would disturb Category II non-friable ACM is subject to the notification requirements in 40 CFR 61.145. Removal of such materials shall be accomplished in accordance with the Statewide special provision for "Asbestos Waterproofing Membrane and Asbestos Bituminous Concrete Surface Removal (BDE)."

A listing of laboratories that are accredited for asbestos testing through the NVLAP is available at <http://ts.nist.gov/ts/htdocs/210/214/scopes/plmtm.html>.

Information concerning laboratories that are accredited through the NELAP is available at <http://www.epa.gov/ttn/nelac/accreditlabs.html>.

27-4.02(e)3 **Results**

If the results of testing confirm that asbestos is not involved, complete the "Structure Identification" and "Certification" sections of BBS 2536 and check box number 3 in the "Asbestos Determination" section. The district shall submit a copy of the completed form to the Bridge

Planning Section of the Bureau of Bridges and Structures at the time the asbestos determination is made. Bridges covered by a signed BBS 2536 indicating that no asbestos is present will be exempt from the IEPA asbestos notification requirements upon submittal of the signed certification form to the Bureau of Bridges and Structures. These bridges will be re-coded as "Asbestos Investigation Status: Complete" and "Bridge Contains Asbestos: N" on the list of bridges under investigation for asbestos. The Bureau of Bridges and Structures will provide the affected district(s) and IEPA updates to the bridge list for any month in which changes occur. A copy of the completed BBS 2536 should be included in the district files and in the Phase I Engineering Report when a project is proposed involving demolition, reconstruction, or rehabilitation of the bridge, or repair of the deck on the bridge.

If the test results confirm that asbestos is involved, refer to the next section.

27-4.02(f) Asbestos Involvement Confirmed

For bridges that are confirmed to involve asbestos in the bridge deck wearing surface and/or waterproofing membrane, if one is present, complete the “Structure Identification” and “Certification” sections of the BBS 2536 and check box number 4. A copy of the completed form should be included in the district files and in the Phase I Engineering Report when a project is proposed involving demolition, reconstruction, or rehabilitation of the bridge, or repair of the deck on the bridge. For structures that the “Asbestos Investigation Status” is shown as “Not Complete” in the list of bridges under investigation for asbestos, the district also should submit a copy of the completed form to the Bridge Planning Section of the Bureau of Bridges and Structures at the time the asbestos determination is made. The information in the list will be re-coded to indicate “Asbestos Investigation Status: Complete” and “Bridge Contains Asbestos: Y” and updates will be provided to the affected district(s) and IEPA for any month in which changes occur in the list.

The district will be responsible for ensuring compliance with the asbestos notification requirements for demolition or renovation of bridges involving deck wearing surfaces or waterproofing membranes containing asbestos. A completed “Notification of Demolition and Renovation” form (available at <http://www.epa.state.il.us/air/asbestos/asbestos-form-combined.pdf>) must be submitted to IEPA at least 10 working days prior to commencing any work that would disturb any of the bituminous materials containing asbestos.

The IEPA has advised that the start date and complete date for demolition and asbestos removal are key items of information for the notification. If exact dates are not known at the time the initial notification form is submitted estimated dates may be used. Revised notification must then be submitted to correct the information when the actual start and complete dates have been determined. The revised notification still must satisfy the requirement for submittal at least 10 working days prior to commencing any work that would disturb any of the bituminous materials containing asbestos. Since the notification forms will generally require information from both the contractor and the district, it is suggested that, where practical, the notification forms should be prepared at the pre-construction conference.

The district will also be responsible for ensuring that the special provision for “Asbestos Waterproofing Membrane and Asbestos Bituminous Concrete Surface Removal (BDE)” is included in the contract for work involving removal of bridge deck wearing surfaces or waterproofing membranes containing asbestos. The district should include a general note in the project plans or in the project commitment file to indicate that asbestos is present and will be subject to a special provision.

When removal operations are completed for all asbestos bituminous concrete surface and asbestos waterproofing membrane on a bridge, the district should complete the “Structure Identification” and “Certification” sections of BBS 2536 and check box number 5 and submit a copy of the completed form to the Bridge Planning Section in the Bureau of Bridges and Structures. The information in the bridge list will be re-coded to indicate “Bridge Contains Asbestos: N” and updates will be provided to the affected district(s) and IEPA for any month in which changes occur. Bridges covered by a signed BBS 2536 form indicating that all asbestos-containing materials have been removed will be exempt from the IEPA asbestos notification requirements upon submittal of the signed certification form to the Bureau of Bridges and Structures. A copy of the completed form should be included in the

district files. For bridges that remain in place following removal of the asbestos-containing materials, a copy of the form also should be included in the Phase I Engineering Report for future work involving demolition, reconstruction, or rehabilitation of the bridge, or repair of the deck on the bridge.

27-4.02(g) Removal of All Asbestos Containing Bridges from the State

When the bridge list indicates that all of the asbestos bituminous concrete surface and asbestos waterproofing membrane has been removed from all highway bridges in the State, the Bridge Planning Section in the Bureau of Bridges and Structures will advise the Bureau of Design and Environment (BDE). BDE will notify the IEPA in writing and request approval to discontinue the asbestos determination and tracking procedures for highway bridges. Upon receipt of approval from IEPA/USEPA, these procedures will be rescinded.

Chapter Twenty-eight
ENVIRONMENTAL PERMITS/CERTIFICATIONS

Table of Contents

<u>Section</u>	<u>Page</u>
28-1 GENERAL	28-1.1
28-2 FEDERAL PERMITS/CERTIFICATIONS	28-2.1
28-3 STATE PERMITS/CERTIFICATIONS	28-3.1
28-4 PROCEDURES/DOCUMENTATION FOR USE OF THE CATEGORICAL EXCLUSION NATIONWIDE SECTION 404 PERMIT	28-4.1
28-4.01 Background	28-4.1
28-4.02 Applicability.....	28-4.1
28-4.03 Procedures.....	28-4.1
28-4.03(a) General	28-4.1
28-4.03(b) CE Projects Potentially Eligible for Nationwide Permit ..	28-4.2
28-4.03(c) CE Projects Ineligible for Nationwide Permit	28-4.3

Chapter Twenty-eight

ENVIRONMENTAL PERMITS/CERTIFICATIONS

28-1 GENERAL

Many activities performed by the Illinois Department of Transportation impact the environment, navigation, public land or private land. Depending upon the nature of the impact, the activity may require the Department to obtain a permit or certification. Some of these permits/certifications may be obtained during the planning phase of project development, and others may be obtained during the design or construction phase. Any necessary permit authorizations/certifications should be obtained before commencement of work requiring the permit/certification. Personnel involved in project development should be aware of the requirements for these permits/certifications to ensure that necessary authorizations and clearances are obtained in a timely manner to allow the work requiring the permit/certification to proceed as scheduled. As practical, the permit authorization/certification should be obtained close to the start date for the work to optimize the time frame available for accomplishing the work before the authorization expires. Districts must carefully monitor expiration dates for permit authorizations to ensure that any necessary extension or renewal request is processed in a timely manner to avoid non-compliance or delay in the work covered by the permit.

Chapter 28 briefly documents the basic information related to the permits/certifications which might be required for a project. Note that a joint application form (NCR Form 426) has been developed by the US Army Corps of Engineers (Corps), Illinois Environmental Protection Agency (IEPA), and Illinois Department of Natural Resources Office of Water Resources (OWR), which is used to apply for Section 10 and Section 404 permits from the Corps and for obtaining the related Section 401 Water Quality Certification from the IEPA. The form is also used for obtaining permits from the OWR for Construction in Floodways of Rivers, Lakes, and Streams and for work affecting public waters. The current version of the joint application form is available on the websites for the Chicago, Rock Island (lead Corps District for Illinois) and St. Louis Corps Districts, and the OWR website. Districts also may contact the Corps, IEPA, or OWR to obtain the current version of the joint application form.

Figure 28-1.A presents and explains the format used for describing each Federal or State permit/certification. The descriptions of each permit or certification are presented in Sections 28-2 and 28-3. Figure 28-1.B identifies the address for each agency from whom a permit or certification is required.

Permit/Certification: Identification of the short or common name typically used for the permit/certification.

Responsible Agency: Identification of the agency responsible for evaluating permit/certification applications and for issuing the permit or certification.

Responsible IDOT Unit: Identification of the Department unit which must obtain the permit/certification.

Legal Reference: Identification of the legal authority for the permit/certification.

Purpose: Identification of the basic intent of the permit/certification.

Applicability: Identification of the type of activity that dictates the need for the permit/certification.

Permit/Certification Information Needs: Identification of the basic information needed for the submission of the permit or certification application.

FORMAT FOR PERMIT/CERTIFICATION INFORMATION

Figure 28-1.A

<u>Federal</u>	<u>State</u>
<u>Corps of Engineers</u>	<u>Illinois Environmental Protection Agency</u>
U.S. Army Corps of Engineers Chicago District 111 North Canal Street, Suite 600 Chicago, Illinois 60606-7206 (312) 846-5530	Illinois Environmental Protection Agency Bureau of Water DWPC Permit Section #15 1021 North Grand Avenue East P.O. Box 19276 Springfield, Illinois 62794-9276 (217) 782-0610
U.S. Army Corps of Engineers Rock Island District Clock Tower Building P.O. Box 2004 Rock Island, Illinois 61204-2004 (309) 794-5371	Illinois Environmental Protection Agency Bureau of Air 1021 North Grand Avenue East P.O. Box 19276 Springfield, Illinois 62794-9276 (217) 524-0636
U.S. Army Corps of Engineers St. Louis District 1222 Spruce Street St. Louis, Missouri 63103-2833 (314) 331-8575	Illinois Environmental Protection Agency Bureau of Land Permit Section 1021 North Grand Avenue East Springfield, Illinois 62794-9276 (217) 524-3300
U.S. Army Corps of Engineers Louisville District P. O. Box 59 Louisville, Kentucky 40201-0059 (502) 582-5452	<u>IDNR Office of Water Resources</u> <i>(For Lake Michigan)</i> Illinois Department of Natural Resources Office of Water Resources 36 South Wabash, Suite 1415 Chicago, Illinois 60603 (312) 793-3123 or (312) 793-3126
U.S. Army Corps of Engineers Memphis District 167 North Main, B-202 Memphis, Tennessee 38103-1894 (901) 544-3005	<i>(For Cook, Lake, McHenry, DuPage, Kane & Will Counties)</i> Illinois Department of Natural Resources Office of Water Resources – Region 2 Office 2050 West Stearns Road Bartlett, Illinois 60103 (847) 608-3100
<u>Coast Guard</u>	<i>(For the remainder of the State)</i> Illinois Department of Natural Resources Office of Water Resources One Natural Resources Way Springfield, Illinois 62702-1271 (217) 782-3863
Commander Attn: Bridge Branch Eighth Coast Guard District Hale Boggs Federal Building 500 Poydras Street New Orleans, LA 70130 (504) 671-2128	<u>Office of State Fire Marshal</u> State Fire Marshal 1035 Stevenson Drive Springfield, Illinois 62703 (217) 785-0969
Commander Attn: Bridge Branch Ninth Coast Guard District 1240 East Ninth Street Cleveland, Ohio 44199 (216) 902-6045	

PERMIT AGENCY OFFICES**Figure 28-1.B**

28-2 FEDERAL PERMITS/CERTIFICATIONS

IDOT is responsible for obtaining several Federal permits/certifications as required on individual projects. This section briefly discusses the identification, applicability, and information needs of each permit/ certification. The Federal permits/certifications are:

1. Section 404 Permit. This permit is obtained from the Corps for the discharge of dredge or fill material into waters of the United States, including wetlands.
2. Section 9 Permit. This permit is obtained from the US Coast Guard (USCG) for construction of bridges or causeways over navigable waters of the United States.
3. Section 10 Permit. This permit is obtained from the Corps for structures or work (other than bridges and causeways) affecting the navigable waters of the United States.
4. Section 401 Water Quality Certification. This certification is obtained from the IEPA and is required in conjunction with a Section 404 permit (i.e., the IEPA must either approve or waive the water quality certification as a condition for issuance of an individual Section 404 permit or for use of a nationwide or regional Section 404 permit).
5. Section 402 National Pollutant Discharge Elimination System (NPDES) Point-Source Permit. This permit is obtained from the IEPA for projects such as rest areas that involve a point-source discharge of pollutants into waters of the United States.
6. Section 402 NPDES Construction Permit. This permit is administered by the IEPA and applies to projects that will involve clearing, grading, and excavation activities that result in the disturbance of one acre (4047 m²) or more of total land area.

Permit: Section 404

Responsible Agency: United States Army Corps of Engineers

Responsible IDOT Unit: District

Legal Reference: Section 404 of the *Federal Water Pollution Control Act* (1972), as amended by the *Clean Water Act* (1977 & 1987): 33 USC 1251-1376, DOT Order 5660.1A; 23 CFR 650, Subpart B; 33 CFR 209, 320-323, 325, 328, 330; 40 CFR 121-125, 129-131, 135-136, and 230-231.

Purpose: To restore and maintain the chemical, physical, and biological integrity of the Nation's waters through prevention, reduction, and elimination of pollution.

Applicability: Permit required for any discharge of dredged or fill material into waters of the United States, including wetlands that are subject to Corps jurisdiction. See the following references, available on the Corps Headquarters website, for guidance on jurisdiction under Section 404:

- Regulatory Guidance Letter 07-01 "Practices for Documenting Jurisdiction under Section 404 of the *Clean Water Act* (CWA) and Sections 9 & 10 of the *Rivers and Harbors Act of 1899*," and
- Regulatory Guidance Letter 08-02 "Jurisdictional Determinations."

Permit Information Needs: The list below indicates the typical items of information required for an individual Section 404 permit. Some Corps districts may require additional items of information (e.g., photographs of the project site, quantity calculations for fill activities, documentation of coordination with Soil and Water Conservation Districts regarding proposed erosion and sediment control measures):

1. Name and address of permit applicant.
2. Complete, detailed description of the proposed activity, its purpose, intended use, and drainage area of the watershed to the downstream limit of the project. The description should include information on temporary stream crossings, work pads, temporary bypass channels, cofferdams, etc., that will be involved in the construction work requiring a Section 404 permit. For dredging and fill activities, describe the location, type, composition, and quantity of material to be dredged/filled, method of dredging/filling, and method of transportation to disposal/fill site. Also, describe the disposal/fill site by including the location, quantity of material it will hold, composition of receiving soil, and method of containment. Identify any practical alternatives that would fulfill the objectives of the proposed project and explain why the final proposal was selected.
3. Location of the proposed activity, including legal description.
4. If applicable, name, address, and title of authorized agent.
5. Names, addresses, and telephone numbers of all adjoining and potentially affected property owners, including the property involved with the permit action, if different from the applicant.

6. Date activity is proposed to commence.
7. Estimated time of construction.
8. Indication of whether any portion of the activity for which authorization is sought is complete.
9. List of all approvals or certifications required by other Federal, interstate, State, or local agencies for any structures, construction, discharges, deposits, or other activities described in the application.
10. Indication of whether any agency has denied approval for the activity described in the application or for any activity directly related to the activity described.
11. Engineering details (e.g., limit of fill activity, amount of fill, area taken, linear feet (meters) of disturbance, erosion control plan, disposal of waste material).
12. Copy of EIS or EA, if prepared, describing environmental impacts (e.g., soils, water quality, groundwater, wetlands, fish, wildlife, floodplains). If EIS or EA not prepared, copy of Wetland Determination Report, Wetland Impact Evaluation form, and Natural Resource Review Tool (NRRT) report or Ecological Compliance Assessment Tool (EcoCAT) report.
13. Mitigation plan.
14. Project drawings (8½ inches x 11 inches (216 mm x 279 mm)), including a vicinity map, plan view of the project and a cross section view of the project.
15. Environmental signoffs.

In addition to individual Section 404 permit authorizations, certain activities may be authorized under a regional or nationwide permit, provided they meet the conditions for use of the permit. Regional permits are addressed in public notices issued by the applicable Corps district(s).

The Chicago Corps District has issued Regional Permits for use in Cook, DuPage, Kane, Lake, McHenry, and Will Counties. The Chicago Corps District's Regional Permit Program includes several permits that may be applicable for IDOT project activities. These include the following:

- *Regional Permit 3 – Transportation Projects,*
- *Regional Permit 4 – Minor Discharges and Minor Dredging,*
- *Regional Permit 5 – Wetland/Stream Restoration and Enhancement,*
- *Regional Permit 7 – Temporary Construction Activities,*
- *Regional Permit 10 – Bank Stabilization, and*
- *Regional Permit 12 – Bridge Scour Protection.*

Information about these Regional Permits is available on the Chicago Corps District website.

The Rock Island Corps District has issued Regional Permits for use anywhere in the State of Illinois. Regional Permits that may be applicable for IDOT project activities include the following:

- *Regional Permit 16 – Bank Stabilization Activities, and*
- *Regional Permit 26 – Emergency Reconstruction and Repair Activities for Flood Damaged Areas.*

Information about these Regional Permits is available on the Rock Island Corps District website. The nationwide permits are published in the Federal Register and are available on the Corps Headquarters website. BDE disseminates current nationwide permit information from the Federal Register via a BDE Information Memorandum.

The information needs, applicability provisions, processing procedures, and conditions applicable to regional and nationwide permits vary according to the specific permit involved. Some Corps districts require submittal of essentially the same information for nationwide or regional permits as for individual permits.

For Nationwide Permit 14, which addresses Linear Transportation Projects, the description of the project provided to the Corps should include information on temporary stream crossings, work pads, temporary bypass channels, cofferdams, etc., that will be involved in the construction work, to the extent that this information is known or can be anticipated at the time of the permit submittal. If these temporary work features are addressed for permitting purposes after the initial permit submittal, they may be eligible for coverage under Nationwide Permit 33 – “Temporary Construction, Access, and Dewatering.” It should be recognized that time will be required to obtain separate permit authorization for the additional temporary work items. This time factor should be anticipated and factored into the project schedule. To minimize potential disruption of the project implementation schedule, districts can include in the original permit submittal, information reflecting their best estimate of the type, size, and location of temporary work features needed for construction of the bridge/culvert requiring the 404 permit. To the extent that this information adequately covers the temporary work features that the contractor ultimately proposes, it will eliminate the need for having the contractor obtain a separate permit authorization for the temporary work and will avoid the associated potential for delays in project implementation.

For Nationwide Permit 23, which covers Approved Categorical Exclusions, the Federal Highway Administration (FHWA) and the Corps have an agreement that applies additional requirements beyond those addressed in the Federal Register notice for the nationwide permits. Section 28-4 provides a discussion of these special requirements applicable to Nationwide Permit 23.

Permit: Section 9 Navigable Waters

Responsible Agency: United States Coast Guard

Responsible IDOT Unit: Bureau of Bridges and Structures

Legal Reference: Section 9 of the *Rivers and Harbors Act* of 1899; 33 USC 401, et seq, as amended and supplemented; 23 CFR part 650, Subpart H; and 33 CFR 114-115.

Purpose: To ensure that there will be no interference to navigation on the navigable waterways of the United States.

Applicability: Permit required for the construction, modification, replacement, or removal of any bridge or causeway over a navigable waterway.

Permit Information Needs: Permit application for Section 9 requires:

1. Name and address of permit applicant.
2. Name of waterway to be bridged.
3. Bridge location (miles (kilometers) above mouth of waterways; nearest city, county).
4. Estimated cost of bridge.
5. Estimated cost of low level bridge at this location.
6. List of property owners adjacent to bridge and its approaches.
7. Cubic yards (cubic meters) of material to be excavated and filled below the 100-year flood contours.
8. Environmental compliance documentation.
9. Any required State permits or a statement that none are required.
10. Evidence of Section 401 water quality certification for the project.
11. Statement concerning planned disposition of any bridge(s) to be removed.
12. Statement that old bridge will be completely removed unless the Corps has approved retention of the bridge or portions of the bridge for purposes other than a bridge or, unless all parts of the old bridges are to be removed at least to natural ground and/or riverbed, in which case, cut-off elevations may be submitted for approval.
13. Plans of existing bridge showing length, width and number of travel lanes, dimension horizontal clearance in channel span(s), elevations of low steel in channel spans, graphic scale, north arrow, name of bridge and year constructed, and owner of bridge.
14. Vicinity map* (small scale) showing location of proposed bridge in relation to major highways and rivers, major communities, and 4(f) lands, if any.
15. Location map* (large scale) showing all highways and rivers; showing local communities; showing existing bridges (with any to be removed labeled as such), docks, locks, dams, dikes, etc.; 4(f) lands, if any; and showing a flow arrow and soundings in feet (meters) below established government datum planes (usually normal pool).
16. Elevation view* of proposed bridge from abutment to abutment showing dimension minimum vertical clearance in navigation span(s) above normal pool or record low water; 2% flowline elevation, 100-year flood, and record high water; elevation of low steel in channel span(s) at channelward faces of channel piers, 25 ft (7.6 m) from each pier, and

- at center of span; cross section of watercourse; and, if bridge is moveable, dimension vertical clearance in open and closed positions.
17. Plan view* of proposed bridge from abutment to abutment showing length of bridge; width of bridge and number of travel lanes; dimension distance between bridges for dual bridges; angle between axis of bridge and channel or flow of river, if applicable; dimension size and location of any proposed pier protection cells, sheer fences, fenders, etc.; dimension minimum horizontal clearance between channel piers, or pier protection, as measured normal to the axis of the channel or flow of the river.

*Samples of these drawings are included in Section 2 of the *IDOT Bridge Manual*.

Permit: Section 10 Navigable Waters

Responsible Agency: United States Army Corps of Engineers

Responsible IDOT Unit: District

Legal Reference: Section 10 of the *Rivers and Harbors Act* of 1899; 33 USC 401, et seq, as amended and supplemented; 23 CFR part 650, Subpart H; 33 CFR 320, 322, 323, 325, 326, 327, 329, and 330.

Purpose: To protect and preserve the navigable waterways of the United States against any degradation in water quality.

Applicability: Permit required for structures or work (other than bridges or causeways) affecting a navigable waterway. Examples of work include dredging, channelization, filling, and construction of pier protection cells.

Permit Information Needs: Permit application for Section 10 requires:

1. Name and address of permit applicant.
2. Complete, detailed description of the proposed activity, including its purpose, intended use, and drainage area of the watershed to the downstream limit of the project. For dredging and fill activities, describe the location, type, composition, and quantity of material to be dredged/filled, method of dredging/filling, and method of transportation to disposal/fill site. Also, describe the disposal/fill site by including the location, quantity of material it will hold, composition of receiving soil, and method of containment. Identify any practical alternatives that would fulfill the objectives of the proposed project and explain why the final proposal was selected.
3. Location of the proposed activity, including legal description.
4. If applicable, name, address, and title of authorized agent.
5. Names, addresses, and telephone numbers of all adjoining and potentially affected property owners, including the property involved with the permit action, if different from the applicant.
6. Date activity is proposed to commence.
7. Estimated time of construction.
8. Indication of whether any portion of the activity for which authorization is sought is complete.
9. List of all approvals or certifications required by other Federal, interstate, State, or local agencies for any structures, construction, discharges, deposits, or other activities described in the application.
10. Indication of whether any agency has denied approval for the activity described in the application or for any activity directly related to the activity described.
11. Engineering details (e.g., limit of fill activity, amount of fill, area taken, linear feet (meters) of disturbance, erosion control plan, disposal of waste material).
12. Copy of EIS or EA, if prepared, describing environmental impacts (e.g., soils, water quality, groundwater, wetlands, fish, wildlife, floodplains).
13. Mitigation plan.

14. Project drawings (8½ inches x 11 inches (216 mm x 279 mm)), including a vicinity map, plan view of the project and a cross section view of the project.
15. Environmental signoffs.

Certification: Section 401 Water Quality Certification

Responsible Agency: Illinois Environmental Protection Agency

Responsible IDOT Unit: District

Legal Reference: Section 401 of the *Federal Water Pollution Control Act* (1972), as amended by the *Clean Water Act* (1977 & 1987): 33 USC 1251-1376, DOT Order 5660.1A; 23 CFR 650, Subpart B; 33 CFR 209, 320-323, 325, 328, 329; 40 CFR 121-125, 129-131, 133, 135-136, and 230-231.

Purpose: To restore and maintain the chemical, physical, and biological integrity of the Nation's waters through prevention, reduction, and elimination of pollution.

Applicability: Certification or a waiver of certification is required in conjunction with any Federal permit or license to conduct any activity which may result in any discharge into waters of the United States.

Permit Information Needs: The information needed for the 401 water quality certification review generally is the same as that which is required in the application for the Federal permit involved. The information is provided to IEPA via a copy of the appropriate permit application form. Refer to the information needs described in this section for Section 404, Section 9, Section 10, and Section 402 permits.

For discharges that require an individual Section 401 water quality certification/waiver (i.e., not covered by a blanket 401 certification/waiver), 35 Ill. Adm. Code 302.105 requires the Illinois EPA to conduct an "anti-degradation assessment" for the proposed discharge. The purpose of the assessment is to evaluate the effect of the discharge (i.e., increase in pollutant loadings) and ensure that it will not cause water quality standards to be exceeded. When an anti-degradation assessment is necessary, IEPA may require the following information from the applicant for purposes of the assessment:

- identification and characterization (e.g., current physical, biological, chemical conditions) of the water body affected by the proposed project and the water body's existing uses;
- quantity of the pollutant load increase to the water body;
- potential impacts of the proposed project on the water body;
- purpose and anticipated benefits of the proposed project;
- assessment of the alternatives to the proposed project that will result in a reduced pollutant load to the water body, no load increase or minimal environmental degradation. Alternatives that result in no discharge to the water body and changes in the location of the activity must be addressed in the submission; and/or
- proof that a copy of the application was provided to the Illinois Department of Natural Resources.

As a part of the public notice process for the individual 401 water quality certification, IEPA will publish a fact sheet containing information on the anti-degradation assessment.

Permit: Section 402 National Pollutant Discharge Elimination System (NPDES) Point-Source Permit

Responsible Agency: US Environmental Protection Agency (USEPA) through the IEPA

Responsible IDOT Unit: District

Legal Reference: Section 402 of the *Federal Water Pollution Control Act* (1972), as amended by the *Clean Water Act* (1977 & 1987): 33 USC 1251-1376, DOT Order 5660.1A; 23 CFR 650, Subpart B; 40 CFR 121-125, 129-131, 133, and 135-136.

Purpose: To restore and maintain the chemical, physical, and biological integrity of the nation's waters through prevention, reduction, and elimination of pollution.

Applicability: Required for all point-source discharges (other than those addressed by the Section 404 Permit) into the Nation's waters (e.g., for rest areas).

Permit Information Needs: Permit application for Section 402 NPDES Point-Source requires:

1. USEPA Identification Number.
2. Facility name and address.
3. Pollutant characteristics (e.g., hazardous wastes, injection of fluids, air, agricultural, industrial wastes).
4. Facility contact and mailing address.
5. Facility location.
6. Standard Industrial Classification (SIC) Code.
7. Operator (e.g., name, Federal/State/private).
8. Existing environmental permits.
9. Map of area (e.g., topographic, locations of existing/proposed intakes and discharges, surface water bodies).
10. Nature of business.
11. Receiving waters (e.g., latitude/longitude).
12. Discharge date.
13. Type of waste.
14. Effluent characteristics (e.g., type of pollutants, maximum daily and average daily discharges).
15. Indication of intermittent or seasonal discharge.
16. Treatment system description.

Permit: Section 402 National Pollutant Discharge Elimination System (NPDES) Construction Permit

Responsible Agency: USEPA through the IEPA

Responsible IDOT Unit: Central Office disseminates information on general permit to district; district files Notice of Intent to use permit. *Note: Contractor must also sign Contractor Certification Statement.*

Legal Reference: Section 402 of the *Federal Water Pollution Control Act* (1972), as amended by the *Clean Water Act* (1977 & 1987): 33 USC 1251-1376, DOT Order 5660.1A; 23 CFR 650, Subpart B; 40 CFR 121-125, 129-131, 133, 135-136

Purpose: To restore and maintain the chemical, physical, and biological integrity of the Nation's waters through prevention, reduction, and elimination of pollution.

Applicability: Required for construction activities involving clearing, grading, and excavation activities that disturb one acre (4047 m²) or more of land area.

Permit Information Needs: Section 402 NPDES Construction Permit requires:

1. Mailing address and location of construction site, if available, and latitude and longitude of the approximate center of the site.
2. The owner's name, address, telephone number, and status as Federal, State, private, public, or other entity.
3. The name, address, and telephone number of the general contractor(s) that has been identified at the time of the Notice of Intent (NOI) submittal.
4. The name of the receiving water(s) or, if the discharge is through a municipal separate storm sewer, the name of the municipal operator of the storm sewer and the ultimate receiving water(s).
5. The number of any NPDES permit for any discharge (including non-storm water discharges) from the site that is currently authorized by an NPDES permit.
6. A yes or no indication of whether the owner or operator has existing quantitative data that describes the concentration of pollutants in storm water discharges.
7. A brief description of the project.
8. Contract/plan information including: contract number, letting date, item number, page numbers in plans where permit-related information can be found and sheet numbers where erosion and sediment control plans can be found.
9. Estimated timetable for major activities.
10. Estimates of the number of acres (hectares) of the site on which soil will be disturbed.
11. Storm Water Pollution Prevention Plan, including site description (e.g., map, nature of construction activity, area disturbed), erosion and sediment controls, storm water management plan, maintenance of site, inspection schedule, reports, and identification of the contractors/sub-contractors.

28-3 STATE PERMITS/CERTIFICATIONS

IDOT is responsible for obtaining several State permits/certifications as required on individual projects. This section discusses the identification, applicability, and information needs of each permit/certification. The State permits/certifications are:

1. Construction in Floodways of Rivers, Lakes, and Streams. This permit is obtained from the Illinois Department of Natural Resources, Office of Water Resources (OWR) for construction in the floodway of identified streams serving a tributary area of 640 acres (259 hectares) or more (urban) or 6400 acres (2590 hectares) or more (rural).
2. Regulation of Public Waters. This permit is obtained from the OWR for construction in those rivers, lakes, streams, and waterways considered public waters.
3. Floodway Construction in Northeastern Illinois. This permit is obtained from the OWR for new construction within the regulatory floodways of rivers, lakes, and streams in Cook, DuPage, Kane, Lake, McHenry, and Will counties excluding the City of Chicago.
4. Open Burning of Landscape Waste Generated by Land Clearing Activities. This permit is obtained from the IEPA for any proposed open burning of landscape waste generated from land clearing activities precipitated by road construction projects.
5. Supplemental Waste Stream Permit. This permit is obtained from the IEPA to allow a disposal facility to accept special waste generated by project involvement.
6. Resource Conservation and Recovery Act (RCRA) Permit. This permit is obtained from the IEPA for any project involvement with hazardous wastes for which the Department will conduct remedial activities.
7. Underground Storage Tank (UST) Permit. This permit is obtained from the Office of the State Fire Marshal (OSFM) for removing any underground storage tank.

Permit Name: Construction in Floodways of Rivers, Lakes, and Streams

Responsible Agency: Illinois Department of Natural Resources, Office of Water Resources

Responsible IDOT Unit: Bureau of Bridges and Structures (for bridges) or district (for culverts, embankments, storm sewers, or other construction within the flood plains of applicable streams and rivers).

Legal Reference: Authorized by Sections 23, 29, and 30 of the *Rivers, Lakes, and Streams Act* 615 ILCS 5/23, 29a and 30. Implementing rules in 17 Ill. Adm. Code 3700.

Purpose: To protect the rights, safety, and welfare of private and public landowners through the regulation of floodway development.

Applicability: All rivers, lakes, and streams under the jurisdiction of the OWR except those in the counties of Cook, Will, DuPage, Kane, Lake, and McHenry for which floodway limits have been defined pursuant to 92 Ill. Adm. Code 708. A permit is required for construction in the floodway of streams serving a tributary area of 640 acres (259 hectares) or more in an urban area or in the floodway of a stream serving a tributary area of 6400 acres (2590 hectares) or more in a rural area.

Permit Information Needs: Refer to the *IDOT Drainage Manual*.

Permit Name: Regulation of Public Waters

Responsible Agency: Illinois Department of Natural Resources, Office of Water Resources

Responsible IDOT Unit: Bureau of Bridges and Structures (for bridges) or district (for culverts, embankments, storm sewers, or other construction affecting public waters).

Legal Reference: Authorized by the *Rivers, Lakes, and Streams Act* 615 ILCS 5. Implementing rules in 17 Ill. Adm. Code 3704.

Purpose: To protect the public's interests, rights, safety, and welfare in the State's public bodies of water by preventing construction or other uses that would:

- obstruct or interfere with the navigability of any public body of water;
- encroach on any public body of water; or
- impair the rights, interests, or uses of the public in any public body of water or in the natural resources thereof.

Applicability: The permit requirements are applicable to those lakes, rivers, streams, and waterways that are considered public waters (listed in the Ill. Adm. Code 92-704, Appendix A).

Permit Information Needs: Refer to the *IDOT Drainage Manual*.

Permit Name: Floodway Construction in Northeastern Illinois

Responsible Agency: Illinois Department of Natural Resources, Office of Water Resources (By agreement with OWR, the Bureau of Bridges and Structures issues floodway construction permits for highway projects in the District One area, excluding the City of Chicago.)

Responsible IDOT Unit: Bureau of Bridges and Structures (for bridges) or district (for culverts and all other construction in regulatory floodways).

Legal Reference: Authorized by Section 18g of the *Rivers, Lakes, and Streams Act* 615 ILCS 5/18g. Implementing rules in 17 Ill. Adm. Code 3708.

Purpose: To regulate construction and filling in the regulatory floodway of rivers, lakes, and streams of Cook, DuPage, Kane, Lake, McHenry, and Will Counties, excluding the City of Chicago, so that periodic inundation will not:

- pose a danger to the general health and welfare of the user,
- require the expenditure of public funds,
- require the provision of public resources or disaster relief services, or
- result singularly or cumulatively in greater flood damages or potential flood damages due to increases in flood stage or velocities or loss of flood storage.

Applicability: A permit under this provision is required for construction, including replacement structures, roadway widening, etc., within the regulatory floodways in Cook, DuPage, Kane, Lake, McHenry, and Will Counties, except for those areas that are within the City of Chicago. A permit is not required for repair, remodeling, or maintenance of buildings or structures in existence as of November 18, 1987.

Permit Information Needs: Refer to the *IDOT Drainage Manual*.

If the regulatory floodway delineation or base flood elevation will change due to the proposed project, the application will not be considered complete until the OWR has indicated conditional approval of the regulatory floodway map change and the completed request for the regulatory floodway map change has been submitted to FEMA.

Permit Name: General Permit for Open Burning of Landscape Waste Generated by Land Clearing Activities Necessitated by Road Construction Projects Included in the “Annual Program” and “Service Bulletins” of the Illinois Department of Transportation

Responsible Agency: Illinois Environmental Protection Agency

Responsible IDOT Unit: Central Office administers renewal of general permit; district processes Notice of Intent to use permit.

Legal Reference: 415 ILCS 5/39.5. Implementing rules in 35 Ill. Adm. Code 237, Subpart B.

Purpose: To impose appropriate conditions and restrictions on open burning of landscape waste to protect public health and welfare.

Applicability: Required for any proposed open burning of landscape waste generated from land clearing activities necessitated by road construction projects.

Permit Information Needs: A completed Notice of Open Burn form must be sent to the IEPA Air Permit Section not less than seven working days prior to each open burn. The Notice of Open Burn form must provide the following information:

1. Name and address of the contractor proposing the open burn.
2. The site location of the proposed open burn (address, county, township), sketch of the immediate vicinity of the proposed open burn site, and a printed map of the general area with the site and nearby features marked and distances to the features (e.g., structures, residences, populated areas, roadways, airports, lakes and waterways, hospitals, nursing homes, schools) indicated.
3. Schedule of the open burning activity (estimated duration and dates).
4. Estimated quantity of material to be burned.
5. IDOT construction contract number.
6. Authorized signature of person responsible for the open burn activity.

Permit Name: Supplemental Waste Stream Permit.

Responsible Agency: Illinois Environmental Protection Agency.

Responsible IDOT Unit: Application is prepared by the disposal facility on behalf of the firm handling waste disposal working for the prime construction contractor. BDE will assist as needed.

Legal Reference: Implementing rules in 35 Ill. Adm. Code 807.210 and 809.302b.

Purpose: To allow disposal facility to accept generated special waste.

Applicability: Permit is required to allow disposal facility to accept special waste generated by project involvement.

Permit Information Needs: The Supplemental Waste Stream Permit requires:

1. Receiving facility information, as follows:
 - a. Name and address of facility.
 - b. Name and address of applicant.
 - c. IEPA site code.
 - d. USEPA site code.
 - e. Facility contact name and telephone number.
2. Waste generator information, as follows:
 - a. Plant address.
 - b. Mailing address.
 - c. Generator IEPA code.
 - d. Generator USEPA code (if applicable).
 - e. Generator contact name and telephone number.
 - f. Generator SIC code.
 - g. Process/Operation code, name, and description.
 - h. Generic waste code and generic waste name.
 - i. Indication of ultimate disposition of treatment residuals or wastes.
3. Waste characteristic information, as follows:
 - a. Indication of whether waste is hazardous or non-hazardous.
 - b. USEPA hazardous waste number(s) (if applicable).
 - c. Results for paint filter test, penetrometer test.
 - d. Waste phase.
 - e. Transport frequency.
 - f. Waste class.
 - g. Flash point.
 - h. Percent Acidity.
 - i. Percent Alkalinity.
 - j. pH.
 - k. Percent solids.
 - l. Land Disposal Restricted Waste (if applicable).
 - m. Waste component names and percentages.
 - n. Total concentrations of heavy metals and other specified constituents in waste.

- o. Summary of all available analytical results for waste.

Permit Name: *Resource Conservation and Recovery Act (RCRA) Permit.*

Responsible Agency: Illinois Environmental Protection Agency.

Responsible IDOT Unit: Application prepared by environmental firm working for prime construction contractor; BDE will assist as needed.

Legal Reference: Section 22.4 and Section 27 of the *Illinois Environmental Protection Act* (415 ILCS 5/22.4 and 27). Implementing rules in 35 Ill. Adm. Code 703.

Purpose: To apply appropriate conditions and restrictions for the operation of hazardous waste storage, hazardous waste treatment, or hazardous waste disposal operations.

Applicability: Applies to any project involvement with hazardous wastes in which the Department will conduct remediation activities involving storage of hazardous waste for more than 90 days.

Permit Information Needs:

1. Description of the activities conducted by the applicant that require it to obtain permits under RCRA.
2. Name, mailing address, and location of the facility for which the application is submitted.
3. Up to four SIC codes that best reflect the principal products or services provided by the facility.
4. The operator's name, address, telephone number, ownership status, and status as Federal, State, private, public, or other entity.
5. The name, address, and phone number of the owner of the facility.
6. A listing of all permits or construction approvals received or applied for under certain listed permit authorities.
7. A topographic map (or other map if a topographic map is unavailable) extending one mile (1.6 km) beyond the property boundaries of the source, depicting the facility and each of its intake and discharge structures; each of its hazardous waste treatment, storage, or disposal facilities; each well where fluids from the facility are injected underground; and those wells, springs, other surface water bodies, and drinking water wells listed in public records or otherwise known to the applicant within 0.25 miles (400 m) of the facility property boundary.
8. A brief description of the nature of the business.
9. Additional specific information regarding facility location; facility layout; groundwater protection; processes to be used for treating, storing, and disposing of hazardous waste; types of wastes to be treated, stored, or disposed of.

Permit Name: Underground Storage Tank (UST) Permit.

Responsible Agency: Office of the State Fire Marshal (OSFM).

Responsible IDOT Unit: Application prepared by environmental firm working for prime construction contractor; BDE will assist as needed. Permit application must be approved by IDOT Chief Counsel prior to sending to OSFM.

Legal Reference: *Gasoline Storage Act* 430 ILCS 15. Implementing rules in 35 Ill. Adm. Code 731.

Purpose: To ensure that tank removal meets acceptable closure standards.

Applicability: A permit is required for removing any underground storage tank. (*Note: Permits for removing an UST can only be obtained by licensed UST removal contractors.*)

Permit Information Needs: The Underground Storage Tank Permit requires:

1. Name and address of owner of tank(s) and type of ownership.
2. Name and address of facility where tanks are located and type of facility.
3. Name and address of person, firm, or company performing work on tanks.
4. Number and size of tanks being removed and their status and age.
5. Reason for removal.
6. ESDA incident number (if tank is leaking).
7. Description of products that were stored in each tank.
8. Date tank was last used.
9. Description of tank construction materials.
10. Description of piping materials and type.

28-4 PROCEDURES/DOCUMENTATION FOR USE OF THE CATEGORICAL EXCLUSION NATIONWIDE SECTION 404 PERMIT

28-4.01 Background

For Categorical Exclusion (CE) actions involving the use of the CE nationwide permit (refer to BDE-IM for *Federal Register* notice containing current nationwide permits), the appropriate Corps district must be contacted and afforded an opportunity to review the proposal. This will ensure that the CE activities requiring a Section 404 permit will have only minimal adverse individual and cumulative impacts on the aquatic environment.

For CE actions that will involve discharges covered by another of the nationwide permits, the permit that is the least burdensome procedurally should be used.

28-4.02 Applicability

The following procedures are applicable to all State highway projects developed in conformance with FHWA procedures to obtain Federal funding (1) that are eligible to be processed as CEs, and (2) for which the responsible IDOT district wishes to pursue use of the CE nationwide Section 404 permit.

28-4.03 Procedures

28-4.03(a) General

Proposed CE projects that will involve an activity (or activities) subject to Section 404 permit requirements should be evaluated as early as practical by the affected IDOT district to assess the potential applicability of the CE nationwide permit. This evaluation should consider (1) whether the activity(ies) requiring a permit will involve placement of substantial amounts of fill that may result in more than minor water quality impacts, and (2) whether applicable nationwide permit conditions can be satisfied for the proposed activities. If additional information is needed concerning the environmental conditions for use of the nationwide permits (e.g., endangered species), coordination should be initiated with BDE to obtain the necessary information.

The results of these evaluations should be discussed with the FHWA Division Office and BDE representatives. These discussions and the determination of whether or not the CE nationwide permit is appropriate for a specific project should be documented either in the minutes of a coordination meeting or through other means (e.g., a memorandum to the file). A copy of this documentation should accompany the project report when it is submitted to BDE for approval to indicate the basis for the permit processing decision.

The CE permit can be used only in conjunction with projects being developed according to Federal procedures (i.e., projects developed as probable State-only funded actions and that, hence, may not conform to Federal procedures are not eligible for CE permit authorization from the FHWA). However, when use of the CE permit has been authorized for a project (and provided the Corps has not advised that it intends to seek assertion of its authority to require an individual permit for

the action), the CE permit will still be valid even if the project is subsequently programmed for State-only funding, provided there are no changes in the project that would result in more than minor water quality impacts or would conflict with the applicable nationwide permit conditions.

Construction-stage activities subject to Section 404 requirements (e.g., runarounds) can be covered under the CE permit authorization if they are identified and addressed when the project is coordinated for purposes of requesting CE permit approval. If such activities are subsequently proposed and were not addressed during the initial CE permit review, a separate permit review by the Corps will be necessary. As practical, districts should identify and address construction-stage activities during the initial CE permit review to eliminate the need for later separate review by the Corps.

28-4.03(b) CE Projects Potentially Eligible for Nationwide Permit

Categorical Exclusion projects are potentially eligible for processing under the CE nationwide permit when the IDOT district has determined they (1) will not involve more than minor water quality impacts (or that it is questionable whether more than minor water quality impacts will be involved) and (2) are such that the applicable permit conditions can be met.

In accordance with Corps Regulatory Guidance Letter 05-07, certain actions proposed for processing under the CE permit require submission of a preconstruction notification to the appropriate Corps district engineer prior to commencing the activity. Submission of the preconstruction notification must be accomplished in accordance with the requirements in the "Preconstruction Notification" general condition of the current nationwide permits, available on the Corps website. Preconstruction notification to the Corps is required for the following actions listed in 23 CFR 771.117 "Categorical exclusions":

- activities occurring under paragraphs:
 - + (c)(3) construction of bicycle and pedestrian lanes, paths and facilities;
 - + (c)(7) landscaping;
 - + (c)(9) emergency repairs under 23 USC 125; and
 - + (c)(12) improvements to existing rest areas and truck weigh stations; and
- all activities under paragraph (d).

The Corps districts will review each preconstruction notification and verify whether the activity meets the terms and conditions of the CE nationwide permit. Special conditions may be added to the CE permit verification to ensure that the individual and cumulative adverse effects on the aquatic environment are minimal. If the Corps district believes concerns for the aquatic environment or any public interest factor warrant further review, discretionary authority may be exercised on a case-by-case basis to require an individual permit.

Corps districts will provide a response, verifying whether the activity meets the terms and conditions for use of the CE permit, within the designated response period for the most recently issued nationwide permits (as provided in the "Notification" general condition for the nationwide

permits) or the appropriate regional condition. If the Corps district does not respond within the designated time, the activity qualifies for CE permit authorization.

For other potentially eligible CE projects that are not subject to the requirement for submitting formal preconstruction notification to the Corps, FHWA may approve use of the CE permit. Such projects should be discussed with BDE and FHWA representatives, and approval should be requested from the FHWA representative for use of the CE nationwide permit. If FHWA does not approve use of the nationwide permit, the procedures discussed in Section 28-4.03(c) for “ineligible” projects will apply. If FHWA approves the use of the permit, the district provides the responsible Corps district:

- documentation of FHWA’s approval,
- a sketch and brief description of the work requiring a 404 permit,
- an indication of the type and approximate quantity of fill involved, and
- a copy of the biological information received in response to the environmental survey request for the action.

A form has been developed for documenting CE permit authorizations by FHWA, issued via a BDE Technical Environmental Memorandum. Upon receipt of FHWA’s approval of the CE permit for a project, the district provides a copy of the signed form, with supporting information as indicated above, to the responsible Corps district and to BDE. *Some Corps districts may require the submittal of a completed permit application form to provide the supporting information.* In addition, when the discussions with FHWA leading to authorization of the CE permit involve substantial problems or conditions for permit authorization, include a copy of the minutes of the meeting, or other documentation of the discussions, as a part of the supporting information submitted to the Corps and BDE.

Upon receiving the necessary Section 401 water quality certification from the IEPA, the action may proceed under the nationwide permit authorization. For CE permit authorizations received from the Corps or FHWA, information concerning the need to comply with the permit conditions should be incorporated into the district’s procedures for ensuring follow-through on commitments. This will ensure that those having later project involvements (including contractors) will be aware of the applicable commitments.

28-4.03(c) CE Projects Ineligible for Nationwide Permit

If the Corps advises that an individual permit will be required, BDE should be advised of this action either by copy of the correspondence from the Corps or by memorandum.

If the IDOT district, BDE, or FHWA determines that a CE-type project activity subject to Section 404 permit requirements will involve more than minor water quality impacts, or that one or more of the conditions for the nationwide permit cannot be met, application to the Corps for an individual or, where appropriate, a regional permit will be necessary for the activity. For CE projects that

the district, BDE, or FHWA determines will require an individual permit, the transmittal letter to the Corps accompanying the permit application should note that the project will be processed as a CE for compliance with NEPA.

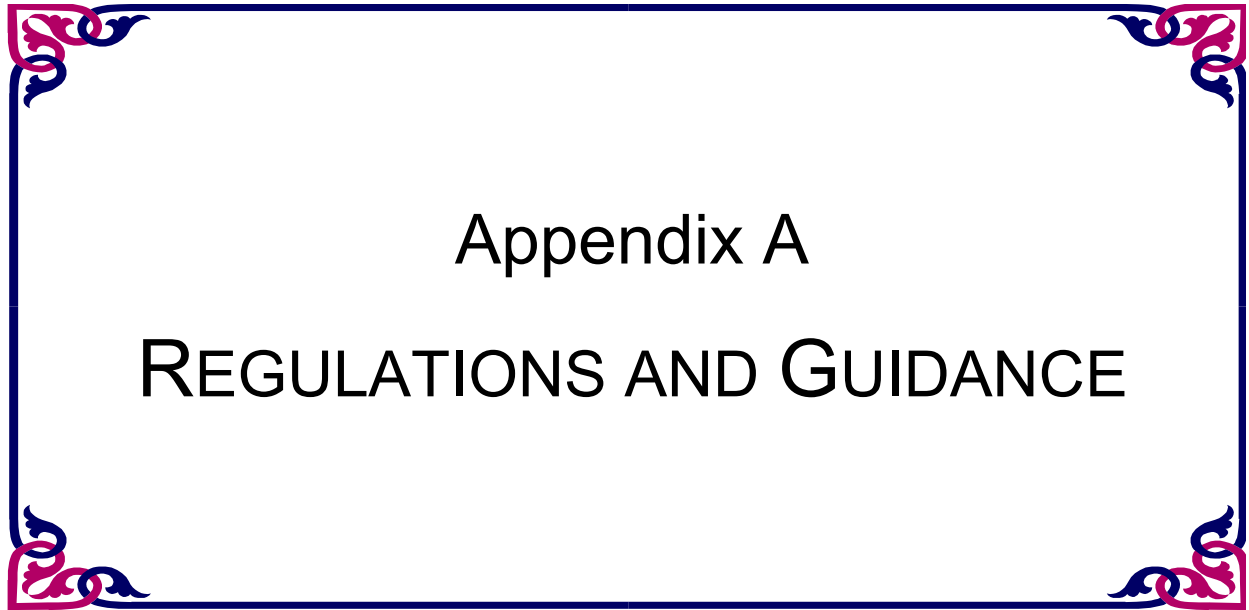

Appendix A

REGULATIONS AND GUIDANCE

BUREAU OF DESIGN AND ENVIRONMENT
MANUAL

Appendix A REGULATIONS AND GUIDANCE

- I. Below are Code of Federal Regulations (CFRs) applicable to the Department. For the latest version of these CFRs, please go to Nation Archives site: www.ecfr.gov.
- 40 CFR 1500 – 1508 “CEQ Regulations”;
 - 23 CFR 771 “Environmental Impact and Related Procedures”;
 - 23 CFR 774 “Parks, Recreation Areas, Wildlife and Waterfowl Refuges, and Historic Sites (Section 4(f))”;
- II. Below are two commonly used National Pollutant Discharge Elimination System (NPDES) permits utilized by the Department during project development
- General NPDES Permit for Construction Projects (ILR10);
 - General NPDES permit for Small Municipal Separate Storm Sewer Systems (ILR40)
- The latest versions can be found on the IEPA’s website: <https://epa.illinois.gov/>
- III. This chapter also includes copies of Federal Guidance, Memorandums of Understanding, and Programmatic Agreements implemented by the Department.
- FHWA Technical Advisory T6640.8A *Guidance for Preparing and Processing Environmental and Section 4(f) Documents*;
 - CEQ Questions and Answers (“40 Questions”);
 - FHWA Section 4(f) Policy Paper, July 20, 2012;
 - Programmatic Section 4(f) Evaluations;
 - + Programmatic Section 4(f) Evaluation and Approval for FHWA Projects that Necessitate the Use of Historic Bridges
 - + Final Nationwide Section 4(f) Evaluation and Approval for Federally-Aided Highway Projects With Minor Involvements With Public Parks, Recreation Lands, and Wildlife and Waterfowl Refuges
 - + Final Nationwide Section 4(f) Evaluation and Approval for Federally-Aided Highway Projects With Minor Involvements With Historic Sites

- + Section 4(f) Evaluation and Approval for Transportation Projects That Have a Net Benefit to a Section 4(f) Property
- + Programmatic Section 4(f) Statement for Independent Bikeway or Walkway Construction Projects
- Federal-aid Highway Program, Illinois Stewardship/Oversight Agreement;
- Programmatic Agreement Between the Federal Highway Administration and the Illinois Department of Transportation Regarding the Processing of Actions Classified as Categorical Exclusions for Federal-Aid Highway Projects;
- Illinois Statewide Implementation Agreement Between the Federal Highway Administration and the Illinois Department of Transportation for Establishment of Timeframes for Environmental Impact Statements and Environmental Assessments;
- Memorandum of Understanding among the Federal Highway Administration, Illinois Department of Transportation, U.S. Army Corps of Engineers, U.S. Fish and Wildlife Service, U.S. Coast Guard, and U.S. Environmental Protection Agency for the Concurrent Transportation Decision-making process and Section 404 of the Clean Water Act for Federal-Aid Highway Projects in Illinois
- Memorandum of Understanding By and Between the Illinois Department of Natural Resources and the Illinois Department of Transportation, January 10, 2013;
- Illinois Department of Transportation Wetlands Action Plan, April 15, 1998;
- Illinois Department of Transportation's Agricultural Land Preservation Policy Statement and Cooperative Working Agreement;
- Memorandum of Understanding amount the Federal Highway Administration, the U.S. Environmental Protection Agency (Region 5), and the Illinois Department of Transportation regarding Sole Source Aquifers in the State of Illinois;
- Programmatic Agreement Among the Federal Highway Administration , Illinois Department of Transportation, the Illinois State Historic Preservation Officer, and the Advisory Council on Historic Preservation Regarding Section 106 Implementation for Federal-Aid Transportation Projects in the State of Illinois;
- Illinois Department of Transportation and Illinois Environmental Protection Agency Agreement on Microscale Air Quality Assessments for Illinois Department of Transportation-Sponsored Transportation Projects;

U.S. DEPARTMENT OF TRANSPORTATION Federal Highway Administration	
SUBJECT GUIDANCE FOR PREPARING AND PROCESSING ENVIRONMENTAL AND SECTION 4(F) DOCUMENT	FHWA TECHNICAL ADVISORY T 6640.8A October 30, 1987

1. **PURPOSE.** To provide guidance to Federal Highway Administration (FHWA) field offices and to project applicants on the preparation and processing of environmental and Section 4(f) documents.
2. **CANCELLATION.** Technical Advisory T 6640.8, "Guidance Material for the Preparation of Environmental Documents," dated February 24, 1982, is canceled effective on November 27, 1987.
3. **APPLICABILITY.**
 - a. This material is not regulatory. It has been developed to provide guidance for uniformity and consistency in the format, content and processing of the various environmental studies and documents pursuant to the National Environmental Policy Act (NEPA), 23 U.S.C. 109(h) and 23 U.S.C. 138 (Section 4(f) of the DOT Act) and the reporting requirements of 23 U.S.C. 128.
 - b. The guidance is limited to the format, content and processing of NEPA and Section 4(f) studies and documents. It should be used in combination with a knowledge and understanding of the Council on Environmental Quality (CEQ) Regulations for Implementing NEPA (40 CFR 1500-1508), FHWA's Environmental Impact and Related Procedures (23 CFR 771) and other environmental statutes and orders (see Appendix A).
 - c. This guidance should not be used until November 27, 1987, the effective date of the 1987 revisions to 23 CFR 771.

Ali F. Sevin
Director, Office of Environmental Policy

Attachment

Distribution: Headquarters
OPI: HEV-11
Special: Regions
Divisions

GUIDANCE FOR PREPARING AND PROCESSING ENVIRONMENTAL AND SECTION 4(F) DOCUMENTS

Background

An earlier edition of this advisory (dated February 24, 1982) placed major emphasis on environmental impact statements (EISs) and provided limited guidance on environmental assessments (EAs) and other environmental studies needed for a categorical exclusion (CE) determination or a finding of no significant impact (FONSI). The revised guidance gives expanded coverage to CE determinations, EAs, FONSI, EISs, supplemental EISs, reevaluations, and Section 4(f) evaluations. This material is not regulatory. It does, however, provide for uniformity and consistency in the documentation of CEs and the development of environmental and Section 4(f) documents.

The FHWA subscribes to the philosophy that the goal of the NEPA process is better decisions and not more documentation. Environmental documents should be concise, clear, and to the point and should be supported by evidence that the necessary analyses have been made. They should focus on the important impacts and issues with the less important areas only briefly discussed. The length of EAs should normally be less than 15 pages and EISs should normally be less than 150 pages for most proposed actions and not more than 300 pages for the most complex proposals. The use of technical reports for various subject areas would help reduce the size of the documents.

The FHWA considers the early coordination process to be a valuable tool in determining the scope of issues to be addressed and in identifying and focusing on the proposed action's important issues. This process normally entails the exchange of information with appropriate Federal, State and local agencies and the public from inception of the proposed action to preparation of the environmental document or to completion of environmental studies for applicable CEs. Formal scoping meetings may also be held where such meetings would assist in the preparation of the environmental document. The role of other agencies and other environmental review and consultation requirements should be established during scoping. The Council on Environmental Quality (CEQ) has issued several guidance publications on NEPA and its regulations as follows: (1) "Questions and Answers about the NEPA Regulations," March 30, 1981; (2) "Scoping Guidance," April 30, 1981; and (3) "Guidance Regarding NEPA Regulations," July 28, 1983. This nonregulatory guidance is used by FHWA in preparing and processing environmental documents. Copies of the CEQ guidance are available in the FHWA Office of Environmental Policy (HEV-11).

Note, highway agency (HA) is used throughout this document to refer to a State and local highway agency responsible for conducting environmental studies and preparing environmental documents and to FHWA's Office of Direct Federal Programs when that office acts in a similar capacity.

<u>SECTION</u>	<u>SUBJECT</u>	<u>PAGE</u>
I	Categorical Exclusion (CE)	5
II	Environmental Assessment (EA)	7
III	Finding of No Significant Impact (FONSI)	9
IV	Distribution of EAs and FONSI	11
V	EIS -- Format and Content	12
	Cover Sheet	12
	Summary	13
	Table of Contents	14
	Purpose of and Need for Action	14
	Alternatives	15
	Affected Environment	17
	Environmental Consequences	18
	Land Use Impacts	19
	Farmland Impacts	20
	Social Impacts	20
	Relocation Impacts	21
	Economic Impacts	22
	Joint Development	23
	Considerations Relating to Pedestrians and Bicyclists	23
	Air Quality Impacts	23
	Noise Impacts	25
	Water Quality Impacts	25
	Permits	26
	Wetland Impacts	27
	Water Body Modification and Wildlife Impacts	28
	Floodplain Impacts	28
	Wild and Scenic Rivers	30
	Coastal Barriers	30
	Coastal Zone Impacts	30
	Threatened or Endangered Species	31
	Historic and Archeological Preservation	32
	Hazardous Waste Sites	33
	Visual Impacts	34
	Energy	34
	Construction Impacts	34
	Relationship of Local Short-term	
	Uses vs. Long-term Productivity	35
	Irreversible and Irretrievable Commitment of Resources	35
	List of Preparers	36
	List of Agencies, Organizations and Persons to	
	Whom Copies of the Statement are Sent	36
	Comments and Coordination	36
	Index	37

<u>SECTION</u>	<u>SUBJECT</u>	<u>PAGE</u>
	Appendices	37
VI	Options for Preparing Final EISs	37
VII	Distribution of EISs and Section 4(f) Evaluations	39
VIII	Record of Decision — Format and Content	41
IX	Section 4(f) Evaluations — Format and Content	42
X	Other Agency Statements	45
XI	Reevaluations	46
XII	Supplemental EISs	47
XIII	Appendices	48
	Appendix A: Environmental Laws, Authority and Related Statutes and Orders	
	Appendix B: Notice of Intent	

I. CATEGORICAL EXCLUSION (CE)

Categorical exclusions are actions or activities which meet the definition in 23 CFR 771.117(a) and, based on FHWA's past experience, do not have significant environmental effects. The CEs are divided into two groups based on the action's potential for impacts. The level of documentation necessary for a particular CE depends on the group the action falls under as explained below.

A. Documentation of Applicability

The first group is a list of 20 categories of actions in 23 CFR 771.117(c) which experience has shown never or almost never cause significant environmental impacts. These categories are non-construction actions (e.g., planning, grants for training and research programs) or limited construction activities (e.g., pedestrian facilities, landscaping, fencing). These actions are automatically classified as CEs, and except where unusual circumstances are brought to FHWA's attention, do not require approval or documentation by FHWA. However, other environmental laws may still apply. For example, installation of traffic signals in a historic district may require compliance with Section 106, or a proposed noise barrier which would use land protected by Section 4(f) would require preparation of a Section 4(f) evaluation (23 CFR 771.135(i)). In most cases, information is available from planning and programming documents for the FHWA Division Office to determine the applicability of other environmental laws. However, any necessary documentation should be discussed and developed cooperatively by the highway agency (HA) and the FHWA.

The second group consists of actions with a higher potential for impacts than the first group, but due to minor environmental impacts still meets the criteria for categorical exclusions. In 23 CFR 771.117(d), the regulation lists examples of 12 actions which past experience has found appropriate for CE classification. However, the second group is not limited to these 12 examples. Other actions with a similar scope of work may qualify as CEs. For actions in this group, site location is often a key factor. Some of these actions on certain sites may involve unusual circumstances or result in significant adverse environmental impacts. Because of the potential for impacts, these actions require some information to be provided by the HA so that the FHWA can

determine if the CE classification is proper (23 CFR 771.117(d)). The level of information to be provided should be commensurate with the action's potential for adverse environmental impacts. Where adverse environmental impacts are likely to occur, the level of analysis should be sufficient to define the extent of impacts, identify appropriate mitigation measures, and address known and foreseeable public and agency concerns. As a minimum, the information should include a description of the proposed action and, as appropriate, its immediate surrounding area, a discussion of any specific areas of environmental concern (e.g., Section 4(f), wetlands, relocations), and a list of other Federal actions required, if any, for the proposal.

The documentation of the decision to advance an action in the second group as a CE can be accomplished by one of the following methods:

(1) Minor actions from the list of examples:

Minor construction projects or approval actions need only minimum documentation. Where project-specific information for such minor construction projects is included with the Section 105 program and clearly shows that the project is one of the 12 listed examples in Section 771.117(d), the approval of the Section 105 program can be used to approve the projects as CEs. Similarly, the three approval actions on the list (examples (6), (7) and (12)) should not normally require detailed documentation, and the CE determination can be documented as a part of the approval action being requested.

(2) Other actions from the list of examples:

For more complex actions, additional information and possibly environmental studies will be needed. This information should be furnished to the FHWA on a case-by-case basis for concurrence in the CE determination.

(3) Actions not on the list of examples:

Any action which meets the CE criteria in 23 CFR 771.117(a) may be classified as a CE even though it does not appear on the list of examples in Section 771.117(d). The actions on the list should be used as a guide to identify other actions that may be processed as CEs. The documentation to be submitted to the FHWA must demonstrate that the CE criteria are satisfied and that the proposed project will not result in significant environmental impacts. The classification decision should be documented as a part of the individual project submissions.

B. Consideration of Unusual Circumstances

Section 771.117(b) lists those unusual circumstances where further environmental studies will be necessary to determine the appropriateness of a CE classification. Unusual circumstances can arise on any project normally advanced with a CE; however, the type and depth of additional studies will vary with the type of CE and the facts and circumstances of each situation. For those actions on the fixed list (first group) of CEs, unusual circumstances should rarely, if ever, occur due to the limited scope of work. Unless unusual circumstances come to the attention of the HA or FHWA, they need not be given further consideration. For actions in the second group of CEs, unusual circumstances should be addressed in the information provided to the FHWA with the request for CE approval. The level of consideration, analysis, and documentation should be commensurate with the action's potential for significant impacts, controversy, or inconsistency with other agencies' environmental requirements.

When an action may involve unusual circumstances, sufficient early coordination, public involvement and environmental studies should be undertaken to determine the likelihood of significant impacts. If no significant impacts are likely to occur, the result of environmental studies and any agency and public involvement should adequately support such a conclusion and be included in the request to the FHWA for CE approval. If significant impacts are likely to occur, an EIS must be prepared (23 CFR 771.123(a)). If the likelihood of significant impacts is uncertain

even after studies have been undertaken, the HA should consult with the FHWA to determine whether to prepare an EA or an EIS.

II. ENVIRONMENTAL ASSESSMENT (EA)

The primary purpose of an EA is to help the FHWA and HA decide whether or not an EIS is needed. Therefore, the EA should address only those resources or features which the FHWA and the HA decide will have a likelihood for being significantly impacted. The EA should be a concise document and should not contain long descriptions or detailed information which may have been gathered or analyses which may have been conducted for the proposed action. Although the regulations do not set page limits, CEQ recommends that the length of EAs usually be less than 15 pages. To minimize volume, the EA should use good quality maps and exhibits and incorporate by reference and summarize background data and technical analyses to support the concise discussions of the alternatives and their impacts.

The following format and content is suggested:

A. Cover Sheet

There is no required format for the EA. However, the EIS cover sheet format, as shown in Section V, is recommended as a guide. A document number is not necessary. The due date for comments should be omitted unless the EA is distributed for comments.

B. Purpose of and Need for Action

Describe the locations, length, termini, proposed improvements, etc. Identify and describe the transportation or other needs which the proposed action is intended to satisfy (e.g., provide system continuity, alleviate traffic congestion, and correct safety or roadway deficiencies). In many cases the project need can be adequately explained in one or two paragraphs. On projects where a law, Executive Order or regulation (e.g., Section 4(f), Executive Order 11990 or Executive Order 11988) mandates an evaluation of avoidance alternatives, the explanation of the project need should be more specific so that avoidance alternatives that do not meet the stated project need can be readily dismissed.

C. Alternatives

Discuss alternatives to the proposed action, including the no-action alternative, which are being considered. The EA may either discuss (1) the preferred alternative and identify any other alternatives considered or (2) if the applicant has not identified a preferred alternative, the alternatives under consideration. The EA does not need to evaluate in detail all reasonable alternatives for the project, and may be prepared for one or more build alternatives.

D. Impacts

For each alternative being considered, discuss any social, economic, and environmental impacts whose significance is uncertain. The level of analysis should be sufficient to adequately identify the impacts and appropriate mitigation measures, and address known and foreseeable public and agency concerns. Describe why these impacts are considered not significant. Identified impact areas which do not have a reasonable possibility for individual or cumulative significant environmental impacts need not be discussed.

E. Comments and Coordination

Describe the early and continuing coordination efforts, summarize the key issues and pertinent information received from the public and government agencies through these efforts, and list the agencies and, as appropriate, members of the public consulted.

F. Appendices (if any).

The appendices should include only analytical information that substantiates an analysis which is important to the document (e.g., a biological assessment for threatened or endangered species). Other information should be referenced only (i.e., identify the material and briefly describe its contents).

G. Section 4(f) Evaluation (if any).

If the EA includes a Section 4(f) evaluation, the EA/Section 4(f) evaluation or, if prepared separately, the Section 4(f) evaluation by itself must be circulated to the appropriate agencies for Section 4(f) coordination (23 CFR 771.135(i)). Section VII provides specific details on distribution and coordination of Section 4(f) evaluations. Section IX provides information on format and content of Section 4(f) evaluation.

If a programmatic Section 4(f) evaluation is used on the proposed project, this fact should be included and the Section 4(f) resource identified in the EA. The avoidance alternatives evaluation called for in Section 771.135(i) need not be repeated in the EA. Such evaluation would be part of the documentation to support the applicability and findings of the programmatic document.

H. EA Revisions.

Following the public availability period, the EA should be revised or an attachment provided, as appropriate, to (1) reflect changes in the proposed action or mitigation measures resulting from comments received on the EA or at the public hearing (if one is held) and any impacts

of the changes, (2) include any necessary findings, agreements, or determination (e.g., wetlands, Section 106, Section 4(f) required for the proposal, and (3) include a copy of pertinent comments received on the EA and appropriate responses to the comments.

III. FINDING OF NO SIGNIFICANT IMPACTS (FONSI)

The EA, revised or with attachment(s) (see paragraph above) is submitted by the HA to the FHWA along with (1) a copy of the public hearing transcript, when one is held, (2) a recommendation of the preferred alternative, and (3) a request that a finding of no significant impact be made. The basis for the HA's finding of no significant impact request should be adequately documented in the EA and any attachment(s).

After review of the EA and any other appropriate information, the FHWA may determine that the proposed action has no significant impacts. This is documented by attaching to the EA a separate statement (sample follows) which clearly sets forth the FHWA conclusions. If necessary, the FHWA may expand the sample FONSI to identify the basis for the decision, uses of land from Section 4(f) properties, wetland findings, etc.

The EA or FONSI should document compliance with NEPA and other applicable environmental laws, Executive Orders, and related requirements. If full compliance with these other requirements is not possible by the time the FONSI is prepared, the documents should reflect consultation with the appropriate agencies and describe when and how the requirements will be met. For example, any action requiring the use of Section 4(f) property cannot proceed until FHWA gives a Section 4(f) approval (49 U.S.C. 303(c)).

(SAMPLE)

**FEDERAL HIGHWAY ADMINISTRATION
FINDING OF NO SIGNIFICANT IMPACT
FOR
(Title of Proposed Action)**

The FHWA has determined that alternative (identify the alternative selected) will have no significant impact on the human environment. This FONSI is based on the attached EA (reference other environmental and non-environmental documents as appropriate) which has been independently evaluated by the FHWA and determined to adequately and accurately discuss the need, environmental issues, and impacts of the proposed project and appropriate mitigation measures. It provides sufficient evidence and analysis for determining that an EIS is not required. The FHWA takes full responsibility for the accuracy, scope, and content of the attached EA (and other documents as appropriate).

Date

For FHWA

IV. DISTRIBUTION OF EAs AND FONSI

A. Environmental Assessment

After clearance by FHWA, EAs must be made available for public inspection at the HA and FHWA Division offices (23 CFR 771.119(d)). Although only a notice of availability of the EA is required, the HA is encouraged to distribute a copy of the document with the notice to Federal, State and local government agencies likely to have an interest in the undertaking and to the State intergovernmental review contacts. The HA should also distribute the EA to any Federal, State or local agency known to have interest or special expertise (e.g. EPA for wetlands, water quality, air, noise, etc.) in those areas addressed in the EA which have or may have had potential for significant impact. The possible impacts and the agencies involved should be identified following the early coordination process. Where an individual permit would be required from the Corps of Engineers (COE) (i.e., Section 404 or Section 10) or from the Coast Guard (CG) (i.e., Section 9), a copy of the EA should be distributed to the involved agency in accordance with the U.S. Department of

Transportation (DOT)/Corps of Engineers Memorandum of Agreement or the FHWA/U.S. Coast Guard Memorandum of Understanding, respectively. Any internal FHWA distribution will be determined by the Division Office on a case-by-case basis.

B. Finding of No Significant Impact

Formal distribution of a FONSI is not required. The HA must send a notice of availability of the FONSI to Federal, State and local government agencies likely to have an interest in the undertaking and the State intergovernmental review contacts (23 CFR 771.121(b)). However, it is encouraged that agencies which commented on the EA (or requested to be informed) be advised of the project decision and the disposition of their comments and be provided a copy of the FONSI. This fosters good lines of communication and enhances interagency coordination.

V. Environmental Impact Statement (EIS) — FORMAT AND CONTENT

A. Cover Sheet

Each EIS should have a cover sheet containing the following information:

(EIS NUMBER)
<u>Route, Termini, City or County, and State</u>
Draft (Final) (Supplement)
Environmental Impact Statement
Submitted Pursuant to 42 U.S.C. 4332 (2) (c)
(and where applicable, 49 U.S.C. 303) by the
U.S. Department of Transportation
Federal Highway Administration
and
State Highway Agency
and
(As applicable, any other joint lead agency)
<u>Cooperating Agencies</u>
(Include List Here, as applicable)
_____ Date of Approval _____ For (State Highway Agency)
_____ Date of Approval _____ For FHWA
The following persons may be contacted for additional information concerning this document:
_____ (Name, address, and telephone number of HA contact) _____ (Name, address, and telephone number of FHWA Division Office contact)

A one-paragraph abstract of the statement.

Comments on this draft EIS are due by (date) and should be sent to (name and address).

The top left-hand corner of the cover sheet of all draft final and supplemental EISs contains an identification number. The following is an example:

FHWA-AZ-EIS-87-01-D(F)(S)

FHWA - name of Federal agency

AZ - name of State (cannot exceed four characters)

EIS - environmental impact statement

87 - year draft statement was prepared

01 - sequential number of draft statement for each calendar year

D - designates the statement as the draft statement

F - designates the statement as the final statement

S - designates supplemental statement and should be combined with draft (DS) or final (FS) statement designation. The year and sequential number will be the same as those used for the original draft EIS.

The EIS should be printed on 8-1/2 x 11-inch paper with any foldout sheets folded to that size. The wider sheets should be 8-1/2 inches high and should open to the right with the title or identification on the right. The standard size is needed for administrative recordkeeping.

B. Summary

The summary should include:

- (1) A brief description of the proposed FHWA action indicating route, termini, type of improvement, number of lanes, length, county, city, State, and other information, as appropriate.
- (2) A description of any major actions proposed by other governmental agencies in the same geographic area as the proposed FHWA action.
- (3) A summary of all reasonable alternatives considered. (The draft EIS must identify the preferred alternative or alternatives officially identified by the HA (40 CFR 1502.14(e)). The final EIS must identify the preferred alternative and should discuss the basis for its selection (23 CFR 771.125(a)(1)).
- (4) A summary of major environmental impacts, both beneficial and adverse.
- (5) Any areas of controversy (including issues raised by agencies and the public).
- (6) Any major unresolved issues with other agencies.

- (7) A list of other Federal actions required for the proposed action (i.e., permit approvals, land transfer, Section 106 agreements, etc.).

C. Table of Contents

For consistency with CEQ regulations, the following standard format should be used:

- (1) Cover Sheet
- (2) Summary
- (3) Table of Contents
- (4) Purpose of and Need for Action
- (5) Alternatives
- (6) Affected Environment
- (7) Environmental Consequences
- (8) List of Preparers
- (9) List of Agencies, Organizations, and Persons to Whom Copies of the Statement are Sent
- (10) Comments and Coordination
- (11) Index
- (12) Appendices (if any)

D. Purpose of and Need for Action

Identify and describe the proposed action and the transportation problem(s) or other needs which it is intended to address (40 CFR 1502.13). This section should clearly demonstrate that a “need” exists and should define the “need” in terms understandable to the general public. This discussion should clearly describe the problems which the proposed action is to correct. It will form the basis for the “no action” discussion in the “Alternatives” section, and assist with the identification of reasonable alternatives and the selection of the preferred alternative. Charts, tables, maps and other illustrations (e.g., typical cross-section, photographs, etc.) are encouraged as useful presentation techniques.

The following is a list of items which may assist in the explanation of the need for the proposed action. It is by no means all-inclusive or applicable in every situation and is intended only as a guide:

- (1) Project Status — Briefly describe the project history including actions taken to date, other agencies and governmental units involved, actions pending, schedules, etc.
- (2) System Linkage — Is the proposed project a “connecting link?” How does it fit in the transportation system?
- (3) Capacity — Is the capacity of the present facility inadequate for the present traffic? Projected traffic? What capacity is needed? What is the level(s) of service for existing and proposed facilities?

- (4) Transportation Demand — Including relationship to any statewide plan or adopted urban transportation plan together with an explanation of the project's traffic forecasts that are substantially different from those estimates from the 23 U.S.C. 134 (Section 134) planning process.
- (5) Legislation — Is there a Federal, State, or local governmental mandate for the action.
- (6) Social Demands or Economic Development — New employment, schools, land use plans, recreation, etc. What projected economic development/land use changes indicate the need to improve or add to the highway capacity?
- (7) Modal Interrelationships — How will the proposed facility interface with and serve to complement airports, rail and port facilities, mass transit services, etc.?
- (8) Safety — Is the proposed project necessary to correct an existing or potential safety hazard? Is the existing accident rate excessively high? Why? How will the proposed project improve it.
- (9) Roadway Deficiencies — Is the proposed project necessary to correct existing roadway deficiencies (e.g., substantial geometrics, load limits on structures, inadequate cross-section, or high maintenance costs)? How will the proposed project improve it?

E. Alternatives

This section of the draft EIS must discuss a range of alternatives, including all “reasonable alternatives” under consideration and those “other alternatives” which were eliminated from detailed study (23 CFR 771.123(c)). The section should begin with a concise discussion of how and why the “reasonable alternatives” were selected for detailed study and explain why “other alternatives” were eliminated. The following range of alternatives should be considered when determining reasonable alternatives:

- (1) “No-action” alternative: The “no-action” alternative normally includes short-term minor restoration types of activities (safety and maintenance improvements, etc.) that maintain continuing operation of the existing roadway.
- (2) Transportation System Management (TSM) alternative: The TSM alternative includes those activities which maximize the efficiency of the present system. Possible subject areas to include in this alternative are options such as fringe parking, ride-sharing, high-occupancy vehicle (HOV) lanes on existing roadways, and traffic signal timing optimization. This limited construction alternative is usually relevant only for major projects proposed in urbanized areas over 200,000 population.

For all major projects in these urbanized areas, HOV lanes should be considered. Consideration of this alternative may be accomplished by reference to the regional transportation plan, when that plan considers this option. Where a regional transportation plan does not reflect consideration of this option, it may be necessary to evaluate the feasibility of HOV lanes during early project development. Where a TSM alternative is identified as a reasonable alternative for a “connecting link” project, it should be evaluated to determine the effect that not building a highway link in the transportation plan will have on the remainder of the system. A similar analysis should be made where a TSM element(s) (e.g., HOV lanes) is part of a build alternative and reduces the scale of the highway link.

While the above discussion relates primarily to major projects in urbanized areas, the concept of achieving maximum utilization of existing facilities is equally important in rural areas. Before selecting an alternative on new location for major projects in rural areas, it is important to demonstrate that reconstruction and rehabilitation of the existing system will not adequately correct the identified deficiencies and meet the project need.

- (3) Mass Transit: This alternative includes those reasonable and feasible transit options (bus systems, rail, etc.) even though they may not be within the existing FHWA funding authority. It should be considered on all proposed major highway projects in urbanized areas over 200,000 population. Consideration of this alternative may be accomplished by reference to the regional or area transportation plan where that plan considers mass transit or by an independent analysis during early project development.

Where urban projects are multi-modal and are proposed for Federal funding, close coordination is necessary with the Urban Mass Transportation Administration (UMTA). In these situations, UMTA should be consulted early in the project-development process. Where UMTA funds are likely to be requested for portions of the proposal, UMTA must be requested to be either a joint lead agency or a cooperating agency at the earliest stages of project development (23 CFR 771.111(d)). Where applicable, cost-effectiveness studies that have been performed should be summarized in the EIS.

- (4) Build alternatives: Both improvement of existing highway(s) and alternatives on new location should be evaluated. A representative number of reasonable alternatives must be presented and evaluated in detail in the draft EIS (40 CFR 1502.14(a)). For most major projects, there is a potential for a large number of reasonable alternatives. Where there is a large number of alternatives, only a representative number of the most reasonable examples, covering the full range of alternatives, must be presented. The determination of the number of reasonable alternatives in the draft EIS, therefore, depends on the particular project and the facts and circumstances in each case. Each alternative should be briefly described using maps or other visual aids such as photographs, drawings, or sketches to help explain the various alternatives. The material should provide a clear understanding of each alternative's termini, location, costs, and the project concept (number of lanes, right-of-way requirements, median width, access control, etc.). Where land has been or will be reserved or dedicated by local government(s), donated by individuals, or acquired through advanced or hardship acquisition for use as highway right-of-way for any alternative under consideration, the draft EIS should identify the status and extent of such property and the alternatives involved. Where such lands are reserved, the EIS should state that the reserved lands will not influence the alternative to be selected.

Development of more detailed design for some aspects (e.g., Section 4(f), COE or CG permits, noise, wetlands, etc.) of one or more alternatives may be necessary during preparation of the draft and final EIS in order to evaluate impacts or mitigation measures or to address issues raised by other agencies or the public. However, care should be taken to avoid unnecessarily specifying features which preclude cost-effective final design options.

All reasonable alternatives under consideration (including the no-build) need to be developed to a comparable level of detail in the draft EIS so that their comparative merits may be evaluated (40 CFR 1502.14(b) and (d)). In those situations where the HA has officially identified a "preferred" alternative based on its early coordination and environmental studies, the HA should so indicate in the draft EIS. In these instances, the draft EIS should include a statement indicating that the final selection of an alternative will not be made until the alternatives' impacts and comments on the draft EIS and from the public hearing (if held) have been fully evaluated. Where a preferred alternative has not been identified, the draft EIS should state that all reasonable

alternatives are under consideration and that decision will be made after the alternatives' impacts and comments on the draft EIS and from the public hearing (if held) have been fully evaluated.

The final EIS must identify the preferred alternative and should discuss the basis for its selection (23 CFR 771.125(a)(1)). The discussion should provide the information and rationale identified in Section VIII (Record of Decision), paragraph (B). If the preferred alternative is modified after the draft EIS, the final EIS should clearly identify the changes and discuss the reasons why any new impacts are not significant.

F. Affected Environment

This section provides a concise description of the existing social, economic, and environmental setting for the area affected by all alternatives presented in the EIS. Where possible, the description should be a single description for the general project area rather than a separate one for each alternative. The general population served and/or affected (city, county, etc.) by the proposed action should be identified by race, color, national origin, and age. Demographic data should be obtained from available secondary sources (e.g., census data, planning reports) unless more detailed information is necessary to address specific concerns. All socially, economically, and environmentally sensitive locations or features in the proposed project impact area (e.g., neighborhoods, elderly/minority/ethnic groups, parks, hazardous material sites, historic resources, wetlands, etc.) should be identified on exhibits and briefly described in the text. However, it may be desirable to exclude from environmental documents the specific location of archeological sites to prevent vandalism.

To reduce paperwork and eliminate extraneous background material, the discussion should be limited to data, information, issues, and values which will have a bearing on possible impacts, mitigation measures, and on the selection of an alternative. Data and analyses should be commensurate with the importance of the impact, with the less important material summarized or referenced rather than be reproduced. Photographs, illustrations, and other graphics should be used with the text to give a clear understanding of the area and the important issues. Other Federal activities which contribute to the significance of the proposed action's impacts should be described.

This section should also briefly describe the scope and status of the planning processes for the local jurisdictions and the project area. Maps of any adopted land use and transportation plans for these jurisdictions and the project area would be helpful in relating the proposed project to the planning processes.

G. Environmental Consequences

This section includes the probable beneficial and adverse social, economic and environmental effects of alternatives under consideration and describes the measures proposed to mitigate adverse impacts. The information should have sufficient scientific and analytical substance to provide a basis for evaluating the comparative merits of the alternatives. The discussion of the proposed project impacts should not use the term significant in describing the level of impacts. There is no benefit to be gained from its use. If the term significant is used, however, it should be consistent with the CEQ definition and be supported by factual information.

There are two principal ways of preparing this section. One is to discuss the impacts and mitigation measures separately for each alternative with the alternatives as headings. The second (which is advantageous where there are few alternatives or where impacts are similar for the various alternatives) is to present this section with the impacts as the headings. Where appropriate, a sub-section should be included which discusses the general impacts and mitigation measures that are the same for the various alternatives under consideration. This would reduce

or eliminate repetition under each of the alternative discussions. Charts, tables, maps, and other graphics illustrating comparisons between the alternatives (e.g., costs, residential displacements, noise impacts, etc.) are useful as a presentation technique.

When preparing the final EIS, the impacts and mitigation measures of the alternatives, particularly the preferred alternative, may need to be discussed in more detail to elaborate on information, firm-up commitments or address issues raised following the draft EIS. The final EIS should also identify any new impacts (and their significance) resulting from modification of or identification of substantive new circumstances or information regarding the preferred alternative following the draft EIS circulation. Note: Where new significant impacts are identified, a supplemental draft EIS is required (40 CFR 1502.9(c)).

The following information should be included in both the draft and final EIS for each reasonable alternative:

- (1) A summary of studies undertaken, any major assumptions made and supporting information on the validity of the methodology (where the methodology is not generally accepted as state-of-the-art).
- (2) Sufficient supporting information or results of analyses to establish the reasonableness of the conclusions on impacts.
- (3) A discussion of mitigation measures. These measures normally should be investigated in appropriate detail for each reasonable alternative so they can be identified in the draft EIS. The final EIS should identify, describe and analyze all proposed mitigation measures for the preferred alternative.

In addition to normal FHWA program monitoring of design and construction activities, special instances may arise when a formal program for monitoring impacts or implementation of mitigation measures will be appropriate. For example, monitoring ground or surface waters that are sources for drinking water supply; monitoring noise or vibration of nearby sensitive activities (e.g., hospitals, schools); or providing an on-site professional archeologist to monitor excavation activities in highly sensitive archeological areas. In these instances, the final EIS should describe the monitoring program.

- (4) A discussion, evaluation and resolution of important issues on each alternative. If important issues raised by other agencies on the preferred alternative remain unresolved, the final EIS must identify those issues and the consultations and other efforts made to resolve them (23 CFR 771.125(a)(2)).

Listed below are potentially significant impacts most commonly encountered by highway projects. These factors should be discussed for each reasonable alternative where a potential for impact exists. This list is not all-inclusive and, on specific projects, there may be other impact areas that should be included.

1. Land Use Impacts

This discussion should identify the current development trends and the State and/or local government plans and policies on land use and growth in the area which will be impacted by the proposed project.

These plans and policies are normally reflected in the area's comprehensive development plan, and include land use, transportation, public facilities, housing, community services, and other areas.

The land use discussion should assess the consistency of the alternatives with the comprehensive development plans adopted for the area and (if applicable) other plans used in the development of the transportation plan required by Section 134. The secondary social, economic, and environmental impacts of any substantial, foreseeable, induced development should be presented for each alternative, including adverse effects on existing communities. Where possible, the distribution between planned and unplanned growth should be identified.

2. Farmland Impacts

Farmland includes 1) prime, 2) unique, 3) other than prime or unique that is of statewide importance, and 4) other than prime or unique that is of local importance.

The draft EIS should summarize the results of early consultation with the Soil Conservation Service (SCS) and, as appropriate, State and local agriculture agencies where any of the four specified types of farmland could be directly or indirectly impacted by any alternative under consideration. Where farmland would be impacted, the draft EIS should contain a map showing the location of all farmlands in the project impact area, discuss the impacts of the various alternatives and identify measures to avoid or reduce the impacts. Form AD 1006 (Farmland Conversion Impact Rating) should be processed, as appropriate, and a copy included in the draft EIS. Where the Land Evaluation and Site Assessment score (from Form AD 1006) is 160 points or greater, the draft EIS should discuss alternatives to avoid farmland impacts.

If avoidance is not possible, measures to minimize or reduce the impacts should be evaluated and, where appropriate, included in the proposed action.

3. Social Impacts

Where there are foreseeable impacts, the draft EIS should discuss the following items for each alternative commensurate with the level of impacts and to the extent they are distinguishable:

- (a) Changes in the neighborhoods or community cohesion for the various social groups as a result of the proposed action. These changes may be beneficial or adverse and may include splitting neighborhoods, isolating a portion of a neighborhood or an ethnic group, generating new development, changing property values, separating residents from community facilities, etc.
- (b) Changes in travel patterns and accessibility (e.g., vehicular, commuter, bicycle, or pedestrian).
- (c) Impacts on school districts, recreation areas, churches, businesses, police and fire protection, etc. This should include both the direct impacts to these entities and the indirect impacts resulting from the displacement of households and businesses.
- (d) Impacts of alternatives on highway and traffic safety as well as on overall public safety.
- (e) General social groups specially benefited or harmed by the proposed project. The effects of a project on the elderly, handicapped, nondrivers, transit-dependent and minority and ethnic groups are of particular concern and should be described to the extent these effects can be reasonably predicted. Where impacts on a minority or ethnic population are likely to be an important issue, the EIS should contain the following information broken down by race, color, and national origin: the population of the study area, the number of displaced residents, the type and number of displaced businesses, and an estimate of the number of displaced employees in each business sector. Changes in ethnic or minority employment

opportunities should be discussed and the relationship of the project to other Federal actions which may serve or adversely affect the ethnic or minority population should be identified.

The discussion should address whether any social group is disproportionately impacted and identify possible mitigation measures to avoid or minimize any adverse impacts. Secondary sources of information such as census and personal contact with community leaders supplemented by visual inspections normally should be used to obtain the data for this analysis. However, for projects with major community impacts, a survey of the affected area may be needed to identify the extent and severity of impacts on these social groups.

4. Relocation Impacts

The relocation information should be summarized in sufficient detail to adequately explain the relocation situation including anticipated problems and proposed solutions. Project relocation documents from which information is summarized should be referenced in the draft EIS. Secondary sources of information such as census, economic reports and contact with community leaders, supplemented by visual inspections (and, as appropriate, contact with local officials) may be used to obtain the data for this analysis. Where a proposed project will result in displacements, the following information regarding households and businesses should be discussed for each alternative under consideration commensurate with the level of impact and to the extent they are likely to occur:

- (a) An estimate of the number of households to be displaced, including the family characteristics (e.g., minority, ethnic, handicapped, elderly, large family, income level, and owner/tenant status). However, where there are very few displacees, information on race, ethnicity and income levels should not be included in the EIS to protect the privacy of those affected.
- (b) A discussion comparing available (decent, safe, and sanitary) housing in the area with the housing needs of the displacees. The comparison should include (1) price ranges, (2) sizes (number of bedrooms), and (3) occupancy status (owner/tenant).
- (c) A discussion of any affected neighborhoods, public facilities, non-profit organizations, and families having special composition (e.g., ethnic, minority, elderly, handicapped, or other factors) which may require special relocation considerations and the measures proposed to resolve these relocation concerns.
- (d) A discussion of the measures to be taken where the existing housing inventory is insufficient, does not meet relocation standards, or is not within the financial capability of the displacees. A commitment to last resort housing should be included when sufficient comparable replacement housing may not be available.
- (e) An estimate of the numbers, descriptions, types of occupancy (owner/tenant), and sizes (number of employees) of businesses and farms to be displaced. Additionally, the discussion should identify (1) sites available in the area to which the affected businesses may relocate, (2) likelihood of such relocation, and (3) potential impacts on individual businesses and farms caused by displacement or proximity of the proposed highway if not displaced.
- (f) A discussion of the results of contacts, if any, with local governments, organizations, groups, and individuals regarding residential and business relocation impacts, including any measures or coordination needed to reduce general and/or specific impacts. These contacts are encouraged for projects with large numbers of relocatees or complex relocation requirements. Specific financial and incentive programs or opportunities (beyond those

provided by the Uniform Relocation Act) to residential and business relocatees to minimize impacts may be identified, if available through other agencies or organizations.

- (g) A statement that (1) the acquisition and relocation program will be conducted in accordance with the Uniform Relocation Assistance and Real Property Acquisition Policies Act of 1970, as amended, and (2) relocation resources are available to all residential and business relocations without discrimination.

5. Economic Impacts

Where there are foreseeable economic impacts, the draft EIS should discuss the following for each alternative commensurate with the level of impacts:

- (a) The economic impacts on the regional and/or local economy such as the effects of the project on development, tax revenues and public expenditures, employment opportunities, accessibility, and retail sales. Where substantial impacts on the economic viability of affected municipalities are likely to occur, they should also be discussed together with a summary of any efforts undertaken and agreements reached for using the transportation investment to support both public and private economic development plans. To the extent possible, this discussion should rely upon results of coordination with and views of affected State, county, and city officials and upon studies performed under Section 134.
- (b) The impacts on the economic vitality of existing highway-related businesses (e.g., gasoline stations, motels, etc.) and the resultant impact, if any, on the local economy. For example, the loss of business or employment resulting from building an alternative on new location bypassing a local community.
- (c) Impacts of the proposed action on established business districts, and any opportunities to minimize or reduce such impacts by the public and/or private sectors. This concern is likely to occur on a project that might lead to or support new large commercial development outside of a central business district.

6. Joint Development

Where appropriate, the draft EIS should identify and discuss those joint development measures which will preserve or enhance an affected community's social, economic, environmental, and visual values. This discussion may be presented separately or combined with the land use and/or social impacts presentations. The benefits to be derived, those who will benefit (communities, social groups, etc.) and the entities responsible for maintaining the measures should be identified.

7. Considerations Relating to Pedestrians and Bicyclists

Where current pedestrian or bicycle facilities or indications of use are identified, the draft EIS should discuss the current and anticipated use of the facilities, the potential impacts of the affected alternatives, and proposed measures, if any, to avoid or reduce adverse impacts to the facility(ies) and its users. Where new facilities are proposed as a part of the proposed highway project, the EIS should include sufficient information to explain the basis for providing the facilities (e.g., proposed bicycle facility is a link in the local plan or sidewalks will reduce project access impact to the community). The final EIS should identify those facilities to be included in the preferred alternative. Where the preferred alternative would sever an existing major route for non-motorized transportation traffic, the proposed project needs to provide a reasonable alternative route or demonstrate that such a route exists (23 U.S.C. 109(n)). To the fullest extent possible, this needs to be described in the final EIS.

8. Air Quality Impacts

The draft EIS should contain a brief discussion of the transportation-related air quality concerns in the project area and a summary of the project-related carbon monoxide (CO) analysis if such analysis is performed. The following information should be presented, as appropriate:

- (a) Mesoscale Concerns: Ozone (O_3), Hydrocarbons (HC) and Nitrogen Oxide (NO_x) air quality concerns are regional in nature and as such meaningful evaluation on a project-by-project basis is not possible. Where these pollutants are an issue, the air quality emissions inventories in the State Implementation Plan (SIP) should be referenced and briefly summarized in the draft EIS. Further, the relationship of the project to the SIP should be described in the EIS by including one of the following statements:
- (1) This project is in an area where the SIP does not contain any transportation control measures. Therefore, the conformity procedures of 23 CFR 770 do not apply to this project.
 - (2) This project is in an area which has transportation control measures in the SIP which was (conditionally) approved by the Environmental Protection Agency (EPA) on (date). The FHWA has determined that both the transportation plan and the transportation improvement program conform to the SIP. The FHWA has determined that this project is included in the transportation improvement program for the (indicate 3C planning area). Therefore, pursuant to 23 CFR 770, this project conforms to the SIP.

Under certain circumstances, neither of these statements will precisely fit the situation and may need to be modified. Additionally, if the project is a Transportation Control Measure from the SIP, this should be highlighted to emphasize the project's air quality benefits.

- (b) Microscale Concerns: Carbon monoxide is a project-related concern and as such should be evaluated in the draft EIS. A microscale CO analysis is unnecessary where such impacts (project CO contribution plus background) can be judged to be well below the 1- and 8-hour National Ambient Air Quality Standards (or other applicable State or local standards). This judgment may be based on (1) previous analyses for similar projects; (2) previous general analyses for various classes of projects; or (3) simplified graphical or "look-up" table evaluations. In these cases, a brief statement stating the basis for the judgment is sufficient.

For those projects where a microscale CO analysis is performed, each reasonable alternative should be analyzed for the estimated time of completion and design year. A brief summary of the methodologies and assumptions used should be included in the draft EIS. Lengthy discussions, if needed, should be included in a separate technical report and referenced in the EIS. Total CO concentrations (project contribution plus estimated background) at identified reasonable receptors for each alternative should be reported. A comparison should be made between alternatives and with applicable State and nation standards. Use of a table for this comparison is recommended for clarity.

As long as the total predicted 1-hour CO concentration is less than 9 ppm (the 8-hour CO standard), no separate 8-hour analysis is necessary. If the 1-hour CO concentration is greater than 9 ppm, an 8-hour analysis should be performed. Where the preferred alternative would result in violations of the 1 or 8-hour CO standards, an effort should be made to develop reasonable mitigation measures through early coordination between FHWA, EPA, and appropriate State and local highway and air quality agencies. The final EIS should discuss the proposed mitigation measures and include evidence of the coordination.

9. Noise Impacts

The draft EIS should contain a summary of the noise analysis including the following for each alternative under detailed study:

- (a) A brief description of noise sensitive areas (residences, businesses, schools, parks, etc.), including information on the number and types of activities which may be affected. This should include developed lands and undeveloped lands for which development is planned, designed, and programmed.
- (b) The extent of the impact (in decibels) at each sensitive area. This includes a comparison of the predicted noise levels with both the FHWA noise abatement criteria and the existing noise levels. (Traffic noise impacts occur when the predicted traffic noise levels approach or exceed the noise abatement criteria or when they substantially exceed the existing noise levels). Where there is a substantial increase in noise levels, the HA should identify the criterion used for defining “substantial increase.” Use of a table for this comparison is recommended for clarity.
- (c) Noise abatement measures which have been considered for each impacted area and those measures that are reasonable and feasible and that would “likely” be incorporated into the proposed project. Estimated costs, decibel reductions and height and length of barriers should be shown for all abatement measures.

Where it is desirable to qualify the term “likely,” the following statement or similar wording would be appropriate: “Based on the studies completed to date, the State intends to install noise abatement measures in the form of a barrier at (location(s)). These preliminary indications of likely abatement measures are based upon preliminary design for a barrier of _____ high and _____ long and a cost of \$_____ that will reduce the noise level by _____ dBA for _____ residences (businesses, schools, parks, etc.). (Where there is more than one barrier, provide information for each one.) If during final design these conditions substantially change, the abatement measures might not be provided. A final decision on the installation of abatement measure(s) will be made upon completion of the project design and the public involvement process.”

- (d) Noise impacts for which no prudent solution is reasonably available and the reasons why.

10. Water Quality Impacts

The draft EIS should include summaries of analyses and consultations with the State and/or local agency responsible for water quality. Coordination with the EPA under the Federal Clean Water Act may also provide assistance in this area. The discussion should include sufficient information to describe the ambient conditions of streams and water bodies which are likely to be impacted and identify the potential impacts of each alternative and proposed mitigation measures. Under normal circumstances, existing data may be used to describe ambient conditions. The inclusion of water quality data spanning several years is encouraged to reflect trends.

The draft EIS should also identify any locations where roadway runoff or other nonpoint source pollution may have an adverse impact on sensitive water resources such as water supply reservoirs, ground water recharge areas, and high quality streams. The 1981 FHWA research report entitled “Constituents of Highway Runoff,” the 1985 report entitled “Management Practices for Mitigation of Highway Stormwater Runoff Pollution” and the 1987 report entitled “Effects of Highway Runoff on Receiving Waters” contain procedures for estimating pollutant loading from highway runoff and would be helpful in determining the level of potential impacts and appropriate mitigation measures. The draft EIS should identify the potential impacts of each alternative and proposed mitigation measures.

Where an area designated as principal or sole-source aquifer under Section 1424(e) of the Safe Drinking Water Act may be impacted by a proposed project, early coordination with EPA will assist in identifying potential impacts. The EPA will furnish information on whether any of the alternatives affect the aquifer. This coordination should also identify any potential impacts to the critical aquifer protection area (CAPA), if designated, within affected sole-source aquifers. If none of the alternatives affect the aquifer, the requirements of the Safe Drinking Water Act are satisfied. If an alternative is selected which affects the aquifer, a design must be developed to assure, to the satisfaction of EPA, that it will not contaminate the aquifer (40 CFR 149). The draft EIS should document coordination with EPA and identify its position on the impacts of the various alternatives. The final EIS should show that EPA's concerns on the preferred alternative have been resolved.

Wellhead protection areas were authorized by the 1986 Amendments to the Safe Drinking Water Act. Each State will develop State wellhead protection plans with final approval by EPA. When a proposed project encroaches on a wellhead protection area, the draft EIS should identify the area, the potential impact of each alternative and proposed mitigation measures. Coordination with the State agency responsible for the protection plan will aid in identifying the areas, impacts and mitigation. If the preferred alternative impacts these areas, the final EIS should document that it complies with the approved State wellhead protection plan.

11. Permits

If a facility such as a safety rest area is proposed and it will have a point source discharge, a Section 402 permit will be required for point source discharge (40 CFR 122). The draft EIS should discuss potential adverse impacts resulting from such proposed facilities and identify proposed mitigation measures. The need for a Section 402 permit and Section 401 water quality certification should be identified in the draft EIS.

For proposed actions requiring a Section 404 or Section 10 (Corps of Engineers) permit, the draft EIS should identify by alternative the general location of each dredge or fill activity, discuss the potential adverse impacts, identify proposed mitigation measures (if not addressed elsewhere in the draft EIS), and include evidence of coordination with the Corps of Engineers (in accordance with the U.S. DOT/Corps of Engineers Memorandum of Agreement) and appropriate Federal, State and local resource agencies and State and local water quality agencies. Where the preferred alternative requires an individual Section 404 or Section 10 permit, the final EIS should identify for each permit activity the approximate quantities of dredge or fill material, general construction grades and proposed mitigation measures.

For proposed actions requiring Section 9 (U.S. Coast Guard bridge) permits, the draft EIS should identify by alternative the location of the permit activity, potential impacts to navigation and the environment (if not addressed elsewhere in the document), proposed mitigation measures and evidence of coordination with the U.S. Coast Guard (in accordance with the FHWA/U.S. Coast Guard Memorandum of Understanding). Where the preferred alternative requires a Section 9 permit, the final EIS should identify for each permit activity the proposed horizontal and vertical navigational clearances and include an exhibit showing the various dimensions.

For all permit activities, the final EIS should include evidence that every reasonable effort has been made to resolve the issues raised by other agencies regarding the permit activities. If important issues remain unresolved, the final EIS must identify those issues, the positions of the respective agencies on the issues and the consultations and other efforts made to resolve them (23 CFR 771.125(a)).

12. Wetland Impacts

When an alternative will impact wetlands the draft EIS should (1) identify the type, quality and function of wetlands involved, (2) describe the impacts to the wetlands, (3) evaluate alternatives which would avoid these wetlands, and (4) identify practicable measures to minimize harm to the wetlands. Wetlands should be identified by using the definition of 33 CFR 328.3(b) (issued on November 13, 1986) which requires the presence of hydrophytic vegetation, hydric soils and wetland hydrology. Exhibits showing wetlands in the project impact area in relation to the alternatives, should be provided.

In evaluating the impact of the proposed project on wetlands, the following two items should be addressed: (1) the importance of the impacted wetland(s) and (2) the severity of this impact. Merely listing the number of acres taken by the various alternatives of a highway proposal does not provide sufficient information upon which to determine the degree of impact on the wetland ecosystem. The wetlands analysis should be sufficiently detailed to provide an understanding of these two elements.

In evaluating the importance of the wetlands, the analysis should consider such factors as: (1) the primary functions of the wetlands (e.g., flood control, wildlife habitat, ground water recharge, etc.), (2) the relative importance of these functions to the total wetland resource of the area, and (3) other factors such as uniqueness that may contribute to the wetlands importance.

In determining the wetland impact, the analysis should show the project's effects on the stability and quality of the wetland(s). This analysis should consider the short- and long-term effects on the wetlands and the importance of any loss such as: (1) flood control capacity, (2) shore line anchorage potential, (3) water pollution abatement capacity, and (4) fish and wildlife habitat value. The methodology developed by FHWA and described in reports numbered FHWA-IP-82-23 and FHWA-IP-82-24, "A Method for Wetland Functional Assessment Volumes I and II," is recommended for use in conducting this analysis. Knowing the importance of the wetlands involved and the degree of the impact, the HA and FHWA will be in a better position to determine the mitigation efforts necessary to minimize harm to these wetlands. Mitigation measures which should be considered include preservation and improvement of existing wetlands and creation of new wetlands (consistent with 23 CFR 777).

If the preferred alternative is located in wetlands, to the fullest extent possible, the final EIS needs to contain the finding required by Executive Order 11990 that there are no practicable alternatives to construction in wetlands. Where the finding is included, approval of the final EIS will document compliance with the Executive Order 11990 requirements (23 CFR 771.125(a)(1)). The finding should be included in a separate subsection entitled "Only Practicable Alternative Finding" and should be supported by the following information:

- (a) a reference to Executive Order 11990;
- (b) an explanation why there are no practicable alternatives to the proposed action;
- (b) an explanation why the proposed action includes all practicable measures to minimize harm to wetlands; and
- (c) a concluding statement that: "Based upon the above considerations, it is determined that there is no practicable alternative to the proposed construction in wetlands and that the proposed action includes all practicable measures to minimize harm to wetlands which may result from such use."

13. Water Body Modification and Wildlife Impacts

For each alternative under detailed study, the draft EIS should contain exhibits and discussions identifying the location and extent of water body modifications (e.g., impoundment, relocation, channel deepening, filling, etc.). The use of the stream or body of water for recreation, water supply, or other purposes should be identified. Impacts to fish and wildlife resulting from loss degradation, or modification of aquatic or terrestrial habitat should also be discussed. The results of coordination with appropriate Federal, State and local agencies should be documented in the draft EIS. For example, coordination with FWS under the Fish and Wildlife Coordination Act of 1958.

14. Floodplain Impacts

National Flood Insurance Program (NFIP) maps or, if NFIP maps are not available, information developed by the highway agency should be used to determine whether an alternative will encroach on the base (100-year) floodplain. The location hydraulic studies required by 23 CFR 650, Subpart A must include a discussion of the following items commensurate with the level of risk or environmental impact, for each alternative which encroaches on base floodplains or would support base floodplain development:

- (a) The flooding risks;
- (b) The impacts on natural and beneficial floodplain values;
- (c) The support of probable incompatible floodplain development (i.e., any development that is not consistent with a community's floodplain development plan);
- (d) The measures to minimize floodplain impacts; and
- (e) The measures to restore and preserve the natural and beneficial floodplain values.

The draft EIS should briefly summarize the results of the location hydraulic studies. The summary should identify the number of encroachments and any support of incompatible floodplain developments and their potential impacts. Where an encroachment or support of incompatible floodplain development results in substantial impacts, the draft EIS should provide more detailed information on the location, impacts and appropriate mitigation measures. In addition, if any alternative (1) results in a floodplain encroachment or supports incompatible floodplain development having significant impacts or (2) requires a commitment to a particular structure size or type, the draft EIS needs to include an evaluation and discussion of practicable alternatives to the structure or to the significant encroachment. The draft EIS should include exhibits which display the alternatives, the base floodplains and, where applicable, the regulatory floodways.

If the preferred alternative includes a floodplain encroachment having significant impacts, the final EIS must include a finding that it is the only practicable alternative as required by 23 CFR 650, Subpart A. The finding should refer to Executive Order 11988 and 23 CFR 650, Subpart A. It should be included in a separate subsection entitled "Only Practicable Alternative Finding" and must be supported by the following information.

- (a) The reasons why the proposed action must be located in the floodplain;
- (b) The alternatives considered and why they were not practicable; and
- (c) A statement indicating whether the action conforms to applicable State or local floodplain protection standards.

For each alternative encroaching on a designated or proposed regulatory floodway, the draft EIS should provide a preliminary indication of whether the encroachment would be consistent with or

require a revision to the regulatory floodway. Engineering and environmental analyses should be undertaken, commensurate with level of encroachment, to permit the consistency evaluation and identify impacts. Coordination with the Federal Emergency Management Agency (FEMA) and appropriate State and local government agencies should be undertaken for each floodway encroachment. If the preferred alternative encroaches on a regulatory floodway, the final EIS should discuss the consistency of the action with the regulatory floodway. If a floodway revision is necessary, the EIS should include evidence from FEMA and local or State agency indicating that such revision would be acceptable.

15. Wild and Scenic Rivers

If the proposed action could have foreseeable adverse effects on a river on the National Wild and Scenic Rivers System or a river under study for designation to the National Wild and Scenic Rivers System, the draft EIS should identify early coordination undertaken with the agency responsible for managing the listed or study river (i.e., National Park Service (NPS), Fish and Wildlife Service (FWS), Bureau of Land Management (BLM), or Forest Service (FS)). For each alternative under consideration, the EIS should identify the potential adverse effects on the natural, cultural, and recreational values of the listed or study river. Adverse effects include alteration of the free-flowing nature of the river, alteration of the setting or deterioration of water quality. If it is determined that any of the alternatives could foreclose options to designate a study river under the Act, or adversely affect those qualities of a listed river for which it was designated, to the fullest extent possible, the draft EIS needs to reflect consultation with the managing agency on avoiding or mitigating the impacts (23 CFR 771.123(c)). The final EIS should identify measures that will be included in the preferred alternative to avoid or mitigate such impacts.

Publicly owned waters of designated wild and scenic rivers are protected by Section 4(f). Additionally, public lands adjacent to a Wild and Scenic River may be subject to Section 4(f) protection. An examination of any adopted or proposed management plan for a listed river should be helpful in making the determination on applicability of Section 4(f). For each alternative that takes such land, coordination with the agency responsible for managing the river (either NPS, FWS, BLM, or FS) will provide information on the management plan, specific affected land uses and any necessary Section 4(f) coordination.

16. Coastal Barriers

The Coastal Barrier Resources Act (CBRA) establishes certain coastal areas to be protected by prohibiting the expenditure of Federal funds for new and expanded facilities within designated coastal barrier units. When a proposed project impacts a coastal barrier unit, the draft EIS should: include a map showing the relationship of each alternative to the unit(s); identify direct and indirect impacts to the unit(s); quantifying and describing the impacts as appropriate; discuss the results of early coordination with FWS, identifying any issues raised and how they were addressed, and; identify any alternative which (if selected) would require an exception under the Act. Any issues identified or exceptions required for the preferred alternative should be resolved prior to its selection. This resolution should be documented in the final EIS.

17. Coastal Zone Impacts

Where the proposed action is within, or is likely to affect land or water uses within the area covered by a State Coastal Zone Management Program (CZMP) approved by the Department of Commerce, the draft EIS should briefly describe the portion of the affected CZMP plan, identify the potential impacts, and include evidence of coordination with the State Coastal Zone Management agency or appropriate local agency. The final EIS should include the State Coastal Zone Management agency's determination on consistency with the State CZMP plan. (In some States,

an agency will make a consistency determination only after the final EIS is approved, but will provide a preliminary indication before the final EIS that the project is “not inconsistent” or “appears to be consistent” with the plan.) (For direct Federal actions, the final EIS should include the lead agency’s consistency determination and agreement by the State CZM agency.) If the preferred alternative is inconsistent with the State’s approved CZMP, it can be Federally funded only if the Secretary of Commerce makes a finding that the proposed action is consistent with the purpose or objectives of the CZM Act or is necessary in the interest of national security. To the fullest extent possible, such a finding needs to be included in the final EIS. If the finding is denied, the action is not eligible for Federal funding unless modified in such a manner to remove the inconsistency finding. The final EIS should document such results.

18. Threatened or Endangered Species

The HA must obtain information from the FWS of the DOI and/or the National Marine Fisheries Service (NMFS) of the Department of Commerce to determine the presence or absence of listed and proposed threatened or endangered species and designated and proposed critical habitat in the proposed project area (50 CFR 402.12(c)). The information may be (1) a published geographical list of such species or critical habitat; (2) a project-specific notification of a list of such species or critical habitat; or (3) substantiated information from other credible sources. Where the information is obtained from a published geographical list the reasons why this would satisfy the coordination with DOI should be explained. If there are no species or critical habitat in the proposed project area, the Endangered Species Act requirements have been met. The results of this coordination should be included in the draft EIS.

When a proposed species or a proposed critical habitat may be present in the proposed project area, an evaluation or, if appropriate, a biological assessment is made on the potential impacts to identify whether any such species or critical habitat are likely to be adversely affected by the project. Informal consultation with FWS and/or NMFS should be undertaken during the evaluation. The draft EIS should include exhibits showing the location of the species or habitat, summarize the evaluation and potential impacts, identify proposed mitigation measures, and evidence coordination with FWS and/or NMFS. If the project is likely to jeopardize the continued existence of any proposed species or result in the destruction or adverse modification of proposed critical habitat, the HA in consultation with the FHWA must confer with FWS and/or NMFS to attempt to resolve potential conflicts by avoiding, minimizing, or reducing the project impacts (50 CFR 402.10(a)). If the preferred alternative is likely to jeopardize the continued existence of any proposed species or result in the destruction or adverse modification of proposed critical habitat, a conference with FWS and/or NMFS must be held to assist in identifying and resolving potential conflicts. To the fullest extent possible, the final EIS needs to summarize the results of the conference and identify reasonable and prudent alternatives to avoid the jeopardy to such proposed species or critical habitat. If no alternatives exist, the final EIS should explain the reasons why and identify any proposed mitigation measures to minimize adverse effects.

When a listed species or a designated critical habitat may be present in the proposed project area, a biological assessment must be prepared to identify any such species or habitat which are likely to be adversely affected by the proposed project (50 CFR 402.12). Informal consultation should be undertaken or, if desirable, a conference held with FWS and/or NMFS during preparation of the biological assessment. The draft EIS should summarize the following data from the biological assessment:

- (a) The species distribution, habitat needs, and other biological requirements;
- (b) The affected areas of the proposed project;
- (c) Possible impacts to the species including opinions of recognized experts on the species at issue;

- (d) Measures to avoid or minimize adverse impacts; and
- (e) Results of consultation with FWS and/or NMFS.

In selecting an alternative, jeopardy to a listed species or the destruction or adverse modification of designated critical habitat must be avoided (50 CFR 402.01(a)). If the biological assessment indicates that there are no listed species or critical habitat present that are likely to be adversely affected by the preferred alternative, the final EIS should evidence concurrence by the FWS and/or NMFS in such a determination and identify any proposed mitigation for the preferred alternative.

If the results of the biological assessment or consultation with FWS and/or NMFS show that the preferred alternative is likely to jeopardize the continued existence of a listed species or result in the destruction or adverse modification of designated critical habitat, to the fullest extent possible, the final EIS needs to contain: (1) a summary of the biological assessment (see data above for draft EIS); (2) a summary of the steps taken, including alternatives or measures evaluated and conferences and consultations held, to resolve the project's conflicts with the listed species or critical habitat; (3) a copy of the biological opinion; (4) a request for an exemption from the Endangered Species Act; (5) the results of the exemption request; and (6) a statement that (if the exemption is denied) the action is not eligible for Federal funding.

19. Historic and Archeological Preservation

The draft EIS should contain a discussion demonstrating that historic and archeological resources have been identified and evaluated in accordance with the requirements of 36 CFR 800.4 for each alternative under consideration. The information and level of effort needed to identify and evaluate historic and archeological resources will vary from project to project as determined by the FHWA after considering existing information, the views of the SHPO and the Secretary of Interior's "Standards and Guidelines for Archeology and Historic Preservation." The information for newly identified historic resources should be sufficient to determine their significance and eligibility for the National Register of Historic Places. The information for archeological resources should be sufficient to identify whether each warrants preservation in place or whether it is important chiefly because of what can be learned by data recovery and has minimal value for preservation in place. Where archeological resources are not a major factor in the selection of a preferred alternative, the determination of eligibility for the National Register of newly identified archaeological resources may be deferred until after circulation of the draft EIS.

The draft EIS discussion should briefly summarize the methodologies used in identifying historic and archeological resources. Because Section 4(f) of the DOT Act applies to the use of historic resources on or eligible for the National Register and to archeological resources on or eligible for the National Register and which warrant preservation in place, the draft EIS should describe the historical resources listed in or eligible for the National Register and identify any archeological resources that warrant preservation in place. The draft EIS should summarize the impacts of each alternative on and proposed mitigation measures for each resource. The document should evidence coordination with the SHPO on the significance of newly identified historic and archaeological resources, the eligibility of historic resources for the National Register and the effects of each alternative on both listed and eligible historic resources. Where the draft EIS discusses eligibility for the National Register of archeological resources, the coordination with the SHPO on eligibility and effect should address both historic and archeological resources.

The draft EIS can serve as a vehicle for affording the Advisory Council on Historic Preservation (ACHP) an opportunity to comment pursuant to Section 106 requirements if the document contains the necessary information required by 36 CFR 800.8. The draft EIS transmittal letter to the ACHP should specifically request its comments pursuant to 36 CFR 800.6.

To the fullest extent possible, the final EIS needs to demonstrate that all the requirements of 36 CFR 800 have been met. If the preferred alternative has no effect on historic or archeological resources on or eligible for the National Register, the final EIS should indicate coordination with and agreement by the SHPO. If the preferred alternative has an effect on a resource on or eligible for the National Register, the final EIS should contain (a) a determination of no adverse effect concurred in by the Advisory Council on Historic Preservation, (b) an executed memorandum of agreement (MOA), or (c) in the case of a rare situation where FHWA is unable to conclude the MOA, a copy of comments transmitted from the ACHP to the FHWA and the FHWA response to those comments.

The proposed use of land from an historic resource on or eligible for the National Register will normally require an evaluation and approval under Section 4(f) of the DOT Act. Section 4(f) also applies to all archaeological sites on or eligible for the National Register and which warrant preservation in place. (See Section IX for information on Section 4(f) evaluation.)

20. Hazardous Waste Sites

Hazardous waste sites are regulated by the Resource Conservation and Recovery ACT (RCRA) and the Comprehensive Environmental Response, Compensation, and Liability Act (CERCLA). During early planning, the location of permitted and nonregulated hazardous waste sites should be identified. Early coordination with the appropriate Regional Office of the EPA and the appropriate State agency will aid in identifying known or potential hazardous waste sites. If known or potential waste sites are identified, the locations should be clearly marked on a map showing their relationship to the alternatives under consideration. If a known or potential hazardous waste site is affected by an alternative, information about the site, the potential involvement, impacts and public health concerns of the affected alternative(s) and the proposed mitigation measures to eliminate or minimize impacts or public health concerns should be discussed in the draft EIS.

If the preferred alternative impacts a known or potential hazardous waste site, the final EIS should address and resolve the issues raised by the public and governmental agencies.

21. Visual Impacts

The draft EIS should state whether the project alternatives have a potential for visual quality impacts. When this potential exists, the draft EIS should identify the impacts to the existing visual resource, the relationship of the impacts to potential viewers of and from the project, as well as measures to avoid, minimize, or reduce the adverse impacts. When there is potential for visual quality impacts, the draft EIS should explain the consideration given to design quality, art, and architecture in the project planning. These values may be particularly important for facilities located in visually sensitive urban or rural settings. When a proposed project will include features associated with design quality, art or architecture, the draft EIS should be circulated to officially designated State and local arts councils and, as appropriate, other organizations with an interest in design, art, and architecture. The final EIS should identify any proposed mitigation for the preferred alternative.

22. Energy

Except for large scale projects, a detailed energy analysis including computations of BTU requirements, etc., is not needed. For most projects, the draft EIS should discuss in general terms the construction and operational energy requirements and conservation potential of various alternatives under consideration. The discussion should be reasonable and supportable. It might recognize that the energy requirements of various construction alternatives are similar and are generally greater than the energy requirements of the no-build alternative. Additionally, the discussion could point out that the post-construction, operational energy requirements of the facility should be less with the build alternative as opposed to the no-build alternative. In such a situation,

one might conclude that the savings in operational energy requirements would more than offset construction energy requirements and thus, in the long term, result in a net savings in energy usage.

For large-scale projects with potentially substantial energy impacts, the draft EIS should discuss the major direct and/or indirect energy impacts and conservation potential of each alternative. Direct energy impacts refer to the energy consumed by vehicles using the facility. Indirect impacts include construction energy and such items as the effects of any changes in automobile usage. The alternative's relationship and consistency with a State and/or regional energy plan, if one exists, should also be indicated.

The final EIS should identify any energy conservation measures that will be implemented as apart of the preferred alternative. Measures to conserve energy include the use of high-occupancy vehicle incentives and measures to improve traffic flow.

23. Construction Impacts

The draft EIS should discuss the potential adverse impacts (particularly air, noise, water, traffic congestion, detours, safety, visual, etc.) associated with construction of each alternative and identify appropriate mitigation measures. Also, where the impacts of obtaining borrow or disposal of waste material are important issues, they should be discussed in the draft EIS along with any proposed measure to minimize these impacts. The final EIS should identify any proposed mitigation for the preferred alternative.

24. The Relationship Between Local Short-term Uses of Man's Environment and the Maintenance and Enhancement of Long-term Productivity

The EIS should discuss in general terms the proposed action's relationship of local short-term impacts and use of resources and the maintenance and enhancement of long-term productivity. This general discussion might recognize that the build alternatives would have similar impacts. The discussion should point out that transportation improvements are based on State and/or local comprehensive planning which consider(s) the need for present and future traffic requirements within the context of present and future land use development. In such a situation, one might then conclude that the local short-term impacts and use of resources by the proposed action is consistent with the maintenance and enhancement of long-term productivity for the local area, State, etc.

25. Any Irreversible and Irretrievable Commitments of Resources Which Would be Involved in the Proposed Action

The EIS should discuss in general terms the proposed action's irreversible and irretrievable commitment of resources. This general discussion might recognize that the build alternatives would require a similar commitment of natural, physical, human, and fiscal resources. An example of such discussion would be as follows:

"Implementation of the proposed action involves a commitment of a range of natural, physical, human, and fiscal resources. Land used in the construction of the proposed facility is considered an irreversible commitment during the time period that the land is used for a highway facility. However, if a greater need arises for use of the land or if the highway facility is no longer needed, the land can be converted to another use. At present, there is no reason to believe such a conversion will ever be necessary or desirable.

Considerable amounts of fossil fuels, labor, and highway construction materials such as cement, aggregate, and bituminous material are expended. Additionally, large amounts of labor and natural resources are used in the fabrication and preparation of construction materials. These materials are generally not retrievable. However, they are not in short supply and their use will not have an

adverse effect upon continued availability of these resources. Any construction will also require a substantial one-time expenditure of both State and Federal funds which are not retrievable.

The commitment of these resources is based on the concept that residents in the immediate area, State, and region will benefit by the improved quality of the transportation system. These benefits will consist of improved accessibility and safety, savings in time, and greater availability of quality services which are anticipated to outweigh the commitment of these resources.”

H. List of Preparers

This section should include lists of:

(1) State (and local agency) personnel, including consultants, who were primarily responsible for preparing the EIS or performing environmental studies, and a brief summary of their qualifications, including educational background and experience.

(2) The FHWA personnel primarily responsible for preparation or review of the EIS and their qualifications.

(3) The areas of EIS responsibility for each preparer.

I. List of Agencies, Organizations, and Persons to Whom Copies of the Statement are Sent

Draft EIS: List all entities from which comments are being requested (40 CFR 1502.10). Final EIS: Identify those entities that submitted comments on the draft EIS and those receiving a copy of the final EIS (23 CFR 771.125(a) and (g)).

J. Comments and Coordination

1. The draft EIS should contain copies of pertinent correspondence with each cooperating agency, other agencies and the public and summarize: 1) the early coordination process, including scoping; 2) the meetings with community groups (including minority and non-minority interests) and individuals; and 3) the key issues and pertinent information received from the public and government agencies through these efforts.

2. The final EIS should include a copy of substantive comments from the U.S. Secretary of Transportation (OST), each cooperating agency, and other commentors on the draft EIS. Where the response is exceptionally voluminous the comments may be summarized. An appropriate response should be provided to each substantive comment. When the EIS text is revised as a result of the comments received, a copy of the comments should contain marginal references indicating where revisions were made, or the response to the comments should contain such references. The response should adequately address the issue or concern raised by the commentor or, where substantive comments do not warrant further response, explain why they do not, and provide sufficient information to support that position.

The FHWA and the HA are not commentors within the meaning of NEPA and their comments on the draft EIS should not be included in the final EIS. However, the document should include adequate information for FHWA and the HA to ascertain the disposition of the comment(s).

3. The final EIS should (1) summarize the substantive comments on social, economic, environmental and engineering issues made at the public hearing, if one is held, or the public involvement activities or which were otherwise considered and (2) discuss the consideration given to any substantive issue raised and provide sufficient information to support that position.

4. The final EIS should document compliance with requirements of all applicable environmental laws, Executive Orders, and other related requirements, such as Title VI of the Civil Rights Act of 1964. To the extent possible, all environmental issues should be resolved prior to the submission of the final EIS. When disagreement on project issues exists with another agency, coordination with the agency should be undertaken to resolve the issues. Where the issues cannot be resolved, the final EIS should identify any remaining unresolved issues, the steps taken to resolve the issues, and the positions of the respective parties. Where issues are resolved through this effort, the final EIS should demonstrate resolution of the concerns.

K. Index

The Index should include important subjects and areas of major impacts so that a reviewer need not read the entire EIS to obtain information on a specific subject or impact.

L. Appendices

The EIS should briefly explain or summarize methodologies and results of technical analysis and research. Lengthy technical discussions should be contained in a technical report. Material prepared as appendices to the EIS should:

- (1) consist of material prepared specifically for the EIS;
- (2) consist of material which substantiates an analysis fundamental to the EIS;
- (3) be analytic and relevant to the decision to be made; and
- (4) be circulated with the EIS within FHWA, to EPA (Region), and to cooperating agencies and be readily available on request by other parties. Other reports and studies referred to in the EIS should be readily available for review or for copying at a convenient location.

VI. OPTIONS FOR PREPARING FINAL EISs

The CEQ regulations place heavy emphasis on reducing paperwork, avoiding unnecessary work, and producing documents which are useful to decision makers and to the public. With these objectives in mind, three different approaches to preparing final EISs are presented below. The first two approaches can be employed on any project. The third approach is restricted to the conditions specified by CEQ (40 CFR 1503.4(c)).

A. Traditional Approach

Under this approach, the final EIS incorporates the draft EIS (essentially in its entirety) with changes made as appropriate throughout the document to reflect the selection of an alternative, modifications to the project, updated information on the affected environment, changes in the assessment of impacts, the selection of mitigation measures, wetland and floodplain findings, the results of coordination, comments received on the draft EIS and responses to these comments, etc. Since so much information is carried over from the draft to the final, important changes are sometimes difficult for the reader to identify. Nevertheless, this is the approach most familiar to participants in the NEPA process.

B. Condensed Final EIS

This approach avoids repetition of material from the draft EIS by incorporating, by reference, the draft EIS. The final EIS is, thus, a much shorter document than under the traditional approach;

however, it should afford the reader a complete overview of the project and its impacts on the human environment.

The crux of this approach is to briefly reference and summarize information from the draft EIS which has not changed and to focus the final EIS discussion on changes in the project, its setting, impacts, technical analysis, and mitigation that have occurred since the draft EIS was circulated. In addition, the condensed final EIS must identify the preferred alternative, explain the basis for its selection, describe coordination efforts, and include agency and public comments, responses to these comments, and any required findings or determinations (40 CFR 1502.14(e) and 23 CFR 771.125(a)).

The format of the final EIS should parallel the draft EIS. Each major section of the final EIS should briefly summarize the important information contained in the corresponding section of the draft, reference the section of the draft that provides more detailed information, and discuss any noteworthy changes that have occurred since the draft was circulated.

At the time that the final is circulated, an additional copy of the draft EIS need not be provided to those parties that received a copy of the draft EIS when it was circulated. Nevertheless, if, due to the passage of time or other reasons, it is likely that they will have disposed of their original copy of the draft EIS, then a copy of the draft EIS should be provided with the final. In any case, sufficient copies of the draft EIS should be on hand to satisfy requests for additional copies. Both the draft EIS and the condensed final EIS should be filed with EPA under a single final EIS cover sheet.

C. Abbreviated Version of Final EIS

The CEQ regulation (40 CFR 1503.4(c)) provides the opportunity to expedite the final EIS preparation where the only changes needed in the document are minor and consist of the factual corrections and/or an explanation of why the comments received on the draft EIS do not warrant further response. In using this approach, care should be exercised to assure that the draft EIS contains sufficient information to make the findings in (2) below and that the number of errata sheets used to make required changes is small and that these errata sheets together with the draft EIS constitute a readable, understandable, full disclosure document. The final EIS should consist of the draft EIS and an attachment containing the following:

(1)Errata sheets making any necessary corrections to the draft EIS;

(2)A section identifying the preferred alternative and a discussion of the reasons it was selected. The following should also be included in this section where applicable:

(a) final Section 4(f) evaluations containing the information described in Section IX of these guidelines;

(b) wetland finding(s);

(c) floodplain finding(s);

(d) a list of commitments for mitigation measures for the preferred alternative; and

(3)Copies (or summaries) of comments received from circulation of the draft EIS and public hearing and responses thereto.

Only the attachment need be provided to parties who received a copy of the draft EIS, unless it is likely that they will have disposed of their original copy, in which case both the draft EIS and the

attachment should be provided (40 CFR 1503.4(c)). Both the draft EIS and the attachment must be filed with EPA under a single final EIS cover sheet (40 CFR 1503.4(c)).

VII. DISTRIBUTION OF EISs AND SECTION 4(f) EVALUATIONS

A. Environmental Impact Statement

1. After clearance by FHWA, copies of all draft EISs must be made available to the public and circulated for comments by the HA to: all public officials, private interest groups, and members of the public known to have an interest in the proposed action or the draft EIS; all Federal, State, and local government agencies expected to have jurisdiction, responsibility, interest, or expertise in the proposed action; and States and Federal land management entities which may be affected by the proposed action or any of the alternatives (40 CFR 1502.19 and 1503.1). Distribution must be made no later than the time the document is filed with EPA for Federal Register publication and must allow for a minimum 45-day review period (40 CFR 1506.9 and 1506.10). Internal FHWA distribution of draft and final EISs is subject to change and is noted in memorandums to the Regional Administrators as requirements change.

2. Copies of all approved final EISs must be distributed to all Federal, State, and local agencies and private organizations, and members of the public who provided substantive comments on the draft EIS or who requested a copy (40 CFR 1502.19). Distribution must be made no later than the time the document is filed with EPA for Federal Register publication and must allow for a minimum 30-day review period before the Record of Decision is approved (40 CFR 1506.9 and 1506.10). Two copies of all approved EISs should be forwarded to the FHWA Washington Headquarters (HEV-11) for recordkeeping purposes.

3. Copies of all EISs should normally be distributed to EPA and DOI as follows, unless the agency has indicated to the FHWA offices the need for a different number of copies:

(a) The EPA Headquarters: five copies of the draft EIS and five copies of the final EIS (This is the "filing requirement" in Section 1506.9 of the CEQ regulation.) To the following address: Environmental Protection Agency, Office of Federal Activities (A-104), 401 M Street, SW., Washington, D.C. 20460.

(b) The appropriate EPA Regional Office responsible for EPA's review pursuant to Section 309 of the Clean Air Act: five copies of the draft EIS and five copies of the final EIS.

(c) The DOI Headquarters to the following address:

U.S. Department of the Interior
Office of Environmental Project Review
Room 4239
18th and C Streets, NW.
Washington, D.C. 20240

(i) All States in FHWA Regions 1, 3, 4, and 5, plus Hawaii, Guam, American Samoa, Virgin Islands, Arkansas, Iowa, Louisiana, and Missouri; 12 copies of the draft EIS and 7 copies of the final EIS.

(ii) Kansas, Nebraska, North Dakota, Oklahoma, South Dakota, and Texas: 13 copies of the draft EIS and 8 copies of the final EIS.

(iii) New Mexico and all States in FHWA Regions 8, 9, and 10, except Hawaii, North Dakota, and South Dakota: 14 copies of the draft EIS and 9 copies of the final EIS.

Note: DOI Headquarters will make distribution within its Department. While not required, advance distribution to DOI field offices may be helpful to expedite their review.

B. Section 4(f) Evaluation

If the Section 4(f) evaluation is included in a draft EIS, the DOI Headquarters does not need additional copies of the draft or final EIS/Section 4(f) evaluation. If the Section 4(f) evaluation is processed separately or as part of an EA, the DOI should receive seven copies of the draft Section 4(f) evaluation for coordination and seven copies of the final Section 4(f) evaluation for information. In addition to coordination with DOI, draft Section 4(f) evaluations must be coordinated with the officials having jurisdiction over the Section 4(f) property and the Department of Housing and Urban Development (HUD) and the United States Department of Agriculture (USDA) where these agencies have an interest in or jurisdiction over the affected Section 4(f) resource (23 CFR 771.135(i)). The point of coordination for HUD is the appropriate Regional Office and for USDA, the Forest Supervisor of the affected National Forest. One copy should be provided to the officials with jurisdiction and two copies should be submitted to HUD and USDA when coordination is required.

VIII. RECORD OF DECISION — FORMAT AND CONTENT

The Record of Decision (ROD) will explain the reasons for the project decision, summarize any mitigation measures that will be incorporated in the project and document any required Section 4(f) approval. While cross-referencing and incorporation by reference of the final EIS (or final EIS supplement) and other documents are appropriate, the ROD must explain the basis for the project decision as completely as possible, based on the information contained in the EIS (40 CFR 1502.2). A draft ROD should be prepared by the HA and submitted to the Division Office with the final EIS. The following key items need to be addressed in the ROD:

A. Decision.

Identify the selected alternative. Reference to the final EIS (or final EIS supplement) may be used to reduce detail and repetition.

B. Alternatives Considered.

This information can be most clearly organized by briefly describing each alternative and explaining the balancing of values which formed the basis for the decision. This discussion must identify the environmentally preferred alternative(s) (i.e., the alternative(s) that causes the least damage to the biological and physical environment) (40 CFR 1505.2(b)). Where the selected alternative is other than the environmentally preferable alternative, the ROD should clearly state the reasons for not selecting the environmentally preferred alternative. If lands protected by Section 4(f) were a factor in the selection of the preferred alternative, the ROD should explain how the Section 4(f) lands influenced the selection.

The values (social, economic, environmental, cost-effectiveness, safety, traffic, service, community planning, etc.) which were important factors in the decision-making process should be clearly identified along with the reasons some values were considered more important than others. The Federal-aid highway program mandate to provide safe and efficient transportation in the context of all other Federal requirements and the beneficial impacts of the proposed transportation improvements should be included in this balancing. While any decision represents a balancing of the values, the ROD should reflect the manner in which these values were considered in arriving at the decision.

C. Section 4(f).

Summarize the basis for any Section 4(f) approval when applicable (23 CFR 771.127(a)). The discussion should include the key information supporting such approval. Where appropriate, this information may be included in the alternatives discussion above and referenced in this paragraph to reduce repetition.

D. Measures to Minimize Harm.

Describe the specific measures adopted to minimize environmental harm and identify those standard measures (e.g., erosion control, appropriate for the proposed action). State whether all practicable measures to minimize environmental harm have been incorporated into the decision and, if not, why they were not (40 CFR 1505.2(c)).

E. Monitoring or Enforcement Program.

Describe any monitoring or enforcement program which has been adopted for specific mitigation measures, as outlined in the final EIS.

F. Comments on Final EIS.

All substantive comments received on the final EIS should be identified and given appropriate responses. Other comments should be summarized and responses provided where appropriate.

For recordkeeping purposes, a copy of the signed ROD should be provided to the Washington Headquarters (HEV-11). For a ROD approved by the Division Office, copies should be sent to both the Washington Headquarters and the Regional Office.

IX. SECTION 4(f) EVALUATIONS — FORMAT AND CONTENT

A Section 4(f) evaluation must be prepared for each location within a proposed project before the use of Section 4(f) land is approved (23 CFR 771.135(a)). For projects processed with an EIS or an EA/FONSI, the individual Section 4(f) evaluation should be included as a separate section of the document, and for projects processed as categorical exclusions, as a separate Section 4(f) evaluation document. Pertinent information from various sections of the EIS or EA/FONSI may be summarized in the Section 4(f) evaluation to reduce repetition. Where an issue on constructive use Section 4(f) arises and FHWA decides that Section 4(f) does not apply, the environmental document should contain sufficient analysis and information to demonstrate that the resource(s) is not substantially impaired.

The use of Section 4(f) land may involve concurrent requirements of other Federal agencies. Examples include consistency determinations for the use of public lands managed by the Bureau of Land Management, compatibility determinations for the use of land in the National Wildlife Refuge System and the National Park System, determinations of direct and adverse effects for Wild and Scenic Rivers, and approval of land conversions under Section 6(f) of the Land and Water Conservation Fund Act. The mitigation plan developed for the project should include measures which would satisfy the various requirements. For example, Section 6(f) directs the Department of the Interior (National Park Service) to assure that replacement lands of equal value, location and usefulness are provided as conditions to approval of land conversions. Therefore, where a Section 6(f) land conversion is proposed for a highway project, replacement land will be necessary. Regardless of the mitigation proposed, the draft and final Section 4(f) evaluations should discuss the results of coordination with the public official having jurisdiction over the Section 4(f) land and document the National Park Service's position on the Section 6(f) land transfer, respectively.

A. Draft Section 4(f) Evaluation

The following format and content are suggested. The listed information should be included in the Section 4(f) evaluation, as applicable.

1. **Proposed Action.**

Where a separate Section 4(f) evaluation is prepared, describe the proposed project and explain the purpose and need for the project.

2. **Section 4(f) Property.**

Describe each Section 4(f) resource which would be used by any alternative under consideration. The following information should be provided:

- (a) A detailed map or drawing of sufficient scale to identify the relationship of the alternatives to the Section 4(f) property.
- (b) Size (acres or square feet) and location (maps or other exhibits such as photographs, sketches, etc.) of the affected Section 4(f) property.
- (c) Ownership (city, county, State, etc.) and type of Section 4(f) property (park, recreation, historic, etc.).
- (d) Function of or available activities on the property (ball playing, swimming, golfing, etc.).
- (e) Description and location of all existing and planned facilities (ball diamonds, tennis courts, etc.).
- (f) Access (pedestrian, vehicular) and usage (approximate number of users/visitors, etc.).
- (g) Relationship to other similarly used lands in the vicinity.
- (h) Applicable clauses affecting the ownership, such as lease, easement, covenants, restrictions, or conditions, including forfeiture.
- (i) Unusual characteristics of the Section 4(f) property (flooding problems, terrain conditions, or other features) that either reduce or enhance the value of all or part of the property.

3. **Impacts on the Section 4(f) Property(EIS).**

Discuss the impacts on the Section 4(f) property for each alternative (e.g., amount of land to be used, facilities and functions affected, noise, air pollution, visual, etc.). Where an alternative (or alternatives) uses land from more than one Section 4(f) property, a summary table would be useful in comparing the various impacts of the alternative(s). Impacts (such as facilities and functions affected, noise, etc.) Which can be quantified should be quantified. Other impacts (such as visual intrusion) which cannot be quantified should be described.

4. **Avoidance Alternatives.**

Identify and evaluate location and design alternatives which would avoid the Section 4(f) property. Generally, this would include alternatives to either side of the property. Where an alternative would use land from more than one Section 4(f) property, the analysis needs to evaluate alternatives which avoid each and all properties (23 CFR 771.135(l)). The design alternatives should be in the immediate area of the property and consider minor alignment shifts, a reduced facility, retaining structures, etc. individually or in combination, as appropriate. Detailed discussions of alternatives in an EIS or EA need not be repeated in the Section 4(f) portion of the document, but should be

referenced and summarized. However, when alternatives (avoiding Section 4(f) resources) have been eliminated from detailed study the discussion should also explain whether these alternatives are feasible and prudent and, if not, the reasons why.

5. Measures to Minimize Harm.

Discuss all possible measures which are available to minimize the impacts of the proposed action on the Section 4(f) property(ies). Detailed discussions of mitigation measures in the EIS or EA may be referenced and appropriately summarized, rather than repeated.

6. Coordination.

Discuss the results of preliminary coordination with the public official having jurisdiction over the Section 4(f) property and with regional (or local) offices of DOI and, as appropriate, the Regional Office of HUD and the Forest Supervisor of the affected National Forest. Generally, the coordination should include discussion of avoidance alternatives, impacts to the property, and measures to minimize harm. In addition, the coordination with the public official having jurisdiction should include, where necessary, a discussion of significance and primary use of the property.

Note: The conclusion that there are no feasible and prudent alternative is not normally addressed at the draft Section 4(f) evaluation stage. Such conclusion is made only

after the draft Section 4(f) evaluation has been circulated and coordinated and any identified issues adequately evaluated.

B. Final Section 4(f) Evaluation

When the preferred alternative uses Section 4(f) land, the final Section 4(f) evaluation must contain (23 CFR 771.135(i) and (j)):

- (1) All the above information for a draft evaluation.
- (2) A discussion of the basis for concluding that there are no feasible and prudent alternatives to the use of the Section 4(f) land. The supporting information must demonstrate that “there are unique problems or unusual factors involved in the use of alternatives that avoid these properties or that the cost, social, economic, and environmental impacts, or community disruption resulting from such alternatives reach extraordinary magnitudes” (23 CFR 771.135(a)(2)). This language should appear in the document together with the supporting information.
- (3) A discussion of the basis for concluding that the proposed action includes all possible planning to minimize harm to the Section 4(f) property. When there are no feasible and prudent alternatives which avoid the use of Section 4(f) land, the final Section 4(f) evaluation must demonstrate that the preferred alternative is a feasible and prudent alternative with the least harm on the Section 4(f) resources after considering mitigation to the Section 4(f) resources.
- (4) A summary of the appropriate formal coordination with the Headquarters Offices of DOI (and/or appropriate agency under that Department) and, as appropriate, the involved offices of USDA and HUD.
- (5) Copies of all formal coordination comments and a summary of other relevant Section 4(f) comments received and an analysis and response to any questions raised. Where new alternatives or modifications to existing alternatives are identified and will not be given further consideration, the basis for dismissing these alternatives should be provided and supported by factual information.

Where Section 6(f) land is involved, the National Park Service's position on the land transfer should be documented.

(6) Concluding statement as follows: "Based upon the above considerations, there is no feasible and prudent alternative to the use of land from the (identify Section 4(f) property) and the proposed action includes all possible planning to minimize harm to the (Section 4(f) property) resulting from such use."

X. OTHER AGENCY STATEMENTS

A. The FHWA review of statements prepared by other agencies will consider the environmental impact of the proposal on areas within FHWA's functional area of responsibility or special expertise (40 CFR 1503.2).

B. Agencies requesting comments on highway impacts usually forward the draft EIS to the FHWA Washington Headquarters for comment. The FHWA Washington Headquarters will normally distribute these EISs to the appropriate Regional or Division Office (per Regional Office request) and will indicate where the comments should be sent. The Regional Office may elect to forward the draft statement to the Division Office for response.

C. When a field office has received a draft EIS directly from another agency, it may comment directly to that agency if the proposal does not fall within the types indicated in item (d) of this section. If more than one DOT Administration is commenting at the Regional level, the comments should be coordinated by the DOT Regional Representative to the Secretary or designee. Copies of the FHWA comments should be distributed as follows:

- (1) Requesting agency — original and one copy.
- (2) P-14 — one copy.
- (3) DOT Secretarial Representative--one copy.
- (4) HEV-11 — one copy.

D. The following types of actions contained in the draft EIS require FHWA Washington Headquarters review and such EISs should be forwarded to the Director, Office of Environmental Policy, along with Regional comments, for processing:

- (1) actions with national implications, and
- (2) legislation or regulations having national impacts or national program proposals.

XI. REEVALUATIONS

A. Draft EIS Reevaluation

If an acceptable final EIS is not received FHWA within 3 years from the date of the draft EIS circulation, then a written evaluation is required to determine whether there have been changes in the project or its surroundings or new information which would require a supplement to the draft EIS or a new draft EIS (23 CFR 771.129(a)). The written evaluation should be prepared by the HA in consultation with FHWA and should address all current environmental requirements. The entire project should be revisited to assess any changes that have occurred and their effect on the adequacy of the draft EIS.

There is no required format for the written evaluation. It should focus on the changes in the project, its surroundings and impacts and any new issues identified since the draft EIS. Field reviews, additional studies (as necessary) and coordination (as appropriate) with other agencies should be undertaken and the results included in the written evaluation. If, after reviewing the written

evaluation, the FHWA concludes that a supplemental EIS or a new draft EIS is not required, the decision should be appropriately documented. Since the next major step in the project development process is preparation of a final EIS, the final EIS may document the decision. A statement to this fact, the conclusions reached and supporting information should be briefly summarized in the Summary Section of the final EIS.

B. Final EIS Reevaluation

There are two types of reevaluation required for a final EIS: consultation and written evaluation (23 CFR 771.129(b) and (c)). For the first, consultation, the final EIS is reevaluated prior to proceeding with major project approval (e.g., right-of-way acquisition, final design, and plans, specifications, and estimates (PS&E)) to determine whether the final EIS is still valid. The level of analysis and documentation, if any, should be agreed upon by the FHWA and HA. The analysis and documentation should focus on and be commensurate with the changes in the project and its surroundings, potential for controversy, and length of time since the last environmental action. For example, when the consultation occurs shortly after final EIS approval, an analysis usually should not be necessary. However, when it occurs nearly 3 years after final EIS approval, but before a written evaluation is required, the level of analysis should be similar to what normally would be undertaken for a written evaluation. Although written documentation is left to the discretion of the Division Administrator, it is suggested that each consultation be appropriately documented in order to have a record to show the requirements was met.

The second type of reevaluation is a written evaluation. It is required if the HA has not taken additional major steps to advance the project (i.e., has not received from FHWA authority to undertake final design, authority to acquire a significant portion of the right-of-way, or approval of the PS&E) within any 3-year time period after approval of the final EIS, the final supplemental EIS, or the last major FHWA approval action. The written evaluation should be prepared by the HA in consultation with FHWA and should address all current environmental requirements. The entire project should be revisited to assess any changes that have occurred and their effect on the adequacy of the final EIS.

There is no required format for the written evaluation. It should focus on the changes in the project, its surroundings and impacts and any new issues identified since the final EIS was approved. Field reviews, additional environmental studies (as necessary), and coordination with other agencies should be undertaken (as appropriate to address any new impacts or issues) and the results included in the written evaluation. The FHWA Division Office is the action office for the written evaluation. If it is determined that supplemental EIS is not needed, the project files should be document appropriately. In those rare cases where an EA is prepared to serve as the written evaluation, the files should clearly document whether new significant impacts were identified during the reevaluation process.

XII. SUPPLEMENTAL ENVIRONMENTAL IMPACT STATEMENTS (EISs)

Whenever there are changes, new information, or further developments on a project which result in significant environmental impacts not identified in the most recently distributed version of the draft or final EIS, a supplemental EIS is necessary (40 CFR 1502.9(c)). If it is determined that the changes or new information do not result in new or different significant environmental impacts, the FHWA Division Administrator should document the determination. (After final EIS approval, this documentation could take the form of notation to the files; for a draft EIS, this documentation could be a discussion in the final EIS.)

A. Format and Content of a Supplemental EIS

There is no required format for a supplemental EIS. The supplemental EIS should provide sufficient information to briefly describe the proposed action, the reason(s) why a supplement is being prepared, and the status of the previous draft or final EIS. The supplemental EIS needs to address only those changes or new information that are the basis for preparing the supplement and were not addressed in the previous EIS (23 CFR 771.130(a)). Reference to and summarizing the previous EIS is preferable to repeating unchanged, but still valid, portions of the original document. For example, some items such as affected environment, alternatives, or impacts which are unchanged may be briefly summarized and reference. New environmental requirements which became effective after the previous EIS was prepared need to be addressed in the supplemental EIS to the extent they apply to the portion of the project being evaluated and are relevant to the subject of the supplement (23 CFR 771.130(a)). Additionally, to provide an up-to-date status of compliance with NEPA, it is recommended that the supplement summarize the results of any reevaluations that have been performed for portions of or the entire proposed action. By this inclusion, the supplement will reflect an up-to-date consideration of the proposed action and its effects on the human environment. When a previous EIS is referenced, the supplemental EIS transmittal letter should indicate that copies of the original (draft or final) EIS are available and will be provided to all requesting parties.

B. Distribution of a Supplemental EIS

A supplemental EIS will be reviewed and distributed in the same manner as a draft and final EIS (23 CFR 771.130(d)). (See Section VII for additional information.)

XIII. Appendices

Two appendices are included as follows:

Appendix A: Environmental Laws, Authority and Related Statutes and Orders

Appendix B: Preparation and Processing of Notices of Intent.

ENVIRONMENTAL LAWS, AUTHORITY, AND RELATED STATUTES AND ORDERS

AUTHORITY:

42 United States Code (U.S.C.) 4321 et seq., National Environmental Policy Act of 1969, as amended.

23 U.S.C. 138 and 49 U.S.C. 303, Section 4(f) of the Department of Transportation (DOT) Act of 1966.

23 U.S.C. 109(h), (i), and (j) standards.

23 U.S.C. 128, Public Hearings.

23 U.S.C. 315, Rules, Regulations and Recommendations.

23 Code of Federal Regulations (CFR), Part 771, Environmental Impact and Related Procedures.

40 CFR 1500 et seq., Council on Environmental Quality, Regulations for Implementing the Procedural Provisions of the National Environmental Policy Act.

49 CFR 1.48(b), DOT Delegations of Authority to the Federal Highway Administration.

DOT Order 5610.1c, Procedures for Considering Environmental Impacts, September 18, 1979, and subsequent revisions.

RELATED STATUTES AND ORDERS: The following is a list of major statutes and orders on the preparation of environmental documents.

7 U.S.C. 4201 et seq., Farmland Protection Policy Act of 1981.

16 U.S.C. 461 et seq., Archaeological and Historic Preservation Act; and 23 U.S.C. 305.

16 U.S.C. 470f, Section 106, 110(d) and 110(f) of the National Historic Preservation Act of 1966.

16 U.S.C. 662, Section 2 of the Fish and Wildlife Coordination Act.

16 U.S.C. 1452, 1456, Sections 303 and 307 of the Coastal Zone Management Act of 1972.

16 U.S.C. 1271 et. seq., Wild and Scenic Rivers Act.

16 U.S.C. 1536, Section 7 of the Endangered Species Act of 1973.

33 U.S.C. 1251 et seq., Clean Water Act of 1977.

33 U.S.C. 1241 et seq., Resource Conservation and Recovery Act.

42 U.S.C. 300(f) et seq., Safe Drinking Water Act.

42 U.S.C. 4371 et seq., Environmental Quality Improvement Act of 1970.

42 U.S.C. 4601 et seq., Uniform Relocation Assistance and Real Property Acquisition Policies Act of 1970.

42 U.S.C. 4901 et seq., Noise Control Act of 1972.

42 U.S.C. 9601 et seq., Comprehensive Environmental Response, Compensation, and Liability Act of 1980.

42 U.S.C. 7401 et seq., Clean Air Act.

42 U.S.C. 2000d-d4, Title VI of the Civil Rights Act of 1964.

43 U.S.C. Coastal Barriers Resources Act of 1982.

Executive Order 11514, Protection and Enhancement of Environmental Quality, as amended by Executive Order 11991, dated May 24, 1977.

Executive Order 11593, Protection and Enhancement of the Cultural Environment, dated May 13, 1971, implemented by DOT Order 5650.1, dated November 20, 1972.

Executive Order 11988, Floodplain Management, dated May 24, 1977, implemented by DOT Order 5650.2, dated April 23, 1979.

Executive Order 11990, Protection of Wetlands, dated May 24, 1977, implemented by DOT Order 5660.1A, dated August 24, 1978.

Preparation and Processing of Notices of Intent

The CEQ regulations and Title 23, Code of Federal Regulations, Part 771, Environmental Impact and Related Procedures, require the Administration to publish a notice of intent in the Federal Register as soon as practicable after the decision is made to prepare an environmental impact statement (EIS) and before the scoping process (40 CFR 1501.7). A notice of intent will also be published when a decision is made to supplement a final EIS, but will not be necessary when preparing a supplement to a draft EIS (23 CFR 771.130(d)). The responsibility for preparing notices of intent has been delegated to Regional Federal Highway Administrators and subsequently redelegated to Division Administrators. The notice should be sent directly to the Federal Register at the address provided in Attachment 1 and a copy provided to the Project Development Branch (HEV-11), Office of Environmental Policy, and the appropriate Region Office.

In cases where a notice of intent is published in the Federal Register and a decision is made not to prepare the draft EIS or, when the draft EIS has been prepared, a decision is made not to prepare a final EIS, a revised notice of intent should be published in the Federal Register advising of the decision and the reasons for not preparing the EIS. This applies to future and current actions being processed.

Notices of intent should be prepared and processed in strict conformance with the guidelines in Attachment 1 in order to ensure acceptance for publication by the Office of the Federal Register. A sample of each notice of intent for preparation of an EIS and a supplemental EIS is provided as Attachment 2.

The Project Development Branch (HEV-11) will serve as the Federal Register contact point for notice of intent. All inquiries should be directed to that office.

GUIDELINES FOR PREPARATION AND PROCESSING OF NOTICES OF INTENT

FORMAT

1. Typed in black on white bond paper.
2. Paper size: 8-1/2" x 11".
3. Margins: Left at least 1-1/2", all others 1".
4. Spacing: All material double spaced (except title in heading).
5. Heading: Four items on first page at head of document (see Attachment 2):
 - Billing Code No. 4910-22 typed in brackets or parentheses
 - DEPARTMENT OF TRANSPORTATION (all upper case)
 - Federal Highway Administration
 - ENVIRONMENTAL IMPACT STATEMENT; COUNTY OR CITY, STATE (all upper case; single space)

6. Text: Five sections - AGENCY, ACTION, SUMMARY, FOR FURTHER INFORMATION CONTACT, AND SUPPLEMENTARY INFORMATION; each section title in upper case followed by colon (see Content (below) and Samples 1 and 2).

7. Closing:

-Include the Catalog of Federal Domestic Assistance number and title

-Issued on:

(Indent 5 spaces and type or stamp in date when document is signed)

-Signature line

(begin in middle of page; type name, title, and city under the signature; use name and title of the official actually signing the document (e.g., "John Doe, District Engineer," not "John Doe, for the Division Administrator"))

8. Document should be neat and in form suitable for public inspection. Two or more notices of intent can be included in a single document by making appropriate revisions to the heading and text of the document.

CONTENT

1. AGENCY: Federal Highway Administration (FHWA), DOT.

2. ACTION: Notice of Intent.

3. SUMMARY: The FHWA is issuing this notice to advise the public that an environmental impact statement will be prepared for a proposed highway project in

4. FOR FURTHER INFORMATION CONTACT: This section should state the name and address of a person or persons within the FHWA Division Office who can answer questions about the proposed action and the EIS as it is being developed. The listing of a telephone number is optional. State and/or local officials may also be listed, but always following the FHWA contact person.

5. SUPPLEMENTARY INFORMATION: This section should contain:

a. a brief narrative description of the proposed action (e.g., location of the action, type of construction, length of the project, needs which will be fulfilled by the action);

For a supplement to a final EIS add: the original EIS number and approval date, and the reason(s) for preparing the supplement;

b. a brief description of possible alternatives to accomplish the goals of the proposed action (e.g., upgrade existing facility, do nothing (should always be listed), construction on new alignment, mass transit, multi-modal design); and

c. a brief description of the proposed scoping process for the particular action including whether, when, and where any scoping meeting will be held.

For a supplement to a final EIS: the scoping process is not required for a supplement; however, scoping should be discussed to the extent anticipated for the development of the supplement;

In drafting this section:

- use plain English
- avoid technical terms and jargon
- always refer to the proposed action or proposed project (e.g., the proposed action would ...)
- identify all abbreviations
- list FHWA first when other agencies (State or local) are listed as being involved in the preparation of the EIS

PROCESSING

1. Send three (3) duplicate originals each signed in ink by the issuing officer to:

Office of the Federal Register
National Archives and Records Administration
Washington, D.C. 20408

2. The duplicates must be identical in all respects. The Federal Register will accept electrostatic copies as long as they are readable and individually signed.
3. Three (3) additional copies are required if material is printed on both sides. If a single original and two certified copies are sent, the statement "CERTIFIED TO BE A TRUE COPY OF THE ORIGINAL" and the signature of a duly authorized certifying officer must appear on each certified copy.
4. A record should be kept of the date on which each notice is mailed to the Federal Register.
5. Send one (1) copy each to the Project Development Branch (HEV-11) and the Regional office.

SAMPLE 1

[4910-22]

DEPARTMENT OF TRANSPORTATION

Federal Highway Administration

ENVIRONMENTAL IMPACT STATEMENT: WASHINGTON COUNTY, WASHINGTON

AGENCY: Federal Highway Administration (FHWA), DOT.

ACTION: Notice of Intent.

SUMMARY: The FHWA is issuing this notice to advise the public that an environmental impact statement will be prepared for a proposed highway project in Washington County, Washington.

FOR FURTHER INFORMATION CONTACT: James West, District Engineer, Federal Highway Administration, 400 Market Street, State Capital, Washington 98507, Telephone: (206) 222-2222.

SUPPLEMENTARY INFORMATION: The FHWA, in cooperation with the Washington Department of Transportation and the Washington County Highway Department, will prepare an environmental impact statement (EIS) on a proposal to improve U.S. Route 10 (U.S.10) in Washington County, Washington. The proposed improvement would involve the reconstruction of the existing U.S. 10 between the towns of Eastern and Western for a distance of about 20 miles.

Improvements to the corridor are considered necessary to provide for the existing and projected traffic demand. Also, included in this proposal is the replacement of the existing East End Bridge and a new interchange with Washington Highway 20 (W.H. 20) west of Eastern. Alternatives under consideration include (1) taking no action ; (2) using alternate travel modes; (3) widening the existing two-lane highway to four lanes; and (4) constructing a four-line, limited access highway on new location. Incorporated into and studied with the various build alternatives will be design variations of grade and alignment.

Letters describing the proposed action and soliciting comments will be sent to appropriate Federal, State, and local agencies, and to private organizations and citizens who have previously expressed or are known to have interest in this proposal. A series of public meetings will be held in Eastern and Western between May and June 1985. In addition, a public hearing will be held. Public notice will be given of the time and place of the meetings and hearing. The draft EIS will be available for public and agency review and comment prior to the public hearing. No formal scoping meeting is planned at this time.

To ensure that the full range of issues related to this proposed action are addressed and all significant issues identified, comments, and suggestions are invited from all interested parties. Comments or questions concerning this proposed action and the EIS should be directed to the FHWA at the address provided above.

(Catalog of Federal Domestic Assistance Program Number 20.205, Highway Planning and Construction. The regulations implementing Executive Order 12372 regarding intergovernmental consultation on Federal programs and activities apply to this program.)

Issued on: March 26, 1985.

John Doe
Division Administrator
Capital

EXECUTIVE OFFICE OF THE PRESIDENT
COUNCIL ON ENVIRONMENTAL QUALITY
722 JACKSON PLACE, N.W.
WASHINGTON, D.C. 20006
March 16, 1981

**MEMORANDUM FOR FEDERAL NEPA LIAISONS, FEDERAL, STATE AND LOCAL
OFFICIALS AND OTHER PERSONS INVOLVED IN THE NEPA PROCESS**

SUBJECT: Questions and Answers About the NEPA Regulations

During June and July of 1980, the Council on Environmental Quality, with the assistance and cooperation of EPA's EIS Coordinators from the ten EPA regions, held one-day meetings with federal, state and local officials in the ten EPA regional offices around the country. In addition, on July 10, 1980, CEQ conducted a similar meeting for the Washington, D.C. NEPA liaisons and persons involved in the NEPA process. At these meetings, CEQ discussed (a) the results of its 1980 review of Draft EIS's issued since the July 30, 1979 effective date of the NEPA regulations, (b) agency compliance with the Record of Decision requirements in Section 1505 of the NEPA regulations, and (c) CEQ's preliminary findings on how the scoping process is working. Participants at these meetings received copies of materials prepared by CEQ summarizing its oversight and findings.

These meetings also provided NEPA liaisons and other participants with an opportunity to ask questions about NEPA and the practical application of the NEPA regulations. A number of these questions were answered by CEQ representatives at the regional meetings. In response to the many requests from the agencies and other participants, CEQ has compiled forty of the most important or most frequently asked questions and their answers and reduced them to writing. The answers were prepared by the General Counsel of CEQ in consultation with the Office of Federal Activities of EPA. These answers, of course, do not impose any additional requirements beyond those of the NEPA regulations. This document does not represent new guidance under the NEPA regulations, but rather makes generally available to concerned agencies and private individuals the answers which CEQ has already given at the 1980 regional meetings. The answers also reflect the advice which the Council has given over the past two years to aid agency staff and consultants in their day-to-day application of NEPA and the regulations.

CEQ has also received numerous inquiries regarding the scoping process. CEQ hopes to issue written guidance on scoping later this year on the basis of its special study of scoping, which is nearing completion.

NICHOLAS C. YOST
General Counsel

INDEX

Range of Alternatives
Alternatives Outside the Capability of Applicant or Jurisdiction of Agency
No-Action Alternative
Agency's Preferred Alternative
Proposed Action v. Preferred Alternative
Environmentally Preferable Alternative
Difference Between Sections of EIS on Alternatives and Environmental Consequences
Early Application of NEPA
Applicant Who Needs Other Permits
Limitations on Actions During 30-Day Review Period for Final EIS
Limitations on Actions by an Applicant During EIS Process
Effective Date and Enforceability of the Regulations
Use of Scoping Before Notice of Intent to Prepare EIS
Rights and Responsibilities of Lead and Cooperating Agencies
Commenting Responsibilities of EPA
Third Party Contracts
Disclosure Statement to Avoid Conflict of Interest
Uncertainties About Indirect Effects of A Proposal
Mitigation Measures
Worst Case Analysis
Combining Environmental and Planning Documents
State and Federal Agencies as Joint Lead Agencies
Conflicts of Federal Proposal With Land Use Plans, Policies, and Controls
Environmental Impact Statements on Policies, Plans, or Programs
Appendices and Incorporation by Reference
Index and Keyword Index In EISs
List of Preparers
Advance of Xerox Copies of EIS
Responses to Comments
Adoption of EISs
Application of Regulations to Independent Regulatory Agencies
Supplements To Old EISs
Referrals
Records of Decision
Time Required for the NEPA Process
Environmental Assessments (EA)
Findings of No Significant Impact (FONSI)
Public Availability of EAs v. FONSI
Mitigation Measures Imposed in EAs and FONSI
Propriety of Issuing EA When Mitigation Reduces Impacts

QUESTIONS AND ANSWERS ABOUT THE NEPA REGULATIONS (1981)

1a. Q. *What is meant by "range of alternatives" as referred to in Section 1505.1(e)? **

A. The phrase "range of alternatives" refers to the alternatives discussed in environmental documents. It includes all reasonable alternatives, which must be rigorously explored and objectively evaluated, as well as those other alternatives, which are eliminated from detailed study with a brief discussion of the reasons for eliminating them. Section 1502.14. A decisionmaker must not consider alternatives beyond the range of alternatives discussed in the relevant environmental documents. Moreover, a decisionmaker must, in fact, consider all the alternatives discussed in an EIS. Section 1505.1(e).

1b. Q. *How many alternatives have to be discussed when there is an infinite number of possible alternatives?*

A. For some proposals there may exist a very large or even an infinite number of possible reasonable alternatives. For example, a proposal to designate wilderness areas within a National Forest could be said to involve an infinite number of alternatives from 0 to 100 percent of the forest. When there are potentially a very large number of alternatives, only a reasonable number of examples, covering the full spectrum of alternatives, must be analyzed and compared in the EIS. An appropriate series of alternatives might include dedicating 0, 10, 30, 50, 70, 90, or 100 percent of the Forest to wilderness. What constitutes a reasonable range of alternatives depends on the nature of the proposal and the facts in each case.

2a. Q. *If an EIS is prepared in connection with an application for a permit or other federal approval, must the EIS rigorously analyze and discuss alternatives that are outside the capability of the applicant or can it be limited to reasonable alternatives that can be carried out by the applicant?*

A. Section 1502.14 requires the EIS to examine all reasonable alternatives to the proposal. In determining the scope of alternatives to be considered, the emphasis is on what is "reasonable" rather than on whether the proponent or applicant likes or is itself capable of carrying out a particular alternative. Reasonable alternatives include those that are practical or feasible from the technical and economic standpoint and using common sense, rather than simply desirable from the standpoint of the applicant.

2b. Q. *Must the EIS analyze alternatives outside the jurisdiction or capability of the agency or beyond what Congress has authorized?*

A. An alternative that is outside the legal jurisdiction of the lead agency must still be analyzed in the EIS if it is reasonable. A potential conflict with local or federal law does not necessarily render an alternative unreasonable, although such conflicts must be considered. Section 1506.2(d). Alternatives that are outside the scope of what Congress has approved or funded must still be evaluated in the EIS if they are reasonable, because the EIS may serve as the basis for modifying the Congressional approval or funding in light of NEPA's goals and policies. Section 1500.1(a).

3. Q. *What does the "no action" alternative include? If an agency is under a court order or legislative command to act, must the EIS address the "no action" alternative?*

* References throughout the document are to the Council on Environmental Quality's Regulations for Implementing the Procedural Provisions of the National Environmental Policy Act. 40 CFR Parts 1500-1508.

A. Section 1502.14(d) requires the alternatives analysis in the EIS to "include the alternative of no action." There are two distinct interpretations of "no action" that must be considered, depending on the nature of the proposal being evaluated. The first situation might involve an action such as updating a land management plan where ongoing programs initiated under existing legislation and regulations will continue, even as new plans are developed. In these cases, "no action" is "no change" from current management direction or level of management intensity. To construct an alternative that is based on no management at all would be a useless academic exercise. Therefore, the "no action" alternative may be thought of in terms of continuing with the present course of action until that action is changed. Consequently, projected impacts of alternative management schemes would be compared in the EIS to those impacts projected for the existing plan. In this case, alternatives would include management plans of both greater and lesser intensity, especially greater and lesser levels of resource development.

The second interpretation of "no action" is illustrated in instances involving federal decisions on proposals for projects. "No action" in such cases would mean the proposed activity would not take place, and the resulting environmental effects from taking no action would be compared with the effects of permitting the proposed activity or an alternative activity to go forward.

Where a choice of "no action" by the agency would result in predictable actions by others, this consequence of the "no action" alternative should be included in the analysis. For example, if denial of permission to build a railroad to a facility would lead to construction of a road and increased truck traffic, the EIS should analyze this consequence of the "no action" alternative.

In light of the above, it is difficult to think of a situation where it would not be appropriate to address a "no action" alternative. Accordingly, the regulations require the analysis of the no action alternative even if the agency is under a court order or legislative command to act. This analysis provides a benchmark, enabling decisionmakers to compare the magnitude of environmental effects of the action alternatives. It is also an example of a reasonable alternative outside the jurisdiction of the agency which must be analyzed. Section 1502.14(c). See Question 2 above. Inclusion of such an analysis in the EIS is necessary to inform the Congress, the public, and the President as intended by NEPA. Section 1500.1(a).

4a. Q. *What is the "agency's preferred alternative"?*

A. The "agency's preferred alternative" is the alternative which the agency believes would fulfill its statutory mission and responsibilities, giving consideration to economic, environmental, technical and other factors. The concept of the "agency's preferred alternative" is different from the "environmentally preferable alternative," although in some cases one alternative may be both. See Question 6 below. It is identified so that agencies and the public can understand the lead agency's orientation.

4b. Q. *Does the "preferred alternative" have to be identified in the Draft EIS and the Final EIS or just in the Final EIS?*

A. Section 1502.14(e) requires the section of the EIS on alternatives to "identify the agency's preferred alternative if one or more exists, in the draft statement, and identify such alternative in the final statement ..." This means that if the agency has a preferred alternative at the Draft EIS stage, that alternative must be labeled or identified as such in the Draft EIS. If the responsible federal official in fact has no preferred alternative at the Draft EIS stage, a preferred alternative need not be identified there. By the time the Final EIS is filed, Section 1502.14(e) presumes the existence of a preferred alternative and requires its identification in the Final EIS "unless another law prohibits the expression of such a preference."

4c. Q. *Who recommends or determines the "preferred alternative"?*

A. The lead agency's official with line responsibility for preparing the EIS and assuring its adequacy is responsible for identifying the agency's preferred alternative(s). The NEPA regulations do not dictate which official in an agency shall be responsible for preparation of EIS's, but agencies can identify this official in their implementing procedures, pursuant to Section 1507.3.

Even though the agency's preferred alternative is identified by the EIS preparer in the EIS, the statement must be objectively prepared and not slanted to support the choice of the agency's preferred alternative over the other reasonable and feasible alternatives.

5a. Q. *Is the "proposed action" the same thing as the "preferred alternative"?*

A. The "proposed action" may be, but is not necessarily, the agency's "preferred alternative." The proposed action may be a proposal in its initial form before undergoing analysis in the EIS process. If the proposed action is internally generated, such as preparing a land management plan, the proposed action might end up as the agency's preferred alternative. On the other hand, the proposed action may be granting an application to a non-federal entity for a permit. The agency may or may not have a "preferred alternative" at the Draft EIS stage (see Question 4 above). In that case, the agency may decide at the Final EIS stage, on the basis of the Draft EIS and the public and agency comments, that an alternative other than the proposed action is the agency's "preferred alternative."

5b. Q. *Is the analysis of the "proposed action" in an EIS to be treated differently from the analysis of alternatives?*

A. The degree of analysis devoted to each alternative in the EIS is to be substantially similar to that devoted to the "proposed action." Section 1502.14 is titled "Alternatives including the proposed action" to reflect such comparable treatment. Section 1502.14(b) specifically requires "substantial treatment" in the EIS of each alternative including the proposed action. This regulation does not dictate an amount of information to be provided, but rather, prescribes a level of treatment, which may, in turn, require varying amounts of information, to enable a reviewer to evaluate and compare alternatives.

6a. Q. *What is the meaning of the term "environmentally preferable alternative" as used in the regulations with reference to Records of Decisions? How is the term "environment" used in the phrase?*

A. Section 1505.2(b) requires that, in cases where an EIS has been prepared, the Record of Decision (ROD) must identify all alternatives that were considered "... specifying the alternative or alternatives which were considered to be environmentally preferable." The environmentally preferable alternative is the alternative that will promote the national environmental policy as expressed in NEPA's Section 101. Ordinarily, this means the alternative that causes the least damage to the biological and physical environment; it also means the alternative which best protects, preserves, and enhances historic, cultural, and natural resources.

The Council recognizes that the identification of the environmentally preferable alternative may involve difficult judgments, particularly when one environmental value must be balanced against another. The public and other agencies reviewing a Draft EIS can assist the lead agency to develop and determine environmentally preferable alternatives by providing their views in comments on the Draft EIS. Through the identification of the environmentally preferable alternative, the decisionmaker is clearly faced with a choice between that alternative

and others, and must consider whether the decision accords with the Congressionally declared policies of the Act.

6b. Q. *Who recommends or determines what is environmentally preferable?*

A. The agency EIS staff is encouraged to make recommendations of the environmentally preferable alternative(s) during EIS preparation. In any event, the lead agency official responsible for the EIS is encouraged to identify the environmentally preferable alternative(s) in the EIS. In all cases, commentors from other agencies and the public are also encouraged to address this question. The agency must identify the environmentally preferable alternative in the ROD.

7. Q. *What is the difference between the sections in the EIS on "alternatives" and "environmental consequences"? How do you avoid duplicating the discussion of alternatives in preparing these two sections?*

A. The "alternatives" section is the heart of the EIS. This section rigorously explores and objectively evaluates all reasonable alternatives including the proposed action. Section 1502.14. It should include relevant comparisons on environmental and other grounds. The "environmental consequences" section of the EIS discusses the specific environmental impacts or effects of each of the alternatives including the proposed action. Section 1502.16. In order to avoid duplication between these two sections, most of the "alternatives" section should be devoted to describing and comparing the alternatives. Discussion of the environmental impacts of these alternatives should be limited to a concise descriptive summary of such impacts in a comparative form, including charts or tables, thus, sharply defining the issues and providing a clear basis for choice among options. Section 1502.14. The "environmental consequences" section should be devoted largely to a scientific analysis of the direct and indirect environmental effects of the proposed action and of each of the alternatives. It forms the analytic basis for the concise comparison in the "alternatives" section.

8. Q. *Section 1501.2(d) of the NEPA regulations requires agencies to provide for the early application of NEPA to cases where actions are planned by private applicants or non-federal entities and are, at some stage, subject to federal approval of permits, loans, loan guarantees, insurance or other actions. What must and can agencies do to apply NEPA early in these cases?*

A. Section 1501.2(d) requires federal agencies to take steps toward ensuring that private parties and state and local entities initiate environmental studies as soon as federal involvement in their proposals can be foreseen. This section is intended to ensure that environmental factors are considered at an early stage in the planning process and to avoid the situation where the applicant for a federal permit or approval has completed planning and eliminated all alternatives to the proposed action by the time the EIS process commences or before the EIS process has been completed.

Through early consultation, business applicants and approving agencies may gain better appreciation of each other's needs and foster a decisionmaking process which avoids later unexpected confrontations.

Federal agencies are required by Section 1507.3(b) to develop procedures to carry out Section 1501.2(d). The procedures should include an "outreach program," such as a means for prospective applicants to conduct pre-application consultations with the lead and cooperating agencies. Applicants need to find out, in advance of project planning, what environmental studies or other information will be required, and what mitigation requirements are likely, in connection with the later federal NEPA process. Agencies should designate staff

to advise potential applicants of the agency's NEPA information requirements and should publicize their pre-application procedures and information requirements in newsletters or other media used by potential applicants.

Complementing Section 1501.2(d), Section 1506.5(a) requires agencies to assist applicants by outlining the types of information required in those cases where the agency requires the applicant to submit environmental data for possible use by the agency in preparing an EIS.

Section 1506.5(b) allows agencies to authorize preparation of environmental assessments by applicants. Thus, the procedures should also include a means for anticipating and utilizing applicants' environmental studies or "early corporate environmental assessments" to fulfill some of the federal agency's NEPA obligations. However, in such cases, the agency must still evaluate independently the environmental issues and take responsibility for the environmental assessment.

These provisions are intended to encourage and enable private and other non-federal entities to build environmental considerations into their own planning processes in a way that facilitates the application of NEPA and avoids delay.

9. Q. *To what extent must an agency inquire into whether an applicant for a federal permit, funding or other approval of a proposal will also need approval from another agency for the same proposal or some other related aspect of it?*

A. Agencies must integrate the NEPA process into other planning at the earliest possible time to ensure that planning and decisions reflect environmental values, to avoid delays later in the process, and to head off potential conflicts. Specifically, the agency must "provide for cases where actions are planned by . . . applicants," so that designated staff are available to advise potential applicants of studies or other information that will foreseeably be required for the later federal action; the agency shall consult with the applicant if the agency foresees its own involvement in the proposal; and it shall ensure that the NEPA process commences at the earliest possible time. Section 1501.2(d). (See Question 8).

The regulations emphasize agency cooperation early in the NEPA process. Section 1501.6. Section 1501.7 on "scoping" also provides that all affected Federal agencies are to be invited to participate in scoping the environmental issues and to identify the various environmental review and consultation requirements that may apply to the proposed action. Further, Section 1502.25(b) requires that the draft EIS list all the federal permits, licenses and other entitlements that are needed to implement the proposal.

These provisions create an affirmative obligation on federal agencies to inquire early, and to the maximum degree possible, to ascertain whether an applicant is or will be seeking other federal assistance or approval, or whether the applicant is waiting until a proposal has been substantially developed before requesting federal aid or approval.

Thus, a federal agency receiving a request for approval of assistance should determine whether the applicant has filed separate requests for federal approval or assistance with other federal agencies. Other federal agencies that are likely to become involved should be then contacted, and the NEPA process coordinated, to ensure an early and comprehensive analysis of the direct and indirect effects of the proposal and any related actions. The agency should inform the applicant that action on its application may be delayed unless it submits all other federal applications (where feasible to do so), so that all the relevant agencies can work together on the scoping process and preparation of the EIS.

10a. Q. *What actions by agencies and/or applicants are allowed during EIS preparation and during the 30-day review period after publication of a final EIS?*

A. No federal decision on the proposed action shall be made or recorded until at least 30 days after the publication by EPA of notice that the particular EIS has been filed with EPA. Sections 1505.2 and 1506.10. Section 1505.2 requires this decision to be stated in a public Record of Decision.

Until the agency issues its Record of Decision, no action by an agency or an applicant concerning the proposal shall be taken which would have an adverse environmental impact or limit the choice of reasonable alternatives. Section 1506.1(a). But this does not preclude preliminary planning or design work which is needed to support an application for permits or assistance. 1506.1(d).

When the impact statement in question is a program EIS, no major action concerning the program may be taken which may significantly affect the quality of the human environment, unless the particular action is justified independently of the program, is accompanied by its own adequate environmental impact statement and will not prejudice the ultimate decision on the program. Section 1506.1(c).

10.b. Q. *Do these limitations on action (described in Question 10a) apply to state or local agencies that have statutory delegated responsibility for preparation of environmental documents required by NEPA, for example, under the HUD Block Grant program?*

A. Yes, these limitations do apply, without any variation from their application to federal agencies.

11. Q. *What actions must a lead agency take during the NEPA process when it becomes aware that a non-federal applicant is about to take an action within the agency's jurisdiction that would either have an adverse environmental impact or limit the choice of reasonable alternatives (e.g., prematurely commit money or other resources towards the completion of the proposal)?*

A. The federal agency must notify the applicant that the agency will take strong affirmative steps to ensure that the objectives and procedures of NEPA are fulfilled. Section 1506.1(b). These steps could include seeking injunctive measures under NEPA, or the use of sanctions available under either the agency's statutory mission. For example, the agency might advise an applicant that, if it takes such action, the agency will not process its application.

12a. Q. *What actions are subject to the Council's new regulations, and what actions are grandfathered under the old guidelines?*

A. The effective date of the Council's regulations was July 30, 1979 (except for certain HUD programs under the Housing and Community Development Act, 42 U.S.C. 5304(h), and certain state highway programs that qualify under Section 102(2)(D) of NEPA for which the regulations became effective on November 30, 1979). All the provisions of the regulations are binding as of that date, including those covering decisionmaking, public participation, referrals, limitations on actions, EIS supplements, etc. For example, a Record of Decision would be prepared even for decisions where the draft EIS was filed before July 30, 1979.

But in determining whether or not the new regulations apply to the preparation of a particular environmental document, the relevant factor is the date of filing of the draft of that document. Thus, the new regulations do not require the redrafting of an EIS or supplement if the draft EIS or supplement was filed before July 30, 1979. However, a supplement prepared after the effective date of the regulations for an EIS issued in final before the effective date of the regulations would be controlled by the regulations.

Even though agencies are not required to apply the regulations to an EIS or other document for which the draft was filed prior to July 30, 1979, the regulations encourage agencies to follow the regulations "to the fullest extent practicable"; i.e., if it is feasible to do so, in preparing the final document. Section 1506.12(a).

12b. Q. *Are projects authorized by Congress before the effective date of the Council's regulations grandfathered?*

No. The date of Congressional authorization for a project is not determinative of whether the Council's regulations or former Guidelines apply to the particular proposal. No incomplete projects or proposals of any kind are grandfathered in whole or in part. Only certain environmental documents, for which the draft was issued before the effective date of the regulations, are grandfathered and subject to the Council's former Guidelines.

12c. Q. *Can a violation of the regulations give rise to a cause of action?*

A. While a trivial violation of the regulations would not give rise to an independent cause of action, such a cause of action would arise from a substantial violation of the regulations. Section 1500.3.

13. Q. *Can the scoping process be used in connection with preparation of an environmental assessment; i.e., before both the decision to proceed with an EIS and publication of a notice of intent?*

A. Yes. Scoping can be a useful tool for discovering alternatives to a proposal, or significant impacts that may have been overlooked. In cases where an environmental assessment is being prepared to help an agency decide whether to prepare an EIS, useful information might result from early participation by other agencies and the public in a scoping process.

The regulations state that the scoping process is to be preceded by a Notice of Intent (NOI) to prepare an EIS. But that is only the minimum requirement. Scoping may be initiated earlier, as long as there is appropriate public notice and enough information available on the proposal so that the public and relevant agencies can participate effectively.

However, scoping that is done before the assessment, and in aid of its preparation, cannot substitute for the normal scoping process after publication of the NOI, unless the earlier public notice stated clearly that this possibility was under consideration, and the NOI expressly provides that written comments on the scope of alternatives and impacts will still be considered.

14a. Q. *What are the respective rights and responsibilities of lead and cooperating agencies? What letters and memoranda must be prepared?*

A. After a lead agency has been designated (Section 1501.5), that agency has the responsibility to solicit cooperation from other federal agencies that have jurisdiction by law or special expertise on any environmental issue that should be addressed in the EIS being prepared. Where appropriate, the lead agency should seek the cooperation of state or local agencies of similar qualifications. When the proposal may affect an Indian reservation, the agency should consult with the Indian tribe. Section 1508.5. The request for cooperation should come at the earliest possible time in the NEPA process.

After discussions with the candidate cooperating agencies, the lead agency and the cooperating agencies are to determine by letter or by memorandum which agencies will

undertake cooperating responsibilities. To the extent possible at this stage, responsibilities for specific issues should be assigned. The allocation of responsibilities will be completed during scoping. Section 1501.7(a)(4).

Cooperating agencies must assume responsibility for the development of information and the preparation of environmental analyses at the request of the lead agency. Section 1501.6(b)(3). Cooperating agencies are now required by Section 1501.6 to devote staff resources that were normally primarily used to critique or comment on the Draft EIS after its preparation, much earlier in the NEPA process — primarily at the scoping and Draft EIS preparation stages. If a cooperating agency determines that its resource limitations preclude any involvement, or the degree of involvement (amount of work) requested by the lead agency, it must so inform the lead agency in writing and submit a copy of this correspondence to the Council. Section 1501.6(c).

In other words, the potential cooperating agency must decide early if it is able to devote any of its resources to a particular proposal. For this reason, the regulation states that an agency may reply to a request for cooperation that "other program commitments preclude any involvement or the degree of involvement requested in the action that is the subject of the environmental impact statement." (Emphasis added.) The regulation refers to the "action," rather than to the EIS, to clarify that the agency is taking itself out of all phases of the federal action, not just draft EIS preparation. This means that the agency has determined that it cannot be involved in the later stages of EIS review and comment, as well as decisionmaking on the proposed action. For this reason, cooperating agencies with jurisdiction by law (those which have permitting or other approval authority) cannot opt out entirely of the duty to cooperate on the EIS. See also Question 15, relating specifically to the responsibility of EPA.

14b. Q. *How are disputes resolved between lead and cooperating agencies concerning the scope and level of detail by analysis and the quality of data in impact statements?*

A. Such disputes are resolved by the agencies themselves. A lead agency, of course, has the ultimate responsibility for the content of an EIS. But it is supposed to use the environmental analysis and recommendations of cooperating agencies with jurisdiction by law or special expertise to the maximum extent possible, consistent with its own responsibilities as lead agency. Section 1501.6(a)(2).

If the lead agency leaves out a significant issue or ignores the advice and expertise of the cooperating agency, the EIS may be found later to be inadequate. Similarly, where cooperating agencies have their own decisions to make and they intend to adopt the environmental impact statement and base their decisions on it, one document should include all of the information necessary for the decisions by the cooperating agencies. Otherwise, they may be forced to duplicate the EIS process by issuing a new, more complete EIS or Supplemental EIS, even though the original EIS could have sufficed if it had been properly done at the outset. Thus, both lead and cooperating agencies have a stake in producing a document of good quality. Cooperating agencies also have a duty to participate fully in the scoping process to ensure that the appropriate range of issues is determined early in the EIS process.

Because the EIS is not the Record of Decision, but instead constitutes the information and analysis on which to base a decision, disagreements about conclusions to be drawn from the EIS need not inhibit agencies from issuing a joint document, or adopting another agency's EIS, if the analysis is adequate. Thus, if each agency has its own "preferred alternative," both can be identified in the EIS. Similarly, a cooperating agency with jurisdiction by law may determine in its own ROD that Alternative A is the environmentally preferable action, even though the lead agency has decided in its separate ROD that Alternative B is environmentally preferable.

14c. Q. *What are the specific responsibilities of federal and state cooperating agencies to review draft EIS's?*

A. Cooperating agencies (i.e., agencies with jurisdiction by law or special expertise) and agencies that are authorized to develop or enforce environmental standards must comment on environmental impact statements within their jurisdiction, expertise or authority. Sections 1503.2, 1508.5. If a cooperating agency is satisfied that its views are adequately reflected in the environmental impact statement, it should simply comment accordingly. Conversely, if the cooperating agency determines that a draft EIS is incomplete, inadequate or inaccurate, or it has other comments, it should promptly make such comments, conforming to the requirements of specificity in Section 1503.3.

14d. Q. *How is the lead agency to treat the comments of another agency with jurisdiction by law or special expertise which has failed or refused to cooperate or participate in scoping or EIS preparation?*

A. A lead agency has the responsibility to respond to all substantive comments raising significant issues regarding a draft EIS. Section 1503.4. However, cooperating agencies are generally under an obligation to raise issues or otherwise participate in the EIS process during scoping and EIS preparation if they reasonably can do so. In practical terms, if a cooperating agency fails to cooperate at the outset, such as during scoping, it will find that its comments at a later stage will not be as persuasive to the lead agency.

15. Q. *Are EPA's responsibilities to review and comment on the environmental effects of agency proposals under Section 309 of the Clean Air Act independent of its responsibility as a cooperating agency?*

A. Yes. EPA has an obligation under Section 309 of the Clean Air Act to review and comment in writing on the environmental impact of any matter relating to the authority of the Administrator contained in proposed legislation, federal construction projects, other federal actions requiring EIS's, and new regulations. 42 U.S.C. Sec. 7609. This obligation is independent of its role as a cooperating agency under the NEPA regulations.

16. Q. *What is meant by the term "third party contracts" in connection with the preparation of an EIS? See Section 1506.5(c). When can "third party contracts" be used?*

A. As used by EPA and other agencies, the term "third party contract" refers to the preparation of EIS's by contractors paid by the applicant. In the case of an EIS for a National Pollution Discharge Elimination System (NPDES) permit, the applicant, aware in the early planning stages of the proposed project of the need for an EIS, contracts directly with a consulting firm for its preparation. See 40 C.F.R. 6.604(g). The "third party" is EPA which, under Section 1506.5(c), must select the consulting firm, even though the applicant pays for the cost of preparing the EIS. The consulting firm is responsible to EPA for preparing an EIS that meets the requirements of the NEPA regulations and EPA's NEPA procedures. It is in the applicant's interest that the EIS comply with the law so that EPA can take prompt action on the NPDES permit application. The "third party contract" method under EPA's NEPA procedures is purely voluntary, though most applicants have found it helpful in expediting compliance with NEPA.

If a federal agency uses "third party contracting," the applicant may undertake the necessary paperwork for the solicitation of a field of candidates under the agency's direction, so long as the agency complies with Section 1506.5(c). Federal procurement requirements do not apply to the agency because it incurs no obligations or costs under the contract, nor does the agency procure anything under the contract.

17a. Q. *If an EIS is prepared with the assistance of a consulting firm, the firm must execute a disclosure statement. What criteria must the firm follow in determining whether it has any "financial or other interest in the outcome of the project" which would cause a conflict of interest?*

A. Section 1506.5(c), which specifies that a consulting firm preparing an EIS must execute a disclosure statement, does not define "financial or other interest in the outcome of the project." The Council interprets this term broadly to cover any known benefits other than general enhancement of professional reputation. This includes any financial benefit such as a promise of future construction or design work on the project, as well as indirect benefits the consultant is aware of (e.g., if the project would aid proposals sponsored by the firm's other clients). For example, completion of a highway project may encourage construction of a shopping center or industrial park from which the consultant stands to benefit. If a consulting firm is aware that it has such an interest in the decision on the proposal, it should be disqualified from preparing the EIS to preserve the objectivity and integrity of the NEPA process.

When a consulting firm has been involved in developing initial data plans for the project, but does not have any financial or other interest in the outcome of the decision, it need not be disqualified from preparing the EIS. However, a disclosure statement in the draft EIS should clearly state the scope and extent of the firm's prior involvement to expose any potential conflicts of interest that may exist.

17b. Q. *If the firm in fact has no promise of future work or other interest in the outcome of the proposal, may the firm later bid in competition with others for future work on the project if the proposed action is approved?*

A. Yes.

18. Q. *How should uncertainties about indirect effects of a proposal be addressed, for example, in cases of disposal of federal lands, when the identity or plans of future landowners is unknown?*

A. The EIS must identify all the indirect effects that are known and make a good faith effort to explain the effects that are not known but are "reasonably foreseeable." Section 1508.8(b). In the example, if there is total uncertainty about the identity of future landowners or the nature of future land uses, then of course, the agency is not required to engage in speculation or contemplation about their future plans. But, in the ordinary course of business, people do make judgments based upon reasonably foreseeable occurrences. It will often be possible to consider the likely purchasers and the development trends in that area or similar areas in recent years; or the likelihood that the land will be used for an energy project, shopping center, subdivision, farm or factory. The agency has the responsibility to make an informed judgment, and to estimate future impacts on that basis, especially if trends are ascertainable or potential purchases have made themselves known. The agency cannot ignore these uncertain, but probable, effects of its decisions.

19a. Q. *What is the scope of mitigation measures that must be discussed?*

A. The mitigation measures discussed in an EIS must cover the range of impacts of the proposal. The measures must include such things as design alternatives that would decrease pollution emission, construction impacts, esthetic intrusion, as well as relocation assistance, possible land use controls that could be enacted, and other possible efforts. Mitigation measures must be considered even for impacts that by themselves would not be considered "significant." Once the proposal itself is considered as a whole to have significant effects, all of

its specific effects on the environment (whether or not "significant") must be considered, and mitigation measures must be developed where it is feasible to do so. Sections 1502.14(f), 1502.16(h), 1508.14.

19b. Q. *How should an EIS treat the subject of available mitigation measures that are (1) outside the jurisdiction of the lead or cooperating agencies, or (2) unlikely to be adopted or enforced by the responsible agency?*

A. All relevant, reasonable mitigation measure that could improve the project are to be identified, even if they are outside the jurisdiction of the lead agency or the cooperating agencies and, thus, would not be committed as part of the ROD's of these agencies. Section 1502.16(h), 1505.2(c). This will serve to alert agencies or officials who can implement these extra measures and will encourage them to do so. Because the EIS is the most comprehensive environmental document, it is an ideal vehicle in which to lay out not only the full range of environmental impacts but also the full spectrum of appropriate mitigation.

However, to ensure that environmental effects of a proposed action are fairly assessed, the probability of the mitigation measures being implemented must also be discussed. Thus, the EIS and the Record of Decision should indicate the likelihood that such measures will be adopted or enforced by the responsible agencies. Sections 1502.16(h), 1505.2. If there is a history of non-enforcement or opposition to such measures, the EIS and Record of Decision should acknowledge such opposition or non-enforcement. If the necessary mitigation measures will not be ready for a long period of time, this fact, of course, should also be recognized.

20a. Q. *When must a worst case analysis be included in an EIS?*

A. If there are gaps in relevant information or scientific uncertainty pertaining to an agency's evaluation of significant adverse impacts on the human environment, an agency must make clear that such information is lacking or that the uncertainty exists. An agency must include a worst case analysis of the potential impacts of the proposal and an indication of the probability or improbability of their occurrence if (a) the information relevant to adverse impacts is essential to a reasoned choice among alternatives and the overall costs of obtaining the information are exorbitant, or (b) the information relevant to adverse impacts is important to the decision and the means to obtain it are not known.

NEPA requires that impact statements, at a minimum, contain information to alert the public and Congress to all known possible environmental consequences of agency action. Thus, one of the federal government's most important obligations is to present to the fullest extent possible, the spectrum of consequences that may result from agency decisions, and the details of their potential consequences for the human environment.

20b. Q. *What is the purpose of a worst case analysis? How is it formulated and what is the scope of the analysis?*

A. The purpose of the analysis is to carry out NEPA's mandate for full disclosure to the public of the potential consequences of agency decisions, and to cause agencies to consider those potential consequences when acting on the basis of scientific uncertainties or gaps in available information. The analysis is formulated on the basis of available information, using reasonable projections of the worst possible consequences of a proposed action.

For example, if there are scientific uncertainty and gaps in the available information concerning the numbers of juvenile fish that would be entrained in a cooling water facility, the responsible agency must disclose and consider the possibility of the loss of the commercial or sport fishery.

In addition to an analysis of a low probability/catastrophic impact event, the worst case analysis should also include a spectrum of events of higher probability but less drastic impact.

21. Q. *Where an EIS or an EA is combined with another project planning document (sometimes called "piggybacking"), to what degree may the EIS or EA refer to and rely upon information in the project document to satisfy NEPA's requirements?*

A. Section 1502.25 of the regulations requires that draft EIS's be prepared concurrently and integrated with environmental analyses and related surveys and studies required by other federal statutes. In addition, Section 1506.4 allows any environmental document prepared in compliance with NEPA to be combined with any other agency document to reduce duplication and paperwork.

However, these provisions were not intended to authorize the preparation of a short summary or outline EIS, attached to a detailed project report of land use plan containing the required environmental impact data. In such circumstances, the reader would have to refer constantly to the detailed report to understand the environmental impacts and alternatives which should have been found in the EIS itself.

The EIS must stand on its own as an analytical document which fully informs decisionmakers and the public of the environmental effects of the proposal and those of the reasonable alternatives. Section 1502.1. But, as long as the EIS is clearly identified and is self-supporting, it can be physically included in or attached to the project report or land-use plan, and may use attached report material as technical backup.

Forest Service environmental impact statements for forest management plans are handled in this manner. The EIS identifies the agency's preferred alternative, which is developed in detail as the proposed management plan. The detailed proposed plan accompanies the EIS through the review process, and the documents are appropriately cross-referenced. The proposed plan is useful for EIS readers as an example to show how one choice of management options translates into effects on natural resources. This procedure permits initiation of the 90-day public review of proposed forest plans, which is required by the National Forest Management Act.

All the alternatives are discussed in the EIS, which can be read as an independent document. The details of the management plan are not repeated in the EIS, and vice versa. This is a reasonable functional separation of the documents: The EIS contains information relevant to the choice among alternatives; the plan is a detailed description of proposed management activities suitable for use by the land managers. This procedure provides for concurrent compliance with the public review requirements of both NEPA and the National Forest Management Act.

Under some circumstances, a project report or management plan may be totally merged with the EIS, and the one document labeled as both "EIS" and "management plan" or "project report." This may be reasonable where the documents are short, or where the EIS format and the regulations for clear, analytical EIS's also satisfy the requirements for a project report.

22. Q. *May State and federal agencies serve as joint lead agencies? If so, how do they resolve law, policy and resource conflicts under NEPA and the relevant State Environmental Policy Act? How do they resolve differences in perspective where, for example, national and local needs may differ?*

A. Under Section 1501.5(b), federal, State or local agencies, as long as they include at least one federal agency, may act as joint lead agencies to prepare an EIS. Section 1506.2 also strongly urges State and local agencies and the relevant federal agencies to cooperate fully with each other. This should cover joint research and studies, planning activities, public hearings, environmental assessments, and the preparation of joint EIS's under NEPA and the relevant "little NEPA" State laws, so that one document will satisfy both laws.

The regulations also recognize that certain inconsistencies may exist between the proposed federal action and any approved State or local plan or law. The joint document should discuss the extent to which the federal agency would reconcile its proposed action with such plan or law. Section 1506.2(d). (see Question 23).

Because there may be differences in perspective as well as conflicts among federal, State and local goals for resource management, the Council has advised participating agencies to adopt a flexible, cooperative approach. The joint EIS should reflect all of their interests and missions, clearly identified as such. The final document would then indicate how State and local interests have been accommodated or would identify conflicts in goals (e.g., how a hydroelectric project, which might induce second home development, would require new land-use controls). The EIS must contain a complete discussion of scope and purpose of the proposal, alternatives, and impacts so that the discussion is adequate to meet the needs of local, State and federal decisionmakers.

23a. Q. *How should an agency handle potential conflicts between a proposal and the objectives of federal, State or local land-use plans, policies and controls for the area concerned? see Section 1502.16(c).*

A. The agency should first inquire of other agencies whether there are any potential conflicts. If there would be immediate conflicts, or if conflicts could arise in the future when the plans are finished (see Question 23b below), the EIS must acknowledge and describe the extent of those conflicts. If there are any possibilities of resolving the conflicts, these should be explained as well. The EIS should also evaluate the seriousness of the impact of the proposal on the land-use plans and policies and whether, or how much, the proposal will impair the effectiveness of land use control mechanisms for the area. Comments from officials of the affected area should be solicited early and should be carefully acknowledged and answered in the EIS.

23b. Q. *What constitutes a "land use plan or policy" for purposes of this discussion?*

A. The term "land use plans," includes all types of formally adopted documents for land-use planning, zoning and related regulatory requirements. Local general plans are included, even though they are subject to future change. Proposed plans should also be addressed if they have been formally proposed by the appropriate government body in a written form and are being actively pursued by officials of the jurisdiction. Staged plans, which must go through phases of development such as the Water Resources Council's Level A, B, and C planning process, should also be included even though they are incomplete.

The term "policies" includes formally adopted statements of land use policy as embodied in laws or regulations. It also includes proposals for action such as the initiation of a planning process or a formally adopted policy statement of the local, regional or state executive branch, even if it has not yet been formally adopted by the local, regional or state legislative body.

23c. Q. *What options are available for the decisionmaker when conflicts with such plans or policies are identified?*

A. After identifying any potential land use conflicts, the decisionmaker must weigh the significance of the conflicts, among all the other environmental and non-environmental factors that must be considered in reaching a rational and balanced decision. Unless precluded by other law from causing or contributing to any inconsistency with the land use plans, policies or controls, the decisionmaker retains the authority to go forward with the proposal, despite the potential conflict. In the Record of Decision, the decisionmaker must explain what the decision was, how it was made, and what mitigation measures are being imposed to lessen adverse environmental impacts of the proposal, among the other requirements of Section 1505.2. This provision would require the decisionmaker to explain any decision to override land use plans, policies or controls for the area.

24a. Q. *When are EIS's required on policies, plans or programs?*

A. An EIS must be prepared if an agency proposed to implement a specific policy, to adopt a plan for a group of related actions, or to implement a specific statutory program or executive directive. Section 1508.18. In addition, the adoption of official policy in the form of rules, regulations and interpretations pursuant to the Administrative Procedure Act, treaties, conventions, or other formal documents establishing governmental or agency policy which will substantially alter agency programs could require an EIS. Section 1508.18. In all cases, the policy, plan, or program must have the potential for significantly affecting the quality of the human environment in order to require an EIS. It should be noted that a proposal "may exist in fact as well as by agency declaration that one exists." Section 1508.23.

24b. Q. *When is an area-wide or overview EIS appropriate?*

A. The preparation of an area-wide or overview EIS may be particularly useful when similar actions, viewed with other reasonably foreseeable or proposed agency actions, share common timing or geography. For example, when a variety of energy projects may be located in a single watershed, or when a series of new energy technologies may be developed through federal funding, the overview or area-wide EIS would serve as a valuable and necessary analysis of the affected environment and the potential cumulative impacts of the reasonably foreseeable actions under that program or within that geographical area.

24c. Q. *What is the function of tiering in such cases?*

A. Tiering is a procedure which allows an agency to avoid duplication of paperwork through the incorporation by reference of the general discussions and relevant specific discussions from an environmental impact statement of broader scope into one of lesser scope or vice versa. In the example given in Question 24b, this would mean that an overview EIS would be prepared for all of the energy activities reasonably foreseeable in a particular geographic area or resulting from a particular development program. This impact statement would be followed by site-specific or project-specific EIS's. The tiering process would make each EIS of greater use and meaning to the public as the plan or program develops, without duplication of the analysis prepared for the previous impact statement.

25a. Q. *When is it appropriate to use appendices instead of including information in the body of an EIS?*

A. The body of the EIS should be a succinct statement of all the information on environmental impacts and alternatives that the decisionmaker and the public need in order to make the decision and to ascertain that every significant factor has been examined. The EIS must explain or summarize methodologies of research and modeling and the results of research that may have been conducted to analyze impacts and alternatives.

Lengthy technical discussions of modeling methodology, baseline studies, or other work are best reserved for the appendix. In other words, if only technically trained individuals are likely to understand a particular discussion, then it should go in the appendix, and a plain language summary of the analysis and conclusions of that technical discussion should go in the text of the EIS.

The final statement must also contain the agency's responses to comments on the draft EIS. These responses will be primarily in the form of changes in the document itself, but specific answers to each significant comment should also be included. These specific responses may be placed in an appendix. If the comments are especially voluminous, summaries of the comments and responses will suffice. (See Question 29 regarding the level of detail required for response to comments.)

25b. Q. *How does an appendix differ from incorporation by reference?*

A. First, if at all possible, the appendix accompanies the EIS, whereas the material which is incorporated by reference does not accompany the EIS. Thus, the appendix should contain information that reviewers will be likely to want to examine. The appendix should include material that pertains to preparation of a particular EIS. Research papers directly relevant to the proposal, lists of affected species, discussion of the methodology of models used in the analysis of impacts, extremely detailed responses to comments, or other information, would be placed in the appendix.

The appendix must be complete and available at the time the EIS is filed. Five copies of the appendix must be sent to EPA with five copies of the EIS for filing. If the appendix is too bulky to be circulated, it instead must be placed in conveniently accessible locations or furnished directly to commentors upon request. If it is not circulated with the EIS, the Notice of Availability published by EPA must so state, giving a telephone number to enable potential commentors to locate or request copies of the appendix promptly.

Material that is not directly related to preparation of the EIS should be incorporated by reference. This would include other EIS's, research papers in the general literature, technical background papers or other material that someone with technical training could use to evaluate the analysis of the proposal. These must be made available, either by citing the literature, furnishing copies to central locations, or sending copies directly to commentors upon request.

Care must be taken in all cases to ensure that material incorporated by reference, and the occasional appendix that does not accompany the EIS, are in fact available for the full minimum public comment period.

26a. Q. *How detailed must an EIS index be?*

A. The EIS index should have a level of detail sufficient to focus on areas of the EIS of reasonable interest to any reader. It cannot be restricted to the most important topics. On the other hand, it need not identify every conceivable term or phrase in the EIS. If an agency believes that the reader is reasonably likely to be interested in a topic, it should be included.

26b. Q. *Is a keyword index required?*

A. No. A keyword index is a relatively short list of descriptive terms that identifies the key concepts or subject areas in a document. For example, it could consist of 20 terms which describe the most significant aspects of an EIS that a future research would need — type of proposal, type of impacts, type of environment, geographical area, sampling or modeling methodologies used. This technique permits the compilation of EIS data banks by facilitating

quick and inexpensive access to stored materials. While a keyword index is not required by the regulations, it could be a useful addition for several reasons. First, it can be useful as a quick index for reviewers of the EIS, helping to focus on areas of interest. Second, if an agency keeps a listing of the keyword indexes of the EIS's it produces, the EIS preparers themselves will have quick access to similar research data and methodologies to aid their future EIS work. Third, a keyword index will be needed to make an EIS available to future researchers using EIS data banks that are being developed. Preparation of such an index now when the document is produced will save a later effort when the data banks become operational.

27a. Q. *If a consultant is used in preparing an EIS, must the list of preparers identify members of the consulting firm as well as the agency NEPA staff who were primarily responsible?*

A. Section 1502.17 requires identification of the names and qualifications of persons who were primarily responsible for preparing the EIS or significant background papers, including basic components of the statement. This means that members of a consulting firm preparing material that is to become part of the EIS must be identified. The EIS should identify these individuals even though the consultant's contribution may have been modified by the agency.

27b. Q. *Should agency staff involved in reviewing and editing the EIS also be included in the list of preparers?*

A. Agency personnel who wrote basic components of the EIS or significant background papers must, of course, be identified. The EIS should also list the technical editors who reviewed or edited the statements.

27c. Q. *How much information should be included on each person listed?*

A. The list of preparers should normally not exceed two pages. Therefore, agencies must determine which individuals had primary responsibility and need not identify individuals with minor involvement. The list of preparers should include a very brief identification of the individuals involved, their qualifications (expertise, professional disciplines), and the specific portion of the EIS for which they are responsible. This may be done in tabular form to cut down on length. A line or two for each person's qualifications should be sufficient.

28. Q. *May an agency file Xerox copies of an EIS with EPA pending the completion of printing the document?*

A. Xerox copies of an EIS may be filed with EPA prior to printing only if the Xerox copies are simultaneously made available to other agencies and the public. Section 1506.9 of the regulations, which governs EIS filing, specifically requires Federal agencies to file EIS's with EPA no earlier than the EIS is distributed to the public. However, this section does not prohibit Xeroxing as a form of reproduction and distribution. When an agency chooses Xeroxing as the reproduction method, the EIS must be clear and legible to permit ease of reading and ultimate microfiling of the EIS. Where color graphs are important to the EIS, they should be reproduced and circulated with the xeroxed copy.

29a. Q. *What response must an agency provide to a comment on a draft EIS which states that the EIS's methodology is inadequate or inadequately explained? For example, what level of detail must an agency include in its response to a simple postcard comment making such an allegation?*

A. Appropriate responses to comments are described in Section 1503.4. Normally, the responses should result in changes in the text of the EIS, not simply a separate answer at the back of the document. But, in addition, the agency must state what its response was, and if the

agency decides that no substantive response to a comment is necessary, it must explain briefly why.

An agency is not under an obligation to issue a lengthy reiteration of its methodology for any portion of an EIS if the only comment addressing the methodology is a simple complaint that the EIS methodology is inadequate. But agencies must respond to comments, however brief, which are specific in their criticism of agency methodology. For example, if a commentor on an EIS said that an agency's air quality dispersion analysis or methodology was inadequate, and the agency had included a discussion of that analysis in the EIS, little if anything need be added in response to such a comment. However, if the commentor said that the dispersion analysis was inadequate because of its use of a certain computational technique, or that a dispersion analysis was inadequately explained because computational techniques were not included or referenced, then the agency would have to respond in a substantive and meaningful way to such a comment.

If a number of comments are identical or very similar, agencies may group the comments and prepare a single answer for each group. Comments may be summarized if they are especially voluminous. The comments or summaries must be attached to the EIS regardless of whether the agency believes they merit individual discussion in the body of the final EIS.

29b. Q. *How must an agency respond to a comment on a draft EIS that raises a new alternative not previously considered in the draft EIS?*

A. This question might arise in several possible situations. First, a commentor on a draft EIS may indicate that there is a possible alternative which, in the agency's view, is not a reasonable alternative. Section 1502.14(a). If that is the case, the agency must explain why the comment does not warrant further agency response, citing authorities or reasons that support the agency's position and, if appropriate, indicate those circumstances which would trigger agency reappraisal or further response. Section 1503.4(a). For example, a commentor on a draft EIS on a coal-fired power plant may suggest the alternative of using synthetic fuel. The agency may reject the alternative with a brief discussion (with authorities) of the unavailability of synthetic fuel within the time frame necessary to meet the need and purpose of the proposed facility.

A second possibility is that an agency may receive a comment indicating that a particular alternative, while reasonable, should be modified somewhat, for example, to achieve certain mitigation benefits or for other reasons. If the modification is reasonable, the agency should include a discussion of it in the final EIS. For example, a commentor on a draft EIS on a proposal for a pumped storage power facility might suggest that the applicant's proposed alternative should be enhanced by the addition of certain reasonable mitigation measures, including the purchase and set-aside of a wildlife preserve to substitute for the tract to be destroyed by the project. The modified alternative including the additional mitigation measures should be discussed by the agency in the final EIS.

A third slightly different possibility is that a comment on a draft EIS will raise an alternative which is a minor variation of one of the alternatives discussed in the draft EIS, but this variation was not given any consideration by the agency. In such a case, the agency should develop and evaluate the new alternative, if it is reasonable, in the final EIS. If it is qualitatively within the spectrum of alternatives that were discussed in the draft, a supplemental draft will not be needed. For example, a commentor on a draft EIS to designate a wilderness area within a National Forest might reasonably identify a specific tract of the forest and urge that it be considered for designation. If the draft EIS considered designation of a range of alternative tracts which encompassed forest area of similar quality and quantity, no supplemental EIS

would have to be prepared. The agency could fulfill its obligation by addressing that specific alternative in the final EIS.

As another example, an EIS on an urban housing project may analyze the alternatives of constructing 2000, 4000, or 6000 units. A commentor on the draft EIS might urge the consideration of constructing 5000 units utilizing a different configuration of buildings. This alternative is within the spectrum of alternatives already considered and, therefore, could be addressed in the final EIS.

A fourth possibility is that a commentor points out an alternative which is not a variation of the proposal or of any alternative discussed in the draft impact statement and is a reasonable alternative that warrants serious agency response. In such a case, the agency must issue a supplement to the draft EIS that discusses this new alternative. For example, a commentor on a draft EIS on a nuclear power plant might suggest that a reasonable alternative for meeting the projected need for power would be through peak load management and energy conservation programs. If the permitting agency has failed to consider that approach in the Draft EIS, and the approach cannot be dismissed by the agency as unreasonable, a supplement to the Draft EIS, which discusses that alternative, must be prepared. (If necessary, the same supplement should also discuss substantial changes in the proposed action or significant new circumstances or information, as required by Section 1502.9(c)(1) of the Council's regulations.)

If the new alternative was not raised by the commentor during scoping, but could have been, commentors may find that they are unpersuasive in their efforts to have their suggested alternative analyzed in detail by the agency. However, if the new alternative is discovered or developed later, and it could not reasonably have been raised during the scoping process, then the agency must address it in a supplemental draft EIS. The agency is, in any case, ultimately responsible for preparing an adequate EIS that considers all reasonable alternatives.

30. Q. *When a cooperating agency with jurisdiction by law intends to adopt a lead agency's EIS and it is not satisfied with the adequacy of the document, may the cooperating agency adopt only the part of the EIS with which it is satisfied? If so, would a cooperating agency with jurisdiction by law have to prepare a separate EIS or EIS supplement covering the areas of disagreement with the lead agency?*

A. Generally, a cooperating agency may adopt a lead agency's EIS without recirculating it if it concludes that its NEPA requirements and its comments and suggestions have been satisfied. Section 1506.3(a), (c). If necessary, a cooperating agency may adopt only a portion of the lead agency's EIS and may reject that part of the EIS with which it disagrees stating publicly why it did so. Section 1506.3(a).

A cooperating agency with jurisdiction by law (e.g., an agency with independent legal responsibilities with respect to the proposal) has an independent legal obligation to comply with NEPA. Therefore, if the cooperating agency determines that the EIS is wrong or inadequate, it must prepare a supplement to the EIS, replacing or adding any needed information, and must circulate the supplement as a draft for public and agency review and comment. A final supplemental EIS would be required before the agency could take action. The adopted portions of the lead agency EIS should be circulated with the supplement. Section 1506.3(b). A cooperating agency with jurisdiction by law will have to prepare its own Record of Decision for its action, in which it must explain how it reached its conclusions. Each agency should explain how and why its conclusions differ, if that is the case, from those of other agencies which issued their Records of Decision earlier.

An agency that did not cooperate in preparation of an EIS may also adopt an EIS or portion thereof. But this would arise only in rare instances, because an agency adopting an EIS for use

in its own decision normally would have been a cooperating agency. If the proposed action for which the EIS was prepared is substantially the same as the proposed action of the adopting agency, the EIS may be adopted as long as it is recirculated as a final EIS and the agency announces what it is doing. This would be followed by the 30-day review period and issuance of a Record of Decision by the adopting agency. If the proposed action by the adopting agency is not substantially the same as that in the EIS (i.e., if an EIS on one action is being adapted for use in a decision on another action), the EIS would be treated as a draft and circulated for the normal public comment period and other procedures. Section 1506.3(b).

31a. Q. *Do the Council's NEPA regulations apply to independent regulatory agencies like the Federal Energy Regulatory Commission (FERC) and the Nuclear Regulatory Commission?*

A. The statutory requirements of NEPA's Section 102 apply to "all agencies of the federal government." The NEPA regulations implement the procedural provisions of NEPA as set forth in NEPA's Section 102(2) for all agencies of the federal government. The NEPA regulations apply to independent regulatory agencies; however, they do not direct independent regulatory agencies or other agencies to make decisions in any particular way or in a way inconsistent with an agency's statutory charter. Sections 1500.3, 1500.6, 1507.1 and 1507.3.

31b. Q. *Can an Executive Branch agency like the Department of the Interior adopt an EIS prepared by an independent regulatory agency such as FERC?*

A. If an independent regulatory agency such as FERC has prepared an EIS in connection with its approval of a proposed project, an Executive Branch agency (e.g., the Bureau of Land Management in the Department of the Interior) may, in accordance with Section 1506.3, adopt the EIS or a portion thereof for its use in considering the same proposal. In such a case, the EIS must, to the satisfaction of the adopting agency, meet the standards for an adequate statement under the NEPA regulations (including scope and quality of analysis of alternatives) and must satisfy the adopting agency's comments and suggestions. If the independent regulatory agency fails to comply with the NEPA regulations, the cooperating or adopting agency may find that it is unable to adopt the EIS, thus, forcing the preparation of a new EIS or EIS Supplement for the same action. The NEPA regulations were made applicable to all federal agencies in order to avoid this result and to achieve uniform application and efficiency of the NEPA process.

32. Q. *Under what circumstances do old EIS's have to be supplemented before taking action on a proposal?*

A. As a rule of thumb, if the proposal has not yet been implemented, or if the EIS concerns an ongoing program, EIS's that are more than five years old should be carefully re-examined to determine if the criteria in Section 1502.9 compel preparation of an EIS supplement.

If an agency has made a substantial change in a proposed action that is relevant to environmental concerns, or if there are significant new circumstances or information relevant to environmental concerns and bearing on the proposed action or its impacts, a supplemental EIS must be prepared for an old EIS so that the agency has the best possible information to make any necessary substantive changes in its decisions regarding the proposal. Section 1502.9(c).

33a. Q. *When must a referral of an interagency disagreement be made to the Council?*

A. The Council's referral procedure is a pre-decision referral process for interagency disagreements. Hence, Section 1504.3 requires that a referring agency must deliver its referral to the Council not later than 25 days after publication by EPA of notice that the final EIS is available (unless the lead agency grants an extension of time under Section 1504.3(b)).

33b. Q. *May a referral be made after the issuance of a Record of Decision?*

A. No, except for cases where agencies provide an internal appeal procedure which permits simultaneous filing of the final EIS and the record of decision (ROD). Section 1506.10(b)(2). Otherwise, as stated above, the process is a pre-decision referral process. Referrals must be made within 25 days after the notice of availability of the final EIS, whereas the final decision (ROD) may not be made or filed until after 30 days from the notice of availability of the EIS. Sections 1504.3(b), 1506.10(b). If a lead agency has granted an extension of time for another agency to take action on a referral, the ROD may not be issued until the extension has expired.

34a. Q. *Must Records of Decision (ROD's) be made public? How should they be made available?*

A. Under the regulations, agencies must prepare a "concise public record of decision," which contains the elements specified in Section 1505.2. This public record may be integrated into any other decision record prepared by the agency, or it may be separate if decision documents are not normally made public. The Record of Decision is intended by the Council to be an environmental document (even though it is not explicitly mentioned in the definition of "environmental document" in Section 1508.10). Therefore, it must be made available to the public through appropriate public notice as required by Section 1506.6(b). However, there is no specific requirement for publication of the ROD itself, either in the Federal Register or elsewhere.

34b. Q. *May the summary section in the final Environmental Impact Statement substitute for or constitute an agency's Record of Decision?*

A. No. An environmental impact statement is supposed to inform the decisionmaker before the decision is made. Sections 1502.1, 1505.2. The Council's regulations provide for a 30-day period after notice is published that the final EIS has been filed with EPA before the agency make take final action. During that period, in addition to the agency's own internal final review, the public and other agencies can comment on the final EIS prior to the agency's final action on the proposal. In addition, the Council's regulations make clear that the requirements for the summary in an EIS are not the same as the requirements for a ROD. Sections 1502.12 and 1505.2.

34c. Q. *What provisions should Records of Decision contain pertaining to mitigation and monitoring?*

A. Lead agencies "shall include appropriate conditions [including mitigation measures and monitoring and enforcement programs] in grants, permits or other approvals" and shall "condition funding of actions on mitigation." Section 1505.3. Any such measures that are adopted must be explained and committed in the ROD.

The reasonable alternative mitigation measures and monitoring programs should have been addressed in the draft and final EIS. The discussion of mitigation and monitoring in a Record of Decision must be more detailed than a general statement that mitigation is being required, but not so detailed as to duplicate discussion of mitigation in the EIS. The Record of Decision

should contain a concise summary identification of the mitigation measures which the agency has committed itself to adopt.

The Record of Decision must also state whether all practicable mitigation measures have been adopted, and if not, why not. Section 1505.2(c). The Record of Decision must identify the mitigation measures and monitoring and enforcement programs that have been selected and plainly indicate that they are adopted as part of the agency's decision. If the proposed action is the issuance of a permit or other approval, the specific details of the mitigation measures shall then be included as appropriate conditions in whatever grants, permits, funding or other approvals are being made by the federal agency. Section 1505.3(a), (b). If the proposal is to be carried out by the federal agency itself, the Record of Decision should delineate the mitigation and monitoring measures in sufficient detail to constitute an enforceable commitment or incorporate by reference the portions of the EIS that do so.

34d. Q. *What is the enforceability of a Record of Decision?*

A. Pursuant to generally recognized principles of federal administrative law, agencies will be held accountable for preparing Records of Decision that conform to the decisions actually made and for carrying out the actions set forth in the Records of Decision. This is based on the principle that an agency must comply with its own decisions and regulations once they are adopted. Thus, the terms of a Record of Decision are enforceable by agencies and private parties. A Record of Decision can be used to compel compliance with or execution of the mitigation measures identified therein.

35. Q. *How long should the NEPA process take to complete?*

A. When an EIS is required, the process obviously will take longer than when an EA is the only document prepared. But the Council's NEPA regulations encourage streamlined review, adoption of deadlines, elimination of duplicative work, eliciting suggested alternatives and other comments early through scoping, cooperation among agencies, and consultation with applicants during project planning. The Council has advised agencies that under the new NEPA regulations even large, complex energy projects would require only about 12 months for the completion of the entire EIS process. For most major actions, this period is well within the planning time that is needed in any event, apart from NEPA.

The time required for the preparation of program EIS's may be greater. The Council also recognizes that some projects will entail difficult long-term planning and/or the acquisition of certain data which of necessity will require more time for the preparation of the EIS. Indeed, some proposals should be given more time for the thoughtful preparation of an EIS and development of a decision which fulfills NEPA's substantive goals.

For cases in which only an environmental assessment will be prepared, the NEPA process should take no more than 3 months and, in many cases, substantially less, as part of the normal analysis and approval process for the action.

36a. Q. *How long and detailed must an environmental assessment (EA) be?*

A. The environmental assessment is a concise public document which has three defined functions: (1) It briefly provides sufficient evidence and analysis for determining whether to prepare an EIS; (2) it aids an agency's compliance with NEPA when no EIS is necessary (i.e., it helps to identify better alternatives and mitigation measures); and (3) it facilitates preparation of an EIS when one is necessary. Section 1508.9(a).

Since the EA is a concise document, it should not contain long descriptions of detailed data which the agency may have gathered. Rather, it should contain a brief discussion of the need for the proposal, alternatives to the proposal, the environmental impacts of the proposed action and alternatives, and a list of agencies and persons consulted. Section 1508.9(b).

While the regulations do not contain page limits for EA's, the Council has generally advised agencies to keep the length of EA's to not more than approximately 10-15 pages. Some agencies expressly provide page guidelines (e.g., 10-15 pages in the case of the Army Corps). To avoid undue length, the EA may incorporate by reference background data to support its concise discussion of the proposal and relevant issues.

36b. Q. *Under what circumstances is a lengthy EA appropriate?*

A. Agencies should avoid preparing lengthy EA's except in unusual cases where a proposal is so complex that a concise document cannot meet the goals of Section 1508.9 and where it is extremely difficult to determine whether the proposal could have significant environmental effects. In most cases, however, a lengthy EA indicates that an EIS is needed.

37a. Q. *What is the level of detail of information that must be included in a finding of no significant impact (FONSI)?*

A. The FONSI is a document in which the agency briefly explains the reasons why an action will not have a significant effect on the human environment and, therefore, why an EIS will not be prepared. Section 1508.13. The finding itself need not be detailed but must succinctly state the reasons for deciding that the action will have no significant environmental effects and, if relevant, must show which factors were weighted most heavily in the determination. In addition to this statement, the FONSI must include, summarize, or attach and incorporate by reference the environmental assessment.

37b. Q. *What are the criteria for deciding whether a FONSI should be made available for public review for 30 days before the agency's final determination whether to prepare an EIS?*

A. Public review is necessary, for example, (a) if the proposal is a borderline case; i.e., when there is a reasonable argument for preparation of an EIS; (b) if it is an unusual case, a new kind of action, or a precedent setting case such as a first intrusion of even a minor development into a pristine area; (c) when there is either scientific or public controversy over the proposal; or (d) when it involves a proposal which is or is closely similar to one which normally requires preparation of an EIS. Section 1501.4(e)(2), 1508.27. Agencies also must allow a period of public review of the FONSI if the proposed action would be located in a floodplain or wetland. E.O. 11988, Section 2(a)(4); E.O. 11990, Section 2(b).

38. Q. *Must EA's and FONSI's be made public? If so, how should this be done?*

A. Yes, they must be available to the public. Section 1506.6 requires agencies to involve the public in implementing their NEPA procedures, and this includes public involvement in the preparation of EA's and FONSI's. These are public "environmental documents" under Section 1506.6(b) and, therefore, agencies must give public notice of their availability. A combination of methods may be used to give notice, and the methods should be tailored to the needs of particular cases. Thus, a Federal Register notice of availability of the documents, coupled with notices in national publications and mailed to interested national groups, might be appropriate for proposals that are national in scope. Local newspaper notices may be more appropriate for regional or site-specific proposals.

The objective, however, is to notify all interested or affected parties. If this is not being achieved, then the methods should be re-evaluated and changed. Repeated failure to reach the interested or affected public would be interpreted as a violation of the regulations.

39. Q. *Can an EA and FONSI be used to impose enforceable mitigation measures, monitoring programs, or other requirements, even though there is no requirement in the regulations in such cases for a formal Record of Decision?*

A. Yes. In cases where an environmental assessment is the appropriate environmental document, there still may be mitigation measures or alternatives that would be desirable to consider and adopt even though the impacts of the proposal will not be "significant." In such cases, the EA should include a discussion of these measures or alternatives to "assist agency planning and decisionmaking" and to "aid an agency's compliance with [NEPA] when no environmental impact statement is necessary." Section 1501.3(b), 1508.9(a)(2). The appropriate mitigation measures can be imposed as enforceable permit conditions, or adopted as part of the agency final decision in the same manner mitigation measures are adopted in the formal Record of Decision that is required in EIS cases.

40. Q. *If an environmental assessment indicates that the environmental effects of a proposal are significant but that, with mitigation, those effects may be reduced to less than significant levels, may the agency make a finding of no significant impact rather than prepare an EIS? Is that a legitimate function of an EA and scoping?*

A. Mitigation measures may be relied upon to make a finding of no significant impact only if they are imposed by statute or regulation or submitted by an applicant or agency as part of the original proposal. As a general rule, the regulations contemplate that agencies should use a broad approach in defining significance and should not rely on the possibility of mitigation as an excuse to avoid the EIS requirement. Sections 1508.8, 1508.27.

If a proposal appears to have adverse effects which would be significant, and certain mitigation measures are then developed during the scoping or EA stages, the existence of such possible mitigation does not obviate the need for an EIS. Therefore, if scoping or the EA identifies certain mitigation possibilities without altering the nature of the overall proposal itself, the agency should continue the EIS process and submit the proposal, and the potential mitigation, for public and agency review and comment. This is essential to ensure that the final decision is based on all the relevant factors and that the full NEPA process will result in enforceable mitigation measure through the Record of Decision.

In some instances, where the proposal itself so integrates mitigation from the beginning that it is impossible to define the proposal without including the mitigation, the agency may then rely on the mitigation measures in determining that the overall effects would not be significant (e.g., where an application for a permit for a small hydro dam is based on a binding commitment to build fish ladders, to permit adequate downstream flow, and to replace any lost wetlands, wildlife habitat and recreational potential). In those instances, agencies should make the FONSI and EA available for 30 days of public comment before taking action. Section 1501.4(e)(2).

Similarly, scoping may result in a redefinition of the entire project, as a result of mitigation proposals. In that case, the agency may alter its previous decisions to do an EIS, as long as the agency or applicant resubmits the entire proposal, and the EA and FONSI are available for 30 days of review and comment. One example of this would be where the size and location of a proposed industrial park are changed to avoid affecting a nearby wetland area.

SECTION 4(f) POLICY PAPER
Office of Planning, Environment and Realty
Project Development and Environmental Review
Washington, DC 20590
July 20, 2012

Table of Contents

PART I – SECTION 4(f) OVERVIEW

1.0 INTRODUCTION

1.1 Purpose

1.2 Agency Authority and Responsibilities

1.2.1 Role of U.S. DOT

1.2.2 Role of Officials with Jurisdiction

1.3 When Does Section 4(f) Apply?

2.0 BACKGROUND

3.0 ANALYSIS PROCESS

3.1 Identification of Section 4(f) Properties

3.2 Assessing Use of Section 4(f) Properties

3.3 Approval Options

3.3.1 Determination of a De minimis Impact to Section 4(f) Property

3.3.2 Programmatic Section 4(f) Evaluations

3.3.3 Individual Project Section 4(f) Evaluations

3.3.3.1 Feasible and Prudent Avoidance Alternatives

3.3.3.2 Alternative with Least Overall Harm

3.4 Examples of Section 4(f) Approvals

3.5 All Possible Planning to Minimize Harm

4.0 Documentation

PART II – QUESTIONS AND ANSWERS REGARDING SECTION 4(f) APPLICABILITY AND COMPLIANCE

IDENTIFICATION OF SECTION 4(F) PROPERTIES

1. Public Parks, Recreation Areas, and Wildlife and Waterfowl Refuges

2. Historic Sites

3. Archeological Resources

4. Public Multiple-Use Land Holdings

5. Tribal Lands and Indian Reservations

6. Traditional Cultural Places

USE OF SECTION 4(F) PROPERTIES

7. Use of Section 4(f) Property

8. Historic Bridges, Highways and Other Transportation Facilities

OFFICIALS WITH JURISDICTION; CONSULTATION; AND DECISIONMAKING

9. Officials with Jurisdiction

10. Section 4(f) Evaluations for Tiered Projects

DE MINIMIS IMPACT DETERMINATIONS

11. De minimis Impact Determinations for Parks, Recreation Areas, and Wildlife and Waterfowl Refuges

12. De minimis Impact Determinations on Historic Sites

13. Other de minimis Impact Considerations

ADDITIONAL EXAMPLES AND OTHER CONSIDERATIONS

14. School Playgrounds

15. Trails and Shared Use Paths

16. User or Entrance Fees

17. Transportation Enhancement Projects

18. Golf Courses

19. Museums, Aquariums, and Zoos

20. Fairgrounds

21. Bodies of Water

22. Scenic Byways

23. Cemeteries

24. Joint Development (Park with Highway Corridor)

25. Planned Section 4(f) Properties

26. Late Designation and Late Discovery of Section 4(f) Properties

27. Temporary Recreational Occupancy or Uses of Highway ROW

28. Tunneling or Bridging (Air Rights) and Section 4(f) Property

29. Mitigation Activities on Section 4(f) Property

30. Emergencies

31. Section 6(f) and Other Non-U.S. DOT Grant-in-Aid Program Requirements

SECTION 4(f) FLOWCHART

GLOSSARY OF ACRONYMS

FHWA SECTION 4(f) POLICY PAPER

PART I — SECTION 4(f) OVERVIEW

1.0 Introduction

This Section 4(f) Policy Paper supplements the Federal Highway Administration's (FHWA) regulations governing the use of land from publicly owned parks, recreation areas, wildlife and waterfowl refuges, and public or private historic sites for Federal highway projects. Although these requirements are now codified at 23 U.S.C. § 138 and 49 U.S.C. § 303, this subject matter remains commonly referred to as Section 4(f) because the requirements originated in Section 4(f) of the Department of Transportation Act of 1966 (Pub. L. 89-670, 80 Stat. 931). The Section 4(f) Policy Paper replaces the FHWA's 2005 edition of the document. The FHWA's Section 4(f) regulations, entitled Parks, Recreation Areas, Wildlife and Waterfowl Refuges, and Historic Sites, are codified at 23 CFR Part 774. Many of the terms used in this Section 4(f) Policy Paper are defined in the regulation at 23 CFR 774.17.

1.1 Purpose

This Section 4(f) Policy Paper was written primarily to aid FHWA personnel with administering Section 4(f) in a consistent manner. In situations where a State has assumed the FHWA responsibility for Section 4(f) compliance, this guidance is intended to help the State fulfill its responsibilities. Such situations may arise when Section 4(f) responsibilities are assigned to the State in accordance with 23 U.S.C. §§ 325, 326, 327, or a similar applicable law. Unless otherwise noted, references to "FHWA" in this document include a State department of transportation (State DOT) acting in FHWA's capacity pursuant to an assumption of FHWA's responsibilities under such laws.

This guidance is also intended to help State DOTs and other applicants for grants-in-aid for highway projects to plan projects that minimize harm to Section 4(f) properties. Experience demonstrates that when Section 4(f) is given consideration early in project planning, the risk of a project becoming unnecessarily delayed due to Section 4(f) processing is minimized. Ideally, applicants should strive to make the preservation of Section 4(f) properties, along with other environmental concerns, part of their long and short range transportation planning processes. Information and tools to help State DOTs, metropolitan planning organizations and other applicants accomplish this goal are available on FHWA's Planning and Environmental Linkages website located at:

http://environment.fhwa.dot.gov/env_programs/PEL.aspx.

This Section 4(f) Policy Paper is based on and is intended to reflect: the statute itself, the legislative history of the statute; the requirements of the Section 4(f) regulations; relevant court decisions; and FHWA's experience with implementing the statute over four decades, including interactions with the public and with agencies having jurisdiction over Section 4(f) properties. The information presented is not regulatory and does not create any right of action that may be enforced by a private citizen in a court of law. This Section 4(f) Policy Paper sets forth the official policy of FHWA on the applicability of Section 4(f) to various types of land and resources, and other Section 4(f) related issues. While the other United States Department of Transportation (U.S. DOT) agencies may choose to rely upon some or all of this Section 4(f) Policy Paper as a reference, it was not written as guidance for any U.S. DOT agency other than FHWA.

This guidance addresses the majority of situations related to Section 4(f) that may be encountered in the development of a transportation project. If a novel situation or project arises which does not completely fit the situations or parameters described in this Section 4(f) Policy Paper, the relevant FHWA Division Office,¹ the FHWA Headquarters Office of Project Development and Environmental Review, the Resource Center Environment Technical Service Team, and/or the Office of Chief Counsel should be consulted as appropriate for assistance. For additional information on Section 4(f) beyond that which is contained in this Section 4(f) Policy Paper, readers should refer to the FHWA Environmental Review Toolkit.²

1.2 Agency Authority and Responsibilities

1.2.1 Role of U.S. DOT

The authority to administer Section 4(f) and make Section 4(f) approvals resides with the Secretary of the U.S. DOT. The statute designates the Secretaries of the Interior, Housing and Urban Development, and Agriculture, as well as the States, for consultation roles as appropriate. This means that the Secretary of Transportation is responsible for soliciting and considering the comments of these other entities, as well as the appropriate official(s) with jurisdiction over the Section 4(f) property, as part of the administration of Section 4(f). However, the ultimate decision maker is the Secretary of Transportation. In a number of instances, the Section 4(f) regulations require the concurrence of various officials in limited circumstances as discussed below.

The Secretary of Transportation has delegated the authority for administering Section 4(f) to the FHWA Administrator in 49 CFR 1.48. The authority has been re-delegated to the FHWA Division Administrators, the Associate Administrator for Planning, Environment, and Realty, and the Federal Lands Highway Associate Administrator by FHWA Order M1100.1A, Chapter 5, Section 17e and Chapter 6, Section 7d. Any approval of the use of Section 4(f) property, other than a use with a de minimis impact or a use processed with an existing programmatic Section 4(f) evaluation is subject to legal sufficiency review by the Office of Chief Counsel.

1.2.2 Role of Officials with Jurisdiction

Consultation

The regulations define the entities and individuals who are considered the officials with jurisdiction for various types of property in 23 CFR 774.17. In the case of historic sites, the officials with jurisdiction are the State Historic Preservation Officer (SHPO), or, if the property is located on tribal land, the Tribal Historic Preservation Officer (THPO).³ If the property is located on tribal land but the relevant Indian tribe has not assumed the responsibilities of the SHPO, then a representative designated by the tribe shall be recognized as an official with jurisdiction in addition to the SHPO. When the Advisory Council on Historic Preservation (ACHP) is involved in consultation concerning a property under Section 106 of the National Historic Preservation Act (NHPA) (16 U.S.C. § 470), the ACHP is also an official with jurisdiction over that resource for the purposes of Section 4(f). When the Section 4(f) property is a National Historic Landmark (NHL), the designated official of the National Park Service is also an official with jurisdiction over that resource for the purposes of Section 4(f). In the case of public parks, recreation areas, and wildlife and waterfowl refuges, the officials with jurisdiction are the officials of the agency or agencies that own or administer the property in question and who are empowered to represent the agency on matters related to the property.

Coordination

The regulations require coordination with the official(s) with jurisdiction for the following situations prior to Section 4(f) approval (recognizing that additional coordination may be required under other statutes or regulations):

- Prior to making approvals, (23 CFR 774.3(a));
- Determining least overall harm, (23 CFR 774.3(c));
- Applying certain programmatic Section 4(f) evaluations, (23 CFR 774.5(c));
- Applying Section 4(f) to properties that are subject to Federal encumbrances, (23 CFR 774.5(d));
- Applying Section 4(f) to archeological sites discovered during construction, (23 CFR 774.9(e));
- Determining if a property is significant, (23 CFR 774.11(c));
- Determining application to multiple-use properties, (23 CFR 774.11(d));
- Determining applicability of Section 4(f) to historic sites, (23 CFR 774.11(e));
- Determining constructive use, (23 CFR 774.15(d));
- Determining if proximity impacts will be mitigated to equivalent or better condition, (23 CFR 774.15(f)(6)); and
- Evaluating the reasonableness of measures to minimize harm, (23 CFR 774.3(a)(2) and 774.17).

Lack of Objection

The regulations require a finding that the official(s) with jurisdiction have been consulted and “have not objected” in the following situations:

- When applying the exception for restoration, rehabilitation, or maintenance of historic transportation facilities, (23 CFR 774.13(a)); and
- When applying the exception for archeological sites of minimal value for preservation in place. (23 CFR 774.13(b)(2)).

Concurrence

The regulations require written concurrence of the official(s) with jurisdiction in the following situations:

- Finding there are no adverse effects prior to making de minimis impact findings, (23 CFR 774.5(b));
- Applying the exception for temporary occupancies, (23 CFR 774.13(d)); and
- Applying the exception for transportation enhancement activities and mitigation activities, (23 CFR 774.13(g)).

1.3 When Does Section 4(f) Apply?

The statute itself specifies that Section 4(f) applies when a U.S. DOT agency approves a transportation program or project that uses Section 4(f) property. The FHWA does not currently approve any transportation programs; thus, Section 4(f) is limited to project approvals. In addition, for the statute to apply to a proposed project there are four conditions that must all be true:

1. The project must require an approval⁴ from FHWA in order to proceed;
2. The project must be a transportation project;⁵
3. The project must require the use of land from a property protected by Section 4(f) (See 23 U.S.C. § 138(a) and 49 U.S.C. § 303(a)); and
4. None of the regulatory applicability rules or exceptions applies (See 23 CFR 774.11 and 13).

Examples of the types of proposed situations where Section 4(f) would not apply include, but are not limited to:

1. A transportation project being constructed solely using State or local funds and not requiring FHWA approval.
2. A project intended to address a purpose that is unrelated to the movement of people, goods, and services from one place to another (i.e., a purpose that is not a transportation purpose).
3. A project to be located adjacent to a Section 4(f) property, causing only minor proximity impacts to the Section 4(f) property (i.e., no constructive use).
4. A project that will use land from a privately owned park, recreation area, or refuge.

Additional information about these examples and many other examples of situations where Section 4(f) approval is or is not required is located in the questions and answers provided in Part II of this Section 4(f) Policy Paper. In situations where FHWA has determined that Section 4(f) does not apply, the project file should contain sufficient information to demonstrate the basis for that determination (See Section 4.0, Documentation).

2.0 Background

The FHWA originally issued the Section 4(f) Policy Paper in 1985, with minor amendments in 1989. A 2005 edition provided comprehensive new guidance on when and how to apply the provisions of Section 4(f), including how to choose among alternatives that all would use Section 4(f) property. Later in 2005, Congress substantially amended Section 4(f) in the Safe, Accountable, Flexible, Efficient Transportation Equity Act: A Legacy for Users (SAFETEA-LU), (Pub. L. 109-59 (Aug. 10, 2005), 119 Stat. 1144). SAFETEA-LU directed the U.S. DOT to revise its Section 4(f) regulations. In response, FHWA and the Federal Transit Administration consulted with interested agencies and environmental organizations before drafting a notice of proposed rulemaking. The notice of proposed rulemaking was published for comment in the Federal Register (71 Fed. Reg. 42611, July 27, 2006).

Following careful consideration of the comments submitted, the new Section 4(f) regulations were issued in March 2008 (73 Fed. Reg. 13368, March 12, 2008). A minor technical correction followed shortly thereafter (73 Fed. Reg. 31609, June 3, 2008). The new Section 4(f) regulations clarified the feasible and prudent standard, implemented a new method of compliance for de minimis impact situations, and updated many other aspects of the regulations, including the adoption of regulatory standards based upon the 2005 edition of the Section 4(f) Policy Paper for choosing among alternatives that all use Section 4(f) property. This 2012 edition of the Section 4(f) Policy Paper includes guidance for all of the changes promulgated in the Section 4(f) regulations in 2008.

If any apparent discrepancy between this Section 4(f) Policy Paper and the Section 4(f) regulation should arise, the regulation takes precedence. The previous editions of this Section 4(f) Policy Paper are no longer in effect.

3.0 Analysis Process

3.1 Identification of Section 4(f) Properties

Section 4(f) requires consideration of:

- Parks and recreational areas of national, state, or local significance that are both publicly owned and open to the public
- Publicly owned wildlife and waterfowl refuges of national, state, or local significance that are open to the public to the extent that public access does not interfere with the primary purpose of the refuge⁶
- Historic sites of national, state, or local significance in public or private ownership regardless of whether they are open to the public (See 23 U.S.C. § 138(a) and 49 U.S.C. § 303(a))

When private institutions, organizations, or individuals own parks, recreational areas or wildlife and waterfowl refuges, Section 4(f) does not apply, even if such areas are open to the public. However, if a governmental body has a permanent proprietary interest in the land (such as a permanent easement, or in some circumstances, a long-term lease), FHWA will determine on a case-by-case basis whether the particular property should be considered publicly owned and, thus, if Section 4(f) applies (See Questions 1B and 1C). Section 4(f) also applies to all historic sites that are listed, or eligible for inclusion, in the National Register of Historic Places (NR) at the local, state, or national level of significance regardless of whether or not the historic site is publicly owned or open to the public.

A publicly owned park, recreational area or wildlife or waterfowl refuge must be a significant resource for Section 4(f) to apply (See 23 CFR 774.11(c) and Question 1A). Resources which meet the definitions above are presumed to be significant unless the official with jurisdiction over the site concludes that the entire site is not significant. The FHWA will make an independent evaluation to assure that the official's finding of significance or non-significance is reasonable. In situations where FHWA's determination contradicts and overrides that of the official with jurisdiction, the reason for FHWA's determination should be documented in the project file and discussed in the environmental documentation for the proposed action.

Section 4(f) properties should be identified as early as practicable in the planning and project development process in order that complete avoidance of the protected resources can be given full and fair consideration (See 23 CFR 774.9(a)). Historic sites are normally identified during the process required under Section 106 of the NHPA and its implementing regulations (See 36 CFR Part 800). Accordingly, the Section 106 process should be initiated and resources listed or

eligible for listing in the NR identified early enough in project planning or development to determine whether Section 4(f) applies and for avoidance alternatives to be developed and assessed (See 23 CFR 774.11(e)).

3.2 Assessing Use of Section 4(f) Properties

Once Section 4(f) properties have been identified in the study area, it is necessary to determine if any of them would be used by an alternative or alternatives being carried forward for detailed study. Use in the Section 4(f) context is defined in 23 CFR 774.17 (Definitions) and the term has very specific meaning (see also Question 7 in this Section 4(f) Policy Paper). Any potential use of Section 4(f) property should always be described in related documentation consistent with this definition, as well as with the language from 23 CFR 774.13(d) (Exceptions- temporary occupancy) and 23 CFR 774.15 (Constructive Use Determinations), as applicable. It is not recommended to substitute similar terminology such as affected, impacted, or encroached upon in describing when a use occurs, as this may cause confusion or misunderstanding by the reader.

The most common form of use is when land is permanently incorporated into a transportation facility. This occurs when land from a Section 4(f) property is either purchased outright as transportation right-of-way or when the applicant for Federal-aid funds has acquired a property interest that allows permanent access onto the property such as a permanent easement for maintenance or other transportation-related purpose.

The second form of use is commonly referred to as temporary occupancy and results when Section 4(f) property, in whole or in part, is required for project construction-related activities. The property is not permanently incorporated into a transportation facility but the activity is considered to be adverse in terms of the preservation purpose of Section 4(f). Section 23 CFR 774.13(d) provides the conditions under which “temporary occupancies of land...are so minimal as to not constitute a use within the meaning of Section 4(f).” If all of the conditions in Section 774.13(d) are met, the temporary occupancy does not constitute a use. If one or more of the conditions for the exception cannot be met, then the Section 4(f) property is considered used by the project even though the duration of onsite activities is temporary. Written agreement by the official(s) with jurisdiction over the property with respect to all the conditions is necessary and should be retained in the project file. Assurances that documentation will eventually be obtained via subsequent negotiations are not acceptable. Also, it is typical that the activity in question will be detailed in project plans as an integral and necessary feature of the project.

The third and final type of use is called constructive use. A constructive use involves no actual physical use of the Section 4(f) property via permanent incorporation of land or a temporary occupancy of land into a transportation facility. A constructive use occurs when the proximity impacts of a proposed project adjacent to, or nearby, a Section 4(f) property result in substantial impairment to the property's activities, features, or attributes that qualify the property for protection under Section 4(f). As a general matter this means that the value of the resource, in terms of its Section 4(f) purpose and significance, will be meaningfully reduced or lost. The types of impacts that may qualify as constructive use, such as increased noise levels that would substantially interfere with the use of a noise sensitive feature such as a campground or outdoor amphitheater, are addressed in 23 CFR 774.15. A project's proximity to a Section 4(f) property is not in itself an impact that results in constructive use. Also, the assessment for constructive use should be based upon the impact that is directly attributable to the project under review, not the overall combined impacts to a Section 4(f) property from multiple sources over time. Since constructive use is subjective, FHWA's delegation of Section 4(f) authority to the FHWA Division Offices requires consultation with the Headquarters Office of Project Development and Environmental Review prior to finalizing any finding of constructive use.

In making any finding of use involving Section 4(f) properties, it is necessary to have up to date right-of-way information and clearly defined property boundaries for the Section 4(f) properties. For publicly owned parks, recreation areas, and refuges, the boundary of the Section 4(f) resource is generally determined by the property ownership boundary. Up-to-date right-of-way records are needed to ensure that ownership boundaries are accurately documented. For historic properties, the boundary of the Section 4(f) resource is generally the NR boundary. If the historic property boundary of an eligible or listed site has not been previously established via Section 106 consultation, care should be taken in evaluating the site with respect to eligibility criteria. Depending upon its contributing characteristics, the actual legal boundary of the property may not ultimately coincide with the NR boundary. Since preliminary engineering level of detail (not final design) is customary during environmental analyses, it may be necessary to conduct more detailed preliminary design in some portions of the study area to finalize determinations of use.

Late discovery and/or late designations of Section 4(f) properties subsequent to completion of environmental studies may also occur. Each situation must be assessed to determine if the change in Section 4(f) status results in a previously unidentified need for a Section 4(f) approval pursuant to 23 CFR 774.13(c) (See Question 26). The determination should be considered and documented, as appropriate, in any re-evaluation of the project.

3.3 Approval Options

When FHWA determines that a project as proposed may use Section 4(f) property, there are three methods available for FHWA to approve the use:

1. Preparing a de minimis impact determination;
2. Applying a programmatic Section 4(f) evaluation; or
3. Preparing an individual Section 4(f) evaluation.

While the applicant will participate in gathering and presenting the documentation necessary for FHWA to make a Section 4(f) approval, the actual approval action is the FHWA's responsibility. The three approval options are set out in 23 CFR 774.3 and are discussed below.

3.3.1 Determination of a De Minimis Impact to Section 4(f) Property

A de minimis impact is one that, after taking into account any measures to minimize harm (such as avoidance, minimization, mitigation or enhancement measures), results in either:

1. A Section 106 finding of no adverse effect or no historic properties affected on a historic property; or
2. A determination that the project would not adversely affect the activities, features, or attributes qualifying a park, recreation area, or refuge for protection under Section 4(f).

In other words, a de minimis impact determination is made for the net impact on the Section 4(f) property. The final project NEPA decision document must include sufficient supporting documentation for any measures to minimize harm that were applied to the project by FHWA in order to make the de minimis impact determination (See 23 CFR 774.7(b)). A use of Section 4(f) property having a de minimis impact can be approved by FHWA without the need to develop and evaluate alternatives that would avoid using the Section 4(f) property. A de minimis impact determination may be made for a permanent incorporation or temporary occupancy of Section 4(f) property.

A de minimis impact determination requires agency coordination and public involvement as specified in 23 CFR 774.5(b). The regulation has different requirements depending upon the type of Section 4(f) property that would be used. For historic sites, the consulting parties identified in accordance with 36 CFR Part 800² must be consulted. The official(s) with jurisdiction must be

informed of the intent to make a de minimis impact determination and must concur in a finding of no adverse effect or no historic properties affected in accordance with 36 CFR Part 800. Compliance with 36 CFR Part 800 satisfies the public involvement and agency coordination requirement for de minimis impact findings for historic sites.

For parks, recreation areas, or wildlife and waterfowl refuges, the official(s) with jurisdiction over the property must be informed of the intent to make a de minimis impact determination, after which an opportunity for public review and comment must be provided. After considering any comments received from the public, if the official(s) with jurisdiction concurs in writing that the project will not adversely affect the activities, features, or attributes that make the property eligible for Section 4(f) protection, then FHWA may finalize the de minimis impact determination. The public notice and opportunity for comment as well as the concurrence for a de minimis impact determination may be combined with similar actions undertaken as part of the NEPA process. If a proposed action does not normally require public involvement, such as for certain minor projects covered by a categorical exclusion, an opportunity for the public to review and comment on the proposed de minimis impact determination must be provided. The opportunity for public input may be part of a public meeting or another form of public involvement. The final determination should be made by the FHWA Division Administrator (or in the case of Federal Lands, the Division Engineer) and all supportive documentation retained as part of the project file (See Section 4.0, Documentation).

A de minimis impact determination (see Part II, Questions 11-12) is a finding. It is not an evaluation of alternatives and no avoidance or feasible and prudent avoidance alternative analysis is required. The definition of all possible planning in 23 CFR 774.17 explains that a de minimis impact determination does not require the traditional second step of including all possible planning to minimize harm because avoidance, minimization, mitigation, or enhancement measures are included as part of the determination.

A de minimis impact determination must be supported with sufficient information included in the project file to demonstrate that the de minimis impact and coordination criteria are satisfied (23 CFR 774.7(b)). The approval of a de minimis impact should be documented in accordance with the documentation requirements in 23 CFR 774.7(f). These requirements may be satisfied by including the approval in the NEPA documentation - i.e., an Environmental Assessment (EA), Environmental Impact Statement (EIS), or Categorical Exclusion (CE) determination, Record of Decision (ROD), or Finding of No Significant Impact (FONSI), – or in an individual Section 4(f) evaluation when one is prepared for a project. When an individual Section 4(f) evaluation is required for a project in which one or more de minimis impact determinations will also be made, it is recommended that the individual Section 4(f) evaluation include the relevant documentation to support the proposed de minimis impact determination(s).

In situations where FHWA concludes in the individual Section 4(f) evaluation that there is no feasible and prudent avoidance alternative and there are two or more alternatives that use Section 4(f) property, a least overall harm analysis will be necessary pursuant to 23 CFR 774.3(c) (See Section 3.3.3.2, Alternative with Least Overall Harm). In such instances, while the de minimis impact will be considered in that analysis, the de minimis impact is unlikely to be a significant differentiating factor between alternatives because the net harm resulting from the de minimis impact is negligible. The determination of least overall harm will depend upon a comparison of the factors listed in the regulation, 23 CFR 774.3(c)(1).

3.3.2 Programmatic Section 4(f) Evaluations

Programmatic Section 4(f) evaluations are a time-saving procedural option for preparing individual Section 4(f) evaluations (discussed in Section 3.3.3) for certain minor uses of Section 4(f) property. Programmatic Section 4(f) evaluations are developed by the FHWA based on experience with many projects that have a common fact pattern from a Section 4(f) perspective.

Through applying a specific set of criteria, based upon common experience that includes project type, degree of use and impact, the evaluation of avoidance alternatives is standardized and simplified. An approved programmatic Section 4(f) evaluation may be relied upon to cover a particular project only if the specific conditions in that programmatic evaluation are met. Programmatic evaluations can be nationwide, region-wide, or statewide. The development of any programmatic evaluation, including region-wide and statewide, must be coordinated with the FHWA Office of Project Development and Environmental Review and the FHWA Office of Chief Counsel.

As of the date of publication of this Section 4(f) Policy Paper, the FHWA has issued five nationwide programmatic Section 4(f) evaluations:⁸

1. Section 4(f) Statement and Determination for Independent Bikeway or Walkway Construction Projects
2. Programmatic Section 4(f) Evaluation and Approval for FHWA Projects that Necessitate the Use of Historic Bridges
3. Final Nationwide Section 4(f) Evaluation and Approval for Federally-Aided Highway Projects with Minor Involvements with Historic Sites
4. Final Nationwide Section 4(f) Evaluation and Approval for Federally-Aided Highway Projects with Minor Involvements with Public Parks, Recreation Lands, Wildlife and Waterfowl Refuges
5. Nationwide Programmatic Section 4(f) Evaluation and Approval for Transportation Projects That Have a Net Benefit to a Section 4(f) Property

Before being adopted, all of the nationwide programmatic Section 4(f) evaluations were published in draft form in the Federal Register for public review and comment. They were also provided to appropriate Federal agencies, including the Department of the Interior (U.S. DOI), for review. Each programmatic Section 4(f) evaluation was reviewed by FHWA's Office of Chief Counsel for legal sufficiency.

It is not necessary to coordinate project-specific applications of approved programmatic Section 4(f) evaluations with the U.S. DOI unless the U.S. DOI owns or has administrative oversight over the Section 4(f) property involved (is an official with jurisdiction or has an oversight role as described Questions 9D and 31). As specified in the applicable programmatic Section 4(f) evaluation, it is still necessary to coordinate with the official(s) with jurisdiction over such properties. A legal sufficiency review of a project-specific application of an approved programmatic Section 4(f) evaluation is not necessary. As such, a primary benefit to using the prescribed step-by-step approach contained in a programmatic evaluation is the reduction of time to process a Section 4(f) approval.

Documentation required to apply a programmatic Section 4(f) evaluation must support that the specific programmatic criteria have been met (See 23 CFR 774.3(d)(1)). A separate Section 4(f) document is not required but an indication in the NEPA documentation that Section 4(f) compliance was satisfied by the applicable programmatic evaluation is required (See 23 CFR 774.7(f)). As specified in the programmatic evaluations, the requirement to assess whether there is a feasible and prudent avoidance alternative and all possible planning applies. The necessary information supporting the applicability of the programmatic evaluation will be retained in the project file (See Section 4.0, Documentation).

3.3.3 Individual Project Section 4(f) Evaluations

An individual Section 4(f) evaluation must be completed when approving a project that requires the use of Section 4(f) property if the use, as described in Sections 3.1 and 3.2 above, results in a greater than de minimis impact and a programmatic Section 4(f) evaluation cannot be applied to the situation (23 CFR 774.3). The individual Section 4(f) evaluation documents the evaluation

of the proposed use of Section 4(f) properties in the project area of all alternatives. The individual Section 4(f) evaluation requires two findings, which will be discussed in turn:

1. That there is no feasible and prudent alternative that completely avoids the use of Section 4(f) property; and
2. That the project includes all possible planning to minimize harm to the Section 4(f) property resulting from the transportation use (See 23 CFR 774.3(a)(1) and (2)).

3.3.3.1 Feasible and Prudent Avoidance Alternatives

The intent of the statute, and the policy of FHWA, is to avoid and, where avoidance is not feasible and prudent, minimize the use of significant public parks, recreation areas, wildlife and waterfowl refuges and historic sites by our projects. Unless the use of a Section 4(f) property is determined to have a de minimis impact, FHWA must determine that no feasible and prudent avoidance alternative exists before approving the use of such land (See 23 CFR 774.3). The Section 4(f) regulations refer to an alternative that would not require the use of any Section 4(f) property as an avoidance alternative. Feasible and prudent avoidance alternatives are those that avoid using any Section 4(f) property and do not cause other severe problems of a magnitude that substantially outweigh the importance of protecting the Section 4(f) property (23 CFR 774.17). This section of the Section 4(f) Policy Paper focuses on the identification, development, evaluation, elimination and documentation of potential feasible and prudent avoidance alternatives in a Section 4(f) evaluation document.

The first step in determining whether a feasible and prudent avoidance alternative exists is to identify a reasonable range of project alternatives including those that avoid using Section 4(f) property. The avoidance alternatives will include the no-build. The alternatives screening process performed during the scoping phase of NEPA is a good starting point for developing potential section 4(f) avoidance alternatives and/or design options.⁹ Any screening of alternatives that may have occurred during the transportation planning phase may be considered as well. It may be necessary, however, to look for additional alternatives if the planning studies and the NEPA process did not identify Section 4(f) properties and take Section 4(f) requirements into account. If Section 4(f) avoidance alternatives were eliminated during the earlier phases of project development for reasons unrelated to Section 4(f) impacts or a failure to meet the project purpose and need, they may need to be reconsidered in the Section 4(f) process. In addition, it is often necessary to develop and analyze new alternatives, or new variations of alternatives rejected for non-Section 4(f) reasons during the earlier phases.

The no-action or no-build alternative is an avoidance alternative and should be included in the analysis as such. In identifying other avoidance alternatives, FHWA should consider the reasonable alternatives that meet the purpose and need of the project. Potential alternatives to avoid the use of Section 4(f) property may include one or more of the following, depending on project context:

- **Location Alternatives** - A location alternative refers to the re-routing of the entire project along a different alignment.
- **Alternative Actions** - An alternative action could be a different mode of transportation, such as rail transit or bus service, or some other action that does not involve construction such as the implementation of transportation management systems or similar measures.
- **Alignment Shifts** - An alignment shift is the re-routing of a portion of the project to a different alignment to avoid a specific resource.
- **Design Changes** - A design change is a modification of the proposed design in a manner that would avoid impacts, such as reducing the planned median width, building a retaining wall, or incorporating design exceptions.

When considering alignment shifts and design changes, it is important to keep in mind the range of allowable configurations and design values for roadway elements and different types of roads. These guidelines are contained within the official state standards and/or the “Green Book,” properly titled A Policy on the Geometric Design of Highways and Streets and published by the American Association of State Highway and Transportation Officials. The guidelines set out the generally acceptable ranges of dimensions for roadway elements and typical applications on different types of roadway facilities. These ranges of values provide planners and designers the ability to develop projects at an acceptable cost and level of performance (e.g. safety, traffic flow, sustainability), while balancing the site-specific conditions, constraints, and implications of design decisions. Where it may be appropriate to select a value or dimension outside of the ranges that are established in State and national guidelines, design exceptions are encouraged and permitted. However, the consideration and selection of a value outside of the established ranges should be based on the context of the facility and an analysis of how the design may affect the safety, flow of traffic, constructability, maintainability, environment, cost, and other related issues.

An important consideration in identifying potential avoidance alternatives is that they should have a reasonable expectation of serving traffic needs that have been identified in the project purpose and need. A final limitation in identifying potential avoidance alternatives is that a project alternative that avoids one Section 4(f) property by using another Section 4(f) property is not an avoidance alternative. The goal is to identify alternatives that would not use any Section 4(f) property. (Note: A determination of a De minimis impact for a specific Section 4(f) property may be made without considering avoidance alternatives for that property, even if that use occurs as part of an alternative that also includes other uses that are greater than De minimis.) Consequently, at this step of analysis the degree of impact to Section 4(f) property is not relevant - the only question is whether the alternative would require any use of Section 4(f) property because an alternative using any amount of Section 4(f) property is not an avoidance alternative. Subsequent steps in the analysis will consider the degree of impact as well as the availability of measures to minimize impacts.

Once the potential avoidance alternative(s) have been identified, the next task is to determine, for each potential avoidance option, whether avoiding the Section 4(f) property is feasible and prudent. The Section 4(f) regulations specify how FHWA is to determine whether a potential avoidance alternative is feasible and prudent in 23 CFR 774.17. The definition explains that a “feasible and prudent avoidance alternative” is one that avoids using Section 4(f) property and does not cause other severe problems of a magnitude that substantially outweigh the importance of protecting the Section 4(f) property. In order to determine whether there are other severe problems of a magnitude that substantially outweighs the importance of protecting the Section 4(f) property, both the feasibility and the prudence of each potential avoidance alternative must be considered.

Care must be taken when making determinations of feasibility and prudence not to forget or de-emphasize the importance of protecting the Section 4(f) property. This stems from the statute itself, which requires that special effort should be made to preserve the natural beauty of the countryside and public park and recreation lands, wildlife and waterfowl refuges, and historic sites. The regulation incorporates this aspect of the statute in the definition of feasible and prudent avoidance alternative which states that “it is appropriate to consider the relative value of the resource to the preservation purpose of the statute.” In effect, the first part of the definition recognizes the value of the individual Section 4(f) property in question, relative to other Section 4(f) properties of the same type. This results in a sliding scale approach that maximizes the protection of Section 4(f) properties that are unique or otherwise of special significance by recognizing that while all Section 4(f) properties are important, some Section 4(f) properties are worthy of a greater degree of protection than others.

The regulations state that a potential avoidance alternative is not feasible if it cannot be built as a matter of sound engineering judgment (23 CFR 774.17). If a potential avoidance alternative cannot be built as a matter of sound engineering judgment it is not feasible and the particular engineering problem with the alternative should be documented in the project files with a reasonable degree of explanation. In difficult situations, the FHWA Division may obtain assistance from FHWA subject matter experts located in FHWA Headquarters or the FHWA Resource Center.

The third and final part of the feasible and prudent avoidance alternative definition sets out standards for determining if a potential avoidance alternative is prudent. An alternative is not prudent if:

1. It compromises the project to a degree that it is unreasonable to proceed in light of the project's stated purpose and need (i.e., the alternative doesn't address the purpose and need of the project);
2. It results in unacceptable safety or operational problems;
3. After reasonable mitigation, it still causes severe social, economic, or environmental impacts; severe disruption to established communities; severe or disproportionate impacts to minority or low-income populations; or severe impacts to environmental resources protected under other Federal statutes;
4. It results in additional construction, maintenance, or operational costs of extraordinary magnitude;
5. It causes other unique problems or unusual factors; or
6. It involves multiple factors as outlined above that, while individually minor, cumulatively cause unique problems or impacts of extraordinary magnitude.

The prudence determination involves an analysis that applies each of the six factors, if applicable, to the potential avoidance alternative. If a factor is not applicable FHWA recommends simply noting that fact in the analysis.

Supporting documentation is required in the Section 4(f) evaluation for findings of no feasible and prudent alternatives (See 23 CFR 774.7(a)). Documentation of the process used to identify, develop, analyze and eliminate potential avoidance alternatives is very important. The Section 4(f) evaluation should describe all efforts in this regard. This description need not include every possible detail, but it should clearly explain the process that occurred and its results. It is appropriate to maintain detailed information in the project file with a summary in the Section 4(f) evaluation. If the information is especially voluminous, a technical report should be prepared, summarized, and referenced in the Section 4(f) evaluation. The discussion may be organized within the Section 4(f) evaluation in any manner that allows the reader to understand the full range of potential avoidance alternatives identified, the process by which potential avoidance alternatives were identified and analyzed for feasibility and prudence. Possible methods for organizing the discussion include a chronological discussion; a discussion organized geographically by project alternatives or project phases of construction; or by the type of Section 4(f) properties.

For larger highway projects with multiple Section 4(f) properties in the project area, it may be desirable to divide the analysis into a macro and a micro-level evaluation in order to distinguish the analysis of end-to-end project alternatives that avoid using any Section 4(f) property from the analysis of design options to avoid using a single Section 4(f) property. The macro-level evaluation would address any end-to-end avoidance alternatives that can be developed, as well as any alternative actions to the proposed highway project such as travel demand reduction strategies or enhanced transit service in the project area. The micro-level evaluation would then address, for each Section 4(f) property, whether the highway could be routed to avoid the property by shifting to the left or right, by bridging over, or tunneling under the property, or through another alignment shift or design change. The analysis may be presented in any manner that

demonstrates, for each Section 4(f) property used, that there is no feasible and prudent avoidance alternative. Even if all of the alternatives use a Section 4(f) property, there is still a duty to try to avoid the individual Section 4(f) properties within each alternative.

3.3.3.2 Alternative with Least Overall Harm

If the analysis described in the preceding section concludes that there is no feasible and prudent avoidance alternative, then FHWA may approve, from among the remaining alternatives that use Section 4(f) property, only the alternative that causes the least overall harm in light of the statute's preservation purpose. Pursuant to substantial case law, if the assessment of overall harm finds that two or more alternatives are substantially equal, FHWA can approve any of those alternatives. This analysis is required when multiple alternatives that use Section 4(f) property remain under consideration.

To determine which of the alternatives would cause the least overall harm, FHWA must compare seven factors set forth in 23 CFR 774.3(c)(1) concerning the alternatives under consideration. The first four factors relate to the net harm that each alternative would cause to Section 4(f) property:

1. The ability to mitigate adverse impacts to each Section 4(f) property (including any measures that result in benefits to the property);
2. The relative severity of the remaining harm, after mitigation, to the protected activities, attributes, or features that qualify each Section 4(f) property for protection;
3. The relative significance of each Section 4(f) property; and
4. The views of the officials with jurisdiction over each Section 4(f) property.

When comparing the alternatives under these factors, FHWA policy is to develop comparable mitigation measures where possible. In other words, the comparison may not be skewed by over-mitigating one alternative while under-mitigating another alternative for which comparable mitigation could be incorporated. In addition, the mitigation measures relied upon as part of this comparison should be incorporated into the selected alternative. If subsequent design or engineering work occurs after the alternative is selected that requires changes to the mitigation plans for Section 4(f) property, FHWA may require revisions to previous mitigation commitments commensurate with the extent of design changes in accordance with 23 CFR 771.109(b) and (d), 127(b), 129, and 130.

The remaining three factors enable FHWA to take into account any substantial problem with any of the alternatives remaining under consideration on issues beyond Section 4(f). These factors are:

5. The degree to which each alternative meets the purpose and need for the project;
6. After reasonable mitigation, the magnitude of any adverse impacts to resources not protected by Section 4(f); and
7. Substantial differences in costs among the alternatives.
- 8.

By balancing the seven factors, four of which concern the degree of harm to Section 4(f) properties, FHWA will be able to consider all relevant concerns to determine which alternative would cause the least overall harm in light of the statute's preservation purpose. The least overall harm balancing test is set forth in 774.3(c)(1). This allows FHWA to fulfill its statutory mandate to make project decisions in the best overall public interest required by 23 U.S.C. § 109(h). Through this balancing of factors, FHWA may determine that a serious problem identified in factors (v) through (vii) outweighs relatively minor net harm to a Section 4(f) property. The least overall harm determination also provides FHWA with a way to compare and select between alternatives that would use different types of Section 4(f) properties when competing

assessments of significance and harm are provided by the officials with jurisdiction over the impacted properties. In evaluating the degree of harm to Section 4(f) properties, FHWA is required by the regulations to consider the views (if any) expressed by the official(s) with jurisdiction over each Section 4(f) property. If an official with jurisdiction states that all resources within that official's jurisdiction are of equal value, FHWA may still determine that the resources have different value if such a determination is supported by information in the project file. Also, if the officials with jurisdiction over two different properties provide conflicting assessments of the relative value of those properties, FHWA should consider the officials' views but then make its own independent judgment about the relative value of those properties. Similarly, if the official(s) with jurisdiction decline to provide any input at all regarding the relative value of the affected properties, FHWA should make its own independent judgment about the relative value of those properties.

FHWA is required to explain how the seven factors were compared to determine the least overall harm alternative (See 23 CFR 774.7(c)). The draft Section 4(f) evaluation will disclose the various impacts to the different Section 4(f) properties thereby initiating the balancing process. It should also disclose the relative differences among alternatives regarding non-Section 4(f) issues such as the extent to which each alternative meets the project purpose and need. The disclosure of impacts should include both objective, quantifiable impacts and qualitative measures that provide a more subjective assessment of harm. Preliminary assessment of how the alternatives compare to one another may also be included. After circulation of the draft Section 4(f) evaluation in accordance with 23 CFR 774.5(a), FHWA will consider comments received on the evaluation and finalize the comparison of all factors listed in 23 CFR 774.3(c)(1) for all the alternatives. The analysis and identification of the alternative that has the overall least harm must be documented in the final Section 4(f) evaluation (See 23 CFR 774.7(c)). In especially complicated projects, the final approval to use the Section 4(f) property may be made in the decision document (ROD or FONSI).

3.4 Examples of Section 4(f) Approvals

The table below describes five project alternative scenarios. In each project scenario various alternatives are considered and there are various options available to approve the use of the Section 4(f) property needed for the project. The examples illustrate the approval options as well as the point that in some situations FHWA may only approve a certain alternative. These examples are not intended to address every possible scenario.

In Project 1 there is a single build alternative A, for which FHWA determines the use to be a de minimis impact and therefore does not require an individual Section 4(f) evaluation. Once the coordination required by 23 CFR 774.5(b) is completed, FHWA may approve the de minimis impact and the applicant may proceed with the build alternative.

Project 2 has two alternatives. The FHWA determines that alternative A has a de minimis impact on one Section 4(f) property, and alternative B has a de minimis impact on three Section 4(f) properties. Upon completion of the coordination required by 23 CFR 774.5(b), FHWA may approve either alternative under Section 4(f). As in the previous example, an individual Section 4(f) evaluation is not required, therefore the feasibility and prudence of avoiding Section 4(f) properties does not have to be determined. Furthermore, when there are only de minimis impacts, even among multiple alternatives, a least harm analysis is not necessary and there is no need to compare the significance of the competing Section 4(f) properties. The process to choose between alternatives A or B in the second example may be based on non-Section 4(f) considerations as determined appropriate through the project development process.

In Project 3, there are three alternatives under consideration. The FHWA determines that alternative A meets the criteria of a de minimis impact, while alternative B has a minor impact on

a Section 4(f) property for which the programmatic Section 4(f) evaluation for minor uses is applicable. Alternative C would use a Section 4(f) property to an extent that a de minimis impact determination is not possible and no programmatic Section 4(f) evaluation applies. In this example, all three alternatives use a Section 4(f) property and thus none can be considered to be an avoidance alternative. For this project, alternative A may proceed immediately once the coordination required by 23 CFR 774.5 is complete, through an approved de minimis impact determination. Alternative B may be approved by following the procedures designated in the applicable programmatic Section 4(f) evaluation, whose end result demonstrates no feasible and prudent avoidance alternative. However, in this example if the applicant favors alternative C, then an individual Section 4(f) evaluation can be prepared to consider whether or not alternative C can be approved under Section 4(f). The individual Section 4(f) evaluation first determines that there is no feasible and prudent avoidance alternative as defined in 23 CFR 774.17. The evaluation then considers which alternative (A, B, or C) has the least overall harm using the factors in 23 CFR 774.3(c). Alternative C could only be approved if it is identified as having the least overall harm, which would be possible; for example, if alternatives A and B both have severe impacts to an important non-Section 4(f) resource and the impacts of alternative C can be adequately mitigated. In that case, upon completion of the coordination required by 23 CFR 775.5(a) and all possible planning to minimize harm as defined in 23 CFR 774.17, alternative C could be approved.

Project 4 differs slightly in having multiple de minimis impacts to Section 4(f) properties with alternative A, and a mix of de minimis impacts and greater than de minimis impacts not covered by a programmatic section 4(f) evaluation with alternative B. If alternative A is chosen, FHWA would satisfy Section 4(f) by making a de minimis impact determination for each property used in accordance with 23 CFR 774.3(b), 774.5(b), and 774.7(c). To consider selecting alternative B, an individual Section 4(f) evaluation would be prepared in accordance with 23 CFR 774.3(a), 774.5(a), and 774.7(a); however, a determination of de minimis impact for a specific Section 4(f) property can be made without considering avoidance alternatives for that property, even if that use occurs as part of an alternative that also includes other uses that are greater than de minimis. In this example, an additional alternative C is developed as part of the Section 4(f) evaluation. Alternative C avoids using any Section 4(f) property, and the evaluation then determines, using the definition in 23 CFR 774.17, that alternative C is feasible and prudent. Alternative C may proceed immediately because it does not use any Section 4(f) property and no Section 4(f) approval is needed. In this example, since alternative C is a feasible and prudent avoidance alternative the FHWA may not approve alternative B, although alternative A would still be available for selection because its impacts on Section 4(f) properties are de minimis. However, if the facts are changed and we now assume that the evaluation of avoidance alternative C had found that it was not feasible and prudent, then the Section 4(f) evaluation could be completed. The evaluation would determine the least overall harm amongst alternatives A and B using the factors in 23 CFR 774.3(c). (In this variation of the example, the least overall harm determination does not include alternative C in the comparison because alternative C was previously eliminated when it was found not to be feasible and prudent.) Alternative B could only be approved if it is identified as having the least overall harm. This would be possible, for example if alternative A would not meet the project purpose and need as well as alternative B, alternative A would be substantially more expensive, and the Section 4(f) property used by alternative B has no unusual significance and could be adequately mitigated. In that example, upon completion of the coordination required by 23 CFR 774.5(a) and all possible planning to minimize harm as defined in 23 CFR 774.17, alternative B could be approved even though it uses Section 4(f) property. Project 5 has two alternatives, both having greater than de minimis impacts on a different Section 4(f) property. To choose among alternatives A and B, an individual Section 4(f) evaluation must be prepared in accordance with 23 CFR 774.3(a), 774.5(a), and 774.7(a) that demonstrates no feasible and prudent avoidance alternative exists, and a least overall harm analysis must be completed using the factors in 23 CFR 774.3(c). The alternative identified as having the least overall harm may proceed upon completion of the coordination required by 23 CFR 774.5(a) and all possible planning to minimize harm as defined in 23 CFR 774.17.

Table 1. Project Alternative Scenarios

ALTERNATIVE	USE OF SECTION 4(f) PROPERTY	INDIVIDUAL SECTION EVALUATION? 4(f)	OUTCOME
Project 1, alternative A	de minimis impact	Not necessary	May proceed with A
Project 2, alternative A	de minimis impact on one property	Not necessary	May proceed with A or B; Section 4(f) is not determinative
Project 2, alternative B	de minimis impact on three properties	Not necessary	
Project 3, alternative A	de minimis impact	Not necessary	May proceed with A or B; Section 4(f) is not determinative
Project 3, alternative B	Minor use, programmatic Section 4(f) evaluation is applicable	Not necessary	
Project 3, alternative C	Greater than de minimis impact	Necessary. If no feasible and prudent avoidance alternative is identified, then a least overall harm analysis would compare A, B, and C.	May proceed with C only if C has less overall harm than A or B.
Project 4, alternative A	de minimis impact on two properties	Not necessary	May proceed with A
Project 4, alternative B	de minimis impact on one property & greater than de minimis impact on another property	Necessary. As part of the evaluation, a new Alternative C is developed that avoids using Section 4(f) property.	If C is found feasible and prudent, cannot proceed with B. If C is not feasible and prudent, may proceed with B only if B has less overall harm than A.
Project 4, alternative C	None	Not necessary to complete the Section 4(f) evaluation to proceed with C.	May proceed with C; no Section 4(f) approval is required.
Project 5, alternative A	Greater than de minimis impact	Necessary. The evaluation must seek to identify feasible and prudent avoidance alternatives. Assuming none are found, then a least harm analysis will compare A and B.	Least overall harm analysis determines which alternative, A or B, may proceed.
Project 5, alternative B	Greater than de minimis impact		

3.5 All Possible Planning to Minimize Harm

After determining that there are no feasible and prudent alternatives to avoid the use of Section 4(f) property, the project approval process for an individual Section 4(f) evaluation requires the consideration and documentation of all possible planning to minimize harm to Section 4(f) property (See 23 CFR 774.3(a)(2)). All possible planning, defined in 23 CFR 774.17, means that all reasonable measures identified in the Section 4(f) evaluation to minimize harm or mitigate for adverse impacts and effects must be included in the project. All possible planning to minimize harm does not require analysis of feasible and prudent avoidance alternatives, since such analysis will have already occurred in the context of searching for feasible and prudent alternatives that avoid Section 4(f) properties altogether under § 774.3(a)(1).

Minimization of harm may entail both alternative design modifications that reduce the amount of Section 4(f) property used and mitigation measures that compensate for residual impacts. Minimization and mitigation measures should be determined through consultation with the official(s) with jurisdiction. These include the SHPO and/or THPO for historic properties or officials owning or administering the resource for other types of Section 4(f) properties.

Mitigation measures involving public parks, recreation areas, or wildlife or waterfowl refuges may involve a replacement of land and/or facilities of comparable value and function, or monetary compensation to enhance the remaining land. Neither the Section 4(f) statute nor regulations requires the replacement of Section 4(f) property used for highway projects, but this option may be the most straightforward means of minimizing harm to parks, recreation areas, and wildlife waterfowl refuges and is permitted under 23 CFR 710.509 as a mitigation measure for direct project impacts.

Mitigation of historic sites usually consists of those measures necessary to preserve the historic integrity of the site and agreed to in accordance with 36 CFR 800 by FHWA, the SHPO or THPO, and other consulting parties. In any case, the cost of mitigation should be a reasonable public expenditure in light of the severity of the impact on the Section 4(f) property in accordance with 23 CFR 771.105(d). Additional laws such as Section 6(f) of the Land and Water Conservation Fund Act may have separate mitigation and approval requirements and compliance with such requirements should also be described within the Section 4(f) discussion of all possible planning to minimize harm.

4.0 Documentation

U.S. DOT departmental requirements for documenting Section 4(f) analysis and approvals (DOT Order 5610.1C) have been incorporated into FHWA regulations, guidance and policy. The FHWA's procedures regarding the preparation and circulation of Section 4(f) documents is contained in 23 CFR 774.5 and FHWA's Technical Advisory, T 6640.8A, Guidance for Preparing and Processing of Environmental and Section 4(f) Documents.¹⁰

The documentation of all Section 4(f) determinations, consultations, coordination and approvals is intended to establish a record of FHWA's compliance with the regulatory process. Documentation also provides evidence that the substantive requirements have been met. Section 4(f) documentation and processing requirements vary depending on the type of Section 4(f) property used and whether or not the use meets the criteria of a de minimis impact. However, all situations which involve Section 4(f) property will necessitate some degree of documentation: either in the NEPA document, a Section 4(f) evaluation, or the project file.

The project file is the agency's written record that memorializes the basis for determining that an impact is de minimis or that there is no feasible and prudent avoidance alternative to the use of the Section 4(f) property and that FHWA undertook all possible planning to minimize harm to Section 4(f) property. When the agency determines that Section 4(f) is not applicable to a particular resource, written documentation of that decision should be maintained as part of the project file.

The project file should include all relevant correspondence which may include emails and other electronic information that is applicable to the decision-making process. The project file should generally be retained until three years after FHWA reimbursement on Federal-aid projects and three years after final payment on non-Federal aid projects (See FHWA Order M.1324.1A, 49 CFR 18.42, and 49 CFR 19.53).

De Minimis Impact Determinations

The de minimis impact determination must include sufficient supporting documentation to demonstrate that the impacts, after avoidance, minimization, mitigation, or enhancement measures are taken into account, are de minimis as defined in 23 CFR 774.17; and that the coordination required by 23 CFR 774.5(b) was completed.

Information related to the de minimis impact determination should be included in the project NEPA document (EA or EIS), or in the project file for a project processed as a CE (See 23 CFR 774.7(c)). Circulation of this information in the project NEPA document may satisfy the public involvement requirements required for de minimis impact findings. For projects which include both de minimis impacts and use of Section 4(f) property with more than a de minimis impact, the determination and supporting data should be included in a separate section of the Section 4(f) evaluation.

Applying Programmatic Section 4(f) Evaluation

Information related to an approval to use Section 4(f) property by applying a programmatic Section 4(f) evaluation should be included in the project NEPA document (EA or EIS), or in the project file for a project processed as a CE. For projects which include both a programmatic Section 4(f) approval and a use of Section 4(f) property for which there is more than a de minimis impact, information regarding the application of the programmatic Section 4(f) evaluation should be included in a separate section of the Section 4(f) evaluation.

The project file should include sufficient supporting documentation to demonstrate that the programmatic evaluation being relied upon applies to the use of the specific Section 4(f) property. In addition, the project file should include documentation that the coordination required by the applicable programmatic evaluation was completed and that all specific conditions of the applicable programmatic evaluation were met.

Individual Section 4(f) Evaluations

Individual Section 4(f) evaluations must include sufficient analysis and supporting documentation to demonstrate that there is no feasible and prudent avoidance alternative and shall summarize the results of all possible planning to minimize harm (23 CFR 774.7(a)). For projects requiring a least overall harm analysis under 23 CFR 774.3(c), that analysis must be included within the individual Section 4(f) evaluation (23 CFR 774.7(c)).

Individual Section 4(f) evaluations are processed in two distinct stages: draft and final. Draft evaluations must be circulated to the U.S. DOI and shared with the official(s) with jurisdiction. The public may review and comment on a draft evaluation during the NEPA process. When a project is processed as a CE the Section 4(f) evaluation must be circulated independently to the U.S. DOI. In all cases, final Section 4(f) evaluations are subject to FHWA legal sufficiency review prior to approval (23 CFR 774.5(d)).

Project Files

In general, the project file should contain the following essential information, with analysis, regarding Section 4(f):

- When making *de minimis* impact determinations

1. Applicability or non-applicability of Section 4(f) to the park, recreation, refuge or historic property proposed to be used by the project;
 2. Whether or not there is a use of section 4(f) property;
 3. Records of public involvement, or Section 106 consultation;
 4. Results of coordination with the officials with jurisdiction;
 5. Comments submitted during the coordination procedures required by 23 CFR 774.5 and responses to the comments; and
 6. Avoidance, minimization or mitigation measures that were relied upon to make the *de minimis* impact finding.
- When applying programmatic Section 4(f) evaluations
 1. Applicability or non-applicability of Section 4(f) to the park, recreation, refuge or historic property proposed to be used by the project;
 2. Whether or not there is a use of section 4(f) property;
 3. Records of public involvement, if any;
 4. Results of coordination with the officials with jurisdiction; and
 5. Documentation of the specific requirements of the programmatic evaluation that is being applied.
 - When applying programmatic Section 4(f) evaluations
 1. Applicability or non-applicability of Section 4(f) to the park, recreation, refuge or historic property proposed to be used by the project;
 2. Whether or not there is a use of section 4(f) property;
 3. Records of public involvement, if any;
 4. Results of coordination with the officials with jurisdiction; and
 5. Documentation of the specific requirements of the programmatic evaluation that is being applied.
 - When preparing an individual Section 4(f) evaluation
 1. Applicability or non-applicability of Section 4(f) to the park, recreation, refuge or historic property proposed to be used by the project;
 2. Whether or not there is a use of Section 4(f) property;
 3. Activities, features, and attributes of the Section 4(f) property;
 4. Analysis of the impacts to the Section 4(f) property;
 5. Records of public involvement;
 6. Results of coordination with the officials with jurisdiction;
 7. Alternatives considered to avoid using the Section 4(f) property, including analysis of the impacts caused by avoiding the Section 4(f) property;
 8. A least overall harm analysis, if appropriate;
 9. All measures undertaken to minimize harm to the Section 4(f) property;
 10. Comments submitted during the coordination procedures required by 23 CFR 774.5 and responses to the comments; and
 11. Results of the internal legal sufficiency review.

Administrative Records

If a Section 4(f) approval is legally challenged, the project file will be the basis of the administrative record that must be filed in the court for review. The administrative record will be reviewed in accordance with the Administrative Procedure Act (APA), (5 U.S.C. §706 (2)(A)), which provides judicial deference to U.S. DOT actions. Under the APA, the agency's action must be upheld unless it is arbitrary, capricious, an abuse of discretion, or otherwise not in accordance with law. The court will review the administrative record to determine whether FHWA complied with the essential elements of Section 4(f). If an inadequate administrative record is prepared, the court will lack the required Section 4(f) documentation to review and, therefore, will be unable to defer to FHWA's decision, especially when a Section 4(f) evaluation was not required. While agency decisions are entitled to a presumption of regularity and the courts are not empowered to substitute their judgment for that of the agency, judges will carefully review whether FHWA followed the applicable requirements.

PART II – QUESTIONS AND ANSWERS REGARDING SECTION 4(f) APPLICABILITY AND COMPLIANCE

The following questions and answers are intended to provide additional and detailed guidance for complying with the requirements of Section 4(f). Examples to aid in determining the applicability of Section 4(f) to various types of property and project situations are included. These examples represent FHWA's policy regarding Section 4(f) compliance for situations most often encountered in the project development process. Since it is impossible to address every situation that could occur, it is recommended that the FHWA Division Office be consulted for advice and assistance in determining the applicability of Section 4(f) to specific circumstances not covered in this paper. The FHWA Division Offices are encouraged to consult with the Headquarters Office of Project Development and Environmental Review, the Resource Center Environment Technical Services Team and/or the Office of the Chief Counsel in cases where additional assistance in Section 4(f) matters is required.

IDENTIFICATION OF SECTION 4(f) PROPERTIES

1. Public Parks, Recreation Areas and Wildlife and Waterfowl Refuges

Question 1A: When is publicly owned land considered to be a park, recreation area or wildlife and waterfowl refuge?

Answer: Publicly owned land is considered to be a park, recreation area or wildlife and waterfowl refuge when the land has been officially designated as such by a Federal, State or local agency, and the officials with jurisdiction over the land determine that its primary purpose is as a park, recreation area, or refuge. Primary purpose is related to a property's primary function and how it is intended to be managed. Incidental, secondary, occasional or dispersed activities similar to park, recreational or refuge activities do not constitute a primary purpose within the context of Section 4(f). Unauthorized activities, such as ad hoc trails created by the public within a conservation area, should not be considered as part of FHWA's determination of Section 4(f) applicability.

In addition, the statute itself requires that a property must be a significant public park, recreation area, or wildlife and waterfowl refuge. The term significant means that in comparing the availability and function of the park, recreation area or wildlife and waterfowl refuge, with the park, recreation or refuge objectives of the agency, community or authority, the property in question plays an important role in meeting those objectives. Except for certain multiple-use land holdings (Question 4), significance determinations are applicable to the entire property and not just to the portion of the property proposed for use by a project.

Significance determinations of publicly owned land considered to be a park, recreation area, or wildlife and waterfowl refuge are made by the official(s) with jurisdiction over the property. The meaning of the term significance, for purposes of Section 4(f), should be explained to the official(s) with jurisdiction if the official(s) are not familiar with Section 4(f). Management plans or other official forms of documentation regarding the land, if available and up-to-date, are important and should be obtained from the official(s) and retained in the project file. If a determination from the official(s) with jurisdiction cannot be obtained, and a management plan is not available or does not address the significance of the property, the property will be presumed to be significant. However, all determinations, whether stated or presumed, and whether confirming or denying significance of a property for the purposes of Section 4(f), are subject to review by FHWA for reasonableness pursuant to 23 CFR 774.11. When FHWA changes a determination of significance, the basis for this determination will be included in the project file and discussed in the environmental documentation for the proposed action.

Question 1B: Can an easement or other encumbrance on private property result in that property being subject to Section 4(f)?

Answer: Yes, in certain instances. Generally, an easement is the right to use real property without possessing it, entitling the easement holder to the privilege of some specific and limited use of the land. Easements take many forms and are obtained for a variety of purposes by different parties. Easements or similar encumbrances restricting a property owner from making certain uses of his/her property, such as conservation easements, are commonly encountered during transportation project development. Easements such as these often exist for the purpose of preserving open space, protection of habitat, or to limit the extent and density of development in a particular area, and they may be held by Federal, State or local agencies or non-profit groups or other advocacy organizations.

Although a conservation easement may not meet all of the requirements necessary to treat the property as a significant publicly-owned public park, recreation area, or wildlife and waterfowl refuge, it is a possibility that mandates careful case-by-case consideration when encountered. The terms of the easement should be carefully examined to determine if Section 4(f) applies to the property. Factors to consider include, but are not limited to, the views of the official(s) with jurisdiction, the purpose of the easement, the term of the easement, degree of public access to the property, how the property is to be managed and by whom, what parties obtained the easement (public agency or non-public group), termination clauses, and what restrictions the easement places on the property owner's use of the easement area. Questions on whether or not an easement conveys Section 4(f) status to a property should be referred to the FHWA Division Office and, if necessary, the Division Office should consult with the Headquarters Office of Project Development and Environmental Review, the Headquarters Office of Real Estate Services, the Resource Center Environment Technical Service Team, or the Office of Chief Counsel.

Easements and deed restrictions for the purpose of historic preservation are also commonly encountered during transportation project development. Section 4(f) applicability questions are unlikely to be encountered for these properties because if the property is not on or eligible for the NR Section 4(f) does not apply, notwithstanding the preservation easement. If the property is on or eligible for the NR, Section 4(f) applies. However, the existence and nature of such easements should be documented and considered as necessary within the feasible and prudent analysis and least harm analysis if a Section 4(f) evaluation is prepared.

Question 1C: When does a lease agreement with a governmental body constitute public ownership?

Answer: In some instances, a lease agreement between a private landowner and a governmental body may constitute a proprietary interest in the land for purposes of Section 4(f). Generally, under

a long term lease to a governmental body, such land may be considered to be “publicly owned” land and if the property is being managed by the governmental body as a significant public park, recreation area, or wildlife and waterfowl refuge then a use of the property will be subject to the requirements of Section 4(f). Such lease agreements should be examined on a case-by-case basis with consideration of such factors as the term of the lease, the understanding of the parties to the lease, the existence of a cancellation clause, and how long the lease has been in place. Questions on whether or not the leasehold constitutes public ownership should be referred to the FHWA Division Office, and if necessary the Division Office should consult with the Headquarters Office of Project Development and Environmental Review, the Resource Center Environment Technical Service Team, or the Office of Chief Counsel. If FHWA determines that the lease agreement creates a proprietary interest that is equivalent to public ownership, FHWA must then determine whether the property is in fact being managed by the government body as a significant public park, recreation area, or wildlife and waterfowl refuge. If so, the property is subject to Section 4(f).

Question 1D: Are significant publicly owned parks and recreation areas that are not open to the general public subject to the requirements of Section 4(f)?

Answer: The requirements of Section 4(f) would apply if the entire public park or public recreation area permits visitation of the general public at any time during the normal operating hours. Section 4(f) would not apply when visitation is permitted to a select group only and not to the entire public. Examples of select groups include residents of a public housing project; military service members and their dependents; students of a public school; and students, faculty, and alumni of a public college or university (See Question 18B). The FHWA does, however, strongly encourage the preservation of such parks and recreation areas even though they may not be open to the general public or are not publicly owned and therefore are not protected by Section 4(f).

It should be noted that wildlife and waterfowl refuges have not been included in this discussion. Many wildlife and waterfowl refuges allow public access, while others may restrict public access to certain areas within the refuge or during certain times or seasons of the year for the protection of refuge habitat or species. In these cases, the property should be examined by the FHWA Division Office to verify that the primary purpose of the property is for wildlife and waterfowl refuge activities and not for other non-Section 4(f) activities, and that the restrictions on public access are limited to measures necessary to protect refuge habitat or species. If it is determined that the primary purpose of the property is for wildlife and waterfowl refuge activities and that the restrictions on public access are limited to the measures necessary to protect the refuge habitat or species, then the property is subject to Section 4(f) notwithstanding the access restriction.

Question 1E: What is a wildlife and waterfowl refuge for purposes of Section 4(f)?

Answer: The term wildlife and waterfowl refuge is not defined in the Section 4(f) law. On the same day in 1966 that Section 4(f) was passed, Congress also passed the National Wildlife Refuge System Administration Act (Pub. L. 89-669, 80 Stat. 926) to provide for the conservation, protection, and propagation of native species of fish and wildlife, including migratory birds, that are threatened with extinction; to consolidate the authorities relating to the administration by the Secretary of the Interior of the National Wildlife Refuge System; and for other purposes. The Refuge System referred to in that Act includes areas that were designated as wildlife refuges and waterfowl refuges.¹¹ FHWA has considered this contemporaneous legislation in our implementation of Section 4(f) regarding refuges. For purposes of Section 4(f), National Wildlife Refuges¹² are always considered wildlife and waterfowl refuges by FHWA in administering Section 4(f); therefore no individual determination of their Section 4(f) status is necessary. In addition, any significant publicly owned public property (including waters) where the primary purpose of such land is the conservation, restoration, or management of wildlife and waterfowl resources including, but not limited to, endangered species and their habitat is considered by FHWA to be a wildlife and waterfowl refuge for purposes of Section 4(f).

In determining the primary purpose of the land, consideration should be given to:

1. The authority under which the land was acquired;
2. Lands with special national or international designations;
3. The management plan for the land; and,
4. Whether the land has been officially designated, by a Federal, State, or local agency with jurisdiction over the land, as an area whose primary purpose and function is the conservation, restoration, or management of wildlife and waterfowl resources including, but not limited to, endangered species and their habitat.

Many refuge-type properties permit recreational activities that are generally considered not to conflict with species conservation, such as trails, wildlife observation and picnicking. Other activities, such as educational programs, hunting, and fishing, may also be allowed when the activity is consistent with the broader species conservation goals for the property.

Examples of properties that may function as wildlife and waterfowl refuges for purposes of Section 4(f) include: State or Federal wildlife management areas, a wildlife reserve, preserve or sanctuary; and waterfowl production areas including wetlands and uplands that are permanently set aside (in a form of public ownership) primarily for refuge purposes. The FHWA should consider the ownership, significance, function and primary purpose of such properties in determining if Section 4(f) will apply. In making the determination, the FHWA should review the existing management plan and consult with the Federal, State or local official(s) with jurisdiction over the property. In appropriate cases, these types of properties will be considered multiple-use public land holdings (See 23 CFR 774.11(d) and Question 4) and must be treated accordingly.

The U.S. DOI administers a variety of Federal grant programs in support of hunting, fishing, and related resource conservation. While the fact that a property owned by a State or local government has at some time in the past been the beneficiary of such a grant does not automatically confer Section 4(f) status, the existence and terms of such a prior grant, when known, should be considered along with the other aspects of the property described above when determining if the property should be treated as a wildlife and waterfowl refuge for purposes of Section 4(f). Finally, it should be noted that sites purchased as mitigation for transportation projects (e.g., for endangered species impacts) can be considered refuges for purposes of Section 4(f) if the mitigation sites meet all of the applicable criteria for Section 4(f) status as a refuge, including public ownership and access, significance, and functioning primarily as a refuge.

2. Historic Sites

Question 2A: How is Section 4(f) significance of historic sites determined?

Answer: Historic site is defined in 23 CFR 774.17. For purposes of Section 4(f), a historic site is significant only if it is on or eligible for the NR. Pursuant to the NHPA, FHWA in cooperation with the applicant consults with the SHPO and/or THPO, tribes that may attach religious and cultural significance to the property, and when appropriate, with local officials to determine whether a site is eligible for the NR. In case of disagreement between FHWA and the SHPO/THPO or if so requested by the ACHP, FHWA shall request a determination of eligibility from the Keeper of the NR (36 CFR 800.4(c)(2)). Any third party may also seek the involvement of the Keeper by asking the ACHP to request that the Federal agency seek a determination of eligibility.

If a site is determined not to be on or eligible for the NR, FHWA still may determine that the application of Section 4(f) is appropriate when an official (such as the Mayor, president of the local historic society, etc.) formally provides information to indicate that the historic site is of local significance. In rare cases such as this, FHWA may determine that it is appropriate to apply Section

4(f) to that property. In the event that Section 4(f) is found inapplicable, the FHWA Division Office should document the basis for not applying Section 4(f). Such documentation might include the reasons why the historic site was not eligible for the NR.

Question 2B: How does Section 4(f) apply in historic districts that are on or eligible for the NR?

Answer: Within a NR listed or eligible historic district, FHWA's long-standing policy is that Section 4(f) applies to those properties that are considered contributing to the eligibility of the historic district, as well as any individually eligible property within the district. Elements within the boundaries of a historic district are assumed to contribute, unless they are determined by FHWA in consultation with the SHPO/THPO not to contribute (See also Question 7C).

Question 2C: How should the boundaries of a property eligible for listing on the NR be determined where a boundary has not been established?

Answer: In this situation, FHWA makes the determination of a historic property's boundary under the regulations implementing Section 106 of the NHPA in consultation with the SHPO/THPO. The identification of historic properties and the determination of boundaries should be undertaken with the assistance of qualified professionals during the early stages of the NEPA process. This process should include the collection, evaluation and presentation of the information to document FHWA's determination of the property boundaries. The determination of eligibility, which would include boundaries of the site, rests with FHWA, but if the SHPO or THPO objects, or if the ACHP or the Secretary of the Interior so requests, then FHWA shall obtain a determination from the Keeper of the NR (36 CFR 800.4(c)(2)).

Selection of boundaries is a judgment based on the nature of the property's significance, integrity, setting and landscape features, functions and research value. Most boundary determinations will take into account the modern legal boundaries, historic boundaries (identified in tax maps, deeds, or plats), natural features, cultural features and the distribution of resources as determined by survey and testing for subsurface resources. Legal property boundaries often coincide with the proposed or eligible historic site boundaries, but not always and, therefore, should be individually reviewed for reasonableness. The type of property at issue, be it a historic building, structure, object, site or district and its location in either urban, suburban or rural areas, should include the consideration of various and differing factors set out in the National Park Service Bulletin: Defining Boundaries for National Register Properties.¹³

Question 2D: How do you reconcile the phased approach to identification and evaluation and treatment of historic properties under Section 106 of the NHPA with the timing for the completion of Section 4(f) requirements?

Answer: Compliance with Section 4(f) requires FHWA to carry out a reasonable level of effort to identify historic properties prior to issuing a Section 4(f) approval. The reasonableness of the level of effort depends upon the anticipated effects of the project and nature of likely historic resources present in the affected project area. Accordingly, the reasonable level of effort varies from project to project. While a visual survey may be necessary to identify above ground resources, it may be possible to rule out the likelihood for the presence of significant below ground resources based on literature review, prior studies of the area, consultation with consulting parties (e.g., Indian tribes) and factors that relate to archeological preservation such as soil and slope types. If a phased approach to identification and evaluation of historic properties is adopted pursuant to the Section 106 regulations, the methodology for that approach should be coordinated with FHWA to ensure that it will also satisfy Section 4(f) requirements.

You may be able to establish without carrying out a field survey that there is little or no potential for the presence of archeological resources that have value for preservation in place, and therefore are subject to Section 4(f). The project file should include documentation of the level of effort and

justification for the conclusion that it is unlikely that there are additional unrecorded historic properties that could be subject to Section 4(f). A Memorandum of Agreement or project specific Programmatic Agreement focusing on a process for subsequent compliance should be executed prior to project approval. Those agreements may provide for the completion of additional identification and evaluation (e.g., archeological resource studies), assessment of effects, and refinement of mitigation measures after NEPA is approved.

Question 2E: How are National Historic Landmarks (NHL) treated under Section 4(f)?

Answer: Section 4(f) requirements related to the potential use of an NHL designated by the Secretary of Interior are essentially the same as they are for any historic property determined eligible under the Section 106 process, except that the July 5, 1983 Programmatic Section 4(f) Evaluation and Approval for FHWA Projects that Necessitate the Use of Historic Bridges may not be relied upon to approve the use of a historic bridge that is an NHL.

Section 110(f) of the NHPA (16 U.S.C. § 470-h-2) outlines the specific actions that an Agency must take when a NHL may be directly and adversely affected by an undertaking. Agencies must, "to the maximum extent possible...minimize harm" to the NHL affected by an undertaking. While not expressly stated in the Section 4(f) statute or regulations, the importance and significance of the NHL should be considered in the FHWA's Section 4(f) analysis of least overall harm pursuant to 23 CFR 774.3(c)(1)(iii). In addition, where there is a potential adverse effect to an NHL determined under the Section 106 process, the Secretary of Interior must be notified and given the option to participate in the Section 106 process. When the U.S. DOI has elected to participate, their representative (typically, the National Park Service) should be recognized as an additional official with jurisdiction and included in the required coordination in the course of the Section 4(f) process.

3. Archeological Resources

Question 3A: When does Section 4(f) apply to archeological sites?

Answer: Section 4(f) applies to archeological sites that are on or eligible for the NR and that warrant preservation in place, including those sites discovered during construction as discussed in Question 3B. Section 4(f) does not apply if FHWA determines, after consultation with the SHPO/THPO, federally recognized Indian tribes (as appropriate), and the ACHP(if participating) that the archeological resource is important chiefly because of what can be learned by data recovery (even if it is agreed not to recover the resource) and has minimal value for preservation in place, and the SHPO/THPO and ACHP (if participating) does not object to this determination (See 23 CFR 774.13(b)). The destruction of a significant archaeological resource without first recovering the knowledge of the past inherent in that resource should not be taken lightly. Efforts to preserve the resource or develop and execute a data recovery plan should be addressed in the Section 106 process.

Question 3B: How are archeological sites discovered during construction of a project handled?

Answer: When archeological sites are discovered during construction(23 CFR 774.9(e) and 11(f)), FHWA must determine if an approval is necessary or if an exception applies under 23 CFR 774.13(c) (See Question 26). Where preservation in place is warranted and a Section 4(f) approval would be required, the Section 4(f) process will be expedited. In such cases, the evaluation of feasible and prudent alternatives will take into account the level of investment already made. The review process, including the consultation with other agencies should be shortened, as appropriate consistent with the process set forth in Section 106 of the NHPA regulations and should include

Indian tribes that may attach religious and cultural significance to sites discovered (36 CFR 800.13). Discoveries may be addressed prior to construction in agreement documents that set forth procedures that plan for subsequent discoveries. When discoveries occur without prior planning, the Section 106 regulation calls for reasonable efforts to avoid, minimize, or mitigate such sites and provides an expedited timeframe for interested parties to reach resolution regarding treatment of the site. A decision to apply Section 4(f), based on the outcome of the Section 106 process, to an archeological discovery during construction would trigger an expedited Section 4(f) evaluation. Because the U.S. DOI has a responsibility to review individual Section 4(f) evaluations and is not usually a party to the Section 106 process, the U.S. DOI should be notified and any comments they provide considered within a shortened response period.

Question 3C: How do the Section 4(f) requirements apply to archaeological districts?

Answer: Section 4(f) requirements apply to archeological districts in the same way they apply in historic districts, but only where preservation in place is warranted. There would not be a Section 4(f) use if, after consultation with the SHPO/THPO, FHWA determines that the project would use only a part of the archaeological district which is considered a non-contributing element of that district or that the project occupies only a part of the district which is important chiefly because of what can be learned by data recovery and has minimal value for preservation in place. As with a historic district, if the project does not use any individual contributing element of the archeological district which is significant for preservation in place and FHWA determines that the project will result in an adverse effect, then FHWA must consider whether or not the proximity impacts will result in a constructive use in accordance with 23 CFR 774.15.

4. Public Multiple-Use Land Holdings

Question 4: Are multiple-use public land holdings (e.g., National Forests, State Forests, Bureau of Land Management lands) subject to the requirements of Section 4(f)?

Answer: When applying Section 4(f) to multiple-use public land holdings, FHWA must comply with 23 CFR 774.11(d). Section 4(f) applies only to those portions of a multiple-use public property that are designated by statute or identified in an official management plan of the administering agency as being primarily for public park, recreation, or wildlife and waterfowl refuge purposes, and are determined to be significant for such purposes. Section 4(f) will also apply to any historic sites within the multiple-use public property that are on or eligible for the NR. Multiple-use public land holdings are often vast in size, and by definition these properties are comprised of multiple areas that serve different purposes. Section 4(f) does not apply to those areas within a multiple-use public property that function primarily for any purpose other than significant park, recreation or refuge purposes. For example, within a National Forest, there can be areas that qualify as Section 4(f) resources (e.g. campgrounds, trails, picnic areas) while other areas of the property function primarily for purposes other than park, recreation or a refuge such as timber sales or mineral extraction. Coordination with the official(s) with jurisdiction and examination of the management plan for the area will be necessary to determine if Section 4(f) should apply to an area of a multiple-use property that would be used by a transportation project.

For multiple-use public land holdings which either do not have formal management plans or when the existing formal management plan is out-of-date, FHWA will examine how the property functions and how it is being managed to determine Section 4(f) applicability for the various areas of the property. This review will include coordination with the official(s) with jurisdiction over the property.

5. Tribal Lands and Indian Reservations

Question 5: How are lands owned by Federally Recognized Tribes, and/or Indian Reservations treated for the purposes of Section 4(f)?

Answer: Federally recognized Indian Tribes are sovereign nations and the land owned by them is not considered publicly owned within the meaning of Section 4(f). Therefore, Section 4(f) does not automatically apply to tribal land. In situations where it is determined that the property or resource owned by a Tribal Government or within an Indian Reservation functions as a significant public park, recreational area, or wildlife and waterfowl refuge (which is open to the general public), or is eligible for the NR, the land would be considered Section 4(f) property.

6. Traditional Cultural Places (TCPs)

Question 6: Are lands that are considered to be traditional cultural places subject to the provisions of Section 4(f)?

Answer: A TCP is defined generally as land that may be eligible for inclusion in the NR because of its association with cultural practices or beliefs of a living community that; (a) are rooted in that community's history, and (b) are important in maintaining the continuing cultural identity of the community.¹⁴ Land referred to as a TCP is not automatically considered historic property, or treated differently from other potentially historic property. A TCP must also meet the NR criteria as a site, structure, building, district, or object to be eligible under Section 106, and thus for Section 4(f) protection. For those TCPs of significance to an Indian tribe or Native Hawaiian Organization (NHO), the THPO or designated representative of the Indian tribe or NHO should be acknowledged as possessing special expertise to assess the NR eligibility of the resources that possess religious and cultural significance to them. TCPs may be eligible under multiple criteria and therefore should not be presumed to be eligible only as archeological resources (See 23 CFR 774.11(e)).

USE OF SECTION 4(f) PROPERTIES

7. Use of Section 4(f) Property

Question 7A: What constitutes a transportation use of property from publicly owned public parks, public recreation areas, wildlife and waterfowl refuges and public or privately owned historic sites?

Answer: A use of Section 4(f) property is defined in 23 CFR 774.17. A use occurs when:

1. Land is permanently incorporated into a transportation facility;
2. There is a temporary occupancy of land that is adverse in terms of the Section 4(f) statute's preservationist purposes; or
3. There is a constructive use of a Section 4(f) property.

Permanent Incorporation: Land is considered permanently incorporated into a transportation project when it has been purchased as right-of-way or sufficient property interests have otherwise been acquired for the purpose of project implementation. For example, a permanent easement required for the purpose of project construction or that grants a future right of access onto a Section 4(f) property, such as for the purpose of routine maintenance by the transportation agency, would be considered a permanent incorporation of land into a transportation facility.

Temporary Occupancy: Examples of temporary occupancy of Section 4(f) land include right-of-entry, project construction, a temporary easement, or other short-term arrangement involving a

Section 4(f) property. A temporary occupancy will not constitute a Section 4(f) use when all of the conditions listed in 23 CFR 774.13(d) are satisfied:

1. Duration must be temporary, i.e., less than the time needed for construction of the project, and there should be no change in ownership of the land;
2. Scope of the work must be minor, i.e., both the nature and the magnitude of the changes to the Section 4(f) property are minimal;
3. There are no anticipated permanent adverse physical impacts, nor will there be interference with the protected activities, features, or attributes of the property, on either a temporary or permanent basis;
4. The land being used must be fully restored, i.e., the property must be returned to a condition which is at least as good as that which existed prior to the project; and
5. There must be documented agreement of the official(s) with jurisdiction over the Section 4(f) resource regarding the above conditions.

In situations where the above criteria cannot be met, the temporary occupancy will be a use of Section 4(f) property and the appropriate Section 4(f) analysis, coordination, and documentation will be required (See 23 CFR 774.13(d)). In those cases where a temporary occupancy constitutes a use of Section 4(f) property and the de minimis impact criteria (Questions 10 and 11) are also met, a de minimis impact finding may be made. de minimis impact findings should not be made in temporary occupancy situations that do not constitute a use of Section 4(f) property.

Constructive Use: FHWA must comply with 23 CFR 774.15 to determine whether or not there is a constructive use of Section 4(f) property. Constructive use of Section 4(f) property is only possible in the absence of a permanent incorporation of land or a temporary occupancy of the type that constitutes a Section 4(f) use. Constructive use occurs when the proximity impacts of a project on an adjacent or near-by Section 4(f) property, after incorporation of impact mitigation, are so severe that the activities, features, or attributes that qualify the property for protection under Section 4(f) are substantially impaired. Substantial impairment occurs when the protected activities, features, or attributes of the Section 4(f) property are substantially diminished. As a general matter this means that the value of the resource, in terms of its Section 4(f) purpose and significance (Questions 1 and 2), will be meaningfully reduced or lost. The degree of impact and impairment must be determined in consultation with the officials with jurisdiction in accordance with 23 CFR 774.15(d)(3). In those situations where a potential constructive use can be reduced below a substantial impairment by the inclusion of mitigation measures, there will be no constructive use and Section 4(f) will not apply.

The Section 4(f) regulations identify specific project situations where constructive use would and would not occur. The impacts of projects adjacent to or in reasonable proximity of Section 4(f) property should be carefully examined early in the NEPA process pursuant to 23 CFR Part 771. If it is determined that the proximity impacts do not cause a substantial impairment, FHWA can reasonably conclude that there will be no constructive use. The analysis of proximity impacts and potential constructive use should be documented in the project file. Documentation of a finding of no constructive use should apply the legal standards and terminology used in 23 CFR 774.15, Constructive Use Determinations. The use of the term “constructive use” is not required in such documentation, but should be used when appropriate – for example, when responding to comments in NEPA documents that specifically address constructive use, or where it is useful in demonstrating that FHWA has specifically considered the potential for a constructive use. Where a constructive use determination seems likely, the FHWA Division Office is required by the Administrator's delegation of Section 4(f) authority to consult with the Headquarters Office of Project Development and Environmental Review before the determination is finalized.

Since a de minimis impact finding can only be made where the transportation use does not adversely affect the activities, features, or attributes that qualify a property for protection under Section 4(f), a de minimis impact finding is inappropriate where a project results in a constructive use (See 23 CFR 774.3(b) and the definition of de minimis impact in 774.17).

Question 7B: Does Section 4(f) apply when there is an adverse effect determination under the regulations implementing Section 106 of the NHPA?

Answer: FHWA's determination of adverse effect under the Section 106 process (See 36 CFR 800.5) does not automatically mean that Section 4(f) will apply. Nor does a determination of no adverse effect mean that Section 4(f) will not apply in some cases. When a project permanently incorporates land of a historic site, regardless of the Section 106 determination, Section 4(f) will apply. If a project does not permanently incorporate land from the historic property but results in an adverse effect, it will be necessary for FHWA to further assess the proximity impacts of the project in terms of the potential for constructive use (Question 7A). This analysis is necessary to determine if the proximity impact(s) substantially impair the features or attributes that contribute to the NR eligibility of the historic site. If there is no substantial impairment, notwithstanding an adverse effect determination, there is no constructive use and Section 4(f) does not apply. The FHWA determines if there is a substantial impairment by consulting with all identified officials with jurisdiction, including the SHPO/THPO and the ACHP if participating, to identify the activities, features, and attributes of the property that qualify it for Section 4(f) protection and by analyzing the proximity impacts of the project (including any mitigation) on those activities, features, and attributes (See 23 CFR 774.15(d)(3)). The determination of Section 4(f) applicability is ultimately FHWA's decision, and the considerations and consultation that went into that decision should be documented in the project file.

An example of a situation in which there is a Section 106 adverse effect but no Section 4(f) use, is a proposed transportation enhancement project that would convert a historic railroad depot into a tourist center. For public use, the project will require consistency with the American with Disabilities Act (ADA). The incorporation of accessible ramps or elevator may result in a determination of adverse effect; however, there is no permanent incorporation of Section 4(f) land into a transportation facility. The FHWA may determine, after consultation with the SHPO/THPO on the historic attributes and impacts thereto, that the project will not substantially impair the attributes of the historic property. There would not be a Section 4(f) use in this case. There would be a Section 4(f) use only if land from the property is either incorporated into a transportation facility or if the property is substantially impaired.

Another example of an adverse effect where there is no Section 4(f) use might be construction of a new highway within the immediate view shed of a historic farmstead that results in an adverse effect finding under Section 106 for the diminishment of the setting. It is unlikely this visual intrusion would reach the threshold of substantial impairment of the attributes which cause the farmstead to be eligible for the NR as it would still retain its historic fabric and use features; however, a constructive use could occur where the proximity of the proposed project substantially impairs esthetic features or attributes of a property protected by Section 4(f), where such features or attributes are considered important contributing elements to the value of the property.

An example of a Section 4(f) use without a Section 106 adverse effect involves a project on existing alignment, which proposes minor modification at an intersection. To widen the roadway sufficiently a small amount of land from an adjacent historic site will be acquired. The land acquisition does not alter the integrity of the historic site and the SHPO concurs in FHWA's determination of no adverse effect. Even though under Section 106 there is no adverse effect, land from the site will be permanently incorporated into the transportation facility and Section 4(f) will apply. The use would likely qualify as a de minimis impact or may be approved using the Nationwide Section 4(f) Evaluation and Approval for Federally-Aided Highway Projects with Minor Involvements with Historic Sites¹⁵ depending on the circumstances of the project.

Question 7C: How is a Section 4(f) use determined in historic districts?

Answer: When a project requires land from a non-historic or non-contributing property lying within a historic district and does not use other land within the historic district that is considered contributing to its historic significance, FHWA's longstanding policy is that there is no direct use of the historic district for purposes of Section 4(f). With respect to constructive use, if the Section 106 consultation results in a determination of no historic properties affected or no adverse effect, there is no Section 4(f) constructive use of the district as a whole. If the project requires land from a non-historic or non-contributing property, and the Section 106 consultation results in a determination of adverse effect to the district as a whole, further assessment is required pursuant to 23 CFR 774.15 to determine whether or not there will be a constructive use of the district. If the use of a non-historic property or non-contributing element substantially impairs the activities, features, or attributes that are related to the NR eligibility of the historic district, then Section 4(f) would apply. In any case, appropriate steps, including consultation with the SHPO/THPO on the historic attributes of the district and impacts thereto, should be taken to establish whether the property is contributing or non-contributing to the district and whether its use would substantially impair the historic attributes of the historic district.

For example, an intersection improvement proposed in a NR listed or eligible historic district, requires the demolition of a modern building that is neither individually eligible for the NR nor is a contributing element of the district. Although no right-of-way will be acquired from an individually eligible or contributing property, it is consistent with the NHPA regulations that there will be an adverse effect to the historic district because of changes resulting from the wider intersection and installation of more extensive traffic signals. It may be reasonably determined, however, that no individually eligible property, contributing element, or the historic district as a whole will be substantially impaired. Accordingly, in this example a Section 4(f) use will not occur in the form of either a permanent incorporation or a constructive use.

When a project uses land from an individually eligible property within a historic district, or a property that is a contributing element to the historic district, Section 4(f) is applicable. In instances where a determination is made under Section 106 of no historic properties affected or no adverse effect, then the use may be approved with a de minimis impact determination. If the use does not qualify for a de minimis impact determination, an individual Section 4(f) evaluation will be necessary. Exceptions recognized in 23 CFR 774.13 may be applied to individually eligible or contributing properties within a historic district, and to contributing elements within a historic district.

Question 7D: How are historic resources within highway rights-of-way considered?

Answer: In some parts of the country it is not uncommon for historic objects or features not associated with the roadway to exist within the highway right-of-way. Examples include rock walls, fences, and structures that are associated with an adjacent historic property. Others are linear properties such as drainage systems or railroad corridors. These properties, objects, or features are either not transportation in nature or are part of the roadway itself. This condition occurs for various reasons such as historic property boundaries coinciding with the roadway centerline or edge of the road, or situations where right-of-way was acquired but historic features were allowed to remain in place. When a future transportation project is advanced resulting in a Section 106 determination of no historic properties affected or no adverse effect to such resources, there would be no Section 4(f) use. If the historic features are determined to be adversely affected, the adverse effect should be evaluated to determine whether it results in a Section 4(f) use.

8. Historic Bridges, Highways and Other Transportation Facilities

Question 8A: How does Section 4(f) apply to historic transportation facilities?

Answer: The Section 4(f) statute imposes conditions on the use of land from historic sites for highway projects but makes no mention of bridges, highways, or other types of facilities such as railroad stations or terminal buildings, which may be historic and are already serving as

transportation facilities. The FHWA's interpretation is that the Congress clearly did not intend to restrict the rehabilitation or repair, of historic transportation facilities. The FHWA therefore established a regulatory provision that Section 4(f) approval is required only when a historic bridge, highway, railroad, or other transportation facility is adversely affected by the proposed project; e.g. the historic integrity (for which the facility was determined eligible for the NR) is adversely affected by the proposed project (See 23 CFR 774.13(a)).

Question 8B: Will Section 4(f) apply to the replacement of a historic bridge that is left in place?

Answer: FHWA's longstanding policy is that Section 4(f) does not apply to the replacement of a historic bridge on new location when the historic bridge is left in its original location and its historic integrity and value will be maintained. To maintain the integrity of the historic bridge, FHWA should ensure that a mechanism is in place for continued maintenance of the bridge that would avoid harm to the bridge due to neglect. In these situations it is also necessary to consider whether or not the proximity impacts of the new bridge will result in substantial impairment of the historic bridge that is left in place or whether there are other properties present which should be afforded consideration pursuant to Section 4(f). These considerations should be documented in the project file.

Question 8C: How do the requirements of Section 4(f) apply to donations of historic bridges to a State, locality, or responsible private entity?

Answer: A State DOT or local public agency that proposes to demolish a historic bridge for a replacement project may first make the bridge available for donation to a State, locality or a responsible private entity. This process is commonly known as marketing the historic bridge and often involves relocation of the structure, if the bridge is of a type suitable for relocation. Provided the State, locality or responsible entity that accepts the bridge enters into an agreement to maintain the bridge and the features that contribute to its historic significance and assume all future legal and financial responsibility for the bridge, Section 4(f) will not apply to the bridge.

If the bridge marketing effort is unsuccessful and the bridge will be demolished or relocated without preservation commitments, Section 4(f) will apply and the appropriate Section 4(f) analysis, consultation and documentation will be required. The Programmatic Section 4(f) Evaluation and Approval for FHWA Projects that Necessitate the Use of Historic Bridges¹⁶ may be used.

Question 8D: Can the Programmatic Section 4(f) Evaluation and Approval for FHWA Projects that Necessitate the Use of Historic Bridges be applied to the replacement of a historic bridge or culvert that lacks individual distinction but is identified as a contributing element of a historic district that is on or eligible for listing on the NR?

Answer: Historic districts may include properties or elements that lack individual distinction but possess sufficient integrity to contribute to the overall significance of the district, as well as individually distinctive features that may be separately listed or determined eligible for the NR. All contributing properties or elements, including identified features and their settings are considered eligible for the NR and are therefore Section 4(f) resources. As such, bridges in historic districts may be individually eligible but may also be identified as contributing features within the larger historic district. The Programmatic Section 4(f) Evaluation and Approval for FHWA Projects that Necessitate the Use of Historic Bridges¹⁷ may be applied to any historic bridge or culvert, either contributing to a district or individually eligible. The application of the historic bridge programmatic Section 4(f) evaluation would be limited to the bridge replacement or rehabilitation only and must meet all the applicability criteria stated in the programmatic Section 4(f) evaluation. If the bridge replacement requires use, either direct or constructive, of surrounding or adjoining property that contributes to the significance of the historic district, the use of that property would have to be evaluated via another form of Section 4(f) evaluation, including possibly an individual evaluation.

Question 8E: Does Section 4(f) apply to the construction of an access ramp providing direct vehicular ingress/egress to a public boat launch area from an adjacent highway?

Answer: When an access ramp is constructed as part of a project to construct a new bridge or to reconstruct, replace, repair, or alter an existing bridge on a Federal-aid system, FHWA's longstanding policy is that Section 4(f) approval is not necessary for the access ramp and public boat launching area. This policy was jointly developed by FHWA and the U.S. DOI in response to the enactment of section 147 of the Federal-Aid Highways Act of 1976 (Pub. L. 94-280 (HR 8235) May 5, 1976). Where public boat launching areas are located in publicly owned parks, recreational areas, or refuges otherwise protected by the provision of Section 4(f), it would be contrary to the intent of section 147 to search for feasible and prudent alternatives to the use of such areas as a site for an access ramp to the public boat launching area. Such ramps must provide direct access to a public boat launching area adjacent to the highway. This policy only applies to the access ramp and public boat launching area; any other use of Section 4(f) property for the project will require Section 4(f) approval.

Question 8F: Is compliance with Section 4(f) necessary for park roads and parkways projects funded under FHWA's Federal Lands Highway Program, 23 U.S.C. § 204?

Answer: No. Park roads and parkways projects funded under FHWA's Federal Lands Highway Program, 23 U.S.C. § 204, are expressly excepted from Section 4(f) requirements within the Section 4(f) statute itself and by 23 CFR 774.13(e). A park road is "a public road, including a bridge built primarily for pedestrian use, but with capacity for use by emergency vehicles, that is located within, or provides access to, an area in the National Park System with title and maintenance responsibilities vested in the United States" and a parkway is a road "authorized by Act of Congress on lands to which title is vested in the United States" (23 U.S.C. § 101(a)).

OFFICIALS WITH JURISDICTION; CONSULTATION; AND DECISIONMAKING

9. Officials with Jurisdiction

Question 9A: Who are the officials with jurisdiction for a park, recreation area, or wildlife and waterfowl refuge and what is their role in determining Section 4(f) applicability?

Answer: The officials with jurisdiction are defined in 23 CFR 774.17. Under that definition, there may be more than one official with jurisdiction for the same Section 4(f) property. For public parks, recreation areas, and wildlife and waterfowl refuges (Question 1) the official(s) with jurisdiction are the official(s) of an agency or agencies that own and/or administer the property in question and who are empowered to represent the agency on matters related to the property.

There may be instances where the agency owning or administering the land has delegated or relinquished its authority to another agency, via an agreement on how some of its land will function or be managed. The FHWA will review the agreement and determine which agency has authority on how the land functions. If the authority has been delegated or relinquished to another agency, that agency should be contacted to determine the purposes and significance of the property. Management plans that address or officially designate the purposes of the property should be reviewed as part of this determination. After consultation, and in the absence of an official designation of purpose and function by the officials with jurisdiction, FHWA will base its decision of Section 4(f) applicability on an examination of the actual functions that exist (See 23 CFR 774.11(c)).

The final decision on the applicability of Section 4(f) to a particular property is the responsibility of FHWA. In reaching this decision FHWA will rely on the official(s) with jurisdiction to identify the kinds of activities and functions that take place, to indicate which of these activities constitute the

primary purpose, and to state whether the property is significant. Documentation of the determination of non- applicability should be included in the project file.

Question 9B: Who are the officials with jurisdiction for historic sites?

Answer: The officials with jurisdiction are defined in 23 CFR 774.17. For historic properties (Question 2 and 7) the official with jurisdiction is the State Historic Preservation Officer (SHPO). If the historic property is located on tribal land the Tribal Historic Preservation Officer (THPO) is considered the official with jurisdiction. If the property is located on tribal land but the tribe has not assumed the responsibilities of the SHPO, as provided for in the NHPA, then the representative designated by the tribe shall be recognized as an official with jurisdiction in addition to the SHPO. When the Advisory Council on Historic Preservation (ACHP) is involved in the consultation concerning a property under Section 106 of the NHPA,¹⁸ the ACHP will also be considered an official with jurisdiction over that resource. For a NHL, the National Park Service is also an official with jurisdiction over that resource.

Question 9C: Who are the officials with jurisdiction when a park, recreation area, or refuge is also a historic site or contains historic sites within its boundaries?

Answer: Some public parks, recreation areas, and wildlife and waterfowl refuges are also historic properties either listed or eligible for listing on the NR. In other cases, historic sites are located within the property boundaries of public parks, recreation areas, or wildlife and waterfowl refuges. When either of these situations exists and a project alternative proposes the use of land from the historic site there will be more than one official with jurisdiction. For historic sites the SHPO/THPO and ACHP if participating are officials with jurisdiction. Coordination will also be required with the official(s) of the agency or agencies that own or administer the property in question and who are empowered to represent the agency on matters related to the property, such as commenting on project impacts to the activities, features, or attributes of property and on proposed mitigation measures. For a NHL, the National Park Service is also an official with jurisdiction over that resource.

Question 9D: When is coordination with the U.S. DOI required?

Answer: Prior to FHWA's final approval of a Section 4(f) use, individual Section 4(f) evaluations are provided to the U.S. DOI Office of Environmental Compliance and Policy, which coordinates the comments of all U.S. DOI agencies involved in the project (See 23 CFR 774.5(a)). However, the official with jurisdiction for Section 4(f) purposes is typically the field official charged with managing the Section 4(f) property at issue. For example, the official with jurisdiction for a project involving the use of a National Wildlife Refuge would be the Refuge Manager. If it is not clear which individual within the U.S. DOI is the official with jurisdiction for a particular Section 4(f) property, U.S. DOI's Office of Environmental Compliance and Policy should be consulted to resolve the question. The U.S. DOI has very specific expectations regarding the submission of Section 4(f) documents.¹⁹ If the Section 4(f) property is under the jurisdiction of the U.S. Forest Service, the Department of Agriculture would be contacted for its review. The final authority on the content and format of Section 4(f) documents is FHWA's, as specified in 23 CFR Part 774, this Section 4(f) Policy Paper and the Technical Advisory, T 6640.8A, Guidance for Preparing and Processing of Environmental and Section 4(f) Documents.

It is not necessary to coordinate project specific applications of existing programmatic Section 4(f) evaluations with the U.S. DOI unless the U.S. DOI owns or has administrative oversight over the Section 4(f) property involved. In these cases, FHWA will need written concurrence from the U.S. DOI as the official with jurisdiction as stipulated in the applicable programmatic Section 4(f) evaluation. Consultation with the U.S. DOI was conducted during the development of all the existing programmatic Section 4(f) evaluations. Development of any new programmatic Section

4(f) evaluations would also require coordination with the U.S. DOI before they are made available for use (See 23 CFR 774.3(d)(2)).

Similarly, it is not necessary to conduct project-level coordination with the U.S. DOI when processing de minimis impact determinations unless the U.S. DOI has administrative oversight over the public park, recreation area, or wildlife and waterfowl refuge involved. In these situations, FHWA must obtain concurrence from the U.S. DOI as the official having jurisdiction that there is no adverse effect to the activities, features, or attributes of the property (See 23 CFR 774.5(b)). When a de minimis impact determination is anticipated for a historic site owned or administered by the U.S. DOI, and when the historic site is a NHL, the U.S. DOI will have the opportunity to participate during the Section 106 consultation as a consulting party (See Questions 11 through 13 for further guidance on de minimis impact determinations).

For situations in which the Section 4(f) property is encumbered with a Federal interest, for example as a result of a U.S. DOI grant, the answer to Question 1D or Question 31 may apply.

Question 9E: What is the official status of the Handbook on Departmental Reviews of Section 4(f) Evaluations, originally issued in February 2002 (and any subsequent revisions) by the U.S. DOI Office of Environmental Policy and Compliance?

Answer: The U.S. DOI Handbook²⁰ is intended to provide guidance to the National Park Service (NPS), the U.S. Fish and Wildlife Service and other designated lead bureaus in the preparation of U.S. DOI comments on the Section 4(f) evaluations prepared by the U.S. DOT pursuant to the authority granted in the Section 4(f) statute. The Handbook is an official U.S. DOI document and includes departmental opinion related to the applicability of Section 4(f) to lands for which they have jurisdiction and authority. The Section 4(f) statute requires U.S. DOT to consult and cooperate with the U.S. DOI as well as the Departments of Agriculture and Housing and Urban Development, as appropriate in Section 4(f) program and project related matters. The FHWA values the U.S. DOI's opinions related to the resources under their jurisdiction, and while the Handbook is a resource which FHWA may consider, it is not the final authority on Section 4(f) determinations.

Official FHWA policy on the applicability of Section 4(f) to lands that fall within the jurisdiction of the U.S. DOI is contained within 23 CFR 774 and this Section 4(f) Policy Paper. While FHWA is not legally bound by the guidance contained within the Handbook or the comments provided by the U.S. DOI or lead bureaus, every attempt should be made to reach agreement during project consultation. In some situations, one of the bureaus may be an official with jurisdiction. When unresolved conflicts arise during coordination with the U.S. DOI related to the applicability of Section 4(f) to certain types of property, it might be necessary for the Division Office to contact the FHWA Headquarters Office of Project Development and Environmental Review for assistance.

Question 9F: Section 4(f) also requires cooperation and consultation with the U.S. Department of Agriculture (USDA) and the U.S. Department of Housing and Urban Development (HUD). When is coordination with the USDA or HUD on a Section 4(f) matter appropriate?

Answer: Many national forests under the jurisdiction of the U.S. Forest Service of the USDA serve as multiple-use land holdings as described in Question 4. If the project uses land of a national forest, coordination with the USDA as the official with jurisdiction over the resource would be appropriate in determining the purposes served by the land holding and the resulting extent of Section 4(f) applicability to the land holding. HUD would be involved only in cases where HUD had an interest in a Section 4(f) property.

Question 9G: Who makes Section 4(f) decisions and de minimis impact determinations?

Answer: The FHWA Division Administrator is the responsible official for all Section 4(f) applicability decisions, approvals, and de minimis impact determinations for Federal-aid projects. The FHWA Federal Lands Highway Division Engineer has this authority for Federal Lands projects.

Coordination with the FHWA Headquarters or the FHWA Office of the Chief Counsel is not required for routine de minimis impact determinations but is recommended where assistance is needed for controversial projects or complex situations. It will be necessary for FHWA to consult and coordinate with the official(s) with jurisdiction as discussed above in making determinations of applicability and in approving the use of Section 4(f) property. When a programmatic Section 4(f) evaluation is relied upon to satisfy Section 4(f), the consultation requirements and approval process for the specific programmatic evaluation must be followed (See 23 CFR 774.3(d)).

10. Section 4(f) Evaluations for Tiered Projects

Question 10: How is Section 4(f) handled in tiered NEPA documents?

Answer: The FHWA must comply with 23 CFR 774.7(e) when tiered NEPA documents are used. In a tiered Environmental Impact Statement (EIS), the project development process moves from a broad scale examination at the first-tier stage to a more site specific evaluation in the second-tier stage. During the first-tier stage the detailed information necessary to complete the Section 4(f) approval may not be available. Even so, this does not relieve the FHWA from its responsibility to determine the possibility of making de minimis impact determinations or to consider alternatives that avoid the use of Section 4(f) properties during the first-tier stage. This analysis and documentation should address potential uses of Section 4(f) property and whether those uses could have a bearing on the decision to be made during this tier.

If sufficient information is available, a preliminary Section 4(f) approval may be made at the first-tier stage as to whether the impacts resulting from the use of a Section 4(f) property are de minimis or whether there are feasible and prudent avoidance alternatives. This preliminary approval must include all possible planning to minimize harm to the extent that the level of detail available at this stage allows (23 CFR 774.7(e)(1)). This planning may be limited to a commitment to ensure that opportunities to minimize harm at subsequent stages in the project development process have not been precluded by decisions made at the first-tier stage. Any preliminary Section 4(f) approvals must be incorporated into the first-tier EIS (23 CFR 774.7(e)(1)).

If sufficient information is unavailable during the first-tier stage, then the EIS may be completed without any preliminary Section 4(f) approvals. The documentation should state why no preliminary approval is possible during the first-tier stage and clearly explain the process that will be followed to complete Section 4(f) evaluations during subsequent tiers. The extent to which a Section 4(f) approval (preliminary or final) anticipated to be made in a subsequent tier may have an effect on any decision made during the first-tier stage should be discussed. Schedules to complete Section 4(f) evaluations, if available, should also be reported.

Preliminary first-tier Section 4(f) approvals will be finalized in the second-tier CE, EA, final EIS, ROD or FONSI, as appropriate (See 23 CFR 774.7(e)(2)). If no new Section 4(f) use, other than a de minimis impact, is identified in the second-tier study and if all possible planning to minimize harm has occurred, then the second-tier Section 4(f) approval may finalize the preliminary approval by reference to the first-tier documentation. Re-evaluation of the preliminary Section 4(f) approval is only needed to the extent that new or more detailed information available at the second-tier stage raises new Section 4(f) concerns not already considered.

DE MINIMIS IMPACT DETERMINATIONS

11. De minimis Impact Determinations for Parks, Recreation Areas, and Wildlife and Waterfowl Refuges

Question 11A: What constitutes a de minimis impact with respect to a park, recreation area, or wildlife and waterfowl refuge?

Answer: An impact to a public park, recreation area, or wildlife and waterfowl refuge may be determined to be de minimis if the transportation use of the Section 4(f) property, including incorporation of any measure(s) to minimize harm (such as any avoidance, minimization, mitigation, or enhancement measures), does not adversely affect the activities, features, or attributes that qualify the resource for protection under Section 4(f). Language included in the SAFETEA-LU Conference Report provides additional insight on the meaning of de minimis impact:

The purpose of the language is to clarify that the portions of the resource important to protect, such as playground equipment at a public park, should be distinguished from areas such as parking facilities. While a minor but adverse effect on the use of playground equipment should not be considered a de minimis impact under Section 4(f), encroachment on the parking lot may be deemed de minimis, as long as the public's ability to access and use the site is not reduced.

(Conference Report of the Committee of Conference on H.R. 3, Report 109-203, page 1057).

This simple example helps to distinguish the activities, features, or attributes of a Section 4(f) property that are important to protect from those which can be used without resulting in adverse effects. Playground equipment in a public park may be central to the recreational value of the park that Section 4(f) is designed to protect. The conference report makes it clear that when impacts are proposed to playground equipment or other essential features, a de minimis impact finding will at a minimum require a commitment to replace the equipment with similar or better equipment at a time and in a location that results in no adverse effect to the recreational activity. A parking lot encroachment or other similar type of land use, on the other hand, could result in a de minimis impact with minimal mitigation, as long as there are no adverse effects on public access and the official(s) with jurisdiction agree.

The impacts of a transportation project on a park, recreation area, or wildlife and waterfowl refuge that qualifies for Section 4(f) protection may be determined to be de minimis if:

1. The transportation use of the Section 4(f) property, together with any impact avoidance, minimization, and mitigation or enhancement measures incorporated into the project, does not adversely affect the activities, features, or attributes that qualify the resource for protection under Section 4(f);
2. The public has been afforded an opportunity to review and comment on the effects of the project on the protected activities, features, or attributes of the Section 4(f) property; and
3. The official(s) with jurisdiction over the property, after being informed of the public comments and FHWA's intent to make the de minimis impact finding, concur in writing that the project will not adversely affect the activities, features, or attributes that qualify the property for protection under Section 4(f).

(See 23 CFR 774.5(b)(2), 23 CFR 774.17). The concurrence of the official(s) with jurisdiction that the protected activities, features, or attributes of the resource are not adversely affected must be in writing (23 CFR 774.5(b)(2)(ii)). The written concurrence can be in the form of a signed letter on agency letterhead, signatures in concurrence blocks on transportation agency documents, agreements provided via e-mail or other method deemed acceptable by the FHWA Division Administrator. Obtaining these agreements in writing and retaining them in the project file is consistent with effective practices related to preparing project administrative records.

Question 11B: What role does mitigation play in the de minimis impact finding?

Answer: De minimis impact determinations are based on the degree of impact after the inclusion of any measure(s) to minimize harm, (such as any avoidance, minimization, mitigation, or enhancement measures) to address the Section 4(f) use (i.e., net impact). The expected positive effects of any measures included in a project to mitigate the adverse effects to a Section 4(f) property must be taken into account when determining whether the impact is de minimis (See 23 CFR 774.3(b)). The purpose of taking such measures into account is to encourage the incorporation of Section 4(f) protective measures as part of the project. De minimis impact findings must be expressly conditioned upon the implementation of any measures that were relied upon to reduce the impact to a de minimis level (See 23 CFR 774.7(b)). The implementation of such measures will become the responsibility of the project sponsor with FHWA oversight (See 23 CFR 771.109(b)).

Question 11C: What constitutes compliance with the public notice, review and comment requirements for de minimis impact findings for parks, recreation areas or wildlife and waterfowl refuges?

Answer: Information supporting a de minimis impact finding for a park, recreation area or refuge should be included in the NEPA document prepared for the project. This information includes, at a minimum, a description of the involved Section 4(f) property(ies), use and impact(s) to the resources and any measure(s) to minimize harm (such as any avoidance, minimization, mitigation, or enhancement measures) that are included in the project as part of the de minimis impact finding. The public involvement requirements associated with specific NEPA document and process will, in most cases, be sufficient to satisfy the public notice and comment requirements for the de minimis impact finding (See 23 CFR 774.5(b)(2)).

In general, the public notice and comment process related to de minimis impact findings will be accomplished through the State DOT's approved public involvement process (See 23 CFR 771.111(h)(1)). For those actions that do not routinely require public review and comment (e.g., certain categorical exclusions and re-evaluations) but for which a de minimis impact finding will be made, a separate public notice and opportunity for review and comment will be necessary. In these cases, appropriate public involvement should be based on the specifics of the situation and commensurate with the type and location of the Section 4(f) property, the impacts, and public interest. Possible methods of public involvement are many and include newspaper advertisements, public meetings, public hearings, notices posted on bulletin boards (for properties open to the public), project websites, newsletters, and placement of notices or documents at public libraries. All comments received and responses thereto, should be documented in the same manner that other comments on the proposed action would be incorporated in the project file. Where public involvement was initiated solely for the purpose of a de minimis impact finding, responses or replies to the public comments may not be required, depending on the substantive nature of the comments. All comments and responses should be documented, as appropriate, in the project file.

12. De minimis Impact Determinations on Historic Sites

Question 12A: What are the requirements for de minimis impact on a historic site?

Answer: A finding of de minimis impact on a historic site may be made when:

1. FHWA has considered the views of any consulting parties participating in the consultation required by Section 106 of the NHPA, including the Secretary of the Interior or his representative if the property is a NHL;

2. The SHPO/THPO, and Advisory Council on Historic Preservation (ACHP) if participating in the Section 106 consultation, are informed of FHWA's intent to make a de minimis impact finding based on their written concurrence in the Section 106 determination of "no adverse effect;" and
3. The Section 106 process results in a determination of "no adverse effect" with the written concurrence of the SHPO/THPO, and ACHP if participating in the Section 106 consultation.²¹ (See 23 CFR 774.5(b)(1) and the definition of de minimis impact in 23 CFR 774.17.)

Question 12B: How should the concurrence of the SHPO/THPO, and ACHP if participating in the Section 106 determination of effect, be documented when the concurrence will be the basis for a de minimis impact finding?

Answer: Section 4(f) requires that the SHPO/THPO, and ACHP if participating, must concur in writing in the Section 106 determination of no adverse effect (See 23 CFR 774.5(b)(1)(ii)). The request for concurrence in the Section 106 determination should include a statement informing the SHPO/THPO, and ACHP if participating, that FHWA or FTA intends to make a de minimis impact finding based upon their concurrence in the Section 106 determination.

Under the Section 106 regulation, if a SHPO/THPO does not respond within a specified time frame FHWA may move forward to the next step of the Section 106 process but Section 4(f) explicitly requires their written concurrence (See 23 CFR 774.5(b)(1)(ii)). It is therefore recommended that transportation officials share this guidance with the SHPOs and THPOs in their States so that these officials fully understand the implication of their concurrence in the Section 106 determinations and the reason for requesting written concurrence.

Question 12C: For historic sites, will a separate public review process be necessary for the determination of a de minimis impact?

Answer: No. The FHWA will consult with the parties participating in the Section 106 process but is not required to provide additional public notice or provide additional opportunity for review and comment. Documentation of consulting party involvement is required (See 23 CFR 774.5(b) and 774.7(b)). In addition, for projects requiring the preparation and distribution of a NEPA document, the information supporting a de minimis impact finding will be included in the NEPA documentation and the public will be afforded an opportunity to review and comment during the formal NEPA process.

Question 12D: Certain Section 106 programmatic agreements (PAs) allow the lead agency to assume the concurrence of the SHPO/THPO in the determination of no adverse effect or no historic properties affected if a response to a request for concurrence is not received within the time period specified in the PA. Does such concurrence through non-response, in accordance with a written and signed Section 106 PA, constitute the written concurrence needed to make a de minimis impact finding?

Answer: In accordance with the provisions of a formal Section 106 programmatic agreement (PA), if the SHPO/THPO does not respond to a request for concurrence in the Section 106 determination within a specified time frame, the non-response together with the written PA, will be considered written concurrence in the Section 106 determination that will be the basis for the de minimis impact finding by FHWA. The FHWA must inform the SHPO/THPO who are parties to such PAs, in writing, that a non-response which is treated as a concurrence in a no adverse effect or no historic properties affected determination will also be treated as the written concurrence for purposes of the FHWA de minimis impact finding (See 23 CFR 774.5(b)(1)(ii)). It is recommended that this understanding of the parties be documented via formal correspondence or other written means and appended to the existing PA. There is no need to amend the PA itself.

13. Other De minimis Impact Considerations

Question 13A: Are de minimis impact findings limited to any particular type of project or National Environmental Policy Act (NEPA) document?

Answer: No, the de minimis impact criteria may be applied to any project, as appropriate, regardless of the type of environmental document required by the NEPA process as described in the FHWA Environmental Impact and Related Procedures (See 23 CFR 771.115).

Question 13B: What effect does the de minimis impact provision have on the application of the existing FHWA nationwide programmatic Section 4(f) evaluations?

Answer: None. Existing FHWA programmatic Section 4(f) evaluations²² remain in effect and may be applied, as appropriate, to the use of Section 4(f) property by a highway project.

Question 13C: Can a de minimis impact finding be made for a project as a whole, when multiple Section 4(f) properties are involved?

Answer: No, when multiple Section 4(f) properties are present in the study area and potentially used by a transportation project, de minimis impact findings must be made for the individual Section 4(f) properties because 23 CFR 774.3 requires an approval to use Section 4(f) property. The impacts to Section 4(f) properties and any impact avoidance, minimization, and mitigation or enhancement measures must be considered on an individual resource basis and de minimis impact findings made individually for each Section 4(f) property. When there are multiple resources for which de minimis impact findings are appropriate, however, the procedural requirements of Section 4(f) can and should be completed in a single process, document and circulation, so long as it is clear that distinct determinations are being made. Also in these cases, the written concurrence of the official(s) with jurisdiction may be provided for the project as a whole, so long as the de minimis impacts findings have been made on an individual resource basis. For example, a no adverse effect determination made on an undertaking as a whole may be used to support individual de minimis impact findings provided individual historic sites are clearly identified in the Section 106 documentation.

ADDITIONAL EXAMPLES AND OTHER CONSIDERATIONS

14. School Playgrounds

Question 14: Are publicly owned school playgrounds subject to the requirements of Section 4(f)?

Answer: While the primary purpose of public school playgrounds is generally for structured physical education classes and recreation for students, these properties may also serve significant public recreational purposes and therefore may be subject to Section 4(f) requirements. When a public school playground serves only school activities and functions, the playground is not subject to Section 4(f). When a public school playground is open to the public and serves either organized or substantial walk-on recreational purposes that are determined to be significant (See Question 1), it will be subject to the requirements of Section 4(f). The actual function of the playground is the determining factor in these circumstances. Documentation should be obtained from the officials with jurisdiction over the facility stating whether or not the playground is of local significance for recreational purposes.

There may be more than one official with jurisdiction over a school playground. A school official is considered to be the official with jurisdiction of the land during school activities. However, in some cases a school board may have authorized another public agency (e.g., the city park and recreation department) to control the facilities after school hours. In such cases, the public agency with authority to control the playground would be considered an official with jurisdiction with regard to

any after-hours use of the playground. The FHWA is responsible for determining which official or officials have jurisdiction over a playground.

The term playground refers to the area of the school property developed and/or used for public park or recreation purposes such as baseball diamonds, soccer fields, tennis courts, track and field facilities, and other features such as jungle gyms or swing sets. This can also include open space or practice fields if those areas serve a park or recreation function. Section 4(f) would apply to the playground areas only and not the entire campus, unless the school and campus are also significant historic sites.

15. Trails and Shared Use Paths

Question 15A: Do the requirements of Section 4(f) apply to shared use paths or similar facilities?

Answer: FHWA must comply with 23 CFR 774.13(f) when determining if a Section 4(f) approval is necessary for the use of a trail, path, bikeway, or sidewalk. If the publicly owned facility is primarily used for transportation and is an integral part of the local transportation system, the requirements of Section 4(f) would not apply since it is not a recreational area. Section 4(f) would apply to a publicly owned, shared use path or similar facility (or portion thereof) designated or functioning primarily for recreation, unless the official(s) with jurisdiction determines that it is not significant for such purpose. During early consultation, it should be determined whether or not a management plan exists that addresses the primary purpose of the facility in question. If the exceptions in 23 CFR 774.13(f) and (g) do not apply, the utilization of the Programmatic Section 4(f) Evaluation for Independent Bikeway or Walkway Construction Projects should be considered if the facility is within a park or recreation area. Whether Section 4(f) applies or not, it is FHWA's policy that every reasonable effort should be made to maintain the continuity of existing and designated shared use paths and similar facilities.²³

Question 15B: The National Trails System Act permits the designation of scenic, historic, and recreation trails. Are these trails or other designated scenic or recreation trails on publicly owned land subject to the requirements of Section 4(f)?

Answer: FHWA must comply with 23 CFR 774.13(f) when determining if a Section 4(f) approval is necessary for the use of a trail, path, bikeway, or sidewalk. National Scenic Trails (other than the Continental Divide National Scenic Trail) and National Recreation Trails that are on publicly owned recreation land are subject to Section 4(f), provided the trail physically exists on the ground thereby enabling active recreational use.

The Continental Divide National Scenic Trail and National Historic Trails are treated differently. Public Law 95-625 provides that "except for designated protected components of the trail, no land or site located along a designated National Historic Trail or along the Continental Divide National Scenic Trail shall be subject to the provisions of [Section 4(f)] unless such land or site is deemed to be of historical significance under the appropriate historical criteria such as those for the [NR]." FHWA interprets this to mean that while the Continental Divide National Scenic Trail and the National Historic Trails themselves are exempt from Section 4(f), trail segments (including similar components such as trail buffers or other adjacent sites that were acquired to complement the trails) that are on or eligible for the NR are subject to Section 4(f) (See 23 CFR 774.13(f)(2)).

Question 15C: Are shared use paths, bikeways, or designated scenic or recreational trails on highway rights-of-way subject to the requirements of Section 4(f)?

Answer: FHWA must comply with 23 CFR 774.13(f) when determining if a Section 4(f) approval is necessary for the use of a trail, path, bikeway, or sidewalk. If a path or trail is simply described as occupying the right-of-way of the highway and is not limited to any specific location within the right-

of-way, a use of land would not occur provided that adjustments or changes in the alignment of the highway or the trail would not substantially impair the continuity of the path or trail. In this regard, it would be helpful if all future designations, including those made under the National Trails System Act, describe the location of the trail only as generally in the right-of-way.

Question 15D: Are trails on privately owned land, including land under public easement and designated as scenic or recreational trails subject to the requirements of Section 4(f)?

Answer: FHWA must comply with 23 CFR 774.13(f) when determining if a Section 4(f) approval is necessary for the use of a trail, path, bikeway, or sidewalk. Section 4(f) generally does not apply to trails on privately owned land. Section 4(f) could apply if an existing public easement permits public access for recreational purposes. In any case, it is FHWA's policy that every reasonable effort should be made to maintain the continuity of existing and designated trails.

Question 15E: Does Section 4(f) apply to trail-related projects funded under the Recreational Trails Program (RTP)?

Answer: No, projects funded under the Recreational Trails Program (RTP)²⁴ are exempt from the requirements of Section 4(f) by statute.²⁵ The exemption is limited to Section 4(f) and does not apply to other environmental requirements, such as NEPA or the NHPA.

16. User or Entrance Fees

Question 16: Does the charging of an entry or user fee affect Section 4(f) eligibility?

Answer: Many eligible Section 4(f) properties require a fee to enter or use the facility such as State Parks, National Parks, publicly owned ski areas, historic sites and public golf courses. The assessment of a user fee is generally related to the operation and maintenance of the facility and does not in and of itself negate the property's status as a Section 4(f) property. Therefore, it does not matter in the determination of Section 4(f) applicability whether or not a fee is charged, as long as the other criteria are satisfied.

Consider a public golf course as an example. Greens-fees are usually if not always required (Question 18A) and these resources are considered Section 4(f) properties when they are open to the public and determined to be significant. The same rationale should be applied to other Section 4(f) properties in which an entrance or user fee is required.

17. Transportation Enhancement Projects

Question 17A: How is Section 4(f) applied to transportation enhancement activity projects?²⁶

Answer: FHWA must comply with 23 CFR 774.13(g) when determining if a Section 4(f) approval is necessary for a use by a transportation enhancement project or a mitigation activity. A transportation enhancement activity (TEA) is one of the specific types of activities set forth by statute at 23 U.S.C. § 101(a)(35). TEAs often involve the enhancement of an activity, feature or attribute on property that qualifies as a Section 4(f) property. In most cases, such work would be covered by the exception in 23 CFR 774.13(g) when the work is solely for the purpose of preserving or enhancing an activity, feature or attribute that qualified the property for Section 4(f) protection. The official(s) with jurisdiction over the Section 4(f) property must concur in writing with this assessment. For a use of Section 4(f) property to occur in conjunction with a TEA, there must be a transportation use of land from an existing Section 4(f) property. In other words, the State DOT or other applicant as defined in 23 CFR 774.17 must acquire land from a Section 4(f) property and convert its function from park, recreation, refuge or historic purposes to a transportation purpose.

Many TEA-funded activities will occur on land that remains owned by a non-transportation entity (such as a local or State parks and recreation agency). An example would be a TEA proposed to construct a new bicycle/pedestrian path within a public park or to reconstruct an already existing bicycle/pedestrian path within a public park. Though related to surface transportation, this type of project is primarily intended to enhance the park. Either scenario would qualify as an exception for Section 4(f) approval assuming the official(s) with jurisdiction agree in writing that the TEA provides for enhancement of the bicycle/pedestrian activities within the park.

A variation of the above example is local public agency that proposes a TEA for construction of a new bicycle/pedestrian facility that requires the acquisition of land from a public park. The purpose of the project is to promote a non-motorized mode of travel for commuters even though some recreational use of the facility is likely to occur. This TEA requires a transfer of land from the parks and recreation agency to the local transportation authority for ultimate operation and maintenance of the newly constructed bicycle/pedestrian facility. Since this TEA would involve the permanent incorporation of Section 4(f) land into a transportation facility, there is a use of Section 4(f) land and the appropriate Section 4(f) evaluation and documentation would be required. In this instance, the Programmatic Section 4(f) Evaluation for Independent Bikeway or Walkway Construction Projects²⁷ would likely apply depending on the particular circumstances of the project.

Other TEAs that involve acquisition of scenic or historic easements, or historic sites, often result in ultimate ownership and management of the facility by a non-transportation entity (such as a tourism bureau or historical society). An example would be the acquisition and/or restoration of a historic railroad station for establishment of a museum operated by a historical society. Even though Federal-aid transportation funds were used to acquire a historic building, a non-transportation entity ultimately will own and manage it. Accordingly, this TEA would qualify as an exception for Section 4(f) approval.

Section 106 still applies for any TEA involving a historic site on or eligible for listing on the NR. Please refer to the Nationwide Programmatic Agreement for Implementation of Transportation Enhancement Activities²⁸ that was issued in 1997 for more details.

For other complex or complicated situations involving TEA projects, it is recommended that the FHWA Division Office contact the Headquarters Office of Project Development and Environmental Review, the Resource Center Environment Technical Services Team, or the Office of the Chief Counsel for assistance.

Question 17B: Is the exception in 23 CFR 774.13(g) limited solely to work that is funded as a TEA pursuant to 23 U.S.C. § 101(a)(35)?

Answer: No. The exception cited in 23 CFR 774.13(g) refers to TEAs – though the term “project” is used instead of “activity” – and to mitigation activities (See Question 29 regarding mitigation activities). The discussion in the corresponding section of the preamble to the regulation involves TEAs within the context of 23 U.S.C. § 101(a)(35), but does not explicitly limit the exception to TEAs funded via the 10% set aside of Surface Transportation Program funds (See 73 Fed. Reg. 13368, March 12, 2008). If proposed work very closely resembles a TEA but is not proposed for funding as a TEA, there are several options to consider.

If the proposed work could be characterized as a project mitigation feature, then the exception in 23 CFR 774.13(g) would apply without further consideration contingent upon the official(s) with jurisdiction concurring in writing that the work is solely for the purpose of preserving or enhancing an activity, feature or attribute that qualified the property for Section 4(f) protection.

In addition, the introductory paragraph of this section of the regulation indicates that the “exceptions include, but are not limited to” those listed in the ensuing paragraphs. If proposed work

resembles a TEA, avoidance of the property could be characterized as being inconsistent with the preservation purpose of the Section 4(f) statute. Uses of Section 4(f) property under the statute have long been considered to include only adverse uses that harm or diminish the resource that the statute seeks to protect. Further, this exception is limited to situations in which the official(s) with jurisdiction over the Section 4(f) property agrees that the use will either preserve or enhance an activity, feature, or attribute of the property that qualifies it for protection under Section 4(f). Work similar to TEAs may be very carefully evaluated on a case-by-case basis to determine if an exception for Section 4(f) approval might be justified consistent with the preservation purpose of the statute and 23 CFR 774.13(g).

If a Section 4(f) use is identified, under any scenario, the potential for complying with Section 4(f) via a de minimis impact finding or utilization of an approved programmatic Section 4(f) evaluation should be considered.

Question 17C: Is it possible for a TEA to create a Section 4(f) property?

Answer: Yes. TEA projects that are funded under TEA categories (A) Provision of facilities for pedestrians and bicycles and (H) Preservation of abandoned railway corridors (including the conversion and use of the corridors for pedestrian or bicycle trails) could create a new Section 4(f) resource. If a future Federal-aid highway project were to use the property, the fact that the resource was created with TEA funding would not preclude the application of Section 4(f).

18. Golf Courses

Question 18A: Are public golf courses subject to Section 4(f), even when fees and reservations are required?

Answer: Section 4(f) applies to golf courses that are owned, operated and managed by a public agency for the primary purpose of public recreation and determined to be significant. Section 4(f) does not apply to privately owned and operated golf courses even when they are open to the general public. Golf courses that are owned by a public agency but managed and operated by a private entity may still be subject to Section 4(f) requirements depending on the structure of the agreement.

The fact that greens-fees (Question 16) or reservations (tee times) are required by the facility does not alter the Section 4(f) applicability, as long as the standards of public ownership, public access and significance are met.

Some golf courses are also historic sites. If a golf course is on or eligible for listing in the NR, then the Section 4(f) requirement for public ownership and public access will not apply.

Question 18B: Are military golf courses subject to the requirements of Section 4(f)?

Answer: Military golf courses are publicly owned (by the Federal Government) but are not typically open to the public at large. Because the recreational use of these facilities is limited to active duty and retired military personnel, family, and guests they are not considered to be public recreational areas and are not subject to the requirements of Section 4(f) (See Question 1D), unless they are significant historic sites (Question 2A).

19. Museums, Aquariums, and Zoos

Question 19: Does Section 4(f) apply to museums, aquariums and zoos?

Answer: Publicly owned museums, aquariums, and zoos are not normally considered parks, recreational areas, or wildlife and waterfowl refuges and are therefore not subject to Section 4(f), unless they are significant historic sites (Question 2A).

Publicly owned facilities such as museums, aquariums or zoos may provide additional park or recreational opportunities and will need to be evaluated on a case-by-case basis to determine if the primary purpose of the resource is to serve as a significant park or recreation area. To the extent that zoos are considered to be significant park or recreational areas, or are significant historic sites they will be treated as Section 4(f) properties.

20. Fairgrounds

Question 20: Are publicly owned fairgrounds subject to the requirements of Section 4(f)?

Answer: Section 4(f) is not applicable to publicly owned fairgrounds that function primarily for commercial purposes (e.g. stock car races, horse racing, county or state fairs), rather than as park or recreation areas. When fairgrounds are open to the public and function primarily for public recreation other than an annual fair, Section 4(f) applies only to those portions of land determined significant for park or recreational purposes (See Question 1A), unless they are significant historic sites (Question 2A).

21. Bodies of Water

Question 21A: How does the Section 4(f) apply to publicly owned lakes and rivers?

Answer: Lakes are sometimes subject to multiple, even conflicting, activities and do not readily fit into one category or another. Section 4(f) would only apply to those portions of publicly owned lakes and/or adjacent publicly owned lands that function primarily for park, recreation, or refuge purposes. Section 4(f) does not apply to areas which function primarily for other purposes or where recreational activities occur on incidental, secondary, occasional or dispersed basis.

In general, rivers are not subject to the requirements of Section 4(f). Those portions of publicly owned rivers, which are designated as recreational trails are subject to the requirements of Section 4(f). Of course, Section 4(f) would also apply to lakes and rivers, or portions thereof, which are contained within the boundaries of a park, recreation area, refuge, or historic site to which Section 4(f) otherwise applies.

Question 21B: Are Wild and Scenic Rivers (WSR) subject to Section 4(f)?

Answer: FHWA must comply with 23 CFR 774.11(g) when determining if there is a use of a WSR. The National Wild and Scenic Rivers Act (WSRA) (16 U.S.C. § 1271 et seq. and 36 CFR 297.3) identifies those rivers in the United States which are designated as part of the WSR System. A WSR is defined as a river and the adjacent area within the boundaries of a component of the National Wild and Scenic Rivers System (National System). WSRs may be designated by Congress or, if certain requirements are met, the Secretary of the Interior. Each river is administered by either a Federal or state agency. Four Federal agencies have primary responsibility for the National Wild and Scenic Rivers System, specifically the Forest Service, the National Park Service, the Fish and Wildlife Service and the Bureau of Land Management.

Within this system there are wild, scenic and recreational designations. A single river can be classified as having separate or combined wild, scenic and recreation areas along the entire river. The designation of a river under the WSRA does not in itself invoke Section 4(f) in the absence of significant Section 4(f) attributes and qualities. In determining whether Section 4(f) is applicable to

these rivers, FHWA should consult with the official with jurisdiction (Question 21D) to determine how the river is designated, how the river is being used and examine the management plan over that portion of the river. If the river is publicly owned and designated a recreational river under the WSRA or is a recreation resource under a management plan, then it would be a Section 4(f) property. Conversely, if a river is included in the System and designated as wild but is not being used as or designated under a management plan as a park, recreation area, wildlife and waterfowl refuge and is not a historic site, then Section 4(f) would not apply.

Significant publicly owned public parks, recreation areas, or wildlife and waterfowl refuges and historic sites (on or eligible of the NR) in a WSR corridor are subject to Section 4(f). Other lands in WSR corridors managed for multiple purposes may or may not be subject to Section 4(f) requirements, depending on the manner in which they are administered by the managing agency. Close examination of the management plan (as required by the WSRA) prior to any use of these lands for transportation purposes is necessary. Section 4(f) would apply to those portions of the land designated in a management plan for recreation or other Section 4(f) purposes as discussed above. Where the management plan does not identify specific functions, or where there is no plan, FHWA should consult further with the official with jurisdiction (Question 21D) prior to making the Section 4(f) determination. Privately owned lands in a WSR corridor are not subject to Section 4(f), except for significant historic and archeological sites when important for preservation in place (Question 3).

Question 21C: Does Section 4(f) apply to potential WSR corridors and adjoining lands under study (pursuant to Section 5(a) of the WSRA)?

Answer: No, Section 4(f) does not apply to potential WSRs and adjoining lands. In these cases, Section 4(f) would apply only to existing significant publicly owned public parks, recreation areas, refuges, or significant historic sites in the potential river corridor. It must be noted, however, that such rivers are protected under Section 12(a) of the WSRA,²⁹ which directs all Federal departments and agencies to protect river values and further recognizes that particular attention should be given to timber harvesting, road construction, and similar activities, which might be contrary to the purposes of this Act.

Question 21D: Who are the Officials with Jurisdiction for WSRs?

Answer: The definition of officials with jurisdiction is located in 23 CFR 774.17. For those portions of a WSR to which Section 4(f) applies, the official(s) with jurisdiction are the official(s) of the Federal agency or agencies that own or administer the affected portion of the river corridor in question. For State administered, federally designated rivers³⁰ the officials with jurisdiction include both the State agency designated by the respective Governor and the Secretary of the Interior.

22. Scenic Byways

Question 22: How does Section 4(f) apply to scenic byways?

Answer: The designation of a road as a scenic byway is not intended to create a park or recreation area within the meaning of Section 4(f). The reconstruction, rehabilitation, or relocation of a publicly-owned scenic byway would not trigger Section 4(f) unless they are significant historic sites (Question 8).

23. Cemeteries

Question 23A: Does Section 4(f) apply to cemeteries?

Answer: Cemeteries would only be considered Section 4(f) properties if they are determined to be on or eligible for the NR as historic sites deriving significance from association with historic events, from age, from the presence of graves of persons of transcendent importance, or from distinctive design features.³¹

Question 23B: Does Section 4(f) apply to other lands that contain human remains?

Answer: Informal graveyards, family burial plots, or Native American burial sites and those sites that contain Native American grave goods associated with burials, are not in and of themselves considered to be Section 4(f) property except when they are individually listed in or eligible for the NR. These sites should not automatically be considered only as archeological resources as many will have value beyond what can be learned by data recovery. If these sites are considered archeological resources on or eligible for the NR and also warrant preservation in place, Section 4(f) applies (See Question 3A).

When conducting the Section 4(f) determination for lands that may be Native American burial sites or sites with significance to a federally recognized tribe, consultation with appropriate representatives from the federally recognized tribes with interest in the site is essential. Sites containing human remains may also have cultural and religious significance to a tribe (See Question 6 for a discussion of Traditional Cultural Places).

24. Joint Development (Park with Highway Corridor)

Question 24: When a public park, recreation area, or wildlife and waterfowl refuge is established and an area within the Section 4(f) property is reserved for transportation use prior to or at the same time the Section 4(f) property was established, do the requirements of Section 4(f) apply?

Answer: The FHWA must comply with 23 CFR 774.11(i) when determining if Section 4(f) applies to a property that was jointly planned for development with a future transportation corridor. Generally, the requirements of Section 4(f) do not apply to the subsequent use of the reserved area for its intended transportation purpose. This is because the land used for the transportation project was reserved from and, therefore, has never been part of the protected Section 4(f) property. Nor is a constructive use of the Section 4(f) property possible, since it was jointly planned with the transportation project. The specific governmental action that must be taken to reserve a transportation corridor with the Section 4(f) property is a question of State and local law, but may include ordinances, adopted land use plans, deed restrictions, or other actions. Evidence that the reservation was contemporaneous with or prior to the establishment of the Section 4(f) property should be documented in the project file. Subsequent statements of intent to construct a transportation project within the resource should not be considered sufficient documentation. All measures which have been taken to jointly develop the transportation corridor and the park should be completely documented in the project files. To provide flexibility for the future transportation project, State and local transportation agencies are advised to reserve wide corridors. Reserving a wide corridor will allow the future transportation project to be designed to minimize impacts on the environmental resources in the corridor. The FHWA encourages the joint planning for the transportation project and the Section 4(f) property to specify that any land not needed for the transportation project right-of-way be transferred to the adjacent Section 4(f) property once the transportation project is completed.

25. Planned Section 4(f) Properties

Question 25: Do the requirements of Section 4(f) apply to publicly owned properties planned for park, recreation area, or wildlife refuge and waterfowl refuge purposes, even though they are not presently functioning as such?

Answer: Section 4(f) applies when the land is one of the enumerated types of publicly owned lands and the public agency that owns the property has formally designated and determined it to be significant for park, recreation area, or wildlife and waterfowl refuge purposes. Evidence of formal designation would be the inclusion of the publicly owned land, and its function as a Section 4(f) property into a city or county Master Plan. A mere expression of interest or desire is not sufficient. For example, when privately held properties of these types are formally designated into a Master Plan for future park development, Section 4(f) is not applicable. The key is whether the planned facility is presently publicly owned, presently formally-designated for Section 4(f) purposes, and presently significant. When this is the case, Section 4(f) would apply.

26. Late Designation and Late Discovery of Section 4(f) Properties

Question 26A: Are properties in the transportation right-of-way designated (as park and recreation lands, wildlife and waterfowl refuges, or historic sites) late in the development of a proposed project subject to the requirements of Section 4(f)?

Answer: FHWA must comply with 23 CFR 774.13(c) when determining if a Section 4(f) approval is necessary to use a late-designated property. Except for archaeological resources, including those discovered during construction (Question 3B), a project may proceed without consideration under Section 4(f) if that land was purchased for transportation purposes prior to the designation or prior to a change in the determination of significance and if an adequate effort was made to identify properties protected by Section 4(f) prior to the acquisition. The adequacy of effort made to identify properties protected by Section 4(f) should consider the requirements and standards that existed at the time of the search.

Question 26B: How do you address a Section 4(f) use identified late in the process?

Answer: When there will be a use of a Section 4(f) property that has changed or was not identified prior to processing a CE, FONSI, or ROD, a separate Section 4(f) approval will be required (23 CFR 774.9(c)) if a proposed modification of the alignment or design would require use of a Section 4(f) property; FHWA determines that Section 4(f) applies to the use of a property; or if a proposed modification of the alignment, design, or measures to minimize harm would result in a substantial increase in the amount of Section 4(f) property used, a substantial increase in the adverse impacts to Section 4(f) property, or a substantial reduction in the measures to minimize harm. Where a separate Section 4(f) approval is required, any activity not directly affected by the separate Section 4(f) approval can proceed during the analysis. A late discovery situation could also result when a property is overlooked despite a good faith effort to carry out adequate identification efforts and FHWA decides Section 4(f) now applies to a property. In cases where Section 4(f) may apply to archeological sites discovered during construction, the Section 4(f) process will be expedited and any required evaluation of feasible and prudent avoidance alternatives will take account of the level of investment already made (See Question 3B).

27. Temporary Recreational Occupancy or Use of Highway Rights-of-way

Question 27: Does Section 4(f) apply to temporary recreational uses of land owned by a State DOT or other applicant and designated for transportation purposes?

Answer: FHWA must comply with 23 CFR 774.11(h) when determining the applicability of Section 4(f) to non-park properties that are temporarily functioning for recreation purposes. In situations where land owned by a SDOT or other applicant and designated for future transportation purposes (including highway rights-of-way) is temporarily occupied or being used for either authorized or unauthorized recreational purposes such as camping or hiking, Section 4(f) does not apply (See 23 CFR 774.11(h)). For authorized temporary occupancy of transportation rights-of-way for park or recreation purposes, it is advisable to make clear in a limited occupancy permit, with a reversionary clause that no long-term right is created and the park or recreational activity is a temporary one that will cease once completion of the highway or transportation project resumes.

28. Tunneling or Bridging (Air Rights) and Section 4(f) Property

Question 28A: Is tunneling under a publicly owned public park, recreation area, wildlife or waterfowl refuge, or historic site subject to the requirements of Section 4(f)?

Answer: Section 4(f) applies to tunneling only if the tunneling:

1. Disturbs archaeological sites that are on or eligible for the NR which warrant preservation in place;
2. Causes disruption which would permanently harm the purposes for which the park, recreation, wildlife or waterfowl refuge was established;
3. Substantially impairs the historic values of a historic site; or
4. Otherwise does not meet the exception for temporary occupancy (See Question 7A).

Question 28B: Do the requirements of Section 4(f) apply to bridging over a publicly owned public park, recreation area, wildlife or waterfowl refuge, or historic site?

Answer: Section 4(f) applies to bridging a Section 4(f) property if piers or other appurtenances are physically located in the Section 4(f) property, requiring an acquisition of land from the property (actual use). Where the bridge will span the Section 4(f) property entirely, the proximity impacts of the bridge on the Section 4(f) property should be evaluated to determine if the placement of the bridge will result in a constructive use (See 23 CFR 774.15 and Question 7A). An example of a potential constructive use would be substantial impairment to the utility of a trail resulting from severely restricted vertical clearance. If temporary occupancy of a Section 4(f) property is necessary during construction, the criteria discussed in Question 7A will apply to determine use.

29. Mitigation Activities on Section 4(f) Property

Question 29: Does the expenditure of Title 23 funds for mitigation or other non-transportation activity on a Section 4(f) property result in a use of that property?

Answer: FHWA must comply with 23 CFR 774.13(g) when determining if a Section 4(f) approval is necessary for a proposed mitigation activity. A Section 4(f) use occurs only when Section 4(f) land is permanently incorporated into a transportation facility, there is a temporary occupancy that is adverse, or there is a constructive use. If mitigation activities proposed within a Section 4(f) property are solely for the preservation or enhancement of the resource and the official(s) with jurisdiction agrees in writing with this assessment, a Section 4(f) use does not occur.

An example involves the enhancement, rehabilitation or creation of wetland within a park or other Section 4(f) property as mitigation for a transportation project's wetland impacts. Where this work is consistent with the function of the existing park and considered an enhancement of the Section 4(f) property by the official with jurisdiction, then Section 4(f) would not apply. In this case the Section 4(f) land is not permanently incorporated into the transportation facility, even though it is a part of the project as mitigation.

30. Emergencies

Question 30: How does Section 4(f) apply in emergency situations?

Answer: In emergency situations, the first concern is responding to immediate threats to human health or safety, or immediate threats to valuable natural resources. Compliance with environmental laws, such as Section 4(f), is considered later. The FHWA may participate in the costs of repair or reconstruction of Federal-aid highways and roads on Federal lands which have suffered serious damage as a result of (1) natural disasters or (2) catastrophic failures from an external cause. The Emergency Relief (ER) Program, (23 U.S.C. § 125), supplements the commitment of resources by States, their political subdivisions, or other Federal agencies to help pay for unusually heavy expenses resulting from extraordinary conditions. As FHWA retains discretionary control over whether to fund projects under this program, Section 4(f) applies to all ER funding decisions. The general sequence of events following the emergency is:

1. Restore essential service. State and local highway agencies are empowered to respond immediately, which includes beginning emergency repairs to restore essential traffic service and to prevent further damage to Federal-aid highway facilities. Section 4(f) compliance is not required at this stage.
2. Governor's proclamation
3. Preliminary notification
4. Acknowledgement
5. Damage assessments
6. Formal state request
7. Division Administrator's finding
8. Implementation of projects (this is where Section 4(f) compliance occurs)

Under the ER Program, repairs are categorized either as “emergency” or “permanent.” Emergency repairs are made during and immediately following a disaster to restore essential traffic, to minimize the extent of damage, or to protect the remaining facilities. Permanent repairs to restore the highway to its pre-disaster condition normally occur after the emergency repairs have been completed.

Section 4(f) compliance occurs during the “implementation of projects” stage for both emergency repairs and permanent repairs. For emergency repairs, Section 4(f) compliance is undertaken after the emergency repairs have been completed. For permanent repairs, Section 4(f) compliance is undertaken as part of the normal NEPA project development process, just as it would be for any other type of Federal-aid or Federal lands project (i.e. it must be completed prior to the authorization of right-of-way and construction).

31. Section 6(f) and Other Non-U.S. DOT Grant-in-Aid Program Requirements

Question 31: How are Section 6(f) of the Land and Water Conservation Fund Act and other non-U.S. DOT Federal grant-in-aid program requirements administered for purposes similar to Section 4(f)'s preservationist purpose treated in the Section 4(f) process?

Answer: For projects that propose the use of land from a Section 4(f) property purchased or improved with Federal grant-in-aid funds under the Land and Water Conservation Fund Act, the Federal Aid in Fish Restoration Act (Dingell-Johnson Act), the Federal Aid in Wildlife Act (Pittman-Robertson Act), or other similar law, or the lands are otherwise encumbered with a Federal interest, coordination with the appropriate Federal agency is required to ascertain the agency's position on

the land conversion or transfer. Other Federal requirements that may apply to the property should be determined through consultation with the officials with jurisdiction and/or appropriate U.S. DOI, Housing and Urban Development, Federal Emergency Management Agency, or other Federal officials (See 23 CFR 774.5(d)). These Federal agencies may have regulatory authority or other requirements for converting land to a different use. These requirements are independent of the Section 4(f) requirements and must be satisfied during the project development process.

Section 4(f) Process

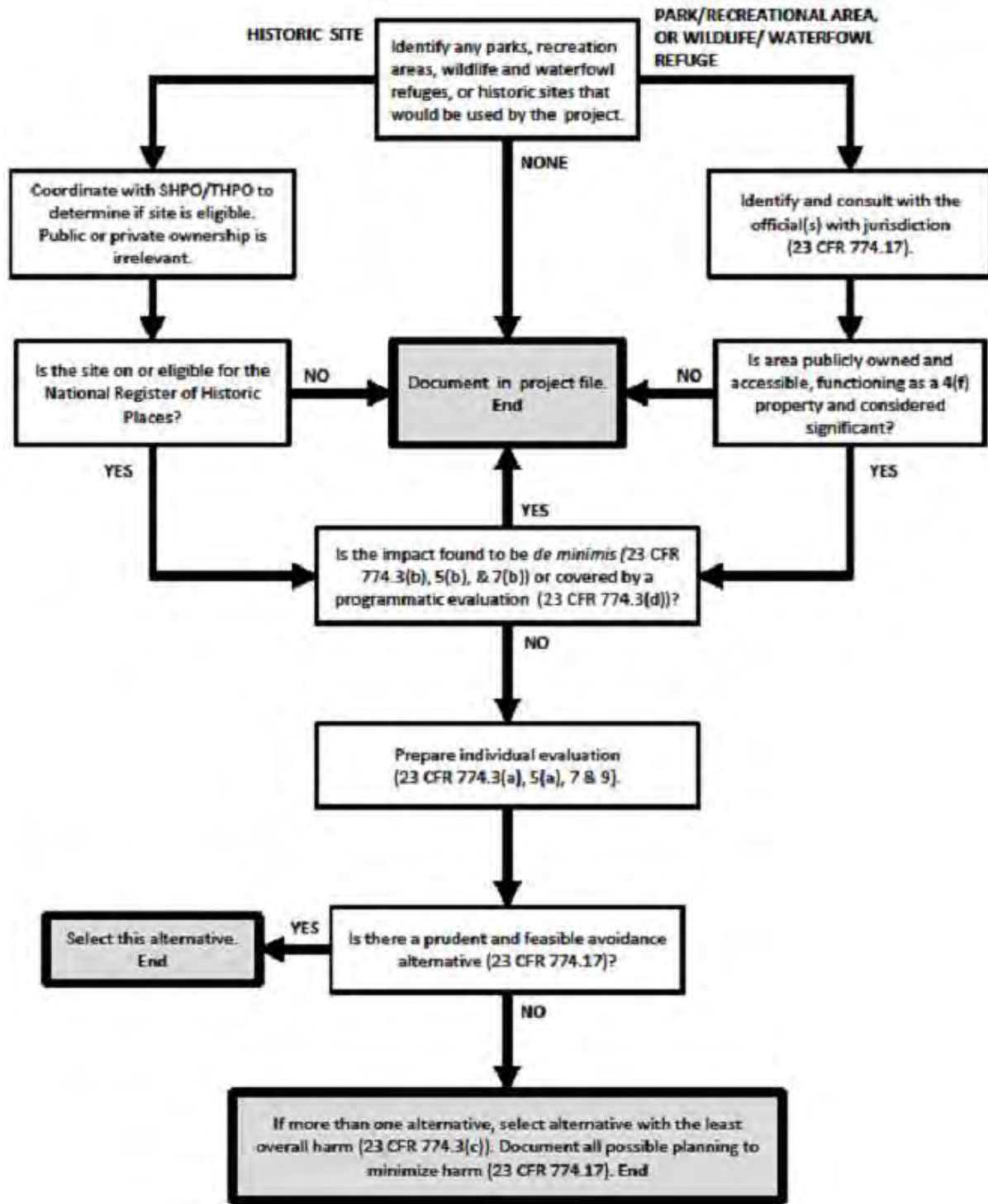

Glossary of Acronyms

ACHP - Advisory Council on Historic Preservation
CE - Categorical Exclusion
CFR - Code of Federal Regulations
DOI - Department of the Interior
DOT - Department of Transportation
EIS - Environmental Impact Statement
EA - Environmental Assessment
FHWA - Federal Highway Administration
FONSI - Finding of No Significant Impact
NEPA - National Environmental Policy Act
NHL - National Historic Landmark
NHPA - National Historic Preservation Act
NR - National Register of Historic Places
RTP - Recreational Trails Program
ROD - Record of Decision
TCP - Traditional Cultural Place
TEA - Transportation Enhancement Activity
THPO - Tribal Historic Preservation Officer
U.S.C. - United States Code
WSR - Wild and Scenic River

This may be a Federal Lands Highway Division Office if the project is located on Federal lands.

¹ <http://www.environment.fhwa.dot.gov/>

² Tribal lands means all lands within the exterior boundaries of any Indian reservation and all dependent Indian communities (16 U.S.C. § 470w).

³ Examples include the obligation of construction funds and the approval of access modifications on the Interstate System.

⁴ Most projects funded by FHWA are transportation projects; however, in a few instances certain projects eligible for funding, such as the installation of safety enhancement barriers on a bridge, have been determined not to have a transportation purpose and therefore do not require a Section 4(f) approval.

⁵ Since the primary purpose of a refuge may make it necessary for the resource manager to limit public access for the protection of wildlife or waterfowl, FHWA's policy is that these facilities are not required to always be open to the public. Some areas of a refuge may be closed to public access at all times or during parts of the year to accommodate preservation objectives.

⁶ Regulations implementing Section 106 of the NHPA.

⁷ <http://www.environment.fhwa.dot.gov/legislation/section4f/4fnationwideevals.aspx>

⁸ In the Section 4(f) statute, the term alternative is used in the context of an option which avoids using land from a Section 4(f) property and is not limited to the context of the end-to-end alternative as defined by the project applicant. This section of the Section 4(f) Policy Paper uses the phrase "avoidance alternatives and/or design options" in order to clarify that, depending upon the project context, the potential alternatives that should be evaluated to avoid Section 4(f) property may be end-to-end alternatives or may be a change to only a portion of the end-to-end project.

⁹ These and other resources are available at the FHWA Environmental Toolkit <http://environment.fhwa.dot.gov/>.

¹⁰ The National Wildlife Refuge System is currently comprised of the various categories of areas that are administered by the Secretary for the conservation of fish and wildlife, including species that are threatened with extinction, all lands, waters, and interests therein administered by the

Secretary as wildlife refuges, areas for the protection and conservation of fish and wildlife that are threatened with extinction, wildlife ranges, game ranges, wildlife management areas, or waterfowl production areas (16 U.S.C. § 668dd(a)(1)).

¹¹ The DOI's regulations state: "All national wildlife refuges are maintained for the primary purpose of developing a national program of wildlife and ecological conservation and rehabilitation. These refuges are established for the restoration, preservation, development and management of wildlife and wildlands habitat; for the protection and preservation of endangered or threatened species and their habitat; and for the management of wildlife and wildlands to obtain the maximum benefits from these resources" (50 CFR 25.11(b)).

¹² <https://www.nps.gov/subjects/nationalregister/upload/Boundaries-Completed.pdf>

¹³ For more information on the subject of TCPs see National Register Bulletin #38, Guidelines for Evaluating and Documenting Traditional Cultural Properties

¹⁴ <http://www.environment.fhwa.dot.gov/Legislation/section4f.aspx>

¹⁵ The Section 4(f) programmatic evaluations are available at <http://www.environment.fhwa.dot.gov/Legislation/section4f.aspx>

¹⁶ The Section 4(f) programmatic evaluations are available at <http://www.environment.fhwa.dot.gov/>

¹⁷ 36 CFR Part 800 (<http://www.achp.gov/work106.html>)

¹⁸ http://www.doi.gov/pmb/oepc/nrm/upload/Environmental_Review_Process.pdf

¹⁹ https://www.fws.gov/r9esnepa/NEPA_Handbook/Section_4f_Evaluations.pdf

²⁰ Although the Section 4(f) statute and regulations also provide for a de minimis impact determination in the situation where there is a use of a historic site resulting in a Section 106 determination of no historic properties affected, FHWA has not yet encountered any such situation in practice. If such situation arises, a de minimis impact determination would be appropriate.

²¹ <http://www.environment.fhwa.dot.gov/legislation/section4f/4fnationwideevals.aspx>

²² Title 23, Section 109(m) states: "The Secretary shall not approve any project or take any regulatory action under this title that will result in the severance of an existing major route or have significant adverse impact on the safety for non-motorized transportation traffic and light motorcycles, unless such project or regulatory action provides for a reasonable alternate route or such a route exists."

²³ More information on the Recreational Trails Program is available at www.fhwa.dot.gov/environment/rectrails/.

²⁴ 23 U.S.C. § 206(h)(2) Recreational purpose.—A project funded under this section is intended to enhance recreational opportunity and is not subject to section 138 of this title or section 303 of title 49.

²⁵ For more information see the FHWA Final Guidance on Transportation Enhancement Activities; December 17, 1999, and the TE Program Related Questions & Answers; August 2002, found at the Transportation Enhancement Website (http://www.fhwa.dot.gov/environment/transportation_enhancements/index.cfm).

²⁶ <http://www.environment.fhwa.dot.gov/legislation/section4f/4fbikeways.aspx>

²⁷ http://www.fhwa.dot.gov/environment/transportation_enhancements/guidance/gmemo_program.cfm

²⁸ "The Secretary of the Interior, the Secretary of Agriculture, and the head of any other Federal department or agency having jurisdiction over any lands which include, border upon, or are adjacent to, any river included within the National Wild and Scenic Rivers System or under consideration for such inclusion, in accordance with section 2(a)(ii), 3(a), or 5(a), shall take such action respecting management policies, regulations, contracts, plans, affecting such lands, following the date of enactment of this sentence, as may be necessary to protect such rivers in accordance with the purposes of this Act."

²⁹ Section 2(a)(ii) of the WSRA, 16 U.S.C. § 1273(a)(ii)

³⁰ For more information on the subject of historic cemeteries see National Register Bulletin #41, Guidelines for Evaluating and Registering Cemeteries and Burial Places; 1992 <https://www.nps.gov/subjects/nationalregister/upload/NRB41-Complete.pdf>

³¹

Programmatic Section 4(f) Evaluation and Approval for FHWA Projects that Necessitate the Use of Historic Bridges

[As published in the Federal Register / Volume 48, No. 163 / Monday, August 22, 1983.]

This statement sets forth the basis for a programmatic Section 4(f) approval that there are no feasible and prudent alternatives to the use of certain historic bridge structures to be replaced or rehabilitated with Federal funds and that the projects include all possible planning to minimize harm resulting from such use. This approval is made pursuant to Section 4(f) of the Department of Transportation Act of 1966, 49 U.S.C. 303, and Section 18(a) of the Federal-Aid Highway Act of 1968, 23 U.S.C. 138.

Use

The historic bridges covered by this programmatic Section 4(f) evaluation are unique because they are historic, yet also part of either a Federal-aid highway system or a State or local highway system that has continued to evolve over the years. Even though these structures are on or eligible for inclusion on the National Register of Historic Places, they must perform as an integral part of a modern transportation system. When they do not or cannot, they must be rehabilitated or replaced in order to assure public safety while maintaining system continuity and integrity. For the purpose of this programmatic Section 4(f) evaluation, a proposed action will "use" a bridge that is on or eligible for inclusion on the National Register of Historic Places when the action will impair the historic integrity of the bridge either by rehabilitation or demolition. Rehabilitation that does not impair the historic integrity of the bridge as determined by procedures implementing the National Historic Preservation Act of 1966, as amended (NHPA), is not subject to Section 4(f).

Applicability

This programmatic Section 4(f) evaluation may be applied by the Federal Highway Administration (FHWA) to projects which meet the following criteria:

1. The bridge is to be replaced or rehabilitated with Federal funds.
2. The project will require the use of a historic bridge structure which is on or is eligible for listing on the National Register of Historic Places.
3. The bridge is not a National Historic Landmark.
4. The FHWA Division Administrator determines that the facts of the project match those set forth in the sections of this document labeled as Alternatives, Findings, and Mitigation.
5. Agreement among the FHWA, the State Historic Preservation Officer (SHPO), and the Advisory Council on Historic Preservation (ACHP) has been reached through procedures pursuant to Section 106 of the NHPA.

Alternatives

The following alternatives avoid any use of the historic bridge:

1. Do nothing.
2. Build a new structure at a different location without affecting the historic integrity of the old bridge, as determined by procedures implementing the NHPA.
3. Rehabilitate the historic bridge without affecting the historic integrity of the structure, as determined by procedures implementing the NHPA.

This list is intended to be all-inclusive. The programmatic Section 4(f) evaluation does not apply if a reasonable alternative is identified that is not discussed in this document. The project record must clearly demonstrate that each of the above alternatives was fully evaluated and that it must further demonstrate that all applicability criteria listed above were met before the FHWA Division Administrator concluded that the programmatic Section 4(f) evaluation applied to the project.

Findings

In order for this programmatic Section 4(f) evaluation to be applied to a project, each of the following findings must be supported by the circumstances, studies, and consultations on the project:

1. *Do Nothing*. The do nothing alternative has been studied. The do nothing alternative ignores the basic transportation need. For the following reasons, this alternative is not feasible and prudent:
 - a. *Maintenance*—The do nothing alternative does not correct the situation that causes the bridge to be considered structurally deficient or deteriorated. These deficiencies can lead to sudden collapse and potential injury or loss of life. Normal maintenance is not considered adequate to cope with the situation.
 - b. *Safety*—The do nothing alternative does not correct the situation that causes the bridge to be considered deficient. Because of these deficiencies, the bridge poses serious and unacceptable safety hazards to the traveling public or places intolerable restriction on transport and travel.
2. *Build on New Location Without Using the Old Bridge*. Investigations have been conducted to construct a bridge on new location or parallel to the old bridge (allowing for a one-way couplet), but, for one or more of the following reasons, this alternative is not feasible and prudent:
 - a. *Terrain*—The present bridge structure has already been located at the only feasible and prudent site, i.e., a gap in the land form, the narrowest point of the river canyon, etc. To build a new bridge at another site will result in extraordinary bridge and approach engineering and construction difficulty or costs or extraordinary disruption to established traffic patterns.
 - b. *Adverse Social, Economic, or Environmental Effects*—Building a new bridge away from the present site would result in social, economic, or environmental impact of extraordinary magnitude. Such impacts as extensive severing of productive farmlands, displacement of a significant number of families or businesses, serious disruption of established travel patterns, and access and damage to wetlands may individually or cumulatively weigh heavily against relocation to a new site.

c. Engineering and Economy—Where difficulty associated with the new location is less extreme than those encountered above, a new site would not be feasible and prudent where cost and engineering difficulties reach extraordinary magnitude. Factors supporting this conclusion include significantly increased roadway and structure costs, serious foundation problems, or extreme difficulty in reaching the new site with construction equipment. Additional design and safety factors to be considered include an ability to achieve minimum design standards or to meet requirements of various permitting agencies such as those involved with navigation, pollution, and the environment.

d. Preservation of Old Bridge—It is not feasible and prudent to preserve the existing bridge, even if a new bridge were to be built at a new location. This could occur when the historic bridge is beyond rehabilitation for a transportation or an alternative use, when no responsible party can be located to maintain and preserve the bridge, or when a permitting authority, such as the Coast Guard requires removal or demolition of the old bridge.

3. *Rehabilitation Without Affecting the Historic Integrity of the Bridge.* Studies have been conducted of rehabilitation measures, but, for one or more of the following reasons, this alternative is not feasible and prudent:

a. The bridge is so structurally deficient that it cannot be rehabilitated to meet minimum acceptable load requirements without affecting the historic integrity of the bridge.

b. The bridge is seriously deficient geometrically and cannot be widened to meet the minimum required capacity of the highway system on which it is located without affecting the historic integrity of the bridge. Flexibility in the application of the American Association of State Highway and Transportation Officials geometric standards should be exercised as permitted in 23 CFR Part 625 during the analysis of this alternative.

Measures to Minimize Harm

This programmatic Section 4(f) evaluation and approval may be used only for projects where the FHWA Division Administrator, in accordance with this evaluation, ensures that the proposed action includes all possible planning to minimize harm. This has occurred when:

1. For bridges that are to be rehabilitated, the historic integrity of the bridge is preserved, to the greatest extent possible, consistent with unavoidable transportation needs, safety, and load requirements;

2. For bridges that are to be rehabilitated to the point that the historic integrity is affected or that are to be moved or demolished, the FHWA ensures that, in accordance with the Historic American Engineering Record (HAER) standards, or other suitable means developed through consultation, fully adequate records are made of the bridge;

3. For bridges that are to be replaced, the existing bridge is made available for an alternative use, provided a responsible party agrees to maintain and preserve the bridge; and

4. For bridges that are adversely affected, agreement among the SHPO, ACHP, and FHWA is reached through the Section 106 process of the NHPA on measures to minimize harm and those measures are incorporated into the project. This programmatic Section 4(f) evaluation does not apply to projects where such an agreement cannot be reached.

Procedures

This programmatic Section 4(f) evaluation applies only when the FHWA Division Administrator:

1. Determines that the project meets the applicability criteria set forth above;
2. Determines that all of the alternatives set forth in the Findings section have been fully evaluated;
3. Determines that use of the findings in this document that there are no feasible and prudent alternatives to the use of the historic bridge is clearly applicable;
4. Determines that the project complies with the Measures to Minimize Harm section of this document;
5. Assures that implementation of the measures to minimize harm is completed; and
6. Documents the project file that the programmatic Section 4(f) evaluation applies to the project on which it is to be used.

Coordination

Pursuant to Section 4(f), this statement has been coordinated with the Departments of the Interior, Agriculture, and Housing and Urban Development.

Issued on July 5, 1983.

Ali F. Sevin

*Director, Office of Environmental Policy,
Federal Highway Administration*

**Final Nationwide Section 4(f) Evaluation and Approval for
Federally-Aided Highway Projects With Minor Involvements
With Public Parks, Recreation Lands, and
Wildlife and Waterfowl Refuges**

[As published in the Federal Register / Volume 52, No. 160 / Wednesday, August 19, 1987.]

This programmatic Section 4(f) evaluation has been prepared for projects which improve existing highways and use minor amounts of publicly owned public parks, recreations lands, or wildlife and waterfowl refuges that are adjacent to existing highways. This programmatic Section 4(f) evaluation satisfies the requirements of Section 4(f) for all projects that meet the applicability criteria listed below. No individual Section 4(f) evaluations need be prepared for such projects.

[Note: A similar programmatic Section 4(f) evaluation has been prepared for projects which use minor amounts of land from historic sites.]

The FHWA Division Administrator is responsible for reviewing each individual project to determine that it meets the criteria and procedures of this programmatic Section 4(f) evaluation. The Division Administrator's determinations will be thorough and will clearly document the items that have been reviewed. The written analysis and determinations will be combined in a single document and placed in the project record and will be made available to the public upon request. This programmatic evaluation will not change the existing procedures for project compliance with the National Environmental Policy Act (NEPA) or with public involvement requirements.

Applicability

This programmatic Section 4(f) evaluation may be applied by FHWA only to projects meeting the following criteria:

1. The proposed project is designed to improve the operational characteristics, safety, and/or physical condition of existing highway facilities on essentially the same alignment. This includes "4R" work (resurfacing, restoration, rehabilitation, and reconstruction); safety improvements, such as shoulder widening and the correction of substandard curves and intersections; traffic operation improvements, such as signalization, channelization, and turning or climbing lanes; bicycle and pedestrian facilities; bridge replacements on essentially the same alignment; and the construction of additional lanes. This programmatic Section 4(f) evaluation does not apply to the construction of a highway on a new location.
2. The Section 4(f) lands are publicly owned public parks, recreation lands, or wildlife and waterfowl refuges located adjacent to the existing highway.
3. The amount and location of the land to be used shall not impair the use of the remaining Section 4(f) land, in whole or in part, for its intended purpose. This determination is to be made by the FHWA in concurrence with the officials having jurisdiction over the Section 4(f) lands, and will be documented in relation to the size, use, and/or other characteristics deemed relevant.

The total amount of land to be acquired from any Section 4(f) site shall not exceed the values in the following Table:

Total size of section 4(f) site	Maximum to be acquired
<10 acres	10 percent of site
10 acres – 100 acres	1 acre
>100 acres	1 percent of site

4. The proximity impacts of the project on the remaining Section 4(f) land shall not impair the use of such land for its intended purpose. This determination is to be made by the FHWA in concurrence with the officials having jurisdiction over the Section 4(f) lands, and will be documented with regard to noise, air, and water pollution, wildlife and habitat effects, aesthetic values, and/or other impacts deemed relevant.

5. The officials having jurisdiction over the Section 4(f) lands must agree, in writing, with the assessment of the impacts of the proposed project on, and the proposed mitigation for, the Section 4(f) lands.

6. For projects using land from a site purchased or improved with funds under the Land and Water Conservation Fund Act, the Federal Aid in Fish Restoration Act (Dingell-Johnson Act), the Federal Aid in Wildlife Act (Pittman-Robertson Act), or similar laws, or the lands are otherwise encumbered with a Federal interest (e.g., former Federal surplus property), coordination with the appropriate Federal agency is required to ascertain the agency's position on the land conversion or transfer. The programmatic Section 4(f) evaluation does not apply if the agency objects to the land conversion or transfer.

7. This programmatic evaluation does not apply to projects for which an environmental impact statement (EIS) is prepared, unless the use of Section 4(f) lands is discovered after the approval of the final EIS. Should any of the above criteria not be met, this programmatic Section 4(f) evaluation cannot be used, and an individual Section 4(f) evaluation must be prepared.

Alternatives

The following alternatives avoid any use of the public park land, recreational area, or wildlife and waterfowl refuge:

1. Do nothing.
2. Improve the highway without using the adjacent public park recreational land, or wildlife and waterfowl refuge.
3. Build an improved facility on new location without using the public park, recreation land, or wildlife or waterfowl refuge.

This list is intended to be all-inclusive. The programmatic Section 4(f) evaluation does not apply if a feasible and prudent alternative is identified that is not discussed in this document. The project record must clearly demonstrate that each of the above alternatives was fully evaluated before the FHWA Division Administrator concluded that the programmatic Section 4(f) evaluation applied to the project.

Findings

In order for this programmatic Section 4(f) evaluation to be applied to a project, each of the following findings must be supported by the circumstances, studies, and consultations on the project:

1. *Do Nothing Alternative*. The Do Nothing Alternative is not feasible and prudent because:

- a. It would not correct existing or projected capacity deficiencies; or
- b. It would not correct existing safety hazards; or
- c. It would not correct existing deteriorated conditions and maintenance problems; and
- d. Not providing such correction would constitute a cost or community impact of extraordinary magnitude, or would result in truly unusual or unique problems, when compared with the proposed use of the Section 4(f) lands.

2. *Improvement Without Using the Adjacent Section 4(f) Lands*. It is not feasible and prudent to avoid Section 4(f) lands by roadway design or transportation system management techniques (including, but not limited to, minor alignment shifts, changes in geometric design standards, use of retaining walls and/or other structures, and traffic diversions or other traffic management measures) because implementing such measures would result in:

- a. Substantial adverse community impacts to adjacent homes, businesses, or other improved properties; or
- b. Substantially increased roadway or structure cost; or
- c. Unique engineering, traffic, maintenance, or safety problems; or
- d. Substantial adverse social, economic, or environmental impacts; or
- e. The project not meeting identified transportation needs; and
- f. The impacts, costs, or problems would be truly unusual or unique, or of extraordinary magnitude when compared with the proposed use of Section 4(f) lands. Flexibility in the application of American Association of State Highway and Transportation Officials (AASHTO) geometric standards should be exercised, as permitted in 23 CFR Part 625, during the analysis of this alternative.

3. *Alternatives on New Location*. It is not feasible and prudent to avoid Section 4(f) lands by constructing on new alignment because:

- a. The new location would not solve existing transportation, safety, or maintenance problems; or
- b. The new location would result in substantial adverse social, economic, or environmental impacts (including such impacts as extensive severing of productive farmlands, displacement of a substantial number of families or businesses, serious disruption of established travel patterns, substantial damage to wetlands or other sensitive natural areas, or greater impacts to other Section 4(f) lands); or
- c. The new location would substantially increase costs or engineering difficulties (such as an inability to achieve minimum design standards, or to meet the requirements of various

permitting agencies such as those involved with navigation, pollution, and the environment); and

d. Such problems, impacts, costs, or difficulties would be truly unusual or unique, or of extraordinary magnitude when compared with the proposed use of Section 4(f) lands. Flexibility in the application of AASHTO geometric standards should be exercised, as permitted in 23 CFR Part 625, during the analysis of this alternative.

Measures to Minimize Harm

This programmatic Section 4(f) evaluation and approval may be used only for projects where the FHWA Division Administrator, in accordance with this evaluation, ensures that the proposed action includes all possible planning to minimize harm. This has occurred when the officials having jurisdiction over the Section 4(f) property have agreed, in writing, with the assessment of impacts resulting from the use of the Section 4(f) property and with the mitigation measures to be provided. Mitigation measures shall include one or more of the following:

1. Replacement of lands used with lands of reasonably equivalent usefulness and location and of at least comparable value.
2. Replacement of facilities impacted by the project including sidewalks, paths, benches, lights, trees, and other facilities.
3. Restoration and landscaping of disturbed areas.
4. Incorporation of design features (e.g., reduction in right-of-way width, modifications to the roadway section, retaining walls, curb and gutter sections, and minor alignment shifts); and habitat features (e.g., construction of new, or enhancement of existing wetlands or other special habitat types); where necessary to reduce or minimize impacts to the Section 4(f) property. Such features should be designed in a manner that will not adversely affect the safety of the highway facility. Flexibility in the application of AASHTO geometric standards should be exercised, as permitted in 23 CFR Part 625, during such design.
5. Payment of the fair market value of the land and improvements taken or improvements to the remaining Section 4(f) site equal to the fair market value of the land and improvements taken.
6. Such additional or alternative mitigation measures as may be determined necessary based on consultation with the officials having jurisdiction over the parkland, recreation area, or wildlife or waterfowl refuge.

If the project uses Section 4(f) lands that are encumbered with a Federal interest (see *Applicability*), coordination is required with the appropriate agency to ascertain what special measures to minimize harm, or other requirements, may be necessary under that agency's regulations. To the extent possible, commitments to accomplish such special measures and/or requirements shall be included in the project record.

Coordination

Each project will require coordination in the early stages of project development with the Federal, State, and/or local agency officials having jurisdiction over the Section 4(f) lands. In the case of non-Federal Section 4(f) lands, the official with jurisdiction will be asked to identify any Federal encumbrances. Where such encumbrances exist, coordination will be required with the Federal agency responsible for the encumbrance.

For the interests of the Department of Interior, Federal agency coordination will be initiated with the Regional Directors of the U.S. Fish and Wildlife Service, the National Park Service, and the Bureau of Reclamation; the State Directors of the Bureau of Land Management; and the Area Directors of the Bureau of Indian Affairs. In the case of Indian lands, there will also be coordination with appropriate Indian Tribal officials.

Before applying this programmatic evaluation to projects requiring an individual bridge permit, the Division Administrator shall coordinate with the U.S. Coast Guard District Commander.

Copies of the final written analysis and determinations required under this programmatic Section 4(f) evaluation shall be provided to the officials having jurisdiction over the involved Section 4(f) area and to other parties upon request.

Approval Procedures

This programmatic Section 4(f) approval applies only after the FHWA Division Administrator has:

1. Determined that the project meets the applicability criteria set forth above;
2. Determined that all of the alternatives set forth in the Findings section have been fully evaluated;
3. Determined that the findings in this document (which conclude that there are no feasible and prudent alternatives to the use of the publicly owned public park, recreation area, or wildlife or waterfowl refuge) are clearly applicable to the project;
4. Determined that the project complies with the Measures to Minimize Harm section of this document;
5. Determined that the coordination called for in this programmatic evaluation has been successfully completed;
6. Assured that the measures to minimize harm will be incorporated in the project; and
7. Documented the project file clearly identifying the basis for the above determinations and assurances.

Issued on December 23, 1986.

Ali F. Sevin

*Director, Office of Environmental Policy,
Federal Highway Administration*

**Final Nationwide Section 4(f) Evaluation and Approval for
Federally-Aided Highway Projects With Minor Involvements
With Historic Sites**

[As published in the Federal Register / Volume 52, No. 160 / Wednesday, August 19, 1987.]

This programmatic Section 4(f) evaluation has been prepared for projects which improve existing highways and use minor amounts of land (including non-historic improvements thereon) from historic sites that are adjacent to existing highways. This programmatic Section 4(f) evaluation satisfies the requirements of Section 4(f) for all projects that meet the applicability criteria listed below. No individual Section 4(f) evaluations need be prepared for such projects.

[Note: A similar programmatic Section 4(f) evaluation has been prepared for projects which use minor amounts of publicly owned parks, recreation lands, or wildlife and waterfowl refuges.]

The FHWA Division Administrator is responsible for reviewing each individual project to determine that it meets the criteria and procedures of this programmatic Section 4(f) evaluation. The Division Administrator's determination will be thorough and will clearly document the items that have been reviewed. The written analysis and determinations will be combined in a single document and placed in the project record and will be made available to the public upon request. This programmatic evaluation will not change the existing procedures for project compliance with the National Environmental Policy Act (NEPA) or with public involvement requirements.

Applicability

This programmatic Section 4(f) evaluation may be applied by FHWA to projects meeting the following criteria:

1. The proposed project is designed to improve the operational characteristics, safety, and/or physical condition of existing highway facilities on essentially the same alignment. This includes "4R" work (resurfacing, restoration, rehabilitation, and reconstruction); safety improvements, such as shoulder widening and the correction of substandard curves and intersections; traffic operation improvements, such as signalization, channelization, and turning or climbing lanes; bicycle and pedestrian facilities; bridge replacements on essentially the same alignment; and the construction of additional lanes. This programmatic Section 4(f) evaluation does not apply to the construction of a highway on new location.
2. The historic site involved is located adjacent to the existing highway.
3. The project does not require the removal or alteration of historic buildings, structures, or objects on the historic site.
4. The project does not require the disturbance or removal of archaeological resources that are important to preserve in place rather than to recover for archaeological research. The determination of the importance to preserve in place will be based on consultation with the State Historic Preservation Officer (SHPO) and, if appropriate, the Advisory Council on Historic Preservation (ACHP).
5. The impact on the Section 4(f) site resulting from the use of the land must be considered minor. The word minor is narrowly defined as having either a "no effect" or "no adverse effect" (when applying the requirements of section 106 of the National Historic Preservation

Act and 36 CFR Part 800) on the qualities which qualified the site for listing or eligibility on the National Register of Historic Places. The ACHP must not object to the determination of “no adverse effect.”

6. The SHPO must agree, in writing, with the assessment of the impacts of the proposed project on and the proposed mitigation for the historic sites.

7. This programmatic evaluation does not apply to projects for which an environmental impact statement (EIS) is prepared, unless the use of Section 4(f) lands is discovered after the approval of the final EIS.

Should any of the above criteria not be met, this programmatic Section 4(f) evaluation cannot be used, and an individual Section 4(f) evaluation must be prepared.

Alternatives

The following alternatives avoid any use of the historic site.

1. Do nothing.
2. Improve the highway without using the adjacent historic site.
3. Build an improved facility on new location without using the historic site.

This list is intended to be all-inclusive. The programmatic Section 4(f) evaluation does not apply if a feasible and prudent alternative is identified that is not discussed in this document. The project record must clearly demonstrate that each of the above alternatives was fully evaluated before the FHWA Division Administrator concluded that the programmatic Section 4(f) evaluation applied to the project.

Findings

In order for this programmatic Section 4(f) evaluation to be applied to a project, each of the following findings must be supported by the circumstances, studies, and consultations on the project:

1. *Do Nothing Alternative*. The Do Nothing Alternative is not feasible and prudent because:
 - a. It would not correct existing or projected capacity deficiencies; or
 - b. It would not correct existing safety hazards; or
 - c. It would not correct existing deteriorated conditions and maintenance problems; and
 - d. Not providing such correction would constitute a cost or community impact of extraordinary magnitude, or would result in truly unusual or unique problems, when compared with the proposed use of the Section 4(f) lands.

2. *Improvement Without Using the Adjacent Section 4(f) Lands*. It is not feasible and prudent to avoid Section 4(f) lands by roadway design or transportation system management techniques (including, but not limited to, minor alignment shifts, changes in geometric design standards, use of retaining walls and/or other structures, and traffic diversions or other traffic management measures) because implementing such measures would result in:

- a. Substantial adverse community impacts to adjacent homes, businesses or other improved properties; or
 - b. Substantially increased roadway or structure cost; or
 - c. Unique engineering, traffic, maintenance, or safety problems; or
 - d. Substantial adverse social, economic, or environmental impacts; or
 - e. The project not meeting identified transportation needs; and
 - f. The impacts, costs, or problems would be truly unusual or unique, or of extraordinary magnitude when compared with the proposed use of Section 4(f) lands. Flexibility in the application of American Association of State Highway and Transportation Officials (AASHTO) geometric standards should be exercised, as permitted in 23 CFR Part 625, during the analysis of this alternative.
3. *Alternatives on New Location*. It is not feasible and prudent to avoid Section 4(f) lands by constructing on new alignment because:
- a. The new location would not solve existing transportation, safety, or maintenance problems, or
 - b. The new location would result in substantial adverse social, economic, or environmental impacts (including such impacts as extensive severing of productive farmlands, displacement of a substantial number of families or businesses, serious disruption of established travel patterns, substantial damage to wetlands or other sensitive natural areas, or greater impacts to other Section 4(f) lands); or
 - c. The new location would substantially increase costs or engineering difficulties (such as an inability to achieve minimum design standards, or to meet the requirements of various permitting agencies such as those involved with navigation, pollution, and the environment); and
 - d. Such problems, impacts, costs, or difficulties would be truly unusual or unique, or of extraordinary magnitude when compared with the proposed use of Section 4(f) lands. Flexibility in the application of AASHTO geometric standards should be exercised, as permitted in 23 CFR Part 625, during the analysis of this alternative.

Measures to Minimize Harm

This programmatic Section 4(f) evaluation and approval may be used only for projects where the FHWA Division Administrator, in accordance with this evaluation, ensures that the proposed action includes all possible planning to minimize harm. Measures to minimize harm will consist of those measures necessary to preserve the historic integrity of the site and agreed to, in accordance with 36 CFR Part 800 by the FHWA, the SHPO, and, as appropriate, the ACHP.

Coordination

The use of this programmatic evaluation and approval is conditioned upon the satisfactory completion of coordination with the SHPO, the ACHP, and interested persons as called for in 36 CFR Part 800. Coordination with interested persons, such as the local government,

the property owner, a local historical society, or an Indian tribe, can facilitate in the evaluation of the historic resource values and mitigation proposals and is therefore highly encouraged.

For historic sites encumbered with Federal interests, coordination is required with the Federal agencies responsible for the encumbrances.

Before applying this programmatic evaluation to projects requiring an individual bridge permit, the Division Administrator shall coordinate with the U.S. Coast Guard District Commander.

Approval Procedure

This programmatic Section 4(f) approval applies only after the FHWA Division Administrator has:

1. Determined that the project meets the applicability criteria set forth above;
2. Determined that all of the alternatives set forth in the Findings section have been fully evaluated;
3. Determined that the findings in this document (which conclude that there are no feasible and prudent alternatives to the use of land from or non-historic improvements on the historic site) are clearly applicable to the project;
4. Determined that the project complies with the Measures to Minimize Harm section of this document;
5. Determined that the coordination called for in this programmatic evaluation has been successfully completed;
6. Assured that the measures to minimize harm will be incorporated in the project; and
7. Documented the project file clearly identifying the basis for the above determinations and assurances.

Issued on December 23, 1986.

Ali F. Sevin

*Director, Office of Environmental Policy,
Federal Highway Administration*

**Section 4(f) Evaluation and Approval
for Transportation Projects
That Have a Net Benefit to a Section 4(f) Property**

[As published in the Federal Register / Volume 70, No. 75 / Wednesday, April 20, 2005.]

This nationwide programmatic Section 4(f) evaluation (programmatic evaluation) has been prepared for certain federally assisted transportation improvement projects on existing or new alignments that will use property of a Section 4(f) park, recreation area, wildlife or waterfowl refuge, or historic property, which in the view of the Administration and official(s) with jurisdiction over the Section 4(f) property, the use of the Section 4(f) property will result in a net benefit to the Section 4(f) property.

Definitions:

"Administration" refers to the Federal Highway Division Administrator or Division Engineer (as appropriate).

"Applicant" refers to a State Highway Agency or State Department of Transportation, local governmental agency acting through the State Highway Agency or State Department of Transportation.

A "net benefit" is achieved when the transportation use, the measures to minimize harm and the mitigation incorporated into the project results in an overall enhancement of the Section 4(f) property when compared to both the future do-nothing or avoidance alternatives and the present condition of the Section 4(f) property, considering the activities, features and attributes that qualify the property for Section 4(f) protection. A project does not achieve a "net benefit" if it will result in a substantial diminishment of the function or value that made the property eligible for Section 4(f) protection.

"Official(s) with jurisdiction" over Section 4(f) property (typically) include: for a park, the Federal, State or local park authorities or agencies that own and/or manage the park; for a refuge, the Federal, State or local wildlife or waterfowl refuge owners and managers; and for historic sites, the State Historic Preservation Officer (SHPO) or Tribal Historic Preservation Officer (THPO), whichever has jurisdiction under Section 106 of the National Historic Preservation Act (16 U.S.C. 470f).

Applicability

The Administration is responsible for review of each transportation project for which this programmatic evaluation is contemplated to determine that it meets the criteria and procedures of this programmatic evaluation. The information and determination will be included in the applicable National Environmental Policy Act (NEPA) documentation and administrative record. This programmatic evaluation will not change any existing procedures for NEPA compliance, public involvement, or any other applicable Federal environmental requirement.

This programmatic evaluation **satisfies** the requirements of Section 4(f) for projects meeting the applicability criteria listed below. An individual Section 4(f) evaluation will not need to be prepared for such projects:

1. The proposed transportation project uses a Section 4(f) park, recreation area, wildlife or waterfowl refuge, or historic site.
2. The proposed project includes all appropriate measures to minimize harm and subsequent mitigation necessary to preserve and enhance those features and values of the property that originally qualified the property for Section 4(f) protection.
3. For historic properties, the project does not require the major alteration of the characteristics that qualify the property for the National Register of Historic Places (NRHP) such that the property would no longer retain sufficient integrity to be considered eligible for listing. For archeological properties, the project does not require the disturbance or removal of the archaeological resources that have been determined important for preservation in-place rather than for the information that can be obtained through data recovery. The determination of a major alteration or the importance to preserve in-place will be based on consultation consistent with 36 CFR part 800.
4. For historic properties, consistent with 36 CFR part 800, there must be agreement reached amongst the SHPO and/or THPO, as appropriate, the FHWA and the Applicant on measures to minimize harm when there is a use of Section 4(f) property. Such measures must be incorporated into the project.
5. The official(s) with jurisdiction over the Section 4(f) property agree in writing with the assessment of the impacts; the proposed measures to minimize harm; and the mitigation necessary to preserve, rehabilitate and enhance those features and values of the Section 4(f) property; and that such measures will result in a net benefit to the Section 4(f) property.
6. The Administration determines that the project facts match those set forth in the Applicability, Alternatives, Findings, Mitigation and Measures to Minimize Harm, Coordination, and Public Involvement sections of this programmatic evaluation.

This programmatic evaluation can be applied to any project regardless of class of action under NEPA.

Alternatives

To demonstrate that there are no feasible and prudent alternatives to the use of Section 4(f) property, the programmatic evaluation analysis must address alternatives that avoid the Section 4(f) property. The following alternatives avoid the use of the Section 4(f) property:

1. Do nothing.
2. Improve the transportation facility in a manner that addresses the project's purpose and need without a use of the Section 4(f) property.
3. Build the transportation facility at a location that does not require use of the Section 4(f) property.

This list is intended to be all-inclusive. The programmatic evaluation does not apply if a feasible and prudent alternative is identified that is not discussed in this document. The project record must clearly demonstrate that each of the above alternatives was fully evaluated before the Administration can conclude that the programmatic evaluation can be applied to the project.

Findings

For this programmatic evaluation to be utilized on a project there must be a finding, given the present condition of the Section 4(f) property, that the do-nothing and avoidance alternatives described in the Alternatives section above are not feasible and prudent. The findings (1, 2, and 3. below) must be supported by the circumstances, studies, consultations, and other relevant information and included in the administrative record for the project. This supporting information and determination will be documented in the appropriate NEPA document and/or project record consistent with current Section 4(f) policy and guidance.

To support the finding, adverse factors associated with the no-build and avoidance alternatives, such as environmental impacts, safety and geometric problems, decreased transportation service, increased costs, and any other factors may be considered collectively. One or an accumulation of these kinds of factors must be of extraordinary magnitude when compared to the proposed use of the Section 4(f) property to determine that an alternative is not feasible and prudent. The net impact of the do-nothing or build alternatives must also consider the function and value of the Section 4(f) property before and after project implementation as well as the physical and/or functional relationship of the Section 4(f) property to the surrounding area or community.

1. *Do-Nothing Alternative.* The Do-Nothing Alternative is not feasible and prudent because it would neither address nor correct the transportation need cited as the NEPA purpose and need, which necessitated the proposed project.

2. *Improve the transportation facility in a manner that addresses purpose and need without use of the Section 4(f) property.* It is not feasible and prudent to avoid Section 4(f) property by using engineering design or transportation system management techniques, such as minor location shifts, changes in engineering design standards, use of retaining walls and/or other structures and traffic diversions or other traffic management measures if implementing such measures would result in any of the following:

- Substantial adverse community impacts to adjacent homes, businesses or other improved properties; or
- Substantially increased transportation facility or structure cost; or
- Unique engineering, traffic, maintenance or safety problems; or
- Substantial adverse social, economic or environmental impacts; or
- A substantial missed opportunity to benefit a Section 4(f) property; or
- Identified transportation needs not being met; and
- Impacts, costs or problems would be truly unusual, unique or of extraordinary magnitude when compared with the proposed use of Section 4(f) property after taking into account measures to minimize harm and mitigate for adverse uses, and enhance the functions and value of the Section 4(f) property.

Flexibility in the use of applicable design standards is encouraged during the analysis of these feasible and prudent alternatives.

3. Build a new facility at a new location without a use of the Section 4(f) property. It is not feasible and prudent to avoid Section 4(f) property by constructing at a new location if:

- The new location would not address or correct the problems cited as the NEPA purpose and need, which necessitated the proposed project; or
- The new location would result in substantial adverse social, economic or environmental impacts (including such impacts as extensive severing of productive farmlands, displacement of a substantial number of families or businesses, serious disruption of community cohesion, jeopardize the continued existence of any endangered or threatened species or resulting in the destruction or adverse modification of their designated critical habitat, substantial damage to wetlands or other sensitive natural areas, or greater impacts to other Section 4(f) properties); or
- The new location would substantially increase costs or cause substantial engineering difficulties (such as an inability to achieve minimum design standards or to meet the requirements of various permitting agencies such as those involved with navigation, pollution, or the environment); and
- Such problems, impacts, costs, or difficulties would be truly unusual or unique or of extraordinary magnitude when compared with the proposed use of the Section 4(f) property after taking into account proposed measures to minimize harm, mitigation for adverse use, and the enhancement of the Section 4(f) property's functions and value.

Flexibility in the use of applicable design standards is encouraged during the analysis of feasible and prudent alternatives.

Mitigation and Measures To Minimize Harm

This programmatic evaluation and approval may be used only for projects where the Administration, in accordance with this evaluation, ensures that the proposed action includes all possible planning to minimize harm, includes appropriate mitigation measures, and that the official(s) with jurisdiction agree in writing.

Coordination

In early stages of project development, each project will require coordination with the Federal, State, and/or local agency official(s) with jurisdiction over the Section 4(f) property. For non-Federal Section 4(f) properties, i.e., State or local properties, the official(s) with jurisdiction will be asked to identify any Federal encumbrances. When encumbrances exist, coordination will be required with the Federal agency responsible for such encumbrances.

Copies of the final written report required under this programmatic evaluation shall be offered to the official(s) with jurisdiction over the Section 4(f) property, to other interested parties as part of the normal NEPA project documentation distribution practices and policies or upon request.

Public Involvement

The project shall include public involvement activities that are consistent with the specific requirements of 23 CFR 771.111, Early coordination, public involvement and project development. For a project where one or more public meetings or hearings are held, information on the proposed use of the Section 4(f) property shall be communicated at the public meeting(s) or hearing(s).

Approval Procedure

This programmatic evaluation approval applies only after the Administration has:

1. Determined that the project meets the applicability criteria set forth in Applicability section;
2. Determined that all of the alternatives set forth in the Findings section have been fully evaluated;
3. Determined that the findings in the programmatic evaluation (which conclude that the alternative recommended is the only feasible and prudent alternative) result in a clear net benefit to the Section 4(f) property;
4. Determined that the project complies with the Mitigation and Measures to Minimize Harm section of this document;
5. Determined that the coordination and public involvement efforts required by this programmatic evaluation have been successfully completed and necessary written agreements have been obtained; and
6. Documented the information that clearly identifies the basis for the above determinations and assurances.

Programmatic Section 4(f) Statement for Independent Bikeway or Walkway Construction Projects

The following pages include the 1977 “Final Negative Declaration/Section 4(f) Statement and Determination for Independent Bikeway or Walkway Construction Projects” and copies of correspondence from the FHWA advising that the Section 4(f) Statement and Determination remains valid. The FHWA correspondence confirms that the programmatic statement may be used, as appropriate, for bikeway and walkway projects financed with transportation enhancement funds.

As indicated in the July 9, 1992 memorandum from FHWA headquarters, where out of date terms and references are used in the programmatic Section 4(f) Statement (e.g., negative declaration, FHPM, references to FHWA offices), current terminology should be substituted when using the programmatic Section 4(f) Statement.

As indicated in the “Application” section on page 2 of the Programmatic Section 4(f) Statement, it is only applicable to independent bikeway or walkway construction projects and its use is subject to the following constraints:

1. It is applicable only to the use of recreation and park areas established and maintained primarily for active recreation, open space, and similar purposes.
2. It is applicable only when the official having specific jurisdiction over the Section 4(f) property has given approval in writing that the project is acceptable and consistent with the designated use of the property and that all possible planning to minimize harm has been accomplished in the location and design of the bikeway or walkway facility.
3. The document does not apply if the project would require the use of critical habitat of endangered species.
4. It does not apply to the use of any land from a publicly owned wildlife or waterfowl refuge or any land from a historic site of national, State, or local significance.
5. It does not apply to projects where there are unusual circumstances (major impacts, adverse effects, or controversy).

To obtain approval under the programmatic Section 4(f) Statement, conformance with each of the above constraints must be documented to the satisfaction of the FHWA. If the applicability criteria cannot be satisfied for an independent bikeway or walkway project involving use of Section 4(f) land, processing with a separate Section 4(f) evaluation or under another programmatic Section 4(f) evaluation, when applicable, will be required.



U.S. Department of Transportation
Federal Highway Administration

Memorandum

Subject: Programmatic Section 4(f) Statement for Independent Bikeway or Walkway Construction Projects
From: Eugene W. Cleckley
Chief, Environmental Operations Division
To: Regional Federal Highway Administrators
Federal Lands Highway Program Administrator

DA:	
ADA	
ADM	
ROW	
S & E	
Date:	JUL 14 1992
BR	
PD	
Reply to	HEP-3
Attn. of:	MPL
	MCS
	LIB
	IDOT

Attached is a copy of the May 23, 1977 memorandum signed by former FHWA Executive Director L.P. Lamm, which transmitted the subject Section 4(f) statement to your office. In an effort to speed up the processing of environmental documentation for the transportation enhancement projects contained in ISTEA, this office has been re-examining all of our policy and guidance material. Based on discussions with our Environmental and Right of Way Law Branch, the subject document is still valid. It should be noted that there are terms and references used in the document which are out of date, such as negative declaration, FHPM, and FHWA office names. However, these are all minor items and do not affect the thought process used in the development of the programmatic document. Where these terms are used, simply substitute the current terminology, such as CE or EA/FONSI for negative declaration, Project Development Branch for Environmental Review Branch, etc. We believe this document combined with the bicycle and pedestrian facilities CE contained in 23 CFR 771.117(c) can greatly reduce the time required to process these types of enhancement projects.

Should you have any questions concerning the document and its use, please contact any of the Project Development Specialist in my office.

Kenneth A. Perret
Kenneth A. Perret

July 14, 1992

1st Endorsement

Fr: Director
Ofc. of Planning & Program Development
Homewood, Illinois

HPP-05

To: Division Administrators - Illinois, Indiana,
Michigan, Minnesota, Ohio, and Wisconsin

The subject programmatic Section 4(f) is being recirculated for your information and appropriate use.

Ennis V. Heathcock
Paul D. Quinn
By: Paul D. Quinn
Regional Environmental Specialist

Attachment

UNITED STATES GOVERNMENT

*Memorandum*DEPARTMENT OF TRANSPORTATION
FEDERAL HIGHWAY ADMINISTRATION

DATE: May 23, 1977

In reply
refer to: HEV-11RECEIVED
REG. 4 F.H.W.A.

MAY 31 1977

SUBJECT: Negative Declaration/Section 4(f) Statement
for Independent Bikeway or Walkway Construction
Projects

FROM : Federal Highway Administrator

TO : Regional Federal Highway Administrators
Regions 1-10, and
Regional Engineer, Region 15

In order to reduce processing time and delays, we have prepared a negative declaration/Section 4(f) statement and determination (copy attached) to cover those independent bikeway and pedestrian walkway projects (FHFM 6-1-1-1) which require the use of recreation and park areas. This approved document should be distributed to Division Offices and State highway agencies for their use.

A draft of the negative declaration/Section 4(f) statement was published in the Federal Register (42 F.R. 15394) on March 21, 1977, inviting interested persons to comment. No major adverse comments were received during this commenting period. The majority of letters received were favorable and recommended approval of the document.

This environmental document will not relieve the Division Administrator from reviewing the impacts, mitigation measures, location, and design of individual bikeways. If there are any unusual circumstances (major impacts or controversy), a separate Section 4(f) statement and environmental document (EIS or negative declaration) should be considered for the individual project. It is likely that most projects which do not involve Section 4(f) properties would be nonmajor actions and would not require a formal environmental document.

It is also important to obtain approval from the official having specific jurisdiction over the Section 4(f) property that the project is acceptable and consistent with the designated use of the property, and that the location and design have been accomplished in a manner that will not cause harm to the property. A copy of the negative declaration/Section 4(f) statement, along with the approval letter from the official, should be placed in the individual project file.

If you have any question concerning the subject document, please contact the Environmental Review Branch, (202) 426-0106, in the Office of Environmental Policy.



For William M. Cox

Final Negative Declaration/Section 4(f) Statement

and Determination for Independent Bikeway or Walkway Construction Projects

Background

There is a growing interest in bicycling and walking for commuting, for recreation, and for other trip purposes. Where this activity occurs on high-speed roadways, both safety and efficiency can be impaired because of the mixture of motorized and non-motorized modes of travel. Construction of bikeways or pedestrian walkways can promote safety and will assist in retaining the motor vehicle carrying capacity of the highway while enhancing bicycle capacity.

The United States Congress recognized the importance of bicycle and pedestrian travel by including special provisions for these modes in the Federal-Aid Highway Act of 1973, Public Law 93-87. Section 124 of this Act (amended Title 23, U.S. Code, by adding Section 217) contained the following principal provisions:

(1) Federal funds available for the construction of preferential facilities to serve pedestrians and bicyclists are those apportioned in accordance with paragraphs (1), (2), (3) and (6) of Section 104(b), 23 U.S.C., and those authorized for Forest highways, Forest development roads and trails, public land development roads and trails, park roads and trails, parkways, Indian reservation roads, and public land highways.

(2) Not more than \$40 million (amended to \$45 million by Section 134 of the Federal-Aid Highway Act of 1976) apportioned in any fiscal year for purposes described in the preceding paragraph may be obligated for bicycle projects and pedestrian walkways.

(3) No State shall obligate more than \$2 million (amended to \$2.5 million by Section 134 of the Federal-Aid Highway Act of 1976) of Federal-aid funds for such projects in any fiscal year.

(4) Such projects shall be located and designed pursuant to an overall plan which will provide due consideration for safety and contiguous routes.

The funding limitations described in (2) and (3) above are applicable only to independent bikeway and walkway construction projects.

Project Description

Independent bikeway or walkway construction projects are those highway construction projects which provide bicycle or pedestrian facilities in contrast to a project whose primary purpose is to serve motorized vehicles. The requirements for qualification of proposed bikeway or walkway facilities as independent bikeway or walkway construction projects are contained in Volume 6, Chapter 1, Section 1, Subsection 1, of the Federal-Aid Highway Program Manual, codified as Part 652 of Chapter 1 of Title 23 of the Code of Federal Regulations (CFR).

The bikeways and walkways will be designed and constructed in a manner suitable to the site conditions and the anticipated extent of usage. In general, a bikeway will be designed with an alignment and profile suitable for bicycle use with a surface that will be reasonably durable that incorporates drainage as necessary, and that is of a width appropriate for the planned one-way or two-way use.

The facilities will be accessible to the users or will form a segment located and designed pursuant to an overall plan.

Projects may include the acquisition of land outside the right-of-way, provided the facility will accommodate traffic which would have normally used a Federal-aid highway route, disregarding any legal prohibitions on the use of the route by cyclists or pedestrians.

It is required that a public agency be responsible for maintenance of the federally funded bikeway or walkway. No motorized vehicles will be permitted on the facilities except those for maintenance purposes and snowmobiles where State or local regulations permit.

Application

This negative declaration/preliminary Section 4(f) document is only applicable for independent bikeway or walkway construction projects which require the use of recreation and park areas established and maintained primarily for active recreation, open space, and similar purposes. Additionally, this document is applicable only when the official having specific jurisdiction over the Section 4(f) property has given his approval in writing that the project is acceptable and consistent with the designated use of the property and that all possible planning to minimize harm has been accomplished in the location and design of the bikeway or walkway facility. This document does not apply if the project would require the use of critical habitat of endangered species.

This document does not cover the use of any land from a publicly owned wildlife or waterfowl refuge or any land from a historic site of national, State, or local significance. It also does not cover those projects where there are unusual circumstances (major impacts, adverse effects, or controversy). A separate Section 4(f) statement and environmental document must be prepared in these categories.

This document does not cover bicycle or pedestrian facilities that are incidental items of construction in conjunction with highway improvements having the primary purpose of serving motor vehicular traffic.

Summary

The primary purpose for the development of independent bikeway and walkway projects is to provide a facility for traffic which would have normally used a Federal-aid highway route. In some cases, the bikeway and walkway projects can serve a dual function by also providing for recreational use. Where this situation occurs, artificially routing a bikeway or walkway around a compatible park area is not a prudent alternative because it would decrease the recreational value of the bikeway or walkway.

The written approval of the official having specific jurisdiction over the Section 4(f) property and construction authorization by FHWA will confirm that all possible planning to minimize harm has been accomplished in the location and design of the bikeway or walkway facility.

Noise and air quality will not be affected by bicycles. There would be increase in the noise level if snowmobiles are permitted. However, this would likely occur at a time when other uses of the recreational facilities will be minimal.

Temporary impacts on water quality will be minimal. Erosion control measures will be used through the construction period. A certain amount of land will be removed from other uses. The type of land and uses will vary from project to project. However, due to the narrow cross-section of the bikeways and walkways, a minimal amount of land will be required for

the individual projects. The projects will be blended into existing terrain to reduce any visual impacts.

Displacement of families and businesses will not be required.

No significant adverse social or economic impacts are anticipated. There will be beneficial impacts such as the enhancement of the recreational potential of the parks and the provision of an alternate mode of transportation for the commuter.

Comments and Coordination

A draft of this negative declaration/Section 4(f) statement was published in the Federal Register (42 F.R. 15394) March 21, 1977, inviting interested persons to comment. The majority of the letters received were favorable and recommended approval of the document.

The document was also circulated to the Departments of the Interior (DOI), Housing and Urban Development (HUD), and Agriculture. Comments were received from DOI and HUD and are included in the appendix along with our responses.

Individual projects will be coordinated at the earliest feasible time with all responsible local officials, including the State Outdoor Recreation Liaison Officer. The use of properties acquired or developed with Federal monies from the Land and Water Conservation Fund will also be coordinated with the Bureau of Outdoor Recreation of DOI.

If HUD Community Development Block Grant Funds are used in conjunction with Federal Highway Administration Funds, HUD environmental review procedures set forth in 24 CFR, Section 58, are applicable.

Determination

Based on the above and on the scope of these bikeway and walkway projects, it is determined that they will not have a significant effect upon the quality of the human environment. It is also our determination that (1) there is no feasible and prudent alternative to the use of Section 4(f) lands, and (2) the conditions for approval will insure that the bikeway proposals will include all possible planning to minimize harm resulting from such use.

May 23, 1977 [Original signed by L.P. Lamm]

DATE

For William M. Cox
Federal Highway Administrator

APPENDIX



United States Department of the Interior

OFFICE OF THE SECRETARY
WASHINGTON, D.C. 20240In reply refer to:
(ER-77/105)

MAR 21 1977

Dear Mr. Lash:

This is in response to your February, 1977 request for the Department of the Interior's comments on the proposed Negative Declaration/Section 4(f) statement for Independent Bikeway or Walkway Construction Projects.

We are pleased that the proposed document responds to a number of the comments made in our letter of June 25, 1976, on the Bikeway Demonstration Program. We note that the present document is not applicable to the use of land from a publicly owned wildlife or waterfowl refuge or any land from a historic site, nor is it applicable if the project would require the use of critical habitat of endangered species. We note further that the document applies only to the use of recreation and park areas established and maintained primarily for active recreation, open space, and similar purposes.

We concur with these limitations on the application of the proposed Negative Declaration/Section 4(f) statement. However, we wish to again express our opinion that the proposed document not be applicable to:

(1)

1. Significant wetlands;
2. Unique ecological areas set aside for the preservation, interpretation, or scientific study of plant and animal communities, e.g., Registered Natural Landmarks and Registered Environmental Education Landmarks.



-2-

3. Play areas for small children (tot lots, etc.); and
4. Small park areas where the bikeway or walkway may use a significant portion of the available space (vest-pocket parks, etc.).

We are also pleased that the document makes provision for early coordination with all responsible local officials, including the State Outdoor Recreation Liaison Officer, and the Bureau of Outdoor Recreation (BOR) when Land and Water Conservation Fund grants are involved. We suggest, however, that you may wish to coordinate all projects of this type with the appropriate Regional Office of BOR for the technical assistance they can provide on bikeways and walkways. (2)

According to our calculations, a funding level of \$45,000,000 for these bikeways and walkways would amount to somewhere between 1,800 and 4,500 miles of trail per year. This would directly remove from all other use (including use by flora and fauna) roughly 1,000 to 6,800 acres per year. This impact should be addressed in the proposed negative declaration. (3)

Thank you for the opportunity to review this proposed document.

Sincerely yours,



Deputy Assistant Secretary of the Interior

Mr. Michael Lash
Director of Environmental Policy
U.S. Department of Transportation
Federal Highway Administration
Washington, D. C. 20590

Responses to the Department of the Interior
Letter of March 21, 1977

- (1) We believe the Application section is adequate to cover those cases where there are unusual circumstances such as major impacts or adverse effects. The key point is that the official having specific jurisdiction over the Section 4(f) property has to agree that the project is acceptable and consistent with the designated use of the property, and that the location and design have been accomplished in a manner that will not cause harm to the property.
- (2) The FHWA Division Administrator and the local officials will have the option of requesting additional coordination with the Bureau of Outdoor Recreation on all bikeway and walkway projects.
- (3) The use of land for the bikeways and walkways has been addressed in the Summary section. However, it should be understood that this document is for individual projects and was not prepared to address the impacts of the entire bikeway program.



DEPARTMENT OF HOUSING AND URBAN DEVELOPMENT
WASHINGTON, D.C. 20410

FEB 15 1977

OFFICE OF THE ASSISTANT SECRETARY
FOR COMMUNITY PLANNING AND DEVELOPMENT

IN REPLY REFER TO:
CSR

Your reference:
HEV-11

Mr. Michael Lash
Director of
Environmental Policy
Department of Transportation
Federal Highway Administration
Nassif Building - Room 3234
Washington, D. C. 20590

Dear Mr. Lash: *For Ke*

Thank you for providing this Office with the opportunity to review and comment on the proposed draft negative declaration/Section 4(f) for the construction of independent bikeways and pedestrian walkways. While your negative declaration proposal will reduce processing time, we propose for your consideration the following recommendations:

1. Under the caption Application insert the following before the last sentence in the first paragraph:
The project must be in accord with a unified and officially coordinated program for the development of open space land as part of local and areawide comprehensive planning. (1)
2. Under the caption Application add the following to the second paragraph: If unusual natural or man-made conditions exist in the proposed project area which might be deleteriously affected by the proposed bikeway or pedestrian walkway, then a Section 4(f) and an environmental impact statement shall be prepared for the project. (2)

2

3. Under the caption Coordination, second paragraph add the following: If HUD Community Development Block Grant (CDBG) funds are used by applicants in conjunction with Section 124 funds, HUD environmental review procedures set forth in 24 CFR Section 58 are applicable. (Copy attached) The CDBG program permits the use of funds for the construction of certain public works in conjunction with recreational purposes.

(3)

Sincerely yours,



Richard H. Broun
Director, Office of
Environmental Quality

Attachment

Responses to the Department of Housing
and Urban Development Letter of
February 15, 1977

- (1) We do not believe it is necessary to add this sentence to the Application section since this is already a Federal-aid qualification requirement. (See 23 CFR, Part 652.)
- (2) This provision has been added to the Application section.
- (3) The Coordination section has been expanded to include this situation.

**STEWARDSHIP AND OVERSIGHT AGREEMENT
ON PROJECT ASSUMPTION AND PROGRAM OVERSIGHT BY AND BETWEEN
FEDERAL HIGHWAY ADMINISTRATION, ILLINOIS DIVISION AND THE
STATE OF ILLINOIS DEPARTMENT OF TRANSPORTATION**

SECTION I. BACKGROUND AND INTRODUCTION

The Federal-aid Highway Program (FAHP) is a federally-assisted program of State-selected projects. The Federal Highway Administration (FHWA) and the State Departments of Transportation have long worked as partners to deliver the FAHP in accordance with Federal requirements. In enacting 23 U.S.C. 106(c), as amended, Congress recognized the need to give the States more authority to carry out project responsibilities traditionally handled by FHWA. Congress also recognized the importance of a risk-based approach to FHWA oversight of the FAHP, establishing requirements in 23 U.S.C. 106(g). This Stewardship and Oversight (S&O) Agreement sets forth the agreement between the FHWA and the State of Illinois Department of Transportation (IDOT) on the roles and responsibilities of the FHWA and the IDOT with respect to Title 23 project approvals and related responsibilities, and FAHP oversight activities.

For the purposes of this agreement, stewardship is defined as the efficient and effective management of the public funds that have been entrusted to FHWA for the Federal-aid Highway Programs. Oversight, an integral part of stewardship, is defined as specific activities which ensure that the implementation of the various elements of the Federal-aid Highway Program is in accordance with applicable laws, regulations, and policies.

The scope of FHWA responsibilities, and the legal authority for IDOT assumption of FHWA responsibilities, developed over time. The U.S. Secretary of Transportation delegated responsibility to the Administrator of the FHWA for the FAHP under Title 23 of the United States Code, and associated laws. (49 CFR 1.84 and 1.85) The following legislation further outlines FHWA's responsibilities:

- Intermodal Surface Transportation Efficiency Act (ISTEA) of 1991;
- Transportation Equity Act for the 21st Century (TEA-21) of 1998;
- Safe, Accountable, Flexible, Efficient Transportation Equity Act: A Legacy for Users (SAFETEA-LU) of 2005; and
- Moving Ahead for Progress in the 21st Century Act (MAP-21) of 2012 (P.L. 112-141).

The FHWA may not assign or delegate its decision-making authority to a State Department of Transportation unless authorized by law. Section 106 of Title 23, United States Code (Section 106), authorizes the State to assume specific project approvals. For projects that receive funding under Title 23, U.S.C., and are on the National Highway System (NHS) including projects on the Interstate System, the State may assume the responsibilities of the Secretary of the U.S. Department of Transportation under Title 23 for design, plans, specifications, estimates, contract awards, and inspections with respect to the projects unless the Secretary determines that the assumption is not appropriate. (23 U.S.C. 106(c)(1)) For projects under Title 23, U.S.C. that are not on the NHS, the State shall assume the responsibilities for design, plans, specifications, estimates, contract awards, and inspections unless the State determines that such assumption is not appropriate. (23 U.S.C. 106(c)(2))

For all other project activities which do not fall within the specific project approvals listed in Section 106 or are not otherwise authorized by law, the FHWA may authorize IDOT to perform work needed to reach the FHWA decision point, or to implement FHWA's decision. However such decisions themselves are reserved to FHWA.

The authority given to the IDOT under Section 106(c)(1) and (2) is limited to specific project approvals listed herein. Nothing listed herein is intended to include assumption of FHWA's decision-making authority regarding Title 23, U.S.C. eligibility or Federal-aid participation determinations. The FHWA always must make the final eligibility and participation decisions for the Federal-aid Highway Program.

Section 106(c)(3) requires FHWA and the IDOT to enter into an agreement relating to the extent to which the IDOT assumes project responsibilities. This Stewardship and Oversight Agreement (S&O Agreement), includes information on specific project approvals and related responsibilities, and provides the requirements for FHWA oversight of the FAHP (Oversight Program), as required by 23 U.S.C. 106(g).

SECTION II. INTENT AND PURPOSE OF S&O AGREEMENT

The intent and purpose of this S&O Agreement is to document the roles and responsibilities of the FHWA's Illinois Division Office (FHWA or Division) and Illinois Department of Transportation (IDOT) with respect to project approvals and related responsibilities, and to document the methods of oversight which will be used to efficiently and effectively deliver the FAHP.

The Project Action Responsibility Matrix, Attachment A to this S&O Agreement and as further described in Section VIII of this S&O Agreement, identifies FHWA FAHP project approvals and related responsibilities State DOT assumes from FHWA on a program-wide basis pursuant to 23

U.S.C. 106(c) and other legal authorities. Upon execution of this agreement, Attachment A shall be controlling and except as specifically noted in Attachment A, no other agreements, attachments, or other documents shall have the effect of delegating or assigning FHWA approvals to State DOT on a program-wide basis under 23 U.S.C 106 or have the effect of altering Attachment A.

SECTION III. ASSUMPTION OF RESPONSIBILITIES FOR FEDERAL-AID PROJECTS ON THE NATIONAL HIGHWAY SYSTEM

A. The IDOT may assume the FHWA's Title 23 responsibilities for design; plans, specifications, and estimates (PS&E); contract awards; and inspections, with respect to Federal-aid projects on the National Highway System (NHS) if both the IDOT and FHWA determine that assumption of responsibilities is appropriate.

B. Approvals and related activities for which the IDOT has assumed responsibilities as shown in Attachment A will apply program wide unless project specific actions for which the Division will carry out the approval or related responsibilities are documented in accordance with the FHWA Project of Division Interest/Project of Corporate Interest Guide (FHWA PoDI/PoCI Guide) located at <http://www.fhwa.dot.gov/federalaid/stewardship/>

Attachment D, "Selection and Monitoring of Projects of Division Interest (PoDI's)" outlines the processes for coordination of PoDI's between IDOT and FHWA.

C. The IDOT may not assume responsibilities for Interstate projects that are in high risk categories. (23 U.S.C. 106(c)(1))

D. The IDOT is to exercise any and all assumptions of the Secretary responsibilities for Federal-aid projects on the NHS in accordance with Federal laws, regulations and policies.

SECTION IV. ASSUMPTION OF RESPONSIBILITIES FOR FEDERAL-AID PROJECTS OFF THE NATIONAL HIGHWAY SYSTEM

A. The IDOT shall assume the FHWA's Title 23 responsibilities for design, PS&Es, contract awards, and inspections, with respect to Federal-aid projects off the NHS (non-NHS) unless the IDOT determines that assumption of responsibilities is not appropriate. (23 U.S.C. 106(c)(2))

B. Except as provided in 23 U.S.C. 109(0), the IDOT is to exercise the Secretary's approvals and related responsibilities on these projects in accordance with Federal laws.

C. The IDOT, in its discretion, may request FHWA carry out one or more non-NHS approvals or related responsibilities listed as "State" in Attachment A on a program-wide basis. For a project specific request, the State may request FHWA carry out any approval or related responsibility listed in Attachment A off the NHS. Such project-specific requests shall be documented in accordance with the FHWA PoDI/PoCI Guide.

Attachment D, "Selection and Monitoring of Projects of Division Interest (PoDI's)" outlines the processes for coordination of PoDI's between IDOT and FHWA. Pursuant to 23 U.S.C. 109(0), non-NHS projects shall be designed and constructed in accordance with State laws, regulations, directives, safety standards, design standards, and construction standards.

SECTION V. ASSUMPTION OF RESPONSIBILITIES FOR LOCALLY ADMINISTERED PROJECTS

The IDOT may permit local public agencies (LPAs) to carry out the IDOT's assumed responsibilities on locally administered projects. The IDOT is responsible and accountable for LPA compliance with all applicable Federal laws and requirements.

SECTION VI. PERMISSIBLE AREAS OF ASSUMPTION UNDER 23 U.S.C. 106(c) An assumption of responsibilities under 23 U.S.C. 106(c) may cover only activities in the following areas:

A. Design which, includes preliminary engineering, engineering, and design-related services directly relating to the construction of a FARP-funded project, including engineering, design, project development and management, construction project management and inspection, surveying, mapping (including the establishment of temporary and permanent geodetic control in accordance with specifications of the National Oceanic and Atmospheric Administration), and architectural-related services.

B. PS&E which, represents the actions and approvals required before authorization of construction. The PS&E package includes geometric standards, drawings, specifications, project estimates, certifications relating to completion of right-of-way acquisition and relocation, utility work, and railroad work.

C. Contract awards which, include procurement of professional and other consultant services and construction-related services to include advertising, evaluating, and awarding contracts.

D. Inspections which, include general contract administration, material testing and quality assurance, review, and inspections of Federal-aid contracts as well as final inspection/acceptance.

E. Approvals and related responsibilities affecting real property as provided in 23 CFR 710.201(i) and any successor regulation in 23 CFR Part 710.

SECTION VII. FEDERAL APPROVALS AND RELATED RESPONSIBILITIES THAT MAY NOT BE ASSUMED BY THE IDOT

A. Any approval or related responsibility not listed in Attachment A cannot be assumed by the State without prior concurrence by FHWA Headquarters. The following is a list of the most frequently-occurring approvals and related responsibilities that may not be assumed by the IDOT:

- Civil Rights Program approvals;
- Environmental approvals, except those specifically assumed under other agreements. (23 U.S.C. 326 and 327; programmatic categorical exclusion agreements);
- Federal air quality conformity determinations required by the Clean Air Act;
- Approval of current bill and final vouchers;
- Approval of federally-funded hardship acquisition, protective buying, and 23 U.S.C. 108(d) early acquisition;
- Project agreements and modifications to project agreements and obligation of funds (including advance construction);
- Planning and programming pursuant to 23 U.S.C. 134 and 135;
- Special Experimental Projects (SEP-14 and SEP-15);
- Use of Interstate airspace for non-highway-related purposes;
- Any Federal agency approval or determination under the Uniform Relocation Assistance and Real Property Acquisition Policies Act of 1970 (Uniform Act), as amended, and implementing regulations in 49 CFR Part 24;
- Waivers to Buy America requirements;
- Approval of Federal participation under 23 CFR 1.9(b);
- Provide pre-approval for preventive maintenance project;
- Requests for credits toward the non-Federal share of construction costs for early acquisitions, donations, or other contributions applied to a project;
- Functional replacement of property;
- Approval of a time extension for preliminary engineering projects beyond the 10-year limit, in the event that actual construction or acquisition of right-of-way for a highway project has not commenced;
- Approval of a time extension beyond the 20-year limit for right of way projects, in the event that actual construction of a road on the right-of-way is not undertaken;
- Determine need for Coast Guard Permit;
- Training Special Provision - Approval of New Project Training Programs; and
- Any other approval or activity not specifically identified in Attachment A unless otherwise approved by the FHWA, including the Office of Chief Counsel.

B. For all projects and programs, the IDOT will comply with Title 23 and all applicable non-Title 23, U.S.C. Federal-aid program requirements, such as metropolitan and statewide planning; environment; procurement of engineering and design related service contracts (except as provided in 23 U.S.C. 109(0)); Civil Rights including Title VI of the Civil Rights Act, and participation by Disadvantaged Business Enterprises; prevailing wage rates; and acquisition of right-of-way, etc.

C. This Agreement does not modify the FHWA's non-Title 23 program approval and related responsibilities, such as approvals required under the Clean Air Act; National Environmental Policy Act, Executive Order on Environmental Justice (E.O. 12898), and other related environmental laws and statutes; the Uniform Act; and the Civil Rights Act of 1964 and related statutes.

SECTION VIII. PROJECT ACTION RESPONSIBILITY MATRIX

Attachment A, Project Action Responsibility Matrix, to this S&O Agreement identifies FAHP project approvals and related responsibilities. The Matrix specifies which approvals and related responsibilities are assumed by the State under 23 U.S.C. 106(c) or other statutory or regulatory authority, as well as approvals and related responsibilities reserved to FHWA.

SECTION IX. HIGH RISK CATEGORIES

A. In 23 U.S.C. 106(c), Congress directs that the Secretary shall not assign any approvals or related responsibilities for projects on the Interstate System if the Secretary determines the project to be in a high risk category. Under 23 U.S.C. 106(c)(B)(8), the Secretary may define high risk categories on a national basis, State-by-State basis, or national and State-by-State basis.

B. The Division has determined there are no high risk categories.

SECTION X. FHWA OVERSIGHT PROGRAM UNDER 23 U.S.C. 106(g)

A. In 23 U.S.C. 106(g), Congress directs that the Secretary shall establish an oversight program to monitor the effective and efficient use of funds authorized to carry out the FAHP. This program includes FHWA oversight of the State's processes and management practices, including those involved in carrying out the approvals and related responsibilities assumed by the State under 23 U.S.C. 106(c). Congress defines that, at a minimum, the oversight-program shall be responsive to all areas relating to financial integrity and project delivery.

B. The FHWA shall perform annual reviews that address elements of the IDOT's financial management system in accordance with 23 U.S.C. 106(g)(2)(A). FHWA will periodically review the IDOT's monitoring of subrecipients pursuant to 23 U.S.C. 106(g)(4)(B).

C. The FHWA shall perform annual reviews that address elements of the project delivery systems of the IDOT, which elements include one or more activities that are involved in the life cycle of project from conception to completion of the project. The FHWA will also evaluate the practices of the IDOT for estimating project costs, awarding contracts, and reducing costs. 23 U.S.C. 106(g)(2) and (3).

D. To carry out the requirements of 23 U.S.C. 106(g), the FHWA will employ a risk management framework to evaluate financial integrity and project delivery, and balance risk with staffing resources, available funding, and the State's transportation needs. The FHWA may work collaboratively with the IDOT to assess the risks inherent with the FAHP and funds management, and how that assessment will be used to align resources to develop appropriate risk response strategies

Techniques the Division and IDOT may use to identify and analyze risks and develop response strategies include the following:

- Program Assessments;
- FIRE Reviews;
- Program Reviews;
- Certification Reviews;
- Recurring or periodic reviews such as the Compliance Assessment Program (CAP);
- and • Inspections of project elements or phases.

These techniques will be carried out in a manner consistent with applicable Division Standard Operating Procedures or other control documents relating to program assessments, FIRE, program reviews, CAP, etc.

The following techniques and processes will be used to carry out the requirements of 23 U.S.C. 106(g):

The FHWA will monitor Federal Highway Programs and will maintain review and/or approval authority of activities that are not delegated to IDOT. In addition, FHWA and IDOT are responsible for ensuring financial integrity and compliance with applicable laws and regulations. The FHWA can review any program or project including those that have unique features, high-risk elements, unusual circumstances, or projects included in program and/or process reviews. FHWA will not require higher standards and policies be applied on a project merely because FHWA is involved in that project. FHWA's involvement in a project does not change governing policies although FHWA may request consideration of more rigorous criteria or alternative approaches.

The IDOT and FHWA are established leaders in the joint process review program. The cooperative approach taken in Illinois has led to reviews that are an integral part of process improvement at IDOT and FHWA. These reviews meet and exceed the requirements of 23 U.S. Code, Section 106(g)(3). During the annual process review selection meeting, IDOT and FHWA will ensure at least one review addressing project delivery is selected. Most of these reviews do address project delivery. Additional program reviews will be conducted at the required frequencies. These include, but are not limited to, the following:

The IDOT research program conducts a peer review of its program.

The FHWA reviews IDOT's Highway Performance Monitoring System program.

The FHWA reviews Illinois' Motor Fuel and Truck Tax collection program.

The FHWA and Federal Transit Administration conduct MPO Certification Reviews. The IDOT and FHWA review construction work zones.

The IDOT and FHWA conduct ad hoc reviews based on issues that emerge.

The IDOT audit program, with some FHWA participation, is conducted.

Other State entities review IDOT's program: Auditor General, Department of Central Management Services.

E. Program Responsibility Matrix

Attachment B to this S&O Agreement is the Program Responsibility Matrix example that identifies all relevant FHWA program actions, and Division and IDOT program contact offices.

F. Manuals and Operating Agreements

IDOT manuals, agreements and other control documents that have been approved for use on Federal-aid projects are listed in Attachment C to this S&O Agreement.

G. Stewardship and Oversight Indicators

FHWA and IDOT will jointly develop a set of Stewardship and Oversight Indicators (Indicators) as tools to assess whether the assumptions of responsibility outlined in this agreement are functioning appropriately. The Indicators will be risk-based, will continue to evolve to meet the needs of FHWA and IDOT and be reviewed annually for effectiveness. Once developed, Indicators will be included in an attachment to this agreement.

SECTION XI. IDOT OVERSIGHT AND REPORTING REQUIREMENTS

A. IDOT Oversight and Reporting Requirements

The IDOT is responsible for demonstrating to the FHWA how it is carrying out its responsibilities in accordance with this S&O Agreement. In order to fulfill this responsibility, the IDOT will meet its responsibilities in accordance with Illinois control documents, which are listed in Attachment C. The IDOT will consult with FHWA in accordance with Attachment A when IDOT considers deviating from the control documents, which represent established policies, guidance, standard procedures, and programmatic agreements. With FHWA approval, IDOT may implement an alternative approach to meeting State and Federal requirements.

IDOT will assume all responsibilities in accordance with Section 106 of Title 23. This applies to all design activities, Plan, Specifications, and Estimates (PS&E) approvals, concurrence in awards, and all construction and maintenance activities. This precludes the need for any FHWA approval or concurrence, except for those actions that require FHWA approval outside of Title 23 U.S.C., such as NEPA (42 USC 4321 et seq), Title VI of the Civil Rights Act (42 USC 2000d et seq), Fair Housing Act (42 USC 3601 et seq), and the Uniform Relocation Assistance and Land Acquisitions Policies Act (42 USC 4601 et seq).

Project level actions from FHWA are summarized in Attachment A. The IDOT will ensure the appropriate approvals are obtained and the appropriate documentation is submitted. For all Federal-aid projects on the NHS, under State or Local jurisdiction, IDOT will conduct all final inspections in lieu of FHWA to ensure the work was completed in substantial conformance with the approved PS&E. Although FHWA may request to participate in a PoDI's final inspection, IDOT will still have the lead in completing this action.

The process by which PoDI's are coordinated between IDOT and FHWA is outlined in Attachment D.

B. IDOT Oversight of Locally Administered Projects

B.1. IDOT is required to provide adequate oversight of subrecipients including oversight of any assumed responsibilities the IDOT delegates to a LPA.

B.2. Pursuant to 23 U.S.C. 106(g)(4), the IDOT shall be responsible for determining that subrecipients of Federal funds have adequate project delivery systems for locally administered projects and sufficient accounting controls to properly manage such Federal-aid funds. The State DOT is also responsible for ensuring compliance with reporting and other requirements applicable to grantees making sub-awards, such as monthly reporting requirements under the Federal Funding Accountability and Transparency Act of 2006, PL 109-282 (as amended by PL 110-252).

B.3. The IDOT acknowledges that it is responsible for sub-recipient awareness of Federal grant requirements, management of grants, awards and sub-awards and is familiar with and comprehends pass through entity responsibilities (2 C.F.R. 200.331 Requirements for Pass-thru Entities) The IDOT shall carry out these responsibilities using the following actions, programs, and processes:

As IDOT makes programs available to local units of government, IDOT provides the parameters, assists the locals in administration, and provides oversight of Federal and State funded programs. Eligible public agencies may be permitted, by IDOT, to take approval actions and administer Federal-aid design and construction projects when IDOT assures the public agency has the knowledge and capability to achieve compliance with State and Federal requirements.

State stewardship efforts include oversight and approval actions, as well as many day-to-day actions that are routinely performed to ensure the Federal-aid Highway Program is administered in regulatory compliance and in ways that enhance the value of the program funds. In addition, IDOT maintains its Bureau of Local Roads and Streets Manual and provides training opportunities to communicate requirements, and IDOT staff reviews project documentation to ensure compliance.

B.4. The IDOT shall assess whether a sub-recipient has adequate project delivery systems and sufficient accounting controls to properly manage projects, using the following actions, programs, and processes:

Control documents, including the IDOT Bureau of Local Roads and Streets Manual, will be followed to ensure LPA projects are suitably administered. IDOT financial monitoring procedures will be applied to these projects.

B.5. The IDOT shall assess whether a sub-recipient is staffed and equipped to perform work satisfactorily and cost effectively, and that adequate staffing and supervision exists to manage the Federal project(s), by using the following actions, programs, and processes:

Control documents, including the IDOT Bureau of Local Roads and Streets Manual, will be followed to ensure LPA projects are suitably administered.

B.6. The IDOT shall assess whether sub-recipient projects receive adequate inspection to ensure they are completed in conformance with approved plans and specifications, by using the following actions, programs, and processes:

Control documents, including the IDOT Bureau of Local Roads and Streets Manual, will be followed to ensure LPA projects are suitably administered.

B.7. The IDOT shall ensure that when LPAs elect to use consultants for engineering services, the LPA, as provided under 23 CFR 635.105(b), shall provide a full-time employee of the agency to be in responsible charge of the project. The IDOT's process to ensure compliance with this requirement is documented by the following actions, programs, and processes:

Control documents, including the IDOT Bureau of Local Roads and Streets Manual, will be followed to ensure LPA projects are suitably administered.

B.8. The IDOT shall ensure that project actions will be administered in accordance with all applicable Federal laws and regulations. The IDOT will use the following process on required approvals on sub-recipient projects as described in control documents, such as the IDOT Bureau of Local Roads and Streets Manual, and approved on sub-recipient administered projects.

B.9. The IDOT shall document its oversight activities for LPA-administered projects and findings, and how it will share this information with the FHWA. FIRE reviews and monitoring projects' financial status will include LPA projects. IDOT will also coordinate resolution of project issues that deviate from control documents with FHWA.

SECTION XII. IMPLEMENTATION AND AMENDMENTS

A. This S&O Agreement will take effect as of the effective date of the signature of the FHWA Illinois Division Administrator, who shall sign this S&O Agreement last.

B. The Division and IDOT agree that updates to this Agreement will be considered periodically on a case-by-case basis or when:

- Significant new legislation, Executive orders, or other initiatives affecting the relationship or responsibilities of one or both parties to the S&O Agreement occurs;
- Leadership, or leadership direction, changes at the IDOT or FHWA; or
- Priorities shift as a result of audits, public perception, or changes in staffing at either the IDOT or Division Office.

C. The Division and IDOT agree that changes may occur to the contents of the Attachments to this S&O Agreement and documents incorporated by reference into the S&O Agreement. Except as provided in paragraph XII.D., and E, changes to the Attachments and documents incorporated by reference will not require the Division and IDOT to amend this S&O Agreement. The effective date of any revisions to one of these documents shall be clearly visible in the header of the revised document. This Agreement and any revised document shall be posted on the Division's S&O Agreement internet site within five (5) business days of the effective date.

D. Any changes to the high risk categories must be documented by an amendment to this S&O Agreement.

E. Any changes to the Project Action Responsibility Matrix must be approved by the FHWA Office of Infrastructure in writing and documented by an amendment to this S&O Agreement. (Drafting Note: The Project Action Responsibility Matrix is generally Attachment A.)

EXECUTION BY THE FHWA ILLINOIS DIVISION OFFICE

Executed this 27 day of May, 2015.



Signature
CATHERINE A. BATEY

Catherine A. Batey
Division Administrator

EXECUTION BY THE ILLINOIS DEPARTMENT OF TRANSPORTATION

Executed this 26 day of May, 2015.



Signature
Randall S. Blankenhorn

Randall S. Blankenhorn
Acting Secretary

ATTACHMENT A
PROJECT ACTION RESPONSIBILITY MATRIX
(As of November 14, 2014)

The following matrix identifies Federal-aid highway program (FAHP) project approvals and related responsibilities. The matrix addresses which ones are subject to State assumption under the provisions of 23 U.S.C. 106(c) or other statutory or regulatory authority, as well as those which are reserved to FHWA.

PROJECT ACTION RESPONSIBILITY MATRIX (Excluding PoDIs, which are subject to separate PoDI Plans)		
ACTION	AGENCY RESPONSIBLE	
	PROJECTS ON THE NHS	PROJECTS OFF THE NHS
PROGRAMMING (All phases)		
Ensure project in Statewide Transportation Improvement Program (STIP)/Transportation Improvement Program (TIP)	STATE	STATE
Identify proposed funding category	STATE (1)	STATE (1)
FINANCIAL MANAGEMENT (All phases)		
Obligate funds/approve Federal-aid project agreement, modifications, and project closures (project authorizations) (Note: this action cannot be assumed by State)	FHWA	FHWA
Authorize current bill (Note: this action cannot be assumed by State)	FHWA	FHWA
Review and Accept Financial Plan and Annual Updates for Federal Major Projects over \$500 million [23 U.S.C. 106(h)] (Note: this action cannot be assumed by State)	FHWA	FHWA
Review Cost Estimates for Federal Major Projects over \$500 million [23 U.S.C. 106(h)] (Note: this action cannot be assumed by State)	FHWA	FHWA

PROJECT ACTION RESPONSIBILITY MATRIX (Excluding PoDIs, which are subject to separate PoDI Plans)		
ACTION	AGENCY RESPONSIBLE	
	PROJECTS ON THE NHS	PROJECTS OFF THE NHS
Develop Financial Plan for Federal Projects between \$100 million and \$500 million. [23 U.S.C. 106(i)]	STATE	STATE
ENVIRONMENT (All phases)		
All EA/FONSI, EIS/ROD, 4(f), 106, 6(f) and other approval actions required by Federal environmental laws and regulations	FHWA (2)	FHWA (2)
Categorical Exclusion approval actions (Note this action cannot be assumed by the State except through an assignment under 23 U.S.C. 326 or 327, or through a programmatic agreement pursuant to Section 1318(d) of MAP-21 and 23 CFR 771.117(g))	FHWA (2) for CEII STATE FOR CE-I	FHWA (2) for CEII STATE FOR CE-I
PRELIMINARY DESIGN (Design Phase)		
Consultant Contract Selection	STATE (3)	STATE (3)
Sole source Consultant Contract Selection	STATE (3)	STATE (3)
Approve hiring of consultant to serve in a "management" role (Note: this action cannot be assumed by State) [23 CFR 172.9]	FHWA	FHWA
Approve consultant agreements and agreement revisions (Federal non-Major Projects) [23 CFR 172.9]	STATE	STATE
Approve consultant agreements and agreement revisions on Federal Major Projects [23 CFR 172.9] (Note: this action cannot be assumed by State)	FHWA	FHWA
Approve exceptions to design standards [23 CFR 625.3(f)]	FHWA for Interstate; STATE for Non-Interstate	STATE
Interstate System Access Change [23 USC 111] (Note: this action	FHWA	N/A

PROJECT ACTION RESPONSIBILITY MATRIX (Excluding PoDIs, which are subject to separate PoDI Plans)		
ACTION	AGENCY RESPONSIBLE	
	PROJECTS ON THE NHS	PROJECTS OFF THE NHS
cannot be assumed by State)		
Interstate System Access Justification Report [23 USC 111] (Note: action may be assumed by State pursuant to 23 USC 111(e))	FHWA	N/A
Airport highway clearance coordination and respective public interest finding (if required) [23 CFR 620.104]	STATE	STATE
Approve Project Management Plan for Federal Major Projects over \$500 million [23 USC 106(h)] (Note: this action cannot be assumed by State)	FHWA	FHWA
Approve innovative and Public-Private Partnership projects in accordance with SEP-14 and SEP-15 (Note: this action cannot be assumed by State)	FHWA	FHWA
Provide pre-approval for preventive maintenance project (until FHWA concurs with STATE procedures) (Note: this action cannot be assumed by State)	FHWA	FHWA
DETAILED / FINAL DESIGN (Design Phase)		
Provide approval of preliminary plans for unusual/complex structures on the Interstate. [23 USC 109(a) and FHWA Policy]	FHWA (4)	N/A
Provide approval of preliminary plans for unusual/complex structures (non-Interstate). [23 USC 109(a) and FHWA Policy]	STATE (4)	STATE
Approve retaining right-of-way encroachments [23 CFR 1.23 (b) & (c)]	STATE (5)	STATE
Approve use of local force account agreements	STATE	STATE

PROJECT ACTION RESPONSIBILITY MATRIX (Excluding PoDIs, which are subject to separate PoDI Plans)		
ACTION	AGENCY RESPONSIBLE	
	PROJECTS ON THE NHS	PROJECTS OFF THE NHS
[23 CFR 635.104 & 204]		
Approve use of publicly owned equipment [23 CFR 635.106]	STATE	STATE
Approve the use of proprietary products, processes [23 CFR 635.411]	STATE	STATE
Concur in use of publicly furnished materials [23 CFR 635.407]	STATE	STATE
RIGHT-OF-WAY (Design and Operational Phases)		
Make feasibility/practicability determination for allowing authorization of construction prior to completion of ROW clearance, utility and railroad work [23 CFR 635.309(b)]	FHWA for Interstate; STATE for Non-Interstate	STATE
Make public interest finding on whether State may proceed with bid advertisement even though ROW acquisition/relocation activities are not complete for some parcels [23 CFR 635.309(c)]	FHWA	FHWA
Ensure compliant ROW certificate is in place [23 CFR 635.309(c)]	STATE	STATE
Approve Hardship and Protective Buying [23 CFR 710.503] (If a Federal-aid project) (Note: this action cannot be assumed by State)	FHWA	FHWA
Approve Interstate Real Property Interest Use Agreements [23 CFR 710.405] (Note: this action cannot be assumed by State)	FHWA	N/A
Approve non-highway use and occupancy [23 CFR 1.23(c)]	FHWA for Interstate STATE for Non-Interstate (3)	STATE (3)
Approve disposal at less than fair	FHWA	FHWA

PROJECT ACTION RESPONSIBILITY MATRIX (Excluding PoDIs, which are subject to separate PoDI Plans)		
ACTION	AGENCY RESPONSIBLE	
	PROJECTS ON THE NHS	PROJECTS OFF THE NHS
market value of federally funded right-of-way, including disposals of access control [23 U.S.C. 156] (Note: this action cannot be assumed by State)		
Approve disposal at fair market value of federally funded right-of-way, including disposals of access control [23 CFR 710.409] (Note: Exception allowed per 23 CFR 710.201)	FHWA for Interstate STATE for Non-Interstate (3)	STATE (3)
Requests for credits toward the non-Federal share of construction costs for early acquisitions, donations or other contributions applied to a project (note: this action cannot be assumed by State)	FHWA	FHWA
Federal land transfers [23 CFR 710, Subpart F] (Note: this action cannot be assumed by State)	FHWA	FHWA
Functional replacement of property [23 CFR 710.509] (Note: this action cannot be assumed by State)	FHWA	FHWA
SYSTEM OPERATIONS AND PRESERVATION (Design Phase)		
Accept Transportation Management Plans (23 CFR 630.1012(b))	STATE	STATE
Approval of System Engineering Analysis (for ITS) [23 CFR 940.11]	STATE	STATE
PS&E AND ADVERTISING (Design Phase)		
Approve PS&E [23 CFR 630.201]	STATE	STATE
Authorize advance construction and conversions [23 CFR 630.703 & 709] (Note: this action cannot be assumed by State)	FHWA	FHWA
Approve utility or railroad force	STATE	STATE

PROJECT ACTION RESPONSIBILITY MATRIX (Excluding PoDIs, which are subject to separate PoDI Plans)		
ACTION	AGENCY RESPONSIBLE	
	PROJECTS ON THE NHS	PROJECTS OFF THE NHS
account work [23 CFR 645.113 & 646.216]		
Approve utility and railroad agreements [23 CFR 645.113 & 646.216]	STATE	STATE
Approve use of consultants by utility companies [23 CFR 645.109(b)]	STATE	STATE
Approve exceptions to maximum railroad protective insurance limits [23 CFR 646.111]	STATE	STATE
Authorize advertising for bids (FHWA authorization done via construction authorization) [23 CFR 635.112, 309]	STATE	STATE
CONTRACT ADVERTISEMENT AND AWARD (Design Phase)		
All contracts to be done by competitive bidding unless otherwise authorized by law		
Approve cost-effectiveness determinations for construction work performed by force account or by contract awarded by other than competitive bidding [23 CFR 635.104 &.204]	STATE	STATE
Approve emergency determinations for contracts awarded by other than competitive bidding [23 CFR 635.104 &.204]	FHWA	FHWA
Approve construction engineering by local agency [23 CFR 635.105]	STATE	STATE
Approve advertising period less than 3 weeks [23 CFR 635.112]	FHWA	FHWA
Approve addenda during advertising period [23 CFR 635.112]	STATE	STATE
Concur in award of contract [23 CFR 635.114]	STATE	STATE
Concur in rejection of all bids [23 CFR 635.114]	STATE	STATE
Approval of Design-Build	STATE	STATE

PROJECT ACTION RESPONSIBILITY MATRIX (Excluding PoDIs, which are subject to separate PoDI Plans)		
ACTION	AGENCY RESPONSIBLE	
	PROJECTS ON THE NHS	PROJECTS OFF THE NHS
Requests-for-Proposals and Addenda [23 CFR 635.112]		
CONSTRUCTION (Construction Phase)		
Approve changes and extra work [23 CFR 635.120]	STATE	STATE
Approve contract time extensions [23 CFR 635.120]	STATE	STATE
Concur in use of mandatory borrow/disposal sites [23 CFR 635.407]	STATE	STATE
Accept materials certification [23 CFR 637.207]	STATE	STATE
Concur in settlement of contract claims [23 CFR 635.124]	STATE	STATE
Concur in termination of construction contracts [23 CFR 635.125]	STATE	STATE
Waive Buy America provisions [23 CFR 635.410] (Note: this action cannot be assumed by State)	FHWA	FHWA
Final inspection/acceptance of completed work [23 USC 114(a)]	STATE	STATE
CIVIL RIGHTS (All phases)		
Approval of Disadvantaged Business Enterprise (DBE) Project Contract Goal set by the State DOT under 49 CFR 26.51(d). [49 CFR 26.51(e)(3)]	STATE	STATE
Acceptance of Bidder's Good Faith Efforts to Meet Contract Goal [49 CFR 26.53] or of Prime Contractor's Good Faith Efforts to Find Another DBE Subcontractor When a DBE Subcontractor is Terminated or Fails to Complete Its Work [49 CFR 26.53(g)] (Note: this action cannot be performed by the FHWA)	STATE	STATE

PROJECT ACTION RESPONSIBILITY MATRIX (Excluding PoDIs, which are subject to separate PoDI Plans)		
ACTION	AGENCY RESPONSIBLE	
	PROJECTS ON THE NHS	PROJECTS OFF THE NHS
Equal Employment Opportunity (EEO) Contract Compliance Review [23 CFR Part 230, Subpart D]).	STATE	STATE
Training Special Provision – Approval of Project Goal for training slots or hours [23 CFR Part 230, Subpart A]	STATE	STATE
Training Special Provision – Approval of New Project Training Programs (Note: this action cannot be assumed by State) [23 CFR 230.111(d), (e)]	FHWA	FHWA
FOOTNOTES:		
<p>(1) State is responsible for ensuring that all individual elements of the project are eligible. FHWA will check that the scope of the project as described in submitted project agreement is eligible for the category of funding sought. All final eligibility and participation determinations are retained by FHWA.</p> <p>(2) This action cannot be assumed by the State except through an assignment under 23 U.S.C. 326 or 327, or through a programmatic agreement pursuant to Section 1318(d) of MAP-21. If there is a 23 U.S.C. 326 or 327 assignment or PCE agreement, decisions are handled in accordance with those assignments or agreements. Illinois has a PCE, and IDOT categorizes CE-I determinations, which are generally items in 23 CFR 771.117 (c) with no unusual circumstances.</p> <p>(3) State’s process and modifications to, or variation in process, require FHWA approval.</p> <p>(4) Unusual/Complex bridges and structures are those that the Division determines to have unique foundation problems, new or complex designs, exceptionally long spans, exceptionally large foundations, complex hydrologic (including climate change and extreme weather events) aspects, complex hydraulic elements or scour related elements, or that are designed with procedures that depart from currently recognized acceptable practices (i.e., cable-stay, suspension, arch, segmental concrete, moveable, truss, tunnels, or complex geotechnical walls or ground improvement systems)</p> <p>(5) FHWA approval is required for revocable occupancy permits of non-conforming outdoor advertising signs.</p>		

**ATTACHMENT B
PROGRAM RESPONSIBILITY MATRIX**

PROGRAM ACTION RESPONSIBILITY

The following matrix is an example list of program actions. The Division should refer to <http://our.dot.gov/office/fhwa.hq/OfficeofInfrastructure/hipa/50/Resources/Lists/Program%20Responsibilities%20Matrix/> for the latest updated version which can be incorporated into the agreement or referenced as a control document. Modify the matrix to reflect the Division and State “Responsible Program Office.” The primary office of contact should be listed, rather than an individual or the approving official.

Activity	Authority ¹	Frequency	Due Date	FHWA HQ Program Office	FHWA Division Responsible Program Office	State DOT Responsible Program Office	Remarks
Appropriations, Allotments, Obligations	31 USC 1341(a)(1)(A)&(B); 31 USC 1517(a); 23 USC 118(b), 23 USC 121	As needed	Not Applicable	Office of Chief Financial Officer	Finance & Logistics	Finance & Administration	State will monitor appropriations, allotments and obligations to ensure that all funding is used efficiently within each quarter and use all Obligation Authority (OA) by the end of the year.
Approval of Indirect Cost Allocation Plans (ICAPs)	2 CFR 200 Subpart E; ASMBC-10	As needed	Not Applicable	Office of Chief Financial Officer	Finance & Logistics	Finance & Administration	The State will certify that the ICAP was prepared in accordance with 2 CFR 200 Subpart E.

¹ All actions taken on or after December 26, 2014, shall be governed by the Uniform Administrative Requirements, Cost Principles, and Audit Requirements for Federal Awards in 2 CFR Part 200. Part 200 of 2 CFR supersedes 49 CFR Parts 18 and 19, and requirements from OMB Circulars A-21, A-87, A-110, and A-122 (which have been placed in OMB guidances); Circulars A-89, A-102, and A-133; and the guidance in Circular A-50 on Single Audit Act follow-up.

Activity	Authority ¹	Frequency	Due Date	FHWA HQ Program Office	FHWA Division Responsible Program Office	State DOT Responsible Program Office	Remarks
FIRE Program Activities	FHWA Order 4560.1C (or as superseded)	Ongoing		Office of Chief Financial Officer	Finance & Logistics	Finance & Administration	State will continue to provide oversight and conduct reviews to ensure Federal-aid compliance. FHWA will review and monitor. State responsibilities include multiple tasks in support of risk assessments, conducting reviews and implementation of recommendations.
Audit Coordination/FHWA Financial Statement Audit/State External Audit Reviews/State Internal Audit Reviews	FMFIA, 2 C.F.R. Part 200, Subpart F.; GAAP, CFO Act of 1990; DOT Order 8000.1C	As needed	Not Applicable	Office of Chief Financial Officer	Finance & Logistics	Finance & Administration	State assures corrective action is taken to resolve audit findings and FHWA will monitor activities to ensure implementation.
Improper Payments Review	Improper Payments Information Act of 2002, PL 107-300, Improper Payments Elimination and Recovery Act of 2010, PL 111-204, Improper Payments Elimination and Recovery Improvement Act of 2012, PL 112-248	Annually		Office of Chief Financial Officer	Finance & Logistics	Finance & Administration	State will provide all information necessary to document sampled payments and FHWA offices will review and complete appropriate data submittal forms.
Transfer of Funds between programs or to other FHWA offices or agencies as requested by State	23 USC 126, 23 USC 132, and FHWA Order 4551.1	As needed	Not Applicable	Office of Chief Financial Officer	Finance & Logistics	Finance & Administration	State will submit requests for transfer and FHWA approves and processes the funding transfers between States, to other agencies, and to FHWA HQ, Federal Lands, or Research offices.

Activity	Authority ¹	Frequency	Due Date	FHWA HQ Program Office	FHWA Division Responsible Program Office	State DOT Responsible Program Office	Remarks
Reviews of State Transportation Departments Financial Management Systems - Financial Integrity	23 USC 106(g)(2)(A)	Annually	Not Applicable	Office of Chief Financial Officer	Finance & Logistics	Finance & Administration	23 USC 106(g)(2)(A) states that the Secretary shall perform annual reviews that address elements of the State transportation departments' financial management systems that affect projects approved under subsection (a).
Review Adequacy of Sub-recipient Project Delivery Systems and Sufficient Accounting Controls to Manage Federal Funds	23 USC 106(g)(4)(A)(i)	As needed	Not Applicable	Office of Chief Financial Officer	Finance & Logistics	Finance & Administration	
Periodic Reviews of States Monitoring of sub-recipients	23 USC 106(g)(4)(B)	As needed	Not Applicable	Office of Infrastructure	Field Engineering	Highways	
Approval of Increased Federal Share Agreement (Sliding Scale)	23 USC 120(b)(2)	As determined by the Federal Share Agreement	Not Applicable	Office of Chief Financial Officer	Finance & Logistics	Finance & Administration	A State must enter into an agreement with FHWA for use of the increased Federal share allowable under this section, which must be reviewed and updated periodically as agreed to in the agreement. States must demonstrate that they are in compliance with the statute and the agreement.
Prepare / Review Title VI Plan Accomplishments and Next Year's Goals	23 CFR 200.9(b)(10)	Annually	1-Oct	Office of Civil Rights	Assistant Division Administrator	Chief Counsel	Division office reviews and comments.
Prepare / EEO Contractor Compliance Plan accomplishments and next year's goals	23 CFR 230, Subpart C, Appendix A, Part I, III	Annually	1-Oct	Office of Civil Rights	Assistant Division Administrator	Business & Workforce Diversity	Division office reviews and comments.

Activity	Authority ¹	Frequency	Due Date	FHWA HQ Program Office	FHWA Division Responsible Program Office	State DOT Responsible Program Office	Remarks
Prepare / Review State Internal EEO Affirmative Action Plan (Title VII) Accomplishments and Goals	23 CFR 230.311	Annually	1-Oct	Office of Civil Rights	Assistant Division Administrator	Chief Counsel	Courtesy copy to HQ.
Review DBE Program Revisions	49 CFR 26.21(b)(2)	As needed	Not Applicable	Office of Civil Rights	Assistant Division Administrator	Business & Workforce Diversity	Division sends to HCR for review and approval as
Prepare / DBE Uniform Awards and Commitment Report	49 CFR 26, Appendix B	Semi-Annual	June 1st December 1st	Office of Civil Rights	Assistant Division Administrator	Business & Workforce Diversity	Division Office reviews and sends to HCR
Prepare / Annual Analysis and Corrective Action Plan (if necessary)	49 CFR 26.47(c)	Annual (as necessary)	December 31st	Office of Civil Rights	Assistant Division Administrator	Business & Workforce Diversity	Division Office approves and sends copy to HCR
Prepare / State DBE Program Goals	49 CFR 26.45(f)(1)	Triennial	August 1st	Office of Civil Rights	Assistant Division Administrator	Business & Workforce Diversity	Division reviews and approves; HCC provides legal sufficiency review and approval sends copy to HCR
Prepare / Review On-the-Job-Training (OJT) goals & accomplishments	23 CFR 230.111(b)	Annually	TBA	Office of Civil Rights	Assistant Division Administrator	Business & Workforce Diversity	Division office reviews and comments.
Approval of OJT and DBE Supportive Services fund requests	23 CFR 230.113 & 23 CFR 230.204	Annual	TBA	Office of Civil Rights	Assistant Division Administrator	Business & Workforce Diversity	Division recommends approval submits to HCR for final approval
Return of any unused discretionary grant program funding	23 CFR 230.117(2)	Annual	TBA	Office of Civil Rights	Assistant Division Administrator	Business & Workforce Diversity	Division works with HCR and CFO
Prepare / Review of Report on Supportive Services (OJT & DBE)	23 CFR 230.113(g), 230.121(e), 230.204(g)(6)	Quarterly		Office of Civil Rights	Assistant Division Administrator	Business & Workforce Diversity	Division office reviews and comments.
Prepare / Review Annual Contractor Employment Report (Construction Summary of Employment Data (Form PR-1392)	23 CFR 230.121(a); Appendix D to Subpart A, Part 230, General Information and Instructions	Annually	1-Dec	Office of Civil Rights	Assistant Division Administrator	Business & Workforce Diversity	Recommendation sent to HQ for approval.

Activity	Authority ¹	Frequency	Due Date	FHWA HQ Program Office	FHWA Division Responsible Program Office	State DOT Responsible Program Office	Remarks
Prepare / Review State DOT Employment Statistical Data (EEO-4)	23 CFR, Subpart C, Appendix A	Biannual	1-Dec	Office of Civil Rights	Assistant Division Administrator	Chief Counsel	Report sent to HQ quarterly for informational purposes and recommendation sent to HQ annually for approval.
Prepare / Review Annual Federal Projected Awards Reports - Historically Black Colleges & Universities/Tribal Colleges & Universities/Hispanic Serving Institutes, American Indian/Alaskan Native, Asian Pacific & American Islander.	Presidential Executive Orders: 13230, 13256, 13270, 13361, 13515	Annual	TBA	Office of Civil Rights	Assistant Division Administrator	Chief Counsel	Divisions submit data to HCR who prepares report for DOCR
Prepare / Review ADA Complaint Reports of Investigation	28 CFR 35.190	As needed	Not Applicable	Office of Civil Rights	Assistant Division Administrator	Chief Counsel	Division office reviews, FHWA HQ approves and issues finding.
Review Americans with Disabilities Act (ADA) /Sec. 504 Program Plan accomplishments and next year's goals	49 CFR 27.11(c), EO 12250	Annually	1-Oct	Office of Civil Rights	Assistant Division Administrator	Chief Counsel	Division office reviews and comments.
Return of unexpended funds used for Summer Transportation Institutes	23 CFR 230.117(2)	Annual	August 30; however, State procurement rules may govern	Office of Civil Rights	Assistant Division Administrator	Chief Counsel	Divisions work with HCR and CFO
Prepare / Review Request for National Summer Transportation Institute (NSTI) Proposals (SOWs)	23 USC 140(b)	Annual	TBA	Office of Civil Rights	Assistant Division Administrator	Chief Counsel	Divisions recommend approval. HCR gives final approval
Prepare / Review NSTI Report (questionnaire)	23 USC 140(b)	Annual	October 15th	Office of Civil Rights	Assistant Division Administrator	Chief Counsel	Divisions provide to HCR
Receipt of State Consultation Process with Tribal Governments	23 CFR 450.210(c)	As needed	Not Applicable	Office of Federal Lands Highway	Assistant Division Administrator Planning, Environment & ROW	Highways	Informational Purposes.

Activity	Authority ¹	Frequency	Due Date	FHWA HQ Program Office	FHWA Division Responsible Program Office	State DOT Responsible Program Office	Remarks
Approval of Contracting Procedures for Consultant Selection	23 CFR 172.5 & 172.9	As needed	Not Applicable	Office of Infrastructure	Field Engineering	Highways	FHWA Division Office Approval.
Determination of High Risk Categories - Limitation on Interstate Projects	23 USC 106(c)(4)(B)	As needed	Not Applicable	Office of Infrastructure	Division Administrator	Highways	Office of Program Administration determines national categories and must concur on any State designations.
Approval of State 3R Program	23 CFR 625.4(a)(3), 23 USC 109(n)	As needed	Not Applicable	Office of Infrastructure	Field Engineering	Highways	FHWA Division Office Approval.
Verify adoption of Design Standards (National Highway System, including Interstate)	23 CFR 625, 23 USC 109(b), 23 USC 109(c)(2), 23 USC 109(o)	As needed	Not Applicable	Office of Infrastructure	Field Engineering	Highways	FHWA HQ regulatory action to adopt NHS standards.
Approval of preliminary plans of Major and Unusual Bridges on the Interstate Highway System	(M1100.A)	As needed	Not Applicable	Office of Infrastructure	Assistant Division Administrator	Highways	Director of HIBT has approval of preliminary plans of Major and Unusual Bridges on the Interstate Highway System (M1100.A)
Approval of State Standard Specifications	23 CFR 625.3	As needed	Not Applicable	Office of Infrastructure	Field Engineering	Highways	FHWA Division Office Approval.
Verify State Design Exception Policy complies with FHWA Policy	23 CFR 625.3	As needed	Not Applicable	Office of Infrastructure	Field Engineering	Highways	FHWA Division Office Approval.
Approval of State Standard Detail Plans	23 CFR 625.3	As needed	Not Applicable	Office of Infrastructure	Field Engineering	Highways	FHWA Division Office Approval.
Approval of Pavement Design Policy	23 CFR 626.3	As needed	Not Applicable	Office of Infrastructure	Planning & Program Development	Highways	FHWA Division Office Approval.
Review of Value Engineering Policy and Procedures	23 CFR 627.1(b)&(c), 23 CFR 627.7, FHWA Order 1311.1B	As needed	Not Applicable	Office of Infrastructure	Field Engineering	Highways	FHWA Division Office Review.
Review of Value Engineering Annual Report	23 CFR 627.7, FHWA Order 1311.1B	Annual	Not Applicable	Office of Infrastructure	Field Engineering	Highways	FHWA Division Office collects, reviews, and submits to HQ for review and reporting.

Activity	Authority ¹	Frequency	Due Date	FHWA HQ Program Office	FHWA Division Responsible Program Office	State DOT Responsible Program Office	Remarks
Review and Approval of Interstate Access Requests	23 USC 111, 23 CFR 710, 74 FR 43743-43746 (Aug. 27, 2009)	As needed	Not Applicable	Office of Infrastructure	Field Engineering	Highways	FHWA Division Office approval with concurrence from HQ on more complex access requests.
Approval of Liquidated Damages Rate	23 CFR 635.127	Every 2 years	Not Applicable	Office of Infrastructure	Field Engineering	Highways	FHWA Division Office Approval.
Approval of Quality Assurance Program	23 CFR 637.205	As needed	Not Applicable	Office of Infrastructure	Planning & Program Development	Highways	State administrators, with programmatic agreement by the Division Office, as part of their materials testing and construction quality assurance/acceptance program.
Assure Central Laboratory accredited by AASHTO Accreditation Program or FHWA approved comparable program	23 CFR 637.209	As needed	Not Applicable	Office of Infrastructure	Planning & Program Development	Highways	State administrators, with programmatic agreement by the Division Office, as part of their materials testing and construction quality assurance/acceptance program.
Assure Non-STD designated lab performing Independent Assurance sampling and testing accredited by AASHTO Accreditation Program or FHWA approved comparable program	23 CFR 637.209	As needed	Not Applicable	Office of Infrastructure	Planning & Program Development	Highways	State administrators, with programmatic agreement by the Division Office, as part of their materials testing and construction quality assurance/acceptance program.
Assure Non-STD designated lab used in dispute resolution accredited by AASHTO Accreditation Program or FHWA approved comparable program	23 CFR 637.209	As needed	Not Applicable	Office of Infrastructure	Planning & Program Development	Highways	State administrators, with programmatic agreement by the Division Office, as part of their materials testing and construction quality assurance/acceptance program.

Activity	Authority ¹	Frequency	Due Date	FHWA HQ Program Office	FHWA Division Responsible Program Office	State DOT Responsible Program Office	Remarks
Review Independent Assurance Annual Report	23 CFR 637.207	Annually	1-Mar	Office of Infrastructure	Planning & Program Development	Highways	State administrators, with programmatic agreement by the Division Office, as part of their materials testing and construction quality assurance/acceptance program.
Assure Labor Compliance - Prevailing Wage Rate	23 USC 113	As needed	Not Applicable	Office of Infrastructure	Assistant Division Administrator	Highways	FHWA Division Office Review and Approval
Determination of Eligible Preventive Maintenance Activity - Cost-Effective Means of Extending Useful Life Determination	23 USC 116(e)	As needed	Not Applicable	Office of Infrastructure	Field Engineering	Highways	FHWA Division Office Approval
Approval of Utility Agreement / Alternate Procedure	23 CFR 645.119	As needed	Not Applicable	Office of Infrastructure	Field Engineering	Highways	FHWA Division Office Approval
Approval of Utility Accommodation Policy	23 CFR 645.215, 23 USC 109(l), 23 USC 123	As needed	Not Applicable	Office of Infrastructure	Field Engineering	Highways	FHWA Division Office Approval
Review Bridge Construction, Geotechnical, and Hydraulics	23 CFR 650	As needed	Not Applicable	Office of Infrastructure	Assistant Division Administrator	Highways	
Review Plans of Corrective Action established to address NBIS compliance issues	23 CFR 650, 23 USC 144	Annually		Office of Infrastructure	Assistant Division Administrator	Highways	Division office performs annual compliance review and reports results to HQ.
Review NBI Data Submittal	23 CFR 650 Subpart C, Annual Memo from HQ, 23 USC 144	Annually	1-Apr	Office of Infrastructure	Assistant Division Administrator	Highways	Division resolve errors with States; States submit to HQ.
Review structurally deficient bridge construction Unit Cost submittal	23 USC 144	Annually	1-Apr	Office of Infrastructure	Assistant Division Administrator	Highways	Submit to HQ.
Review Section 9 of the Rivers and Harbors Act Submittals (Bridge Permits)	23 CFR 650 Subpart H; 33 CFR 114 & 115	As needed	Not Applicable	Office of Infrastructure	Field Engineering	Highways	

Activity	Authority ¹	Frequency	Due Date	FHWA HQ Program Office	FHWA Division Responsible Program Office	State DOT Responsible Program Office	Remarks
Approval for reduction of expenditures for off-system bridges	23 USC 133(g)(2)(B)	As needed	Not Applicable	Office of Infrastructure	Assistant Division Administrator	Highways	The FHWA Administrator may reduce the requirement for expenditures for off-system bridges if the FHWA Administrator determines that the State has inadequate needs to justify the expenditure.
Determination on Adequacy of State's Asset Management Plan	23 USC 119(5)	Annually beginning second fiscal year after establishment of the process		Office of Infrastructure	Planning & Program Development	Planning & Programming	
Certification and Recertification of States Process for Development of State Asset Management Plan	23 USC 119(6)	Recertification every four years after establishment of the process		Office of Infrastructure	Planning & Program Development	Planning & Programming	
Review Reporting on Performance Targets	23 USC 150(e)	Beginning four years after enactment of MAP-21 and biennially thereafter		Office of Infrastructure	Planning & Program Development	Planning & Programming	
Review National Highway System Performance Achievement Plan for Actions to achieve the targets (when State does not achieve or make significant progress toward achieving)	23 USC 119(7)	Required if State does not achieve targets (or significant progress) for 2 consecutive reports		Office of Infrastructure	Planning & Program Development	Planning & Programming	
States and sub-recipient failure to maintain projects - Notice and withholding Federal-aid Funds	23 USC 116(d)	As needed	Not Applicable	Office of Infrastructure	Planning & Program Development	Planning & Programming	
Emergency Relief (ER) Damage Assessments and Reports	23 CFR 668 23 USC 120 and 125	As needed	Not Applicable	Office of Infrastructure	Field Engineering	Highways	Perform with State.

Activity	Authority ¹	Frequency	Due Date	FHWA HQ Program Office	FHWA Division Responsible Program Office	State DOT Responsible Program Office	Remarks
Toll Credit and Maintenance of Effort (MOE) Calculation and Agreement	23 USC 120(i)	Annually		Office of Infrastructure	Field Engineering	Planning & Programming	State will calculate the amount of eligible toll credit and submit for approval. FHWA will review and approve the request.
Local Public Agency (LPA) Oversight	2 CFR 200.331; 23 USC 106(g)(4)	As needed	Not Applicable	Office of Infrastructure	Field Engineering	Highways	States are responsible to ensure that LPAs are aware of all the applicable Federal-aid Program requirements; States are responsible to ensure monitoring and oversight to assure compliance with Federal requirements. 23 USC further reinforces stressing accountability on "project delivery systems" and "accounting controls."
Approval to Sell, Lease or Otherwise Dispose of a Ferry Purchased with Federal-aid Funds	23 USC 129 (c)(6)	As needed	Not Applicable	Office of Infrastructure	Planning, Environment & ROW	Highways	Division Office reviews and submits for Office of Program Administration for Administrator Approval
Territorial Highway Program - Approval of Territory Agreement	23 USC 165(c)(5)	Reviewed and Revised as needed every two years		Office of Infrastructure	N/A	N/A	Division Office works with Office of Program Administration and HCC
TIFIA Credit Program	23 USC 601-609	As needed	Not Applicable	Office of Innovative Program Delivery	Finance & Logistics	Innovative Project Delivery	Project sponsors submit requests for credit assistance to the TIFIA JPO for review; approval by the Secretary
GARVEEs	23 USC 122; GARVEE Guidance 3/14	As needed	Not Applicable	Office of Innovative Program Delivery	Finance & Logistics	Innovative Project Delivery	MOUs strongly suggested for each GARVEE issue. FM contacts OIPD for review/concurrence before final approval

Activity	Authority ¹	Frequency	Due Date	FHWA HQ Program Office	FHWA Division Responsible Program Office	State DOT Responsible Program Office	Remarks
State Infrastructure Banks	NHS Act Section 308; 23 USC 610; SIB Guidance 3/14	Annual Report	Not Applicable	Office of Innovative Program Delivery	Finance & Logistics	Innovative Project Delivery	Division sends copy of report to OIPD. SIB submits annual report to Division Office.
Section 129 Tolling Authority Requests	23 USC 129(a)	As needed	Not Applicable	Office of Innovative Program Delivery	Field Engineering	Innovative Project Delivery	At the option of the project sponsor, may execute a Tolling Eligibility MOU with the Division Office; HIN coordinates FHWA HQ review
Section 166 HOV/HOT Lanes Tolling Authority Requests	23 USC 166(d)	As needed	Not Applicable	Office of Innovative Program Delivery	Field Engineering	Innovative Project Delivery	At the option of the project sponsor, may execute a Tolling Eligibility MOU with the Division Office; HIN coordinates FHWA HQ review
Value Pricing Pilot Program Tolling Authority Requests	ISTEA Section 1012(b)	As needed	Not Applicable	Office of Innovative Program Delivery	Field Engineering	Innovative Project Delivery	Requests submitted to HIN to coordinate review; approval by the Administrator
Interstate System Reconstruction and Rehabilitation Pilot Program Tolling Authority Requests	TEA-21 Section 1216(b)	As needed	Not Applicable	Office of Innovative Program Delivery	Field Engineering	Innovative Project Delivery	Applications submitted to HIN to coordinate review; approval by the Administrator
Annual Audit of Toll Facility Records and Certification of Adequate Maintenance - Report Submittal	23 USC 129(a)(3)(B); TEA-21 Section 1216(b)(5)(B); SAFETEA-LU Section 1604(b)(3)(A); ISTEA Section 1012(b)(3)	Annually	Not Applicable	Office of Innovative Program Delivery	Field Engineering	Innovative Project Delivery	Division Office to receive the reports.
Project Management Plan (Major Projects)	23 U.S.C. 106(h)(2)	Prior to first federal authorization of construction funds for a Major Project	Not Applicable	Office of Innovative Program Delivery	Division Office will conduct concurrent review with HQ Office of Innovative Program Delivery.	State DOT or Project Sponsor will prepare and submit Project Management Plan.	Division Office will provide approval after receiving concurrence from HQ Office of Innovative Program Delivery.

Activity	Authority ¹	Frequency	Due Date	FHWA HQ Program Office	FHWA Division Responsible Program Office	State DOT Responsible Program Office	Remarks
Financial Plan (Major Projects)	23 U.S.C. 106(h)(3)	Prior to first federal authorization of construction funds for a Major Project and then annually.	Annually as noted in the approved Initial Financial Plan	Office of Innovative Program Delivery	Division Office will conduct concurrent review with HQ Office of Innovative Program Delivery.	State DOT or Project Sponsor will prepare and submit annual Financial Plans.	Division Office will provide approval after receiving concurrence from HQ Office of Innovative Program Delivery.
Financial Plan (Other Projects)	23 U.S.C. 106(i)	Prior to first federal authorization of construction funds for an Other Project and then annually.	Annually as noted in the approved Initial Financial Plan	Office of Innovative Program Delivery	Division Office will review and approve Financial Plans for Other Projects in accordance with its stewardship and oversight agreement with the State DOT or Project Sponsor.	State DOT or Project Sponsor will prepare and submit annual Financial Plans to the Division Office, only upon request.	Other Projects are defined as projects with an estimated total cost of \$100 million or more that have not been designated as Major Projects.
Review Designation and Re-designation of Primary Freight Network	23 USC 167(d)	One year after enactment of MAP-21 and every ten years thereafter		Office of Operations	Planning, Environment & ROW	Planning & Programming	Under development, initial PFN designation scheduled for Spring 2014 completion.
Review Development and Update of National Freight Strategic Plan	23 USC 167(f)	Three years after enactment of MAP-21 and every five years thereafter		Office of Operations	Planning, Environment & ROW	Planning & Programming	OST lead
Review Freight Transportation Conditions and Performance Report	23 USC 167(g)	Two years after enactment of MAP-21 and every two years thereafter		Office of Operations	Planning, Environment & ROW	Planning & Programming	OST lead
Review HOV Operations Report for Tolloed Use and Low-Emission and Energy-Efficient Vehicle Use	23 USC 166(d)	Annually		Office of Operations	Planning, Environment & ROW	Planning & Programming	
Congestion Partnerships Assessment	Annual Memo from HQ	Annually	1-Jul	Office of Operations	Planning, Environment & ROW	Planning & Programming	Complete with partners and forward to HQ.

Activity	Authority ¹	Frequency	Due Date	FHWA HQ Program Office	FHWA Division Responsible Program Office	State DOT Responsible Program Office	Remarks
Traffic Incident Management Self-Assessment	Annual Memo from HQ	Annually	1-Jul	Office of Operations	Mobility & Safety	Highways	Complete with partners and forward to HQ.
Work Zone Self-Assessment	Annual Memo from HQ	Annually	7/1/2013, This project is currently on hiatus and has not been determined whether it will be reestablished or not.	Office of Operations	Mobility & Safety	Highways	Complete with partners and forward to HQ.
Approval of State-Prepared Manual on Uniform Traffic Control Devices - State Traffic Control Manuals	23 CFR 655.603, 23 USC 109(d)	As needed	Not Applicable	Office of Operations	Mobility & Safety	Highways	
Review Vehicle Size & Weight Enforcement Plan	23 CFR 657.11, 23 USC 127	Annually	1-Oct	Office of Operations	Mobility & Safety	Highways	
Review Vehicle Size & Weight Enforcement Certification.	23 CFR 657.13, 23 USC 141	Annually	1-Jan	Office of Operations	Mobility & Safety	Highways	
Approval of National Network Modifications	23 CFR 658.11	As needed	Not Applicable	Office of Operations	Mobility & Safety	Highways	
Intelligent Transportation System Architecture & Standards	23 CFR Part 940	As needed	Not Applicable	Office of Operations	Mobility & Safety	Highways	
Approval of Work Zone Significant Project Determination	23 CFR 630.1010	As needed		Office of Operations	Mobility & Safety	Highways	
Approval of Exceptions to Work Zone Procedures for Interstate Projects	23 CFR 630.1010	As needed		Office of Operations	Mobility & Safety	Highways	
Approval of Work Zone Policy and Procedures Conformance Review	23 CFR 630.1014	At appropriate intervals		Office of Operations	Mobility & Safety	Highways	
Process Review of Work Zone Safety and Mobility Procedures	23 CFR 630.1008, 23 USC 109(e)(2), 23 USC 112(g)	Every 2 years		Office of Operations	Mobility & Safety	Highways	

Activity	Authority ¹	Frequency	Due Date	FHWA HQ Program Office	FHWA Division Responsible Program Office	State DOT Responsible Program Office	Remarks
Approval of State Planning Work Program and Revisions (Part 1)	23 CFR 420.111, 23 CFR 420.115, and 23 CFR 420.209	Annually	Prior to Program Period	Office of Planning, Environment & Realty	Planning, Environment & ROW	Planning & Programming	FHWA Division Office Approval.
Approval of State Research and Development Work Program (Part 2)	23 CFR 420.111, 23 CFR 420.115, and 23 CFR 420.209	Annually	Prior to Program Period	Office of Planning, Environment & Realty	Planning, Environment & ROW	Planning & Programming	FHWA Division Office Approval.
Approval of State's Distribution of Planning Funds Formula - Allocation Formulas for PL Funds	23 CFR 420.109, 23 USC 104(d)(2)(A)(i)	When Revised	Not Applicable	Office of Planning, Environment & Realty	Planning, Environment & ROW	Planning & Programming	FHWA Division Office Approval.
Review of State Public Involvement Procedures	23 CFR 450.210(a)	As needed	Not Applicable	Office of Planning, Environment & Realty	Planning, Environment & ROW	Planning & Programming	FHWA Division Office Review to Assure Compliance.
Receipt of State Consultation Process for Non-metropolitan Local Officials	23 CFR 450.210(b)	As needed	Not Applicable	Office of Planning, Environment & Realty	Planning, Environment & ROW	Planning & Programming	Informational Purposes.
Review of Long-range Statewide Transportation Plan	23 CFR 450.214	As needed	Not Applicable	Office of Planning, Environment & Realty	Planning, Environment & ROW	Planning & Programming	FHWA Division Office Review to Assure Compliance.
Approval of Statewide Transportation Improvement Program (STIP)	23 CFR 450.216, 23 CFR 450.218(a) & (c), 23 USC 135(g)(7)	At least every 4 years	Not Applicable	Office of Planning, Environment & Realty	Planning, Environment & ROW	Planning & Programming	Joint FHWA and FTA approval.
Approval of STIP Amendments	23 CFR 450.218(a) & (c)	As needed	Not Applicable	Office of Planning, Environment & Realty	Planning, Environment & ROW	Planning & Programming	Joint FHWA and FTA approval.
Finding of Consistency of Planning Process with Section 134 and 135	23 USC 135(g)(8), 23 CFR 450.218(b)	Concurrent with STIP approval	Not Applicable	Office of Planning, Environment & Realty	Planning, Environment & ROW	Planning & Programming	FHWA and FTA issue a joint finding concurrent with STIP approval.
Review of State Self-certification that Planning Process is in Accordance with Applicable Requirements	23 CFR 450.218(a)	Submitted with proposed STIP or STIP amendments	Not Applicable	Office of Planning, Environment & Realty	Planning, Environment & ROW	Planning & Programming	Received with STIP.
Approval of Transportation Management Area (TMA) MPO Unified Planning Work Programs (UPWP)	23 CFR 450.308(b) and 23 CFR 420 (Subpart A)	Prior to Program End	Not Applicable	Office of Planning, Environment & Realty	Planning, Environment & ROW	Planning & Programming	

Activity	Authority ¹	Frequency	Due Date	FHWA HQ Program Office	FHWA Division Responsible Program Office	State DOT Responsible Program Office	Remarks
Approval of Non-TMA UPWA	23 CFR 450.308(b) and 23 CFR 420 (Subpart A)	Prior to Program End	Not Applicable	Office of Planning, Environment & Realty	Planning, Environment & ROW	Planning & Programming	May use simplified work statement.
Approval of UPWP Revisions and Amendments (All MPO's)	23 CFR 420.115	As needed	Not Applicable	Office of Planning, Environment & Realty	Planning, Environment & ROW	Planning & Programming	
Review of UPWP Performance and Expenditure Reports (All MPO's)	23 CFR 420.117(b)	Not more frequently than quarterly	Not Applicable	Office of Planning, Environment & Realty	Planning, Environment & ROW	Planning & Programming	
Approval of Report Before Publication (All MPO's)	23 CFR 420.117(e)	As needed	Not Applicable	Office of Planning, Environment & Realty	Planning, Environment & ROW	Planning & Programming	Waiver may be granted.
Approval to use Planning Funds outside Urbanized Areas for States Receiving Minimum Apportionment	23 USC 104(d)(1)(A)(ii)	As needed	Not Applicable	Office of Planning, Environment & Realty	Planning, Environment & ROW	Planning & Programming	
Review of Metropolitan Planning Area Boundary (Establishment and Changes)	23 CFR 450.312	As needed	Not Applicable	Office of Planning, Environment & Realty	Planning, Environment & ROW	Planning & Programming	Approval by MPO and the Governor, shape files forwarded to HQ. (Comment: No action is required by FHWA/FTA).
Review of Metropolitan Transportation Planning Organizations (MPO) Designation and Re-designation	23 CFR 450.310	As needed	Not Applicable	Office of Planning, Environment & Realty	Planning, Environment & ROW	Planning & Programming	Require agreement between Governor and local governments.
Review of Metropolitan Planning Agreements (MPA) for Attainment or Entire Nonattainment Area	23 CFR 450.314(a)	When Completed	Not Applicable	Office of Planning, Environment & Realty	Planning, Environment & ROW	Planning & Programming	Between MPO/State DOT/Transit Operator. Included in UPWP or Prospectus (23 CFR 450.314(d)).
Review of MPA - for MPA that do not include the entire nonattainment or maintenance area	23 CFR 450.314(b), 23 USC 109(i)	When Completed	Not Applicable	Office of Planning, Environment & Realty	Planning, Environment & ROW	Planning & Programming	Between MPO/State DOT/State AQ Agency.
Review of MPO Public Participation Procedures	23 CFR 450.316(a)	As needed	Not Applicable	Office of Planning, Environment & Realty	Planning, Environment & ROW	Planning & Programming	Must be developed and published.

Activity	Authority ¹	Frequency	Due Date	FHWA HQ Program Office	FHWA Division Responsible Program Office	State DOT Responsible Program Office	Remarks
Review of Metropolitan Transportation Plan (MTP) in Attainment Areas (and Updates)	23 CFR 450.322	Every 4 years	Not Applicable	Office of Planning, Environment & Realty	Planning, Environment & ROW	Planning & Programming	
Review of MTP in Non-Attainment and Maintenance Areas (and Updates)	23 CFR 450.322	Every 5 years	Not Applicable	Office of Planning, Environment & Realty	Planning, Environment & ROW	Planning & Programming	
Review of MTP Amendments	23 CFR 450.322(c)	As Needed	Not Applicable	Office of Planning, Environment & Realty	Planning, Environment & ROW	Planning & Programming	
Air Quality Conformity Determination on LRTP in Non-attainment and Maintenance Areas	23 CFR 450.322(d)	Concurrent with LRTP updates at least every 4 years and as needed on amendments	Not Applicable	Office of Planning, Environment & Realty	Planning, Environment & ROW	Planning & Programming	After receipt of MPO determination; Joint FHWA and FTA determination; In consultation with the Environmental Protection Agency (EPA).
Review of Transportation Improvement Program (TIP)	23 CFR 450.300(a); 23 CFR 450.324(b); 23 CFR 450.328(a); 23 USC 134(i)(1)(D)	Prior to Program Period	Not Applicable	Office of Planning, Environment & Realty	Planning, Environment & ROW	Planning & Programming	No succinct Federal approval action is required for the TIP. FHWA/FTA approval of the TIP is through the STIP approval process.
Review of TIP Amendments	23 CFR 450.324(a); 23 CFR 450.328(b)	As needed	Not Applicable	Office of Planning, Environment & Realty	Planning, Environment & ROW	Planning & Programming	No succinct Federal approval action is required for the TIP. FHWA/FTA approval of the TIP is through the STIP approval process.
Approval of Air Quality Conformity Determination on TIP	23 CFR 450.326; 23 CFR 450.328	At least every 4 years, or when the TIP has been modified (unless exempt projects)	Not Applicable	Office of Planning, Environment & Realty	Planning, Environment & ROW	Planning & Programming	Applies to non-attainment and maintenance areas only. After receipt of MPO determination, joint determination with FTA (in cooperation with EPA).

Activity	Authority ¹	Frequency	Due Date	FHWA HQ Program Office	FHWA Division Responsible Program Office	State DOT Responsible Program Office	Remarks
Federal Finding of Consistency with Section 134 and 135	23 CFR 450.218(b); 23 CFR 450.334(a)	Concurrent with (S)TIP submittal	Not Applicable	Office of Planning, Environment & Realty	Planning, Environment & ROW	Planning & Programming	At least every four years, joint finding with FTA when TIP is submitted.
In Metropolitan Planning Areas, Review of State and MPO Self-certification that Planning Process is in Accordance with Applicable Requirements	23 CFR 450.334 (a), 23 CFR 218(a)	Annually or concurrent with the STIP/TIP cycle	Not Applicable	Office of Planning, Environment & Realty	Planning, Environment & ROW	Planning & Programming	Required for all MPO's. May be included in the STIP, TIP, or UPWP, at least every 4 years.
In TMA's, Certification that Planning Process is in Accordance with Applicable Requirements	23 CFR 450.334(b), 23 USC 134(k)(6)	Every 4 years		Office of Planning, Environment & Realty	Planning, Environment & ROW	Planning & Programming	Joint FHWA and FTA Certification.
Approval of Federal-Aid Urban Area Boundaries	23 CFR 470.105 (a), 23 USC 101(a)(33)	As needed	Not Applicable	Office of Planning, Environment & Realty	Planning, Environment & ROW	Planning & Programming	
Approval of Revision of Functional Classification	23 CFR 470.105 (b)	As needed	Not Applicable	Office of Planning, Environment & Realty	Planning, Environment & ROW	Planning & Programming	
Approval by Administrator of Interstate Additions & Revisions	23 USC 103(c)(1)(D), 23 CFR 470.111, 23CFR 470.115 (a)	As needed	Not Applicable	Office of Planning, Environment & Realty	Planning, Environment & ROW	Planning & Programming	Approval by HQ – Administrator.
Approval by Office Director of National Highway System (NHS) Additions and Revisions	23 USC 103(b)(3), 23 CFR 470.113 and 470.115(a)	As needed	Not Applicable	Office of Planning, Environment & Realty	Planning, Environment & ROW	Planning & Programming	Approved by HQ - Office Director.
Review of CMAQ Annual Report	CMAQ Guidance Memo October 31, 2006	Annually	1-Mar	Office of Planning, Environment & Realty	Planning, Environment & ROW	Planning & Programming	Division provides information on CMAQ projects including: amount of obligation, project description and location, and air quality benefits. The report must be submitted via the web-based CMAQ Tracking System.

Activity	Authority ¹	Frequency	Due Date	FHWA HQ Program Office	FHWA Division Responsible Program Office	State DOT Responsible Program Office	Remarks
Transportation Planning Excellence Awards		Annually	1-Feb	Office of Planning, Environment & Realty	Planning, Environment & ROW	Planning & Programming	Call for entries for the FHWA FTA Transportation Planning and Excellence Awards.
Approval of Local Technical Assistance Program (LTAP) Centers Work Plan and Budget	FHWA LTAP Field Manual	Annually	31-Mar	Office of Planning, Environment & Realty	Field Engineering	Highways	FHWA HQ approval.
Approval of Public Involvement Program Procedures	23 CFR 771.111(h), 23 USC 128	As needed	Not Applicable	Office of Planning, Environment & Realty	Planning, Environment & ROW	Highways	
Approval of NEPA Procedures, including Section 4(f)	23 CFR 771; 23 CFR 774; SAFETEA-LU 6007 & 6009, 23 USC 109(h)	As needed	Not Applicable	Office of Planning, Environment & Realty	Planning, Environment & ROW	Highways	
Approval of Noise Policies	23 CFR 772.7, 772.9, and 772.13; 23 USC 109(i)	As needed	Not Applicable	Office of Planning, Environment & Realty	Planning, Environment & ROW	Highways	FHWA approves State' noise abatement policy.
EIS Status Updates	FHWA Strategic Goal - EIS Timeliness	Quarterly	(Fiscal Year - Oct, Jan, Apr, Jul)	Office of Planning, Environment & Realty	Planning, Environment & ROW	Highways	Monitor time required to complete EIS's. Determine projects which have exceeded recommended timeline (3 years). Identify projects which should be listed as dormant. Submit to HEPE.
Endangered Species Act Cost Report		Annually	1-Mar	Office of Planning, Environment & Realty	Planning, Environment & ROW	Highways	
Exemplary Ecosystem Initiatives Applications		Annually	1-Apr	Office of Planning, Environment & Realty	Planning, Environment & ROW	Highways	
Approval of Acquisitions, Appraisals, and Relocations Program and Procedures	49 CFR Part 24, The UA	As needed	Not Applicable	Office of Planning, Environment & Realty	Planning, Environment & ROW	Highways	
Early Acquisitions	23 CFR 710.501	As needed	Not Applicable	Office of Planning, Environment & Realty	Planning, Environment & ROW	Highways	
Local Public Agency Oversight	49 CFR 24.4(b); 23 CFR 710.201	As needed	Not Applicable	Office of Planning, Environment & Realty	Planning, Environment & ROW	Highways	

Activity	Authority ¹	Frequency	Due Date	FHWA HQ Program Office	FHWA Division Responsible Program Office	State DOT Responsible Program Office	Remarks
Approval of Highway Facility Relinquishment	23 CFR 620.203	As needed	Not Applicable	Office of Planning, Environment & Realty	Planning, Environment & ROW	Highways	
Approval of ROW Disposal Authorization Request	23 CFR 710.409	As needed	Not Applicable	Office of Planning, Environment & Realty	Planning, Environment & ROW	Highways	
Approval of ROW Operations Manual (Organization, Policies and Procedures), Updates, and Certification	23 CFR 710.201	January 1, 2001 and every 3 years thereafter or as required by changes in State law or Federal regulation or law	Not Applicable	Office of Planning, Environment & Realty	Planning, Environment & ROW	Highways	
Approval of Exception to Charging Fair Market Value	23 CFR 710.403 and 23 CFR 710.409	As needed	Not Applicable	Office of Planning, Environment & Realty	Planning, Environment & ROW	Highways	
Approval of Interstate Real Property Use Agreements	23 CFR 710.405	As needed	Not Applicable	Office of Planning, Environment & Realty	Planning, Environment & ROW	Highways	
Approval of Request for Federal Land Transfer	23 CFR 710.601	As needed	Not Applicable	Office of Planning, Environment & Realty	Planning, Environment & ROW	Highways	
Approval of Request for Direct Federal Acquisition	23 CFR 710.603	As needed	Not Applicable	Office of Planning, Environment & Realty	Planning, Environment & ROW	Highways	
Approval of Outdoor Advertising Policies and Procedures, and Regulation and Procedure Approval	23 CFR 750.304, 23 CFR 750.705, 23 USC 131	As needed	Not Applicable	Office of Planning, Environment & Realty	Planning, Environment & ROW	Highways	
Approval of Requests to Exempt Certain Nonconforming Signs, Displays, and Devices	23 CFR 750.503	As needed	Not Applicable	Office of Planning, Environment & Realty	Planning, Environment & ROW	Highways	

Activity	Authority ¹	Frequency	Due Date	FHWA HQ Program Office	FHWA Division Responsible Program Office	State DOT Responsible Program Office	Remarks
Approval of Railroad Agreement Alternate Procedure	23 CFR 646.220	As needed	Not Applicable	Office of Planning, Environment & Realty	Field Engineering	Highways	
Approval of Uniform Act Waivers and Waivers from Availability of Comparable Replacement Dwelling before Displacement	49 CFR 24.7, 49 CFR 24.204(b)	As needed	Not Applicable	Office of Planning, Environment & Realty	Planning, Environment & ROW	Highways	Requests reviewed and approved by HEPR Office Director.
Review of Uniform Relocation Assistance & Real Property Acquisition Report - (OMB Form 2125-0030)	49 CFR 24.9c & Appendix B 49 CFR 24.603	Annually	15-Nov	Office of Planning, Environment & Realty	Planning, Environment & ROW	Highways	Submitted to FHWA Headquarters (HQ).
Review of Real Property Acquisition Statistical Report	FHWA Order 6540.1	Annually	15-Nov	Office of Planning, Environment & Realty	Planning, Environment & ROW	Highways	
Approval of Management Process and Project Selection Procedures and Certification for Research, Development & Technology Transfer Program and Revisions to Process	23 CFR 420.115 and 23 CFR 420.209	As needed	Not Applicable	Office of Planning, Environment & Realty	Planning & Program Development	Highways	FHWA Division Office Approval.
Periodic Review of States Management Process of the Research, Development & Technology Transfer Program	23 CFR 420.209	Periodic	Not Applicable	Office of Planning, Environment & Realty	Planning & Program Development	Highways	FHWA Division Office Periodic Review.
Approval of Performance and Expenditure Reports for SPR Research Work Programs	23 CFR 420.117	No less frequently than annual and no more frequently than quarterly	90 Days After End Of Period	Office of Planning, Environment & Realty	Planning, Environment & ROW	Planning & Programming	FHWA Division Office Approval.
Approval of SPR research reports	23 CFR 420.117	Prior to publication unless prior approval is waived	Not Applicable	Office of Planning, Environment & Realty	Planning, Environment & ROW	Planning & Programming	FHWA Division Office Approval unless waived.

Activity	Authority ¹	Frequency	Due Date	FHWA HQ Program Office	FHWA Division Responsible Program Office	State DOT Responsible Program Office	Remarks
Annual Traffic Reports	Traffic Monitoring Analysis System and Traffic Monitoring Guide reporting	When Published	As needed	Office of Highway Policy information	Planning, Environment & ROW	Planning & Programming	When Published
Approval of Annual Field Review Report	HPMS Field Review Guidelines (June 2001) Continuous Process Improvement Model for HPMS(February 2003)	Annually	1-Nov	Office of Highway Policy information	Planning, Environment & ROW	Planning & Programming	Review memo to HQ.
Approval of Certified Public Road Mileage	23 CFR 460.3(b)	Annually	1-Jun	Office of Highway Policy information	Planning, Environment & ROW	Planning & Programming	Each year, the Governor of each State and territory or a designee must certify Public Road Mileage. FHWA division reviews the Mileage and sends to HQ with division review/concurrence. This is reported to NHTSA for Apportionment of Safety Funds.
Approval of Data Submittal	23 CFR 420.105(b), HPMS Field Manual	Annually	15-Jun	Office of Highway Policy information	Planning, Environment & ROW	Planning & Programming	State DOT sends directly to Division Office and HQ.
Highway Statistics Reports	Guide to Reporting Highway Statistics	Due 60 days after end of each reporting month		Office of Highway Policy information	Planning, Environment & ROW	Planning & Programming	State DOT of Division Office sends directly to HQ.
Motor Fuels Report	A Guide to Reporting Highway Statistics, Chapter 2	1-Apr	1-Apr	Office of Highway Policy information	Planning, Environment & ROW	Planning & Programming	
Vehicles and Drivers (561, 562, 566, and 571)	A Guide to Reporting Highway Statistics, Chapters 3, 4, 5, and 6	1-Apr	1-Apr	Office of Highway Policy information	Planning, Environment & ROW	Planning & Programming	
Finance (531, 532, 541, 542, and 543 (optional))	A Guide to Reporting Highway Statistics, Chapters 8 and 9	1-Apr	1-Apr	Office of Highway Policy information	Planning, Environment & ROW	Planning & Programming	
Transportation Bond Referendums	A Guide to Reporting Highway Statistics, Chapter 9	When Published	When Published	Office of Highway Policy information	Planning, Environment & ROW	Planning & Programming	

Activity	Authority ¹	Frequency	Due Date	FHWA HQ Program Office	FHWA Division Responsible Program Office	State DOT Responsible Program Office	Remarks
State DOT / Toll Authority Audits and Published Annual Reports and Form 539 (optional)	A Guide to Reporting Highway Statistics, Chapter 10	When Published	When Published	Office of Highway Policy information	Planning, Environment & ROW	Planning & Programming	Annually, Due as soon as available.
Finance (536)	A Guide to Reporting Highway Statistics, Chapter 11	30-Sep	30-Sep	Office of Highway Policy information	Finance & Logistics	Finance & Administration	Biennially for odd-numbered years. Due nine months after end of reporting year.
Finance (534)	A Guide to Reporting Highway Statistics, Chapter 12	15-Jun	15-Jun	Office of Highway Policy information	Finance & Logistics	Finance & Administration	Annually for State, Biennially for local
Highway Finance and Tax Legislation	A Guide to Reporting Highway Statistics, Chapter 13	When Published	When Published	Office of Highway Policy information	Finance & Logistics	Finance & Administration	
State DOT Budgets and Published Annual Reports	A Guide to Reporting Highway Statistics, Chapter 13	When Published	When Published	Office of Highway Policy information	Finance & Logistics	Finance & Administration	
Motor Fuel Oversight Review	July 24, 2001 HQ Memo	Initial baseline reports no later than December 31, 2003		Office of Highway Policy information	Planning, Environment & ROW	Finance & Administration	Annual progress reports and statement of verification by June 30. Submitted via UPACS.
Review of Biennial - Toll Facilities in the United States	23 CFR 450.105(b) HPMS Field Manual	Biennially - Odd Years	June 15 (Odd Years)	Office of Highway Policy information	Planning, Environment & ROW	Planning & Programming	Division Office sends to HQ.
State Highway Maps (Tourist)		When Published	When Published	Office of Highway Policy information	Planning, Environment & ROW	Planning & Programming	Two copies to each Division Office and 100 copies to HQ.
Traffic Flow Maps		When Published		Office of Highway Policy information	Planning, Environment & ROW	Planning & Programming	When Published.
Vehicle Classification Data	MAP-21, HPMS Field Manual, Traffic Monitoring Guide	15-Jun	15-Jun	Office of Highway Policy information	Planning, Environment & ROW	Planning & Programming	Part of Annual HPMS submittal.

Activity	Authority ¹	Frequency	Due Date	FHWA HQ Program Office	FHWA Division Responsible Program Office	State DOT Responsible Program Office	Remarks
Highway Use Tax Evasion Grant Awards	23 USC 143	Annual	Not Applicable	Office of Highway Policy information	Finance & Logistics	N/A	FHWA along with the Internal Revenue Service will review applications and select awardees for projects designed to reduce or eliminate fuel tax evasion. FHWA will also review annual progress reports on projects.
Heavy Vehicle Use Tax (HVUT) – Certification of verifying proof-of-payment of HVUT	23 CFR 669.7	1-Jul	1-Jul	Office of Highway Policy information	Planning, Environment & ROW	N/A	Each year, the Governor of each State, or a designee must certify that the State is verifying that the HVUT has been paid before they issue or renew registrations on vehicles over 55,000 lbs. The HVUT program is administered by the Internal Revenue Service.
Heavy Vehicle Use Tax (HVUT) – Certification of verifying proof-of-payment of HVUT	23 CFR 669	Annual	1-Jan	Office of Highway Policy information	Planning, Environment & ROW	N/A	Each year, the Governor of each State, or a designee must certify that the State is verifying that the HVUT has been paid before they issue or renew registrations on vehicles over 55,000 lbs. The HVUT program is administered by the Internal Revenue Service.

Activity	Authority ¹	Frequency	Due Date	FHWA HQ Program Office	FHWA Division Responsible Program Office	State DOT Responsible Program Office	Remarks
Heavy Vehicle Use Tax (HVUT) – Triennial review of State program	23 CFR 669.21	Triennial	Not Applicable	Office of Highway Policy Information	Planning, Environment & ROW	N/A	Every 3 years, the local Division Office will perform a review of the State process for verifying that the HVUT has been paid before a registration can be issued or renewed for vehicles over 55,000 lbs. The HVUT program is administered by the Internal Revenue Service.
Permanent ATR Data	Heavy Vehicle Travel Information System Field Manual	Monthly	Monthly	Office of Highway Policy Information	Planning, Environment & ROW	Planning & Programming	Submit monthly, within 20 days after the close of the month for which the data were collected.
Continuous Automatic Vehicle Classifier Data	Heavy Vehicle Travel Information System Field Manual	Monthly	Monthly	Office of Highway Policy Information	Planning, Environment & ROW	Planning & Programming	Send up to one week of data per quarter
Weight and Vehicle Classification Data Collected at Weigh-in-motion sites	Heavy Vehicle Travel Information System Field Manual	15-Jun	As needed	Office of Highway Policy Information	Planning, Environment & ROW	Highways	WIM data collected at non-continuous sites during a year should be submitted by June 15 of the following year. If continuous WIM data are available, then up to one week of data per quarter.
Approval of MAP-21 compliant SHSP update within the legislatively required timeframe.	23 U.S.C. 148 (d)(2)(B)	Non Recurring	By Aug. 1 of the fiscal year after the HSIP final rule is established	Office of Safety	Mobility & Safety	Highways	FHWA Division Offices provide copy of SHSP process approval letter to HQ.
Highway Safety Improvement Program (HSIP) and Railway-Highway Crossing Program (RHCP) Reports	23 USC 148(h), 23 CFR 924.15	Annually	31-Aug	Office of Safety	Mobility & Safety	Highways	As per MAP-21 guidance, reports are due to FHWA Division Office by August 31st and to the Office of Safety by September 30.

Activity	Authority ¹	Frequency	Due Date	FHWA HQ Program Office	FHWA Division Responsible Program Office	State DOT Responsible Program Office	Remarks
Transportation Performance Management (TPM) for Safety	23 USC 150, 23 USC 134, 23 USC 135, 23 USC 148(i)	Annually	31-Aug	Office of Safety	Mobility & Safety	Transportation Safety	Per MAP-21, States and MPOs must set targets for established measures. Targets must be assessed for achievement
Review Drug Offender Driver's License Suspension Law & Enforcement Certification (Section 159)	23 USC 159 23, CFR 192.5	Annually	1-Jan	Office of Safety	Mobility & Safety	Transportation Safety	Certifications due to the Division Office by January 1.
Section 154/164 Compliance Status - Funds Reservation	23 USC 154 and 23 USC 164	Annually	30-Oct	Office of Safety	Mobility & Safety	Transportation Safety	States must submit a Shift letter to the Division Office by Oct. 30 indicating how to apply the penalty. New penalty states have additional time. The Office of Safety processes the compilation of information in a memo to the CFO.
Review Safety Belt Compliance Status	23 USC 153, 23 CFR 1215.6	Annually	Annually	Office of Safety	Mobility & Safety	Transportation Safety	NHTSA
High Risk Rural Roads (HRRR) Special Rule	23 USC 148(g)(1)	Annually	Annually	Office of Safety	Mobility & Safety	Highways	After the final FARS and HPMS data are available, FHWA HQ will inform the States if the HRRR Special Rule applies for the following FY.

Activity	Authority ¹	Frequency	Due Date	FHWA HQ Program Office	FHWA Division Responsible Program Office	State DOT Responsible Program Office	Remarks
Older Drivers and Pedestrians Special Rule	23 USC 148 (g)(2)	Annually	31-Aug	Office of Safety	Mobility & Safety	Highways	States should include in their annual HSP reports (due August 31st) the calculations performed, verifying whether the Older Driver Special Rule applies in the State. If the Special Rule applies to a State in a given year, the State must include in its subsequent SHSP strategies to address the increases in the fatality and serious injury rates for drivers and pedestrians over the age of 65.
FHWA Emergency Preparedness Program	Executive Order 12656 and FHWA Order 1910.2C	As needed	Not Applicable	Office of Operations	Field Engineering	Highways	National Programs.

**ATTACHMENT C
MANUALS AND OPERATING AGREEMENTS**

IDOT Manuals

Bureau of Design and Environment Manual
Land Acquisition Policies and Procedures Manual
Construction Manual
Manual for Materials Inspection – Project Procedures Guide
Standard Specifications for Road and Bridge Construction
Bureau of Operations Traffic Policies and Procedures Manual
Illinois Manual on Uniform Traffic Control Devices
Highway Standards
Bridge Manual
Bureau of Local Roads & Streets Manual
Water Quality Manual
Disadvantaged Business Enterprise (DBE) Plan
Title VI Plan
Affirmative Action Plan
Civil Rights Procedures Manual
Procedural Memoranda

Access Policy
Bid Evaluation Procedures
Consultant Selection Process
Contract Administration Manual
Contract Compliance Plan
Environmental Process Manual
Financial Services Manual
Highway Safety Improvement Plan
Indirect Cost Allocation Plan (Cost Pool Composition/Eligibility)
Statewide Transportation Improvement Plan
Supplemental and Standard Specifications
Transportation Improvement Plan
Utility Manual
Work Programs

- Local Technical Assistance Program (LTAP)
- Statewide Planning and Research
- Transportation Management Area/Metropolitan Planning Organization (TMA/MPO)

Operating (Programmatic) Agreements

NEPA/404

Endangered Species Act Section 7

Endangered Species Act Informal Consultation

Risk-Based Project Level Oversight

Categorical Exclusions

EIS/EA Timeframes

ATTACHMENT D
SELECTION AND MONITORING OF PROJECTS OF DIVISION INTEREST (PODI'S)
IDOT/FHWA STEWARDSHIP AND OVERSIGHT AGREEMENT

Projects of Division Interest (PoDI's)² are IDOT projects on which there will be any sort of direct FHWA involvement beyond actions shown in Attachment A, "Project Action Responsibility Matrix". Projects of Corporate Interest (PoCI's) are a subset of PoDI's. PoCI's are IDOT projects on which there will be direct FHWA involvement but also have national significance and the increased potential for additional FHWA resources beyond the Illinois Division.

Projects designated as a PoDI / PoCI will typically be on the National Highway System (NHS). Due to special requirements needed to address federal requirements, projects funded through the TIGER program and projects classified as Major Projects will be designated as PoDI's regardless of the NHS status. Otherwise, projects off the NHS will only be considered for PoDI designation by IDOT request and FHWA concurrence although FHWA may prompt IDOT to make the request for a project with complex challenges or unusual circumstances.

Attachment A, "Project Action Responsibility Matrix", identifies the FHWA's level of direct involvement on the routine Federal Highway Program delivery. However, when a project is designated as a PoDI/ PoCI, various project actions normally marked State, will be assumed by FHWA due to the projects significance or risk identified, and stipulated in the project PoDI plan. The form of FHWA's approvals can be documented either through an FHWA letter, signature on an IDOT document, captured in meeting minutes sent to FHWA, or informal email from a FHWA representative.

The coordination process of PoDI's / PoCI's between the IDOT and the FHWA will be governed as follows:

- Annually, the IDOT will publish its Multi-Year Program on the IDOT website. The MYP is typically available in April of each year.
- The FHWA will then select PoDI's / PoCI's from the MYP and also identify the specific area(s) of federal involvement for each project. The PoDI / PoCI list will be finalized in June of each year.
- PoDI / PoCI milestones, such as designation and completion will be memorialized via formal correspondence between FHWA and IDOT. The PoDI plan will be the guide for when FHWA involvement is limited to a project phase and not the entirety of the authorized work.
- PoDI / PoCI status and tracking will be done electronically (i.e. website or SharePoint site) and FHWA will provide the tracking information to IDOT on an agreed upon frequency.

² *The following are considered PoDI projects: Major Projects (>\$500M); Appalachian Development Highway Projects; TIGER Discretionary Grant Projects; NHS Projects with Retained FHWA Project Approval; Non-NHS Projects with Retained FHWA Project Approval; and Projects Selected by FHWA for Risk-based Stewardship & Oversight. Regardless of retained project approval actions, any Federal-aid Highway Project either on or off the NHS that the Division identifies as having an elevated level of risk can be selected for risk-based stewardship and oversight and would then be identified as a PoDI. Please see "Projects of Division Interest (PoDI)/Projects of Corporate Interest (PoCI) Guidance (available at <http://www.fhwa.dot.gov/federalaid/stewardship/>)*

**PROGRAMMATIC AGREEMENT
BETWEEN THE FEDERAL HIGHWAY ADMINISTRATION
AND THE ILLINOIS DEPARTMENT OF TRANSPORTATION
REGARDING THE PROCESSING OF ACTIONS CLASSIFIED AS
CATEGORICAL EXCLUSIONS FOR FEDERAL-AID HIGHWAY PROJECTS**

THIS PROGRAMMATIC AGREEMENT (“Agreement”), made and entered into this 14th day of October 2020, by and between the FEDERAL HIGHWAY ADMINISTRATION, UNITED STATES DEPARTMENT OF TRANSPORTATION (“FHWA”) and the STATE OF ILLINOIS acting by and through its DEPARTMENT OF TRANSPORTATION (“IDOT”) hereby provides as follows:

WITNESSETH:

Whereas, the National Environmental Policy Act of 1969 (NEPA), 42 U.S.C. §§ 4321-4370h (2014), and the Regulations for Implementing the Procedural Provisions of NEPA (40 CFR parts 1500-1508) direct Federal agencies to consider the environmental impacts of their proposed major Federal actions through the preparation of an environmental assessment (EA) or environmental impact statement (EIS) unless a particular action is categorically excluded;

Whereas, the FHWA distribution and spending of Federal funds under the Federal-aid Highway Program and approval of actions pursuant to Title 23 of the U.S. Code are major Federal actions subject to NEPA;

Whereas, the Secretary of Transportation has delegated to FHWA the authority to carry out functions of the Secretary under NEPA as they relate to matters within FHWA’s primary responsibilities (49 CFR 1.81(a)(5));

Whereas, the FHWA’s NEPA implementing procedures (23 CFR part 771) list a number of categorical exclusions (CE) for certain actions that FHWA has determined do not individually or cumulatively have a significant effect on the human environment and therefore do not require the preparation of an EA or EIS;

Whereas, IDOT is a State agency that undertakes transportation projects using Federal funding received under the Federal-aid Highway Program and must assist FHWA in fulfilling its obligations under NEPA for IDOT projects (23 CFR 771.109);

Whereas, this Agreement applies to all action as defined in 23 CFR 771.107(b), which includes local government projects, in the State of Illinois;

Whereas, Section 1318(d) of the Moving Ahead for Progress in the 21st Century Act (MAP-21), Pub. L. 112-141, 126 Stat. 405 (July 6, 2012), amended by Section 1315(a) of Fixing America’s Surface Transportation Act (FAST Act), allows FHWA to enter into programmatic agreements with the States that establish efficient administrative procedures for carrying out environmental and other required project reviews, including agreements that allow a State to determine whether a project qualifies for a CE on behalf of FHWA;

Whereas, the FHWA developed regulations implementing the authorities in section 1318(d), effective November 6, 2014;

Whereas, per 23 CFR 771.113(a), the FHWA must not authorize final design activities, property acquisition, or construction activities until a CE approval has been made;

Whereas, this Agreement supersedes all previous CE processing agreements held between FHWA and IDOT;

Whereas, FHWA has issued a Wetland Finding for Federal Aid Projects processed as Categorical Exclusions and is attached to this Agreement as Attachment I; and

Now, therefore, the FHWA and IDOT enter into this Programmatic Agreement (“Agreement”) for the processing of CEs.

I. PARTIES

The Parties to this Agreement are FHWA and IDOT.

II. PURPOSE

A. The purpose of this Agreement is to authorize IDOT to determine on behalf of FHWA whether a project qualifies for a CE specifically listed in 23 CFR 771.117 (listed in Appendix A and B of this Agreement) subject to the conditions specified in Section V of this Agreement.

B. This Agreement also requires IDOT to present information to FHWA for CE actions that 1) do not meet the conditions specified in this Agreement for IDOT to approve and 2) are not specifically listed in 23 CFR 771.117, but meet the CE criteria in 40 CFR 1508.4 and 23 CFR 771.117(a). For these actions, IDOT must request FHWA’s approval of the action as a CE.

III. AUTHORITIES

This agreement is entered into pursuant to the following authorities:

- A. National Environmental Policy Act, 42 U.S.C. 4321 - 4370
- B. Moving Ahead for Progress in the 21st Century Act, P.L. 112-141, 126 Stat. 405, Sec. 1318(d)
- C. Fixing America’s Surface Transportation Act, P.L. 114-94, 129 Stat. 1312, Sec. 1315(a)
- D. 40 CFR parts 1500 - 1508
- E. DOT Order 5610.1C
- F. 23 CFR 771.117

IV. RESPONSIBILITIES

A. IDOT is responsible for:

1. Ensuring the following process is completed for each project that qualifies for a CE:
 - a. IDOT may make a CE approval on behalf of FHWA (“State Approved CE”) for actions qualifying for a CE listed in Appendix A (CEs established in 23 CFR 771.117(c)) and Appendix B (CEs established in 23 CFR 771.117(d)), that do not exceed the thresholds in Section V of this Agreement (“Potential for Unusual Circumstances and Exclusions to State Approved CEs”). IDOT will identify the applicable listed CE, ensure any conditions or constraints are met, verify that there is no potential for unusual circumstances, address any and all other environmental requirements, and complete the review with an appropriate signature evidencing approval, per Section VII of this Agreement (“NEPA Approvals and Re-evaluations”). No separate review or approval of State Approved CEs by FHWA is required. Additionally, IDOT may request FHWA approval on an action that

does not exceed the thresholds in Section V. For any of these actions, IDOT must compile and present to FHWA information that the action qualifies for a CE classification.

b. IDOT may not approve actions listed in Appendices A and B that exceed the thresholds in Section V. IDOT may not approve any actions that meet the definition of a CE and that may be classified as a CE according to the open-ended authority in 771.117(d). These actions require FHWA review, and if in agreement with the CE classification, FHWA approval of the CE ("Federal Approved CE") based on the information IDOT provides on the action.

c. IDOT shall submit, at a minimum, the following information to FHWA for review and CE approval prior to the time FHWA considers its next approval action for the project:

i. If requested by FHWA, IDOT shall provide a copy of the CE documentation prepared for the actions(s) in accordance with Section VI of this Agreement.

ii. If any project requires a Section 4(f) de minimis determination or programmatic evaluation, IDOT shall submit the 4(f) documentation for FHWA determination and approval.

iii. If FHWA determines that the information IDOT has provided is inadequate, they may request additional studies and documentation, and/or consultation with other agencies.

2. Consulting with FHWA for actions that involve potential for unusual circumstances (23 CFR §771.117(b)), to determine the appropriate class of action for environmental analysis and documentation. IDOT may decide, or FHWA may require that additional studies need to be performed prior to making a CE approval or deciding on the need to prepare an EA or EIS.

3. Meeting applicable documentation requirements in Section VI for State Approved CEs and Federal Approved CEs, providing information on CE projects to FHWA, applicable approval and re-evaluation requirements in Section VII, and applicable quality control/quality assurance, monitoring, and performance requirements in Section VIII.

4. Relying only upon employees directly employed by IDOT to make CE approvals, or requesting CE approvals from FHWA, under this agreement. IDOT may not delegate its responsibility for CE approvals, or requests for FHWA approval, to third parties (i.e., consultants, local government staff, and other State agency staff).

5. Maintaining adequate organizational and staff capability and expertise to effectively carry out the provisions of this Agreement. This includes, without limitation:

a. Using appropriate technical and managerial expertise to perform the functions set forth under this Agreement.

b. Devoting adequate financial and staff resources to carry out the approvals and processing of projects under this Agreement.

c. All individuals participating in the determination and approval of projects under this Agreement will be familiar with and follow the appropriate subsections of 23 CFR 771, the NEPA process, IDOT policy manuals, memoranda, and any other policies relevant to the documentation of CE determinations.

6. Whenever there is a conflict between FHWA regulations and this Agreement or IDOT's policies and procedures manual, FHWA regulations shall be followed.

B. The FHWA is responsible for:

1. Providing timely advice and technical assistance on CEs to IDOT, as requested.
2. Providing timely input and review of CE actions requiring FHWA approval. FHWA will base its approval of CE actions on the project documentation prepared by IDOT under this Agreement.
3. Overseeing the implementation of this Agreement in accordance with the provisions in Section VIII, including applicable monitoring and performance provisions.

V. POTENTIAL FOR UNUSUAL CIRCUMSTANCES AND EXCLUSIONS TO STATE-APPROVED CEs

When IDOT proposes to approve an action as a CE on FHWA's behalf, IDOT shall evaluate the action for unusual circumstances. This evaluation must consider the effects of all aspects of the project, which includes, but is not limited to, detours, runarounds, or ramp closures that the action will require. IDOT CE documentation will record the outcome of this evaluation (see Part VI(A)(1) below).

For activities that do not lead to construction and are consistent with Appendix A Item (1) (also 23 CFR 771.117(c)(1)), IDOT hereby determines that these projects have no potential to exceed the thresholds in this stipulation and are programmatically approved as State Approved Categorical Exclusions. These activities require no additional review, approval, or documentation. Activities that do not involve, or lead directly to construction, includes but is not limited to:

- planning and/or research activities (MPO funding, annual research program, etc.);
- training (Local Technical Assistance Program (LTAP), National Summer Transportation Institute (NSTI), etc.)
- bridge inspections;
- studies (feasibility, corridor, project reviews, etc.)
- DBE/Supportive Services Work Plans
- engineering services to define the elements of a proposed action or alternatives so that social, economic, and environmental effects can be assessed (Phase I/NEPA); and
- Federal-aid system revisions that establish classes of highways on the Federal-aid highway system.

IDOT may not approve actions listed in Appendices A and B that exceed the following thresholds. An action requires FHWA CE review and approval if it involves any of the following circumstances:

- 1) Require one or more residential or business relocations and/or the acquisition of more than 10 acres total for a non-linear improvement (spot improvement, e.g. bridge, intersection) or the acquisition of more than 3 acres per mile; or
- 2) Are defined as a "Type I project" per 23 CFR 772.5 and therefore requires a noise analysis; or
- 3) Result in an "adverse effect" finding to a historic property, as defined in 36 CFR 800.16(l); or

- 4) Requires an Individual Section 4(f) evaluation for the use of properties protected by Section 4(f) of the Department of Transportation Act (49 U.S.C. 303); or
- 5) Involve impacts that would require an Individual Section 404 Permit from the U.S. Army Corps of Engineers; or
- 6) Through Section 7 of the Endangered Species Act consultation, result in a finding of "may affect, likely to adversely affect" a federally listed or candidate species, or proposed or designated critical habitat; or
- 7) Require substantial changes in access, access control, or travel patterns. IDOT will present such information to FHWA to determine if changes are substantial; or
- 8) Require the use of a temporary road, detour or ramp closure, unless the use of such facilities satisfies the following conditions:
 - a) Provisions are made for access by local traffic and so posted,
 - b) Businesses dependent on through-traffic will not be adversely affected,
 - c) To the extent possible, there is no interference with any local special event or festival,
 - d) There is no substantial change to the environmental consequences of the action, and
 - e) There is no substantial controversy associated with such facilities.
- 9) Involve State designated Nature Preserves; or
- 10) Exceed the IDNR threshold for an increase in 100-year flood water surface elevations, or has potential for a "significant encroachment" to floodplains, as defined in Executive Order 11988; or
- 11) Require a permit from U.S. Coast Guard under Section 9 of the Rivers and Harbors Act of 1899; or
- 12) Require the acquisition of lands under the protection of Section 6(f) of the Land and Water Conservation Act of 1965; or
- 13) Involve impacts to a stream listed on the National Park Service's National Rivers Inventory and would adversely affect the listings Outstandingly Remarkable Value; or
- 14) Have potential for controversy on environmental grounds as determined by FHWA, or inconsistency with Federal, State, or local requirements relating to the environment or planning.

VI. DOCUMENTATION OF CE APPROVALS

A. For both IDOT CE approvals and FHWA CE approvals, IDOT shall ensure that it fulfills the following responsibilities for documenting the project-specific determinations made:

1. For actions listed in Appendix A and B that do not exceed the thresholds in Section V of this Agreement, IDOT will identify the applicable action, ensure any conditions specified in FHWA regulation are met, verify that there are no potential unusual circumstances, address all other environmental requirements, and complete the review with the appropriate IDOT signature evidencing approval.

2. Actions listed in Appendix A and B that exceed the thresholds in Section V of this Agreement require FHWA CE approval. IDOT shall prepare documentation that supports the CE determination and that no unusual circumstances exist that would make the CE approval inappropriate, and will address all other environmental requirements.

B. IDOT shall maintain a project record for State Approved CEs and Federal Approved CEs. This record should include as appropriate:

1. Any checklists, forms, or other documents and exhibits that summarize the consideration of project effects and potential for unusual circumstances;
2. A summary of public involvement complying with the requirements of IDOT's public involvement procedures;
3. Any stakeholder (including resource and regulatory agencies) communication, correspondence, consultation, or public meeting documentation;
4. The name and title of the CE approver and the date of the approval; and
5. If a documented re-evaluation was required, the date of approval of the determination that the CE decision is still valid, per Section VII.B. of this Agreement ("NEPA Approvals and Re-evaluations").

C. Any project records maintained by IDOT shall be provided to FHWA at their request. IDOT should retain those records for a period of no less than three (3) years after completion of project construction. Records should include, as appropriate: any stakeholder (including resource and regulatory agencies) communication, correspondence, consultation, and public meeting documentation. This 3-year retention provision does not relieve IDOT of its project or program recordkeeping responsibilities under 2 CFR § 200.333 or any other applicable laws, regulations, or policies.

VII. NEPA APPROVALS AND RE-EVALUATIONS

A. IDOT approval of Appendix A and Appendix B CEs is delegated to the Approving Officials and their Designees as identified in Appendix C.

B. In accordance with 23 CFR 771.129, prior to requesting any subsequent project approvals from FHWA, regardless of how much time has passed since the CE approval, IDOT shall ensure that CE determinations are still valid. IDOT will utilize their system of policy controls and procedures to determine if there are any changes to the proposed actions or new information or circumstances relevant to the project actions that necessitate IDOT to re-evaluate CE approvals. IDOT will determine if it is necessary to consult with FHWA, and/or prepare additional documentation to ensure that CE determinations are still valid. If additional documentation is prepared, IDOT shall maintain the documentation in the project file, per Section VI.B.5.

VIII. QUALITY CONTROL/QUALITY ASSURANCE, MONITORING AND PERFORMANCE

A. IDOT Quality Control & Quality Assurance

IDOT agrees to carry out regular quality control and quality assurance activities to ensure that its CE approvals and CE submissions to FHWA for approval are made in accordance with applicable law and this Agreement.

B. IDOT Performance Monitoring and Reporting

1. The FHWA and IDOT should cooperate in monitoring performance under this Agreement and work to assure quality performance.

2. IDOT shall annually submit to FHWA a report summarizing its performance under this Agreement, no later than February 28 of each calendar year. The report will identify any areas where improvement is needed and what measures IDOT is taking to implement those improvements. The report will include a description of actions taken by IDOT as part of its quality control efforts under Section VIII(A).

C. FHWA Oversight and Monitoring

1. Monitoring by FHWA will include consideration of the technical competency and organizational capacity of IDOT, as well as IDOT's performance of its CE processing functions. Performance considerations include, without limitation, the quality and consistency of IDOT's CE approvals, CE submissions to FHWA for approval, adequacy and capability of IDOT staff and consultants, and the effectiveness of IDOT's administration of its internal CE approvals. FHWA will conduct this oversight and monitoring through its participation in the regularly scheduled coordination meetings in each IDOT District Office.

2. Through the joint process review program, FHWA and IDOT will conduct one or more program reviews, during the term of this Agreement. This will serve to satisfy FHWA's oversight requirements under this Agreement. IDOT and FHWA, prior to completing the joint process review, will prepare and implement a corrective action plan to address any findings or observations identified in the joint process review. The results of the joint process review and corrective actions taken by IDOT shall be considered at the time this Agreement is considered for renewal.

3. Nothing in this Agreement prevents FHWA from undertaking other monitoring or oversight actions, including audits, with respect to IDOT's performance under this Agreement. The FHWA may require IDOT to perform such other quality assurance activities, including other types of monitoring, as may be reasonably required to ensure compliance with applicable Federal laws and regulations.

4. IDOT agrees to cooperate with FHWA in all oversight and quality assurance activities.

IX. AMENDMENTS

A. If the parties agree to amend this Agreement, then FHWA and IDOT may execute an amendment with new signatures and dates of the signatures. The term of the Agreement shall remain unchanged unless otherwise expressly stated in the amended Agreement.

B. Appendix A and B may be modified through verbal agreement by FHWA and IDOT without new signatures to this agreement based on activities added through FHWA rulemaking to those listed in 23 CFR 771.117(c) or example activities listed in 23 CFR 771.117(d) after the date of the execution of this Agreement. A modification date will be noted on the revised Appendix A and B.

C. IDOT may request in writing to modify Appendix C. Upon written concurrence from FHWA, Appendix C may be modified without new signatures to this Agreement. A modification date will be noted on the revised Appendix C.

X. TERM, RENEWAL, AND TERMINATION

A. This Agreement shall have a term of five (5) years, effective on the date of the last signature. IDOT shall post and maintain an executed copy of this Agreement on its website, available to the public.

B. This Agreement is renewable for additional five (5) year terms if IDOT requests renewal and FHWA determines that IDOT has satisfactorily carried out the provisions of this Agreement. In considering any renewal of this Agreement, FHWA will evaluate the effectiveness of the Agreement and its overall impact on the environmental review process.

C. Either party may terminate this Agreement at any time only by giving at least 30 days written notice to the other party.

D. Expiration or termination of this Agreement shall mean that IDOT is not able to make CE approvals on FHWA's behalf.

Execution of this Agreement and implementation of its terms by both parties provides evidence that both parties have reviewed this Agreement and agree to the terms and conditions for its implementation. This Agreement is effective upon the date of the last signature below.



 Omer Osman
 Acting Secretary of Transportation
 Illinois Department of Transportation

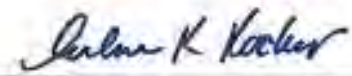

 Arlene K. Kocher
 Division Administrator, Illinois Division
 Federal Highway Administration

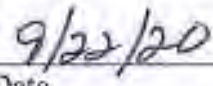

 Date

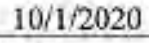

 Date

APPENDIX A
(From 23 CFR 771.117(c))

- (1) Activities which do not involve or lead directly to construction, such as planning and research activities; grants for training; engineering to define the elements of a proposed action or alternatives so that social, economic, and environmental effects can be assessed; and Federal-aid system revisions which establish classes of highways on the Federal-aid highway system.
- (2) Approval of utility installations along or across a transportation facility.
- (3) Construction of bicycle and pedestrian lanes, paths, and facilities.
- (4) Activities included in the State's *highway safety plan* under 23 U.S.C. 402.
- (5) Transfer of Federal lands pursuant to 23 U.S.C. 107(d) and/or 23 U.S.C. 317 when the land transfer is in support of an action that is not otherwise subject to FHWA review under NEPA.
- (6) The installation of noise barriers or alterations to existing publicly owned buildings to provide for noise reduction.
- (7) Landscaping.
- (8) Installation of fencing, signs, pavement markings, small passenger shelters, traffic signals, and railroad warning devices where no substantial land acquisition or traffic disruption will occur.
- (9) The following actions for transportation facilities damaged by an incident resulting in an emergency declared by the Governor of the State and concurred in by the Secretary, or a disaster or emergency declared by the President pursuant to the Robert T. Stafford Act (42 U.S.C. 5121):
 - (i) Emergency repairs under 23 U.S.C. 125; and
 - (ii) The repair, reconstruction, restoration, retrofitting, or replacement of any road, highway, bridge, tunnel, or transit facility (such as a ferry dock or bus transfer station), including ancillary transportation facilities (such as pedestrian/bicycle paths and bike lanes), that is in operation or under construction when damaged and the action:
 - (A) Occurs within the existing right-of-way and in a manner that substantially conforms to the preexisting design, function, and location as the original (which may include upgrades to meet existing codes and standards as well as upgrades warranted to address conditions that have changed since the original construction); and
 - (B) Is commenced within a 2-year period beginning on the date of the declaration.
- (10) Acquisition of scenic easements.
- (11) Determination of payback under 23 U.S.C. 156 for property previously acquired with Federal-aid participation.

- (12) Improvements to existing rest areas and truck weigh stations.
- (13) Ridesharing activities.
- (14) Bus and rail car rehabilitation.
- (15) Alterations to facilities or vehicles in order to make them accessible for elderly and handicapped persons.
- (16) Program administration, technical assistance activities, and operating assistance to transit authorities to continue existing service or increase service to meet routine changes in demand.
- (17) The purchase of vehicles by the applicant where the use of these vehicles can be accommodated by existing facilities or by new facilities which themselves are within a CE.
- (18) Track and railbed maintenance and improvements when carried out within the existing right-of-way.
- (19) Purchase and installation of operating or maintenance equipment to be located within the transit facility and with no significant impacts off the site.
- (20) Promulgation of rules, regulations, and directives.
- (21) Deployment of electronics, photonics, communications, or information processing used singly or in combination, or as components of a fully integrated system, to improve the efficiency or safety of a surface transportation system or to enhance security or passenger convenience. Examples include, but are not limited to, traffic control and detector devices, lane management systems, electronic payment equipment, automatic vehicle locaters, automated passenger counters, computer-aided dispatching systems, radio communications systems, dynamic message signs, and security equipment including surveillance and detection cameras on roadways and in transit facilities and on buses.
- (22) Projects, as defined in 23 U.S.C. 101, that would take place entirely within the existing operational right-of-way. Existing operational right-of-way refers to right-of-way that has been disturbed for an existing transportation facility or is maintained for a transportation purpose. This area includes the features associated with the physical footprint of the transportation facility (including the roadway, bridges, interchanges, culverts, drainage, fixed guideways, mitigation areas, etc.) and other areas maintained for transportation purposes such as clear zone, traffic control signage, landscaping, any rest areas with direct access to a controlled access highway, areas maintained for safety and security of a transportation facility, parking facilities with direct access to an existing transportation facility, transit power substations, transit venting structures, and transit maintenance facilities. Portions of the right-of-way that have not been disturbed or that are not maintained for transportation purposes are not in the existing operational right-of-way.
- (23) Federally-funded projects:
- (i) That receive less than \$5,000,000 of Federal funds; or
- (ii) With a total estimated cost of not more than \$30,000,000 and Federal funds comprising less than 15 percent of the total estimated project cost.

(24) Localized geotechnical and other investigation to provide information for preliminary design and for environmental analyses and permitting purposes, such as drilling test bores for soil sampling; archeological investigations for archeology resources assessment or similar survey; and wetland surveys.

(25) Environmental restoration and pollution abatement actions to minimize or mitigate the impacts of any existing transportation facility (including retrofitting and construction of stormwater treatment systems to meet Federal and State requirements under sections 401 and 402 of the Federal Water Pollution Control Act (33 U.S.C. 1341; 1342)) carried out to address water pollution or environmental degradation.

(26) Modernization of a highway by resurfacing, restoration, rehabilitation, reconstruction, adding shoulders, or adding auxiliary lanes (including parking, weaving, turning, and climbing lanes), if the action meets the constraints in paragraph (e)* of this section.

(27) Highway safety or traffic operations improvement projects, including the installation of ramp metering control devices and lighting, if the project meets the constraints in paragraph (e)* of this section.

(28) Bridge rehabilitation, reconstruction, or replacement or the construction of grade separation to replace existing at-grade railroad crossings, if the actions meet the constraints in paragraph (e)* of this section.

(29) Purchase, construction, replacement, or rehabilitation of ferry vessels (including improvements to ferry vessel safety, navigation, and security systems) that would not require a change in the function of the ferry terminals and can be accommodated by existing facilities or by new facilities which themselves are within a CE.

(30) Rehabilitation or reconstruction of existing ferry facilities that occupy substantially the same geographic footprint, do not result in a change in their functional use, and do not result in a substantial increase in the existing facility's capacity. Example actions include work on pedestrian and vehicle transfer structures and associated utilities, buildings, and terminals.

*Note: In items (26), (27), and (28), "paragraph (e)" constraints are as follows:

23 CFR 117.117(e) Actions described in (c)(26), (c)(27), and (c)(28) of this section may not be processed as CEs under paragraph (c) if they involve:

(1) An acquisition of more than a minor amount of right-of-way or that would result in any residential or non-residential displacements;

(2) An action that needs a bridge permit from the U.S. Coast Guard, or an action that does not meet the terms and conditions of a U.S. Army Corps of Engineers nationwide or general permit under section 404 of the Clean Water Act and/or section 10 of the Rivers and Harbors Act of 1899;

(3) A finding of "adverse effect" to historic properties under the National Historic Preservation Act, the use of a resource protected under 23 U.S.C. 138 or 49 U.S.C. 303 (section 4(f)) except for actions resulting in *de minimis* impacts, or a finding of "may affect, likely to adversely affect" threatened or endangered species or critical habitat under the Endangered Species Act;

(4) Construction of temporary access, or the closure of existing road, bridge, or ramps, that would result in major traffic disruptions;

- (5) Changes in access control;
- (6) A floodplain encroachment other than functionally dependent uses (e.g., bridges, wetlands) or actions that facilitate open space use (e.g., recreational trails, bicycle and pedestrian paths); or construction activities in, across or adjacent to a river component designated or proposed for inclusion in the National System of Wild and Scenic Rivers.

Appendix B
(From 23 CFR 771.117(d))

- (1)-(3) [Reserved]
- (4) Transportation corridor fringe parking facilities.
- (5) Construction of new truck weigh stations or rest areas.
- (6) Approvals for disposal of excess right-of-way or for joint or limited use of right-of-way, where the proposed use does not have significant adverse impacts.
- (7) Approvals for changes in access control.
- (8) Construction of new bus storage and maintenance facilities in areas used predominantly for industrial or transportation purposes where such construction is not inconsistent with existing zoning and located on or near a street with adequate capacity to handle anticipated bus and support vehicle traffic.
- (9) Rehabilitation or reconstruction of existing rail and bus buildings and ancillary facilities where only minor amounts of additional land are required and there is not a substantial increase in the number of users.
- (10) Construction of bus transfer facilities (an open area consisting of passenger shelters, boarding areas, kiosks and related street improvements) when located in a commercial area or other high activity center in which there is adequate street capacity for projected bus traffic.
- (11) Construction of rail storage and maintenance facilities in areas used predominantly for industrial or transportation purposes where such construction is not inconsistent with existing zoning and where there is no significant noise impact on the surrounding community.
- (12) Acquisition of land for hardship or protective purposes. Hardship and protective buying will be permitted only for a particular parcel or a limited number of parcels. These types of land acquisition qualify for a CE only where the acquisition will not limit the evaluation of alternatives, including shifts in alignment for planned construction projects, which may be required in the NEPA process. No project development on such land may proceed until the NEPA process has been completed.
- (i) Hardship acquisition is early acquisition of property by the applicant at the property owner's request to alleviate particular hardship to the owner, in contrast to others, because of an inability to sell his property. This is justified when the property owner can document on the basis of health, safety or financial reasons that remaining in the property poses an undue hardship compared to others.

(ii) Protective acquisition is done to prevent imminent development of a parcel which may be needed for a proposed transportation corridor or site. Documentation must clearly demonstrate that development of the land would preclude future transportation use and that such development is imminent. Advance acquisition is not permitted for the sole purpose of reducing the cost of property for a proposed project.

(13) Actions described in paragraphs (c)(26), (c)(27), and (c)(28) of this section that do not meet the constraints in paragraph (e) of this section.*

* Note: In Item (13), paragraphs (c)(26), (c)(27), and (c)(28) are in reference to actions listed in Appendix A as items (26), (27), and (28).

Appendix C

IDOT Officials Approval Authority for State Approved CEs

Table C-1

State Projects		
	Approving Officials	Designees
Districts	Regional Engineer	Authorized Designees
Central Office	Bureau Chief	Authorized Designees

Table C-2

Local Public Agency Projects		
	Approving Officials	Designees
Districts	Regional Engineer	District Engineer of Local Roads and Streets AND IDOT Local Roads and Streets Field Engineers
Central Office	Engineer of Local Roads and Streets	Local Project Implementation Engineer AND Local Project Development Engineer

Attachment I – Programmatic Wetland Finding**WETLAND FINDING FOR FEDERAL AID PROJECTS COVERED
UNDER THE PROGRAMMATIC AGREEMENT REGARDING THE PROCESSING OF
CATEGORICAL EXCLUSIONS***Introduction*

This wetland finding is made on a program-wide basis and has been prepared for transportation improvement projects, which are classified as a categorical exclusion (CE). It satisfies the requirements of Executive Order 11990 (EO) titled “Protection of Wetlands” and U.S. Department of Transportation Order 5660.1A (DOT Order) titled “Preservation of the Nation’s Wetlands.” No individual wetland finding needs to be prepared for such projects. An individual wetland finding shall be made for each Environment Assessment (EA) and Environmental Impact Statement (EIS).

Background

EO 11990, issued on May 24, 1977, requires each agency to develop procedures for Federal actions whose impact is not significant enough to require the preparation of an EIS under Section

102 (2)(c) of the National Environmental Policy Act (NEPA), as amended. The EO states that each Federal agency “shall avoid undertaking or providing assistance for new construction located in wetlands unless the head of the agency finds (1) that there is no practicable alternative to such construction, and (2) that the proposed action includes all practicable measures to minimize harm to wetlands which may result for such use.”

The EO defines “new construction” to include “draining, dredging, channelizing, filling, diking, impounding, and related activities.” This EO essentially requires a wetland finding for all Federal undertakings, which have virtually any impact to a wetland. DOT Order 5660.1A, issued on August 24, 1978 clarified “new construction” by excluding only “routine repairs and maintenance of existing facilities.”

The U.S. DOT Order states, “In carrying out any activities (including small scale projects which do not require documentation) with a potential effect on wetlands, operating agencies should consider the following factors...” This requires U.S. DOT agencies to consider the effects on wetlands for all projects (including CEs). Effects on wetlands are considered through coordination and consultation with the Illinois Department of Natural Resources and with the US Fish and Wildlife Service (USWS), US Army Corps of Engineers (USACE), US Environmental Protection Agency (USEPA), and the Illinois Environmental Protection Agency (IEPA), as appropriate. The Illinois Department of Transportation (IDOT) and Federal Highway Administration (FHWA) evaluate wetland resources and consider practicable avoidance alternatives or options. If avoidance alternatives are not practicable, then practicable measures to minimize harm are considered and included in the project. Unavoidable impacts are mitigated.

Federal-aid applicants consider these effects through the NEPA evaluation process and further consider these effects through the wetland permitting process and any associated meetings with resource agencies (USACE, USEPA, USFWS, and IEPA). IDOT and FHWA evaluate practicable avoidance alternatives or options. If avoidance alternatives are not practicable, then practicable measures to minimize harm are considered and included in the

project.

The U.S. DOT Order requires U.S. DOT agencies to make a formal wetland finding for all EAs and EISs. This formal wetland finding will be made in the EA/Finding of No Significant Impact or Final EIS/Record of Decision.

Finding:

In accordance with Executive Order 11990, and based on the above procedures, the FHWA Illinois Division finds for all Federal-aid projects classified as a categorical exclusion with an approved USACE permit that:

1. There will be no practicable alternative to the proposed construction in wetlands, and
2. The proposed project will include all practicable measures to minimize harm to the involved wetlands which may result from such use.

Any Federal-aid transportation project requiring an EA or EIS shall require an individual wetland finding.

 10/14/2015
Date

Catherine A. Batey
Division Administrator

**ILLINOIS STATEWIDE IMPLEMENTATION AGREEMENT
BETWEEN
THE FEDERAL HIGHWAY ADMINISTRATION
AND
THE ILLINOIS DEPARTMENT OF TRANSPORTATION
FOR
ESTABLISHMENT OF TIMEFRAMES FOR ENVIRONMENTAL IMPACT STATEMENTS
AND ENVIRONMENTAL ASSESSMENTS**

I. BACKGROUND

Section 1309 of the Transportation Equity Act of the 21st Century (TEA-21) established the need to conduct a coordinated environmental review process with concurrent interagency reviews and established time periods. This need was also reflected in Executive Order 13274, *Environmental Stewardship and Transportation Infrastructure Project Reviews*.

In July 1999 the U.S. Department of Transportation (DOT) and six Federal agencies entered into a National Environmental Streamlining Memorandum of Understanding (MOU). The six agencies included the Environmental Protection Agency, the Advisory Council on Historic Preservation, the US Army Corps of Engineers, and the Departments of Commerce, Agriculture and the Interior. In the MOU, all of the agencies agreed to streamline environmental review processes in accordance with TEA-21 and other relevant environmental statutes in ways that reinforce the federal responsibility to protect the environment. With respect to establishing timeframes, the MOU calls upon all agencies to:

“Support and encourage field offices to explore flexible streamlining opportunities on their own and with state transportation and environmental partners including developing MOUs to lay out mutual expectations, funding agreements in support of streamlining, and concurrent review within cooperatively determined time frames.”

Through an intensive and interactive process to identify the Federal Highway Administration’s (FHWA) goals, objectives, and performance targets, FHWA selected the establishment and meeting of timeframes as a measure of improved timeliness. The FHWA has established specific national targets, which include the following that apply to all Environmental Impact Statements (EISs) and Environmental Assessments (EAs):

- o Establish timeframes for EAs and EISs and meet the schedules for 90% of those projects by 09/30/07;
- o Decrease the median time it takes to complete an EIS from 54 months to 36 months by 09/30/07; and
- o Decrease the median time to complete an EA from approximately 18 months to 12 months by 09/30/07.

II. PURPOSE

This Statewide Implementation Agreement (SIA) is based on the legislation and actions cited above and the attached “Questions and Answers Regarding the Environmental Vital Few Goal of Negotiated Timeframes”.

Good project management: The establishment of timeframes for the environmental review process is viewed as an element of good project management. Timeframes can provide goals

and structure for the process and can be an effective continuous process improvement tool to identify bottlenecks, conflicts, and systematic issues, as well as to monitor progress.

Timeliness: There may be sources of delays throughout the entire project development process, such as changes in program/political priorities, local controversy, or other issues outside the control of the parties involved in negotiating timeframes. However, since congressional directives and statutory mandates focus heavily on the Federal environmental review process as a source of project delay, FHWA deems it important to pursue the improvement of timeliness, and thus selected a target goal of 90% of EIS and EA timeframes being met by 09/30/07.

Project efficiencies: Establishing timeframes will require upfront discussion among FHWA, the State DOT and other involved agencies (Federal, State and local) and can lead to the realization of project efficiencies, such as the following:

- Improved timeliness of the process
- Early identification of issues
- Early participation of environmental resource and permitting agencies
- Recognition of resource limitations upfront

Accountability: Timeframes should create a sense of predictability and accountability with the public and agencies. There are no legal consequences for not meeting the established timeframes. Reasons for schedule delays should be analyzed for lessons learned and, where appropriate, these lessons should be applied to future studies.

III. APPLICABILITY OF SIA

All EIS and EA documents initiated after the start of the federal FY 04 (October 1, 2003) shall have negotiated timeframes for the environmental review process.

IV. IMPLEMENTING PROCEDURES

A. DEFINITIONS

The following definitions are adopted for this SIA:

Timeframe: This term refers to the established schedule or timeline for the processing of an EIS or EA. This schedule is generally part of a larger project schedule that includes final design, right-of-way acquisition, and construction.

Negotiated: Project schedules should be developed by the FHWA Illinois Division office in cooperation with the Illinois Department of Transportation (IDOT). On locally sponsored projects the appropriate local agency should be involved in the negotiation process.

Initiated. For an EIS, this is the date that the Notice of Intent (NOI) is published in the *Federal Register*. For an EA, this is the date of the initial public meeting held to present the general scope of work, the possible alternatives that have been identified, and the preliminary decision on preparing an EA for the project (herein referred to as "initial public meeting").

Median Time. A national aggregate of processing times for environmental documents. This is the value below and above which there is an equal number of values. Using the median helps avoid the disproportionate skew due to extremely short or long processing times.

B. PROCESS

The appropriate IDOT District office will notify the FHWA Illinois Division office early in the project planning to allow ample time to establish timeframes for each EIS and EA prior to its initiation (NOI or initial public meeting).

The FHWA and IDOT (and local agencies when applicable) will work together to establish timeframes using the attached flowcharts as examples. The timeframes should cover the environmental review process and identify milestones as well as set a target completion date for each milestone. Actual milestone activities and time periods may vary from project to project.

Timeframe negotiations should typically occur in conjunction with FHWA/IDOT coordination meetings. The meeting minutes will document the approval of the timeframe for the project by the appropriate FHWA and IDOT district personnel. The dated flowcharts with the agreed-upon timeframes will be attached to the minutes. These same procedures will apply if timeframes are revised (see Section E).

Timeframes will account for the necessary review periods by the FHWA Division Office and IDOT Headquarters, and legal sufficiency review by the FHWA Office of Chief Counsel. Both the FHWA and IDOT are committed to a timely review of all documents.

The FHWA and IDOT will then provide a copy of the timeframes to the involved environmental review and permitting agencies (e.g., U.S. Army Corps of Engineers, U.S. Fish and Wildlife Service) as part of the early coordination/scoping process (e.g., NEPA/404 Merger or other meetings, electronic or written correspondence).

Timeframes should be established based on the complexity and characteristics of the project(s), as well as IDOT's own sense of priority. Dates will be adjusted as necessary, depending on agency resources or known project issues that are likely to affect the dates. A complex project may require acknowledgement upfront that a long timeframe will be required and that, as the project progresses, ongoing assessment and tracking must be provided to determine if it is necessary to modify the timeframe.

Timeframes can be affected by limitations of human, financial, and time resources, as well as seasonal schedules beyond human control, such as growing seasons for assessment of biological resources. These issues should be considered early in the process, along with a general level of priority established for the project.

Schedules should be achievable and realistic, and should strive to maintain high quality of documents and reviews.

All parties involved will receive a copy of the agreed upon schedule, including revisions when they occur.

C. GOALS FOR COMPLETION DATES

All EIS and EA projects initiated after the start of federal FY 04 (**October 1, 2003**) are to have negotiated timeframes for the environmental review process.

In **Illinois** the established goals for establishing maximum completion timeframes for projects initiated in federal FY 04-07 are:

FY 04: EIS – 54 months	FY 06: EIS – 42 months
EA – 18 months	EA – 15 months

FY 05: EIS – 48 months	FY 07: EIS – 36 months
EA – 18 months	EA – 12 months

In pursuing the targets of reducing the median processing times, all agencies involved in the environmental review process should continue seeking methods to streamline, yet also maintain a high quality of decision-making documents. Timeframe objectives should not compromise quality.

D. TRACKING OF DATES

Coordinating with IDOT, the FHWA will enter the actual dates on the project's individual flowchart to assess whether the milestone dates are being met throughout the project's development and whether the final target date will be achieved. FHWA will also enter the information in the Illinois Division's ITRACKS database and in the FHWA's national Environmental Document Tracking System (EDTS), including any reasons for delays and revision of dates.

E. REVISIONS TO TIMEFRAMES

When new issues arise or priorities change, the timeframes may be reviewed and revised as necessary, subject to the following limits:

Modifications to the timeframe of an EIS may be made up to 30 days following the end of the Draft EIS comment period, and on an EA up to 15 days following the end of the public availability period.

The updated timeframes will typically be discussed at FHWA/IDOT coordination meetings. Approval by the applicable IDOT district and the FHWA Division personnel will be documented in the minutes, and the date of the agreed revision will be included on the flowchart attached to the minutes. All involved agencies should be provided a copy of these changes.

F. MODIFICATION / TERMINATION

This agreement may be modified at any time by mutual agreement of both FHWA and IDOT. Proposal for modification will be given a 30-day review period, after which approval by the other agency will be indicated by written acceptance. Either agency may also terminate participation in this agreement upon written notice to the other agency.

G. APPROVAL OF AGREEMENT

The undersigned have reviewed this agreement and determined that it complies with Section 1309 of TEA-21 and related guidance. Accordingly, it is hereby approved and becomes effective on the last date noted below.

Illinois Department of Transportation

Federal Highway Administration

[signed 3/29/05]

[signed 3/3/05]

Victor A. Modeer, P.E. Norman R. Stoner, P.E.
Director of Highways Division Administrator

**MEMORANDUM OF UNDERSTANDING
AMONG THE FEDERAL HIGHWAY ADMINISTRATION, ILLINOIS DEPARTMENT OF
TRANSPORTATION, U.S. ARMY CORPS OF ENGINEERS, U.S. FISH AND WILDLIFE
SERVICE, U.S. COAST GUARD AND
U.S. ENVIRONMENTAL PROTECTION AGENCY
FOR THE CONCURRENT TRANSPORTATION DECISION-MAKING PROCESS AND
SECTION 404 OF THE CLEAN WATER ACT FOR FEDERAL-AID HIGHWAY
PROJECTS IN ILLINOIS**

This Memorandum of Understanding (“MOU”) is entered into among the Federal Highway Administration (FHWA) Illinois Division, the U.S. Army Corps of Engineers (Chicago, Rock Island, St. Louis, Louisville, and Memphis districts), the U.S. Environmental Protection Agency (Region 5), and the U.S. Fish and Wildlife Service (Chicago and Illinois and Iowa Field offices), the U.S. Coast Guard (St. Louis and Cleveland) and the Illinois Department of Transportation (IDOT), herein referred to as the Signatory Agencies.

This MOU is intended to be complimentary to the statutes, regulations, and policies of the Signatory Agencies. This MOU is not intended to supersede, diminish, modify, conflict with, or otherwise affect the Signatory Agencies’ statutory or regulatory authorities or directives, or those of the National Environmental Policy Act (NEPA). All activities conducted pursuant to this MOU shall be carried out in compliance with all applicable laws, regulations, and other legal requirements.

The Signatory Agencies agree to the following:

PURPOSE

The purpose of this MOU is to establish a process that integrates the procedural requirements of NEPA with the substantive Section 404 Clean Water Act decision-making process in a manner that facilitates synchronized review and decision-making for projects subject to the applicability criteria in this MOU. This MOU is also intended to ensure that the documentation developed for NEPA will satisfy the statutory requirements of the Signatory Agencies, and to increase the likelihood that the preferred alternative identified through the NEPA process does not conflict with the Section 404(b)(1) Guidelines.

This MOU supersedes the Statewide Implementation Agreement on the same processes, entered into by the Signatory Agencies on May 8, 2008.

AUTHORITIES

This MOU is consistent with the following authorities:

National Environmental Policy Act (NEPA), 42 U.S.C. 4321 - 4370
Moving Ahead for Progress in the 21st Century Act, P.L. 112-141, 126 Stat. 405, Sec. 1305
Fixing America’s Surface Transportation Act, P.L. 114-94, 129 Stat. 1312, Sec. 1304(k)

40 CFR parts 1500 – 1508, as amended
23 U.S.C. Sec. 139 Efficient environmental reviews for project decisionmaking
DOT Order 5610.1C

APPLICABILITY

This MOU is applicable for NEPA projects when:

The FHWA is the lead agency for the preparation of an Environmental Impact Statement (EIS) or an Environmental Assessment (EA), and;

The USACE is a cooperating agency under NEPA and the project is likely to require an individual permit from the USACE under Section 404 of the Clean Water Act (Section 404) and/or Section 10 of the Rivers and Harbors Act (Section 10).

A Signatory Agency may request that this MOU be applied to a project that does not meet the applicability criteria; however, FHWA and IDOT reserve the right to make that determination and will consult with the other Signatory Agencies as appropriate.

NEPA projects that meet the applicability criteria may be excluded from this MOU if the Signatory Agencies agree that the project is not of sufficient complexity to warrant coordination under this MOU.

If a NEPA project initially meets the applicability criteria and is later determined that an individual permit will not be required, then FHWA and IDOT may notify the Signatory Agencies that the project will no longer be processed under this MOU.

This MOU is also applicable to projects being evaluated pre-NEPA when:

IDOT is developing a planning product (e.g., Purpose and Need, Alternatives Analysis) as part of a Planning and Environment Linkages (PEL) study for a potential transportation project, and;

FHWA will be the lead agency for the NEPA process; and

IDOT expects an individual Section 404 permit will be required and either an EIS or EA will be prepared after the PEL study is complete.

DEFINITIONS

Concurrence – Confirmation by the concurring agency that the information presented is sufficient for this stage of the NEPA process and the project may proceed to the next stage of project development. Concurrence does not imply that an agency endorses the project or releases its obligation to determine if the project meets statutory review criteria.

Concurrence Points – Milestones with the NEPA process where FHWA and IDOT request concurrence from the Signatory Agencies to this agreement. There are three Concurrence Points for NEPA projects processed under this MOU:

Purpose and Need

Alternatives to be Carried Forward, and

Preferred Alternative

Consistency Determination – Confirmation by the Signatory Agencies that the information presented as part of a PEL study contains appropriate documentation and analysis, on par with a NEPA-level analysis, such that the information could be incorporated into a NEPA document at a later date, with no revisions or minimal revisions due to changed conditions in the project area or revised laws.

Coordination Points – Milestones within PEL studies where IDOT requests a consistency determination from the Signatory Agencies. There are two Coordination Points for a PEL under this MOU:

Purpose and Need
Alternatives to be Carried Forward

Planning and Environment Linkages (PEL) - Planning and Environment Linkages (PEL) represents a collaborative and integrated approach to transportation decision-making that 1) considers environmental, community, and economic goals early in the transportation planning process, and 2) uses the information, analysis, and products developed during planning to inform the environmental review process. Using a PEL approach can facilitate the accelerated review process timeline required by the Council on Environmental Quality NEPA regulations.

Waters of the United States – Those waters as defined in 33 CFR 328.3, as amended.

SIGNATORY AGENCIES' ROLES AND RESPONSIBILITIES

The Signatory Agencies agree to:

Consider the potential impacts to Waters of the United States in Illinois at the earliest practicable time in project development;

Avoid adverse impacts to such waters to the extent practicable;

Minimize and mitigate unavoidable adverse impacts and for wetlands, strive to achieve a goal of no overall net loss of values and functions; and

Pursue interagency cooperation and consultation diligently throughout this process to ensure that the concerns of the Signatory Agencies are given timely and appropriate consideration and that the Signatory Agencies are involved at key decision points in project development.

IDOT will ensure data collection, including information for determining compliance with the Section 404(b)(1) guidelines, will take place early in the coordination process so that information will be available for discussion at the concurrence point meetings. All Signatory Agencies will be responsible for reviewing the data and evaluations, and providing supplemental information and/or comments, as appropriate.

IDOT will provide information to the Signatory Agencies regarding the analysis of alternatives to avoid, minimize, and mitigate adverse impacts to Waters of the United States. This information may be presented in a matrix or similar summary. The Signatory Agencies will provide input on the adequacy of the avoidance, minimization, and mitigation analysis of the alternatives.

IMPLEMENTING PROCEDURES

FHWA and IDOT will hold “NEPA-404 merger meetings” to present projects under this MOU for information only, to seek concurrence for NEPA projects, or to seek a consistency determination for a PEL planning product. The NEPA-404 merger meetings will be held in February, June, and September and as necessary based on project priority, FHWA and IDOT may hold additional NEPA-404 merger meetings. FHWA and IDOT may invite additional resource agencies to attend meetings, as appropriate, based on the project impacts and the agencies’ expertise.

At least 30-days in advance of each merger meeting, FHWA or IDOT will provide the Signatory Agencies, and other agencies as appropriate, the Concurrence Point or Coordination Point package for each proposed action that will be discussed to allow agencies adequate time to review and prepare their comments. The notification letter will include the time and place of the meeting, an agenda, descriptions of the proposed actions to be discussed, and the Concurrence Point(s) or Coordination Point(s) being sought by FHWA and IDOT.

About two weeks before each NEPA-404 merger meeting, FHWA and IDOT will host a teleconference call with the Signatory Agencies. The purpose of the call is for the Signatory Agencies to identify any data gaps or questions they have for projects that will be presented for a Concurrence Point or a Coordination Point. FHWA and IDOT will convey that information to the project teams so they can be prepared to address the Signatory Agencies' questions at the merger meeting.

During the merger meeting, the project teams will present the information and address questions from the Signatory Agencies. The FHWA will seek concurrence, or a consistency determination for PEL products, from each agency attending the meeting. The agencies' verbal concurrence will be documented in the merger meeting summary, which will be coordinated with the Signatory Agencies before being finalized. The finalized merger meeting summaries will serve as written concurrence by the agencies with the Concurrence Points and/or consistency determinations for the Coordination Points. Agencies may also provide concurrence via e-mail or letter if they are unable to attend a meeting or if they need additional time to decide.

Normally, FHWA and IDOT will seek concurrence on each Concurrence Points and consistency determinations on Coordination Points separately. On less complex actions, FHWA and IDOT may seek concurrence on NEPA Alternatives to be Carried Forward and Preferred Alternative simultaneously.

For NEPA projects, Concurrence Points will not be revisited unless there is new information, or if there are substantial changes to the project, the environment, or laws and regulations which affect the concurrence point achieved.

Because a PEL product (i.e., Purpose and Need and/or Alternatives to be Carried Forward) is a planning document and not a NEPA milestone, IDOT and FHWA will re-coordinate with the Signatory Agencies when the PEL study transitions to NEPA. FHWA and IDOT will review, and update if necessary, the information developed in the PEL study and submit it to the Signatory Agencies. FHWA and IDOT will request written concurrence that the NEPA Purpose and Need and/or NEPA Range of Alternatives to be Carried Forward is/are adequate to advance to the next stage of the NEPA process. The Signatory Agencies have 10 days to concur or not concur. If the Signatory Agency does not concur, they shall provide a written statement detailing why concurrence was not achieved. If a Signatory Agency requires more than 10 days to make a concurrence decision, a request for additional time may be made to FHWA and IDOT.

If a consistency determination has been made for two Coordination Points (i.e., purpose and need, alternatives to be carried forward), then FHWA and IDOT may seek concurrence on both of these NEPA milestones at the same time.

DOCUMENTATION REQUIREMENTS

Purpose and Need (Concurrence Point/Coordination Point)

The Purpose and Need documentation will include the following:

Sufficient data and analysis to support the reasons for proposing the action;

The logical termini for the proposed action;

Evidence that the proposed action has independent utility; and

A purpose and need as comprehensive, specific and concise as possible, while not being so narrowly constrained that it limits the range of alternatives or establishes the preferred alternative.

Alternatives to be Carried Forward (Concurrence Point/Coordination Point)

The Alternatives to be Carried Forward documentation will include the following:

A description of all alternatives considered;

The alternatives analysis methodology for eliminating alternatives; and

An explanation of the way in which Alternatives to be Carried Forward are reasonable, practicable, and address the Purpose and Need.

Alternatives may be dismissed for reasons including, but not limited to, not satisfying the Purpose and Need, environmental impacts, or engineering and economic factors.

3) *Preferred Alternative (Concurrence Point)*

The Preferred Alternative documentation will include the following:

Identification of the environmentally Preferred Alternative/least environmentally damaging practicable alternative,

Summary of comments received from the public and other government entities, if any,

Explanation of the rationale for the selection of the preliminary Preferred Alternative,

Explanation of the rationale for the dismissal of the other alternatives carried forward, and

DISPUTE RESOLUTION

If any Signatory Agency does not agree with any Concurrence Point or Coordination Point, FHWA and IDOT will work with them to the extent feasible to address their concerns. If FHWA and IDOT, after making good-faith efforts to address their concerns, conclude that an impasse has been reached with one or more Signatory Agencies, FHWA and IDOT may proceed to the next stage of project development without that agency's concurrence. FHWA and IDOT will notify all Signatory Agencies of their decision and proposed course of action. The decision to move an action forward without concurrence does not eliminate a Signatory Agency's statutory or regulatory authorities, or their right to elevate the dispute through established agency dispute resolution procedures. FHWA and IDOT recognize and accept the risk of proceeding with an action without receiving a Signatory Agency's concurrence.

MODIFICATION/TERMINATION

This MOU may be modified upon approval of all Signatory Agencies. Signatory agencies may submit proposed modifications to FHWA and IDOT. FHWA and IDOT will circulate proposals for modification to the other Signatory Agencies for a 30-day period of review.

Approval of such proposals must be in writing.

A Signatory Agency may terminate participation in this agreement upon written notice to all other Signatory Agencies.

The Federal Agencies in cooperation with the Illinois Department of Transportation (IDOT) agree to implement, to the fullest extent practicable and as funding and staffing level allow, the process in this Memorandum of Understanding.

This agreement becomes effective upon signature of the agencies and may be modified by written approval of each agency. This agreement may be revoked by agreement of all agencies or by any agency upon 30-days written notice to the other agencies.

GENERAL PROVISIONS

Nothing contained in this MOU is intended to or should be construed to limit or affect the authority or legal responsibilities of the undersigned agencies or binds the undersigned agencies to perform actions beyond their respective authorities.

Nothing in this MOU shall be construed to impair or otherwise adversely affect:

the authority granted by law to an executive department or agency, or the head thereof; or the functions of the Director of the Office of Management and Budget relating to budgetary, administrative, or legislative proposals.

Nothing in this MOU is intended to, or should, be construed to restrict the agencies from participating in similar activities or arrangements with other public or private entities, organizations, or individuals.

Independent agency staff will comply with this MOU to the maximum extent practicable, consistent with such agency's status as an independent agency, statutory requirements, and such agency's regulations and procedures.

The mission requirements, funding, personnel, and other priorities of the undersigned agencies may affect their ability to fully implement all the provisions identified in this MOU.

This MOU shall be implemented consistent with applicable law and subject to the availability of appropriations.

Specific activities that involve the transfer of money, services, or property between or among the undersigned agencies may require execution of separate agreements or contracts.

This MOU is not intended to, and does not, create any right or benefit, substantive or procedural, enforceable at law or in equity by any party against the United States, its departments, agencies, or entities, its officers, employees, or agents, or any other person.

SIGNATORY PAGE

**MEMORANDUM OF UNDERSTANDING
AMONG THE FEDERAL HIGHWAY ADMINISTRATION, ILLINOIS DEPARTMENT
OF TRANSPORTATION, U.S. ARMY CORPS OF ENGINEERS, U.S. FISH AND
WILDLIFE SERVICE, U.S. COAST GUARD AND U.S. ENVIRONMENTAL
PROTECTION AGENCY**

**FOR THE CONCURRENT TRANSPORTATION DECISION-MAKING PROCESS AND
SECTION 404 OF THE CLEAN WATER ACT FOR FEDERAL-AID HIGHWAY
PROJECTS IN ILLINOIS**

U.S. ARMY CORPS OF ENGINEERS – ROCK ISLAND DISTRICT

G. Ward Lenz

Digitally signed by G. Ward Lenz
Date: 2021.09.15 10:46:33
-05'00'

G. Ward Lenz
Regulatory Division Chief
Rock Island, Illinois District

15/Sep/2021
Date

SIGNATORY PAGE

**MEMORANDUM OF UNDERSTANDING
AMONG THE FEDERAL HIGHWAY ADMINISTRATION, ILLINOIS DEPARTMENT
OF TRANSPORTATION, U.S. ARMY CORPS OF ENGINEERS, U.S. FISH AND
WILDLIFE SERVICE, U.S. COAST GUARD AND U.S. ENVIRONMENTAL
PROTECTION AGENCY**

**FOR THE CONCURRENT TRANSPORTATION DECISION-MAKING PROCESS AND
SECTION 404 OF THE CLEAN WATER ACT FOR FEDERAL-AID HIGHWAY
PROJECTS IN ILLINOIS**

U.S. ARMY CORPS OF ENGINEERS – CHICAGO DISTRICT

Keith L.

Digitally signed by Keith L.

Wozniak

Date: 2021.09.15 09:45:43
-05'00'

Wozniak

15 September 2021

Keith L. Wozniak
Regulatory Branch Chief
Chicago District

Date

SIGNATORY PAGE

**MEMORANDUM OF UNDERSTANDING
AMONG THE FEDERAL HIGHWAY ADMINISTRATION, ILLINOIS DEPARTMENT
OF TRANSPORTATION, U.S. ARMY CORPS OF ENGINEERS, U.S. FISH AND
WILDLIFE SERVICE, U.S. COAST GUARD AND U.S. ENVIRONMENTAL
PROTECTION AGENCY**

**FOR THE CONCURRENT TRANSPORTATION DECISION-MAKING PROCESS AND
SECTION 404 OF THE CLEAN WATER ACT FOR FEDERAL-AID HIGHWAY
PROJECTS IN ILLINOIS**

U.S. ARMY CORPS OF ENGINEERS – ST. LOUIS DISTRICT

Robert S. Gramke

Robert S. Gramke
Regulatory Division Chief
St. Louis, Missouri District

Digitally signed by Robert S. Gramke
Date: 2021.09.24 12:44:48 -05'00'

Date

SIGNATORY PAGE

**MEMORANDUM OF UNDERSTANDING
AMONG THE FEDERAL HIGHWAY ADMINISTRATION, ILLINOIS DEPARTMENT
OF TRANSPORTATION, U.S. ARMY CORPS OF ENGINEERS, U.S. FISH AND
WILDLIFE SERVICE, U.S. COAST GUARD AND U.S. ENVIRONMENTAL
PROTECTION AGENCY**

**FOR THE CONCURRENT TRANSPORTATION DECISION-MAKING PROCESS AND
SECTION 404 OF THE CLEAN WATER ACT FOR FEDERAL-AID HIGHWAY
PROJECTS IN ILLINOIS**

U.S. ARMY CORPS OF ENGINEERS – LOUISVILLE DISTRICT

Michael Ricketts

Michael S. Ricketts
Regulatory Division Chief
Louisville, Kentucky District

16SEP2021
Date

SIGNATORY PAGE

MEMORANDUM OF UNDERSTANDING
AMONG THE FEDERAL HIGHWAY ADMINISTRATION, ILLINOIS DEPARTMENT
OF TRANSPORTATION, U.S. ARMY CORPS OF ENGINEERS, U.S. FISH AND
WILDLIFE SERVICE, U.S. COAST GUARD AND U.S. ENVIRONMENTAL
PROTECTION AGENCY

FOR THE CONCURRENT TRANSPORTATION DECISION-MAKING PROCESS AND
SECTION 404 OF THE CLEAN WATER ACT FOR FEDERAL-AID HIGHWAY
PROJECTS IN ILLINOIS

U.S. ARMY CORPS OF ENGINEERS – MEMPHIS DISTRICT

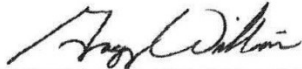

Date: 2021.09.15 10:50:21 -05'00'

Gregory W. Williams
Regulatory Division Chief
Memphis District

Date

SIGNATORY PAGE

**MEMORANDUM OF UNDERSTANDING
AMONG THE FEDERAL HIGHWAY ADMINISTRATION, ILLINOIS DEPARTMENT
OF TRANSPORTATION, U.S. ARMY CORPS OF ENGINEERS, U.S. FISH AND
WILDLIFE SERVICE, U.S. COAST GUARD AND U.S. ENVIRONMENTAL
PROTECTION AGENCY**

**FOR THE CONCURRENT TRANSPORTATION DECISION-MAKING PROCESS AND
SECTION 404 OF THE CLEAN WATER ACT FOR FEDERAL-AID HIGHWAY
PROJECTS IN ILLINOIS**

U.S. FISH AND WILDLIFE SERVICE – CHICAGO FIELD OFFICE

LOUISE CLEMENCY Digitally signed by LOUISE CLEMENCY
Date: 2021.09.15 11:32:18 -05'00'

Louise Clemency
Field Supervisor
Chicago Illinois Field Office

Date

SIGNATORY PAGE

MEMORANDUM OF UNDERSTANDING
AMONG THE FEDERAL HIGHWAY ADMINISTRATION, ILLINOIS DEPARTMENT
OF TRANSPORTATION, U.S. ARMY CORPS OF ENGINEERS, U.S. FISH AND
WILDLIFE SERVICE, U.S. COAST GUARD AND U.S. ENVIRONMENTAL
PROTECTION AGENCY

FOR THE CONCURRENT TRANSPORTATION DECISION-MAKING PROCESS AND
SECTION 404 OF THE CLEAN WATER ACT FOR FEDERAL-AID HIGHWAY
PROJECTS IN ILLINOIS

U.S. FISH AND WILDLIFE SERVICE – ILLINOIS AND IOWA FIELD OFFICE



Kraig McPeck
Field Supervisor
Illinois and Iowa Field Office

9/14/21

Date

SIGNATORY PAGE

**MEMORANDUM OF UNDERSTANDING
AMONG THE FEDERAL HIGHWAY ADMINISTRATION, THE ILLINOIS
DEPARTMENT OF TRANSPORTATION, THE US ARMY CORPS OF ENGINEER, US
FISH AND WILDLIFE SERVICE AND THE US ENVIRONMENTAL PROTECTION
AGENCY**

**FOR THE CONCURRENT TRANSPORTATION DECISION-MAKING PROCESS AND
SECTION 404 OF THE CLEAN WATER ACT FOR FEDERAL-AID HIGHWAY
PROJECTS IN ILLINOIS**

U.S. ENVIRONMENTAL PROTECTION AGENCY

**CHERYL
NEWTON**

Digitally signed by CHERYL
NEWTON
Date: 2021.10.18 11:54:33 -05'00'

Cheryl L. Newton
Acting Regional Administrator
Region V

Date

SIGNATORY PAGE

**MEMORANDUM OF UNDERSTANDING
AMONG THE FEDERAL HIGHWAY ADMINISTRATION, ILLINOIS DEPARTMENT
OF TRANSPORTATION, U.S. ARMY CORPS OF ENGINEERS, U.S. FISH AND
WILDLIFE SERVICE, U.S. COAST GUARD AND U.S. ENVIRONMENTAL
PROTECTION AGENCY**

**FOR THE CONCURRENT TRANSPORTATION DECISION-MAKING PROCESS AND
SECTION 404 OF THE CLEAN WATER ACT FOR FEDERAL-AID HIGHWAY
PROJECTS IN ILLINOIS**

U.S. COAST GUARD – EIGHTH COAST GUARD DISTRICT

Bridge Administrator
Eighth Coast Guard District

Date

SIGNATORY PAGE

**MEMORANDUM OF UNDERSTANDING
AMONG THE FEDERAL HIGHWAY ADMINISTRATION, ILLINOIS DEPARTMENT
OF TRANSPORTATION, U.S. ARMY CORPS OF ENGINEERS, U.S. FISH AND
WILDLIFE SERVICE, U.S. COAST GUARD AND U.S. ENVIRONMENTAL
PROTECTION AGENCY**

**FOR THE CONCURRENT TRANSPORTATION DECISION-MAKING PROCESS AND
SECTION 404 OF THE CLEAN WATER ACT FOR FEDERAL-AID HIGHWAY
PROJECTS IN ILLINOIS**

U.S. COAST GUARD – NINTH COAST GUARD DISTRICT

Bridge Administrator
Ninth Coast Guard District

Date

SIGNATORY PAGE

MEMORANDUM OF UNDERSTANDING
AMONG THE FEDERAL HIGHWAY ADMINISTRATION, ILLINOIS DEPARTMENT
OF TRANSPORTATION, U.S. ARMY CORPS OF ENGINEERS, U.S. FISH AND
WILDLIFE SERVICE, U.S. COAST GUARD AND U.S. ENVIRONMENTAL
PROTECTION AGENCY

FOR THE CONCURRENT TRANSPORTATION DECISION-MAKING PROCESS AND
SECTION 404 OF THE CLEAN WATER ACT FOR FEDERAL-AID HIGHWAY
PROJECTS IN ILLINOIS

ILLINOIS DEPARTMENT OF TRANSPORTATION

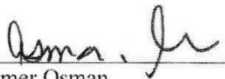

Omer Osman
Secretary

11-09-21

Date

SIGNATORY PAGE

**MEMORANDUM OF UNDERSTANDING
AMONG THE FEDERAL HIGHWAY ADMINISTRATION, ILLINOIS DEPARTMENT
OF TRANSPORTATION, U.S. ARMY CORPS OF ENGINEERS, U.S. FISH AND
WILDLIFE SERVICE, U.S. COAST GUARD AND U.S. ENVIRONMENTAL
PROTECTION AGENCY**

**FOR THE CONCURRENT TRANSPORTATION DECISION-MAKING PROCESS AND
SECTION 404 OF THE CLEAN WATER ACT FOR FEDERAL-AID HIGHWAY
PROJECTS IN ILLINOIS**

FEDERAL HIGHWAY ADMINISTRATION



Arlene K. Kocher
Division Administrator

January 13, 2022

Date

**MEMORANDUM OF UNDERSTANDING BY AND BETWEEN
THE ILLINOIS DEPARTMENT OF NATURAL RESOURCES
AND
THE ILLINOIS DEPARTMENT OF TRANSPORTATION**

Pursuant to Title 17 Part 1075.30(d) of the Illinois Administrative Code, this agreement between the Illinois Department of Natural Resources (IDNR) and the Illinois Department of Transportation (IDOT) sets forth the framework for an expedited review process for compliance with Section 11(b) of the Illinois Endangered Species Protection Act (520 ILCS 10/11(b)), Section 17 of the Illinois Natural Areas Preservation Act (525 ILCS 30/17), and administrative rules promulgated thereunder (11 Ill. Admin. Code 1075). The parties enter into this MOU pursuant to the provisions of the Intergovernmental Cooperation Act (5 ILCS 220/1-16). This Memorandum of Understanding (MOU) supersedes the MOU effective December 30, 2010.

General Principles of Coordination

The review processes required under the Illinois Endangered Species Act and the Illinois Natural Areas Preservation Act, and provisions of the Interagency Wetland Policy Act of 1989, are designed to examine potential impacts to protected natural resources. The IDNR Division of Ecosystems and Environment (E&E) and the IDOT Bureau of Design and Environment (BDE) will be the points of contact for processing of all proposed projects. All official comments, recommendations, and responses made by either IDNR or IDOT shall be made via email or letter, except in emergency situations as defined in 17 Ill. Admin. Code 1075.60.

The IDOT agrees to:

1. Ensure that proposed projects funded or performed by IDOT comply with the Interagency Wetland Policy Act of 1989 and the IDOT Wetlands Action Plan.
2. Review proposed projects that will be funded or performed by IDOT to determine if they could have an adverse effect on a State-listed threatened or endangered species (T&E species), or a site listed on the Illinois Natural Areas Inventory (INAI site), which include Illinois Natural Area Inventory sites, dedicated Illinois Nature Preserves, and registered Land and Water Reserves.
3. Submit to the IDNR EcoCAT website consultation requests for proposed actions that could have an adverse effect, that are adjacent to a Nature Preserve or Land and Water Reserve, or that entail excavation outside of an existing right-of-way and are within one mile of a Nature Preserve or Land and Water Reserve.
4. Determine if proposed projects funded or performed by IDOT could adversely affect additional natural resources (listed below). Submit to IDNR for review those actions that could have an adverse effect on these resources.
 - a. Streams
 - b. Forest/trees
 - i. Alignment bisects or fragments a block of trees \geq 20 acres
 - ii. New alignment on any stream segment
 - iii. Existing alignment in a riparian corridor
 - c. Prairie/savanna areas
 - d. Properties owned, leased, or managed by IDNR

5. Conduct biological surveys at IDOT's discretion or when recommended by IDNR. Provide copies of the survey results to IDNR, or a written explanation if recommended surveys are not conducted.
6. Develop measures to avoid, minimize or mitigate potential adverse effects to T&E species, INAI sites, or the natural resources listed in Paragraph 4. Submit the measures to IDNR for concurrence.
7. Implement and monitor mitigation measures per IDNR 3(b).
8. By February 1st of each year, report to IDNR the total number of proposed actions that were reviewed by BDE the previous year and not submitted for consultation because there were no protected resources in the vicinity or IDOT determined that the actions were unlikely to have an adverse effect. Provide copies of a random 2% of those reviews to IDNR.
9. Take all reasonable precautions to protect and maintain the confidentiality of protected natural resource data consistent with the use intended by this MOU.

The IDNR agrees to:

1. Review BDE EcoCAT reports within 30 days of receipt. After review, IDNR will either:
 - a. Terminate consultation because adverse effects are unlikely, or
 - b. Request additional information and/or request a biological survey.
2. Review mitigation measures submitted by IDOT and coordinate with appropriate IDNR staff to determine whether further analysis or recommendations are required.
3. Within 90 days of receipt of IDOT-proposed mitigation measures, IDNR will either:
 - a. Recommend additional measures to avoid or minimize adverse effects, or
 - b. Concur with proposed mitigation measures and terminate consultation.

Both agencies have 45 days to resolve any differences that may remain. If resolution is not reached within this time, both parties can agree to: terminate consultation, elevate the issue within each department, or continue negotiations.

TERMS OF THE MOU

The term of this MOU shall be a period of three (3) years from the date this MOU is executed by all parties. This MOU shall automatically be renewed for an additional three (3) year period unless terminated per the terms of this agreement. Either party shall have the right to terminate this MOU at any time by providing at least ninety (90) days written notice to the other party.

IN WITNESS WHEREOF, the Departments have entered into this Agreement as of the date written below.

ILLINOIS DEPARTMENT OF
NATURAL RESOURCES

By: 
Marc Miller, Director

Date: 1-10-13

ILLINOIS DEPARTMENT OF
TRANSPORTATION

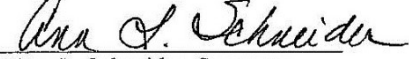
By: 
Ann L. Schneider, Secretary

Date: 12/12/12

APPROVED FOR EXECUTION

Date: 1/03/2013

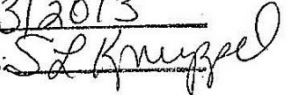
Legal Counsel: 

APPROVED FOR EXECUTION

Date: 1-4-13

Chief Fiscal Officer: 

**Illinois Department of Transportation
WETLANDS ACTION PLAN**

April 15, 1998

[signed] 4/15/98
IDOT Approval Date

[signed] 4/21/98
IDNR Approval Date

I. Purpose

The purpose of this Action Plan is to set forth a framework of policy and procedures for the Illinois Department of Transportation (IDOT) that will establish compliance with the goals of the Interagency Wetland Policy Act of 1989 (the Act) and the "Implementing Procedures for the Interagency Wetland Policy Act" (17 Ill. Admin. Code 1090).

II. Applicability

This Action Plan applies to all IDOT and IDOT pass-through funded projects involving adverse impacts to wetlands except those actions specifically exempted. Approvals to proceed with construction of non-exempted actions adversely affecting wetlands will be contingent on demonstrating compliance with this Plan. For IDOT pass-through funded projects, the entity receiving the pass-through funds will be responsible for complying with the provisions of this Plan. For such projects, IDOT may require the entity receiving the pass-through funds to assume responsibility for necessary wetlands-related studies and coordination with the Illinois Department of Natural Resources (IDNR) which this Plan describes as IDOT responsibilities.

In accordance with 17 Ill. Admin. Code 1090.20 (Implementing Procedures for the Interagency Wetland Policy Act), actions that may involve adverse wetlands impacts include, but are not limited to:

- The alteration, removal, excavation, or dredging of soil, sand, gravel, minerals, organic matter, vegetation, or naturally occurring materials of any kind from a wetland;
- The discharge or deposit of fill material or dredged material into a wetland;
- The alteration of existing drainage characteristics, sedimentation patterns, or flood retention characteristics of a wetland;
- The disturbance of the water level or water table of a wetland;
- The destruction or removal of plant life that would alter the character of a wetland, except for activities undertaken in accordance with the Illinois Noxious Weed Act; and
- The transfer of State-owned wetlands to any entity other than another State agency.

Compliance with this Action Plan is not required for any construction, land management, or other activity funded or performed by IDOT which will *not* result in an adverse impact to a wetland. In addition, in accordance with 17 Ill. Admin. Code 1090.20, the following activities also are specifically excluded from the State wetlands compliance requirements:

- Activities undertaken for the maintenance of existing ponds, storm water detention basins and channels, drainage ditches or navigation channels
- Installation of signs, lighting and fences and the mowing of vegetation within existing maintained rights-of-way, provided such actions do not jeopardize the existence of a threatened or endangered species, Illinois Natural Area Inventory Site, or the designated essential habitat of a threatened or endangered species
- Repair and maintenance of existing buildings, facilities, lawns, and ornamental plantings
- Issuance of permits and licenses
- Construction projects that were let for bidding prior to May 6, 1996

Application of media (including deicing chemicals) on the surface of existing roads for the purposes of public safety

Non-surface disturbing surveys and investigations for construction, planning, maintenance or location of environmental resources

After initial approval by IDNR, this Plan shall continue in effect, subject to renewal through IDNR every 4 years in accordance with 17 Ill. Admin. Code 1090.40(d).

III. Consistency with Existing IDOT Policies and Procedures

Upon acceptance by IDNR, this Action Plan becomes IDOT's framework for compliance with the Interagency Wetland Policy Act. To the extent that there are any inconsistencies between this Plan and existing IDOT Departmental Orders, policies, and operating procedures regarding wetlands, this Action Plan supersedes such Orders, policies, and procedures until they are revised to achieve consistency.

IV. Identification and Delineation of Wetlands

At the earliest practical stage in the project planning process, an assessment will be made of the extent to which wetlands will be affected. Unless an Illinois-specific manual is available and approved for use, the current approved federal manual for identifying and delineating wetlands shall be used as the basis for determining wetlands subject to the Act. Wetlands shall be categorized according to the types listed in Appendix B. Additional regulatory guidance issued by the Corps of Engineers for the federal wetlands manual (e.g., concerning the treatment of farmed wetlands) also will be followed, as applicable. The most recent version of the "National List of Plant Species that Occur in Wetlands" published by the U S Fish and Wildlife Service will be used to determine hydrophytic vegetation. The most recent list of hydric soil map units maintained by each county Natural Resources Conservation Service Office will be used when locating areas of hydric soils.

The National Wetlands Inventory (NWI) maps and wetland maps that may be produced by local jurisdictions shall be used in determining the need to undertake field surveys to delineate and evaluate wetlands affected by IDOT or IDOT pass-through funded projects. Consideration also shall be given to the location of the project in the landscape and the proposed scope of work. Where wetlands are likely to occur and where such wetlands could be affected by the proposed project, field investigations shall be conducted to verify the presence of wetlands and to delineate any wetlands in the area the project may affect.

V. Policy on Wetlands Impacts and Compensation

Each Division of IDOT responsible for activities subject to the requirements of this Action Plan shall ensure that its policies and operating procedures reflect the following sequence of actions for addressing adverse wetlands impacts while giving due consideration to safety and appropriate design standards:

First priority: Avoidance of adverse wetland impacts.

Second priority: Minimization of adverse wetland impacts.

Third priority: Compensation for unavoidable adverse wetland impacts in accordance with the ratios in 17 Ill. Admin. Code 1090.50(c)(8).

Wetland impacts of less than 0.3 acre resulting from IDOT or IDOT pass-through funded projects will be compensated for from a wetland compensation account site or other approved

source of preexisting wetland credits (e.g., commercial wetland bank), or may be accumulated for compensation in a larger compensation site or sites. In either case, the compensation will be subject to the applicable ratios specified in 17 Ill. Admin. Code 1090.50(c)(8). Opportunities to compensate for accumulated impacts will be pursued, as practical, when developing project-specific wetlands compensation for larger impacts, when new wetland compensation account/bank sites become available for use, or when establishment of a site or sites to offset accumulated impacts is determined appropriate as a stand-alone project.

Any accumulated acres of impact associated with IDOT or IDOT pass-through funded projects will be accounted for on the basis of the boundaries of the nine IDOT highway districts. IDOT will confer with IDNR at least once each year regarding the status of any accumulated impact balances in each of the IDOT highway districts and the status of compensation to offset the accumulated balances. The total of accumulated acres of impacts at any given time shall not exceed 5 acres in any IDOT highway district or 25 acres statewide. If accumulated balances approach either of these thresholds, IDOT will confer with IDNR to decide how compensation will be provided to reduce the accumulated balances.

Compensation for unavoidable adverse impacts of 0.3 acre or more, will be provided prior to or concurrent with the project action causing the wetland impact. In proposing such compensation for IDOT or IDOT pass-through funded projects, priority shall be given to locating the compensation close to the impacted wetlands to the extent practical. In evaluating the practicality of sites for potential use, the following will be considered:

The site must be suitable for establishment of wetlands; i.e., contain hydric soils and be capable of providing suitable wetlands hydrology.

IDOT, or the local agency responsible for an IDOT pass-through funded project, must be able to acquire the site for wetlands compensation purposes (i.e., for sites that are not adjacent to existing or proposed project right-of-way, either the site must have a willing seller or IDNR will provide written documentation confirming suitability of the site for use, in order to support condemnation action by IDOT, or local agency, in the case of an IDOT pass-through funded project).

For sites that are not adjacent to existing or proposed project right-of-way, it must be possible for an agreement to be reached for transferring jurisdiction and responsibility for long-term management to the IDNR or another entity that meets the requirements of 17 Ill. Admin. Code 1090.90. (IDOT or a local highway agency ordinarily will assume responsibility for long-term management of sites adjacent to existing or proposed highway rights-of-way.)

When adverse wetlands impacts occur, one-for-one replacement of new wetlands of comparable functional type and size will be provided through wetlands restoration or creation before acquisition or research alternatives are considered. Buffer areas may be included for compensation credit when such areas are important to the protection of the compensation wetlands and the maintenance of their functions. The amount of credit allowed for buffer areas will be determined in consultation with IDNR on a case-by-case basis.

If a wetland compensation plan that meets the objectives of the Act cannot be developed, or if unique opportunities exist to further the goals of the Act through other means, approval may be requested from IDNR for the following:

Acquisition of high quality wetlands and associated buffer;

Funding of needed relevant research; or

Wetlands compensation that provides replacement of the same and different wetland types as the adversely impacted wetlands.

Consistent with the requirements of the Interagency Wetland Policy Act, IDOT Divisions shall consider opportunities for increasing the quantity and quality of the State's wetlands resources as a component of ongoing operations to augment the amounts of wetlands provided through compensatory mitigation. These opportunities will be pursued primarily through cooperative initiatives with the IDNR. Such opportunities will be assessed for practicality and implemented as funding and manpower resources allow.

In identifying and evaluating potential sites for IDOT wetlands compensation accounts or other project-specific wetlands compensation, IDOT will coordinate with IDNR to obtain information as appropriate on potential sites that would be suitable for establishment of wetlands and that would complement IDNR natural resource programs and property management objectives. IDOT will consider the information from IDNR along with information obtained from other sources in proposing sites for approval. As practical, IDOT will give priority to pursuing the sites that would complement IDNR programs and objectives in developing compensation for IDOT projects.

VI. Processing Procedures

Project coordination with IDNR for actions subject to this Action Plan will be in accordance with the "Natural Resource Review and Coordination Agreement Between IDNR and IDOT," as executed in January 1996, or as subsequently amended, and the procedures in this section.

When potential impacts are identified, alternatives for avoiding and minimizing adverse impacts will be analyzed, consistent with applicable design standards and safety considerations. When the analysis of alternatives determines that the project will involve unavoidable adverse wetland impacts, IDOT will coordinate wetlands issues with IDNR in accordance with the following:

A. Programmatic Review Actions

For purposes of this Action Plan, Programmatic Review Actions are those which involve impacts to wetlands only in areas where construction is within existing rights-of-way or in new right-of-way which is contiguous to (i.e., does not separate from) the existing right-of-way and for which there is no practicable alternative which would avoid adverse wetlands impacts. Examples of project-types that could qualify as Programmatic Review Actions if they meet the preceding criteria include, but are not limited to, the following: adding through or auxiliary lanes to an existing highway, widening and resurfacing existing pavements, widening shoulders on an existing highway, realigning an existing intersection, reconstructing or replacing an existing bridge, constructing runaround detours or temporary stream crossings, and installing scour countermeasures (e.g., flexible revetment, rigid revetment, or flow control structures) for existing bridges.

Adverse wetland impacts resulting from Programmatic Review Actions will be compensated in accordance with the "minimal alteration" ratios specified in 17 Ill. Admin. Code 1090.50(c)(8) except when the affected wetlands involve any of the factors specified in that section as requiring application of a 5.5:1 ratio.

For projects which qualify as Programmatic Review Actions, project-specific coordination with IDNR for wetlands compliance generally will not be required. However, when the work involving wetlands will require coordination with the Corps of Engineers for approval of a wetlands compensation plan, IDOT will provide information describing the proposed compensation to IDNR. This submittal will allow appropriate IDNR staff the opportunity to review and comment on the proposed compensation prior to receiving the compensation plan information as a part of the permit information from the Corps. In addition, IDOT will provide IDNR periodic lists of all projects that qualified as Programmatic Review Actions and were not coordinated with IDNR. The lists will be provided quarterly during the first year of operation under this Wetlands Action Plan,

semiannually during the second year of operation, and annually thereafter. The lists will include the following information for each Programmatic Review Action:

Project name/number
Project type and location
NWI classification code for each wetland affected
Approximate size of the wetlands area(s) to be adversely affected by the project
Description of compensation
Current status and anticipated year of construction

IDOT will maintain complete files on all actions processed under this programmatic procedure. These files will be made available for audit by IDNR upon request.

For each Programmatic Review Action in which compensation will be provided through wetlands restoration or creation on a project-specific basis, IDOT will provide periodic monitoring reports in accordance with Section X of this Plan. IDOT also will notify IDNR at the end of the wetland compensation monitoring period to advise that the compensation work has been completed and to report on its success.

B. Standard Review Actions

For purposes of this Plan, Standard Review Actions are projects which involve unavoidable adverse wetlands impacts and which do not qualify as Programmatic Review Actions. Consultation with IDNR regarding wetlands shall occur on a project-by-project basis for Standard Review Actions. As the initial step in the wetlands coordination process for Standard Review Actions, IDOT will submit a Wetland Impact Evaluation to IDNR. This evaluation will be submitted after the analysis of avoidance and minimization alternatives has been completed and the anticipated location and extent of any unavoidable adverse wetlands impacts has been determined. The Wetland Impact Evaluation will include the following:

Information identifying the wetland site(s) affected and the relationship to the proposed action (including wetland delineation report(s), forms, and map(s), and NWI map(s) for the project area);

Information describing the proposed work affecting each individual wetland (e.g., placement of fill, excavation, draining, removal of vegetation) in sufficient detail to allow a thorough review of the potential adverse wetlands impacts;

Anticipated starting and ending dates for the project, if known;

Indication of the total acreage expected to be converted from wetland habitat to other use(s); and

Description of alternatives considered and an explanation of why there are no practicable alternatives to the proposed action.

Within 30 days of receipt of the Wetlands Impact Evaluation, IDNR will advise IDOT of any deficiencies in the information provided. IDNR will notify IDOT in writing of the date the Wetlands Impact Evaluation is deemed filed. Unless extended by written agreement between IDOT and IDNR, IDNR will complete its review of the Wetland Impact Evaluation within 60 days of the date it is deemed filed and will respond in accordance with 17 Ill. Admin. Code 1090.50(a)(2). IDOT may request a reevaluation of IDNR's response in accordance with 17 Ill. Adm. Code 1090.50(a)(2)(D). IDNR's final response to the Wetland Impact Evaluation will be valid for 3 years and shall be extended by IDNR upon demonstration that the project is being pursued in good faith and the conditions of the site have remained substantially unchanged.

For unavoidable adverse wetlands impacts resulting from Standard Review Actions, a project-specific wetland compensation plan will be prepared for approval by IDNR. When the necessary compensation is proposed from a wetland compensation account or other approved source of preexisting compensation credits, the compensation plan will provide information in accordance with Section VII A, below. For all other Standard Review Actions, IDNR will be provided a project-specific conceptual plan (see Section VII B) for concurrence and a wetland compensation plan (see Section VII C) for approval. IDOT will expect that the response from IDNR to the conceptual plan will indicate whether compensation sites proposed are acceptable, and whether IDNR has any other suitable sites available on which the necessary compensation would be feasible.

Unless IDOT and IDNR mutually agree to a longer time period, IDNR will respond to compensation plan submittals within 45 days of receipt. IDOT will accomplish follow-up coordination with IDNR as necessary to respond to comments from IDNR regarding the compensation proposal.

Proposals for use of wetland research funds to provide any part of the required compensation will be developed in consultation and coordination with IDNR and the Interagency Wetland Committee. Review and processing times described above will not be operative when compensation plans propose use of research funding for compensation. In these cases, IDNR will notify IDOT within 30 days of receipt of the compensation plan as to when the Committee will be convened to review the proposal for use of research funds. The review by the Committee should occur at the next regularly-scheduled Committee meeting or within 60 days of receipt of the plan by IDNR, whichever occurs first.

For Standard Review Actions, construction that would adversely affect wetlands will not commence until consultation with IDNR has occurred and IDNR has either approved the wetland compensation plan for unavoidable adverse wetland impacts or agreed that the impacts may be accumulated for after-the-fact compensation.

As provided in 17 Ill. Admin. Code 1090.50(5), IDNR approval of a compensation plan is valid for three years. For projects involving a conceptual plan and a wetland compensation plan, the three-year time frame will begin upon approval of the wetland compensation plan. If IDOT does not commence implementation of a wetland compensation plan within the three year time frame, IDOT will re-coordinate with IDNR to renew the approval prior to proceeding with implementation of the compensation plan. IDOT will determine whether any changes have occurred at the proposed compensation site which would require revision of the compensation plan and will advise IDNR. If such changes have occurred, the plan will be revised as necessary to respond to those changes.

For Standard Review Actions, status reports will be provided to IDNR on implementation of wetland compensation plans involving wetlands restoration or creation, in accordance with 17 Ill. Admin. Code 1090.50(6). These reports will include the following:

A post-construction site evaluation report which will be submitted within 90 days after completion of any construction, seeding, planting, etc. necessary for establishing the replacement wetlands; Up to 4 annual reports on the status of the replacement wetlands and any associated buffer; and A final report on the status of the replacement wetlands and any associated buffer which will be submitted 5 years after the post-construction evaluation report.

VII. Content of Wetland Compensation Plans

A. Plans for Use of Approved Preexisting Compensation Credits

When all of the necessary wetland compensation for a project is proposed from an approved wetland compensation account or other approved source of preexisting wetland credits, the following information will be provided in the wetland compensation plan:

Project name/number, location, and description

Name and address of the office responsible for the project

Indication of type(s) (per Appendix B), amount(s), and locations of wetlands affected, including the drainage basin(s) and watercourses involved

Description of alternatives which would avoid or minimize adverse impacts to the wetland and, as applicable, the reasons for their rejection

Reasons for proposing use of an approved wetland compensation account or other source of preexisting wetland credits

Description of the applicable compensation ratio(s), the amount and type (per Appendix B) of compensation credit to be provided, and the source of the credits, including location, current balances and any pending changes.

B. Conceptual Plan

When all or a part of the necessary compensation will be provided through establishment of wetlands on a project-specific basis, a conceptual plan will be provided to outline the proposed compensation. The conceptual plan will present sufficient preliminary information to enable IDNR to concur in the proposed location and approach to providing compensation prior to proceeding with development of the details necessary for actually implementing the compensation.

The following is an outline of information that a conceptual compensation plan may include. The first two items will be provided in all cases. The remaining items will be addressed as necessary and appropriate to adequately describe the project's involvement with wetlands and the proposed compensation.

Project name/number, location, and description

Name and address for the office responsible for implementation of the wetland compensation plan

Date of and summary statement of wetland surveys and the name, work address, and phone number of person(s) conducting surveys

Indication of type(s) (per Appendix B) and amount(s) of wetland affected, including drainage basin(s) and watercourse(s) involved

Description of alternatives considered which would avoid or minimize adverse impacts to the wetland and, as applicable, the reasons for their rejection

Description of the precise location of the proposed wetland replacement site (including a map, legal description, and an indication of the distance from the wetland impact location(s) for which it provides compensation) and an indication of its current land use, biological, hydrological, and soils characteristics

Description of the proposed wetlands compensation, including a clear statement of goals, description of compensating wetlands to be created, restored, or acquired (including type(s) per Appendix B, and a conceptual plan drawing showing approximate layout, shape, etc.); compensation ratios to be applied; any research funding proposed in lieu of other compensation; and, if use of preexisting wetlands credits is proposed as a component of the compensation, the source of the credits, including current balances and pending changes

General description of the work (e.g., grading, planting, importation of topsoil, alteration of hydrology) proposed to establish compensation site(s)

Indication of the entity(ies) that will assume long-term responsibility for compensation sites to be established

C. Wetland Compensation Plan

A detailed wetlands compensation plan will provide the level of information necessary for implementing proposed compensation. The wetland compensation plan will include the information from the conceptual plan in addition to the items listed in 17 Ill. Admin. Code 1090.50(c)(3), as necessary and appropriate for the specific compensation proposed.

VIII. Wetland Compensation Accounts

IDOT recognizes the benefits of consolidating compensation for numerous small impacts in larger sites. Such consolidation allows for economies of scale in planning, implementation, and maintenance of compensation and promotes the establishment of wetlands in advance of impacts that offer the potential for providing a broader range of functional benefits. IDOT also acknowledges the advantages such sites offer in terms of their potential for being located and sized to complement the plans and programs of resource agencies to make the sites more desirable for long term management and to provide enhanced environmental and social benefits for the people of Illinois. IDOT will actively pursue the development and use of wetland compensation account sites as practical for IDOT and IDOT pass-through funded projects, to maximize the benefits such sites provide. Establishment of wetland compensation accounts by IDOT or local agencies and project sponsors for use in complying with wetlands compensation requirements under the Act will be accomplished through formal agreement with IDNR. The unit of measurement for debits and credits will be established in the agreement for the compensation account. Use of credits from wetland compensation accounts will be subject to the compensation ratios in 17 Ill. Admin. Code 1090.50.

IX. Authority and Policies for Acquisition of Wetland Compensation Land

IDOT may acquire for highway purposes any property necessary for a highway project, or any other property for which a specific appropriation has been made. Mitigation property on-site or contiguous to a project will be described and discussed in appropriate project planning and design documents to adequately establish the necessity of acquisition. For other mitigation parcels, the need will be documented in wetland compensation account proposals or compensation plans submitted by IDOT and in written approval of such proposals and plans by IDNR.

Lands for IDOT wetland compensation accounts will be acquired through whatever means IDOT determines appropriate, consistent with IDOT's statutory powers and authorities.

Local agencies and sponsors may use available eminent domain authority for compensation land within project rights-of-way and, when specifically allowed by law, for off-site compensation.

X. Monitoring

Monitoring and reporting procedures for wetland compensation areas will be addressed in accordance with the following:

For IDOT or local agency wetlands compensation account (bank) sites, monitoring and reporting requirements will be specified in the interagency agreement with IDNR and other appropriate signatories authorizing establishment of the sites.

For project-specific wetlands restoration or creation associated with Standard Review Actions or with Programmatic Review Actions that will require coordination with the Corps of Engineers for approval of the wetland compensation plan, monitoring and reporting procedures will be determined in consultation with the IDNR and the Corps of Engineers as a part of the Wetland Compensation Plan.

For project-specific wetlands restoration or creation associated with Programmatic Review Actions that do not require coordination with the Corps of Engineers for approval of a wetlands compensation plan, monitoring procedures will be documented in the compensation plan on file for the project and will be based on the guidance in Chapter 5 of the "Illinois Wetland Restoration and Creation Guide" (Illinois Natural History Survey Special Publication 19, March 1997), and Chapter 8 of NCHRP Report 379 "Guidelines for the Development of Wetland Replacement Areas." The monitoring procedures will be commensurate with the size and complexity of the wetlands to be restored/created. For these actions, IDNR will be provided an annual report of the monitoring results for a period of up to 5 years, as necessary to verify wetlands success. This will be in addition to the information provided in the periodic summary reports on Programmatic Review Actions described in Section VI A.

Monitoring will be carried out by or under the direction of IDOT except when that responsibility is delegated to a local agency or sponsor, subject to approval by IDNR of the monitoring plan of that local agency or sponsor.

XI. Transfer of Wetlands

Whenever IDOT can transfer management responsibility for wetland compensation areas without jeopardizing project operation, it will submit a written request to IDNR for approval of the transfer. IDOT will ask that IDNR respond to such requests within 60 days. IDOT will identify the proposed recipient of the land and will provide or outline the terms of the transfer agreement. IDOT generally will give preference to qualified entities which can ensure appropriate management without need for funding support from IDOT for assuming the management activities.

In accordance with the requirements of the Act, and subject to obtaining any required approvals from the Governor or the State Legislature, IDOT will transfer compensation wetlands (other than those which are located within or that are otherwise an integral part of project rights-of-way) to IDNR or other eligible sponsors subject to formal transfer agreements that will fulfill all obligations of IDOT related to the approved compensation plan. In the event that IDOT is unable to find any other suitable entity to assume responsibility for long-term management of IDOT-developed wetland compensation sites, IDOT will transfer such sites to IDNR for long-term management. Such transfer shall not require a commitment from IDOT to provide funds to IDNR to support the management activities.

As long as wetland compensation property is held by IDOT, it will be maintained for its designated use. Where wetland compensation sites for IDOT pass-through funded projects are under the jurisdiction of a local agency, IDOT will require the local agency to ensure that the site will be maintained for wetlands purposes. Local agencies or sponsors may transfer wetlands or maintenance responsibilities to other public or private entities when allowed by law, subject to obtaining IDNR approval of such transfer.

If IDOT proposes the sale, exchange, or release of State-owned land containing wetlands to an entity other than another State agency, it will require the recipient of the land to grant a conservation easement which must contain provisions to protect the wetlands and any associated buffer areas from adverse impacts. Such easements will be written and recorded pursuant to the Real Property Conservation Rights Act. IDOT will attempt to have a unit of local government be the grantee of the easement. If a unit of local government cannot be obtained, IDOT will attempt to have an acceptable not-for-profit corporation or charitable trust be the grantee. If a unit of local government or not-for-profit entity cannot be obtained, IDOT will reserve conservation rights in its deed or release document and will transfer those rights to IDNR. Prior to the sale, exchange, or release of State-owned lands under IDOT control to an entity other

than another State agency, the department will submit a written request to IDNR in accordance with 17 Ill. Admin. Code 1090.90(c)(4).

XII. Compliance with Other Requirements

In implementing the provisions of this Action Plan, IDOT will ensure appropriate compliance with laws and regulations applicable to significant historic and archaeological sites and other resources requiring special consideration.

XIII. Conflict Resolution Procedures

Every effort will be made to cooperate with and coordinate wetland matters with IDNR. If circumstances arise in which a disagreement occurs over any substantive matter contained in this Action Plan or its application to IDOT actions or projects, the first attempt at resolution shall occur with technical managers in both Departments. If the matter cannot be resolved at this level within a reasonable period, it may be referred to higher management levels for resolution. The priority of the issues involved and the urgency of the need for resolution shall determine the time frames for referral to higher levels and how high within each organization the matter ultimately will be referred. If a conflict cannot be satisfactorily resolved between administrators in IDOT and IDNR, up to and including the Secretary of IDOT and Director of IDNR, the matter may be referred to the Governor's office for resolution.

XIV. Reports on Action Plan Implementation

Following approval of this Action Plan, IDOT will submit to IDNR a biennial report summarizing actions taken to implement the provisions of the Action Plan. The report will provide a listing of projects advanced through the wetlands compliance process and a tabulation of the amounts and types of associated mitigation accomplished. The report also will provide a description of other activities that resulted in the establishment of wetlands and a tabulation of the amount and type(s) of wetlands generated by those activities. The first biennial report will be submitted to IDNR on or before June 30 of the second year following initial approval of the Action Plan. Subsequent reports will be submitted on or before June 30 every other year thereafter.

Appendix A

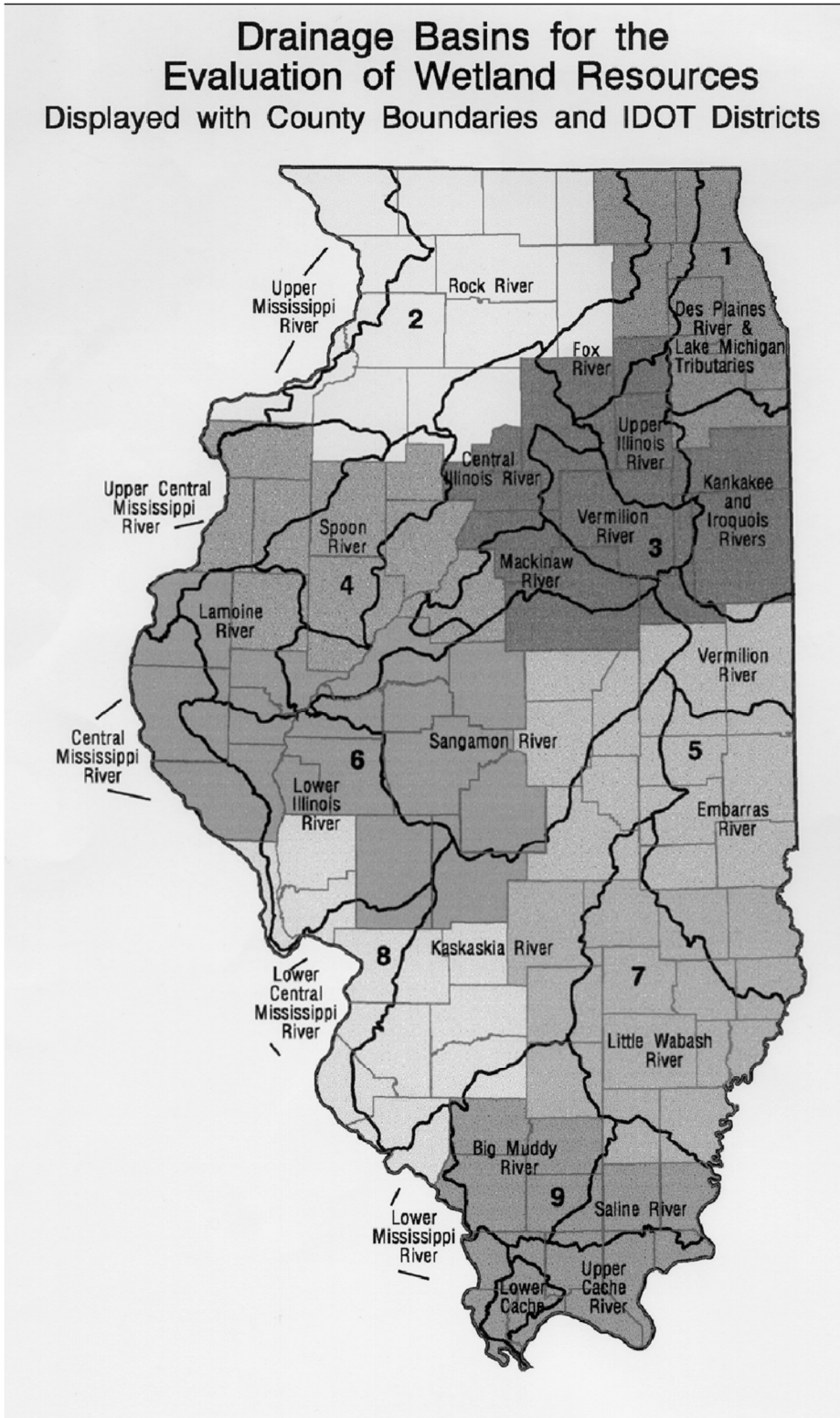

Appendix B

Wetlands Categories

Wetlands in Illinois can be classified into 12 categories as indicated below (refer to the accompanying category definitions), all of which are afforded protection under the Interagency Wetland Policy Act of 1989. For purposes of the IDOT wetland action plan, “disturbed” wetlands are treated as a separate category and the remaining categories are placed in three groups indicating their relative quality/complexity/rarity. (The order in which the wetland types are listed within each group does not indicate a relative ranking of the types within the group.) The groups are discussed in the following paragraphs and are intended primarily to guide project decision makers in planning wetlands compensation that will contribute to improving the quality of wetlands in Illinois.

□Group 1

**Bog
Fen
Flatwoods**

Wetland types represented by the Group 1 categories are the rarest types in Illinois. Because of the unique geological and topographic conditions essential to their existence, the potential for creating replacement wetlands of these types is extremely limited (in the case of fens) or nonexistent (in the case of bogs and flatwoods). The utmost effort shall be made to avoid any adverse impacts to wetlands in these categories.

□Group 2

**Sedge Meadow
Prairie, wet
Swamp**

Group 2 wetland types are high quality, relatively complex systems. They are somewhat limited in their occurrence in the State because of the special conditions on which their existence depends. Because of their complexity, they will be somewhat difficult to create or establish and will have to meet demanding site criteria in order to be sustainable. For unavoidable impacts to Group 2 wetlands, compensation shall be of the same type as the wetland affected, to the fullest extent possible.

□Group 3

**Marsh
Wet meadow
Forested
Scrub-shrub
Open water**

Group 3 wetlands are the most prevalent in Illinois. These categories also can be more readily created or established in more areas of the State than can Group 1 or Group 2 wetlands.

□Disturbed wetlands

Disturbed wetlands include sites such as farmed wetlands, successional old fields, and urban disturbed areas which, because of their disturbed nature, do not readily fit any other wetlands category. For Disturbed wetlands, compensation for unavoidable adverse impacts will not be in-kind; it shall be either a Group 3 type or a Group 2 type.

Definitions of Wetland Categories

Bog The bog communities of Illinois are found almost exclusively in glaciated depressions of the northeast corner of the state. Drainage is usually restricted, and this, coupled with an abundance of sphagnum moss, results in conditions which are highly acidic. The soils of a bog are saturated throughout the growing season in most years, and small open water areas are common. Vegetation consists of a variety of emergents with shrubs and/or small trees occurring on more consolidated peat. (At the beginning of 1994, there were 10 identified bogs in Illinois which comprised 232.8 acres.)

Definition adapted from A Field Guide to the Wetlands of Illinois, 1988)

Fen A fen is a type of wet meadow fed by an alkaline water source such as a calcareous spring or seep. The deposition of calcium and magnesium in the soil results in an elevated soil pH and gives rise to a variety of unique plants adapted to surviving these conditions. The vegetation is normally comprised of herbaceous emergents although woody shrubs or even trees sometimes occur. (At the beginning of 1994, there were 20 identified fens in Illinois which comprised 153.1 acres.)

Definition adapted from A Field Guide to the Wetlands of Illinois, 1988.

Flatwoods Flatwoods are woodlands growing on level surfaces, usually with widely spaced trees, with slowly permeable and poorly drained soils that contain an argillic horizon or claypan. (At the beginning of 1994, there were 24 identified flatwoods in Illinois which comprised 617.5 acres.)

Definition adapted from White, John, 1978. Illinois Natural Areas Inventory Technical Report, Volume 1 Survey Methods and Results.

Sedge Meadow A sedge meadow is a wetland dominated by sedges (*Carex*) and occurring on peat, muck, or wet sand.

Definition adapted from White, John, 1978. Illinois Natural Areas Inventory Technical Report, Volume 1 Survey Methods and Results.

Prairie, wet A wet prairie is a community dominated by graminoid vegetation on mineral soil which is almost always saturated.

Definition adapted from White, John, 1978. Illinois Natural Areas Inventory Technical Report, Volume 1 Survey Methods and Results.

Swamp A swamp is a wetland characterized by the presence of permanent to semi-permanent water and a greater than 30% areal canopy cover of tall (over 20 feet) woody vegetation. In many areas, the canopy cover exceeds 80%.

Definition adapted from A Field Guide to the Wetlands of Illinois, 1988.

Marsh A marsh is a wetland in which tall graminoid plants dominate the plant communities. Marshes have water near or above the surface for most of the year. Soils may be peat, muck, or mineral.

Definition adapted from White, John, 1978. Illinois Natural Areas Inventory Technical Report, Volume 1 Survey Methods and Results.

Wet meadow A wet meadow is a wetland characterized by moist to saturated soils with standing water present for only brief to moderate periods during the growing season. Vegetation includes a wide variety of herbaceous species, from sedges and rushes to forbs and grasses. Woody vegetation, if present, accounts for less than 30% of the total areal cover.

Definition adapted from A Field Guide to the Wetlands of Illinois, 1988.

Forested Forested wetlands differ from true swamps in that they lack continuously standing water, although repeated flooding is common. Differences in the length of inundation give rise to a variety of community types within this classification.

Definition adapted from A Field Guide to the Wetlands of Illinois, 1988.

Scrub-shrub A scrub-shrub wetland typifies a community in transition and exemplifies the dynamic nature of wetlands in general. Many emergent wetlands left undisturbed, will gradually be replaced through succession by woody vegetation that will in time develop into a mature forest. The scrub-shrub wetland is often found grading shoreward from an emergent wetland which borders a lake, stream, or pond. The woody vegetation accounts for at least 30% of the vegetation present, and must be less than 20 feet (6 meters) tall. Species composition is dependent on the length of inundation, with willows and dogwood growing in the temporarily to seasonally wet areas and buttonbush in semi-permanently flooded areas.

Definition adapted from A Field Guide to the Wetlands of Illinois, 1988.

Open water wetlands Small and shallow [area < 20 acres (8.1 ha) and depth < 6.6 ft. (2 m)] open water areas that lack emergent woody or graminoid vegetation. Natural ponds, farm ponds, borrow pits, and open water areas that occur within a marsh or swamp are included in this category. (Lacustrine and riverine systems are not included in this category.)

**ILLINOIS DEPARTMENT OF TRANSPORTATION'S
AGRICULTURAL LAND PRESERVATION POLICY STATEMENT AND
COOPERATIVE WORKING AGREEMENT**

PREFACE

The Farmland Preservation Act [505 ILCS 75/1 et seq.] requires the Department of Transportation (IDOT) and seven other State agencies to develop a policy statement specifying each agency's policy toward farmland preservation. IDOT has prepared the following statement in response to that requirement. A working agreement has also been prepared to describe the administrative process that will be used to implement the policy. The Agricultural Land Preservation Policy prepared in response to Executive Order 80-4, signed by Governor James R. Thompson on July 22, 1980, will also remain in effect in accordance with Section 4 of the Farmland Preservation Act.

POLICY

Recognizing that its transportation objectives must be in concert with the overall goals of the State, it is the policy of the IDOT, in its programs, procedures, and operations, to preserve Illinois farmland to the extent practicable and feasible, giving appropriate consideration to the State's social, economic, and environmental goals.

BACKGROUND/PERSPECTIVE

Highways, rail systems, airports, and port terminals by their nature, occupy land. The extent that transportation facilities will occupy today's farmland in the future primarily will depend on the IDOT's programs, safety and operational requirements, and the degree to which a responsible balance is established among the various development and preservation interests of the State of Illinois.

With the existence of a comprehensive and largely complete transportation system in Illinois, the IDOT's major program emphasis is directed toward preservation and rehabilitation of existing facilities, rather than expansion. Rehabilitation of the system for full and effective use, however, will require some additional land acquisitions to satisfy current safety and operational requirements. A limited number of new or expanded transportation facilities will be required in order to attract business and industry and improve service and access to Illinois markets. Expansion efforts must be carefully managed to preserve the agricultural community while serving the rural areas of the State.

In the past, new transportation facilities often were constructed on farmlands. This was due, in part, to a number of Federal laws and regulations pertaining to the protection of other sensitive areas, such as floodplains, wetlands, wildlife habitat, etc. Special protection is also provided for parks and historic sites. Federal law requires that such lands not be used for Federal-aid highway purposes, unless no feasible and prudent alternative is available. Executive Order 80-4 and the Farmland Preservation Act increase the protection afforded to farmland, so that it is commensurate with the importance of the resource.

It should be noted that new transportation facilities generally involve some conversion of farmland since farmland occupies a major portion of the State and engineering constraints, safety considerations, occurrence of developed areas and protection afforded to other types of resources (e.g., historic sites, publicly owned parks, recreation area and wildlife and waterfowl refuges, wetlands and habitat essential to threatened or endangered) often limit the options for avoiding conversion.

AGRICULTURAL IMPACTS OF HIGHWAY CONSTRUCTION

The rate of farmland conversion for highway usage is expected to remain near current levels. The current emphasis on rehabilitation of the existing system is expected to continue in the future and such a program is not expected to require significant land acquisitions. Because much of today's system was constructed in the 1920's and 1930's, an extensive and continuing program is necessary to rehabilitate and replace narrow and deteriorated bridges and pavements. However, a great amount of farmland could sustain conversion due to the rehabilitation of existing highways and the construction of new interstate projects. Mitigation measures for reducing adverse agricultural impacts are routinely introduced into highway designs. For example, current design practices encourage use of narrower medians and smaller interchanges. There is an increased importance given to agricultural conversions in decisions regarding highway projects. Where practicable, highway designs feature reduced medians, larger crossovers to accommodate farm equipment, minimization of landlocked parcels and severances, as well as upgraded field entrances to reduce farmland conversion impacts and secondary impacts to agricultural operations.

AGRICULTURAL IMPACTS OF AIRPORT DEVELOPMENT

With a few exceptions, the State Airport System is mature and in place. One exception includes the development of a third major airport to serve the Chicago area and its environs. In addition, construction of four or five new small airports is anticipated over the next 20 years. Limited expansion of existing airports may also be undertaken. Safety requirements of proposed airport projects will be balanced with an analysis of farmland impacts as required by Executive Order 80-4, the Farmland Protection Act, and this Department Policy Statement.

AGRICULTURAL IMPACTS OF RAILROADS

The Illinois railroad system is a mature network which includes mainlines and branchlines. This system has been gradually shrinking over the years as light density lines are abandoned and traffic is concentrated on fewer lines. Occasionally, the net result of branchline abandonment has been an increase in the amount of land in agricultural production since abandoned right-of-way can be restored to farmland usage.

The IDOT does not own or operate railroad lines and does not exercise jurisdiction over most railroad project which might affect farmland. However, in those instances where future IDOT decisions regarding railroad projects might impact the State's farmland resources, due consideration will be given to preserving agricultural land and minimizing adverse impacts on its productive capacity.

IMPACT MITIGATION

The IDOT is committed to initiating special measures when transportation projects affect agricultural lands. Design standards are periodically reviewed and revised, and the new standards tend to favor minimal land acquisition, taking only those lands needed for construction and maintenance. For example, standardized right-of-way requirements for certain types of highways have been eliminated in favor of flexible requirements that stipulate acquisition of only those lands essential for construction and maintenance. Minimum median widths and compressed diamond interchanges also are representative of mitigation measures that reduce the adverse impact of highway construction on agricultural resources. The IDOT will also place a high priority on selecting lands which are not upland prime farmlands for wetland mitigation purposes in devising wetland compensation plans. Consideration will also be given to mitigating wetland impacts on publicly owned lands (State or Federal lands). In developing proposals for wetland compensation or other environmental mitigation and in the selection of State furnished borrow pits, IDOT will pursue practical alternatives to minimize impacts to prime and important farmland and farm

operations. Where land is purchased to prevent developments incompatible with transportation system safety or noise standards, such as land adjacent to airports, the IDOT will give priority to acquiring easements on its own projects and will encourage other agencies to acquire only the development rights in the surrounding areas, so that the acreage can continue in agricultural use.

Planning studies for transportation will include an early determination of the potential for farmland impacts. The IDOT will carefully consider the impacts of farmland conversion on the agricultural economy of the State. Studies conducted in conjunction with transportation projects will include early coordination and consultation with the Illinois Department of Agriculture (IDOA) and, when appropriate, other agricultural representatives. This interdisciplinary approach should assure that the impacts of IDOT projects on the agricultural community are adequately and accurately assessed.

Although the IDOT's mitigation measures will not necessarily eliminate the conversion of farmland to non-agricultural purposes, impact analysis and extensive coordination will assure that a given conversion is consistent with our programmatic responsibilities, Executive Order 80-4, and the Farmland Preservation Act.

Illinois Department of Transportation – Illinois Department of Agriculture Cooperative Working Agreement

Pursuant to Section 4 of the Farmland Preservation Act, the Illinois Department of Transportation ("IDOT") and the Illinois Department of Agriculture ("IDOA") hereby mutually agree to the following:

This Cooperative Working Agreement ("AGREEMENT") sets the guidelines for the implementation of the IDOT Agricultural Land Preservation Policy.

This AGREEMENT shall apply to those projects which the IDOT authorizes, or in which it participates, except the following:

- a) Those non-linear (spot) projects acquiring 10 acres or less of land;
- b) Those linear projects acquiring 3 acres or less of land per project mile;
- c) Those projects located within the boundary of an incorporated municipality.

If any of the above thresholds are exceeded, it is the responsibility of IDOT to coordinate projects that will convert prime and important farmland to nonagricultural purposes. The IDOT agrees to notify, in writing, the IDOA of projects that will have an impact on farmland in Illinois. The notice from the IDOT should always be sent to the IDOA in the early planning stage of project development, within the location and environmental study phase and prior to the holding of any public hearings related to the project. For projects involving compensation for wetland or other environmental impacts, environmental analysis provided to IDOA in accordance with this Section will include information describing the impacts and associated proposed mitigation. This notice may be accomplished by the transmission of documents such as, but not limited to, the following:

- a) proposed airport layout plans;
- b) draft and / or final Environmental Assessments, Environmental Impact Statements, or Technical Reports;
- c) Illinois Rail Plan, and
- d) FY Highway Improvement Plan

The IDOA shall determine whether a Study of Agricultural Impacts is needed or not. When IDOA finds that such a study is necessary, the study shall be conducted as provided in paragraph 8 below.

The IDOT will update its notices of farmland impacts to the IDOA as plans are changed and new information becomes available.

The IDOT will cooperate in IDOA's preparation of its annual report to the Governor and to the General Assembly on the amount of farmland converted to non-agricultural uses as a result of State agency action. The IDOA will attempt to advise the IDOT of the type of information needed one year in advance of the request for that information.

The IDOT will mitigate the agricultural impacts of its projects covered by this AGREEMENT as provided in the Illinois Department of Transportation "Agricultural Land Preservation Policy" and its subsequent amendments.

The IDOA further agrees to the following:

- a) to follow its project review process contained in its "Agricultural Land Preservation Policy" as amended, or other procedures upon which the parties have agreed, in carrying out its review under this AGREEMENT;
- b) to complete its review of IDOT projects within 30 days after notice with all required project information from the IDOT;
- c) to provide information and assistance to the IDOT and its consultant upon request, and
- d) to provide its comments in accordance with the procedures specified in the relevant documents or as otherwise agreed between it and the IDOT.

The Illinois Departments of Agriculture and Transportation further agree that this AGREEMENT shall bind each only to the other and creates no rights in third parties.

All changes to the AGREEMENT shall be made after consultation with and concurrence by both parties.

This AGREEMENT shall become effective upon its signature by the Secretary of Transportation and the Director of Agriculture and shall remain in effect until January 1, 2011.

APPROVED:

ILLINOIS DEPARTMENT OF AGRICULTURE

By: _____ [signed] _____ 5/21/08
Thomas E. Jennings, Acting Director Date

ILLINOIS DEPARTMENT OF TRANSPORTATION

By: _____ [signed] _____ 5/12/08
Milton R. Sees, Secretary Date

**Memorandum of Understanding
Among the Federal Highway Administration,
the U.S. Environmental Protection Agency (Region 5),
and the Illinois Department of Transportation Regarding
Sole Source Aquifers
in the State of Illinois**

I. INTRODUCTION

The purpose of this memorandum is to develop an understanding among the U.S. Environmental Protection Agency (EPA) Region 5, the Federal Highway Administration (FHWA), and the Illinois Department of Transportation (IDOT), collectively referred to as the "PARTIES" and individually referred to as "PARTY," concerning the review of Federal-aid highway projects that may contaminate any Sole Source Aquifer (SSA) located in the State of Illinois (hereinafter referred to as the "Aquifers"), as shown in Attachment A. Section 1424(e) of the Safe Drinking Water Act of 1974 (the Act) (42 U.S.C. § 300h-3(e)) states that once the EPA issues a notice of determination designating all or part of an aquifer as an SSA, "no commitment for Federal financial assistance (through a grant, contract, loan guarantee, or otherwise) may be entered into for any project which the Administrator determines may contaminate such aquifer through a recharge zone so as to create a significant hazard to public health, but a commitment for Federal financial assistance may, if authorized under another provision of law, be entered into to plan or design the project to assure that it will not so contaminate the aquifer."

This Memorandum of Understanding (MOU) outlines the criteria used to evaluate proposed projects within the State of Illinois that are subject to review under the Act and the procedures to be followed by the PARTIES in evaluating and reviewing proposed projects. This MOU also outlines the categories of proposed projects that do not need to be submitted to EPA for review.

The IDOT will caution all contractors of the location of designated SSAs, identify applicable permits and recommended Best Management Practices (BMPs) necessary to minimize impact to the Aquifers.

This MOU is a voluntary agreement that expresses the good-faith intentions of the parties, is not intended to be legally binding, and is not enforceable by any party.

This MOU does not create any right or benefit, substantive or procedural, enforceable by law or equity, by persons who are not party to this MOU, or against the PARTIES, their officers or employees, subrecipients, or any other person. This MOU does not apply to any person outside of the PARTIES except for subrecipients of FHWA-funding where IDOT has oversight authority.

II. APPLICABILITY

This MOU applies to the review of all projects within all current and future SSA areas in the State of Illinois. When an aquifer in the State of Illinois is designated as an SSA, EPA will notify FHWA and IDOT, and Attachment A will be updated as necessary.

III. GOAL

The goal of this MOU is to assure each project receiving Federal-aid highway funding or requiring FHWA approval is planned, designed and constructed in a manner that will not contaminate an SSA so as to not create a significant hazard to public health as defined in Attachment B.

IV. GUIDING PRINCIPLES FOR PROJECT REVIEW

For the purposes of this MOU, in determining whether the act of constructing a proposed project would create a significant hazard to public health, the following factors, at a minimum, shall be considered:

1. The toxicity and migration/transformation potential of the contaminants involved;
2. The volume of contaminants that may enter any of the Aquifers; and
3. Characteristics of the Aquifers in the area affected by the project (i.e., geochemical, hydrological, geological, etc.), and attenuation capability of the Aquifers.

Attachment B contains additional definitions for terms used in this MOU.

V. CRITERIA AND PROCEDURES

A. The current procedure for submission and review of projects is as follows:

1. The IDOT will review proposed projects to determine if they require EPA SSA review. The Illinois Bureau of Design and Environment (BDE) Manual contains steps to determine if a project requires EPA SSA review.

2. The IDOT will submit a brief written narrative to EPA describing the proposed project highlighting any risks that could create a significant hazard to public health. If there are any risks due to the project that could create a significant hazard to public health, the narrative will identify the proposed mitigation measures to the EPA SSA Coordinator.

3. The EPA agrees that all requests for Region 5 SSA reviews shall be responded to within thirty (30) calendar days of receipt unless:

a) There are comments (with substantiating data) arising from review by the public, interested agencies, and tribes, indicating potential adverse impacts on the Aquifers. The IDOT, through FHWA, will immediately send these comments to EPA who will notify FHWA and IDOT within thirty (30) calendar days of receipt of the comments regarding EPA's decision. The EPA reserves the right to extend this time period when it finds that additional information is needed, that additional administrative review is necessary, or that it will be in the public interest to hold a public meeting. The EPA will notify FHWA of any extension of the review time period.

b) The EPA receives a citizen's request at any time during the review or at any time before FHWA has approved the project's final environmental document, the EPA will immediately notify FHWA and IDOT (in writing, if time permits or by telephone if the end of the comment period is near). The EPA will consult with FHWA and IDOT as necessary to reevaluate the project with respect to the concern[s] contained in the request, and will notify FHWA and IDOT within thirty (30) calendar days of receiving such request information of EPA's decision.

c) The EPA requests additional review time either by telephone or in writing. If EPA requests additional time, EPA will inform FHWA and IDOT within thirty (30) additional calendar days, or any other reasonable period of time needed to conduct the review, of the results of this evaluation.

4. The EPA review will result in one of the following outcomes, which will be submitted in writing to IDOT and, if appropriate, FHWA:

- a) A determination that the proposed project as designed most likely will not result in contamination of the Aquifers so as to create a significant hazard to public health and no further assessment or evaluation is required.
- b) A determination that the project has the potential to result in contamination of the Aquifers so as to create a significant hazard to public health, and a Detailed Ground Water Impact Assessment is required.
- i. If such a determination is made, EPA and FHWA will agree on measures that must be implemented to assure that no contamination of the Aquifers that would result in a significant hazard to the public health will occur; and
- ii. The FHWA and IDOT will inspect and monitor to ensure that such measures are implemented.
5. FHWA and IDOT may advance the project after notifying in writing the EPA Region 5 Sole Source Aquifer Coordinator that the official review period has concluded. Although comments from EPA will be accepted at any time, FHWA and IDOT will consider to the maximum extent practicable those comments that are submitted after the official review period has concluded, and will accept EPA's final determination (which will be announced after consultation with FHWA and IDOT).
6. When roadways and/or bridges need emergency repair as determined by FHWA, most such repairs will meet the criteria in Section V.B. "Projects Exempt from EPA Review". If emergency activities do not meet the Section V.B. criteria, EPA will strive to complete its review in such emergency situations within seven (7) calendar days of receipt of FHWA's notification. In the rare cases when the emergency circumstances require immediate attention to address threats to life or property, and the activities do not meet the exemption criteria, then emergency repairs will proceed and FHWA shall notify EPA as soon as practicable.
- To the extent practicable for the emergency situation, IDOT will ensure that emergency repairs are conducted in a manner that will not contaminate an SSA so as to create a significant hazard to public health.
7. The EPA will maintain a project review file that includes copies of all project review documents and correspondence.

B. Projects Exempt from EPA Review

Federal-aid highway projects that do not pose a significant hazard to public health in the Project Review Area are excluded from EPA review. Those projects classified as Categorical Exclusions (CEs) under 23 C.F.R. § 771.117 typically will not impact the Aquifers because they do not require substantial excavation depth (greater than 10 feet), and do not require the use of chemicals listed in the National Primary Drinking Water Regulations, 40 C.F.R. Part 141. In addition, all IDOT projects, including CEs, are subject to permit requirements in the Clean Water Act (CWA), including CWA BMPs. Implementation of these BMPs will prevent the exceedance of drinking water standards in surface waters, so will be protective of the SSA. Therefore, CEs will not pose a significant hazard to public health and are exempt from EPA review.

The EPA reserves the right to review an exempt project upon written notice to FHWA and IDOT should new information lead it to conclude the project may contaminate an SSA so as to create a significant hazard to public health.

VI. MODIFICATION AND TERMINATION

This MOU is to take effect upon signature and remain in effect for a period of five (5) years. This MOU may be extended or modified, at any time through the mutual written consent of the PARTIES. Additionally, a PARTY may terminate its participation in this MOU at any time by providing written notice to the other PARTIES, at least ninety (90) days in advance of the desired termination date.

VII. COORDINATION AND CONTACTS

Materials furnished to EPA by IDOT, with a copy to FHWA, under this MOU will be addressed to the attention of the SSA Program Contact listed on the Region 5 EPA SSA website.

Agency contact information is listed as follows: FHWA: Environmental Engineer
FHWA Illinois Division
3250 Executive Park Drive Springfield, IL 62703
(217) 492-4600

IDOT: Illinois Department of Transportation
Design and Environment Bureau Chief, Room 330 2300 S. Dirksen Parkway
Springfield, IL 62764
(217) 782-7820

USEPA: Sole Source Aquifer Coordinator
Water Division, Groundwater and Drinking Water Branch
U.S. Environmental Protection Agency, Region 5 (WG-15J) 77 W. Jackson Blvd.
Chicago, IL 60604
(see the Region 5 EPA SSA website for current contact information)

This MOU is subject to revision upon agreement of all of the following agencies.



Randall S. Blankenhorn, Secretary
Illinois Department of Transportation
Date:



Catherine A. Batey, Division Administrator
Illinois Division, Federal Highway Administration
Date: *July 28, 2017*

 *8/28/17*

Robert A. Kaplan, Acting Regional Administrator
Environmental Protection Agency, Region 5
Date:

ATTACHMENT A - AQUIFERS

Pursuant to the Safe Drinking Water Act, EPA has determined that the Mahomet Aquifer System in Illinois is the sole or principal drinking water source for its designated area. See EPA's March 19, 2015 Notice of Determination at 80 Fed. Reg. 14370. As such, no commitment for Federal financial assistance identified by FHWA as Federal-aid highway funding may be authorized, and no FHWA approval may be given, for projects within the boundaries of the Mahomet Aquifer's designated Project Review Area for any project that EPA determines may contaminate this designated aquifer through its recharge area so as to create a significant hazard to public health.

Map of the Mahomet Sole Source Aquifer Project Review Area:

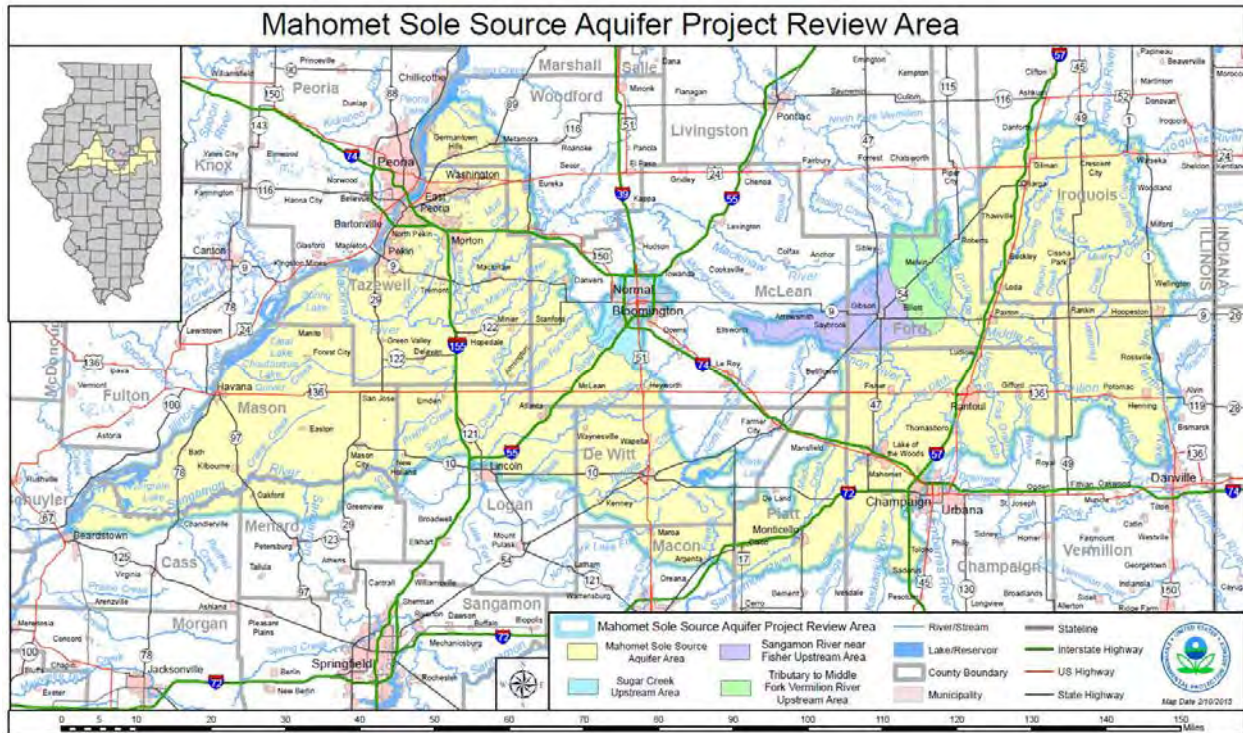

ATTACHMENT B - DEFINITIONS

Aquifer means a geological formation, group of formations, or part of a formation that is sufficiently permeable that when saturated can yield useful quantities of groundwater to wells, springs, or streams (Illinois Groundwater Protection Act 1987).

Designated Area means the surface area above the aquifer and its recharge area.

Federal Financial Assistance for the purpose of this MOU is defined as Federal-aid highway projects (described below). It does not include actions or programs carried out directly by or on behalf of the Federal government (e.g., U.S. Army Corps of Engineers 404 permits, U.S. Coast Guard permits, etc.). EPA determines whether projects receive "Federal financial assistance" on a case- by-case basis and based on the specific project, person, or entity completing the project, source of Federal funds involved, and any other relevant factors.

Federal-Aid Highway Project is any roadway or bridge project that receives Federal-aid highway funding (i.e., "Federal financial assistance" referred to in Section 1424(e) of the Safe Drinking Water Act) or that requires any FHWA approval action, such as interstate access approvals.

Pollution Generating Impervious Surface (PG/SJ) means an impervious surface that is considered a significant source of pollutants in stormwater runoff, including surfaces that receive direct rainfall (or run-on or blow-in of rainfall) and are subject to vehicular use; industrial activities; or storage of erodible or leachable materials, wastes, or chemicals. Erodeable or leachable materials, wastes, or chemicals are substances that, when exposed to rainfall, measurably alter the physical or chemical characteristics of the rainfall runoff. Examples include roadways, sidewalks that are regularly treated with salt or other deicing chemicals, erodible soils that are stockpiled, uncovered process wastes, fertilizers, oily substances, ashes, kiln dust, and garbage container leakage. A surface, whether paved or not, is considered subject to vehicular use if it is regularly used by motor vehicles. The following are considered regularly used surfaces: roads, un-vegetated road shoulders, bicycle lanes within the travel lane of a roadway, driveways, parking lots, unfenced fire lanes, vehicular equipment storage yards, and airport runways.

Project Review Area means the area within which Federal financially-assisted projects will be reviewed, which could include all or part of the designated area and streamflow source areas identified on the Project Review Area map.

Significant Hazard to Public Health means the level of contaminants in an Aquifer that would:

1. Exceed National Primary Drinking Water Standards, or
2. Exceed Federal, Tribal or State public health advisory levels for currently unregulated contaminants, or
3. Violate the intent of Executive Order 12088, "Federal Compliance with Pollution Control Standards".

Sole Source Aquifer (SSA) means an aquifer which is designated as a Sole or Principal Source Aquifer under section 1424(e) of the Safe Drinking Water Act. An SSA is an aquifer designated by EPA as the "sole or principal source" of drinking water for a given aquifer service area; that is, an aquifer which is needed to supply 50% or more of the drinking water for that area and for which there is no reasonably available alternative sources should the aquifer become contaminated. A project that is "located within a sole source aquifer" means a Federal-aid highway project with any associated construction element that is situated within the boundaries defined on the Sole Source Aquifer Project Review Area map.

**PROGRAMMATIC AGREEMENT AMONG
THE FEDERAL HIGHWAY ADMINISTRATION,
THE ILLINOIS DEPARTMENT OF TRANSPORTATION,
THE ILLINOIS STATE HISTORIC PRESERVATION OFFICER,
AND THE ADVISORY COUNCIL ON HISTORIC PRESERVATION REGARDING
SECTION 106 IMPLEMENTATION FOR FEDERAL-AID TRANSPORTATION PROJECTS
IN THE STATE OF ILLINOIS**

WHEREAS, the Federal Highway Administration (FHWA), under the authority of 23 USC 101 et seq., implements the Federal-aid Highway Program (Program) in the State of Illinois by funding and approving state and locally sponsored transportation projects that are administered by the Illinois Department of Transportation (IDOT); and

WHEREAS, the Illinois FHWA Division Administrator is the "Agency Official" responsible for ensuring that the Program in the state of Illinois complies with Section 106 of the National Historic Preservation Act (NHPA) of 1966, as amended (54 USC 300101) (Section 106), and codified in its implementing regulations, 36 CFR Part 800, as amended (August 5, 2004); and

WHEREAS, federal Aid Highway projects are subject to the National Environmental Policy Act of 1969 (NEPA), 42 U.S.C. § 4321 et seq., and the Regulations for Implementing the Procedural Provisions of NEPA (40 CFR parts 1500-1508), which require Federal agencies to consider one of three classes of action: 1) environmental impact statement (EIS), 2) environmental assessment (EA), or 3) categorical exclusion (CE); and

WHEREAS, as used herein, the term "SHPO" means the official appointed or designated pursuant to section 101(b)(1) of the NHPA, as amended (54 U.S. Code § 302301(1)), to administer the State historic preservation program or a representative designated to act for the State historic preservation officer (see 36 CFR § 800.16(v)); and

WHEREAS, the responsibilities of the Illinois State Historic Preservation Officer (SHPO) under Section 106 and 36 CFR Part 800 are to advise, assist, review, and consult with federal agencies as they carry out their historic preservation responsibilities and to respond to federal agencies' requests within a specified period of time; and

WHEREAS, the Illinois State historic preservation program presently resides within the Illinois Department of Natural Resources (IDNR), and the current Director of IDNR, Wayne A. Rosenthal, is the duly designated SHPO; and

WHEREAS, FHWA has determined that implementation of the Program in Illinois may have an effect upon properties included in, or eligible for inclusion in, the National Register of Historic Places (NRHP), hereafter referred to as historic properties, and has consulted with SHPO and the Advisory Council on Historic Preservation (ACHP) pursuant to 36 CFR 800.14(b) concerning this Programmatic Agreement (Agreement); and

WHEREAS, PHWA, SHPO, and IDOT cooperate in meaningful, long-term planning for the protection of historic properties and desire to (1) devote time and energy to identifying transportation-related concerns potentially affecting historic properties; (2) create innovative programs to address those concerns; and (3) develop a comprehensive and efficient Section 106 process that simplifies procedural requirements; and

WHEREAS, 36 CFR Part 800 encourages federal agencies to fulfill their obligations efficiently under Section 106 through the development and implementation of cooperative programmatic agreements; and

WHEREAS, in the spirit of stewardship, PHWA and IDOT are committed to designing transportation projects to 1) avoid, minimize, and mitigate adverse effects to historic properties, 2) utilize IDOT's "Context-Sensitive Solutions" approach, and 3) balance transportation needs with other needs of Illinois' communities; and

WHEREAS, FHWA has notified the public, federal and state agencies, Certified Local Governments (CLGs), and federally recognized Indian Tribes (Tribes) with an interest in Illinois lands about this Agreement, has requested their comments, and has taken any comments received into account; and

WHEREAS, FHWA retains the government-to-government responsibility to consult with federally recognized Tribes, and will follow the stipulations contained in the Memorandum of Understanding Regarding Tribal Consultation Requirements for the Illinois Transportation Program, as amended (Tribal MOU) which shall remain in effect, and is attached to this Agreement; and

WHEREAS, pursuant to the consultation conducted under 36 CFR 800.14(b), the signatories have developed this Agreement in order to establish an efficient and effective program alternative for taking into account the effects of the Program on historic properties in Illinois and for affording ACHP a reasonable opportunity to comment on undertakings covered by this Agreement; and

WHEREAS, ACHP has approved an exemption on March 10, 2005 that relieves federal agencies from the requirement of taking into account the effects of their undertakings on the Interstate Highway System, with the only exception in Illinois being the Interstate 74 Iowa-Illinois Memorial Bridge connecting Bettendorf, Iowa, with Moline, Illinois; and

WHEREAS, IDOT will apply ACHP's November 16, 2012 "Program Comment Issued for Streamlining Section 106 Review for Actions Affecting Post-1945 Concrete and Steel Bridges" that eliminates historic review requirements under Section 106 of the NHPA for the repair or replacement of common types of post-1945 concrete and steel bridges; and

WHEREAS, FHWA and IDOT will align their compliance with Section 106 to the fullest extent possible in coordination with their policies and procedures under the National Environmental Policy Act (NEPA) and Section 4(f) of the Department of Transportation Act of 1966, pursuant to Section 1301 of the Fixing America's Surface Transportation (FAST) Act.; and

WHEREAS, IDOT has participated in consultation and has been invited to be a signatory to this Agreement; and

WHEREAS, IDOT primarily utilizes the services of the Illinois State Archaeological Survey (ISAS) through an intergovernmental agreement with the Prairie Research Institute at the University of Illinois, to gather information, analyze data, prepare documentation, make eligibility recommendations, and complete mitigation requirements; and

WHEREAS, IDOT publishes and maintains a manual that establishes uniform policies and procedures for the location, design, and environmental evaluation of highway construction projects (the IDOT Manual); and

WHEREAS, the IDOT Manual describes the public involvement guidelines for involving the public in the project development process and the procedures followed to comply with Section 106; and

WHEREAS, this Agreement shall supersede the Programmatic Agreement among FHWA, IDOT, ACHP, and SHPO "Regarding the Implementation of Delegation of Authority for Minor Projects of the Federal-aid Highway Program in the State of Illinois", executed on September 21, 2010;

NOW, THEREFORE, FHWA, ACHP, SHPO, and IDOT agree that the Program in Illinois shall be carried out in accordance with the following stipulations in order to take into account the effects of the Program on historic properties in Illinois, and that these stipulations shall govern compliance of the Program with Section 106 until this Agreement expires or is terminated.

STIPULATIONS

The FHWA, with the assistance of IDOT, and SHPO shall ensure that the following stipulations are carried out.

I. Purpose and applicability

This Agreement sets forth the process by which FHWA, with the assistance of IDOT, will meet its responsibilities pursuant to Sections 106 and 110 of the NHPA for FHWA undertakings implemented by IDOT. This Agreement establishes the basis for considering the effects of FHWA undertakings on historic properties and establishes alternative procedures to implement Section 106 for the review of such undertakings by FHWA, SHPO, and ACHP.

II. Responsibilities of FHWA, IDOT, and SHPO

A. FHWA

1. The FHWA, as the Agency Official, will ensure that IDOT carries out the requirements of this Agreement, in compliance with its responsibilities under the NHPA.
2. The FHWA remains responsible for ensuring that the terms of this Agreement are carried out and for all findings and determinations made pursuant to this Agreement by IDOT under the authority of FHWA, consistent with the requirements of 36 CFR 800.2(a) and 800.2(c)(4).
3. The FHWA may intervene at any point in the Section 106 process, request documentation of any undertaking carried out under the authority of this Agreement, and may participate directly in any undertaking at its discretion.

B. IDOT

1. The IDOT agrees that the Cultural Resources Unit Chief shall meet the Secretary of Interior's Professional Qualification standards (36 CFR Part 61) and shall have the primary responsibility for ensuring that IDOT complies with this Agreement.
2. The IDOT will ensure that their District staff who conduct initial assessments of undertakings (Trained Staff) will receive training on the Section 106 process and on the implementation of this Agreement. The FHWA and IDOT will develop the training in cooperation with SHPO and ACHP.
3. The IDOT will ensure that historic property identification and effect determinations conducted under this Agreement are carried out by IDOT staff and/or consultants that meet the qualifications set forth in the Secretary of the Interior's Professional Qualifications Standards (Qualified Staff).
4. The IDOT is authorized by FHWA to independently perform the work and consultation described in 36 CFR 800.3 through 800.6, except where noted in "Stipulation VI- Review process for undertakings that may affect historic properties."

5. Consistent with 36 CFR 800.2(a)(3), IDOT may use consultants who meet the Secretary of Interior's qualifications to gather information, analyze data, and prepare documentation. The FHWA and IDOT remain responsible for all consultation, findings, and determinations made under this Agreement.

6. The IDOT Manual shall be updated to detail the process for implementing this Agreement within one year of its execution. The IDOT will work with FHWA on the draft revisions to the Manual implementing the provisions of this Agreement. Once FHWA and IDOT agree upon the draft revisions, the draft will be provided to SHPO for a 30-day review and comment opportunity.

C. SHPO

1. The SHPO is responsible for responding to FHWA and IDOT requests according to the terms of this Agreement.

2. The SHPO will participate in site visits and meetings to discuss large or complex undertakings upon request by IDOT or FHWA, as staff time and resources permit.

3. The SHPO will continue to share information related to the identification, evaluation, management, and treatment of Illinois cultural resources. The SHPO shall integrate archeological survey data into the Illinois State Archaeological Survey Cultural Resources Management Archives (CRMA), the State Museum Illinois Inventory of Archaeological and Paleontological Sites (HAPS), and SHPO shall integrate newly designated historic properties into the Historic and Architectural Resources Geographic Information System (HARGIS).

4. The SHPO may assist FHWA and IDOT in training staff in the implementation of this Agreement.

III. Consultation with Tribes

The FHWA retains the responsibility for government-to-government consultation with federally recognized Tribes that have expressed an interest in Illinois lands. FHWA shall take the lead in identifying Tribes and establishing consultation with Tribes consistent with the requirements of 36 CFR 800.2(c)(2) and 36 CFR 800.3(c)-(f). Tribes that might attach religious and cultural significance to historic properties in the Area of Potential Effects (APE) for an undertaking shall be invited by FHWA to be consulting parties. To allow adequate time for consideration of Tribes' concerns or comments, the FHWA will ensure that opportunities for consultation with Tribes are initiated early and provided throughout the development of the undertaking. FHWA may ask IDOT to assist in consultation if an individual Tribe agrees.

The IDOT may provide notification of undertakings and participate in consultation with Tribes in accordance with the Tribal MOU. If a Tribe requests notification and consultation procedures other than those in the Tribal MOU, FHWA and IDOT will consult with the Tribe to develop potential alternative procedures.

IV. Applicability to other federal agencies

Any federal agency may recognize FHWA as the lead federal agency for any undertaking covered by this Agreement and may adopt findings made pursuant to this Agreement, provided the federal agency's undertaking does not have the potential to cause effects to historic properties beyond those considered in FHWA undertaking.

V. Review process for undertakings unlikely to affect historic properties

A. "Appendix A - Exempt Activities" lists activities that have no potential to affect historic properties, whether or not there may be historic properties in the area of the undertaking. The IDOT Trained Staff will evaluate an undertaking to determine if it is limited to the activities listed in "Appendix A- Exempt Activities." If the undertaking is limited to these activities, then IDOT Trained Staff will document in the file that the undertaking does not require further obligation under Section 106, pursuant to 36 CFR 800.3(a).

B. If an undertaking is not limited to activities in "Appendix A - Exempt Activities," then IDOT Trained Staff will determine if the undertaking involves any of the following criteria:

1. new right-of-way,
2. new temporary or permanent easement,
3. in-stream work,
4. a bridge or culvert 40 years or older,
5. standing structures visible from the area of the undertaking that are greater than 40 years old,
6. previously undisturbed soil (includes land that has agricultural use), or
7. public controversy related to any historic property.

If none of these criteria applies, then IDOT Trained Staff will document in the file that the undertaking is unlikely to affect historic properties and that Section 106 has been completed. No additional review or consultation by the SHPO is required.

If any of these criteria do apply, then IDOT Trained Staff will coordinate with the IDOT Qualified Staff, and IDOT will initiate the review process for undertakings that may affect historic properties.

VI. Review process for undertakings that may affect historic properties

A. Initiate consultation

1. The IDOT will determine the Area of Potential Effects (APE). If the undertaking is either an EA or an EIS, then IDOT will consult with SHPO on the determination of the APE. When IDOT consults with SHPO on the APE, SHPO will have 30 days to respond. If SHPO does not respond within that time period, FHWA and IDOT may proceed to the next step.
2. The IDOT in consultation with FHWA, and SHPO as appropriate, will identify consulting parties (36 CFR 800.2(c) and 800.3(b)(c)(e) and (f)).
3. In accordance with the Tribal MOU, Tribes and the SHPO will be notified of the undertaking through the Project Notification System (PNS) when IDOT Qualified Staff determines that an archaeological field survey is required. The FHWA will conduct government-to-government consultation with Tribes upon their request, in accordance with the Tribal MOU.
4. The IDOT will follow the IDOT Manual to solicit public participation early in project development consistent with 36 CFR 800.2(d). The IDOT's consultation with consulting parties and the public will be appropriate to the scale and the scope of the undertaking.

B. Identify historic properties

1. The IDOT Qualified Staff shall determine the scope of identification efforts within the APE, consistent with 36 CFR 800.4. The IDOT Qualified Staff will determine if the undertaking requires an archaeological or architectural field survey by applying his/her professional judgment based on a review of appropriate databases. For archaeological resources, the databases include, but are not limited to, HAPS, soils maps, and aerial photographs. For architectural resources, the databases include, but are not limited to, HARGIS, NRHP databases, local landmark listings, and local government databases, in addition to photo logs.
2. The IDOT may use a phased process to conduct identification and evaluation efforts consistent with 36 CFR 800.4(b)(2) where alternatives under consideration consist of corridors or large land areas, or where access to properties is restricted.
3. The IDOT will involve consulting parties, the public, and Tribes in identification of historic properties, as appropriate (36 CFR 800.2(c) and 800.4(a)(3)). Consulting parties and the public will be offered opportunities through IDOT's public involvement process to participate in the identification of historic properties. Individuals and organizations not already so designated may become consulting parties upon request. The Tribes are provided opportunities to participate in the identification of historic properties through the procedures described in the Tribal MOU and may participate in consultation at any time during the process.
4. If IDOT Qualified Staff have determined that there are no historic properties present, then IDOT Qualified Staff will document in the file a finding of "no historic properties affected" pursuant to 36 CFR 800.1 I(d). The SHPO case-by-case review and concurrence with these findings of "no historic properties affected" is not required. The Section 106 process is concluded upon the IDOT Qualified Staff documenting the "no historic properties affected" finding.
5. If IDOT Qualified Staff have determined that historic properties are present, then IDOT will submit documentation of eligibility to SHPO for review. The documentation will identify historic properties, including those archaeological properties that are important chiefly because of what can be learned by data recovery and have minimal value for preservation in place. If SHPO does

not respond within 30 days, IDOT may assume that SHPO has no objection and IDOT may proceed to the next step of the process.

C. Assess effects to historic properties

1. No historic properties affected

When historic properties have been identified, FHWA and IDOT will make efforts to avoid and minimize effects to those properties. If effects can be avoided, then IDOT Qualified Staff will document in the file a finding of "no historic properties affected" pursuant to 36 CFR 800.1 I(d). The SHPO case-by-case review and concurrence with these findings of "no historic properties affected" is not required. The Section 106 process is concluded upon the IDOT Qualified Staff documenting the "no historic properties affected" finding.

2. Historic properties affected

a) Consulting parties and the public will be offered opportunities through IDOT's public involvement process to provide their views on effects to historic properties. Participating Tribes are provided opportunities to provide their views on effects to historic properties through the procedures described in the Tribal MOU.

b) The IDOT Qualified Staff shall apply the criteria of adverse effect (36 CFR 800.5(a)), shall consider views provided by consulting parties, the public, and participating Tribes, and shall document either a finding of "no adverse effect" or "adverse effect."

(1) Finding of no adverse effect

i. The IDOT will prepare the "no adverse effect" documentation which will include:

- information required by 36 CFR 800.1 I(e),
 - a list of all historic properties identified within the APE,
 - the finding of effect to each of those properties, and
- measures to be incorporated into the design to ensure adherence to the Secretary's Standards for the Treatment of Historic Properties (36 CFR part 68).
- ii. The IDOT will submit the finding of "no adverse effect" documentation to SHPO for a 30-day review. If the SHPO does not respond within 30 days, IDOT may assume that the SHPO has no objection and IDOT may proceed with the undertaking.

(2) Finding of adverse effect

i. The IDOT will prepare the "adverse effect" documentation which will include:

- information required by 36 CFR 800.1 I(e),
- a list of all historic properties identified within the APE,
- the finding of effect to each of those properties, and

- when applicable, measures to be incorporated into the design to ensure adherence to the Secretary's Standards for the Treatment of Historic Properties (36 CFR part 68), or other conditions to minimize harm.

ii. The IDOT will notify ACHP of the adverse effect and will copy FHWA and the SHPO on the submittal.

D. Resolve adverse effect to historic properties

1. The FHWA and IDOT will consult with the SHPO, participating Tribes, and other consulting parties as appropriate, and follow the requirements of 36 CFR 800.6 to resolve the adverse effect.

2. If IDOT Qualified Staff determines that an undertaking may adversely affect a National Historic Landmark, IDOT, in coordination with FHWA, shall request ACHP and the Secretary of the Interior to participate in consultation to resolve adverse effects, as outlined in 36 CFR 800.10.

3. If an undertaking has an adverse effect on only Euro-American Tradition archaeological habitation sites, FHWA and IDOT may follow the Illinois Programmatic Agreement for the Mitigation of Adverse Effects to Euro-American Tradition Archaeological Sites, and the Section 106 process is concluded. A memorandum of agreement is not required so long as all effects are limited to Euro-American Tradition archeological habitation sites. The IDOT may, with the concurrence of SHPO and ACHP (if participating) develop an undertaking-specific "treatment plan" that describes how adverse effects will be resolved for the undertaking. The treatment plan will be coordinated with consulting parties, the public, the participating Tribes, and SHPO. If SHPO and ACHP (if participating) concur in writing with the treatment plan, then the Section 106 process is concluded and the preparation of a memorandum of agreement is not required. The IDOT will file the treatment plan with ACHP.

4. When appropriate, IDOT will prepare a memorandum of agreement or programmatic agreement that stipulates the mitigation measures agreed upon by IDOT, FHWA, SHPO, and ACHP (if participating). The IDOT will file the executed agreement with ACHP, which concludes the Section 106 process. The IDOT will ensure the undertaking will be implemented in accordance with the agreement.

5. If there is a failure to resolve adverse effects or FHWA is unable to execute an agreement pursuant to 36 CFR 800.6(c), FHWA will request ACHP comment in accordance with 36 CFR 800.7.

VII. Standard treatment plans

The IDOT, in consultation with SHPO and FHWA, may develop standard treatment plans to address adverse effects for specific types of historic properties, such as archaeological habitation sites and historic buildings. For archaeological habitation sites, FHWA and IDOT will consult with the Tribes in the development of the treatment plan. A standard treatment plan may be added to this Agreement provided that IDOT, FHWA, and SHPO agree in writing with the standard treatment plan, the plan is appended to this Agreement, and all the signatories are notified. When IDOT applies an approved standard treatment plan to an undertaking, the Section 106 process is concluded.

VIII. IDOT reporting to SHPO and FHWA

Every two months, IDOT shall provide to SHPO and FHWA a list of undertakings that have received a finding of "no historic properties affected," for which the Section 106 process has been concluded.

The list shall include the following information for each undertaking:

- The IDOT Sequence Number
- The IDOT District number
- County and municipality
- Location of undertaking
- Description of undertaking
- Identified historic properties

The IDOT will also provide to the SHPO the documentation supporting the findings. The list and documentation will be provided per the following schedule:

If Section 106 is completed between:	Then documentation will be submitted no later than:
Jul 1-Aug31	Sept 30
Sept 1- Oct 31	Nov 30
Nov 1-Dec 31	Jan 31
Jan 1-Feb 28	Mar 31
Mar 1-Apr 30	May31
May 1 - June 30	July 31

IX. Curation of archaeological materials

All archaeological materials collected on archaeological sites owned or controlled by the State and related records resulting from research, surveys and excavation under this Agreement shall be curated with the Illinois State Museum in compliance with 20 ILCS 3435 (Illinois Archaeological and Paleontological Resources Protection Act). The IDOT shall ensure that all records and materials resulting from the archaeological investigations will be processed, prepared for curation, and curated in accordance with 36 CFR Part 79.

X. Monitoring implementation of this Agreement

A. The FHWA, ACHP and SHPO may review activities carried out pursuant to this Agreement. The ACHP may provide advice or assistance to FHWA, IDOT, or other parties, and it may review any findings made by IDOT or FHWA pursuant to 36 CFR 800.2(b) and 36 CFR 800.9. The SHPO may request from IDOT Section 106 documentation for any undertaking and review it for compliance with this Agreement. The IDOT shall cooperate in carrying out any review activities.

B. The Tribes may submit comments to the FHWA at any time regarding the implementation of this Agreement.

C. The FHWA, SHPO, and IDOT shall meet annually, on or before August 31, to review the effectiveness of this Agreement and to discuss any comments received by the Tribes during the previous year. The FHWA shall notify ACHP in advance of these meetings and invite its participation. The FHWA will prepare a meeting summary and provide it to SHPO, IDOT, ACHP, and the Tribes.

XI. Emergency undertakings

As defined in 36 CFR 800.12, an emergency undertaking is an essential and immediate response to a disaster or emergency formally declared by the President or Governor; such undertakings that affect transportation infrastructure can be separated into two categories which shall be addressed as follows:

A. Undertakings that will be implemented within 30 days after the formal declaration of the disaster or emergency: The DOT Qualified Staff shall immediately determine if the emergency response could affect the physical integrity, character and/or use of historic properties. If so, IDOT shall notify FHWA, SHPO and ACHP within 48 hours. The parties will then consult, review and comment on the emergency undertaking as soon as possible to determine how to, as fully as practicable under the circumstances, avoid, minimize and/or mitigate for any potential adverse effects to historic properties. Nothing in this Agreement shall be construed as prohibiting IDOT from taking such actions as it deems necessary to stabilize the situation to protect the safety of the traveling public.

B. Immediate rescue and salvage operations conducted to preserve life or property such as necessitated by natural disaster or other catastrophic events are exempt from the provisions of Section 106 and this Agreement, in accordance with 36 CFR 800.12(d).

XII. Training

A. The IDOT Qualified Staff, IDOT Trained Staff, and supervisory staff of IDOT's contractor (currently ISAS) responsible for implementing the terms of this Agreement will complete the following training requirements:

1. Section 106 course(s) provided by FHWA, ACHP, or an equivalent qualified entity, with refresher course every five years or as necessary.
2. Annual meeting to review the implementation of this Agreement.

B. The FHWA and IDOT will invite SHPO staff to attend Section 106 courses and refresher training.

C. Whenever major changes to 36 CFR Part 800 become effective, IDOT Qualified and Trained Staff will participate in training on the new regulations within one year of the effective date of the new regulations. The FHWA and IDOT will invite SHPO staff to attend the training.

XIII. Human remains

In the event that human remains are identified prior to (during archaeological investigations), during, or after project construction, IDOT will comply with the Illinois Human Skeletal Remains Protection Act (20 ILCS 3440) and the provisions of the Tribal MO.

XIV. Unanticipated discovery of or effects to historic properties

If unanticipated discoveries of historic properties are identified by IDOT during the implementation of an undertaking, FHWA will follow the provisions of the Tribal MO, FHWA and IDOT shall comply with 36 CFR 800.13 by stopping work in the immediate area, taking measures to protect the historic property, and informing the SHPO of such unanticipated discoveries or effects within two (2) business days.

If IDOT or FHWA determine that unanticipated effects on historic properties have occurred during the implementation of an undertaking, FHWA and IDOT shall comply with 36 CFR 800.13 and inform SHPO immediately.

XV. Administrative stipulations

A. Dispute resolution. If SHPO, IDOT, ACHP, Tribes, or other consulting party for an individual undertaking carried out under the terms of this Agreement objects in writing to FHWA regarding

any action carried out or proposed with respect to the implementation of this Agreement, then FHWA shall consult with the objecting party to resolve the objection. If after such consultation FHWA determines that the objection cannot be resolved through consultation, then FHWA shall forward all documentation relevant to the objection to ACHP, including FHWA's proposed response to the objection. Within 30 days after receipt of all pertinent documentation, ACHP shall exercise one of the following options:

- Advise FHWA that ACHP concurs in FHWA's proposed response to the objection, whereupon FHWA will respond to the objection accordingly; or
- Provide FHWA with recommendations, which FHWA shall take into account in reaching a final decision regarding its response to the objection.

Should ACHP not exercise one of the above options within 30 days after receipt of all pertinent documentation, FHWA may assume ACHP's concurrence with the proposed response to the objection.

B. Amendment. Any signatory to this Agreement may request that it be amended, whereupon the parties shall consult to consider such amendment. The amendment will be effective on the date a copy is signed by all of the original signatories.

C. Modifications. Standard Treatment Plans may be added or modified by the mutual written agreement of FHWA, IDOT, and SHPO, and shall not require an amendment to this Agreement. The FHWA and IDOT may add or modify activities listed in "Appendix A - Exempt Activities." The FHWA will provide the updated list to the signatory agencies and provide a 30-day review and comment period before the updated list goes into effect. This modification does not require an amendment to this Agreement.

D. Termination. Any signatory to this Agreement may terminate it by providing 30 days written notice to the other parties, provided that the parties shall consult during the period prior to termination to seek agreement on amendments or other action that would avoid termination. In the event of termination, FHWA shall conduct individual reviews of undertakings pursuant to 36 CFR Part 800.

E. Term of this Agreement. This Agreement remains in force for a period of five (5) years from the date of its execution by ACHP, and will remain in effect regardless of which individual is designated as the SHPO, or to which Illinois State Agency the SHPO may be assigned. Six months prior to the conclusion of the five (5) year period, IDOT will notify all signatories in writing. If IDOT receives no written objections from the signatories, the term of the Agreement will automatically be extended for an additional five (5) years. If any signatory objects in writing to extending the Agreement or proposes amendments, FHWA will consult with the signatories to consider amendments or other actions to avoid termination.

Execution and implementation of this agreement evidence that FHWA has delegated certain Section 106 responsibilities to IDOT, and has afforded ACHP a reasonable opportunity to comment on the Program and its individual undertakings in Illinois; that FHWA has taken into account the effects of the program and its individual undertakings on historic properties, and that FHWA has complied with Section 106 of the NHPA and 36 CFR 800 for the Program and its individual undertakings.

SIGNATORIES

FEDERAL HIGHWAY ADMINISTRATION

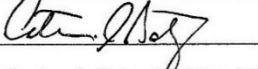
 02/15/2018
Catherine A. Batey, Division Administrator

ADVISORY COUNCIL ON HISTORIC PRESERVATION

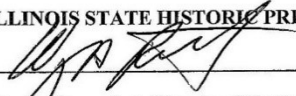

for John M. Fowler, Executive Director

ILLINOIS STATE HISTORIC PRESERVATION OFFICER

Wayne Rosenthal, Director, Illinois Department of Natural Resources, and Illinois State
Historic Preservation Officer

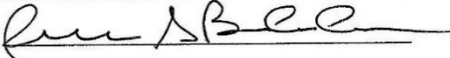
ILLINOIS DEPARTMENT OF TRANSPORTATION

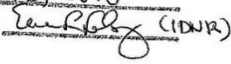
Randall S. Blankenhorn, Secretary, IDOT

APPROVED FOR EXECUTION
Date: Feb 13, 2018
Legal Counsel:  (IDNR)

APPENDIX - Exempt Activities

The following activities have no potential to affect historic properties, whether or not there may be historic properties in the area of the undertaking.

(1) Activities which do not involve or lead directly to construction, such as planning and research activities; grants for training; engineering to define the elements of a proposed action or alternatives so that social, economic, and environmental effects can be assessed.

(2) General highway maintenance and repair, including but not limited to filling potholes, crack sealing, joint grinding, milling, resurfacing in kind, shoulder reconstruction, erosion control, ditch cleaning, storm sewer repair, and debris removal.

(3) Removal and replacement of existing sidewalks and ADA ramps with in-kind materials.

(4) Repair and replacement of highway signs or other traffic control devices.

(5) General pavement marking activities that include, but are not limited to, installation of raised pavement markers, striping, or installation of sensors in existing pavements.

(6) Repair and replacement of appurtenances such as glare screens, median barriers, fencing, guardrails, safety barriers, crash attenuators, safety cable, or lighting.

(7) Repair, rehabilitation, or removal of railroad grade crossings, separations or grade crossing protection.

(8) Roadway surface treatments such as pavement repair, median repair, seal coating, and pavement grinding.

(9) Improvements and repairs to Interstate Highway System including bridges, weigh and inspection stations, toll facilities, and rest areas.

(10) Establishment, replacement, or removal of landscaping or other vegetation on the interstate.

(11) Installation of interstate surveillance, changeable message signs, ramp metering equipment, appurtenances such as glare screens, median barriers, fencing, guardrails, safety barriers, crash attenuators, safety cable, or lighting.

**Illinois Department of Transportation and
Illinois Environmental Protection Agency Agreement on
Microscale Air Quality Assessments
for Illinois Department of Transportation-Sponsored
Transportation Projects**

The United States Department of Transportation (DOT) issued Environmental Impact and Related Procedures (23 CFR Part 771) to comply with directives of the National Environmental Policy Act (NEPA), the Council on Environmental Quality regulations, and other federal statutes and to incorporate the requirements of DOT Order 5610.1C, "Procedures for Considering Environmental Impacts." Subsequently, the Federal Highway Administration (FHWA) provided the "FHWA Technical Advisory T 6640.SA," as guidance to states for performing air quality analysis for federally assisted highway projects. In addition, the Illinois Department of Transportation "Illinois COSIM Version 4.0 Carbon Monoxide Screen for Intersection Modeling Air Quality Manual," dated April 2013, provides specific detailed information for performing carbon monoxide air quality analyses in Illinois.

In order to reflect current air quality practices, the Illinois Department of Transportation (IDOT) and the Illinois Environmental Protection Agency (Illinois EPA) hereby agree to the following:

1. The March 2010 "Illinois Department of Transportation and Illinois Environmental Protection Agency Agreement on Microscale Air Quality Assessments for Illinois Department of Transportation-Sponsored Transportation Projects" between IDOT and the Illinois EPA will be superseded by this Agreement on the date this Agreement is signed.
2. As outlined in FHWA's Technical Advisory T 6640.8A, dated October 30, 1987, IDOT is required and will continue to conduct project level microscale carbon monoxide (CO) analyses. Projects listed in Attachment A are exempt from the requirement for a CO analysis provided the projects do not increase capacity such as through the addition of through lanes or auxiliary turn lanes and have no sensitive receptors.

Historically, IDOT used 16,000 average daily traffic (ADT) as the threshold for conducting a microscale CO analysis. Since the 16,000 ADT threshold was in use for over 20 years, and CO emissions from vehicles were significantly reduced over this time-frame through various vehicle technology and fuel improvements, IDOT initiated and completed a study with the University of Illinois to develop a computer screening model to estimate CO emissions in order to replace the labor-intensive hand-calculated CO method and the 16,000 ADT threshold. Through this IDOT study, in 1999, the University of Illinois, in conjunction with the Illinois EPA and FHWA, developed the Illinois Carbon Monoxide Screen for Intersection Modeling (Illinois COSIM), Version 1.0. In 2003, the Illinois COSIM was updated to Illinois COSIM Version 2.0, which incorporated the United States Environmental Protection Agency's (USEPA) new MOBILE6 model and a pre-screen feature. The pre-screen feature requires input of the county in which the project is located, the ADT or peak hourly traffic volumes (vph) of the busiest intersection leg and the distance to the nearest sensitive receptor (as defined in the IDOT COSIM Air Quality Manual). As a result, the September 2003 "Agreement on Microscale Air Quality Assessments for IDOT-Sponsored Transportation Projects" between IDOT and the Illinois EPA required use of the Illinois COSIM Version 2.0 screening model. Illinois COSIM Version 3.0, developed in 2008 and required for use pursuant to the March 2010 "Agreement on Microscale Air Quality Assessments for Illinois Department of Transportation-Sponsored Transportation Projects" between IDOT and the Illinois EPA, incorporated new emission factors that resulted from the Illinois EPA's implementation of an On-Board Diagnostic-based vehicle inspection and

maintenance program in the Chicago and Metro-East St. Louis areas, updates to the pre-screen feature, and other minor model updates. Illinois COSIM Version 4.0, developed in 2012-13, incorporates CO emission factors generated by the USEPA's Motor Vehicle Emission Simulator (MOVES) model, which replaced the MOBILE6 model.

3. Illinois COSIM Version 4.0 will be used for conducting CO microscale air quality analyses. IDOT will conduct a full COSIM analysis for intersection projects (except Modern Roundabouts) that increase capacity such as through the addition of through lanes or auxiliary turn lanes and if traffic on one leg of an intersection is greater than or equal to 5,000 vehicles per hour (vph) or 62,500 average daily traffic (ADT), and which have sensitive receptors as identified in the IDOT COSIM Air Quality Manual (April, 2013). If the COSIM screening model shows a potential violation of the CO National Ambient Air Quality Standard, a further refined modeling analysis will be conducted for the project using the USEPA's CAL3QHC model.

4. Project level microscale CO analysis (using the Illinois COSIM Version 4.0 screening model) will be conducted using vehicle emission factors generated from the USEPA's MOVES 2010b model. IDOT will consult with the Illinois EPA for proper inputs to use for the MOVES 2010b model.

5. IDOT, Bureau of Design and Environment, will continue to work closely with the Illinois EPA, Bureau of Air, on general, as well as microscale, air quality issues.

6. This Agreement shall become effective upon execution by appropriate representatives of IDOT and the Illinois EPA. It shall terminate 30 days after written notice by either party.

7. It is anticipated that this Agreement may be modified to reflect experiences in its implementation and evolution of the air pollution control program. This Agreement may be modified only by mutual written agreement by the Illinois EPA and IDOT.



Signature

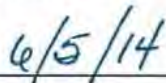

Date

Secretary

Illinois Department of Transportation

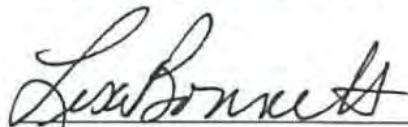

Signature

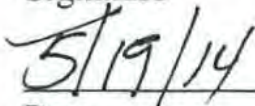

Date

Director

Illinois Environmental Protection Agency

Attachment A

Projects Exempt from CO Analysis Requirement

As outlined in 40 CFR Part 93.126, the following projects are exempt from the requirement for a conformity determination. For purposes of this Agreement, these projects also are exempt from the requirement for a CO analysis, provided the projects do not involve the addition of through lanes or auxiliary turn lanes and have no sensitive receptors.

Safety

- Railroad/highway crossing.
- Projects that correct, improve, or eliminate a hazardous location or feature. Safer non-Federal-aid system roads.
- Shoulder improvements. Increasing sight distance.
- Highway Safety Improvement Program implementation.
- Traffic control devices and operating assistance other than signalization projects.
- Railroad/highway crossing warning devices.
- Guardrails, median barriers, crash cushions.
- Pavement resurfacing and/or rehabilitation.
- Pavement marking.
- Emergency relief (23 U.S.C. 125).
- Fencing.
- Skid treatments.
- Safety roadside rest areas. Adding medians.
- Truck climbing lanes outside the urbanized area.
- Lighting improvements.
- Widening narrow pavements or reconstructing bridges (no additional travel lanes).
- Emergency truck pullovers.

Air Quality

- Continuation of ride-sharing and van-pooling promotion activities at current levels.
- Bicycle and pedestrian facilities.

Other

Specific activities which do not involve or lead directly to construction, such as:

- Planning and technical studies.
- Grants for training and research projects.
- Planning activities conducted pursuant to titles 23 and 49 U.S.C.
- Federal-aid systems revisions.
- Engineering to assess social, economic, and environmental effects of the proposed action or alternatives to that action.
- Noise attenuation.

-
- Emergency or hardship advance land acquisitions (23 CFR 710.503).
 - Acquisition of scenic easements.
 - Plantings, landscaping, etc.
 - Sign removal.
 - Directional and informational signs.
 - Transportation enhancement activities (except rehabilitation and operation of historic transportation buildings, structures, or facilities).
 - Repair of damage caused by natural disasters, civil unrest, or terrorist acts, except projects involving substantial functional, locational, or capacity changes.



Appendix B

ACRONYMS/GLOSSARY OF ENVIRONMENTAL TERMS

BUREAU OF DESIGN AND ENVIRONMENT MANUAL

Appendix B

ACRONYMS/GLOSSARY OF ENVIRONMENTAL TERMS

Appendix B presents acronyms and a glossary of environmental terms that are commonly used in the application of environmental procedures.

B-1 ACRONYMS

The evolution of environmental procedures has generated a considerable number of acronyms. These have been created for the names of many Federal and State agencies, laws, studies, terms, etc. The following identifies the more significant acronyms which have gained common usage:

1. AASHTO. American Association of State Highway and Transportation Officials
2. ACHP. Advisory Council on Historic Preservation
3. ADA. Americans with Disabilities Act
4. BDE. (IDOT) Bureau of Design and Environment
5. BMP. Best Management Practices
6. CAAA. Clean Air Act Amendments
7. CE. Categorical Exclusion
8. CERCLIS. Comprehensive Environmental Response, Compensation, and Liability Information System
9. CEQ. Council on Environmental Quality
10. CFR. Code of Federal Regulations
11. CWA. Clean Water Act
12. CZM. Coastal Zone Management
13. DEIS. Draft Environmental Impact Statement
14. DOI. (United States) Department of Interior

15. EA. Environmental Assessment
16. EIS. Environmental Impact Statement
17. EO. Executive Order
18. EPA. (United States) Environmental Protection Agency
19. ESA. (Federal) Endangered Species Act
20. FAA. Federal Aviation Administration
21. FEIS. Final Environmental Impact Statement
22. FEMA. Federal Emergency Management Agency
23. FHWA. Federal Highway Administration
24. FIFRA. Federal Insecticide, Fungicide, and Rodenticide Act
25. FOIA. Freedom of Information Act
26. FONSI. Finding of No Significant Impact
27. FPPA. (Federal) Farmland Protection Policy Act
28. FRA. Federal Railroad Administration
29. FSA. (Federal) Farm Service Agency
30. FTA. Federal Transit Administration (Note: This was formerly the Urban Mass Transit Administration (UMTA))
31. FWCA. Fish and Wildlife Coordination Act
32. FWPCA. Federal Water Pollution Control Act
33. FWS. (United States) Fish and Wildlife Service
34. HABS/HAER. Historic American Building Survey/Historic American Engineering Record
35. HOV. High-Occupancy Vehicle
36. HUD (United States Department of) Housing and Urban Development
37. IDNR. Illinois Department of Natural Resources
38. IDOA. Illinois Department of Agriculture
39. IDOT. Illinois Department of Transportation

40. IEPA. Illinois Environmental Protection Agency
41. IHPA. Illinois Historic Preservation Agency
42. INHS. Illinois Natural History Survey
43. INPC. Illinois Nature Preserves Commission
44. ISGS. Illinois State Geological Survey
45. ISTEA. Intermodal Surface Transportation and Efficiency Act (of 1991)
46. ISTHA. Illinois State Toll Highway Authority
47. ISWS. Illinois State Water Survey
48. LAWCON. Land and Water Conservation Fund (Act)
49. LUST. Leaking Underground Storage Tank
50. MOA. Memorandum of Agreement
51. MOU. Memorandum of Understanding
52. MPO. Metropolitan Planning Organization
53. MWRDGC. Metropolitan Water Reclamation District of Greater Chicago
54. NAAQS. National Ambient Air Quality Standards
55. NEPA. National Environmental Policy Act
56. NFIP. National Flood Insurance Program
57. NHPA. National Historic Preservation Act
58. NMFS. National Marine Fisheries Service
59. NPDES. National Pollutant Discharge Elimination System
60. NPS. National Park Service
61. NRCS. Natural Resources Conservation Service (Note: This was formerly the Soil Conservation Service (SCS))
62. NRHP. National Register of Historic Places
63. NWP. Nationwide (Section 404) Permit
64. OCZM. Office of Coastal Zone Management

65. OEPC. (DOI) Office of Environmental Policy and Compliance
66. OWR. Office of Water Resources (IDNR)
67. PE. Preliminary Engineering
68. PESA. Preliminary Environmental Site Assessment
69. PL. Public Law
70. PSI. Preliminary Site Investigation
71. RCRA. Resource Conservation and Recovery Act
72. REO. (DOI) Regional Environmental Officers
73. RMP. Risk Managed Project
74. ROD. Record of Decision
75. ROW. Right-of-Way
76. RPTA. Responsible Property Transfer Act
77. SAFETEA-LU. Safe, Accountable, Flexible, Efficient Transportation Equity Act: A Legacy for Users
78. SARA. Superfund Amendments and Reauthorization Act
79. SDWA. Safe Drinking Water Act
80. SEE. Social, Economic, and Environmental
81. SIP. State Implementation Plan
82. SIR. State Improvement Report
83. SHPO. State Historic Preservation Officer
84. STIP. State Transportation Improvement Program
85. SWA. Special Waste Assessment
86. 3-C. Continuing, Cooperative, and Comprehensive (Planning)
87. TEA-21. Transportation Equity Act for the 21st Century
88. TCM. Transportation Control Measure
89. TIP. Transportation Improvement Program

- 90. TSM. Transportation System Management
- 91. URAA. Uniform Relocation Assistance Act
- 92. USC. United States Code
- 93. USACOE. United States Army Corps of Engineers
- 94. USCG. United States Coast Guard
- 95. USDA. United States Department of Agriculture
- 96. USDOT. United States Department of Transportation
- 97. USFS. United States Forest Service
- 98. USGS. United States Geological Survey
- 99. UST. Underground Storage Tank

B-2 DEFINITIONS

The following presents definitions typically used for environmental procedures:

1. Action. For purposes of 23 CFR 771, a highway ... project proposed for FHWA... funding. It also includes activities such as joint and multiple-use permits, changes in access control, etc., which may or may not involve a commitment of Federal funds. For Federal floodplain regulations, "action" is any highway construction, reconstruction, rehabilitation, repair, or improvement undertaken for Federally funded/regulated projects. For purposes of Illinois Endangered Species Act regulations, construction, land management, or other activities that are authorized, funded, or performed in whole or in part by agencies of State and local governments and that will result in a change to the existing environmental conditions or may affect listed threatened or endangered species or their essential habitat or Natural Areas.
2. Action Area. (For purposes of Federal Endangered Species Act regulations.) All areas to be affected directly or indirectly by the proposed action and not merely the immediate area involved in the action.
3. Administration Action. The approval by FHWA or UMTA of the applicant's request for Federal funds for construction. It also includes approval of activities such as joint and multiple-use permits, changes in access control, etc., which may or may not involve a commitment of Federal funds.
4. Adverse Impact. (For purposes of Illinois Endangered Species Act regulations.) A direct or indirect alteration of the physical or biological features or the air, land, or water which may affect the survival, reproduction, or recovery of a listed species or that may diminish the viability of a Natural Area.
5. Agency Action Report. A report submitted to the IDNR for a proposed action requiring consultation. The information required to be submitted shall be sufficient to determine the presence or absence of a threatened or endangered species or Natural Area in the vicinity of the proposed action.
6. Agricultural Land Conversion. (For purposes of Illinois Farmland Protection Act regulations.) The taking of land directly out of agricultural production or displacing it by another use and not returning it to production.
7. Agricultural Land or Farmland. (For purposes of Illinois Farmland Protection Act regulations.) All land in farms including cropland, hayland, pastureland, forestland, corrals, gardens, orchards, land used for farmsteads, buildings, barns, machinery sheds, adjacent yards or corrals, pens, waste lagoons, feedlots, farmstead or feedlot windbreaks, grain bins, lanes for farm residences and fields, field windbreaks, ponds, commercial feedlots, greenhouses, nurseries, broiler facilities, and farm landing strips.

8. Area of Potential Effects. (For purposes of the Section 106 historic preservation regulations.) The geographic area or areas within which an undertaking may cause changes in the character or use of historic properties, if any such properties exist.
9. Base Flood. The flood or tide having a 1-percent chance of being exceeded in any given year.
10. Base Floodplain. The area subject to flooding by the base flood.
11. Biological Assessment. Information on listed and proposed species and designated and proposed critical habitat that may be present in the action area and the evaluation of potential effects of the action on such species and habitat.
12. Biological Opinion (Federal). The document that states the opinion of the US Fish and Wildlife Service (USFWS) on whether or not an action is likely to jeopardize the continued existence of listed species or result in the destruction or adverse modification of critical habitat. (Illinois). The component of the Detailed Action Report prepared by the IDNR when a valid record of an occurrence for a threatened or endangered species or Natural Area exists within the vicinity of a proposed action. This opinion will conclude whether the action will jeopardize the listed species present, destroy or adversely modify their essential habitat, or adversely modify a Natural Area.
13. Categorical Exclusion (CE). (For purposes of 40 CFR 1500, *CEQ Regulations*.) A category of actions which do not individually or cumulatively have a significant effect on the human environment for which, therefore, neither an environmental assessment nor an environmental impact statement is required.
14. Class of Action. In Federal environmental parlance, the categorization of the significance of the environmental impact of a proposed action and the corresponding level of environmental documentation required.
15. Conference. (For purposes of Federal Endangered Species Act regulations.) A process involving coordination with USFWS for actions likely to jeopardize the continued existence of proposed species or result in the destruction or adverse modification of proposed critical habitat.
16. Cooperating Agency. Any Federal agency other than a lead agency which has jurisdiction by law or special expertise with respect to any environmental impact involved in a proposal (or a reasonable alternative) for legislation or other major Federal action significantly affecting the quality of the human environment. A State or local agency of similar qualifications may, by agreement with the lead agency, become a cooperating agency.
17. Council. (For purposes of the Section 106 historic preservation regulations.) The Advisory Council on Historic Preservation or a Council member or employee designated to act for the Council.

18. Critical Habitat. An area designated by USFWS as critical habitat.
19. Cumulative Effects. (For purposes of Illinois Endangered Species Act regulations.) Direct and indirect effects of a proposed action(s) together with the identifiable effects of actions that are interrelated or interdependent with the action. Indirect effects are those that are caused by the action but are later in time or farther in distance. Interrelated actions are those that are a part of a larger action. Interdependent actions are those that have independent utility apart from the action.
20. Cumulative Impact. (For purposes of 40 CFR 1500 *CEQ Regulations*.) The impact on the environment which results from the incremental impact of the action when added to other past, present, and reasonably foreseeable future actions regardless of what agency (Federal or non-Federal) or person undertakes such other actions. Cumulative impacts can result from individually minor but collectively significant actions taking place over a period of time.
21. Destruction or Adverse Modification. (For purposes of Federal Endangered Species Act regulations.) A direct or indirect alteration that appreciably diminishes the value of critical habitat for both the survival and recovery of listed species. Such alterations include, but are not limited to, alterations adversely modifying any of those physical or biological features that were the basis for determining the habitat to be critical.
22. Detailed Action Report. A written report that is prepared by an agency when a threatened or endangered species or Natural Area has been identified within the vicinity of a proposed action. This report shall contain sufficient information to make a judgment regarding the potential adverse impacts to a listed species or its essential habitat or a Natural Area.
23. Effects. (For purposes of 40 CFR 1500, *CEQ Regulations*.) Effects include:
 - a. Direct effects, which are caused by the action and occur at the same time and place.
 - b. Indirect effects, which are caused by the action and are later in time or farther removed in distance, but are still reasonably foreseeable. Indirect effects may include growth inducing effects and other effects related to induced changes in the pattern of land use, population density or growth rate, and related effects on air and water and other natural systems, including ecosystems.
24. Encroachment. An action within the limits of the base floodplain.
25. Environmental Assessment (EA). A concise public document for which a Federal agency is responsible that serves to briefly provide sufficient evidence and analysis for determining whether to prepare an environmental impact statement or a finding of no significant impact.

26. Environmental Documentation. Refers to environmental reports (e.g., EIS, EA) and the environmental information contained in Phase I Engineering Reports.
27. Environmental Impact Statement (EIS). A detailed written statement, prepared for major Federal actions significantly affecting the quality of the human environment, which discusses the environmental impact of the proposed action; any adverse environmental effects which cannot be avoided should the proposal be implemented; alternatives to the proposed action; the relationship between local short-term uses of man's environment and the maintenance and enhancement of long-term productivity; and any irreversible and irretrievable commitments of resources which would be involved in the proposed action should it be implemented.
28. Environmental Report. Refers specifically to an EIS or an EA.
29. Environmental Studies. The investigations of potential environmental impacts to determine the environmental process to be followed and to assist in the preparation of the environmental document.
30. Essential Habitat. The physical and biological environment that is required to maintain viable populations of a listed species to ensure the survival and recovery of that species.
31. Federally Funded/Regulated. Refers to the involvement of Federal funds and/or jurisdictional authority by any Federal agency for a proposed action.
32. Finding of No Significant Impact (FONSI). A document by a Federal agency briefly presenting the reasons why an action, not otherwise excluded, will not have a significant impact on the human environment and for which an environmental impact statement therefore will not be prepared.
33. Formal Consultation. (For purposes of Federal Endangered Species Act regulations.) A process between USFWS and the Federal agency responsible for a proposed action that commences with the Federal agency's written request for consultation and concludes with USFWS' issuance of a biological opinion.
34. Historic Property. (For purposes of the Section 106 historic preservation regulations.) Any prehistoric or historic district, site, building, structure, or object included in or eligible for inclusion in the National Register. This term includes artifacts, records, and remains that are related to and located within such properties. The term "eligible for inclusion in the National Register" includes both properties formally determined as such by the Secretary of the Interior and all other properties that meet National Register listing criteria.
35. Historic Significance. For purposes of Section 4(f), based on whether or not a historic site is included on or eligible for inclusion on the National Register of Historic Places (National Register).

36. Indian Tribe. The governing body of any Indian tribe, band, nation, or other group that is recognized as an Indian tribe by the Secretary of the Interior and for which the United States holds land in trust or restricted status for that entity or its members.
37. Interdisciplinary. Combining or involving various academic disciplines to ensure the integrated use of the natural and social sciences and the environmental design arts.
38. Interested Person. (For purposes of the Section 106 historic preservation regulations.) Those organizations and individuals that are concerned with the effects of an undertaking on historic properties.
39. Jeopardize. (For purposes of Illinois Endangered Species Act regulations.) To engage in an action which would reduce the likelihood of the survival or recovery of a listed species or would result in the destruction or adverse modification of the essential habitat of such a species or which would result in the destruction or adverse modification of a Natural Area.
40. Jeopardize the Continued Existence of. (For purposes of Federal Endangered Species Act regulations.) To engage in an action that reasonably would be expected, directly or indirectly, to reduce appreciably the likelihood of both the survival and recovery of a listed species in the wild by reducing the reproduction, numbers, or distribution of that species.
41. Land Class. One of eight classes of land in the Land Capability Classification System (Handbook 210, issued September 1961, and approved for reprinting January, 1973) as developed by the Natural Resources Conservation Service, United States Department of Agriculture. Incorporation by reference does not include any future editions or amendments. The land capability classification shows, in a general way, the suitability of soils for most kinds of field crops. The soils are grouped according to their limitations for field crops, the risk of damage to the soil if they are used for crops, and the way they respond to management.
42. Lead Agency. The agency or agencies preparing or having assumed primary responsibility for preparing the environmental document.
43. Listed Species (Federal). Any species of fish, wildlife, or plant which has been determined to be endangered or threatened pursuant to the Federal Endangered Species Act.
44. Listed Species (State). Any species of plant or animal which has been listed as threatened or endangered by the Illinois Endangered Species Protection Board or the USFWS.
45. Local Government. A city, county, parish, township, municipality, borough, or other general purpose political subdivision of a State.

46. Maintenance Area. Any geographic region of the United States previously designated nonattainment pursuant to the Clean Air Act Amendments of 1990 and subsequently redesignated to attainment, subject to the requirement to develop a maintenance plan under Section 175A of the Clean Air Act, as amended.
47. Major Construction Activity. (For purposes of Federal Endangered Species Act regulations.) A construction project (or other undertaking having similar physical impacts) which is a major Federal action significantly affecting the quality of the human environment as referred to in the National Environmental Policy Act (NEPA).
48. May. A permissive condition allowing individual judgment and discretion in the evaluation and decision-making. If the term is used in specifying a procedure, that procedure is optional.
49. Mitigation. Mitigation includes:
- a. Avoiding the impact altogether by not taking a certain action or parts of an action.
 - b. Minimizing impacts by limiting the degree or magnitude of the action and its implementation.
 - c. Rectifying the impact of repairing, rehabilitating, or restoring the affected environment.
 - d. Reducing or eliminating the impact over time by preservation and maintenance operations during the life of the action.
 - e. Compensating for the impact by replacing or providing substitute resources or environments.
50. Mitigation Measures. Activities identified in the environmental process intended to lessen the severity of any unavoidable environmental impacts precipitated by the proposed action.
51. Modern Soil Survey. A document published after 1965 by NRCS containing a description of a county's soils, maps showing their distribution, and discussions concerning their behavior and adaptability.
52. National Historic Landmark. A historic property that the Secretary of the Interior has designated as a National Historic Landmark.
53. National Register. (For purposes of the Section 106 historic preservation regulations.) The National Register of Historic Places maintained by the Secretary of the Interior.
54. National Register Criteria. (For purposes of the Section 106 historic preservation regulations.) The criteria established by the Secretary of the Interior for use in evaluating the eligibility of properties for the National Register.

55. Natural Area. Any area of land in public or private ownership which is registered under the Illinois Natural Areas Preservation Act 525 ILCS 30 or is identified in the Illinois Natural Areas Inventory.
56. Natural and Beneficial Floodplain Values. These include but are not limited to fish, wildlife, plants, open space, natural beauty, scientific study, outdoor recreation, agriculture, aquaculture, forestry, natural moderation of floods, water quality maintenance, and groundwater recharge.
57. NEPA Process. The process for complying with the intent of NEPA to make environmental information available to decision makers at the appropriate time and to help public officials make decisions that are based on the understanding of environmental consequences and take actions that protect, restore, and enhance the environment.
58. Nonattainment Area. Any geographic region of the United States which has been designated as nonattainment under Section 107 of the Clean Air Act for any pollutant for which a national ambient air quality standard exists.
59. Notice of Intent. A notice that an Environmental Impact Statement will be prepared and considered.
60. Participating Agency. A Federal, State, Tribal, regional or local government agency that accepts an invitation to be involved in the NEPA process for a proposed transportation project. The roles and responsibilities of participating agencies include, but are not limited to:
- a. Participating in the NEPA process starting at the earliest possible time, especially with regard to the development of the purpose and need statement, range of alternatives, methodologies and level of detail for the analysis of alternatives.
 - b. Identifying, as early as practicable, any issues of concern regarding the project's potential environmental or socioeconomic impacts. Participating agencies also may participate in the issue resolution process.
 - c. Providing meaningful and timely input on unresolved issues.
 - d. Participating in the scoping process.
61. Policy. For purpose of Part III of the *BDE Manual*, this is a general statement describing the official posture of IDOT on a particular matter.
62. Practicable. For purpose of the Federal floodplain regulations, means capable of being done within reasonable natural, social, or economic constraints.

63. Preserve. For purposes of the Federal floodplain regulations, to avoid modification to the functions of the natural floodplain environment or to maintain it as closely as practical in its natural state.
64. Programmatic Section 4(f) Evaluation and Approval. An evaluation and approval addressing a specific category of actions involving use of Section 4(f) land.
65. Proposed Critical Habitat. (For purposes of Federal Endangered Species Act regulations.) Habitat proposed in the Federal Register to be designated or revised as critical habitat for any listed or proposed species.
66. Proposed Species. (For purposes of Federal Endangered Species Act regulations.) Any species of fish, wildlife, or plant that is proposed to be listed under Section 4 of the Federal Endangered Species Act.
67. Reasonably Foreseeable. Deemed likely to occur in the future based on the best available planning information for the project area (such as formal planning documents, information from community officials, or local land-use/zoning/permitting processes).
68. Record of Decision (ROD). A FHWA document, prepared after the publication of the Final EIS, which a) presents the basis for the decision (i.e., the selected alternative), b) summarizes any mitigation measures that will be incorporated into the project, and c) documents any required Section 4(f) approval.
69. Regulatory Floodway. The floodplain area that is reserved in an open manner by Federal, State, or local requirements (i.e., unconfined or unobstructed either horizontally or vertically) to provide for the discharge of the base flood so that the cumulative increase in water surface elevation is no more than a designated amount (not to exceed 1 ft (300 mm)) as established by the Federal Emergency Management Agency (FEMA) for Administering the National Flood Insurance Program.
70. Restore. For purposes of the Federal floodplain regulations, to reestablish a setting or environment in which the functions of the natural and beneficial floodplain values adversely impacted by the highway agency action can again operate.
71. Risk. For purpose of the Federal floodplain regulations, the consequences associated with the probability of flooding attributable to an encroachment. It includes the potential for property loss and hazard to life during the service life of the highway.
72. Scoping. An early and open process for determining the scope of issues to be addressed in Environmental Impact Statements or Environmental Assessments and for identifying potentially significant issues related to the proposed action. Scoping is intended to focus the study effort on issues that are significant and avoid the collection of needless detailed information on insignificant issues.

73. Section 4(f) Approval. A finding that there is no feasible and prudent alternative to use of Section 4(f) land and that all possible planning to minimize harm to Section 4(f) land is included in the proposed action.
74. Section 4(f) Evaluation. Documentation of the involvement a project would have with Section 4(f) land, addressing alternatives to use of such land and measures to minimize any harm that would result from such use.
75. Section 4(f) Land. Land protected under 49 USC 303 (Section 4(f) of the USDOT Act of 1966); i.e., any significant publicly owned park, recreational area, or wildlife and waterfowl refuge or a historic site of national, State, or local significance. Significance is determined by the Federal, State, or local officials having jurisdiction over the park, recreational area, refuge or site. The term "historic site" includes both historic and prehistoric archaeological sites determined important for preservation in place.
76. Section 6(f) Lands. Lands which had Land and Water Conservation (LAWCON) funds involved in their purchase or development.
77. Shall, must. A mandatory condition. Users are obligated to adhere to the recommendations and applications presented in this context or to perform the evaluation indicated. If these terms are used in specifying a procedure, that procedure is mandatory.
78. Should. An advisory condition. Users are strongly encouraged to follow the criteria and guidance presented in this context. If these terms are used in specifying procedures, that procedure is recommended. Deviations from the specified procedure should be justified.
79. Significantly. Significantly as used in NEPA requires considerations of both context and intensity:
- a. Context. This means that the significance of an action must be analyzed in several contexts such as society as a whole (human, national), the affected region, the affected interests, and the locality. Significance varies with the setting of the proposed action. For instance, in the case of a site-specific action, significance would usually depend upon the effects in the locale rather than in the world as a whole. Both short- and long-term effects are relevant.
 - b. Intensity. This refers to the severity of impact. Responsible officials must bear in mind that more than one agency may make decisions about partial aspects of a major action. The following should be considered in evaluating intensity:
 - Impacts that may be both beneficial and adverse. A significant effect may exist even if the Federal agency believes that on balance the effect will be beneficial.
 - The degree to which the proposed action affects public health or safety.

- Unique characteristics of the geographic area such as proximity to historic or cultural resources, park lands, prime farmlands, wetlands, wild and scenic rivers, or ecologically critical areas.
 - The degree to which the effects on the quality of the human environment are likely to be highly controversial.
 - The degree to which the possible effects on the human environment are highly uncertain or involve unique or unknown risks.
 - The degree to which the action may establish a precedent for future actions with significant effects or represents a decision in principle about a future consideration .
 - Whether the action is related to other actions with individually insignificant but cumulatively significant impacts. Significance exists if it is reasonable to anticipate a cumulatively significant impact on the environment. Significance cannot be avoided by terming an action temporary or by breaking it down into small component parts.
 - The degree to which the action may adversely affect districts, sites, highways, structures, or objects listed in or eligible for listing in the National Register of Historic Places or may cause loss or destruction of significant scientific, cultural, or historical resources.
 - The degree to which the action may adversely affect an endangered or threatened species or its habitat that has been determined to be critical under the Endangered Species Act of 1973.
 - Whether the action threatens a violation of Federal, State, or local law or requirements imposed for the protection of the environment.
80. Significant Encroachment. A highway encroachment and any direct support of likely base floodplain development that would involve one or more of the following construction- or flood-related impacts:
- a significant potential for interruption or termination of a transportation facility which is needed for emergency vehicles or provides a community's only evacuation route,
 - a significant risk, or
 - a significant adverse impact on natural and beneficial floodplain values.
81. Site. For purposes of Federal Farmland Protection Policy Act regulations, the location(s) that would be converted by the proposed action(s).

82. State Historic Preservation Officer. The official appointed or designated pursuant to Section 101(b)(1) of the National Historic Preservation Act to administer the State historic preservation program or a representative designated to act for the State Historic Preservation Officer. The State Historic Preservation Officer for Illinois is the Director of the State Historic Preservation Agency.
83. Supplemental Environmental Impact Statement (SEIS). A detailed written statement on changes in the proposed action and/or on the identification and analysis of new circumstances or information not addressed in the Draft or Final EIS, which would introduce new or changed environmental effects of significance on the quality of the human environment.
84. Support Base Floodplain Development. To encourage, allow, serve, or otherwise facilitate additional base floodplain development. Direct support results from an encroachment, while indirect support results from an action out of the base flood plain.
85. Tiering. Covering broad or more general matters in one EIS with a subsequent EIS (or EIS's) addressing narrower, more specific matters. The subsequent EIS(s) would incorporate by reference the general discussions and would concentrate solely on the issues specific to the latter. Tiering usually is applied to broad program or system EIS's and subsequent project-specific EIS's. It is intended to be an aid in focusing on issues which are ready for decision and excluding issues already decided or not yet ready.
86. Type I Project. (For purposes of the FHWA noise regulations.) A proposed highway project for the construction of a highway on new location or the physical alteration of an existing highway which significantly changes either the horizontal or vertical alignment or increases the number of through traffic lanes.
87. Type II Project. (For purposes of the FHWA noise regulation.) A proposed highway project for noise abatement on an existing highway.
88. Undertaking. (For purposes of the Section 106 historic preservation regulations.) Any project, activity, or program that can result in changes in the character or use of historic properties, if any such historic properties are located in the area of potential effects. The project, activity, or program must be under the direct or indirect jurisdiction of a Federal agency or licensed or assisted by a Federal agency. Undertakings include new and continuing projects, activities, or programs and any of their elements not previously considered under Section 106.
89. Undeveloped Lands. (For purposes of noise analyses.) Those tracts of land or portions thereof which do not contain improvements or activities devoted to frequent human habitation or use (including low-density recreational use) and for which no such improvements or activities are planned or programmed.
90. Use. For Section 4(f), use occurs (1) when land from a Section 4(f) site is acquired for a transportation project, (2) when there is an occupancy of land that is adverse in terms of

the preservationist purposes of Section 4(f), or (3) when the proximity impacts of a transportation project on a Section 4(f) site, without acquisition of land, are so great that the purposes for which the Section 4(f) site exists are substantially “impaired” (normally referred to as a “constructive use”).

91. Vicinity. (For purposes of the State Endangered Species Protection Act regulations.) The area surrounding the action, as determined by the life history requirements of the species of concern or proximity to a Natural Area.
92. Wetlands (Federal). Those areas inundated or saturated by surface or ground water at a frequency and duration sufficient to support, and that under normal circumstances do support, a prevalence of vegetation typically adapted for life in saturated soil conditions. Wetlands generally include swamps, marshes, bogs, and similar areas.
93. Wetlands (Illinois). Means land that has a predominance of hydric soils (soils which are usually wet and where there is little or no free oxygen) and that is inundated or saturated by surface or groundwater at a frequency and duration sufficient to support, and that under normal circumstances does support, a prevalence of hydrophytic vegetation (plants typically found in wet habitats) typically adapted for life in saturated soil conditions. Areas which are restored or created as the result of mitigation or planned construction projects and which function as a wetland are included within this definition even when all three wetland parameters are not present.



Appendix C

AUTHORITY/RESPONSIBILITIES

BUREAU OF DESIGN AND ENVIRONMENT MANUAL

Appendix C

AUTHORITY/RESPONSIBILITIES

The proper application of environmental procedures requires an understanding of the governing structure. Appendix C presents the legal authority for environmental regulations and the functional responsibilities of the governmental agencies which implement environmental law.

C-1 LEGAL AUTHORITY

The following subsections present a brief description of the significant Federal and State laws which impact environmental procedures. Where both a Federal and State law apply to a given situation, it is necessary to comply with both.

C-1.01 Federal

C-1.01(a) General Environmental Statutes

1. National Environmental Policy Act (NEPA). 42 U.S.C. 4321-4347 (P.L. 91-190 and 94-83), 23 CFR 771, 40 CFR 1500-1508, Executive Order 11514 as amended by Executive Order 11991 on NEPA responsibilities.

Purpose: Consider environmental factors through systematic interdisciplinary approach before committing to a course of action.

Applicability: All Federal actions.

General Procedures: Procedures set forth in *CEQ Regulations* and 23 CFR 771.

Coordination: Appropriate Federal, State, and local agencies.

2. Section 4(f) of the Department of Transportation Act. 23 U.S.C. 138, 49 U.S.C. 303 (P.L. 100-17, 97-449, and 86-670), 23 CFR 774.

Purpose: Preserve publicly owned public parklands, waterfowl and wildlife refuges, and significant historic sites.

Applicability: Significant publicly owned public parklands, recreation areas, wildlife and waterfowl refuges, and all significant historic sites "used" for a highway project.

General Procedures: Specific finding required: (1) selected alternative must avoid protected areas, unless there are no feasible and prudent avoidance alternatives; and (2) selected alternative must include all possible planning to minimize harm.

Coordination: Department of Interior (DOI), Department of Agriculture (DOA), Department of Housing and Urban Development (HUD), State, or local agencies having jurisdiction, and State Historic Preservation Officer (for historic sites).

3. Section 6002 of the Safe, Accountable, Flexible, Efficient Transportation Equity Act: A Legacy for Users (SAFETEA-LU). 23 U.S.C. 139 ((P.L. 109-59).

Purpose: To make the environmental review process more efficient and timely. This statute describes the roles of the project sponsor and the lead, participating and cooperating agencies; sets new requirements for coordinating and scheduling agency reviews; broadens the authority for States to use Federal funds to ensure timely environmental reviews; and specifies a process for resolving interagency disagreements.

Applicability: The requirements of this directive apply to all Federally-funded transportation projects requiring preparation of an Environmental Impact Statement for compliance with the National Environmental Policy Act. The requirements also may apply to projects involving preparation of an Environmental Assessment, as determined by FHWA on a case-by-case basis.

General Procedures: Key requirements of the new environmental review process established by this statute include the following:

- early notification to Federal Highway Administration (FHWA) of the initiation of the NEPA process;
- identification and invitation of Federal, State, Tribal, regional and local government agencies to serve as participating agencies in the NEPA process;
- opportunity for involvement of participating agencies and the public in defining the project purpose and need;
- opportunity for involvement of participating agencies and the public in developing the range of alternatives for the project; and
- collaboration with participating agencies to determine the appropriate methodologies and the level of detail required in the analysis of alternatives.

Coordination: FHWA, appropriate Federal, State, regional and local agencies, and the public

4. Economic, Social, and Environmental Effects. 23 U.S.C. 109(h) (P.L. 91-605), 23 U.S.C. 128, 23 CFR 771.

Purpose: To assure that possible adverse, economic, social, and environmental effects of proposed highway projects and project locations are fully considered and that final decisions on highway projects are made in the best overall public interest.

Applicability: Planning and development of proposed projects on any Federal-aid system for which the FHWA approves the plans, specifications, and estimates, or has the responsibility for approving a program.

General Procedures: Identification of social, economic, and environmental effects; consideration of alternative courses of action; involvement of other agencies and the public; systematic interdisciplinary approach. The report required by Section 128, on the consideration given to the social, economic, and environmental impacts of the project, may serve as part of the NEPA compliance document.

Coordination: Appropriate Federal, State, and local agencies.

5. Uniform Relocation Assistance and Real Property Acquisition Act of 1970. 42 U.S.C. 4601 et seq., P.L. 91-646 as amended by the Uniform Relocation Act Amendments of 1987 (P.L. 100-17), 49 CFR 24.

Purpose: To implement the Uniform Act as amended in an efficient manner; to ensure property owners of real property acquired for and persons displaced by Federal-aid projects are treated fairly, consistently, and equitably; and so they will not suffer disproportionate injuries.

Applicability: All projects involving Federal-aid funds.

General Procedures: Procedures set forth in 49 CFR 24.

Coordination: DOT/FHWA has lead responsibility. Appropriate Federal, State, and local agencies.

6. Title VI of the Civil Rights Act of 1964. 42 U.S.C. 2000D et seq. and related statutes, 49 CFR 21, 23 CFR 200.

Purpose: To ensure that no person shall, on the grounds of race, color, national origin, age, sex, or disability, be subjected to discrimination under any program or activity receiving Federal financial assistance.

Applicability: All Federal programs and projects.

General Procedures: Procedures set forth in 49 CFR 21 and 23 CFR 200.

Coordination: FHWA headquarters and field offices.

7. Executive Order 12898: Environmental Justice. Federal Register Vol. 60, No. 125, pp 33896-33903.

Purpose: Avoid Federal actions which cause disproportionately high and adverse impacts on minority and low-income populations with respect to human health and the environment.

Applicability: All Federal programs and projects.

General Procedures: Procedures set forth in DOT Final Environmental Justice Strategy and final DOT Order (Federal Register, Volume 62, No. 72, pp. 18377-18381.)

Coordination: FHWA headquarters and field offices.

8. Public Hearings. 23 U.S.C. 128, 23 CFR 771.111.

Purpose: To ensure adequate opportunity for public hearing(s) on the social, economic and environmental effects of alternative project locations and major design features, as well as the consistency of the project with local planning goals and objectives.

Applicability: Public hearings or hearing opportunities are required for projects described in each State's FHWA-approved public involvement procedures.

General Procedures: Public hearings or opportunities for public hearings during the consideration of highway location and design proposals are conducted as described in the State's FHWA-approved, public involvement procedures. States must certify to FHWA that such hearings have been held, or the opportunity for hearings has been offered and, when a hearing is held, must submit a transcript to FHWA.

Coordination: Appropriate Federal, State, and local agencies.

9. Surface Transportation and Uniform Relocation Assistance Act of 1987. Section 123(f) Historic Bridges, 23 U.S.C. 144(o) (P.L. 100-17).

Purpose: Complete an inventory of on-system and off-system bridges to determine their historic significance. Encourage the rehabilitation, reuse, and preservation of historic bridges.

Applicability: Any bridge that is listed on, or eligible for listing on, the National Register of Historic Places.

General Procedures: (1) Identify historic bridges on and off system, (2) seek to preserve or reduce impact to historic bridges, and (3) seek a recipient prior to demolition.

Coordination: State Historic Preservation Officer and Advisory Council on Historic Preservation.

10. Surface Transportation and Uniform Relocation Assistance Act of 1987. Section 130 Wildflowers, 23 U.S.C. 319(b) (P.L. 100-17), 23 CFR 752.

Purpose: To encourage the use of native wildflowers in highway landscaping.

Applicability: Native wildflowers are to be planted on any landscaping project undertaken on the Federal-aid highway system.

General Procedures: At least 1/4 of 1% of funds expended on a landscaping project must be used to plant native wildflowers on that project.

Coordination: FHWA - State, Division, Regional contacts.

11. Highway Beautification Act of 1965. 23 U.S.C. 131, 136, 319 (P.L. 89-285), 23 CFR 750, 751, 752.

Purpose: To provide effective control of outdoor advertising and junkyards, to protect the public investment, to promote the safety and recreational value of public travel and preserve natural beauty, and to provide landscapes and roadside development reasonably necessary to accommodate the traveling public.

Applicability: Interstate and primary systems including toll sections thereof.

General Procedures. Procedures set forth in 23 CFR 750, 751, and 752.

Coordination: DOT/FHWA, State, and local agencies.

C-1.01(b) Health

1. Safe Drinking Water Act. 42 U.S.C. 300f - 300j-6 (P.L. 93-523 and 99-339), 23 CFR 650, Subpart E, 40 CFR 141, 149.

Purpose: Ensure public health and welfare through safe drinking water.

Applicability: (1) All public drinking water systems and reservoirs (including rest area facilities), (2) actions which may have a significant impact on an aquifer or wellhead protection area which is the sole or principal drinking water source, as designated through the Federal Register process.

General Procedures: (1) Compliance with national primary drinking water regulations, (2) compliance with State wellhead protection plans, (3) compliance with MOAs between EPA and FHWA covering specific sole-source aquifers.

Coordination: US Environmental Protection Agency (EPA) and appropriate State agency.

2. Solid Waste Disposal Act, as amended by the Resource Conservation and Recovery Act of 1976. 42 U.S.C. 6901, et seq., see especially 42 U.S.C. 6961-6964 (P.L. 89-272, 91-512, and 94-580), 23 CFR 751, 40 CFR 256-300.

Purpose: Provide for the recovery, recycling, and environmentally safe disposal of solid wastes.

Applicability: All projects which involve the recycling or disposal of solid wastes.

General Procedures: Solid wastes will be disposed of according to the rules for specific waste involved.

Coordination - EPA.

3. Federal Insecticide, Fungicide, and Rodenticide Act (FIFRA). 7 U.S.C. 136-136y (P.L. 92-516), 40 CFR 152-171.

Purpose: Control the application of pesticides to provide greater protection to man and the environment.

Applicability: All activities which necessitate use of restricted pesticides.

General Procedures: Using or supervising "restricted use" pesticides will require certification.

Coordination: EPA.

C-1.01(c) Historic and Archeological Preservation

1. Section 106 of the National Historic Preservation Act, as amended. 16 U.S.C. 470f (P.L. 89-665, 91-243, 93-54, 94-422, 94-458, 96-199, 96-244, and 96-515), Executive Order 11593, 23 CFR 771, 36 CFR 60, 36 CFR 63, 36 CFR 800.

Purpose: Protect, rehabilitate, restore, and reuse districts, sites, buildings, structures, and objects significant in American architecture, archeology, engineering, and culture.

Applicability: All properties on or eligible for inclusion on the National Register of Historic Places.

General Procedures: (1) Identify and determine the effects of project on subject properties, (2) coordinate with the State Historic Preservation Officer, other consulting parties, and, as appropriate, the Advisory Council on Historic Preservation, in accordance with 36 CFR 800, (3) avoid or mitigate damages to greatest extent possible.

Coordination: State Historic Preservation Officer, Advisory Council on Historic Preservation, DOI National Park Service (NPS).

2. Section 110 of the National Historic Preservation Act, as amended. 16 U.S.C. 470h-2 (P.L. 96-515), 36 CFR 65, 36 CFR 78.

Purpose: Protect national historic landmarks and record historic properties prior to demolition.

Applicability: All properties designated as National Historic Landmarks. All properties on or eligible for inclusion on the National Register of Historic Places.

General Procedures: (1) Identify and determine the effects of a project on subject properties, (2) afford Advisory Council an early opportunity to comment, in accordance with 36 CFR 800.

Coordination: State Historic Preservation Officer, Advisory Council on Historic Preservation, DOI (NPS).

3. Archeological and Historic Preservation Act. 16 U.S.C. 469-469c (P.L. 93-291) (Moss-Bennett Act), 36 CFR 66 (draft).

Purpose: Preserving significant historical and archeological data from loss or destruction.

Applicability: Any unexpected archeological resources discovered as a result of a Federal construction project or Federally licensed activity or program.

General Procedures: (1) Notify DOI (NPS) when a Federal project may result in the loss or destruction of a historic or archeological property, (2) DOI and/or the Federal agency may undertake survey or data recovery.

Coordination: DOI (NPS) Departmental consulting archeologist and State Historic Preservation Officer.

4. Archeological Resources Protection Act. 16 U.S.C. 470AA-11 (P.L. 96-95), 18 CFR 1312, 32 CFR 229, 36 CFR 79, 296, 43 CFR 7.

Purpose: Preserve and protect paleontological resources, historic monuments, memorials, and antiquities from loss or destruction.

Applicability: Archeological resources on Federal or Native American-owned property.

General Procedures: (1) Ensure contractor obtains permit, and identifies and evaluates resource. (2) Mitigate or avoid resource in consultation with appropriate officials in the State. (3) If necessary, apply for permission to examine, remove, or excavate such objects.

Coordination: Department or agency having jurisdiction over land on which resources may be situated (Bureau of Indian Affairs (BIA), Bureau of Land Management (BLM), DOA, Department of Defense (DOD), NPS, Tennessee Valley Authority (TVA), US Forest Service (USFS), State Historic Preservation Officer, Recognized Indian Tribe, if appropriate).

5. Act for the Preservation of American Antiquities. 16 U.S.C. 431-433 (P.L. 59-209), 36 CFR 251.50-.64, 43 CFR 3.

General Procedures: (1) Notify DOI (NPS) when a Federal project may result in the loss or destruction of a historic or archaeological property, (2) DOI and/or the Federal agency may undertake survey or data recovery.

Coordination: DOI (NPS) Departmental consulting archeologist, State Historic Preservation Officer.

6. American Indian Religious Freedom Act. 42 U.S.C. 1996 (P.L. 95-341).

Purpose: Protect places of religious importance to American Indians, Eskimos, and Native Hawaiians.

Applicability: All projects which affect places of religious importance to Native Americans.

General Procedures: Consult with knowledgeable sources to identify and determine any effects on places of religious importance. Comply with Section 106 procedures if the property is historic.

Coordination: BIA, State Historic Preservation Officer, State Indian liaison, Advisory Council on Historic Preservation, if appropriate.

7. Native American Grave Protection and Repatriation Act. (P.L. 101-601), 43 CFR 10.

Purpose: Protect human remains and cultural material of Native American and Hawaiian groups.

Applicability: Federal lands and Tribal lands.

General Procedures: Consult with Native American group.

Coordination: DOI (NPS), BIA, State Historic Preservation Officer.

C-1.01(d) Land and Water Usage

1. Wilderness Act. 16 U.S.C. 1131-1136, 36 CFR 251, 293, 43 CFR 19, 8560, 50 CFR 35.

Purpose: Preserve and protect wilderness areas in their natural condition for use and enjoyment by present and future generations.

Applicability: All lands designated as part of the wilderness system by Congress.

General Procedures: Apply for modification or adjustment of wilderness boundary by either Secretary of the Interior or Agriculture, as appropriate.

Coordination: Agriculture (USFS), DOI (US Fish and Wildlife Service (FWS), NPS, BLM), and State agencies.

2. Wild and Scenic Rivers Act. 16 U.S.C. 1271-1287, 36 CFR 297, 43 CFR 8351.2.

Purpose: Preserve and protect wild and scenic rivers and immediate environments for benefit of present and future generations.

Applicability: All projects which affect designated and potential wild, scenic, and recreational rivers, and/or immediate environments.

General Procedures: Submit project plans and reports to appropriate Federal agency.

Coordination: DOI (BLM, NPS, FWS) and/or Agriculture (USFS), State agencies.

3. Land and Water Conservation Fund Act (Section 6(f)). 16 U.S.C. 4601-4 to -11 (P.L. 88-578).

Purpose: Preserve, develop, and assure the quality and quantity of outdoor recreation resources for present and future generations.

Applicability: All projects that impact recreational lands purchased or improved with land and water conservation funds.

General Procedures: The Secretary of the Interior must approve any conversion of property acquired or developed with assistance under this Act to other than public, outdoor recreation use.

Coordination: DOI, State agencies.

4. Executive Order 11990, Protection of Wetlands. DOT Order 5660.1A, 23 CFR 777.

Purpose: To avoid direct or indirect support of new construction in wetlands wherever there is a practicable alternative.

Applicability: Federally undertaken, financed, or assisted construction, and improvements in or with significant impacts on wetlands.

General Procedures: Evaluate and mitigate impacts on wetlands. Specific finding required in final environmental document.

Coordination: DOI (FWS), EPA, US Army Corps of Engineers (USACOE), National Marine Fisheries Service (NMFS), Natural Resources Conservation Service (NRCS), State agencies.

5. Intermodal Surface Transportation Efficiency Act of 1991 (Wetlands Mitigation Banks). Sec. 1006-1007 (P.L. 102-240, 105 STAT 1914), 23 CFR 771.

Purpose: To mitigate wetlands impacts directly associated with projects funded through NHS and STP, by participating in wetlands mitigation banks restoration, enhancement and creation of wetlands authorized under the Water Resources Development Act, and through contributions to Statewide and regional efforts.

Applicability: Federally undertaken, financed, or assisted construction, and improvements in, or with impacts on wetlands.

General Procedures: Evaluate and mitigate impacts on wetlands. Specific finding required in final environmental document.

Coordination: DOI (FWS), EPA, USACOE, NMFS, NRCS, State agencies.

6. Emergency Wetlands Resources Act of 1986. 16 U.S.C. - 3901 note (P.L. 99-645).

Purpose: To promote the conservation of wetlands in the U. S. in order to maintain the public benefits they provide.

Applicability: All projects that may impact wetlands.

General Procedures: (1) Preparation of a National Wetlands Priority Conservation Plan which provides priority with respect to Federal and State acquisition, (2) provide direction for the National Wetlands Inventory Project.

Coordination: FWS.

7. National Trails Systems Act. 16 U.S.C. 1241-1249, 36 CFR 251, 43 CFR 8350.

Purpose: Provide for outdoor recreation needs and encourage outdoor recreation.

Applicability: Projects affecting national recreational, scenic, or historic trails designated by Congress and lands through which such trails pass. National recreation trails and side and connecting trails are proposed by local sponsors and approved by DOI and DOA.

General Procedures: (1) Apply for right-of-way easement from the Secretary of Interior or Agriculture, as appropriate, and (2) ensure that potential trail properties are made available for use as recreational and scenic trails.

Coordination: DOI (NPS) or Agriculture (USFS). Other Federal land management agencies may apply for designation.

8. National Recreational Trails Fund Act of the Intermodal Surface Transportation Efficiency Act of 1991. 16 U.S.C. 1261 (P.L. 102-240).

Purpose: To establish a program to allocate funds to the States to provide and maintain recreational trail and trail-related projects.

Applicability: Trails and trail-related projects which are identified in, or which further a specific goal of, a trail plan included or referenced in a Statewide comprehensive outdoor recreation plan, as required by the Land and Water Conservation Fund Act.

General Procedures: Project-sponsor applies to the State, and FHWA approves spending for project. The State may be a project sponsor. Assured access to funds is given for motorized, non-motorized, and discretionary recreation uses. States shall give preference to projects with diversified uses.

Coordination: FHWA.

9. Rivers and Harbors Act of 1899. 33 U.S.C. 401, et seq., as amended and supplemented, 23 CFR 650, Subparts D and H, 33 CFR 114-115.

Purpose: Protection of navigable waters in the U.S.

Applicability: Any construction affecting navigable waters and any obstruction, excavation, or filling.

General Procedures: Must obtain approval of plans for construction, dumping, and dredging permits (Section 10) and bridge permits (Section 9).

Coordination: USACOE, US Coast Guard (USCG), EPA, State agencies.

10. Federal Water Pollution Control Act (1972), as amended by the Clean Water Act (1977 & 1987). 33 U.S.C. 1251-1376 (P.L. 92-500, 95-217, 100-4), DOT Order 5660.1A, FHWA Notices N5000.3 and N5000.4, 23 CFR 650, Subpart B, 771, 33 CFR 209, 320-323, 325, 328, 329, 40 CFR 121-125, 129-131, 133, 135-136, 230-231.

Purpose: Restore and maintain chemical, physical, and biological integrity of the Nation's waters through prevention, reduction, and elimination of pollution.

Applicability: Any discharge of a pollutant into waters of the U.S.

General Procedures: (1) Obtain permit for dredge or fill material from USACOE or State agency, as appropriate (Section 404); (2) permits for all other discharges are to be acquired from EPA or appropriate State agency (Section 402), Phase I - NPDES - Issued for municipal separate storm sewer systems (MS4) serving large populations (over 250,000), medium populations (over 100,000) and regulated systems serving urbanized areas (i.e., areas that have a residential population of at least 50,000 and an overall population density of at least 1,000 people per square mile). Storm water discharges associated with industrial waste. Activities including construction sites disturbing one acre (4047 m²) or more of total land area; (3) water quality certification is required from State water resource agency (Section 401); and (4) all projects shall be consistent with the State non-point source pollution management program (Section 319).

Coordination: USACOE, EPA, designated State water quality control agency, designated State non-point source pollution agency.

11. Executive Order 11988, Floodplain Management, as amended by Executive Order 12148. DOT Order 5650.2, 23 CFR 650, Subpart A, 771.

Purpose: To avoid the long- and short-term adverse impacts associated with the occupancy and modification of floodplains, and to restore and preserve the natural and beneficial values served by floodplains.

Applicability: All construction of Federal or Federally aided buildings, structures, roads, or facilities which encroach upon or affect the base floodplain.

General Procedures: (1) Assessment of flood hazards, and (2) specific finding required in final environmental document for significant encroachments.

Coordination: Federal Emergency Management Agency (FEMA), State and local agencies.

12. National Flood Insurance Act. (P.L. 90-448), Flood Disaster Protection Act: (P.L. 93-234) 42 U.S.C. 4001-4128, DOT Order 5650.2, 23 CFR 650, Subpart A, 7, 23 CFR 771, 44 CFR 59-62, 64-68, 70-71, 75-77.

Purpose: (1) Identify flood-prone areas and provide insurance, and (2) requires purchase of insurance for buildings in special flood-hazard areas.

Applicability: Any Federally assisted acquisition or construction project in area identified as having special flood hazards.

General Procedures: Avoid construction in, or design to be consistent with, FEMA-identified flood-hazard areas.

Coordination: FEMA, State, and local agencies.

13. Marine Protection Research and Sanctuaries Act of 1972, as amended. 33 U.S.C. 1401-1445 (P.L. 92-532, 93-254, 96-572), 33 CFR 320, 330, 40 CFR 220-225, 227-228, 230-231.

Purpose: Regulate dumping of materials into U.S. ocean waters.

Applicability: Any transportation to and dumping into the open sea.

General Procedures: Apply for permit in accordance with existing procedures.

Coordination: EPA, USACOE (if dredge material).

14. Water Bank Act. 16 U.S.C. 1301-1311 (P.L. 91-559, 96-182), 7 CFR 752.

Purpose: Preserve, restore, and improve wetlands of the Nation.

Applicability: Any agreements with landowners and operators in important migratory waterfowl nesting and breeding areas.

General Procedures: Apply procedures established for implementing Executive Order 11990.

Coordination: Secretary of Agriculture, Secretary of Interior.

15. Coastal Zone Management Act of 1972. 16 U.S.C. 1451-1464 (P.L. 92-583, 94-370, 96-464), 15 CFR 923, 926, 930, 23 CFR 771.

Purpose: Preserve, protect, develop, and (where possible) restore and enhance resources of the coastal zone.

Applicability: All projects significantly affecting areas under the control of the State coastal zone management agency for which a plan is approved by the Dept. of Commerce.

General Procedures: Ensure that projects comply with Federal consistency regulations, management measures, and the appropriate approved State plan for coastal zone management programs.

Coordination: State coastal zone management agency and the Dept. of Commerce Office of Coastal Zone Management (OCZM) National Oceanic and Atmospheric Administration (NOAA), and EPA.

16. Coastal Zone Management Act Reauthorization Amendments of 1990. 6217(g)

Purpose: Manage non-point source pollution of activities located in coastal zones.

Applicability. All developmental activities located in coastal zone areas will be subject to non-point source control measures developed by the State Coastal Zone Agency.

General Procedures: Ensure projects comply with State CZM plans for controlling non-point sources.

Coordination: State CZM Agency, OCZM (NOAA), EPA.

17. Coastal Barrier Resources Act, as amended. 16 U.S.C. 3501-3510, 42 U.S.C. 4028 (P.L. 97-348), Great Lakes Coastal Barrier Act of 1988 (P.L. 100-707), 13 CFR 116 Subparts D, E, 44 CFR 71, 205 Subpart N.

Purpose: Minimize the loss of human life, wasteful expenditures of Federal revenues, and the damage to fish, wildlife, and other natural resources.

Applicability: Any project that may occur within the boundaries of a designated coastal barrier unit. Exemptions for certain actions are possible.

General Procedures: Coordinate early with the FWS Regional Director. Consult maps that depict the boundaries of each coastal barrier resources system unit.

Coordination: FEMA, DOI (FWS).

18. Farmland Protection Policy Act of 1981. 7 U.S.C. 4201-4209 (P.L. 97-98, 99-198), 7 CFR 658.

Purpose: Minimize impacts on farmland and maximize compatibility with State and local farmland programs and policies.

Applicability: All projects that take right-of-way in farmland, as defined by regulation.

General Procedures: (1) Early coordination with the NRCS, (2) land evaluation and site assessment, and (3) determination of whether or not to proceed with farmland conversion, based on severity of impacts and other environmental considerations.

Coordination: NRCS.

19. Resource Conservation and Recovery Act of 1976 (RCRA), as amended. 42 U.S.C. 6901, et seq. (P.L. 94-580, 98-616), 40 CFR 260-271.

Purpose: Protect human health and the environment, prohibit open dumping, manage solid wastes, and regulate treatment, storage, transportation, and disposal of hazardous waste.

Applicability: Any project that takes right-of-way containing a hazardous waste.

General Procedures: Coordinate with EPA or State agency on remedial action.

Coordination: EPA or State agency approved by EPA, if any.

20. Comprehensive Environmental Response, Compensation, and Liability Act of 1980 (CERCLA), as amended. 42 U.S.C. 9601-9657 (P.L. 96-510), 40 CFR 300, 43 CFR 11. Superfund Amendments and Reauthorization Act of 1986 (SARA) (P.L. 99-499).

Purpose: Provide for liability, compensation, cleanup, and emergency response for hazardous substances released into the environment and the cleanup of inactive hazardous waste disposal sites.

Applicability: Any project that might take right-of-way containing a hazardous substance.

General Procedures: (1) Avoid hazardous waste sites, if possible, (2) check EPA lists of hazardous waste sites, (3) field surveys and reviews of past and present land use, (4) contact appropriate officials if uncertainty exists, (5) if hazardous waste is present or suspected, coordinate with appropriate officials, and (6) if hazardous waste encountered during construction, stop project and develop remedial action.

Coordination: EPA or State agency approved by EPA, if any.

21. Endangered Species Act of 1973, as amended. 16 U.S.C. 1531-1543 (P.L. 93-205, 94-359, 95-632, 96-159, 97-304), 7 CFR 355, 50 CFR 17, 23, 81, 222, 225-227, 402, 424, 450-453.

Purpose: Conserve species of fish, wildlife and plants facing extinction.

Applicability: Any action that is likely to jeopardize continued existence of such threatened/ endangered species or result in destruction or modification of critical habitat.

General Procedures: Consult with the Secretary of the Interior or Commerce, as appropriate.

Coordination: DOI (FWS), Commerce (NMFS).

22. Fish and Wildlife Coordination Act. 16 U.S.C. 661-666(c) (P.L. 85-624, 89-72, 95-616).

Purpose: Conservation, maintenance, and management of wildlife resources.

Applicability: (1) Any project which involves impoundment (surface area of 4.05 hectares [ten acres] or more), diversion, channel deepening, or other modification of a stream or other body of water, and (2) transfer of property by Federal agencies to State agencies for wildlife conservation purpose.

General Procedures: Coordinate early in project development with FWS and State fish and wildlife agency.

Coordination: DOI (FWS), State fish and wildlife agencies.

23. Migratory Bird Treaty Act. 16 U.S.C. 760c-760g

Purpose: To protect most common wild birds found in the United States.

Applicability: Makes it unlawful for anyone to kill, capture, collect, possess, buy, sell, trade, ship, import, or export any migratory bird. Indirect killing of birds by destroying their nests and eggs is covered by the act so construction in nesting areas can constitute a taking.

General Procedures: The FWS is to review and comment on the effects of a proposal that could kill birds, even indirectly.

Coordination: DOI (FWS), State fish and wildlife agencies.

24. Intermodal Surface Transportation Efficiency Act of 1991. Transportation Enhancement Activities: Sec. 1007 (P.L. 102-240).

Purpose: To provide funds for Transportation Enhancement activities, such as landscaping and beautification, rehabilitation and operation of historic transportation facilities.

Applicability: Funds are to be used in all areas except roads classified as local or rural minor collectors, unless such roads are on a Federal-aid highway system.

General Procedures: 10% of STP funds annually apportioned to each State are for Transportation Enhancement activities.

Coordination: FHWA.

25. Intermodal Surface Transportation Efficiency Act of 1991, Sec. 1038 Recycled Paving Material. (P.L. 102-240).

Purpose: To reduce the use of virgin materials used for paving our nation's highways.

Applicability: Each State shall certify that it has satisfied the minimum utilization requirement for asphalt pavement containing recycled rubber.

General Procedures: 20% of asphalt funded with Federal-aid in each State is required to include recycled rubber by 1997.

Coordination: FHWA.

26. Intermodal Surface Transportation Efficiency Act of 1991 Sec. 1047 Scenic Byways Program. (P.L. 102-240).

Purpose: To identify and develop those special scenic byways that offer outstanding scenic, historic, natural, cultural, recreational, or archaeological values.

Applicability: Any public road or highway which meets the criteria for inclusion as a Scenic Byway or an All-American Road.

General Procedures: Nominations may originate from any local government, private group or individual, but must come through the States. Final designations will be made by the Secretary of Transportation.

Coordination: FHWA.

C-1.01(e) Noise

1. Standards. 23 U.S.C. 109(I) (P.L. 91-605), (P.L. 93-87), 23 CFR 772.

Purpose: Promulgate noise standards for highway traffic.

Applicability: All Federally funded projects for the construction of a highway on new location, or the physical alteration of an existing highway which significantly changes either the vertical or horizontal alignment or increases the number of through traffic lanes.

General Procedures: (1) Noise impact analysis. (2) Analysis of mitigation measures. (3) Incorporate reasonable and feasible noise abatement measures to reduce or eliminate noise impact.

C-1.01(f) Air Quality

1. Clean Air Act (as amended) Transportation Conformity Rule. 23 U.S.C. 109(j), 42 U.S.C. 7521(a) (P.L. 101-549), 23 CFR 771, 40 CFR 51 and 93.

Purpose: To insure that transportation plans, programs and projects conform to the State's air quality implementation plans.

Applicability: Non-attainment and maintenance areas.

General Procedures: Transportation plans, programs, and projects must conform with State Implementation Plans (SIPs) that provide for attainment of the national ambient air quality standards.

Coordination: Federal Transit Administration (FTA), EPA, Metropolitan Planning Organizations (MPOs), State Departments of Transportation and State and local Air Quality Control Agencies.

2. Clean Air Act (as amended), Sanctions. 42 U.S.C. 7509, Sec. 179(b), Sec. 110(m) (P.L. 101-549), 40 CFR 52.

Purpose: To restrict Federal funding and approvals for highway projects in States that fail to submit or implement an adequate State Implementation Plan (SIP).

Applicability: In non-attainment areas 24 months after EPA has identified a SIP deficiency. May be applied Statewide under separate rulemaking.

General Procedures: (1) After EPA finds that a State failed to submit or implement a SIP, that the SIP is incomplete, or disapproves a SIP, an 18-month time clock begins. (2) Unless deficiencies are corrected within 18 months, 2:1 offset sanctions are applied. Six months later, highway sanctions are applied.

Coordination: EPA.

3. Intermodal Surface Transportation Efficiency Act of 1991, Congestion Mitigation and Air Quality Improvement Program (CMAQ). Sec 1008, 23 U.S.C. 149.

Purpose: To assist non-attainment and maintenance areas in reducing transportation-related emissions.

Applicability: Transportation programs or projects in non-attainment areas and areas redesignated to maintenance that are likely to contribute to the attainment or maintenance of the National Ambient Air Quality Standards (NAAQS).

General Procedures: (1) Project sponsor (transit operator, municipal office, etc.) develops formal proposal to improve air quality. (2) Submit to the MPO, State for evaluation and approval. (3) Included in the TIP and approved as eligible by FTA and FHWA in consultation with EPA.

Coordination: FTA, EPA, MPOs, State Departments of Transportation, and State and local Air Quality Control Agencies.

C-1.02 State

In addition to the Federal environmental legislation, the State of Illinois has enacted considerable State legislation for the implementation of environmental requirements. The following briefly discusses the significant State laws on environmental policies:

1. Interagency Wetland Policy Act of 1989, 20 Illinois Compiled Statutes (ILCS) 830/1-1, et seq., (P.A. 86-157). This Act establishes a State goal of “no net loss” of wetlands acreage and their functional values due to State or State-supported activities. It provides that State agencies shall preserve, enhance, and create wetlands where necessary to increase the quality and quantity of the State’s wetlands resource base. The Act establishes a State wetlands mitigation policy and requires designated State agencies to prepare Agency Action Plans for implementation procedures. The Act authorizes State agencies to establish wetlands compensation accounts, and it requires agencies to consider the avoidance and minimization of adverse impacts to wetlands and to provide compensation for unavoidable adverse impacts with a schedule of compensation ratios. The Act is administered by Illinois Department of Natural Resources (IDNR).
2. Illinois Historic Preservation Act, 20 ILCS 3410/1, et seq. This Act establishes the Illinois Register of Historic Places. It stipulates that no person shall demolish, cause to be demolished, or permit or order the demolition of any Critical Historical Feature of a Registered Illinois Historic Place unless the Director of the Illinois Historic Preservation Agency (IHPA) has issued a Certificate of Compliance stating that the requirements of the Act have been satisfied and setting forth any conditions agreed to. The Act provides that public funds shall not be used in any project that will have an adverse economic or environmental impact on a Registered Illinois Historic Place unless the Director of the IHPA determines:
 - the project is necessary to provide an important public service or benefit,
 - the project cannot be implemented practically to avoid the adverse effect, and
 - the adverse effect is minimized to the maximum extent feasible.

3. Illinois State Agency Historic Resources Preservation Act, 20 ILCS 3420/1, et seq. (P.A. 86-707). This Act establishes a program whereby State agencies (1) administer historic resources under their control to foster and enhance their availability to future generations; (2) prepare policies and plans to contribute to the preservation, restoration, and maintenance of State-owned historic resources for the inspiration and benefit of the people; and (3) consult with the Illinois Historic Preservation Agency to ensure that State projects consider the preservation and enhancement of State-owned and non-State-owned historic resources. The Act provides that consultation is not required for actions being reviewed in accordance with Section 106 of the National Historic Preservation Act.
4. Archaeological and Paleontological Resources Protection Act, 20 ILCS 3435/.01, et seq., (P.A. 86-459, 86-707). This Act reserves to the State of Illinois the right of regulating, exploring, excavating, or surveying, through the Historic Preservation Agency, all archaeological and paleontological resources found upon State lands. It requires a permit from the Historic Preservation Agency for conducting any of these activities on public lands. The Act prohibits any person from knowingly disturbing any protected archaeological or paleontological resource or knowingly offering for sale or exchange any object collected or excavated in violation of the Act.
5. Soil and Water Conservation Districts Act of 1937, 70 ILCS 405/1, et seq., as amended. This Act establishes a policy to strengthen and extend erosion and sedimentation control activities for both rural and urban lands. It provides for establishing and implementing, through the Illinois Department of Agriculture and Soil and Water Conservation Districts and in cooperation with units of local government, school districts, other political subdivisions of the State, agencies of the State and other public and private entities, a Statewide comprehensive and coordinated erosion and sediment control program to conserve and protect land, water, air, and other resources. The Act requires State agencies to cooperate with the Illinois Department of Agriculture and Soil and Water Conservation Districts in implementing programs undertaken pursuant to the Act.
6. Illinois Environmental Protection Act of 1970, 415 ILCS 5/8, et seq.(P.A. 76-2429). This Act establishes a unified, Statewide regulatory program to restore, protect, and enhance the quality of the environment and to ensure that adverse effects upon the environment are fully considered and borne by those who cause them. The Act implements permit and control programs for air pollution, water pollution, public water supplies, land pollution, noise, atomic radiation, used tires, potentially infectious medical wastes, and petroleum underground storage tanks.
7. Illinois Groundwater Protection Act, 415 ILCS 55/1, et seq. This Act establishes a State policy to restore, protect, and enhance the groundwater of the State as a natural and public resource, to prevent waste and degradation of groundwater resources, and to manage the underground water resource to allow for maximum benefit of the people of the State. The Act establishes within State government an Interagency Committee on Groundwater which is responsible for reviewing and coordinating the State's policy on groundwater protection and for reviewing various aspects of the State's groundwater protection program and making recommendations on those aspects. The Act authorizes

- the establishment of an education program, a data collection program, and appropriate regulations for groundwater protection.
8. Agricultural Areas Conservation and Protection Act of 1979, 505 ILCS 5/1, et seq (P.A. 81-1173). This Act establishes a program whereby agricultural land may be protected and enhanced through designation as an “Agricultural Area.” It provides that no land within an Agricultural Area shall be used for purposes other than agricultural production. The Act provides that any person may petition for withdrawal of land from a designated Agricultural Area, and this person must submit documentation of the proposed alternative use for the land, an explanation of the need for a change from the current use of the land, and an explanation of why land outside the Agricultural Area would not be suitable for the proposed use. The Act indicates that the County Board either accepts or rejects the petition for withdrawal of land after a hearing and an opportunity for review and comment by the county Agricultural Areas Committee and regional and county planning commissions, if any.
 9. Farmland Preservation Act of 1982, 505 ILCS 75/1, et seq. (P.A. 82-945). This Act requires designated agencies to prepare policy statements and working agreements with the Illinois Department of Agriculture specifying the policy of the agencies toward farmland preservation and the administrative process used to implement that policy. It requires agencies to provide notice to the Illinois Department of Agriculture of projects that may lead to agricultural land conversion unless such projects are exempted from review by an agency’s cooperative working agreement. The Act provides that the Department of Agriculture shall determine whether an agency’s projects comply with its policy statement and cooperative working agreement and that the Department of Agriculture shall conduct a study of the agricultural impacts for any project that does not comply.
 10. Endangered Species Protection Act of 1972, 520 ILCS 10/1, et seq., (P.A. 77-2186). This Act protects State-listed animals and plants from unauthorized actions. It requires agencies of State and local governments to evaluate, through a consultation process with the Illinois Department of Natural Resources, whether actions authorized, funded, or implemented by them are likely to jeopardize the continued existence of Illinois-listed threatened or endangered species or are likely to result in the destruction or adverse modification of the designated essential habitat of such species. When an agency has so consulted, it shall be deemed to have complied with its obligations under the Act, provided that the agency action shall not result in the killing or injuring of any Illinois-listed animal species.
 11. Illinois Natural Areas Preservation Act, 525 ILCS 30/1, et seq., (P.A. 82-445). This Act establishes provisions for a system of dedicated nature preserves and registered natural areas. It provides that dedicated nature preserves may not be acquired under power of eminent domain or by other means for any other use except another public use and except upon approval by the Illinois Nature Preserves Commission, the Governor, and any public owner of a dedicated interest therein after a finding by the Commission of the existence of an imperative and unavoidable public necessity for such other public use,

and upon such terms and conditions as the Commission may determine, except as may otherwise be provided in the instrument of dedication. The Act requires the Commission to give public notice of the proposed action for which a finding of an imperative and unavoidable public necessity is being considered and to provide an opportunity for any person to request the holding of a public meeting and to be heard at such public meeting. It provides for promoting, by advice and other assistance, the protection of registered natural areas.

12. Regulation of Rivers, Lakes, and Streams Act, 615 ILCS 5/4, et seq. This Act assigns to the Office of Water Resources of the Department of Natural Resources jurisdiction over public waters of the State. It provides for general supervision of such waters to ensure that none are encroached upon or wrongfully seized by any private interest in any way. The Act establishes authority for requiring permits from the IDNR for actions affecting public waters, and it requires permits from the IDNR for construction within defined floodplains in the State.
13. Preservation of Illinois Farmland, Illinois Executive Order No. 4 (1980). This Order establishes a State policy to protect, through the administration of its current programs and regulations, the State's prime agricultural land from irreversible conversion to uses which result in its loss as an environmental or essential food production resource. It designates the Illinois Department of Agriculture as the lead for implementing the policy and requires designated agencies to prepare Agricultural Land Preservation Policies. The policies must include an analysis of the impact on agricultural land conversions caused by their programs, regulations, procedures, and operations, and they also must detail measures that can be implemented that will mitigate conversions to the maximum extent practicable. The policies must provide a greater degree of protection for Classes I, II, and III lands than for Classes IV through VIII. The Order provides that the Department of Agriculture will analyze State-funded capital projects that impact farmland conversion and advise the Governor's Office on the consistency of agency actions with the policy established by the Executive Order.

C-2 FUNCTIONAL RESPONSIBILITIES

Many governmental agencies, both Federal and State, have various functional responsibilities related to the implementation of environmental laws, regulations, policies, and procedures. This section briefly describes the functional responsibilities for these agencies, and it provides an address and phone number for preliminary contacts.

C-2.01 Federal

The following briefly describes the functional responsibilities of the major Federal agencies in the implementation of environmental procedures:

1. Council on Environmental Quality (CEQ). The Council is composed of three members appointed by the President which maintains a quality awareness of the nation's environmental resources. The CEQ oversees the implementation of NEPA by issuing regulations (40 CFR 1500-1508) to guide all Federal agencies.

Address: Executive Director
Council on Environmental Quality
722 Jackson Place NW
Washington, D.C. 20503

Telephone No.: (202) 633-7032

2. Environmental Protection Agency (EPA). EPA is responsible for determining which pollutants and what concentrations are harmful to the health and safety of the human population. It establishes minimum safe requirements for the concentration of pollutants, and it establishes procedures for achieving and maintaining these concentration levels. For the CEQ, EPA conducts quality control tests on the proper implementation of NEPA. EPA issues the basic air quality, water quality, hazardous waste, and solid waste regulations for nationwide implementation.

Address: Environmental Protection Agency
Region 5 Office
77 W. Jackson Boulevard
Chicago, Illinois 60604-3507

Telephone No.: (312) 353-2000

3. Federal Highway Administration (FHWA). The Federal Highway Administration (FHWA) administers the Federal-aid program that funds eligible highway improvements nationwide. Its basic responsibility is to ensure that the State DOT's comply with all applicable Federal laws in their expenditure of Federal funds and to ensure that the State DOT's meet the applicable requirements for proposed highway projects. This includes all applicable environmental laws, regulations, policies, and procedures. FHWA

maintains a Division Office within each State, and this is the primary point of contact for a State DOT. FHWA also maintains four regional Resource Centers to provide technical program assistance to the FHWA Division Offices and their partners.

Address: Environmental Programs Engineer
Illinois FHWA Division Office
3250 Executive Park Drive
Springfield, Illinois 62703

Telephone No.: (217) 492-4625

Address: FHWA Resource Center
One Prairie Office Center
4749 Lincoln Mall Drive – 6th Floor
Matteson, Illinois 60443

Telephone No.: (708) 283-3500

4. Federal Transit Administration (FTA). As an agency of the U.S. Department of Transportation, FTA administers the national transit program and all federal laws, regulations, policies, and procedures applicable to the use of Federal transit funds. This includes those that pertain to the environment.

Address: Regional Administrator, Federal Transit Administration
200 West Adams Street, Suite 320
Chicago, Illinois 60606

Telephone No.: (312) 353-2789

5. US DOT - Chicago Metropolitan Office. FHWA and FTA jointly operate four metropolitan offices around the country that are extensions of their respective Division and Regional offices and Resource Centers. These offices provide assistance, guidance, and information on Federal transportation programs to local, State, and other Federal agencies in the affected metropolitan areas.

Address: US DOT Chicago Metropolitan Office
200 West Adams Street, Suite 320
Chicago, Illinois 60606

Telephone No.: (312) 886-1616

6. US Coast Guard (USCG). As an agency of the US Department of Transportation, the USCG administers the nation's waterways for vessels operating on navigable streams. Its responsibilities include the issuance of permits for bridges over navigable streams (Section 9 Permit).

Address: Commander
Attn: Bridge Branch
Ninth Coast Guard District
1240 E. 9th
Cleveland, Ohio 44199-2060

Telephone No.: (216) 902-6045

Address: Commander
Attn: Bridge Branch
Eighth Coast Guard District
Hale Boggs Federal Building
500 Poydras Street
New Orleans, LA 70130

Telephone No.: (504) 671-2128

Address: Commander
Attn: Bridge Branch
Ninth Coast Guard District
1240 E. 9th
Cleveland, Ohio 44199-2060

Telephone No.: (216) 902-6045

7. US Army Corps of Engineers (USACOE). The USACOE is responsible for maintaining the shipping lanes on navigable waters and the permitting process for the wetlands program (Section 404 Permit), and it operates many of the dams on navigable waters.

Address: Regulatory Branch
U.S. Army Corps of Engineers, Rock Island
Clock Tower Building
P.O. Box 2004
Rock Island, Illinois 61204-2004

Telephone No.: (309) 794-5376

Address: Regulatory Branch
U.S. Army Corps of Engineers, Chicago
111 North Canal Street, Suite 600
Chicago, Illinois 60606-7206

Telephone No.: (312) 846-5530

Address: Regulatory Branch

U.S. Army Corps of Engineers, St. Louis
1222 Spruce Street
St. Louis, Missouri 63103-2833

Telephone No.: (314) 331-8575

Address: Regulatory Branch
U.S. Army Corps of Engineers, Louisville
P.O. Box 59
Louisville, Kentucky 40201-0059

Telephone No.: (502) 582-5452

Address: Regulatory Branch
U.S. Army Corps of Engineers, Memphis
167 North Main Street, B-202
Memphis, Tennessee 38103-1894

Telephone No.: (901) 544-3005

8. Department of the Interior (DOI). The DOI includes the National Park Service, US Fish and Wildlife Service, Bureau of Indian Affairs, US Geological Survey, Bureau of Reclamation, and Bureau of Land Management. It is responsible for preserving and protecting the natural resources of the nation. Contacts are made to the individual agencies within USDOT, as presented in the following.

- a. National Park Service (NPS). The NPS is responsible for administering the national parks, monuments, and parkways, and it is responsible for the national historic and archaeological programs including the National Register of Historic Places. The NPS maintains the national recreational programs including Section 6(f) of the Land and Water Conservation Fund Act. The NPS also administers the wild and scenic rivers program except for rivers on lands of the US Forest Service.

Address: Outdoor Recreation Planner
National Park Service
601 Riverfront Drive
Omaha, Nebraska 68102-4226

Telephone No.: (402) 661-1736

- b. US Fish and Wildlife Service (FWS). The FWS administers the national freshwater fish program, wildlife programs and threatened and endangered species program.

Address: US Fish and Wildlife Service
Rock Island Field Office
1511 47th Ave.
Moline, IL 61265

Telephone No.: (309) 757-5800

Address: US Fish and Wildlife Service
Chicago Field Office
1250 South Grove Ave., Suite 103
Barrington, Illinois 60010-5010

Telephone No.: (847) 318-2253

Address: US Fish and Wildlife Service
8588 Route 148
Marion, Illinois 62959-4565

Telephone No.: (618) 997-3344

9. US Forest Service (USFS). The USFS administers the national forests.

Address: Shawnee National Forest Supervisor's Office
50 Hwy. 145 South
Harrisburg, Illinois 62946

Telephone No.: (618) 253-7114

10. Natural Resources Conservation Service (NRCS). Formerly the Soil Conservation Service, the NRCS maintains national farm soil maps and determines which farmlands are prime and unique. The contact will be the local county NRCS agent. Form NRCS-CPA-106 should be sent to the State NRCS office at the following address:

Address: United States Department of Agriculture
Natural Resources Conservation Services
Attention: State Soil Scientist
2118 West Park Court,
Champaign, Illinois 61821

C-2.02 State

The following briefly describes the functional responsibilities of the major State agencies in the implementation of environmental procedures:

1. Illinois Department of Transportation (IDOT). Within the Division of Highways, the program development offices in the nine districts are responsible for project development and the accompanying environmental documentation addressing the potential project impacts. The central Bureau of Design and Environment supports the environmental studies by providing environmental expertise and policy guidance, by securing appropriate environmental field surveys and data collection upon the request of the districts, by accomplishing and facilitating coordination with resource and regulatory agencies, and by reviewing and commenting on preliminary and final environmental documentation.

2. Illinois Department of Natural Resources (IDNR). IDNR includes the former Illinois Department of Conservation, the former Illinois Department of Mines and Minerals, the former Division of Water Resources from IDOT, the Illinois Natural History Survey, the Illinois State Geological Survey, and the Illinois State Water Survey. IDNR is responsible for reviewing proposed projects, as applicable, to ensure compliance with the Illinois Endangered Species Protection Act, the Illinois Natural Areas Preservation Act, and the Illinois Interagency Wetland Policy Act. The agency also reviews and comments on projects, as appropriate, regarding the following additional resources:

- streams,
- forests/trees,
- prairie/savanna areas,
- IDNR properties,
- nature preserves,
- natural area inventory sites,
- sites included in the Illinois Register of Land and Water Reserves, and
- Office of Water Resources permits.

Address: IDNR
One Natural Resources Way
Springfield, Illinois 62702-1271

Telephone No.: (217) 785-5500 (Division of Ecosystems and Environment, Impact Assessment Section)

3. Illinois Environmental Protection Agency (IEPA). IEPA is responsible for issuing Section 401 Water Quality Certification on Section 404 permits. The Agency also reviews and comments on projects, as appropriate, relative to the following issues:
 - air quality/conformity,
 - water quality,
 - land pollution (including hazardous and special wastes),
 - noise, and
 - underground storage tanks.

Address: IEPA
1021 North Grand Avenue East
Springfield, Illinois 62794-9276

Transmittals sending environmental documents to IEPA for review should be addressed to the Director of the IEPA at the above office location.

Telephone No.: (217) 782-2829 (General Number)

4. Illinois Department of Agriculture (IDOA). IDOA reviews projects for impacts on farmland conversion to ensure compliance with the Illinois Farmland Preservation Act and Illinois Executive Order Number 4 (1980) for the preservation of Illinois farmland. This agency also completes the State component of the AD-1006 form in accordance with the regulations of the USDA Natural Resources Conservation Service.

Address: IDOA
State Fairgrounds
P. O. Box 19281
Springfield, Illinois 62794-9281

Telephone No.: (217) 782-2172 (General Number)

5. Illinois Historic Preservation Agency (IHPA). The Director of IHPA is designated as the State Historic Preservation Officer (SHPO). The Agency reviews projects for impacts to historical, architectural, archaeological, and paleontological resources to ensure compliance with Section 106 of the National Historic Preservation Act and the following State Acts:

- Illinois Historic Preservation Act (Illinois Register of Historic Places),
- Illinois State Agency Historic Resources Preservation Act, and
- Archaeological and Paleontological Resources Protection Act.

Address: IHPA
Preservation Services Division
#1 Old State Capitol Plaza
Springfield, Illinois 62701-1507

Telephone No.: (217) 782-4836 (General Number)

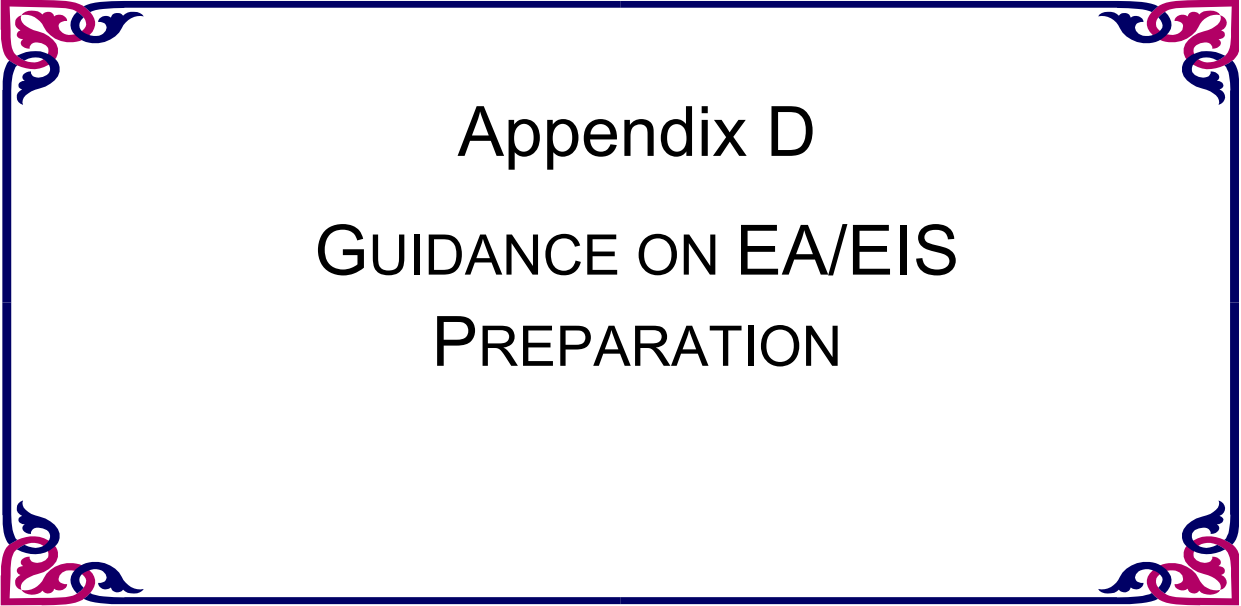

Appendix D
GUIDANCE ON EA/EIS
PREPARATION

BUREAU OF DESIGN AND ENVIRONMENT MANUAL

Appendix D**GUIDANCE on EA/EIS Preparation****Table of Contents**

<u>Section</u>	<u>Page</u>
GENERAL.....	1
PART I: How to Write an Environmental Assessment (EA) or Environmental Impact Statement (EIS)	2
Cover Sheet	4
Summary (for EISs only).....	7
Chapter 1 - Purpose and Need	10
1.1 Where is the project located?	10
1.2 What is the project's background?	10
1.3 What is the Need for the Proposed Project?	10
1.4 What is the Purpose of the Proposed Project?	11
Chapter 2 – Alternatives	14
2.1 What alternatives were considered?	14
2.2 What alternatives were eliminated and why?	15
2.3 What are the Alternatives to be Carried Forward?.....	16
2.4 What is the Preferred Alternative?.....	17
Chapter 3 – Environmental Setting, Impacts, and Mitigation	18
3.1 Social and Economic Factors	18
3.2 Agricultural	233
3.3 Historic Properties.....	24
3.4 Air Quality	26
3.5 Noise	28
3.6 Energy	33
3.7 Natural Resources	34
3.8 Surface Water Resources	37
3.9 Groundwater Resources	40
3.10 Floodplains	42
3.11 Wetlands.....	433
3.12 Special Waste	46
3.13 Special Lands	466
3.14 Section 4(f) Evaluation	488
3.15 Indirect and Cumulative Impacts	50
3.16 Greenhouse Gases and Climate Change (EIS only)	511
3.17 Irretrievable and Irreplaceable Resources	52

Table of Contents

(Continued)

<u>Section</u>	<u>Page</u>
3.18 Environmental Commitments	52
3.19 Permits/Certifications Required	522
3.20 Other.....	52
Chapter 4 – Comments and Coordination.....	53
Part II: How to Write a Finding of No Significant Impact (FONSI) and Errata.....	544
FONSI	544
Errata	577
Part III: How to Write a Record of Decision AND Final Environmental Impact Statement	588
Cover Page	58
ROD Format.....	611
Final Environmental Impact Statement (FEIS) Preparation.....	63

GENERAL

The purpose of this guidance is assist district and consultant staff in the development of well written and easily understood Environment Assessments or Environmental Impact Statements. Chapter 24 (Environmental Assessments) and Chapter 25 (Environment Impact Statements) tell the reader the procedure to follow when an EA or EIS is required.

PART I: HOW TO WRITE AN ENVIRONMENTAL ASSESSMENT (EA) OR ENVIRONMENTAL IMPACT STATEMENT (EIS)

Part 1 provides guidance on how to write an Environmental Assessment (EA), a Draft Environmental Impact Statement (EIS), and a Draft Supplemental EIS. The EA, EIS, and Supplemental EIS will follow the same format except where noted. The purpose of the guidance is to set clear expectations for what information should be included in these documents and how the information should be displayed. The EA or EIS should¹

- “tell the project’s story” using clear and concise writing and quality graphics,
- be as brief as possible,
- be understandable to the general public, and
- demonstrate regulatory and legal compliance.
- be 75 pages in length for an EA or 150 pages in length for an EIS, unless the project is determined to be of unusual scope or complexity (see below).

To accomplish this, the EA or EIS must only include information that helps determine the significance of the environment impacts and inform the understanding of the environmental consequences of the proposed action, rather than including needless detail. If the EA or EIS exceeds the page limits, certain information may be moved to appendices to meet this requirement. Guidance on what to include in the appendices can be found at the end of Chapters 1 and 2 and the beginning of Chapter 3 of this document. EAs or EISs that are determined to be of unusual scope or complexity may be 150 or 300 pages, respectively. This determination may only be made by the FHWA Administrator. Figure 1 depicts techniques that can be used to make EAs and EISs understandable to the general public.

¹ *Improving the Quality of Environmental Documents* (A Report to the Joint AASHTO/ACEC Committee in Cooperation with the Federal Highway Administration), May 2006, p. 4.

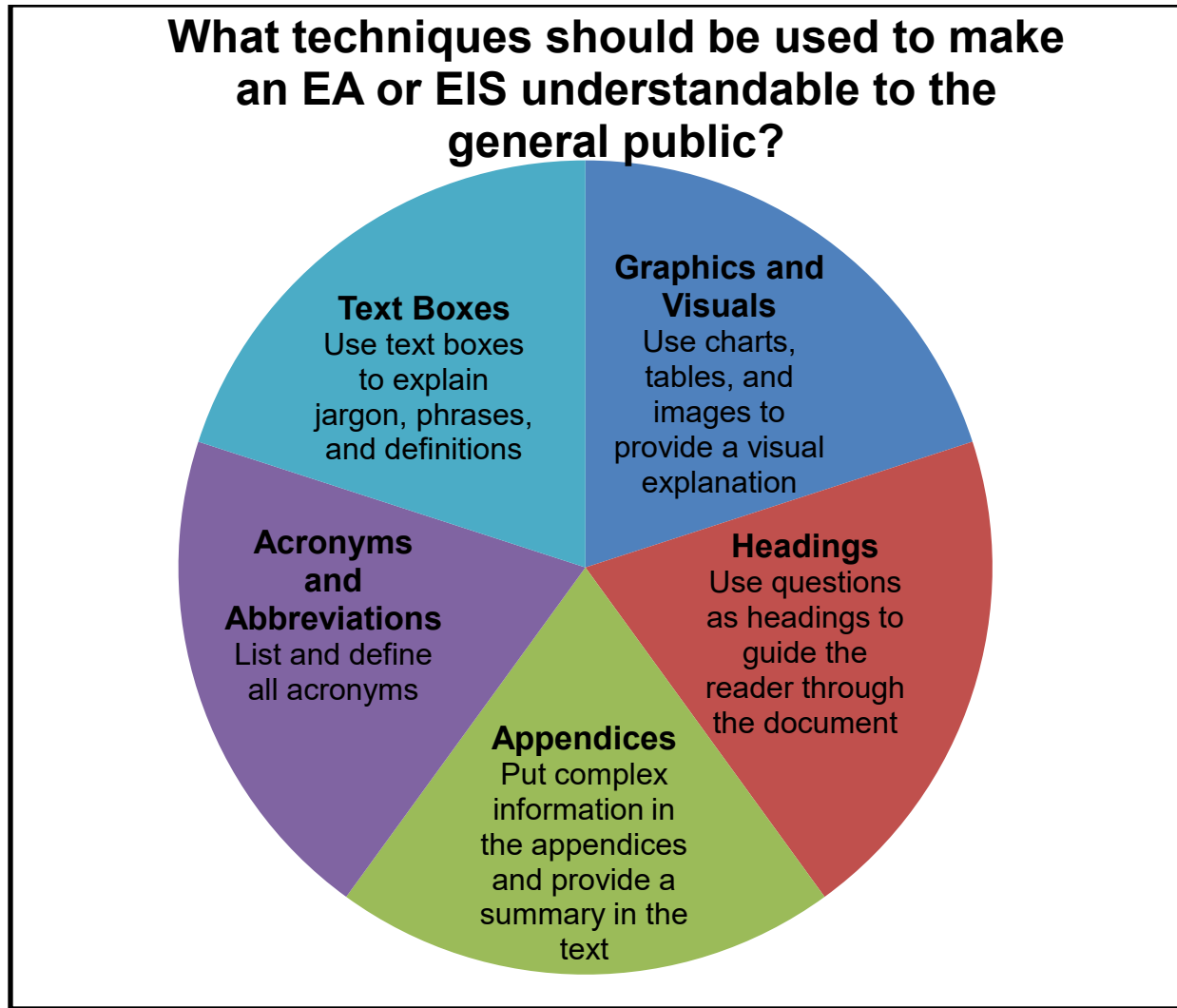

Techniques for EA/EIS Understandability

Figure 1

Cover Sheet

If the project is an EA, use Figure 2 to format the Cover Sheet. If the project is a Draft Environmental Impact Statement use Figure 3. The Cover Sheets were adapted from FHWA Technical Advisory T6640.8A (see Appendix A) to provide information specific to Illinois. The Engineer of Design and Environment signs the Cover Sheet for the Department.

Please note that all cooperating agencies must be included on the cover sheet.

[Route, Termini, City or County, and State]

ENVIRONMENTAL ASSESSMENT

Submitted Pursuant to 42 USC 4332 (2)(c)

by the

U. S. Department of Transportation
Federal Highway Administration

and

Illinois Department of Transportation

Cooperating Agencies

[Include list here, as applicable]

Date of Approval

For IDOT

Date of Approval

For FHWA

The following persons may be contacted for additional information concerning this document:

(Name)
Division Administrator
Federal Highway Administration
3250 Executive Park Drive
Springfield, Illinois 62703
Telephone: 217-492-4640

(Name, office address, and phone number
of IDOT Regional Engineer)

A one-paragraph abstract of the EA indicating project type, length, etc. Describe quantifiable environmental impacts (e.g., number of acres of wetlands affected, acres of agricultural impacts, number of displacements).

EA Cover Sheet

Figure 2

[Route, Termini, City or County, and State]

DRAFT (SUPPLEMENTAL)
ENVIRONMENTAL IMPACT STATEMENT

Submitted Pursuant to 42 U.S.C. 4332 (2)(c)
(and where applicable, 49 U.S.C. 303) by the

U. S. Department of Transportation
Federal Highway Administration

and

Illinois Department of Transportation
and
[As applicable, any other joint lead agency]

Cooperating Agencies
[Include List Here, as applicable]

Date of Approval

For IDOT

Date of Approval

For FHWA

The following persons may be contacted for additional information concerning this document:

[Name]
Division Administrator
Federal Highway Administration
3250 Executive Park Drive
Springfield, Illinois 62703
Telephone: 217-492-4640

*[Name, office address, and phone number
of IDOT Regional Engineer]*

[A one-paragraph abstract of the statement.]

*FHWA will issue a single FEIS and Record of Decision document pursuant to Public Law 11: 141, 126 Statute 405, Section 1319(b) unless FHWA determines statutory criteria or practicability consideration preclude issuance of the combined document pursuant to section 1319.

Comments on this document are due by *[Date]* and should be sent to *[Name and office address of IDOT Regional Engineer]*.*

DEIS/ Supplemental Cover Sheet

Figure 3

Summary (for EISs only)

Per 40 CFR 1502.10, summaries are required for EISs. EAs do not require a summary. In EISs the summary should include:

1. A brief description of the proposed project indicating route, termini, type of improvement, number of lanes, length, county, city, State, and other information, as appropriate.
2. A description of any major actions proposed by other governmental agencies in the same geographic area as the proposed FHWA action.
3. A summary of all reasonable alternatives considered, including alternatives that were carried forward for further study.
 - a. If a preferred alternative is identified in the Draft EIS then the summary must identify the preferred alternative.
 - b. The Final EIS must identify the preferred alternative and should discuss the basis for its selection.
4. A summary of major environmental impacts, both beneficial and adverse.
5. Any areas of controversy (including issues raised by agencies and the public).
6. Any major unresolved issues with other agencies.
7. A list of other Federal actions required for the proposed project (i.e., permit approvals, land transfer, Section 106 agreements, etc.).
8. The project's web address. All EAs and EISs are uploaded to IDOT's website. If there is a project specific website then the project specific website must be linked to IDOT's website.

The following is the recommended format for EAs, DEISs, and the FEIS traditional approach discussed in Part III.

Environmental Assessment/ [Draft, Final] Environmental Impact Statement Table of Contents

Summary (for EISs only).....

Chapter 1- Purpose and Need.....

- 1.1 Where is the project located?
- 1.2 What is the project's background?
- 1.3 What is the Need for the Proposed Project?
- 1.4 What is the Purpose of the Proposed Project?

Chapter 2- Alternatives.....

- 2.1 What alternatives were considered?
- 2.2 What alternatives were eliminated and why?
- 2.3 What are the Alternatives to be Carried Forward?
- 2.4 What is the Preferred Alternative?

Chapter 3 – Environmental Setting, Impacts, and Mitigation.....

- 3.1 Social and Economic Factors
- 3.2 Agricultural
- 3.3 Historic Properties
- 3.4 Air Quality
- 3.5 Noise
- 3.6 Energy
- 3.7 Natural Resources
- 3.8 Surface Water Resources
- 3.9 Groundwater Resources
- 3.10 Floodplains
- 3.11 Wetlands
- 3.12 Special Waste

3.13 Special Lands

3.14 Section 4(f) Evaluation

3.15 Indirect and Cumulative Impacts

3.16 Greenhouse Gases and Climate Change

3.17 Irretrievable and Irreplaceable Resources

3.18 Environmental Commitments

3.19 Permits/Certifications Required

3.20 Comments and Coordination

3.21 Other

Chapter 4 – Comments and Coordination.....

Chapter 1 - Purpose and Need

Every effort should be made to develop a concise purpose and need statement that focuses on the primary transportation challenges to be addressed. The purpose and need shall focus on identifying the transportation challenges and not a solution to the transportation challenges. The purpose and need should not be narrowly defined, point to a single solution, or predetermine an outcome.

1.1 Where is the project located?

Provide a clearly labeled map of the project study area and briefly describe:

- geographic features within the area
- the existing facility
- the length of the project
- the logical termini

Logical Termini:

Logical termini are typically two reasonably-determined locations that geographically delineate a transportation project. The most common logical termini are points of major traffic generation, especially intersecting roadways. Logical termini should be selected so:

- environmental issues can be treated on a sufficiently broad scope to ensure that the project will function properly without requiring additional improvements elsewhere,
- the project will not restrict consideration of alternatives for other reasonably foreseeable transportation improvements, and
- the action has stand-alone use or independent value and is a usable and reasonable expenditure even if no additional transportation improvements in the area are made.

1.2 What is the project's background?

Provide a summary of the following:

- the history of the proposed project
- summary of any planning or corridor studies relevant to the proposed project
- any other transportation projects occurring, or scheduled to occur within the project area

1.3 What is the Need for the Proposed Project?

This section includes the data and data analyses that demonstrate a traffic need not currently being met via other roadways or modes of transportation. The data presented shall demonstrate that a transportation problem exists and should answer the question "Why is the proposed project

necessary?” The data may include, but is not limited to, safety ratings, sufficiency ratings, substandard geometrics, crash data and analysis, traffic models, origin-destination studies, etc.

Some examples of how the transportation need can be identified are:

- Identify and describe current and projected traffic, show data on maps;
- Describe the inadequacy of the existing capacity and performance conditions (e.g., level of service, quantified delays);
- Identify and describe any structural, operational, or functional deficiencies (e.g., substandard geometrics, load limits on structures, inadequate cross-section) and their effect on performance or safety;
- Describe regional population/traffic forecasts, including the proposed project’s relationship to any statewide plan or adopted urban transportation plan, and any reasonable foreseeable land use changes;
- Describe and compare both the existing and projected crash rates without the project to the current statewide average. Include relevant crash data based on the latest 3-5 years using the crash severity scale (K, A, B, C, and O). Analyze the data to describe trends, locations, crash types, etc. that would assist in determining potential causes of crashes and contributing factors specifically associated with the roadway environment. Show crash locations on maps; and
- Discuss any maintenance issues and costs.

Identify any key assumptions and explain why those key assumptions were made.² For example, traffic forecasts are based on assumptions about future population and employment trends. The underlying assumptions must be credible for the results to be credible.

1.4 What is the Purpose of the Proposed Project?

State the primary purpose(s) of the proposed project and how it will address each of the identified transportation need(s). The purpose of a proposed project should lead directly back to the identified needs. For example, if data analysis supports the conclusion that there is insufficient highway capacity to support current or future traffic, the purpose would be to address the insufficient capacity. A project may contain more than one purpose if the data demonstrates the need for such. Any secondary purpose(s) should be stated after the primary purpose(s) have been stated.

The following considerations and questions should be used to identify the purpose(s) of the project (for additional information see FHWA Technical Advisory T6640.8A). Once identified, discuss.

Primary Purpose

The primary purpose answers why the project is being studied. All alternatives considered, except the No Build alternative, must meet the primary purpose.

Secondary Purposes

Secondary purposes are additional outcomes or benefits that are desired. Alternatives considered are not required to meet the secondary purpose.

² AASHTO Improving the Quality of Environmental Documents (A Report to the Joint AASHTO/ACEC Committee in Cooperation with the Federal Highway Administration), May 2006, p. 7.

1. System Linkage (Connectivity)

- Is the proposed project a “connecting link?”
- Describe the inadequacy of connectivity and/or continuity in the existing system.

2. Capacity

- Is the capacity of the existing facility adequate for current and projected traffic?
- Provide and analyze supporting data such as Level of Service and traffic volumes.

3. Legislation

- Explain any Federal, State, or local governmental mandate for the proposed project.

4. Social Demands or Economic Development

- Describe any social or economic developments that necessitate the proposed project (e.g., new schools, places of employment, land development, etc.)
- Consider what method would be used for evaluating economic development among alternatives.

5. Modal Interrelationships

- Describe how the proposed will serve to complement airports, rail and port facilities, mass transit services, etc.

6. Safety

- Describe the likely conditions related to crashes/safety without the project.
- Is the proposed project necessary to correct an existing or potential safety hazard?
- Is the existing accident rate excessively high? Why?

7. Transportation Facility Deficiencies

- Describe any foreseeable deficiencies that may result if no action is taken.
- Is the proposed project necessary to correct existing roadway deficiencies?

Connectivity refers to the effective movement of people, goods, and services.

Continuity refers to uniform speed and pavement widths that promote free flow movements of people, goods, and services.

Economic Development

Per FHWA Technical Advisory T6640.8A, social demands and economic development are allowed as part of a project’s purpose. However, economic development should be a secondary need and not a primary need, when **transportation continuity and connectivity** (that promote economic development) are identified as a project need. Thus, addressing the primary need for continuity and connectivity may result in the promotion of economic development

Improving safety

Highway improvements produce safety benefits. In order to include safety as a primary purpose, data supporting the need to improve safety must be documented and analyzed. The data and analysis should clearly demonstrate that there is a specific safety problem and the analysis will identify the root cause(s) and contributing roadway factors.

Do not include in the purpose or need section:

- **A discussion of alternatives.** The purpose and need create the foundation for an alternatives analysis; this section should not discuss alternatives.
- **The solution to the identified transportation purpose and need.**
- **A discussion of the potential environmental impacts.** The purpose and need statement only should identify transportation problems based on existing conditions and analysis of supporting data.

Page Limit Guidance:

EAs must be 75 pages

EIS must be 150 pages.

To assist in meeting these page limit requirements, the following section can be moved to the Appendix:

- Section 1.2 Project Background

Chapter 2 – Alternatives

2.1 What alternatives were considered?

The alternative analysis should include a reasonable range of alternatives that meet the purpose and need. Explain the alternatives development, screening, and evaluation process adequately so that it is rational, reasonable, and complete. Include the No Build alternative, Transportation System Management alternative, Mass transit alternative, and Build alternatives.³

2.1.1 No Build alternative

The No Build alternative typically includes maintenance and short-term minor restoration types of activities (such as resurfacing or safety improvements) that maintain continued operation of the existing roadway. It includes all reasonably foreseeable transportation improvements that will be implemented within the design year of the proposed project, but excludes the proposed project. Although the no-build frequently does not meet the purpose and need, it must be carried through the NEPA process as a baseline for comparison of impacts and benefits.

In the discussion of the No Build alternative:

- Describe the existing conditions;
 - + State all key transportation improvements that are assumed to be in place in the forecast year;
 - + Describe the conditions that will exist in the design year if the proposed project is not implemented;
- Include land use and traffic forecast data;
 - + Consider other reasonably foreseeable actions that may affect the project (e.g., new subdivision, planned intermodal facility, industrial/commercial development, community development initiatives, etc.); and
 - + Include supporting data for any assumptions made. Supporting data may come from Local Agencies, STIP, community development plans, etc.

Note: It is possible, though very rare, for No Build to be selected as the preferred alternative. This generally occurs in circumstances where there are substantial impacts or the need is not sufficiently supported to justify the impacts.

2.1.2 Transportation system management (TSM)

The TSM alternative includes better management and operation of existing transportation facilities to improve traffic flow and air quality, as well as enhance system accessibility and safety.

Evaluate if reconstruction and rehabilitation of the existing system corrects the identified deficiencies and meets the project purpose and need. TSM strategies are operational in nature and include, but are not limited to, improvements or additions of:

- intersections and signals,
- fringe parking,

³ FHWA Technical Advisory T 6640.8A

- ride sharing,
- High Occupancy Vehicle lanes,
- acceleration/deceleration lanes, ramps, and weaving sections,
- horizontal and vertical curves,
- signage and pavement striping, and
- geometrics.

See Section 22-6.04 for additional requirements that apply if a proposed action is in a Transportation Management Area (i.e., an urban area with a population of 200,000 or more).

2.1.3 Mass transit or multi-modal alternative concepts

Include and describe those reasonable and feasible transit options even though they may not be within the existing FHWA funding authority. Close coordination is necessary with the transit agency(ies) and the local Metropolitan Planning Organization, if applicable, to ensure that IDOT's specific project is consistent those entities' plans.

2.1.4 Build alternatives

Build alternatives may include improvement of existing highways and alternatives on new locations, or a combination of both.

Evaluate and describe a reasonable range of build alternatives that will address the purpose and need using text plus maps and charts, or other visual aids.

2.2 What alternatives were eliminated and why?

- Evaluate and state whether each alternative meets the purpose and need.
- Eliminate all alternatives that do not meet the purpose and need.
- Explain the methods and criteria used for developing and screening alternatives.
- Disclose environmental impacts considered for all alternatives, including the No Build. Use the most current reasonably available information. Do not eliminate alternatives based on outdated information.
- Eliminate the alternatives anticipated to have disproportionately large environmental impacts (e.g., relocations, wetlands, cultural resources, etc.)
- For each alternative eliminated, provide an explanation why it was eliminated.
 - + Do not dismiss alternatives for not meeting a screening criterion or evaluation measure, but then carry forward other alternatives that also do not meet that same criterion/measure, without providing the context of why such decisions are logical.
 - + Support the decision to eliminate alternatives with sufficient explanation and documentation. Do not eliminate alternatives based on generalities without adequate explanation or documentation to support the decision.
- Summarize public and agency comments that influence which alternatives will be carried forward.
- Summarize the results of this process using visual aids such as charts and tables.
- Provide maps showing the alignments of the alternatives and environmental resources considered..

2.3 What are the Alternatives to be Carried Forward?

The alternatives to be carried forward are those reasonable alternatives that are studied in detail.

Discuss alternatives to be carried forward at a comparable level of detail to avoid any indication of bias toward a particular alternative. Disclose environmental impacts considered for all alternatives, including the No Build. Provide maps showing the alignments of the alternatives and environmental resources considered. Identify and describe any unique features and common design elements of each alternative.

The table below is an example of how to illustrate the alternatives analysis in a graphic form.

Alternative	Does the alternative meet the purpose and need?		Was the alternative carried forward for detailed study?	Alternatives studied in detail
	Yes	If no, why?	If no, why?	
1	X		6-lane road has greater impacts than 4-lane alternatives and is substantially more costly.	
2		The planter median included in the alternatives would decrease safety and roadway capacity.		
3	X			X
4	X			X
5	X		Requires major traffic flow changes.	

2.4 What is the Preferred Alternative?

Preferred alternative is the alternative that best meets the project's purpose and need while balancing and minimizing the impacts to environmental resources.

Place a brief summary of the preferred alternative at the beginning of the alternatives chapter when writing the EA or EIS.

Describe the preferred alternative. Explain the rationale for selecting the preferred alternative. Include a map of the preferred alternative alignment. When introducing the preferred alternative, do not use the term “determined” or “recommended.” Instead use the term “identified.”

Does the preferred alternative have to be identified in the Draft EIS?

FHWA strongly recommends that the preferred Alternative be identified in the Draft EIS (DEIS). This facilitates the process of having a combined Final EIS (FEIS) and Record of Decision (ROD) since MAP-21, Section 1319(b), requires FHWA, to the maximum extent practicable, to develop a single document that combines the FEIS and ROD. More information about this can be found in Chapter 25 of the BDE Manual .

Page Limit Guidance:

EAs must be 75 pages

EIS must be 150 pages.

To assist in meeting these page limit requirements, the following is suggested:

The NEPA/404 alternatives to be carried forward concurrence package can be added to the appendix. Then sections 2.1-2.3 should be succinctly summarized.

Chapter 3 – Environmental Setting, Impacts, and Mitigation

Page Limit Guidance:

EAs must be 75 pages

EIS must be 150 pages.

To assist in meeting these page limit requirements, the following is suggested:

- State all resources which have no impacts at the beginning of this section. If a resource has no impacts then any discussion, if needed, can be moved to the appendix, and;
- State all resources that are present but not affected at the beginning of this section. If a resource is present but not affected, the discussion can be moved to the appendix.

For example, if wetlands are not present in the project study area, state that fact at the beginning of this section. No further discussion is required in the EA or EIS.

Another example, if wetlands are present in the project study area but the preferred alternative will not impact wetlands then state that fact at the beginning of this section. No further discussion is required in the EA or EIS. Additional information regarding wetlands should be included in the appendix.

This chapter describes the current land uses, economy and jobs, noise, air quality, wildlife, wetlands, park land, cultural, and other resources that exist within the project study area. This chapter also describes the potential effects of the project on these resources.

3.1 Social and Economic Factors

Need more information? Please see IDOT's Community Impact Assessment Manual.

3.1.1 What community(ies) exist within the project study area?

Describe the community(ies) within the project study area. Include in the description, community name, population, any ethnic, racial, religious minorities, elderly, and disabled groups. Use demographic data from the US Census decennial (ten year) data or American Community Survey (5 year) data, or both. Present median household income and unemployment rate for the project study area. As applicable, present population trends and future population projections. Present an exhibit that delineates and shows boundaries, as applicable, for neighborhoods, U.S. Census Tracts, cities, and county(ies).

Identify community facilities and community service centers (schools, places of worship, libraries, hospitals, parks, fire and police facilities, etc.). Public facilities in the project study area should be described and shown on exhibits.

3.1.2 Will the project impact Title VI, minority, or low-income populations?

State the following:

No groups or individuals have been, or will be, excluded from participation in public involvement activities, denied the benefit of the project, or subjected to discrimination in any way on the basis of ethnicity, religion, race, elderly, color, age, sex, national origin, or religion.

Clearly state if minority, or low income populations are present using the following language:

The project area was evaluated in accordance with Executive Order 12898, Federal Actions to Address Environmental Justice in Minority Populations and Low-Income Populations, to determine if there is a potential for disproportionate and adverse impacts to low-income or minority populations. Based on demographic information [2017 U.S. Census' American Community Survey or most recent data] and field observations of the project area indicates that residents of the project area are ___% white; ___% black; ___% American Indian and Alaskan native; ___% Hispanic; and ___% Asian and Hawaiian. The median family income for the project area is \$____. ___% of the residents are below the median family income within the project area. The [Health and Human Services 2017 or most recent guideline] Poverty Guidelines for a family of four is \$_____.

If minority and low-income populations are not present, then state the following:

Based on this demographic information and field observations of the project area, there are no minority or low-income populations in the project area.

What is the relationship between Title VI and environmental justice?

Title VI of the Civil Rights Act of 1964 specifically provides that "...no person in the United States shall, on the ground of race, color, or national origin, be excluded from participation in, be denied the benefits of, or be subjected to discrimination under any program or activity receiving Federal financial assistance."

Environmental justice ensures that federal programs, policies, and other activities do not have disproportionately high and adverse effects on minority or low-income populations. This goal is to be achieved, in part, by actively adhering to the principles and practices of both Title VI and NEPA during the development and implementation of transportation activities.

If minority, or low-income populations are present, state whether there the proposed action will or will not cause adverse impacts to any minority, or low-income populations. If there are adverse impacts, clearly identify those impacts. Next, state if these *are* or *are not* disproportionate to minority or low-income populations. If there are disproportionate and adverse impacts, discuss relevant and reasonable mitigation measures in this order: avoiding the impacts, minimizing the impacts, rectifying the impacts, reducing the impacts, or off-setting benefits to the impacts. Discuss the public participation efforts to seek participation by underserved populations.

For access-controlled roadways in urban areas, evaluate and provide a brief history of transportation projects in the area to determine if there were any historical disproportionately high and adverse effects on minority or low-income and communities. For example, a roadway's original construction through a downtown area may have divided a neighborhood, or it may have restricted local travel to an important community center. State if there still exists evidence of the original neighborhood that has been isolated due to the presence of the roadway. If such actions occurred, document this history, and coordinate with FHWA to determine if there are reasonable measures that could reconnect the community, e.g. alternative alignments, design elements that facilitate better access across the transportation facility, etc. Proposed mitigation is eligible for federal funding, and must be a reasonable public expenditure after considering impacts and benefits.

What impacts may be evaluated in an Environmental Justice analysis?

All reasonably foreseeable adverse social, economic, and environmental effects to minority populations and low-income populations are to be identified and addressed. Adverse effects include, but are not limited to:

Bodily impairment, infirmity, illness, or death..

- Air, noise, and water pollution; and soil contamination.
- Destruction or disruption of man-made or natural resources.
- Destruction or diminution of aesthetic values.
- Destruction or disruption of community cohesion or a community's economic vitality.
- Destruction or disruption of the availability of public and private facilities and services.
- Vibration.
- Adverse employment effects.
- Displacement of persons, businesses, farms, or nonprofit organizations.
- Increased traffic congestion, isolation, exclusion, or separation of minority or low-income individuals within a given community or from the broader community.
- The denial of, reduction in, or significant delay in the receipt of benefits of DOT programs, policies, or activities.

3.1.3 Will the project have any change in travel patterns?

- Describe whether traffic patterns will change after completion of the proposed project.
- Discuss if travel times will increase or decrease. Typically, a project will result in a savings in travel time and allow transportation users to journey from their origin to their destination more quickly; if so, then discuss.
- Discuss if the project has the potential for dividing or isolating communities or neighborhoods.
- Discuss if the project will positively or negatively disrupt community access from residential neighborhoods to public facilities (e.g., places of worship, schools, libraries, hospitals, community centers, parks, child care facilities) services (e.g., fire, police, ambulance), or businesses. Would any of these disruptions require mitigation? If any of these disruptions cause an adverse travel impact, then the EA or EIS must discuss avoidance and minimization efforts?
- Where projects involve temporary changes in access due to road closures, traffic detours, etc., the analysis and assessment of impacts should summarize:
 - + changes in neighborhood travel patterns;
 - + disruptive effects of traffic detours;
 - + “barrier” effects related to change in access for police, fire, or health services;
 - + and if travel times will increase or decrease. The assessment of travel pattern impacts should include all potential travel, including pedestrians, bicyclists, and persons with disabilities.

The assessment of travel pattern impacts should include all potential travel, including pedestrians, bicyclists, and persons with disabilities. The assessment of travel patterns is a factor in community cohesion.

Transportation effects on community cohesion can be difficult to quantify. Thus, qualitative effects should be discussed. For example, an obvious negative impact to community cohesion would be a new road that creates a physical barrier between residents and community facilities, where prior to the transportation change the facilities could be accessed by an easy walk, bicycle or short drive.

3.1.4 Will the project change or impact any pedestrian, bicycle, or transit facilities?

Discuss if any changes to pedestrian, bicycle, or transit facilities are consistent with local and regional plans. Discuss any impacts to existing pedestrian, bicycle, or transit facilities including temporary or permanent

New pedestrian facilities and new bikeways can improve connections between residents and community facilities. If this occurs it should be documented in the EA or EIS.

changes. Discuss if the project increases transit options (bus, rail, etc.) for the project study area. Discuss impacts to school bus routes.

3.1.5 Will the project require any residential or business relocations?

If relocations are not involved the EA or EIS needs to contain a sentence stating “this project has no residential or commercial relocations.”

If relocations are involved, state the number and types (i.e., residential, commercial, and agricultural). Discuss how the project avoided and minimized relocations. Discuss the availability of replacement property in the project vicinity. The discussion on relocation impacts shall include the following statements:

- the provisions of the “Uniform Relocation Assistance and Real Property Acquisition Policies Act of 1970, as amended” and the *IDOT Land Acquisition Procedures Manual* will be followed. *Note: This statement is needed whenever land must be acquired for any purpose;*
- a commitment to “provide housing of last resort, if necessary”; and
- the housing resources are available to all relocatees without discrimination.

3.1.6 Land Use

Describe existing and planned land use within the study area and indicate whether the proposed project is consistent with local and regional land use plans. Cite the applicable local government’s land use plan(s). Discuss the effect of the proposed action on existing or planned land use in the community. If the proposed project is not reasonably expected to change land use in the project study area, then clearly state that fact.

3.1.7 Will the project cause any economic impacts, economic growth or economic development?

Describe types of businesses within the project study area. All major employers within the project study area should be identified and their respective number of employees stated. Discuss the potential for impacts to businesses, specifically for access changes and parking loss. Discuss if the project could decrease sales at an established, traffic-oriented businesses (e.g., gasoline service station, restaurant, or retail store). For each displaced business, state the estimated number of people employed.

The necessity and degree for conducting an economic assessment is determined by the nature of the impact in the project study area, and the nature of the impact within the context of the larger regional area.

Discuss the freight network and its multi-modal aspects for projects within metropolitan areas and Projects of National and Regional Significance.

Describe the potential for economic growth (typically quantitative) in the region. Discuss the potential for economic development (typically qualitative) in the region, such as it relates to a sustained longer-term change in economic activity leading to an improvement in the jobs, wealth, tax base, and well-being in the neighborhood, city, or county. Discuss the number of jobs created as a result of the proposed transportation project, using three distinct multipliers:

- Direct jobs are (for example: engineers, workers, and laborers on the road crew). The direct employment multiplier is 8.35 jobs for every \$1 million spent on the project.
- Indirect jobs that may increase are (for example: employment at the local asphalt plant and various road supplies). The indirect employment multiplier is 9.25 to 12.7 jobs for every \$1 million spent on the project.
- Induced jobs are increased secondary spending at a local restaurant. The induced employment multiplier is 10.5 jobs for every \$1 million spent on the project.

The project team may utilize other methods to discuss and evaluate economic impacts, economic growth, economic development, or jobs created

3.2 Agricultural

Need more information? Please see Chapter 26-10.

Include the following language:

Conversion of agricultural land to highway right of way can lead to reductions in agricultural production. Minimizing these effects is required by the Federal Farmland Protection Policy Act and the Illinois Farmland Preservation Act.

Note: the taking of a farm residence and known agricultural tax loss from right-of-way purchased should be summarized under the Social and Economic discussion.

3.2.1 Will the project impact farms or convert farmland to other uses?

Identify the estimated amount of farmland (prime or important farmland) to be converted to non-agricultural use. If known, include the estimated conversion of agricultural land for borrow or contractor-use areas and other proposed mitigation efforts (e.g., wetland mitigation).

The discussion of agricultural impacts shall include a summary of the following information:

- the number of agricultural parcel severances created;
- the number of agricultural landlocked parcels created;
- the number of uneconomical agricultural remnants of three acres or less in size;
- the potential loss in crop production and potential cash receipts;
- the number of agricultural businesses relocated;
- the number of farmstead relocations;
- if the project adversely impacts farm equipment travel, describe the impact and the proposed mitigation measures; and
- the soil type and class information..

Where possible, use tables and exhibits to illustrate agricultural impacts.

3.2.2 Will the project impact Protected Agricultural Areas?

Identify and discuss avoidance or non-avoidance of:

- land registered in the Illinois Agricultural Areas Conservation and Protection Act,
- farms and acreage enrolled in the federal Conservation Reserve Program, and
- farms certified by Illinois as Centennial or Sesquicentennial Farms.

State if any farms are registered with any farmland protection program administered by the respective county or by the Illinois Department of Agriculture.

3.2.3 Has coordination with the Natural Resources Conservation Service and the Illinois Department of Agriculture occurred?

Coordination is required with the Natural Resources Conservation Service (NRCS), unless the project is exempt per 523.10(B) or 523.11(E)(1) of the National Resource Conservation Service manual. If coordination with the NRCS is required, include a copy of the Form NRCS-CPA-106 as an exhibit. Refer to Section 26-10 for the basis of coordination with the Illinois Department of Agriculture (IDOA). If coordination is not required for either NRCS or IDOA, explain why not.

3.3 Historic Properties

Need more information? See Section 26-5.

Include the following language:

Historic properties are any properties that are on or eligible for listing in the National Register of Historic Places (NRHP), and include below ground resources, like archaeological sites, and above ground resources, like buildings and bridges. These resources are protected by Section 106 of the National Historic Preservation Act (NHPA).

Please note that if a property is not on the NRHP but is determined to be eligible, it is still protected under Section 106.

3.3.1 How were historic properties identified in the project study area?

Depict the boundaries of the project's Area of Potential Effect (APE), as coordinated by FHWA with the Illinois State Historic Preservation Officer (SHPO), on the environmental inventory map. The APE may or may not be the same area as the ESR study area. Describe the steps taken to identify historic properties, including a list of consulting parties invited to be included in the process.

Archaeological site locations are protected and should not be depicted on maps or otherwise shared with the general public.

3.3.2 Do archaeological properties exist within the Area of Potential Effect?

If no, state that there are no archaeological properties within the APE. If yes, discuss the number and types (cemetery, mound, or habitation) of archaeological sites listed or eligible for listing on the NRHP within the APE, including the applicable criteria for eligibility.

Archaeological sites are typically habitation areas, but also include burial mounds and cemeteries. Special efforts should be made to avoid potential impacts to mounds and cemeteries.

3.3.3 Do historic architectural properties (buildings, bridges or structures) exist within the Area of Potential Effect?

If no, state that there are no historic architectural properties affected. If yes, describe each historic property's boundary (e.g., building plus parcel as concurred upon by the SHPO) including the characteristics that qualify them for the NRHP and the applicable criteria for eligibility, and clearly identify the NRHP boundaries of the properties in the appendix. Please note that the historic boundaries might include only the structure, or might also include additional land surrounding the structure.

3.3.4 Will the project impact archaeological properties?

If there are no archaeological properties in the APE or if archaeological properties are present but not affected, state that there are "no historic properties affected."

If there are archaeological properties, describe what steps were taken to avoid and minimize potential impacts to those sites. If the sites were avoided, state this fact.

If potential impacts to the sites cannot be avoided explain why not, state that the project will cause an adverse effect, that further archaeological work is necessary and that work will be completed according to stipulations specified in a Memorandum of Agreement (MOA) or project Programmatic Agreement (PA). The MOA or PA must be fully ratified prior to FHWA approving a FONSI or ROD.

3.3.5 Will the project impact historic architectural properties?

If there are historic architectural properties, describe what steps were taken to avoid and minimize potential impacts to those properties. If the properties were avoided, state this fact.

If potential impacts to architectural properties cannot be avoided, describe the effects on each historic property. If any land from within the historic property's NRHP boundary will be converted to transportation use by the project, clearly describe where and how much (in square feet or acres). This must be done for each historic property.

- If the impacts will not adversely affect the historic property, state that there will be "no adverse effect." Explain the basis for this determination and why the criteria of adverse effect do not apply. Cite and include in the appendix the letter that documents SHPO concurrence in this determination.

- If the impacts are determined to be “adverse effect”, state the effect determination, explain the basis for this determination and why the criteria of adverse effect apply. State that work must be completed according to stipulations specified in a Memorandum of Agreement (MOA) or project Programmatic Agreement (PA). The MOA or PA must be fully ratified prior to FHWA approving a FONSI or ROD.

Include the following in the appendix:

- Copies or summaries of any views provided by consulting parties, including Tribes and the public, and SHPO letter(s) of concurrence on eligibility and effect determinations.
- If an adverse effect finding is made, include a copy of the letter to the Advisory Council on Historic Preservation notifying them of the Adverse Effect finding, and a copy of the executed MOA or PA.
- If the project is an EIS, all of the above information should be included in the DEIS if it is available. If the final effect finding and/or the MOU or PA is not available until the Final EIS is prepared, make note of the additional steps that will be taken prior to completion of the FEIS in the DEIS.

3.4 Air Quality

Include the following language:

Air quality is protected by the Clean Air Act and air quality standards established by the U.S. Environmental Protection Agency.

3.4.1 Carbon Monoxide Microscale Analysis

Need more information? See Section 26-14.

If the project does not add through lanes or auxiliary turning lanes, or does not involve any sensitive receptors and is not suitable for using COSIM, state the following:

In accordance with the IDOT-IEPA “Agreement on Microscale Air Quality Assessments for IDOT Sponsored Transportation Projects,” this project is exempt from a project-level carbon monoxide air quality analysis because it does not add through lanes or auxiliary turning lanes and has no sensitive receptors.

If the project does not exceed 5,000 vph or 62,500 ADT, COSIM analysis is not required, so state the following:

In accordance with the IDOT-IEPA “Agreement on Microscale Air Quality Assessments for IDOT Sponsored Transportation Projects,” this project is exempt from a project-level carbon monoxide air quality analysis because the highest design year approach volume on the busiest leg of the intersection is less than 5,000 vph or 62,500 ADT.

If COSIM analysis is required state the following:

The air quality effects of the proposed project were analyzed using the Illinois Carbon Monoxide Screen for Intersection Modeling (COSIM). The “worst case” analysis provided by the COSIM model indicated that the proposed undertaking does not have the potential for contributing to a violation of the National Ambient Air Quality Standards for CO. CO concentrations for the worst case receptor (i.e., residence) located [_____] (see Exhibit [____]) were as follows: Existing ([year]) - ____ ppm; Build – Time of Completion (TOC) ([year]) - ____ ppm, TOC + 10 years ([year]) - ____ ppm, and Design Year ([year]) - ____ ppm; No Action - ____ ppm in [TOC year], ____ ppm in [TOC + 10 year], and ____ ppm in [design year].

3.4.2 Air Quality Conformity

Need more information? See Section 26-11.

If the project is outside of a nonattainment or maintenance area, state the following:

No portion of this project is within a designated nonattainment or maintenance area for any of the air pollutants for which the U.S. Environmental Protection Agency has established standards. Accordingly, a conformity determination under 40 CFR Part 93 (“Determining Conformity of Federal Actions to State or Federal Implementation Plans”) is not required.

If the project is exempt from conformity requirements state the following:

This project is located within a designated nonattainment or maintenance area but is a project type that the U.S. Environmental Protection Agency (USEPA) has designated as exempt from regional emissions analyses of transportation plans and Transportation Improvement Programs for purposes of determining conformity with the State Implementation Plan (SIP). This designation is based on USEPA’s determination that the nature of the project is such that it would not affect the outcome of a regional emissions analysis.

If the project is not exempt and is within a nonattainment or maintenance area, see Section 26-11.03(d) for specific language to be used.

3.4.3 PM_{2.5} and PM₁₀ Nonattainment and Maintenance Areas

Need more information? See Section 26-12

Currently per the USEPA the state is in unclassifiable/attainment and therefore a Hot-Spot Analysis is not required for any projects.

3.4.4 Mobile Source Air Toxics (Section 26-13)

Need more information? See Section 26-13.

If the project is exempt under the Clean Air Act conformity rule under 40 CFR 93.126, then no analysis or discussion of MSATs is necessary.

If the project has potential MSAT effects, see Section 26-13.03(b), (c), and (d) for procedures and appropriate language.

3.4.5 Construction Related Particulate-Matter

State the following language:

Demolition and construction activities can result in short-term increases in fugitive dust and equipment-related particulate emissions in and around the project study area. (Equipment-related particulate emissions can be minimized if the equipment is well maintained.) The potential air quality impacts will be short-term, occurring only while demolition and construction work is in progress and local conditions are appropriate. The potential for fugitive dust emissions typically is associated with building demolition, ground clearing, site preparation, grading, stockpiling of materials, on-site movement of equipment, and transportation of construction activity, and during high wind conditions.

The Department's Standard Specifications for Road and Bridge Construction include provisions on dust control. Under these provisions, dust and airborne dirt generated by construction activities will be controlled through dust control procedures or a specific dust control plan, when warranted. The contractor and the Department will meet to review the nature and extent of dust-generating activities and will cooperatively develop specific types of control techniques appropriate to the specific situation. Techniques that may warrant consideration include measures such as minimizing track-out of soil onto nearby publicly-traveled roads, reducing speed on unpaved roads, covering haul vehicles, and applying chemical dust suppressants or water to exposed surfaces, particularly those on which construction vehicles travel. With the application of appropriate measures to limit dust emissions during construction, this project will not cause any significant, short-term particulate matter air quality impacts.

3.5 Noise

See Section 26-6 and the IDOT Highway Traffic Noise Assessment Manual to assist in completing this section.

Begin with a brief explanation about the regulations that pertain to noise analysis (federal regulations (23 CFR 772) and IDOT noise policy).

If the project did not require a noise analysis, then state the following and there is no need to continue with the rest of this section.

"The types of projects that do not require a noise analysis are stated in 23 CFR Part 772. This project meets those criteria and does not require a traffic noise analysis, noise barrier, or other noise abatement measures."

If the project required a traffic noise analysis include the following language:

3.5.1 How is noise assessed for roadway projects?

Roadway noise depends on four main factors:

- *The number of vehicles present;*
- *Traffic speed;*
- *The number of large trucks present; and*
- *How far the listener is from the roadway.*

Traffic noise is predicted for Existing, future No Build, and future Build conditions. The Department uses data and findings from traffic noise reporting to determine if traffic noise impacts will occur due to the proposed project, then methods to reduce noise for the listener (called noise abatement) are considered.

There are four steps in highway traffic noise analysis:

- 1) *Identify places with similar noise and land use. This is done by determining Common Noise Environments (CNEs), which are a group of receptors with similar noise exposure, topography, traffic characteristics, and land use. CNEs are grouped by noise sensitivity based on FHWA Activity Categories (i.e., residential, parks, hotels, etc.). Assign one representative receptor per CNE, as the worst-case noise location in the CNE. A receptor is a location analyzed for noise impacts and is typically an exterior area of frequent human use (bench, patio, etc.).*
- 2) *Conduct noise modeling for each receptor. Existing, future No Build, and future Build conditions are modeled using FHWA Traffic Noise Model 2.5 (TNM 2.5) for each representative receptor, using comparative field monitoring to ensure the model accurately represents the area's noise characteristics.*
- 3) *Analyze representative receptors (one per CNE) for noise impacts. If the representative receptor is impacted, the entire CNE is considered to have a noise impact. There are two ways to identify noise impacts:*
 - a) *Compare modeled future Build noise levels to the FHWA Noise Abatement Criteria (NAC) to determine if noise impacts will occur (see table below). The NAC does the following:*
 - *classifies where noise levels interfere with human speech;*
 - *differs by land use; and*
 - *establishes noise levels at which noise barriers need to be studied.**The CNE has a noise impact if future Build noise at the representative receptor is within one decibel, meet, or exceed the NAC.*
 - b) *For each representative receptor, the CNE has a noise impact if future Build noise is predicted to increase by 15 decibels or more at a representative receptor(s).*

- 4) *Determine if noise abatement is feasible and reasonable for each impacted CNE. Noise abatement are measures taken to reduce traffic noise impacts (i.e., construction of berms or noise walls, shifting roadway alignment, etc.). For each CNE determined to be impacted by noise, noise abatement is assessed.*

Noise abatement must

- *be feasible to construct;*
- *effectively reduce noise;*
- *be cost-effective; and*
- *have a majority of those benefited by each abatement measure support its construction. This is called viewpoints solicitation, and depending on the project's characteristics, is completed in either preliminary engineering or after the final design has been approved.*

What is noise abatement?

Noise abatement reduces traffic noise impacts. Examples of noise abatement are construction of berms or noise walls, shifting roadway alignment, etc.

<i>Example Land Uses</i>	<i>FHWA Noise Abatement Category</i>	<i>FHWA Noise Abatement Criteria - Noise Level Where Impact Occurs (dB(A))</i>
<i>Residential</i>	<i>B</i>	<i>67</i>
<i>Recreational areas, cemeteries, hospitals, medical facilities, parks, places of worship, schools, trails</i>	<i>C</i>	<i>67</i>
<i>Hotels, motels, restaurants, bars, offices</i>	<i>E</i>	<i>72</i>
<i>Agriculture, airports, emergency services, industrial, manufacturing, retail facilities, utilities, warehousing</i>	<i>F</i>	<i>None</i>
<i>Undeveloped lands that are not permitted for development</i>	<i>G</i>	<i>None</i>

Table 1: Noise Abatement Criteria Categories and Noise Levels Where Impact Occurs

3.5.2 Are there any noise sensitive areas in the project study area?

Describe the type and number of Common Noise Environments (CNEs) (residences, businesses, schools, recreational, etc.) in the project study area. Make sure to include any undeveloped lands for which development is permitted.

3.5.3 Are there any noise impacts in the project study area?

If necessary, include a brief explanation of noise terminology (e.g., A-weighting, decibels, etc.) Reference the noise study that was conducted. State the Existing, No Build, and Build noise levels (in dB(A)) for all representative receptors at each CNE. The table below is an example of how to present the information.

Receptor # (keyed to a map)	Receptor Description	Represents	FHWA Noise Abatement Criteria (dB(A))	Existing Noise Level (Year) (dB(A))	Future No Build Noise Level (Year) (dB(A))	Build Noise Level (Year) (dB(A))	Noise Level Change (Build minus Existing) (dB(A))	Impacted?
1	Residential	12 homes	67	65	67	66	1	Yes
2	Commercial	3 businesses	72	70	70	74	4	Yes

Table 2 : Example Traffic Noise Modeling Summary

If there are no traffic noise impacts, state:

“Future noise levels for the receptors would not approach, meet, or exceed the noise abatement criteria, or substantially exceed existing noise levels.”

If there are traffic noise impacts, state which CNEs have predicted traffic noise impacts, the types of activities which may be affected, and state the need to conduct a noise abatement evaluation.

3.5.4 Would a noise barrier be feasible and reasonable?

Describe the traffic noise abatement types considered for each CNE which are listed in Section 26-6.05(d)2. State the traffic noise abatement types that are feasible and reasonable and will likely be incorporated into the proposed project. For all abatement measures, state estimated costs, height and length of barriers, and if the barriers provide adequate noise reduction (meet the state Noise Reduction Design Goal (NRDG)). The table below is an example of how to do this.

Recept or #	Barrier Height	Barrier Length	Total Cost	Does the Barrier meet NRDG? ¹	Estimated Build Cost per Benefited Receptor	Allowable Cost per Benefited Receptor ²	Will the barrier likely be implemented?	If No, Reason(s) Why
1	18 feet	800 feet	\$	Yes	\$/benefited receptor	\$/benefited receptor	No	Not cost effective

¹ There must be at least one benefited receptor that has noise levels reduced at least 8 dB(A) to meet the Noise Reduction Design Goal (NRDG).

² The allowable cost is calculated based on the IDOT Noise Policy.

Table 3: Example Noise Mitigation Summary

If abatement measures are NOT feasible and reasonable, document why and state the following:

“The proposed project is anticipated to have traffic noise impacts, but the noise barriers studied and identified in Table (reference table in NEPA documentation) do not meet IDOT’s feasibility and reasonableness criteria. Due to this, traffic noise abatement measures are not likely to be implemented based on preliminary design. If the project’s final design is different from the preliminary design, IDOT will determine if revisions to the traffic noise analysis are necessary. A final decision on noise abatement will not be made until the project’s final design is approved and the public involvement processes is complete.”

If abatement measures are determined to be feasible, meets the IDOT Noise Reduction Design Goal, and are cost effective, but the solicitation of viewpoints from benefitted receptors will be deferred until Phase II Design then state the following:

“The noise barriers were determined to meet the feasibility criteria, the noise reduction design goal, and the cost effectiveness criteria as identified in Table (reference table in NEPA documentation). In order to determine if noise barrier(s) will be implemented, viewpoints solicitation still needs to occur. Viewpoints solicitation will occur after the project’s final design is approved. If the project’s final design is different from the preliminary design, IDOT will determine if revisions to the traffic noise analysis are necessary. A final decision on noise abatement will not be made until the project’s final design is approved and the public involvement processes is complete.”

What is viewpoints solicitation in a noise analysis?

Those that would be benefitted by a noise barrier are asked to vote on whether they support the barrier’s construction. If more than 50 percent of received votes are in support of the barrier, the barrier is recommended for construction.

If noise abatement measures are determined to be feasible and reasonable, and viewpoints solicitation is completed during Phase I, then state the following:

“The noise barriers were determined to meet the feasibility and reasonableness criteria. If the project’s final design characteristics is different from the preliminary design, IDOT will determine if revisions to the traffic noise analysis are necessary. A final decision on noise abatement will not be made until the project’s final design is approved and the public involvement processes is complete.”

3.6 Energy

State the following:

Construction of the proposed (Route) improvement will require indirect consumption of energy for processing materials, construction activities, and maintenance for the lane miles to be added within the project limits. Energy consumption by vehicles in the area may increase during construction due to possible traffic delays.

Construction of the proposed improvement will reduce traffic congestion and turning conflicts along the route and thereby reduce vehicular stopping and slowing conditions. Additional benefits would be realized from increased capacity and smoother riding surfaces. This will result in less direct and indirect vehicular operational energy consumption for the build alternative than for the no-action alternative. Thus, in the long term, post-construction operational energy requirements should offset construction and maintenance energy requirements and result in a net savings in energy usage.

The following should be added when applicable:

The project includes provisions for improved bicycling and walking conditions, thereby encouraging travel by these non-motorized and thus non-energy consuming modes of transportation.

Energy impacts should only be presented if it is an issue of concern in the project area or if substantial differences between alternatives are anticipated.

3.7 Natural Resources

3.7.1 Upland Plant Communities

Need more information? See Section 26-17 Tree/Vegetation Assessments and 26-18 Invasive Species.

If there will be a substantial impact to forest, prairie, or savanna, describe the location of the project in relation to the Natural Divisions of Illinois and provide a brief characterization of the Division(s) involved. Next, compare the characteristics of the Division(s) involved with the types and acreages of forest, prairie, and/or savanna in the project study area. This comparison can help provide context for upland plant communities and wildlife resource impacts.

3.7.1.1 What type of upland plant communities occur within the project study area?

Include a table indicating the number of acres of each cover type in the project study area. Include the following as applicable.

- Identify and depict on the environmental inventory map forested blocks greater than 20 acres in size, prairies, and savannas.
- Describe forested blocks of 20 acres (8 ha) or more based on dominant species, relative age, and quality.
- Trees on the inventory of state record trees, trees possessing exceptional size, form, etc., trees having recognized historical significance, or trees that perform a special function shall be discussed per Design and Environment Policy 18, Preservation and Replacement of Trees (D&E-18).
- Describe prairie/savanna areas by size (acres), prairie/savanna type (e.g. mesic, sand, dolomite), dominant species, grade of natural quality (A-E), and types of disturbance.
- Briefly describe dominant species and health of trees occurring as landscape elements in urban settings.

Cover types are discussed in Section 26-17.06(b), Cover Type and Vegetation Surveys.

The Memorandum of Understanding by and between Illinois Department of Natural Resources and Illinois Department of Transportation requires IDOT to coordinate with IDNR for actions adversely affecting prairies, savanna, and/or bisecting or fragmenting blocks of trees greater than or equal to 20 acres in size.

3.7.1.2 Will the project impact any upland plant communities?

Summarize project impacts (acres) to upland plant communities.

3.7.1.3 How were forested areas, prairies, and savannas avoided and minimized?

If applicable, discuss measures taken to avoid and minimize impacts to forested areas, prairies, and savannas.

3.7.1.4 Proposed Mitigation

If trees/forests will be impacted discuss the mitigation ratio per Design & Environment Departmental Policy 18 (D&E-18). If applicable, discuss plans for providing prairie/savanna replacement.

3.7.1.5 Are invasive plant species present in the project study area?

Briefly discuss the likely effects of the project on the introduction or spread of invasive species during construction and/or as a result of project maintenance. Identify invasive species in the project study area and briefly describe their potential effects on sensitive resources (e.g., adjacent natural areas, nature preserves, parks or forest preserves). Describe measures used to control invasive species during project construction and maintenance.

3.7.2 Wildlife Resources

Need more information? See Section 26-15 Migratory Birds and 26-16 Wildlife Resources.

3.7.2.1 What type of wildlife habitat occurs within the project study area?

Wildlife habitats in a project area coincide with major plant communities (i.e., cover types). Identify and briefly describe important wildlife habitats and habitats suitable for area-sensitive migratory birds. Identify and discuss wildlife species that occur in the project study area and are addressed in *The Illinois Comprehensive Wildlife Conservation Plan & Strategy* (Illinois Wildlife Action Plan) as “Species in Greatest Need of Conservation for Illinois.”

3.7.2.2 Will the project impact wildlife habitat?

Briefly describe impacts to wildlife habitat. Any environmental commitments and mitigation should conform to the recommendations in the Illinois Wildlife Action Plan, to the fullest extent practical.

3.7.3 Threatened and Endangered Species

Need more information? See Section 26-9 Threatened and Endangered Species/Natural Area Impact Assessments and 27 Environmental Surveys.

Include the following language:

“The Federal Endangered Species Act protects species of plants and animals that are threatened or endangered within the U.S. The Illinois Endangered Species Protection Act protects species of plants and animals that are listed under the federal act plus additional plants and animals. Both acts provide for the

conservation of threatened and endangered species and the ecosystems upon which they depend.”

3.7.3.1 Federally-listed Species/Habitat

3.7.3.1.1 What federally threatened or endangered species exist in the project study area?

State the Federally listed species, species proposed to be listed, designated critical habitat, and/or proposed critical habitat and status for the county(ies) where the project is located.

3.7.3.1.2 Will the project affect federally threatened or endangered species?

An effect determination and the basis for that determination must be discussed for each federally listed species. The effect determinations are “no effect”, “may affect, not likely to adversely affect”, or “may affect, likely to adversely affect”. Summarize the following information, as applicable:

- species distribution, habitat needs, and other biological requirements;
- affected areas of the proposed project;
- biological survey and database search results;
- possible impacts, including opinions of recognized experts on the species involved;
- measures to avoid impacts; and
- measures to minimize adverse impacts.

Federal species that are delisted are still State listed species until the Illinois Endangered Species Protection Board delists them.

If formal consultation is required, a copy of the Biological Assessment (BA) and the Biological Opinion (BO) should be included as an appendix to the EA or EIS and must be completed prior to the approval of the FONSI or ROD. The BA and BO should be summarized in the text of the EA or EIS.

3.7.3.2 State-Listed Species

3.7.3.2.1 What state threatened or endangered species exist in the project study area?

Identify each state-listed species that has a record of occurrence in IDNR’s Natural Heritage Database in the vicinity of the project’s study area. Also, identify any state listed species found during biological surveys conducted for the project.

3.7.3.2 Will the project affect state threatened or endangered species?

Summarize the habitat of each state listed species identified above and the results of the biological surveys conducted. Discuss potential project impacts to the species. Describe any avoidance measures, minimization and mitigation for any impacts. Reference any applicable compliance documentation (e.g., Detailed Action Report, Biological Opinion, and Incidental Take Authorization, as applicable) and include the documentation in the EA appendix.

3.8 Surface Water Resources

Need more information? See Section 26-19, 26-20 and 26-21.

Include the following language:

Surface water resources include wetlands, streams, rivers, lakes, and ponds. Wetlands are discussed in Section 3.10. Surface water resources are protected by the Clean Water Act.

3.8.1 What waterbodies exist in the project study area?

Briefly describe all streams, rivers, lakes, and ponds that occur in the project study area and indicate their location on an environmental inventory map. Include a brief summary of important physical, biological, and chemical characteristics unique or pertinent to the project and the decision-making process.

In the appendix to the EA or EIS include the following three tables if data was collected or is available.

Chemical data for the streams, rivers, lakes, and ponds		
Date sample was collected	Amount detected of the following: pH, dissolved oxygen, total phosphorus, chloride, dissolved copper, dissolved lead, dissolved zinc, dissolved sulfate, total dissolved solids, water temperature, hardness, etc.	Include water quality standards for each parameter as appropriate

Physical Characteristics of Streams and Rivers					
Stream name	Upstream drainage are (square miles)	Flow water depth	Riparian habitat	Mean habitat score	Watershed characteristics

Biological Characteristics of Streams and Rivers						
# of fish present	# of intolerant fish species	Dominant fish species	% of intolerant fish species	Aquatic habitat quality	# of mussels	<i>Ephemeroptera, Plecoptera, and Trichoptera</i> (EPT) richness

3.8.2 Are there any water bodies that the Illinois Environmental Protection Agency lists as impaired or fully supporting for a designated use?

Identify impaired waterbodies in the project area plus the designated use, support level, and causes and sources of impairment. Also, identify any waterbodies that are fully supporting a designated use. This information can be found in Appendix B-2, B-3, and B-4 of the *IEPA Integrated Water Quality Report and Section 303d List*. Identify water bodies in the project area that have a Total Maximum Daily Load developed. This can be depicted in table form.

3.8.3 Are there any streams in the project study area that have a special designation?

Identify those resources that have a special designation including

- navigable waters,
- Wild and Scenic River,
- Nationwide Rivers Inventory stream,
- stream designated as a Illinois Natural Area Inventory Site,
- Advanced Identification (ADID) Stream,
- Illinois Biologically Significant Stream,
- Biological Stream Rating (BSR) for diversity or integrity, and/or
- Outstanding Resource Water (listed in 35 Ill. Adm. Code 303.206).

3.8.4 How will the project impact water resources during construction of the project?

Identify the types of construction activities (e.g., vegetation removal, in-stream work, bridge or culvert construction, bridge demolition, channel change, riprap placement) that will occur in and adjacent to each water crossing. Identify any potential effects on the biological and physical parameters and water quality characteristics of each water resource. Identify any minimization measures. If the proposed project will involve an Outstanding Resource Water, list and briefly describe measures to be implemented to avoid introducing water pollution from the project into an Outstanding Resource Water.

3.8.5 Will construction impacts to water resources be mitigated?

Depending on the nature of the impact, mitigation should be discussed. If channel realignment is necessary discuss what type of mitigation is proposed and if the mitigation will follow the Illinois Stream Mitigation Method. Aquatic habitat mitigation should be based on the wildlife needs as described in the Management Guidelines included in the Natural Division Assessments that are a part of the Illinois Wildlife Action Plan. If a watershed plan is available discuss mitigation in relation to the plan.

3.8.6 Will the project impact water resources during operation of the proposed project?

State any measures implemented to minimize water quality impacts. For any water listed as impaired on the 303(d) list or has a TMDL, discuss whether the project will contribute to the cause(s) of the impairment. If a pollutant loading analysis is required, discuss the results. Compare the results to the State water quality standard. If the chemical concentrations exceed

the water quality standard, state the mitigation measures that will be implemented to reduce the chemical concentration below the water quality standard.

3.8.7 Will the project impact water resources during maintenance of the proposed project?

Pollutant loading analysis should be conducted if additional impervious surface will be added and one of the following occurs:

- the highway runoff is being discharged into a sensitive stream, seep, fen, or nature preserve;
- a waterbody is listed as impaired on the 303(d) list or has a Total Maximum Daily Load for a chemical in which the highway runoff would contribute additional load;

For projects that meet one of these criteria use SELDM to conduct the pollutant loading analysis for copper, lead, zinc, chloride and the chemical in which the water body is impaired.

If a pollutant loading analysis was used to analyze chloride concentrations discuss the results of the analysis. If chloride is a cause of impairment to the water body and an individual 401 Water Quality Certification is needed, demonstrate how the project will have a no net increase in chloride. If the water body being impacted has a TMDL for chloride, demonstrate how the project will meet compliance with the TMDL.

If SELDM was not used to analyze chloride concentrations discuss standard Best Management Practices with regards to IDOT's use of chloride.

Use the FHWA and USGS SELDM to analyze chloride concentrations if the project will add impervious surface and any of the following apply:

- The project is in an area with an IEPA-designated, chloride impaired watershed(s), or
- A water quality sample result is proximate to an exceedance of the chloride water quality standard.

3.8.8 What water related permits will the project require?

Indicate water body crossings requiring IDNR Office of Water Resources permit, US Coast Guard permit, NPDES permit, Section 401 Water Quality Certification, and the type of USACE 404 permit(s) anticipated for each water body crossing. If an NPDES construction permit is required, incorporate the following paragraph into the EA or EIS:

It is anticipated this project will result in the disturbance of one or more acres of land. As a result, a National Pollutant Discharge Elimination System (NPDES) permit for stormwater discharges from the construction sites is required. Permit coverage for the project will be obtained either under the IEPA General Permit for Stormwater Discharges from Construction Site Activities (NPDES Permit No. ILR10) or under an individual NPDES permit. Requirements applicable to such a permit will be followed, including the preparation of a Stormwater Pollution

Prevention Plan. Such a plan shall identify potential sources of pollution which may reasonably be expected to affect the quality of stormwater discharges from the construction site and shall describe and ensure the implementation of practices which will be used to reduce the pollutants in discharges associated with construction site activity and to assure compliance with the terms of the permit.

3.9 Groundwater Resources

Need more information? See Section 26-22

3.9.1 Are any aquifer recharge areas, wellhead protection zones, or private and public water supply wells located in the project study area?

For the project study area, identify and describe aquifer recharge areas and wellhead protection zones. Due to public safety concerns the exact location of private and public water supply wells should not be identified in the EA/EIS, but should be explained in relationship to the project by stating the number of public and private water supply wells, depth of construction, and the proximity to the alternatives that are carried forward or the preferred alternative. This information can be accomplished via a table. If the project will potentially impact these groundwater resources or quality, discuss commitments for avoiding, minimizing, and mitigating for these impacts within the EA or EIS.

3.9.2 Will there be any impacts to any aquifer recharge areas, wellhead protection zones, or private and public water supply wells?

As applicable, include this statement in the EA or EIS

"This project will not create any new "potential routes" for groundwater pollution or any new potential sources of groundwater pollution as defined in the Illinois Environmental Protection Act (415 ILCS 5/3, et seq.)."

If the project will create a new potential route or source for groundwater pollution, describe the nature of the route or source and indicate whether it will be within a setback zone (minimum or maximum) for a potable water supply well. Indicate the type of well (i.e., community water supply or private water supply) and discuss any permits or mitigation measures that may be needed for the route or source to protect groundwater resources. Indicate whether the project is within a regulated recharge area established through Illinois Pollution Control Board rulemaking and describe the extent of the regulated area.

New "potential route" is defined by the Illinois Environmental Protection Act to mean a potential route which is not in existence or a potential route which expands laterally beyond the current permitted boundary. "Potential route" is defined as abandoned and improperly plugged wells of all kinds and any excavation for the discovery, development or production of stone, sand, or gravel.

3.9.3 Will the project impact karst topography?

If karst topography does not exist in the project area, state "The site is not located within karst topography according to the IEPA Source Water Assessment Program." If karst does exist in the project area, then the environmental document should briefly identify and discuss avoidance of

the karst features, and, if applicable the use of storm water pollution prevention BMPs during construction and operation of the transportation facility. If there will be any project impacts to karst features the potential for groundwater contamination shall be discussed.

3.9.4 Will the project impact the Mahomet Sole Source Aquifer?

If the project is not within the Mahomet Sole Source Aquifer project review area, state the following:

There are no Sole Source Aquifers, as designated under Section 1424(e) of the Safe Drinking Water Act, within the project area.

If the project is located within the Mahomet SSA project review area, use the following language:

“On March 11, 2015 the U.S. Environmental Protection Agency (USEPA) designated a portion of the Mahomet Aquifer system as a sole source aquifer (SSA) under Section 1424(e) of the Safe Drinking Water Act, as shown in the attached map. The Safe Drinking Water Act gives USEPA authority to designate all or part of an aquifer as a "sole source" if contamination of the aquifer would create a significant hazard to public health and there are no physically available or economically feasible alternative sources of drinking water to serve the population that relies on the aquifer. The designation authorizes USEPA review of projects that receive Federal financial assistance to assess the potential for contamination of the aquifer system that would create a significant hazard to public health.

This project is within the review area of the Mahomet SSA and the potential to impact the SSA and create a significant hazard to public health has been evaluated as established by the memorandum of understanding between IDOT, FHWA, and USEPA Region 5, which is based upon procedures that ensure compliance with the requirements of Section 1424(e) of the Safe Drinking Water Act.”

Note: A significant hazard to public health is defined as the level of contaminants in an aquifer would exceed National Primary Drinking Water Standards or exceed Federal, Tribal or state public health advisory levels for currently unregulated contaminants, or violate the intent of EO 12088, “Federal Compliance with Pollution Control Standards.”

If the project is located within the Mahomet SSA project review area, include a discussion of the following issues in the appendix:

- the extent of substantial excavation (greater than 10 feet in depth)
- addition of drainage wells, or stormwater infiltration facilities that do not meet IDOT treatment requirements
- adding Pollution Generating Impervious Surface (PGIS) of more than 5,000 square feet without applying pollution prevention BMPs
- opening of new material sources that could result in potential contamination
- replacement of drywells or other injection wells that do not meet IDOT treatment requirements or Underground Injection Control regulations

- drilled shafts or pile-driving, for bridge or other foundations that penetrate, or come close to penetrating the SSA
- installation, repair, or abandonment of a public or private water supply well that accesses the SSA
- construction or upgrading of sewage disposal stations at rest areas, weigh stations, scenic overlooks, or other locations
- use of pesticides, herbicides, and fertilizers that contain any of the chemicals listed in the National Primary Drinking Water Regulations, 40 CFR Part 141
- project located within the boundaries of a site listed on the USEPA National Priorities List (i.e., a Superfund site)
- removal of underground storage tanks that are known to have leaked (i.e., a Leaking Underground Storage Tank as listed in the Office of the Illinois State Fire Marshal (OSFM) website

Based on the evaluation, state whether the project will or will not cause risks to the Mahomet Aquifer that could create a significant hazard to public health. If there are risks, explain the risks. Coordination with USEPA can occur via the EA and EIS. Document the results of coordination with USEPA in the FONSI or ROD.

3.10 Floodplains

Need more information? See Section 26-7 Floodplains Encroachments.

Include the following language:

Floodplains are flat areas along streams and water bodies that hold excess water after a storm. Executive Order 11988 states that impacts to floodplains should be avoided when possible.

If available for the project study area, use National Flood Insurance Program (NFIP) maps to identify the 100-year floodplain. If no floodplains are identified in the project study area then state how this conclusion was reached and the questions below can be removed from the document. If floodplains are identified please answer the following questions according to the directions below.

3.10.1 How were floodplains identified in the project study area?

Depict 100 year floodplain and, where applicable, regulatory floodways on the environmental inventory map. State the data being used to identify floodplains (i.e., NFIP map year). Describe the natural and beneficial values of the floodplain and regulatory floodways. Summarize comments on floodplain issues received through public meetings and Context Sensitive Solutions (CSS) processes, if applicable.

3.10.2 Will the project impact any floodplains in the project study area?

Discuss the project's potential effects on floodplains. Identify the number of floodplain encroachments. Each encroachment must be classified as a longitudinal or transverse

encroachment and depicted on the environmental inventory map. Identify if there will be a significant floodplain encroachment.

If the project will affect a regulatory floodway, summarize the results of coordination with the Federal Emergency Management Agency and the local flood control agency regarding consistency of the project with the regulatory floodway requirements.

3.10.3 How were impacts to floodplains avoided or minimized?

State measures to minimize floodplain impacts, measures to avoid longitudinal encroachments, measures to avoid supporting incompatible floodplain development.

If the preferred alternative includes a significant encroachment, as defined in 23 CFR 650.105(q), an “Only Practicable Alternative Finding” must be documented. Include the following in the EA or EIS:

- a reference to Executive Order 11988 and 23 CFR 650 Subpart A,
- the reasons why the proposed action must be located in the floodplain,
- the alternatives considered and why they were not practicable, and
- a statement indicating whether the action conforms to applicable State or local floodplain protection standards.

If the preferred alternative encroaches in a regulatory floodway and mitigation is required the EA or EIS should describe the mitigation. An IDNR/Office of Water Resources (OWR) permit is required for construction within a regulatory floodway.

3.11 Wetlands

Need more information? See Section 26-8 “Wetlands”, Chapter 27 “Environmental Surveys”, and Chapter 28 “Environmental Permits/Certifications”.

Include the following language:

Wetlands are transitional areas between aquatic and terrestrial habitats where water occurs at or near the soil surface during the growing season. All wetlands are protected by the Illinois Interagency Wetlands Policy Act and some wetlands are protected by the Clean Water Act.

If no wetlands were identified in the project study area then state how this conclusion was reached (wetland delineations, completely urban, etc.) and the questions below can be removed from the document. If wetlands were identified answer the following questions according to the directions below.

3.11.1 What wetlands were identified in the project study area?

Depict the boundaries of the delineated wetlands and Advanced Identification (ADID) wetlands, where applicable, on an environmental inventory map of the project study area. Identify the version of the USACE Wetland Delineation Manual used to delineate the wetlands plus the date and author of the delineations. Briefly characterize each wetland plant community type, quality and functions. Functions discussed will be based on the project study area and may include wildlife habitat, heritage characteristics, flood storage, groundwater discharge, recreation values, and shoreline erosion control. Discuss wetlands with a Floristic Quality Index of 20 or higher or a mean C of 4 or higher. In northeastern Illinois, discuss wetlands that are classified as High Quality Aquatic Resource (HQAR) and Advanced Identification (ADID) because the USACE requires higher mitigation ratios for impacts to these wetlands.

The Interagency Wetland Policy Act requires a mitigation ratio of 5.5:1.0 for impacts to wetlands with at least one of the following present:

- Wetlands with an FQI of 20 or greater or a mean C of 4.0 or greater
- Presence of a federally or state listed species
- Presence of an INAI site
- Presence of essential habitat for a listed species

If there are a large number of wetlands in the project study area, identify the wetland types and acreages that occur within the watershed(s) based on the National Wetlands Inventory (NWI). Next, compare the types and amount of wetlands that occur within the watershed to the amount and type which exist in the project study area. This comparison can help determine context and intensity for wetland impacts.

3.11.2 Will the project impact wetlands?

Include a table (as shown below) that details each wetland impacted in the project area. The table should include the FQI, mean C, wetland site number, wetland type, total size, impact, mitigation ratio, mitigation needed.

Please note that in an EA and EIS, impacts must be calculated as a worst case scenario. Thus, calculate from the estimated edges of right of way limits, not the proposed construction limits.

State that the wetland impacts included in the EA are based on the project's proposed right-of-way and is the worst case scenario. State that avoidance and minimization measures will continue during the design and permitting process. Identify impacts to each plant community type (acreage) and loss of function(s). Discuss the severity of the impact. If the project will have a significant impact on wetlands, preparation of an EIS is required.

Example Table of Wetland Impacts

Site Number	Wetland Type	FQI	Mean C	Total Area of Wetland (Acres)	Total Area of Wetland Impacted (Acres)	Mitigation Ratio	Total Area of Wetland Mitigation Required (Acres)	Map Sheet Number
-------------	--------------	-----	--------	-------------------------------	--	------------------	---	------------------

3.11.3 How were wetlands avoided? How were wetland impacts minimized?

Provide a brief discussion of avoidance and minimization efforts (BDE 26-8.05(c)3). Identify practicable measures to reduce the impact.

3.11.4 How will mitigation for wetland loss be accomplished?

Provide a brief discussion of how much mitigation is required, what type of mitigation is proposed (bank, creation, etc.), and where mitigation will occur in relation to the impact (on-site, off-site, out of basin). Mitigation ratios should be based on the Interagency Wetland Policy Act of 1989.

Wetland Finding

See Section 26-8.05(e)2. If there are no practicable alternatives to construction in a wetland then an “Only Practicable Alternative Finding must be made. This must be included in the EA. It can be included in the DEIS if a preferred alternative has been chosen. If a preferred alternative was not chosen then it must be included in the FEIS. If there are no practicable alternatives to construction in a wetland, include the following items to support an “Only Practicable Alternative Finding”:

- a reference to Executive Order 11990;
- an explanation why there are no practicable alternatives to the proposed action;
- an explanation why the proposed action includes all practicable measures to minimize harm to the wetlands; and
- a concluding statement that:

Based upon the above considerations, it is determined that there is no practicable alternative to the proposed construction in wetlands and that the proposed action includes all practicable measures to minimize harm to wetlands that may result from such use.

3.12 Special Waste

Need more information? See Section 27-3.

State the title, date, and author of the Phase I special waste assessment report. When the assessment is completed by the Illinois State Geological Survey (ISGS), include in the appendix the memorandum from IDOT stipulating additional special waste studies may be required during Phase II Engineering.

It is unnecessary to include the Phase I special waste assessment report in the EA or EIS. The main points of the report should be summarized in the text of the EA or EIS.

Discuss the following as applicable:

- If the assessment results in a finding of no properties with a confirmed or potential environmental condition (e.g., UST, dry cleaners, etc.), state that finding.
- If the assessment results in a finding of a property(ies) that may contain one or more potential environmental conditions,
 - + summarize the categories of these properties (e.g., UST, dry cleaners, etc.),
 - + characterize the potential magnitude of the environmental conditions,
 - + compare the potential impacts of environmental conditions to each alternative, and
 - + describe measures recommended to address or avoid them.

3.13 Special Lands

Depict locations of any special lands on the environmental inventory map.

3.13.1 Land and Water Conservation (LAWCON) Fund

If the project area includes LAWCON funded land, depict the location on the environmental inventory map. If no impact will occur state this fact. If the project will convert lands that used LAWCON funds to a transportation use, state any avoidance and minimization measures then describe the following:

- the land that will be taken and the potential replacement land,
- the process to obtain approval from the National Park Service (NPS) for the Section 6(f) land conversion, and
- the coordination that has occurred with IDNR and NPS and the timeline for requesting the approval of the conversion.

3.13.2 Open Space Lands Acquisition and Development (OSLAD)

If the project area includes OSLAD funded land, depict the location on the environmental inventory map. If no impact will occur state this fact. If the project will convert lands that have OSLAD funds to a transportation use, state any avoidance and minimization measures then describe the following:

- the land that will be taken and the potential replacement land,
- the process to obtain approval from IDNR, and

- the coordination that has occurred and the timeline for requesting the approval of the OSLAD land conversion request.

3.13.3 Other special lands

If the project will involve the use of lands that had grant funds including Illinois Bicycle Path Grant, Illinois Boat Access Area Development, Illinois Snowmobile Grant, Illinois Snowmobile Trail Establishment Fund, Illinois Off-Highway Vehicle Program, Federal Recreation Trails Program, Public Museum Capital Grants Program, Park and Recreational Facility Construction Program involved in their purchase or development, describe the involvement and summarize coordination with IDNR.

3.13.4 State Designated Lands

Need more information? See Section 26-9 Threatened and Endangered Species/Natural Area Impact Assessments and Chapter 27 Environmental Surveys.

State the following language:

State designated lands include Illinois Natural Area Inventory (INAI) Sites, Land and Water Reserves, Natural Heritage Landmarks, and Nature Preserves. The Illinois Natural Areas Preservation Act sets the criteria for these land designations to help protect Illinois' sensitive natural resources.

3.13.4.1 Are there any state designated land in the project study area?

Depict the location of state designated lands in the project study area on an environmental inventory map. Indicate the name of each state designated land in the project study area, its size (acres/hectares), ownership (public or private) and the features that are the basis for its significance (i.e., "Element Occurrence").

Use of land from significant, publicly-owned Illinois Nature Preserves, Land and Water Reserves and Illinois Natural Area Inventory Sites also may be subject to Section 4(f); see Section 26-2.

3.13.4.2 Will the project affect any state designated lands?

Impacts to Illinois Natural Areas and Natural Heritage Landmarks should be avoided to the extent practical. Taking of land from a Land and Water Reserve requires the Illinois Nature Preserves Commission and Illinois Department of Natural Resources to agree that the take is in the public's interest. If impacts cannot be avoided to these sites, identify the acreage (hectares) to be taken by the project and the effects on the elements which allowed the land to be designated.

3.13.4.3 How was the state designated land avoided? How were impacts minimized?

Identify any environmental commitments and/or mitigation associated with the impacts to the state designated land. Summarize the results of coordination with IDNR and the Illinois Nature Preserves Commission (for Land and Water Reserves) and include copies of correspondence

Illinois Statutes in 525 ILCS 30, afford dedicated Nature Preserves a high level of protection from conversion to other uses. The statutes include the following language:

Areas dedicated as nature preserves are hereby declared to be put to their highest, best and most important use for the public benefit. They shall be protected, managed and used in the manner provided by rules. They may not be taken under power of eminent domain or by other means for any other use except another public use and, except upon approval of the Commission, the Governor and any public owner of a dedicated interest therein after a finding by the Commission of the existence of an imperative and unavoidable public necessity for such other public use, and upon such terms and conditions as the Commission may determine, except as may otherwise be provided in the instrument of dedication.

In light of these provisions, every effort should be made to avoid impacts to dedicated Nature Preserves.

with these entities in the Comments and Coordination section of the EA or EIS.

3.14 Section 4(f) Evaluation

When Section 4(f) resources are involved, the EA should contain a separate heading entitled "Section 4(f) Evaluation;" unless an individual Section 4(f) evaluation is required, in which case it shall contain a separate chapter titled "Section 4(f) Evaluation." This Section should not repeat information contained in the EA. Rather, information should be included by reference only.

Need more information about Section 4(f)? See Section 26-4 and consult with FHWA. Note that only FHWA approves Section 4(f) determinations.

3.14.1 Are there any Section 4(f) properties in the project study area?

If no, state this fact. If yes, identify each property, describe why each property is protected by Section 4(f), and identify the boundary of the 4(f) property on the environmental inventory map.

3.14.2 Will any land from the 4(f) property be needed for the project (either temporarily or permanently)?

If no, state this fact. If yes do the following for each 4(f) property where land is needed:

- If an “exception” to 4(f) is applicable under 23 CFR 774.13, provide explanation and documentation on how the exception criteria are met (see criteria in 23 CFR 774.13(d) for temporary occupancy which is one of the most common exceptions).
- If the “use qualifies for a de minimis determination then explain why and provide documentation listed in Section 26-2.04(d)2. Please note that the public must be provided the opportunity to comment on the use of the Section 4(f) property *prior* to the OWJ concurrence that the attributes of the property are not adversely affected by the project (“no adverse effect” if historic property and Section 106 applies).
 - + If the public opportunity to comment on the de minimis *has* already occurred, include the written concurrence from the Official With Jurisdiction.
 - + If the public comment opportunity *has not* occurred, explain that we are seeking public comment prior to making the de minimis determination. Provide concurrence from the Official With Jurisdiction; or explain we’re seeking public comment prior to making determination.
- If the “use” requires a Section 4(f) programmatic agreement evaluations or an individual evaluation then discuss feasible and prudent avoidance alternatives and, if appropriate, least harms analysis.

3.15 Indirect and Cumulative Impacts

Discuss the environmental resource areas identified during scoping and ongoing coordination that could have substantial indirect and cumulative impacts and methodologies for analyzing those impacts. Discuss reasonably foreseeable indirect and cumulative impacts for each of these environmental resource areas. This includes effects that would be caused by the project action later in time or further removed in distance, but that would still be reasonably foreseeable. Figure 4 illustrates the difference between indirect impacts and cumulative impacts.

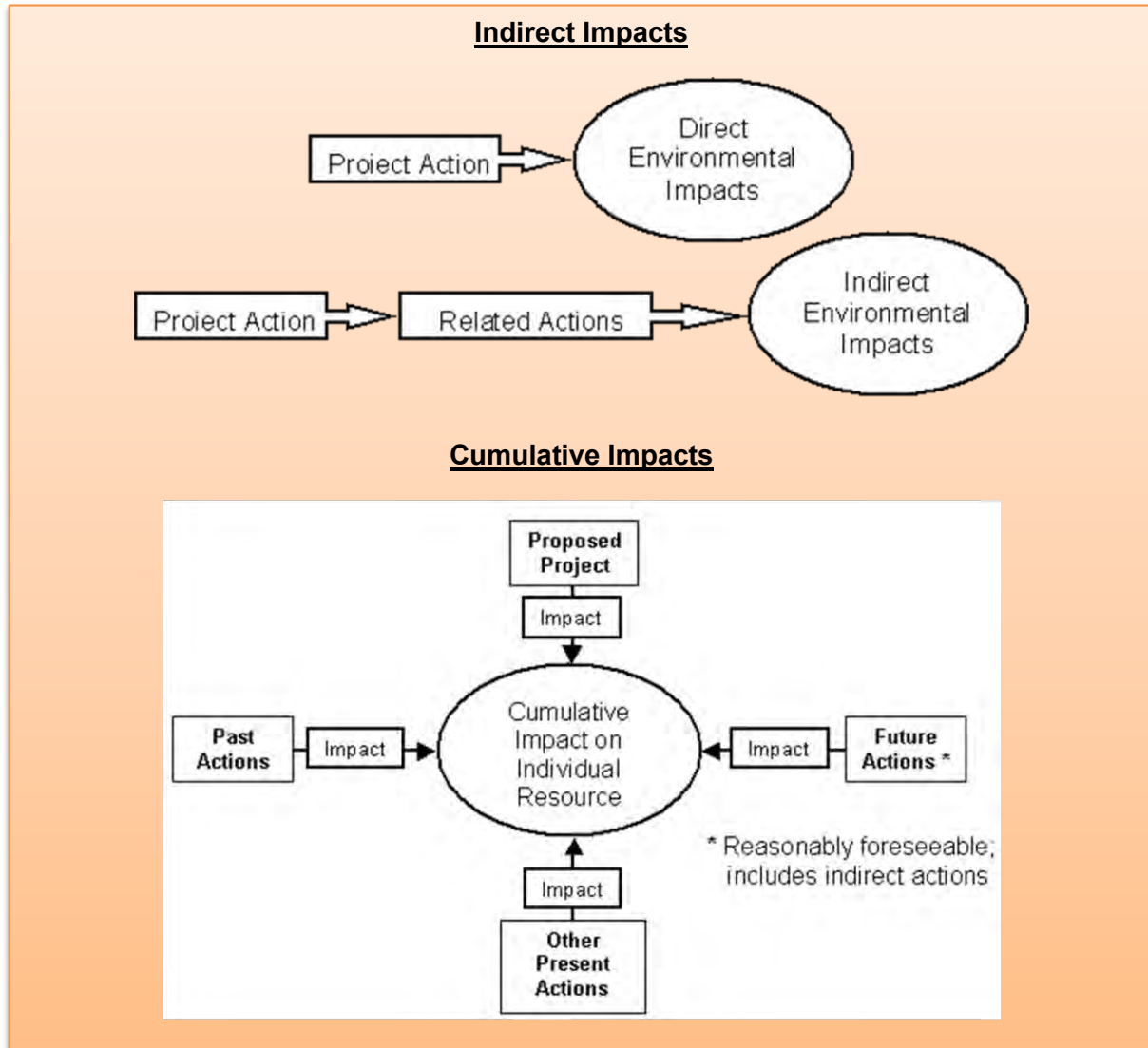

Figure 4 - Illustration of indirect and cumulative impacts

3.16 Greenhouse Gases and Climate Change (EIS only)

Include the following text:

Greenhouse gases (GHGs), which contribute to climate change, are both a national and global concern. While the earth has gone through many natural climate variations in its history, there is general agreement that the earth's climate is currently changing at an accelerated rate and will continue to do so for the foreseeable future. Anthropogenic (human-caused) GHG emissions contribute to this rapid change. Carbon dioxide (CO₂) makes up the largest component of these GHG emissions. Other prominent transportation GHGs include methane (CH₄) and nitrous oxide (N₂O).

Discuss if the project is located in an area considered vulnerable to the effects of climate change. Describe the effect of the alternatives on GHG emissions compared to the no-build.

3.17 Irretrievable and Irreplaceable Resources

Include the following language:

Implementation of the proposed action involves a commitment of a range of natural, physical, human, and fiscal resources. Land used in the construction of the proposed facility is considered an irreversible commitment during the time period that the land is used for a highway facility. However, if a greater need arises for use of the land or if the highway facility is no longer needed, the land can be converted to another use. At present, there is no reason to believe such a conversion will ever be necessary or desirable.

Considerable amounts of fossil fuels, labor, and highway construction materials such as cement, aggregate, and bituminous material are expended. Additionally, large amounts of labor and natural resources are used in the fabrication and preparation of construction materials. These materials are generally not retrievable. However, they are not in short supply and their use will not have an adverse effect upon continued availability of these resources. Any construction will also require a substantial one-time expenditure of both State and Federal funds which are not retrievable.

The commitment of these resources is based on the concept that residents in the immediate area, State, and region will benefit by the improved quality of the transportation system. These benefits will consist of improved accessibility and safety, savings in time, and greater availability of quality services which are anticipated to outweigh the commitment of these resources.

3.18 Environmental Commitments

Provide a brief description of each environmental commitment associated with the proposed project, including who made the commitment and to whom it was made. Summarize mitigation measures to be provided for unavoidable adverse environmental impacts.

3.19 Permits/Certifications Required

List the permits and certifications required for the project and should reference the section(s) and subsection(s) where the related permit/certification issues are discussed.

3.20 Other

If the project would have a substantial visual impact, discuss with BDE if a visual analysis is necessary. Typically, in Illinois, an EA does not warrant an analysis of visual resources and aesthetics.

An environmental commitment is a documented promise or obligation concerning an environmental issue made by a representative of IDOT to an entity outside the Department.

Commitments must be listed in the EA, EIS, FONSI, and/or ROD.

Chapter 4 – Comments and Coordination

Summarize the coordination that occurred and the results of the coordination. Include in the appendix copies of correspondence sent and received from the agencies.

PART II: HOW TO WRITE A FINDING OF NO SIGNIFICANT IMPACT (FONSI) AND ERRATA

Part II provides guidance on how to write an Errata and Finding of No Significant Impact (FONSI). The purpose of the guidance is to set clear expectations for what information should be included in these documents and how the information should be displayed.

FONSI

For additional information regarding FONSI and associated documentation refer to 23 CFR 771.121, FHWA's regulations for Environmental Impact and Related Procedures, and Chapter 24 of the BDE Manual.

The following provides guidance on how to write a FONSI.

For formatting purposes the header shall appear as the following:

U.S. Department of Transportation
Federal Highway Administration
FINDING OF NO SIGNIFICANT IMPACT
[Project Name, City, County, State]

The body of the FONSI should be organized in the following manner:

Project Description

In a paragraph or two, briefly describe the proposed action, its location (city, county, state), and the preferred alternative, including any changes resulting from the comments received. Do not restate the Purpose and Need. If in an urbanized area, describe the project's inclusion in the metropolitan planning organization's (MPO's) long range plan and transportation improvement program. If not in an urbanized area, describe how the project is consistent with the State's long range plan and where it is included in the statewide transportation improvement program.

Commitments

List the commitments that were included in the EA, and any that have been made since. Commitments are defined in IDOT D&E 19.

PUBLIC HEARING AND COMMENT

Provide general information regarding when and how the EA was made available for comment, e.g., public notice, legal notice, letters, a copy available at IDOT District Office, FHWA office, libraries, project website, etc. Here is an example:

The Environmental Assessment was made available for public review on [date]. A public hearing was held on [date]. Comments on the Environmental Assessment

were accepted at the public hearing and from the date the EA was made available to the public through the comment closing period on [date].

All comments received during the public comment period were responded to and are included in the Errata.

AGENCY DETERMINATIONS

The following findings are always included in the EA, not the FONSI:

- Executive Order 12898, Federal Actions to Address Environmental Justice in Minority
- Relocation Assistance and Real Property Acquisition Policies Act of 1970 as amended;
- Executive Order 11990, Protection of Wetlands;
- Executive Order 11988, Floodplain Management.

Any and all findings not included in the EA must be included in the FONSI.

The following findings establish the project's adherence to applicable laws intended to protect sensitive environmental and socioeconomic resources:

- **Endangered Species Act of 1973**

Include this section only if a Biological Opinion was required and Section 7 formal consultation was not completed prior to the EA approval. The results of the BO and summary of the BA will be included under this section.

- **Section 106 of the National Historic Preservation Act of 1966**

Include the finding that was made (no historic properties affected; no adverse effect; adverse effect) and date of concurrence from SHPO. Reference ratified MOA if an MOA was prepared.

- **Section 4(f) of the U.S. DOT Act of 1966**

Identify if any Section 4(f) resources will be used. Describe any findings (de minimis) or feasible and prudent determinations. Describe any applicable exceptions (e.g., temporary occupancy).

- **Section 176(c) of the Clean Air Act, as amended**

Include the following language if the project is in a nonattainment or maintenance area:

This project is located in a nonattainment area for transportation-related criteria pollutants; therefore, the transportation conformity requirements of the Clean Air Act apply. FHWA has determined that the preferred alternative meets project-level conformity requirements because it is included in the conforming metropolitan transportation plans and transportation improvement programs of the appropriate metropolitan planning organization.

Add the following text to the paragraph above if the project is not a project of air quality concern in a PM_{2.5} nonattainment/maintenance area:

The project was determined to be a project that is not an air quality concern under 40 CFR 93.123(b)(1), because it primarily services gasoline operated vehicular traffic. None of the roadways in the study area carry a substantial amount of diesel truck traffic currently nor are they expected to under the 2040 No-Build or Build condition. It has been determined that the project will not cause or contribute to any new localized PM_{2.5} or PM₁₀ violations or increase the frequency or severity of any PM_{2.5} or PM₁₀ violations.

Add the following text to paragraph above if it is a project of air quality concern in a PM_{2.5} nonattainment/maintenance area:

A quantitative PM_{2.5} hot-spot analysis demonstrated the project would not cause, contribute to, or delay timely attainment of the PM_{2.5} National Ambient Air Quality Standards.

CONCLUSION

Include the following language:

The FHWA has determined that the Preferred Alternative identified in the Environmental Assessment will have no significant impact on the human environment. The Finding of No Significant Impact (FONSI) is based on the attached Environmental Assessment and Errata which has been independently evaluated by the FHWA and determined to adequately and accurately assess the need, environmental issues, and impacts from the proposed project. It provides sufficient evidence and analysis for determining that an Environmental Impact Statement is not required. The FHWA takes full responsibility for the accuracy, scope, and content of the attached Environmental Assessment and Errata.

Date

[Insert name of IL Division
Administrator]

Division Administrator

Errata

The Errata shall include the following language:

This Errata includes corrections, revisions, and/or additions to the Environmental Assessment (EA) for the [project name and county(ies)], following the signed approval by the Illinois Department of Transportation (IDOT) and the Federal Highway Administration on [date of EA signature].

Document changes and corrections to the EA in the following format.

Chapter #: Chapter Name

Page #, Section # - Section name – Paragraph #, Sentence #, and description of change.

- Include changes and corrections to the EA. The changes to the EA shall include any modifications to the proposed actions or mitigation measures in response to any new information or comments received on the EA or at the public hearing, as well as any impacts of the modifications.
- Include revisions to tables and figures.

Chapter #: Comments and Coordination

- Include a summary of comments and responses received
- List and describe any ongoing coordination and follow-up documentation.

Appendix #: Public Involvement

- Add public hearing documentation, court reporter transcript, all comments received, and responses to comments.

PART III: HOW TO WRITE A RECORD OF DECISION AND FINAL ENVIRONMENTAL IMPACT STATEMENT

Part III provides guidance on how to write a Final Environmental Impact Statements (FEIS) and Record of Decision. The purpose of the guidance is to set clear expectations for what information should be included in these documents and how the information should be displayed.

Cover Pages

The cover page is different if the project will have a combined FEIS and ROD or if the FEIS and ROD are separate. Use the applicable cover page:

- For combined FEIS and ROD
 - + Use the cover sheet outlined in Figure 6 which combines the signatures for the FEIS and ROD.
- For separate FEIS and ROD
 - + Use the cover sheet outlined in Figure 5 for the FEIS.
 - + An approval paragraph must be included in the ROD.

[Route, Termini, City or County, and State]
 FINAL ENVIRONMENTAL IMPACT STATEMENT
 AND

RECORD OF DECISION
 Submitted Pursuant to 42 U.S.C. 4332 (2)(c)
 (and where applicable, 49 U.S.C. 303) by the
 U. S. Department of Transportation
 Federal Highway Administration
 and
 Illinois Department of Transportation

and

[As applicable, any other joint lead agency]

Cooperating Agencies

[Include List Here, as applicable]

 Date of Approval of FEIS¹

 For IDOT

The following persons may be contacted for additional information concerning this document:

[Name]
 number

[Name, office address, and phone

Division Administrator
 Federal Highway Administration
 3250 Executive Park Drive
 Springfield, Illinois 62703
 Telephone: 217-492-4640

of IDOT Regional Engineer]

[A one-paragraph abstract of the statement.]

Based on the analysis and evaluation contained in the Final EIS and after careful consideration of all the social, economic, and environmental factors contained in the Final EIS with input received from other agencies, organization, and the public, it is the decision of the FHWA to approve [[Selected Alternative Description]] as the Selected Alternative.

 Date of Approval of FEIS and ROD

 For FHWA

¹ IDOT's signature commits it to implement the project as described in the FEIS, including all mitigation measures contained therein, and serves to recommend to FHWA to approve the FEIS and ROD.

Figure 5

FEIS Cover Page for Combined FEIS and ROD

[Route, Termini, City or County, and State]

FINAL
ENVIRONMENTAL IMPACT STATEMENT

Submitted Pursuant to 42 U.S.C. 4332 (2)(c)
(and where applicable, 49 U.S.C. 303) by the

U. S. Department of Transportation
Federal Highway Administration

and

Illinois Department of Transportation
and
[As applicable, any other joint lead agency]

Cooperating Agencies
[Include List Here, as applicable]

Date of Approval

For IDOT

Date of Approval

For FHWA

The following persons may be contacted for additional information concerning this document:

[Name]
Division Administrator
Federal Highway Administration
3250 Executive Park Drive
Springfield, Illinois 62703
Telephone: 217-492-4640

[Name, office address, and phone number
of IDOT Regional Engineer]

[A one-paragraph abstract of the statement.]

*FHWA will issue a single FEIS and Record of Decision document pursuant to Public Law 112-141, 126 Statute 405, Section 1319(b) unless FHWA determines statutory criteria or practicability consideration preclude issuance of the combined document pursuant to section 1319.

Comments on this document are due by [Date] and should be sent to [Name and office address of IDOT Regional Engineer].*

Figure 6

FEIS cover page for separate FEIS and ROD

ROD Format

The purpose of the Record of Decision (ROD) is to explain the reasons for the project decision, summarize any mitigation measures that will be incorporated in the project, and document any required Section 4(f) approval. The following format is recommended for the ROD in order to organize the key items most efficiently:

A. Decision

Identify the selected alternative. Reference to the Final EIS may be used to reduce repetition. The following text is recommended as an introduction to this section:

This Record of Decision is the official decision document that concludes the National Environmental Policy Act process. Through this ROD, FHWA grants IDOT approval to proceed with final design, completion of acquisition of needed property, and construction of the project. This ROD is executed in conformance with the Council on Environmental Quality (CEQ) regulations implementing NEPA (40 CFR Part 1500) as well as FHWA's own regulations (23 CFR Parts 771 and 774). This ROD documents FHWA's compliance with NEPA and identifies additional requirements that must be met to proceed with the project. The decision is based on analyses contained in the Draft EIS issued on [[date]]; the Final EIS issued on [[date]]; and the comments of federal and state agencies, members of the public, and elected officials; and other information in the project record.

This ROD approves [[identify Selected Alternative]] as the Selected Alternative ("the Project").

B. Alternatives Considered

To organize the information most clearly, describe each alternative and explain the balancing of values that led to the final decision. The environmentally preferred alternative must be identified (the alternative that causes the least damage to the biological and physical environment). If the environmentally preferable alternative is not selected, the ROD should clearly state the reason(s) that the environmentally preferred alternative was not selected.

Identify the values that were important in the decision making process, as well as the reason(s) that some values were considered more important than others.

C. Section 4(f)

Briefly describe Section 4(f) resources within the project area that will be avoided and summarize the basis for any Section 4(f) approval. The discussion should include the key information that supports the approval

D. Measures to Minimize Harm

Identify and describe the specific measures adopted to minimize environmental harm (e.g., erosion control, appropriate for the proposed action). State whether all practicable measures to minimize environmental harm have been incorporated into the decision and, if not, why they were not (40 CFR 1505.2(c)).

E. Monitoring or Enforcement Program

Describe any monitoring or enforcement program which has been adopted for specific mitigation measures, as outlined in the final EIS.

F. Comments on Final EIS

If FEIS and ROD are combined do not include this section. If FEIS and ROD are prepared separately, identify all substantive comments received on the FEIS and provide appropriate responses. Other comments should be summarized and responses provided where appropriate.

The following language shall be included in the ROD if the FEIS and ROD are being completed separately.

G. Approval

This section includes a conclusive paragraph followed by a signature block for the Federal approving official. The following conclusive paragraph is recommended:

Based on the analysis and evaluation contained in the FEIS and after careful consideration of all the social, economic, and environmental factors contained in the FEIS with input received from other agencies, organizations, and the public, it is the decision of the FHWA to approve [insert name of the Selected Alternative here] as the Selected Alternative.

The following signature block is required:

[Date]

[Name of Illinois Division Administrator]

Division Administrator

H. Appendices

Items that may be included in the appendices are:

- Public and agency comments on the FEIS (separate FEIS and ROD only)
- Responses to FEIS comments (separate FEIS and ROD only)
- FEIS Errata sheet (if applicable)
- Biological Opinion (if applicable)
- Section 106 Memorandum of Agreement or Programmatic Agreement (if applicable)

Final Environmental Impact Statement (FEIS) Preparation

There are three approaches for preparing a Final EIS. The traditional approach (most common) and condensed Final EIS can be used for any EIS. The abbreviated version of the Final EIS is restricted to conditions specified by 40 C.F.R. 1503.4(c).

1. Traditional Approach (most common)

Make changes to the DEIS to add information regarding alternative selection, the selection of mitigation measures, wetland and floodplain findings, the results of coordination, comments received on the DEIS and responses to the comments, and any other relevant information not incorporated in the DEIS. Changes should be marked so that the reader knows that it is new information.

2. Condensed Final EIS

The condensed approach should be much shorter than the traditional approach while still providing the reader a complete overview of the project and its impacts. Incorporate material from the DEIS by reference to avoid repetition of material already presented in the DEIS.

Each major section of the FEIS should briefly summarize the important information contained in the corresponding section of the DEIS, reference the section of the DEIS that provides more detailed information, and discuss any noteworthy changes that have occurred since the draft was circulated. Discussion in the FEIS is focused on new information that was not presented in the DEIS. The format of the condensed FEIS should mimic that of the DEIS.

Items to include are:

- The preferred alternative and the basis for its selection
- Description of any coordination efforts not listed in the DEIS
- Agency and public comments to the DEIS and responses to these comments
- Any required findings or determinations (40 CFR 1502.14(e) and 23 CFR 771.125(a))

3. Abbreviated Version of Final EIS

When the only changes needed in the document are minor and consist of factual corrections and/or an explanation of why the comments received on the DEIS do not warrant further response, 40 CFR 1503.4(c) provides an opportunity to expedite the final EIS preparation. Care should be exercised to assure that the DEIS contains sufficient information to make the findings below and that the number of errata sheets used to make the required changes is small and that these errata sheets together with the DEIS constitute a readable, understandable, full disclosure document.

The Abbreviated FEIS should include the following sections:

- A summary. In the summary state that the FEIS consists of the DEIS and the Errata. And explain that this is consistent with the FHWA's guidance on implementing Section 1319(a) of MAP-21.

- Identify the preferred alternative and a discussion of the reasons it was selected;
- A list of the factual corrections made to the DEIS with references to the relevant page numbers in the DEIS;
- A summary of comments received on the DEIS and at the public hearing, and responses to these comments. Identify any coordination activities that have occurred since the issuance of the DEIS, as well as any specific circumstances that would trigger FHWA/FTA's reappraisal or further response (when appropriate);
- Discuss effect determination and any mitigation for Final 23 U.S.C. 138/49 U.S.C. 303 (Section 4(f) evaluation). If no 4(f) properties were impacted, state this fact;
- Any agency findings or determinations not included in the DEIS;
- A list of commitments for mitigation measures for the preferred alternative (when applicable); and Copies (or summaries) of comments received from circulation of the draft EIS and public hearing and responses thereto; and
- DEIS (include in full).

Chapter Twenty-nine

RESERVED

BUREAU OF DESIGN AND ENVIRONMENT MANUAL

Chapter Twenty-nine
RESERVED

Chapter Thirty

RESERVED

Chapter Thirty
RESERVED

Chapter Thirty-one
BASIC DESIGN CONTROLS

BUREAU OF DESIGN AND ENVIRONMENT MANUAL

Chapter Thirty-one
BASIC DESIGN CONTROLS

Table of Contents

<u>Section</u>	<u>Page</u>
31-1	DEFINITIONS..... 31-1.1
31-1.01	Qualifying Words..... 31-1.1
31-1.02	Acronyms..... 31-1.3
31-2	SPEED..... 31-2.1
31-2.01	Definitions..... 31-2.1
31-2.02	Design Speed Selection..... 31-2.2
31-3	SIGHT DISTANCE..... 31-3.1
31-3.01	Stopping Sight Distance..... 31-3.1
31-3.01(a)	Theoretical Discussion (Passenger Cars)..... 31-3.1
31-3.01(b)	Passenger Cars (Level Grade)..... 31-3.1
31-3.01(c)	Trucks..... 31-3.2
31-3.01(d)	Downgrade-Adjusted SSD..... 31-3.3
31-3.02	Decision Sight Distance..... 31-3.3
31-3.02(a)	Theoretical Discussion..... 31-3.3
31-3.02(b)	Applications..... 31-3.5
31-3.03	Passing Sight Distance..... 31-3.5
31-3.04	Intersection Sight Distance..... 31-3.5
31-4	CAPACITY METHODOLOGY..... 31-4.1
31-4.01	Definitions..... 31-4.1
31-4.02	Design Year Selection..... 31-4.3
31-4.02(a)	Roadway Design..... 31-4.3
31-4.02(b)	Other Highway Elements..... 31-4.4
31-4.03	Design Hourly Volume Selection..... 31-4.5
31-4.04	Level of Service..... 31-4.5
31-4.05	Capacity Analyses..... 31-4.6
31-4.05(a)	Objective..... 31-4.6
31-4.05(b)	Responsibility..... 31-4.8
31-4.06	Service Flow Rate..... 31-4.8

Table of Contents*(Continued)*

<u>Section</u>	<u>Page</u>
31-5 NON-HIGHWAY DESIGN CONTROLS	31-5.1
31-5.01 Driver	31-5.1
31-5.01(a) Typical Driver	31-5.1
31-5.01(b) Elderly Driver	31-5.2
31-5.02 Vehicle	31-5.4
31-5.03 Pedestrians	31-5.4
31-5.04 Bicyclists	31-5.11
31-6 PROJECT SCOPE OF WORK	31-6.1
31-6.01 New Construction	31-6.1
31-6.02 Reconstruction	31-6.1
31-6.03 3R Projects (Non-Freeways)	31-6.2
31-6.04 3R Projects (Freeways)	31-6.3
31-6.05 3P Projects	31-6.3
31-6.06 SMART Projects	31-6.4
31-7 ADHERENCE TO DESIGN CRITERIA	31-7.1
31-7.01 Department Intent	31-7.1
31-7.02 Hierarchy of Design Criteria	31-7.1
31-7.02(a) Level One Design Exceptions	31-7.1
31-7.02(b) Level Two Design Exceptions	31-7.2
31-7.02(c) ADA Accessibility Criteria – Maximum Extent Practicable	31-7.2
31-7.03 Design Criteria Checklists	31-7.2
31-7.04 Design Exception Process	31-7.2
31-7.04(a) General Procedures	31-7.2
31-7.04(b) Procedures for Meeting ADA Accessibility Criteria to the Maximum Extent Practicable	31-7.4
31-7.04(c) Vertical Clearances Exceptions on the Interstate System	31-7.4
31-8 REFERENCES	31-8.1

Chapter Thirty-one

BASIC DESIGN CONTROLS

Road design is predicated on many basic controls that establish the overall objective of the highway facility and identify the basic purpose of the highway project. Chapter 31, in combination with Chapter 43, presents those basic controls that impact road design. Chapter 31 includes a discussion on speed, sight distance, traffic volume controls, non-highway controls (e.g., the driver), project scope of work, and the design exception process. The application of these items to a project will impact all elements of road design.

31-1 DEFINITIONS

31-1.01 Qualifying Words

Many qualifying words are used in road design and in this *Manual*. For consistency and uniformity in the application of various design criteria, the following definitions apply:

1. Shall, require, will, must. A mandatory condition. Designers are obligated to adhere to the criteria and applications presented in this context or to perform the evaluation indicated. For the application of geometric design criteria, this *Manual* limits the use of these words.
2. Should, recommend. An advisory condition. Designers are strongly encouraged to follow the criteria and guidance presented in this context, unless there is reasonable justification not to do so.
3. May, could, can, suggest, consider. A permissive condition. Designers are allowed to apply individual judgment and discretion to the criteria when presented in this context. The decision will be based on a case-by-case assessment.
4. Desirable, preferred. An indication that the designer should make every reasonable effort to meet the criteria and that the designer should only use a “lesser” design after due consideration of the “better” design.
5. Ideal. Indicating a standard of perfection (e.g., traffic capacity under “ideal” conditions).
6. Minimum, maximum, upper, lower (limits). Representative of generally accepted limits within the design community but not necessarily suggesting that these limits are inviolable. However, where the criteria presented in this context will not be met, the designer will in many cases need approval.
7. Practical, feasible, cost-effective, reasonable. Advising the designer that the decision to apply the design criteria should be based on a subjective analysis of the anticipated

- benefits and costs associated with the impacts of the decision. No formal analysis (e.g., cost-effectiveness analysis) is intended, unless otherwise stated.
8. Possible. Indicating that which can be accomplished. Because of its rather restrictive implication, this word is rarely used in this *Manual* for the application of design criteria.
 9. Significant, major. Indicating that the consequences from a given action are obvious to most observers and, in many cases, can be readily measured.
 10. Insignificant, minor. Indicating that the consequences from a given action are relatively small and not an important factor in the decision-making for road design.
 11. Warranted, justified. Indicating that some well-accepted threshold or set of conditions has been met. As used in this *Manual*, “warranted” or “justified” may apply to either objective or subjective evaluations. Note that, once the warranting threshold has been met, this is an indication that the design treatment should be considered and evaluated – not that the design treatment is automatically required.
 12. Standard. Indicating a design value that cannot be violated without severe consequences. This suggestion is generally inconsistent with geometric design criteria. Therefore, “standard” will not be used in this *Manual* to apply to geometric design criteria.
 13. Guideline. Indicating a design value that establishes an approximate threshold which should be met if considered practical.
 14. Criteria. A term typically used to apply to design values, usually with no suggestion on the criticality of the design value. Because of its basically neutral implication, this *Manual* frequently uses “criteria” to refer to the design values presented.
 15. Typical. Indicating a design practice that is most often used in application and which is likely to be the “best” treatment at a given site.
 16. Target. If practical, criteria the designer should be striving to meet. However, not meeting these criteria will typically not require a justification.
 17. Acceptable. Design criteria that may not meet desirable values, but yet is considered to be reasonable and safe for design purposes.
 18. Policy. Indicating IDOT practice which the Department generally expects the designer to follow, unless otherwise justified.

31-1.02 Acronyms

The following are acronyms for common terminology, agencies, and publications used in road design:

- AASHTO. American Association of State Highway and Transportation Officials.
- ADA. Americans with Disabilities Act.
- CFR. Code of Federal Regulations.
- FAHP. Federal-aid Highway Program.
- FAST. *Fixing America's Surface Transportation Act* of 2015.
- FEMA. Federal Emergency Management Agency.
- FHWA. Federal Highway Administration.
- HCM. *Highway Capacity Manual*.
- HSM. Highway Safety Manual.
- IDOT. Illinois Department of Transportation.
- ITE. Institute of Transportation Engineers.
- ISTEA. *Intermodal Surface Transportation Efficiency Act* of 1991.
- LOS. Level of Service.
- MAP – 21. *Moving Ahead for Progress in the 21st Century Act* of 2012.
- MASH. *Manual for Addressing Safety Hardware*.
- MUTCD. *Manual of Uniform Traffic Control Devices*.
- NCHRP. National Cooperative Highway Research Program.
- NHS. National Highway System.
- PS&E. Plans, Specifications & Estimates.
- SAFETEA-LU. *Safe, Accountable, Flexible, Efficient Transportation Equity Act — Legacy for Users* of 2005.
- STP. Surface Transportation Program.
- TEA-21. *Transportation Equity Act* for the 21st Century of 1998.

- TRB. Transportation Research Board.
- TRR. Transportation Research Record.
- USC. United States Code.
- USDOT. United States Department of Transportation.

31-2 SPEED

31-2.01 Definitions

1. Design Speed. Design speed is a selected speed used to determine the various geometric design features of the roadway. A design speed is selected for each project which will establish criteria for several design elements including horizontal and vertical curvature, superelevation, and sight distance. Section 31-2.02 discusses the selection of design speed.
2. Low Speed. For geometric design purposes, low speed is defined as 45 mph (70 km/h) or less.
3. High Speed. For geometric design purposes, high speed is defined as 50 mph (80 km/h) or greater.
4. Average Running Speed. Running speed is the average speed of a vehicle over a specified section of highway. It is equal to the distance traveled divided by the running time (the time the vehicle is in motion). The average running speed is the distance summation for all vehicles divided by the running time summation for all vehicles.
5. Average Travel Speed. Average travel speed is the distance summation for all vehicles divided by the total time summation for all vehicles. Note: Average running speed only includes the time the vehicle is in motion. Therefore, on uninterrupted flow facilities where travel is not congested, average running speed, and average travel speed are equal.
6. Operating Speed. Operating speed is the speed at which drivers are observed operating their vehicles during free-flow conditions. In practice, the term "operating speed" is commonly used to characterize prevailing vehicular speeds on a highway segment, either through field measurements of speed or through informal field observations. Although no precise percentile is used to define operating speed, it may be assumed to be between the 80th and 90th percentile of actual travel speeds.
7. 85th-Percentile Speed. The 85th-percentile speed is the speed below which 85 percent of vehicles travel on a given highway. The most common application of the value is its use as one of the factors for determining the posted, legal speed limit of a highway section. In most cases, field measurements for the 85th-percentile speed will be conducted during off-peak hours when drivers are free to select their desired speed.
8. Posted Speed Limit. The posted speed limit on State highways is typically based on traffic and engineering investigations, where statutory requirements do not apply. The district Bureau of Operations conducts traffic speed studies on the State highway system. The selection of a posted speed limit is based on several factors:

- the design speed used during project development;
- median type on multilane facilities;
- the 85th-percentile speed and pace speed*;
- highway functional classification and type of area;
- road surface characteristics, grade, alignment, and sight distance;
- type and density of roadside development;
- use of curb and gutter;
- the crash experience during the previous 12 months;
- the need for traffic signal progression; and
- parking practices and pedestrian and bicycle activity.

**Note: Pace speed is the specified increment of spot speed that includes the greatest number of speed measurements.*

9. Legal Speed Limit. Legal speed limits are those set by the Federal government or by the Illinois Statutes that will apply, for example, to those public roads that do not have a posted speed limit.

31-2.02 Design Speed Selection

A design speed is selected for each project, which will establish criteria for several geometric design elements including horizontal and vertical curvature, superelevation, cross sectional features, and sight distance. Part V, Highway Systems, presents the design speed criteria for new construction and reconstruction projects, 3R non-freeway projects, and 3R freeway projects. In general, the selected design speed is based on the following road design elements:

1. Functional Classification. The higher class facilities (i.e., arterials) are designed with a higher design speed than the lower class facilities (i.e., collectors and locals).
2. Urban/Rural. Design speeds in rural areas are generally higher than those in urban areas. This is consistent with the typically fewer constraints in rural areas (e.g., less development).
3. Terrain. The flatter the terrain, the higher the selected design speed can be. This is consistent with the typically higher construction costs associated with more rugged terrain.
4. Traffic Volumes. On some facilities (e.g., unmarked rural collectors), the design speed varies by traffic volumes; i.e., as traffic volumes increase, higher design speeds are used.

For geometric design application, the relationship between these road design elements and the selected design speed reflects general cost-effective considerations. For example, the higher the traffic volumes, the more benefits to the traveling public from a higher design speed.

In addition to the above, the selected design speed should equal or exceed the anticipated posted/regulatory speed limit of the facility after construction. This applies to all projects. For new construction/reconstruction projects, it is usually desirable practice to use a design speed 5 mph (10 km/h) over posted speed. For 3R, 3P, or SMART projects, the proposed design speed may be relaxed to equate the existing posted speed if practical. The posted speed limit on state highways will be determined based on actual operating speeds of the completed facility and on several factors not directly related to the project design speed. Therefore, to avoid a potential conflict, the designer should coordinate the design speed selection with the district Bureau of Operations early in project development to assist in predicting the posted speed limit of the completed facility. If the proposed design speed will be less than the predicted posted speed limit, the designer must choose one of the following approaches:

- increase the project design speed to equal the anticipated posted speed limit,
- post the project with a legal speed limit equal to the design speed, or
- seek a design exception.

In selecting a design speed, the designer should avoid artificially selecting a design speed low enough to eliminate any design exceptions. For example, if the IDOT criteria yield a design speed of 60 mph (100 km/h) and one or more geometric features are adequate only for 55 mph (90 km/h), the project design speed should be 60 mph (100 km/h) and not 55 mph (90 km/h). The designer will then be required to make project improvements to meet the specific geometric features for a 60 mph design speed or seek design exceptions for the specific 55 mph (90 km/h) geometric features, rather than requesting a single design exception for the 55 mph design speed.

31-3 SIGHT DISTANCE

31-3.01 Stopping Sight Distance

31-3.01(a) Theoretical Discussion (Passenger Cars)

Stopping sight distance (SSD) is the sum of the distance traveled during a driver's perception/reaction (or brake reaction) time and the distance traveled while decelerating to a stop. To calculate SSD, the following formulas are used:

$$\text{SSD} = 1.47 Vt + 1.075 \frac{V^2}{a} \quad (\text{US Customary}) \text{ Equation 31-3.1}$$

$$\text{SSD} = \frac{Vt}{3.6} + 0.039 \frac{V^2}{a} \quad (\text{Metric}) \text{ Equation 31-3.1}$$

where: SSD = stopping sight distance, ft (m)
 V = design speed, mph (km/h)
 t = brake reaction time, 2.5 seconds
 a = driver deceleration, ft/s² (m/s²)

For calculating adjusted SSD for downgrades, see Equation 31-3.2.

The following briefly discusses the theoretical rationale for each assumption within the SSD model for passenger cars:

1. Brake Reaction Time. This is the time interval between when the obstacle in the road can first be physically seen and when the driver first applies the brakes. Based on several studies of observed driver reactions, the assumed value is 2.5 seconds. This time is considered adequate for approximately 90% of drivers in simple to moderately complex highway environments.
2. Braking Action. The braking action is based on the driver's ability to decelerate the vehicle while staying within the travel lane and maintaining steering control during the braking maneuver. A deceleration rate of 11.2 ft/s² (3.4 m/s²) is considered comfortable for 90% of drivers for passenger cars.
3. Speed. The highway design speed is used to determine the initial driver speed.

AASHTO's *A Policy on Geometric Design of Highways and Streets* presents additional information on the assumptions used to develop the SSD model.

31-3.01(b) Passenger Cars (Level Grade)

Figure 31-3.A provides stopping sight distances for passenger cars on grades less than 3%. When applying the SSD values for passenger cars, the height of eye is assumed to be 3.5 ft (1080 mm) and the height of object 2 ft (600 mm). Except as noted in the following subsections, the SSD values in Figure 31-3.A apply to all projects.

US Customary					Metric				
Design Speed (mph)	Brake ¹ Reaction Distance (ft)	Braking ² Distance On Level (ft)	Stopping Sight Distance		Design Speed (km/h)	Brake ¹ Reaction Distance (m)	Braking ² Distance On Level (m)	Stopping Sight Distance	
			Calculated (ft)	Design (ft)				Calculated (m)	Design (m)
30	110.3	86.4	196.7	200	50	34.8	28.7	63.5	65
35	128.6	117.6	246.2	250	60	41.7	41.3	83.0	85
40	147.0	153.6	300.6	305	70	48.7	56.2	104.9	105
45	165.4	194.4	359.8	360	80	55.6	73.4	129.0	130
50	183.8	240.0	423.8	425	90	62.6	92.9	155.5	160
55	202.1	290.3	492.4	495	100	69.5	114.7	184.2	185
60	220.5	345.5	566.0	570	110	76.5	138.8	215.3	220
65	238.9	405.5	644.4	645	120	83.4	165.2	248.6	250
70	257.3	470.3	727.6	730					
75	275.6	539.9	815.5	820					

Notes:

1. Brake reaction distance based on a time of 2.5 s.
2. Driver deceleration based on a rate of 11.2 ft/s² (3.4 m/s²).

**STOPPING SIGHT DISTANCE
(Passenger Cars – Level Grade)**

Figure 31-3.A

31-3.01(c) Trucks

The passenger SSD in Figure 31-3.A are not designed for truck operations. In general, trucks require longer SSD for a given speed than passenger vehicles. However, truck's higher height of eye (7.6 ft (2330 mm)) and driver experience tends to balance the need for additional stopping lengths for trucks than those for passenger cars (e.g., the truck driver can generally see further beyond a crest vertical curve). Consequently, separate truck SSD are generally not used in highway design. However, the designer should still consider providing longer SSD at the following sites:

- weigh stations;
- rest areas;
- in the vicinity of truck terminals;
- industrial parks;

- coal mining and quarry areas;
- where horizontal sight restrictions occur on downgrades;
- highway/railroad grade crossings on high-volume truck routes (e.g., truck DDHV of 250 or greater);
- other facilities with high truck traffic (e.g., routes with truck DDHV of 250 or greater); and
- locations that have a high incidence of truck crashes.

31-3.01(d) Downgrade-Adjusted SSD

The longitudinal gradient of the roadway impacts the distance needed for vehicles to brake to a stop. IDOT practice is to only consider the grade adjustment for downgrades, which increases braking distances. Equation 31-3.1 is modified as follows to calculate the adjusted SSD for downgrades:

$$\text{SSD} = 1.47Vt + \frac{V^2}{30 \left[\frac{a}{32.2} \pm G \right]} \quad (\text{US Customary}) \text{ Equation 31-3.2}$$

$$\text{SSD} = \frac{Vt}{3.6} + \frac{V^2}{254 \left[\frac{a}{9.81} \pm G \right]} \quad (\text{Metric}) \text{ Equation 31-3.2}$$

where: SSD = stopping sight distance, ft (m)
 V = design speed, mph (km/h)
 t = brake reaction time, typically 2.5 seconds
 a = driver deceleration, typically 11.2 ft/s² (3.4 m/s²)
 G = grade expressed as a decimal. Downgrades are expressed as a negative.

Figure 31-3.B presents the downgrade SSDs for passenger cars. The designer should make a reasonable effort to meet these SSD values when downgrades are 3% or steeper. However, the grade-adjusted SSD values do not require a design exception when not met.

31-3.02 Decision Sight Distance

31-3.02(a) Theoretical Discussion

At some sites, drivers may be required to make decisions where the highway environment is difficult to perceive or where unexpected maneuvers are required. These are areas of concentrated demand where the roadway elements, traffic volumes, and traffic control devices

US Customary									
SSD for Downgrades (ft)									
Design Speed (mph)	(3%)	(4%)	(5%)	(6%)	(7%)	(8%)	(9%)	(10%)	
30	205	210	215	215	220	225	230	235	
35	260	265	270	275	280	285	290	295	
40	315	325	330	335	340	350	355	365	
45	380	385	395	400	410	420	430	440	
50	450	455	465	475	485	495	510	525	
55	520	530	545	555	570	580	595	610	
60	600	615	625	640	655	670	690	705	
65	685	700	715	730	750	765	790	810	
70	775	790	810	825	850	870	895	920	
75	870	885	905	930	955	980	1005	1035	
Metric									
SSD for Downgrades (m)									
Design Speed (km/h)	(3%)	(4%)	(5%)	(6%)	(7%)	(8%)	(9%)	(10%)	
50	66	67	68	70	71	72	74	75	
60	87	88	90	92	93	95	97	100	
70	110	112	114	116	119	122	124	127	
80	136	138	141	144	147	151	154	158	
90	164	167	171	174	178	183	187	192	
100	194	198	203	207	212	218	223	230	
110	227	232	238	243	249	256	263	270	
120	263	268	275	281	288	296	304	313	

1. Calculated SSDs are not shown. Values in table have been determined by using Equation 31-3.2 and rounding up to the next highest 5 ft (1 m) increment.
2. For grades less than 3%, no adjustment is necessary; i.e., use the level SSD values (Figure 31-3.A).
3. For grades intermediate between table values, use a straight-line interpolation to determine the SSD or use Equation 31-3.2 and round up to the next highest 5 ft (1 m) increment.

**STOPPING SIGHT DISTANCE
(Passenger Cars — Adjusted for Downgrades)**

Figure 31-3.B

may all compete for the driver's attention. This relatively complex environment may increase the required driver perception/reaction time beyond that provided by the SSD values (2.5 seconds) and, in some locations, the desired vehicular maneuver may be a speed/path/direction change rather than a stop. At these locations, the designer should consider providing decision sight distance to provide an additional margin of safety. The various avoidance maneuvers assumed in the development of Figure 31-3.C are:

1. Avoidance Maneuver A. Stop on rural road.
2. Avoidance Maneuver B. Stop on urban road.
3. Avoidance Maneuver C. Speed/path/direction change on rural road.
4. Avoidance Maneuver D. Speed/path/direction change on suburban road.
5. Avoidance Maneuver E. Speed/path/direction change on urban road.

31-3.02(b) Applications

In general, the designer should consider using decision sight distance at any relatively complex location where the driver perception/reaction time may exceed 2.5 seconds. Example locations where decision sight distance may be appropriate include:

- freeway exit/entrance gores;
- freeway lane drops;
- freeway left-side entrances or exits;
- intersections near a horizontal curve;
- highway/railroad grade crossings;
- approaches to detours and lane closures;
- along high-speed, high-volume urban arterials with considerable roadside friction; or
- isolated traffic signals on high-speed rural highways.

As with SSD, the driver height of eye is 3.5 ft (1080 mm) and the height of object is typically 2 ft (600 mm). However, candidate sites for decision sight distance may also be candidate sites for assuming that the "object" is the pavement surface (e.g., freeway exit gores). Therefore, the designer may assume a 0.0 in (0.0 mm) height of object for application at some sites.

31-3.03 Passing Sight Distance

Passing sight distance only applies to two-lane, two-way highways. Therefore, its theoretical derivation and application are discussed in Chapter 47.

31-3.04 Intersection Sight Distance

Intersection sight distance applies to the determination of the sight triangle in the corners of at-grade intersections. Therefore, its theoretical derivation and application are discussed in Chapter 36.

US Customary					
Design Speed (mph)	Decision Sight Distance for Avoidance Maneuver (ft)				
	A	B	C	D	E
30	220	490	450	535	620
35	275	590	525	625	720
40	330	690	600	715	825
45	395	800	675	800	930
50	465	910	750	890	1030
55	535	1030	865	980	1135
60	610	1150	990	1125	1280
65	695	1275	1050	1220	1365
70	780	1410	1105	1275	1445
75	875	1545	1180	1365	1545
Metric					
Design Speed (km/h)	Decision Sight Distance for Avoidance Maneuver (m)				
	A	B	C	D	E
50	70	155	145	170	195
60	95	195	170	205	235
70	115	235	200	235	275
80	140	280	230	270	315
90	170	325	270	315	360
100	200	370	315	355	400
110	235	420	330	380	430
120	265	470	360	415	470

Note:

Avoidance Maneuver A: Stop on rural road.

Avoidance Maneuver B: Stop on urban road.

Avoidance Maneuver C: Speed/path/direction change on rural road.

Avoidance Maneuver D: Speed/path/direction change on suburban road.

Avoidance Maneuver E: Speed/path/direction change on urban road.

DECISION SIGHT DISTANCE**Figure 31-3.C**

31-4 CAPACITY METHODOLOGY

31-4.01 Definitions

1. Actuated Control. A defined phase sequence in which the presentation of each phase is on recall or the associated traffic movement has submitted a call for service through a detector.
2. Annual Average Daily Traffic (AADT). The total yearly volume in both directions of travel divided by the number of days in a year.
3. Average Daily Traffic (ADT). The calculation of average traffic volumes in both directions of travel in a time period greater than one day and less than one year and divided by the number of days in that time period. Although not precisely correct, ADT is often used interchangeably with AADT. The use of an ADT could produce a bias because of seasonal peaks and, therefore, the user should be aware of this.
4. Back of Queue. The maximum backward extent of queued vehicles during a typical cycle, as measured from the stop line to the last queued vehicle.
5. Capacity. The maximum number of vehicles that can reasonably be expected to traverse a point or uniform section of a lane or roadway during a given time period under prevailing roadway, traffic, and traffic control conditions. The time period most often used for analysis is 15 minutes. "Capacity" corresponds to Level of Service E.
6. Cycle. A complete sequence of signal indications.
7. D-Factor. The portion of traffic moving in the peak direction of travel on a given roadway during the peak hour.
8. Delay. Additional travel time experienced by a driver, passenger, bicyclist, or pedestrian beyond that required to travel at the desired speed. The primary performance measure on interrupted flow facilities
9. Demand Flow Rate. The count of vehicles arriving at the system element during the analysis period, converted to an hourly rate. This manual uses the term design hourly volume (defined below) in a similar manner as demand flow rate.
10. Density. The number of vehicles occupying a given length of lane, averaged over time. It is usually expressed as vehicles per mile (kilometer) per lane.
11. Design Hourly Volume (DHV). The one-hour volume in both directions of travel in the design year selected for determining the dimensions and configuration of the highway design elements. For capacity analyses, the DHV is typically converted to an hourly flow rate based on the maximum 15-minute flow rate during the DHV. The term DHV is not used in the *Highway Capacity Manual*, but its utility is similar to how demand flow rate (defined above) is used.

12. Directional Design Hourly Volume (DDHV). The traffic volume in the peak direction of flow during the design hour.
13. Directional Distribution (D). A characteristic of traffic that volume may be greater in one direction than in the other during any particular hour on a highway.
14. 85th Percentile Speed. A speed value that is exceeded by 15% of the vehicles in a traffic stream.
15. Flow Rate. The equivalent hourly rate at which vehicles or other roadway users pass over a given point or section of a lane or roadway during a given time interval of less than one hour, usually 15 minutes.
16. Free Flow. A flow of traffic unaffected by upstream or downstream conditions.
17. Green Time (g/c) Ratio. The ratio of the effective green time of a phase to the cycle length.
18. Heavy Vehicles. A vehicle with more than four wheels touching the pavement during normal operation.
19. K-Factor. The portion of AADT that occurs during the peak hour. (DHV/AADT)
20. Lane Group. A lane or set of lanes designated for separate analysis.
21. Level of Service (LOS). A quantitative stratification of a performance measure or measures that represent quality of service, measured on an A to F scale, with LOS A representing the best operating conditions from the traveler's perspective and LOS F the worst.
22. Passenger-Car Equivalent. The number of passenger cars that will result in the same operational conditions as a single heavy vehicle of a particular type under specified roadway, traffic, and control conditions.
23. Peak Hour. The hour of the day in which the maximum volume occurs.
24. Peak-Hour Factor (PHF). A ratio of the volume occurring during the peak hour to the maximum rate of flow during a given time period within the peak hour (typically 15 minutes).
25. Pedestrian. An individual traveling on foot.
26. Permitted Turn. A left or right turn at a signalized intersection that is made by a vehicle during a time in the cycle in which the vehicle does not have the right-of-way.
27. Phase. The part of the signal cycle allocated to any combination of traffic movements receiving the right-of-way simultaneously during one or more intervals. A phase includes the green, yellow, and red clearance intervals.

28. Progression. The act of various controllers providing specific green indications in accordance with a time schedule to permit continuous operation of groups of vehicles along the street at a planned speed.
29. Protected Turn. The left or right turns at a signalized intersection that are made by a vehicle during a time in the cycle when the vehicle has the right-of-way.
30. Queue Storage Ratio. The maximum back of queue as a proportion of the available storage on the subject lane or link.
31. Red Clearance Interval. A brief period of time following the yellow indication during which the signal heads associated with the ending phase and all conflicting phases display a red indication.
32. Saturation Flow Rate. The equivalent hourly rate at which previously queued vehicles can traverse an intersection approach under prevailing conditions, assuming that the green signal is available at all times and no lost times are experienced.
33. Semi-Actuated Control. A signal control in which some approaches (typically on the minor street) have detectors and some approaches (typically on the major street) have no detectors.
34. Service Flow Rate. The maximum directional rate of flow that can be sustained in a given segment under prevailing roadway, traffic, and control conditions without violating the criteria for level of service.
35. Service Measure. A performance measure used to define LOS for a transportation system element.
36. Volume-to-Capacity (v/c) Ratio. The ratio of flow rate to capacity for a system element.
37. Weaving. The crossing of two or more traffic streams traveling in the same direction along a significant length of highway, without the aid of traffic control devices (except for guide signs).

31-4.02 Design Year Selection

31-4.02(a) Roadway Design

The geometric design of a highway should be developed to accommodate expected traffic volumes during the life of the facility assuming reasonable maintenance. This involves projecting the traffic volumes to a selected future year. Recommended design years are presented in Figure 31-4.A. The design year is measured from the expected construction completion date. Projected traffic volumes on State highways are provided by each district or from regional transportation studies with support from the OPP, Planning Services Section.

Project Scope Of Work	Typical
New Construction/Reconstruction	20 Years
3R Freeway Projects	Current*
3R Non-Freeway Projects	Current*

* *In general, current traffic volumes may be used. However, if a 3R project will introduce a new geometric design element (e.g., relocation of a horizontal curve), the element should be designed based on reconstruction policies.*

RECOMMENDED DESIGN YEAR SELECTION (Traffic Volumes for Road Design)

Figure 31-4.A

31-4.02(b) Other Highway Elements

The following presents the recommended criteria for selection of a design year for highway elements other than road design:

1. **Bridges.** The structural life of a bridge may be 75 years or more. For new bridges, bridge replacement, and bridge reconstruction, the clear roadway width of the bridge will be based on the 20-year traffic volume projection beyond the construction completion date. In addition, the designer may, on selected projects, evaluate if the bridge design will reasonably accommodate structural expansion to meet the clear roadway width across the bridge based on a traffic volume projection beyond 20 years.

For bridges within the limits of 3R projects, see Chapters 49 and 50.

2. **Underpasses.** The design year used for the geometric design of underpasses will be determined on a case-by-case basis.
3. **Right-of-Way/Grading.** The designer may consider potential right-of-way needs for the anticipated long-term corridor growth for a year considerably beyond that used for roadway design, especially in large metropolitan areas. No specific design year is recommended for use. For example, when selecting an initial median width on a divided highway, the designer may evaluate the potential need for future expansion of the facility to add through travel lanes. Other examples include potential future interchanges, potential reconstruction of a two-lane, two-way facility to a multilane highway, and the use of flatter side slopes to provide more future options.
4. **Drainage Design.** Drainage appurtenances are designed to accommodate a flow rate based on a specific design year (or frequency of occurrence). The selected design year or frequency will be based on the functional class of the facility, the ADT, and the

specific drainage appurtenance (e.g., culvert). The IDOT *Drainage Manual* presents the Department's criteria for selecting the frequency of occurrence. The design life of new drainage structures is typically 50 years.

5. Pavement Design. The pavement structure is designed to withstand the vehicular loads during the design analysis period without falling below a selected pavement serviceability rating. Chapter 54 presents the Department's criteria for selecting a design year for pavements.
6. Environmental Analyses. Some environmental analyses require the selection of a future year for design (e.g., noise analyses). BDE determines the specific criteria for environmental analyses.

31-4.03 Design Hourly Volume Selection

For most geometric design elements that are determined by traffic volumes, the peaking characteristics are most significant. The highway facility should be able to accommodate the design hourly volume (adjusted for the peak-hour factor) at the selected level of service. This design hourly volume (DHV) will affect many design elements including the number of through travel lanes, lane and shoulder widths, and intersection geometrics. The designer should also analyze the proposed design using the a.m. and p.m. DHV's separately. This could have an impact on the geometric design of the highway. The *Highway Capacity Manual* uses the term demand flow rate similarly as design hourly volume.

Traditionally, the 30th highest hourly volume in the selected design year has been used to determine the DHV for design purposes. This is still considered appropriate for rural facilities. However, at the discretion of the district, for urban facilities it may be more appropriate to base the DHV on the 10th to 20th highest hourly volume in the selected design year. Because the design of the project is significantly dependent upon the projected design hourly volumes, these projections must be carefully examined before using for design purposes.

31-4.04 Level of Service

Level of service (LOS) describes a quantitative stratification of a performance measure or measures that represent quality of service, measured on an A to F scale. A designated LOS is described in terms of service measures such as speed, density, delay, or percent time-spent-following.

Because drivers will accept different driving operational conditions, including lower travel speeds on different facilities, it is not practical to establish one level of service for application to every type of highway. Therefore, various levels of service have been established for the different types of highways facilities, location (i.e., rural or urban) and the scope of the improvement.

Part V, Highway Systems, presents LOS criteria for each highway type.

31-4.05 Capacity Analyses

31-4.05(a) Objective

The highway mainline, intersection, or interchange should be designed to accommodate the design hourly volume (DHV) at the selected level of service (LOS). The methodologies in the *Highway Capacity Manual* (HCM) uses the DHV, or demand flow rate, and the various highway factors which affect capacity to determine the LOS.

The maximum directional rate of flow that can be sustained in a given segment for a selected LOS, the definition for service flow rate, should be accommodated by adjusting the various highway factors which affect capacity until a suitable design is determined. The service flow rate of the facility is calculated by applying adjustments such as heavy vehicles and driver population to a base flow rate. By definition, the service flow rate for LOS E is synonymous with capacity for all uninterrupted-flow facilities and their components.

The HCM has established service measures to determine the level of service for various highway elements on different types of highway facilities. These are presented in Figure 31-4.B. For each service measure, the HCM will provide the analytical tools to calculate the numerical value. The designer should note that highway capacity service measures are segregated into two broad categories: (1) uninterrupted flow, or open highway conditions, which occurs on facilities that have no fixed causes of delay or interruption external to the traffic stream such as the influence of an intersection, and (2) interrupted flow which occur on facilities characterized by traffic signals, STOP signs, YIELD signs or other fixed causes of periodic delay or interruption to the traffic stream.

The following presents the simplified procedure for conducting a capacity analysis for the highway mainline:

1. Select the design year (Section 31-4.02).
2. Determine the DHV (Section 31-4.03).
3. Select the design LOS (see Part V, Highway Systems).
4. Document the proposed highway geometric design (lane width, length of weaving section, number and width of approach lanes at intersections, etc.).
5. Using the HCM, analyze the capacity of the highway element for the proposed design:
 - determine the maximum flow rate under ideal conditions;
 - adjust the maximum flow rate for prevailing roadway, traffic, and traffic control conditions; and
 - calculate the service flow rate for the selected level of service.

6. Compare the calculated service flow rate to the DHV. If the DHV is less than or equal to the service flow rate, the proposed design will meet the objectives of the capacity analysis. If the DHV exceeds the service flow rate, the proposed design may need further evaluation. The designer should either adjust the highway design or should adjust one of the capacity elements (e.g., the selected design year or the level-of-service goal).

Type of Facility	Service Measures
Vehicular	
Interrupted Flow Urban street segment Signalized intersection Two-way stop intersection All-way stop intersection Interchange ramp terminal Roundabout Uninterrupted Flow Two-lane highway Multilane highway Freeway Basic segment Ramp merge segment Ramp diverge segment Weaving segment	travel speed/Base FFS delay delay delay delay delay average travel speed, percent time-spent-following percent of free-flow speed density density density density density
Other Road Users	
Pedestrian Bicycle	space, delay, LOS score LOS score

SERVICE MEASURES FOR LEVEL OF SERVICE

Figure 31-4.B

31-4.05(b) Responsibility

For IDOT projects, the district Geometrics Engineer (or sometimes the project engineer) is responsible for performing all capacity analyses required by the project. The Policy and Procedures Section or the Project Development Unit is available as a resource to the district to assist in all capacity analyses. For consultant-designed projects, the consultant is responsible for performing capacity analyses. Consultants must use only highway capacity software that is approved by BDE.

31-4.06 Service Flow Rate

For general design purposes, IDOT uses a volume threshold designated as the service flow rate (SF) for the various highway classes. Service flow rate is taken from the *Highway Capacity Manual* (HCM) and is defined as the maximum volume that can be accommodated at a selected level of service (LOS) based on a typical set of operational assumptions for each facility.

As discussed in the HCM the base capacity of a facility at any LOS varies with the free-flow speed. For example, the base capacity for a basic freeway segment for LOS E ranges from 2250 at 55 mph (90 km/h) to 2400 at 75 mph (120 km/h) passenger cars per hour per lane under base conditions. The maximum service flow rate at LOS E, or MSF_E , is, also considered the capacity of a freeway, expressway, or arterial multilane highway. Base conditions include 12 foot lanes, a minimum of 6 foot right-side clearance, no heavy vehicles, no ramps, and a driver population composed primarily of regular users who are familiar with the facility.

The geometric design criteria tables in Part V, Highway Systems, present the service flow rate volumes for the applicable highway types at the design LOS. Factors which determine SF are the same as the base conditions above exclusive of lane width, lateral clearance and ramp density. Variances from the remaining base conditions causing operational constraints will cause a decrease to the SF. As discussed in the HCM these adjustments include the number of lanes (N), percent of heavy vehicles (f_{HV}), and driver population (f_p). To determine the SF_i at LOS i , use the MSF_i at the desired LOS i (e.g. see Exhibit 11-17 of the HCM). The equation for determining the SF_i for LOS i is:

$$SF_i = (MSF_i) (N) (f_{HV}) (f_p). \quad \text{Equation 31-4.1}$$

This equation is applicable for basic freeway segments (Chapter 44), expressways (Chapter 45), and arterial multilane highways (Chapter 47).

The SF's shown in the tables in Part V for multilane highways are one-way volumes derived from the above equation using appropriate HCM values and assume the following truck percentages for f_{HV} : freeways – 16%, expressways and arterial multilane highways– 8%. A PHF = 1.0 has been assumed, and the SF's found in the Part V tables for multilane highways must be multiplied by the actual PHF.

Capacity for a two lane rural highway (Chapter 47), which also exists at the boundary between LOS E and LOS F, is not determined by a measure of effectiveness. Under base conditions (12 foot or wider lanes, 6 foot or wider shoulders, no no-passing zones, all passenger cars, level

terrain, and no impediments to through traffic) the capacity of a two-lane rural highway (in one direction) is 1700 passenger cars per hour (pcph). The capacity of two-lane rural highway under base conditions is 3200 pcph total in both directions.

The equation for determining the SF_i for LOS i for two-lane rural highways is:

$$SF_i = (2800) (v/c)_i (f_d) (f_w) (f_{HV}) \text{ where;} \quad \text{Equation 31-4.2}$$

v/c = the ratio of flow rate to an ideal capacity of 2800 pcph in both directions;

f_d = the adjustment factor for the directional distribution of traffic (assumed as 60%/40%);

f_w = the adjustment factor for narrow lanes and shoulders and;

f_{HV} = the adjustment factor for the presence of heavy vehicles.

This equation and method to determine SF are from Chapter 8 of the 1994 HCM. Service flow rates in the 2011 HCM are ancillary to the performance measures for two-lane rural highways; therefore, the method to determine SF for two-lane rural highways is complicated requiring an iterative process giving questionable results. The method to determine SF using the 1994 HCM is accurate enough for planning purposes. The volumes shown in Part V for rural two-lane highways assume 100% passing sight distance, a 60%/40% directional distribution, 6% heavy vehicle percentage, and a PHF = 1. On a project length basis, as much passing sight distance as practical should be provided with approximately 60% available as a minimum for level terrain and approximately 40% as a minimum for rolling terrain.

31-5 NON-HIGHWAY DESIGN CONTROLS

The characteristics of drivers and vehicles significantly influence the selected design criteria. When the driver and vehicle are properly accommodated, the safety and serviceability of the highway system are enhanced. When they are not accommodated, crashes and inefficient operation may result.

31-5.01 Driver

31-5.01(a) Typical Driver

The appropriate considerations for drivers are already built into the applicable geometric design values (stopping sight distance, horizontal curvature, superelevation, roadway widths, etc.). However, a brief discussion of the “typical” driver is warranted.

Drivers vary widely in their operating skills, experience, intelligence, and physical condition. The highway should be as forgiving as practical to minimize the adverse effects of driver errors. The following describes certain principles and driver traits that should be incorporated into the roadway design:

1. Information Processing. Drivers are limited in how quickly they can gather information, make a decision, and take action. They must process information related to lane placement, speed, traffic control devices, highway alignment, roadside conflicts, and weather. If the amount, complexity, or clarity of the information is inappropriate or excessive, driver error leading to a crash can result.
2. Primacy. Certain driving functions are more important than others. In order of importance they are:
 - Control — activities related to the physical control of the vehicle via the steering wheel, brake, or accelerator.
 - Guidance — activities related to selecting a safe speed and vehicular path on the highway.
 - Navigation — activities related to planning and executing a trip from point of origin to destination.

The roadway designer must be aware of the relative importance of these activities and ensure that the more important highway information is properly conveyed to the driver. This could result in the decision to remove or relocate lower priority information, if it were likely to interfere with the higher priority information.

3. Expectancy. Drivers are conditioned through experience and training to expect and anticipate what lies ahead on the highway. If this driver expectancy is violated, it will increase the time needed by the driver to assess the situation and make the correct

decision. These violations should be avoided. Where they are unavoidable, the designer should allow for increased warning time.

4. Speed. Speed must be considered when accommodating the driver. Higher speeds reduce the visual field and restrict peripheral vision.

A User's Guide to Positive Guidance (FHWA) contains more detailed information related to driver characteristics and highway design accommodations for the driver.

31-5.01(b) Elderly Driver

In general, the median age of drivers in the United States is increasing and, specifically, the age bracket of over 60 years is the fastest growing segment of the driver population. This reality greatly emphasizes the criticality of the relationship between the driver and the highway environment. Although the opinions are not unanimous, there is general agreement that advancing age has a deleterious effect on an individual's perceptual, mental, and motor skills — critical factors in vehicular operation.

The research community has conducted several studies of the elderly driver, including:

- "Older Driver Study of Traffic Control Devices in Illinois," Illinois Department of Transportation, 1991;
- "Highway Design and Traffic Operation Needs of Older Drivers," University of Illinois at Urbana - Champaign, January 1994;
- "Strategies for Improving the Safety of Elderly Drivers," University of Nebraska/Midwest Transportation Center, 1991; and
- "Highway Design Handbook for Older Drivers and Pedestrians," FHWA, 2001.

These four studies were primarily focused on the relationship between the elderly driver and traffic control devices where, arguably, a greater opportunity exists for cost-effective countermeasures than for roadway design. However, it is important for the road designer to be aware of the needs of the elderly driver and, where desirable, factor these needs into the roadway design. The following summarizes the more important observations from these studies:

1. Elderly Driving Characteristics. When compared to younger drivers, the elderly driver often exhibits the following operational deficiencies:
 - slower information processing;
 - slower reaction times;
 - slower decision making;
 - visual deterioration;
 - hearing deterioration;
 - decline in ability to judge time, speed, and depth perception;

- limitations on physical mobility; and
 - side effects from prescription drugs.
2. Crash Frequency. Predictably, elderly drivers are involved in a disproportionate number of crashes where there is a higher than average demand imposed on driving skills. The driving maneuvers that most often precipitate higher crash frequencies among older drivers include:
- making left turns across traffic,
 - merging with high-speed traffic,
 - changing lanes on congested streets,
 - crossing high-volume intersections,
 - stopping quickly for queued traffic,
 - attempting backing maneuvers, and
 - parking.
3. Countermeasures. The studies identified several countermeasures to alleviate the potential problems of the elderly driver. These included:
- increasing driver education;
 - increasing vehicular clearance times at signalized intersections;
 - increasing pedestrian phase times;
 - providing wider and brighter pavement markings;
 - providing larger and brighter signs;
 - reducing sign clutter;
 - providing more redundant information (e.g., advance guide signs);
 - installing grade separations;
 - revising warrants for traffic signals to increase their usage;
 - enforcing speed limits;
 - widening intersections;
 - increasing use of protected left-turn phases; and
 - increasing sight distance.

Most of the proposed countermeasures are related to traffic control devices. Perhaps the most practical measure related to road design is increasing sight distance. From an implementation perspective, this recommendation may be related to the warrants for the use of decision sight distance, as discussed in Section 31-3. The gradual aging of the driver population suggests that an increased use of decision sight distance may produce a commensurate reduction in the crash frequency for elderly drivers. These findings suggest that, where decision sight distance cannot physically be provided, an increased use of advance warning signs may be appropriate.

31-5.02 Vehicle

The physical and operational characteristics of vehicles using the highway are important controls in roadway design. Design criteria may vary according to the type of vehicle and the volume of each type of vehicle in the traffic stream.

Vehicular characteristics that impact design include:

1. Size. Vehicular sizes determine lane and shoulder widths, vertical clearances and, indirectly, highway capacity calculations.
2. Off-tracking. The design of intersection turning radii, traveled way widening for horizontal curves, and pavement widths for interchange ramps are usually controlled by the largest design vehicle likely to use the facility with some frequency.
3. Storage Requirements. Turn bay storage lengths, bus turnouts, and parking lot layouts are determined by the number and types of vehicles to be accommodated.
4. Sight Distance. Eye height and braking distances vary for passenger cars and trucks, which can impact sight distance considerations.
5. Acceleration and Deceleration. Acceleration and deceleration rates often govern the dimensioning of such design features as speed-change lanes at intersections and interchange ramps and climbing lanes.
6. Vehicular Stability. Certain vehicles with high centers of gravity may be prone to skidding or overturning, affecting design speed selection and superelevation design elements.

Figures 31-5.A and 31-5.B present vehicular dimensions and minimum turning radii for typical design vehicles. Figures 31-5.C and 31-5.D present two combination trucks to illustrate the application of the basic dimensions.

The selection of appropriate design vehicles for intersections and interchanges are discussed in Chapters 36 and 37, respectively.

31-5.03 Pedestrians

The pedestrian must be considered as an integral part of the highway environment, especially in urban areas. Except on fully access-controlled facilities, pedestrians are legally allowed to use the highway right-of-way consistent with the restrictions placed on pedestrian use. Therefore, the roadway design should provide for the safe and efficient movement of pedestrians, within practical limits, without compromising the accommodation of the vehicles using the highway facility.

Design Vehicle Type	Symbol	Dimensions (feet)											Typical Kingpin to Center of Rear Axle			
		Overall			Overhang		Wheelbases				T	WB ₃				
		Height	Width	Length	Front	Rear	WB ₁	WB ₂	S							
Passenger car	P	4.25	7	19	3	5	-	-	-	-	-	-	-	-	-	-
Single unit truck	SU	11-13.5	8.0	30	4	6	-	-	-	-	-	-	-	-	-	-
City transit bus	CITY-BUS	10.5	8.5	40	7	8	-	-	-	-	-	-	-	-	-	-
Articulated bus	A-BUS	11.0	8.5	60	8.6	10	19.4	-	6.2 ^a	13.2 ^a	-	-	-	-	-	-
School bus (84 passenger)	S-BUS	10.5	8.0	40	7	13	-	-	-	-	-	-	-	-	-	-
Combination trucks:																
Intermediate Semitrailer	WB-40	13.5	8.0	45.5	3	2.5 ^a	12.5	27.5	-	-	-	-	-	-	-	27.5
Large Semitrailer	WB-50	13.5	8.5	55	3	2 ^a	14.6	35.4	-	-	-	-	-	-	-	37.5
Large Semitrailer*	WB-55	13.5	8.5	66	3.5	7.5	14.6	40.4	-	-	-	-	-	-	-	42.5
Semitrailer - Full Trailer ("Double Bottom")	WB-67D	13.5	8.5	73.3	2.33	3	11.0	23.0	3.0 ^b	7.0 ^b	23.0	-	-	-	-	23.0
Interstate Semitrailer*	WB-65	13.5	8.5	73.5	4	4.5-2.5 ^a	21.6	43.4-45.4	-	-	-	-	-	-	-	45.5-47.5
Recreational vehicles:																
Motor home	MH	12	8	30	4	6	20	-	-	-	-	-	-	-	-	-
Car and camper trailer	P/T	10	8	48.7	3	10	11	-	5	19	-	-	-	-	-	-
Car and boat trailer	P/B	10	8	42	3	8	11	-	5	15	-	-	-	-	-	-
Motor home and boat trailer	MH/B	12	8	53	4	8	20	-	6	15	-	-	-	-	-	-

* On semitrailers longer than 48 ft, the maximum distance between the kingpin and the rear axle shall not exceed 45.5 ft.

a = Combined dimension of 19.4 ft is typical.

b = Combined dimension of 10.0 ft is typical.

WB₁, WB₂, WB₃ are effective vehicle wheelbases, starting at the front and moving towards the back of the vehicle.

S is the distance from the rear effective axle of a vehicle to the hitch point or, for A-BUS, the distance from second axle to articulating section.

T is the distance from the hitch point of a vehicle to the lead effective axle or axle set of the following unit or, for A-BUS, the distance from articulating section to rear axle.

TYPICAL DESIGN VEHICLE DIMENSIONS
(US Customary)

Figure 31-5.A

Design Vehicle Type	Symbol	Dimensions (meters)										Typical Kingpin to Center of Rear Axle			
		Overall		Overhang		Wheelbases									
		Height	Width	Length	Front	Rear	WB ₁	WB ₂	S	T	WB ₃				
Passenger car	P	1.3	2.1	5.8	0.9	1.5	3.4	-	-	-	-	-	-	-	-
Single unit truck	SU	3.4-4.1	2.4	9.2	1.2	1.8	6.1	-	-	-	-	-	-	-	-
City transit bus	CITY-BUS	3.2	2.6	12.2	2.1	2.4	7.6	-	-	-	-	-	-	-	-
Articulated bus	A-BUS	3.4	2.6	18.3	2.6	3.1	6.7	5.9	1.9 ^a	4.0 ^a	-	-	-	-	-
School bus (94 passenger)	S-BUS	3.2	2.4	12.2	2.1	4.0	6.1	-	-	-	-	-	-	-	-
Combination trucks:															
Intermediate Semitrailer	WB-12	4.1	2.4	13.9	0.9	0.8 ^a	3.8	8.4	-	-	-	-	-	-	8.4
Large Semitrailer	WB-15	4.1	2.6	16.8	0.9	0.6 ^a	4.5	10.8	-	-	-	-	-	-	11.4
Large Semitrailer*	WB-17	4.1	2.6	20.19	1.13	2.29	4.45	12.32	-	-	-	-	-	-	13.0
Semitrailer - Full Trailer ("Double Bottom")	WB-20D	4.1	2.6	22.4	0.7	0.9	3.4	7.0	0.9 ^b	2.1 ^b	7.0	-	-	-	7.0
Interstate Semitrailer*	WB-20	4.1	2.6	22.4	1.2	1.4-0.8 ^a	6.6	13.2-13.8	-	-	-	-	-	-	13.9-14.5
Recreational vehicles:															
Motor home	MH	3.7	2.4	9.2	1.2	1.8	6.1	-	-	-	-	-	-	-	-
Car and camper trailer	P/T	3.1	2.4	14.0	0.9	3.1	3.4	-	-	1.5	5.8	-	-	-	-
Car and boat trailer	P/B	3.1	2.4	12.8	0.9	2.4	3.4	-	-	1.5	4.6	-	-	-	-
Motor home and boat trailer	MH/B	3.7	2.4	16.2	1.2	2.4	6.1	-	-	1.8	4.6	-	-	-	-

* On semitrailers longer than 14.63 m, the maximum distance between the kingpin and the rear axle shall not exceed 13.87 m.

a = Combined dimension of 5.91 m is typical.

b = Combined dimension of 3.25 m is typical.

WB₁, WB₂, WB₃ are effective vehicle wheelbases, starting at the front and moving towards the back of the vehicle.

S is the distance from the rear effective axle of a vehicle to the hitch point or, for A-BUS, the distance from second axle to articulating section.

T is the distance from the hitch point of a vehicle to the lead effective axle or axle set of the following unit or, for A-BUS, the distance from articulating section to rear axle.

**TYPICAL DESIGN VEHICLE DIMENSIONS
(Metric)**

Figure 31-5.A

Design Vehicle Type	Passenger Car	Single-Unit Truck	Intercity Bus (Motor Coach)		City Transit Bus	Conventional School Bus (65 pass.)	Large ² School Bus (84 pass)	Articulated Bus	Inter-mediate Semi-Trailer	Inter-mediate Semi-Trailer
Symbol	P	SU	BUS-40	BUS-45	CITY-BUS	S-BUS36	S-BUS40	A-BUS	WB-40	WB-50
Minimum Design Turning Radius (ft)	24	42	45	45	42.0	38.9	39.4	39.8	40	45
Centerline ¹ Turning Radius (CTR) (ft)	21	38	40.8	40.8	37.8	34.9	35.4	35.5	36	41
Minimum Inside Radius (ft)	14.4	28.3	27.6	25.5	24.5	23.8	25.4	21.3	19.3	17.0

Design Vehicle Type	Large Semi-trailer	Semitrailer Interstate		"Double Bottom" Combination	Semi-trailer/trailers	Turnpike Double Semi-trailer/trailer	Motor Home	Car with Camper Trailer	Car with Boat Trailer	Motor Home and Boat Trailer	Farm ³ Tractor w/One Wagon
Symbol	WB-55	WB-62*	WB-65**or WB-67	WB67D	WB-100T	WB-109D*	MH	P/T	P/B	MH/B	TR/W
Minimum Design Turning Radius (ft)	45	45	45	45	45	60	40	33	24	50	18
Centerline ¹ Turning Radius (CTR) (ft)	41	41	41	41	41	56	36	30	21	46	14
Minimum Inside Radius (ft)	18.4	17.9	4.4	19.3	9.9	14.9	25.9	17.4	8.0	35.1	10.5

* Design vehicle with 48-ft trailer as adopted in 1982 *Surface Transportation Assistance Act (STAA)*.

** Design vehicle with 53-ft trailer as grandfathered in with 1982 *Surface Transportation Assistance Act (STAA)*.

- 1 The turning radius assumed by a designer when investigating possible turning paths and is set at the centerline of the front axle of a vehicle. If the minimum turning path is assumed, the CTR approximately equals the minimum design-turning radius minus one-half the front width of the vehicle.
- 2 School buses are manufactured from 42-passenger to 84-passenger sizes. This corresponds to wheel base lengths of 11.0 ft to 20.0 ft, respectively. For these different sizes, the minimum design turning radii vary from 28.8 ft to 39.4 ft and the minimum inside radii vary from 14.0 ft to 25.4 ft.
- 3 Turning radius is for 150-200 hp tractor with one 18.5-ft long wagon attached to hitch point. Front wheel drive is disengaged and without brakes being applied.

**MINIMUM TURNING RADII OF TYPICAL DESIGN VEHICLES
(US Customary)**

Figure 31-5.B

Design Vehicle Type	Passenger Car	Single-Unit Truck	Intercity Bus (Motor Coach)		City Transit Bus	Conventional School Bus (65 pass.)	Large ² School Bus (84 pass)	Articulated Bus	Inter-mediate Semi-Trailer	Inter-mediate Semi-Trailer
			BUS-12	BUS-14						
Symbol	P	SU	BUS-12	BUS-14	CITY-BUS	S-BUS11	S-BUS12	A-BUS	WB-12	WB-15
Minimum Design Turning Radius (m)	7.3	12.8	13.7	13.7	12.8	11.9	12.0	12.1	12.2	13.7
Centerline ¹ Turning Radius (CTR) (m)	6.4	11.6	12.4	12.4	11.5	10.6	10.8	10.8	11.0	12.5
Minimum Inside Radius (m)	4.4	8.6	8.4	7.8	7.5	7.3	7.7	6.5	5.9	5.2

Design Vehicle Type	Large Semi-trailer	Interstate Semitrailer		"Double Bottom" Combination	Semi-trailer/trailers	Semi-trailer/trailer	Motor Home	Car with Camper Trailer	Car with Boat Trailer	Motor Home and Boat Trailer	Farm ³ Tractor w/One Wagon
		WB-19*	WB-20**								
Symbol	WB-17	WB-19*	WB-20**	WB-20D	WB-30T	WB-33D*	MH	P/T	P/B	MH/B	TR/W
Minimum Design Turning Radius (m)	13.7	13.7	13.7	13.7	13.7	18.3	12.2	10.1	7.3	15.2	5.5
Centerline ¹ Turning Radius (CTR) (m)	12.5	12.5	12.5	12.5	12.5	17.1	11.0	9.1	6.4	14.0	4.3
Minimum Inside Radius (m)	5.6	2.4	1.3	5.9	3.0	4.5	7.9	5.3	2.4	10.7	3.2

Note: Numbers in table have been rounded to the nearest tenth of a meter.

* Design vehicle with 14.63-m trailer as adopted in 1982 Surface Transportation Assistance Act (STAA).

** Design vehicle with 16.16-m trailer as grandfathered in with 1982 Surface Transportation Assistance Act (STAA).

- 1 The turning radius assumed by a designer when investigating possible turning paths and is set at the centerline of the front axle of a vehicle. If the minimum turning path is assumed, the CTR approximately equals the minimum design-turning radius minus one-half the front width of the vehicle.
- 2 School buses are manufactured from 42-passenger to 84-passenger sizes. This corresponds to wheel base lengths of 3.35 m to 6.1 m, respectively. For these different sizes, the minimum design turning radii vary from 8.78 m to 12.01 m and the minimum inside radii vary from 4.27 m to 7.74 m.
- 3 Turning radius is for 150-200 hp tractor with one 5.64-m long wagon attached to hitch point. Front wheel drive is disengaged and without brakes being applied.

**MINIMUM TURNING RADII OF TYPICAL DESIGN VEHICLES
(Metric)**

Figure 31-5.B

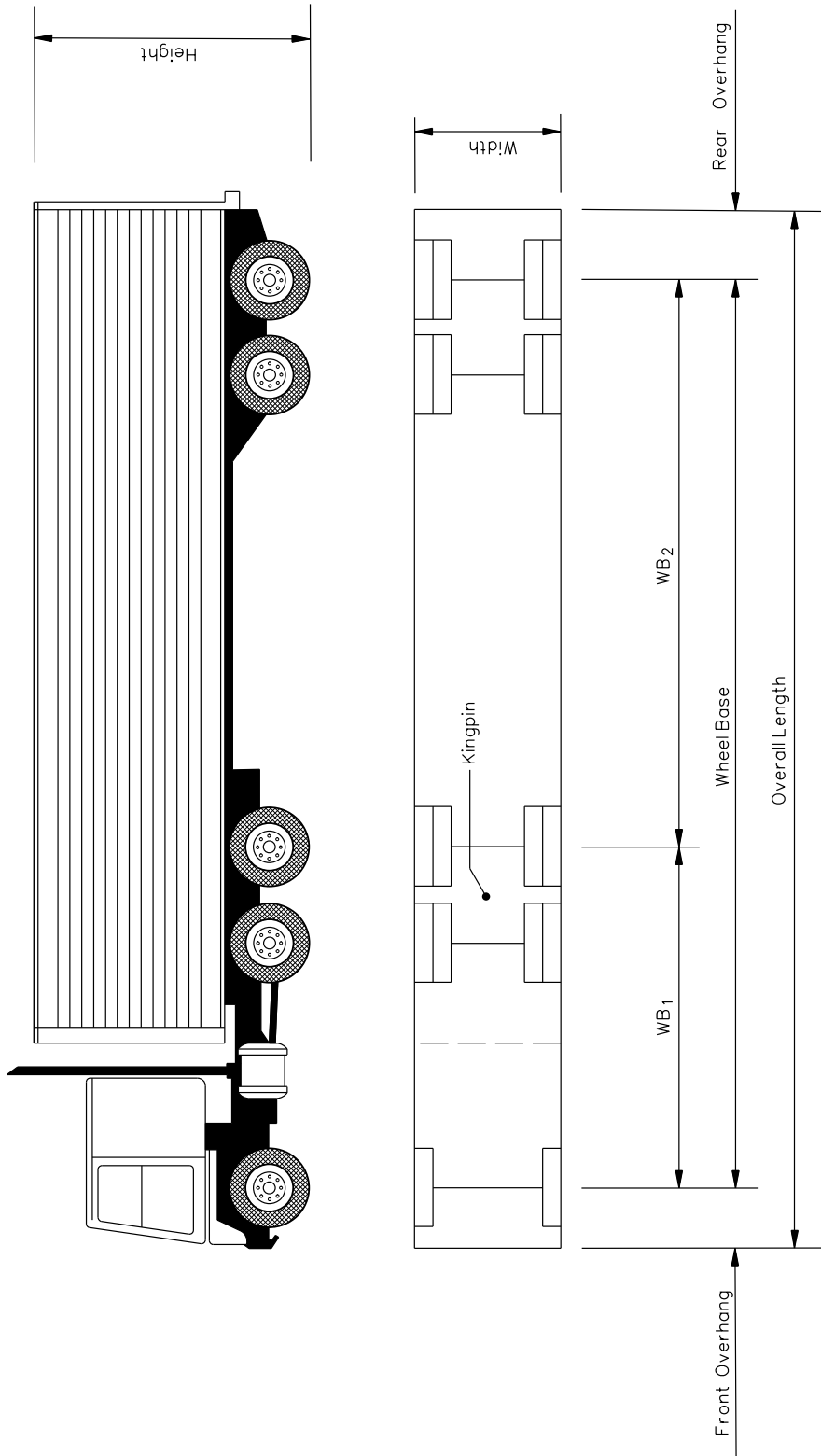

Note: For the legal dimensions of trucks allowed on Illinois highways, refer to information from the Central Bureau of Operations, Maintenance Operations Section.

BASIC DIMENSIONS OF TRACTOR-SEMITRAILER VEHICLE

Figure 31-5.C

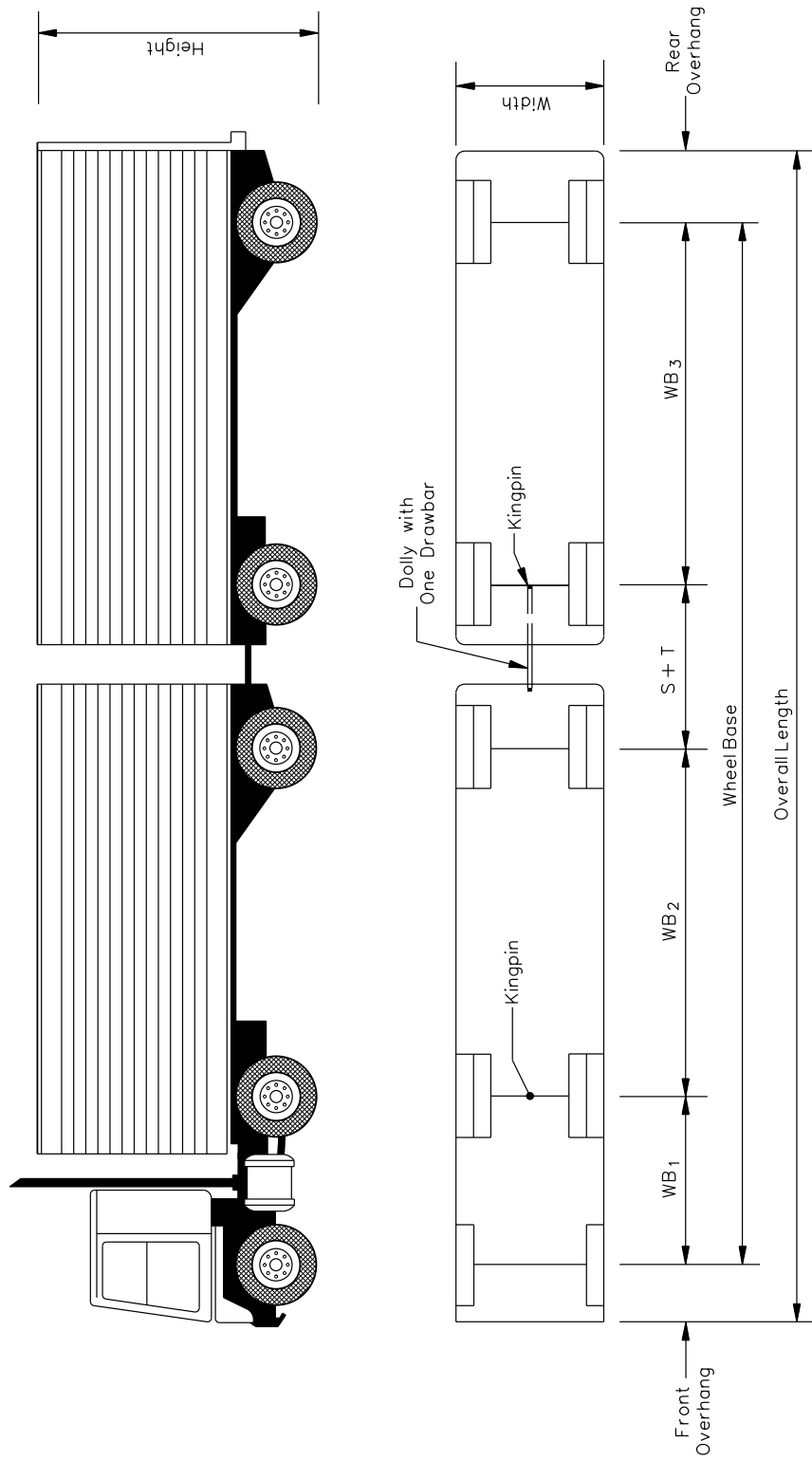

Note: For the legal dimensions of trucks allowed on Illinois highways, refer to information from the Central Bureau of Operations, Maintenance Operations Section.

BASIC DIMENSIONS OF TRACTOR-SEMITRAILER/TRAILER VEHICLE

Figure 31-5.D

The *BDE Manual* presents many specific design criteria for the accommodation of pedestrians as follows:

- Chapter 17 discusses pedestrian accommodation warrants, sidewalk location considerations, pedestrian networks, accommodations on structures, and crosswalks at both intersections and midblock locations.
- Chapter 36 discusses pedestrian accommodation at intersections.
- Chapter 48 discusses sidewalks.
- Chapter 55 discusses the considerations involved in safely accommodating pedestrians through and around work zones.
- Chapter 56 discusses pedestrian accommodation with traffic signals.
- Chapter 58 discusses accessibility criteria.

31-5.04 Bicyclists

Similar to pedestrians, bicyclists are an important element of the highway environment. Chapter 17 discusses the detailed design criteria for bicycle accommodation.

31-6 PROJECT SCOPE OF WORK

The project scope of work will reflect the basic intent of the highway project and will determine the overall level of highway improvement. This decision, in combination with the highway functional classification (see Chapter 43), will determine which criteria in the *Manual* apply to the geometric design of the project. Selection of the scope of work for a project should not be an arbitrary decision, but may be based on such engineering factors including, but not limited to, safety, functional classification, traffic volume, pavement condition, project cost, available funding, funding sources, etc. Note that cost alone should not be the single factor driving project scope.

The following provides general definitions for the project scopes of work, and it references the applicable chapters for determining the related design criteria, which are found in *Part V, "Highway Systems"*, for new construction, reconstruction, or 3R projects, or *Part VI, "Other Highway Design Elements"*, for 3P and SMART projects.

31-6.01 New Construction

Generally, new construction is defined as horizontal and vertical alignment on a new location. Typically, the overall project will have a significant length and will connect major termini, but may be comprised of several smaller contracts due to funding constraints, optimization for type of work, etc. Where an existing two-lane, two-way facility becomes a multilane facility with a rural-type median, the new median and proposed roadway are considered new construction. In addition, new construction also includes any intersection or interchange that falls within the project limits of a new highway mainline or is relocated to a new point of intersection. Freeways, expressways, and bypasses are typical new construction projects.

Because of the significant level of work and the up-front costs associated with a project on new alignment, a 20-year design period is utilized at minimum, and the highest order of design criteria are typically applied.

Chapters 44 through 48 present IDOT criteria for new construction.

31-6.02 Reconstruction

Reconstruction of an existing highway will typically include the addition of travel lanes and/or reconstruction of the existing horizontal and vertical alignment, widening of the roadway, and flattening side slopes, but the highway will remain essentially within the existing highway corridor. These projects will usually require some right-of-way acquisitions. The primary reasons for reconstructing an existing highway are because the facility cannot accommodate its current or future traffic demands, because the existing alignment or cross section is deficient, and/or because the service life of the pavement has been exceeded. In addition, any intersection that falls within the limits of a reconstruction project will be reconstructed as needed to meet policy requirements.

Because of the significant level of work for reconstruction, the design of the project generally will be determined by the criteria for new construction and based on a 20-year design period. However, some existing cross section elements may be allowed to remain in place.

Chapters 44 through 48 will apply to reconstruction projects.

31-6.03 3R Projects (Non-Freeways)

3R projects (resurfacing, restoration, and/or rehabilitation) on non-freeways are primarily intended to extend the service life of the existing facility and to enhance highway safety. In addition, 3R projects should make cost-effective improvements to the existing geometrics, where practical and where existing crash data analyses point to a need. 3R work on the mainline or at an intersection is typically completed within the existing alignment. However, right-of-way acquisition is sometimes justified for flattening of side slopes, changes in horizontal alignment, changes in vertical profile, turn lane additions, intersection radii upgrades, and safety enhancements such as culvert extensions and guardrail length of need.

The overall objective of a 3R non-freeway project is to perform work necessary to return the highway to a condition of acceptable structural and/or functional adequacy. 3R projects may include any number of the following types of improvements:

- providing pavement resurfacing, rehabilitation, and/or short sections of pavement reconstruction;
- providing lane and/or shoulder widening (without adding through lanes);
- adding a two-way, left-turn lane (TWLTL);
- providing intersection improvements (e.g., adding or lengthening turn lanes, improving turning radii, channelization, corner sight distance improvements);
- flattening a horizontal or vertical curve;
- adding auxiliary lanes (e.g., truck-climbing lane);
- converting an existing uncurbed urban street into a curbed street;
- widening and/or resurfacing parking lanes;
- upgrading at-grade railroad crossings;
- rehabilitating and/or widening existing bridges;
- upgrading guardrail and other roadside safety appurtenances to meet current criteria;
- adjusting the roadside clear zone;

- flattening side slopes;
- providing drainage improvements, including pump stations; and/or
- implementing improvements to meet the Department's accessibility criteria (e.g., sidewalks, sidewalk curb ramps).

Any of the above may also be an element of work for a reconstruction project. Chapter 49 presents IDOT criteria for the design of 3R non-freeway projects, including criteria that may be allowed to remain in place.

31-6.04 3R Projects (Freeways)

3R projects (resurfacing, restoration, and/or rehabilitation) on existing freeways are primarily intended to extend the service life of the existing facility and to enhance highway safety. In addition, these projects should make cost-effective improvements to the existing geometrics, where practical. 3R freeway projects may include any number of the following types of improvements:

- providing pavement resurfacing, rehabilitation, and/or short sections of pavement reconstruction;
- realigning or widening an existing ramp or modifying an existing interchange;
- lengthening existing acceleration or deceleration lanes at freeway entrances and exits;
- flattening a horizontal or vertical curve;
- adding auxiliary lanes (e.g., a truck-climbing lane);
- rehabilitating and/or widening existing bridges;
- upgrading guardrail and other roadside safety appurtenances to meet current criteria;
- adjusting the roadside clear zone;
- flattening side slopes; and/or
- providing drainage improvements, including pump stations.

Chapter 50 presents IDOT criteria for the design of 3R freeway projects, including criteria that may be allowed to remain in place.

31-6.05 3P Projects

The Pavement Preservation Program (3P) is a category of projects consisting of repairing and resurfacing existing paved roadways on the State highway system (excluding Interstates). The

intent of the program is to cost effectively address specific pavement deficiencies. Besides marked non-interstate routes, unmarked roads including any urban minor arterials (without the need for a jurisdictional transfer) and collector and local roads (as part of a jurisdictional transfer) are eligible to be resurfaced under the program, given certain existing pavement condition criteria are met. The purpose of the 3P Program is to rehabilitate existing roadways and thus extend the roadway's service life. Typically the scope of a 3P project includes only ancillary items beyond resurfacing of the pavement and shoulder and does not include geometric improvements.

3P projects can sometimes provide a low-cost opportunity to reallocate the roadway width to better accommodate bicyclists. Bike lanes or shared lanes can be created by adjusting pavement marking. The possibility of removing traffic through lanes (a road diet) or parking lanes may also be investigated. Refer to Chapter 17 for further discussion.

Chapter 53 presents IDOT criteria for the selection and design of 3P projects.

31-6.06 SMART Projects

Surface Maintenance at the Right Time (SMART) is a category of projects with the intent of cost effectively extending the service life of the pavement without significantly increasing its structural capacity. If the SMART overlay is applied at the correct time, it can delay serious pavement distresses, thereby extending the life of the pavement, and decreasing overall life cycle costs. Typically the scope of a SMART project includes only ancillary items beyond resurfacing of the pavement lanes and does not include geometric improvements.

The selection criteria for SMART projects are presented in Figure 52-5.B. SMART overlays are not allowed on Interstate highways or bare PCC pavements. Four-lane routes, with the exception of Interstates, may be considered if the two-lane truck and patching directional criteria presented in Figure 52-5.B are met. Also, consider ramps and unmarked narrow pavements that do not have excessive rutting or shoving for SMART projects.

Considerations related to bicyclist accommodation may be applied as noted for 3P projects above.

Chapter 52 presents IDOT criteria for the selection and design of SMART projects.

31-7 ADHERENCE TO DESIGN CRITERIA

Parts IV, V, and VI of the *BDE Manual* (Roadway Design Elements, Highway Systems, and Other Highway Design Elements, respectively) present a vast amount of design criteria for application on individual projects. In general, the designer is responsible for making every reasonable effort to meet these criteria in the project design. However, it will not always be practical to meet the criteria. Therefore, this section presents IDOT's procedures for the appropriate action when the design criteria are not met.

31-7.01 Department Intent

The general intent of the Illinois Department of Transportation is that all design criteria in Parts IV, V, and VI be met and that, wherever practical, the proposed design should exceed the lower criteria. In addition, where a range of values is presented, the designer should make every reasonable effort to provide a design that is near the desirable or preferred value. Also, the designer should pay special attention regarding the possible cumulative effects of using more than one minimum design criteria within a particular project's limits; analyze the effects the proposed design has on safety performance; and, when necessary, provide additional design features, if feasible, to mitigate a potential reduction in safety. The overall intent is to ensure that the Department will provide a highway system that meets the transportation needs of the State and provides a reasonable level of safety, comfort, and convenience for the traveling public.

31-7.02 Hierarchy of Design Criteria

The Department, in concert with 23 CFR 625, FHWA's May 5, 2016 policy memorandum on controlling criteria, and the FHWA/IDOT Stewardship and Oversight (S&O) Agreement, has established the following hierarchy of design criteria as they pertain to the potential for design exceptions (see Section 31-7.04 for information on the design exception submittal and approval process):

31-7.02(a) Level One Design Exceptions

Level One design exceptions involve the controlling design criteria established by FHWA, but only on the interstate system, pursuant to the S&O Agreement. When not met, Level One design exceptions require documentation and justification by the district, concurrence by BDE, and formal approval by FHWA. These criteria are judged to be those design elements that are the most critical indicators of an interstate highway's safety and overall serviceability. There are 10 controlling design criteria for interstate routes, per FHWA's May 5, 2016 policy memorandum on controlling criteria and the S&O Agreement. These 10 Level One criteria are listed in form BDE 3107, "Level One Design Criteria Checklist." The appropriate reference chapter of the BDE Manual has been listed along with each criterion on form BDE 3107.

31-7.02(b) Level Two Design Exceptions

Level Two design exceptions involve two distinct sub-sets, per the S&O Agreement. In addition to FHWA controlling design criteria for projects off the interstate system, Level Two design criteria are also additional design criteria identified by IDOT, over and above the FHWA controlling criteria, on both interstate and non-interstate projects. When not met, Level Two design exceptions require documentation and justification by the district and formal approval by BDE only. The additional IDOT criteria are other important indicators of a highway's safety and serviceability. The FHWA controlling design criteria and additional IDOT criteria have been integrated and listed in form BDE 3108, "Level Two Design Criteria Checklist." The appropriate reference chapter of the BDE Manual has been listed along with each criterion on form BDE 3108.

31-7.02(c) ADA Accessibility Criteria – Maximum Extent Practicable

Chapter 58 presents most of the accessibility criteria applicable to an IDOT project and references their sources, which include: the 2010 ADA Standards for Accessible Design, the Public Rights-of-Way Accessibility Guidelines, and the Illinois Accessibility Code. These codified standards and guidelines have the effect of law and as such, design exceptions in the traditional sense, are not possible. That being said, the standards do recognize that in certain situations (e.g. alterations of existing facilities) full compliance will not always be possible within the scope of the project. Where accessibility requirements cannot be fully met, the barriers to full compliance must be well documented as well as the measures taken to comply with the standards to the maximum extent practicable. See Section 31-7.04(b) for more information.

31-7.03 Design Criteria Checklists

The "Level One Design Criteria Checklist" (form BDE 3107) and "Level Two Design Criteria Checklist" (form BDE 3108) were created to ensure designers have considered the relevant design criteria and evaluated the need for design exceptions. The appropriate checklist must be completed for each new construction, reconstruction, or 3R project. The checklist is then included in the Phase I engineering report and becomes a part of the permanent project file. The results from the checklists should also be discussed at the district coordination meetings.

31-7.04 Design Exception Process

31-7.04(a) General Procedures

The design exception process applies to all capital improvement projects considered new construction, reconstruction, 3R, 3P, SMART, HSIP, etc.

Design exceptions are discussed at project coordination meetings held in each district. These meetings are scheduled monthly or bi-monthly, are attended by representatives from FHWA and BDE, and allow for a timely approval process. With sufficient notice in advance of the coordination meeting and with adequate justification, BDE and FHWA can typically inform the

district during the meeting if a design exception is denied or granted. In addition to presentation at a coordination meeting, design exceptions require the completion of form BDE 3100 "Design Exception Request – Project Identification" with attachments if needed. The approved Design Exception Request form then becomes part of the permanent project file. As an aide in filling out form BDE 3100, see Figure 31-7.A, "Guidelines for Completion of Design Exception Request – Project Identification."

The documentation for design exceptions shall be included with the coordination meeting agenda and submitted to BDE two weeks prior to the scheduled meeting. During coordination meetings, the district discusses the design details for each project; and, provides justification as to the need for design exceptions to the design criteria, when necessary. For projects on the interstate highway system that involve FHWA's controlling criteria, design exceptions (i.e., Level One) are evaluated for a determination by FHWA and BDE in accordance with the FHWA/IDOT Stewardship and Oversight Agreement. For projects on the interstate highway system that do not involve FHWA's controlling criteria, or for projects off the interstate highway system, design exceptions (i.e., Level Two) are evaluated for a determination by BDE.

The reason for design exceptions shall be clearly justified and documented. The justification may be presented by a combination of crash analysis, safety analysis, cost comparisons, level of social, environmental, and economic impacts, capacity analysis, and other relevant information as to the rationale and basis for the design exception. A benefit/cost analysis may also be included if it will help with the decision making process. Level One design exceptions may require the preparation of a report and a formal request to the FHWA for determination, or submittal of form BDE 3107, in addition to the completion of form BDE 3100.

All discussions and agreements reached at the coordination meeting and relevant to any Level One or Level Two design exception shall be documented by both minutes prepared each time the project is presented and the completed form BDE 3100. The documentation within the meeting minutes, or as an attachment to the minutes, and form BDE 3100 shall include the individual listing of each design exception, the location, the justification, and whether the design exception was approved or denied by BDE and, if necessary, FHWA. The minutes and form BDE 3100, in addition to form BDE 3107 and/or BDE 3108 on all new construction, reconstruction, or 3R projects, shall be included in the Phase I engineering report. Note that safety cannot be compromised through the design exception process to meet scope/schedule/budget.

If the district determines that a design change involving a design exception is required after the Phase I engineering report process is complete, the proposed design change and exception must be coordinated with BDE. In order for the Regional Field Engineer to make an informed determination, the district must prepare either a memo with attachments discussing the design change and exception, or discuss the proposed issue at a District coordination meeting. To expedite the process, if the issue is to be discussed at a coordination meeting, submit a short report addressing the change to the BDE Regional Field Engineer in advance of the meeting.

31-7.04(b) Procedures for Meeting ADA Accessibility Criteria to the Maximum Extent Practicable

The ADA accessibility criteria presented in Chapter 58 and the various Federal and State ADA standards are applicable whenever pedestrian access, circulation, or use is affected, or could be affected, by the project. As described in Section 58-1.01(b), newly constructed facilities and elements added to existing facilities must be fully compliant with the criteria. However, existing elements that are altered must comply with the criteria to the maximum extent practicable within the scope of the project. This typically means that alterations must also be fully compliant unless there are existing physical constraints or qualified historic facilities which make full compliance impracticable. The following steps are the procedure to go by when a feature does not fully meet accessibility guidelines, but will be built to the maximum extent practicable.

1. District Coordination Meetings. Any proposed element not able to be made fully compliant within the scope of the project shall be discussed at the district coordination meetings. The district shall complete form BDE 3101 "Maximum Extent Practicable" and attach any supporting documentation. This documentation shall be included with the coordination meeting agenda and submitted to BDE two weeks prior to the scheduled meeting. The BDE representative should be able to determine, following the presentation at the coordination meeting, whether or not the element is designed to the maximum extent practicable.
2. Documentation. In addition to the general procedures for documentation listed in Section 38-7.04(a), the district shall fully document its evaluation of the non-compliant element and must clearly demonstrate that compliance is not feasible. Furthermore, the district shall document what will be otherwise done to apply the ADA standards to the maximum extent practicable. The documentation in the maximum extent practicable request will vary on a case-by-case basis; however, cost is not a factor. The completed form BDE 3101 and any supporting documentation shall become part of the permanent project file. Include a copy of the completed form BDE 3101 with the District's inventory until the non-compliant element is improved to full compliance and removed from the transition plan.

Accessibility criteria must be fully considered in the initial scope of a project. As such, most, if not all, of the features in an alteration type of project should be able to be fully compliant and this is the Department's goal. In other words, if too many requests for a Maximum Extent Practicable determination are being sought for a project, it is likely the project's scope is too narrow and the scope must be re-evaluated.

31-7.04(c) Vertical Clearances Exceptions on the Interstate System

The integrity of the Interstate System for national defense purposes shall be maintained to meet AASHTO Policy as stated in A Policy on Design Standards - Interstate System. IDOT requires vertical clearances on new construction/reconstruction Interstate sections in rural areas and single routing through or around urban areas to be no less than 16 ft 09 in (5.1 m). The clear height of structures over other urban interstate routes shall not be less than 15 ft 00 in (4.5

meters). This clearance is required over the full roadway width (travel lanes and usable shoulders), including ramps and collector-distributor roadways within Interstate-to-Interstate interchanges.

The FHWA allows a minimum 16 ft 00 in (4.9 m) in rural areas and along the single routing in urban areas. The minimum vertical clearance in other urban areas shall be no less than 14 ft 00 in (4.3 m). The extra clearance IDOT requires allows for future overlays. The urban areas in Illinois where single routing occurs are:

- Peoria,
- Quad Cities,
- Metro-east St. Louis area, and
- the Chicago metropolitan area.

Maps of the single interstate route for these urban areas are shown in the figures in Section 44-6.

Design exceptions must be approved whenever the criteria are not met. These criteria apply whether it is a new construction project, a project that does not provide for correction of an existing substandard condition, or a project which creates a substandard condition at an existing structure.

There is a distinction between FHWA criteria and IDOT criteria for the vertical clearance over the Interstate. If the minimum clearances exceed those required by the FHWA, but are less than that required by IDOT, a design exception shall be presented as in Section 31-7.03(a) as a Level One design exception.

If the minimums required by the FHWA are not met, form BDE 3102 must be used to request approval for substandard vertical clearances over interstate routes. Form BDE 3102 will be filled out by the District and submitted to the Illinois Division of the FHWA. The FHWA will complete the "Date to SDDCTEA," "Response Requested by," and FHWA contact information and forward the completed form to the Surface Deployment and Distribution Command Transportation Engineering Agency (SDDCTEA) prior to taking any action on the design exception. If the SDDCTEA does not respond within 10 working days (after receipt by SDDCTEA), it can be concluded that the SDDCTEA does not have any concerns with the proposed exception. If comments are forthcoming, the FHWA and IDOT will consider mitigation to the extent feasible.

Coordination with SDDCTEA, as discussed above, is not required for interstates in urban areas with a minimum vertical clearance of 14 ft 00 in (4.3 m) and also served by a single interstate route, however IDOT policy must be considered.

PROJECT IDENTIFICATION FIELDS

Key Route: This should be the key route number for the facility, if it has one. Typically, this will be an FAI, FAP, FAU, or FAS number, e.g. FAP 341.

Marked Route/Road Name: This should be the interstate, state or U.S. route marking, if the route has one, e.g. Illinois Route 72, followed by the name the route is known as locally, if one exists. Typically, this will be a street, road, avenue or such, e.g. Higgins Road, Main Street.

Contract #: This should be state contract number associated with the project, if any, e.g. 60166.

State Job #: This should be a P-, D- or C- number assigned to the project, e.g. C-91-367-10.

Section: This should be a section number assigned to the project, e.g. 177-2-1A, 177-2B-1, 177-2VB-1.

County(ies): This should be any counties in which the project is located, e.g. Cook, Pike.

Municipality: This should be any municipalities in which the project located, e.g. Schaumburg, Moline.

Local Agency: This should be any local public agency, if it is a primary lead on the project, e.g. Village of Schaumburg.

LRS Section #: This should be the section number assigned to the project by the Bureau of Local Roads and Streets, e.g. 11-00237-10-WR.

Permit Applicant: This should be the name of any entity named as applicant for the Highway Permit associated with the work of the project. This can be a local agency or a private property owner, e.g. City of Rockford or Rubloff Development Group.

Permit #: This should be the number assigned to any associated Highway Permit by district staff, e.g. C-050658.

Project Limits: This should be the specific limits of the project for which an exception is being requested.

Project Length: This should be expressed in miles and feet, if possible.

Estimate of Cost: This should be the construction cost of the entire project for which the exception is being requested.

**GUIDELINES FOR COMPLETION OF FORM BDE 3100,
“DESIGN EXCEPTION REQUEST- PROJECT IDENTIFICATION”**

Figure 31-7.A
(1 of 6)

Design Year: This is the year of the conditions for which the project is being designed. For instance, the design year and construction year is typically 20 years in advance of the construction year for new construction/reconstruction projects.

Functional Classification: This should be the functional classification as described in BDE Manual Chapter 43 and shown on the Getting Around Illinois website at <http://www.gettingaroundillinois.com/gai.htm?mt=fc> - interstate, non-interstate freeway or expressway, other principal arterial, minor arterial, major collector, minor collector and local road or street. Please note that Strategic Regional Arterial (SRA) is not a functional classification, but a highway type.

Design Traffic: ADT: This should be the average daily traffic for the design year which appears in the field directly above.

Design Traffic: DHV: This should be the design hour traffic for the design year shown above for both the a.m. and p.m. weekday peaks. Non-weekday peak hour design volumes can be added, if appropriate.

Current Posted Speed: This should be the posted speed limit in the vicinity of the requested exception.

On the NHS System? This should indicate the route's presence, or lack thereof, on the National Highway System (NHS). Check applicable box. NHS status can be verified at <http://www.gettingaroundillinois.com/gai.htm?mt=fc#>.

Structure Numbers: Include the number of any structures included in the project.

Type of Project (Construction, Reconstruction, 3R, 3P, SMART, HSIP): This should be project categories as described in the BDE Manual Chapters 44 through 50, 52, and 53; and Safety Policy 1-06.

Brief Project Description: This should be a brief and concise, yet comprehensive, synopsis of the work to be undertaken for the project.

EXCEPTION DOCUMENTATION FIELDS

Level of Exception: Level One exceptions are the 13 controlling design criteria established by FHWA on the interstate system only, and noted on the "Level One Design Criteria Checklist" form BDE 3107. Exceptions to all other design criteria on the interstate and non-interstate system are considered to be Level Two, and noted on the "Level Two Design Criteria Checklist" form BDE 3108. Check the applicable box.

GUIDELINES FOR COMPLETION OF FORM BDE 3100, "DESIGN EXCEPTION REQUEST- PROJECT IDENTIFICATION"

Figure 31-7.A
(2 of 6)

Design Element for Which an Exception Is Requested: This should be the specific criterion for which the designer is requesting an exception. This should also not typically contain the location of that exception. Each form should have only one design criterion for which an exception is being requested, e.g. guardrail length of need; turn lane taper length; level-of-service. Examples of what this should NOT be: encroachment; RT movements; painted median; isolated ditch cleaning; outside roadway ditch. If there is more than one location which requires the exception, this should be noted in the field, e.g. level-of-service (5).

Design Element Policy Value: This should be the specific value of the criterion noted in the field above from the appropriate design document. For instance, the criterion for which an exception could be requested is turn lane storage at a signalized intersection. The BDE Manual Section 36-3.02.b dictates such minimum storage based on a red-time equation, as an example, say 400 feet. Also, the specific design document for the policy value should also be noted in this field to facilitate review of the form and its associated exception. The proper entry for this field in this case would be: 400 feet, BDE Manual Section 36-3.02.b.

Proposed Design Element Value: This should be the proposed value of the design feature for which the exception is being requested. The designer should arrive at this value by weighing all the project constraints, impacts and costs to optimize the feature's value. For the example in the field above, the entry could be "300 feet". Each form should have only one value of a design feature for which an exception is being requested.

Location(s) of Exception: This should include any and all locations of the specific exception noted above.

Crash History and Potential of Exception Location(s): This should be a very brief summary, and should always include the presence of any Five Percent Report Location, or lack thereof. Also, note any specific incidents which might directly affect the design feature for which an exception is being requested.

Cost of Using Policy Value: This should be the cost which would be required if the policy-stipulated design feature value would be used on all locations noted above.

Cost of Using Proposed Exception Value: This should be the cost if the design feature value for which the exception is being requested would be used on all locations noted above on the project. The purpose of this field and the one directly above is to determine both the difference in cost between the two design feature values, as well as that cost compared to the total construction cost of the project.

Impacts Other Than Cost, of Using Policy Value: This should comprise any considerations other than strictly monetary which compelled the designer to choose the excepted design feature value. Typically, this includes impacts to historic or recreational properties or the requirement to increase project scope to accommodate the policy-stipulated design feature value. If there are none, the appropriate response is N/A.

**GUIDELINES FOR COMPLETION OF FORM BDE 3100,
"DESIGN EXCEPTION REQUEST- PROJECT IDENTIFICATION"**

Figure 31-7.A
(3 of 6)

Proposed Mitigation to Address Exception: This should include any measures added to the project to alleviate the potential effects of the use of the excepted design value. This typically includes augmented traffic control, street lighting or other relatively low cost improvements. If there are none, the appropriate response is N/A.

Geometric Compatibility with Adjacent Sections: This is to ensure that the cross-section of the project containing the excepted design feature is consistent with those into which it will match at its termini. The appropriate text for this field is “Compatible.” If this is not the case, the designer should re-evaluate the project’s proposed design choices.

Potential Effects on Other Design Elements: This should contain any conceivable impacts to other project design features resulting from the choice of the policy-stipulated design feature value versus the excepted feature value. For instance, there are cases where the choice of a compliant policy value for a turn lane taper would require reducing the needed storage for that lane. Or, establishing both full storage and taper lengths at that location might require relocation of the intersection with consequent effects on the storage and taper lengths of the opposing approach. If there are none, the appropriate response is N/A.

Potential Impacts on Mobility or Traffic Operations: This should contain any possible effects the choice of the excepted value might have on facility safety, capacity or level-of-service. For instance, the choice of an excepted value for turn lane storage could increase queues sufficiently on that approach such that traffic regularly does not clear during a single traffic signal cycle, with consequent reduction in capacity and level-of-service. This excepted value could also possibly increase the likelihood of rear-end crashes on that approach. If there are none, the appropriate response is N/A.

Summary of Justification for Exception: This should be a brief and concise synopsis of why the excepted value would be the best choice given the totality of the pertinent circumstances.

Coordination Meeting Date: This should be the date of the meeting at which the exception was presented to BDE/FHWA representatives and at which the exception was approved or denied. Alternatively, if the exception was processed by e-mail or phone, this should be the date the exception was requested.

Prepared By: This should be the name of the individual who actually filled out the form and did the requisite analysis for the exception. If the person is employed by an outside entity, such as a consulting firm or local agency, that should also be noted in this field, e.g. John Doe, ABC Consulting.

Date: This should be the date the form was completed or revised for final approval or denial.

**GUIDELINES FOR COMPLETION OF FORM BDE 3100,
“DESIGN EXCEPTION REQUEST- PROJECT IDENTIFICATION”**

Figure 31-7.A
(4 of 6)

PAVEMENT/RESURFACING EXCEPTIONS FIELDS

New Pavement, Pavement Widening, Resurfacing: The appropriate box should be checked, based on the scope of the project in question. All Pavement/Resurfacing Exceptions fields should be blank or contain N/A, unless the exception requested is pavement-related only.

Design Period/Expected Service Life: This should be the result from the design procedures outlined in the BDE Manual Chapters 52, 53, and 54.

Design Year: This should be the result of the design procedures outlined in the BDE Manual Chapters 52, 53, and 54.

Structural Design Traffic: This should be the result of the design procedures outlined in the BDE Manual Chapters 52, 53, and 54.

%PV, %SU, and %MU: This should be the result of the design procedures outlined in the BDE Manual Chapters 52, 53, and 54.

Design Element Policy Value: This should be the specific criterion for which the designer is requesting an exception, from the BDE Manual Chapters 52, 53, and 54.

Proposed Design Element Value: This should be the result of the design procedures outlined in the BDE Manual Chapters 52, 53, and 54.

Location(s) of Exception: This should include any and all locations of the specific exception.

Cost of Using Policy Value: This should be the cost which would be required if the policy-stipulated design feature value would be used on all locations noted above.

Cost of Using Proposed Exception Value: This should be the cost which would be required if the design feature value for which the exception is being requested would be used on all locations noted above on the project. The purpose of this field and the one directly above is to determine both the difference in cost between the two design feature values, as well as that cost compared to the total construction cost of the project.

Summary of Justification: This should be a brief and concise synopsis of why the excepted value would be the best choice given the totality of the pertinent circumstances.

Prepared By: This should be the name of the individual who actually filled out the form and did the requisite analysis for the exception. If the person is employed by an outside entity, such as a consulting firm or local agency, that should also be noted in this field, e.g. John Doe, ABC Consulting.

Date: This should be the date the form was completed or revised for final approval or denial.

GUIDELINES FOR COMPLETION OF FORM BDE 3100, “DESIGN EXCEPTION REQUEST- PROJECT IDENTIFICATION”

Figure 31-7.A
(5 of 6)

APPROVAL FIELDS

BDE Approval Date: This is the date on which the BDE staff approves the exception. This date may or may not coincide with a date in the Coordination Meeting Date field, from above on the form.

FHWA Approval Date: This is the date on which the FHWA staff approves the exception. Such exceptions are granted pursuant to the BDE Manual Section 31-7.04 and the department's stewardship and oversight agreement with FHWA. This date may or may not coincide with a date in the Coordination Meeting Date field, from above on the form.

GENERAL

Separate forms should be completed for each specific exception. For instance, say the level-of-service criterion for a given location on the project is "C". If the designer determines the best choice for actual design for the project is "D" at the same location, or for the entire project. This will require completion of a single BDE 3100 form. If it happens that precisely the same exception to precisely the same design criterion occurs on other places on the project, those exceptions may be added to this form. This should then be duly noted in the Location(s) of Exception and Design Element for Which an Exception Is Requested fields as previously discussed.

Conversely, say a designer requests an exception for a Turn Lane Storage value of 100 feet. The BDE Manual dictates a minimum value of 135 feet. This exception will require one BDE 3100 form. Say the designer has a similar exception to the 135 feet criterion, but it is 90 feet, not 100 feet as in the first exception. This second exception would require a second BDE 3100 form because the exception is not precisely the same as that requested in the first exception form.

If a request is for an exception to a geometric or drainage design criterion, all fields in the areas of Project Identification and Exception Documentation should be filled. If a specific field does not apply, it should be completed with N/A. In such cases, all fields in the area of Pavement/Resurfacing Exceptions should be left blank.

If a request is for an exception to a pavement or resurfacing design criterion, all fields in the area of Pavement/Resurfacing Exceptions should be filled. If a specific field does not apply, it should be completed with N/A. In such cases, all fields in the area of Exception Documentation should be left blank. Also in such cases, all fields in the areas of Project Identification should be filled. If one of those specific fields does not apply, it should be completed with N/A.

GUIDELINES FOR COMPLETION OF FORM BDE 3100, "DESIGN EXCEPTION REQUEST- PROJECT IDENTIFICATION"

Figure 31-7.A
(6 of 6)

31-8 REFERENCES

1. *A Policy on Geometric Design of Highways and Streets*, AASHTO, 2011.
2. *Highway Capacity Manual 2010*, Transportation Research Board, 2010.
3. NCHRP Report 400, *Determination of Stopping Sight Distances*, Transportation Research Board, 1997.
4. *Stopping Sight Distance for Large Trucks*, TRR 1208, Transportation Research Board, 1989.
5. Report No. FHWA-TO-81-1, *A User's Guide to Positive Guidance* (2nd Edition), FHWA, 1981.
6. *Manual on Uniform Traffic Control Devices*, FHWA, ATSSA, AASHTO, and ITE, 2009.
7. Martin, S.F.J., *Design Exceptions: Legal Aspects*, TRR 1445, Transportation Research Board, 1994.
8. *A Policy on Design Standards – Interstate System*, AASHTO, 2005.

Chapter Thirty-two
HORIZONTAL ALIGNMENT

BUREAU OF DESIGN AND ENVIRONMENT MANUAL

Chapter Thirty-two
HORIZONTAL ALIGNMENT

Table of Contents

<u>Section</u>	<u>Page</u>
32-1 DEFINITIONS	32-1.1
32-2 HORIZONTAL CURVES	32-2.1
32-2.01 Types of Horizontal Curves	32-2.1
32-2.01(a) General	32-2.1
32-2.01(b) Simple Curves	32-2.1
32-2.01(c) Compound Curves	32-2.1
32-2.01(d) Spiral Curves	32-2.1
32-2.01(e) Reverse Curves	32-2.2
32-2.01(f) Broken-Back Curves	32-2.2
32-2.02 General Theory	32-2.3
32-2.02(a) Ball-Bank Indicator	32-2.3
32-2.02(b) Basic Curve Equation	32-2.4
32-2.02(c) Theoretical Approaches	32-2.4
32-2.02(d) Superelevation	32-2.5
32-2.02(e) Side Friction	32-2.5
32-2.02(f) Distribution of Superelevation and Side Friction	32-2.5
32-2.03 Minimum Radii	32-2.7
32-2.04 Maximum Deflection Without Curve	32-2.7
32-2.05 Minimum Length of Curve	32-2.7
32-3 SUPERELEVATION DEVELOPMENT (OPEN ROADWAY CONDITIONS)	32-3.1
32-3.01 Superelevation Rates	32-3.1
32-3.01(a) Maximum Superelevation Rate	32-3.1
32-3.01(b) Superelevation Tables	32-3.1
32-3.01(c) Minimum Radii Without Superelevation	32-3.1
32-3.02 Transition Lengths	32-3.8
32-3.02(a) Two-Lane Highways	32-3.8
32-3.02(b) Multilane Highways	32-3.14
32-3.02(c) Application of Transition Length	32-3.16
32-3.03 Axis of Rotation	32-3.17
32-3.03(a) Two-Lane, Two-Way Highways	32-3.17

Table of Contents

(Continued)

<u>Section</u>		<u>Page</u>
	32-3.03(b) Multilane Divided Highways	32-3.18
	32-3.03(c) Multilane Highways with Narrow/Flush Medians.....	32-3.18
32-3.04	Shoulder Superelevation	32-3.18
	32-3.04(a) Shoulder (High Side of Curve)	32-3.19
	32-3.04(b) Shoulder (Low Side of Curve).....	32-3.20
32-3.05	Compound Curves.....	32-3.20
	32-3.05(a) Case I.....	32-3.20
	32-3.05(b) Case II.....	32-3.20
	32-3.05(c) Multilane Highways	32-3.21
32-3.06	Reverse Curves	32-3.21
32-3.07	Bridges	32-3.22
32-3.08	Typical Superelevation Figures	32-3.23
32-3.09	Examples.....	32-3.29
32-4	HORIZONTAL SIGHT DISTANCE.....	32-4.1
	32-4.01 Sight Obstruction (Definition).....	32-4.1
	32-4.02 Length > Sight Distance	32-4.1
	32-4.02(a) Stopping Sight Distance (SSD).....	32-4.1
	32-4.02(b) Other Sight Distance Criteria	32-4.4
	32-4.02(c) Entering/Exiting Portions (Typical Application)	32-4.4
	32-4.03 Length < Sight Distance	32-4.4
	32-4.04 Application	32-4.6
	32-4.05 Longitudinal Barriers.....	32-4.6
	32-4.06 Compound Curves.....	32-4.8
32-5	DESIGN CONTROLS	32-5.1
32-6	MATHEMATICAL DETAILS FOR HORIZONTAL CURVES	32-6.1
32-7	CURVE DATA	32-7.1
	32-7.01 Rounding	32-7.1
	32-7.02 Chord Distances	32-7.2
32-8	REFERENCES.....	32-8.1

Chapter Thirty-two

HORIZONTAL ALIGNMENT

Chapter 32 presents IDOT criteria for the design of horizontal alignment elements. This includes horizontal curvature, superelevation, sight distance around horizontal curves, and mathematical computations. Chapter 32 presents the information on horizontal alignment that has an application to several functional classes of highway. Where a horizontal alignment treatment only applies to a specific highway type, Part V, Design of Highway Types, presents this information. For example:

- Chapter 48 discusses horizontal alignment for low-speed urban streets ($V \leq 45$ mph (70 km/hr)).
- Each of the functional classification chapters in Part V presents typical superelevated sections.

32-1 DEFINITIONS

This Section presents definitions for basic elements of horizontal alignment. Section 32-6 presents definitions and illustrations for mathematical details for horizontal curves (e.g., deflection angle (Δ), point of curvature (PC)).

1. Axis of Rotation. The line about which the pavement is revolved to superelevate the roadway. This line will maintain the normal highway profile throughout the curve.
2. Broken-Back Curves. Closely spaced horizontal curves with deflection angles in the same direction with an intervening, short tangent section (less than 1500 ft (500 m)).
3. Compound Curves. A series of two or more simple curves with deflections in the same direction immediately adjacent to each other.
4. Low-Speed Urban Streets. All streets within urbanized or small urban areas with a design speed of 45 mph (70 km/hr) or less.
5. Maximum Side Friction (f_{\max}). Limiting values selected by AASHTO for use in the design of horizontal curves. The designated f_{\max} values represent a threshold of driver discomfort and not the point of impending skid.
6. Maximum Superelevation (e_{\max}). The maximum rate of superelevation (e_{\max}) is an overall superelevation control used on a widespread basis. Its selection depends on several factors including climatic conditions, terrain conditions, type of area (rural or urban), and highway functional classification.

7. Normal Crown (NC). The typical cross section on a tangent section of roadway (i.e., no superelevation).
8. Open Roadway Conditions. Rural facilities for all design speeds and urban facilities with a design speed ≥ 50 mph (80 km/hr).
9. Relative Longitudinal Slope. For superelevation transition sections on two-lane facilities, the relative gradient between the centerline profile grade and edge of traveled way.
10. Remove Adverse Crown (RC). A superelevated roadway section that is sloped across the entire traveled way in the same direction and at a rate equal to the cross slope on the tangent section (typically, 3/16"/ft or 1/4"/ft (1.5% or 2%)).
11. Reverse Curves. Two simple curves with deflections in opposite directions that are joined by a relatively short tangent distance or that have no intervening tangent (i.e., the PT and PC are coincident).
12. Side Friction (f). The interaction between the tire and the pavement surface to counterbalance, in combination with the superelevation, the centrifugal force or lateral acceleration of a vehicle traversing a horizontal curve.
13. Simple Curves. Continuous arcs of constant radius that achieve the necessary highway deflection without an entering or exiting transition.
14. Spiral Curves. A transitional curve where the rate of curvature begins at $R = \infty$ (tangent) and gradually decreases to R , which is the curvature of a simple curve.
15. Superelevation (e). The amount of cross slope or "bank" provided on a horizontal curve to counterbalance, in combination with the side friction, the centrifugal force of a vehicle traversing the curve.
16. Superelevation Rollover. The algebraic difference (A) between the superelevated travel lane slope and shoulder slope on the high side of a horizontal curve.
17. Superelevation Transition Length. The distance required to transition the roadway from a normal crown section to the design superelevation rate. Superelevation transition length is the sum of the tangent runout (TR) and superelevation runoff (L) distances:
 - a. Tangent Runout (TR). Tangent runout is the distance needed to change from a normal crown section to a point where the adverse cross slope of the outside lane or lanes is removed (i.e., the outside lane(s) is level).
 - b. Superelevation Runoff (L). Superelevation runoff is the distance needed to change the cross slope from the end of the tangent runout (adverse cross slope removed) to a section that is sloped at the design superelevation rate (e).

32-2 HORIZONTAL CURVES

Horizontal curves are, in effect, transitions between two tangents. These deflectional changes are necessary in virtually all highway alignments to avoid impacts on a variety of field conditions (e.g., right-of-way, natural features, man-made features).

32-2.01 Types of Horizontal Curves

32-2.01(a) General

This section discusses the several types of horizontal curves that may be used to achieve the necessary roadway deflection. For each type, the discussion briefly describes the curve and presents the IDOT usage of the curve type. Section 32-6 presents detailed figures for the basic curve types (simple, compound, and spiral), and it presents the necessary details and mathematical equations for the typical applications of horizontal curves to highway alignment.

32-2.01(b) Simple Curves

Simple curves are continuous arcs of constant radius that achieve the necessary roadway deflection without an entering or exiting taper. The radius (R) defines the circular arc that a simple curve will transcribe. All angles and distances for simple curves are computed in a horizontal plane.

Because of their simplicity and ease of design, survey, and construction, IDOT typically uses the simple curve on highways.

32-2.01(c) Compound Curves

Compound curves are a series of two or more simple curves with deflections in the same direction. IDOT uses compound curves on highway mainline only to meet field conditions (e.g., to avoid obstructions that cannot be relocated) where a simple curve is not applicable and a spiral curve normally would not be used. Where a compound curve is used on a highway mainline, the radius of the flatter circular arc (R_1) should not be more than 50% greater than the radius of the sharper circular arc (R_2). In other words, $R_1 \leq 1.5 R_2$.

Chapter 36 discusses the use of compound curves for intersections (e.g., for curb radii, for turning roadways). Chapter 37 discusses the use of compound curves on interchange ramps.

32-2.01(d) Spiral Curves

Spiral curves provide an entering transition into a simple curve with a variable rate of curvature along its layout. As an option to a simple curve, a restricted horizontal alignment and high-

speed conditions may be conducive to the introduction of a spiral curve. Figure 32-2.A presents the guidelines for the use of spiral curves under these conditions. The parts of a spiral curve may be calculated with the use of the Department's approved computer software.

32-2.01(e) Reverse Curves

Reverse curves are two simple curves with deflections in opposite directions that are joined by a relatively short tangent distance. In rural areas, a minimum of 500 ft (150 m) should be provided between the PT and PC of the two curves for appearance. Superelevation development for reverse curves requires special attention. This is discussed in Section 32-3.

32-2.01(f) Broken-Back Curves

Broken-back curves are closely spaced horizontal curves with deflection angles in the same direction with an intervening, short tangent section (less than 1500 ft (500 m) from PT to PC). Avoid broken-back curves on highway mainline because of the potential for confusing a driver, problems with superelevation development, and the unpleasant view of the roadway that is created. Instead, use a single, flat simple curve or, if necessary, a compound curve.

US Customary		Metric	
Design Speed (mph)	Maximum Radius (ft)	Design Speed (km/hr)	Maximum Radius (m)
50	1265	80	379
55	1530	90	480
60	1820	100	592
65	2140	110	716
70	2480	120	852
75	2846		

Notes:

1. *Spiral curves are typically only used on new construction/reconstruction projects on freeways, expressways, and rural principal arterials.*
2. *Do not use spiral curves on bridges.*
3. *The benefits of spiral curve transitions are likely to be negligible for larger radii.*
4. *Maximum radius for use of a spiral is based on a minimum lateral acceleration rate of 4.25 ft/s² (1.3 m/s²).*

GUIDELINES FOR SPIRAL CURVES

Figure 32-2.A

32-2.02 General Theory

This section summarizes the theoretical basis for the design of horizontal curves. For more information, the designer should refer to the latest edition of *AASHTO A Policy on Geometric Design of Highways and Streets*.

32-2.02(a) **Ball-Bank Indicator**

When a vehicle moves in a circular path, it is forced radially outward by centrifugal force. Figure 32-2.B illustrates the dynamics of a vehicle negotiating a horizontal curve, and it presents the geometry of the ball-bank indicator. This is a device that can be mounted on a vehicle in motion. The ball-bank reading indicates the combined effect of the body roll angle (ρ), centrifugal force angle (θ), and superelevation angle (ϕ). The centrifugal force is counterbalanced by the vehicle weight component related to the roadway superelevation or by the side friction developed between tires and surface or by a combination of the two.

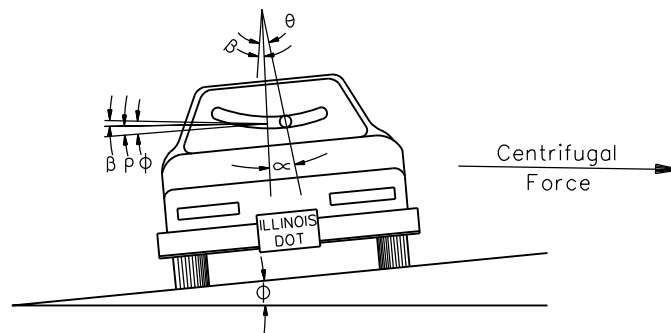

- α = *Ball-bank indicator angle*
- ρ = *Body roll angle*
- θ = *Centrifugal force angle*
- ϕ = *Superelevation angle*
- β = $\phi - \rho$

GEOMETRY FOR BALL-BANK INDICATOR

Figure 32-2.B

32-2.02(b) Basic Curve Equation

The point-mass formula is used to define vehicular operation around a curve. Where the curve is expressed using its radius, the basic equation for a simple curve is:

$$R = \frac{V^2}{15(e + f)} \quad \text{(US Customary) Equation 32-2.1}$$

$$R = \frac{V^2}{127(e + f)} \quad \text{(Metric) Equation 32-2.1}$$

where:

R	=	Radius of curve, ft (m)
e	=	Superelevation rate, decimal
f	=	Side-friction factor, decimal
V	=	Vehicular speed, mph (km/hr)

32-2.02(c) Theoretical Approaches

Establishing horizontal curvature criteria requires a determination of the theoretical basis for the various factors in the basic curvature equation (Equation 32-2.1). These include the set of side-friction factor (f) values and the distribution method between side friction and superelevation. The theoretical basis will be one of the following:

1. Open-Roadway Conditions. Open-roadway conditions apply to all rural facilities and to urban facilities where the design speed (V) \geq 50 mph (80 km/hr). Open suburban highways may be designed for open roadway conditions if there is a good potential for such a highway becoming closed suburban in 10-15 years. The theoretical basis for horizontal curvature assuming open-roadway conditions includes:
 - relatively low side-friction factors (i.e., a relatively small level of driver discomfort; see Section 32-2.02(e)); and
 - the use of AASHTO Method 5 to distribute side friction and superelevation (see Section 32-2.02(f)).
2. Low-Speed Urban Streets. Low-speed urban streets are defined as streets within an urban or urbanized area where the design speed (V) \leq 45 mph (70 km/hr). Chapter 48 presents the detailed criteria for horizontal alignment design on these facilities. The theoretical basis for horizontal curvature assuming low-speed urban street conditions includes:
 - relatively high side-friction factors to reflect a high level of driver acceptance of discomfort (see Section (32-2.02(e)); and
 - the use of AASHTO Method 2 to distribute side friction and superelevation (see Section 32-2.02(f)).

3. Turning Roadway Conditions. Turning roadway conditions typically apply to roadways at intersections. See Chapter 36. The theoretical basis for horizontal curvature assuming turning roadway conditions includes:
 - relatively high side-friction factors to reflect a higher level of driver acceptance of discomfort (see Section 32-2.02(e)); and
 - a range of acceptable superelevation rates for combinations of curve radius and design speed to reflect the need for flexibility to meet field conditions for turning roadway design.

32-2.02(d) Superelevation

Superelevation allows a driver to negotiate a curve at a higher speed than would otherwise be comfortable. Superelevation and side friction work together to offset the outward pull of the vehicle as it traverses the horizontal curve. In highway design, it is necessary to establish limiting values of superelevation (e_{\max}) based on the operational characteristics of the facility. Section 32-3 discusses e_{\max} values for open-roadway conditions on new construction/reconstruction projects.

32-2.02(e) Side Friction

AASHTO has established limiting side-friction factors (f) for various design speeds; see Figure 32-2.C. It is important to realize that the f values used in design represent a threshold of driver discomfort and not the point of impending skid. As indicated in Figure 32-2.C, different sets of f values have been established for different operating conditions; see Section 32-2.02(c). The basis for the distinction is that drivers will accept different levels of discomfort for different operational conditions.

32-2.02(f) Distribution of Superelevation and Side Friction

As discussed above, the minimum radius is based on the e_{\max} and f_{\max} that apply to the facility. For curvature flatter than the minimum, a methodology must be applied to distribute superelevation and side friction for a given radius and design speed. The following describes the distribution methods:

1. Open-Roadway Conditions. Superelevation and side friction are distributed by AASHTO Method 5, which allows e and f to gradually increase in a curvilinear manner up to e_{\max} and f_{\max} . This method yields superelevation rates for which the superelevation counteracts nearly all centrifugal force at the average running speed and, therefore, considerable side friction is available for those drivers who are traveling near or above the design speed. Section 32-3 presents the superelevation rates which result from the use of Method 5.

2. Low-Speed Urban Streets. Superelevation and side friction are distributed by AASHTO Method 2, which allows f to increase up to f_{max} before any superelevation is introduced. The practical effect of AASHTO Method 2 is that superelevation is rarely warranted on low-speed urban streets ($V \leq 45$ mph (70 km/hr)). Chapter 48 presents the superelevation rates which result from the use of Method 2. For this method of distribution, the superelevation rates may be calculated directly from Equation 32-2.1 using $f = f_{max}$.

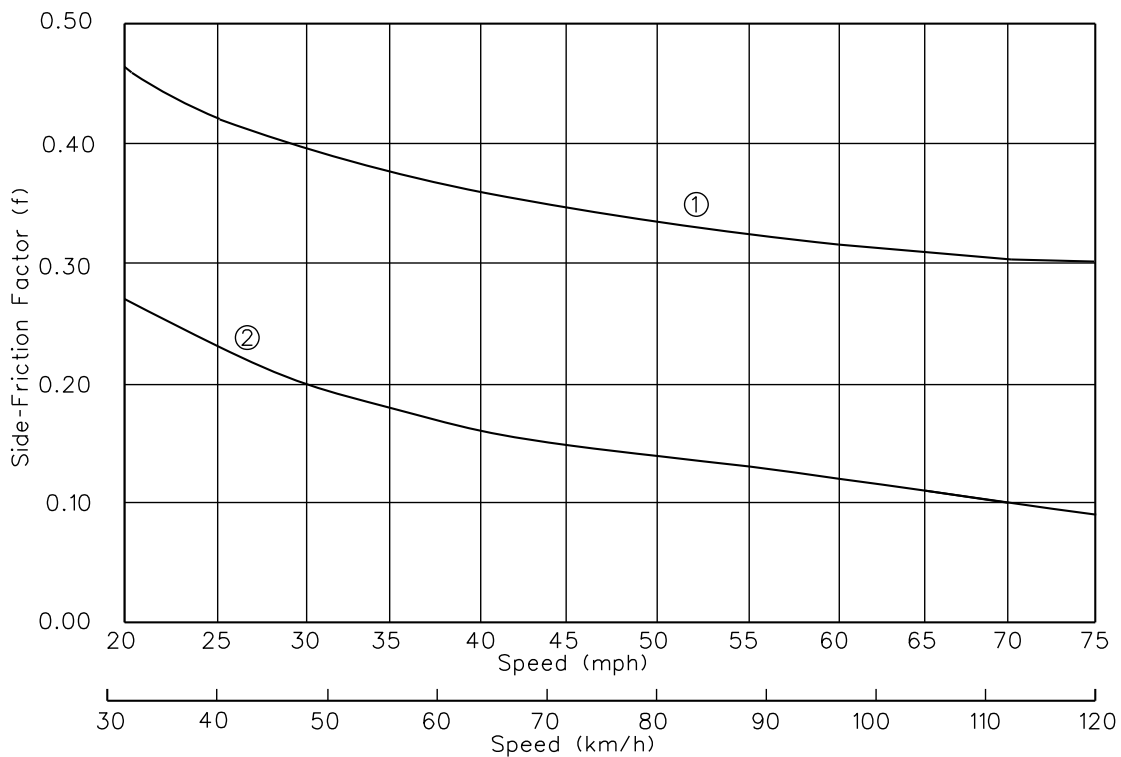

- ① Estimated point of impending skid assuming smooth tires and wet PCC pavement.
- ② Side-friction factors for design.

COMPARISON OF SIDE-FRICTION FACTORS (f)

Figure 32-2.C

32-2.03 Minimum Radii

The minimum radii is calculated from Equation 32-2.1 using the applicable values of e_{\max} and f_{\max} . In most cases, the designer should avoid the use of minimum radii because this results in the use of maximum superelevation rates. These rates are not desirable because the highway facility must accommodate vehicles traveling over a wide range of speeds. This is particularly true in Illinois where the entire State is subject to ice and snow, and the rate of superelevation should preclude vehicles that are stopped or traveling slowly from sliding down the cross slope when the pavement is icy. Figures 32-2.D ($e_{\max} = 8.0\%$), 32-2.E ($e_{\max} = 6.0\%$), and 32-2.F ($e_{\max} = 4.0\%$) present the minimum radii for open-roadway conditions.

32-2.04 Maximum Deflection Without Curve

It may be appropriate to omit a horizontal curve where very small deflection angles are present. As a guide, the designer may retain deflection angles of about 1° or less (urban) and $0^\circ 15'$ or less (rural) on the highway mainline. For these angles, the absence of a horizontal curve should not affect aesthetics.

32-2.05 Minimum Length of Curve

For small deflection angles, horizontal curves should be sufficiently long to avoid the appearance of a kink. For aesthetics, a minimum 550 ft (170 m) length of curve for a 5° central angle will eliminate the sense of abruptness for speeds of 75 mph (120 km/hr). For lower design speeds, however, a 550 ft (170 m) minimum length of curve is not required to eliminate the sense of abruptness, and this length would impose undue requirements on the horizontal curvature. The length of curve required to permit superelevation transition at a speed of 30 mph (50 km/hr) is approximately 100 ft (30 m) at $e_{\max} = 8.0\%$. Assuming 100 ft (30 m) for 30 mph (50 km/hr) and 550 ft (170 m) for 75 mph (120 km/hr), Figure 32-2.G is produced by providing logical increments for minimum length of curve for a 5° central angle for the intermediate design speeds.

Where the central angle is less than 5° , the minimum length of curve may be less than the values in Figure 32-2.G. Figure 32-2.H provides approximate adjustments for smaller deflection angles.

For central deflection angles more than 5° , the radius should be used to calculate the length of curve using the following equation:

$$L = \frac{2\pi R\Delta}{360} \quad \text{Equation 32-2.2}$$

where: L = length of curve, ft (m)
 Δ = deflection angle, degrees
R = radius of curve, ft (m)

US Customary			Metric		
Design Speed, V (mph)	f _{max} (for comfort)	Minimum Radii, R _{min} * (ft)	Design Speed, V (km/hr)	f _{max} (for comfort)	Minimum Radii, R _{min} * (m)
20	0.27	76	30	0.28	20
25	0.23	134	40	0.23	41
30	0.20	214	50	0.19	73
35	0.18	314	60	0.17	113
40	0.16	444	70	0.15	168
45	0.15	587	80	0.14	229
50	0.14	758	90	0.13	304
55	0.13	960	100	0.12	394
60	0.12	1200	110	0.11	501
65	0.11	1480	120	0.09	667
70	0.10	1810			
75	0.09	2210			

MINIMUM RADII
(e_{max} = 8.0%, Open-Roadway Conditions)

Figure 32-2.D

US Customary			Metric		
Design Speed, V (mph)	f _{max} (for comfort)	Minimum Radii, R _{min} * (ft)	Design Speed, V (km/hr)	f _{max} (for comfort)	Minimum Radii, R _{min} * (m)
20	0.27	81	30	0.28	21
25	0.23	144	40	0.23	43
30	0.20	231	50	0.19	79
35	0.18	340	60	0.17	123
40	0.16	485	70	0.15	184
45	0.15	643	80	0.14	252
50	0.14	833	90	0.13	336
55	0.13	1060	100	0.12	437
60	0.12	1330	110	0.11	560
65	0.11	1660	120	0.09	756
70	0.10	2040			
75	0.09	2500			

MINIMUM RADII
(e_{max} = 6.0%, Open-Roadway Conditions)

Figure 32-2.E

* (US Customary) $R_{min} = \frac{V^2}{15(e_{max} + f_{max})}$; values for design have been rounded to the nearest 1 ft.

* (Metric) $R_{min} = \frac{V^2}{127(e_{max} + f_{max})}$; values for design have been rounded to the nearest 1 m.

US Customary			Metric		
Design Speed, V (mph)	f_{max} (for comfort)	Minimum Radii, R_{min}^* (ft)	Design Speed, V (km/hr)	f_{max} (for comfort)	Minimum Radii, R_{min}^* (m)
20	0.27	86	30	0.28	22
25	0.23	154	40	0.23	47
30	0.20	250	50	0.19	86
35	0.18	371	60	0.17	135
40	0.16	533	70	0.15	203
45	0.15	711	80	0.14	280
50	0.14	926	--	--	--

Note: The use of minimum radii for $e_{max} = 4\%$ is only intended for certain conditions as described in Figure 32-3.A.

$$*(US\ Customary)\ R_{min} = \frac{V^2}{15(e_{max} + f_{max})}; \quad \text{values for design have been rounded to the nearest 1 ft.}$$

$$*(Metric)\ R_{min} = \frac{V^2}{127(e_{max} + f_{max})}; \quad \text{values for design have been rounded to the nearest 1 m.}$$

MINIMUM RADII
($e_{max} = 4.0\%$, Open-Roadway Conditions)

Figure 32-2.F

US Customary			Metric		
Design Speed, V (mph)	Minimum Length of Curve, L (ft)	Curve Radius* (ft)	Design Speed, V (km/hr)	Minimum Length of Curve, L (m)	Curve Radius* (m)
30	100	1145	50	30	344
35	150	1720	60	50	573
40	200	2290	70	70	802
45	250	2865	80	90	1031
50	300	3440	90	110	1260
55	350	4010	100	130	1490
60	400	4585	110	150	1719
65	450	5155	120	170	1948
70	500	5730			
75	550	6300			

$$* R = \frac{360L}{2\pi\Delta}$$

Note: Calculated values have been rounded to the nearest 5 ft (1 m) increment. In all cases, the designer must consider the length of superelevation runoff in conjunction with the minimum length of curve. Under certain conditions, this may increase the minimum length of curve.

MINIMUM LENGTHS OF CURVE
($\Delta = 5^\circ$)

Figure 32-2.G

Central Deflection Angle * (Δ)	Adjustment Factor Applied to Figure 32-2.G
5°	1.00
4°	0.80
3°	0.60
2°	0.40
1°	0.20

* For intermediate central deflection angles, use a straight-line interpolation.

ADJUSTMENTS FOR MINIMUM LENGTHS OF CURVE
($\Delta < 5^\circ$)

Figure 32-2.H

32-3 SUPERELEVATION DEVELOPMENT (Open Roadway Conditions)

This section presents IDOT criteria for superelevation development when using open-roadway conditions. These types of facilities generally exhibit relatively uniform traffic operations. Therefore, for superelevation development, the flexibility normally exists to design horizontal curves with the more conservative AASHTO Method 5 (for distribution of superelevation and side friction) and by providing gentler superelevation transition lengths. This will maximize driver comfort and safety. The following sections present the specific design criteria for superelevation rates and transition lengths assuming open-roadway conditions.

32-3.01 Superelevation Rates

32-3.01(a) Maximum Superelevation Rate

As discussed in Section 32-2, the selection of a maximum rate of superelevation (e_{max}) depends upon several factors. These include urban/rural location, type of existing or expected roadside development, type of traffic operations expected, and prevalent climatic conditions within Illinois. For open-roadway conditions on new construction/reconstruction projects, Figure 32-3.A identifies the selection of e_{max} .

32-3.01(b) Superelevation Tables

Based on the selection of e_{max} and the use of AASHTO Method 5 to distribute e and f , Figures 32-3.B, 32-3.C, and 32-3.D allow the designer to select the appropriate superelevation rate (e) for any combination of curve radius (R) and design speed (V). Note that the superelevation rates in the tables are expressed as percents, which is the accepted presentation on construction plans. For the equations in which superelevation is included (e.g., superelevation runoff equation, point-mass equation for curve radius), e is expressed as a decimal (i.e., $(e \text{ in } \%) \div 100$).

32-3.01(c) Minimum Radii Without Superelevation

A horizontal curve with a very large radius does not require superelevation, and the normal crown section (NC) used on tangent can be maintained throughout the curve. On sharper curves for the same design speed, a point is reached where a superelevation rate of 1.5% across the total traveled way width is appropriate. Figures 32-3.B, 32-3.C, and 32-3.D provide the threshold (or minimum) radius for a normal crown section at various design speeds.

Type of Facility	Design Speed ⁴	e_{max}
Rural Highways	$V \geq 60$ mph ($V \geq 100$ km/hr)	6.0%
Rural Two-Lane Directional or Semi-directional Roadways	$V \geq 55$ mph ($V \geq 90$ km/hr)	6.0%
Rural Frontage Roads (Type A, B, or C)	$V \leq 55$ mph ($V \leq 90$ km/hr)	8.0%
Rural Strategic Regional Arterials (SRAs)	$V = 60$ mph ($V = 100$ km/hr)	6.0%
High Speed Urban Highways and Urban Two-Lane Directional or Semi-directional Roadways	$V \geq 50$ mph ($V \geq 80$ km/hr)	6.0%
Open Suburban Likely to Become Closed Suburban Within Next 10 Years ^{1,2}	$V = 50$ mph ($V = 80$ km/hr)	4.0%
Open Suburban Likely to Remain Open Suburban for Next 10 Years ¹	$V = 50$ or 55 mph ($V = 80$ or 90 km/hr)	6.0%
Low-Speed, Wrap-Around Frontage Roads (Suburban Areas) and Realigned Township/County Roads Near State Route Intersections	$V = 25, 30, 35, 40, 45$ mph ($V = 40, 50, 60, 70$ km/hr)	4.0%
Ramps	km/hr See Section 37-4.04	6.0% or 8.0% ³
Last Curve on Stop/Signal Controlled Exit Ramp Tying into Crossroad	$V \leq 40$ mph ($V \leq 60$ km/hr)	6.0%

Notes:

1. See Section 43-2 for definitions of suburban types.
2. For low-speed urban conditions, see Section 48-5 for values of e_{max} .
3. With snow and ice conditions and considering stop and go traffic during rush hours, use a maximum superelevation of 6%.
4. For more information on selection of design speeds for different highway types, see the chapters in Part V and Chapters 36 and 37.

**SELECTION OF E_{max}
(Open-Roadway Conditions)**

Figure 32-3.A

e (%)	V = 20 mph	V = 25 mph	V = 30 mph	V = 35 mph	V = 40 mph	V = 45 mph	V = 50 mph	V = 55 mph	V = 60 mph	V = 65 mph	V = 70 mph	V = 75 mph
	R(ft) > 1640	R(ft) > 2370	R(ft) > 3240	R(ft) > 4260	R(ft) > 5410	R(ft) > 6710	R(ft) > 8150	R(ft) > 9720	R(ft) > 11,500	R(ft) > 12,900	R(ft) > 14,500	R(ft) > 16100
NC												
1.5	1640	2370	3240	4260	5410	6710	8150	9720	11,500	12,900	14,500	16100
2.0	1190	1720	2370	3120	3970	4930	5990	7150	8440	9510	10,700	12000
2.2	1070	1550	2130	2800	3570	4440	5400	6450	7620	8600	9660	10800
2.4	959	1400	1930	2540	3240	4030	4910	5870	6930	7830	8810	9850
2.6	872	1280	1760	2320	2960	3690	4490	5370	6350	7180	8090	9050
2.8	796	1170	1610	2130	2720	3390	4130	4950	5850	6630	7470	8370
3.0	730	1070	1480	1960	2510	3130	3820	4580	5420	6140	6930	7780
3.2	672	985	1370	1820	2330	2900	3550	4250	5040	5720	6460	7260
3.4	620	911	1270	1690	2170	2700	3300	3970	4700	5350	6050	6800
3.6	572	845	1180	1570	2020	2520	3090	3710	4400	5010	5680	6400
3.8	530	784	1100	1470	1890	2360	2890	3480	4140	4710	5350	6030
4.0	490	729	1030	1370	1770	2220	2720	3270	3890	4450	5050	5710
4.2	453	678	955	1280	1660	2080	2560	3080	3670	4200	4780	5410
4.4	418	630	893	1200	1560	1960	2410	2910	3470	3980	4540	5140
4.6	384	585	834	1130	1470	1850	2280	2750	3290	3770	4310	4890
4.8	349	542	779	1080	1390	1750	2160	2610	3120	3590	4100	4670
5.0	314	499	727	991	1310	1650	2040	2470	2960	3410	3910	4460
5.2	284	457	676	929	1230	1560	1930	2350	2820	3250	3740	4260
5.4	258	420	627	870	1160	1480	1830	2230	2680	3110	3570	4090
5.6	236	387	582	813	1090	1390	1740	2120	2550	2970	3420	3920
5.8	216	358	542	761	1030	1320	1650	2010	2430	2840	3280	3760
6.0	199	332	506	713	965	1250	1560	1920	2320	2710	3150	3620
6.2	184	308	472	669	909	1180	1480	1820	2210	2600	3020	3480
6.4	170	287	442	628	857	1110	1400	1730	2110	2490	2910	3360
6.6	157	267	413	590	808	1050	1330	1650	2010	2380	2790	3240
6.8	146	248	386	553	761	990	1260	1560	1910	2280	2690	3120
7.0	135	231	360	518	716	933	1190	1480	1820	2180	2580	3010
7.2	125	214	336	485	672	878	1120	1400	1720	2070	2470	2900
7.4	115	198	312	451	628	822	1060	1320	1630	1970	2350	2780
7.6	105	182	287	417	583	765	980	1230	1530	1850	2230	2650
7.8	94	164	261	380	533	701	901	1140	1410	1720	2090	2500
8.0	76	134	214	314	444	587	758	960	1200	1480	1810	2210
	R _{min} = 76 ft	R _{min} = 134 ft	R _{min} = 214 ft	R _{min} = 314 ft	R _{min} = 444 ft	R _{min} = 587 ft	R _{min} = 758 ft	R _{min} = 960 ft	R _{min} = 1200 ft	R _{min} = 1480 ft	R _{min} = 1810 ft	R _{min} = 2210 ft

NC = Normal Crown = 1.5%
 □ = Superelevation rates for speeds in this range should only be used to check for existing curves to remain in place.

MINIMUM RADII (R) for DESIGN SUPERELEVATION RATES (e), DESIGN SPEEDS (V), and e_{max} = 8% (Open-Roadway Conditions - AASHTO Method 5)

Figure 32-3.B (US Customary)

e (%)	V = 30 km/h		V = 40 km/h		V = 50 km/h		V = 60 km/h		V = 70 km/h		V = 80 km/h		V = 90 km/h		V = 100 km/h		V = 110 km/h		V = 120 km/h	
	R(m)	R(m)	R(m)	R(m)	R(m)	R(m)	R(m)	R(m)	R(m)	R(m)	R(m)	R(m)	R(m)	R(m)	R(m)	R(m)	R(m)	R(m)	R(m)	R(m)
NC	> 443	> 784	> 1090	> 1490	> 1970	> 2440	> 2970	> 3630	> 4180	> 4900										
1.5	443	784	1090	1490	1970	2440	2970	3630	4180	4900										
2.0	322	571	791	1090	1450	1790	2190	2680	3090	3640										
2.2	288	512	711	976	1300	1620	1980	2420	2790	3290										
2.4	261	463	644	885	1190	1470	1800	2200	2550	3010										
2.6	237	421	587	808	1080	1350	1650	2020	2340	2760										
2.8	216	385	539	742	992	1240	1520	1860	2160	2550										
3.0	199	354	496	684	916	1150	1410	1730	2000	2370										
3.2	183	326	458	633	849	1060	1310	1610	1870	2220										
3.4	169	302	425	588	790	988	1220	1500	1740	2080										
3.6	156	279	395	548	738	924	1140	1410	1640	1950										
3.8	144	259	368	512	690	866	1070	1320	1540	1840										
4.0	134	241	344	479	648	813	1010	1240	1450	1740										
4.2	124	224	321	449	608	766	948	1180	1380	1650										
4.4	115	208	301	421	573	722	895	1110	1300	1570										
4.6	106	192	281	395	540	682	847	1050	1240	1490										
4.8	96	178	263	371	509	645	803	996	1180	1420										
5.0	87	163	246	349	480	611	762	947	1120	1360										
5.2	78	148	229	328	454	579	724	901	1070	1300										
5.4	71	136	213	307	429	549	689	859	1020	1250										
5.6	65	125	198	288	405	521	656	819	975	1200										
5.8	59	115	185	270	382	494	625	781	933	1150										
6.0	55	106	172	253	360	469	595	746	894	1100										
6.2	50	98	161	238	340	445	567	713	857	1060										
6.4	46	91	151	224	322	422	540	681	823	1020										
6.6	43	85	141	210	304	400	514	651	789	982										
6.8	40	79	132	198	287	379	489	620	757	948										
7.0	37	73	123	185	270	358	464	591	724	914										
7.2	34	68	115	174	254	338	440	561	691	879										
7.4	31	62	107	162	237	318	415	531	657	842										
7.6	29	57	99	150	221	296	389	499	621	803										
7.8	26	52	90	137	202	273	359	462	579	757										
8.0	20	41	73	113	168	229	304	394	501	667										
	R _{min} = 20 m	R _{min} = 41 m	R _{min} = 73 m	R _{min} = 113 m	R _{min} = 168 m	R _{min} = 229 m	R _{min} = 304 m	R _{min} = 394 m	R _{min} = 501 m	R _{min} = 667 m										

NC = Normal Crown = 1.5%

■ = Superelevation rates for speeds in this range should only be used to check for existing curves to remain in place.

MINIMUM RADII (R) for DESIGN SUPERELEVATION RATES (e), DESIGN SPEEDS (V), and e_{max} = 8% (Open-Roadway Conditions - AASHTO Method 5)

Figure 32-3.B (Metric)

e (%)	V = 20 mph	V = 25 mph	V = 30 mph	V = 35 mph	V = 40 mph	V = 45 mph	V = 50 mph	V = 55 mph	V = 60 mph	V = 65 mph	V = 70 mph	V = 75 mph
	R(ft)	R(ft)	R(ft)	R(ft)	R(ft)	R(ft)	R(ft)	R(ft)	R(ft)	R(ft)	R(ft)	R(ft)
NC	> 1580	> 2290	> 3130	> 4100	> 5230	> 6480	> 7870	> 9410	> 11,100	> 12,600	> 14,100	> 15,700
1.5	1580	2290	3130	4100	5230	6480	7870	9410	11,100	12,600	14,100	15,700
2.0	1120	1630	2240	2950	3770	4680	5700	6820	8060	9130	10,300	11,500
2.2	991	1450	2000	2630	3370	4190	5100	6110	7230	8200	9240	10,400
2.4	884	1300	1790	2360	3030	3770	4600	5520	6540	7430	8380	9420
2.6	791	1170	1610	2130	2740	3420	4170	5020	5950	6770	7660	8620
2.8	709	1050	1460	1930	2490	3110	3800	4580	5440	6200	7030	7930
3.0	635	944	1320	1760	2270	2840	3480	4200	4990	5710	6490	7330
3.2	566	850	1200	1600	2080	2600	3200	3860	4600	5280	6010	6810
3.4	498	761	1080	1460	1900	2390	2940	3560	4250	4890	5580	6340
3.6	422	673	972	1320	1740	2190	2710	3290	3940	4540	5210	5930
3.8	358	583	864	1190	1590	2010	2490	3040	3650	4230	4860	5560
4.0	309	511	766	1070	1440	1840	2300	2810	3390	3950	4550	5220
4.2	270	452	684	960	1310	1680	2110	2590	3140	3680	4270	4910
4.4	238	402	615	868	1190	1540	1940	2400	2920	3440	4010	4630
4.6	212	360	555	788	1090	1410	1780	2210	2710	3220	3770	4380
4.8	189	324	502	718	995	1300	1640	2050	2510	3000	3550	4140
5.0	169	292	456	654	911	1190	1510	1890	2330	2800	3330	3910
5.2	152	264	413	595	833	1090	1390	1750	2160	2610	3120	3690
5.4	136	237	373	540	759	995	1280	1610	1990	2420	2910	3460
5.6	121	212	335	487	687	903	1160	1470	1830	2230	2700	3230
5.8	106	186	296	431	611	806	1040	1320	1650	2020	2460	2970
6.0	81	144	231	340	485	643	833	1060	1330	1660	2040	2500
	R _{min} = 81 ft	R _{min} = 144 ft	R _{min} = 231 ft	R _{min} = 340 ft	R _{min} = 485 ft	R _{min} = 643 ft	R _{min} = 833 ft	R _{min} = 1060 ft	R _{min} = 1330 ft	R _{min} = 1660 ft	R _{min} = 2040 ft	R _{min} = 2500 ft

NC = Normal Crown = 1.5%

MINIMUM RADII (R) for DESIGN SUPERELEVATION RATES (e), DESIGN SPEEDS (V), and e_{max} = 6%
 (Open-Roadway Conditions - AASHTO Method 5)

Figure 32-3.C (US Customary)

e (%)	V = 30 km/h	V = 40 km/h	V = 50 km/h	V = 60 km/h	V = 70 km/h	V = 80 km/h	V = 90 km/h	V = 100 km/h	V = 110 km/h	V = 120 km/h
	R(m)	R(m)	R(m)	R(m)	R(m)	R(m)	R(m)	R(m)	R(m)	R(m)
NC	> 421	> 738	> 1050	> 1440	> 1910	> 2360	> 2880	> 3510	> 4060	> 4770
1.5	421	738	1050	1440	1910	2360	2880	3510	4060	4770
2.0	299	525	750	1030	1380	1710	2090	2560	2970	3510
2.2	265	465	668	919	1230	1530	1880	2300	2670	3160
2.4	236	415	599	825	1110	1380	1700	2080	2420	2870
2.6	212	372	540	746	1000	1260	1540	1890	2210	2630
2.8	190	334	488	676	910	1150	1410	1730	2020	2420
3.0	170	300	443	615	831	1050	1290	1590	1870	2240
3.2	152	269	402	561	761	959	1190	1470	1730	2080
3.4	133	239	364	511	697	882	1100	1360	1600	1940
3.6	113	206	329	465	640	813	1020	1260	1490	1810
3.8	96	177	294	422	586	749	939	1170	1390	1700
4.0	82	155	261	380	535	690	870	1090	1300	1590
4.2	72	136	234	343	488	635	806	1010	1220	1500
4.4	63	121	210	311	446	584	746	938	1140	1410
4.6	56	108	190	283	408	538	692	873	1070	1330
4.8	50	97	172	258	374	496	641	812	997	1260
5.0	45	88	156	235	343	457	594	755	933	1190
5.2	40	79	142	214	315	421	549	701	871	1120
5.4	36	71	128	195	287	386	506	648	810	1060
5.6	32	63	115	176	260	351	463	594	747	980
5.8	28	56	102	156	232	315	416	537	679	900
6.0	21	43	79	123	184	252	336	437	560	756
	R _{min} = 21 m	R _{min} = 43 m	R _{min} = 79 m	R _{min} = 123 m	R _{min} = 184 m	R _{min} = 252 m	R _{min} = 336 m	R _{min} = 437 m	R _{min} = 560 m	R _{min} = 756 m

NC = Normal Crown = 1.5%

MINIMUM RADII (R) for DESIGN SUPERELEVATION RATES (e), DESIGN SPEEDS (V), and e_{max} = 6%
 (Open-Roadway Conditions - AASHTO Method 5)

Figure 32-3.C (Metric)

US CUSTOMARY

e (%)	V = 20 mph		V = 25 mph		V = 30 mph		V = 35 mph		V = 40 mph		V = 45 mph		V = 50 mph	
	R(ft)	R(ft)	R(ft)	R(ft)	R(ft)	R(ft)	R(ft)	R(ft)	R(ft)	R(ft)	R(ft)	R(ft)	R(ft)	R(ft)
NC	> 1410	> 2050	> 2830	> 3730	> 4770	> 5930	> 7220							
1.5	1410	2050	2830	3730	4770	5930	7220							
2.0	902	1340	1880	2490	3220	4040	4940							
2.2	723	1110	1580	2120	2760	3480	4280							
2.4	513	838	1270	1760	2340	2980	3690							
2.6	388	650	1000	1420	1930	2490	3130							
2.8	308	524	817	1170	1620	2100	2660							
3.0	251	433	681	982	1370	1800	2290							
3.2	209	363	576	835	1180	1550	1980							
3.4	175	307	490	714	1010	1340	1720							
3.6	147	259	416	610	865	1150	1480							
3.8	122	215	348	512	730	970	1260							
4.0	86	154	250	371	533	711	926							
R _{min} = 86 ft		R _{min} = 154 ft		R _{min} = 250 ft		R _{min} = 371 ft		R _{min} = 533 ft		R _{min} = 711 ft		R _{min} = 926 ft		

METRIC

e (%)	V = 30 km/h		V = 40 km/h		V = 50 km/h		V = 60 km/h		V = 70 km/h		V = 80 km/h	
	R(m)	R(m)	R(m)	R(m)	R(m)	R(m)	R(m)	R(m)	R(m)	R(m)	R(m)	R(m)
NC	> 371	> 679	> 951	> 1310	> 1740	> 2170						
1.5	371	679	951	1310	1740	2170						
2.0	237	441	632	877	1180	1490						
2.2	187	363	534	749	1020	1290						
2.4	132	273	435	626	865	1110						
2.6	99	209	345	508	720	944						
2.8	79	167	283	422	605	802						
3.0	64	137	236	356	516	690						
3.2	54	114	199	303	443	597						
3.4	45	96	170	260	382	518						
3.6	38	81	144	222	329	448						
3.8	31	67	121	187	278	381						
4.0	22	47	86	135	203	280						
R _{min} = 22 m		R _{min} = 47 m		R _{min} = 86 m		R _{min} = 135 m		R _{min} = 203 m		R _{min} = 280 m		

NC = Normal Crown = 1.5%

MINIMUM RADII (R) for DESIGN SUPERELEVATION RATES (e), DESIGN SPEEDS (V), and e_{max} = 4% (Open-Roadway Conditions - AASHTO Method 5)

Figure 32-3.D

32-3.02 Transition Lengths

As defined in Section 32-1, the superelevation transition length is the distance required to transition the roadway from a normal crown section to the full design superelevation rate. The superelevation transition length is the sum of the tangent runout distance (TR) and superelevation runoff length (L_1).

32-3.02(a) Two-Lane Highways

Superelevation Runoff

Figure 32-3.E presents the superelevation runoff lengths (L_1) for two-lane highways for various combinations of curve radii and design speed. These lengths are calculated using the following equation:

$$L_1 = (e)(W)(RS) \quad \text{Equation 32-3.1}$$

- where:
- L_1 = Calculated superelevation runoff length for a two-lane highway (assuming the axis of rotation is about the roadway centerline), ft (m)
 - e = Design superelevation rate, decimal
 - W = Width of rotation for one lane (assumed to be 12 ft (3.6 m))
 - RS = Reciprocal of relative longitudinal gradient between the profile grade and outside edge of two-lane highway (see Figure 32-3.F)

Tangent Runout

To ensure that the relative longitudinal gradient for the tangent runout (TR) will equal that for the superelevation runoff, the tangent runout distance should be calculated using the following equation:

$$TR = \frac{S_{\text{normal}}}{e} (L_1) \quad \text{Equation 32-3.2}$$

- where: S_{normal} = Travel lane cross slope on tangent, decimal

Superelevation Transition Length

Once the tangent runout (TR) distance is calculated, this distance is added to the design superelevation runoff length (L_1). The total equals the theoretical superelevation transition length used for design at an isolated horizontal curve.

e (%)	V = 20 mph		V = 25 mph		V = 30 mph		V = 35 mph		V = 40 mph		V = 45 mph	
	Number of lanes rotated. Note that 1 lane rotated is typical for a 2-lane highway, 2 lanes rotated is typical for a 4-lane highway.											
	1	2	1	2	1	2	1	2	1	2	1	2
	L ₁ (ft)	L _{ML} (ft)	L ₁ (ft)	L _{ML} (ft)	L ₁ (ft)	L _{ML} (ft)	L ₁ (ft)	L _{ML} (ft)	L ₁ (ft)	L _{ML} (ft)	L ₁ (ft)	L _{ML} (ft)
1.5	24	37	26	39	27	41	29	44	31	47	33	50
2.0	32	49	34	51	36	55	39	58	41	62	44	67
2.2	36	53	38	57	40	60	43	64	45	68	49	73
2.4	39	58	41	62	44	66	46	70	50	74	53	80
2.6	42	63	45	67	47	71	50	75	54	80	58	87
2.8	45	68	48	72	51	77	54	81	58	87	62	93
3.0	49	73	51	77	55	82	58	87	62	93	67	100
3.2	52	78	55	82	58	88	62	93	66	99	71	107
3.4	55	83	58	88	62	93	66	99	70	105	75	113
3.6	58	87	62	93	66	98	70	104	74	111	80	120
3.8	62	92	65	98	69	104	73	110	78	118	84	127
4.0	65	97	69	103	73	109	77	116	83	124	89	133
4.2	68	102	72	108	77	115	81	122	87	130	93	140
4.4	71	107	76	113	80	120	85	128	91	136	98	147
4.6	75	112	79	118	84	126	89	133	95	142	102	153
4.8	78	117	82	124	88	131	93	139	99	149	107	160
5.0	81	122	86	129	91	137	97	145	103	155	111	167
5.2	84	126	89	134	95	142	100	151	107	161	115	173
5.4	87	131	93	139	98	148	104	156	111	167	120	180
5.6	91	136	96	144	102	153	108	162	116	173	124	186
5.8	94	141	100	149	106	159	112	168	120	180	129	193
6.0	97	146	103	154	109	164	116	174	124	186	133	200
6.2	100	151	106	160	113	170	120	180	128	192	138	206
6.4	104	156	110	165	117	175	124	185	132	198	142	213
6.6	107	160	113	170	120	181	128	191	136	204	147	220
6.8	110	165	117	175	124	186	131	197	140	211	151	226
7.0	113	170	120	180	128	192	135	203	144	217	155	233
7.2	117	175	124	185	131	197	139	209	149	223	160	240
7.4	120	180	127	190	135	202	143	214	153	229	164	246
7.6	123	185	130	196	139	208	147	220	157	235	169	253
7.8	126	190	134	201	142	213	151	226	161	241	173	260
8.0	130	194	137	206	146	219	155	232	165	248	178	266

Key:

- L₁ = Superelevation Runoff for Two-Lane Highways, ft
- L_{ML} = Superelevation Runoff for Four-lane Divided Highways, ft
- V = Design speed, mph
- e = Superelevation rate, %

SUPERELEVATION RUNOFF LENGTHS FOR HORIZONTAL CURVES

Figure 32-3.E (US Customary)
(1 of 2)

e (%)	V = 50 mph		V = 55 mph		V = 60 mph		V = 65 mph		V = 70 mph		V = 75 mph	
	Number of lanes rotated. Note that 1 lane rotated is typical for a 2-lane highway, 2 lanes rotated is typical for a 4-lane highway.											
	1	2	1	2	1	2	1	2	1	2	1	2
	L ₁ (ft)	L _{ML} (ft)	L ₁ (ft)	L _{ML} (ft)	L ₁ (ft)	L _{ML} (ft)	L ₁ (ft)	L _{ML} (ft)	L ₁ (ft)	L _{ML} (ft)	L ₁ (ft)	L _{ML} (ft)
1.5	36	54	38	58	40	60	42	63	45	68	47	71
2.0	48	72	51	77	53	80	56	84	60	90	63	95
2.2	53	79	56	84	59	88	62	92	66	99	69	104
2.4	58	86	61	92	64	96	67	101	72	108	76	114
2.6	62	94	66	100	69	104	73	109	78	117	82	123
2.8	67	101	72	107	75	112	78	117	84	126	88	133
3.0	72	108	77	115	80	120	84	126	90	135	95	142
3.2	77	115	82	123	85	128	89	134	96	144	101	152
3.4	82	122	87	130	91	136	95	143	102	153	107	161
3.6	86	130	92	138	96	144	101	151	108	162	114	171
3.8	91	137	97	146	101	152	106	159	114	171	120	180
4.0	96	144	102	153	107	160	112	168	120	180	126	189
4.2	101	151	107	161	112	168	117	176	126	189	133	199
4.4	106	158	112	169	117	176	123	185	132	198	139	208
4.6	110	166	118	176	123	184	129	193	138	207	145	218
4.8	115	173	123	184	128	192	134	201	144	216	152	227
5.0	120	180	128	192	133	200	140	210	150	225	158	237
5.2	125	187	133	199	139	208	145	218	156	234	164	246
5.4	130	194	138	207	144	216	151	226	162	243	171	256
5.6	134	202	143	215	149	224	157	235	168	252	177	265
5.8	139	209	148	222	155	232	162	243	174	261	183	275
6.0	144	216	153	230	160	240	168	252	180	270	189	284
6.2	149	223	158	238	165	248	173	260	186	279	196	294
6.4	154	230	164	245	170	256	179	268	192	288	202	303
6.6	158	238	169	253	176	264	185	277	198	297	208	313
6.8	163	245	174	261	181	272	190	285	204	306	215	322
7.0	168	252	179	268	186	280	196	294	210	315	221	332
7.2	173	259	184	276	192	288	201	302	216	324	227	341
7.4	178	266	189	284	197	296	207	310	222	333	234	351
7.6	182	274	194	291	202	304	212	319	228	342	240	360
7.8	187	281	199	299	208	312	218	327	234	351	246	369
8.0	192	288	204	307	213	320	224	336	240	360	253	379

Key:

- L₁ = Superelevation Runoff for Two-Lane Highways, ft
- L_{ML} = Superelevation Runoff for Four-lane Divided Highways, ft
- V = Design speed, mph
- e = Superelevation rate, %

SUPERELEVATION RUNOFF LENGTH FOR HORIZONTAL CURVES

Figure 32-3.E (US Customary)

(2 of 2)

e (%)	V = 30 km/hr		V = 40 km/hr		V = 50 km/hr		V = 60 km/hr		V = 70 km/hr		V = 80 km/hr	
	Number of lanes rotated. Note that 1 lane rotated is typical for a 2-lane highway, 2 lanes rotated is typical for a 4-lane highway.											
	1	2	1	2	1	2	1	2	1	2	1	2
	L ₁ (m)	L _{ML} (m)	L ₁ (m)	L _{ML} (m)	L ₁ (m)	L _{ML} (m)	L ₁ (m)	L _{ML} (m)	L ₁ (m)	L _{ML} (m)	L ₁ (m)	L _{ML} (m)
1.5	7	11	8	12	8	13	9	14	10	15	11	16
2.0	10	14	10	15	11	16	12	18	13	20	14	22
2.2	11	16	11	17	12	18	13	20	14	22	16	24
2.4	11	17	12	19	13	19	14	22	16	24	17	26
2.6	12	19	13	20	14	21	16	23	17	26	19	28
2.8	13	20	14	22	15	23	17	25	18	28	20	30
3.0	14	22	15	23	16	24	18	27	20	29	22	32
3.2	15	23	16	25	17	26	19	29	21	31	23	35
3.4	16	24	18	26	18	28	20	31	22	33	24	37
3.6	17	26	19	28	19	29	22	32	24	35	26	39
3.8	18	27	20	29	21	31	23	34	25	37	27	41
4.0	19	29	21	31	22	32	24	36	26	39	29	43
4.2	20	30	22	32	23	34	25	38	28	41	30	45
4.4	21	32	23	34	24	36	26	40	29	43	32	48
4.6	22	33	24	36	25	37	28	41	30	45	33	50
4.8	23	34	25	37	26	39	29	43	31	47	35	52
5.0	24	36	26	39	27	41	30	45	33	49	36	54
5.2	25	37	27	40	28	42	31	47	34	51	37	56
5.4	26	39	28	42	29	44	32	49	35	53	39	58
5.6	27	40	29	43	30	45	34	51	37	55	40	60
5.8	28	42	30	45	31	47	35	52	38	57	42	63
6.0	29	43	31	46	32	49	36	54	39	59	43	65
6.2	30	45	32	48	33	50	37	56	41	61	45	67
6.4	31	46	33	49	35	52	38	58	42	63	46	69
6.6	32	47	34	51	36	53	40	60	43	65	48	71
6.8	33	49	35	53	37	55	41	61	45	67	49	73
7.0	34	50	36	54	38	57	42	63	46	69	50	76
7.2	34	52	37	56	39	58	43	65	47	71	52	78
7.4	35	53	38	57	40	60	44	67	48	73	53	80
7.6	36	55	39	59	41	62	46	69	50	75	55	82
7.8	37	56	40	60	42	63	47	70	51	77	56	84
8.0	38	57	41	62	43	65	48	72	52	79	58	86

Key:

- L₁ = Superelevation Runoff for Two-Lane Highways, m
- L_{ML} = Superelevation Runoff for Four-lane Divided Highways, m
- V = Design speed, km/hr
- e = Superelevation rate, %

SUPERELEVATION RUNOFF LENGTHS FOR HORIZONTAL CURVES

Figure 32-3.E (Metric)

(1 of 2)

e (%)	V = 90 km/hr		V = 100 km/hr		V = 110 km/hr		V = 120 km/hr	
	Number of lanes rotated. Note that 1 lane rotated is typical for a 2-lane highway, 2 lanes rotated is typical for a 4-lane highway.							
	1	2	1	2	1	2	1	2
	L ₁ (m)	L _{ML} (m)	L ₁ (m)	L _{ML} (m)	L ₁ (m)	L _{ML} (m)	L ₁ (m)	L _{ML} (m)
1.5	12	17	12	18	13	20	14	21
2.0	15	23	16	25	18	26	19	28
2.2	17	25	18	27	19	29	21	31
2.4	18	28	20	29	21	32	23	34
2.6	20	30	21	32	23	34	25	37
2.8	21	32	23	34	25	37	27	40
3.0	23	35	25	37	26	40	28	43
3.2	25	37	26	39	28	42	30	45
3.4	26	39	28	42	30	45	32	48
3.6	28	41	29	44	32	47	34	51
3.8	29	44	31	47	33	50	36	54
4.0	31	46	33	49	35	53	38	57
4.2	32	48	34	51	37	55	40	60
4.4	34	51	36	54	39	58	42	62
4.6	35	53	38	56	40	61	44	65
4.8	37	55	39	59	42	63	45	68
5.0	38	58	41	61	44	66	47	71
5.2	40	60	42	64	46	69	49	74
5.4	41	62	44	66	47	71	51	77
5.6	43	64	46	69	49	74	53	80
5.8	44	67	47	71	51	76	55	82
6.0	46	69	49	74	53	79	57	85
6.2	48	71	51	76	54	82	59	88
6.4	49	74	52	78	56	84	61	91
6.6	51	76	54	81	58	87	62	94
6.8	52	78	56	83	60	90	64	97
7.0	54	81	57	86	61	92	66	99
7.2	55	83	59	88	63	95	68	102
7.4	57	85	60	91	65	98	70	105
7.6	58	87	62	93	67	100	72	108
7.8	60	90	64	96	69	103	74	111
8.0	61	92	65	98	70	105	76	114

Key:

- L₁ = Superelevation Runoff for Two-Lane Highways, m
- L_{ML} = Superelevation Runoff for Four-lane Divided Highways, m
- V = Design speed, km/hr
- e = Superelevation rate, %

SUPERELEVATION RUNOFF LENGTHS FOR HORIZONTAL CURVES

Figure 32-3.E (Metric)

(2 of 2)

US Customary		
Design Speed (mph)	1:RS	Edge of Traveled Way Slope Relative to Centerline G(%) (max.)*
20	1:135	0.74
25	1:143	0.70
30	1:152	0.66
35	1:161	0.62
40	1:172	0.58
45	1:185	0.54
50	1:200	0.50
55	1:213	0.47
60	1:222	0.45
65	1:233	0.43
70	1:250	0.40
75	1:263	0.38
Metric		
Design Speed (km/hr)	1:RS	Edge of Traveled Way Slope Relative to Centerline G(%) (max.)*
30	1:133	0.75
40	1:143	0.70
50	1:150	0.65
60	1:167	0.60
70	1:182	0.55
80	1:200	0.50
90	1:213	0.47
100	1:227	0.44
110	1:244	0.41
120	1:263	0.38

$$* G(\%) = \frac{1}{RS} \times 100$$

Equation 32-3.3

Notes:

1. *The relative longitudinal slopes are assumed to be measured between two lines set 12 ft (3.6 m) apart.*
2. *The gradients shown were derived from values contained in the AASHTO A Policy on Geometric Design of Highways and Streets.*

RELATIVE LONGITUDINAL GRADIENTS**Figure 32-3.F**

32-3.02(b) Multilane Highways

There is a wide variety of potential typical cross sections for a multilane highway. The variables include:

- number of lanes in each direction;
- type of median;
- use of a uniform cross slope or a crowned section;
- for crowned sections, location of crown point; and
- use of variable cross slopes for individual travel lanes (e.g., the lanes not adjacent to the crown point may be sloped at a steeper rate than those adjacent to the crown).

In all cases, the first objective in superelevation development is to transition the highway from the typical cross section to a section that slopes at a uniform rate across the traveled way in the same direction. Regardless of the typical cross section on tangent, this transition must be achieved to meet certain criteria and principles, including:

1. Rate of Transition. The rate of transition (i.e., the relative longitudinal gradient) should be the same as that for the superelevation runoff. This requires that the runoff be calculated first and the resultant relative gradient be calculated for the runoff. Note that Equation 32-3.4 can be used to calculate the superelevation runoff (L_{ML}) for all multilane highways regardless of the typical section on tangent.
2. Point of Rotation. Section 32-3.03(b) discusses the axes of rotation for multilane highways, which is in many cases the two median edges. However, an “initial” axis of rotation (and sometimes more than one) must be selected to remove any crown and achieve a planar section. This will often be a point other than that used for the “primary” axes of rotation to transition from the uniform cross slope to the design superelevation rate.
3. Tangent Runout. The end of the tangent runout occurs where the outside travel lane(s) are level. Where this involves more than one travel lane, the length of the tangent runout must be consistent with the criteria in Figure 32-3.G, which varies the length of transition according to the number of lanes rotated. Also, note that the initial part of the superelevation runoff is used to transition from the end of the tangent runout to a roadway section with a uniform slope.

Number of Lanes Rotated	"C" Ratio
1	1.0
1.5	1.25
2	1.5
2.5	1.75
3	2.0
3.5	2.25

"C" RATIO
(Adjustment Factor for Number of Lanes Rotated)

Figure 32-3.G

Because of the many variables in superelevation development on multilane highways, the following discussion is predicated on the following roadway characteristics:

- a four-lane divided highway,
- a median type and width where Department practice is to rotate about the two median edges (see Section 32-3.03(b)), and
- a typical section on tangent where each roadway is crowned at the centerline.

Section 48-5 discusses superelevation development for a raised median section where each traveled way has a uniform slope away from the raised median.

Superelevation Runoff

Figure 32-3.E provides the superelevation run off lengths (L_{ML}) for a four-lane divided highway for various combinations of curve radii and design speeds. The superelevation runoff length for a multilane highway is calculated by using the following equation:

$$L_{ML} = C \times L_1 \quad \text{Equation 32-3.4}$$

- where:
- L_{ML} = Superelevation runoff length for multilane highway, ft (m)
 - L_1 = Calculated superelevation runoff length for a two-lane highway (assuming rotation about the centerline), ft (m)
 - C = Ratio of runoff length for a multilane highway to L_1 (see Figure 32-3.G)

Tangent Runout

For multilane highways, the relative longitudinal gradient for the tangent runout should equal that for the superelevation runoff. This first requires the calculation of the gradient (or its reciprocal, RS) for the runoff:

$$G_{SR} = \frac{(2W)(e) - (S_{normal})(W)}{L_{ML}} \quad \text{Equation 32-3.5}$$

where: G_{SR} = relative longitudinal gradient for superelevation runoff (at the outside edge of the traveled way), decimal

W = width of one travel lane, ft (m)

e = design superelevation rate, decimal

S_{normal} = travel lane cross slope on tangent, decimal

L_{ML} = superelevation runoff length for multilane highway, ft (m)

Now, the tangent runout (TR_{ML}) can be calculated from the following equation:

$$TR_{ML} = (S_{normal})(W)(RS_{SR}) \quad \text{Equation 32-3.6}$$

where: $RS_{SR} = (1/G_{SR}) =$ reciprocal of relative longitudinal for superelevation runoff

Superelevation Transition Length

The theoretical superelevation transition length is the sum of the superelevation runoff and tangent runout distances. This length is used for design at an isolated horizontal curve.

32-3.02(c) Application of Transition Length

Once the superelevation runoff and tangent runout have been calculated, the designer must determine how to fit the length into the horizontal and vertical planes. The following will apply:

1. Simple Curves. Typically for new construction/reconstruction projects, 67% of the superelevation runoff length will be placed on the tangent and 33% on the curve. Exceptions to this practice may be necessary to meet field conditions. The generally accepted range is 60% - 80% on tangent and 40% - 20% on curve. In extreme cases (e.g., to avoid placing any superelevation transition on a bridge or approach slab), the superelevation runoff may be distributed 50% - 100% on the tangent and 50% - 0% on the curve. This will usually occur only in urban or suburban areas with highly restricted right-of-way conditions.

When considering the tangent runout distance, the result is a distribution of the total superelevation transition length of approximately 75% on the tangent and 25% on the curve. IDOT also uses this approximate distribution ratio at isolated horizontal curves. However, because the distribution of the superelevation transition length is not an exact science, the ratio should be rounded up or down slightly (to the nearest 5 ft (1 m) increment) to simplify design and layout in construction.

2. Spiral Curves. The design superelevation runoff length is typically assumed to fit the spiral curve length (TS to SC and CS to ST). Therefore, all of the tangent runoff is placed on the tangent before the TS and after the ST.
3. Field Application (Vertical Profile). At the beginning and end of the superelevation transition length, angular breaks occur in the profile if not smoothed. Field personnel usually smooth these abrupt angular breaks out during construction. This is usually accomplished by visually adjusting the wire used to control the vertical and horizontal position of the bituminous concrete paver or slip-form paver.

As a guide, the vertical curve transitions, to eliminate angular breaks, should have a length in feet numerically equivalent to approximately the design speed in mph (in meters approximately 20% of design speed in km/hr). In addition, designers should graphically or numerically investigate the transition areas to identify potential flat spots for drainage before finalizing construction plans.

4. Ultimate Development. If the proposed facility is planned for an ultimate development of additional lanes, the designer should, where practical, reflect this length in the initial superelevation transition application. For example, a four-lane divided facility may be planned for an ultimate six-lane divided facility. Therefore, the superelevation transition length for the initial four-lane facility should be consistent with the future requirements of the six-lane facility.
5. Typical Figures/Examples. Section 32-3.08 presents typical figures for superelevation development of tangent runoff and superelevation runoff for two-lane highways and different median types on multilane facilities. Section 32-3.09 presents two examples to illustrate superelevation development.

32-3.03 Axis of Rotation

The following discusses the axis of rotation for two-lane, two-way highways and multilane highways. Section 32-3.08 presents typical figures illustrating the application of the axis of rotation in superelevation development.

32-3.03(a) Two-Lane, Two-Way Highways

The axis of rotation will typically be about the centerline of the roadway on two-lane, two-way highways. This method will yield the least amount of elevation differential between the pavement edges and their normal profiles. Occasionally, it may be necessary to rotate the pavement about the inside or outside edge of the traveled way. This may be necessary to meet field conditions (e.g., drainage on a curbed facility, roadside development). Note that, in this case, two travel lane widths will be rotated, and the superelevation runoff should be lengthened according to Figure 32-3.G.

On a two-lane highway with an auxiliary lane (e.g., a climbing lane), the axis of rotation will typically be about the centerline of the two through lanes.

32-3.03(b) Multilane Divided Highways

The axis of rotation will typically be about the two median edges for a multilane divided facility with a concrete barrier, a raised curb median > 16 ft (5.0 m), or a depressed median \geq 40 ft (12 m). When the median edges are used as the axes of rotation, the median will remain in the same horizontal plane throughout the curve.

Several highway features may significantly influence superelevation development for multilane divided highways. These could include guardrail, median barriers, drainage, and major at-grade intersections. If a major cross road intersection is present where the median width is 18 ft (5.5 m), 22 ft (7.0 m), 30 ft (9.5 m), or 36 ft (10.5 m), it is recommended that the entire cross section of the mainline be rotated about the centerline of the roadway. This method of rotation will provide better operations for cross road traffic.

The designer should carefully consider the intended function of all highway features and ensure that the superelevated section and selected axis of rotation does not compromise traffic operations. In addition, the designer should consider the likely ultimate development of the facility and select an axis of rotation that will lend itself to future expansion.

32-3.03(c) Multilane Highways with Narrow/Flush Medians

The following types of multilane highways should develop superelevation by rotating the roadway about its centerline:

- existing 4 ft (1.2 m) wide median or undivided multilane highways not planned for reconstruction;
- multilane highways with flush medians;
- proposed multilane highways with a 16 ft (5.0 m) wide traversable median;
- proposed multilane highways with a raised curb median equal to 16 ft (5 m); or
- all highways with proposed flush two-way, left-turn lane (TWLTL).

The raised curb median 16 ft (5 m) wide should only be considered in the reconstruction category where right-of-way is highly restricted.

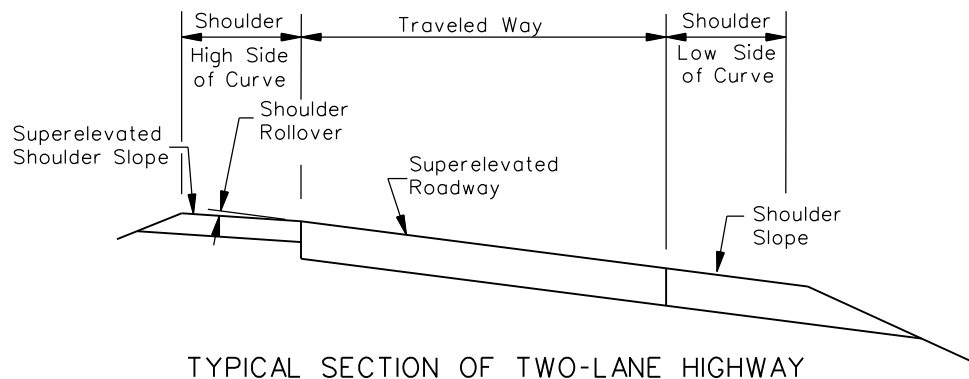

SHOULDER TREATMENT THROUGH SUPERELEVATED CURVE

Figure 32-3.H

32-3.04 Shoulder Superelevation

Figure 32-3.H illustrates the shoulder treatment on superelevated sections. The following discusses specific criteria.

32-3.04(a) **Shoulder (High Side of Curve)**

On the high side of superelevated sections, there will be a break in the cross slopes of the travel lane and shoulder. The following criteria will apply to this shoulder rollover:

1. Algebraic Difference. The rollover should not exceed 8.0% for new construction or reconstruction projects.
2. Minimum Shoulder Slope. On the high side of a curve, the shoulder slope may be designed for 0% so that maximum rollover is not exceeded. However, in this case, the longitudinal gradient at the edge of the traveled way should not be less than 0.5% for proper shoulder drainage.
3. Direction of Slope. If practical, the shoulder should slope away from the travel lane.
4. Shoulder as Deceleration Lane. Figure 36-2.L presents cross slope rollover criteria between a turning roadway and a through travel lane at an intersection. Where turning vehicles might use the shoulder, the designer may want to use the turning roadway rollover criteria (4.0% to 5.0%) rather than the 8.0% maximum rollover.

32-3.04(b) Shoulder (Low Side of Curve)

On the low side of a superelevated section, IDOT's typical practice is to retain the normal shoulder slope (4% typical) until the adjacent superelevated travel lane reaches that slope. The shoulder is then superelevated concurrently with the travel lane until the design superelevation rate is reached (i.e., the inside shoulder and travel lane will remain in a plane section).

32-3.05 Compound Curves

Superelevation development for compound curves requires the consideration of several factors. For two-lane roadways, these are discussed in the following sections for two Cases:

- Case I: The distance between the PC and PCC is 300 ft (90 m) or less.
- Case II: The distance between the PC and PCC is greater than 300 ft (90 m).

32-3.05(a) Case I

For Case I, superelevation development for compound curvature on two-lane roadways should meet the following objectives:

1. Relative Longitudinal Gradient (RS). A uniform RS should be provided throughout the superelevation transition (from normal crown section to design superelevation rate at the PCC).
2. Superelevation at PC. Section 32-3.02 will yield the design superelevation rate (e_1) for the first curve. At the PC, 67% e_1 should be reached.
3. Superelevation at PCC. The criteria in Section 32-3.02 will yield the design superelevation rate (e_2) for the second curve; e_2 should be reached at the PCC.
4. Superelevation Runoff Length. Section 32-3.02 will yield the superelevation runoff (L_1) for the first curve. The superelevation should be developed such that 67% of L_1 is reached at the PC.
5. Tangent Runout Length. TR will be determined as described in Section 32-3.02.

To meet all or most of these objectives, the designer may need to try several combinations of curve lengths, curve radii, and longitudinal gradients to find the most practical design. Section 32-3.08 presents a typical figure for Case I superelevation development for a compound curve.

32-3.05(b) Case II

For Case II, the distance between the PC and PCC (> 300 ft (90 m)) is normally large enough to allow the two curves to be evaluated individually. Therefore, the superelevation development on two-lane roadways should meet the following objectives for Case II:

1. First Curve. Superelevation should be developed assuming the curve is an independent simple curve. Therefore, the criteria in Section 32-3 for superelevation rate, transition length, and distribution between tangent and curve apply.
2. Intermediate Treatment. Superelevation for the first curve (e_1) is reached a distance of 33% of the superelevation runoff length beyond the PC. e_1 is maintained until it is necessary to develop the needed superelevation rate (e_2) for the second curve.
3. Second Curve. Assuming the second curvature has a sharper radius of curve than the first curve, a higher rate of superelevation will be required ($e_2 > e_1$). e_2 should be reached at the PCC. The distance needed for the additional superelevation development is not specified, except that the maximum RS for the highway design speed should not be exceeded. One logical treatment would be to apply the same RS used for the superelevation transition of the first curve. This would provide a uniform change in gradient for the driver negotiating the compound curve.

Section 32-3.08 presents a typical figure for Case II superelevation development for a compound curve.

32-3.05(c) Multilane Highways

Superelevation development for compound curvature on multilane highways should, as practical, be designed to:

- meet the principles of superelevation development for simple curves on multilane highways (see applicable criteria in Section 32-3); and
- meet the objectives for Case I or Case II as described for two-lane roadways.

The treatment for multilane highways will be determined on a case-by-case basis, reflecting individual site conditions.

32-3.06 Reverse Curves

Reverse curves are two closely spaced simple curves with deflections in opposite directions. For this situation, it may not be practical to achieve a normal crown section between the curves. A plane section continuously rotating about its axis (e.g., the centerline) can be maintained between the two curves, if they are close enough together. The designer should adhere to the applicable superelevation development criteria for each curve. The following will apply to reverse curves:

1. **Normal Section.** The designer should not attempt to achieve a normal tangent section between reverse curves unless the normal section can be maintained for a minimum of two seconds of travel time, and the superelevation transition requirements can be met for both curves. These criteria yield the following minimum tangent distance (between PT of first curve and PC of second curve) by using the following equation:

$$L_{\tan} \geq 0.67L_A + TR_A + 2(1.47V) + TR_B + 0.67L_B \quad (\text{US Customary}) \text{ Equation 32-3.7}$$

$$L_{\tan} \geq 0.67L_A + TR_A + 2(0.278V) + TR_B + 0.67L_B \quad (\text{Metric}) \text{ Equation 32-3.7}$$

where: L_{\tan} = Tangent distance between PT and PC, ft (m)
 L_A = Superelevation runoff length for first curve, ft (m)
 TR_A = Tangent runout length for first curve, ft (m)
 V = Design speed, mph (km/hr)
 TR_B = Tangent runout length for second curve, ft (m)
 L_B = Superelevation runoff length for second curve, ft (m)

2. **Continuously Rotating Plane.** If a normal section is not provided, the pavement will be continuously rotated in a plane about its axis. In this case, the minimum distance between the PT and PC will be 67% of each superelevation runoff requirement added together. Use the following equation:

$$L_{\tan} = 0.67L_A + 0.67L_B \quad \text{Equation 32-3.8}$$

where terms are as defined in No. 1 above.

Figure 32-3.1 illustrates superelevation development for reverse curves designed as a continuously rotating plane.

32-3.07 **Bridges**

Superelevation transitions should be avoided on bridges and their approaches. To achieve this in rural areas, the beginning of a horizontal curve should usually be a minimum of 400 ft (120 m) from the back of the bridge abutment. Where a curve is necessary on a bridge, the desirable treatment is to place the entire bridge and its approaches on a flat horizontal curve with minimum superelevation. In this case, a uniform superelevation rate is provided throughout (i.e., the superelevation transition is neither on the bridge nor its approaches). In some cases, however, superelevation transitions are unavoidable on urban bridges due to right-of-way constraints.

Where a bridge is located within a superelevated horizontal curve, the entire bridge roadway will be sloped in the same direction and at the same rate (i.e., the shoulder and travel lanes will be in a plane section). This also applies to the approach slab and approach slab shoulders before and after the back of the abutment. This is illustrated in Chapter 39. However, as discussed in Section 32-3.04, the high-side shoulder on a roadway section will slope away from the traveled way at a rate such that the maximum rollover does not exceed 8.0%.

Therefore, to not exceed the rollover criteria, it is necessary to transition the longitudinal shoulder slope adjacent to the roadway travel lanes to meet the shoulder slope adjacent to the travel lanes on the bridge. This transition should be accomplished by using a maximum relative longitudinal gradient of 0.40% between the edge of traveled way and outside edge of shoulder.

32-3.08 Typical Superelevation Figures

Figures 32-3.J through 32-3.M present superelevation development methods that will often be the most applicable to typical site conditions. Other superelevation methods or strategies may need to be developed on a case-by-case basis to meet specific field conditions. The acceptability of superelevation development methods other than those in the typical figures will be judged individually.

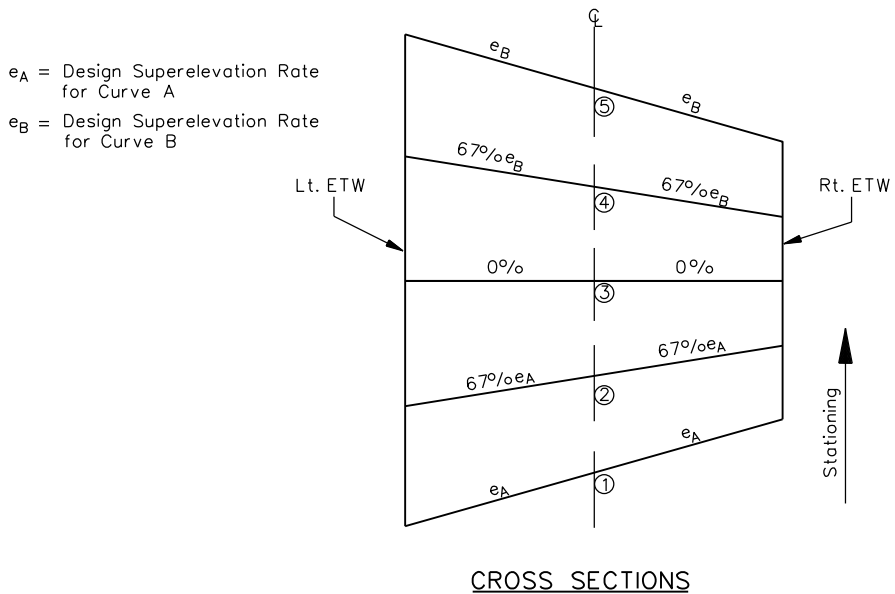
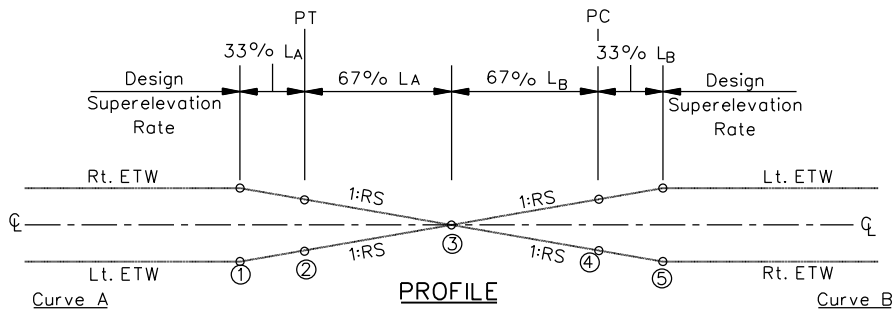
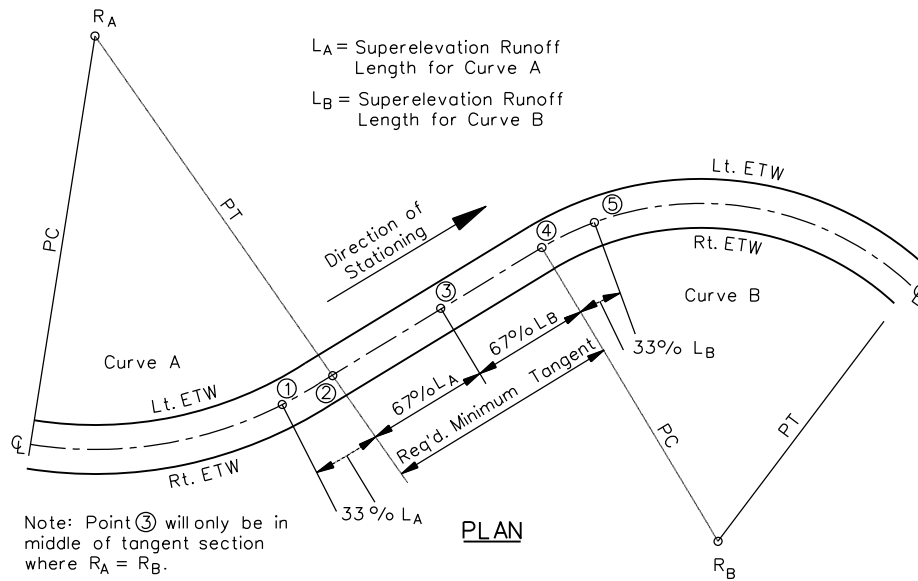

**SUPERELEVATION DEVELOPMENT FOR REVERSE CURVES
(Continuously Rotating Plane)**

Figure 32-3.I

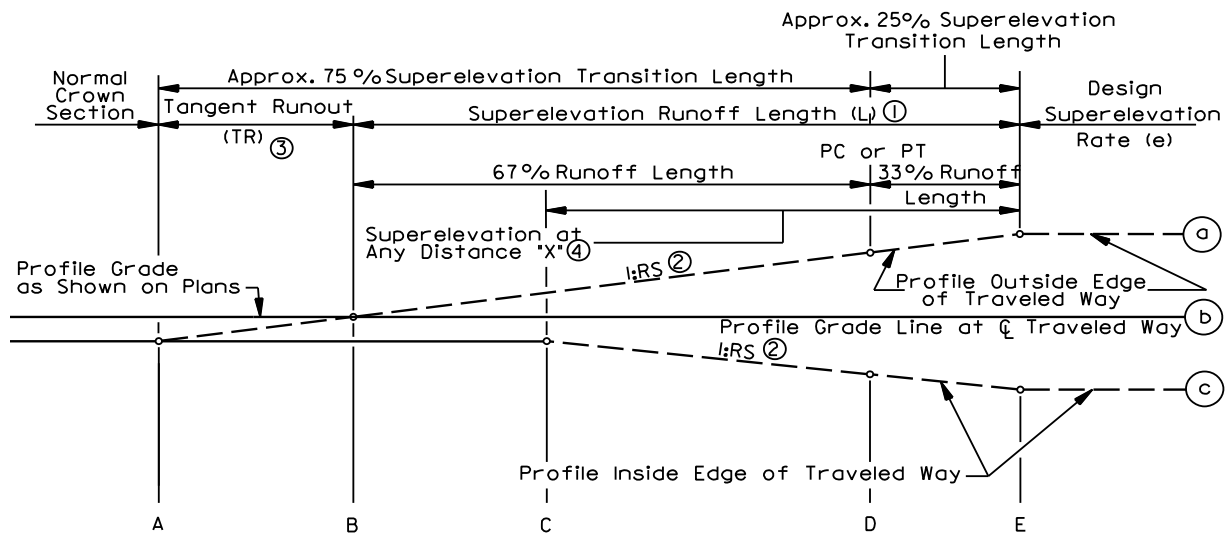

Note: Round all edge breakpoints in field.

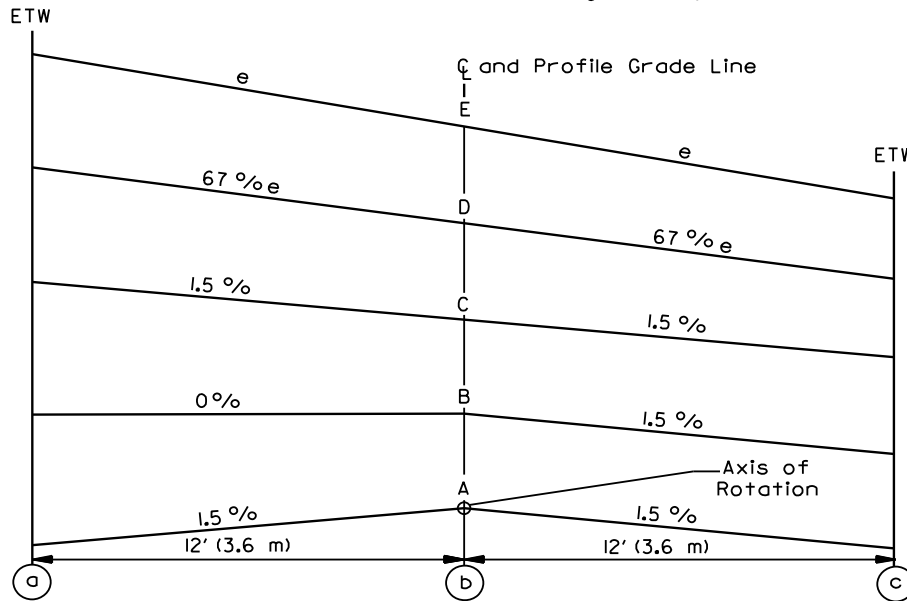

① $L_1 = e \times W \times RS$

See Section 32-3.02(a) for a discussion on superlevation runoff calculations.

② The relative gradient of the superlevation runoff (G_{SR}, decimal) is:

$G_{SR} = 12e/L_1$ (US Customary)
 $G_{SR} = 3.6e/L_1$ (Metric)
 $RS = 1/G_{SR}$

③ $Tangent\ Runout = \frac{S_{normal}}{e} (L_1)$

④ Superlevation rate (e) at any distance "X" up to full superlevation attainment

$$= 0.015 + \frac{G_{SR} \times Distance\ "X"}{12}$$
 (US Customary)

$$0.015 + \frac{G_{SR} \times Distance\ "X"}{3.6}$$
 (Metric)

**AXIS OF ROTATION ABOUT CENTERLINE
(Two-Lane Highway)**

FIGURE 32-3.J

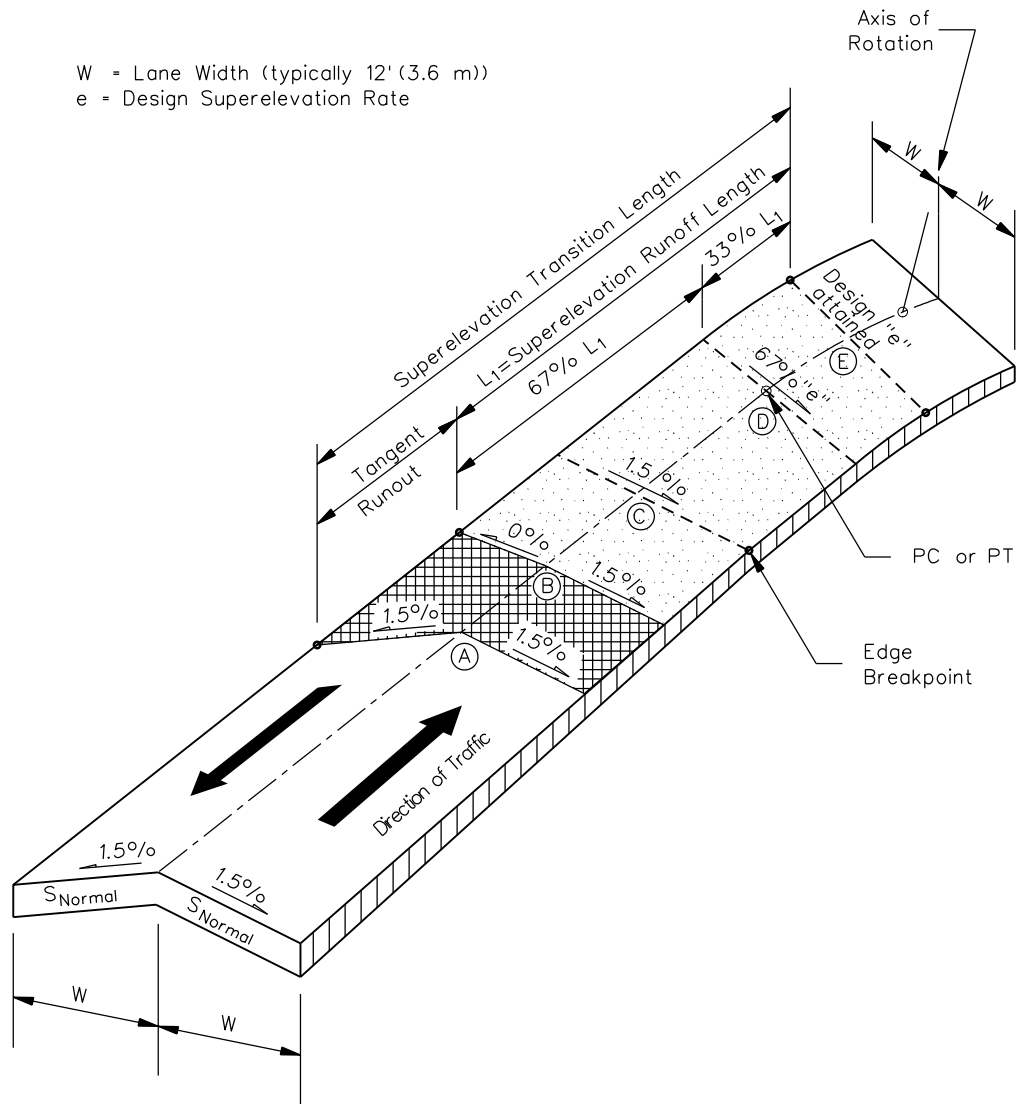

Note: Round all edge breakpoints in field.

**THREE-DIMENSIONAL VIEW OF SUPERELEVATION TRANSITION
 (Two-Lane Highway)**

Figure 32-3.K

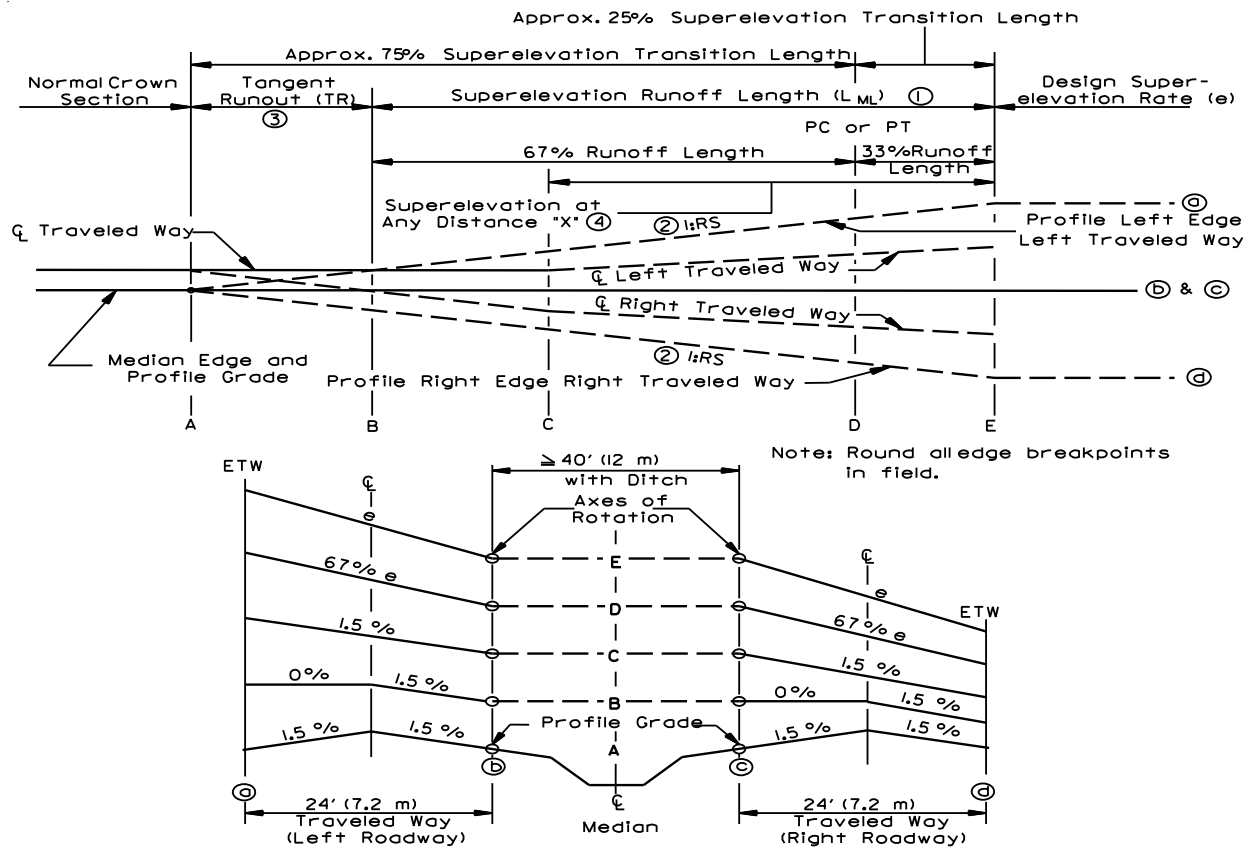

① $L_{ML} = L_1 \times C$.

See Section 32-3.02(b) for a discussion on multilane superelevation calculations

② The relative gradient of the superelevation runoff (G_{SR})

$$RS = \frac{1}{G_{SR}}$$

$$G_{SR} = \frac{(24)(e) - (0.015)(12)}{L_{ML}} \quad (\text{US Customary})$$

$$G_{SR} = \frac{(7.2)(e) - (0.015)(3.6)}{L_{ML}} \quad (\text{Metric})$$

③ $TR_{ML} = \frac{(0.015)(12)}{G_{SR}} \quad (\text{US Customary})$

$TR_{ML} = \frac{(0.015)(3.6)}{G_{SR}} \quad (\text{Metric})$

④ Superelevation rate at any distance up to full superelevation attainment =

$$0.015 + \frac{G_{SR} \times \text{Distance "X"}}{24} \quad (\text{US Customary})$$

$$0.015 + \frac{G_{SR} \times \text{Distance "X"}}{7.2} \quad (\text{Metric})$$

**AXIS OF ROTATION ABOUT MEDIAN EDGES OF TRAVELED WAY
(Four-Lane Divided Highways with a Depressed Median)**

Figure 32-3.L

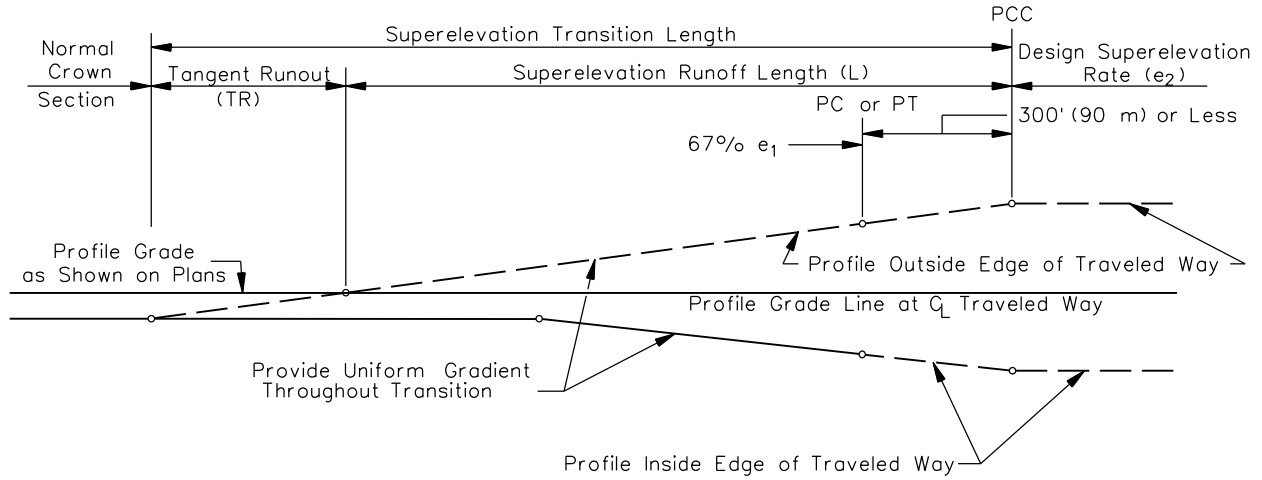

CASE I

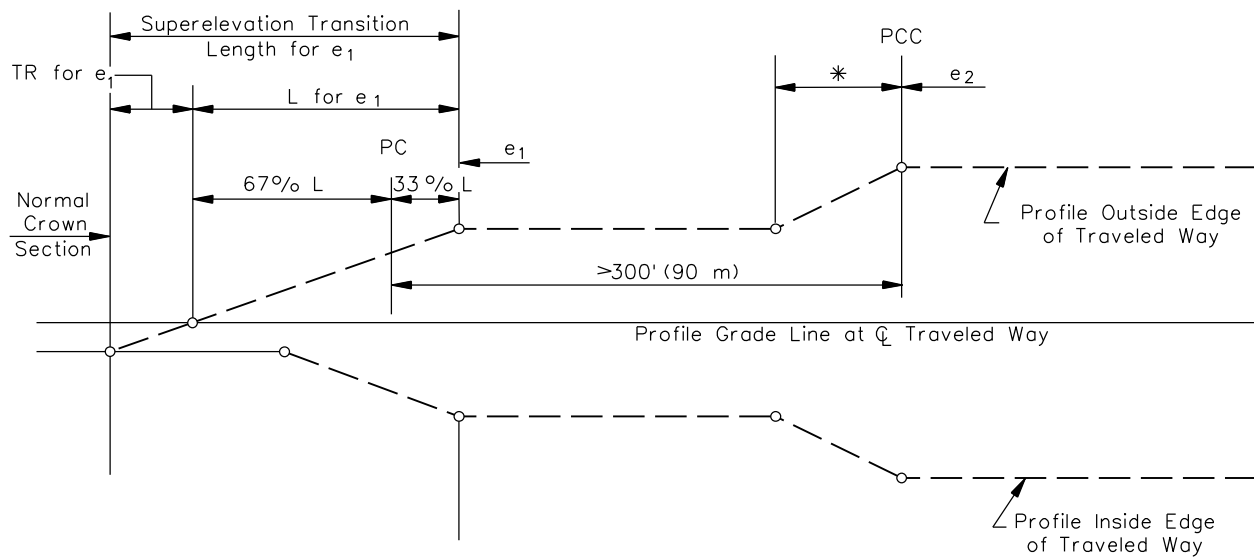

CASE II

* This distance may be determined by application of RS for the first curve to the increase in superelevation for the second curve (i.e., $e_2 - e_1$).

SUPERELEVATION DEVELOPMENT FOR COMPOUND CURVES

Figure 32-3.M

32-3.09 Examples

The following examples illustrate the application of the superelevation development criteria in Section 32-3.

Example 32-3.1

Given: Facility — New four-lane divided freeway with a depressed median
Travel lane cross slope = 3/16"/ft (on tangent) = 0.015 = S_{normal}
Crown at centerline of each roadway
Shoulder cross slope = 1/2"/ft (on tangent) = 0.04
Lane width = 12 ft
Inside shoulder width = 8 ft
Outside shoulder width = 10 ft
Median width = 56 ft
Design speed = 70 mph
 $R = 2500$ ft
PC = Station 65 + 50.00 (Curve to the right)

Note: Cross section A in Figure 32-3.N illustrates the typical tangent section.

Problem: With the axes of rotation about the median edges, determine the following details for superelevation development of the above horizontal curve:

- e_{max}
- design superelevation rate, e
- design superelevation runoff length, L_{ML}
- relative longitudinal gradients for superelevation runoff, G_{SR}
- tangent runout length, TR_{ML}
- shoulder rollover treatment, and
- reciprocal of relative longitudinal gradients (RS) between centerline and median edge of traveled way and between the two edges of the traveled way.

Solution: The details for the superelevated curve are determined as follows, and Figure 32-3.N presents the completed example and shows all stationing:

1. Determine e_{max}
Based on Figure 32-3.A, $e_{max} = 6.0\%$ for rural highways with open-roadway conditions ($V \geq 70$ mph).
2. Determine Design Superelevation Rate (e).
From Figure 32-3.C, for $R = 2500$ ft and $V = 70$ mph, $e = 5.8\%$.

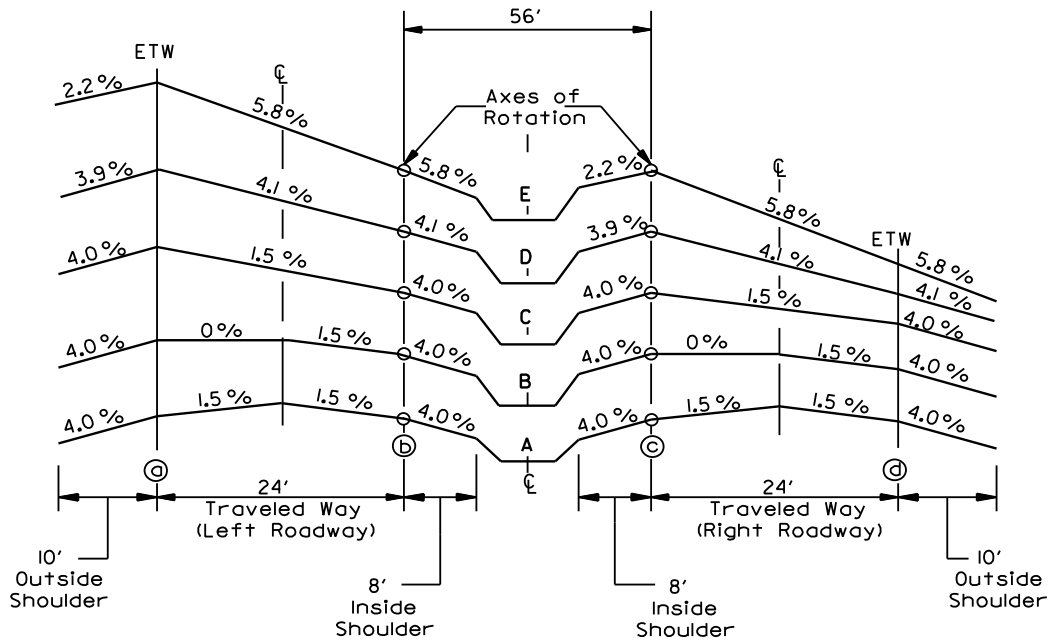
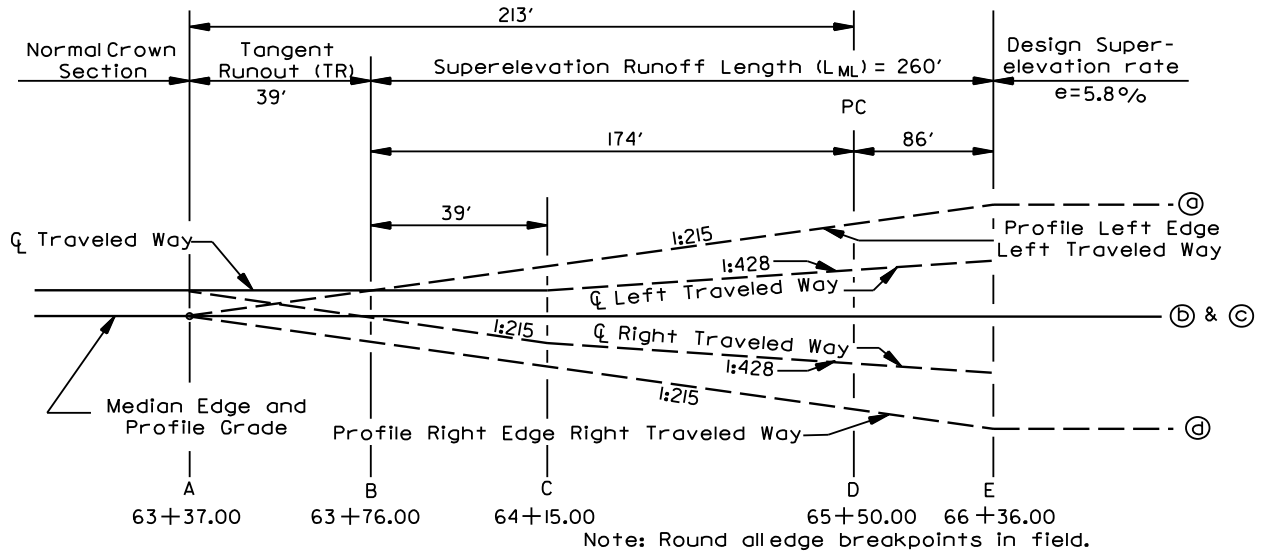

AXIS OF ROTATION ABOUT MEDIAN EDGES
(Example 32-3.1)

Figure 32-3.N

3. Determine Design Superelevation Runoff Length (L_{ML}).

For a divided highway with a 56 ft depressed median, rotate the travel lanes about the two median edges.

From Figure 32-3.E, for a four-lane divided highway, $L_{ML} = 261$ ft

To calculate L_{ML} :

Based on Equation 32-3.4, runoff length (L_{ML}) is equal to $(L_1) \times (C)$.

Using Equation 32-3.1 to calculate $L_1 = (e)(W)(RS)$

From Figure 32.3.F, $RS = 250$

Therefore, $L_1 = (0.058)(12)(250) = 174$ ft

From Figure 32-3.G, the "C" ratio for rotating two lanes about the median edge is = 1.5.

Therefore: $L_{ML} = (L_1)(C) = (174)(1.5) = 261$ ft Use 260 ft

Distribution of L_{ML} is $67\%(260) = 174$ ft on tangent and $33\%(260) = 86$ ft on curve.

4. Determine Tangent Runout Length (TR).

Use Equation 32-3.5 to calculate the relative longitudinal gradient of the superelevation runoff:

$$G_{SR} = \frac{(2W)(e) - (S_{normal})(W)}{L_{ML}}$$

$$G_{SR} = \frac{(2)(12)(0.058) - (0.015)(12)}{260}$$

$$G_{SR} = 0.0046615 \quad RS_{SR} = (1/G_{SR}) = 215$$

Use Equation 32-3.6 to calculate the tangent runout:

$$TR_{ML} = (S_{normal})(W)(RS_{SR})$$

$$TR_{ML} = (0.015)(12)(215)$$

$$TR_{ML} = 38.7 \text{ ft} \approx 39 \text{ ft}$$

5. Determine Shoulder Rollover Treatment.

Desirably, the maximum shoulder rollover on the high side of each curve should not exceed 8.0%. Therefore, with a shoulder cross slope of 4.0% on tangent, begin rotating the high-side shoulder where the travel lanes reach a superelevation rate of -4.0% (negative sign for downward slope away from the shoulder break). To determine where $e = 4.0\%$, use $G_{SR} = 0.0046615$ for the superelevation runoff length.

Next, use the equation in Note ④ from Figure 32-3.L and set the superelevation rate to 4% to calculate the distance X from Section C:

$$e_x = 0.015 + \frac{G_{SR} \times \text{Distance "X"}}{24}$$

$$X = \frac{(24)(e_x - 0.015)}{G_{SR}}$$

$$X = \frac{(24)(0.04 - 0.015)}{0.0046615}$$

$$X = 128.71 \text{ ft (from Section C)}$$

On the high-side of each roadway, the shoulder slope remains at 4% until the superelevation rate equals 4%, which will occur at 128.71 ft beyond where the travelways become planar (Section C). Once 4% is attained, the high-side shoulder is rotated such that the shoulder rollover remains at 8% until reaching the design superelevation rate and remains at this slope until the pattern is reversed when superelevation starts transitioning again. Where the superelevation reaches 5.8%, the shoulder will be sloped 2.2% away from the traveled way. See Figure 32-3.N for schematic details.

6. Determine Relative Longitudinal Slopes (RS).

The RS values and relative gradients can be calculated using the basic equation:

$$RS = \frac{\text{Length of Transition}}{\Delta \text{ Elevation}}; G(\%) = \frac{1}{RS} \times 100$$

a. Between Two Edges of Traveled Way.

As previously calculated in Step 4:

$$G (\%) = 0.0046615 \times 100 = 0.47\%$$

$$RS = 215$$

b. Between Median Edge and Centerline.

Determine G_{CL} , which is the longitudinal gradient of the centerline relative to the median edge:

$$G_{CL} = \frac{(e \times W) - (\text{cross slope@Section C} \times W)}{\text{Length of slope along median edge}}$$

$$G_{CL} = \frac{(0.058 \times 12) - (0.015 \times 12)}{(174 + 86) - 39}$$

$$G_{CL} = \frac{0.696 - 0.18}{221} = 0.0023348 = 0.23\%$$

$$RS_{CL} = \left(\frac{1}{G_{CL}} \right) = 428$$

Example 32-3.2

Given: Facility — Four-lane divided highway with raised-curb median (open suburban area likely to become closed suburban within 10 years)
Travel lane width = 12 ft
Travel lane cross slope = 1/4"/ft (on tangent) = 0.02 = S_{normal}
Travel lanes all slope away from median edges
Gutter width = 2 ft
Gutter cross slope = 3/4"/ft (on tangent) = 0.06
Median gutter slopes towards median
Outside gutter slopes away from traveled way
Median width = 22 ft
Design speed = 50 mph and will post at 45 mph.
 $R = 1800$ ft
PC = Station 65 + 50.00 (Curve to Right)
Superelevation runoff is distributed 67% on tangent and 33% on curve.

Note: Cross section A in Figure 32-3.O illustrates the tangent section.

Problem: With the axes of rotation about the median edges, determine the following details for superelevation development of the above horizontal curve:

- e_{max}
- design superelevation rate, e
- design superelevation runoff length, L_{ML}
- relative longitudinal gradient for superelevation runoff, G_{SR}
- tangent runout length, TR_{ML}
- gutter treatment, and
- reciprocal of relative longitudinal gradients (RS) between the two outside edges of traveled way and between the centerline and median edge of traveled way.

Solution: The details of the superelevated curve are determined as follows, and Figure 32-3.O presents the completed example and shows all stationing:

1. Determine e_{max} .

Based on Figure 32-3.A, $e_{max} = 4.0\%$ for an open suburban area likely to become closed suburban within next 10 years ($V = 50$ mph).

2. Determine Design Superelevation Rate (e).

From Figure 32-3.D, for $R = 1800$ ft and $V = 50$ mph, $e = 3.4\%$.

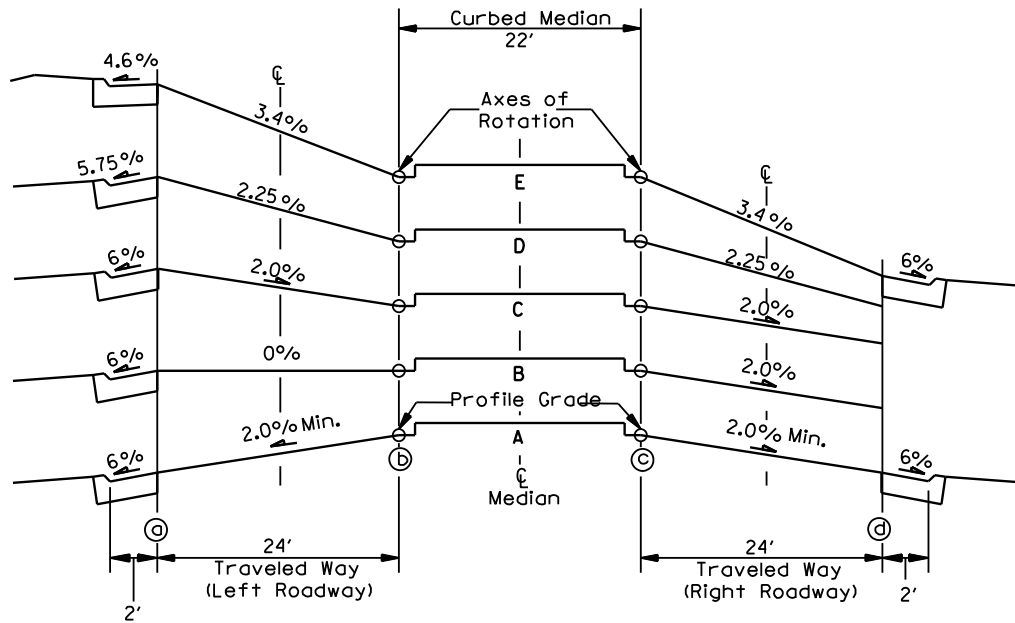
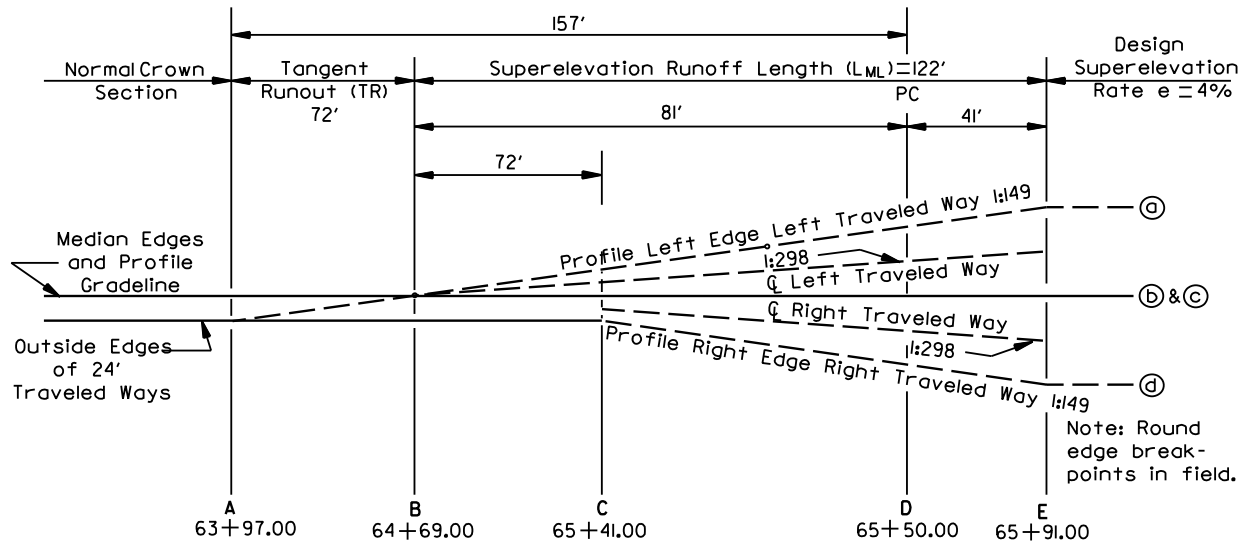

**AXIS OF ROTATION ABOUT MEDIAN EDGES
(Multilane Highway With Curbed Median)
(Example 32-3.2)**

Figure 32-3.0

3. Determine Design Superelevation Runoff Length (L_{ML}).

For a divided highway with a 22 ft raised-curb median, rotate the travel lanes about the two median edges.

From Figure 32-3.E, for a four-lane divided highway, $L_{ML} = 122$ ft

To calculate L_{ML} :

Based on Equation 32-3.4, runoff length (L_{ML}) is equal $(L_1) \times (C)$.

Using Equation 32-3.1 to calculate $L_1 = (e)(W)(RS)$

From Figure 32-3.F, $RS = 200$

Therefore, $L_1 = (0.034)(12)(200) = 81.6$ ft

From Figure 32-3.G, the “C” ratio for rotating two lanes about the median edge is = 1.5.

Therefore, $L_{ML} = (L_1)(C) = 81.6 \times 1.5 = 122.4$ ft. Use $L_{ML} = 122.4$ ft.

Distribution of L_{ML} is 67% (122) = 81 ft on tangent and 33% (122) = 41 ft on curve.

4. Determine Tangent Runout Length (TR).

Because the typical section includes a uniform cross slope across the traveled way, modify Equation 32-3.2 for multi-lanes, using the runoff length (L_{ML}), and calculate the tangent runout (TR_{ML}):

$$TR_{ML} = \frac{S_{normal}}{e} (L_{ML})$$

$$TR_{ML} = \frac{0.02}{0.0034} (122)$$

$$TR_{ML} = 71.6 \text{ ft} \approx 72 \text{ ft}$$

5. Determine Outside Gutter Treatment.

On the low side of each traveled way, the slope gutters will remain at the standard 6% throughout the curve. On the high side of each traveled way, the gutters will be set at 6% until an 8% breakover occurs between the gutter pans and the adjacent pavement. From this point, the cross slope of the gutter pans on the high side are rotated with the roadway through the superelevation transition maintaining an 8% breakover. See Figure 48-5.E. Therefore, with a gutter slope of 6%, keep the high side gutter slopes at 6% up to the location where the superelevation rate is 2% downward away from the gutters. To determine where $e = 2\%$, first use the equation in Note ② from Figure 48-5.E to determine the relative longitudinal gradient for the superelevation runoff length:

$$G_{SR} = \frac{24e}{L_{ML}} = \frac{(24)(0.034)}{122}$$

$$G_{SR} = 0.00669$$

$$RS_{SR} = (1/G_{SR}) = 149$$

Next, use the equation in Note ④ from Figure 48-5.E and set the superelevation rate to 2%. Calculate distance X:

$$e_x = \frac{G_{SR} \times \text{Distance "X"}}{24}$$

$$X = \frac{(24)(e_x)}{G_{SR}} = \frac{(24)(0.02)}{0.00669}$$

$$X = 71.75 \text{ ft}$$

On the high side of the traveled ways, the gutter slope remains at 6% until the superelevation rate equals 2%, which occurs 71.75 ft beyond the end of the tangent runout. Once 2% is attained on each traveled way, the gutter is rotated up until reaching the location of the design superelevation rate. Where e reaches 3.4%, the gutter is sloped at 4.6% away from the traveled way and remains at this slope until the pattern is reversed when superelevation starts transitioning again. See Figure 32-3.O.

6. Determine Relative Longitudinal Slopes (RS).

The RS values and relative gradients can be calculated using the basic equation:

$$RS = \frac{\text{Length of Transition}}{\Delta \text{ Elevation}}; G(\%) = \frac{1}{RS} \times 100$$

a. Outside Edges of the Traveled Way. Previously calculated in Step 5:

$$G(\%) = 0.00669 \times 100 = 0.669\%$$

$$RS = 149$$

b. Centerline of Each Traveled Way. Determine G_{CL} , which is the longitudinal gradient of the centerline relative to the median edge:

$$G_{CL} = \frac{(e \times W_L) - (\text{cross slope @ Section C} \times W_L)}{\text{Length of slope along median edge}}$$

$$G_{CL} = \frac{(0.034 \times 12) - (0.02 \times 12)}{(81 - 72) + 41}$$

$$G_{CL} = \frac{0.408 - 0.24}{50} = 0.00336 = 0.336\%$$

$$RS_{CL} = \left(\frac{1}{G_{CL}} \right) = 298$$

32-4 HORIZONTAL SIGHT DISTANCE

32-4.01 Sight Obstruction (Definition)

Sight obstructions on the inside of a horizontal curve are defined as obstacles of considerable length which interfere with the line of sight on a continuous basis. These include walls, cut slopes, wooded areas, buildings, and high farm crops. In general, point obstacles such as traffic signs and utility poles are not considered sight obstructions on the inside of horizontal curves. The designer must examine each curve individually to determine whether it is necessary to remove an obstruction or adjust the horizontal alignment to obtain the required sight distance.

32-4.02 Length > Sight Distance

Where the length of curve (L) is greater than the sight distance (S) used for design, the needed clearance on the inside of the horizontal curve is calculated using the following equation:

$$\text{HSO} = R \left(1 - \cos \left[\frac{28.65S}{R} \right] \right) \quad \text{Equation 32-4.1}$$

where: HSO = Middle ordinate, or horizontal sightline offset from the center of the inside travel lane to the obstruction, ft (m)

 R = Radius of curve, ft (m)

 S = Sight distance, ft (m)

32-4.02(a) **Stopping Sight Distance (SSD)**

At a minimum, SSD will be available throughout the horizontal curve. The following discusses the application of SSD to sight distance at horizontal curves:

1. Passenger Cars (Level Grade). Figure 32-4.A provides the horizontal clearance criteria (i.e., horizontal sightline offset) for various combinations of stopping sight distance (see Figure 31-3.A) and curve radii for passenger cars on level grades. For those selections of S which fall outside of the figure (i.e., HSO > 40 ft (12 m) and/or R < 100 ft (50 m)), the designer should use Equation 32-4.1 to calculate the needed clearance.
2. Passenger Cars (Downgrade Adjustment). Figure 31-3.B presents SSD values for passenger cars adjusted for 3%-10% downgrades. If the downgrade on the facility is 3% or steeper, the designer should consider providing horizontal clearances adjusted for grade. These SSD values should be used directly in Equation 32-4.1 to calculate the horizontal sightline offset.

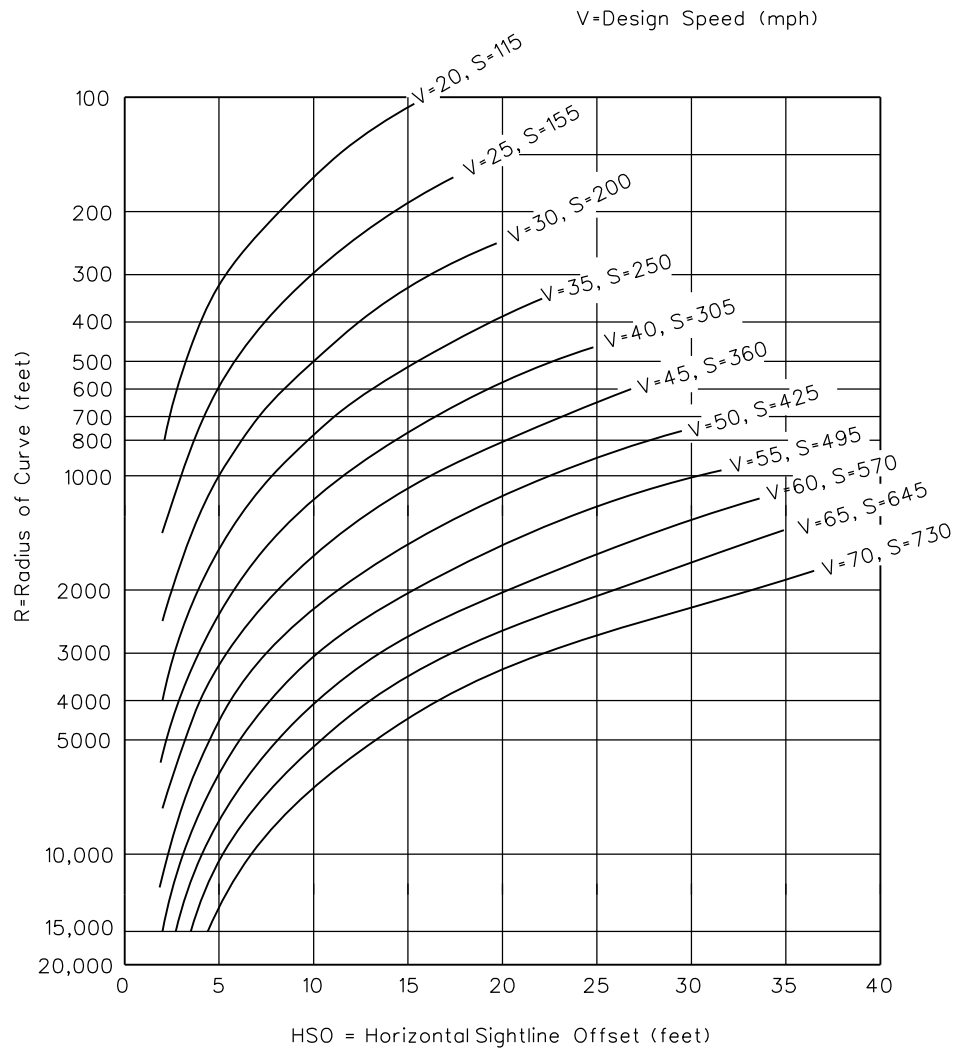
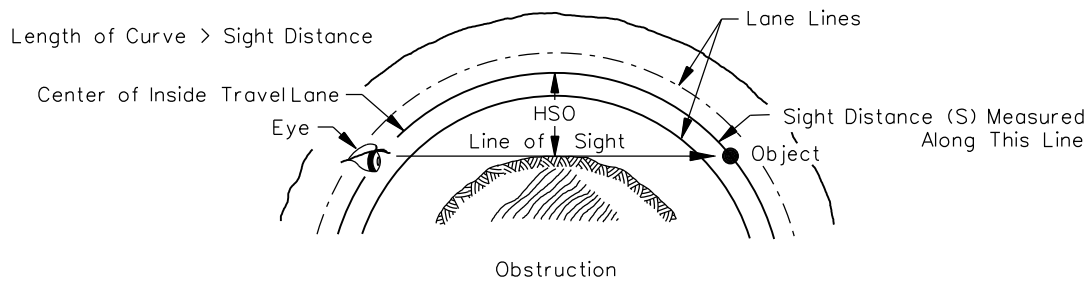

SIGHT DISTANCE AT HORIZONTAL CURVES (SSD) (US Customary)

Figure 32-4.A

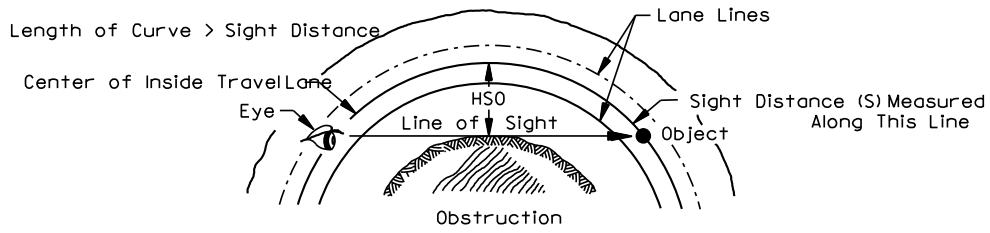

V=Design Speed (km/h)

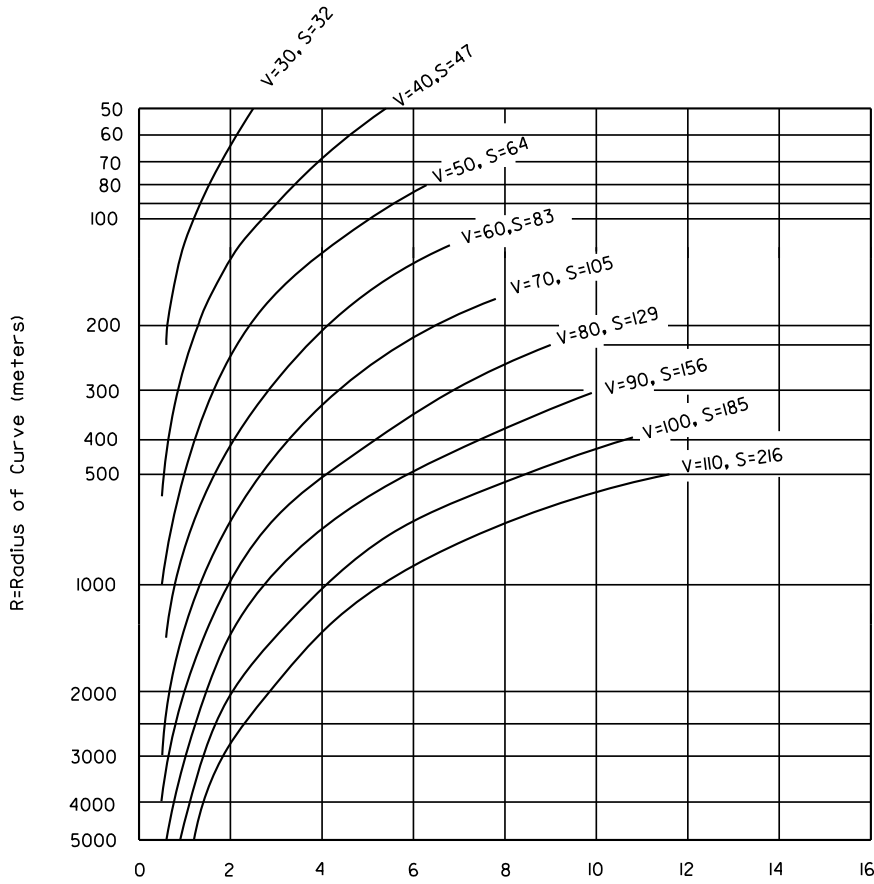

HSO = Horizontal Sight Line Offset (meters)

SIGHT DISTANCE AT HORIZONTAL CURVES (SSD) (Metric)

Figure 32-4.A

32-4.02(b) Other Sight Distance Criteria

At some locations, it may be warranted to provide SSD for decision sight distance or passing sight distance at the horizontal curve. Section 31-3 discusses candidate sites and provides design values for decision sight distance. Section 47-2 discusses passing sight distance on rural two-lane highways. These “S” values should be used in the basic equation to calculate “HSO” (Equation 32-4.1).

32-4.02(c) Entering/Exiting Portions (Typical Application)

The HSO values from Figure 32-4.A apply between the PC and PT. In addition, some transition is needed on the entering and exiting portions of the curve. The designer should typically use the following steps:

- Step 1: Locate the point which is on the outside edge of shoulder and a distance of $S/2$ before the PC.
- Step 2: Locate the point which is a distance HSO measured laterally from the center of the inside travel lane at the PC.
- Step 3: Connect the two points located in Steps 1 and 2. The area between this line and the roadway should be clear of all continuous obstructions.
- Step 4: A symmetrical application of Steps 1 through 3 should be used beyond the PT.

The example on Figure 32-4.B illustrates the determination of clearance requirements for the entering and exiting portions of a curve.

32-4.03 Length < Sight Distance

When the length of curve is less than the sight distance used in design, the HSO value from the basic equation will never be reached. As an approximation, the horizontal clearance for these curves should be determined as follows:

- Step 1: For the given R and S, calculate HSO assuming $L < S$.
- Step 2: The maximum HSO' value will be needed at a point of $L/2$ beyond the PC. Using Equation 32-4.2, HSO' is calculated from the following proportion:

$$\frac{\text{HSO}'}{\text{HSO}} = \frac{1.2L}{S}$$

$$\text{HSO}' = \frac{1.2(L)(\text{HSO})}{S}$$

Equation 32-4.2

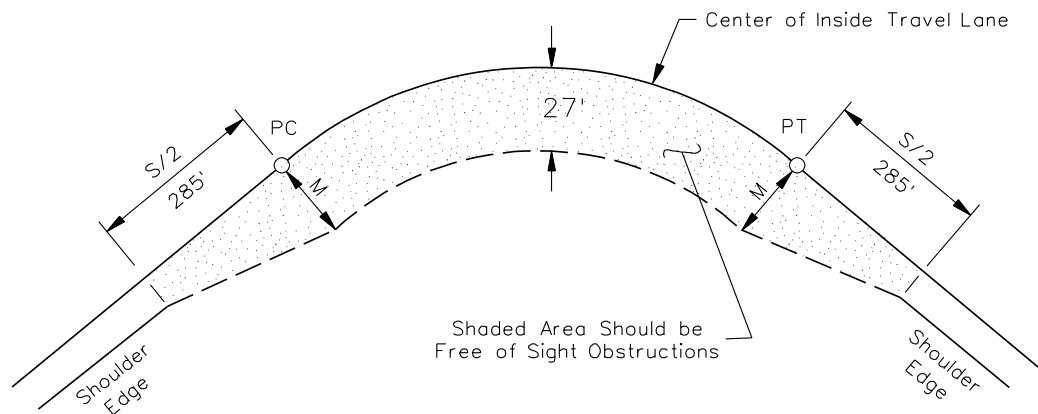
**Example 32-4.1**

Given: Design Speed = 60 mph
 R = 1500 ft
 Level Grade

Problem: Determine the horizontal sightline offset requirements for a horizontal curve on a two-lane highway assuming passenger car SSD.

$$HSO = R \left(1 - \cos \left[\frac{28.65 S}{R} \right] \right)$$

$$HSO = 1500 \left(1 - \cos \left[\frac{(28.65)(570)}{1500} \right] \right) = 27 \text{ ft}$$

Solution: Figure 31-3.A yields a SSD = 570 ft. Using Equation 32-4.1 for horizontal clearance ($L > S$):

This answer is verified by Figure 32-4.A.

The above figure also illustrates the horizontal clearance requirements for the entering and exiting portion of the horizontal curve.

**SIGHT CLEARANCE REQUIREMENTS FOR HORIZONTAL CURVES
 ($L > S$)**

Figure 32-4.B

- where:
- HSO' = Horizontal sightline distance for a curve where $L < S$, ft (m)
 - HSO = Horizontal sightline distance for the curve based on Equation 32-4.1, ft (m)
 - L = Length of the curve, ft (m)
 - S = Sight distance, ft (m)

- Step 3: Locate the point which is on the outside edge of shoulder and a distance of $S/2$ before the PC.
- Step 4: Connect the two points located in Steps 2 and 3. The area between this line and the roadway should be clear of all continuous obstructions.
- Step 5: A symmetrical application of Steps 2-4 should be used on the exiting portion of curve.

The Example on Figure 32-4.C illustrates the determination of clearance requirements for the entering and exiting portions of a curve where $L < S$.

32-4.04 Application

For sight distance applications at horizontal curves, the height of eye is 3.5 ft (1080 mm) and the height of object is 2 ft (600 mm). Both the eye and object are assumed to be in the center of the inside travel lane. The line-of-sight intercept with the obstruction is at the midpoint of the sightline and 2.75 ft (840 mm) above the center of the inside lane.

32-4.05 Longitudinal Barriers

Longitudinal barriers (e.g., bridge rails, guardrail, concrete barrier) can cause sight distance problems at horizontal curves because barriers are placed relatively close to the travel lane (often, 10 ft (3 m) or less) and because their height may be greater than 2.75 ft (840 mm).

The designer should check graphically the line of sight over a barrier along a horizontal curve and determine what height of object can actually be discerned. If this is higher than 2.75 ft (840 mm), the designer should attempt, if practical, to locate the barrier so that it does not block the line of sight. The following should be considered:

1. Superelevation. A superelevated roadway will elevate the driver's eye and, therefore, improve the line of sight over the barrier.
2. Barrier Height. The higher the barrier, the more obstructive it will be to the line of sight.

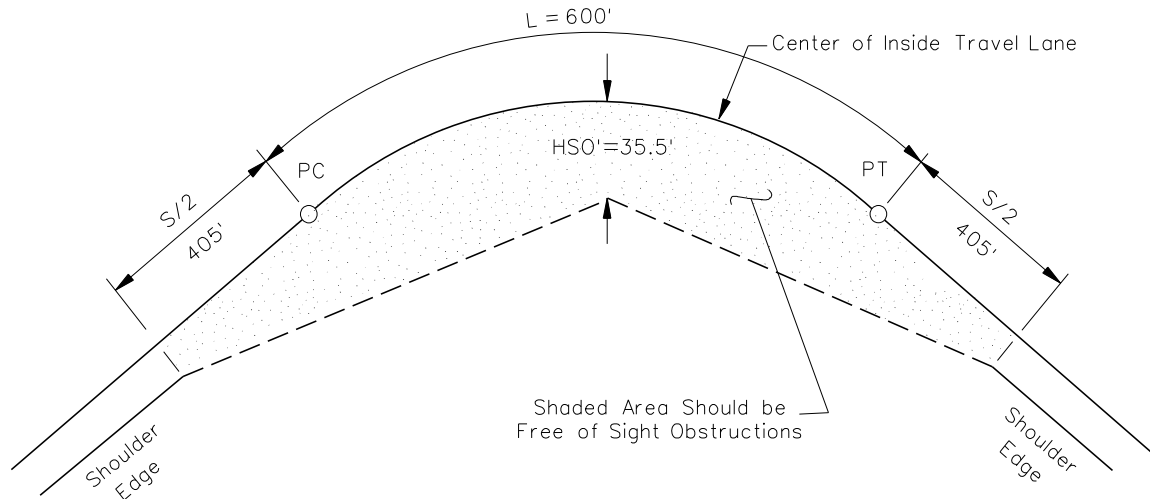

Example 32-4.2

Given: Design Speed = 70 mph
 $R = 2050$ ft
 $L = 600$ ft
 Grade = 5.0% downgrade

Problem: Determine the horizontal sightline offset requirements for the horizontal curve on a two-lane highway assuming passenger car SSD.

Solution: Because the downgrade is greater than 3.0%, the curve should desirably be designed for passenger cars adjusted for grade. Figure 31-3.C yields a SSD of 810 ft for 70 mph and a 5.0% downgrade. Therefore, $L < S$ (600 ft) < 810 ft, and the horizontal clearance is calculated from Equation 32-4.2 as follows:

$$HSO (L > S) = 2050 \left[1 - \cos \frac{(28.65)(810)}{2050} \right] = 39.88 \text{ ft}$$

$$HSO' (L < S) = \frac{1.2(600)(39.88)}{810}$$

$$HSO' = 35.5 \text{ ft}$$

Therefore, a minimum clearance of 35.5 ft should be provided at a distance of $L/2 = 300$ ft beyond the PC. The obstruction-free triangle around the horizontal curve would be defined by HSO' (35.5 ft) at $L/2$ and by points at the shoulder edge at $S/2 = 405$ ft before the PC and beyond the PT.

SIGHT CLEARANCE REQUIREMENTS FOR HORIZONTAL CURVES ($L < S$)

Figure 32-4.C

Each barrier location adjacent to a horizontal curve will require an individual analysis to determine its impacts on the line of sight. The designer must determine the elevation of the driver eye (3.5 ft (1080 mm) above the pavement surface), the elevation of the object (2 ft (600 mm)) above the pavement surface, and the elevation of the barrier where the line of sight intercepts the barrier run. If the barrier does block the line of sight to a 2 ft (600 mm) object, the designer should consider relocating the barrier or revising the horizontal alignment. If the barrier blocks the sight line needed for SSD on the mainline, it will be necessary to obtain a design exception.

32-4.06 Compound Curves

When a compound curve exists or is proposed on mainline highway, the designer should check sight distance across the inside of the curve graphically or, for a more accurate determination, the designer can use the Department's approved software program for cross sections and earthwork. Once detailed cross sections are finalized using the software package, the designer can also request 3D plots of the alignments to determine the view of the roadway ahead, which can then be reviewed for available sight distance.

32-5 DESIGN CONTROLS

As discussed elsewhere in Chapter 32, the design of horizontal alignment involves, to a large extent, complying with specific limiting criteria. These include minimum radii, superelevation rates, and sight distance around curves. In addition, the designer should adhere to certain design principles and controls that will determine the overall safety of the facility and will enhance the aesthetic appearance of the highway. These design principles include:

1. Consistency. Alignment should be consistent. Avoid sharp curves at the ends of long tangents and sudden changes from gentle to sharply curving alignment.
2. Directional. Alignment should be as directional as practical and consistent with physical and economic constraints. On divided highways, a flowing line that conforms generally to the natural contours is preferable to one with long tangents that slash through the terrain. Directional alignment will be achieved by using the smallest practical central angles.
3. Use of Minimum Radii. Avoid the use of minimum radii, if practical, especially in level terrain.
4. High Fills. Avoid sharp curves on long, high fills. Under these conditions, it is difficult for drivers to perceive the extent of horizontal curvature.
5. Alignment Reversals. Avoid abrupt reversals in alignment (reverse curves). Provide a sufficient tangent distance between the curves to ensure proper superelevation transitions for both curves and to allow time for the motorist to perceive the next decision point.
6. Broken-Back Curvature. Avoid where possible. This arrangement is not aesthetically pleasing, violates driver expectancy, and creates undesirable superelevation development requirements.
7. Compound Curves. Do not use compound curves on the highway mainline.
8. Coordination with Natural/Man-Made Features. The horizontal alignment should be properly coordinated with the existing alignment at the ends of new projects, natural topography, available right-of-way, utilities, roadside development, and natural/man-made drainage patterns.
9. Environmental Impacts. Horizontal alignment should be properly coordinated to minimize environmental impacts (e.g., encroachment onto wetlands).
10. Intersections. Horizontal alignment through intersections may present special problems (e.g., intersection sight distance, superelevation development crossover crowns). See Chapter 36 for the design of intersections.
11. Coordination with Vertical Alignment. Chapter 33 discusses general design principles for the coordination between horizontal and vertical alignment.

12. Bridges. Horizontal alignment must be coordinated with the location of bridges. The need for curvature and superelevation development should be evaluated for each bridge location. Crossing angles between the mainline and other features must also be considered. See Chapter 39 for additional information on horizontal alignment at bridges.

32-6 MATHEMATICAL DETAILS FOR HORIZONTAL CURVES

This Section presents mathematical details used by IDOT for various applications to the design of horizontal curves. The chart below summarizes the figures in Section 32-6. For ease of solving any horizontal alignment problems, the designer should refer to the Department's approved software program. The part of the program entitled "Coordinate Geometry" provides the necessary tools to solve most alignment problems.

Figure Number	Figure Title
Figure 32-6.A	Basic Trigonometric Formulas (Right Triangle Solution)
Figure 32-6.B	Basic Trigonometric Formulas (Oblique Triangle Solution)
Figure 32-6.C	Simple Curve Elements
Figure 32-6.D	Curve Symbols, Abbreviations and Formulas
Figure 32-6.E	Simple Curves (Geometric Principles)
Figure 32-6.F	Simple Curves (Various Elements)
Figure 32-6.G	Simple Curve Computation (Example)
Figure 32-6.H	Simple Curves (Stationing)
Figure 32-6.I	Curve Computation (Different Radius, Tangent Offset & Parallel)
Figure 32-6.J	Curve Computation (Compute PC & PT, Joining Parallel Tangent Offsets)
Figure 32-6.K	Curve Computation (Between Two Fixed Curves)
Figure 32-6.L	Curve Computation (Between a Fixed Curve and Fixed Tangent)
Figure 32-6.M	Curve (Establish a Tangent Between Two Curves)
Figure 32-6.N	Curve Introduction
Figure 32-6.O	Curve Introduction
Figure 32-6.P	Alignment (Common Point of Tangency for Two Curves)
Figure 32-6.Q	Common Point of Tangency for Two Curves (Sample Problem)
Figure 32-6.R	POC Computation Using Right Triangles
Figure 32-6.S	POC Computation Using Right Triangles (Sample Problem)
Figure 32-6.T	POC Computation Using Right Triangles
Figure 32-6.U	POC Computation Using Right Triangles (Sample Problem)
Figure 32-6.V	POC Computation Using Oblique Triangle
Figure 32-6.W	POC Computation Using Oblique Triangle (Sample Problem)
Figure 32-6.X	POC of Line 90° to Curve Tangent
Figure 32-6.Y	Reverse Curves to Parallel Tangents
Figure 32-6.Z	Reverse Curves to Parallel Tangents (Sample Problem)
Figure 32-6.AA	Reverse Curves (Tangents Not Parallel)
Figure 32-6.BB	Reverse Curves (Between Parallel Curves)
Figure 32-6.CC	Reverse Curves (Parallel Tangents with Tangent Segment Between)
Figure 32-6.DD	Curve Between Fixed Tangent and Fixed Curve (Case I)
Figure 32-6.EE	Curve Between Fixed Tangent and Fixed Curve (Case I) (Sample Problem)
Figure 32-6.FF	Curve Between Fixed Tangent and Fixed Curve (Case II)
Figure 32-6.GG	Curve Between Fixed Tangent and Fixed Curve (Case III)
Figure 32-6.HH	Curve Between Fixed Tangent and Fixed Curve (Case IV)
Figure 32-6.II	Curve Between Fixed Tangent and Fixed Curve (Case V)

MATHEMATIC DETAILS FOR HORIZONTAL CURVES

Table 32-6.A

(1 of 2)

Figure Number	Figure Title
Figure 32-6.JJ	Three Curves Tangent to Each Other
Figure 32-6.KK	Intersection of Two Curves
Figure 32-6.LL	Simple Curve with Spirals
Figure 32-6.MM	Spiral Curve Nomenclature
Figure 32-6.NN	Spiral Curve Formulas
Figure 32-6.OO	Three-Centered Compound Curve
Figure 32-6.PP	Two-Centered Compound Curve

MATHEMATIC DETAILS FOR HORIZONTAL CURVES**Table 32-6.A**

(2 of 2)

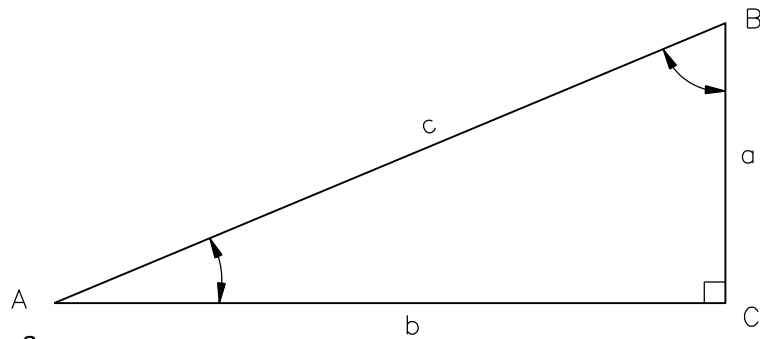

1. $\sin A = \frac{a}{c}$
2. $\cos A = \frac{b}{c}$
3. $\tan A = \frac{a}{b}$
4. $\csc A = \frac{1}{\sin A} = \frac{c}{a}$
5. $\sec A = \frac{1}{\cos A} = \frac{c}{b}$
6. $\cot A = \frac{1}{\tan A} = \frac{b}{a}$
7. $a^2 + b^2 = c^2$
8. $\text{Area} = \frac{1}{2} ab$
9. $A + B = 90^\circ$

**BASIC TRIGONOMETRIC FORMULAS
(Right Triangle Solution)**

Figure 32-6.A

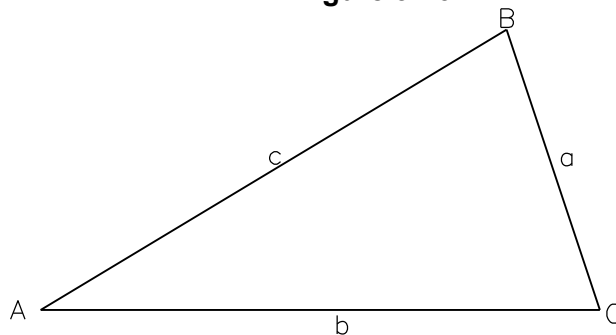

1. $a = \frac{c \sin A}{\sin C}$
2. $b = \frac{a \sin B}{\sin A}$
3. $c = \frac{a \sin C}{\sin A}$
4. $\tan A = \frac{a \sin C}{b - a \cos C}$
5. $\tan B = \frac{b \sin C}{a - b \cos C}$
6. $a^2 = b^2 + c^2 - 2bc \cos A$
7. $b^2 = a^2 + c^2 - 2ac \cos B$
8. $c^2 = a^2 + b^2 - 2ab \cos C$
9. $\cos A = \frac{b^2 + c^2 - a^2}{2bc}$
10. $\cos B = \frac{a^2 + c^2 - b^2}{2ac}$
11. $\cos C = \frac{a^2 + b^2 - c^2}{2ab}$
12. $\text{Area} = \sqrt{s(s-a)(s-b)(s-c)}$
where: $s = \frac{1}{2}(a + b + c)$

**BASIC TRIGONOMETRIC FORMULAS
(Oblique Triangle Solution)**

Figure 32-6.B

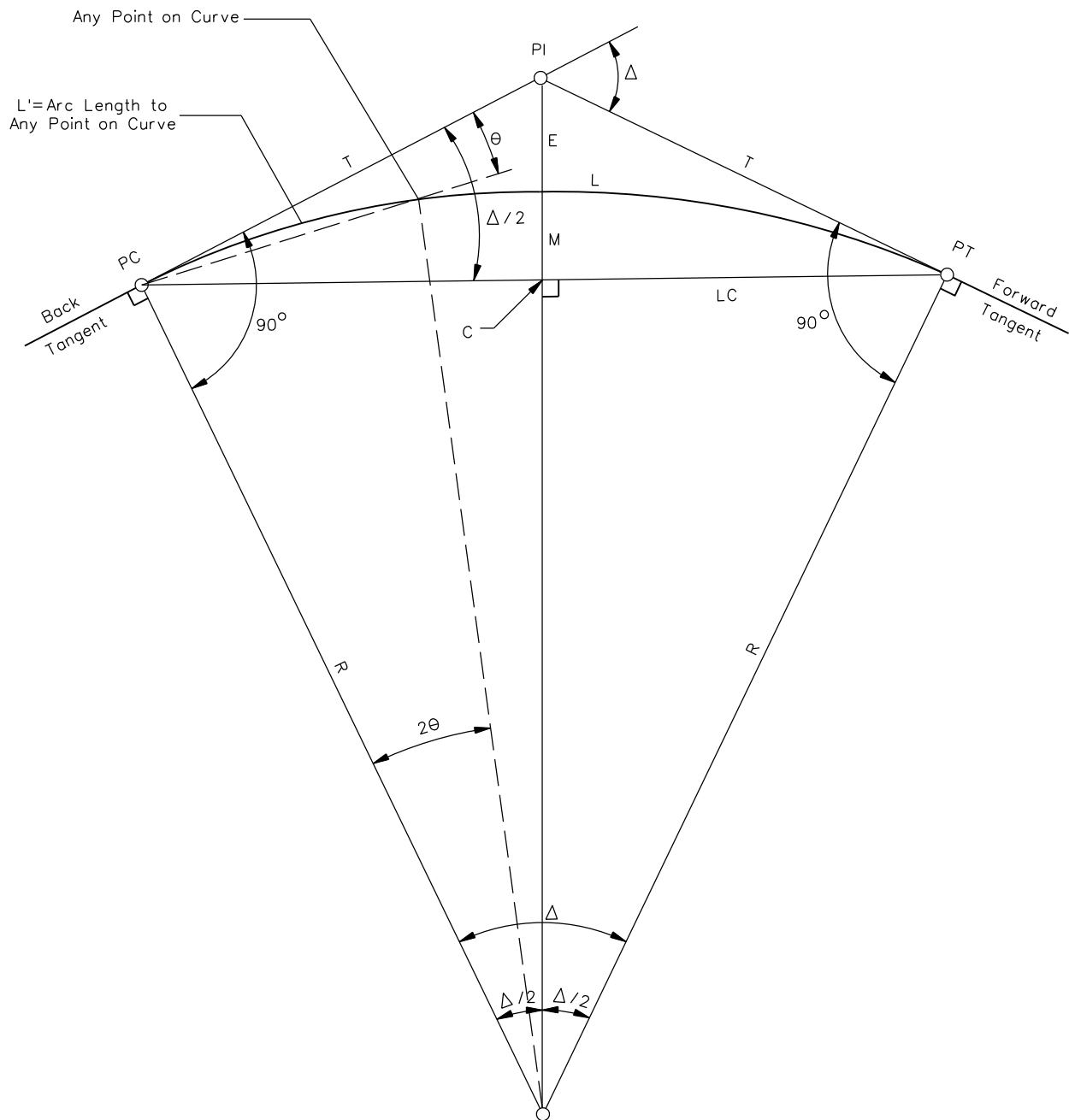

Note: See Figure 32-6.D for definition of terms.

SIMPLE CURVE ELEMENTS

Figure 32-6.C

CURVE SYMBOLS

- Δ = Deflection angle between tangents or central angle, degrees
 T = Tangent distance = distance from PC to PI = distance from PI to PT
 L = Length of curve = distance from PC to PT along curve
 R = Radius of curve, ft (m)
 E = External distance (PI to mid-point of curve)
 LC = Length of long chord: PC to PT
 M = Middle ordinate (mid-point of arc to mid-point of long chord)
 C = Mid-point of long chord

CIRCULAR CURVE ABBREVIATIONS

- P.C. = PC = Point of Curvature
 (Beginning of Curve)
 P.T. = PT = Point of Tangency (End of Curve)
 P.I. = PI = Point of Intersection of Tangents
 P.R.C. = PRC = Point of Reverse Curvature
 P.C.C. = PCC = Point of Compound Curvature
 P.O.T. = POT = Point on Tangent

CURVE FORMULA

$$T = R(\tan (\Delta / 2)) = R \frac{\sin (\Delta / 2)}{\cos (\Delta / 2)}$$

$$L = \frac{\Delta}{360} 2\pi R = \frac{\Delta R}{57.2958}, \text{ where } \Delta \text{ is in degrees (decimals) to four places.}$$

$$E = T \tan (\Delta / 4)$$

$$E = R \left(\frac{1}{\cos (\Delta / 2)} - 1 \right)$$

$$LC = 2R(\sin (\Delta / 2)) = 2T(\cos (\Delta / 2))$$

$$M = R(1 - \cos (\Delta / 2))$$

$$M = E \cos (\Delta / 2)$$

$$\pi = 3.141592653$$

To find the deflection angle θ , in degrees, to any point on the curve (see Figure 32-6.C):

$$\frac{2\theta}{L'} = \frac{360^\circ}{2\pi R}, \text{ where } L' \text{ is any arc length}$$

To find the deflection angle θ in minutes to any point:

$$\theta = \frac{(360^\circ) \left(\frac{60 \text{ min.}}{\text{deg}} \right) (L')}{(2)(2\pi R)}$$

$$\theta = \frac{21,600 L'}{4\pi R}$$

$$\theta = \frac{1718.873 L'}{R}$$

CURVE SYMBOLS, ABBREVIATIONS, AND FORMULAS**Figure 32-6.D**

The radius of a circular curve drawn to the tangent point is perpendicular to the tangent at that point.

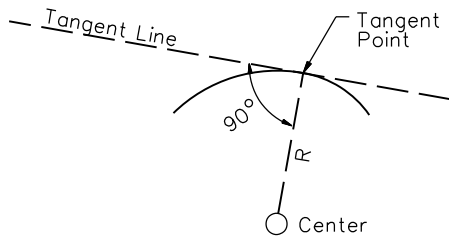

The figure below forms an isosceles triangle. Therefore, Angle O = Angle D. Also $B + D + O = 180^\circ$ (sum of the interior angles of a triangle). Also, $\Delta + B = 180^\circ$ (angle around a point forming a straight line). Therefore, $\Delta = O + D$ and, having shown that $O = D$, then $\Delta = O + O = (2) (O)$ or $O = (\Delta/2)$.

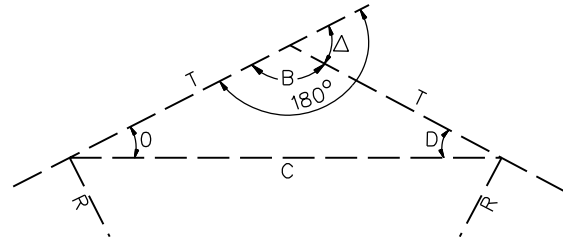

From any point on a circular curve, the angle intercepting a given arc on the same circular curve is equal to $\frac{1}{2}$ the central angle (Δ) for that particular arc.

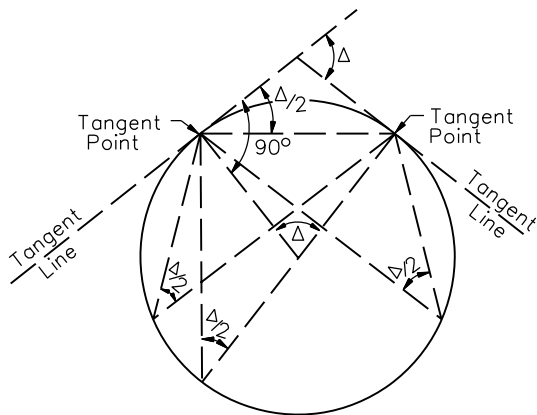

The figure below shows the 2 tangents and 2 radii of a simple curve. $A + \Delta = 180^\circ$. Also, $A + 90^\circ + 90^\circ + C = 360^\circ$ (sum of the interior angles in a 4-sided figure) or $A + C = 180^\circ$. Therefore, $\Delta = C$. C is also called the central angle but is usually designated by Δ .

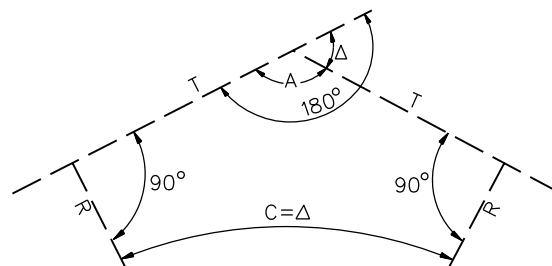

**SIMPLE CURVES
(Geometric Principles)**

Figure 32-6.E

Δ = DEFLECTION ANGLE

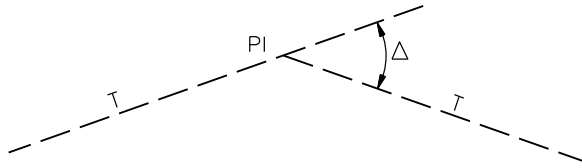

Δ = The deflection angle from the first tangent extended to the second tangent. This is the same angle as the angle between radii (central angle). This should be known before the other parts of the curve are computed.

L = LENGTH OF CURVE

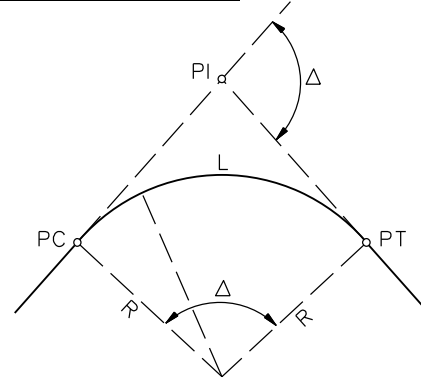

With a constant Δ , L increases or decreases in direct ratio to R. Thus:

$$L = \frac{\Delta}{360} (2\pi R)$$

Reducing to: $L = \Delta R / 57.2958$

Where L and R are in feet (meters) and Δ is in degrees (decimals) to four places.

R = RADIUS

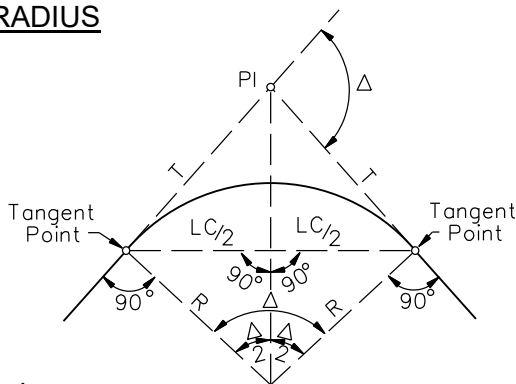

Formulas:

$$R = \frac{T}{\tan (\Delta / 2)}$$

OR

$$R = \frac{LC}{2 \sin (\Delta / 2)}$$

Where R is in feet (meters) and Δ is in degrees (decimals).

T = TANGENT LENGTH

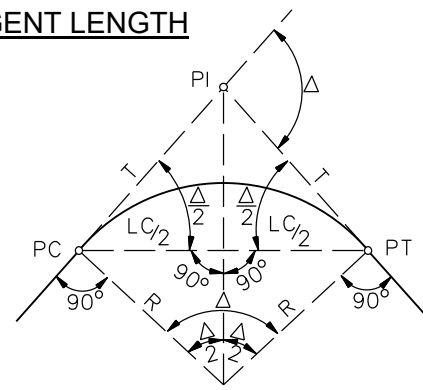

Formulas:

$$T = R \tan (\Delta / 2)$$

$$T = \frac{LC}{2 \cos (\Delta / 2)}$$

Where T, LC, & R are in feet (meters).

**SIMPLE CURVES
(Various Elements)**

**Figure 32-6.F
(1 of 2)**

M = MIDDLE ORDINATE

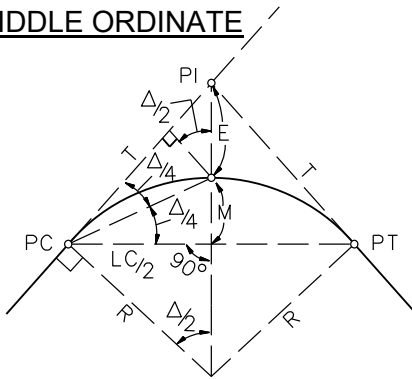

Where M, LC, R, and E are in feet (meters).

Formulas:

$$M = \frac{LC}{2} \tan(\Delta/4)$$

$$M = E \cos(\Delta/2)$$

$$M = R(1 - \cos(\Delta/2))$$

LC = LONG CHORD

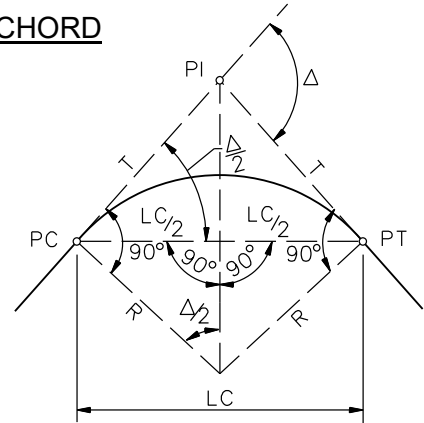

Formulas:

$$LC = 2R \sin(\Delta/2)$$

$$LC = 2T \cos(\Delta/2)$$

The main chord and short chords are often convenient to use in laying out the curve.

Figure can be applied to the whole chord or to the chord of any part of the curve. Δ would then be the central angle of the arc of whatever part of the curve is being considered.

E = EXTERNAL DISTANCE

Formulas:
$$E = R \left(\frac{1}{\cos(\Delta/2)} - 1 \right)$$

Also:
$$E = \frac{M}{\cos(\Delta/2)}$$

$$E = T \tan(\Delta/4)$$

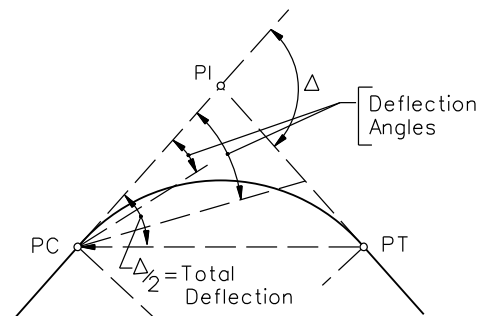

DEFLECTION ANGLES

In circular curves for highways, the deflection angle to a point on a curve is usually turned from the tangent with a set-up on the PC (see figure above).

**SIMPLE CURVES
(Various Elements)**

Figure 32-6.F
(2 of 2)

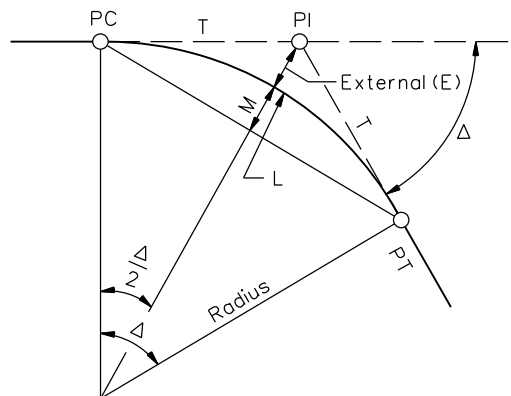
Example:

Given:

PI = Sta 161 + 60.36; $\Delta = 62^\circ 10'$; $R = 700$ ft

To find: Sta. of PC and PT:

Calculate:

$$1. \quad T = R \tan (\Delta / 2) = (700) \tan (31^\circ 05')$$

$$T = 421.99 \text{ ft}$$

$$2. \quad L = \Delta R / 57.2958 = 759.51 \text{ ft}$$

3. Therefore:

$$\begin{array}{rcl} \text{PI} & = & \text{Sta. } 161 + 60.36 \\ \text{T} & = & \underline{\quad - 421.99 \quad} \\ \text{PC} & = & \text{Sta.} \\ \text{L} & = & \underline{\quad + 759.51 \quad} \\ \text{PT} & = & \text{Sta. } 164 + 97.88 \end{array}$$

SIMPLE CURVE COMPUTATION
(Example)

Figure 32-6.G

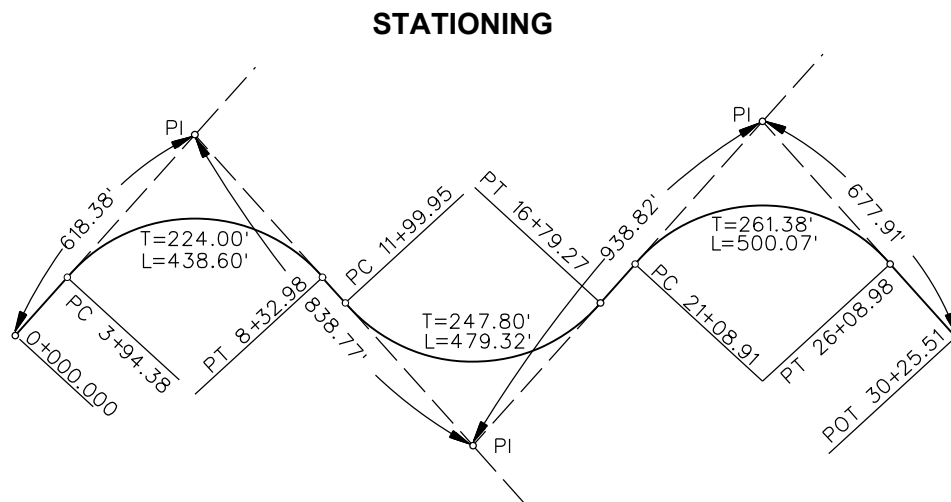

Note: All dimensions in feet.

1. The station at the first PI is $6 + 18.38$.
2. The station at the first PC = $6 + 18.38 - 224.00 = 3 + 94.38$.
3. The station at the first PT = $3 + 94.38 + 438.60 = 8 + 32.98$.
4. The station at the second PC = $8 + 32.98 + (838.77 - 224.00 - 247.80) = 11 + 99.95$.
5. The station at the second PI = $11 + 99.95 + 247.80 = 14 + 47.75$.
6. The station at the second PT = $11 + 99.95 + 479.32 = 16 + 79.27$.
7. The station at the third PC = $16 + 79.27 + (938.82 - 247.80 - 261.38) = 21 + 08.91$.
8. The station at the third PI = $21 + 08.91 + 261.38 = 23 + 70.29$.
9. The station at the third PT = $21 + 08.91 + 500.07 = 26 + 08.98$.
10. The station at the final POT = $26 + 08.98 + (677.91 - 261.38) = 30 + 25.51$.
11. Check: $(618.38 + 838.77 + 938.82 + 677.91) - (2(224.00) + 2(247.80) + 2(261.38) - 438.60 - 479.32 - 500.07) = 30 + 25.51$.

**SIMPLE CURVE
(Stationing)**

Figure 32-6.H

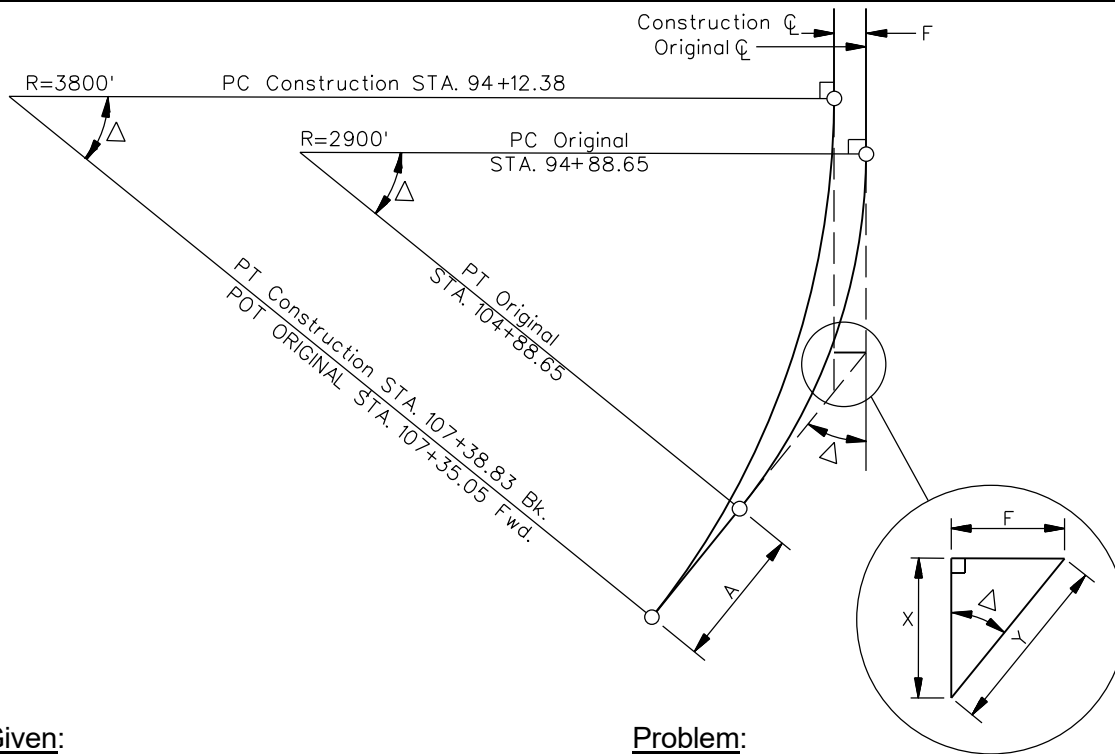

Given:

Simple Curve

Original PI = 100 + 00.00
 Δ = 20°00' Rt.
 T = 511.35 ft
 L = 1000 ft
 R = 2900 ft

Problem:

Compute: Simple curve of different radius where one tangent is offset a specified distance from and parallel to the original tangent.

R = 3800 ft, F = 30 ft Rt.

Solution:

$Y = F/\sin \Delta = 30/\sin 20^\circ = 87.71$ ft
 $X = F/\tan \Delta = 30/\tan 20^\circ = 82.42$ ft
 $T = (R)\tan (\Delta/2) = (3800) (\tan 10^\circ) = 670.04$ ft
 $L = \Delta 2\pi R / 360 = 1326.45$ ft

CONSTRUCTION CURVE DATA

PI = 100 + 82.42
 Δ = 20°00' Rt.
 T = 670.04 ft
 L = 1326.45 ft
 R = 3800 ft

STATIONING

Orig. PI = 100 + 00.0	Const. T = 670.04
+X = 82.42	+Y = 87.71
Const. PI = 100 + 82.42	757.75
-T = -670.04	-Orig. T = -511.35
Const. PC = 94 + 12.38	A = 246.40
+L = 1326.45	Orig. PT = 104 + 88.65
Const. PT = 107 + 38.83	Orig. POT = 107 + 35.05

Equation: Const. PT 107 + 38.83 Bk = Orig. POT 107 + 35.05 Fwd

**CURVE COMPUTATION
 (Different Radius, Tangent Offset & Parallel)**

Figure 32-6.I

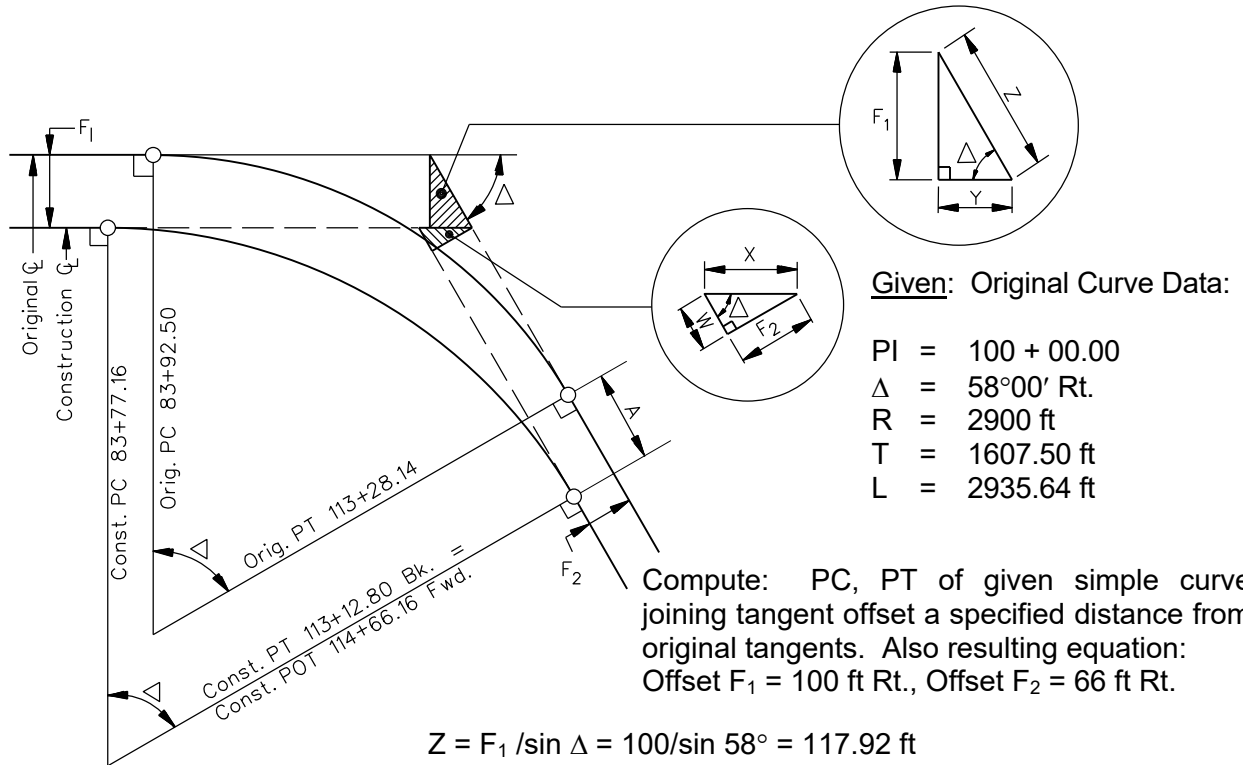

$$Z = F_1 / \sin \Delta = 100 / \sin 58^\circ = 117.92 \text{ ft}$$

$$Y = F_1 / \tan \Delta = 100 / \tan 58^\circ = 62.49 \text{ ft}$$

$$X = F_2 / \sin \Delta = 66 / \sin 58^\circ = 77.83 \text{ ft}$$

$$W = F_2 / \tan \Delta = 66 / \tan 58^\circ = 41.24 \text{ ft}$$

$$\text{Const. PI} = \text{Orig. PI} + Y - X = 99 + 84.66$$

Note: In many cases, $Y > X$ & $W > Z$ or offsets may be to other side of original tangents causing the problem to look different, but the principles of the problem remain the same.

Const. PI	=	99 + 84.66	
-T	=	- 1607.50	
Const. PC	=	83 + 77.16	
+L	=	+ 2935.64	
Const. PT	=	113 + 12.80	
A = Z - W	=	+ 76.68	
Orig. PT	=	113 + 89.48	
+A	=	+ 76.68	
		114 + 66.16	(Orig. POT 66 ft Lt. of PT 114 + 66.16)

Equation: Const. PT 113 + 12.80 Bk = Sta. 114 + 66.16 Fwd

CURVE COMPUTATION
 (Compute PC & PT, Joining Parallel Tangent Offsets)

Figure 32-6.J

INTRODUCE A CURVE OF SELECTED RADIUS BETWEEN TWO FIXED CURVES

Part A: Fixed curves of equal radii.

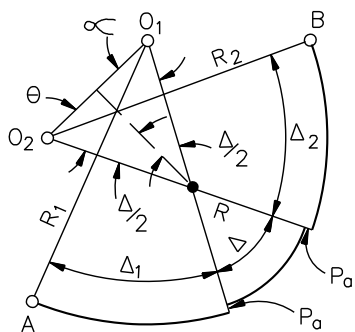

Given:

R_1 and R_2 = Radii of fixed curves with radials AO_1 and BO_2 fixed on coordinate system.

R = Radius selected for intermediate curve.

P_a , P_{a1} and P_{a2} = Offset ("p" distance) to permit insertion of selected spirals; without spirals, $P_a = 0$.

Problem:

To determine Δ , Δ_1 and Δ_2 and the remaining properties of each curve.

Solution:

Determine length and bearing of O_1O_2 from given coordinates of O_1 and O_2 :

$$\Delta = 2 \sin^{-1} \frac{O_1O_2}{2(R_1 - R - P_a)^*}$$

$$\alpha = \theta = 90^\circ - \frac{\Delta}{2}$$

Determine bearing O_1O by applying α to bearing O_1O_2 .

Determine bearing O_2O by applying θ to bearing O_1O_2 .

Δ_1 = difference in bearings of O_1O and O_1A .

Δ_2 = difference in bearings of O_2O and O_2B .

Determine remaining properties of each curve through usual procedures.

* Where R is greater than R_1 and/or R_2 :

$$\Delta = 2 \sin^{-1} \frac{O_1O_2}{2(R - R_1 - P_a)}$$

CURVE COMPUTATION (Between Two Fixed Curves)

Figure 32-6.K
(1 of 2)

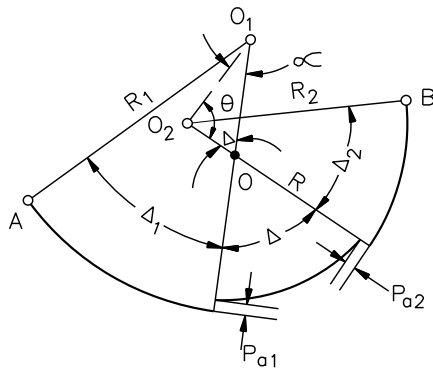
Part B: Fixed curves of unequal radii.**Given:**

R_1 and R_2 = Radii of fixed curves with radials AO_1 and BO_2 fixed on coordinate system.

R = Radius selected for intermediate curve.

P_a , P_{a1} and P_{a2} = Offset ("p" distance) to permit insertion of selected spirals; without spirals, $P_a = 0$.

Problem:

To determine Δ , Δ_1 and Δ_2 and the remaining properties of each curve.

Solution:

Determine length and bearing of O_1O_2 from given coordinates of O_1 and O_2 .

$$OO_1 = R_1 - (R + P_{a1})^*$$

$$OO_2 = R_2 - (R + P_{a2})^*$$

$$\Delta = \cos^{-1} \frac{OO_1^2 + OO_2^2 - O_1O_2^2}{2 \times OO_1 \times OO_2}$$

$$\alpha = \cos^{-1} \frac{OO_1^2 + OO_2^2 - O_1O_2^2}{2 \times OO_1 \times O_1O_2}$$

$$\theta = 180^\circ - (\Delta + \alpha)$$

Determine bearing O_1O by applying α to bearing O_1O_2 .

Determine bearing O_2O by applying θ to bearing O_1O_2 .

Δ_1 = difference in bearings of O_1O and O_1A .
 Δ_2 = difference in bearings of O_2O and O_2B .

Determine remaining properties of each curve through usual procedures.

* Where R is greater than R_1 and/or R_2 :

$$OO_1 = R - (R_1 + P_{a1})$$

$$OO_2 = R - (R_2 + P_{a2})$$

**CURVE COMPUTATION
(Between Two Fixed Curves)**

**Figure 32-6.K
(2 of 2)**

INTRODUCE A CURVE OF SELECTED RADIUS BETWEEN A FIXED CURVE AND A FIXED TANGENT

Part A: Selected curve of flatter radius than the fixed curve.

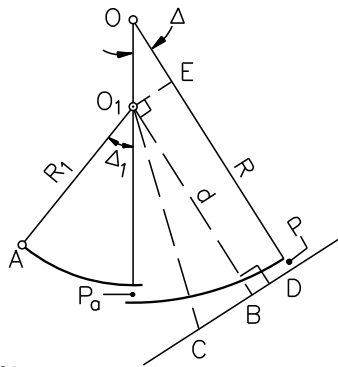

Given:

R_1 = Radius of fixed curve with coordinates of radial AO_1 .

C = Any coordinate point on fixed tangent of known bearing.

R = Radius of selected curve.

P & P_a = Offset ("p" distance) to permit insertion of selected spirals; without spirals, P and P_a = 0.

Problem:

To determine Δ (deflection angle of selected curve) and remaining properties of each curve.

Solution:

In triangle O_1CB , solve for O_1B , or d.

$$OE = OD - ED = (R + P) - d$$

$$\Delta = \cos^{-1} \frac{OE}{OO_1} = \cos^{-1} \frac{(R + P) - d}{R - (R_1 + P_a)}$$

Determine remaining properties of each curve through usual procedures.

Part B: Selected curve of sharper radius than the fixed curve.

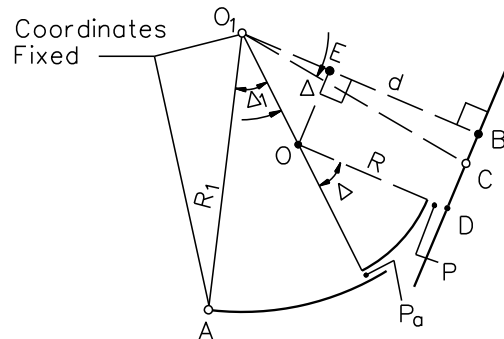

Given:

R_1 = Radius of fixed curve with coordinates of radial AO_1 .

C = Any coordinate point on fixed tangent of known bearing.

R = Radius of selected curve.

P & P_a = Offset ("p" distance) to permit insertion of selected spirals; without spirals, P and P_a = 0

Problem:

To determine Δ (deflection angle of selected curve) and remaining properties of each curve.

Solution:

In triangle O_1CB , solve for O_1B , or d.

$$O_1E = d - (R + P)$$

$$\Delta = \cos^{-1} \frac{O_1E}{O_1O} = \cos^{-1} \frac{d - (R + P)}{R_1 - (R + P_a)}$$

Determine remaining properties of each curve through usual procedure.

**CURVE COMPUTATION
(Between a Fixed Curve and Fixed Tangent)**

Figure 32-6.L

ESTABLISH A TANGENT BETWEEN TWO CURVES

Part A: Curves in reverse direction.

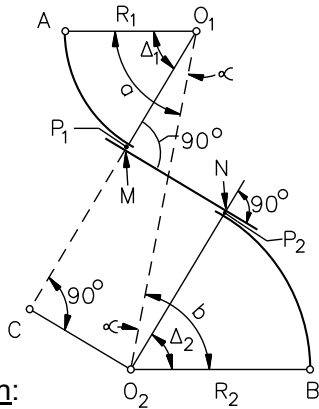

Given:

R_1 & R_2 = Radii of fixed curves with coordinates of radials AO_1 & BO_2 .

P_1 & P_2 = Offset ("p" distance) to permit insertion of selected spirals; without spirals, P_1 and $P_2 = 0$.

Problem:

To determine length and bearing of tangent MN , Δ_1 , Δ_2 and the remaining properties of each curve.

Solution:

Determine length and bearing of O_1O_2 from known coordinates; then, in triangle O_1O_2C :

$$\alpha = \cos^{-1} \frac{(R_1 + P_1)^* + (R_2 + P_2)^*}{O_1O_2}$$

$$CO_2 = MN = [(R_1 + P_1)^* + (R_2 + P_2)^*] \tan \alpha$$

Determine angles a and b from bearings of O_1A , O_2B and O_2O_1 :

$$\Delta_1 = a - \alpha; \quad \Delta_2 = b - \alpha$$

Determine remaining properties of each curve through usual procedures.

Part B: Curves in same direction.

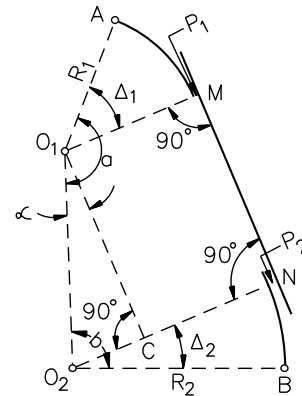

Given:

R_1 & R_2 = Radii of fixed curves with coordinated radials AO_1 & BO_2 .

P_1 & P_2 = Offset ("p" distance) to permit insertion of selected spirals; without spirals, P_1 and $P_2 = 0$.

Problem:

To determine length and bearing of tangent MN , Δ_1 , Δ_2 and the remaining properties of each curve.

Solution:

Determine length and bearing of O_1O_2 from known coordinates; then, in triangle O_1O_2C :

$$\alpha = \sin^{-1} \frac{(R_2 + P_2)^* - (R_1 + P_1)^*}{O_1O_2}$$

$$O_1C = MN = [(R_2 + P_2)^* - (R_1 + P_1)^*] / \tan \alpha$$

Determine angles a and b from bearings of O_1A , O_2B and O_2O_1 :

$$\Delta_1 = a - 90^\circ - \alpha; \quad \Delta_2 = b - 90^\circ + \alpha$$

Determine remaining properties of each curve through usual procedures.

* P_1 and $P_2 = 0$ when spirals are not used.

CURVE
(Establish a Tangent Between Two Curves)

Figure 32-6.M

INTRODUCE A CURVE, AND DETERMINE ITS RADIUS, BETWEEN A GIVEN POINT ON A FIXED CURVE AND SOME POINT ON A FIXED TANGENT

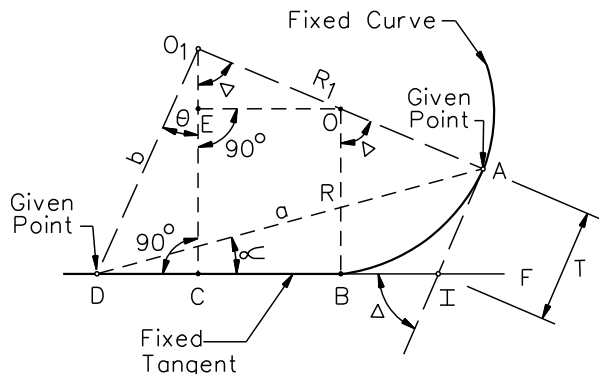

Given:

Tangent DF, its bearing and coordinates of D.

R_1 and coordinates of O_1 and A.

Problem:

To determine R and Δ .

Solution:

Method 1: Determine bearing and length of DA or a from known coordinates. Determine α from bearings DA and DF. Determine Δ from bearings O_1A and O_1C .

From solution for side of oblique triangle DIA and equation for tangent, T, of simple curve:

$$R = \frac{a \sin \alpha}{\sin (180^\circ - \Delta) \tan (\Delta / 2)}$$

$$T = R \tan (\Delta / 2)$$

$$T = \frac{a \sin \alpha}{\sin (180^\circ - \Delta)}$$

Method 2: Determine bearing and length of DO_1 , or b, from known coordinates. Determine θ from bearings O_1D and O_1C . Determine Δ from bearings O_1A and O_1C . From solution of right triangles DO_1C and EO_1O :

$$R = \frac{b \cos \theta - R_1 \cos \Delta}{1 - \cos \Delta}$$

Note: If spiral is used at B, Method 2 must be employed; then:

$$R = \frac{b \cos \theta - R_1 \cos \Delta - P}{1 - \cos \Delta}$$

Where P is offset of curve for spiral at B, use expression for R without P first, and find approximate R; then substitute in latter equation, using value of P for the approximate R and find new R. Same formulas apply whether $R <$ or $> R_1$.

CURVE INTRODUCTION

Figure 32-6.N

INTRODUCE A CURVE AND TO DETERMINE ITS RADIUS BETWEEN A GIVEN POINT ON A FIXED TANGENT AND SOME POINT ON A FIXED CURVE

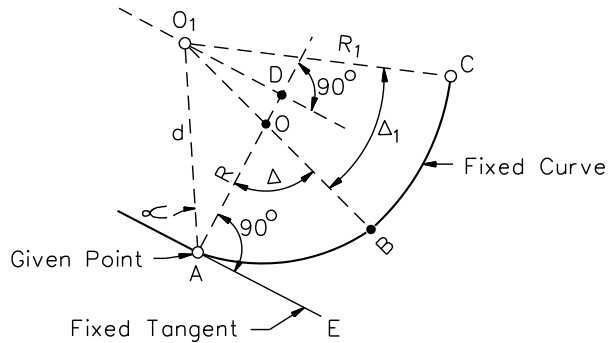

$$R = \frac{d^2 - R_1^2}{2(d \cos \alpha - R_1)}$$

and

$$\Delta = \sin^{-1} \frac{d \sin \alpha}{R_1 - R}$$

Determine bearing BO_1 by application of Δ to bearing AD_1 , then Δ_1 = difference in bearings of BO_1 and CO_1 .

Note: This solution is applicable whether $R < \text{or} > R_1$.

Given:

R_1 and coordinates of O_1 and C. Tangent AE, its bearing, and coordinates of A.

Problem:

To determine R, Δ , and Δ_1 .

Solution:

Erect right triangles AO_1D and O_1OD . Determine length and bearing of AO_1 or d from known coordinates of A and O_1 . From solution of triangles AO_1D and O_1OD :

CURVE INTRODUCTION

Figure 32-6.O

Triangles Involved:

1. GHI
2. DFG
3. ABC & CDE

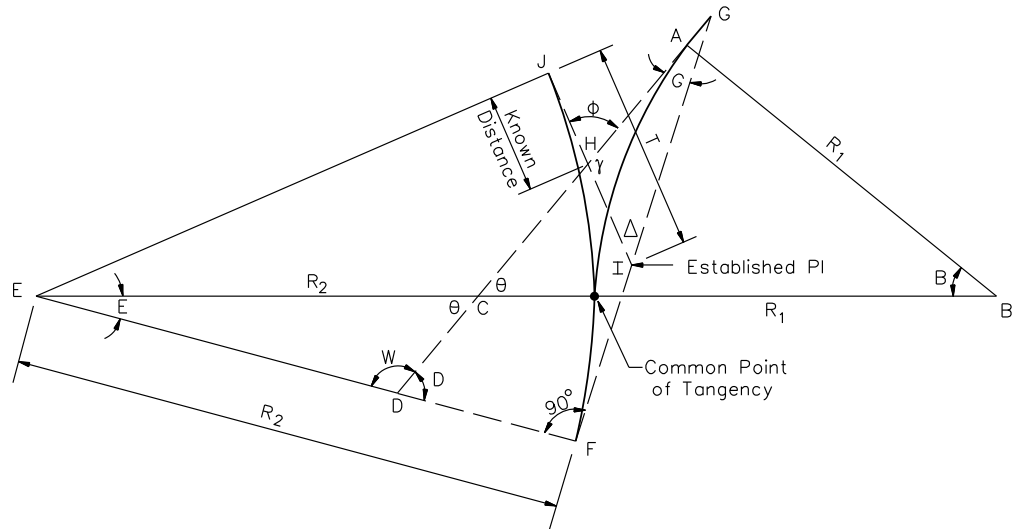

Given:

One of the curves already established (JF, Δ, T): Radii of curves (R₁ & R₂). Intersection point and angle of the two centerlines (H & φ).

Distance JH is thereby known and HI can be determined by subtracting JH from T for established curve.

Distance between curve centers (BE = R₁ + R₂).

Triangle No. 1, GHI

Find: ∠G & GI

1. $\gamma = 180^\circ - \phi$
2. $\angle G = 180^\circ - (\gamma + \Delta)$
3. $HI = T \text{ (est. curve)} - JH$
4. $GI = \frac{HI \sin \gamma}{\sin \angle G}$

Triangle No. 2, DGF

Find: ∠D & DF

5. $FG = T \text{ (est. curve)} + GI$
6. $DF = FG \tan \angle G$
7. $\angle D = 90^\circ - \angle G$

Triangles No. 3, ABC & CDE

Find: ∠θ (Angles at B & E are thus determined)

$$BC + CE = R_1 + R_2$$

In triangle ABC:

$$BC = \frac{R_1}{\sin \theta}$$

$$BC + CE = \frac{R_1}{\sin \theta} + \frac{DE \sin W}{\sin \theta} = R_1 + R_2$$

In triangle CDE:

8. $DE = R_2 - DF$
9. $W = 180^\circ - \angle D$

$$CE = \frac{DE \sin W}{\sin \theta}$$

$$10. \sin \theta = \frac{R_1 + DE \sin W}{R_1 + R_2}$$

$$11. \angle B = 90^\circ - \theta$$

$$12. \angle E = 180^\circ - (\theta + W)$$

Length of curves, tangent length, etc., are determined.

ALIGNMENT
(Common Point Of Tangency For Two Curves)

Figure 32-6.P

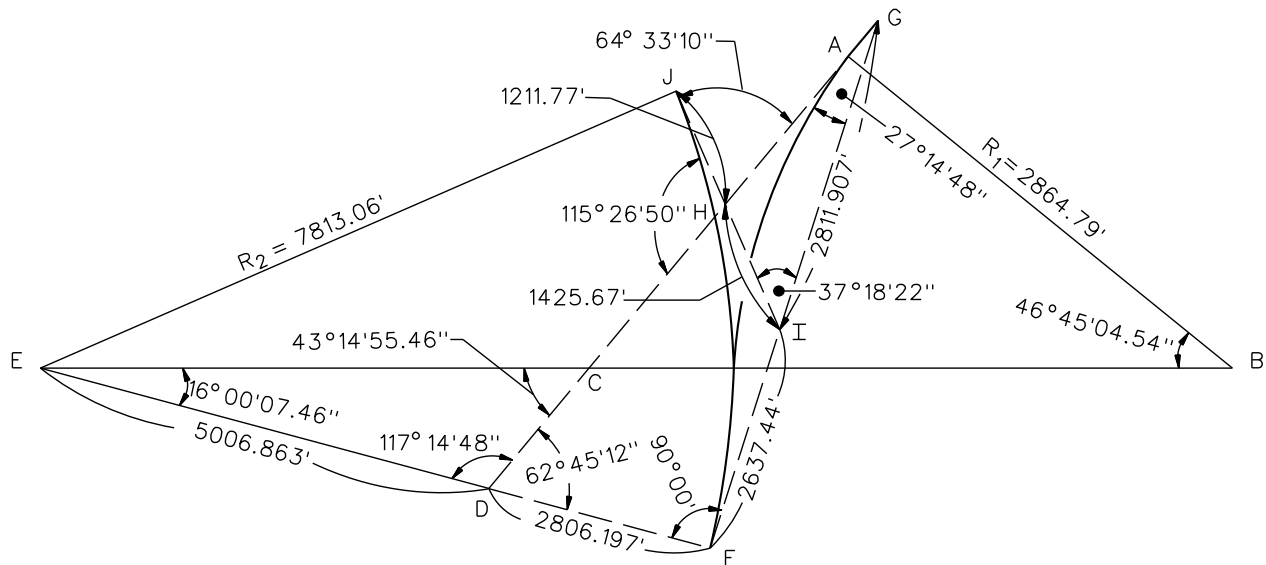
**Given:**

$$\begin{aligned}\phi &= 64^\circ 33' 10'' \\ JH &= 1211.77 \text{ ft} \\ \Delta &= 37^\circ 18' 22'' \\ T &= 2637.44 \text{ ft} \\ R_2 &= 7813.06 \text{ ft} \\ R_1 &= 2864.79 \text{ ft}\end{aligned}$$

1. $\gamma = 180^\circ 00' 00'' - 64^\circ 33' 10'' = 115^\circ 26' 50''$
2. $\angle G = 180^\circ 00' 00'' - (115^\circ 26' 50'' + 37^\circ 18' 22'') = 27^\circ 14' 48''$
3. $HI = 2637.44 - 1211.77 = 1425.67 \text{ ft}$
4. $GI = (1425.67) (0.90298146 / (0.45782219)) = 2811.907 \text{ ft}$
5. $FG = 2637.44 + 2811.907 = 5449.357 \text{ ft}$
6. $DF = (5449.347) (0.5149602) = 2806.197 \text{ ft}$
7. $\angle D = 90^\circ 00' 00'' - 27^\circ 14' 48'' = 62^\circ 45' 12''$
8. $DE = 7813.06 - 2806.197 = 5006.863 \text{ ft}$
9. $\angle W = 180^\circ 00' 00'' - 62^\circ 45' 12'' = 117^\circ 14' 48''$
10. $\sin \theta = (2864.79 + (5006.863) (0.88904378)) / (2864.79 + 7813.06) = 0.68516695$
 $\theta = 43^\circ 14' 55.46''$
11. $\angle B = 90^\circ 00' 00'' - 43^\circ 25' 55.46'' = 46^\circ 45' 04.54''$
12. $\angle E = 180^\circ 00' 00'' - (46^\circ 45' 04.54'' + 117^\circ 14' 48'') = 16^\circ 00' 07.46''$

**COMMON POINT OF TANGENCY FOR TWO CURVES
(Sample Problem)**

Figure 32-6.Q

Given:

AB, Angle A, and Curve Data

Required:

AE and Arc Dist. BE

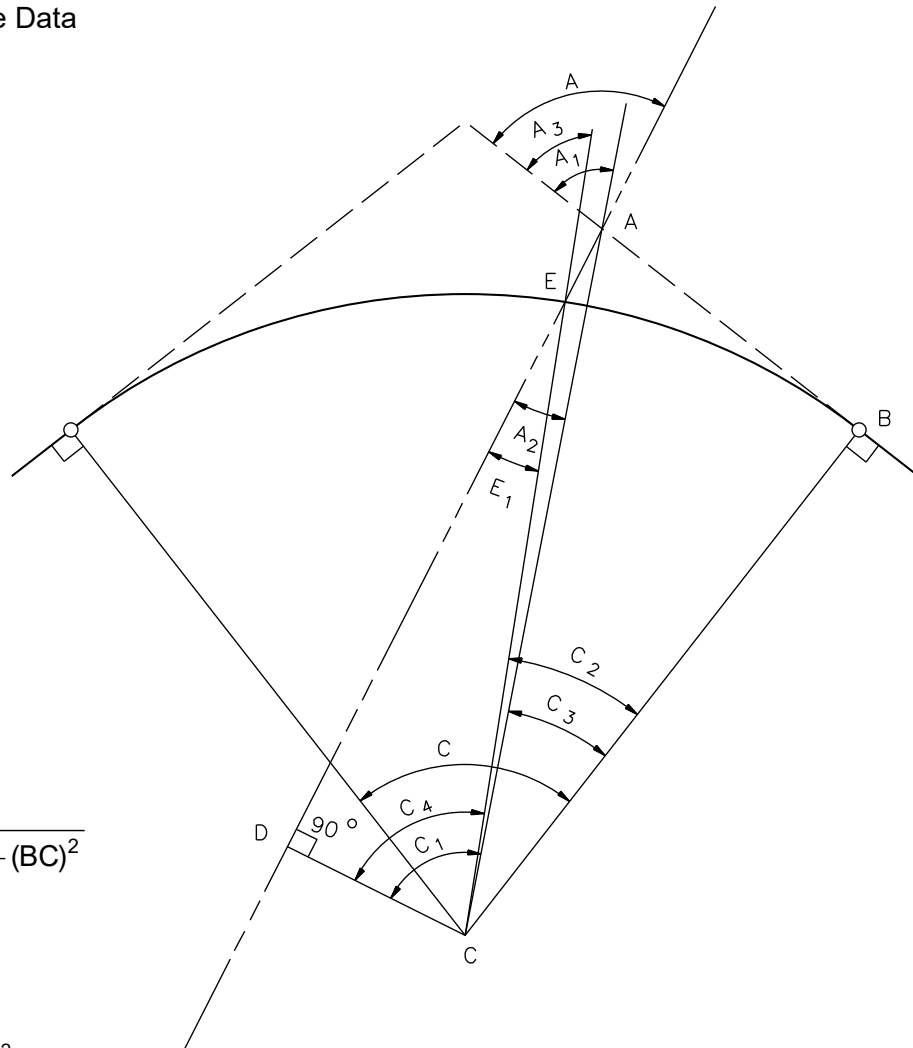

Solution:

1. BC = Radius
2. AC = $\sqrt{(AB)^2 + (BC)^2}$
3. $\sin C_3 = \frac{AB}{AC}$
4. $A_1 = 90^\circ - C_3$
5. $A_2 = A - A_1$
6. CD = AC sin A₂
7. AD = AC cos A₂
8. EC = Radius
9. $\sin E_1 = \frac{CD}{EC}$
10. DE = EC cos E₁
11. C₁ = 90° - A₂
12. C₄ = 90° - E₁
13. C₂ = C₃ + C₁ - C₄
14. AE = AD - DE
15. Arc Dist. BE = $\frac{C_2}{360} 2\pi R$

POC COMPUTATION USING RIGHT TRIANGLES

Figure 32-6.T

Given:

Angle A = 80°07'23"
 AB = 1732.60 ft
 Radius = 7813.06 ft

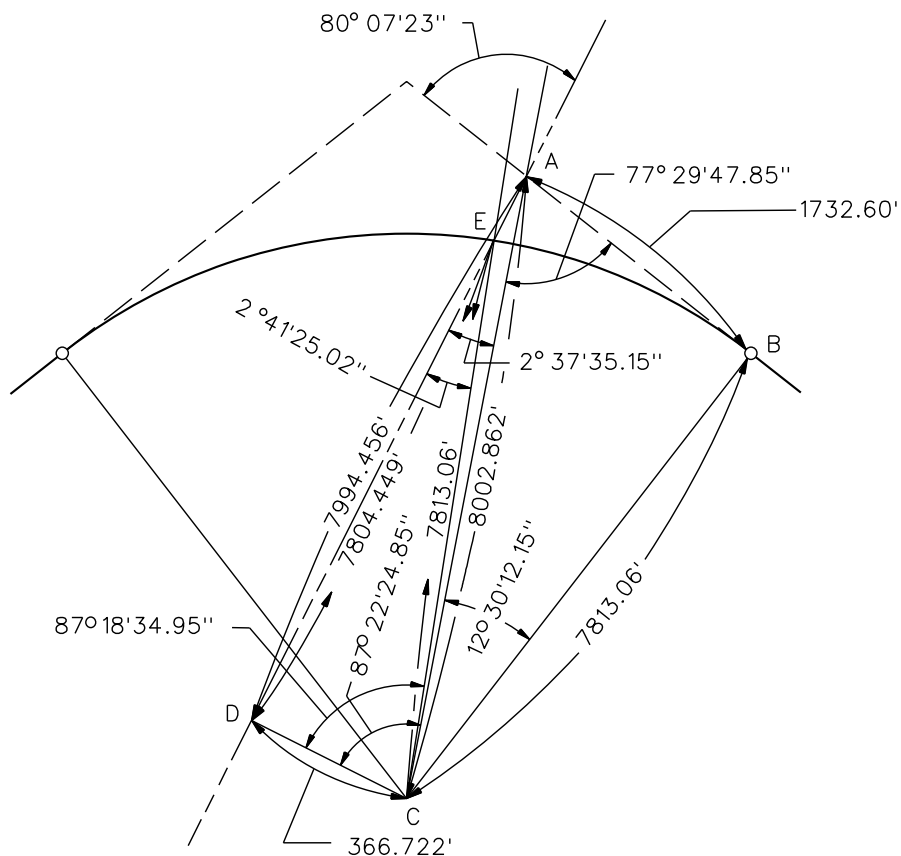

1. BC = 7813.06 ft
2. AC = $\sqrt{(1732.60)^2 + (7813.06)^2} = 8002.862$ ft
3. $\sin C_3 = 1732.60 / 8002.86 = 0.2164975$ $C_3 = 12^\circ 30' 12.15''$
4. $A_1 = 90^\circ 00' 00'' - 12^\circ 30' 12.15'' = 77^\circ 29' 47.85''$
5. $A_2 = 80^\circ 07' 23.00'' - 77^\circ 29' 47.85'' = 2^\circ 37' 35.15''$
6. CD = $(8002.862) (0.04582381) = 366.722$ ft
7. AD = $(8002.862) (0.99894954) = 7994.456$ ft
8. EC = 7813.06 ft
9. $\sin E_1 = 366.722 / 7813.06 = 0.04693705$ $E_1 = 2^\circ 41' 25.02''$
10. DE = $(7813.06) (0.99889785) = 7804.449$ ft
11. $C_1 = 90^\circ 00' 00'' - 2^\circ 37' 35.15'' = 87^\circ 22' 24.85''$
12. $C_4 = 90^\circ 00' 00'' - 2^\circ 41' 25.02'' = 87^\circ 18' 34.95''$
13. $C_2 = 12^\circ 30' 12.15'' + 87^\circ 22' 24.85'' - 87^\circ 18' 34.98'' = 12^\circ 34' 02.02''$
14. AE = $7994.456 - 7804.449 = 190.02$ ft
15. Arc BE = $(12.567228) (2\pi) (7813.06) / 360 = 1713.71$ ft

**POC COMPUTATION USING RIGHT TRIANGLES
 (Sample Problem)**

Figure 32-6.U

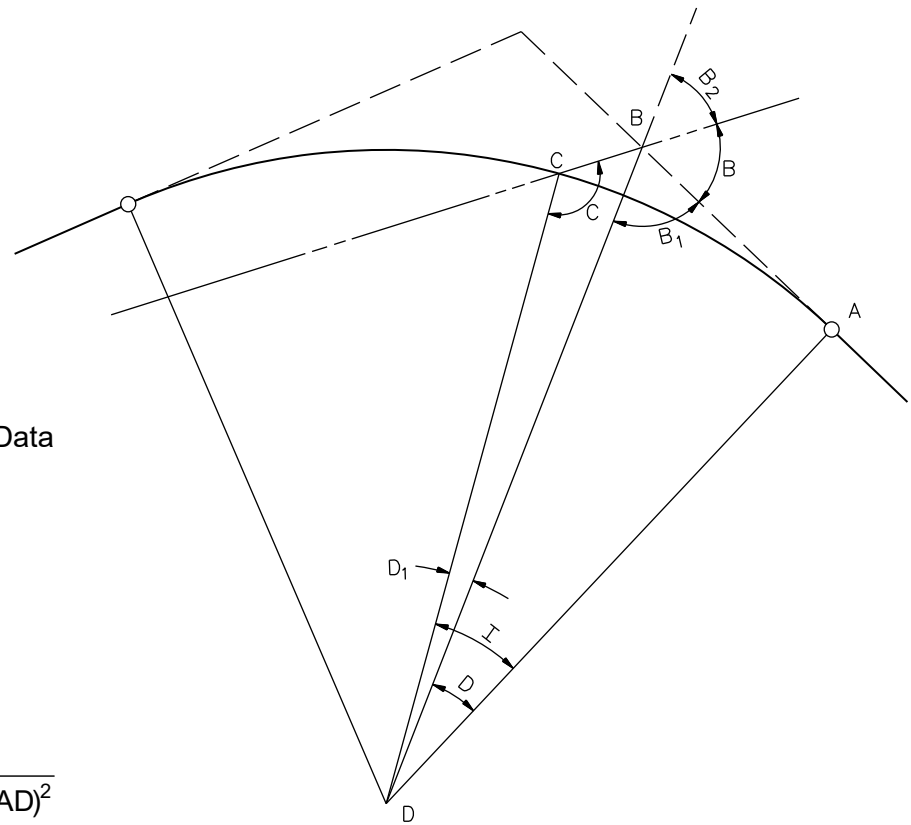
Given:

AB, Angle B, and Curve Data

Required:

BC and Arc Dist. AC

Solution:

1. $AD = \text{Radius}$
2. $BD = \sqrt{(AB)^2 + (AD)^2}$
3. $\sin D = \frac{AB}{BD}$
4. $B_1 = 90^\circ 00' - D$
5. $B_2 = 180^\circ 00' - (B + B_1)$
6. $\sin C = \frac{BD \sin B_2}{\text{Radius}}$
7. $D_1 = 180^\circ - (B_2 + C)$
8. $BC = \frac{R \sin D_1}{\sin B_2}$
9. $I = D + D_1$
10. Arc Dist. AC = $\frac{I}{360} 2\pi R$

POC COMPUTATION USING OBLIQUE TRIANGLE

Figure 32-6.V

Given:

AB = 1732.60 ft
 Angle B = $99^{\circ}52'37''$
 Radius = 8000 ft

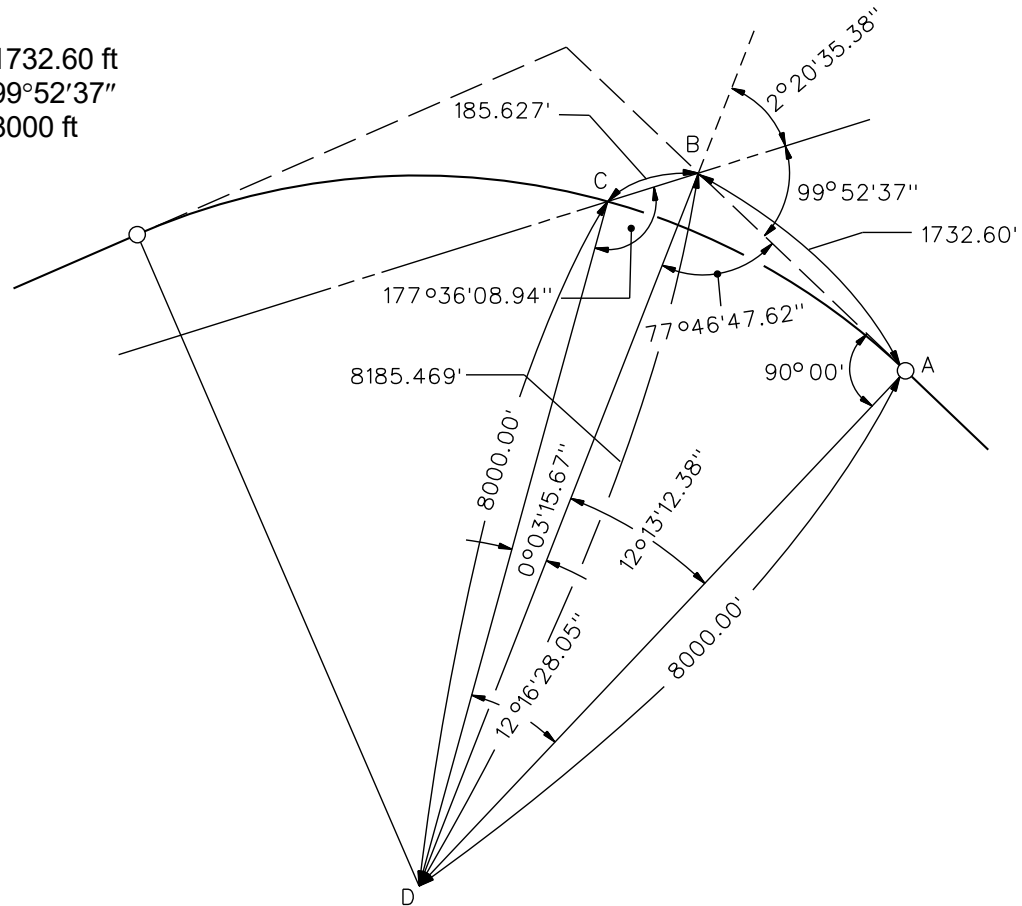
Solution:

1. AD = 8000.00 ft
2. BD = $\sqrt{(1732.60)^2 + (8000.00)^2} = 8185.469$ ft
3. $\sin D = 1732.60 / 8185.469 = 0.211667773$ $D = 12^{\circ}13'12.38''$
4. $B_1 = 90^{\circ}00' - 12^{\circ}13'12.38'' = 77^{\circ}46'47.62''$
5. $B_2 = 180^{\circ}00' - (99^{\circ}52'37'' + 77^{\circ}46'47.62'') = 2^{\circ}20'35.38''$
6. $\sin C = (8185.469) (0.04088448) / 8000.00 = 0.041832334$ $C = 177^{\circ}36'08.94''$
7. $D_1 = 180^{\circ}00' - (2^{\circ}20'35.38'' + 177^{\circ}36'08.94'') = 0^{\circ}03'15.67''$
8. BC = $(8000.00) (0.00094866) / (0.040884478) = 185.627$ ft
9. I = $12^{\circ}13'12.38'' + 0^{\circ}03'15.67'' = 12^{\circ}16'28.05''$
10. Arc AC = $(12.2744583) (2\pi) (8000.00) / 360 = 1713.838$ ft

**POC COMPUTATION USING OBLIQUE TRIANGLE
(Sample Problem)**

Figure 32-6.W

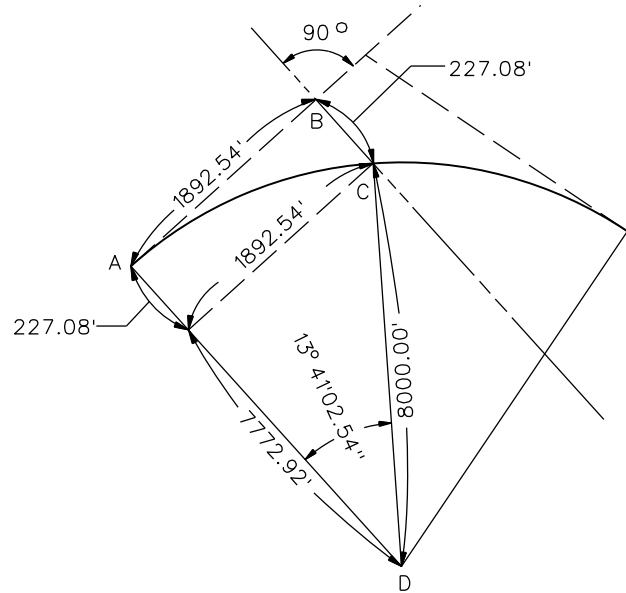
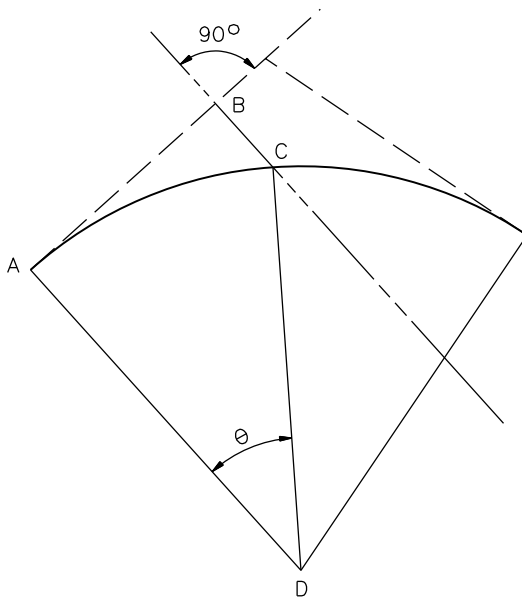

Given:

AB and Curve Data.

Required:

BC and Arc Dist. AC.

Solution:

1. CD = Radius
2. $\sin \theta = \frac{AB}{CD}$
3. $BC = CD - \sqrt{(CD)^2 - (AB)^2}$
4. $\text{Arc AC} = \frac{\theta}{360} 2\pi R$

EXAMPLE

Given:

- AB = 1892.54 ft
 Radius = 8000.00 ft

Solution:

1. CD = 8000.00 ft
2. $\sin \theta = 1892.54 \text{ ft} / 8000.00 = 0.2365675$
 $\theta = 13^\circ 41' 02.54''$
3. $BC = 8000.00 - \sqrt{(8000.00)^2 - (1892.54)^2}$
 $= 227.08 \text{ ft}$
4. $\text{Arc AC} = (13.68403956) (2\pi) (8000.00) / 360$
 $= 1910.65 \text{ ft}$

POC OF LINE 90° TO CURVE TANGENT

Figure 32-6.X

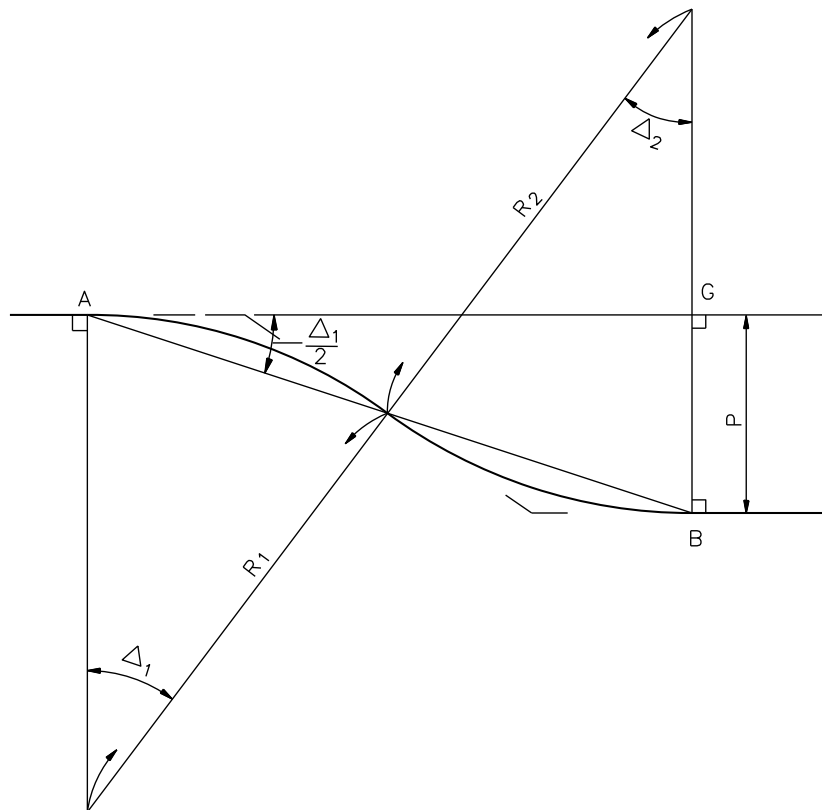
EQUAL RADIIGiven: Radius & BG

1. $R_1 = R_2$
2. $\Delta_1 = \Delta_2$
3. $BG = P$
4. $\cos \Delta_1 = \frac{R_1 - \frac{1}{2}P}{R_1}$
5. $AG = \sqrt{4PR_1 - P^2}$
6. $\sin \Delta_1 = \frac{AG}{R_1 + R_2}$
7. $\tan \Delta_1 = \frac{AG}{R_1 + R_2 - P}$

UNEQUAL RADIIGiven: R_1 , AG, & P

1. $\Delta_1 = \Delta_2$
2. $AB = \sqrt{AG^2 + P^2}$
3. $R_2 = \frac{(AB)^2}{2P} - R_1$
4. $\sin \Delta_1 = \frac{AG}{R_1 + R_2}$
5. $\cos \Delta_1 = \frac{R_1 + R_2 - P}{R_1 + R_2}$
6. $\tan \Delta_1 = \frac{AG}{R_1 + R_2 - P}$

REVERSE CURVES TO PARALLEL TANGENTS**Figure 32-6.Y**

EQUAL RADIIGiven:

$$R_1 = R_2 = 2000.00 \text{ ft}$$

$$P = 12 \text{ ft}$$

Required:Find Δ_1 and Δ_2 Solution:

1. $\cos \Delta_1 = (2000 - 6) / 2000 = 0.997$
 $\Delta_1 = \Delta_2 = 4^\circ 26' 21.20''$
2. $AG = \sqrt{(4)(12)(2000) - (12)^2} = 309.606 \text{ ft}$
3. $\sin \Delta_1 = 309.606 / (2)(2000) = 0.07740155$
 $\Delta_1 = 4^\circ 26' 21.20''$
4. $\tan \Delta_1 = 309.606 / ((2)(2000) - 12) = 0.077634403$
 $\Delta_1 = 4^\circ 26' 21.20''$

UNEQUAL RADIIGiven:

$$R_1 = 2000.00 \text{ ft}$$

$$P = 12 \text{ ft}$$

$$AG = 300 \text{ ft}$$

Required:Find Δ_1 and Δ_2 Solution:

1. $AB = \sqrt{(300)^2 + (12)^2} = 300.24 \text{ ft}$
2. $R_2 = (300.24)^2 / (2)(12) - 2000 = 1756.00 \text{ ft}$
3. $\sin \Delta_1 = (300) / (2000.00 + 1756.00) = 0.079872204$
 $\Delta_1 = \Delta_2 = 4^\circ 34' 52.39''$
4. $\cos \Delta_1 = (2000.00 + 1756.00 - 12.00) / (2000.00 + 1756.00) = 0.99680511$
 $\Delta_1 = \Delta_2 = 4^\circ 34' 52.39''$
5. $\tan \Delta_1 = 300 / (2000.00 + 1756.00 - 12.00) = 0.080128205$
 $\Delta_1 = \Delta_2 = 4^\circ 34' 52.39''$

REVERSE CURVES TO PARALLEL TANGENTS
(Sample Problem)

Figure 32-6.Z

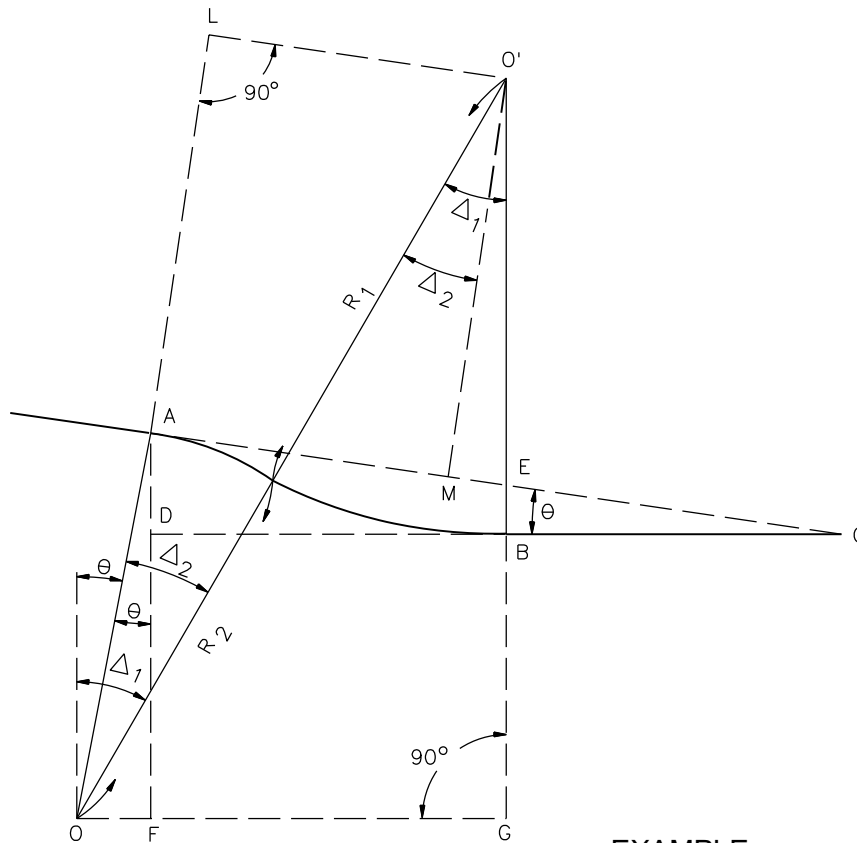

EXAMPLE

Given:

θ , AD, R_1 , and R_2

Required:

Δ_1 and Δ_2

1. $AC = \frac{AD}{\sin \theta}$
2. $BG = DF = R_2 \cos \theta - AD$
3. $\cos \Delta_1 = \frac{R_1 + BG}{R_1 + R_2}$
4. $\Delta_2 = \Delta_1 - \theta$

Given:

$\theta = 2^\circ 13' 16''$
 $AD = 54.00 \text{ ft}$
 $R_1 = 17,200.00 \text{ ft}$
 $R_2 = 21,500.00 \text{ ft}$

Solution:

1. $AC = 54.00 / 0.038755993 = 1393.33 \text{ ft}$
2. $BG = (21500.00) (0.99924874) - 54.00 = 21,429.85 \text{ ft}$
3. $\cos \Delta_1 = (17,220.00 + 21,429.85) / (17,200.00 + 21,500.00) = 0.998187261$
 $\Delta_1 = 3^\circ 27' 01.48''$
4. $\Delta_2 = 3^\circ 27' 01.48'' - 2^\circ 13' 16'' = 1^\circ 13' 45.48''$

**REVERSE CURVES
(Tangents Not Parallel)**

Figure 32-6.AA

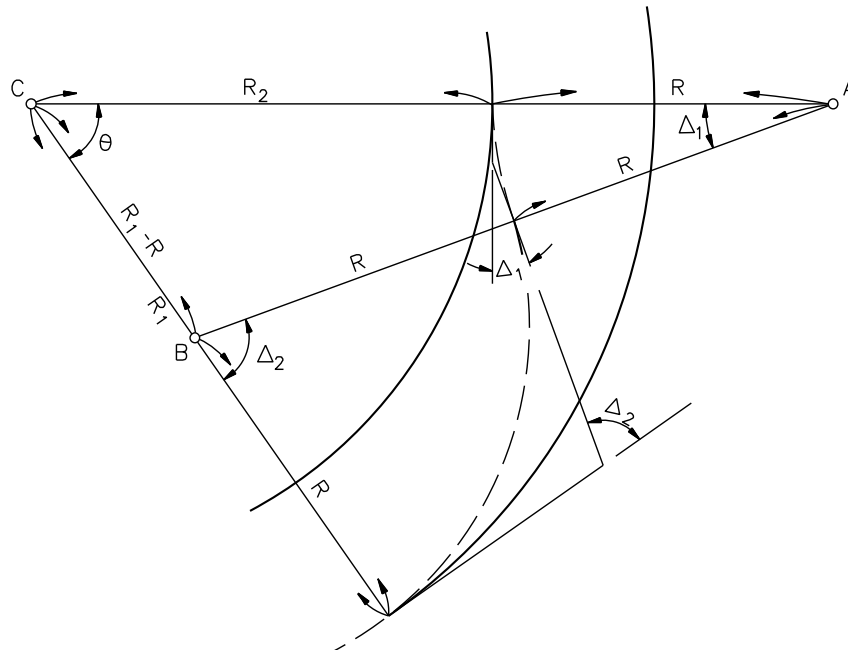
**EQUATIONS:**

$$1. \frac{\sin \Delta_1}{2} = \sqrt{\frac{(s-b)(s-c)}{bc}}$$

Where:

$$\begin{aligned} a &= R_1 - R \\ b &= R_2 + R \\ c &= 2R \\ s &= \frac{1}{2}(a + b + c) \end{aligned}$$

$$2. \sin \theta = \frac{2R \sin \Delta_1}{R_1 - R}$$

$$3. \Delta_2 = \Delta_1 + \theta$$

Given:

R_2 = Inside Curve Radius
 R_1 = Outside Curve Radius
 R = Equal Radii of Reverse Curve

Required:

Δ_1 & Δ_2

EXAMPLE:

$R_2 = 10,700.00$ ft, $R_1 = 10,800.00$ ft,
 $R = 2000.00$ ft

$a = 10,800.00 - 2000.00 = 8800.00$ ft
 $b = 10,700.00 + 2000.00 = 12,700.00$ ft
 $c = (2)(2000.00) = 4000.00$ ft
 $s = 12,750.00$ ft

$$1. \frac{\sin \Delta_1}{2} = \sqrt{\frac{(12,750 - 12,700)(12,750 - 4000)}{(12,700)(4000)}}$$

$$= 0.092801965$$

$$\Delta_1 = 10^\circ 41' 46.84''$$

$$2. \sin \theta = \frac{(2)(2000.00)(0.18560393)}{(10,800.00 - 2000.00)}$$

$$= 0.084365422$$

$$\theta = 4^\circ 50' 22.33''$$

$$3. \Delta_2 = 10^\circ 41' 46.84'' + 4^\circ 50' 22.33''$$

$$= 15^\circ 32' 09.17''$$

REVERSE CURVES
(Between Parallel Curves)

Figure 32-6.BB

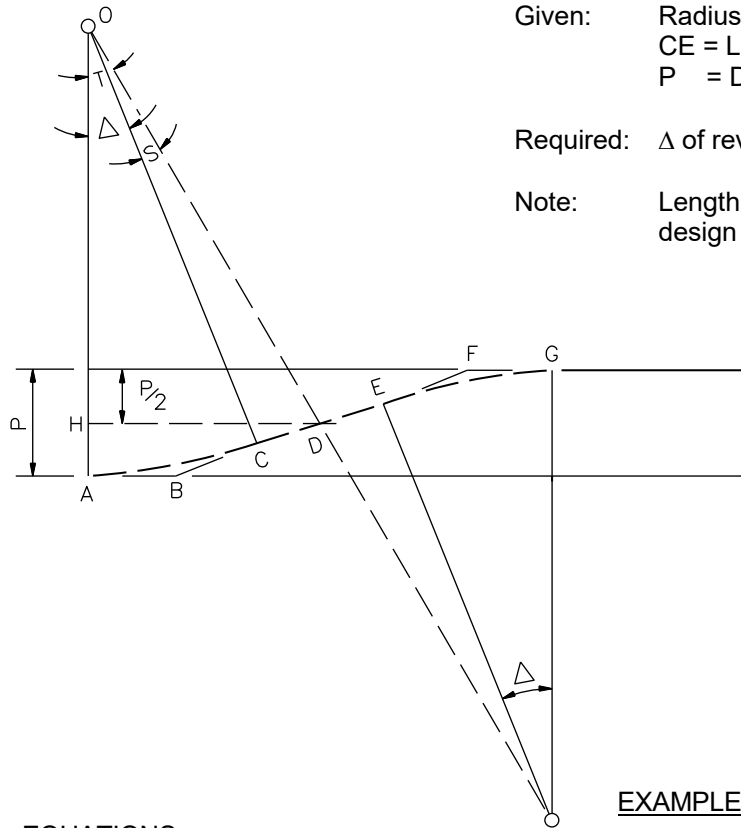

Given: Radius of Reverse Curve
 CE = Length of tangent between curves
 P = Distance between parallel tangents

Required: Δ of reverse curves

Note: Length CE is governed by superelevation runoff design criteria for each curve.

EQUATIONS:

1. $OC = OA = \text{Radius}$
2. $CD = \frac{CE}{2}$
3. $OH = OA - \frac{P}{2}$
4. $OD = \sqrt{(CD)^2 + (OC)^2}$
5. $\sin S = \frac{CD}{OD}$
6. $HD = \sqrt{(OD)^2 - (OH)^2}$
7. $\sin T = \frac{HD}{OD}$
8. $\Delta = T - S$

EXAMPLE:

Given: $R = 5800.00 \text{ ft}$
 Tangent Length = $CE = 200.00 \text{ ft}$
 $P = 130.00 \text{ ft}$

Solution:

1. $OA = 5800.00 \text{ ft}$
2. $CD = 200.00 / 2 = 100.00 \text{ ft}$
3. $OH = 5800.00 - 130.00 / 2 = 5735.00 \text{ ft}$
4. $OD = \sqrt{(100.00)^2 + (5800.00)^2}$
 $= 5800.86 \text{ ft}$
5. $\sin S = 100.00 / 5800.86 = 0.017238817$
 $S = 0^\circ 59' 15.94''$
6. $HD = \sqrt{(5800.00)^2 - (5735.00)^2} = 865.90 \text{ ft}$
7. $\sin T = 865.90 / 5800.00 = 0.149292325$
 $T = 8^\circ 37' 01.23''$
8. $\Delta = 8^\circ 35' 09.30'' - 0^\circ 59' 15.94''$
 $= 7^\circ 35' 53.37''$

REVERSE CURVES
(Parallel Tangents with Tangent Segment Between)

Figure 32-6.CC

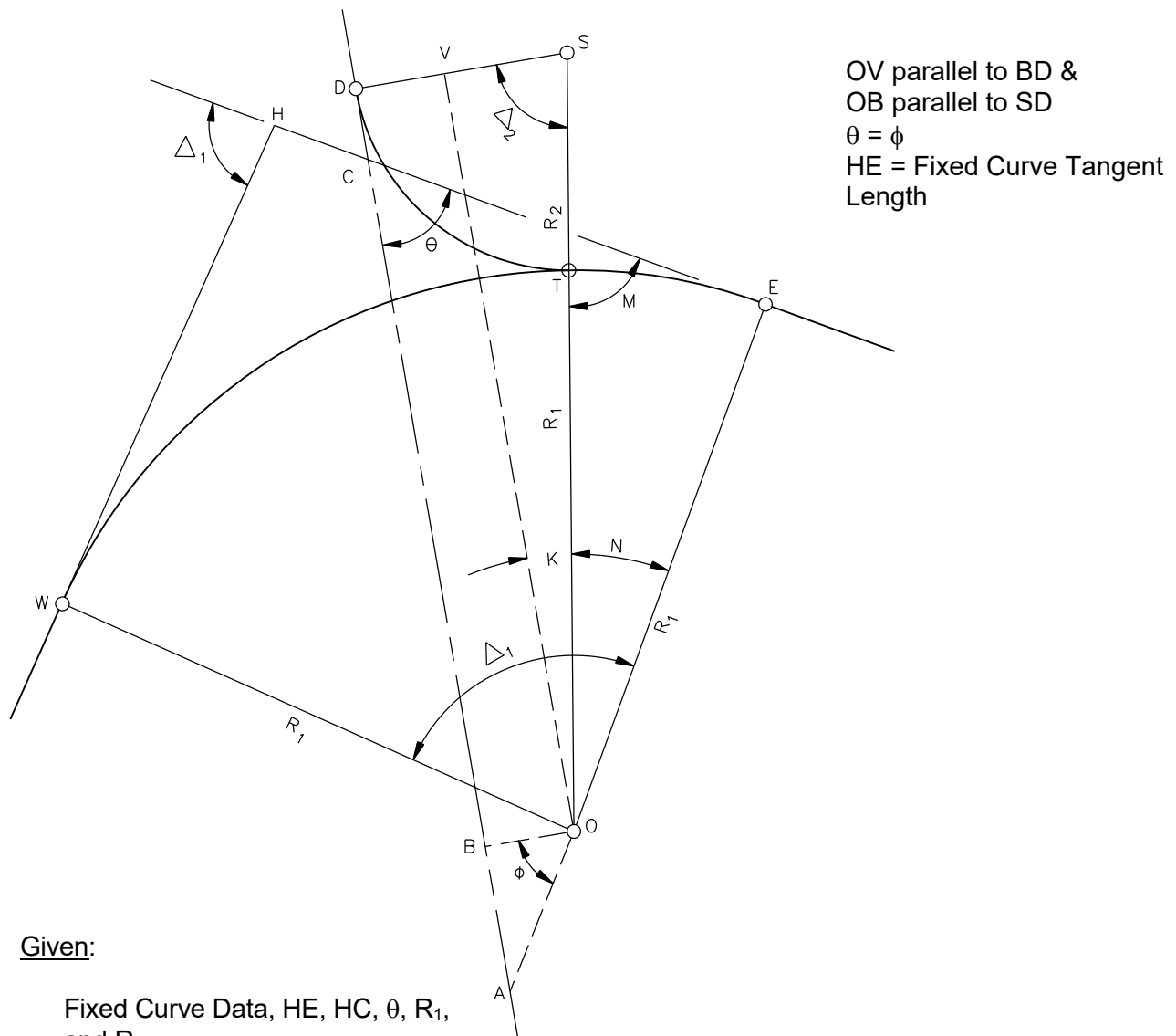

Given:

Fixed Curve Data, HE, HC, θ , R_1 , and R_2

Note:

θ must be less than 90° for this solution.
 WE = fixed curve

Equations:

1. $CE = HE - HC$
2. $OA = CE \tan \theta - R_1$
3. $OB = DV = OA \cos \phi$
4. $SV = R_2 - DV$

5. $\sin K = \frac{SV}{R_1 + R_2}$
6. $\Delta_2 = 90^\circ - K$
7. $M = \theta + K$
8. $N = 90^\circ - M$
9. $\text{ArcLengthET} = \frac{N}{360} 2\pi R_1$

**CURVE BETWEEN FIXED TANGENT AND FIXED CURVE
 (Case 1)**

Figure 32-6.DD

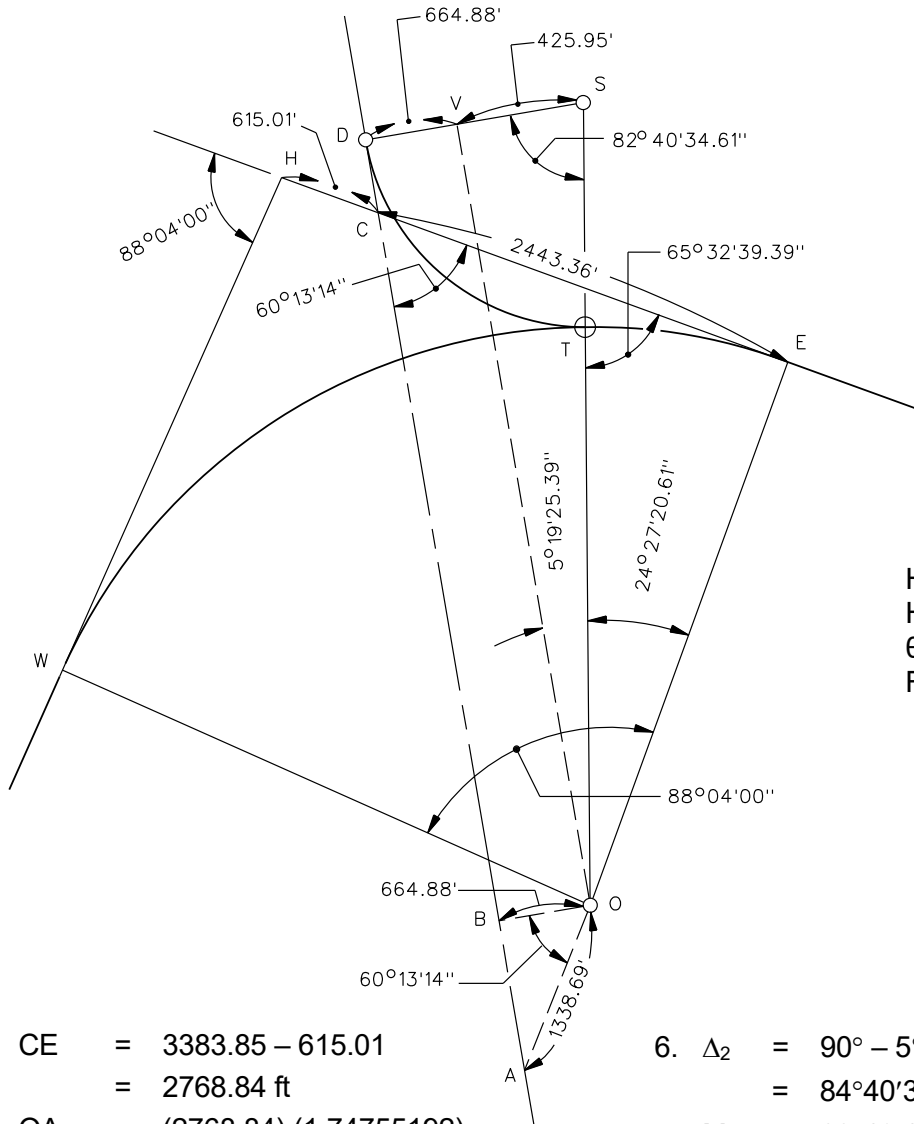

PI Sta. 116 + 82.47
 $\Delta_1 = 88^\circ 04' 00''$
 $R_1 = 3500.00$ ft
 $T = 3383.85$ ft
 $L = 5000.00$ ft

$HE = 3058.37$ ft
 $HC = 615.01$ ft
 $\theta = \phi = 60^\circ 13' 14''$
 $R_2 = 1090.83$ ft

1. $CE = 3383.85 - 615.01 = 2768.84$ ft
2. $OA = (2768.84)(1.74755192) - 3500.00 = 1338.69$ ft
3. $OB = DV = (1338.69)(0.49666261) = 664.88$ ft
4. $SV = 1090.83 - 664.88$ ft = 425.95 ft
5. $\sin K = (425.95) / (3500.00 + 1090.83) = 0.092782786$
 $K = 5^\circ 19' 25.39''$

6. $\Delta_2 = 90^\circ - 5^\circ 19' 25.39'' = 84^\circ 40' 34.61''$
7. $M = 60^\circ 13' 14.00'' + 5^\circ 19' 25.39'' = 65^\circ 32' 39.39''$
8. $N = 90^\circ - 65^\circ 32' 39.39'' = 24^\circ 27' 20.61''$

Arc Length ET = $(24.45572531)(2)(\pi)(3500) / 360 = 1493.92$ ft

CURVE BETWEEN FIXED TANGENT AND FIXED CURVE (CASE 1)
(Sample Problem)

Figure 32-6.EE

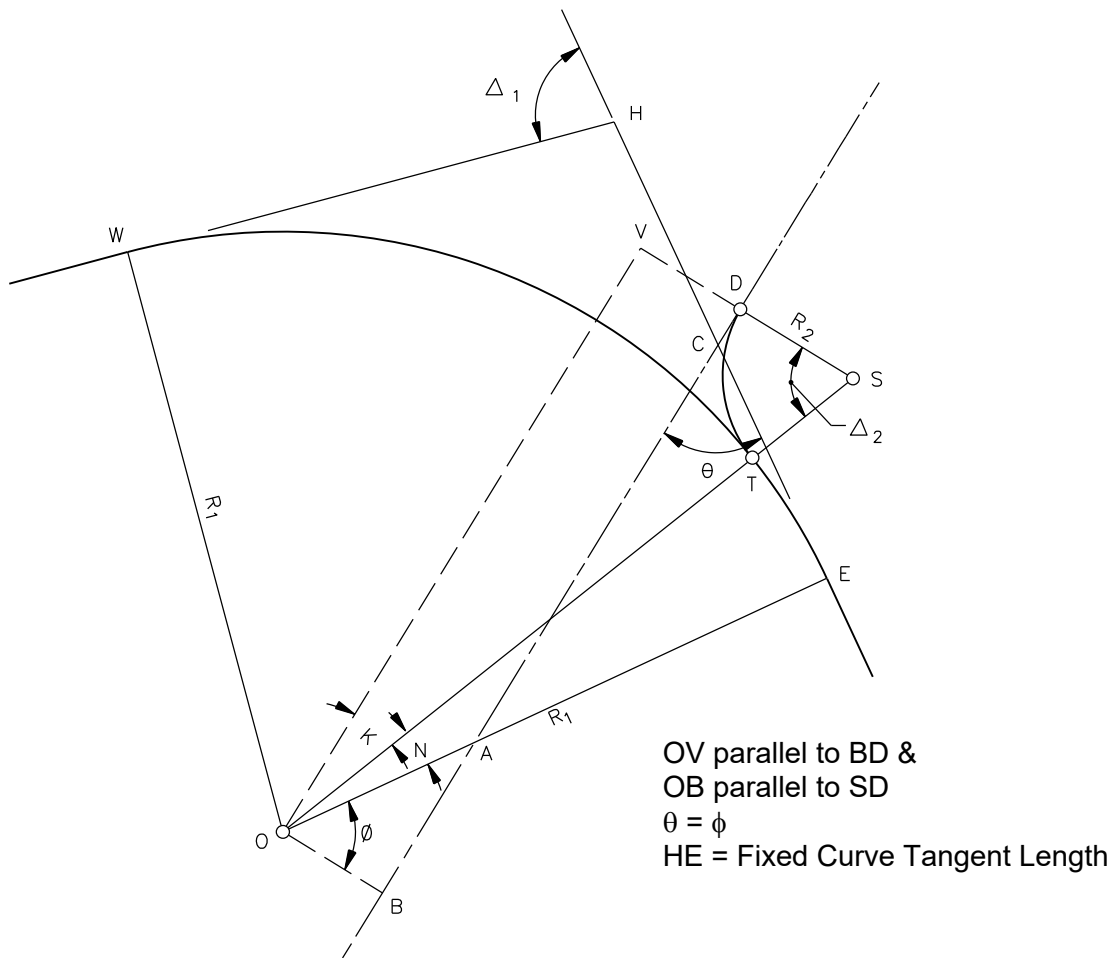

Given:

Fixed Curve Data, HE, HC, θ , R_1 & R_2

Note:

θ must be less than 90° for this solution
 WE = Fixed Curve

Equations:

1. $CE = HE - HC$
2. $OA = R_1 - CE \tan \theta$
3. $OB = DV = OA \cos \phi$
4. $SV = R_2 + DV$
5. $\sin K = \frac{SV}{R_1 + R_2}$
6. $\Delta_2 = 90^\circ - K$
7. $N = 90^\circ - (K + \phi)$
8. Arc Length ET = $\frac{N}{360} 2\pi R_1$

**CURVE BETWEEN FIXED TANGENT AND FIXED CURVE
 (Case II)**

Figure 32-6.FF

Given:

Fixed Curve Data, HC, θ , R_1 , & R_2 .

Note:

θ must be less than 90°

WE = Fixed Curve

OV parallel to BC &

OB parallel to SD

$\theta = \phi$

HE = Fixed Curve Tangent Length

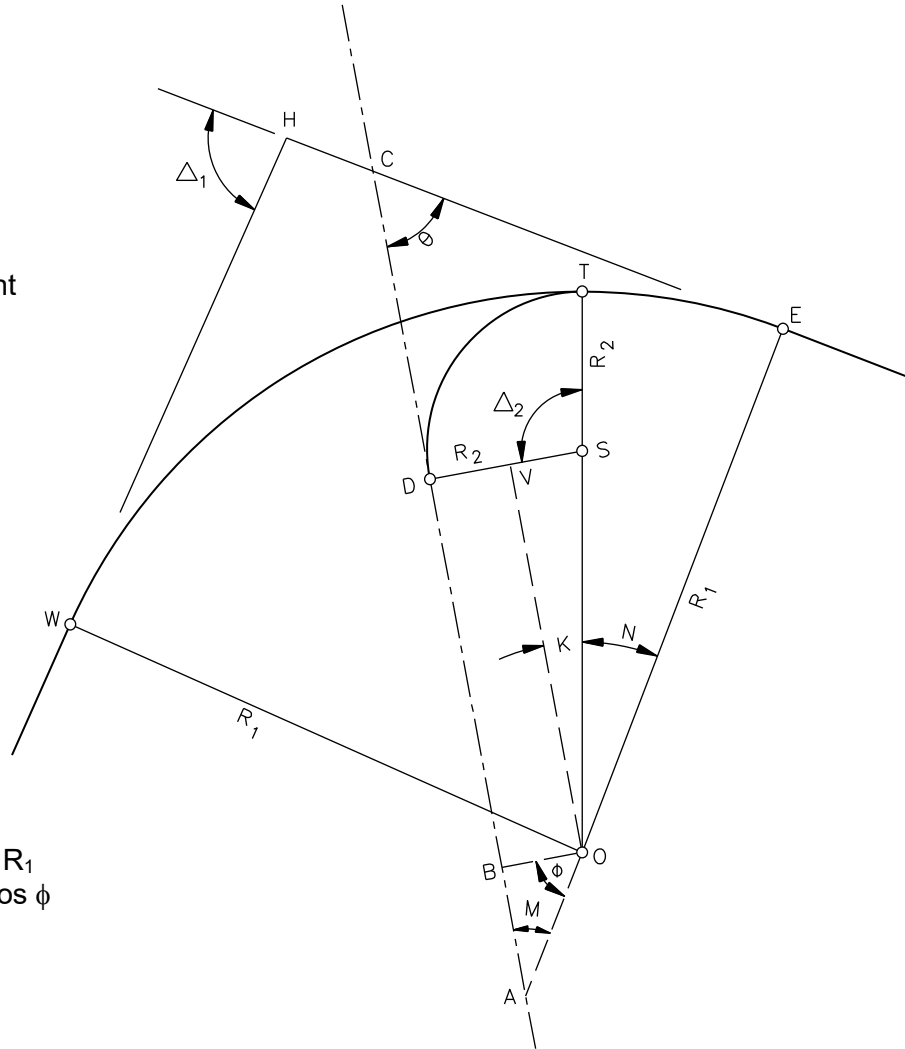

Equations:

1. CE = HE - HC
2. OA = CE tan θ - R_1
3. OB = DV = OA cos ϕ
4. SV = R_2 - DV
5. sin K = $\frac{SV}{R_1 - R_2}$
6. Δ_2 = $90^\circ + K$
7. M = $90^\circ - \phi$
8. N = M - K
9. Arc Length ET = $\frac{N}{360} 2\pi R_1$

**CURVE BETWEEN FIXED TANGENT & FIXED CURVE
(Case III)
Figure 32-6.GG**

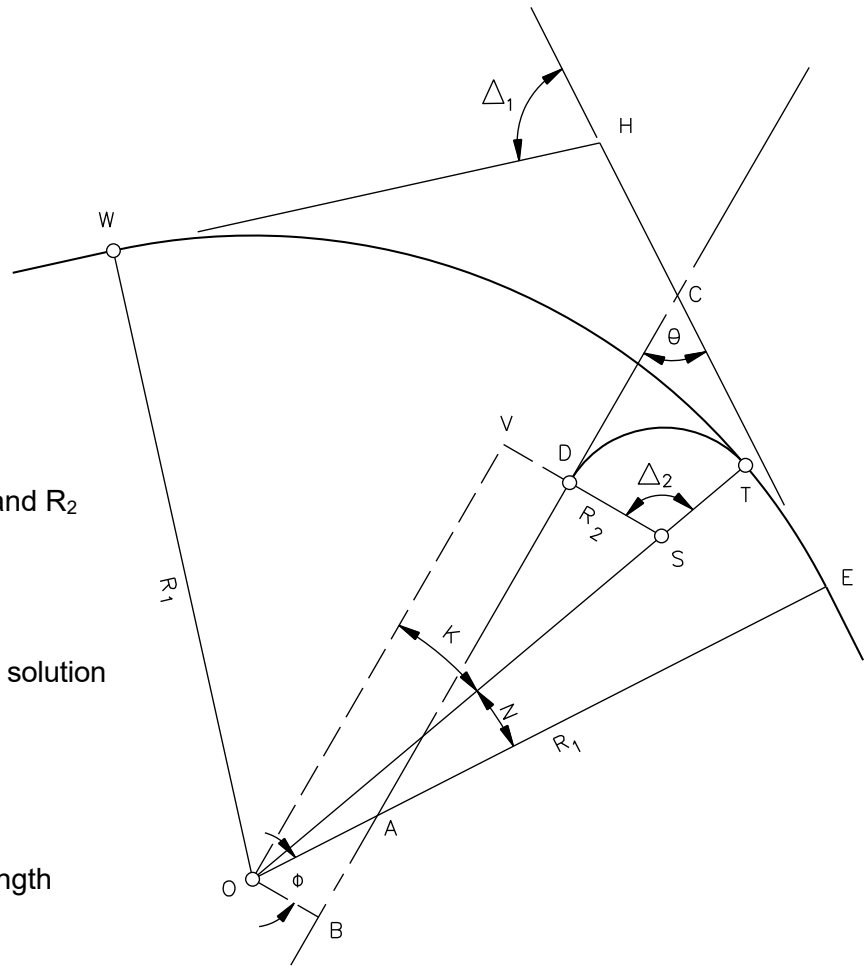

Given:

Fixed Curve Data, HC, θ , R_1 , and R_2

Note:

θ must be less than 90° for this solution

WE = Fixed Curve

OV parallel to BC &

OB parallel to SD

$\theta = \phi$

HE = Fixed Curve Tangent Length

Equations:

1. CE = HE - HC
2. OA = $R_1 - CE \tan \theta$
3. OB = DV = OA cos ϕ
4. SV = $R_2 + DV$
5. $\sin K = \frac{SV}{R_1 - R_2}$
6. $\Delta_2 = 90^\circ + K$
7. N = $90^\circ - (K + \phi)$
8. Arc Length ET = $\frac{N}{360} 2\pi R_1$

**CURVE BETWEEN FIXED TANGENT & FIXED CURVE
(Case IV)**

Figure 32-6.HH

Given:

“WE” Curve Data, HC, θ , R_1 , and R_2

WE = Fixed Curve
 OF parallel to VD
 VF parallel to AD

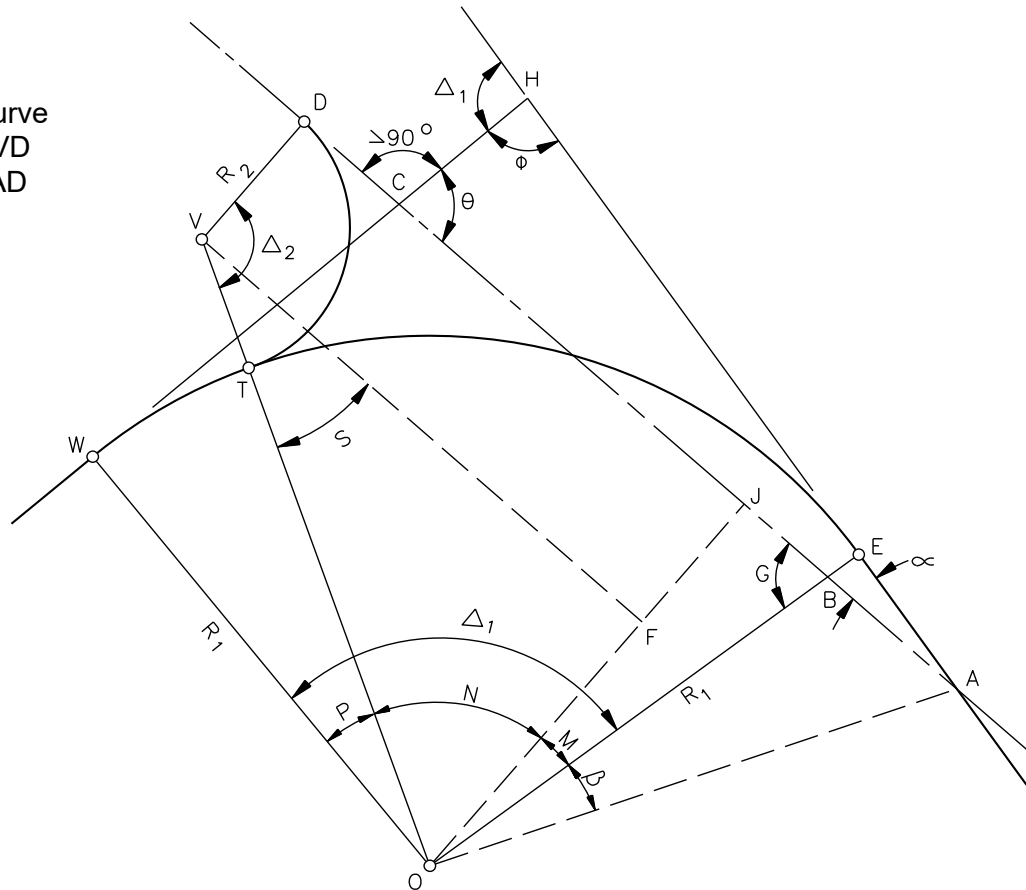

Equations:

1. $\alpha = 180^\circ - (\theta + \phi)$
2. $HA = \frac{HC \sin \theta}{\sin \alpha}$
3. $AE = HA - HE$
4. $BE = AE \tan \alpha$
5. $OB = R_1 - BE$
6. $G = 90^\circ - \alpha$
7. $OJ = OB \sin G$

8. $OF = OJ - R_2$
9. $\sin S = \frac{OF}{R_1 + R_2}$
10. $\tan \beta = \frac{AE}{R_1}$
11. $\Delta_2 = 90^\circ + S$
12. $M = 90^\circ - G$
13. $N = 90^\circ - S$
14. $P = \Delta_1 - M - N$
15. $\text{ArcLength WT} = \frac{P}{360} 2\pi R_1$

**CURVE BETWEEN FIXED TANGENT & FIXED CURVE
 (Case V)**

Figure 32-6.II

Given:

“WE” Curve Data, HC, θ , R_1 , R_2 , and R_3

Note:

θ must be less than 90°

AD = Fixed Tangent
WE = Fixed Curve

Δ_2 & N computed according to example in Case I

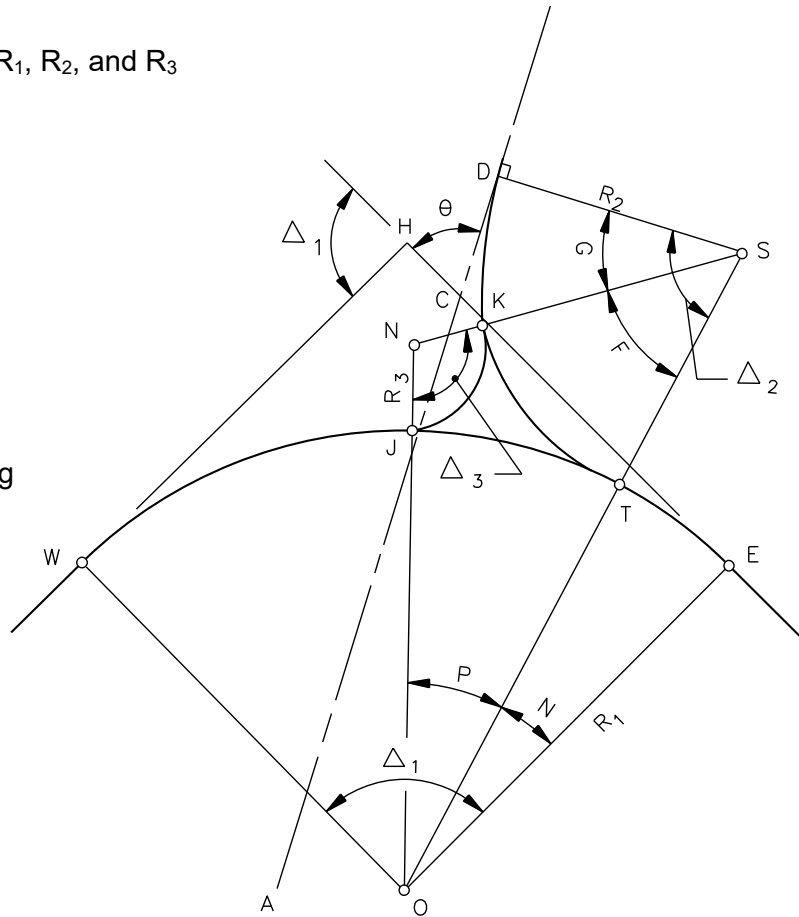

Equations:

1. $\frac{\sin \Delta_2}{2} = \sqrt{\frac{(s-b)(s-c)}{bc}}$

2. $\sin P = \frac{(R_2 + R_3) \sin \Delta_2}{R_1 + R_2}$

3. $\sin F = \frac{(R_1 + R_3) \sin \Delta_2}{R_1 + R_2}$

4. Arc Length EJ = $\frac{(N + P)}{360} 2\pi R_1$

5. $G = \Delta_2 - F$

6. Arc Length DK = $\frac{G}{360} 2\pi R_2$

7. Arc Length KJ = $\frac{\Delta_3}{360} 2\pi R_3$

where: $a = OS = R_1 + R_2$
 $b = NS = R_2 + R_3$
 $c = ON = R_1 + R_3$
 $s = \frac{1}{2}(a + b + c)$

THREE CURVES TANGENT TO EACH OTHER
Figure 32-6.JJ

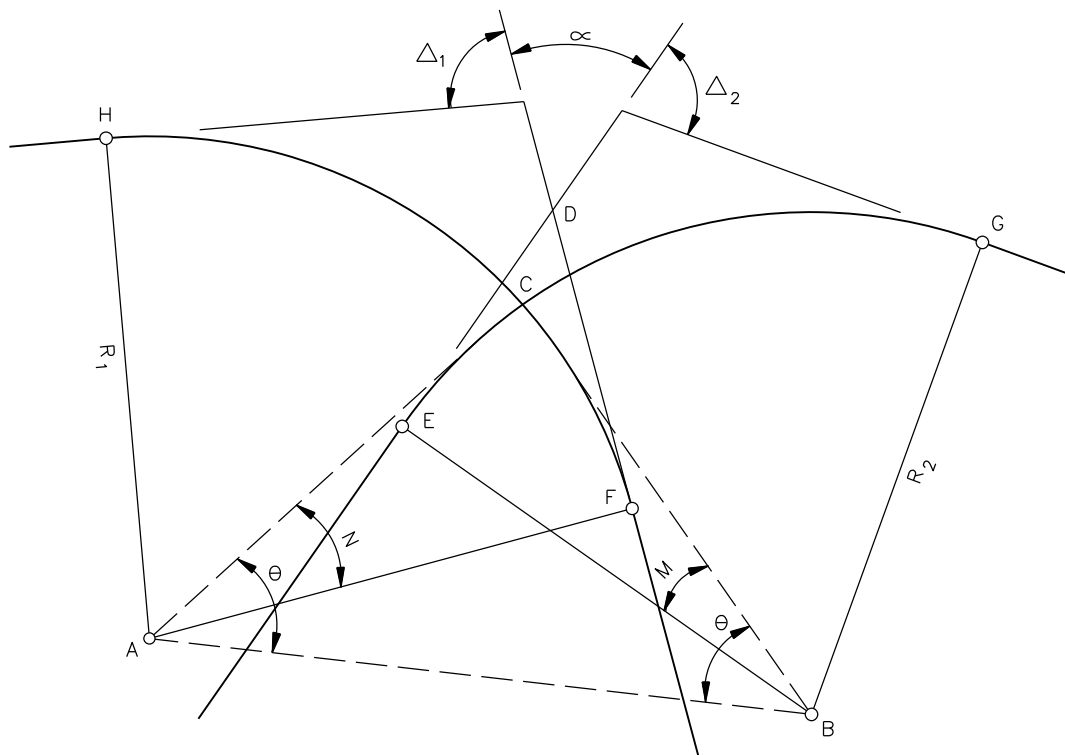
**Given:**

Curve data, azimuth, or bearing of curve tangents, DE, DF, & ∞ .

Required:

Arc EC and Arc FC

1. Coordinates at D either given or assume grid system
2. Determine coordinates at centers of curves (A & B)
3. Determine length and bearing AB
4. $BC = R_2 = a$, $AC = R_1 = b$,
 $AB = c$

$$5. s = \frac{1}{2}(a + b + c)$$

$$6. \frac{\sin \theta}{2} = \sqrt{\frac{(s-b)(s-c)}{bc}}$$

$$7. \sin \phi = \frac{R_1 \sin \theta}{R_2}$$

8. Determine bearings of AC & BC

9. Determine N & M from bearings

$$10. \text{ArcEC} = \frac{M}{360} 2\pi R_2$$

$$11. \text{ArcFC} = \frac{N}{360} 2\pi R_1$$

INTERSECTION OF TWO CURVES

Figure 32-6.KK

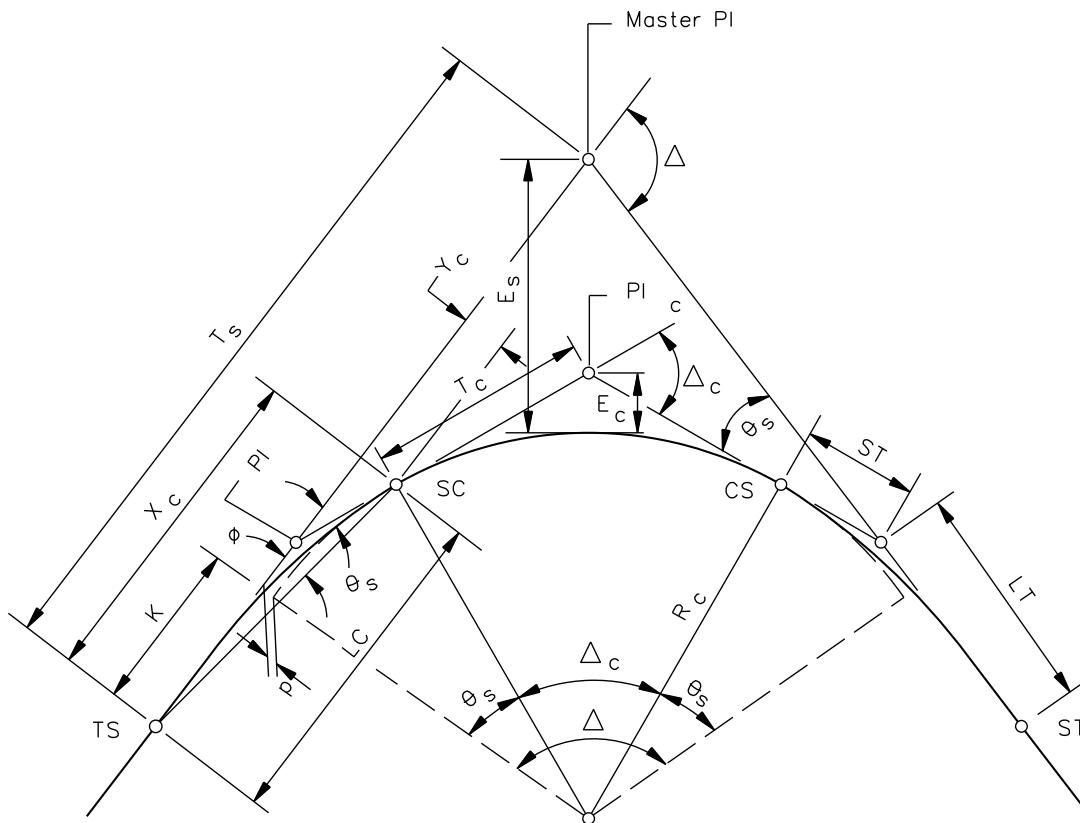

Notes:

1. All highway spirals to be computed with Department's approved software.
2. PI_c to circular curve must be set on External (E_s) and not from spiral PI (PI_s) and spiral end point (SC or CS).
3. A simple method for locating the points on a spiral transition is to divide the length of spiral into 10 or 20 equal parts, set up on the TS or SC, and locate the points by calculating deflection angles and using equal chord lengths.
4. See Figure 32-6.MM for definition of terms.

SIMPLE CURVE WITH SPIRALS

Figure 32-6.LL

SPIRAL TRANSITION CURVE NOMENCLATURE

Master PI = Point of intersection of the main tangents.	LT = Long tangent of spiral only.
PI _c = Point of intersection of circular curve tangents.	ST = Short tangent of spiral only.
PI _s = Point of intersection of the main tangent and tangent of circular curve.	LC = Long chord of spiral.
TS = Tangent to spiral, common point of spiral and near transition.	p = Offset distance from the main tangent to the PC or PT of the circular curve extended.
SC = Spiral to curve, common point of spiral and circular curve of near transition.	k = Distance from TS to point on main tangent opposite the PC of the circular curve produced.
CS = Curve to spiral, common point of circular curve and spiral of far transition.	Δ = Intersection angle between main tangents of the entire curve.
ST = Spiral to tangent, common point of spiral and tangent of far transition.	Δ _c = Intersection angle between tangents at the SC and the CS or the central angle of the circular curve.
R _c = Radius of the circular curve.	θ _s = Intersection angle between the tangent of the complete curve and the tangent at the SC, the spiral tangents intersection angle.
L _s = Length of spiral.	φ = Deflection angle from main tangent at TS to SC along the line of the long chord.
L _c = Length of circular curve.	x _{cy_c} = Coordinates of SC from the TS.
T _s = Tangent distance from Master PI to TS or ST, or tangent distance of completed combination of curves.	L' = Length of spiral arc from the TS to any point on the spiral.
T _c = Tangent distance from SC or CS to PI _c .	θ = The central angle of spiral arc L'. θ equals θ _s when L' equals L _s . Note: The θ referred to in Table II of <i>Transition Curves for Highways</i> is actually θ _s .
E _s = External distance from Master PI to midpoint of circular curve portion	

SPIRAL CURVE NOMENCLATURE**Figure 32-6.MM**

CURVE FUNCTIONS

1. $\theta_s = (L_s / R_c) (90/\pi)$
2. $\Delta_c = \Delta - 2\theta_s$
3. $L_c = \frac{\Delta_c}{360} 2\pi R_c$
4. $T_s = (R_c + p) \tan (\Delta/2) + k$
5. $E_s = (R_c + p) (1/\cos (\Delta/2) - 1) + p = \left[\frac{(R_c + p)}{\cos(\Delta/2)} - (R_c + p) \right] + p$

Where Δ , R_c , and L_s are given. To find p and k , calculate θ_s and use Table II from *Transition Curves for Highways* or use tables in the Department's approved software.

SPIRAL FUNCTIONS

Corrections for C in Formula $\phi = \frac{\theta}{3} - C$								
θ_s in Degrees	15	20	25	30	35	40	45	50
C in Minutes	0.2	0.4	0.8	1.4	2.2	3.4	4.8	6.6

6. $\phi = \frac{\theta}{3}$, if $\theta_s < 15^\circ 00'$ (approx. value)
7. $\phi = \frac{\theta}{3} - C$, if $\theta_s \geq 15^\circ 00'$ (approx. value)
8. Deflection angle from TS or ST to any point "n" on spiral curve:

$$\phi = \frac{\theta_s}{3} \left[\frac{L'}{L_s} \right]^2$$
9. The exact values of ϕ can be determined by coordinates:

$$\tan \phi = \frac{y_c}{x_c}$$
10. $ST = \frac{y_c}{\sin \theta_s}$
11. $LT = x_c - \left(\frac{y_c}{\tan \theta_s} \right)$
12. $LC = \frac{x_c}{\cos \phi}$
13. $x_c = LC \cos \phi$
14. $y_c = LC \sin \phi$
15. $\theta = \frac{(L')^2}{L_s^2} \theta_s$

Note: These equations are based on *Transition Curves for Highways* by Joseph Barnett.

SPIRAL CURVE FORMULAS

Figure 32-6.NN

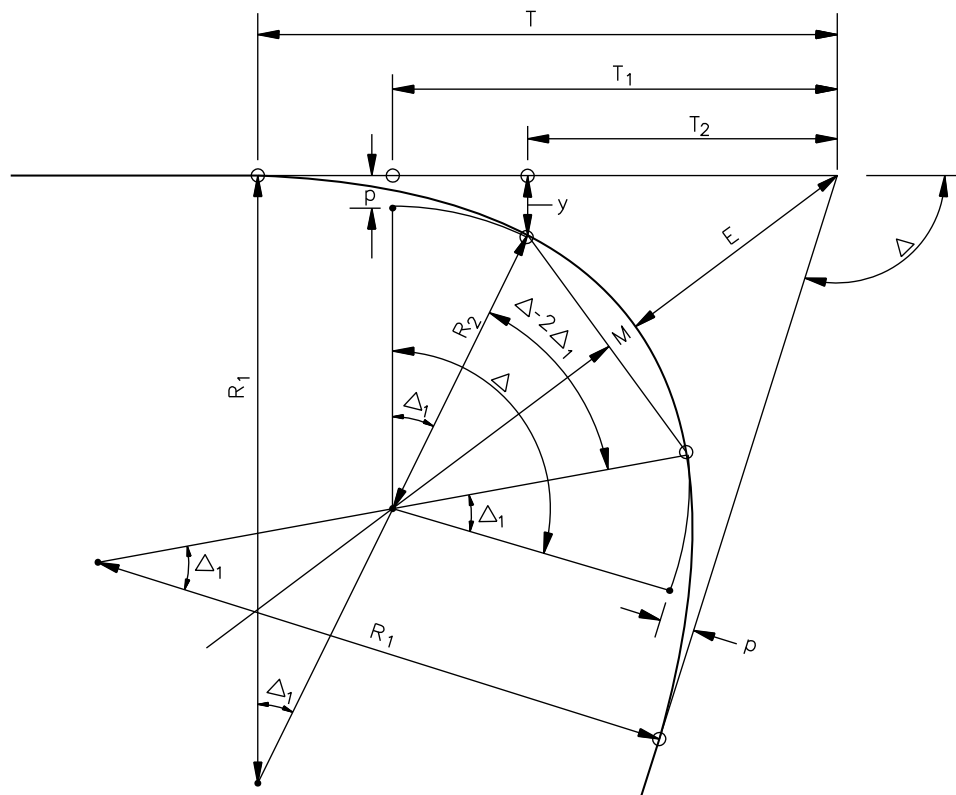

Given: R_1 , R_2 , Δ_1 , and p

$$1. T_1 = (R_2 + p) \tan \frac{\Delta}{2}$$

$$2. \Delta_1 = \cos^{-1} \left[\frac{R_1 - R_2 - p}{R_1 - R_2} \right]$$

$$3. T = T_1 + (R_1 - R_2) \sin \Delta_1$$

$$4. T_2 = T_1 - R_2 \sin \Delta_1$$

$$5. E = \frac{R_2 + p}{\cos(\Delta/2)} - R_2$$

$$6. M = R_2 - [R_2 \cos(\Delta/2 - \Delta_1)]$$

$$7. y = (R_2 + p) - R_2 \cos \Delta_1$$

Note: "p" is the offset location between the interior curve (extended) to a point where it becomes parallel with the tangent line.

THREE-CENTERED COMPOUND CURVE

Figure 32-6.00

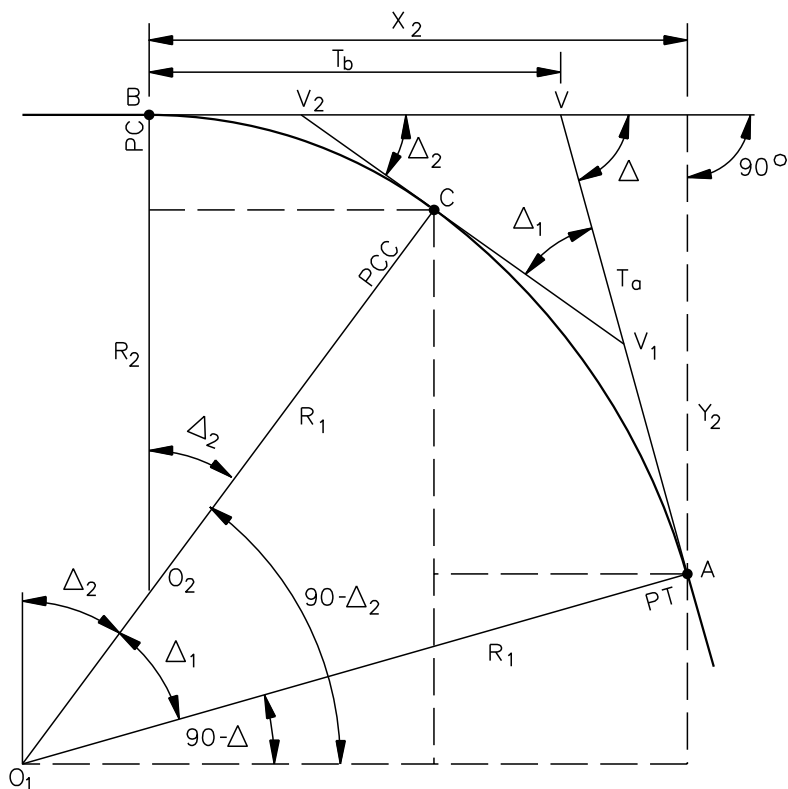

Given: R_1, R_2, Δ

Equations:

$$\Delta = \text{Total Deflection Angle} = \Delta_1 + \Delta_2$$

$$X_2 = R_1 \sin \Delta - (R_1 - R_2) \sin \Delta_2$$

$$Y_2 = R_2 - R_1 \cos \Delta + (R_1 - R_2) \cos \Delta_2$$

$$T_a = AV = Y_2 / \sin \Delta$$

$$T_b = BV = X_2 - T_a \cos \Delta$$

$$\tan(\Delta_2/2) = \frac{R_1(1 - \cos \Delta) - T_a \sin \Delta}{R_1(\sin \Delta) - T_a \cos \Delta - T_b}$$

TWO-CENTERED COMPOUND CURVE

Figure 32-6.PP

32-7 CURVE DATA**32-7.01 Rounding**

The following will apply to rounding the radii of horizontal curves:

1. New Horizontal Curve. Radii will be expressed in multiples of 5 ft (1 m) increments.
2. Existing Horizontal Curve. Alignments that incorporate a previously defined horizontal curve should continue to use the same existing radius, and the radius will be re-defined to the nearest 0.01 ft (0.001 m). For example, a 3-degree curve which is a re-creation of a previously established curve will be assigned a 1909.86 ft (582.125 m) radius.

* * * * *

Example 32-7.1

Shown below are three possible cases defining horizontal curvature. In all three cases, it is assumed the curve starts at PC Sta 300 + 59.41 (English units) or the equivalent PC station in metric units of kilometer Sta 9 + 162.126.

Case A: English curve definition.

Case B: Metric definition assuming that Case A curve data defines the roadway centerline from a previous survey and will be retained. All curve data is a direct or soft conversion from English to metric units.

Case C: Metric definition of a paper relocation on mapping. The PC location will start at metric Sta 9 + 162.125 and have approximately the same curvature as the Case A curve. Therefore, R will be set at 580 m.

The following table illustrates the curve data for all three Cases.

Case A	Case B	Case C
PI Sta = 302 + 68.57	PI Sta = 9 + 225.879	PI Sta 9 + 225.646
$\Delta = 12^{\circ}30'$	$\Delta = 12^{\circ}30'$	$\Delta = 12^{\circ}30'$
D = 3°00'	R = 582.125 m	R = 580.000 m
T = 209.16 ft	T = 63.753 m	T = 63.520 m
L = 416.67 ft	L = 127.000 m	L = 126.536 m

* * * * *

32-7.02 Chord Distances

When laying out a horizontal curve, the following guidelines are recommended for measuring chord distances around a curve. Where the radius is greater than 2000 ft (600 m), use 100 ft (25 m) chords. For radii between 2000 ft (600 m) and 800 ft (250 m), use 50 ft (15 m) chords. For radii between 800 ft (250 m) and 400 ft (125 m), use 25 ft (10 m) chords.

32-8 REFERENCES

1. *A Policy on Geometric Design of Highways and Streets*, AASHTO, 2011.
2. *Bureau of Engineering Manual, Part E - Street Design Manual*, City of Los Angeles, July 1986.
3. *Transition Curves for Highways*, Public Roads Administration, 1940.

Chapter Thirty-three
VERTICAL ALIGNMENT

BUREAU OF DESIGN AND ENVIRONMENT MANUAL

Chapter Thirty-three
VERTICAL ALIGNMENT

Table of Contents

<u>Section</u>	<u>Page</u>
33-1 DEFINITIONS.....	33-1.1
33-2 GRADES	33-2.1
33-2.01 Terrain.....	33-2.1
33-2.02 Maximum Grades.....	33-2.1
33-2.03 Minimum Grades	33-2.1
33-2.04 Critical Length of Grade	33-2.2
33-3 TRUCK-CLIMBING LANES.....	33-3.1
33-3.01 Warrants.....	33-3.1
33-3.01(a) Two-Lane Highways.....	33-3.1
33-3.01(b) Multilane Highways.....	33-3.1
33-3.02 Capacity Analysis.....	33-3.2
33-3.03 Design Guidelines	33-3.2
33-3.04 Downgrades	33-3.6
33-3.05 Truck Speed Profile.....	33-3.6
33-4 VERTICAL CURVES.....	33-4.1
33-4.01 Crest Vertical Curves	33-4.1
33-4.01(a) Stopping Sight Distance	33-4.1
33-4.01(b) Decision Sight Distance.....	33-4.2
33-4.01(c) Passing Sight Distance.....	33-4.6
33-4.01(d) Drainage	33-4.6
33-4.02 Sag Vertical Curves	33-4.8
33-4.02(a) Stopping Sight Distance	33-4.8
33-4.02(b) Decision Sight Distance.....	33-4.11
33-4.02(c) Comfort Criteria.....	33-4.11
33-4.02(d) Underpasses.....	33-4.12
33-4.02(e) Drainage	33-4.12
33-4.03 Vertical Curve Computations.....	33-4.14
33-5 VERTICAL CLEARANCES.....	33-5.1

Table of Contents

(Continued)

<u>Section</u>		<u>Page</u>
33-6	DESIGN PRINCIPLES AND PROCEDURES.....	33-6.1
33-6.01	General Controls for Vertical Alignment.....	33-6.1
33-6.02	Coordination of Horizontal and Vertical Alignment.....	33-6.2
33-6.03	Aesthetics.....	33-6.8
	33-6.03(a) General.....	33-6.8
	33-6.03(b) Rural Visual Impacts.....	33-6.9
	33-6.03(c) Urban Visual Impacts.....	33-6.14
33-6.04	Design of Profile Gradelines	33-6.17
	33-6.04(a) General.....	33-6.17
	33-6.04(b) Design of Urban Profile Gradelines.....	33-6.18
	33-6.04(c) Design of Rural Profile Gradelines.....	33-6.19
	33-6.04(d) Soils.....	33-6.19
	33-6.04(e) Drainage/Snow.....	33-6.21
	33-6.04(f) Erosion Control	33-6.22
	33-6.04(g) Earthwork Balance.....	33-6.22
	33-6.04(h) Bridges	33-6.23
	33-6.04(i) At-Grade Railroad Crossings.....	33-6.24
	33-6.04(j) Distance Between Vertical Curves	33-6.24
	33-6.04(k) Ties With Existing Highways	33-6.24
33-7	REFERENCES	33-7.1

Chapter Thirty-three

VERTICAL ALIGNMENT

The vertical alignment contributes significantly to a highway's safety, aesthetics, operations, and costs. Long, gentle vertical curves provide greater sight distances and a more pleasing appearance for the driver. Chapters 43 through 50 provide numerical criteria for various vertical alignment elements based on highway functional class, project scope of work, and urban/rural location. Chapter 33 provides additional guidance on these and other vertical alignment elements, including maximum and minimum grades, critical lengths of grade, truck-climbing lanes, vertical curvature, vertical clearances, aesthetics, and developing a profile gradeline.

33-1 DEFINITIONS

1. Broken-Back Curves. A gradeline with two vertical curves in the same direction separated by a short section of tangent grade.
2. Bus. A heavy vehicle involved in the transport of passengers on a for-hire, charter, or franchised transit basis. Also, can be called a motor coach in rural areas.
3. Critical Length of Grade. The maximum length of a specific upgrade on which a loaded truck can operate without an unreasonable reduction in speed.
4. Grade Slopes. The rate of slope expressed as a percent between two adjacent VPI's. The numerical value for the grade is the vertical rise or fall in feet (meters) for each foot (meter) of horizontal distance. The numerical value is multiplied by 100 and is expressed as a percent. Upgrades in the direction of stationing are identified as plus (+). Downgrades are identified as minus (-).
5. Heavy Vehicles. Any vehicle with more than four wheels touching the pavement during normal operation. Heavy vehicles collectively include trucks, recreational vehicles, and buses.
6. K-Values. The horizontal distance needed to produce a 1% change in gradient.
7. Level Terrain. Level terrain generally is considered to be flat and has minimal impact on vehicular performance. Highway sight distances are either long or could be made long without major construction expense.
8. Momentum Grade. A site where an upgrade is preceded by a downgrade. These locations may allow a truck to increase its speed on the downgrade before ascending the upgrade.
9. Performance Curves. A set of curves which illustrate the effect grades will have on the design vehicle's acceleration and/or deceleration.

10. Profile Gradeline. A series of tangent lines connected by vertical curves. Typically, the gradeline is located along the roadway centerline of undivided multilane facilities and two-lane, two-way highways. For divided highways, it is typically located at the median edge of the traveled way for each roadway.
11. Recreational Vehicle. A heavy vehicle, generally operated by a private motorist, engaged in the transportation of recreational equipment or facilities; examples include campers, boat trailers, motorcycle trailers, etc.
12. Rolling Terrain. The natural slopes consistently rise above and fall below the roadway gradeline and, occasionally, steep grades present some restriction to the desirable horizontal and vertical alignment. In general, rolling terrain generates steeper grades causing trucks to reduce speeds below those of passenger cars.
13. Rugged Terrain. Longitudinal and transverse changes in elevation are abrupt, and benching and side hill excavation are usually required to provide the desirable horizontal and vertical alignment. Rugged terrain aggravates the performance of trucks relative to passenger cars and results in some trucks operating at crawl speeds.
14. Truck. A heavy vehicle engaged primarily in the transport of goods and materials or in the delivery of services other than public transportation. For geometric design and capacity analyses, trucks are defined as vehicles with six or more tires. Trucks may be defined as either single units (SU) or multiple units (MU). Data on trucks is compiled and reported by the district with assistance from the Office of Planning and Programming.
15. VPC (Vertical Point of Curvature). The point at which a tangent grade ends and the vertical curve begins.
16. VPI (Vertical Point of Intersection). The point where the extension of two tangent grades intersect.
17. VPT (Vertical Point of Tangency). The point at which the vertical curve ends and the tangent grade begins.

33-2 GRADES

33-2.01 Terrain

The topography throughout most of Illinois is considered to be either level or rolling. However, the northwest corner of the State, southern Illinois, and bluff areas near major rivers may be considered rugged. In general, if the terrain designation is not clear (e.g., level versus rolling), select the flatter of the two terrains. Where a multilane divided highway is proposed in rugged terrain, independent alignments with separate profiles are recommended.

33-2.02 Maximum Grades

Chapters 44 through 50 present Department criteria for maximum grades based on functional classification, urban/rural location, type of terrain, design speed, and project scope of work. Only use the maximum grades where it is absolutely necessary. Wherever practical, use grades flatter than the maximum.

33-2.03 Minimum Grades

The following provides the Department's criteria for minimum grades:

1. Uncurbed Roadways. It is desirable to provide a minimum longitudinal gradient of approximately 0.5%. This allows for the possibility of alterations to the original pavement cross slope due to swell, consolidation, maintenance operations, or resurfacing. Longitudinal gradients of approximately 0% may be acceptable on some pavements that have adequate cross slopes. These locations typically occur where a highway traverses a wide flood plain. In these cases, check the flow lines of the outside ditches for adequate drainage.
2. Curbed Streets. The median edge or centerline profile of streets with curb and gutter desirably should have a minimum longitudinal gradient of 0.5%. Where the adjacent development or flatter terrain precludes the use of a profile with a 0.5% grade, provide a minimum longitudinal gradient of at least 0.3%.

On curbed facilities, the longitudinal gradient at the gutter line will have a significant impact on the pavement drainage characteristics (e.g., water encroaching on traveled ways, flow captures rates by grates). See Chapter 40 of the *BDE Manual* and the *IDOT Drainage Manual* for more information on pavement drainage.

3. New Bridges. For bridges on new construction and reconstruction projects, provide a minimum longitudinal gradient of 0.5% across the bridge.

33-2.04 Critical Length of Grade

The critical length of grade is the maximum length of a specific upgrade on which a truck can operate without an unreasonable reduction in speed. The highway gradient in combination with the length of the grade will determine the truck speed reduction on upgrades. For additional guidance, see the *Highway Capacity Manual* and the AASHTO *Policy on Geometric Design of Highways and Streets*.

The following will apply to the critical length of grade:

1. Design Vehicle. Figure 33-2.A presents the critical length of grade for a 200 lb/hp (120 kg/kW) truck. This vehicle applies to all truck routes in Illinois.

For additional guidance on truck routes, see Sections 36-1.08 and 43-5 and the latest IDOT Designated State Truck Route System Map.

2. Criteria. Figure 33-2.A provides the critical lengths of grade for a given percent grade and acceptable truck speed reduction. Although these figures are based on an initial truck speed of 70 mph (110 km/h), they apply to any design or posted speed. For design purposes, use the 10 mph (15 km/h) speed reduction curve in the figure to determine if the critical length of grade is exceeded.
3. Momentum Grades. Where an upgrade is preceded by a downgrade, trucks will often increase their speed to ascend the upgrade. A speed increase of 5 mph (10 km/h) on moderate downgrades (3%-5%) and 10 mph (15 km/h) on steeper downgrades (6%-8%) of sufficient length are reasonable adjustments to the initial speed. This assumption allows the use of a higher speed reduction curve in Figure 33-2.A. However, the designer should also consider that these speed increases may not always be attainable. If traffic volumes are sufficiently high, a truck may be behind another vehicle when descending the momentum grade thereby restricting the increase in speed. Therefore, only consider these increases in speed if the highway has a Level of Service C or better.
4. Measurement. Vertical curves are part of the length of grade. Figure 33-2.B illustrates how to measure the length of grade to determine the critical length of grade using Figure 33-2.A.
5. Application. If the critical length of grade is exceeded, flatten the grade, if practical, or evaluate the need for a truck-climbing lane; see Section 33-3. Typically, only two-lane highways have operational problems that require truck-climbing lanes.
6. Highway Types. The critical-length-of-grade criteria applies equally to two-lane or multilane highways and applies equally to urban and rural facilities.
7. Example Problems. Examples 33-2.1 and 33-2.2 illustrate the use of Figure 33-2.A to determine the critical length of grade. Example 33-2.3 illustrates the use of Figures 33-2.A and 33-2.B. In the examples, the use of subscripts 1, 2, etc., indicate the successive gradients and lengths of grade on the highway segment.

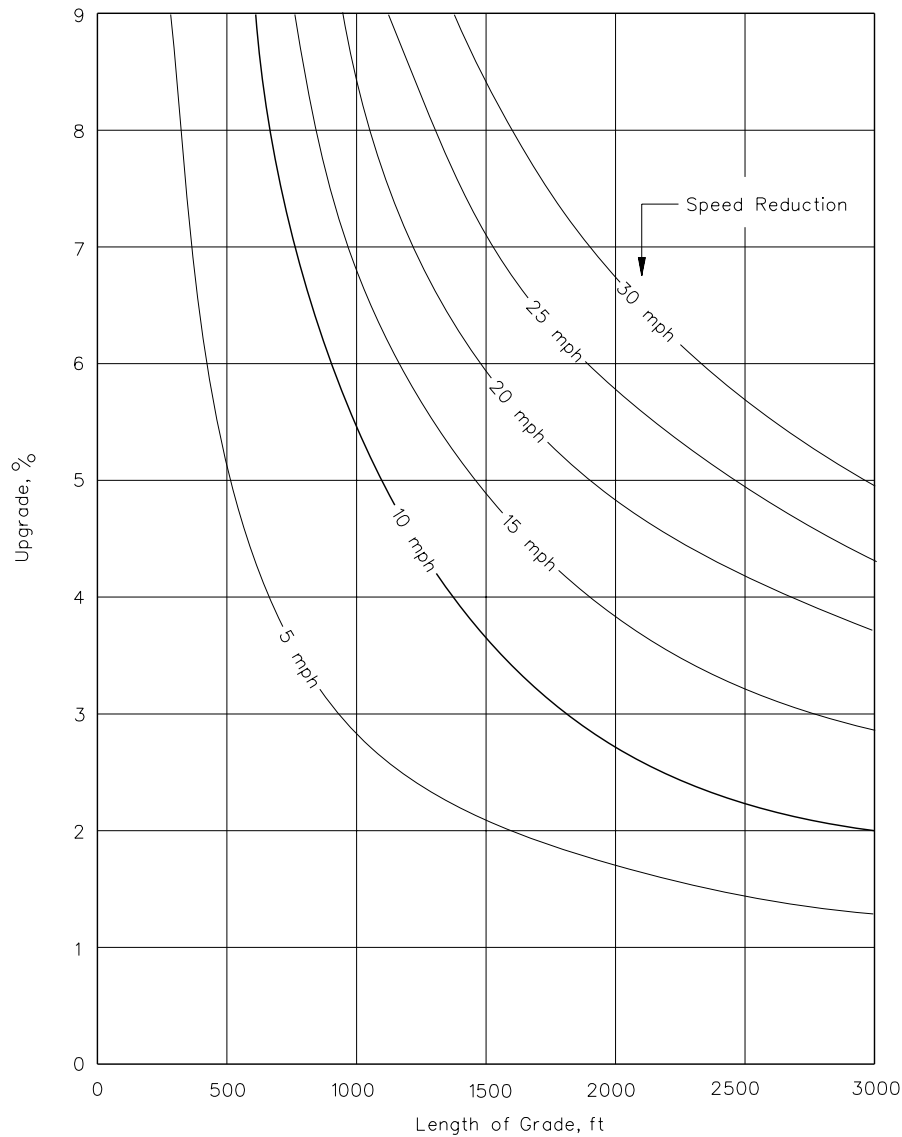
**Notes:**

1. Typically, the 10 mph curve will be used.
2. See examples in Section 33-2.04 for use of figure.
3. Figure is based on a truck with initial speed of 70 mph. However, it may be used for any design or posted speed.
4. This figure is based on a 200 lb/hp truck.

**CRITICAL LENGTH OF GRADE
(US Customary)****Figure 33-2.A**

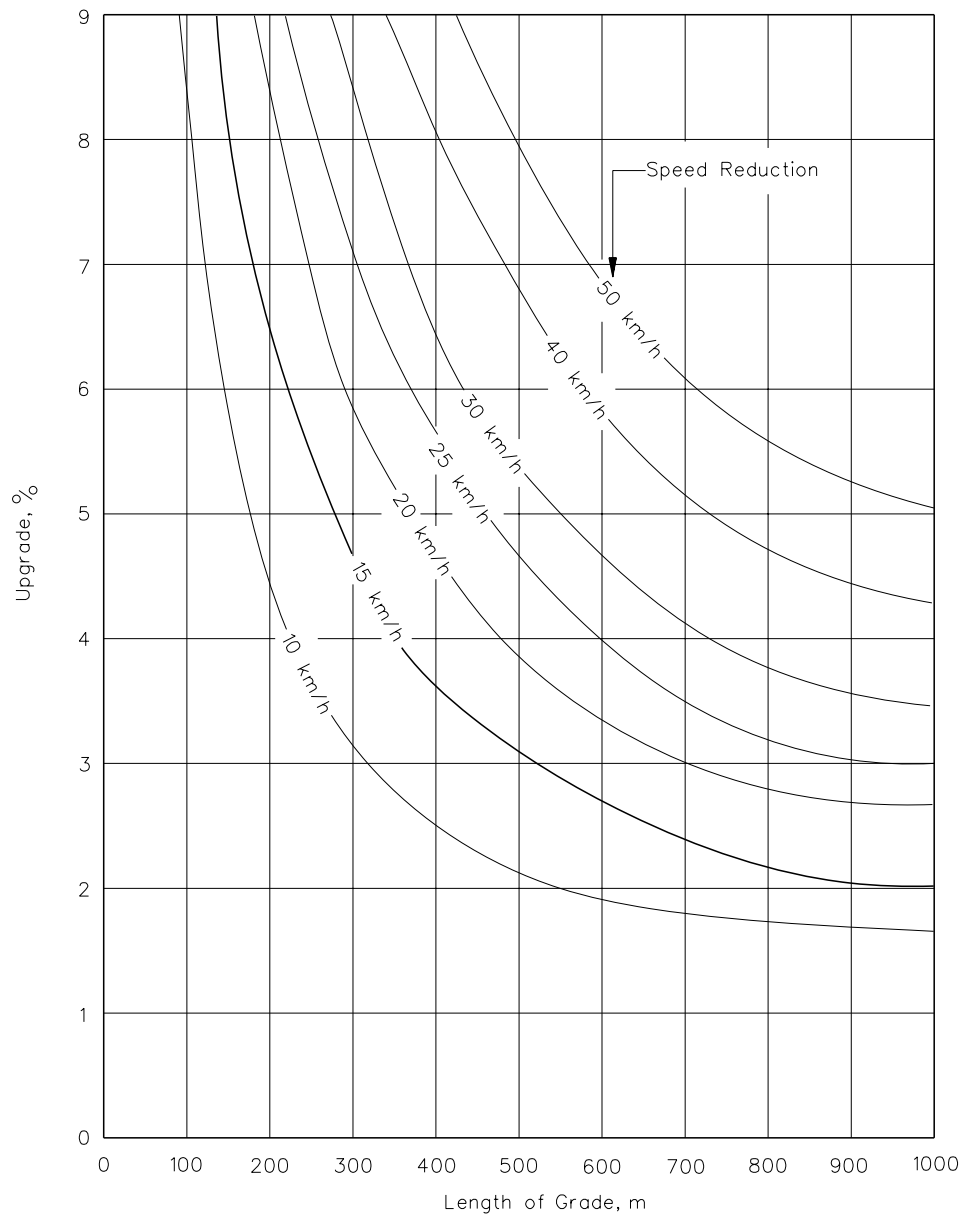
**Notes:**

1. Typically, the 15 km/h curve will be used.
2. See examples in Section 33-2.04 for use of figure.
3. Figure based on a truck with initial speed of 110 km/h. However, it may be used for any design or posted speed.
4. This figure is based on a 120 kg/kW truck.

**CRITICAL LENGTH OF GRADE
(Metric)**

Figure 33-2.A

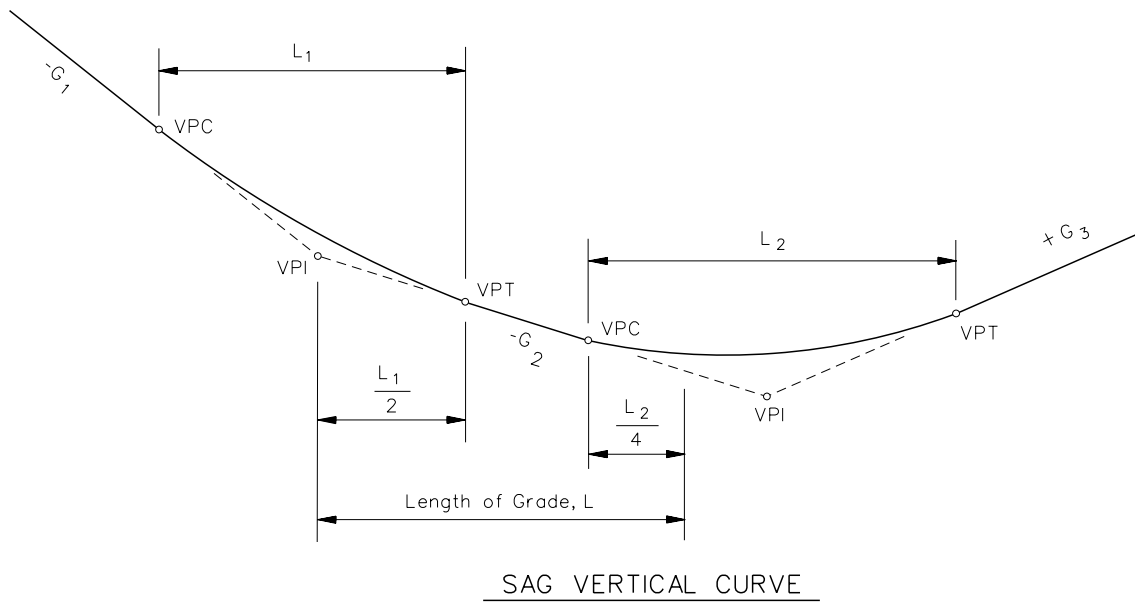
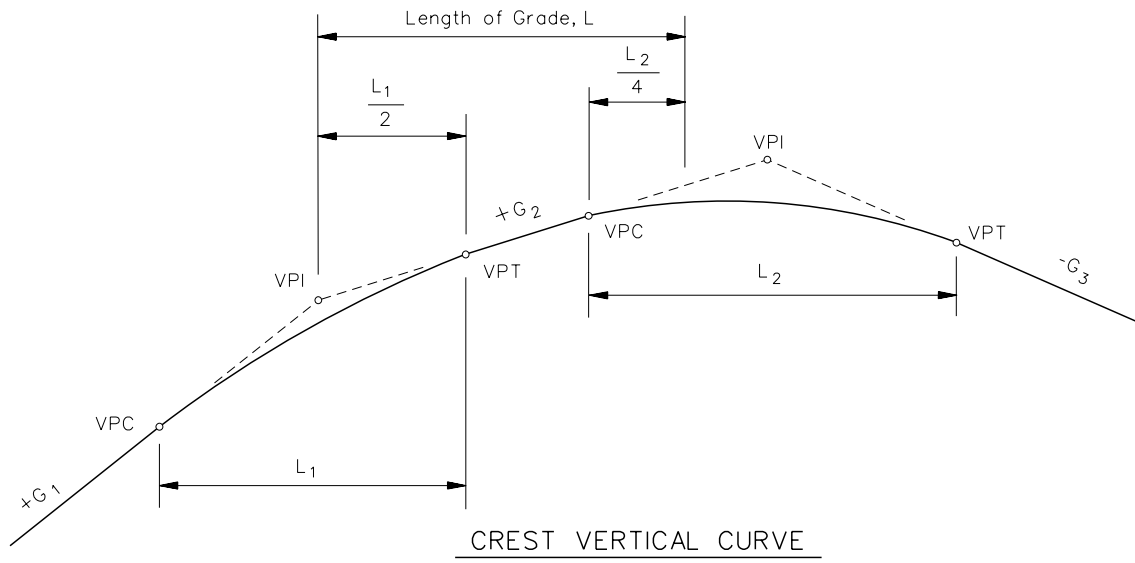

Notes:

1. For vertical curves where the two tangent grades are in the same direction (both upgrades or both downgrades), 50% of the curve length will be part of the length of grade.
2. For vertical curves where the two tangent grades are in opposite directions (one grade up and one grade down), 25% of the curve length will be part of the length of grade.
3. The above diagram is included for illustrative purposes only. Broken back vertical curves are to be avoided where practical. Distances less than 1500 ft (500 m) between VPI's are considered to be broken back.

MEASUREMENT FOR LENGTH OF GRADE

Figure 33-2.B

* * * * *

Example 33-2.1

Given: Level Approach
G = +4%
L = 1500 ft (length of grade)
Rural Principal Arterial (Class II Highway)

Problem: Determine if the critical length of grade is exceeded.

Solution: For a Class II Highway, Figure 33-2.A yields a critical length of grade of 1200 ft for a 10-mph speed reduction. The length of grade (L) exceeds this value. Therefore, flatten the grade, if practical, or evaluate the need for a truck-climbing lane.

Example 33-2.2

Given: Level Approach
G₁ = +4.5%
L₁ = 500 ft
G₂ = +2%
L₂ = 700 ft
Marked Route Rural Collector with a significant number of heavy trucks

Problem: Determine if the critical length of grade is exceeded for the combination of grades G₁ and G₂.

Solution: From Figure 33-2.A, G₁ yields a truck speed reduction of 5 mph. G₂ yields a speed reduction of approximately 3 mph. The total of 8 mph is less than the maximum 10 mph speed reduction. Therefore, the critical length of grade is not exceeded.

Example 33-2.3

Given: Figure 33-2.C illustrates the vertical alignment on a low-volume, two-lane rural collector highway with no large trucks. It is a Class II Highway.

Problem: Determine if the critical length of grade is exceeded for G₂ or for the combination upgrade G₃ and G₄.

Solution: Use the following steps:

Step 1. Determine the length of grade using the criteria in Figure 33-2.B. For this example, these are calculated as follows:

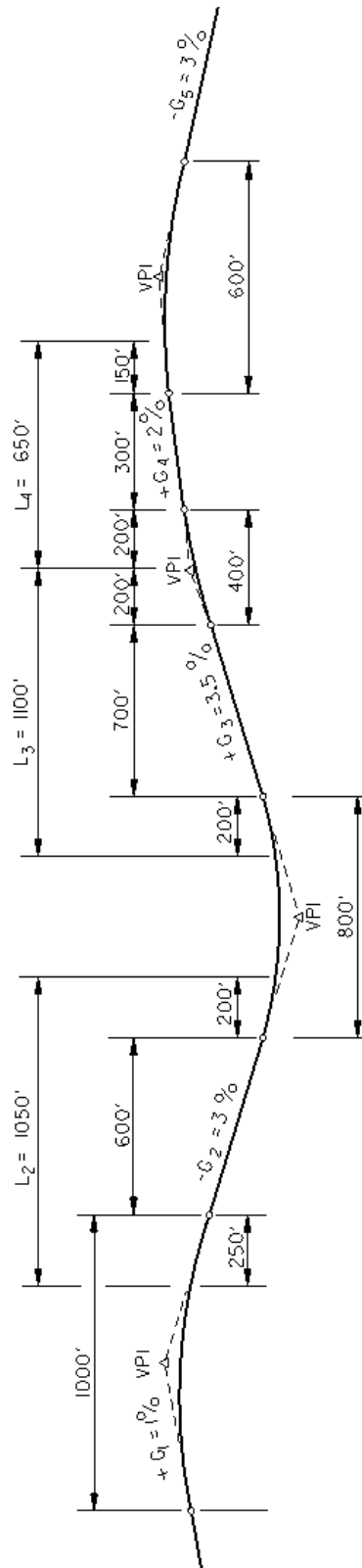

CRITICAL LENGTH OF GRADE CALCULATIONS
(Example 33-2.3)

Figure 33-2.C

$$L_2 = \frac{1000}{4} + 600 + \frac{800}{4} = 1050 \text{ ft}$$

$$L_3 = \frac{800}{4} + 700 + \frac{400}{2} = 1100 \text{ ft}$$

$$L_4 = \frac{400}{2} + 300 + \frac{600}{4} = 650 \text{ ft}$$

Step 2. Determine the critical length of grade in both directions. On a Class II Highway, use Figure 33-2.A to determine the critical length of grade.

- For trucks traveling left to right, enter into Figure 33-2.A the value for G_3 (3.5%) and $L_3 = 1100$ ft. The speed reduction is 7.0 mph. For G_4 (2%) and $L_4 = 650$ ft, the speed reduction is approximately 3.5 mph. The total speed reduction on the combination upgrade G_3 and G_4 is 10.5 mph. This exceeds the maximum 10 mph speed reduction. However, on low-volume roads, one can assume a 5 mph increase in truck speed for the 3% “momentum” grade (G_2) which precedes G_3 . Therefore, a speed reduction may be as high as 15 mph before concluding that the combination grade exceeds the critical length of grade. Assuming the benefits of the momentum grade, this leads to the conclusion that the critical length of grade is not exceeded.
- For trucks traveling in the opposite direction using Figure 33-2.A and a grade of $G_2 = 3\%$, the critical length of grade for the 10 mph speed reduction is 1700 ft. Because L_2 , (1050 ft) is less than 1700 ft, the critical length of grade for this direction is not exceeded.

33-3 TRUCK-CLIMBING LANES

33-3.01 Warrants

A truck-climbing lane may be warranted to allow a specific upgrade to operate at an acceptable level of service (LOS). The following criteria will apply.

33-3.01(a) Two-Lane Highways

On a two-lane, two-way highway, a truck-climbing lane generally will be warranted if the following conditions are satisfied:

- the critical length of grade is exceeded for the 10 mph (15 km/h) speed reduction curve (see Figure 33-2.A); and
- the heavy-vehicle volume (i.e., trucks, buses, and recreational vehicles) exceeds 20 veh/h during the design hour; and
- one of the following conditions exists:
 - + the LOS on the upgrade is E or F, or
 - + there is a reduction of two or more LOS when moving from the approach segment to the upgrade; and
 - + the construction costs and the construction impacts (e.g., environmental, right-of-way) are considered reasonable.

Also, truck-climbing lanes may be warranted where the above criteria are not met and if there is an adverse crash experience on the upgrade related to slow-moving trucks.

33-3.01(b) Multilane Highways

A truck-climbing lane generally will be warranted on a multilane highway if the following conditions are satisfied:

- the critical length of grade is exceeded for the 10 mph (15 km/h) speed reduction curve (see Figure 33-2.A); and
- the directional service volume exceeds 1000 veh/h; and
- one of the following conditions exists:
 - + the LOS on the upgrade is E or F, or
 - + there is a reduction of one or more LOS when moving from the approach segment to the upgrade; and

- + the construction costs and the construction impacts (e.g., environmental, right-of-way) are considered reasonable.

Also, truck-climbing lanes may be warranted where the above criteria are not met and if there is an adverse crash experience on the upgrade related to slow-moving trucks.

33-3.02 Capacity Analysis

See the *Highway Capacity Manual* for guidance on conducting capacity analyses for climbing lanes on two-lane and multilane highways.

33-3.03 Design Guidelines

Figure 33-3.A summarizes the design criteria for a truck-climbing lane. Also consider the following:

1. Design Speed. For entering speeds equal to or greater than 55 mph (90 km/h), use 55 mph (90 km/h) for the truck design speed. For speeds less than 55 mph (90 km/h), use the roadway design speed or the posted speed limit, whichever is less. Under restricted conditions, the designer may want to consider the effect a momentum grade will have on the entering speed. See Section 33-2.04 for additional information on momentum grades. However, the maximum speed will be 55 mph (90 km/h).
2. Superelevation. For horizontal curves, superelevate the truck-climbing lane at the same rate as the adjacent travel lane. When selecting the superelevation rate, consider the following:
 - a. Snow and Ice Conditions. Where snow and ice conditions are expected, the selected superelevation rate should not exceed 6%.
 - b. New Construction. The maximum superelevation rate should not exceed 6%.
 - c. Reconstruction and 3R Projects. The maximum superelevation rate is 8%. However, where practical, select a horizontal curve radii so that the actual superelevation rate is 6% or less.
 - d. Curves to the Left. Where there is a curve to the left, use as flat of a curve as practical to minimize superelevation and reduce the possibility of vehicles sliding down the cross slope during icy conditions into opposing traffic.
3. Performance Curves. Figure 33-3.B presents the deceleration and acceleration rates for a 200 lb/hp (120 kg/kW) truck.

Design Element	Desirable	Minimum
Lane Width	12 ft (3.6 m)	Freeway/Expressway: 12 ft (3.6 m) Other Facilities: 11 ft (3.3 m)
Shoulder Width	6 ft (1.8 m)	4 ft – 6 ft (1.2 m – 1.8 m)
Cross Slope on Tangent	¼"/ft (2%)	¼"/ft (2%)
Beginning of Full-Width Lane ⁽¹⁾	Location where the truck speed has been reduced to 10 mph (15 km/h) below the posted speed limit.	Location where the truck speed has been reduced to 45 mph (70 km/h).
End of Full-Width Lane ⁽²⁾	Location where truck has reached highway posted speed or 55 mph (90 km/h), whichever is less.	Location where truck has reached 10 mph (15 km/h) below highway posted speed limit.
Entering Taper	25:1	300 ft (90 m)
Exiting Taper	600 ft (180 m)	50:1
Minimum Full-Width Length	1000 ft (300 m) or greater	1000 ft (300 m)

Notes:

1. Use Figure 33-3.B to determine truck deceleration rates. In determining the applicable truck speed, the designer may consider the effect of momentum grades.
2. Use Figure 33-3.B to determine truck acceleration rates. Also, see Comment 4 in Section 33-3.03.

DESIGN CRITERIA FOR TRUCK-CLIMBING LANES

Figure 33-3.A

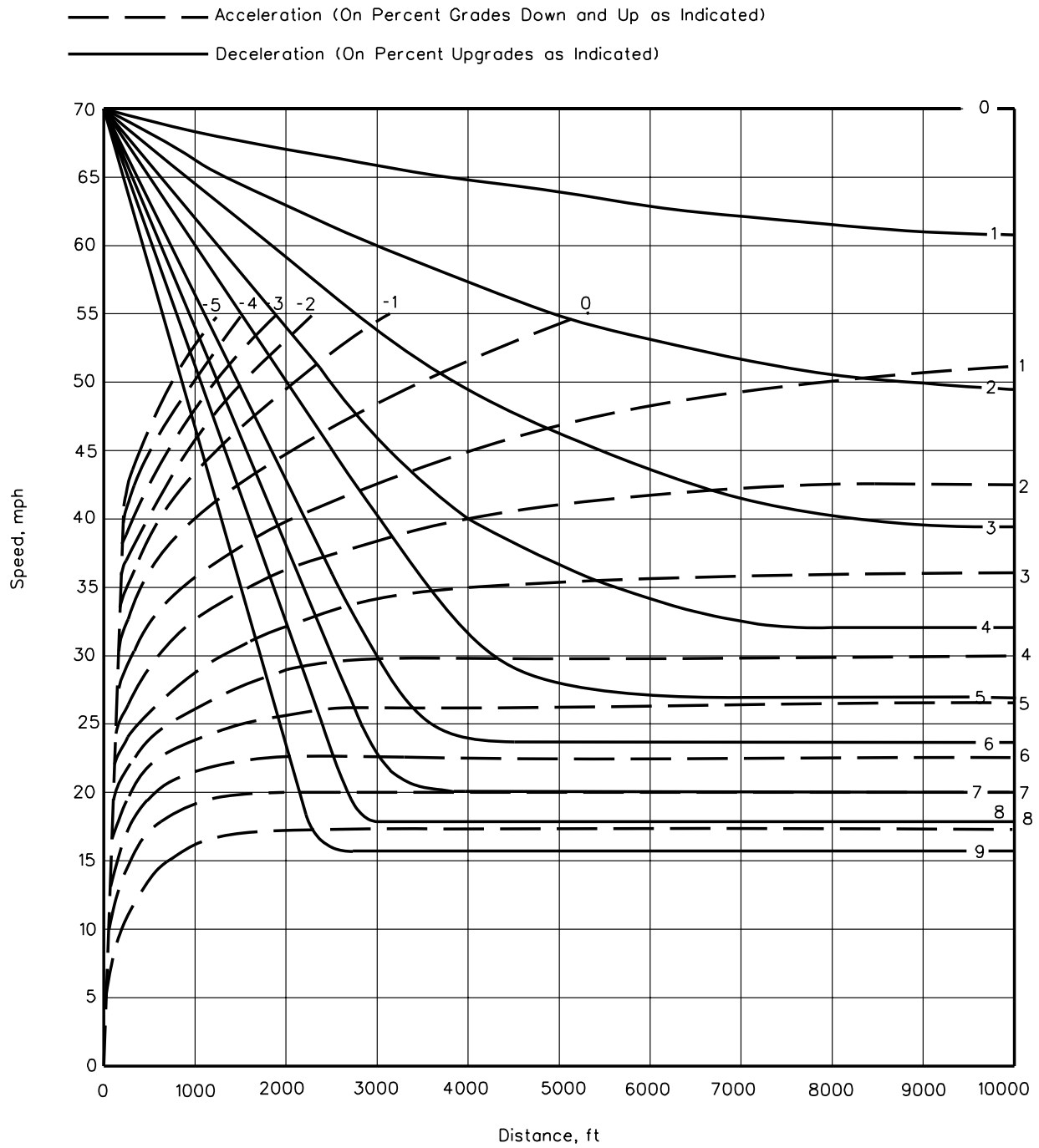

Note: For entering speeds equal to or greater than 70 mph, use an initial speed of 70 mph. For speeds less than 70 mph, use the design speed or posted speed limit as the initial speed.

**PERFORMANCE CURVES FOR TRUCKS
(200 lb/hp) (US Customary)**

Figure 33-3.B

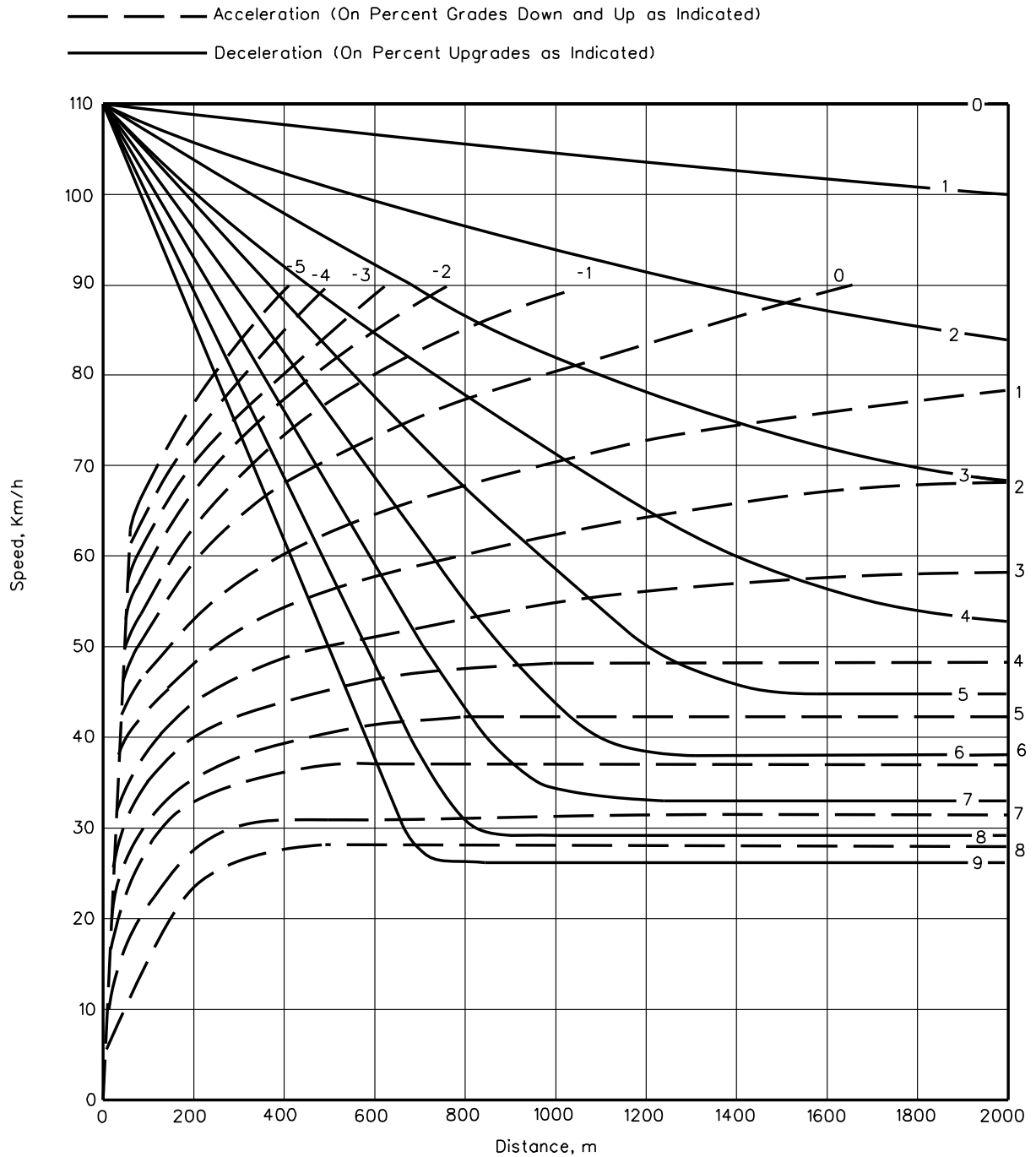

Note: For entering speeds equal to or greater than 110 km/h, use an initial speed of 110 km/h. For speeds less than 110 km/h, use the design speed or posted speed limit as the initial speed.

**PERFORMANCE CURVES FOR TRUCKS
(120 kg/kW) (Metric)**

Figure 33-3.B

4. End of Full-Width Lane. In addition to the criteria in Figure 33-3.A, ensure that there is sufficient sight distance available to the point where the truck, RV, or bus will begin to merge back into the through travel lane. At a minimum, this will be stopping sight distance. Desirably, the driver should have decision sight distance available to the end of the taper. See Section 31-3 for decision sight distance values.

Do not end the full lane width just beyond a crest vertical curve, but instead extend it beyond the crest vertical curve. The full lane width should not end on a horizontal curve.

5. Signing and Pavement Markings. Figure 33-3.C illustrates the Department's practice for signing and marking climbing lanes. Where deemed necessary, contact the district Bureau of Operations for additional information.

33-3.04 Downgrades

Truck lanes on downgrades are not typically considered. However, steep downhill grades may also have a detrimental effect on the capacity and safety of facilities with high traffic volumes and numerous heavy trucks. Although specific criteria have not been established for these conditions, trucks descending steep downgrades in low gear may produce nearly as great an effect on operations as an equivalent upgrade. The need for a truck lane for downhill traffic will be considered on a site-by-site basis.

33-3.05 Truck Speed Profile

For highways with a single grade, the critical length of grade and deceleration and acceleration rates can be directly determined from Figure 33-3.B. However, most highways have a continuous series of grades. Often, it is necessary to find the impact of a series of significant grades in succession. If several different grades are present, then a speed profile may need to be developed.

The following example illustrates how to construct a truck speed profile and how to use Figure 33-3.B.

Example 33-3.2

Given: Level Approach
 $G_1 = +3\%$ for 800 ft (VPI to VPI)
 $G_2 = +5\%$ for 3200 ft (VPI to VPI)
 $G_3 = -2\%$ beyond the composite upgrade (G_1 and G_2)
 $V = 60$ mph design speed with a 55 mph posted speed limit
 Rural Principal Arterial (Class I Highway)

Problem: Using the criteria in Figure 33-3.A and Figure 33-3.B, construct a truck speed profile and determine the beginning and ending points of the full-width climbing lane.

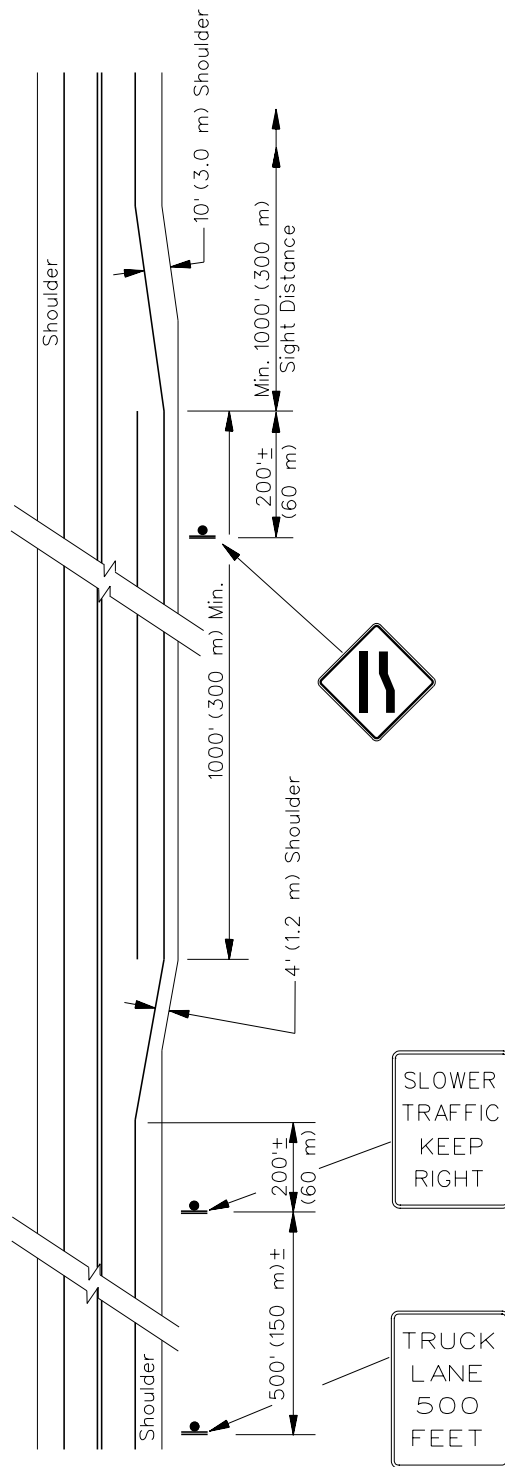

CLIMBING LANE MARKINGS

Figure 33-3.C

Solution: Apply the following steps:

Step 1: Determine the truck speed on G_1 using Figure 33-3.B and plot the truck speed at 200 ft increments in Figure 33-3.D. Assume an initial truck speed of 55 mph. Move horizontally along the 55 mph line to the 3% deceleration curve. This is approximately 2800 ft along the horizontal axis. This is the starting point for G_1 .

Distance From VPI ₁ (ft)	Horizontal Distance on Figure 33-3.B(ft)	Truck Speed (mph)	Comments
0	2800	55	VPI ₁
200	3000	54	
400	3200	53	
600	3400	52	
800	3600	51	VPI ₂

Step 2: Determine the truck speed on G_2 using Figure 33-3.B and plot the truck speed at 200 ft increments in Figure 33-3.D. From Step 1, the initial speed on G_2 is the final speed from G_1 (i.e., 51 mph). Move right horizontally along the 51 mph line to the 5% deceleration curve. This is approximately 1900 ft along the horizontal axis. This is the starting point for G_2 .

Figure 33-3.D Distance From VPI ₁ (ft)	Horizontal Distance on Figure 33-3.B (ft)	Truck Speed (mph)	Comments
800	1900	51	VPI ₂
1000	2100	49	
1200	2300	47	
1400	2500	45	
1600	2700	43	
1800	2900	41	
2000	3100	39	
2200	3300	37	
2400	3500	35	
2600	3700	33	
2800	3900	32	
3000	4100	31	
3200	4300	30	
3400	4500	29	
3600	4700	29	
3800	4900	28	
4000	5100	28	VPI ₃

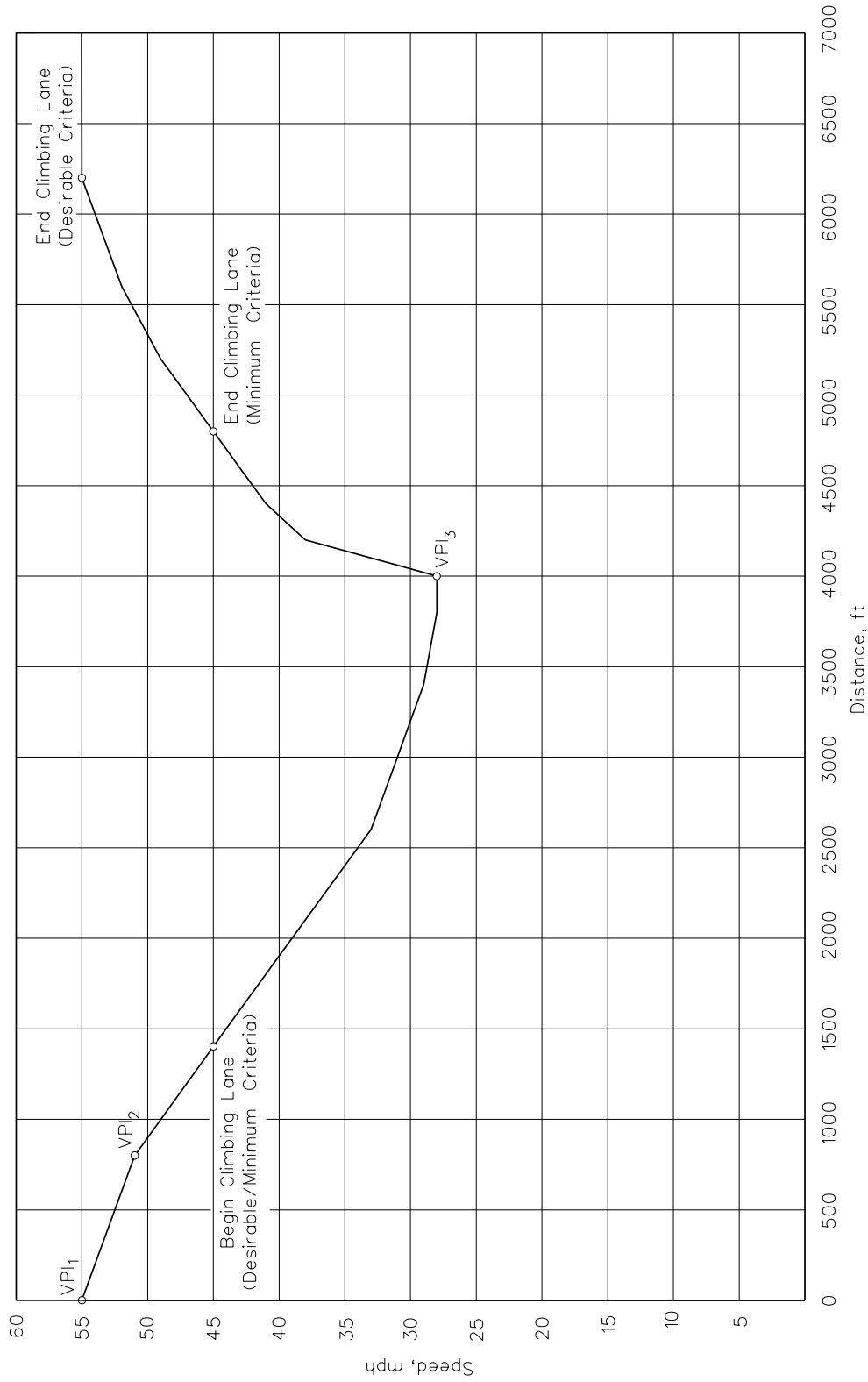

TRUCK SPEED PROFILE
(Example 33-3.2)

Figure 33-3.D

Step 3: Determine the truck speed on G_3 using Figure 33-3.B until the truck has fully accelerated to 55 mph and plot the truck speed at 200 ft increments in Figure 33-3.D. The truck will have a speed of 28 mph as it enters the 2% downgrade at VPI_3 . Read into Figure 33-3.B at the 28 mph point on the vertical axis and move over horizontally to the -2% line. This is approximately 150 ft along the horizontal axis. This is the starting point for G_3 .

Figure 33-3.D Distance From VPI_1 (ft)	Horizontal Distance on Figure 33-3.B (ft)	Truck Speed (mph)	Comments
4000	150	28	VPI_3
4200	350	38	
4400	550	41	
4600	750	43	
4800	950	45	
5000	1150	47	
5200	1350	49	
5400	1550	50	
5600	1750	52	
5800	1950	53	
6000	2150	54	
6200	2350	55	

Step 4: Determine the beginning and end of the full-width climbing lane. From Figure 33-3.A, the desirable and minimum beginning of the full-width lane will be where the truck has reached a speed of 45 mph (10 mph below the posted speed). This point occurs 1400 ft beyond VPI_1 .

For ending the full-width climbing lane, the desirable criteria from Figure 33-3.A is where the truck speed has reached the posted speed limit (55 mph) or 6200 ft beyond the VPI_1 . The minimum criteria is where the truck has reached a speed of 45 mph (10 mph below the posted speed). This occurs at 4800 ft beyond VPI_1 .

33-4 VERTICAL CURVES

33-4.01 Crest Vertical Curves

Crest vertical curves are in the shape of a parabola. The basic equations for determining the minimum length of a crest vertical curve are:

$$L = \frac{AS^2}{200(\sqrt{h_1} + \sqrt{h_2})^2} \quad \text{Equation 33-4.1}$$

$$K = \frac{S^2}{200(\sqrt{h_1} + \sqrt{h_2})^2} \quad \text{Equation 33-4.2}$$

$$L=KA \quad \text{Equation 33-4.3}$$

where:

- L = length of vertical curve, ft (m)
- A = algebraic difference between the two tangent grades, %
- S = sight distance, ft (m)
- h_1 = height of eye above road surface, ft (m)
- h_2 = height of object above road surface, ft (m)
- K = horizontal distance needed to produce a 1% change in gradient

The length of a crest vertical curve will depend upon “A” for the specific curve and upon the selected sight distance, height of eye, and height of object. Equation 33-4.1 and the resultant values of K are predicated on the sight distance being less than the length of vertical curve. However, these values can also be used, without significant error, where the sight distance is greater than the length of vertical curve. The following sections discuss the selection of K-values. For design purposes, round the calculated length up to the next highest 50 ft (10 m) increment.

33-4.01(a) **Stopping Sight Distance**

The principal control in the design of crest vertical curves is to ensure that minimum stopping sight distance (SSD) is available throughout the vertical curve. The following discusses the application of K-values for various operational conditions:

1. Passenger Cars (Level Grade). Figure 33-4.A presents K-values for passenger cars on a level grade. Level conditions are assumed where the grade on the far side of the vertical curve is less than 3%. These are calculated by assuming $h_1 = 3.5$ ft (1.080 m), $h_2 = 2$ ft (600 mm) and $S = \text{SSD}$ in the basic equation for crest vertical curves (Equation 33-4.1). The values represent the lowest acceptable sight distance on a facility. Where cost effective, use higher stopping sight distances.

2. Passenger Cars (Grade Adjusted). For a given speed, the safe stopping distance on downgrades is greater than that for a level roadway. Where grades on the far side of a crest vertical curve are -3% or greater, design the length of curve using K-values that have been adjusted for the increased braking distances resulting from the downgrade. No adjustment is necessary for grades less than 3% or for upgrades. Figure 33-4.B presents minimum and desirable K-values adjusted for downgrades for passenger cars. Make every reasonable effort to meet these values where the grade is -3% or greater. However, the grade-adjusted K-values do not require a design exception when not met. The level K-values in Figure 33-4.A apply when determining whether or not a design exception for stopping sight distance will be required; see Section 31-7.
3. Minimum Length. For design speeds of 60 mph (100 km/h) or less, the minimum length of a crest vertical curve in feet (meters) should be $3V$ ($0.6V$), where V is the design speed in mph (km/h). For design speeds greater than 60 mph (100 km/h), the minimum length of a crest vertical curve in feet (meters) should be $5V$ ($1V$). These distances apply regardless of the calculated length of vertical curve. For aesthetics, the suggested minimum length of a crest vertical curve on a rural highway is 1000 ft (300 m).

33-4.01(b) Decision Sight Distance

At some locations, decision sight distance may be warranted in the design of crest vertical curves. Section 31-3.02 discusses candidate sites and provides design values for decision sight distance. In complex environments, decision sight distance provides drivers with additional time to adjust their speed and additional distance to make unexpected maneuvers. Crest vertical curve designed with decision sight distance will be longer than those using stopping sight distance. These "S" values should be used in the basic equation for crest vertical curves (Equation 33-4.1). In addition, the following will apply:

1. Height of Eye (h_1). For passenger cars, $h_1 = 3.5$ ft (1.080 m).
2. Height of Object (h_2). Decision sight distance, in many cases, is predicated upon the same principle as stopping sight distance; i.e., the driver needs sufficient distance to see a 2 ft (600 mm) object. Therefore, $h_2 = 2$ ft (600 mm) at many locations. However, at some elevations, decision sight distance may be determined assuming the pavement surface (e.g., freeway exit gores). At these locations, $h_2 = 0.0$ ft (0.0 mm).
3. K-Values. Figure 33-4.C presents the K-values for passenger cars using the decision sight distances presented in Section 31-3.02.

US Customary				Metric			
Design Speed (mph)	Stopping ⁽¹⁾ Sight Distance (ft)	Rate of Vertical Curvature, K ⁽³⁾		Design Speed (km/h)	Stopping ⁽¹⁾ Sight Distance (m)	Rate of Vertical Curvature, K ⁽⁴⁾ Design	
		Calculated	Design			Calculated	Design
30	200	18.5	19	50	65	6.4	7
35	250	29.0	29	60	85	11.0	11
40	305	43.1	44	70	105	16.8	17
45	360	60.1	61	80	130	25.7	26
50	425	83.7	84	90	160	38.9	39
55	495	113.5	114	100	185	52.0	52
60	570	150.6	151	110	220	73.6	74
65	645	192.8	193	120	250	95.0	95
70	730	246.9	247				
75	820	311.6	312				

Notes:

1. *Stopping sight distances (SSD) are from Figure 31-3.A.*
2. *Maximum K-value for drainage on curbed roadways is 167 (51). Where a crest vertical curve falls on a bridge and the design speed is greater than 60 mph (90 km/h), the design speed consideration will override the drainage maximum. However, to adequately handle shoulder drainage on the bridge, it may be necessary to provide drainage scuppers on the bridges; see the IDOT Drainage Manual.*
3.
$$K = \frac{SSD^2}{2158}, \text{ where: } h_1 = 3.5 \text{ ft, } h_2 = 2 \text{ ft} \quad (\text{US Customary})$$
4.
$$K = \frac{SSD^2}{658}, \text{ where: } h_1 = 1.080 \text{ m, } h_2 = 600 \text{ mm} \quad (\text{Metric})$$

**K-VALUES FOR CREST VERTICAL CURVES — STOPPING SIGHT DISTANCES
(Passenger Cars — Level Grades)**

Figure 33-4.A

K-VALUES ROUNDED FOR DESIGN								
US Customary								
Design Speed (mph)	(3%)	(4%)	(5%)	(6%)	(7%)	(8%)	(9%)	(10%)
30	20	21	22	22	23	24	25	26
35	32	33	34	35	37	38	39	41
40	46	49	51	52	54	57	59	62
45	67	69	73	75	78	82	86	90
50	94	96	101	105	109	114	121	128
55	126	131	138	143	151	156	164	173
60	167	176	181	190	199	208	221	231
65	218	227	237	247	261	272	290	304
70	279	290	304	316	335	351	372	393
75	351	363	380	401	422	445	468	496
Metric								
Design Speed (km/h)	(3%)	(4%)	(5%)	(6%)	(7%)	(8%)	(9%)	(10%)
50	7	7	7	8	8	8	9	9
60	12	12	13	13	14	14	15	16
70	19	20	20	21	22	23	24	25
80	29	29	31	32	33	35	36	38
90	41	43	45	46	49	51	54	56
100	58	60	63	66	69	73	76	81
110	79	82	87	90	95	100	106	111
120	105	109	115	120	126	133	140	149

Notes:

1. *K-values in table have been determined by using the SSD rounded for design from Figure 31-3.B.*
2. *For grades less than 3%, no adjustment is necessary; i.e., use the level K-values in Figure 33-4.A.*
3. *For grades intermediate between table values, use a straight-line interpolation in Figure 31-3.B or use Equation 31-3.2 and roundup to the next highest 5 ft (1 m) increment to determine the SSD and then calculate the appropriate K-value.*
4.
$$K = \frac{SSD^2}{2158}, \text{ where: } h_1 = 3.5 \text{ ft, } h_2 = 2 \text{ ft} \quad (\text{US Customary})$$
5.
$$K = \frac{SSD^2}{658}, \text{ where: } h_1 = 1.080 \text{ m, } h_2 = 600 \text{ mm} \quad (\text{Metric})$$

**K-VALUES FOR CREST VERTICAL CURVES — STOPPING SIGHT DISTANCES
(Passenger Cars — Adjusted For Downgrades)**

Figure 33-4.B

US Customary											
Design Speed (mph)	Avoidance Maneuver A (Stop on Rural Road)		Avoidance Maneuver B (Stop on Urban Road)		Avoidance Maneuver C (Speed/Path/Direction Change on Rural Road)		Avoidance Maneuver D (Speed/Path/Direction Change on Suburban Road)		Avoidance Maneuver E (Speed/Path/Direction Change of Urban Road)		
	DSD (ft)	K-Value	DSD (ft)	K-Value	DSD (ft)	K-Value	DSD (ft)	K-Value	DSD (ft)	K-Value	
30	220	23	490	112	450	94	535	133	620	179	
35	275	35	590	162	525	128	625	181	720	241	
40	330	51	690	221	600	167	715	237	825	316	
45	395	73	800	297	675	211	800	297	930	401	
50	465	101	910	384	750	261	890	367	1030	492	
55	535	133	1030	492	865	347	980	445	1135	597	
60	610	173	1150	613	990	455	1125	587	1280	760	
65	695	224	1275	754	1050	511	1220	690	1365	864	
70	780	282	1410	922	1105	566	1275	754	1445	968	
75	875	354	1545	1106	1180	645	1365	863	1545	1106	

Metric												
(km/h)	DSD (m)		K-Value		DSD (m)		K-Value		DSD (m)		K-Value	
	50	70	8	155	37	145	32	170	44	195	58	
60	95	14	195	58	170	44	205	64	235	84		
70	115	21	235	84	200	61	235	84	275	115		
80	140	30	280	120	230	81	270	111	315	151		
90	170	44	325	161	270	111	315	151	360	197		
100	200	61	370	209	315	151	355	192	400	244		
110	235	84	420	269	330	166	380	220	430	281		
120	265	107	470	336	360	197	415	262	470	336		

Notes:

1. See Section 31-3.02 for decision sight distances (DSD).

2. $K = \frac{DSD^2}{2158}$, where: $h_1 = 3.5$ ft. $h_c = 2$ ft. (US Customary)

3. $K = \frac{DSD^2}{658}$, where: $h_1 = 1.080$ m. $h_2 = 600$ mm (Metric)

4. Where it is desirable to see the road surface, the object height h_3 may be set at zero and the K-values recalculated.

K-VALUES FOR CREST VERTICAL CURVES — DECISION SIGHT DISTANCE (Passenger Cars)

Figure 33-4.C

33-4.01(c) Passing Sight Distance

At some locations, it may be desirable to provide passing sight distance in the design of crest vertical curves. Section 47-2.03 discusses the application and design values for passing sight distance on two-lane, two-way highways. These “S” values are used in the basic equation for crest vertical curves (Equation 33-4.1). In addition, the following will apply:

1. Height of Eye (h_1). For passenger cars, $h_1 = 3.5$ ft (1.080 m).
2. Height of Object (h_2). Passing sight distance is predicated upon the passing driver being able to see a sufficient portion of the top of the oncoming car. Therefore, $h_2 = 3.5$ ft (1.080 m).
3. K-Values. Figure 33-4.D presents the K-values for passenger cars using the passing sight distances presented in Section 47-2.03.

33-4.01(d) Drainage

Proper drainage must be considered in the design of crest vertical curves on curbed sections, bridges, and medians with concrete barriers. Typically, drainage problems will not be experienced if the vertical curvature is sharp enough so that a minimum longitudinal gradient of at least 0.3% is reached at a point about 50 ft (15 m) from either side of the apex. To ensure that this objective is achieved, determine the length of the crest vertical curve assuming a K-value of 167 (51) or less. Where a crest vertical curve lies within a curbed section or bridge and where the maximum drainage K-value is exceeded, carefully evaluate the drainage design near the apex. If a bridge is within a crest vertical curve and the design speed is greater than 60 mph (90 km/h), the design speed consideration will override the drainage maximum. However, to adequately handle the shoulder drainage, it may be necessary to provide drainage scuppers on the bridge. See the *IDOT Drainage Manual* for more information.

For uncurbed sections of highway, drainage should not be a problem at crest vertical curves. However, it still may be desirable to provide a longitudinal gradient of at least 0.15% at points about 50 ft (15 m) on either side of the high point. To achieve this, K must equal 334 (100) or less.

US Customary			Metric		
Design Speed (mph)	Passing ⁽¹⁾ Sight Distance (ft)	Rate of Vertical Curvature, K ⁽²⁾ Design	Design Speed (km/h)	Passing ⁽¹⁾ Sight Distance (m)	Rate of Vertical Curvature, K ⁽³⁾ Design
30	1090	424	50	345	138
35	1280	585	60	410	195
40	1470	772	70	485	272
45	1625	943	80	540	338
50	1835	1203	90	615	438
55	1985	1407	100	670	520
60	2135	1628	110	730	617
65	2285	1865			
70	2480	2197			

Notes:

1. Design passing sight distances (PSD) are from Section 47-2.03.

2. $K = \frac{PSD^2}{2800}$, where: $h_1 = 3.5 \text{ ft}$, $h_2 = 3.5 \text{ ft}$ (US Customary)

3. $K = \frac{PSD^2}{864}$, where: $h_1 = 1.080 \text{ m}$, $h_2 = 1.080 \text{ m}$ (Metric)

**K-VALUES FOR CREST VERTICAL CURVES — PASSING SIGHT DISTANCES
(Passenger Cars)**

Figure 33-4.D

33-4.02 Sag Vertical Curves

Sag vertical curves are in the shape of a parabola. Typically, they are designed to allow the vehicular headlights to illuminate the roadway surface (i.e., the height of object = 0.0 ft (0.0 mm)) for a given distance “S.” The light beam from the headlights is assumed to have a 1° upward divergence from the longitudinal axis of the vehicle. These assumptions yield the following basic equations for determining the minimum length of sag vertical curves:

$$L = \frac{AS^2}{200[h_3 + S(\tan 1^\circ)]} = \frac{AS^2}{200h_3 + 3.5S} \quad \text{Equation 33-4.4}$$

$$K = \frac{S^2}{200h_3 + 3.5S} \quad \text{Equation 33-4.5}$$

$$L = KA \quad \text{Equation 33-4.6}$$

where: L = length of vertical curve, ft (m)
 A = algebraic difference between the two tangent grades, %
 S = sight distance, ft (m)
 h₃ = height of headlights above pavement surface, ft (m)
 K = horizontal distance needed to produce a 1% change in gradient

The length of a sag vertical curve will depend upon “A” for the specific curve and upon the selected sight distance and headlight height. Equation 33-4.4 and the resultant values of K are predicated on the sight distance being less than the length of vertical curve. However, these values can also be used, without significant error, where the sight distance is greater than the length of vertical curve. The following sections discuss the selection of K-values.

33-4.02(a) Stopping Sight Distance

The principal control in the design of sag vertical curves is to ensure a minimum stopping sight distance (SSD) is available for headlight illumination throughout the sag vertical curve. The following discusses the application of K-values for various operational conditions:

1. Passenger Cars (Level Grade). Figure 33-4.E presents K-values for passenger cars. These are calculated by assuming h₃ = 2 ft (600 mm) and S = SSD in the basic equation for sag vertical curves (Equation 33-4.4). The minimum values represent the lowest acceptable sight distance on a facility. However, because sag vertical curves greatly affect the aesthetics of a highway alignment, use longer than the minimum lengths of curves to provide a more aesthetically pleasing design.
2. Passenger Cars (Grade Adjusted). For a given speed, the safe stopping sight distance on downgrades is greater than that for a level surface. For sag vertical curves, only consider grade adjustments when the sag curve is between two downgrades and where the downgrades are -3% or greater. Figure 33-4.F presents K-values adjusted for grades for passenger cars. However, grade-adjusted K-values do not require a design exception when not met. The level K-values in Figure 33-4.E apply when determining whether or not a design exception for stopping sight distance will be required; see Section 31-7.

US Customary				Metric			
Design Speed (mph)	Stopping Sight Distance (ft)	Rate of Vertical Curvature, K ⁽³⁾		Design Speed (km/h)	Stopping Sight Distance (m)	Rate of Vertical Curvature, K ⁽⁴⁾	
		Calculated (ft)	Design (ft)			Calculated (m)	Design (m)
30	200	36.4	37	50	64	11.9	12
35	250	49.0	49	60	83	16.8	17
40	305	63.4	64	70	105	22.6	23
45	360	78.1	79	80	129	29.1	30
50	425	95.7	96	90	156	36.5	37
55	495	114.9	115	100	185	44.6	45
60	570	135.7	136	110	216	53.3	54
65	645	156.5	157	120	250	62.8	63
70	730	180.3	181				
75	820	205.6	206				

Notes:

1. Stopping sight distances (SSD) are from Figure 31-3.A.
2. Maximum K-value for drainage on curbed roadways and bridges is 167 (51).
3.
$$K = \frac{SSD^2}{400 + 3.5SSD}, \text{ where: } h_3 = 2 \text{ ft} \quad (\text{US Customary})$$
4.
$$K = \frac{SSD^2}{120 + 3.5SSD}, \text{ where: } h_3 = 600 \text{ mm} \quad (\text{Metric})$$

**K-VALUES FOR SAG VERTICAL CURVES — STOPPING SIGHT DISTANCES
(Passenger Cars — Level Grades)**

Figure 33-4.E

K VALUES ROUNDED FOR DESIGN								
US Customary								
Design Speed (mph)	(3%)	(4%)	(5%)	(6%)	(7%)	(8%)	(9%)	(10%)
30	38	39	41	41	42	43	44	46
35	52	53	55	56	57	59	60	61
40	67	69	71	72	73	76	77	80
45	84	85	88	89	92	95	98	100
50	103	104	107	110	113	115	120	124
55	122	125	129	132	136	139	143	147
60	144	149	151	156	160	164	170	174
65	168	172	177	181	186	191	198	203
70	193	198	203	208	215	220	227	234
75	219	224	230	237	244	251	258	266
Metric								
Design Speed (km/h)	(3%)	(4%)	(5%)	(6%)	(7%)	(8%)	(9%)	(10%)
50	13	13	13	14	14	14	15	15
60	18	19	19	20	20	20	21	22
70	24	25	26	26	27	28	28	29
80	32	32	33	34	35	36	36	38
90	39	40	41	42	43	45	46	47
100	48	49	50	51	53	54	56	58
110	57	58	60	61	63	65	67	69
120	66	68	70	72	74	76	78	81

Notes:

1. *K-values in table have been determined by using the SSD rounded for design from Figure 31-3.B.*
2. *For grades less than 3%, no adjustment is necessary; i.e., use the level K-values in Figure 33-4.E.*
3. *For grades intermediate between table values, use a straight-line interpolation in Figure 31-3.B to determine the SSD and then calculate the appropriate K-value.*
4.
$$K = \frac{SSD^2}{400 + 3.5 SSD}, \text{ where: } h_3 = 2 \text{ ft} \quad \text{(US Customary)}$$
5.
$$K = \frac{SSD^2}{120 + 3.5 SSD}, \text{ where: } h_3 = 600 \text{ mm} \quad \text{(Metric)}$$

**K-VALUES FOR SAG VERTICAL CURVES — STOPPING SIGHT DISTANCES
(Passenger Cars — Adjusted For Downgrades)**

Figure 33-4.F

3. **Minimum Length.** For design speeds of 60 mph (100 km/h) or less, the minimum length of a sag vertical curve in feet (meters) should be $3V$ ($0.6V$), where V is the design speed in mph (km/h). For design speeds greater than 60 mph (100 km/h), the minimum length of a sag vertical curve in feet (meters) should be $5V$ ($1V$). For aesthetics on rural highways, the minimum length of a sag vertical curve is dependent upon the driver's view of the highway. The greater the distance a highway can be seen ahead, the longer the sag vertical curve should be.

One exception to the minimum length on sag vertical curves applies in curbed sections and on bridges. If the sag is in a low point, the use of the minimum length criteria may produce longitudinal slopes too flat to drain stormwater without ponding. For additional guidance, see Chapter 40 of the *BDE Manual* and the *IDOT Drainage Manual*.

33-4.02(b) Decision Sight Distance

At some locations, decision sight distance may be warranted in the design of sag vertical curves. Section 31-3.02 discusses candidate sites and provides design values for decision sight distance. In complex environments, decision sight distance provides drivers with additional time to adjust their speed or additional distance to make unexpected maneuvers. Sag vertical curves designed with decision sight distance will be longer than those using stopping sight distance. These "S" values should be used in the basic equation for sag vertical curves (Equation 33-4.4). The height of headlights $h_3 = 2$ ft (600 mm). Figure 33-4.G provides K-values for sag vertical curves using decision sight distance.

33-4.02(c) Comfort Criteria

On fully lighted, continuous sections of highway and where it is impractical to provide stopping sight distance, a sag vertical curve may be designed to meet the comfort criteria. These criteria are based on the effect of change in the vertical direction of a sag vertical curve due to the combined gravitational and centrifugal forces. The general consensus is that riding is comfortable on sag vertical curves when the centripetal acceleration does not exceed 1 ft/s^2 (0.3 m/s^2). The length-of-curve equation for the comfort criteria is:

$$L = \frac{AV^2}{46.5} \quad \text{(US Customary) Equation 33-4.7}$$

$$L = \frac{AV^2}{395} \quad \text{(Metric) Equation 33-4.7}$$

where: L = length of vertical curve, ft (m)
 A = algebraic difference between the two tangent grades, %
 V = design speed, mph (km/h)

33-4.02(d) Underpasses

Check sag vertical curves through underpasses to ensure that the underpass structure does not obstruct the driver's visibility. Use the following equation to check sag vertical curves through underpasses:

$$L = \frac{AS^2}{800(C - 4.25)} \quad \text{(US Customary) Equation 33-4.8}$$

$$L = \frac{AS^2}{800(C - 1.3)} \quad \text{(Metric) Equation 33-4.8}$$

where: L = length of vertical curve, ft (m)
 A = algebraic difference between the two tangent grades, %
 S = sight distance, ft (m)
 C = vertical clearance of underpass, ft (m)

Compare the L calculated from Equation 33-4.8 for underpasses with the L calculated based on headlight illumination (Equation 33-4.4). The larger of the two lengths will govern.

33-4.02(e) Drainage

Proper drainage must be considered in the design of sag vertical curves on curbed sections, bridges, and medians with concrete barriers. Drainage problems are minimized if the sag vertical curve is sharp enough so that both of the following criteria are met:

- a minimum longitudinal gradient of at least 0.3% is reached at a point about 50 ft (15 m) from either side of the low point, and
- there is at least a 4 in (100 mm) elevation differential between the low point in the sag and the two points 50 ft (15 m) to either side of the low point.

To ensure that the first objective is achieved, base the length of the vertical curve upon a K-value of 167 (51) or less. For most design speeds, the K-values are less than 167 (51); see Figure 33-4.E. However, for higher design speeds and/or where longer sag vertical curves are required in curbed sections or on bridges, it may be necessary to install flanking inlets on either side of the low point.

For uncurbed sections of highway, drainage should not be a problem at sag vertical curves.

US Customary											
Design Speed (mph)	Avoidance Maneuver A (Stop on Rural Road)		Avoidance Maneuver B (Stop on Urban Road)		Avoidance Maneuver C (Speed/Path/Direction Change on Rural Road)		Avoidance Maneuver D (Speed/Path/Direction Change on Suburban Road)		Avoidance Maneuver E (Speed/Path/Direction Change of Urban Road)		
	DSD (ft)	K-Value	DSD (ft)	K-Value	DSD (ft)	K-Value	DSD (ft)	K-Value	DSD (ft)	K-Value	
30	220	42	490	114	450	103	535	126	620	150	
35	275	56	590	142	525	124	625	151	720	178	
40	330	70	690	170	600	144	715	177	825	208	
45	385	88	800	200	675	165	800	200	930	237	
50	465	107	910	231	750	186	890	226	1030	265	
55	535	126	1030	265	865	219	980	251	1135	295	
60	610	147	1150	299	990	254	1125	292	1280	336	
65	695	171	1275	335	1050	271	1220	319	1365	360	
70	780	195	1410	373	1105	287	1275	335	1445	383	
75	875	221	1545	411	1180	307	1365	360	1545	411	

Metric												
(km/h)	DSD (m)		K-Value		DSD (m)		K-Value		DSD (m)		K-Value	
	50	70	14	155	38	145	34	170	41	195	48	
60	95	20	195	51	170	41	205	51	235	59		
70	115	26	235	63	200	49	235	59	275	70		
80	140	33	280	77	230	58	270	69	315	82		
90	170	41	325	94	270	69	315	82	360	94		
100	200	49	370	110	315	82	355	93	400	106		
110	235	59	420	121	330	86	380	100	430	114		
120	265	67	470	125	360	94	415	110	470	125		

Notes:

1. See Section 31-3.02 for decision sight distances (DSD).

2. $K = \frac{DSD^2}{400 + 3.5 DSD}$, where: $h_3 = 2 \text{ ft}$ (US Customary)

3. $K = \frac{DSD^2}{120 + 3.5 DSD}$, where: $h_3 = 600 \text{ mm}$ (Metric)

K-VALUES FOR SAG VERTICAL CURVES—DECISION SIGHT DISTANCES (Passenger Cars)

Figure 33-4.G

33-4.03 Vertical Curve Computations

The following will apply to the mathematical design of vertical curves:

1. Definitions. Figure 33-4.H presents the common terms and definitions used in vertical curve computations.
2. Measurements. All measurements for vertical curves are made on the horizontal or vertical plane, not along the profile gradeline. With the simple parabolic curve, the vertical offsets from the tangent vary as the square of the horizontal distance from the VPC or VPT. Elevations along the curve are calculated as proportions of the vertical offset at the point of vertical intersection (VPI). The necessary equations for computing a symmetrical vertical curve are shown in Figure 33-4.I. Example 33-4.03(1) is a sample problem using these formulas.
3. Unsymmetrical Vertical Curve. Occasionally, it is necessary to use an unsymmetrical vertical curve to obtain clearance on a structure or to meet other existing field conditions. This curve is similar to the parabolic vertical curve, except the curve does not vary symmetrically about the VPI. Note that, with the unsymmetrical vertical curve, the curve is treated as two separate parabolas. The necessary equations for computing an unsymmetrical vertical curve are shown in Figure 33-4.J.
4. Vertical Curve Through Fixed Point. A vertical highway curve often must be designed to pass through an established elevation and location. For example, it may be necessary to tie into an existing side road or to clear existing structures. Figure 33-4.K provides the procedure for determining how to pass a vertical curve through a fixed point. Example 33-4.03(2) illustrates how to use these equations.
5. Vertical Curve Gradient Percents. Occasionally, the designer may want to determine the gradient percent of a point on a vertical curve or to determine at what location a given gradient percent occurs on the vertical curve. Figure 33-4.L provides the equations for making these determinations. Examples 33-4.03(3) and 33-4.03(4) illustrate how to use these equations.
6. Vertical Curve Extension. During a reconstruction project, it may be necessary to extend an existing vertical curve to ensure that the new profile gradeline will pass through a critical point (e.g., new bridge clearance). Figure 33-4.M provides the equations for determining the required vertical curve length extension and the new gradient. Example 33-4.03(5) illustrates how to use these equations.
7. VPI Stationing. The designer may need to determine the VPI station between two known VPI's. Figure 33-4.N illustrates how to determine the intermediate VPI given the gradients, stations, and elevations of the other VPI's.

Element	Abbreviation	Definition
Vertical Point of Curvature	VPC	The point at which a tangent grade ends and the vertical curve begins.
Vertical Point of Tangency	VPT	The point at which the vertical curve ends and the tangent grade begins.
Vertical Point of Intersection	VPI	The point where the extension of two tangent grades intersect.
Grade	G_1, G_2	The rate of slope between two adjacent VPIs expressed as a percent. The numerical value for percent of grade is the vertical rise or fall in feet (meters) for each 100 ft (100 m) of horizontal distance. Upgrades in the direction of stationing are identified as plus (+). Downgrades are identified as minus (-).
External Distance	E	The vertical distance (offset) between the VPI and the roadway surface along the vertical curve.
Algebraic Difference in Grade	A	The value of A is determined by the deflection in percent between two tangent grades ($G_2 - G_1$).
Length of Vertical Curve	L	The horizontal distance in feet (meters) from the VPC to the VPT.
Tangent Elevation	Tan. Elev.	The elevation on the tangent line between the VPC and VPI and the VPI and VPT.
Elevation on Vertical Curve	Curve Elev.	The elevation of the vertical curve at any given point along the curve.
Horizontal Distance	x	Horizontal distance measured from the VPC or VPT to any point on the vertical curve, in feet (meters).
Tangent Offset	y	Vertical distance from the tangent line to any point on the vertical curve, in feet (meters).
Low/High Point	x_T	The station at the high point for crest curves or the low point for sag curves. At this point, the slope of the tangent to the curve is equal to 0%.
Symmetrical Curve	—	The VPI is located at the mid-point between VPC and VPT stationing
Unsymmetrical Curve	—	The VPI is not located at the mid-point between VPC and VPT stationing.

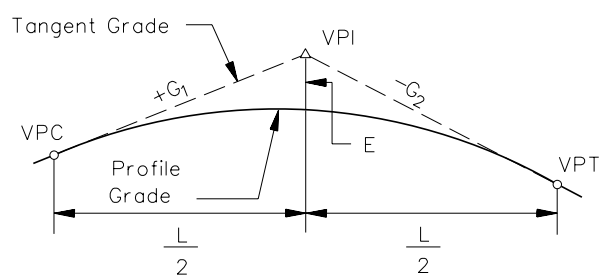

CREST VERTICAL CURVE

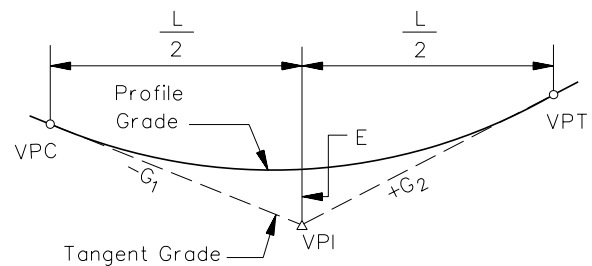

SAG VERTICAL CURVE

VERTICAL CURVE DEFINITIONS

Figure 33-4.H

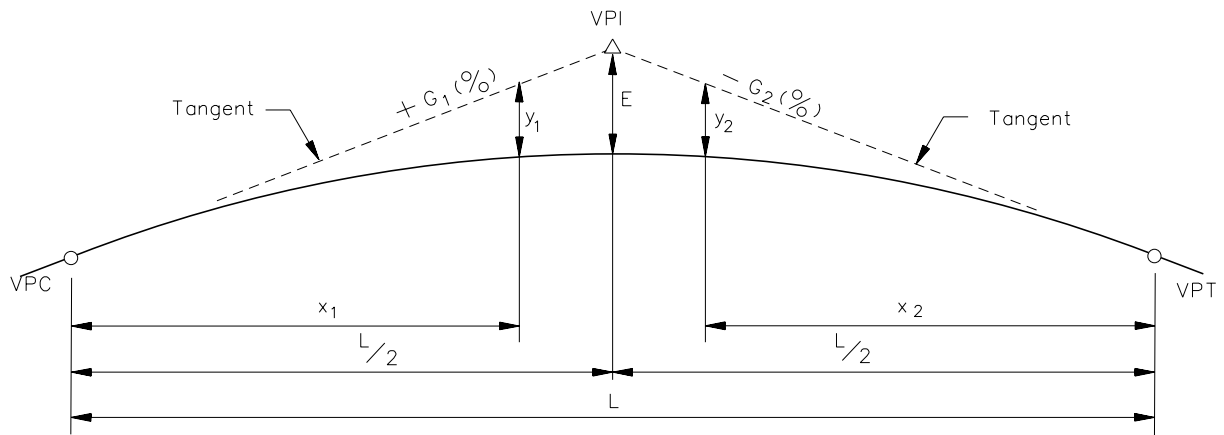

- E = External distance @VPI, ft (m)
 y = Any tangent offset, ft (m)
 L = Horizontal length of vertical curve, ft (m)
 x = Horizontal distance from VPC or VPT to any ordinate "y", ft (m)
 G_1 & G_2 = Rates of grade, expressed algebraically, %

NOTE: All expressions to be calculated algebraically. (Use algebraic signs of grades; grades in percent.)

1. Elevations of VPC and VPT:

2.
$$\text{VPC Elev.} = \text{VPI Elev.} - \left(\frac{G_1}{100} \times \frac{L}{2} \right) \quad \text{Equation 33-4.9}$$

$$\text{VPT Elev.} = \text{VPI. Elev.} + \left(\frac{G_2}{100} \times \frac{L}{2} \right) \quad \text{Equation 33-4.10}$$

For the elevation of any point "x" on a vertical curve:

$$\text{Curve Elev.} = \text{Tan Elev.} \pm y \quad \text{Equation 33-4.11}$$

Where:

Left of VPI (x_1 measured from VPC):

(a)
$$\text{Tan Elev.} = \text{VPC Elev.} + \left(\frac{G_1}{100} \right) x_1 \quad \text{Equation 33-4.12}$$

(b)
$$y_1 = x_1^2 \frac{(G_2 - G_1)}{200 L} \quad \text{Equation 33-4.13}$$

SYMMETRICAL VERTICAL CURVE EQUATIONS

Figure 33-4.1
(Continued)

Right of VPI (x_2 measured from VPT):

$$(a) \quad \text{Tan Elev.} = \text{VPT Elev.} - \left(\frac{G_2}{100} \right) x_2 \quad \text{Equation 33-4.14}$$

$$(b) \quad y_2 = x_2^2 \frac{(G_2 - G_1)}{200 L} \quad \text{Equation 33-4.15}$$

At the VPI:

$$y = E \quad \text{and} \quad x = L / 2$$

$$(a) \quad \text{Tan Elev.} = \text{VPC Elev.} + \frac{G_1 L}{200}$$

$$\quad \text{or Tan Elev.} = \text{VPT Elev.} - \frac{G_2 L}{200} \quad \text{Equation 33-4.16}$$

$$(b) \quad E = \frac{L(G_2 - G_1)}{800} \quad \text{Equation 33-4.17}$$

3. Calculating high or low point on the vertical curve:

(a) To determine distance " x_T " from VPC:

$$x_T = - \frac{L G_1}{G_2 - G_1} \quad \text{Equation 33-4.18}$$

(b) To determine high or low point stationing:

$$\text{High or Low Point Sta.} = \text{VPC Sta.} + x_T \quad \text{Equation 33-4.19}$$

(c) To determine high or low point elevation on a vertical curve:

$$\text{High or Low Point Elev.} = \text{VPC Elev.} - \frac{L G_1^2}{(G_2 - G_1) 200} \quad \text{Equation 33-4.20}$$

SYMMETRICAL VERTICAL CURVE EQUATIONS

Figure 33-4.1

Example 33-4.03(1) Symmetrical Vertical Curve Computations

Given: $G_1 = -1.75\%$
 $G_2 = +2.25\%$
 Elev. of VPI = 591.00 ft
 Station of VPI = 10 + 85.00
 $L = 1200$ ft
 Symmetrical Vertical Curve
 Rural Area

Problem: Compute the vertical curve elevations for each 100 ft station. Compute the low point elevation and stationing.

Solution:

1. **Draw a diagram.**

Show the vertical curve and determine the stationing at the beginning (VPC) and the end (VPT) of the curve.

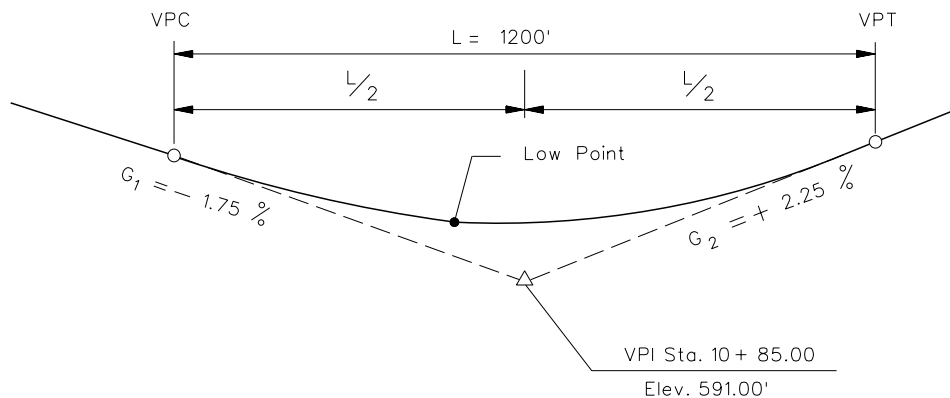

$$\begin{aligned} \text{VPC Station} &= \text{VPI Sta} - \frac{1}{2}L = (\text{Sta. } 10 + 85) - 600 = \text{Sta. } 4 + 85.00 \\ \text{VPT Station} &= \text{VPI Sta} + \frac{1}{2}L = (\text{Sta. } 10 + 85) + 600 = \text{Sta. } 16 + 85.00 \end{aligned}$$

2. **Elevations of VPC and VPT:**

$$\text{VPC Elev.} = 591.00 - \left(\frac{-1.75}{100} \times \frac{1200}{2} \right) = 601.50 \text{ ft} \quad \text{Equation 33-4.9}$$

$$\text{VPT Elev.} = 591.00 + \left(\frac{2.25}{100} \times \frac{1200}{2} \right) = 604.50 \text{ ft} \quad \text{Equation 33-4.10}$$

3. **Set up a table.**

Show the vertical curve elevations at the 100 ft stations, substituting the values into Equations 33-4.12 through 33-4.15. Calculate the elevation to the nearest 0.01 ft.

Station	Control Point	Tangent Elevation (ft)	x	x ²	y= x ² /60,000	Grade Elevation (ft)
4+85	VPC	601.50	0	0	0.00	601.50
5+00		601.24	15	225	0.00	601.24
6+00		599.49	115	13,225	0.22	599.71
7+00		597.74	215	46,225	0.77	598.51
8+00		595.99	315	99,225	1.65	597.64
9+00		594.24	415	172,225	2.87	597.11
10+00		592.49	515	265,225	4.42	596.91
10+85	VPI	591.00	600	360,000	6.00	597.00
11+00		591.34	585	342,225	5.70	597.04
12+00		593.59	485	235,225	3.92	597.51
13+00		595.84	385	148,225	2.47	598.31
14+00		598.09	285	81,225	1.35	599.44
15+00		600.34	185	34,225	0.57	600.91
16+00		602.59	85	7,225	0.12	602.71
16+85	VPT	604.50	0	0	0.00	604.50

4. Calculate the station and elevation of the low point:

$$x_T = -\frac{1200(-1.75)}{2.25 - (-1.75)} = -\frac{-2100}{4.00} = 525 \text{ ft from VPC} \quad \text{Equation 33-4.18}$$

Therefore, the station at the low point is:

$$\text{VPC}_{\text{STA}} + x_T = (\text{Sta. } 4 + 85) + (525) = \text{Sta. } 10 + 10.00 \quad \text{Equation 33-4.19}$$

The elevation at the low point on curve is:

$$\text{Elev. of low point} = 601.50 - \frac{1200(-1.75)^2}{(2.25 - (-1.75))200} \quad \text{Equation 33-4.20}$$

$$\text{Elev. of low point} = 601.50 - 4.59 = 596.91 \text{ ft}$$

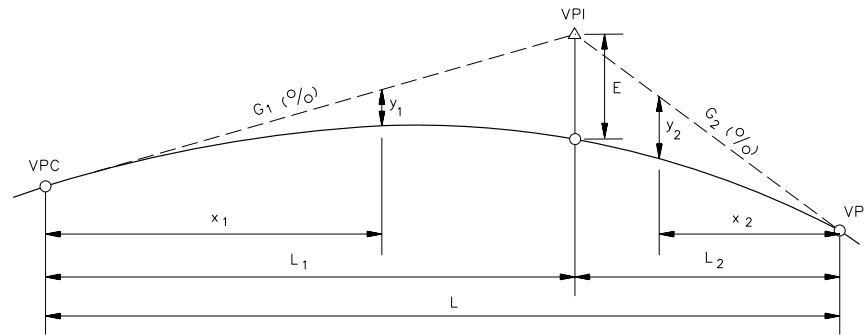

- E = Offset from the VPI to the curve (external distance), ft (m)
 y = Any tangent offset, ft (m)
 L = Horizontal length of vertical curve, ft (m)
 L_1 = Horizontal distance from VPC to VPI, ft (m)
 L_2 = Horizontal distance from VPT to VPI, ft (m)
 x = Horizontal distance from VPC or VPT to any ordinate “ y ”, ft (m)
 G_1 & G_2 = Rates of grade, expressed algebraically, %

Note: All expressions to be calculated algebraically. (Use algebraic signs of grades; grades in percent.)

1. Elevations of VPC and VPT:

$$\text{VPT Elev.} = \text{VPI Elev.} + \left(\frac{G_2}{100}\right)L_2 \quad \text{Equation 33-4.21}$$

$$\text{VPC Elev.} = \text{VPI Elev.} - \left(\frac{G_1}{100}\right)L_1 \quad \text{Equation 33-4.22}$$

2. For the elevation of any point “ x ” on a vertical curve:

$$\text{Curve Elev.} = \text{Tan. Elev.} \pm y \quad \text{Equation 33-4.23}$$

Where:

Left of VPI (x_1 measured from VPC):

$$(a) \text{ Tan Elev.} = \text{VPC Elev.} + \left(\frac{G_1}{100}\right)x_1 \quad \text{Equation 33-4.24}$$

$$(b) \ y_1 = x_1^2 \left(\frac{L_2}{L_1}\right) \left(\frac{G_2 - G_1}{200L}\right) \quad \text{Equation 33-4.25}$$

Right of VPI (x_2 measured from VPT):

$$(a) \text{ Tan Elev.} = \text{VPT Elev.} - \left(\frac{G_2}{100}\right)x_2 \quad \text{Equation 33-4.26}$$

$$(b) \ y_2 = x_2^2 \left(\frac{L_1}{L_2}\right) \left(\frac{G_2 - G_1}{200L}\right) \quad \text{Equation 33-4.27}$$

UNSYMMETRICAL VERTICAL CURVE EQUATIONS

Figure 33-4.J
(Continued)

At the VPI:

$$y = E \text{ and } x = L_1$$

$$(a) \quad \text{Tan Elev.} = \text{VPC Elev.} + \left(\frac{G_1}{100} \right) L_1 \text{ or} \quad \text{Equation 33-4.28}$$

$$\text{Tan Elev.} = \text{VPT Elev.} - \left(\frac{G_2}{100} \right) L_2$$

$$(b) \quad E = L_1 L_2 \left(\frac{G_2 - G_1}{200 L} \right) \quad \text{Equation 33-4.29}$$

3. Calculating High or Low Point Station and Elevation on a Curve:

Note: Where $x_T < L_1$ the high or low point is on the left side of the VPI or where $x_T > L_1$ the high or low point is on the right side of the VPI.

- a. Assume high or low point occurs left of VPI to determine the distance, x_T , from VPC:

$$x_T = \left(\frac{L_1}{L_2} \right) \left(\frac{G_2 L}{G_1 - G_2} \right) \quad \text{Equation 33-4.30}$$

Note: Is $x_T < L_1$?

If yes, the high or low point is on the left side of the VPI. Proceed to Steps b. and c. to solve for the high or low point elevation. If no, then skip to Steps d., e., and f. below to solve for the high or low point station and elevation.

- b. To determine the high or low point stationing where $x_T < L_1$:

$$\text{High or Low Point Sta} = \text{VPC Sta.} + x_T \quad \text{Equation 33-4.31}$$

- c. To determine the high or low point elevation when $x_T < L_1$:

$$\text{High or Low Point Elev.} = \text{VPC Elev.} - \left(\frac{L_1}{L_2} \right) \left(\frac{L G_1^2}{(G_2 - G_1) 200} \right) \quad \text{Equation 33-4.32}$$

- d. If $x_T > L_1$ from Step a., the high or low point occurs right of the VPI. Determine the distance x_T from the VPT:

$$x_T = \left(\frac{L_2}{L_1} \right) \left(\frac{G_2 L}{(G_2 - G_1)} \right) \quad \text{Equation 33-4.33}$$

- e. To determine high or low point stationing:

$$\text{High or Low Point Sta} = \text{VPT Sta.} - x_T \quad \text{Equation 33-4.34}$$

- f. To determine high or low point elevation on a vertical curve:

$$\text{High or Low Point Elev.} = \text{VPT Elev.} - \left(\frac{L_2}{L_1} \right) \left(\frac{L G_2^2}{(G_2 - G_1) 200} \right) \quad \text{Equation 33-4.35}$$

UNSYMMETRICAL VERTICAL CURVE EQUATIONS**Figure 33-4.J**

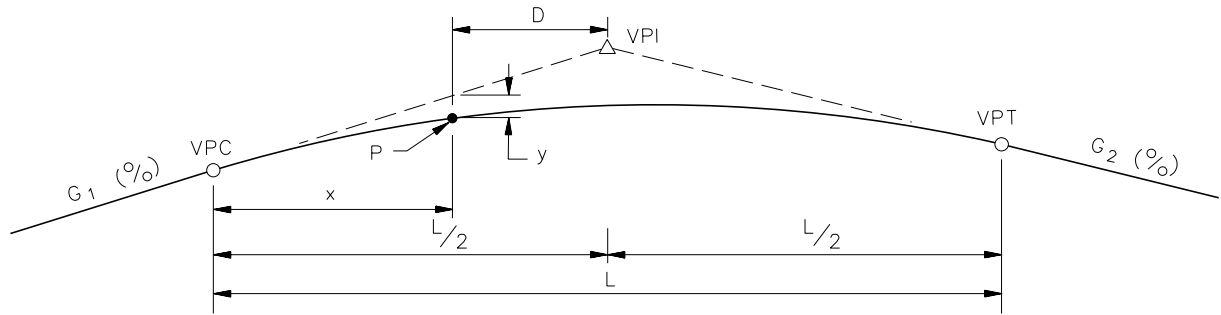

- G_1 = Grade in, %
 G_2 = Grade out, %
 A = Algebraic difference between the grades, %
 y = Vertical curve correction at point "P", ft (m)
 x = Distance from VPC to "P", ft (m)
 D = Distance from "P" to VPI, ft (m)
 L = Length of the vertical curve, ft (m)

Given: G_1, G_2, D

Problem: Determine the length of a vertical curve required to pass through a given point "P".

Solution:

1. Find the algebraic difference between the grades, G_2 and G_1 :

$$A = G_2 - G_1$$

2. Find the tangent offset at Point P:

From inspection of the above diagram:

$$x + D = L/2$$

and solving for "L" gives:

$$L = 2(x + D)$$

Equation 33-4.36

Use Equation 33-4.13 to determine the tangent offset:

$$y = x^2 \left(\frac{G_2 - G_1}{200 L} \right)$$

3. Solve for "x" by using the quadratic equation. Substituting $2(x + D)$ for L, and A for $(G_2 - G_1)$ into Equation 33-4.13 from Step 2 above yields:

$$0 = Ax^2 + (-400y)x + (-400Dy)$$

Equation 33-4.37

SYMMETRICAL VERTICAL CURVE THROUGH A FIXED POINT

Figure 33-4.K
(Continued)

Fill in the quadratic equation:

$$x = \frac{-b \pm \sqrt{b^2 - 4ac}}{2a} = \frac{400y \pm \sqrt{160000 y^2 + 1600ADy}}{2A} \quad \text{Equation 33-4.38}$$

Solving for “x” will result in two answers. If both answers are positive, there are two solutions. If one answer is negative, the negative answer can be eliminated and only one solution exists.

4. Substitute x and D into Equation 33-4.36 and solve for L:

Note: Two positive x values, will result in two L solutions. Desirably, use the longer vertical curve solution provided it meets the sight distance criteria (based on the selected design speed and algebraic difference in grades).

SYMMETRICAL VERTICAL CURVE THROUGH A FIXED POINT

Figure 33-4.K

Example 33-4.03(2) SYMMETRICAL VERTICAL CURVE THROUGH A FIXED POINT

Given: Design Speed = 55 mph
 $G_1 = -1.5\%$
 $G_2 = +2.0\%$
 $A = 3.5\%$
 VPI Station = 29 + 00.00
 VPI Elevation = 652.40 ft

Problem: At Station 27 + 50, a new highway must pass under the center of an existing railroad which is at elevation 679.78 ft at the highway centerline. The railroad bridge that will be constructed over the highway will be 4 ft in depth, 20 ft in width, and at right angles to the highway. Determine the length of the symmetrical vertical curve that would be required to provide a 16 ft 6 in clearance under the railroad bridge.

Solution:

- Sketch the problem with known information labeled.

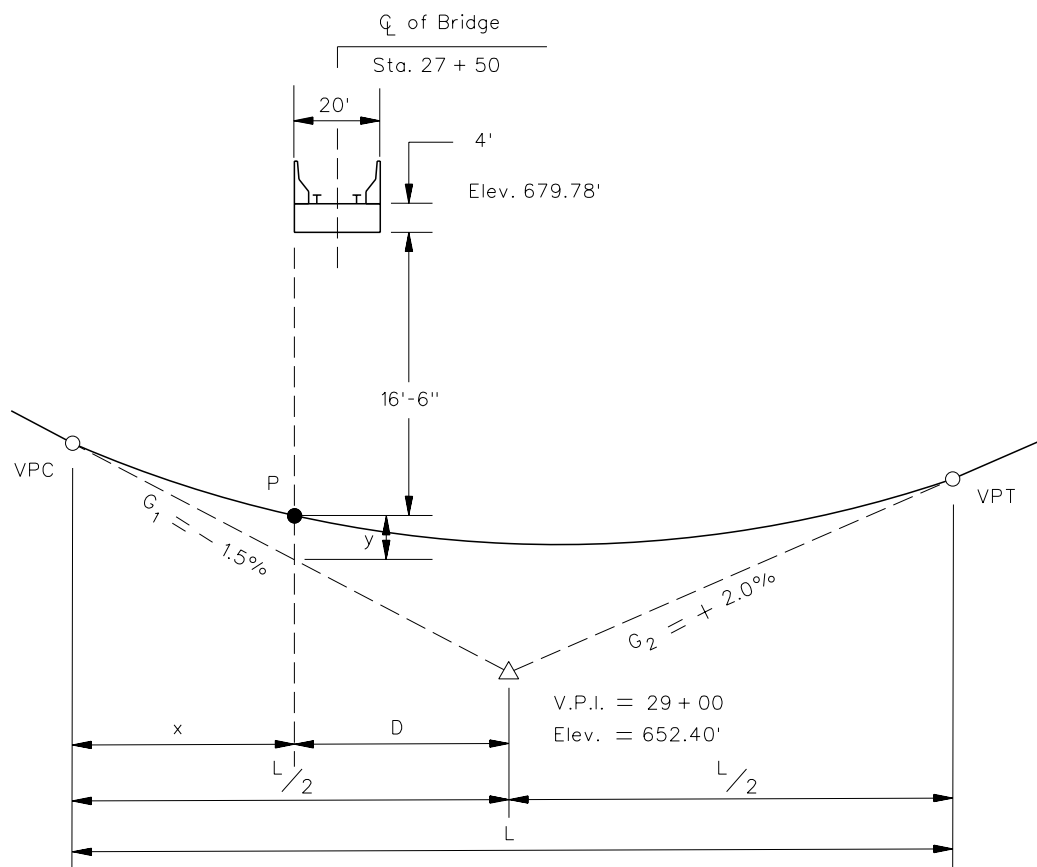

2. Determine the station where the minimum 16 ft6 in vertical clearance will occur (Point P):

*From inspection of the sketch, the critical location is on the left side of the railroad bridge.
The critical station is:*

$$\text{Sta. P} = \text{Bridge Centerline Station} - \frac{1}{2} (\text{Bridge Width})$$

$$\text{Sta. P} = \text{Sta. } 27 + 50 - \frac{1}{2} (20)$$

$$\text{Sta. P} = \text{Sta. } 27 + 40$$

3. Determine the elevation of Point P:

$$\text{Elev. P} = \text{Elev. of the top of the Railroad Bridge} - \text{Bridge Depth} - \text{Clearance}$$

$$\text{Elev. P} = 679.78 - 4.0 - 16.5$$

$$\text{Elev. P} = 659.28 \text{ ft}$$

4. Determine distance, D, from Point P to VPI:

$$D = \text{Sta. VPI} - \text{Sta. P} = (29 + 00) - (27 + 40) = 160 \text{ ft}$$

5. Determine the tangent elevation at Point P:

$$\text{Tangent Elev. at P} = \text{VPI Elev.} - \left(\frac{G_1}{100} \right) D = 652.40 - \left(\frac{-1.5}{100} \right) 160 = 654.80 \text{ ft}$$

6. Determine the tangent offset (y) at Point P:

$$y = \text{Elev. on Curve} - \text{Elev. of Tangent} = 659.28 - 654.80 = 4.48 \text{ ft}$$

7. Solve for x using the quadratic equation, Equation 33-4.38:

$$x = \frac{400(4.48) \pm \sqrt{(160000)(4.48)^2 + 1600(3.5)(160)(4.48)}}{2(3.5)}$$

$$x = 640 \text{ ft} \quad \text{and} \quad x = -128 \text{ ft} \quad (\text{Disregard negative solutions})$$

8. Using Equation 33-4.36, solve for L:

$$L = 2(x + D)$$

$$L = 2(640 + 160)$$

$$L = 1600 \text{ ft}$$

9. Check stopping sight distance.

Determine if the solution meets the desirable passenger car stopping sight distance for the 55 mph design speed. From Figure 33-4.E, the design K-value:

$$K = 115$$

The algebraic difference in grades:

$$A = G_2 - G_1 = (+2.0) - (-1.5) = 3.5$$

From Equation 33-4.6, determine the minimum length of vertical curve which meets the desirable stopping sight distance:

$$L_{MIN} = KA$$

$$L_{MIN} = (115) 3.5 = 402.5 \text{ ft}$$

$L = 1600 \text{ ft}$ which exceeds the design stopping sight distance.

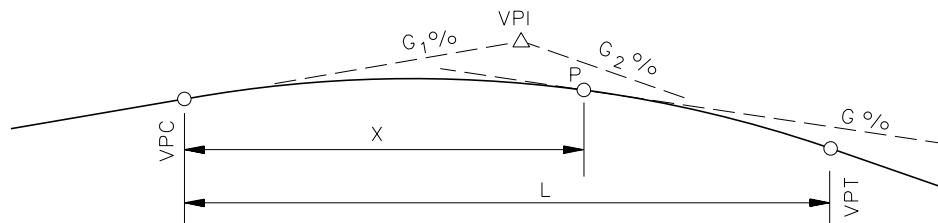

L = Horizontal length of vertical curve, ft (m)

x = Horizontal distance from VPC, ft (m)

G_1 and G_2 = Rates of grade, expressed algebraically, %

1. Rate of change of vertical curve per foot:

$$a = \frac{G_2 - G_1}{L} \quad \text{Equation 33-4.39}$$

2. Gradient at a point on curve at "x" distance from the VPC:

$$G = G_1 + ax \quad \text{Equation 33-4.40}$$

3. To find the horizontal distance "x" from VPC to point of a selected gradient, use Equation 33-4.40 and solve for x:

$$x = \frac{G - G_1}{a} \quad \text{Equation 33-4.41}$$

FIND THE PERCENT GRADE AT ANY POINT ON A VERTICAL CURVE

Figure 33-4.L

Example 33-4.03(3) GRADE AT A SPECIFIC LOCATION ON A VERTICAL CURVE

Given: $G_1 = +2.0\%$
 $G_2 = -3.5\%$
 $L = 1200 \text{ ft}$

Problem: Find the gradient at a point 900 ft from the VPC.

Solution:

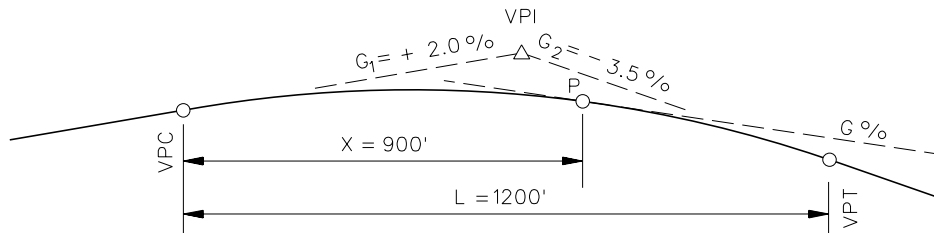

To determine the gradient at Point P, use Equations 33-4.39 and 33-4.40:

$$a = \frac{-3.5\% - 2.0\%}{1200} = -0.00458\%/ft$$

$$G = +2.0\% - 0.00458(900) = -2.125\%$$

Example 33-4.03(4) LOCATION ON A VERTICAL CURVE OF A SPECIFIC GRADE

Given: $G_1 = +2.0\%$
 $G_2 = -3.5\%$
 $L = 1200 \text{ ft}$

Problem: Find the point on the vertical curve where the gradient is -1.5% ($G = 1.5\%$).

Solution:

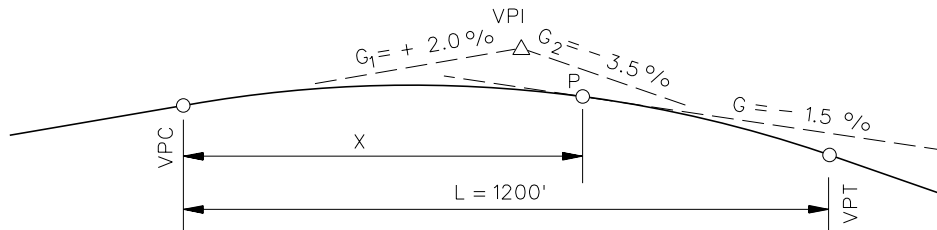

To find the point on the vertical curve where the gradient is -1.5% , use Equations 33-4.39 and 33-4.41:

$$a = \frac{3.5\% - 2.0\%}{1200} = 0.00458\%/ft$$

$$x = \frac{-1.5\% - 2.0}{-0.00458} = 764.19 \text{ ft from the VPC}$$

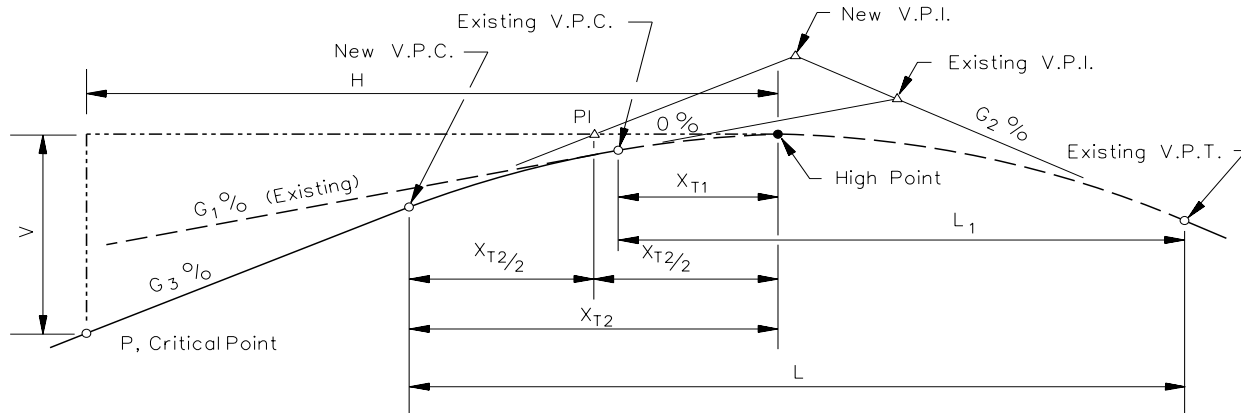

- L = Horizontal length of new vertical curve, ft (m)
- L₁ = Horizontal length of old vertical curve, ft (m)
- X_{T1} = Horizontal distance from the old VPC to high point, ft (m)
- X_{T2} = Horizontal distance from the new VPC to high point, ft (m)
- P = Critical point outside of the vertical curve
- G₁, G₂ & G₃ = Rates of grade, expressed algebraically, %

Note: New vertical curve is symmetrical.

Given: G₁, G₂, L₁, Station and Elevation of P, and Station and Elevation of old VPC

Find: Location of new VPC and G₃

Solution:

1. Find the algebraic difference in grades:

$$A = G_2 - G_1$$

2. Calculate the high point of existing vertical curve. The elevation and station of the high point can be determined by using Equations 33-4.18, 33-4.19, and 33-4.20.

$$x_T = - \frac{L G_1}{G_2 - G_1} \tag{Equation 33-4.18}$$

EXTENSION OF A VERTICAL CURVE THROUGH A POINT

Figure 33-4.M
(Continued)

$$\text{High or Low Point Sta.} = \text{VPC Sta.} + x_T \quad \text{Equation 33-4.19}$$

$$\text{High or Low Point Elev.} = \text{VPC Elev.} - \frac{L G_1^2}{(G_2 - G_1) 200} \quad \text{Equation 33-4.20}$$

3. Determine the distance from Point P to the vertical curve high point:

$$H = \text{Station of high point} - \text{Station of Point P}$$

4. Determine elevation difference between the vertical curve high point and Point P:

$$V = \text{Elevation of high point} - \text{Elevation of Point P}$$

5. Determine the distance from the vertical curve high point to the new VPC:

$$x_{T2} = H - \frac{\sqrt{(AH/L_1)^2 - 200(AV/L_1)}}{(A/L_1)} \quad \text{Equation 33-4.42}$$

6. Determine Station of new VPC:

$$\text{Station of new VPC} = \text{Station of high point} - x_{T2}$$

7. Determine the required new gradient:

$$G_3 = \frac{A x_{T2}}{L_1} \quad \text{or} \quad G_3 = \frac{V}{H \frac{x_{T2}}{2}} \times 100 \quad \text{Equation 33-4.43}$$

EXTENSION OF A VERTICAL CURVE THROUGH A POINT

Figure 33-4.M

$$\text{High Point Elev.} = 587.00 - \frac{1000(1)^2}{(-3-1)200} = 587.00 + 1.25 = 588.25 \text{ ft}$$

3. Determine the distance from Point P to the vertical curve high point:

$$H = (\text{Sta. } 47 + 50) - (\text{Sta. } 36 + 00) = 1150 \text{ ft}$$

4. Determine the elevation difference between Point P and the high point:

$$V = 588.25 \text{ ft} - 568.50 \text{ ft} = 19.75 \text{ ft}$$

5. Determine the location of the new VPC using Equation 33-4.42:

$$X_{T2} = H - \frac{\sqrt{(AH/L_1)^2 - 200(AV/L_1)}}{(A/L_1)} = 1150 - \frac{\sqrt{\left(\frac{4 \times 1150}{1000}\right)^2 - 200\left(\frac{4 \times 19.75}{1000}\right)}}{(4/1000)}$$

$$X_{T2} = 1150 - 578.79 = 571.21 \text{ ft}$$

$$\text{New VPC}_{\text{STA}} = (\text{Sta. } 47 + 50) - 571.21 = \text{Sta. } 41 + 78.79$$

6. Determine the new gradient (G_3), using Equation 33-4.43:

$$G_3 = \frac{AX_{T2}}{L_1} = \frac{4 \times 571.21}{1000} = +2.285\%$$

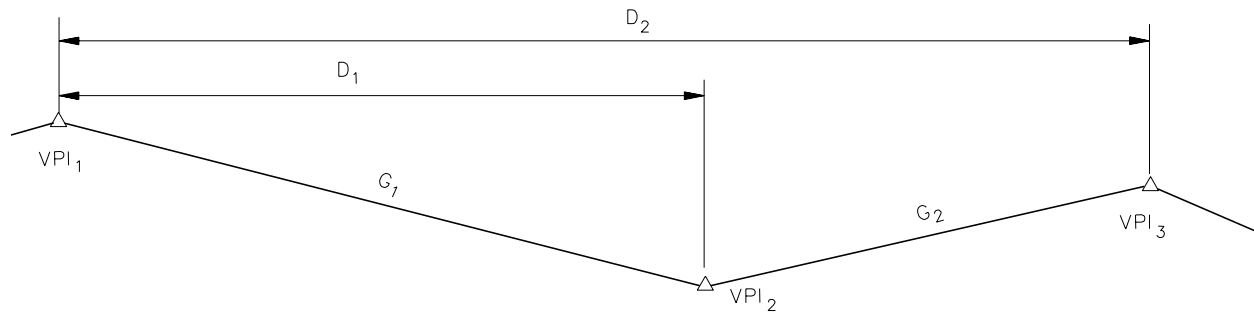

D_1 = Distance between VPI₁ and VPI₂, ft

D_2 = Distance between VPI₁ and VPI₃, ft

Given: Station and Elevation at VPI₁
 Station and Elevation at VPI₃
 G_1, G_2 (%)

Problem: Find Station and Elevation of VPI₂.

Solution:

1. Find the station of VPI₂:

$$D_1 = \frac{(\text{Elev. VPI}_3 - \text{Elev. VPI}_1) - G_2 D_2}{G_1 - G_2} \quad \text{Equation 33-4.44}$$

$$\text{Sta. VPI}_2 = \text{Sta. VPI}_1 + D_1$$

2. Find the elevation of VPI₂:

$$\text{Elev. VPI}_2 = \text{Elev. VPI}_1 + G_1 D_1 \quad \text{Equation 33-4.45}$$

VERTICAL CURVE COMPUTATION (Intermediate VPI)

Figure 33-4.N

33-5 VERTICAL CLEARANCES

Figure 33-5.A provides a table with the minimum roadway vertical clearances for newly constructed and reconstructed structures, for structures allowed to remain-in-place, and for structures impacted by 3R projects. The vertical clearances in Figure 33-5.A cover the travel lanes, usable shoulders, and usable medians. The vertical clearances account for future resurfacing of roadways under the structures when the scope is new construction or reconstruction. Vertical clearances should always be verified in advance of all roadway projects which have structures within their limits. Section 39-5 provides typical sections for highway and railway underpasses and illustrates where to measure vertical clearances.

Functional Classification	Newly Constructed and Reconstructed Structures¹	Existing Structures Allowed to Remain in Place¹	3R Projects Under Structures¹
Interstates (rural and single routing ² around urban areas)	16'-09" (5.1 m)	16'-00" (4.9 m)	16'-00" (4.9 m)
Interstates (urban interstates other than single routing ²)	15'-00" (4.5 m)	15'-00" (4.5 m)	15'-00" (4.5 m)
Expressways ³	16'-06" (5.0 m)	16'-00" (4.9 m)	16'-00" (4.9 m)
Strategic Regional Arterial (Urban/suburban)	14'-09" (4.5 m)	14'-00" (4.3 m)	14'-00" (4.3 m)
Strategic Regional Arterial (Rural)	16'-06" (5.0 m)	16'-00" (4.9 m)	14'-00" (4.3 m)
Rural Principal or Minor Arterial or Marked Collector ⁴	16'-06" (5.0 m)	16'-00" (4.9 m)	14'-00" (4.3 m)
Urban/Suburban Principal or Minor Arterial	14'-09" (4.5 m)	14'-00" (4.3 m)	14'-00" (4.3 m)
Urban One-way and Urban Two-way Streets	14'-09" (4.5 m)	14'-00" (4.3 m)	14'-00" (4.3 m)
Local Roads or Unmarked Collectors ⁴	14'-09" (4.5 m)	14'-00" (4.3 m)	14'-00" (4.3 m)
Frontage Road A	16'-00" (4.9 m)	14'-00" (4.3 m)	14'-00" (4.3 m)
Frontage Road B or C	14'-09" (4.5 m)	14'-00" (4.3 m)	14'-00" (4.3 m)
Railroads under Highway	23'-00" (7.0 m)	21'-06" (6.6 m)	21'-06" (6.6 m)
Traffic Signal Heads ⁵	16'-00" (5.0 m)	16'-00" (5.0m)	16'-00" (5.0m)
Pedestrian Overpasses	17'-03" (5.25 m)	17'-00" (5.2 m)	17'-00" (5.2 m)
Cross bracing on Through Truss Structures	17'-03" (5.25 m)	17'-03" (5.25 m)	17'-00" (5.2 m)
Sign Trusses ⁶	17'-03" (5.25 m)	17'-00" (5.2 m)	17'-00" (5.2 m)
Bicycle Underpass ⁷	10'-00" (3.0 m)	10'-00" (3.0 m)	10'-00" (3.0 m)

Vertical Clearances

Figure 33-5.A

1. The minimum required vertical clearance must be available over the traveled way, any usable shoulder, and usable median, or measured from the top of the rail for clearances above railroad tracks.
2. Single routing around or through an urban area is defined in Section 31-7.04(c). Maps of urban areas in Illinois with a single routing are shown in Section 44-6.
3. A 15'-00" (4.5 m) vertical clearance may be used in an urban area where an alternative route is available with a 16'-00" (4.9 m) vertical clearance.
4. Includes unmarked rural and urban collectors and local highways on the State highway system.
5. Vertical clearances are for mast arm mounted signal heads. Provide 17'-00" (5.2 m) vertical clearance for all spanwire mounted signal heads and spanwire mounted flashing beacons.
6. On interstate routes with less than 16'-0" (4.9 m) clearance, the vertical clearance to sign trusses shall be 1 ft (0.3 m) greater than the minimum clearance of other structures.
7. An 8'-00" (2.4 m) vertical clearance is permitted in constrained areas.

Footnotes to Figure 33-5.A

33-6 DESIGN PRINCIPLES AND PROCEDURES

33-6.01 General Controls for Vertical Alignment

As discussed elsewhere in Chapter 33, the design of vertical alignment involves, to a large extent, complying with specific limiting criteria. These include maximum and minimum grades, sight distance at vertical curves, and vertical clearances. In addition, the designer should adhere to certain general design principles and controls which will determine the overall safety and operation of the facility and will enhance the aesthetic appearance of the highway. These design principles for vertical alignment include:

1. Consistency. Use a smooth gradeline with gradual changes, consistent with the type of highway and character of terrain, rather than a line with numerous breaks and short lengths of tangent grades.
2. Coordination with Natural/Man-Made Features. The vertical alignment should be properly coordinated with the natural topography, available right-of-way, utilities, roadside development, and natural/man-made drainage patterns. This is especially important in rugged terrain.
3. Roller Coaster. Avoid a “roller-coaster” type of profile, especially where the horizontal alignment is relatively straight. This type of profile may be proposed in the interest of the economy, but it is aesthetically undesirable and may be hazardous. To avoid this type of profile, incorporate into the design horizontal curvature and/or flatter grades that may require greater excavations and higher embankments.
4. Broken-Back Curvature. Avoid “broken-back” gradelines (two crest or sag vertical curves separated by a short tangent). This alignment is particularly noticeable on divided highways with open-ditch median sections. One long vertical curve is more desirable. In rural areas, any distance less than 1500 ft (500 m) between VPI’s is considered to be a broken-back profile.
5. Long Grades. On a long ascending grade, it is preferable to place the steepest grade at the bottom and flatten the grade near the top. It is also preferable to break the sustained grade with short intervals of flatter grades. Evaluate substantial lengths of grades for their effect on traffic operations (e.g., trucks).
6. Sags. Avoid sag vertical curves in cuts unless adequate drainage can be provided. Also, to avoid drainage problems on bridges, do not place the low point of sag vertical curves on a bridge.
7. Intersections. Maintain moderate grades through intersections to facilitate braking and turning movements. See Chapter 36 for specific information on vertical alignment through intersections.
8. Environmental Impacts. Vertical alignment should be properly coordinated with environmental impacts. However, the safety of the highway should not be compromised.

33-6.02 Coordination of Horizontal and Vertical Alignment

Do not design the horizontal and vertical alignments independently. Instead they should complement each other. This is especially true for new construction projects. Poorly coordinated designs can detract from the benefits and emphasize the deficiency of each alignment. A thorough study of the alignment is always warranted.









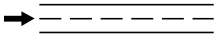
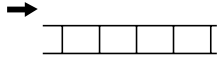

Horizontal alignments and vertical profiles are among the most important permanent design elements for a highway. Excellence in their design and coordination increases the highway's utility and safety, encourages uniform speeds, and can greatly improve the highway's appearance. This usually can be accomplished with little additional costs. The designer should coordinate the layout of the horizontal and vertical alignment as early as practical in the design process. Alignment layouts are typically completed after the topography and ground line have been drafted. Use the computer visualization program within CADD (e.g., GEOPAK) to visualize how the layout will appear in the field. Review several alternatives to ensure that the most pleasing and practical design is selected.

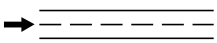
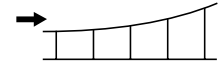
It is difficult to discuss the combination of horizontal alignment and vertical profile without reference to the broader subject of highway location. The subjects are mutually interrelated and what may be said about one generally is applicable to the other. The physical controls or influences that act singularly or in combination that determine the type of alignment are:

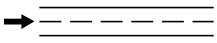
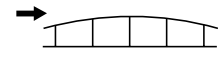
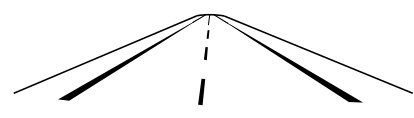
- the character of highway, justified by traffic volumes;
- topography and subsurface conditions;
- existing highway and cultural developments;
- likely future developments; and
- suitable locations for intersections and interchanges.

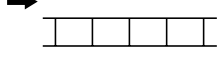
Figures 33-6.A through 33-6.E illustrate poor and preferred examples of horizontal and vertical alignment coordination. In addition, consider the following when coordinating horizontal and vertical alignment on rural and suburban highways:

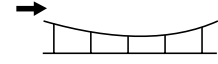
1. **Balance.** Horizontal curvature and grades should be in proper balance. Maximum curvature with flat grades or flat curvature with maximum grades does not achieve this desired balance. A compromise between the two extremes produces the best design relative to safety, capacity, ease, uniformity of operations, and aesthetics.
2. **Coordination.** Vertical curvature superimposed upon horizontal curvature (i.e., vertical and horizontal P.I.'s at approximately the same stations) generally results in a more pleasing appearance and reduces the number of sight distance restrictions. Successive changes in profile, not in combination with horizontal curvature, may result in a series of humps visible to the driver for some distance, which may produce an unattractive design. However, under some circumstances, superimposing the horizontal and vertical alignment must be tempered somewhat by Items 3 and 4 below.

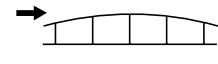
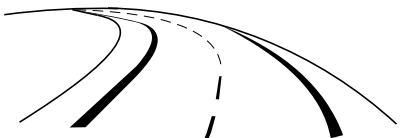
Horizontal Design Element	Vertical Design Element	Three Dimensional Design Element
 <p>Tangent</p>	 <p>Tangent</p>	 <p>Tangent with Constant Gradeline</p>
 <p>Tangent</p>	 <p>Sag Curve</p>	 <p>Tangent with Sag Vertical Curve</p>
 <p>Tangent</p>	 <p>Crest Curve</p>	 <p>Tangent with Crest Vertical Curve</p>
 <p>Curve</p>	 <p>Tangent</p>	 <p>Horizontal Curve with Constant Gradeline</p>
 <p>Curve</p>	 <p>Sag Curve</p>	 <p>Horizontal Curve with Sag Vertical Curve</p>
 <p>Curve</p>	 <p>Crest Curve</p>	 <p>Horizontal Curve with Crest Vertical Curve</p>

HORIZONTAL AND VERTICAL ALIGNMENT COORDINATION

Figure 33-6.A

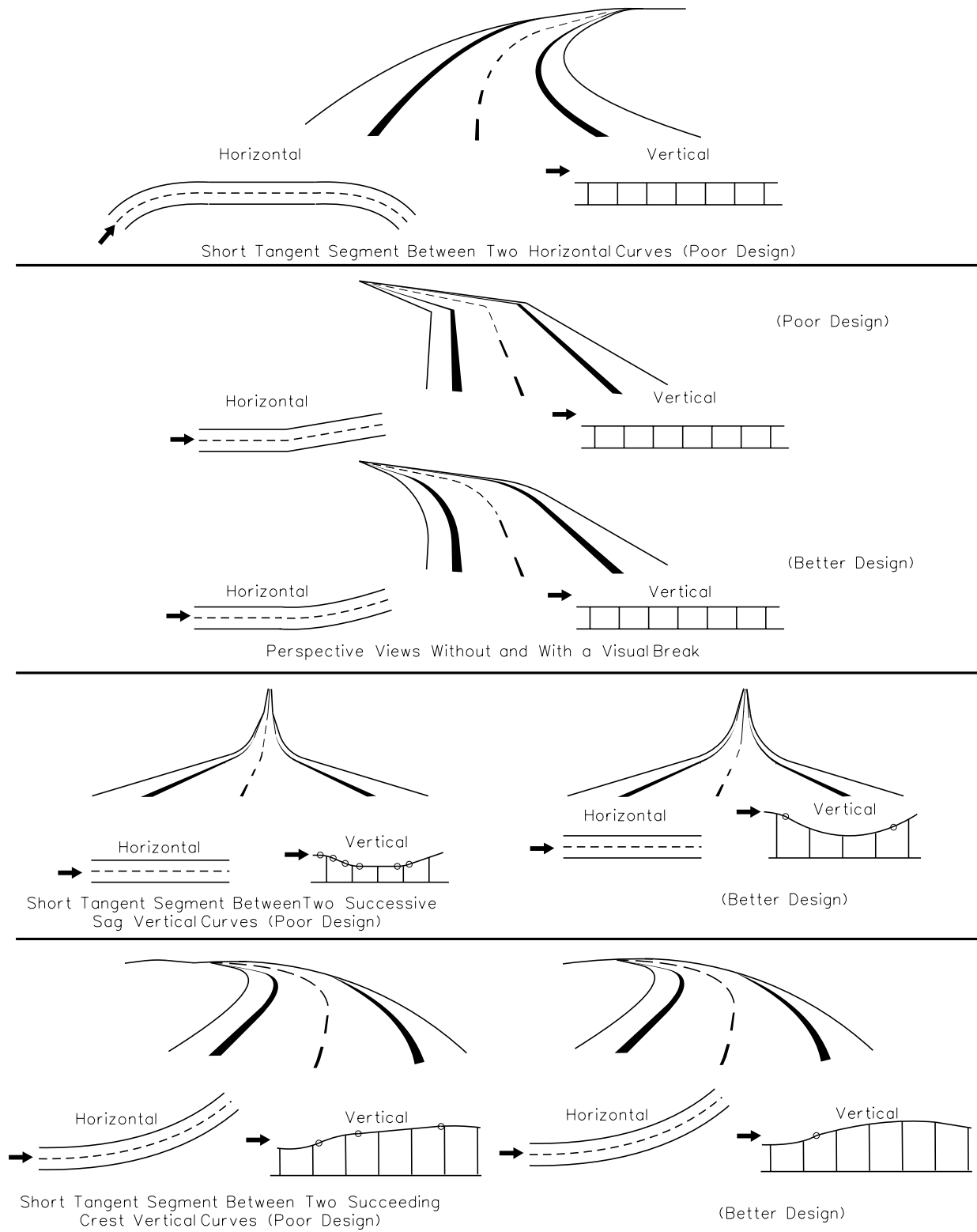

EXAMPLES OF UNDESIRABLE AND GOOD ALIGNMENT COORDINATION

Figure 33-6.B

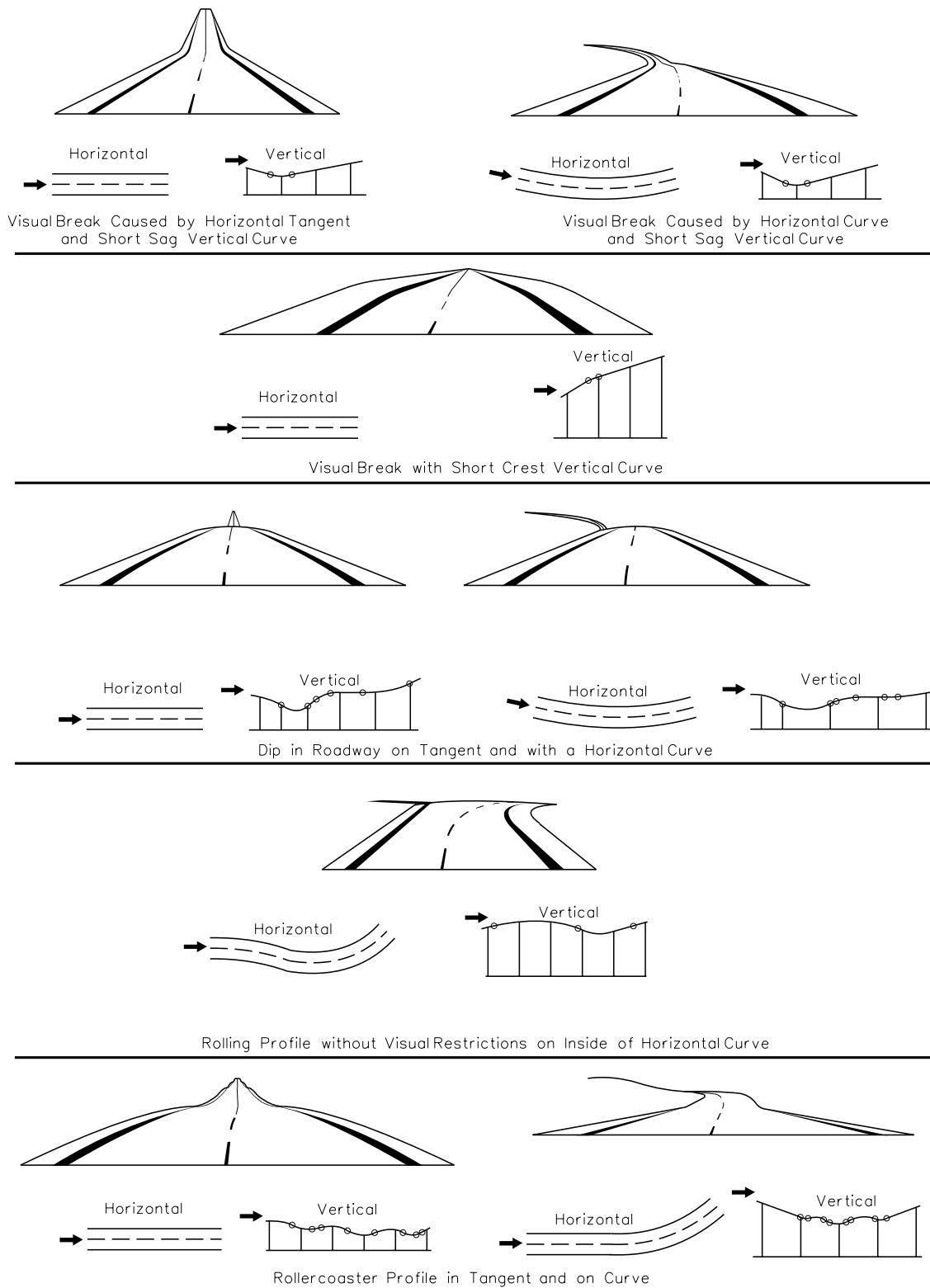

COMBINED ALIGNMENT DESIGNS TO AVOID

Figure 33-6.C

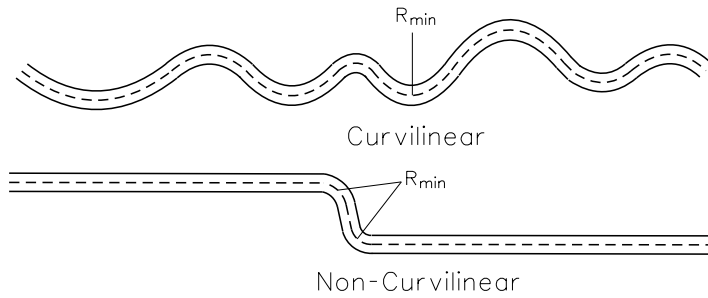

a) Horizontal Alignments

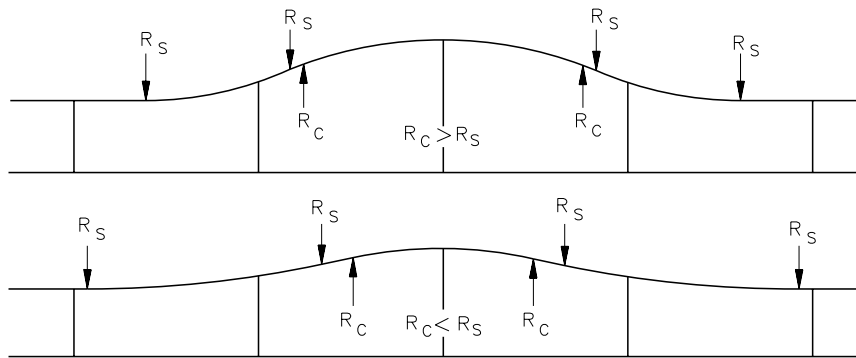

R_S = Radius (Sag)
 R_C = Radius (Crest)
 Where $R \approx 300K$ (100K)
 and K is defined as
 sharpness of vertical
 curve or $L = KA$

b) Vertical Alignments: (Relation $R_C : R_S$)

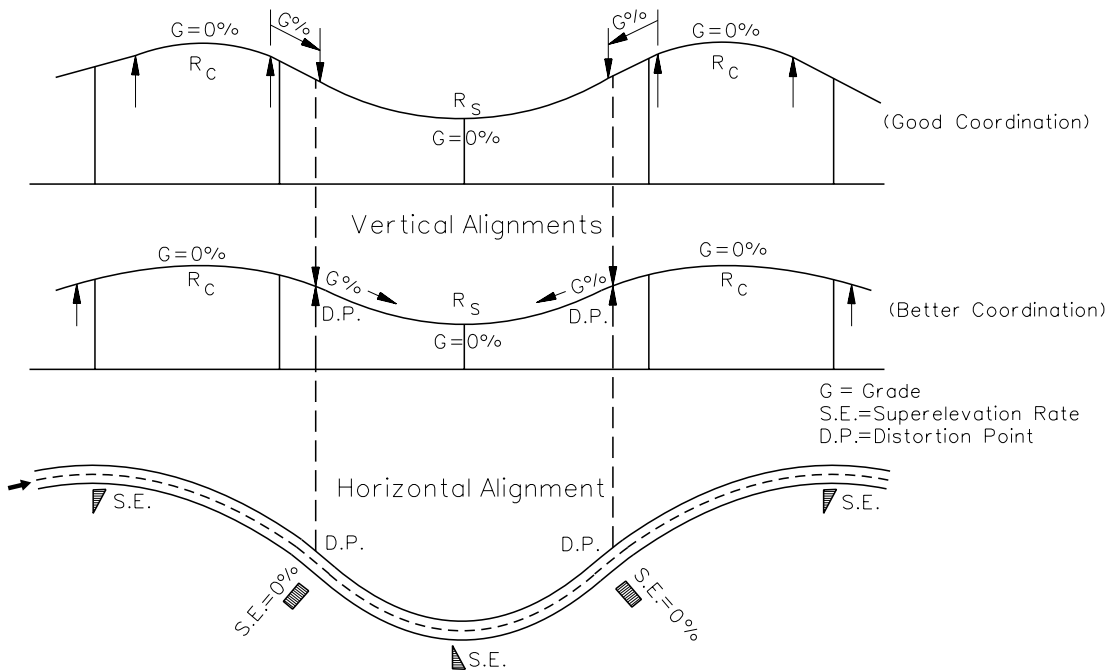

c) Coordination of Distortion Points in Horizontal and Vertical Alignments

SUPERIMPOSITION OF HORIZONTAL AND VERTICAL ALIGNMENTS

Figure 33-6.D

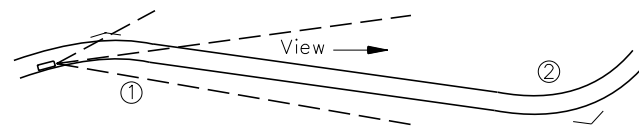
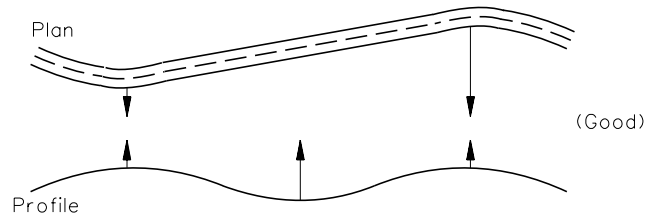
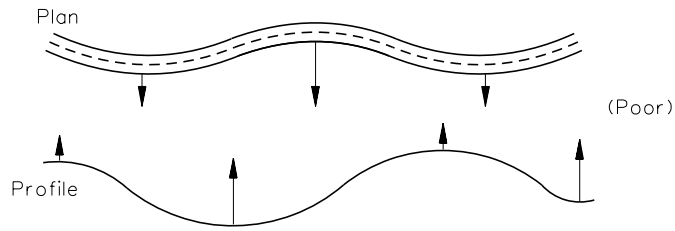
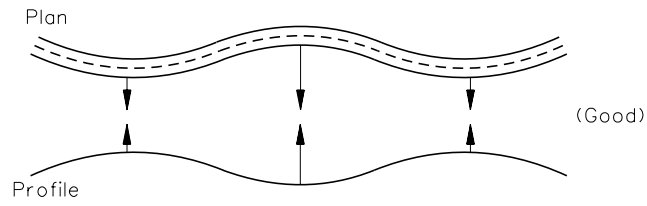

Horizontal Alignment
View - 2 Breaks Max.

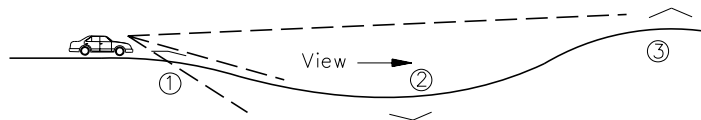

Vertical Alignment
View - 3 Breaks Max.

EXAMPLES OF SUPERIMPOSITION OF HORIZONTAL AND VERTICAL ALIGNMENTS

Figure 33-6.E

3. Crest Vertical Curves. Do not introduce sharp horizontal curvature at or near the top of pronounced crest vertical curves. This is undesirable because the driver cannot perceive the horizontal change in alignment, especially at night when headlight beams project straight ahead into space. This problem can be avoided if the horizontal curvature leads the vertical curvature or by using design values which well exceed the minimums.
4. Sag Vertical Curves. Do not introduce sharp horizontal curves at or near the low point of pronounced sag vertical curves or at the bottom of steep grades. Because visibility to the road ahead is foreshortened, only flat horizontal curvature will avoid an undesirable, distorted appearance. At the bottom of long grades, vehicular speeds often are higher, particularly for trucks, and erratic operations may occur, especially at night and during icy conditions.
5. Passing Sight Distance. In some cases, the need for frequent passing opportunities and a higher percentage of passing sight distance may supersede the desirability of combining horizontal and vertical alignment. In these cases, it may be necessary to provide long tangent sections to secure sufficient passing sight distance.
6. Intersections. At intersections, horizontal and vertical alignment should be as flat as practical to provide a design which produces sufficient sight distance and gradients for vehicles to slow, stop, or turn; see Chapter 36.
7. Divided Highways. On divided facilities with wide medians, it is frequently advantageous to provide independent alignments for the two one-way roadways. Where traffic volumes justify a divided facility, and where rolling or rugged terrain exists, a superior design can result from the use of independent alignments and profiles.
8. Residential Areas. For highways near subdivisions, design the alignment and profile to minimize nuisance factors to neighborhoods. For freeways, a depressed facility can make the highway less visible and reduce the noise to adjacent residents. Also, for all highway types, minor adjustments to the horizontal alignment may increase the buffer zone between the highway and residential areas.

33-6.03 Aesthetics

The coordination of the horizontal and vertical alignment should be designed to enhance the aesthetics of the facility. A proper layout as discussed in Section 33-6.02 will generally provide an attractive facility. In addition, the designer should consider the effect the cross section will have on the facility's aesthetics. The following sections present several ideas that may enhance the attractiveness of a facility.

33-6.03(a) General

A major problem may develop with the layout of a new highway if the designer attempts to superimpose a linear roadway configuration onto nonlinear land forms. A properly developed alignment will reduce driver monotony, provide a positive visual experience, and integrate the

roadway into the landscape without providing unsightly visual impacts. To accomplish this, design the vertical and horizontal alignment to:

- fit the landscape with minimal land form modifications;
- enhance the area's landscape character;
- direct the driver's attention to positive visual features in the landscape (e.g., the highway should lead into, rather than away from those views considered aesthetically pleasing); and
- capitalize on other opportunities that will create a pleasant visual experience (e.g., the roadway should descend towards those features of interest at a low elevation and rise toward those features which are best viewed from below or in silhouette against the sky).

Often the use of various impact reduction methods described in the following sections are in conflict with each other (e.g., slope rounding versus vegetation retainage). To resolve these conflicts, the designer must determine for whom the visual impact reductions are made (e.g., the driver, local residents, tourists). Some of the factors that should be considered include the:

- number of potential viewers;
- location of the viewer;
- duration of the view (length and number of times the view is seen);
- type of potential viewers (tourists, local residents, pass-throughs);
- type of area from which it is viewed (recreational areas, farms, major highways, urban); and
- other focal points that will draw attention from the road.

The designer should use the Department's computerized visualization CADD program (i.e., GEOPAK) to review the design from both the perspective view of the driver and the perspective view from outside the roadway.

33-6.03(b) Rural Visual Impacts

One of the goals of producing an aesthetically pleasing design is to reduce the visual impact the roadway has on the landscape. The following presents several ideas for reducing this impact:

1. Horizontal and Vertical Alignment Coordination. Properly coordinated horizontal and vertical alignments can lead to aesthetically pleasing designs. Section 33-6.02 discusses the coordination of the vertical and horizontal alignments.

2. Cut and Fill Slopes. Explore possible alternatives that will reduce the magnitude of exposed cut and fill slopes. Some of these alternatives include moving the alignment slightly or changing the geometric design through a specific area. For example, reducing the ditch width by 3 ft (1.0 m) and increasing the slope rates, say, for 3000 ft (1000 m) on the project may significantly reduce the amount of exposed cut slope and thereby enhance the visual impact of the facility on the landscape. Figure 33-6.F illustrates examples of poor and good alignments for reducing exposed cut and fill slopes.
3. Reducing Earthwork Modifications. Once measures have been adopted to reduce the magnitude of exposed cut and fill slopes, additional earthwork modifications can be used to further improve visual impacts. Some of these modifications include:
 - a. Slope Rounding. Slope rounding allows the fill and cut slopes to blend naturally into the existing landscape. It reduces the sharp, unnatural edges formed by the junction of a constant pitch cut or fill slope with the naturally rounded landscape. Figure 33-6.G illustrates an example of slope rounding.
 - b. Warping Slopes. Warping slopes allows the designer to vary the slope pitch to more closely match the surrounding land form and to present a more natural landscape.
 - c. Waste Materials. Positive utilization of waste materials can enhance the visual impacts of the facility. On freeways and expressways with independent alignments, contrasts can be reduced by creating low-earth mounds or by filling unnatural looking depressions.
4. Color. Freshly cut rock faces often produce very sharp contrasts to the surrounding landscape. "Aging" the rock cut or fill slope can be accomplished with replanting vegetation or by covering the rock cut or fill slope with asphalt emulsions, paints, etc.
5. Texture. Rock cuts should be textured to match the local rock faces. This may require using smooth cuts or broken-face cuts. Broken-face cuts also provide pockets which allow for a more rapid natural revegetation of the face. Another way to provide texture is to scarify cut slopes. A random pattern of scarification is the most desirable.
6. Vegetation. One of the easiest ways to reduce the visual impact of the roadway is to retain as much of the existing vegetation and riparian habitat as practical. Figure 33-6.H illustrates an example of the advantages of retaining vegetation. However, retaining vegetation is often limited by roadside safety factors, sight distance requirements, the desire to open views and vistas (see Figure 33-6.I), construction requirements, maintenance requirements, etc.

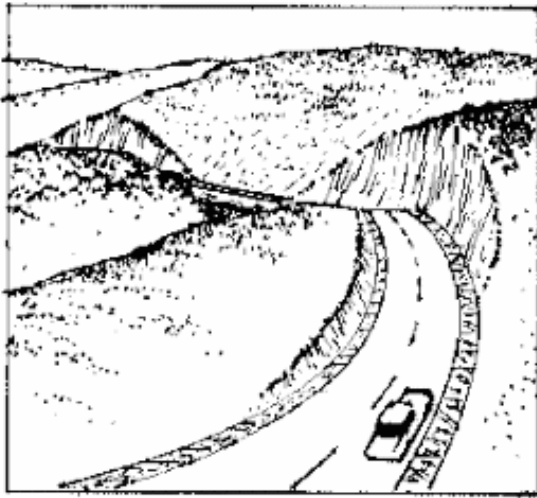

POOR VISUAL EFFECT

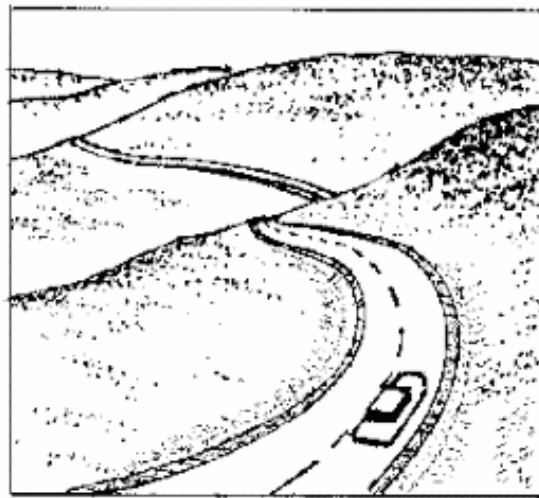

GOOD VISUAL EFFECT

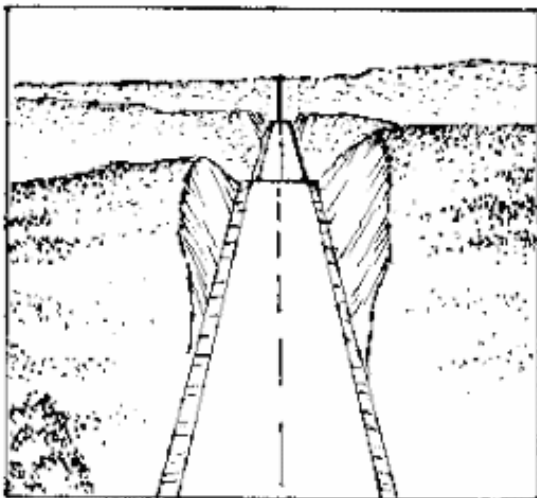

POOR VISUAL EFFECT

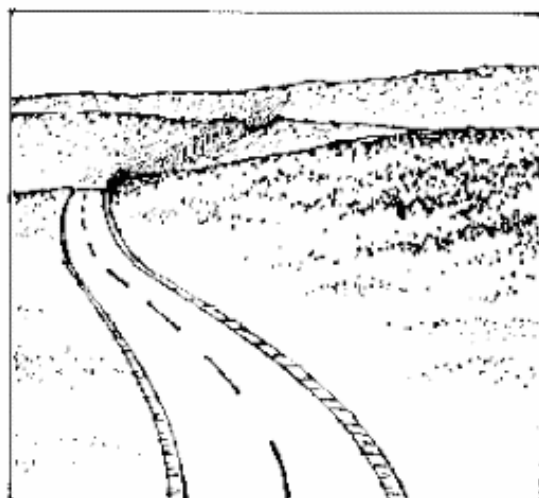

GOOD VISUAL EFFECT

ALIGNMENT EFFECTS ON FILL AND CUT SLOPES

Figure 33-6.F

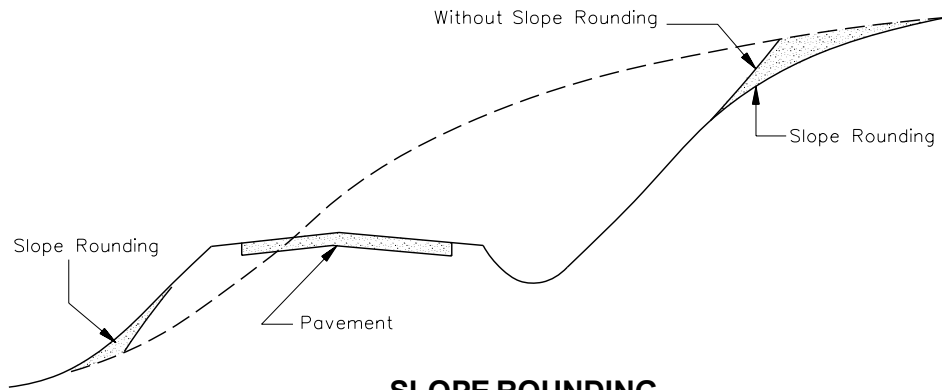

SLOPE ROUNDING

Figure 33-6.G

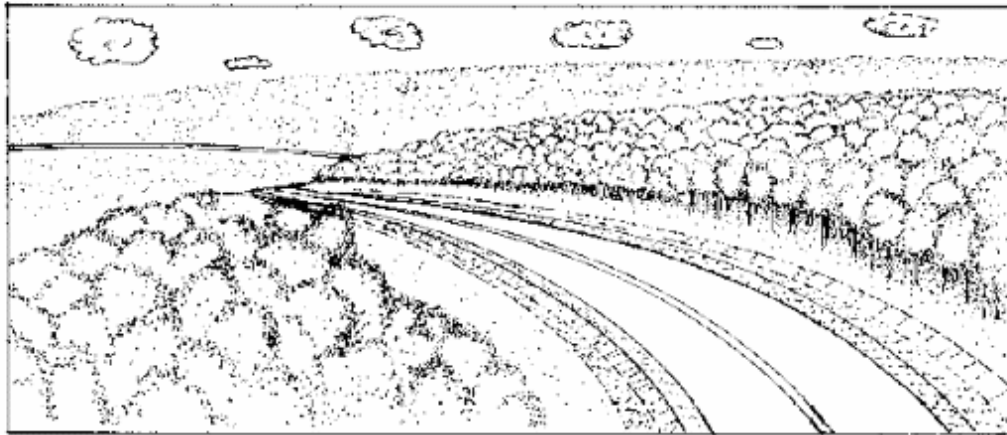

POOR VISUAL EFFECT

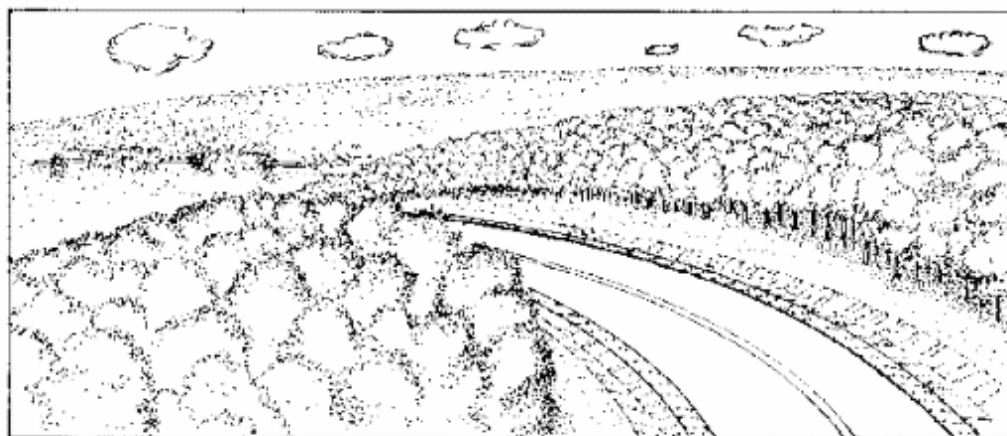

GOOD VISUAL EFFECT

DISAPPEARING FOCAL POINT AND VEGETATION RETAINAGE

Figure 33-6.H



SELECTIVE THINNING

Figure 33-6.1

Wildflowers can significantly improve the roadway aesthetics with minimal effort and may reduce the roadside maintenance requirements. Freeway medians, interchanges, and large open roadside areas are common locations for wildflowers. Give special attention to selecting the color, texture, soil conditions, and flower types to ensure successful plantings.

7. Daylighting. Daylighting can be used to open the roadway to broad panoramic views which otherwise may be hidden by cuts. However, do not use daylighting if the desire is to hide the road from other viewers or if the desire is to retain the existing vegetation and wildlife habitat.

33-6.03(c) Urban Visual Impacts

Generally, it is more difficult to obtain aesthetically pleasing designs in urban areas due to limited right-of-way, limited design options, and competing distractions. However, as practical, the designer should work with local officials to produce an aesthetically pleasing design. The following presents several options for improving the visual impact of roadways in urban areas:

1. Structures. Structure aesthetics do not necessarily require ornamentation or decoration. However, giving special attention to scale, proportion, form, line, material, texture, color, and other principles of art and architecture can produce aesthetically pleasing structures. Also, consider views from bridges. For example, views of rivers, lakes, or city centers from high bridges can often present spectacular views.
2. Medians. Because of right-of-way restrictions in urban areas, the use of wide medians on arterial streets are seldom practical. However, raised-curb or depressed medians in the suburban areas may allow some type of landscaping in the median. Where landscaping is proposed, ensure that it will not affect the roadside safety or restrict sight distances.
3. Sound Walls. On many urban freeways and expressways, sound walls are an integral part of the highway cross section. However, sound walls can often produce a tunnel-like effect. To reduce this effect, give special consideration to changing the alignment and profile of the wall. This can be accomplished by changing material types and texture, stepping the top of the wall, providing curvilinear designs, and providing plantings along the wall. Also, give special care to adjacent properties behind the wall to ensure satisfied property owners.
4. Grading. Use of contour grading on urban freeways and expressways can significantly reduce the highway impact on the surrounding area. Figure 33-6.J illustrates a good contour grading plan at an interchange. In addition, lowering urban freeways below grade can often reduce the noise and visual impacts of the highway to nearby neighborhoods.

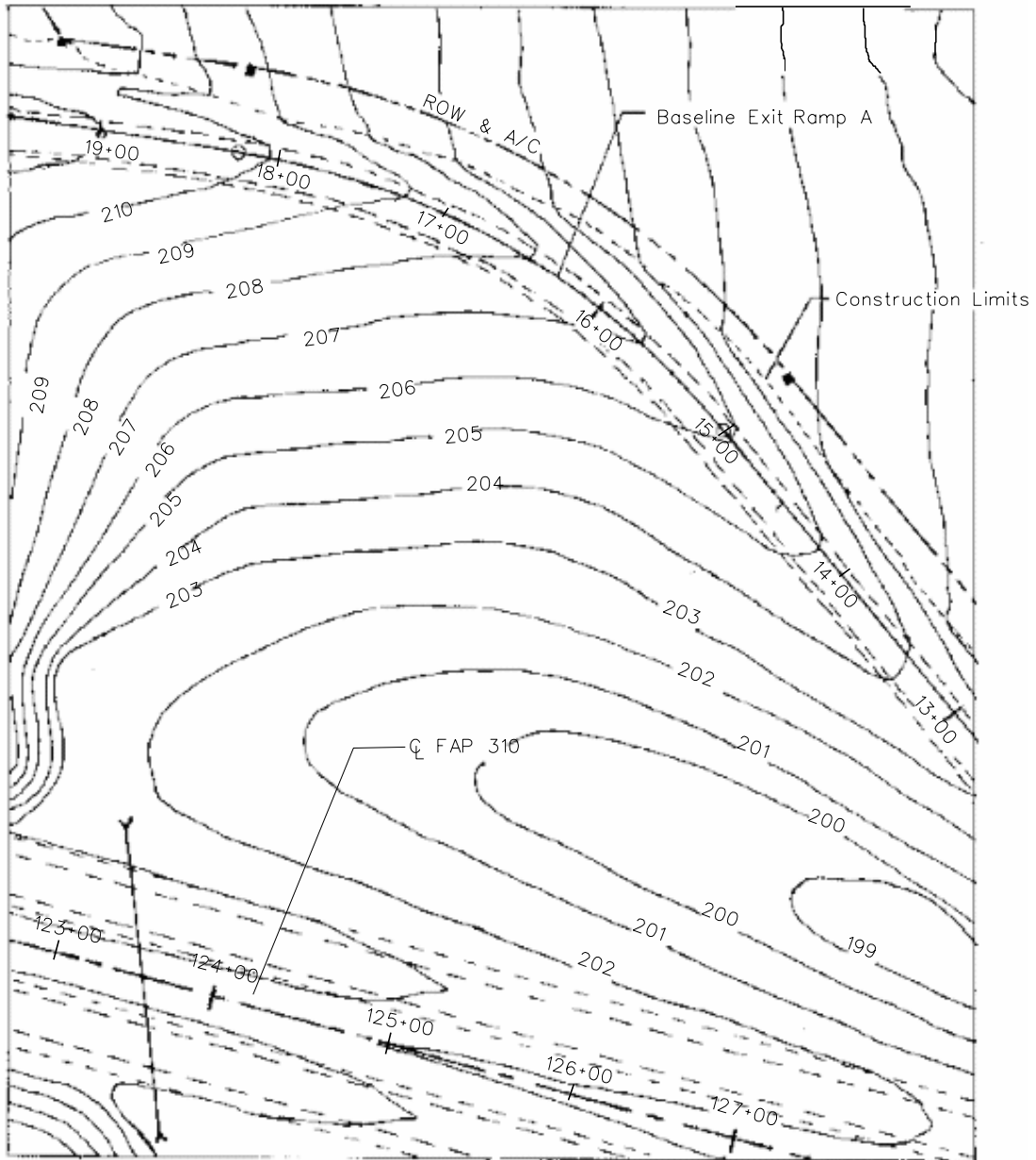

**CONTOUR GRADING
(US Customary)**

Figure 33-6.J

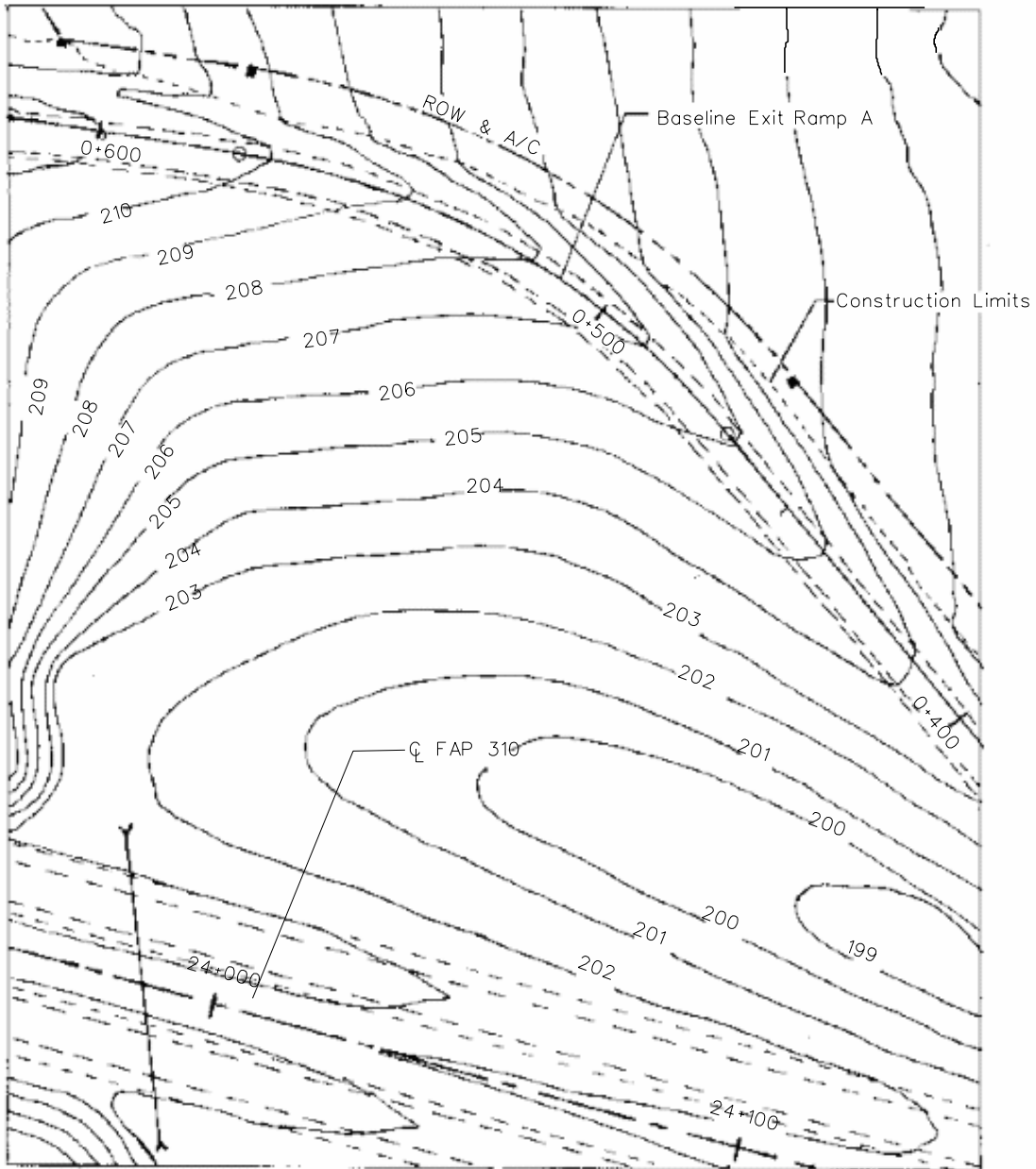

**CONTOUR GRADING
(Metric)**

Figure 33-6.J

5. Sidewalks and Other Amenities. The use of varied sidewalk widths, material types, and street furniture can significantly improve the appearance of the urban street. Traffic signals, luminaires, benches, planting boxes, ornamental trees, bus stops, etc., can be artistically designed to meet the local decor and to improve the streets' visual impact on the surrounding neighborhood. These elements should be coordinated with the municipalities with appropriate agreement on cost-sharing. For additional guidance, see Chapters 5, 17, and 48.
6. Bicycle Facilities. In addition to increasing the safety of bicyclists, separate bicycle facilities often allow the designer to enhance the roadside aesthetics by providing additional room for plantings, aesthetically pleasing barriers, etc. Chapter 17 provides additional information on bicycle facilities.
7. Utilities. Desirably, place all utilities underground. This removes unsightly poles and lines and generally improves the safety of the urban facility. However, because of installation costs and limited right-of-way, this option may not always be practical.

33-6.04 Design of Profile Gradelines

33-6.04(a) General

The profile gradeline of a highway typically has the greatest impact on a facility's cost, aesthetics, safety, and operation. The profile is a series of tangent lines connected by parabolic vertical curves. It is typically placed along the roadway centerline of undivided facilities and at the two median edges of the traveled way on divided facilities.

The designer must carefully evaluate many factors when establishing the profile gradeline of a highway. These include:

- maximum and minimum gradients;
- sight distance criteria;
- earthwork balance;
- location of bridges and drainage structures;
- high-water levels (flood frequency);
- drainage considerations;
- water table elevations;
- location of highway intersections and interchanges;
- snow drifting;
- frost penetration;
- highway/railroad crossings;
- types of soil;
- adjacent land use and values;
- highway safety;
- coordination with other geometric features (e.g., the cross section);
- topography/terrain;

- truck performance;
- available right-of-way;
- type and location of utilities;
- urban/rural location;
- aesthetics/landscaping;
- construction costs;
- environmental impacts;
- driver expectations;
- airport flight paths (e.g., grades and lighting); and
- pedestrian and disabled accessibility in urban areas.

The following sections discuss the establishment of the profile gradeline in more detail. Section 11-5.04(d) discusses the procedures for establishing the profile gradeline during Phase I studies.

33-6.04(b) Design of Urban Profile Gradelines

Laying out profile gradelines in urban areas often is more complicated than in rural areas due to limited right-of-way, closely spaced intersections, existing roadside development, and accommodation of drainage on curbed streets including drainage from outside the street. Evaluate the following factors when developing a profile gradeline on an urban project:

1. Vertical Curves. Long vertical curves on urban streets are generally impractical. The designer will typically need to lay out the profile gradeline to meet existing field conditions. Therefore, the minimum vertical curve lengths generally are provided on urban streets. Where practical, locate VPI's at or near the centerlines of cross streets. For flat urban areas where the algebraic difference in grades is between 0.6% and 1%, use the minimum length of sag or crest curve as discussed in Sections 33-4.01(a) and 33-4.02(b) (i.e., $L = 3V$ ($L = 0.6V$)). At signalized and stop-controlled intersections, some flattening of the approaches also may be required for better traffic operations.
2. Surface Drainage. Urban streets will usually have curbs and gutters, which may complicate the layout of the profile gradeline to facilitate drainage. Take special care to avoid flat spots where water may pond, especially through radius returns. Section 33-2 provides the minimum gradients for curbed streets. In very flat areas, the profile gradeline may be rolled up and down at 0.3% to 0.5% to provide the necessary drainage. Also, see the *IDOT Drainage Manual* for guidance on encroachment of water onto the traveled way. At intersections, the surface drainage preferably should be intercepted upstream of an intersection.
3. Spline Curves. Spline curves can be helpful in laying grades in urban areas where it is necessary to meet numerous elevation restrictions in relatively short distances. Spline curves are thin, flexible pieces of plastic that can be bent into any curved shape. The designer will need to tie these curves to the profile gradeline at the beginning and end. Show the elevations along a spline curve at 20 ft (5 m) intervals.

4. Existing Roadside Development. Where roadside development is extensive, the cross-section design of a curb and gutter street is critical. Ensure adequate drainage is provided behind curbs, that the profiles for existing driveways are acceptable, and that sidewalk elevations match existing development in built-up areas.
5. Earthwork Balance. Balancing earthwork is typically impractical in urban areas; see Section 33-6.04(g). An excess of excavation is preferable to the need for borrow, due to the generally higher cost of borrow in urban areas. The designer should account for excavation from storm sewer installation when suitable soil is available.
6. Underground Utilities. On existing streets, ensure that any change in the profile gradeline will still provide the minimum coverage for utilities. For additional guidance on minimum utility clearances, see Chapter 6.
7. Limited Right-of-Way. Careful consideration is warranted when substantially lowering or raising the profile gradeline. This will often result in more right-of-way impacts (e.g., steeper driveways, removing parking, reducing front lawns, adding retaining walls).

33-6.04(c) Design of Rural Profile Gradelines

When developing rural profile gradelines, the designer should review the following sections:

- Section 11-5.04(d) for the procedures of establishing the profile gradeline,
- Section 33-6.01 for the general controls for vertical alignment, and
- Section 33-6.02 for the coordination of horizontal and vertical alignments.

33-6.04(d) Soils

The type of earth material encountered often influences the profile gradeline at certain locations. For example, if rock is encountered, it may be more economical to raise the gradeline and reduce the rock excavation. Soils that are unsatisfactory for embankment or cause a stability problem in cut areas may also be determining factors in establishing the profile gradeline.

During Phase I studies, review the preliminary Geotechnical Report before determining the final profile gradeline. The Geotechnical Report describes the effects soils and geology may have on the selected profile gradeline. Figure 33-6.K can be used to determine the effected various profiles and roadway designs may have on subsurface drainage and, subsequently, pavement performance. To reduce possible stability problems, coordinate the development of the profile gradeline with the district materials staff during Phase I and again during the preparation of construction plans in Phase II. For more detailed information on soils, see the *Geotechnical Manual*.

Profile		Soil Type														
Less Than 3 ft (900 mm) Fill to Less Than 6 ft (1.8 m) Cut	6 ft (1.8 m) or Greater Cut	A-4			A-7-6 (15) to (20)			A-7-6 Less than (15) or A-6			Fine Sand or Sandy Soil			Gravel and/ or Coarse Sand		
		Very Wet	Moist	Dry	High Water Table	Very Wet	Moist	Dry	High Water Table	Very Wet	Moist	Dry	High Water Table	Very Wet	Moist	Dry
Cross Section		Moisture Condition														
Ditch 900 mm or Deeper	Shallow Ditch Or Gutter	Ditch 10 m or Deeper	Shallow Ditch Or Gutter													
Grade		Classification														
	Less Than 0.5%	Less Than 0.5%	Less Than 0.5%	Very Poor	Poor	Fair	Good	Very Poor	Poor	Fair	Good	Very Poor	Poor	Fair	Good	
	0.5% or Greater	0.5% or Greater	0.5% or Greater	Poor	Very Poor	Poor	Fair	Poor	Very Poor	Poor	Fair	Poor	Very Poor	Poor	Fair	
Less Than 0.5%				Very Poor	Poor	Fair	Good	Very Poor	Poor	Fair	Good	Very Poor	Poor	Fair	Good	
0.5% or Greater				Poor	Very Poor	Poor	Fair	Poor	Very Poor	Poor	Fair	Poor	Very Poor	Poor	Fair	

Notes:

1. Fills greater than 3 ft (900 mm) are classified as good drainage situations.
2. Adjust the moisture rating if other than normal rainfall precedes survey.
3. To use table, determine soil types, proposed profile, cross section type, and ditch grades. The values obtained from table provide the expected subgrade drainage.

DRAINAGE CLASSIFICATIONS

Figure 33-6.K

33-6.04(e) Drainage/Snow

Proper placement of the pavement structure above the surrounding topography in rural areas can significantly enhance the life and serviceability of the roadway. Consequently, the profile gradeline should be compatible with the roadway drainage design and should minimize snow drifting problems. Consider the following:

1. **Culverts.** The roadway elevation should meet the Department criteria for minimum cover at culverts and minimum freeboard above the headwater level at culverts. See the *IDOT Drainage and Culvert Manuals* for more information on the hydraulic and structural design of culverts, respectively.
2. **Coordination with Geometrics.** The profile gradeline must reflect compatibility between drainage design and roadway geometrics. These include the design of sag and crest vertical curves, spacing of inlets on curbed facilities, impacts on adjacent properties, superelevated curves, intersection design elements, and interchange design elements. For example, avoid placing sag vertical curves in cuts or placing long crest vertical curves on curbed pavements or on bridges.
3. **Snow Drifting.** Where practical, in level terrain, the profile gradeline should be at least 3 ft (1.0 m) above the natural ground level to prevent snow from drifting onto the roadway and to promote snow blowing off the roadway. Slope rounding and tree planting adjacent to the right-of-way line may also help to prevent drifting in cut areas. For additional guidance, see the SHRP-H-381 *Design Guidelines for the Control of Blowing and Drifting Snow*.
4. **Water Tables.** Establish the profile gradeline so that the top of the subgrade elevation is not less than 3 ft (1.0 m) above the water table at all points along any cross section within the paved roadway surface. The elevation of the water table is typically documented in the Geotechnical Report. If it is not practical to provide the 3 ft (1.0 m) clearance, coordinate the profile design with the District Studies and Plans Engineer and the District Geotechnical Engineer to develop an alternative solution.
5. **Frost Penetration.** The minimum embankment height should not be less than the anticipated maximum depth of frost penetration, unless the drainage classification of the underlying soil is rated "good" as described in Figure 33-6.K. However, if the roadway is essentially at ground level, this could cause a problem. In cut sections or with shallow embankments, the roadside ditch depth should be equal to the expected maximum level of frost penetration but not less than 3 ft (1.0 m).
6. **Flooding.** For highways within a floodplain area and which have a DHV of 100 or more, the profile gradeline should be at least 3 ft (1.0 m) higher than the high water mark for the design flood frequency. For flood frequencies to be used on highways, review the *IDOT Drainage Manual* and Chapter 39 of the *BDE Manual*.

33-6.04(f) Erosion Control

To minimize erosion, consider the following relative to the profile gradeline:

- Minimize the number of deep cuts and high fill sections.
- On high fill sections (e.g., over railroads where 1V:2H slopes are used), provide a mountable curb at the edge of shoulder to collect the drainage.
- Conform the highway to the contour and drainage patterns of the area.
- Use natural land barriers and contours to channelize runoff and confine erosion and sedimentation.
- Minimize the amount of disturbance.
- Preserve and use existing vegetation.
- Reduce the slope length by benching and ensure that erosion is confined to the right-of-way and does not deposit sediment on or erode away adjacent lands.
- Avoid locations having high erosion potential (e.g., loess soils).
- Avoid cut or fill sections in seepage areas.

33-6.04(g) Earthwork Balance

Where practical and where consistent with other project objectives, design the profile gradeline to provide a balance of earthwork. However, this should not be achieved at the expense of smooth grade lines, aesthetics, or sight distance requirements at vertical curves, or where there is excessive land acquisition costs. Ultimately, a project-by-project assessment will determine whether a project will be borrow, waste, or balanced.

Consider the following when determining earthwork balance:

1. Basic Approach. The best approach to laying grade and balancing earthwork is to provide a significant length of roadway in embankment and to limit the number and amount of excavation areas. As practical, avoid long lengths of roadway in excavation and several short balance distances. Use topographic mapping to layout profile gradelines.
2. Urban/Rural. Earthwork balance is typically a practical objective only in rural areas. In urban areas, other project objectives (e.g., limiting right-of-way impacts) typically have a higher priority than balancing earthwork. In addition, excavated materials from urban projects are often unsuitable for embankments (e.g., near gas stations).
3. Borrow Sites. The availability and quality of borrow sites in the vicinity of the project will impact the desirability of balancing the earthwork. Triangular shaped remainders or landlocked right-of-way parcels usually provide potential locations for borrow sites.

4. Earthwork Computations. On large projects (e.g., freeways or expressways, bypasses, horizontal curve relocations) preliminary earthwork is calculated during Phase I using topographic mapping and is later refined during the preparation of construction plans. Section 64-2 discusses the proper methods to compute and record the project earthwork quantities.

33-6.04(h) Bridges

Carefully coordinate the design of the profile gradeline with any bridges within the project limits. The following will apply:

1. Vertical Clearances. The criteria in Chapters 44 through 50 must be met. When laying the preliminary grade line, an important element in determining the available vertical clearance is the assumed structure depth. This will be based on the structure type, span lengths, and depth/span ratio. For preliminary designs, see the *Bridge Manual* and Chapter 39. For final design, the designer must coordinate with the Bureau of Bridges and Structures to determine the roadway and bridge gradelines. This is typically accomplished with a Type, Size, and Location (TS&L) Drawing.
2. Bridges Over Waterways. Where a proposed facility will cross a body of water, the bridge elevation must be consistent with the necessary waterway opening to meet the Department's hydraulic requirements. The elevation of the bottom of the superstructure must meet the requirements of Chapter 39. The designer must coordinate with the Hydraulics Unit in the Bureau of Bridges and Structures to determine the appropriate bridge elevation. In addition, where a bridge over a waterway is located in a sag curve, desirably, locate the low point of the sag vertical curve off the bridge deck, and provide at least a 0.5% grade on the bridge deck.
3. Railroad Bridges. Any proposed highway over a railroad must meet the applicable criteria (e.g., vertical clearances, structure type and depth). For rural freeways and expressways over railroads, the approach grades are usually set at 3%. Use the K-value, as discussed in Section 33-4.01, for the crest vertical curve. Use a long sag vertical curve at the bottom of each 3% grade to provide a smooth and aesthetically pleasing profile. In addition, if the alignment of the highway over the railroad will have a horizontal curve near the crest of the vertical curve, do not place the P.C. of the horizontal curve any closer than 400 ft (120 m) from the back of the bridge abutment. This guideline will ensure proper sight distance to the beginning of the horizontal curve.
4. Highway Under Bridge. Where practical, the low point of a roadway sag vertical curve should not be within the shadow of the bridge. This will help minimize ice accumulations, and it will reduce the ponding of water beneath the bridge. To achieve these objectives, the low point of a roadway sag should be approximately 100 ft (30 m) or more from the side of the bridge.

5. High Embankments. Consider the impact that high embankments will have on bridges and culverts. High embankments will increase the span length thus increasing structure costs and increase the length and type of culvert to carry the overburden.
6. Bridges Over Another Highway. Typically, the overpassing bridge will be located on a crest vertical curve. For bridges on crossroads through an interchange, use the desirable K-value for the crest vertical curve. For other bridges, the use of minimum K-values is acceptable.

33-6.04(i) At-Grade Railroad Crossings

The profile gradeline should be essentially level across the railroad tracks and extend level for a minimum distance of 2 ft (600 mm) on either side of the outermost rails. After this point, the grade should not exceed $\pm 1\%$ for a distance of at least 26 ft (8 m) or to the railroad right-of-way line. Profile gradelines outside of the railroad right-of-way but within the jurisdiction of the Illinois Commerce Commission should be as flat as practical and should not exceed 5%. Where superelevated tracks make strict compliance with this criteria impractical, construct the grade of the approaches to provide the best (smoothest) profile practical.

33-6.04(j) Distance Between Vertical Curves

A desirable objective on rural facilities is to provide at least 1500 ft (500 m) between two successive VPI's. This objective only applies to projects which have a considerable length and where implementation is judged to be practical.

33-6.04(k) Ties With Existing Highways

A smooth transition is needed between the proposed profile gradeline of the project and the existing gradeline of an adjacent highway section. Consider existing gradelines for a sufficient distance beyond the beginning and end of a project to ensure adequate sight distances. Connections should be made that are compatible with the design speed of the new project and that can be used if the adjoining road section is reconstructed. For example, do not transition a four-lane highway section to two lanes just beyond a crest vertical curve but, instead, locate the transition away from the high point of the crest vertical curve.

33-7 REFERENCES

1. *A Policy on Geometric Design of Highways and Streets*, AASHTO, 2011.
2. *Highway Capacity Manual 2010*, Transportation Research Board, 2010.
3. *Metric Analysis Reference Guide, Supplement to 1997 Update of Special Report 209 Highway Capacity Manual*, TRB, 1997.
4. *Methods for Predicting Truck Speed Loss on Grades*, Federal Highway Administration, Report No. FHWA/RD-86/059, October 1986.
5. *New Methods for Determining Requirements for Truck-Climbing Lanes*, Federal Highway Administration, Publication No. FHWA-IP-89-022, September 1989.
6. *Traffic Policies and Procedures Manual*, Bureau of Operations, IDOT.
7. Chapter Four "Roads," *National Forest Landscape Management*, Volume 2, Forest Service, US Department of Agriculture, March 1977.
8. *A Guide for Transportation Landscape and Environmental Design*, AASHTO, June 1991.
9. "Coordination of Horizontal and Vertical Alignment With Regard to Highway Aesthetics," *Transportation Research Record 1445*, TRB, 1994.
10. *Design Guidelines for the Control of Blowing and Drifting Snow*, Strategic Highway Research Program, National Research Council, 1994.

Chapter Thirty-four
CROSS SECTION ELEMENTS

BUREAU OF DESIGN AND ENVIRONMENT MANUAL

Chapter Thirty-four
CROSS SECTION ELEMENTS

Table of Contents

<u>Section</u>	<u>Page</u>
34-1 GENERAL	34-1.1
34-1.01 Definitions	34-1.1
34-1.02 Nomenclature	34-1.3
34-1.03 Classification by Area Type	34-1.3
34-2 ROADWAY SECTION.....	34-2.1
34-2.01 Travel Lanes.....	34-2.1
34-2.01(a) Width	34-2.1
34-2.01(b) Cross Slopes.....	34-2.1
34-2.01(c) Stage Construction	34-2.2
34-2.02 Shoulders.....	34-2.2
34-2.02(a) Functions.....	34-2.2
34-2.02(b) Widths.....	34-2.3
34-2.02(c) Additional Shoulder Thickness	34-2.4
34-2.02(d) Cross Slopes.....	34-2.4
34-2.02(e) Rumble Strips.....	34-2.5
34-2.03 Auxiliary Lanes	34-2.6
34-2.04 Curbs and Curbed Sections	34-2.7
34-2.04(a) Warrants	34-2.7
34-2.04(b) Curb Types	34-2.8
34-2.04(c) Curb Type Selection.....	34-2.8
34-2.04(d) Design Considerations	34-2.12
34-3 MEDIANS.....	34-3.1
34-3.01 Functions	34-3.1
34-3.02 Median Widths.....	34-3.1
34-3.03 Median Types.....	34-3.2
34-3.03(a) Flush Medians.....	34-3.5
34-3.03(b) Traversable TWLTL Medians	34-3.5
34-3.03(c) Raised-Curb Medians.....	34-3.6
34-3.03(d) Depressed Medians	34-3.7

Table of Contents

(Continued)

<u>Section</u>		<u>Page</u>
34-3.04	Median Selection	34-3.7
	34-3.04(a) General	34-3.7
	34-3.04(b) Urban Median Types	34-3.8
	34-3.04(c) Suburban Median Types	34-3.9
	34-3.04(d) Rural Median Types	34-3.13
34-4	ROADSIDE ELEMENTS	34-4.1
	34-4.01 General	34-4.1
	34-4.02 Fill Sections	34-4.1
	34-4.03 Ditch Sections	34-4.4
	34-4.03(a) Typical Slope Rates	34-4.4
	34-4.03(b) Material and Soils Conditions	34-4.4
	34-4.03(c) Hydraulic Design	34-4.6
	34-4.04 Cut Sections With Curbs	34-4.6
	34-4.05 Rock Cuts (Back Slopes)	34-4.6
	34-4.06 Roadside Safety	34-4.9
	34-4.07 Transverse Slopes	34-4.9
	34-4.08 Geotechnical Features	34-4.9
	34-4.09 Aesthetics	34-4.10
34-5	RIGHT-OF-WAY	34-5.1
	34-5.01 General	34-5.1
	34-5.02 Definitions	34-5.1
	34-5.03 Establishment of Right-of-Way Lines	34-5.2
	34-5.04 Right-of-Way Width	34-5.2
	34-5.05 Other Considerations	34-5.2
34-6	UTILITIES	34-6.1
	34-6.01 Definition	34-6.1
	34-6.02 Location	34-6.1
	34-6.03 Design Considerations	34-6.1
34-7	REFERENCES	34-7.1

Chapter Thirty-four

CROSS SECTION ELEMENTS

This Chapter provides guidance to consider in the design of cross section elements including lane and shoulder widths, cross slopes, width and type of medians, side slopes, right-of-way, and utilities. Part V, Design of Highway Types, provides criteria for various cross section elements on new construction, reconstruction, and 3R projects. Where a cross section element applies to a specific highway type, Part V presents this information. For example:

- Cross sectional widths for bridges and underpasses are discussed in Chapter 39.
- Median widths and median openings for freeways and expressways are discussed in Chapters 44 and 45, respectively.
- Typical cross section figures for the various functional classifications are presented in Chapters 44 through 48.
- For definitions on area classifications, see Chapter 43.
- Chapter 48 discusses sidewalk and on-street parking design criteria.
- Cross section criteria for 3R projects are discussed in Chapters 49 and 50.
- For surface type and structural design of pavements, see Chapter 54.

34-1 GENERAL

34-1.01 Definitions

The following definitions apply to the highway cross section:

Auxiliary Lane. The portion of the roadway adjoining the traveled way for purposes supplementary to through traffic movement including parking, speed change, turning, storage for turning, weaving, or truck climbing.

Back Slope. The side slope created by connecting the ditch bottom, shelf, or shoulder at the hinge point, upward and outward, to the natural ground line.

Barrier (Vertical) Curb. A longitudinal element placed at the edge of the traveled way for delineation, to control drainage, to manage access, and to minimize right-of-way acquisitions. Vertical curbs range in height between 6 in. (150 mm) and 9 in. (225 mm) and are vertical or nearly vertical.

Buffer Area. The space between the back of curb and sidewalk.

Cross Slope. The slope in the cross sectional view of the traveled way, travel lanes, shoulders, median surface, or gutters, expressed as inch(es) per foot (percent) based on the change in vertical compared to the change in horizontal.

Concrete Barrier. A rigid barrier constructed in a narrow median where no or minimal deflection distance is available and which can accommodate most vehicle impacts without penetration.

Depressed Median. The area located between opposing directions of the traveled ways which is designed with shoulders and fill slopes and is lower in elevation than the traveled ways. Its main function is to provide a safe distance between opposing traffic. It is also designed to carry a certain portion of roadway drainage and for snow storage.

Flush Median. A median which is in the same plane as the surface of the adjacent traveled ways.

Front Slope. The side slope created by connecting the shoulder or shelf at the hinge point, downward and outward, to the ditch bottom or natural ground.

Hinge Point. The point from which the fill height or depth of cut is determined. For fills, the point is located at the intersection of the shoulder and the fill slope. For cuts, the hinge point is located at the toe of the back slope.

Maintenance Border Area. Additional width which is set aside for right-of-way purposes adjacent to each side of the construction limits. This clear width provides an area for maintenance operations, retention of natural growth, erosion control, slope rounding and, in some cases, for accommodating public utilities.

Median. The portion of a cross section which separates the opposing directions of the traveled ways. The median width includes the inside shoulders or curb and gutters.

Median Slope. The slope in the cross section view of a median beyond the inside shoulders, expressed as a ratio of the change in vertical to the change in horizontal (V:H).

Mountable (Sloping) Curb. A longitudinal element placed at the edge of the traveled way for delineation, to control drainage, to manage access, and to outline corner islands. Sloping curbs have a height of 6 in (150 mm) or less with a slope face of approximately 45 degrees.

Raised-Curb Median. A median which contains a raised-curb, greater than 2 inches (50 mm) in height, within its limits.

Roadside. A general term denoting the area adjoining the outer edge of the roadway.

Roadside Clear Zone. The distance beyond the edge of traveled way that should be clear of any non-traversable hazards or fixed objects.

Roadway. The combination of the traveled way, both shoulders or curb and gutters, and any auxiliary lanes on the mainline highway. Traveled ways separated by a depressed median have two or more roadways.

Shelf. On curbed facilities, the relatively flat area (2% to 5% slope) located between the back of the curb and the break for the fill slope or back slope.

Shoulder. The portion of the roadway contiguous to the traveled way for the accommodation of stopped vehicles, for emergency use, and for lateral support of subbase, base, and surface courses.

Side Slope. A ratio used to express the steepness of a slope adjacent to the roadway. The ratio is expressed as vertical to horizontal (V:H).

Sidewalk. That portion of the highway cross section separated from the roadway and constructed for the use of pedestrians.

Toe of Slope. The intersection of the front slope or back slope with the natural ground or ditch bottom.

Top of Slope. The intersection of the back slope with the natural ground, before any rounding is applied.

Traveled Way. The portion of the roadway for the movement of vehicles, exclusive of shoulders, curb and gutter, and auxiliary lanes.

Traversable Median. A median which is outlined with 2 in. (50 mm) high mountable curb and gutter and used as a direct substitute for the flush two-way, left-turn lane (TWLTL). It is not designed to be a physical barrier nor is it intended to impede left-turn movements across the median.

34-1.02 Nomenclature

Figures 34-1.A, 34-1.B, and 34-1.C provide the basic nomenclature for cross section elements of freeways and expressways, rural highways, and urban streets.

34-1.03 Classification by Area Type

The functional classification system is divided into urban and rural categories. However, the urban designation is not sufficiently specific to determine the appropriate project design. Therefore, IDOT has divided its urban design classifications into “suburban” and “urban” based on the extent of roadside development. IDOT has further subdivided these categories into central business districts and fringe area/outlying business district for urban areas, and open and closed subcategories for suburban areas. These subcategories are discussed in Chapter 43.

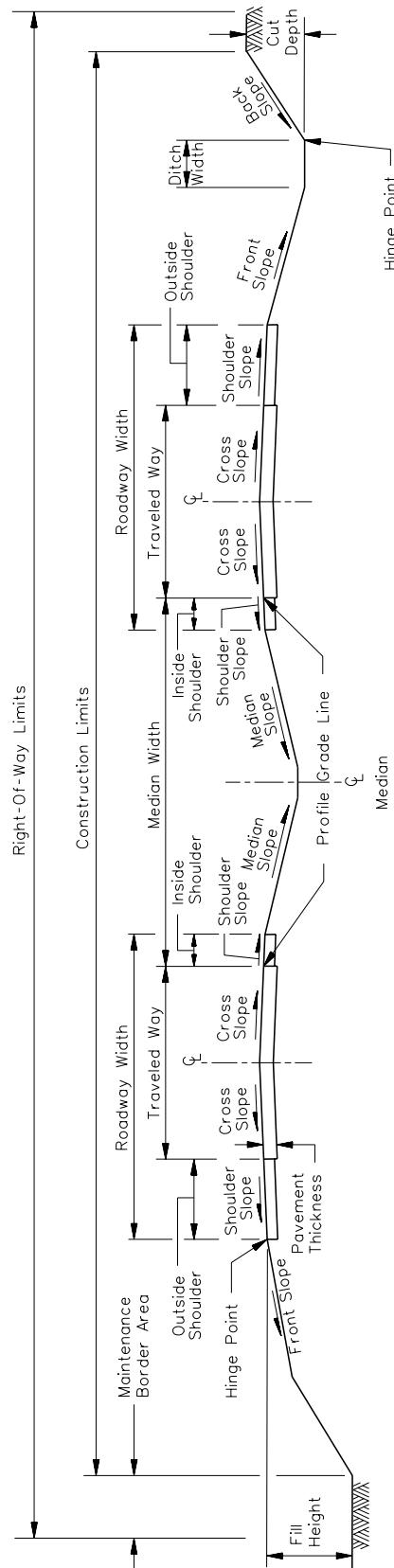

FREEWAY AND EXPRESSWAY NOMENCLATURE

Figure 34-1.A

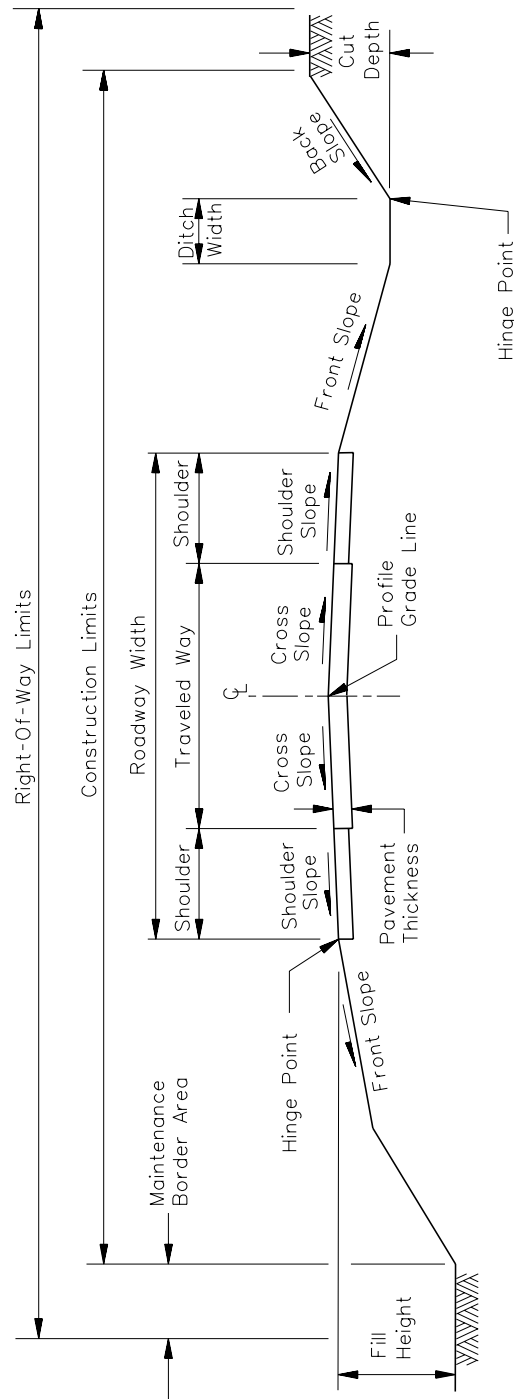

**RURAL HIGHWAY NOMENCLATURE
(Two-Lane Highways)**

Figure 34-1.B

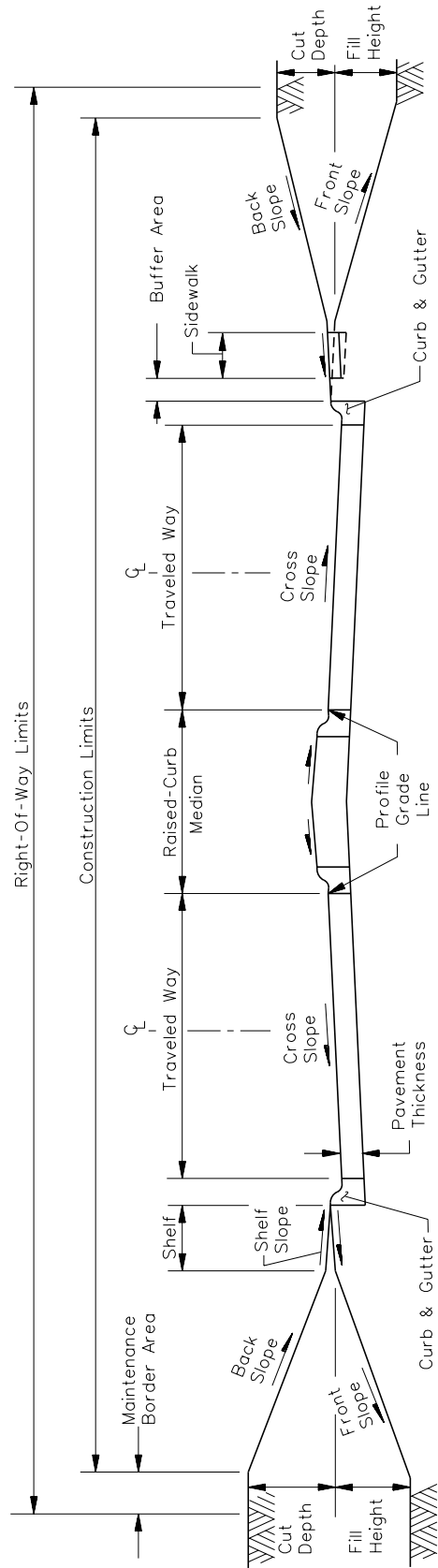

URBAN STREET NOMENCLATURE

Figure 34-1.C

34-2 ROADWAY SECTION

34-2.01 Travel Lanes

34-2.01(a) Width

Travel lane widths can vary between 9 ft (2.7 m) and 14 ft (4.2 m), depending upon the functional classification, traffic volumes, design speed, rural/urban location, and project scope of work. The tables in Chapters 44 through 50 provide specific travel lane widths for these conditions. The traveled way width is the combined width of all travel lanes. For divided highways, the traveled way width is the combined width in one direction.

The use of wider travel lanes generally increases the operational safety and efficiency of the facility. In general, 12 ft (3.6 m) wide travel lanes are preferable for most rural and high-speed urban facilities. Lane widths of 11 ft (3.3 m) are acceptable for restricted urban areas and may be considered on reconstruction projects. Lane widths may need to be increased to accommodate bicycles; see Chapter 17.

34-2.01(b) Cross Slopes

Surface cross slopes are required for proper drainage of the traveled way on tangent sections. A sufficient cross slope reduces the hazards of wet pavements by quickly removing water from the surface. On State highways, the following will apply for tangent roadway sections:

1. Two-Lane Highways with Shoulders. Crown the traveled way pavement at the centerline and use a cross slope of 3/16"/ft (1.5%) away from the centerline. Where an open-graded friction course is used, the minimum cross slope should be 1/4"/ft (2%).
2. Two-Lane Curbed Streets. Crown the traveled way pavement at the centerline and use a cross slope of 1/4"/ft (2%) away from the centerline.
3. Multilane Curbed Streets. On multilane streets with raised-curb medians, the pavement cross slope of a two-lane traveled way should be 1/4"/ft (2%) sloping away from the median curb. If there are three lanes in one direction, provide a 5/16"/ft (2.5%) cross slope on the third lane from the median curb.
4. Multilane Streets with a Traversable Curbed Median. The traveled way cross slopes are the same as discussed in Item 3 above. Crown the traversable median surface at the centerline of the median and use a cross slope of 3/16"/ft (1.5%) away from the centerline.
5. Four-Lane Streets with a Flush Median. Crown the entire paved surface of the roadway about the centerline of the flush median and use a cross slope of 1/4"/ft (2%) away from the centerline to the outside curb and gutter.
6. Highways without Curbed Medians. For roadways divided by a median, the following cross slopes will apply:

- a. Two-Lane Traveled Ways. For highways with two lanes in each direction and either a depressed median or narrow median with a concrete barrier, each traveled way is crowned at its centerline with a cross slope of $3/16''/\text{ft}$ (1.5%) sloping away from the centerline.
- b. Three-Lane Traveled Ways (New Construction/Reconstruction). For highways with three lanes in each direction and either a depressed median or a narrow median with a concrete barrier, the traveled way is typically crowned along the lane edge between the middle lane and outside lane. The inside and middle lanes are sloped towards the median. The two lanes adjacent to the crown are sloped at $3/16''/\text{ft}$ (1.5%) away from the crown line and the lane adjacent to the median is sloped at $1/4''/\text{ft}$ (2%) toward the median.
- c. Three- or Four-Lane Traveled Ways (Adding Lanes to Existing Facilities). When adding new lanes in the median or on the outside of the traveled way, the existing crown is typically maintained. The added travel lane cross slope generally will be the same direction as the adjacent lane. The rate of cross slope for each added lane will be $1/16''/\text{ft}$ (0.5%) steeper than that of the adjacent lane, but not greater than $5/16''/\text{ft}$ (2.5%). See Chapter 44 for typical sections.

For service drives, access roads, side roads, frontage roads, etc., the traveled way cross slopes will vary depending upon the pavement surface and local practices. For paved surfaces (including chip seal), the cross slope is generally the same as for State highways (i. e., $3/16''/\text{ft}$ (1.5%)). For gravel surfaces, the cross slopes can range from $1/4''/\text{ft}$ to $1/2''/\text{ft}$ (2% to 4%).

34-2.01(c) Stage Construction

The 30th highest hourly traffic volumes, measured 10 years from the anticipated date of construction, may be significantly less than those for the design year (e.g., 20 years) such that initial construction may consist of one less lane in each direction. In this case, the designer may want to consider using stage construction. For rural expressways, this may initially include only providing one roadway of the four-lane divided facility. In urban areas, this may initially include only providing four lanes instead of six. For these situations, sufficient right-of-way for the ultimate improvement should be acquired at the time of the initial improvement. See the Corridor Preservation section in the *IDOT Land Acquisition Policies and Procedures Manual* for additional guidance. For urban facilities, also include the appropriate earthwork and consideration for placement and sizing of drainage structures in the initial construction to allow for the additional lanes in the median area in the future.

34-2.02 Shoulders

34-2.02(a) Functions

Shoulder widths can vary between 4 ft (1.2 m) to 12 ft (3.6 m) depending upon the highway classification. They also provide many structural and operational advantages. Where shoulders

are not available, a stopped vehicle often disrupts traffic in all lanes in that direction. The following are some of the important functions of shoulders:

- provides structural support for the traveled way;
- provides support for guardrail and prevents erosion around guardrail posts;
- prevents or minimizes pavement edge drop-offs;
- increases highway capacity;
- encourages uniform travel speeds;
- provides space for emergency and discretionary stops;
- improves roadside safety by providing more recovery area for run-off-the-road vehicles;
- provides lateral clearance for encroaching vehicles (e.g., during construction or maintenance operations);
- provides a sense of openness;
- improves sight distance around horizontal curves;
- enhances highway aesthetics;
- facilitates maintenance operations (e.g., snow removal and storage);
- provides additional lateral clearance to roadside appurtenances (e.g., guardrail, parapet walls, traffic signals, highway signs);
- facilitates pavement drainage, water is discharged farther from the traveled way;
- provides space for pedestrian and bicycle use; and
- provides space for bus stops and mailbox turnouts.

34-2.02(b) Widths

Shoulder widths will vary according to functional classification, traffic volumes, urban/rural location, curbed/uncurbed, and the project scope of work. The tables in Chapters 44 through 50 present the shoulder width criteria for these conditions. A vehicle stopped on the shoulder should clear the traveled way edge by at least 1 ft (300 mm) and preferably 2 ft (600 mm). Therefore, a width of 8 ft (2.4 m) is desirable along high-type facilities to accommodate passenger vehicles and 10 ft (3.0 m) for trucks. Where bicyclists will be accommodated, see Chapter 17 for guidance.

Where right-of-way is severely restricted, shoulders may be designed with a curb and gutter or a Type B gutter at the outer shoulder edge. This helps to minimize construction costs and to confine drainage runoff to the shoulder area. Gutters also may be used on the outside of shoulders along long cut sections.

34-2.02(c) Additional Shoulder Thickness

For all new construction or reconstruction projects on the State system, increase the shoulder pavement thickness to allow the shoulders to be used to carry traffic during current and future construction improvements. Design the shoulder pavement using the following guidelines:

1. 2-Lane Major Principal Arterials. These highways should normally have 8 ft to 10 ft (2.4 m to 3.0 m) paved shoulders. These shoulders could be used to carry traffic when needed. When the 20-year projected traffic exceeds 2000 multiple unit trucks (MU) per day or 10,000 Average Daily Traffic (ADT), construct the shoulders to the same thickness as the traveled way pavement. The 2000 MU threshold is based on the traffic that would require a shoulder thickness greater than 8 in. (200 mm) to handle the occasional load.
2. 4-Lane Highways. When the 20-year projected traffic exceeds 3000 MUs per day or 25,000 ADT, design the shoulders pavement using the same thickness as the adjoining traveled way pavement. The MU threshold is based on the traffic that would require thicker pavement to carry the load. While the inside shoulder is only 6 ft (1.8 m) wide and would not normally be used as a lane, it will still allow traffic to be shifted away from the closed lane for patching and paving operations. At locations where the 20 year projected ADT is less than 25,000, the traffic should be examined at peak times. If the expected one-way Vehicles Per Hour (VPH) exceeds 1700, design the shoulder pavement using the same thickness as that of the adjacent traveled way pavement. Where it is anticipated that the shoulders will be used for an extended period of time (more than 3 years) during the design life of the pavement, design the shoulder pavement using the same pavement design, details, and materials as the traveled way pavement.
3. Highways of 6 or More Lanes. Build all shoulder pavements using the same pavement design, details and materials as the traveled way pavement. This will allow for keeping at least two, and in some cases, three lanes open at all times, as warranted by the high ADT on these types of highways.

34-2.02(d) Cross Slopes

The cross slope of a shoulder depends on the type of shoulder and the construction project type. The following summarizes typical practices:

1. Paved Shoulders. On new construction projects, full-width paved shoulders on tangent sections are sloped at 1/2"/ft (4%). On reconstruction and 3R projects, the shoulder slopes range from 1/4"/ft to 3/4"/ft (2% to 6%).

2. Combination Shoulders. Combination paved/aggregate shoulders are sloped at 1/2"/ft (4%).
3. Aggregate Shoulders. Aggregate shoulders are sloped from 1/2"/ft to 3/4"/ft (4% to 6%).
4. Sodded Shoulders. Sodded shoulders are sloped from 5/8"/ft to 1"/ft (5% to 8%).
5. Superelevated Sections. Chapter 32 and the *IDOT Highway Standards* discuss the application of shoulder cross slopes on superelevated sections for new construction and reconstruction projects. For allowable shoulder rollover values on 3R projects, see Chapters 49 and 50.

34-2.02(e) Rumble Strips

1. Shoulder Rumble Strips. Shoulder rumble strips are an effective way to reduce run-off-the-road crashes. They provide a very cost effective means of alerting motorists that they have drifted off the pavement. The greatest benefit is from the installation of milled rumble strips on rural expressways, freeways, and other facilities in which a significant number of run-off-the-road crashes occur.

Shoulder rumble strips shall be:

- installed on all Interstates and other freeways built to Interstate criteria and on all rural expressways with posted speeds > 50 mph (80 km/h);
- installed along all highways that have high-crash locations, as identified in the Bureau of Safety Engineering's Highway Safety Improvement Program (HSIP), in which run-off-the-road crashes are a concern and have an adequate paved shoulder width; and
- considered at other locations where run-off-the-road crashes are a concern.

On facilities in which bicyclists are prohibited or the paved shoulders are wider than 6 ft (1.8 m), the 16 in. (400 mm) rumble strip design should be used. On facilities in which bicyclists are permitted and the paved shoulder width is 6 ft (1.8 m) or less, the 8 in. (200 mm) rumble strip design should be used to maximize the clear shoulder width available for cyclists. See Section 17-2.02(a) for a discussion of bicycle accommodations utilizing paved shoulders.

Milling is the preferred method for installing rumble strips; however a formed-in option is allowed for installing the 16 in. (400 mm) rumble strips in Portland Cement Concrete shoulders. When the shoulder will be used for traffic during construction, the formed-in option should be reviewed and not allowed if conflicts will occur. It may also be necessary to specify when the milled shoulder rumble strips may be installed if they conflict with the staging of traffic.

2. Centerline Rumble Stripes. The primary purpose of centerline rumble stripes (CLRS) is to warn drivers whose vehicles are crossing the centerline of two-lane, two-way

roadways (and, in some cases, four-lane undivided highways) to avoid potential crashes with opposing traffic.

CLRS address the problem of drowsy or inattentive drivers drifting left out of their lane and striking an oncoming vehicle. Two types of crashes are generally considered correctable by CLRS—head-on and opposite-direction sideswipes often referred to as cross-over or cross-centerline crashes.

The use of CLRS can be an effective countermeasure on roadways where there are a high number of crashes with opposing traffic. Consult with the Bureau of Safety Programs and Engineering if CLRS are being considered for the project. The BSPE will provide details for the CLRS.

3. Shoulder Rumble Stripes. Shoulder rumble stripes are similar to shoulder rumble strips, but include an edge line pavement marking installed within the rumble strip. There is evidence that shoulder rumble stripes provide a better wet pavement marking and actually provide a more durable pavement marking than just a regular flat pavement marking. Shoulder rumble strips are considered an experimental feature. Consult with the Bureau of Safety Programs and Engineering for further guidance on their use.

34-2.03 Auxiliary Lanes

Auxiliary lanes are lanes adjacent to the basic through traveled way. They are intended for use by vehicular traffic for specific functions. Auxiliary lanes include:

- single left- and right-turn lanes at intersections;
- double left-turn lanes at intersections;
- truck-climbing lanes;
- acceleration/deceleration lanes at interchanges or intersections;
- weaving lanes within an interchange;
- continuous auxiliary lanes between two closely spaced interchanges;
- two-way, left-turn lanes (TWLTL) (flush-type median);
- parking lanes; and
- passing lanes.

Desirably, auxiliary lanes should be the same width as the adjacent through lanes, although in many cases a greater or lesser width may be appropriate. The tables in Chapters 44 through 50 present specific width criteria for auxiliary lanes and curb type or shoulder widths adjacent to auxiliary lanes.

Normally, the rate of cross slope for an auxiliary lane will be 1/16"/ft (0.5%) steeper than that of the adjacent through lane except for curbed left-turn lane and TWLTL. Single left-turn lanes with curb and gutter are usually sloped at 1/8"/ft to 3/16"/ft (1.0% to 1.5%) away from the median to allow for snow plowing. TWLTL and flush left-turn lanes are crowned at the centerline and sloped at 1/4"/ft (2%) in each direction.

34-2.04 Curbs and Curbed Sections

Curbs are used on urban and suburban facilities due to restricted right-of-way conditions and to control drainage, delineate pavement edges, channelize vehicular movements, manage access, provide separation between vehicles and pedestrians, and present an attractive appearance. In urban areas, curbs have a major benefit in containing the drainage within the pavement area and in channelizing or controlling traffic into and out of adjacent properties. In rural areas, curbing may be applicable where restricted right-of-way prohibits the use of a ditch section, or to channelize traffic at isolated intersections.

34-2.04(a) Warrants

Selecting a curbed section or section with shoulders and outside ditches depends upon many variables, including vehicular speeds, urban/rural location, drainage, and construction costs. The following discusses some of the factors the designer should consider when determining whether or not a curbed section is warranted:

1. Urban Location. Because of restricted right-of-way, the need to control drainage, and other constraints, curb and gutter sections on the outside edges of the traveled way are almost always used in urban areas.
2. Suburban Location. The use of curbs and/or gutters will depend upon whether the suburban area is considered closed or open. Section 43-2 defines open and closed suburban areas. For closed suburban areas, the street will have outside curb and gutter sections based on drainage requirements, pedestrian activities, channelization needs, and the desire to manage access to the street. For open suburban areas, the outside edge of the traveled way may have either shoulders or curb and gutter depending on the proposed median type and the preferred design speed. The exceptions listed under Item 3 for rural locations also apply to open suburban streets.
3. Rural Location. In general, the use of mountable type curbs and/or gutters along rural high-speed highways is limited to the edge of shoulder and to the following special conditions:
 - for roadway delineation in conjunction with channelization at intersections;
 - where there is sufficient development along the highway and there is a need to channelize traffic into and out of properties;
 - where drainage control is required;
 - where right-of-way is restricted for roadside ditches; and/or
 - at other sites deemed necessary (e.g., interchange crossroads, major intersections with restricted sight distance, where the route turns, offset left-turn lanes).

34-2.04(b) Curb Types

IDOT uses two basic types of curbs – barrier (vertical) and mountable (sloping). The *IDOT Highway Standards* provide information on design details and placement for various curb types used by the Department. For most situations, an integral concrete curb and gutter (CC&G) is used. The following notations are used by the Department to define the various curb types (e.g., M-10.60):

1. Initial Letter. The initial letter “B” or “M” is used to denote whether the curb is barrier (vertical) type or mountable (sloping) type.
2. Numbers Prior to the Decimal Point. The first set of numbers indicates the height of the curb in inches (centimeters).
3. Numbers After the Decimal Point. The second set of numbers, if used, indicates the width of the gutter in inches (centimeters).

34-2.04(c) Curb Type Selection

The designer should consider the following factors when selecting a curb type:

1. Low-Speed Facilities (Outside Edge of Traveled Way). Where the design speed is 45 mph (70 km/h) or less, use B-6.24 (B-15.60) CC&G along the right edge of the traveled way or parking lane. A lesser gutter width may be used adjacent to a right-turn lane, parking lane, or where highly restricted right-of-way conditions exist.
2. High-Speed Facilities (Outside Edge of Shoulder). Where a high-speed facility (\geq 50 mph (80 km/h)) is proposed with shoulders and side slopes, there may be occasional locations where the right-of-way is restricted. In these cases, use an M-4 (M-10) curb and gutter along the right edge of the shoulder. Do not place curb and gutter immediately adjacent to the edge of the traveled way.
3. Pedestrians. In urban and suburban areas, consider the use of B-9 (B-22) curb along the right edge of the traveled way where some additional protection is desired for pedestrians (e.g., adjacent to school yards, playgrounds). Use the B-9 (B-22) curb on sidewalks across bridges. Where the B-9 (B-22) curb is used, the design speed on the street should be 45 mph (70 km/h) or less. The gutter width may vary depending on drainage requirements or type of lane; however, the preferred gutter width is 2 ft (600 mm).
4. Two-Lane Facilities (Raised-Curb Median). Use M-4 (M-10) curb with a preferred gutter width of 6 in. (150 mm) on two-lane approaches where curbed channelization is required and where the design speed is 50 mph (80 km/h) or greater. This may include some rural intersections and all channelizing islands through rural interchange areas.
5. Multi-Lane Facilities (Raised-Curb Median). The main function of a raised-curb median is to manage access to and from the street or to channelize traffic. The following will apply:

- Use Type-M CC&G on channelizing islands and medians where the design speed is 30 to 40 mph (50 or 60 km/h). The selection of the appropriate gutter pan width will be based on the proposed cross-slope and drainage needs for the specific location, available overall median top width, and safety considerations.
 - Use Type-B CC&G on channelizing islands and medians where the design speed is 40 or 45 mph (60 or 70 km/h). The selection of the appropriate gutter pan width will be based on the proposed cross-slope and drainage needs for the specific location, available overall median top width, and safety considerations. For corner islands see Item 7 below.
 - For the design speed of 40 mph (60 km/h), the designer has the option to use either an M-6 or B-6 (M-15 or B-15) curb depending upon the aggressiveness of drivers in a particular area and upon the 85th percentile speeds of similar type streets in the area. For corner islands see Item 7 below.
 - Use M-4 (M-10) curb on channelizing islands or medians where the design speed is 50 mph (80 km/h) or greater. Typically, curbing is only used at locations that would be channelized (e.g., offset left-turn lanes), near at-grade intersections where a concrete barrier is terminated, or on the crossroad through an interchange. Section 36-4 provides additional details for curbing at intersections.
 - Where posted speeds will exceed 45 mph, raised-curb medians are generally not considered an appropriate type of median cross section.
6. Traversable Medians. Use M-2.12 (M-5.30) CC&G where there is a need to provide a continuous two-way, left-turn lane (TWLTL) along the street and where raised delineation of the center turn lane is desirable. This is usually applicable only in major metropolitan areas where painted or thermoplastic turn lanes are quickly worn by vehicular use and maintenance of such pavement markings is a potential hazard to striping crews. The traversable TWLTL median should be marked with directional turn arrows to enhance proper traffic operations. See Figure 48-4.B for a typical traversable TWLTL detail.
7. Corner Islands. On streets or highways with a design speed of 45 mph (70 km/h) or less, use the M-6 (M-15) curb on all corner islands. On facilities with design speeds of 50 mph (80 km/h) or greater, the following will apply relative to corner islands and traffic signals:
- Where traffic signals are not proposed, use an M-4 (M-10) curb with a specified gutter width on all corner islands adjacent to the high-speed facility.
 - Where traffic signals are present or proposed, use an M-6 (M-15) curb with a specified gutter width on corner islands adjacent to high-speed facilities.
8. Freeway Over Crossroad. Figure 34-2.A illustrates part of a diamond interchange where an existing freeway overpasses the crossroad. In this case, it may be necessary to

place a pier in the crossroad channelization, or a pier may already exist in the median. Under these circumstances, and if the design speed is 50 mph (80 km/h) or greater, the bridge pier will require shielding with an impact attenuator. For this situation, use an M-4 (M-10) curb as shown in Figure 34-2.A and reduce the curb height to an M-2 (M-5) curb for a minimum of 30 ft (9 m) in front of the attenuator. This special condition could occur on either a two-lane or multilane channelized cross section where the design speed is 50 mph (80 km/h) or greater.

9. Special Median Conditions. There are certain special conditions where the median curb selection in the above guidelines is not appropriate. These may include:

- a. Railroads. Where a highway approaches an at-grade railroad crossing and the design speed is 45 mph (70 km/h) or less, provide B-6.24 or B-9.24 (B-15.60 or B-22.60) CC&G along the median edges for a short distance adjacent to the crossing. This barrier curb type will discourage motorists from driving around the railroad gates. See Figure 7-3.E for guidance.

Where a highway departs an at-grade railroad crossing and the design speed is 45 mph (70 km/h) or less, provide M-4 (M-10) CC&G along the median edges for a short distance adjacent to the crossing. When the design speed is 50 mph (80 km/h) or greater, provide M-2 (M-5) CC&G. These mountable curb types will provide an escape area for vehicles. See Figure 7-3.E for guidance.

- b. Median Piers. Where a street approaches a bridge pier in the median island and the design speed is 45 mph (70 km/h) or less, a B-9.24 (B-22.60) CC&G may be used along the median edges for a short distance adjacent to the pier.
- c. Bridge Decks (Icing). In areas of the State where bridge decks are subject to frequent icing and where curbed medians are proposed, either the B-6 or B-9 (B-15 or B-22) curb may be used on the bridge deck median depending on the proposed design speed of the street. The B-6 (B-15) may be used with 30 to 40 mph (50 or 60 km/h) design speeds and the B-9 (B-22) for 40 or 45 mph (60 or 70 km/h) design speeds.
- d. Curbed Medians on Bridge Decks. Where a center channelizing island is used on a rural high-speed highway (e.g., on the crossroad through an interchange), use the B-6 (B-15) curb rather than the M-4 (M-10) curb across the structure. Because the curbed median is doweled to the completed bridge deck, the 6 in. (150 mm) height and barrier face of the curb is needed for proper attachment to the deck and for long-term stability of the concrete median.
- e. Other Uses. Where landscaping, traffic control devices, or light standards are located in the median, B-6.24 (B-15.60) CC&G may be used on the median.

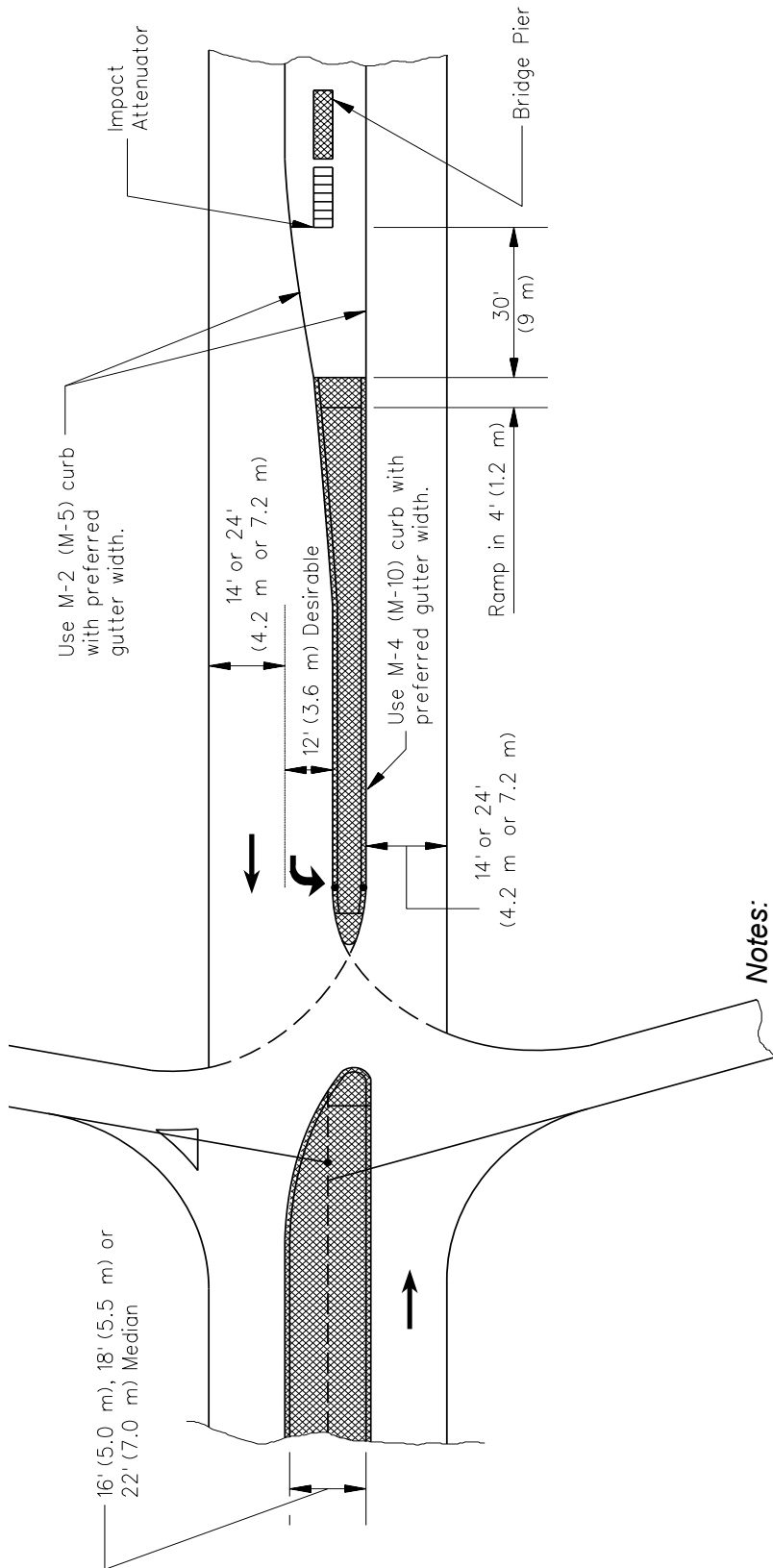

Notes:

- The design speed on crossroad is 50 mph (80 km/h) or greater.
- With 2 @ 14 ft (4.2 m) wide through lanes and an 18 ft (5.5 m) wide median, use an M-4.6 and M-2.6 (M-10.15 and M-5.15) CC&G.
- With 2 @ 24 ft (7.2 m) wide through lanes and a 22 ft (7.0 m) wide median, use an M-4.24 and M-2.24 (M-10.60 and M-5.60) CC&G.

FREEWAY OVER CROSSROAD
(Existing Interchange)

Figure 34-2.A

34-2.04(d) Design Considerations

The use of a curbed section requires the consideration and implementation of many design elements. The following discussion includes the major design considerations:

1. Drainage. Water ponding on the traveled way should be limited by using a closed drainage system. A complete hydraulic analysis will consider the pavement cross slopes adjacent to the gutter, the gutter slope, shape of the curb face, and the gradeline of the gutter. See Chapter 40 in the *BDE Manual* and the *IDOT Drainage Manual* for specific criteria and procedures for drainage analysis.
2. Cross Slopes. Where an integral curb and gutter section is used, the gutter has a steeper cross slope, typically 3/4"/ft (6%), than the adjacent pavement surface. For curb and gutter sections along the outside of the roadway, the gutter is sloped away from the roadway. For raised-curb medians, the direction of slope for the gutter will depend upon the width of the median. Section 34-3.03(c) discusses this criteria.
3. Gutter Width. Where cross section space is critical, the normal gutter width adjacent to the left edge of a left-turn lane or right edge of a right-turn lane may be narrowed or eliminated adjacent to 12 ft (3.6 m) lanes and narrowed adjacent to 11 ft (3.3 m) lanes.
4. Design Speed. Relative to curbing and design speeds, the following will apply:
 - a. High Speed. Facilities with high design speeds (≥ 50 mph (80 km/h)) should not be designed with continuous curbs. However, if necessary for drainage, a mountable curb may be used if it is placed at the outside shoulder edge.
 - b. Low Speed. Depending on the specific conditions, streets may be designed with either a mountable or barrier curb. Curb and gutters may be placed at the edge of the traveled way.
5. Running Speeds. Curb and gutter is used along the outside edges of traveled ways in urban areas because of restricted right-of-way, to contain drainage, and to provide for access management. In addition, the more compact cross section of outside curb and gutter tends to provide motorists with a subtle message of restricted space. Consequently, there is a tendency to travel at a lower running speed than the posted speed. This is especially true in open and closed suburban areas.
6. Vehicular Encroachment. Where sidewalks, roadside appurtenances, etc., are present, it is desirable to minimize the probability of vehicular encroachment beyond the curb. Although no curb type will prohibit encroachments, barrier curbs tend to discourage motorists from driving too close to the curb. Note that barrier curbs are not used on facilities with design speeds of 50 mph (80 km/h) or greater.
7. Roadside Safety. When examining curbs relative to roadside safety, the designer should review Chapter 38 for clear zone and roadside barrier guidance.

8. Transitions. Figure 34-2.B illustrates two situations where a shoulder section is transitioned to a curbed section.
9. Driveways. The IDOT *Policy on Permits for Access Driveways to State Highways* presents the design details for the use of curbs at driveways. Also review Section 36-7.
10. Mail Delivery. In many cases where a roadway is changed from a rural cross section with shoulders to a curb and gutter section (e.g., through a small town or adjacent to the urban development of a city), the designer must consider how the curb and gutter might affect mail delivery. One option requires the construction of mailbox turnouts along the street. Another is the construction of a continuous 6 ft (1.8 m) shoulder with a curb and a 2 ft (600 mm) gutter behind the shoulder. See Chapter 58 for design details.
11. Accessibility. Curbs shall be designed with sidewalk ramps at all pedestrian crosswalks to provide access for the safe and convenient movement of individuals with disabilities. Chapter 58 and the *IDOT Highway Standards* provide details on the design and location of sidewalk ramps.
12. Parking Considerations. Curb heights adjacent to on-street parking should be 6 in. (150 mm) or less. If a 9 in. (225 mm) curb height is used, provide a wider gutter width. Curb heights on streets and parking lots with diagonal or perpendicular parking should be limited to a 6 in. (150 mm) maximum height.

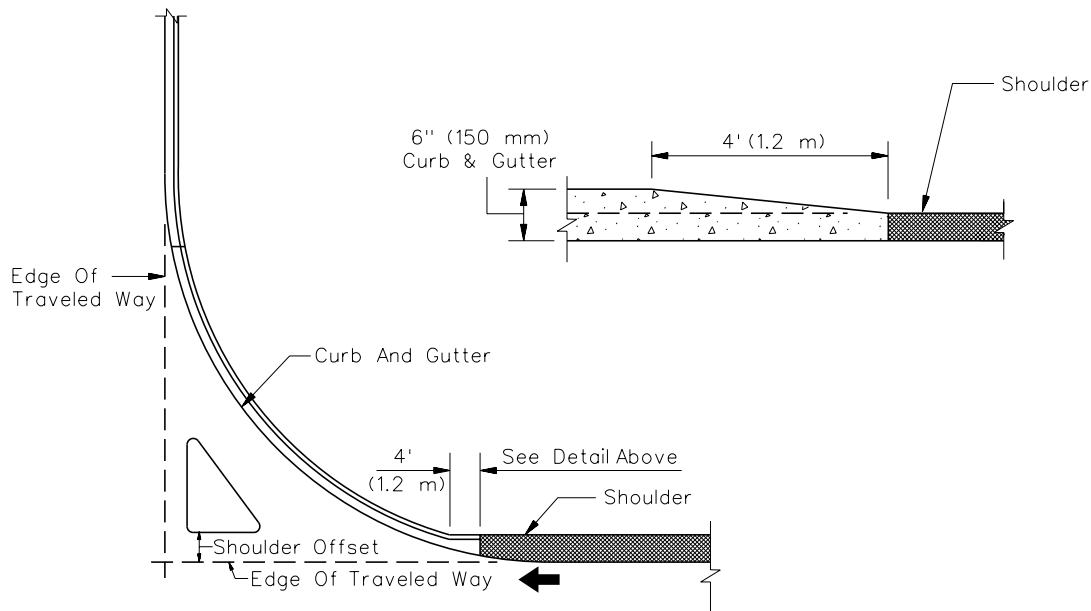
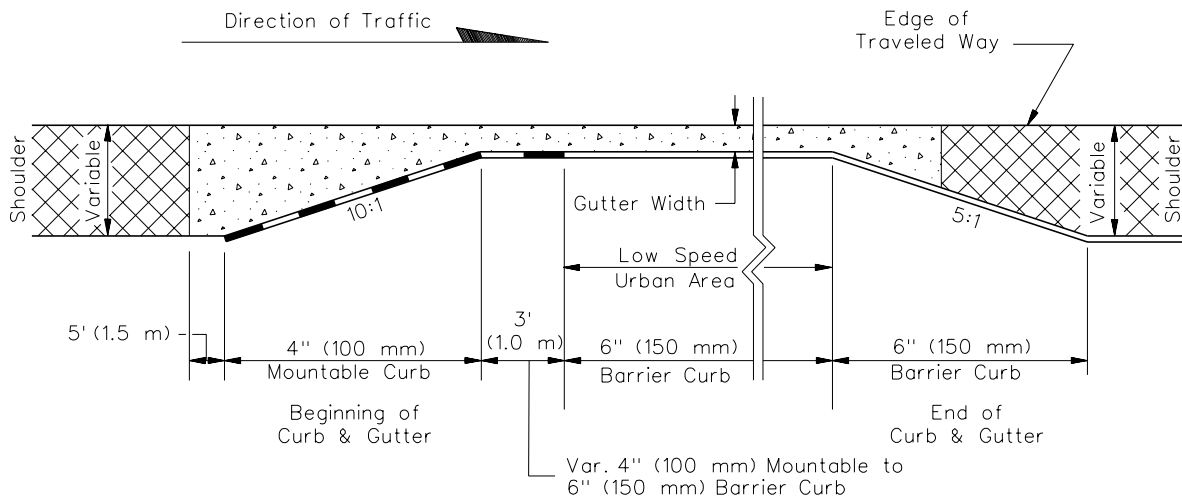

CURB TRANSITIONS

Figure 34-2.B

34-3 MEDIANS

34-3.01 Functions

A median is defined as the portion of a cross section that separates the opposing directions of the traveled ways. The principal functions of a median are:

- to provide a separation between opposing traveled ways;
- to provide a recovery area for out-of-control vehicles;
- to provide a storage area for emergencies;
- to prevent undesirable turning movements (manage access to the highway), provided the median is non-traversable;
- to provide areas for deceleration and storage of left-turning and U-turning vehicles;
- to minimize headlight glare;
- to provide an area for storage of vehicles crossing the mainline highway at intersections;
- to facilitate drainage and snow collection (raised-curb or depressed medians);
- to permit the use of shorter span lengths for overhead structures;
- to provide an area for pedestrian refuge (raised-curb median); and
- to provide width for future expansion of the roadway.

34-3.02 Median Widths

Median widths should be based upon economic, operational, and environmental considerations. The median width is measured from the inside edge of the two traveled ways and includes both inside shoulders and/or median curb and gutters. A median must be at least 4 ft (1.2 m) wide to meet the minimum functional requirements; however, this minimum width is not used on State highways. Section 34-3.03 presents several median schematics which define the width for the basic median types. The design width will depend on the functional class of the highway, design speed, type of access management proposed, availability of right-of-way, construction costs, maintenance considerations, acceptable median slopes, the anticipated ultimate development of the facility, operations at crossroad intersections, and field conditions. Chapters 44 through 48 present specific numerical criteria for median widths on new construction and reconstruction projects for arterial highways. In addition, the designer should consider the following:

1. Unsignalized Intersections. In urban areas, curbed median widths preferably should be a minimum of 22 ft (7.0 m) to safely allow a crossing passenger vehicle to stop between

the two traveled ways. In rural areas where trucks and/or buses are commonly present (e.g., truck terminals, light industrial), depressed median widths of 60 ft to 65 ft (18 m to 19 m) are recommended to allow trucks to stop between roadways.

2. Signalized Intersections. Wide medians may lead to increased clearance times and inefficient traffic operations at signalized intersections.
3. Median Barriers. With narrow medians, a median barrier may be warranted. See Section 38-7. Desirably, select a median width which will be wide enough to eliminate the need for a barrier.
4. Operations. Several vehicular maneuvers at intersections are partially dependent on the median width of the mainline highway (e.g., U-turns, left turns). Evaluate these likely maneuvers at intersections and provide a median width that will accommodate the selected design vehicle. Also, consider the need for single or dual left-turn lanes. For more information on designing intersections, see Chapter 36.
5. Uniformity. In general, a uniform median width is desirable. However, variable-width medians may be advantageous where right-of-way is restricted, intersections are widely spaced (3000 ft (1 km) or more), and/or where independent alignments are practical.
6. Sight Distance. Where a median barrier is proposed at a horizontal curve, the median width may be a factor in whether or not adequate sight distance is available around the horizontal curve. Section 32-4 discusses horizontal sight distance.
7. Separation. Median widths of 40 ft (12 m) or greater, from the driver's perspective, are considered to be physically and psychologically separated from the opposing traffic.
8. Maintenance. If glare screens, light poles, or other appurtenances are placed on a median barrier, use a 22 ft (7.0 m) wide median. This provides sufficient clearance for emergency or maintenance vehicles to stop on the shoulders without blocking the traveled way.

34-3.03 Median Types

Figure 34-3.A provides typical sections for various median type—flush, flush with concrete barriers, traversable TWLTL and depressed. Figure 34-3.B provides illustrations of raised-curb medians.

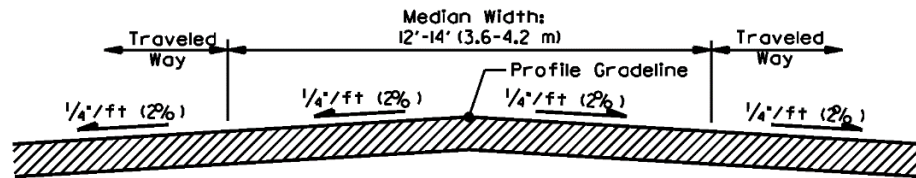

PAINTED FLUSH MEDIAN
LEFT-TURN LANES
OR TWLTL

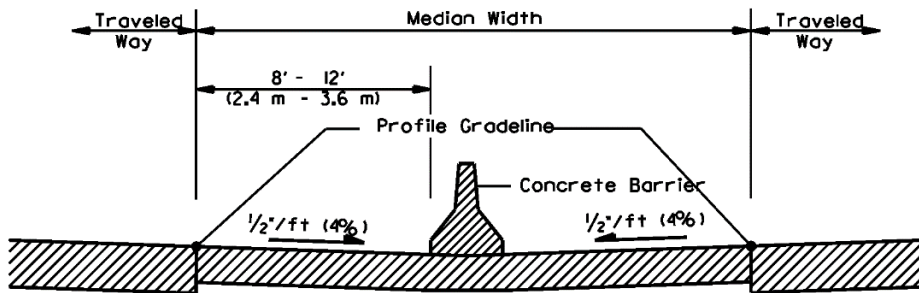

FLUSH MEDIAN
WITH CONCRETE BARRIER

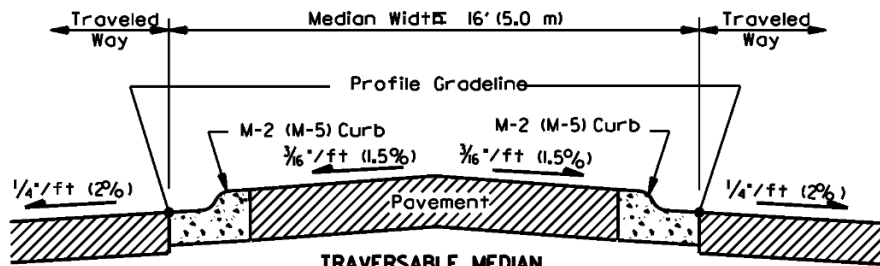

TRAVERSABLE MEDIAN

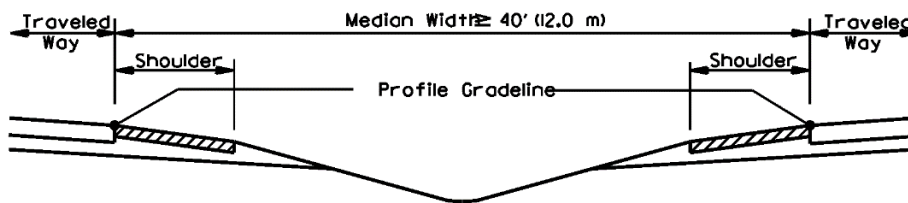

DEPRESSED MEDIAN

TYPICAL MEDIAN TYPES
(Flush/Traversable/Depressed)

Figure 34-3.A

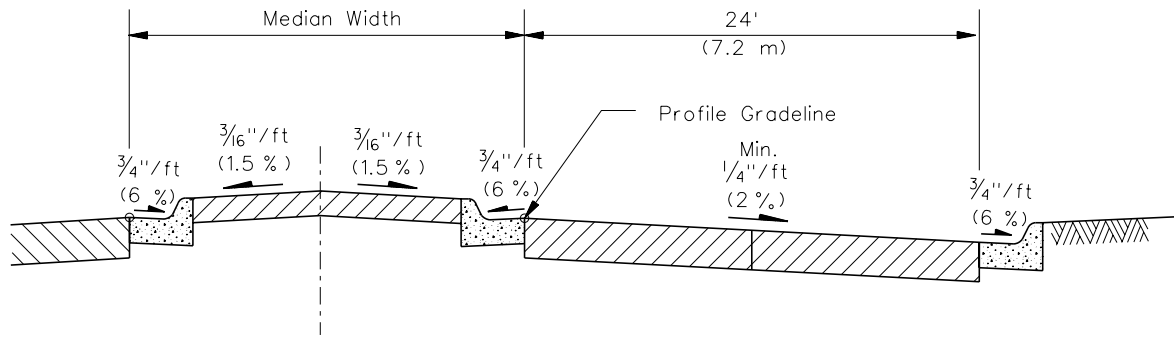

(A) MEDIAN WIDTH 16' TO 22' (5.0 m TO 7.0 m)

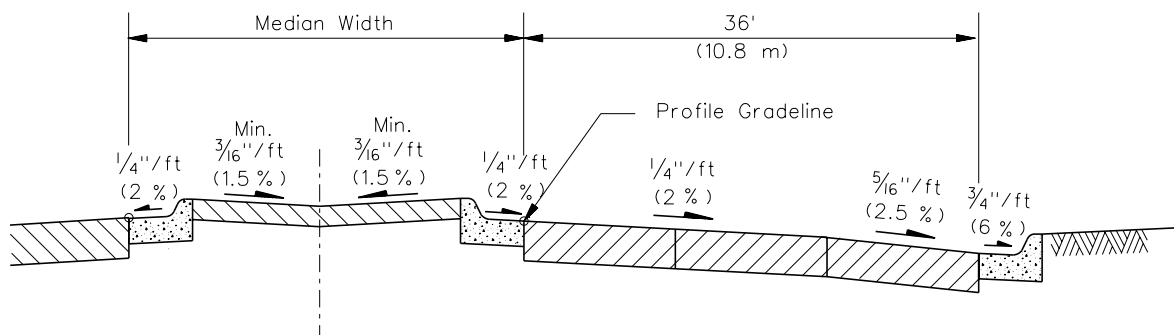

(B) MEDIAN WIDTH > 22' (7.0 m)

**MEDIAN TYPES
(Raised-Curb Medians)**

Figure 34-3.B

34-3.03(a) Flush Medians

A flush median is defined where the surface is constructed as a smooth plane in conjunction with the adjacent roadway pavement. Flush medians are used most often on low-speed urban highways and streets. This flush type median should be slightly crowned to avoid ponding water in the median area. However, with high-speed conditions, flush medians can also be used with the placement of concrete barriers. In this case, the flush median should be depressed to collect water within a closed drainage system. The following discusses the various types of flush medians:

1. Painted Flush Median. Widths for painted flush medians can range from 4 ft (1.2 m) to 14 ft (4.2 m). Such medians serve as a buffer between opposing traffic, or for the development of dedicated left-turn lanes at median crossovers. To accommodate a separate left-turn lane, a flush median should desirably be between 12 ft (3.6 m) and 14 ft (4.2 m) wide. This will allow for separation between left-turning vehicles and the opposing traffic.
2. Two-Way Left-Turn Lanes (TWLTL). TWLTL's are also considered flush medians. Design criteria, advantages, and disadvantages of a TWLTL are discussed in Chapter 48. Note that where a TWLTL is used, provide curb and gutter along the outside edges of the traveled way. Operating speeds, truck and bus volumes, number and spacing of entrances and intersections, availability of right-of-way, character of abutting property, parking facilities, etc., should be considered when determining appropriate TWLTL widths for specific projects.

The usual design width of a TWLTL is between 12 ft (3.6 m) and 14 ft (4.2 m). There is some evidence that a wide TWLTL encourages drivers to place their vehicles in an angular, rather than parallel, turning position and thereby cause encroachments on adjacent through lanes. Evidence also suggests an increased probability for head-on crashes for a TWLTL less than 12 ft (3.6 m) or greater than 14 ft (4.2 m) in width. Therefore, maximum widths for flush TWLTL medians should be 14 ft (4.2 m) in order to discourage opposing side by side operations within the TWLTL.

3. Flush Median with Concrete Barrier. A flush median with a concrete barrier may be used on urban freeways and expressways where the right-of-way does not allow for the use of a depressed median. For new construction and reconstruction projects, the minimum width of a flush median for an urban freeway is 20 ft (6.0 m). This allows for the use of two 8 ft (2.4 m) wide left shoulders and provides space for the width of the concrete barrier.

34-3.03(b) Traversable TWLTL Medians

Where an M-2 (M-5) curb is used to delineate the edges of a median, this median is designated as a traversable median and traffic is allowed to turn left across the median. On certain streets in large metropolitan areas where traffic volumes and mid-block left turns are unusually high, the traversable median with an M-2.12 (M-5.30) CC&G, although having a slightly higher initial cost

than a flush TWLTL median, may be the appropriate design option. This median type eliminates the frequent and somewhat hazardous striping operations and yet provides for TWLTL movements. Because the traversable TWLTL median was developed as a direct substitute for the flush TWLTL, the M-2.12 (M-5.30) CC&G is not designed to be a physical barrier nor is it intended to impede left-turn movements across the median.

The normal traversable TWLTL median width for new construction is 16 ft (5.0 m). As discussed for the flush TWLTL, wide traversable TWLTL medians also may encourage drivers to store in an angular position or encourage opposing side by side operations. Therefore, wider widths should not be provided.

34-3.03(c) Raised-Curb Medians

A median is defined as a raised-curb median if it contains a curb height greater than 2 in. (50 mm) within its limits. Usually, a raised-curb median is proposed when the Department needs to manage access to the street and to control left-turn movements. Chapter 48 discusses several advantages and disadvantages of raised-curb medians compared to TWLTL medians. If a raised-curb median is proposed, consider the following in the design of the median:

1. Widths. The minimum raised-curb median width on urban and suburban streets is 18 ft (5.5 m). This width is used only where the majority of intersections along the street will be signalized. If many intersections do not need to be signalized, then the recommended minimum width is 22 ft (7.0 m), assuming no right-of-way restrictions. The 22 ft (7.0 m) median width allows passenger vehicles to comfortably store within median crossovers at unsignalized intersections when making a maneuver in two moves. Where dual left-turn lanes are required, the minimum raised-curb median width is 30 ft (9.5 m) and desirably 36 ft (10.5 m).
2. Tapered versus Parallel Left-turn Lanes. Consider the use of tapered left-turn lanes within the median to provide additional sight distance to on-coming traffic at both signalized and unsignalized median crossings.
3. Cross Slopes. For raised-curb medians, the following cross slopes will apply:
 - a. Median Width Less Than or Equal to 22 ft (7.0 m). Slope the median surface or median pavement towards the through traveled way; see Illustration "A" in Figure 34-3.B. Slope the gutter towards the median to capture median runoff and ice melt and provide a closed drainage system.
 - b. Median Width Greater Than 22 ft (7.0 m). The median surface typically will be sloped toward the centerline of the median; see Illustration "B" in Figure 34-3.B. The gutter will typically be sloped toward the traveled way because median runoff and ice melt are insignificant considerations.

4. Median Island (Paved Surface). For raised-curb medians up to 22 ft (7.0 m) wide, pave the island according to the details in the *IDOT Highway Standards*. A 4 in. (100 mm) thickness typically is used. At the noses of islands where vehicles frequently ride over the nose, ramp the median nose and construct it as one solid element. See the *IDOT Highway Standards*.
5. Median Island (Sodded Surface). For raised-curb medians greater than 22 ft (7.0 m), the area between the curbs may be backfilled and sodded. However, where there are numerous signs, median barriers, bridge piers, etc., in the island or where median crossovers are closely spaced with left-turn lanes, it may be more economical to pave the island to eliminate excessive hand mowing.
6. Drainage. Give consideration to providing subsurface drainage (underdrains) of raised curb medians. Earth or aggregate backfill in the medians may become saturated and bleed water through joints or cracks in the pavement.

34-3.03(d) Depressed Medians

Wherever practical, use a depressed median on rural freeways, expressways, and other designated arterials. Depressed medians have better drainage and snow storage characteristics and, therefore, are preferred on high-speed arterial highways. In addition, they provide the driver with a greater sense of comfort and freedom of operation. Where a depressed median is proposed, the designer should consider the following:

1. Widths. Depressed medians should be as wide as practical to allow for the addition of future travel lanes on the inside while maintaining a sufficient median width. In addition, the median should be sufficiently wide so that a median barrier will not be warranted. Chapters 44 through 48 provide the recommended minimum depressed median widths.
2. Longitudinal Gradeline. The recommended center longitudinal gradeline of a depressed median with an unpaved ditch is 0.5% with 0.3% considered as a minimum. However, on long approach roadways to major river or stream crossings, the design profile gradeline of the roadways may be 0% with the median ditch gradeline designed as a special ditch to provide proper drainage.
3. Drainage. Because water is allowed to flow into a depressed median, the designer needs to consider drainage when determining the appropriate depth of a depressed median. The usual depth is 3 ft (1.0 m). Chapter 40 of the *BDE Manual* and the *IDOT Drainage Manual* provide additional details on drainage design.

34-3.04 Median Selection

34-3.04(a) General

When selecting a median type, recognition must be given to urban/rural location, access needs, design speeds, availability of right-of-way, safety, capacity, intersection spacing, traffic signals,

economics, environmental impacts, public acceptance, and functional classification. Note that higher functional classifications will warrant a greater effort in managing access to a street or highway and in retaining mobility.

Guidelines for median types through large “residential” areas are not provided. These areas typically are avoided in the location of arterial routes and should be treated as special cases. When selecting median types within urban fringe areas, urban outlying business districts, and throughout the entire suburban area (especially within the limits of “closed suburban”), special efforts will be necessary to coordinate the proposed median design with existing and planned zoning regulations. This will require contacting the responsible zoning boards and/or local officials to coordinate the planning and selection of a median type.

On certain projects, more than one median type may be necessary and/or desirable. The length of a project will be a major influence in this determination. On relatively short highway sections, the number of different median types should be limited to a select few. On longer highway projects, changes of median types should generally be made at the borders of natural cultural subdivisions.

For the selection of curb type for raised medians, see Section 34-2.04.

34-3.04(b) Urban Median Types

On streets in downtown areas or central business districts (CBD), abutting building development often prohibits space for off-street parking and entrance driveways for individual businesses. These conditions, plus the extensive use of one-way street systems in the CBD, generally lessen the need for medians and protective left-turn lanes. However, where a median may be required, a 12 ft (3.6 m) flush median delineated by paint and/or thermoplastic pavement markings is usually appropriate. Where intersections are closely spaced, the median generally will be delineated as an “S” shape to provide overlapping left-turn lanes. Figure 34-3.C provides an example of a typical median design in the CBD and typically widths.

In the urban fringe areas and outlying business districts, off-street parking and entrance driveways usually are quite numerous. Consequently, a raised-curb median generally is not appropriate in these areas because it deters access to abutting businesses and homes. In these areas, a 12 ft (3.6 m) to 14 ft (4.2 m) wide flush TWLTL median or a 16 ft (5.0 m) wide traversable TWLTL median generally is desirable. These median widths provide space for left-turn lanes at intersections and offer protection for the mid-block left-turning vehicles. Where traffic volumes and mid-block left turns are unusually high, the traversable TWLTL median with an M-2.12 (M-5.30) CC&G may be the most desirable design. Figure 34-3.D provides an example of a typical median design in fringe areas and outlying business districts. The design speeds are usually either 30 mph to 40 mph (50 km/h or 60 km/h).

Freeways and expressways in urban areas will generally require a flush median with concrete barrier due to the need to incorporate the necessary cross section within a restricted right-of-way. Desirably, this median width should be 22 ft (7.0 m), which allows for 10 ft (3.0 m) left shoulders and 2 ft (1.0 m) for the concrete barrier. Wider widths may be required; see Chapters

44 and 45. At a minimum, a 20 ft (6.0 m) width with a concrete barrier is considered acceptable under the reconstruction category with only two lanes in each direction.

34-3.04(c) Suburban Median Types

Suburban areas are divided into two subcategories—closed and open. These are discussed in Section 43-2. The appropriate medians for each of these area types are discussed below:

1. Closed Suburban. The following median types will apply:
 - a. TWLTL Medians. This median type can consist of either a flush TWLTL median or a traversable TWLTL median and is typically used with curb and gutter along the outside edges of the traveled way. These median types are applicable where the existing predominant abutting development includes numerous and closely spaced commercial entrance driveways. It is particularly appropriate where there is strip development and no appreciable street network. Design speeds should not exceed 45 mph (70 km/h). Preferably, the maximum number of through lanes should not be greater than two in each direction. The traversable TWLTL median is occasionally used in metropolitan areas where traffic volumes and mid-block left turns are unusually high.
 - b. Raised-Curb Medians. This median type is generally applicable where a design speed of 40 mph or 45 mph (60 km/h or 70 km/h) is desired and a street network exists to permit access to the predominant abutting development. On six-lane urban streets, the raised-curb median is the most appropriate design. Normally, right-of-way should be available to provide for either a 16 ft (5.0 m), 18 ft (5.5 m), or 22 ft (7.0 m) wide curbed median. These widths provide space for the initial and future installation of left-turn lanes at public street intersections and high-traffic generator locations. Access to any strip development or open-space segments usually can be provided by properly spaced median openings and service drives. This median type should be coordinated with the local officials because mid-block left turns are prohibited.

Where managing access to the street is practical and desirable, consider using the 22 ft (7.0 m) wide median as the first design option. Where right-of-way is more restricted, or if most intersections will be signalized in the future, consider using the 18 ft (5.5 m) wide median. The use of the 16 ft (5.0 m) wide raised-curb median only should be considered in areas where right-of-way is highly restricted and the use of a wider curbed median is not feasible. If dual left-turn lanes are required, the median width at intersections should be a minimum of 30 ft (9.5 m) wide and desirably 36 ft (10.5 m) wide.

2. Open Suburban. The following median types will apply:
 - a. TWLTL Medians. Selection of this median type is based on the same criteria as discussed in Item 1 above for a closed suburban area.

- b. Raised-Curb Medians. This median type is applicable where a maximum 45 mph (70 km/h) design speed is desired and where managing access to the street is practical and desirable. Availability of right-of-way typically favors a median width narrower than 44 ft (13.2 m). For open suburban areas, raised-curb median widths of 18 ft (5.5 m) or 22 ft (7.0 m) generally are considered the most feasible widths. The 22 ft (7.0 m) width allows for U-turn movements and the storage of passenger vehicles in the median crossover at unsignalized intersections. Consider using the 18 ft (5.5 m) wide median where right-of-way is restricted.

In conjunction with these median widths, provide spacing of median openings at approximately 500 ft to 600 ft (150 m to 180 m) apart. Construct all necessary median openings initially allowing for slight adjustment of the spacing requirements to fit existing intersections, property limits, drainage ways, and terrain. The location of all possible future median openings should be shown in the approved Phase I report. Provide left-turn lanes at all median crossovers and at future median openings as they are constructed.

Existing and future developments abutting the highway should plan their traffic circulation according to the initial median openings or the proposed median openings as shown in the Phase I report. Accordingly, it should be emphasized in discussions with municipalities and developers, that private service drives and/or coordination of other traffic circulation facilities with adjacent property owners will be a necessary part of the land-use planning.

- c. Depressed Medians. This median design in suburban locations is applicable for non-access controlled highways where a 50 mph (80 km/h) design and posted speed are preferred and where right-of-way reasonably can be acquired for inclusion of necessary safety features. The following will apply:
- Typical median widths are 44 ft (13.2 m) to 50 ft (15 m). These widths provide for 6 ft (1.8 m) to 8 ft (2.4 m) wide median shoulders, 1V:6H or 1V:5H median slopes, and a 2 ft (500 mm) wide median ditch.
 - U-turns are afforded better protection with these median widths and can be permitted indefinitely even with left-turn lanes.
 - As a minimum, access to abutting properties with this type median would be accommodated in the same manner as described above for raised-curb medians. Where practical, consider more restrictive access to the highway in a manner similar to expressway designs.

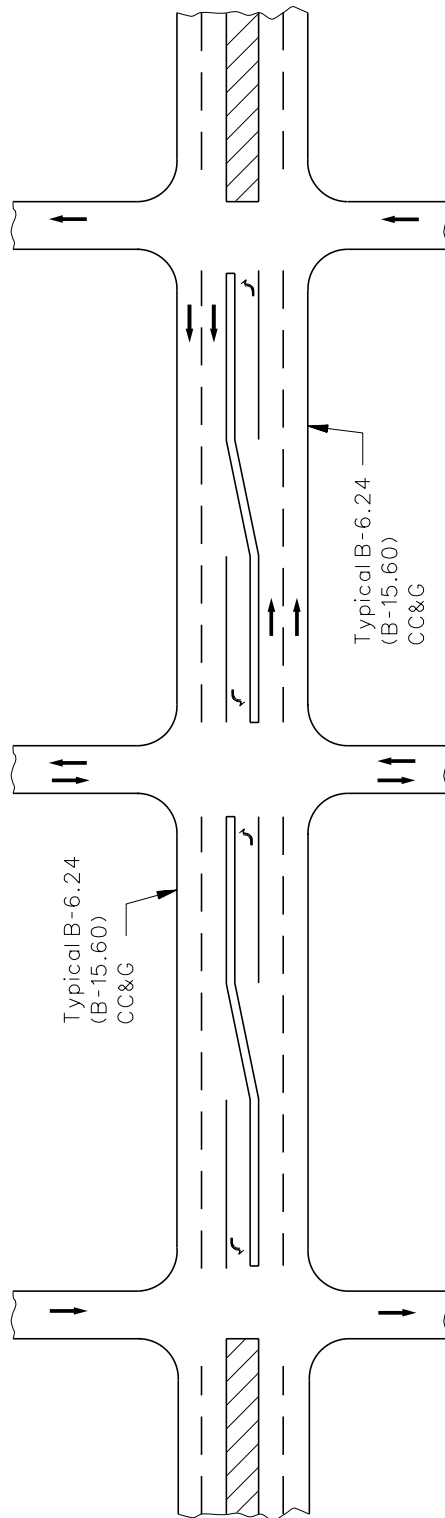

Notes:

- Assumed design speed is 30 mph (50 km/h).
- Overlapping left-turn lanes in median are usually marked with paint or thermoplastic.
- Uniform width: 12 ft (3.6 m).

TYPICAL MEDIAN DESIGN
(Central Business District)

Figure 34-3.C

* The designer may use M-6 (M-15) curb in these areas to restrict access at the intersection.

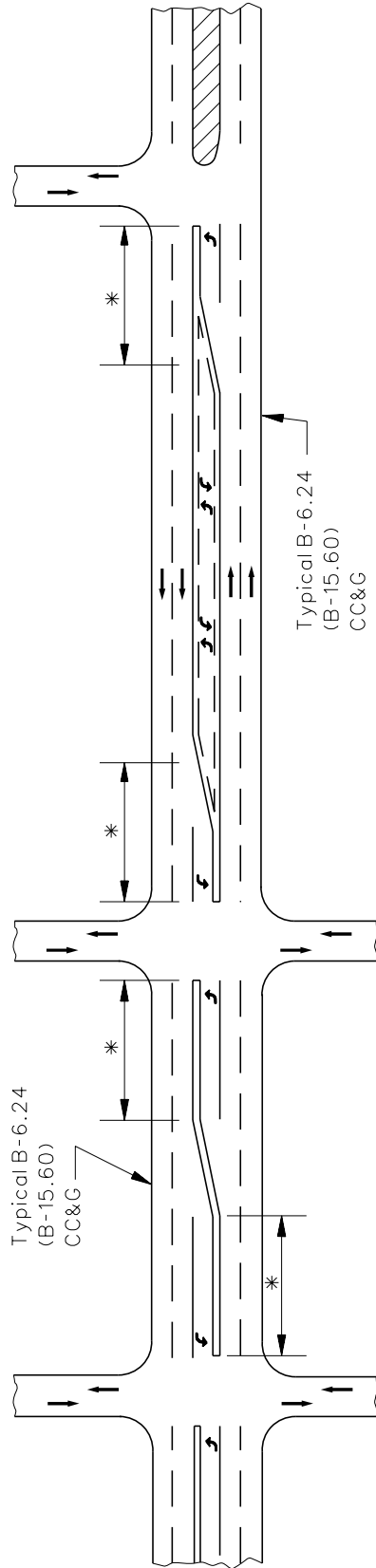

FLUSH TYPE MEDIAN	TRAVERSABLE TYPE MEDIAN
Uniform Width: 12 ft - 14 ft (3.6 m - 4.2 m)	Uniform Width: 16 ft (5.0 m)
Usually marked with paint or thermoplastic.	Median outlined with M-2.12 (M-5.30) CC&G.
Used as two-way, left-turn lane in mid-block locations.	Used as two-way, left-turn lane in mid-block locations.

TYPICAL MEDIAN DESIGNS
(Fringe and Outlying Business District)

Figure 34-3.D

34-3.04(d) Rural Median Types

In rural areas, medians are typically only provided on freeways, expressways, and other designated high-speed arterials. Also, median islands are provided at rural intersections for the inclusion of left-turn lanes and on crossroads through interchanges. In general, right-of-way is more available in rural areas. Typical median types in rural areas include depressed medians, flush medians with barriers, and short sections of raised-curb medians. The primary function of a median in rural areas is to increase operational safety of the highway by neutralizing the interference of opposing traffic. Selection of rural median types is based on the following:

1. Depressed Medians. This median design is applicable for both access controlled and non-access controlled highways and where right-of-way can be reasonably acquired. Depressed medians are mainly used on the following:
 - a. Freeways. Depressed median widths for new freeways are either 56 ft (17 m) (four lanes) or 60 ft (18 m) (six lanes). These median widths provide for 8 ft (2.4 m) or 10 ft (3.0 m) wide left shoulders, 1V:6H median slopes, and a 4 ft (1.2 m) wide ditch. See Chapter 44 for typical sections of four-lane and six-lane freeways.
 - b. Expressways and Four-Lane Minor Arterials. For new construction and reconstruction projects, the median width for these type highways is typically 50 ft (15 m). This median width will also accommodate 1V:6H median slopes and a 2 ft (600 mm) wide ditch based on the narrower median shoulders. See Chapter 45 for typical sections.

On expressway-type highways, median widths wider than 50 ft (15.0 m) may be desirable at isolated intersection locations where a large number of tractor-trailer movements exist and where traffic signals will not be required. In this situation, it is recommended that the designer consider a 64 ft (19 M) wide median. These wider medians through the intersection will allow for median storage of the tractor-trailer unit.

Where expressways are developed through reconstruction of existing two-lane highways, the addition of near-parallel lanes may cause extra-wide median widths at existing horizontal curves. Where the added roadway is on the outside of an existing curve, the alignment transition to a uniform median width generally should be constructed on one end of the proposed horizontal curve only (i.e., either upstream or downstream). Where the added roadway for the proposed expressway is located on the inside of an existing curve (allowed to remain in place), the proposed horizontal curve is designed to fit into back and forward tangents. This design then provides for a variable width median through the two adjacent horizontal curves. See Chapter 45 for median widths allowed to remain in place.

2. Flush Medians. Flush medians consist of two double yellow lines marked at the edge of the traveled way with transverse striping in the median area. This median type is mainly used at rural intersections where left-turn lanes are needed and as an alternative to raised-curb median islands at isolated intersections.
3. Raised-Curb Medians. On high speed (≥ 50 mph (80 km/h)) rural multilane highways, do not delineate medians with continuous curbing because it may constitute a safety hazard. However, median curbing may be used at isolated intersections (see Chapter 36) and through interchange crossroad locations where more positive control measures are needed to promote safer traffic operations or where required for proper drainage. In these situations, use an M-2 (M-10) curb along the crossroad median; see Figure 34-2.A.

34-4 ROADSIDE ELEMENTS

34-4.01 General

Earth slopes are required to provide roadside and median ditches adjacent to highway facilities and to provide a stable transition from the highway profile to adjacent terrain features. With maintenance operations, economy may be attained through the use of mechanized equipment which operates best on relatively flat earth slopes. Flat slopes also facilitate turf establishment and are often required for soil stability. In addition to aesthetic enhancement, flat and well-rounded side slopes, combined with proper roadway elevations above natural ground lines, minimize snow drifting problems. With proper elevations, cross winds sweep the snow from the roadway surface, thus facilitating snow removal operations.

Using broad flat slopes on roadside ditches, which are totally visible to the driver, lessens the feeling of restriction and add considerably to a driver's willingness to use the shoulder and earth slope area in emergencies. The use of flat side slopes for roadside ditches reduces both the depth and velocity of water, and thereby minimizes damage from erosion. See Chapter 38 for guidance on earth slopes and clear zones.

For urban facilities other than freeways and expressways, side slopes generally will be determined on a case-by-case basis considering the roadside development and right-of-way restrictions. For some urban projects, relatively steep side slopes and/or retaining walls may be required.

34-4.02 Fill Sections

Front slopes in fill sections are the slopes extending outward and downward from the hinge point to intersect the ditch bottom or natural ground line. The slope criteria depend upon the fill height, urban/rural location, project scope of work, and the presence of curbs. Figures 34-4.A and 34-4.B present the fill slope criteria. The designer should also consider the following:

1. Maximum Slope. As indicated in Figures 34-4.A and 34-4.B, the maximum front slope should be 1V:3H. A 1V:3H slope is a practical maximum when considering maintenance operations (e.g., mowing), erosion control, and roadside safety. Slopes steeper than 1V:3H should be used where fill heights are greater than 30 ft (9.0 m). Slopes steeper than 1V:3H will normally require a roadside barrier; see Figure 38-6.X for the location of the barrier where curbs are present.
2. Shelf. For curbed sections, a 3 ft to 10 ft (900 mm to 3.0 m) shelf is provided beyond the curb. If sidewalks are present or anticipated, the shelf width should be 10 ft (3.0 m) and sloped away from the roadway at a rate of 2%. If no sidewalks are present or anticipated, slope the shelf away from the roadway at 5%.

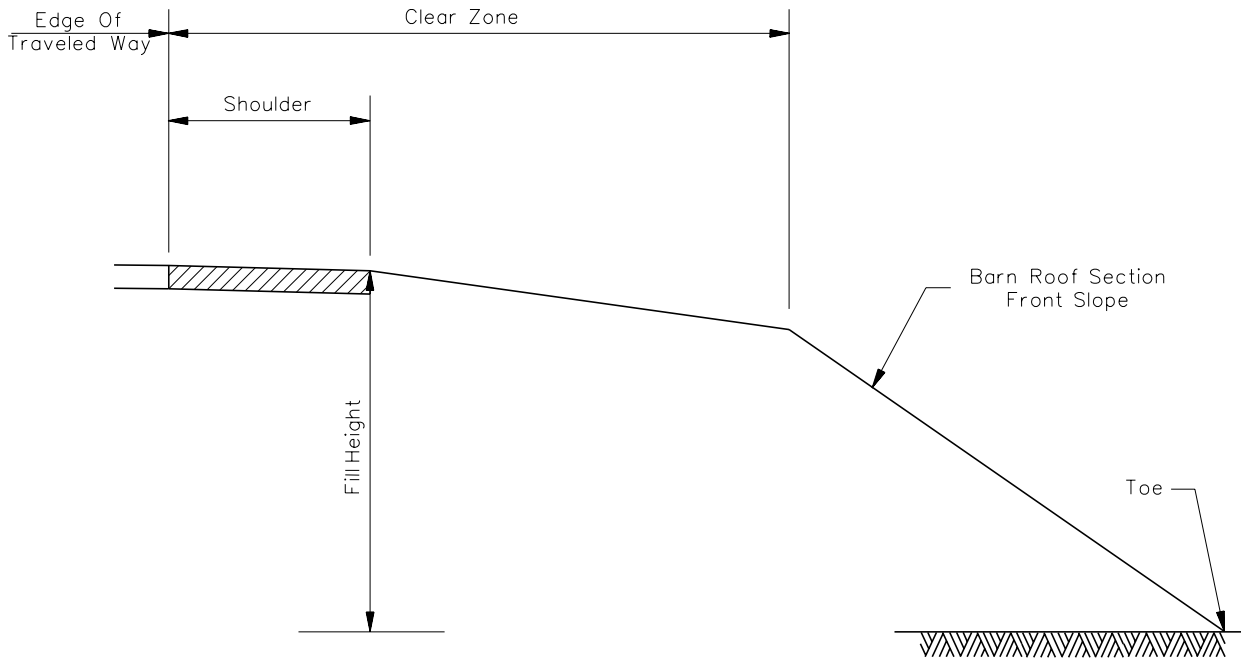

Project Scope of Work	Fill Height	Front Slopes (V:H)
New Construction and Reconstruction	0 ft – 30 ft (0-9 m)	1:6 to clear zone edge 1:3 maximum to toe
	>30 ft (>9 m)	1:2 uniform slope with a roadside barrier
Existing to Remain (Reconstruction)	0 ft – 30 ft (0-9 m)	1:4 to clear zone edge 1:3 maximum to toe
	>30 ft (>9 m)	1:2 uniform slope with a roadside barrier

**TYPICAL FILL SECTIONS
(Highways Without Curbs)**

Figure 34-4.A

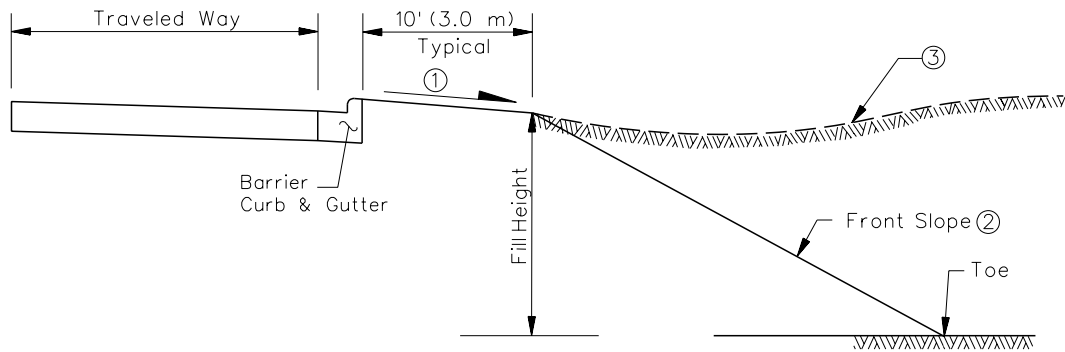

Notes:

- ① See Item 2 in Section 34-4.02 for slope rates.
- ② Desirable - 1V:4H; see Chapter 38.
- ③ For urban and suburban reconstruction projects, see Item 4 in Section 34-4.02.

(A) DESIGN SPEED ≤ 45 mph (70 km/h)

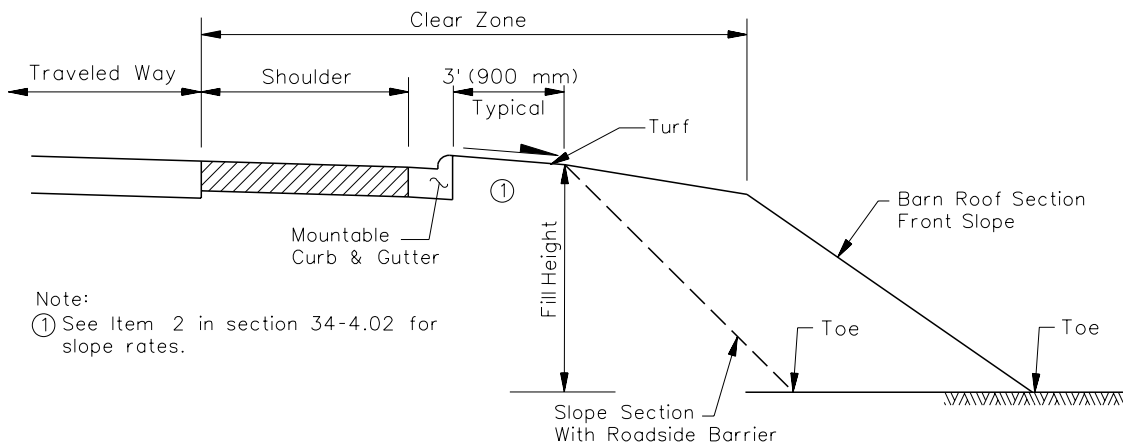

Note:

- ① See Item 2 in section 34-4.02 for slope rates.

(B) DESIGN SPEED ≥ 50 mph (80 km/h)

Project Scope of Work	Fill Height	Front Slopes (V:H)
New Construction and Reconstruction	0 ft – 30 ft (0-9 m)	1:6 to clear zone edge 1:3 maximum to toe
	> 30 ft (>9 m)	1:2 uniform slope with a roadside barrier
Existing to Remain (Reconstruction)	0 ft – 30 ft (0-9 m)	1:4 to clear zone edge 1:3 maximum to toe
	> 30 ft (>9 m)	1:2 uniform slope with a roadside barrier

Note: For clear zones in curbed sections, see Section 38-3.

**TYPICAL FILL SECTIONS
(Curbed Facilities)**

Figure 34-4.B

3. **Benching.** Where the height of a fill exceeds 30 ft (9.0 m), consider benching of the slope to minimize erosion problems. Approximately halfway down the slope, provide a bench with a V-type ditch. On short sections, the bench can be graded to drain to one side. For longer sections, grade the bench to drain from both directions. For more guidance on benching designs, the designer should contact the district geotechnical engineer.
4. **Reconstruction Projects.** For some reconstruction projects in urban or suburban locations, the existing pavement may be slightly above the surrounding topography. If this occurs, provide a drainage swale behind the curb and gutter as illustrated in Figure 34-4.B.
5. **Other Considerations.** Although Figures 34-4.A and 34-4.B provide specific criteria for front slopes, also consider right-of-way restrictions, utility considerations, and roadside development when determining the appropriate front slope for the site conditions. If practical, consider using flatter front slopes than indicated.

34-4.03 Ditch Sections

34-4.03(a) Typical Slope Rates

On facilities without curb and gutter, roadside ditches are provided adjacent to embankment locations and in cut sections to control drainage. Figure 34-4.C presents IDOT criteria for embankment locations and cut sections. As illustrated in Figure 34-4.C, the ditch section includes the front slope, ditch width and back slope for the type of highway. Where the cut height exceeds 10 ft (3.0 m) from the bottom of the ditch to the existing ground line, the designer may consider using a 1V:2H back slope beyond the clear zone to reduce excavation costs.

Where the height of a cut exceeds 30 ft (9.0 m), consider benching the back slope to minimize erosion problems. Approximately halfway down the slope, provide a bench with a V-type ditch. On short sections, the bench can be graded to drain to one side. For longer sections, grade the bench to drain from both directions. For additional guidance on benching designs, the designer should contact the district geotechnical engineer.

34-4.03(b) Material and Soils Conditions

The designer must ensure that permanent erosion control is considered in the design of ditches in cut slopes. The designer should contact the district landscape architect and the district geotechnical engineer, who will review the existing soil conditions to determine if additional measures may be required to control erosion (e.g., additional topsoil, special plantings, paving). It will be the designer's responsibility to consider their recommendations for incorporation into the plans. As a general guide, longitudinal ditch slopes less than 1% can be seeded, slopes of 1% to 3% usually will require sodding or seeding with an erosion control blanket, and slopes greater than 3% will require riprap or other protective lining. Very flat longitudinal ditch slope

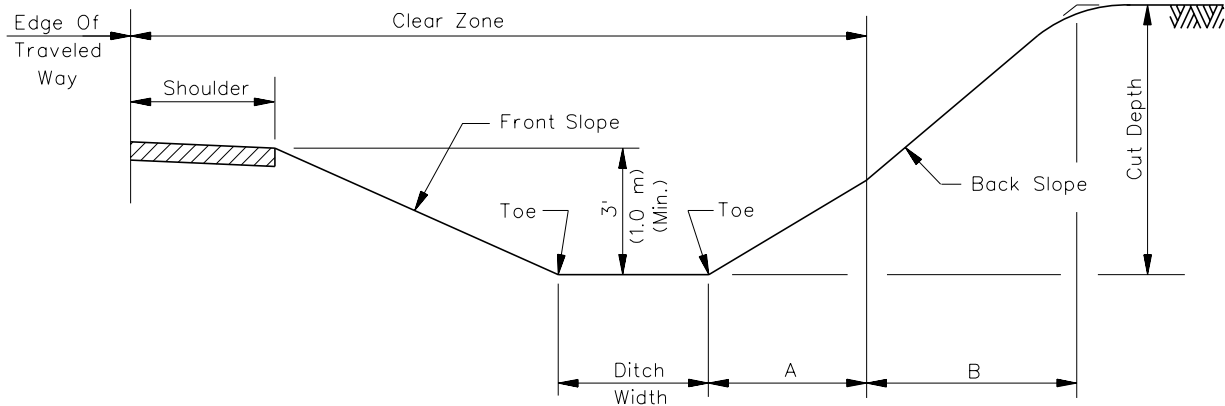

Project Scope of Work	Front Slope (V:H)	Minimum Ditch Bottom Width	Back Slopes (V:H)	
			A	B
New construction or reconstruction	1:6	4 ft (1.2 m) ⁽¹⁾	1:3	(2)
Reconstruction (allowed to remain in place) and 3R	1:4	2 ft (600 mm) ⁽¹⁾	1:3	(2)

Notes:

- (1) A wider ditch may be used where detention storage of storm water is an important consideration.
- (2) Where the height of cut exceeds 10 ft (3.0 m), consider using a 1V:2H back slope beyond the clear zone. See Section 38-3 for discussion on clear zones.

TYPICAL DITCH SECTIONS

Figure 34-4.C

(i.e., < 0.4%) may require a paved ditch so as to maintain the flow line over time. For more information on the design of ditch linings, the designer should review Chapter 40 in the *BDE Manual* and the *IDOT Drainage Manual*.

34-4.03(c) Hydraulic Design

Roadside and median ditches are to be designed according to the criteria presented in Chapter 40 and the *IDOT Drainage Manual*. The use of these criteria will ensure the proper drainage of the pavement subgrade and the adequate conveyance of surface flow without creating erosion of ditch sections.

34-4.04 Cut Sections With Curbs

On facilities with curbs, a shelf is provided with a back slope beyond the shelf. The shelf is usually sloped towards the roadway to eliminate the need for a separate drainage system behind the curb. Where sidewalks are present or anticipated in the future, provide a shelf width of 10 ft (3.0 m) with a cross slope of 2%. Where sidewalks are not present or anticipated in the future, the shelf cross slope should be 5% to provide for adequate drainage. This criteria is illustrated in Figure 34-4.D.

Where the height of a cut exceeds 30 ft (9.0 m), consider benching the back slope to minimize erosion problems. Approximately halfway down the slope, provide a bench with a V-type ditch. On short sections, the bench can be graded to drain to one side. For longer sections, grade the bench to drain from both directions. For additional guidance on benching designs, the designer should contact the district geotechnical engineer.

34-4.05 Rock Cuts (Back Slopes)

In rock cuts, the back slope generally is 1V:0.25H but could vary depending on the type of rock and field conditions; see Figure 34-4.E. For large cuts, benching of the back slope may be required. For guidance on benching designs in rock cuts, the designer should contact the district geotechnical engineer.

Conduct a cost-effective study to determine if a rock cut should encroach into the clear zone area or be located outside of the clear zone. If the rock face is located within the clear zone, provide a smooth rock cut or shield it with a roadside barrier. If the rock face and ditch to capture falling rock is outside of the clear zone, a roadside barrier typically will not be warranted.

In addition, conduct a hydraulic analysis to evaluate the need to control cascading water from the top of the cut and to determine the conveyance needs or roadside drainage at the toe of the cut.

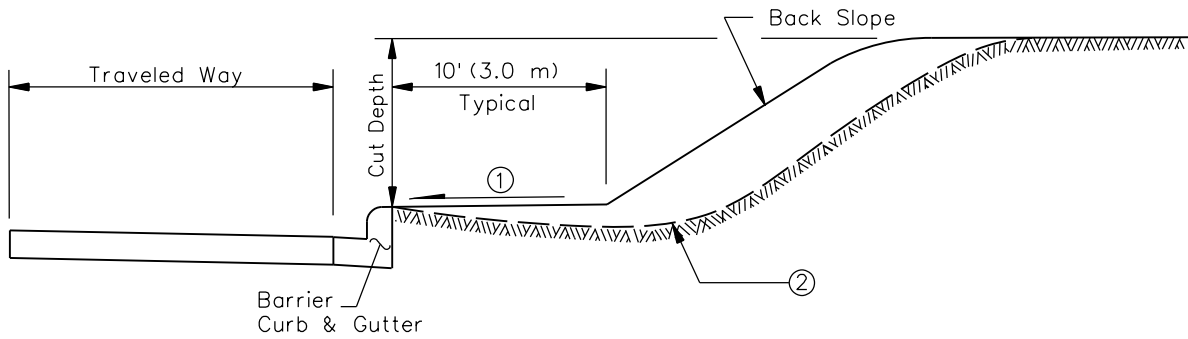

Notes:

- ① 2% If sidewalks are present or anticipated.
5% If sidewalks are not present or anticipated.
- ② Drainage swale may be needed to meet field conditions.

Facility	Back Slopes (V:H)
Urban Arterials	1:3
Urban Marked Route Collectors	1:2

(A) DESIGN SPEED \leq 45 mph (70 km/h)

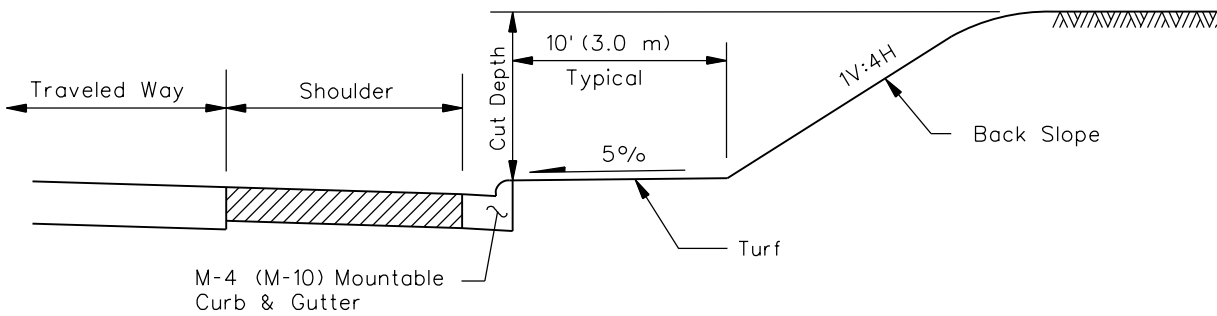

(B) DESIGN SPEED \geq 50 mph (80 km/h)
(RESTRICTED RIGHT-OF-WAY)

Note: See Section 38-3 for clear zone discussion.

**TYPICAL CUT SECTIONS
(Curbed Facilities)**

Figure 34-4.D

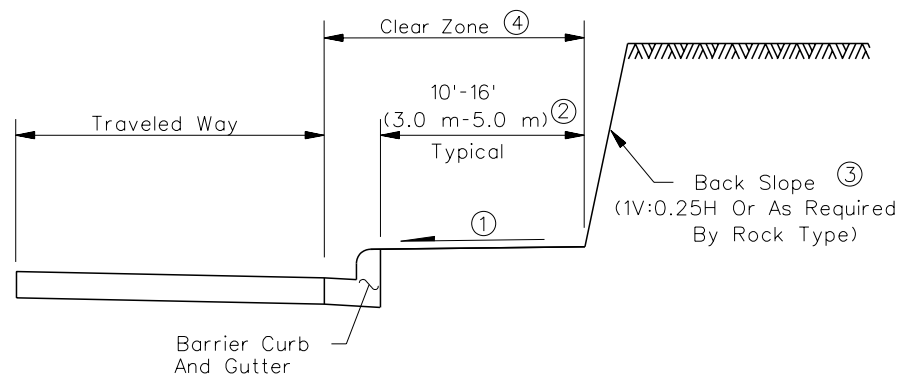
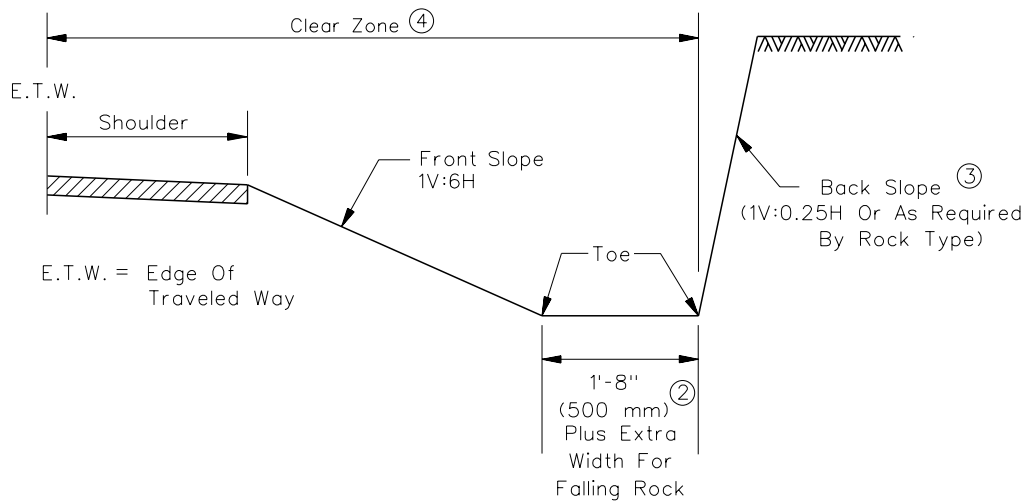
(A) DESIGN SPEED ≤ 45 mph (70 km/h)(B) DESIGN SPEED ≥ 50 mph (80 km/h)**Notes:**

- ① Use 2% if sidewalks are presented or anticipated. Use 5% if sidewalks are not present or anticipated.
- ② Discuss with the district geotechnical engineer to determine extra width needed for falling rock.
- ③ Back slopes in rock may require benching. Contact the district geotechnical engineer.
- ④ See Section 38-3.04.4 for clear zone discussion on rock cuts.

TYPICAL ROCK CUT SECTIONS**Figure 34-4.E**

34-4.06 Roadside Safety

To safely accommodate a run-off-the-road vehicle, all slopes should be as flat as practical. Section 38-3 presents specific criteria to determine desirable front slope, ditch width, and back slope combinations. All hazards within the clear zone should be removed, relocated, made breakaway, or shielded.

34-4.07 Transverse Slopes

Common obstacles along roadsides are embankment (transverse) slopes created by median crossovers, driveways, or intersecting side roads. The criteria for designing transverse slopes are discussed in Section 38-4.

34-4.08 Geotechnical Features

During the Phase I development stage, the designer must ensure that the topography and geology of the selected alignment and profile are compatible with the proposed fill and cut slope sections. The use of earthwork computer programs will help to determine cross section limits. In addition, on new construction or reconstruction projects, the Phase I Geotechnical Report and any additional data must be analyzed during the preparation of the construction plans. This will help to ensure the stability of selected cut and fill slopes which are 1V:3H or steeper.

Major or unusual geotechnical features within the project limits will require special consideration. These features should be reviewed with the district geotechnical engineer. Usually, a meeting to discuss the geotechnical features will be warranted. The designer should discuss geotechnical features with the district geotechnical engineer, when the project includes the following:

1. Earthwork. Soil or rock cuts or fills where:
 - the maximum height of cut or fill exceeds 30 ft (9.0 m), or
 - the cuts or fills are located in topography and/or geologic areas with known stability problems.
2. Soil and Rock Instability Corrections. Cut, fill, or natural slopes which are presently or potentially unstable.
3. Retaining Walls. Where the maximum height at any point along the length of the retaining wall exceeds 10 ft (3.0 m), the Bureau of Bridges and Structures will be responsible for the retaining wall design and review. Geotechnical aspects may include bearing capacity, settlement, overturning, and sliding. When selecting the wall type, note that precast concrete block walls are not appropriate:

- in areas which will be exposed to salt or other de-icing chemicals;
 - in wet areas which will keep them in a saturated condition, therefore allowing detrimental freezing to occur (e.g., a wall next to a pond, lake, or stream);
 - for structurally critical applications (e.g., a wall to retain a road, support a bridge cone, support an abutment/pier);
 - for tiered wall systems; and
 - for walls higher than 5 ft (1.5 m), as measured from the top of the block elevation to the finished grade line at the wall face.
4. Difficult or Unusual Geotechnical Problems. These conditions may include embankment construction on weak and compressible foundation material (difficult) or fills constructed using degradable shales (unusual).
 5. New or Complex Designs. This may include geotextile soil reinforcement, permanent ground anchors, wick drains, stone columns, etc.
 6. Unusual Design Methods. This may include experimental retaining wall systems or pile foundations where dense soils exist.

34-4.09 Aesthetics

The designer should explore various options to improve the visual impact a roadway will have on the landscape. Varying the cross section elements will typically improve the aesthetics of the roadway. This may include:

- increasing or decreasing the side slopes to reduce the magnitude of exposed cut and fill slopes,
- reducing ditch widths or depths to reduce the amount of cut,
- using slope rounding to blend cuts and fills into the natural ground,
- warping side slopes to match the natural landscape,
- retaining existing vegetation,
- using a raised-curb or depressed median with plantings, and
- providing structures which match the natural landscape.

Section 33-6.03 provides additional guidance for improving highway aesthetics relative to its surroundings. Address aesthetic issues with the Stakeholders during the Context Sensitive Solutions (CSS) process.

34-5 RIGHT-OF-WAY

34-5.01 General

The purpose of acquiring highway rights-of-way is to provide sufficient room to construct the facility, to enable the safe operation of vehicles on the facility, and to permit the safe and efficient maintenance of the facility.

The Bureau of Program Development in Districts 2 through 9 and the Bureau of Programming in District 1 are responsible for plotting highway cross sections during Phase I studies. These cross sections aid in establishing the right-of-way width required for the construction and future maintenance of the highway. However, the exact final location of the right-of-way line will be the responsibility of the District Chief of Plats and Plans after all environmental commitments, construction, safety, and maintenance requirements have been met. The guidance used by the District Chief of Plats and Plans is contained in *IDOT Land Acquisition Policies and Procedures Manual*.

34-5.02 Definitions

The following definitions apply:

1. Permanent Right-of-Way. Right-of-way acquired for permanent ownership by the State for activities which are the responsibility of the State for an indefinite period of time. The State obtains the title to the property. Permanent right-of-way is typically acquired for roadways, roadsides, etc.
2. Temporary Construction Easement. Easements acquired for the legal right of usage by the State to serve a specific purpose for a limited period of time (e.g., construction, maintenance and protection of traffic during construction). Once the activity is completed, the State yields its legal right of usage.
3. Permanent Easements. Easements acquired with the perpetual right to construct and maintain a public highway and incidental facilities over and across the surface of lands. Types of permanent easements include:
 - highway easements,
 - utility easements,
 - storm sewer easements, and
 - areas of soil or ground water contamination.
4. Channel Easements. Easements acquired specifically for stream channel construction and maintenance, which provides the State with a permanent right of ingress and egress. The property owner relinquishes the right to modify the channel dimensions (e.g., slopes).

34-5.03 Establishment of Right-of-Way Lines

Proposed right-of-way lines will be dimensioned from a centerline or survey line. Centerlines may be the centerline of pavement to remain in place, proposed centerline of pavement, centerline of median, or centerline of platted streets. Survey lines may be a survey line of the proposed improvement or relocated survey line. Do not dimension the right-of-way line from a centerline of pavement in place, existing right-of-way line, or any other line that will be removed. Dimensions must be from a line that can be located in the field (e.g., monuments, physical objects, ties).

34-5.04 Right-of-Way Width

Width of the proposed right-of-way or break points in rural areas should be based on multiples of 5 ft (2.0 m) (e.g., 65 ft, 70 ft, 75 ft). Avoid widths of right-of-way or break points that are a decimal of a foot (meter) unless the proposed right-of-way line is along the property line. However, there may be cases where the proposed right-of-way or break points are rounded off to the nearest foot (300 mm) (e.g., existing development, near or at the back edge of the sidewalk). Right-of-way lines parallel or concentric with the existing centerline or survey line are the most desirable. On curves, it also may be advantageous to use a series of straight lines.

In general, for new facilities, the minimum right-of-way width will be the sum of the traveled way(s), outside shoulders, median width (if applicable), necessary width for fill and cut slopes, plus a maintenance border area beyond the construction limits. The total width will vary according to the functional classification and urban/rural environment.

In general, minimal additional right-of-way will be required for 3R projects. However, ditch cleaning and slope flattening may be desirable on these projects. Consequently, strips of minimum width of right-of-way or easements may be required.

Adequate right-of-way must also be attained around side road radius returns to accommodate the shoulder and ditch/drainage transition from the mainline to the side road. Culverts also require special attention particularly on extensions. Right-of-way may be required to match existing channels.

In addition to the border area beyond the construction limits, allowance may be necessary for the provision of frontage roads, special drainage facilities, roadside clear zones, and future expansion of the highway. These border areas are required for maintenance operations, the retention of natural growth for scenic and ecological purposes, erosion control and, in some cases, for accommodating public utilities; see Section 34-6. Border areas also serve as a buffer between the limits of construction and abutting private development.

34-5.05 Other Considerations

In addition to the minimum right-of-way widths, the designer should consider the following:

1. Design of Right-of-Way Breaks. Desirably, the right-of-way limits should be uniform and the number of breaks minimized. This will limit the number of right-of-way markers or corner fence posts. In addition, the designer should consider the following:
 - a. Break Points. Identify each “break point” in the right-of-way line by a station and offset distance from the centerline or the survey line of construction.
 - b. Changes. Avoid abrupt changes in the right-of-way lines. Where changes are required, the rate of change should be as flat as practical.
 - c. Breaks on Property Lines. A change in the distance from the centerline to the right-of-way line should not occur on a property line if there is a taking from two adjacent properties. Right-of-way markers set on apparent property lines in the past are now considered by their owners as located on the property lines, which may or may not be correct.
 - d. Non-Stakeable Breaks. Avoid right-of-way breaks where the break points cannot be staked. For example, avoid a right-of-way break point in a stream or in a driveway. Also, right-of-way breaks should be at least 20 ft (6.0 m) from the edge of any body of water (e.g., lakes, streams).
 - e. Small Parcels. Additional right-of-way break points and short distances between breaks may be considered only where it will eliminate a taking (parcel) or will avoid leaving a small uneconomical remnant. In rural areas, small irregular and triangular-shaped remainders less than 50 ft (15 m) in width will be included as part of the right-of-way. To avoid relocating a building in urban areas, the right-of-way line may need to be adjusted.
2. Acquiring Fee to Dedicated Right-of-Way. Obtain the fee interest in right-of-way. When the owner has a fee interest to dedicated right-of-way which is adjacent to the property, the fee interest may be acquired for that portion of the right-of-way which lies between the existing right-of-way line and the property line. This would be in addition to any new right-of-way required. This procedure will eliminate the owner from having to pay taxes on the dedicated right-of-way and will make it easier for utility companies to obtain permits.
3. Utility Adjustments. Problems may occur with utility adjustments where the right-of-way lines are irregular and/or are placed too close to the outer limits of construction. For example, where a pole line is relocated on State right-of-way, the utility company may be faced with the following problems:
 - numerous guy wires,
 - poles or guy wires on private property that require easements and which may cause delays, and/or

- requesting cross sections from the State for the utility company to identify where it may or may not place power and/or communication poles.

Similar problems are encountered with relocated water and gas mains. Although these matters often do not cause direct and tangible cost to the Department, they may create unnecessary expense to the utility and indirectly may create delays to construction and increase user delays.

4. End Right-of-Way Taking (Terminal Parcel). Where a construction project ends within the limits of a particular property, it is desirable to continue the right-of-way across the property if additional right-of-way will be required for a future project. If the proposed project ends within the property, taper the proposed right-of-way line into the existing right-of-way line.
5. Variable Median. For variable width medians, describe the right-of-way from one survey line or centerline, wherever practical. For wide medians (200 ft (60 m) or more), it may be necessary to describe the right-of-way from two survey lines or centerlines.
6. Sidewalks. If a sidewalk will be constructed on a project, locate the right-of-way line a minimum of 1 ft (300 mm) from the back edge of the sidewalk, if practical. Grading for sidewalk construction, which lies outside of the existing or proposed right-of-way, Requires a temporary easement.
7. Intersection Sight Distance (Corner Cuts). Acquire adequate right-of-way to provide the applicable intersection sight distance as described in Chapters 36 and 49.
8. Fee Taking Versus Temporary Easement. Where it is necessary to work outside the existing right-of-way lines for grading of roadside ditches, channel changes, slope rounding, construction of temporary access roads at bridges, and/or other locations, the Department should acquire additional working area in fee interest in lieu of a temporary easement on construction projects. Additional width of right-of-way at bridges will allow for easier access for bridge maintenance and for work on channels (e.g., realignment, placement of riprap, jetties).

34-6 UTILITIES

34-6.01 Definition

A “utility” is defined as a privately, publicly, or cooperatively owned line, facility, or system for producing, transmitting, or distributing communications, cable television, power, electricity, light, heat, gas, oil, crude products, water, steam, waste, storm water not connected with highway drainage, or any other similar commodity. This includes any fire or police signal system or street lighting system, which directly or indirectly serves the public. The term “utility” will also apply to a utility company inclusive of any wholly owned or controlled subsidiary. The term “utility” includes those facilities used solely by the utility which are a part of its operating plant.

34-6.02 Location

In general, it will be the responsibility of the planner and designer to locate, identify and, to the maximum extent practical, avoid disturbance of all existing utilities and to determine, initially, the appropriate utility locations on new construction and reconstruction projects. The planner and/or designer should review Chapter 6 of the *BDE Manual* and the current edition of the *IDOT Accommodation of Utilities on Right-of-Way of the Illinois Highway System* for the latest utility accommodation criteria.

34-6.03 Design Considerations

The overall Department objective is to ensure completion of the required adjustment for all conflicting utility facilities in a mutually satisfactory manner in advance of the roadway construction. The district utility coordinator is responsible for working with the utility companies to develop the relocation design details for utility relocations or adjustments. This criteria is presented in the *IDOT Accommodation of Utilities on Right-of-Way of the Illinois State Highway System*. The designer should ensure that the proposed design is consistent with the proposed highway improvement.

1. Utility Locations. Utility installations should be located as follows:
 - Locate longitudinal utilities parallel and as near as practical to the right-of-way line but not more than 8 ft (2.4 m) from the right-of-way line.
 - Locate ground-mounted appurtenances for underground facilities within 1 ft (300 mm) or as near as practical to the right-of-way line.
 - No new above-ground longitudinal utilities, including any above-ground appurtenances for underground installations, will be placed within the clear zone.
 - No new longitudinal utility installations will be permitted under the paved portion of streets and highways under State jurisdiction.

- Utilities will not be permitted to cross under State highways in cattle passes, culverts, or other drainage facilities.
 - New manholes will not be permitted in the traveled way or shoulders of State highways. Existing manholes may remain in place.
 - Utility crossings should be approximately 90 degrees to the highway centerline as practical.
 - No utility appurtenances (e.g., pumping stations, transformers) will be allowed within interchange right-of-way.
 - Special restrictions may be placed on utility companies where visual quality is an important consideration. See *IDOT Accommodation of Utilities on Right-of-Way of the Illinois Highway System* for more information.
2. Cover. The following cover criteria, below the pavement surface, will be required for underground installations:
- a. Power. These installations will require a minimum cover of 30 in. (750 mm).
 - b. Communication. Where these installation are installed by the plowed method, the minimum cover will be 2 ft (600 mm).
 - c. Gas Pipelines. Gas installations must have a minimum cover of 30 in. (750 mm) at all locations within the highway right-of-way.
 - d. Water Lines. To prevent freezing, place water lines below the frost line.
 - e. Sewers and Drain Lines. Storm sewers, sanitary sewers, and drain lines must have a minimum clearance of 30 in. (750 mm) to the top of pipe to prevent freezing.
3. Aerial. The following will apply to power lines and/or communication lines:
- a. Guy Wires and Brace Posts. These devices will not be allowed on the State right-of-way.
 - b. Overhead Clearances. For overhead power and communication lines crossing fully access-controlled facilities, the minimum vertical clearance is 20 ft (6.1 m) and for other facility types 18 ft (5.5 m).
 - c. Location. In general, aerial utility poles should be located as close to the right-of-way line as practical. However, for urban areas the following will apply:
 - Curbed. For curbed sections, the minimum placement distance of poles behind the face of the curb is 18 in. (500 mm) to the closest face of the pole.

- Shoulder with Curb and Gutter at Shoulder Edge. The minimum pole placement is 4 ft (1.2 m) beyond the outside of the shoulder to the closest face of the pole. In addition, the clear zone distance must be checked.
4. Light Standards. Place light standards and power poles in accordance with the criteria presented in Chapter 56.
 5. Detours. Awareness of potential utility conflicts is extremely important when constructing detours near the right-of-way line or on temporary right-of-way.

34-7 REFERENCES

1. *A Policy on Geometric Design of Highways and Streets*, AASHTO, 2011.
2. NCHRP Report 375, *Median Intersection Design*, 1995.
3. *Highway Standards*, IDOT, current edition.
4. *Highway Capacity Manual 2010*, Transportation Research Board, 2010.
5. *IDOT Drainage Manual*, Bureau of Bridges and Structures, IDOT.
6. *IDOT Policy on Permits for Access Driveways to State Highways*, IDOT, 1990.
7. *Manual on Uniform Traffic Control Devices*, 2003 Edition, FHWA, ATSSA, AASHTO, and ITE, 2009.
8. *Roadside Design Guide*, AASHTO, 2011.
9. *Land Acquisition Policies and Procedures Manual*, Bureau of Land Acquisition, IDOT.
10. *Accommodation of Utilities on Right-of-Way of the Illinois State Highway System*, IDOT, 1992.
11. *Flexibility in Highway Design*, FHWA and AASHTO, 1997.
12. *Determining Economic Impacts on Adjacent Businesses Due to Restricting Left Turns*, NCHRP 25-4, Research Results Digest No. 231, 1998.

Chapter Thirty-five

ACCESS CONTROL/ ACCESS MANAGEMENT

BUREAU OF DESIGN AND ENVIRONMENT MANUAL

Table of Contents

(Continued)

<u>Section</u>		<u>Page</u>
	35-6.01(b) Relationship to Functional Classification	35-6.1
35-6.02	Objectives of Access Management	35-6.1
35-6.03	Benefits of Access Management	35-6.2
35-6.04	Disadvantages of Access Management	35-6.2
35-6.05	Elements of an Access Management Program	35-6.3
	35-6.05(a) Coordination.....	35-6.3
	35-6.05(b) Enforcement.....	35-6.3
	35-6.05(c) Engineering.....	35-6.4
35-7	ACCESS MANAGEMENT TECHNIQUES	35-7.1
35-8	REFERENCES.....	35-8.1

Chapter Thirty-five

ACCESS CONTROL/ACCESS MANAGEMENT

Chapter 35 discusses the general concepts of access management, describes common access management techniques, and presents detailed figures on providing access control for interchange crossroads and for crossroads intersecting expressways. Additional access control criteria and access management techniques are contained in the following chapters:

- Chapter 36, Section 36-7.01, provides general guidelines for designing the connections of proposed driveways and entrances to State highways in conjunction with new construction highway projects, and modifying the connections of existing driveways and entrances to State highways in conjunction with new construction, reconstruction, or 3R highway projects.
- Chapter 37 briefly describes access control criteria around interchanges.
- Chapter 44 presents access control drawings illustrating the mainline of rural and urban freeways.
- Chapter 45 discusses access control policies regarding expressways and includes illustrations of access control at frontage road/service drive intersections.
- Chapter 46 discusses access management techniques regarding Strategic Regional Arterials.

The IDOT Bureau of Operations handbook entitled, *Policy on Permits for Access Driveways to State Highways* (governed by the Illinois Highway Code sections 605 ILCS 5/4-209, 4-210, 4-211, and 4-212 and 92 Ill. Admin. Code 550) discusses procedures for obtaining access to non-access controlled State highways. It also describes the design requirements for driveways and entrances in conjunction with individual permits. Section 36-7.02 of this Manual also provides general information regarding the highway access permit process for new or revised individual entrances to a State highway.

35-1 GENERAL CONCEPTS

35-1.01 Definitions

1. Access Control. The condition where the public authority regulates the right of abutting owners to have access to and from a public highway by declaring the highway to be either fully or partially access controlled. This is accomplished through the purchase of access rights or right-of-way, driveway controls, turning restrictions, or geometric design (e.g., grade separations).

2. Access Management. The process of governing access to land development by a public agency where the agency considers the highway facility and its surrounding activities as part of an overall system. Individual parts of the system (e.g., zoning, land-use planning, site plan development, driveway permits, public transportation, roadway network) should be properly integrated and coordinated. Through proper application of access management, the objectives of providing safe and efficient traffic flow coupled with access to abutting properties can be achieved.
3. Controlled Access Highway. A highway where the right of abutting property owners or occupants of land to access, light, air rights, or view, in conjunction with a highway design, is controlled by a public authority (605 ILCS 5/8-101).
4. Full Control of Access. Highways which are designated to have full control of access are referred to as freeways. Priority is given to through traffic and access to the highway is only provided at interchanges with selected public roads. All other intersecting roads are either terminated at the right-of-way line, perpetuated with grade separations, or interconnected with other roads. Access is provided to properties abutting the freeway via frontage roads, service drives, or the existing public road system. Full control of access maximizes the capacity, safety, and vehicular speeds on the highway.
5. Partial Control of Access. An expressway design is the common term used for this type of facility. Priority is given to through traffic. Some intersections will be provided and private entrance connections will be allowed by permit. The proper selection and spacing of intersections and other connections provides a balance between the mobility and access functions of the highway.

Partial access control is required on rural multilane highways designated as expressways. These highways generally are of significant length and connect major termini. In urban areas, an existing highway or street may be designated as an expressway design with partial access control. In addition, some suburban highways on the minor arterial system, which are planned for upgrading to a multilane highway, should be investigated and considered for partial access control.

Access to expressways is provided by means of interchange facilities or by the following at-grade connections:

- selected public crossroads,
- frontage roads,
- service drives, and
- one point of direct access from an abutting property which is used solely for farming purposes and/or one point of access for a single family residence. Such points of access must meet the spacing requirements as stated in Chapter 45.

Direct commercial access to an expressway is prohibited.

6. Managed Access. On highways with neither full nor partial control of access, the concepts of access management are applied to provide an optimum balance between mobility and access functions. Private development is not guaranteed direct access to State-marked highways. However, reasonable access is guaranteed.
7. Control by Regulation. All highways warrant some degree of access management. Control by regulation is exercised by the Department, county highway departments or municipalities to specify the location of private access to and from the public road system. Occasionally, statutory control is used on arterials to restrict access to only public roads and major traffic generators. Zoning may be used to effectively control development on adjacent property so that major generators do not hinder traffic operations. However, zoning restrictions are at the discretion of the local government. Driveway regulations and permits are used to control the geometric design of an entrance, driveway spacing, and driveway proximity to public road intersections.
8. Access Control Line. A line established by the Department that prohibits ingress to and egress from a highway facility. When an existing access controlled highway is reconstructed, the access control lines should be reviewed for possible revisions.

35-1.02 Authority

35-1.02(a) Freeways and Expressways

Chapter 605 ILCS 5 of the Illinois Compiled Statutes is commonly known as the *Illinois Highway Code*. Section 8-101 of the *Code* authorizes the Department, a county, or municipality to evaluate and establish an access controlled type highway which promotes the safety and convenience of highway traffic.

The governing agency also has the authority to control existing and future highway access to land abutting an access controlled highway (Section 8-107) and may extinguish the right of access by purchase or condemnation (Sections 8-102 and 8-103). The *Illinois Highway Code* further authorizes the relocation or termination of intersecting roads (Section 8-106) and the location of first access points on a side road or street (Section 8-101). BDE is responsible for the administration of access requirements for access-controlled highways. The details of access control around major intersections on expressways or along interchange crossroads are shown in figures contained in this Chapter.

35-1.02(b) Other State Highways

Chapter 605, Section 5/4-210, of the *Illinois Highway Code* authorizes the Department to adopt and amend reasonable and necessary rules, regulations, and specifications covering standard entrance or exit driveways that serve residential, farm, commercial, industrial, and roadside service establishments and other uses of property abutting upon highways. These regulations are contained in the *92 Ill. Admin. Code 550, Policy on Permits for Access Driveways to State Highways*. The central Bureau of Operations is responsible for administration of the Permit

Policy. In a general sense, Section 5/4-210 of the *Code* enables the Department to manage access to its network of non-access controlled State routes.

In addition, under Section 5/4-210, the Department may introduce controls such as conversion of streets or highways to one-way traffic operation, the prohibition of turning movements, the channelization of traffic by marked lanes, and the wide use of a variety of median types and median barriers.

35-2 ACCESS CONTROL CRITERIA

35-2.01 General

The extent of access control on any freeway or expressway is indicated by the access control line. During the development of location/design studies for a project, access control information is placed on aerial mosaics. The aerial mosaic exhibits are placed in an 11 in x 17 in format and are designated as an appendix to the Phase I report. See Section 35-5 for information on the preparation of access control plans. Access control lines are also placed on construction plans and right-of-way plats and plans.

The access control line is generally coincident with or parallel to the right-of-way line of the normal roadway section and is continuous throughout or intermittent, depending upon the degree of access control provided. The access control line, however, must assume various configurations at grade separation structures and bridges and also must be extended along intersecting highways. The extended distance along intersecting highways shall be sufficient to protect traffic movements near intersections or at interchange ramp terminals.

35-2.02 Access Control Along Interchange Crossroads

The development of the Interstate System and other access-controlled highways in Illinois has demonstrated the importance of minimizing congestion at freeway interchanges. This has been achieved by optimizing the relationship between the highway facilities and the use of land in interchange areas. Sound development of the area of influence around an interchange requires:

- proper land-use of the area adjacent to the interchange to maximize potential development, and
- proper highway design and length of access control along the crossroad.

Land-use planning in the interchange area is the responsibility of the local agency. One of their most valuable assets is undeveloped land. Unplanned development of this area can result in a substantial economic loss to the community and congestion on the adjacent highway system.

The design of the crossroad and the need for access control is a function of the design speed and projected traffic volumes. Also, operational maneuvers between the ramp terminal and the nearest access connection and adequate distance for advance guide signs have an important role in determining access control distances along the crossroad.

If private driveways, commercial entrances, and public streets are located too close to ramp terminals, they cause congested conditions due to conflicts between the ramp traffic, the through traffic on the crossroad, and the turning traffic at the first access connection. Substantial relief from these conditions can be obtained by the extension of access control a predetermined distance along the crossroads. This essential length of protected roadway will allow crossroad/ramp traffic to enter or leave the crossroad free of conflict with access

connection traffic. Such a design will also result in safer and more efficient access to land around the interchange area.

To promote safe and efficient traffic operations in the proximity of interchange ramp terminals and to promote proper land-use planning, the Department has adopted several methods of establishing access control limits along crossroads. Figures 35-2.B through 35-2.J present the Department's access control criteria for interchange areas. These apply to various combinations of interchange type (diamond, parclo, or trumpet), mainline facility type (freeway or expressway), crossroad type (two-lane or multilane divided), ramp type (on, off, or slip), and type of control at ramp terminal intersections with the crossroad (controlled ramp or free-flow). Each figure includes narrative information specifically applicable to that figure. In addition, the following comments apply to all figures:

1. Dimension Values. Figure 35-2.A presents the values for distances (D), bay tapers (T), and lengths to first access condition (L) based on the design speed of the crossroad.
2. Application to Both Sides. The lengths of access control (A/C) as shown in the figures should be provided equally on both sides of the crossroad. This will preclude minor entrances from developing between the ramps and access connections creating closely spaced offset intersections.
3. Existing/Proposed Access Connections. The lengths as shown in the figures should be used for determining the location of access connections. However, where there are existing access connections on the crossroad, the exact termination points of access control may require a detailed study. The study may determine that certain access connections be closed and relocated to a new service drive or frontage road.

For both existing and proposed connections, the specific design should also include consideration of the character of the area, cultural development, location of property lines, and skew angle of the intersection.

4. Extension of Access Control Beyond Minimums. At certain locations, it may be desirable to extend access control beyond the minimum limits to a nearby intersection or a major traffic generator. However, because the interchange area has marked potential for economic benefit to the community and for providing motorist services, discretion should be used in extending access control beyond the requirements. In all cases, an analysis should be made to determine if an extension of access control beyond the minimum requirements is a sound investment in the interest of highway safety and efficiency and consistent with abutting land use.
5. Controlled Ramp Terminal. A controlled ramp terminal is one through which traffic operations are normally regulated by either stop signs or traffic signals and entrance to or exit from such a terminal is through short-radius turns at a relatively slow speed. The establishment of minimum access control limits adjacent to a controlled ramp terminal is based on the need for auxiliary right- or left-turn lanes on the crossroad and for proper signing distance.

In evaluating operational maneuvers as a basis for establishing the extent of access control, the nearest access connection, whether existing, proposed, or future, is considered to be capable of generating traffic volumes of such magnitude as to require auxiliary turning lanes between the ramp terminal and access connection. Such consideration is necessary because the nature of such connections is readily susceptible to changes in development.

6. Free-Flow Ramp Terminals. A free-flow ramp terminal permits traffic to either enter or exit the crossroad at a relatively high speed without regulation of these maneuvers by either stop signs or traffic signals. The establishment of access control limits beyond free-flow ramp terminals, to the nearest access point, is based on the need for providing adequate space for critical operational maneuvers and to provide adequate geometric facilities for these maneuvers. Adequate distance for the placement of guide signs must also be provided.

USE TO DETERMINE MINIMUM "L" IN ACCESS CONTROL FIGURES			
Design Speed on Crossroad	D	T	G + C
US Customary			
30 mph	250 ft	150 ft	180 ft
40 mph	300 ft	175 ft	300 ft
45 mph	350 ft	200 ft	350 ft
50 mph	425 ft	225 ft	450 ft
55 mph	500 ft	250 ft	550 ft
60 mph	550 ft	275 ft	650 ft
70 mph	600 ft	300 ft	900 ft
Metric			
50 km/hr.	75 m	45 m	55 m
60 km/hr.	95 m	50 m	90 m
70 km/hr.	110 m	60 m	110 m
80 km/hr.	130 m	70 m	135 m
90 km/hr.	150 m	75 m	165 m
100 km/hr.	170 m	85m	190 m
110 km/hr.	185 m	90m	270 m

- L = Length used to determine location of first access connection, ft (m)
T = Length of taper of left- or right-turn lanes, ft (m)
D* = Deceleration distance (which includes T) to a stop condition for left- and right-turn lanes, ft (m)
G = Distance a motorist travels while seeking a gap in the median lane after a free-flow entry, ft (m)
C = Distance traveled while changing lanes (assume 3 seconds of travel time), ft (m)
R₁ = Radius return (see Section 36-2), ft (m)
R₂ = Control radius (see Section 36-2), ft (m)

In some areas, the storage distance (S) may govern, and the length of the turn lane will be either D or S + T, whichever is larger. See Section 36-3 to determine S.

General Notes for Figures 35-2.B through 35-2.H

1. *Where the access connection is a marked route or potential high-volume generator, "L" should not be less than 700 ft (215 m) in rural areas and 500 ft (155 m) in urban areas. These distances will permit the proper placement of the M2-1 (Junction Marker) sign assembly or the placement of the D3 (street name) sign assembly for local roads and streets.*
2. *If the first access connection is a two-lane street or highway, the minimum distance to the first entrances on the access connection should be 300 ft (90 m). For multilane access connections, longer lengths must be considered to the first entrances to allow for the installation of left-turn lanes on the access connection. In all cases, access control is used in each of the four quadrants of the intersection of the first access connection with the crossroad.*

DIMENSIONS FOR ACCESS CONTROL FIGURES AND GENERAL NOTES

Figure 35-2.A

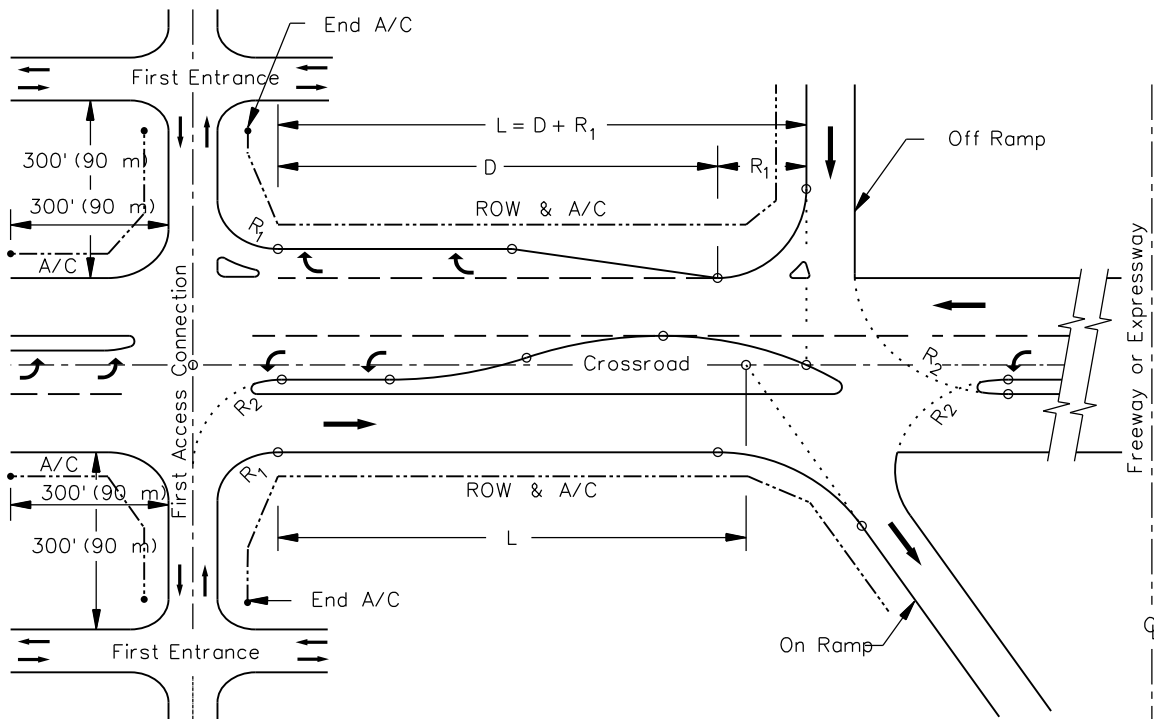

Notes:

1. The critical length "L" between the off ramp and first access connection usually is governed by a need for a future right-turn lane into the access connection.
2. In some cases, the length "L" on the same side of the crossroad as the on ramp may control the location of the first access connection. Check the length "L" on this side for sufficient signing distance. In rural areas, "L" should not be less than 600 ft (180 m). This distance will permit the proper placement of the Advance Route Turn assembly (Freeway) signs.
3. Also, refer to General Note 1 on Figure 35-2.A.
4. Refer to General Note 2 on Figure 35-2.A.

**ACCESS CONTROL ALONG CROSSROAD AT DIAMOND INTERCHANGE
(Two-Lane or Multilane Divided Crossroad)**

Figure 35-2.B

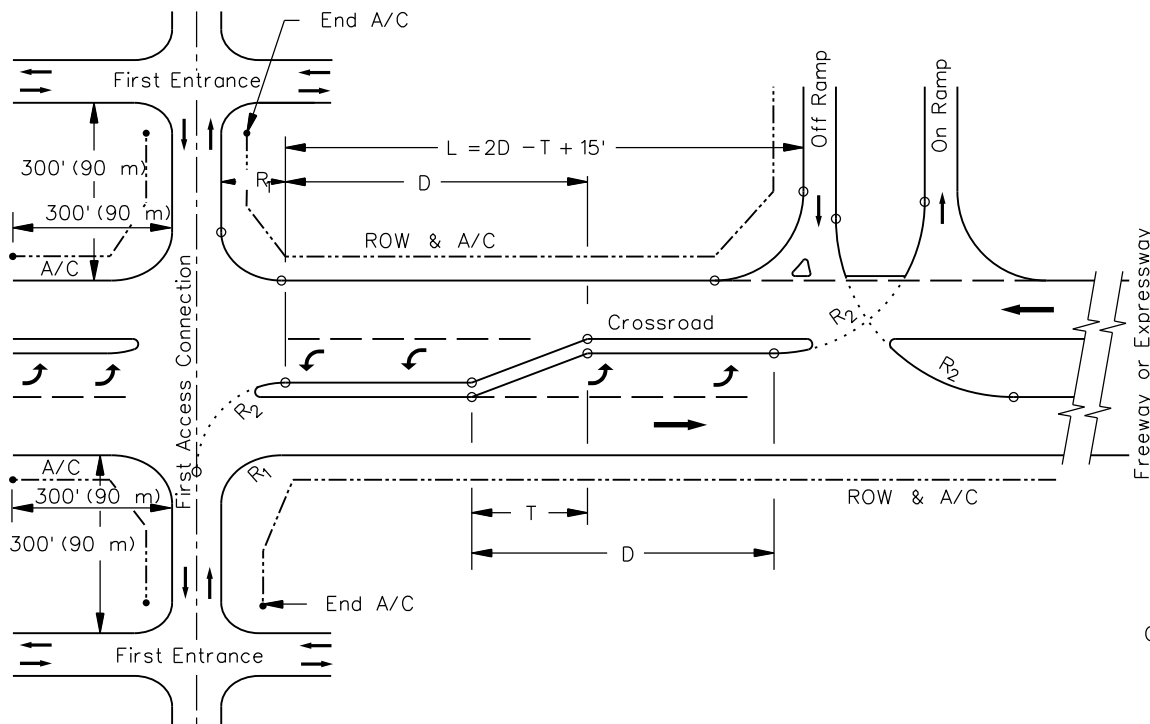

Notes:

1. The critical length "L" between the off ramp and first access connection is governed by the need for a left-turn lane into the access connection and the need for a left-turn lane into the on ramp. In addition, refer to General Note 1 on Figure 35-2.A.
2. On the opposite side of the crossroad from the off ramp, check the available distance to permit the proper placement of the Advance Route Turn assembly (Freeway) signs. In rural areas, this distance should not be less than 600 ft (180 m) from the access connection to the end of the left-turn lane on the crossroad.
3. Refer to General Note 2 on Figure 35-2.A.

**ACCESS CONTROL ALONG CROSSROAD FROM OFF RAMP AT
TWO-QUADRANT PARCLO INTERCHANGE
(Two-Lane or Multilane Divided Crossroad)**

Figure 35-2.C

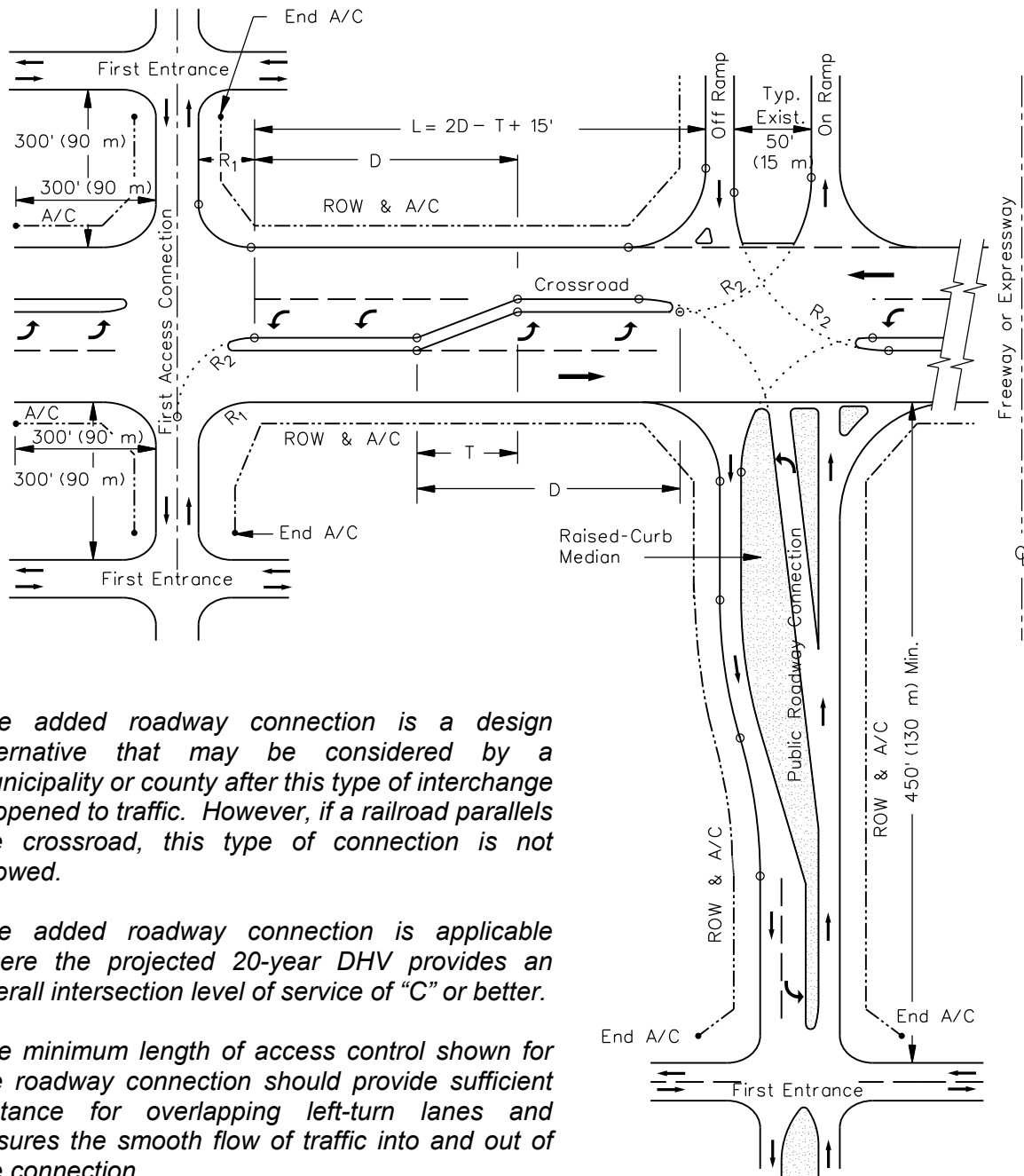

Notes:

1. The added roadway connection is a design alternative that may be considered by a municipality or county after this type of interchange is opened to traffic. However, if a railroad parallels the crossroad, this type of connection is not allowed.
2. The added roadway connection is applicable where the projected 20-year DHV provides an overall intersection level of service of "C" or better.
3. The minimum length of access control shown for the roadway connection should provide sufficient distance for overlapping left-turn lanes and ensures the smooth flow of traffic into and out of the connection.
4. Refer to General Note 2 on Figure 35-2.A for the proper design of access control for the first access connection on the crossroad.

**ACCESS CONTROL ALONG ADDED ROADWAY TO CROSSROAD
ACROSS FROM OFF/ON RAMP AT TWO-QUADRANT PARCLO INTERCHANGE
(Two-Lane or Multilane Divided Crossroad)**

Figure 35-2.D

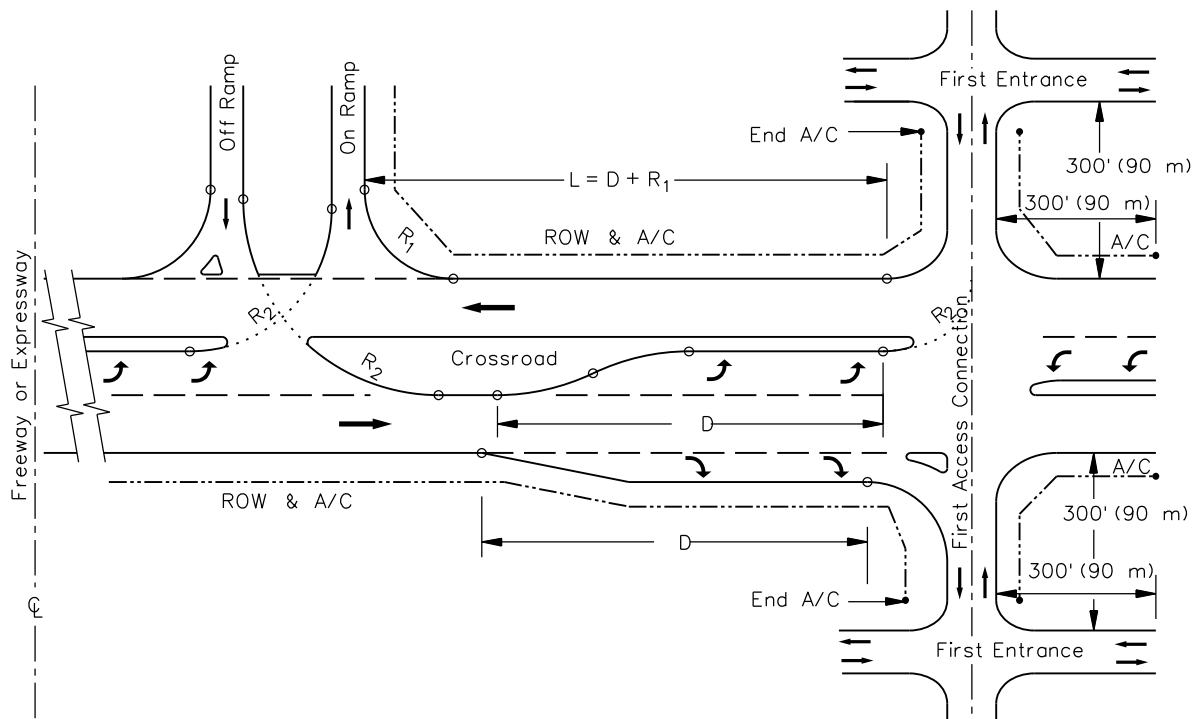

Notes:

1. The critical length "L" between the first access connection and the on ramp usually is governed by the future need for a right-turn lane into the on ramp. In rural areas, "L" should not be less than 600 ft (180 m). This distance will permit the proper placement of the Advance Route Turn assembly (Freeway) sign.
2. In some cases, the future need of a right-turn lane into the access connection on the opposite side of the crossroad from the on ramp may control the location of the first access connection. Check the layout for the distance available to construct a right-turn deceleration lane.
3. Refer to General Note 1 on Figure 35-2.A.
4. Refer to General Note 2 on Figure 35-2.A.

**ACCESS CONTROL ALONG CROSSROAD FROM ON RAMP AT
TWO-QUADRANT PARCLO INTERCHANGE
(Two-Lane or Multilane Divided Crossroad)**

Figure 35-2.E

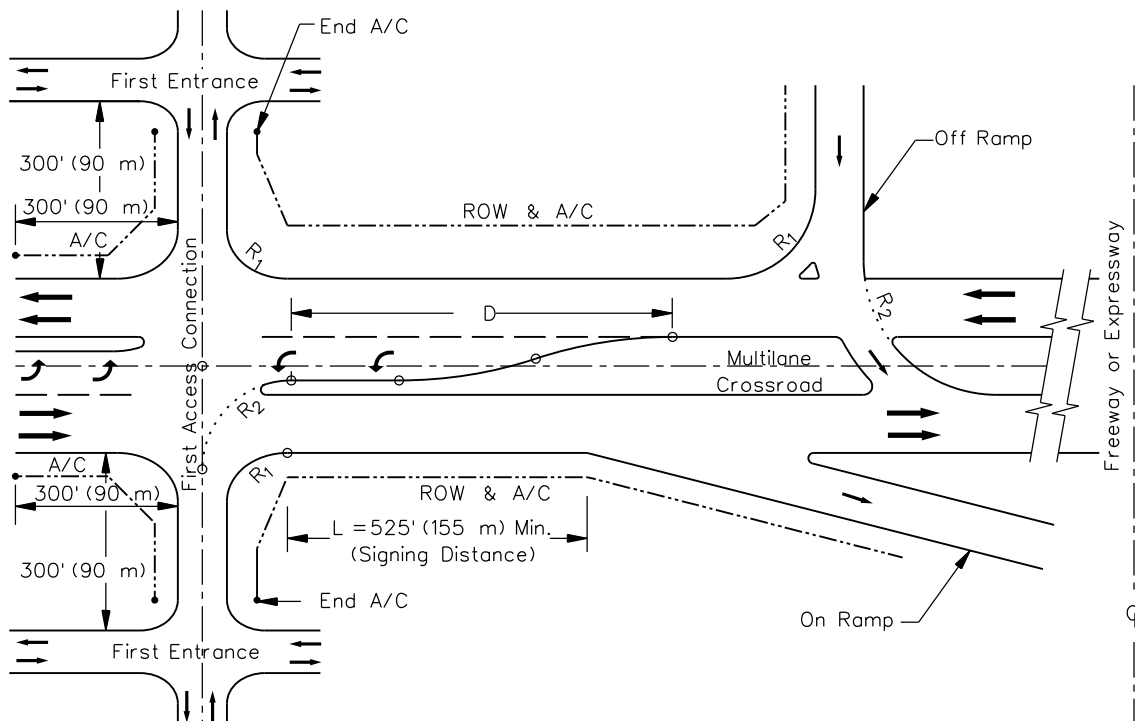

Notes:

1. The critical length "L" between the first access connection and the 1 ft (300 mm) stub of the free-flow on ramp is governed by the minimum advance signing distance. This minimum length will provide sufficient distance for the placement of the Advance Route Turn assembly (Freeway) signs.
2. Also, check the critical length "L" between the off ramp and the first access connection for adequate distance for a future right-turn lane into the access connection. In addition, refer to General Note 1 on Figure 35-2.A.
3. Refer to General Note 2 on Figure 35-2.A.

**ACCESS CONTROL ALONG CROSSROAD AT
FOUR-QUADRANT PARCLO (Type A) INTERCHANGE
(Free-Flow On Ramp)**

Figure 35-2.F

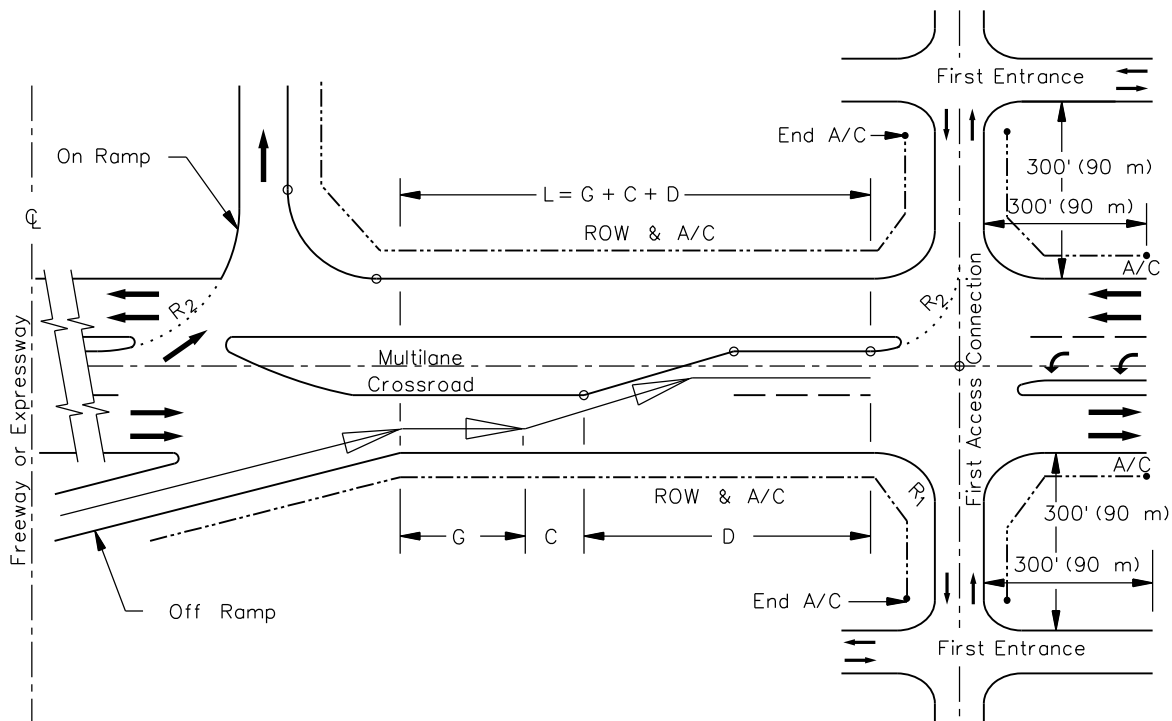

Notes:

1. *The critical length "L" is controlled by the free-flow off ramp maneuver. The minimum required distance to the first access connection is based on the design speed of the crossroad and is the combination of the operational maneuvers as shown schematically above. See the table in Figure 35-2.A for distances. Use the equation $L = (n - 1)(G + C) + D$, where $n = 2$ or 3 lanes, to determine the total required distances.*
2. *Refer to General Note 2 on Figure 35-2.A.*

**ACCESS CONTROL ALONG CROSSROAD AT
FOUR-QUADRANT PARCLO (Type B) INTERCHANGE
(Free-Flow Off Ramp)**

Figure 35-2.G

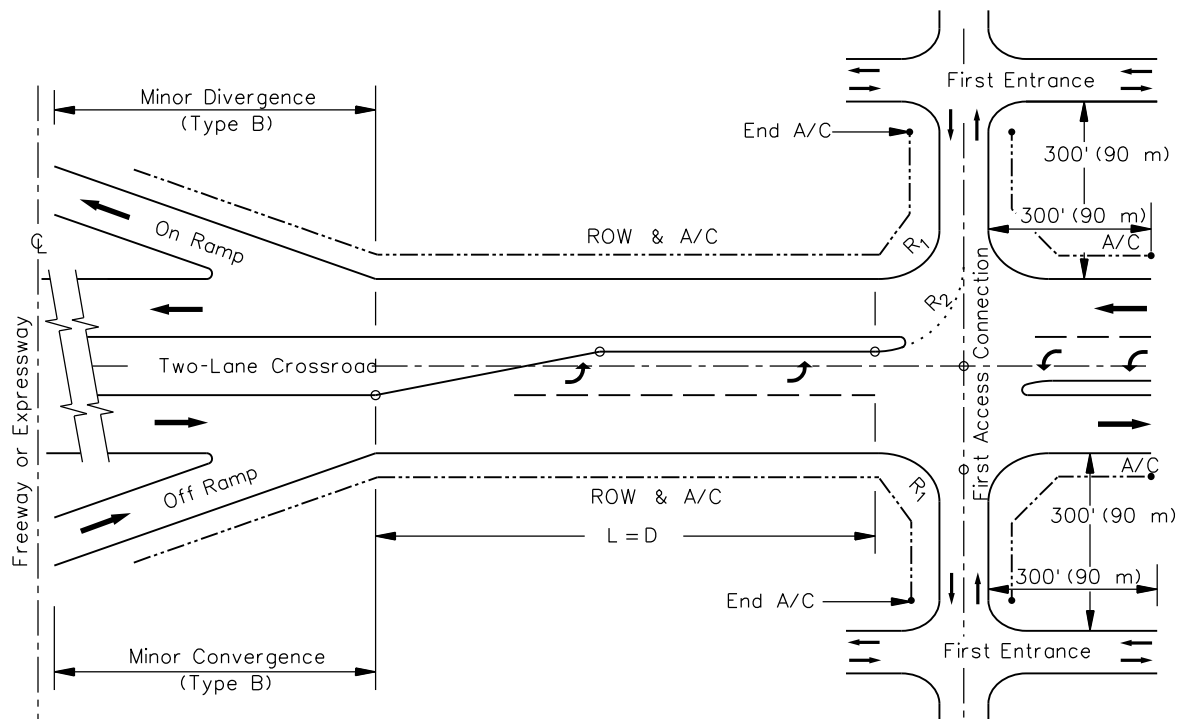

Notes:

1. The critical length "L" between the ends of the Type B convergence and divergence on the crossroad to the first access connection usually is governed by the need for a left-turn lane into the access connection. Select a design speed and refer to the table in Figure 35-2.A.
2. In the case of a trumpet interchange stem which is designed as a multilane crossroad (Type A design), refer to Figure 35-2.G and use distances of "C" plus "D" to determine the critical length "L." Start at the end of the minor convergence.
3. Refer to General Note 1 on Figure 35-2.A.
4. Refer to General Note 2 on Figure 35-2.A.

**TRUMPET INTERCHANGE
(Two-Lane Divided Crossroad)**

Figure 35-2.H

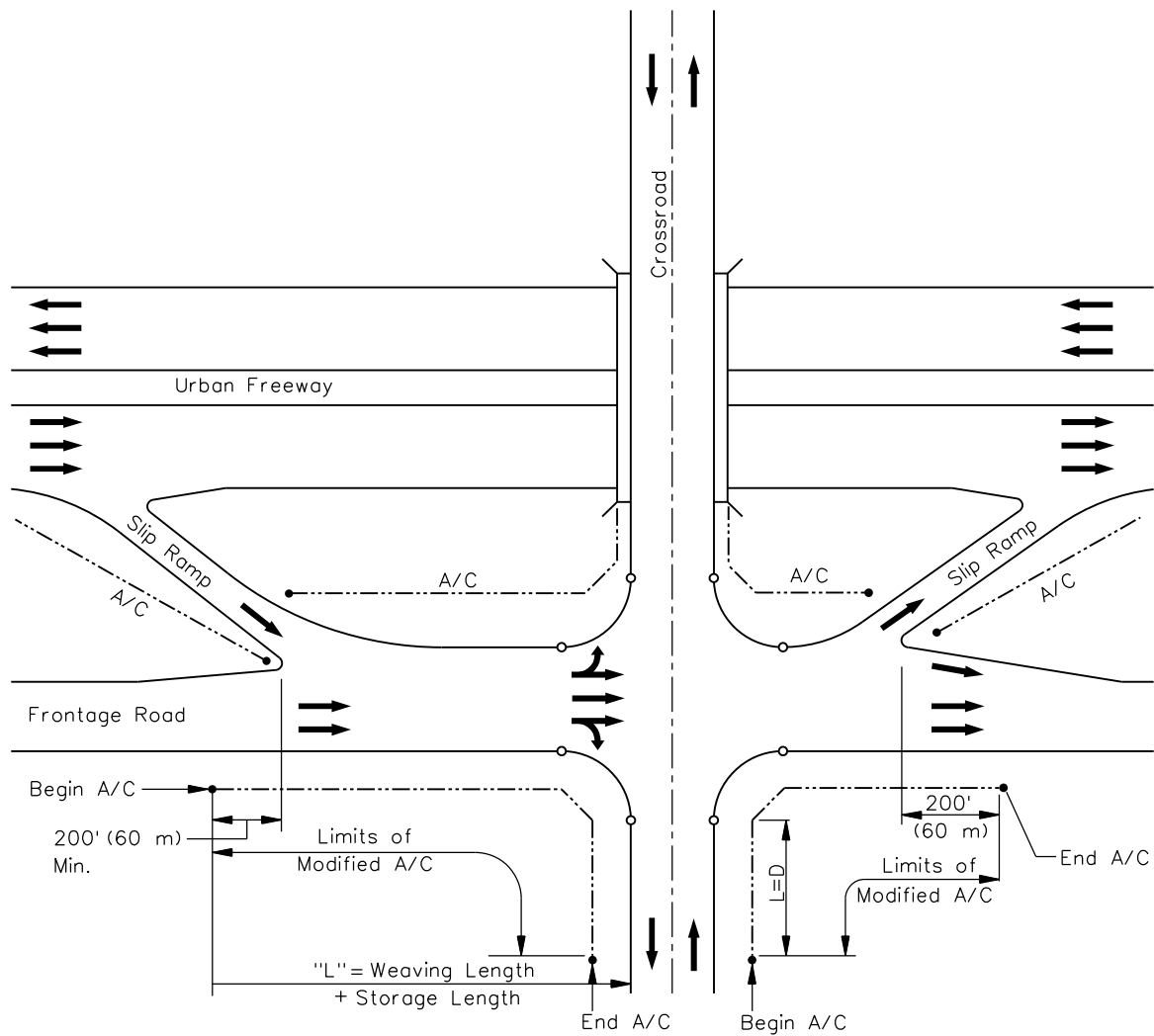

Note: The modified access control line is only used where single family residential entrances exist. For other types of development, full access control should be used along the frontage road and crossroad.

**ACCESS CONTROL LIMITS NEAR URBAN FREEWAY SLIP RAMPS
(On And Off Of One-Way Frontage Road)**

Figure 35-2.I

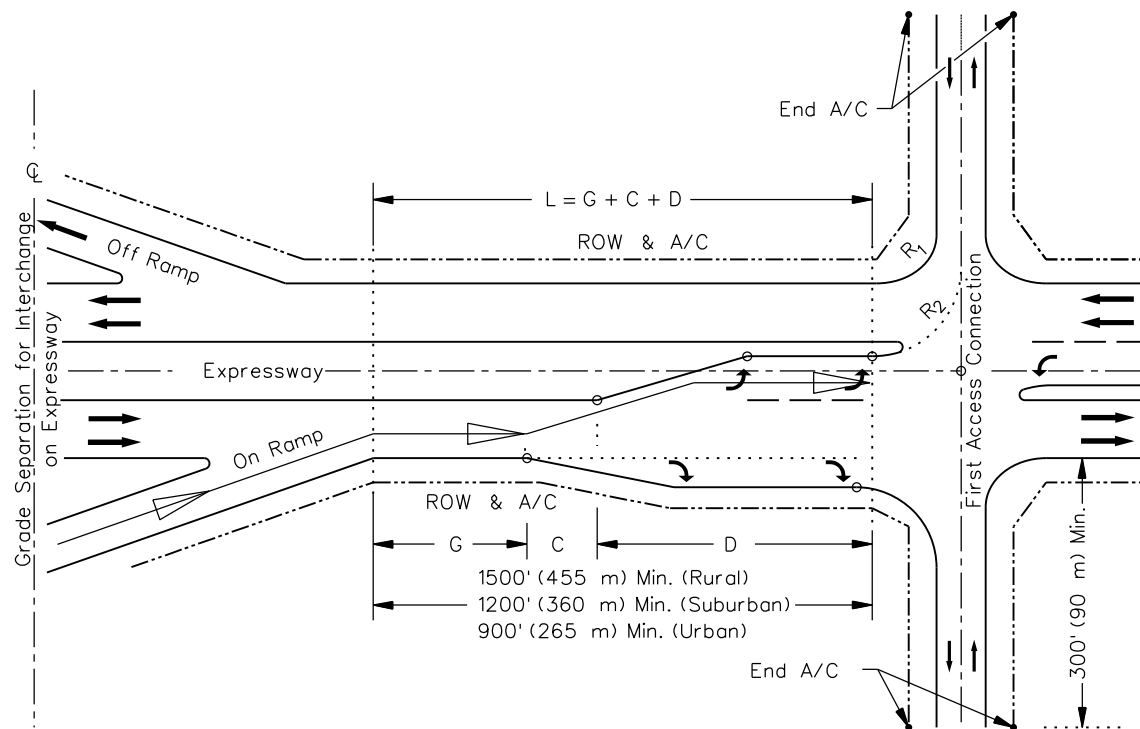

Notes:

1. This figure illustrates the first access connection on an expressway type highway beyond the end of the entrance ramp terminal. The minimum required distance to the first access connection is based on the design speed of the expressway and is the combination of the operational maneuvers as shown schematically in the above figure. See the table in Figure 35-2.A for distances. Use the equation $L = (n-1)(G+C) + D$, where $n = 2$ or 3 lanes, to determine the total minimum required distance.
2. For details on the required length of access control on the first access connection, refer to Figures 35-2.K through 35-2.M.

**INTERCHANGE ON FOUR-LANE DIVIDED EXPRESSWAY
(Distance to First Access Connection on Expressway)**

Figure 35-2.J

35-2.03 Expressways

35-2.03(a) Access Control at Crossroads

Where private driveways, commercial entrances, and access connections to public streets/highways are located too close to the expressway, they can cause hazardous and congested conditions due to conflicts between the expressway traffic, the through traffic on the crossroad, and the turning traffic at the access connections. Substantial relief from congested conditions can be obtained by the extension of access control a predetermined distance along the crossroad. This essential length of protected roadway will allow expressway traffic to enter or leave the crossroad free of conflict with access connection traffic.

The design criteria for access control on expressways are under the jurisdiction of BDE. Figures 35-2.K through 35-2.M illustrate examples of minimum access control requirements at expressway intersections with various crossroad configurations. At certain locations, it may be desirable to extend access control beyond minimum limits to a nearby intersection or a major traffic generator. Where future interchanges may be likely or are definitely planned at a crossroad, full control of access should be established along the crossroad to accommodate the actual type of future interchange or, if not known, at least 1000 ft to 1200 ft (300 m to 350 m) on each approach.

Figure 35-2.K illustrates an intersection of an expressway with a two-lane channelized crossroad. The use of left-turn lanes on both legs of the crossroad may be desirable from either a safety or operational perspective. If no access connections are existing or proposed and the 20-year DHV on the crossroad does not require more than two traffic lanes on the channelized approaches, terminate the access control along the crossroad near the ends of the mountable median strip or at a comparable point with flush channelization. The access connections shown in the figure indicate the minimum distance from the edge of the expressway where an existing or proposed public road or commercial access driveway may be connected.

Figure 35-2.L illustrates an intersection of an expressway with a multilane divided crossroad. Where a public road or commercial access connections are existing or proposed in the vicinity of the expressway intersection, terminate access control near the beginning of the radius returns as shown in the figure. Otherwise, terminate the length of access control along the crossroad opposite the theoretical nose location of a properly designed left-turn lane that will serve a future access connection. In determining the length of access control, assume that left-turn lanes will be required initially, for either safety or capacity, on both approaches of the crossroad intersection and for future turns into the access connections. The taper lengths for the left-turn lanes may be overlapped.

Figure 35-2.M shows an intersection of an expressway with an undivided crossroad (township road, county highway, or low-volume city street). Acquire access control along the crossroad for a minimum distance of 300 ft (90 m), as shown in the figure, which allows for the provision of constructing future overlapping left-turn lanes on the crossroad. The radius returns for existing, proposed, or future commercial access connections or public roads may begin near the point where the access control terminates.

With any of the three different crossroad designs, existing minor entrances may be permitted within the limits of access control under the following conditions:

- An existing private driveway for one single-family residence or one field entrance for farming purposes can be allowed to remain, by highway permit, as close as 100 ft (30 m) from the edge of the expressway traveled way.
- If it is determined that an existing commercial development will be significantly damaged, one low-volume entrance to such a development (on each side of the crossroad) can be allowed to remain by highway permit and access agreement as close as 200 ft (60 m) from the edge of the expressway traveled way. The decision to allow the existing commercial entrance to remain in operation must be carefully analyzed and a design exception must be requested in the Phase I report.

The design of access control as shown in Figures 35-2.K through 35-2.M will help to eliminate backups onto the expressway in the vicinity of the main intersection and thereby minimize any adverse operational effects on expressway traffic.

35-2.03(b) Access Control at Frontage Road or Service Drive Connections

Frontage road or service drive connections to expressways are in essence minor intersections and, therefore, require some measure of access control to ensure satisfactory operating conditions and safety. Frontage road connections should be designed to avoid storage deficiencies and operational difficulties in association with large traffic generators that may locate opposite or near the connection. Therefore, frontage road or service drive connections should be designed with access control provided as illustrated in Figures 45-2.H and 45-2.I. Access control is provided opposite the "T" to prevent future operational problems and could allow the connection of a public street in the future.

35-2.03(c) Elimination of Commercial Access

Direct access from commercial developments to the expressway is not permitted. Refer to Chapter 45 for a discussion on the design of commercial access points off of crossroads, frontage roads, and service drives.

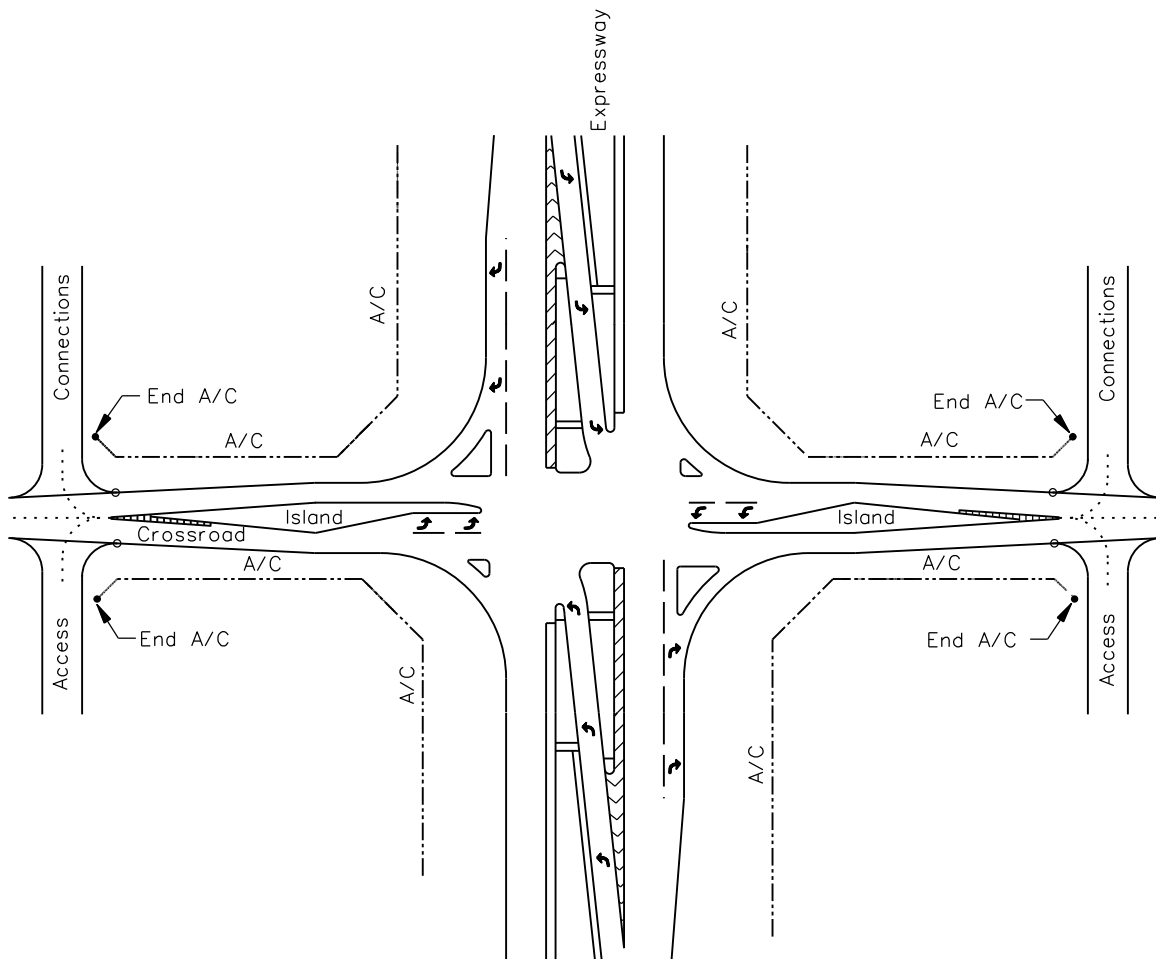

Notes:

1. *The channelizing islands on the crossroad usually are constructed as a raised-curb median for optimum delineation.*
2. *Refer to text in Section 35-2.03(a) for further guidance*

**TWO-LANE DIVIDED CROSSROAD INTERSECTING EXPRESSWAY
(Limits of Access Control)**

Figure 35-2.K

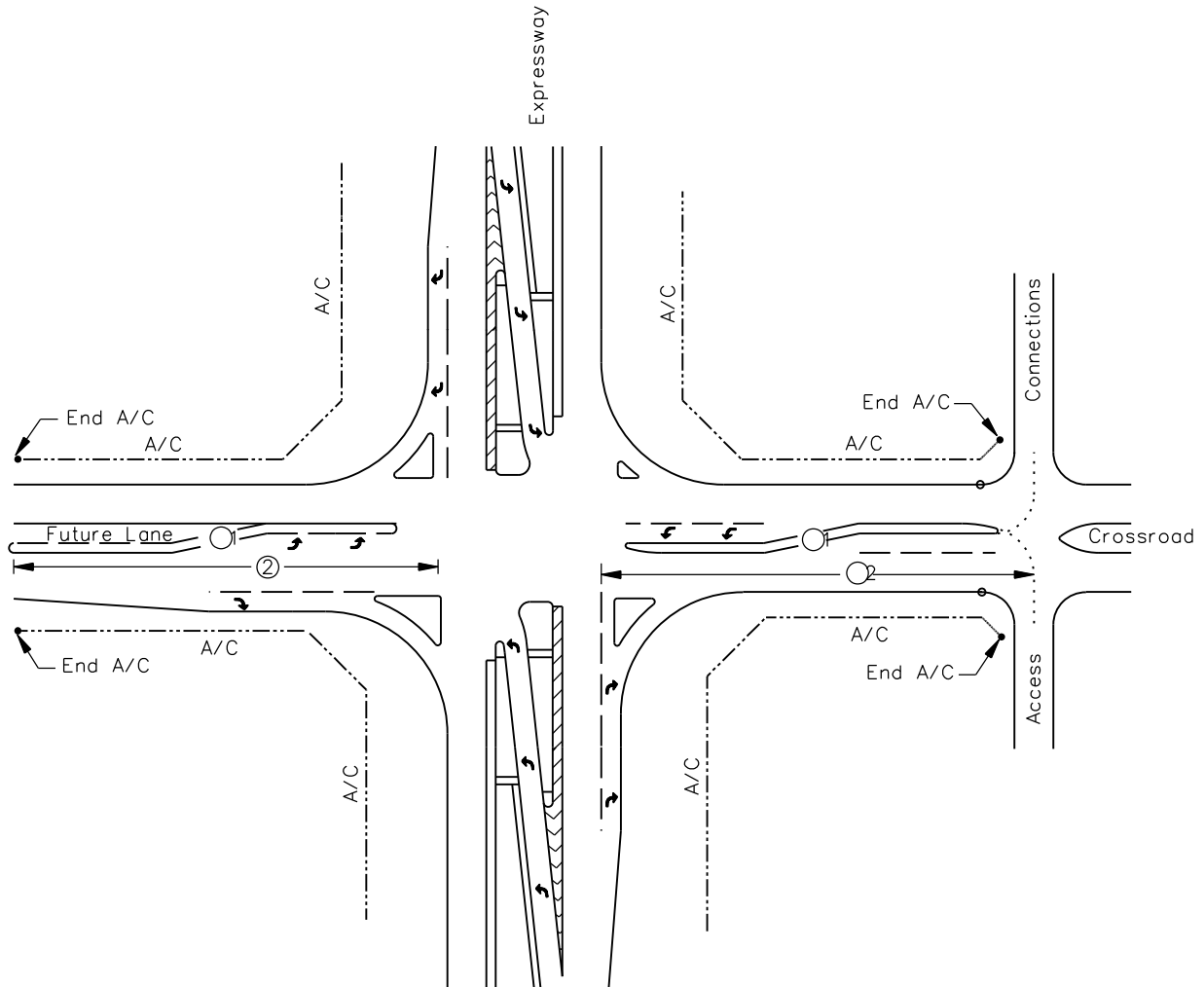

Notes:

- ① Construct as a raised-curb median for optimum delineation.
- ② The distance to accomplish the length of access control along the crossroad is approximately 525 ft (160 m).
- ③ Refer to text in Section 35-2.03(a) for further guidance.

**MULTILANE DIVIDED CROSSROAD INTERSECTING EXPRESSWAY
(Limits of Access Control)**

Figure 35-2.L

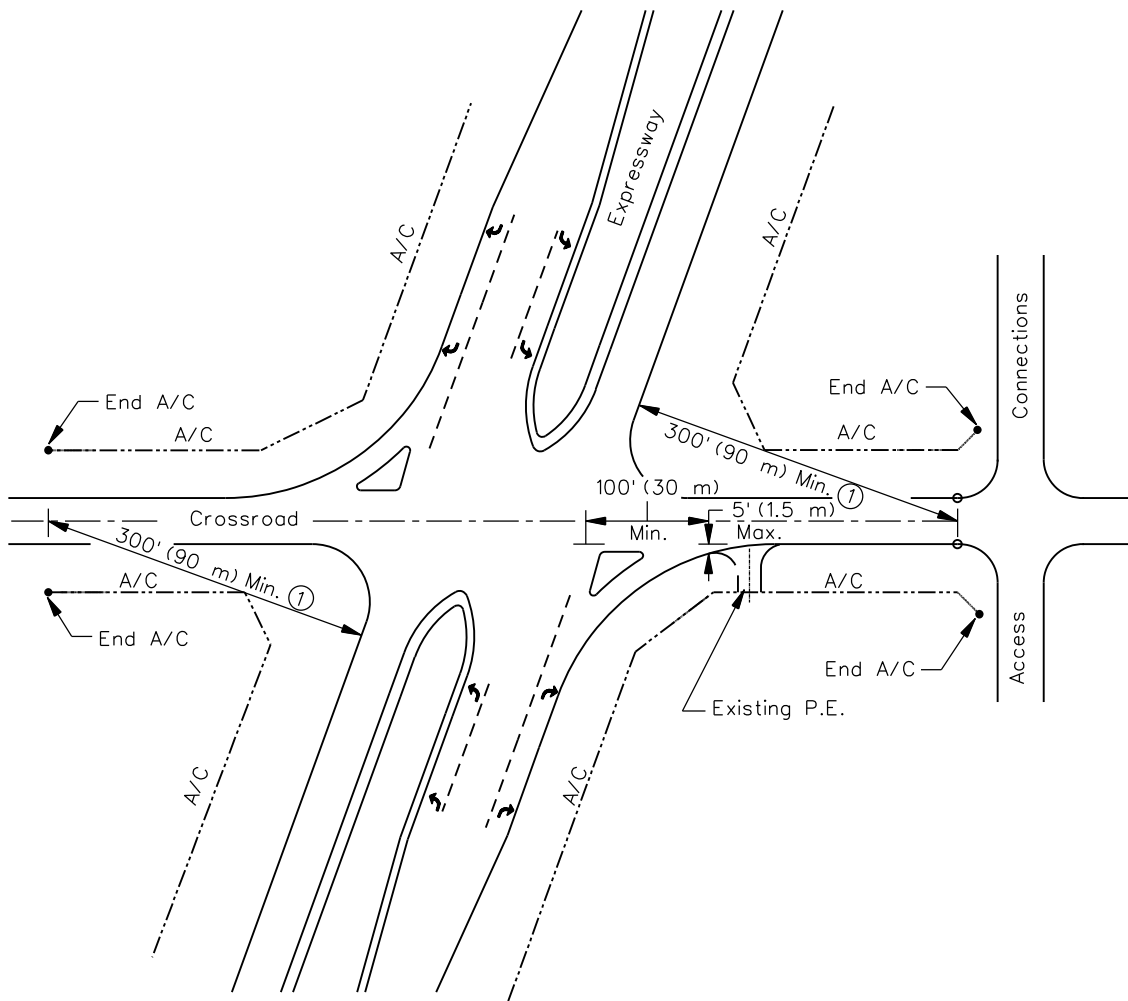

Notes:

- ① The 300 ft (90 m) minimum access control distance is measured at right angles from the edge of the expressway traveled way to or along the centerline of the crossroad.
- ② Refer to text in Section 35-2.03(a) for further guidance.

**UNDIVIDED CROSSROAD INTERSECTING EXPRESSWAY
(Limits of Access Control)**

Figure 35-2.M

35-2.04 Access Restrictions Along Side Roads

Where a commercial entrance or street intersects a State highway, additional care should be taken to ensure future operational integrity of both routes, regardless of State highway cross section or current use of access control. This is typically completed by providing an access restriction along the side road for a sufficient distance beyond the nearest mainline edge of travel. See Section 36-7.02, item 4 for additional discussion. Additionally, Figure 36-7.D shows a typical design for a high-volume commercial entrance to a State highway utilizing an access restriction. This access restriction dimension is typically established at 300 feet (90 m) minimum, and can be increased based on proposed side road traffic. The district geometrics engineer will determine the proper distance for this dimension after analyzing traffic operations and performing a capacity analysis on the two closely spaced intersections. For existing locations without existing access control, or for locations where this length is proposed to be increased, coordination is required with the property owner, and purchase of access control rights will follow general land acquisition procedures and guidelines.

35-3 ESTABLISHING ACCESS CONTROLLED HIGHWAYS

35-3.01 Applicability

Highways are established as access controlled facilities where they comprise either a portion of a system of freeways (e.g., National System of Interstate and Defense Highways) or where a need to control access exists on the highway, such as on an expressway or on a portion of a highway (crossroads and side roads). Refer to the Illinois Compiled Statutes (605 ILCS 5/8-101).

35-3.02 Freeways or Expressways on New Location

An Access Control Plan is prepared as part of the location/design study. See Chapters 11 and 12 and Section 35-5 for details. After the detailed design for feasible alternatives is completed and after the Draft EIS is authorized for distribution, the district is required to conduct public involvement activities (usually an open house public hearing). Chapter 19 discusses the details of public involvement activities. The announcement for the public hearing should include a notice for road closures (see Chapter 11) and a statement on the implementation of corridor preservation. Guidelines for corridor preservation can be found in the *Land Acquisition Policy and Procedures Manual*.

After the public hearing is completed, the Design Report, Final EIS, disposition of comments received, and other documents (see Chapter 12) are submitted for approval by the Regional Engineer. For major new alignment projects or at the request of the Regional Engineer, submit the documents to BDE with a request for design approval. Once design approval is given and the Access Control Plan approved by the Regional Engineer/BDE, the district can then proceed to prepare and file a Route Location Decision and an Order Establishing a Freeway. These two documents are forwarded to BDE for execution. See Chapter 12 for examples of these two documents.

35-3.03 Freeways or Expressways on Existing Location

There are two types of access control scenarios in this category:

1. Where a highway is being studied as part of an overall system and a location/design study is initiated to examine whether the freeway or expressway should be located on new or existing locations, it will be necessary to complete the design study, the preparation of environmental documents, and public involvement before an existing alignment can be established as the preferred alternative.

Assuming the preferred alternative is designated along the existing highway, the district then submits all reports to the Regional Engineer and requests design approval. After approval of the Design Report, which includes the Access Control Plan, the district can prepare and submit an Order Establishing a Freeway to BDE for execution. In addition,

guidelines for implementing corridor preservation should be considered for the preferred alternative.

2. Where an existing segment of highway is already declared as an access controlled facility and the district wishes to extend the length of access control along the existing roadway or along a crossroad to provide for additional safety and mobility, it will not be necessary to prepare a design study on the proposed access extension. Instead, the following must be completed:
 - Discuss the proposal at a district coordination meeting.
 - Notify all existing property owners along the highway segment and discuss the proposed changes in access control with them. Document the results of each meeting. Single family residences and field entrances can be considered to remain in place by permit. No commercial entrances will be allowed.
 - Publish in the local newspaper an offer to hold a public informational meeting on the proposed changes in access control. Requests to hold a meeting must be submitted in writing to the district.
 - If the district decides to hold an informational meeting, summarize all comments received on the proposed changes in access control with proper documentation.
 - Submit a revised Access Control Plan and the disposition of any comments received on the proposed changes to BDE and request concurrence of the Plan. The revised Access Control Plan can be shown on an aerial mosaic, on revised plan sheets, or on an Intersection Design Study drawing as appropriate. FHWA must approve any changes in access control on the Interstate System.
 - Once the appropriate central office bureau has concurred with the revised Access Control Plan, the district can prepare a revised Order Establishing a Freeway and forward it to BDE for execution. The documents must include a copy of the previously approved Access Control Plan as an attachment.

A Route Location Decision is not required with either of the two scenarios described above.

35-3.04 Acquisition of Access Rights

The acquisition of access rights to property is a function of the Land Acquisition Office in each district. The *Land Acquisition Policies and Procedures Manual* includes a detailed discussion of the Department's policies and responsibilities in the acquisition of freeway (or expressway) rights-of-way and the provisions involved in purchasing access rights. To exercise full or partial control of access on an existing highway, the Department must acquire, by purchase or condemnation, the access rights of abutting property owners. However, the filing of an Order Establishing a Freeway on an existing highway (see Chapter 12) does not require the Department to immediately acquire all access rights but, whenever an access permit is

requested on such a route, the Department has the option of either issuing a temporary permit or acquiring the access rights of the applicant.

When establishing an access controlled highway on a new location, a location not replacing an existing roadway to which an abutting owner formerly had access, the Department need not acquire nor pay for access rights because none exist.

35-4 REVISIONS TO EXISTING ACCESS CONTROL

Normally, changes in established access control are made only to allow additional or modified access to a local public road or designated street system as opposed to direct access to private property. However, revised access to private property is technically possible and legal although considerably more difficult to achieve.

When a release of access control is primarily intended to enhance transportation needs, it is referred to as “relinquishment of access control,” and the *Bureau of Operations Policy and Procedures Manual* will govern the release. When the release of access control is primarily intended to serve a commercial development, the release is referred to as “disposal of access control,” and the Bureau of Land Acquisition will determine the value of the previously acquired access rights, which will be credited to the Department’s road fund.

The detailed discussion of these procedures is contained in Chapter 6 of the *Bureau of Operations Policies and Procedures Manual* and in Chapter 12 of this *Manual* (see Order Establishing a Freeway). Also for major revisions to existing access control on freeways and expressways, such as adding a new access point, see Section 37-1 for documenting and processing any requested changes.

35-5 ACCESS CONTROL PLANS

35-5.01 General

During the location study phase of an expressway or freeway design, an Access Control Plan is prepared by the district/consultant and included as an Appendix to the design or combined study for the project (see Chapter 12). Design approval of the project will constitute approval of the Access Control Plan. The Access Control Plan must be approved prior to the execution of an Order Establishing a Freeway.

35-5.02 Aerial Photography

Aerial photography is requested from the Surveys, Mapping and Modeling Section at the same time that mapping is ordered for the project. Once the photography is obtained, a mosaic is made of the photographic prints to alleviate some of the distortion between frames.

After the aerial mosaic is completed, it is re-photographed and made into half-tone positive exhibits. These base exhibits are then used to prepare the actual Access Control Plan. Original half-tone positive exhibits on mylar are never enlarged or reduced in size due to the distortion that would be created by such a procedure.

The half-tone positives should be made into one of the following scale ratios:

Urban Areas	Rural Areas
US Customary	
1:100 or 1:200	1:500 or 1:600
Metric	
1:1000 or 1:2500	1:5000 or 1:7500

The larger scale exhibit is requested where the designer wishes to show more detail on the Access Control Plan. The final Access Control Plan is developed into 11 x 17 in. sheets and assembled into a booklet format for ease of use by design and right-of-way personnel.

35-5.03 Fully Access Controlled Highways (Freeways)

The following data and information should be shown on the Access Control Plans for freeways:

- point of beginning and ending (stationing proceeds from west to east or south to north);
- North arrow;
- centerline distances, numbered to indicate every 100 ft (100 m) (urban) and every 1000 ft (300 m) (rural);

- property lines and ownership of land;
- major drainage courses with structure symbol;
- identity of all crossroads or streets by number and/or name;
- design traffic on the freeway between interchanges and on all crossroads to be separated or relocated;
- current ADT on all roads to be closed;
- existing and approximate proposed right-of-way lines;
- interchange locations with approved type and the ends of access control located on crossroad;
- frontage roads and proposed service drives (service drives may be revised as a result of ROW negotiations);
- data on intersecting railroads to include name, number and type of tracks, and number of trains per day; and
- any information that might be relevant to major environmental issues (wetlands, natural areas, etc.).

35-5.04 Partially Access Controlled Highways (Expressways)

The data and information described in Section 35-5.03 should be shown on the Access Control Plans for expressways. In addition, indicate the following information:

- all proposed or relocated field and private entrances to the expressway;
- proposed service drives and frontage roads and their direct connection to the expressway;
- proposed median crossovers;
- all existing entrances and median crossovers to be eliminated, where the expressway lies parallel and adjacent to an existing roadway; and
- limits of access control along each crossroad and at each direct connection.

35-5.05 Access Control Plan Symbols

To facilitate the preparation of Access Control Plans, Figure 35-5.A presents standard symbols for use. The symbols are drafted onto the half-tone positive exhibits. Attach a copy of the standard symbols to each Access Control Plan.

35-5.06 Construction and Right-of-Way Plans

Once the Access Control Plan has been approved through the design approval process, it is used as a guide in the preparation of construction plans and right-of-way plans. See Chapter 63 and the *Computer Aided Design, Drafting, Modeling and Deliverables Manual* for information on the preparation of plan sheets and CADD drafting guidelines.

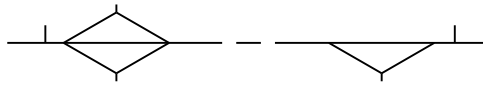

Intersection: Left - Crossroad Intersection
 Right - Tee Intersection

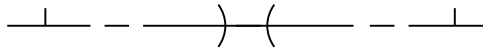

Crossover through Median (Connecting to service drive/frontage road or for U-turns)



Crossover to be Eliminated

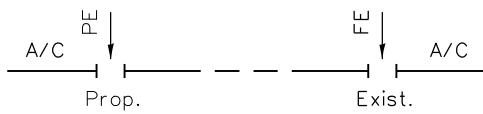

Existing or Proposed Access Points:
 PE (Private Entrance)
 FE (Field Entrance)

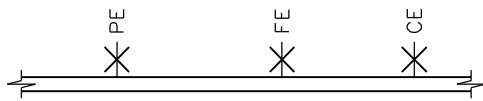

Existing Access to be Eliminated:
 PE (Private Entrance)
 FE (Field Entrance)
 CE (Commercial Entrance)

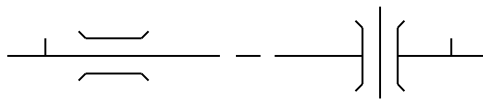

Highway Grade Separation:
 Left - Mainline Over
 Right - Mainline Under

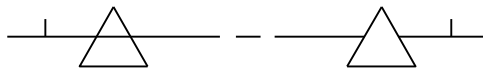

Railroad Grade Separation:
 Left - Mainline Over
 Right - Mainline Under

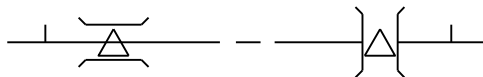

Combination Highway/Railroad Grade Separation:
 Left - Mainline Over
 Right - Mainline Under

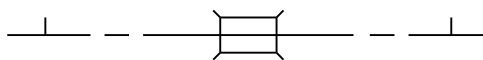

Drainage Structure
 (Over 20 ft (6 m) in Length)

LEGEND FOR ACCESS CONTROL PLANS

Figure 35-5.A
 (2 of 2)

35-6 ACCESS MANAGEMENT

35-6.01 Access vs. Mobility

35-6.01(a) Basic Conflicts

A functional highway system must provide both traffic service and land access. However, this dual need creates a fundamental conflict. Achieving maximum efficiency and safety in traffic operations requires restriction of access and, conversely, increased access may result in a degradation of safety and capacity.

The typical business development and highway improvement cycle illustrate the problem. When businesses request and are granted access to a highway facility, they generate more traffic and consequently more businesses are attracted to the area, thereby generating a need for yet more access. As the cycle continues, the originally efficient highway becomes more congested and safety may be compromised.

With further increased development resulting in increased property values, major improvements of the existing highway become impractical, and new service on a new location may be warranted. The access-mobility conflict could be repeated on the new facility. Implementing access management techniques can reduce such occurrences from disrupting the transportation system.

35-6.01(b) Relationship to Functional Classification

The fundamental differences in the need for access versus mobility have resulted in the current practice of functionally classifying highways. The functional classification system is discussed in Section 43-1. Ideally, the balanced highway system will provide high-mobility arterials with full or partial access control, collectors to provide an intermediate level of access and mobility, and local roads and streets with limited mobility and a higher level of access. The highway system, when viewed in aggregate, fulfills both the needs of mobility and access via the functional classification system and the application of access management.

Access management techniques are directed primarily at principal arterials (other than access controlled highways) and minor arterials where the potential for conflicts are most severe.

35-6.02 Objectives of Access Management

Improved traffic service is a primary objective of access management. From a highway engineering perspective, the objectives of access management are to optimize the balance between safe, efficient transportation (or mobility), and access. Section 35-7 presents access management techniques that accomplish these objectives.

35-6.03 Benefits of Access Management

When successfully implemented, the application of access management to arterial streets will yield several benefits, as discussed in the following:

1. **Enhanced Mobility.** Significant benefits may be derived by minimizing the number of traffic conflict points, separating conflict areas, removing traffic queues from the through lanes, and providing more space for acceleration-deceleration at access points. The result is increased traffic-carrying capacity of the highway and a higher level of service (e.g., higher operating speeds, fewer delays, increased convenience, less driver frustration, lower operating costs).
2. **Improved Safety.** Access management techniques that enhance mobility also improve safety. Smoother traffic flow, with lower speed differentials between through traffic and turning traffic and with the number of crossing opportunities reduced or eliminated, results in improved safety. Reducing traffic crashes has tangible economic benefits by reducing injuries, property damage, and delays.
3. **Property Owner Benefits.** Access management techniques typically improve access to abutting properties along the highway corridor. The convenience of smoother-flowing traffic with safer access attracts commercial development and business. Growth in traffic attracts businesses and will likely increase commercial property values even if access is restricted to a few strategic points.
4. **Preservation of Highway Investment.** By increasing the traffic-carrying capacity of a highway, access management techniques can extend the functional service life of a facility and postpone the need for major highway improvements. Highway widening or relocation frequently results in disruption and/or displacement of people and businesses. New highways are expensive and often involve significant impacts. Access management offers an alternative that can postpone or eliminate the impacts of new highway construction or reconstruction and associated problems of relocations and traffic delays.

35-6.04 Disadvantages of Access Management

Although access management techniques may be in the best overall public interest, individual road users and property owners may object to the inconvenience associated with the elimination or denial of a specific access point. A property owner or business customer, for example, may be required to drive a longer distance to reach the desired location.

When proposing an access management strategy, the advantages and disadvantages of various alternatives should be considered and the public must be involved in the final decisions. If implementation of access management techniques eliminates previously available access, then the property owner may be entitled to compensation.

35-6.05 Elements of an Access Management Program

35-6.05(a) Coordination

An effective access management program on a particular street must involve not only the engineering aspects of highway design and traffic operations but also the broader issues of land-use planning and zoning, public involvement, and enforcement powers. Most of these issues are addressed outside the highway agency; therefore, close coordination with other agencies and the public is needed to develop and implement an effective program.

Highway agencies have some authority to regulate access; however, local governments control land use and zoning. Unless there is coordination between the highway agency and land-use planners, attempts by the highway agency alone to manage access are not likely to succeed. A comprehensive and rational access management plan, developed in cooperation with local agencies in charge of planning and zoning, has a much greater chance of success.

The following administrative processes are usually included in individual access management programs:

- zoning regulations,
- subdivision approval (Plat Act),
- site plan development (Access Agreement),
- driveway permits, and
- roadway design and construction.

35-6.05(b) Enforcement

In coordination with public involvement, attaining and retaining access management may be implemented via the following:

1. Regulatory Authority. A public agency can manage access to streets through the use of its regulatory authority to control traffic movements. These powers can be used to manage access directly (e.g., through the use of driveway permits and regulations) or indirectly (e.g., through the use of raised-curb median and curbs along the edges of the street). Access management is effectively achieved when abutting property owners are required to comply with regulations necessary for the efficient flow of traffic. This presently occurs through the plat approval process, with access agreements for major developments and through approval of individual driveway permits.
2. Eminent Domain. By using “eminent domain,” a highway agency can acquire private property when the action is deemed to be in the best interests of the public.

35-6.05(c) Engineering

The engineering component of an access management program consists of design criteria that control the number, location, and design of access points along the highway. The engineering components are grouped as follows:

1. Techniques. Access management includes the implementation of specific techniques that can be used individually or in aggregate to address an access problem. See Section 35-7.
2. Overall Design Criteria. Access management includes overall design criteria for the spacing between intersections, spacing between median openings, frequency of driveways, and the number of entrances and exits per property. These criteria are intended to provide the overall management of access along significant lengths of highway and, if the criteria are met, will help to ensure a continuous, high level of serviceability for the facility.
3. Detailed Design. All access elements must be properly designed to fulfill their intended function. For example, if a left-turn lane is installed, it must be sufficiently long to allow for vehicular storage. Driveway entrances should be designed for ease of entering and exiting considering their turning radii or flares, width, profile, etc.

Chapter 36 provides criteria and discusses details related to the spacing of intersections and design of median openings. The IDOT *Policy on Permits for Access Driveways to State Highways*, 92 Ill. Admin. Code 550 provides criteria and discusses details related to driveway location, spacing, and design.

35-7 ACCESS MANAGEMENT TECHNIQUES

In general, access management techniques are intended to minimize the frequency and severity of traffic conflicts, particularly at commercial driveway entrances. There are four major objectives for minimizing conflicts and increasing efficiency:

1. Category A — Limit the Number of Conflict Points. These techniques directly reduce the frequency of conflicts or reduce the area of conflict at some or all driveways on the highway by limiting or preventing certain maneuvers.
2. Category B — Separate Basic Conflict Areas. These techniques either reduce the number of driveways or increase the spacing between driveways or between driveways and intersections. They indirectly reduce the frequency of conflicts by separating turning vehicles at adjacent access points and by providing greater decision-making time for the through driver between successive conflicts with vehicles at driveways.
3. Category C — Reduce Deceleration Requirements. These techniques reduce the severity of conflicts by increasing driveway turning speeds or by improving sight distance.
4. Category D — Remove Turning Vehicles From Through Lanes. These techniques reduce both the frequency and severity of conflicts by providing separate lanes and adequate storage areas for turning vehicles.

With a decision to pursue access management on a particular street, many techniques are available from which to select an appropriate solution for a specific access problem. Figure 35-7.A summarizes 36 applicable techniques. Figures 35-7.B through 35-7.I provide sketches to illustrate some of the more common techniques.

Category A — Limit Number of Conflict Points

- * A-1: Install raised curb median with left-turn deceleration lanes.
- A-2: Install one-way operations on the highway.
- A-3: Install traffic signal at high-volume driveways when warranted.
- * A-4: Channelize median openings to prevent left-turn ingress and/or egress maneuvers.
- A-5: Install physical barrier (curbs, ditches) to prevent uncontrolled access along property frontages.
- A-6: Locate driveway opposite a three-leg intersection or driveway and install traffic signals where warranted.
- * A-7: Install two two-way driveways with limited turns in lieu of one standard two-way driveway.
- * A-8: Install driveway channelizing island to prevent outbound left-turn maneuvers.
- A-9: Close certain median openings (raised curb-median used on the street).
- * A-10: Provide barrier curb median adjacent to dual left turn lanes and the left turn taper.

Category B — Separate Basic Conflict Areas

- B-1: Regulate minimum spacing of driveways.
- B-2: Regulate minimum corner clearance.
- B-3: Regulate minimum property clearance.
- B-4: Regulate maximum number of driveways per property frontage.
- * B-5: Consolidate access for adjacent properties.
- B-6: Consolidate existing access wherever separate parcels are assembled under one purpose, plan, entity, or usage.
- B-7: Encourage access onto a collector street (where available) in lieu of an additional driveway on main highway.

* See accompanying figure.

ACCESS MANAGEMENT TECHNIQUES

Figure 35-7.A
(1 of 2)

Category C — Reduce Deceleration Requirements

- C-1: Install traffic signals where warranted to meter traffic for larger gaps.
- C-2: Time traffic signals to platoon traffic queues to create larger gaps.
- C-3: Install visual cues (signing) at the driveway entrance.
- C-4: Improve driveway sight distance.
- C-5: Regulate minimum sight distance.
- C-6: Optimize sight distance in the permit authorization stage.
- C-7: Move sidewalk-driveway crossing laterally away from highway.

Category D — Remove Turning Vehicles From the Through Lanes

- D-1: Install two-way left-turn lane.
- * D-2: Install alternating left-turn lanes.
- * D-3: Install left-turn deceleration lane in existing median.
- D-4: Increase storage capacity of existing left-turn deceleration lane.
- D-5: Install continuous right-turn lane.
- D-6: Construct a local frontage road or service drive.
- D-7: Install additional driveway when total driveway demand exceeds capacity.
- D-8: Install right-turn deceleration lane.
- D-9: Install additional exit lane on driveway.
- D-10: Encourage connections between adjacent properties.
- D-11: Encourage adequate internal design with circulation plan.
- D-12: Provide a one-way frontage road.

* See accompanying figure.

ACCESS MANAGEMENT TECHNIQUES

Figure 35-7.A
(2 of 2)

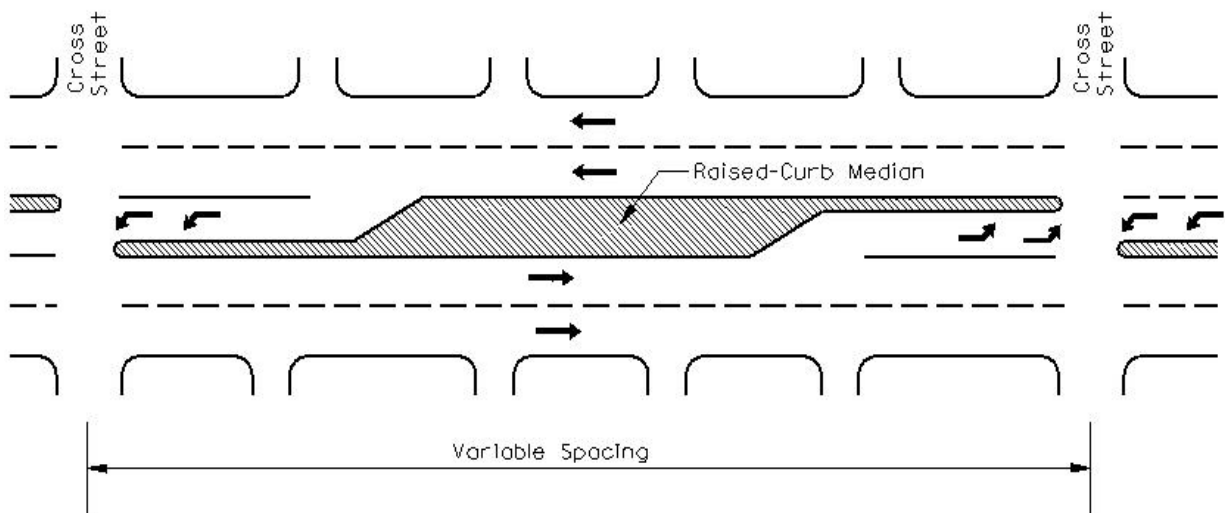

- Direct left turns prevented at all but major streets or major entrances.
- Desirable spacing between median openings is 660 ft (200 m) to 1320 ft (400 m)

**A-1: INSTALL RAISED-CURB MEDIAN
(With Left-Turn Lanes)**

Figure 35-7.B

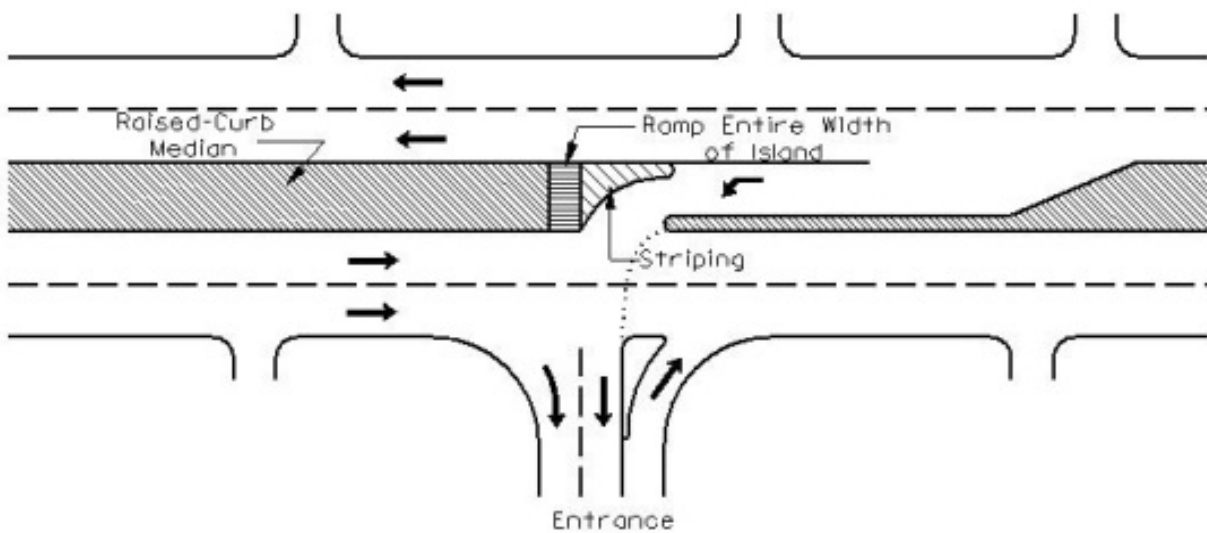

- Elimination of left-turn egress shown.
- Used on high-volume divided arterials where prevented left-turn volume from the entrance is relatively low.

A-4: CHANNELIZE MEDIAN OPENINGS

Figure 35-7.C

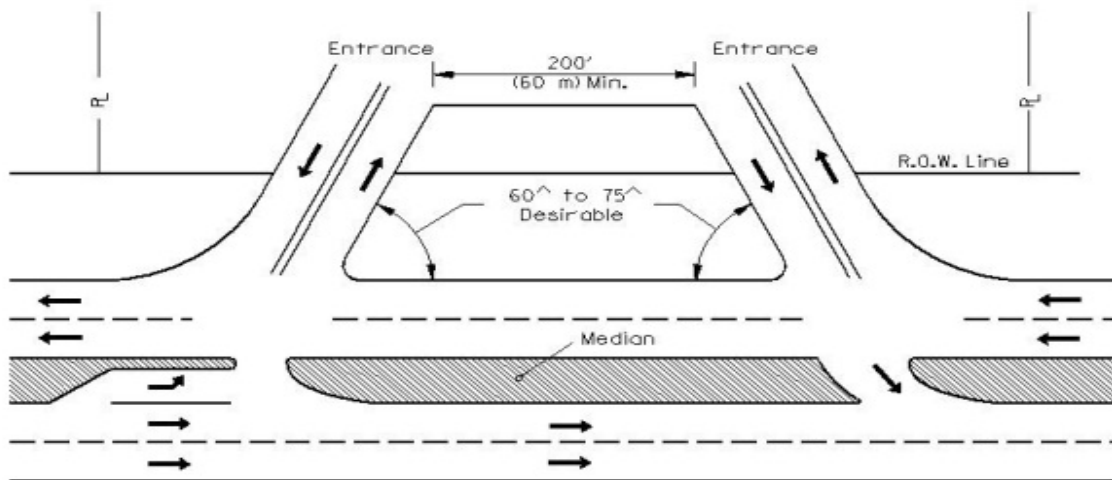

- Used where good internal circulation is available on property and frontage is relatively long.
- Reduces the frequency of conflicts at a single property.

**A-7: INSTALL TWO TWO-WAY DRIVEWAYS
(With Limited Turns)**

Figure 35-7.D

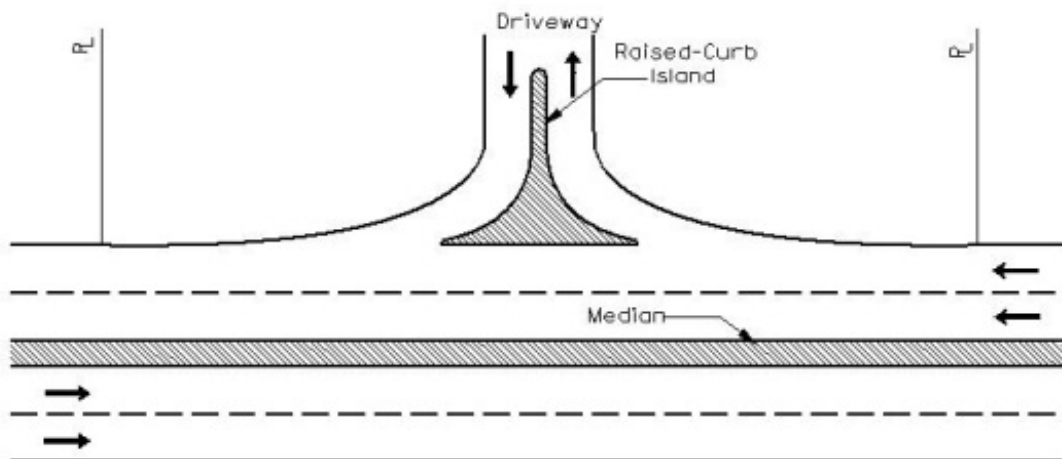

- Used on highway with medians in conjunction with major two-way driveways with low left-turn egress movements.
- Reduces conflict points from 9 to 2.

**A-8: INSTALL DRIVEWAY CHANNELIZING ISLAND
(To Prevent Left-Turn Maneuvers)**

Figure 35-7.E

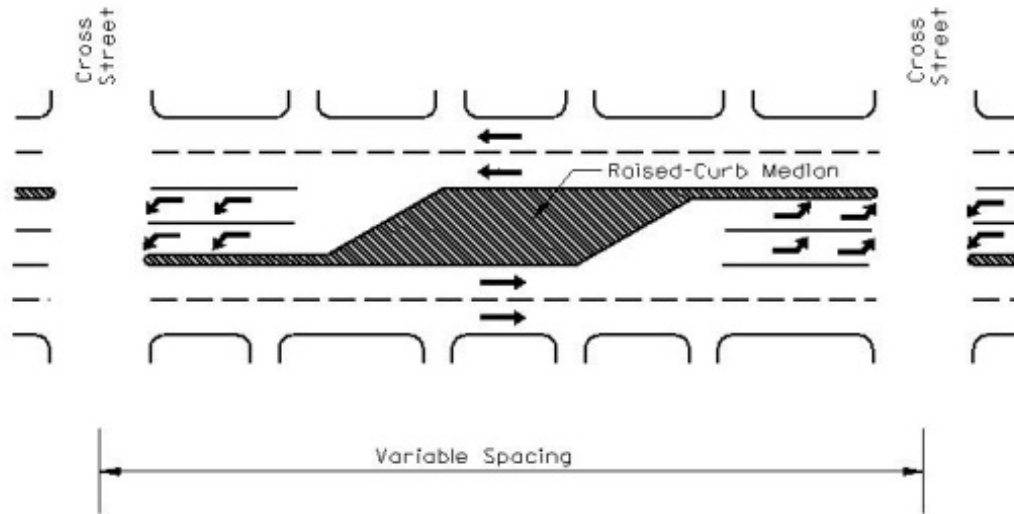

- Used to limit movements at access points near high-activity intersections

A-10: INSTALL BARRIER CURB MEDIAN (With Dual Left-turn Lanes)

Figure 35-7.F

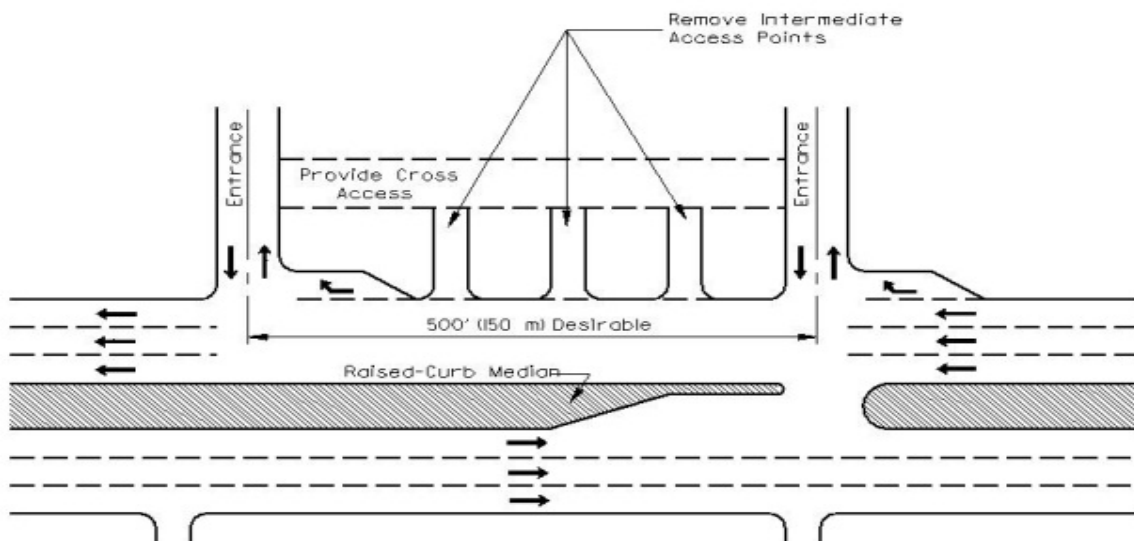

- Used where adjacent properties have continuous parking lots.
- Used when separate parcels are assembled under one entity or usage.

B-5: CONSOLIDATE ACCESS FOR ADJACENT PROPERTIES

Figure 37-7.G

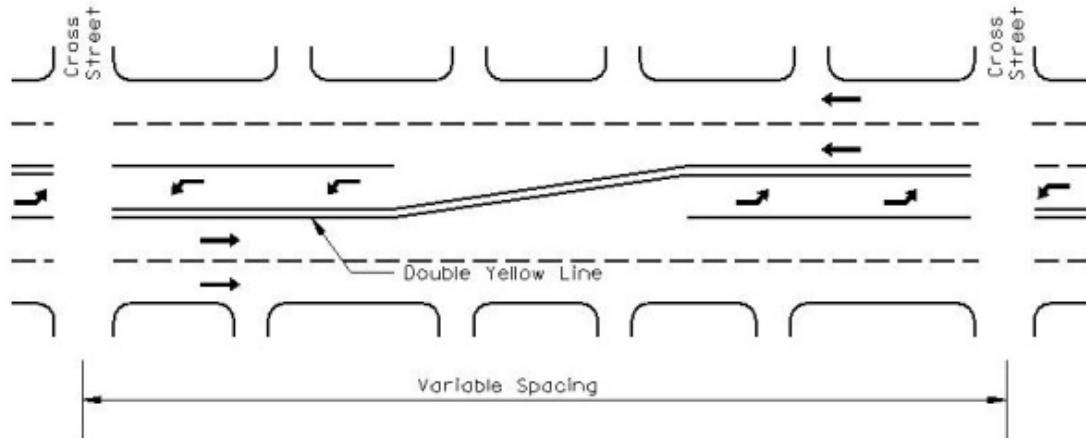

- Used in low-speed urbanized areas where right-of-way is restricted and left-turn demand into entrances is light.
- Usual spacing between cross streets is 450 ft (140m) to 650 ft (200m).

D-2: INSTALL ALTERNATING LEFT-TURN LANES

Figure 37-7.H

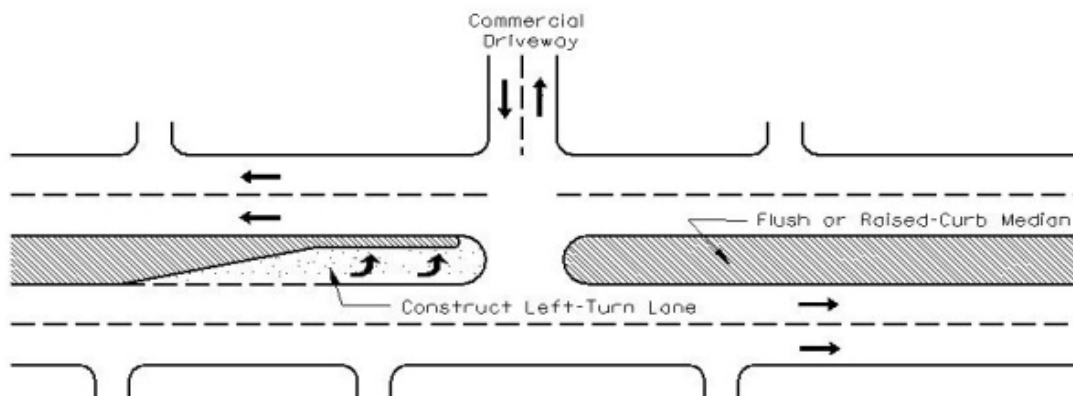

- Mainly used where median opening provides left-turn access into a commercial driveway.
- Reduces frequency of rear-end conflicts.

**D-3: INSTALL LEFT-TURN DECELERATION LANE
(Existing Median)**

Figure 37-7.I

35-8 REFERENCES

1. *Access Management Manual*, Transportation Research Board, 2014.
2. *Technical Guidelines for the Control of Direct Access to Arterial Highways*, Volumes I and II, FHWA, August 1975.
3. *Guidelines for Medial and Marginal Access Control on Major Roadways*, NCHRP Report 93, Transportation Research Board, 1970.
4. *A Policy on Geometric Design of Highways and Streets*, AASHTO, 2011.
5. *Policy on Permits for Access Driveways to State Highways*, 92 Ill. Admin. Code 550.
6. *Capacity and Operational Effects of Midblock Left-Turn Lanes*, NCHRP Report 395, Transportation Research Board, 1997.
7. *Driveway and Street Intersection Spacing*, Transportation Circular 456, March 1996.
8. *Access Management Guidelines for Activity Centers*, NCHRP Report 348, Transportation Research Board, 1992.
9. *Impacts of Access Management Techniques*, NCHRP Report 420, Transportation Research Board, 1999.
10. *Access Rights*, NCHRP Synthesis 351, Transportation Research Board, 2005.
11. *Driveway Regulation Practices*, NCHRP Synthesis 304, Transportation Research Board, 2002.
12. *Access Management on Crossroads in the Vicinity of Interchanges*, NCHRP Synthesis 332, Transportation Research Board, 2004.
13. *Cooperative Agreements for Corridor Management*, NCHRP Synthesis 337, Transportation Research Board, 2004.
14. *Guide for Analysis of Corridor Management Policies and Practices*, Center for Urban Transportation Research, May 2007.
15. *Displaced Left-Turn Intersection*, FHWA Techbrief, FHWA-HRT-09-055, October 2009.
16. *Summary: Evaluation of Sign and Marking Alternatives for Displaced Left-Turn Lane Intersections*, FHWA Summary Report, FHWA-HRT-08-071, February 2009.
17. *Benefits of Access Management Brochure*, FHWA-OP-03-066, 2003.

Chapter Thirty-six
INTERSECTIONS

BUREAU OF DESIGN AND ENVIRONMENT MANUAL

Chapter Thirty-six
INTERSECTIONS

Table of Contents

<u>Section</u>	<u>Page</u>
36-1 GENERAL DESIGN CONTROLS.....	36-1.2
36-1.01 General Design Considerations	36-1.2
36-1.02 Intersection Components.....	36-1.5
36-1.03 Intersection Types	36-1.6
36-1.03(a) General.....	36-1.6
36-1.03(b) Alternative Intersection Designs	36-1.6
36-1.04 Intersection Spacing	36-1.7
36-1.05 Intersection Alignment	36-1.7
36-1.05(a) Angled Intersections	36-1.7
36-1.05(b) Intersections on Curves.....	36-1.10
36-1.05(c) Offset Intersections.....	36-1.13
36-1.06 Profiles.....	36-1.16
36-1.06(a) Approach Gradients	36-1.16
36-1.06(b) Cross-Section Transitions	36-1.17
36-1.06(c) Profiles at Intersections.....	36-1.18
36-1.06(d) Drainage	36-1.20
36-1.07 Intersection Capacity Analysis.....	36-1.20
36-1.08 Design Vehicles.....	36-1.21
36-1.08(a) Types.....	36-1.21
36-1.08(b) Selection.....	36-1.22
36-1.09 Pedestrians and Bicyclists.....	36-1.23
36-1.10 Pavement Markings/Reflectorized Markers	36-1.23
36-1.11 Intersection Lighting	36-1.24
36-1.12 Bus Turnouts.....	36-1.24
36-2 TURNING RADII.....	36-2.1
36-2.01 Design for Right-Turning Vehicles.....	36-2.1
36-2.01(a) Design Vehicle	36-2.1
36-2.01(b) Inside Clearance	36-2.1
36-2.01(c) Encroachment.....	36-2.1
36-2.01(d) Parking Lanes/Shoulders	36-2.2
36-2.01(e) Pedestrian Considerations	36-2.3

Table of Contents
(Continued)

<u>Section</u>	<u>Page</u>
36-2.01(f) Visibility of Traffic Control Devices.....	36-2.3
36-2.01(g) Types of Radius Return Designs	36-2.3
36-2.01(h) Turning Template(s).....	36-2.8
36-2.01(i) Stop Bar Locations	36-2.8
36-2.01(j) Summary	36-2.8
36-2.01(k) Local Street Reconstruction	36-2.9
36-2.02 Corner Islands	36-2.9
36-2.02(a) General Design Considerations.....	36-2.9
36-2.02(b) Design Parameters	36-2.10
36-2.02(c) Design Techniques	36-2.11
36-2.03 Turning Roadways.....	36-2.14
36-2.03(a) Guidelines.....	36-2.14
36-2.03(b) Design Speed	36-2.17
36-2.03(c) Width	36-2.17
36-2.03(d) Horizontal Alignment	36-2.20
36-2.03(e) Deceleration/Acceleration Lanes	36-2.22
36-2.04 Left-Turn Control Radii.....	36-2.26
36-3 AUXILIARY TURN LANES	36-3.1
36-3.01 Turn Lane Guidelines	36-3.1
36-3.01(a) Right-Turn Lane Warrants	36-3.1
36-3.01(b) Left-Turn Lane Warrants	36-3.4
36-3.02 Turn Lane Design Parameters.....	36-3.15
36-3.02(a) Turn Lane Widths.....	36-3.15
36-3.02(b) Turn Lane Lengths.....	36-3.15
36-3.03 Left-Turn Lane Design	36-3.20
36-3.03(a) General Criteria.....	36-3.20
36-3.03(b) Parallel Left-Turn Lanes Without Offset	36-3.25
36-3.03(c) Offset Left-Turn Lanes	36-3.28
36-3.04 Right-Turn Lane Design.....	36-3.35
36-3.04(a) General.....	36-3.35
36-3.04(b) Access within Right-turn Lanes.....	36-3.35

Table of Contents
(Continued)

<u>Section</u>	<u>Page</u>
36-3.04(c) Offset Right-turn Lanes	36-3.35
36-3.05 Dual Turn Lanes	36-3.37
36-3.05(a) Guidelines.....	36-3.37
36-3.05(b) Design	36-3.37
36-4 CHANNELIZING ISLANDS AND MEDIAN TREATMENTS	36-4.1
36-4.01 Island Types.....	36-4.1
36-4.02 Selection of Island Type.....	36-4.1
36-4.02(a) Flush or Traversable Islands.....	36-4.2
36-4.02(b) Raised-Curb Islands.....	36-4.2
36-4.02(c) Pavement Edge Islands.....	36-4.3
36-4.03 Design of Islands and Median Treatments.....	36-4.3
36-4.03(a) Channelizing Islands	36-4.3
36-4.03(b) Pedestrian Refuge Within Islands.....	36-4.7
36-4.04 Median Openings	36-4.8
36-4.04(a) Location/Spacing.....	36-4.8
36-4.04(b) Design	36-4.9
36-5 EXTENSION OF THROUGH LANES BEYOND AN INTERSECTION.....	36-5.1
36-6 INTERSECTION SIGHT DISTANCE	36-6.1
36-6.01 General	36-6.1
36-6.02 Design Procedures.....	36-6.1
36-6.03 Stop-Controlled Intersections.....	36-6.4
36-6.03(a) Turns Onto Major Roadway	36-6.4
36-6.03(b) Vehicle Crossing Mainline	36-6.9
36-6.03(c) Four-Way Stop.....	36-6.10
36-6.04 Signal-Controlled Intersections	36-6.10
36-6.05 Left Turns From the Major Road.....	36-6.11
36-6.06 Effect of Skew	36-6.13
36-6.07 Examples of ISD Applications.....	36-6.16
36-7 DRIVEWAYS, ENTRANCES, AND MINOR SIDEROADS	36-7.1
36-7.01 General Considerations	36-7.1

Table of Contents
(Continued)

<u>Section</u>	<u>Page</u>
36-7.01(a)	Definitions..... 36-7.2
36-7.01(b)	Construction Projects Involving Proposed Entrances ... 36-7.3
36-7.01(c)	Construction Projects Involving Existing Entrances..... 36-7.3
36-7.01(d)	Construction Projects Involving Proposed Sideroads ... 36-7.4
36-7.01(e)	Construction Projects Involving Existing Sideroads 36-7.4
36-7.01(f)	Driveway Profiles 36-7.10
36-7.01(g)	Driveway Sight Distance..... 36-7.12
36-7.01(h)	Auxiliary Lanes..... 36-7.12
36-7.01(i)	Typical Entrance Drawings 36-7.12
36-7.02	Entrance/Driveway Access Permit Process 36-7.14
36-8	INTERSECTION DESIGN NEAR RAILROADS..... 36-8.1
36-9	ROUNDBABOUTS..... 36-9.1
36-9.01	General 36-9.1
36-9.02	Roundabout Selection 36-9.3
36-9.02(a)	Comparison of Performance of Alternative Intersection Types..... 36-9.3
36-9.02(b)	Selection Consideration Factors..... 36-9.3
36-9.02(c)	Locations 36-9.7
36-9.02(d)	Types..... 36-9.7
36-9.03	Public Involvement..... 36-9.8
36-9.04	Geometric Design..... 36-9.9
36-9.04(a)	Design Speed 36-9.10
36-9.04(b)	Vehicle Paths 36-9.10
36-9.04(c)	Speed Consistency 36-9.17
36-9.04(d)	Design Vehicle 36-9.17
36-9.04(e)	Non-motorized Design Users 36-9.17
36-9.04(f)	Size..... 36-9.17
36-9.04(g)	Alignment of Approaches and Entries 36-9.18
36-9.04(h)	Entry Design 36-9.19
36-9.04(i)	Entry Width 36-9.20
36-9.04(j)	Circulatory Roadway Width..... 36-9.22
36-9.04(k)	Central Island 36-9.22
36-9.04(l)	Truck Aprons 36-9.22
36-9.04(m)	Exit Design..... 36-9.23
36-9.04(n)	Splitter Islands..... 36-9.24
36-9.04(o)	Stopping Sight Distance 36-9.25
36-9.04(p)	Intersection Sight Distance..... 36-9.25
36-9.04(q)	Vertical Considerations 36-9.27
36-9.04(r)	Bus Stop Locations 36-9.29

Table of Contents
(Continued)

<u>Section</u>	<u>Page</u>
36-9.04(s) Right-turn Bypass Lane	36-9.29
36-9.04(t) Rural Roundabouts	36-9.31
36-9.04(u) Mini-roundabouts	36-9.32
36-9.04(v) Staging Single-Lane versus Multilane Roundabout	36-9.32
36-9.05 Operational Performance	36-9.33
36-9.05(a) Entering, Circulating, and Exiting Volumes	36-9.34
36-9.05(b) Capacity	36-9.37
36-9.05(c) Capacity Software	36-9.38
36-9.05(d) Traffic Control	36-9.38
36-9.05(e) Access Control	36-9.38
36-9.06 Safety	36-9.39
36-9.07 Pedestrian and Bicycle Accommodations	36-9.40
36-9.07(a) Pedestrians	36-9.40
36-9.07(b) Bicycles	36-9.42
36-9.08 Parking	36-9.42
36-9.09 Illumination	36-9.43
36-9.10 Signing and Delineation	36-9.43
36-10 ALTERNATIVE INTERSECTIONS	36-10.1
36-10.01 Restricted Crossing U-turn Intersections	36-10.1
36-10.01(a) General Design Considerations	36-10.4
36-10.01(b) Signalization	36-10.8
36-10.01(c) Safety	36-10.8
36-10.01(d) Signing	36-10.8
36-10.01(e) Access Management and Right of way Considerations	36-10.8
36-10.01(f) Pedestrian Accommodations	36-10.9
36-10.01(g) Stakeholder Outreach	36-10.12
36-10.02 Median U-Turn Intersections	36-10.13
36-10.02(a) General Design Considerations	36-10.15
36-10.02(b) Safety	36-10.15
36-10.02(c) Signing	36-10.16
36-10.02(d) Access Management and Right of way Considerations	36-10.16
36-10.02(e) Pedestrian Accommodations	36-10.16
36-10.02(f) Stakeholder Outreach	36-10.16
36-10.03 Displaced Left-Turn Intersections	36-10.17

Table of Contents
(Continued)

<u>Section</u>	<u>Page</u>
36-10.03(a) General Design Considerations.....	36-10.19
36-10.03(b) Safety	36-10.21
36-10.03(c) Operations and Signing	36-10.21
36-10.03(d) Pedestrian and Bicyclist Accommodations	36-10.21
36-10.03(e) Access Issues	36-10.24
36-10.03(f) Stakeholder Outreach	36-10.24
36-10.04 Continuous Green T Intersections.....	36-10.25
36-10.04(a) General Design Considerations.....	36-10.25
36-10.04(b) Signalization.....	36-10.25
36-10.04(c) Access	36-10.27
36-10.04(d) Safety	36-10.27
36-10.04(e) Pedestrian Accommodations	36-10.27
36-11 REFERENCES	36-11.1

Chapter Thirty-six

INTERSECTIONS

Intersections are an important part of the highway system. The operational efficiency, capacity, safety, and cost of the overall system are largely dependent upon its design, especially in urban areas. The primary objective of intersection design is to provide for the convenience, ease, comfort, and safety of those traversing the intersection while reducing potential conflicts between vehicles, bicycles, and pedestrians. Chapter 36 provides guidance in the design of intersections including alignment, profile, design vehicles, turning radii, right-turning roadways, left- and right-turn lanes, intersection sight distance, channelized islands, and intersections near railroads. Information that is also applicable to intersections is included in the following Chapters:

- Guidelines for preparing and processing intersection design studies are discussed in Chapter 14.
- Application of bicycle and pedestrian accommodations through intersections is discussed in Chapter 17.
- The various curb types used for channelization, islands, and medians are discussed in Chapter 34.
- Selection of median widths at intersections is discussed in Chapter 34.
- Access management near intersections is discussed in Chapter 35.
- Guidance pertaining to intersections on Strategic Regional Arterials (SRA's) is discussed in Chapter 46.
- Two-way left-turn lanes are discussed in Chapter 48.
- Criteria for intersections on 3R projects are discussed in Chapter 49.
- The warrants and design criteria for intersection lighting are discussed in Chapter 56.
- Guidance on intersection traffic control devices, including striping, signing, and traffic signals is discussed in Chapter 57.
- Accessibility at intersections for persons with disabilities, including the design of compliant curb ramps, crosswalks, and roadway approach grades is discussed in Chapter 58.

36-1 GENERAL DESIGN CONTROLS

36-1.01 General Design Considerations

In every intersection design, there are many conflicting requirements that must be balanced against each other to produce a safe and efficient design. The five basic elements that must be taken into consideration include:

1. Human Factors. These include:

- driving habits,
- ability to make decisions,
- driver expectancy,
- decision and reaction time,
- conformance to natural paths of movement, and
- pedestrian use and habits.

2. Traffic Considerations. These include:

- capacity,
- DHV,
- vehicular composition,
- turning movements,
- vehicular speeds (design and operating), and
- safety.

3. Physical Elements. These include:

- character and line of abutting property,
- topography,
- right-of-way,
- horizontal alignment,
- vertical alignment,
- coordination of vertical profiles of the intersecting roads,
- coordination of horizontal and vertical alignment for intersections on curves,
- available sight distance,
- intersection angle,
- conflict area,
- geometrics,
- channelization,
- traffic control devices,
- lighting,
- safety features,
- bicycle traffic,
- environmental impact, and
- drainage requirements.

4. Economic Factors. These include:
 - cost of improvements;
 - crash history;
 - effects on adjacent property (e.g., access to businesses); and
 - impact on energy.

5. Functional Intersection Area. An intersection can be defined by both functional and physical areas. These are illustrated in Figure 36-1.A. The functional area of the intersection extends both upstream and downstream from the physical intersection area and includes any auxiliary lanes and their associated channelization.

The essence of good intersection design requires that the physical elements be designed to minimize the potential conflicts among cars, trucks, buses, bicycles, and pedestrians. In addition, human factors of the drivers and pedestrians must be taken into account while keeping costs and impacts to a minimum.

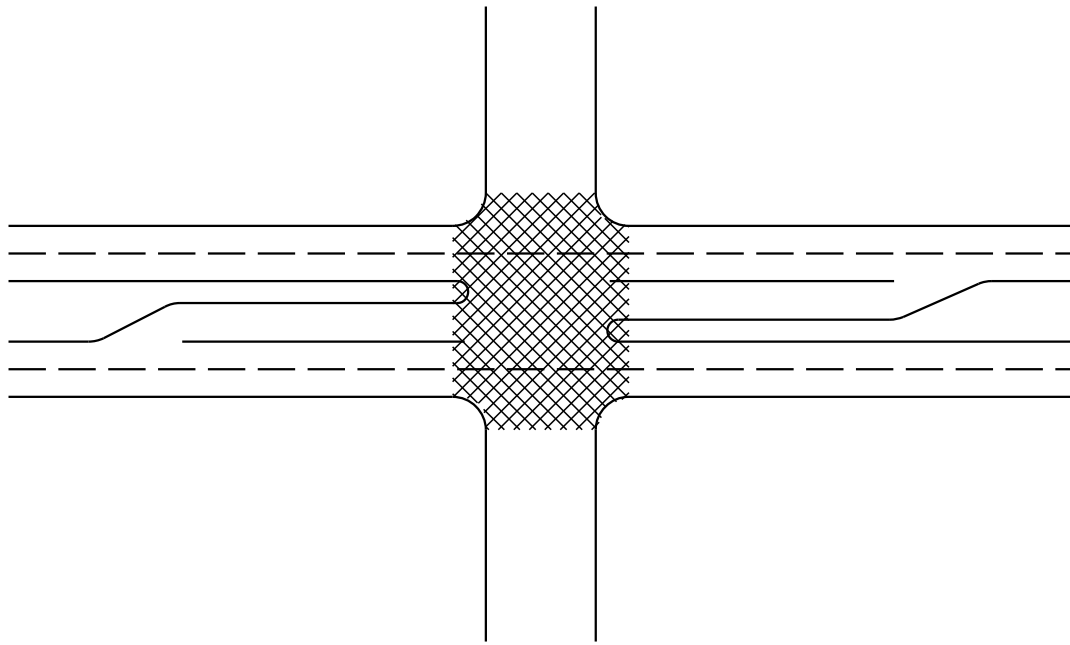

PHYSICAL AREA

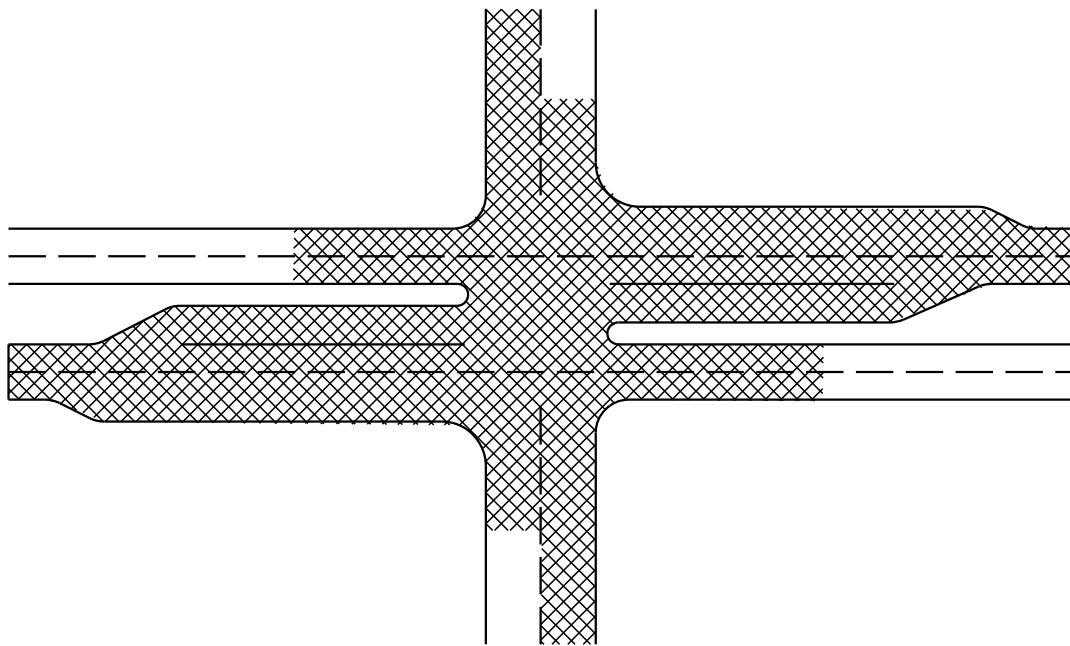

FUNCTIONAL INTERSECTION AREA

PHYSICAL AND FUNCTIONAL INTERSECTION AREA

Figure 36-1.A

36-1.02 Intersection Components

Figure 36-1.B illustrates several of the components that may be included in a typical intersection.

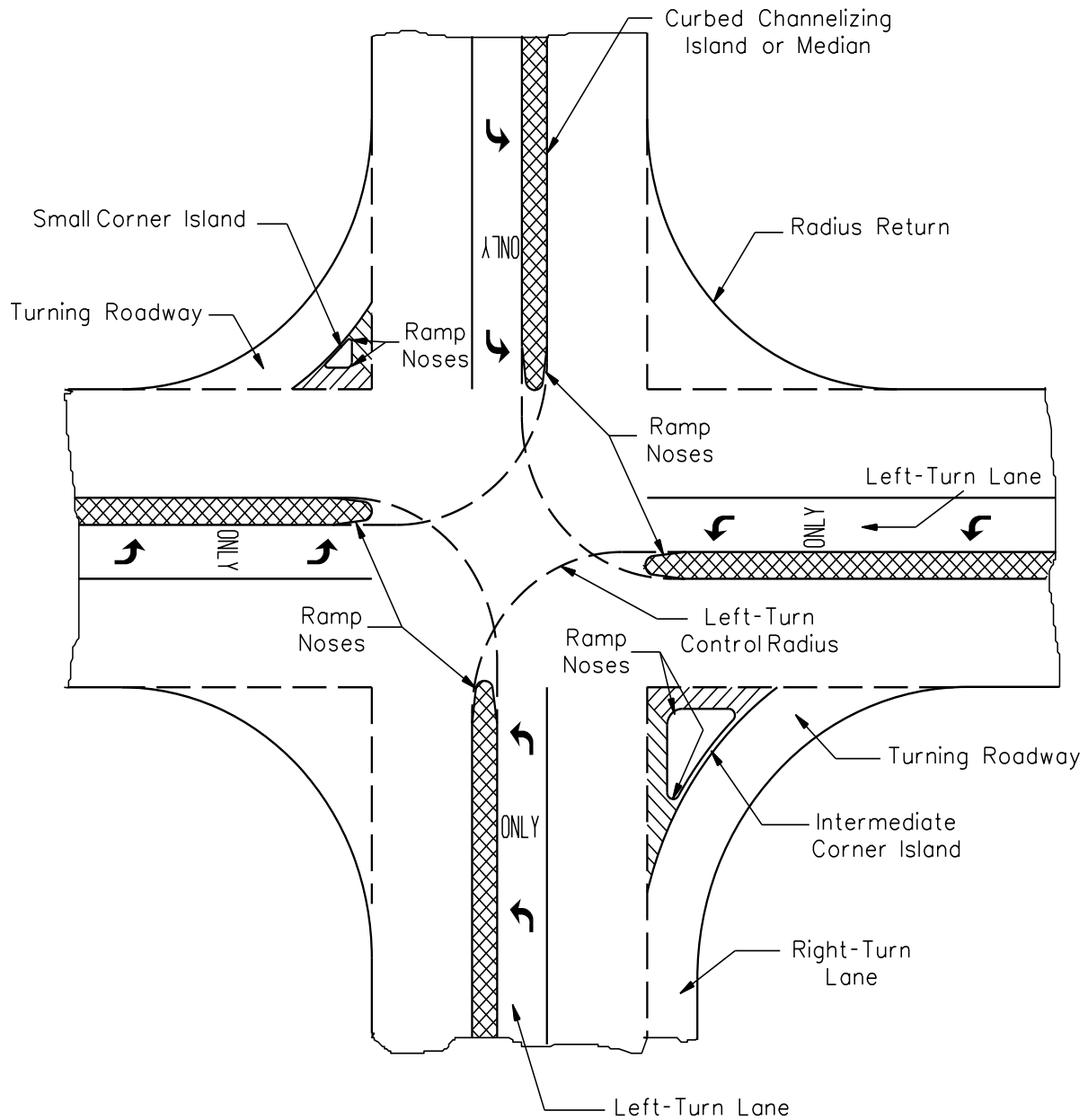

TYPICAL INTERSECTION COMPONENTS

Figure 36-1.B

36-1.03 Intersection Types

36-1.03(a) General

Intersections are usually a three-leg, four-leg, or multi-leg design. Individual intersections may vary in size and shape and may be channelized. The principal design factors that affect the selection of intersection type and its design characteristics are discussed in Section 36-1.01. Selection of the intersection type will be determined on a case-by-case basis.

Multi-leg intersections are those with five or more intersection legs. Where volumes are light and stop control is used, it may be satisfactory to have all intersection legs intersect at a common, all-paved area. At other than minor intersections, safety and efficiency are improved by rearrangements that remove some conflicting movements from the major intersection. This may be accomplished by realigning one or more of the intersecting legs and combining some traffic movements at adjacent subsidiary intersections or, in some cases, making one or more legs one-way departing from the intersection. Wherever practical, avoid using multi-leg intersections.

36-1.03(b) Alternative Intersection Designs

Some nontraditional designs may offer substantial advantages under certain conditions compared to corresponding conventional at-grade intersections or grade-separated diamond interchanges. The most commonly considered design options include: The FHWA publication entitled, *Alternative Intersections/Interchanges: Information Report (AIIR)*, which can be found on the FHWA website, addresses geometric design features, operational and safety issues, access management, costs, construction sequencing, environmental benefits, and applicability for alternative intersections. The *Report* provides guidance on the following alternative designs that may provide a unique solution to special situation

- displaced left-turn (DLT) intersection, also known as continuous flow intersection (CFI),
- median U-turn intersection (MUT),
- quadrant roadway intersection (QR),
- restricted crossing U-turn intersection (RCUT), also known as a J-turn or Superstreet,
- continuous green T intersection (CGT)
- double crossover diamond (DCD) interchange, also known as diverging diamond interchange (DDI), and
- displaced left-turn (DLT) interchange.

Section 36-10 provides guidance for RCUT, MUT, DLT and CGT intersections. Section 37-3.10 describes opportunities and design considerations for DDIs. Highway Capacity Software (HCS) now addresses the capacity of many of these alternative intersection types, in addition to more traditional intersection types; see Section 36-1.07.

Designers may also reference the FHWA publication entitled, *Alternative Intersections/Interchanges: Information Report (AIIR)*, which can be found on the FHWA website. Some potentially useful information is presented on geometric design features, operational and safety issues, access management, costs, construction sequencing, and environmental benefits.

36-1.04 Intersection Spacing

Spacing for unsignalized intersections and driveways will depend on the available stopping sight distance, intersection sight distance, traffic volumes, turning volumes, the addition of turn lanes, turning speeds, access control, and local development. The actual spacing will be determined on a case-by-case basis.

When introducing a new intersection, the designer must ensure that there is sufficient distance between the new and adjacent intersections so that they form distinct intersections. Avoid short distances between intersections, if practical, because they may impede traffic operations. For example, if two intersections are close together, they must be considered as one intersection for signal phasing purposes. To operate safely, each leg of the intersection may require a separate green phase; however, this may reduce the capacity for both intersections.

The need to efficiently move high volumes of traffic, especially during peak periods, is a major consideration in the spacing of signalized intersections. It is important that the signals be synchronized to efficiently move traffic. Figure 36-1.C illustrates the relationship between speed of progression, cycle length, and signalized intersection spacing.

36-1.05 Intersection Alignment

36-1.05(a) Angled Intersections

Highways should intersect at right angles. Intersections at acute angles are undesirable because they:

- restrict vehicular turning movements,
- require additional pavement and channelization for large trucks,
- increase the exposure time for vehicles and pedestrians crossing the main traffic flow, and
- restrict the crossroad sight distance.

Preferably, the angle of intersection should be within 15 degrees of perpendicular. This amount of skew can often be tolerated because the impact on sight lines and turning movements is not significant. Under restricted conditions where obtaining the right-of-way to straighten the angle of intersection would be impractical, an intersection angle up to 30 degrees from perpendicular may be retained for existing intersections, where historical crash data corroborates this decision. Where turning movements are significantly unbalanced, the intersections may be angled to favor the predominant movement. Intersection angles beyond these ranges may warrant more positive traffic control (e.g., all stop, traffic signals) or geometric improvements (e.g., realignment, greater corner sight distance).

Figure 36-1.D illustrates various angles of intersections and potential improvements to the alignment. Avoid using short-radius curves or unnatural travel paths near the intersection simply to reduce the intersection skew.

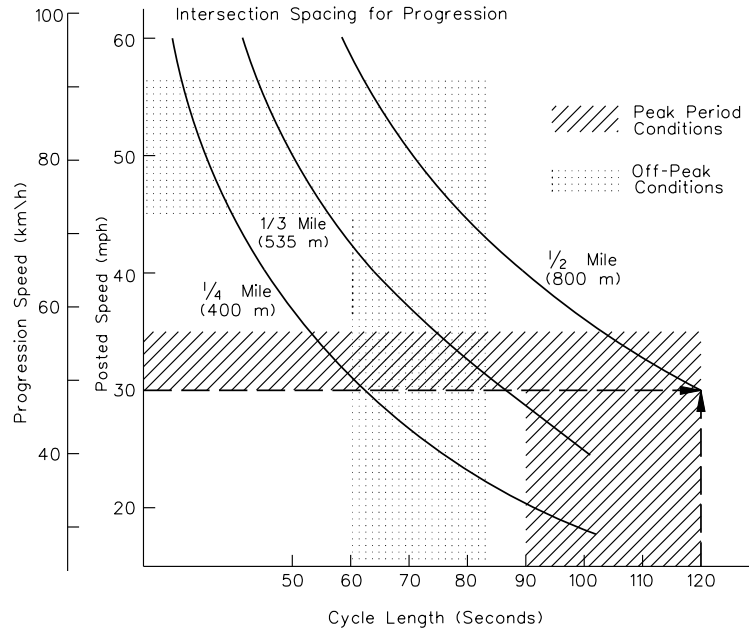

US Customary							
Cycle Length (sec)	Posted Speed (mph)						
	25	30	35	40	45	50	55
Intersection Spacing for Progression ⁽²⁾							
60	1,100 ft	1,320 ft	1,540 ft	1,760 ft	1,980 ft	2,200 ft	2,430 ft
70	1,280 ft	1,540 ft	1,800 ft	2,050 ft	2,310 ft	2,500 ft	2,640 ft
80	1,470 ft	1,760 ft	2,050 ft	2,350 ft	2,640 ft	2,640 ft	2,640 ft
90	1,630 ft	1,980 ft	2,310 ft	2,640 ft	2,640 ft	2,640 ft	2,640 ft
120	2,200 ft	2,640 ft	2,640 ft	2,640 ft	2,640 ft	2,640 ft	2,640 ft
150 ⁽¹⁾	2,640 ft	2,640 ft	2,640 ft	2,640 ft	2,640 ft	2,640 ft	2,640 ft
Metric							
Cycle Length (sec)	Posted Speed (mph)						
	25	30	35	40	45	50	55
Intersection Spacing for Progression ⁽²⁾							
60	335 m	400 m	470 m	535 m	605 m	670 m	730 m
70	390 m	470 m	550 m	625 m	705 m	760 m	800 m
80	450 m	535 m	625 m	715 m	800 m	800 m	800 m
90	495 m	605 m	705 m	800 m	800 m	800 m	800 m
120	670 m	800 m	800 m	800 m	800 m	800 m	800 m
150 ⁽¹⁾	800 m	800 m	800 m	800 m	800 m	800 m	800 m

Notes:

1. Represents maximum cycle length for actuated signal if all phases are used.
2. From a practical standpoint when considering progression, the distance between signalized intersections will usually be 2640 ft (800 m) or less. Therefore, the values in the table have been limited to 2640 ft (800 m)

SIGNALIZED INTERSECTION SPACING GUIDELINES

36-1.05(b) Intersections on Curves

Preferably, all legs of an intersection should be on a tangent section. Where a minor road intersects a major road on a horizontal curve, the geometric design of the intersection becomes significantly more complicated, particularly for sight distance, turning movements, channelization, and superelevation. The following guidelines address horizontal alignment at intersections:

1. **Realignment.** If relocation of the intersection is not practical, the designer may be able to realign the minor road to intersect the major road perpendicular to a tangent on the horizontal curve; see example “E” in Figure 36-1.D. Although an improvement, this arrangement may still result in difficult turning movements due to superelevation on the major road.
2. **Superelevated Mainline.** If the mainline is on a horizontal curve, the mainline superelevation rate must be minimized so that slowing or stopped vehicles do not slide across the pavement during wet or icy conditions. Figure 36-1.E provides the criteria for the maximum superelevation rate and rollover criteria that should be used where an important crossroad intersects a superelevated State highway. An important crossroad may be a marked highway, county highway, township road, or town street.
3. **Curved Approach.** Where a State highway or local road is on a curved alignment and is approaching a stop condition, special consideration is required in the design of the horizontal curvature prior to the intersection. This condition is illustrated in Figure 36-1.F. When designing this type of an approach, consider the following guidelines:
 - To design the horizontal curve, assume a design speed 20 mph (30 km/hr) less than the approach speed, but not less than 30 mph (50 km/hr) for design speeds less than or equal to 50 mph (80 km/hr).
 - The superelevation rate on the approach curve to an intersection should be limited to a maximum superelevation rate of 5% or less. The objective is to use as flat an alignment as practical with lower superelevation. The preferred design is to maintain a normal crown section through the curve assuming Method 2 distribution of superelevation. The minimum radius should not be less than that permitted for the highway classification. For additional guidance on horizontal curve designs; see Chapter 32.
 - Provide a short tangent section prior to the intersection. This will allow for the superelevation runoff to be developed outside of the intersection radius returns.

This procedure recognizes the need to accommodate a reasonable operating speed on a stop-controlled approach, while minimizing the potential for adverse operations on superelevated pavements during snow and ice conditions. Where the curved road is a local facility, design the curvature using the Bureau of Local Roads and Streets’ criteria. With the local roads criteria, the design is dependent on ADT and, in many cases due to the low ADT, the local facility can be designed with a normal crown section.

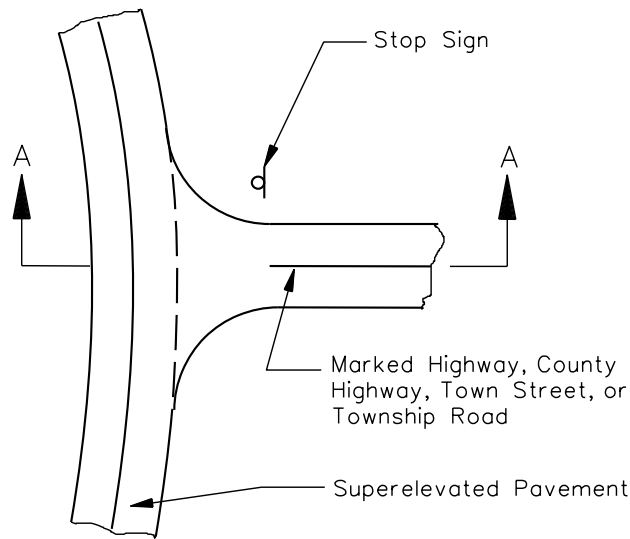

PLAN VIEW

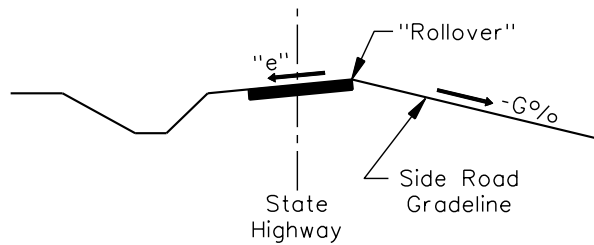

CROSS SECTION A-A

Type of Improvement Category	Maximum Superelevation Rate "e" for Intersections on Curve	Rollover Guidelines
"New Construction" at an important crossroad	4% Desirable Maximum	5% Desirable Maximum 6% Maximum
To remain in place with "Reconstruction" at an important crossroad	6% Maximum	7% Desirable Maximum 8% Maximum
To remain in place with "Reconstruction" at a minor crossroad	8% Maximum	9% Desirable Maximum 10% Maximum

INTERSECTION WITH SUPERELEVATED MAINLINE

Figure 36-1.E

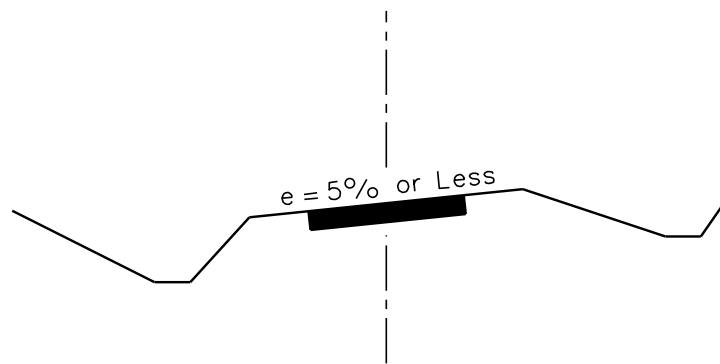
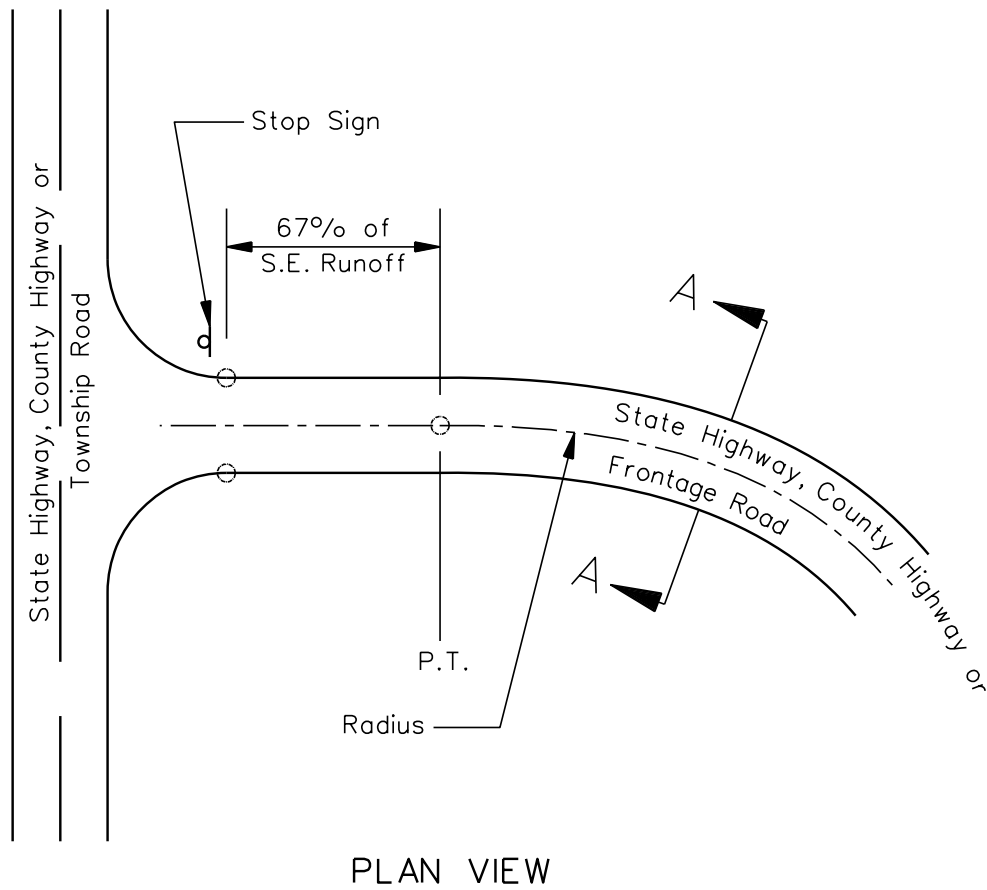

CROSS SECTION A-A
INTERSECTION WITH SUPERELEVATED SIDE ROAD

Figure 36-1.F

4. Frontage Road Approach. Where a stop-controlled frontage road approaches a grade separated crossroad, the typical curved alignment may be replaced with a “buttonhook” design to minimize impacts and land acquisition; see Figure 36-1.G. This layout is especially suited to those cases where turning traffic between the frontage road and crossroad is light compared to the through traffic on the frontage road.

36-1.05(c) Offset Intersections

In general, 4-leg intersections should be designed such that opposing approaches line up with each other (i.e., there is no offset between opposing approaches). However, this is not always practical. Figure 36-1.H presents a diagram of an intersection with an offset between opposing approaches. Because of possible conflicts with overlapping turning vehicles, offset intersections should only be allowed to remain on low-volume approaches. The following criteria will apply for offset intersection approaches:

1. Maximum Offset. The maximum offset is determined from the application of a taper equal to V:1 (0.6V:1) applied to the intersection width, where V is the design speed in miles per hour (kilometers per hour); see Figure 36-1.H. In restricted locations and where $V \leq 45$ mph (70 km/hr), the applied taper may be $V^2/60$ ($V^2/155$). V is selected as follows:
 - V = 20 mph (30 km/hr) for stop-controlled approaches.
 - V = the roadway design speed for the free-flowing approaches at a stop-controlled intersection.
 - V = the roadway design speed for the offset approaches at a signalized intersection.
2. Turning Conflicts. Evaluate the entire intersection for conflicts that may result from turning vehicles at an offset intersection. For example, offsets where the “jog” is to the left may result in significant interference between simultaneous left-turning vehicles.
3. Evaluation Factors. In addition to potential vehicular conflicts, the designer should evaluate the following at existing or proposed offset intersections:
 - through and turning volumes;
 - type of traffic control;
 - impact on all turning maneuvers;
 - intersection geometrics (e.g., sight distance, curb/pavement edge radii); and
 - crash history at existing intersections.

Where existing offset intersections are being considered to remain, the designer should coordinate the intersection design and traffic control requirements with BDE and the district Bureau of Operations.

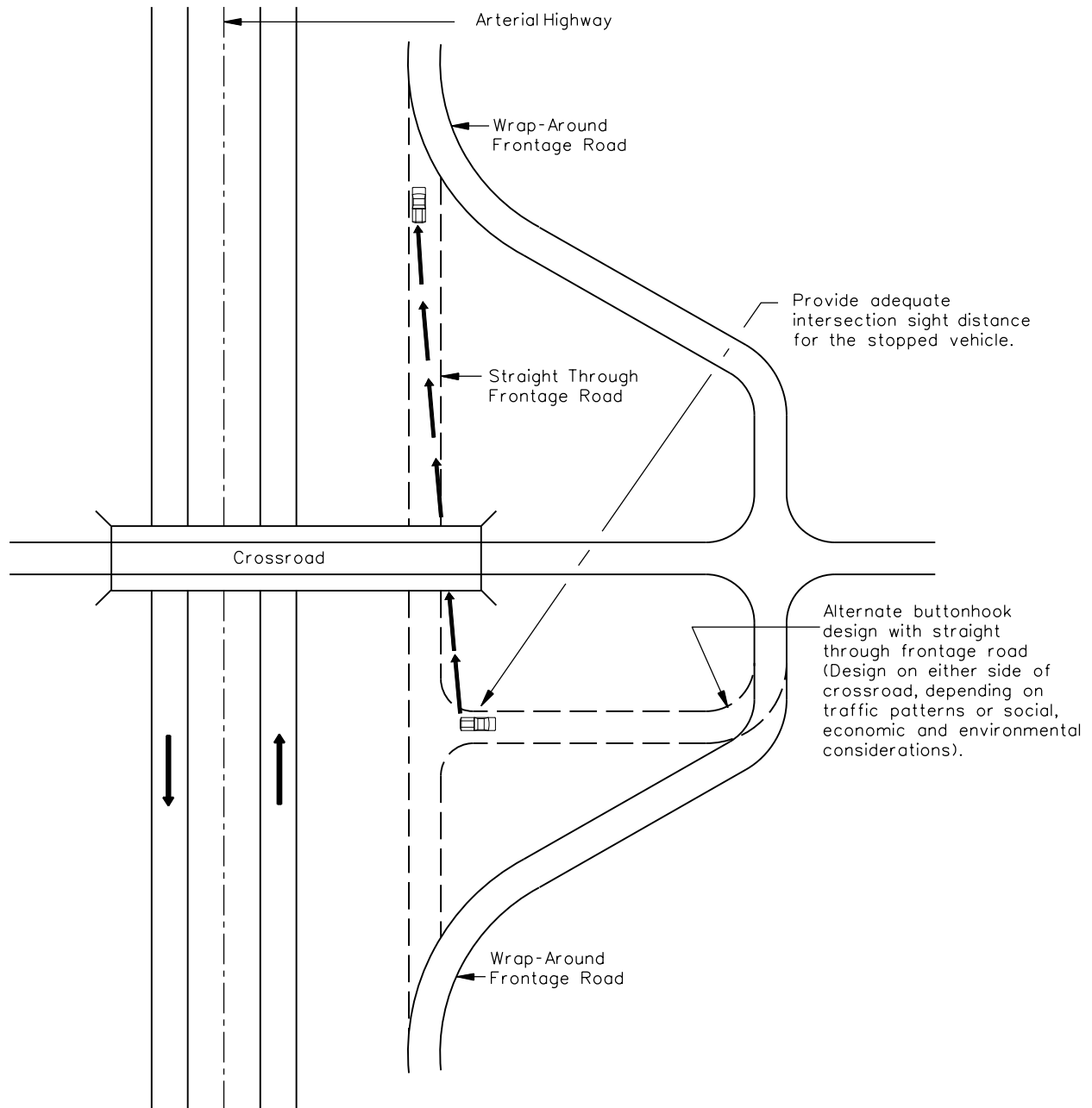

**ALTERNATIVE FRONTAGE ROAD INTERSECTION
(Buttonhook Design)**

Figure 36-1.G

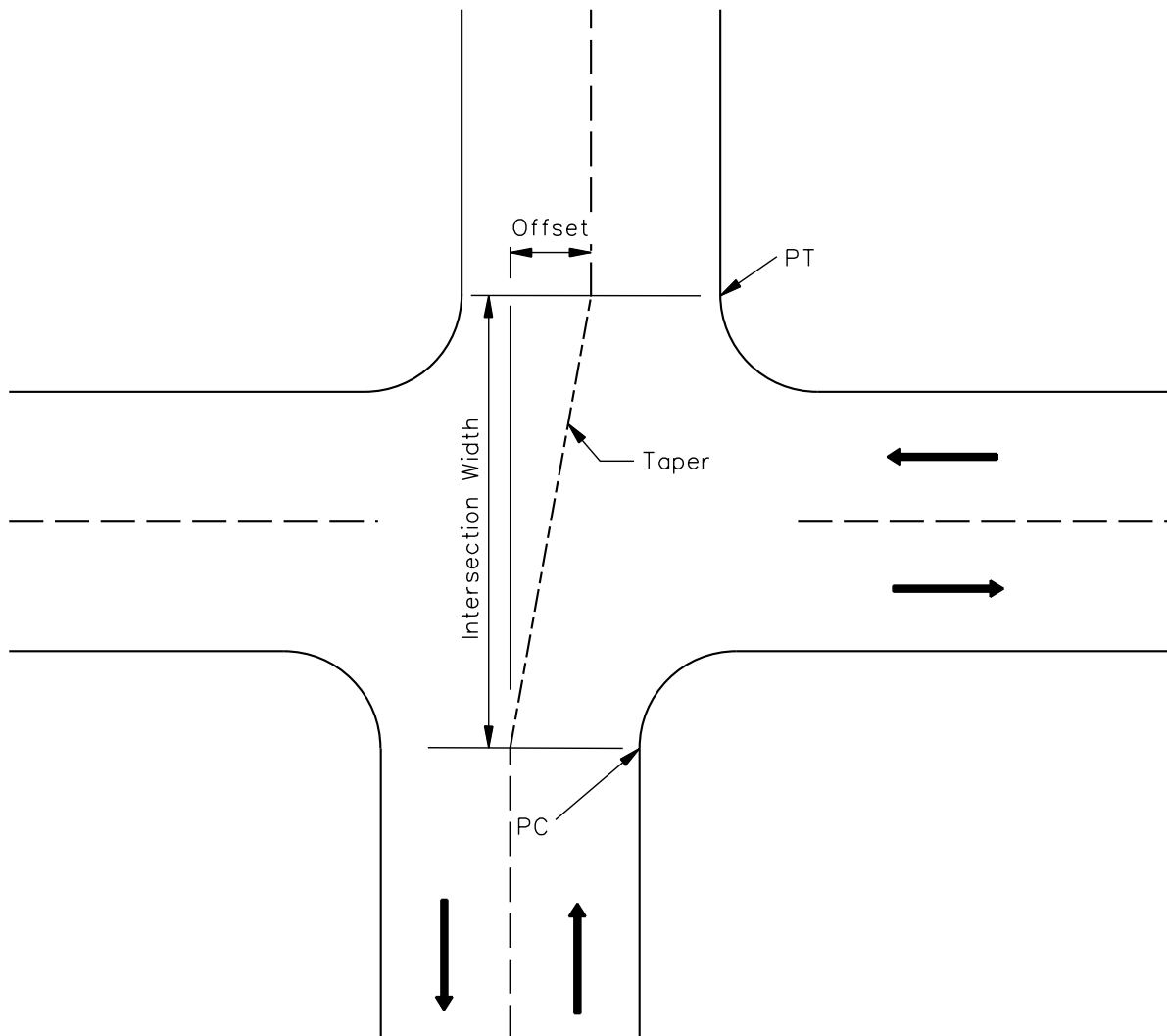

Notes:

1. *Desirable taper rate is $V:1$ ($0.6V:1$), where V = design speed in mph (km/hr).*
2. *See discussion in Section 36-1.05(c) for more information.*

OFFSET INTERSECTION

Figure 36-1.H

36-1.06 Profiles

Many drivers are unable to judge the effect of substantial profile grades on stopping and accelerating distances. Their normal deductions and reactions may thus be in error at a critical time. The design should avoid combinations of grade lines that make vehicular control difficult at intersections. To accomplish this, consider the profile for all roadway approaches to and through the intersection. The following criteria will apply.

36-1.06(a) Approach Gradients

The profile gradients of intersecting highways should be as flat as practical on those intersection approaches that will be used for storage of stopped vehicles and the crossing of pedestrians. This area is commonly referred to as the storage space or storage platform.

The designer shall consider the following in the design of intersection approach gradients:

1. State Highways. On the mainline highway, the storage platform gradient should be a minimum of 1% and a maximum of 2%, which will optimize operations for motorists and bicyclists and ensure both compliance with ADA standards (see Chapter 58 for information on Accessibility Standards) and proper roadway drainage.

On important side roads (e.g., other state highway, county highway, local arterial) approaching the state highway, the storage platform gradient should be a minimum of 1% and a maximum of 2% draining away from the mainline highway. Maintain this gradient through the expected storage distance on that leg. At a minimum, provide the storage platform gradient on the side road for a distance of 50 ft to 100 ft (15 m to 30 m) beyond the edge of the mainline traveled way or to the ditch line of an arterial highway. Again, the selection of grades 2% or less will optimize operations for motorists and bicyclists and ensure compliance with ADA standards.

For new intersection construction projects where pedestrians are a design user of the facility, compliance with accessibility standards is mandatory. For new construction/reconstruction projects involving intersections, intersection gradients complying with ADA criteria should be initially designed and constructed regardless of existing pedestrian presence. Should pedestrian accommodations be added along the facility in the future, applying this approach will ensure ADA compliance can be met without the need for costly intersection reconstruction.

For existing locations within roadway improvement project limits, intersection gradients greater than 2% may necessitate geometric modifications to the roadway profile to meet accessibility standards, when either marked or unmarked crosswalks exist or are proposed. Sections 58-1.09 and 58-1.10 describe crosswalk cross-slope requirements based on whether or not there is “yield or stop control” for approaching vehicle traffic, and how this can affect roadway approach gradients. Where pedestrians are not a design user of the facility, intersection gradients greater than 3% will require correction of certain

design factors (e.g., stopping sight distances, deceleration lengths, traffic signal timing) to produce operating conditions as equivalent as practicable to those on level highways.

Any gradient through an intersection must reflect the practicalities of matching the basic profiles of the intersecting roadways and shoulders. When desirable intersection approach gradients, as discussed above, cannot be achieved due to terrain, right-of-way, or other important concerns on any project defined as an alteration of the facility, see Section 58-1.01, a design exception and/or a request for a maximum extent practicable determination (MEP) may be necessary; see Chapter 31.

2. **Local Roads and Streets.** For local collectors, local roads or streets, and entrances to the mainline highway, provide a profile that will drain away from the mainline highway. Where a local facility (e.g., township road, county roadway, low-volume town street) intersects a State highway on a tangent section, the side-road storage platform gradient may be a maximum of 4% draining away from the State highway, unless a marked or unmarked crosswalk exists or is proposed across the storage platform of the facility. For these locations, approach gradients steeper than 2% may necessitate geometric modifications to the roadway profile to meet accessibility standards; see Section 58-1.09.
3. **Intersection Rollover.** The algebraic difference between mainline highway and side road should not exceed the rollover guidelines described in Figure 36-1.E.
4. **Grade Lines.** The principles for coordinating the horizontal and vertical alignment discussed in Chapter 33 are also applicable to vertical profiles through intersections. In addition, do not place intersections on or near crest vertical curves unless the vertical curve is flat enough for the intersection pavement to be seen assuming decision sight distance criteria.

36-1.06(b) Cross-Section Transitions

One or more of the approaching legs of an intersection may need to be transitioned (or warped) to meet the cross section of the two crossing roads. The following applies:

1. **Stop Controlled.** Where the minor road is stop controlled, maintain the profile and cross section of the major road through an intersection and transition the cross slope of the stop-controlled roadway to match the major road cross slope and profile.
2. **Signalized Intersection.** At signalized intersections, or potentially signalized intersections, transition the cross section of the minor road to meet the profile and cross slope of the major road. Where compromises are necessary between two major roadways, provide the smoother riding characteristics to the roadway with the higher traffic volumes and operating speeds.
3. **Transition Rates.** Where one or both intersecting roadways are transitioned, the designer must determine the length and rate of transition from the typical section to the modified section. Desirably, design the transition to meet the general principles of superelevation transition which apply to that roadway (i.e., open-roadway or low-speed urban street

conditions); see Section 32-3. When these criteria are applied to intersection transition rates, the applied design speed is typically:

- 20 mph (30 km/hr) below the design speed but not less than 30 mph (50 km/hr) for a stop-controlled roadway,
- the highway design speed for a free-flowing roadway, or
- the highway design speed on each roadway of a signalized intersection.

At a minimum and consistent with field conditions, transition the approach pavements of an urban intersection within the curb or radius returns and for rural intersections within a distance of 50 ft (15 m).

36-1.06(c) Profiles at Intersections

Where the cross section of the minor road is warped to meet the major road, provide a vertical curve between the side road approach gradient and the mainline pavement; see Figure 36-1.I. The following vertical curve options are presented in order from the most desirable to the least desirable:

1. Vertical Curves (SSD). The criteria for stopping sight distance as described in Chapter 33 should be used for the vertical curve. Use the design speed discussed in Section 36-1.06(b) to design the vertical curve.
2. Sag Vertical Curves (Minimum Comfort). Under restricted conditions where the SSD criteria is not practical, the sag vertical curves at intersection approaches may be based on the following formulas:

$$K = (0.1 V)^2 \quad \text{Equation 36-1.1 (US Customary)}$$

$$K = (0.034V)^2 \quad \text{Equation 36-1.1 (Metric)}$$

$$L = KA \quad \text{Equation 36-1.2}$$

where: K = the horizontal distance in ft (meters) needed to produce a 1% change in the gradient along the curve

A = algebraic difference between the two tangent grades, %

V = design speed, mph (km/hr)

L = length of vertical curve, ft (m)

3. Angular Breaks. At stop-controlled intersections, angular breaks are typically provided when warping the cross section of the minor approach to meet the mainline cross section. Figure 36-1.I presents a schematic of vertical profiles through an intersection. Figure 36-1.E provides the maximum rollover guidelines which are also applicable for changes in angular breaks.

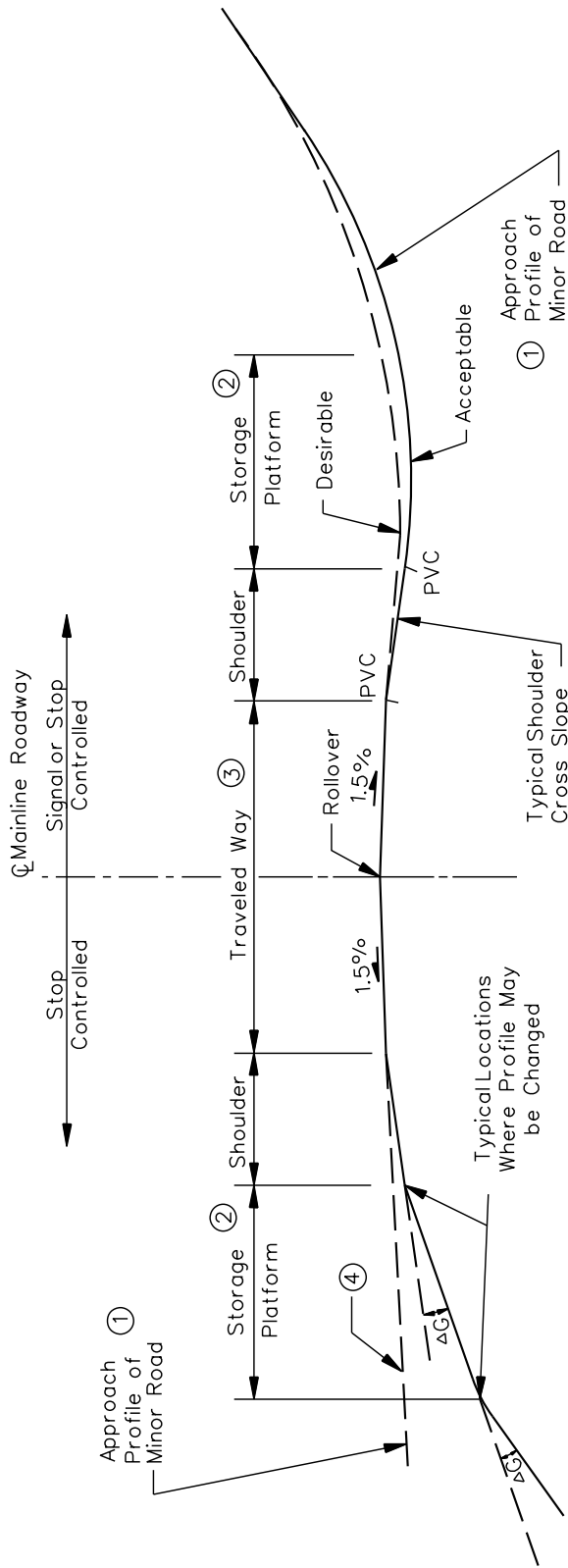

Notes:

Desirably, the minor road profile should tie into the mainline travel lane cross slope; however, where the minor road is stop controlled, it will be acceptable for the minor road profile to tie into the mainline shoulder cross slope. Actual field conditions will determine the final design

See Item 1 in Section 36-1.06(a) for storage platform gradients.

At signalized intersections, the most desirable cross slope option will be to transition all approach legs into a planar surface through the intersection and to limit the centerline rollover on the mainline to 2% - 3%.

For a signal controlled minor road descending from the mainline, maintain the travel lane cross slope of the mainline roadway through the length of the storage platform.

VERTICAL PROFILES OF INTERSECTING ROADS

Figure 36-1.1

4. Driveways. For driveway profiles with and without sidewalks, the designer should refer to Section 36-7 and the *IDOT Policy on Permits for Access Driveways to State Highways*, 92 Ill. Admin. Code 550.

36-1.06(d) Drainage

Evaluate the profile and transitions at all intersections for impacts on drainage. This is especially important for channelized intersections on curves and grades. This may require the designer to check superelevation transition lengths to ensure flat sections are minimized. Low points on approach roadway profiles should be beyond a raised corner island to prevent water from being trapped and causing ponding.

36-1.07 Intersection Capacity Analysis

Capacity analysis influences several geometric design features including the number of approach lanes, auxiliary lanes, lane widths, channelization, and number of departure lanes. In addition, this analysis in conjunction with the *Illinois Manual on Uniform Traffic Control Devices* will determine whether an intersection may need to be signalized or stop controlled. Any considered change in traffic control should be reviewed with the district Bureau of Operations for concurrence.

It is important that the level of service for a signalized intersection be calculated for each lane group (a lane group may be one or more movements), each intersection approach, and the intersection as a whole. Level of service criteria are provided in the geometric design tables in Part V, Design of Highway Types, of the *BDE Manual*.

Once the minimum level of service has been selected and design traffic volumes are determined, use the *Highway Capacity Manual* and the *Highway Capacity Software* (HCS) to perform the detailed capacity analyses. Ensure that data used in the analyses are applicable for the intersection (i.e., do not assume the program default values are automatically applicable for the intersection). Other capacity and signal analysis programs may be used provided they are approved for use by the BDE. To be eligible for approval, the output results must be comparable to the HCS.

If the intersection is part of a traffic signal system, check the intersection design with an approved traffic progression program. These programs analyze all signalized intersections in the system to determine the overall capacity of the system. HCS is now able to perform both standalone intersection and corridor analyses. Whenever the information is available and relevant to the design, the capacity analysis should include nearby adjacent intersections within the corridor, as both upstream and downstream intersections can have a significant impact on overall capacity and delay. Also, see Figure 36-1.C for signalized intersection spacing guidelines.

In addition, if the capacity analysis at an intersection shows a saturated or over-saturated flow (i.e., flow rate at or over capacity, $v/c \geq 1.0$) for any movement, a multi-period analysis within HCS is necessary to appropriately calculate the effects of residual queue back-up and sustained spillback in determining the actual level of service and delay for the intersection. See the Highway Capacity Manual (HCM) and HCS for more information.

36-1.08 Design Vehicles

36-1.08(a) Types

The design vehicle affects the radius returns, left-turn radii, lane widths, median openings, turning roadways, and sight distances at an intersection. The basic design vehicles used by IDOT for intersection design are:

- P — Passenger car; includes vans and pickup trucks.
- S-BUS-40 (S-BUS-12) — 84-passenger school bus.
- SU-30 (SU-9) — Single-unit truck with an overall vehicle length of 30 ft.
- WB-40 (WB-12) — Tractor/Semitrailer combination with an overall wheelbase of 40 ft (12.2 m).
- WB-50 (WB-15) — Tractor/Semitrailer combination with an overall wheelbase of 50 ft (15.2 m).
- WB-55 (WB-17) — Tractor/Semitrailer combination with an overall wheelbase of 55 ft (16.8 m).
- WB-65/67 (WB-20) — Tractor/Semitrailer combination with an overall wheelbase of 65 ft or 67 ft (20.4 m).
- WB-67D (WB-20D) — Tractor/Semitrailer/Trailer combination with an overall wheelbase of 67 ft (20.4 m).
- P/T — Recreational vehicle, car, and camper trailer.

Figure 36-1.J illustrates the turning characteristics for a typical tractor/semitrailer design vehicle and definitions for terms that make up the characteristics. Figure 36-1.K shows the dimensions of commonly used truck tractors. For IDOT's purposes, the long-haul tractors are used for the WB-65 and WB-67 design vehicles. The city and short haul tractors are used for the remaining multi-unit design vehicles. Figure 36-1.L shows the relationship between the maximum steering angle, effective wheelbase of a tractor, and the centerline turning radius on which the turning paths for combination trucks is based.

Figures 36-1.M through 36-1.U provide vehicular dimensions and turning templates for typical design vehicles. The turning path parameters for the design vehicles in Figures 36-1.M through 36-1.U may vary from the software used for intersection and other types of geometric layout. Vehicle turning software is periodically updated by the software manufacturers to be current with industry standards, while the turning path parameters for the design vehicles are meant to visually represent a turning path. The minimum turning radii shown in the figures are for turns less than 10 mph (15 km/hr).

36-1.08(b) Selection

Figure 36-1.V presents the recommended design vehicles at intersections based on the functional classification of the intersecting highways which the vehicle is turning from and onto. Figure 36-1.W presents the recommended truck type that should be used based on the Illinois “Designated State Truck Route System.” Chapter 43 further discusses the National Truck Network. The design vehicles shown in Figures 36-1.V and/or 36-1.W are for new construction and reconstruction projects. For 3R projects, the design vehicle will be site specific, and it may be a smaller design vehicle than that used for new construction and reconstruction projects.

In addition to Figures 36-1.V and 36-1.W, use the following guidelines when selecting a design vehicle:

1. **Minimum Designs.** The SU-30 and/or S-BUS-40 design vehicles are generally the smallest vehicles used in the design of State highway intersections. This design reflects that, even in urban residential or sparsely populated rural areas, garbage trucks, delivery trucks, and school buses will be negotiating turns with some frequency. Rural intersections which may serve school bus traffic should, at a minimum, accommodate a turning school bus without encroachment onto the opposing lanes of travel. Intersections of State highways with suburban residential streets should also accommodate, at a minimum an S-BUS-40. Encroachment onto the opposing lanes of travel is permitted, but not desirable. Urban intersections only need to accommodate design vehicles that are expected to use that intersection. See Section 36-2.01 for further discussion on encroachment.
2. **Recreational Areas.** Recreational areas typically will be designed using the SU design vehicle. This reflects that service vehicles are typically required to maintain the recreational area. Under some circumstances the passenger car with a trailer (P/T) may be the appropriate design vehicle (e.g., campground areas, boat launches).
3. **Mixed Use.** Some portions of an intersection may be designed with one design vehicle and other portions with another vehicle. For example, it may be desirable to design physical characteristics (e.g., corner islands) for the WB-67 (WB-20) truck but provide painted channelization for the SU design vehicle. This technique can improve safety by providing additional guidance to motorists, bicyclists, and pedestrians at locations where a smaller design vehicle may comprise the majority of usage at an intersection.
4. **Turning Template.** The intersection design and layout should be checked with an approved computer simulated turning template program or with an actual turning template.

Federal law prohibits limiting the overall length of tractor/semitrailer and tractor/semitrailer/trailer combinations on the National Network; see Section 43-5 for a discussion on the National Network. Thus tractor/semitrailer and tractor/semitrailer/trailer combinations longer than WB-67 are allowed on some Illinois roads without permits, however unless vehicle surveys indicate a need for designing for larger vehicles, designing for WB-67's is adequate for the facilities shown in Figure 36-1.V.

The Illinois Statutes applied the Federal law to all Class I highways. On Class II highways, the Illinois statutes do not have an overall length limits but limits the length from the front axle to the rear axle to 65 ft (WB-65) on Class II highways.

36-1.09 Pedestrians and Bicyclists

In the design of an intersection, safe and convenient movement of pedestrians and bicyclists shall be considered. Where present, pedestrians and bicyclists should be treated as design users of the intersection and given the same consideration in the design process as the design vehicle. Overly wide intersections can significantly increase the crossing distance for pedestrians and bicyclists, resulting in increased exposure that can lead to higher crash potential for vulnerable users. Additionally, longer signal phase times, more potential pedestrian conflicts with turning vehicles, and lower overall intersection capacity can result with very wide intersections.

To address these issues and improve pedestrian and bicycle accommodation, initially consider ways to minimize the outside return radii and therefore overall intersection size. Further, the geometric layout may incorporate refuge islands, curb extensions, raised medians, special markings added for bicyclists, additional traffic signal actuation devices specifically for pedestrians or bicyclists, or other design features. In general, geometry that reduces vehicle turning speeds will improve non-motorized safety performance. Returns and corner island designs can constrain vehicle speeds while adding bicycle/pedestrian refuge areas. Mountable aprons, to accommodate larger design vehicles while affecting smaller vehicle turning paths, are supported by FHWA and are utilized throughout the U.S. to achieve multi-modal goals and address safety concerns.

Place crosswalks at approximate right angles to traffic movements and at locations where they will provide for maximum visibility while meeting both driver and pedestrian expectations. All sight lines to crosswalks and adjacent pedestrian waiting areas, including those within medians, must be free of high vegetation plantings or other obstructions.

Chapter 58 discusses the application of curb ramps at intersections for individuals with disabilities. Chapter 17 provides several applications for accommodating bicycle lanes and pedestrians through an intersection. Crosswalk lighting, which can be an effective safety countermeasure for pedestrian crashes, is covered in Chapter 56. The majority of pedestrian crashes occur in dark conditions.

36-1.10 Pavement Markings/Reflectorized Markers

See the Bureau of Operations Departmental Policy TRA-14 and use the current edition of the Bureau of Operation's *Traffic Policies and Procedures Manual; Pavement Marking Selection, Installation, and Inspection Manual; the Manual on Uniform Traffic Control Devices; and the Illinois Highway Standards* to select and design the appropriate pavement markings and crosswalks at intersections. Chapter 57 provides general guidelines for the placement of pavement markings and reflectorized markers.

36-1.11 Intersection Lighting

The primary objective of highway lighting is to enhance highway safety. Intersection lighting enables the driver to determine the geometry and condition of the intersection at extended distances thereby simplifying the driving task. This in turn increases driver comfort and reduces fatigue which may contribute to highway safety. Chapter 56 discusses the warrants and design criteria for highway and intersection lighting.

36-1.12 Bus Turnouts

For design of bus turnouts near intersections, see Chapter 58.

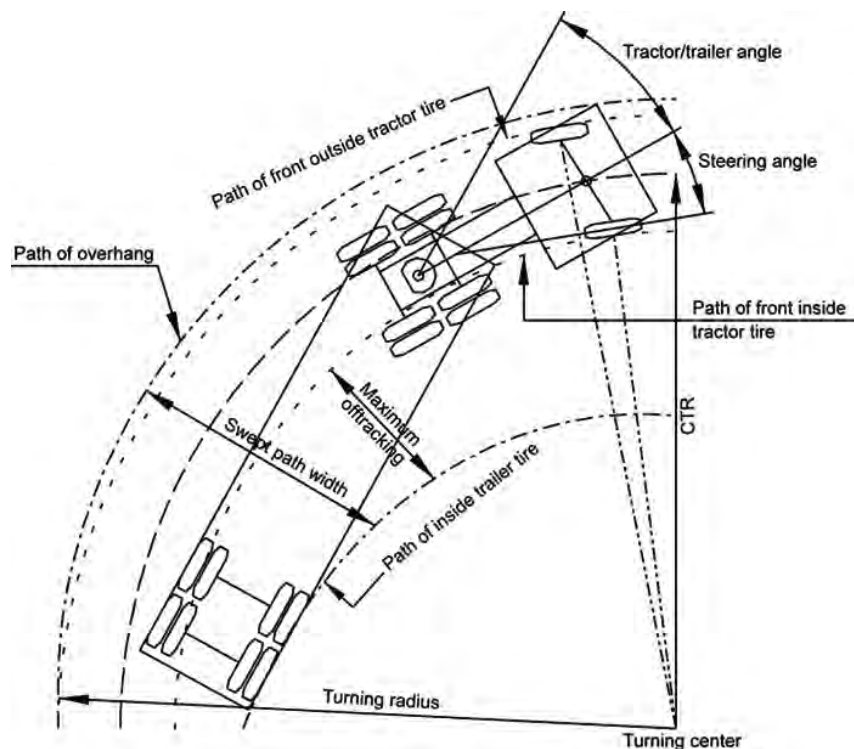

Definitions:

1. **Turning Radius.** The circular arc formed by the turning path radius of the front outside tire of a vehicle. This radius is also described by vehicular manufacturers as the “turning curb radius.”
2. **Centerline Turning Radius (CTR).** The turning radius of the centerline of the front axle of a vehicle with its steering wheels at the steering lock position.
3. **Offtracking.** The difference in the paths of the front and rear wheels of a tractor/semitrailer as it negotiates a turn. The path of the rear tires of a turning truck does not coincide with that of the front tires. This effect is shown in the drawing above.
4. **Swept Path Width.** The amount of roadway width that a truck covers in negotiating a turn and is equal to the amount of off-tracking plus the width of the tractor unit. The most significant dimension affecting the swept path width of a tractor/semitrailer is the distance from the kingpin to the rear trailer axle or axles. The greater this distance is, the greater the swept path width.
5. **Steering Angle.** The average of the angles made by the left and right steering wheels with the longitudinal axis of the vehicle when the wheels are turned to their maximum angle. The Maximum angle controls the minimum turning radius of the vehicle.
6. **Tractor/Trailer Angle.** The angle between adjoining units of a tractor/semitrailer when the combination unit is placed into a turn. This angle is measured between the longitudinal axes of the tractor and trailer as the vehicle turns. The maximum tractor/trailer angle occurs when a vehicle makes a 180 degree turn at the minimum turning radius and is reached slightly beyond the point where a maximum swept path width is achieved.

**TURNING CHARACTERISTICS OF A TYPICAL
TRACTOR-SEMITRAILER COMBINATION DESIGN VEHICLE**

Figure 36-1.J

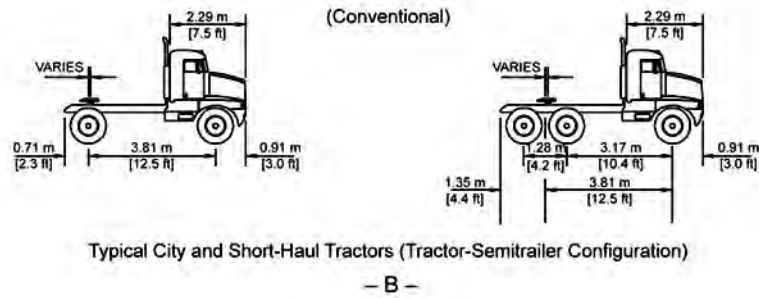
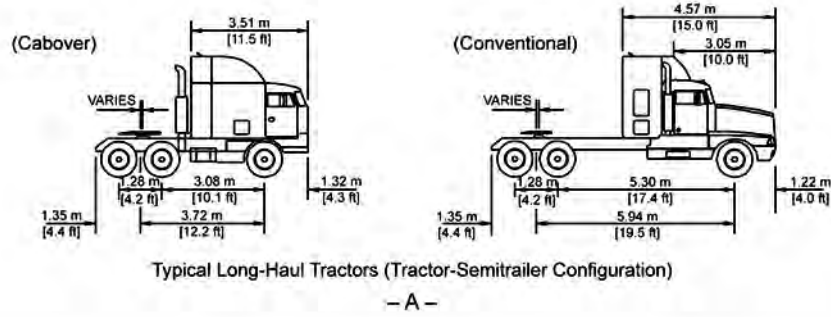

DIMENSIONS OF COMMONLY USED TRUCK TRACTORS

FIGURE 36-1.K

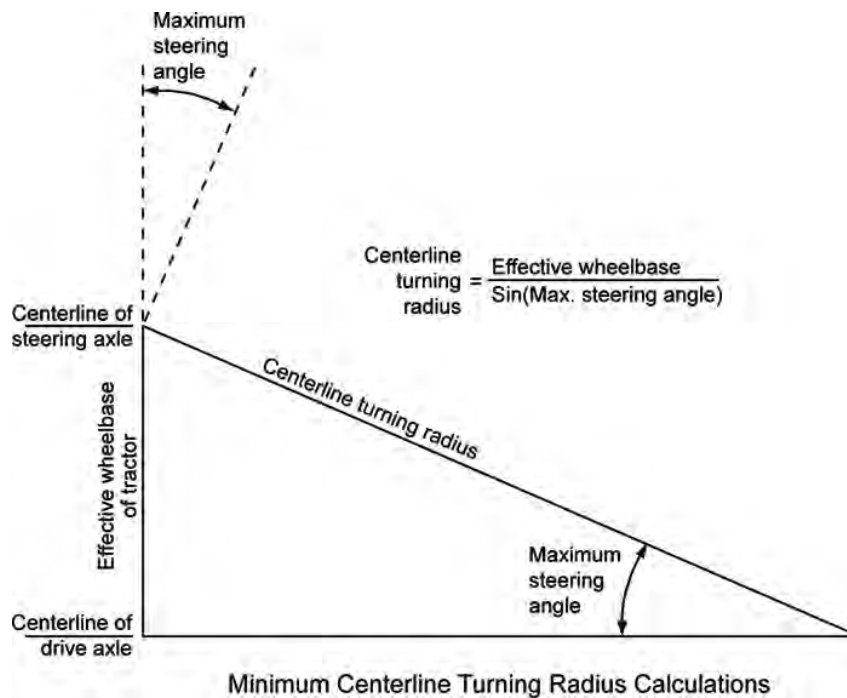

COMPUTATION METHOD FOR DETERMINING THE CTR FOR TRACTOR-SEMITRAILER COMBINATION TRUCKS

FIGURE 36-1.L

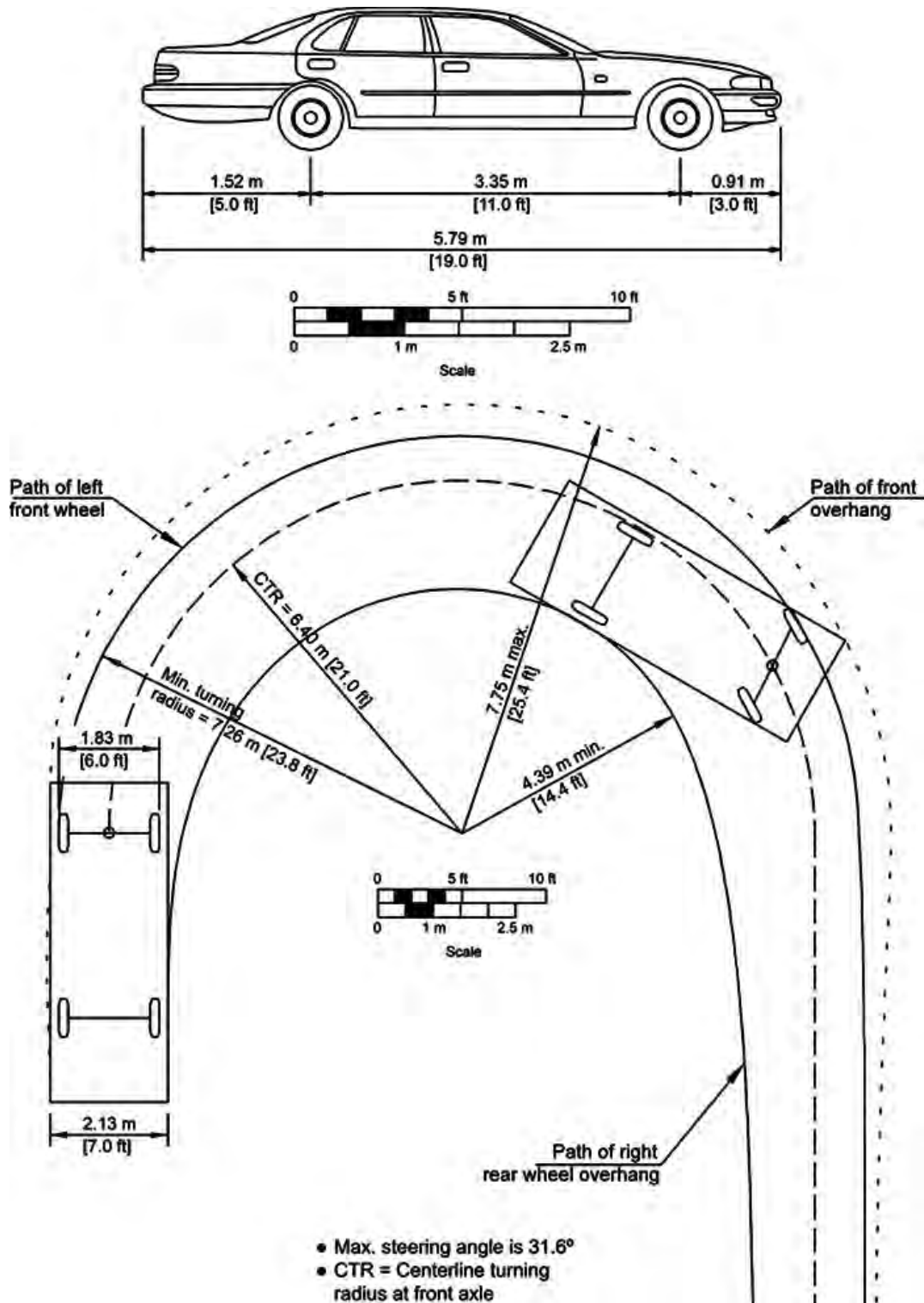

**MINIMUM TURNING PATH OF PASSENGER CAR
(P) DESIGN VEHICLE**

Figure 36-1.M

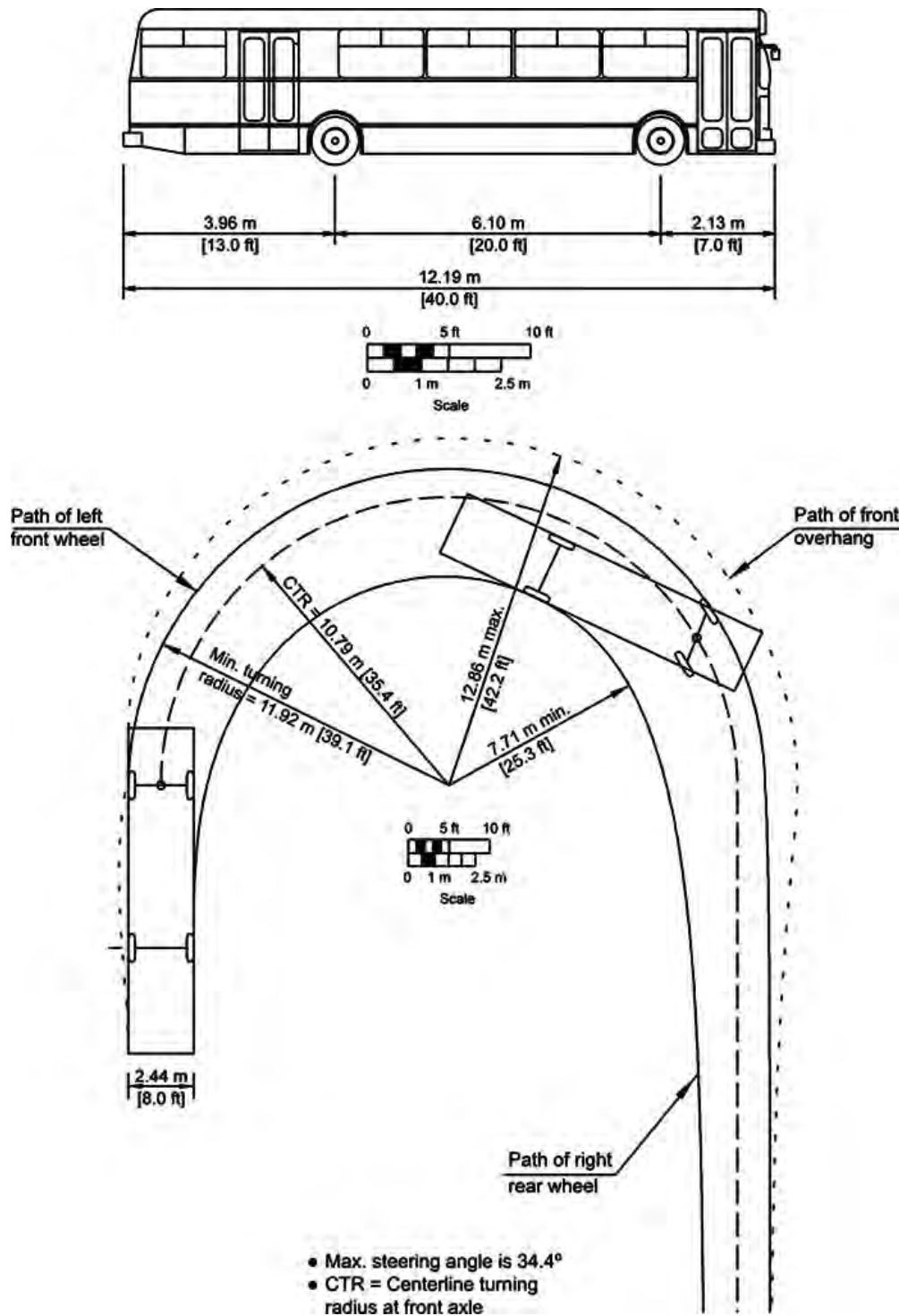

*Note: The 84-passenger school bus is the largest school bus presently manufactured.

MINIMUM TURNING PATH OF 84-PASSENGER SCHOOL BUS (S-BUS) DESIGN VEHICLE

Figure 36-1.N

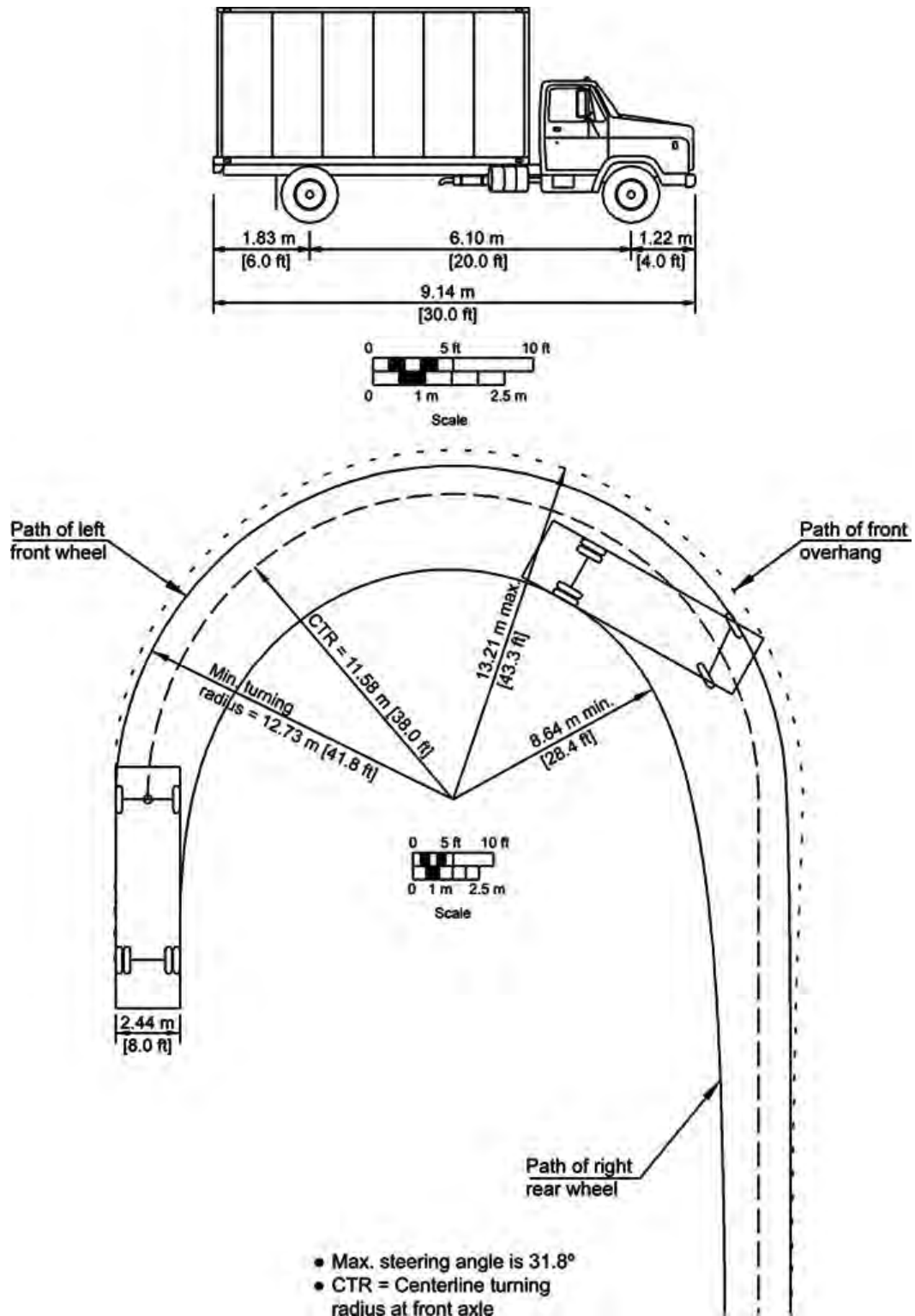

MINIMUM TURNING PATH OF SINGLE UNIT [SU-30 (SU-9)] DESIGN VEHICLE

Figure 36-1.0

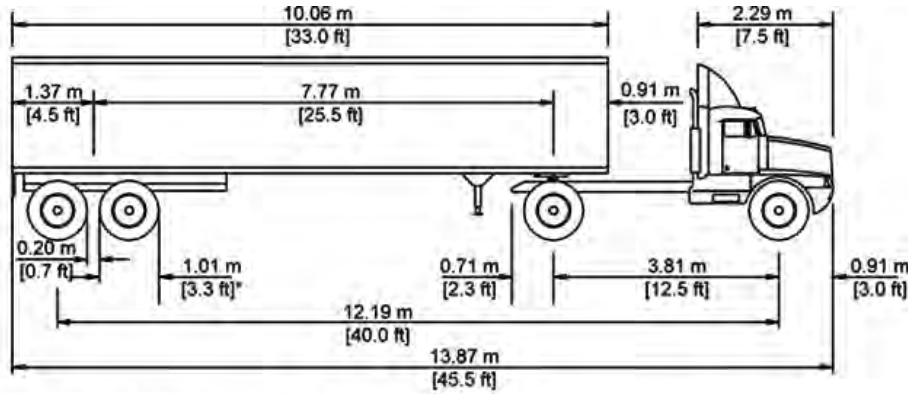

* Typical tire size and space between tires applies to all trailers

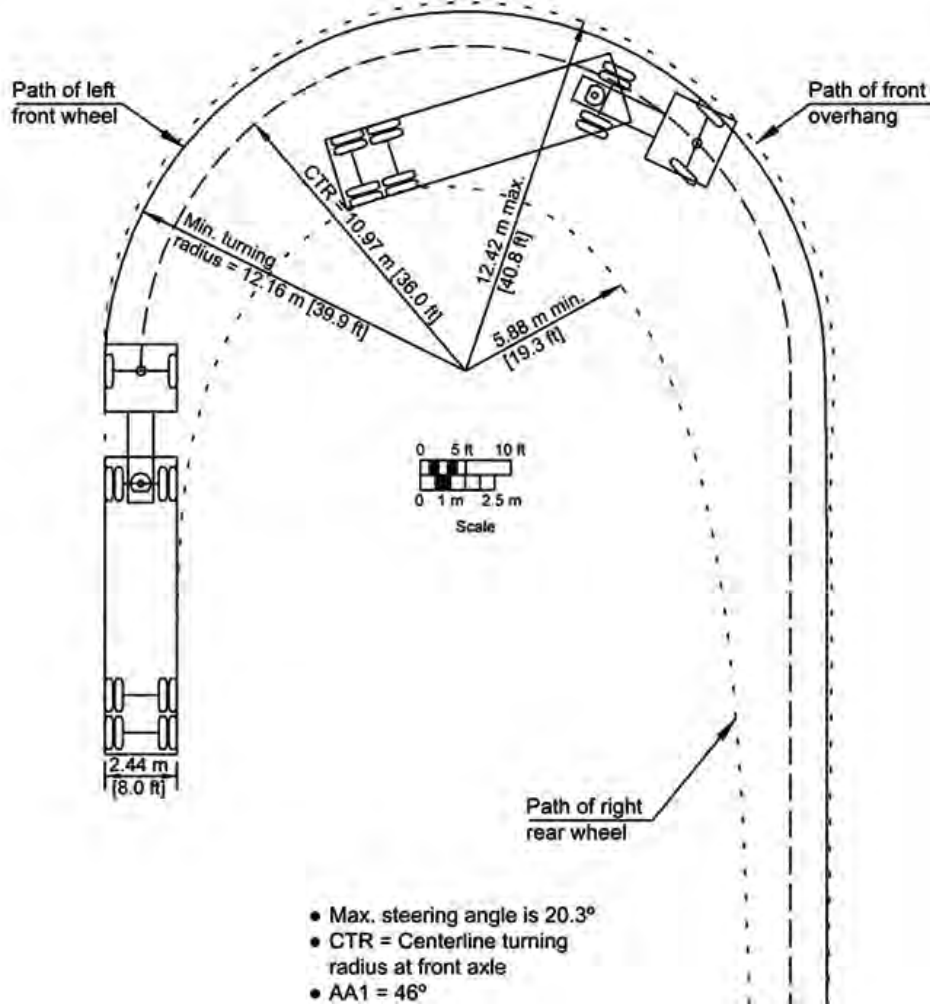
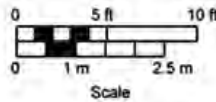

- Max. steering angle is 20.3°
- CTR = Centerline turning radius at front axle
- AA1 = 46°

**TURNING PATH OF TRACTOR/SEMITRAILER
[WB-40 (WB-12)] DESIGN VEHICLE**

Figure 36-1.P

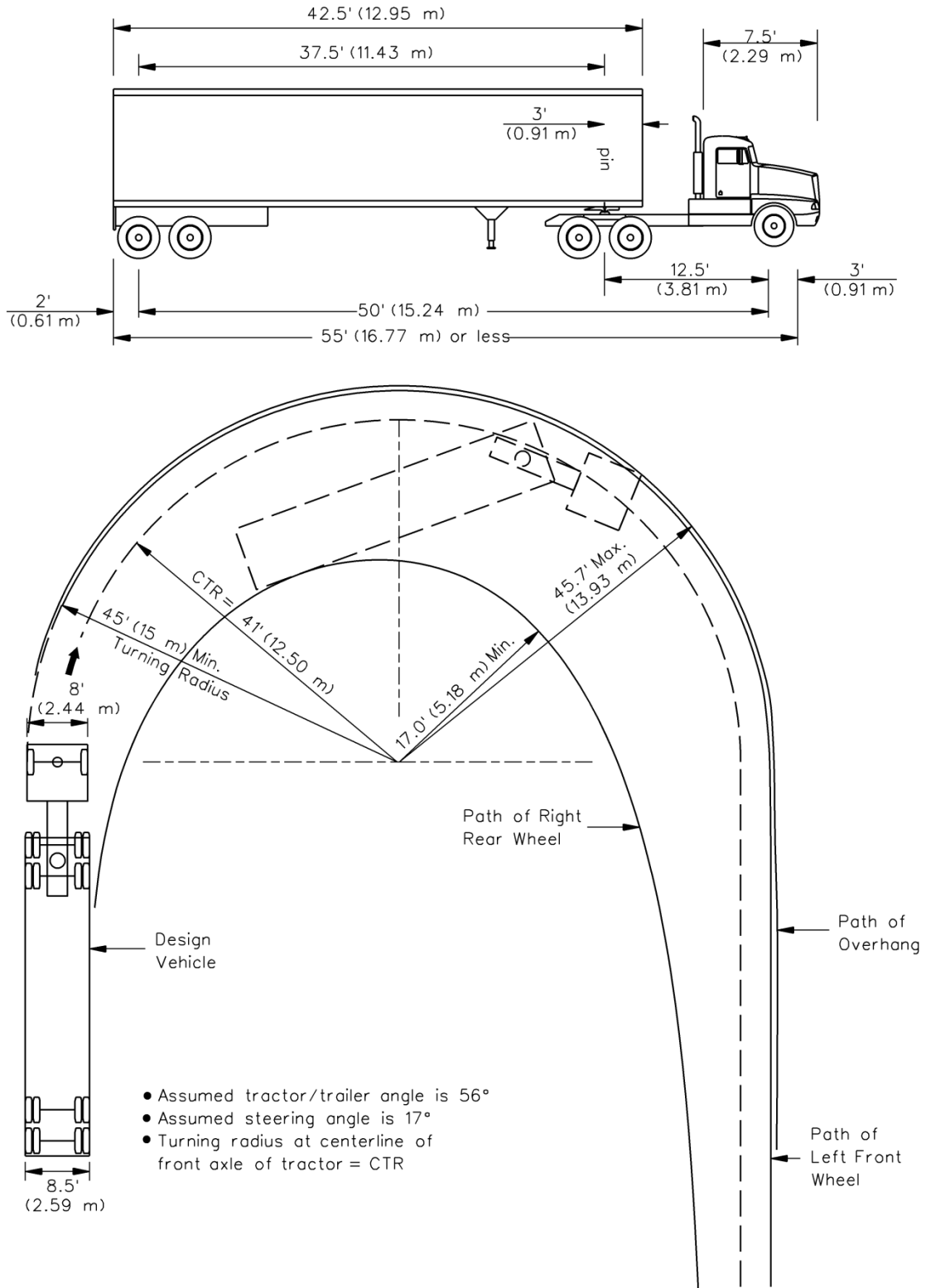

**TURNING PATH OF TRACTOR/SEMITRAILER
[WB-50 (WB-15)] DESIGN VEHICLE**

Figure 36-1.Q

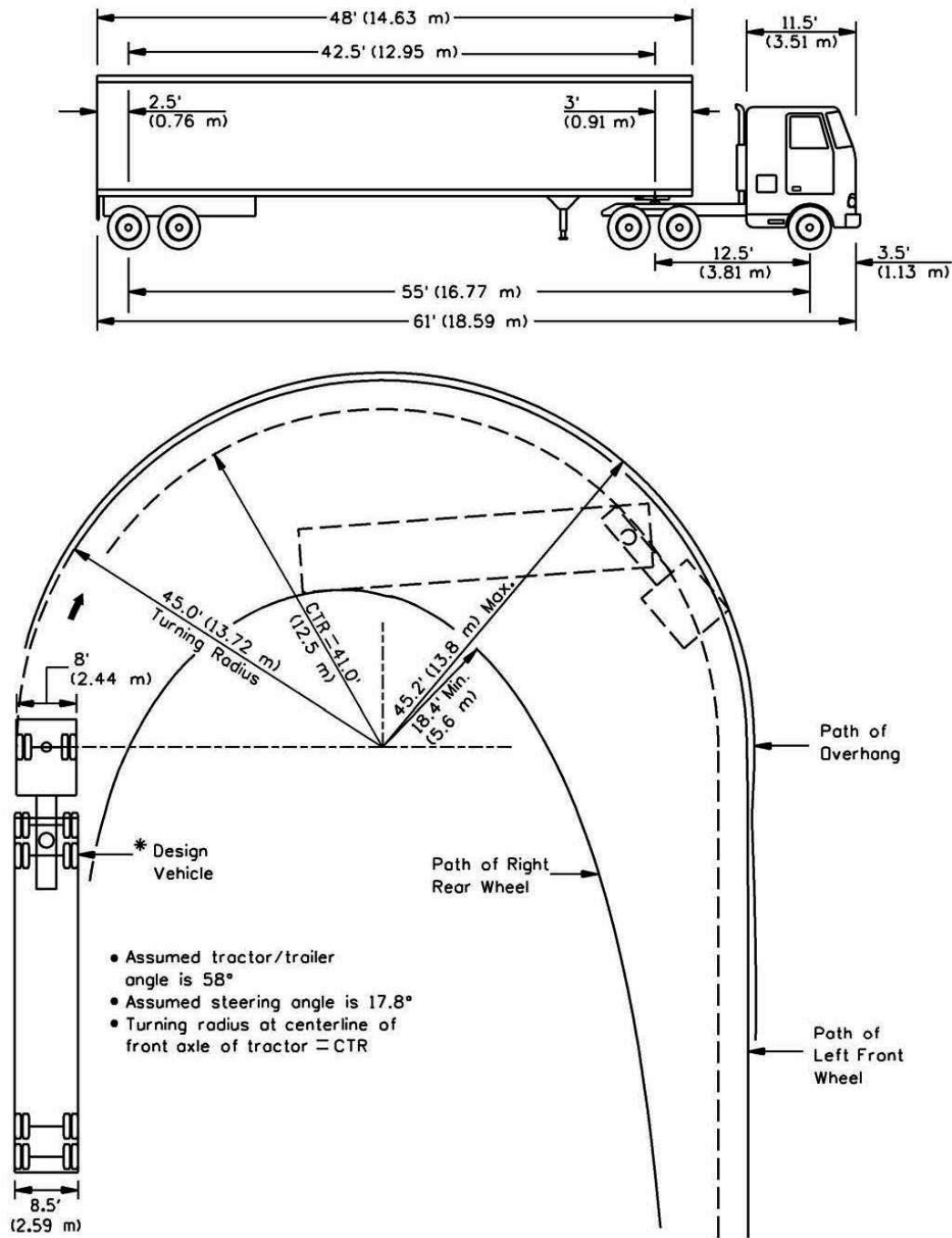

*Note: Presently, trailers are manufactured in lengths of 40 ft (12.19 m), 42.5 ft (12.95 m), 45 ft (13.72 m), 48 ft (14.63 m), and 53 ft (16.16 m).

**TURNING PATH OF TRACTOR/SEMITRAILER
[WB-55 (WB-17)] DESIGN VEHICLE**

Figure 36-1.R

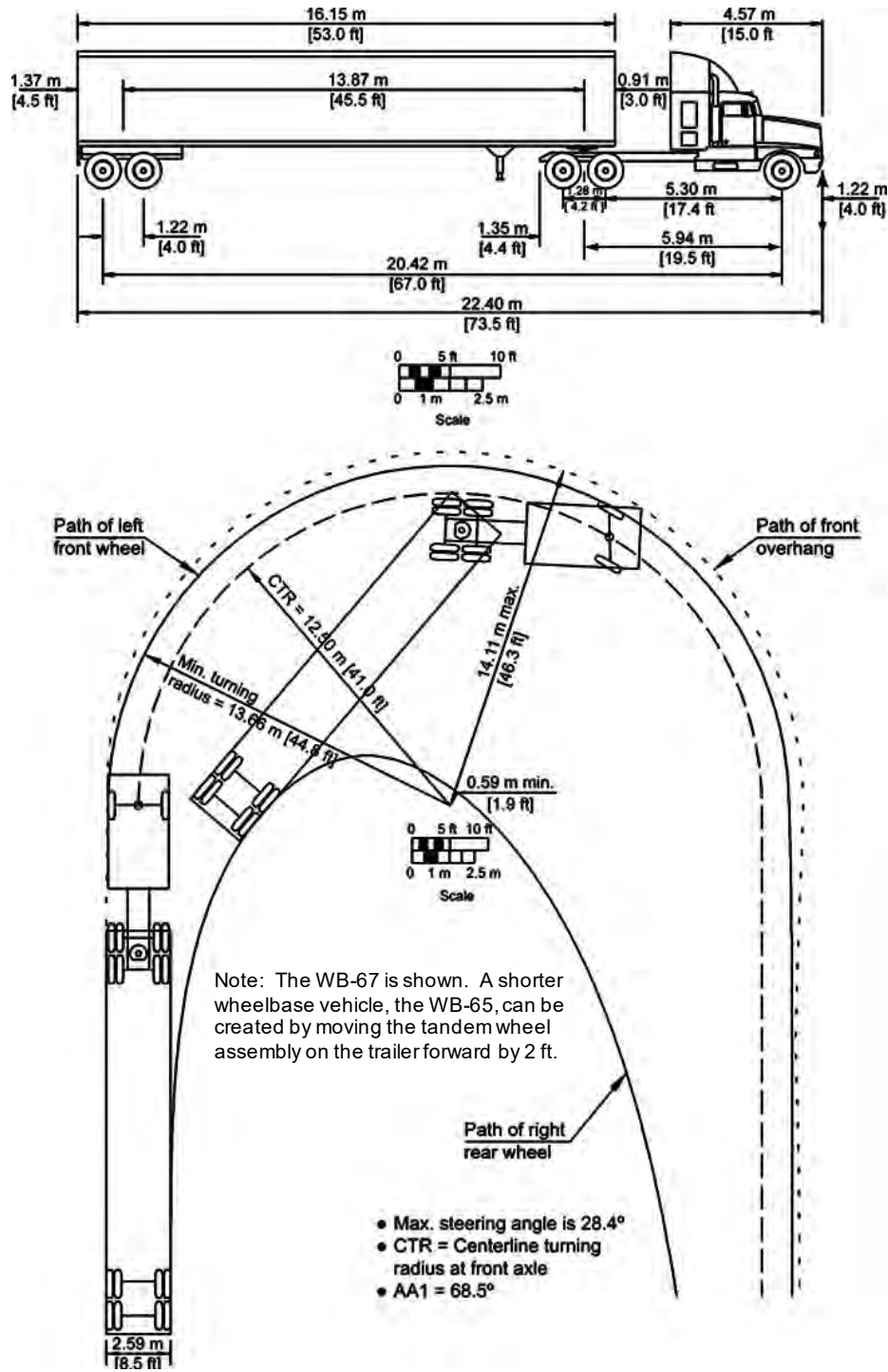

*Note: Presently, trailers are manufactured in lengths of 40 ft (12.19 m), 42.5 ft (12.95 m), 45 ft (13.72 m), 48 ft (14.63 m), and 53 ft (16.16 m).

**TURNING PATH OF TRACTOR/SEMITRAILER
[WB-65 AND WB-67 (WB-20)] DESIGN VEHICLE**

Figure 36-1.S

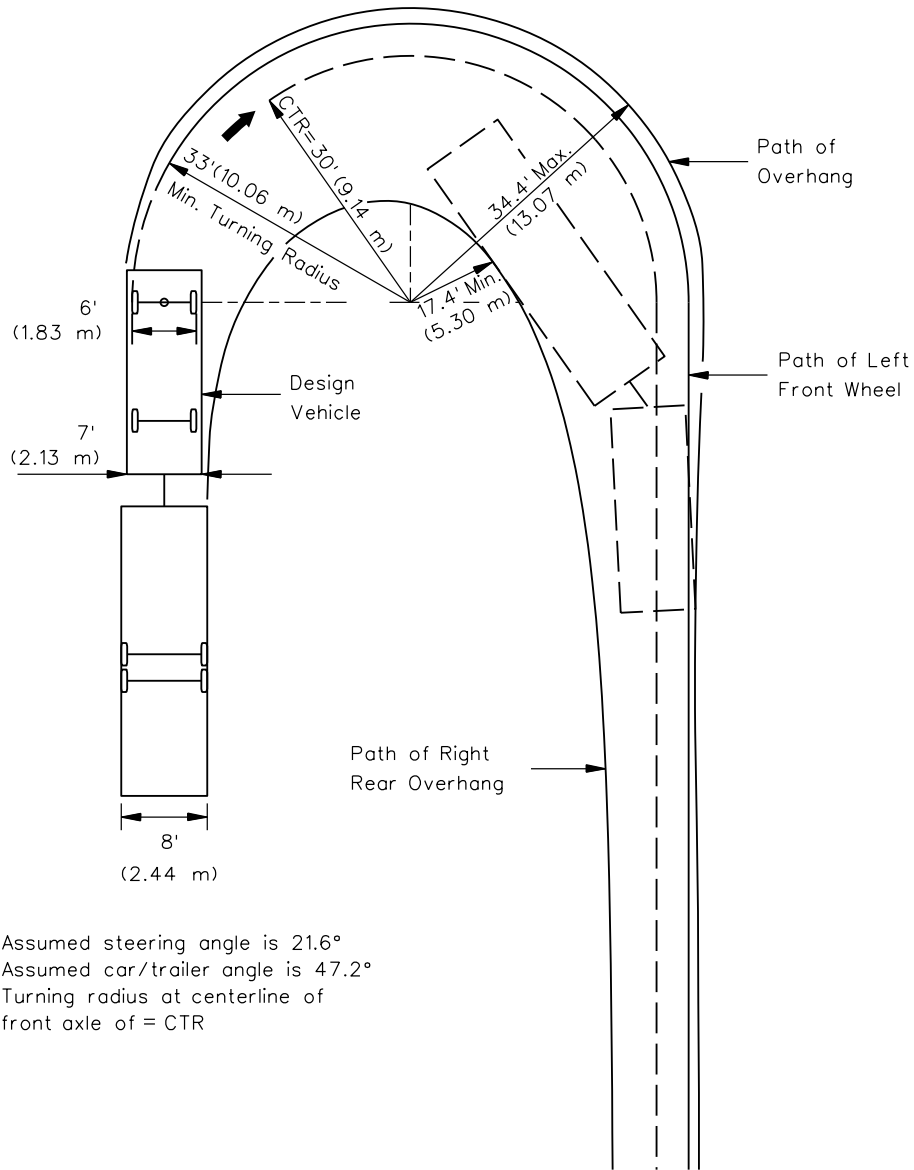
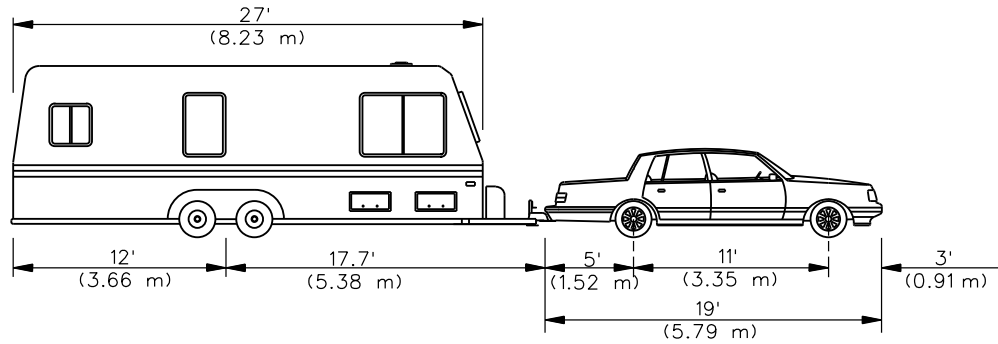

- Assumed steering angle is 21.6°
- Assumed car/trailer angle is 47.2°
- Turning radius at centerline of front axle of = CTR

MINIMUM TURNING PATH OF PASSENGER CAR AND TRAILER (P/T) DESIGN VEHICLE

Figure 36-1.U

For Turn Made		Design Vehicle ⁽¹⁾⁽²⁾⁽³⁾⁽⁴⁾
From	Onto	
Freeway Ramp	Other Facilities	WB-67 (WB-20)
Other Facilities	Freeway Ramp	WB-67 (WB-20)
Arterial or SRA ⁽⁵⁾	Arterial/SRA Collector Local Local (Residential)	WB-65 (WB-20) WB-55 (WB-17)* WB-50 (WB-15)* S-BUS*
Collector	Arterial/SRA Collector Local Local (Residential)	WB-55 (WB-17)* WB-55 (WB-17)* WB-50 (WB-15)* S-BUS*
Local	Arterial/SRA Collector Local Local (Residential)	WB-50 (WB-15)* WB-50 (WB-15)* SU* SU*
Local (Residential)	Arterial/SRA Collector Local Local (Residential)	S-BUS* S-BUS* SU* SU*

**With encroachment, a WB-65 (WB-20) vehicle should physically be able to make the turn.*

Notes:

1. Use this figure for new construction and reconstruction projects.
2. A smaller design vehicle may be considered as a design exception after an investigation of conditions and with justification.
3. For 3R projects, the design vehicle will be site specific with justification.
4. See also Section 36-1.08(b) regarding design vehicle selection.
5. SRA is a Strategic Regional Arterial route.

**SELECTION OF DESIGN VEHICLE AT INTERSECTIONS
(Functional Classification)**

Figure 36-1.V

Highway Type	Design Vehicle	Maximum Length of Trailer Allowed (m)	Maximum Length Kingpin to Center Rear Axle (m)
Class I State	WB-67 (WB-20)	53' (16.16 m)	45.5' (13.87 m)
Class II State and Local	WB-65 (WB-20)	53' (16.16 m)	45.5' (13.87 m)
Non-designated State	WB-55 (WB-17)	53' (16.16 m)	42.5' (12.96 m)
Non-designated Local	WB-50 (WB-15)	Not Specified	Not Specified

Notes:

1. *Section 43-1 defines the roadway functional classification system, and the Illinois Vehicle Code, 625 ILCS 5/1-126.1 defines highway designations in the system of State highways. Additionally, 625 ILCS 5/15-107 defines truck lengths and truck access requirements, and 625 ILCS 5/15-116 sets forth State and local agency reporting requirements for Designated Truck Route System routes. The Office of Planning & Programming maintains Designated State Truck Route System maps.*
2. *Any tractor/semitrailer and tractor/semitrailer/trailer vehicle operating on a Class I highway shall have access onto any street or highway for a distance of 1 mile (1.61 km) for the purpose of loading, unloading, and obtaining food, fuel, rest, or repairs, so long there are no signs posted prohibiting such access. Under this condition, the combination truck units allowed access from the Class I highway may be up to 8 ft-6 in. (2.59 m) wide with a 53 foot (16.16 m) long trailer (28.5 ft trailer for tractor/semitrailer/trailer combinations).*
3. *Any tractor/semitrailer vehicle operating on a Class I or II highway shall have access onto any non-designated street or highway for a distance of five miles (8.05 km) on such streets or highways for the purpose of loading, unloading, and obtaining food, fuel, rest, or repairs, provided there are no signs posted prohibiting such access, and if the route is not being used as a thoroughfare between such designated highways.*
4. *Local authorities may designate as Class II any highway within their system. Posting of signs for Class II routes is not required; when large vehicles are prohibited from using streets and highways under local jurisdiction posted signs will identify such restrictions. Local agencies are responsible for reporting to the Department all streets and highways under their jurisdiction designated as Class II highways or affirming that they have no such routes. Specific vehicle prohibitions established by local agencies through ordinance or resolution are compiled by the Department and available on the IDOT website.*

The statutes referred to above do not imply geometric components such as intersection turn radii or driveway aprons be provided to accommodate trucks without encroachment.

**DESIGN VEHICLE SELECTION
(Designated State Truck Route System)**

Figure 36-1.W

36-2 TURNING RADII

Turning radii treatments for intersections are important design elements in that they influence the operation, safety, and construction costs of the intersection. The designer must ensure that the proposed design is compatible with the expected intersection operations.

36-2.01 Design for Right-Turning Vehicles

The following sections present several basic parameters the designer needs to consider in determining the proper pavement edge/curb line for right-turning vehicles.

36-2.01(a) Design Vehicle

Section 36-1.08 discusses the selection of the applicable design vehicle for different intersections. These vehicles are used to determine the pavement edge or curb line. Note that the design vehicle will determine the turning width, vehicular path width or swept-path width. The assumed speed of the vehicle is less than 10 mph (15 km/hr).

Where present, pedestrians and bicyclists should be treated as design users of the intersection and given the same consideration in the design process as the design vehicle.

36-2.01(b) Inside Clearance

Desirably, the selected design vehicle will make the right turn while maintaining approximately a 2 ft (600 mm) clearance from the pavement edge or face of curb.

36-2.01(c) Encroachment

To determine the amount of acceptable encroachment, the designer should evaluate several factors. These would include traffic volumes, one-way or two-way operations, urban/rural location, and the type of traffic control. For turns made onto local facilities, desirably the selected design vehicle will not encroach into the opposing travel lanes. However, this is not always practical or cost effective in urban areas. The designer must evaluate these encroachment conditions against the construction and right-of-way impacts and the effect on the pedestrian crosswalk distance. If these impacts are significant, and if through and/or turning volumes are relatively low, the designer may consider accepting some encroachment of the design vehicle into opposing lanes; see Figure 36-2.D.

The encroachment allowed into adjacent lanes of the road or street onto which the turn is made will depend on the following:

1. Urban. No encroachment should be allowed into opposing lanes for a right-turning vehicle from a side road or street onto a State route.

2. Rural. For rural intersections, the selected design vehicle should not encroach into the opposing lanes of traffic.
3. Multilane Highways. If there are two or more lanes of traffic in the same direction on the road onto which the turn is made, the selected design vehicle can occupy both travel lanes. Desirably, the right-turning vehicle will be able to make the turn while remaining entirely in the right through lane; see Figure 36-2.C. However, conditions do exist where this is not practical or desirable and can lead to inordinately wide intersections, deficient head-turn angles for right-turning vehicles (see Figure 36-2.E), and excessive pedestrian crossing times. Engineering judgment must be used in creating an intersection design that safely and efficiently accommodates all roadway users.

All intersections of two designated State truck routes should be checked to see if the WB-65 (WB-20) design vehicle can physically make the right-turn without backing up and without impacting curbs, parked cars, utility poles, culvert end sections, mailboxes, traffic control devices, or any other obstructions, regardless of the selected design vehicle or allowable encroachment.

36-2.01(d) Parking Lanes/Shoulders

At many intersections, parking lanes and/or shoulders will be available on one or both approach legs. This additional roadway width may be carried through the intersection. The following will apply:

1. Parking Lanes. Under restricted conditions, the designer may take advantage of shoulder and/or parking lane to ease the problems of large vehicles turning right at intersections with small radius returns. It will be necessary to restrict the parking a significant distance from the intersection. This area should be delineated with striped pavement markings. Parking should be removed from the intersection according to the *ILMUTCD*.
2. Paved Shoulders. At rural intersections, it may be preferable to continue a paved shoulder throughout the radius return. If a shoulder width transition is required, design it according to Figure 36-2.A.
3. Curbing. If certain conditions such as drainage requirements, restricted right-of-way, greater delineation, or the desire to minimize off-tracking warrant the use of curbing along the radius return at rural intersections, terminate the curbing at the shoulder edge and transition the curb height as indicated in Figure 36-2.A. Where posted speeds are 50 mph or greater, use a mountable type curb. If a mountable curb is deemed to be ineffective at the specific location in deterring large trucks from making impermissible maneuvers and unwanted encroachments, a barrier curb may be utilized on a case-by-case basis, so long as a design exception is justified by the district and granted by BDE; see Section 31-7.

36-2.01(e) Pedestrian Considerations

The larger the right-turning radius, the farther pedestrians must walk across the street. This is especially important to persons with disabilities. Therefore, the designer must consider the number and type of pedestrians using an intersection when determining the edge of pavement or curb line design. This may lead to a decision to design a right-turn corner island (small or intermediate) for use as a pedestrian refuge.

36-2.01(f) Visibility of Traffic Control Devices

In addition to providing pedestrian refuge and reducing pedestrian exposure within the intersection by creating several shorter crossing maneuvers rather than a single, longer pedestrian maneuver, raised corner islands may be desirable to improve motorist visibility to traffic control devices, such as traffic signal posts and stop signs. Raised corner islands should be considered where there is current or proposed presence of large vehicles and/or pedestrians at an intersection, where visibility of traffic control devices may otherwise be limited, or where proposed geometrics through the use of a computer simulated turning template program and engineering analyses otherwise dictate. See Section 36-2.02 for more information regarding the use of corner islands.

36-2.01(g) Types of Radius Return Designs

Once the designer has determined the basic right-turning parameters (e.g., design vehicle, amount of allowable encroachment, inside clearance, need for corner island), it will be necessary to select the type of turning design for the curb return or pavement edge which will meet these criteria and will fit the intersection constraints.

The simple radius is the easiest to design and construct. However, two-centered or three-centered curves provide a better fit to the transitional turning paths of tractor/semitrailer design vehicles. Because the WB-67, WB-55, or WB-50 (WB-20, WB-17, or WB-15) trucks are allowed on all State highways, the Department has determined that two-centered or three-centered curves are desirable at all major intersections. Note that using these curves may require a corner island to improve visibility of traffic control devices, to reduce pedestrian crossing time exposure, and to provide pedestrian refuge.

Some of the advantages of the two-centered and three-centered curves as compared to the simple radius design include:

- When accommodating a specific design vehicle, they require less intersection pavement than a simple radius design, and especially for angles of turn greater than 90 degrees. For large vehicles, a simple radius is often an unreasonable design unless a corner island is used and, in effect, a turning roadway is provided.
- There are less right-of-way impacts at the intersection corners.
- A simple radius results in greater distances for pedestrians to cross the intersection.

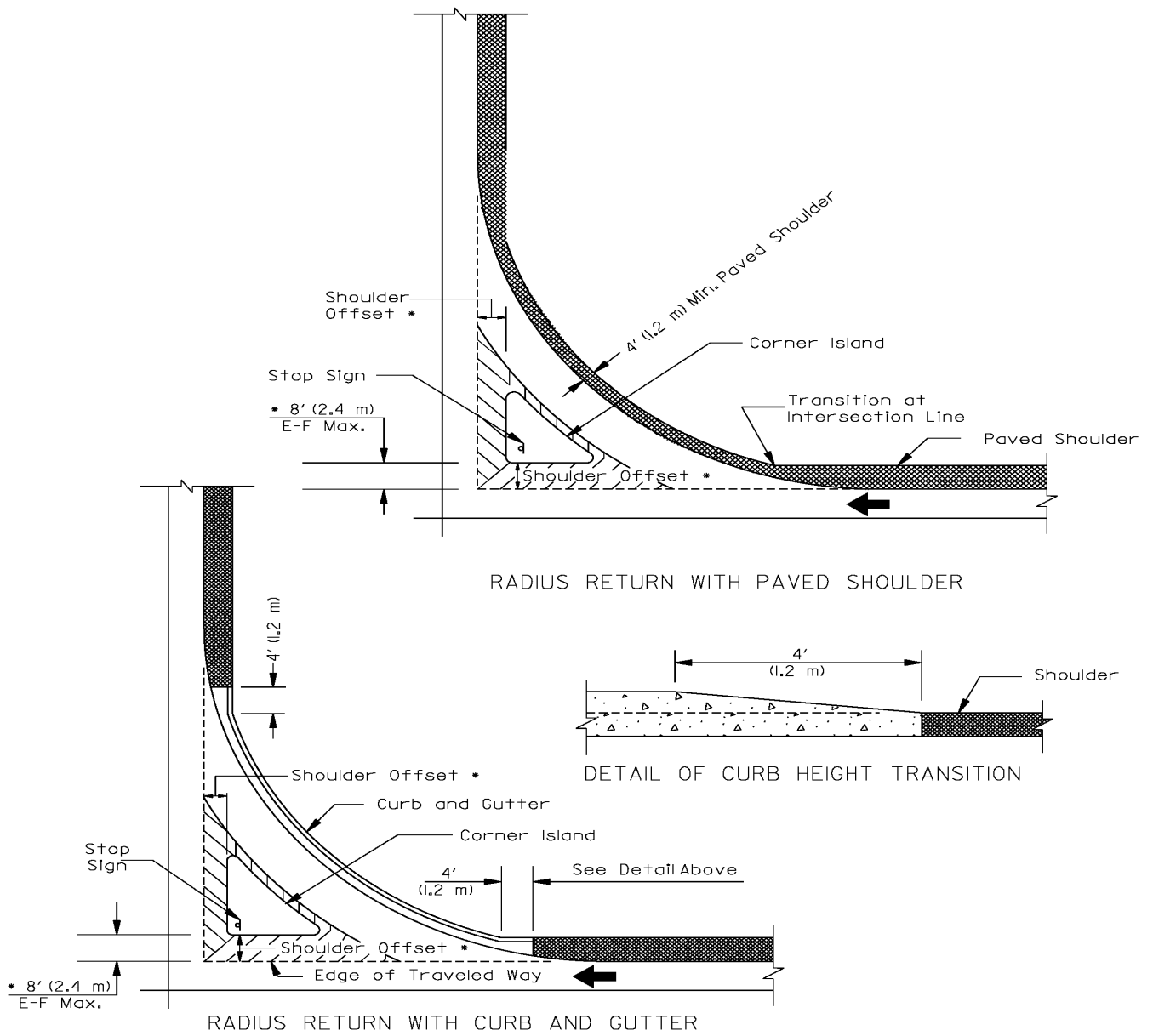

**Note: Only use M-type curb on corner islands.*

SHOULDER/CURB AND GUTTER RADIUS RETURN TRANSITIONS

Figure 36-2.A

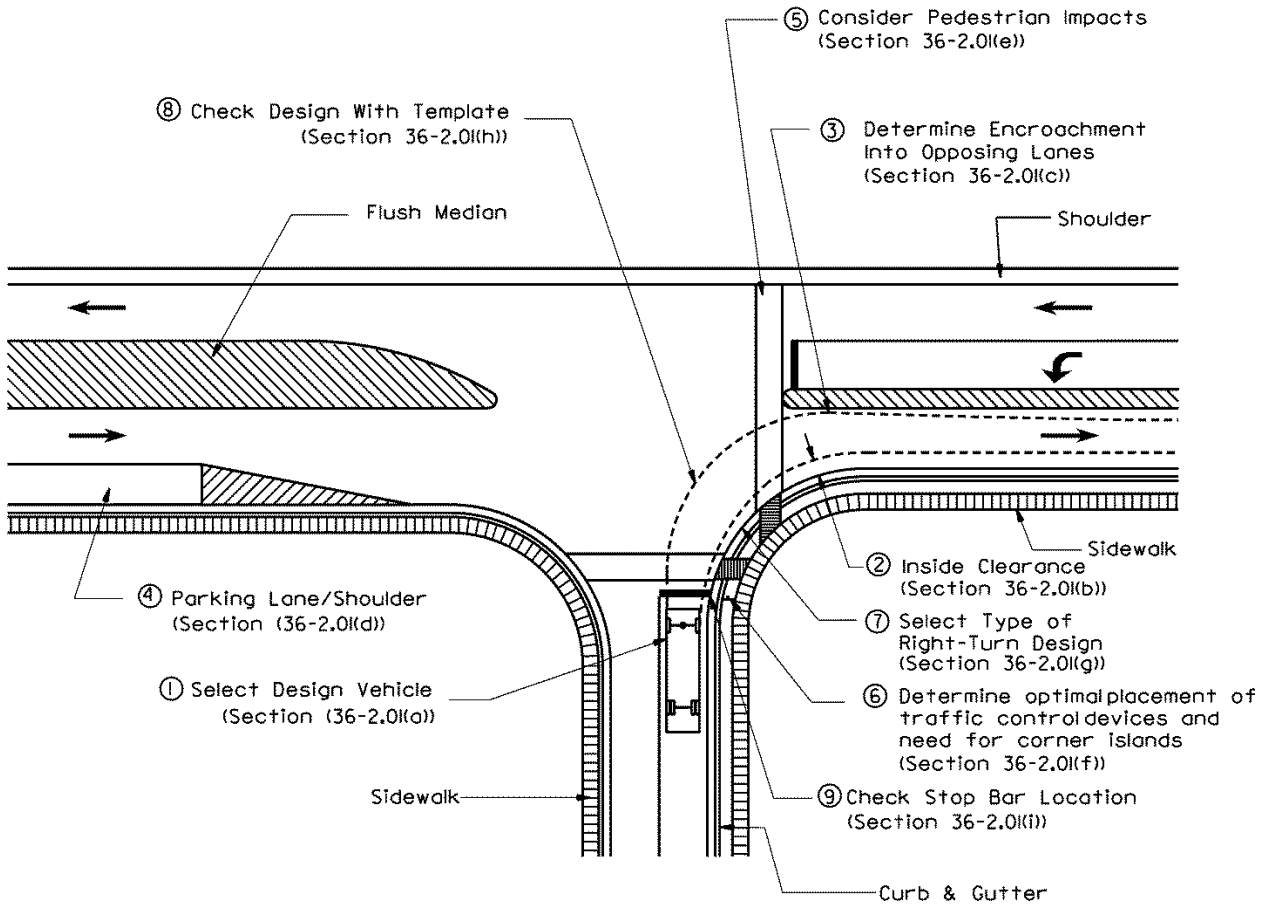

SUMMARY OF RIGHT-TURN DESIGN ISSUES

Figure 36-2.B

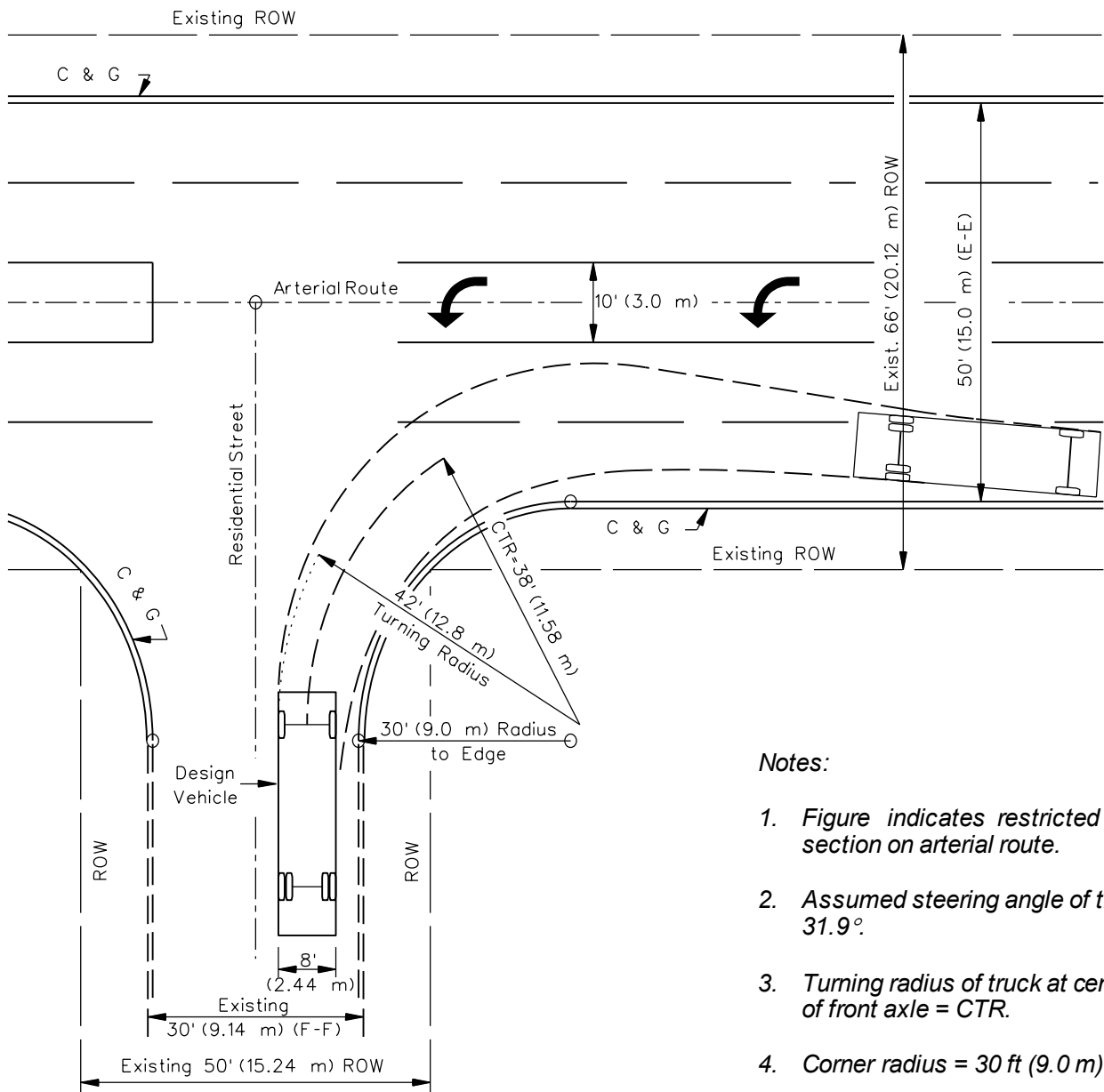

Notes:

1. Figure indicates restricted cross section on arterial route.
2. Assumed steering angle of truck is 31.9°.
3. Turning radius of truck at centerline of front axle = CTR.
4. Corner radius = 30 ft (9.0 m).

**RECONSTRUCTION OF LOCAL RESIDENTIAL STREET INTERSECTION
AT MULTILANE ARTERIAL ROUTE
(Right Turn Out of SU Truck)**

Figure 36-2.C

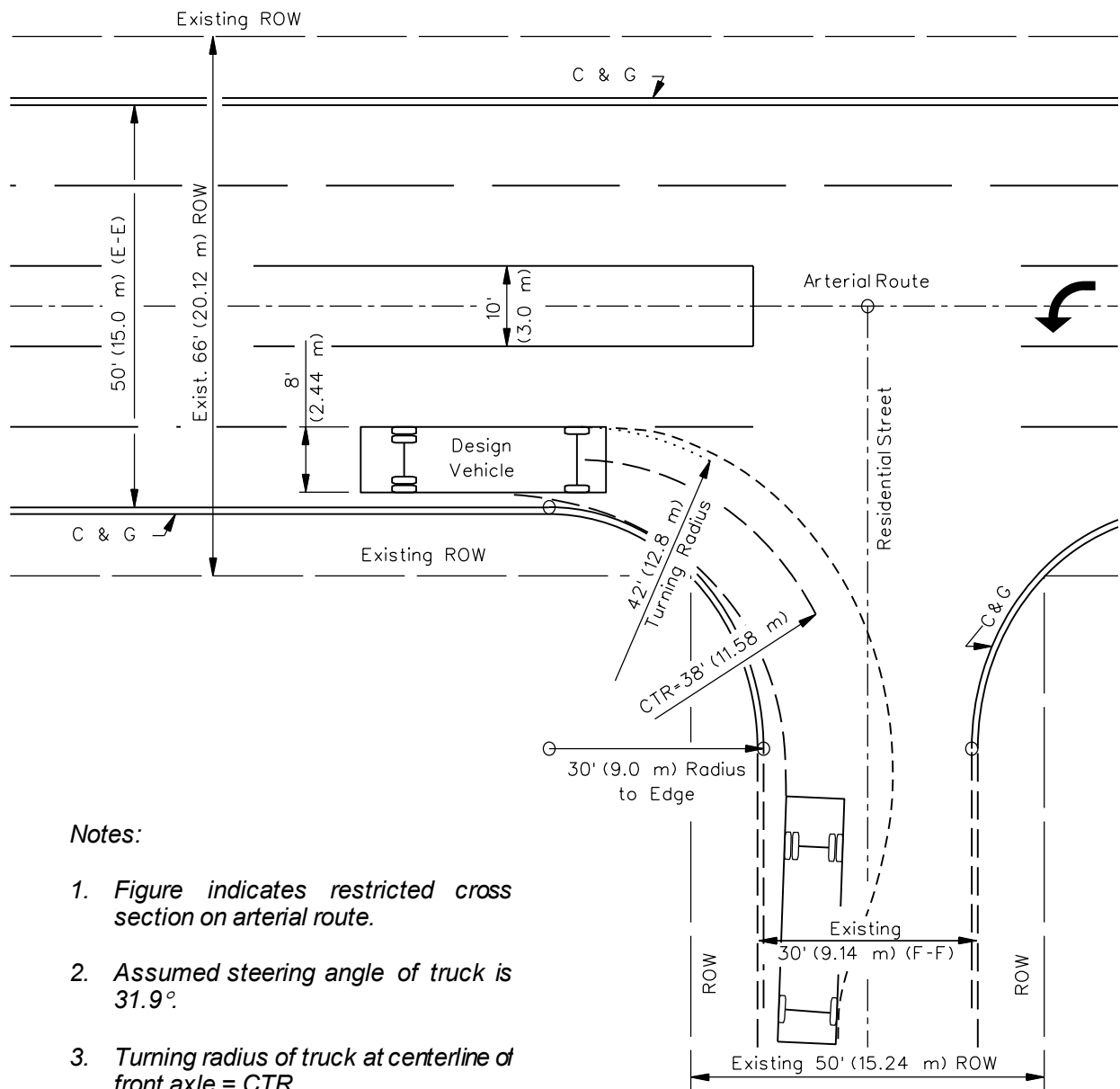

Notes:

1. Figure indicates restricted cross section on arterial route.
2. Assumed steering angle of truck is 31.9°.
3. Turning radius of truck at centerline of front axle = CTR.
4. Corner radius = 30 ft (9.0 m).

**RECONSTRUCTION OF LOCAL RESIDENTIAL STREET INTERSECTION
AT MULTILANE ARTERIAL ROUTE
(Right Turn In of SU Truck)**

Figure 36-2.D

36-2.01(h) Turning Template(s)

To determine the preliminary right-turn design, the designer should use the applicable turning template for the selected design vehicle and speed. Check all turning movements of the final intersection design with the applicable turning templates or with a computer simulated turning template program. If computer simulation is used to determine right-turn design, include the printout with the intersection design study.

36-2.01(i) Stop Bar Locations

See the *Illinois Supplement to the Manual on Uniform Traffic Control Devices (ILMUTCD)* regarding stop bar placement at intersections. Stop bar locations should be checked against the criteria in the *ILMUTCD* at wide throat intersections. This is especially important where no corner island is used. On multilane approaches or approaches with corner islands, care should be taken in design to ensure the proposed stop bar placement of one lane does not create a line of sight restriction for the adjacent stopping maneuver. See Section 36-2.02(a) and (c) for more information on stop bar placement when using a corner island.

36-2.01(j) Summary

Figure 36-2.B illustrates the many factors that should be evaluated in determining the proper design for right-turns movements at intersections. In summary, the following procedure applies:

1. Select the design vehicle(s) (Section 36-2.01(a)).
2. Determine the acceptable inside clearance (Section 36-2.01(b)).
3. Determine the acceptable encroachment (Section 36-2.01(c)).
4. Consider the benefits of any parking lanes or shoulders (Section 36-2.01(d)).
5. Consider impacts on pedestrians (Section 36-2.01(e)).
6. Consider the visibility of traffic control devices and determine the need for raised corner islands (Section 36-2.01(f)).
7. Design the radius returns (Section 36-2.01(g)).
8. Check all turning movements of all proposed designs with the applicable vehicular turning templates or computer simulated turning template program (Section 36-2.01(h)).
9. Check the location of stop bars (Section 36-2.01(i)).
10. Using this iterative process, revise the design as necessary to accommodate the right-turning vehicle or determine that it is not practical to meet this design because of adverse impacts. If necessary, prepare a design exception request or seek a maximum extent practicable (MEP) determination for all non-compliant items; see Chapter 31.

36-2.01(k) Local Street Reconstruction

When reconstructing an arterial, the designer often must maintain the existing width on the local street. Figure 36-2.C illustrates the turning path for an SU-30 design vehicle turning out of an existing local street with a 30 ft (9.0 m) radius. Figure 36-2.D illustrates the turning path for an SU -30 design vehicle turning onto an existing local street.

36-2.02 Corner Islands**36-2.02(a) General Design Considerations**

Raised corner islands, although they will require additional long-term maintenance, often provide substantial benefits, especially in urban environments. Corner islands can create positive driver guidance which may be especially advantageous where a tractor/semi-trailer is used as the design vehicle and/or at oblique angle crossing intersections. Corner islands can also help moderate vehicle turning speeds, provide pedestrian and bicyclist refuge areas, and allow for placement and optimal visibility of signs and signalized traffic control devices that may also include pedestrian signal heads and push buttons. Where non-motorized users will be present, corner islands can provide flush surfaces within the depressed sidewalk that can be used as relatively safe waiting areas for these users, while also shortening crossing distances and allowing a reduction in the time allocated for pedestrian movements.

Safety research shows that right-turn crashes may be of greater concern when one or a combination of any of the following factors exist or is proposed; see Figure 36-2.E:

- Right-turn radius return designed for WB-55 design vehicle or greater,
- Intersection angle less than 75 degrees,
- Right-turn angle between 25 and 30 degrees, or greater than 45 degrees,
- Head-turn angle greater than 140 degrees,
- Right-turning volume greater than 250 vph, or right-turn approach AADT greater than 3,125 vpd, or
- Moderate truck volumes (greater than 5%).

The standard corner island design (described in detail in Section 36-2.02(c)) has been shown to improve intersection sight distance by reducing necessary driver head-turn. As compared to past design practice, the standard design lengthens the approach side of the island along the turning roadway while reducing the length along the departure side of the turning roadway. This provides positive guidance for the approaching vehicle, while optimizing the motorist's line of sight when completing the right-turn maneuver. This standard corner island design is expected to reduce the potential for right-turn crashes and improve intersection safety.

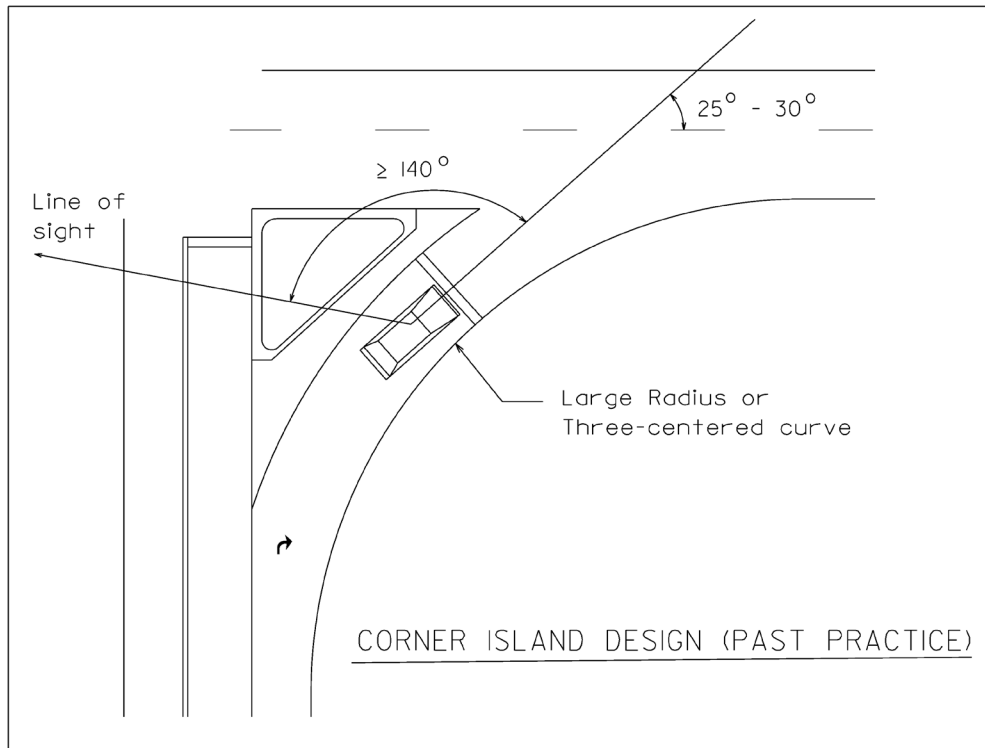

HEAD-TURN ANGLE CONCERN AT CORNER ISLANDS

Figure 36-2.E

During the design process, assess the factors described in this section with the goal of minimizing right-turning crashes. See Figure 36-2.F for design options. Specifically:

- A standard corner island design incorporating the optimum geometrics should typically be implemented upon initial design and construction of those proposed facilities which include a raised corner island.
- Existing locations with a raised corner island should also be considered for retrofit to the standard corner island design whenever intersection improvements are proposed and existing crash data supports this modification.

36-2.02(b) Design Parameters

The type and size of triangular or corner islands will vary according to the angle of intersection, design vehicle, right-turn operation, available right-of-way, and safety considerations. Figure 36-2.G illustrates the typical designs for corner islands. Also consider the following:

1. Island Sides. The sides of the island are controlled by minimum island size and visibility requirements. The sides should not be less than 12 ft (3.6 m) after rounding the corners. If traffic signal posts or pedestrian accommodations are installed within the island, the sides of the island may need increased above minimum.

2. **Island Size.** The minimum island size for rural areas is 100 ft² (9.5 m²). For urban islands, the island area typically should be 75 ft² (7.0 m²) but not less than 50 ft² (4.7 m²). When traffic signal equipment or pedestrian accommodations are present within the island, the island size may need increased significantly above these minimums. When two pedestrian crossing directions need to be accounted for within the depressed portions of the island, an island of significant size must be designed to provide a sufficient size for the remaining raised island portions. Note the island area includes the concrete median surface and the top of the curb.
3. **Flush or Raised-Curb.** For proper delineation of corner islands, under all conditions (e.g., nighttime, rain, fog, snow), the raised-curb design is preferable.
4. **Curbing.** Only use the M-type curb on corner islands. Also consider the following:
 - a. Use M-6 (M-15) curb on islands that are located adjacent to a highway with speeds of 45 mph (70 km/hr) or less.
 - b. Use M-4 (M-10) curb on islands that are located adjacent to high-speed traffic (50 mph (80 km/hr) or greater). However, use M-6 (M-15) curb on islands where traffic signal supports, sign truss supports, or any other post with a foundation generally larger than a standard highway sign are present. Note that a stop sign is a standard highway sign.
 - c. Use M-6.06 (M-15.15) or M-4.06 (M-10.15) concrete curb and gutter on all sides of islands where the island is offset the shoulder width from the edge of the traveled way.
5. **Island Offsets.** On streets with outside curb and gutter, offset the corner island face of curb from the edge of the traveled way according to Figure 36-2.G.

In rural areas or for facilities with shoulders, the corner island is offset the shoulder width, but not greater than 8 ft (2.4 m) to the face of curb; see Figure 36-2.H. If a right-turn deceleration lane is provided on a rural facility, offset the corner island face of curb 8 ft (2.4 m) to the edge of pavement along that approach.
6. **Curb Cuts.** When a raised corner island or median is utilized, and a depressed sidewalk curb cut will be provided for accommodation of pedestrians and/or bicyclists, always seek to provide a minimum of 6 ft (1.8 m) of refuge width and include detectable warnings at all crosswalk locations, subject to ADA policy (see Chapter 58).

36-2.02(c) Design Techniques

The approach angle for right-turning vehicles is critical in the design of new corner islands or the modification of existing corner islands. If designed without the approach angle in mind, corner island design may impose challenges to the motorist regarding excessive head-turn and reduced sight distance. These challenges in the driving task are further amplified at intersection approaches on heavy skew angles. Figure 36-2.F depicts two options for a standard corner island design that will minimize potentially adverse operating characteristics.

In the design of a corner island, seek to meet or approach a head-turn angle goal of 115 degrees for the line of sight as shown for drivers at the stop bar. To accomplish this, consider the following techniques in developing the proposed geometrics at corner islands:

- Reducing the edge of pavement radius (in conjunction with island modifications),
- Adjusting the stop bar position,
- Reducing the island length adjacent to the mainline roadway,
- Removing or re-designing the raised island, or
- Placing additional pavement markings immediately adjacent to the outside radius, rather than immediately adjacent to the corner island.

These techniques are suggested to provide good approach visibility for drivers of passenger vehicles, while also allowing large trucks to complete the turn without encroaching onto the curb or shoulder.

Note that corner island design is not wholly a standardized design procedure; rather, design customization may be needed for urban and rural applications based on site specific factors and engineering judgment. When implementing the standard corner island design at skewed intersections, meeting the head-turn angle goal often becomes very challenging and designs different from those depicted may be necessary. In urban areas, adjustments to the stop bar locations depicted in Figure 36-2.F may be needed to accommodate pedestrian crosswalks and traffic signal equipment.

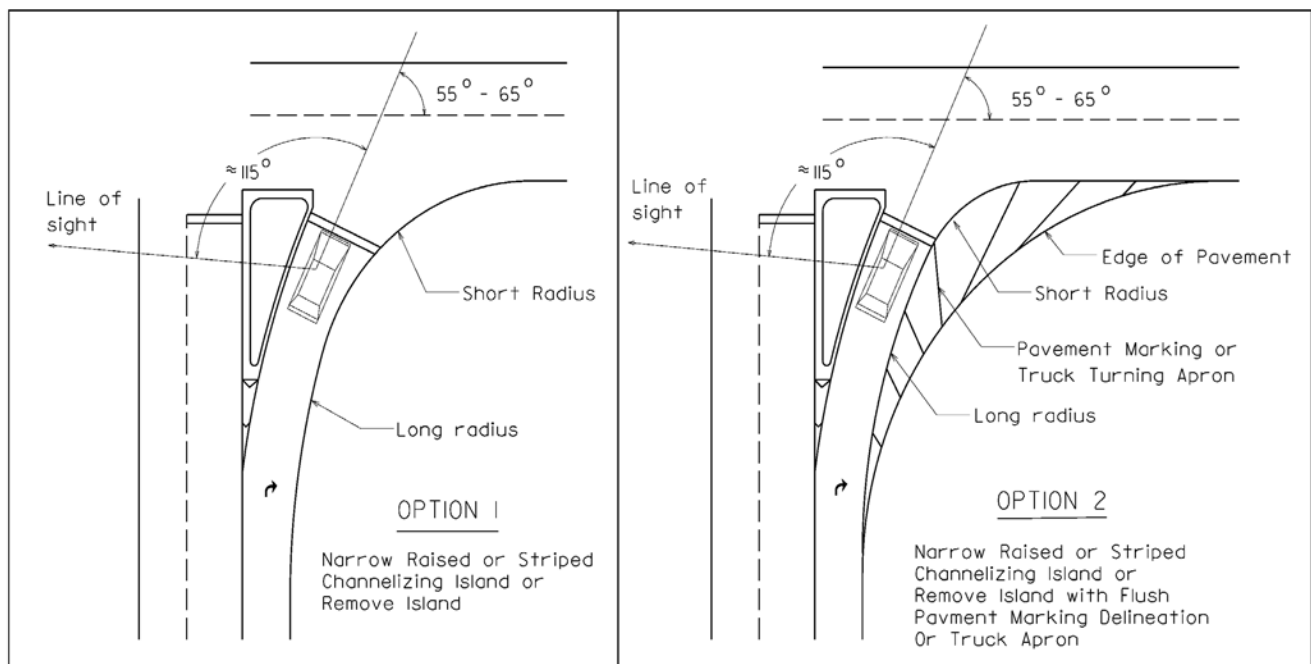

STANDARD CORNER ISLAND DESIGN OPTIONS

Figure 36-2.F

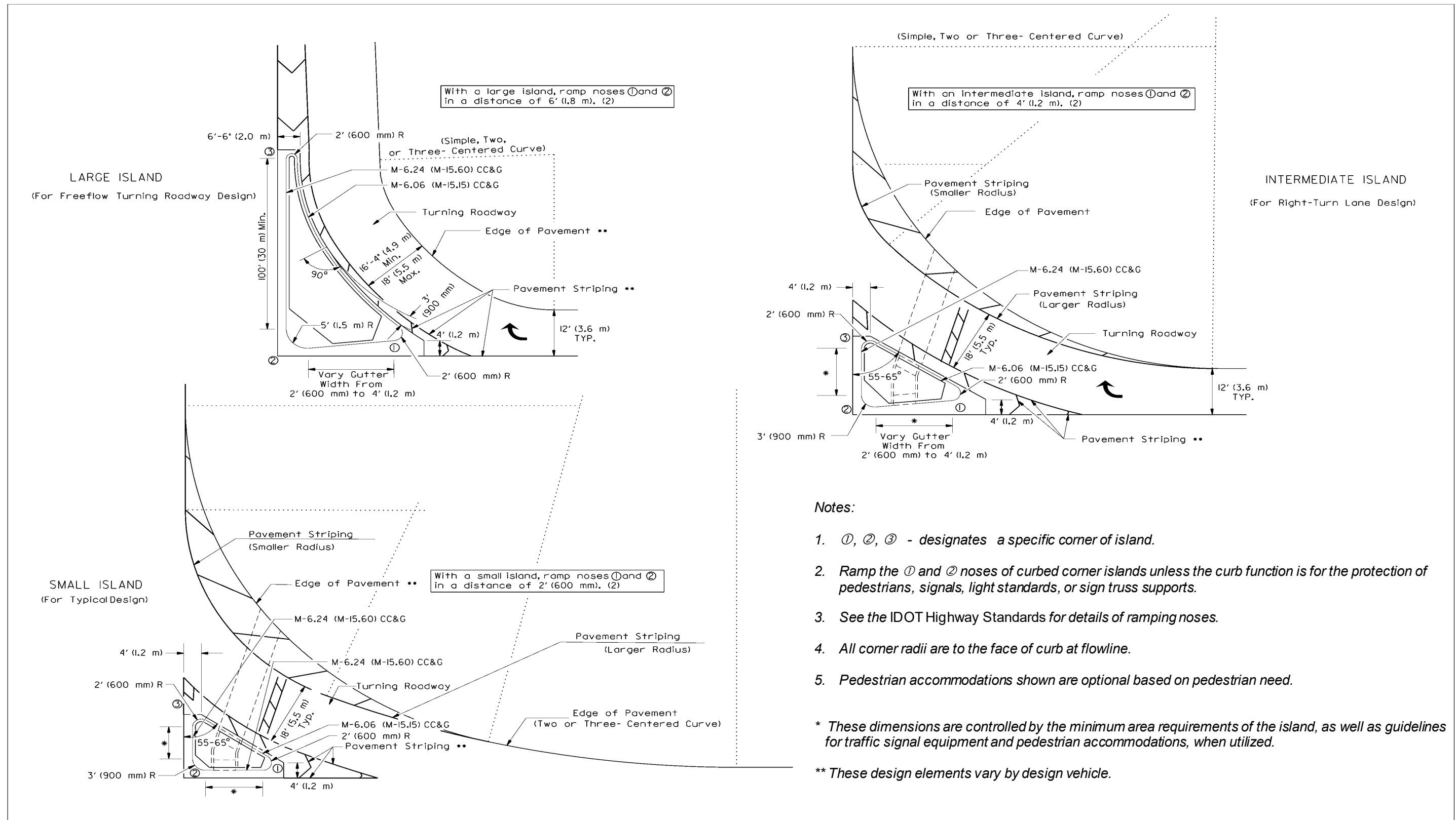

Notes:

1. ①, ②, ③ - designates a specific corner of island.
2. Ramp the ① and ② noses of curbed corner islands unless the curb function is for the protection of pedestrians, signals, light standards, or sign truss supports.
3. See the IDOT Highway Standards for details of ramping noses.
4. All corner radii are to the face of curb at flowline.
5. Pedestrian accommodations shown are optional based on pedestrian need.

* These dimensions are controlled by the minimum area requirements of the island, as well as guidelines for traffic signal equipment and pedestrian accommodations, when utilized.

** These design elements vary by design vehicle.

DETAILS OF CORNER ISLANDS
FIGURE 36-2.G

36-2.03 Turning Roadways

Where the inner edges of pavements for right turns at intersections are designed to accommodate tractor/semi-trailer combinations or where the desired design permits passenger vehicles to turn at speeds of 15 mph (25 km/hr) or greater, the pavement area at the corner of the intersection may become excessively large for proper control of traffic. To avoid this, a raised corner island is used and the connecting roadway between the two intersection legs is defined as a turning roadway.

36-2.03(a) Guidelines

The need for a turning roadway will be determined on a case-by-case basis. The designer should consider the following guidelines in determining the need for a turning roadway:

1. Trucks. A turning roadway is usually required when the selected design vehicle is a tractor/semitrailer combination.
2. Island Type and Size. Desirably, the raised corner island size should be at least 100 ft² (9.0 m²). At a minimum, the island should be at least 100 ft² (9.0 m²) in rural areas and 50 ft² (4.5 m²) in urban areas; see Figure 36-2.G.
3. Level of Service. A turning roadway can often improve the level of service through the intersection. At signalized intersections, a turning roadway with a free-flow acceleration lane may significantly improve the capacity of the intersection by removing the right-turning vehicles from the signal phasing. Level-of-service criteria are provided in the geometric design tables in Part V, Design of Highway Types, of the *BDE Manual*.
4. Crashes. Consider using a turning roadway with a right-turn lane if there are significant numbers of rear-end type crashes at an intersection. Turning roadways with larger radii, in conjunction with a right-turn lane, will allow vehicles to make the turning movements at higher speeds and, consequently, should reduce these types of accidents. However, where pedestrians are expected to be present it is important to also consider ways to maximize their visibility and safety.

Figure 36-2.H illustrates two options for turning roadway layout. Typically use a two-centered curve for the radius at the intersection. When designing the turning roadway, consider the effects of corner island design on safety (see Section 36-2.02). The High Speed Design is not recommended where pedestrians will be present.

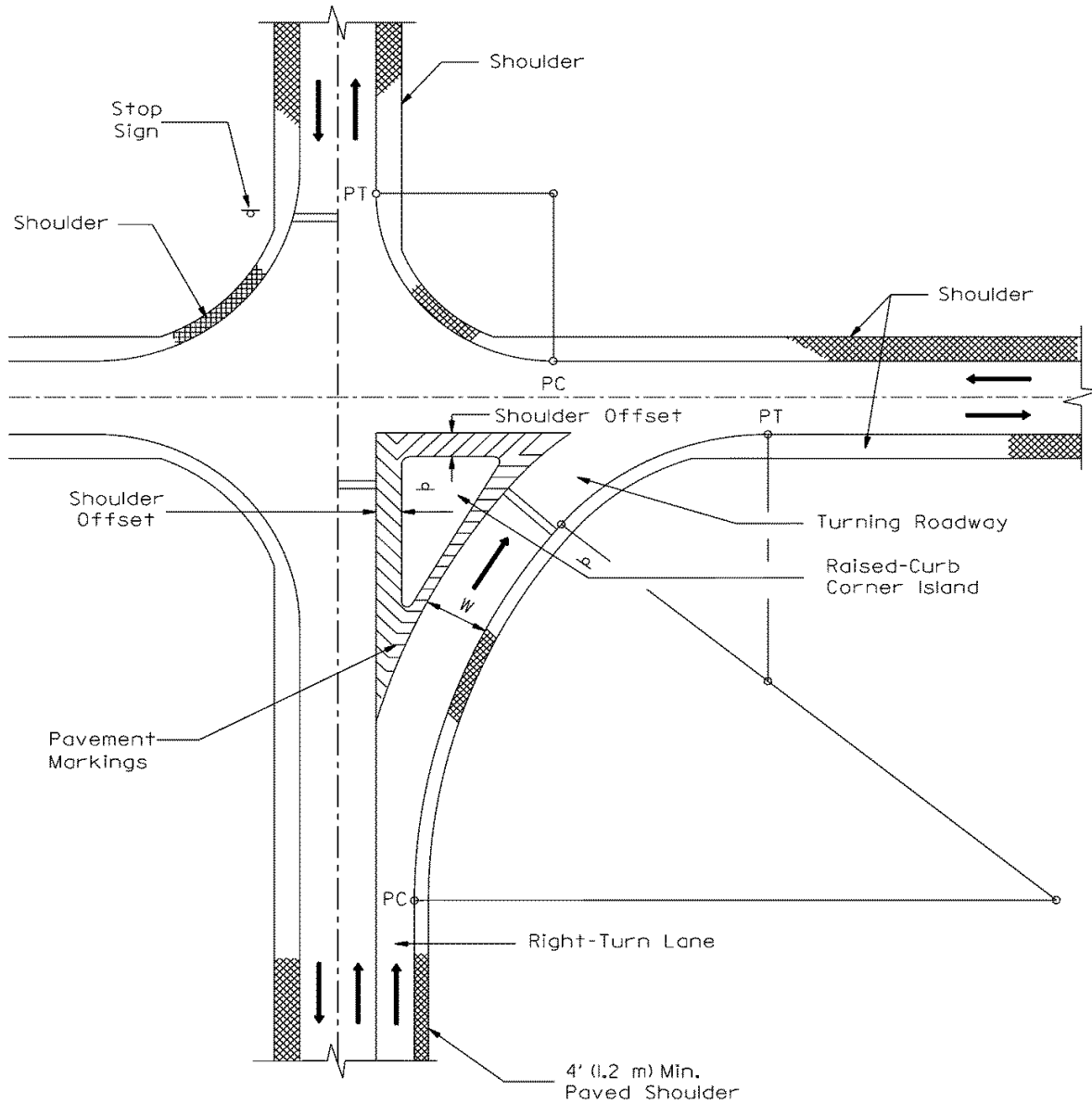

Notes:

1. W = Width of turning roadway, see Figure 36-2.I.
2. See Figure 36-2.G for details of the corner island design.

**TYPICAL TURNING ROADWAY LAYOUT
(Low/Intermediate Speed Design)**

Figure 36-2.H
(1 of 2)

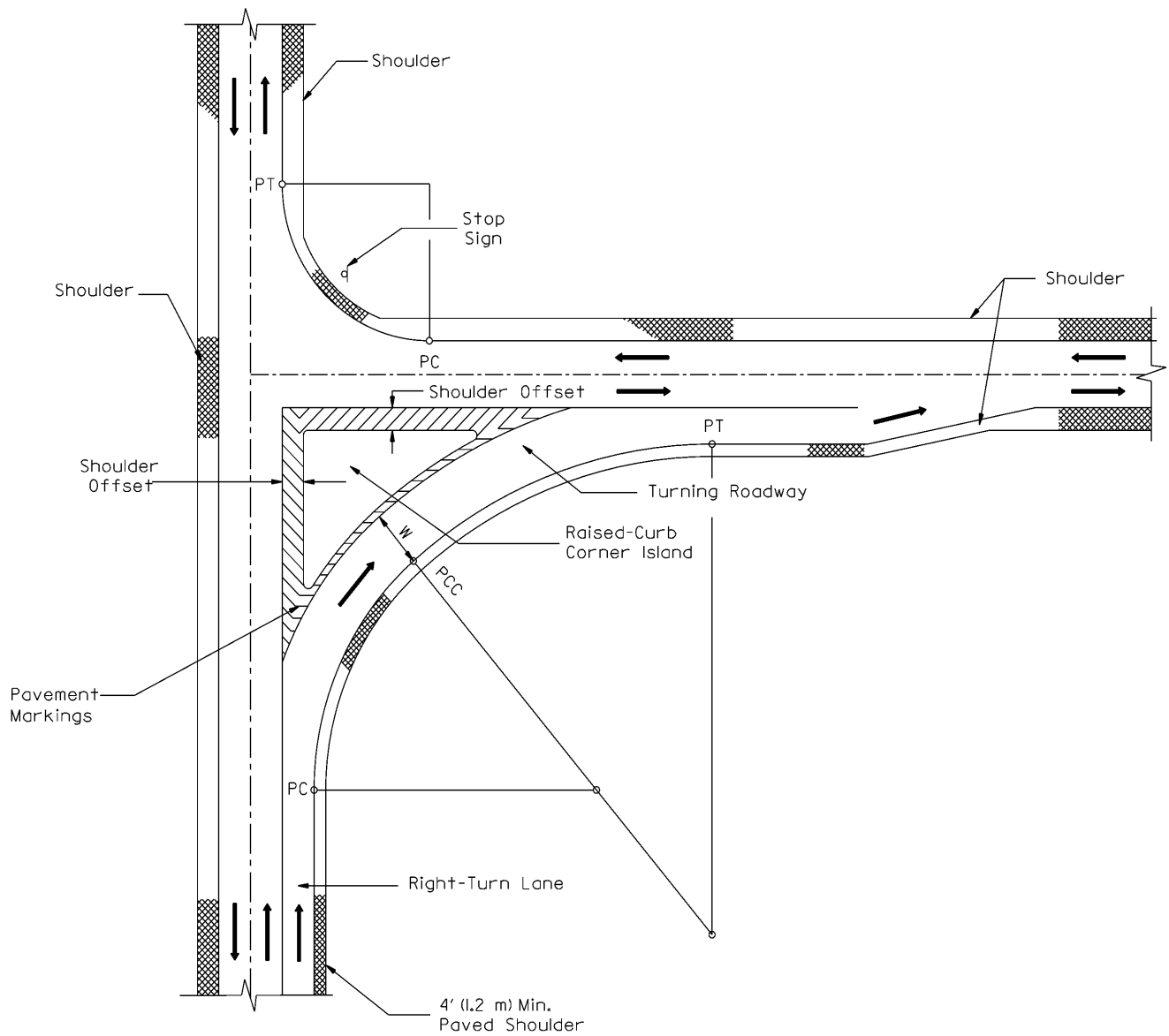

Notes:

1. *W = Width of turning roadway, see Figure 36-2.I.*
2. *See Figure 36-2.G for details of the corner island design.*

TYPICAL TURNING ROADWAY LAYOUT
(High Speed Design)

Figure 36-2.H
(2 of 2)

36-2.03(b) Design Speed

A turning roadway even at a low design speed (e.g., 10 mph (20 km/hr)) may still provide a significant benefit to turning vehicles regardless of the speed on the approaching highway. Typically, the design speed for a turning roadway will be in the range of 10-20 mph (15-30 km/hr).

36-2.03(c) Width

Turning roadway widths are dependent upon the turning radii design, design vehicle selected, angle of turn, design at edges of the turning roadway, and type of operation. Section 36-1.08 provides the criteria for selection of the appropriate design vehicle at an intersection. Turning roadways are designed for one-way operation and are segregated as follows:

1. Case I. One-lane with no provisions for passing a stalled vehicle on the traveled way.
2. Case II. One-lane with provision for passing a stalled vehicle on the traveled way.
3. Case III. Two-lane operation on the traveled way.

Figure 36-2.I presents guidelines for turning roadway widths for various design vehicles based on the above operations. Selection of the appropriate operation will depend on the intersection and will be determined on a case-by-case basis. The following presents several guidelines to consider:

1. Case I. For most turning roadway designs, use the Case I widths from Figure 36-2.I. The pavement widths in Figure 36-2.I provide an extra 6 ft (1.8 m) clearance beyond the design vehicle's swept path. This additional width provides extra room for maneuverability and driver variances.
2. Case II and III. Case II and III widths are seldom required on turning roadways. This is due to the relatively short roadway lengths involved. The Case II widths may be appropriate where channelized islands are provided next to through traffic lanes. Case III widths are only applicable where two lanes are used through the turning roadway.
3. Larger Vehicles. In selecting the turning roadway width, the designer should also consider the possibility that a larger vehicle may also use the turning roadway. To some extent, the extra 6 ft (1.8 m) clearances in Case I widths will allow for the accommodation of the occasional larger vehicle at a lower speed and with less clearance. For example, a turning roadway designed for a WB-50 (WB-15) with a 100 ft (30 m) radius will still accommodate an occasional WB-55 (WB-17) vehicle. However, it will not accommodate a WB-67 (WB-20) vehicle. If there are a significant number of the larger vehicles using the turning roadway, it should be selected as the design vehicle.
4. Shoulders. For shoulder designs adjacent to turning roadways, see Figures 36-2.A and 36-2.H.
5. Curbing. Where curb and gutter is provided on the left and/or right side of the turning roadway, add the gutter widths to the widths shown in Figure 36-2.I.

Radius on Inner Edge of Pavement, R (ft)	Case I, One-Lane, One-Way Operation, No Provision for Passing a Stalled Vehicle (ft)						
	P	P/T	S-BUS-40	SU	WB-50	WB-55	WB-67
50	13	19	18	18	32	38	49
75	13	17	17	17	25	28	32
100	13	16	16	16	22	24	27
150	12	16	15	15	19	20	22
200	12	15	15	15	18	18	20
300	12	15	15	15	17	17	18
400	12	15	15	15	17	17	18
500	12	15	15	15	17	17	18
Tangent	12	14	14	14	15	15	15
Case II, One-Lane, One-Way Operation with Provision for Passing a Stalled Vehicle by Another of the Same Type (ft)							
50	20	30	32	30	56	69	93
75	19	27	28	27	42	46	56
100	18	25	26	25	36	39	46
150	18	23	24	23	31	33	37
200	17	22	23	22	28	30	33
300	17	22	22	22	26	27	29
400	17	21	21	21	25	26	27
500	17	21	21	21	24	25	26
Tangent	17	20	20	20	21	21	21
Case III, Two-Lane, One-Way Operation (Same Type Vehicle in Both Lanes) (ft)							
50	26	36	38	36	62	75	99
76	25	33	34	33	48	53	62
100	24	31	32	31	42	48	52
150	24	29	30	29	37	40	43
200	23	28	29	28	34	35	39
300	23	28	28	28	32	33	35
400	23	27	27	27	31	33	33
500	23	27	27	27	30	32	32
Tangent	23	26	26	26	27	27	27

- Notes:
1. Only use the turning roadway widths in this figure as a guide and check with a turning template or a computer simulated turning template program.
 2. See Section 36-1.08 for dimensions of design vehicles.

**TURNING ROADWAY WIDTHS
(US Customary)**

Figure 36-2.1

Radius on Inner Edge of Pavement, R (m)	Case I, One-Lane, One-Way Operation, No Provision for Passing a Stalled Vehicle (m)						
	P	P/T	S-BUS-12	SU	WB-15	WB-17	WB-20
15	4.0	5.7	5.5	5.5	9.7	12.2	15.7
25	3.9	5.1	5.0	5.0	7.2	8.0	9.0
30	3.8	5.0	4.9	4.9	6.7	7.4	8.1
50	3.7	4.7	4.6	4.6	5.7	6.1	6.5
75	3.7	4.5	4.5	4.5	5.3	5.6	5.9
100	3.7	4.5	4.5	4.5	5.3	5.6	5.9
125	3.7	4.5	4.5	4.5	5.3	5.6	5.9
150	3.7	4.5	4.5	4.5	5.3	5.6	5.9
Tangent	3.6	4.2	4.2	4.2	4.4	4.4	4.4
Case II, One-Lane, One-Way Operation with Provision for Passing a Stalled Vehicle by Another of the Same Type (m)							
15	6.0	9.3	9.7	9.2	17.3	22.4	29.5
25	5.6	7.9	8.2	7.9	12.1	13.8	16.0
30	5.5	7.7	7.8	7.6	11.1	12.4	14.2
50	5.3	7.0	7.1	7.0	9.1	9.9	10.9
75	5.2	6.7	6.8	6.7	8.2	8.7	9.3
100	5.2	6.5	6.6	6.5	7.7	8.2	8.6
125	5.1	6.4	6.5	6.4	7.5	7.8	8.1
150	5.1	6.4	6.4	6.4	7.3	7.5	7.8
Tangent	5.0	6.1	6.1	6.1	6.4	6.4	6.4
Case III, Two-Lane, One-Way Operation (Same Type Vehicle in Both Lanes) (m)							
15	7.8	11.1	11.5	11.0	19.1	24.2	31.3
25	7.4	9.7	10.0	9.7	13.9	15.7	17.8
30	7.3	9.4	9.6	9.4	12.9	14.2	16.0
50	7.1	8.8	8.9	8.8	10.9	11.7	12.7
75	7.0	8.5	8.6	8.5	10.0	10.5	11.1
100	7.0	8.3	8.4	8.3	9.5	10.1	10.4
125	6.9	8.2	8.3	8.2	9.3	9.6	9.9
150	6.9	8.2	8.2	8.2	9.1	9.3	9.6
Tangent	6.8	7.9	7.9	7.9	8.2	8.2	8.2

- Notes:
1. Only use the turning roadway widths in this figure as a guide and check with a turning template or a computer simulated turning template program.
 2. See Section 36-1.08 for dimensions of design vehicles.

**TURNING ROADWAY WIDTHS
(Metric)**

Figure 36-2.1

36-2.03(d) Horizontal Alignment

The horizontal alignment for turning roadway design differs from that of open-roadway conditions, which are discussed in Chapter 32. In comparison, turning roadway designs reflect more restrictive field conditions, and less demanding driver expectation and driver acceptance of design limitations. The following assumptions are used to design horizontal alignment for turning roadways:

1. **Curvature Arrangement.** The radii designs discussed in Section 36-2.01 (e.g., simple radius, two or three-centered curves) are also applicable to turning roadways. For most turning roadway designs, a two-centered curve is desirable. A large simple radius can be used where right-of-way is available and where a higher turning speed is desired (e.g., 20-25 mph (30-40 km/hr)).
2. **Superelevation.** Turning roadways are relatively short in length as indicated in Figure 36-2.H. This increases the difficulty of superelevating the roadway. For turning roadways developed with two-centered curves, a low design speed (e.g., 10–20 mph (15-30 km/hr)) is appropriate and the superelevation rate will typically be 2%. The maximum superelevation rate for turning roadways should not exceed 4%. This would apply only where a large simple radius is used. The factors that control the amount of superelevation are the need to meet pavement elevations of the two intersecting roadways, providing for drainage within the turning roadway, and design speed. Selection of the appropriate superelevation rate will be based on field conditions and will be determined on a site-by-site basis.
3. **Superelevation Development.** Figure 36-2.J illustrates a schematic of superelevation development for a turning roadway adjacent to a tangent section of highway and includes both a right-turn lane and an acceleration-lane taper. The actual development will depend upon the practical field conditions combined with a reasonable consideration of the theory behind horizontal curvature. The following criteria should be met:
 - No change in the normal cross slope is necessary up to Section B-B. Here, the width of the right-turn lane is less than 3 ft (1.0 m).
 - At Section C₁-C₁, the full width of the right-turn lane is obtained and should be sloped at 2.5%. The 2.5% cross slope is carried through to C₂-C₂.
 - The full width of the turning roadway should be attained at Section D-D. The amount of superelevation at D-D will depend upon the practical field conditions.
 - Beyond Section D-D, rotate the turning roadway pavement as needed to provide the required superelevation for the design speed of the turning roadway.
 - The superelevation treatment for the exiting portion of the turning roadway should be similar to that described for the entering portion. However, the superelevation rate on the turning roadway at the beginning of the acceleration taper should match the cross slope of the merging highway or street plus 0.5%.

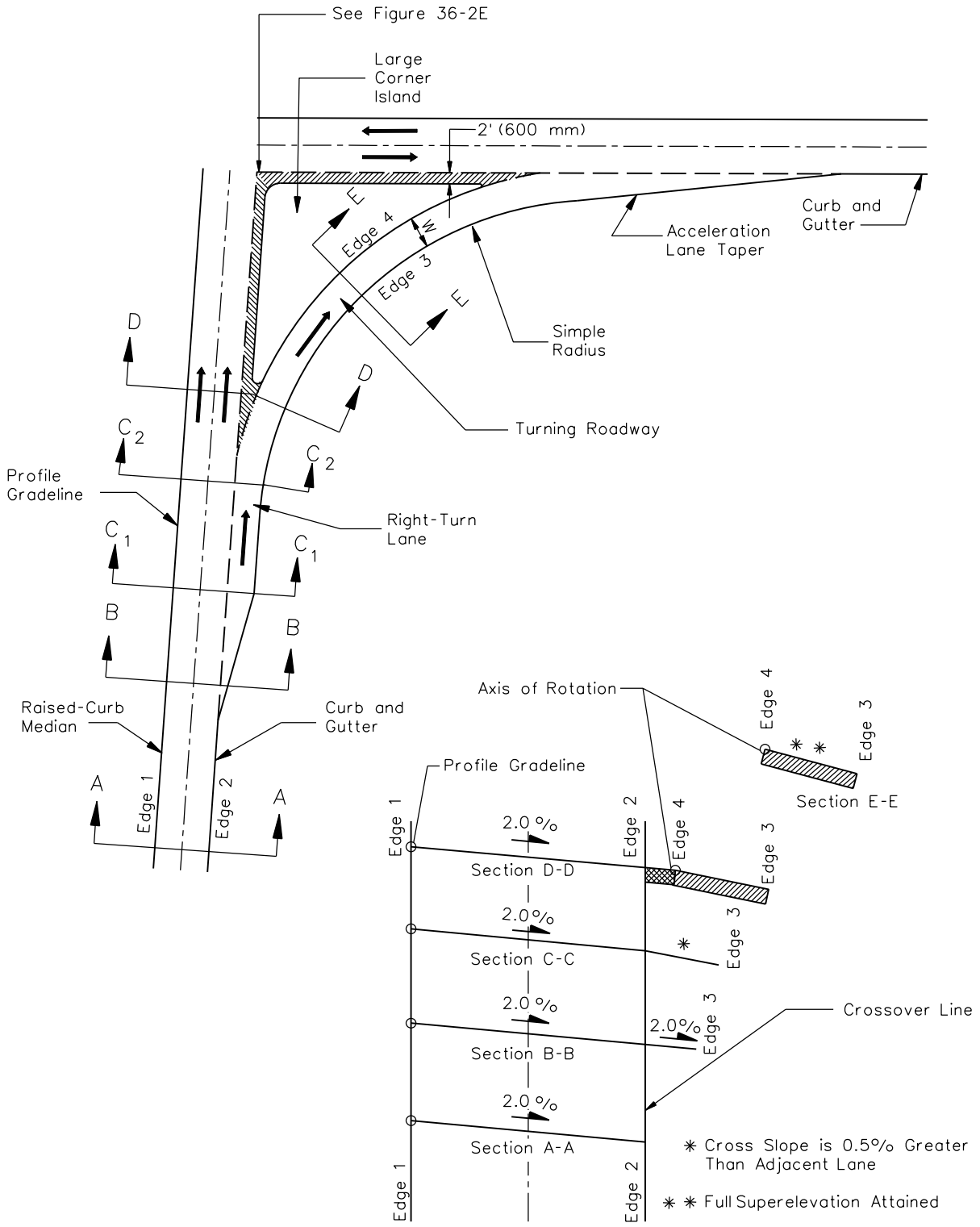

**SUPERELEVATION DEVELOPMENT OF TURNING ROADWAY
(High Speed Design - Mainline on Tangent or Curved to the Right)**

Figure 36-2.J

Figure 36-2.K illustrates an existing situation where the mainline curves to the left and away from the crossroad. The designer should make every effort to avoid designing intersections on a curve where superelevation is needed. If this is not practical, the designer can compensate for this problem by proposing the use of a parallel right-turn deceleration lane prior to the turning roadway as shown in Figure 36-2.K.

4. Cross Slope Rollover. Figure 36-2.L presents the maximum allowable algebraic difference in the cross slopes between the mainline and the right-turn lane that precedes the turning roadway. In Figures 36-2.J and 36-2.K, this criterion applies between Section A-A and Section D-D. This likely will be a factor only for a superelevated mainline to the left.
5. Minimum Radius. The minimum turning roadway radii are based on the design speed, side-friction factors, and superelevation rate. Figure 36-2.M presents minimum radii for various turning roadway conditions.

36-2.03(e) Deceleration/Acceleration Lanes

Consider the following guidelines for using an acceleration or deceleration lane with turning roadways:

1. Deceleration Lane Guidelines. Consider the following guidelines for including a deceleration lane prior to the turning roadway:
 - a. Turning Roadway Design Speed. A right-turn deceleration lane may be considered where the turning roadway design speed is more than 20 mph (30 km/hr) lower than that of the mainline design speed.
 - b. Storage Length. A right-turn deceleration lane may be beneficial at signalized intersections where the through lane storage may limit access to the turning roadway. In these cases, the deceleration lane should extend upstream beyond the through lane storage requirements.
2. Acceleration Lane Guidelines. Consider the following guidelines for including an acceleration lane after the turning roadway:
 - a. Traffic Condition. Consider providing an acceleration lane where it is desirable to provide a free-flowing traffic merge. The acceleration lane should not be preceded by a stop or yield condition.
 - b. Traffic Volumes. Consider providing an acceleration lane where the turning traffic must merge with the through traffic of a high-speed, high-volume facility and/or where there is a high volume of trucks turning onto the mainline.
 - c. Sight Distance. Acceleration lanes may be considered if there is inadequate sight distance available to allow the driver to safely merge with the mainline facility.

US Customary		
Design Speed of Turning Roadway Curve (mph)	Rollover (Algebraic Difference) in Cross Slope at Crossover Line (%)	
	Desirable Maximum	Maximum
10-20	5	8
25-30	5	6
>30	4	5
Metric		
Design Speed of Turning Roadway Curve (km/hr)	Rollover (Algebraic Difference) in Cross Slope at Crossover Line (%)	
	Desirable Maximum	Maximum
20-30	5	8
40-50	5	6
>50	4	5

Note: Values apply between the traveled way and the right-turn lane for turning roadways.

MAXIMUM PAVEMENT CROSS SLOPES AT TURNING ROADWAYS

Figure 36-2.L

US Customary				
Turning Roadway Design Speed (mph)	Assumed Maximum Comfortable Side Friction (f)	Assumed Superelevation (e)	Calculated Radius (ft)	Design Radius (R ₁) (ft)
10	0.38	2%	16.7	15
		3%	16.3	15
		4%	15.9	15
15	0.32	2%	44.1	45
		3%	42.9	45
		4%	41.7	40
20	0.27	2%	92.0	90
		3%	88.9	90
		4%	86.0	85
25	0.23	2%	166.7	165
		3%	160.3	160
		4%	154.3	155
30	0.20	2%	272.7	275
		3%	260.9	260
		4%	250.0	250
35	0.18	2%	408.3	410
		3%	388.9	390
		4%	371.2	375
40	0.16	2%	595.6	595
		3%	561.4	560
		4%	533.3	535
Metric				
Turning Roadway Design Speed (km/hr)	Assumed Maximum Comfortable Side Friction (f)	Assumed Superelevation (e)	Calculated Radius (m)	Design Radius (R ₁) (m)
20	0.35	2%	8.5	9
		3%	8.3	8
		4%	8.1	8
30	0.28	2%	23.6	24
		3%	22.9	23
		4%	22.1	22
40	0.23	2%	50.4	50
		3%	48.5	49
		4%	46.7	47
50	0.19	2%	93.7	94
		3%	89.5	90
		4%	85.6	86
60	0.17	2%	149.2	149
		3%	141.7	142
		4%	135.0	135

Note: For design speeds greater than 45 mph (60 km/hr), use open-roadway conditions; see Chapter 32.

MINIMUM RADII FOR TURNING ROADWAYS

Figure 36-2.M

- d. Right-Turn vs. Left-Turn Lanes. Right-turn acceleration lanes are more common than left-turn acceleration lanes. Left-turn acceleration lanes can be considered only after an engineering study has been completed and approved by BDE.
3. Deceleration Lane Design. For guidance on the design of right-turn deceleration lanes, see Section 36-3.02.
 4. Acceleration Lane Design. Consider the following when designing an acceleration lane:
 - a. Type. Design acceleration lanes at intersections in the same manner as for interchange ramps using the taper design; see Section 37-6.02. Under some circumstances, a parallel-lane design may be more appropriate (e.g., steep upgrade, large volume of trucks). Parallel-lane design criteria are presented in the current edition of the AASHTO *A Policy on Geometric Design of Highways and Streets*.
 - b. Lengths. Right-turn acceleration lanes should meet the criteria presented in Figure 36-2.N. The “controlling curve” at an intersection is the design speed of the turning roadway or the speed at which a vehicle can make the right turn. The acceleration distance from Figure 36-2.N should be adjusted for grades using the factors presented in Figure 36-2.O. Where there is a significant number of turning trucks, the designer may consider lengthening the acceleration lane to account for their longer acceleration distances.
 - c. Taper. See Figure 36-2.N for the taper length distance to be provided at the end of the acceleration lane.

36-2.04 Left-Turn Control Radii

For left turns, the motorist generally has a guide at the beginning and end of the turn and an open intersection in the middle. Therefore, the precise alignment of a two-centered or three-centered curve is generally not applicable. Simple curves are typically used for left-turn control radii. Occasionally, a two-centered curve may be desirable to accommodate the off-tracking of large vehicles provided the second curve has a larger radius.

The design values for left-turn control radii are usually a function of the design vehicle, angle of intersection, number of lanes, and median widths. For roadways intersecting at approximately 90 degrees, radii of 50 ft to 80 ft (15 m to 24 m) should typically satisfy all controlling factors. If center divisional islands are present, select control radii so that the nose of each divisional island is no closer than 4 ft (1.2 m) nor greater than 10 ft (3.0 m) from the edge of the traveled way of the intersecting highway. The nose location is also affected by the selected nose radii. For additional guidance on median openings and median nose designs, see Section 36-4.04.

Left-turn control radii for dual-lane turning movements should be larger than those indicated for the single-lane design. See Section 36-3.05 for additional design details.

Design Speed of Highway (mph)	Speed Reached at End of Full Lane Width (mph) (V_a) ^③	Length of Taper (ft) ^④	L = Length of Acceleration Lane Excluding Taper (ft) ^①						
			For Design Speed of Turning Roadway (mph)						
			Stop	15	20	25	30	35	40
			For Average Running Speed (mph) (V'_a)						
			0	14	18	22	26	30	36
30	23	135	180	140	—	—	—	—	—
35	27	155	280	220	160	—	—	—	—
40	31	175	360	300	270	210	120	—	—
45	35	200	560	490	440	380	280	160	—
50	39	220	720	660	610	550	450	350	130
55	43	240	960	900	810	780	670	550	320
60	47	265	1200	1140	1100	1020	910	800	550
65	50	285	1410	1350	1310	1220	1120	1000	770
70	53	310	1620	1560	1520	1420	1350	1230	1000

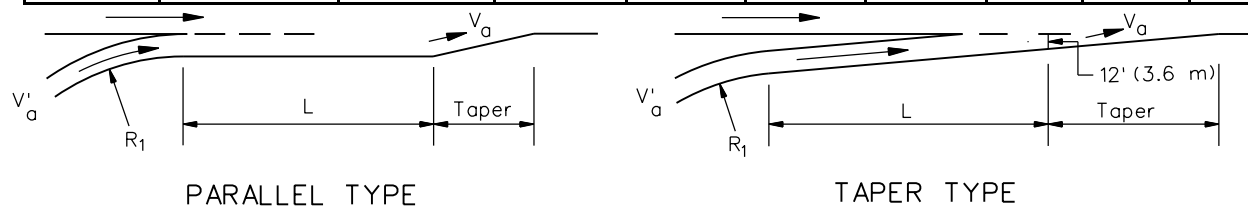

Notes:

1. These values are for grades 3% or less. See Figure 36-2.O for steeper upgrades or downgrades.
2. See Figure 36-2.M for radii of turning roadways.
3. The acceleration lengths are calculated from the distance needed for a passenger car to accelerate from the average running speed of the entrance curve to reach a speed (V_a) of approximately 5 mph below the average running speed on the mainline.
4. Length of taper approximates 3 seconds travel time at the design speed.

**DESIGN LENGTHS FOR ACCELERATION LANES
(Passenger Cars)
(US Customary)**

Figure 36-2.N

Design Speed of Highway (km/hr)	Speed Reached at End of Full Lane Width (km/hr) (V_a) ^③	Length of Taper (m) ^④	L = Length of Acceleration Lane Excluding Taper (m) ^①					
			For Design Speed of Turning Roadway (km/hr)					
			Stop	20	30	40	50	60
			For Average Running Speed (km/hr) (V'_a)					
			0	20	28	35	42	51
50	37	45	60	50	30	—	—	—
60	45	50	95	80	65	45	—	—
70	53	60	150	130	110	90	65	—
80	60	70	200	180	165	145	115	65
90	67	75	260	245	225	205	175	125
100	74	85	345	325	305	285	255	205
110	81	90	430	410	390	370	340	290

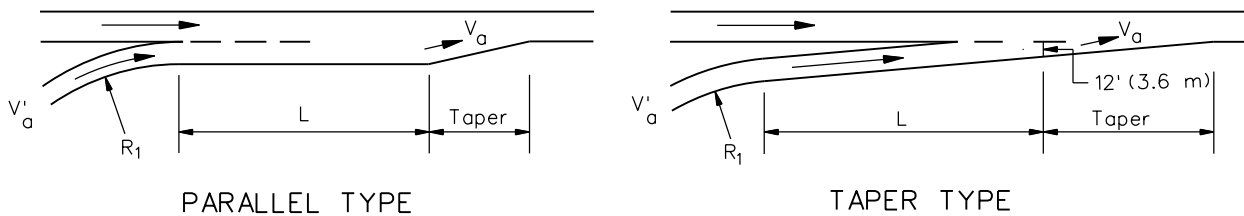

Notes:

1. These values are for grades 3% or less. See Figure 36-2.O for steeper upgrades or downgrades.
2. See Figure 36-2.M for radii of turning roadways.
3. The acceleration lengths are calculated from the distance needed for a passenger car to accelerate from the average running speed of the entrance curve to reach a speed (V_a) of 10 km/hr below the average running speed on the mainline.
4. Length of taper approximates 3 seconds travel time at the design speed.

**DESIGN LENGTHS FOR ACCELERATION LANES
(Passenger Cars)
(Metric)**

Figure 36-2.N

Design Speed of Highway (mph)	Difference of Length on Grade to Length on Level				
	Design Speed of Acceleration Lane (mph)				
	20	30	40	50	All Speeds
	3.01% to 4.00% Upgrade				3.01% to 4.00% Downgrade
40	1.30	1.30	—	—	0.700
45	1.30	1.35	—	—	0.675
50	1.30	1.40	1.40	—	0.650
55	1.35	1.45	1.45	—	0.625
60	1.40	1.50	1.50	1.60	0.600
65	1.45	1.55	1.60	1.70	0.600
70	1.50	1.60	1.70	1.80	0.600
	4.01% to 6% Upgrade				4.01% to 6% Downgrade
40	1.50	1.50	—	—	0.600
45	1.50	1.60	—	—	0.575
50	1.50	1.70	1.90	—	0.550
55	1.60	1.80	2.05	—	0.525
60	1.70	1.90	2.20	2.50	0.500
65	1.85	2.05	2.40	2.750	0.500
70	2.00	2.20	2.60	3.00	0.500

Notes:

1. Where an acceleration lane is proposed on a grade greater than 3%, select a length of lane from Figure 36-2.L and multiply that value by the ratio obtained from above to determine the design length on grade.
2. No adjustment is needed on grades 3% or less.
3. The "grade" in the table is the average grade measured over the distance for which the acceleration length applies.

**GRADE ADJUSTMENTS FOR ACCELERATION
(Passenger Cars)
(US Customary)**

Figure 36-2.O

Design Speed of Highway (km/hr)	Difference of Length on Grade to Length on Level					
	Design Speed of Acceleration Lane (km/hr)					
	40	50	60	70	80	All Speeds
	3.01% to 4.00% Upgrade					3.01% to 4.00% Downgrade
60	1.3	1.4	1.4	—	—	0.70
70	1.3	1.4	1.4	1.5	—	0.65
80	1.4	1.5	1.5	1.5	1.6	0.65
90	1.4	1.5	1.5	1.5	1.6	0.60
100	1.5	1.6	1.7	1.7	1.8	0.60
110	1.5	1.6	1.7	1.7	1.8	0.60
	4.01% to 6% Upgrade					4.01% to 6% Downgrade
60	1.5	1.5	—	—	—	0.60
70	1.5	1.6	1.7	—	—	0.60
80	1.5	1.7	1.9	1.8	—	0.55
90	1.6	1.8	2.0	2.1	2.2	0.55
100	1.7	1.9	2.2	2.4	2.5	0.50
110	2.0	2.2	2.6	2.8	3.0	0.50

Notes:

1. Where an acceleration lane is proposed on a grade greater than 3%, select a length of lane from Figure 36-2.L and multiply that value by the ratio obtained from above to determine the design length on grade.
2. No adjustment is needed on grades 3% or less.
3. The "grade" in the table is the average grade measured over the distance for which the acceleration length applies.

**GRADE ADJUSTMENTS FOR ACCELERATION
(Passenger Cars)
(Metric)**

Figure 36-2.O

36-3 AUXILIARY TURN LANES

When turning maneuvers for left- and right-turning vehicles occur from the through travel lanes, it typically disrupts the flow of through traffic. This is especially true on high-volume highways. To minimize potential conflicts and to improve the level of service and safety, the use of auxiliary turn lanes may be warranted for intersections.

36-3.01 Turn Lane Guidelines

36-3.01(a) Right-Turn Lane Warrants

The use of right-turn lanes at intersections can significantly improve operations. Consider using an exclusive right-turn lane for the following:

- at any unsignalized intersection on a two-lane urban or rural highway that satisfies the criteria in Figure 36-3.A;
- at any unsignalized intersection on a high-speed, four-lane urban or rural highway that satisfies the criteria in Figure 36-3.B;
- on expressways at all public road intersections where the current ADT on the side road is greater than 250;
- at any intersection where a capacity analysis determines a right-turn lane is necessary to meet the level-of-service criteria;
- at any signalized intersections where the right-turning volume is greater than 150 vph and where there is greater than 300 vphpl on the mainline;
- for uniformity of intersection design along the highway if other intersections have right-turn lanes;
- at any intersection where the mainline is curved to the left and where the mainline curve requires superelevation;
- at railroad crossings where the railroad is located close to the intersection and a right-turn lane would be desirable to efficiently move through traffic on the parallel roadway; or
- at any intersection where the crash experience, existing traffic operations, sight distance restrictions (e.g., intersection beyond a crest vertical curve), or engineering judgment indicates a significant conflict related to right-turning vehicles.

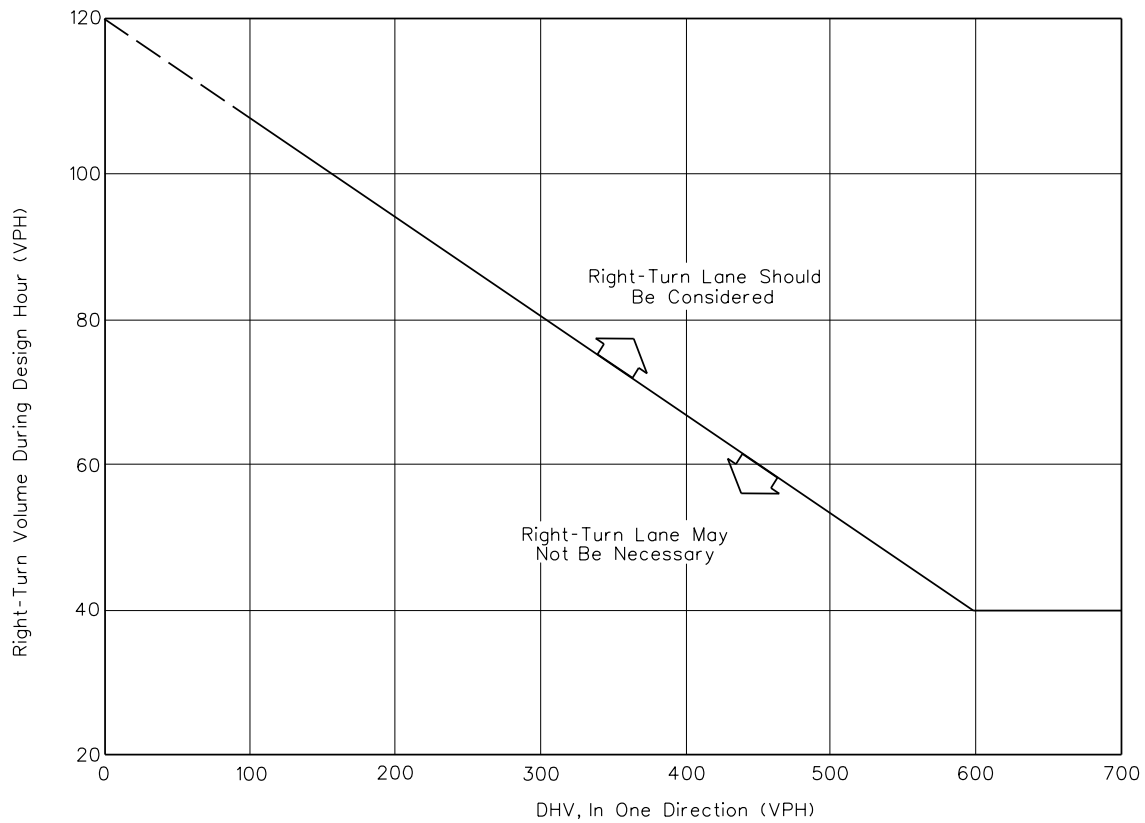

Note: For highways with a design speed below 50 mph (80 km/hr), with a DHV in one direction of less than 300, and where right turns are greater than 40, an adjustment should be used. To read the vertical axis of the chart, subtract 20 from the actual number of right turns.

Example

Given: Design Speed = 35 mph (60 km/hr)
 DHV (in one direction) = 250 vph
 Right Turns = 100 vph

Problem: Determine if a right-turn lane is warranted.

Solution: To read the vertical axis, use $100 - 20 = 80$ vph. The figure indicates that right-turn lane is not necessary, unless other factors (e.g., high crash rate) indicate a lane is needed.

GUIDELINES FOR RIGHT-TURN LANES AT UNSIGNALIZED INTERSECTIONS ON TWO-LANE HIGHWAYS

Figure 36-3.A

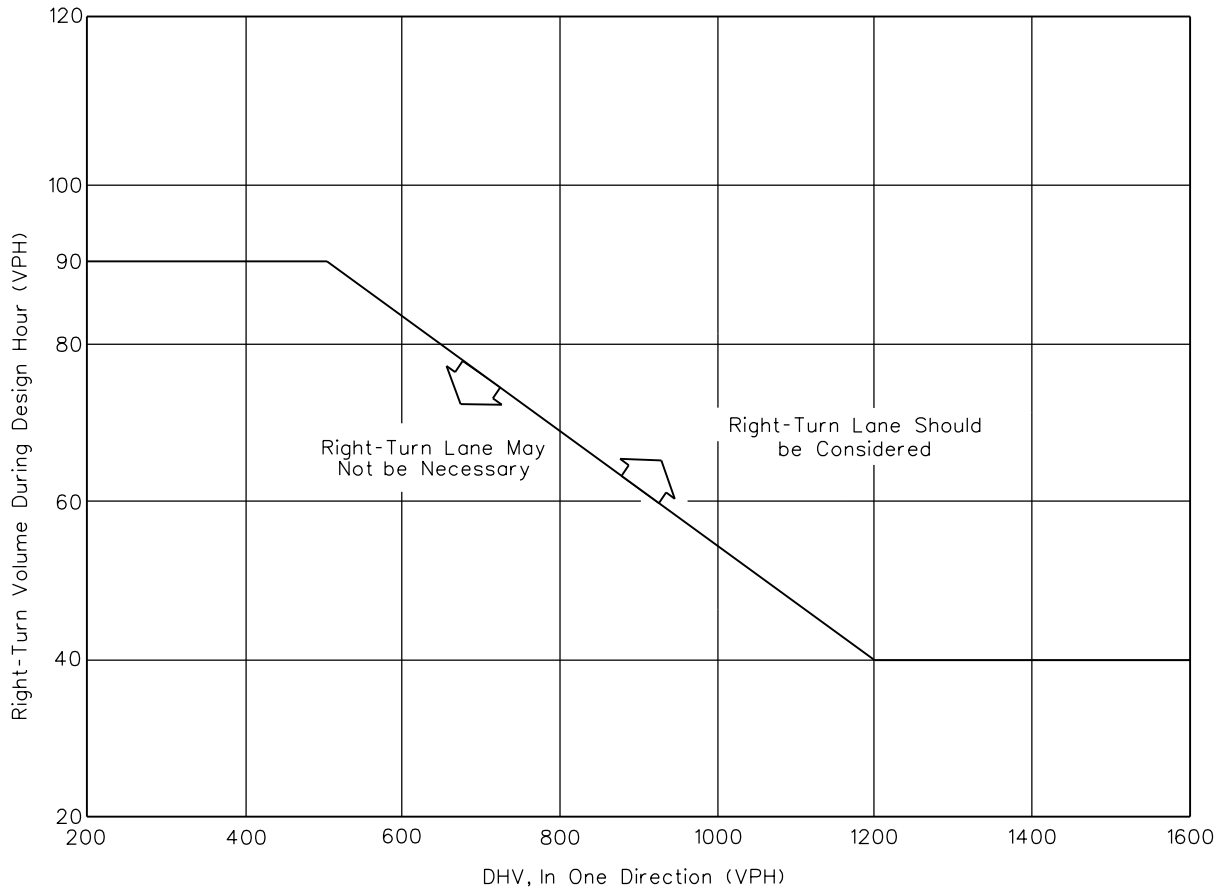

Note: For speeds less than 50 mph (80 km/hr), see Section 36-3.01(a).

**GUIDELINES FOR RIGHT-TURN LANES AT UNSIGNALIZED INTERSECTION
ON FOUR-LANE HIGHWAYS
(Design Speed of 50 mph (80 km/hr) or Greater)**

Figure 36-3.B

36-3.01(b) Left-Turn Lane Warrants

The accommodation of left turns is often the critical factor in proper intersection design. Left-turn lanes can significantly improve both the level of service and intersection safety. Always use an exclusive left-turn lane at all intersections on divided urban and rural highways with a median wide enough to accommodate a left-turn lane, regardless of traffic volumes. Consider using an exclusive left-turn lane for the following:

- at any unsignalized intersection on a two-lane urban or rural highway that satisfies the criteria in Figures 36-3.C, D, E, F, or G;
- at any signalized intersection where the left-turning volume is equal to or greater than 75 vph for a single turn lane or 300 vph for a dual turn lane;
- at any intersection where a capacity analysis determines a left-turn lane is necessary to meet the level-of-service criteria, including dual left-turn lanes;
- for uniformity of intersection design along the highway if other intersections have left-turn lanes (i.e., to satisfy driver expectancy); or
- at any intersection where the crash experience, traffic operations, sight distance restrictions (e.g., intersection beyond a crest vertical curve), or engineering judgment indicates a significant conflict related to left-turning vehicles.

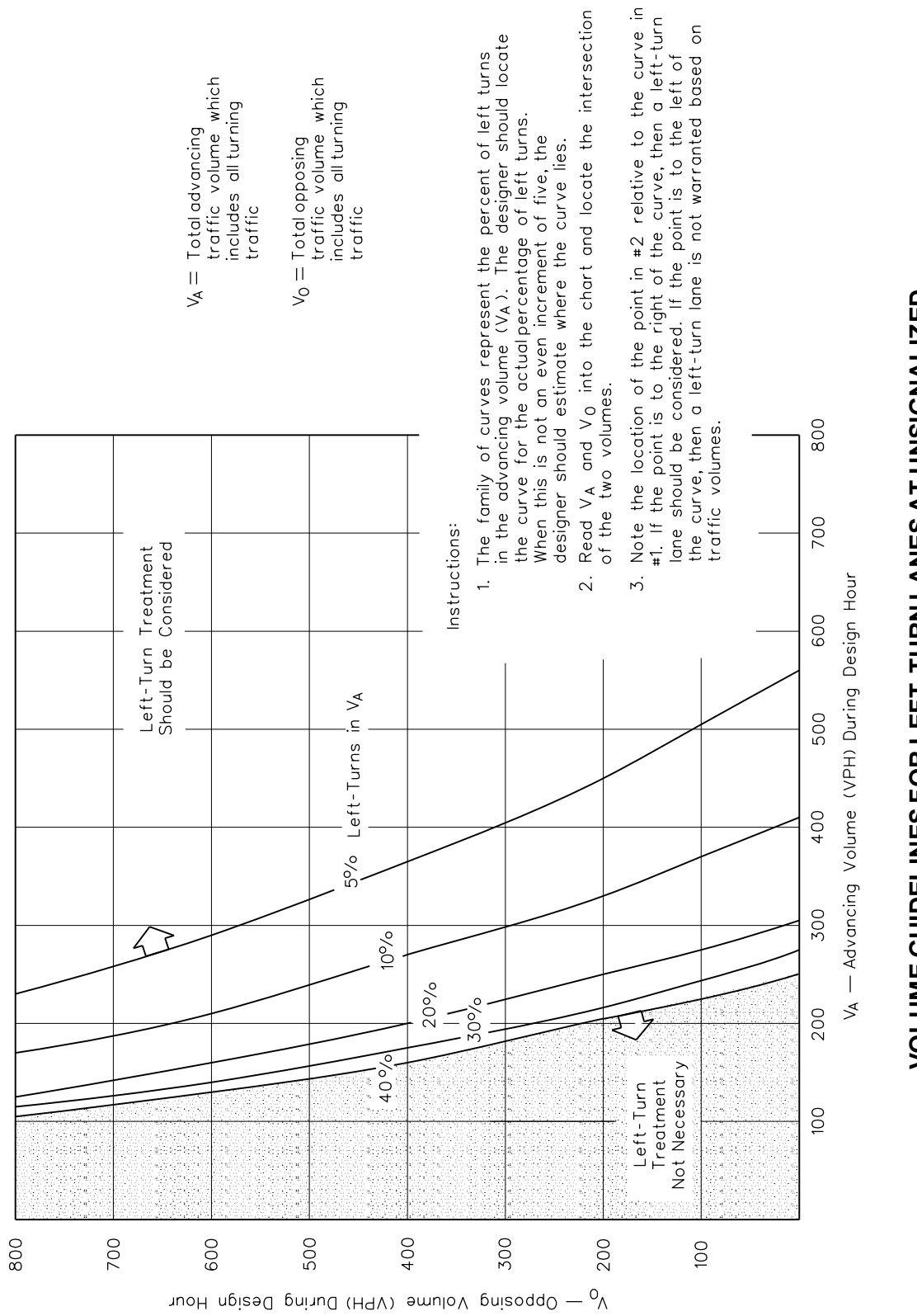

V_A = Total advancing traffic volume which includes all turning traffic

V_O = Total opposing traffic volume which includes all turning traffic

Instructions:

1. The family of curves represent the percent of left turns in the advancing volume (V_A). The designer should locate the curve for the actual percentage of left turns. When this is not an even increment of five, the designer should estimate where the curve lies.
2. Read V_A and V_O into the chart and locate the intersection of the two volumes.
3. Note the location of the point in #2 relative to the curve in #1. If the point is to the right of the curve, then a left-turn lane should be considered. If the point is to the left of the curve, then a left-turn lane is not warranted based on traffic volumes.

VOLUME GUIDELINES FOR LEFT-TURN LANES AT UNSIGNALIZED INTERSECTIONS ON TWO-LANE HIGHWAYS (60 mph Design Speed)

Figure 36-3.C

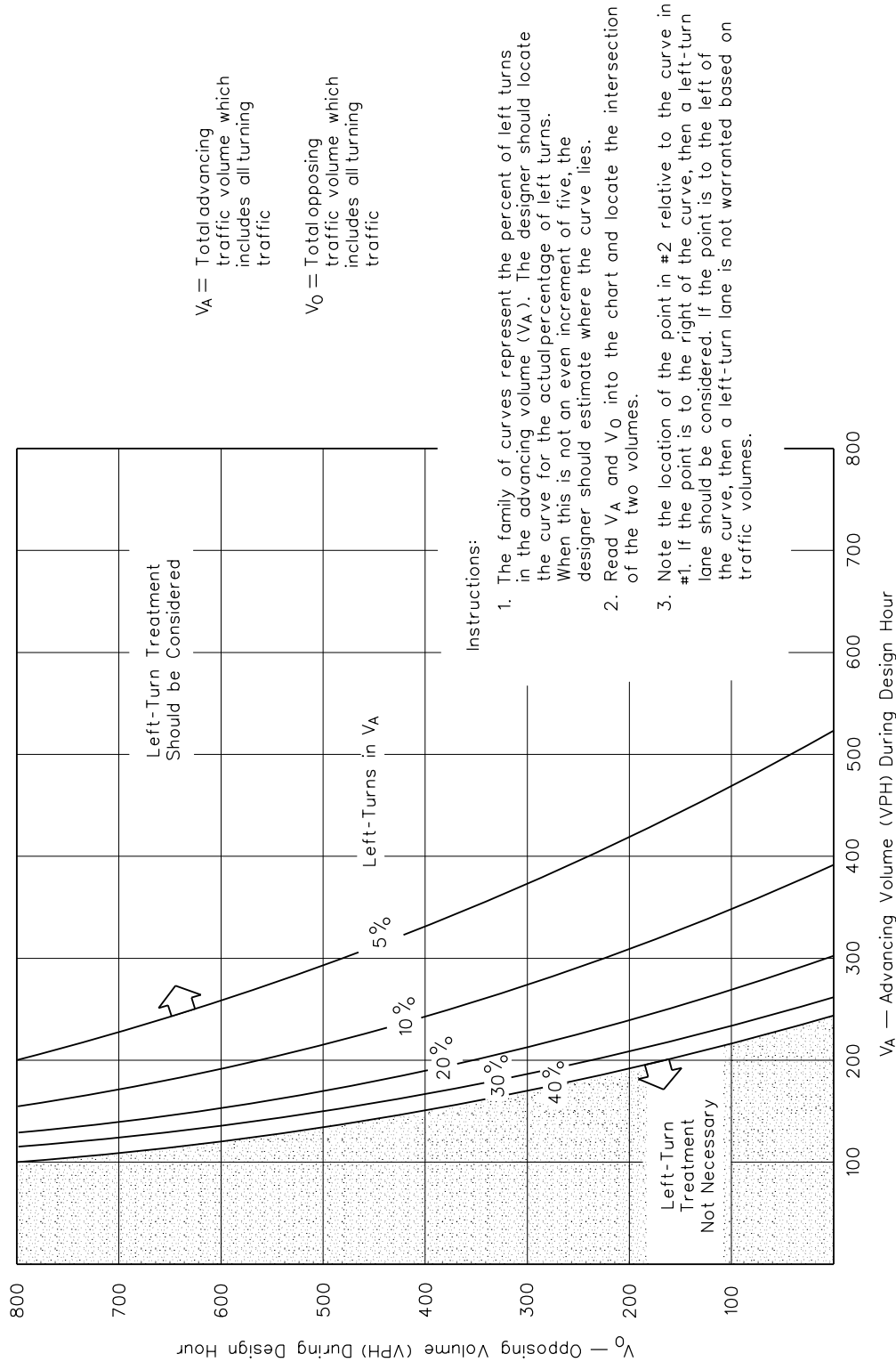

VOLUME GUIDELINES FOR LEFT-TURN LANES AT UNSIGNALIZED INTERSECTIONS ON TWO-LANE HIGHWAYS (100 km/hr Design Speed)

Figure 36-3.C

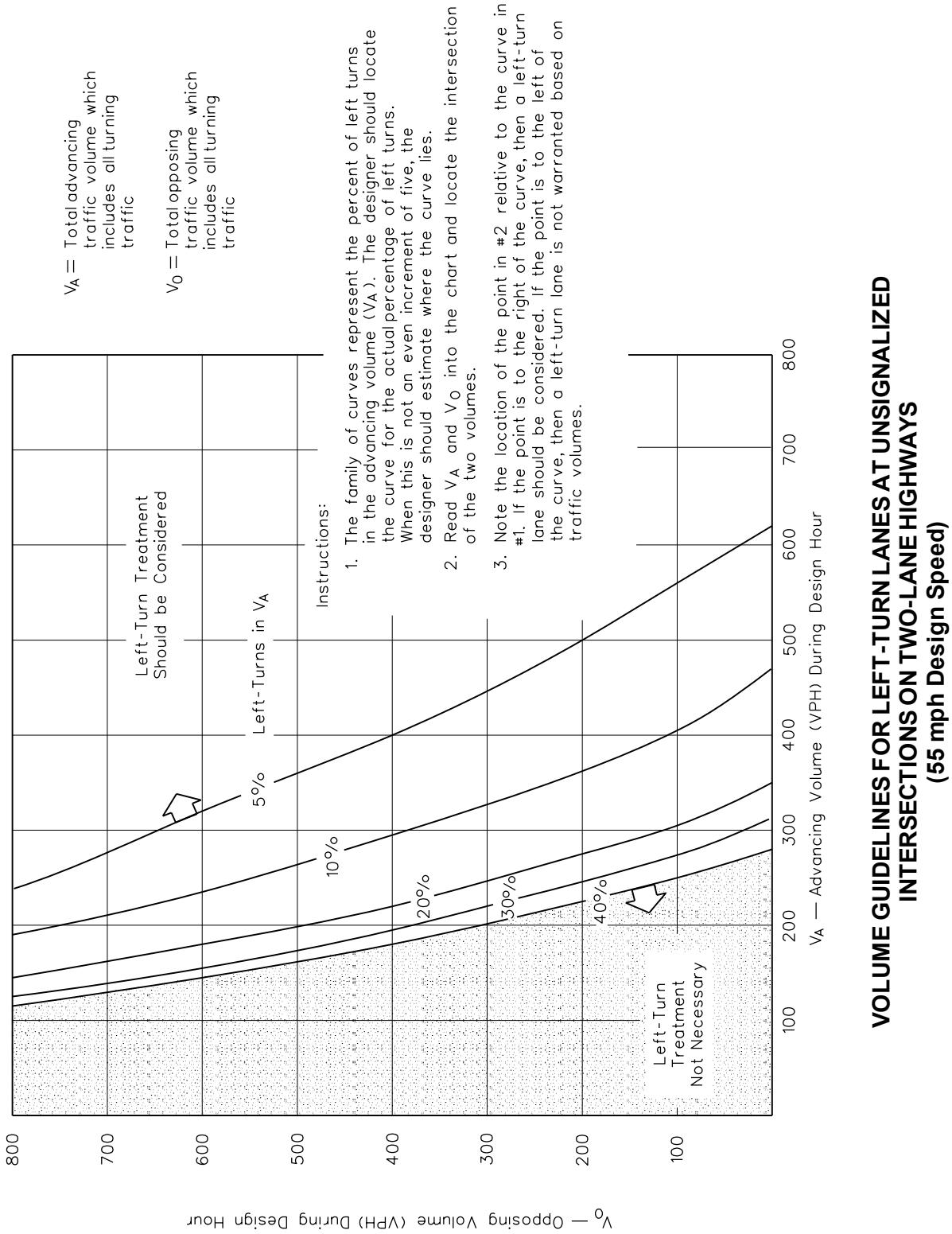

VOLUME GUIDELINES FOR LEFT-TURN LANES AT UNSIGNALIZED INTERSECTIONS ON TWO-LANE HIGHWAYS (55 mph Design Speed)

Figure 36-3.D

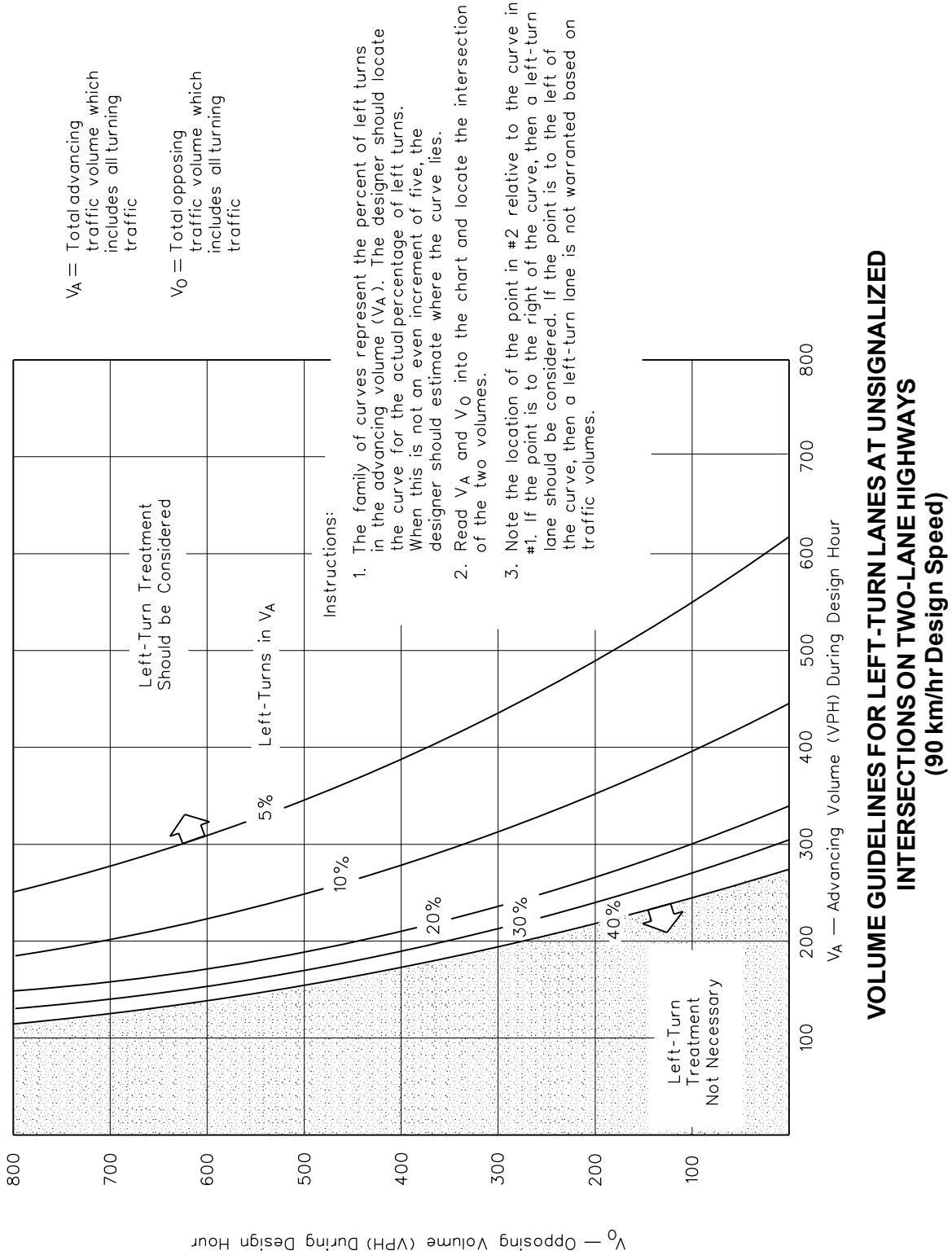
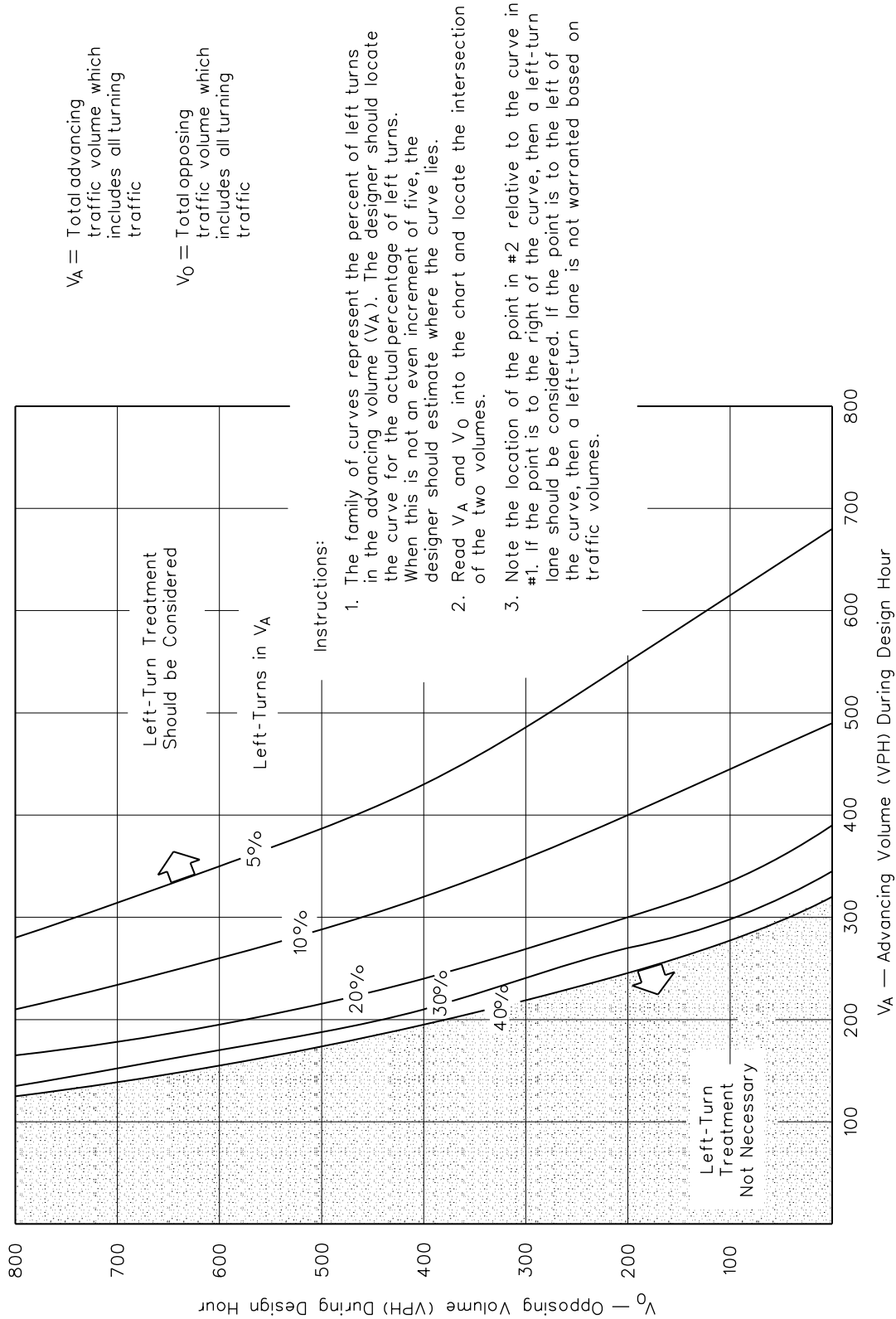
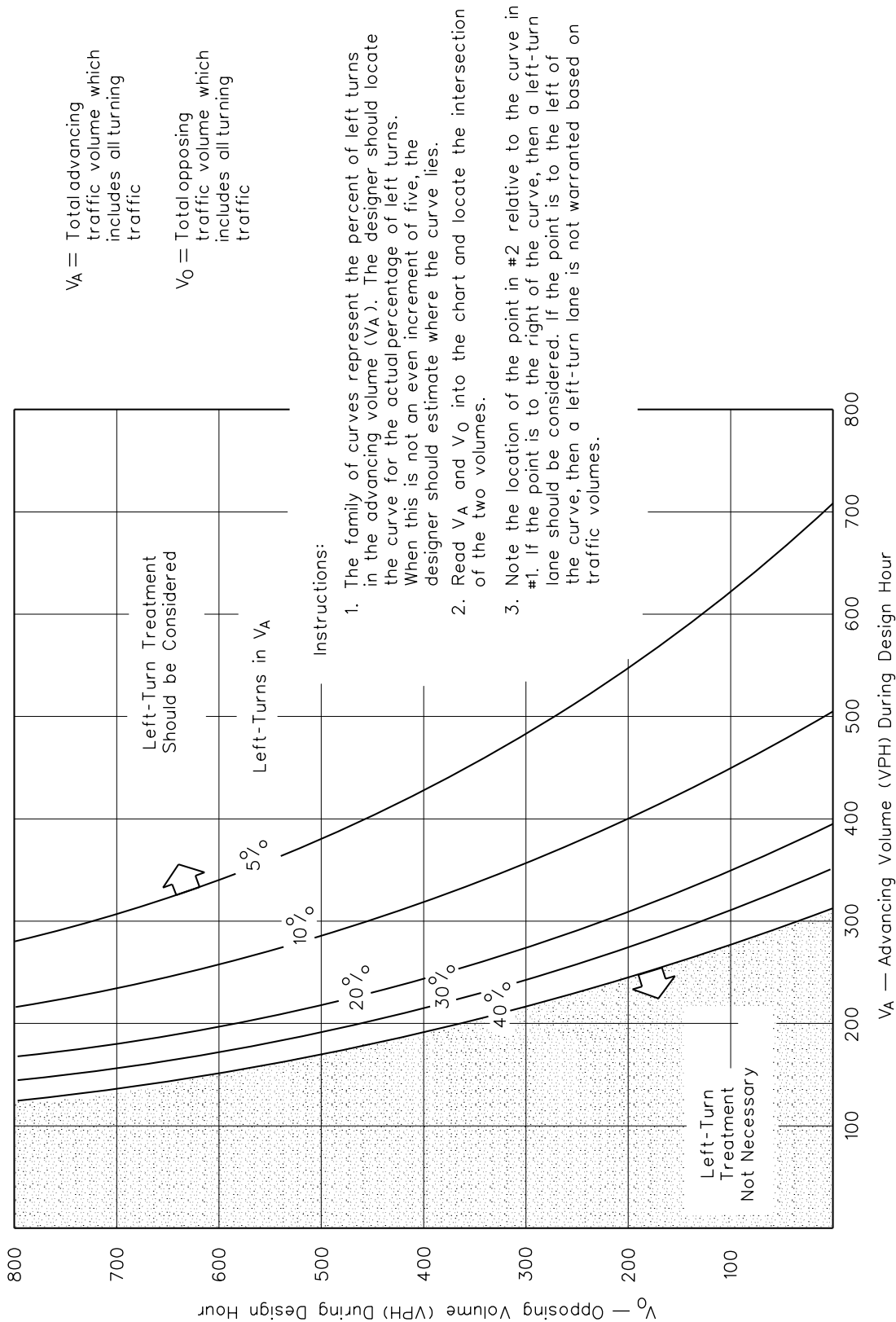

Figure 36-3.D



VOLUME GUIDELINES FOR LEFT-TURN LANES AT UNSIGNALIZED INTERSECTIONS ON TWO-LANE HIGHWAYS (50 mph Design Speed)

Figure 36-3.E



VOLUME GUIDELINES FOR LEFT-TURN LANES AT UNSIGNALIZED INTERSECTIONS ON TWO-LANE HIGHWAYS (80 km/hr Design Speed)

Figure 36-3.E

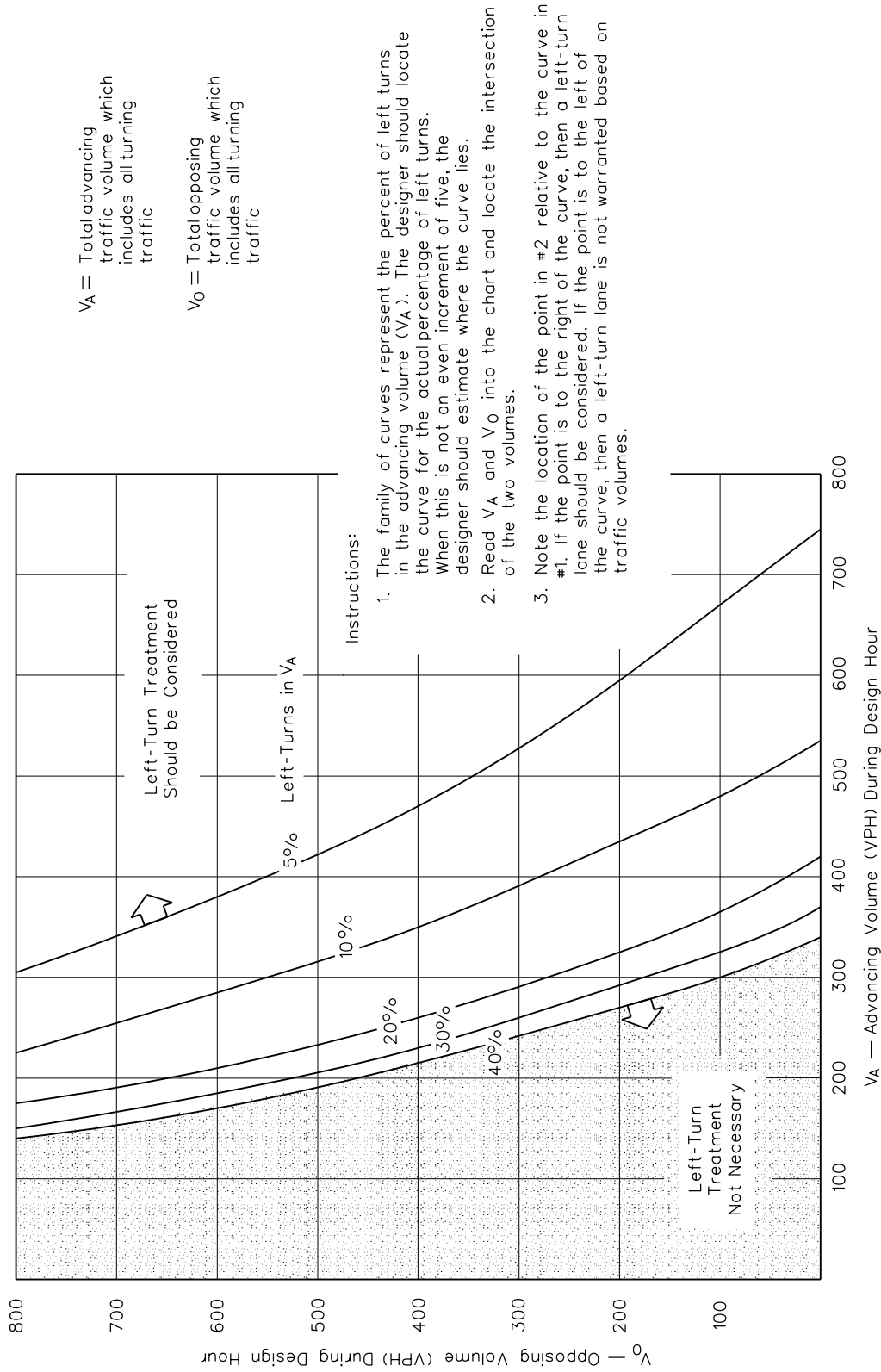

VOLUME GUIDELINES FOR LEFT-TURN LANES AT UNSIGNALIZED INTERSECTIONS ON TWO-LANE HIGHWAYS (45 mph Design Speed)

Figure 36-3.F

V_A = Total advancing traffic volume which includes all turning traffic

V_O = Total opposing traffic volume which includes all turning traffic

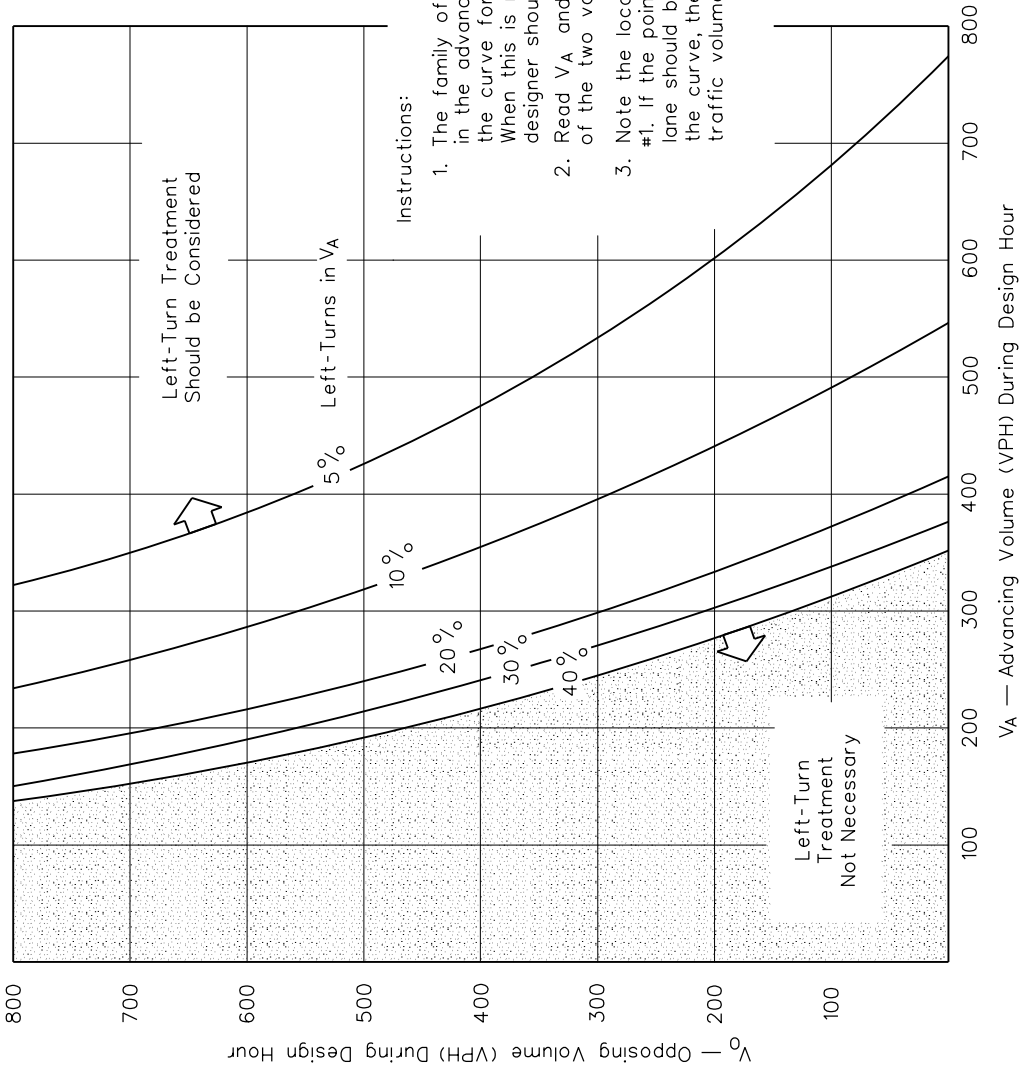

Instructions:

1. The family of curves represent the percent of left turns in the advancing volume (V_A). The designer should locate the curve for the actual percentage of left turns. When this is not an even increment of five, the designer should estimate where the curve lies.
2. Read V_A and V_O into the chart and locate the intersection of the two volumes.
3. Note the location of the point in #2 relative to the curve in #1. If the point is to the right of the curve, then a left-turn lane should be considered. If the point is to the left of the curve, then a left-turn lane is not warranted based on traffic volumes.

VOLUME GUIDELINES FOR LEFT-TURN LANES AT UNSIGNALIZED INTERSECTIONS ON TWO-LANE HIGHWAYS (70 km/hr Design Speed)

Figure 36-3.F

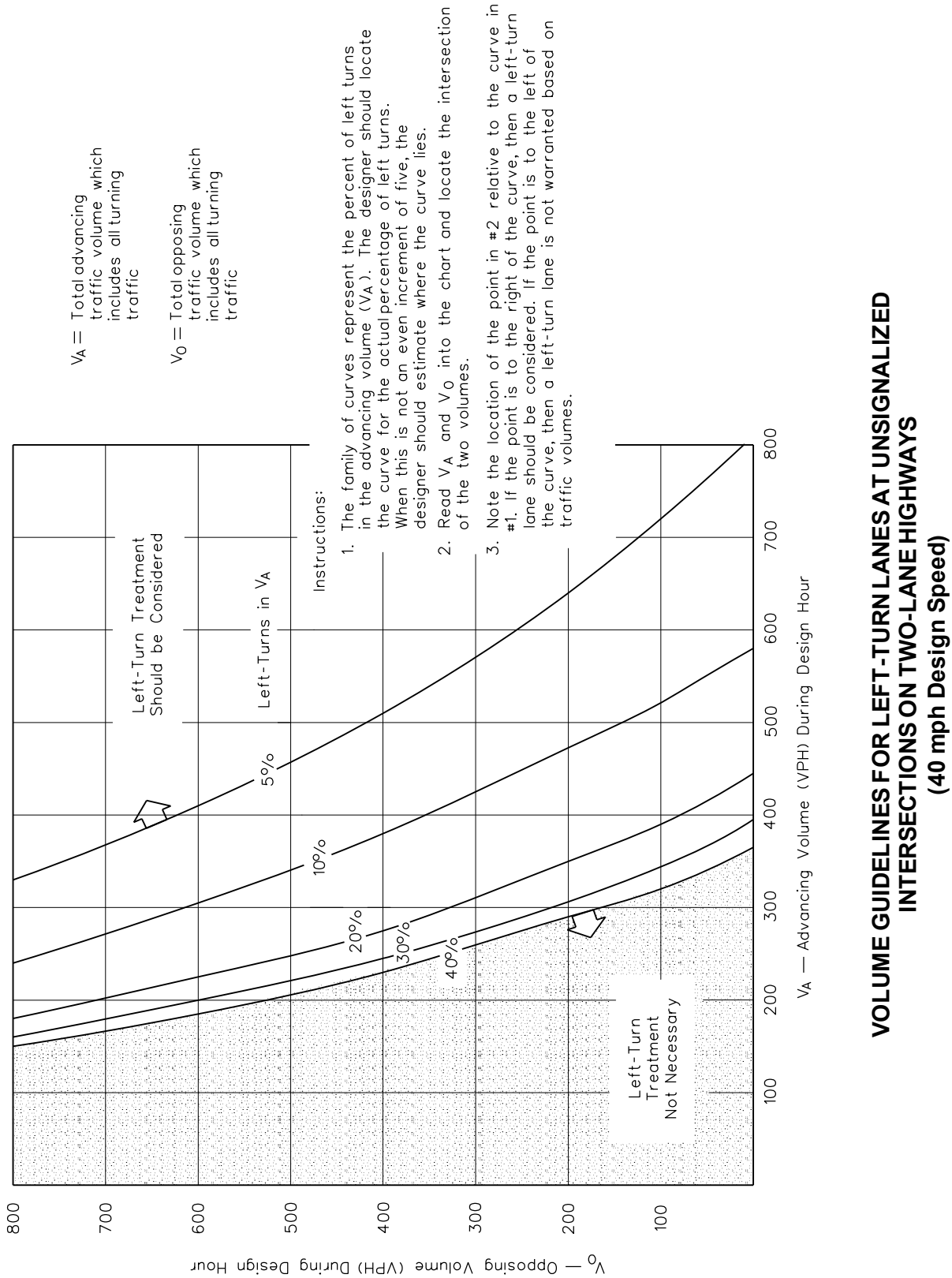
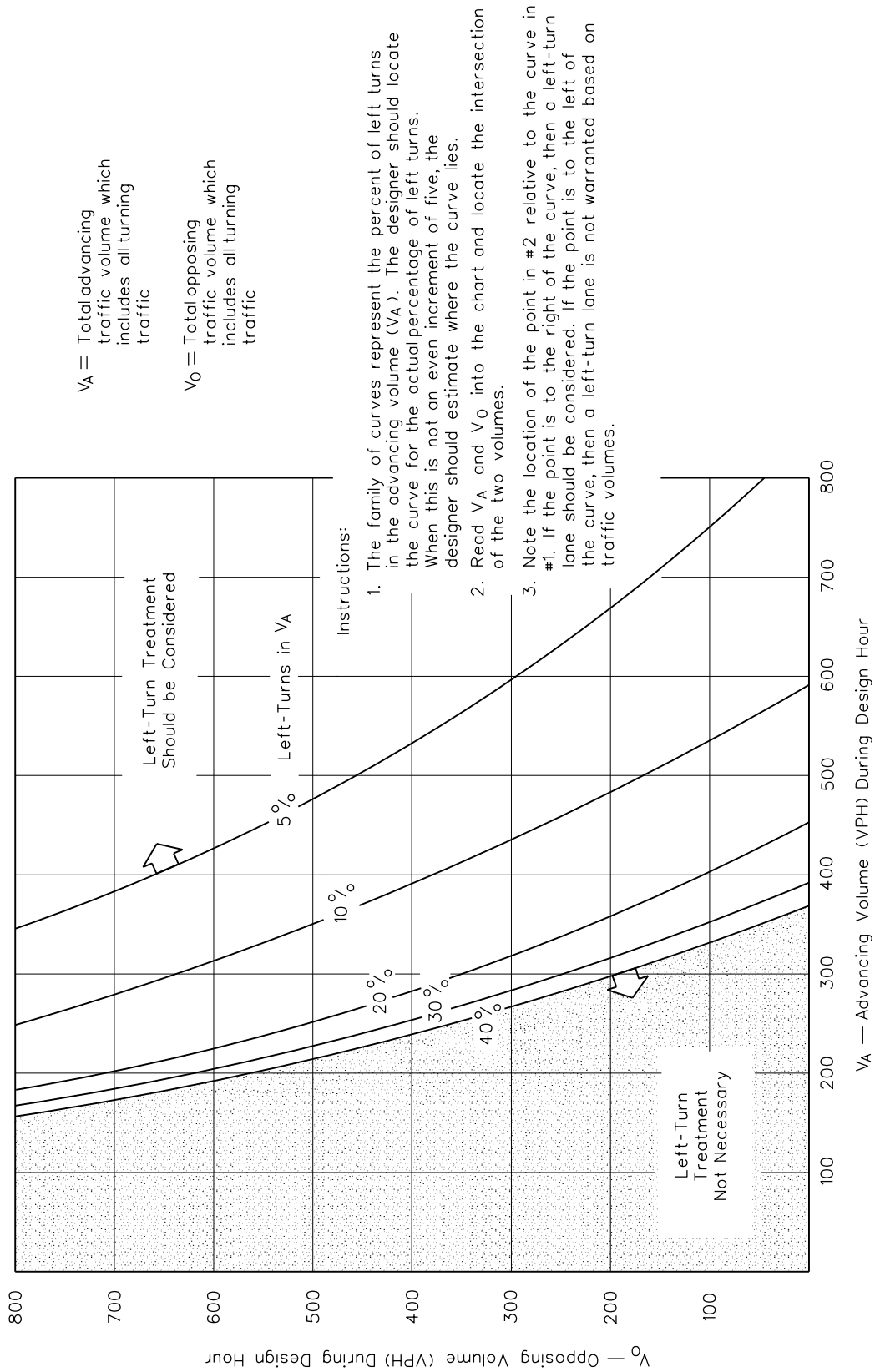

Figure 36-3.G



VOLUME GUIDELINES FOR LEFT-TURN LANES AT UNSIGNALIZED INTERSECTIONS ON TWO-LANE HIGHWAYS (60 km/hr Design Speed)

Figure 36-3.G

36-3.02 Turn Lane Design Parameters

36-3.02(a) Turn Lane Widths

The width of the turn lane should be determined relative to the functional class, urban/rural location, and project scope of work (new construction, reconstruction, 3R). Part V, Design of Highway Types, of the *BDE Manual* presents the applicable widths for auxiliary lanes based on these criteria. Desirably, turn-lane widths should be 12 ft (3.6 m) or a minimum of 11 ft (3.3 m). However, for 3R projects, lane widths as narrow as 10 ft (3.0 m) are allowed for urban auxiliary lanes or through lanes on non-designated truck routes; see Chapter 49. The geometric design tables in Part V also provide criteria for the applicable shoulder widths adjacent to auxiliary lanes. In general, the minimum shoulder widths adjacent to a turn lane with shoulders should be 4 ft (1.2 m). For curbed sections, the minimum width of the gutter adjacent to the turn lane should be 6 in. to 24 in. (150 mm to 600 mm), with drainage requirements usually dictating the appropriate width.

36-3.02(b) Turn Lane Lengths

Desirably, the length of a right- or left-turn lane at an intersection should allow for both safe vehicular deceleration and storage of turning vehicles outside of the through lanes. However, this is often not practical. The length of auxiliary lanes will be determined by a combination of its taper length (L_T), deceleration length (L_D), and storage length (L_S). For urban areas, the functional length will be the taper length plus the storage length, or the deceleration length that includes the taper length, whichever is larger. For rural areas, typically the functional length will be the deceleration length that includes the taper length. In most high-speed, low-volume rural situations, the storage length will not be a controlling factor. Figure 36-3.H illustrates a schematic of auxiliary lanes at an intersection.

The following discusses IDOT criteria for turn lane lengths:

1. Taper. The entrance taper into the turn lane may be either a straight or a reverse curve taper. Always use the straight taper across bridges for ease of construction. Figure 36-3.I provides the recommended taper rates for a straight or reverse curve taper. Where the highway is on a curved alignment, the taper of the turn lane should be more pronounced than usual to ensure that the through motorists are not inadvertently directed into the turn lane. This is accomplished by shortening the taper length. Where the entrance taper is shortened, ensure that the overall deceleration distance from Figure 36-3.I is still provided for the turn lane.
2. Deceleration. For rural facilities, the deceleration distance (L_D) should meet the criteria presented in Figure 36-3.I. The following will apply:
 - a. Design Speed. The deceleration length will depend upon the mainline design speed and the proposed type of operation at the end of the turn lane. These

design speeds are provided in the geometric design tables in *Part V, Design of Highway Types*.

- b. Location. The deceleration distance includes the taper lengths. For left turns, the deceleration distance is usually measured beginning at the end of the left-turn control radii. For right turns, the deceleration distance may be set at either one of two locations; see Figure 36-3.H. At intersections with minor public roads (e.g., frontage roads, service drives, local roads with current ADT volumes less than 400), a design speed of 50 mph (80 km/hr) may be used to determine the deceleration length.
- c. Strategic Regional Arterials (SRA). For SRA routes, the minimum storage length should be 150 ft (45 m).
- d. Grades. Where grades are greater than 3%, adjust the deceleration distance using the factors in Figure 36-3.I.
- e. Urban. These distances are desirable on urban facilities; however, this is not always feasible. Under restricted urban conditions, deceleration may have to be accomplished entirely within the travel lane. For these cases, the length of full-width turn lane will be based solely on providing adequate vehicular storage (i.e., $L_D = 0.0$ ft (0.0 m)).
- f. Trucks. Where it is determined that a turn lane will be used by a large number of trucks, increase the length of the deceleration distance by approximately 30%. This will compensate for the braking constraints of large trucks.

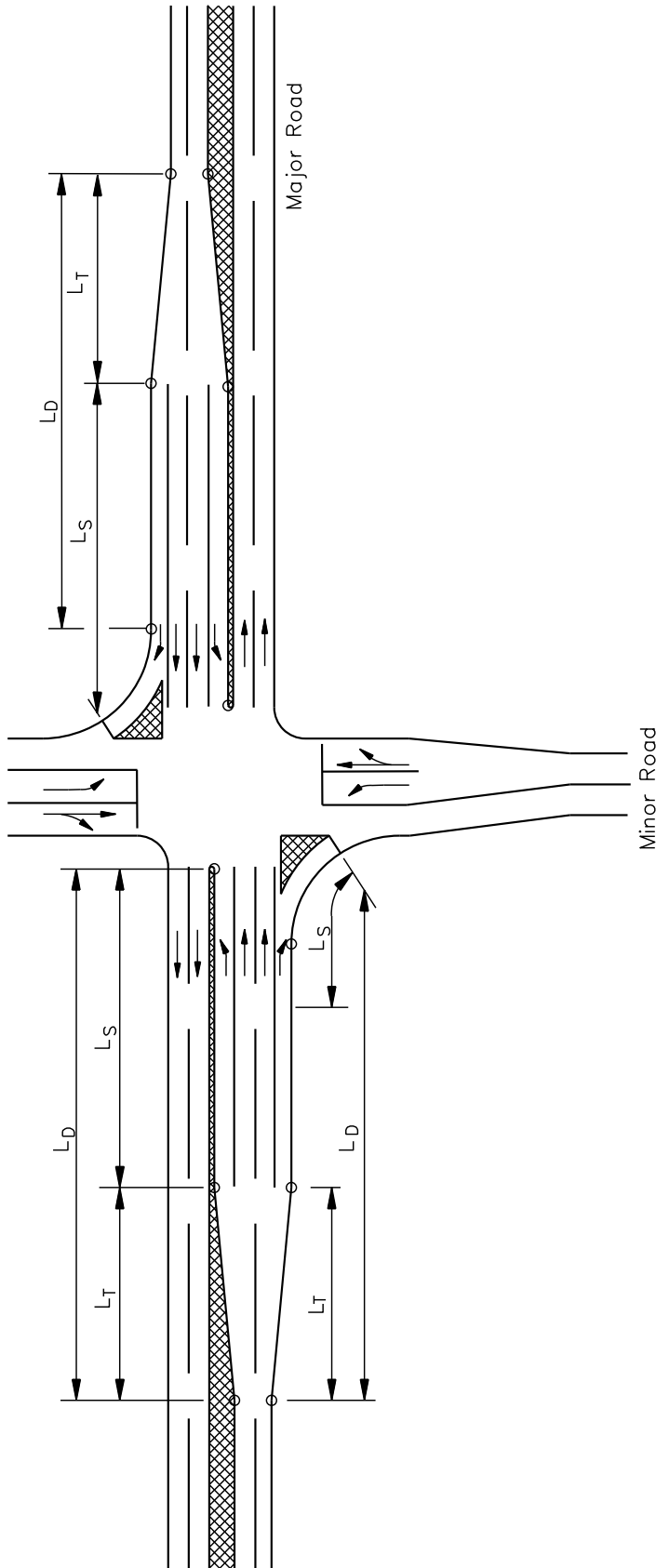

Note: The schematic of the major road (free flowing) also applies to all legs of a signalized intersection.

- Key:
- L_T = Taper length
 - L_D = Deceleration length
 - L_S = Storage length

See Section 36-3.02(b) for additional guidance.

TYPICAL AUXILIARY LANES AT AN INTERSECTION

Figure 36-3.H

US Customary											
Design Speed of Highway (mph)	Assumed Running Speed (mph) ⁽¹⁾	Length of Taper (ft)	Stop Condition	Speed Reduced to (mph)							
				15	20	25	30	35	40	45	50
				Total Length of Deceleration Lane Including Taper Length (ft)							
30	28	135	250	200	170	140	—	—	—	—	—
35	32	155	280	250	210	185	150	—	—	—	—
40	36	175	320	295	265	235	185	155	—	—	—
45	40	200	385	350	325	295	250	220	—	—	—
50	44	220	435	405	385	355	315	285	225	175	—
55	48	240	480	455	440	410	380	350	285	235	—
60	52	265	530	500	480	460	430	405	350	300	240
65	55	285	570	540	520	500	470	440	390	340	280
70	58	310	615	590	570	550	520	490	440	390	340
Metric											
Design Speed of Highway (km/hr)	Assumed Running Speed (km/hr) ⁽¹⁾	Length of Taper (m)	Stop Condition	Speed Reduced to (km/hr)							
				20	30	40	50	60	70	80	
				Total Length of Deceleration Lane Including Taper Length (m)							
50	47	45	80	70	60	45	—	—	—	—	—
60	55	50	95	90	80	65	55	—	—	—	—
70	63	60	110	105	95	85	70	55	—	—	—
80	70	70	130	125	115	100	90	80	55	—	—
90	77	75	145	140	135	120	110	100	75	60	—
100	85	85	170	165	155	145	135	120	100	85	—
110	91	90	180	180	170	160	150	140	120	105	—
Grade Adjustment Factors ⁽²⁾											
Downgrade											
6.00% to 5.00%			4.99% to 4.00%			3.99% to 3.01%			3.00% to 0%		
1.35			1.28			1.20			1.00		
Upgrade											
0% to 3.00%			3.01% to 3.99%			4.00% to 4.99%			5.00% to 6.00%		
1.00			0.90			0.85			0.80		

(1) Average running speed assumed for calculations.

(2) Ratio from this table multiplied by the length provided above will yield the total deceleration length adjusted for grade. Adjustment factors apply to all design speeds and are added to the tangent or storage length.

DECELERATION DISTANCES FOR TURNING LANES

Figure 36-3.1

3. Storage Length (Signalized Intersections). The storage length (L_s) for turn lanes should be sufficient to store the number of vehicles likely to accumulate during the red phase of the signal cycle in the design hour. The designer should consider the following in determining the recommended storage lengths for signalized intersections:

- a. Determine the distance using the criteria for signalized intersections in the *Highway Capacity Manual* and Highway Capacity Software, or use the following formula:

$$\text{Storage Length (ft)} = \frac{(1-G/C)(\text{DHV})(1 + \frac{\% \text{trucks}}{100})(2 \times 25)}{(\# \text{ cycles per hour})(\# \text{ traffic lanes})} \text{ (US Customary)}$$

$$\text{Storage Length (ft)} = \frac{(1-G/C)(\text{DHV})(1 + \frac{\% \text{trucks}}{100})(2 \times 25)}{(\# \text{ cycles per hour})(\# \text{ traffic lanes})}$$

Equation 36-3.1 (US Customary)

$$\text{Storage Length (m)} = \frac{(1-G/C)(\text{DHV})(1 + \frac{\% \text{trucks}}{100})(2 \times 7.5)}{(\# \text{ cycles per hour})(\# \text{ traffic lanes})}$$

$$\text{Storage Length (m)} = \frac{(1-G/C)(\text{DHV})(1 + \frac{\% \text{trucks}}{100})(2 \times 7.5)}{(\# \text{ cycles per hour})(\# \text{ traffic lanes})}$$

Equation 36-3.1 (Metric)

where:

G	=	green time (sec)
	=	g(protected) + g(unopposed/permitted) time values from HCM analysis (sec)
C	=	cycle length (sec)
DHV	=	Design Hourly Volume (vph) for turn lane

- b. Where right-turns-on-red are permitted or where separate right-turn signal phases are provided, the length of the right-turn lane may be reduced due to less accumulation of turning vehicles. The storage length (L_s) needed for a separate right-turn lane is measured from the stop bar for the right-turning roadway; see Figure 36-3.H.
- c. At signalized intersections, the designer should also consider that entry into right- and left-turn lanes may be blocked by the signal storage needs of the adjacent through lanes. If this occurs, provide longer lengths of turn lanes.

4. Storage Length (Unsignalized Intersections). To determine the minimum storage length for unsignalized intersections, complete an unsignalized intersection capacity analysis based on guidance provided in the *Highway Capacity Manual* and output provided by Highway Capacity Software. Then utilize the vehicle queuing information from the analysis output, length of a typical vehicle, and estimation of heavy vehicles at the intersection to determine the expected storage length.
5. Minimum Turn Lane Length. With safety improvement or 3R type projects, the full width length of the right- or left-turn lanes may be 115 ft (35 m) plus the taper length.

36-3.03 Left-Turn Lane Design

36-3.03(a) General Criteria

In addition to the criteria for left-turn lane widths and lengths discussed in Section 36-3.02, the designer should consider the following general criteria:

1. Transition Areas. Do not locate left-turn lanes within any portion of a channelized approach island which is transitional in width. Allow the median width to be fully developed before beginning any additional tapers. If at all possible, refrain from placing tapers within the limits of another taper.
2. Taper Design. Figures 36-3.H, 36-3.J, and 36-3.K illustrate the use of a straight-line taper. Figure 36-3.L illustrates the use of reverse curves for an entrance taper.
3. Offset Turn Lanes. Providing an offset design ensures that opposing left-turning motorists can see past one another to view oncoming through traffic. Offset left-turn lanes can be either a parallel or tapered type.
4. Indirect Turns. Where operational or safety concerns preclude the use of typical left-turn lanes, the designer may consider the use of indirect left turns or jughandles that cross the mainline or intersect the crossroad at a different location. Because these require special consideration and treatment, they must be developed in consultation with BDE.
5. Opposing Left-Turning Traffic. If simultaneous and opposing left-turn lanes are proposed, the designer must ensure that there is sufficient space for all turning movements. Desirably, the separation between pavement markings should be 10 ft (3.0 m). If space is unavailable, it will be necessary to alter the signal phasing to allow the two directions of turning traffic to move through the intersection on separate phases. See Section 36-3.05 for additional guidance.
6. Opposing Through Traffic. Where more than two through traffic lanes will oppose the movement from a left-turn lane, the left-turns should be operated only as a protected movement. This is because crash issues can result from permitted phasing as left-turning drivers can have difficulty processing approaching vehicles from more than two oncoming lanes.

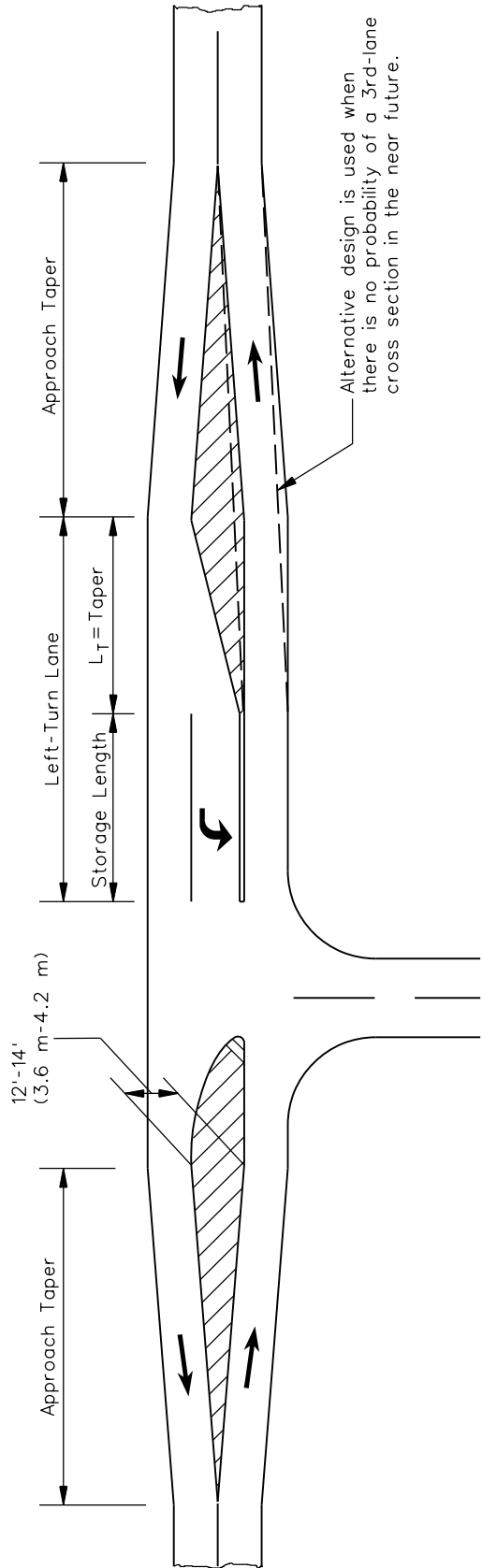

APPROACH TAPER RATES FOR FLUSH CHANNELIZATION						
Present Posted Speed (mph)	Design Speed	Approach Taper Rates			Left-Turn Lane	
		Widening on Both Sides	Widening All on One Side	Taper Rate	Storage Length*	
≥50	50 mph (80 km/h)	50:1	40:1	15:1	115 ft (35 m)	
45	45 mph (70 km/h)	45:1	35:1	13:1	115 ft (35 m)	
40/35	40 mph (60 km/h)	40:1	30:1	11:1	115 ft (35 m)	
≤30	30 mph (50 km/h)	35:1	25:1	9:1	115 ft (35 m)	

* Storage lengths may be increased if necessary.

FLUSH CHANNELIZED ISLANDS AT ISOLATED RURAL OR URBAN INTERSECTIONS
(Safety Improvement or 3R Projects)

Figure 36-3.J

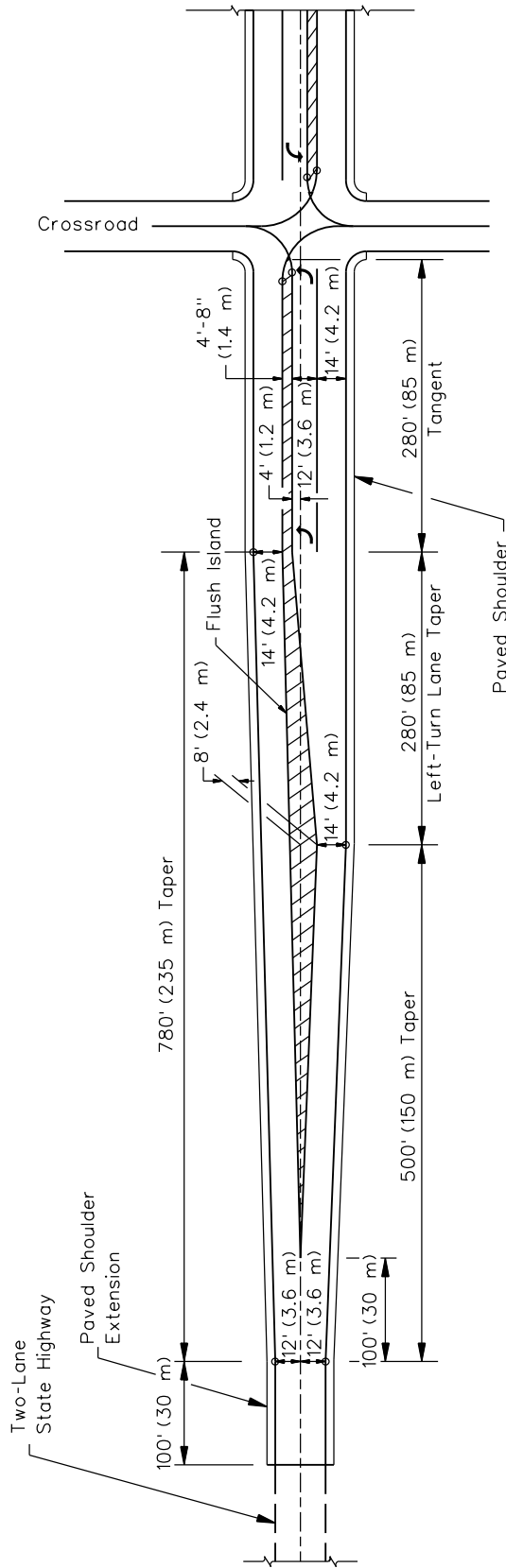

Note: Paved shoulders through the intersection area should be a minimum of 4 ft (1.2 m) wide.

FLUSH CHANNELIZED ISLANDS AT AN ISOLATED, HIGH-SPEED RURAL INTERSECTION
(New Construction/Reconstruction Projects)

Figure 36-3.K

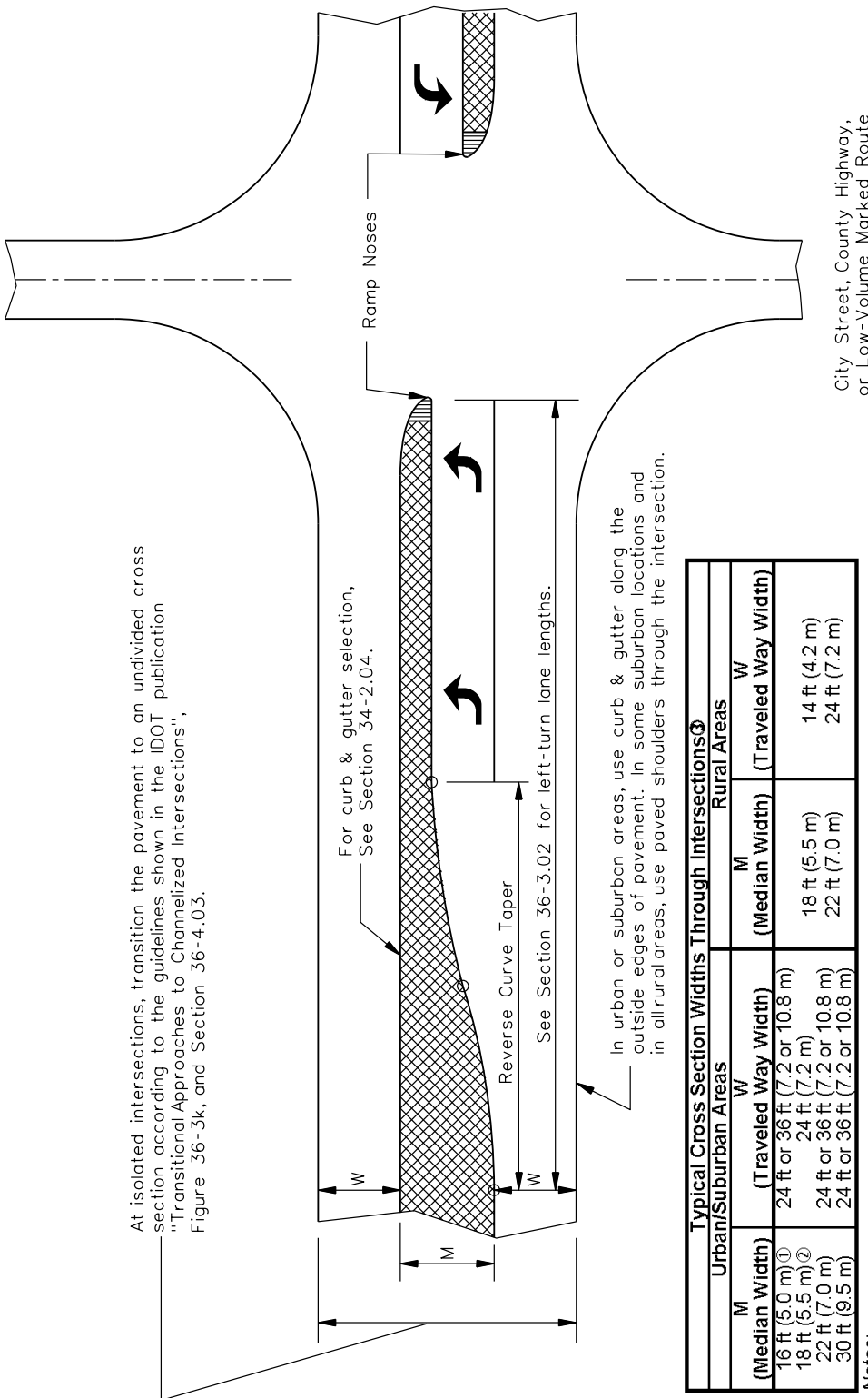

Typical Cross Section Widths Through Intersections ^③			
Urban/Suburban Areas		Rural Areas	
M	W	M	W
(Median Width)	(Traveled Way Width)	(Median Width)	(Traveled Way Width)
16 ft (5.0 m) ^①	24 ft or 36 ft (7.2 or 10.8 m)	18 ft (5.5 m)	14 ft (4.2 m)
18 ft (5.5 m) ^②	24 ft (7.2 m)	22 ft (7.0 m)	24 ft (7.2 m)
22 ft (7.0 m)	24 ft or 36 ft (7.2 or 10.8 m)		
30 ft (9.5 m)	24 ft or 36 ft (7.2 or 10.8 m)		

- Notes:
- ① This width of curbed median usually is used on city streets where a traversable median is desired between intersections.
 - ② Generally, this width of raised-curb median should not be used on city streets with unsignalized intersections and median crossovers.
 - ③ For additional guidance on median and traveled way widths, see the geometric design tables in Part V, Design of Highway Types.

RAISED-CURB CHANNELIZED INTERSECTION
(Parallel Left-Turn Lane)

Figure 36-3.L

36-3.03(b) Parallel Left-Turn Lanes Without Offset

Figures 36-3.J through 36-3.N and the following provide the design criteria for left-turn lanes that are adjacent and parallel to the through traveled way and are not offset:

1. **Two-Lane Facilities**. For safety improvements and 3R projects, use a flush median design at isolated intersections as shown in Figure 36-3.J. For new construction or reconstruction projects, a channelized left-turn lane with a flush island or a raised-curb island may be used depending on specific site conditions. Figure 36-3.K illustrates the flush design and Figure 36-3.L illustrates the raised-curb median design. Both figures depict parallel left-turn lanes with negative left-turn lane offset. Additional design details may be needed to incorporate a tapered left-turn lane or positive offset left-turn lane design to improve sight distance and safety; see Section 34-3. Where the raised-curb median is channelized back to a two-lane traveled way, use the criteria discussed in the IDOT publication, *Transitional Approaches to Channelized Intersections*, Figure 36-3.K, and Section 36-4.03(a).
2. **Narrow Raised-Curb Medians**. Left-turn lanes generally will be the parallel design. This design is illustrated in Figure 36-3.L. To properly develop left-turn lanes for new construction and reconstruction projects, see the footnotes in Figure 36-3.L. Additional design details may be needed to incorporate a tapered left-turn lane or positive offset left-turn lane design to improve sight distance and safety; see Section 34-3.
3. **Narrow Expressway Medians**. Left-turn lanes generally will be the parallel design due to restricted right of way. This is illustrated in Figure 36-3.M. Figure 36-3.M also illustrates how to terminate a median barrier before the development of the left-turn lane. Additional design details may be needed to incorporate a tapered left-turn lane or positive offset left-turn lane design to improve sight distance and safety; see Section 34-3.
4. **Multilane Highways with Wide Medians**. Figure 36-3.N illustrates a typical parallel left-turn lane design with a wide depressed median. When using this design, consider the following:
 - This design is generally only used where the current crossroad ADT is less than 1500 and where the current left-turn DHV in each direction from the mainline is no greater than 60 vph.
 - On existing expressways or multilane facilities, median widths of 40 ft to 70 ft (12.0 m to 21.5 m) are allowed to remain in place.
 - On new construction or reconstruction projects, use a median width of 50 ft (15 m) and median slopes of 1V:6H.
 - Additional design details may be needed to incorporate a tapered left-turn lane or positive offset left-turn lane design to improve sight distance and safety; see Section 34-3.

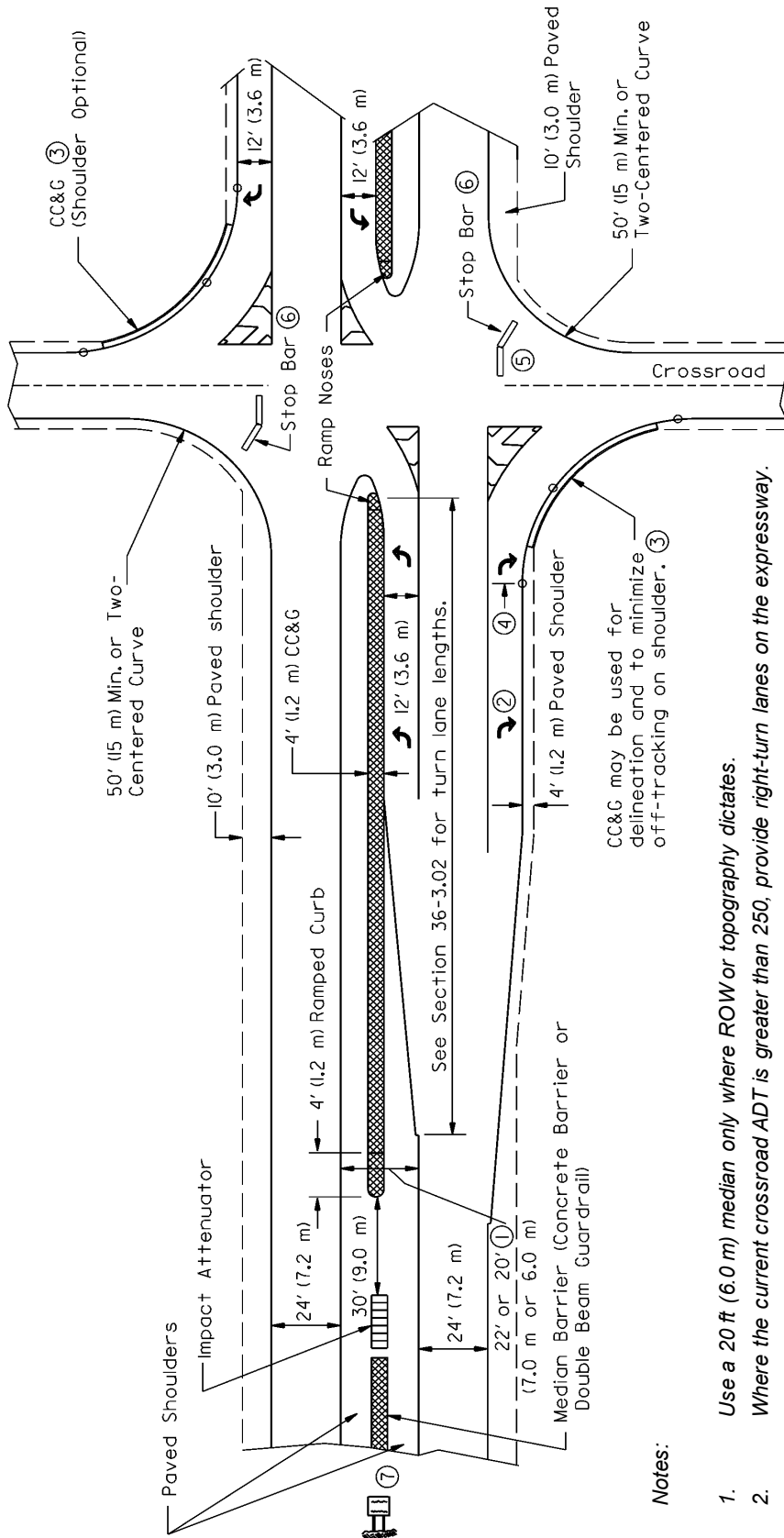

Notes:

1. Use a 20 ft (6.0 m) median only where ROW or topography dictates.
2. Where the current crossroad ADT is greater than 250, provide right-turn lanes on the expressway.
3. A two-centered curve is desirable with right-turn lanes; see Section 36-2.01.
4. End the right-turn deceleration length at the beginning of the radius return.
5. Intersection sight distance must be checked for the vehicle on the side road for the line of sight past the median barrier.
6. For proper placement of a stop sign, a small triangular corner island may be required on the crossroad approach to the expressway.
7. See the Bureau of Operations' Policy and Procedures Manual for proper placement of advance guide signs.

**EXPRESSWAY INTERSECTION WITH MEDIAN BARRIERS
(Design Speed ≥ 50 mph (80 km/hr) and Narrow Median with Restricted ROW)**

Figure 36-3.M

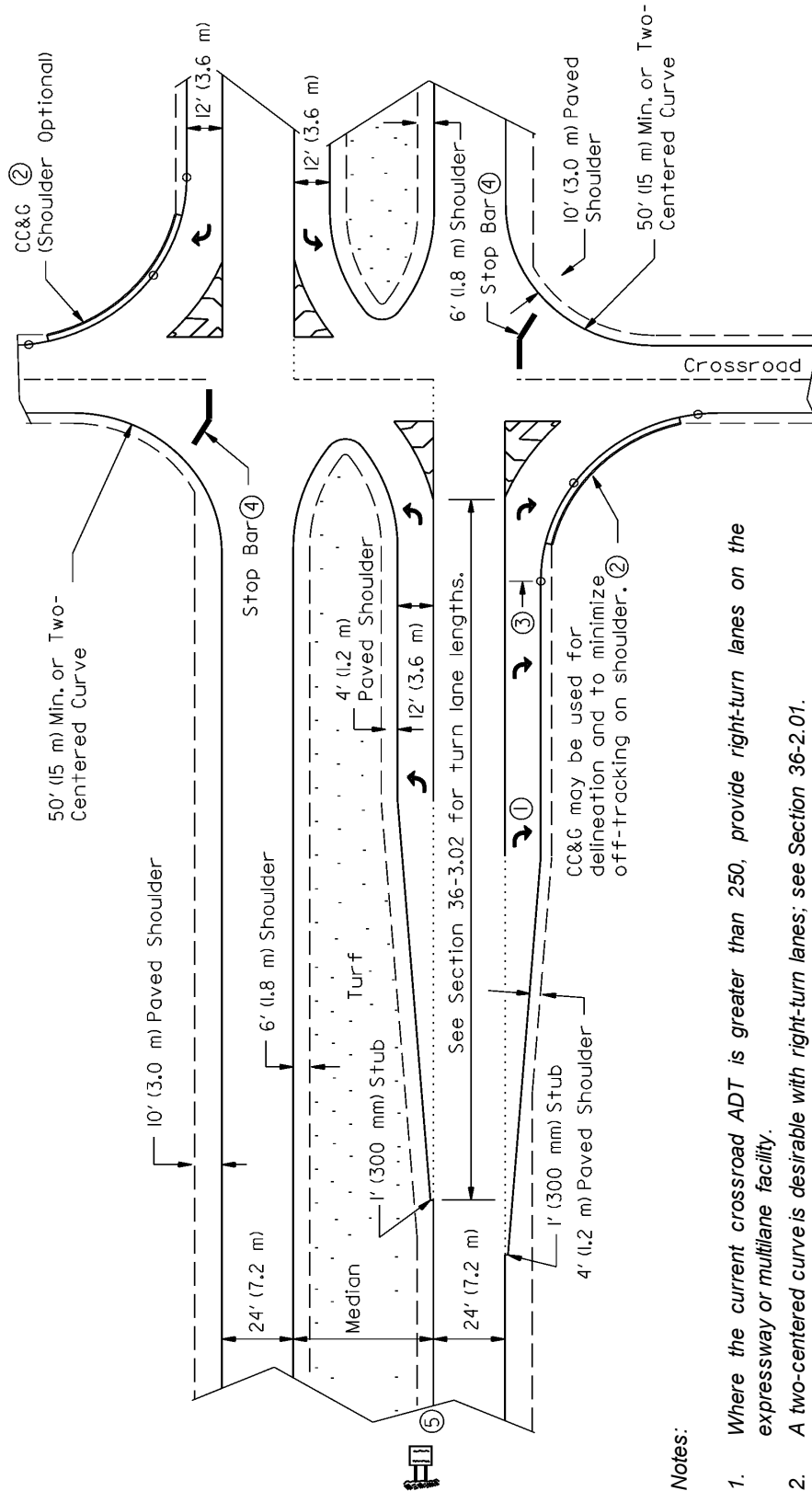

Notes:

1. Where the current crossroad ADT is greater than 250, provide right-turn lanes on the expressway or multilane facility.
2. A two-centered curve is desirable with right-turn lanes; see Section 36-2.01.
3. End the right-turn deceleration length at the beginning of the radius return.
4. For proper placement of a stop sign, a small triangular corner island may be required on the crossroad approach to the expressway.
5. See the Bureau of Operations' Policy and Procedures Manual for proper placement of advance guide signs.

See Section 36-3.03(b) for additional design details.

EXPRESSWAY OR MULTILANE FACILITY WITH A WIDE MEDIAN ≥ 40 ft (12 m)
 (Parallel Left-Turn Lane Design without Offset)

Figure 36-3.N

36-3.03(c) Offset Left-Turn Lanes

Offset left-turn lanes can consist of either a tapered design or a parallel design. Figures 36-3.O through 36-3.S illustrate the various designs for offset left-turn lanes. In addition, the designer should consider the following:

1. **Tapered Offset Left-Turn Lanes.** Figure 36-3.O(1) illustrates a typical tapered offset left-turn lane design in a wide median. Figure 36-3.O(2) provides the details on the channelization portion of the offset design. The advantages of the tapered offset design versus a parallel lane design without an offset is that the offset design provides better visibility for the turning motorist to the opposing traffic, decreases the possible conflict between opposing left-turning vehicles, and serves more left-turning vehicles in a given time period. In addition, the designer should consider the following:
 - a. **Guidelines.** Provide a tapered offset left-turn lane design where at least two of the following are applicable:
 - the median width is equal to or greater than 40 ft (12 m) and only one left-turn lane in each direction on the mainline highway is required for capacity;
 - the current mainline ADT is 1500 or greater and the left-turn DHV in each direction from the mainline is greater than 60 vph. Under these conditions, vehicles waiting in opposing left-turn lanes have the probability of obstructing each other's line of sight; and
 - the intersection will be signalized.
 - b. **Median Widths.** Median widths of 40 ft to 70 ft (12 m to 21.5 m) are allowed to remain in place on existing expressways or multilane facilities. On new construction or reconstruction projects, use a median width of 50 ft (15 m) and median slopes of 1V:6H.
 - c. **Curb and Gutter.** Use M-4 (M-10) curb and gutter on all corner and channelizing island, unless signals are placed within the island. In this situation, use M-6 (M-15) curb and gutter.
2. **Parallel Offset Left-Turn Lanes.** By maximizing sight distance for left-turning vehicles, parallel offset left-turn lanes offer similar advantages as the tapered design. However, they may be used at intersections with medians less than 40 ft (12 m) but greater than 13 ft (4.0 m). Figures 36-3.P, 36-3.Q, and 36-3.R illustrate the plan views for parallel offset left-turn lanes for median widths of 16 ft, 18 ft, and 22 ft (5.0 m, 5.5 m, and 7.0 m), respectively. Figure 36-3.S provides the typical section design criteria for all three median widths.

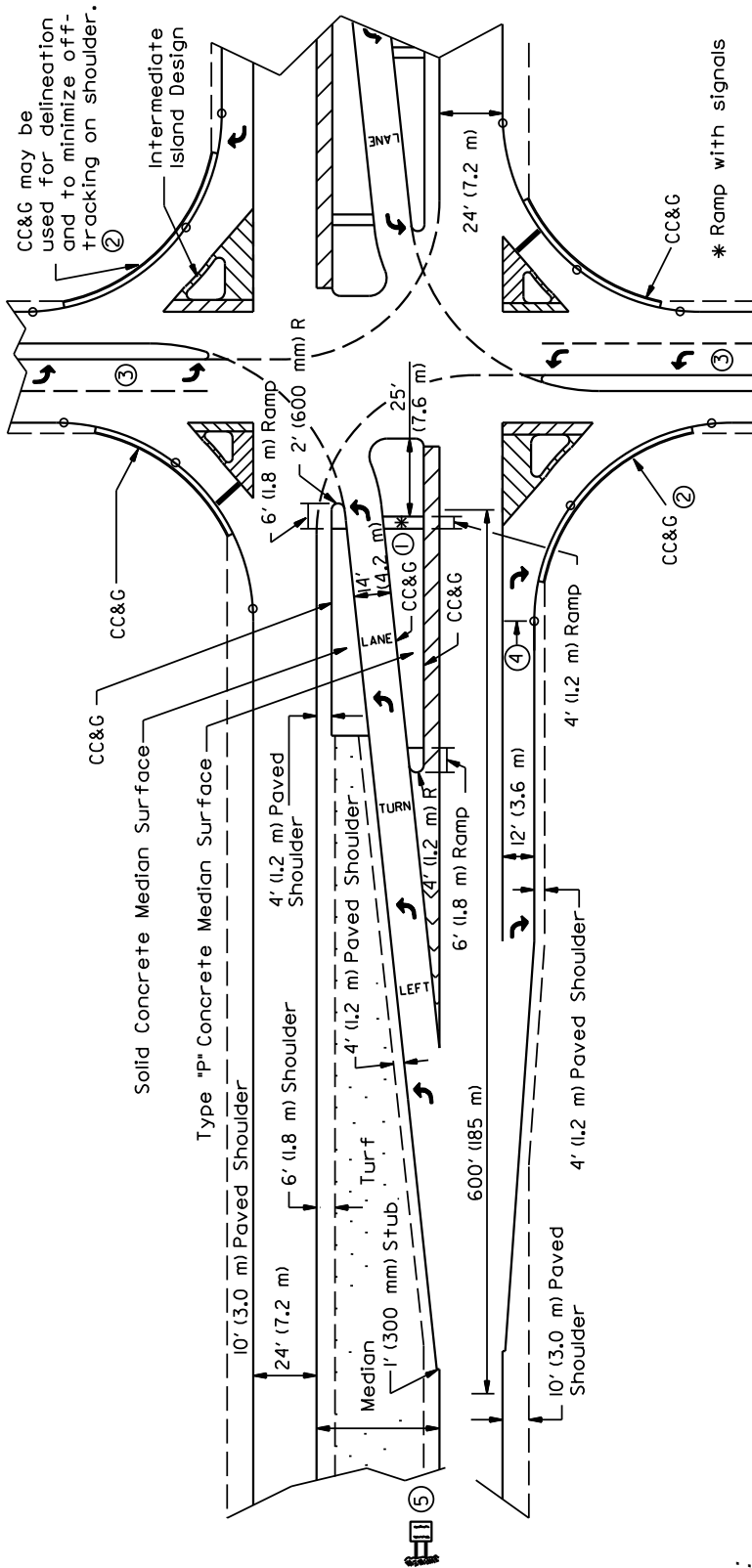

CC&G may be used for delineation and to minimize off-tracking on shoulder.

Notes:

1. Place drainage inlets in the M-4.24 (M-10.60) gutter to facilitate drainage within the left-turn bay.
 2. A two-centered curve is desirable with right-turn lanes; see Section 36-2.01.
 3. Where a left-turn lane is required, design the median as a raised-curb median for delineation. Where no median is proposed, the minimum traveled way width should be 22 ft (6.6m).
 4. End the right-turn deceleration length at beginning of the radius turn.
 5. See the Bureau of Operation's Policy and Procedures Manual for proper placement of guide sign.
- Consider providing lighting at this intersection.

EXPRESSWAY OR MULTILANE FACILITY WITH MEDIAN WIDTH ≥ 40 ft (12 m)
 (Tapered Offset Left-Turn Lane Design)

Figure 36-3.0(1)

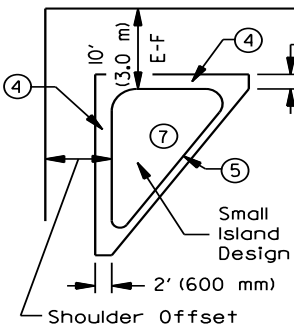
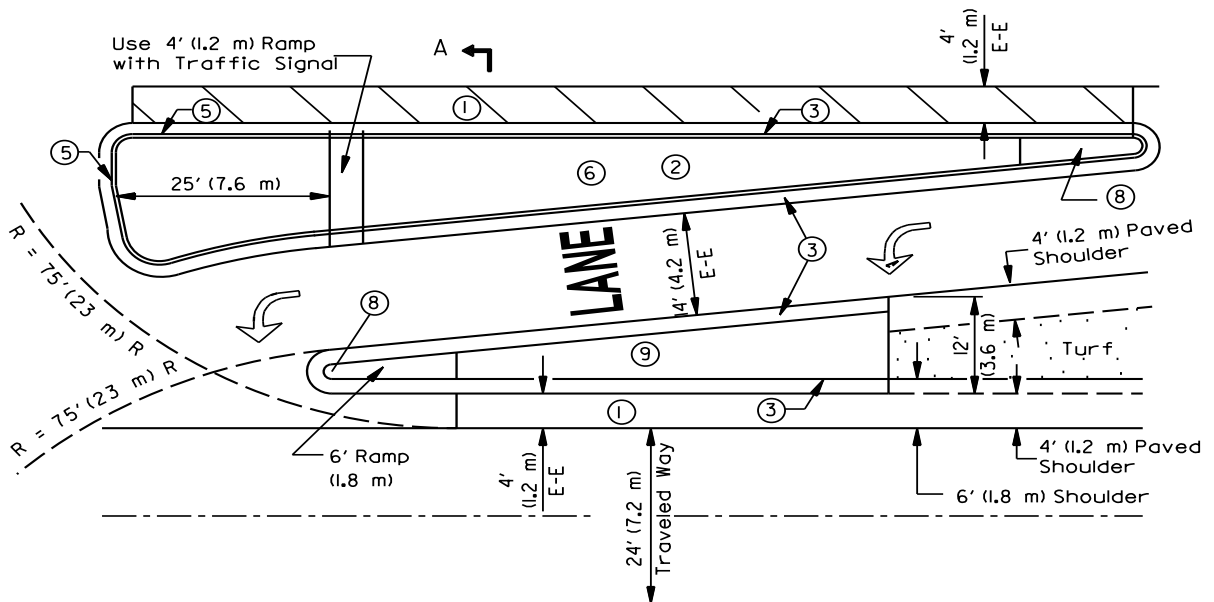

Legend:

- ① P.C. Concrete or bituminous concrete shoulders.
- ② Provide reflectorized markers on corner islands and on top of curbs within the concrete median areas.
- ③ Combination concrete curb and gutter, Type M-4.24 (M-10.60) or M-4.24 (SM-10.60).
- ④ Combination concrete curb and gutter, Type M.
- ⑤ Use combination concrete curb and gutter, Type M-6.24 (M-15.60) with signals.
- ⑥ Concrete median surface 6" (150 mm).
- ⑦ Concrete median surface 4" (100 mm).
- ⑧ Ramp median nose according to DOT Highway Standards.
- ⑨ Use SM concrete surface.

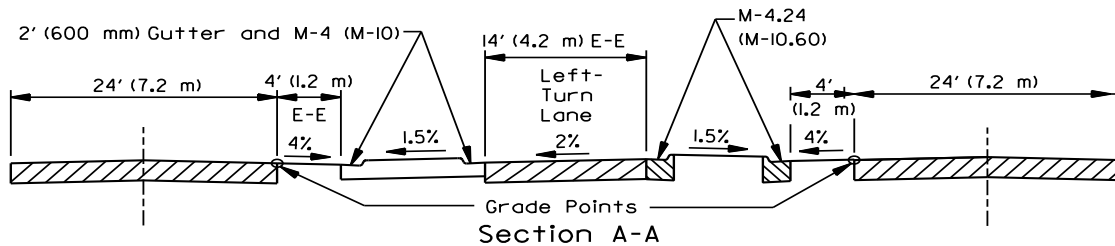

**TYPICAL CORNER ISLAND AND CHANNELIZATION DETAILS
(Tapered Offset Left-Turn Lane)**

Figure 36-3.0(2)

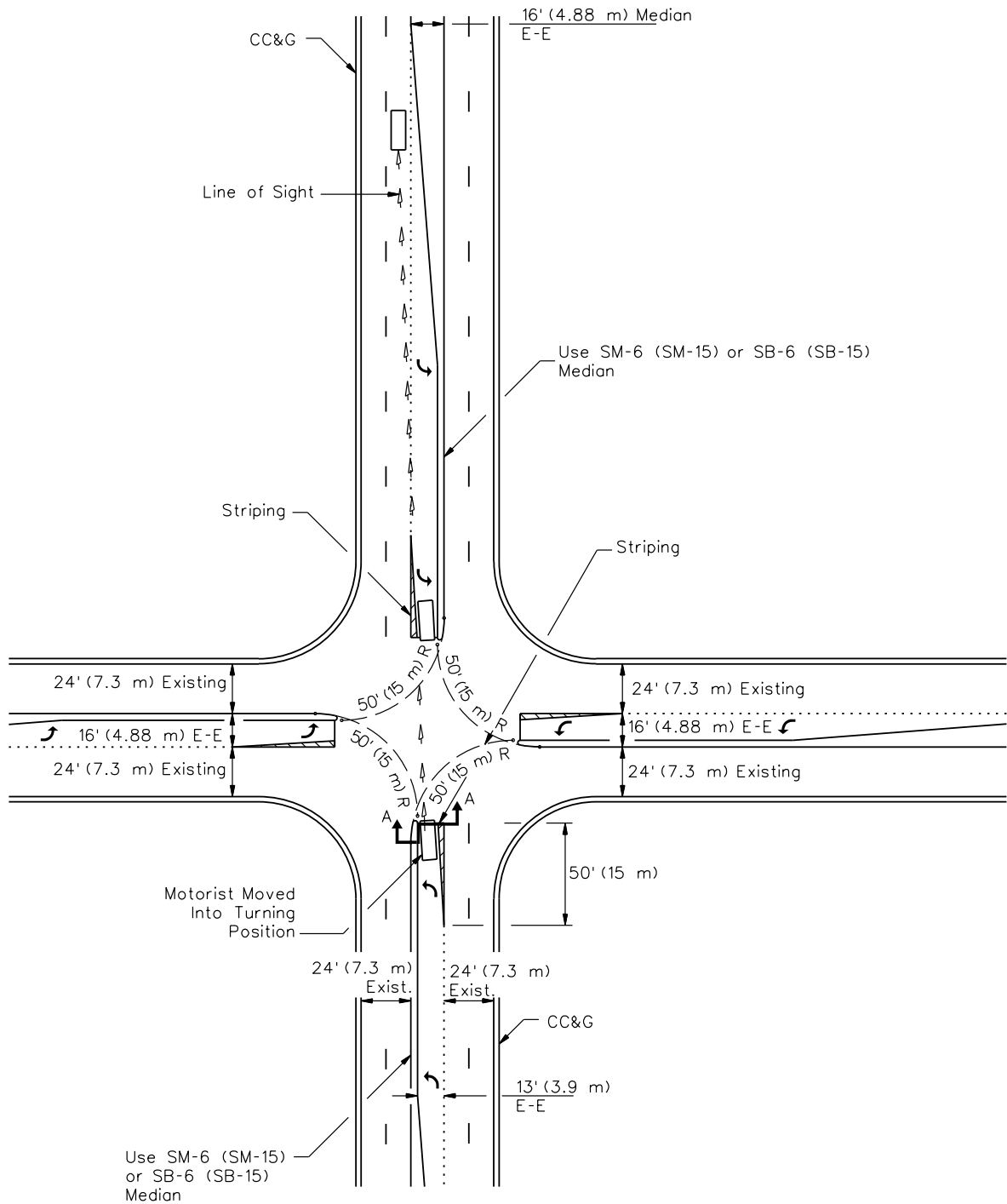

Note: See Figure 36-3.S for typical Section A-A.

**TYPICAL DESIGN FOR PARALLEL OFFSET LEFT-TURN LANES
(Existing 16 ft (4.88 m) Wide Traversable Median)**

Figure 36-3.P

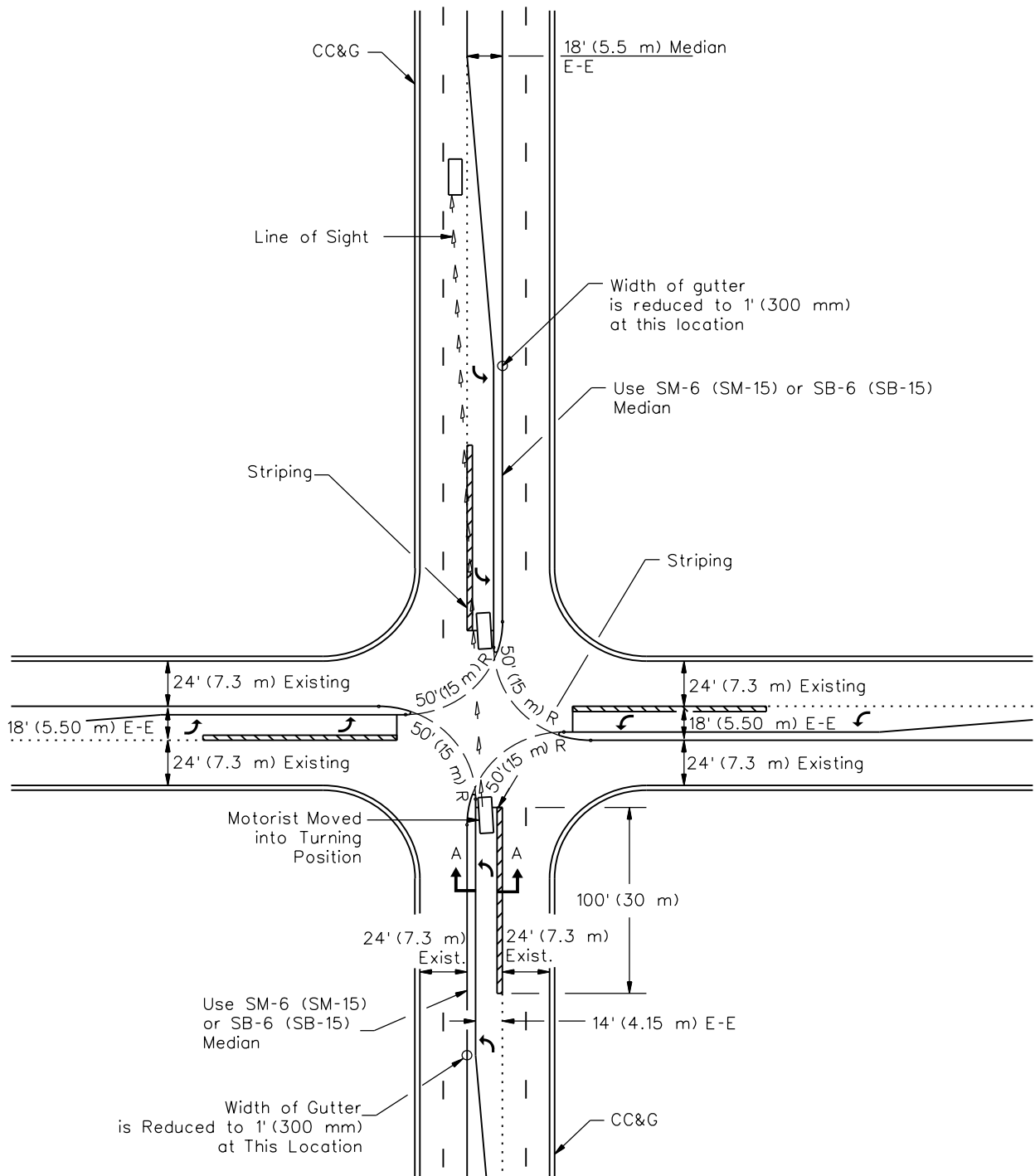

Note: See Figure 36-3.S for typical Section A-A.

**TYPICAL DESIGN FOR PARALLEL OFFSET LEFT-TURN LANES
(18 ft (5.5 m) Raised-Curb Median)**

Figure 36-3.Q

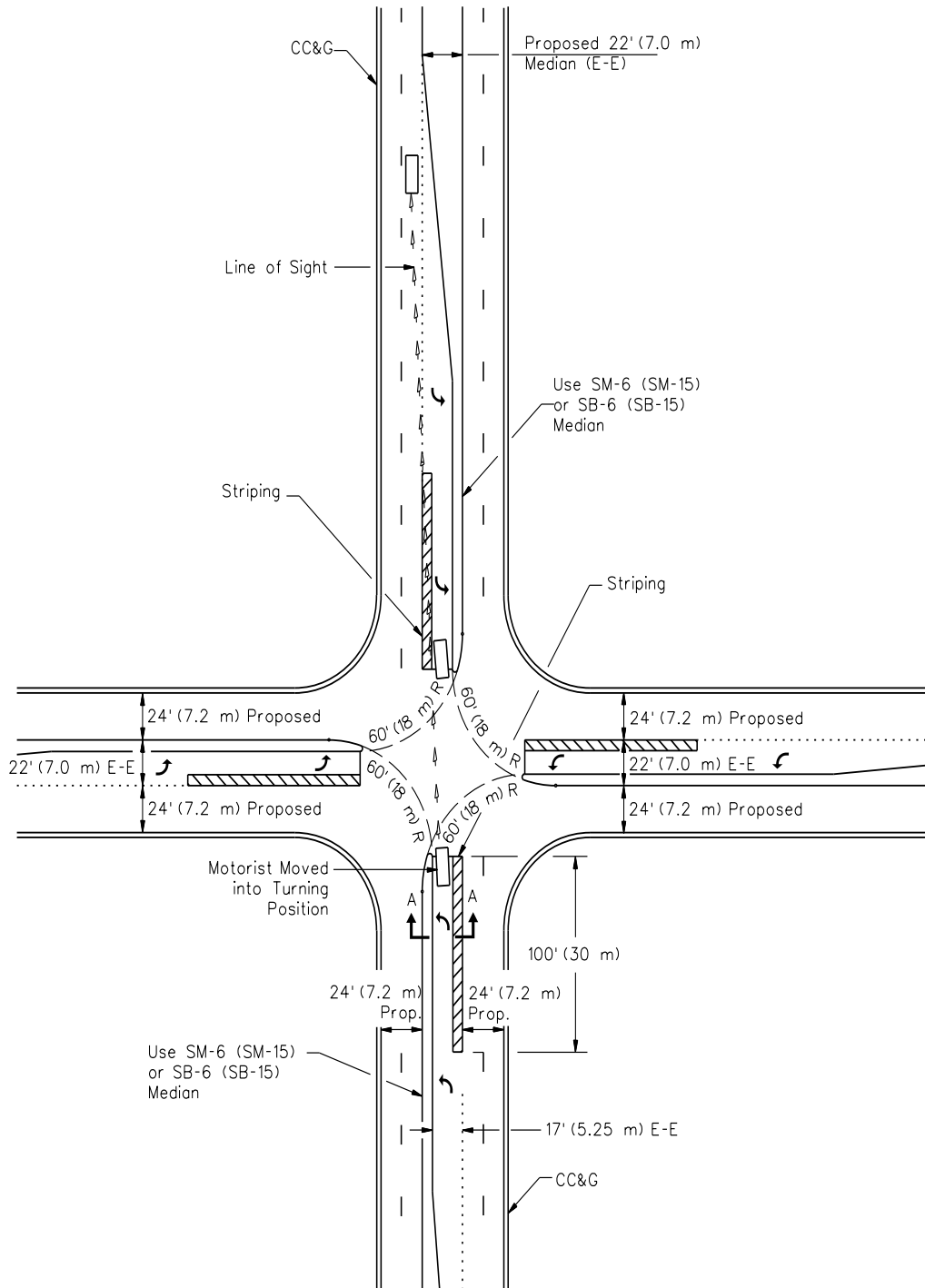

Note: See Figure 36-3.S for typical Section A-A.

**TYPICAL DESIGN FOR PARALLEL OFFSET LEFT-TURN LANES
(22 ft (7.0 m) Raised-Curb Median)**

Figure 36-3.R

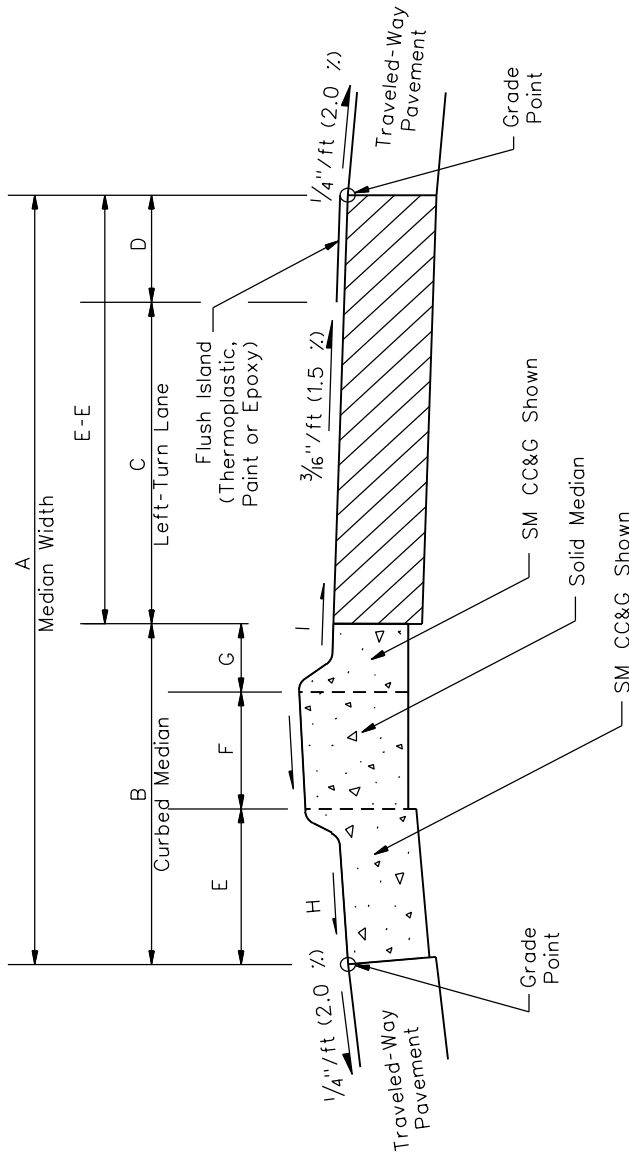

SECTION A-A

"A" Median Width E-E	"B" Curbed Median	"C" Left-Lane Turn	"D" Offset	"E"	"F"	"G" Left-Turn Curb	"H" Flow Direction	"I" Flow Direction
US Customary								
16 ft	3 ft	10 ft	3 ft	20 in	2 in	14 in	1/4"/ft/traveled way	3/16"/ft/traveled way
18 ft	4.5 ft	11 ft	2.5 ft	20 in	20 in	14 in	3/4"/ft/traveled way	3/16"/ft/traveled way
22 ft	6 ft	12 ft	4 ft	32 in	26 in	14 in	3/4"/ft/traveled way	3/16"/ft/traveled way
Metric								
4.88 m	980 mm	3.0 m	900 mm	500 mm	130 mm	350 mm	2.0%/traveled way	1.5%/traveled way
5.5 m	1.35 m	3.3 m	850 mm	500 mm	500 mm	350 mm	6.0%/median	1.5%/traveled way
7.0 m	1.75 m	3.6 m	1.65 m	800 mm	600 mm	350 mm	6.0%/median	1.5%/traveled way

Note: See Figures 36-3.P, 36-3.Q, and 36-3.R for location of Section A-A.

TYPICAL SECTION WITH PARALLEL OFFSET LEFT-TURN LANES

Figure 36-3.S

36-3.04 Right-Turn Lane Design

36-3.04(a) General

Section 36-3.02 provides design criteria for right-turn lane widths and lengths. Right-turn lanes may be designed with or without turning roadways depending on site conditions. Figures 36-3.H, 36-3.M, 36-3.N, and 36-3.O(1) illustrate typical designs for right-turn lanes. For information on the design of offset right-turn lanes see item (c) below.

36-3.04(b) Access within Right-turn Lanes

Because of potential conflicts with right-turning traffic, commercial entrances should not be allowed within the limits of the right-turn lane storage or taper.

36-3.04(c) Offset Right-turn Lanes

A potential problem in installing exclusive right-turn lanes at intersections is that vehicles in the right-turn lane on the major road, especially buses and large trucks, may block the minor-road drivers' view of through traffic approaching from the left. This can lead to crashes between vehicles departing from the minor road and those proceeding through on the major road. To reduce the potential for crashes of this type, right-turn lanes can be offset laterally so that vehicles in the right-turn lanes do not obstruct the view of the minor road driver. Figure 36-3.T(1) illustrates a typical tapered design for an offset right-turn lane at a high speed rural location. Alternatively, a parallel offset right-turn lane design can be considered which achieves the same sight distance enhancement objectives. An example of the parallel design is shown in Figure 36-3.T(2).

When an exclusive right-turn lane is proposed or currently exists within the project at an unsignalized tee or four-legged intersection, the use of an offset right-turn lane should be considered for the initial construction or as an intersection improvement, respectively, when any of the following factors exist or are proposed within the project's design life:

- Heavy volume of right-turning vehicles;
- High proportion of heavy vehicles (large trucks and buses) in the right-turning traffic stream, which may impede sight distance to the adjacent through lane(s) of traffic;
- Mainline horizontal curvature which reduces available sight lines, or
- Multi-lane crossroad approach.

Existing crash data should also be used to support the decision to either install an offset right-turn lane or maintain or install a traditional right-turn lane, on existing routes.

Installation of offset right-turn lanes increases the overall width of the intersection. The additional width lengthens intersection crossing times thereby increasing pedestrian and bicyclist exposure

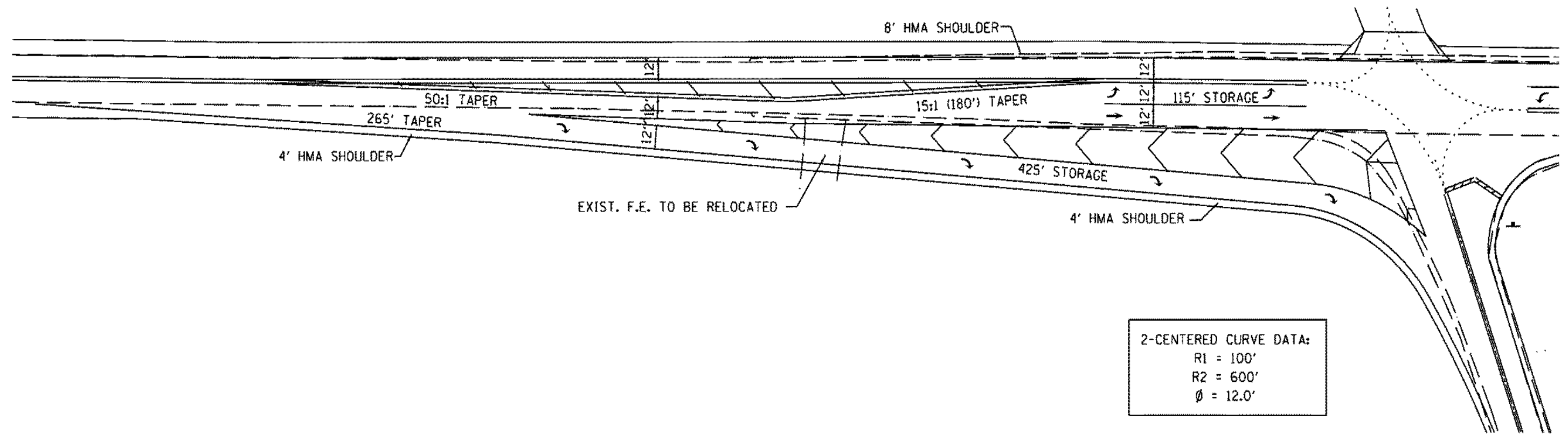

TAPERED OFFSET RIGHT-TURN LANE DESIGN EXAMPLE

Figure 36-3.T(1)

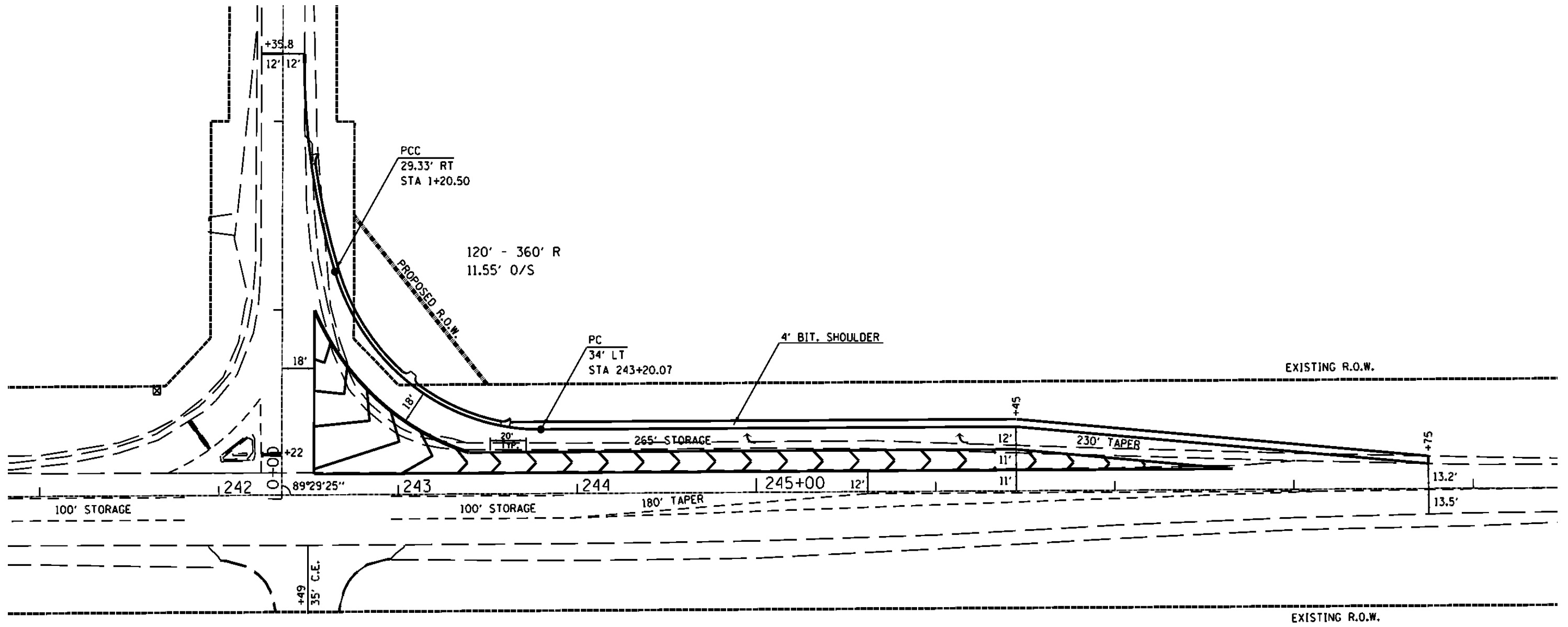

PARALLEL OFFSET RIGHT-TURN LANE DESIGN EXAMPLE

Figure 36-3.T(2)

within the intersection. This increase in exposure for these vulnerable users, in addition to the higher travel speeds that often result from this type of design, could lead to additional crash risks. A pedestrian refuge island could be installed between the offset right-turn lane and through lanes to mitigate these risks. However, raised islands should not typically be used on high speed approaches. Where pedestrians and bicyclists will be present, additional consideration should therefore be given before implementing offset right-turn lanes. In cases where an on-street bike lane is provided along the mainline, an offset right-turn lane would not typically be used.

36-3.05 Dual Turn Lanes

36-3.05(a) Guidelines

At intersections with high-turning volumes throughout the day, dual left- and/or right-turn lanes may be considered. However, multiple turn lanes may cause problems with right-of-way, lane alignment, local access, traffic signal phasing and visibility, signing locations, accommodating pedestrians, and erratic movements for turning drivers. In place of dual right-turn lanes, and while addressing pedestrian safety concerns, the designer may consider providing a turning roadway with a design speed of 15 mph (25 km/hr) or more and a free-flow, right-turn acceleration lane; see Section 36-2.03. Dual left- and/or right-turn lanes are generally considered where:

- there is insufficient space to provide the necessary length of a single turn lane because of restrictive site conditions (e.g., closely spaced intersections);
- based on a capacity analysis, the necessary time for a protected left-turn phase for a single lane becomes unattainable to meet the level of service criteria (average delay per vehicle); and/or
- more than 300 vph are projected to be turning.

Dual left and right-turn lanes should only be used with signalization providing a separate protected turning phase. Since a protected signal phase may increase signal inefficiencies that may negatively affect overall delay and level of service (LOS), it may be more prudent to provide a single left- or right-turn lane, and with it, a permissive left-turn signal and/or the allowance of right-turns on red if the volume warranting dual turn lanes only occurs for one or two hours of the day. However, permissive left-turns across three lanes of opposing through traffic should be avoided.

36-3.05(b) Design

Figure 36-3.V illustrates the more important design elements for dual left-turn and right-turn lanes. Figure 36-3.W illustrates a typical cross section for a dual left-turn lane design. In addition, the designer should consider the following:

1. Taper Length. Taper lengths for dual turn lanes should be a minimum of 300 ft (90 m); see Figure 36-3.V.

2. Turning Radii. The turning radii for dual left-turns should be a minimum of 90 ft (27 m). This will allow for two vehicles to comfortably negotiate the turns side-by-side.

Two-Lane Left-Turn Facilities		
Inner Radius	Traveled Way Edge Design	Minimum Width of Departure Opening
90 ft to 160 ft (27 m to 49 m)	Shoulder and Shoulder Curb and Shoulder Curb and Curb	35 ft (10.5 m) E-E 35 ft (10.5 m) + GW 35 ft (10.5 m) + GWs
160 ft to 250 ft (50 m to 75 m)	Shoulder and Shoulder Curb and Shoulder Curb and Curb	33 ft (9.8 m) E-E 33 ft (9.8 m) + GW 33 ft (9.8 m) + GWs

GW = Gutter Width E-E = Edge to Edge

MINIMUM DEPARTURE OPENINGS FOR DUAL LEFT-TURN LANES

Figure 36-3.U

3. Throat Width. On dual left-turn lanes, the presence of center and corner islands may lead to an increase in shy distances that will restrict turning paths, therefore, the design width of the left-turning paths is critical. Also, the magnitude of the inner radius influences the amount of off-tracking and, as such, the required width of the turning path. Figure 36-3.U gives the minimum widths of two-lane, left-turn departure openings based on the dimension of the inner radius and on the design of the traveled way edges at the most critical location of off-tracking. A computer simulated turning template program should be used when possible to check turning path/throat width design.
4. Median Widths and Type. Dual left-turn lanes require a minimum median width of 30 ft (9.0 m). For access management, the median shall be barrier curb, where the design speed is less than 50 mph (80 km/hr). If the design speed is 50 mph (80 km/hr) or greater, a divided median should be considered or mountable curb should be utilized. The median approaching the left turn lanes should fully shadow the dual left-turn lanes. If the median width approaching (upstream) the intersection is less than 30 ft (9.0 m), 30 ft (9.0 m) minimum median width and barrier type curb should extend, at a minimum, throughout the length of the left turn bay taper and storage up to the stop bar.
5. Special Pavement Markings. Consult with the District Bureau/Section of Traffic or the Bureau of Operations in the Central Office for the use of pavement marking within the intersection to effectively and safely guide two lines of vehicles turning abreast.

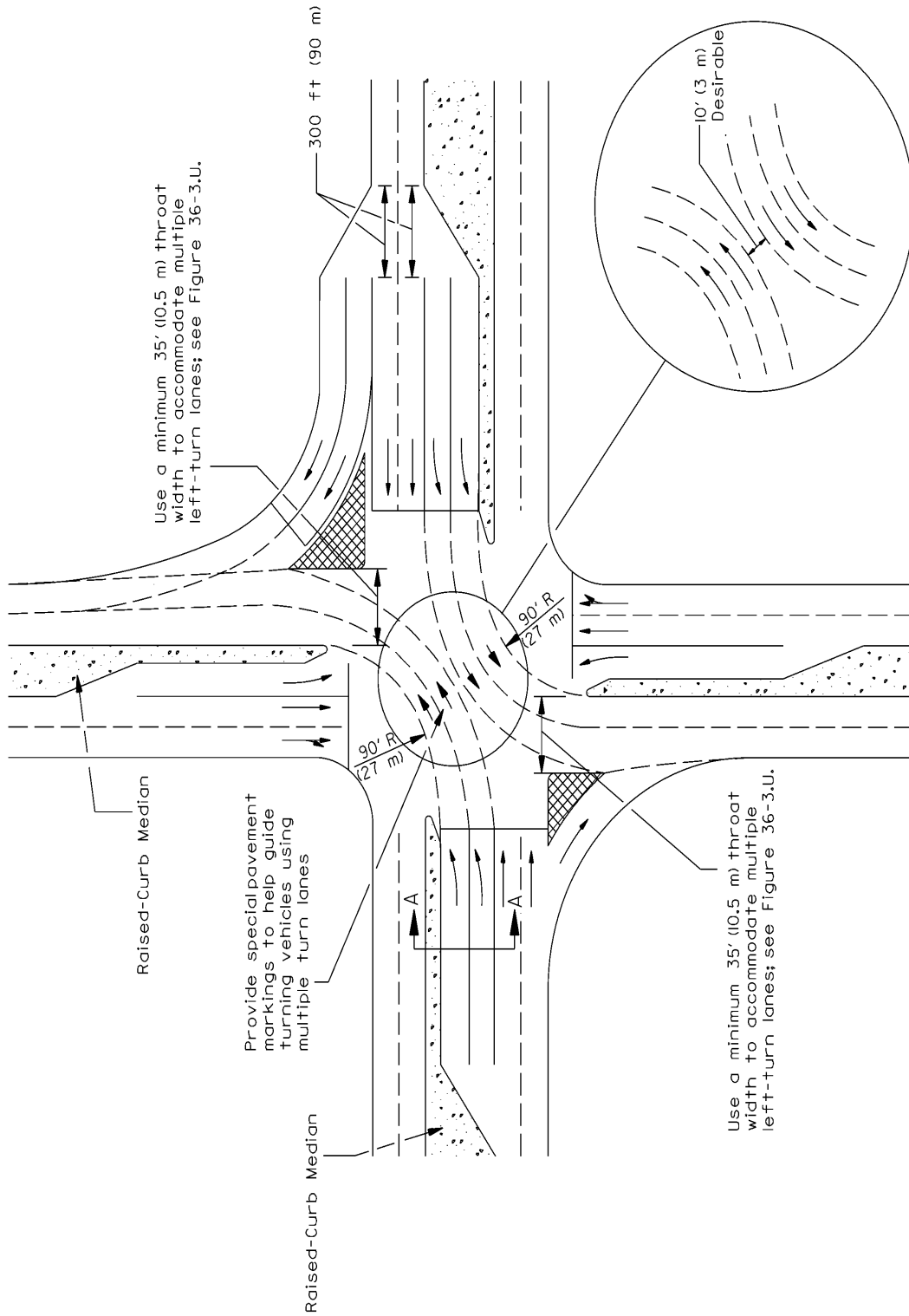

**SCHEMATIC FOR DUAL LEFT AND RIGHT-TURN LANES
(Raised-Curb Median)**

Figure 36-3.V

6. Opposing Left-Turning Traffic. If opposing dual left-turn lanes are proposed, the designer must ensure that there is sufficient space for all turning movements. Desirably, the separation between the outside edges of the opposing left-turn turning paths should be 10 ft (3.0 m); see Figure 36-3.V. If space is unavailable, it will be necessary to alter the signal phasing to allow the two directions of turning traffic to move through the intersection on separate phases.
7. Turning Templates. The turning paths for multiple turn lanes must be checked for conflicts by using the applicable turning templates or a computer simulated turning template program. The designer should assume that the selected design vehicle will turn from the outside lane of the multiple turn lanes. Desirably, the inside vehicle should be an SU but, as a minimum, the inside vehicle can be assumed to be a passenger car turning side by side with the selected design vehicle. Include a printout of the computer simulated turning paths with the IDS, if applicable.

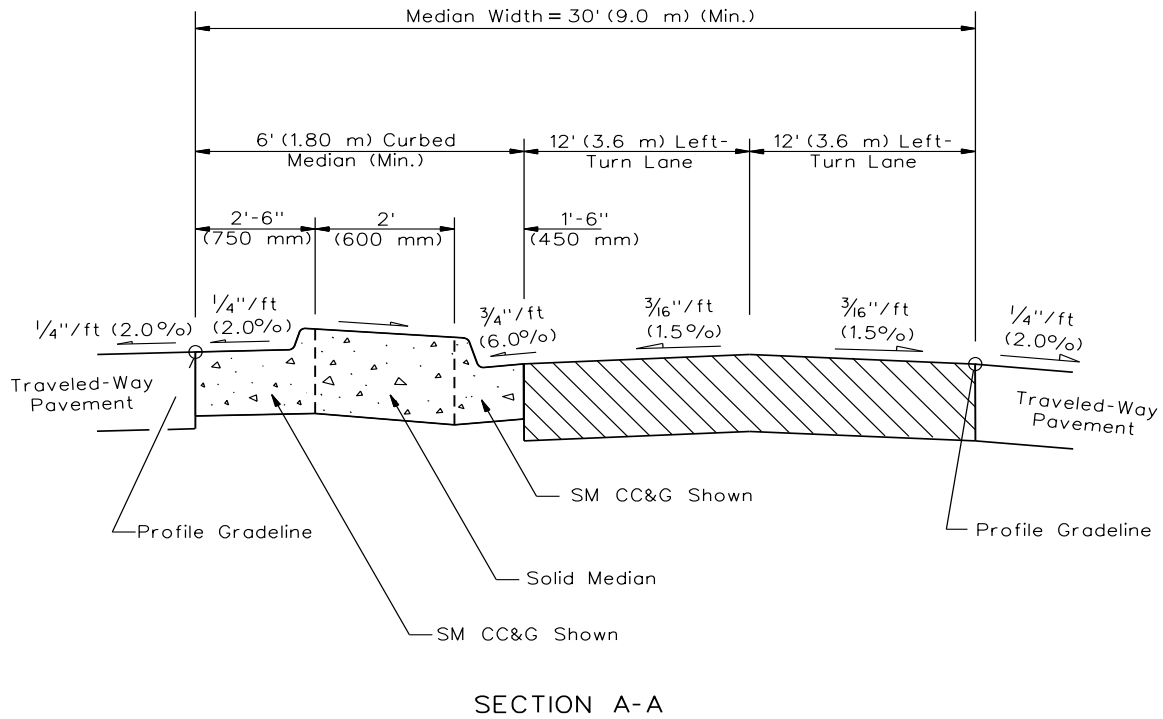

Note: See Figure 36-3.U for location of Section A-A.

**TYPICAL SECTION WITH DUAL LEFT-TURN LANES
(Raised-Curb Median and Posted Speed < 50 mph (80 km/hr))**

Figure 36-3.W

36-4 CHANNELIZING ISLANDS AND MEDIAN TREATMENTS

Several of the design elements described in this chapter require flush or raised channelizing islands and/or median treatments within the intersection area. Some intersections, especially those with oblique angle crossings, result in large paved areas that may cause motorists to wander from natural or expected paths and may cause long pedestrian crossings. These movements may result in conflicts and/or unpredictable operations, and could be enhanced by incorporating channelizing islands or medians in the design of the intersection.

At rural locations where higher speeds are prevalent, flush channelizing medians and islands can be used in conjunction with left-turn lanes and for turning roadways. In urban areas where speeds generally are lower, but where traffic volumes are generally higher, raised channelizing islands are used in conjunction with added lanes primarily to increase capacity and safety at the intersection.

36-4.01 Island Types

Islands can be grouped into the following classifications. Most island types serve multiple functions:

1. Corner/Directional Islands. Directional or corner triangular islands control right-turn movements by providing positive alignment guidance. Section 36-2.02 discusses corner islands.
2. Center Channelizing Islands. Center channelizing islands (also known as channelizing medians) separate opposing traffic flows, alert the driver to the crossroad ahead, and regulate traffic through an intersection. These islands are often introduced at intersections on undivided highways and are particularly advantageous in controlling left-turns at skewed intersections.
3. Refuge Islands. Refuge islands may include both corner islands and center channelizing islands, and function to aid and protect pedestrians who cross a wide roadway. These islands may be required for pedestrians where complex signal phasing is used and may permit the use of two-stage crossings. Their use may also increase traffic signal efficiency by allowing the time allocated for pedestrian movements to be reduced. In order to qualify as a pedestrian refuge area islands must have raised curb and certain minimum dimensions, including 6 ft (1.8 m) between curb faces.

36-4.02 Selection of Island Type

Islands may be some combination of flush, traversable, raised-curb, or turf, and could be triangular or elongated in shape. Selection of an appropriate type of channelizing island should be based on:

- traffic characteristics;
- cost considerations;

- location type (urban, suburban, or rural);
- degree of access management desired,
- safety of all roadway users, and
- maintenance considerations.

The remainder of this section offers guidance on the selection and design of islands and medians.

36-4.02(a) Flush or Traversable Islands

Flush islands, which are delineated by pavement markings (e.g., paint, thermoplastic, epoxy), or traversable islands, which are delineated by M-2 (M-5) curbs, are appropriate:

- on highways to delineate separate left-turn lanes (flush or traversable);
- in restricted locations where delineation of vehicular paths is desirable, but space for larger, raised-curb islands is not available (flush);
- in areas where better long-term visual delineation is needed at night and during inclement weather, but space for raised-curb islands is not available (traversable);
- to separate opposing traffic streams on low-speed urban streets (flush or traversable); and/or
- for temporary channelization during construction (flush).

36-4.02(b) Raised-Curb Islands

Raised-curb islands are bordered by barrier (B-type) or mountable (M-type) curb at least 4 in. (100 mm) high, and are appropriate as follows:

- on low-speed highways where the primary function is to provide positive separation for opposing traffic movements;
- at locations requiring positive delineation of vehicular paths, such as where a major route turns or at intersections with unusual geometry (including approaches to roundabouts);
- where the island is intended to prohibit or prevent traffic movements (e.g., wrong-way movements or to manage access within the intersection);
- where the number of lanes and/or volume of traffic being crossed by motorists attempting to turn left from adjacent entrances in the vicinity of the intersection would otherwise pose safety concerns;
- where traffic back-ups on the mainline intersection approach could otherwise cause sight distance restrictions to traffic turning from either the mainline or adjacent entrances in the vicinity of the intersection;
- where a primary or secondary island function is to provide a location for traffic signal poles or signs; and/or
- where one function of the island is to provide a pedestrian refuge.

Raised-curb islands and medians are generally not used in rural environments, but may be utilized to address specific safety and operational concerns at rural intersections having the following characteristics:

- on the crossroad through an interchange to delineate median crossovers and turn lanes, and to prevent wrong-way movements, and
- at unusual or complex intersection configurations where higher visibility would promote greater safety and more efficient traffic operations.

Where curb and gutter is proposed in rural areas with design speeds of 50 mph (80 km/h) or greater, use only mountable curbs, offset the curb faces from the edges of pavement by up to the shoulder width, and consider providing supplemental intersection illumination. In addition, provide prismatic reflectors on the top of curbs to enhance delineation of the island and turn lanes at night. Section 34-2.04 provides further guidance on the types of curbing used for islands.

36-4.02(c) Pavement Edge Islands

Channelizing islands formed by pavement edges generally only apply to rural or suburban areas. One example of this channelization type is where a divided four-lane facility with a median ditch section is temporarily tapered to a two-lane highway section. This reduction of the four lanes down to two is considered channelization. See Chapter 45 for details of these channelized approaches.

36-4.03 Design of Islands and Median Treatments

36-4.03(a) Channelizing Islands

Special care is necessary in their design of channelizing islands to ensure that they do not become a hazard. The designer should consider the following criteria:

1. **Nose**. Place the noses of raised-curb islands so that they are conspicuous to approaching motorists and clear of the assumed vehicular paths. This clearance should be both physical and visually apparent so that drivers will not shy away from the island.
2. **Nose Ramping**. Ramp the approach nose of raised-curb according to the criteria presented in the *IDOT Highway Standards*. Nose ramping is applicable where:
 - a raised-curb median or curbed centerline channelization is introduced to separate opposing lanes of traffic;
 - a change is made from a flush or traversable two-way, left-turn lane to a raised-curb median; and
 - median crossovers or openings are outlined with curb and gutter.

At locations that are designed for pedestrian refuge, and/or include traffic signal poles or light standards, nose ramping is typically not done.

3. Alignment. Provide a smooth, free-flowing alignment both into and out of the divided roadway. On entering the channelized approach, widen the traveled way out opposite the curbed nose and gradually transition it to the normal divided traveled way width. Also, provide a gradual transition on the departure side of the divided roadway. Where two lanes are being funneled down to one lane on the departure side of the channelizing island, provide sufficient pavement width and/or an outside paved shoulder at the curbed nose to provide some lateral escape clearance for merging vehicles. This addresses a situation where, for example, a motorist has failed to observe the single lane warning signs and is mistakenly operating two abreast as the vehicle approaches the transition to two-lane, two-way operations.
4. Island Size. Traffic channelizing islands should be designed to command the driver's attention. Island shapes and sizes are unique at every intersection. For raised-curb islands introduced at isolated intersections, the divisional island should be designed according to the IDOT publication *Transitional Approaches to Channelized Intersections* and Figure 36-3.L. Also, see Figure 36-4.A. For flush, channelizing islands introduced at isolated intersections; see Figures 36-3.J and 36-3.K.
5. Island Length. The island should be of sufficient length to forewarn a motorist of an approaching intersection and to provide space for the proper development of a free-flowing alignment. The edge of the traveled way, the width of the divided roadways, and the width of the center channelizing island normally control the length of island and the pavement edge radii.
6. Delineation. Channelizing islands should be delineated based on their size, location, and function. Raised-curb islands present the most positive means of delineation. Where space is limited, use paint to delineate the island. Raised pavement markers, curb-top reflectors, or paint striping can be used in advance of, and around, an island to help alert the driver of an approaching island. These traffic control devices are especially important at the approach to raised-curb divisional islands.

Round the approach and merging ends of curbed islands according to Figure 36-4.A.
7. Offsets. Figure 36-4.A provides guidance on the applicable offsets that should be used with curbed-channelizing islands.
8. Corrugated Median Surface. In advance of the curbed nose of a divisional island, provide a sufficient length of corrugated median that allows the driver enough warning time to move away from the raised-curb island. Use 1½ seconds of travel time based on the design speed to determine the length of the corrugated surface.
9. Cross Slopes. With center curbed-channelizing islands up to approximately 32 ft (9.5 m) wide, and where such islands are located on tangent segments or on very flat curvature, the length of the island normally provides sufficient distance for gradual lateral shifts of traffic either to the right (entering) or to the left (departing). Because the required lateral shifts usually are not greater than the normal rate of lane shifts made during a passing measure, the cross slope of the pavement through the channelized approach can be unidirectional at 3/16"/ft (1.5%) or 1/4"/ft (2%) and should be sloped away from the island.

10. Stopping Sight Distance. At a minimum, provide stopping sight distance to the ramped nose of the island. Desirably, provide decision sight distance to the ramped nose.
11. Typical Designs. Figure 36-4.A illustrates a typical curbed divisional island and applicable approach treatment. Guidance for standardized designs based on various design speeds, pavement widths, and island widths are provided in IDOT's *Transitional Approaches to Channelized Intersections*. This document can be found on the IDOT website. For flush-channelizing islands, see Figures 36-3.J and 36-3.K.
12. Simplicity. Do not introduce divisional islands in areas which can create confusion due to complexity or which cause excessive restrictions. Complex intersections, which present multiple choices of movement, are undesirable. Ensure that the design remains simple to minimize the potential for driver confusion.

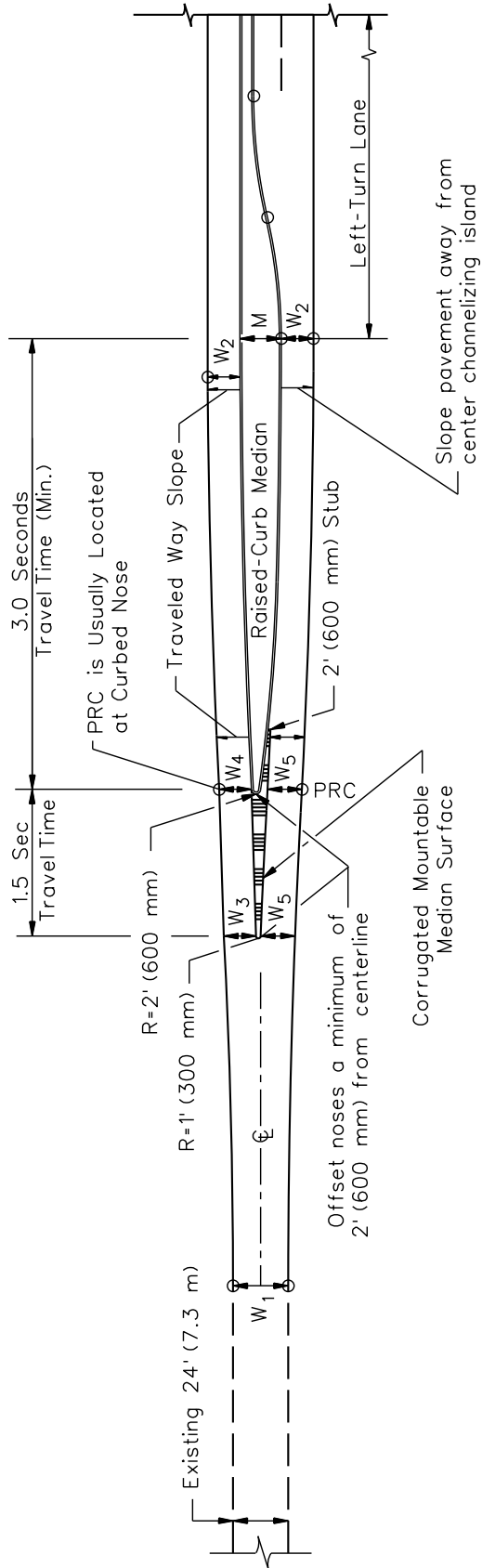

Notes:

1. For additional design details, see the IDOT publication Transitional Approaches to Channelized Intersections.
2. The length and shape of channelizing islands derived from the above sketch also may be used as a guide for determining a flush, center island design.
3. If $W_2 = 14$ ft (4.2 m), use a $3/16$ " /ft (1.5%) drainage slope on the traveled way.
4. If $W_2 = 22$ ft (6.6 m) or 24 ft (7.2 m), use a $1/4$ " /ft (2.0%) drainage slope on the traveled way.
5. Ramp nose at W_4 location.

M = See Figure 36-3.L for typical median widths

W_1 = Undivided approach width

W_2 = Divided approach width

$W_3 = \frac{W_1}{2}$ or 14 ft (4.2 m), whichever is larger

$W_4 = \frac{W_3 + W_2}{2}$, desirable

$W_5 = W_2 + 1$ ft (300 mm)

**TYPICAL CHANNELIZING ISLAND DESIGN
(Raised-Curb Medians)**

Figure 36-4.A

36-4.03(b) Pedestrian Refuge Within Islands

Raised islands may be incorporated into the design of signalized intersections for multiple reasons. The FHWA notes that overall safety will usually be enhanced in urban and suburban areas if crosswalks at signalized intersections direct pedestrians through raised curb islands with adequate space for refuge. These areas allow pedestrians to break major street crossings into multiple shorter stages. This allows for shorter cycle lengths and places pedestrians in locations that make them more highly visible to drivers.

Concerns related to the provision of raised median refuge and raised corner island refuge may include added right of way, challenges in snow removal, the need for future island repairs, and the potential for more fixed object hazards immediately adjacent to traffic. Consider providing delineation of refuge islands using curb-mounted delineators. To the extent possible, locate signal poles outside intersection returns. Coordinate with district operations staff regarding the advantages of refuge areas and to hear any operational concerns. Weigh trade-offs related to any return widening required to create space for raised corner islands. Ideally, provide a balanced design that includes raised pedestrian refuge features within a compact overall intersection footprint.

See Sections 36-2.02 and 36-2.03 for overall design guidance applicable to corner islands, and Section 58-1 for the application of ADA criteria at intersections. Refer also to Section 17-4 for additional pedestrian intersection design guidance.

Corner islands at urban and suburban intersections must meet all requirements for pedestrian accessibility and refuge. Rather than designing with sloped curb ramps it is often preferable to maintain pedestrian access routes (PARs) at pavement-level through islands. Standard 424031 provides details for median pedestrian crossings that include curb ramps, and Standard 606001 shows the associated depressed curb requirements. By keeping the PAR at pavement level there will typically be no grade breaks within the island; depressed curb in those cases can be optional. In either case, the portion of raised island surrounding the PAR area(s) should be of sufficient size to distinguish it as a raised island and to make it easily constructible.

The minimum PAR width at all points through islands shall be 5 ft (1.5 m). Corner islands will often serve as the junction of three crosswalks and will have multiple PARs that each must meet accessibility requirements. Consider each PAR independently and ensure that the cross slope along each is 2.0 percent or less.

At signalized locations pedestrian pushbuttons and pedestrian signal heads will typically be incorporated into any raise island that provides refuge opportunities. Exceptions may occur, however, for raised medians where cycle lengths are sufficient to clear pedestrians through the entire crossing of a leg. There may be a need for two or three pushbuttons and pedestrian signal heads within a corners island. In those cases, size limitations will make it acceptable to provide less than the preferred 10 ft (3.0 m) separation between pushbuttons. The face of each pushbutton should be parallel to the crosswalk to be used, and buttons should be offset sufficiently such that users of each pushbutton location can simultaneously dwell within the island. Criteria for both the maximum side reach offset and minimum pole distance from face of

curb must be satisfied. Within these constraints minimize the total number of poles within each island. Provide pushbutton extensions as necessary to achieve a fully accessible design within required reach ranges. Keep utility covers out of the PAR to the extent possible.

To further inform design that incorporates refuge areas, refer to the Central Bureau of Operations' document entitled *Policy on Pedestrian Pushbutton Locations and Accessible Pedestrian Signals*, Section 4E.08 of the *Manual on Uniform Traffic Control Devices*, and Sections R403, R406, and R407 of the *draft PROWAG*.

36-4.04 Median Openings

36-4.04(a) Location/Spacing

Property owners and/or local agencies may desire that median openings be provided on divided highways at all public roads and major traffic generators. However, this may result in close intersection spacing that may impair the operation of the facility. The following recommended minimum spacings should be evaluated when determining the location for a median opening:

1. Rural Facilities. Median openings should be at least $\frac{1}{2}$ mile (800 m) apart and, desirably, 1 mile (1.6 km) apart, subject to public service requirements and as determined by an engineering study.
2. Urban Facilities. The desirable minimum spacing between median openings should be approximately $\frac{1}{4}$ mile (400 m). At a minimum, the spacing of median openings should be far enough apart to allow for the development of exclusive left-turn lanes with proper lengths.

For both rural and urban facilities, the available sight distance in the vicinity of a median opening is also a factor in the determination of its location. In addition, on some facilities, commercial establishments with heavy truck traffic may dictate the location of median openings. For additional details on the location and spacing of median openings, see Chapters 45 through 48.

36-4.04(b) Design

Figure 36-4.B presents a general figure for the design of a median opening at an intersection. The following will apply to the design of median openings:

1. **Design Vehicle.** Use the largest vehicle that will be making a left turn with some frequency. See Section 36-1.08 for guidelines in selecting the design vehicle.
2. **Encroachment.** The desirable design will allow the design vehicle to make a left turn and to remain entirely within the through inside lane of the divided facility. In addition, the turning vehicle should be no closer than 2 ft (600 mm) to the inside curb or inside edge of pavement. However, depending on traffic control or available intersection sight distance, it would be acceptable for the design vehicle to occupy both travel lanes; see Figure 36-4.B.
3. **Length of Opening.** The length of a median opening should properly accommodate the turning path of the design vehicle. The minimum length is the largest of the following:
 - approach width plus 8 ft (2.4 m), including crossroad median width;
 - approach width plus the width of shoulders, including crossroad median width;
 - the length based on the selected design vehicle; or
 - 40 ft (12 m).

Evaluate each median opening individually to determine the proper length. Consider the following factors in the evaluation:

- a. **Turning Templates.** Check the proposed design with the turning template for the selected design vehicle. Give consideration to the frequency of the turn and to the encroachment onto adjacent travel lanes or shoulders by the turning vehicle.
- b. **Nose Offset.** At four-leg intersections, traffic traveling through the median opening (going straight) will pass the nose of the median end (semicircular or bullet nose). To provide a sense of comfort for these drivers, the offset between the crossroad through travel lane (extended) and the median nose should be at least 4 ft (1.2 m).
- c. **Lane Alignment.** Provide a design where the lanes line up properly across the intersection. Consider the use of tapered left-turn lanes within the median to provide additional sight distance to oncoming traffic at both signalized and unsignalized median crossings.

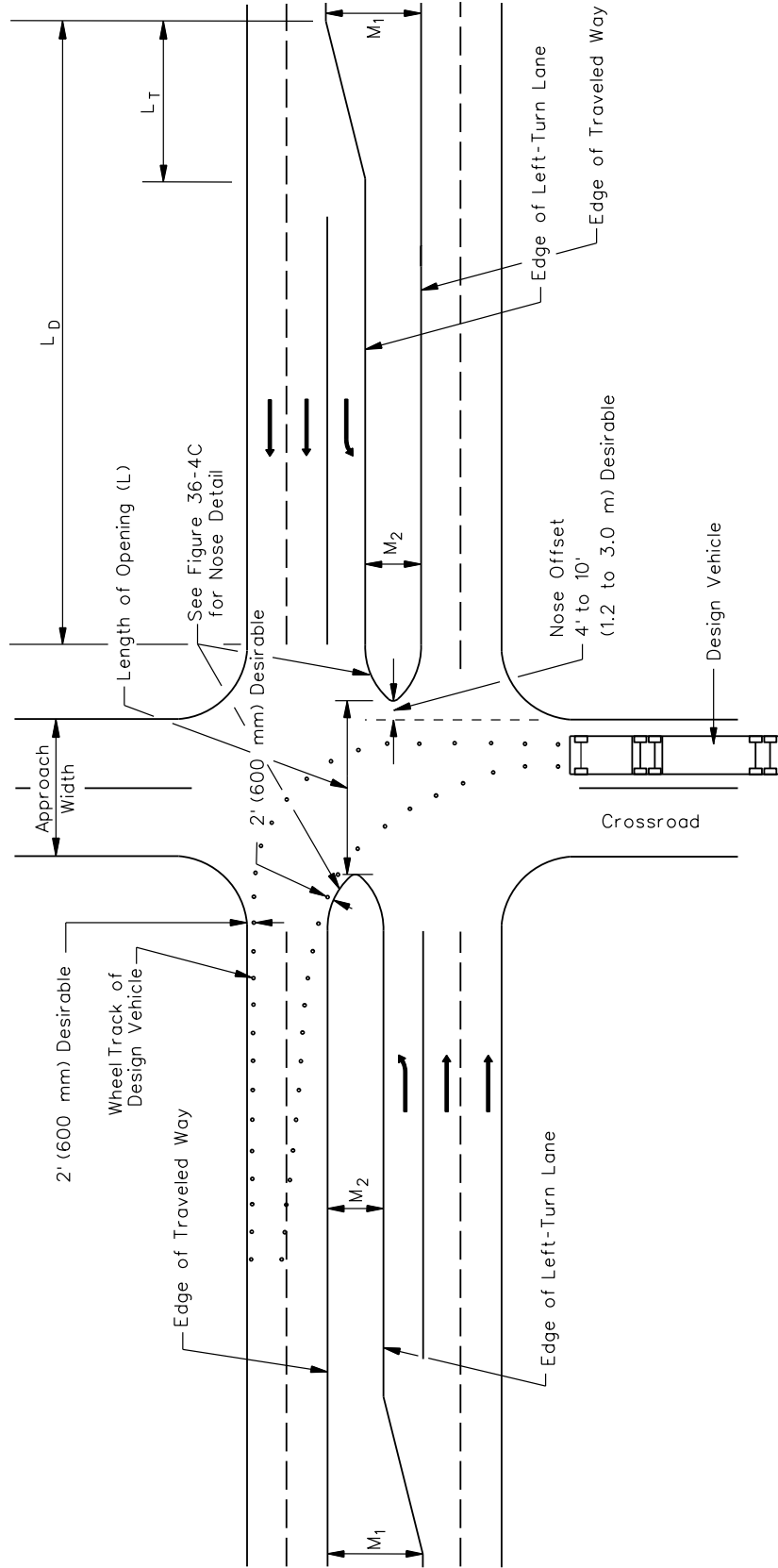

Note: See discussion in Section 36-4.04(b) for minimum L criteria.

MEDIAN OPENING DESIGN

Figure 36-4.B

- d. Location of Crosswalks. Wherever pedestrians may be present and geometrics allow, consider a crosswalk design that intersects a raised median near the nose to provide a refuge area.
 - e. Traffic Control. The geometrics engineer should coordinate with the district Bureau of Operations on the design of the intersection for signing, striping, and traffic control.
4. Median Nose Design. The shape of the nose at median openings is determined by the width of the median (M_1) or (M_2). The two basic types of median nose designs are the semicircular design and bullet-nose design. The following summarizes their usage:
- For medians up to 4 ft (1.2 m) in width, there is little operational difference between the two designs.
 - The semicircular design is generally acceptable for median widths (M_1) up to 10 ft (3.0 m).
 - For medians (M_1) wider than 10 ft (3.0 m), use the bullet-nose design. Also use this design for the divisional island remaining after locating a left-turn lane in median.
 - As medians become successively wider, the minimum length of the median opening becomes the governing design control.
- For the bullet-nose design, a compound curvature arrangement should be used. Figure 36-4.C provides the typical details for a median opening with a bullet-nose design.
5. U-turns. Median openings are sometimes used to accommodate U-turns on multilane divided highways and urban arterials. Preferably, a smaller vehicle should be able to begin and end the U-turn on the inner lanes next to the median. Figure 36-4.D provides the minimum median widths for U-turn maneuvers for various design vehicles and various levels of encroachment. Check the U-turn design with the applicable turning template. For inner-lane-to-shoulder designs it is often appropriate to incorporate an extended pavement area, or loon, so that larger design vehicles making frequent U-turns may do so within an area of full-depth pavement.
6. Sight Distance. Check all median openings for applicable sight distance criteria; see Section 36-6.

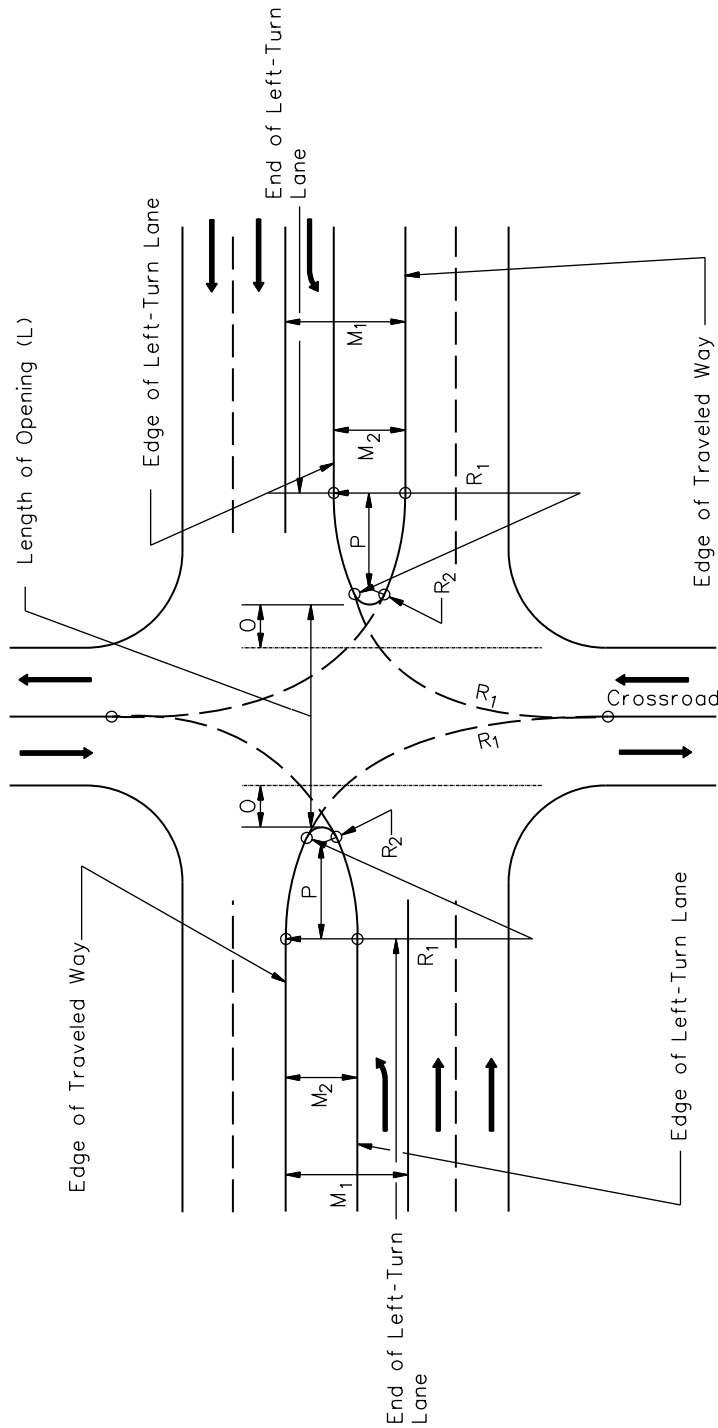

- L = Length of median opening. See discussion in Section 36-4.04(b) for minimum L values.
 - M₁ = median width measured between the two edges of the inside travel lanes
 - M₂ = width of divisional island (raised-curb or depressed) remaining after the width of the left-turn (if present) has been subtracted from the median width (M₁)
 - O = Nose offset.
 - P = As shown in figure.
 - R₁ = variable, based on design vehicle and median width (M₂)
 - R₂ = M₂/5 to edge of left-turn lane
 - R₂ = M₁/5 to edge of traveled way where a left-turn lane is not present
- R₂ is typically rounded up to the next highest whole number

**MEDIAN NOSE DESIGN
(Multilane Divided Highways)**

Figure 36-4.C

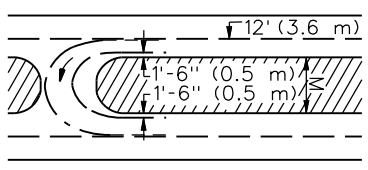
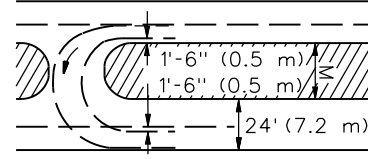
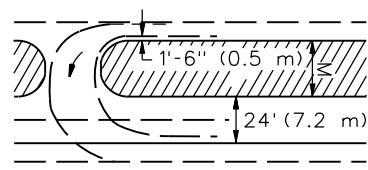
Type of Maneuver		M - Min. width of median for design vehicle				
		P	SU	BUS	WB-40 (WB-12)	WB-50 (WB-15)
		Length of design vehicle				
		19 ft (5.7 m)	30 ft (9.0 m)	40 ft (12.0 m)	50 ft (15.0 m)	55 ft (16.5 m)
Inner Lane to Inner Lane		30 ft (9 m)	63 ft (19 m)	63 ft (19 m)	61 ft (18 m)	71 ft (21 m)
Inner Lane to Outer Lane		18 ft (5 m)	51 ft (15 m)	51 ft (15 m)	49 ft (15 m)	59 ft (18 m)
Inner Lane to Shoulder		8 ft (2 m)	41 ft (12 m)	41 ft (12 m)	39 ft (12 m)	49 ft (15 m)

**MINIMUM WIDTHS NEEDED FOR U-TURNS
(Multilane Divided Highways)**

Figure 36-4.D

36-5 EXTENSION OF THROUGH LANES BEYOND AN INTERSECTION

Where traffic volumes drop off considerably after passing a crossroad, one lane can be dropped beyond the intersection. A lane may be dropped downstream as an exclusive turn lane or with a merging taper into the adjacent through lane. In either scenario, proper highway signing and pavement striping is critical in order to convey the upstream lane drop to the motorist.

To fully realize capacity benefits and to provide for a safe merge when utilizing a merging taper, the through lanes must be extended beyond the intersection for a defined minimum distance. Figure 36-5.A provides preliminary design criteria for determining the minimum distance a lane should be extended beyond an intersection. For higher volume locations, additional length beyond the minimum may be required for the formation of adequate gaps in traffic that will minimize conflicts during merging. Each intersection should therefore be designed on a case-by-case basis, considering all site specific factors.

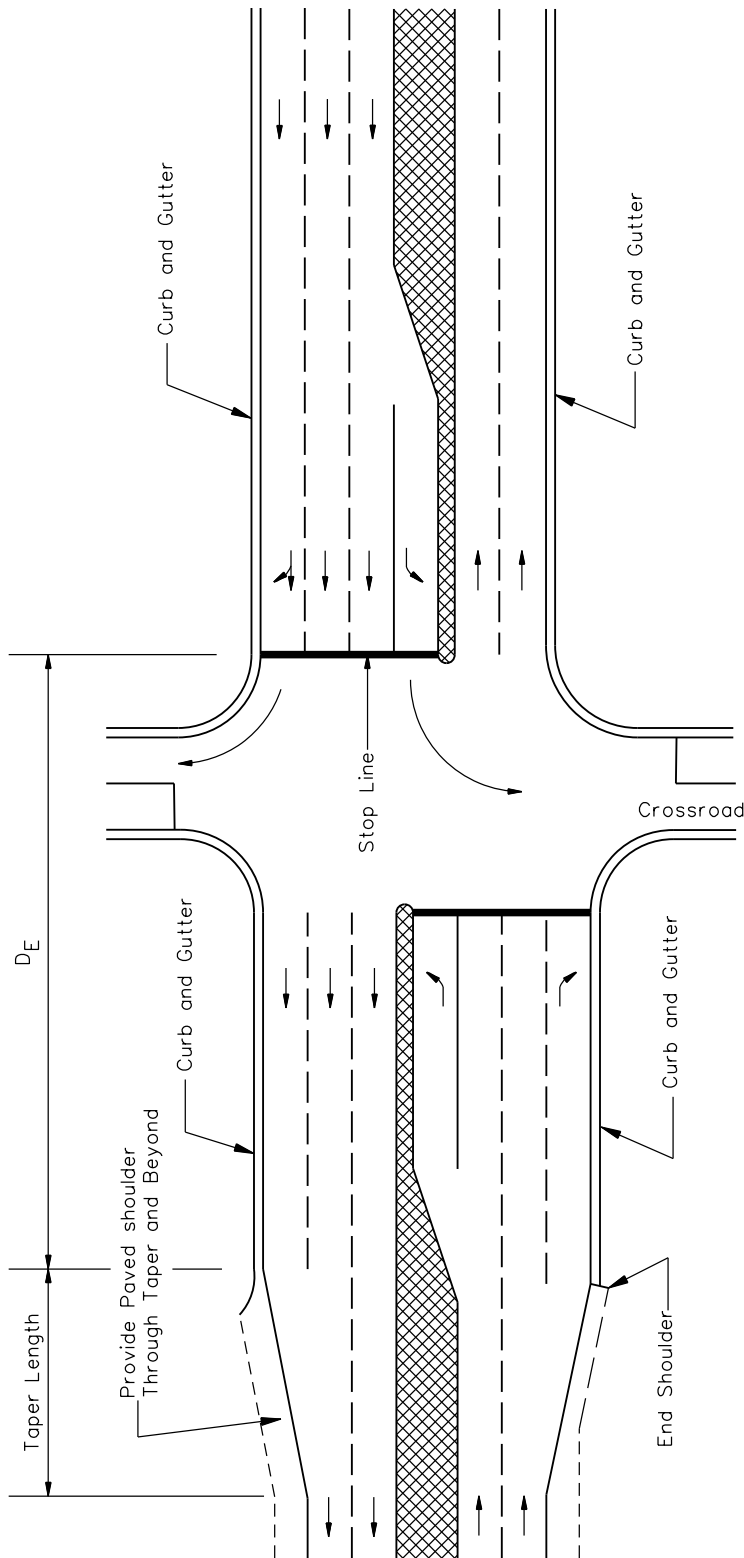

Notes:

1. *D_E is that distance required by a vehicle to accelerate from a stop to 5 mph (10 km/hr) below the design speed of the highway.*
2. *The taper distance is calculated assuming a 12 ft (3.6 m) lane and a taper rate of 45:1 for design speeds of 45 mph (70 km/hr) or less or 50:1 for design speeds of 50 mph (80 km/hr) or greater.*

US Customary		Metric	
Design Speed (mph)	D _E (ft)	Design Speed (km/h)	D _E (m)
30	160	50	40
35	215	60	70
40	320	70	110
45	430	80	160
50	585	90	235
55	780	100	325
60	1010	110	455
65	1300		
70	1750		
		Taper Length (ft)	Taper Length (m)
		540	162
		540	162
		540	162
		540	180
		600	180
		600	180
		600	180
		600	180

EXTENSION OF THROUGH LANE BEYOND AN INTERSECTION

Figure 36-5.A

36-6 INTERSECTION SIGHT DISTANCE

36-6.01 General

At each intersection the potential exists for vehicles to conflict with each other when entering, exiting, or crossing the intersection. The designer should provide sufficient sight distance for a driver to perceive these potential conflicts and to perform the necessary actions needed to negotiate the intersection safely. The additional costs and impacts to achieve this sight distance are often justified based on the safety and operational considerations.

Because all intersections on State highways are either stop controlled or signalized, no guidelines are provided for no control or yield-controlled intersections. For these types of intersections, the designer is referred to NCHRP Report 383, *Intersection Sight Distance* for guidance and/or the *AASHTO Policy on the Geometric Design of Highways and Streets*.

36-6.02 Design Procedures

The Department uses gap acceptance as the conceptual basis for its intersection sight distance (ISD) criteria. The ISD criteria used by the Department is intended to find a balance between an acceptable level of safety and what can be provided at an intersection on a practical basis. This ISD methodology ensures that an intersection operates smoothly without forcing a vehicle on the major road to stop. As the crossroad vehicle makes the turn and accelerates, field studies have indicated that mainline vehicles reduce their speed to approximately 70% of the mainline design speed to compensate for the entering vehicle.

The intersection sight distance is obtained by providing clear sight triangles both to the right and left as shown in Figure 36-6.A. The lengths of legs of these sight triangles are determined as follows:

1. Minor Road. The length of leg along the minor road is based on two parts. The first is the location of the driver's eye on the minor road. This distance is not wholly based on the location of the stop bar, but instead through research on how far away from through traffic the stopping motorist feels comfortable, even potentially after a two-stop process (stop at stop bar, then pull up and stop at a safe spot closer to the edge of pavement that maximizes sight lines). This distance is typically assumed to be 14.4 ft (4.4 m) from the edge of the major road traveled way, but can be increased due to sight specific issues. The second part is based on the distance to the center of the vehicle on the major road. For right-turning vehicles, this is assumed to be the center of the closest travel lane from the left. For left-turning vehicles, this is assumed to be the center of the closest travel lane for vehicles approaching from the right.

2. Major Road. The length of the sight triangle or ISD along the major road is determined using the following equation:

3.

$$b = \text{ISD} = 1.467 V_{\text{major}} t_c$$

Equation 36-6.1 (US Customary)

$$b = \text{ISD} = 0.278 V_{\text{major}} t_c$$

Equation 36-6.1 (Metric)

where:

b	=	length of sight triangle along the major road or ISD, ft (m)
ISD	=	Intersection Sight Distance, ft (m)
V_{major}	=	design speed of major road, mph (km/hr)
t_c	=	critical gap for entering or crossing the major road, sec

The critical gap time (t_c) varies according to the design vehicle, the grade on the minor road approach, the number of lanes on the major roadway, the type of operation, and the intersection skew.

Within this clear sight triangle, if practical, remove or lower any object that would obstruct the driver's view. These objects may include buildings, parked or turning vehicles, trees, hedges, tall crops, unmowed grass, fences, retaining walls, and the actual ground line. In addition, where an interchange ramp or crossroad intersects the major road near a bridge on a crest vertical curve, items such as bridge parapets, piers, abutments, guardrail, or the crest vertical curve itself may restrict the clear sight triangle. Figure 36-6.B illustrates, in both the plan view and profile view, the application of the clear sight triangles at an interchange ramp. This figure also applies to any crossroad intersection.

The height of eye for passenger cars is assumed to be 3.5 ft (1080 mm) above the surface of the minor road. The height of object for an approaching vehicle on the major road is also assumed to be 3.5 ft (1080 mm). An object height of 3.5 ft (1080 mm) assumes that a sufficient portion (9 in. (225 mm)) of an oncoming passenger car must be seen to identify it as an object of concern by the minor road driver. Using the 3.5 ft (1080 mm) height for both vehicles assumes that each driver can see and recognize the other vehicle. If there are a sufficient number of trucks on the minor road or ramp to warrant their consideration, use Figure 36-6.C to determine the appropriate eye height for the minor road vehicle.

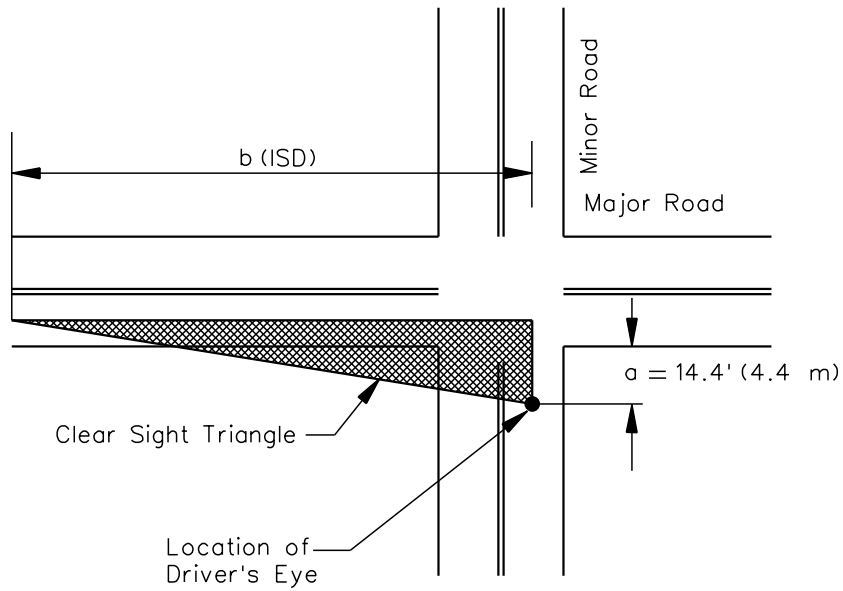

CLEAR SIGHT TRIANGLE FOR VIEWING TRAFFIC APPROACHING FROM LEFT

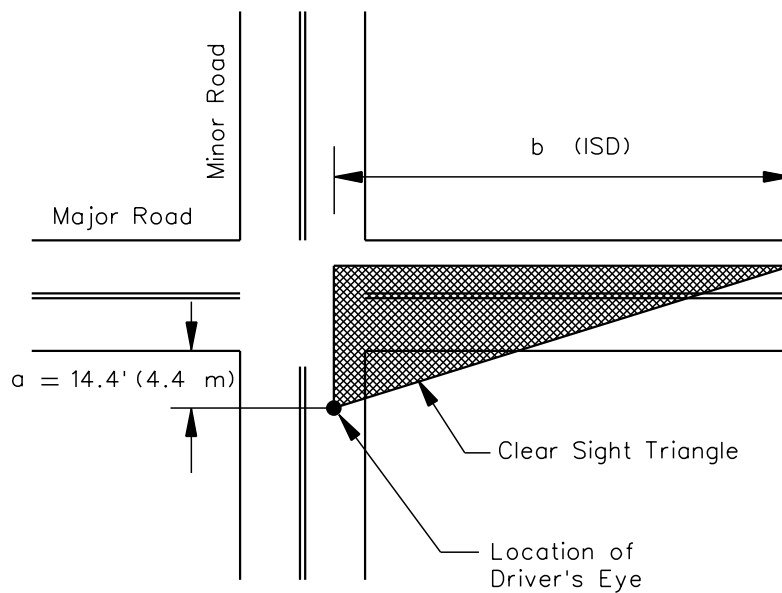

CLEAR SIGHT TRIANGLE FOR VIEWING TRAFFIC APPROACHING FROM RIGHT

CLEAR SIGHT TRIANGLES FOR STOP-CONTROLLED INTERSECTIONS

Figure 36-6.A

36-6.03 Stop-Controlled Intersections

Where traffic on the minor road or an exit ramp of an intersection is controlled by stop signs, the driver of the vehicle on the minor road must have adequate sight distance for a safe departure from the stopped position. This assumes that the approaching vehicle comes into view just as the stopped vehicle begins its departure. The following sections discuss the application of the Department's ISD methodology at stop-controlled intersections.

36-6.03(a) Turns Onto Major Roadway

To determine the intersection sight distance for vehicles turning left or right onto the major road, the designer should use Equation 36-6.1 and the gap times (t_g) presented in Figure 36-6.D. Figure 36-6.D also presents adjustments to the gap times for multilane facilities and steep grades on the minor road approach. These adjustments are further discussed below. Figure 36-6.E provides the ISD values for typical design vehicles on two-lane, level facilities. The designer should also consider the following:

1. Turning Maneuver. There is only a minimal difference in the base gap acceptance times between the left- and right-turning drivers. Consequently, only one gap time is provided for both the left- and right-turning vehicle onto the major road. See Figure 36-6.B.
2. Multilane Facilities. For multilane facilities, the gap acceptance times presented in Figure 36-6.D may need to be adjusted to account for the additional distance required by the turning vehicle to cross the additional lanes or median. The following will apply:
 - a. Left-Turns. For left-turns onto multilane highways without a median, add 0.5 seconds for passenger cars or 0.7 seconds for trucks for each additional lane from the left, in excess of one, to be crossed by the turning vehicle. Assume that the left-turning driver will enter the left most travel lane on the far side of the major road.
 - b. Right Turns. Because the turning vehicle is assumed to be turning into the nearest right through lane, no adjustments to the gap times are required. This is the same for either two-lane or multilane facilities.
 - c. Medians. Depending on the median width, it also may be necessary to add additional time to the base gap time; see Item 3.

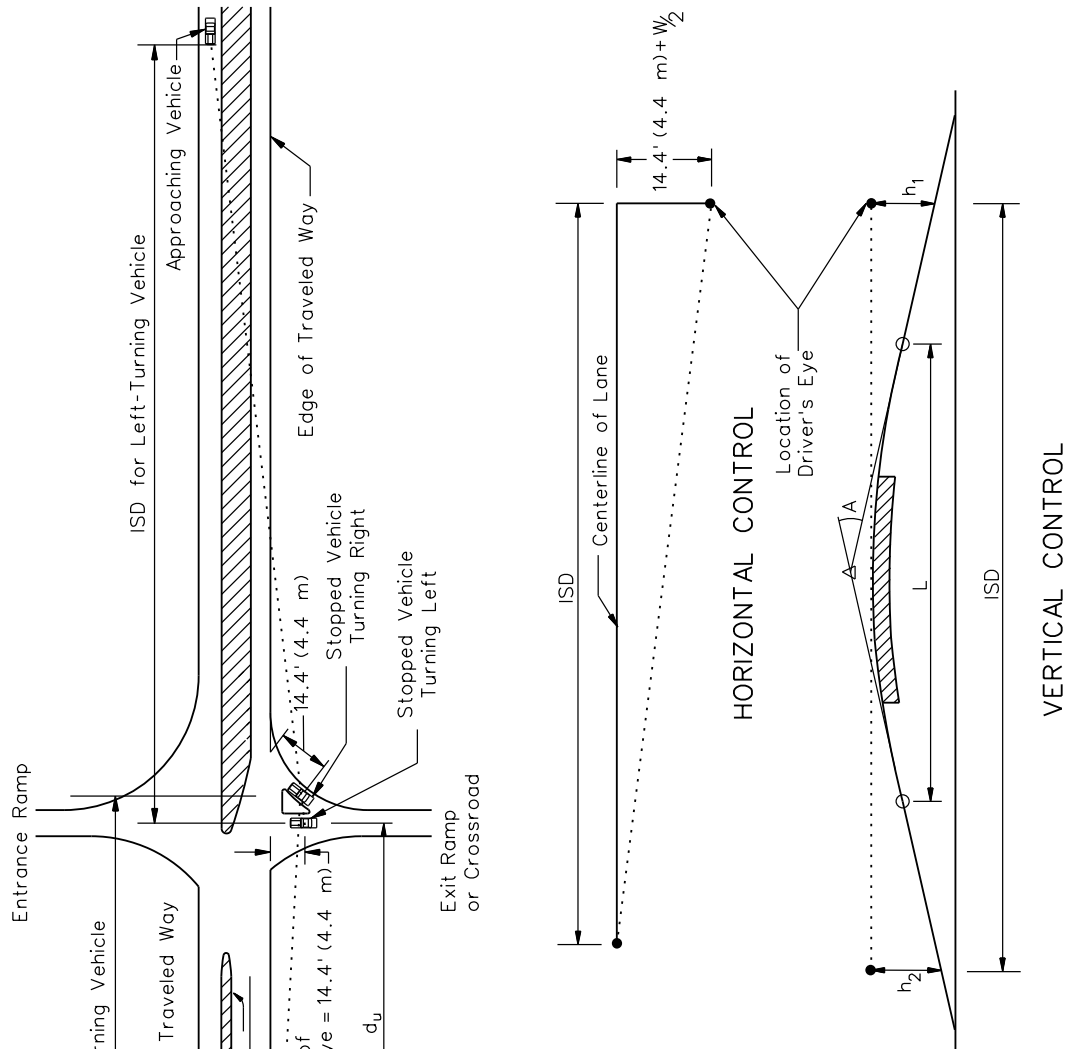

INTERSECTION SIGHT DISTANCE CONTROLS

Figure 36-6.B

- ISD — intersection sight distance, ft (m)
- d — minimum distance needed from back of parapet extension or side of structure to vehicle position, ft (m)
- do — when minor road is over
- du — when minor road is under
- A — maximum algebraic difference of grades (%)
- L — Length of crest vertical curve, ft (m)
- W — width of lane, ft (m)
- h₁ — height of eye, see Figure 36-6.C
- h₂ — height of obstacle = 3.5 ft (1080mm) (passenger car assumed)

20-Year ADT of Tractor/ Semitrailers on Exit Ramp or Crossroad	Approaching Vehicle on Mainline ⁽²⁾	Stopped Design Vehicle on Crossroad ⁽¹⁾
ADT \leq 40	Passenger Car $h_2 = 3.5$ ft ($h_2 = 1080$ mm)	Passenger Car $h_1 = 3.5$ ft ($h_1 = 1080$ mm)
$40 < \text{ADT} \leq 100$	Passenger Car $h_2 = 3.5$ ft ($h_2 = 1080$ mm)	Single Unit (SU) or Bus $h_1 = 6$ ft ($h_1 = 1.8$ m)
ADT > 100	Passenger Car $h_2 = 3.5$ ft ($h_2 = 1080$ mm)	Tractor/Semitrailers (MU) $h_1 = 8$ ft ($h_1 = 2.5$ m)

Notes:

1. h_1 - Assumed height of eye for stopped motorist.
2. h_2 - Assumes 9 in. (225 mm) of top of approaching vehicle can readily be seen by stopped motorist.
3. Where a mainline crest vertical curve lies close to an intersection of a crossroad or ramp, it may be necessary to increase the length of the vertical curve (designed for either existing or proposed stopping sight distance) or to reduce the grades in order to obtain the proper ISD in the vertical plane.

**DESIGN VEHICLES USED TO DETERMINE AVAILABLE ISD
ALONG A CROSSROAD**

Figure 36-6.C

Design Vehicle	Gap Acceptance Time (t_c) (sec)
Passenger Car	7.5
Single-Unit Truck	9.5
Tractor/Semitrailer	11.5

Note: Times are for turns onto a two-lane highway without a median and may require adjustments to the base time gaps.

Adjustments:

1. Multilane Highways. *The following will apply:*
 - *For left turns onto two-way multilane highways without a median, add 0.5 seconds for passenger cars or 0.7 seconds for trucks for each additional lane from the left, in excess of one, to be crossed by the turning vehicle. See discussion in Section 36- 6.03(a) for additional guidance.*
 - *For right turns, no adjustment is necessary.*
2. Minor Road Approach Grades. *If the approach grade on the minor road exceeds +3%, the following will apply:*
 - *For right turns, multiply 0.1 seconds times the actual percent grade on the minor road approach and add this number to the base time gap.*
 - *For left turns, multiple 0.2 seconds times the actual percent grade on the minor approach and add this number to the base time gap.*
3. Major Road Approach Grade. *Major road grade does not affect calculations.*

**GAP ACCEPTANCE TIMES
(Left and Right Turns From Minor Road)**

Figure 36-6.D

Design Speed (V_{major})	ISD		
	Passenger Cars	Single-Unit Trucks	Tractor/Semitrailers
US Customary			
20 mph	225 ft	280 ft	340 ft
25 mph	280 ft	350 ft	425 ft
30 mph	335 ft	420 ft	510 ft
35 mph	390 ft	490 ft	595 ft
40 mph	445 ft	560 ft	675 ft
45 mph	500 ft	630 ft	760 ft
50 mph	555 ft	700 ft	845 ft
55 mph	610 ft	770 ft	930 ft
60 mph	665 ft	840 ft	1015 ft
65 mph	720 ft	910 ft	1100 ft
70 mph	775 ft	980 ft	1185 ft
Metric			
30 km/hr	63 m	80 m	96 m
40 km/hr	84 m	106 m	128 m
50 km/hr	105 m	132 m	160 m
60 km/hr	126 m	159 m	192 m
70 km/hr	146 m	185 m	224 m
80 km/hr	167 m	212 m	256 m
90 km/hr	188 m	238 m	288 m
100 km/hr	209 m	264 m	320 m
110 km/hr	230 m	291 m	352 m

Notes:

1. These ISD values assume turns onto a two-lane facility without a median.
2. These ISD values assume a minor road approach grade $\leq +3\%$.

**INTERSECTION SIGHT DISTANCES FOR TWO-LANE HIGHWAY
(Left and Right Turns From Minor Road)**

Figure 36-6.E

3. Left Turns Through Medians.

- a. Narrow Medians. For a facility that does not have a median wide enough to store a stopped design vehicle, divide the median width by 12 ft (3.6 m) to get the corresponding number of lanes and then use the criteria in Item 2a above to determine the additional time factor.
- b. Wide Medians. For a facility that does have a median wide enough to store a stopped design vehicle, the designer should evaluate the sight distance needed in two separate steps:
 - First, with the design vehicle stopped on the side road, use the gap acceptance times for a vehicle turning right or use Figure 36-6.E directly to determine the applicable ISD. Under some circumstances, it may also be necessary to check the straight through crossing maneuver to determine if it is the critical movement. Straight through crossing criteria are discussed in Section 36-6.03(b).
 - Second, with the design vehicle stopped in the median, assume a two-lane roadway design and use the gap acceptance times for a vehicle turning left or use Figure 36-6.E directly to determine the applicable ISD.

Section 36-6.07 provides an example of school bus crossing a wide median.

4. Approach Grades. If the approach grade on the minor road exceeds 3%, see the criteria in Figure 36-6.D.
5. Trucks. At some intersections (e.g., near truck stops, interchange ramps, grain elevators), the designer may want to use the truck as the design vehicle for determining the ISD. The gap acceptance times (t_c) for single-unit and tractor/semitrailer trucks are provided in Figure 36-6.D. Calculated ISD values for two-lane roadways are presented in Figure 36-6.E. The height of eye for these vehicles is discussed in Section 36-6.02 as shown in Figure 36-6.C.

36-6.03(b) Vehicle Crossing Mainline

In the majority of cases, the intersection sight distance for a crossing maneuver is less than that required for a left- or right-turning vehicle. However, in the following situations, the straight through crossing sight distance may be the more critical movement:

- where left and/or right-turns are not permitted from a particular approach and the crossing maneuver is the only legal or expected movement (e.g., indirect left turns);
- where the design vehicle must cross more than four travel lanes or, with medians, the equivalent distance; or
- where a substantial volume of heavy vehicles cross the highway and there are steep grades on the minor road approaches.

Use Equation 36-6.1 and the gap acceptance times (t_c) and adjustment factors in Figure 36-6.F to determine the ISD for crossing maneuvers. Where narrow medians are present which cannot store the design vehicle, include the median width in the overall width to determine the applicable gap time. Divide this overall width by 12 ft (3.6 m) to determine the corresponding number of lanes for the crossing maneuver. Add 0.5 seconds for passenger cars or 0.7 seconds for trucks for each additional lane, in excess of two, to be crossed by the design vehicle.

Design Vehicle	Gap Acceptance Time (t_c) (sec)
Passenger Car	6.5
Single-Unit Truck	8.5
Tractor/Semitrailer	10.5

Note: Times are for crossing a two-lane highway without a median.

Adjustments:

1. Multilane Highway. Where the design vehicle is crossing a major road with more than two lanes and/or where there is a narrow median which cannot store the design vehicle, add 0.5 seconds for passenger cars or 0.7 seconds for trucks for each additional lane in excess of two. See the discussion in Section 36-6.03(b) for additional guidance.
2. Approach Grade. If the approach grade on the minor road exceeds +3%, multiply 0.1 seconds times the actual percent grade of the minor road approach and add this number to the base time gap.

GAP ACCEPTANCE TIMES (Vehicle Crossing Mainline)

Figure 36-6.F

36-6.03(c) Four-Way Stop

At intersections with all-way stop control, provide enough sight distance so that the first stopped vehicle on each approach is visible to all the other approaches. The ISD criteria for left- or right-turning vehicles as discussed in Section 36-6.03(a) are not applicable in this situation. Often intersections are converted to all-way stop control to address limited sight distance at the intersection. Therefore, providing additional sight distance at the intersection is unnecessary.

36-6.04 Signal-Controlled Intersections

At signalized intersections, provide sufficient sight distance so that the first vehicle on each approach is visible to all other approaches. Traffic signals are often used at high-volume intersections to address accidents related to restricted sight distances. Therefore, the ISD criteria for left- or right-turning vehicles as discussed in Section 36-6.03(a) is typically not applicable at signalized intersections. However, where right-turn-on-red is allowed, check to see that the ISD as presented in Section 36-6.03(a) for a stop-controlled right-turning vehicle is available to the left. If it is not, this may warrant restricting the right-turn-on-red movement. In addition, if the

traffic signal is placed on two-way flash operation (i.e., flashing amber on the major-road approaches and flashing red on the minor-road approaches) under off-peak or nighttime conditions, provide the ISD criteria as discussed in Section 36-6.03(a) for a stop-controlled intersection.

36-6.05 Left Turns From the Major Road

At all intersections, regardless of the type of traffic control, the designer should consider the sight distance needs for a stopped vehicle turning left from the major road. This situation is illustrated in Figure 36-6.G. The driver will need to see straight ahead for a sufficient distance to turn left and clear the opposing travel lanes before an approaching vehicle reaches the intersection. In general, if the major highway has been designed to meet the stopping sight distance criteria, intersection sight distance only will be a concern where the major road is on a horizontal curve, where there is a median, or where there are opposing vehicles making left turns at an intersection. Sight distance for opposing left turns may be increased by offsetting the left-turn lanes; see Section 36-3.03(c).

Use Equation 36-6.1 and the gap acceptance times (t_c) from Figure 36-6.H to determine the applicable intersection sight distances for the left-turning vehicle. Where the left-turning vehicle must cross more than one opposing lane, add 0.5 seconds for passenger cars or 0.7 seconds for trucks for each additional lane in excess of one. Where medians are present and the left-turn lanes are not offset, the designer will need to consider the median width in the same manner as discussed in Section 36-6.03. Figure 36-6.I provides the ISD values for typical design vehicles and two common left-turning situations on a facility without a median.

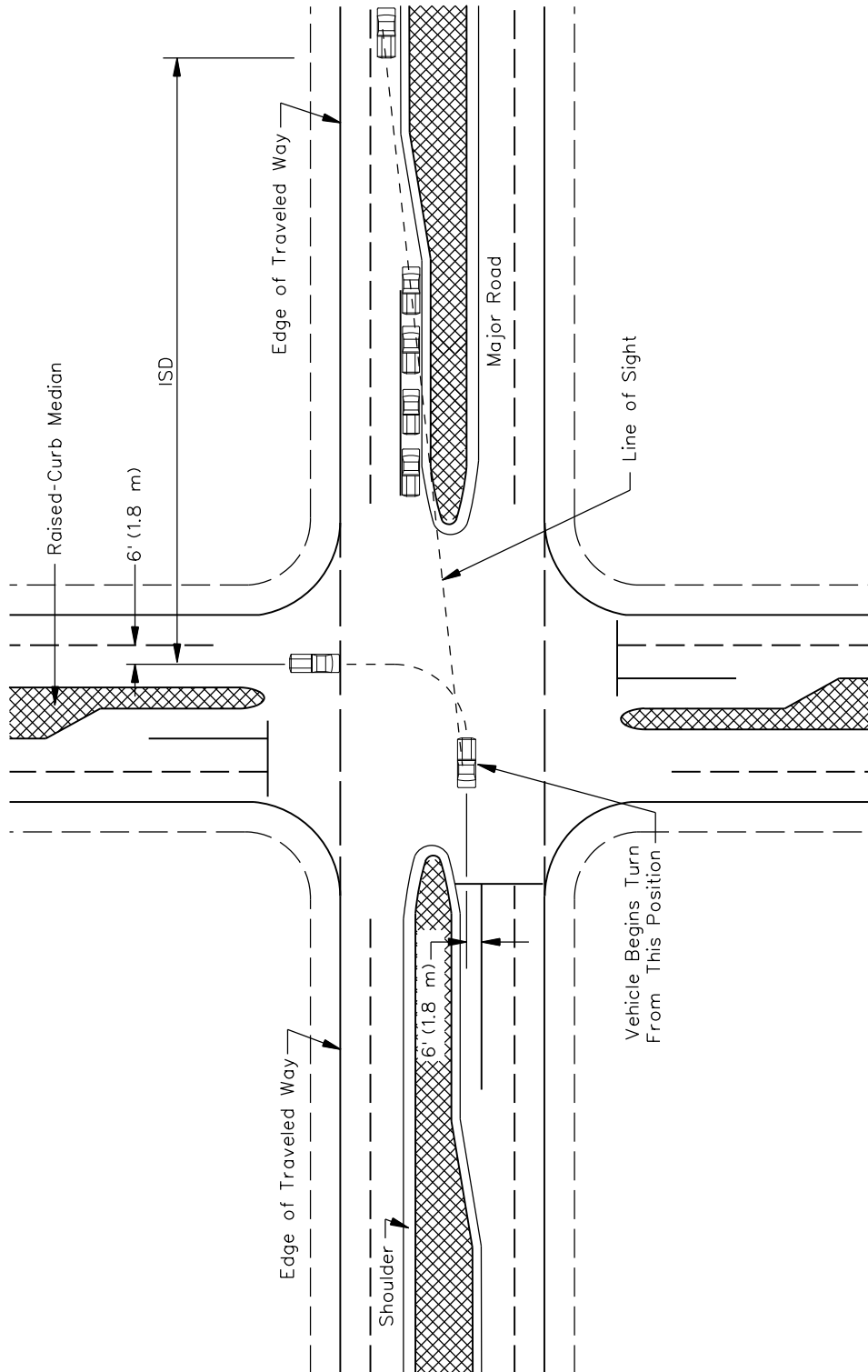

Note: See Section 36-6.05 for discussion and application

**INTERSECTIONS SIGHT DISTANCE CONTROLS
(Left Turns from the Major Road)**

Figure 36-6.G

Design Vehicle	Gap Acceptance Time (t_c) (sec)
Passenger Car	5.5
Single-Unit Truck	6.5
Tractor/Semitrailer	7.5

Adjustments: Where left-turning vehicles cross more than one opposing lane, add 0.5 seconds for passenger cars or 0.7 seconds for trucks for each additional lane in excess of one. See Section 36-6.05 for additional guidance on median widths.

**GAP ACCEPTANCE TIMES
(Left Turns From Major Road)**

Figure 36-6.I

36-6.06 Effect of Skew

Where it is impractical to realign an intersection which is greater than 30 degrees from perpendicular, adjust the gap acceptance times presented in the above sections to account for the additional travel time required for a vehicle to make a turn or cross a facility. At oblique-angled intersections, determine the actual path length for a turning or crossing vehicle by dividing the total distance of the lanes and/or median to be crossed by the sine of the intersection angle. If the actual path length exceeds the total width of the lanes to be crossed by 12 ft (3.6 m) or more, apply the applicable adjustment factors; see Figure 36-6.J.

Design Speed (V_{major})	ISD					
	Passenger Cars		Single-Unit Trucks		Tractor/Semitrailers	
	Crossing 1 lane	Crossing 2 lanes	Crossing 1 lane	Crossing 2 lanes	Crossing 1 lane	Crossing 2 lanes
US Customary						
20 mph	165 ft	180 ft	195 ft	210 ft	225 ft	240 ft
25 mph	205 ft	225 ft	240 ft	260 ft	280 ft	295 ft
30 mph	245 ft	265 ft	290 ft	310 ft	335 ft	355 ft
35 mph	285 ft	310 ft	335 ft	365 ft	390 ft	415 ft
40 mph	325 ft	355 ft	385 ft	415 ft	445 ft	475 ft
45 mph	365 ft	400 ft	430 ft	465 ft	500 ft	530 ft
50 mph	405 ft	445 ft	480 ft	515 ft	555 ft	590 ft
55 mph	445 ft	490 ft	525 ft	570 ft	610 ft	650 ft
60 mph	490 ft	530 ft	575 ft	620 ft	665 ft	710 ft
65 mph	530 ft	575 ft	625 ft	670 ft	720 ft	765 ft
70 mph	570 ft	620 ft	670 ft	720 ft	775 ft	825 ft
Metric						
30 km/hr	50 m	50 m	55 m	59 m	63 m	67 m
40 km/hr	65 m	67 m	73 m	78 m	84 m	89 m
50 km/hr	77 m	84 m	91 m	98 m	105 m	112 m
60 km/hr	92 m	100 m	109 m	117 m	125 m	134 m
70 km/hr	107 m	117 m	127 m	137 m	146 m	156 m
80 km/hr	123 m	134 m	145 m	156 m	167 m	178 m
90 km/hr	138 m	150 m	163 m	175 m	188 m	200 m
100 km/hr	153 m	167 m	181 m	195 m	209 m	223 m
110 km/hr	169 m	184 m	199 m	214 m	230 m	245 m

Note: Assumes no median on major road.

**INTERSECTION SIGHT DISTANCES
(Left Turns From Major Road)**

Figure 36-6.J

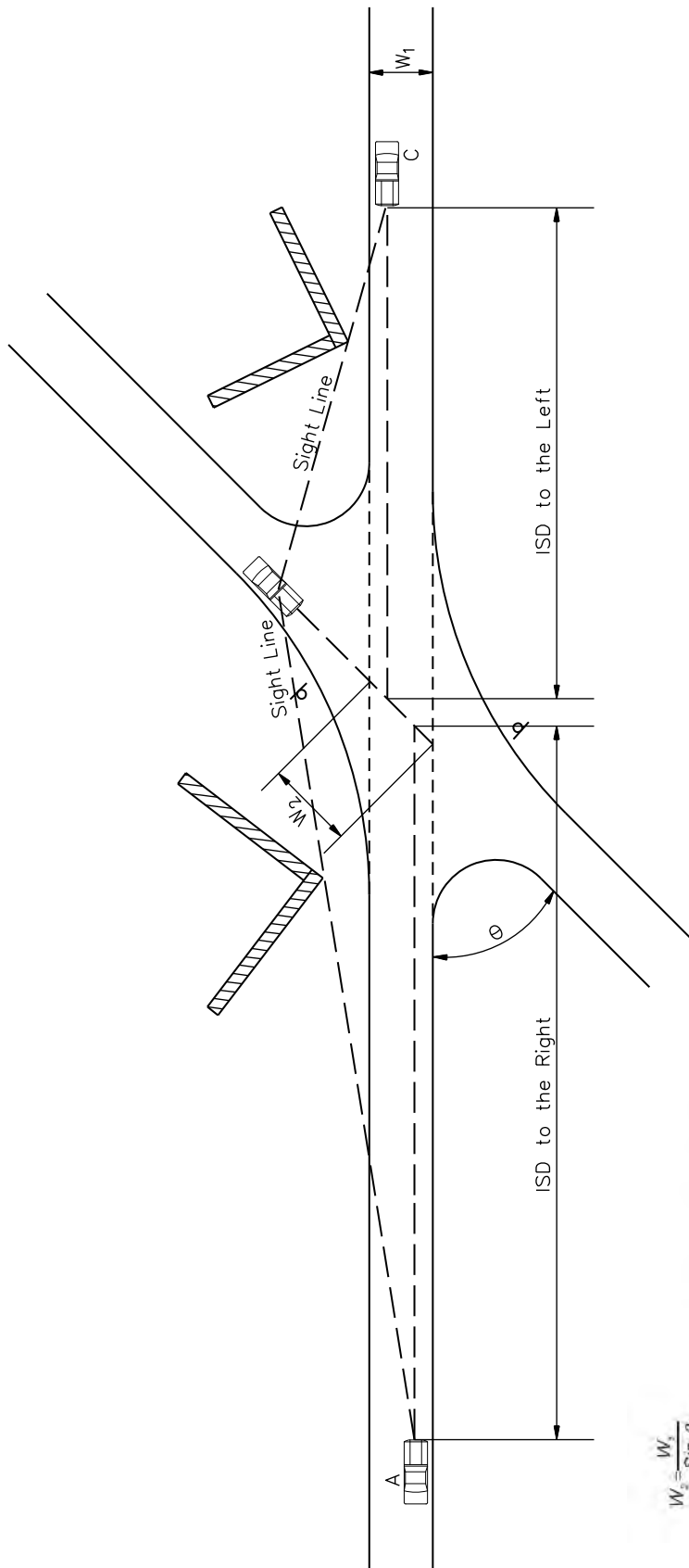

$$W_2 = \frac{W_1}{\sin \theta}$$

Where: W_1 = Major road traveled way width, ft (m)

W_2 = Adjusted width for skew, ft (m)

θ = Intersection angle

SIGHT DISTANCE AT SKEWED INTERSECTIONS

Figure 36-6.K

36-6.07 Examples of ISD Applications

The following three examples illustrate the application of the ISD criteria:

Example 36-6.07(1)

Given: Minor road intersects a four-lane highway with a TWLTL.
 Minor road is stop controlled and intersects major road at 90 degrees.
 Design speed of the major highway is 45 mph.
 All travel lane widths are 12 ft.
 The TWLTL width is 12 ft.
 Grade on minor road is 1%.
 Trucks are not a concern.

Problem: Determine the intersection sight distance needed to the left and right of the minor road; see Figure 36-6.B.

Solution:

1. For the passenger car turning right, the ISD to the left can be determined directly from Figure 36-6.E, because the right-turning motorist is assumed to turn into the near lane. For the 45 mph design speed, the ISD to the left is 500 ft.
2. For the passenger car turning left, the ISD to the right must reflect the additional time required to cross the additional lanes and TWLTL; see in Section 36-6.03(a). The following will apply:

- a. First, determine the extra width required by the one additional travel lane and the TWLTL and divide this number by 12 ft:

$$\frac{(12 + 12)}{12} = 2 \text{ lanes}$$

- b. Next, multiply the number of lanes by 0.5 seconds to determine the additional time required:

$$(2 \text{ lanes})(0.5 \text{ sec/lane}) = 1.0 \text{ second}$$

- c. Add the additional time to the basic gap time of 7.5 seconds and insert this value into Equation 36-6.1:

$$\text{ISD} = (1.467)(45)(7.5 + 1.0) = 561 \text{ ft}$$

Provide an ISD of 561 ft to the right for the left-turning vehicle.

3. Check the passenger vehicle crossing the mainline, as discussed in Section 36-6.03(b). The following will apply:

- a. First determine the extra width required by the two additional travel lanes and the TWLTL and divide this number by 12 ft:

$$\frac{(12 + 12 + 12)}{12} = 3.0 \text{ lanes}$$

- b. Next, multiply the number of lanes by 0.5 seconds to determine the additional time required:

$$(3.0 \text{ lanes})(0.5 \text{ sec/lane}) = 1.5 \text{ seconds}$$

- c. Add the additional time to the basic gap time of 6.5 seconds and insert this value into Equation 36-6.1:

$$\text{ISD} = (1.467)(45)(6.5 + 1.5) = 530 \text{ ft}$$

The 530 ft for the crossing maneuver is less than the 561 ft required for the left-turning vehicle and, therefore, is not the critical maneuver.

4. Prepare a scaled drawing in the horizontal and vertical planes and graphically check to determine if the applicable ISD is available.

Example 36-6.07(2)

Given: Minor road intersects a four-lane divided highway.
 Minor road is stop controlled and intersects major road at 90 degrees.
 Design speed of the major highway is 60 mph.
 All travel lane widths are 12 ft.
 The median width is 50 ft.
 Grade on minor road is +2%.
 The design vehicle is a 64-passenger school bus that is 35.8 ft long.

Problem: Determine the intersection sight distance needed to the left and right of the minor road; see Figure 36-6.B.

Solution:

1. For a school bus, assume a SU design vehicle for gap acceptance times.
2. For the school bus turning right, the ISD to the left can be determined directly from Figure 36-6.E. For the 60 mph design speed, the ISD to the left is 840 ft.
3. Determine if the straight through crossing maneuver is critical; see Section 36-6.03(b). No adjustments are required to the base time of 8.5 seconds. Therefore, use Equation 36-6.1 directly:

$$\text{ISD} = (1.467)(60)(8.5) = 750 \text{ ft}$$

The crossing maneuver ISD is less than the right-turning maneuver and, therefore, is not critical.

4. For the school bus turning left, it can be assumed the school bus can safely stop in the median (i.e., 50 ft minus 35.8 ft). The ISD to the right can be determined directly from Figure 36-6.E. For the 60 mph design speed, the ISD to the right for the left turn is 840 ft. The crossing maneuver will not be critical.
5. Prepare a scaled drawing in the horizontal and vertical planes and graphically check to determine if the applicable ISD is available.

Example 36-6.07(3)

Given: Minor road intersects a four-lane divided highway.
Minor road is stop controlled and intersects major road at 90°.
Design speed of the major highway is 50 mph.
All travel lane widths are 12 ft.
Existing median width is 48 ft.
Traffic signals are likely within 10 years.
Current mainline ADT is 1600 and left-turn volumes exceed 60 vph.
Trucks are not a concern.

Problem: Determine the intersection design and sight distance for a vehicle turning left from the major road.

Solution:

1. From Section 36-3.03(c), the recommended left-turn lane design is a tapered offset left-turn lane.
2. Because the offset left-turn lane design places vehicles near the median edge of the opposing lanes, no adjustment is necessary for the median width in computing the gap acceptance time.
3. For the left-turning vehicle, the ISD can be determined directly from Figure 36-6.I. For the 50 mph design speed and crossing two lanes, the required ISD is 480 ft.
4. Prepare a scaled drawing in the horizontal and vertical planes and graphically check to determine if the applicable ISD is available.

36-7 DRIVEWAYS, ENTRANCES, AND MINOR SIDEROADS

Section 36-7.01 discusses the design of proposed driveways, entrances, and minor side road approaches to State highways; as well as modifying the connections of existing driveway, entrance, or minor side road approaches to State highways in conjunction with new construction, reconstruction, or 3R highway projects.

Chapter 5 and the Bureau of Operations' *Maintenance Policy Manual* provide information regarding necessary local agency agreements and maintenance obligations on state highway projects with side roads or local participation.

Section 36-7.02 provides general information regarding the highway access permit process for new or revised individual entrances to a State highway. For detailed information regarding requirements for the construction or modification of permitted access to State Highways or the access permit process in general, refer to the Bureau of Operations publication entitled, *Handbook for the Policy on Permits for Access Driveways to State Highways*. The information in the *Handbook* is governed by the *Illinois Highway Code sections 605 ILCS 5/4-209, 4-210, 4-211 and 4-212 and 92 Ill. Admin. Code 550*.

For information regarding access management concepts, objectives, benefits, and techniques, see Chapter 35.

For additional access management concepts applicable to Strategic Regional Arterials, see Chapter 46.

36-7.01 General Considerations

The Department has the authority to make access revisions pursuant to the *Illinois Highway Code, 605 ILCS 5/4-211*. During the design of highway reconstruction projects or when changes in operational conditions warrant review and potential revisions, sideroads, driveways and entrances to public or non-public facilities may be altered, relocated, or eliminated after notification and appropriate discussion with the local agency or property owner. (For public connections to State highways, public involvement may be required. See Chapter 19). Any such revisions will typically be accomplished at Department expense for existing access locations that are legally permitted. Owners or developers who construct access facilities not in accordance with the approved access permit or without an access permit, must correct or remove the access within a specified period of time as directed by the Department; otherwise the Department will cause the removal or closure of the access facility at the owner's expense.

Although all types of property tracts need access to and from public roadways and are guaranteed that right by the *Illinois Highway Code, 605 ILCS 5/4-209, 4-210, 4-211, 4-212*, the nature of that need varies according to the type of facility (see *605 ILCS 5/8-102, 8-103* regarding access to freeways), land use (e.g., agricultural, industrial, commercial, or residential), the characteristics of the mainline roadway (urban, suburban, or rural), and safety considerations. Details of the access design depend on factors such as the volume of traffic, the types of vehicles using the entrance, and adjacent compatible land uses.

In all cases for new construction, reconstruction, or 3R projects, district staff are required as part of the roadway project to examine what changes are needed to existing side roads, entrances and driveways, and to document any recommended changes in the Phase I Engineering Report. See Chapter 11 for Phase I Engineering Report guidelines. The designer must exercise good judgment that reflects an understanding of traffic characteristics when categorizing a particular entrance and applying appropriate design standards.

36-7.01(a) Definitions

The following definitions are used in the design of driveways, entrances, and side roads. Note for the purposes of this section, the terms “entrance” and “driveway” will be used interchangeably.

1. Access Facility. A driveway, entrance, or side road approach facilitating vehicular movement between abutting property or right-of-way and a State highway. Normally, it includes only the part of the driveway, entrance, or side road that lies within the established right-of-way limits of the State highway.
2. Commercial Entrance (CE). A driveway that provides access to a single property or business being used for commercial purposes (such as office, retail, or services) or industrial purposes, or provides access for more than a single-family residence or duplex, or more than two single family residences sharing a common entrance.
3. High-Volume Commercial Entrance. A driveway that provides access to a development with substantially more trips than average commercial generators. Such developments are characterized by large parking areas, high-type access facilities, and traffic volumes of sufficient magnitude to have a pronounced effect on the safety and capacity of adjacent streets and highways. Examples of high-volume commercial generators include shopping centers, industrial complexes, office parks, and sports stadiums.
4. Non-Commercial Entrance. A driveway that provides access to a single-family residence, a duplex, or to not more than two single family residences on adjacent properties which are served by a common entrance. Also provides access to agricultural land, including field entrances, but excluding entrances used for the sale of agricultural products to the general public.
5. Private Entrance (PE). A special type of non-commercial access facility that provides access to a single-family residence, or to not more than two single family residences on adjacent properties which are served by a common entrance.
6. Field Entrance (FE). A special type of non-commercial access facility that provides access to land for agricultural uses.
7. Street or Side Road Approach. A special type of access facility that provides a direct connection between a State highway and an intersecting public road.

36-7.01(b) Construction Projects Involving Proposed Entrances

New entrance design practices should consider the following concerns and variables:

- Convenient and safe vehicle ingress and egress;
- Functional classification and design/posted speeds of mainline;
- ADT's and heavy vehicle percentages of mainline and entrance;
- Access control limits, density of access points, and mainline roadway operations;
- Proposed parcel usage and size of entrance design vehicle;
- Interactions with other nearby entrances or side streets;
- Accessibility and safety of all pedestrians (including individuals with disabilities), and incorporation of proper ADA requirements;
- Interactions where bicycle lanes or side paths are present;
- Interactions where public transportation stops are in the vicinity of the driveway;
- Terrain and drainage; and
- Visibility and sight distance requirements.

These considerations will affect entrance geometric design details such as alignment, entry shape (radius returns or side flares), width, grade, and cross slope, in addition to related design items such as sidewalk or bike path alignment and the location of first available parking bays beyond the entrance.

See Figure 36-7.A for general design guidelines for proposed entrances and driveways abutting the State highway system. Also see Sections 36-7.01(d)–(g) of this manual and the *Handbook for the Policy on Permits for Access Driveways to State Highways* for additional design information specific to IDOT. Additionally, *NCHRP Report 659* provides detailed guidance for the geometric design of new driveways and entrances.

36-7.01(c) Construction Projects Involving Existing Entrances

When the Department undertakes the improvement of an existing roadway, district staff must examine limits of the entire project for safety, sight distance, and operational issues. In all cases for new construction, reconstruction, or 3R type projects, the designer is required to examine what changes are needed to existing side roads, major entrances, and driveways, and to document any recommended changes in the Phase I Engineering Report. See Chapter 11 for Phase I Engineering Report guidelines. For any existing entrance that does not meet design, safety or operational criteria, contact the property owner during the project development phase to discuss the potential or observed issues, historical crash data, and current safety analyses of the subject location. Identify and discuss potential solutions for closing, reconstructing, or realigning the entrance to improve safety and operational objectives. Do not allow such substandard entrances to remain without addressing the issues.

For basic design parameters to remain in place for various entrance types, see Figure 36-7.A. See also Sections 36-7.01(d) – (g) of this manual, the *Handbook for the Policy on Permits for Access Driveways to State Highways* and *NCHRP Report 659* for additional design information.

36-7.01(d) Construction Projects Involving Proposed Sideroads

Construction projects involving proposed sideroads intersecting a State highway should adhere to the following procedures, depending on project scope:

- For new sideroads being constructed through the development process, follow the general procedures for driveway and entrance permits; see Section 36-7.02 and the *Handbook for the Policy on Permits for Access Driveways to State Highways*.
- For new sideroad intersections being constructed as part of the state highway improvement, follow the design guidelines set forth throughout Chapter 36, as well as either New Construction/Reconstruction or 3R guidelines, as appropriate.
- For new sideroad intersections being constructed as a locally led project, see the *Bureau of Local Roads and Streets Manual*.

36-7.01(e) Construction Projects Involving Existing Sideroads

Construction projects involving existing sideroads intersecting a State highway should adhere to the following procedures, depending on project scope:

- Intersections with existing sideroads should be evaluated on all New Construction/Reconstruction projects using the design criteria presented throughout Chapter 36. Revisions should be made to the existing facility when operational and safety factors dictate.
- Intersections with existing sideroads should be evaluated on all 3R projects using the criteria presented in Section 49-3.06. Revisions should be made to the existing facility when operational and safety factors dictate.

	NON-COMMERCIAL RURAL	NON-COMMERCIAL URBAN	COMMERCIAL RURAL	COMMERCIAL URBAN	INDUSTRIAL-COMMERCIAL-RECREATIONAL HIGH-VOLUME TRAFFIC GENERATORS	STREETS AND SIDE ROADS
WIDTH OF DRIVE	12' Min. ⁽¹⁾ 24' Max.		35' Max. (60' Max. at 6' from Edge of Pavement)	35' Max. (85' Max. at Face of Curb)	2 @ 24' or 35' Max.	30' Min. Urban 24' Min. (Rural)
RADII OF FLARE	10' Min. ⁽²⁾ 30' Max.	5' Min. ⁽²⁾ 15' Max.	10' Min. ⁽²⁾ 40' Max.	10' Min. ⁽²⁾ 25' Max.	30' - 50' or 3-Centered Curve	
ANGLE OF DRIVE	60°-90°	45°-90° ⁽³⁾				
ISLAND AREA	---		10' Min. at ROW 5' Min. Radius (10' Min. 6' from Edge of Pavement)	6' Min. at Edge of Pavement and at ROW 5' Min. Radius	4' - 18' Wide Median	
DISTANCE FROM PROPERTY LINE (to any part of driveway or flare)	0' Min.		5' Min. (6' from Edge of Pavement)	3' Min.	10' Min.	---
DISTANCE FROM INTERSECTING STREET (edge of road to beginning of driveway flare)	50' Min.	5' Min. ⁽⁴⁾	50' Min.	---	100' Min.	---
	5' min. from beginning of flare to extension of intersecting road ROW					
DISTANCE BETWEEN DRIVES	---		10' Min. (6' from Edge of Pavement and at ROW)	6' min. (At Edge of Pavement and at ROW)	440' Min. 660' Desirable	

HORIZONTAL DESIGN GUIDELINES FOR ENTRANCES, DRIVEWAYS AND SIDE ROADS

**Figure 36-7.A
(US Customary)
(1 of 3)**

Notes:

- (1) The desirable width of field entrances (FE's) is 24' to allow for the use of oversized farm implements.
- (2) Non-commercial and low to moderate volume commercial entrances may be designed with a straight flare rather than radius.
- (3) 45° angle of intersection is permitted only for one-way drives. 60° is minimum for two-way drives.
- (4) This dimension is the undisturbed length of curb between the driveway flare and intersecting street flare.

HORIZONTAL DESIGN GUIDELINES FOR ENTRANCES, DRIVEWAYS AND SIDE ROADS**Figure 36-7.A****(US Customary)**

(2 of 3)

	NON-COMMERCIAL RURAL	NON-COMMERCIAL URBAN	COMMERCIAL RURAL	COMMERCIAL URBAN	INDUSTRIAL-COMMERCIAL-RECREATIONAL HIGH-VOLUME TRAFFIC GENERATORS	STREETS AND SIDEROADS
WIDTH OF DRIVE	3.6 m Min. ⁽¹⁾ 7.2 m Max.		10.6 m Max. (18.3 m Max. at 1.8 m from Edge of Pavement)	10.6 m Max. (25.9 m Max. at Face of Curb)	2 @ 7.2 m or 10.6 m Max.	9.1 m Min. (Urban) 7.2 m Min. (Rural)
RADII OF FLARE	3.0 m Min. ⁽²⁾ 9.1 m Max.	1.5 m Min. ⁽²⁾ 4.6 m Max.	3.0 m Min. ⁽²⁾ 12.2 m Max.	3.0 m Min. ⁽²⁾ 7.6 m Mix.	9.1 m - 15 m or 3-Centered Curve	
ANGLE OF DRIVE	60°-90°	45°-90° ⁽³⁾				
ISLAND AREA	---		3.0 m Min. at ROW 1.5 m Min. Radius (3.0 m Min. at 1.8 m from Edge of Pavement)	1.8 m Min. at Edge of Pavement and at ROW 1.5 m Min. Radius	1.2 m - 5.4 m Wide Median	
DISTANCE FROM PROPERTY LINE (to any part of driveway or flare)	0.0 m Min.		1.5 m Min. (1.8 m from Edge of Pavement)	900 mm Min.	3.0 m Min.	---
DISTANCE FROM INTERSECTING STREET (edge of road to beginning of driveway flare)	15 m Min.	1.5 m Min. ⁽⁴⁾	15 m Min.	---	30 m Min.	---
	1.5 m Min. from beginning of flare to extension of intersecting road ROW					
DISTANCE BETWEEN DRIVES	---		3.0 m Min. (1.8 m from Edge of Pavement and at ROW)	1.8 m Min. (At Edge of Pavement and at ROW)	135 m Min. 200 m Desirable	

HORIZONTAL DESIGN GUIDELINES FOR ENTRANCES, DRIVEWAYS AND SIDE ROADS (Metric)

Figure 36-7.A

(1 of 3)

Notes:

- (1) The desirable width of field entrances (FE's) is 7.2 m to allow for the use of oversized farm implements.
- (2) Non-commercial and low to moderate volume commercial entrances may be designed with a straight flare rather than radius.
- (3) 45° angle of intersection is permitted only for one-way drives. 60° is minimum for two-way drives.
- (4) This dimension is the undisturbed length of curb between the driveway flare and intersecting street flare.

HORIZONTAL DESIGN GUIDELINES FOR ENTRANCES, DRIVEWAYS AND SIDE ROADS (Metric)

Figure 36-7.A

(2 of 3)

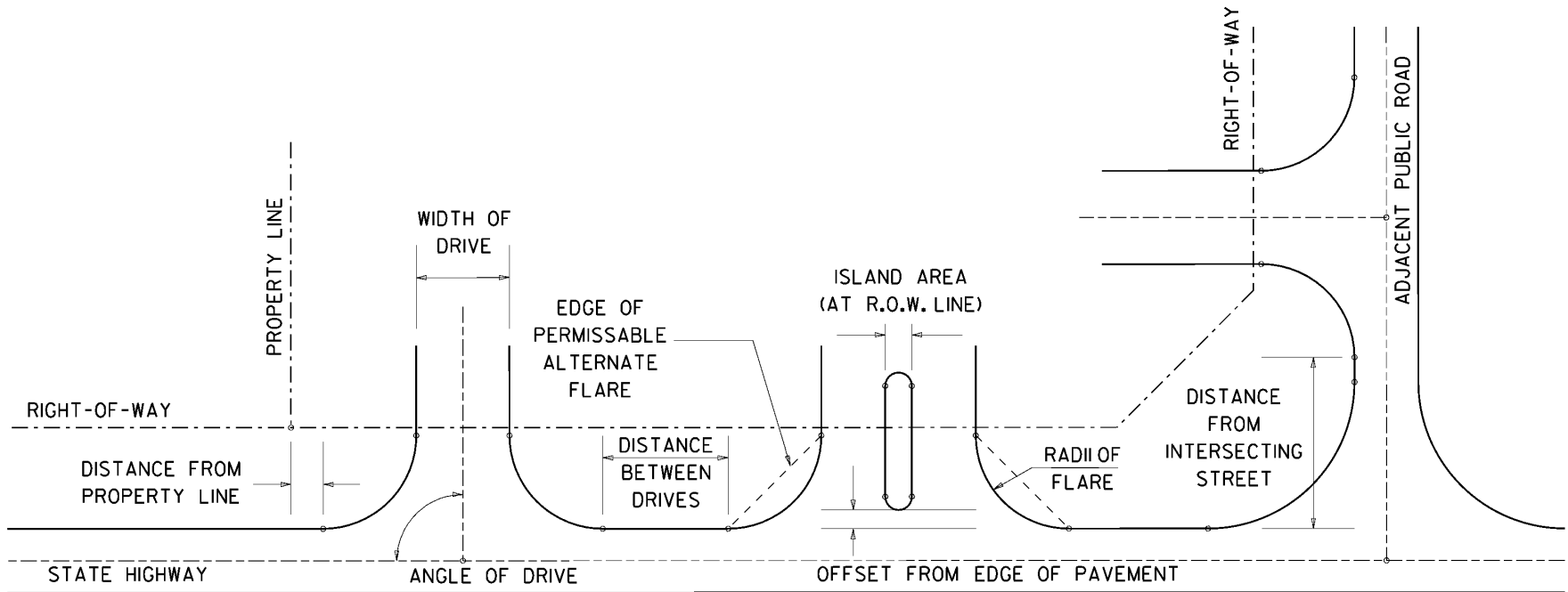

HORIZONTAL DESIGN GUIDELINES FOR ENTRANCES, DRIVEWAYS AND SIDE ROADS

Figure 36-7.A

(Figure Parameters)

(3 of 3)

36-7.01(f) Driveway Profiles

An important item to consider in the design of new entrances or the evaluation of existing entrances is the change in grade without a vertical curve.

Desirably, vertical curves should be used to connect slopes of different grades. Where the change in grade of the entrance is critical, the designer should insert a vertical curve to prevent a vehicle from bottoming out. To prevent drag, vertical curves should be used where a hump or dip is greater than 6 inches (150 mm) within a wheel base length of approximately 10 ft (3.0 m). To prevent center or overhang drag, with some allowance for load and bounce, crest vertical curves should not exceed a 3 inch (80 mm) hump in a 10 foot (3.0 m) chord, and sag vertical curves should not exceed a 2 inch (50 mm) depression in a 10 foot (3.0 m) chord. Based on these constraints, the maximum grade on driveways, and the maximum algebraic difference in grade where an omission of a vertical curve may be considered, are shown in Figure 36-7.B.

If sidewalks intersect with the driveway profile, the profile must be adjusted to fit policy sidewalk slope criteria. See Figure 36-7.C and the *Illinois Highway Standards* for compliant sidewalk details. Also Chapter 58 provides additional accessibility discussion.

For considerations in the design of sideroad profiles, see Section 36-1.06.

	Non-Commercial Rural	Non-Commercial Urban	Commercial Rural	Commercial Urban	High-Volume Commercial Entrance	Streets and Roads
Maximum Grade on Driveway Proper	12% (1)	8% (1)	10% (1)	6% (1)	4% (1)	Design as a Local Road
Maximum Algebraic Difference in Grades where Omission of Vertical Curve may be Considered	6%	8%	3%	6%	Use Vertical Curves See Section 36-7.01(d)	

(1) Note: If sidewalk or a side path is present adjacent to the entrance, the entrance grade used shall be broken to allow the extension of the sidewalk or side path through the entrance at a maximum cross slope of 2% (1.5% preferred). See Figure 36-7.C.

VERTICAL PROFILE GUIDELINES FOR ENTRANCES, DRIVEWAYS AND SIDE ROADS
Figure 36-7.B

**PROFILES FOR URBAN DRIVEWAYS
(ASSUMES PARALLEL SIDEWALK OR SIDEPATH)**

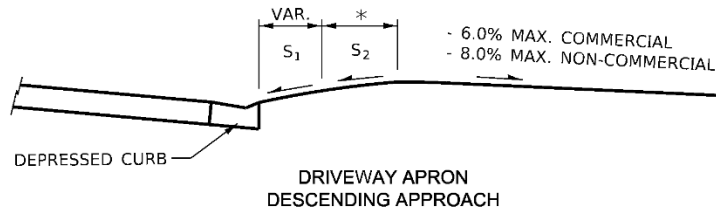

$S_1 = +1.5\%$ MIN.
 $+6.0\%$ MAX. COMMERCIAL
 $+8.0\%$ MAX. NON-COMMERCIAL
 $S_2 = +1.5\%$ PREFERRED
 $+2.0\%$ MAX.

$*$ + 5' (Typ.) (4' MIN.) FOR SIDEWALK
 7' - 12' TYP. FOR SIDE PATH (SEE FIG. 17-2.T)

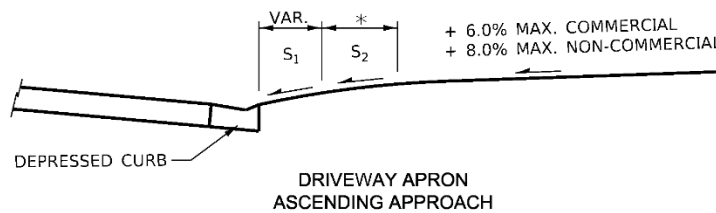

**PROFILES FOR RURAL DRIVEWAYS
(ASSUMES NO PARALLEL SIDEWALK OR SIDEPATH)**

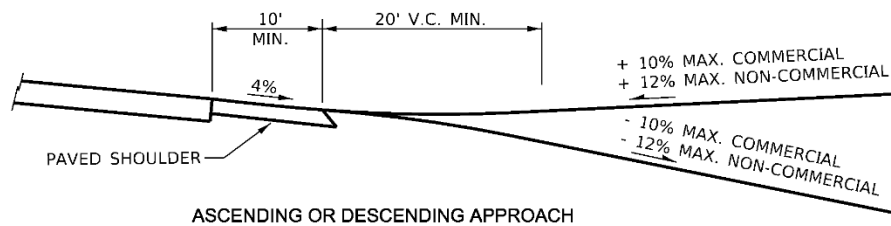

TYPICAL ENTRANCE PROFILES

Figure 36-7.C

36-7.01(g) Driveway Sight Distance

Section 36-6 discusses intersection sight distance (ISD) criteria for State highway intersections with public roads on new construction or reconstruction projects. Section 49-3.06(e) discusses intersection sight distance criteria for State highway intersections with public roads on 3R projects.

Desirably, these criteria, depending on project type, will also apply to intersection sight distances for exiting vehicles at driveways and entrances, however, the use of full intersection criteria may not always be practicable. It is important to check for sight obstructions (e.g., buildings, trees, hedges, bushes, fences, signs) in the vicinity of the driveway entrance which may restrict sight lines, and to reduce sight line constraints to the extent possible. To perform the check for exiting vehicles, it is reasonable to assume an eye location of approximately 12 ft (3.6 m) from the edge of traveled way. As a minimum, provide stopping sight distance (SSD) for an approaching vehicle on the traveled way to an exiting vehicle at a driveway. Locations of non-compliant sight distance identified during project development must still meet the lesser 3R SSD requirements found in Section 49-3.06(e). When driveway sight distance cannot be provided to the minimum 3R distances, note and discuss this issue at a district coordination meeting with warrant justification and documentation as a Level Two design exception. See Section 31-7 regarding the design exception process.

36-7.01(h) Auxiliary Lanes

Consider using deceleration and acceleration lanes at high-volume commercial entrances, especially on high speed or high volume arterials. Section 36-3 further discusses the design and guidelines for using auxiliary lanes. In addition to traffic-volume considerations, it may be necessary to provide a right-turn lane into a driveway if the change in grade is abrupt at the driveway entrance. Where a separate right-turn lane is provided, no part of the auxiliary lane taper should encroach on the radius return of an adjacent intersecting side road.

36-7.01(i) Typical Entrance Drawings

Closely spaced or improperly designed entrances may cause operational problems, especially when high volume roadways and/or high-volume driveways are involved. Also, operational and safety problems can result if driveways are located too close to side road intersections. As an aide in the design process, typical drawings have been developed and provided for various access scenarios. See the following for additional information:

- Illustrations 2 and 4 through 10 of the *Handbook for the Policy on Permits for Access Driveways to State Highways* provide typical entrance drawings applicable to both the design and permitting processes.
- Figures 35-7.E and 46-2.C give examples of right-in/right-out channelized driveways, which may be an effective alternative in improving safety and operations for entrances in close proximity to intersections.
- Figures 35-7.B through 35-7.I provide details of general access management scenarios that can be applied to commercial entrance design.

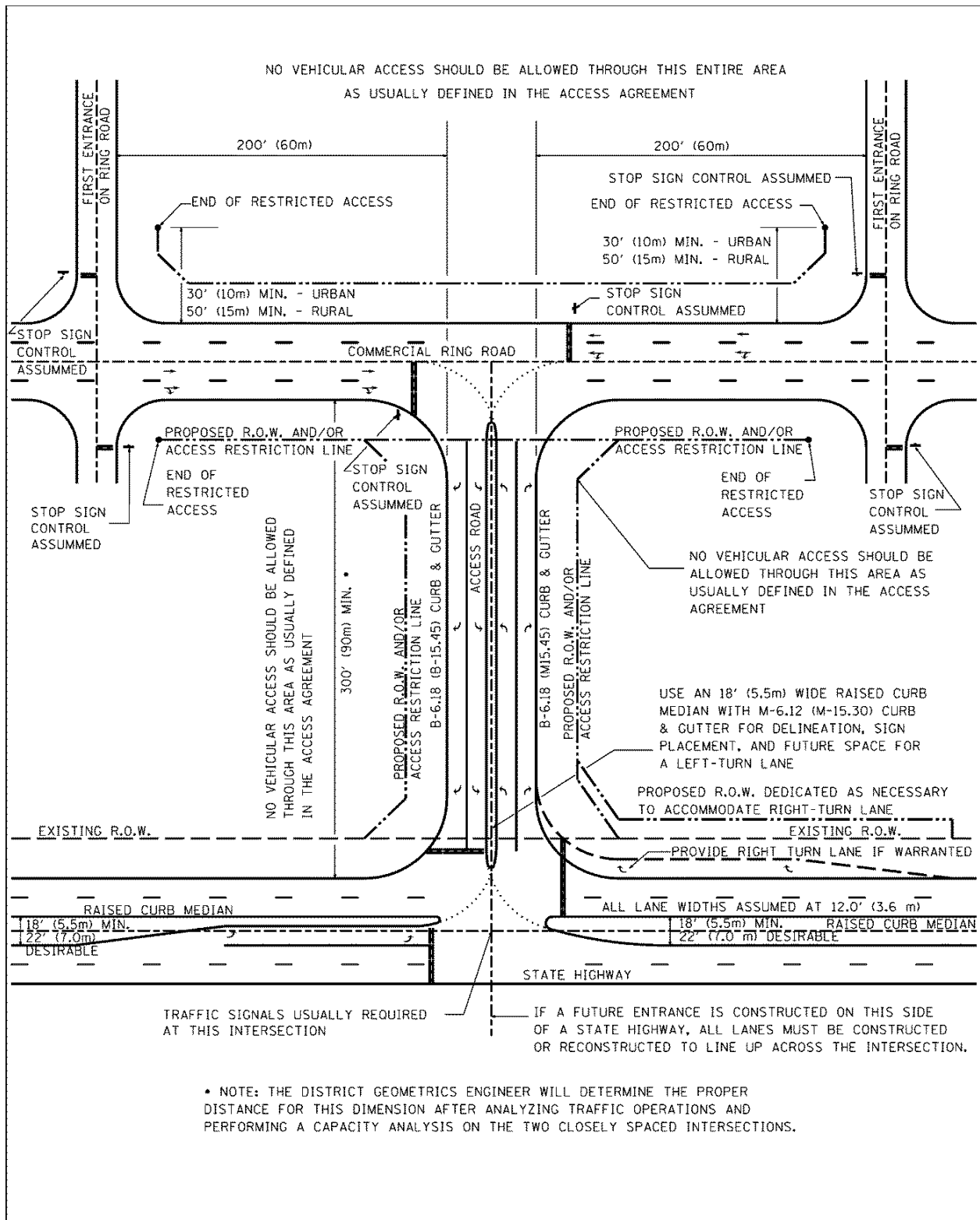

TYPICAL HIGH VOLUME COMMERCIAL ENTRANCE (TEE INTERSECTION TO A STATE HIGHWAY WITH NO ACCESS CONTROL)

Figure 36-7.D

Entrances to major developments adjacent to State highways are designed using the same criteria required for street intersections. Figure 36-7.D shows a typical design for a high-volume commercial entrance to a State highway. Modifications of this typical design are possible and would be dependent on specific factors such as the classification of the State highway, traffic flow characteristics of the two closely spaced intersections, results of a capacity analysis, potential for safety issues, and the potential immediate or future need for traffic signals on the ring road resulting in the need for proper vehicular storage.

36-7.02 Entrance/Driveway Access Permit Process

The State statutes listed in Section 36-7.01 grant the Department authority to permit driveways and entrances to State highways. The IDOT Bureau of Operations publication entitled, *Handbook for the Policy on Permits for Access Driveways to State Highways* contains the detailed procedures for obtaining new or revised access to State highways. The general procedure is noted below.

1. General Permitting Procedures. An access permit is required for the construction of any new access facility, or the revision of an existing access facility, within the right-of-way of a State highway when the work is to be done by any person or agency other than the Department. Such proposed entrance work is reviewed by district staff to ensure conformance with Departmental policies.

Access permits are issued by the permit's unit of the appropriate district office. In some cases where the curbing along a State highway is maintained by a municipality, permits for access work may be issued by that municipality with the Department's concurrence. The district office will advise an applicant of the appropriate issuing authority. In all cases where the proposed access is to a State highway, final jurisdiction concerning the permit will remain with the Department. No work shall be undertaken on State right-of-way until the person or agency has received an approved access permit and after a notice is provided to the permits unit that driveway construction is to begin.

An approved access permit only covers the use of entrances, driveways, and/or side roads for land uses as permitted. Changes in land use, land use density, or ownership typically void any individual permit and necessitate new permit applications. Within a development, access to individual parcels subsequently established must be by internal circulation. Therefore, include all phased development as part of an original permit in order to maintain the integrity of the access facility and avoid the reconstruction of the access facility in the future.

2. Procedures for Platting Developments. In accordance with the *Plat Act, 765 ILCS 205/2*, for municipalities with population less than one million, the local agency must submit the plat to the appropriate district's plats and plans office for approval, and the Department has 90 days to respond to the submittal in writing. Failure by the Department to respond within 90 days, once submitted, allows the public agency to approve the plat without Departmental concurrence. For municipalities with population greater than one million, Department approval is not required for the local agency to approve the plat, although

coordination with the Department is preferable to assure overall conformance to local and Departmental policies on land subdivision, safety, and access control.

3. Procedures for Major Developments. The approval process for a proposed access facility to a major development adjacent to a State highway is a two-part process.

The first part of the approval process for major developments involves initial planning. During this first phase, a traffic study, intersection design study, and hydraulic study may be required to be submitted by the developer for review and approval to both State and local roadway agencies.

The developer is required to meet and discuss the proposed development with the Department's district personnel prior to beginning such studies. It is recommended that appropriate local roadway agency representatives also be in attendance in order to discuss additional local regulations and access requirements. This preliminary meeting is held to discuss the Department's access permitting process and policy requirements well in advance of the developer's decisions on final arrangement of buildings, internal driveways, and parking facilities, and must involve the entire developable area rather than only a portion of the property or only along the State highway frontage of the proposed development. This helps to ensure that proposed access to the facility will operate satisfactorily beyond any proposed initial phase of development. The preliminary discussions provide a proposed framework for the required analysis and also help to ensure that the final entrance location(s) to the State highway and proposed layout of the development will be acceptable to both the Department and municipality, while also compatible with adjacent land development.

The meeting discussion should also include the need for, and requirements of, hydraulic, traffic, and intersection design studies for the proposed development. These studies shall be completed by the developer's engineering consultant at the developer's expense and submitted to the district's permit unit for review, coordination, and approval. The permits unit will forward the studies to other district bureaus and units as necessary for adequate review to ensure all Departmental policies are met.

The planning documents that may need to be submitted, depending on project scope and size, are:

- a. Hydraulic Study. Drainage collected by ditches, gutters, or pipes on private property shall not be discharged into the highway drainage system unless expressly approved by the Department. The hydraulic study must include all calculations necessary in assessing stormwater run-off for the proposed facility and for mitigating potential increases in flow or flow-rate onto the State system. The study must show that proposed storm water detention is provided on private property and that runoff which enters the State's drainage system does not exceed that which naturally occurs from the property to be developed.
- b. Traffic Study. The traffic study must project traffic being generated by the proposed development out to a 20-year design life from the date of proposed

construction (as mandated in Figure 31-4.A), assess warrants for the potential mitigation of development traffic through permitted improvements such as the addition of travel lanes or traffic signals, and propose potential locations of development ingress/egress that meet Department operational and safety criteria for both the mainline and side road or entrance. Depending on traffic being generated by the proposed development, the developer's engineer may need to analyze additional intersections adjacent to the proposed development to assess potential impacts to capacity and public safety. These requirements will be discussed at the initial meeting with the Department.

After the initial meeting, and only after total site traffic is submitted to and reviewed and approved by district personnel, shall the developer's engineering consultant use the capacity analysis results of the traffic study to assess and recommend proposed locations of optimal ingress/egress, and the need, in accordance with IDOT policy, for mitigation of development traffic through permitted improvements. Potential improvements may consist of additional lanes or existing lane extensions (both through and/or turn lanes) or modifications to existing traffic control, including the addition of traffic signals or proposed changes to existing traffic signal timing.

- c. Intersection Design Study. Only after completion and approval of the traffic study, can work begin on the intersection design study (IDS), if required. See Chapter 14 for IDS warrants and requirements.

The second part of the approval process for major developments involves the preparation of detailed design construction plans for the entrance or new intersection. The detailed design, including intersection or entrance details and design of the stormwater runoff and detention system(s) for the development, must be one which provides good service to users while at the same time minimizes interference to the safe and efficient movement of through highway traffic. This second part of the process requires obtaining an entrance permit pursuant to the *Illinois Highway Code, 605 ILCS 5/4-210*. See the *Handbook for the Policy on Permits for Access Driveways to State Highways* for a typical example of a highway permit application. See Figure 36-7.D for a typical example of an entrance to a major development.

In addition to the guidelines listed above, an Access Agreement is also required for most major developments. The district permits unit will be responsible for preparing and finalizing an Access Agreement with the developer. See the *Handbook for the Policy on Permits for Access Driveways to State Highways* for a typical example of an Access Agreement. The Access Agreement must be signed by the developer before an access permit can be issued for this type of entrance or new intersection.

4. Access Restrictions for Major Developments. With any new major access point, it is important to consider managing access to the development to preserve the operational integrity of the highway system. This is most easily achieved by an entrance or side road design which will minimize the likelihood of traffic queuing out onto the highway from the development and will not provide inordinate vehicular delay or deficient levels of service through the standard 20-year design period. See Section 31-4.02 regarding design year

selection. See Section 31-4.04 regarding Level of Service criteria.

As an aide to ensure operational integrity of both routes upon initial construction of the proposed development and in the future, a restriction to full access should be created along the proposed development entrance or side road for a sufficient distance beyond the nearest mainline edge of travel way. This access restriction dimension is typically established at 300 ft (90 m) minimum, but can be increased as needed based on proposed side road traffic and capacity; see Figure 36-7.D. The access restriction is generally defined within the Intersection Design Study completed for the proposed intersection, and is also placed as a note and dimension on the subdivision plat at the time of development. The access restriction is then established as part of the plat of right-of-way dedication for the proposed entrance or side road following general Land Acquisition guidelines. For more on the Department's access management principles; see Section 35-6.

36-8 INTERSECTION DESIGN NEAR RAILROADS

These design guidelines apply to all State highway geometric improvement projects where the route is adjacent and parallel to a railroad. Where an at-grade railroad crossing is within 200 ft (60 m) of an intersection, the design should address efforts to keep vehicles from stopping or storing on the tracks. This applies to either signal- or stop-controlled intersections. Intersection designs within 200 ft (60 m) of a grade crossing, or greater than 200 ft (60 m), if capacity and queuing analyses determine that queuing will be possible over the grade crossing, should be coordinated with the Illinois Commerce Commission's Railroad Safety Section as soon as possible during the design phase. For roundabout intersections near railroads; see Section 36- 9.02 (d).

The following factors should be identified and considered during the planning stages:

1. Clear Storage Distance. Consider alternative designs that provide a minimum distance of 75 ft (23 m) between the proposed intersection stop bar and a point 6 ft (1.8 m) from the closest rail.
2. Space for Vehicular Escape. On the far side of any railroad crossing, consider providing an escape area for vehicles (e.g., shoulder with curb and gutter behind the shoulder, flush medians, flush-corner islands, right-turn acceleration lanes, improved corner radii).
3. Conflicting Commercial Access. Left-turn vehicular movements that may inhibit the clearance of queued traffic on the approaches to railroad tracks should be discouraged. If entrances exist on the street approach, consider using design features that would eliminate the problems (e.g., left-turn lane, raised-curb median). Entrances should be placed at a sufficient distance from an at-grade railroad crossing to ensure that the turning path of a passenger vehicle is completed and on tangent at the stop line in advance of the warning devices. No part of an entrance should be placed closer to the track(s) than the warning devices or the stop line extended perpendicular to the roadway centerline, except in the case of entrances used exclusively by railroads to access railroad property.
4. Pre-Signal Traffic Signals. Pre-signals should be installed at a grade crossing where the distance between the stop bar and the nearest rail is 56 ft (17.0 m) or less. If the crossing is on a State highway, or if a high percentage of multi-unit vehicles cross the tracks, then pre-signals should be installed where the distance between the stop bar and the nearest rail is 81 ft (24.7 m) or less. If pre-signals are required on the near side of the tracks, a raised-curb median may be necessary adjacent to the tracks to provide for proper placement of signals. When pre-signals are included in the design, all left turn movements must be designed as protected only for all legs (or split-phase on the highway-railroad grade crossing legs in conjunction with protected only left turns on the parallel street). Exceptions to some of these requirements may include the use of 4-quadrant gates at the highway-railroad grade crossing and/or the use of flashing yellow arrows on the street paralleling the tracks. Flashing yellow arrow designs (protected-permitted or permitted left-turn phasing) on the street paralleling the tracks may be considered as long as a red left arrow is displayed towards the crossing during the entire railroad preemption sequence. The pre-signal indications terminate before the associated downstream intersection indications terminate on a cycle-by-cycle basis. This should be simulated in

the corresponding capacity analysis as extended amber and all-red times (12-14 seconds per pre-signal phase terminated), which can lead to significant delay and detrimental level-of-service results. This will affect required storage length calculations for many movements as overall intersection delay will significantly increase. Storage length calculations on the highway-railroad grade crossing leg shall not include the area between the pre-signal and intersection.

5. Restricted Intersection Capacity. During periods of frequent railroad preemption of traffic signals, consider the effects of reduced traffic flow, lack of progression on the street paralleling the tracks, and traffic backups. Available computer programs should be used to analyze different capacity and operational scenarios and to recommend any countermeasures. Plans for geometric changes proposed at or near intersections having railroad preemption of traffic signals should be coordinated with the Illinois Commerce Commission's Railroad Safety Section.
6. Sight Restrictions. Review and analyze sight distance triangles along railroad tracks and eliminate any restrictions. Guidance on this analysis can be found in AASHTO, *A Policy on Geometric Design of Highways and Streets*. Notify the ICC of any obstructions on railroad right-of-way.
7. Protected Left-Turn Storage. On the street that parallels the tracks, analyze the storage length needed for left-turns into the side street and across the tracks during preemption of the traffic signals. Without the proper storage length available, this could cause backups into the through lanes.
8. Right-Turn Lanes. On the street which runs parallel to the railroad and where an actuated NO RIGHT TURN SIGN is proposed in conjunction with railroad preemption, a right-turn lane should be considered for the right-turn movement across the tracks. The auxiliary lane provides a refuge for right-turning vehicles during railroad preemption and eliminates the problem of traffic temporarily blocking the through lanes.
9. Side Street Left-Turn Lane Capacity. On streets that cross railroad tracks, provide sufficient left-turn storage lengths that will avoid the problem of left turns spilling out onto through lanes and blocking the through lanes.
10. Other. See the Bureau of Operations *Policies and Procedures Manual* and memorandum for additional information.

36-9 ROUNDABOUTS

36-9.01 General

Roundabouts are a type of circular intersections in which traffic travels counterclockwise (in right-hand traffic countries) around a central island. Specific design and traffic control features define and distinguish roundabouts from traffic circles. These features include yield control of all entering traffic, channelized approaches that deflect traffic flow, and appropriate geometric curvature to ensure that travel speeds on the circulatory roadway are typically less than 30 mph (50 km/hr). Figure 36-9.A illustrates the key components of a roundabout.

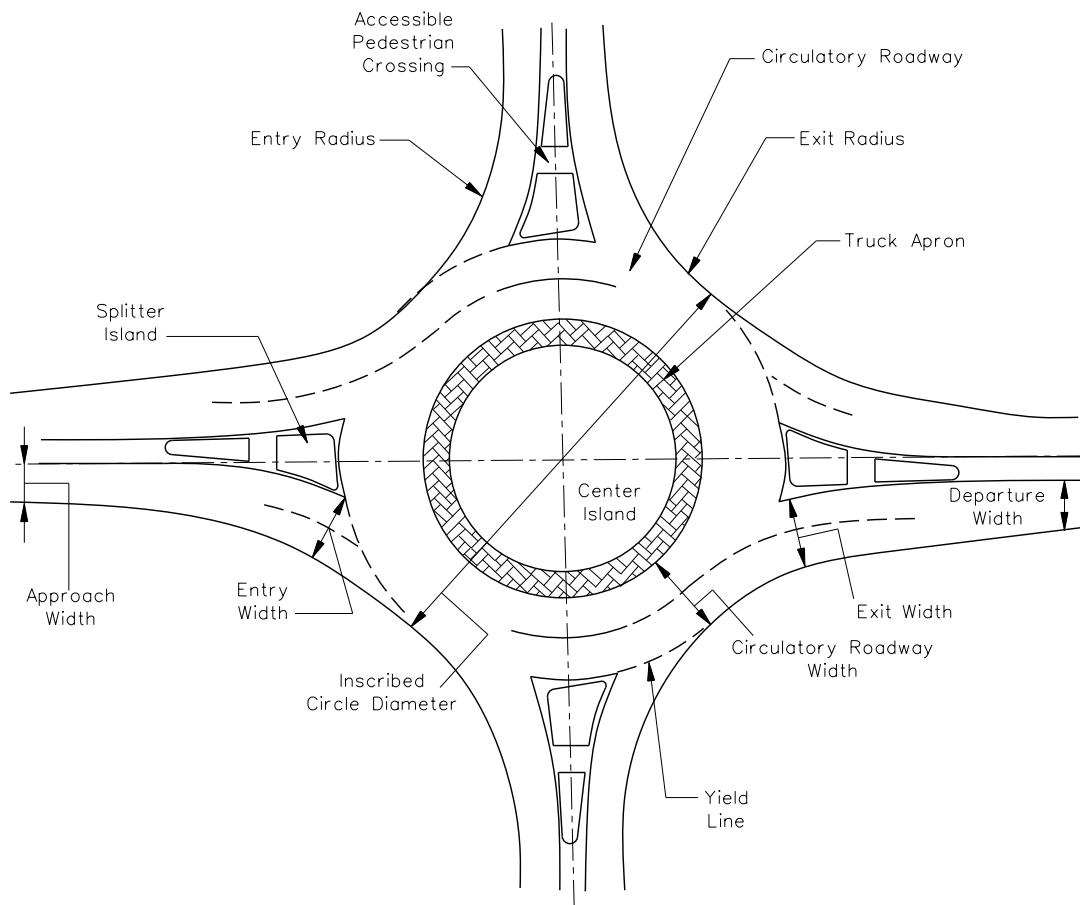

ROUNDABOUT ELEMENTS

Figure 36-9.A

When operating within their capacity, roundabouts typically operate with lower vehicle delays than other intersection forms and control types. With no conflicts within a roundabout it is unnecessary for traffic to come to a complete stop. When queues exist at one or more approaches, traffic within the queues usually continues to move, and this is typically more tolerable to drivers than a stopped or standing queue.

Studies have shown that compared to other types of intersections, roundabouts have:

Improved safety:

- Elimination of high conflict angles;
- Lower operating speeds; and
- Fewer vehicular conflict points.

Reduced congestion:

- Efficient during peak hours and other times, and
- Typically less delay.

Reduced pollution and fuel use:

- Fewer stops and hard accelerations, and
- Less time idling.

Reduced costs:

- No signal equipment to install, power, and maintain, although some savings may be offset by the need and cost of illumination;
- Smaller roundabouts may require less right-of-way than traditional intersections; and
- Often less pavement needed.

Complement other common community values:

- Quieter operation, and
- More functional and aesthetically pleasing.

Public acceptance of roundabouts is often one of the biggest challenges facing a jurisdiction that is planning to install its first roundabout. Without the benefit of explanation or first-hand experience and observation, the public is likely to incorrectly associate roundabouts with older, nonconforming traffic circles that they have either experienced or about which they have heard. Equally possible, without adequate education, the public (and agencies alike) will often have a natural hesitation or resistance against changes in their driving behavior and driving environment. In this situation, a proposal to install a roundabout may initially experience a negative public reaction. However, the history of the first few roundabouts installed in the United States also indicated that public attitude toward roundabouts improved significantly after construction. A survey conducted of jurisdictions across the United States reported a significant negative public attitude toward roundabouts prior to construction (68% of the responses were negative or very negative), but a positive attitude after construction (73% of the responses were positive or very positive).

36-9.02 Roundabout Selection

36-9.02(a) Comparison of Performance of Alternative Intersection Types

A roundabout is often compared to other intersection types, usually either a stop- or signal-controlled intersection. To simplify the selection process, the following generalized information is offered for a planning-level operational comparison of control modes:

- A roundabout will almost always provide a higher capacity and lower delays than all-way stop-controlled operating with the same traffic volumes.
- A roundabout is unlikely to offer better performance in terms of lower overall delays than two-way stop control (TWSC) at intersections with minor movements (including cross-street entry and major-street left turns) that are not experiencing, nor predicted to experience, operational problems under TWSC.
- A single-lane roundabout may be assumed to operate within its capacity at any intersection that does not exceed the peak-hour volume warrant for signals.
- A roundabout that operates within its capacity will generally produce lower delays than a signalized intersection operates with the same traffic volumes and right-of-way limitations.

Unlike traffic signal control, there are no warrants for roundabouts currently included in the ILMUTCD. Each roundabout must be justified on its own merits as the most appropriate intersection treatment alternative.

36-9.02(b) Selection Consideration Factors

In determining whether to use a roundabout or a more traditional intersection at a site, consider the following:

1. **Safety**. The frequency of crashes at an intersection is related to the number of conflict points at an intersection, as well as the magnitude of conflicting flows at each conflict point. A conflict point is a location where the paths of two vehicles, or a vehicle and a bicycle or pedestrian diverge, merge, or cross each other. For example, the number of vehicle-vehicle conflict points for four-leg intersections drops from 32 to 8 with roundabouts, a 75% decrease. Fewer conflict points mean fewer opportunities for collisions. Also, a roundabout has zero vehicle crossing points.

The severity of a collision is determined largely by the speed of impact and the angle of impact. The higher the speed and the higher the angle of impact the more severe the collision. Roundabouts reduce in severity or eliminate many severe conflicts that are present in traditional intersections.

2. **Construction Costs**. The costs of installing roundabouts will vary significantly from site to site. A roundabout may cost more or less than a traffic signal, depending on the amount of new pavement area and the extent of other roadway work required. At some existing

unsignalized intersections, a traffic signal can be installed without significant modifications to the pavement area or curbs. In these instances, a roundabout is likely to be more costly to install than a traffic signal, as the roundabout can rarely be constructed without significant pavement and curb modifications. Consideration of maintenance and power should be included with the long-term signal costs.

However, at new sites, and at signalized intersections that require widening at one or more approaches to provide additional turn lanes, a roundabout can be a comparable or less expensive alternative. While roundabouts typically require more pavement area at the intersection, they may require less pavement width on the upstream approaches and downstream exits if multiple turn lanes associated with a signalized intersection can be avoided. The cost savings of reduced approach roadway widths is particularly advantageous at interchange ramp terminals and other intersections adjacent to grade separations where wider roads may result in larger bridge structures.

In most cases, a roundabout is more expensive to construct than the two-way or all-way stop-controlled intersection alternatives.

3. Movements. Roundabouts tend to treat all movements at an intersection equally. Each approach is required to yield to circulating traffic, regardless of whether the approach is a local street or major arterial. In other words, all movements are given equal priority. This may result in more delay to the major movements than might otherwise be desired.

This problem is most acute at the intersection of high-volume major streets with low- to medium-volume minor streets (e.g., major arterial streets with minor collectors or local streets). Therefore, the overall street classification system and hierarchy should be considered before selecting a roundabout (or stop-controlled) intersection. This limitation should be specifically considered on emergency response routes in comparison with other intersection types and control. The delays depend on the volume of turning movements and should be analyzed individually for each approach.

4. Vehicle Delay and Queue Storage. When operating within their capacity, roundabout intersections typically operate with lower vehicle delays than other intersection forms and control types. With a roundabout, it is unnecessary for traffic to come to a complete stop when no conflicts are present. Where there are queues on one or more approaches, traffic within the queues usually continues to move. This is typically more tolerable to drivers than a stopped or standing queue. The performance of roundabouts during off-peak periods is particularly good in contrast to other intersection forms, typically with very low average delays.
5. Signal Progression and Access. It is common practice to coordinate traffic signals on arterial roads to minimize stops and delay to through traffic on the major road. By requiring coordinated platoons to yield to traffic in the circulatory roadway, the introduction of a roundabout into a coordinated signal system may disperse and rearrange platoons of traffic if other conflicting flows are significant, thereby reducing progressive movement. To minimize overall system delay, it may be beneficial to divide the signal system into subsystems separated by the roundabout, assigning each subsystem its own cycle.

The traffic performance of the combination roundabout-signal system should be tested in advance with traffic modeling software. In some cases, total delay, stops, and queues will be reduced by the roundabout. The number of available gaps for midblock unsignalized intersections and driveways may also be reduced by the introduction of roundabouts, although this may be offset by the reduced speeds near roundabouts. In addition, roundabouts can enable safe and quick U-turns that can substitute for more difficult midblock left turns, especially where there is no left turn lane.

6. Environmental Factors. Roundabouts may provide environmental benefits if they reduce vehicle delay and the number and duration of stops compared with another alternative. Even where there are heavy volumes, vehicles continue to advance slowly in moving queues rather than coming to a complete stop. This may reduce noise and air quality impacts and fuel consumption significantly by reducing the number of acceleration/deceleration cycles and the time spent idling. In general, if stop or yield control is insufficient, traffic through roundabouts generates less pollution and consumes less fuel than traffic at fixed-time signalized intersections. However, vehicle-actuated signals typically cause less delay, less fuel consumption, and fewer emissions than roundabouts as long as traffic volumes are low. During busy hours, vehicle-actuated signals tend to operate like fixed-time signals, and the percentage of cars that must stop becomes high.
7. Space Requirements. Roundabouts usually require more space for the circular roadway and central island than the rectangular space inside traditional intersections. Therefore, roundabouts may have a significant right-of-way impact on the corner properties at the intersection, especially when compared with other forms of unsignalized intersection. The dimensions of a traditional intersection are typically comparable to the envelope formed by the approaching roadways. However, to the extent that a comparable roundabout would outperform a signal in terms of reduced delay and thus shorter queues, it will generally require less queue storage space on the approach legs.

If a signalized intersection requires long and/or multiple turn lanes to provide sufficient capacity or storage, a roundabout with similar capacity may require less space on the approaches. As a result, roundabouts may reduce the need for additional right-of-way on the links between intersections, at the expense of additional right-of-way requirements at the intersections themselves. The right-of-way savings between intersections may make it feasible to accommodate parking, wider sidewalks, planter strips, wider outside lanes, and/or bicycle lanes in order to better accommodate pedestrians and/or bicyclists. Another space-saving strategy is the use of flared approach lanes to provide additional capacity at the intersection while maintaining the benefit of reduced spatial requirements upstream and downstream of an intersection.

At interchange ramp terminals, paired roundabouts have been used to reduce the number of lanes in freeway over- and underpasses. In compact urban areas, there are typically signalized intersections at both ends of overpass bridges, necessitating two additional overpass lanes to provide capacity and storage at the signalized intersections.

8. Older Drivers. Roundabouts assist older drivers by reducing the speed at the intersection (i.e., conditions change more slowly allowing for more time to make proper responses), providing less complicated situations and decision-making, judging gaps is easier and mistakes are rarely fatal, providing less demand to accurately judge speeds of traffic, and reducing the required visual scans.
9. Corner Property Access. Access to corner properties may be restricted or require driveways to be offset at roundabouts due to the prohibition of driveways within the circulatory roadway.
10. Operations and Maintenance Costs. Compared to signalized intersections, a roundabout does not have signal equipment that requires constant power, periodic light bulb and detection maintenance, and regular signal timing updates. Roundabouts, however, can have higher landscape maintenance costs, depending on the degree of landscaping provided on the central island, splitter islands, and perimeter. Illumination costs for roundabouts and signalized intersections are similar.

Drivers sometimes face a confusing situation where they approach a signalized intersection during a power failure, but such failures have minimal temporary effect on roundabouts or any other unsignalized intersections, other than the possible loss of illumination. The service life of a roundabout is significantly longer, approximately 25 years, compared with 10 years for a typical signal.

11. Traffic Calming. A series of roundabouts can have secondary traffic calming effect on streets by reducing vehicular speeds. Speed reduction at roundabouts is caused by geometry rather than by traffic control devices or traffic volume. Consequently, speed reduction can be realized at all times of day and on streets of any traffic volume. It is difficult to speed through an appropriately designed roundabout with raised channelization that forces vehicles to physically change direction. In this way, roundabouts can complement other traffic calming measures.

Roundabouts have also been used successfully at the interface between rural and urban areas where speed limits change. In these applications, the traffic calming effects of roundabouts force drivers to slow and reinforce the notion of a significant change in the driving environment.

12. Aesthetics. Roundabouts offer the opportunity to provide attractive entries or centerpieces to communities. However, hard objects in the central island directly facing the entries are a safety hazard. The portions of the central island and, to a lesser degree, the splitter islands that are not subject to sight-distance requirements offer opportunities for aesthetic landscaping. Pavement textures can be varied on the aprons as well. They can also be used in tourist or shopping areas to facilitate safe U-turns and to demarcate commercial uses from residential areas. Avoid “attractive nuisances” in the central island, which could attract pedestrians to cross the circulating roadway for closer inspection.
13. Pedestrian Conflicts. If a queuing analysis determines frequent interruptions from pedestrians to the traffic flow at the exit, causing traffic to regularly back into the circulatory

roadway, consideration should be given to a conventionally controlled intersection instead of a roundabout.

36-9.02(c) Locations

Consider providing roundabouts at intersections having one of more of the following conditions:

- intersections with high crash rates/high severity rates;
- intersection with complex geometry (e.g., more than four approaches);
- rural intersections with high-speed approaches;
- freeway interchange ramp terminals;
- closely spaced intersections;
- closely spaced offsetting intersections;
- replacement of all-way stops;
- replacement of signalized intersections;
- at intersections with high left-turn volumes;
- replacement of two-way stops with high side-street delay;
- intersections with high U-turn movements;
- transitions from higher-speed to lower-speed areas (traffic calming);
- where aesthetics are important; and
- where accommodating older drivers is an objective.

Roundabouts are not appropriate everywhere. Intersections that may not be good candidates include those with topographic or site constraints that limit the ability to provide appropriate geometry, those with highly unbalanced traffic flows (i.e., very high traffic volumes on the main street and very light traffic on the side street), and isolated intersections in a network of traffic signals.

Roundabouts often require more space in the immediate vicinity of the intersection than a comparable stop-controlled or signalized intersection. This space requirement is dictated by a number of factors, including the size and shape of the roundabout (e.g., circular versus noncircular). However, in the context of a corridor, the additional space needed in the vicinity of a roundabout may be offset by reduced space needed between intersections.

36-9.02(d) Types

1. Single-lane. A single-lane roundabout can be assumed to operate acceptably if the sum of the entering and circulating volumes for each approach is less than 1000 vph. Maximum entering design speeds based on a theoretical fastest path [fastest path discussed in Section 36-9.04(b)] of 20 mph to 25 mph (30 km/hr to 40 km/hr) are recommended at single-lane roundabouts. Generally, the diameter of the inscribed circle of a single-lane roundabout ranges from 105 ft to 150 ft (32 m to 46 m) with the larger size capable of accommodating a WB-67 (WB-20) design vehicle. The typical maximum service volume is 25,000 vpd.

Single-lane roundabouts are much simpler for bicyclists than multilane roundabouts since they do not require bicyclists to change lanes to make left-turn movements or otherwise select the appropriate lane for their direction of travel. In addition, at single-lane roundabouts, motorists are less likely to cut off bicyclists when exiting the roundabout. These are important factors for selecting a single-lane roundabout over a multi-lane roundabout in the short term, even when long-term traffic predictions suggest that a multilane roundabout may be desirable.

2. **Multilane.** Multilane roundabouts have at least one approach with at least two lanes on the entries or exits. Multilane roundabout design tends to be less forgiving than single-lane roundabout design. Geometry, pavement markings, and signs must be designed together to create a comprehensive system to guide and regulate road users who are traversing roundabouts.

Key considerations for all multilane roundabouts include:

- Lane arrangements to allow drivers to select the appropriate lane on approach and navigate through the roundabout without changing lanes.
- Alignment of vehicles at the entrance line into the correct lane within the circulatory roadway.
- Accommodation of side-by-side vehicles through the roundabout.
- Alignment of the legs to prevent exiting-circulating conflicts.
- Accommodation for all travel modes.

At multilane roundabouts, maximum entering design speeds of 25 mph to 30 mph (40 km/hr to 50 km/hr) are recommended based on a theoretical fastest path [fastest path discussed in Section 36-9.04(b)] assuming vehicles ignore all lane lines. Generally, the inscribed circle diameter of a multilane roundabout ranges from 150 ft to 250 ft (46 m to 76 m). Roundabouts with three-or-four-lane entries may require larger diameters of 180 ft to 350 ft (55 m to 100 m) to achieve adequate speed control and alignment. The typical maximum service volume for a two-lane roundabout is 45,000 vpd.

3. **Mini.** With a diameter less than 100 ft, the mini roundabout is smaller than the typical single-lane roundabout. The smaller diameter is made possible by the use of a fully traversable central island to accommodate large vehicles, as opposed to the typical single-lane roundabout where the diameter must be large enough to accommodate a multi-unit within the circulatory roadway (and truck apron if applicable) without it needing to travel over the central island. The small footprint of a mini-roundabout offers flexibility in working within constrained sites. The typical maximum service volume is 15,000 vpd.

36-9.03 Public Involvement

Public acceptance of roundabouts is often one of the biggest challenges facing a jurisdiction that is planning to install its first roundabout, thus the use of Context Sensitive Solution principles is

recommended for regions new to roundabout operations. Without the benefit of explanation or first-hand experience and observation, the public (and agencies alike) is likely to incorrectly associate roundabouts with older, non-conforming traffic circles that they have either experienced or heard about.

In such a situation, a proposal to install a roundabout may initially experience a negative public reaction. However, the history of roundabouts installed in the United States also indicates that public attitude toward roundabouts typically improves significantly after construction. Surveys conducted by the Insurance Institute for Highway Safety reported a significant negative public attitude toward roundabouts prior to construction (41% oppose), but a positive attitude after construction (63% positive or very positive).

A variety of techniques have been used successfully in the United States to inform and educate the public about new roundabouts. Some of these include public meetings, websites, informational brochures and videos, and announcements in the newspaper or on television and radio. A public involvement process should be initiated as soon as practical, preferably early in the planning stages of a project while other intersection forms are being considered.

The FHWA has brochures promoting roundabouts available for distribution at public meetings as well as informational videos for viewing. If a roundabout has been constructed in the vicinity, make recommendations for the public to visit the site or discuss with officials within the jurisdiction in which the roundabout is located. Include animated traffic software to show roundabout operations. Other states have created informational videos and brochures of their own which they have used successfully.

36-9.04 Geometric Design

The geometric design of a roundabout requires the balancing of competing design objectives. Designing a roundabout is a process of determining the optimal balance between safety provisions, operational performance, accommodation of the design vehicle, and consideration of non-motorized travel modes.

Roundabout design is an iterative process where a variety of design objectives must be considered and balanced within site-specific constraints. Individual geometric components are not independent of each other; the interaction between the components of the geometry is more important than the individual pieces. Favoring one component of design may negatively affect another. When developing a design, the trade-offs of safety, capacity, cost and so on must be recognized and assessed throughout the design process. A common example of such a trade-off is accommodating large trucks on the roundabout approach and entry while maintaining low design speeds. Increasing the entry width or entry radius to better accommodate a large truck may simultaneously increase the speeds that passenger vehicles enter the roundabout. Therefore, the designer must balance these competing needs and may need to adjust the initial design parameters. To both accommodate the design vehicle and maintain low speeds, additional design modifications could be required, such as offsetting the approach alignment to the left or increasing the inscribed circle diameter of the roundabout.

Once a roundabout location, an initial inscribed diameter, and approach alignment are identified, the design can be more fully developed to include establishing the entry widths, circulatory roadway width, and initial entry and exit geometry. Once the initial designs for the entries and exits on each approach have been laid out, performance checks should be undertaken to evaluate the design versus the principles (including fastest path and design vehicle accommodation) to identify any required design refinements. Based on the performance checks, it may be necessary to perform design iterations to adjust the inscribed circle diameter, approach alignments, roundabout locations, and/or entry and exit design to improve the composition of the design.

36-9.04(a) Design Speed

A well-designed roundabout reduces vehicle speeds upon entry and achieves consistency in the relative speeds between conflicting traffic streams by requiring vehicles to negotiate the roundabout along a curved path. Speed management is often a combination of managing speeds at the roundabout itself and managing speeds on the approaching highways. In urban settings, entering vehicles negotiate a curve sharp enough to slow speeds to about 15 mph to 20 mph (25 km/hr to 30 km/hr); in rural settings, entering vehicles may be held to somewhat higher speeds of 30 mph to 35 mph (50 km/hr to 55 km/hr). Within the roundabout and as vehicles exit, low speeds are maintained by the deflection of traffic around the center island and the relatively tight radius of the roundabout at the exit lanes. Low speeds aid in the smooth movement of vehicles into, around, and out of a roundabout.

Maximum entering design speeds based on a theoretical fastest path of 20 mph to 25 mph (30 km/hr to 40 km/hr) are recommended at single-lane roundabouts. At multilane roundabouts, maximum entering design speeds of 25 mph to 30 mph (40 km/hr to 50 km/hr) are recommended based on a theoretical fastest path assuming vehicles ignore all lane lines.

36-9.04(b) Vehicle Paths

1. Natural Path. The natural path is the path approaching vehicles will tend to naturally take through the roundabout geometry, assuming there is traffic in all approach lanes. The natural path does not have sudden changes in curvature. It has transitions between tangents and curves and between consecutive reversing curves. Secondly, it means that consecutive curves should be of similar radius. If a second curve has a significantly smaller radius than the first curve, the driver may be traveling too fast to negotiate the turn and may not be able to stay within the lane.

With single-lane roundabouts, it is relatively simple to achieve the speed objectives. With a single traffic stream entering and circulating, there is no conflict between traffic in adjacent lanes. The outside curb line of the entry is commonly designed curvilinearly tangential to the outside edge of the circulatory roadway. Likewise, the projection of the inside (left) edge of the entry roadway is commonly curvilinearly tangential to the central island. Figure 36-9.B shows a typical single-lane roundabout entrance design.

A good multilane entry design aligns vehicle into the appropriate lane within the circulatory roadway. Likewise, the design of the exits should also provide appropriate alignment to allow drivers to intuitively maintain the appropriate lane. These alignment considerations often compete with the fastest path speed objectives.

A useful surrogate used by some practitioners for capturing the effects of entry speed, path alignment, and visibility to the left is the entry (ϕ) angle. Typically, entry angles are between 20 and 40 degrees. The entry (ϕ) angle is discussed in Section 36-9.4(h).

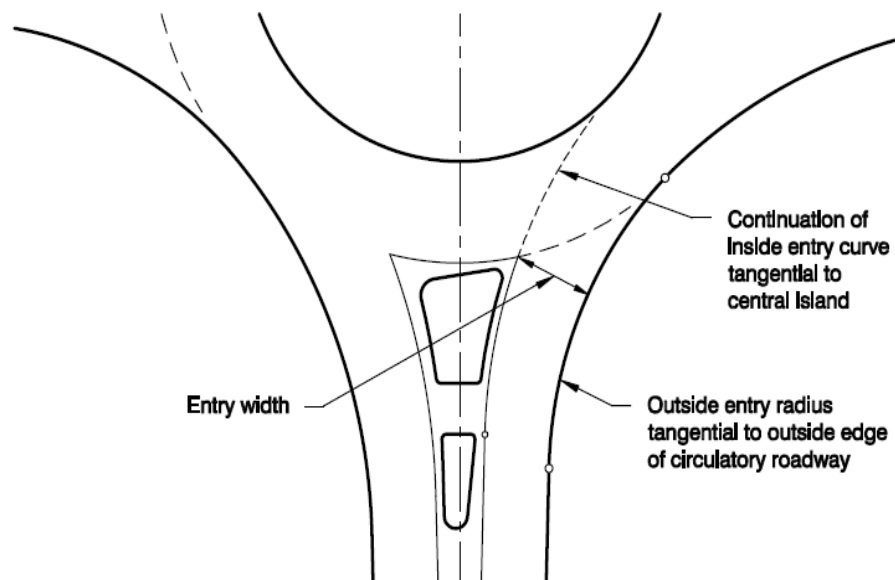

SINGLE-LANE ROUNDABOUT ENTRY DESIGN

Figure 36-9.B

2. Fastest Path. Fastest path is a critical element in the design of roundabouts. The fastest path is the smoothest, flattest path possible for a single vehicle, in the absence of other traffic and ignoring all lane markings. The fastest path through a roundabout is drawn to ensure that the geometry imposes sufficient curvature to achieve a safe design speed. The fastest path is drawn for a vehicle traversing through the entry, around the central island, and out the relevant exit. The fastest path must be drawn for all approaches and all movements, including left-turn movements. Note that the fastest path methodology does not represent expected vehicle speeds, but rather theoretically attainable entry speeds for design purposes.

Figure 36-9.C illustrates and gives a description of the five fastest paths that must be checked for each approach.

To determine the speed of a roundabout, the fastest path allowed by the geometry is drawn. The design speed of the roundabout is determined from the smallest radius along the fastest allowable path. The smallest radius usually occurs on the circulatory roadway as the vehicle curves to the left around the central island. Figure 36-9.D and Figure 36-9.E illustrate the construction of the fastest through paths at a single-lane roundabout and a multilane roundabout, respectively.

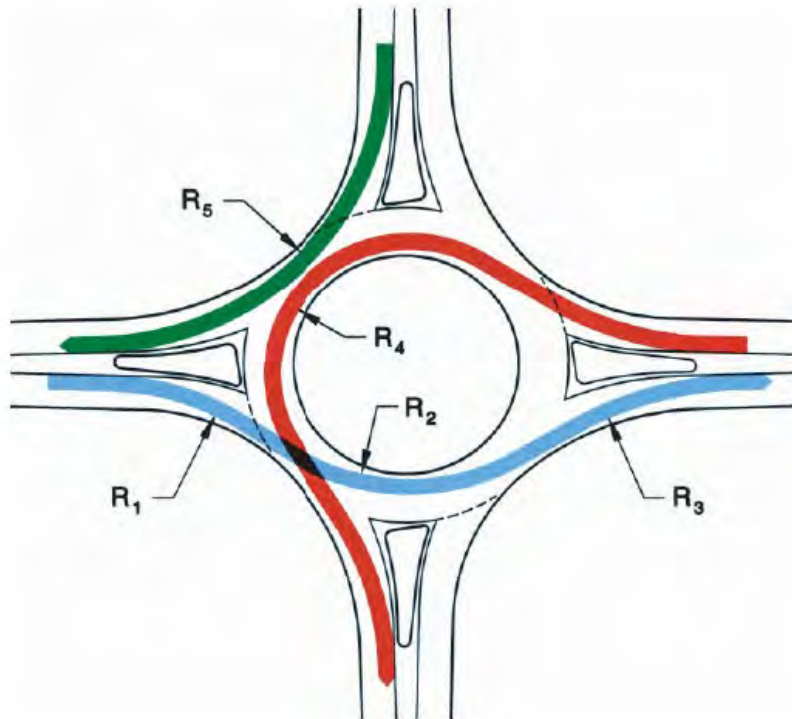

Radius	Description
Entry Path Radius, R ₁	The minimum radius on the fastest through path prior to the yield line. This is not the same as Entry Radius.
Circulating Path Radius, R ₂	The minimum radius on the fastest through path around the central island.
Exit Path Radius, R ₃	The minimum radius on the fastest through path into the exit.
Left Turn Path Radius, R ₄	The minimum radius on the path of the conflicting left-turn movement.
Right Turn Path Radius, R ₅	The minimum radius on the fastest path of a right-turning vehicle.

FASTEST PATH RADII

Figure 36-9.C

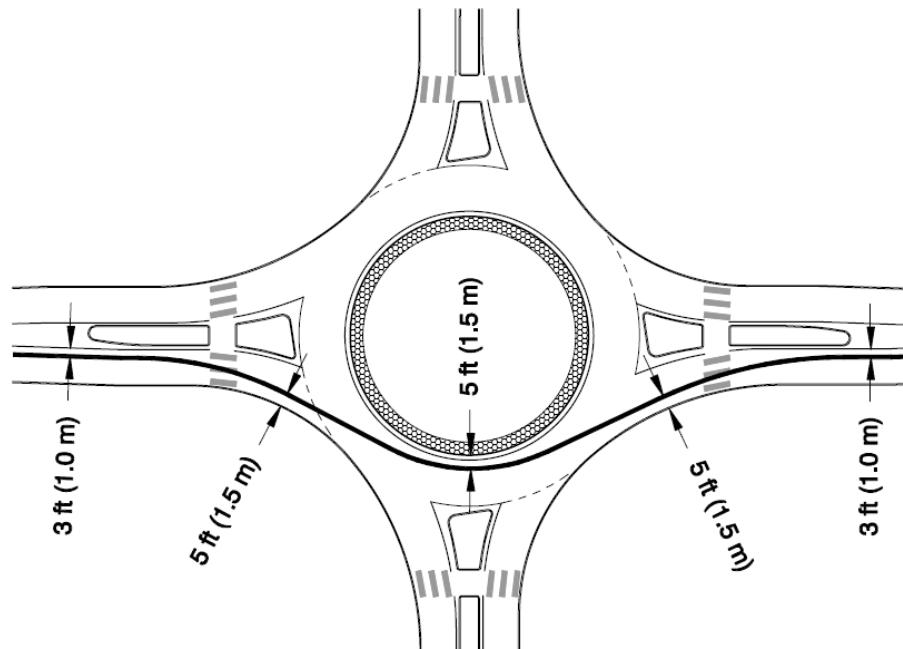

OFFSETS AND FASTEST THROUGH PATH FOR A SINGLE-LANE ROUNDABOUT

Figure 36-9.D

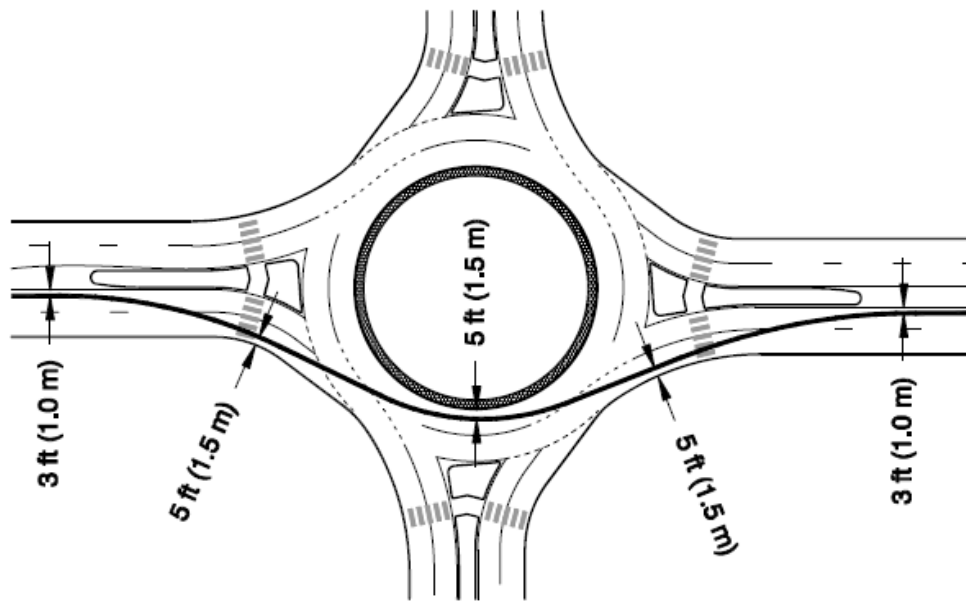

OFFSETS AND FASTEST THROUGH PATH FOR A MULTI-LANE ROUNDABOUT

Figure 36-9.E

When drawing the fastest path, use spiral curves or place a tangent of approximately three (3) seconds of travel distance between consecutive curves to account for the time it takes for a driver to rotate the steering wheel. The entry path radius, R_1 , is a measure of the deflection imposed on a vehicle prior to entering the roundabout. The ability of the roundabout to control speed at the entry is a proxy for determining the potential safety of the roundabout and whether drivers are likely to yield to circulating vehicles. The construction of the fastest path should begin at least 165 ft (50 m) prior to the entrance line using the appropriate offsets identified in Figure 36-9.D and Figure 36-9.E. The R_1 radius should be measured as the smallest best-fit circular curve over a distance of at least 65 ft to 80 ft (20 m to 25 m) near the entrance line. See Figure 36-9.F for additional guidance.

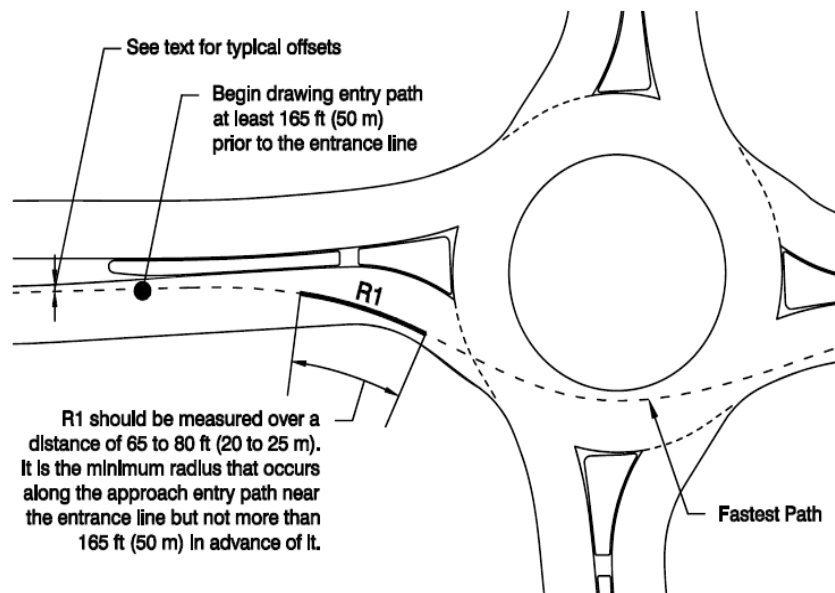

ENTRY PATH RADIUS

Figure 36-9.F

3. Vehicle Path Overlap. Vehicle path overlap occurs within the circulatory roadway of multilane roundabouts when the natural path through the roundabout of one traffic stream overlaps the path of another. The main consequence of vehicle path overlap is reduced capacity because vehicles will tend to not fully utilize both entry lanes. Also, path overlap can create safety problems since the potential for sideswipe and single-vehicle crashes is increased. The most common type of path overlap is where vehicles in the left lane on entry are cut off by vehicles in the right lane due to inadequate entry path alignment. Path overlap can also occur upon the exit from the roundabout where the exit radii are too small or the overall exit geometry does not adequately align the vehicle paths into the appropriate lanes. See Figure 36-9.G for examples of vehicle overlap. The desired result of the entry design is for vehicles to naturally be aligned into their correct lane within the circulatory roadway, as illustrated in Figure 36-9.H.

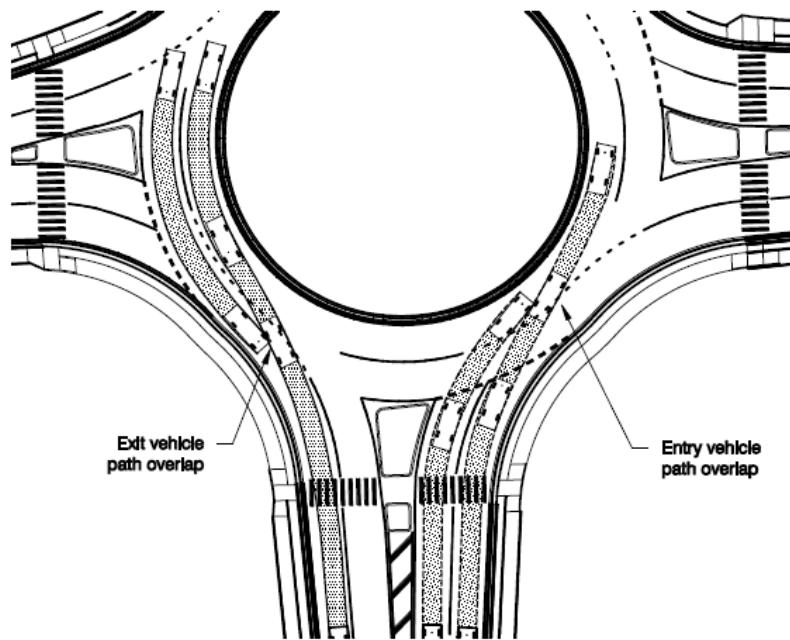

PATH OVERLAP AT A MULTILANE ROUNDABOUT

Figure 36-9.G

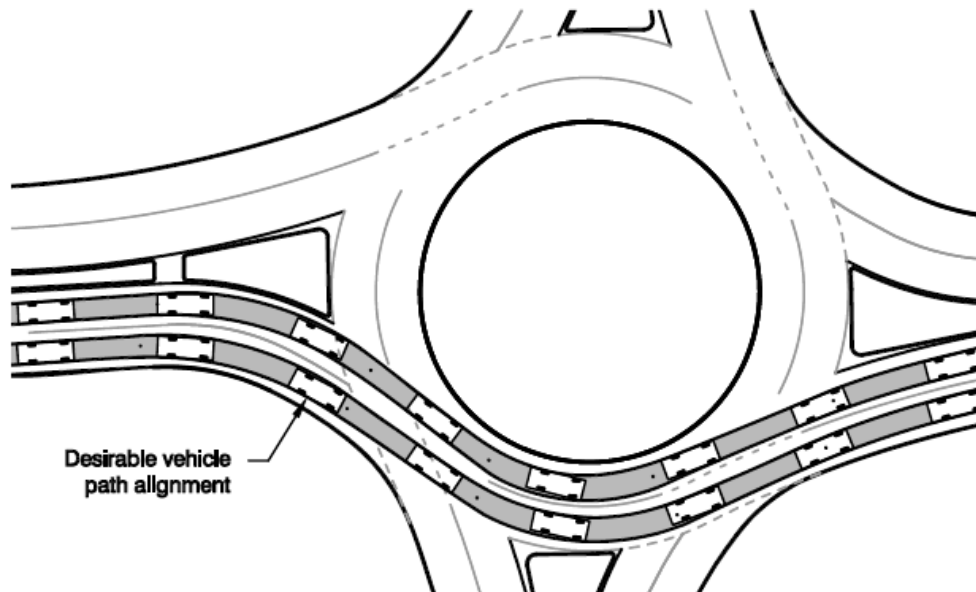

DESIRABLE VEHICLE PATH ALIGNMENT

Figure 36-9.H

36-9.04(c) Speed Consistency

Consistency between the speeds of various movements within the intersection can help to minimize conflicts between adjacent traffic streams. Minimize relative speeds that occur between conflicting traffic streams and between consecutive geometric elements. The speed differential should be no more than approximately 10 mph to 15 mph (15 km/hr to 25 km/hr). These values are typically achieved by providing a low absolute maximum speed for the fastest entering movement.

36-9.04(d) Design Vehicle

Passenger buses should be accommodated within the circulatory roadway without tracking over the truck apron, which could jostle bus occupants. Where the design dictates the need to accommodate large design vehicles within their own lane, there are a number of design considerations that come into play. First a larger inscribed circle diameter and entry/exit radii may be required to accommodate the design vehicle and maintain speed control. Another technique for accommodations on the entry is to provide gore striping, i.e., a striped vane island between the entry lanes. This method can help center the vehicles within the lane and allow a cushion for off-tracking by the design vehicle. Also, the use of a mountable truck apron [discussed in Section 36-9.04(i)] around the perimeter of the central island can provide the additional width needed for the off-tracking of the trailer wheels.

36-9.04(e) Non-motorized Design Users

This group includes bicyclists, pedestrians, skaters, and strollers. There are two general design issues that are most important for non-motorized users. First, lowering the speeds of motorized vehicles make roundabouts both easier to use and safer for non-motorized users. Therefore, the use of low design speeds is recommended in areas where non-motorized users are common. Second, one-lane roundabouts are generally easier and safer for non-motorized users than multilane roundabouts.

See Sections 36-9.7(a) and 36-9.7(b) for discussion on pedestrian and bicycle accommodations, respectively, and the design of splitter islands to accommodate the same.

36-9.04(f) Size

The inscribed circle diameter is the distance across the circle inscribed by the outer edge of the circulatory roadway, i.e., the sum of the central island diameter plus twice the circulatory roadway width. For single-lane roundabouts, the inscribed circle diameter typically should be at least 105 ft (32 m) to accommodate a WB-50 (WB-15) design vehicle and 130 to 150 ft (40 to 46 m) to accommodate a WB-67 (WB-20) design vehicle. Truck aprons are typically needed to keep the inscribed circle diameter reasonable while accommodating the larger design vehicles. Generally, the inscribed circle diameter of a multilane roundabout ranges from 150 ft to 250 ft (46 to 76 m).

36-9.04(g) Alignment of Approaches and Entries

The alignment of an approach affects the amount of deflection (speed control) that is achieved, the ability to accommodate the design vehicle, and the visibility angles to adjacent legs. There are three alternatives to the approach alignment: Offset to the left of center; alignment through the center; and offset to the right of center. Figure 36-9.1 shows examples of the three approach alignments.

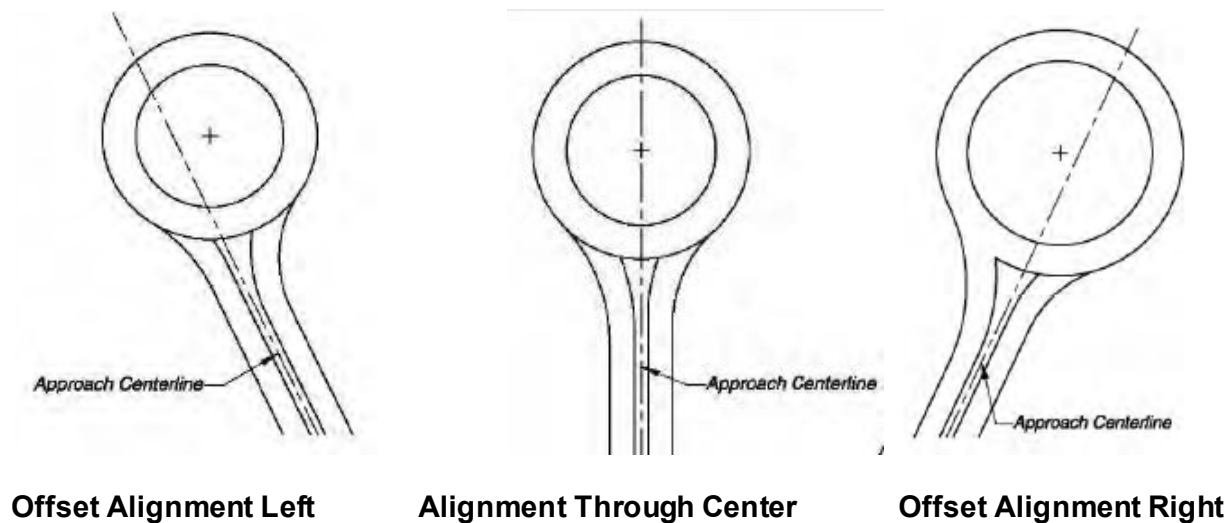

ENTRY ALIGNMENT ALTERNATIVES

Figure 36-9.1

1. Alignment Through Center. A common starting point in design is to center the roundabout so that the centerline of each leg passes through the center of the inscribed circle. This location typically allows the geometry of a single-lane roundabout to be adequately designed such that vehicles will tend to maintain slow speeds through both the entries and exits. The radial alignment also makes the central island more conspicuous to approaching drivers and minimizes roadway modifications required upstream of the intersection.
2. Offset Left Alignment. An offset of the centerline to the left of the roundabout's center point will typically increase the deflection achieved at the entry to improve speed control and is the preferred alignment of the Department. A disadvantage that may result is the possibility of a tangential exit that may provide less speed control for the downstream pedestrian crossing.
3. Offset Right Alignment. Approach alignments that are offset to the right of the roundabout's center point typically do not achieve satisfactory results, primarily due to a

lack of deflection and lack of speed control that result from this alignment, thus should be avoided. An offset-right alignment brings the approach in at a more tangential angle and reduces the opportunity to provide sufficient entry curvature. Vehicles may enter the roundabout too fast and are less likely to yield to vehicles in the circulating roadway.

4. Approach Curve. As long as the offset left alignment is utilized, simple entry curves will provide sufficient deflection to reduce entry speeds. With the offset left alignment, additional approach curves should not be needed. With a radial design or if high entry speeds exist, an S-curve or a series of reverse curves may be needed to slow approaching vehicles. Do not superelevate the approach curves as superelevation would counter the affect curve deflection has for speed control. High entry speed design is discussed in more detail under Section 36-9.4(t), "Rural Roundabouts."

36-9.04(h) Entry Design

1. Single-lane Entry Design. The design of the entry curvature should balance the competing objectives of speed control, adequate alignment of the natural paths, and the need for appropriate visibility lines. The entry curb radius should produce a maximum design speed of 20 mph to 25 mph (30 km/hr to 40 km/hr) on the theoretical fastest path. The entry curb radius should not be confused with the entry path curve, (R_1 in Figure 36-9.C) defined by the fastest vehicular travel path through the entry geometry.

The typical design for the entry curb radius for single lane entry approach alignment is to align the outside (right) curb line of the entry curvilinearly tangential to the outside edge of the circulatory roadway. Likewise, the projection of the inside (left) edge of the entry roadway is commonly curvilinearly tangential to the central island. Figure 36-9.A shows the components discussed. The entry radius at urban single-lane entries typically range from 50 ft to 100 ft (15 m to 30 m). The entry curb radius should produce an appropriate design speed on the fastest vehicular path.

Entry from high-speed approaches is started upstream by establishing designs which encourage drivers to slow down in advance of the roundabout. A recommended method to achieve speed reduction is through the use of successive reverse curves. An acceptable speed change on successive geometric elements through the approach is approximately 12 mph (20 km/hr). Tangent segments must be place between reverse curves to allow drivers to rotate the steering wheel between the reverse curves. Refer to the fourth point under Section 36-9.04(t) for further direction on high-speed approaches.

Another important principle in the design of an entry is sight distance and visibility. The angle of visibility to the left must be adequate for entering drivers to comfortably view oncoming traffic from the immediate upstream entry or from the circulatory roadway. Sections 36-9.4(o) and 36-9.4(p) discuss sight distance issues.

2. Multilane Entry Design. The entry geometry should provide adequate horizontal curvature to channelize drivers into the circulatory roadway to the right of the central island. The desired result of the entry design is for vehicles to naturally be aligned into their correct lane within the circulatory roadway.

The use of small entry radii [less than 45 ft (14 m)] at multilane roundabout entries may produce low entry speeds, small fastest path radii (R_1), and reduced capacity, but often leads to vehicle path overlap [discussed in Section 36-9(b)] on the entry, since the geometry of the outside (right) lane tends to lead vehicles into the inside (left) circulatory lane; see Figure 36-9.J. Values of R_1 in the range of 175 ft to 275 ft (53 m to 84 m) are generally preferable. This results in a design speed of 25 mph to 30 mph (40 km/hr to 50 km/hr).

A common technique to promote good path alignment for multilane entry approaches is to use a compound curve or curve followed by a tangent. This design consists of an initial small-radius entry curve [65 ft to 120 ft (20 m to 35 m)] set back at least 20 ft (6.0 m) from the edge of the circulatory roadway. A short section of large-radius [greater than 150 ft (45 m)] or a tangent is fitted between the entry curve and the circulatory roadway to align vehicles into the proper circulatory lane at the entrance line. See Figure 36-9.K for a layout of the entry curve described above.

3. Entry Angle Phi (Φ). A useful surrogate used by some practitioners for capturing the effects of entry speed, path alignment, and visibility to the left is the entry angle phi (Φ). Typically Φ entry angles are between 20 and 40 degrees. Refer to the Wisconsin DOT Roundabout Guide for the uses of the phi angle.

36-9.04(i) Entry Width

1. Single-lane Entries. Entry width at single lane entries is measured from the point where the entrance line intersects the left edge of traveled way to the right edge of the traveled way, along a line perpendicular to the right curb line as shown in Figure 36-9.A. Typical entry widths for single-lane entrances range from 14 ft to 18 ft (4.2 m to 5.5 m). The entry is often widened through a flare from the upstream approach width.
2. At Multilane Entries. A typical entry width for a two-lane entry ranges from 24 ft to 30 ft (7.2 m to 9 m) and 36 ft to 45 ft (11 m to 14 m) for a three-lane entry. The entry width should be primarily determined based upon the number of lanes identified in the operational analysis combined with the turning requirements for the design vehicle.

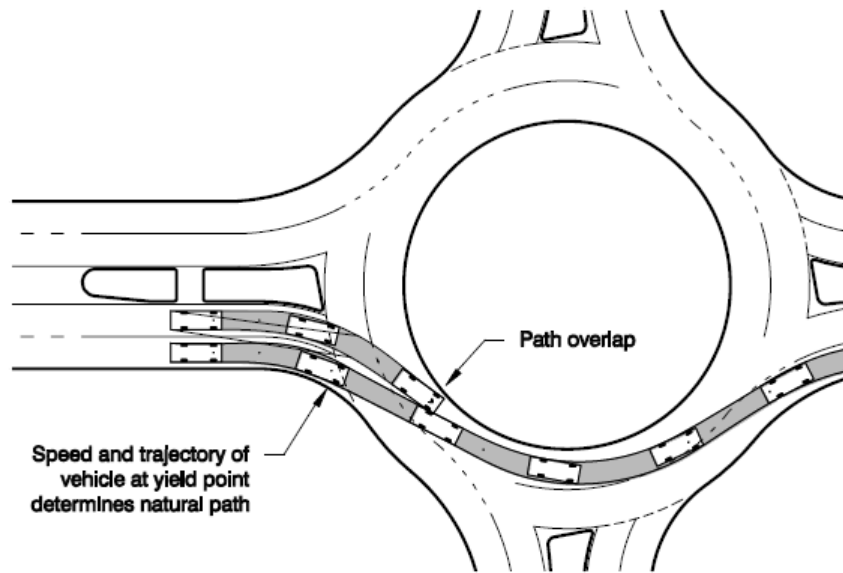

ENTRY VEHICLE PATH OVERLAP

Figure 36-9.J

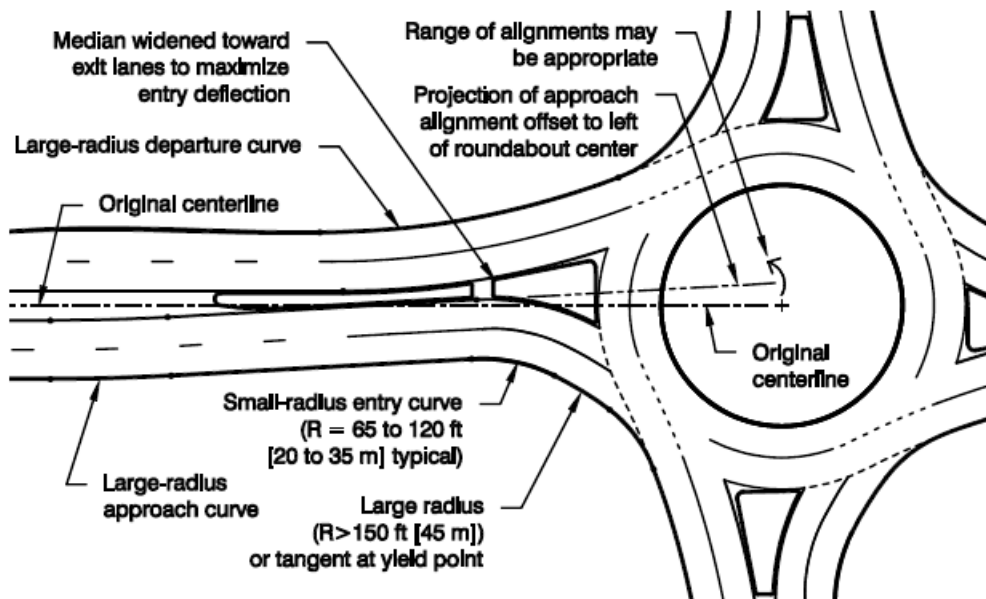

MINOR APPROACH OFFSET TO INCREASE ENTRY DEFLECTION

Figure 36-9.K

36-9.04(j) Circulatory Roadway Width

The required width of the circulatory roadway is determined from the number of entering lanes and the turning requirements of the design vehicle. Except opposite a right-turn only lane, the circulating width should be at least as wide as the maximum entry width and up to 120% of the maximum entry width.

1. **Single-lane Roundabouts.** For single-lane roundabouts, the circulatory roadway width usually remains constant throughout the roundabout. Typically circulatory roadway widths range from 16 ft to 20 ft (4.9 m to 6.1 m). A truck apron will often be needed within the central island to accommodate larger design vehicles, but maintain a relatively narrow circulatory roadway to adequately constrain vehicle speeds. Additional discussion of truck aprons is provided in Section 36-9.04(l). To avoid jostling passengers the circulatory roadway, width should be wide enough to accommodate a bus without use of the truck apron.
2. **Multilane Roundabouts.** The circulatory roadway width is usually governed by the design criteria relating to the types of vehicles that may need to be accommodated adjacent to one another through a multilane roundabout. It is acceptable for multi-unit vehicles to encroach upon adjacent lanes. Multilane circulatory roadway lane widths typically range from 14 ft to 16 ft (4.2 m to 4.9 m).

36-9.04(k) Central Island

The central island is the raised non-traversable area (except for mini-roundabouts and the truck apron) surrounded by the circulatory roadway. If a truck apron is provided the truck apron is part of the central island. The island is typically landscaped for aesthetic reasons and raised about 3 ft to enhance driver recognition of the roundabout upon approach. A circular central island is preferred because the constant radius circulatory roadway helps promote constant speeds around the central island, but oval or irregular shapes can be used at irregularly shaped intersections such as offsetting intersections.

Roundabouts in rural environments typically need larger central islands than urban roundabouts to enhance their visibility, accommodate larger design vehicles, enable better approach geometry to be designed in the transition from higher speeds, and be more forgiving to errant vehicles.

Avoid “attractive nuisances” in the central island, which could encourage pedestrians to cross the circulating roadway for closer inspection.

36-9.04(l) Truck Aprons

A truck apron provides additional paved area to allow the over-tracking of large semi-trailer vehicles upon the central island without compromising the deflection for smaller vehicles. A traversable truck apron is typical for most roundabouts to accommodate large vehicles while minimizing other roundabout dimensions. The truck apron should be designed such that they are traversable to trucks but discourage passenger vehicles from using them by distinguishing the

apron from the circulatory roadway. Distinguishing characteristics include bordering at the edge of the circulating roadway with a raised 2 in. or 3 in. (50 mm to 75 mm) curb and constructing the apron with a different surface or color from the circulating roadway. The recommended maximum cross slope of the truck apron is 1.5% sloping to the roadway or outside to be compatible with the drainage within the inscribed circle. The minimum width for the truck apron is 12 ft (3.6 m). Figure 36-9.L shows a multi-unit truck utilizing a truck apron.

The vertical design of the truck apron should be reviewed to confirm that there is sufficient clearance for low-boy type trailers which may have only 6 in. to 8 in. (150 mm to 200 mm) between a level roadway surface and the bottom of the trailer.



LARGE TRUCK OVERTOPPING THE TRUCK APRON

Figure 36-9.L

36-9.04(m) Exit Design

The exit curb radii are usually larger than the entry curb radii in order to minimize the likelihood of congestion and crashes at the exits. This, however, is balanced by the need to maintain low speeds through the pedestrian crossing on the departure. The exit curb radius is commonly designed to be curvilinearly tangential to the outside edge of the circulatory roadway. Likewise, the projection of the inside (left) edge of the exit roadway is commonly curvilinearly tangential to the central island.

1. **Single-lane Exits.** Single-lane exits in urban environments should be designed to enforce slow exit path speeds to maximize safety for pedestrians crossing the exiting stream. Pedestrian activities should be considered at all exits except where separate pedestrian facilities or other restrictions eliminate the likelihood of pedestrian activity in the foreseeable future.

For designs using an offset-left approach alignment, the exit design may require much larger radii, ranging from 300 ft to 800 ft (90 m to 240 m) or greater. These radii may provide acceptable speed through the pedestrian crossing area given that the acceleration characteristics of the vehicles will typically result in a practical limit to the speeds that can be achieved on the exit. The fastest-path methodology can be used to verify the exit speed.

2. **Multilane Exits.** Inadequate horizontal design of the exits can result in exit vehicle path overlap. If the exit radius on a multilane exit is too small, traffic on the inside of the circulatory roadway will tend to exit into the outside exit lane on more comfortable turning radius causing vehicle path overlap, similar to that occurring at entries.

36-9.04(n) Splitter Islands

Purposes of a splitter island are to provide refuge for pedestrians, assist in controlling speeds, guide traffic into the roundabout, physically separate entering and exiting traffic streams, control access, and deter wrong-way movements. Additionally, splitter islands can be used as a place for mounting signs. Splitter islands should be provided on all the legs of a roundabout.

A properly designed splitter island deflects traffic and positions vehicles into a correct alignment to enter the circulatory roadway. This deflection is critical to slowing vehicles before they enter the circulatory roadway. The splitter island should have enough curvature to block a direct path to the central island for approaching vehicles.

When used as a pedestrian refuge, splitter islands shall be a minimum of 6 ft (1.8 m) and preferably 8 ft (2.4 m) from the back of the curb to the back of the curb within the pedestrian refuge area. The total length of the raised island should generally be at least 50 ft (15 m), although 100 ft (30 m) is desirable, to provide sufficient protection for pedestrians and to alert approaching drivers to the geometry of the roundabout. On higher speed roadways, splitter island lengths of 150 ft (45 m) or more are often beneficial; see Figure 36-9.M.

The raised portion of the island controls access to adjacent driveways. Refer to Section 36-9.5(e) for a discussion on access control strategies for the approach and departure of a roundabout.

If the roadway does not have a median at the approach to the splitter island, the approach should have a corrugated median and the nose should be ramped.

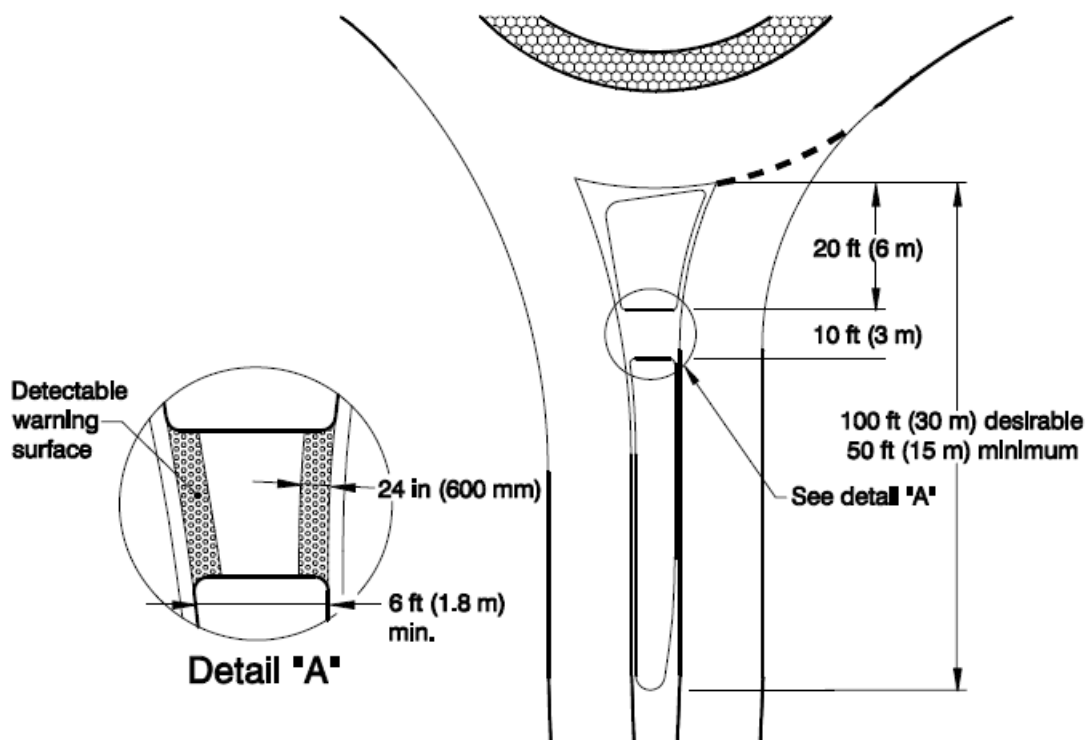

MINIMUM SPLITTER ISLAND DIMENSIONS

Figure 36-9.M

36-9.04(o) Stopping Sight Distance

Stopping sight distance should be provided at every point within a roundabout and on each entering and exiting approach.

36-9.04(p) Intersection Sight Distance

Intersection sight distance is the distance required for a driver without the right-of-way to perceive and react to the presence of conflicting vehicles. Intersection sight distance is achieved through the establishment of sight triangles that allow a driver to see and safely react to potentially conflicting vehicles. The only locations requiring evaluation of intersection sight distance within roundabouts are the entries.

The sight triangle is bound by a length of roadway defining a limit away from the intersection on each of the two conflicting approaches and by a line connecting those two limits. For roundabouts, these legs should be assumed to follow the curvature of the roadway, and thus distances should be measured not as straight lines but as distances along the vehicular path.

Figure 36-9.N presents a diagram showing the method for determining intersection sight distance. The following two subsections discuss each of the approaching sight limits.

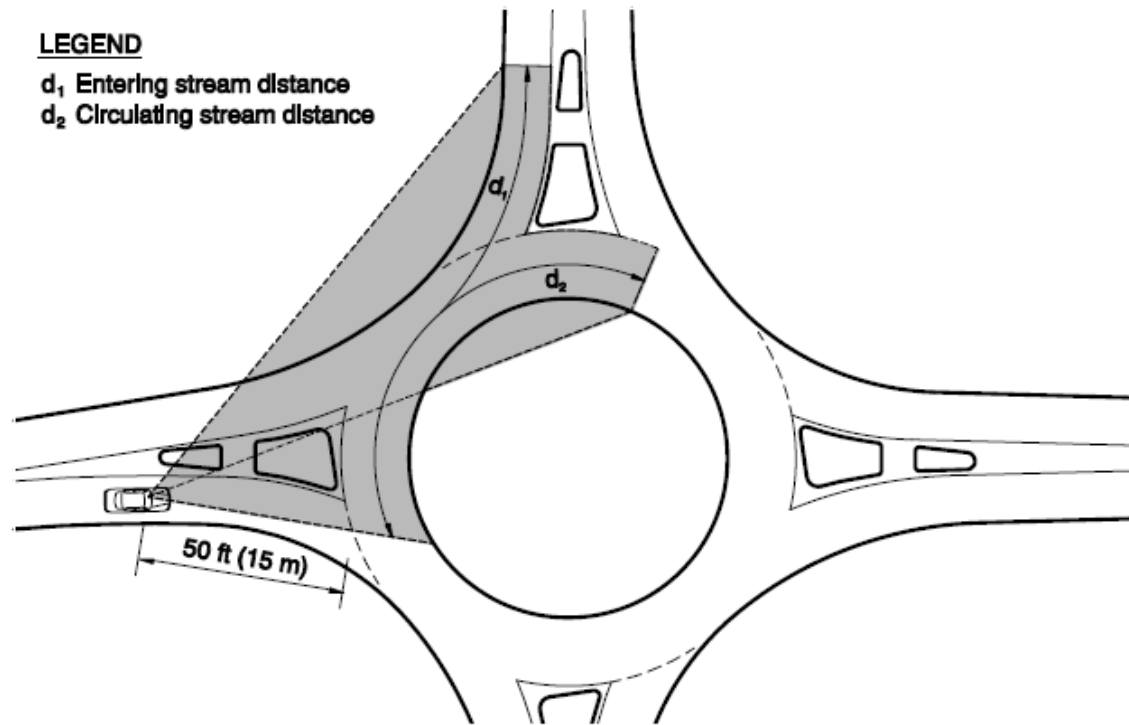

INTERSECTION SIGHT DISTANCE

Figure 36-9.N

1. **Approach Leg of Sight Triangle.** The length of the approach leg of the sight triangle should be limited to 50 ft (15 m). This value is intended to require vehicles to slow down prior to entering the roundabout, which supports the need to slow down and yield at the roundabout entry and allows drivers to focus on the pedestrian crossing prior to entry.
2. **Conflicting Leg of Sight Triangle.** A vehicle approaching an entry to a roundabout faces conflicting vehicles within the circulating roadways and on the immediate upstream entry. In most cases it is best to provide no more than the minimum required intersection sight distance on each approach. Excessive intersection sight distance can lead to higher vehicle speeds that reduce the safety of the intersection for all road users.

Section 6.7.3.2 of *NCHRP Report 672, Roundabouts: An Informational Guide*, defines the limits of the intersection sight triangle and the methodology of calculating the lengths of each leg.

36-9.04(q) Vertical Considerations

Components of vertical alignment design for roundabouts include profiles, superelevation, approach grades, and drainage.

1. **Profiles.** Each approach profile should be designed to the point where the approach baseline intersects with the central island. A profile for the central island is then developed that passes through these four points (in the case of a four-legged roundabout). The approach roadway profiles are then readjusted as necessary to meet the central island profile.

Another method has the PGL/profile line following the inside exit path side of the splitter island making it a physical/tangible line to follow for plan prep and construction. From the intersection of the PGL/profile and the outside of the circulatory roadway the PGL/profile line runs across the circulatory roadway to the center of the central island; see Figure 36-9.O.

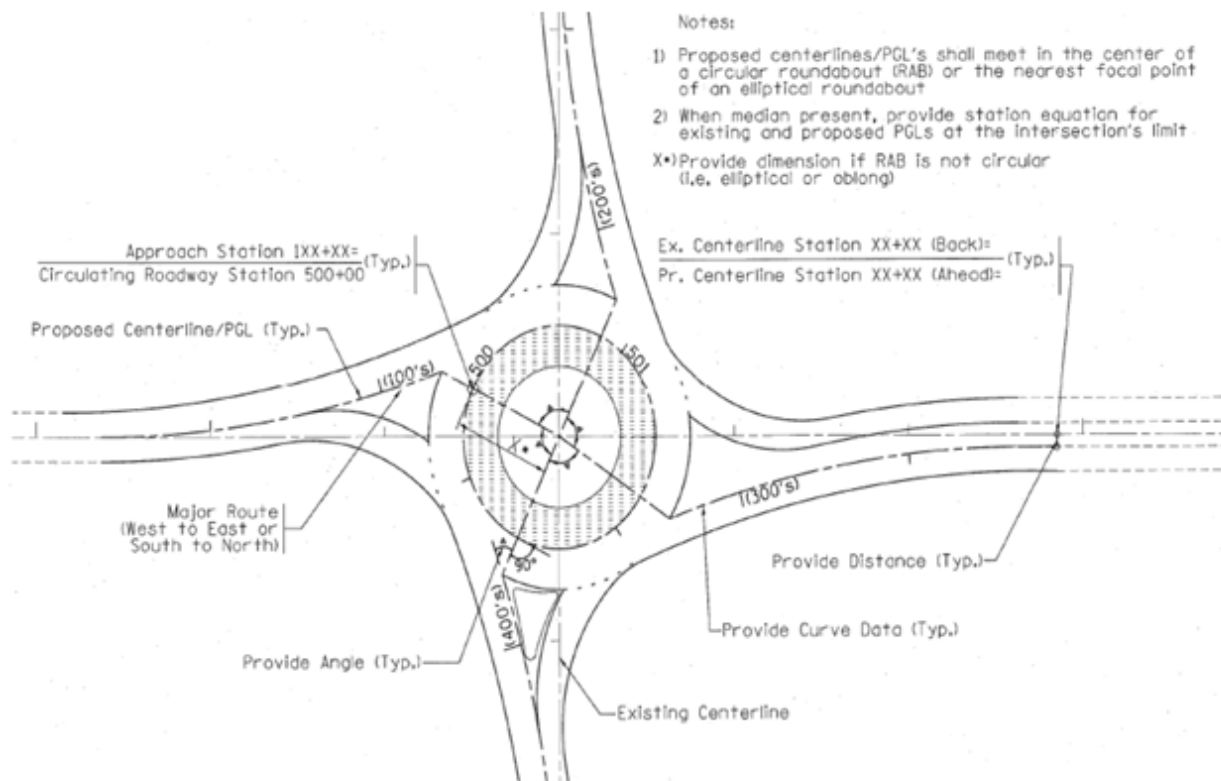

ALTERNATIVE PGL/PROFILE LAYOUT

Figure 36-9.O

2. Superelevation/Cross Slope. Two primary methods for the superelevation of the circulating roadway are recommended: outward sloping or crowned circulating roadway. Outward sloping is the most common type of vertical design, especially for single-lane roundabouts. Outward sloping means the pavement slopes away from the central island. When the outward sloping cross section is used, the circulating roadway is graded independently of each approach, with the circulatory roadway draining outward with a grade of 1.5% to 2%.

Crowned circulatory roadways consists of approximately 2/3 width sloping toward the central island and 1/3 width sloping outward. Exact location of the crown may vary according to the joint plan and future staging. The cross slopes should range from 1.5% to 2%. Placing the crown 2/3 of the width into the circulatory roadway is more compatible for lowboy trailers by allowing more height to raise the low-boy bed. The intent is to minimize the occurrence of the trailer bottoming-out upon the curb of the truck apron. Figure 36-9.P shows an example of a cross section of a roundabout with a crowned circulatory roadway.

3. Approach Grades. Grades of the approach legs should follow guidelines in Section 36-1.06(a).
4. Drainage. If the circulating roadway slopes away from the central island, inlets will generally be placed on the outer curb line of the roundabout. For circulating roadways that are crowned, drainage inlets will be required along the central island, since a portion of the circulating roadway drains toward the central island.

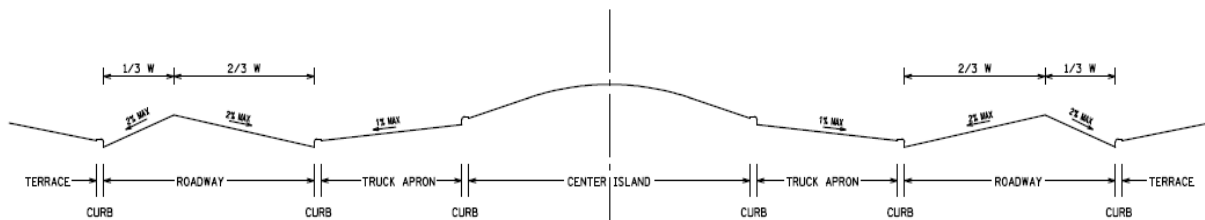

CIRCULATORY ROADWAY AND TRUCK APRON CROSS SECTION

Figure 36-9.P

36-9.04(r) Bus Stop Locations

Transit considerations at a roundabout are similar to those at a conventional intersection.

1. Nearside stops. If an approach has only one lane and capacity is not an issue on that entry, the bus stop could be located at the pedestrian crossing in the lane of traffic. Do not locate the bus stop at the pedestrian crossing for entries with more than one lane because vehicles in the lane next to the bus may not see pedestrians as pedestrians use the crossing. For multilane approaches, a nearside bus stop can be included in the travel lane as long as it is set back at least 50 ft (15 m) from the crosswalk.
2. Far-side stops. Bus stops should be located carefully to minimize the probability of vehicle queues spilling back into the circulatory roadway. This typically means that bus stops located on the far side of the intersection need to have pullouts or be further downstream than the splitter island. If a pullout is used, position the pullout beyond the pedestrian crossing to improve visibility of pedestrians to other exiting vehicles. Pedestrian access routes to transit should be designed for safety, comfort, and convenience. If demand is significant (e.g., near a station or terminus), pedestrian crossing capacity should be taken into account.

36-9.04(s) Right-turn Bypass Lane

A right-turn bypass lane allows right-turning traffic to bypass the roundabout, providing additional capacity for the through and left-turn movements at the approach. Bypass lanes are most beneficial when the demand of an approach exceeds its capacity and a significant proportion of the traffic is turning right. In some cases, the use of a right-turn bypass lane can avoid the need to build an additional entry or circulatory lane. To determine if a right-turn bypass lane should be used, the capacity and delay calculations should be performed. A right-turn bypass lane should only be implemented where needed, especially in urban areas with pedestrian and bicycle activities. There are two options for right-turn bypass lanes: Figure 36-9.Q gives examples of both a full and partial bypass lane.

1. Full bypass. A full bypass lane carries the bypass lane parallel to the adjacent exit roadway, and then merges it into the main exit lane.
2. Partial bypass. A partial bypass lane, with or without a vane, provides a yield-controlled entrance onto the adjacent exit roadway. This option is generally better for bicyclists and pedestrians and is recommended as the preferred option in urban areas where pedestrians and bicyclists are prevalent. The partial bypass lane should direct the vehicle to the adjacent leg's splitter island to minimize the likelihood of the driver using the bypass lane as a through lane.

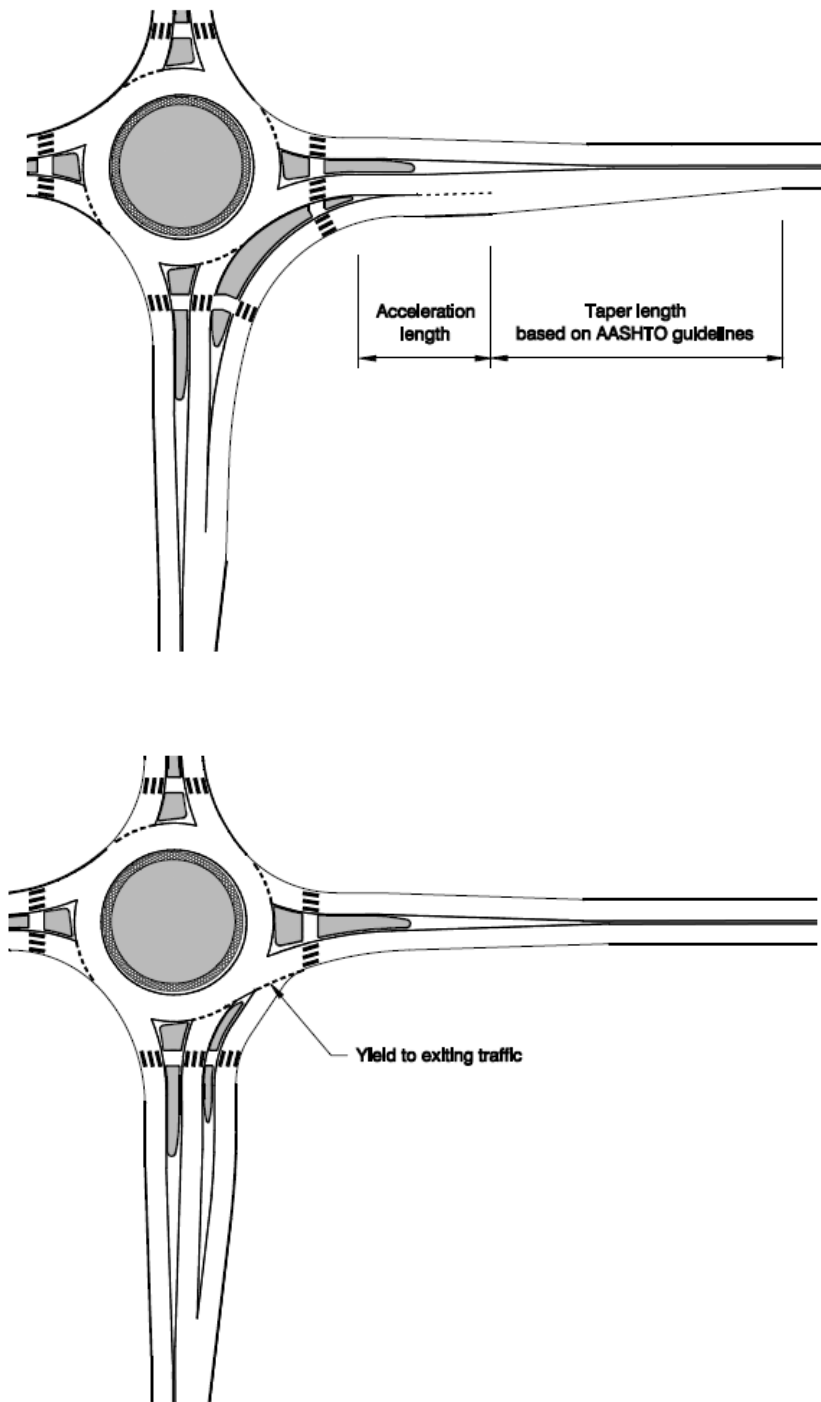

RIGHT TURN BYPASS LANES
(Top view, full bypass. Bottom view, partial bypass)

Figure 36-9.Q

36-9.04(t) Rural Roundabouts

Roundabouts located on rural roads often have special design considerations because approach speeds are higher than for urban or local streets, and drivers are less likely to expect to encounter speed interruptions. The primary safety concern in rural locations is to make drivers aware of the roundabout with ample distance to comfortably decelerate to the appropriate speed. The design of a roundabout in a high-speed environment typically employs all the techniques of a roundabout in a lower-speed environment, with greater emphasis on the items presented below.

1. **Visibility**. The potential for single-vehicle crashes can be minimized with attention to proper visibility of the roundabout and its approaches. Where possible, the geometric alignment of approach roadways should be constructed to maximize the visibility of the central island and the shape of the roundabout. Where adequate visibility cannot be provided solely through geometric alignment, additional treatments (signing, pavement markings, advanced warning beacons, etc.) should be considered. Note that many of these treatments are similar to those that would be applied to rural stop-controlled or signalized intersections.
2. **Curbing**. Narrow shoulder widths and curbs on the outside edges of pavement generally give drivers a sense they are entering a more controlled setting, causing them to naturally slow down. Thus, when installing a roundabout on an open rural highway, curbs should be provided at the roundabout and on the approaches, and consideration should be given to reducing shoulder widths. Extend the curbing from the approach for at least the length of the required deceleration to the roundabout.
3. **Splitter Islands**. Splitter islands should generally be extended upstream of the entrance line to the point at which entering drivers are expected to begin decelerating comfortably. A minimum of 200 ft (60 m) is recommended for high-speed approaches.
4. **Approach Curves**. The radius of an approach curve (and subsequent vehicular speeds) has a direct impact on the frequency of crashes at roundabouts. A study has shown that decreasing the radius of an approach curve generally decreases the approaching rear-end vehicle crash rate and the entering-circulating and exiting-circulating vehicle crash rates. On the other hand, decreasing the radius of an approach curve may increase the single vehicle crash rate on the curve. This may encourage drivers to cut across lanes and increase sideswipe crashes on the approach.

One method to achieve speed reduction in order to reduce crashes at the roundabout is the use of successive reverse curves on the approaches; see Figure 36-9.R. By limiting the reduction in the design speed on successive reverse curves to approximately 12 mph (20 km/hr), the crash rate was reduced. Provide tangents between successive reverse curves of approximately 3 seconds of travel distance to allow a change in rotation of the steering wheel and do not superelevate the curves. A report recommended the approach speed be limited to no more than 35 mph (60 km/hr) immediately prior to the entry curves to minimize high-speed rear-end crashes and entering-circulating vehicle crashes.

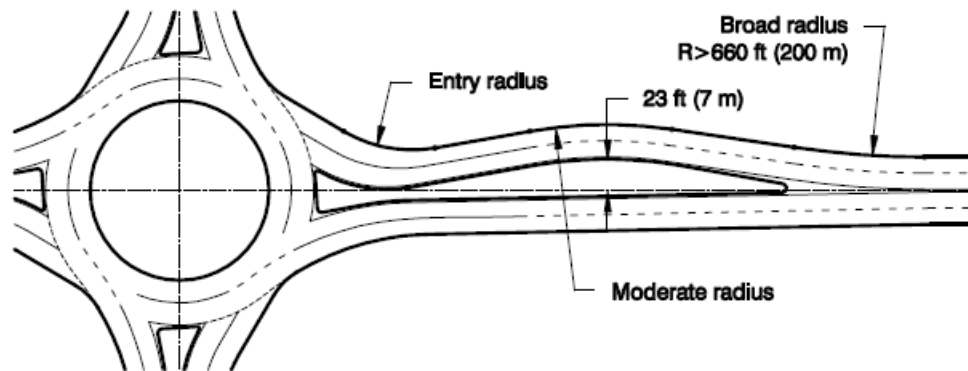

USE OF SUCCESSIVE CURVES ON HIGH-SPEED APPROACHES

Figure 36-9.R

36-9.04(u) Mini-roundabouts

A mini-roundabout is characterized by a smaller diameter and traversable island. Mini-roundabouts are best suited to environments where speeds are already low and environmental constraints would preclude the use of a larger roundabout with a raised central island.

Mini-roundabouts operate in the same manner as larger roundabouts, with yield control on all entries and counterclockwise circulation around a central island. Due to the small footprint, large vehicles are typically required to travel over the fully traversable central island, but buses should be accommodated within the circulatory roadway to avoid jostling passengers by running over a traversable central island.

36-9.04(v) Staging Single-Lane versus Multilane Roundabout

When projected traffic volumes indicate that a multilane roundabout is required for future year conditions, engineers should evaluate the duration of time that a single-lane roundabout would operate acceptably before requiring additional lanes. Where a single lane roundabout should be sufficient for much of its design life, engineers should evaluate whether it is best to first construct a single-lane roundabout until traffic volumes dictate the need for expansion to a multilane roundabout. One reason to stage the construction of a multilane roundabout is that future traffic predictions may never materialize due to the significant number of assumptions that must be made when developing volume estimates for a 20 or 30-year design horizon. Also, non-motorized users are better accommodated on single-lane roundabouts.

Single lane roundabouts are generally simpler for motorists to learn and are more easily accepted in new locations. This, combined with fewer vehicle conflicts, should result in a better overall crash experience and allow for a smooth transition into the ultimate multilane build-out of the intersection.

When considering an interim single-lane roundabout, the engineer should evaluate the right-of-way and geometric needs for both the single-lane and multilane configurations.

Two methods to expand from a single-lane to a double lane roundabout:

1. Expansion to the outside. When using this option, care should be taken to provide adequate geometric features, including entry and splitter island design, to ensure that speed reduction and adequate natural paths can be provided at build-out. This configuration has the potential to be less of a disruption to vehicular traffic during the expansion since the majority of the improvements are on the outside of the roadway.
2. Expansion to the inside. Expansion to the inside involves adding any necessary lanes for the ultimate configuration to the inside of the interim roundabout configuration, with the outer curbs and inscribed circle diameter remaining the same in both interim and ultimate configurations. This allows the engineer to set the outer limits of the intersection during the initial construction and limits the future construction impacts to surrounding properties during widening, as sidewalks, drainage features, and outer curb lines will not typically require adjustments.

36-9.05 Operational Performance

The operational performance of roundabouts is relatively simple, although the techniques used to model performance can be quite complex. A few features are common to the modeling techniques employed by all analysis tools:

- Drivers must yield the right-of-way to circulating vehicles and accept gaps in circulating traffic stream. Therefore, the operational performance of a roundabout is directly influenced by traffic patterns and gap acceptance.
- As with other types of intersections, the operational performance of a roundabout is directly influenced by its geometry

Influences to roundabout operations follow:

1. Gap Acceptance. The operation of vehicular traffic at a roundabout is determined by gap acceptance: Entering vehicles look for and accept gaps in circulating traffic. The low speed of a roundabout facilitates these gap acceptance practices. Furthermore, the operational efficiency (capacity) of roundabouts is greater at lower circulating speeds because of the following two phenomena.
 - The faster the circulating traffic, the larger the gaps that entering traffic will comfortably accept. This translates to fewer acceptable gaps and therefore more instances of entering vehicles stopping at the yield line.
 - Entering traffic, which is first stopped at the yield line, requires even larger gaps in the circulating traffic in order to accelerate and merge with the circulating traffic. The faster the circulating traffic, the larger this gap must be. This translates into fewer acceptable gaps and therefore longer delays for entering traffic.

2. Traffic Flow and Driver Behavior. The capacity of a roundabout decreases as the conflicting flow increases. In general, the primary conflicting flow is the circulating flow that passes directly in front of the subject entry. Exiting flow may also affect a driver's decision on when to enter the roundabout. This phenomenon is similar to the effect of the right-turning stream approaching from the left side of a two-way stop-controlled intersection. Another behavioral affect occurs when both the entering and conflicting flow volumes are high. Limited priority (where circulating traffic adjusts its headway to allow entering vehicles to enter) or priority reversal (where entering traffic forces circulating traffic to yield) may occur.
3. Geometry. Geometry plays a significant role in the operational performance of a roundabout in a number of key ways:
 - It affects the speed of vehicles through the intersection, thus influencing their travel time by virtue of geometry alone (geometric delay).
 - It dictates the number of lanes over which entering and circulating vehicles travel. The width of the approach roadway and entry determine the number of vehicle streams that may form side-by-side at the yield line and govern the rate at which vehicles may enter the circulating roadway.
 - It can affect the degree to which flow in a given lane is facilitated or constrained. For example, the angle at which a vehicle enters affects the speed of that vehicle, with entries that are more perpendicular requiring lower speeds and thus longer headway. Likewise, the geometry of multilane entries may influence the degree to which drivers are comfortable entering next to one another.
 - It may affect the driver's perception of how to navigate the roundabout and their corresponding lane choice approaching the entry. Improper lane alignment can increase friction between adjacent lanes and thus reduce capacity. Imbalanced lane flows on an entry can increase the delay and queuing on an entry despite the entry operating below its theoretical capacity.

Lane changes within circulating lanes should not be required other than when a lane is added within the circulatory roadway. A lane added within the circulating roadway does not create any additional conflicts.

36-9.05(a) Entering, Circulating, and Exiting Volumes

The analytic methods in the *Highway Capacity Manual* allow the assessment of the operational performance of an existing or planned one-lane or two-lane roundabout when given traffic demand levels.

1. Determining Roundabout Flow Rates. The circulating flow rate opposing a given entry is defined as the flow conflicting with the entry flow of that leg. See Exhibit 21-11 of the 2010 *Highway Capacity Manual* (HCM). For example the movements that contribute to the northbound circulating flow rate (shown as $V_{c,NB}$ in Exhibit 21-11 of the HCM) are the movements that flow in front of the northbound entry, which are the eastbound through, eastbound left-turn, eastbound U-turn, southbound Left-turn, southbound U-turn, and westbound U-turn movements.

Conversion of Turning-Movement Volumes to Roundabout Volumes

Prior to conducting a roundabout analysis, turning-movement volumes must first be converted to roundabout volumes.

Turning-Movement Data

- Percent heavy vehicles for all movements = 2%
- Peak Hour Factor (PHF) = 0.97

Step 1: Convert Movement Demand Volumes to Flow Rates

Each turning-movement volume given in the problem is converted to a demand flow rate by dividing by the peak-hour factor. As an example, the northbound left volume is converted to a flow rate in passenger cars per hour as follows:

$$v_{NBL} = \frac{V_{NBL}}{PHF} = \frac{145}{0.97} = 149 \text{ pc/h}$$

Step 2: Adjust Flow Rates for Heavy Vehicles

The flow rate for each movement may be adjusted to account for vehicle stream characteristics as follows (northbound left turn illustrated):

$$f_{HVV} = \frac{1}{1 + P_T(E_T - 1)} = \frac{1}{1 + 0.02(2 - 1)} = 0.980$$

$$v_{NBL,adj} = \frac{v_{NBL}}{f_{HVV}} = \frac{149}{0.980} = 152 \text{ pc/h}$$

The resulting adjusted flow rates for all movements accounting for Steps 1 and 2 are therefore computed as follows:

CONVERSION OF TURNING-MOVEMENT VOLUMES TO ROUNDABOUT VOLUMES

Figure 36-9.S

(1 of 2)

Conversion of Turning-Movement Volumes to Roundabout Volumes

Step 3: Determine Entry Flow Rates by Lane

The entry flow rate is calculated by summing up the movement flow rates that enter the roundabout. For single-lane roundabouts, all approach volumes are summed together. Additional lane-use calculations are required for multilane roundabouts.

The entry flow rates are calculated as follows for the south leg (northbound entry):

$$V_{e,NB,pcr} = V_{NBU,pcr} + V_{NBL,pcr} + V_{NRT,pcr} + V_{NBR,e,pcr}$$

$$= 0 + 152 + 220 + 79 = 451 \text{ pc/h}$$

Step 4: Determine Circulating Flow Rates

The circulating flow is calculated for each leg. The circulating volumes are the sum of all volumes that will conflict with entering vehicles on the subject approach. For the south leg (northbound entry), the circulating flow is calculated as follows:

$$V_{c,NB,pcr} = V_{WBU,pcr} + V_{SBL,pcr} + V_{SBU,pcr} + V_{ERT,pcr} + V_{ERL,pcr} + V_{EBU,pcr}$$

$$= 0 + 268 + 0 + 315 + 258 + 0 = 841 \text{ pc/h}$$

Step 5: Determine Exiting Flow Rates

The exiting flow is calculated for each leg by summing all flow that will be exiting the roundabout on a particular leg. For the south leg (northbound entry), the exiting volume is calculated as follows:

$$V_{ex,pcr,NB} = V_{NBU,pcr} + V_{WBL,pcr} + V_{SBL,pcr} + V_{EBR,e,pcr}$$

$$= 0 + 105 + 100 + 110 = 315 \text{ pc/h}$$

Result

The following figure illustrates the final volumes converted into roundabout entering, exiting, and circulating flow rates.

CONVERSION OF TURNING-MOVEMENT VOLUMES TO ROUNDABOUT VOLUMES

Figure 36-9.S

(2 of 2)

2. Conversion of Turning-Movement Volumes to Roundabout Volumes. See Figure 36-9.S. After determining the demand flow rate, by dividing by the peak-hour factor, and then adjusting for heavy vehicles to determine the passenger car equivalents, one can determine the entry flow rates, circulating flow rates, and the exiting flow rates.
 - Entry flow rates are calculated by summing up the movement flow rates that enter the roundabout. For single-lane roundabouts, all approach volumes are summed together. Additional lane-use calculations are required for multilane roundabouts.
 - Circulating flow rates are the sum of all volumes that are expected to conflict with entering vehicles on the subject approach.
 - Exiting flow rates are calculated for each leg by summing all flow that will be exiting the roundabout on a particular leg.

The exiting flow rate for a given leg is used primarily in the calculation of conflicting flow for right-turn bypass lanes and in determining queuing at exit-side crosswalks. For example the movements contributing to the southbound exiting flow rate (shown as $v_{ex,SB}$ in Exhibit 21-12 of the HCM) are the eastbound right-turn, southbound through, westbound left-turn, and northbound U-turn movements.

36-9.05(b) Capacity

The maximum flow rate that can be accommodated at a roundabout entry depends on two factors: The circulating flow rate in the roundabout that conflicts with the entry flow, and the geometric elements of the roundabout. The larger gaps in the circulating flow are more useful to the entering drivers and more than one vehicle may enter each gap. As the circulating flow increases, the size of the gaps in the circulating flow decreases, thus the rate at which vehicles can enter also decreases.

The geometric elements of the roundabout also affect the rate of entry flow. The most important geometric elements are the width and number of lanes at entry, and the circulatory roadway width within the roundabout. Two entry lanes permit nearly twice the rate of entry flow compared to one lane. A wider circulatory roadway allows vehicles to travel side-by-side or staggered, which creates a tighter group of vehicles, thereby providing longer gaps.

1. Single-lane Roundabout Entry Capacity. A single-lane roundabout can be expected to handle 25,000 vpd and peak-hour flows between 2000 vph and 2500 vph. This rate exceeds 1900 vph, which is the typical single-lane capacity of a signalized intersection. This higher rate is achievable for several reasons. First, this is the total of all the approaches of the roundabout, not a single approach. Second, because of multiple approaches and right turns, much of the traffic does not conflict and may enter the intersection nearly simultaneously.
2. Single-lane Exit Capacity. It is difficult to achieve an exit flow on a single lane of more than 1400 vph, even under good operating conditions for vehicles (i.e., tangential

alignment, and no pedestrians or bicyclists). Under normal urban conditions, the exit lane capacity should be in the range of 1200 vph to 1300 vph. Therefore, exit flows exceeding 1200 vph may indicate a lower LOS or the need for a multilane exit.

3. **Multilane Roundabout Capacity.** For planning purposes, multilane roundabouts (two-lane entries) can be expected to handle ADT's between 25,000 vpd and 45,000 vpd and peak-hour flows between 2500 vph and 4500 vph.
4. **Pedestrian Effects on Entry and Exit Capacity.** Pedestrians crossing at a marked crosswalk that have priority over entering motor vehicles can have a significant effect on the entry capacity. In such cases, if the pedestrian crossing volume and circulating volume are known, multiply the vehicular capacity by a factor, f_{ped} , according to the relationship shown in Exhibit 21-18 or Exhibit 21-20 of the 2010 *Highway Capacity Manual* (HCM) for single-lane and double-lane roundabouts, respectively. Note that the effects of conflicting pedestrians on the approach capacity decrease as conflicting vehicular volumes increase, as entering vehicles become more likely to have to stop regardless of whether pedestrians are present. Consult the (HCM) for additional guidance on the capacity of pedestrian crossings if the capacity of the crosswalk itself is an issue. A similar concern may occur at the roundabout exit where pedestrians cross.

36-9.05(c) Capacity Software

IDOT requires the current version of Signalized (and unsignalized) Intersection Design and Research Aid (SIDRA) for capacity analyses of roundabouts. SIDRA closely follows the methods used in the *Highway Capacity Manual* (HCM), which IDOT requires for computing highway capacity analyses. SIDRA software also includes alternative tools for applications beyond the ability of the HCM.

36-9.05(d) Traffic Control

Vehicles entering the roundabout must yield to the traffic within the circle. A YIELD sign is required at the entry along with the appropriate pavement markings. There is no traffic control within the circular roadway.

36-9.05(e) Access Control

Roundabouts can be used at key public and private intersections to facilitate major movements and enhance access management. Major commercial driveways may be allowed as legs of the roundabout, however, installation of a roundabout strictly for access to private development is discouraged. Minor public and private access points between roundabouts can be accommodated by partially or fully restricted two-way stop-controlled intersections, with the roundabouts providing U-turn opportunities.

Most of the principles used for access management at conventional intersections can also be applied at roundabouts. Property access within the vicinity of an individual roundabout

intersection must be carefully evaluated. If an access, such as a driveway, is necessary within an intersection a roundabout should be discouraged at the location. As a corollary to this, do not include driveways within the circulating area of a roundabout. Driveways introduce conflicts into the circulating roadway, including acceleration and deceleration. Traditional driveways do not discourage wrong way movements as a splitter island does.

Access points should be no closer to the roundabout intersection than the splitter islands. On a larger consideration, access points near roundabouts are governed by a number of factors:

1. Capacity of the Minor Movements at the Access Point. While roundabouts may allow for fewer lanes between intersections, the traffic pattern that emerges from roundabouts can have a significant impact on existing midblock access. Unlike the platooned flow typically downstream of a signalized intersection, traffic passing in front of an access point downstream of a roundabout should be more randomly distributed. As a result, an access point downstream of a roundabout may have less capacity and higher delay than one downstream of a traffic signal.
2. Need to Provide Left-turn Storage on the Major Street to Serve the Access Point. For all but low-volume driveways, it is desirable to provide separate left-turn storage for access points downstream of a roundabout to minimize the likelihood that a left-turning vehicle could block the major street traffic. If an access point is necessary and left turn access is permitted, it should be located far enough from the splitter island of the roundabout that the required deceleration and storage lengths can be provided.
3. Sight distance needs. A driver at the access point should have proper intersection sight distance. Vehicles within the roundabout should be visible when approaching or departing the roundabout.

36-9.06 Safety

The use of roundabouts is a proven safety strategy for improving intersection safety by eliminating or altering conflict types, reducing crash severity, and causing drivers to reduce speeds as they proceed into and through the intersections. This is true for urban, suburban, and rural environments in replacing two-way stop and signal controls. While overall crash frequencies have been reduced, the crash reductions are most pronounced for motor vehicles, less pronounced for pedestrians, and equivocal for bicyclists and motorcyclists depending on the study and bicycle treatments.

The reasons for the increased safety level at roundabouts are:

- Roundabouts have fewer vehicular conflict points in comparison to conventional intersections and the potential for the most severe types of conflicts, such as right angle and left turn head-on crashes, is greatly reduced with roundabout use.

- Lower absolute speeds generally associated with roundabouts decrease the braking distance required to avoid potential conflicts. Low vehicle speeds help reduce crash severity, making fatalities and serious injuries much less common at roundabouts.
- Since most users travel at similar speeds through roundabouts, crash severity can be reduced compared to some traditionally controlled intersections.
- Pedestrians need only cross one direction of traffic at a time at each approach as they traverse roundabouts (i.e., crossing in two stages), as compared with many traditional intersections. Pedestrian-vehicle conflict points are reduced at roundabouts; from the pedestrian perspective, conflicting vehicles come from fewer directions.

NCHRP Report 572, *Roundabouts in the United States* and NCHRP Report 672, *Roundabouts: An Informational Guide* include intersection-level crash prediction models to evaluate the safety performance of an existing roundabout relative to its peers, and in the estimation of the expected safety changes, if a roundabout is contemplated for constructions at an existing conventional intersection.

Although the frequency of crashes is most directly tied to volume, the severity is most directly tied to speed. Therefore, careful attention to the design speed of a roundabout is fundamental to attaining good safety performance.

36-9.07 Pedestrian and Bicycle Accommodations

As with the motorized design vehicle, the design criteria for non-motorized potential roundabouts users (bicyclists, pedestrians, wheelchairs, etc.) shall be considered when developing many of the geometric components of a roundabout design. There are two general design issues that are most important for non-motorized users. First, lower motorized vehicle speeds make roundabouts both easier to use and safer for non-motorized users. Second, one-lane roundabouts are generally easier and safer for non-motorized users than multilane roundabouts. When non-motorized users are a significant consideration, do not design a multilane roundabout when a single lane roundabout should be sufficient.

36-9.07(a) Pedestrians

Pedestrian activities shall be considered at all roundabouts except where separate pedestrian facilities or other restrictions eliminate the likelihood of pedestrian activity in the foreseeable future.

Pedestrians desire crossing locations as close to the roundabout as possible to minimize out-of-direction travel. The further the crossing is from the roundabout, the more likely pedestrians will choose a shorter route that may put them in greater danger. In general, at a minimum, locate the pedestrian crossing one car length or approximately 20 ft (6.0 m) upstream from the yield point and place the crossing at full vehicle-length-increments from the yield line for crossings further from the yield line.

For pedestrian safety the crossing should not be located too far back from the yield line so that entering vehicle speeds are not sufficiently reduced or exiting vehicles are accelerating. It may be appropriate to design the pedestrian crossing at two or three car lengths from the yield point at some multilane entries. At single-lane roundabouts in urban environments, exits should be designed to enforce low exit path speeds to maximize safety for pedestrians crossing the exiting stream.

At roundabouts with multilane pedestrian street crossings, a pedestrian activated signal should be provided for each multilane segment of each pedestrian street crossing. A pedestrian signal found to be effective in increasing yielding rates is the rectangular rapid flashing beacon. Pedestrian hybrid beacons (commonly referred to as HAWK signals) are not recommended for pedestrian signals at roundabouts.

Regardless of the type of pedestrian signal, the operation for a pedestrian crossing a roundabout approach should be done in two stages. A single-stage pedestrian signal can result in excessive amount of delay to vehicular traffic. At two-stage signalized pedestrian crossings, there are two separate pedestrian walk intervals, one for crossing the entry roadway and one for crossing the exit roadway.

Roundabouts with single lane approach and exit legs are not required to provide pedestrian activated signals. If a roundabout consists of multilane and single lane pedestrian crossings consider including pedestrian activated signals at the single lane pedestrian street crossings for consistency.

The raised splitter island width shall be a minimum of 6 ft (1.8 m) wide (from the back-of-curb to the back-of-curb) at the crosswalk to adequately provide shelter for users and to provide the minimum width for the use of detectable warnings within the splitter island.

Roundabout operations at the exit can be affected by pedestrian use of the crosswalk. A queuing analysis at the exit crosswalk may determine that a crosswalk location of more than one vehicle length from the circulatory roadway may be desirable to reduce the likelihood of queuing into the circulatory roadway due to pedestrians crossing. Also, it may be easier for pedestrians to visually distinguish exiting vehicles from circulating vehicles at crosswalks located further from the roundabout. If a queuing analysis determines frequent interruptions from pedestrians to the traffic flow at the exit, causing traffic to regularly back into the circulatory roadway, consideration should be given to a conventionally controlled intersection instead of a roundabout.

The draft Public Rights-of-Way Accessibility Guidelines (PROWAG) from the United States Access Board include a requirement to provide a detectable edge treatment between sidewalks and roundabouts wherever pedestrian crossings are not intended, such as adjacent to the perimeter of the circulatory roadway, along the approaches, or along the exit/entrance radii.

Landscape strips are an effective method to provide a detectable edge treatment. Landscape strips provide many benefits, including increased comfort for pedestrians, room for street furniture and snow storage, and a buffer to allow for the overhang of large vehicles as they navigate the roundabout. Also, the setback discourages pedestrians from crossing to the central island or

cutting across the circulatory roadway of the roundabout. The setback helps guide pedestrians with vision impairment to the designated crosswalk.

If the sidewalk must be flush with the back of the curb, provide a detectable edge treatment along the street side of the sidewalk. If chains, fences, or railings are used for edge treatment, the bottom of the edge treatments shall be no higher than 15 in. (380 mm) above the sidewalk. Detectable warning surfaces, such as truncated domes, shall not be used for edge treatment because detectable warning surfaces indicate the flush transition between the sidewalk and the roadway. In addition to chains, fences, or railings, low shrubs or grass may be used for edge treatments.

36-9.07(b) Bicycles

Bicyclists' decisions at roundabouts depend on how the bicyclist chooses to travel through the intersection. If traveling as a vehicle, as is often the case for experienced cyclists and cyclists in lower volume and low speed environments, the decision process mirrors that of motorized vehicles. Effective designs that constrain motorized vehicles to speeds more compatible with bicycle speed, around 15 mph to 20 mph (20 km/hr to 30 km/hr), are much safer for bicyclists. If traveling as a pedestrian, as is often the case for less experienced cyclists and cyclists in higher traffic volume environments, the decision process mirrors that of pedestrians.

Although the best design provides bicyclists the choice of proceeding through the roundabout as either a vehicle or as a pedestrian, in general, bicyclists are better served by being treated by roundabout designers as vehicles. When entering traffic volumes are projected to be large (i.e., greater than 12,000 ADT), look at other options such as shared use-paths, which provide a physical separation from vehicles around the periphery of the roundabout.

If bicycle lanes are provided on the roadway approaches provide a ramp from the roadway to a shared-use path prior to the intersection to allow a bicyclist to exit the roadway and proceed around the intersection safely through the use of cross walks if the bicyclist is uncomfortable mixing with vehicles. Consider bicycle ramps and a shared-use path around the circulatory roadway for bicycle accommodations even if no sidewalks or shared-use paths are proposed approaching the roundabout. Continue the shared-use path around the circulatory roadway, but separate from the circulatory roadway, where bicycle use is expected. Do not provide bike lanes within the circulatory roadway.

For bicycle design considerations through a roundabout; see Section 17-2.04.

36-9.08 Parking

Parking within the circulatory roadway is prohibited. Parking on entries and exits to the roundabout should be set back far enough so as not to hinder roundabout operations or to impair visibility of pedestrians.

36-9.09 Illumination

For a roundabout to operate satisfactorily, a driver must be able to enter the roundabout, move through the circulating traffic, and separate from the circulatory stream in a safe and efficient manner. Pedestrians must also be able to safely use the crosswalks. To accomplish this, a driver must be able to perceive the general layout and operation of the intersection in time to make the appropriate maneuvers at all times of the day. Adequate lighting shall therefore be provided at all roundabouts including those in rural locations.

Lighting of roundabouts provides:

1. visibility from a distance for users approaching the roundabout;
2. visibility of the key conflict areas to improve users' perception of the layout and visibility of other users within the roundabout;
3. additional visibility for signing and pavement markings; and
4. visibility of pedestrians at and within the crosswalks.

The effectiveness of auto headlights is limited in a roundabout due to the constrained curve radius, making the roadway lighting system very important for nighttime visibility of obstructions and hazards. Approach lighting should provide good perception of the presence of the roundabout.

See Section 56-2.08 for more guidance on lighting for roundabouts.

36-9.10 Signing and Delineation

Pavement marking and signs are integral to the design of roundabouts, especially multilane roundabouts. The *ILMUTCD*, the latest version of FHWA's *Standard Highway Signs*, and any applicable state and local standards govern the design and placement of traffic control devices, including signs, pavement markings and signals. Consult the Bureau of Operations or Bureau of Traffic within the respective District of the roundabout location for specific standards for delineating and signing roundabouts.

Entry lanes should be well referenced, especially for multilane roundabouts, which should have cars in their proper lane at the approach so lane changing is not required through circulating lanes. Signs should be located where they have the maximum visibility for road users, but a minimal likelihood of even momentarily obscuring pedestrians and bicyclists.

A YIELD sign is required at the entry along with the appropriate pavement markings. There is no traffic control within the circular roadway.

36-10 ALTERNATIVE INTERSECTIONS

Some nontraditional intersection designs may offer substantial advantages, under certain conditions, compared to conventional at-grade intersections or grade-separated interchanges. This section provides background information and design guidance for RCUT, MUT, DLT and CGT intersections.

36-10.01 Restricted Crossing U-turn Intersections

Restricted Crossing U-Turn intersections (RCUTs) are also referred to as *superstreets* (where signalized locations are in series) or *J-turn* intersections (if unsignalized). These intersections may be an effective design option for addressing operational and/or safety concerns along urban multi-lane arterials and high-speed multi-lane highways (expressways). At an RCUT all traffic enters the primary route via right-turns. The left-turn and through traffic approaching on the side (or minor) road is redirected to a U-turn maneuver at a downstream median opening (crossover), and drivers then continue along the mainline or turn back (right) onto the side road. Figure 36-10.A shows a schematic of the most common RCUT type. Left turn lanes allow for direct left-in access, while movements from the side road are right-in, right-out. Crossovers for U-turns are typically located 500 ft to 2,000 ft (150 m to 600 m) downstream of the main intersection, with locations dependent on mainline speed and geometric factors. If present at signalized RCUTs, pedestrians would be directed to cross the primary route in a diagonal fashion, from one corner to the opposite corner. See Section 36-10.1(f) for guidance on pedestrian accommodation.

In some cases, left turns off of the primary route are also eliminated, with that traffic redirected beyond the main intersection to the crossover for U-turns as shown schematically in Figure 36-10.B. This design could be appropriate based on a history of mainline left-turn crashes, very low mainline left-turn demand, or constrained intersection sight distance in rolling terrain. In either design type, signalization at the main intersection could be considered for the allowed turning vehicles or for pedestrians; signalization of the U-turn movements may also be considered when an ILMUTCD signal warrant is met. Other unique RCUT designs are illustrated in Figure 36-10.C and Figure 36-10.D.

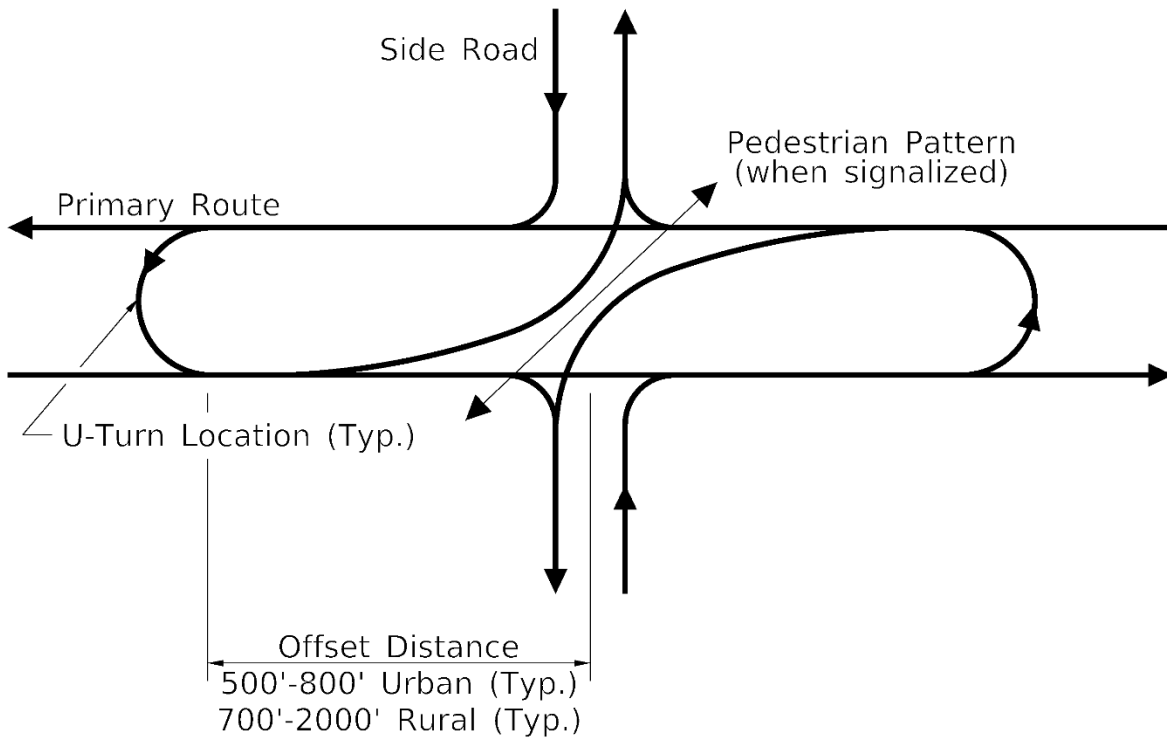

RCUT SCHEMATIC WITH MAINLINE DIRECT LEFT TURNS

Figure 36-10.A

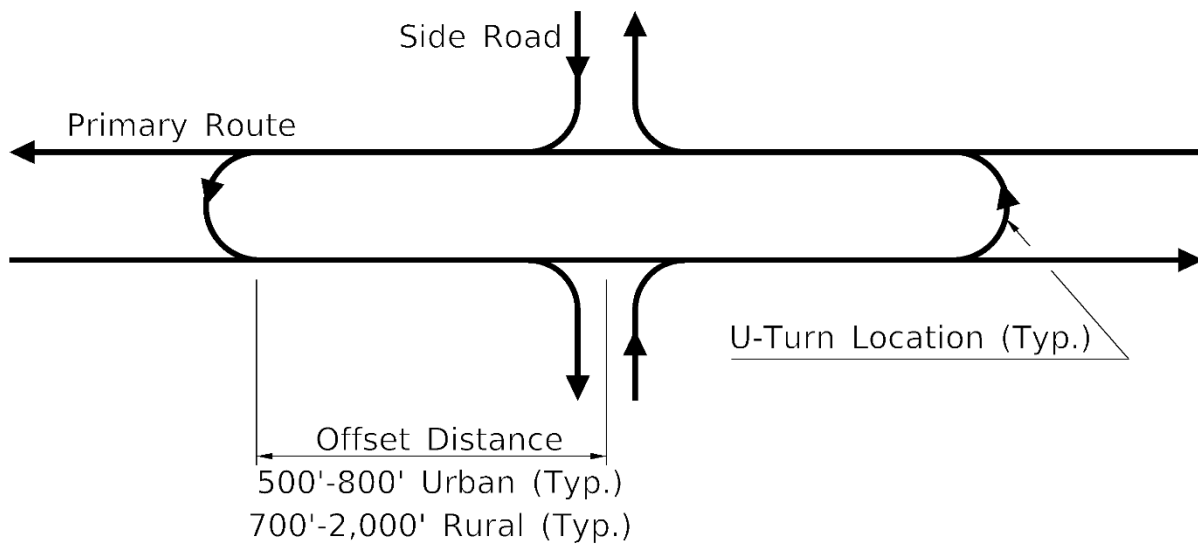

RCUT SCHEMATIC WITHOUT MAINLINE DIRECT LEFT TURNS

Figure 36-10.B

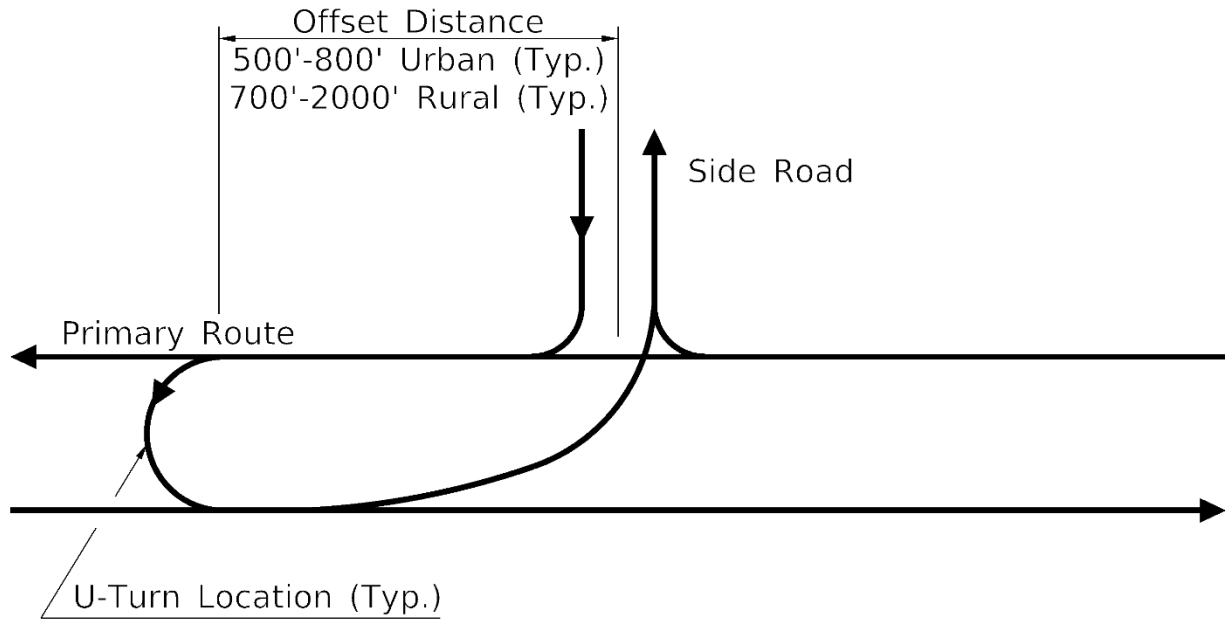

THREE LEGGED RCUT SCHEMATIC

Figure 36-10.C

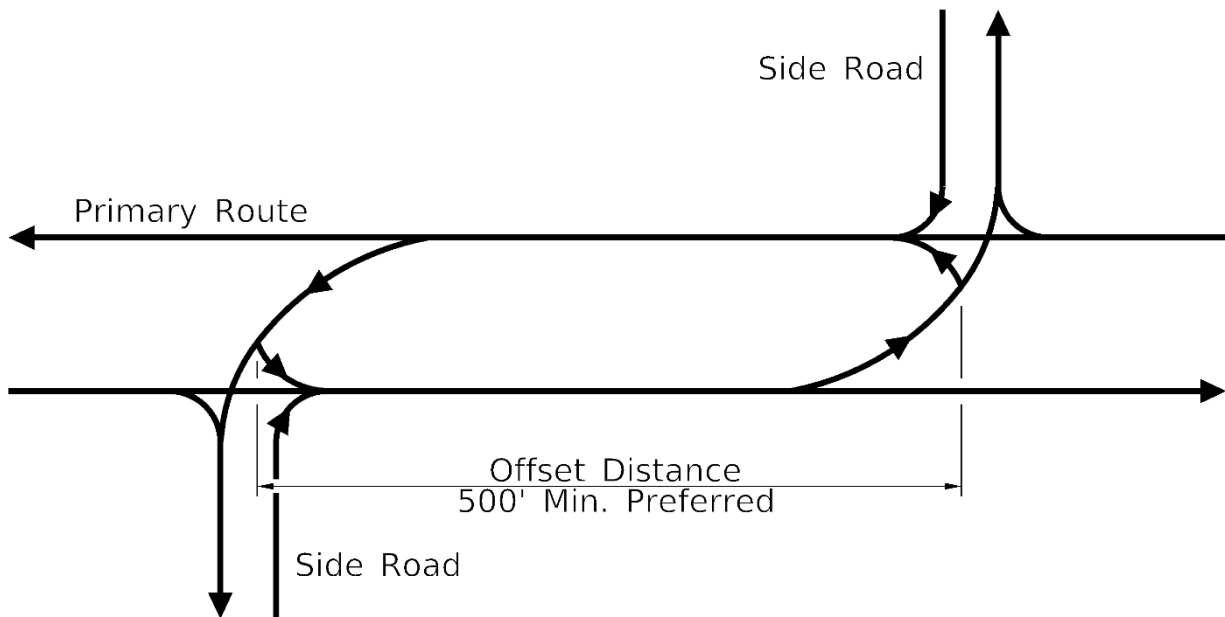

OFFSET RCUT SCHEMATIC

Figure 36-10.D

RCUTs improve safety performance by causing drivers to split their driving task into a series of low-complexity decisions and allowing them to find adequate gaps more easily. Based on the changes in movement types, crashes that do occur at RCUTs tend to be less severe than those that occur at traditional full-access intersections, whether signalized or 2-way stop-controlled. RCUTs may be used along urban and suburban roadways with medians as narrow as 18 ft (5.5 m), and on high-speed rural open-median facilities. Signalized RCUT corridors can be developed by converting multiple intersections along high-ADT primary routes.

An overall layout showing common features of an RCUT is shown in Figure 36-10.E. A more detailed example of a rural RCUT intersection and adjacent median crossover is provided in Figure 36-10.F. The primary route may have either four or six lanes, and side roads may have two or four lanes. The most common situation will be a four-lane mainline and two-lane minor road. Signal warrants should always be checked for the redirected traffic patterns created by the main RCUT intersections and U-turn crossovers. Note that meeting a warrant does not mean that signals will be required; signalization is an operational and safety decision. When provided, two-phase signals are the norm at both the main intersection and the U-turn location(s). If traffic volumes are expected to grow substantially after initial opening, an RCUT design can provide for additional turn lanes and/or signalization to be added later through phased implementation.

RCUT intersections and corridors may be especially suitable where:

- There is heavy through and/or heavy left-turn volumes on primary route approaches;
- The ratio of the minor road approach volume to the total intersection approach volume is less than 0.20;
- The primary route left-turning volume per lane is greater than 80 percent of the minor road traffic per lane moving concurrently during a signal phase;
- During peaks the intersection is heavily-congested with signal phase failures (LOS F) occurring for through and/or left-turn traffic on the primary route;
- Corridor access management is desirable;
- The history of intersection crashes, both overall and for turning and angle crashes, shows rates above the statewide average for peer group locations; or
- Sight distance constraints for left turns onto or off of the primary route seem to have led to crashes or documented near-misses.

RCUTs may be less effective where there are heavy through and left-turn volumes from the side road approaches. Concerns may include extra travel time incurred by side road drivers and/or congestion related to the U-turn movements. Both an operational analysis and a safety performance assessment are typically necessary. Refer to Chapters 49 or 50 for operational criteria associated with arterial and freeway projects.

36-10.01(a) General Design Considerations

The spacing from the main intersection to the U-turn crossover, the “offset distance”, is influenced by several factors. For rural unsignalized locations a very conservative design would consider the acceleration, weaving, and deceleration maneuvers using the combined peak-hour through and side road volumes. Offset distance would be the sum of acceleration distance (moving into

the mainline assuming a merge), weaving length (for moves from the right lane to the left lane along the expressway), and deceleration (left-turn lane) length. If the U-turn is unsignalized, similar calculations could be applied to the return path. This procedure for setting offset distance is overly conservative in practice. The criteria for the weaving length is not fully applicable, and weaving distances can usually be ignored. The designer may consider providing an acceleration lane in accordance with Figure 36-2.L for slow moving (heavy truck) traffic entering the mainline.

For a two-lane minor road and four-lane mainline, a 500 ft to 800 ft (150 m to 240 m) offset distance will typically suffice in urban/suburban areas. A 700 ft to 2,000 ft (210 m to 600 m) offset distance is often appropriate for rural high-speed locations. Consider the need for guide signs and the presence of trucks in setting design offset distances. Values at the higher end of these ranges involve more out-of-direction travel but may decrease the probability of queue spillback and also provide more time and space for drivers to read signs and change lanes. Closer spacing reduces driving distances and travel times and is typically favored by drivers. The designer should consider these factors as well as topography, sight lines, and access points when setting offset distances.

The main intersection must physically eliminate the possibility of side road through and left-turn movements by inserting raised curb and wide grass areas in conjunction with left turn channelization. However, coordination with state and local emergency services may affect design details. The crossover intersection must clearly guide turning movements and allow for the design vehicle(s) to complete U-turns within the pavement. Accommodating these movements typically require widening pavement for a “loon” area along the far side of the mainline, as depicted in Figures 36-10.E and 36-10.F. The designer may incorporate low-volume existing and relocated driveways, or minor side roads, into a crossover intersection; provide channelization and where applicable an additional signal phase. Consider intersection sight distance, vehicle turning paths, and the need for signing or geometric measures to deter wrong-way movements.

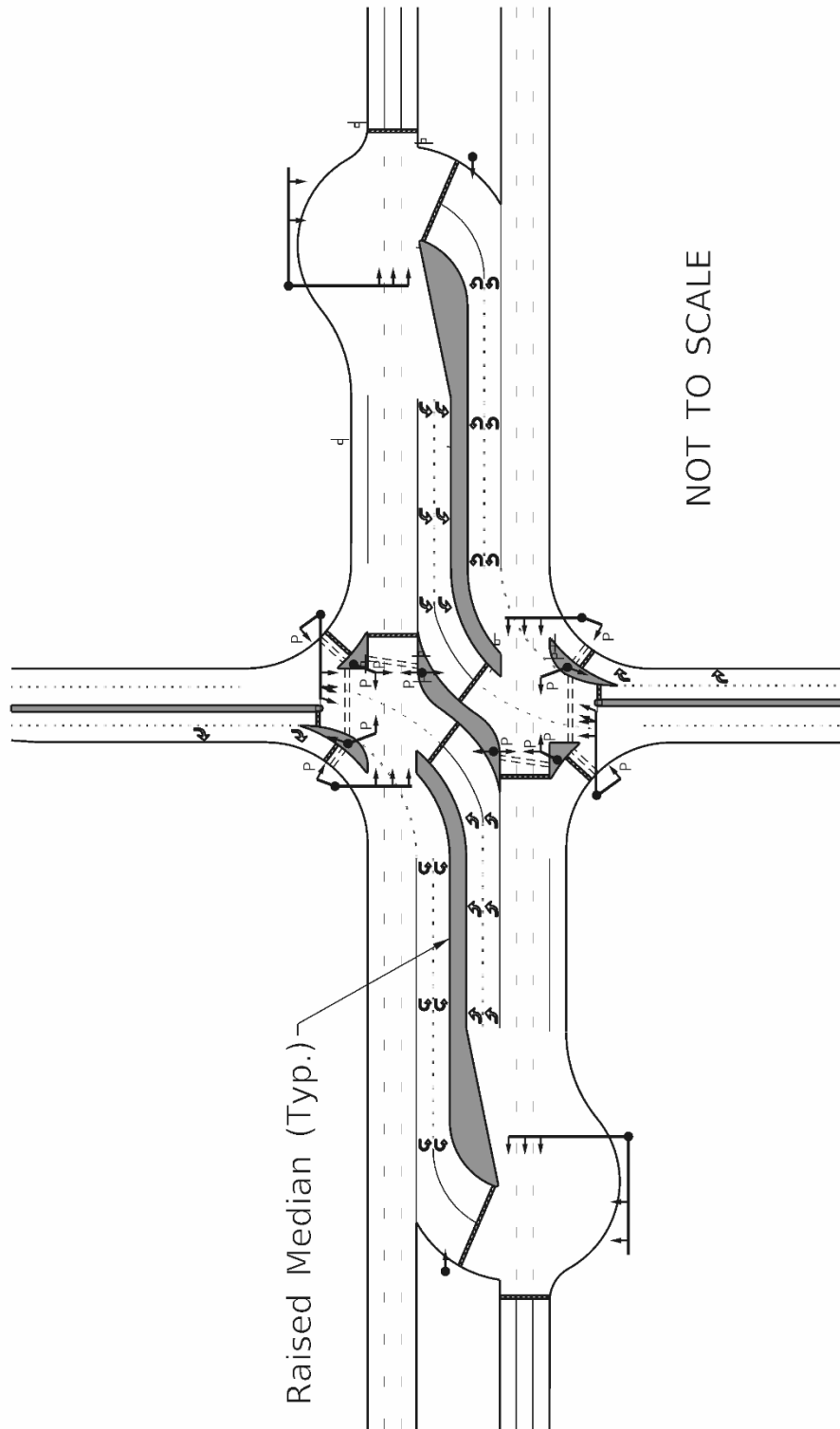

TYPICAL RCUT LAYOUT INCLUDING SIGNAL LOCATIONS

Figure 36-10.E

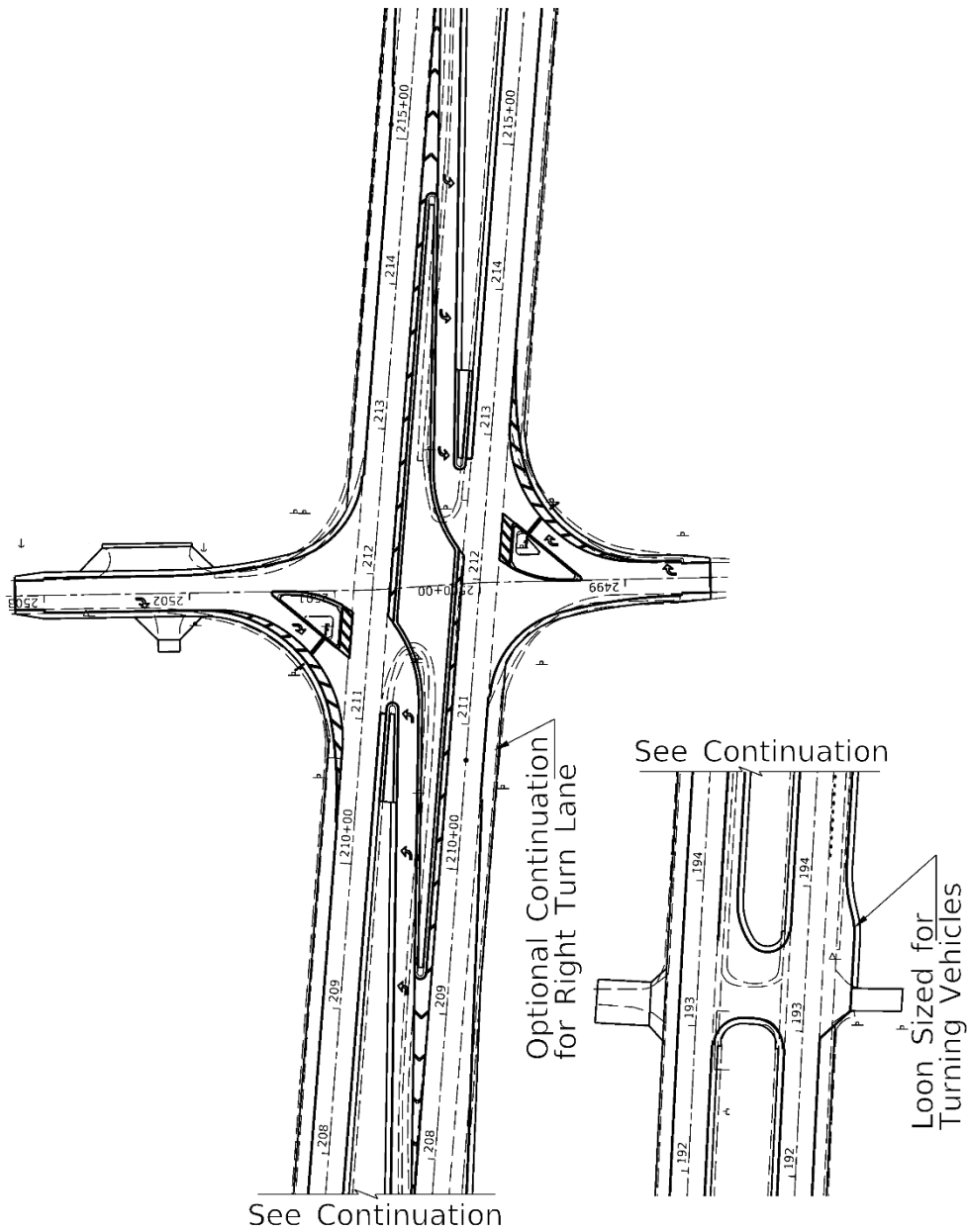

EXAMPLE RCUT GEOMETRICS

Figure 36-10.F

36-10.01(b) Signalization

Expressways and four-lane divided arterials typically move large volumes of through traffic as a primary function. Signals that provide a high percentage of mainline green promote progression and improve operations over a wide range of traffic demands. Because RCUTs can require only two phases instead of the four (or more) phases needed at conventional intersections, and because the two mainline directions will operate independently, opportunities to optimize primary route progression is a primary advantage for RCUT corridors. Select cycle lengths that provide for effective mainline flows while not unduly delaying side road vehicles (and pedestrians where present). The timing offset for crossover signals (where needed) will typically fit within a progression band on the primary route regardless of offset distance. Guidance on signal operations at RCUTs and superstreet corridors is provided in the FHWA's *Restricted Crossing U-Turn Intersection Informational Guide*.

36-10.01(c) Safety

Safety benefits typically result from the redirection of the minor road through and left-turning movements. The number of vehicle-vehicle conflict points is reduced and the modified movements tend to result in less severe crashes. Compare the crash history of each existing intersection with statewide peer group intersections as a starting point in assessing the potential safety benefits of an RCUT design. Focus on assessment of crash types. RCUTs typically experience fewer angle and turning crashes than do conventional 4-legged intersections; however, increases in less-severe same-direction sideswipe and rear end crashes may be seen. Consider using Crash Modification Factors (CMFs) from the FHWA CMF Clearinghouse for converting unsignalized conventional intersections to unsignalized RCUTs; such assessment can be a primary justification for RCUT implementation.

36-10.01(d) Signing

Driver unfamiliarity can be a concern at RCUTs immediately after implementation, since some movements do not meet the expectations of drivers unfamiliar with this intersection type. However, experience in other states has indicated that drivers adapt fairly quickly to RCUT operations. Proper signing at an RCUT will typically lead to good operational and safety performance. Diagrammatic guide signs may be considered to aid drivers on the minor road approaches. Prominent "Right Turn Only" regulatory signs are required facing the side road approaches. Utilize "One Way" and "No Left Turn" signs strategically in accordance with the ILMUTCD. Signing can generally be ground-mounted rather than overhead. The Central Bureau of Operations can assist by providing a typical design; statewide consistency is sought.

36-10.01(e) Access Management and Right of way Considerations

Driveway access should be limited to the extent possible in close proximity to the main RCUT intersection. Because of access restrictions RCUTs can be perceived as adversely affecting businesses located near intersection or at the corners. Inferences can be drawn from the *NCHRP*

Report 420, which indicates that some land uses suffer economic losses with wide median installations. Businesses that rely on pass-by traffic, such as gas stations and convenience stores, may be affected by the less-direct access typically provided with an RCUT. Manage access in consideration of safety and efficiency. Discuss required access restrictions with potentially-affected property owners and local agency officials.

The combined median and loon area width needed to accommodate large vehicle U-turns at crossovers can sometimes result in ROW acquisition and/or spot location impacts. Given inherent flexibility, seek to locate crossovers and loons to minimize impacts while satisfying operational requirements. The potential for oversize loads should be discussed with the Bureau of Operations, as there may need to be restrictions placed on routing.

36-10.01(f) Pedestrian Accommodations

Figure 36-10.G shows typical pedestrian accommodations for a signalized RCUT at a minor side road; Figure 36-10.H depicts an accommodation scenario at a major side road. A raised median area is needed to establish refuge, and pedestrian signal heads and pushbuttons are required for the multi-stage crossings. Wayfinding signing may sometimes be helpful in guiding pedestrians. Offset sideroads, as illustrated schematically in Figure 36-10.I, would further simplify pedestrian movements where such a configuration is possible.

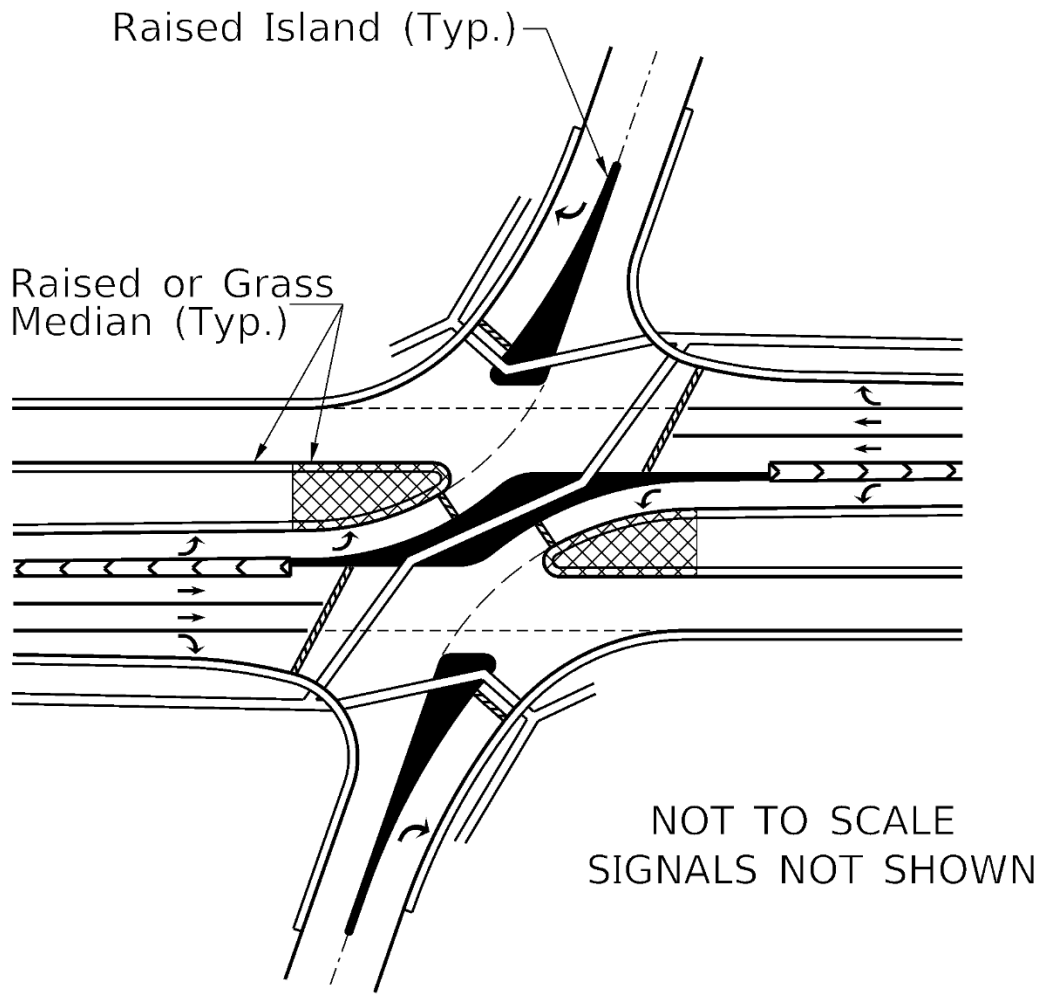

SIGNALIZED RCUT WITH MINOR SIDEROAD, INCLUDING PEDESTRIAN MOVEMENTS

Figure 36-10.G

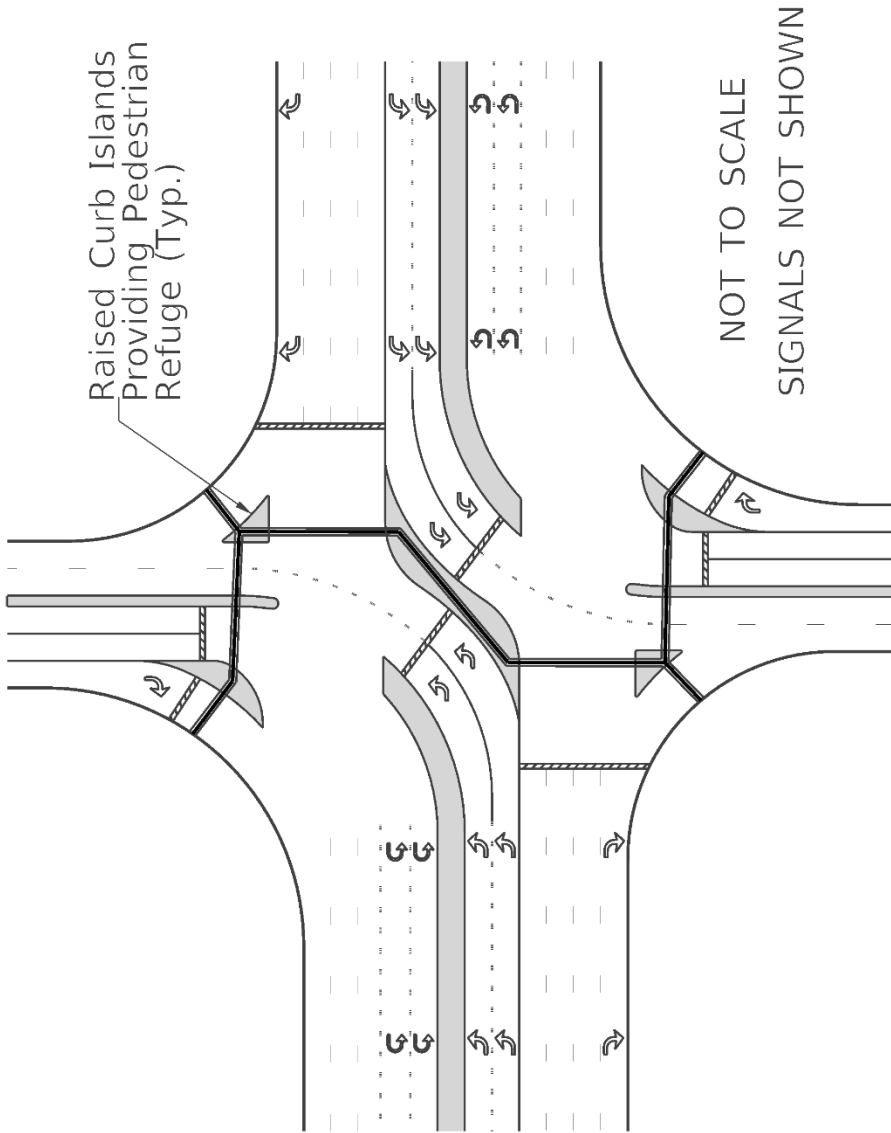

SIGNALIZED RCUT WITH MAJOR SIDEROAD, INCLUDING PEDESTRIAN MOVEMENTS

Figure 36-10.H

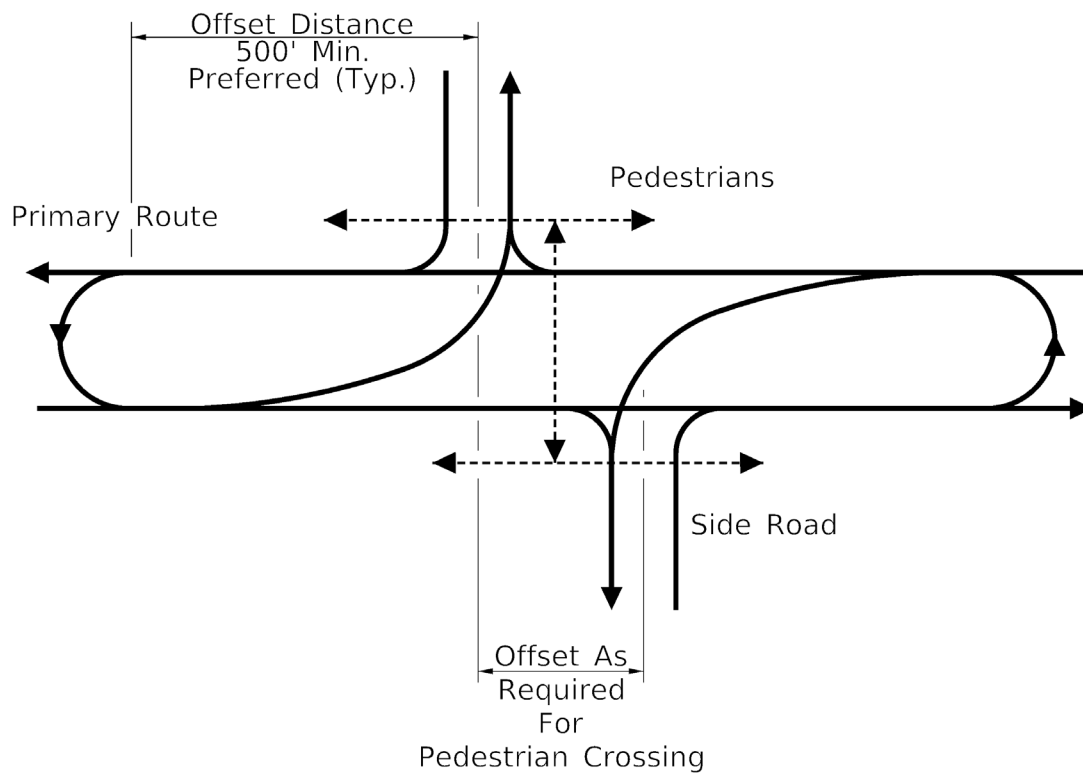

OFFSET RCUT SCHEMATIC

Figure 36-10.1

36-10.01(g) Stakeholder Outreach

When RCUTs are considered it is important to provide effective outreach with communities and roadway users. Multiple forums can be used, including public informational meetings, local agency council meetings, and media campaigns. Highlight safety analyses that show a likely reduction in serious crashes. Investigate and report on the performance of similar RCUT locations already in service. Driver education can be important in reducing the potential for driver confusion; potentially coordinate with the Illinois Secretary of State's office on a local education program.

36-10.02 Median U-Turn Intersections

Median U-Turn (MUT) intersections are at-grade signalized intersections where all left turns are indirect. U-turn movements occur at adjacent crossovers that are usually but not always also signalized. MUTs are very similar in many respects to signalized RCUTs but allow the minor road through movements. MUTs must always be signalized to handle those movements. They may be an effective design option for existing intersections with either operational and/or safety concerns along urban and suburban multi-lane arterials, and in series along corridors where the higher-volume cross streets warrant signals.

In almost all cases the MUT will redirect left-turning traffic from both primary and minor road approaches. Mainline drivers intending to turn left will continue beyond the main intersection, complete a U-turn maneuver at a downstream median opening, and then turn right to continue along the minor road. Sideroad traffic intending to turn left instead turns right and performs a U-turn at a crossover.

A schematic view of the MUT design movements is provided in Figure 36-10.J. An example layout of an overall MUT design is shown in Figure 36-10.K. The details of a typical U-turn intersection, incorporating a loon, are consistent with RCUT layouts shown in Section 36-10.1.

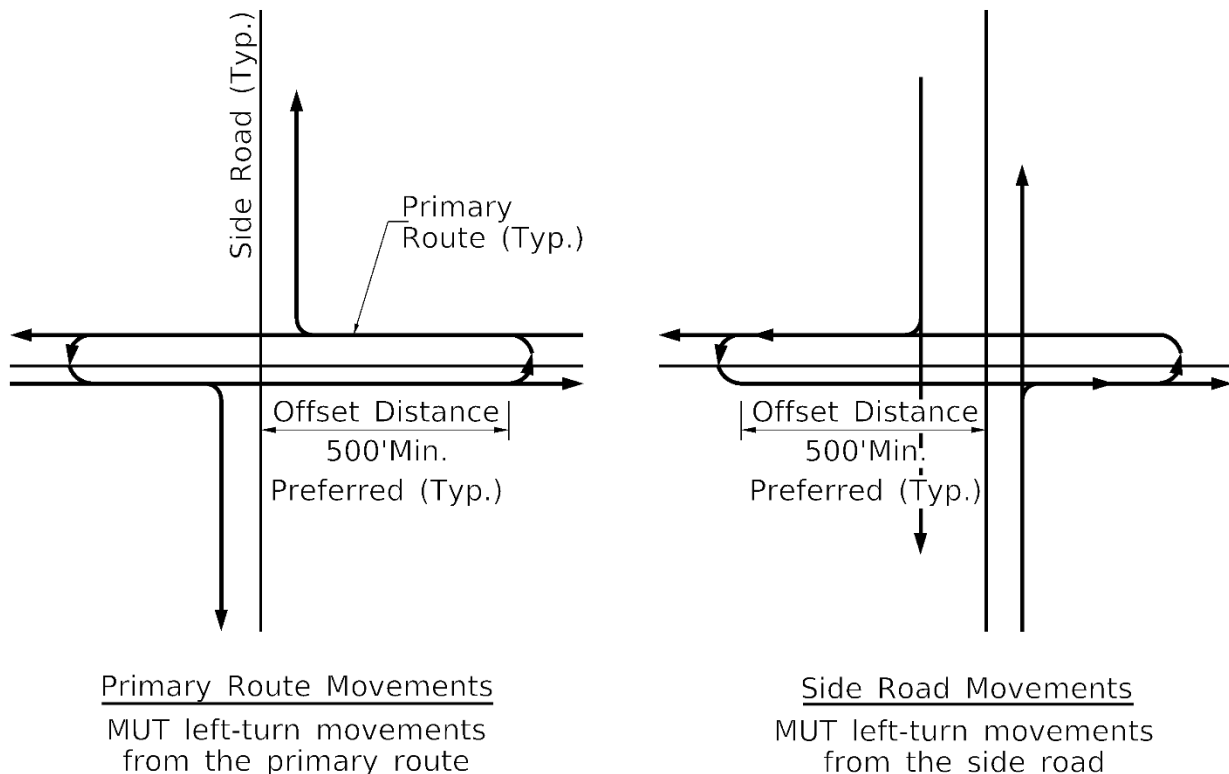
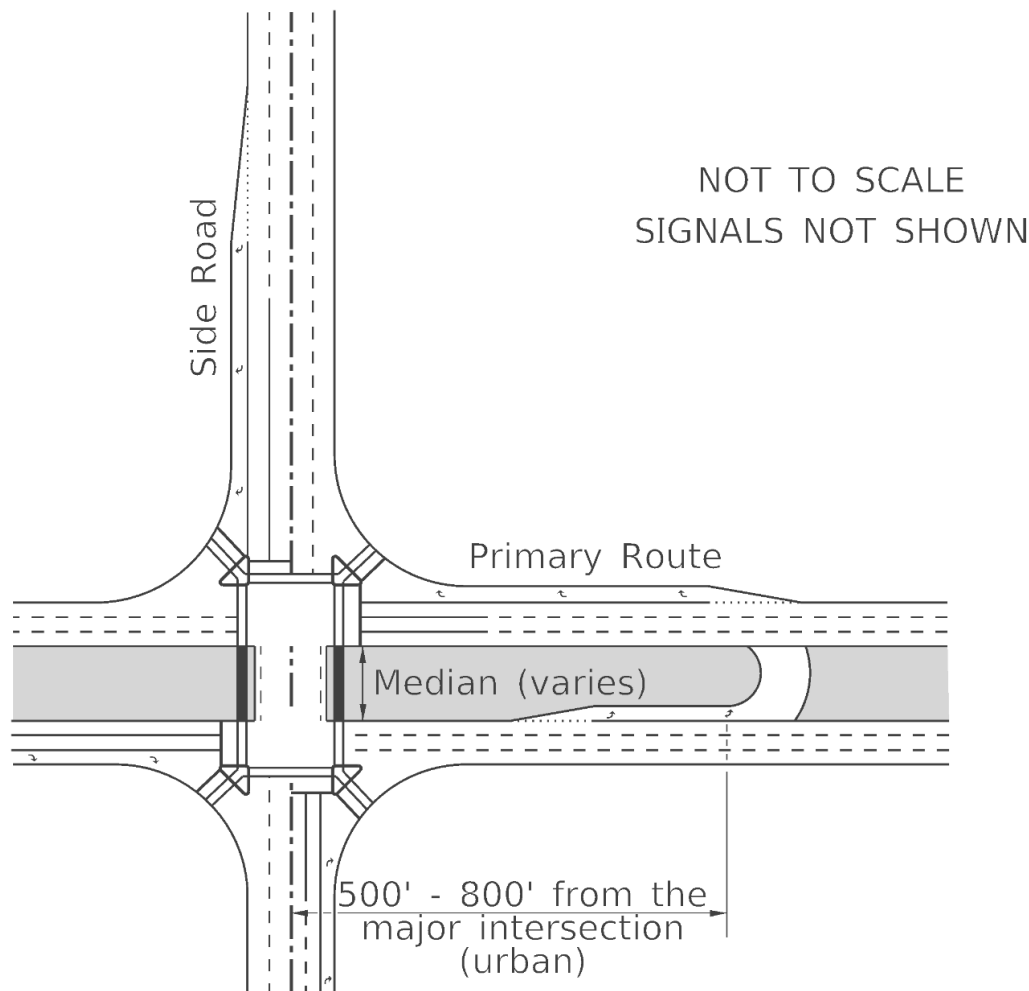

Figure 36-10.J



TYPICAL MUT LAYOUT

Figure 36-10.K

MUTs typically improve safety performance by causing drivers to make a series of low-complexity decisions and allowing them to find adequate gaps more easily. Based on the changes in movement types, crashes that do occur at MUTs tend to be less severe than those that occur at traditional full-access signalized intersections. The total number of vehicular conflict points is reduced by approximately fifty percent.

Multiple MUTs can be installed along high-ADT primary routes as a signalized corridor treatment. This will typically improve traffic flow efficiency and improve safety performance compared to corridors with conventionally-designed intersections. Medians at MUTs can be very narrow; side road through vehicles are typically not allowed to store in the median. Wider open medians could be designed to allow for occasional vehicle storage in the median; however, clearing all median queues will improve efficiency and eliminate potential conflicts.

With maximum posted mainline speed limits of 45 mph (70 km/hr), median openings (crossovers) for U-turns are typically located 500 ft to 800 ft (150 m to 240 m) downstream of the main intersection, with locations dependent on speed and geometric factors. Two-phase signals are typically used. If traffic volumes are expected to grow substantially after initial opening, a MUT design can provide for expansion through a phased implementation. At least one ILMUTCD signal warrant must be met when MUTs are installed. The two mainline directions will not operate independently with MUTs; optimization of corridor progression bands is critical.

MUT intersections and corridors may be especially suitable where:

- There is heavy through and/or heavy left-turn volumes on primary route approaches;
- The ratio of the minor road approach volume to the total intersection approach volume is less than 0.40;
- The intersection is heavily-congested and signal phase failures (LOS F) occur for through and/or left-turn traffic on the primary route;
- Corridor access management is desirable;
- The history of intersection crashes, both overall and for turning and angle crashes, shows rates above the statewide average for peer group locations; and
- Sight distance constraints for left turns onto or off of the primary route seem to have led to crashes or documented near-misses.

36-10.02(a) General Design Considerations

The design spacing from the main intersection to the U-turn crossover, the “offset distance”, is guided by geometric limitations such as turn lane lengths and adjacent access points; 500 ft to 800 ft (150 m to 240 m) being the typical design range. Signals for the U-turn locations may be included where warranted and needed operationally. Pedestrians (usually present) are accommodated with crosswalks at each of the signalized intersections; see Section 36-10.2(e).

The crossover intersection must incorporate sufficient space for the design vehicle(s) to make the required U-turn movements. This typically requires widening pavement for a “loon” area along the far side of the mainline. It is possible to incorporate existing or relocated access points into a crossover intersection. If the crossover is signalized an additional phase will be required. Consider intersection sight distance, design vehicle turning paths, and the need for signing or geometric measures to deter wrong-way movements. Other potential design considerations are covered in Section 36-10.1(a).

36-10.02(b) Safety

Safety benefits typically result from the redirection of all left-turning movements at MUTs. The number of vehicle-vehicle conflict points is reduced and the conflict types are modified to be typically less severe than those at conventional intersections. Compare the crash history of each existing intersection with statewide peer group intersections as a starting point in assessing potential safety benefits of MUT.

36-10.02(c) Signing

Driver confusion can be a concern at MUTs immediately upon implementation, but experience in other states has indicated that drivers adapt fairly quickly to MUT operations. Proper signing at a MUT is critical to operational and safety performance, because some movements do not meet the expectations of drivers unfamiliar with this intersection type. Diagrammatic guide signs may be considered to aid drivers on all approaches. Prominent “No Left Turn” regulatory signs are needed facing each of the approaches. Most or all of the signing can be ground-mounted signs rather than overhead; signing design involves unique considerations at each location. The Central Bureau of Operations can assist by providing a typical design; statewide consistency is sought.

36-10.02(d) Access Management and Right of way Considerations

Driveways should not typically be allowed in close proximity to the main MUT intersection. MUTs can be perceived as adversely affecting businesses located near intersection or at the corners. Inferences can be drawn from the *NCHRP Report 420*, which indicates that some land uses suffer economic losses with wide median installations. Businesses that rely on pass-by traffic, such as gas stations and convenience stores, may be affected by less-direct access provided with a MUT. Designers should manage access in light of both safety and efficiency. Discuss issues with potentially-affected property owners and local agency officials.

Another concern with MUT designs is that the combined median and loon area width needed to accommodate large vehicles making U-turns at crossovers can result in ROW acquisition and/or impacts. Designers should seek to locate the loons to minimize impacts while satisfying operational requirements.

36-10.02(e) Pedestrian Accommodations

The two-phase signal at a MUT typically allows for a shorter cycle length than with a conventional intersection. Along the primary route a central raised median area is typically used, but suburban roadways may have wide medians. Based on these conditions, pedestrian crossings will often occur in two stages, with use of a median refuge. Typically include pedestrian signal heads and push buttons in the median to allow for two-stage crossings. For shorter crossings it may be possible for pedestrians to cross during a single phase. As always, it is important that all pedestrians follow the marked crosswalks; additional guidance may be provided to help ensure safe operations.

36-10.02(f) Stakeholder Outreach

When MUTs are considered it is important to provide effective outreach with communities and roadway users. Multiple forums can be used, including public informational meetings, local agency council meetings, and media campaigns. Highlight the potential safety benefits of the

design. Driver education can be important in reducing any initial driver confusion; potentially coordinate with the Illinois Secretary of State's office on a local education program.

36-10.03 Displaced Left-Turn Intersections

Displaced Left Turn Intersections (DLTs), also known as a Continuous Flow Intersections (CFIs), have been implemented nationally as high-volume operational improvements. Compared to traditional signalized intersections, a DLT's reduced traffic signal phases and fewer conflict points will improve traffic operations and safety performance under a range of relative-volume conditions. They may provide an effective design option for existing high-volume intersections along either multi-lane urban arterials with medians as narrow as 30 ft (9.0 m), and for rural multi-lane expressways with wide medians.

DLTs relocate, or displace, a left-turn movement to the other side of the opposing directional roadway in advance of the main intersection. This eliminates the separate left-turn phase at the main intersection since all through-movements and left turns from the main route proceed concurrently. The removal of high-volume conflicts from the main intersection to a preceding crossover often leads to both operational and safety-performance improvements. Coordinated traffic signals are required at the main intersection and each of the new crossover intersections. Figure 36-10.L illustrates a full DLT.

Designers must carefully consider each individual lane group volume in developing proposed geometry and selecting signal timings that accomplish the following goals:

- Reduce delay for the through vehicles,
- Reduce delay for left turning vehicles,
- Reduce the number of stops for all vehicles, and
- Increase the efficiency of pedestrian crossings (for relevant intersection legs).

Full interchanges are often the only effective alternative for handling the higher-end traffic volumes that can be processed at a DLT. A DLT design has a potential to reduce right-of-way acquisition and costs substantially when volumes are projected such that an interchange is under consideration. Specific safety concerns can also be successfully addressed as part of DLT designs, especially those related to left turns. Safety analyses will be an important part of alternatives evaluations.

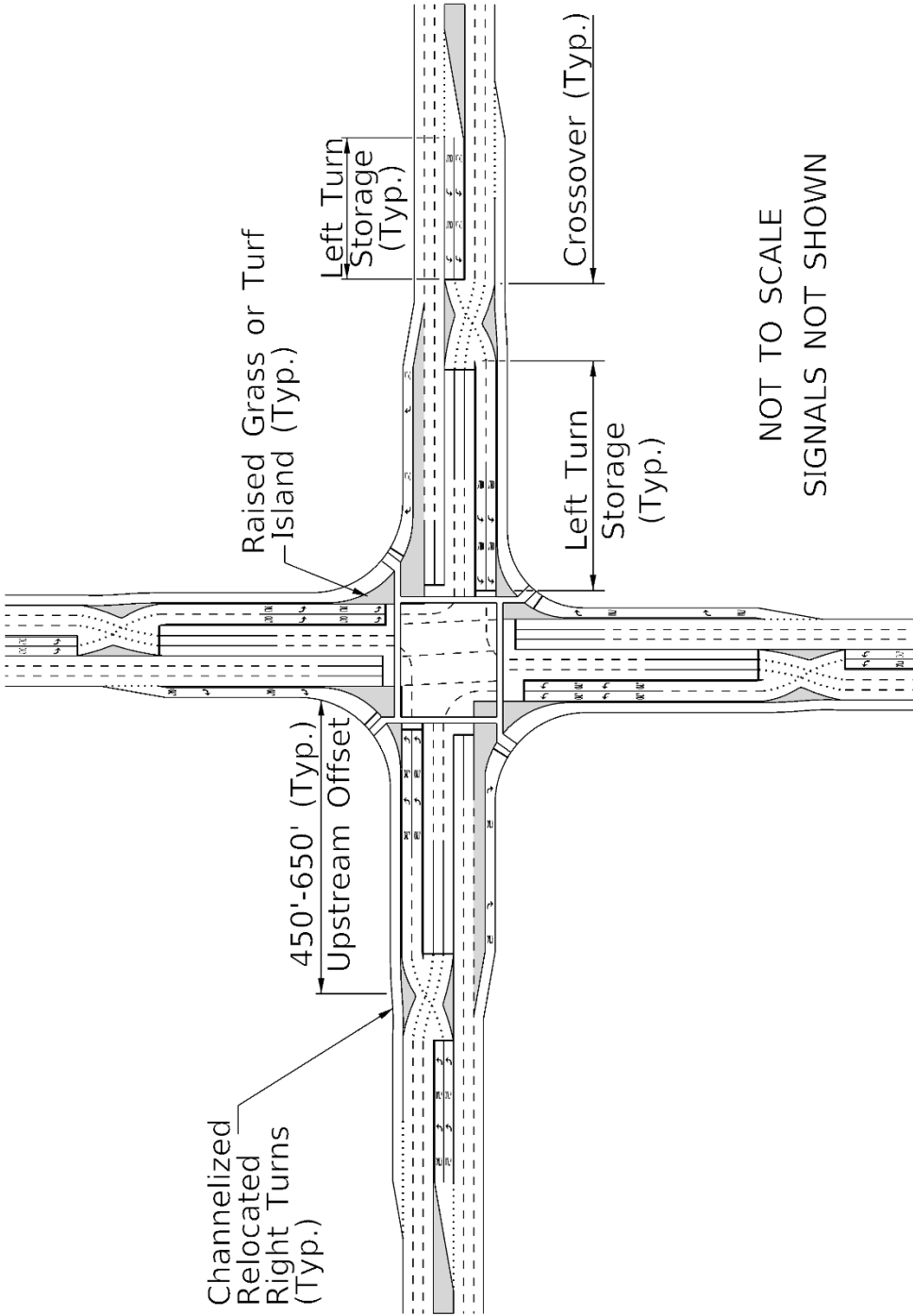

TYPICAL PLAN VIEW WITH DISPLACED LEFT TURNS ON ALL APPROACHES

Figure 36-10.L

36-10.03(a) General Design Considerations

Figure 36-10.M shows typical DLT geometrics along one leg of a DLT intersection. Primary route left turning vehicles should typically cross the opposing through traffic lanes 450 ft to 650 ft (140 m to 200 m) upstream of the main intersection. This 'upstream offset' distance depends on the signal design and anticipated queuing under the coordinated system; offsets may need to be greater in some cases. Dual left-turn lanes are typically required based on the high-volumes of left turns at intersections where this design type is implemented. The signal control at the main intersection can often operate with two-phases and opposing mainline traffic lanes moving together. DLTs allow for a wide range of cycle lengths to be tested to optimize progression along a corridor.

Radii leading to the crossover movements will typically range from 90 ft to 200 ft (27 m to 60 m). The radii of the left-turn movements at each intersection depend on the dual turning movements of the design vehicle combination; refer to Section 36-3.05 for design guidance on dual turn lanes. Lane widths at the crossover reverse curves should typically be 13 ft to 14 ft (4.0 m to 4.3 m) wide and must accommodate the selected design vehicles side-by-side.

A full DLT with left-turn crossovers on all approaches would have five signalized junctions. Signal coordination with adjacent upstream and downstream intersections is very important to proper DLT operations. The location illustrated in Figure 36-10.M shows that the DLT concept can be implemented on a single mainline leg without changing operations on other legs. In this case, at a minimum a third signal phase would be required to handle the opposing mainline left turns.

The provision of separate right-turning lanes and channelized right-turn paths up to the crossover intersection is a typical feature of the DLT. Most but not all DLTs will relocate right turns in this way to improve overall LOS. Two options are then available for the right-turning traffic entering the primary route flow:

1. provide a non-stop merge condition (appropriate for single right-turn lanes with substantial mainline intersection spacing), or
2. stop traffic at the crossover intersection and allow it to proceed concurrently with the left turn crossing movement (required with dual right-turn lanes and/or with constrained mainline intersection spacing).

The upstream offset distance is primarily dependent on the expected queuing of through and left-turning vehicles from the main intersection. Greater offsets can substantially increase costs given the need to construct the left-turn storage area (for the crossed-over traffic) and often the right-turning pavement for the opposite movement traffic. Typically the offset distance should be minimized within operational constraints.

DLTs are usually retrofit designs. If the existing arterial has a wide median that is no longer needed for left-turn storage designers may consider narrowing the median by using transition curves on the approaches. Refer to Figure 36-10.L for an example of such median use. Balance operations with impacts and overall construction costs.

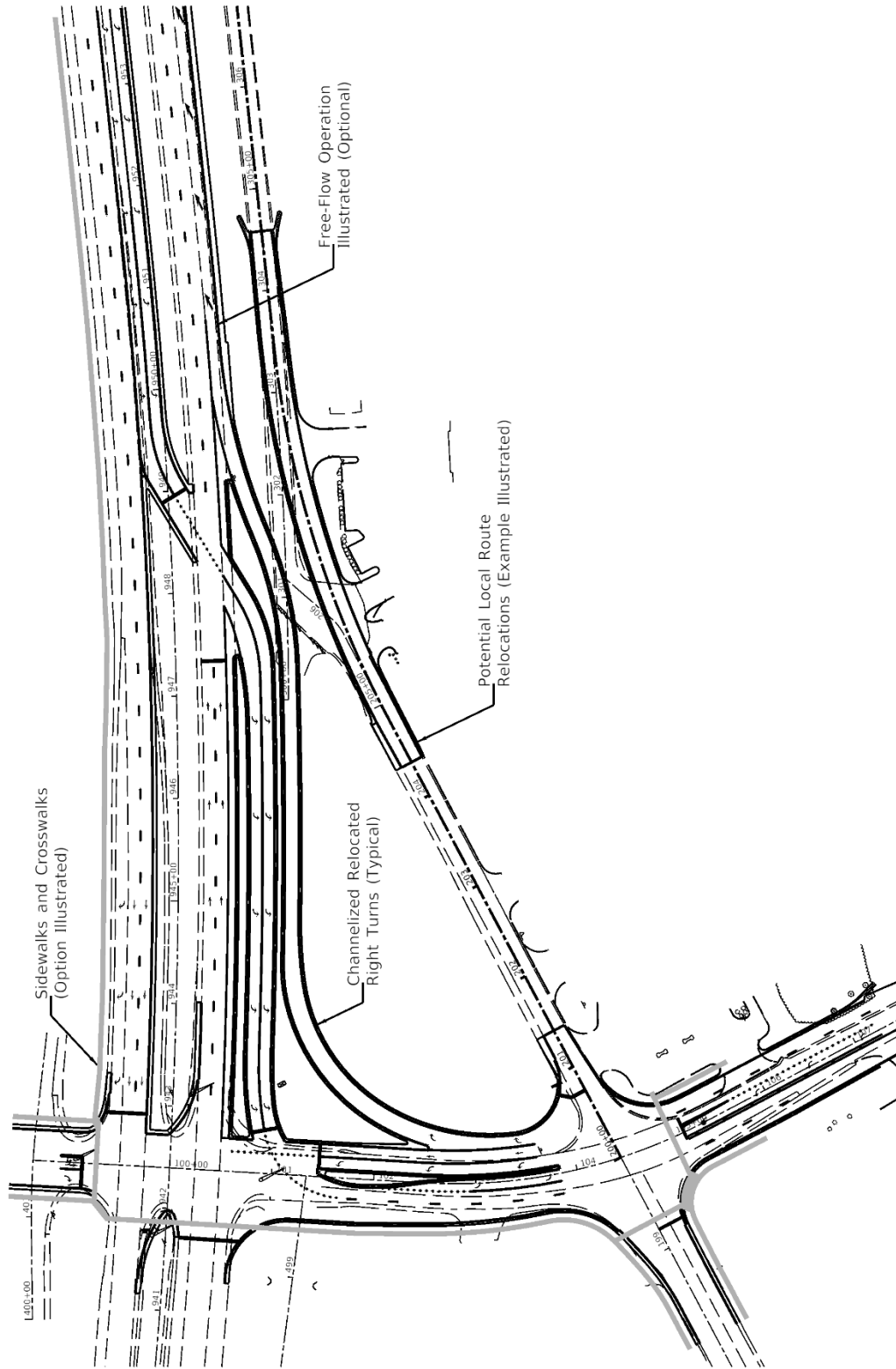

PARTIAL PLAN VIEW, DLT ON ONE MAJOR ROAD APPROACH

Figure 36-10.M

36-10.03(b) Safety

The DLT has marginally fewer conflict points compared to a conventional intersection. At this time, no direct Crash Modification Factors (CMFs) are available from the FHWA CMF Clearinghouse for assessing the safety benefits of converting a traditional signalized intersection to a DLT. However, individual movements with crash history may be considered in order to estimate a potential change in safety performance. Compare the crash history of an existing intersection with statewide peer group intersections as a starting point in assessing the potential benefits of a DLT. Measures to increase non-motorized user safety should also be considered, as discussed in Chapter 17 and earlier in this chapter.

36-10.03(c) Operations and Signing

Operational benefits of a DLT are most evident with high left-turning and overall traffic volumes. Simultaneous movement of the left-turn and through traffic improves progression of traffic platoons and increases overall vehicular throughput. As part of an alternatives analysis designers should investigate and consider the value of vehicle delay reduction, queue length reduction, and overall capacity changes with a DLT.

Signing and marking of a DLT involve unique considerations. Emphasis should be given to 'wrong-way' pavement markings and signing to warn drivers of restrictions that they might not immediately recognize. Overhead and/or post-mounted guide signing should be placed at the left-turn crossover intersections. Since some movements can initially be counterintuitive to unfamiliar drivers unambiguous signing is critical. Consider providing 'No Left Turn' signs facing through traffic at the main intersection. Provide notification of lane assignments in advance of the intersection. Through-arrow pavement marking may be considered at locations such as those shown on Figure 36-10.M in order to reinforce required driving patterns. Other design features to improve effectiveness and safety at DLTs include channelizing islands, right-in-right-out driveways (rather than full access), high-visibility pedestrian refuge areas and crosswalks, raised pavement markers for lane delineation, and traffic flow separation using raised medians. Experience in other states has indicated that any initial driver confusion is quickly reduced as these intersections are opened and driver experience levels increase.

36-10.03(d) Pedestrian and Bicyclist Accommodations

For accommodating bicycle left turns at DLT intersections it may be appropriate to guide riders to the intersection proper, to proceed as would a pedestrian, rather than following the left turning paths of vehicles. Alternatively, adding a two-stage bicycle turning box encourages left-turning bicyclists to store at an appropriate location within the intersection before completing the second stage of their intended left turn.

Pedestrians are required to cross DLTs in multiple stages. Existing literature describes alternative pedestrian signal strategies including clockwise and counterclockwise optimization of pedestrian flows at a DLT intersection. Figure 36-10.M shows an accommodation example. There are

situations where accommodating pedestrians on only one side of the minor road crossing may provide overall operational advantages.

The position of intersection approach lanes can be counter-intuitive to pedestrians. The wide geometric footprint of the DLT, often combined with shorter signal cycle lengths, make pedestrian crossings a critical part of system optimization. Medians and corner islands must provide adequate pedestrian refuge. Refer to Section 36-4.03(b) for pedestrian refuge requirements.

Pedestrian time and distance considerations are less important than pedestrian safety. Figure 36-10.N shows typical pedestrian crossing paths among the four quadrants. Crossing the street diagonally typically requires the following procedure, following pedestrian signal heads:

1. Cross a channelized right-turn roadway to a pedestrian refuge island. Crosswalks for single-lane right-turning roadways may be provided with or without pedestrian pushbuttons at designer discretion (they are advisable for some wider crossings). Pedestrian pushbuttons are required for crossings of dual right turn lanes.
2. Cross all lanes of the first street that offers a "Walk" signal to reach the pedestrian refuge island on the opposite side.
3. Cross all lanes of the second street by crossing with a "Walk" signal to the diagonally opposite pedestrian refuge island.
4. Complete the crossing procedure by crossing a right-turn roadway; see #1 above.

The push-buttons for crossing the major legs of the intersection are located on the channelizing corner islands which serve as pedestrian refuge areas and must be sized for storage of the expected pedestrian streams at all locations.

Lighting designs may involve unique considerations at a DLT, particularly if pedestrian crosswalks will be part of the design; refer to Chapter 56.

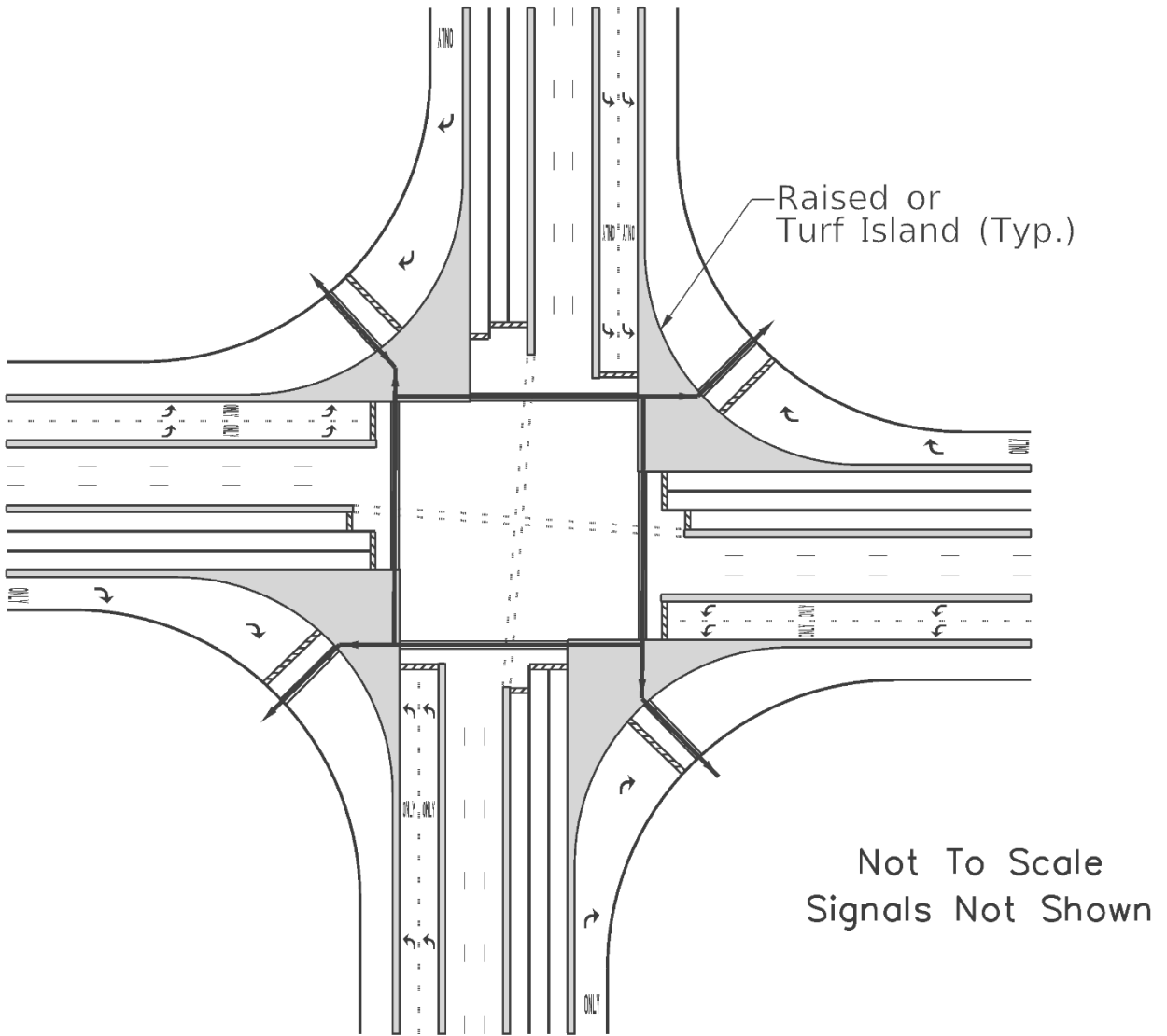

PEDESTRIAN MOVEMENTS AT A DLT

Figure 36-10.N

36-10.03(e) Access Issues

It is advisable to evaluate with the Central Bureau of Operations emergency vehicle access for addressing crashes or disabled vehicle situations. The use of mountable curbs in the crossover area helps facilitate emergency vehicle access to the crossover and adjacent areas. Where present, the use of frontage roads may be part of an overall emergency access plan. Consider appropriate response procedures for the removal of disabled vehicles or a signal malfunction event.

Restriction of access to parcels located close to the main intersection is typically necessary. Locate driveways as far from the signalized intersections as possible. Approaches that have left-turn crossovers cannot accommodate median breaks within the distance of the new right-turn lanes (i.e., up to the crossover intersections). If any driveways on the approaches to the main intersection are allowed to remain, they must be right-in-right-out (RIRO) only.

36-10.03(f) Stakeholder Outreach

When a DLT is considered it is important to provide effective outreach with communities and roadway users. Multiple forums can be used, including public informational meetings, local agency council meetings, and media campaigns of various types. The results of the analysis related to vehicle delay and LOS may be an important area of discussion during local agency and public coordination. Public information and educational campaigns prior to opening a DLT can help mitigate local concerns. Driver education can be important to help minimize any initial driver confusion.

36-10.04 Continuous Green T Intersections

The continuous green T intersection, or CGT, is a 3-legged signalized intersection that allows for one of the mainline through movement (opposite the sideroad) to flow freely with a continuous green indication. CGTs have the potential to simultaneously address safety and operational concerns at existing T intersections, especially in suburban and rural locations that have higher than average crash rates, specific over-represented crash types, excessive delay, or high tractor-trailer truck traffic.

CGTs are typically used in locations where safety or operational concerns make a traditional 3-legged signalized intersection less effective. Example concerns could include low LOS for minor road movements during peak periods or rear-end crash patterns along the mainline. For locations currently unsignalized yet meeting at least one signal warrant, a CGT may provide a way to minimize disruption and address both increasing congestion and safety concerns related to inserting a new signal along rural or suburban roadways.

CGTs are most often appropriate in locations with design and posted speeds of 40 mph to 55 mph (60 km/hr to 90 km/hr). In lower speed urban locations with pedestrian presence the potential conflicts created by the preferential mainline vehicle flows can run counter to the safety and accommodation goals common to urban and urban core contexts.

36-10.04(a)

Figure 36-10.O shows a typical CGT layout. CGTs are signalized intersections. It may be possible, however, to incorporate CGT geometric design features into an unsignalized T intersection location, with a plan to add signals later as traffic demand grows.

CGTs require that adequate median width is available to develop channelization. A raised curb or barrier median is included along the mainline to provide channelized left-turning movements, physically separate median left turn (diverging) traffic, and allow accelerating traffic to reach appropriate speeds before merging with mainline flows.

Raised curb islands are most commonly used for the channelization, but at high speeds concrete median barriers may be used. In either case, offset the face of curb/barrier by a full shoulder width when the posted speed is greater than 45 mph (70 km/hr). An advantage of a raised curb treatment is that the better visibility provided between vehicles allows drivers to react appropriately to adjacent traffic.

36-10.04(b) Signalization

The traffic signal at a CGT operates with three phases, with left turns from the mainline usually having protected-only phasing. The far-side mainline through movement is typically free-flow, and green arrow signal faces are provided to inform drivers of that condition. The provision of a typically free-flow movement means that CGTs will have limited applications in urban areas.

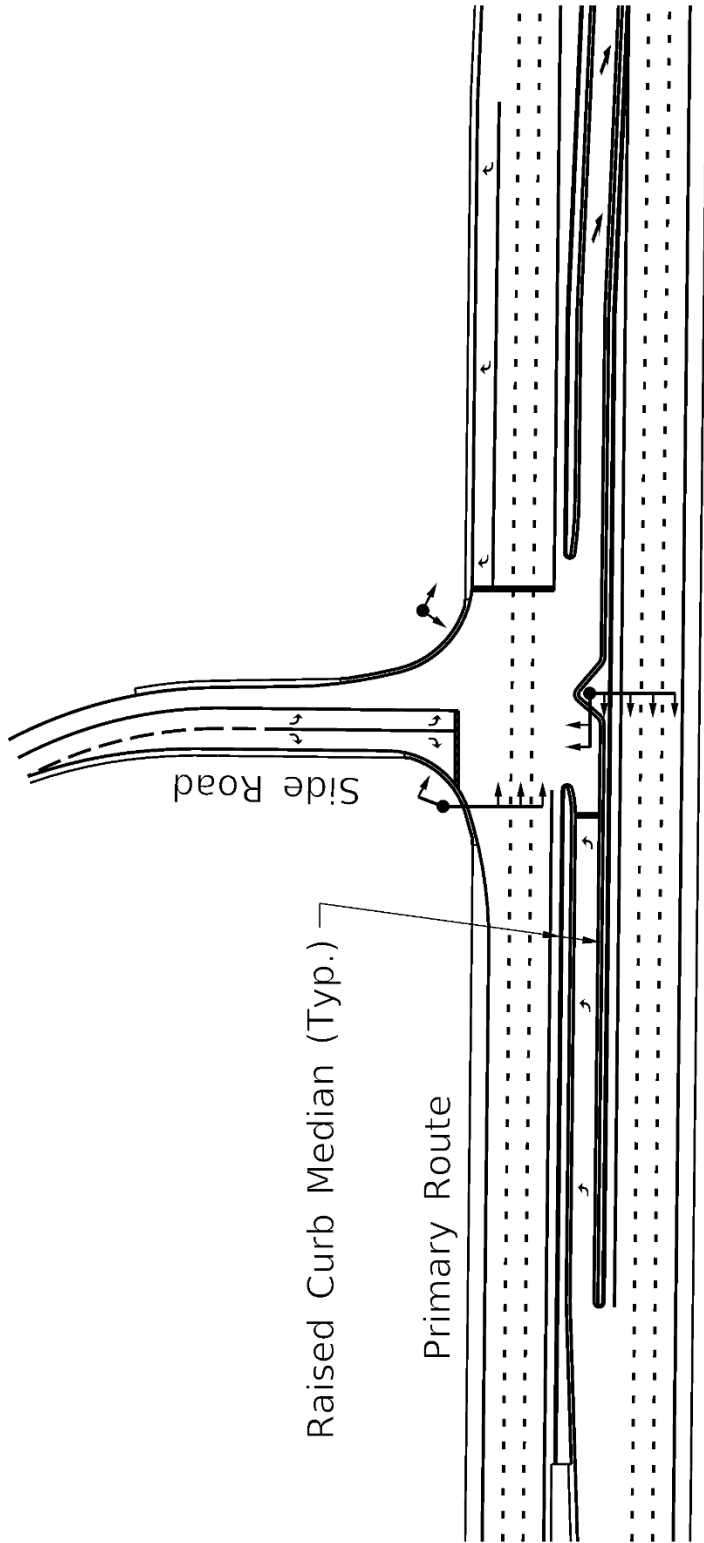

TYPICAL CGT LAYOUT

Figure 36-10.0

36-10.04(c) Access

In some cases, one or more mainline access point may need to be located within or immediately adjacent to the intersection. However, the number of driveways should be limited and those present should be offset from the signal location to the extent possible. Busier commercial entrances and sideroads should preferably be located completely outside of the intersection (channelization) area. Major driveways may require both STOP and RIGHT TURN ONLY signs. Consider ONE WAY signs in the median facing private entrances.

36-10.04(d) Safety

CGT intersections address safety primarily by improving the operational characteristics of the intersection, channelizing the left turn movements, and providing for protected left-turn movements.

36-10.04(e) Pedestrian Accommodations

With any level of pedestrian activity, the free-flow movement will need to be stopped whenever pedestrians activate a pushbutton or are passively detected. Due to this additional phase, and the potential for safety issues, pedestrian presence at an intersection may be of sufficient concern that CGTs not be considered. If implemented in areas with pedestrian presence, signalization and high-visibility pedestrian crossings will be needed. In urban locations, overall operational advantages in comparison to a more traditional design could be justification for CGT implementation. However, stress high-visibility crossings and added safety features as part of CGT designs in urban and suburban locations.

36-11 REFERENCES

1. *A Policy on Geometric Design of Highways and Streets*, 7th Edition, AASHTO, 2018.
2. *Highway Capacity Manual*, 6th Edition, Transportation Research Board, 2016.
3. *Manual on Uniform Traffic Control Devices (MUTCD)*, 2009.
4. *Illinois Manual on Uniform Traffic Control Devices (ILMUTCD)*, IDOT Bureau of Operations, current version.
5. *Access Control Issues Related to Urban Arterial Intersection Design*, Transportation Research Record 1385, Transportation Research Board, 1993.
6. *Driveway and Street Intersection Spacing*, Transportation Research Circular 456, Transportation Research Board, 1996.
7. NCHRP Report 279, *Intersection Channelization Design Guide*, Transportation Research Board, 1985.
8. *Median Intersection Design for Rural High-Speed Divided Highways*, NCHRP Report 650, Transportation Research Board, 2010.
9. *Illinois Highway Standards*, IDOT, current edition.
10. *Highway Safety Design and Operations Guide*, AASHTO, 1997.
11. NCHRP Report 383, *Intersection Sight Distance*, Transportation Research Board, 1996.
12. NCHRP Synthesis 225, *Left-Turn Treatments at Intersections*, Transportation Research Board, 1996.
13. *Policy on Permits for Access Driveways to State Highways*, 92 Ill. Admin. Code 550.
14. Bureau of Operations *Policies and Procedures Manual*, IDOT, current version.
15. *Pavement Marking Selection, Installation, and Inspection Manual*, Bureau of Operations, IDOT, current version.
16. Bureau of Operations *Maintenance Policy Manual*, IDOT, current version.
17. NCHRP Report 572, *Roundabouts in the United States*, Transportation Research Board, 2007.
18. NCHRP Report 672, *Roundabouts: An Informational Guide*, Transportation Research Board, 2010.

19. Roundabout Guide, Wisconsin Department of Transportation, 2013.
20. *Restricted Crossing U-Turn Intersection Informational Guide*, FHWA, 2014.
21. NCHRP Report 420, *Impacts of Access Management Techniques*, 1999
22. *Alternative Intersections/Interchanges: Information Report (AIIR)*, FHWA-HRT-09-060, 2009.
23. *Policy on Pedestrian Pushbutton Locations and Accessible Pedestrian Signals*, IDOT Bureau of Operations, current version.

Chapter Thirty-seven
INTERCHANGES

BUREAU OF DESIGN AND ENVIRONMENT MANUAL

Chapter Thirty-seven
INTERCHANGES

Table of Contents

<u>Section</u>	<u>Page</u>
37-1 GENERAL	37-1.1
37-1.01 Responsibilities	37-1.1
37-1.02 Guidelines	37-1.2
37-1.03 New or Revised Interstate Access Approval	37-1.3
37-1.03(a) FHWA Regulations	37-1.3
37-1.03(b) Applicability	37-1.4
37-1.03(c) Processing Procedures	37-1.6
37-1.03(d) FHWA Approvals	37-1.8
37-1.03(e) Access Justification Report Contents	37-1.10
37-2 GENERAL DESIGN CONSIDERATIONS	37-2.1
37-2.01 Interchange Spacing	37-2.1
37-2.02 Basic Number of Lanes	37-2.1
37-2.03 Lane Balance	37-2.1
37-2.04 Capacity and Level of Service	37-2.3
37-2.05 Auxiliary Lanes	37-2.3
37-2.06 Route Continuity	37-2.4
37-2.07 Uniformity	37-2.4
37-2.08 Left-Hand Ramps	37-2.7
37-2.09 Signing and Marking	37-2.7
37-2.10 Ramp Metering	37-2.7
37-2.11 Weaving Sections	37-2.7
37-2.12 Grading and Landscaping	37-2.8
37-2.13 Review for Ease of Operation	37-2.8
37-2.14 Geometric Design Criteria	37-2.8
37-2.15 Operational/Safety Considerations	37-2.11
37-2.16 Distance Between Successive Freeway Ramp Terminals	37-2.13
37-3 INTERCHANGE TYPES AND LAYOUTS	37-3.1
37-3.01 General	37-3.1
37-3.02 Conventional Diamond	37-3.1
37-3.02(a) General	37-3.1
37-3.02(b) Left-Turn Lanes	37-3.4
37-3.02(c) Ramp/Crossroad Intersections	37-3.4
37-3.02(d) Ramp Layout	37-3.5
37-3.03 Modified Diamond	37-3.9

Table of Contents
(Continued)

<u>Section</u>	<u>Page</u>
37-3.04 Compressed Diamond	37-3.11
37-3.04(a) General	37-3.11
37-3.04(b) Ramp/Crossroad Intersections	37-3.12
37-3.05 Single-Point Urban Diamond	37-3.14
37-3.05(a) General	37-3.14
37-3.05(b) Design Considerations	37-3.15
37-3.06 Full Cloverleafs	37-3.20
37-3.06(a) General	37-3.20
37-3.06(b) Design Considerations	37-3.22
37-3.07 Partial Cloverleafs	37-3.26
37-3.07(a) General	37-3.26
37-3.07(b) Two-Quadrant Parclo Interchange	37-3.34
37-3.07(c) Four-Quadrant Parclo Interchange	37-3.35
37-3.08 Trumpet Interchange	37-3.35
37-3.08(a) General	37-3.35
37-3.08(b) Design Considerations	37-3.38
37-3.09 Directional and Semi-Directional Interchanges	37-3.38
37-3.10 Diverging Diamond Interchange (Double Crossover Diamond Interchange)	37-3.41
37-3.11 Selection	37-3.49
37-4 RAMP DESIGN	37-4.1
37-4.01 Ramp Types	37-4.1
37-4.01(a) Loop Ramps	37-4.1
37-4.01(b) Diagonal Ramps	37-4.1
37-4.01(c) Outer-Connector Ramps	37-4.1
37-4.01(d) Semi-Directional Ramps	37-4.3
37-4.01(e) Directional Ramps	37-4.3
37-4.02 Collector-Distributor Roadways	37-4.3
37-4.02(a) Usage	37-4.3
37-4.02(b) Design	37-4.4

Table of Contents
(Continued)

<u>Section</u>	<u>Page</u>
37-4.03 High-Speed Directional/Semi-Directional Roadways	37-4.4
37-4.04 Design Speed	37-4.11
37-4.05 Sight Distance	37-4.12
37-4.06 Cross Section Elements	37-4.16
37-4.07 Horizontal Alignment	37-4.17
37-4.07(a) Theoretical Basis	37-4.17
37-4.07(b) Design Controls	37-4.17
37-4.07(c) Length of Arc.....	37-4.18
37-4.08 Vertical Alignment.....	37-4.19
37-4.08(a) Grades	37-4.19
37-4.08(b) Vertical Curvature	37-4.19
37-4.08(c) Cross Sections Between Adjacent Ramps.....	37-4.20
37-4.09 Roadside Safety	37-4.20
37-5 RAMP/CROSSROAD INTERSECTIONS.....	37-5.1
37-5.01 General Design Criteria	37-5.1
37-5.02 Typical Intersection Designs.....	37-5.4
37-5.02(a) Diamond Interchange.....	37-5.4
37-5.02(b) Two-Quadrant Partial Cloverleaf Interchange.....	37-5.5
37-5.02(c) Four-Quadrant Partial Cloverleaf Interchange	37-5.19
37-5.02(d) Compressed Diamond with Slip Ramps.....	37-5.19
37-5.03 Crossroad Access Control.....	37-5.25
37-6 FREEWAY RAMP TERMINALS	37-6.1
37-6.01 Exit Ramp Terminals	37-6.1
37-6.01(a) Types	37-6.1
37-6.01(b) Sight Distance.....	37-6.4
37-6.01(c) Alignment.....	37-6.4
37-6.01(d) Superelevation and Cross Slopes.....	37-6.18
37-6.01(e) Gore Area	37-6.19
37-6.01(f) Structures.....	37-6.21
37-6.02 Entrance Ramps.....	37-6.21
37-6.02(a) Types	37-6.21
37-6.02(b) Length.....	37-6.27

Table of Contents
(Continued)

<u>Section</u>	<u>Page</u>
37-6.02(c) Sight Distance	37-6.29
37-6.02(d) Superelevation and Cross Slopes	37-6.29
37-6.02(e) Gore Area	37-6.29
37-6.03 Ramp/Roadway Divergence Applications	37-6.30
37-6.03(a) Major Divergences	37-6.30
37-6.03(b) Minor Divergences	37-6.30
37-6.04 Ramp/Roadway Convergence Applications	37-6.30
37-6.04(a) Major Convergences	37-6.30
37-6.04(b) Minor Convergences	37-6.36
37-7 REFERENCES	37-7.1

Chapter Thirty-seven

INTERCHANGES

AASHTO defines an interchange as a system of interconnecting roadways in conjunction with one or more grade separations that provide for the movement of traffic between two or more roadways on different levels. The operational efficiency, capacity, safety, and cost of the highway facility are largely dependent upon its design. Chapter 37 provides guidance in the design of interchanges including interchange types, selection, layout, operations, spacing, freeway ramp terminals, ramps, and ramp/crossroad terminals. Information that is also applicable to interchanges is included in the following chapters:

- Chapter 15 discusses the procedures and content for interchange type and design studies.
- The application of bicycle lanes through interchanges is discussed in Chapter 17.
- Chapter 35 discusses access control along interchange crossroads.
- Chapter 36 discusses intersection designs, including left and right-turn lanes, channelizing islands, turning radii, design vehicles, sight distance requirements, etc.
- Chapter 44 discusses freeway new construction and reconstruction design criteria, lane drops, frontage roads, grade separations, and access control along the freeway.
- Chapter 50 discusses freeway 3R design criteria.
- The warrants and design criteria for interchange lighting are discussed in Chapter 56.
- Guidance on interchange and/or ramp/crossroad terminal intersection traffic control devices, including striping, signing, and traffic signals is discussed in Chapter 57.
- Accessibility for persons with disabilities, including the design of compliant curb ramps, crosswalks, and roadway approach grades at interchange ramp/crossroad terminals is discussed in Chapter 58.

37-1 GENERAL

37-1.01 Responsibilities

The district is responsible for determining the need for, location of, type of, and design of interchanges. For interchange types other than the conventional diamond and parclo Type C, BDE involvement in type studies is recommended because of the larger number of alternatives requiring analysis and the typically higher costs; see Chapter 15.

37-1.02 Guidelines

The need for an interchange will vary based on site-specific conditions. Consider the following guidelines when determining the need for and practicality of an interchange:

1. Access Control. The following will apply:
 - a. Full Access Control. On all fully access-controlled facilities, intersecting crossroads must be terminated, rerouted, provided a grade separation, or provided an interchange. The importance of the continuity of the crossroad, the feasibility of an alternative route, traffic volumes, construction costs, environmental impacts, etc., are evaluated in order to determine which option is most practical. Interchanges generally are provided at:
 - all freeway-to-freeway crossings;
 - all major highways, unless determined inappropriate; and
 - other highways based on the anticipated demand for regional access.
 - b. Partial Access Control. On facilities with partial access control (expressways), intersections with public roads will be accommodated by an interchange, an intersection, and occasionally a grade separation. Refer to Section 45-1.03 for the decision-making process for the treatment of crossroads at expressways.
 - c. No Access Control. On a facility with no access control, the need for an interchange will be determined on a case-by-case basis emphasizing cost effectiveness, safety, and operations. A road-user benefit analysis will generally be required to determine the economic feasibility of an interchange. See Item 5. However, this analysis alone is not sufficient justification for the provision of an interchange.
2. Congestion. Consider providing an interchange where the level of service (LOS) at an intersection is unacceptable, and the intersection cannot be redesigned to operate at an acceptable LOS.
3. Safety. In special cases, consider the crash reduction benefits of an interchange at an existing intersection that exhibits extremely high-crash frequencies and rates.
4. Site Topography. Where access is necessary, the topography may dictate an interchange or a grade separation rather than an intersection.
5. Road-User Benefits. If an analysis reveals that road-user benefits over the service life of the interchange will exceed costs, then an interchange may be considered. The designer must consider all costs including right-of-way, construction, maintenance, and user costs in the analysis. For additional guidance, the designer may refer to the AASHTO publication, *A Manual on User Benefit Analysis of Highway and Bus-Transit Improvements*.

6. Access. An interchange may be required in an area where access availability from other sources is not practical, and the freeway is the only facility that serves the area.
7. Traffic Volumes. Although there are no specific traffic volumes that warrant an interchange, consider providing an interchange where the traffic volumes at an intersection are at or near capacity and where other improvements are not practical.

37-1.03 New or Revised Interstate Access Approval

37-1.03(a) FHWA Regulations

The FHWA states, in their current *Policy on Access to the Interstate System* that it is in the national interest to preserve and enhance the Interstate System to meet the needs of the 21st Century by assuring that it provides the highest level of service in terms of safety and mobility. Full control of access along the mainline and ramps, along with control of access on the crossroad at interchanges, is critical to providing such service. Therefore, an FHWA decision to approve new or revised access points to the Interstate System under Title 23, United States Code (U.S.C.), Section 111, must be supported by substantiated information justifying and documenting that decision.

Section 111 of Title 23, *United States Code* (23 U.S.C. 111) identifies that all agreements between FHWA and IDOT for the construction of projects on the Interstate System must contain a clause that IDOT will not add any points of access to, or exit from, the project in addition to those approved by FHWA in the plans for the project, without the prior approval of FHWA. 23 CFR 625 designates those criteria and policies that are acceptable to FHWA for the geometric and structural design of highways, including Interstate facilities.

The original FHWA policy regarding new or revised access points to existing Interstate facilities was first published in the *Federal Register* (55 Fed. Reg. 42670) on October 22, 1990, revised in the February 11, 1998 *Federal Register* (63 Fed. Reg. 7045), and then revised again in the August 27, 2009 *Federal Register* (74 Fed. Reg. 43743). The February 1998 revision incorporates the planning requirements of the *1991 Intermodal Surface Transportation and Efficiency Act*, clarifies the coordination between the access request and environmental procedures, and updates the policy language at various locations. The August 2009 revisions were made to reflect the direction provided in the *Safe, Accountable, Flexible, Efficient Transportation Equity Act: A Legacy for Users* (SAFETEA-LU), to clarify the operational and safety analysis and assessment of impacts that provides the basis for proposed changes in access to the Interstate System, and to update language at various locations to reference Federal laws, regulations, and FHWA policies. Additional guidance from FHWA Headquarters office was established in 1996 and 1997. This guidance allowed FHWA Division Offices to approve more Interstate revisions in access and established a two-step process for approving these changes. Finally, on May 22, 2017, FHWA clarified its policy for documenting new or revised access points on the Interstate system, including separation of issues related to engineering, operations, and safety (to be included within Illinois as part of an Access

Justification Report) from other issues such as planning requirements and land use (to be included in NEPA documents). New or revised access points to the existing Interstate System will be reviewed against the criteria in Section 37-1.03(b). Sections 37-1.03(d) and 37-1.03(e) define the information required to be included in final submittals to FHWA when requesting approval for revisions in Interstate access. Section 37-1.03(c) provides the procedures for obtaining approvals from IDOT and/or FHWA.

37-1.03(b) Applicability

New and/or revised access points that degrade mainline operations or safety should be minimized on existing fully access-controlled facilities. Avoiding such degradation is the primary focus of FHWA and BDE reviews and approval.

Each entrance and exit point on the mainline, including “locked gate” access (e.g., utility opening), is defined as an access point. For example, a standard diamond interchange configuration has four access points. Revised access is considered to be a change in the existing interchange configuration although the number of access points may not change. For example, replacing one of the direct ramps of a diamond interchange with a loop or changing a cloverleaf interchange into a fully directional interchange is considered to be a revised access.

The criteria in Section 37-1.03 is applicable to new or revised access points to existing fully access-controlled facilities (Interstate and non-Interstate facilities) regardless of the funding source. Consequently, it applies to private developers, and any changes to an access-controlled facility, which may be required of the private developer by IDOT or a local agency.

Each access revision will need to be analyzed on a case-by-case basis. Consider the following:

1. Revisions Requiring BDE/FHWA Access Approval. The following revisions to access-controlled facilities are considered changes in access and will require BDE/FHWA access approval:
 - new freeway-to-freeway interchange;
 - major modification of freeway-to-freeway interchange configuration (e.g., adding new ramp(s), abandoning/removing ramp(s), completing basic movements);
 - new partial interchange or new ramps to-from a continuous frontage road that creates a partial interchange (e.g., slip ramps);
 - new freeway-to-crossroad interchange (e.g., addition of a combination of on-ramps and off-ramps);
 - modification of existing freeway-to-crossroad interchange configuration (e.g., replacing one of the direct ramps of a diamond interchange with a loop);
 - completion of basic movements at a partial interchange (e.g., completing a partial diamond interchange by adding a ramp, the addition of any on- or off-ramp to the mainline);

- locked gate access (e.g., access via locked gates by privately employed personnel); and
 - abandonment of ramps or interchanges.
2. Revisions Requiring BDE Access Approval. The following revisions to, and immediately-adjacent to, access-controlled facilities are not considered a change in access and do not require FHWA access approval; however, these typically do require BDE approval:
- a. Ramp/Crossroad Improvements. This includes the addition of left-turn storage lanes, right-turn storage lanes, and/or through travel lanes at the local road end of exit ramps. These additions will inherently and expeditiously increase ramp safety for ramps that chronically back-up onto the mainline travel lanes, by shortening the queue lengths and minimizing the occurrence of high-speed, rear-end collisions. Ensure that adequate stopping sight distance, decision sight distance, geometrics, etc., are provided. Any ramp/ crossroad intersection improvements (e.g., constructing roundabouts) should be assessed regarding both capacity and safety performance.
 - b. Ramp Relocation. This includes relocation or shifting of existing crossroad/ramp termini (i.e., moving the ramp end that connects with the local road). The designer must ensure that adequate stopping sight and decision sight distance are provided at the ramp terminals.
 - c. Services Ramps. Ramps providing access to rest areas, information centers, and weigh stations within the Interstate controlled access are not considered access points requiring FHWA approval. These facilities can only be accessible to vehicles to and from the Interstate System. Access between these facilities and local roads or adjoining property is prohibited. The only allowed exception is for access to adjacent publicly owned conservation and recreation areas, if access to these areas is only available through the rest area, as allowed under 23 CFR 752.5(d).
 - d. Auxiliary Lanes. This includes the addition of a single auxiliary lane between two adjacent interchange ramps. The single auxiliary lane should not function as a mainline travel lane and must be shown to provide both operational and safety benefits.
 - e. Acceleration and Deceleration Lanes.
 - i. Decreasing the Length. Prior to decreasing the length of these types of lanes, conduct an HSM safety analysis by analyzing the crash history and future crash potential. Also review sight distance and ensure appropriate signing revisions are provided.
 - ii. Increasing the Length. If the adjacent upstream on-ramp or adjacent downstream off-ramp exists at a distance equal to or less than the criteria

in Section 37-2.16 (i.e., measured between physical gore areas), conduct an operational analysis (e.g., weaving, capacity, signing). The spacing between interchanges should safely accommodate weaving, diverging, merging maneuvers, and provide for good directional signing.

- iii. Design Exceptions. If design criteria cannot be met, request a design exception for the improvement. See Section 31-7 for the procedures for obtaining a design exception.
- f. Addition of On-Ramp Lanes. This consists of adding a lane to a single lane on-ramp, resulting in a two-lane on-ramp. Conduct an operational analysis (e.g., weaving, capacity, signing) to show operational and safety benefits.
- g. Traffic Signals. This includes traffic signalization improvements at ramp termini with local roads. Improvements in the level-of-service for the ramp leg traffic at the exit ramp terminal must be shown.
- h. Signing and Pavement Markings. This includes new signing, striping, and/or resurfacing of an on-ramp or off-ramp where geometric features are not changed.
- i. Roadside Safety. Installation of roadside guardrail or barriers (e.g., for resurfacing and safety projects) will not require access approval.

37-1.03(c) Processing Procedures

BDE and FHWA must approve all proposed changes in access, in accordance with the list in Section 37-1.03(b), along the Interstate System. For proposed changes in access on non-Interstate freeways, BDE and/or the Bureau of Operations will review and approve any access changes; FHWA will not be regularly involved for these facilities.

The following procedures are applicable where 1) the highway is on the State highway system and Federal funds were used for right-of-way and/or construction costs of the roadway segment; and 2) the highway is access controlled and the proposed access revisions will modify previous commitments made in environmental documents:

1. Environmental Procedures. The FHWA revised access approval constitutes a Federal action and, as such, requires that the transportation planning, conformity, congestion management process, and the *National Environmental Policy Act* (NEPA) procedures be followed and their requirements satisfied. NEPA procedures also apply even when changes to an Interstate facility are being financed completely by the State, local municipality, or a private developer. The NEPA procedures will be accomplished as part of the normal project development process and as a condition of the access approval. The district will determine the type and scope of the necessary environmental process in cooperation with FHWA; see Chapter 22. Generally, this will occur at scheduled district coordination meetings. Compliance with the NEPA procedures should proceed concurrently with the analyses to determine engineering acceptability and feasibility.

Although compliance with the NEPA procedures need not precede the determination of engineering acceptability and feasibility, the FHWA Illinois Division Office will not give final access approval before the completion of the NEPA process.

2. Secondary Impacts. Determine the secondary impacts associated with the proposed access revisions based on traffic-induced impacts on the State highway facility and on the potential environmental impacts on the surrounding area. Because the area of influence on the highway facilities and surrounding land use will vary, describe the limits of influence for each case prior to determining impacts.
3. Outside Agency Proposals. The district will recommend whether IDOT or the agency requesting the revision will conduct the studies. BDE will review and approve Phase I reports.
4. FHWA Coordination. BDE usually will review and approve the interchange type and interchange design studies (IDS) using the Department's Certification Acceptance procedures except where the action is proposed on the Interstate system. For Interstates, FHWA must also agree on the type and the design details, see Sections 37-1.03(d) and 37-1.03(e). IDOT must discuss with FHWA any proposed access control revisions on the NHS at scheduled district coordination meetings.
5. Central Office Processing. Access control revisions along a freeway will be processed by the Central Office in the following manner:
 - a. Bureau of Operations. In general, proposed revisions in the access control along freeways and along interchange crossroads on the State highway system will be reviewed and processed by the Bureau of Operations except where location/design studies are necessary and/or where IDOT construction funds are used in the action.
 - b. BDE. Where design studies and/or construction funds are used in the proposed action requiring access control revisions, BDE will review and process the proposed action.
 - c. Freeway Orders. Projects involving a revision to an existing Freeway Order will be handled by either BDE or the Bureau of Operations up to the stage where a Freeway Order revision is filed for approval. After this stage, BDE will process the revision of the Freeway Order.
 - d. Impact Assessments. Where assessments of the impacts of proposed access control revisions are required, BDE will determine what elements should be considered in the review and processing of the assessment. Proposed access changes should be discussed at district coordination meetings and then submitted for review early in the NEPA process. This procedure will allow for a timely determination of engineering and operational acceptability and will ensure that the proposed design is acceptable for inclusion as an alternative in the environmental process.

- e. Overlapping. Where the criteria are overlapping, unclear, or there is uncertainty about who is responsible for conducting the review and processing of the request, BDE and the Bureau of Operations will coordinate to determine which Bureau will take responsibility for the request.
 - f. FHWA Approval. BDE will work with the district to submit an Access Justification Report (AJR) to the FHWA Division Office for review, comment and approval. This submission will be a “stand-alone” document that will show reasonable care has been performed and confirm future safety and traffic operations along the Interstate corridor will not be adversely affected by the proposed new or revised Interstate access. Section 37-1.03(d) further discusses FHWA approvals.
 - g. Filing. BDE will retain on file the approved revision in access submittal.
6. Coordination Meetings. The agendas for scheduled district coordination meetings should clearly distinguish projects involving proposed access control revisions from other projects. Furnish this information in adequate time to allow either BDE or Bureau of Operations to facilitate their attendance.

37-1.03(d) FHWA Approvals

FHWA approval is required where there are new or revised access points to the Interstate System. The following will apply to Interstate routes:

1. Design Criteria. All FHWA approvals for new, added or revised access are conditioned upon IDOT complying with all applicable Federal rules and regulations. For Illinois, the design criteria are contained in the *BDE Manual* and the *Illinois Highway Standards* which meet or exceed the criteria presented in the AASHTO publications, *A Policy on Geometric Design of Highways and Streets* and *A Policy on Design Standards - Interstate System*.
2. FHWA Concept Approval. Concept approval is the first step in the FHWA approval process and involves a determination of safety, engineering, and operational acceptability. Ideally, it should be done as soon as the Department has a good understanding of the proposed scope of the improvement. The FHWA Division Office and IDOT will develop a consensus on proposed access concepts at coordination meetings. FHWA concept approval will need to be received from either the FHWA Headquarters Office or from the FHWA Illinois Division Office as in accordance with the following:
 - a. FHWA Headquarters Concept Approval. Concept review and approval is required from the FHWA Headquarters (HQ) Office for the specific major Interstate access requests that are listed below. IDOT will send three copies of the official transmittals requesting FHWA HQ concept approval, and local FHWA Division Office final approval, will need to be sent to the FHWA Division Office. Note that advance coordination with the FHWA HQ Office may be necessary,

and appropriate, on certain complex and/or controversial projects that will require FHWA HQ concept review and approval during the project's environmental process. In these cases, IDOT should coordinate directly with the local FHWA Division Office. The FHWA HQ Office concept approval is required for the following types of Interstate revised access:

- new freeway-to-freeway interchange,
- major modification of freeway-to-freeway interchange configuration,
- new partial interchange or new ramps to/from continuous frontage road that create a partial interchange, and
- new freeway-to-crossroad interchange located in a Transportation Management Area (TMA).

b. FHWA Illinois Division Office Concept Approval. The FHWA Division Office and the Department will develop a consensus on proposed access concepts at coordination meetings, which are subsequently documented in the Access Justification Report (AJR); see Section 37-1.03(e). FHWA Division Office concept approval will be given by the FHWA Division Administrator. IDOT will send the AJR to the FHWA Division Office with signature lines for the FHWA Division Office Field Engineering Manager (FEM) (recommend approval) and for the FHWA Division Office Division Administrator (for approval). The signed AJR will document FHWA concept approval. Once signed, the AJR will be sent back to IDOT. The FHWA Division Office gives concept approval for the following types of Interstate revised access:

- new freeway-to-crossroad interchange not located in a TMA,
- modification of existing freeway-to-crossroad interchange configuration,
- completion of basic movements at partial interchange,
- locked gate access, and
- abandonment of ramps or interchanges.

3. FHWA Final Approval. The FHWA Division Administrator gives final approval for all types of Interstate access changes. Concept Approval and completion of the NEPA process are needed for the Final Approval of Access Revision. No additional information is required for the final approval request unless any conditions previously noted in the AJR have changed substantially.

4. Reevaluation. An affirmative determination by FHWA of engineering and operational acceptability for proposals for new or revised access points to the Interstate System should be reevaluated whenever a significant change in conditions occurs (e.g., land use, traffic volumes, roadway configuration or design, environmental commitments). Proposals must be reevaluated if the project has not progressed to construction within

eight years of receiving an affirmative determination of engineering and operational acceptability (23 CFR 625.2(a)). If the project is not constructed within this time period, an updated Access Justification Report based on current and projected future conditions must be submitted to FHWA to receive either an affirmative determination of engineering and operational acceptability, or final approval if all other requirements have been satisfied.

37-1.03(e) Access Justification Report Contents

All requests for new or revised access points on completed Interstate highways must closely adhere to the planning and environmental review processes as required in 23 CFR 450 and 771. As part of their May 22, 2017, Policy on Access to the Interstate System, the FHWA moved documentation for issues not directly related to engineering, operations, and safety of Interstate access changes (all but two points, numbered 13 and 18 in the list below) out of the AJR and solely into other required NEPA documentation. Refer also to Section 37-1.03(c). The final FHWA approval of requests for new or revised access, the *acceptability determination*, cannot precede the completion of NEPA processes. The AJR provides a primary basis for a timely approval decision by the FHWA and IDOT on new or revised access.

To provide for an efficient review IDOT continues to require that a wide range of information be included within the AJR, although many points may be briefly summarized. The AJR must include the information described below in 20 points:

1. Description. Provide a description of the proposed new or revised access. It is acceptable to present more than one alternative, with identification of a preferred design.
2. Purpose. Describe the purpose and need specifically related to the new or revised access point. Project purpose and need is typically a product derived from discussions by the project scoping team and with input from an array of project stakeholders. The new or revised access point may be one element of an overall project.
3. Cost. Include the estimated total cost of the overall project and the new or revised access point.
4. Background Information. Provide any additional background support information to explain and/or support the access proposal (e.g., developer input, known public opposition, status of the NEPA process, summary of input received from public meetings, sources of project funding, and implementation schedule).
5. Concerns. List any known areas of concern (e.g., operational, environmental, safety) in the direct vicinity of the access change. Always include a crash history summary for all new or revised access requests. The project must include proposed mitigation measures to improve the safety issues identified here. FHWA and IDOT must be convinced that there will be steps taken to improve safety and operations of the Interstate facility itself.

6. Communities. Note the distances to and size of communities or facilities directly served.
7. Connections. Describe the relationship and distance of the interchange to adjacent interchanges, the adequacy of acceleration, deceleration and weaving lengths, and the ability to provide adequate signing.
8. Design Exceptions. Clearly identify any necessary design exceptions from current BDE design criteria; see Section 31-7.
9. Traffic Signals/Signing. Include a conceptual plan of the type and location of the signs proposed to support the preferred alternative. Identify locations of additional proposed traffic signalization, if applicable.
10. Lane Balance. Describe how the interchange will provide lane balance with a consistent basic number of lanes.
11. Alternative Existing Facility Improvements. Show that all reasonable alternatives, including improvements to the existing local roads and streets in lieu of new freeway access, have been properly considered. Could streets generally parallel to the Interstate facility be used as connections to existing adjacent interchange ramps in lieu of adding a new interchange or ramps? Could improvements such as access control along surface streets, improving traffic control, modifying ramp terminals and intersections, adding turn bays or lengthening storage satisfactorily accommodate the design-year traffic demands? Diagrammatic figures may be helpful in describing the alternatives assessed. Designers must demonstrate that an access point is needed for regional traffic needs and not to solve local system problems. The freeway facility must primarily serve regional traffic.
12. Alternative Mainline or Transportation System Management Improvements. Explain whether transportation system management type improvements (such as ramp metering, mass transit, and HOV facilities), and/or geometric design improvements to the Interstate, could address existing issues without the proposed change in access.
13. Access Connections and Design. FHWA policy states: "The proposed access connects to a public road only and will provide for all traffic movements. Less than "full interchanges" may be considered on a case-by-case basis for applications requiring special access, such as managed lanes (e.g., transit or high occupancy vehicle and high occupancy toll lanes) or park and ride lots. The proposed access will be designed to meet or exceed current standards (23 CFR 625.2(a), 625.4(a)(2), and 655.603(d)). In rare instances where all basic movements are not provided by the proposed design, the report should include a full interchange option with a comparison of the operational and safety analyses to the partial interchange option. The report should also include the mitigation proposed to compensate for the missing movements, including wayfinding signage, impacts on local intersections, mitigation of driver expectation leading to wrong-way movements on ramps, etc. The report shall describe whether future provision of a

full interchange is precluded by the proposed design.” Partial interchanges usually have undesirable operational characteristics. If circumstances exist where a partial interchange is considered appropriate, then commitments to the FHWA, possibly even purchase of necessary right-of-way during the initial project stage for future completion, must be made by IDOT. Special purpose access for HOV’s, for transit vehicles, or for park and ride lots should be treated as special cases and the movements to be provided decided on a case-by-case basis.

14. Transportation Land Use Plans. Show that the proposal considers and is consistent with local and regional land use and transportation plans and that necessary coordination has begun. Prior to Phase I approval, new or revised access must be included in a Metropolitan Transportation Plan, a Statewide or Metropolitan Transportation Plan (STIP or TIP), and a Congestion Management Process(as applicable).
15. Comprehensive Interstate Network Study. If applicable, analyze and consider all proposed changes in access for an area at the same time. If a new or revised interchange is being proposed and another new or revised adjacent interchange is being planned and programmed by IDOT then analyze both changes together.
16. Coordination with Transportation System Improvements. If the new or revised access point is in part due to a new, expanded, or substantial change in current or planned future development or land use, demonstrate coordination has occurred with the property developers. Describe the commitments agreed upon to assure adequate collection and dispersion of the traffic resulting from the development with the adjoining local street network and Interstate access point. It is incumbent upon IDOT to ensure that highway facilities are developed in an orderly and coordinated manner to serve the public. The developer might, for example, be required to have certain parts of the local circulation system ready before ramps can be constructed or opened to traffic.
17. Status of Planning and NEPA. Confirm and report information relative to the status of the planning and NEPA processes.
18. Operational and Safety Analyses. FHWA policy states: “An operational and safety analysis has concluded that the proposed change in access does not have a significant adverse impact on the safety and operation of the Interstate facility (which includes mainline lanes, existing, new, or modified ramps, and ramp intersections with crossroad) or on the local street network based both the current and the planned future traffic projections. The analysis should, particularly in urbanized areas, include at least the first adjacent existing or proposed interchange on either side of the proposed change in access (23 CFR 625.2(a), 655.603(d) and 771.111(f)). The crossroads and the local street network, to at least the first major intersection on either side of the proposed change in access, should be included in this analysis to the extent necessary to fully evaluate the safety and operational impacts that the proposed change in access and other transportation improvements may have on the local street network (23 CFR 625.2(a) and 655.603(d)). Requests for a proposed change in access should include a description and assessment of the impacts and ability of the proposed changes to safely

and efficiently collect, distribute and accommodate traffic on the Interstate facility, ramps, intersection of ramps with crossroad, and local street network (23 CFR 625.2(a) and 655.603(d)). Each request should also include a conceptual plan of the type and location of the signs proposed to support each design alternative (23 U.S.C. 109(d) and 23 CFR 655.603(d)).”

Highway Safety Manual methods, or other approved safety analysis methodologies, will be used to present a robust assessment of the potential safety effects of the changes in access. Typically, the current *Highway Capacity Manual* analysis procedures will be used for the operational analyses. Refer to #20 below for the specific tables, maps, and outputs required to summarize the operational analyses.

Analyze safety and operations on the mainline between the proposed new/revised access and the adjacent existing interchanges on either side. Extend the analyses as far along the mainline as is necessary to establish the extent and scope of the impacts. In urban areas with several relatively closely-spaced interchanges more than three locations may need to be included.

The safety and operational analyses must use current traffic data and extend to a design year that is 20 years after the date when the construction is scheduled to be complete.

Include the following in the analyses:

- Summarize the crash history of the affected Interstate segment, provide a comparison of this history with statewide averages for comparable facilities, and identify any over-represented crash types on the affected Interstate segment.
- Identify the anticipated safety implications of the proposed access point on mainline Interstate traffic, and at applicable nearby interchanges. Of critical importance are the geometrics associated with the proposal and shifts in nearby traffic patterns. Include a brief concluding statement summarizing the level of impact the proposed access point change is expected to have on safety performance of the mainline Interstate facility.
- Summarize the level of impact the proposed access point change is expected to have on traffic flow performance of the mainline Interstate facility.

The safety and operational analyses should typically include or directly refer to some or all of the information in Items 19 and 20.

19. Interchange Drawing. For the preferred and analyzed alternative, provide a dimensioned, detailed drawing of the design elements and a comparison to existing conditions. Include, as applicable:

- project limits,
- adjacent interchange(s),
- ramp to be added and removed,

- relocation of ramp gores,
- travel lanes and shoulder widths,
- ramp radii,
- ramp grades,
- acceleration lane lengths,
- deceleration lane lengths,
- taper lengths,
- auxiliary lane lengths,
- auxiliary/operational lane(s), and
- collector/distributor road(s).

Together, the drawing and report should identify all presently known pertinent engineering design details of the proposed change. Clearly identify any design exceptions and compare them with the latest BDE and AASHTO criteria.

Include a separate drawing showing the traffic volumes for all turning movements as well as mainline, ramp, and local road traffic volumes. Include current and design year ADTs and DHVs (Refer to the following section for details).

20. Highway Capacity Analysis. Use the current version of the *Highway Capacity Software* (HCS), for the operational analyses, supplemented by modeling as agreed by BDE and FHWA. Include all the following information and engineering analyses unless otherwise agreed to by BDE and FHWA:
- a. Existing Peak Hour Volumes. Provide a plan view map, with ramps and mainline through lanes labeled with Existing “AM Peak Hour” and “PM Peak Hour” volumes.
 - b. Design Year No-Build Peak Hour Volumes. Provide a plan view map, with ramps and mainline through lanes labeled with the Design Year No-Build “AM Peak Hour” and “PM Peak Hour” volumes.
 - c. Design Year Build Peak Hour Volumes. Provide a plan view map, with ramps and mainline through lanes labeled with the Design Year Build “AM Peak Hour” and “PM Peak Hour” volumes.
 - d. Summary of Operational Analysis. As applicable, provide a table listing the “Freeway LOS”, “Ramp LOS”, “Weave LOS”, and “Non-Weave LOS” for the corresponding Existing AM/PM, Design Year “No-Build” AM/PM, and Design Year “Build” AM/PM for on-ramps, off-ramps, and through lanes.
 - e. Existing Peak Hour Levels of Service. Provide a plan view map, with ramps, mainline through lanes, and crossroads labeled with calculated Existing “AM Peak Hour Level of Service” values and “PM Peak Hour Level of Service” values.

- f. Design Year No-Build Peak Hour Levels of Service. Provide a plan view map, with ramps, mainline through lanes, and crossroads labeled with calculated Design Year No-Build “AM Peak Hour Level of Service” values and “PM Peak Hour Level of Service” values.
- g. Design Year Build Peak Hour Levels of Service. Provide a plan view map, with ramps, mainline through lanes, and crossroads labeled with calculated Design Year Build “AM Peak Hour Level of Service” values and “PM Peak Hour Level of Service” values.
- h. Basic Freeway Segments Analyses of Existing Conditions. Provide program outputs for adjacent freeway segments.
- i. Basic Freeway Segments Analyses of the Design Year “No-Build” Conditions. Provide program outputs for all adjacent freeway segments.
- j. Basic Freeway Segments Analyses of the Design Year “Build” Conditions. Provide program outputs for all adjacent freeway segments.
- k. Ramp Junction Analyses of the Existing Conditions. Provide program outputs for all ramp junctions.
- l. Ramp Junction Analyses of the Design Year “No-Build” Conditions. Provide program outputs, including queue analysis, for all ramp junctions.
- m. Ramp Junction Analyses of the Design Year “Build” Conditions. Provide program outputs, including queue analysis, for all ramp junctions.
- n. Weave Area Analyses of the Existing Conditions. Provide program outputs for all weaving areas.
- o. Weave Area Analyses of the Design Year “No-Build” Conditions. Provide program outputs for all weaving areas.
- p. Weave Area Analyses of the Design Year “Build” Conditions. Provide program outputs for all weaving areas.

37-2 GENERAL DESIGN CONSIDERATIONS

37-2.01 Interchange Spacing

Where interchanges are spaced farther apart, freeway operations, level of service, and safety between connecting facilities are improved. Desirably, the spacing between interchanges on the average should not be less than 2 miles (3 km) in urban areas, 4 miles (6 km) in suburban areas, and 7.5 miles (12 km) in rural areas. These values allow adequate distances for an entering driver to adjust to the freeway environment, for proper weaving maneuvers between entrance and exit ramps, and for adequate signing distances. However, considering the effects of existing streets and highways, traffic operations, and social considerations, the spacing between adjacent interchanges may vary considerably. The minimum distance between adjacent interchanges should not be less than 1 mile (1.5 km) in urban areas, 2 miles (3 km) in suburban areas, and 3 miles (5 km) in rural areas. In urban areas, a spacing of less than 1 mile (1.5 km) may be developed by using grade-separated ramps or collector-distributor roads.

37-2.02 Basic Number of Lanes

The basic number of lanes is the minimum number of lanes designated and maintained over a significant length of a route based on the overall operational needs of that section. The number of lanes should remain constant over short distances. For example, do not drop a lane at the exit of a diamond interchange and then add it at the downstream entrance simply because the traffic volume decreases between the exit and entrance ramps. Likewise, do not drop a basic lane between closely spaced interchanges simply because the estimated traffic volume does not warrant the higher number of lanes. Lane drops should only occur where there is general lowering of the traffic volumes on the freeway route as a whole.

37-2.03 Lane Balance

Lane balance refers to certain principles that apply at freeway exits and entrances:

1. Exits. The number of approach lanes on the highway should equal the sum of the number of mainline lanes beyond the exit plus the number of exiting lanes minus one; see Figure 37-2.A. An exception to this principle would be at cloverleaf loop ramp exits that follow a loop ramp entrance or at exits between closely spaced interchanges (e.g., interchanges where the distance between the taper end of the entrance terminal (1 ft (300 mm) stub) and the beginning taper (1 ft (300 mm) stub) of the exit terminal is less than 1500 ft (450 m) and a continuous auxiliary lane is used between the terminals). In these cases, the auxiliary lane may be dropped at a single-lane exit with the number of lanes on the approach roadway being equal to the number of through lanes beyond the exit plus the lane on the exit.
2. Entrances. At entrances, the number of lanes beyond the merging of the two traffic streams should be not less than the sum of the approaching lanes minus one; see Figure 37-2.A.

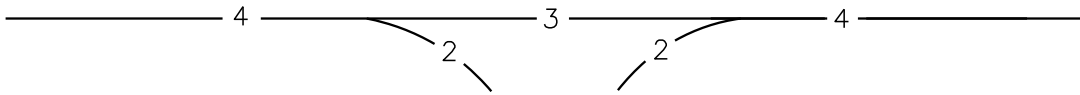

LANE BALANCE BUT NO COMPLIANCE WITH BASIC NUMBER OF LANES
-A-

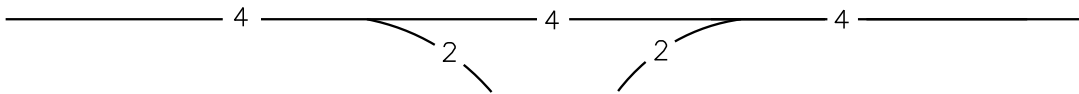

NO LANE BALANCE BUT COMPLIANCE WITH BASIC NUMBER OF LANES
-B-

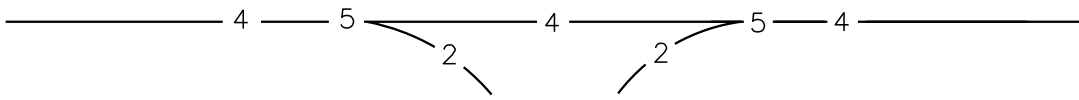

COMPLIANCE WITH BOTH LANE BALANCE AND BASIC NUMBER OF LANES
-C-



Where:

N_C = Number of Lanes for Combined Traffic

N_F = Number of Lanes on Freeway

N_E = Number of Lanes on Exit or Entrance Ramp

LANE BALANCE EQUATIONS

-D-

COORDINATION OF LANE BALANCE AND BASIC NUMBER OF LANES

Figure 37-2.A

3. Travel Lanes. Reduce the number of travel lanes on the freeway only one lane at a time.

For example, dropping two mainline lanes at a two-lane exit ramp would violate the principle of lane balance. One lane should provide the option of remaining on the freeway. Lane balance would also prohibit immediately merging both lanes of a two-lane entrance ramp into a highway mainline without the addition of at least one additional lane beyond the entrance ramp. Figure 37-2.A illustrates how to coordinate lane balance and the basic number of lanes at an interchange. Figure 37-2.A also illustrates how to achieve lane balance at the merging and diverging points of branch connections.

37-2.04 Capacity and Level of Service

The capacity of an interchange will depend upon the operation of its individual elements that include:

- basic freeway section where interchanges are not present,
- freeway ramp terminals,
- weaving areas,
- ramp proper,
- collector-distributor roadways, and
- ramp/crossroad intersections.

The basic capacity reference is the *Highway Capacity Manual* (HCM). The HCM and the *Highway Capacity Software* (HCS) provide the analytical tools required to analyze the level of service for each element listed above. Other capacity analysis programs and techniques may be used provided they are approved by BDE. To be eligible for approval, the output results of other programs and techniques must compare closely with the HCS.

Level of service values presented in Chapter 44 for freeways will also apply to interchanges. Desirably, the level of service of each interchange element should be equal to the level of service provided on the basic freeway section. Individual elements should not operate at more than one level of service below that of the basic freeway section. In addition, the operation of the ramp/crossroad intersection in urban areas should not impair the operation of the mainline. This will likely involve a consideration of the operational characteristics on the minor road for some distance in either direction from the interchange. For most projects, the district geometrics engineer will be responsible for conducting or reviewing the capacity analysis at interchanges.

37-2.05 Auxiliary Lanes

As applied to interchange design, auxiliary lanes are most often used to comply with the principle of lane balance, to increase capacity, to accommodate weaving, or to accommodate entering and exiting vehicles. Operational efficiency of the freeway may be improved if a continuous auxiliary lane is provided between entrance and exit terminals where interchanges

are closely spaced. An auxiliary lane may be dropped at an exit if properly signed and designed. The following statements apply to the use of an auxiliary lane within or between interchanges:

1. Within Interchange. Figure 37-2.B provides the basic schematics of alternative designs for adding and dropping auxiliary lanes within interchanges. The selected design will depend upon traffic volumes for the exiting, entering, and through movements.
2. Between Interchanges. Where interchanges are closely spaced, the designer should provide an auxiliary lane where the distance between the taper end of the entrance terminal and beginning taper of the exit taper is less than 1500 ft (450 m). Figure 37-2.C illustrates where an auxiliary lane is used between two closely spaced interchanges.

Auxiliary lane drops beyond the interchange may be merged approximately 2500 ft (750 m) beyond the influence of the last interchange. Design details for auxiliary lane drops beyond an interchange are provided in Chapter 44. Design details for dropping auxiliary lanes at exits or adding them at entrances are provided in Section 37-6. If the auxiliary lane is dropped at a single lane exit, a recovery area beyond the gore should be provided as shown in Figure 37-2.B. Where certain sight distance restrictions are unavoidable (e.g., on structures), the recovery area should be extended 500 ft to 1000 ft (150 m to 300 m) downstream from the exit. This distance should be increased to 1500 ft (450 m) or more with complex designs.

37-2.06 Route Continuity

The major route should flow continuously through an interchange. For freeway and expressway routes that change direction, the driver should not be required to change lanes or exit to remain on the major route. Route continuity without a change in the basic number of lanes is consistent with driver expectancy, simplifies signing, and reduces the decision demands on the driver. Interchange configurations should not necessarily favor the heavier traffic movement. Other marked routes that turn or exit at an interchange can be accomplished by a single-lane ramp if capacity is adequate. If these ramps are longer than ½ mile (800 m), consider providing a two-lane ramp for better traffic operations.

37-2.07 Uniformity

Interchange configurations should be uniform from one interchange to another. All ramps should exit and enter on the right except under highly unusual conditions. Dissimilar arrangements between interchanges can cause confusion resulting in undesirable lane switches, reduced speeds, etc., especially in urban areas where interchanges are closely spaced.

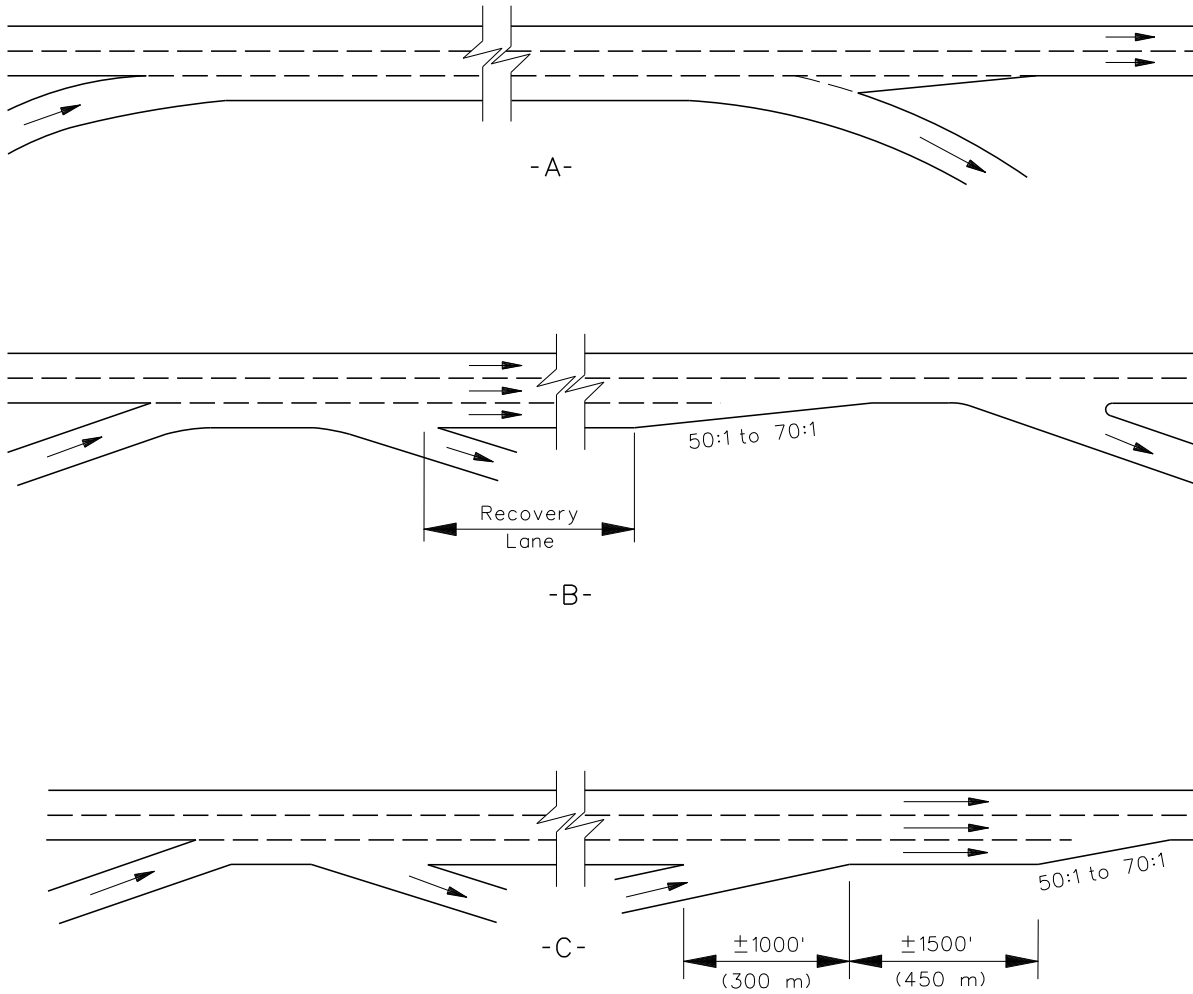

AUXILIARY LANES WITHIN AN INTERCHANGE

Figure 37-2.B

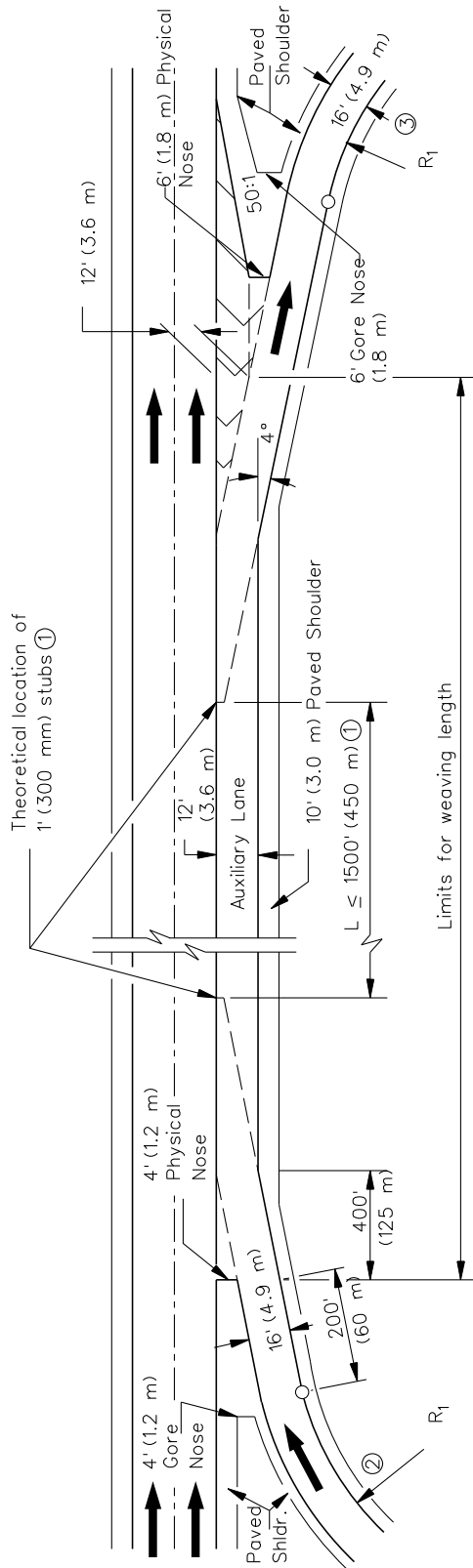

Notes:

1. If the distance between the theoretical 1 ft (300 mm) stubs is less than or equal to 1500 ft (450 m), provide an auxiliary lane connecting the entrance terminal to the exit terminal even if the auxiliary lane would not be required by a weaving analysis.
2. See Figure 37-6.L for Entrance Ramp Terminal with auxiliary lane.
3. See Figure 37-6.B for Exit Terminal with auxiliary lane.

AUXILIARY LANE BETWEEN TWO INTERCHANGES

Figure 37-2.C

37-2.08 Left-Hand Ramps

Avoid the use of left-hand exit and entrance ramps. They are less efficient operationally than right-hand ramps and may present a serious crash potential. They also introduce an undesirable element of non-uniformity into the design of a freeway system that leads to confusion and, in some cases, hazardous behavior by drivers. The disadvantages of left-hand ramps greatly outweigh the potential for directional turning movements and the increased flexibility of design. Therefore, where a left-hand ramp is being considered, approval of the design and analysis must be obtained from BDE for the Interchange Design Study (IDS).

37-2.09 Signing and Marking

Proper interchange operations depend partially on the compatibility between its geometric design and the traffic control devices at the interchange. The proper application of signs and pavement markings will increase the clarity of paths to be followed, safety, and operational efficiency. The logistics of signing along a highway segment will also impact the minimum acceptable spacing between adjacent interchanges. See the Bureau of Operations Departmental Policy TRA-14, and use the current edition of the Bureau of Operation's *Traffic Policies and Procedures Manual*, the *Pavement Marking Selection, Installation, and Inspection Manual*, the *Manual on Uniform Traffic Control Devices*, and the *Illinois Highway Standards* to select and design the appropriate pavement markings and crosswalks at interchanges. Chapter 57 provides general guidelines for the placement of pavement markings and reflectorized markers. For complex interchanges and location/design studies involving closely spaced interchanges, include a preliminary signing plan with the IDS.

37-2.10 Ramp Metering

Ramp metering may be used to improve freeway operations. Ramp metering consists of traffic signals installed on entrance ramps before the entrance terminal to control the number of vehicles entering the freeway. The Bureau of Operations will determine the need for ramp metering. If ramp metering is used, the designer will need to coordinate with the Bureau of Operations to determine the placement of the ramp signal to ensure that there is sufficient storage area before the ramp signal and that sufficient acceleration distance is available beyond the signal to allow a vehicle to reach the freeway operating speed.

37-2.11 Weaving Sections

Weaving sections are highway segments where the pattern of traffic entering and exiting at contiguous points of access results in vehicular paths crossing each other. The turbulent effect of weaving operations can result in reduced operating speeds and levels of service for the through traffic. Weaving sections may be eliminated at an interchange between two major highways by using directional or semi-directional connections or by using collector-distributor roadways.

Consider the following for weaving sections:

1. Weave Length. Weaving sections on freeways other than cloverleafs should be at least 1000 ft (300 m) or the length determined using the *Highway Capacity Manual* (HCM), whichever is greater. Section 37-3.06(b) discusses the minimum design criteria for one-sided weaving sections at cloverleaf interchanges.
2. Level of Service. The level of service of a weaving section should be the same as the adjacent mainline; however, at a minimum, it can be one level lower. A higher volume in weaving sections may be accommodated and their adverse impact on through traffic minimized by providing the weaving section on collector-distributor roadways. Section 37-4.02 discusses the use and design of collector-distributor roadways.

37-2.12 Grading and Landscaping

Consider the grading around an interchange early in the design process. Alignment, fill and cut sections, median widths, lane widths, drainage, structural design, and infield contour grading, all affect the aesthetics of the interchange. Properly graded interchanges allow the overpassing structure to blend naturally into the terrain. In addition, ensure that the crossroad and ramp slopes are not too steep to compromise safety and that they can support plantings that prevent erosion and enhance the appearance of the area. Flatter slopes also allow easier maintenance. Transitional grading between cut and fill slopes should be long and natural in appearance. The designer must ensure that plantings will not affect the sight distance within the interchange and that larger plantings are a significant distance from the traveled way. See Chapter 59 for additional guidelines.

37-2.13 Review for Ease of Operation

Review the proposed design from the driver's perspective. Examine all possible movements that a motorist might encounter. Several computer programs are available that allow a designer to test drive the design. Review the plans for areas of possible confusion, sufficient weaving and sight distances, proper signing, and ease of operation.

37-2.14 Geometric Design Criteria

Design all roadways through an interchange with the same criteria as used for the approaches including design speed, sight distance, horizontal and vertical alignment, cross section, and roadside safety elements. The applicable chapters in Parts IV, Roadway Design Elements, and V, Design of Highway Types, present the geometric design criteria that apply to the roadways through interchanges. In addition, consider the following:

1. Functional Classification. Determine the crossroad functional classification using the criteria in Chapter 43.
2. Design Year. Typically, use a 20-year design period based on the anticipated opening date of the facility.

3. Design Speed. The crossroad design speed will be based on its functional classification and its urban or rural classification; see the geometric design tables in Part V, Design of Highway Types. For rural crossroads (e.g., county highways, township roads), the minimum design speed of the crossroad through the interchange should be 55 mph (90 km/hr).
4. Horizontal Alignment. In general, lay out the alignment of the freeway/expressway and crossroad through the interchange on a tangent. Where this is not practical, consider the following:
 - a. Freeway Mainline. Avoid curves to the left.
 - b. Freeway Ramp Terminals. Lay out the freeway alignment so that only one exit terminal departs from the mainline curving to the right, or design the mainline curve to lie entirely within the limits of the interchange and away from the exit and entrance terminals.
 - c. Superelevation. Desirably, lay out the horizontal alignment so that superelevation and superelevation transitions will not be required through the freeway ramp terminals or through the ramp/crossroad intersection.
 - d. Crossroad. Where a curve is necessary, provide a significantly large horizontal curve so that superelevation is not required on the crossroad.
 - e. Structures. For a freeway or expressway over a crossroad, place the PC or PT of the horizontal curve 400 ft (120 m) or more from the back of the bridge abutment.
5. Vertical Alignment. Vertical profiles for both roadways through the interchange should be as flat as practical. Where compromises are necessary, use the flatter grade on the major facility. In addition, the designer should consider the following:
 - a. Sight Distance. To improve the sight distance to exit gores, locate exit ramp terminals and major divergences where the mainline is on an upgrade.
 - b. Ramps. Avoid creating a hidden ramp roadway in the vertical plane. Also, provide flat approach grades adjacent to the crossroad. For additional information on storage platforms at the ramp/crossroad intersection, see Sections 36-1.06 and 37-5.01.
 - c. Exit Ramp Terminals. Where a freeway or expressway is proposed to cross over the crossroad, locate the exit ramp terminals on the mainline no closer than 1000 ft (300 m) from the high point of a crest vertical curve on the mainline. This will ensure that no hidden ramps exist and will provide for safer operations at the exit ramp terminal.
 - d. Turning Trucks. Large trucks may become unstable when executing a nonstop, left turn from a crossroad on a downgrade. The combination of a downgrade,

sharp turning maneuvers into a ramp, and reverse superelevation may produce instability in large trucks. Therefore, the maximum grade for all crossroads associated with these conditions is desirably 2% through the ramp/crossroad terminal. For existing crossroads to remain in place, limit the downgrade to 3%. At a maximum, limit the up and downgrades to 4%.

6. Cross Sections. When designing the crossroad through the interchange, consider the following:
 - a. Widths. In general, carry the approach cross section of the major facility through the interchange. See Sections 37-5.01 and 37-5.02 for typical cross sections of a crossroad through an interchange.
 - b. Raised-Curb Medians. Raised-curb medians are used throughout the limits of the interchange. This facilitates the construction of separate left-turn lanes and promotes the proper use of the ramp/crossroad intersections. To determine the crossroad channelized approach in conjunction with the crossroad design speed and number of lanes on the crossroad, see the IDOT publication *Transitional Approaches to Channelized Intersections* for additional information. Chapter 36 also provides guidance on the design of channelized left-turn lanes and islands.
 - c. Side Slopes. Side slopes on the crossroad through the interchange area should be 1V:4H or flatter. Chapter 34 and Part V further discuss roadway side slopes.
7. Sight Distance. Because of the additional demand placed on the driver at an interchange, the designer should consider the following sight distance elements:
 - a. Stopping Sight Distance. Provide adequate stopping sight distance on both intersecting highways throughout the interchange and on all ramps. Check both the vertical and horizontal alignment to ensure that the location of piers, abutments, structures, bridge rails, vertical curves, etc., will not restrict sight distance. Chapter 32 discusses the application of horizontal sight distance. Chapter 33 discusses the application of vertical sight distance.
 - b. Decision Sight Distance. Desirably, provide decision sight distance to all decision points (e.g., exit and entrance terminals). Driver expectancy should not be violated; see Chapter 31.
 - c. Intersection Sight Distance. Section 36-6 discusses intersection sight distance (ISD), which is also applicable at ramp/crossroad intersections (non-merging sites). Section 37-5.01 provides additional ISD guidance that should be considered at ramp/crossroad intersections that are stop controlled.

8. Ramp/Crossroad Intersections. When designing the ramp/crossroad intersection, consider the following:
 - a. Angle of Ramp Intersection. To determine the appropriate angle for the ramp/crossroad intersection, see Section 37-5.
 - b. Access Control. To determine the required length of access control along the crossroad at the interchange, see Chapter 35.
 - c. Left-Turn Lanes. Select the appropriate left-turn lane lengths based on the design speed of the crossroad and/or the required storage lengths; see Section 36-3.02. For guidance on the design of left-turn lanes across or under a structure, see Section 37-5.
 - d. Design Vehicle. Check the ramp/crossroad intersection with the applicable design vehicle turning template or use a computer-simulated turning template program. As discussed in Section 36-1.08, use the WB-67 (WB-20) design vehicle at all ramp/crossroad intersections.
 - e. Design Users. Where present and permitted users along the crossroad, pedestrians and bicyclists should be treated as design users of the facility and given the same consideration as the design vehicle.
 - f. Corner Islands. See Section 36-2.02 when designing or modifying corner islands at ramp/crossroad intersections.
9. Mainline/Crossroad Point of Intersection. Once Items 1 through 8 above have been determined, the designer must decide where the mainline alignment best intersects with the crossroad. The overall size of the interchange, crossroad gradelines, required length of access control along the crossroad, access to property at the ends of access control on the crossroad, and topography are the most influential factors in this determination. Complete this investigation before the detailed design of an interchange is initiated.
10. Structures. Chapter 39 provides the geometric design criteria for structures designed in conjunction with interchanges.
11. Trucks. Check truck merging speeds at entrance terminals. This typically is only critical where the:
 - mainline profile is on an upgrade of 3% or greater,
 - the ramp profile is on a steep upgrade, and/or
 - the mainline volume is heavy.

37-2.15 Operational/Safety Considerations

Operations and safety are important considerations in interchange design. The following summarizes several major considerations:

1. Exit Ramps. For exit ramps, consider the following:
 - Provide decision sight distance, where practical, to the freeway exit; see Chapter 31. Desirably, use the pavement surface for the height of object (i.e., 0.0 inches (0.0 mm)).
 - Ramps should depart from the mainline where there will be no vertical curvature to restrict visibility along the ramp. Avoid ramp designs that drop out of sight.
 - Avoid locating exit terminals where the mainline curves to the left.
 - Proper advance signing of exits is essential to allow necessary lane changes before the exit.
 - Provide sufficient distance to allow safe deceleration from the freeway design speed to the design speed of the first governing geometric feature on the ramp, typically a horizontal curve.
2. Entrance Ramps. Provide an acceleration distance of sufficient length to allow a vehicle to attain an appropriate speed for merging. Where entrance ramps enter the mainline on an upgrade, the acceleration distance may need to be lengthened, or an auxiliary lane may be required to allow vehicles to reach a safe speed prior to merging.
3. Driver Expectancy. Ensure that the interchange is designed to conform to the principles of driver expectation. These may include the following:
 - Avoid left-hand exit or entrance terminals. Drivers expect single-lane exit and entrance terminals to be located on the right side of the freeway.
 - Do not locate exit ramps so that it gives the appearance of a continuing mainline tangent as the mainline curves to the left.
 - Do not mix operational patterns between interchanges, lane continuity, or interchange types.
 - Provide lane balance and basic number of lanes on the freeway.
 - Provide sufficient spacing between interchanges to allow proper signing distances to decision points.
4. Fixed Objects. Because of traffic operations at interchanges, many fixed objects may be located within interchanges (e.g., signs at exit gores, bridge piers, rails). Avoid locating these objects near decision points, make them breakaway, or shield them with barriers or impact attenuators. Make any concrete footings flush with the ground line. See Chapter 38 for additional guidance on roadside safety.
5. Controlled Ramp Terminals. The designer must ensure that ramp/crossroad intersections have sufficient capacity so that the queuing traffic at the crossroad

- intersection does not backup onto the freeway. Also, sufficient access control and intersection sight distance must be maintained along the crossroad to allow the ramp intersection to work properly.
6. Wrong-Way Maneuvers. Provide channelized medians, islands, and adequate signing to minimize wrong-way possibilities. Avoid designs that may result in poor visibility, confusing ramp arrangements, or inadequate signing.
 7. Weaving. Areas of vehicular weaving may create a high demand on driver skills and attentiveness. Where practical, design interchanges without weaving areas by changing the sequence of ramps, increasing the spacing between ramps, or removing the weaving areas from the highway mainline by using collector-distributor roads.
 8. Pedestrians and Bicyclists. Use signing and lane markings to increase awareness of pedestrians and bicyclists. Signing, crosswalks, barriers, over and underpasses, bridge sidewalks, and other traffic control devices may be required to manage traffic movements and to control pedestrian and bicycle movements.

37-2.16 Distance Between Successive Freeway Ramp Terminals

Successive freeway ramp terminals may be placed relatively close to each other especially in urban areas. The distance between the terminals should provide for vehicular maneuvering, signing, and capacity. Figure 37-2.D provides recommended guidelines for spacing distances of various freeway ramp terminals. The criteria in Figure 37-2.D should be considered for the initial planning stages of interchange location. The final decision on the spacing between freeway ramp terminals must satisfy the level-of-service criteria. This will be determined by conducting a detailed capacity analysis using the *Highway Capacity Manual*. Where the distance between the tapers of successive entrance and exit terminals is less than 1500 ft (450 m), connect the two terminals with an auxiliary lane and provide a recovery area beyond the exit terminal as illustrated in Figure 37-6.B.

EN-EN	EX-EX	EX-EN	Directional Ramps	EN-EX (Weaving)
Full Freeway CDR or FDR	Full Freeway CDR or FDR	Full Freeway CDR or FDR	System Interchange Service Interchange	System to Service Interchange Service Interchange
300 ft (100 m)	1000 ft (300 m)	500 ft (150 m)	800 ft (240 m)	2000 ft (600 m)
	800 ft (240 m)	400 ft (120 m)	600 ft (180 m)	1600 ft (480 m)
				1000 ft (300 m)
				1600 ft (480 m)
				1000 ft (300 m)
				1600 ft (480 m)

FDR - Freeway Distributor Road
CDR - Collector-Distributor Road
EN - Entrance
EX - Exit

- Notes:
1. Distance is measured from the end of taper (1 ft (300 mm) stub) to the gore nose and desirably should be 400 ft (120 m) or more; see Figure 37-6.K.
 2. For cloverleaf loop ramps, this distance is determined from Figure 37-3.N and a weaving analysis.
 3. The lengths are based on operational experience and the need for flexibility and adequate signing. They should be checked according to the procedure in the Highway Capacity Manual. The larger of the values is suggested for use. Also, a procedure for measuring the length of the weaving section is given in the Highway Capacity Manual.

RAMP TERMINAL SPACING GUIDELINES

Figure 37-2.D

37-3 INTERCHANGE TYPES AND LAYOUTS

37-3.01 General

In Illinois, there are six basic interchange types — the diamond, the cloverleaf, the partial cloverleaf, the trumpet, the directional, and the semi-directional. These interchange types, and variations within each type, permit adaptation to traffic needs, available right-of-way, terrain, and cultural features. The following sections discuss these basic interchange types and the design elements for laying out the interchange. The FHWA publication *Alternative Intersection/Interchange: Informational Report (AIIR)* discusses alternative interchange designs (e.g., diverging diamond interchange, displaced left-turn interchange). Each interchange must be designed to fit the individual site considerations. The final design may be a minor or major modification of one of the basic types or may be a combination of two or more basic types. Sections 37-2, 37-4, 37-5, and 37-6 provide the general design criteria for the individual elements of the interchange.

37-3.02 Conventional Diamond

37-3.02(a) General

The conventional diamond is the simplest and most common interchange type. Diamonds include one-way diagonal ramps in each quadrant and two intersections at the crossroad. With proper treatments at the crossroad, the diamond interchange can accommodate a wide variety of circumstances in suburban and urban areas where the crossroad operating speeds are 45 mph (70 km/hr) or less. The diamond is usually the best interchange choice where the intersecting road is not access controlled. Figures 37-3.A and 37-3.B illustrate typical diamond interchanges. Some of its advantages and disadvantages include:

Advantages

- All exits from the mainline occur before reaching the crossroad structure and entrances occur after the structure. This conforms to driver expectancy and therefore minimizes confusion.
- All traffic can enter and exit the mainline at relatively high speeds.
- At the crossroad, adequate sight distance can usually be provided, and the operational maneuvers are consistent with other intersections on the crossroad.
- They require less right-of-way than other interchange types.
- The diamond configuration easily allows modifications to provide greater ramp capacity, if needed in the future.
- Their common usage has resulted in a high level of driver familiarity.
- Typically, it is the least expensive of all interchange types.

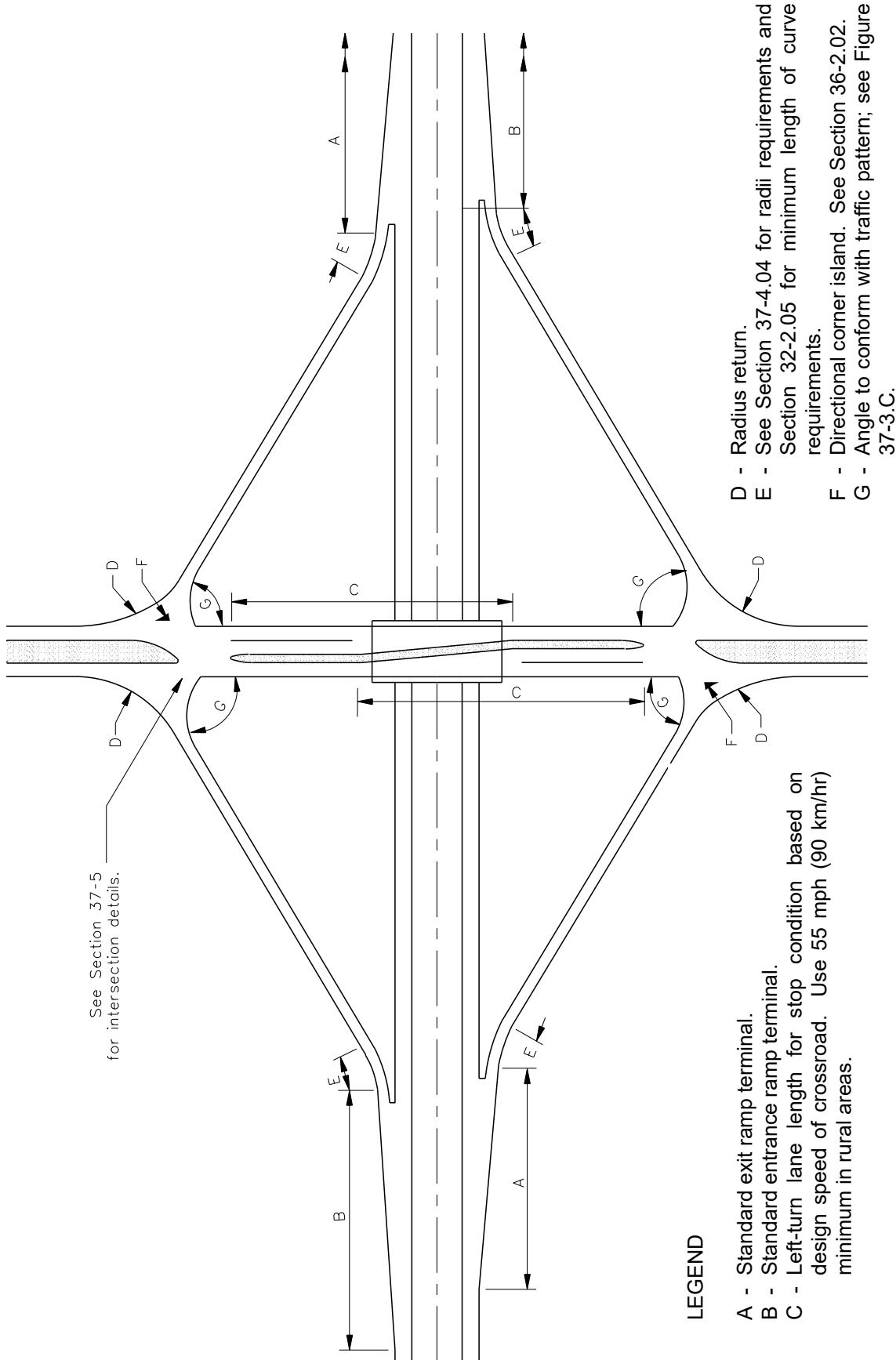

LEGEND

- A - Standard exit ramp terminal.
- B - Standard entrance ramp terminal.
- C - Left-turn lane length for stop condition based on design speed of crossroad. Use 55 mph (90 km/hr) minimum in rural areas.

- D - Radius return.
- E - See Section 37-4.04 for radii requirements and Section 32-2.05 for minimum length of curve requirements.
- F - Directional corner island. See Section 36-2.02.
- G - Angle to conform with traffic pattern; see Figure 37-3.C.

DIAMOND INTERCHANGE LAYOUT (60 Degree Design)

Figure 37-3.A

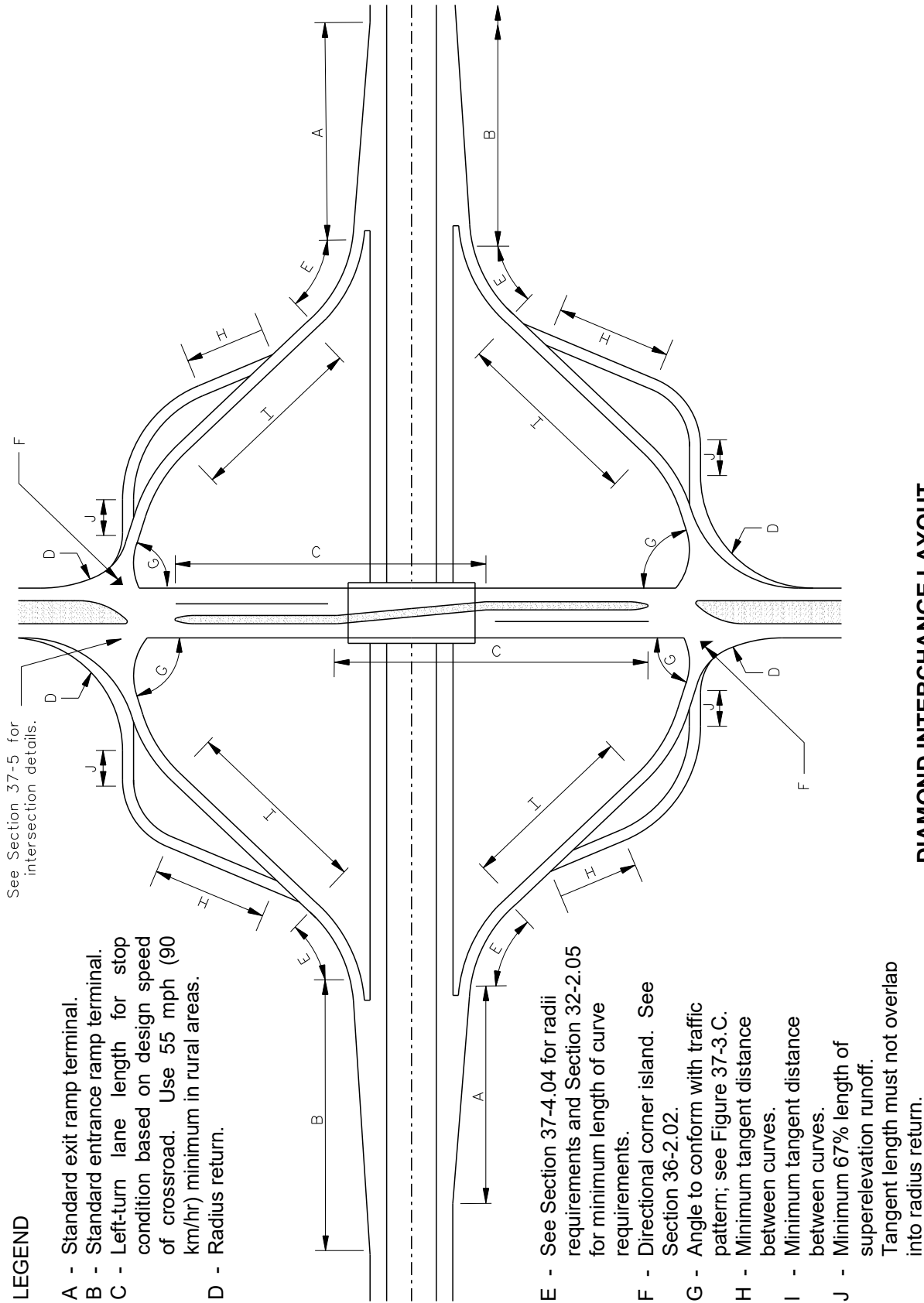

See Section 37-5 for intersection details.

LEGEND

- A - Standard exit ramp terminal.
- B - Standard entrance ramp terminal.
- C - Left-turn lane length for stop condition based on design speed of crossroad. Use 55 mph (90 km/hr) minimum in rural areas.
- D - Radius return.

- E - See Section 37-4.04 for radii requirements and Section 32-2.05 for minimum length of curve requirements.
- F - Directional corner island. See Section 36-2.02.
- G - Angle to conform with traffic pattern; see Figure 37-3.C.
- H - Minimum tangent distance between curves.
- I - Minimum tangent distance between curves.
- J - Minimum 67% length of superelevation runoff. Tangent length must not overlap into radius return.

**DIAMOND INTERCHANGE LAYOUT
(75 Degree OR 90 Degree Design)**

Figure 37-3.B

Disadvantages

- Traffic is subject to stop-and-go operations rather than free flow.
- In suburban and urban areas, signalization is generally required at the crossroad intersections. These signals should be interconnected for progression.
- They require right-of-way in all four quadrants of the interchange.
- A diamond has a greater potential for wrong-way entry onto the ramps than, for example, a full cloverleaf. Raised-curb channelization is used on the crossroad to minimize the likelihood of driver confusion and wrong-way maneuvers.

37-3.02(b) Left-Turn Lanes

The first step in laying out diamond interchange ramps is to determine the location of the ramp/crossroad intersections. The length of the overlapping left-turn lanes generally will determine the location of these intersections; see Figure 37-5.A. Section 36-3.02 provides the criteria for determining the length for these separate left-turn lanes. Once the lengths are determined and located away from the grade separation, set the left-turn control radii and establish the baseline control; see Figures 37-5.D through 37-5.G.

37-3.02(c) Ramp/Crossroad Intersections

Figures 37-5.D through 37-5.G illustrate typical diamond ramp/crossroad intersections. Figure 37-3.C provides guidelines for determining allowable ramp/crossroad intersection angles where the crossroad is approximately perpendicular to the freeway. The preferred ramp/crossroad intersection angle is 90 degrees, but if avoidance of agricultural property or other adjacent right-of-way is desired, other angles are permitted according to Figure 37-3.C. The ramp angles in Figure 37-3.C are based on the volume of left-turning vehicles from either the crossroad or the ramp.

Left-Turn DHV at Ramp/Crossroad Intersection	Allowable Ramp/Crossroad Intersection Angles
125 or less	60° - 90°
125 - 250	75° - 90°
250 or more	90°

Note: This figure assumes the freeway and crossroad intersect at approximately 90°.

RAMP/CROSSROAD INTERSECTION ANGLES

Figure 37-3.C

37-3.02(d) Ramp Layout

Although the angle of ramp intersection with the crossroad is important, the complete development of ramp geometry may be influenced by a combination of other factors (e.g., conservation of agricultural land, avoiding existing development, angle of intersection of the crossroad with the freeway). Because the angle of the crossroad with the freeway is a major factor in determining the ramp alignment and length, the following design considerations are provided:

1. Freeway and Crossroad — Perpendicular. Where the crossroad is approximately perpendicular to the freeway, consider the following guidelines:
 - a. Angle of Intersection. Figure 37-3.C provides the preferred ramp intersection angles with the crossroad. These angles are based on the number of left-turning vehicles on either the crossroad or the exit ramp.
 - b. Number of Curves. With a 60° intersection angle, only one curve is required on the ramp; see Figure 37-3.A. For other angles of intersection, a second curve adjacent to the crossroad will generally be required. For rural ramps with a 75 degree intersection angle with the crossroad, design the ramp curve nearest to the crossroad with a minimum 30 mph (50 km/hr) design speed and, desirably, with a 40 mph (60 km/hr) design speed. In urban areas, the design speed should be at least 25 mph (40 km/hr) unless available right-of-way is highly restricted by existing development; see Figure 37-3.B.
 - c. Minimum Tangent Length. The minimum tangent length between two reverse curves should be $(2/3T_1 + 2/3T_2)$. T_1 and T_2 are the individual superelevation runoff lengths for each curve. See Figure 37-4.F for the applicable runoff lengths.
 - d. Curve Locations. Where two curves are designed on an exit ramp, the curve nearest the freeway ramp terminal may be located by computing the center-to-center distance of the two curves. This center-to-center distance, "L," passes through a point of intersection with a line drawn parallel to the edge of the freeway and passing through the center of the curve located next to the freeway. This procedure is illustrated in Figure 37-3.D.
2. Freeway and Crossroad — Skewed. If the crossroad is skewed, in either direction, strict adherence to the guidelines for perpendicular intersections in Item 1 can result in unacceptable design features (e.g., excessive ramp lengths, short curve lengths, steep grades, indirect alignment). Therefore, design modifications are generally necessary. Under these conditions, give primary consideration to the ramp alignment rather than the intersection angle as determined from Figure 37-3.C. With skewed crossroads, the ramp alignment should be, in order of preference, one of the following:

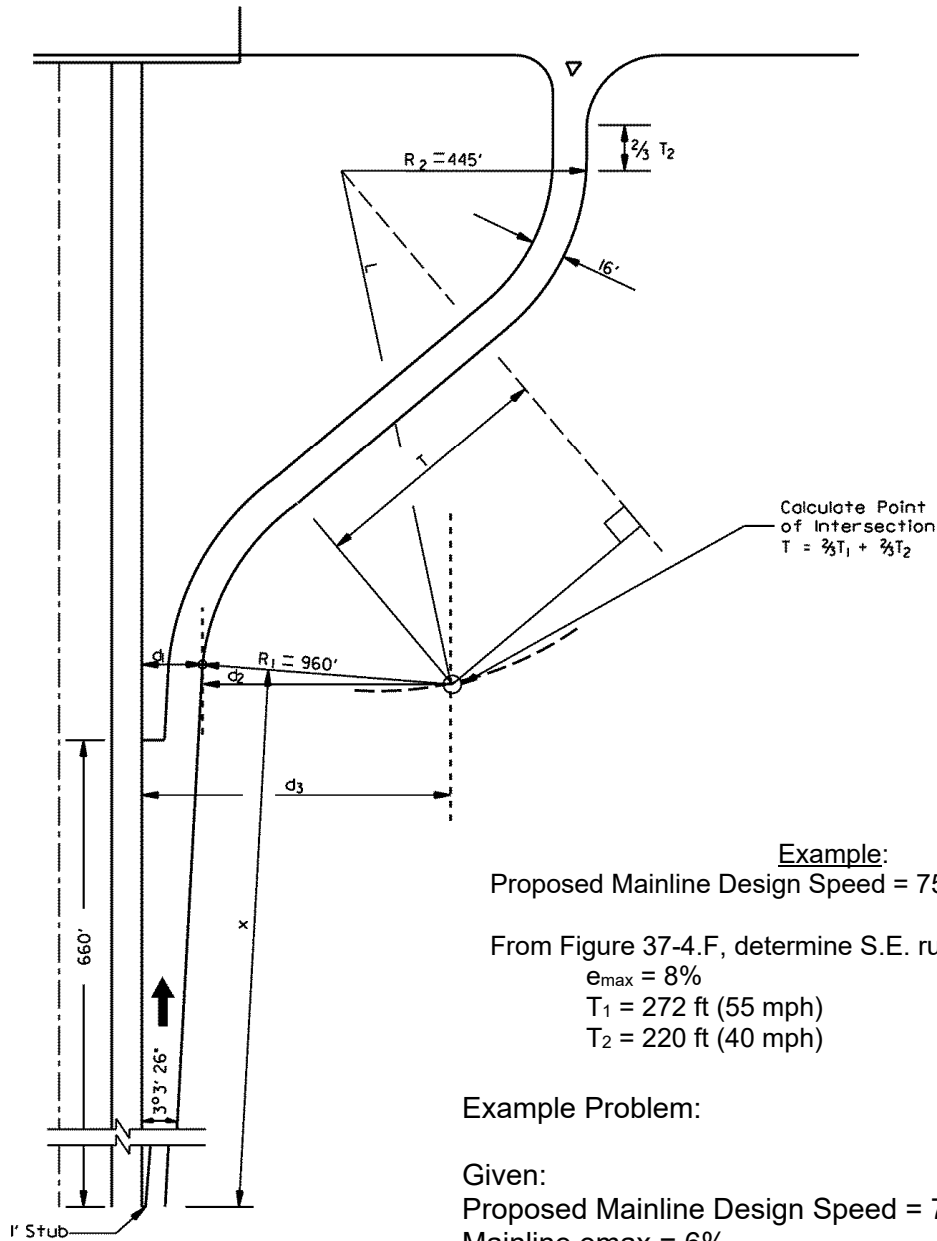

Example:
 Proposed Mainline Design Speed = 75 mph
 From Figure 37-4.F, determine S.E. runoff length.
 $e_{max} = 8\%$
 $T_1 = 272 \text{ ft (55 mph)}$
 $T_2 = 220 \text{ ft (40 mph)}$

Example Problem:

Given:
 Proposed Mainline Design Speed = 75 mph
 Mainline $e_{max} = 6\%$
 Ramp $e_{max} = 8\%$

Determine:
 Values for x , T , L , d_1 , d_2 , and d_3 .

**LOCATION OF INITIAL CURVE FOR AN EXIT RAMP
 (Diamond Interchange)**

Figure 37-3.D
 (1 of 3)

Solution:

From Figure 37-4.F, determine S.E. runoff length for R₁ and R₂:

$$T_1 = 272 \text{ ft (55 mph)}$$

$$T_2 = 220 \text{ ft (40 mph)}$$

$$T = (2/3) T_1 + (2/3) T_2$$

$$T = (2/3) 272 + (2/3) 220$$

$$T = 328.00 \text{ ft}$$

From the law of triangles:

$$a^2 + b^2 = c^2$$

$$c = \sqrt{a^2 + b^2}$$

$$b = \sqrt{c^2 - a^2}$$

Using dimensions from *Highway Standard 406101*:

$$a = 660 + 1/\tan 3^\circ 3' 26''$$

$$a = 678.72 \text{ ft}$$

$$b = 20.23 + 16/\cos 3^\circ 3' 26''$$

$$b = 36.25 \text{ ft}$$

$$c = \sqrt{(678.72)^2 + (36.25)^2}$$

$$c = 679.69 \text{ ft}$$

Calculate x, the length along the ramp alignment from the 1 foot stub to the point of curvature of the ramp:

$$x = 679.69 + 140 - 16 \tan 3^\circ 3' 26'' - (1/\sin 3^\circ 3' 26'')$$

$$x = 800.09 \text{ ft}$$

$$L = \sqrt{(960 + 445)^2 + (328)^2}$$

$$L = 1442.78 \text{ ft}$$

$$d_1 = (800.09 \sin 3^\circ 3' 26'') + 1$$

$$d_1 = 43.67 \text{ ft}$$

$$d_2 = 960 \cos 3^\circ 3' 26''$$

$$d_2 = 958.63 \text{ ft}$$

$$d_3 = d_1 + d_2$$

$$d_3 = 43.67 \text{ ft} + 958.63 \text{ ft}$$

$$d_3 = 1002.30 \text{ ft}$$

**LOCATION OF INITIAL CURVE FOR AN EXIT RAMP
(Diamond Interchange)**

Figure 37-3.D

(3 of 3)

- a tangent ramp with a single curve adjacent to the freeway;
- reverse curves with radii connected by a tangent length greater than the minimum required for superelevation runoff lengths, see Item 1c above; or
- reverse curves with radii connected by a tangent equal to the minimum superelevation runoff needs, see Item 1c above.

In the design of the preferred alignment, the designer must also control the overall ramp length. Normally, the gore nose of a ramp should be located about 1250 ft (375 m) from the crossroad structure. If the first preference alignment cannot be developed with a gore within 1250 ft to 1400 ft (375 m to 425 m) of the structure, the second preference should be investigated and the third, if necessary, until an acceptable ramp length is achieved for both grade and directness.

37-3.03 Modified Diamond

The modified diamond interchange is a combination of the diamond interchange and partial cloverleaf. Figure 37-3.E illustrates typical schematics of a modified diamond interchange. This design type is typically used where subdivisions, extensive commercial or industrial development, lakes, ponds, or other adverse topography and/or soil conditions are located in one of the interchange quadrants, making right-of-way acquisition, design, or construction unusually expensive. Some of the advantages and disadvantages of the modified diamond include:

Advantages

- Depending upon site conditions, modified diamonds may offer the opportunity to increase weaving distances.
- It allows access where one of the quadrants presents adverse right-of-way, topography, or environmental constraints.
- It can be used where a full parclo is not desirable.

Disadvantages

- Modified diamonds may be more expensive than a conventional diamond interchange due to longer ramp lengths and wider structures.
- The loop results in a longer travel distance for the turning vehicle than for a conventional diamond, and the operating speeds on the loop ramp are generally slower.
- The exit or entrance terminal is located before or after the crossroad structure that may require additional signing to guide the motorist.

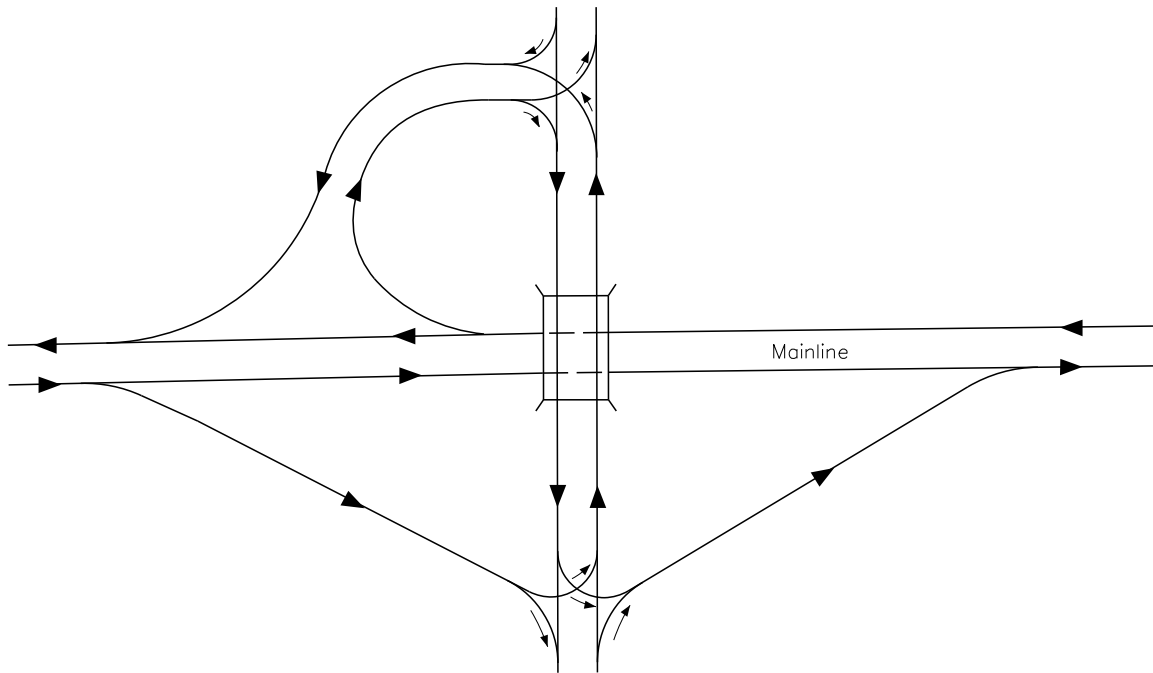
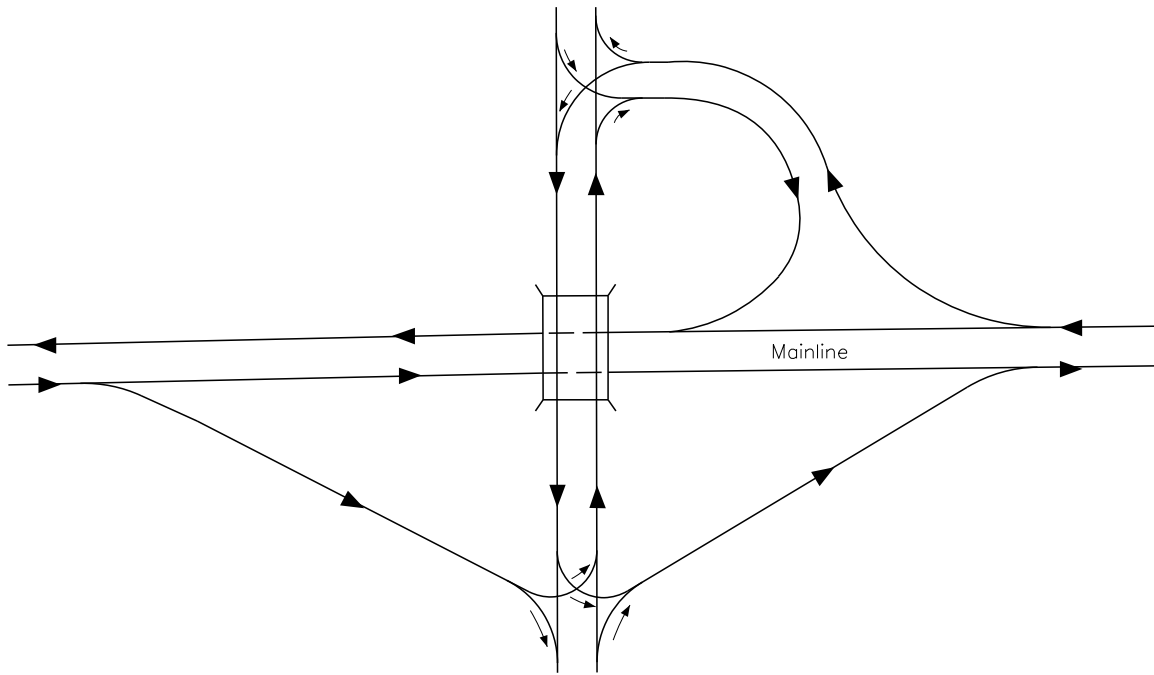

MODIFIED DIAMOND INTERCHANGE

Figure 37-3.E

37-3.04 Compressed Diamond

37-3.04(a) General

A compressed diamond, also called a tight diamond interchange, is similar to the conventional diamond except that the ramp termini on the crossroad are located near the structure. Figure 37-3.F presents a schematic of a compressed diamond interchange without frontage roads. This design type is generally only used in urban areas where a diamond interchange is appropriate, but right-of-way or other environmental features preclude the use of the conventional diamond. Although operationally a compressed diamond is similar to a single-point diamond discussed in Section 37-3.05, they have significant differences. Some of the advantages and disadvantages of the compressed diamond include:

Advantages

- Less right-of-way is required than that for a conventional diamond.
- The open pavement area at the intersection is significantly less than that for a single point diamond.
- The grade separation structure is significantly smaller than that for a single-point diamond, retaining walls and/or embankments are less expensive, and construction costs are lower.
- The ramp/crossroads intersections operate as two typical intersections, similar to a conventional diamond and, therefore, are less confusing to drivers.
- Slip ramps for one-way frontage roads can be easily incorporated into the design.

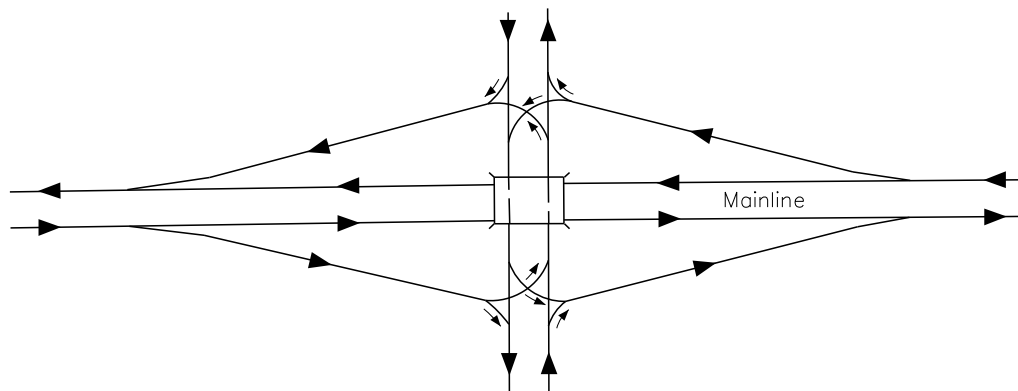

COMPRESSED DIAMOND INTERCHANGE

Figure 37-3.F

Disadvantages

- Left-turn lanes between the ramp termini usually need to be overlapped (i.e., side-by-side opposing left-turn lanes). Consequently, the cross section of the crossroad is generally wider than a conventional diamond.
- Signal timing and interconnection are necessary in order to eliminate left-turn queues from overlapping each other and causing gridlock.
- Due to the close proximity of the two intersections, the compressed diamond typically will need to operate as a six-phase overlap signal system. Consequently, longer clearance times are required.
- Length of access control on the crossroad may be more extensive than that for a conventional diamond.

37-3.04(b) Ramp/Crossroad Intersections

Section 37-5 presents the criteria for ramp/crossroad intersections, which is also applicable to compressed diamonds. However, the minimum length for left-turn lanes is based on the storage length and not on the deceleration distance. See Section 36-3.02 to determine the minimum storage length. If there is insignificant space for storage, the designer will need to consider optimizing the traffic signals.

Figure 37-3.F illustrates a schematic of a compressed diamond without frontage roads. Figure 37-5.M presents the criteria for a compressed diamond with one-way frontage roads and slip ramps. Where there are one-way frontage roads and where there is significant U-turn traffic to the opposite frontage road, the designer may want to consider using a turnaround design. Figure 37-3.G illustrates the general layout and cross section for a turnaround design. Depending upon specific site conditions, this arrangement may significantly improve traffic operations at the interchange. The major operational feature of the turnaround is to provide access for traffic on the freeway to the one-way frontage road in the opposite direction without passing through the two intersections on the crossroad. If U-turn movements are considered to be significant, prepare an origin and destination study to determine the need for a turnaround prior to the development of IDS.

Some advantages and disadvantages of the turnaround design are as follows:

Advantages

- It preserves and enhances the accessibility to property abutting one-way frontage roads.
- U-turning vehicles do not have to pass through the two intersections on the crossroad.
- The capacity of the crossroad intersections is improved.

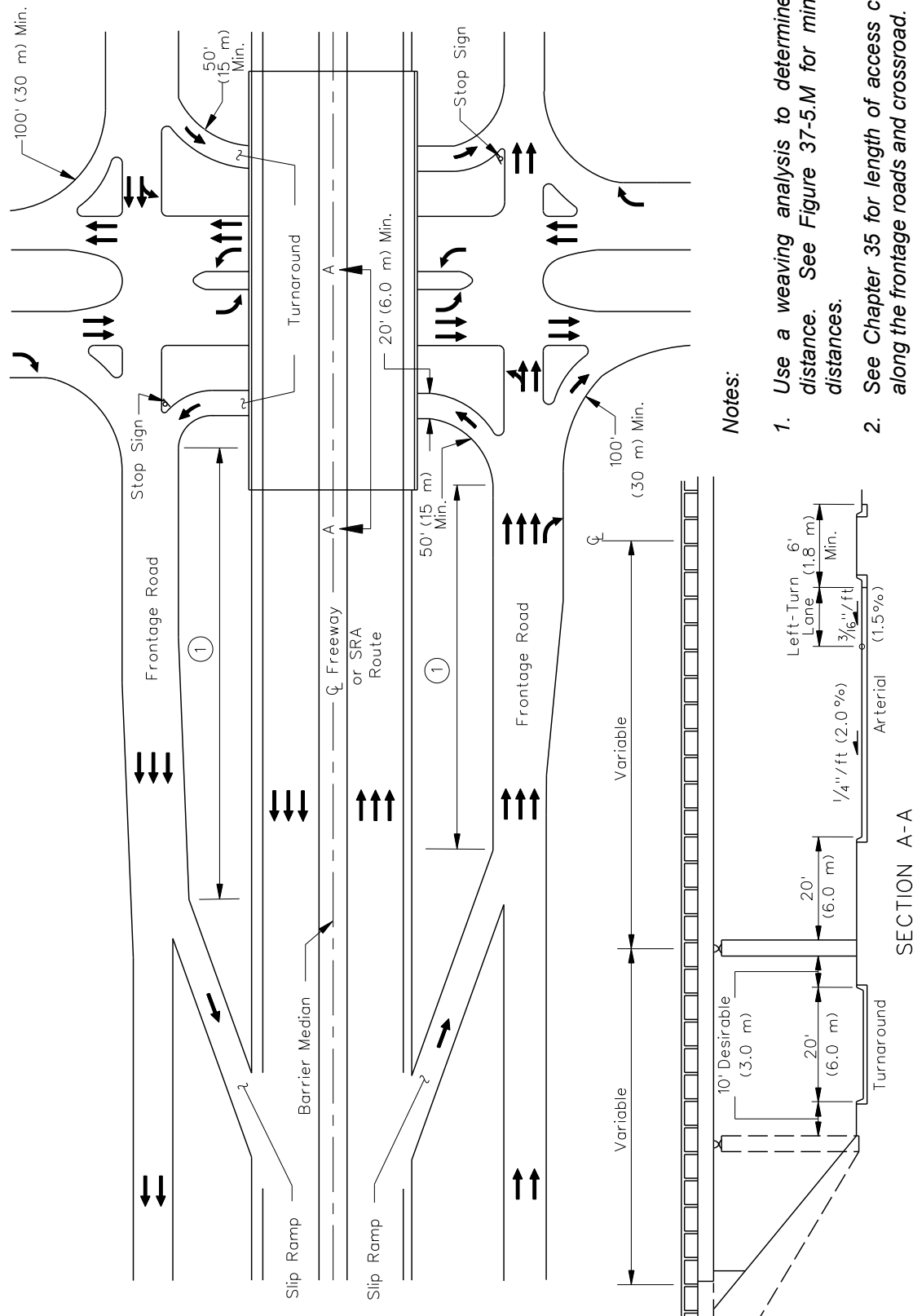

Notes:

1. Use a weaving analysis to determine this distance. See Figure 37-5.M for minimum distances.
2. See Chapter 35 for length of access control along the frontage roads and crossroad.
3. See Section 36-2.02 for corner island design.

COMPRESSED DIAMOND WITH TURNAROUND

Figure 37-3.G

Disadvantages

- It is more costly than a typical compressed diamond due to the longer structure.
- It may be confusing to non-repeat drivers because it violates driver expectancy (i.e., driving to the left of the oncoming traffic).
- Longer distances are required between the slip ramp frontage road merge point and the crossroad.

37-3.05 Single-Point Urban Diamond

37-3.05(a) General

The single-point urban diamond interchange (SPUI) offers improved traffic-carrying capabilities, safer operations, and reduced right-of-way needs under certain conditions when compared with other interchange configurations. The distinguishing feature of this interchange is the convergence of all through and left-turning movements into a single, large signalized intersection area. Figure 37-3.H illustrates a schematic of a SPUI. Some of its advantages and disadvantages include:

Advantages

- Only requires one intersection instead of two intersections at a typical diamond.
- Allows for better traffic signal progression on the crossroad.
- It can increase interchange capacity and alleviate storage problems from two closely spaced intersections on the crossroad.

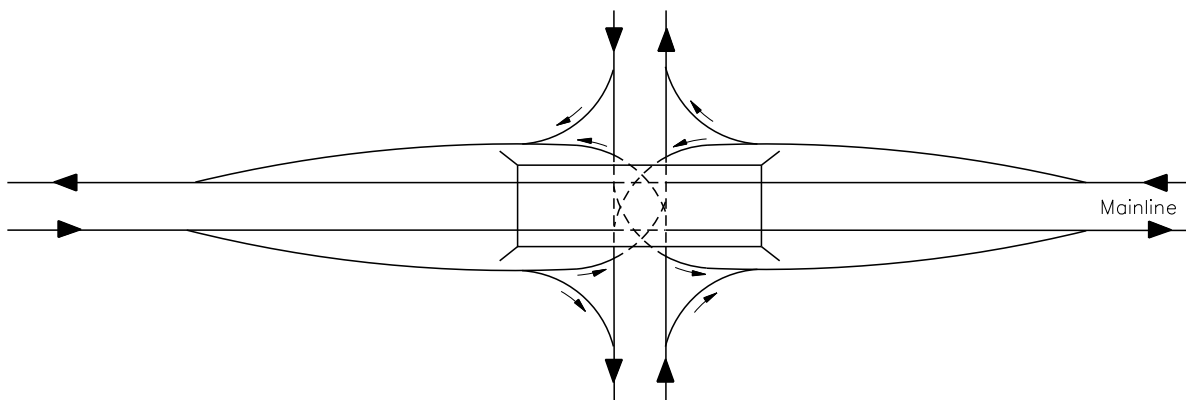

SINGLE-POINT URBAN DIAMOND INTERCHANGE

Figure 37-3.H

- Opposing left turns operate to the left of each other so that their paths do not cross each other.
- Less right-of-way is required than any other interchange type.
- At the intersection of the ramps with the crossroad, the design typically includes flatter curves for turning radii, which allows left turns to be completed at higher speeds.

Disadvantages

- Special pavement markings and a centrally located diamond-shaped island are required to guide the left-turning drivers through the intersection.
- There is a significantly wider pavement area for pedestrians to cross and may create greater delays in traffic when compared to the conventional diamond.
- Because of wide pavement areas, it requires longer signal clearance times.
- It has a higher cost than the conventional or compressed diamond because of the need for a long, single-span structure and the need for retaining walls or reinforced earth walls along the mainline.
- In the case of the mainline over a crossroad, lighting is required under the structure.

37-3.05(b) Design Considerations

The interrelationship of the design elements is extremely important in the design of single-point diamond interchanges (SPUI). Therefore, make every effort to use the desirable values for all design features of the interchange. See NCHRP 345 *Single-Point Urban Interchange Design and Operational Analysis* for complete design details. Figures 37-3.I and 37-3.J illustrate the typical layout for a SPUI. In addition, consider the following:

1. Over versus Under. One of the first things the designer must address is whether to place the freeway or expressway over or under the crossroad. The overpass SPUI, illustrated in Figure 37-3.I, typically includes a conventional, single-span structure 220 ft (67 m) in length with a depth of 8 ft to 9 ft (2.4 m to 2.7 m). The underpass design (freeway over) typically includes two spans of approximately 65 ft (20 m) in length and a depth of 3 ft to 4 ft (1.0 m to 1.2 m). The underpass design tends to provide a more open and less restrictive feeling as the driver approaches the intersection area. For both designs, the crossroad profile should be as flat as practical. Section 44-4.02 discusses additional considerations when determining whether to place the crossroad over or under the freeway.

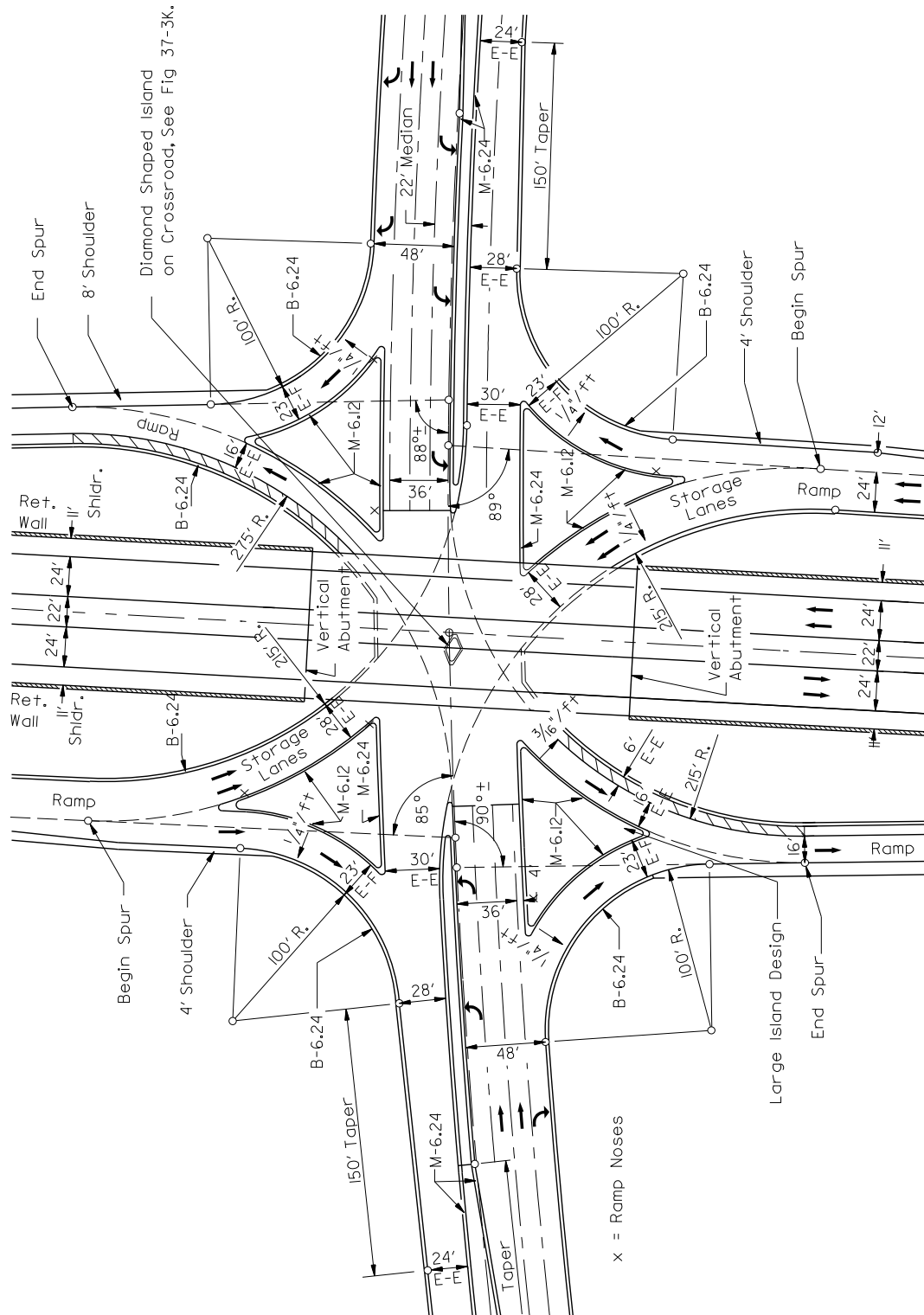

SINGLE-POINT URBAN DIAMOND INTERCHANGE
(Example of Central Intersection Details)

Figure 37-3.I

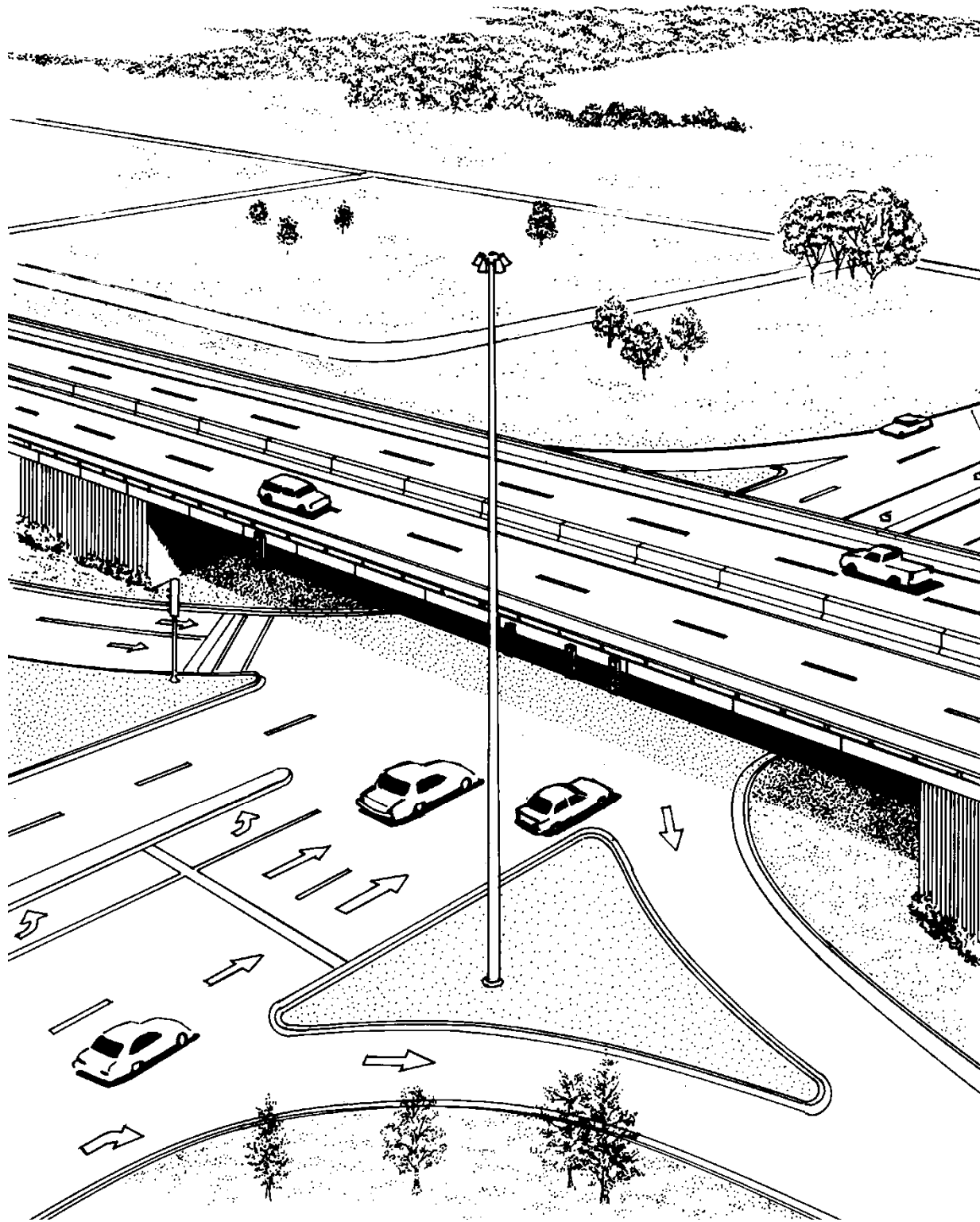

PERSPECTIVE VIEW OF SINGLE-POINT URBAN DIAMOND INTERCHANGE

Figure 37-3.J

2. Sight Distance. Sight distance along the exit ramp to the crossroad intersection is especially critical with the SPUI because the decision point to turn left or right generally will occur sooner at a SPUI than at other diamond type interchanges. The point of initial driver perception of the large triangular intersection island and the point for the left- or right-turn decision should occur at or just beyond the gore nose of the off ramp. At a minimum, provide the stopping sight distance as discussed in Section 31-3.01 and, desirably, decision sight distance wherever practical (Section 31-3.02). The designer must also check the horizontal sight distance to ensure that the structure abutments or parapet walls do not block the sight distance.
3. Intersection Sight Distance. Provide adequate intersection sight distance as discussed in Section 36-6. The designer must check both the vertical and horizontal planes to ensure that adequate intersection sight distance is available. The profile of the crossroad should be flat to allow motorists to see the entire crossroad surface and all ramps in one view.
4. Design Speed. Desirably, the design speed for the turns should be 30 mph to 40 mph (50 km/hr to 60 km/hr). In highly restricted ROW areas, the left-turning roadway from the exit ramp onto the crossroad may be designed with a 25 mph (40 km/hr) design speed.
5. Horizontal Alignment. One benefit of the SPUI is it provides high-speed, left-turning roadways in comparison to the compressed diamond interchange design. Design the left-turning roadways with 2% superelevation and radii between 200 ft and 400 ft (60 m and 120 m). See Figure 48-5.B to determine radii for other design speeds.
6. Number of Lanes. A capacity analysis is required to determine the number of turn lanes for the overall intersection design. At a minimum, provide sufficient space to allow two through lanes for each direction on the crossroad, one left-turn lane on the crossroad, dual-turn lanes on the exit ramp for left-turning movements, and one right-turn lane from the exit ramp onto the crossroad.
7. Intersection Angle. The intersection angle should be approximately 90 degrees.
8. Median Design. Crossroad medians should be in the range of 18 ft to 30 ft (5.5 m to 9.5 m) wide and with sufficient distance provided for left-turn storage in the median.
9. Central Island. Figure 37-3.K illustrates the central island that should be used on the crossroad.
10. Offset Turning Movements. To allow ease of movements for left-turns, the separation between opposing left-turning vehicles on the crossroad should be at least 10 ft (3.0 m).
11. Right-Turn Lanes. Ensure the right-turn lanes on the exit ramps are of sufficient length to allow right-turning vehicles to bypass the queue of left-turning vehicles on the ramp.

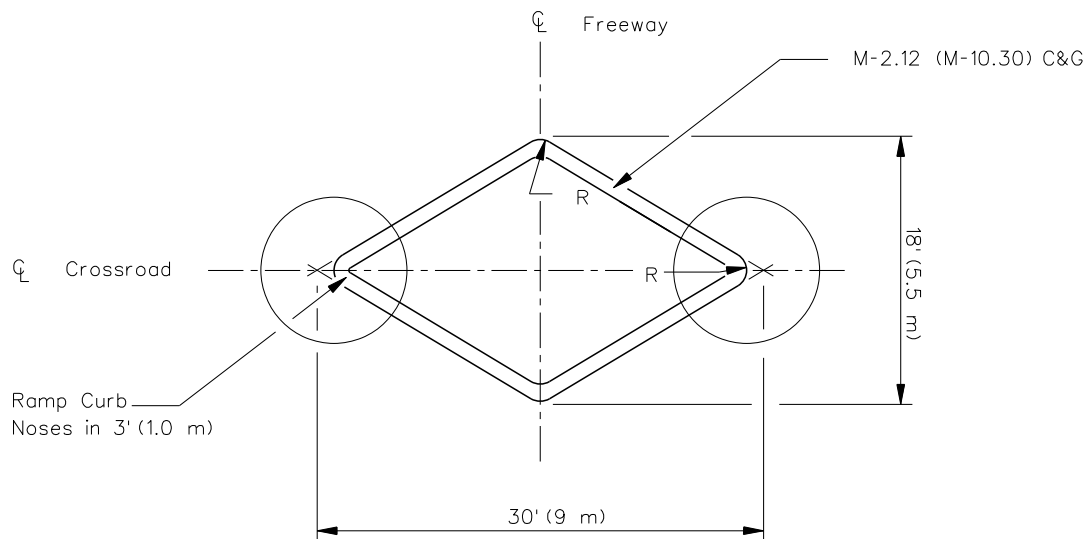

Note: $R = 3 \text{ ft (1.0 m)}$ to edge of pavement.

**DIAMOND ISLAND ON CROSSROAD
(Single-Point Urban Diamond Interchange)**

Figure 37-3.K

12. **Traffic Control Devices.** To eliminate confusion at the SPUI, proper exit ramp guide signing, pavement markings, and lane-use signing must be included to provide the necessary positive guidance through the intersection. Contact the Bureau of Operations for the applicable signing and pavement marking criteria.
13. **Traffic Signal Placement.** When determining signal locations, consider the following:
 - Due to possible lane confusion, mount signal heads directly over the travel lanes.
 - For overpass SPUI's, mount vertical signal heads outside the structure; see Figure 37-3.J.
 - The visibility of the signal heads controlling the exit-ramp left-turning movements is critical. An additional signal for advance notice may be required within the large triangular island.
 - A "pull-through" signal on the opposite island may be required where travel distances through the intersection are relatively long.
 - Contact the Bureau of Operations for the design of all signal installations.

37-3.06 Full Cloverleafs

37-3.06(a) General

Cloverleaf interchanges are used at four-leg intersections and employ loop ramps to accommodate left-turn movements. Full cloverleaf interchanges are those with loops in all four quadrants; all others are partial cloverleafs and are discussed in Section 37-3.07.

Where two access-controlled highways intersect, a full cloverleaf is the minimum type of interchange design that will suffice. In addition, they also may be used at the intersection of other multilane arterials to accommodate large volumes of traffic.

The operation of a cloverleaf with high weaving volumes is greatly improved through the addition of collector-distributor (C-D) roadways; see Section 37-4.02. The C-D roadways may be advantageous in suburban areas because of the need for smaller loops. This may reduce the amount of right-of-way acquisition necessary for the development of the interchange. Although right-of-way requirements may be reduced, overall costs usually increase due to longer and wider structures and additional pavement costs.

Figure 37-3.L provides typical examples of full cloverleafs with and without C-D roads.

Some of the advantages and disadvantages of full cloverleafs include:

Advantages

- Full cloverleafs eliminate all vehicular stops through the use of free-flow terminals and they provide continuous free-flow operation on both intersecting highways.
- Full cloverleafs eliminate all at-grade intersections, eliminate left turns across traffic and, therefore, eliminate the need for traffic signals.

Disadvantages

- Because of the geometric design of loops, full cloverleafs require large amounts of right-of-way.
- They are typically more expensive than diamond interchanges due to considerably more lengths of ramps, wider structures, and the desirability of providing C-D roads.
- The loops in cloverleafs result in a greater travel distance for left-turning vehicles than do diamonds and the speeds on the ramps are generally slower.
- Exit and entrance terminals are located before and after the crossroad structure, which require additional signing to guide motorists.
- Weaving sections between loop ramps must be made long enough to provide for satisfactory traffic operations.
- Where the crossroad is an expressway or other multilane highway, considerable length of access control distance is needed along the crossroad to the first point of access.

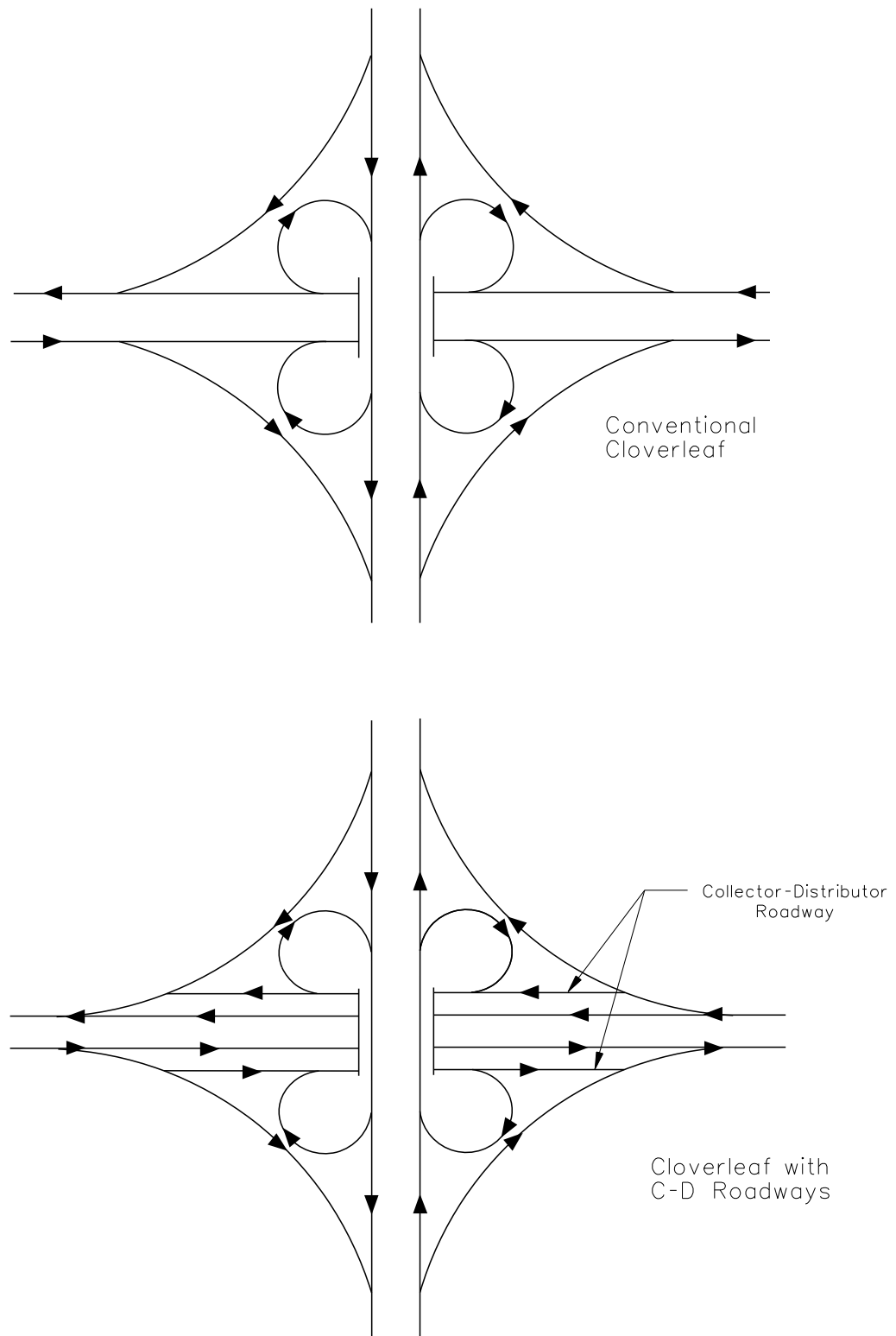

CLOVERLEAF INTERCHANGES

Figure 37-3.L

37-3.06(b) Design Considerations

Figure 37-3.M illustrates the design and layout of a typical cloverleaf interchange. In developing the cloverleaf interchange, consider the following steps:

1. Exit Gore. The first step is to locate the physical nose of the exit gore of the weaving section a minimum of three seconds of travel time at the design speed beyond the structure on each of the four interchange legs; see Figures 37-3.N.
2. Weaving Section. The second step is to determine the minimum lengths required for the weaving sections. The following will apply:
 - a. Length. Figure 37-3.N illustrates various weaving lengths based on the design speed of the highway and ramp curvature of the preceding entrance ramp and the following exit ramp. The length of the weaving section also must be determined using the *Highway Capacity Manual* (HCM) and the appropriate level of service; see Item 2b below. The minimum weaving section length will be based on the greater value from the HCM or Figure 37-3.N.
 - b. Capacity. At a minimum, the level of service of the weaving sections may be one level lower than the adjacent freeway. Desirably, the level of service should be the same as the adjacent mainline. When the total volume on the two successive ramps reaches approximately 1000 vph, interference increases rapidly with a resulting reduction of the through traffic speed. At these weaving volume levels, consider using a collector-distributor road. Section 37-4.02 discusses the use and design of collector-distributor roadways. Expected design capacities for single-lane loops range from 800 to 1200 vph. The higher figures are generally only achievable where the design speed is 30 mph (50 km/hr) or higher and few trucks use the loop.
 - c. Superelevation. Figure 37-3.N provides the superelevation criteria for a weaving section adjacent to the tangent mainline. The cross slope of the auxiliary lane between control point(s) c should not be flatter than 1/4"/ft (2%) draining toward the right edge. For mainline alignments curving to the right, control points a, b, and e are maintained as shown in Figure 37-3.N. The cross slope of the auxiliary lane between the two points labeled c should be congruent with the cross slope of the traveled way, but not greater than 5%. For alignments curving to the left, control points a and e are maintained according to Figure 37-3.N. The superelevation rate at control point b is 6%. Where the mainline is curving to the left, the crossover crown between the two points labeled c should not exceed 5%. In all cases where weaving sections are located on a curved horizontal alignment, engineering judgment will be required where the above criteria cannot be maintained.

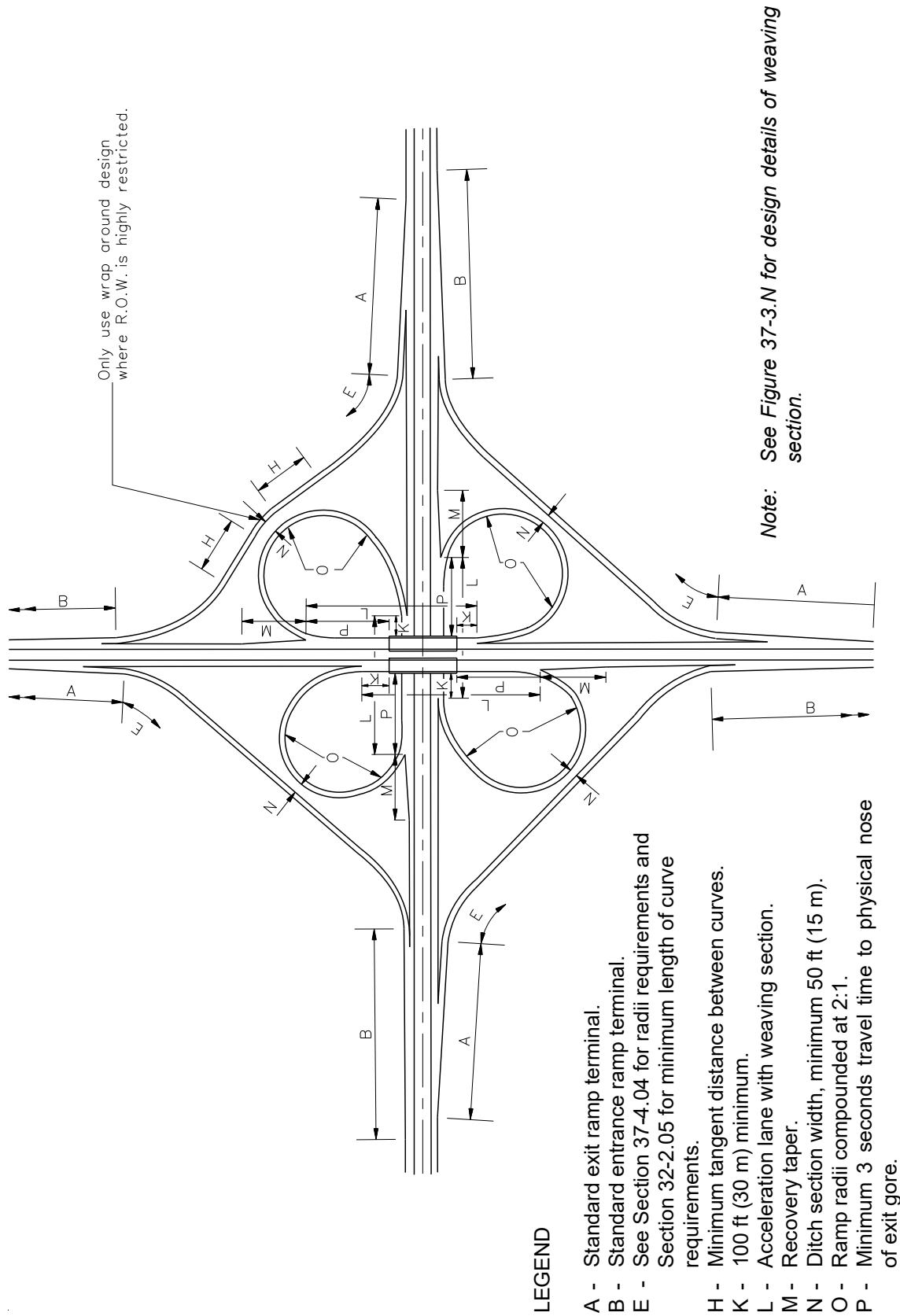

LEGEND

- A - Standard exit ramp terminal.
- B - Standard entrance ramp terminal.
- E - See Section 37-4.04 for radii requirements and Section 32-2.05 for minimum length of curve requirements.
- H - Minimum tangent distance between curves.
- K - 100 ft (30 m) minimum.
- L - Acceleration lane with weaving section.
- M - Recovery taper.
- N - Ditch section width, minimum 50 ft (15 m).
- O - Ramp radii compounded at 2:1.
- P - Minimum 3 seconds travel time to physical nose of exit gore.

CLOVERLEAF INTERCHANGE LAYOUT

Figure 37-3.M

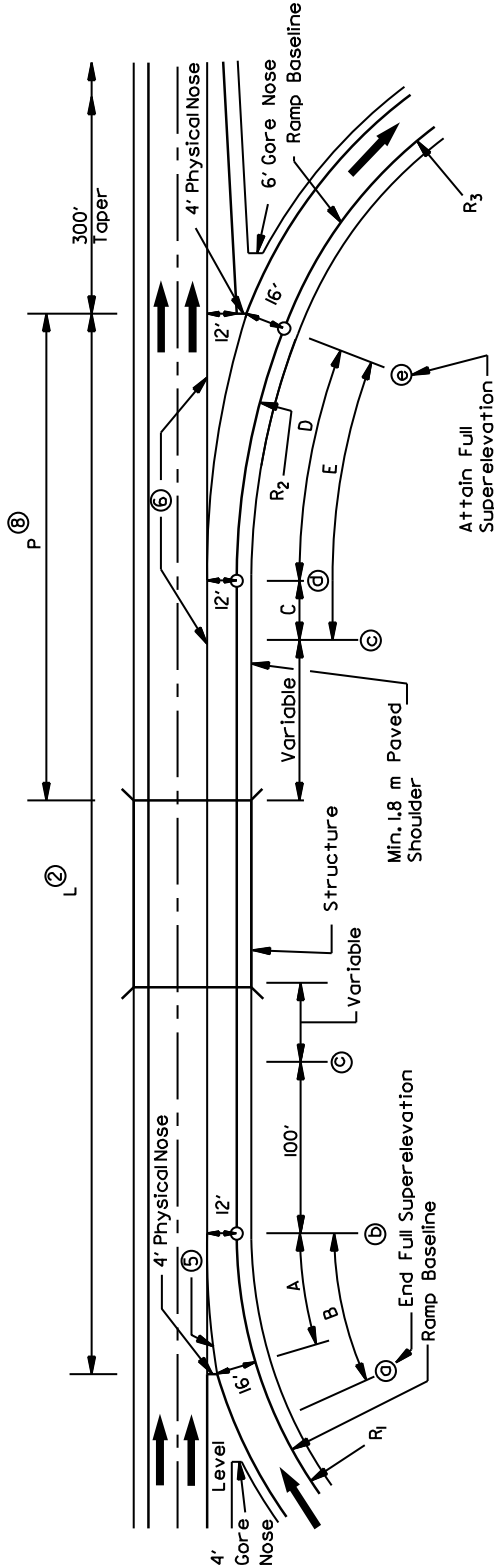

Mainline Des Spd (mph)	A (ft)	B (ft)	C (ft)	D (ft)	E (ft)	L (ft)	P (ft)	R_1 (ft)	R_2 (ft)	R_3 (ft)
75	87	100	80	160	240	650	330	758 (50 mph)	960 (55 mph)	578 (45 mph) 444 (40 mph)
70	87	100	75	150	225	750	310	587 (45 mph)	758 (50 mph)	444 (40 mph) 314 (35 mph)
60	87	100	65	130	195	650	265	444 (40 mph)	587 (45 mph)	314 (35 mph) 214 (30 mph)
50	75	90	45	90	135	550	220	314 (35 mph)	444 (40 mph)	214 (30 mph) 134 (25 mph)
40	64	85	30	60	90	550	180	214 (30 mph)	314 (35 mph)	134 (25 mph)

Elevation of Ramp Edges with Respect to Mainline Edge of Traveled Way

Elev.	Right	Left	S.E.
Ⓐ	- 1.28'	-	(8 %)
Ⓑ	- 0.72'	-	(6 %)
Ⓒ	- 0.24'	-	(2 %)
Ⓓ	- 0.48'	-	(4 %)
Ⓔ	- 1.52'	- 0.24'	(8 %)

Notes:

- For weaving sections on curved alignments, see Section 37-3.06(b).
- L must be analyzed for weaving and increased if necessary. The weaving limits, as defined in the Highway Capacity Manual, differ from the limits shown as "L" above.
- The design speed of C-D roadways must be 40 mph minimum to 50 mph maximum.
- Super-elevation transitions should not be used on structures.
- Ramp narrowing should be effected throughout the limits of "A."
- The maximum algebraic difference in slopes at the crossover crown lines should not exceed 5%.
- Radii are only used with restrictive right-of-way. Increased weave length "L" provides longer deceleration distance to accommodate the lower design speed of R_3 .
- "P" equals 3-seconds of travel distance at the design speed of the mainline.
- Refer to Section 37-4.04 for special conditions.

CLOVERLEAF INTERCHANGE
(Weaving Section) (US Customary)

Figure 37-3.N

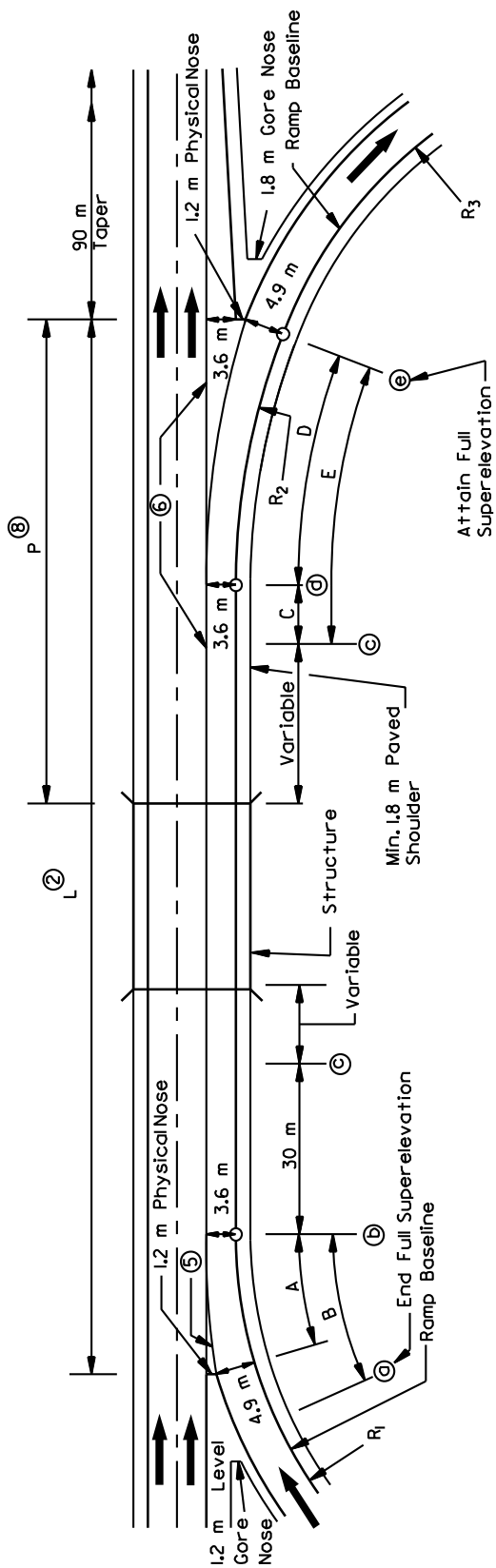

Mainline Design Speed (km/h)	A (m)	B (m)	C (m)	D (m)	E (m)	L (m)	P (m)	R ₁ (m)	R ₂ (m)	R ₃ (m)
120	27	30	24	48	72	200	100	229 (80 km/h)	304 (90 km/h)	168 (70 km/h)
110	27	30	23	46	69	200	92	170 (70 km/h)	229 (80 km/h)	140 (65 km/h)
						230		95 (55 km/h)		
100	27	30	20	40	60	200	84	140 (65 km/h)	168 (70 km/h)	95 (55 km/h)
						230		73 (50 km/h)		
80	23	28	14	28	42	170	67	95 (55 km/h)	140 (65 km/h)	73 (50 km/h)
						200		41 (40 km/h)		
60	20	26	9	18	27	170	50	73 (50 km/h)	95 (65 km/h)	41 (40 km/h)
						41				

Elev.	Elevation of Ramp Edges with Respect to Mainline Edge of Traveled Way		S.E.
	Right	Left	
Ⓐ	- 392 mm	-	(8 %)
Ⓑ	- 216 mm	-	(6 %)
Ⓒ	- 72 mm	-	(2 %)
Ⓓ	- 144 mm	-	(4 %)
Ⓔ	- 464 mm	- 72 mm	(8 %)

- Notes:
- For weaving sections on curved alignments, see Section 37-3.06(b).
 - L must be analyzed for weaving and increased if necessary. The weaving limits, as defined in the Highway Capacity Manual, differ from the limits shown as "L" above.
 - The design speed of C-D roadways must be 40 mph minimum to 50 mph maximum.
 - Superelevation transitions should not be used on structures.
 - Ramp narrowing should be effected throughout the limits of "A."
 - The maximum algebraic difference in slopes at the crossover crown lines should not exceed 5%.
 - Radii are only used with restrictive right-of-way. Increased weave length "L" provides longer deceleration distance to accommodate the lower design speed of R₃.
 - "P" equals 3-seconds of travel distance at the design speed of the mainline.
 - Refer to Section 37-4.04 for special conditions.

**CLOVERLEAF INTERCHANGE
(Weaving Section) (Metric)**

Figure 37-3.N

3. Entrance Gore. The location of the entrance gore is determined by adding the minimum weaving length to the exit gore nose location determined in Step 1. At a minimum, place the entrance gore 100 ft (30 m) before the structure and, desirably, 200 ft (60 m) before the structure; see Figure 37-3.N.
4. Inner Loops. Once the physical noses of the exit and entrance gores have been determined, the horizontal alignment between the corresponding exit and entrance gores must be determined. Circular curve loop ramps are the most desirable geometrically because speeds and travel paths tend to be more uniform. However, this is often impractical and compound curvature is generally required. The initial and final arcs of the loops may preclude using the specified radii for the design speed of the respective highways and length of the weaving sections. A third intermediate arc is then compounded with initial and final arcs. If necessary, in obtuse quadrants, two arcs may be compounded between the initial and final curves. If the intermediate arc cannot be compounded with the minimum arc lengths provided in Section 37-4.07, one or both of the adjacent weaving sections containing the loop terminals must be adjusted and the process repeated.
5. Outer Connections. Once a satisfactory inner loop design has been developed, the designer must select the appropriate outer connection design. Desirably, this will be a tangent section connected by radii at the exit and entrance terminals. In place of the tangent section, compound curves having a radius greater than the radius preceding the exit terminal may be used. In urbanized areas where right-of-way may be restricted, a “wrap around” design may be used. In this situation, the central curve of the outer connector is normally made concentric to the arc at the center of the inner loop and the selected radius should provide a minimum design speed of 40 mph (60 km/hr). Set the outer connector to provide a common drainage section between the inner loop and the outer connection. Figure 37-3.O illustrates a typical layout with a wrap-around design.

37-3.07 Partial Cloverleafs

37-3.07(a) General

Partial cloverleaf (parclo) interchanges are those with loops in one, two, or three quadrants. Several of the disadvantages listed for full cloverleafs also apply to partial cloverleafs (e.g., geometric restriction of loops). However, some specific advantages of partial cloverleafs include:

- Partial cloverleafs provide access where one or more quadrants present adverse right-of-way and/or topographic problems that preclude a typical diamond interchange.
- Partial cloverleafs may accommodate heavy left-turn traffic by means of a loop and thereby improve capacity, operations, and safety.
- Depending upon site conditions, partial cloverleafs may offer the opportunity to increase weaving distances.

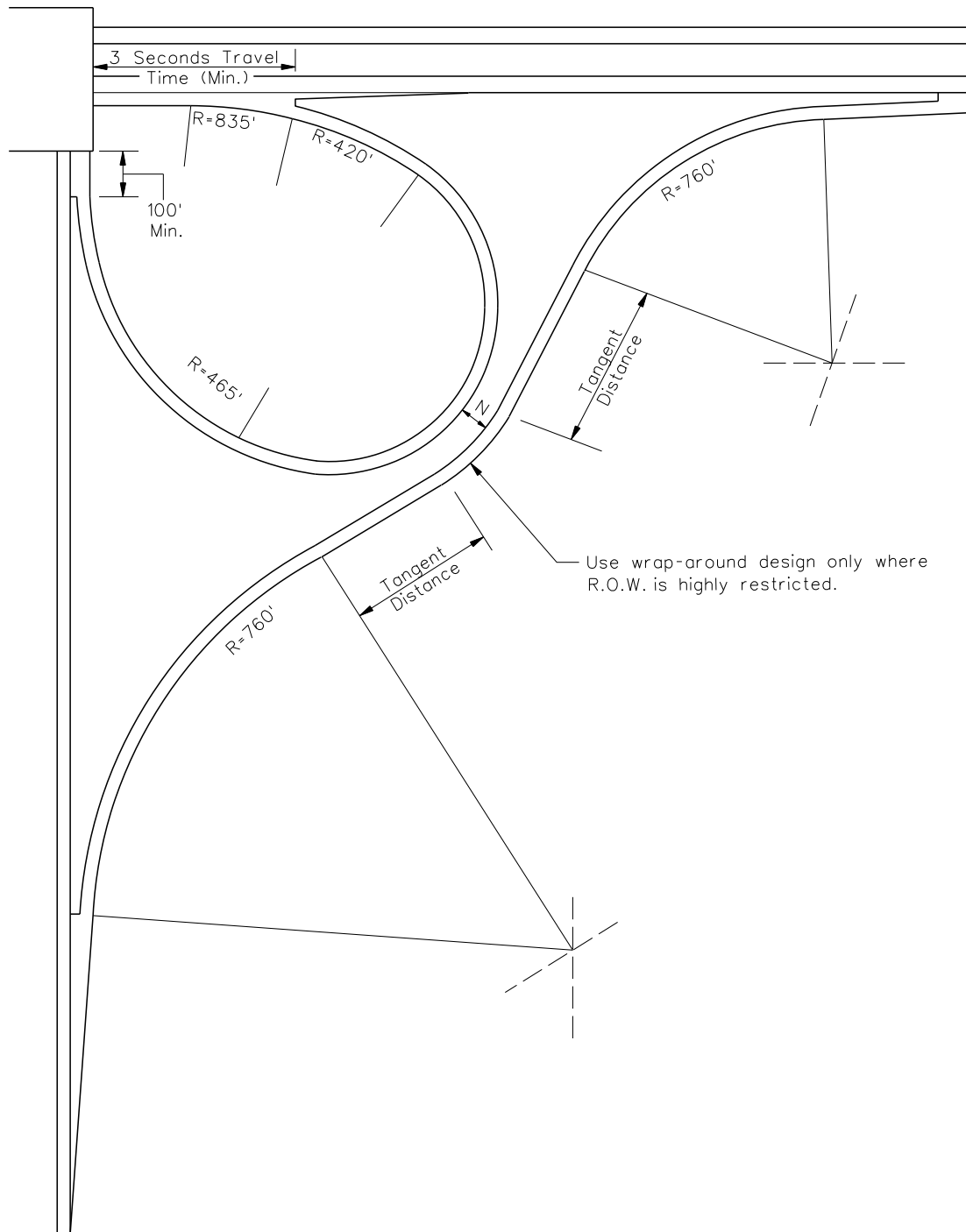

Note: Where the two ramps parallel each other, the elevations of the left edge of the outer ramp should approximately match the elevation of the inner loop ramp.

**EXAMPLE OF CLOVERLEAF QUADRANT DESIGN
(Wrap-Around Outer Ramp)**

Figure 37-3.0

Partial cloverleaf designs can be segregated into the two-quadrant and four-quadrant partial cloverleaf. These are further explained as follows:

1. Two-Quadrant Partial Cloverleaf Interchanges. The two-quadrant partial cloverleaf interchange is normally used at those locations where cultural or natural features restrict the development of the diamond interchange. The two-quadrant partial interchanges Type A (Figure 37-3.P) and Type B (Figure 37-3.Q) are used where right-of-way and/or construction is precluded in opposite quadrants of the interchange. The two-quadrant partial interchange Type C (Figure 37-3.R) is used at intersections where additional structures or extensive relocation of the crossroad would be required to develop the diamond interchange (e.g., adjacent to rivers, railroads).

The operations of the two-quadrant partial interchanges can be further defined as follows:

- a. Type A. Both the exit and entrance terminals are located in advance of the structure and two channelized “T” intersections are formed on the crossroad. This arrangement reduces the probability of wrong-way movements. However, all turning movements from the crossroad must undergo a “reverse” operation; i.e., drivers traveling to the right must turn left and those traveling to the left must turn right.
 - b. Type B. Because the “T” intersections allow normal operations for turning movements from the crossroad, the probability of wrong-way movements are greatly reduced. The exit terminals are located beyond the structure and, due to the lower design speed on the loop ramp, drivers tend to decelerate more on the mainline through lanes in advance of the exit.
 - c. Type C. No uniform pattern of operation is realized because traffic on the freeway exits in advance of the structure in one direction and beyond the structure in the other. Movements to the right or left from the crossroad are made by turning to the right for one direction and by turning left for the opposite direction. Consequently, channelization of the crossroad, with separate left-turn lanes is essential for proper operation.
2. Four-Quadrant Partial Cloverleaf Interchange. Figures 37-3.S and 37-3.T illustrate the Type A and Type B four-quadrant partial interchanges, respectively. The four-quadrant partial interchange is used to provide for higher traffic volumes than the conventional diamond through the elimination of left-turning traffic at the crossroad ramp terminals.

Although there is a mixture of free-flowing and controlled terminals on the crossroad, there is little operational difficulty because the relative turning volumes and the arrangement of the ramp designs are compatible. Of the two types, Type A is probably more desirable, because it eliminates all conflicting left-turns from the crossroad.

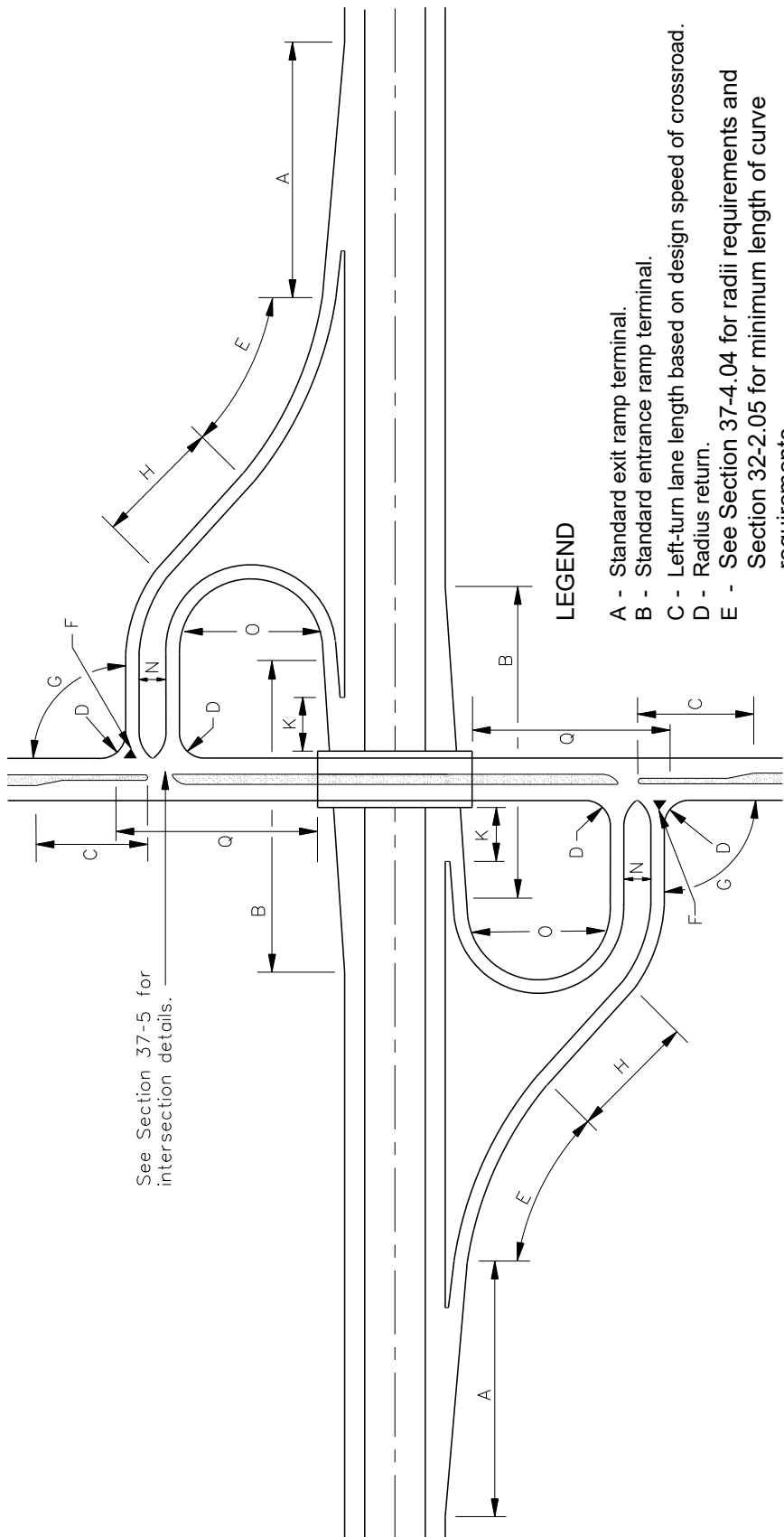

See Section 37-5 for intersection details.

LEGEND

- A - Standard exit ramp terminal.
- B - Standard entrance ramp terminal.
- C - Left-turn lane length based on design speed of crossroad.
- D - Radius return.
- E - See Section 37-4.04 for radii requirements and Section 32-2.05 for minimum length of curve requirements.
- F - Directional corner island. See Section 36-2.02.
- G - Typically 90 degrees.
- H - Minimum tangent distance between curves.
- K - 100 ft (30 m) minimum.
- N - Ditch section width, minimum 50 ft (15 m).
- O - Ramp radii compounded at 2:1.
- Q - Minimum distance between structure and exit ramp based on intersection sight distance.

Note: Where the two ramps parallel each other, the elevations of the left edge of the outer ramp should approximately match the left edge elevations of the inner loop ramp.

PARTIAL CLOVERLEAF INTERCHANGE LAYOUT (Two-Quadrant - Type A)

Figure 37-3.P

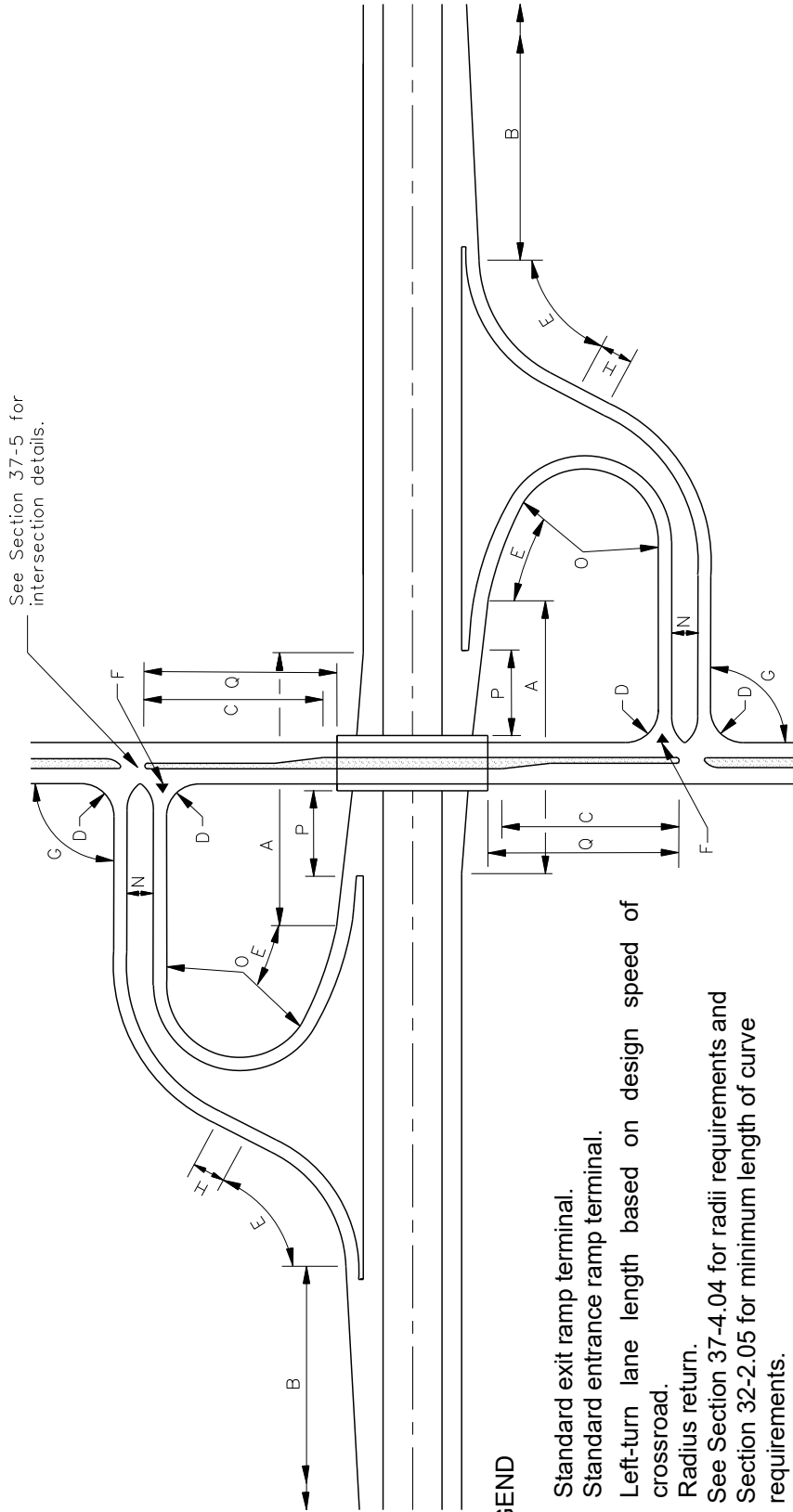

LEGEND

- A - Standard exit ramp terminal.
- B - Standard entrance ramp terminal.
- C - Left-turn lane length based on design speed of crossroad.
- D - Radius.
- E - Radius return.
- F - See Section 37-4.04 for radii requirements and Section 32-2.05 for minimum length of curve requirements.
- G - Directional corner island. See Section 36-2.02.
- H - Typically 90 degrees.
- N - Minimum tangent distance between curves.
- O - Ditch section width, minimum 50 ft (15 m).
- P - Ramp radii compounded at 2:1.
- Q - Minimum 3 seconds travel time at design speed of mainline to physical nose.

**PARTIAL CLOVERLEAF INTERCHANGE LAYOUT
(Two-Quadrant – Type B)**

Figure 37-3.Q

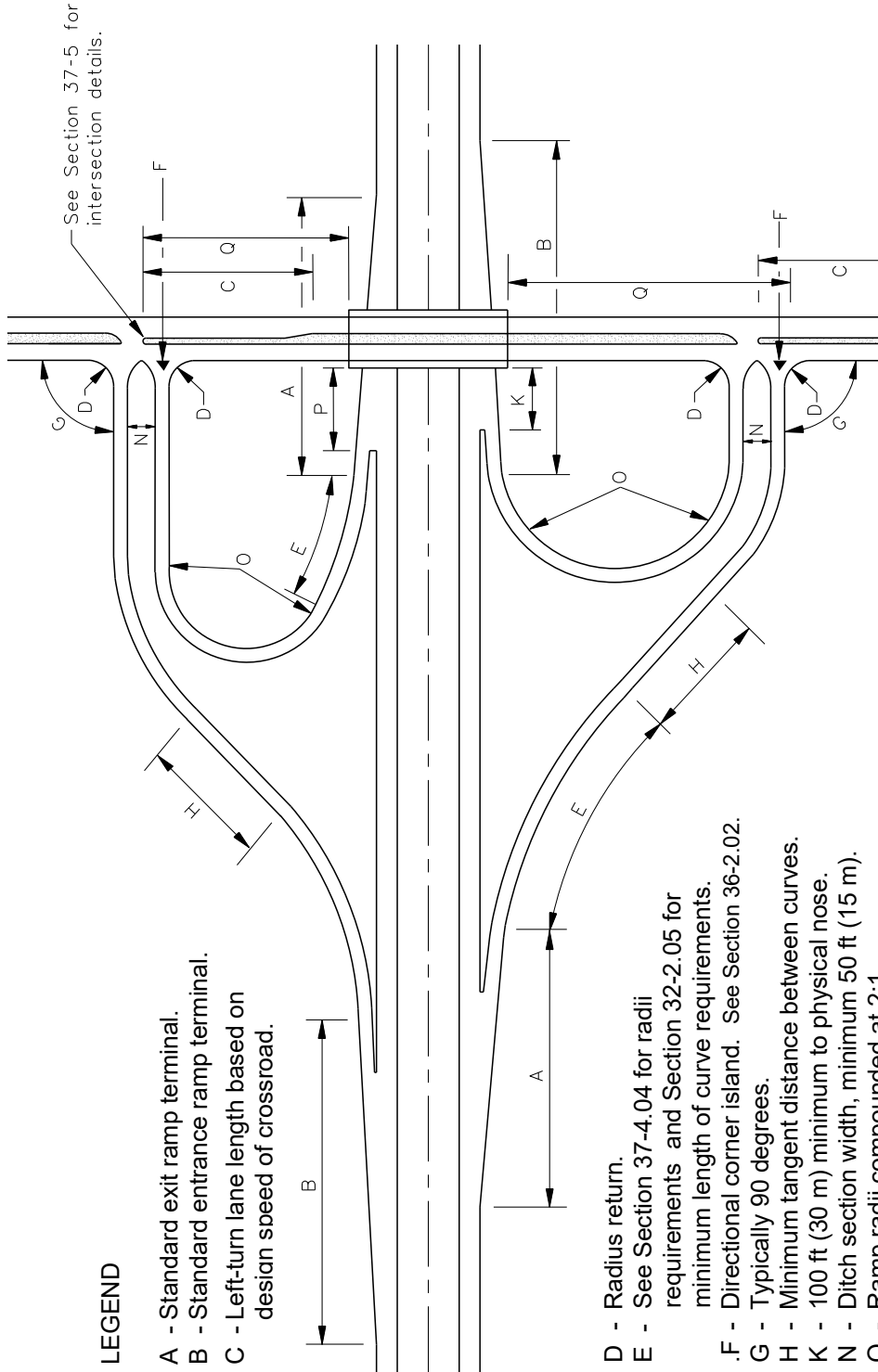

LEGEND

- A - Standard exit ramp terminal.
- B - Standard entrance ramp terminal.
- C - Left-turn lane length based on design speed of crossroad.

- D - Radius return.
- E - See Section 37-4.04 for radii requirements and Section 32-2.05 for minimum length of curve requirements.
- F - Directional corner island. See Section 36-2.02.
- G - Typically 90 degrees.
- H - Minimum tangent distance between curves.
- K - 100 ft (30 m) minimum to physical nose.
- N - Ditch section width, minimum 50 ft (15 m).
- O - Ramp radii compounded at 2:1.
- P - Minimum 3 seconds travel time at design speed of mainline to physical nose.
- Q - Minimum distance between structure and exit ramp based on intersection sight distance.

Note: Where the two ramps parallel each other, the elevations of the left edge of the outer ramp should approximately match the left edge elevations of the inner loop ramp.

PARTIAL CLOVERLEAF INTERCHANGE LAYOUT
(Two-Quadrant – Type C)

Figure 37-3.R

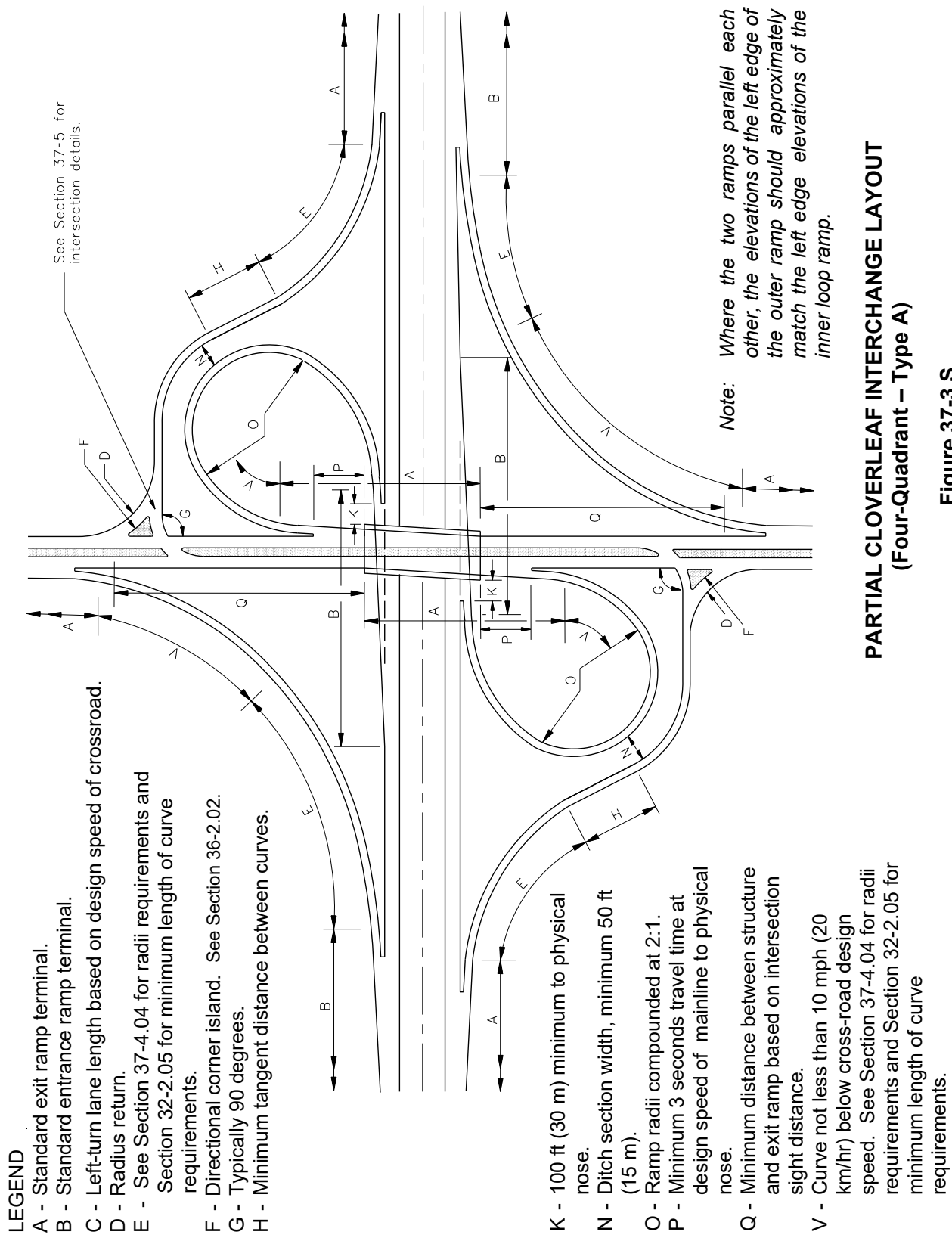

LEGEND

- A - Standard exit ramp terminal.
- B - Standard entrance ramp terminal.
- C - Left-turn lane length based on design speed of crossroad.
- D - Radius return.
- E - See Section 37-4.04 for radii requirements and Section 32-2.05 for minimum length of curve requirements.
- F - Directional corner island. See Section 36-2.02.
- G - Typically 90 degrees.
- H - Minimum tangent distance between curves.

- K - 100 ft (30 m) minimum to physical nose.
- N - Ditch section width, minimum 50 ft (15 m).
- O - Ramp radii compounded at 2:1.
- P - Minimum 3 seconds travel time at design speed of mainline to physical nose.
- Q - Minimum distance between structure and exit ramp based on intersection sight distance.
- V - Curve not less than 10 mph (20 km/hr) below cross-road design speed. See Section 37-4.04 for radii requirements and Section 32-2.05 for minimum length of curve requirements.

Note: Where the two ramps parallel each other, the elevations of the left edge of the outer ramp should approximately match the left edge elevations of the inner loop ramp.

**PARTIAL CLOVERLEAF INTERCHANGE LAYOUT
(Four-Quadrant – Type A)**

Figure 37-3.S

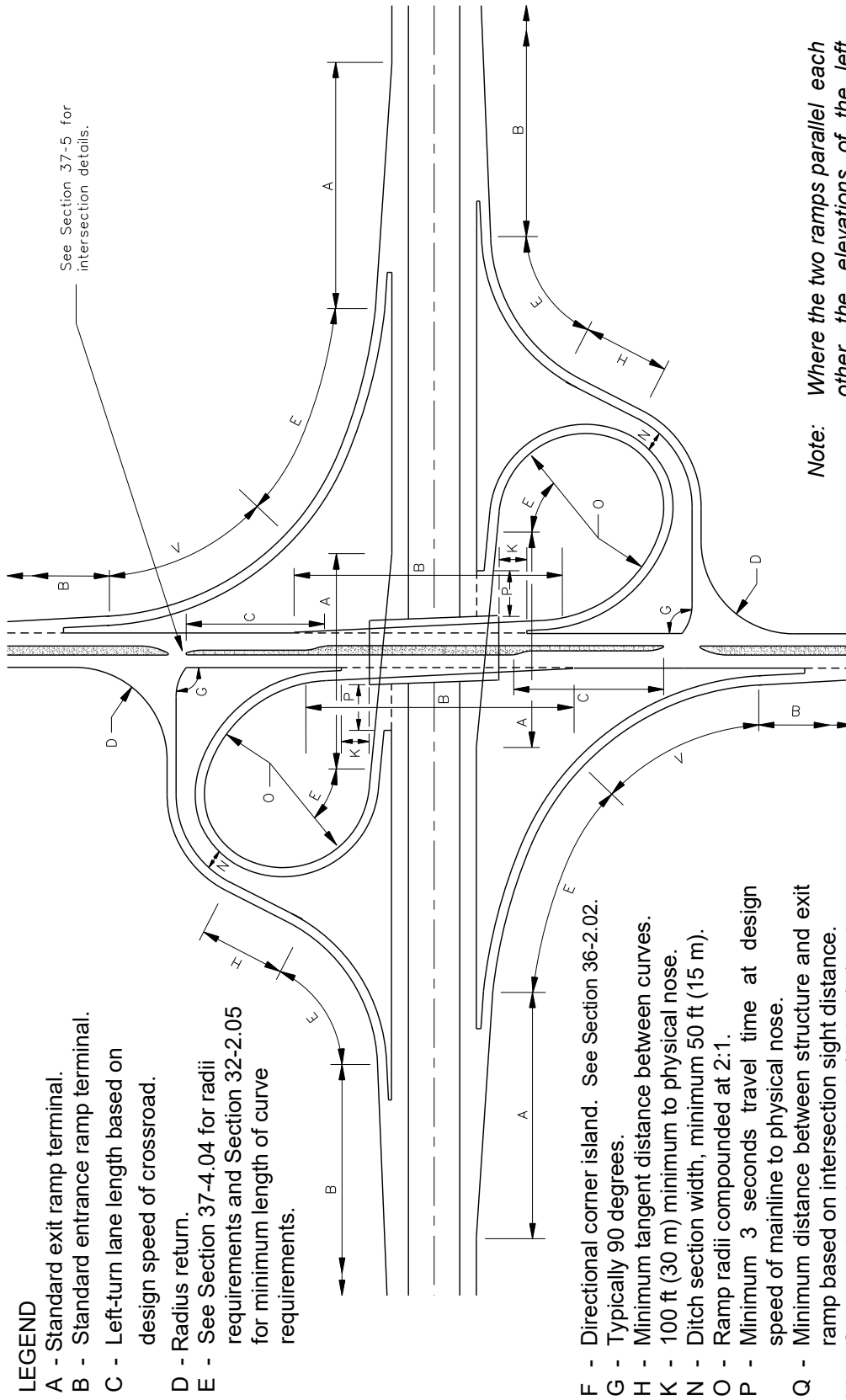

LEGEND

- A - Standard exit ramp terminal.
- B - Standard entrance ramp terminal.
- C - Left-turn lane length based on design speed of crossroad.
- D - Radius return.
- E - See Section 37-4.04 for radii requirements and Section 32-2.05 for minimum length of curve requirements.

- F - Directional corner island. See Section 36-2.02.
- G - Typically 90 degrees.
- H - Minimum tangent distance between curves.
- K - 100 ft (30 m) minimum to physical nose.
- N - Ditch section width, minimum 50 ft (15 m).
- O - Ramp radii compounded at 2:1.
- P - Minimum 3 seconds travel time at design speed of mainline to physical nose.
- Q - Minimum distance between structure and exit ramp based on intersection sight distance.
- V - Curve not less than 10 mph (20 km/hr) below crossroad design speed. See Section 37-4.04 for radii requirements and Section 32-2.05 for minimum length of curve requirements.

Note: Where the two ramps parallel each other, the elevations of the left edge of the outer ramp should approximately match the left edge elevations of the inner

**PARTIAL CLOVERLEAF INTERCHANGE LAYOUT
(Four-Quadrant – Type B)**

Figure 37-3.T

37-3.07(b) Two-Quadrant Parclo Interchange

Figures 37-3.P, 37-3.Q, and 37-3.R provide the general design and layout criteria for Type A, Type B, and Type C parclo cloverleafs, respectively. During the layout and design of the two-quadrant partial cloverleaf, consider the following steps:

3. Ramp/Crossroad Intersection Location:

- a. Type A. Place the physical nose of the standard entrance terminal a minimum of 100 ft (30 m) upstream from the structure. Design the smallest loop radius with a 30 mph or 40 mph (50 km/hr or 60 km/hr) design speed in rural areas and 25 mph or 30 mph (40 km/hr or 50 km/hr) design speed in urban areas. Project a tangent line from the loop radius to intersect with the crossroad at approximately 90 degrees. This procedure sets the location of both ramps and the location for the beginning of the left-turn lane on the crossroad. Check the intersection sight distance at the intersection of the exit ramp with the crossroad back to the left along the crossroad; see Section 36-6.
 - b. Type B. Place the physical nose of the exit terminal three seconds of travel time beyond the structure. Design the smallest loop radius with a 30 mph to 40 mph (50 km/hr or 60 km/hr) design speed in rural areas and 25 mph or 30 mph (40 km/hr or 50 km/hr) design speed in urban areas. Project a tangent line from the loop radius to intersect with the crossroad at approximately 90 degrees. Layout the location of the left-turn lane on the crossroad to fit into the intersection of the entrance ramp. Check the intersection sight distance at the intersection of the exit ramp with the crossroad back to the right along the crossroad; see Section 36-6.
 - c. Type C. The ramp/crossroad intersections for a Type C parclo are located in the same manner as the respective terminals for Types A and B.
4. Loop Ramps. For Type A parclos, the radii of succeeding arcs should increase in the direction of travel so that the traffic may enter the mainline highway at a reasonably high operating speed. For Type B parclos, the radii of succeeding arcs should decrease at a ratio of 2:1, with the arc of the sharpest curve being located immediately before the tangent section of the ramp.
 5. Outer Connections. The tangent portions of the outer connectors are set parallel to the tangent portions of the loop ramps and are separated by a 50 ft (15 m) median. This width provides for a suitable common drainage section and minimizes headlight glare from opposing traffic. The remaining portion of the outer connection is developed concentric with the loop ramp and then follows a line approximately 45 degrees in relationship to the mainline. The intervening tangent length between the reverse curves should be no less than the sum of 67% of the two superelevation runoff lengths.

37-3.07(c) Four-Quadrant Parclo Interchange

Figures 37-3.S and 37-3.T illustrate the typical design and layout criteria for four-quadrant partial cloverleaf interchange Types A and B. The design procedures for the four-quadrant parclo are similar to those for the cloverleaf and the corresponding two-quadrant parclo. The loop ramps are designed in the same manner as those of the cloverleaf. However, because they use the standard entrance and exit terminals rather than the weaving section terminals, the loops are smaller than the conventional cloverleaf loops. The outer connectors are designed in the same manner as those of the two-quadrant parclo interchange.

Provide a common drainage section between the outer connectors and the free-flow loops and set the tangent approach to the crossroad to intersect the crossroad at approximately 90 degrees. The right-turn free-flow directional ramps located in opposite quadrants consist of compound circular arcs where the adjacent radii should not exceed a ratio of 2:1. The standard exit and entrance terminals of the directional ramps are located a certain minimum distance from the intersection of the outer connections with the crossroad. These features are illustrated in Figures 37-5.K and 37-5.L.

37-3.08 Trumpet Interchange

37-3.08(a) General

The trumpet type interchanges, illustrated in Figures 37-3.U and 37-3.V, are examples of three-leg interchanges where three of the turning movements are accommodated with directional or semi-directional ramps and one movement by a loop ramp.

Trumpet Types A and B are used primarily:

- at intersections with non-freeway spur connections or routes which are terminated at the freeway,
- at intersections with other highways which are contiguous with the freeway for a short distance and then diverge on their own alignment, or
- where future expansion to the unused quadrant is not practical or likely.

They are typically limited to intermediate traffic volumes that can be accommodated by single-lane ramps.

The “bell” of the trumpet is normally oriented to favor the predominant turning movements. Where the volume of traffic exiting from the freeway exceeds the volume entering from the minor highway, use the trumpet Type A. Where the volume entering from the minor highway exceeds the volume exiting from the freeway, use the trumpet Type B. Where the entering and exiting volumes are comparable, the trumpet Type A is preferred due to its better operational characteristics.

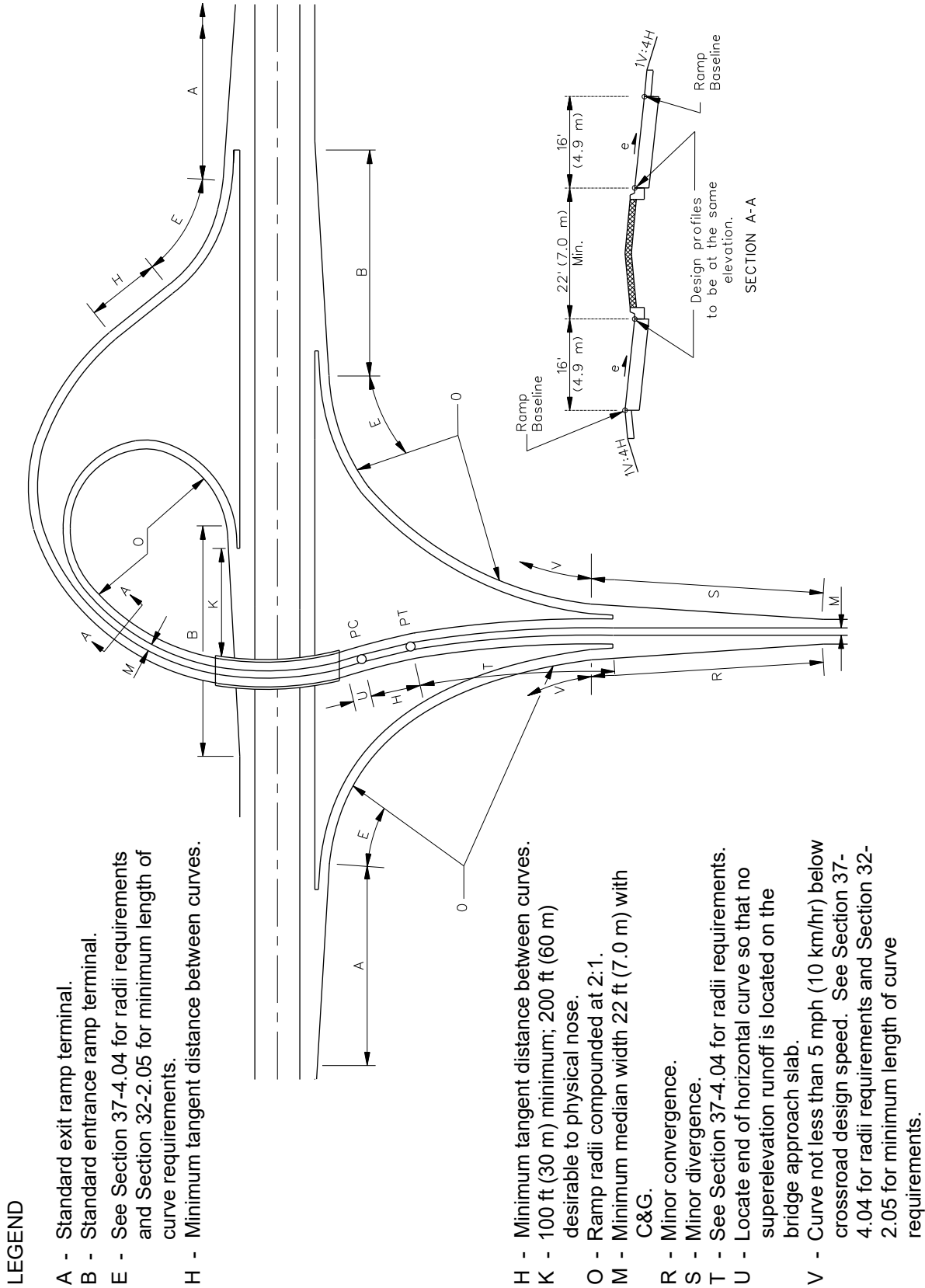

LEGEND

- A - Standard exit ramp terminal.
- B - Standard entrance ramp terminal.
- E - See Section 37-4.04 for radii requirements and Section 32-2.05 for minimum length of curve requirements.
- H - Minimum tangent distance between curves.

- H - Minimum tangent distance between curves. 100 ft (30 m) minimum; 200 ft (60 m) desirable to physical nose.
- K - Ramp radii compounded at 2:1.
- M - Minimum median width 22 ft (7.0 m) with C&G.
- R - Minor convergence.
- S - Minor divergence.
- T - See Section 37-4.04 for radii requirements.
- U - Locate end of horizontal curve so that no super-elevation runoff is located on the bridge approach slab.
- V - Curve not less than 5 mph (10 km/hr) below crossroad design speed. See Section 37-4.04 for radii requirements and Section 32-2.05 for minimum length of curve requirements.

**TRUMPET INTERCHANGE LAYOUT
(Type A)**

Figure 37-3.U

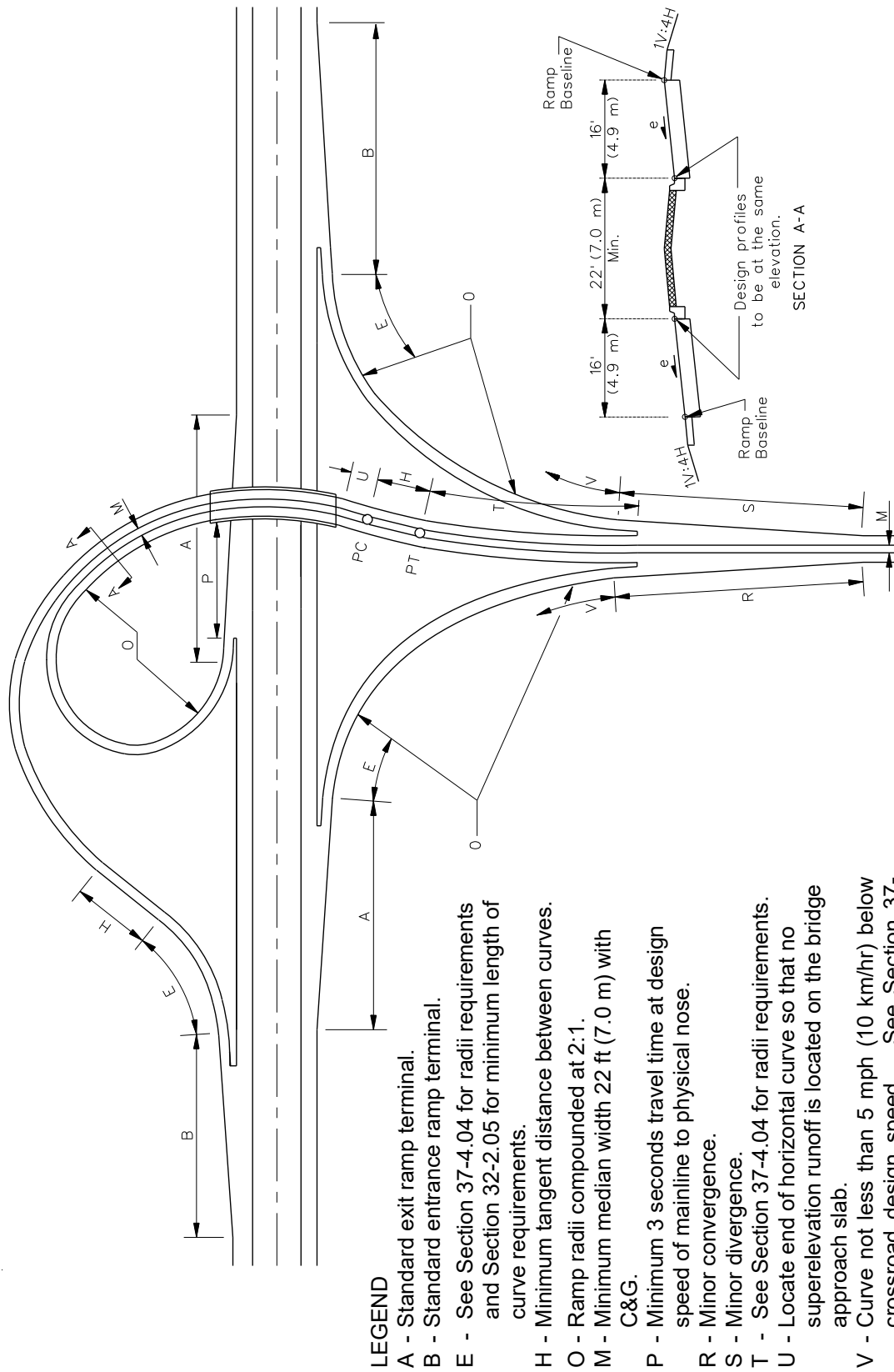

LEGEND

- A - Standard exit ramp terminal.
- B - Standard entrance ramp terminal.
- E - See Section 37-4.04 for radii requirements and Section 32-2.05 for minimum length of curve requirements.
- H - Minimum tangent distance between curves.
- O - Ramp radii compounded at 2:1.
- M - Minimum median width 22 ft (7.0 m) with C&G.
- P - Minimum 3 seconds travel time at design speed of mainline to physical nose.
- R - Minor convergence.
- S - Minor divergence.
- T - See Section 37-4.04 for radii requirements.
- U - Locate end of horizontal curve so that no superelevation runoff is located on the bridge approach slab.
- V - Curve not less than 5 mph (10 km/hr) below crossroad design speed. See Section 37-4.04 for radii requirements and Section 32-2.05 for minimum length of curve requirements.

**TRUMPET INTERCHANGE LAYOUT
(Type B)**

Figure 37-3.V

37-3.08(b) Design Considerations

Figures 37-3.U and 37-3.V illustrate the design and layout criteria for Type A and Type B trumpet interchanges. Use Type A configuration where the predominate movement is left-turns from the freeway to the minor road. Use Type B configuration where the predominant movement is right turns from the freeway to the minor road.

In designing the trumpet interchange, first develop the location of the loop ramp and structure. This requires a certain amount of trial and error because the loop is a continuation of the minor highway rather than a connection to a standard entrance and exit terminal. The loop and the outer connection are placed on curved alignment as they pass over the major highway. Reverse curvature is used before the structure for operational purposes. Because the minor highway is typically carried over, full superelevation should be attained before the structure approach slab so that the structure and approach slabs may be designed with a constant superelevation rate.

The outer connector is located adjacent and parallel to the roadway of the loop ramp and the rest of the ramp is located based on the selected design speed. These directional ramps provide turning movements to and from the minor highway through the use of standard entrance and exit terminals on the freeway and minor convergence and divergence terminals on the minor highway. Design the directional ramps for right turns to and from the minor highway using compound curves and a minimum design speed of 50 mph (80 km/hr).

As shown in Figures 37-3.U and 37-3.V, the loop ramps or outer connectors do not exit from the minor highway with the standard terminals, but are a continuation of the single-lane roadways formed by the minor divergence and convergence terminals; see Figures 37-6.R and 37-6.T. Because of sight distance restrictions, due to the presence of the structure or piers and higher possible speeds on the stem approach, motorists may be confronted with an abrupt transition in speed and alignment immediately beyond the structure. To minimize these operational difficulties, place the ramps on curved alignment before passing over or under the freeway with larger radii.

37-3.09 Directional and Semi-Directional Interchanges

Directional or semi-directional ramps are used for heavy left-turn movements, to reduce travel distance, to increase speed and capacity, and to eliminate weaving. These types of connections allow an interchange to operate at a better level of service than is possible with loops. Figures 37-3.W and 37-3.X illustrate common directional and semi-directional ramps and/or roadways. Left-hand exits and entrances should be avoided.

Directional or semi-directional interchanges are most often provided in urban or suburban areas at freeway-to-freeway or freeway-to-arterial intersections. In rural areas, there is generally an insufficient traffic volume to justify the use of directional or semi-directional ramps in all quadrants. A directional interchange provides the highest possible capacity and level of service, but it is often costly to construct due to the number of structures required and amount of embankment.

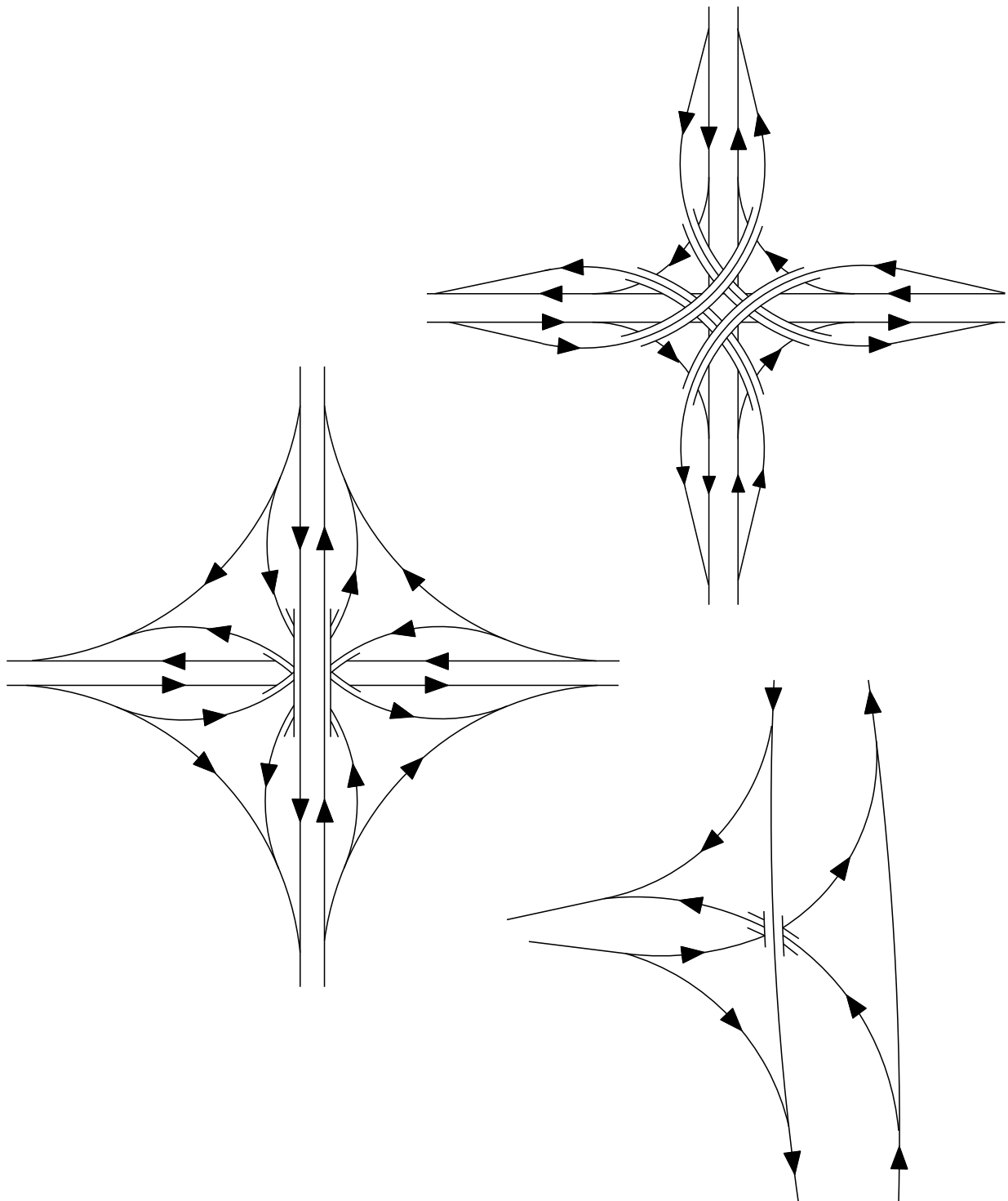

DIRECTIONAL INTERCHANGES

Figure 37-3.W

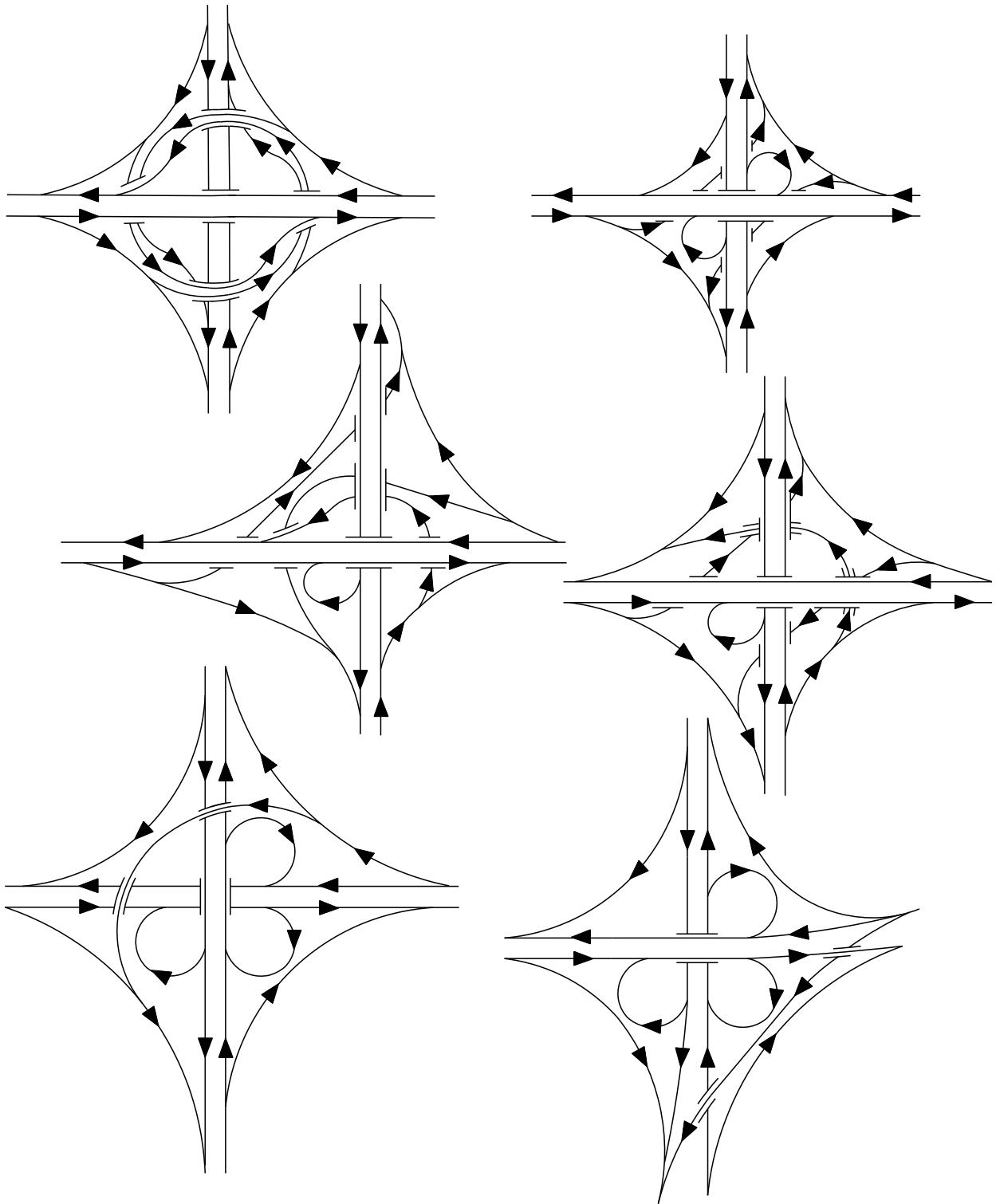

SEMI-DIRECTIONAL INTERCHANGES

Figure 37-3.X

No uniform design procedures can be established for directional or semi-directional ramps at interchanges due to the great variety of configurations. Loop ramps and weaving sections, where used, are designed as discussed in Sections 37-3.06 and 37-3.07. Because motorists perceive that higher operating speeds are possible on directional and semi-directional roadways, the alignment of these facilities should be as free flowing as practical.

37-3.10 Diverging Diamond Interchange (Double Crossover Diamond Interchange)

A diverging diamond interchange (DDI) has the basic form of a standard diamond interchange but incorporates directional crossover intersections that transpose traffic along the crossroad between the ramp terminals. DDIs thereby typically accommodate left-turning onto the on-ramps as free-flow movements and eliminate the need for left-turn signal phasing. This helps reduce overall interchange delay in comparison to other interchange types. Figure 37-3.Y shows a schematic layout of a typical DDI. Figure 37-3.Z provides more detailed information on geometry, signing, and striping of a typical DDI, and identifies some issues to consider in the design of a DDI. For additional guidance see the FHWA Report “Diverging Diamond Interchange Informational Guide” (2014) and other resources at the following FHWA website: <https://safety.fhwa.dot.gov/intersection/innovative/crossover/>.

37-3.10(a) General

Within certain contexts and project constraints DDIs can offer improved traffic-carrying capabilities, safer operations, and reduced right-of-way needs in comparison to other interchange designs. Some DDI advantages and disadvantages include:

Advantages:

- By separating the crossroad left-turn movements from the signalized intersection operations overall delay can be reduced, since the two-phase signal operations can minimize lost time per cycle. Where left-turning movements are high the operational advantages can be very significant.
- Safety performance is generally improved since there are fewer conflicts points at the signalized intersections, and specific conflicts typically involved with serious crashes are eliminated, e.g. crossing movements from the off ramps. National crash modification factors (CMFs) are available through the online CMF Clearinghouse to aid in predicting DDI safety performance.
- Where shared use paths and/or sidewalks are included along the crossroad the number of conflict points between motor vehicles and non-motorized users can be reduced. Non-motorized users can also use median refuge areas to cross one direction of traffic at a time.
- The geometrics along the crossroad encourage lower traffic speeds, typically 35 mph (55 km/hr) or less, and therefore can reduce the severity of crashes that may occur.

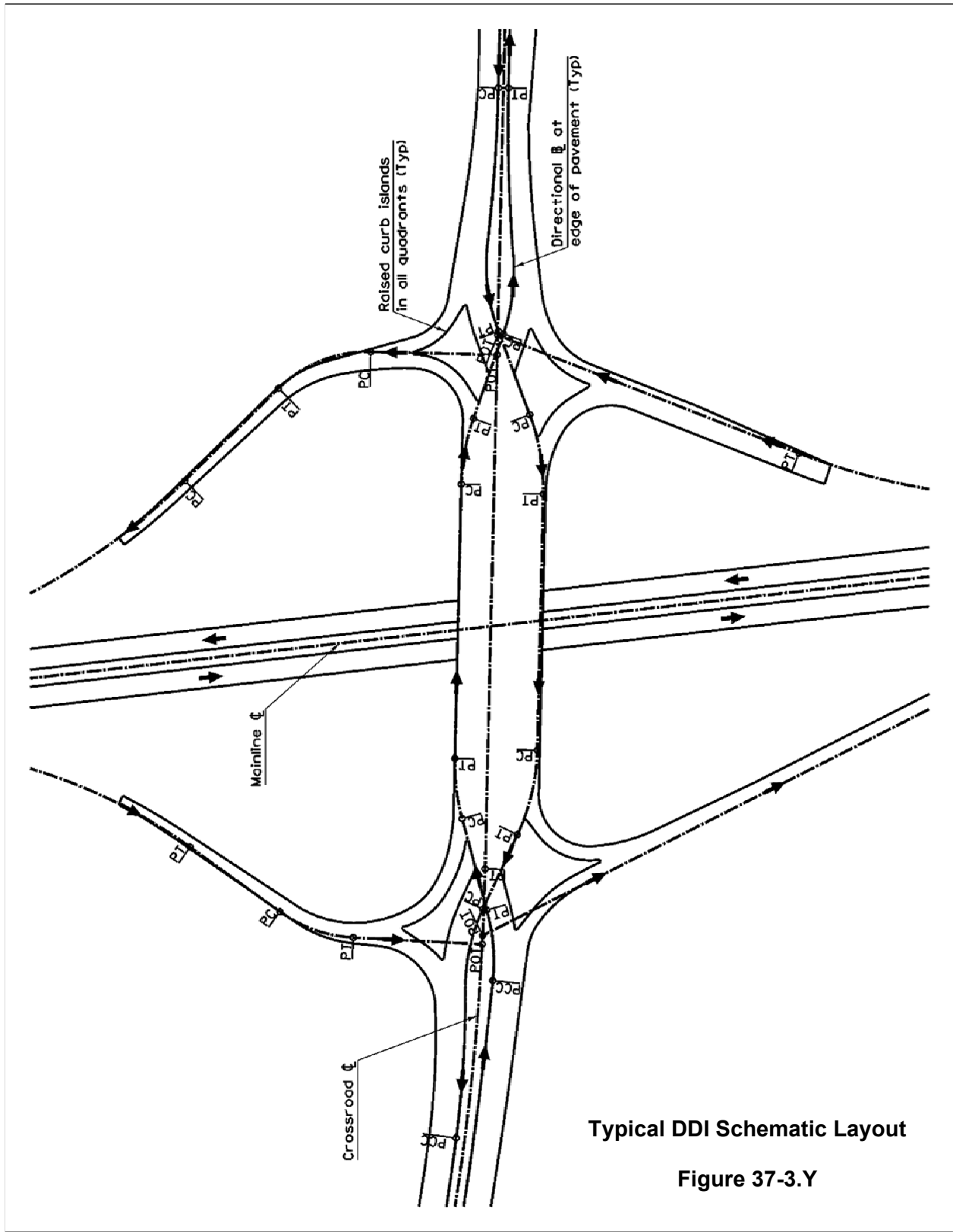

- Intersection spacing can better allow for traffic signal progression along the crossroad due to the reduced speeds.
- Because left-turning vehicles need not be queued in the median it may be possible to substantially reduce total bridge deck area, typically a major element of interchange cost.
- The flexibility in alignment options can reduce cost, allow for continued use of an existing structure, and create advantageous staging options.

Disadvantages:

- Operational concerns must be considered for unfamiliar drivers. For example, it has been observed that some drivers may look along the wrong set of lanes for approaching traffic when turning from an exit ramp. Signing and pavement marking are critical and different than for other interchange forms.
- The DDI design removes the opportunity to directly route traffic (or operational equipment) along an exit-ramp-to-entrance-ramp path. This may be considered a relevant movement for traffic incident management or the movement of permit loads.
- For lower volume locations in rural contexts, especially where there are low left-turning volumes from the crossroad, DDIs may not provide any operational or safety benefits over traditional diamond configurations.
- Where signals would not otherwise be warranted the crossings of the two directions of through traffic along the crossroad would likely create additional conflicts and delay.

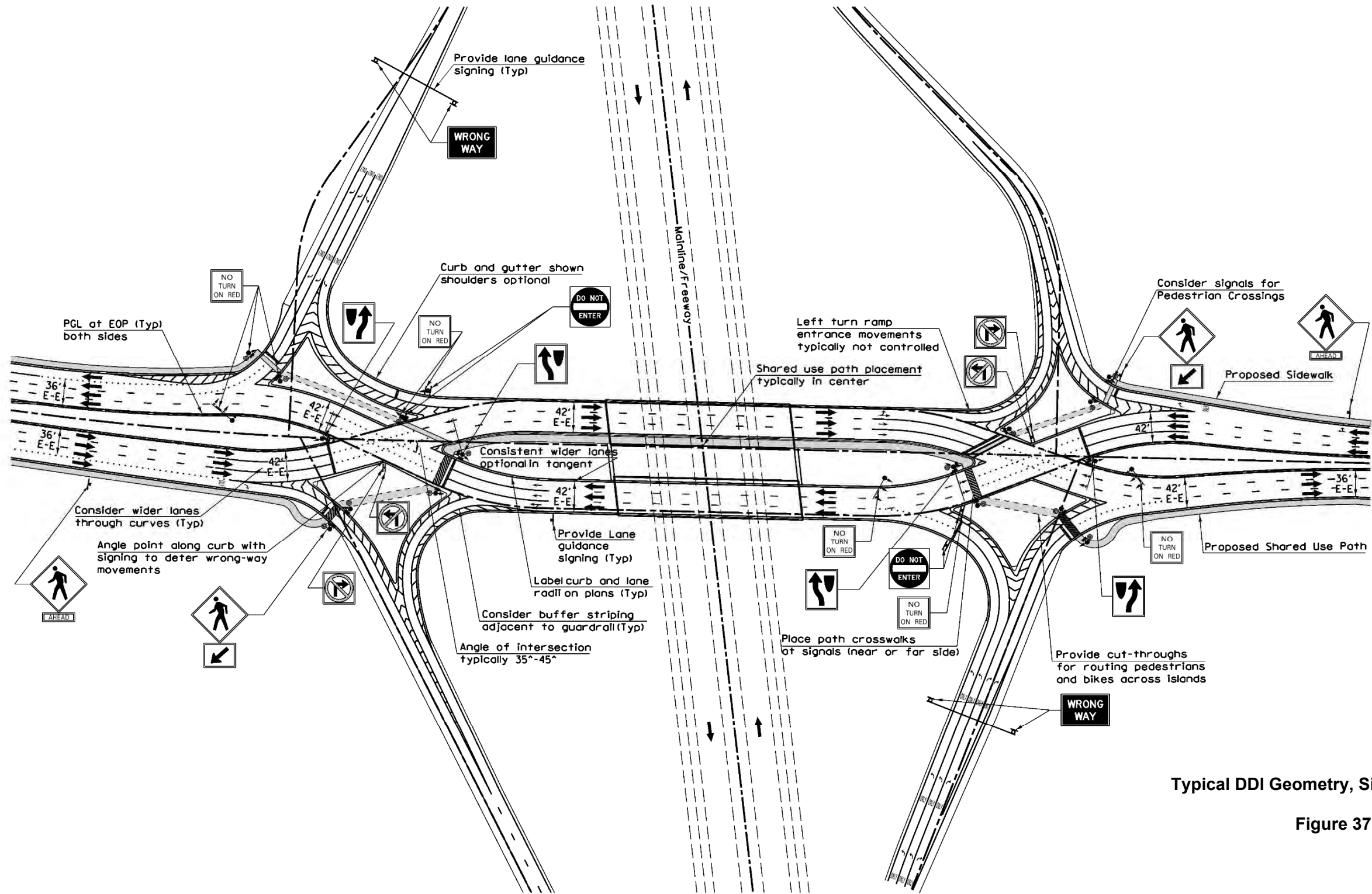

Typical DDI Geometry, Signing and Striping

Figure 37-3.Z

37-3.10(b) Design Considerations

DDI design requires consideration of issues unique to this interchange type. Consider the following when designing a DDI:

1. Over versus Under. One of the first things the designer must address is whether to place the crossroad over or under the freeway or expressway. Especially on retrofit projects, this decision is usually dictated by existing conditions. Either option is possible for a DDI. Section 44-4.02 discusses additional considerations when determining whether to place the crossroad over or under the freeway.
2. Design Speed. Design speeds for the through movements along the crossroad will typically be 35 mph (55 km/hr) or lower. Desirably, the design speed along the crossroad should be 25 mph to 35 mph (40 km/hr to 55 km/hr). The primary goal is to promote a consistent and moderate speed through the crossover intersections while reinforcing the intended movements through geometric design, signing, and pavement marking. The free-flowing left-turn movements onto the ramps may be designed for speeds of 10 mph to 20 mph (15 km/hr to 30 km/hr), with the lower end of this range being advisable for unsignalized ramp movements where pedestrian crossings may be present. The design speed of the crossroad outside of the area of influence of the interchange will typically be higher than that within the interchange, but the regulatory speed limit need not typically be lowered for the short section of roadway, and the geometry of the roadway will work to control travel speeds. Utilize W3-3 signal ahead warning signs to identify the traffic signal and, if there is a 10 mph or greater difference versus the approach, also identify the lower advisory speed.
3. Continued Use of an Existing Structure. Either a single bridge or dual bridges could be utilized for a crossroad passing over a freeway. Utilizing an existing bridge structure in the ultimate condition usually offers substantial cost advantages in comparison to a new larger structure. At retrofit locations DDIs provide inherent flexibility of alignments at lower design speeds and can provide opportunities to utilize existing structures and minimize staging and construction costs.
6. Roadway Alignment and Superelevation. Design the curves for the crossroad through movements using AASHTO Method 2 to distribute superelevation and side friction. Refer to Section 48-5.02. Open Roadway conditions (using AASHTO Method 5) may exist along the crossroad adjacent to the interchange, but drivers are expected to accept a higher driving demand through the lower-speed crossover curves. Typically limit the design superelevation rate to 2.0 percent maximum. Adverse crown slopes may be necessary at some locations due to the interactions of the two directions of travel through the intersection. It is of great importance to maintain positive drainage throughout all parts of the intersection.

Curve radii approaching the crossover intersections will usually range between 250 ft (75 m) and 600 ft (180 m). Avoid abrupt reverse curvature (i.e. a point of reverse curvature - PRC) since such designs can make it difficult for drivers of larger vehicles to stay within their lanes. Instead, provide tangent sections through the intersections where possible,

and preferably extend the tangent onto the entry approach by 15 to 25 ft (5 to 8 m). Providing a Point of Curvature (PC) immediately on the departure side of the intersection creates little concern operationally.

In retrofit projects it may be appropriate to shift the alignment of only one of the two directional travelled ways and provide an asymmetrical design. Issues to consider related to alignment include: minimizing the cross section under or over a bridge, reducing ROW requirements, meeting necessary spacing of the ramp terminals, and providing staging flexibility. The vertical alignment of the crossroad should be assessed to ensure adequate sight lines approaching the signalized crossover intersections. Refer to further discussion of Traffic Signal Placement below.

7. Intersection Crossing Angle. At each intersection, the crossover intersection angle is an important design criterion that can affect both operational and safety performance. The crossing angle is the acute angle between the two directional travelled ways, based on the tangent sections or the lines perpendicular to the radii at points of reverse curvature. Although at most traditional intersections the goal is to provide 75 to 90-degree angles, such angles are not feasible or desirable at DDI crossover intersections. This is primarily due to the large footprint and overly sharp reverse curves that would likely be required with larger angles. The preferred range for the intersection angle is 35 to 45 degrees. Lower/shallower angles may increase the risk of wrong-way movements, compromise sight lines, and require greater driver head-turn. Shallow angles also tend to make intersections overly expansive, hamper operations and make crosswalk design more challenging. Note that as the number of lanes increases beyond two each way a crossover angle of 40 to 45 degrees may be appropriate to introduce adequate median width for the shared use path.
8. Intersection Sight Distance. Provide intersection sight distance as discussed in Section 36-6, checking both the vertical and horizontal planes. The profile of the crossroad should be relatively flat to allow motorists to see the entire crossroad surface and approaches in one view. The extent of head-turn required by drivers at any proposed right-turn-on-red locations is a key consideration if such movements will be allowed. Left-turn-on-red opportunities can be unique to DDIs and require similar assessment.
9. Pedestrian and Bicycle Accommodation. DDIs often provide good opportunities for separated and comfortable pedestrian accommodations. Shared use paths are usually the best way to optimize safety and accommodate less confident bicyclists along the crossroad at minimum cost. A sidewalk and/or a shared-use path will typically be incorporated within the median between the two directions of traffic. This center location allows for crosswalks to be placed where most or all traffic can be controlled by a signal. Crossings of right-turning entrance ramp traffic will require signalization or clearly-visible uncontrolled crossing safety countermeasures.

The two-phase DDI signal operations can better serve pedestrians by providing more crossing time per phase and/or shorter cycle lengths that can reduce wait times. Crossing distances are usually shorter and pedestrians can deal with one direction of

vehicle traffic at a time. Barrier walls are typically incorporated along both sides of a median path but may not be required away from structures depending on speeds and offsets. Cut-through islands are used to provide clear and positive guidance to pedestrians near crosswalks. Bicyclists may also be accommodated directly on the roadway in the traffic lane or by provision of a bicycle lane or paved shoulder in each direction.

10. Lane Widths. Design lane widths for the crossroad through movements at DDIs based on speed, project context, and the need to accommodate the design vehicle either side-by-side or in one lane. This choice can depend on the truck volumes at the site. It is usually impractical to apply the turning roadway design criteria in Section 36-2.03 to develop the lane widths for curved crossroad through movements. Review truck and other vehicle templates with the goal of providing lanes that are adequate, yet not excessively wide. Modest curvatures may allow lane widths of 12 to 14 ft (3.6 to 4.3 m). Tighter curves, especially when heavy truck volumes are high, could warrant through lane widths of up to 15 ft (4.6 m). Lanes wider than 15 ft (4.6 m) should be avoided since they may unduly increase intersection size and could create operational issues in tangent sections. As an alternative where truck templates indicate that additional operational width may be appropriate in urban cross sections, consider adding narrow shoulders of 2 to 3 ft (600 to 900 mm) along the crossroad. Also consider providing hatched buffers along guardrail locations to help reduce nuisance hits by trucks. Section 36-2.03 and vehicle turning software may be used for ramp approach and departure design. Include hatched or chevron striping to properly guide passenger cars along ramp movements while accommodating trucks.
11. Median Width and Design. DDI median width can vary with the independent directional crossroad alignments. Since left-turn storage is not required within the median, the minimum median width between the crossovers may be based on the width of a shared use path plus barrier walls, the proposed single or twin structures (when located over the freeway or expressway), or the proposed piers (when located under the freeway or expressway). Experience in other states has indicated that the use of colored/stamped median surfaces can improve driver understanding within DDIs. It seems that the median color change leading into a DDI helps drivers perceive the unique design and better follow the provided signing and marking guidance. When a paved median surface will be used within the limits of a DDI appropriately colored/stamped median surfaces should be included in the design. Maintenance is also reduced in comparison to grass medians.
12. Shoulders and Lane Striping. Shoulder considerations are different at DDIs than at other locations because of the reversal of the two directional pavements. Because the right-side shoulder is typically considered by motorists to be the most appropriate refuge location, the median is the better side to maintain wider shoulders on rural crossroads. Such right-side shoulders would also provide continuity for bicyclists using a shoulder (or bike lane) through the interchange.

13. Traffic Control Devices. Signals will normally be warranted at DDI intersections. Installation of signals is limited to locations meeting ILMUTCD warrants. No special traffic control devices, beyond those included in the ILMUTCD, are necessary or appropriate at a DDI.

Some early national experience found that over-signing or over-marking DDIs to clarify the unusual traffic pattern could result in driver overload. Minimize potential driver confusion at a DDI by providing positive guidance to drivers in the form of exit ramp guide signing, lane use signing, and pavement markings. Consider guide and lane use signs to position drivers in appropriate lanes before entry into the interchange area. Warning signs should only be used to call driver attention to potential hazards that would be otherwise difficult to perceive. Where present, white edge lines are typically maintained on the right (median) side between intersections, based on driver familiarity. Contact the Bureau of Operations with any specific questions regarding proposed signing and pavement marking.

14. Traffic Signal Placement and Design. When determining signal head locations, proactively address the potential of lane confusion for some drivers. Mount a signal head directly over each travel lane. Consider providing supplemental near-side signal heads to reinforce the intersection traffic control, especially where alignment issues may restrict sight lines and where the maximum allowable distance from a stop line to a signal is approached. Refer to the ILMUTCD for signal head location requirements. Green arrow displays are typically recommended in lieu of circular green signal indications to further enhance directional guidance at DDI intersections. Contact the Bureau of Operations with any specific questions regarding the design of signal installations.

15. Operational Analysis. Use the *Highway Capacity Manual* (HCM) and *Highway Capacity Software* (HCS) to perform a detailed operational analysis of a DDI. Given the crossover geometry and documented DDI driver behavior, operational analysis for DDI interchanges includes several unique inputs, including those for lane utilization, saturation flow rate, lost time, and capacity of yield-controlled turns (where present). The procedures are documented in the HCM and applied in the current HCS. Note that off-ramp left- and right-turn movements may be a significant distance from the crossover, requiring longer intersection clearance (i.e. all-red) time.

Where there are existing and adjacent signals, consideration of a DDI design alternative may dictate that a comparative analysis be completed for the alternatives under consideration. Synchro or VISSIM software may be used to model corridor traffic operations for alternatives. First perform location-specific calibration of the model for the existing corridor and then compare future no-build and build alternative conditions. Default settings in the software may be used, but analysts can and should apply local adjustments based on professional judgement. Such operational analysis should include any signalized intersections within one-half mile (800 m) of the interchange.

The typical split-phasing of the signals can allow the two crossover movements to operate independently. Traffic progression along the crossroad can be favored in some periods, while prioritizing the turning movements from the ramps may sometimes be necessary to avoid queue build-up on the ramps. Corridor modeling will help identify the potential for unique issues that can occur with DDIs, such as demand starvation due to the increased efficiency of the two-phase signals.

37-3.11 Selection

Typically, several interchange types will be evaluated for potential application considering the following:

- compatibility with the highway system and functional classification of the intersecting highway;
- route continuity and uniformity with adjacent interchanges;
- level of service for each interchange element (e.g., freeway ramp terminal, ramp proper, ramp/crossroad terminal);
- operational and safety considerations (e.g., signing);
- availability of access control along the crossroad;
- road-user impacts (e.g., travel distance and time, convenience, comfort);
- driver expectancy;
- topography and geometric design;
- right-of-way impacts and availability, construction and maintenance costs, and potential for stage construction;
- accommodation of pedestrians and bicyclists on crossroad;
- environmental impacts; and
- potential growth of surrounding area.

In addition, consider the following, which will influence the selection of an interchange type:

1. Basic Types. A freeway interchange will be one of two basic types. A “systems” interchange will connect a freeway to a freeway; a “service” interchange will connect a freeway to a lesser facility.
2. Urban/Rural. In rural areas where interchanges occur relatively infrequently, the type selected is normally influenced by existing topography and environmental factors. In urban areas where restricted right-of-way and close spacing of interchanges are common, the type selection and design of the interchange may become more complex.

The operational characteristics of the crossroad and proximity of nearby interchanges must be considered when selecting and designing an urban interchange.

3. Capacity. The need for loop ramps or other free-flowing ramps may depend upon the capacity of the ramp termini to adequately accommodate the turning traffic. Conduct a capacity analysis to determine if the ramp termini will be adequate and to determine the appropriate number of approach lanes on the crossroad and ramps.
4. Movements. All interchanges should provide for all movements, even when the anticipated turning volume is low.

For certain projects it may be appropriate to evaluate alternative interchange design types by applying an Intersection Control Evaluation (ICE) analysis. ICE tools set up a performance-based framework in order to more objectively analyze alternatives while considering all users. Factors considered in ICE analyses include safety, traffic operations, non-motorized accommodations, environmental impacts, right-of-way, stakeholder and political considerations, and life-cycle costs. The ICE process can begin by assessing a wide range of alternate designs in a preliminary screening. This is followed by a secondary analysis for a short list of the best-performing alternatives. Those could, for example, be presented to project stakeholders leading to a preferred/selected design. The ICE process includes steps to define the issues (based on the project purpose and need), establish project objectives and constraints, screen and analyze alternatives for performance, and select one (or more) best-performing alternative(s). The FHWA has developed the CAP-X and SPICE tools for use by transportation agencies in performing ICE analyses. Contact the Bureau of Design and Environment when considering such an analysis for a project. Project design teams are in the end responsible for type selection and design based on the factors unique to their specific location and should use the tools that best allow them to make an effective project-specific interchange type selection.

37-4 RAMP DESIGN

37-4.01 Ramp Types

The components of a ramp include the freeway ramp terminal, the ramp proper, and a free-flow or controlled ramp terminal at the crossroad. Although ramps have varying shapes, each can be classified into one or more of the types illustrated in Figure 37-4.A and discussed in the following sections.

37-4.01(a) Loop Ramps

There are two types of loop ramps:

1. Free-Flow. The free-flow loop, Figure 37-4.A(a), consists of compounded circular arcs which turn through approximately 270 degrees. The initial and final curves of the loop are tangent to the standard exit or entrance terminal or to a weaving section, depending upon the interchange type. The free-flow loop is a standard component of the cloverleaf interchange, the four-quadrant partial cloverleaf interchange, and the trumpet interchange. Free-flow loops are designed so that the central arc is a sharper radius than that of either the initial or final arcs, or the central arc is intermediate between the two. Motorists decelerate from the speed of the through highway over the initial portion of the ramp and accelerate uniformly over the final portion of the ramp.

Avoid flatback loops or loop ramps where the central arc has a greater radius than either the initial or final arcs.

2. Controlled Terminal. Controlled terminal loops, Figure 37-4.A(b), are a component of the two-quadrant partial cloverleaf interchange. They are used most often with the standard entrance and exit terminals. Controlled terminals are provided at the intersections with the crossroad and permit both right- and left-turning movements. Wherever practical, design the angle of intersection for 90 degrees.

37-4.01(b) Diagonal Ramps

Diagonal ramps, Figure 37-4.A(c), are a component of the diamond interchange. Standard entrance and exit terminals are used on the major road, and controlled terminals are provided on the crossroad. The angle of intersection with the crossroad varies between 60 and 90 degrees; see Section 37-3.02(d).

37-4.01(c) Outer-Connector Ramps

Outer-connector ramps are in the same quadrant and to the outside of loop ramps; see Figure 37-4.A(d). They may have free-flow operation (e.g., at cloverleaf or trumpet interchanges) or have controlled operations (e.g., at partial cloverleaf interchanges).

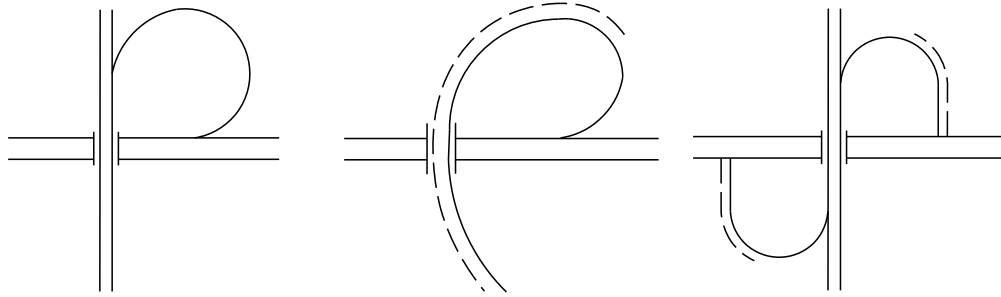

(a) FREE-FLOW LOOP RAMP

(b) CONTROLLED-LOOP RAMP

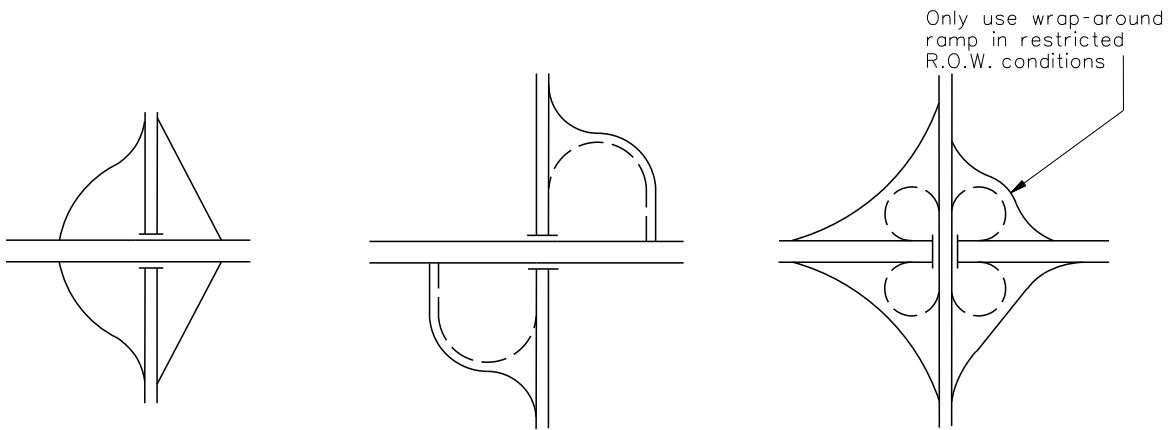

(c) DIAGONAL RAMP

(d) OUTER-CONNECTOR RAMP

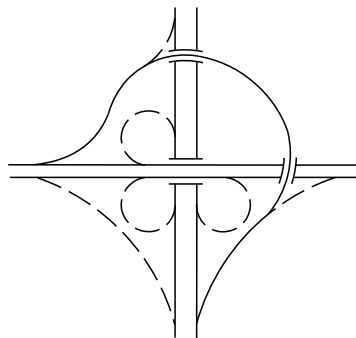

(e) SEMI-DIRECTIONAL RAMP

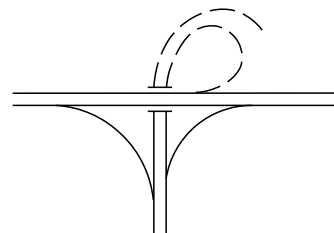

(f) DIRECTIONAL RAMP

RAMP TYPES

Figure 37-4.A

37-4.01(d) Semi-Directional Ramps

Semi-directional ramps are indirect in alignment, yet more direct than a loop ramp. These ramps are illustrated in Figure 37-4.A(e). Motorists making a left turn normally exit to the right and initially turn to the right, reversing direction before entering the intersecting highway. The outer connection of the trumpet interchange is also a semi-directional ramp.

37-4.01(e) Directional Ramps

Directional ramps do not deviate greatly from the intended direction of travel. These are illustrated in Figure 37-4.A(f) as an element of a trumpet interchange. They are also used to accommodate single lane, right-turning traffic on four-quadrant partial cloverleaves, semi-directional, and directional interchanges.

37-4.02 Collector-Distributor Roadways

37-4.02(a) Usage

A collector-distributor (C-D) roadway is an auxiliary roadway parallel to and separated from the main traveled way which serves to collect and distribute traffic from several access points. It provides greater capacity and permits higher operating speeds to be maintained on the main traveled way. C-D roadways may be provided at single interchanges, through two adjacent interchanges or, in urban areas, continuously through several interchanges. Figure 37-3.L illustrates a schematic of a C-D roadway within a full cloverleaf interchange.

Usually, interchanges designed with single exits are superior to those with two exits, especially if one exit is a loop ramp or the second exit is a loop ramp preceded by a loop entrance ramp. Whether used in conjunction with a full cloverleaf or with a partial cloverleaf interchange, the single-exit design may improve the operational efficiency of the entire interchange. C-D roadways use the single exit approach to improve the interchange operational characteristics. C-D roadways will:

- remove weaving maneuvers from the mainline and transfer them to the slower speed C-D roadways,
- provide high-speed single exits and entrances from and onto the mainline,
- satisfy driver expectancy by placing the exit before the grade separation structure,
- simplify signing and the driver decision-making process, and
- provide uniformity of exit patterns.

C-D roadways are most often warranted when traffic volumes (especially in weaving sections) are so high that the interchange cannot operate at an acceptable level of service. They also may be warranted where the speed relationship between weaving and non-weaving vehicles is significant.

37-4.02(b) Design

When designing C-D roadways, consider the following:

1. Design Speed. The design speed of a C-D roadway usually ranges from 40 to 55 mph (60 to 90 km/hr). Typically, use a design speed within 20 mph (30 km/hr) of the mainline design speed, but not exceeding 55 mph.
2. Lane Balance. Maintain lane balance at the exit and entrance points of the C-D roadways; see Section 37-2.03.
3. Width. C-D roadways may be one or two lanes, depending upon the traffic volumes and weaving conditions. C-D roadways are designed similar to ramps with traveled way widths of either 16 ft or 24 ft (4.9 m or 7.2 m).
4. Separations. The separation between the C-D roadway and mainline should be as wide as practical. Figure 37-4.B provides the minimum separation that should be provided with and without a median barrier.
5. Terminal Designs. Figure 37-4.C illustrates typical entrance terminal designs for C-D roadways. Figure 37-4.D illustrates typical exit terminal designs.

37-4.03 High-Speed Directional/Semi-Directional Roadways

High-speed directional or semi-directional roadways, like ramps, accommodate turning movements at interchange facilities, but they are distinguished from ramps in that they provide two-lane, one-way operations. These roadways are provided for large traffic movements that exceed the capacity of a one-lane ramp, for route continuity, or for improved traffic operations. For route continuity purposes, directional roadways may carry any route including expressways and freeways. These roadways are directional or semi-directional in alignment and generally have major divergence and convergence at their terminals. Design criteria for these roadways are:

1. Directional Roadways. The design speed of directional roadways, in rural areas may be 60 mph or 70 mph (100 km/hr or 110 km/hr). In urban areas, directional roadways may be designed for 50 mph, 55 mph, or 60 mph (80 km/hr, 90 km/hr, or 100 km/hr) depending on traffic volumes, right-of-way, motorist expectations, and importance of route. In all cases, the maximum superelevation rate is 6%. Shoulder widths are the same as the mainline roadway.
2. Semi-Directional Roadways. Desirably, use the criteria for directional roadways. However, use minimum design speeds, 55 mph (90 km/hr) in rural areas and 50 mph (80 km/hr) in urban areas. Where two-lane roadways are required for capacity or route continuity, the maximum superelevation rate is 6%. However, where a two-lane roadway is desirable because of the long design length of a single-lane ramp, a maximum superelevation rate of 8% may be used.

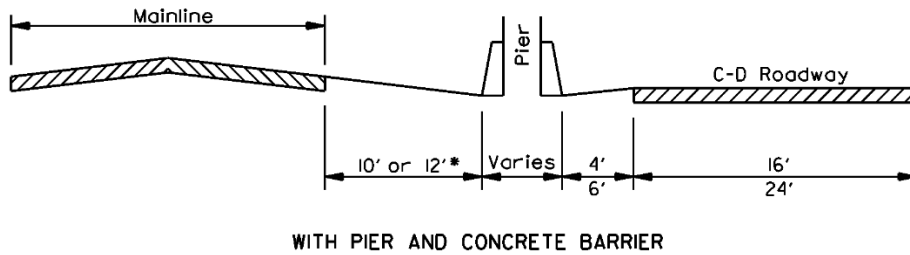
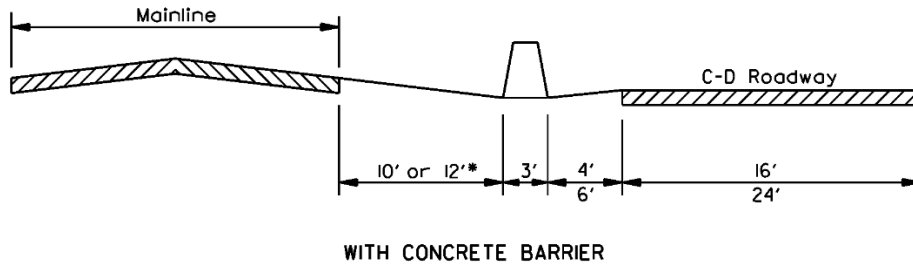
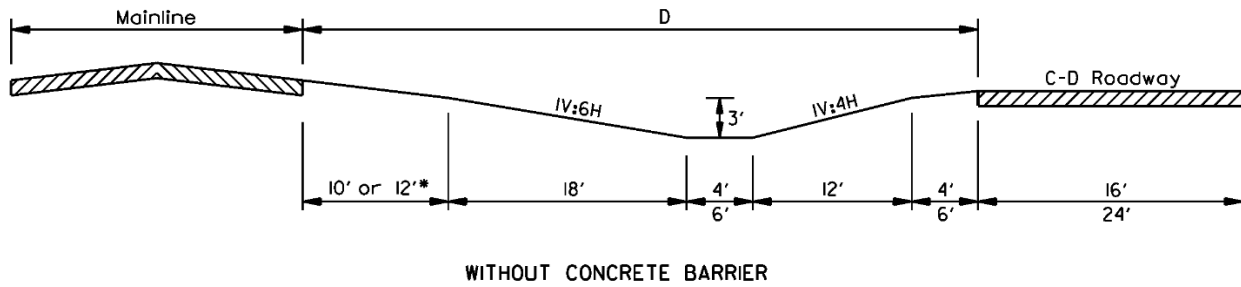

*12 ft. paved shoulders should be considered where the directional distribution of trucks exceeds 250 DDHV.

**SEPARATION WIDTH BETWEEN C-D ROADWAY AND MAINLINE
(US Customary)**

Figure 37-4.B

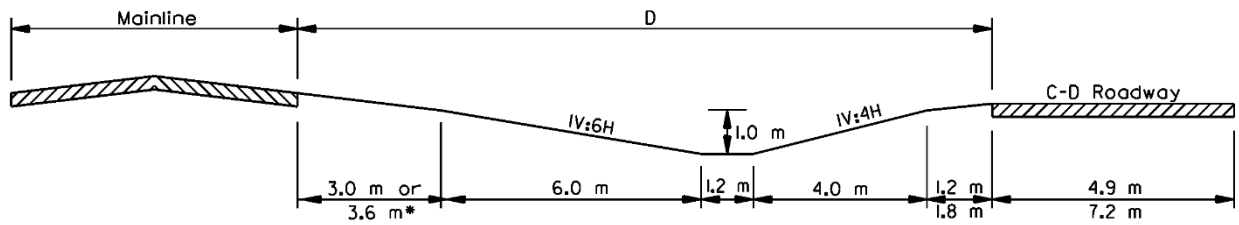

WITHOUT CONCRETE BARRIER

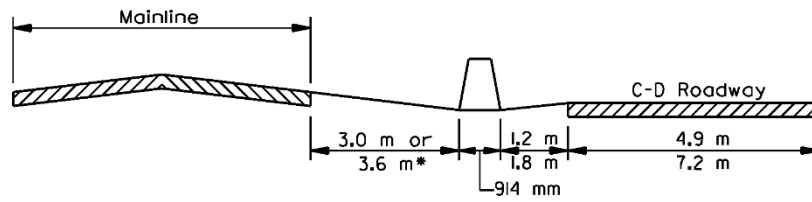

WITH CONCRETE BARRIER

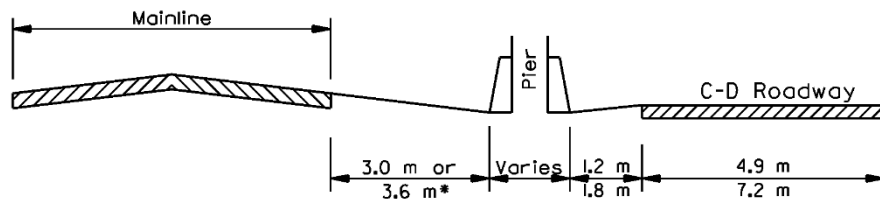

WITH PIER AND CONCRETE BARRIER

* 3.6 m paved shoulders should be considered where the directional distribution of trucks exceeds 250 DDHV.

**SEPARATION WIDTH BETWEEN C-D ROADWAY AND MAINLINE
(Metric)**

Figure 37-4.B

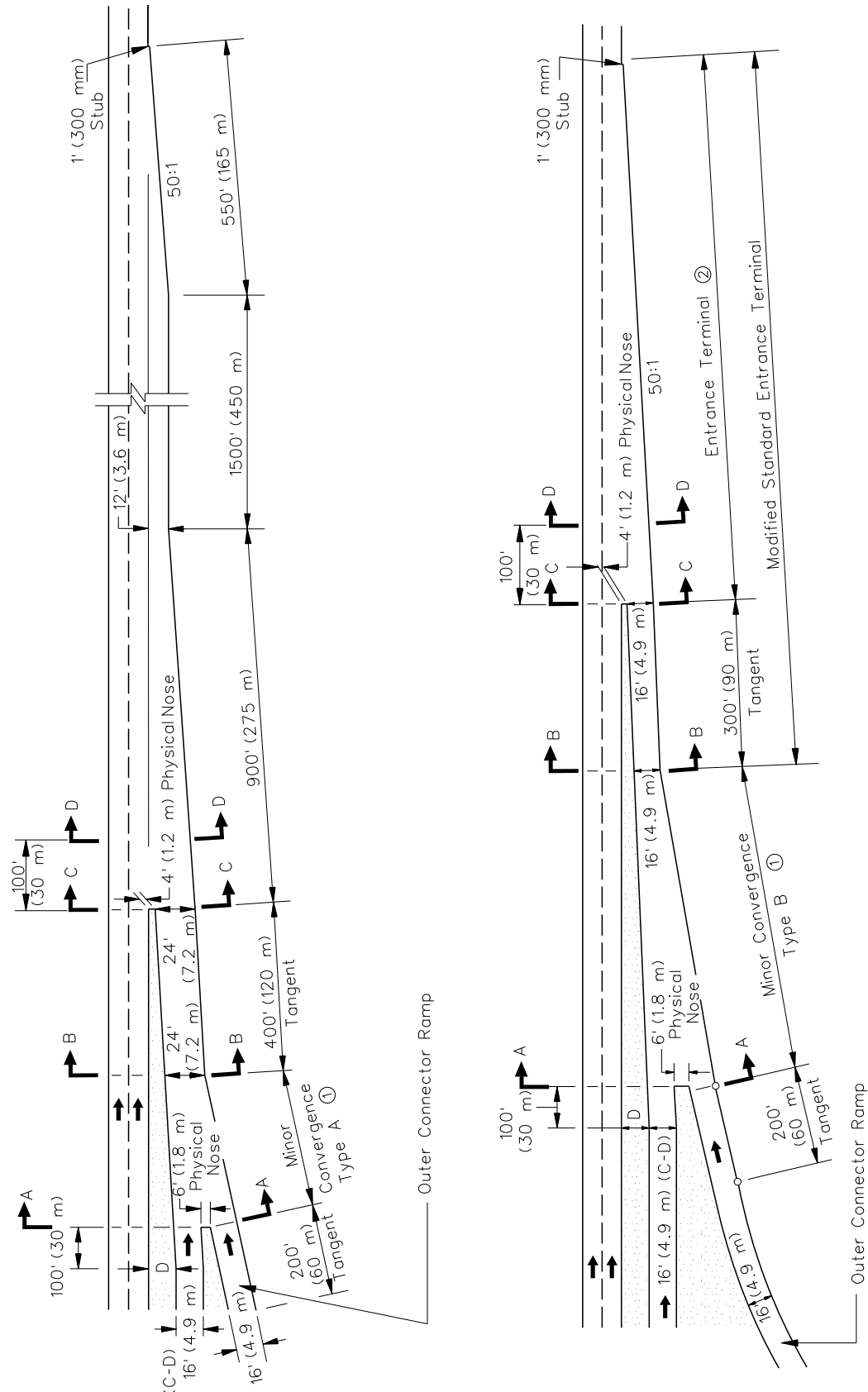

COLLECTOR-DISTRIBUTOR ENTRANCE TERMINAL DESIGNS

Figure 37-4.C
(1 of 2)

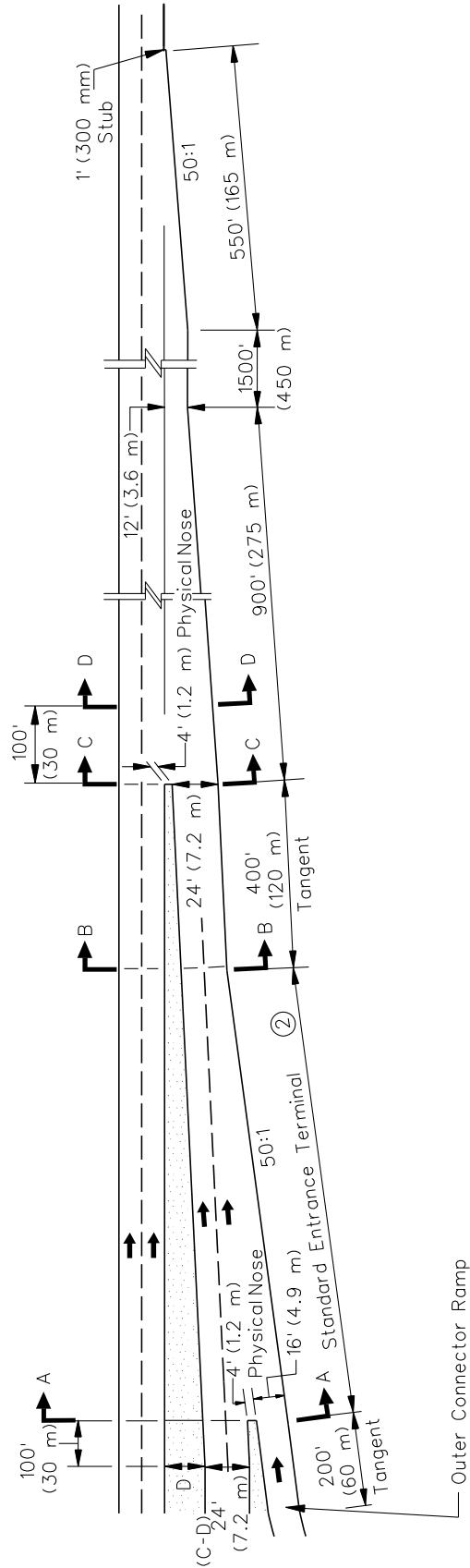

Notes:

1. See Figure 37-6.T for minor convergence designs.
2. See Figure 37-6.K for standard entrance design.
3. D = median width, see Figure 37-4.B.
4. Develop cross sections A-A, B-B, C-C, and D-D during the preparation of the IDS.

COLLECTOR-DISTRIBUTOR ENTRANCE TERMINAL DESIGNS

Figure 37-4.C
(2 of 2)

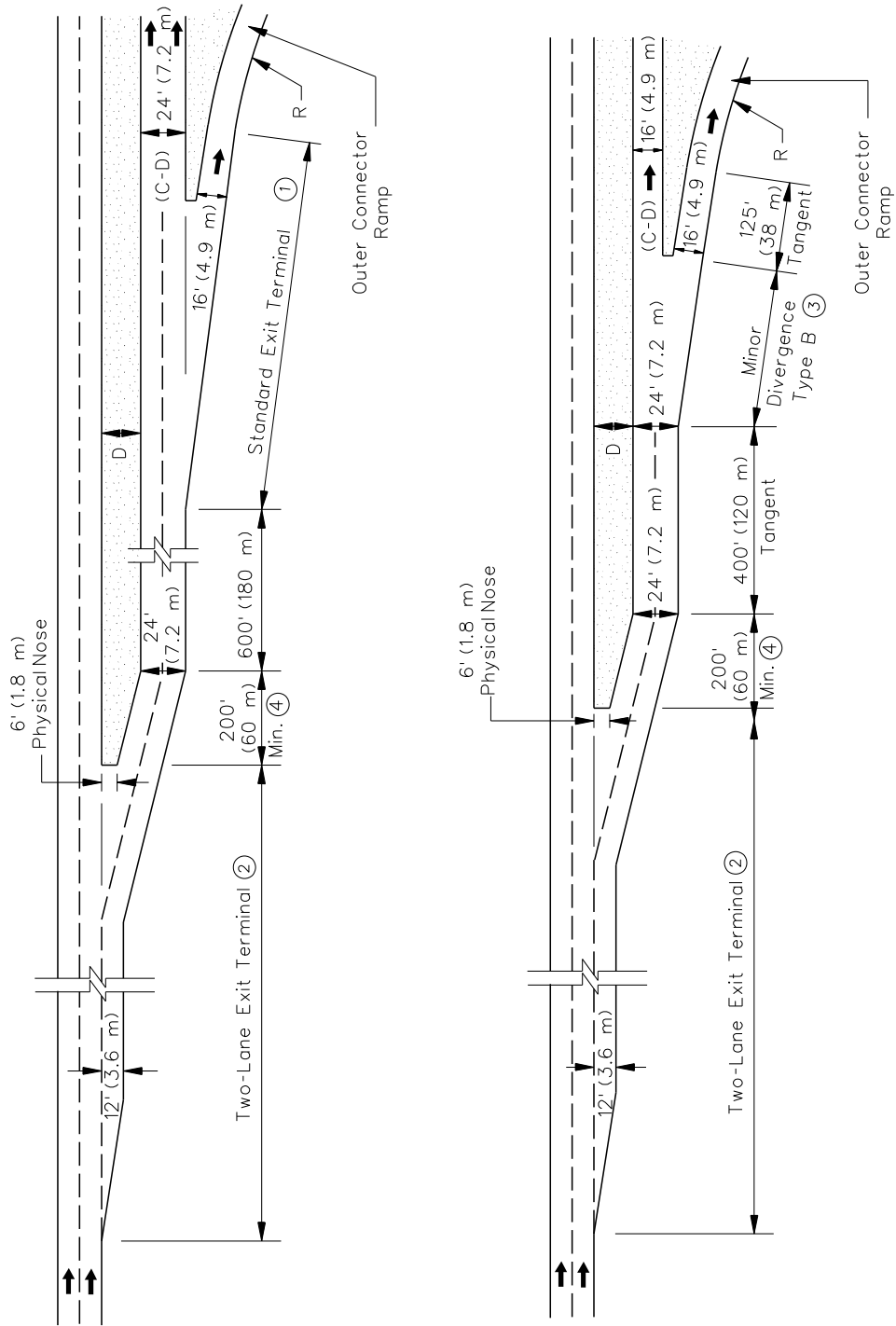

COLLECTOR-DISTRIBUTOR EXIT TERMINAL DESIGNS

Figure 37-4.D
(1 of 2)

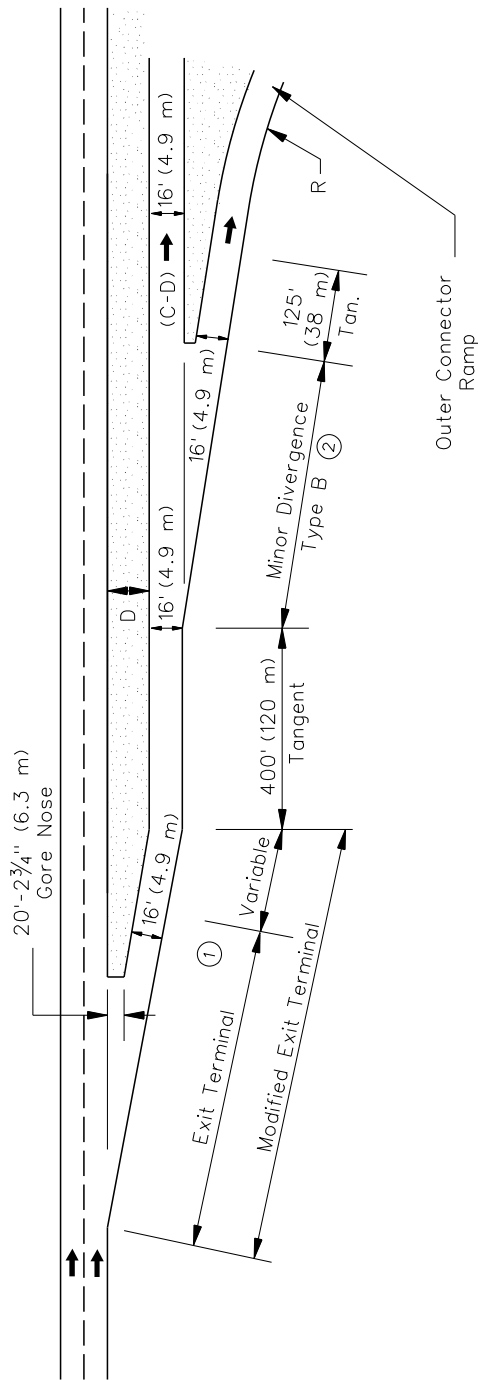

Notes:

1. See Figure 37-6.A for standard exit design.
2. See Figure 37-6.C for two-lane exit design.
3. See Figure 37-6.R for minor divergence designs.
4. D = median width, see Figure 37-4.B. Note minimum lengths may increase median width "D."
5. Develop cross sections for all critical locations during the preparation of the IDS.

COLLECTOR-DISTRIBUTOR EXIT TERMINAL DESIGNS

Figure 37-4.D
(2 of 2)

37-4.04 Design Speed

Figure 37-4.E provides the AASHTO recommended ranges of ramp design speeds based on the design speed of the mainline. IDOT targets the middle range and the values apply to the entire ramp (i.e., ramp terminal and ramp proper). In addition to Figure 37-4.E, consider the following when selecting the ramp design speed:

1. Loop Ramps. Design speeds in the middle and high range are generally not attainable for loop ramps. The following apply to loop ramps:
 - For loop ramps on collector-distributor roadways or in restricted urban conditions, the minimum design speed for loops should be 25 mph (40 km/hr).
 - Where the truck ADT is greater than 15%, use a minimum design speed of 30 mph (50 km/hr) for the initial curve after the exit curve; see Figure 37-3.N.
 - For rural loop ramps, a 30 mph (50 km/hr) design speed is preferred.
 - Use a design speed of 35 mph (60 km/hr) for cloverleaf interchange loop ramps between freeways.

Mainline Design Speed	US Customary						Metric				
	50 mph	55 mph	60 mph	65 mph	70 mph	75 mph	80 km/hr	90 km/hr	100 km/hr	110 km/hr	120 km/hr
	Ramp Design Speed (mph)						Ramp Design Speed (km/hr)				
High Range	45	45	50	55	60	65	70	80	90	100	110
Middle Range	35	40	45	45	50	55	60	60	70	80	90
Low Range	25	30	30	30	35	40	40	50	50	60	70

RAMP DESIGN SPEEDS

Figure 37-4.E

2. Outer Connector Ramps. The design speed for the outer connector ramp of a rural cloverleaf interchange should be in the middle range however, where a wrap-around type ramp is used, a design speed 5 mph (10 km/hr) less than the middle range may be used for the center curve.
3. Semi-Directional Ramps. Use design speeds in the middle range for semi-directional ramps. In restricted urban conditions do not use a design speed less than 40 mph (60 km/hr).
4. Directional Ramps. These include both diagonal ramps at a diamond interchange and ramps at a directional interchange. The design speed shall be in the middle range.
5. Directional Roadways. Two-lane directional roadways within an interchange shall be designed in the middle range.
6. Controlled Terminals. If a ramp is terminated at an intersection with a stop or signal control, the design speeds in Figure 37-4.E are not applicable to a portion of the ramp near the intersection. The design speed on the ramp near the crossroad intersection is usually assumed to be 40 mph (60 km/hr) but can be a minimum of 25 mph (40 km/hr) in restricted areas.
7. Variable Speeds. The ramp design speed may vary based on the two design speeds of the intersecting roadways. Use a higher design speed on the portion of the ramp near the higher speed facility and a lower design speed near the lower speed facility. When using variable design speeds, the maximum speed differential between controlling design elements (e.g., horizontal curves, vertical curves) should not be greater than 10 mph (20 km/hr). The designer must ensure that sufficient deceleration distance is available between design elements with varying design speeds (e.g., two horizontal curves).

Figure 37-4.F presents geometric design criteria for interchange ramps based on the selected design speed (e.g., sight distance, horizontal alignment and vertical alignment). These are discussed in detail in the following sections.

37-4.05 Sight Distance

The designer should review the ramp cross-section, horizontal alignment, and vertical alignment to ensure that stopping sight distance is continuously provided along the interchange ramp. Because ramps are composed of curves of various radii and design speeds, sight distance requirements may vary over the length of the ramp. Figure 37-4.F provides a summary of the geometric criteria for ramps, including stopping sight distance.

GEOMETRIC REQUIREMENTS								
Ramp Design Speed at R_1 (mph)		55	50	45	40	35	30	25
Stopping Sight Distance (ft)		495	425	360	305	250	200	155
HORIZONTAL ALIGNMENT								
Minimum Radius (ft) for R_1 for $e = e_{\max}$ (Entrance and Exit Ramps)	8%	960	758	587	444	314	214	134
	6%	1060	833	643	485	340	231	144
Minimum Length of Arc (ft)		See Figure 37-4.H						
Superelevation Runoff Length for One Lane Ramp (ft) (adjusted for 16 ft width)	8%	272	255	235	220	205	195	185
	6%	204	190	180	165	155	145	135
VERTICAL ALIGNMENT								
Maximum Grades		+4% and -6%						
Crest Vertical Curves K-values		114	84	61	44	29	19	12
Sag Vertical Curves K-values		115	96	79	64	49	37	26
<u>GENERAL NOTES:</u>								
<ul style="list-style-type: none"> • Where radii greater than R_1 are used, determine the ramp superelevation rate according to Section 32-3. • $e_{\max} = 6\%$ values are applicable to areas with snow and ice conditions and/or highly congested traffic operations. 								

**SUMMARY OF ROADWAY DESIGN CRITERIA
FOR INTERCHANGE RAMPS
(US Customary)**

Figure 37-4.F

GEOMETRIC REQUIREMENTS							
Ramp Design Speed at R_1 (km/hr)	90	80	70	60	50	40	
Stopping Sight Distance (m)	160	130	105	85	65	50	
HORIZONTAL ALIGNMENT							
Minimum Radius (m) for R_1 for $e = e_{\max}$ (Entrance and Exit Ramps)	8%	304	229	168	113	73	41
	6%	336	252	184	123	79	43
Minimum Length of Arc (m)	See Figure 37-4.H						
Superelevation Runoff Length for One Lane Ramp (m) (adjusted for 4.9 m width)	8%	83	78	71	65	60	55
	6%	63	58	53	49	45	42
VERTICAL ALIGNMENT							
Maximum Grades	+4% and -6%						
Crest Vertical Curves K-values	39	26	17	11	7	4	
Sag Vertical Curves K-values	38	30	23	17	12	8	
<u>GENERAL NOTES:</u>							
<ul style="list-style-type: none"> Where radii greater than R_1 are used, determine the ramp superelevation rate according to Section 32-3. $e_{\max} = 6\%$ values are applicable to areas with snow and ice conditions and/or highly congested traffic operations. 							

**SUMMARY OF ROADWAY DESIGN CRITERIA
FOR INTERCHANGE RAMPS
(Metric)**

Figure 37-4.F

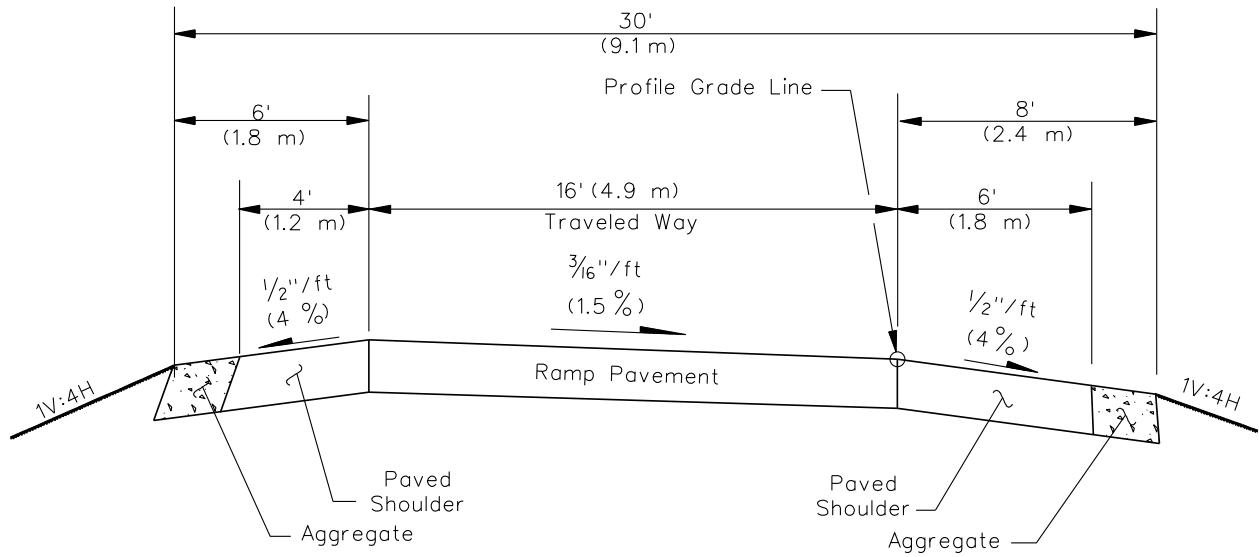

TANGENT SECTION

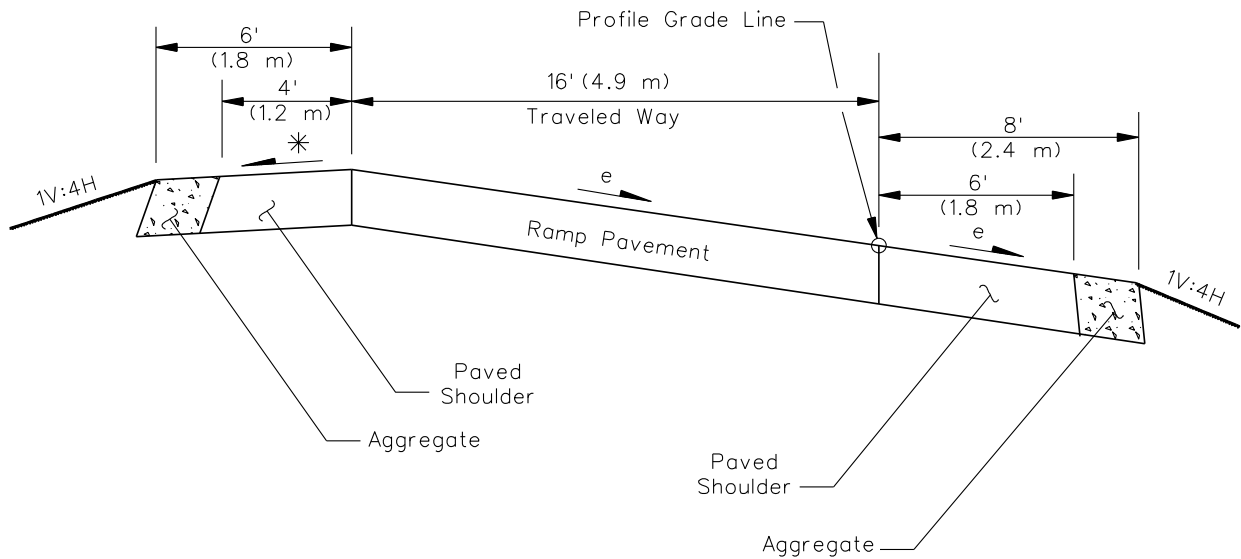

SUPERELEVATED SECTION

*See Section 32-3 for maximum shoulder break.

TYPICAL RAMP CROSS SECTIONS

Figure 37-4.G

37-4.06 Cross Section Elements

Figure 37-4.G presents the typical cross section criteria for tangent and superelevated portions of ramps. The following also applies to the ramp cross section:

1. Width. The minimum width of a one-way, one-lane ramp is 30 ft (9.1 m). The 30 ft (9.1 m) width includes a 6 ft (1.8 m) left shoulder (4 ft (1.2 m) paved), an 8 ft (2.4 m) right shoulder (6 ft (1.8 m) paved), and a 16 ft (4.9 m) paved traveled way. This arrangement is illustrated in the ramp cross sections in Figure 37-4.G. For multilane directional roadways, the cross sectional width is the same as the freeway design (e.g., 24-ft (7.2-m) traveled way width plus shoulders); see Chapter 44.
2. Pavement Design. For pavement design information that is also applicable to ramps, see Chapter 54.
3. Cross Slope. For tangent sections, the 16 ft (4.9 m) traveled way is sloped unidirectionally at 3/16"/ft (1.5%) towards the right shoulder. Shoulder cross slopes, for both the paved and unpaved portions, are typically 1/2"/ft (4%). The left shoulder is typically sloped away from the traveled way. For all superelevated ramps, the ramp traveled way and shoulders are sloped as discussed for open roadways conditions in Section 32-3.
4. Curbs. If curb and gutter is required, place it on the outside edge of the full-width paved shoulders. See Chapters 34 and 38 for information on the use of curbs.
5. Bridges and Underpasses. Carry the full paved width of the ramp, including the paved shoulders over a bridge. See Chapters 38 and 39 when determining the clear ramp width for an underpass.
6. Side Slopes/Ditches. For the ramp proper, use a side slope of 1V:4H or flatter. Chapters 34 and 38 provide the applicable design information for side slopes and ditches.
7. Clear Zones. Measure the clear zone from the edge of the traveled way on both sides of the ramp using the criteria in Section 38-3.
8. Right-of-Way. The right-of-way adjacent to the ramp is fully access controlled and the right-of-way is fenced.

37-4.07 Horizontal Alignment

37-4.07(a) Theoretical Basis

Establishing horizontal alignment criteria for any highway element requires a determination of the theoretical basis for the various alignment factors. These include the side-friction factor (f), the distribution method between side friction and superelevation, the relative longitudinal gradients, and the distribution of the superelevation runoff length between the tangent and horizontal curve. For horizontal alignment on the ramp proper, the theoretical basis will be open-roadway conditions as discussed in Chapter 32. In summary, this includes:

- relatively low side-friction factors (i.e., a relatively small level of driver discomfort);
- the use of AASHTO Method 5 to distribute side friction and superelevation;
- relatively flat longitudinal gradients for superelevation runoff lengths; and
- distributing 67% of the superelevation runoff length on the tangent and the remainder on the horizontal curve.

The following sections discuss the specific horizontal alignment criteria for ramps.

37-4.07(b) Design Controls

The following will apply to the horizontal alignment of ramps:

1. Minimum Curve Radii. Figure 37-4.F provides the minimum curve radii based on ramp design speed, open-roadway conditions, and e_{\max} .
2. Superelevation Rates. For most areas, the maximum superelevation rate on the ramp is $e_{\max} = 8\%$. For areas with snow and ice conditions and/or areas with high congestion, the maximum superelevation rate is $e_{\max} = 6\%$. For two-lane directional roadways within an interchange, use an $e_{\max} = 6\%$ throughout the State.

Because of the typically restricted site conditions for interchanges (e.g., the need to minimize right-of-way), the majority of horizontal curves on ramps will be superelevated at e_{\max} . Where practical, use curves flatter than R_{\min} . For these curves, the design superelevation rate will be determined from the applicable e_{\max} figure in Section 32-3 for open roadways.

3. Trucks. Where there are a significant number of trucks on loop ramps, the designer may need to consider how the design may increase the rollover potential for large trucks. To reduce this potential, consider using flatter curve radii on the second curve. Modified radii can be obtained by reducing the superelevation rates and/or lowering the side-friction factors. For additional guidance on modified truck friction factors, see the article in Transportation Research Record No. 1385 entitled "Interchange Ramp Geometrics — Alignment and Superelevation Design."

4. Superelevation Runoff Lengths. Open-roadway conditions, as discussed in Section 32-3, apply to transitioning the ramp from its normal cross slope on tangent to the needed superelevation on curves. The relative longitudinal slopes in Figure 32-3.F apply to ramps. Based on these gradients, $e = e_{\max}$, and a 16 ft (4.9 m) ramp traveled way, Figure 37-4.F presents the superelevation runoff lengths for horizontal curves on ramps.
5. Ramp Baseline. Typically, the right edge of the ramp traveled way is used for horizontal and vertical control, and the control point for the axis of rotation.
6. Shoulder Superelevation. The criteria presented in Section 32-3 for superelevating the high and low side of shoulders for open roadways will apply to superelevated curves on ramps.
7. Reverse Curves. Reverse curves may be required to:
 - meet restrictive right-of-way conditions,
 - provide for a better location of the intersection on the crossroad, and/or
 - provide a preferred angle of intersection with the crossroad.

Design the reverse curves with a minimum tangent section consisting of a continuously rotating plane between the curves. This continuously rotating plane will determine the necessary distance between the PT and the succeeding PC and is based on the 67% superelevation runoff lengths for each curve. See Section 32-3 for more information on superelevating reverse curves.

8. Sight Distance. Section 32-4 presents the criteria for sight distance around horizontal curves based on the curve radii and design speed. These criteria also apply to curves on ramps.
9. Controlled Ramp Termini. Exit ramps may end at a controlled intersection — stop control or signal control. If horizontal curves on the ramps are near the intersection, a design speed for the curve should be selected which is appropriate for expected operations at the curve. See Section 36-1.05(b) for more information.

37-4.07(c) Length of Arc

Where compound arcs of decreasing radius are used on exit ramps, the arcs should have sufficient length to enable motorists to decelerate at a reasonable rate over the range of design speeds; see Figure 37-4.H. The radii of the flatter arc compared to the radii of the sharper arc should not exceed a ratio of 2:1 to prevent abruptness in operation and appearance.

Comparable radii and length controls may be used on entrance ramps with compound arcs of increasing radii. However, for entrance ramps, the 2:1 ratio of compound curves is not critical because the vehicle is accelerating into a curve with a larger radius or into a tangent section.

US Customary							
Radius (ft)	100	150	200	250	300	400	500 or more
Minimum (ft)	40	50	60	80	100	120	140
Desirable (ft)	60	70	90	120	140	180	200
Metric							
Radius (m)	30	50	60	75	100	125	150 or more
Minimum (m)	12	15	20	25	30	35	45
Desirable (m)	20	20	30	35	45	55	60

Note: These lengths are applicable where the ramp curve is followed by a curve 1/2 the radius or preceded by a curve of double radius.

ARC LENGTHS FOR COMPOUND CURVES

Figure 37-4.H

37-4.08 Vertical Alignment

37-4.08(a) Grades

Values of limiting gradients are +4% to -6% regardless of the design speed but, for any one ramp, the selected gradient is dependent upon several factors. These include:

- Where steep grades are required, locate them within the center portion of the ramp.
- Locate freeway ramp terminals and approach areas near intersections on as flat a grade as practical; see Section 37-5 for grades near ramp/crossroad intersections and Section 37-6 for freeway ramp terminal grades.
- Ramp grades may affect the location of ramp termini. This may be a concern where the ramp intersects the crossroad at an angle of 70 degrees or less. Section 37-5.01 further discusses the location of ramp/crossroad intersections.

37-4.08(b) Vertical Curvature

Design vertical curves on ramps to meet the stopping sight distance criteria based on the ramp design as presented in Chapter 33. Figure 37-4.F provides the K-values for both crest and sag vertical curves. The ramp profile often assumes the shape of the letter S with a sag vertical curve at one end and a crest vertical curve at the other. In addition, design the vertical curvature adjacent to the standard exit and entrance terminals using a design speed of 50 mph (80 km/hr) or greater.

37-4.08(c) Cross Sections Between Adjacent Ramps

Where the horizontal alignment of a ramp is designed to be parallel to an adjacent ramp (e.g., parclo, cloverleaf, trumpet interchanges), first establish the profile of the loop ramp and then set the profile of the outer ramp to be approximately parallel to the inner-loop ramp profile. This is accomplished by calculating the left-edge elevations of the loop ramp and matching those elevations for the left-edge elevations of the outer ramp. To ensure the median edges between the two ramps are approximately level, develop a typical cross section during the preparation of the IDS.

37-4.09 Roadside Safety

The criteria in Chapter 38 (e.g., clear zones, barrier warrants, length of need) will apply to the roadside safety design of interchange ramps.

37-5 RAMP/CROSSROAD INTERSECTIONS

37-5.01 General Design Criteria

At diamond and partial cloverleaf interchanges, the ramp will terminate or begin at a controlled intersection on the crossroad, either with a stop sign or traffic signal. In general, the intersection should be designed as described in Chapter 36. Consider the following in the design of ramp/crossroad intersections:

1. Length of Left-Turn Lanes. For diamond interchanges, typically the minimum distance between ramp/crossroad intersections is set by the length of overlapping left-turn lanes. Note that in rural areas, the minimum design speed for determining the length of left-turn lanes on the crossroad is 55 mph (90 km/hr). Left-turn lanes are usually designed with straight-line tapers when the crossroad goes over the freeway and with reverse curves when the crossroad goes underneath the freeway; see Figure 37-5.A. For compressed diamond interchanges, the length of the left-turn lanes will be determined based on left-turn storage requirements, see Section 36-3.02 and Figure 37-5.B. The left-turn control radii into the ramps are set at the ends of the left-turn lanes. This also determines the location of the ramp baselines.
2. Turn Lanes on Ramps. Exclusive turn lanes are often required at the end of an exit ramp. Chapter 36 provides information on the design of turn lanes at intersections, which are also applicable for ramps.
3. Signalization. Where queuing at one intersection is long enough to effect operations at another, the two intersections may need a larger separation, interconnected signals, or a six-phase overlap signal design.
4. Ramp Grades. Where the exit and entrance ramps intersect with the crossroad, design the first 150 ft to 200 ft (45 m to 60 m) of the ramp with a profile grade of 1.5% to 2%.
5. Crossroad Grades. Design the crossroad grades for a maximum of 2% through the ramp/ crossroad intersection.
6. Capacity. Ensure that sufficient capacity and storage for the ramp/crossroad intersection is available. This may require adding lanes at the intersection or on the ramp proper. The analysis must also consider the operational impacts of the traffic characteristics in either direction on the crossroad.
7. Sight Distance. Section 36-6 discusses the criteria for intersection sight distance. These criteria also apply to the ramp/crossroad intersection. Give special attention to the location of the bridge piers, abutments, sidewalks, bridge railing, roadside barrier, etc.; these elements may present major sight distance obstacles. The bridge obstruction and the required intersection sight distance may result in the relocation of the ramp/crossroad intersection further from the structure. In addition, the crest vertical curve on the crossroad may need to be lengthened to provide adequate sight distance in the vertical plane.

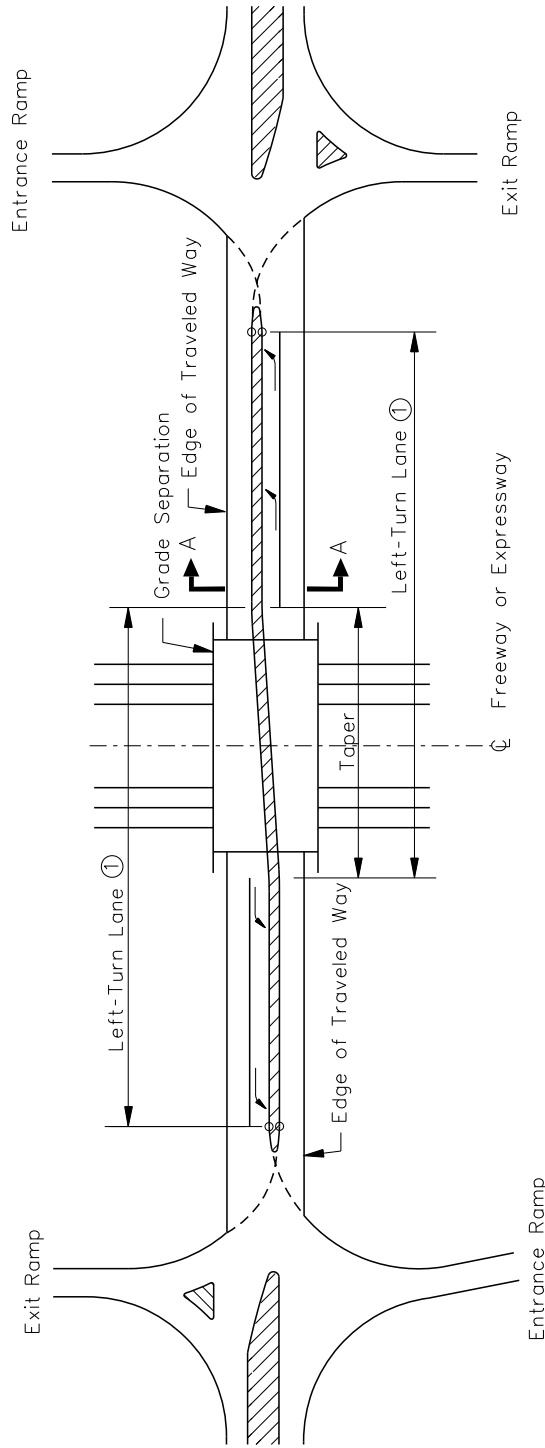

Notes:

1. Determine the left-turn length on the crossroad using Section 36-3.02 and by assuming the distance needed for a stop condition.
2. Set the location of left-turn control radii to and from the crossroad at the same crossroad station.
3. See Figure 37-5.C for Section A-A.

**LEFT-TURN LANES ON CROSSROADS
(Diamond Interchanges)**

Figure 37-5.A

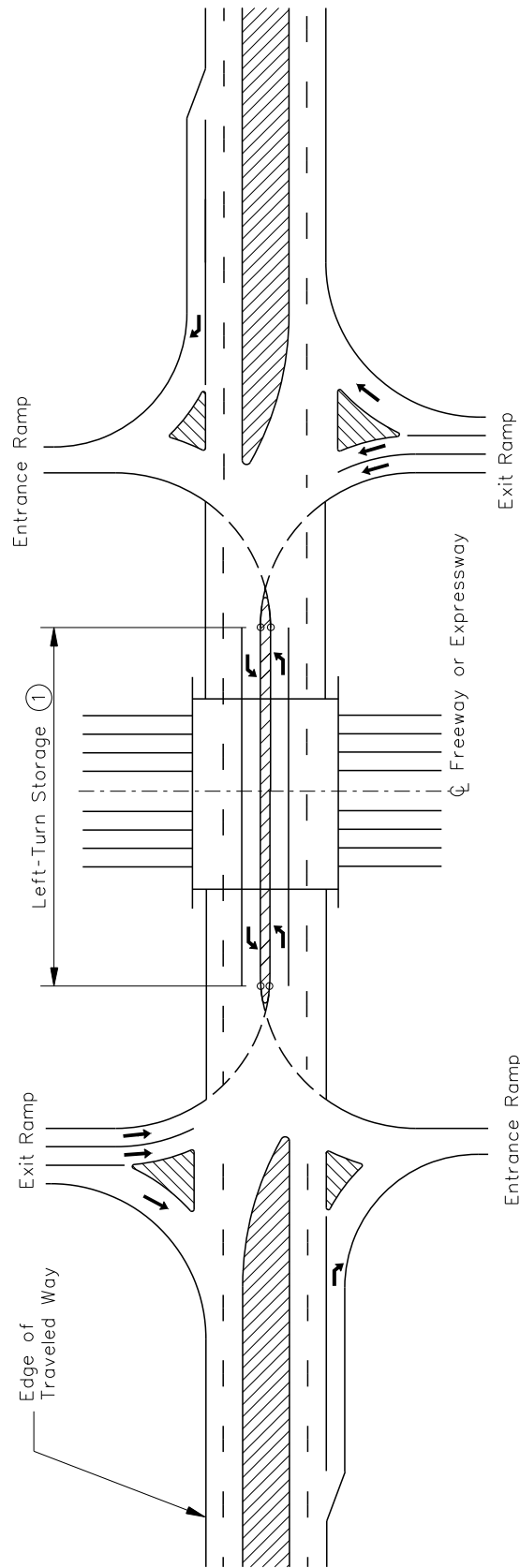

Notes:

1. Determine the left-turn length on the crossroad using Section 36-3.02. For this design, the storage requirements will govern.
2. Set the location of left-turn control radii to and from the crossroad at the same crossroad station.
3. For new construction, use a 30 ft (9.0 m) minimum median width on the crossroad.

LEFT-TURN LANES ON CROSSROADS
(Compressed Diamond Interchange)

Figure 37-5.B

8. Wrong-Way Movements. Wrong-way movements may originate at the ramp/crossroad intersection onto an exit ramp. To minimize the probability of these movements, provide a raised-curb median on the crossroad and sign the ramp according to the *ILMUTCD*.
9. Crossroad Cross Section. For safety and capacity, the crossroad through an interchange should be as wide as practical. The minimum cross section is an 18 ft (5.5 m) raised-curb median separating two 14 ft (4.2 m) lanes and 8 ft (2.4 m) outside shoulders. See Figure 37-5.C and Section 37-2.14 for additional information on the crossroad dimensions.
10. Design Vehicle. Radius returns and left-turn control radii for ramp/crossroad intersections should be designed using a WB-67 (WB-20) design vehicle; see Section 36-1.08.
11. Design Users. Where present and a permitted user of the crossroad, pedestrians and bicyclists should be treated as design users of the facility and given the same consideration as the design vehicle.
12. Corner Islands. The approach angle for right-turning vehicles is critical in the design of new corner islands or the modification of existing corner islands. If designed without the approach angle in mind, corner island design may impose challenges to the motorist regarding excessive head-turn and reduced sight distance. These challenges in the driving task are further amplified at intersection approaches on heavy skew angles. Figure 36-2.F depicts two options for a standard corner island design that will minimize potentially adverse operating characteristics. In the design of a corner island, seek to meet or approach a head-turn angle goal of 115 degrees for the line of sight as shown for drivers at the stop bar. See Section 36-2.02 for more information when designing or modifying corner islands at ramp/crossroad intersections.
13. Stop Bar Locations. See the *Illinois Supplement to the Manual on Uniform Traffic Control Devices (ILMUTCD)* regarding stop bar placement at intersections. On multilane approaches or approaches with corner islands, care should be taken in design to ensure the proposed stop bar placement of one lane does not create a line of sight restriction for the adjacent stopping maneuver. See Section 36-2.02(a) and (c) for more information on stop bar placement when using a corner island.

37-5.02 Typical Intersection Designs

37-5.02(a) Diamond Interchange

Typical ramp/crossroad intersections at a diamond interchange are shown in Figures 37-5.D, 37-5.E, 37-5.F, and 37-5.G. The appropriate radius returns, based on the WB-67 (WB-20) design vehicle, are used to delineate the right-turning paths for the corner island design. For left turns from an exit ramp onto a 14 ft (4.2 m) traveled way, offset the median nose as shown in Figure 37-5.H.

37-5.02(b) Two-Quadrant Partial Cloverleaf Interchange

The ramp/crossroad intersections with a two-quadrant partial cloverleaf interchange are similar in design to a channelized “T” intersection; see Figure 37-5.I. To discourage wrong-way movements into the exit ramp, use a maximum left-turn control radius of 80 ft (24 m) from the crossroad into the entrance ramp and a 100 ft (30 m) left-turn control radius from the exit ramp onto the crossroad.

Figure 37-5.J illustrates a typical median design on the crossroad for a parclo type interchange.

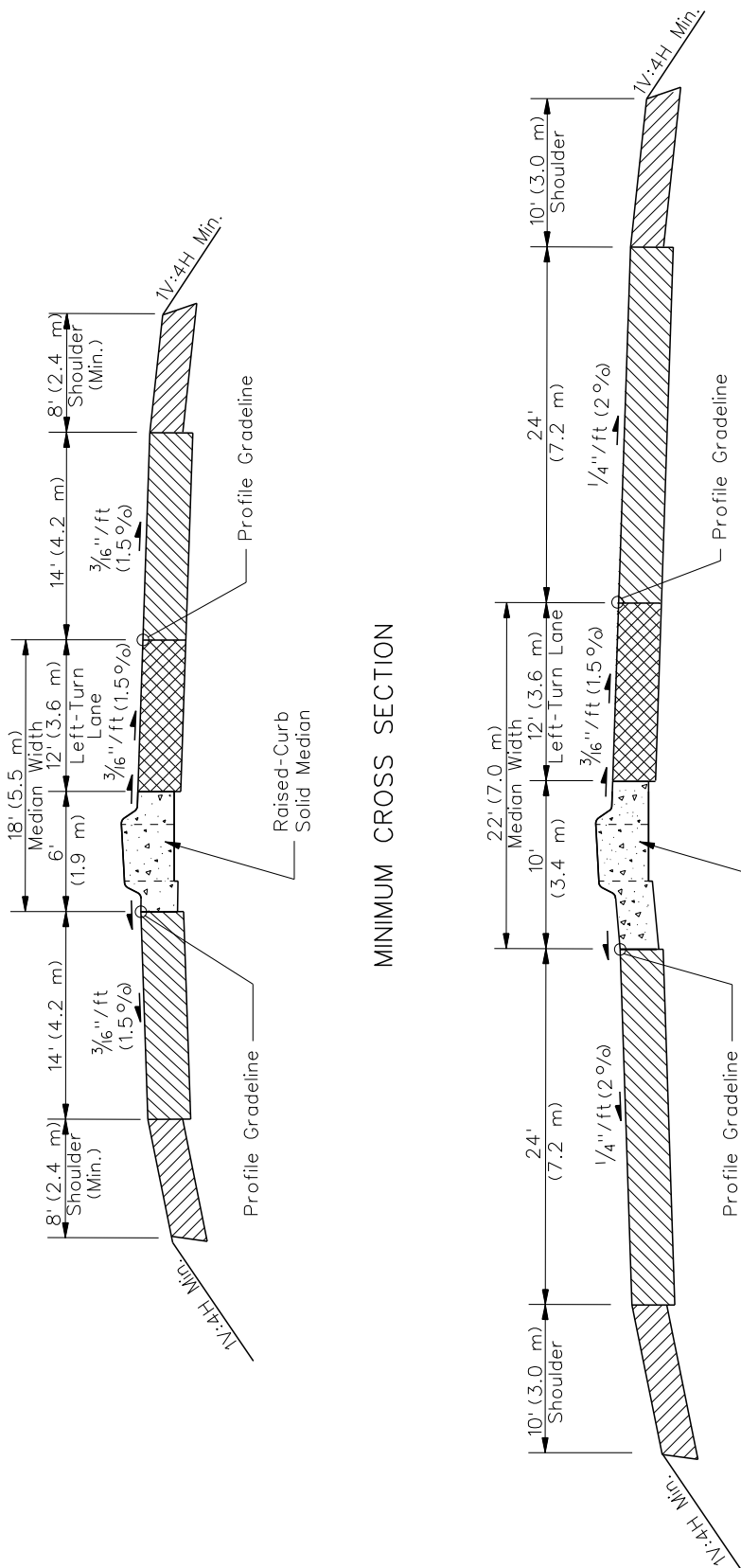

MINIMUM CROSS SECTION

MULTILANE CROSS SECTION

Notes:

1. See Figure 37-5.A for location of Section A-A.
2. See Section 34-2.04(c) for curb type determination.

TYPICAL CROSS SECTIONS FOR AN INTERCHANGE CROSSROAD
(Left-Turn Bay at Section A-A)

Figure 37-5.C

Notes:

1. Intersection designed for a WB-67 design vehicle.
2. Ramp noses of channelizing islands as shown.
3. Provide full depth (Min. 10") paved shoulder.
4. Use 6' wide gutters on median islands.

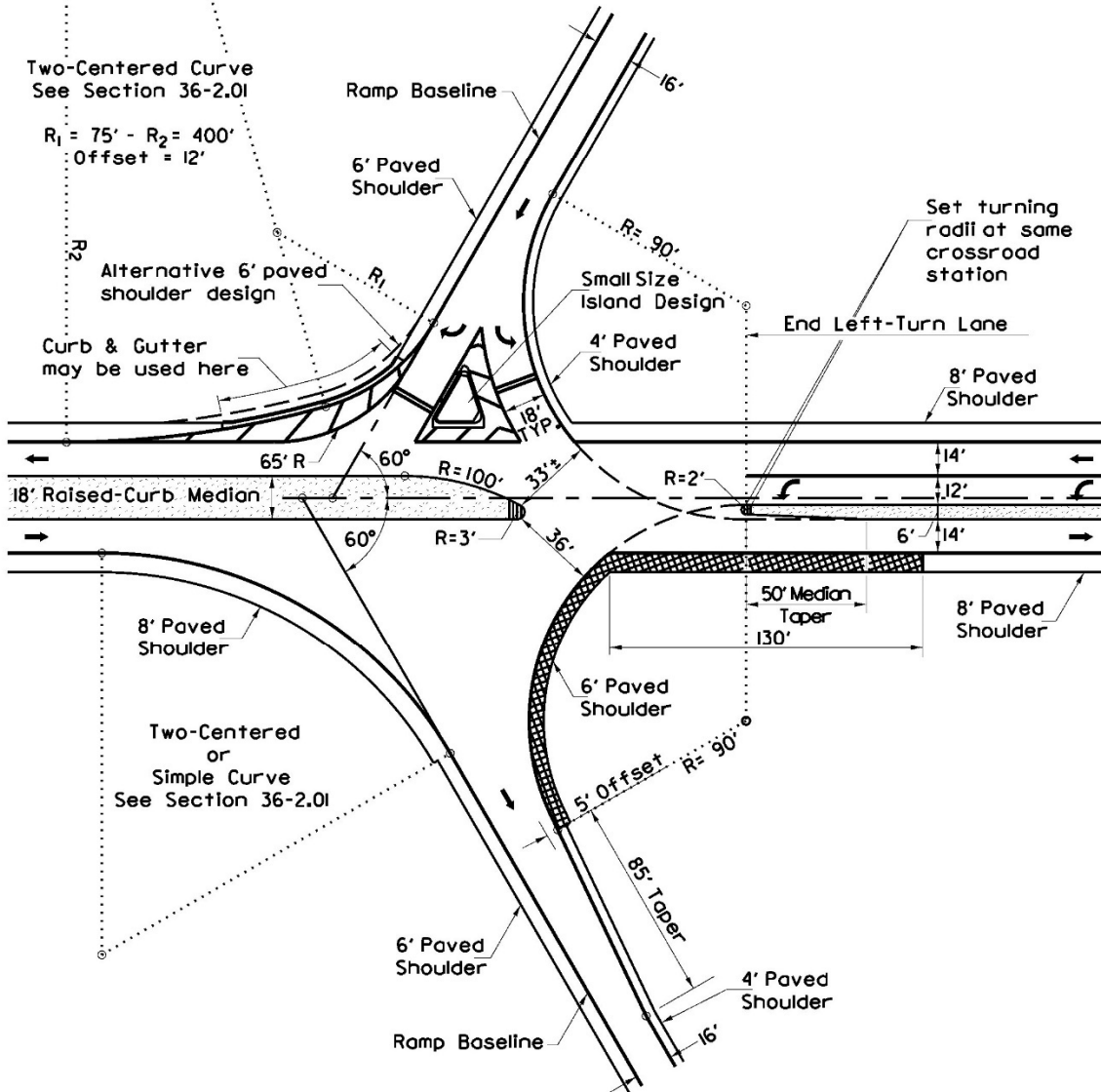

**TYPICAL RAMP/CROSSROAD INTERSECTION — DIAMOND INTERCHANGE
(60 Degrees on Exit and 60 Degrees on Entrance)
(US Customary)**

Figure 37-5.D

Notes:

1. Intersection designed for a WB-20 design vehicle.
2. Ramp noses of channelizing islands as shown.
3. Provide full depth (Min. 250 mm) paved shoulder.
4. Use 150 mm wide gutters on median islands.

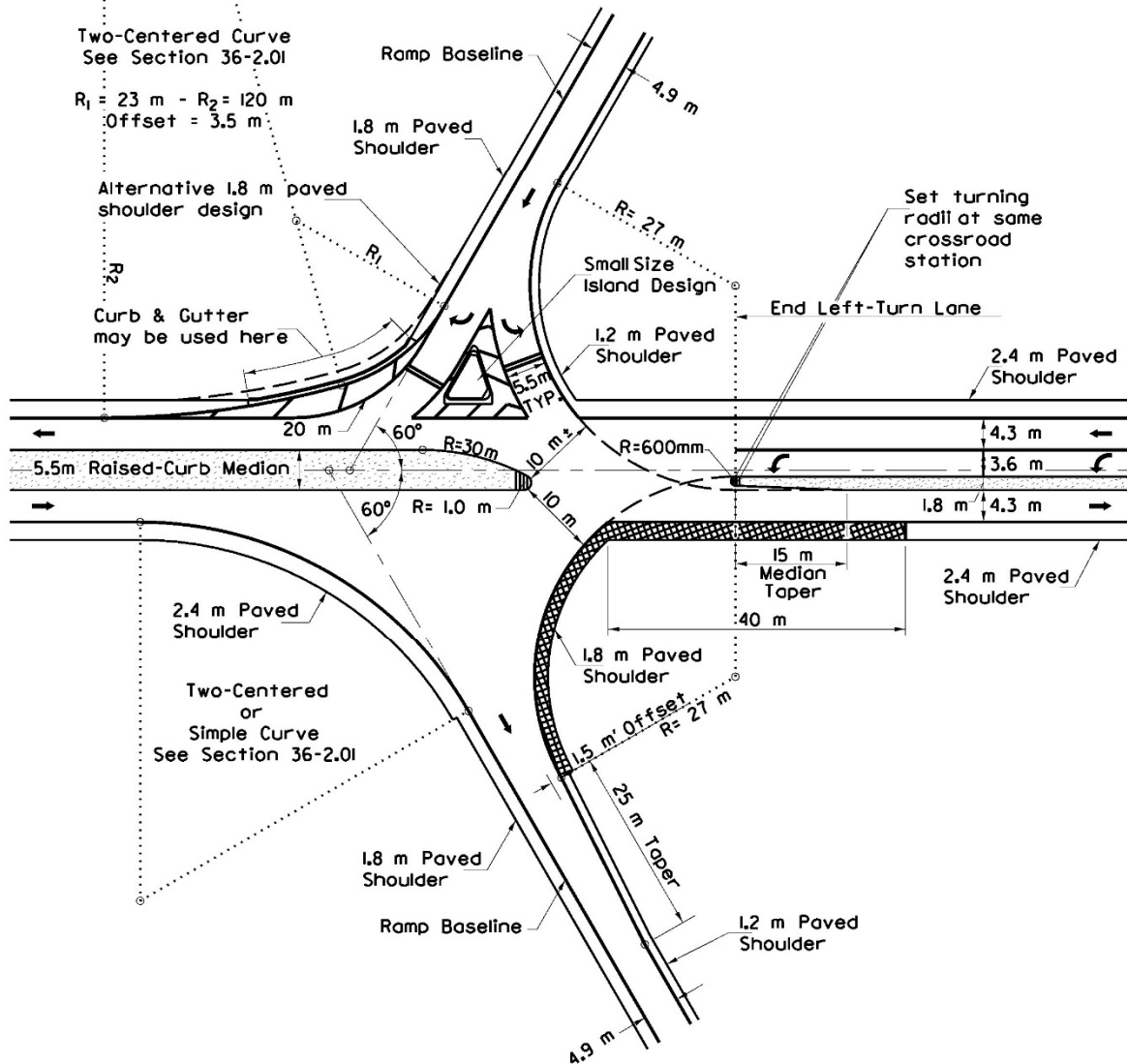

**TYPICAL RAMP/CROSSROAD INTERSECTION — DIAMOND INTERCHANGE
(60 Degrees on Exit and 60 Degrees on Entrance)
(Metric)**

Figure 37-5.D

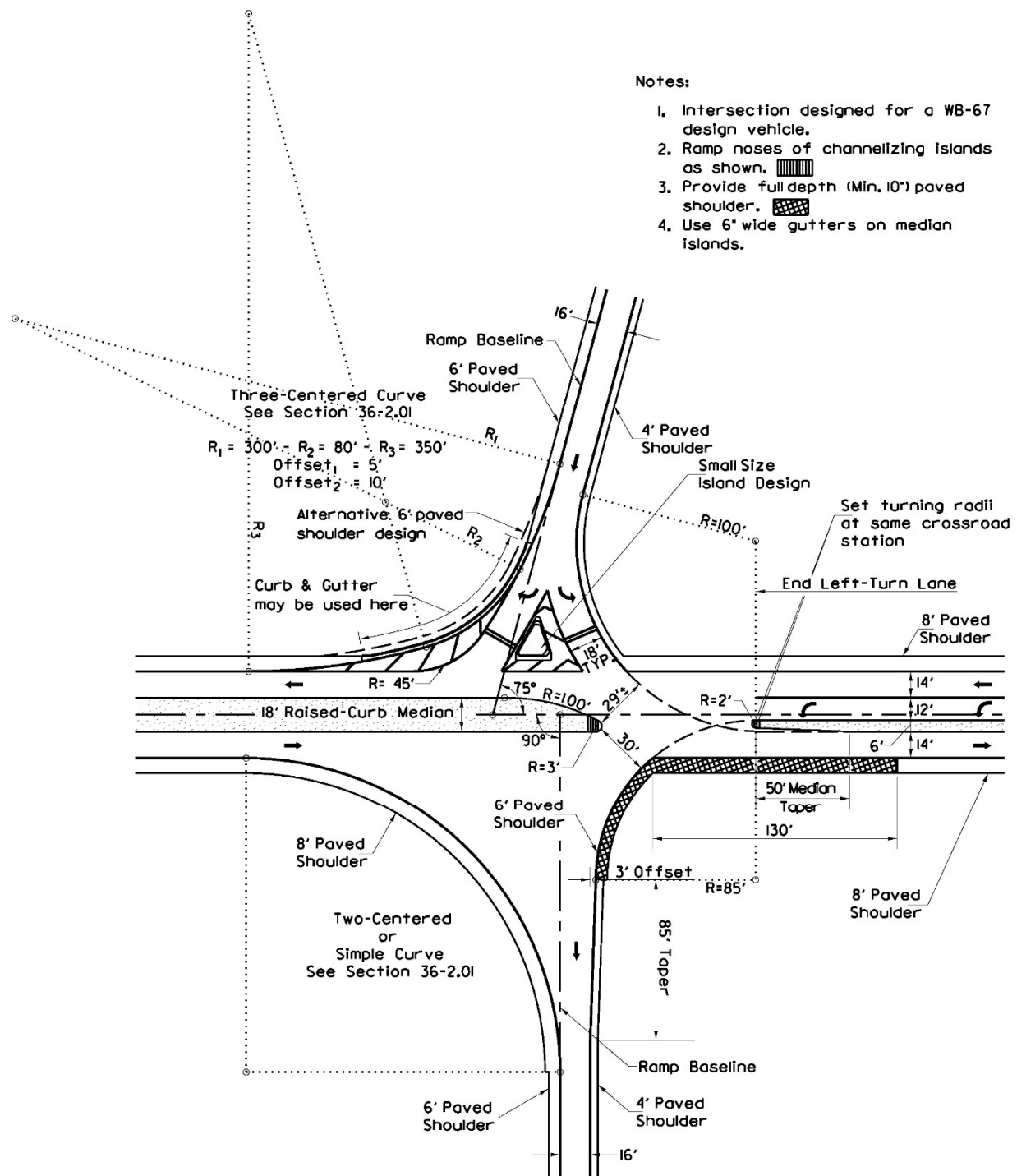

**TYPICAL RAMP/CROSSROAD INTERSECTION — DIAMOND INTERCHANGE
(75 Degrees on Exit and 90 Degrees on Entrance)
(US Customary)**

Figure 37-5.E

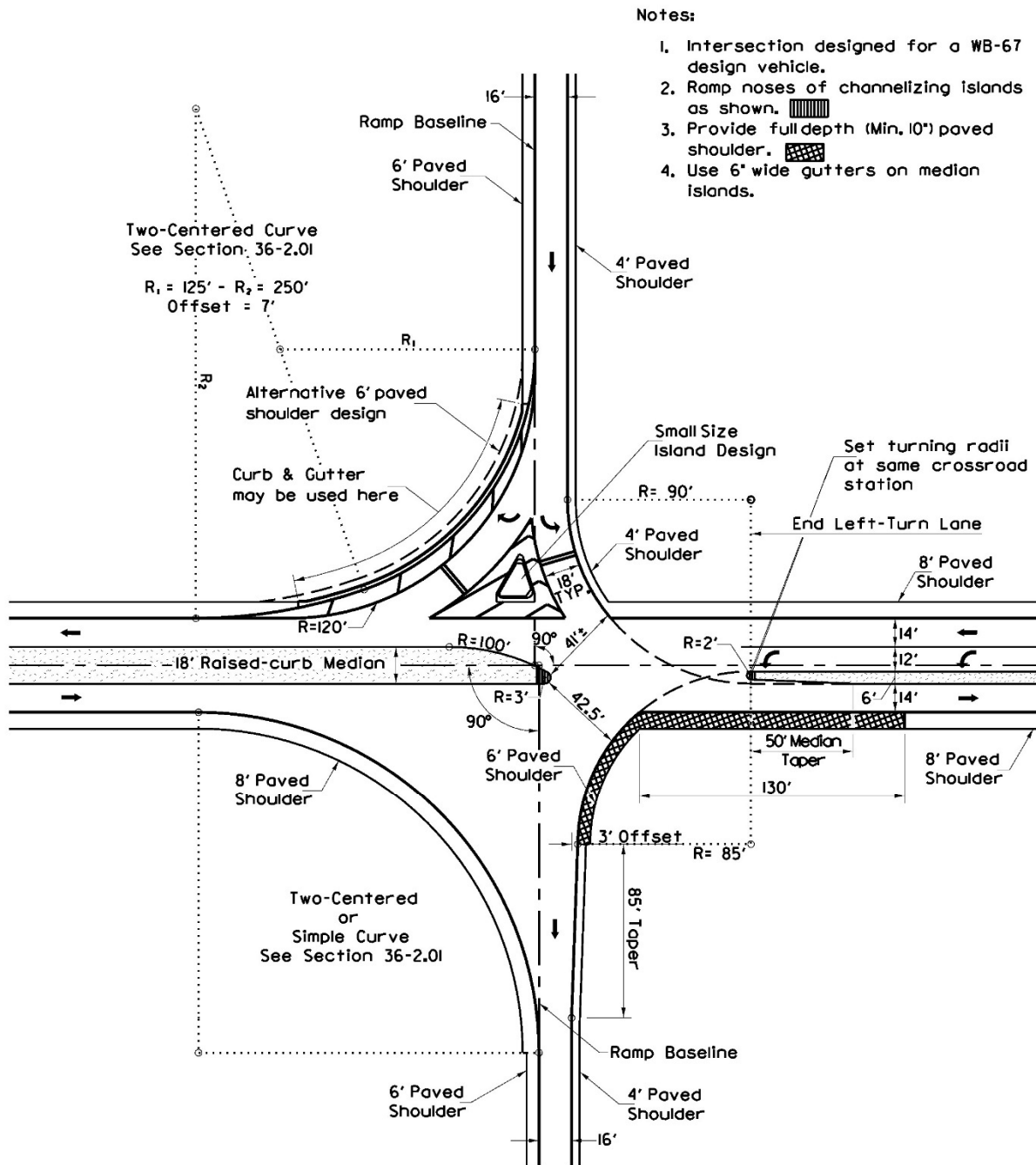

**TYPICAL RAMP/CROSSROAD INTERSECTION — DIAMOND INTERCHANGE
(90 Degrees on Exit and 90 Degrees on Entrance)
(US Customary)**

Figure 37-5.F

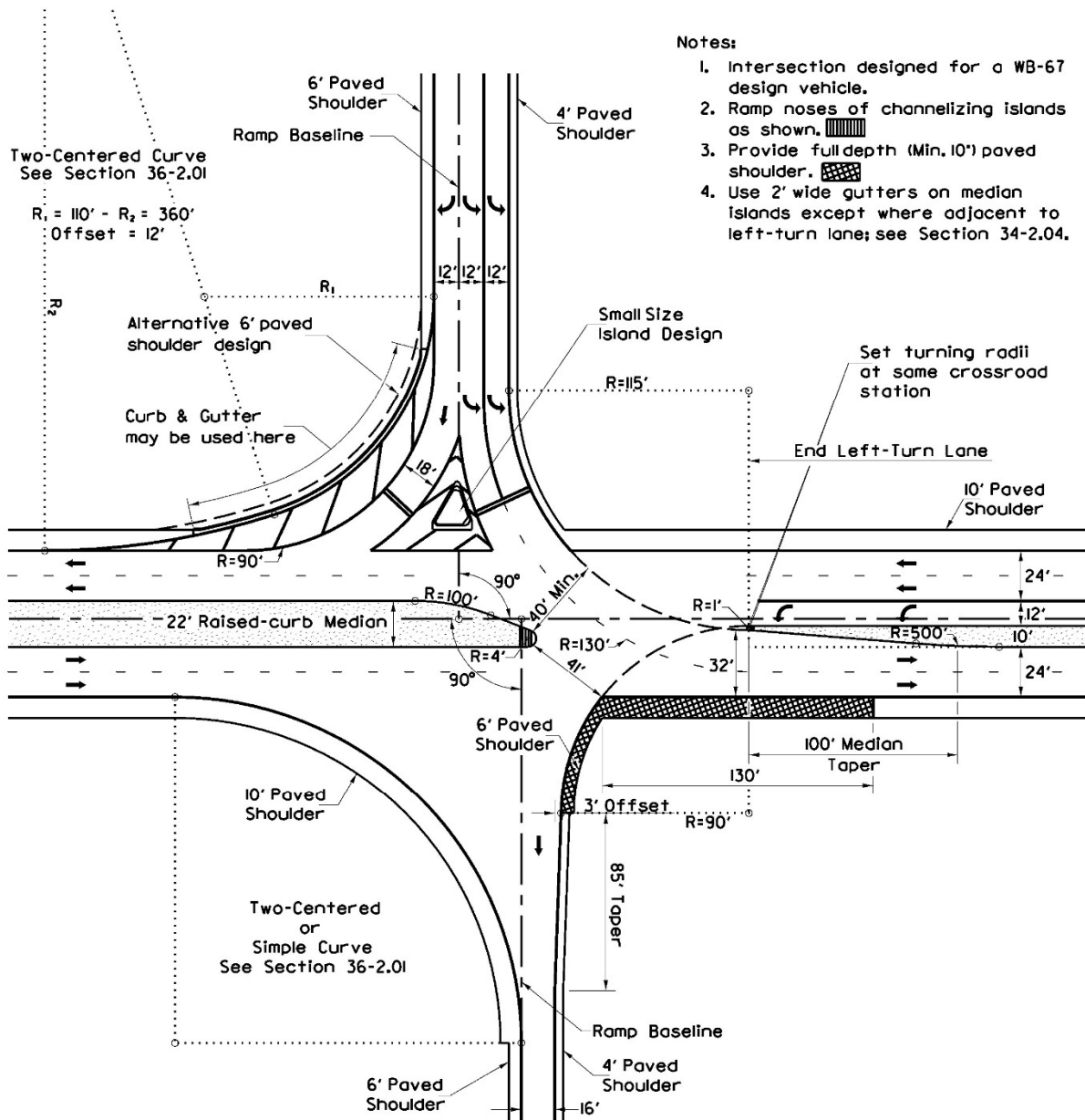

- Notes:
- 1. Intersection designed for a WB-67 design vehicle.
 - 2. Ramp noses of channelizing islands as shown.
 - 3. Provide full depth (Min. 10') paved shoulder.
 - 4. Use 2' wide gutters on median islands except where adjacent to left-turn lane; see Section 34-2.04.

TYPICAL RAMP/CROSSROAD INTERSECTION — DIAMOND INTERCHANGE
(90 Degrees on Entrance and Exit and Dual Left Turns on Exit Ramp)
(US Customary)

Figure 37-5.G

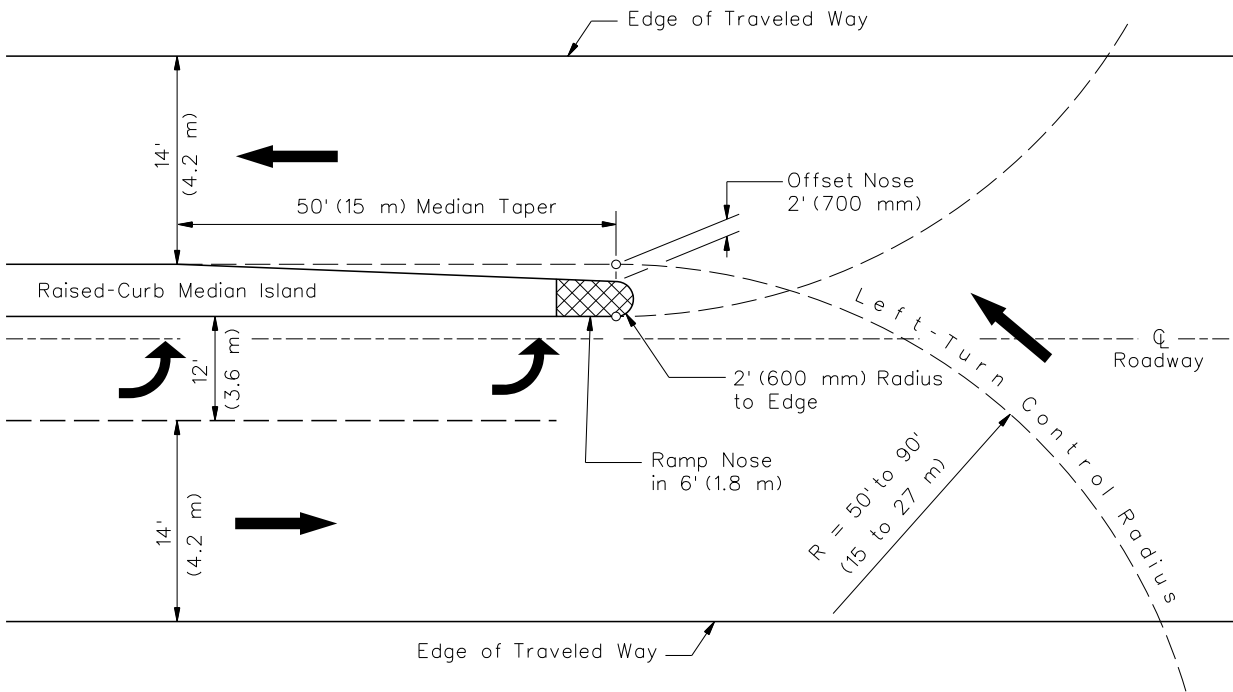

**OFFSET MEDIAN NOSE DETAIL
(Interchange Crossroad)**

Figure 37-5.H

Notes:

1. Intersection designed for a WB-67 design vehicle.
2. Ramp noses of channelizing islands as shown.
3. The angle of ramp/crossroad intersection should be approximately 90°.
4. Use 6' wide gutters on median islands.
5. Use lighting and signing to minimize wrong-way movements.

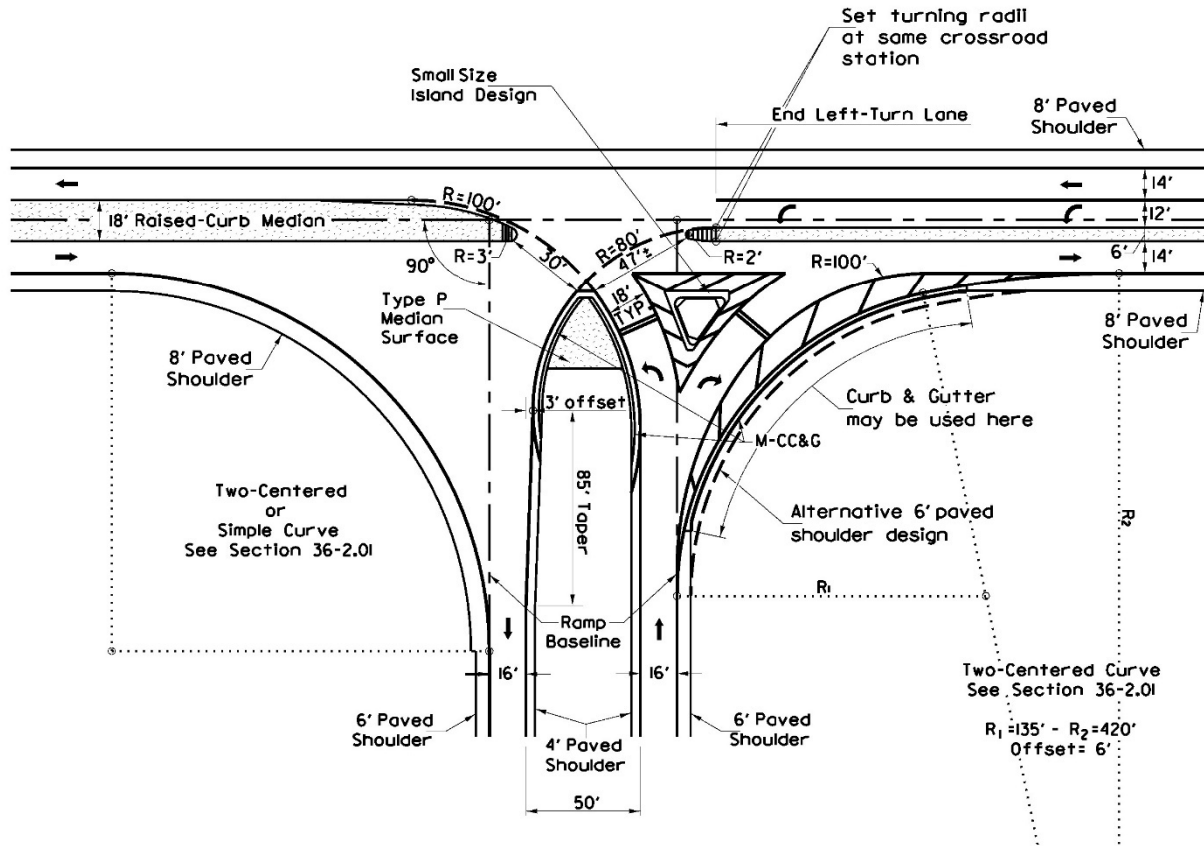

TYPICAL RAMP/CROSSROAD INTERSECTION — PARCLO INTERCHANGE
(Two-Quad) (US Customary)

Figure 37-5.1

Notes:

1. Intersection designed for a WB-20 design vehicle.
2. Ramp noses of channelizing islands as shown. 
3. The angle of ramp/crossroad intersection should be approximately 90°.
4. Use 150 mm wide gutters on median islands.
5. Use lighting and signing to minimize wrong-way movements.

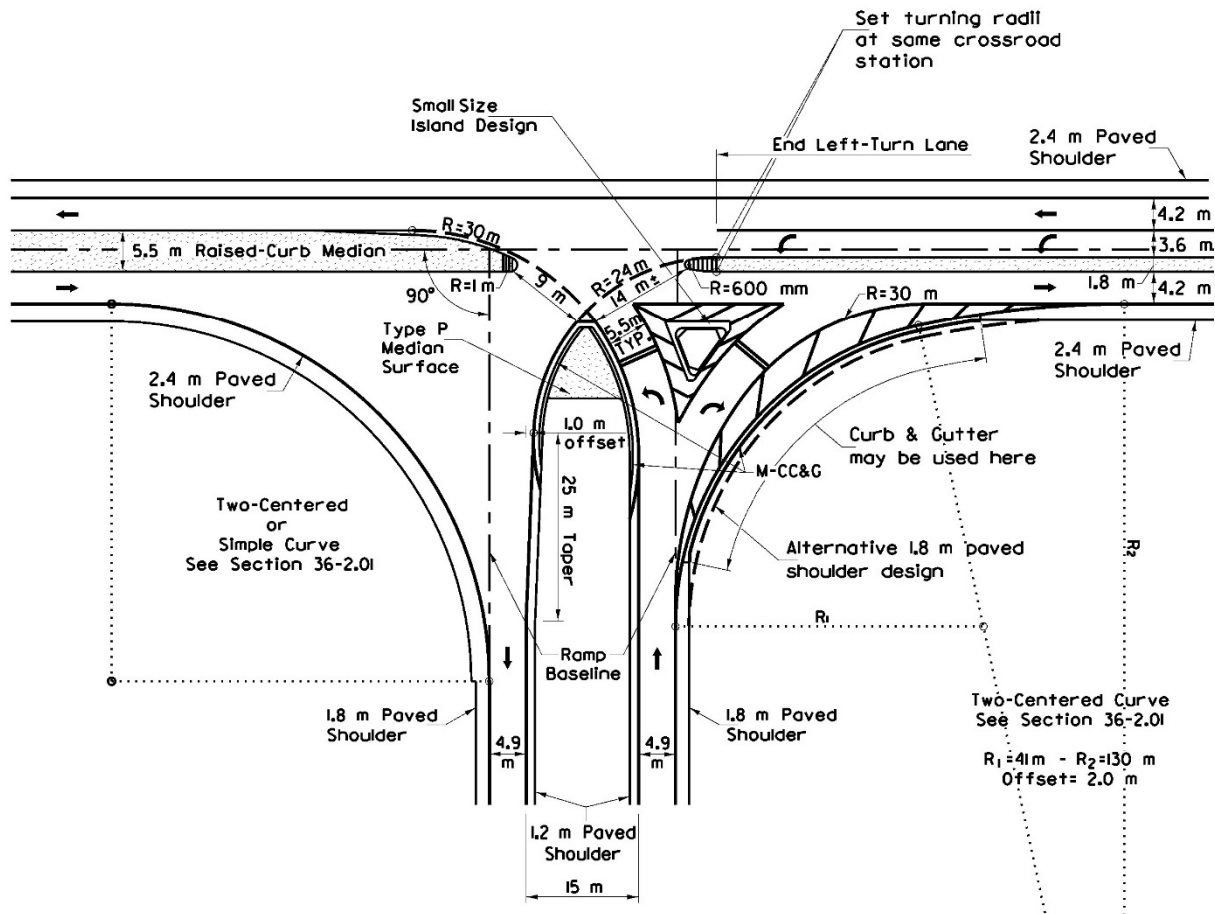

TYPICAL RAMP/CROSSROAD INTERSECTION — PARCLO INTERCHANGE
(Two-Quad) (Metric)

Figure 37-5.1

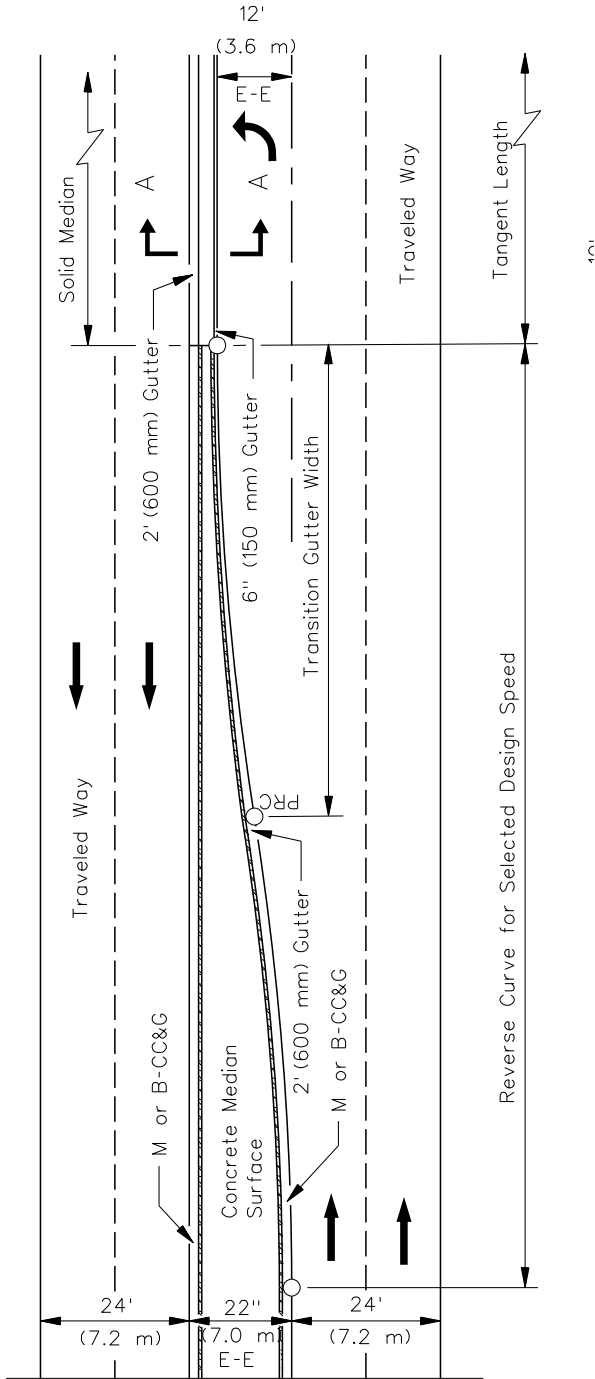

Notes:

1. Ramp terminals with the crossroad usually will be signalized.
2. For the design speed of 50 mph (80 km/hr), use an M-4.24 (M-10.60) curb and gutter on the median.

TYPICAL CROSSROAD MEDIAN DETAIL
(Diamond Interchange)

Figure 37-5.J

37-5.02(c) Four-Quadrant Partial Cloverleaf Interchange

The controlled ramp terminals of a four-quadrant partial cloverleaf interchange are similar in design to the ramp/crossroad intersections of a diamond interchange; however, they must be located to minimize any adverse operational effects on the directional ramps in the opposite quadrants. The left-turning path from the controlled ramp terminal of the four-quadrant partial cloverleaf Type A must intersect the crossroad downstream from the gore of the exit terminal, as illustrated in Figure 37-5.K. The minimum distance of 200 ft (60 m) discourages wrong-way movements and allows for stored vehicles on the crossroad when signalized.

For the four-quadrant partial cloverleaf Type B, illustrated in Figure 37-5.L, terminate the left-turn lane from the crossroad into the controlled entrance ramp in advance of the merging nose of the entrance terminal. Providing this separation minimizes confusion between two decision points on the crossroad and provides better traffic operations when signalized.

37-5.02(d) Compressed Diamond with Slip Ramps

The designer must consider the impact of frontage roads, where present, on interchange design. At some urban interchanges, separating the intersection of the ramp and frontage road with the crossroad may be impractical. In these cases, the only alternative is to provide a slip ramp to a one-way frontage road before the intersection with the crossroad. This can apply to either an exit or entrance ramp. Sufficient distance must then be provided between the freeway ramp terminal and the ramp/frontage road terminal to provide the necessary acceleration or deceleration distance and weaving distance.

Figure 37-5.M provides the basic schematic for this design. The critical design element is the distance “A” between the ramp/frontage road merge and the crossroad. This distance must be sufficient to allow traffic weaving, vehicular deceleration and stopping, and vehicular storage to avoid interference with the merge point. Figure 37-5.M presents general guidelines that may be used to estimate this distance during the preliminary design phase. A number of assumptions have been made including weaving volume, operating speeds, and intersection queue distance. Therefore, a detailed analysis will be necessary to firmly establish the needed distance to properly accommodate vehicular operations. Additional information can be found in a Transportation Research Record 682 article entitled, “Distance Requirements for Frontage-Road Ramps to Cross Streets: Urban Freeway Design” or in the Texas Transportation Institute publication *Procedures to Determine Frontage Road Level of Service and Ramp Spacing*.

Distance “B” in Figure 37-5.M is determined on a case-by-case basis. It should be determined based on the number of frontage road lanes and the intersection design. This distance is typically determined by the necessary weave distance from the intersection to the ramp entrance. For capacity analysis of the weave section, see the *Highway Capacity Manual*.

Notes:

1. Intersection designed for a WB-67 design vehicle.
2. Ramp noses of channelizing islands as shown. 
3. The angle of ramp/crossroad intersection should be approximately 90°.
4. Use 2' wide gutters on median islands.
5. Traffic signals may be required at the intersection.
6. Use lighting and signing to minimize wrong-way movements.

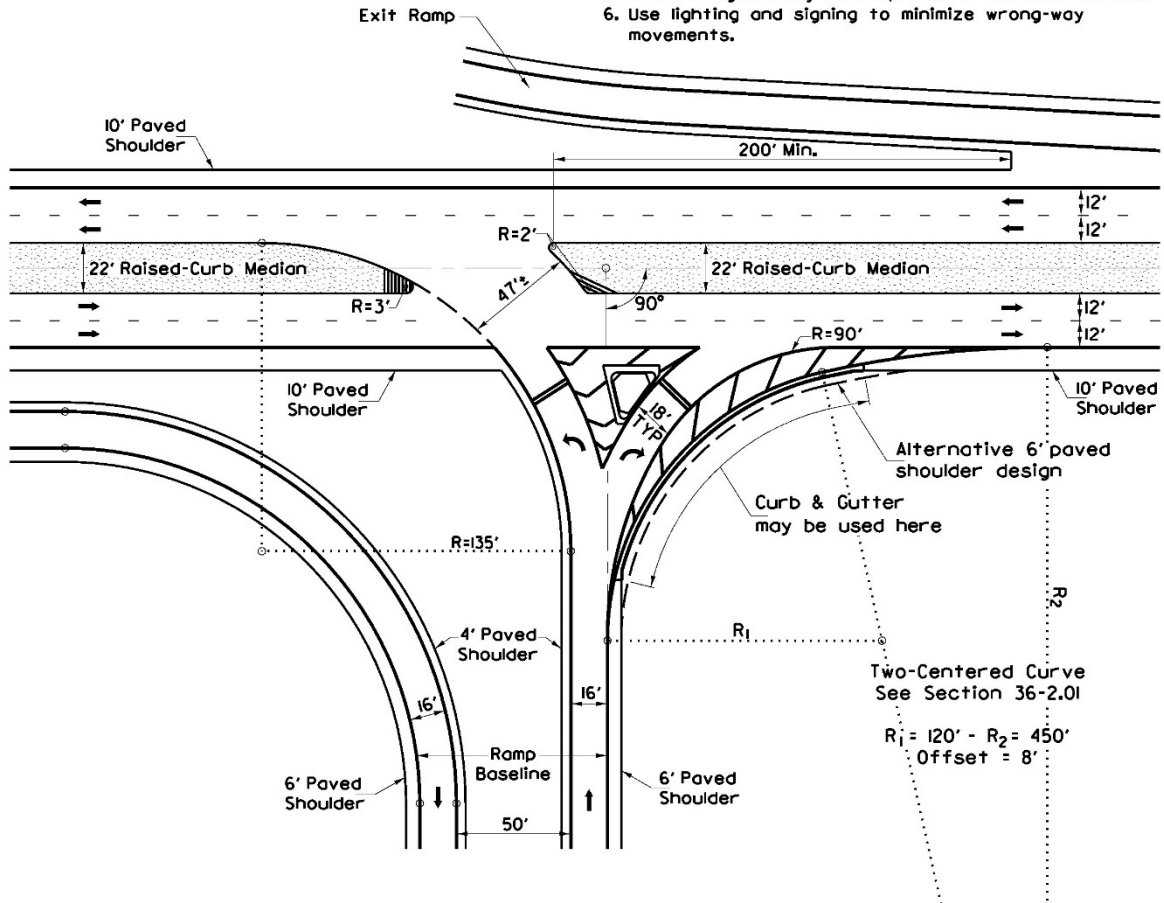

**CONTROLLED TERMINAL — PARCLO INTERCHANGE
(Four-Quad – Type A)
(US Customary)**

Figure 37-5.K

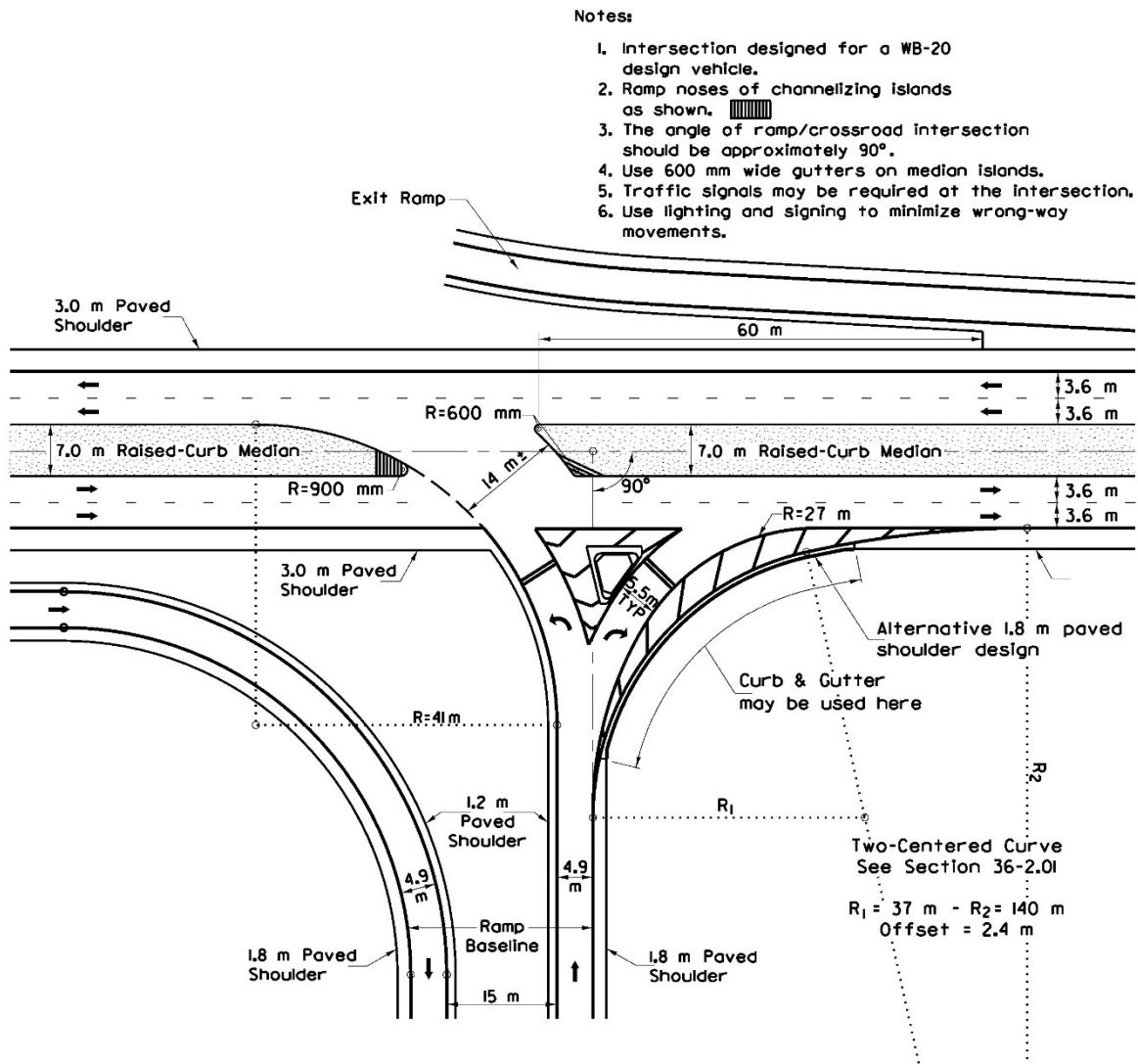

**CONTROLLED TERMINAL — PARCLO INTERCHANGE
(Four-Quad - Type A)
(Metric)**

Figure 37-5.K

Notes:

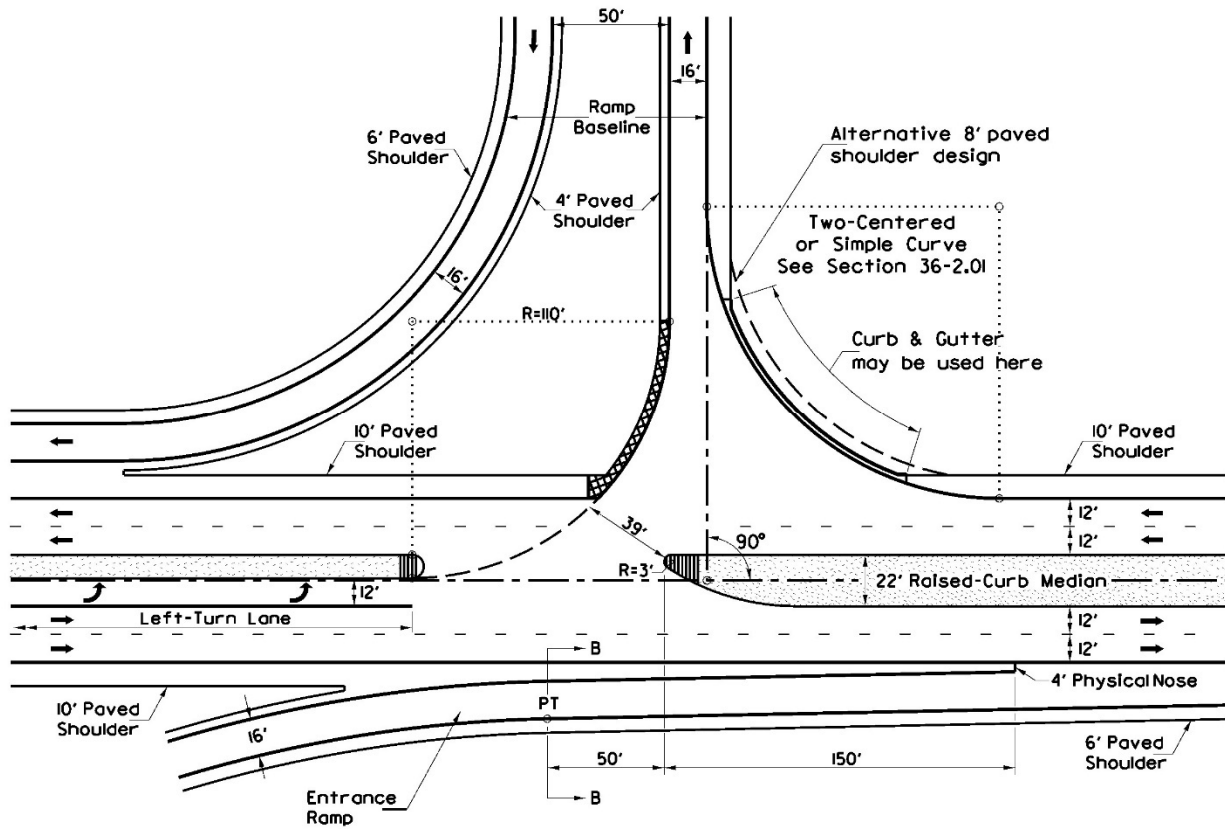

1. Intersection designed for a WB-67 design vehicle.
2. Ramp noses of channelizing islands as shown.
3. Provide full depth (Min. 10') paved shoulder.
4. The angle of ramp/crossroad intersection should be approximately 90°.
5. Use 2' wide gutters on median islands except where adjacent to left-turn lane; see Section 34-2.04.
6. Traffic signals may be required at the intersection.
7. Use Lighting and signing to minimize wrong-way movements.
8. See Section B-B on Standard Entrance Terminal.



**CONTROLLED TERMINAL — PARCLO INTERCHANGE
(Four-Quad – Type B)
(US Customary)**

Figure 37-5.L

Notes:

1. Intersection designed for a WB-20 design vehicle.
2. Ramp noses of channelizing islands as shown. 
3. Provide full depth (Min. 250 mm) paved shoulder. 
4. The angle of ramp/crossroad intersection should be approximately 90°.
5. Use 600 mm wide gutters on median islands except where adjacent to left-turn lane; see Section 34-2.04.
6. Traffic signals may be required at the intersection.
7. Use Lighting and signing to minimize wrong-way movements.
8. See Section B-B on Standard Entrance Terminal.

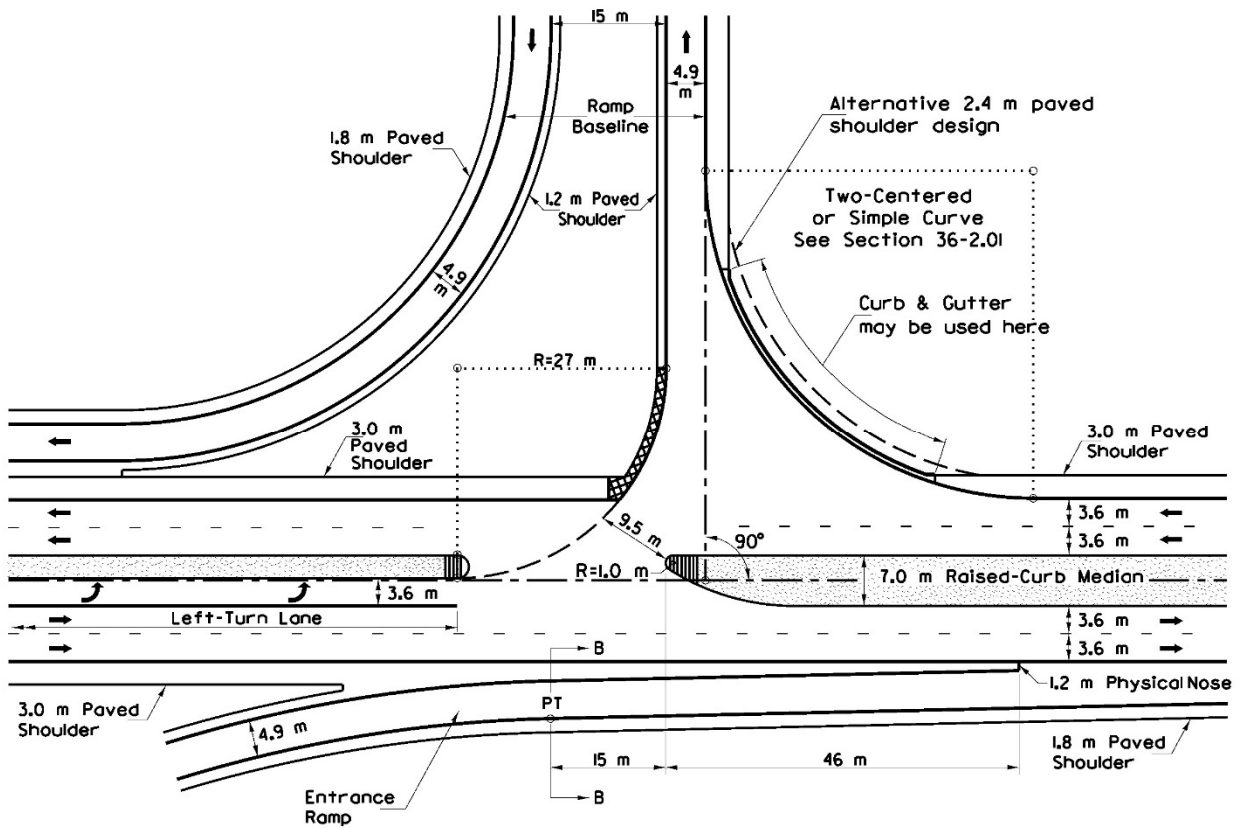

**CONTROLLED TERMINAL — PARCLO INTERCHANGE
(Four-Quad – Type B)
(Metric)**

Figure 37-5.L

Frontage Road Volume at Intersection (vph)①	Exit Ramp Volume (vph)②	“A”		
		Typical Minimum	Typical Desirable	Special Considerations
200	140	380 ft (115 m)	500 ft (150 m)	270 ft (80 m)
400	280	465 ft (140 m)	565 ft (170 m)	370 ft (110 m)
600	420	500 ft (150 m)	635 ft (190 m)	400 ft (120 m)
800	560	550 ft (165 m)	700 ft (210 m)	435 ft (130 m)
1000	700	600 ft (180 m)	765 ft (230 m)	465 ft (140 m)
1200	840	650 ft (195 m)	885 ft (265 m)	485 ft (145 m)
1400	980	700 ft (210 m)	985 ft (295 m)	500 ft (150 m)
1600	1120	785 ft (235 m)	1085 ft (325 m)	535 ft (160 m)
1800	1260	865 ft (260 m)	1200 ft (360 m)	565 ft (170 m)
2000	1400	985 ft (295 m)	1315 ft (395 m)	600 ft (180 m)

- ① Assumes the total volume of traffic on the frontage road including the merged exit-ramp volume.
- ② Assumed to be 70% of total volume in first column.

Notes:

1. Table values are acceptable for planning purposes only. Final lengths will be based on a detailed operational analysis. This design may be used only in restricted urban areas.
2. Distance “B” is determined on a case-by-case basis.
3. “C” is a slip ramp.
4. See Chapter 35 for access control design along frontage road and crossroad.

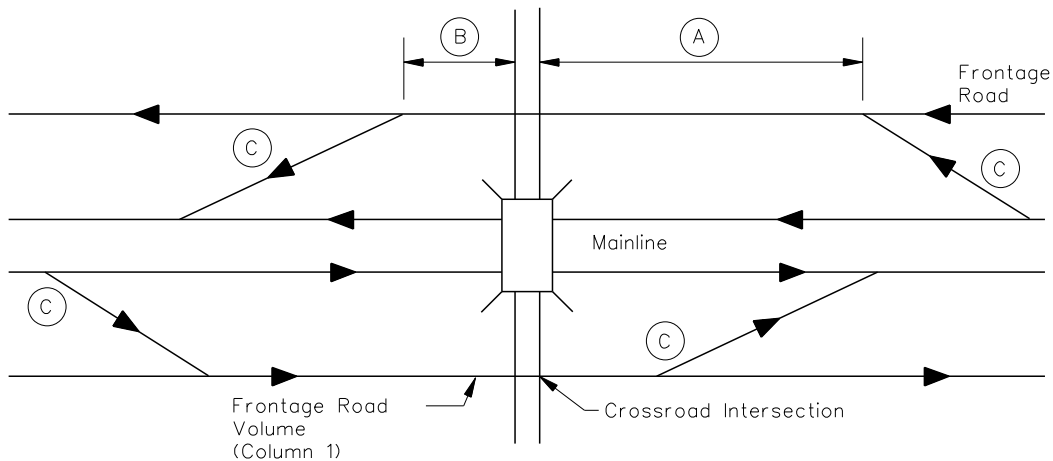

RAMP/CONTINUOUS FRONTAGE ROAD INTERSECTION

Figure 37-5.M

37-5.03 Crossroad Access Control

Providing access control along the crossroad of an interchange is an important design feature for both the safety and efficient operation of an interchange. The access control line is defined as a line established by the Department that restricts direct access to property abutting a highway. See Chapter 35 for additional details on access control limits.

37-6 FREEWAY RAMP TERMINALS

37-6.01 Exit Ramp Terminals

37-6.01(a) Types

The exit ramp terminal is a speed-change lane that permits high-speed traffic to exit from the through lane of the highway and enter the ramp proper. The exit terminal must be visible to the approaching motorist and provide a clear indication for the point of departure from the traveled way. When designing the interchange, consider the following exit ramp types:

1. Standard Exit Terminal. There are two basic types of exit freeway ramp terminals — the parallel design and the taper design. For all new and reconstructed ramps, use the taper design. Figure 37-6.A and the *Illinois Highway Standards* illustrate the Department's standard exit ramp terminal design. Exit ramp terminals may carry a marked route provided the marked route is not a freeway or expressway. Where a freeway or expressway turns through an interchange, use the major divergence design as discussed in Section 37-6.03.
2. Exit Terminal With an Auxiliary Lane. An auxiliary lane may be required prior to the exit terminal:
 - to meet the guidelines discussed in Section 37-2.05,
 - where the exiting design traffic exceeds the appropriate service volume of a standard exit terminal design but does not require a two-lane exit, and/or
 - proceeding a left-hand exit terminal. Note that interchange designs should not use left-hand exit terminals. However, where necessary, left-hand exits must be first approved by BDE before the interchange type approval.

Figure 37-6.B illustrates the design criteria for an exit terminal preceded by an auxiliary lane. Extend the pavement markings on the left edge of the ramp to the right edge of the mainline traveled way. Provide transverse pavement markings in the recovery area to discourage the use of the auxiliary lane beyond the exit gore. Pavement markings in the recovery area should be according to the Bureau of Operations' *Policies and Procedures Manual*.

3. Two-Lane Exits. These terminals are typically required where the traffic volumes on the ramp exceed the capacity of a single-lane exit ramp. The following lists several elements the designer should consider for two-lane exit terminals:
 - a. Lane Balance. For consistent freeway operations, maintain lane balance at the freeway ramp terminal; see Section 37-2.03.

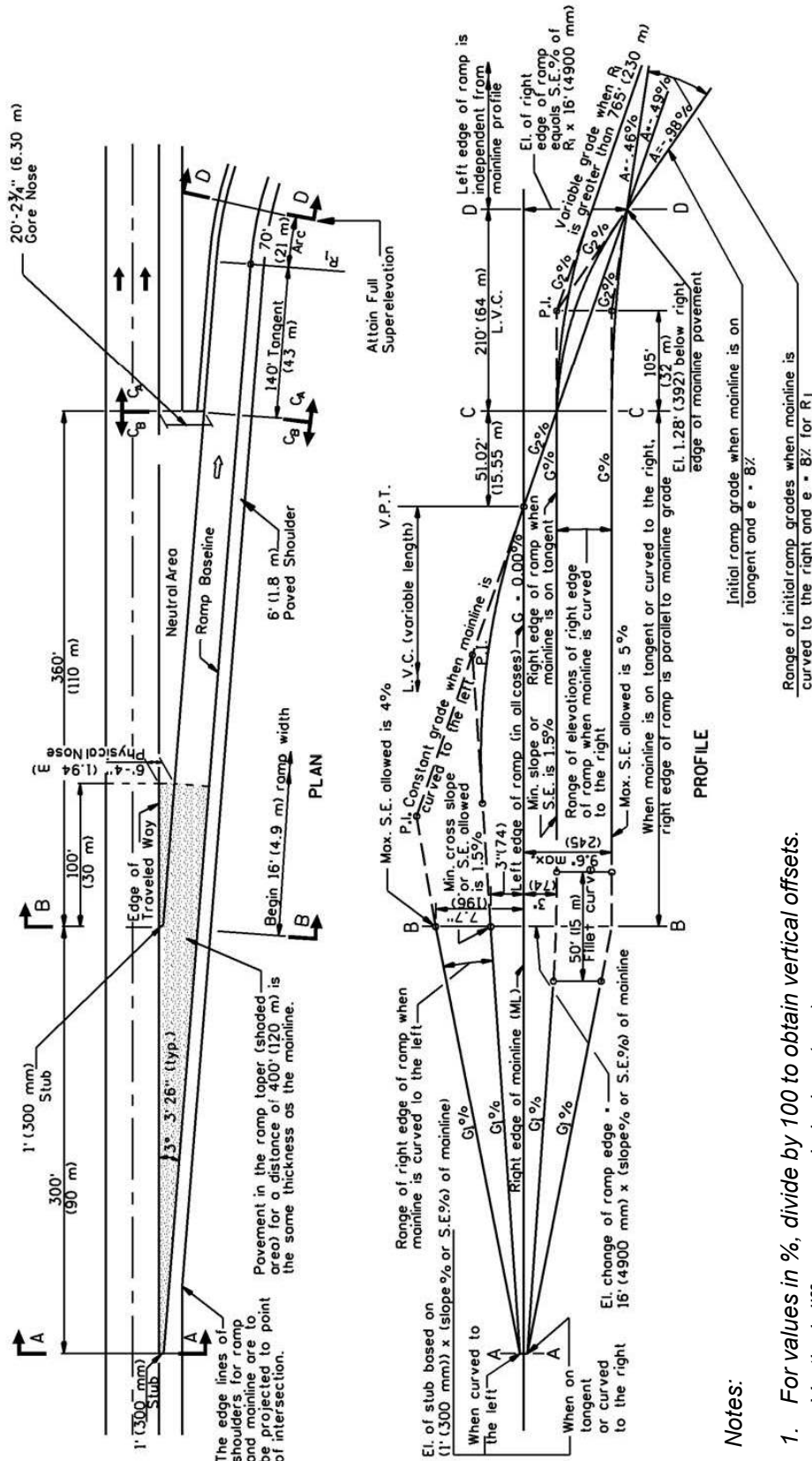

STANDARD EXIT RAMP TERMINAL

Figure 37-6.A

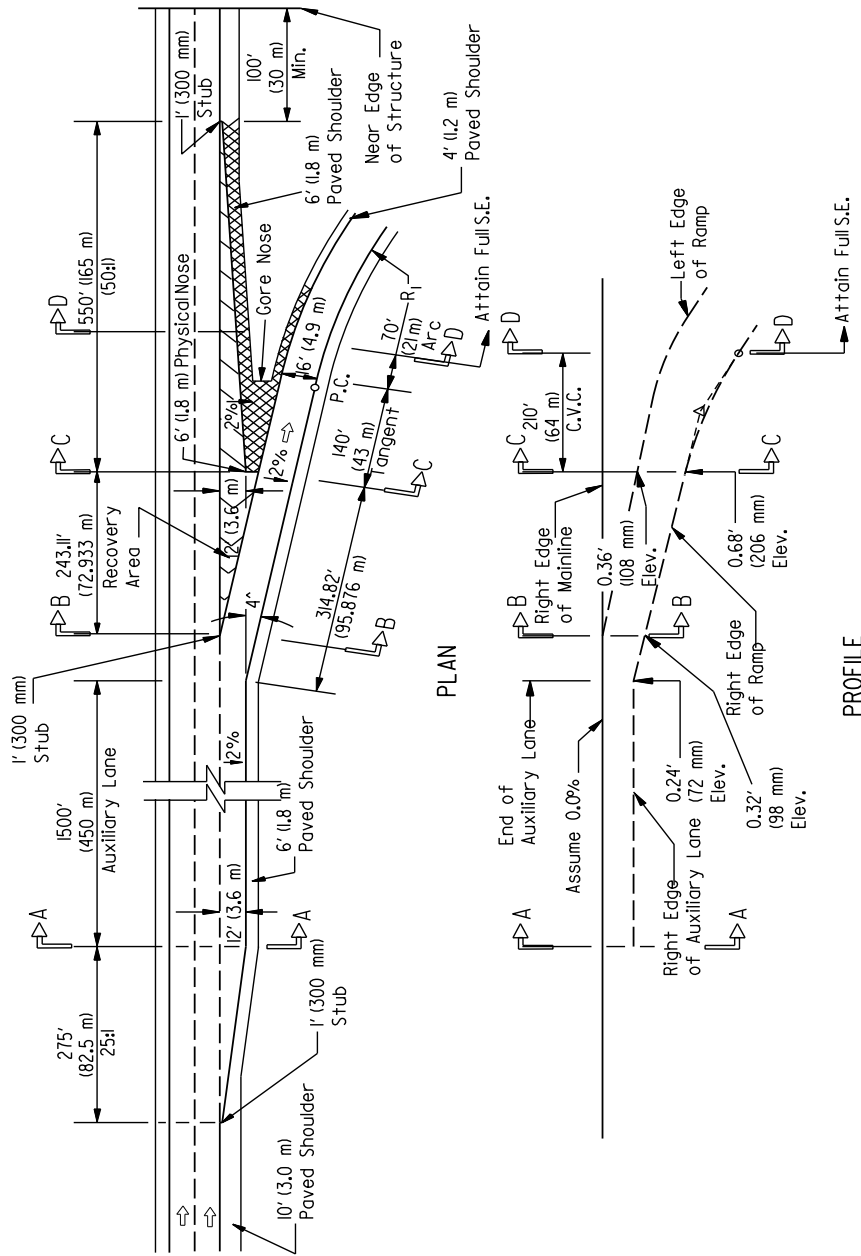

Notes:

1. Where the mainline is superelevated to the left or right, the terminal elevations and grades must be adjusted.
2. A 50 ft (15 m) vertical curve may be used for comfort and aesthetics along the right edge of the ramp at the grade changes.
3. Include cross sections A-A, B-B, C-C, and D-D with the IDS.
4. Regardless of the % S.E. at D-D, the % cross slope at the PC is always $\frac{2}{3}$ the difference between C-C and D-D.

EXIT RAMP TERMINAL WITH AUXILIARY LANE

Figure 37-6.B

- b. Design. A typical two-lane exit terminal design is illustrated in Figure 37-6.C. To develop the proper level of service at a two-lane exit facility and provide proper lane balance, add a minimum 1500 ft (450 m) long auxiliary lane prior to the exit terminal. The concepts for controlling gradelines and pavement cross slopes on two-lane exit terminals are generally the same as those described for major divergences. Prepare detailed cross sections for critical locations on the two-lane exit ramp and present them in the Interchange Design Study (IDS).

37-6.01(b) Sight Distance

The sight distance approaching the gore nose should exceed the stopping sight distance for the through traffic, desirably by 25% or more. Where there are unusual conditions, consider providing decision sight distance to the exit terminal. Extra sight distance is particularly important for exit loops immediately beyond a structure. When measuring for adequate sight distance, ensure that the motorist can see the pavement surface at and beyond the gore nose. Locating the exit terminal and gore nose where the mainline is on an upgrade provides the best design condition. Do not locate exit terminals near mainline crest vertical curves where the ramp pavement may disappear from the driver's view.

37-6.01(c) Alignment

Figures 37-6.D through 37-6.F illustrate methods to determine the grades along sections of typical exit ramp terminals where the mainline is on tangent, curving to the right, and curving to the left. The Department's preferred practice is to locate exit terminals on tangent sections or on mainline curves to the right. However, this may not be practical in highly restricted areas. Section 37-4.07 discusses the minimum alignment criteria for the ramp proper, including the minimum radii for the initial ramp curve (R_1).

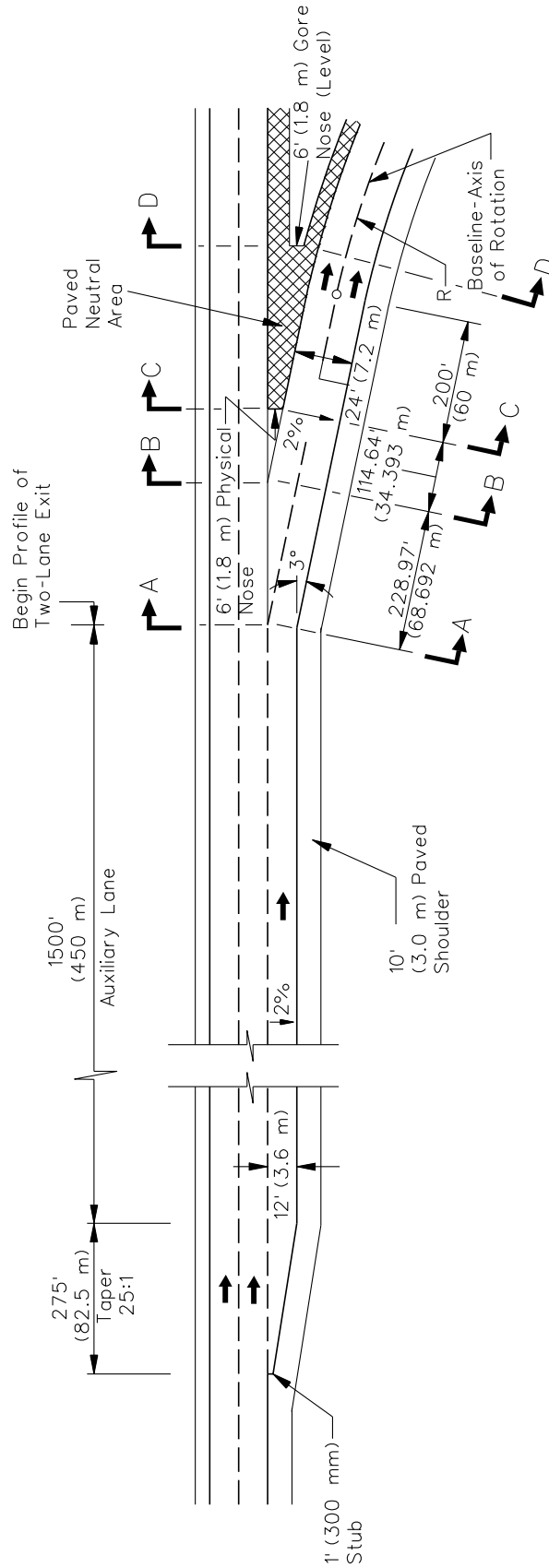

Notes:

1. Attain full superelevation at Section D-D.
2. Include cross sections A-A, B-B, C-C, and D-D with the IDS.

TWO-LANE EXIT RAMP TERMINAL

Figure 37-6.C

Example 37-6.1

Given: Freeway design speed = 70 mph
 Freeway is on tangent
 Freeway grade, $G = +2.00\%$
 Initial ramp curve radius, $R_1 = 760$ ft
 Ramp $e_{max} = 8\%$

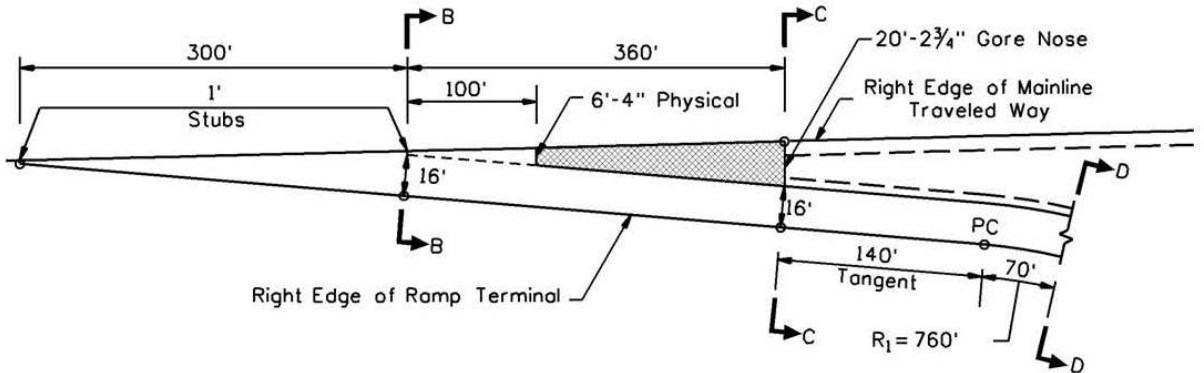

PLAN VIEW FOR BASE CONDITIONS

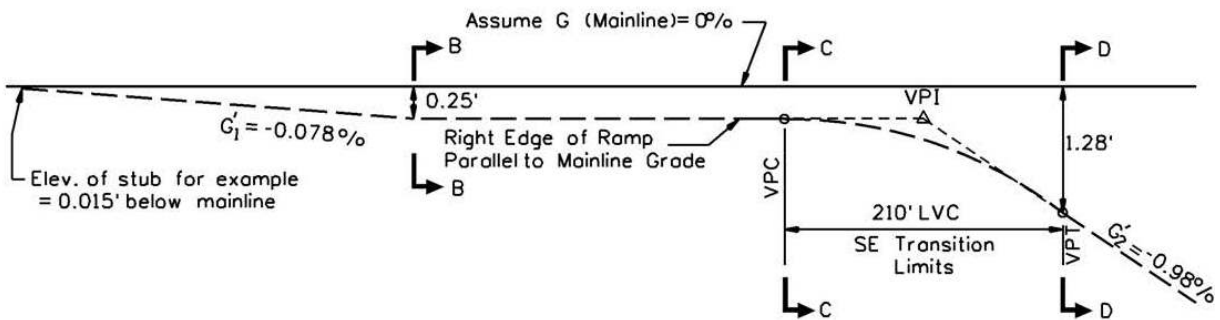

PROFILE FOR BASE CONDITIONS

APPLICATION: See Figure 37-6.A.

Problem: Find G_1 and G_2 , where G_1 and G_2 are the actual design grades.

**EXAMPLE EXIT RAMP TERMINAL
 (Mainline on Tangent)**

Figure 37-6.D(1)
 (1 of 2)

Solution:

1. Determine G_1 .

$$G_1 = G + G_1'$$

Use the profile equation for base conditions for the mainline:

Mainline profile = 0.0%

Mainline on tangent

$$G_1' = \left[\frac{(e/100 \times 16) - (e/100 \times 1)}{300} \right] \times 100$$

Where: e = superelevation of the mainline (maximum 5% for G_1').

Determine actual G_1

$$G_1 = 2.00 + \left[\frac{(-1.56/100 \times 16) - (-1.56/100 \times 1)}{300} \right] \times 100$$

$$G_1 = 2.00\% + (-0.078\%) = +1.922\%$$

2. Determine G_2 .

$$G_2 = G + G_2'$$

Use the profile equation for base conditions for the ramp:

Mainline profile = 0.0%

$R_1 = 760$ ft

$$G_2' = \left[\frac{(e/100 \times 16) - (\text{Elev. Of VPI})}{105} \right] \times 100$$

Where: 105 ft = half of LVC

And e = superelevation for the radius R_1

From Figure 32-3.B, ramp superelevation: $e = 8.0\%$ for R_1 of 760 ft.

Determine actual G_2

$$G_2 = 2.00 + \left[\frac{(-8.0/100 \times 16) - (-0.25)}{105} \right] \times 100$$

$$G_2 = 2.00\% + (-0.98\%) = +1.02$$

**EXAMPLE EXIT RAMP TERMINAL
(Mainline on Tangent)**

Figure 37-6.D(1)
(2 of 2)

Example 37-6.2

Given: Freeway design speed = 70 mph
 Freeway is on tangent
 Ramp design speed = 50 mph
 Freeway grade, $G = +2.00\%$
 Initial ramp curve radius, $R_1 = 1560$ ft
 Ramp $e_{max} = 8\%$

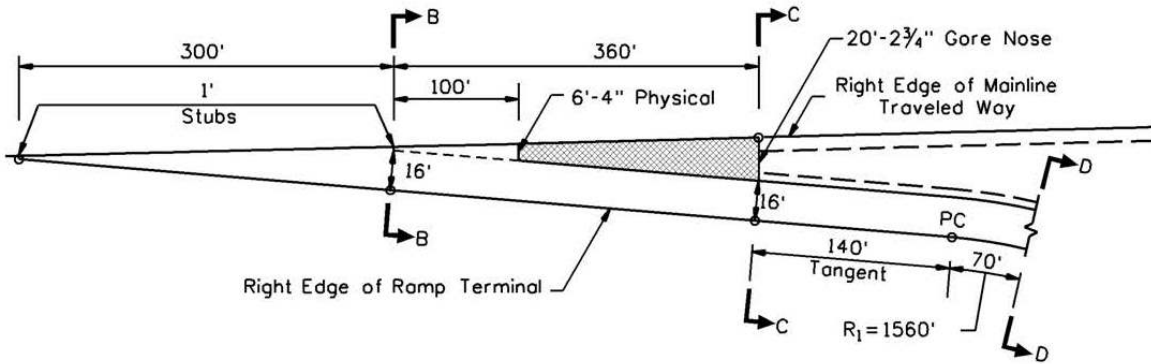

PLAN VIEW FOR BASE CONDITIONS

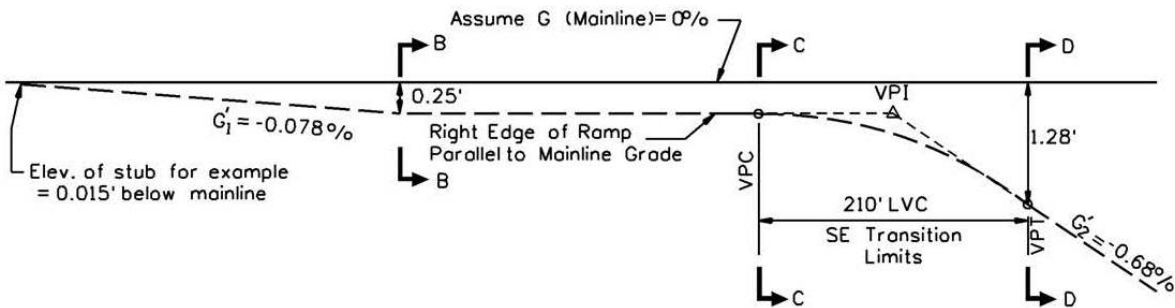

PROFILE FOR BASE CONDITIONS

APPLICATION: See Figure 37-6.A.

Problem: Find G_1 and G_2 , where G_1 and G_2 are the actual design grades.

**EXAMPLE EXIT RAMP TERMINAL
 (Mainline on Tangent)**

Figure 37-6.D(2)
 (1 of 2)

Solution:

1. Determine G_1 .

$$G_1 = +1.922\%$$

(See Example Problem 37-6.1 for G_1 calculations.)

2. Determine G_2 .

$$G_2 = G + G_2'$$

Use the profile equation for base conditions for the ramp except for R_1 :

Mainline profile = 0.0%

$R_1 = 1560$ ft

$$G_2' = \left[\frac{(e/100 \times 16) - (\text{Elev. Of VPI})}{105} \right] \times 100$$

Where: 105 ft = half of LVC

And e = superelevation for the radius R_1

From Figure 32-3.B, ramp superelevation: $e = 6.0\%$ for R_1 of 1560 ft.

Determine actual G_2

$$G_2 = 2.00 + \left[\frac{(-6.0/100 \times 16) - (-0.25)}{105} \right] \times 100$$

$$G_2 = 2.00\% + (-0.68\%) = +1.32\%$$

**EXAMPLE EXIT RAMP TERMINAL
(Mainline on Tangent)**

Figure 37-6.D(2)
(2 of 2)

Example 37-6.3

Given: Freeway Design Speed = 70 mph
 Freeway curves to the right, $R = 3330$ ft
 Initial Ramp Radius, $R_1 = 760$ ft
 Freeway Grade, $G = -1.80\%$
 Freeway $e_{max} = 6\%$
 Ramp $e_{max} = 8\%$

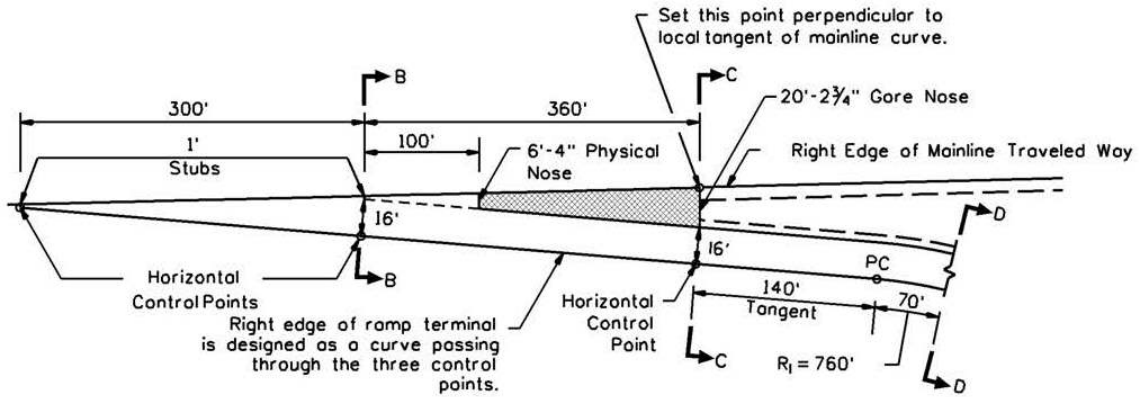

PLAN VIEW FOR BASE CONDITIONS

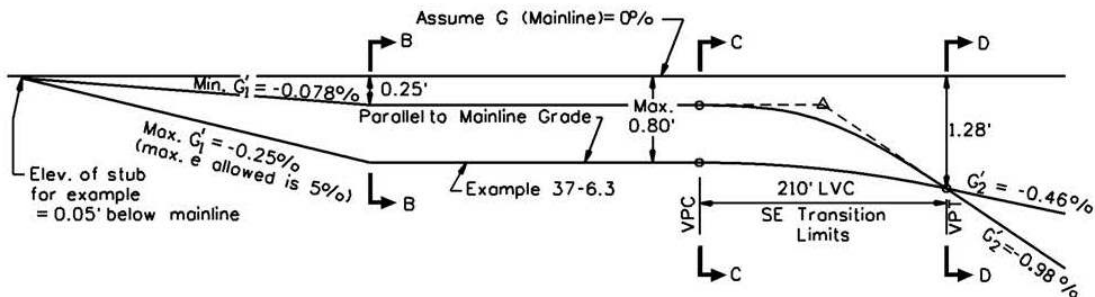

PROFILE FOR BASE CONDITIONS

APPLICATION: See Figure 37-6.A.

Problem: Find G_1 and G_2 , where G_1 and G_2 are the actual design grades.

**EXAMPLE EXIT RAMP TERMINAL
 (Mainline Curving to the Right)**

Figure 37-6.E(1)
 (1 of 2)

Solution:

1. Determine
- G_1
- .

$$G_1 = G + G_1'$$

Use the profile equation for base conditions for the mainline except mainline is on curve:

Mainline profile = 0.0%

From Figure 32-3.C, the freeway superelevation, $e = 5.0\%$.

5% is the maximum superelevation of the ramp terminal when the mainline is curved to the right.

$$G_1' = \left[\frac{(e/100 \times 16) - (e/100 \times 1)}{300} \right] \times 100$$

Where: e = superelevation of the mainline (maximum SE is 5% for G_1').

Determine actual G_1

$$G_1 = -1.80 + \left[\frac{(-5.0/100 \times 16) - (-5.0/100 \times 1)}{300} \right] \times 100$$

$$G_1 = -1.80\% + (-0.25\%) = -2.05\%$$

2. Determine
- G_2
- .

$$G_2 = G + G_2'$$

Use the profile equation for base conditions for the ramp.

Mainline profile = 0.0%

$R_1 = 760$ ft

$$G_2' = \left[\frac{(e/100 \times 16) - (\text{Elev. of VPI})}{105} \right] \times 100$$

Where: 105 ft = half of LVC

And e = superelevation for the radius R_1

From Figure 32-3.B, ramp superelevation: $e = 8.0\%$ for R_1 of 760 ft.

Determine actual G_2

$$G_2 = -1.80 + \left[\frac{(-8.0/100 \times 16) - (-0.80)}{105} \right] \times 100$$

$$G_2 = -1.80\% + (-0.46\%) = -2.26\%$$

**EXAMPLE EXIT RAMP TERMINAL
(Mainline Curving to the Right)**

Figure 37-6.E(1)
(2 of 2)

Example 37-6.4

Given: Freeway Design Speed = 70 mph
 Freeway curves to the right, $R = 6490$ ft
 Initial Ramp Radius, $R_1 = 760$ ft
 Freeway grade, $G = +2.50\%$
 Freeway $e_{max} = 6\%$
 Ramp $e_{max} = 8\%$

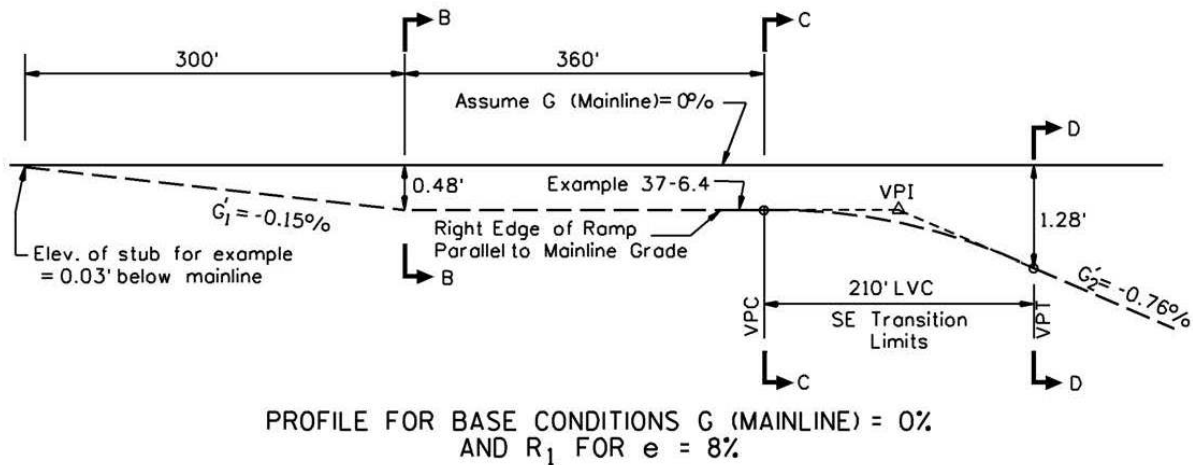
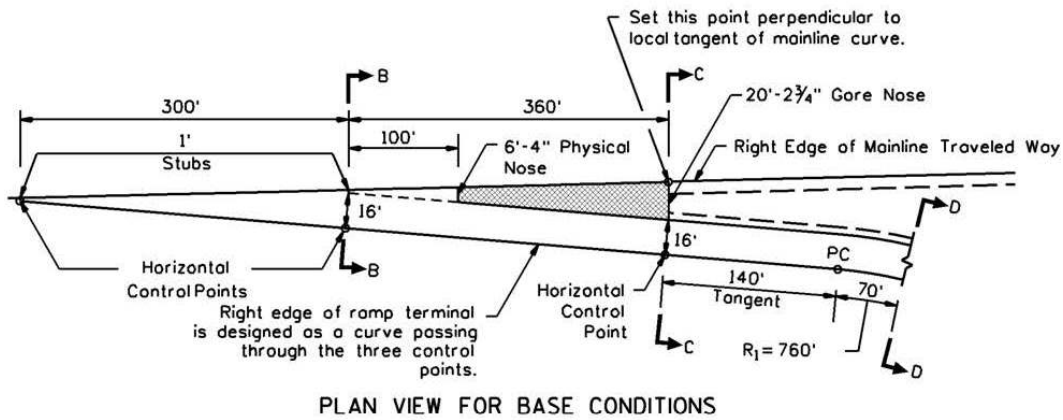

APPLICATION: See Figure 37-6.A.

Problem: Find G_1 and G_2 .

**EXAMPLE EXIT RAMP TERMINAL
 (Mainline Curving to the Right)**

Figure 37-6.E(2)

(1 of 2)

Solution:

1. Determine G_1 .

$$G_1 = G + G_1'$$

Use the profile equation for base conditions for the mainline except mainline is on curve:

Mainline profile = 0.0%

From Figure 32-3.C, the freeway superelevation, $e = 3.0\%$.

5% is the maximum superelevation of the ramp terminal when the mainline is curved to the right.

$$G_1' = \left[\frac{(e/100 \times 16) - (e/100 \times 1)}{300} \right] \times 100$$

Where: e = superelevation of the mainline (maximum SE is 5% for G_1').

Determine actual G_1

$$G_1 = +2.50 + \left[\frac{(-3.0/100 \times 16) - (-3.0/100 \times 1)}{300} \right] \times 100$$

$$G_1 = +2.50\% + (-0.15\%) = +2.35\%$$

2. Determine G_2 .

$$G_2 = G + G_2'$$

Use the profile equation for base conditions for the ramp.

Mainline profile = 0.0%

$R_1 = 760$ ft

$$G_2' = \left[\frac{(e/100 \times 16) - (\text{Elev. of VPI})}{105} \right] \times 100$$

Where: 105 ft = half of LVC

And e = superelevation for the radius R_1

From Figure 32-3.B, ramp superelevation: $e = 8.0\%$ for R_1 of 760 ft.

Determine actual G_2

$$G_2 = +2.50 + \left[\frac{(-8.0/100 \times 16) - (-0.48)}{105} \right] \times 100$$

$$G_2 = +2.50\% + (-0.76\%) = +1.74\%$$

**EXAMPLE EXIT RAMP TERMINAL
(Mainline Curving to the Right)**

Figure 37-6.E(2)

(2 of 2)

Example 37-6.5

- Given:** Freeway Design Speed = 70 mph
 Freeway curves to the left, $R = 6010$ ft
 Initial Ramp Radius, $R_1 = 760$ ft (curved to the right)
 Freeway Grade, $G = + 2.00\%$
 Freeway $e_{max} = 6\%$
 Ramp $e_{max} = 8\%$

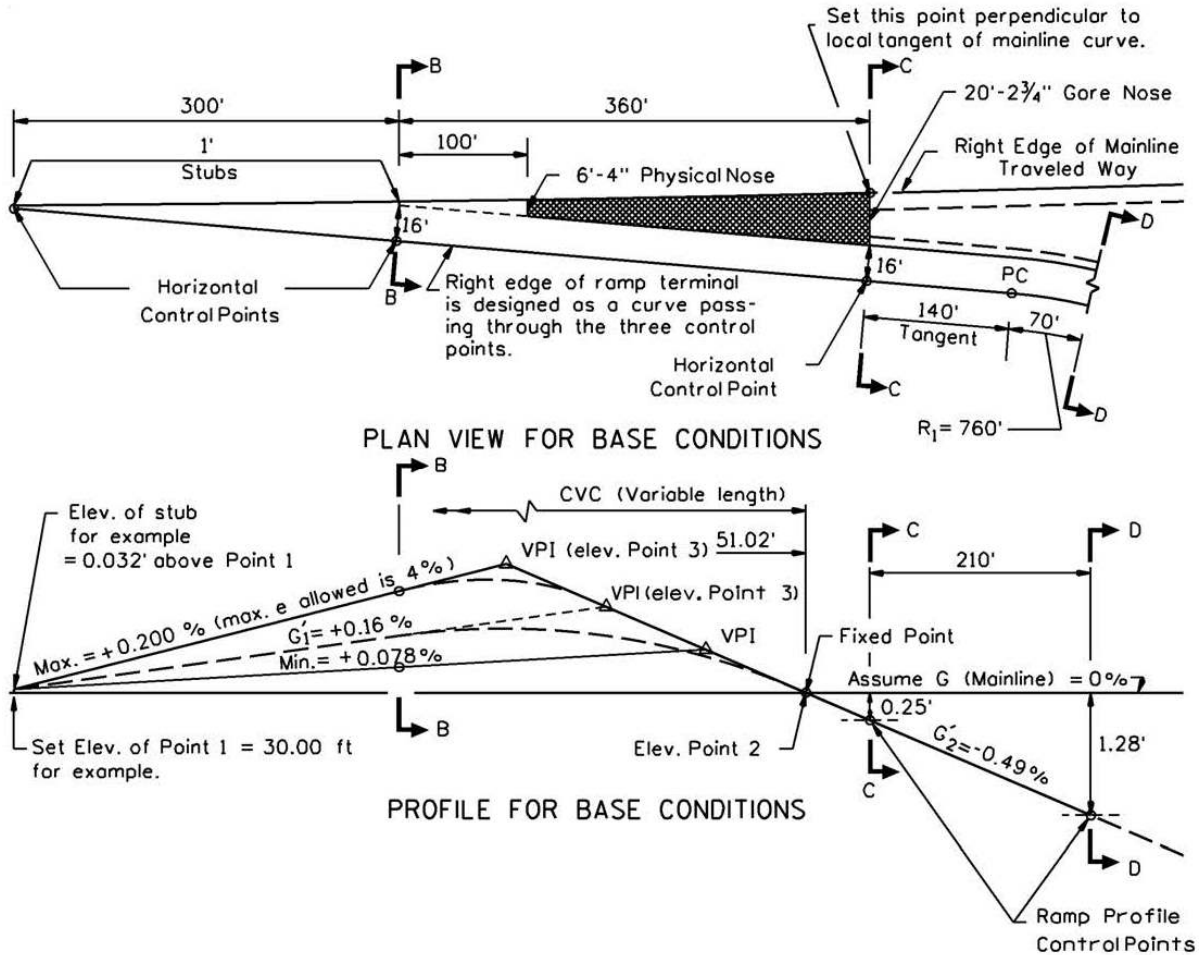

APPLICATION: See Figure 37-6.A.

Problem: Find G_1 and G_2 .
 Find the location and the elevation of the VPI along the right edge of the ramp.

**EXAMPLE EXIT RAMP TERMINAL
 (Mainline Curving to the Left)
 Figure 37-6.F(1)
 (1 of 3)**

Solution:

1. Determine G_1 .

$$G_1 = G + G_1'$$

Use the profile equation for base conditions for the mainline except mainline is on curve:

Mainline profile = 0.0%

From Figure 32-3.C, the freeway superelevation, $e = 3.2\%$.

4% is the maximum superelevation of the ramp terminal when the mainline is curved to the left.

$$G_1' = \left[\frac{(e/100 \times 16) - (e/100 \times 1)}{300} \right] \times 100$$

Where: e = superelevation of the mainline (maximum SE is 4% for G_1').

Determine actual G_1

$$G_1 = +2.00 + \left[\frac{(3.2/100 \times 16) - (3.2/100 \times 1)}{300} \right] \times 100$$

$$G_1 = +2.00\% + (0.16\%) = +2.16\%$$

2. Determine G_2 .

$$G_2 = G + G_2'$$

Use the profile equation for base conditions for the ramp.

Mainline profile = 0.0%

$R_1 = 760$ ft

$$G_2' = \left[\frac{(e/100 \times 16) - (-0.25)}{210} \right] \times 100$$

Where: 210 ft is the distance between the points in the numerator.

- 0.25 is the fixed elevation of the right edge of the ramp at C-C relative to the right edge of the mainline

and e = superelevation for the radius R_1

From Figure 32-3.B, ramp superelevation: $e = 8.0\%$ for R_1 of 760 ft.

Determine actual G_2

$$G_2 = +2.00 + \left[\frac{(-8.0/100 \times 16) - (-0.25)}{210} \right] \times 100$$

$$G_2 = +2.00\% + (-0.49\%) = +1.51\%$$

**EXAMPLE EXIT RAMP TERMINAL
(Mainline Curving to the Left)**

Figure 37-6.F(1)
(2 of 3)

3. Find the location and elevation of the VPI where the two design grades, G_1 and G_2 , intersect:

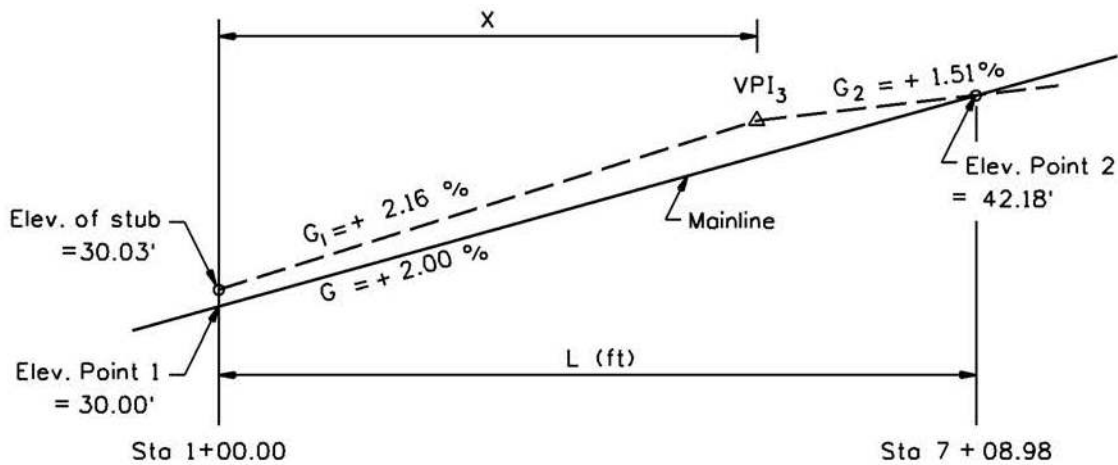

See Chapter 33 for basic equation of two lines intersecting:

$$x = \frac{(\text{Elev. of Pt. 2} - \text{Elev. of Stub}) - G_2/100 \times L}{(G_1 - G_2)/100}$$

$$x = \frac{(42.18 - 30.03) - (1.51/100 \times 608.98)}{(2.16 - 1.51)/100}$$

$$x = 454.52 \text{ ft}$$

$$\text{Elev. of VPI}_3 = G_1 X + \text{Elev. Stub}$$

$$\text{Elev. of VPI}_3 = \frac{2.16}{100} (454.52) + 30.03$$

$$\text{Elev. VPI}_3 = 39.84 \text{ ft}$$

**EXAMPLE EXIT RAMP TERMINAL
(Mainline Curving to the Left)**

Figure 37-6.F(1)
(3 of 3)

Example 37-6.6

A high speed freeway with a mainline curve to the left may have certain situations where the typical profile design shown in Example 37-6.5 does not provide the best fit for an exit terminal. In these cases, extend the 140 ft tangent section of the standard exit terminal ahead on tangent before an initial ramp curve to the right is designed into the ramp alignment. The cross slope of the ramp at Section C-C and beyond should be set at 3/16"/ft. Near the end of the tangent section, the ramp is then rotated to transition into the superelevation runoff length.

**EXAMPLE EXIT RAMP TERMINAL
(Mainline Curving to the Left)****Figure 37-6.F(2)**

37-6.01(d) Superelevation and Cross Slopes

Ramp cross slopes and superelevation rates for horizontal curves on ramps near the freeway ramp terminal must be developed to properly transition the driver from the mainline to the first curve on the exit ramp. The following will apply:

1. Cross Slope. The cross slope of the initial segment of the ramp departure from the through lane, or an auxiliary lane preceding the exit ramp is usually sloped at the same rate as the mainline. However, if the mainline has a flat longitudinal grade (i.e., less than 0.35%), consider increasing the cross slope rate on an auxiliary lane and the exit terminal to 2%. Where the mainline is curving to the right, the maximum cross slope on the exit terminal is 5%. Where the mainline is curving to the left, the maximum cross slope on the terminal is 4%.
2. Maximum Ramp Superelevation. In general, use an e_{\max} of 8%. However, in highly congested areas with snow and ice conditions, use an e_{\max} of 6%.
3. Radius/Superelevation Rate. Section 32-3 discusses the use of Method 5 for open roadway conditions to distribute superelevation and side friction. This theoretical basis also applies to the ramp portion of freeway exit terminals. Therefore, Figure 32-3.B ($e_{\max} = 8\%$) and Figure 32-3.C ($e_{\max} = 6\%$) are used to determine the proper radius and superelevation rate for horizontal curves on exit ramps. Also, see Figure 37-4.F. To determine the applicable design speed to use, see Figure 37-6.G.

US Customary		Metric	
Mainline Design Speed (mph)	Minimum Design Speed (mph) of Initial Curve (R_1)	Mainline Design Speed (km/hr)	Minimum Design Speed (km/hr) of Initial Curve (R_1)
75	55	120	90
70	50	110	80
60	45	100	70
50	40	80	60
40*	30	60*	50

*C-D roads only

MINIMUM DESIGN SPEED FOR INITIAL EXIT CURVE

Figure 37-6.G

37-6.01(e) Gore Area

The gore area is normally considered both the paved triangular area between the through lane and the exit ramp, plus the graded area that extends a significant distance downstream beyond the gore nose; see Figure 37-6.H. The following definitions will apply:

1. Physical Nose. This is a point 100 ft (30 m) downstream of Section B-B from where the 16 ft (4.9 m) ramp width begins. As illustrated in Figure 37-6.H, the physical nose has a dimensional width of 6 ft 4 in. (1.94 m).
2. Gore Nose. This is the point where the paved shoulders separate from each other and the sodded area begins as the ramp and mainline diverge. As illustrated in Figure 37-6.H, the gore nose has a dimensional width of 20 ft 2¾ in. (6.3 m), which includes the 10 ft (3.0 m) right shoulder of the freeway and the 4 ft (1.2 m) paved left shoulder of the ramp.

Consider the following when designing the gore area:

1. Roadside Obstacles. Desirably, the area beyond the gore nose should be free of all obstacles (except the ramp exit sign) for at least 100 ft (30 m) or more beyond the gore nose. Any obstacles within approximately 350 ft (100 m) of the gore nose should be made breakaway or shielded by a barrier. See Chapter 38 for additional guidance for the treatment of roadside obstacles.
2. Curbing. Do not use curbing within the gore area of an exit terminal.
3. Side Slopes. Side slopes and ditches adjacent to the gore area should meet the same criteria as the mainline. The graded area beyond the gore nose should be as flat as practical, but still drain properly. The exit terminal should be located so there are no major elevation differences in this area. For some reconstruction projects, the vertical divergence of the ramp and mainline profiles may warrant protection for both roadways beyond the gore nose (e.g., guardrail and/or impact attenuators).
4. Cross Slopes. The paved triangular gore area between the through lanes and exit ramp should be flat and traversable. The cross slopes in the gore area from the physical nose to the gore nose are 3/16"/ft (1.5%). This design provides a drainage swale in the neutral area of the terminal and is shown in Figure 37-6.H.
5. Traffic Control Devices. Signing in advance of the exit and at the divergence should be according to the *ILMUTCD* and Bureau of Operations' *Policies and Procedures Manual*.

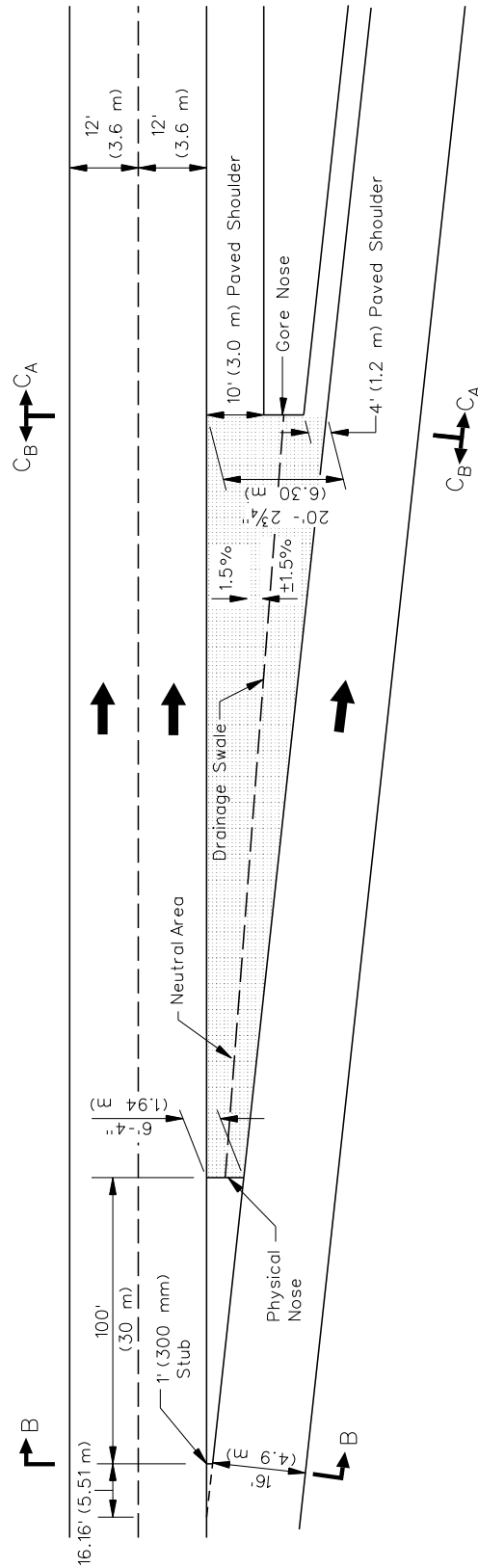

Note: Add drainage inlet in neutral area where required.

EXIT RAMP GORE AREA

FIGURE 37-6.H

37-6.01(f) Structures

Exit ramp terminals on or near structures can create a split-bridge design which, because of safety, economic, and maintenance considerations, should be avoided. A split-bridge deck design may be required where the distance from the right edge of the mainline traveled way to the left edge of the ramp exceeds 36 ft (11 m). This results in a fixed object on the structure that must be shielded by an impact attenuator. The following, in order of preference, presents options for addressing this problem:

1. Physical Nose Beyond Structure. Figure 37-6.I(a) illustrates the desirable position of the exit ramp terminal on a structure. This position allows an appropriate perception and reaction distance between the structure and ramp gore nose. It also permits the placement of the 30 ft (9 m) bridge approach pavement to be coordinated with the preferred terminal construction.
2. Gore Nose on Structure. Figure 37-6.I(b) illustrates a single structure design with the exit ramp terminal positioned so that the distance between the mainline and ramp does not exceed 36 ft (11 m). Preferably, the structure should be placed upstream of the 36 ft (11 m) maximum offset.
3. Gore Nose on Split Structure. Figure 37-6.I(c) illustrates a split-bridge design which cannot be avoided due to the length and location of a structure. The designer must provide an impact attenuator for this special situation. For information on the required minimum impact attenuator area, see Section 38-8.

Figure 37-6.J illustrates the minimum position for an exit ramp terminal near an overhead structure. To achieve the optimized design and travel distance, locate the physical nose three seconds of travel time from the edge of the structure.

37-6.02 Entrance Ramps

37-6.02(a) Types

The entrance ramp terminal is a speed-change lane that permits ramp traffic to accelerate and merge with the high-speed traffic on the mainline. When designing the interchange, consider the following entrance ramp types:

1. Standard Entrance Terminal. There are two basic types of entrance freeway ramp terminals — the parallel design and the taper design. For all new and reconstructed ramps, use the taper design, except as noted in Section 37-6.02(b). Figure 37-6.K and the *Illinois Highway Standards* illustrate the standard entrance ramp terminal design used by the Department. Use this ramp design for all single-lane entrances where the level of service of the ramp terminal is equal to or greater than that of the mainline. Entrance ramp terminals may carry a marked route provided the marked route is not a freeway or expressway. Where a freeway or expressway merges at an interchange, use the major convergence design as discussed in Section 37-6.04.

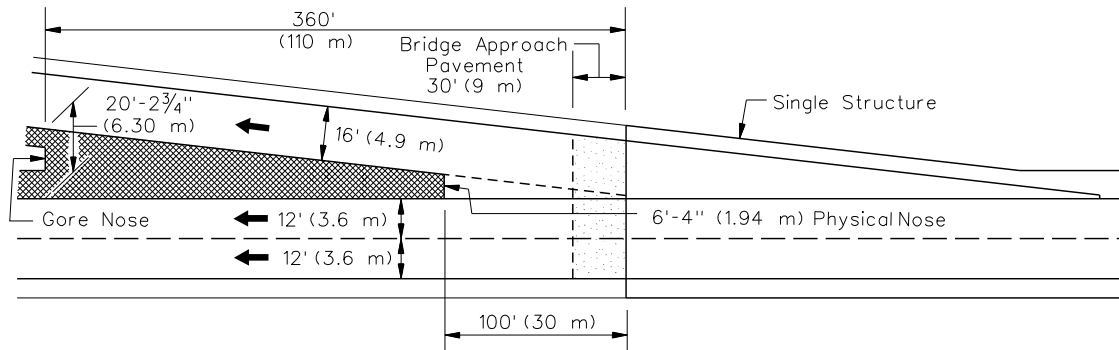

(a) PHYSICAL NOSE BEYOND STRUCTURE

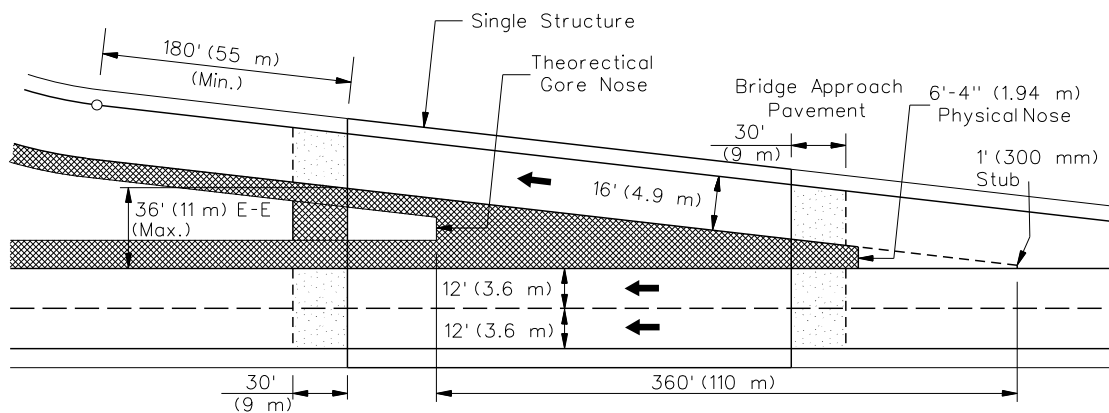

(b) GORE NOSE ON STRUCTURE

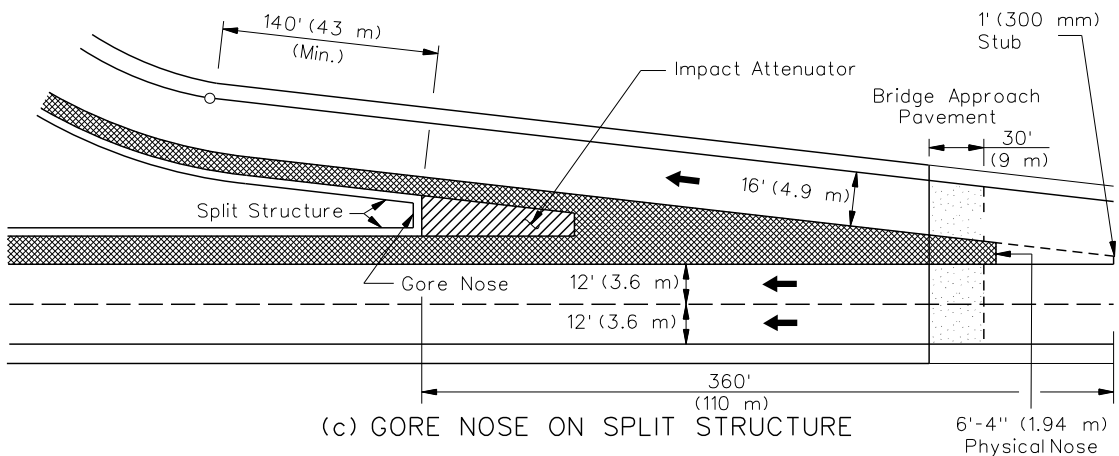

(c) GORE NOSE ON SPLIT STRUCTURE

Note: Where an exit terminal is placed on a structure, the minimum cross slope is 1/4"/ft (2%). The 1/4"/ft (2%) is measured perpendicular to the edge of the mainline pavement, which will require a modification of the standard exit terminal profile.

EXIT TERMINALS ON STRUCTURES

Figure 37-6.I

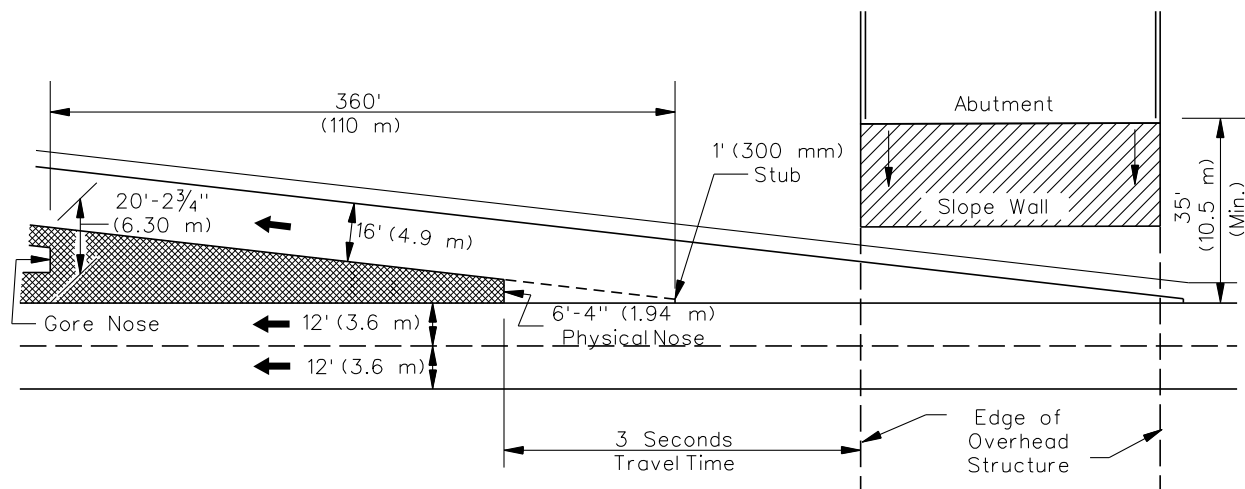

EXIT TERMINAL NEAR OVERHEAD STRUCTURE

Figure 37-6.J

2. Entrance Terminal with an Auxiliary Lane. An auxiliary lane may be required after the entrance terminal:

- to meet the requirements in Section 37-2.05, and/or
- where the entering traffic exceeds the appropriate service volume of a standard entrance terminal design but where a two-lane entrance ramp is not required.

Figure 37-6.L illustrates the design criteria for an entrance terminal with an auxiliary lane. The final ramp radius typically is 760 ft (230 m), which requires a 200 ft (60 m) tangent section preceding the physical nose. Typically, the auxiliary lane should be at least 1000 ft (300 m). Where the final ramp radius is less than 760 ft (230 m), the length of the auxiliary lane will be based on the necessary acceleration distance as discussed in Section 37-6.02(b).

3. Two-Lane Entrances. Where the entrance design traffic exceeds the service volume of a single-lane entrance ramp terminal with an auxiliary lane, it may be necessary to provide a two-lane entrance terminal as illustrated in Figure 37-6.M. Where a two-lane entrance ramp is required, an additional lane on the freeway is necessary to accommodate the additional traffic. This lane may be dropped 2500 ft (750 m) downstream or at the next interchange.

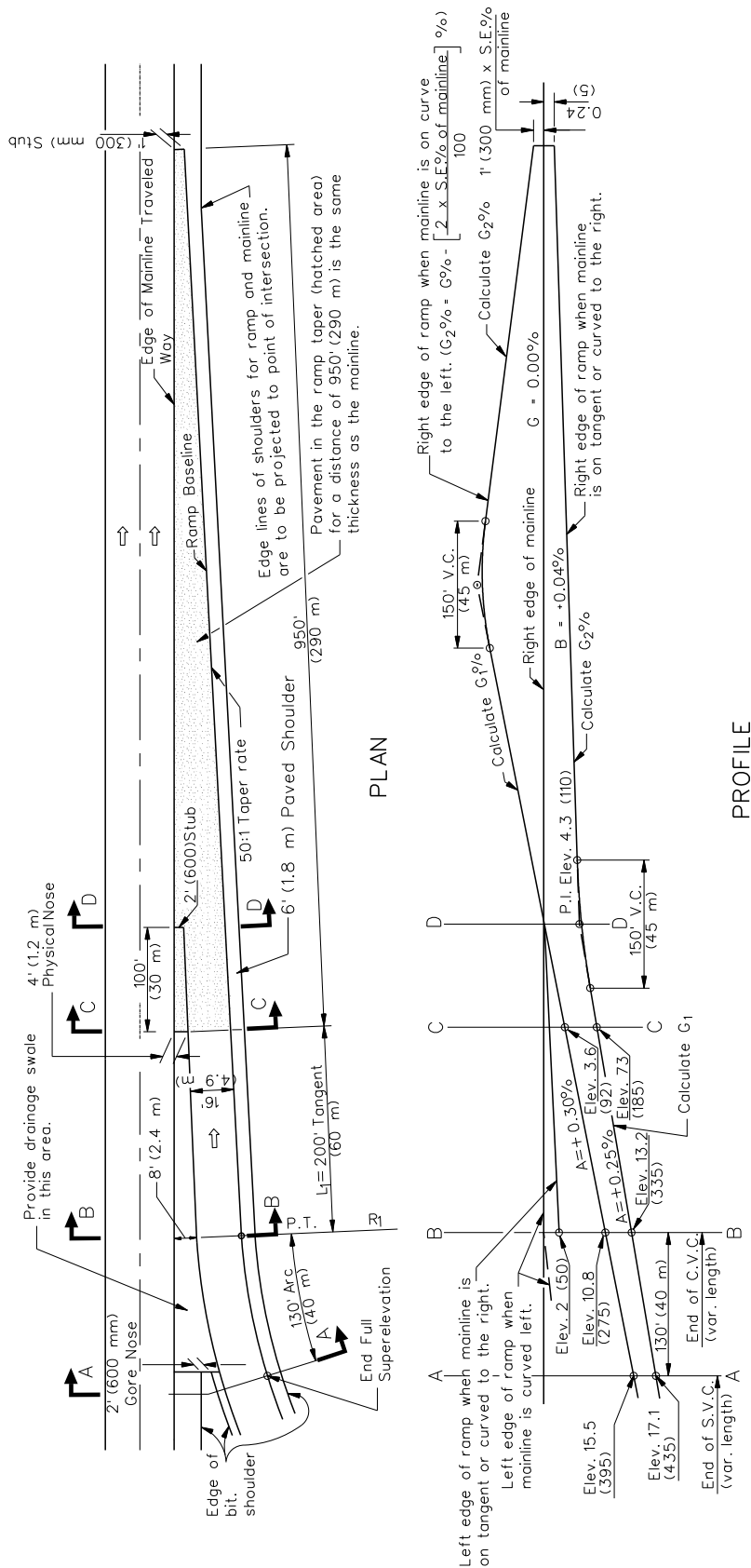

STANDARD ENTRANCE RAMP TERMINAL

Figure 37-6.K

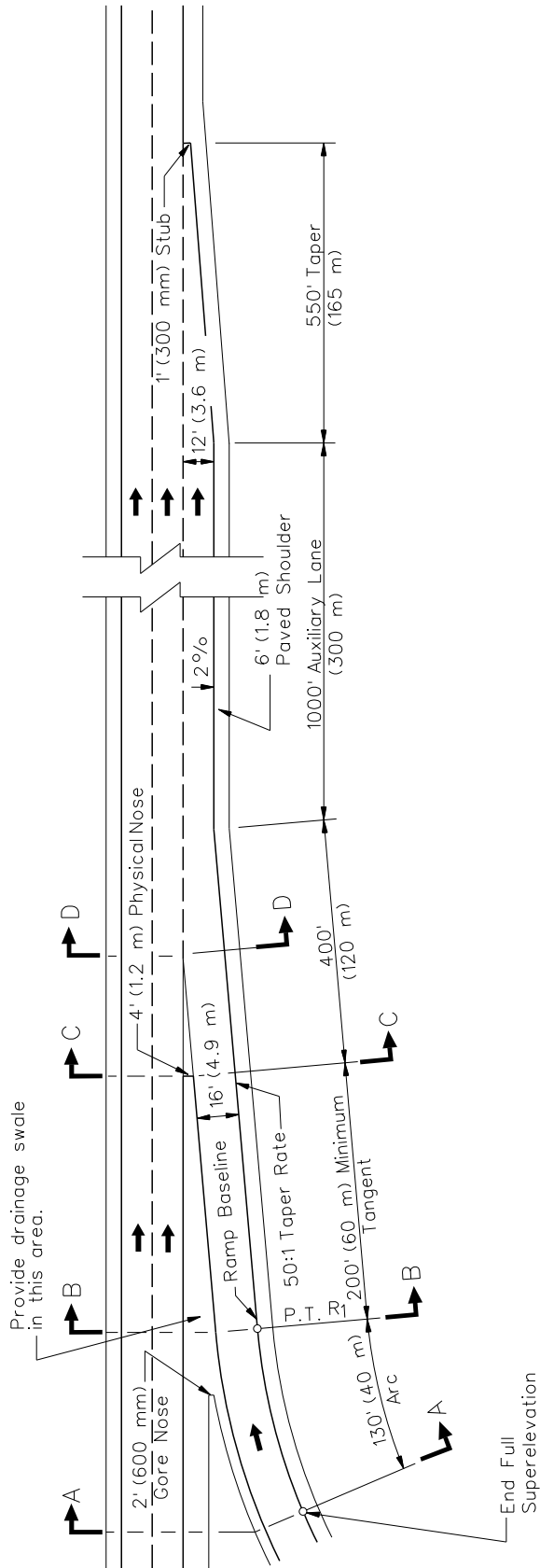

Notes:

1. Include cross sections A-A, B-B, C-C, and D-D with the IDS.
2. See Figure 37-6.K for Standard Entrance Ramp Terminal.

ENTRANCE RAMP TERMINAL WITH AUXILIARY LANE

Figure 37-6.L

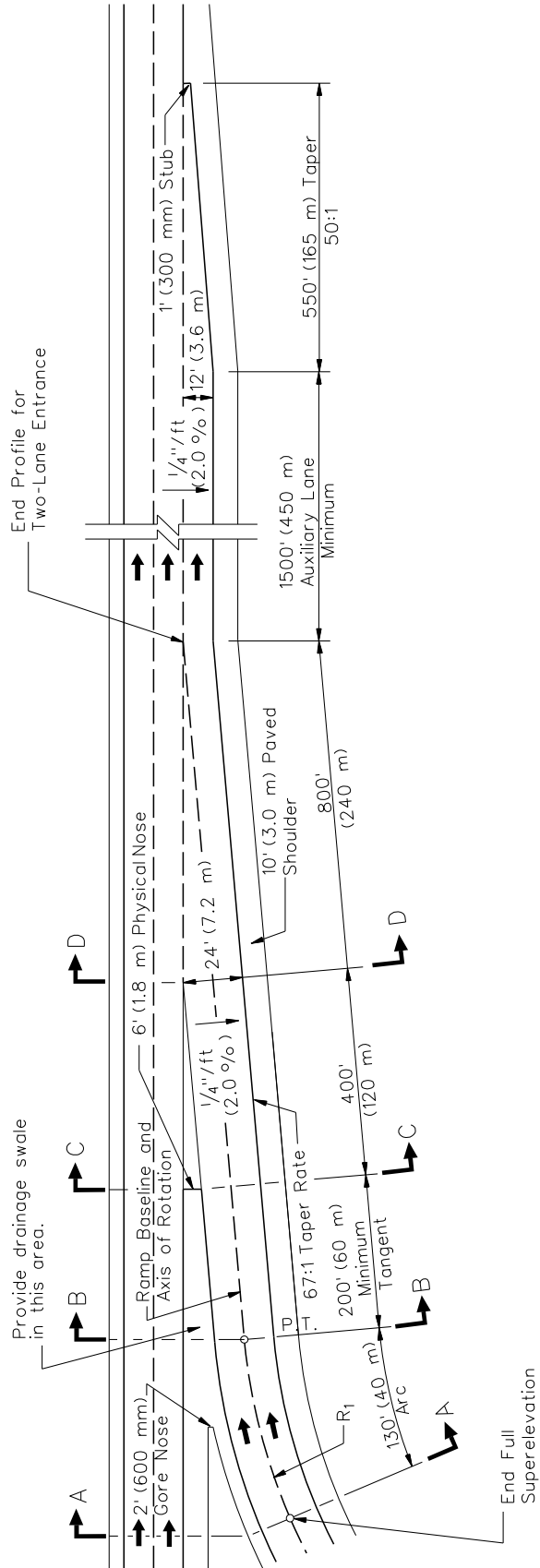

Note: Include cross sections A-A, B-B, C-C, and D-D with the IDS.

TWO-LANE ENTRANCE RAMP TERMINAL

Figure 37-6.M

If the two-lane entrance is preceded by a two-lane exit ramp terminal, an increase in the basic number of lanes will generally not be required. In this case, the added lane that results from the two-lane entrance is considered an auxiliary lane. Note that this design violates lane balance guidelines discussed in Section 37-2.03. Where the demand volume of the entering traffic exceeds this design or where the entering roadway is a freeway or expressway, use the major convergence design as discussed in Section 37-6.04.

37-6.02(b) Length

Consider the following when determining the appropriate length of an entrance terminal:

1. Capacity. Where the mainline and ramp will carry traffic volumes approaching the design capacity of the merge area, consider using an auxiliary lane entrance ramp design as discussed in Section 37-6.02(a).

Trucks. Where there are a significant number of trucks to impact the level of service on the freeway and ramp, acceleration lanes may need to be treated as truck-climbing lanes. The designer should reference the AASHTO publication *A Policy on Geometric Design of Highways and Streets* for truck acceleration rates. Typical areas where trucks might govern the ramp design include weigh stations, rest areas, truck stops, and transfer staging terminals. Also consider using truck acceleration criteria where there is substantial entering truck traffic and where the interchange crossroad has a high-skew angle or there is a significant crash history involving trucks attributable to an inadequate acceleration length.

2. Gradients. Where the gradient of the mainline and/or ramp exceeds +3%, the acceleration length may need to be adjusted. These adjustments are discussed in Section 36-2.03(e). For downgrades, use the standard entrance terminal design, and do not reduce the acceleration distance.
3. Horizontal Curves. The application of the acceleration criteria regarding horizontal curves preceding the entrance terminal are as follows:
 - a. Design Speed. The design speed of the horizontal curve adjacent to an entrance terminal should be determined by open-roadway conditions. See Figure 37-4.F and Chapter 32.
 - b. Curve Radii/Tangent Lengths. Figure 37-6.N provides the minimum controlling ramp curve radii (R_1) that should be used prior to the standard entrance terminal based on the mainline design speed.
4. Additional Lengths. If it has been determined that additional acceleration distance is required beyond that provided with the standard entrance terminal, the following options may be considered:

US Customary					
Mainline Design Speed (mph)					
e_{\max}	75	70	60	50	40 ⁽²⁾⁽³⁾
	Design Speed for R_1				
	55 mph	50 mph	45 mph	40 mph	30 mph
6%	1060 ft	833 ft	643 ft	485 ft	231 ft
8%	960ft	758 ft	587 ft	444 ft	214 ft
Metric					
Mainline Design Speed (km/hr)					
e_{\max}	120	110	100	80	60 ⁽²⁾⁽³⁾
	Design Speed for R_1				
	90 km/hr	80 km/hr	70 km/hr	60 km/hr	50 km/hr
6%	336 m	252 m	184 m	123 m	79 m
8%	304 m	229 m	168 m	113 m	73 m

Notes:

1. R_1 is the radius of curve connecting to L_1 of the standard entrance terminal. See Figure 37-6.K.
2. Use with C-D Roads only.
3. 100 ft (30 m) allowed for L_1 at this mainline design speed. See figure 37-6.K.

MINIMUM CURVE RADII (R_1) FOR ENTRANCE TERMINALS

Figure 37-6.N

- a. Typical Design. If substantial additional distance is required for acceleration, use the auxiliary lane terminal design as shown in Figure 37-6.L.
- b. Optional Design. If only a small additional distance is required to meet the necessary acceleration length, the additional distance may be gained by extending the L_1 distance. The designer must ensure that this will not create other undesirable aspects in the design of the ramp proper.
- c. Low-Volume Conditions. Where existing volumes on the mainline are low and where the slower entering vehicles will not reduce the level of service on the mainline, the use of the standard entrance terminal may be considered. The speed profile of merging trucks onto the mainline must be investigated and documented. However, provide sufficient right-of-way so that an auxiliary lane can be added in the future.
- d. Secondary Impacts. Before providing any additional acceleration lane length, the designer must consider its impacts (e.g., additional construction costs, wider structures, right-of-way impacts).

37-6.02(c) Sight Distance

Decision sight distance desirably should be provided for drivers on the mainline approaching an entrance terminal. They need sufficient distance to see the merging traffic and adjust their speed or change lanes to allow the merging traffic to enter the freeway. Likewise, drivers on the entrance ramp need to see a sufficient distance to locate gaps in the traffic stream for merging. Section 31-3 discusses decision sight distance in more detail.

37-6.02(d) Superelevation and Cross Slopes

Standard entrance terminal designs have been developed to include appropriate superelevation transitions and desirable crossover crown conditions where the terminal connects onto the mainline; see Figure 37-6.K and the *Highway Standards*. When an IDS is prepared, develop and show on the IDS the detailed cross section at A-A as indicated in Figure 37-6.K.

37-6.02(e) Gore Area

The following presents the nose criteria for entrance gores:

1. Physical Nose. This is a point located at Section C-C, as illustrated in Figure 37-6.K and has a dimensional width of 4 ft (1.2 m).
2. Gore Nose. This is a point where the sodded area ends and the paved shoulders connect. The gore nose, excluding the mainline right shoulder and ramp left shoulder, is 2 ft (600 mm) wide as shown in Figure 37-6.K.

37-6.03 Ramp/Roadway Divergence Applications

37-6.03(a) Major Divergences

Where two freeways separate, provide a major divergence as shown in Figures 37-6.O, 37-6.P, and 37-3.Q. The most important concept in the use of a major divergence is that if the route turns at an interchange, the physical divergence of the roadways should also occur in the same direction. To maintain lane balance, an additional interior lane will be required preceding the divergence. The widening of the interior lane from 12 ft to 24 ft (3.6 m to 7.2 m) should occur in a distance of 1000 ft (300 m). This provides a driver in the center lane the option of selecting either direction of travel without having to change lanes.

Add additional lanes to the side of the lesser-preferred route. Check for lane balance. Pavement joints should normally favor the freeway with the higher volume of traffic. An exception to this rule is that in most cases, regardless of the traffic volume split, the Interstate is considered the preferred route. Provide a minimum tangent length of 200 ft (60 m) beyond the 6 ft (1.8 m) physical nose to facilitate a change of cross slope preceding the initial curve of any diverging roadway.

Where a major divergence is required but the preferred design of an equal split of the roadways cannot be achieved due to the existing freeway alignment, a modified divergence design can be used as shown in Figure 37-6.P. In addition, where a divergence design is required and sufficient right-of-way is not available to build the one-sided divergence and where the diverging traffic volume is not significant, a two-lane exit terminal design may be considered. However, before using the two-lane exit design, coordination and approval must be received from BDE.

37-6.03(b) Minor Divergences

Consider a minor divergence for the following situations; see Figure 37-6.R:

- where a highway terminates into separate single lane ramps (e.g., at a trumpet interchange);
- where a ramp or roadway separates within a complex interchange (e.g., directional interchanges); or
- as part of a collector-distributor roadway design.

37-6.04 Ramp/Roadway Convergence Applications

37-6.04(a) Major Convergences

Where two freeways merge, provide a major convergence design as illustrated in Figure 37-6.S. The number of lanes downstream from the convergence generally will be one less than the combined total of the two approaching roadways. Under some circumstances, traffic demand may require that the number of lanes departing the merge area be the same number as the two approaching roadways.

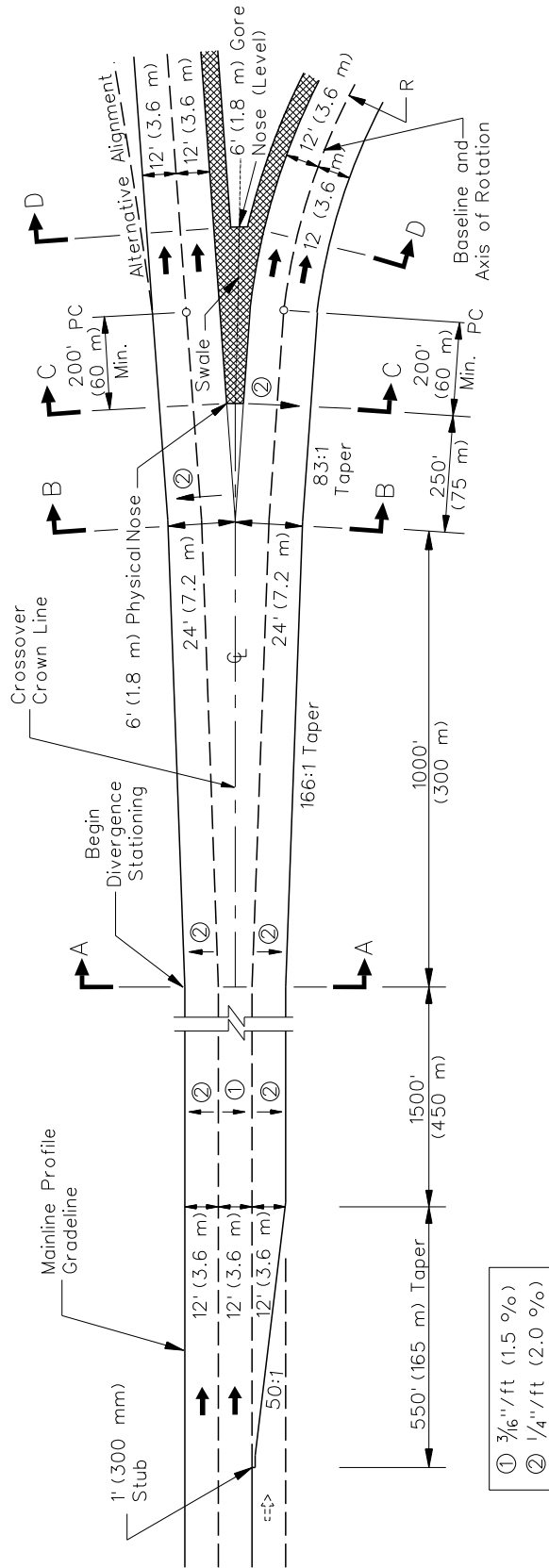

Notes:

1. Develop cross sections A-A, B-B, C-C, and D-D during the preparation of the IDS.
2. The divergence can be designed to divert traffic from either side of an existing roadway.
3. Full superelevation is attained at Section D-D.

EQUAL-SPLIT MAJOR DIVERGENCE
(Two- or Three-Lane Approaching Roadway with Two-Lane Roadways Diverging)

Figure 37-6.O

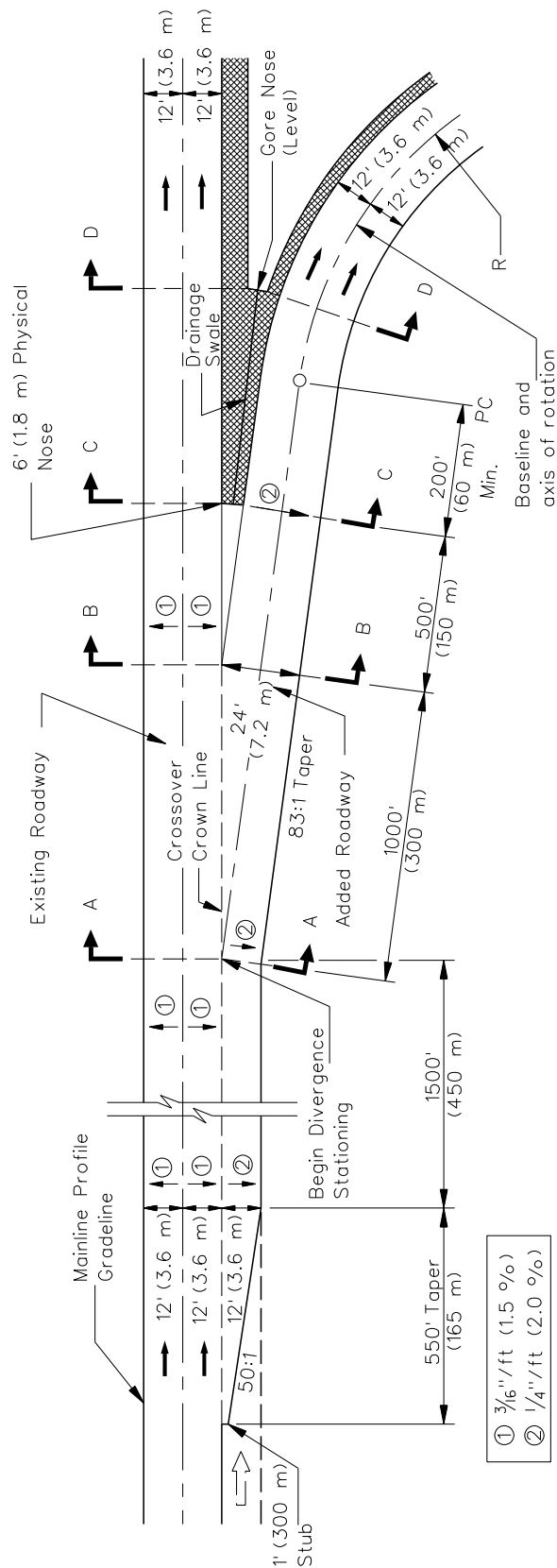

Notes:

1. Develop cross sections A-A, B-B, C-C, and D-D during the preparation of the IDS.
2. The divergence can be designed to divert traffic from either side of an existing roadway.
3. Full superelevation is attained at Section D-D.

**ONE-SIDED MAJOR DIVERGENCE
(Two- or Three-Lane Approaching Roadway with Two-Lane Roadway Diverging)**

Figure 37-6.P

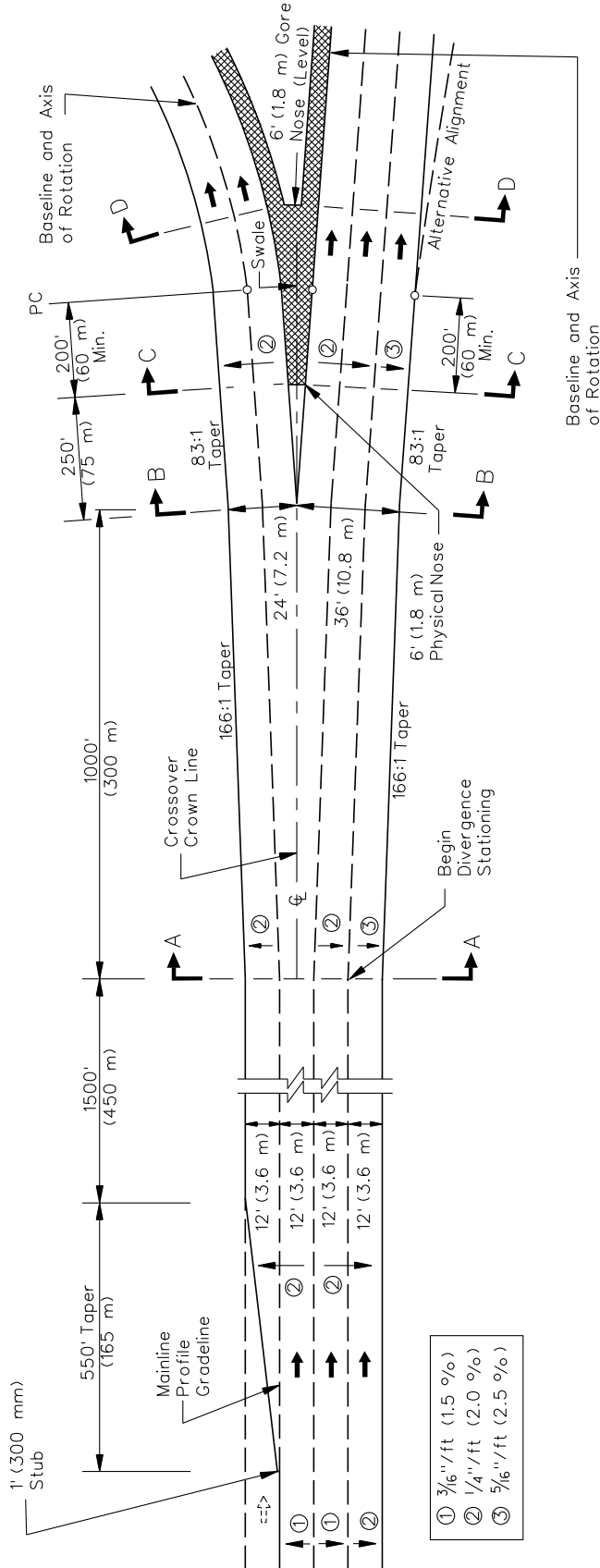

Notes:

1. Develop cross sections A-A, B-B, C-C, and D-D during the preparation of the IDS.
2. The divergence can be designed to divert traffic from either side of an existing roadway.
3. Where a horizontal curve is provided downstream from the divergence, full superelevation is attained at Section D-D.

MAJOR DIVERGENCE
(Three- or Four-Lane Approaching Roadway with Two- and Three-Lane Roadways Diverging)

Figure 37-6.Q

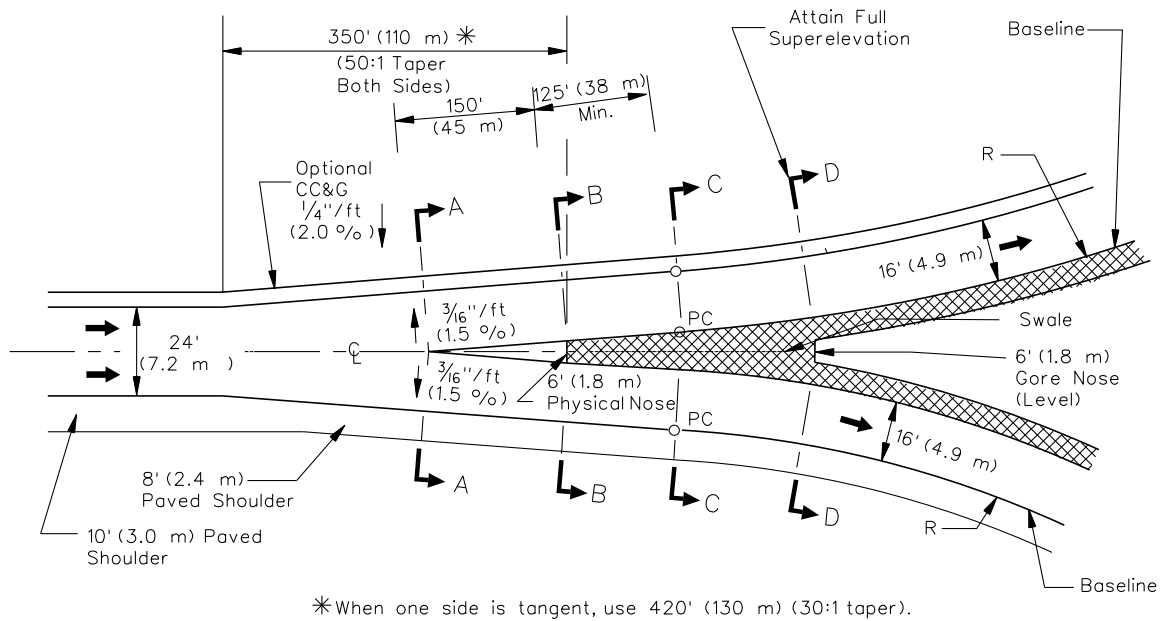

TYPE A - 24 ft (7.2 m)

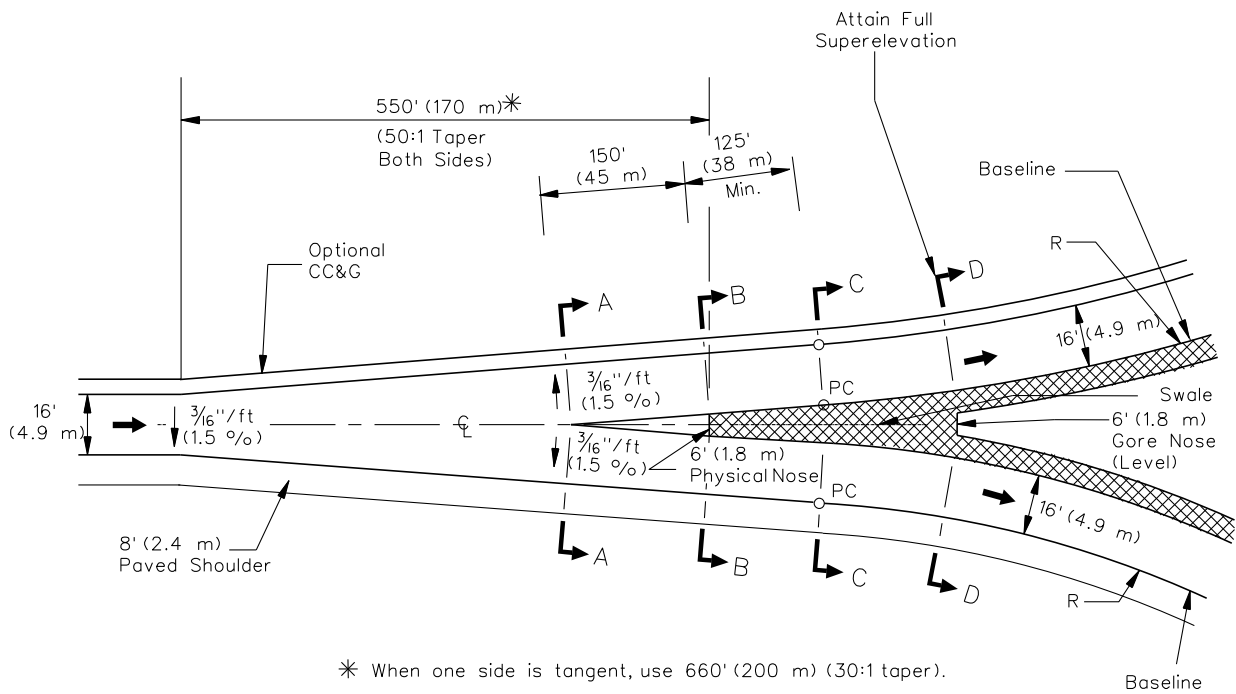

TYPE B - 16 ft (4.9 m)

Note: Develop cross sections A-A, B-B, C-C, and D-D during the preparation of IDS.

MINOR DIVERGENCES

Figure 37-6.R

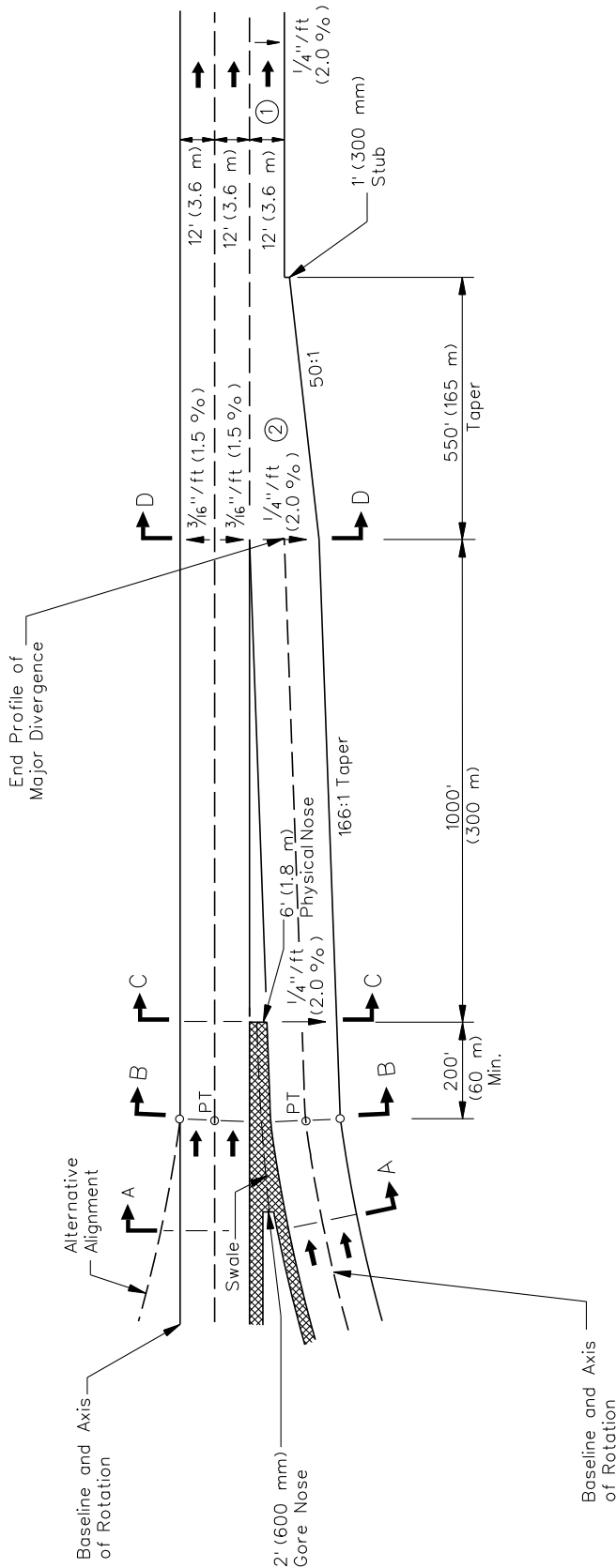

Notes:

1. If the right-hand lane is proposed to be dropped for capacity reasons, provide a minimum 1500 ft (450 m) auxiliary lane and a 550 ft (165 m) taper.
2. The convergence can be designed to merge from either side.
3. Develop cross sections A-A, B-B, C-C, and D-D during the preparation of IDS.

MAJOR CONVERGENCE

Figure 37-6.S

Typically, a lane drop will be required downstream from the convergence. The most desirable and typical design will be to drop the right slow-speed lane versus the left high-speed lane. However, it also may be desirable to drop the left lane of the merging roadway if it is serving the lowest volume per lane. This design should be reviewed during the development of the IDS.

37-6.04(b) Minor Convergences

Consider a minor convergence for the following situations; see Figure 37-6.T:

- where interchange ramps converge to form either a single or double lane roadway (e.g., trumpet interchanges) within complex interchanges; or
- as part of a collector-distributor roadway design.

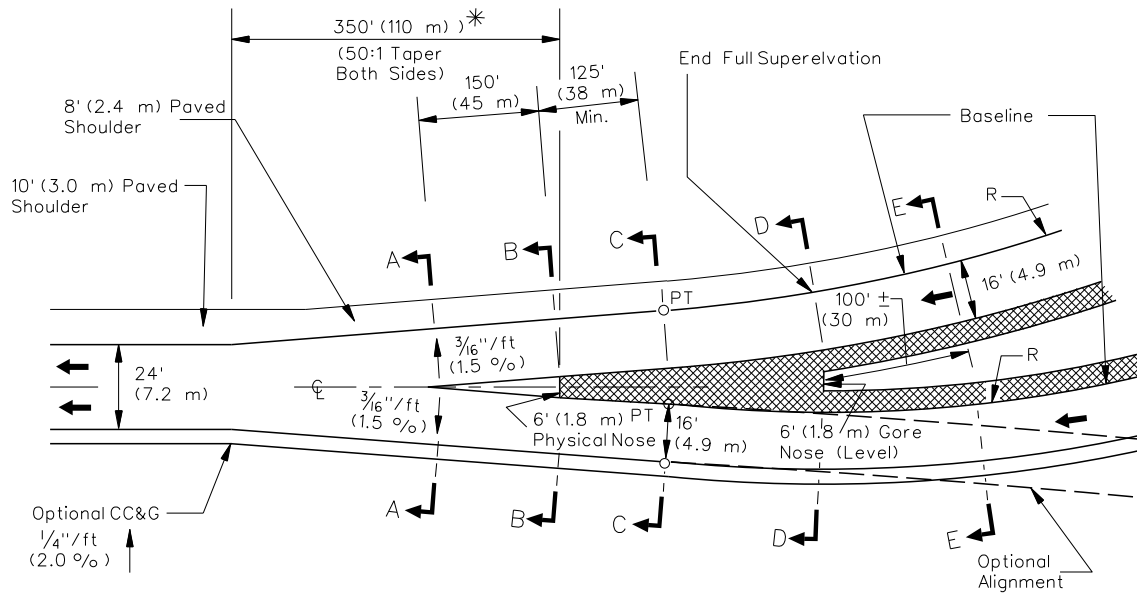

* When one side is tangent, use 420' (130 m) (30:1 taper)
 TYPE A - 24 ft (7.2 m)

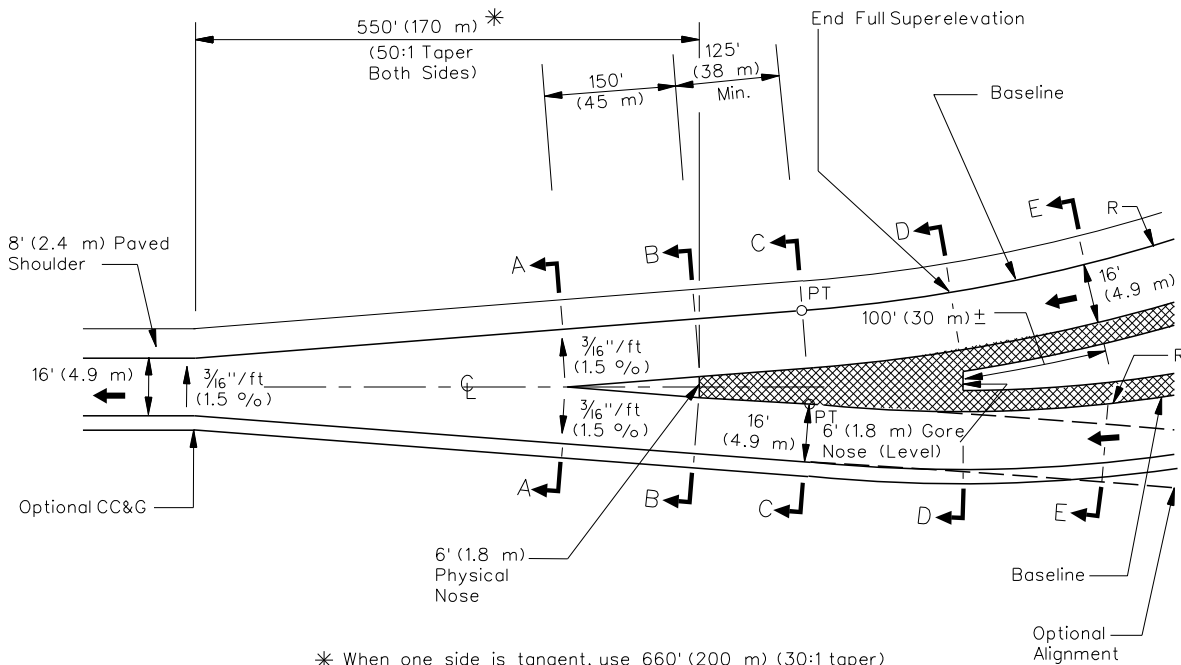

* When one side is tangent, use 660' (200 m) (30:1 taper)
 TYPE B - 16 ft (4.9 m)

Notes:

1. Develop cross sections A-A, B-B, C-C, D-D, and E-E during the preparation of IDS.
2. Ramp cross slope should be determined by downstream horizontal alignment.

MINOR CONVERGENCES

Figure 37-6.T

37-7 REFERENCES

1. *A Policy on Geometric Design of Highways and Streets*, AASHTO, 2018.
2. Agreement Relating to Use of and Access to Rights-of-Way – Interstate System, 23 U.S.C. 111.
3. Design Standards for Highways, 23 CFR 625, November 1, 2018,
4. *Policy on Access to the Interstate System*, FHWA, May 22, 2017.
5. A Policy on Design Standards – Interstate System, AASHTO, May, 2016.
6. Additional Interchanges to the Interstate System, 55 Fed. Reg. 42570, October 22, 1990.
7. Additional Interchanges to the Interstate System, 63 Fed. Reg. 7045, February 11, 1998.
8. Access to the Interstate System, 74 Fed. Reg. 43743, August 27, 2009.
9. Access Control on Non-Interstate NHS Freeways, FHWA Memorandum, December 8, 1997.
10. *Single Point Urban Interchange Design and Operations Analysis*, NCHRP Report 345, Transportation Research Board, 1991.
11. “A Comparison of Two Diamond Interchange Forms in Urban Areas”, *ITE Journal*, May 1989.
12. “An Operational Comparison of the Single-Point Urban and Tight-Diamond Interchanges”, *ITE Journal*, April 1993.
13. *Guidelines for Preliminary Selection of the Optimum Interchange Type for Specific Location*, FHWA/VTRC99-R15, January 1999.
14. *Highway Capacity Manual 2010*, Transportation Research Board, 2010.
15. *Highway Safety Design and Operations Guide*, AASHTO, 1997.
16. *Distance Requirements for Frontage-Road Ramps to Cross Streets: Urban Freeway Design*” Transportation Research Record 682, Transportation Research Board, 1978.
17. *Capacity and Quality of Service of Weaving Zones*, NCHRP 3-55(5), Transportation Research Board, November 2007.
18. *Manual on Uniform Traffic Control Devices*, FHWA, ATSSA, AASHTO, and ITE, 2009.
19. *Interchange Operations on the Local Street Side: State of the Art*, Transportation Research Circular 430, Transportation Research Board, 1994.

20. *Geometric Design Features of Single-Point Urban Interchanges* Transportation Research Record 1385, Transportation Research Board, 1993.
21. "Interchange Ramp Geometrics — Alignment and Superelevation Design," Transportation Research Record 1385, Transportation Research Board, 1993.
22. *Illinois Highway Standards*, IDOT, current edition.
23. *Diverging Diamond Interchange Informational Guide*, FHWA, August 2014.
24. "Driver's Evaluation of the Diverging Diamond Interchange", *FHWA Techbrief*, FHWA-HRT-07-048, January 2017.

Chapter Thirty-eight
ROADSIDE SAFETY

BUREAU OF DESIGN AND ENVIRONMENT MANUAL

HARD COPIES UNCONTROLLED

Chapter Thirty-eight
ROADSIDE SAFETY

Table of Contents

<u>Section</u>	<u>Page</u>
38-1 APPLICATION	38-1.1
38-1.01 Project Type	38-1.1
38-1.02 Appurtenance Type	38-1.2
38-2 DEFINITIONS	38-2.1
38-3 ROADSIDE CLEAR ZONES	38-3.1
38-3.01 Background	38-3.1
38-3.02 Clear Zone Values	38-3.1
38-3.02(a) Speed	38-3.1
38-3.02(b) Design Year	38-3.4
38-3.02(c) Traffic Volumes	38-3.4
38-3.02(d) Side Slopes	38-3.4
38-3.02(e) Alignment (Horizontal Curve Adjustment)	38-3.4
38-3.02(f) Curbed Sections	38-3.9
38-3.02(g) Lane Width	38-3.9
38-3.02(h) Auxiliary Lanes	38-3.10
38-3.03 Front Slopes	38-3.10
38-3.03(a) Recoverable Front Slopes	38-3.10
38-3.03(b) Non-Recoverable Front Slopes	38-3.10
38-3.03(c) Barn-Roof Front Slope (Recoverable/Non-Recoverable)	38-3.11
38-3.03(d) Barn-Roof Front Slope (Recoverable/Recoverable)	38-3.11
38-3.03(e) Critical Front Slope	38-3.11
38-3.04 Back Slopes	38-3.14
38-3.05 Roadside Ditches	38-3.14
38-3.06 Transitional Slopes	38-3.18
38-4 ROADSIDE HAZARD REMEDIATION	38-4.1
38-4.01 Examples of Roadside Hazards	38-4.1
38-4.02 Range of Treatments	38-4.1
38-4.03 Warrant Methodologies	38-4.2
38-4.03(a) Department Policy	38-4.2
38-4.03(b) Cost-Effectiveness Method	38-4.2
38-4.03(c) Engineering Judgment Method	38-4.2

Table of Contents

(Continued)

<u>Section</u>		<u>Page</u>
38-4.04	Embankments.....	38-4.3
38-4.05	Transverse Slopes.....	38-4.3
38-4.06	Roadside Drainage Features.....	38-4.7
	38-4.06(a) Curbs	38-4.7
	38-4.06(b) Culverts.....	38-4.8
	38-4.06(c) Roadside Ditches (Earth Cuts)	38-4.10
38-4.07	Rock Cuts	38-4.10
38-4.08	Bridge Parapet Ends	38-4.12
38-4.09	Retaining Walls.....	38-4.12
38-4.10	Traffic Control Devices	38-4.12
	38-4.10(a) Highway Signs	38-4.12
	38-4.10(b) Traffic Signal Equipment.....	38-4.13
38-4.11	Lighting	38-4.14
38-5	ROADSIDE BARRIERS	38-5.1
38-5.01	Types.....	38-5.1
	38-5.01(a) Steel Plate Beam Guardrail (Semi-Rigid Types).....	38-5.1
	38-5.01(b) Concrete Barrier (Rigid Type)	38-5.3
	38-5.01(c) High-Tension Cable Barrier (Flexible Type).....	38-5.3
	38-5.01(d) Cable Road Guard Single Strand	38-5.4
	38-5.01(e) Other Systems	38-5.4
	38-5.01(f) Aesthetic Treatments	38-5.4
38-5.02	Barrier Selection	38-5.4
38-6	ROADSIDE BARRIER LAYOUT	38-6.1
38-6.01	Length of Need	38-6.1
	38-6.01(a) Graphical Solution.....	38-6.2
	38-6.01(b) Nomograph Solution	38-6.5
38-6.02	Guardrail Post Foundations.....	38-6.48
38-6.03	Barrier Offset	38-6.48
38-6.04	Barrier Flare.....	38-6.53
38-6.05	Terrain	38-6.53
38-6.06	Terminal Treatments	38-6.57
	38-6.06(a) Guardrail End Terminals	38-6.57
	38-6.06(b) Median Barriers.....	38-6.60

Table of Contents

(Continued)

<u>Section</u>		<u>Page</u>
	38-6.06(c) Bridge Rail Connections	38-6.60
38-6.07	Minimum Length/Gaps	38-6.61
38-6.08	Typical Applications	38-6.62
38-6.09	Short Radius Guardrail	38-6.62
	38-6.09(a) Design Alternatives	38-6.62
38-7	MEDIAN BARRIERS	38-7.1
38-7.01	Median Barrier Warrants	38-7.1
	38-7.01(a) Freeways	38-7.1
	38-7.01(b) Highways with a Flush/Depressed Median and Partial Access Control	38-7.1
	38-7.01(c) Benefit/Cost (B/C) Ratio Procedure	38-7.2
38-7.02	Median Barrier Types	38-7.5
	38-7.02(a) Rigid Median Barriers	38-7.5
	38-7.02(b) Semi-Rigid Median Barriers	38-7.5
	38-7.02(c) Flexible Median Barriers	38-7.5
38-7.03	Median Barrier Selection	38-7.6
	38-7.03(a) Selection Guidelines	38-7.6
	38-7.03(b) Design Considerations	38-7.9
38-7.04	Median Barrier Layout	38-7.15
	38-7.04(a) Sloped Medians	38-7.15
	38-7.04(b) Flared/Divided Median Barriers	38-7.15
	38-7.04(c) Barrier-Mounted Features	38-7.15
	38-7.04(d) Terminal Treatments	38-7.16
	38-7.04(e) Superelevation	38-7.16
	38-7.04(f) Median Crossovers Locations	38-7.16
38-7.05	Glare Screens	38-7.20
	38-7.05(a) General	38-7.20
	38-7.05(b) Design Considerations	38-7.21
	38-7.05(c) Glare Screen Types	38-7.22
	38-7.05(d) Glare Screen Design	38-7.22

Table of Contents

(Continued)

<u>Section</u>	<u>Page</u>
38-8 IMPACT ATTENUATORS (CRASH CUSHIONS).....	38-8.1
38-8.01 General.....	38-8.1
38-8.02 Warrants.....	38-8.1
38-8.03 Impact Attenuator Types	38-8.1
38-8.03(a) Overview.....	38-8.1
38-8.03(b) Redirective Properties.....	38-8.2
38-8.03(c) Operational Principles.....	38-8.2
38-8.04 Maintenance and Repair Issues.....	38-8.6
38-8.04(a) Resettable Devices.....	38-8.6
38-8.04(b) Severe Use.....	38-8.8
38-8.05 Approved Devices	38-8.8
38-8.06 Physical Placement Requirements.....	38-8.8
38-8.07 Cost.....	38-8.10
38-8.08 Pedestrian/Bicyclist Environment.....	38-8.10
38-8.09 Impact Attenuator Selection.....	38-8.12
38-8.10 Temporary Installations.....	38-8.12
38-8.11 Additional Guidance.....	38-8.16
38-9 ROADSIDE SAFETY IN URBAN OR RESTRICTED ENVIRONMENTS.....	38-9.1
38-9.01 Safety Performance – Evaluation of Urban and Restricted Locations... 38-9.1	38-9.1
38-9.02 Operational Offset, Clear Zone, and Enhanced Lateral Offset.....	38-9.1
38-9.03 Roadside Features in Urban and Restricted Areas	38-9.3
38-9.04 Use of Roadside Barriers in Urban or Restricted Environments	38-9.5
38-9.05 Barrier Warrants.....	38-9.6
38-9.06 Common Urban Barrier Treatments.....	38-9.6
38-10 REFERENCES.....	38-10.1

Chapter Thirty-eight

ROADSIDE SAFETY

The ideal roadway would be entirely free of any roadside obstructions or other hazardous conditions. This is rarely practical because of natural, economic, and environmental factors. Chapter 38 presents clear zone distances which should adequately provide a clear recovery area for about 80% of the errant vehicles that run off the road and the chapter provides criteria for the use of roadside barriers, median barriers, and impact attenuators where providing the clear zone is not practical. The chapter also discusses the use of cost-effective methodologies to determine roadside safety treatments.

Information applicable to roadside safety is also included in the following Chapters:

- Chapter 7 - roadside safety near railroads.
- Chapter 17 - roadside safety along bikeways.
- Chapter 34 – roadside safety addressed through shoulder rumble strips and stripes
- Chapter 49 - roadside safety on 3R projects on rural and urban highways.
- Chapter 50 - roadside safety on 3R projects on freeways.
- Chapter 55 - roadside safety in work zones.

38-1 APPLICATION

This Section presents the IDOT application of roadside safety decisions based on project type and appurtenance type.

38-1.01 Project Type

The following summarizes the use of the *BDE Manual* for roadside safety applications based on the project type or project scope of work:

1. New Construction/Reconstruction Projects. Chapter 38 presents the roadside safety criteria for all new construction/reconstruction projects.
2. 3R Non-Freeway Projects. Chapter 49 presents the roadside safety criteria for non-freeway 3R rural and urban highway freeway projects. Roadside safety criteria not covered in Chapter 49 shall be as described in Chapter 38. For example, Chapter 49 modifies clear zone values, however it does not modify their application on non-recoverable slopes. Clear recovery area at the toe-of-slope of non-recoverable slopes is controlled by Chapter 38.
3. 3R Freeway Projects. Chapter 50 presents the roadside safety criteria for 3R freeway projects. Roadside safety criteria not covered in Chapter 50 shall be as described in Chapter 38.

4. Highway Safety Improvement Projects. The IDOT Bureau of Safety Programs and Engineering (BSPE) is responsible for approving the project scope of work for highway safety improvement projects (HSIP) that use the Federal-aid funds set aside for highway safety improvements. The scope of work for these projects may include roadside safety improvements. In this case, the designer will use the criteria in Chapter 38 with the specific application determined on a case-by-case basis considering:
 - the crash patterns at the site,
 - the project scope as outlined by the BSPE,
 - the project budget, and
 - the estimated construction costs of an application as compared to the anticipated safety benefits and the costs of other design solutions.
5. Work Zones. Chapter 55 presents the roadside safety criteria for work zones.

38-1.02 Appurtenance Type

The following summarizes the Department's roadside safety responsibilities based on type of appurtenance:

1. Bridge Rails. The IDOT Bureau of Bridges and Structures is responsible for establishing Department criteria for the selection and design of all bridge rails. The Bureau of Design and Environment (BDE) is responsible for establishing selection and design criteria for the roadside barrier and terminal section approaching the bridge rail.
2. Traffic Control Devices. The Bureau of Operations and the Bureau of Bridges and Structures are jointly responsible for establishing Department criteria for the design of structural supports for traffic control devices (e.g., breakaway bases for large signs). For the location of traffic control devices, the Bureau of Operations determines the initial placement and the road designer ensures that the proposed location is compatible with the roadway design.
3. All Other Appurtenances. BDE and BSPE are jointly responsible for establishing Department criteria for all other roadside safety appurtenances (e.g., roadside barriers, median barriers, impact attenuators, lighting).

38-2 DEFINITIONS

1. Back Slope. The side slope created by connecting the ditch bottom, shelf, or shoulder at the hinge point, upward and outward, to the natural ground line.
2. Barrier (Vertical) Curb. A longitudinal element placed at the edge of the traveled way to provide delineation, to control drainage, to manage access, and to minimize right-of-way acquisition. Barrier curbs range between 6 in. and 9 in. (150 mm to 230 mm) in height with a face steeper than 3 vertical to 1 horizontal. Barrier curbs do not have significant re-directional capability for errant vehicles.
3. Barrier Terminals. End treatments for both roadside barriers and transitions to other types of barriers (e.g., to bridge rails).
4. Clear Zone. The area provided beyond the edge of through traveled way for the recovery of errant vehicles, which ideally should be kept clear of any non-traversable hazards or fixed objects. The clear zone includes shoulders, bike lanes, and auxiliary lanes, except those auxiliary lanes that function like through lanes.
5. Concrete Barrier. A rigid barrier typically constructed in a narrow median where no deflection distance is available and which can accommodate most vehicular impacts without penetration. In most applications these barriers are double-faced as shown on the Highway Standard.
6. Critical Parallel Slope. Fill sections with front slopes steeper than 1V:3H that cannot be safely traversed by a run-off-the-road vehicle. Depending on the encroachment conditions, a vehicle on a critical slope may overturn.
7. End Treatments. The terminal devices for roadside barriers, including both the approaching and departing ends.
8. Enhanced Lateral Offset. An offset in an urban environment beyond that used to provide clearance to keep the overhang of a truck from striking an object [1.5 ft (0.5 m) from the face of the curb], but less than the normal clear-zone width. The recommended offset to obstructions typically range from 4 ft to 6 ft (1.2 m to 1.8 m) from the face of curb and 8 ft (2.4 m) without a vertical curb. A 12 ft (3.6 m) offset is recommended for urban areas which are without a vertical curb and on the outside of a horizontal curve.
9. Experimental System. A roadside barrier, end terminal, or impact attenuator which has performed satisfactorily in full-scale crash tests but has not been installed in sufficient locations or exposed to traffic for a sufficient time to adequately evaluate its in-service performance.
10. Front Slope (or Foreslope). The side slope created by connecting the shoulder or shelf at the hinge point, downward and outward, to the ditch bottom or natural ground line.
11. Gating. A term used to describe barrier end treatments which are designed to allow controlled penetration by an impacting vehicle.

12. Hinge Point. The first major discontinuity in the roadway encountered by the vehicle after it leaves the traveled way and shoulder. The top of the front slope. The planar intersection between the shoulder and the front slope when the slope of the shoulder is 1H:10V or flatter.
13. Impact Angle. For a longitudinal barrier, the angle between a tangent to the face of the barrier and a tangent to the vehicular path at impact. For an impact attenuator, it is the angle between the axis of symmetry of the impact attenuator and a tangent to the vehicular path at impact.
14. Impact Attenuator (Crash Cushion). A protective device used to safely shield roadside hazards, typically point obstacles, from approximately head-on impacts by errant vehicles.
15. Length of Need. Total length of a longitudinal barrier, measured with respect to the centerline of roadway, needed to shield an area of concern. The length of need (LON) is measured to the last point of redirective rail. The beginning point of the length of need is referred to as the BLON (beginning length of need) point.
16. MASH. Manual for Assessing Safety Hardware, AASHTO 2016. The processes and testing described in MASH typically represent the latest requirements for the range of roadside safety hardware required for use on the state highway system. The assessment of roadside hardware for crashworthiness continues to transition from NCHRP 350 standards to MASH standards, and the term *crashworthy* is used in this chapter as the general term to describe devices that satisfy current Department requirements.
17. Median Barrier. A longitudinal barrier used to prevent an errant vehicle from crossing the median of a divided highway thereby preventing head-on collisions between opposing traffic.
18. Mountable (Sloping) Curb. A longitudinal element placed at the edge of traveled way to provide delineation, to control drainage, to manage access, and to outline corner islands. Mountable curbs have a height of 6 in. (150 mm) or less with a sloping face of approximately 45 degrees. Mountable curbs do not have significant re-directional capability for errant vehicles.
19. Non-Recoverable Parallel Slope. Slopes which can be safely traversed but upon which an errant vehicle is unlikely to recover. The run-off-the-road vehicle will likely continue down to the toe of the slope. For most embankment heights, if a front slope is between 1V:3H (inclusive) and 1V:4H (exclusive), it is considered a non-recoverable parallel slope.
20. Non-Redirective. A descriptive term which indicates that the roadside safety device will not redirect an impacting vehicle but will, rather, “capture” the vehicle (e.g., sand barrels) or allow the vehicle to pass through (e.g., breakaway sign supports).
21. Operational System. A roadside barrier, end terminal, or crash cushion that has performed satisfactorily in full-scale crash tests and has demonstrated satisfactory in-service performance.

22. Parallel Slopes. Front and back slopes for which the toe runs approximately parallel to the roadway.
23. Pocketing. The potential for a vehicle impacting a redirective device to undergo relatively large lateral displacements within a relatively short longitudinal distance.
24. Recoverable Parallel Slope. Slopes that can be safely traversed and upon which an errant motorist has a reasonable opportunity to regain control of the vehicle. Front slopes 1V:4H and flatter are considered recoverable.
25. Redirective. A term which indicates that the roadside safety device is designed to redirect an impacting vehicle approximately parallel to the longitudinal axis of the device.
26. Roadside Barrier. A longitudinal barrier (e.g., guardrail, concrete barrier) used to shield roadside hazards while addressing the safety of vehicle occupants. A longitudinal barrier may occasionally be used to shield pedestrians from vehicular traffic.
27. Roadside Hazards. A general term to describe roadside features that cannot be safely impacted by a run-off-the-road vehicle. Roadside hazards include both fixed objects and non-traversable roadside features (e.g., rivers).
28. Roadway. The combination of the traveled way, both shoulders or curb and gutters, and any auxiliary lanes on the mainline highway. Traveled ways separated by a depressed median have two (or more).
29. Shy Distance. The distance from the edge of traveled way beyond which a roadside object will not be perceived as an immediate hazard by the typical driver, to the extent that the driver will change vehicular placement or speed.
30. Side Slope. A ratio used to express the steepness of a slope adjacent to the roadway. The ratio is expressed as vertical to horizontal (V:H).
31. Test Level. The test levels represent sets of conditions defined in terms of vehicular type and mass, vehicular speed, and vehicular impact angle that quantify the impact severity of a matrix of crash tests. Six performance levels, or test levels, are available. Test Levels 1 through 3 use a small passenger car and a pickup truck as design vehicles. Test Level 1 (TL-1) is applicable at roadside design speeds up to 30 mph (50 km/hr), TL-2 up to and including 45 mph (70 km/hr), and TL-3 up to 60 mph (100 km/hr). Higher test levels retain the TL-3 performance requirements for the small passenger car and pickup truck, but also introduce larger trucks. TL-4 includes a 22,000 pound (10,000 kg) single unit truck, TL-5 an 80,000 pound (36,000 kg) tractor-van trailer, and TL-6 an 80,000 pound (36,000 kg) tractor-tanker trailer.
32. Toe of Slope. The intersection of the front slope or back slope with the natural ground line or ditch bottom, before any rounding is applied.
33. Top of Slope. The intersection of the back slope with the natural ground line, before any rounding is applied.

34. Transverse Slopes. Front and back slopes for which the toe runs approximately perpendicular to the flow of traffic on the major roadway. Transverse slopes are typically formed by intersections between the mainline and entrances, median crossovers, or side roads.
35. Traveled Way. The portion of the roadway for the movement of vehicles, exclusive of medians, shoulders, curb and gutter, and auxiliary lanes.
36. Warrant. The criteria by which the justification for a safety treatment or improvement can be determined. The warrant may be based on IDOT/AASHTO guidelines, on a “cost-effective” assessment, or on engineering judgment.

38-3 ROADSIDE CLEAR ZONES

38-3.01 Background

The clear zone widths are based on limited empirical data that has then been extrapolated to a wide range of conditions. Therefore, the distances imply a degree of accuracy that does not exist. They do, however, provide a good frame of reference for making decisions on providing a safe roadside area. Each application of the clear zone distance must be evaluated individually, and the designer must exercise good judgment.

When using the recommended clear zone distances, the designer should consider the following:

1. Project Scope of Work. The clear zone distances in Section 38-3 apply to all freeway projects and to new construction/reconstruction projects on non-freeways. Chapter 49 presents the criteria for 3R projects on non-freeways.
2. Context. If a formidable obstacle lies just beyond the clear zone, it may be appropriate to remove or shield the obstacle if costs are reasonable. Conversely, the clear zone should not be achieved at all costs. Limited right-of-way (see item 4 below) or unacceptable construction costs may lead to installation of a barrier or perhaps no protection at all. As a general statement, the use of an appropriate clear zone distance is a compromise between maximum safety and minimum construction costs.
3. Boundaries. The designer should not use the clear zone distances as boundaries for introducing roadside hazards (e.g., bridge piers, non-breakaway sign supports, utility poles, landscaping features). These should be placed as far from the traveled way as practical.
4. Right-of-Way. Even for new construction/reconstruction projects, the availability of right-of-way may be a serious project issue. The acquisition of additional right-of-way solely to provide the clear zone distance may not be cost effective. If, on the other hand, the right-of-way width exceeds the design clear zone, this may offer an opportunity to increase safety by removing all hazards within the right-of-way.

38-3.02 Clear Zone Values

Figure 38-3.A presents clear zone distances for design. The following discusses the use of Figure 38-3.A to determine the applicable clear zone.

38-3.02(a) Speed

The designer will use the design speed for the facility from Figure 38-3.A to determine the applicable clear zone.

Design Speed (mph)	Design Year ADT	Front Slopes			Back Slopes		
		1V:6H or Flatter	1V:5H to 1V:4H	1V:3H	1V:3H	1V:5H to 1V:4H	1V:6H or Flatter
≤ 40	Under 750	7 – 10	7 – 10	**	7 – 10	7 – 10	7 – 10
	750 – 1500	10 – 12	12 – 14	**	10 – 12	10 – 12	10 – 12
	1500 – 6000	12 – 14	14 – 16	**	12 – 14	12 – 14	12 – 14
	Over 6000	14 – 16	16 – 18	**	14 – 16	14 – 16	14 – 16
45 – 50	Under 750	10 – 12	12 – 14	**	8 – 10	8 – 10	10 – 12
	750 – 1500	12 – 14	16 – 20	**	10 – 12	12 – 14	14 – 16
	1500 – 6000	16 – 18	20 – 26	**	12 – 14	14 – 16	16 – 18
	Over 6000	18 – 20	24 – 28	**	14 – 16	18 – 20	20 – 22
55	Under 750	12 – 14	14 – 18	**	8 – 10	10 – 12	10 – 12
	750 – 1500	16 – 18	20 – 24	**	10 – 12	14 – 16	16 – 18
	1500 – 6000	20 – 22	24 – 30	**	14 – 16	16 – 18	20 – 22
	Over 6000	22 – 24	26 – 32*	**	16 – 18	20 – 22	22 – 24
60	Under 750	16 – 18	20 – 24	**	10 – 12	12 – 14	14 – 16
	750 – 1500	20 – 24	26 – 32*	**	12 – 14	16 – 18	20 – 22
	1500 – 6000	26 – 30	32 – 40*	**	14 – 18	18 – 22	24 – 26
	Over 6000	30 – 32*	36 – 44*	**	20 – 22	24 – 26	26 – 28
65 – 70 ⁶	Under 750	18 – 20	20 – 26	**	10 – 12	14 – 16	14 – 16
	750 – 1500	24 – 26	28 – 36*	**	12 – 16	18 – 20	20 – 22
	1500 – 6000	28 – 32*	34 – 42*	**	16 – 20	22 – 24	26 – 28
	Over 6000	30 – 34*	38 – 46*	**	22 – 24	26 – 30	28 – 30

* Clear zones may be limited to 30 ft for practicality and to provide a consistent roadway template. When a site-specific investigation indicates a high probability of continuing crashes or when such occurrences are indicated by crash history, the designer should consider clear zone distances greater than the clear zone shown above.

** See procedure in Section 38-3.03(b).

Notes:

- All distances are measured from the edge of the traveled way. For opposing traffic on an undivided two-way roadway, the traveled way begins at the centerline separating opposing traffic.
- For clear zones, the "Design Year ADT" will be the total ADT for both directions of travel for the design year. This applies to both divided and undivided facilities. Traffic volumes will be based on a minimum 20-year projection from the anticipated date of construction.
- The values for "back slopes" only apply to a section where the toe of the back slope is adjacent to the shoulder; see Figure 38-3.B(d). For sections with roadside ditches, see Section 38-3.04.
- The values in the figure apply to tangent sections of highway. See the discussion in Section 38-3.02(e) for possible adjustments on horizontal curves.
- The values in the figure apply to all uncurbed sections and curbed sections in rural areas. See Section 38-3.02(f) for curbed sections in urban areas.
- 70 mph is highest design speed provided in the Roadside Design Guide. When design speeds are greater than the values provided, the designer may provide clear-zone distances greater than those shown in the table.

**RECOMMENDED CLEAR ZONE DISTANCES (ft)
(New Construction/Reconstruction)
(US Customary)**

Figure 38-3.A

Design Speed (km/hr)	Design Year ADT	Front Slopes			Back Slopes		
		1V:6H or Flatter	1V:5H to 1V:4H	1V:3H	1V:3H	1V:5H to 1V:4H	1V:6H or Flatter
≤ 60	Under 750	2.0 – 3.0	2.0 – 3.0	**	2.0 – 3.0	2.0 – 3.0	2.0 – 3.0
	750-1500	3.0 – 3.5	3.5 – 4.5	**	3.0 – 3.5	3.0 – 3.5	3.0 – 3.5
	1500-6000	3.5 – 4.5	4.5 – 5.0	**	3.5 – 4.5	3.5 – 4.5	3.5 – 4.5
	Over 6000	4.5 – 5.0	5.0 – 5.5	**	4.5 – 5.0	4.5 – 5.0	4.5 – 5.0
70-80	Under 750	3.0 – 3.5	3.5 – 4.5	**	2.5 – 3.0	2.5 – 3.0	3.0 – 3.5
	750-1500	4.5 – 5.0	5.0 – 6.0	**	3.0 – 3.5	3.5 – 4.5	4.5 – 5.0
	1500-6000	5.0 – 5.5	6.0 – 8.0	**	3.5 – 4.5	4.5 – 5.0	5.0 – 5.5
	Over 6000	6.0 – 6.5	7.5 – 8.5	**	4.5 – 5.0	5.5 – 6.0	6.0 – 6.5
90	Under 750	3.5 – 4.5	4.5 – 5.5	**	2.5 – 3.0	3.0 – 3.5	3.0 – 3.5
	750-1500	5.0 – 5.5	6.0 – 7.5	**	3.0 – 3.5	4.5 – 5.0	5.0 – 5.5
	1500-6000	6.0 – 6.5	7.5 – 9.0	**	4.5 – 5.0	5.0 – 5.5	6.0 – 6.5
	Over 6000	6.5 – 7.5	8.0 – 10.0*	**	5.0 – 5.5	6.0 – 6.5	6.5 – 7.5
100	Under 750	5.0 – 5.5	6.0 – 7.5	**	3.0 – 3.5	3.5 – 4.5	4.5 – 5.0
	750-1500	6.0 – 7.5	8.0 – 10.0*	**	3.5 – 4.5	5.0 – 5.5	6.0 – 6.5
	1500-6000	8.0 – 9.0	10.0 – 12.0*	**	4.5 – 5.5	5.5 – 6.5	7.5 – 8.0
	Over 6000	9.0 – 10.0*	11.0 – 13.5*	**	6.0 – 6.5	7.5 – 8.0	8.0 – 8.5
110 ⁶	Under 750	5.5 – 6.0	6.0 – 8.0	**	3.0 – 3.5	4.5 – 5.0	4.5 – 5.0
	750-1500	7.5 – 8.0	8.5 – 11.0*	**	3.5 – 5.0	5.5 – 6.0	6.0 – 6.5
	1500-6000	8.5 – 10.0*	10.5 – 13.0*	**	5.0 – 6.0	6.5 – 7.5	8.0 – 8.5
	Over 6000	9.0 – 10.5*	11.5 – 14.0*	**	6.5 – 7.5	8.0 – 9.0	8.5 – 9.0

* Clear zones may be limited to 9.0 m for practicality and to provide a consistent roadway template. When a site-specific investigation indicates a high probability of continuing crashes or when such occurrences are indicated by crash history, the designer may provide clear zone distances greater than the clear zone shown above.

** See procedure in Section 38-3.03(b).

Notes:

1. All distances are measured from the edge of the traveled way. For opposing traffic on an undivided two-way roadway, the traveled way begins at the centerline separating opposing traffic.
2. For clear zones, the "Design Year ADT" will be the total ADT for both directions of travel for the design year. This applies to both divided and undivided facilities. Traffic volumes will be based on a minimum 20-year projection from the anticipated date of construction.
3. The values for "back slopes" only apply to a section where the toe of the back slope is adjacent to the shoulder; see Figure 38-3.B(d). For sections with roadside ditches, see Section 38-3.04.
4. The values in the figure apply to tangent sections of highway. See the discussion in Section 38-3.02(e) for possible adjustments on horizontal curves.
5. The values in the figure apply to all uncurbed sections and curbed sections in rural areas. See Section 38-3.02(f) for curbed sections in urban areas.
6. 110 km/hr is highest design speed provided in the Roadside Design Guide. When design speeds are greater than the values provided, the designer may provide clear-zone distances greater than those shown in the table.

**RECOMMENDED CLEAR ZONE DISTANCES (m)
(New Construction/Reconstruction)
(Metric)**

Figure 38-3.A

38-3.02(b) Design Year

For all freeway projects and non-freeway new construction/reconstruction projects, the design year for safety features will be a minimum of 20 years from the anticipated date of construction.

38-3.02(c) Traffic Volumes

As indicated in Figure 38-3.A, the ADT is a parameter when determining the clear zone value. The figure is divided into ranges of traffic volumes and ranges of recommended clear zones. In general, the higher clear zones apply to the higher traffic volumes.

38-3.02(d) Side Slopes

The roadway side slope will influence the recommended clear zone distance from Figure 38-3.A. Figure 38-3.B presents a schematic of the general side slope configurations, which may include:

- a straight front slope,
- a variable or barn roof section,
- a section with a roadside ditch, or
- a section where the toe of the back slope is adjacent to the edge of shoulder.

Note: The values in Figure 38-3.A for back slopes only apply to a section as illustrated in Figure 38-3.B(d); they do not apply where a roadside ditch is present.

Many variables influence the selection of a clear zone distance for the various side slope configurations. Sections 38-3.03, 38-3.04, and 38-3.05 discuss side slopes in detail.

38-3.02(e) Alignment (Horizontal Curve Adjustment)

The clear zone values in Figure 38-3.A assume a tangent alignment. Horizontal curves may increase the angle of departure from the roadway, and thus increase the distance the vehicle will need to recover. Adjustments to the clear zone for curved alignment are considered only when the crash histories indicate such a need, as when a specific site investigation shows a definitive crash potential that could be significantly lessened by increasing the clear zone width, and when such increases are cost-effective.

It is unnecessary, to purchase additional right-of-way solely to provide the clear zone adjusted for horizontal curvature, unless inclusion of all right-of-way costs and impacts still shows a cost-effective safety improvement. See Section 38-4.01 for the recommended cost effectiveness software. Where adjustments are determined to be cost effective, Figure 38-3.C illustrates the application of the clear zone adjustment on a curve. Figure 38-3.D provides recommended adjustments for clear zones on horizontal curves.

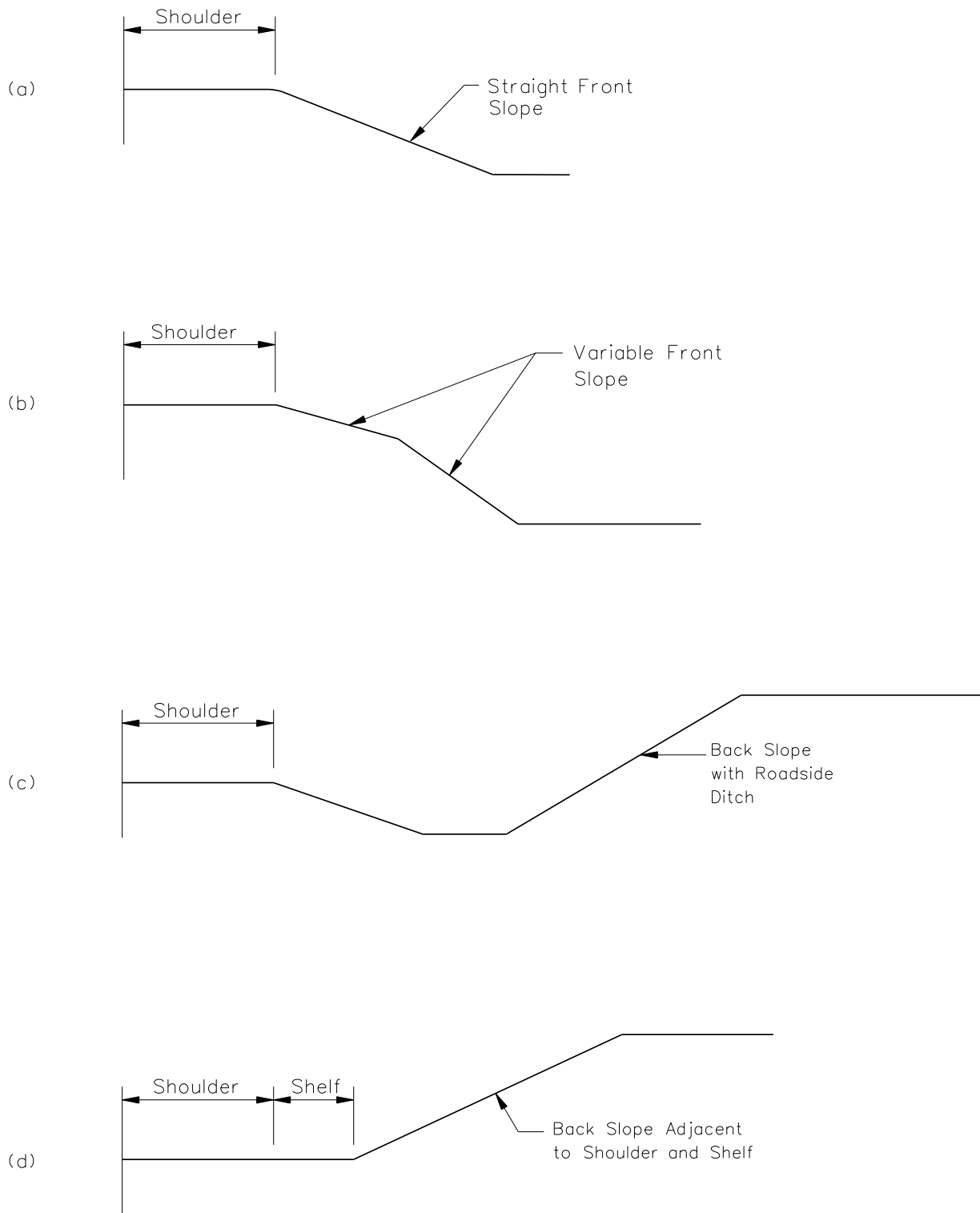

SIDE SLOPE CONFIGURATIONS

Figure 38-3.B

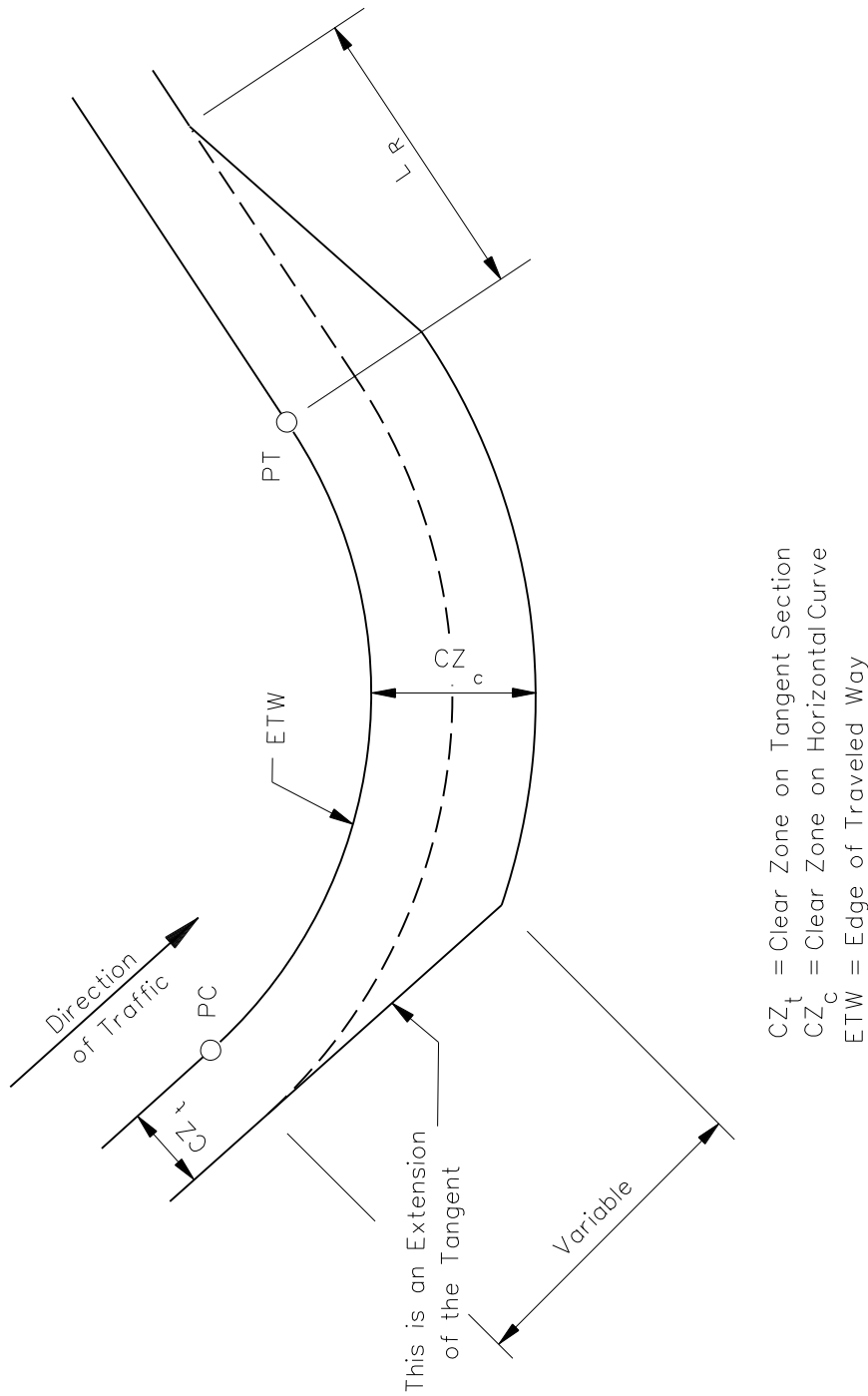

CZ_t = Clear Zone on Tangent Section
 CZ_c = Clear Zone on Horizontal Curve
 ETW = Edge of Traveled Way

Note: See Figure 38-6.E for L_R distances.

CLEAR ZONE WIDENING ON THE OUTSIDE OF HORIZONTAL CURVES

Figure 38-3.C

Radius (ft)	Design Speed (mph)						
	40	45	50	55	60	65	70 and greater
2860	1.1	1.1	1.1	1.2	1.2	1.2	1.3
2290	1.1	1.1	1.2	1.2	1.2	1.3	1.3
1910	1.1	1.2	1.2	1.2	1.3	1.3	1.4
1640	1.1	1.2	1.2	1.3	1.3	1.4	1.5
1430	1.2	1.2	1.3	1.3	1.4	1.4	
1270	1.2	1.2	1.3	1.3	1.4	1.5	
1150	1.2	1.2	1.3	1.4	1.5		
950	1.2	1.3	1.4	1.5	1.5		
820	1.3	1.3	1.4	1.5			
720	1.3	1.4	1.5				
640	1.3	1.4	1.5				
570	1.4	1.5					
380	1.5						

Notes:

1. Adjustments apply to the outside of a horizontal curve only.
2. No adjustments are warranted for curve radii greater than 2860 ft.
3. The applicable clear zone distance on a horizontal curve is calculated by:

$$CZ_c = (K_{cz})(CZ_t)$$

where: CZ_c = clear zone on a curve, ft
 K_{cz} = curve adjustment factor
 CZ_t = clear zone on a tangent section from Figure 38-3.A, ft

Round calculated CZ_c up to the next highest 1 ft increment.

4. For curve radii intermediate in the figure, use a straight-line interpolation.
5. See Figure 38-3.C for the application of CZ_c to the roadside around a curve.

**CLEAR ZONE ADJUSTMENT FACTORS FOR HORIZONTAL CURVES (K_{cz})
(US Customary)**

Figure 38-3.D

Radius (m)	Design Speed (km/hr)					
	60	70	80	90	100	110 and greater
900	1.1	1.1	1.1	1.2	1.2	1.2
850	1.1	1.1	1.1	1.2	1.2	1.3
800	1.1	1.1	1.1	1.2	1.2	1.3
750	1.1	1.1	1.1	1.2	1.2	1.3
700	1.1	1.1	1.2	1.2	1.2	1.3
650	1.1	1.2	1.2	1.2	1.3	1.4
600	1.1	1.2	1.2	1.2	1.3	1.4
550	1.1	1.2	1.2	1.3	1.3	1.4
500	1.1	1.2	1.2	1.3	1.3	1.4
450	1.2	1.2	1.3	1.3	1.4	
400	1.2	1.2	1.3	1.3	1.4	
350	1.2	1.2	1.3	1.4		
300	1.2	1.3	1.4	1.5		
250	1.3	1.3	1.4			
200	1.3	1.4				
150	1.4	1.5				
100	1.5					

Notes:

- Adjustments apply to the outside of a horizontal curve only.
- No adjustments are warranted for curve radii greater than 900 m.
- The applicable clear zone distance on a horizontal curve is calculated by:

$$CZ_c = (K_{cz})(CZ_t)$$

where: CZ_c = clear zone on a curve, m
 K_{cz} = curve adjustment factor
 CZ_t = clear zone on a tangent section from Figure 38-3.A, m

Round calculated CZ_c up to the next highest 0.5 m increment.

- For curve radii intermediate in the figure, use a straight-line interpolation.
- See Figure 38-3.C for the application of CZ_c to the roadside around a curve.

**CLEAR ZONE ADJUSTMENT FACTORS FOR HORIZONTAL CURVES (K_{cz})
(Metric)**

Figure 38-3.D

Example 38-3.02(1)

Given: Design Speed = 55 mph
 Design ADT = 3000
 Horizontal curve with a radius of 2000 ft
 Flat side slope

Problem: Find the clear zone adjusted for the horizontal curve.

Solution: From Figure 38-3.A, the clear zone on the tangent (CZ_t) = 20 ft.

From Figure 38-3.D, the curve correction factor (K_{cz}) = 1.2.
 The clear zone for the curve (CZ_c) = $(20)(1.2) = 24$ ft.

The transition length (equal to the runout length (L_R)) from Figure 38-6.E = 185 ft.

* * * * *

38-3.02(f) Curbed Sections

The values in Figure 38-3.A apply to curbed sections in rural areas and all uncurbed sections of highway. Where curbs are present, the following additional considerations will apply:

1. Urban/Suburban Facilities. A minimum horizontal, obstruction-free clearance of 1.5 ft (500 mm) should be provided as measured from the face of the curb. This offset provides sufficient clearance to keep the overhang of a truck from striking an object. See Section 38-9 for guidance regarding an enhanced lateral offset. This applies to both barrier and mountable curbs, except that M2 (M5) curb will be treated as an uncurbed section.

Because curbs do not have re-directional capabilities, except at speeds below 25 mph (40 km/hr), the presence of curbs does not affect determination or application of the calculated clear zone value. See Section 38-9 for more discussion of roadside safety for urban cross sections.

5. Rural Facilities. For specific field conditions, it may be acceptable to use mountable curbs on rural facilities or barrier curbs in conjunction with standard guardrail. See Chapter 34. However, the clear zone will be determined assuming that the facility is uncurbed; i.e., the clear zone criteria presented in Chapter 38 will apply to all rural facilities whether curbed or uncurbed. Limit the location of curbs along high-speed rural facilities to the outer edge of the shoulder. See point 3 under Section 34-2.04(a) for more information.

38-3.02(g) Lane Width

The clear zone distances in Figure 38-3.A are, theoretically, predicated upon a 12 ft (3.6 m) lane width. However, they will be used for any lane width.

38-3.02(h) Auxiliary Lanes

Auxiliary lanes are defined as any lanes beyond the basic through travel lanes that are intended for use by vehicular traffic for specific functions. These include turn lanes at intersections, truck-climbing lanes, weaving lanes, acceleration/deceleration lanes at interchanges, etc. The clear zone for auxiliary lanes will be determined as follows:

1. Turn Lanes at Intersections. Where the intersection is uncurbed, clear zones will be determined based on the design speed and traffic volumes associated with the through travel lanes; i.e., the presence of the turn lane is ignored when determining clear zones, provided that a minimum 10 ft (3.0 m) clear zone is maintained beyond the outside edge of the shoulder. Where the intersection is curbed, the criteria in Section 38-3.02(f) will apply; i.e., the minimum obstruction-free zone is 1.5 ft (500 mm) from the gutter line with an enhanced lateral offset of 4 ft to 6 ft (1.2 m to 1.8 m) preferred.
2. Auxiliary Lanes Adjacent to Mainline. Use the following clear zone applications for climbing lanes, acceleration/deceleration lanes, ramp terminals, weaving lanes, etc. Two independent clear zone determinations are necessary. First, the designer calculates the clear zone from the edge of the through traveled way based on the total traffic volume, including the auxiliary lane volume. Second, the designer calculates the clear zone from the edge of the auxiliary lane based on the traffic volume in the auxiliary lane. The clear zone distance that extends further will apply.

38-3.03 Front Slopes

Figure 38-3.B illustrates the two basic configurations for front slopes (i.e., straight slope or variable slope). Section 38-2 presents definitions of parallel front slopes that apply to clear zone determinations. Figure 38-3.E presents schematics for these definitions, and the following discusses the clear zone application in conjunction with Figure 38-3.A.

38-3.03(a) Recoverable Front Slopes

For parallel front slopes 1V:4H and flatter [Figure 38-3.E(a)], the recommended clear zone distance can be determined directly from Figure 38-3.A.

38-3.03(b) Non-Recoverable Front Slopes

For parallel front slopes steeper than 1V:4H, but 1V:3H or flatter [Figure 38-3.E(b)], a clear runout area beyond the toe of the non-recoverable front slope is recommended. The width of the non-recoverable front slope is not to be counted as part of the clear runout width. Use the following procedure to determine the clear zone:

1. Determine the clear zone for a 1V:6H or flatter slope from Figure 38-3.A for the applicable design speed and traffic volume.

2. To determine the clear runout area beyond the toe, subtract the shoulder width [or the distance from the edge of traveled way to the hinge point, noted as “A” in Figure 38-3.E(b)] from the distance in Step 1.
3. The clear runout area beyond the toe shall be the greater distance of the value determined in Step 2 or 10 ft (3.0 m).

Example problem 38-3.03(2) illustrates this procedure.

38-3.03(c) Barn-Roof Front Slope (Recoverable/Non-Recoverable)

Barn-roof front slopes may be designed with a recoverable slope leading to a non-recoverable slope; see Figure 38-3.E(c). This design requires less right-of-way and embankment material than a continuous, flatter slope. The distance from the break between the two slopes to the clear zone [noted as “X” on Figure 38-3.E(c)] should be applied as an addition outside the toe of the non-recoverable slope. This addition should be a minimum of 10 ft (3.0 m) wide; i.e., a clear area of 10 ft (3.0 m) beyond the toe of slope will be needed where the clear zone extends beyond the break between the recoverable and non-recoverable slopes. If the distance from the edge of traveled way to the break between the two slopes is a minimum of 30 ft (9.0 m), no additional clear area will be required at the toe of slope.

38-3.03(d) Barn-Roof Front Slope (Recoverable/Recoverable)

Barn-roof front slopes may also be designed with consecutive recoverable slopes — the second slope steeper, but also recoverable, than the slope adjacent to the shoulder. Although a weighted average of the slopes may be used, a simple average of the clear zone distances for each slope is sufficiently accurate, if the variable slopes are approximately the same width. If one slope is significantly wider, the clear zone computation based on that slope alone may be used.

38-3.03(e) Critical Front Slope

Front slopes steeper than 1V:3H are critical; see Figure 38-3.E(d). These typically require a barrier and, therefore, there is no clear zone application; see Section 38-4.

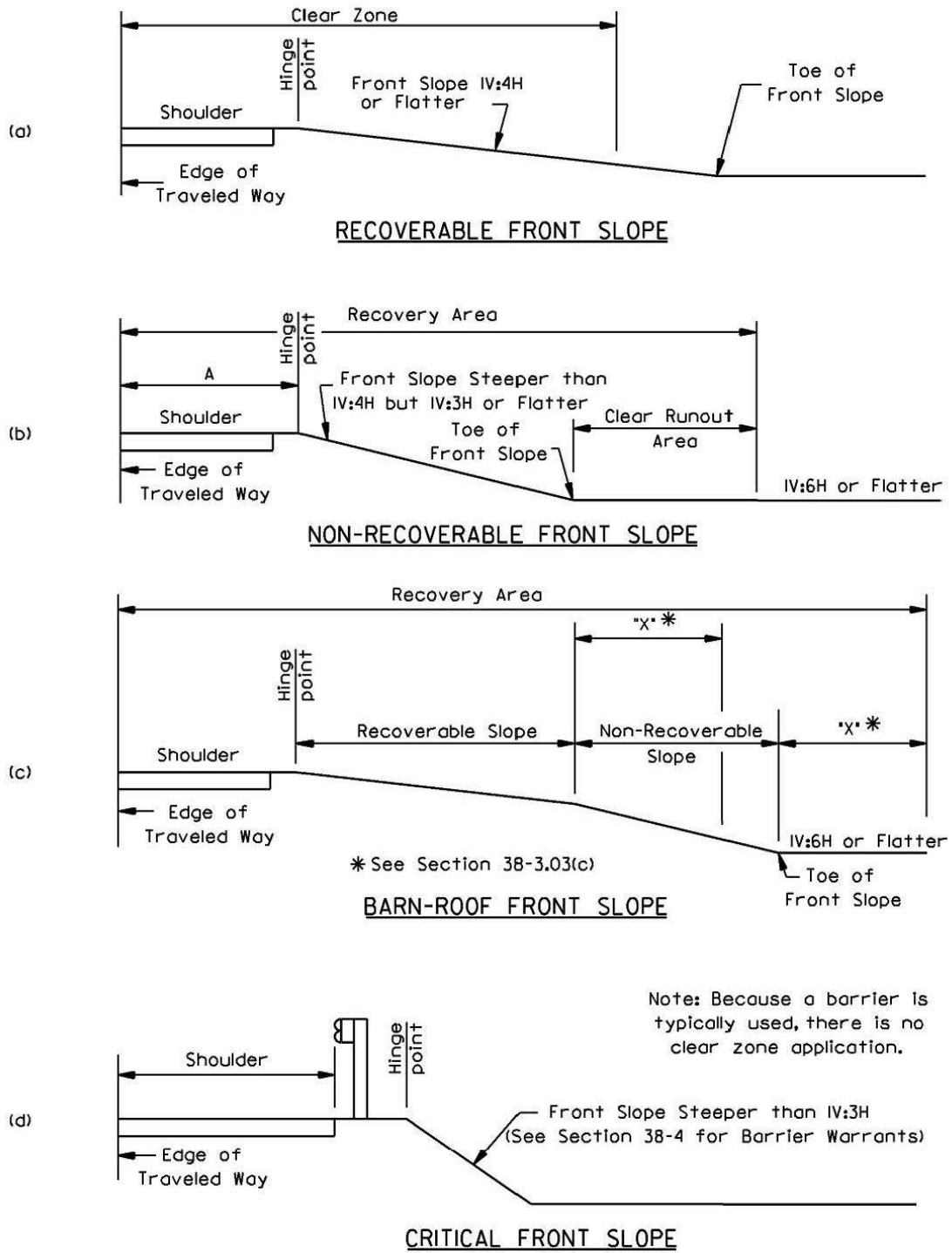

**CLEAR ZONE APPLICATION FOR FRONT SLOPES
(Uncurbed)**

Figure 38-3.E

Example 38-3.03(1) (Recoverable Front Slope)

Given: Front Slope — 1V:4H
Design Speed — 60 mph
Design ADT — 7000

Problem: Determine the recommended clear zone distance.

Solution: From Figure 38-3.A, the clear zone distance should be 36 ft to 44 ft. However, as indicated in a footnote to the figure, the clear zone distance may be limited to 30 ft based on specific site conditions to provide a more practical design.

* * * * *

Example 38-3.03(2) (Non-Recoverable Front Slope)

Given: Front Slope — 1V:3H
Shoulder Width — 10 ft
Design Speed — 60 mph
Design ADT — 7000

Problem: Determine the recommended clear zone distance.

Solution: The procedure in Section 38-3.03(b) for non-recoverable front slopes is used as follows:

1. From Figure 38-3.A, the clear zone for a front slope 1V:6H or flatter is 30 ft to 32 ft.
2. The recommended clear distance beyond the toe of the non-recoverable slope (1V:3H) is 30 ft to 32 ft (9.1 m to 9.8 m) minus 10 ft (3.0 m) shoulder width yields 20 ft to 22 ft (6.1 m to 6.7 m).
3. The clear distance beyond the toe of slope shall be the greater of the value determined in Step 2 [20 ft to 22 ft (6.1 m to 6.7 m)] , or 10 ft (3.0 m), therefore the clear zone extends to 20 ft to 22 ft (6.1 m to 6.7 m) beyond the toe of the front slope.

* * * * *

38-3.04 Back Slopes

Back slopes in cut sections or slope walls at overhead bridges may be traversable depending upon their surface conditions and presence of fixed objects. Where the front slope is 1V:3H or flatter and the back slope is stable, firm, and free of fixed objects or snag points it may not be a significant hazard. However, back slopes that are rough-faced rock cuts, tree-lined, or where significant wheel rutting would be expected are examples of back slopes that would pose significant hazards.

Where a pier for an overhead structure is located near a back slope (i.e. a slopewall), design the roadside guardrail for the pier using a minimum clear zone value of 25 ft (7.6 m).

38-3.05 Roadside Ditches

Ditch sections, as illustrated in Figure 38-3.F, are typically constructed in roadside cut sections without curbs. Figure 38-3.H provides preferred ditch sections based on slopes and bottom widths.

When a preferred ditch cross section, according to Figure 38-3.H, is not used, the applicable clear zone across a ditch section will depend upon the front slope, the ditch width, the back slope, the horizontal location of the toe of the back slope, and various highway factors. The designer shall use the following procedure to determine the recommended clear zone distance when a preferred ditch cross section is not used:

1. Determine the Nominal Clear Zone. Use Figure 38-3.A to determine the clear zone based on the ditch front slope.
2. Check the Location of the Toe of the Back Slope. Based on the distance determined in Step 1, refer to Section 38-3.03 to establish if the toe of the back slope is within the clear zone. The toe of back slope is defined as the point at which the ditch rounding ends and the (uniform) back slope begins. If the toe is at or beyond the clear zone, then the designer usually need only consider roadside hazards within the clear zone on the front slope or within the ditch. If the toe is within the clear zone, the designer should evaluate the practicality of relocating the toe of back slope. If the toe of back slope will remain within the clear zone, Step 3 below will apply to ditch sections in earth cuts.
3. Determine Clear Zone on Back Slope (Earth Cuts). If the toe of the back slope is within the clear zone distance, a clear zone should be provided on the back slope. This clear zone will be a distance beyond the toe of back slope as follows:
 - a. Where the back slope is 1V:6H or flatter, treat the back slope as level and use the clear zone based on the front slope rate to determine the clear zone limit on the back slope.
 - b. Where the back slope is steeper than 1V:6H but 1V:3H or flatter [Figure 38-3.F(b)], assume the vehicle cannot make it up to the top of the back slope, if the slope is at least 10 ft (3.0 m) wide. The initial 10 ft (3.0 m) beyond the toe of the back slope or

the distance in Step 3a, whichever is less, should be clear of roadside hazards. Any obstacles beyond this point would be considered outside of the clear zone.

- c. Where the back slope is steeper than 1V:3H [see Figure 38-3.F(c)], the initial 5 ft (1.5 m) beyond the toe of the back slope should be clear of roadside hazards.
4. Clear Zones (Rock Cuts). No clear zone is required beyond the toe of back slope for rock cuts with steep back slopes. However, the rock cut should be relatively smooth to minimize the hazards of vehicular snagging. If the face of the rock is rough or rock debris is present, a barrier may be warranted.

The Department's configuration for rock cuts, typically, is the following:

- a 1V:6H front slope,
 - a 1.5 ft (500 mm) ditch bottom plus additional width for falling rock, and
 - a 1V:0.25H back slope or as required by rock type.
5. Deep Cuts. For earth cuts where the height of the cut from the bottom of the ditch is greater than 10 ft (3.0 m), the designer may consider using a 1V:2H back slope above the 10 ft (3.0 m) elevation to reduce costs.

Example problem 38-3.04(1), below, illustrates the method to determine the clear zone when a preferred ditch cross section is not used.

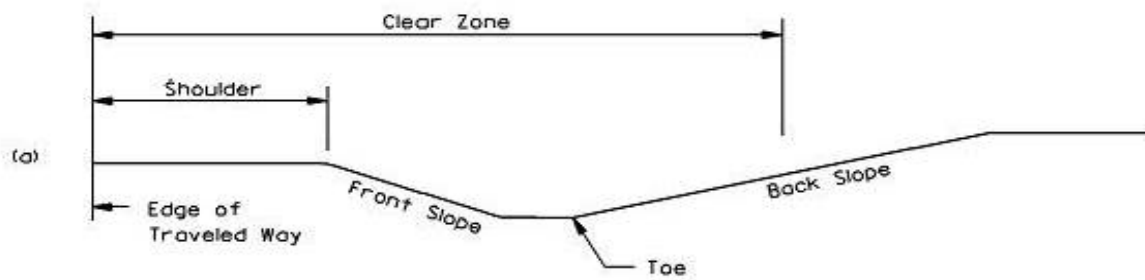

PREFERRED DITCH CROSS SECTION

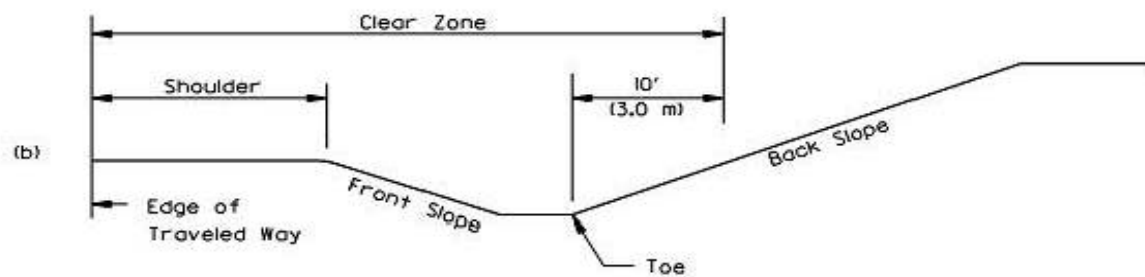

BACK SLOPE STEEPER THAN 4:6 BUT 4:3 OR FLATTER AND NOT MEETING THE CRITERIA FOR A PREFERRED DITCH CROSS SECTION

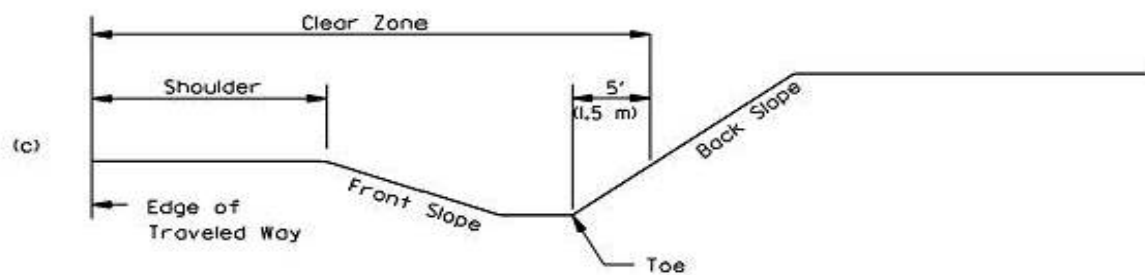

BACK SLOPE STEEPER THAN 4:3 AND NOT MEETING THE CRITERIA FOR A PREFERRED DITCH CROSS SECTION

CLEAR ZONE APPLICATION FOR ROADSIDE DITCHES

Figure 38-3.F

Example 38-3.04(1) (Not a Preferred Ditch Section)

Given: Design ADT = 7000
 V = 60 mph
 Front Slope = 1V:4H
 Ditch Width = 2 ft
 Back Slope = 1V:3H
 Toe of back slope is 18 ft from edge of traveled way
 See Figure 38-3.H

Problem: Determine the clear zone application across the ditch section.

Solution: From Figure 38-3.G, the 1V:4H front slope with 2 ft bottom and 1V:3H back slope does not meet the criteria for a preferred ditch. Using the procedure in Section 38-3.04:

1. Determine the Clear Zone. Figure 38-3.A yields a clear zone of 36 ft to 44 ft for a 1V:4H front slope. However, as indicated in the footnote, a 30-ft clear zone may be used.
2. Check the Location of the Toe of the Back slope. The toe of back slope is within the clear zone. Therefore, proceed to Step 3.
3. Determine the Clear Zone on the Back slope (Earth Cuts). With a 1V:3H back slope, the criteria in Step 3.b. will apply. Based on these criteria, the lesser of 10 ft beyond the toe of back slope or the clear zone from Step 1 above will control. 10 ft beyond the toe of back slope yields a total distance of 28 ft from the edge of traveled way versus 30 ft from Step 1. Therefore, the procedure yields a 28 ft clear zone for the roadside.

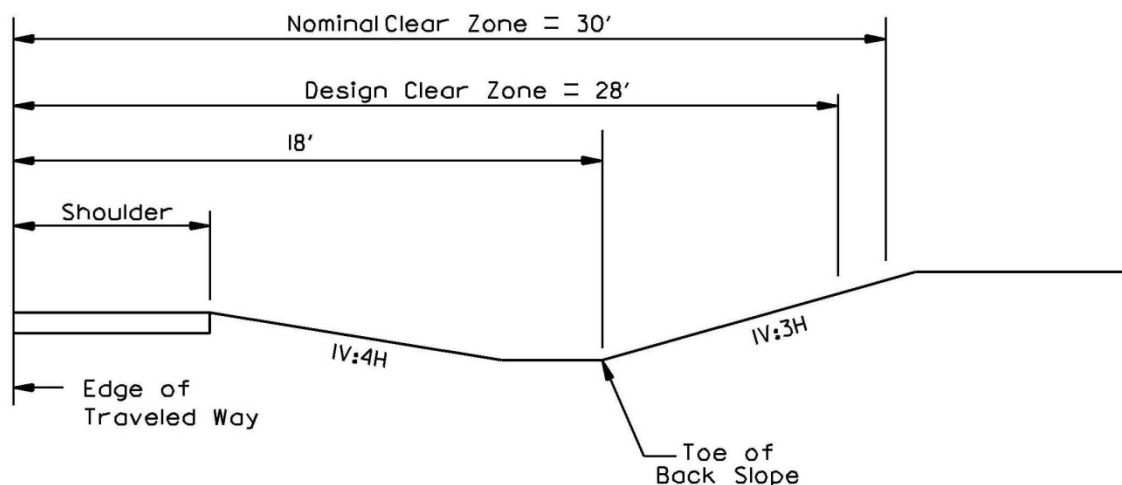

CLEAR ZONE AT DITCH SECTION
Example 38-3.04(1)

Figure 38-3.G

38-3.06 Transitional Slopes

As practical, slopes that transition between differing slope rates, types of slopes (e.g. transverse slope to front slope), or from a fill section to a cut section should be designed to provide a recoverable and forgiving roadside by meeting or exceeding the various design criteria for slopes from Section 38-3 and 38-4. Transitions of parallel front slopes, parallel back slopes, or ditch side slopes should be, over a distance, sufficient to avoid the perception of a transverse slope (suggested 25H:1V or flatter). Transitions from fill slopes to cut slopes should be designed on a case-by-case basis, with special attention given to the drainage channel created where these cross sections transition.

PREFERRED DITCH CROSS SECTIONS		
Front Slope	Preferred Maximum Ditch Back Slope	
	Trapezoidal Ditch with Vee or <4 ft (1.2 m) Flat Bottom	Trapezoidal Ditch with Minimum 4 ft (1.2 m) Flat Bottom
1:8	1:3.5	1:2.5
1:6	1:4	1:3
1:5	1:5	1:3.5
1:4	1:6	1:4

Note: For front or back slope values falling between those given above, round down to the next steeper slope, i.e., do not interpolate between slope values.

PREFERRED DITCH CROSS SECTIONS**Figure 38-3.H**

38-4 ROADSIDE HAZARD REMEDIATION

During Phase I of a project the designer evaluates and establishes the roadside barrier warrants. Refer also to Section 11-2.04(g). Safety design decisions may affect right-of-way needs, earthwork quantities, and other design elements that must be recognized early in project development. Safety issues must be addressed early so as to not severely restrict the designer's options. Design exceptions related to roadside hazards should be very uncommon and will require approval and documentation in the Phase I engineering report. Refer to Section 31-7 for the design exception process and Chapter 12 regarding Phase I engineering report content.

38-4.01 Examples of Roadside Hazards

Examples of roadside hazards include:

- non-breakaway sign supports, non-breakaway luminaire supports, traffic signal poles, and railroad signal poles;
- concrete footings, traffic signal foundations, etc., extending more than 4 in. (100 mm) above the ground;
- bridge piers and abutments at underpasses;
- culvert headwalls;
- trees with diameters greater than 4 in. (100 mm) (at maturity);
- rough rock cuts;
- large boulders;
- critical parallel slopes (i.e., embankments);
- streams or permanent bodies of water (where the depth of water \geq 2 ft (600 mm));
- non-traversable ditches;
- utility poles or towers;
- drainage appurtenances; and
- transverse slopes.

The severity of a specific roadside hazard will depend upon many factors. The Roadside Safety Analysis Program (RSAP) may be used to quantify the relative severity of roadside hazards. The RSAP software, user's manual, engineer's manual, and programmer's manual are found at: <http://rsap.roadsafellc.com/>. For questions about the RSAP, contact the Bureau of Safety Programs and Engineering.

38-4.02 Range of Treatments

If a roadside hazard is within the clear zone, the designer should select the treatment that is judged to be the most practical and cost-effective for the site conditions. The range of treatments, in order of preference, includes:

- Eliminate the hazard (flatten embankment, remove rock outcroppings, etc.);
- redesign the hazard so it can be safely traversed (e.g., culvert grating);
- relocate the hazard to a point where it is less likely to be struck;
- where applicable, make the hazard breakaway (sign posts, luminaire supports);
- shield the hazard with a roadside barrier;
- delineate the hazard; or
- do nothing.

38-4.03 Warrant Methodologies

Warrants for roadside barriers imply that other options higher in the preference order for range of treatments (see Section 38-4.02) have first been considered. Whether objectively or subjectively, the decision will be based upon the traffic volumes, roadway geometry, proximity of the hazard to the traveled way, nature of the hazard, expected crash severity, installation costs and, where applicable, crash experience. The following briefly discusses the Department's decision-making methods for barrier warrants.

38-4.03(a) Department Policy

For specific applications, the Department has adopted policies on warrants for roadside barriers. These are documented throughout Section 38-4.

38-4.03(b) Cost-Effectiveness Method

Where practical, the designer should use an approved cost-effectiveness methodology to determine roadside barrier warrants. This will provide an objective means to analyze many of the factors that impact roadside safety, and it will support effective use of funds to realize safety benefits. It will also promote uniformity of decision-making for roadside safety throughout the Department. The currently approved cost-effectiveness method is the Roadside Safety Analysis Program (RSAP) software presented in Section 38-4.01.

38-4.03(c) Engineering Judgment Method

Until the development of cost-effectiveness models, barrier warrants were typically determined based on engineering judgment. With this approach, the designer first analyzes the site by a "relative severity" assessment—which is the greater hazard, the roadside barrier or the roadside hazard? Next, the designer subjectively evaluates the site-specific parameters (e.g., traffic volumes, design speed, location of hazard, barrier installation costs) to determine if a barrier installation is a reasonable and practical solution. If yes, a barrier is warranted; if no, the do-nothing alternative is selected. For example, it would probably not be practical to install a barrier to shield an isolated point obstacle (e.g., tree) located near the edge of the clear zone. The

designer must realize that a barrier is also a hazard and, if a clear decision cannot be reached, the general rule of “when in doubt, leave it out” should apply.

It is acceptable to use engineering judgment to determine the warrants for roadside barriers for two conditions:

1. If the decision is obvious for a specific site, the designer may forego the use of a cost-effectiveness method and use engineering judgment to install or not install a roadside barrier.
2. If extenuating circumstances exist, the designer may override Department policies for barrier warrants or the results of a cost-effectiveness method, either to install or not install a roadside barrier. In this case, the designer must document the reasons for the decision. This documentation should include crash histories for the section of roadway, traffic volumes, posted speed, and roadway geometry.

38-4.04 Embankments

Figure 38-4.A presents barrier warrants for embankments.

38-4.05 Transverse Slopes

Where the mainline highway intersects an entrance, side road, or median crossing, a slope transverse to the mainline will be present; see Figure 38-4.B. Even at moderate speeds, vehicles encountering transverse slopes can become airborne. Abrupt transverse slopes may also snag errant vehicles. In general, transverse slopes should be as flat as practical. Figure 38-4.C presents IDOT criteria for transverse slopes within the clear zone based on the type of facility and design speed.

The bridge cones of overhead roadway structures also introduce transverse slopes. Both the transverse slope intersecting the ditch and the transverse slope beyond the ditch, but within the clear zone, should be addressed with the slopes given in Figure 38-4.C. The recommended transverse slopes intersecting the ditch should reach to approximately 4 ft (1.2 m) vertical above the shoulder. The recommended transverse slopes beyond the ditch should reach approximately 4 ft (1.2 m) above the natural or graded ground out to the clear zone. Treat any parallel culvert as instructed in Section 38-4.06.

Figure 38-4.C presents both desirable (i.e., flatter) and acceptable (i.e., steeper) transverse slopes. The application at a specific site will depend upon an evaluation of many factors, including:

- height of transverse embankment,
- traffic volumes,
- design speed,
- presence of culverts and practicality of treating the culvert end (see Section 38-4.06),

- construction costs, and
- right-of-way and environmental impacts.

Although the 1V:10H transverse slope may be desirable, its practicality may be limited because of drainage structures, width restrictions, and maintenance problems associated with the long tapered ends of pipes or culverts. On arterial highways including freeways, however, the 1V:10H transverse slope should be used unless regrading of existing 1V:6H transverse slopes would require the installation of new drainage features.

If the criteria in Figure 38-4.C cannot be met, the designer should consider the installation of a roadside barrier.

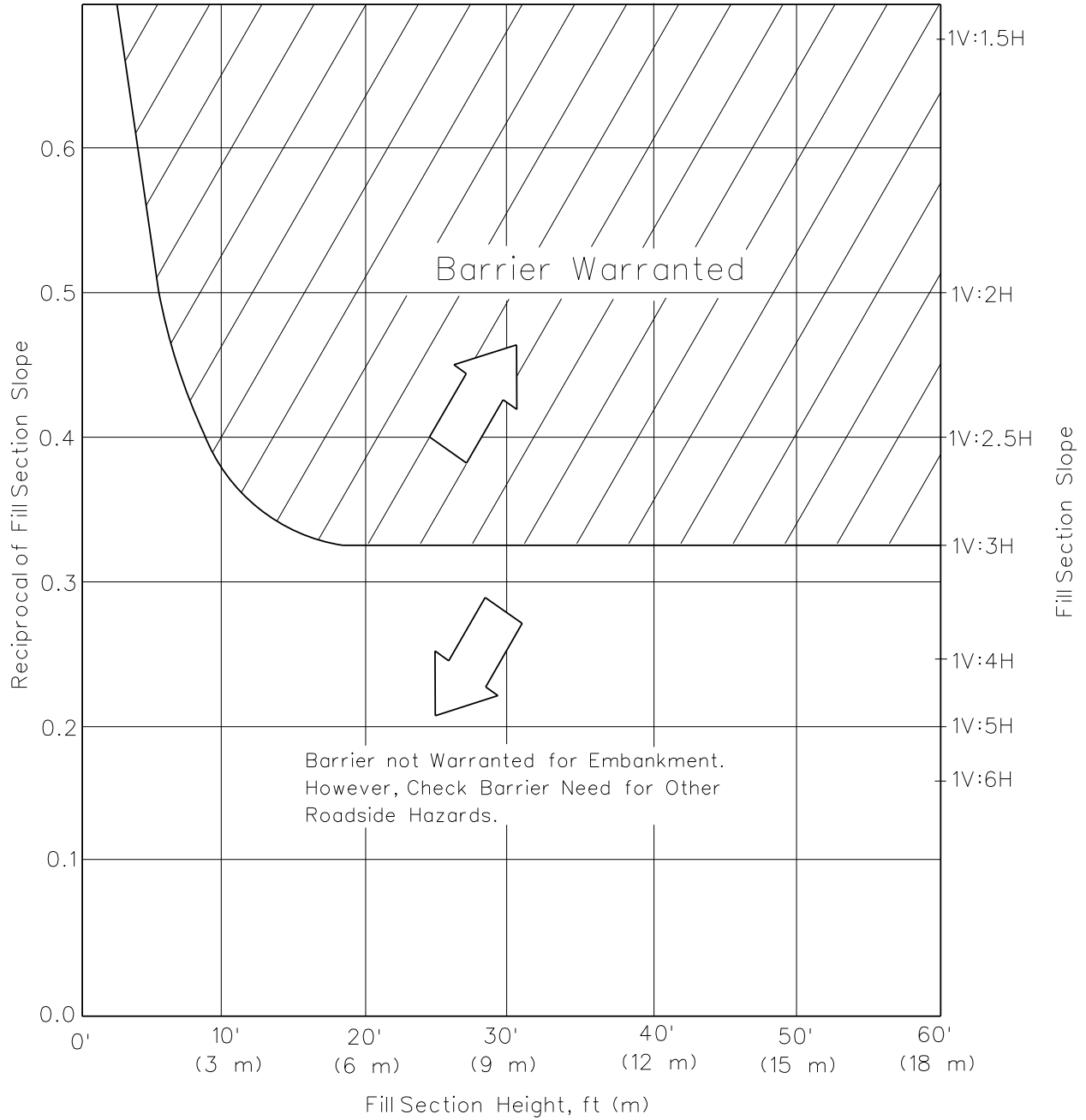

Note: Points that fall on the solid line do not warrant a barrier.

BARRIER WARRANTS FOR EMBANKMENTS

Figure 38-4.A

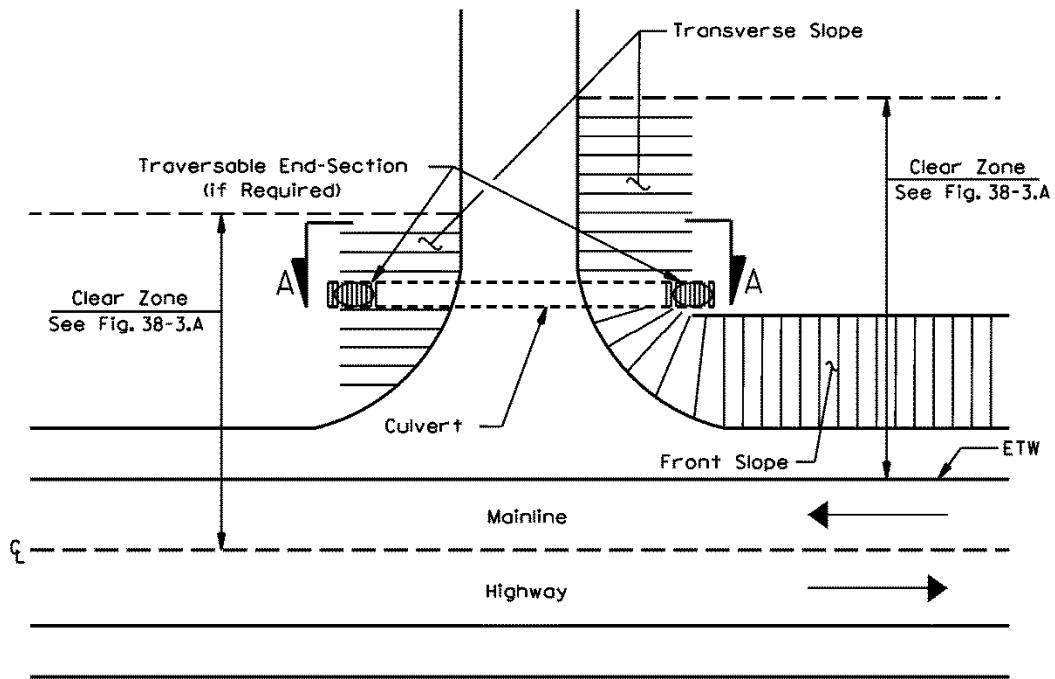

Note: On a one-way facility, the traversable end-section on the departure end is not required.

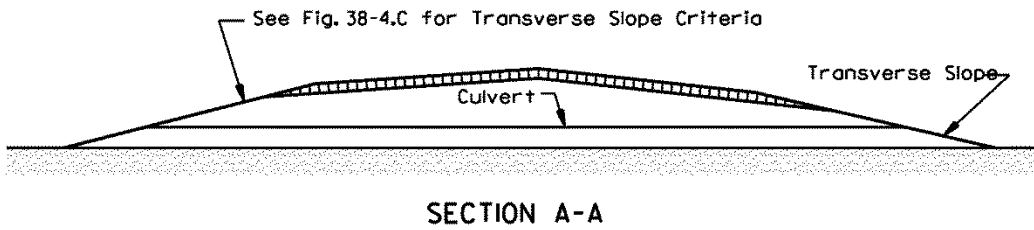

TRANSVERSE SLOPES ON A TWO-LANE, TWO-WAY ROADWAY

Figure 38-4.B

Type of Facility	Desirable (V:H)	Acceptable (V:H)
Freeway	1:10	1:6
Rural Non-Freeways ($V \geq 50$ mph (80 km/hr))	1:10	1:6
Urban Non-Freeways ($V \geq 50$ mph (80 km/hr))	1:6	1:4
Urban and Rural Low-Speed Facilities ($V \leq 45$ mph (70 km/hr))	1:6	1:4

RECOMMENDED TRANSVERSE SLOPES

Figure 38-4.C

38-4.06 Roadside Drainage Features

Effective drainage is a critical element in the design of a highway or street. In addition to hydraulic considerations, ditches, curbs, culverts, and drop inlets should be designed and constructed considering their consequences to roadside safety.

The *Illinois Drainage Manual* and Chapter 40 of the *BDE Manual* discuss the Department's practices for hydrology and hydraulics and for the physical design of roadside drainage structures. Sections 38-4.06(b) discusses the safety design of these structures.

38-4.06(a) Curbs

Curbs are typically used to control drainage or to protect erodible soils. Chapter 34 and the *IDOT Highway Standards* provide detailed information on the warrants and types of curbs used by the Department. Curbs may pose a roadside hazard because of their potential to adversely affect a run-off-the-road vehicle. When evaluating curbs relative to roadside safety, the designer should consider the following:

1. Design Speed. On high speed roadways, curbs may cause errant vehicles to overturn or become airborne. Facilities with a design speed greater than 45 mph (70 km/hr) should be designed without curbs.

However, if necessary along high-speed roadways, a 4 in. (100 mm) Type M (sloped) curb or Type B gutter may be used and placed only at the outside of the paved shoulder. If a shoulder is initially designed with aggregate, and a curb is proposed at the back of the aggregate width, change the aggregate width to a paved surface. See Section 34-2.04 for curb types for facilities with a design speed of 45 mph (70 km/hr) or less.

Where a guardrail is proposed, a 6 in. (150 mm) barrier curb may be used if it is placed such that the face of the guardrail is within 6 in. (150 mm) behind the face of the curb.

Guardrail terminals should be placed beyond the limits of the curb in this situation. See Section

38-6.05, item 1, for more guidance regarding guardrail placement along curb.

2. Roadside Barriers. The use of curbs with a roadside barrier is discouraged and, specifically, curbs higher than 6 in. (150 mm) should not be used with a barrier. See Sections 38-6.03 and 38-6.05. If a guardrail adjacent to a curb is unavoidable, the lateral placement of the guardrail relative to the curb face is critical. Refer to the *Highway Standards* for proper guardrail placement and coordination with the design speed.
3. Redirection. Curbs offer no safety benefits on high-speed roadways and will not redirect errant vehicles.
4. M2 (M5) Curb. It is acceptable to use the 2 in. (50 mm) high M2 (M5) curb in conjunction with a roadside barrier.

38-4.06(b) Culverts

1. Cross Drainage Structures. Cross drainage structures are designed to convey water through the roadway embankment. If not properly designed, they and their associated end sections, roadside slopes and ditches may present a hazard to run-off-the-road vehicles. In priority order, the available roadside safety treatments to minimize the potential hazard of the end sections for cross drainage culverts are:
 - a. eliminate the culvert;
 - b. provide a traversable end section;
 - c. extend the culvert opening beyond the clear zone with smooth, traversable graded earth transitions;
 - d. shield the culvert with a roadside barrier; or
 - e. delineate the culvert if the above alternatives are not feasible.

The following summarizes the Department's practices for providing a traversable end section for cross drainage structures within the clear zone (note that metal end sections on front slopes are only available for slopes of 1V:4H and 1V:6H):

- for culverts less than 27 in. (700 mm) in diameter, install an end section from the *Illinois Highway Standards* which matches the front slope; or
- for culverts 27 in. (700 mm) and greater in diameter, install an end section with a traversable grate from the *Illinois Highway Standards* which matches the front slope. Elliptical pipe culverts are listed by equivalent round size in the Standards.

The above requirement for a traversable grate is based upon Section 3.4.2.1 of AASHTO's *Roadside Design Guide*, which states that structures with end sections having more than a 3 ft (900 mm) wide opening can be made traversable by using a pipe grate. When

evaluating the need for a traversable grate for multi-cell pipe culverts, elliptical pipes, pipe arches, or box culverts, the same end section criteria should be applied.

If the culvert end section cannot be made traversable, install an appropriate end section and then determine if guardrail is warranted based on analyses throughout this chapter.

2. Parallel Drainage Structures. Parallel drainage structures, those that are oriented parallel to the main flow of traffic, must be considered when within the mainline clear zone. They are typically used under driveways, field entrances, access ramps, intersecting side roads, and median crossovers. Such culverts represent a hazard because an errant vehicle may impact the open end of the culvert. Therefore, the designer must coordinate design of the drainage structures with that of the surrounding transverse slope (Section 38-4.05) to minimize the hazard.

Safety treatment options are very similar to those for cross-drainage structures. In priority order, the options are:

- a. eliminate the culvert;
- b. provide a traversable end section;
- c. move the culvert laterally to a less vulnerable location;
- d. shield the culvert with a roadside barrier; or
- e. delineate the culvert if the above alternatives are not feasible.

Figure 38-4.D presents a generic design for grate protection of a parallel drainage structure. *Highway Standards* 542411 and 542416 depict design specifications for metal end sections. Safety treatment is also subject to the following considerations for travel along both the highway and entrance:

- For metal culverts less than 24 in. (600 mm) in diameter, install a metal end section from the *Illinois Highway Standards* which matches the transverse slope.
- For metal culverts 24 in. (600 mm) or greater in diameter, install a metal end section and a traversable grate for metal end sections from the *Illinois Highway Standards* which matches the transverse slope.
- If the proposed end section is an unacceptable hazard from only the entrance, driveway, etc., look to decrease the hazard along the entrance by following the guidance for cross drainage structures in the preceding section. If a guardrail installation is indicated, consider its relation to both roadways.
- If the proposed end section remains an unacceptable hazard to both roadways and a roadside barrier is proposed along both roadways, a grate is not required. Use of guardrail will create a short radius guardrail installation, refer to 38-6.09.

Note that per Section 38-4.05, the transverse slope should be as flat as practicable, with 1V:6H or flatter considered desirable for most urban facilities and required for freeways and rural high-speed roadways.

Parallel drainage structures may be closely spaced because of frequent driveways and intersecting roads. In such locations, it may be desirable to convert the open ditch into a closed drainage system and backfill the areas between adjacent driveways. This treatment will eliminate the ditch section and the transverse embankments with pipe inlets and outlets. However, care must be used to avoid creation of open frontage that would allow uncontrolled access.

38-4.06(c) Roadside Ditches (Earth Cuts)

In the absence of other information (e.g., crash data), a roadside barrier is not warranted for the preferred ditch configuration shown in Figure 38-3.F. For other ditch configurations that would introduce a more abrupt change in direction for errant vehicles than a preferred ditch, the designer should conduct a cost-effective analysis to determine:

1. if a revised ditch configuration is appropriate,
2. if a roadside barrier is warranted, or
3. if the do-nothing alternative is appropriate.

38-4.07 Rock Cuts

If the toe of the rock cut is outside of the clear zone, or if the toe of the rock is within the clear zone and the rock face is smooth, a roadside barrier is not warranted unless other information (e.g., crash data) indicates otherwise. If the toe is within the clear zone and the rock face will cause excessive vehicle snagging, the designer should conduct a cost-effectiveness analysis to determine:

1. if the rock cut should be relocated outside of the clear zone or the face made smooth,
2. if a roadside barrier is warranted, or
3. if the do-nothing alternative is appropriate.

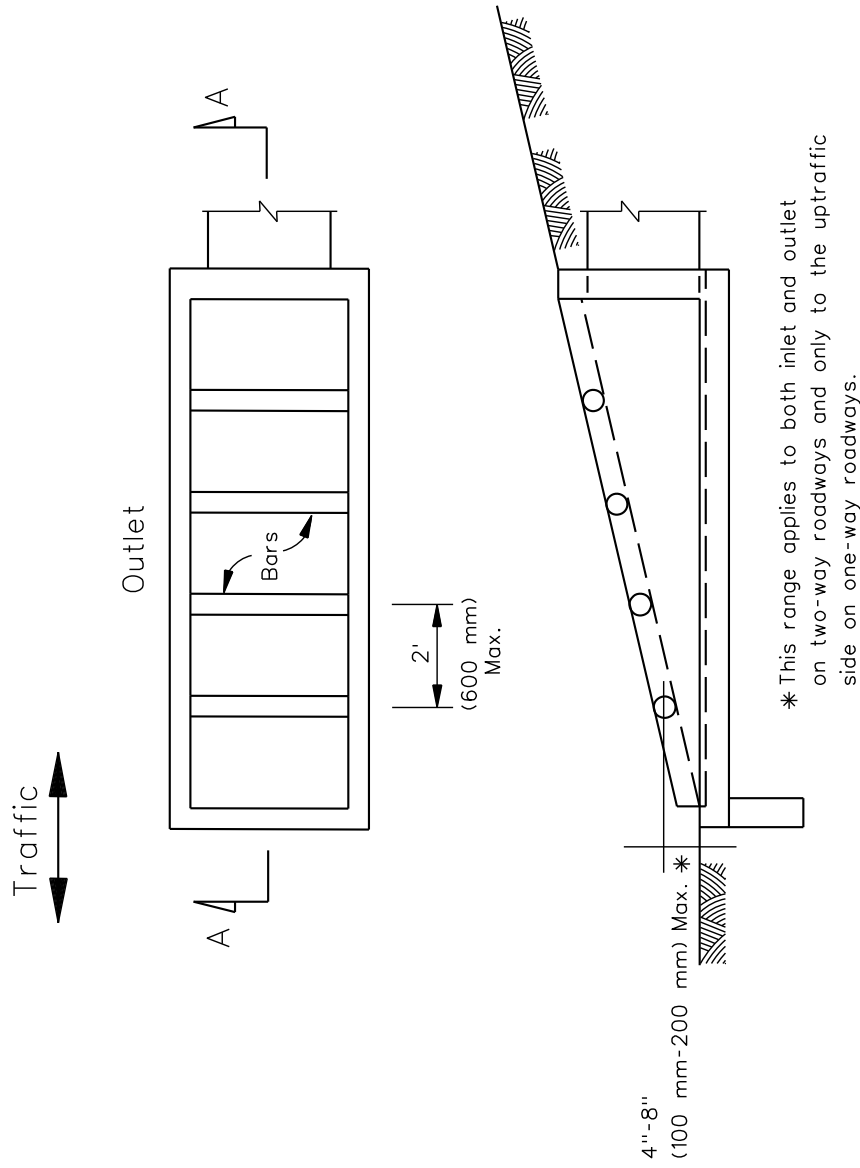

DESIGN FOR PARALLEL DRAINAGE STRUCTURES
(Diameter ≥ 24 in. (600 mm))

Figure 38-4.D

38-4.08 Bridge Parapet Ends

For bridge parapet ends on two-way roadways without median, a roadside barrier and transition should be installed at each corner unless the posted speed limit is less than 25 mph on an urban curbed section. No roadside barrier is needed on the departure end of a one-way roadway, unless a barrier is warranted for other reasons (e.g., front slopes steeper than 1V:3H).

If other hazards [e.g., permanent body of water more than 2 ft (600 mm) deep] exist, then additional guardrail may be considered. To determine the required length of need for the opposing traffic, use the L_C for the approach end measured from the centerline. L_B and the departing point for L_R will be measured from the centerline; also see Figures 38-6.A and 38-6.B for definitions of L_C , L_B , and L_R .

38-4.09 Retaining Walls

Barrier protection is not necessary for the face of retaining walls that are considered smooth (i.e., the general absence of any unevenness in the wall that may adversely affect an impacting vehicle). Retaining walls built of sheet piling, H-piling with timber, or precast concrete inserts are usually considered smooth. In addition, the following will apply to the roadside safety aspects of retaining walls:

1. Flare Rates. Use the same rates as those for concrete barrier. See Figure 38-6.X.
2. End Treatment. Preferably, the retaining wall will be buried in a back slope thereby shielding its end. If this is not practical, use a crashworthy end treatment or impact attenuator. Where the design speed is 35 mph (60 km/hr) or less, it is acceptable to transition the top of the wall from its normal height down to the ground line.

38-4.10 Traffic Control Devices

Traffic control devices include highway signs and traffic signals. If not properly designed and located, these devices may become a hazard to errant vehicles. The Bureau of Operations is responsible for the initial placement of traffic control devices, based on proper conveyance of information to the motorist, and the road designer reviews the location to ensure that it is compatible with the roadway design.

38-4.10(a) Highway Signs

For roadside safety applications, the following will apply to highway signs:

1. Design. The *Illinois Highway Standards and Sign Structures Manual* contain the Department's details for structural supports for traffic control devices.

2. Supports for Small Roadside Signs. All supports for small [$< 50 \text{ ft}^2$ (5.0 m^2)] roadside signs should be made breakaway or yielding, including those outside of the clear zone. Where practical, the designer should locate signs behind a roadside barrier that is warranted for other reasons. There should be adequate clearance to the back of the guardrail post to provide for the barrier dynamic deflection; see Section 38-6.02. In addition, sign supports should not be placed in drainage ditches where erosion and freezing might affect the proper operation of breakaway supports. It is also possible that a vehicle entering the ditch will be inadvertently guided into the support.

It is critical that breakaway supports not be located where a vehicle is likely to be partially airborne at the time of impact. Supports placed on a front slope of 1V:6H or flatter are acceptable. Supports placed on front slopes that are 1V:4H to 1V:6H are only acceptable when the face of the support is within 2 ft (600 mm) of the intersection of the shoulder slope and front slope.

3. Supports for Large Roadside Signs. Large signs [over 50 ft^2 (5.0 m^2) in area] should have slip base breakaway supports, whether within or outside the clear zone, and/or be located behind a roadside barrier. Where practical, the designer should locate large signs behind a roadside barrier that is warranted for other reasons, or at other locations where they are very unlikely to be hit.

It is critical that breakaway devices, including slip bases, not be located where a vehicle is likely to be partially airborne at the time of impact. Supports placed on a front slope of 1V:6H or flatter are acceptable. Supports placed on front slopes that are 1V:4H to 1V:6H are only acceptable when the face of the support is within 2 ft (600 mm) of the intersection of the shoulder slope and front slope.

Breakaway sign supports should not be located in or near the flow line of ditches. If these supports are placed on a back slope, they should be offset at least 5 ft (1.5 m) from the toe of the back slope of the ditch.

4. Overhead Sign Supports. All overhead signs will use non-breakaway supports. Within the clear zone, the designer should conduct a cost-effectiveness analysis to determine if these structures should be protected with a roadside barrier or, where applicable, with an impact attenuator.

38-4.10(b) Traffic Signal Equipment

In general, the designer has limited options available in determining acceptable locations for the placement of signal pedestals, signal poles, pedestrian detectors, and controllers. Considering roadside safety, these elements should be placed as far from the roadway as practical. However, due to visibility requirements, limited mast-arm lengths, limited right-of-way, restrictive geometrics, or pedestrian requirements, traffic signal equipment often must be placed relatively close to the traveled way. The designer should consider the following when determining the placement of traffic signal equipment:

1. Clear Zones. If practical, the placement of traffic signals on new construction and reconstruction projects should meet the clear zone criteria presented in Section 38-3. A cost-effectiveness analysis may be used to support this decision. In lower speed urban and suburban areas where it is not practical to place traffic signal supports outside the clear zone, the obstruction-free clearance criteria and enhanced lateral offset described in Section 38-9 apply. Where it is not practical to place isolated traffic signal supports outside the clear zone on rural high-speed facilities, evaluate shielding them with impact attenuators.
2. Controller. In determining the location of the controller cabinet, the designer should consider the following:
 - a. The controller cabinet should be placed in a position so that it is unlikely to be struck by errant vehicles. It should be outside the clear zone or obstruction-free zone, if practical.
 - b. The controller cabinet should be located where it can be easily accessed by maintenance personnel.
 - c. The controller cabinet should be located so that a technician working in the cabinet can see the signal indications in at least one direction.
 - d. The controller cabinet should be located where the potential for water damage is minimized.
 - e. The controller cabinet should not obstruct intersection sight distance.
 - f. The power service connection should be reasonably close to the controller cabinet.
3. Pedestrians. If the signal pole must be located very near or within the sidewalk, it shall be placed in a location that minimizes pedestrian conflicts. In addition, the signal pole shall not restrict access to curb ramps or reduce the sidewalk width below minimum; see Chapter 58.
4. Channelizing Islands. It is preferable not to place traffic signal equipment on islands within the roadway or intersection. However, the designer may need to use the islands for traffic signal placement to balance signal visibility, safety, cost and practicality.

38-4.11 Lighting

Because of the potential hazard posed to vehicles by roadside fixed objects, the general approach to lighting standards will be to use breakaway supports wherever possible. All new lighting standards located within the clear zone of a roadway where no pedestrian facilities exist will be placed on breakaway supports, unless they are located behind or on a barrier or protected by impact attenuators, which are necessary for other roadside safety reasons. Poles outside the clear zone on these roadways should be breakaway where there is a possibility of being struck by errant vehicles.

Breakaway devices should be given first consideration, except where extensive pedestrian exposure exists. Breakaway devices should be considered in urban areas where the combination of pedestrian activities concentrate during daylight hours and run-off-the road crashes are more prevalent outside of this period.

Although breakaway devices generally should receive first consideration, in some cases extensive pedestrian exposure may override the fixed object concern. Examples of locations where the hazard potential to pedestrian traffic indicate the use of non-breakaway devices include:

- transportation terminals,
- sports stadiums and associated parking areas,
- tourist attractions,
- school zones, or
- central business districts and local residential neighborhoods where the posted speed limit is 30 mph or less.

Other locations that require the use of non-breakaway bases, regardless of the pedestrian traffic volume, are rest areas and weigh station parking lots and combined light and traffic signal poles.

It is critical that breakaway devices be located where a vehicle is likely not to be partially airborne at the time of impact. Supports placed on a front slope of 1V:6H or flatter are acceptable. Supports placed on front slopes that are 1V:4H to 1V:6H are only acceptable when the face of the support is within 2 ft (600 mm) of the intersection of the shoulder slope and front slope.

Breakaway devices should not be located in or near the flow line of ditches. If these supports are placed on a back slope, they should be offset at least 5 ft (1.5 m) from the toe of the back slope of the ditch.

38-5 ROADSIDE BARRIERS

38-5.01 Types

The FHWA requires roadside safety hardware used on the National Highway System (NHS) to be crashworthy. IDOT then extends this requirement to all State jurisdiction routes for consistency. To be considered crashworthy, a piece of hardware is typically subjected to laboratory crash testing and engineering analysis which is then supported by in-service performance data. The hardware which has been accepted for use in Illinois can be found on one of several Qualified Products Lists (QPLs), as well as the *Illinois Highway Standards* maintained on the Department's website.

38-5.01(a) **Steel Plate Beam Guardrail (Semi-Rigid Types)**

Steel plate beam guardrail (SPBGR), commonly known as the W-beam system, is a semi-rigid system when installed with strong posts. The Department uses the Midwest Guardrail System (MGS), developed by the Midwest Roadside Safety Facility (MwRSF) under a pooled fund in which Illinois participates. Versions of the MGS using blockouts display better safety performance and are preferred over non-blocked versions of the MGS. The use of the non-blocked MGS should be limited to locations where the MGS with blockouts is not practical due to roadway width and/or steep front slope constraints. Various adaptations of the MGS are included in the *Illinois Highway Standards* and are briefly described below:

1. Type A. Type A guardrail is an MGS version with blockouts and with posts spaced at 6 ft 3 in. (1905 mm). The Type A guardrail meets Test Level 3 and is the most commonly used roadside barrier on Illinois highways. Refer to Figure 38-6.V for guardrail deflection criteria. Refer to Section 38-6.03 and Highway Standard 630001 for grading requirements behind guardrail.
2. Type B. Type B guardrail is an MGS version with blockouts and with posts at a reduced spacing of 3 ft 1½ in. (953 mm). The Type B guardrail meets Test Level 3. Type B is used where a semi-rigid roadside barrier is needed but the deflection space behind the posts is somewhat limited. Refer to Figure 38-6.V for guardrail deflection criteria. Refer to Section 38-6.03 and Highway Standard 630001 for grading requirements behind guardrail.
3. Type D. Type D guardrail is an MGS adaptation with blockouts for use as a semi-flexible median barrier. See Section 38-7.02(b) for the use of this guardrail type.
4. W-beam Guardrail with Quarter-post Spacing. This system with blockouts uses a further-reduced spacing of 1 ft 6¾ in. (476 mm). It is used where the deflection distance for the Type B system is not available. Though feasible for use in rare conditions, this post spacing is not shown in the *Illinois Highway Standards*, and job-specific details and pay items are needed in order to utilize it. Refer to Figure 38-6.V for guardrail deflection criteria.

5. Attached to Culverts. There are two options to attach MGS to culverts as described below.
- a. Strong Post Attached to Culvert. This attachment uses the conventional strong post version of the MGS with blockouts at a post spacing of 3 ft 1 ½ in. (953 mm) that can be attached to the top slab of a culvert, inboard of the culvert headwall. When transitioning from the standard MGS post spacing of 6 ft 3 in. (Type A) to the culvert-mounted MGS, at least five posts embedded 40 1/8 in. (1.02 m) in soil at half post spacing are recommended to be installed on both the upstream and downstream from the culvert-mounted posts. When transitioning from half post spacing MGS (Type B) to culvert-mounted MGS no special transition is necessary. Refer to Highway Standard 630101 for more detail.
 - b. Weak Post Attached to Culvert. This attachment to culvert headwalls uses smaller “weak posts” (S3 X 5.7 [S76 X 8.5]) at a spacing of 3 ft 1½ in. (953 mm) without blockouts across the culvert. The posts are placed in steel sockets that are mounted to the face or top of the headwall. There are six different options for mounting the sockets (Case I through VI). Refer to Highway Standard 630111 for more details.

Both options above are crashworthy. The designer may choose either option based on their unique situation.

6. Long Span Guardrail. This MGS adaptation with blockouts allows for omitting a few posts in order to span up to 25 ft (7.62 m) over low-fill culverts or where there are other obstructions to post placement. This version includes three “controlled release terminal” (CRT) posts on either side of the long span and requires a minimum installation length to assure performance consistent with the crash tested hardware. Refer to Highway Standard 630106 for more details.
7. Non-Blocked Steel Plate Beam Guardrail. The MGS without blockouts uses strong steel posts spaced at 6 ft 3 in. (1905 mm). The non-blocked guardrail meets Test Level 3; however, this system cannot be used everywhere that Type A, Type B, or guardrail with quarter-post spacing can be used. Specifically, Non-Blocked Steel Plate Beam Guardrail:
- May not be used at the three control release terminal (CRT) post locations on either side of a long span guardrail’s gap in posts. Only the CRT posts and blockouts may be used at these six posts.
 - When used where a slope steeper than 1V:3H is present within 24 in. (610 mm) from the back of post, the longer post as shown on the Standard shall be used, and a minimum top of rail height is 31 in. (787 mm).
 - Shall not be placed adjacent to or behind a curb.
 - Shall not be placed within 25 ft (7.62 m) of the pay limits of any bridge rail transition (e.g., Type 5, Type 6, Type 6A, Type 6B, Type 13, Type 14).

- Shall not be placed within 12.5 ft (3.81 m) of the pay limits of any Type 1 terminal.
- Shall not be placed within 50 ft (15.24 m) of the pay limits of a Type 2 terminal.
- Shall not be used where the post spacing is other than 6 ft 3 in. (1905 mm).
- Shall not be used with wood posts.
- Shall not be flared. It must run parallel to the traveled way.

See Section 38-6 for other roadside barrier layout requirements.

38-5.01(b) Concrete Barrier (Rigid Type)

Concrete barrier is a rigid barrier system that does not deflect upon impact. See Section 38-5.02 for information on where concrete barrier should be used.

The Department will meet MASH Test Level 5 criteria for concrete barrier at new or replacement locations. For Test Level 5 under MASH a minimum of 42 in. (1065 mm) height may be used with either a single slope barrier or vertical face barrier. However, the Department has adopted a taller concrete barrier height of 44 in. (1120 mm) to accommodate a future 2 in. (50 mm) profile increase. The barrier is single slope with a 10.3 degree slope and a top width of 19 in. (480 mm). See *Highway Standard 637006*.

For use of concrete barrier as a roadside barrier (i.e. a single faced barrier), the standard single slope shape should be used along the traffic side with a vertical face on the back. Backfill behind the barrier for lateral support (retaining wall design) or use a special footing design (e.g., barrier tied to a concrete footing with reinforcing steel). Contact BSPE for design parameters.

38-5.01(c) High-Tension Cable Barrier (Flexible Type)

Cable barrier is a flexible barrier system with weak posts. The posts are designed to bend over or break off upon impact. Cable barrier and other weak-post systems provide a forgiving impact with low deceleration forces exerted on vehicle occupants. See Section 38-5.02 for information on where cable barrier may be used.

IDOT requires the use of high-tension cable barriers that have passed Test Level 4 crash test criteria on flat slopes or Test Level 3 crash test criteria with slopes steeper than 1V:6H to as steep as 1V:4H. Deflection distances for these proprietary systems are greater than W-beam guardrail and vary depending on the product and the post spacing. See Section 38-6 for additional guidance on high-tension cable barriers.

38-5.01(d) Cable Road Guard Single Strand

Cable Road Guard Single Strand (Highway Standard 636001) is not a roadside safety system. Its only use is to inhibit unwanted vehicular encroachments. Place Cable Road Guard as far as practical from the traveled way, and well outside the clear zone.

38-5.01(e) Other Systems

Many other roadside barrier systems are available which may have application at specific sites (e.g., three-beam guardrail). The designer should reference the latest edition of the AASHTO *Roadside Design Guide* for information on these systems. Both BDE and BSPE must approve the use of any system not included on one of the several QPLs or in the *Illinois Highway Standards*.

38-5.01(f) Aesthetic Treatments

Aesthetic treatments are not included in the *Illinois Highway Standards* due to concerns of safety performance, durability, and cost. Weathering steel guardrail has produced excessive rusting at lap joints and has performed poorly, thus it should not be installed. Experience from other States with winter road salting have shown that embossed (form liner) patterns for concrete parapets and barriers can trap salt and accelerate deterioration. These treatments should not be used on the traffic face of any concrete barrier. Contact BSPE for information regarding suitability of any aesthetic treatments.

38-5.02 Barrier Selection

This section presents considerations when selecting barriers for specific applications along roadways in Illinois.

1. **Test Levels.** The designer should consider the expected speeds and vehicle composition when selecting a test level for a barrier. Barriers that have passed Test Level 3 criteria are required on high-speed roadways (design speeds higher than 45 mph [70 km/hr]). There is no Test Level defined for speeds higher than 60 mph (100 km/hr) and studies of crashes have shown that Test Level 3 is adequate for the typical mix of vehicles where the design speed is higher than 60 mph (100 km/hr). However, if the objective is a higher probability of containing large trucks or commercial passenger vehicles such as buses, a barrier that has passed Test Level 4 or 5 may be appropriate. Barriers tested at Test Level 2 may be appropriate for roadways where the design speed is 45 mph (70 km/hr) or less and this is judged to represent the typical roadway operating speed.
2. **Dynamic Deflection.** Allowable dynamic deflection affects barrier selection. A barrier should be selected that is consistent with the available deflection space between the barrier and fixed objects behind the barrier; see Figure 38-6.U. Figure 38-6.V provides

the deflection distances for guardrail and Section 38-7.03(b)3 discusses deflection distances for high-tension cable barrier (flexible).

3. Maintenance Considerations. Review the following maintenance issues when selecting a barrier:
 - W-beam guardrail will require structural repair after hits that contain or redirect vehicles, and nuisance hits may inflict tears or kinks requiring repairs. In high-speed, high-traffic locations it may be unacceptable to have damaged sections of guardrail at locations where repair operations can create hazardous conditions for repair crews and can degrade traffic operations and safety.
 - Concrete barrier may be the best choice in locations where traffic and speed dictate that a damaged barrier and subsequent traffic disruption for repairs are not acceptable.
 - High-tension cable barriers will require repairs for virtually all nuisance and other hits. Depending upon the design specified, many repairs may be performed without specialized or heavy equipment.
 - Taller and more substantial barriers may aggravate snow drifting.
4. Preferred Barriers. W-beam guardrail is the preferred roadside barrier for non-freeways and for rural freeways where there is adequate deflection space. However, other barriers may be considered based on site-specific traffic volumes, speeds, vehicle mix, available deflection space and cost of installation. *NCHRP Report 638*, "Guidelines for Guardrail Implementation" provides general guidance that may apply for recommending higher test levels for roadside barriers in Illinois. Detailed analysis of project alternatives may be made using the Roadside Safety Analysis Package (RSAP) software.
5. Concrete Barrier Uses. Consider using concrete barrier for urban freeways (double-faced) and the following additional cases (single- or double-faced):
 - to shield objects close to the roadway where deflection space is limited;
 - where there is a high volume of heavy trucks;
 - where there is a high volume of commercial passenger vehicles, such as buses;
 - to minimize repair and maintenance. Concrete barrier will often remain undamaged after an impact, while guardrail will require more frequent maintenance and repair;
 - to reduce headlight glare into nearby buildings or other sensitive areas;
 - to reduce headlight glare between frontage roads and the mainline, especially where the alignment directs headlights at opposing traffic; and
 - areas where it is especially critical to contain errant vehicles.

Figure 38-5.A summarizes the advantages and disadvantages of the roadside barriers used by IDOT and provides their typical usage. Figure 38-5.B summarizes the general selection criteria that apply.

System	Advantages	Disadvantages	Typical Usage
High Tension Cable Barrier	<ol style="list-style-type: none"> 1. Lower initial cost. 2. More forgiving impact. 3. Weak-post systems maintain vehicle stability. 4. Relatively easy installation. 5. Remains functional after moderate collisions. 6. Some systems have features that make repair more efficient. 7. Minimizes snow drifting. 	<ol style="list-style-type: none"> 1. Larger deflection spaces needed. 2. Less likely to contain large vehicles than concrete barrier, although the systems used by IDOT have passed Test Level 4 (single-unit truck crash test) on slopes of 1:6 or flatter. 3. Some potential for vehicles to under ride the barrier. 4. Cannot be used in conjunction with curbing. 5. Any impact requires repair. 	<ol style="list-style-type: none"> 1. Non-freeways. 2. Rural freeways. 3. Side hazards where deflection space is adequate and a Test Level 4 barrier is preferred.
W-Beam Guardrail	<ol style="list-style-type: none"> 1. Lower initial cost. 2. High level of familiarity by maintenance personnel. 3. Can safely accommodate a wide range of impact conditions for passenger vehicles. 4. Relatively easy installation. 5. Remains functional after nuisance collisions. 6. Can be used in conjunction with curbing. 	<ol style="list-style-type: none"> 1. Less likely to contain large vehicles than concrete barrier or cable barrier. 2. At high-impact locations, will require frequent maintenance. 3. Will cause more snow drifting than cable barrier. 4. Hits that redirect or contain vehicles will require repair. 	<ol style="list-style-type: none"> 1. Non-freeways with narrow medians. 2. Rural freeways. 3. Side hazards where deflection space is adequate.
Concrete Barrier	<ol style="list-style-type: none"> 1. Can accommodate most vehicular impacts without penetration. 2. No deflection distance required behind barrier. 3. Little or no damage sustained for most vehicular impacts; therefore, least need for maintenance. 4. Minimal vehicular under ride/ override potential for snagging potential. 	<ol style="list-style-type: none"> 1. Highest initial cost. 2. For given impact conditions, highest occupant decelerations; therefore, least forgiving of barrier systems 3. Reduced performance where offset between traveled way and barrier exceeds 12 ft (3.6 m). 4. Usually requires subsurface drainage. 5. Increased snow drifting. 	<ol style="list-style-type: none"> 1. Urban freeways. 2. Where very high traffic volumes are present. 3. Where high volumes of large vehicles are present. 4. Narrow medians.

ROADSIDE BARRIER SELECTION

Figure 38-5.A

Criteria	Comments
1. Performance Capability	Barrier must be structurally able to contain and redirect design vehicle.
2. Deflection	Adequate deflection space should be available so that the barrier can deflect on impact without contacting fixed objects behind the barrier.
3. Site Conditions	Slope approaching the barrier, slope behind the barrier, and distance from traveled way may preclude use of some barrier types.
4. Compatibility	Barrier must be compatible with planned terminal treatment and capable of transition to other barrier systems (e.g., bridge railing).
5. Cost	Standard barrier systems are relatively consistent in cost, but special-use systems can cost significantly more.
6. Maintenance <ul style="list-style-type: none"> <li data-bbox="250 730 391 762">a. Routine <li data-bbox="250 785 509 816">b. Collision Damage <li data-bbox="250 930 464 961">c. Nuisance Hits <li data-bbox="250 1102 509 1134">d. Materials Storage <li data-bbox="250 1213 412 1245">e. Simplicity 	<p data-bbox="623 730 1398 762">Few systems require a significant amount of routine maintenance.</p> <p data-bbox="623 785 1451 909">W-beam guardrail will require the most extensive repair after a collision. Many high-tension cable barriers will require less extensive repair. Concrete barrier will have the least repair requirements after a collision.</p> <p data-bbox="623 930 1451 1083">High-tension cable barrier will require the most frequent attention for nuisance hits (e.g., mowers, snowplows, minor vehicular encroachments). W-beam guardrail will require repairs where nuisance hits causes kinks or tears or disturbance of terminal impact heads. Concrete barrier will seldom require repairs for nuisance hits.</p> <p data-bbox="623 1102 1451 1194">The fewer the number of different systems used, the fewer inventory items/storage space required. High-tension cable barrier specifications allow a number of competing proprietary systems.</p> <p data-bbox="623 1213 1451 1276">Simpler designs, in addition to costing less, are more likely to be repaired properly by field personnel.</p>
7. Aesthetics	Use caution in applying aesthetic treatments to roadside hardware. See Section 38-5.01.
8. Field Experience	The performance and maintenance requirements of existing systems should be monitored to identify problems that could be lessened or eliminated by using a different barrier type.

SELECTION CRITERIA FOR ROADSIDE BARRIERS

Figure 38-5.B

38-6 ROADSIDE BARRIER LAYOUT

38-6.01 Length of Need

A roadside barrier must intercept and contain or redirect errant vehicles before they reach the roadside hazard or area to be shielded. The barrier should extend a sufficient distance upstream and/or downstream of the hazard such that a vehicle does not travel behind the barrier and reach the hazard.

Figures 38-6.A and 38-6.B show the principal dimensions and relationships necessary to design a roadside barrier system that will adequately shield traffic from reaching a hazard area. Figure 38-6.A is applicable to a one-way roadway and to a two-way roadway where the roadside hazard and guardrail is not within the clear zone for opposing traffic. Figure 38-6.B applies to a two-way roadway where the hazard is within the clear zone for opposing traffic. The essence of the procedure is to find the intersection of the vehicle's runout path for use in setting the location of the beginning of redirective barrier (the beginning of length of need point, or BLON point) of the proposed guardrail or other barrier.

The clear zone on the right begins at the edge of the traveled way. For traffic on a two-way roadway without a median, the clear zone on the left begins at the centerline of the roadway. The departure end of a roadside barrier on a two-way roadway may or may not be within the clear zone of the opposing traffic. However, this departure end of the roadside barrier is a formidable hazard introduced to the roadside and should typically be shielded, regardless of lateral offset. When beyond the clear zone for opposing traffic, at a minimum, provide an approved crashworthy end section to the end of the roadside barrier facing opposing traffic.

Terminal ends for guardrail are discussed in Section 38-6.06. The selection of the terminal end in the design phase will affect LON. Therefore Section 38-6.06 should be reviewed along with Figures 38-6.A and 38-6.B, the example problems located in this section, and specific manufacturer information available on the IDOT Qualified Products List (QPL) when determining LON and quantities for design purposes. The procedures presented in this chapter will result in sufficient quantities of guardrail being included in the plans. The contractor's selection of terminals will affect the final contract quantity of guardrail. Conservative assumptions are necessary in the design process to prevent conflicts with adjacent driveways or field entrances during construction, assure that appropriate length of need will be installed in the field, and ensure sufficient guardrail quantity is provided in the construction plans.

Example problems 38-6.01(1) through 38-6.01(6) show how to determine the required LON for various design situations. The assumptions made for TBT T1 devices in these examples do not reflect actual MASH devices and are meant only to illustrate the procedures. Note that calculations are typically not rounded in these examples; the designer should apply significant figures consistent with actual design precision. Guardrail quantity rounding is covered in Chapter 64.

Note that Figures 38-6.A and 38-6.B are depicted for a tangent alignment, as are the following development of length of need examples. When curves are present, a graphical, plan-based

solution is necessary, as described below. Designers may also reference the equations in the Roadside Design Guide.

Divided highway medians warrant unique considerations. The practice of limiting clear zone widths based on practicality often may not be appropriate. Median piers should be shielded with barrier runs or crash cushions in accordance with Section 38-8.2. The openings created when freeways overpass roadways, railroads and rivers may be considered by designers to represent severe hazards that can be addressed by shielding a wider-than-typical clear zone. Refer to Example 38-6.01(4) for further discussion.

38-6.01(a) Graphical Solution

Whether on tangent or curved alignment, the preferred way to lay out guardrail and determine the length of need is by drawing and measuring the installation in plan view using CADD software. Designing graphically offers several advantages:

- Laying out installations along horizontal curves often requires some judgment, and it is helpful to review the design visually and to-scale; see Figure 38-6.C.
- A graphical layout allows the designer to look at various flare rates (note that non-blocked guardrail shall not be flared) while considering guardrail length and the extent to which the guardrail projects toward the ditch; see Figure 38-6.D. Greater flare rates will shorten guardrail lengths, but may increase the amount of earthwork required in order to provide the 1V:10H slopes needed in front of the guardrail. Designers will typically balance these issues based on site-specific characteristics (e.g., steepness of the front slope, width of the ditch).
- When designing graphically in plan view, the designer can look at contours and cross sections to determine if guardrail should be extended for steep slopes.
- As a quality-control measure, a graphical layout allows the designer to simply look at the design, drawn to scale, and confirm that the design is appropriate.
- Graphic layout can accurately depict all post locations, and related utility, drainage, or other conflicts.

For guardrail layout on curves, Figure 38-6.C shows an example of using the tangential runout path from the edge of traveled way to the back of the hazard or area of concern. Compare the tangential runout path and the runout length (L_R) and use the shorter of these values for design. The tangential runout path will tend to control on smaller radius curves, and the runout length on flatter curves. This procedure will help to minimize the required guardrail installation. The general relationship between flaring of guardrail and the grading required is depicted on Figure 38-6.D.

Using CADD is particularly efficient if cells are developed for the various guardrail components that make up a guardrail installation. Cells can be created for transitions to bridge ends, terminals, standard 12.5 ft (3.81 m) sections, and other components, etc., which can be efficiently placed in CADD to develop layouts and compare designs.

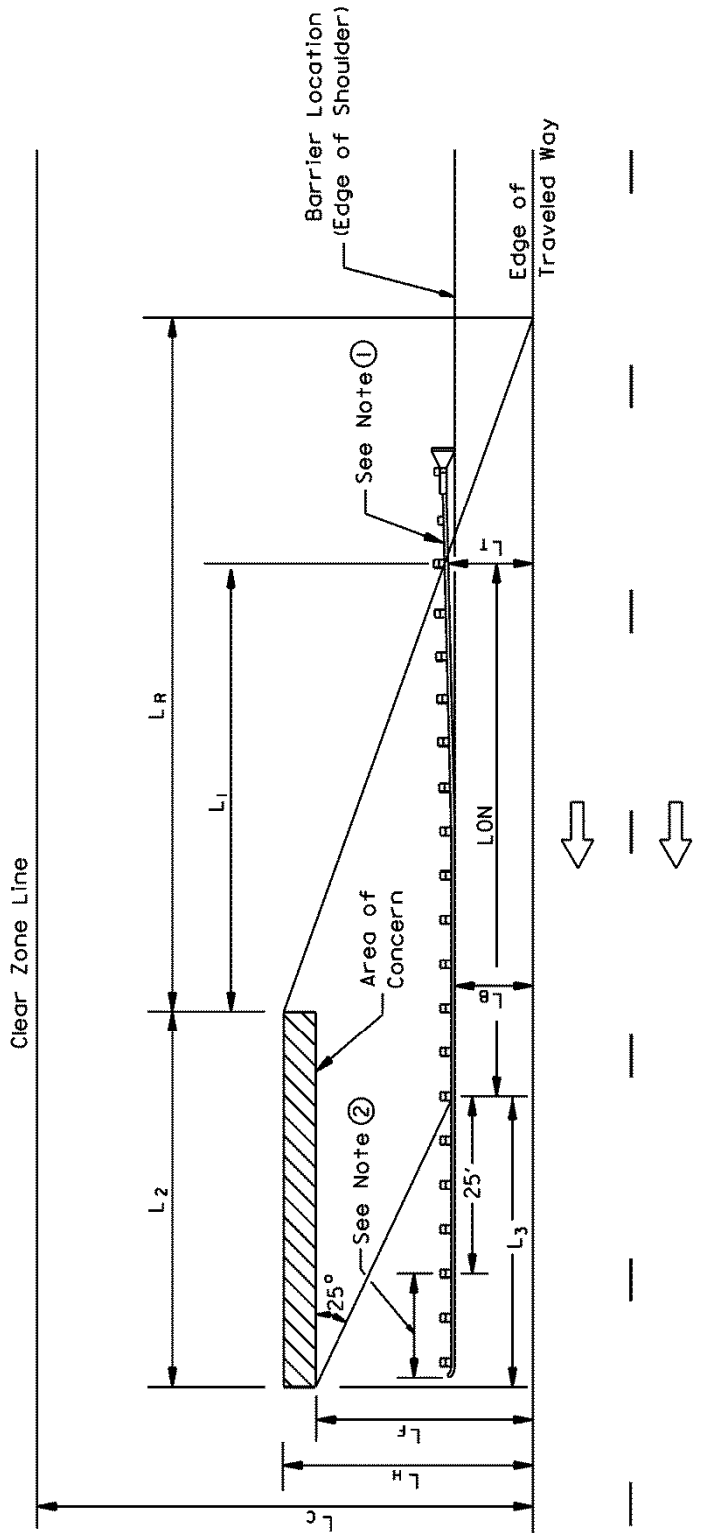

- L_T = Distance to the barrier at the third post of the terminal
- L_B = Distance to the barrier
- L_C = Distance to the clear zone
- L_H = Distance to the back of the hazard
- L_F = Distance to the front of the hazard
- L_R = Runout length (see Figure 38-6.E)
- L_1 = Length of need for the approach end
- L_2 = Length of the hazard
- L_3 = Distance from the downstream end of the hazard
- L_{ON} = Length of Need

$$L_{ON} = L_1 + L_2 - L_3$$

- Notes:
- ① Use appropriate crashworthy terminal. See Section 38-6.06.
 - ② Use a Type 2 terminal for one-way traffic. For two way traffic where L_c for opposing traffic $> (L_f + 12)$, use an appropriate crashworthy terminal, with LON point passing through the third post of the crashworthy terminal.

BARRIER LENGTH OF NEED LAYOUT
(One-Way Roadways or Two-Way Roadways Where the Hazard and Guardrail are Beyond the Clear Zone of Opposing Traffic)

Figure 38-6.A

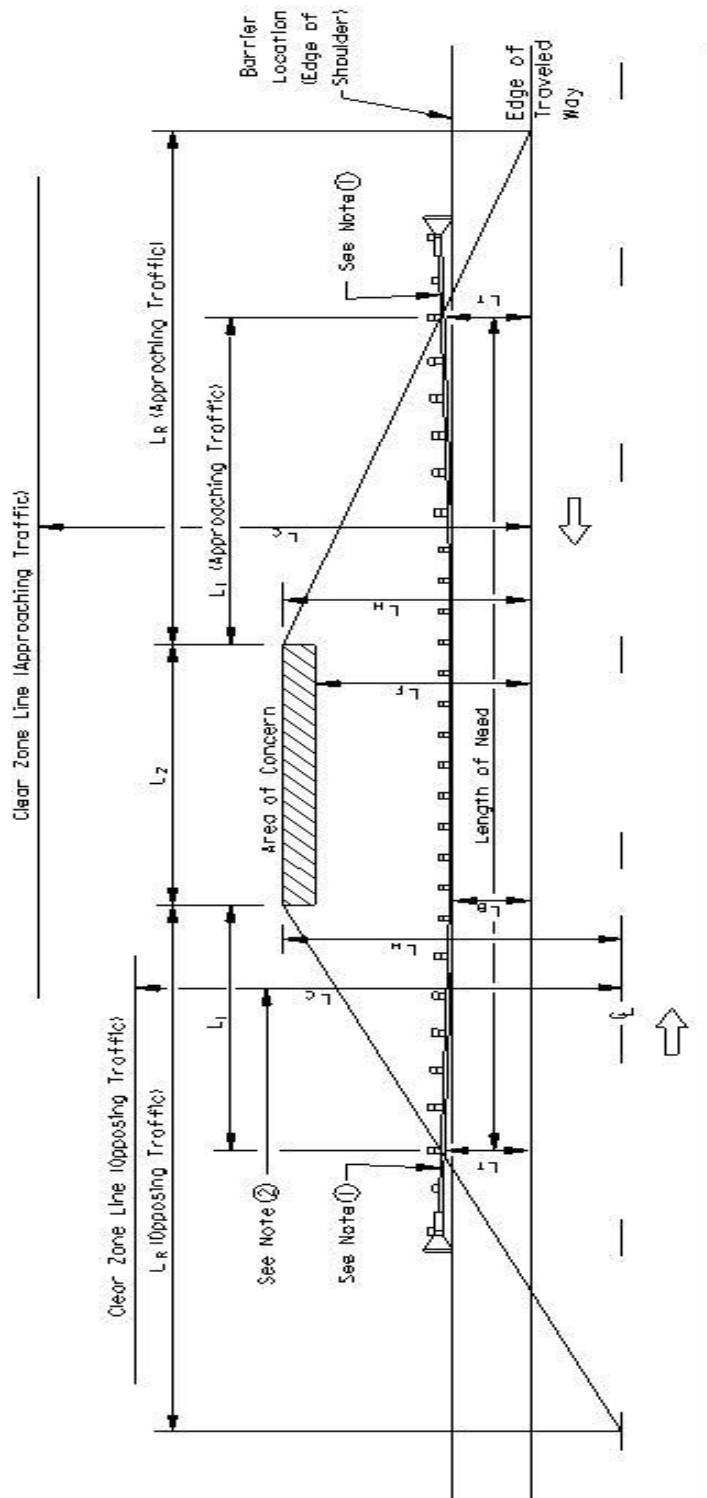

- L_T = Distance to the barrier at the third post of the terminal
- L_B = Distance to the barrier
- L_C = Distance to the clear zone
- L_H = Distance to the back of the hazard
- L_F = Distance to the front of the hazard
- L_R = Runout length (see Figure 38-6.E)
- L_1 = Length of need for the approach end
- L_2 = Length of the hazard
- LON = Length of Need

$$LON = L_1 (\text{approaching}) + L_2 + L_1 (\text{opposing})$$

Notes:

- ① Use appropriate crashworthy terminal. See Section 38-6.06.
- ② If L_C for opposing traffic $< (L_F + 12)$ then refer to Figure 38-6.A.

BARRIER LENGTH OF NEED LAYOUT
(Two-Way Roadways Where the Hazard and Guardrail are
within the Clear Zone of Opposing Traffic)

Figure 38-6.B

38-6.01(b) Nomograph Solution

If the installation is on a tangent section of roadway, the nomograph in Figure 38-6.F can be used to determine the length of need. The procedure for using the nomograph is as follows, assuming a hazard is present requiring protection:

1. Draw a horizontal line at L_B on the y-axis (the lateral distance of the barrier from the edge of traveled way). This assumes that the barrier is not flared; i.e., it is parallel to the roadway.

If a crashworthy terminal is provided, draw the horizontal line at L_T instead of L_B to account for the offset at the third post of the Traffic Barrier Type 1, Special (TBT T1). Normally this is an additional 2.7 ft (0.8 m) for a TBT T1 (Flared) and 0.75 ft (0.2 m) for a TBT T1 (Tangent).

If the guardrail itself is flared, draw a line from L_B on the y-axis equal to the flare rate of the guardrail. If a flared section of guardrail connects to a tangent portion, such as a Type 6 terminal, show both the tangent and flared portions on the nomograph. For a TBT T1 attached to a flared section of guardrail, the TBT T1 will often have the same flare rate as the guardrail to which it is attached, but the flare rate must not exceed the maximum rate established through crash testing for the terminal selected. Example problem 38-6.01(5) illustrates all of these scenarios.

2. Locate L_H or L_C , whichever is less, on the y-axis. Check the hazard location for the opposing direction if the roadway is two-way. Also check for the need of a crashworthy terminal end section for the opposing direction of traffic. Example problem 36-6.01(3) illustrates this situation.
3. Determine L_R from Figure 38-6.E and locate L_R on the x-axis. If barrier protection is needed for only the approaching traffic, use only the "Edge of Traveled Way Scale." If needed for both directions of travel, locate L_R on both the "Edge of Traveled Way Scale" and the "Centerline Scale." See Step 7 to address the downstream end of the barrier where the hazard does not require shielding for the opposing traffic.
4. Connect the points in Steps 2 and 3 with a straight line(s).
5. Locate the intersection(s) of the lines in Steps 1 and 4. From this point(s), draw a line vertically to the "Edge of Traveled Way Scale" and, if required, to the "Centerline Scale" to determine L_1 .
6. Read L_1 from the "Edge of Traveled Way Scale" and, if required, from the "Centerline Scale." As illustrated on Figures 38-6.A and 38-6.B, L_1 is measured from the lateral edge of the hazard to the third post of the terminal. The LON does not include the gating portion of the terminal.

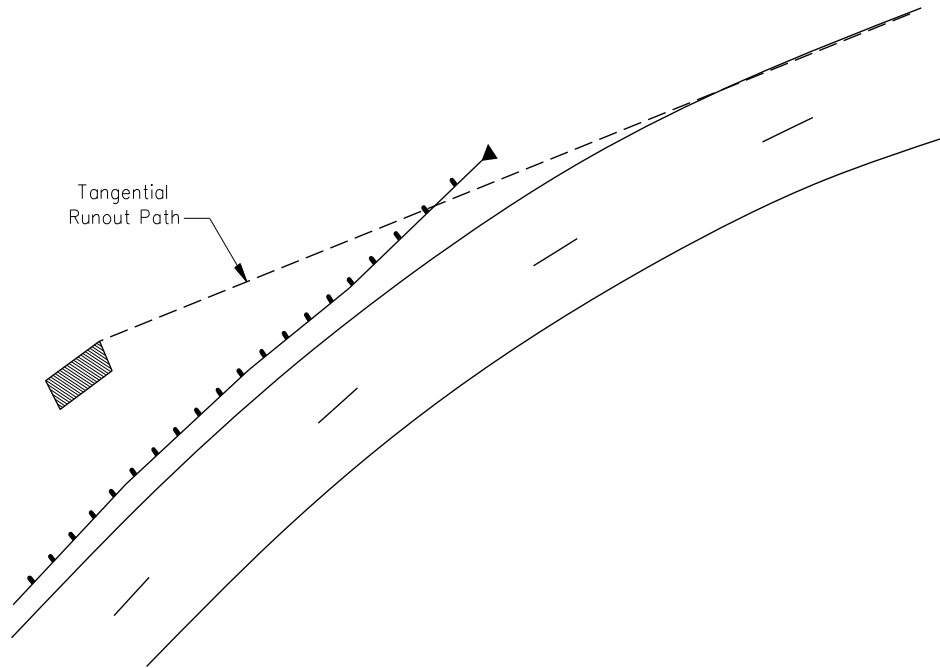

GRAPHICAL LAYOUT OF GUARDRAIL ALONG A HORIZONTAL CURVE

Figure 38-6.C

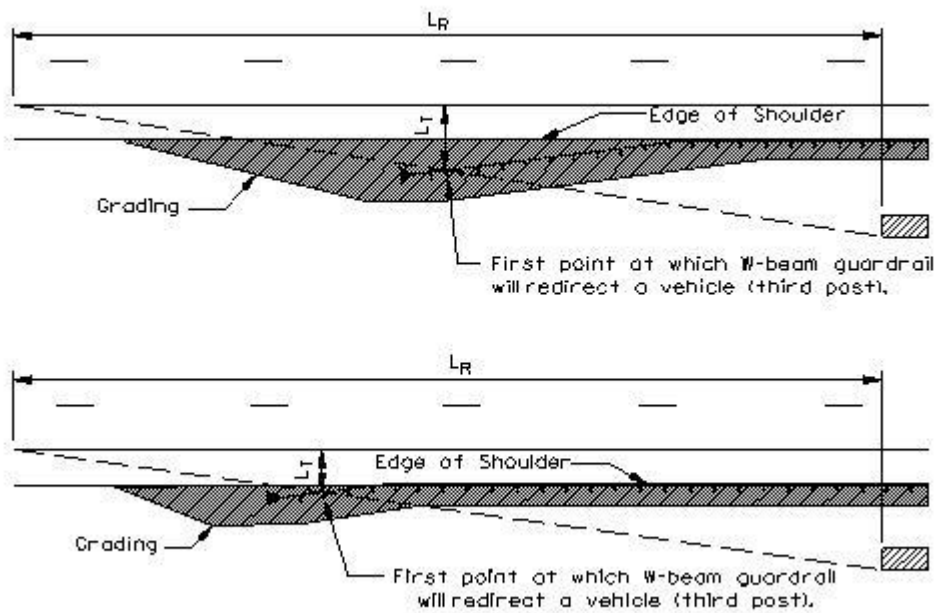

GUARDRAIL LENGTH (AMOUNT OF FLARE) VS. AMOUNT OF GRADING

Figure 38-6.D

Design Speed		Traffic Volume (ADT)*			
		Over 10,000	5000-10,000	1000-4999	Under 1000
		Runout Length L_R	Runout Length L_R	Runout Length L_R	Runout Length L_R
mph (km/hr)	ft (m)	ft (m)	ft (m)	ft (m)	
75 (130)	415 (127)	380 (116)	335 (102)	290 (86)	
70 (110)	360 (110)	330 (101)	290 (88)	250 (76)	
60 (100)	300 (91)	250 (76)	210 (64)	200 (61)	
55 (90)	265 (81)	220 (67)	185 (57)	175 (54)	
50 (80)	230 (70)	190 (58)	160 (49)	150 (46)	
45 (70)	195 (60)	160 (49)	135 (42)	125 (38)	
40 (60)	160 (49)	130 (40)	110 (34)	100 (30)	
30 (50)	110 (34)	90 (27)	80 (24)	70 (21)	

*Based on a 10 year projection from the anticipated date of construction.

RUNOUT LENGTHS (L_R) FOR BARRIER DESIGN

Figure 38-6.E

7. If barrier protection is only warranted for one direction of travel (Figure 38-6.A), use the following procedure to determine the downstream end of the length of need, otherwise proceed to Step 8:
 - a. If not done in Step 1, draw a horizontal line from L_B at the y-axis to represent the lateral distance of the barrier from the edge of travel way (i.e., no adjustment for the flare of the terminal).
 - b. Locate L_F on the y-axis as the distance from the hazard to the edge of traveled way, at the downstream end of the hazard.
 - c. From point L_F , draw a line parallel to the 25 degree line in Figure 38-6.F until it intersects the L_B line.
 - d. From the intersection between the L_B line and the L_F line, draw a line vertically to the "Edge of Traveled Way Scale" and read L_3 .
8. Calculate the length of need (LON):

If barrier protection is warranted for only one direction of travel:

$$\text{LON} = L_1 + L_2 - L_3 \quad \text{Equation 38-6.1}$$

If barrier protection is warranted for both directions of travel:

$$\text{LON} = L_1 \text{ approaching} + L_2 + L_1 \text{ opposing} \quad \text{Equation 38-6.2}$$

The next three steps consider the contribution of various guardrail terminals to completing the length of need.

9. Because the various proprietary TBT T1 terminals vary in the location of their beginning of length of need (BLON) point and in total length, it is not possible to provide absolute positions of the end of guardrail or the limits of the terminal. Where a TBT T1 is to be installed, specify the BLON station and offset in the plans. For design purposes, use a consistent TBT T1 available from the Qualified Products List (QPL) throughout the project, with the BLON point at post 3. Use this information to determine how much redirective barrier the TBT T1 provides toward completing the LON. While utilizing the shortest available TBT T1 will provide the most conservative value for guardrail plan quantity, consider the effects of a longer TBT T1 being used in the field and its impact on the location of proposed entrances and grading. Standard assumptions introduce an assumed gating section 12.5 ft long from post 1 to post 3 of the TBT T1.

For a TBT T2 the length of need begins at 37.5 ft (11.43 m) from the end post of the TBT T2. This means that the TBT T2 and the adjacent 25 ft (3.81 m) of guardrail do not contribute to the LON. Using a TBT T2 requires adding at least 25 ft (3.81 m) of guardrail beyond the LON when calculating the pay item quantities.

10. For connection of guardrail to other terminals from the *Illinois Highway Standards*, determine the contribution of the terminals toward completing the LON. These terminals are connections between guardrail and other barrier types. Typically, their entire length contributes to the LON. For example:
 - The entire length of a TBT Type 6, 6A, or 6B counts toward the LON so that length needs to be subtracted from the LON adjusted in Step 9 (see applicable *IDOT Highway Standard* for terminal length).
11. Check that the LON and layout is adequate and does not create conflicts.

Determine the pay item plan locations and quantities. When a TBT T1 is used in a run of guardrail, it is not necessary or possible to determine the guardrail or terminal limits with certainty. Use the nominal pay item limits based on the BLON location and assume TBT T1 parameters. As-built adjustments in construction will be necessary to determine splice locations, specific devices to be used, and final pay quantities. These adjustments are considered nominal in providing the LON.

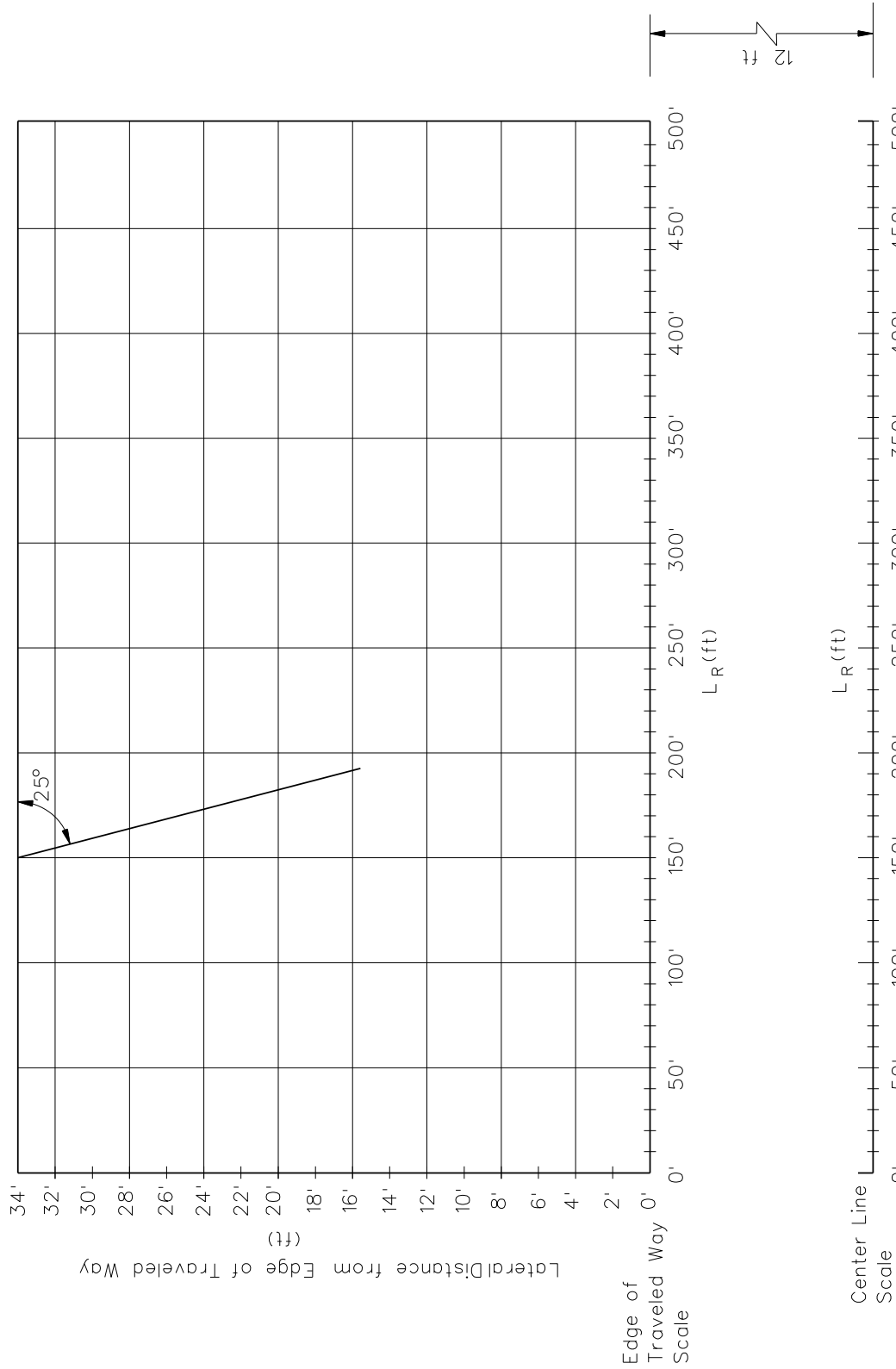

Note: Centerline scale assumes a 12-ft lane width. For other lane widths, appropriate adjustments must be made.

**BARRIER LENGTH OF NEED CALCULATION (TANGENT ROADWAYS ONLY)
(US Customary)**

Figure 38-6.F

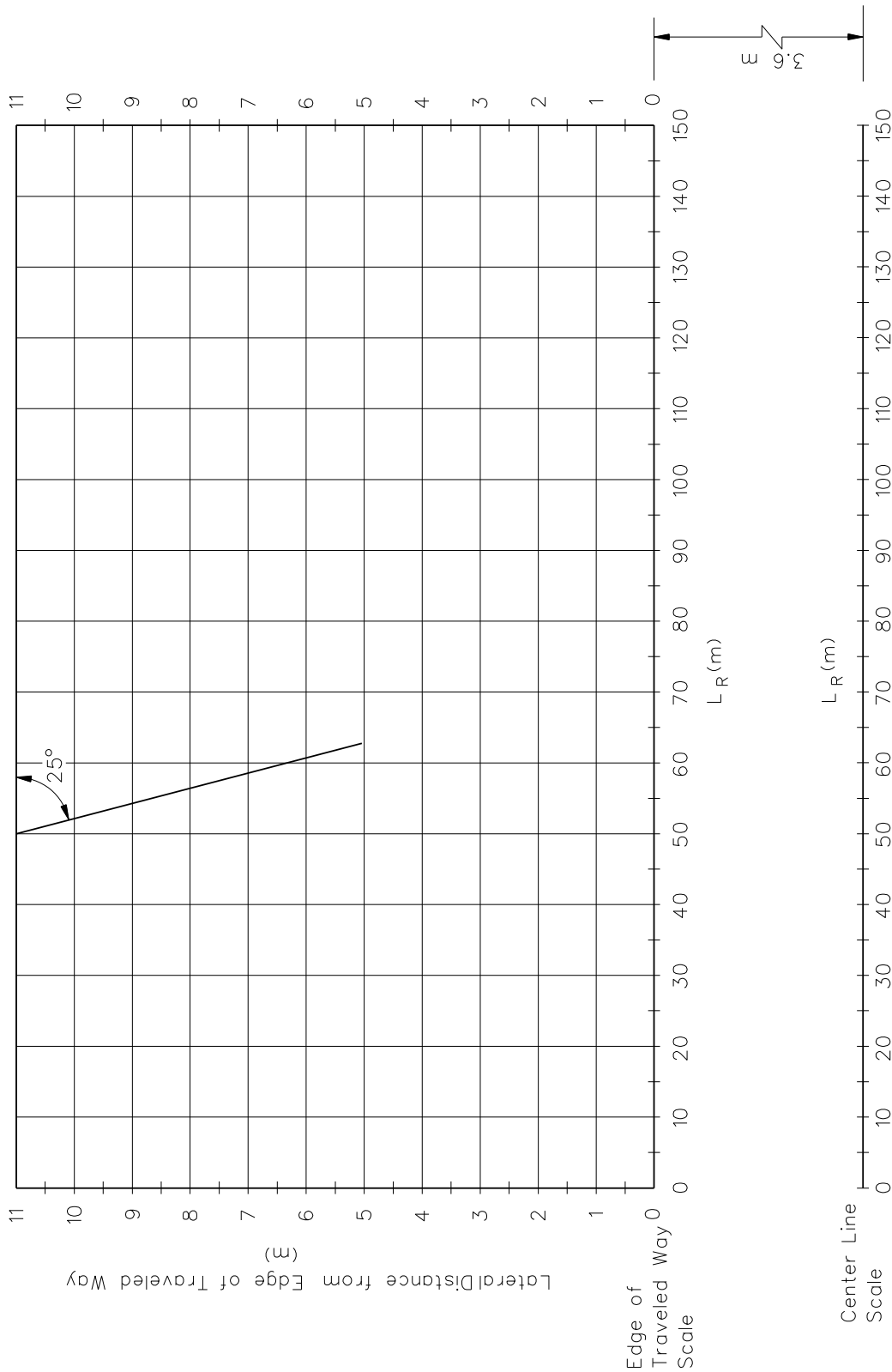

Note: Centerline scale assumes a 3.6-m lane width. For other lane widths, appropriate adjustments must be made.

**BARRIER LENGTH OF NEED CALCULATIONS
(Metric)**

Figure 38-6.F

Example 38-6.01(1) (One-Way Traffic)

Given: New Construction (See Figure 38-6.G)
One-way roadway
Design ADT = 7000 vpd
Design speed = 70 mph
Slope = 1V:6H front slope
Tangent roadway
Shoulder width = 10 ft
 $L_H = 25$ ft
 $L_2 = 40$ ft
 $L_F = 15$ ft
Unflared barrier (steel plate beam guardrail, Type A) located at the edge of the shoulder ($L_B = 10$ ft).
Traffic Barrier Terminal Type 1 (TBT T1), Special (Flared)

Problem: Determine the barrier length of need (LON) and plan length of guardrail, Type A.

Solution: Use the nomograph procedure starting on page 38-6.5 (refer to the nomograph in Figure 38-6.H).

1. Since a TBT T1, Special (Flared) terminal is proposed, draw a horizontal line at L_T on the y-axis of the nomograph,

$$\text{Where: } L_T = 10 + 2.7 = 12.7 \text{ ft}$$

The 2.7 ft is added to the shoulder width to take into account the flare of the guardrail terminal at the third post.

2. From Figure 38-3.A, the clear zone (L_C) is 30 ft and the hazard warrants protection since $L_F < L_C$. Locate the lesser of L_H or L_C , on the y axis. In this case locate $L_H = 25$ ft on the y-axis.
3. From Figure 38-6.E, $L_R = 330$ ft. Locate this point on the "Edge of Traveled Way Scale." Since the roadway is one-way, protection is only warranted from one direction, and therefore L_R is not located on the "Centerline Scale."
4. Connect the points in Steps 2 and 3.
5. From the intersection between the lines from Step 1 and Step 4, draw a vertical line down to the "Edge of Traveled Way Scale" to get L_1 .
6. Read $L_1 = 162$ ft from the "Edge of Traveled Way Scale."

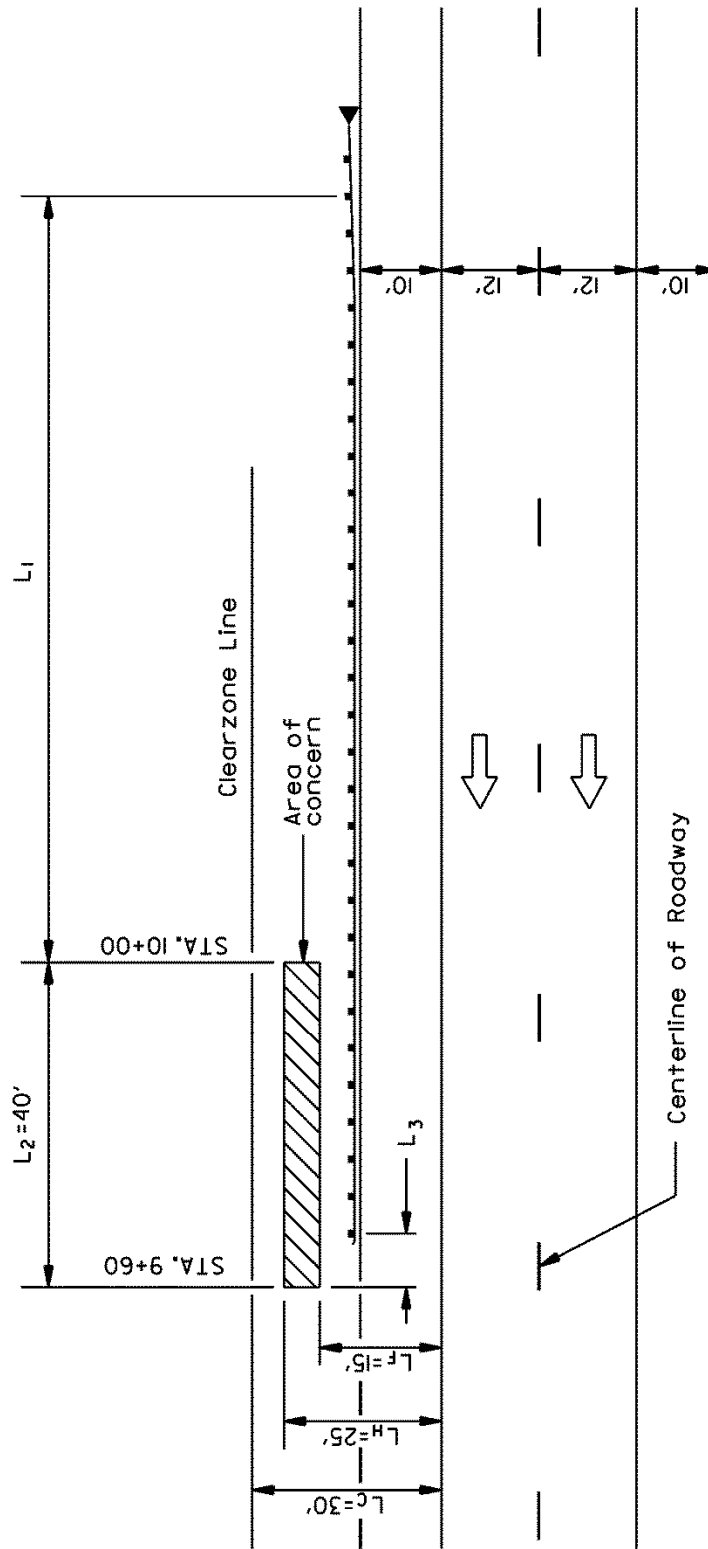

$$L_{ON} = L_1 + L_2 - L_3$$

PLAN VIEW
EXAMPLE 38-6.01(1)
Figure 38-6.G

7. Since barrier protection is only warranted for one direction, perform the following steps to establish L_3 , and thus determine the location of the downstream end of the barrier:
 - a. Draw a horizontal line from $L_B = 10$ on the y-axis.
 - b. Locate $L_F = 15$ ft on the y-axis.
 - c. Draw a line from L_F parallel to the 25 degree line until it intersects the L_B line.
 - d. From the intersection between the lines formed from Step 7a and Step 7c, draw a vertical line down to the "Edge of Traveled Way Scale" to find L_3 . Read $L_3 = 11$ ft.

8. Calculate the length of need (LON) of guardrail. In this example barrier protection is needed only in one direction of travel. Therefore:

$$LON = 162 + 40 - 11 = 191 \text{ ft} \qquad \text{Equation 38-6.1}$$

9. Based on the stationing shown in Figure 38-6.G, the BLON for the approach end (TBT T1) falls at, Station 11+62.00, 24.7 ft left. This is set as the face of rail location at post 3 of the TBT T1 (see QPL for specific end terminal dimensions). For this example, a 37.5 ft long TBT T1 is selected from the QPL. So the TBT T1 will provide at least (37.5 ft– 12.5 ft =) 25 ft of the length of need. As described, this TBT T1 will also include a gating section from post 1 to post 3 (12.5 ft).
10. A TBT T2 is used for the departure end of the guardrail since there is one-way traffic. The TBT T2 requires an additional 25 ft of guardrail which is added to the estimated length beyond the BLON for the TBT T2.
11. Standard terminals other than the TBT T2 are not used, so this step does not apply
12. Determine the pay item plan locations and quantities.

The BLON for the approach end (TBT T1) is at Station 11+62.00, 24.7 ft left.

The steel plate beam guardrail has one end at:

$$(\text{Station } 11+62) - 25 \text{ ft} = \text{Station } 11+37.00$$

The other end of the steel plate beam guardrail is at:

$$(\text{Station } 11+37) - (191 \text{ ft (LON)} + 25 \text{ ft (provided by TBT T1)} - 25 \text{ ft (additional needed with TBT T2)}) = \text{Station } 9+46.00$$

The pay item quantity of guardrail is (Station 11+37) – Station (9+46) = 191 ft.

The TBT T2 is from Station 9+46, 22.0 ft left to:

$$(\text{Station } 9+46) - 12.5 \text{ ft} = \text{Station } 9+33.50, 22.0 \text{ ft left.}$$

13. Check that the LON and layout is adequate after all adjustments. By inspection, the design LON matches the LON from the nomograph and plan layout. For the TBT T1, the BLON is at 24.7 ft left of roadway centerline at Station 11+62.00.

No constraints are shown that would interfere with a gating end of a TBT T1, or adjustment of +/- 12.5 ft of the Station of the TBT T1 location.

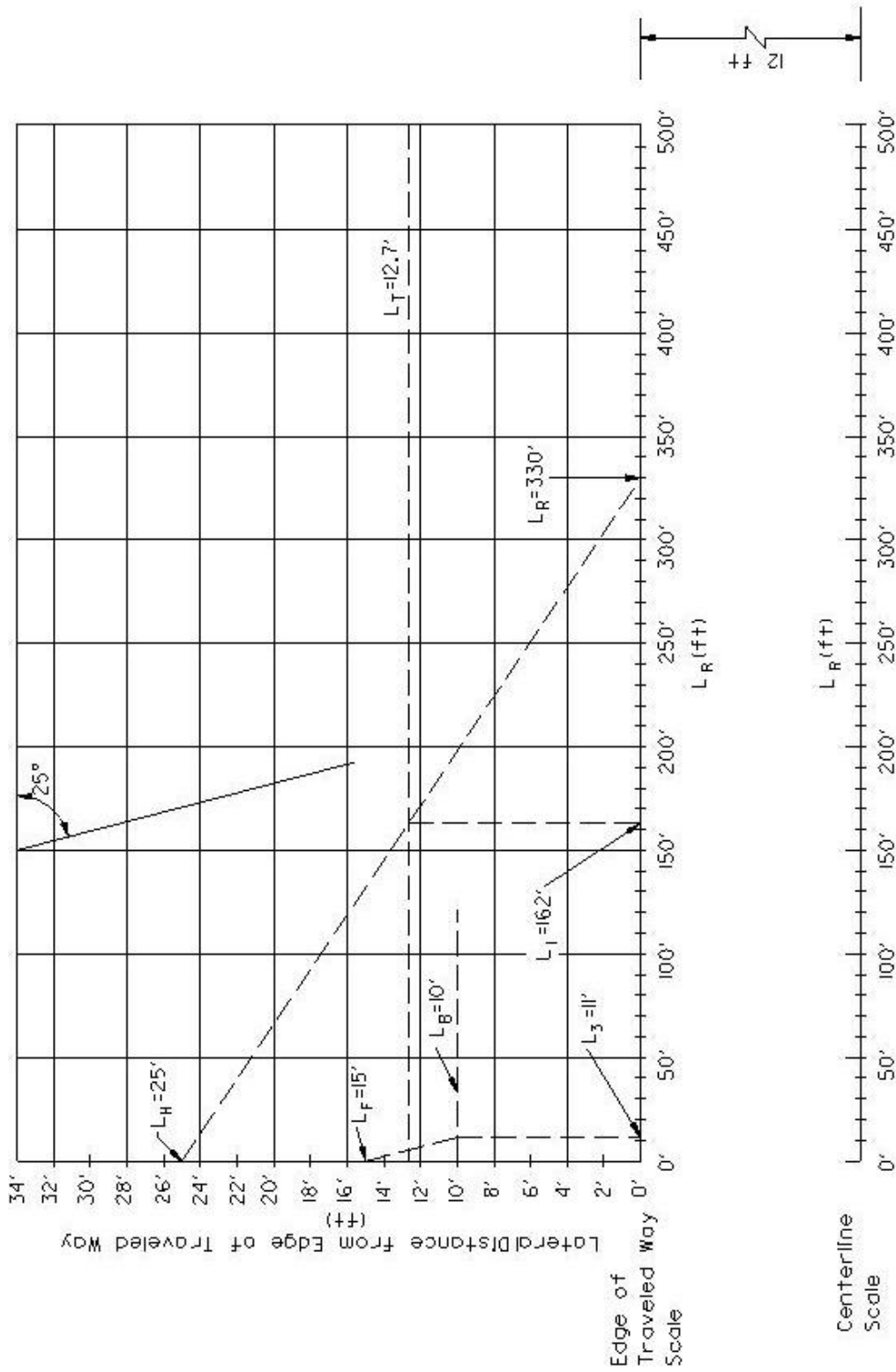

BARRIER LENGTH OF NEED CALCULATION
Example 38-6.01(1)

Figure 38-6.H

Example 38-6.01(2) (Two-Way Traffic)

Given: Reconstruction (See Figure 38-6.I)
Two-lane/two-way roadway
Design ADT = 5000 vpd
Design speed = 60 mph
Slope = 1V:4H front slope
Tangent roadway
Lane width = 12 ft
Shoulder width = 8 ft
 $L_H = 15$ ft
 $L_2 = 10$ ft
 $L_F = 10$ ft
Traffic Barrier Terminal Type 1 (TBT T1), Special (Tangent)

Problem: Determine the barrier length of need and plan length of guardrail needed.

Solution: Use the nomograph procedure starting on page 38-6.5 (refer to the nomograph in Figure 38-6.J).

1. Since a TBT T1 (Tangent) terminal is proposed, draw a horizontal line at L_T on the y-axis of the nomograph,

$$\text{Where: } L_T = 8 + 0.75 = 8.75 \text{ ft}$$

The 0.75 ft is added to the shoulder width to take into account the flare of the guardrail terminal at the third post. The offset from the centerline is thus: $12 + 8 + 0.75 = 20.75$ ft.

2. From Figure 38-3.A, the clear zone (L_C) is 30 ft and the hazard warrants protection for approaching traffic since $L_F < L_C$. Locate the lesser of L_C or L_H on the y-axis. In this case locate $L_H = 15$ ft on the y-axis for the travel lane closest to the hazard.

Add 12 ft, the lane width, to L_F to determine if the hazard is within the clear zone for opposing traffic.

Since $L_F + 12 = 22$ ft, and is less than the L_C , guardrail protection is also needed for the opposing direction of traffic at the face of the hazard.

Similarly, $L_H + 12 = 27$ ft which is also less than L_C , therefore protection is needed for the full lateral width of the hazard.

3. From Figure 38-6.E, $L_R = 250$ ft. Locate this point on the "Edge of Traveled Way Scale" and the "Center Line Scale", since protection is required for both directions of travel.
4. Connect the points in Steps 2 and 3. Draw a line for the approaching traffic from the y-axis to the "Edge of Traveled Way Scale" and a line for the opposing traffic from the y-axis to the "Center Line Scale."

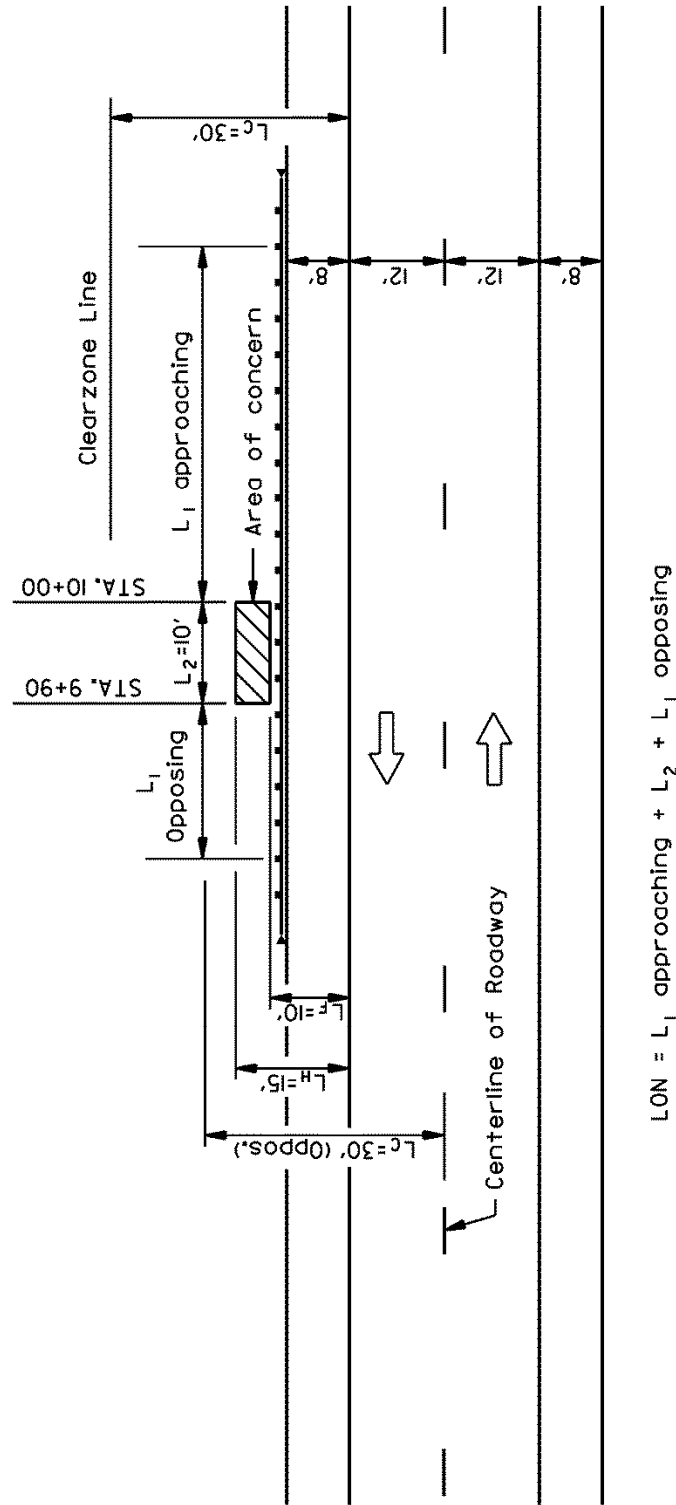

$$LON = L_1 \text{ approaching} + L_2 + L_1 \text{ opposing}$$

PLAN VIEW
EXAMPLE 38-6.01(2)
Figure 38-6.1

5. From the intersection between the lines from Step 1 and Step 4, draw vertical lines down to the “Edge of Traveled Way Scale” and the “Centerline Scale” to get L_1 for both directions of travel.
6. Read $L_1 = 103$ ft from the “Edge of Traveled Way Scale” and $L_1 = 57$ ft from the “Centerline Scale.”
7. Skip this step, since protection is warranted from both directions of travel.
8. Calculate the length of need, LON, of guardrail. In this example, barrier protection is needed from both directions. Therefore:

$$LON = 103 \text{ ft} + 10 \text{ ft} + 57 \text{ ft} = 170 \text{ ft} \qquad \text{Equation 38-6.2}$$

9. Based on the stationing shown in Figure 38-6.I, the station and offset of the approach end BLON is

$$(\text{Station } 10+00) + 103 \text{ ft} = \text{Station } 11+03.00, 20.75 \text{ ft left.}$$

The station for the end of opposing traffic is:

$$(\text{Station } 10+00) - 10 \text{ ft} - 57 \text{ ft} = \text{Station } 9+33.00, 20.75 \text{ ft left.}$$

10. Step 10 does not require any action as no terminals from the *Illinois Highway Standards* are used.
11. Step 11 does not apply as no TBT T2 terminals are being placed.
12. Determine the pay item lengths and plan locations.

By inspection, placement of the TBT T1 BLON points at the plan locations will satisfy the design length of need. Although some field adjustment using standard panels and specific TBT T1 products will be needed, these adjustments are considered nominal.

The plan Stations of the TBTs T1 are:

The selected TBT T1 for this example is 37.5 ft long, and its BLON is at post 3, 12.5 ft from its end.

BLON is at Station 11+03.00, 20.75 ft left.

Begin TBT T1 at (Station 11+03) – 25 ft = Station 10+78.00, 20.0 ft left.

End TBT T1 at (Station 11+03) + 12.5 ft = Station 11+15.50 ft, 20.75 ft left.

BLON is at Station 9+33.00, 20.75 ft left.

Begin TBT T1 at (Station 9+33) - 12.5 ft = Station 9+20.50, 20.75 ft left.

End TBT T1 at (Station 9+33) + 25 ft = Station 9+58.00, 20.0 ft left.

The plan stations for the guardrail pay item are thus:

Station 9+58.00, 20.0 ft left.

To

Station 10+78.00, 20.0 ft left.

Quantity of guardrail pay item = (Station 10+78) – (Station 9+58) = 120 ft.

It is not necessary to round to an even number of 12.5 ft guardrail panels because the precise location and dimensions of the TBTs T1 are not known until the contractor selects an item from the QPL.

Special design note. A special design will be needed at the hazard because the space from the face of guardrail ($L_B = 8$ ft) and the face of the hazard ($L_F = 10$ ft) is only 2 ft. Because the width of the guardrail system is 21 in., there are only 3 in. between the back of the posts and the face of the hazard for deflection of the guardrail. Per Figure 38-6.V, Type A guardrail requires 38 in. clear width for deflection between the back of the post and the face of the hazard.

Because there is not an acceptable deflection distance between the back of the guardrail posts and the area of concern (hazard), the guardrail needs to transition to a rigid barrier across the width of the hazard. If the nature of the hazard is such that guardrail may be bolted to it, using details similar to the Traffic Barrier Terminal Type 6B, transition the post spacing on both sides of the structure to minimize the consequence of “pocketing”, and carry a continuous barrier across the structure. If the area of concern does not provide a suitable backup for guardrail attachment, then provide a concrete barrier and provide transitions and connections as just described. Job-specific details and special provisions will be needed.

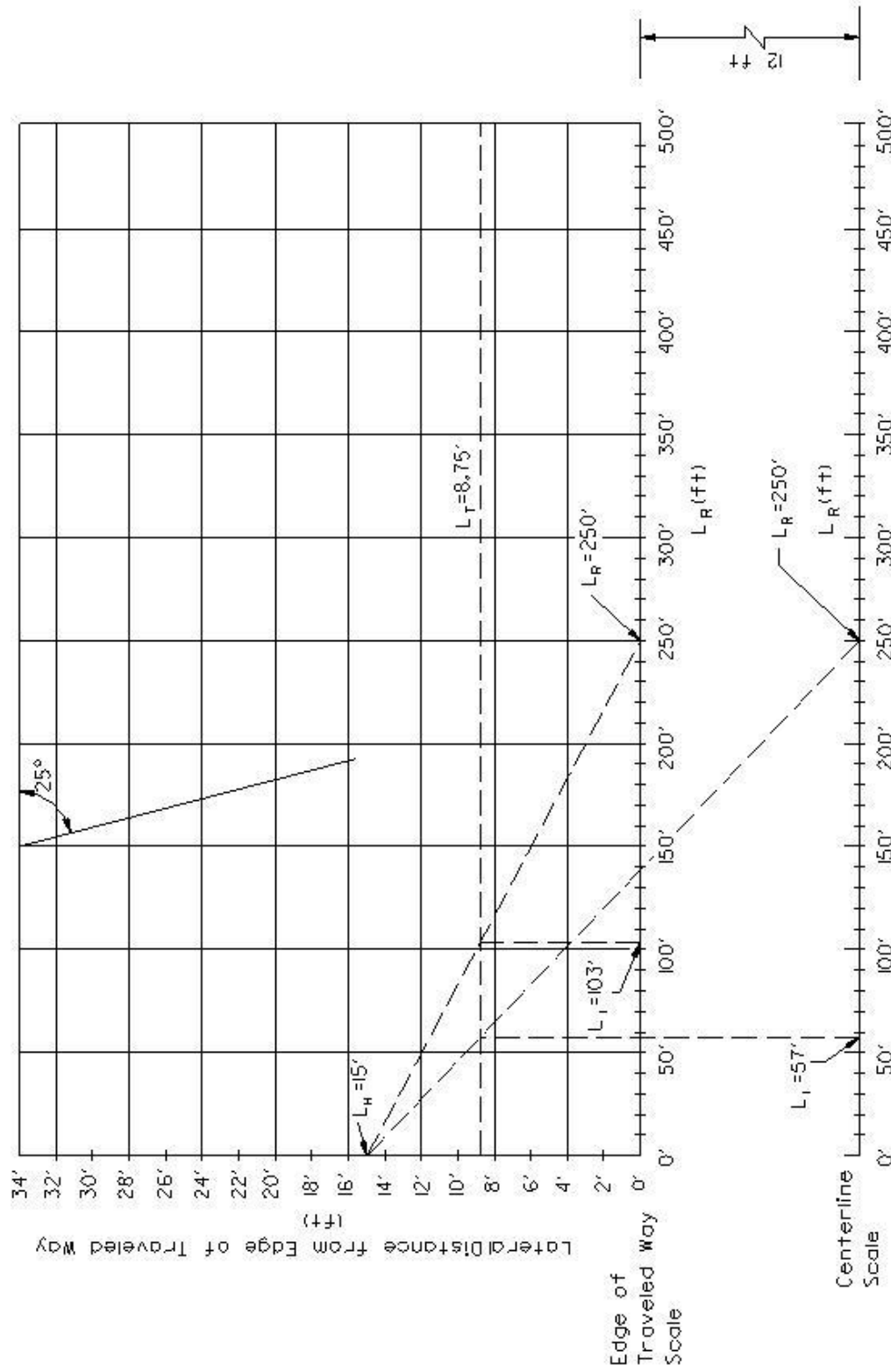

BARRIER LENGTH OF NEED CALCULATION
Example 38-6.01(2)

Figure 38-6.J

Example 38-6.01(3) (Two-Way Traffic — Hazard Beyond Opposing Traffic's Clear Zone)

Given: Reconstruction (See Figure 38-6.K)
Two-lane/two-way roadway
Design ADT = 5000 vpd
Design speed = 60 mph
Slope = 1V:4H front slope
Tangent roadway
Shoulder width = 8 ft
 $L_H = 23$ ft
 $L_2 = 2$ ft (i.e., a point hazard)
 $L_F = 21$ ft
 $L_B = 8$ ft
Traffic Barrier Terminal Type 1, Special (Tangent) (TBT T1)

Problem: Determine the barrier length of need and plan length of guardrail, Type A.

Solution: Use the nomograph procedure starting on page 38-6.5 (refer to the nomograph in Figure 38-6.L).

1. Since a TBT T1 (Tangent) terminal is proposed, draw a horizontal line at L_T on the y-axis of the nomograph,

$$\text{Where } L_T = 8 + 0.75 = 8.75 \text{ ft.}$$

The 0.75 ft is added to the shoulder width to take into account the flare of the guardrail terminal at the third post. The offset from the centerline is thus: $12 + 8 + 0.75 = 20.75$ ft.

2. From Figure 38-3.A, the clear zone (L_C) is 30 ft and the hazard warrants protection for approaching traffic since $L_F < L_C$. Locate the lesser of L_C or L_H on the y-axis. In this case locate $L_H = 23$ ft on the y-axis.

Add 12 ft, the lane width, to L_F to determine if the hazard is within the clear zone for opposing traffic.

Since $L_F + 12 = 33$ ft, and is greater than L_C , guardrail protection may not be required for the opposing direction of traffic. Use engineering judgment or follow the guidance in Section 38-3 to determine the need for roadway protection for the opposing direction of traffic.

Although, for this example, it is assumed guardrail protection from the point hazard for the opposing direction traffic is not required, a crashworthy terminal is needed downstream because of two-way traffic.

3. From Figure 38-6.E, $L_R = 250$ ft. Locate this point on "Edge of Traveled Way Scale." Since protection is warranted for approaching traffic only, there is no need to locate L_R on the "Centerline Scale."

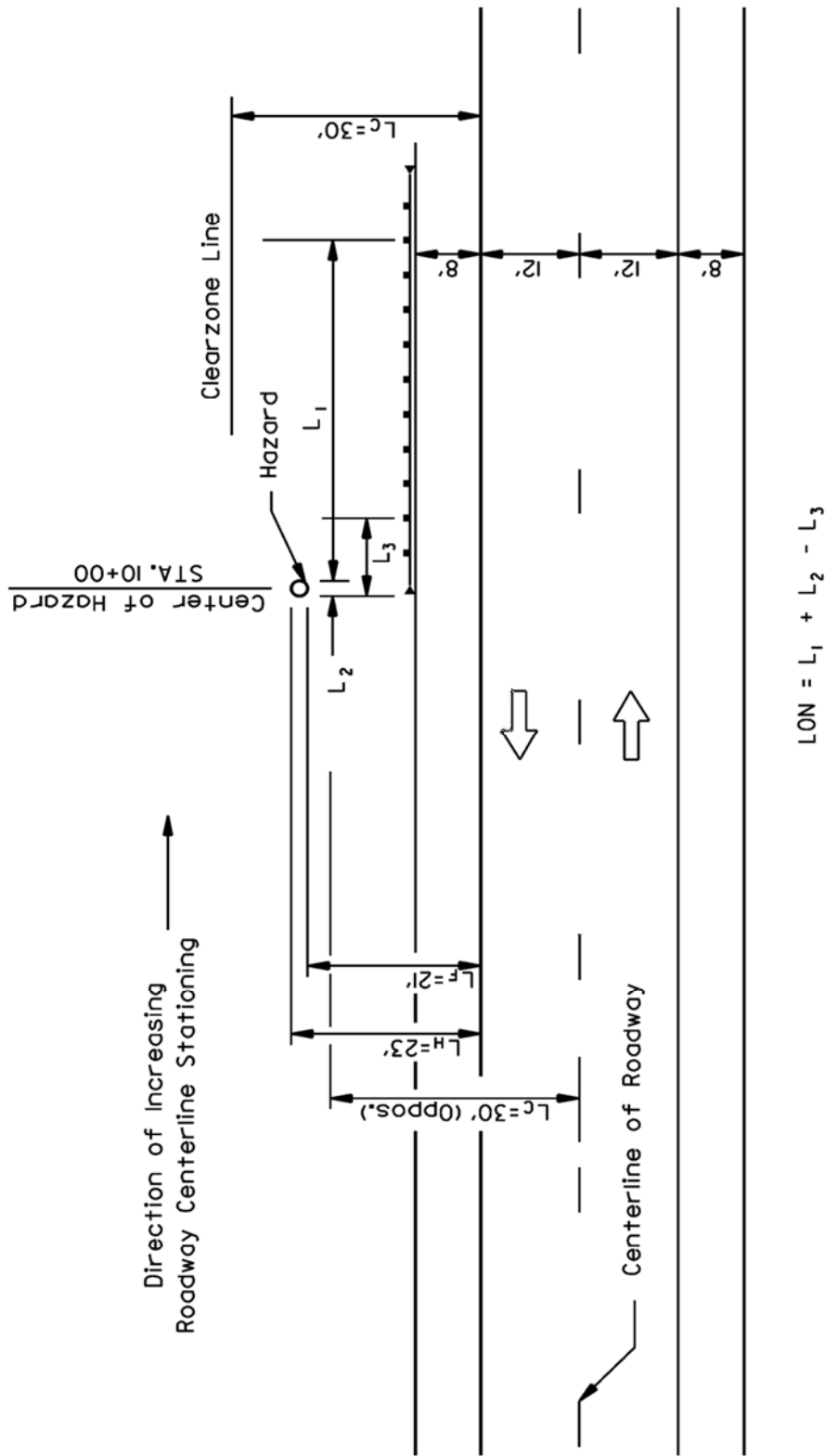

PLAN VIEW
EXAMPLE 38-6.01(3)
Figure 38-6.K

4. Connect the points in Steps 2 and 3.
5. From the intersection between the lines from Step 1 and Step 4, draw a vertical line down to the “Edge of Traveled Way Scale” To get L_1 .
6. Read $L_1 = 153$ ft from the “Edge of Traveled Way Scale” for approaching traffic.
7. Since barrier protection is only warranted for one direction, perform the following steps to establish L_3 , and thus determine the location of the downstream end of the barrier.
 - a. Draw a horizontal line L_B . $L_B = 8$ ft.
 - b. Locate $L_F = 21$ ft on the y-axis.
 - c. Draw a line parallel to the 25 degree line from L_F until it intersects the L_B line.
 - d. From the intersection between the lines formed from Step 7a and 7c, draw a vertical line down to the “Edge of Traveled Way Scale.” Read $L_3 = 29$ ft.
8. Calculate the length need, LON, of guardrail. In this example barrier protection is needed in one direction of traffic. Therefore:

$$LON = 153 + 2 - 29 = 126 \text{ ft} \qquad \text{Equation 38-6.1}$$
9. Based on the stationing shown in Figure 38-6.K, the station and offset of the approach end BLON is:

$$(\text{Station } 10+00) + 1 \text{ ft} + 153 \text{ ft} = \text{Station } 11+54.00, 20.75 \text{ ft left.}$$
 The stationing for the opposing traffic’s end is:

$$(\text{Station } 10+00) - 1 \text{ ft} + 29 \text{ ft} = \text{Station } 10+28.00, 20.75 \text{ ft left.}$$
10. Step 10 does not require any action as no terminals from the *Illinois Highway Standards* are used.
11. Step 11 does not apply as no TBT T2 terminals are being placed.
12. Determine the pay item lengths and plan locations.

By inspection, placement of the TBT T1 BLON points at the plan locations will satisfy the design length of need. Although some field adjustment using standard panels and specific TBT T1 products will be needed, these adjustments are considered nominal.

The plan Stations of the TBTs T1 are calculated as follows:

The selected TBT T1 for this example is 37.5 ft long, and its BLON is at post 3, 12.5 ft from its end.

The BLON is at Station 11+54.00, 20.75 ft left. Therefore:

Begin TBT T1 at (Station 11+54) - 25 ft = Station 11+29.00, 20.0 ft left.

End TBT T1 at (Station 11+54) + 12.5 ft = Station 11+66.50, 20.75 ft left.

BLON at Station 10+28.00, and 20.75 ft left.

Begin TBT T1 at (10+28) - 12.5 ft = Station 10+15.50, 20.75 ft left.

End TBT T1 at (10+28) + 25 ft = Station 10+53.00, 20.0 ft left.

The plan stations for the guardrail pay item are thus:

Station 10+53.00, 20.0 ft left.

To

Station 11+29.00, 20.0 ft left.

Quantity of guardrail pay item = (Station 11+29) – (Station 10+53) = 76 ft.

It is not necessary to round to an even number of 12.5 ft guardrail panels because the precise location and dimensions of the TBTs T1 are not known until the contractor selects an item from the QPL.

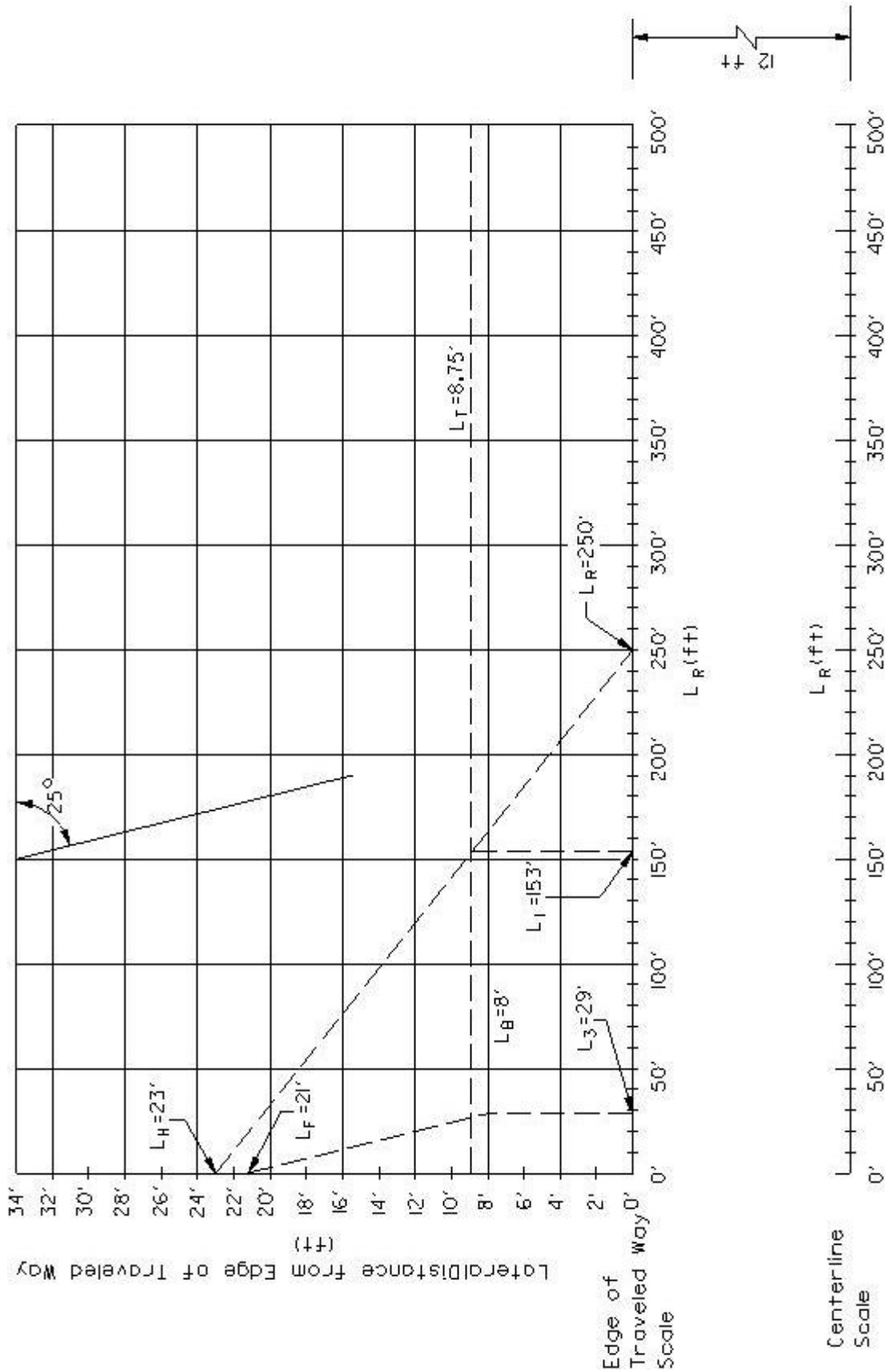

BARRIER LENGTH OF NEED CALCULATION
Example 38-6.01(3)

Figure 38-6.L

Example 38-6.01(4) (Bridge on Two-Way Two-Lane Highway with Recoverable Front Slope)

Given: New Construction (See Figure 38-6.M)
Two-way, two-lane highway
Design ADT = 5500 vpd
Design speed = 60 mph
Guardrail for shielding of bridge parapet ends and steep slope adjacent to the slope wall
Bridge slope wall = 1V:2H
Typical front slopes = 1V:4H (Assume a front slope of at least 1V:3H prevails to within 100 ft of the bridge, then transitions over 100 ft to match the bridge cone/sloped wall).
Tangent roadway
Lane width = 12 ft
Shoulder width = 8 ft
Unflared barrier (steel plate beam guardrail, Type A) located at the edge of the shoulder ($L_B = 8$ ft)
Traffic Barrier Terminal Type 1 (TBT T1), Special (Flared)

Problem: Determine the location and limits of the hazard, the barrier length of need, and the pay item length of guardrail. This problem assumes a symmetrical layout with the same hazards for traffic approaching at both ends of the bridge.

Solution: Approach Side:

The hazards are the 1V:2H slope off the end of the bridge cone, the drop-off to the stream below the bridge, and the transition slope steeper than 1V:3H. For simplicity, it has been previously determined that the location where the slope becomes steeper than 1V:3H is located 100 ft from either side of the bridge. Since the layout is symmetrical, for simplicity, the analysis will be done for one side of the bridge/one direction of travel. Use the nomograph procedure starting on page 38-6.5 (refer to the nomograph in Figure 38-6.N).

1. Since a TBT T1 (Flared) terminal is proposed, draw a horizontal line at L_T on the y-axis of the nomograph for the approach side of the roadway, where:

$$L_T = 8 \text{ ft} + 2.7 \text{ ft} = 10.7 \text{ ft}$$

The 2.7 ft is added to the shoulder width to take into account the flare of the guardrail terminal at the third post. The offset from the centerline is thus: $12 + 8 + 2.7 = 22.7$ ft.

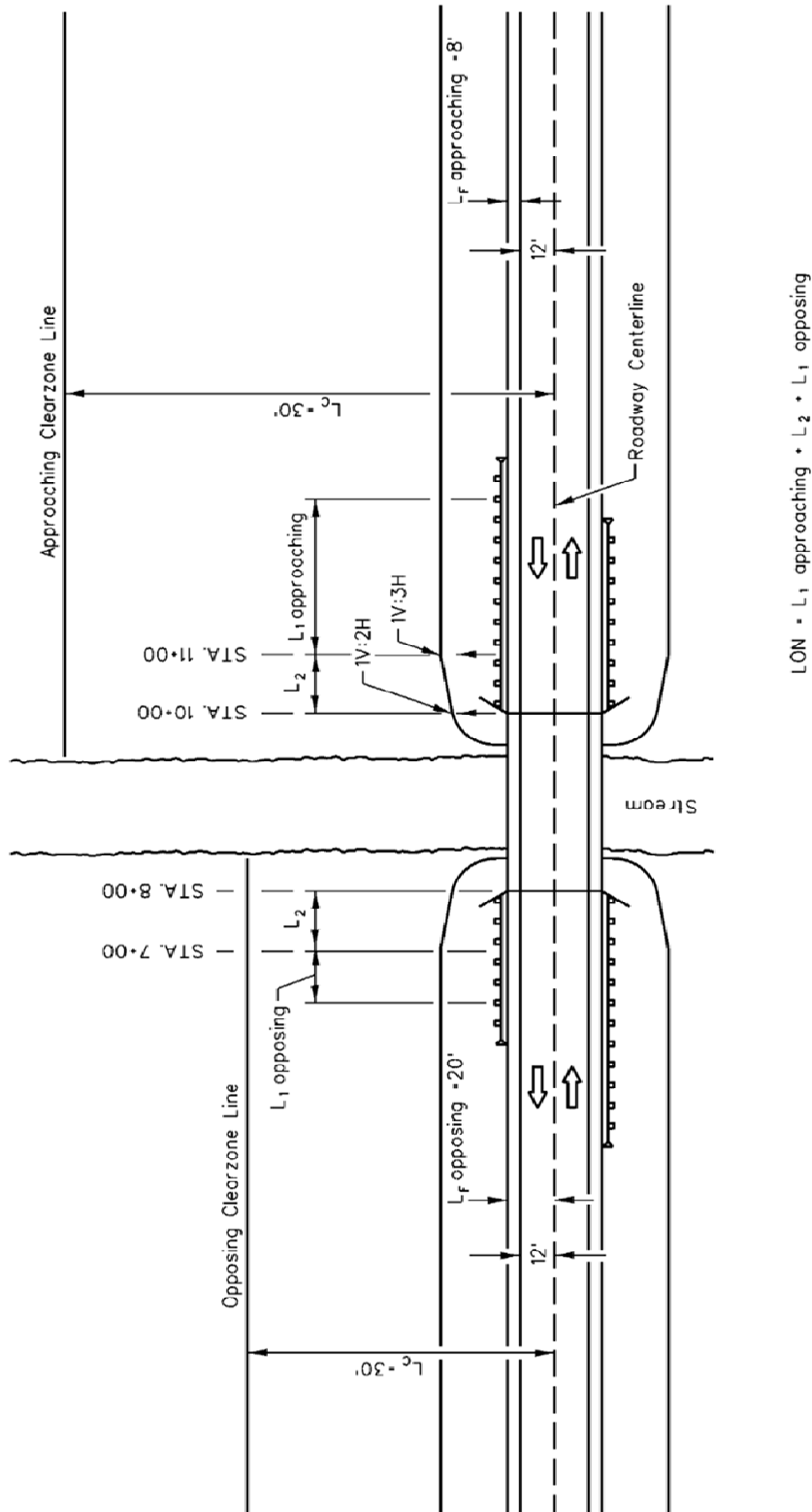

PLAN VIEW
EXAMPLE 38-6.01(4)
Figure 38-6.M

2. The face of the closest hazards, L_F , the end of the parapet wall and the drop-off below the bridge, is 8 ft from the edge of the traveled way. From Figure 38-3.A, the clear zone (L_C) is 30 ft, thus the hazard warrants protection for the approach side since $L_F < L_C$. Locate the lesser of L_H or L_C on the y-axis. The L_H , defined by the drop-off below the bridge and the end of the bridge embankment cone, extends to the flood plain beyond the clear zone, so plot $L_C = 30$ ft on the y-axis. This represents the largest offset that is of concern for shielding.
3. From Figure 38-6.E, $L_R = 250$ ft. Locate this point on the “Edge of Traveled Way Scale.”
4. Connect the points in Steps 2 and 3. Draw a line for the right side of traffic from the y-axis to the “Edge of Traveled Way Scale.”
5. From the intersection between the lines from Step 1 and Step 4, draw vertical lines down to the “Edge of Traveled Way Scale.”
6. Read $L_1 = 161$ ft from the “Edge of Traveled Way Scale.” Note that assuming the layout is symmetrical, this need be calculated only once, and then mirrored for the other direction of travel.
7. This is a two-way, two-lane roadway and the guardrail is within the clear zone for both directions, so Step 7 does not apply.
8. Calculate the length of need, LON, of guardrail for the approach side.

Guardrail upstream from the bridge, L_1 protects vehicles from the transition side slope to the bridge cone. Because this is the widest area protected and because the parapet wall and bridge cone are located further downstream for traffic, they are also protected at least to the clear zone. The parapet wall protects vehicles from the bridge drop-off. Thus, for analyzing the approach sides, L_2 starts 100 ft from the end of the parapet wall. The parapet wall is not part of the guardrail LON, thus:

$$L_2 = 100 \text{ ft}$$

So, L_1 for the approaching direction on the right side is 161 ft.

$$\text{LON} = 100 \text{ ft} + 161 \text{ ft} = 261 \text{ ft} \quad \text{Equation 38-6.2}$$

9. Based on the stationing shown in Figure 38-6.M, the stations and offsets of the BLON points are:

$$(\text{Station } 10+00) + 261 \text{ ft} = \text{Station } 12+61.00, 22.7 \text{ ft left.}$$

Selecting a 37.5 ft TBT T1 from the QPL for this example, and applying the BLON at post 3 (12.5 ft from the end), the plan Stations of the TBT T1 are:

$$(\text{Station } 12+61) - 25 \text{ ft} = \text{Station } 12+36.00, 20.0 \text{ ft left}$$

To

$$(\text{Station } 12+61) + 12.5 \text{ ft} = \text{Station } 12+73.50, 22.7 \text{ ft left.}$$

10. At each corner of the bridge a TBT T6 will connect to the bridge parapet. As noted from *Highway Standard* 631031, the length of the pay item for the TBT T6 is 37.5 ft and this overlaps the end of the bridge parapet by 7.25 in. (0.6 ft) The distance from the end of the parapet to the end of the TBT T6 pay item is then 36.9 ft.

The pay item limits for the TBT T6 are:

$$(\text{Station } 10+00) - 0.6 = \text{Station } 9+99.40, 20.0 \text{ ft left}$$

$$\text{To Station } 10+36.90, 20.0 \text{ ft left.}$$

11. Step 11 does not apply as no TBTs T2 are being used.
12. Based on the information provided, and by inspection, the BLON points are set to provide adequate length of need for all hazards. The designer should also check the locations of the TBTs T1 to determine if the sites are suitable for the required grading at these terminals and that the typical cross sections stated still prevail at these locations.
13. Determine the plan lengths and stationing for guardrail. Use the stations for the TBTs T1 and TBTs T6 from above to determine the plan quantities and stationing.

$$\text{Station } 10+36.90, 20.0 \text{ ft left to Station } 12+36.00, 20.0 \text{ ft left} = 199.1 \text{ ft.}$$

Opposing Side:

The hazards are the 1V:2H slope off the end of the bridge cone, the drop-off to the stream below the bridge, and the transition slope steeper than 1V:3H. For simplicity, it has been previously determined that the location where the slope becomes steeper than 1V:3H is located 100 ft from either side of the bridge. Since the layout is symmetrical, and for simplicity, the analysis will be done for one side of the bridge/one direction of travel. Use the nomograph procedure starting on page 38-6.5 (refer to the nomograph in Figure 38-6.N).

1. Since a TBT T1 (Flared) terminal is proposed, draw a horizontal line at L_T on the y-axis of the nomograph for the opposing side of the structure, where:

$$L_T = 8 \text{ ft} + 2.7 \text{ ft} = 10.7 \text{ ft}$$

The 2.7 ft is added to the shoulder width to take into account the flare of the guardrail terminal at the third post. The offset from the centerline is thus: $12 + 8 + 2.7 = 22.7 \text{ ft}$.

2. Add 12 ft, the lane width to L_F to determine if the hazard is within the clear zone for an opposing departure. Since $L_F + \text{Lane width} = 12 + 8 = 20 \text{ ft}$, is less than L_C , protection is also needed from hazards on the left side of the roadway. L_C is less than L_H , so plot $L_C = 30 \text{ ft}$ from the centerline scale on the y-axis for the left side of the roadway. In this case a distance 30 ft from the road centerline scale falls at 18 ft from the edge of travelled way scale.
3. From Figure 38-6.E, $L_R = 250 \text{ ft}$. Locate this point on the "Center Line Scale."

4. Connect the points in Steps 2 and 3. Draw a line for the left side departure of traffic from the y-axis to the "Center Line Scale."
5. From the intersection between the lines from Step 1 and Step 4, draw a vertical line down to the "Center Line Scale."
6. Read $L_1 = 61$ ft from the "Center Line Scale" Note that assuming the layout is symmetrical, this need be calculated only once, and then mirrored for the other side of the bridge.
7. This is a two-lane, two-way roadway and the guardrail is within the clear zone for both directions, so Step 7 does not apply.
8. Calculate the length of need, LON, of guardrail for the opposing side.

Guardrail upstream from the bridge, L_1 protects vehicles from the transition side slope and bridge cone. Because this is the widest area protected and because the parapet wall and bridge cone are located further upstream, they are also protected to at least the clear zone. The parapet wall protects vehicles from the bridge drop-off. Thus, for analyzing the right side, L_1 starts 100 ft from the end of the parapet wall. The parapet wall is not part of the guardrail LON, thus:

$$L_2 = 100 \text{ ft}$$

And, L_1 for the opposing direction is 61 ft.

$$\text{So, LON} = 100 \text{ ft} + 61 \text{ ft} = 161 \text{ ft.} \quad \text{Equation 38-6.2}$$

9. Based on the stationing shown in Figure 38-6.M, the stations and offsets of the BLON points are:

$$(\text{Station } 8+00) - 161 \text{ ft} = \text{Station } 6+39.00, 22.7 \text{ ft left.}$$

Using a 37.5 ft TBT T1 from the QPL, for this example, and applying the BLON at post 3 (12.5 ft from the end), the plan Stations of the TBT T1 are:

$$(\text{Station } 6+39) - 12.5 \text{ ft} = \text{Station } 6+26.50, 22.7 \text{ ft left.}$$

To

$$(\text{Station } 6+39) + 25 \text{ ft} = \text{Station } 6+64.00, 20.0 \text{ ft left.}$$

10. At each corner of the bridge a TBT T6 will connect to the bridge parapet. The length of the pay item for the TBT T6 is 37.5 ft and this overlaps the end of the bridge parapet by 7.25 in. (0.6 ft). The distance from the end of the parapet to the end of the TBT T6 pay item is then 36.9 ft.

The pay item limits of the TBT T6 for the opposing approach to the bridge are:

$$\text{Station } 8+00.60, 20.0 \text{ ft left.}$$

To

Station 7+63.10, 20.0 ft left.

11. Step 11 does not apply as no TBTs T2 are being used.
12. Based on the information provided and by inspection the BLON points are set to provide adequate length of need for all hazards. The designer should also check the locations of the TBT T1s to determine if the sites are suitable for the required grading at these terminals and that the typical cross sections stated still prevail at these locations.
13. Determine the plan lengths and stationing for guardrail. Use the stations for the TBTs T1 and TBTs T6 from above to determine the plan quantities and stationing.

Station 6+64.00, 20.0 ft left to Station 7+63.10, 20.0 ft left = 99.1 ft.

Discussion: This example illustrates compliance with nominal clear zone requirements. However, engineering judgment may apply for application of clear zones. Suppose the vertical drop of the bridge cones to the flood plain is 20 ft. Also note that the discussion of clear zones in Section 38-3.01(2) states: "If a formidable obstacle lies just beyond the clear zone, it may be appropriate to remove or shield the obstacle if costs are reasonable."

The guardrail as designed protects against vehicles traversing it as far as the 30 ft clear zone. However, this leaves another 5 ft vertically (10 ft horizontally) unshielded. Note also that except for the transition slope in the last 100 ft approaching the bridge, the roadside slopes are traversable and a vehicle running out behind the guardrail might reach the transition area with some speed remaining and still some drop to the flood plain.

How much additional guardrail would be needed to shield against roadway departures to the toe of the bridge cones?

The bridge cone begins about 2 ft beyond the shoulder and then extends horizontally about 40 ft to the flood plain. For the approach side roadway departure, extend the vertical axis and plot a point at 42 ft, the total width of the bridge cone hazard, L_H . See Figure 38- 6.N.

Connect this point to the runout length point (250 ft) on the "Edge of Traveled Way Scale."

Connect these two points and draw a vertical line where they cross $L_T = 10.7$ ft and find that this intersects the "Edge of Traveled Way Scale" at 186 ft.

Therefore, in this case, the length of need in advance of the bridge (L_A), 186 ft, needed to shield the full bridge cone is less than the total length of need to shield the slope transition area (261 ft) and this concern is resolved.

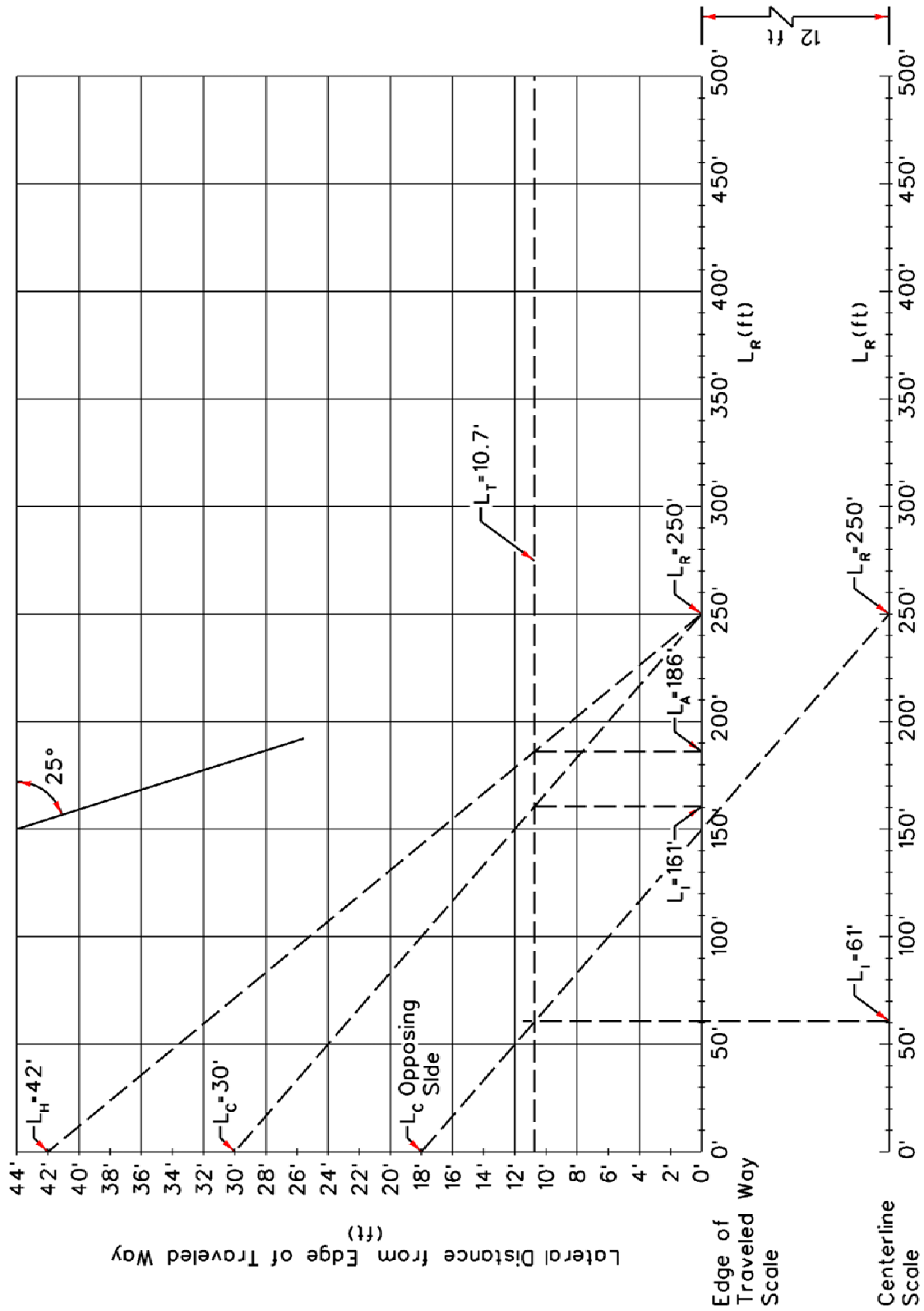

BARRIER LENGTH OF NEED CALCULATION
 Example 38-6.01(4)

Figure 38-6.N

Example 38-6.01(5) (Bridge on Two-Way Two-Lane Highway with Non-recoverable Front Slope)

Given: New Construction (See Figure 38-6.O)
Two-way, two-lane highway
Design ADT = 7000 vpd
Design speed = 60 mph
Guardrail for shielding of bridge parapet ends and steep slope adjacent to the slope wall
Bridge slope wall = 1V:2H
Typical front slopes = 1V:3H
Tangent roadway
Lane width = 12 ft
Shoulder width = 8 ft
Unflared barrier (steel plate beam guardrail, Type A) located at the edge of the shoulder ($L_B = 8$ ft)
Traffic Barrier Terminal Type 1 (TBT T1), Special (Flared)

Problem: Determine the location and limits of the hazard, the barrier length of need, and the pay item length of guardrail. This problem assumes a symmetrical layout with the same hazards for traffic approaching at both ends of the bridge.

Solution: Approach Side:

The hazards are the 1V:2H slope off the end of the bridge cone, the drop-off below the bridge, and the transition slope steeper than 1V:3H. For simplicity, it has been previously determined that the location where the slope becomes steeper than 1V:3H is located 100 ft from either side of the bridge. Since the layout is symmetrical, and for simplicity, the analysis will be done for one side of the bridge. First, complete the non-recoverable front slope procedure. See Section 38-3.03(b) to determine the recommended clear zone distance. Then use the nomograph procedure starting on page 38-6.5 (refer to the nomograph in Figure 38-6.P).

Non-Recoverable Front Slope Procedure

1. Determine the clear zone for a 1V:6H or flatter slope for the design speed and traffic volume given above. From Figure 38-3.A, the standard clear zone value for this case is 30 ft to 32 ft.
2. To determine the clear runout area beyond the toe of the front slope, subtract the shoulder width or the distance from the edge of the travelled way to the shoulder hinge point from the distance in Step 1. For this example, the shoulder width is 8 ft and the bridge cone begins about 2 ft beyond the shoulder and then extends horizontally about 40 ft to the flood plain. At minimum, the recommended clear distance beyond the toe of the non-recoverable slope (1V:3H) is:

30 ft minus 22 ft, which yields 8 ft.

3. The clear runout area beyond the toe of the front slope is the greater distance of the value determined in Step 2 (8 ft) or 10 ft. Thus for this example the clear zone, L_c , extends 10 ft beyond the toe of the front slope, which is 40 ft from the hinge point. Utilizing this more conservative value of 10 ft yields a recommended clear zone for approaching traffic of $8 \text{ ft} + 2 \text{ ft} + 40 \text{ ft} + 10 \text{ ft} = 60 \text{ ft}$.

Length of Need Procedure

1. Since a TBT T1 (Flared) terminal is proposed, draw a horizontal line at L_T on the y-axis of the nomograph for the approach side of the roadway, where:

$$L_T = 8 \text{ ft} + 2.7 \text{ ft} = 10.7 \text{ ft}$$

The 2.7 ft is added to the shoulder width to take into account the flare of the guardrail terminal at the third post. The offset from the centerline is thus: $12 + 8 + 2.7 = 22.7 \text{ ft}$.

2. The face of the closest hazards, L_F , the end of the parapet wall and the drop-off below the bridge, is 8 ft from the edge of the traveled way. From the discussion above, the clear zone (L_c) is 60 ft, thus the hazard warrants protection for the approach side since $L_F < L_c$.
3. Locate the lesser of L_H or L_c on the y-axis. The L_H , defined by the drop-off below the bridge and the end of the bridge embankment cone, extends to the flood plain beyond the clear zone, so plot $L_c = 60 \text{ ft}$ on the y-axis. This represents the largest offset that is of concern for shielding. From Figure 38-6.E, $L_R = 250 \text{ ft}$. Locate this point on the "Edge of Traveled Way Scale."
4. Connect the points in Steps 2 and 3. Draw a line for the right side of traffic from the y-axis to the "Edge of Traveled Way Scale."
5. From the intersection between the lines from Step 1 and Step 4, draw vertical lines down to the "Edge of Traveled Way Scale."
6. Read $L_1 = 205 \text{ ft}$ from the "Edge of Traveled Way Scale." Note that assuming the layout is symmetrical, this need be calculated only once, and then mirrored for the other direction of travel.
7. This is a two-way, two-lane roadway and the guardrail is within the clear zone for both directions, so Step 7 does not apply.

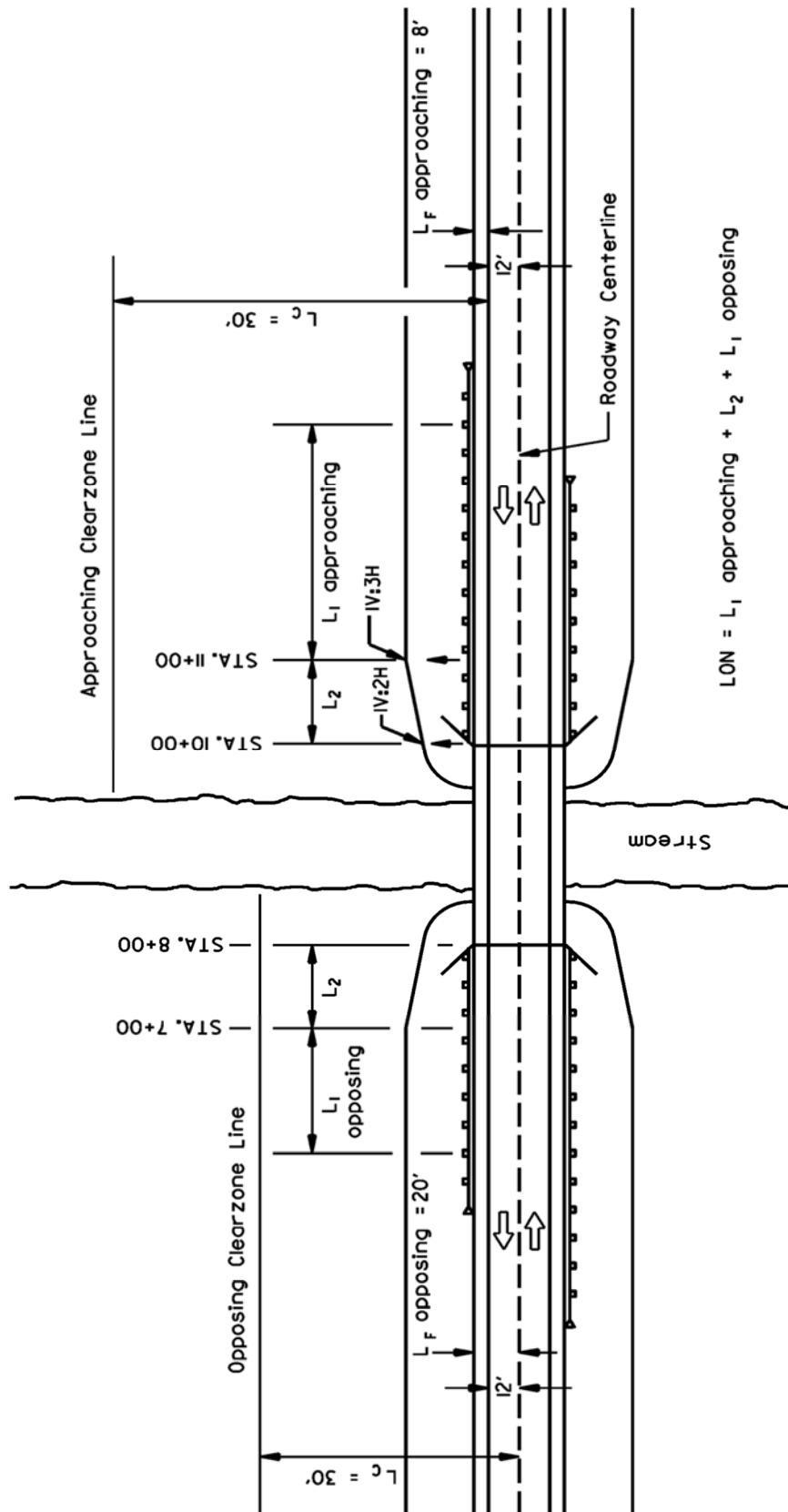

PLAN VIEW
EXAMPLE 38-6.01(5)
Figure 38-6.0

8. Calculate the length of need, LON, of guardrail for the approach side.

Guardrail upstream from the bridge, L_1 , protects vehicles from the transition side slope to the bridge cone. Because this is the widest area protected and because the parapet wall and bridge cone are located further downstream for traffic, they are also protected at least to the clear zone. The parapet wall protects vehicles from the bridge drop-off. Thus for analyzing the approach sides, L_2 starts 100 ft from the end of the parapet wall. The parapet wall is not part of the guardrail LON, thus:

$$L_2 = 100 \text{ ft}$$

So, L_1 for the approaching direction on the right side is 205 ft.

$$\text{LON} = 100 \text{ ft} + 205 \text{ ft} = 305 \text{ ft} \quad \text{Equation 38-6.2}$$

9. Based on the stationing shown in Figure 38-6.O, the stations and offsets of the BLON points are:

$$(\text{Station } 10+00) + 305 \text{ ft} = \text{Station } 13+05.00, 22.7 \text{ ft left.}$$

Selecting a 37.5 ft TBT T1 from the QPL for this example, and applying the BLON at post 3 (12.5 ft from the end), the plan Stations of the TBT T1 are:

$$(\text{Station } 13+05) - 25 \text{ ft} = \text{Station } 12+80.00, 20.0 \text{ ft left}$$

To

$$(\text{Station } 13+05) + 12.5 \text{ ft} = \text{Station } 13+17.50, 22.7 \text{ ft left.}$$

10. At each corner of the bridge a TBT T6 will connect to the bridge parapet. As noted from *Highway Standard* 631031, the length of the pay item for the TBT T6 is 37.5 ft and this overlaps the end of the bridge parapet by 7.25 in. (0.6 ft). The distance from the end of the parapet to the end of the TBT T6 pay item is then 36.9 ft.

The pay item limits for the TBT T6 are:

$$(\text{Station } 10+00) - 0.6 = \text{Station } 9+99.40, 20.0 \text{ ft left}$$

$$\text{To Station } 10+36.90, 20.0 \text{ ft left.}$$

11. Step 11 does not apply as no TBTs T2 are being used.
12. Based on the information provided, and by inspection, the BLON points are set to provide adequate length of need for all hazards. The designer should also check the locations of the TBTs T1 to determine if the sites are suitable for the required grading at these terminals and that the typical cross sections stated still prevail at these locations.
13. Determine the plan lengths and stationing for guardrail. Use the stations for the TBTs T1 and TBTs T6 from above to determine the plan quantities and stationing.

$$\text{Station } 10+36.90, 20.0 \text{ ft left to Station } 12+80.00, 20.0 \text{ ft left} = 243.1 \text{ ft.}$$

Opposing Side:

The hazards are the 1V:2H slope off the end of the bridge cone, the drop-off below the bridge, and the transition slope steeper than 1V:3H. For simplicity, it has been previously determined that the location where the slope becomes steeper than 1V:3H is located 100 ft from either side of the bridge. Since the layout is symmetrical, and for simplicity, the analysis will be done for one side of the bridge/one direction of travel. Use the nomograph procedure starting on page 38-6.5 (refer to the nomograph in Figure 38-6.P).

1. Since a TBT T1 (Flared) terminal is proposed, draw a horizontal line at L_T on the y-axis of the nomograph for the opposing side of the roadway, where:

$$L_T = 8 \text{ ft} + 2.7 \text{ ft} = 10.7 \text{ ft}$$

The 2.7 ft is added to the shoulder width to take into account the flare of the guardrail terminal at the third post. The offset from the centerline is thus: $12 + 8 + 2.7 = 22.7 \text{ ft}$.

2. Add 12 ft, the lane width to L_F to determine if the hazard is within the clear zone for an opposing departure. Since $L_F + \text{Lane width} = 12 + 8 + 2 = 22 \text{ ft}$, is less than L_C , protection is also needed from hazards on the left side of the roadway, opposing side. L_C is less than L_H , so plot the enhanced $L_C = 60 \text{ ft}$ on the y-axis and note that this falls 72 ft from the centerline scale.
3. From Figure 38-6.E, $L_R = 250 \text{ ft}$. Locate this point on the "Center Line Scale".
4. Connect the points in Steps 2 and 3. Draw a line for the left side departure of traffic from the y-axis to the "Center Line Scale."
5. From the intersection between the lines from Step 1 and Step 4, draw a vertical line down to the "Center Line Scale."
6. Read $L_1 = 171 \text{ ft}$ from the "Center Line Scale" Note that assuming the layout is symmetrical, this need be calculated only once, and then mirrored for the other side of the bridge.
7. This is a two-lane, two-way roadway and the guardrail is within the clear zone for both directions, so Step 7 does not apply.
8. Calculate the length of need, LON, of guardrail for the opposing side.

Guardrail upstream from the bridge, L_1 protects vehicles from the transition side slope and bridge cone. Because this is the widest area protected and because the parapet wall and bridge cone are located further upstream, they are also protected to at least the clear zone. The parapet wall protects vehicles from the bridge drop-off. Thus for analyzing the right side, L_1 starts 100 ft from the end of the parapet wall. The parapet wall is not part of the guardrail LON, thus:

$$L_2 = 100 \text{ ft}$$

And, L_1 for the opposing direction is 171 ft.

$$\text{So, } LON = 100 \text{ ft} + 171 \text{ ft} = 271 \text{ ft} \quad \text{Equation 38-6.2}$$

9. Based on the stationing shown in Figure 38-6.O, the stations and offsets of the BLON points are:

(Station 8+00) - 271 ft = Station 5+29.00, 22.7 ft left.

Using a 37.5 ft TBT T1 from the QPL, for this example, and applying the BLON at post 3 (12.5 ft from the end), the plan Stations of the TBT T1 are:

(Station 5+29) - 12.5 ft = Station 5+16.50, 22.7 ft left.

To

(Station 5+29) + 25 ft = Station 5+54.00, 20.0 ft left.

10. At each corner of the bridge a TBT T6 will connect to the bridge parapet. The length of the pay item for the TBT T6 is 37.5 ft and this overlaps the end of the bridge parapet by 7.25 in. (0.6 ft). The distance from the end of the parapet to the end of the TBT T6 pay item is then 36.9 ft.

The pay item limits of the TBT T6 for the opposing departure approaching the bridge are:

Station 8+00.60, 20.0 ft left.

To

Station 7+63.10, 20.0 ft left.

11. Step 11 does not apply as no TBTs T2 are being used.
12. Based on the information provided and by inspection the BLON points are set to provide adequate length of need for all hazards. The designer should also check the locations of the TBT T1s to determine if the sites are suitable for the required grading at these terminals and that the typical cross sections stated still prevail at these locations.
13. Determine the plan lengths and stationing for guardrail. Use the stations for the TBTs T1 and TBTs T6 from above to determine the plan quantities and stationing.

Station 5+54.00, 20.0 ft left to Station 7+63.10, 20.0 ft left = 209.1 ft.

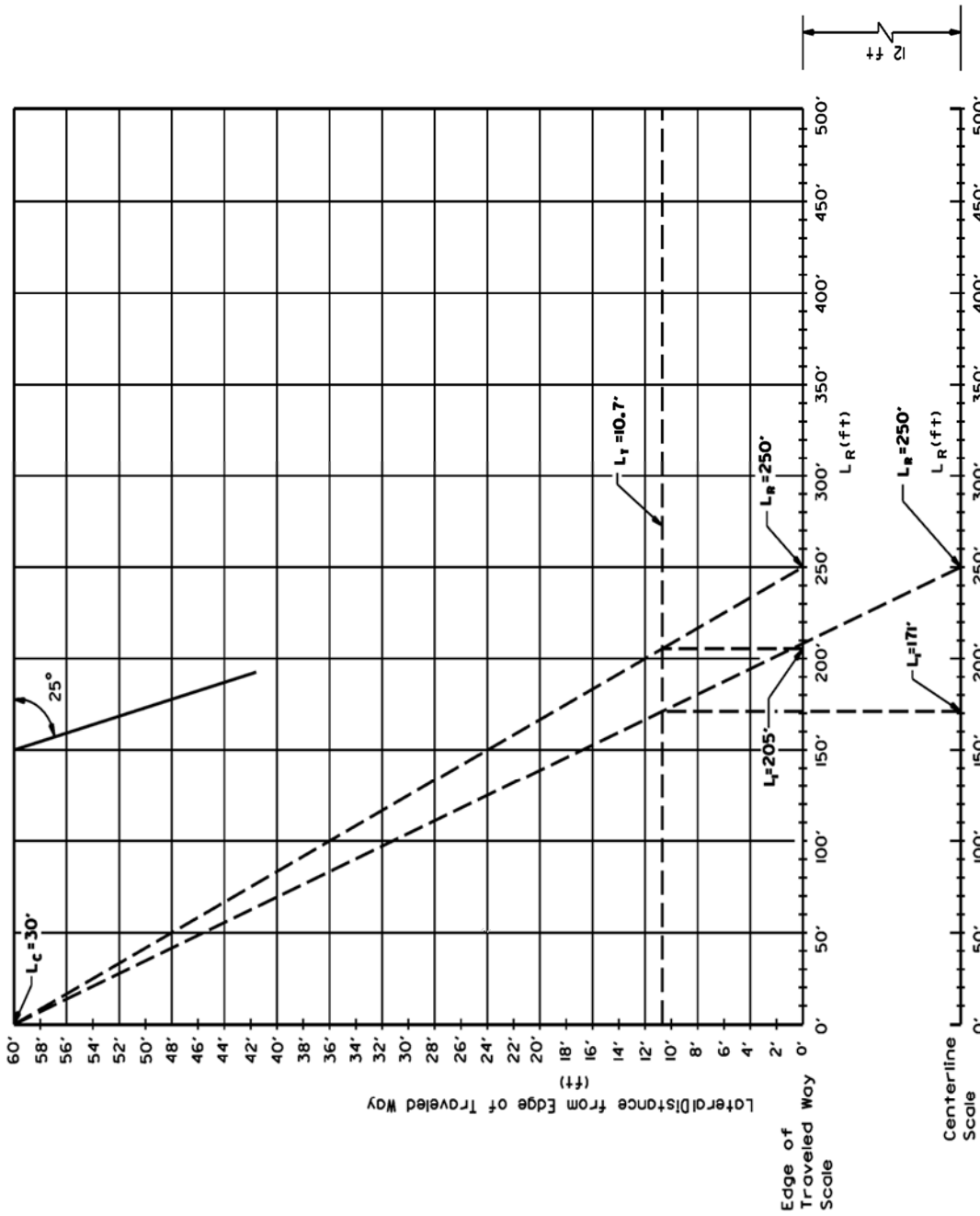

**BARRIER LENGTH OF NEED
CALCULATION
EXAMPLE 38-6.01(5)**

Figure 38-6.P

Example 38-6.01(6) (Divided Four-lane Freeway with 64 ft Median between Dual Structures)

Given: Reconstruction (See Figure 38-6.Q)
 Divided four-lane freeway with 64 ft median between dual structures
 Design ADT = 20,000 vpd
 Design speed = 75 mph
 Tangent roadway
 Lane width = 12 ft
 Shoulder width (right) = 10 ft
 Shoulder width (left) = 6 ft
 Unflared barrier (steel plate beam guardrail, Type A) located along the right edge of the shoulder ($L_B = 10$ ft).
 Traffic Barrier Terminal Type 1, Special (Flared) (TBT T1) on right side of the shoulder
 Traffic Barrier Type 6 at each bridge parapet end
 Flared (1:20) barrier (steel plate beam guardrail, Type A) with a Traffic Barrier Terminal Type 1, Special on the median side of the roadway
 Side slopes on the right edge of roadway:

<u>Station</u>	<u>Front Slope*</u>	<u>Height</u>
Project limit to 11+00	1V:4H	10 ft
11+00 to 12+00	1V:3.5H	12 ft
12+00 to 13+00	1V:3H	15 ft
13+00 to 14+00	1V:2.5H	18 ft
14+00 to 15+00	1V:2H	20 ft

Beginning of bridge parapet at Station 15+00.

*Front slope begins at 14 ft from the edge of pavement to allow for 2 ft of embankment behind the guardrail posts. (10 ft shoulder, 2 ft guardrail width, and 2 ft additional embankment width for guardrail post support.)

Problem: Determine the barrier length of need and length of guardrail pay item for the roadside guardrail on the right side and on the median side.

Solution: Guardrail is needed on the approach of the right side of the roadway for shielding from the front slope steeper than 1V:3H, and the bridge cone, on the approach for the median side of the roadway for the gap between the dual structures in the median, and on the approach for both sides of the roadway due to the highway beneath. Each side of the roadway must be analyzed independently. This problem will only analyze the roadway approaching the bridge and not any of the roadway past the bridge. Use the nomograph procedure starting on page 38-6.5 (refer to the nomographs in Figure 38-6.R and Figure 38-6.S).

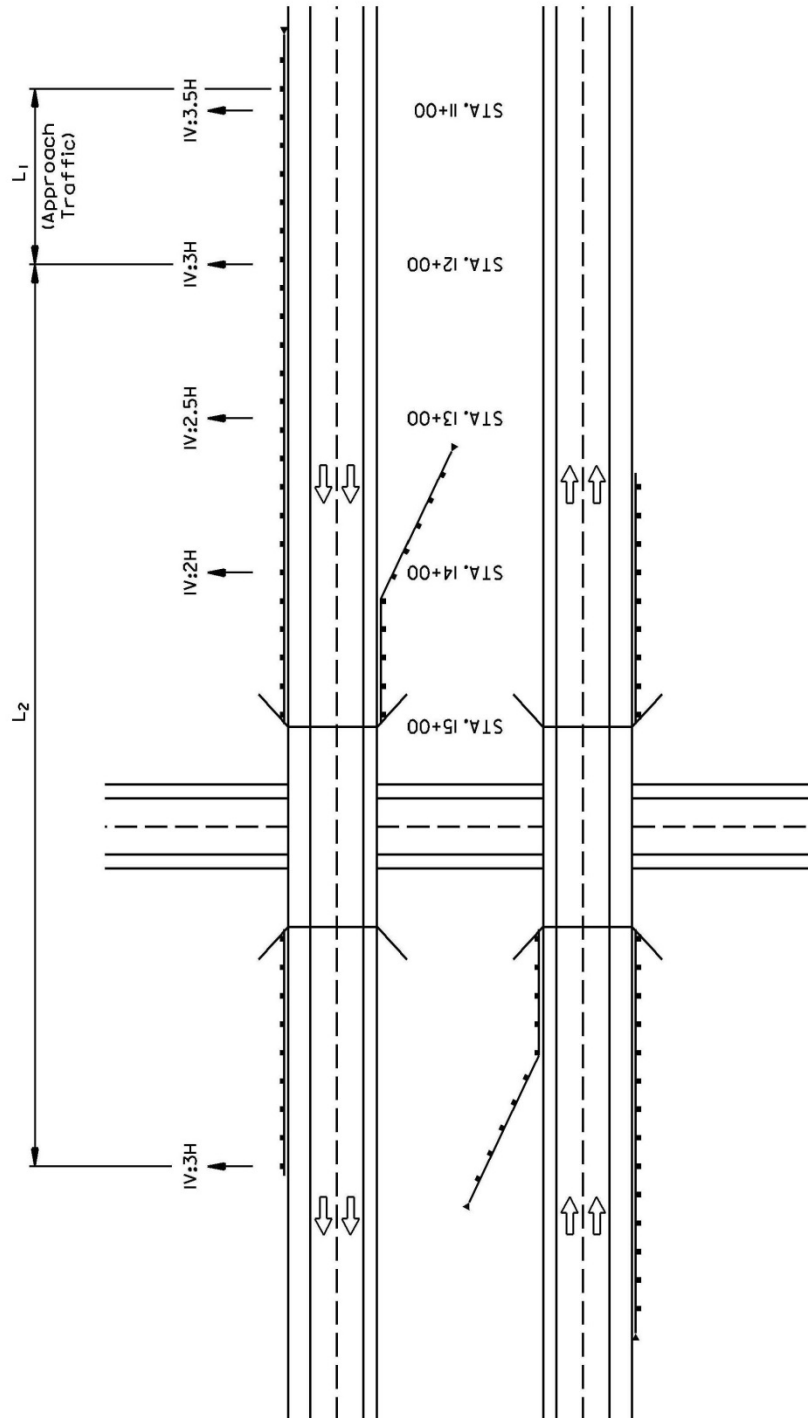

PLAN VIEW
EXAMPLE 38-6.01(6)
Figure 38-6.Q

Length of Need – Right Side

1. Since a TBT T1 (Flared) terminal is proposed on the right side, draw a horizontal line at L_T on the nomograph for the right side of the roadway, where:

$$L_T = 10 \text{ ft} + 2.7 \text{ ft} = 12.7 \text{ ft}$$

The 2.7 ft is added to the shoulder width to take into account the flare of the guardrail terminal at the third post. The offset from the centerline is thus: $\frac{1}{2}(64) + 24 + 10 + 2.7 = 68.7 \text{ ft}$.

2. From Figure 38-3.A, the clear zone (L_C) is 30 ft and the hazard warrants protection for traffic on the right side approach since $L_F (10 \text{ ft}) < L_C$. Locate the lesser of L_C or L_H on the y-axis. L_H , defined by front slope and bridge embankment cones, begins longitudinally at the station of the critical slope (Sta. 12+00) and extends laterally to the flood plain beyond the clear zone, so plot $L_C = 30 \text{ ft}$ on the y-axis.
3. From Figure 38-6.E, $L_R = 360 \text{ ft}$. Locate this point on the “Edge of Traveled Way Scale.” The two directions of travel are separated by a 64 ft median, so the separate roadways can be analyzed independently for roadside hazards as two one-way roadways. There is no need to locate L_R on the “Centerline Scale.” Protection is needed on the left side of the roadway for traffic approaching the bridge, however. This is addressed below.
4. Connect the points in Steps 2 and 3. Draw a line for the traffic on the right from the y-axis to the “Edge of Traveled Way Scale.”
5. From the intersection between the lines from Step 1 and Step 4, draw vertical lines down to the “Edge of Traveled Way Scale” to get L_1 .
6. Read $L_1 = 207 \text{ ft}$ from the “Edge of Traveled Way Scale.”
7. This step determines L_3 , for situations where barrier protection is only warranted for one direction of traffic. L_3 determines the amount of barrier protection that may be deducted due to the lateral location of the hazard. Although this design would result in an L_3 analysis, L_3 is on the downstream end of the bridge, thus an analysis is beyond the scope of this problem and therefore not needed.
8. Calculate the length of need, LON, of guardrail. The length of need due to the critical side slope, or L_1 , is 207 ft upstream of Station 12+00. The L_2 distance is made up of a combination of lengths. L_2 is the length of guardrail from Sta. 12+00 to the parapet wall end at Sta. 15+00, includes the parapet wall across the bridge, and includes the guardrail downstream of the bridge end, therefore:

$$LON = 207 + 300 + 0 + 0 = 507 \text{ ft} \qquad \text{Equation 38-6.2}$$

Since the scope of this problem is only to calculate the amount of Steel Plate Beam Guardrail upstream from the bridge end, and not the guardrail downstream from the bridge or length of the concrete parapet wall representing part of L_2 , the length of the parapet wall and guardrail downstream from the bridge end are both set equal to 0.

9. Based on the stationing shown in Figure 38-6.Q, the station and offset of the approach end BLON is:

(Station 15+00) -507 ft = Station 9+93, 68.7 ft right.

Limits of the TBT T1, using a length of 37.5 ft and the BLON point at post 3, 12.5 ft from the end of the TBT T1.

(Station 9+93) + 25 ft = Station 10+18.00, 66.0 ft right.

To

(Station 9+93) – 12.5 ft = Station 9+80.50, 68.7 ft right.

10. At each corner of the bridges a TBT T6 will connect to the bridge parapet. The length of the pay item for the TBT T6 is 37.5 ft and this overlaps the end of the bridge parapet by 7.25 in. (0.6 ft). The distance from the end of the parapet to the end of the TBT T6 pay item is then 36.9 ft.

The pay item limits for the TBT T6 are:

(Station 15+00) + 0.6 ft = Station 15+00.60, 66.0 ft right.

To

(Station 15+00.6) - 37.5 ft = Station 14+63.10, 66.0 ft right.

11. Step 11 does not apply, as no TBT T2s are being used.
12. Determine the pay item quantity and stations for the remaining item(s).

The guardrail run will connect the TBT T6 and the TBT T1.

From

End of TBT T6 = Station 14+63.10, 66.0 ft right.

To

End of TBT T1 = Station 10+18.00, 66.0 ft right.

Length of guardrail plan quantity = 445.1 ft.

13. Check that LON is adequate and check for conflicts.

Sum the redirective portion of the TBT T1, the TBT T6, and the guardrail.

$25 \text{ ft} + 36.9 \text{ ft} + 445.1 \text{ ft} = 507 \text{ ft}$.

This is as expected because the nominal BLON point has been used without adjustment. Because the actual dimensions of the TBT T1 are not known until construction, use this information for plan locations and quantities. Field adjustments to accommodate a specific proprietary device and common guardrail panel lengths are considered nominal.

The designer should also check the location of the TBTs T1 to assure that they can be installed with proper grading and that design assumptions for the front slopes or other roadside obstacles are valid.

Length of Need – Median (left) side (Use a new nomograph for the median side of the roadway from that used for the right side of the roadway)

1. With the left side having a flared barrier and a TBT Type 6, which offers protection from the bridge parapet end, multiple considerations are required for the guardrail run. The TBT Type 6 is not designed to be flared, therefore it is located at the back of shoulder. Draw a horizontal line at L_B , equal to 36.9 ft long, for the length of the TBT Type 6 on the nomograph for the left side of the roadway, where:

$$L_B = 6 \text{ ft on the } y\text{-axis}$$

From 36.9 ft the steel plate beam guardrail, Type A flares at a ratio of 1 lateral: 20 longitudinal. Draw a line on the nomograph with a 1:20 flare starting at 36.9 feet. The TBT T1, Special is to be placed in line with the guardrail flare, therefore do not show any additional offset or flaring for the TBT T1, Special.

2. From Figure 38-3.A, the clear zone (L_C) is 30 ft. The hazards are the bridge parapet end at 6 feet and the gap between the dual structures that can lead onto the highway below. The left side of the roadway warrants protection for approaching traffic since $L_F < L_C$. Locate the lesser of L_C or L_H on the y -axis, so plot $L_C = 30$ ft on the y -axis.
3. From Figure 38-6.E, $L_R = 360$ ft. Locate this point on “Edge of Traveled Way Scale.” Since the approaching and opposing roadways are on separate alignment, this problem resembles a one-way alignment, and there is no need to locate L_R on the “Centerline Scale.”
4. Draw a line connecting the points plotted in steps 2 and 3.
5. From the intersection between the lines from Step 1 and Step 4, draw vertical line down to the “Edge of Traveled Way Scale” to get L_1 .
6. Read $L_1 = 194$ ft from the “Edge of Traveled Way Scale”
7. This step determines L_3 , for situations where barrier protection is only warranted for one direction of traffic. L_3 determines the amount of barrier protection that may be deducted due to the lateral location of the hazard. Although this design would result in an L_3 analysis, L_3 is on the downstream end of the bridge, thus an analysis is beyond the scope of this problem and not needed.
8. Calculate the length need, LON, of guardrail.

$$LON = 194 + (\text{length of the concrete parapet wall}) - 0 = 194 \text{ ft} \quad \text{Equation 38-6.1}$$

Since the scope of this problem is only to calculate the amount of Steel Plate Beam Guardrail upstream from the bridge end, and not the guardrail downstream from the

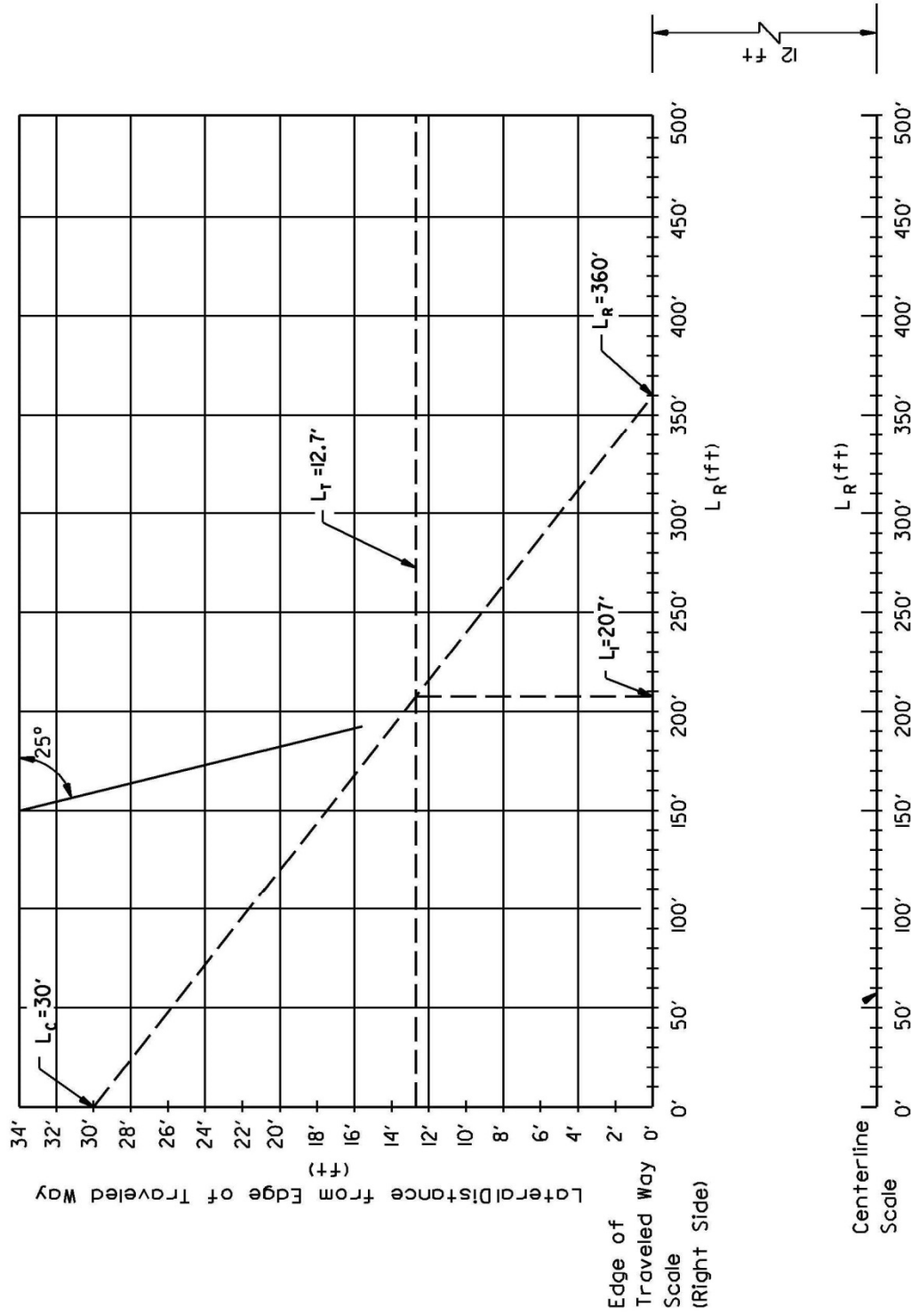

BARRIER LENGTH OF NEED CALCULATION

Example 38-6.01(6)

Figure 38-6.R

bridge or length of the concrete parapet wall representing part of L₂, the length of the parapet wall and guardrail downstream from the bridge end is set equal to 0.

9. Based on the stationing shown in Figure 38-6.Q, the station and offset of the BLON for the median side barrier is:

(Station 15+00) – 194 ft = Station 13+06.00.

The guardrail is flared at 1:20 beyond (Station 15+00)-36.9 ft = Station 14+63.10

The additional offset is [(Station 14+63.1) - Station 13+06)]/20 = 7.9 ft.

The total offset from the edge of pavement is 7.9 ft taper + 6 ft shoulder = 13.9 ft.

The edge of pavement is located at 32.0 ft right.

The BLON is located at Station 13+06.00, 18.1 ft right.

No length corrections are made for the 1:20 flare because field adjustments of pay item lengths will be needed, and the adjustment factor would be only 1.00125.

The pay item limits for the TBT T1, assuming a 37.5 ft long device from the QPL and assuming that the BLON of the device is at post 3, 12.5 ft from its end:

(Station 13+06) + 25 ft = Station 13+31.00, 19.35 ft right.

To

(Station 13+06 – 12.5 ft = Station 12+93.50, 17.48 ft right.

With 18.1 ft + (25/20) = 19.35 ft, and

19.35 ft - (37.5/20) = 17.48 ft.

10. At each corner of the bridges a TBT T6 will connect to the bridge parapet. The length of the pay item for the TBT T6 is 37.5 ft and this overlaps the end of the bridge parapet by 7.25 in. (0.6 ft). The distance from the end of the parapet to the end of the TBT T6 pay item is then 36.9 ft.

The pay item limits for the TBT T6 are:

(Station 15+00) + 0.6 ft = Station 15+00.60, 32.0 ft right.

To

(Station 15+00.6) - 37.5 ft = Station 14+63.10, 32.0 ft right.

11. Step 11 does not apply, as no TBTs T2 are being used.

12. Determine the pay item limits and quantities for the remaining items.

Guardrail will connect from the TBT T6 to the TBT T1.

Station 14+63.10, 32.0 ft right

To

Station 13+31.00, 19.35 ft right

Length of guardrail = 132.1 ft

13. Check that the LON is adequate.

TBT T6 = 36.9 ft

Guardrail = 132.1 ft

TBT T1 = 25 ft

Total = 194 ft

As expected, placing the BLON at the design length of need point results in a design that exactly matches the calculated length of need. Minor field adjustments will account for the specific proprietary device selected for the TBT T1 and for use of common guardrail panel lengths and splice locations.

38-6.02 Guardrail Post Foundations

Design and testing of strong post guardrail are generally done using strong soils. The systems allow the posts to rotate in the soil such that vehicle impact loads are distributed through the post into the soil material, avoiding bending or breaking of the posts. With the Midwest Guardrail System, this movement of the post along with the 12 in. (300 mm) blockout also keeps the rail near its design height until the rail releases from the blockout. If posts bend or break due to excessive foundation strength, they can provide excessive resistance to movement of the rail, resulting in failure of the rail. Also, the bent posts can become launching ramps to an errant vehicle.

The following are general guidance on use of guardrail with a full range of foundation types:

1. Guardrail Posts in Soil. *Highway Standard 630001* shows the application of guardrail posts in soil. Where the front slope falls within 2 ft (600 mm) behind the guardrail posts and is steeper than 1V:3H use 9 ft (2.74 m) posts. Otherwise use the 6 ft (1.83 m) posts.
2. Guardrail Posts in Mow Strips [≤ 8 in. (200 mm) thick]. *Highway Standard 630001* shows the provisions needed to allow guardrail posts to function when placed in a stabilized surface no thicker than 8 in. (200 mm). The “leave out” or backfilled cored hole for the post is designed to allow the post to deflect and absorb a portion of the impact energy before the rail releases from the deflected post. Also, allowing the post to rotate in the soil is critical to avoid both over-stressing of the rail element and excessive vehicle uplift along a bending post. The capping material for the post deflection space is intended as a weed suppression layer, and is intentionally weak to allow the post to break through when hit. Although the minimum dimensions for the deflection space are shown, wider “leave outs” may be used if this reduces crash damage to the shoulder or mow strip.
3. Guardrail Posts in Rock or in Paved Areas >8 in. (200 mm) Thick. Where rock is encountered, or where the depth of a paved area exceeds 8 in. (200 mm), the detail “Footing for Post When Impervious Material is Encountered” (from *Highway Standard 630001*) should be applied. For paved locations, the “V” value shown is the thickness of the paved material at the post location. Where no rock or other impervious material is encountered below the paved area, the post should not be shortened.

38-6.03 Barrier Offset and Grading

Generally, roadside hardware should be placed as far as practical from the edge of traveled way consistent with proper operation and performance of the barrier system. Such placement gives an errant motorist a greater chance to regain control and avoid a crash. It also provides for increased sight distance. Consider the following when determining barrier lateral placement:

1. Driver Expectations. It is generally desirable to have consistent clearance between traffic and roadside features such as bridge railings, parapets, retaining walls, and roadside barriers, particularly in urban areas where there is a preponderance of these elements. Uniform development enhances highway safety by providing the driver with a level of

- expectation, thus reducing driver concern, and perceived need for altering their driving path within the lane.
2. Shoulder. Typically, the roadside barrier is located with the face of barrier at the edge of the shoulder unless flared away from the shoulder. In areas with SPBG this will result in the hinge point for the front slope being located approximately 4 ft (1.2 m) from the outside edge of shoulder to provide proper backfilling to the posts. Refer to Standard 630001.
 3. Shy Line. The distance from the edge of the traveled way beyond which a roadside object will not be perceived as an obstacle and result in a motorist's reducing speed or changing vehicle position on the roadway is called the shy-line offset. (See Figure 38-6.T). Where possible, barriers should be placed beyond the shy line. This is more important for short, isolated instances. For long, continuous runs of barrier this is less important, especially if the barrier is introduced outside the shy line and gradually tapered in toward the traveled way.
 4. Embankment. Where possible, provide 2 ft (600 mm) of embankment at a 1:10 or flatter slope between the back of guardrail barrier posts to the hinge point with the front slope. See *Highway Standard* 630001 for options.
 5. Deflection Distance. Most roadside barriers will deflect when impacted. Adequate deflection space should be provided so that guardrail can deflect without contacting fixed objects behind the barrier as displayed in Figure 38-6.U. Figure 38-6.V provides the deflection distances for the types of guardrail typically used by IDOT. Refer to Section 38-7.03(b)3 for a discussion on the deflection distance of high-tension cable.
 6. Zone of Intrusion. The Zone of Intrusion (ZOI) is the region measured above and behind the face of a barrier system where an impacting vehicle or any major part of the system may extend during an impact. The amount of intrusion behind the barrier is related to the barrier height and profile as well as the vehicle size, speed, and angle of impact. For TL-2, TL-3 and TL-4 where practical, the designer should try to accommodate this additional distance behind the barrier as part of new construction or reconstruction projects. Figure 38-6.W shows the ZOI for TL-2, TL-3 and TL-4 for a typical concrete barrier wall section. No ZOI is currently available for TL-5. Narrowing of the roadway is not preferred on high-speed facilities to accommodate additional clearance for ZOI. For example, at an existing overpass structure where the pavement underneath is being reconstructed, it is usually not recommended to reduce shoulder width in order to gain additional clearance behind the barrier to provide ZOI clearance.

Customary		Metric	
Design Speed (mph)	Shy Line Offset, S (ft)	Design Speed (km/hr)	Shy Line Offset, S (m)
75	10	120	3.2
70	9	110	2.8
60	8	100	2.4
55	7	90	2.2
50	6.5	80	2.0
45	6	70	1.7
40	5	60	1.4
30	4	50	1.1

SUGGESTED SHY LINE OFFSET

Figure 38-6.T

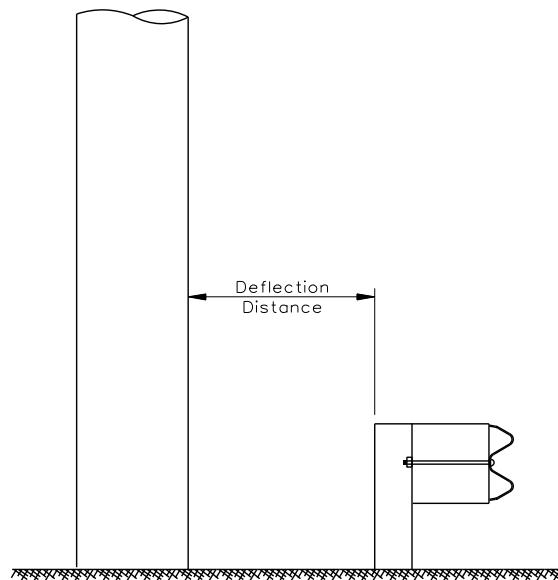

DEFLECTION DISTANCE FOR W-BEAM GUARDRAIL

Figure 38-6.U

Guardrail Type	Deflection Distance					
	Condition					
	Tangent	1:13 flare	1:7 flare	0 in. to 6 in. behind 6 in. curb (0 mm to 150 mm behind 150 mm curb)	*4 ft to 12 ft behind 6 in. curb *(1.2 m to 3.6 m behind 150 mm curb)	**Long span
Type A W-Beam Guardrail @ 6'-3" (1905 mm) post spacing	38 in. (965 mm)	63 in. (1.60 m)	83 in. (2.11 m)	47 in. (1.19 m)	25 in. (635 mm)	73 in. (1.85 m)
Type B W-Beam Guardrail @ 3' 1 1/2" (953 mm) post spacing	30 in. (762 mm)	Do not flare Type B	Do not flare Type B	Do not use Type B	Do not use Type B	Do not use Type B
W-Beam Guardrail @ 1' 6 3/4" (476 mm) post spacing	22 in. (559 mm)	Do not flare	Do not flare	Do not use	Do not use	Do not use
Weak Post SPBGR Attached to Culverts	38 in. (965 mm)	Do not flare	Do not flare	Do not use	Do not use	Do not flare
Non-Blocked SPBGR	34 in. (864 mm)	Do not flare	Do not flare	Do not use	Do not use	34 in. (864 mm) (Use only beyond required CRT posts)

*Test Level 2 only. Face of the guardrail located from >6 in. to <4 ft (>150 mm to < 1.2 m) behind the face of curb has not been approved for TL-2 or TL-3 and is not included above.

**Culvert headwalls may be placed at lesser distances than the deflection. Refer to Highway Standard 630106.

Check allowable flare rate based on speed in Figure 38-6.X.

DYNAMIC DEFLECTION OF GUARDRAIL
Figure 38-6.V

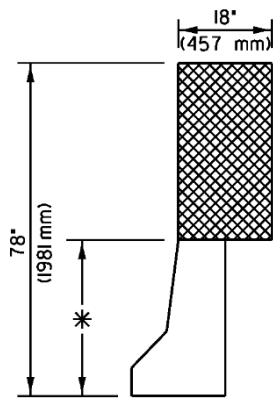

* Reviewed TL-3 sloped-faced concrete barrier heights fell in a range of 30 in. (762 mm) to 32 in. (813 mm)

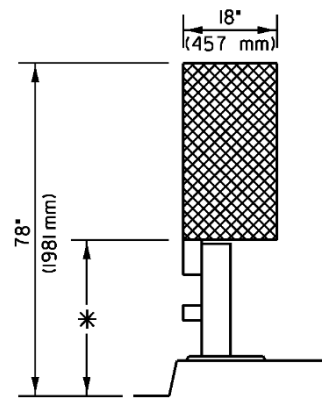

* Reviewed TL-3 steeltubular barrier on curb (curb greater than 6') heights fell in a range of to 32 in. (813 mm) to 34 in. (846 mm)

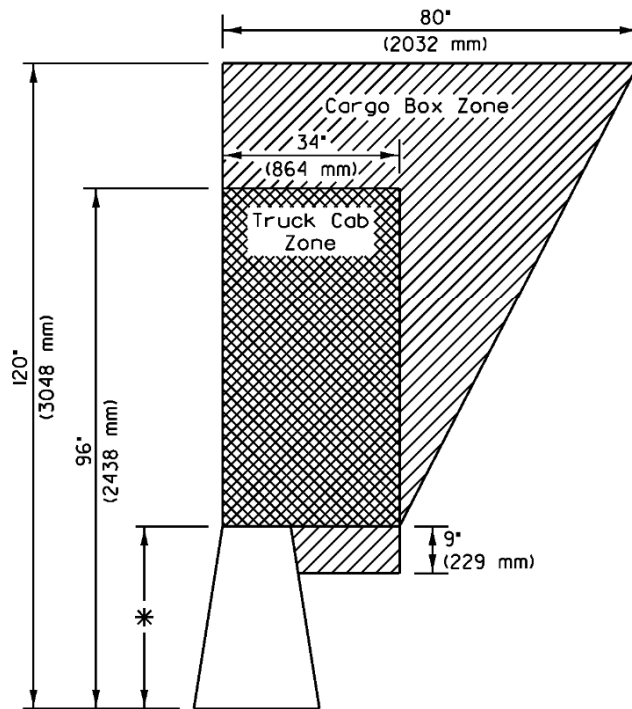

* Reviewed TL-3 sloped-faced concrete barrier heights fell in a range of 30 in. (762 mm) to 32 in. (813 mm)

SELECTED ZONE of INTRUSION VALUES

Figure 38-6.W

38-6.04 Barrier Flare

A roadside barrier is considered flared when it is not parallel to the edge of the traveled way. Barrier flare has advantages and disadvantages. Flaring moves the barrier further from the traveled way where it is less likely to be hit, it helps to reduce the length of need and amount of barrier needed, it can improve sight distance, and it can serve to introduce a barrier from outside the shy zone into the shy zone. However, flared barrier increases the quantities of earthwork, and results in increased angles of impact.

At the point where tangent guardrail meets flared guardrail, a 12.5 ft (3.81 m) section of guardrail is normally installed on a slight curve by adjusting the posts back a small distance at the transition. This creates a smoother transition and makes the guardrail easier to construct at this point.

Cable barrier for shielding roadside hazards is normally installed parallel to the roadway, with no flare. In special situations where flare is needed with cable barrier, use a 1:50 flare rate.

Figure 38-6.X presents the maximum recommended flare rates as a function of roadside safety, design speed, and barrier type. Flatter flare rates may be used, and can still be very effective in reducing length. Where a barrier approaches or crosses the shy line with approaching traffic, flatter flare rates based on “inside shy line” values should be considered.

Design Speed		Flare Rate for Barrier Inside Shy Line*	Flare Rate for Barrier Beyond Shy Line*		
(mph)	(km/hr)		Rigid (Concrete)	Semi-Rigid (W-Beam)	Flexible (Cable)
70	110	1:30	1:20	1:15	1:50
60	100	1:26	1:18	1:14	1:50
55	90	1:24	1:16	1:12	1:50
50	80	1:21	1:14	1:11	1:50
45	70	1:18	1:12	1:10	1:50
40	60	1:16	1:10	1:8	1:50
30	50	1:13	1:8	1:7	1:50

*See Figure 38-6.T for shy line distances.

Note: Non-blocked guardrail is not to be flared.

MAXIMUM FLARE RATES FOR BARRIER DESIGN

Figure 38-6.X

38-6.05 Terrain

Crash testing and acceptance of roadside safety hardware is based on test conditions with the impacting vehicle rolling on all four wheels, and at normal ride height when it impacts the device or feature. Vehicles traversing curbs, slopes, or changes in slopes may arrive at a roadside device sliding, spinning, or above or below normal ride height. This can result in unfavorable crash results. Roadside terrain needs to be considered in roadside safety design to achieve a more forgiving roadside.

1. Curbs. When practical, avoid combining a curb and guardrail when using the Midwest Guardrail System (MGS) and blockouts. Where a curb up to 6 in. (150 mm) and guardrail combination is needed, two applications, as noted below, have been crash tested and accepted using the Midwest Guardrail System.
 - a. Test Level 3 (TL 3). MGS Type A guardrail may be placed with the face of guardrail located zero to 6 in. (150 mm) behind the face of curb. Figure 38-6.Y shows this configuration. Note that the height of this installation is referenced from the edge of pavement in front of the guardrail face.
 - b. Test Level 2 (TL 2). At locations where the roadside safety design speed is 45 mph (70 km/hr) or less, MGS Type A guardrail may be placed at offsets from 4 ft (1.2 m) to 12 ft (3.6 m) from the face of curb. This is useful for placement behind sidewalks in urban areas, including approaches to bridges. Note that the height of this installation is referenced from the ground surface at the guardrail. The terminal section may be tangent or flared, provided it is within the 4 ft to 12 ft (1.2 m to 3.6 m) zone; see Figure 38-6.Z.

Designers should consider options for avoiding placement of curb in advance and adjacent to a Traffic Barrier Terminal Type 1 or Type 2 guardrail terminal. Neither of these terminals has been tested with a curb. As a first choice, extend the guardrail beyond the limits of the curbing, tapering out the curb height appropriately. It may also be possible to shift the curb laterally behind the terminal and apply the same shift on the approach. If a terminal end is needed along the section with curb, provide a tangent terminal with a 50:1 flare so that the impact head of the terminal does not protrude on the roadway. Whenever curbs and guardrail terminals will be in close proximity review the design to confirm that the terminal will operate properly at the proposed height. Vertical transitions may be necessary in some cases.

2. Slopes. Slopes in front of a W-beam guardrail system should be 1V:10H or flatter. This also applies to the embankment between the back of the guardrail posts and the hinge point, the areas in front of the flared section of guardrail, the area approaching the terminal ends, and the area behind the terminal ends as shown on *Highway Standard 630301*.

Some high tension cable barriers may be used on approach slopes of 1V:4H or flatter; see Section 38-7.03(b).

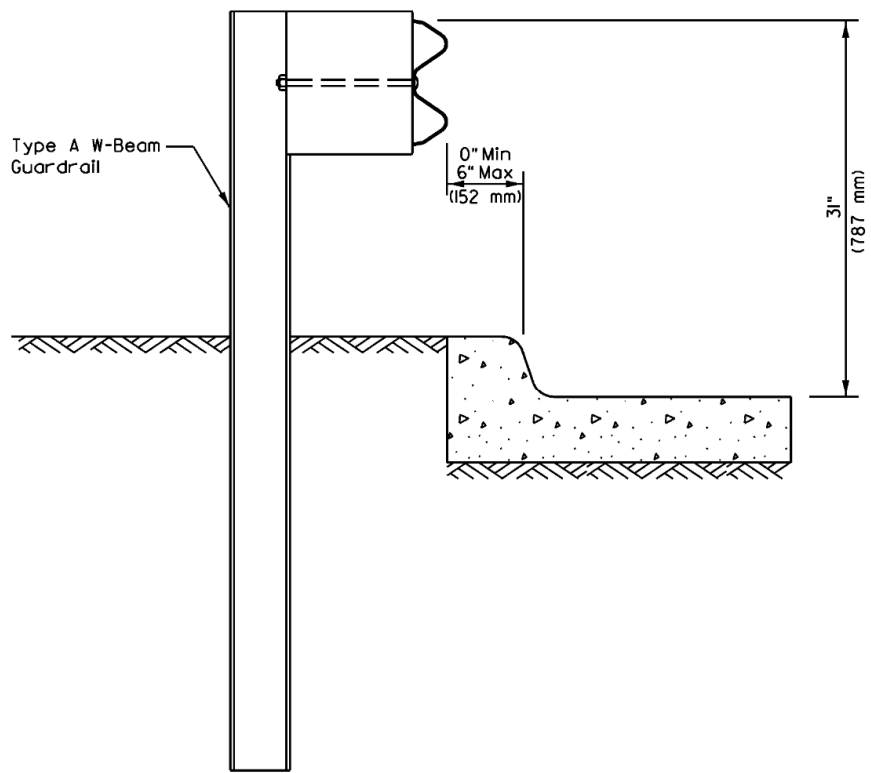

PLACEMENT OF W-BEAM GUARDRAIL WITH CURB

Figure 38-6.Y

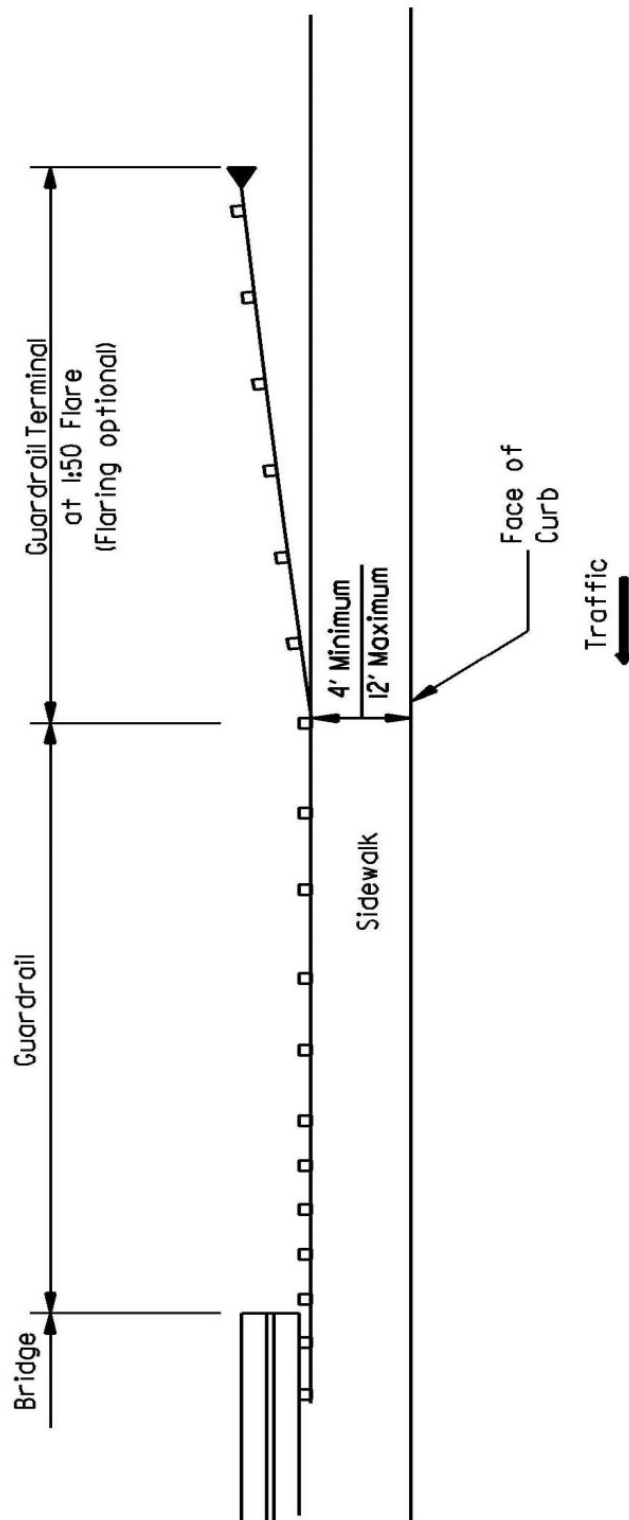

W-BEAM GUARDRAIL WITH SIDEWALK AND CURB
(45 mph (70 km/hr) or less)

Figure 38-6.Z

38-6.06 Terminal Treatments

Barrier terminal sections present potential roadside hazards for run-off-the-road vehicles; however, they are also critical to the proper structural performance of the barrier system. Therefore, the designer must carefully consider the selection and placement of the terminal end.

The *Illinois Highway Standards* present the design details for several end treatments used by the Department. Other proprietary terminal treatments are allowed under various Specifications and Special Provisions. The particular proprietary items routinely allowed for use on IDOT projects are included in the Department's Qualified Products List (QPL) that is published in the Material Approvals section of the "Doing Business" page of the IDOT internet site. The process of approving MASH-tested devices, replacing NCHRP Report 350 devices, is continuing for several of these systems. The QPL lists both the products and the current requirements during this transition period. The following sections briefly describe each system and, where applicable, discuss typical uses of the system.

38-6.06(a) Guardrail End Terminals

The following terminals are applicable to the steel plate beam guardrail:

1. Type 1, Special (Flared). This terminal section is for use with steel plate beam guardrail. The designer should choose a flared terminal where practical, if no additional right-of-way must be purchased for installation and the grading needed to provide a 1V:10H approach slope to the terminal is reasonable. Each device has a maximum flare rate measured versus normal traffic flow. Note that this flare rate can potentially be flatter than a flare rate proposed for a guardrail run.

Note that both the beginning of length of need (BLON) location point and the length of the Traffic Barrier Terminal Type 1, Special (TBT T1 SPL), will vary depending on which proprietary item the contractor chooses for termination of the guardrail. Refer to the QPL for drawings showing detailed dimensions of, and maximum flare rates for, the currently-approved devices.

For design purposes, using the shortest TBT T1 SPL will provide the most conservative guardrail plan quantity; however, the effects of the contractor's potential selection of a longer TBT T1 SPL than assumed in design must be evaluated in the design phase for its impact on the location of proposed entrances and grading.

The ends of some TBT T1 SPL devices have redirective properties beginning at the first post, however the first 12.5 ft (3.81 m) of most TBT T1 SPL terminals is called the gating portion and is not included in the length of need. The purpose of the non-redirective, or gating portion of the TBT's, is to provide anchorage for the adjacent redirective guardrail run. A steel cable, with ends attached to the first rail and the first post, provides tension that stiffens the adjacent redirective rail pieces. Therefore, when designing a TBT T1 SPL end terminal, assume the length of need begins at the third post, 12.5 ft (3.81 m) from the

free end. This conservative assumption will ensure sufficient guardrail quantities are present in the plans and will prevent conflicts with driveways, etc., during construction.

Based on crash testing, the area behind and beyond the terminal should be traversable and free of fixed objects. The minimum recommended distance is a rectangular area approximately 75 ft (23 m) beyond the terminal parallel to the rail and 20 ft (6.0 m) behind and perpendicular to the rail, where right-of-way, environmental concerns, and other resources allow.

2. Type 1, Special (Tangent). This terminal section is for use with steel plate beam guardrail. Tangent terminals should typically be chosen in areas where the cross section or drainage requirements would require additional right-of-way to accommodate the Type 1 Special (Flared) terminal. Each device has a maximum flare rate measured versus normal traffic flow. Note that this flare rate can potentially be flatter than a flare rate proposed for a guardrail run.

Note that both the beginning of length of need (BLON) location point and the length of the Traffic Barrier Terminal Type 1, Special (TBT T1 SPL), will vary depending on which proprietary item the contractor chooses for termination of the guardrail. Refer to the QPL for drawings showing detailed dimensions of, and maximum flare rates for, the currently-approved devices.

For design purposes, using the shortest TBT T1 SPL will provide the most conservative guardrail plan quantity; however, the effects of the contractor's potential selection of a longer TBT T1 SPL than assumed in design must be evaluated in the design phase for its impact on the location of proposed entrances and grading.

The ends of some TBT T1 SPL devices have redirective abilities beginning at the first post, however the first 12.5 ft (3.81 m) of most TBT T1 SPL terminals is called the gating portion and is not included in the length of need. The purpose of the non-redirective, or gating portion of the TBT's, is to provide anchorage for the adjacent redirective guardrail run. A steel cable, with ends attached to the first rail and the first post, provides tension that stiffens the adjacent redirective rail pieces. Therefore, when designing a TBT T1 SPL end terminal, assume the length of need begins at the third post, 12.5 ft (3.81 m) from the free end. This conservative assumption will ensure sufficient guardrail quantities are present in the plans and will prevent conflicts with driveways, etc. during construction.

Based on crash testing, the area behind and beyond the terminal should be traversable and free of fixed objects. The minimum recommended distance is a rectangular area approximately 75 ft (23 m) beyond the terminal parallel to the rail and 20 ft (6.0 m) behind and perpendicular to the rail where right-of-way, environmental concerns, and other resources allow.

3. Type 1B. In areas of cut sections on the roadway, or where the road is transitioning from cut to fill, it is sometimes possible to terminate a guardrail installation by burying the end in the natural or typically-graded back slope. When properly designed and located, this generic system provides full shielding of the identified hazard, eliminates the possibility of

any end-on impact with the terminal, and minimizes the likelihood of the vehicle passing behind the rail. The length of need point for this terminal begins at the transition from cut to fill, and the guardrail and terminal extend more than 75 ft (23 m) beyond this point.

Currently, the Type 1B end terminal meets NCHRP Report 350 criteria. Through research there is potential for approval of a MASH Type 1B terminal; in the meantime Highway Standard 631006 can be applied in the specific circumstances described here. Use of the Type 1B terminal shall meet all of the following criteria:

- a. The steepness of the slope into which the barrier is buried should be as nearly vertical as possible, so the slope effectively becomes part of the barrier. This slope should be at least 1V:3H or steeper, with steeper slopes preferred.
- b. The length of need for the roadside barrier begins where the guardrail crosses the ditch flowline.
- c. The beginning of the length of need for the roadside barrier (where it crosses the ditch flowline) is positioned about 75 ft (23 m) upstream of the transition from cut to fill. This provides a buffer area for any vehicles that might get behind or over the buried terminal.
- d. Front slopes must be 1V:4H or flatter.
- e. The height of the rail must be held constant with respect to the edge of the roadway shoulder.
- f. The maximum height of the top of the rail where it crosses the ditch bottom is 45 in. (1143 mm).
- g. Depending on site conditions, the terminal may be anchored by driven posts or a poured concrete block or may be anchored to sound rock.

Careful site review, along with design of profiles and cross slopes, is necessary to satisfy the criteria listed above. If all of these criteria cannot be met, another terminal type should be considered.

4. Type 2. This is an unflared terminal with a cable anchor. The Traffic Barrier Terminal, Type 2 (TBT T2), should be used on the departing end of W-beam guardrail where end-on impacts are not a consideration; i.e., on one-way roadways. The full length of a TBT T2 plus the adjacent 25 ft (7.62 m) will not redirect an impacting vehicle and is therefore not to be considered as part of the length of need required to shield the hazard. Therefore, the BLON for a guardrail run with a TBT T2, is at 37.5 ft (11.43 m) from the end post of the TBT T2.

When providing the additional 25 ft of steel plate beam guardrail as shown in Figure 38- 6.A, the Type 2 end terminal is considered crashworthy for departing impacts only.

38-6.06(b) Median Barriers

See Section 38-7.04(d) for guidance on Department-approved end terminals (impact attenuators) for median barriers. These also apply to the ends of the concrete barrier where it is used as a roadside barrier.

38-6.06(c) Bridge Rail Connections

Roadside barriers are often terminated with a transition into a bridge rail. Terminals used as bridge rail connections are discussed below and shown on the Highway Standards.

1. Type 5. This is a connector terminal that should be used to connect steel plate beam guardrail to the concrete bridge parapet or end post at the departing end of a new one-way bridge. Refer to Highway Standard 631026 for more detail.
2. Type 5A. This is a connector terminal that should be used only for repair of existing installations on the State system, and for Local Roads projects, if specified by the Local Agency. It is used to connect steel plate beam guardrail to a steel bridge rail at either the approaching end or departing end of the bridge. For applications on the State highway system, or other locations where compliance with *NCHRP Report 350* or *MASH* is required, see Type 6A.
3. Type 6. This is a connector terminal that includes a transition section, special posts, blockouts, and end shoe. It also requires the use of a curb. Use Type 6 to attach steel plate beam guardrail to the end(s) of bridges with concrete parapet or to a permanent concrete barrier. It may also be used to connect the steel plate beam guardrail to the face of other concrete structures where the required curb can be installed. Refer to Highway Standard 631031 for more detail.
4. Type 6A. This is a connector terminal that is similar to the Type 6, except it is used for attachment of steel plate beam guardrail to side-mounted steel bridge rail (SMX and SM). When used with a bridge rail system that includes a curb, a curb must be used with the Type 6A. If there is no curb used on the bridge, do not use a curb with the Type 6A. Refer to Highway Standard 631032 for more detail.
5. Type 6B. This is a connector terminal that should be used when connecting steel plate beam guardrail to the face of a concrete structure (e.g., a pier) and where the installation of a curb is either not possible or not desirable. It requires blocking out the three beam rail of the transition by 8 in. (200 mm) at the connection point. The designer must carefully weigh the relative merits of this potential loss of horizontal clearance against the complications of adding a curb when selecting between the Type 6B terminal and the Type 6 for attachment to a structure. Refer to Highway Standard 631033 for more detail.
6. Type 10. This is a connector terminal that may be used to connect steel plate beam guardrail to the departing end of concrete parapets or concrete bridge rails of one-way

bridges, except for bridges or culverts with concrete post and beam rails. Existing concrete post and beam rails should be removed and retrofitted with a steel bridge rail or a structurally designed concrete parapet and connected using an appropriate connector. Refer to Highway Standard 631046 for more detail.

7. Type 11. This is a connector terminal that should be used to connect temporary bridge railing to temporary concrete barrier. Specifications for the temporary concrete barrier require that the last segment of barrier be fixed in place by anchor pins. These pins are critical to the performance of this terminal to avoid a potential “pocketing” location for impacting vehicles. This terminal, as shown on *Highway Standard 631051*, is considered adequate for *NCHRP Report 350 Test Level 2*; for design speeds up to 45 mph (70 km/hr). Where speeds are higher, the post spacing for the temporary bridge railing shall be no more than 3' -1½" (953 mm). With the reduced post spacing for the temporary bridge rail, this transition is considered adequate for *NCHRP Report 350 Test Level 3*. Refer to Highway Standard 6310051 for more detail.
8. Type 13. This is a connector terminal that should be used to connect the steel plate beam guardrail to the steel-tube side mounted bridge railing (Type IL -OH, R-40). The thrie beam section of the terminal is designed with a top mounting height of 34 in. (864 mm) at the bridge rail connection to account for future deck overlays of up to 3 in. (76 mm). Refer to Highway Standard 631061 for more detail.
9. Type 14. This is a connector terminal that should be used to connect the steel plate beam guardrail to the curb mounted bridge rail (Type CO-10). Refer to Highway Standard 631066 for more detail.

38-6.07 Minimum Length/Gaps

The minimum length of guardrail should include 75 ft (23 m) of length of need (redirective) guardrail. Common configurations meeting this minimum requirement include a pair of Traffic Barrier Terminals Type 1, Special; a Traffic Barrier Terminal Type 1, Special, connected to a Traffic Barrier Terminal Type 6, 6A, 6B, 13 or 14; or a Traffic Barrier Terminal Type 1, Special, plus 50 ft (15.24 m) of guardrail connected to a Traffic Barrier Terminal Type 2.

Where gaps exist in the need for a roadside barrier, it is typically economically justified to provide continuous runs of guardrail, rather than to leave gaps of 200 ft (60 m) or less. This is because the pair of Traffic Barrier Terminals Type 1, Special, that would be required to form a gap cost about the same as a run of guardrail 200 ft (60 m) long. It may also be safer by reducing exposure to additional terminal ends. Shorter gaps may be necessary and prudent where the guardrail is warranted, as access needs, sight distance, or other reasons dictate the need for a gap.

38-6.08 Typical Applications

Figures 38-6.AA through 38-6.CC illustrate typical applications of roadside barrier installations. See Figure 38-6.DD for the minimum length of Type A or Type B guardrail that must be installed between non-blocked guardrail and a traffic barrier terminal (TBT).

38-6.09 Short Radius Guardrail

There are currently no short radius (radius = 150 ft (45 m) or less) guardrail systems that the Department has identified and adopted as a standard design element. A side road or entrance within the length of need of a guardrail installation poses a severe challenge to the design of a safe roadside. Although installing a short radius Type A guardrail around one or both of the roadway radius returns is possible, a vehicle impacting the radius at a high angle and speed may penetrate the barrier, or vault over the barrier after the posts lean back, creating a ramping effect. Where penetration or vaulting does not occur, the vehicle may be decelerated at an excessive rate.

Recognizing that it is often not practical to change the site conditions by relocating the roadway or entrance to allow for the proper length of need of guardrail, the 2011 edition of the AASHTO *Roadside Design Guide (RDG)* acknowledges that some compromise will be necessary. Where a short radius guardrail is appropriate for addressing roadside safety the RDG recommends that the installation should be made as forgiving as practical. However, prior to choosing this solution, alternatives should be assessed as summarized in this section.

38-6.09(a) Design Alternatives

1. Relocate or Close the Intersecting Roadway/Entrance. This is the preferred solution and should be considered during project scoping or Phase I preliminary engineering. Proceeding with a relocation or closure will involve consideration of expected crash risk, barrier maintenance costs, project scope, cost, and impacts to adjacent properties and the environment. This action generally provides the most positive solution for roadside safety. If it is undertaken, give additional consideration to flattening side slopes, widening embankments, etc., to reduce the need for any barrier.
2. Terminate the Guardrail in Advance of the Intersecting Roadway. When relocating or closing the roadway/entrance is not feasible and where the nominal length of need falls near the intersecting roadway the designer may choose to truncate the standard guardrail with an approved terminal section or impact attenuator in advance of the intersection. Flaring the guardrail away from the roadway can be combined with guardrail truncation to improve length of need coverage. Truncating a guardrail run and exposing a hazard such as a slope or dropoff should be compared to the hazard posed by a short radius guardrail installation.

Termination of guardrail short of the length of need is considered a design exception and shall be discussed at a coordination meeting with the reason(s) for the short length documented in the meeting minutes; see Section 31-7.

3. Short Radius Guardrail. If relocating a roadway/entrance cannot be accomplished and terminating the guardrail short of its length of need is undesirable, the designer may consider a short radius guardrail installation. Considerations in application include how close it can be installed to a bridge, what radius can be used, and how far it must run along the intersecting side road.

Steel Plate Beam Guardrail, Type A is the only current system usable for a short radius installation. The design should introduce strong posts likely to rotate out of a vehicle's path and minimize vaulting, blockouts to minimize snagging, and mounting height to minimize override. This system has not met any crash testing criteria, but when a short radius guardrail installation is required, it represents an effort to provide a forgiving installation.

When terminating the radius guardrail system, the guardrail on the intersecting roadway should be completed to any required length of need and terminated with an appropriate end treatment. On a very low speed roadway (e.g., private driveway), this may be a Type 2 terminal. On most public roadways, or other roadways where higher speeds are possible, provide a Traffic Barrier Terminal Type 1, Special. These terminals are important to provide adequate anchoring of the radius system, and safety for the traffic on the intersecting roadway.

Given that the preferred method is to relocate or close the intersecting roadway or entrance, and that the short radius guardrail does not meet *MASH* or *NCHRP Report 350* criteria, the decision to use the strong post design (current standard) for a short radius installation is considered a design exception. The design shall be discussed at a coordination meeting and documented in the meeting minutes. The strong post design is the Department's current Standard Type A guardrail installed on the necessary radius. Do not use Type B guardrail in radius applications, as it increases the likelihood that posts will only deflect partially and launch a vehicle.

Because the strong post radius guardrail system represents some compromise in roadside design, consider an attempt to shadow it from impacts. This can be done by applying a tangent run of guardrail on the approach side of the intersecting roadway. Radius guardrail is available in five foot increments of radius from 5 ft (1.52 m) to 150 ft (45.72 m). For radii longer than 150 ft (45.72 m), the straight sections can be deflected in the field to match curves.

4. Other Solutions. Other solutions may be possible on a case-by-case basis. For example, in some locations it may be feasible to locate an impact attenuator system in the radius area. Another idea is to flare the guardrail approaching the short radius and provide guardrail on the other side of the entrance to "shadow" the radius installation. If desired, coordinate with BSPE for specific situations that may present multiple design options.

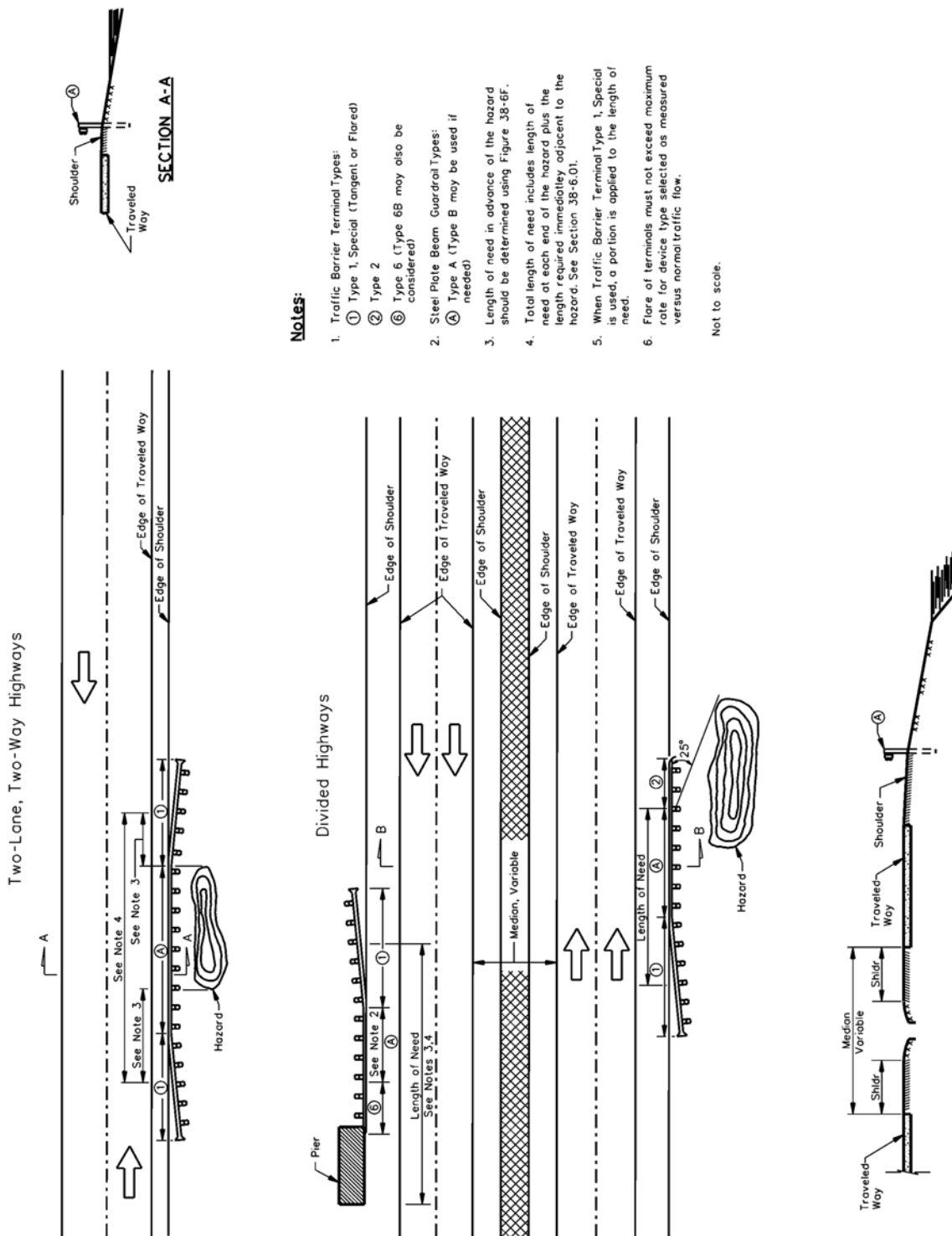

Notes:

1. Traffic Barrier Terminal Types:
 - ① Type 1, Special (Tangent or Flared)
 - ② Type 2
 - ③ Type 6 (Type 6B may also be considered)
2. Steel Plate Beam Guardrail Types:
 - ④ Type A (Type B may be used if needed)
3. Length of need in advance of the hazard should be determined using Figure 38-6F.
4. Total length of need includes length of need at each end of the hazard plus the length required immediately adjacent to the hazard. See Section 38-6.01.
5. When Traffic Barrier Terminal Type 1, Special is used, a portion is applied to the length of need.
6. Force of terminals must not exceed maximum rate for device type selected as measured versus normal traffic flow.

Not to scale.

TYPICAL APPLICATION OF GUARDRAIL AND TRAFFIC BARRIER TERMINALS

Figure 38-6.AA

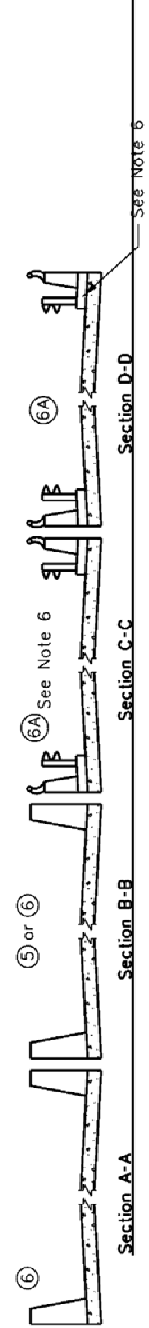
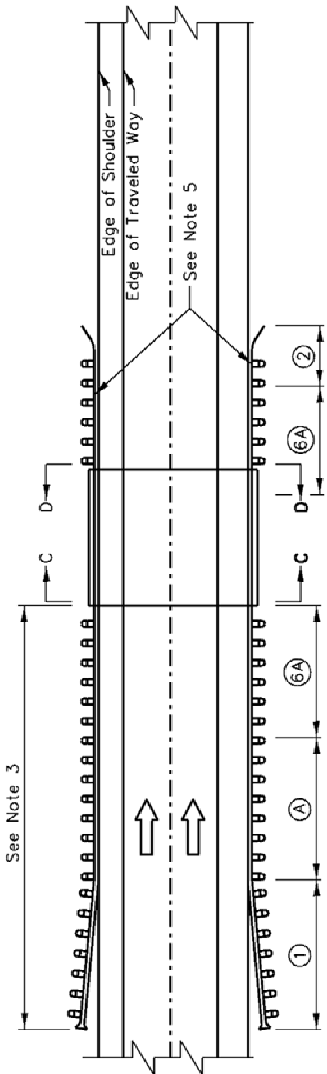
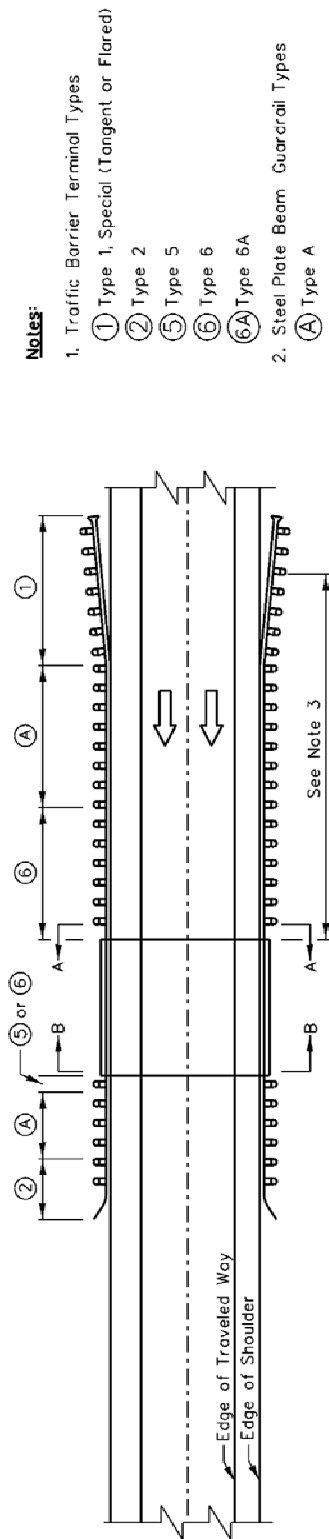

Notes:

1. Traffic Barrier Terminal Types
 - ① Type 1, Special (Tangent or Flared)
 - ② Type 2
 - ⑤ Type 5
 - ⑥ Type 6
 - ⑥A Type 6A
2. Steel Plate Beam Guardrail Types
 - Ⓐ Type A
3. Guardrail length of need should be determined using Figure 38-6.F. Designer may consider shielding wider for median hazards. See section 38-6.01.
4. When Traffic Barrier Terminal Type 1, Special is used, a portion of terminal is applied to the length of need.
5. Guardrail is to be placed at the departing end of one-way bridges only when guardrail is needed for some other uncorrectable hazard length of need as per Note 3 above.
6. Safety walk greater than 9 in (225 mm) high must be removed or retrofitted.
7. Flare of terminals must not exceed maximum rate for device type selected, as measured versus normal traffic flow.

Not to scale

TYPICAL APPLICATION OF GUARDRAIL AND TRAFFIC BARRIER TERMINALS
 (Median Widths Less Than 64 ft (19.5 m) at Dual Structures)

Figure 38-6.BB

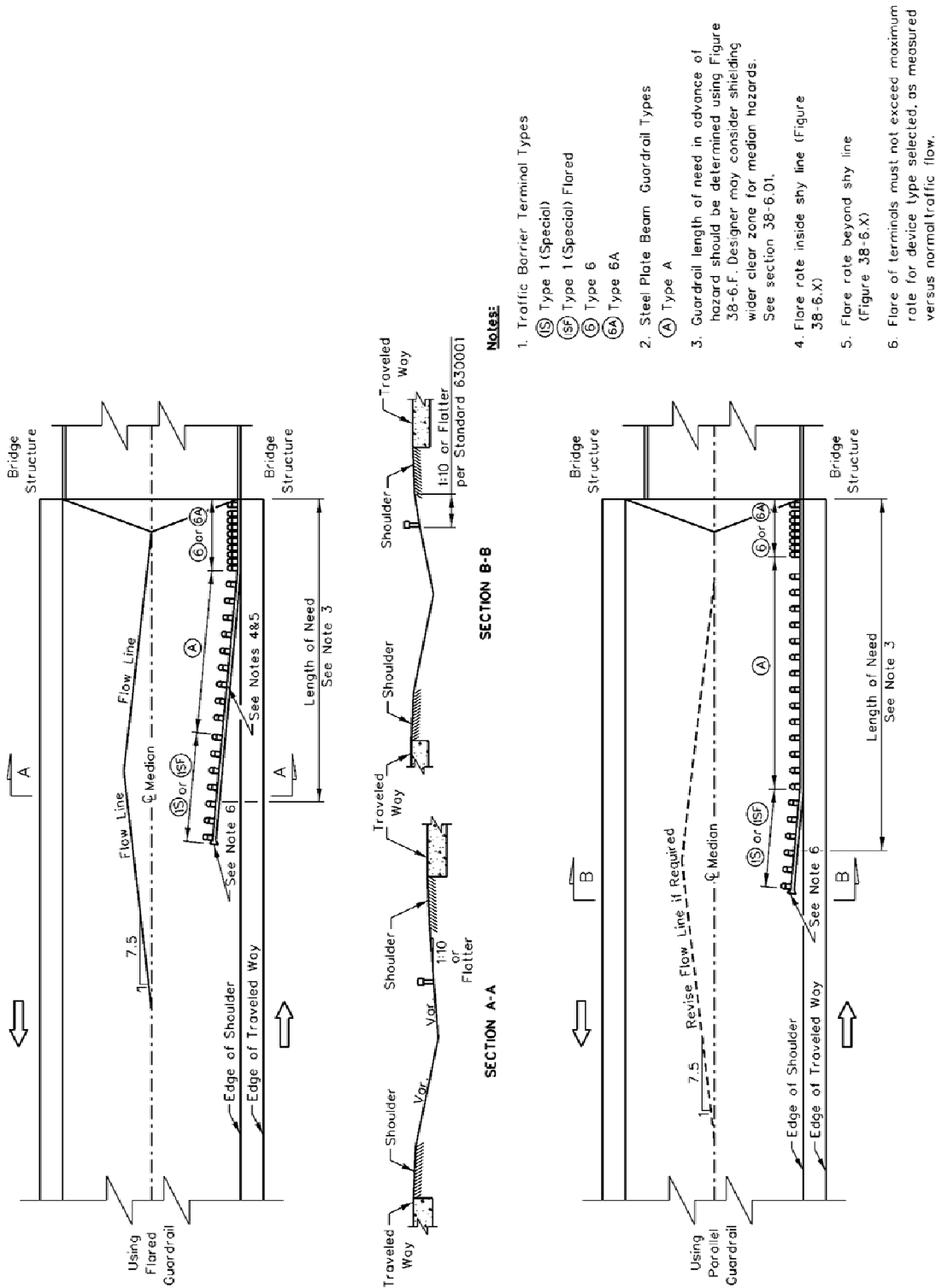

**TYPICAL APPLICATION OF GUARDRAIL AND TRAFFIC BARRIER TERMINALS
(For Median Widths at Dual Structures)**

Figure 38-6.CC

MINIMUM LENGTH TYPE A OR TYPE B GUARDRAIL BETWEEN NON-BLOCKED GUARDRAIL AND A TRAFFIC BARRIER TERMINAL

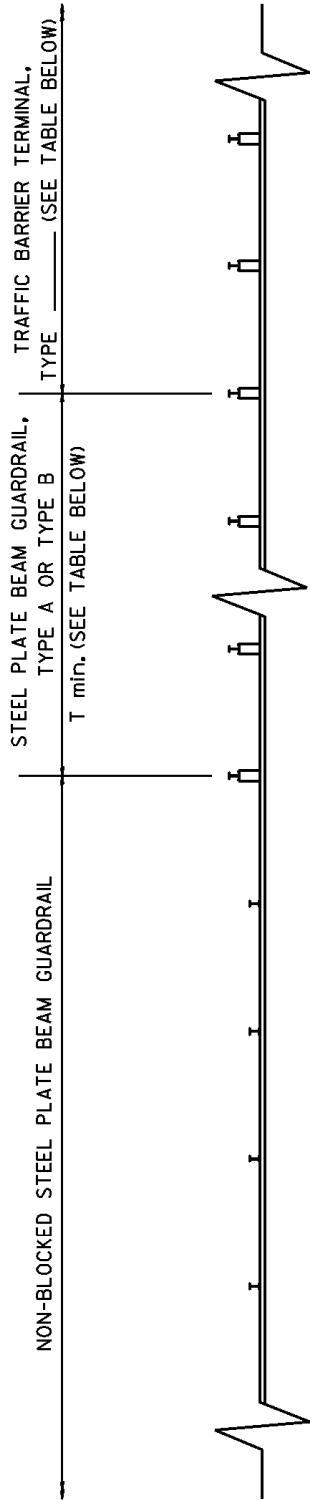

TRAFFIC BARRIER TERMINAL, TYPE ____	T min. ft (m)
2	50 (15.24)
5	25 (7.62)
6, 6A, OR 6B	25 (7.62)
13 or 14	25 (7.62)
1, SPECIAL (TANGENT)	12.5 (3.81)
1, SPECIAL (FLARED)	12.5 (3.81)

NON -BLOCKED GUARDRAIL/END-TERMINAL DETAIL
Figure 38-6.DD

38-7 MEDIAN BARRIERS

Median barriers prevent errant vehicles from crossing the median of a divided highway and colliding with vehicles in the opposing direction of travel. The decision to use a median barrier, as well as the selection of barrier type should be identified in the Phase I engineering report for the project. This decision is especially important for early and accurate coordination with bridge cross section details.

38-7.01 Median Barrier Warrants

38-7.01(a) Freeways

For freeways with a posted speed of 55 mph or greater, use Figure 38-7.B to determine if a median barrier may be warranted. The figure uses the inputs of median width and traffic volume, along with Illinois-specific cross-median crash data, to determine the benefit/cost (B/C) ratio of installing a barrier using the procedure shown in Section 38-7.01(c).

In the “Median Barrier Recommended” area of the Figure 38-7.B, the B/C ratio is expected to be at least 2.00 and the barrier is warranted. In the “Evaluate Cost Effectiveness” area of the figure, the B/C ratio is less definitive and additional analysis should be performed to determine if the barrier is warranted.

For existing freeways, the additional analysis involves determining a project specific B/C ratio using existing crash data for the section and other factors such as: route continuity of the median barrier, a progressive and logical “build out” of the barriers, area development trends, future programming for the location, and proximity to interchanges. A study of Illinois’ fatal cross-median crashes has shown that almost 70% happen within one mile (1.6 km) of an interchange.

For proposed freeways, the additional analysis is similar to that above for existing freeways, except for the need to use the Enhanced Interchange Safety Analysis Tool (ISATe) to predict crash frequency and severity in determining a more project-specific B/C ratio for installation of median barrier. Alternatively, the ISATe and cost-effectiveness study can be used to determine if the use of a wider median, which will eliminate the need for median barrier on a new facility, is a preferable alternative to the initial construction of the barrier. Contact BSPE regarding the use of ISATe.

38-7.01(b) Highways with a Flush/Depressed Median and Partial Access Control

For highways with both a flush/depressed median and partial access control, the decision to use a median barrier should consider the B/C ratio. As the median barrier must terminate at each at-grade intersection, give special consideration to sight distance and the need to provide a safety treatment at each end of the barrier, as well as right-of-way constraints, property access needs, number of intersections and driveway openings, and adjacent commercial development.

38-7.01(c) Benefit/Cost (B/C) Ratio Procedure

To determine the B/C ratio of a median barrier, use the following procedure. This procedure assumes a 15-year life for the median barrier and a 3% discount rate:

1. Determine the Benefit.

- Determine the annual number of fatal (K), severe injury (A), and moderate injury (B) cross-median crashes. Cross median crashes shall be determined from reading the narrative portions of crash reports. For existing roadways, use an average of at least five years of crash data.
- Determine the annual cost of K, A, and B cross-median crashes. Apply the cost per crash method (not per fatality or injury) according to Figure 38-7.A to determine the annual cost.
- Determine the annual benefit (AB) for installing the median barrier. The AB is estimated as the current year KAB crash cost multiplied by 0.92.

$$AB = \text{Current year KAB crash cost} \times 0.92.$$

- Determine the total benefit (B) of the median barrier.

$$B = AB \times 11.94$$

where: 11.94 = present worth factor (for current year)

2. Determine the Cost.

- Select the most appropriate median barrier according to Sections 38-7.02 and 38-7.03.
- Determine the installation cost (IC) of the median barrier. Include in the cost any additional items that are required for the selected barrier (e.g., grading, drainage, paving, mow strips).
- Estimate the number of crashes (encroachments) into the median barrier per year using the Roadside Safety Analysis Program (RSAP).
- Determine the annual repair cost (ARC) of the median barrier. Multiply the estimated number of crashes per year (from the RSAP) by the following:

+ \$0 for rigid median barrier,

+ \$1200 x (1.03)^(Construction Year - 2012) for semi-rigid median barrier, and

+ \$800 x (1.03)^(Construction Year - 2012) for flexible median barrier.

Documented repair costs in the area may be used in place of these.

- Determine the total cost (C) of the median barrier.

$$C = IC + (ARC \times 11.94)$$

where: 11.94 = present worth factor (for current year)

3. Determine the Benefit/Cost Ratio.

$$B/C \text{ ratio} = B/C$$

A minimum B/C ratio of 2.00 warrants installation of a median barrier. When the B/C ratio is between 1.00 and 2.00, other factors should be considered. Other factors include route continuity of median barrier, a progressive and logical “build out” of the barriers, area development trends, future programming for the location, and proximity to interchanges. A study of Illinois’ fatal, cross-median crashes has shown that almost 70% happen within one mile (1.6 km) of an interchange.

Crash Severity*	2018 Cost Per Crash
Fatal Crash (K)	\$ 6,626,000
Severe Injury Crash (A)	\$ 357,000
Moderate Injury Crash (B)	\$ 131,000

* Crash severity is determined by the most severe injury in a given crash.

Use the following procedures to determine the cost (losses) over a study period due to cross median crashes.

1. Cross median crashes are those in which a vehicle traveling in the correct direction on one side of a divided freeway crosses the median into opposing traffic and has a collision with a vehicle traveling in its correct direction in the opposing traffic lanes.

$$\begin{aligned} & \#K \text{ cross median crashes} \times (\$ 6,626,000) \\ & + \#A \text{ cross median crashes} \times (\$ 357,000) \\ & + \#B \text{ cross median crashes} \times (\$ 131,000) \end{aligned}$$

Total KAB crash cost for the study period (2018 dollars)

2. Annual KAB crash cost for the study period

$$= (\text{Total KAB crash cost for the study period}) / N$$

where N = Length of study period

3. The designer must update this dollar figure to the current year using a 3% discount rate.

Current year annual KAB crash cost

$$= \text{Annual KAB crash cost} \times 1.03^{(\text{current year} - 2018)}$$

ANNUAL KAB CRASH COST FOR A STUDY PERIOD

Figure 38-7.A

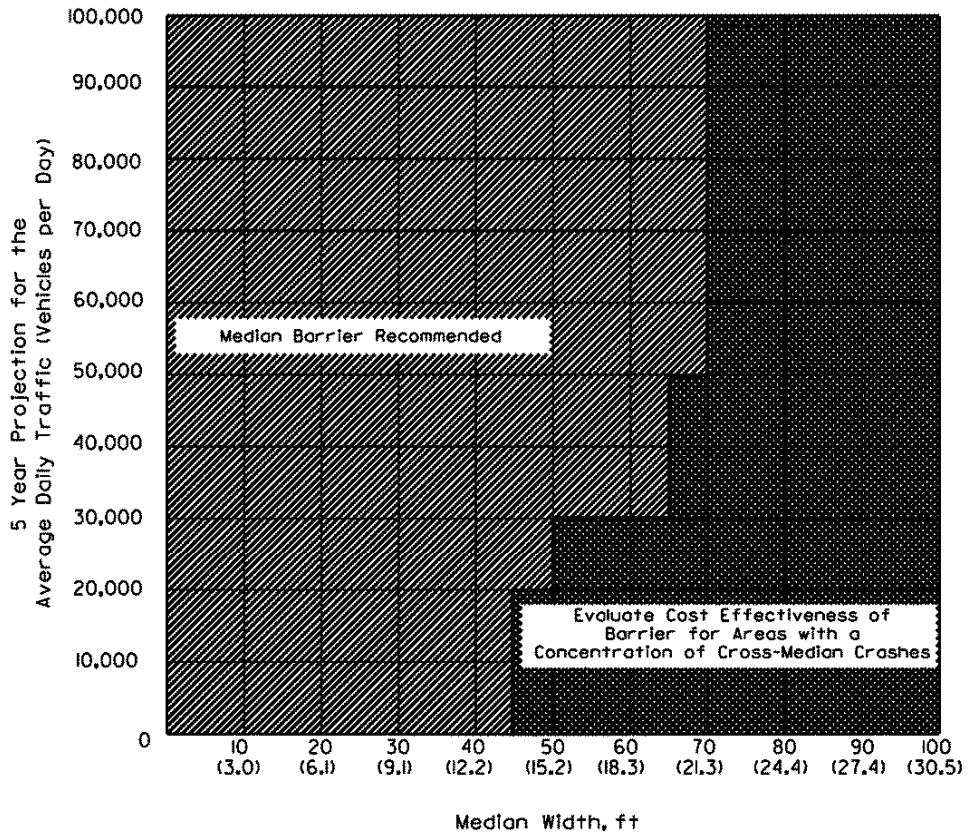
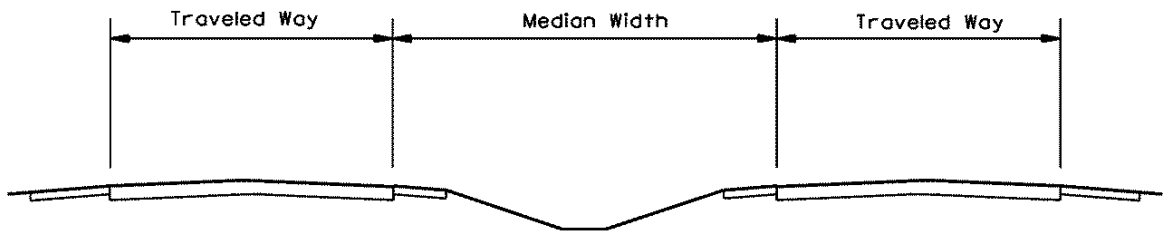

WARRANTS FOR MEDIAN BARRIERS ON FREEWAYS

Figure 38-7.B

38-7.02 Median Barrier Types

As with roadside barriers, median barriers can be categorized as rigid, semi-rigid, and flexible.

38-7.02(a) Rigid Median Barriers

The rigid median barrier currently used by the Department is a single slope concrete barrier with a 44 in. (1120 mm) height. See *Highway Standard* 637006. This design has been certified as meeting MASH (Test Level 5). The minimum height required for Test Level 5 is 42 in. (1065 mm) but the additional height of the current design allows for a future 2 in. (50 mm) overlay and matches the height of the Test Level 5 parapet design used by the Bureau of Bridges and Structures.

In the median, the concrete barrier is typically double faced but a single-faced design may be used to go around a fixed object in the median (e.g., bridge piers) or where twin separated structures are encountered. Single-faced barriers must be designed on a case-by-case basis, require structural reinforcement, and are normally tied to the supporting pavement/shoulder.

Prior to the current single slope design, the Department used two different heights of F-Shape concrete barrier and they are allowed to remain in service until a project scope involves barrier replacement. The 32 in (815 mm) height F-Shape design was an NCHRP Report 350 Test Level 4 barrier. The 42 in (1065 mm) height design was an NCHRP Report 350 Test Level 5 barrier.

38-7.02(b) Semi-Rigid Median Barriers

The semi-rigid median barrier used by the Department is steel plate beam guardrail, Type D (double rail). See *Highway Standard* 630001. This median barrier meets Test Level 3 and is most applicable to medians with intermediate widths of 20 ft to 30 ft (6.0 m to 9.0 m) and/or low-to-moderate truck traffic volumes (< 5000 MU per day). Another application is for the separation of adjacent on/off ramps at interchanges.

38-7.02(c) Flexible Median Barriers

The flexible median barriers used by the Department are high-tension cable (HTC) median barriers. HTC median barriers consist of cables under high tension, suspended on lightweight posts, with an anchorage foundation at each end to hold the tension on the cables.

The tension present in the cables of an HTC system allow the cable to remain at an effective height after the removal of several supporting posts. This is valuable after a moderate crash, as some level of protection remains until repairs can be completed. However, the weak post component of these systems usually results in some damage, even from minor or nuisance hits. The repair of the weak posts is straightforward, and with socketed systems may not require any specialized equipment.

The HTC median barriers approved for use on slopes of 1V:6H or flatter meet *Test Level 4*. The barriers approved for use on slopes steeper than 1V:6H, but not steeper than 1V:4H, meet *Test Level 3*. The terminals for HTC median barriers meet *Test Level 3*. For each of these systems slope, placement, and other criteria limit where and how they may be used.

38-7.03 Median Barrier Selection

38-7.03(a) Selection Guidelines

The selection of a median barrier type starts with the median width and slopes. These two median conditions will have the greatest impact on the barrier's performance. Figure 38-7.C provides selection guidelines based upon these conditions and also provides the recommended placement for that barrier within the median.

Where more than one type of median barrier is recommended, consider the following factors:

1. Traffic Volumes. Higher traffic volumes generate more impacts on a median barrier. Also, closing lanes to work on median barriers causes more traffic complications where traffic volumes are high. In high-traffic volume locations, rigid barriers are generally preferred because they usually provide continuous, crashworthy service without generating maintenance and repair.

As a guide, a rigid barrier is likely to be more cost-effective where the peak hour level of service is LOS C or worse and the distance to the median barrier from the traveled way is 12 ft (3.6 m) or less.

2. Heavy Vehicle Traffic. Where there is a high volume of heavy vehicles, or a history of heavy vehicle, cross-median crashes, a rigid barrier would be preferred as it is more likely to contain and redirect heavy vehicles. Maintenance and repairs are not usually required after a hit.
3. Median Appurtenances. A roadway with a median barrier may also warrant other appurtenances in the median (e.g., highway lighting, signs, glare screens). This favors the use of the concrete barrier, which can more readily accommodate these appurtenances.
4. Maintenance Operations. Two factors are important:
 - a. First, maintenance response time will influence safety. The longer a damaged section of median barrier is present, the greater the likelihood of a second impact with a damaged barrier. A damaged semi-rigid barrier may remain at operational height after some impacts and may still provide protection in the event of a second impact. However, if substantially damaged it can itself become a greater hazard close to traffic until it is fully repaired and operational. This consideration favors the use of a rigid barrier which normally sustains little or no damage when impacted.

- b. Second, the maintenance operations for repairing a median barrier can be disruptive to traffic. It is important to consider worker safety and traffic safety when developing a traffic control scheme for barrier repair. Lane closures are typically necessary where working room is limited. This consideration favors the use of a rigid barrier in narrow medians and/or high-traffic volume areas, or a flexible barrier where sufficient space is available adjacent to or behind the barrier to accommodate the smaller equipment needed to repair it.
5. Benefit/Cost Ratio. The B/C ratio is important but does not consider additional crash or user delay costs due to traffic backups for repair. Consider the safety consequences based on the other factors listed above to make sure the system is acceptable for the specific site.

Figure 38-7.D compares the advantages and disadvantages of the different types of median barriers used by the Department and their typical usage.

Median barriers may also be used in locations other than medians. This would typically occur where a barrier is needed to separate lanes of traffic moving in the same direction or beginning to diverge.

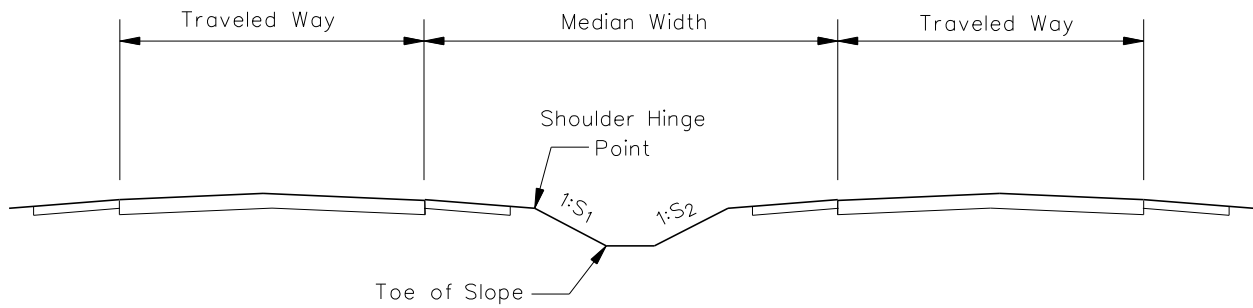

Median Conditions		Recommended Median Barrier Type	Recommended Placement
Width	Slopes		
W < 25 ft (7.6 m)	S ₁ and S ₂ ≥ 10	Rigid or Semi-Rigid	Near center of median
	S ₁ or S ₂ < 10 and S ₁ and S ₂ ≥ 8	Semi-Rigid	Near center of median
	S ₁ or S ₂ < 8	N/A – Consider a roadside barrier along each shoulder.	
W ≥ 25 ft (7.6 m)	S ₁ and S ₂ ≥ 10	Rigid, Semi-Rigid, or Flexible	Near center of median
	S ₁ or S ₂ < 10 and S ₁ and S ₂ ≥ 8	Semi-Rigid or Flexible	Near center of median
	S ₁ or S ₂ < 8 and S ₁ and S ₂ ≥ 6	Flexible	2 ft (600 mm) or more from shoulder hinge point <u>and</u> more than 8 ft (2.4 m) from the ditch line bottom
	S ₁ or S ₂ < 6 and S ₁ and S ₂ ≥ 4	Flexible	Within 4 ft (1.2 m) of shoulder hinge point <u>and</u> more than 8 ft (2.4 m) from the toe of any front slope
	S ₁ or S ₂ < 4	N/A – Consider a roadside barrier along each shoulder.	
Other median conditions (e.g., stepped, bermed)		Contact the Bureau of Safety Programs and Engineering.	

GUIDELINES FOR MEDIAN BARRIER SELECTION/PLACEMENT

Figure 38-7.C

38-7.03(b) Design Considerations

Each type of median barrier involves design elements that must be considered in the selection process. Consider the following:

1. Rigid Median Barriers. As noted earlier, the IDOT 44 in. (1120 mm) Double Face Concrete Barrier has been certified as meeting MASH criteria (Test Level 5). As a double-face concrete barrier nears the median pier of an overhead structure or twin separated structures, it may be necessary to split the barrier into two single-face barriers; this requires detailed design. There may also be a need to design details for a transition from the current single-sloped barrier into one of the older F-shape or New Jersey shaped barriers. The Bureau of Bridges and Structures and Bureau of Safety Programs and Engineering should be asked to provide guidance when such treatment is necessary.
2. Semi-Rigid Median Barriers. See Section 38-7.02(b) as it applies to Type D guardrail.
3. Flexible Median Barriers.
 - a. Line Post Foundations. The line posts of High Tension Cable (HTC) median barriers may be driven directly into the ground or through a mow strip or may be set into socket-type concrete foundations. Consider the depth of frost penetration. As a rule of thumb, the foundations should be at least 30 in. (762 mm) deep south of I-72, 36 in. (915 mm) deep along, and north of, I-72 to I-80, and 42 in. (1065 mm) deep along I-80 and north to the state border.
 - b. End Anchorages. HTC median barriers use significant anchorages (foundations) at each end of a run of cables to hold the high tension. The HTC specifications set design requirements and require shop drawings from the contractor for the end anchorages. Where it is necessary to change from a flexible median barrier to another roadside barrier or median barrier, provide an appropriate longitudinal overlap so that each system can operate and the entire median has adequate protection. Leave at least a 10 ft (3.0 m) transverse gap between the systems to provide access and ensure operational integrity. Another option for avoiding conflicts between different barrier types is to begin runs of flexible barrier at the departure ends of bridges; see Figure 38-7.E.
 - c. Mow Strips. Mow strips provide a paved area under and immediately adjacent to the barrier. They are provided as a maintenance consideration to ease mowing and minimize nuisance hits. A typical design is a 4 ft (1.2 m) wide, 4 in. (100 mm) thick mat of hot-mix asphalt. If within the shoulder limits, mow strips need to conform to the shoulder slope. Beyond the shoulder limits, mow strips need to conform to the front slope. Avoid drop-offs along the edge of a mow strip. Provide grading, if necessary, to smoothly match the mow strips to the slopes.
 - d. Length of Need. The length of an HTC median barrier that can be used to satisfy the length of need (see Section 38-6.01) will vary among the manufacturers.

Because the brand of HTC will not be known during the design, define the length of need point for all types as 50 ft (15.2 m) from the end of the terminal section.

Type	Advantages	Disadvantages	Typical Usage
Rigid	<ol style="list-style-type: none"> 1. Can accommodate most vehicular impacts without penetration 2. Little or no deflection distance required behind the barrier. 3. Little or no damage sustained for most vehicular impacts; therefore, least need for maintenance. 4. Minimum potential for vehicle underride/override or snags. 5. Light supports, sign supports, glare screens, etc., may be mounted on top. 	<ol style="list-style-type: none"> 1. Highest initial cost. 2. Can induce vehicular rollover. 3. For some conditions, it has highest occupant decelerations (i.e., it is the least forgiving barrier type). 4. Reduced performance where offset between the barrier and the traveled way exceeds 12 ft (3.6 m). 5. Snow drifting. 	<ol style="list-style-type: none"> 1. Urban freeways. 2. For high traffic volumes. 3. For high volumes of heavy vehicles. 4. Where maintenance of a median barrier would result in lane closures with significant impacts to traffic. 5. Works well for moderate to narrow medians.
Semi-Rigid	<ol style="list-style-type: none"> 1. Lower initial cost. 2. High level of familiarity by maintenance personnel. 3. Can safely accommodate wide range of impact conditions for passenger vehicles. 4. Relatively easy installation. 	<ol style="list-style-type: none"> 1. Performance for vehicles above 5000 lb (2270 kg) (PU) is not assured. 2. At high-impact locations, will require frequent maintenance. 3. Snow drifting. 4. Hazard until repaired. 	<ol style="list-style-type: none"> 1. Moderate median widths, 25 ft to 40 ft (7.6 m to 12.2 m). 2. Low to mid-range of traffic volumes.
Flexible	<ol style="list-style-type: none"> 1. Lowest initial cost. 2. Can be installed in medians where slopes are as steep as 1V:4H. 3. Repairs usually do not require specialized or heavy equipment. 4. Repairs can be quick. 5. Minimizes snow drifting. 6. Can safely accommodate wide range of impact conditions for passenger vehicles and, on 1V:6H or flatter slopes, single-unit trucks. 7. Remains at height and provides some protection after moderate hits. 	<ol style="list-style-type: none"> 1. Performance for heavy vehicles (above 18000 lb (8000 kg) (SU) is not assured where slopes are 1:6 or flatter. 2. Performance for vehicles above 5000 lb (2270 kg) (PU) is not assured where slopes are 1:4 to 1:6. 3. Virtually every impact will require some repair. 4. Susceptible to snowplow damage. 5. Learning curve for maintenance forces when introduced to a new area. 6. Deflection space required behind the barrier is 12 ft (3.6 m) unless special designs are developed. 	<ol style="list-style-type: none"> 1. Medians wider than 25 ft (7.6 m). 2. For low to moderate traffic volumes where repairs can be made without significant traffic impacts.

COMPARISON OF MEDIAN BARRIER TYPES

Figure 38-7.D

- e. Deflection. Flexible median barriers will deflect more than the other median barrier types. When laying out a flexible barrier, allow for 12 ft (3.6 m) of deflection.

If designs for reduced deflection are needed, refer to Figure 38-7.F. This figure allows for reduced deflection based on 10 ft (3.0 m) or 15 ft (4.6 m) post spacing and limited space between end anchors from 300 ft (90 m) and 3000 ft (915 m). If reduced post spacing and/or reduced anchor spacing are required, these must be shown in the contract documents. Deflection values may be interpolated between these two curves, but may not be extrapolated. These curves are not to be used where the convex side of a curved flexible barrier installation is between traffic and a hazard. Contact BSPE for this case.

It is desirable to locate flexible median barriers so that an impacting vehicle will not be allowed to encroach into the traveled way beyond the barrier. However, in some applications, the deflection distance of a median barrier will encroach into the opposing lane. This is permissible when the barrier placement requirements dictate because not all hits will develop the full deflection, the encroachments will be momentary, and the limited encroachment is preferable to allowing a vehicle to enter the opposing traffic unchecked. In addition, many cases may occur where the cable is an interim safety measure until more extensive reconstruction can be accomplished.

- f. Length of Installation. Very long installations (more than 3 miles (5.0 km)) of HTC may be possible; review manufacturer's recommendations. However, the designer should remember that an impact at the terminal will release tension throughout the entire run of cable. The designer should weigh the advantages and disadvantages of long runs of barrier versus the loss of performance during the time between a terminal hit and its repair.

Very long runs of HTC will also inhibit turnarounds by police and emergency first responders.

- g. Alignment. HTC will not accommodate abrupt changes in vertical alignment. Crossing of abrupt sags will leave the cable too high and cause posts to be pulled upwards or cables to be lifted above correct mounting heights. Crossing of abrupt crests will place severe downward stress on cable supports and will result in low cable height after one impact. Mainline freeway alignments are unlikely to experience this problem, but cable profiles along median surfaces may vary due to drainage features, crossovers, pier locations, and other median details. These issues are minimized with an installation along or near a shoulder and usually must be addressed for locations closer to the median center. Breaking and overlapping the runs of HTC at crest or sag vertical curves is a strategy to minimize this effect, and may also be coordinated with changes in the preferred side of installation; see Figure 38-7.E.

If the radius of horizontal curvature is 1200 ft (366 m) or less, check the manufacturers' recommendations to confirm which systems may be used.

When placing HTC near a shoulder around a curve, it should ideally be located where the near traffic is making the left-hand curve (inside of curve relative to near traffic). This may reduce nuisance hits and allow more vehicles leaving the opposing roadway to come to a stop in the median before reaching the barrier. Also, traffic impacting the barrier on its convex side will result in increased deflection that can better be tolerated in the median.

If the barrier must be placed on the outside of a curve with superelevation of 3% or greater, it must be within 2 ft (0.600 m) of the edge of shoulder.

- h. Elevation Differences. Where each roadway is on independent profile, especially if one is significantly higher than the other, it is generally preferred to place the median barrier along the higher roadway. This consideration should be balanced along with the alignment considerations; see Item g. above.
- i. Delineation. Where the HTC is placed along a shoulder, apply reflective caps, reflective tape, or reflectors to the posts of the system at spacing and offsets similar to those used for guardrail reflectors.
- j. Coordination. It is important to involve local emergency responders during Phase I development, at the preconstruction meeting, and during any hands-on demonstrations provided by the HTC manufacturer. Cutting of cables should be discouraged. Replacement/splicing of cut cables is much more expensive and time consuming than resetting of intact cables. Contractor and manufacturer personnel can instruct emergency responders about alternatives to cutting cables and methods to disengage vehicles. Also, coordinate with emergency responders to ensure safe median and shoulder access is provided.

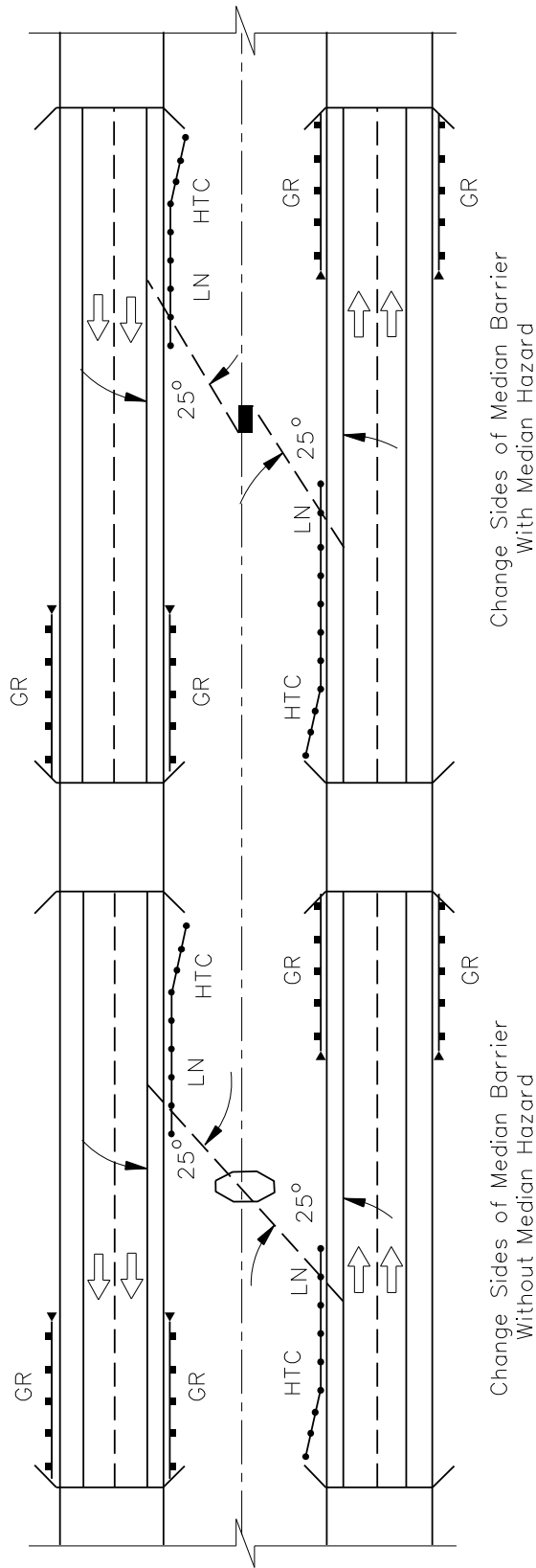

LN = Length of Need Point
GR = Guardrail
HTC = High Tension Cable

COORDINATION OF HIGH TENSION CABLE WITH STRUCTURES AND CROSSOVERS

Figure 38-7.E

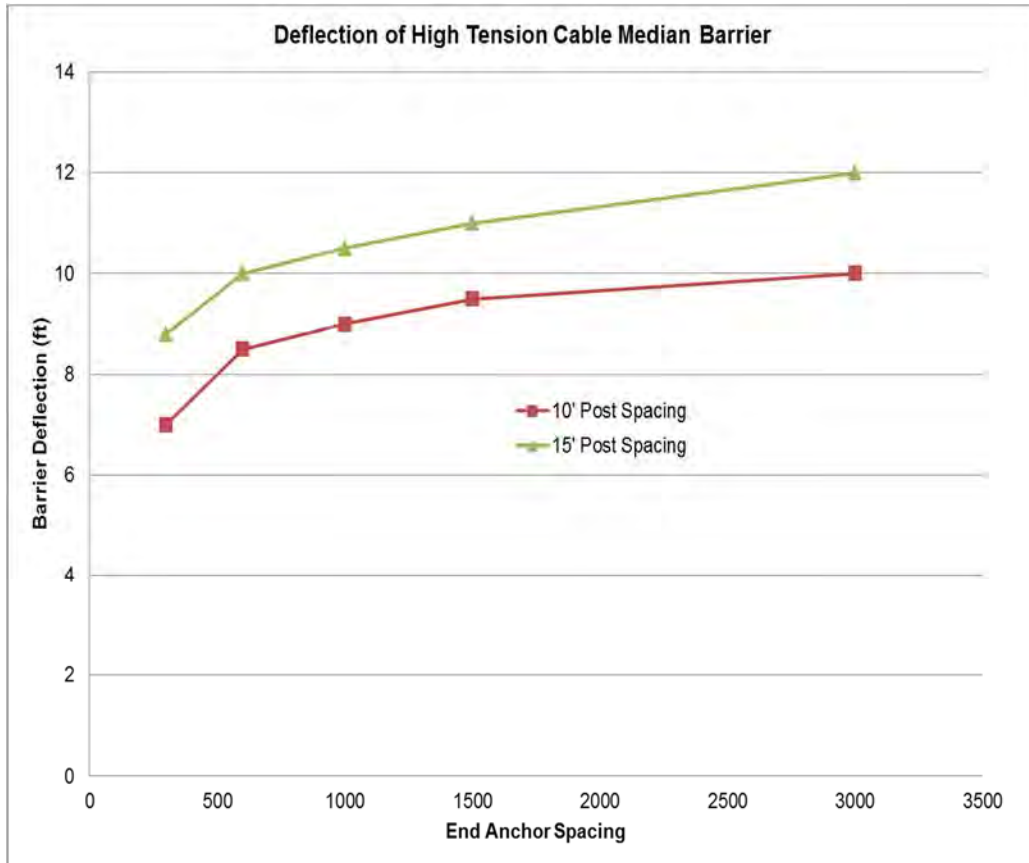

Cable Median Barrier Deflection vs Post Spacing and End Anchor Spacing

Figure 38-7.F

38-7.04 Median Barrier Layout

Much of the information presented in Section 38-6 on roadside barrier layout also applies to median barriers (e.g., placement behind curbs). The following sections present criteria specifically for the design of median barriers.

38-7.04(a) Sloped Medians

Slopes in the median affect the performance of a barrier. A vehicle traversing a slope, or transitioning between two slopes, prior to impact may not impact the barrier with all four tires on the ground, may have its suspension compressed, or may have a tendency to roll. Where the impact is made under these types of conditions, the crash results may be undesirable. The recommendations for median barrier type and placement considering slopes are shown in Figure 38-7.C.

38-7.04(b) Flared/Divided Median Barriers

It may be necessary to flare a median barrier to a different offset from the traffic lane. Also, a sloped median, a fixed object in the median, or twin separate bridges may require that a median barrier be divided. The median barrier may be divided by one of the following methods:

1. Rigid Median Barriers. A fixed object may be encased within a concrete barrier or a single-faced concrete barrier may be placed on both sides of a fixed object, see Figure 38-7.G.
2. Semi-Rigid Median Barriers. Steel plate beam guardrail, Type D, may be divided into two separate runs of guardrail passing on each side of the median hazard (fixed object or slope), see Figure 38-7.H.
3. Flexible Median Barriers. HTC barriers may be placed on either or both sides of a median hazard, provided adequate deflection distance is available. If the HTC runs on only one side of the hazard, a roadside barrier or impact attenuator should be used as needed to protect traffic in the opposing direction.

Flare rates for rigid or semi-rigid systems should be according to the guidelines for roadside barriers. Flexible barrier may be flared at a rate of 1:50.

38-7.04(c) Barrier-Mounted Features

Luminaire supports are often mounted on top of concrete barriers, and the top height is typically able to accommodate them. However, the designer should recognize that a zone of intrusion [see Section 38-6.03(6)] is a relevant concern when a concrete barrier divides to pass on either side of an obstacle or when features are mounted on top of a concrete barrier. If trucks or buses impact the concrete barrier, their high center of gravity may result in a vehicular roll angle which

possibly will allow the truck or bus to impact the features on top of or immediately adjacent to the concrete barrier. The 44 in. (1120 mm) Double Face Concrete Barrier provides sufficient height to substantially reduce past concerns (with lower-height barriers) regarding the zone of intrusion. However, a designer should consider whether there are opportunities to split a standard barrier into two separate single-face barriers while providing a 2 ft (600 mm) to 3 ft (900 mm) offset distance between the barrier face and obstacle (e.g., bridge piers or poles).

38-7.04(d) Terminal Treatments

As with roadside barrier terminals, median barrier terminals present a potential roadside hazard for run-off-the-road vehicles. Therefore, the designer must carefully consider the selection and placement of the terminal end. Where practical, the median barrier should be extended into a wider median area so that the terminal is further from traffic. The following *NCHRP Report 350* or *MASH* terminals are used by the Department for median barriers:

1. Rigid Median Barriers. The end of a concrete barrier is typically shielded with an impact attenuator. The Department maintains a Qualified Products List (QPL) on its website. *NCHRP Report 350* or *MASH* passed devices are required as noted on the QPL, which is regularly updated to list the approved devices, noting their *MASH* testing status and associated Test Level.
2. Semi-Rigid Median Barriers. Steel plate beam guardrail, Type D, is typically shielded with an impact attenuator. Refer to the discussion on rigid median barriers above.
3. Flexible Median Barriers. For HTC barriers each system has its own proprietary terminals. The terminals included in the QPL meet the requirements of *NCHRP Report 350* or *MASH*, and testing status is noted.

38-7.04(e) Superelevation

Chapter 32 discusses superelevation development for multilane divided facilities. Where a median barrier is present, the axis of rotation is typically about the two median edges. This will allow the median (and the barrier) to remain in a horizontal plane through the curve. See Chapter 32 for more information.

38-7.04(f) Median Crossovers Locations

1. Permanent Locations. Chapter 44 provides guidance and further reference for the location and design of permanent median crossovers. Proper installation of median barriers must take permanent median crossovers into account as there will be a break in the barrier. Where a break is exposed to approaching traffic, it will require treatment according to Section 38-7.04(d). Consider the following:
 - a. The most common method for providing an opening in a median barrier for a permanent crossover is to establish a gap in the barrier.

- b. For rigid or semi-rigid barriers, the gap should fit the geometry of the permanent crossover and provide the required throat width for the crossover, plus allowance for any radii or flares.
 - c. For flexible barriers, keep the end anchorage location about an additional 30 ft (9.0 m) away from the completion of the radii or flares. This will help to prevent damage to the terminals by vehicles using the median crossovers that would release tension on the entire run of barrier. Also, for HTC consider changing sides of the median at median crossovers. This will provide slightly better length of need coverage and also provide an opportunity to introduce the change of sides for reasons discussed in Section 38-7.03(b) and as shown in Figure 38-7.I.
 - d. Another way to create an emergency location for crossing the median is to leave a gap while at the same time changing the side of the median for the barrier. In this application, the length of need points for the barriers should be connected by a line departing the traveled way at a 25 degree angle. This will provide continuous protection of the median for most departing vehicles; see Figure 38-7.E.
 - e. Proprietary barrier gates are available for concrete median barriers. These gates are opened by manual means or by electric motors depending on the brand and options selected. These gates should only be used on a case-by-case basis and when supported by a decision according to Section 66-1.04(b).
2. Temporary Locations. For HTC barriers it is possible to create or anticipate temporary locations for emergency use.
- a. Where socketed posts are used, it is possible to remove the cables from a sufficient number of posts, or disconnect the cables at the turnbuckles, and create slack. Once cable slack is present, sufficient posts may be removed to create temporary crossover locations.
 - b. Careful selection of well-drained locations for changing sides for HTC can allow emergency vehicles to make serpentine moves across the median were soil conditions are sufficiently stable. For example, this may indicate ditch check locations or pier locations.

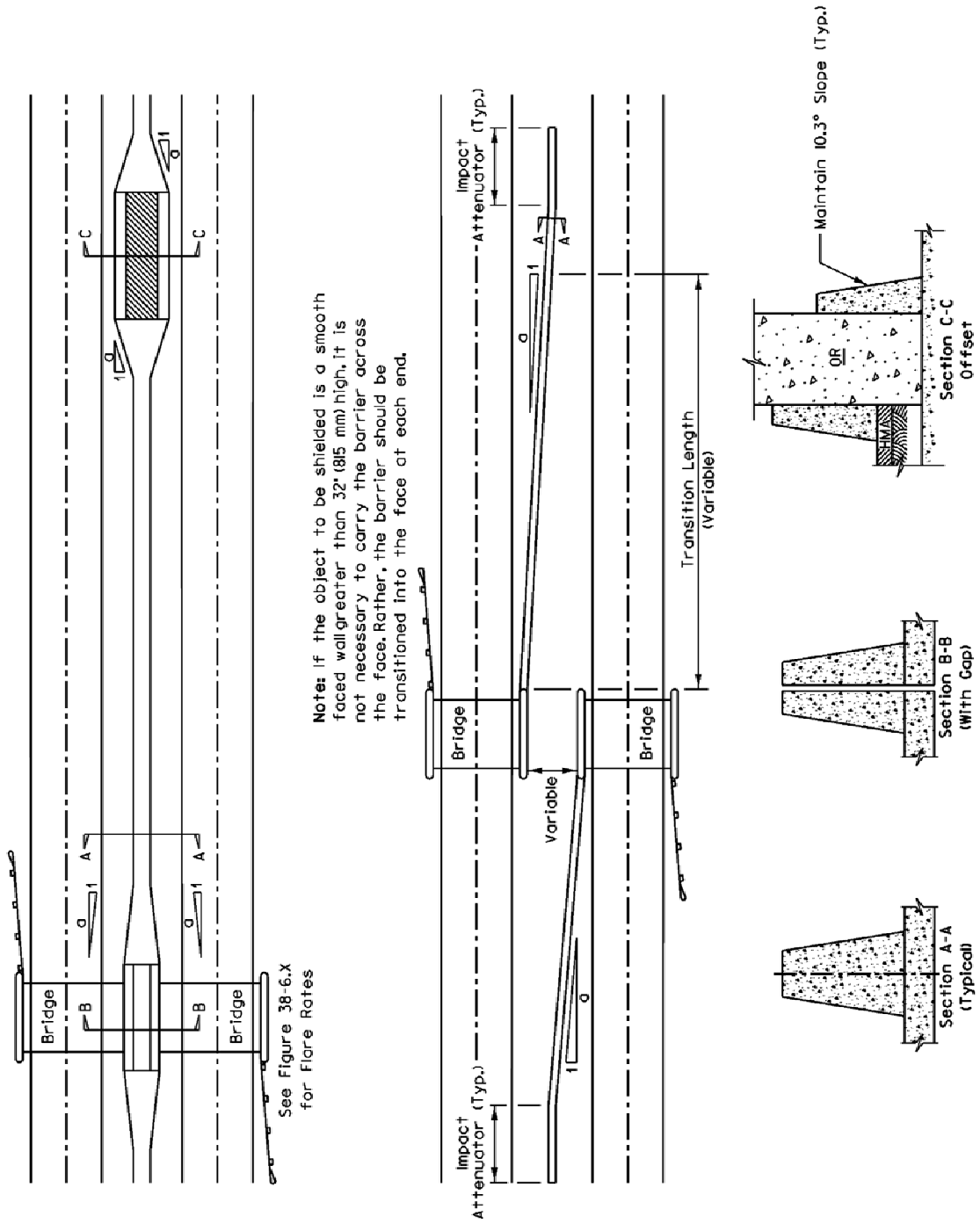

FLARING/DIVIDING CONCRETE BARRIER

Figure 38-7.G

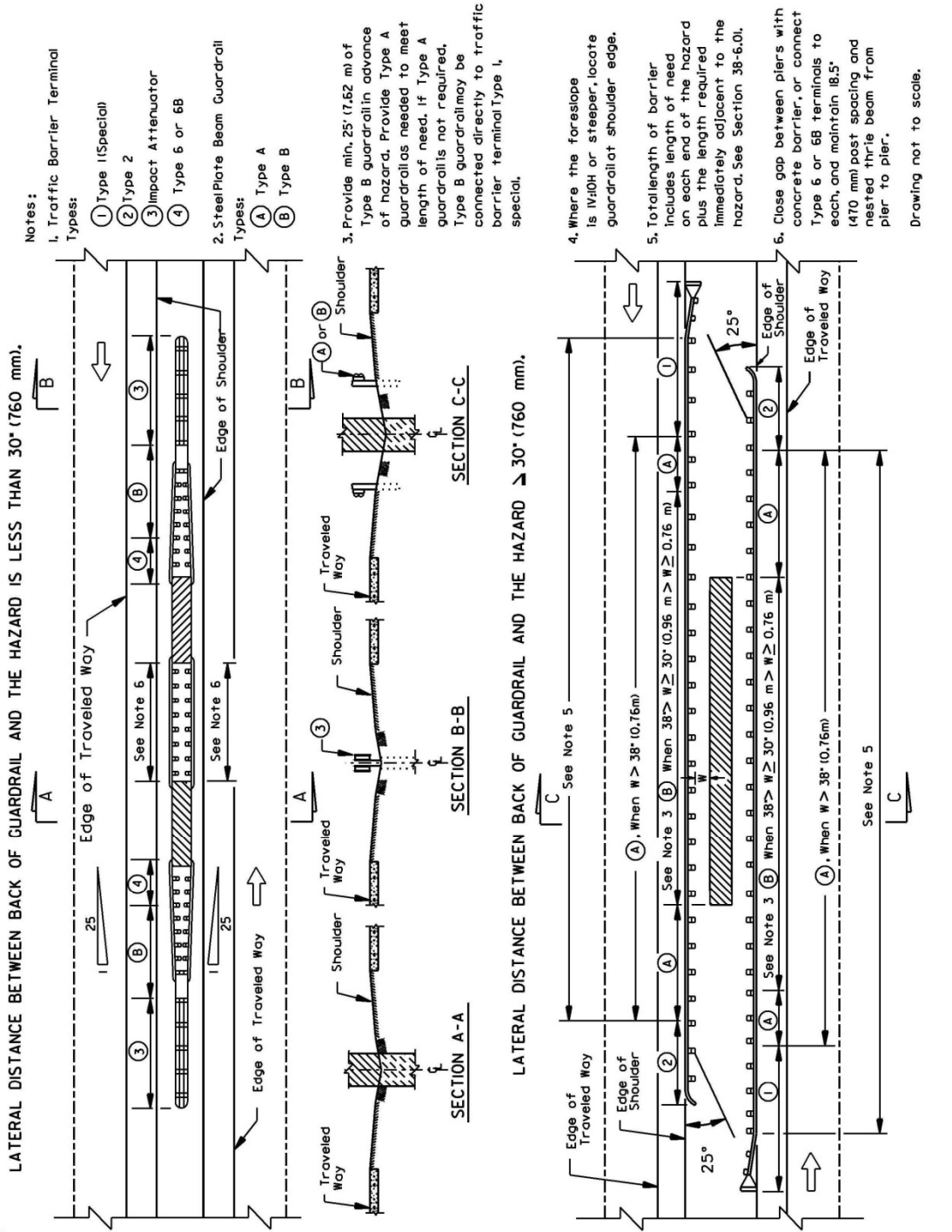

DIVIDING STEEL PLATE BEAM GUARDRAIL

Figure 38-7.H

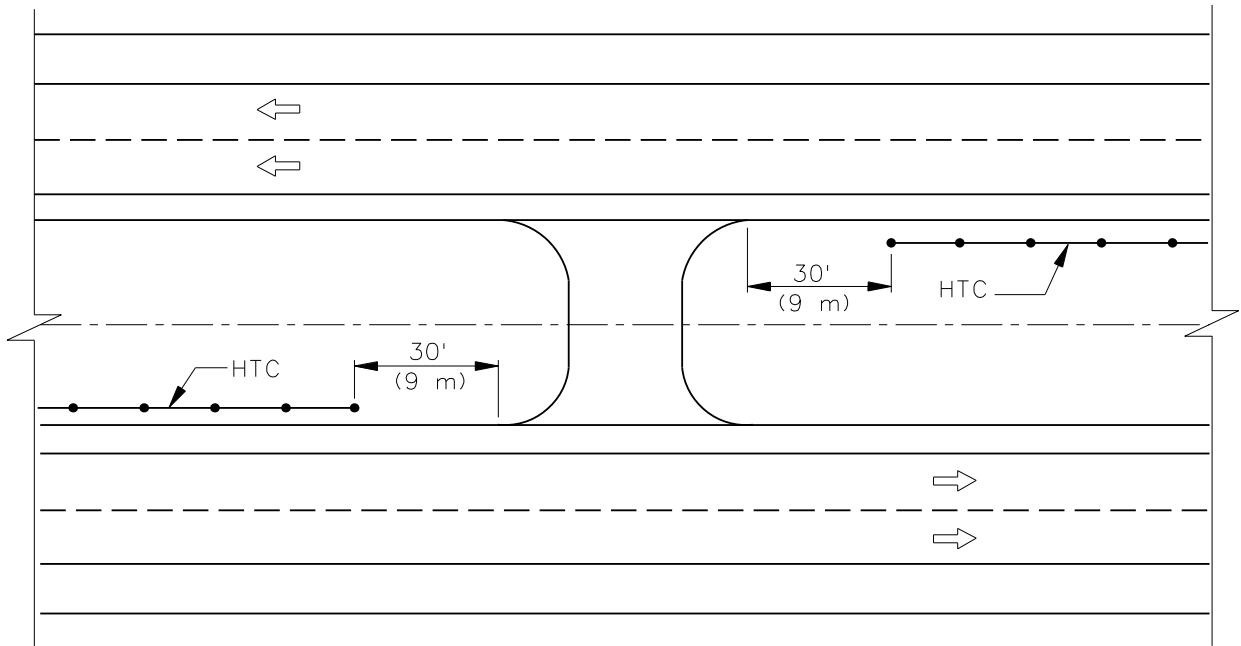

HIGH TENSION CABLE AT MEDIAN CROSSOVERS

Figure 38-7.1

38-7.05 Glare Screens

38-7.05(a) General

Headlight glare may be defined as a sensation experienced when a person's vision is interrupted by a light source which has a much higher intensity than the surrounding area. It is frequently cited as a major contributing factor in nighttime crashes that occur on unlighted highways. The magnitude and severity of headlight glare depends on various combinations of a wide variety of factors, including:

- headlight systems, which include the headlight configuration, mounting height, and output intensity;
- roadway features, which include the roadway alignment, geometrics, and pavement reflectivity;
- transmission media, which includes the atmosphere and physical features through which the light must pass, such as windshields and eyeglasses; and
- human variables, which include driver's age, visual ability, and fatigue.

Depending on the severity and effect glare has on a driver, it may be classified as discomfort or disability glare, defined as follows:

1. **Discomfort.** Discomfort glare does not necessarily impair the vision. However, it frequently causes drivers to become tense and apprehensive, which increases the level of fatigue and may lead to driver error. This type of glare is common and usually occurs where median or outer separator widths are greater than approximately 30 ft (10 m).
2. **Disability.** Disability glare definitively impairs a driver's vision, frequently causing temporary blindness; consequently, it should be addressed whenever practical. Disability glare occurs usually where median or outer separator widths are less than approximately 30 ft (10 m) in width, on horizontal curves, where the opposing traveled ways are at different elevations, and/or where transitions alter the highway horizontal alignments of the directional roadways.

38-7.05(b) Design Considerations

As indicated, headlight glare from opposing traffic can be bothersome and distracting. Glare screens can be used with or without median barriers to greatly reduce the problem and should be used when no other practical alternative exists to eliminate disability glare (e.g., wider median, outer separation, highway lighting, landscaping). The designer should consider if the following conditions exist when determining the need for a glare screen:

- unlighted divided highways where design speeds are 50 mph (80 km/hr) or greater and medians 30 ft (9.0 m) or less in width;
- horizontal curves on divided highways;
- points where the separation between a mainline and frontage road is minimal and alignment is such that mainline traffic is affected by the lights of vehicles using the frontage road;
- points of transition which create critical glare angles between opposing vehicles;
- locations where nighttime crash rates are unusually high; and
- any location where conflicting light sources cause a distorted or confusing view of the driver's field of vision.

The Department has not adopted specific warrants for the use of glare screens. The typical application, however, is on urban freeways with narrow medians and high traffic volumes. Another application is between on/off ramps at interchanges where the two ramps adjoin each other. Here, the sharp radii and the narrow separation may make headlight glare especially bothersome. The designer should consider the use of glare screens at these sites. A key element warranting their use is the number of public complaints received for a highway section.

38-7.05(c) Glare Screen Types

The following describes the glare screens used by the Department:

1. Concrete Glare Screen. The current single slope double face concrete barrier has a height that lessens the frequency of glare concerns compared to older lower barriers, but these concerns persist under certain conditions. Where a glare screen is warranted for a section of roadway with concrete barrier, the designer may specify a concrete glare screen. See the *Illinois Highway Standards* for details. This type of glare screen is advantageous on high-volume routes due to its low maintenance.
2. Glare Screen Blades. As an alternative to the concrete glare screen, a series of thin vertical blades may be mounted on top of the concrete barrier. The designer must specify the spacing, height, and longitudinal spacing of the blades on the plans. Please contact the Central Bureau of Materials when considering the use of glare screen blades.
3. Fence Glare Screen. A fence glare screen usually consists of fabric lined fence or a fence with slats woven into the fence material. This type of glare screen is typically used in controlling glare between the mainline and adjacent frontage roads where an access control fence is usually required. In addition to alleviating glare, the fence will restrict potential unpermitted access between two closely spaced facilities.

38-7.05(d) Glare Screen Design

The following applies to the design of a glare screen:

1. General. Glare screens must not be used as a wind or snow shield nor should they detract from the aesthetics of the highway. However, they should be durable and easy to maintain.
2. Cutoff Angle. Glare screens should be designed for a cutoff angle of 22 degrees. This is the angle between the median centerline and the line of sight between two vehicles traveling in opposite directions; see Figure 38-7.J. The glare screen should be designed to block the headlights of oncoming vehicles up to the 22 degree cutoff angle. On horizontal curves, the design cutoff angle should be increased to allow for the effect of curvature on headlight direction:

$$\text{Cutoff Angle (in degrees)} = 22 + \frac{5729.6}{R} \quad (\text{US Customary})$$

$$\text{Cutoff Angle (in degrees)} = 22 + \frac{1746.8}{R} \quad (\text{Metric})$$

Where:

R = radius of horizontal curve in feet (meters)

3. Horizontal Sight Distance. Glare screens may reduce the available horizontal sight distance. For curves to the left, the designer will need to check the middle ordinate to determine if adequate stopping sight distance will be available; see Section 32-4.
4. Sag Vertical Curves. When determining the necessary glare screen height, the designer may ignore the effect of sag vertical curvature.
5. Height of Eye. The average driver's eye height is 3.5 ft (1065 mm) for passenger vehicles and 7.6 ft (2.3 m) for large trucks. These heights are averages and must be adjusted when considering outlying conditions.
6. Glare Screen Height. The upper and lower elevations of the glare screen must be such that light does not shine over or under the barrier. The height of glare screens may be established by examining the following factors:
 - a. height of driver's eye in relation to the pavement,
 - b. height of the headlights of various size vehicles in relation to the pavement, and
 - c. changes in elevation across the entire roadway width including the median.
7. Coordination of Glare Screen with Concrete Barrier. The preceding steps cover design of glare screen. However, calculation of detailed height requirements does not imply that the height of glare screen should vary repeatedly from location to location along a job. Select the height to bracket the needs of the section or logical segments. In addition, the height to the top of glare screen should be determined using standard devices and the following steps:

For locations where the 44 in. (1120 mm) concrete barrier is used, the concrete glare screen may be added to reach a height of 63 in. (1600 mm). If heights greater than 63 in. (1600 mm) are required, then glare screen blades or special designs using concrete may be considered. The addition of taller concrete barrier or concrete glare screen raises issues regarding control of debris scatter from a collision, as well as the necessary shape and slopes for the taller sections. Contact BDE to coordinate any designs using concrete glare screens above a height of 63 in. (1600 mm).

* * * * *

Example 38-7.05(1)

Given: Six-lane divided highway
12 ft travel lanes
2% pavement cross slope
5 ft median width

Problem: Determine the upper and lower elevations of the glare screen.

Solution: First, determine the lower elevation based on the following factors:

1. The most severe condition is two sport cars traveling in opposite directions each using the right-hand lane.
2. The eye level of the drivers is 3 ft above the pavement.
3. The lower edge of the sport car's headlights is 1.75 ft above the pavement.
4. The driver's eyes are approximately 8.75 ft from the outer edge of the traveled way.
5. Figure 38-7.K presents the determination of the lower edge of the glare screen.

Next, determine the upper elevation based on the following factors:

1. The most severe condition is two large trucks traveling in opposite directions, one using the right-hand lane and the other using the left-hand lane.
2. The eye level of the drivers is approximately 7.6 ft above the pavement.
3. The lower edge of the truck headlights is 3.75 ft above the pavement.
4. The eye of the driver using the left-hand lane is approximately 5.75 ft from the median centerline.
5. The left headlight of the truck using the right-hand lane is approximately 4.5 ft from the outer edge of the traveled way.
6. Figure 38-7.L presents the determination of the upper edge of the glare screen.

For most locations, it is not necessary to use this upper level; see Section 38-7.05(c).

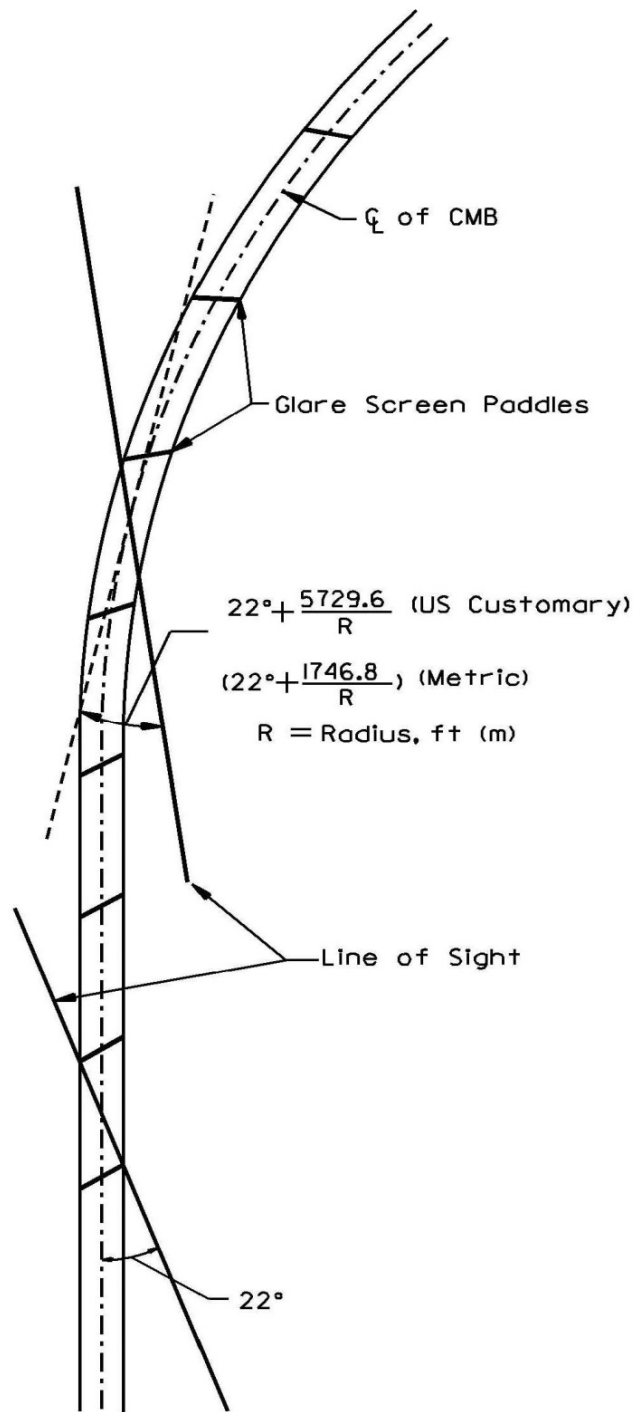

CUTOFF ANGLE FOR GLARE SCREENS

Figure 38-7.J

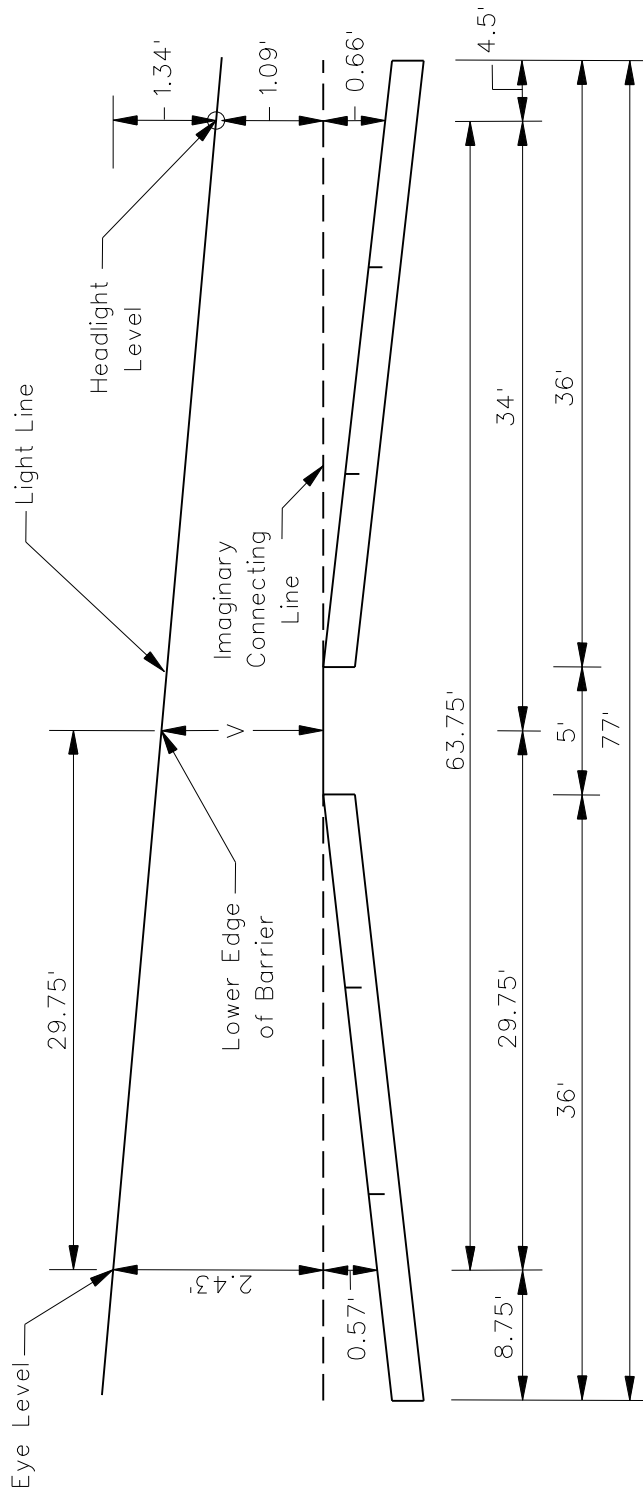

$$V = 2.43 - \left(\frac{1.34}{63.75} \right) (29.75)$$

$$V = 1.84'$$

LOWER ELEVATION OF GLARE SCREENS
(Example 38-7.05(1))

FIGURE 38-7.K

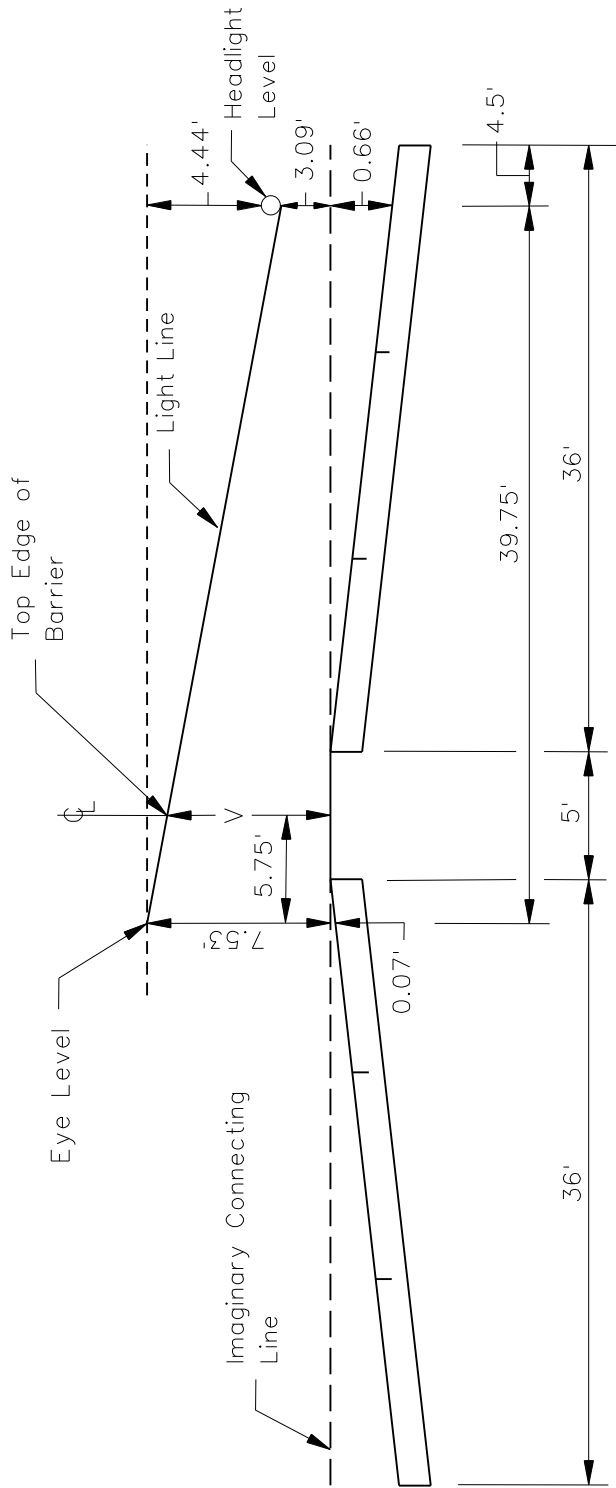

$$V = 7.53 - \left(\frac{4.44}{39.75} \right) (5.75)$$

$$V = 6.89'$$

UPPER ELEVATION OF GLARE SCREENS
 (Example 38-7.05(1))

Figure 38-7.L

38-8 IMPACT ATTENUATORS (Crash Cushions)

38-8.01 General

Impact attenuators (crash cushions) are protective systems that prevent errant vehicles from impacting hazards by decelerating them to a stop after a frontal impact, by redirecting them away from the hazard, or by decelerating them after a side impact. They operate on the basis of either energy absorption or momentum transfer. Impact attenuators are adaptable to many roadside hazard locations where longitudinal barriers cannot practically be used. Selection of the appropriate device or system must consider the corridor design speed and required test level as described earlier in this chapter.

Impact attenuators have two primary applications. They may be installed as stand-alone devices to shield point hazards (e.g., bridge piers, sign foundations) or they may be used as terminal treatments for roadside or median barrier systems. Where used to shield a point hazard, the impact attenuator is placed very near or in contact with the hazard; therefore, no length of need applies, and no additional barrier is required. This application may be appropriate only where the shoulder and/or front slope in the runout area is 1V:10H or flatter and other requirements of the impact attenuator layout (e.g., pad or base, physical room for the system) can be accommodated. Otherwise, a roadside barrier or median barrier, as appropriate should be used.

38-8.02 Warrants

Impact attenuator warrants are the same as barrier warrants. Once a hazard is identified, the designer should first attempt to remove, relocate, or make the hazard break away. If these options are impractical an impact attenuator should be considered.

For median widths of 84 ft (26 m) or less, all piers, sign foundations, and similar hazards in medians of divided highways warrant shielding. For median widths greater than 84 ft (26 m), the need should be considered on a case-by-case basis.

38-8.03 Impact Attenuator Types

38-8.03(a) Overview

Selection of the most appropriate impact attenuator type depends on a variety of factors:

1. Redirective Properties. The impact attenuator devices have various properties related to the path of a vehicle after impact.
2. Operational Principles. The systems have varied means to deal with the energy or momentum impacted by an impact.
3. Maintenance and Repair Issues. Some systems retain residual capacity to absorb additional frontal impacts during the time between an initial crash and full repair of the system. Systems vary in the cost and effort required for repair of crash and nuisance hits.

4. Approved Devices. To be considered for use on Illinois highways, a given device must be included on the Department's QPL.
5. Physical Placement Requirements. The size, layout and anchorage requirements may dictate or eliminate various systems depending on the type of location where protection is required.
6. Costs. Given the wide variation in the approaches to the above considerations, the systems vary in cost of installation and repair. Life cycle cost analysis using the Roadside Safety Analysis Program (RSAP) may be a useful tool.
7. Pedestrians/Bicyclists. In some installations, impact attenuators may be introduced into the pedestrian/bicyclist environment. This will require consideration of various factors to evaluate the relative risks to the vehicular traffic and pedestrian/bicyclist traffic.

All of these factors, taken together, guide impact attenuator selection. The selection process for both permanent and temporary devices, is covered in this section. Impact attenuators are moving toward compliance with MASH testing criteria. The QPL is regularly updated to note the testing status of each proprietary device as well as the approved test levels.

38-8.03(b) Redirective Properties

Impact attenuators are further categorized by how they redirect impacting vehicles.

1. Fully Redirective Devices. A fully redirective device will safely redirect a vehicle that impacts at any location along the face of the device.
2. Partially Redirective Devices. A partially redirective device will safely redirect a vehicle that impacts downstream of a given length of need point along the length of the device. This type of device will allow a vehicle impacting between the length of need point and the free end of the impact attenuator to pass through to the area behind the device.
3. Non-Redirective Devices. A non-redirective device will either capture an impacting vehicle or allow it to pass through when hit along the face of the device.

38-8.03(c) Operational Principles

1. Energy Absorbing Devices. This type of impact attenuator operates on the principle of absorbing the energy of the vehicle by various means, including crushing or deformation of engineered modules, friction of moving parts, or by compression of a hydraulic cylinder. Some energy is also absorbed by the impacting vehicle as the front end of the vehicle is crushed on impact. Energy absorbing attenuators require rigid back-up support or connection to another barrier system to contain the forces created by the deformation of the device. This support may be supplied as part of the impact attenuator or may be derived from its connection to the barrier or hazard (e.g., concrete structure). This distinction may preclude the use of some systems for shielding point hazards that will not

provide this support. In these cases, a special provision limiting the selection to no less than two alternatives may be required. This type of device also requires vertical and lateral anchoring. This is accomplished by attachment to a bituminous or concrete base or by placement of posts. Devices of this type capture or rebound the vehicle in a frontal impact. For side impacts, the devices work either as fully redirective or partially redirective.

2. Momentum Transfer Devices. This type of system operates by transferring the momentum of an impacting vehicle to an expendable mass of material contained in the device.
 - a. Sand Modules. A typical momentum transfer device is an array of sand-filled plastic modules. The Department has developed standard arrays for both Test Level 2 and Test Level 3 (see *Highway Standard 643001*). Once the Test Level is selected for a project (TL-2 or TL-3), the number of modules used in the standard sand module array need not be altered, except to provide lateral protection as discussed immediately below:

The sand module impact attenuator design should allow for safe side impacts. Figures 38-8.A and 38-8.B illustrate two methods to modify the sand module design to accommodate angle impacts. Figure 38-8.A illustrates how the modules may be shifted to afford attenuation at the end points and direction along the sides of the hazard by closing or covering the gap between pier columns. Figure 38-8.B illustrates where the side of the hazard and available space are such that full protection, through attenuation only, can be provided by the use of additional modules to widen the standard array. Although the entire area of the hazard must be shielded from angle impacts either by attenuation or redirection, the permissible attenuation may be varied to optimize space and economy.

The sand module systems require no back-up support or connection to another system. However, they do require a firm and stable base. For permanent systems, an HMA or PCC base is required. For temporary installations not to be placed over a winter, an aggregate base may be used. Sand modules have no redirective capability and generate considerable debris upon impact. On the approaching traffic corner, the exterior modules must be laterally offset at least 2.5 ft (750 mm) from the corner of the hazard; see Figure 38-8.A.

Show the layout of sand modules, including positioning relative to the hazard, in the plans. Note the Test Level (TL-2 or TL-3) for which the array is designed.

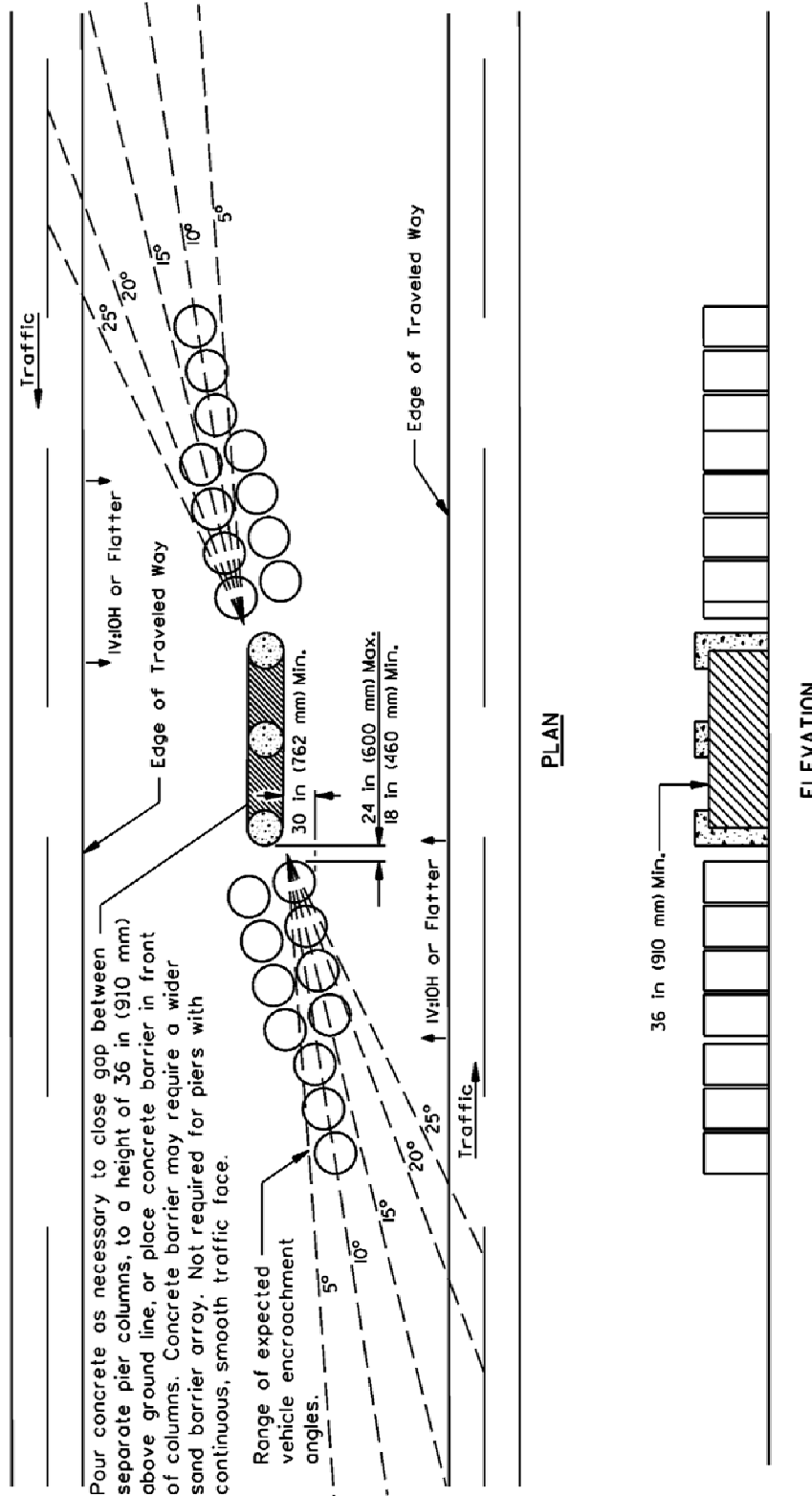

Typical installation of a freestanding, sand-filled container type impact attenuator in median.

ANGLE IMPACT AND POSITIONING DESIGN FOR SAND BARRELS

Figure 38-8.A

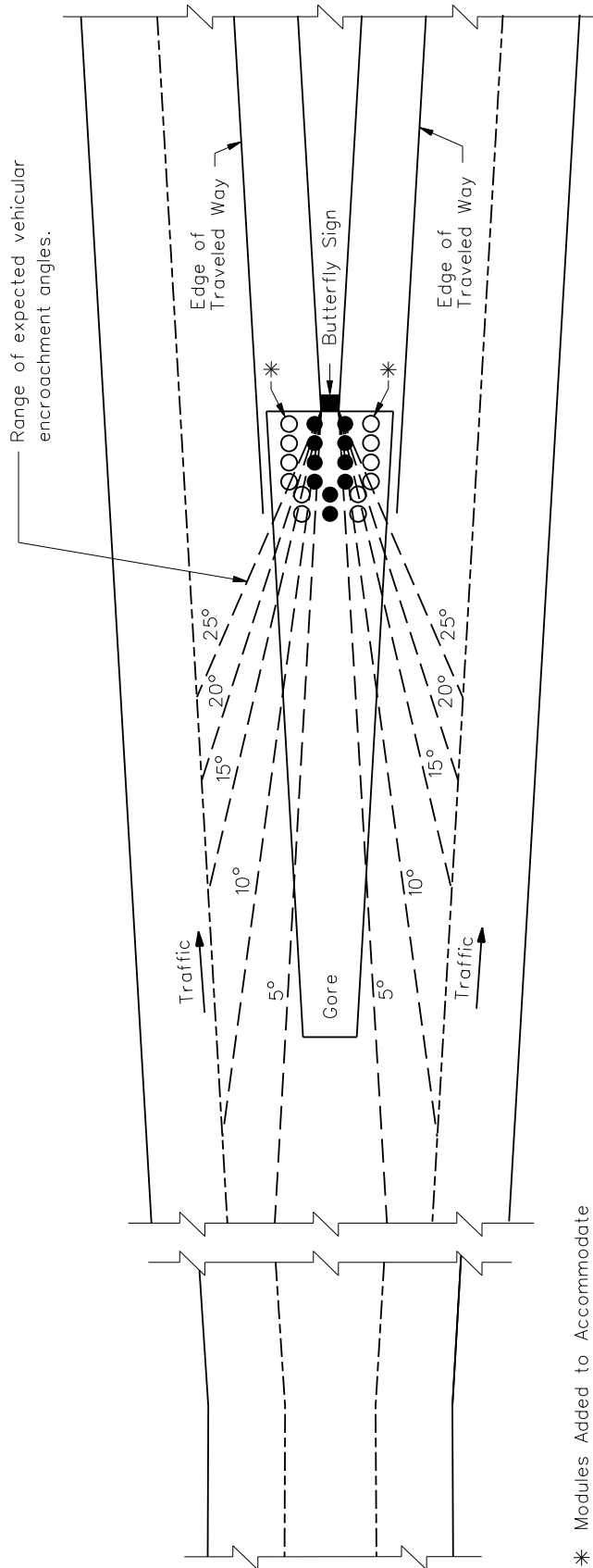

TYPICAL INSTALLATION OF A FREESTANDING, SAND-FILLED, CONTAINER-TYPE IMPACT ATTENUATOR SYSTEM IN A MAJOR FORK

ANGLE IMPACT DESIGN FOR SAND BARRELS

Figure 38-8.B

- b. Water Filled Impact Attenuator. The water-filled barrier dissipates energy both by energy transfer (crushing of modules) and by momentum transfer to the system's mass. Water filled impact attenuators also have no redirective capability and may spread water in the area of an impact. These impact attenuators are used with temporary barriers only when freezing is not a concern, and must be attached to the barrier system. They do not require anchorage to the pavement or base. Water filled impact attenuators require less width for placement than do sand module impact attenuators.

Figure 38-8.C gives comparisons of systems based on their operational principles.

38-8.04 Maintenance and Repair Considerations

Some systems require extensive repairs or replacement after a full speed impact, while some others may only require minor adjustments and/or replacement of drop-in modules or simply resetting with minimal repair parts. Additionally, some systems retain partial capability to shield a hazard after an initial impact and before repair.

Sand modules are particularly vulnerable to nuisance hits from mowers or wide vehicles. Such occurrences may puncture the plastic modules and cause loss of sand, thereby rendering the devices less effective. Care should be taken to provide some buffer space on the pad for sand modules to allow for mower overhang. A minimum suggested buffer is 12 in. (300 mm) along the sides and front of the array.

Impact attenuators that incorporate tracks or guides anchored to a base may be subject to accumulation of road debris (e.g., sand and silt). In extreme cases and conditions these may interfere with the operation of the attenuator. Generally, attenuator locations should be kept out of depressed locations or other sites that encourage deposition of debris. Where this is unavoidable, the designer may "write out," by special provision, any specific impact attenuators that have critical moving parts (e.g., tracks, guides, rollers, cables) near the ground line.

38-8.04(a) Resettable Devices

Resettable devices are those that do not usually require significant repair parts but may require some work to return the system to a crashworthy configuration ready for the next impact. The initial cost for these systems is intermediate between severe use (see Section 38-8.04(b)) and other fully-redirective devices. These devices are cost-effective where significant impacts may occur one or more times in a three-year period. Spreadsheets are available for more detailed analysis. Contact the Bureau of Safety Programs and Engineering for more information.

Operational Principal	Advantages	Disadvantages
Energy Absorbing Devices	<ul style="list-style-type: none"> • Little or no debris after a hit. • Ease of maintenance after a hit. • Some systems retain partial attenuation capacity after a hit. • Protection from pocketing at transition from impact attenuator to hazard. • Adaptable to very narrow hazards. 	<ul style="list-style-type: none"> • Possible high initial cost. • Considerable site preparation (e.g., pad, back-up structure, mounting bolts or anchors). • IDOT pay items and specifications will cover hazards up to only 90 in. (2.25 m) wide. See Section 38-8.06. • Not suitable for spanning structural expansion joints. Special details required in plans. Contact BSPE if this application is required.
Momentum Transfer Devices (Sand Modules)	<ul style="list-style-type: none"> • Relatively low initial cost. • Ease of installation. • Versatile; can be used to cover a large area. 	<ul style="list-style-type: none"> • Considerable debris after a unit is hit. • Generally, no residual attenuation capacity after a major hit. • No side redirection and little or no protection at transition for impact attenuator to hazard. • Considerable inventory of parts and space for replacements required. • Modules may “walk” when placed on structures. Contact BDE if this application is required.
Momentum Transfer Devices (Water Filled)	<ul style="list-style-type: none"> • Relatively low initial cost. • Ease of installation. • Little or no site preparation. • Does not require anchorage to a paved base. • Adaptable to very narrow hazards. • After impact, can be restored quickly by two laborers and a water supply/tank. 	<ul style="list-style-type: none"> • Water on ground or pavement immediately after a hit. • Require environmentally friendly antifreeze for cold weather application. • Attaches only to concrete barrier, although the barrier may transition then to other systems. • Generally, no residual attenuation capacity after a major hit. • No side redirection. Must be placed beyond the length of need point. • Modules may “walk” when placed on cross-sloped structures. Contact BDE if this application is required.

COMPARISON BY OPERATIONAL PRINCIPLE

Figure 38-8.C

There is no specification for wide impact attenuators in the resettable category. This is because the available systems vary in their treatment of this issue. Where a wide hazard is to be shielded with a resettable attenuator, the designer may prepare a special barrier transition from the hazard to the attenuator connection. See the manufacturer's specifications and drawings as well as Section 38-6.05.

38-8.04(b) Severe Use

Severe use applies to installations where the crash cushion should retain some residual capacity to absorb additional frontal impacts while awaiting repairs. The crash cushion should also require minimum cost and time for repairs after an impact. These installations are those where repeated or frequent hits are known or anticipated, and where lane closures to repair the crash cushion need to be kept to a minimum time window.

The residual frontal impact capacity available in the severe use items may be offset by some reduction in redirective capability. The residual capacity is not a substitute for proper inspection and repair after each impact. Also, the elastic components will deteriorate with time and repeated impacts and will require replacement. Some current indications are that about 13 to 15 impacts may warrant replacement.

38-8.05 Approved Devices

1. Approved Devices. For routine use by the Department, a system must be on the Department's QPL for Impact Attenuators. Unless otherwise noted, all items on the QPL are crash tested and accepted at Test Level 3. This level of safety is adequate for facilities with design speeds greater than 45 mph. For facilities with normal roadside design speeds of 45 mph or less, the designer may specify the use of devices accepted at Test Level 2. Information relative to Test Level 2 devices is included in Figure 38-8.G and the list of approved devices. Also, see Figure 38-8.G for a partial review and comparison of attributes of various approved systems.
2. Other Devices. There are some crashworthy devices that are not listed on the Department's QPL. For information about these devices, see the FHWA website, the AASHTO *Roadside Design Guide*, and the various manufacturers' brochures and Internet sites. A proposed use of these devices must be coordinated with BDE and BSPE.

Figure 38-8.H correlates the various systems relative to contract pay items.

38-8.06 Physical Placement Requirements

Several factors should be considered in the placement of an impact attenuator:

1. Level Terrain. All impact attenuators have been designed and tested for level conditions. Vehicular impacts on devices placed on an excessively sloped site could result in an impact at an improper height, which could produce undesirable vehicular behavior. Therefore, the attenuator should be placed on a base or pavement slightly sloped to

facilitate drainage, but the cross slope should not to exceed 5%, or as allowed by the proprietary specifications. Impact attenuators that require anchorage to the base should not be placed over a break in slope as this can misalign necessary guide rails and other components.

2. Curbs. No curbs higher than 2 in. (50 mm) should be constructed at impact attenuator installations. On existing highways, all curbs higher than 4 in. (100 mm) should be removed at proposed installations, if feasible.
3. Surface. Many impact attenuator systems require a paved, bituminous or concrete pad. To minimize nuisance hits, especially for sand module impact attenuators, the total base width should be 2 ft (600 mm) wider than the array.
4. Elevated Structures. The unanchored sand modules or water-filled impact attenuators may “walk” due to the vibration of an elevated structure with a cross-sloped surface. This could adversely affect its performance. If it is necessary to place sand modules or water-filled impact attenuators on elevated structures, contact BDE for assistance.
5. Orientation. The impact attenuator should be oriented to accommodate the probable impact angle of an encroaching vehicle. See Figures 38-8.A and 38-8.B for sand modules. This will maximize the likelihood of a head-on impact. However, this is not as important for impact attenuators with redirective capability. The proper orientation angle will depend upon the design speed, roadway alignment, and lateral offset distance to the attenuator. A maximum angle of approximately 15° toward oncoming traffic, as measured between the highway and impact attenuator longitudinal centerlines, is considered appropriate.
6. Location. The system must not infringe on the traveled way. There should be a minimum of 2 ft (600 mm) behind sand module systems and in front of the hazard to allow access to the system. The space or transition behind other impact attenuator systems should be according to the manufacturer’s specifications.
7. Bridge Joints. Avoid the placement of fully or partially redirective impact attenuators over bridge expansion joints or deflection joints in deep superstructures because movement in these joints could create destructive strains on the system’s anchor cables or other continuous parts.
8. Transitions. If required, transitions between systems and backwalls, bridge rails, or other objects are detailed in various proprietary systems. Review the acceptance information and Figure 38-8.G to ensure that systems are approved for bidirectional applications where necessary.

Many impact attenuators can connect to guardrail or to concrete barrier. In these cases, and where the available length allows, width transitions may be designed using a barrier extended back from the impact attenuator to a connection to or protective position in front of the wide hazard. The barrier design and flare rates should be according to Section 38-6 and the *IDOT Highway Standards*. Any flared barrier or impact attenuator may somewhat increase the redirection angle for impacting vehicles.

38-8.07 Cost

The designer should investigate relative costs for items under consideration. In some cases, a premium for fully redirective properties, for a resettable system, or for items for severe use installations will be offset by the maintenance or repair benefits provided. However, the designer should be careful not to apply premium systems where crashes are rare (1 or less expected impact per 10 years). In these cases, consider using simpler, lower priced systems.

Conversely, use of a low-cost, sacrificial system in an area with occasional (up to 1 crash per 3 years) to frequent impacts (2 or more impacts per year) will lead to high costs for repeated replacement of the attenuator.

38-8.08 Pedestrian/Bicyclist Environment

Impact attenuators are designed to contribute to a forgiving roadside for errant vehicles. The crash testing takes place at 60 mph (100 km/hr) (nominal) and angles up to 25° for Test Level 3 and at 45 mph (70 km/hr) (nominal) and similar angles for Test Level 2 devices. The impact attenuators developed to buffer such crashes are often constructed of steel panels and frames, cables, and steel or wood posts. Also, during an impact, these parts are designed to move, crush, or break in a controlled manner. As result, the impacting vehicle may rotate, rebound, or glance off the impact attenuator.

Placing an impact attenuator in a pedestrian environment imposes compromises and tradeoffs between vehicle occupant safety and pedestrian/bicyclist safety. Consider the following:

- As much as practical, impact attenuators should be placed away from pedestrian/bicyclist facilities. For example, where an impact attenuator must be located at the end of a parapet or wall crossing a bridge, if space permits, extend the wall or parapet beyond the bridge and separate the pedestrian/bicyclist pathway from the wall and roadway before introducing the impact attenuator.
- Evaluation of the tradeoffs between vehicular and pedestrian/safety should include factors contributing to the relative risk for each user class. These include exposure of individuals, quality of the design/design constraints, and expected severity of each crash category.
- Exposure measures include ADT for vehicular traffic, pedestrian volumes, and bicycles.
- Measuring the quality of the design includes mainly the offset between the impact attenuator and the roadway and/or pedestrian/bicyclist way along with any constraints on developing the offset.
- To evaluate the expected severity of any crashes, consider the operating speed of the roadway facility, the treatment under consideration (e.g., impact attenuator, blunt end, sloped end), and the nature of any particular impact attenuators.
- Figure 38-8.D offers guidance regarding pedestrian/bicyclist considerations for particular impact attenuators.

Impact Attenuator System or Family	Pedestrian/Bicyclist Considerations
QuadGuard	<ul style="list-style-type: none"> • Side panels face pedestrians/bicyclists from opposing direction. • Gaps should be installed as tight as possible on pedestrian side. • Top edge exposed similar to guardrail.
SCI-100GM	<ul style="list-style-type: none"> • Side panels face pedestrians/bicyclists from opposing direction. • Exposed edges are beveled and should minimize snagging. • Side panels remain nested upon head on impact. • Gaps should be installed as tight as possible on pedestrian side. • Top edge exposed similar to guardrail.
TRACC	<ul style="list-style-type: none"> • Side panels face pedestrians/bicyclists from opposing direction. • Gaps should be installed as tight as possible on pedestrian side. • Top edge exposed similar to guardrail.
TAU-II	<ul style="list-style-type: none"> • Same as TRACC.
QUEST	<ul style="list-style-type: none"> • Same as TRACC.
REACT 350	<ul style="list-style-type: none"> • Heavy plastic drums connected/restrained by steel cables. • Steel cables are main hazard to pedestrians/bicyclists on the face. • Tops are 4.5 ft (1.4 m) off the ground and should not be hazardous to pedestrians/bicyclists.
CAT-350	<ul style="list-style-type: none"> • Similar to guardrail terminal.
Brakemaster 350	<ul style="list-style-type: none"> • Similar to guardrail terminal.
FLEAT-MT	<ul style="list-style-type: none"> • Similar to guardrail terminal.
Sand Modules	<ul style="list-style-type: none"> • Plastic drums weighted with sand. Any spilled sand may affect walking/cycling surface.
ABSORB 350	<ul style="list-style-type: none"> • Plastic barrier shape filled with water. • Temporary use only. • Any spilled water may freeze or otherwise wet the walking/cycling surface.
Compressor	<ul style="list-style-type: none"> • Steel side panels with exposed ends edges and connectors. • Varying height, including heavy plastic energy absorbing panels.
HEART	<ul style="list-style-type: none"> • Heavy plastic side panels surround and overhang steel diaphragms, posts, and base. • Bolted external steel retainers hold plastic panels to diaphragms.
SLED	<ul style="list-style-type: none"> • Water filled plastic modules. • External steel framing on first module.

PEDESTRIAN/BICYCLIST CONSIDERATIONS FOR IMPACT ATTENUATORS

Figure 38-8.D

38-8.09 Impact Attenuator Selection

The selected impact attenuator must be compatible with the specific site characteristics. For each category of device, more than one approved system must be allowed for competitive bidding, unless specific approval is made according to Section 66-1.04(b). Selection of the correct category (pay item) will require comparison and analysis of possible solutions. Factors to consider include:

- type and width of hazard (see Section 38-8.06 on transitions);
- space, or reserve area, available for installation of the system. The reserve area allows for placement of the barrier and any necessary clearances; see Figure 38-8.E;
- whether the hazard to be shielded is located in a high- or low-risk impact area;
- initial, maintenance, and restoration costs;
- ease or difficulty of restoration of the system after impact. The importance of this factor will be related to the traffic and hazard levels at a site. More traffic and higher hazards will make speedy repair or replacement a higher priority; and
- presence and direction of travel of traffic on each side of the impact attenuator.

Figure 38-8.F summarizes the advantages and disadvantages of the impact attenuator principles and categories provided in Department specifications. There are many other factors that will influence the selection of an impact attenuator for a given site. Therefore, the designer should only use this figure as a starting point in the comparison and analysis process for selection of the best category.

38-8.10 Temporary Installations

Access to the work site becomes an additional consideration for temporary installations, especially where temporary concrete barriers are used to close a lane or to channel traffic.

Also, in some cases (e.g., stage construction of two-lane bridges) it may be desirable for the impact attenuator to block the closed lane, reducing the likelihood that an errant vehicle could reach the construction area. These competing needs, access and physical closure of the lane, may be mutually exclusive at some sites where shoulders and right of way are restrictive.

Where construction access can be provided on the shoulders or by other available means (e.g., temporary widening, easement), the preferred layout would include concrete barriers and an impact attenuator placed to effectively block the closed lane. The designer should provide necessary plan details to show the positioning of the concrete barrier and impact attenuator devices. If sand module impact attenuators are allowed, appropriate configuration from *Highway Standard 643001* should be noted in the plans. Width restrictions may not allow for angling the array toward traffic. In this case, the array should be installed parallel to the roadway.

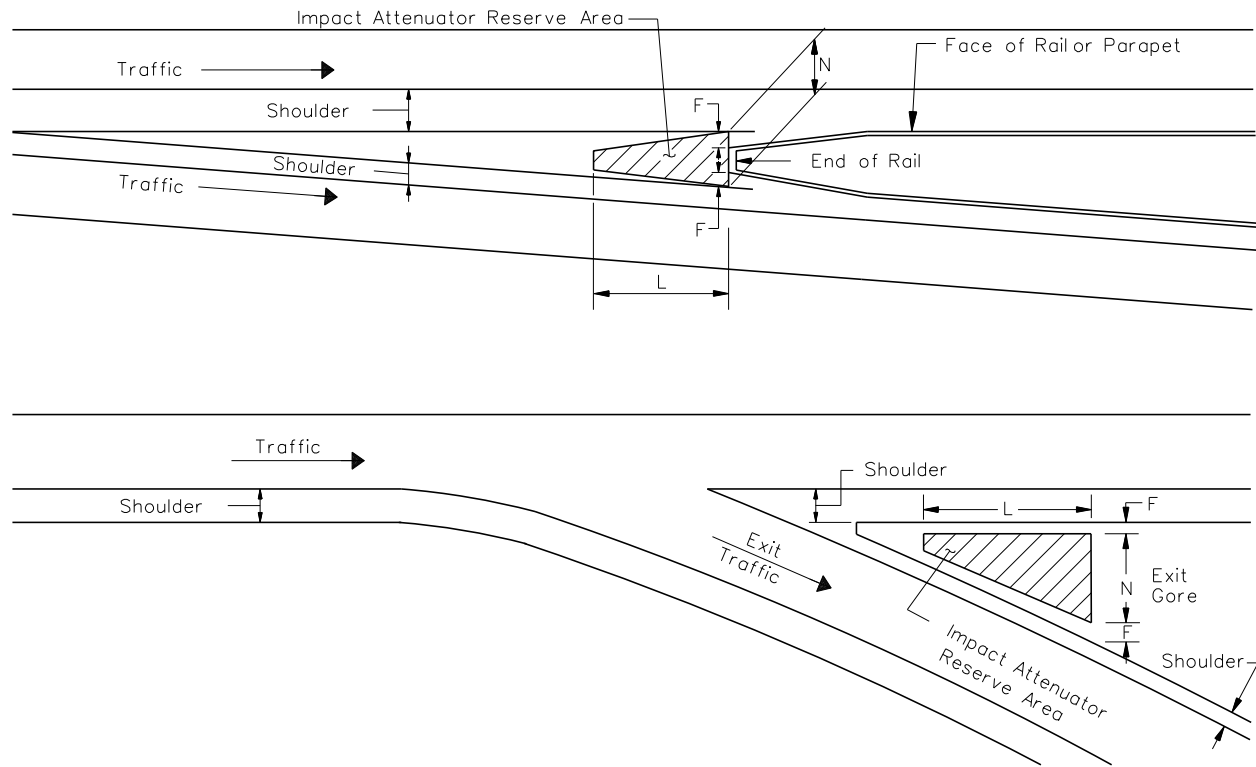

Design Speed (DS) On Mainline (mph)	Dimensions for Impact Attenuator Reserve Area (feet)								
	Minimum						Preferred		
	Restricted Conditions			Unrestricted Conditions					
	N	L	F	N	L	F	N	L	F
DS ≤ 30	6	8	2	8	11	3	12	17	4
30 < DS ≤ 50	6	17	2	8	25	3	12	33	4
50 < DS ≤ 70	6	26	2	8	45	3	12	55	4
70 < DS ≤ 80	6	35	2	8	55	3	12	70	4

Design Speed (DS) On Mainline (km/hr)	Dimensions for Impact Attenuator Reserve Area (meters)								
	Minimum						Preferred		
	Restricted Conditions			Unrestricted Conditions					
	N	L	F	N	L	F	N	L	F
DS ≤ 50	2.0	2.5	0.5	2.5	3.5	1.0	3.5	5.0	1.5
50 < DS ≤ 80	2.0	11.6	0.6	2.8	12.2	1.0	3.5	10.0	1.5
80 < DS ≤ 110	2.0	8.5	0.5	2.5	13.5	1.0	3.5	17.0	1.5
110 < DS ≤ 130	2.0	11.0	0.5	2.5	17.0	1.0	3.5	21.0	1.5

RESERVE AREA FOR IMPACT ATTENUATORS

Figure 38-8.E

Operational Principle (Pay Item)	Advantages	Disadvantages	Typical Uses*
Energy Absorbing	See Figure 38-8.C.	See Figure 38-8.C.	
Impact Attenuators (fully redirective, narrow) and Impact Attenuators, Temporary (fully redirective, narrow)	<ul style="list-style-type: none"> Prevents encroaching vehicle from traveling behind the impact attenuator. Space efficient. Can fit narrow hazards. Where space permits, connection to a barrier system may allow shielding of wider hazards. 	<ul style="list-style-type: none"> Residual capacity after an impact varies among items. Requires anchoring to a slab or pavement. Not suited to wide hazards. 	<ul style="list-style-type: none"> Ends of concrete barrier beyond full shoulder width where impacts are expected to be rare. Intermediate width medians, piers. Type D guardrail.
Impact Attenuators (fully redirective, wide), and Impact Attenuators, Temporary (fully redirective, wide)	<ul style="list-style-type: none"> Prevents encroaching vehicle from traveling behind the impact attenuator. IDOT pay items and specifications will cover hazards up to only 90 in (2.25 m) wide. See Section 38-8.06 Space efficient. 	<ul style="list-style-type: none"> Residual capacity after an impact varies among items in this category. Requires anchoring to a slab or pavement. 	<ul style="list-style-type: none"> As above, but for wide hazards (e.g., wide piers) or gore hazards.
Impact Attenuators (severe use, narrow) and Impact Attenuators, Temporary (severe use, narrow)	<ul style="list-style-type: none"> Prevents encroaching vehicle from traveling behind the impact attenuator. May retain significant useful impact capacity after some hits. Space efficient. Can fit narrow hazard. 	<ul style="list-style-type: none"> Higher cost than items not requiring severe use characteristics. Requires anchoring to a slab or pavement. Not suited to wide hazards. May rebound a vehicle as the system restores after a frontal hit. This may create secondary collisions with traffic. Requires post impact monitoring to ensure that reusable modules are replaced at the end of their service life. 	<ul style="list-style-type: none"> Ends of concrete barrier separating opposing traffic where repeated or frequent hits are expected and/or where it is necessary to keep repair visits and times to a minimum. Narrow medians. Type D guardrail. Roadside concrete barrier or bridge parapet in a temporary application. Other narrow point hazards. This may require limiting the list of devices to those that are free-standing with respect to the hazard.

* See Figures 38-8H and 38-8.I for additional information.

COMPARISON BY PAY ITEM

Figure 38-8.F

Operational Principle (Pay Item)	Advantages	Disadvantages	Typical Uses*
Energy Absorbing	See Figure 38-8.C.	See Figure 38-8.C.	
Impact Attenuators (fully redirective, resettable)	<ul style="list-style-type: none"> • Requires minimal parts and labor for repairs. Low life-cycle cost where there are occasional to frequent impacts. • Prevents encroaching vehicle from getting behind the impact attenuator. • Space efficient. • Can fit narrow hazard. 	<ul style="list-style-type: none"> • Initial cost higher than non-premium system. • Not required to self-restore after impact. • May require a special barrier detail to transition to a wide hazard. 	<ul style="list-style-type: none"> • As above, but where impacts are expected on an occasional basis. (At least 1 per 3 years, up to 2 per year, depending on accessibility for repairs and impacts to traffic.)
Impact Attenuators (severe use, wide) and Impact Attenuators, Temporary (severe use, wide)	<ul style="list-style-type: none"> • May retain significant useful frontal impact capacity after some hits. • Space efficient. • Can cover a hazard width up to about 90 in (2.25 m). 	<ul style="list-style-type: none"> • Higher cost than items not requiring severe use characteristics. • Requires anchoring to a slab or pavement. • May rebound a vehicle as the system restores after a frontal hit. This may create secondary collisions with traffic. 	<ul style="list-style-type: none"> • Piers or gore areas separating opposing traffic where repeated or frequent hits are expected and/or where it is necessary to keep repair visits and times to a minimum. • Narrow medians.
Impact Attenuators (partially redirective)	<ul style="list-style-type: none"> • Lower cost than fully redirective systems. • Suited for direct attachment to Type D guardrail. 	<ul style="list-style-type: none"> • For narrow hazards. • Requires posts to be driven. • Lack of reserve impact capacity after a hit. 	<ul style="list-style-type: none"> • Ends of Type D guardrail separating traffic lanes moving in the same direction, and where impacts are expected to be infrequent. • Wide medians, gore areas. • Concrete barrier on right side shoulders, or at gores.
Impact Attenuators (non-redirective)	See Figure 38-8.C for Sand Modules.	See Figure 38-8.C for Sand Modules.	Point hazards (e.g., piers or sign foundations) not near a travel lane.

*See Figures 38-8.H and 38-8.I for additional information.

COMPARISON BY PAY ITEM

Figure 38-8.F
(Continued)

Operational Principle (Pay Item)	Advantages	Disadvantages	Typical Uses*
Momentum Transfer	See Figure 38-8.C.	See Figure 38-8.C.	
Impact Attenuators Temporary (non-redirective)	See Figure 38-8.C.	<ul style="list-style-type: none"> • Area for application must have enough room to accommodate either the sand modules or the water filled impact attenuator (ABSORB 350). • Applies principally where it will shield end of a temporary concrete barrier. 	<ul style="list-style-type: none"> • Ends of concrete barriers or other hazards well off the traffic lane, and where it is acceptable to allow a vehicle to encroach behind the device. • See <i>Highway Standards</i> 701321 and 701402.

*See Figures 38-8.H and 38-8.I for additional information.

COMPARISON BY PAY ITEM

Figure 38-8.F
(Continued)

Where shoulders of sufficient width or other means of access are not available, the designer can arrange the concrete barriers according to the minimums shown on the *Illinois Highway Standards* and choose among the various pay items for temporary impact attenuators, as appropriate for the site and traffic. This will allow the contractor a range of options to weigh for access, cost and maintenance factors.

38-8.11 Additional Guidance

Figure 38-8.G provides a partial review and comparisons of the attributes for the various Department approved systems. Figures 38-8.H and 38-8.I correlate the operational principles to the specific systems and typical applications; refer to the QPL regarding any questions regarding these systems and their MASH testing status.

Specific dimensions, installation requirements, and other details are best documented by the various manufacturers. Refer to the Department's lists of approved devices for manufacturer names, contact information and web page links.

System	Non-Redirective	Partially Redirective	Fully Redirective	Resetttable	Residual Capacity	Width	Connects To:	Bidirectional? (Y/N)	Length** (Test Level 3)	Length** (Test Level 2)	Min width (Out to Out)**	Max Width*	Notes
Quadguard			X			Up to 120"	Generic	Y	23'-11"	12'-9"	2'-7"	120"	Requires paved pad.
Quadguard II			X			Up to 120"	Generic	Y	19'-2"	10'-2"	2'-7"	120"	Requires paved pad.
Quadguard Elite			X		X	Up to 120"	Generic	Y	35'-8"	23'-11"	2'-7"	120"	Requires paved pad.
Quadguard LMC			X		X	Up to 120"	Generic	Y	35'-8"	23'-11"	2'-7"	120"	Requires paved pad.
CAT-350		X				Narrow	Type D Guardrail or Concrete Barrier	Y	31'-3"	N/A	2'-7"	2'-7"	Installs on driven posts
REACT 350			X	X		Up to 120"	Generic	Y	31'-1"	23'-1"	3'	120"	Requires paved pad.
Brakemaster 350		X				Narrow	Type D Guardrail or Concrete Barrier	Y	31'-8"	N/A	2'-1"	2'-1"	Installs on driven posts
Universal TAU-II			X			Up to 96"	Generic	Y	28'-11"	16'-5"	2'-11"	8'-8"	Requires paved pad.
FLEAT MT		X				Narrow	Type D Guardrail or Concrete Barrier	Yes, but intended for wide median	37'-6"	25'	Match Type D Guardrail	Match Type D Guardrail	Installs on driven posts
TRACC			X			Narrow	Generic	Y	21"	14'	2'-7"	4'-10" (See Note)	Requires paved pad.
QUEST			X			Narrow	Type D Guardrail or Concrete Barrier	Y	16'-10"	N/A	2'	2'	Requires paved pad.
SAND MODULES	X					As needed	Generic	Case-by-case design issue	30'-7"	23'-7"	6'-6"	As needed	Requires paved pad For permanent installation. Requires aggregate pad for temporary installation
ABSORB 350	X					Narrow	Temporary Concrete Barrier	Y	28'-9"	19'-1/4"	2'	2'	Does not require paved surface. Temporary use only.
SCI 100-GM			X	X		Narrow	Generic	Y	21'-6"	N/A	3'-1 7/8"	3'-1 7/8"	Requires paved pad.
SCI 75-GM			X	X		Narrow	Generic	Y	N/A	13'-6"	3'-1 7/8"	3'-1 7/8"	Requires paved pad.
Compressor			X		X	Narrow	Generic	Y	21'-3"	N/A	4'-1"	4'-1"	Requires paved pad.
HEART			X		X	Narrow	Generic	Y	26'-3"	N/A	2'-4"	2'-4"	Requires paved pad.
Sentry Longitudinal Energy Dissipator (SLED)	X					Narrow	Traffic water-filled Barrier or generic concrete safety shape	Y	26'	N/A	22 1/2"	22 1/2"	Does not require paved surface. Temporary use only.

Notes:

The TRACC may be widened. At its nominal length and at Test Level 3, the maximum width is 58 in. (1.47 m). Additional width may be gained in approximately 6½ in. (165.1 mm) increments by the addition of 28 in. (711 mm) extension wings.

* The minimum widths shown are nominal out-to-out of the impact attenuator. The various backup systems, transition pieces, etc., are considered part of the impact attenuator, and are to be considered part of the pay item.

ATTRIBUTES OF IMPACT ATTENUATORS

Figure 38-8.G

Systems and Allowable Products to Fit Needs	Typical Applications
<p><i>Impact Attenuators (fully redirective, narrow)</i></p> <p>QuadGuard QuadGuard Elite QuadGuard LMC QuadGuard II REACT 350 Universal TAU-II Universal TAU-II-R TRACC family SCI-100GM (Test Level 3) SCI-70GM (Test Level 2) QUEST Compressor HEART</p>	<ul style="list-style-type: none"> • Where the expected rate of crashes involving the system are rare to infrequent (less than 1 crash per 3 years). • *Narrow median (< 40 ft (12 m)). • Narrow hazard, concrete barrier, narrow pier. • End of median barrier or Type D rail. • Alignment or traffic operations do not contribute to added likelihood of run off the road incidents.
<p><i>Impact Attenuators (fully redirective, wide)</i></p> <p>QuadGuard QuadGuard Elite QuadGuard II React 350 TRACC family Universal TAU-II Universal TAU-II-R SCI-100GM (Test Level 3) SCI-70GM (Test Level 2)</p>	<ul style="list-style-type: none"> • *Narrow median (< 40 ft (12 m)). • Up to 90 in. (2.25 m) wide hazard, sign base, pier, etc. • Narrow gap between bridges. • Alignment or traffic operations do not contribute to added likelihood of run off the road incidents. • Hazards where space does not allow development of width transitions from other impact attenuators.
<p><i>Impact Attenuators (fully redirective, resettable)</i></p> <p>REACT 350 SCI-100GM (Test Level 3) SCI-70GM (Test Level 2) Universal TAU-II Universal TAU-II-R Compressor HEART</p>	<ul style="list-style-type: none"> • Where crashes are expected to be more than 1 per 3 years. • Similar locations to fully redirective, narrow.
<p><i>Impact Attenuators (severe use, narrow)</i></p> <p>QuadGuard Elite REACT 350 Universal TAU-II-R SCI-100GM (Test Level 3) SCI-70GM (Test Level 2)</p>	<ul style="list-style-type: none"> • *Narrow median (< 40 ft (12 m)). • Expect repeated impacts (> 2/yr). • Narrow hazard, concrete barrier, narrow pier. • End of median barrier or Type D rail. • Outside of curves, areas near weaving, lane drops. • Near entrances/exits on freeways/expressways. • Also appropriate on outside shoulder hazards where repeated impacts and traffic levels make continued capability and ease of repairs critical.

IMPACT ATTENUATORS – PERMANENT INSTALLATIONS

Figure 38-8.H

Systems and Allowable Products to Fit Needs	Typical Applications
<p><i>Impact Attenuators (severe use, wide)</i></p> <p>QuadGuard Elite REACT 350 Universal TAU-II-R</p>	<ul style="list-style-type: none"> • *Narrow median (< 40 ft (12 m)) • Expect repeated impacts. • Up to 90 in. (2.25 m) wide hazard, sign base, pier, etc. • Narrow gap between bridges. • Outside of curves, areas near weaving, lane drops. • Near entrances/exits on freeways/expressways. • Also appropriate on outside shoulder hazards where repeated impacts and traffic levels make continued capability and ease of repairs critical. • Hazards where space does not allow development of width transitions from other impact attenuators.
<p><i>Impact Attenuators (partially redirective)</i></p> <p>*CAT 350 *FLEAT MT</p>	<ul style="list-style-type: none"> • Outside shoulder, gore area. • Narrow hazard, pier, barrier wall, D rail. • Separation of lanes moving in same direction. • Expected low frequency of hits.
<p><i>Impact Attenuators (non-redirective)</i></p> <p>Energite III Big Sandy Sand Barrels CrashGard Sand Barrel System</p>	<ul style="list-style-type: none"> • Outside shoulder, gore area, wide median. • Sign support, etc. • Separation of lanes moving in same direction, or where there is a wide separation.

Notes:

The TRACC may be widened. At its nominal length, the maximum width is 58 in. (1.47 m). Additional width may be gained in approximately 6½ in. (165.1 mm) increments by the addition of 28 in. (711 mm) extension wings.

**See Figure 38-7.B. Warrants for median barriers may be considered also as an estimate of when to begin consideration of fully-redirective crash cushions in a median area.*

Use of standard barrier sections and approved flare rates may allow installation of narrow impact attenuators in advance of wide hazards, depending on space available.

IMPACT ATTENUATORS – PERMANENT INSTALLATIONS

Figure 38-8.H
(Continued)

Systems and Allowable Products to Fit Needs	Typical Applications
<p><i>Impact Attenuators (temporary) (fully redirective, narrow)</i></p> <p>QuadGuard CZ QuadGuard LMC QuadGuard Elite REACT 350 TRACC Family Universal TAU-II Universal TAU-II-R SCI-100GM (Test Level 3) SCI-70GM (Test Level 2) HEART QUEST Compressor</p>	<ul style="list-style-type: none"> • Locations where the rate of crashes is expected to be less than 1 per 3 years, and first costs control.** • *Narrow median locations. • Temporary locations where errant vehicles must not encroach behind the device. • Head to head traffic. • Severe hazards beyond the device.
<p><i>Impact Attenuators (temporary) (fully redirective, wide)</i></p> <p>QuadGuard Elite QuadGuard LMC REACT 350 TRACC Family Universal TAU-II Universal TAU-II-R SCI-100GM (Test Level 3) SCI-70GM (Test Level 2)</p>	<ul style="list-style-type: none"> • Similar to locations for fully redirective, narrow, but where the hazard is wide.
<p><i>Impact Attenuators (temporary) (fully redirective, resettable)</i></p> <p>REACT 350 SCI-100GM(Test Level 3) SCI-70GM (Test Level 2) Universal TAU-II-R Compressor HEART</p>	<ul style="list-style-type: none"> • Where crashes are expected to be more than 1 per 3 years and life cycle costs control.** • Similar to locations for fully redirective, narrow.
<p><i>Impact Attenuators (temporary) (non-redirective)</i></p> <p>Fitch Universal Module System Energite III Big Sandy Sand Barrels CrashGard Sand Barrel System Sentry Longitudinal Energy Dissipater (SLED) Absorb 350</p>	<ul style="list-style-type: none"> • Temporary locations where errant vehicle may continue behind the crash cushion. • See <i>Highway Standards</i> 701321 and 701402 as site conditions permit.

IMPACT ATTENUATORS – TEMPORARY INSTALLATIONS

Figure 38-8.I

Systems and Allowable Products to Fit Needs	Typical Applications
<i>Impact Attenuators, Temporary (non-redirective, narrow)</i> ABSORB 350 Sentry Longitudinal Energy Dissipater (SLED) ACZ 350 System	Space limitations preclude sand barrel arrays.
<i>Impact Attenuators, Temporary (severe use, narrow)</i> QuadGuard LMC QuadGuard Elite REACT 350 Compressor	<ul style="list-style-type: none"> • *Narrow median locations. • Temporary locations where frequent impacts are expected and/or where access for repairs would create unacceptable traffic control or operational problems. These systems are fully redirective. This must be acceptable at the site.
<i>Impact Attenuators, Temporary (severe use, wide)</i> QuadGuard Elite REACT 350 Universal TAU-II-R	<ul style="list-style-type: none"> • Similar to locations for Severe Use, Narrow, but where the hazard is wide.

Notes:

**See Figure 38-7.B. Warrants for median barriers may be considered also as an estimate of when to begin consideration of fully-redirective crash cushions in a median area.*

***Generally, life cycle costs are the responsibility of the contractor for temporary installations.*

IMPACT ATTENUATORS – TEMPORARY INSTALLATIONS

Figure 38-8.I
(Continued)

38-9 ROADSIDE SAFETY IN URBAN OR RESTRICTED ENVIRONMENTS

This section applies to roadways characterized by built-up locations with curbed sections, frequent stops, off-peak operating speeds of 45 mph (70 km/hr) and lower, frequent traffic conflicts with driveways and side streets, multiple fixed objects in the roadside, restricted right of way, and closed drainage.

Within such areas, the application of open road clear zones may not be practical. This guidance will balance the need for a clear zone with practicality and demonstrated safety benefits in urban and restricted environments.

38-9.01 Safety Performance – Evaluation of Urban and Restricted Locations

Although a clear roadside concept is still preferred, it is more practical and most cost-beneficial to identify critical locations and features with a history of over-representation for roadside crash mitigation in urban/restricted locations.

The general hierarchy of treatments, as shown in Section 38-4.02, applies also in urban/restricted environments.

38-9.02 Operational Offset, Clear Zone, and Enhanced Lateral Offset

The lateral offset procedures in this section should be applied to any urban facility where feasible. However, lower speed facilities (posted speed limit below 30 mph), central business districts, locations with 24 hour on-street parking, and locations with limited right of way and competing uses for roadside space may minimize the application of this section.

Lateral offset concepts should be applied to built-up locations with curbed sections, frequent stops, off-peak operating speeds 45 mph (70 km/hr) and lower, frequent traffic conflicts with driveways and side streets, multiple fixed objects in the roadside, restricted right of way, and closed drainage. Lateral offset concepts and other focused roadside safety treatments should be emphasized at locations of safety performance problems related to roadside safety, and systematically to types of locations representing roadside safety issues.

1. Operational Offset. At a minimum, provide an operational offset from the face of curb to fixed objects of 1.5 ft (0.5 m) on tangents and 3 ft (0.9 m) along the radii of the curb return at intersections. These values are intended only to ease traffic operations, preserve sight distance, keep truck mirrors from striking objects, and do not represent a criterion for roadside safety design.
2. Clear Zone. Section 38-3 or applicable portions of Chapter 49 or 50 provide the appropriate clear zone values for roads, including urban and restricted locations. However, achieving full clear zones in urban or restricted environments is often not practical due to limited right of way and the many competing transportation uses and other uses in the corridor.

3. Enhanced Lateral Offset. An enhanced lateral offset of 4 ft (1.2 m) from the face of curb to any fixed object should be provided on tangent sections, and an enhanced lateral offset of 6 ft (1.8 m) should be provided on the outside of curves. For built up urban locations with no curb, the greater of these offsets doubled, or the clear zone, should be applied and measured from the edge of the traveled way.

Additional lateral offset (wider than the enhanced lateral offset) should be provided at some specific locations.

- a. Inside of Curves. In addition to creating a wider lateral offset on the outside of curves, attention should be paid to (stopping) sight distance at the inside of sharp horizontal curves to assure that the roadway is not obstructed by roadside objects or embankments; see Figure 38-9.A.
- b. Lane Merge Locations. At the taper point where the lane drop is complete, a lateral offset of 12 ft (3.6 m) should be considered. This offset should be extended at least 10 ft (3.0 m) in both directions from the taper point, and desirably along the taper to where it will intersect the extension of the lateral offset of the roadway prior to the beginning of the lane drop. Breakaway objects should have lateral offsets of at least 4 ft to 6 ft (1.2 m to 1.8 m) at these locations. A wider lateral offset at taper points on urban roadways will reduce roadside crashes at these locations and allow the driver to focus solely on merging into the traffic stream; see Figure 38-9.B.
- c. Driveway locations. A lateral offset of 10 ft to 15 ft (3.0 m to 4.6 m) should be considered for a distance of 10 ft to 15 ft (3.0 m to 4.6 m) beyond the far edge of driveways to account for driver error and times of poor visibility. Sight triangles should also be maintained; see Figure 38-9.C.
- d. Intersections. Roadside crashes at intersections are a significant concern. Particular configurations related to roadside crashes include channelization islands, objects in the curb/radius return, and objects aligned opposite pedestrian curb ramps.
 - Channelizing islands and median noses should be designed according to Chapter 36. Rigid objects at either the corner island or the median nose should be avoided where practical.
 - Object placement on the inside edge of intersection turning movements should be as far as practical from the curb face or lane edge. A target lateral offset value of the intersection return should be 6 ft (1.8 m) for curbed facilities with a minimum value of 3 ft (0.9 m). Similarly, for locations without curbs, these values should be as far as possible from the edge of the traveled way because drivers will not have a curb to help them realize their vehicles have strayed from the designated turning path.

- Rigid objects should not be positioned such that errant vehicles are directed toward them along the path of a curb ramp. It is preferable that the pedestrian pushbutton be placed on a breakaway pedestal pole adjacent to the curb ramp rather than on a rigid traffic signal pole when possible. This may also enable the traffic signal pole placement to occur further away from the curb return region.

38-9.03 Roadside Features in Urban and Restricted Areas

1. Curbs. Curbs do not typically redirect errant vehicles. Vehicles impacting barrier curbs are likely to lose contact with the ground and become uncontrollable for some distance.

When a vehicle strikes a curb, the trajectory depends on several variables including the size and suspension characteristics of the vehicle, its impact speed and angle, and the height and shape of the curb. Details of guardrail placement behind curbs are shown in *Highway Standard* 630001. Guardrail placed from 4 ft to 12 ft (1.2 m to 3.6 m) behind a curb, as shown on the standard has been crash tested to comply with *MASH* at Test Level 2.

2. Roadside Development. If objects must be placed within the enhanced lateral offset, these should be frangible or breakaway objects that do not trigger further remediation.
3. Utility Poles. Utility poles are the second most common object hit in fatal fixed object crashes and are predominately represented in urban locations.

Some practical suggestions for mitigating utility pole crashes include:

- Place utility poles as far as possible from the active travel lanes.
 - Place utility poles away from access points where poles may restrict sight distance and be more likely to be struck.
 - Place utility poles on the inside of sharp horizontal curves.
 - Place utility poles only on one side of the road.
4. Lighting. Refer to 38-4.11 for recommendations regarding rigid versus breakaway light supports.

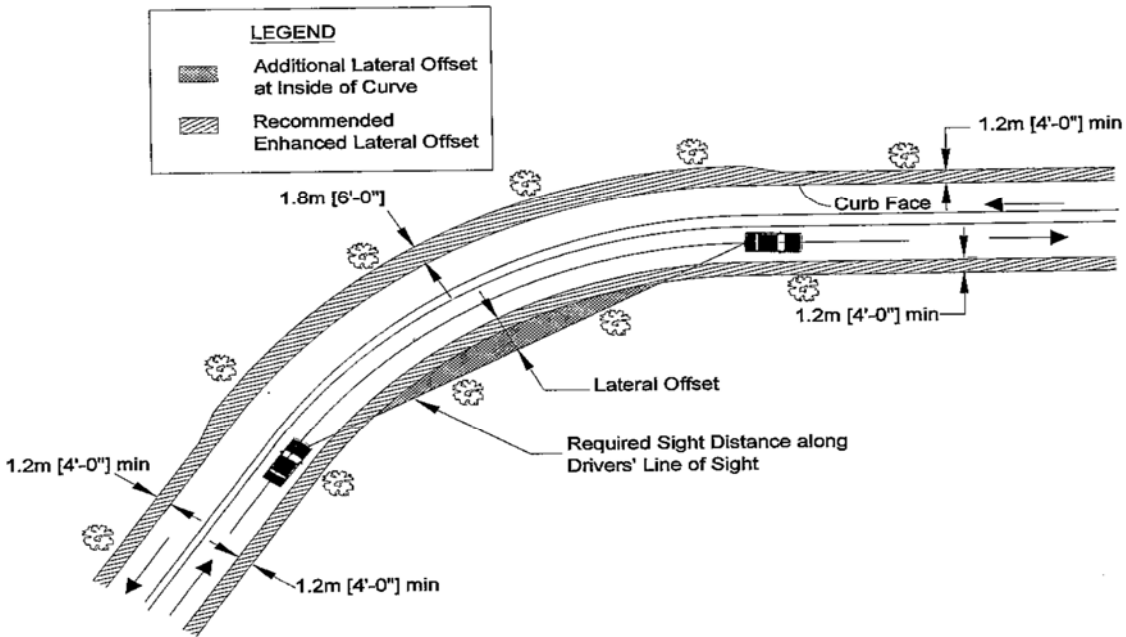

ENHANCED LATERAL OFFSET FOR CURVES IN URBAN OR RESTRICTED LOCATIONS

FIGURE 38-9.A

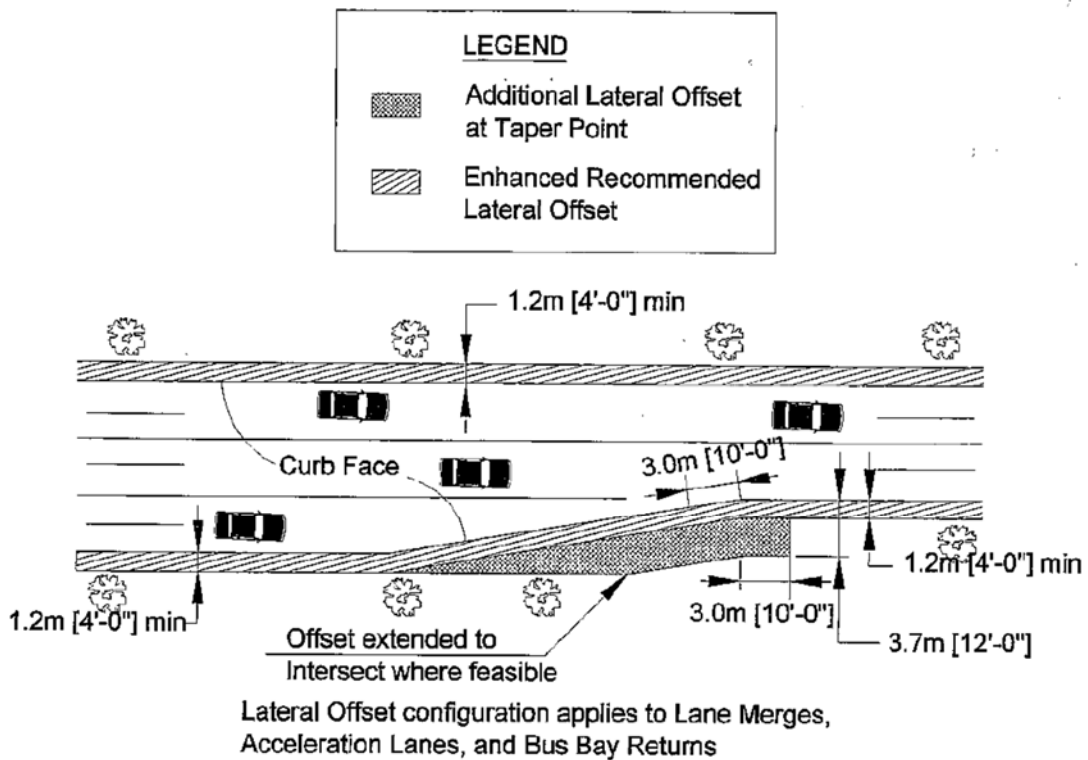

LATERAL OFFSET AT MERGE POINTS

FIGURE 38-9.B

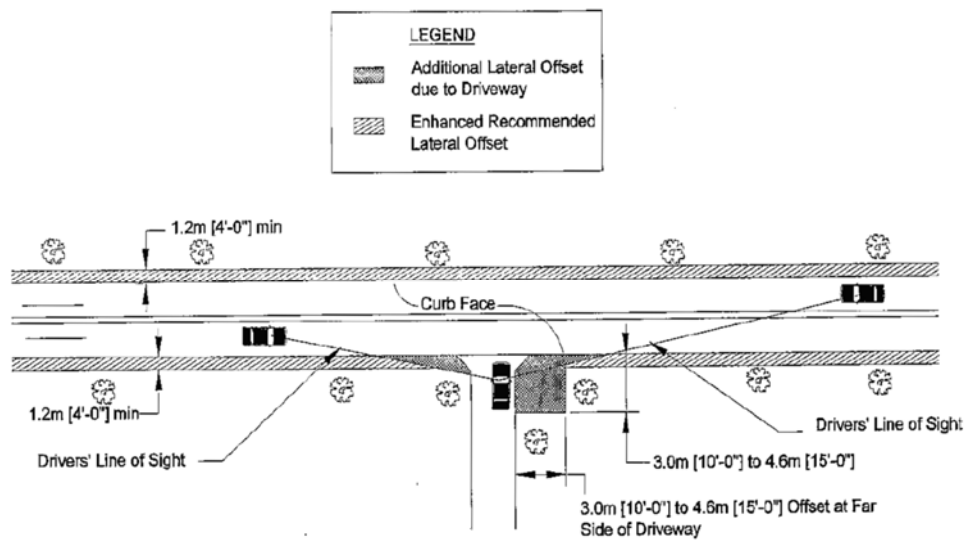

ENHANCED LATERAL OFFSET AT DRIVEWAYS

FIGURE 38-9.C

38-9.04 Use of Roadside Barriers in Urban or Restricted Environments

Barriers and their end treatments within the clear zone shall be crashworthy and approved by the Department. The use of curbs with these devices may alter details of application or rule out certain systems. The selection of the appropriate test level shall be based upon the design speed of the roadway.

Many uses and competing concerns that define the urban or restricted environment also complicate selection and application of roadside barriers in these locations. When a roadside barrier is to be used, consider all of the following to evaluate the suitability of various barrier options, and placement:

- Lateral offset from the edge of pavement or curb,
- Deflection distance of the barrier,
- Terrain effects,
- Flare rate,
- Length of need,
- Corner sight distance,
- Pedestrian activity, including the needs of persons with disabilities, and
- Bicycle activity.

Generally, a barrier should be placed as far from the traveled way as possible, but it is also desirable that a uniform clearance to items such as bridge railings, retaining walls, and roadside barriers be presented to motorists.

38-9.05 Barrier Warrants

Remediation guidelines, including barrier warrants, are presented in Section 38-4.03. However, for urban or restricted environments these warrants may be less applicable due to the variety of needs addressed by these roadways. The Roadside Safety Analysis Program (discussed in Section 38-4.01) may be used to model these environments and arrive at specific warrants where questions arise. The major premise should remain that a traffic barrier should be installed only if it is expected to reduce the likelihood of severe crashes.

Innocent Bystander and Adjacent Land Use Protection. There are no set warrants or guidelines for these situations. Design judgment should be used. Consider crash history and site-specific factors.

38-9.06 Common Urban Barrier Treatments

1. Roadside and Median Barriers. Generally, median barriers will not be warranted or recommended in urban areas with street intersections, curbs, and design speeds of 45 mph (70 km/hr) or less. The use of roadside barriers will be tempered by the considerations of Section 38-9.05.
2. Crash Cushions. Crash cushions, especially those that are fully-redirective, take less space than standard roadside barrier installations. They may be more practical in many cases, especially for shielding fixed objects.

38-10 REFERENCES

1. *Roadside Design Guide*, AASHTO, 2011.
2. *A Supplement to "A Guide for Selecting, Locating, and Designing Traffic Barriers,"* Texas Transportation Institute, March 1980.
3. *Safety Design and Operational Practices for Streets and Highways*, FHWA, March 1980.
4. "A Roadside Design Procedure," James Hatton, Federal Highway Administration, January 1974.
5. NCHRP Synthesis 66, *Glare Screen Guidelines*, Transportation Research Board, December 1979.
6. NCHRP Report 350, *Recommended Procedures for the Safety Performance Evaluation of Highway Features*, Transportation Research Board, 1993.
7. *Illinois Highway Standards*, current edition.
8. *Manual for Assessing Safety Hardware*, AASHTO, 2016.
9. NCHRP Report 638, *Guidelines for Guardrail Implementation*, Transportation Research Board, 2009.
10. NCHRP Report 711, *Guidelines for Selection, Use, and Maintenance of Cable Barrier Systems*, Transportation Research Board, 2012.
11. "Report on The Advisability of Expanding the Use of Cable Median Barrier in Illinois", Prepared for Illinois Legislature by CH2M Hill for the Illinois Department of Transportation, 2009.

Chapter Thirty-nine

STRUCTURE PLANNING/GEOMETRICS

BUREAU OF DESIGN AND ENVIRONMENT MANUAL

Chapter Thirty-nine
STRUCTURE PLANNING/GEOMETRICS

Table of Contents

<u>Section</u>	<u>Page</u>
39-1 ADMINISTRATION.....	39-1.1
39-1.01 Introduction	39-1.1
39-1.02 BB&S Functions.....	39-1.1
39-1.03 BB&S Organization	39-1.2
39-2 BRIDGE POLICIES AND DESIGN	39-2.1
39-2.01 Specifications for Bridge Design.....	39-2.1
39-2.02 Specifications for Bridge Construction.....	39-2.1
39-2.03 Standard Practice Manuals	39-2.1
39-2.04 Policy Memoranda	39-2.2
39-2.05 Experimental Bridge Features	39-2.2
39-3 BRIDGE PLANNING PROCESS	39-3.1
39-3.01 Bridge Improvements	39-3.1
39-3.01(a) Scope of Work Definitions	39-3.1
39-3.01(b) Coordination.....	39-3.2
39-3.02 Bridge Condition Reports	39-3.3
39-3.02(a) Definition.....	39-3.3
39-3.02(b) Purpose	39-3.3
39-3.02(c) Applicability	39-3.3
39-3.02(d) Proposed Structure Sketches.....	39-3.4
39-3.03 Preliminary Bridge Investigations	39-3.7
39-3.03(a) Bridge Type Studies.....	39-3.7
39-3.03(b) Selection of a Superstructure System	39-3.7
39-3.03(c) Temporary In-Stream Work.....	39-3.10
39-3.04 Type, Size, and Location Plans	39-3.10
39-4 BRIDGE SIZING/GEOMETRICS	39-4.1
39-4.01 Type of Highway Facility	39-4.1
39-4.02 Bridge Widths.....	39-4.1
39-4.03 Underpass Width.....	39-4.2
39-4.04 Vertical Clearances	39-4.2
39-4.05 Sidewalks and Bikeways	39-4.2

Table of Contents
(Continued)

<u>Section</u>		<u>Page</u>
39-4.06	Highways Over Railroad.....	39-4.3
39-4.07	Design Flood Frequency	39-4.3
39-4.08	Bridges on Horizontal Curves.....	39-4.3
39-4.09	Skew Angle	39-4.4
39-4.10	Cross Slopes.....	39-4.4
39-4.11	Gradeline on Bridges	39-4.4
39-5	TYPICAL SECTIONS	39-5.1
39-6	TABLES OF DESIGN CRITERIA.....	39-6.1

Chapter Thirty-nine

STRUCTURE PLANNING/GEOMETRICS

39-1 ADMINISTRATION

39-1.01 Introduction

The Bureau of Bridges and Structures (BB&S), the Bureau of Design and Environment (BDE), the Central Bureau of Land Acquisition (CBLA), the Central Bureau of Local Roads and Streets (CBLRS), and the Bureau of Safety Programs and Engineering (BSPE) comprise the Office of Program Development within IDOT. The BB&S provides expertise in bridge management, bridge design, and structural, hydraulic, and foundation engineering.

The Engineer of Bridges and Structures is responsible for formulating and administering policies and procedures that will ensure development of the bridge program and result in safe, economical, visually pleasing structures on the State highway system with the best use of resources for accomplishing the Department's objectives. The Bureau Chief of BB& S fulfills the role of "State Bridge Engineer" in relations with FHWA and AASHTO.

39-1.02 BB&S Functions

The functions of the Bureau of Bridges and Structures include:

- the development of policies and procedures for the administration of highway bridges and structures;
- the preparation of preliminary and final bridge and structure designs, plans, and specifications;
- the review and approval of structural work performed by consulting engineers;
- the review and approval of fabrication shop plans;
- the inspection of structural steel fabrication;
- the preparation and review of plans for bridge repairs;
- the load capacity rating and inventory of bridges on the State highway system;
- the preparation or review of retaining walls over 10 ft (3.0 m) in height;
- the directing of bridge maintenance and inspection activities; and
- the administration and technical expertise for local agencies on bridge issues.

39-1.03 BB&S Organization

To administer its responsibilities, the BB&S is organized into four sections:

- Structural Services,
- Bridge Planning,
- Bridge Design, and
- Services Development.

Organizational charts and functions of the sections are presented in the *Bridge Manual*, Section 1, "Introduction."

39-2 BRIDGE POLICIES AND DESIGN

The Bureau of Bridges and Structures (BB&S) administers policies for the design, structural details, and preparation of plans for bridges and structures on the State highway system by using a system of design specifications, standard practice manuals, standard plans, and policy memoranda. The following sections discuss these.

39-2.01 Specifications for Bridge Design

IDOT uses the *AASHTO Standard Specifications for Highway Bridges and AASHTO LRFD Bridge Design Specifications* as its principal specifications for the design of bridges and other structures. This includes all interim specifications and guide specifications when published and as directed by policy memoranda. These specifications form the basis for all bridge design by the BB&S or by an outside entity retained by the State of Illinois.

39-2.02 Specifications for Bridge Construction

The Department's *Standard Specifications for Road and Bridge Construction* govern all bridge construction contracts unless supplemented, revised, or superseded by the plans or in the special provisions for the contract documents. All bridge designs shall be prepared to be consistent with these specifications and provisions.

39-2.03 Standard Practice Manuals

The BB&S publishes a series of standard practice manuals to guide bridge and structural designs and plans in Illinois. These manuals represent a second level of control under the *AASHTO Standard Specifications for Highway Bridges and AASHTO LRFD Bridge Design Specifications*, and they present the preferred design methods, treatments, and standardized designs of the BB&S. These manuals guide the bridge designer in preparing bridge designs and plans to meet the specifications and preferences of the BB&S, but they are not intended to restrict progressive technology, innovation, or architectural improvements. Any proposed improvements other than typical designs should be thoroughly discussed with BB&S management prior to initiating any action.

The BB&S has developed the following standard practice manuals:

1. *Bridge Manual*. This *Manual* provides policies and practices for the planning and design of the component parts of bridges in general, and it guides the development of Type, Size, and Location (TS&L) plans and final plans.
2. *Prestressed Concrete Manual*. This *Manual* provides policies and design procedures for prestressed concrete bridge members and presents standard designs for prestressed concrete bridge members for use on State and local bridges.

3. *Culvert Manual*. This *Manual* provides standard design parameters for single-cell, reinforced concrete box culverts. When used within the limitations set forth, the *Manual* allows engineers and technicians outside the BB&S to prepare plans for these structures without direct structural engineering supervision.
4. *Sign Structures Manual*. This *Manual* provides standard design procedures and standard base sheets for steel and aluminum sign structures.
5. *Drainage Manual*. This *Manual* provides the drainage policies and procedures for use in the planning and design of drainage structures on the State Highway System.
6. *Structural Services Manual*. This *Manual* assists Department personnel and consulting engineers in the preparation of bridge repair plans. Information and details are provided for the types of repairs most often required for typical bridge structures.

See Chapter 60 for more information on standard practice manuals published by the BB&S.

39-2.04 Policy Memoranda

Policies of the Bureau of Bridges and Structures may be issued, amended, or supplemented by a Bridge Memorandum. These memoranda are effective the date of issuance on designs and plans not yet approved by the Engineer of Bridges and Structures, unless otherwise stated in the memorandum. Before initiating a project, bridge designers should check with the BB&S for the latest Department version of Bridge Memoranda.

39-2.05 Experimental Bridge Features

In cooperation with authorized agencies, the BB&S advises other agencies and/or develops construction plans for structures that include new products or design concepts in part or for all of the structure. These experimental projects are cataloged and periodic field inspections are made to evaluate the benefits from the experimental components.

After adequate study under actual traffic and weather conditions, the experimental products or design concepts are either included as acceptable for policy use and placed in the appropriate manual (see Section 39-2.03) or they are rejected.

39-3 BRIDGE PLANNING PROCESS

39-3.01 Bridge Improvements

39-3.01(a) Scope of Work Definitions

The scope of work for a bridge project may be any of the following:

1. Bridge Replacement. Replacement of the entire existing bridge (i.e., superstructure, substructure, and foundation).
2. Bridge Reconstruction. At a minimum, complete replacement of the superstructure and could include work on the substructure and foundation.
3. Existing Bridge to Remain in Place. If an existing bridge is structurally sound, if it meets the Department's design loading capacity, if it meets the minimum width criteria, and if it is not a high-crash location, it is unlikely to be cost effective to improve the geometrics of the bridge. When these conditions are met, an existing bridge can remain in place. In some cases, only the bridge substructure (e.g., abutments, piers) and/or foundation (e.g., footings, piles) may require rehabilitative work. These may also be considered existing bridges to remain in place for the application of geometric design criteria.
4. Bridge Rehabilitation. Major work on one or more of the components of an existing bridge (i.e., superstructure, substructure, and/or foundation).
5. Bridge Deck Rehabilitation. If the existing bridge deck is structurally deficient, it may be rehabilitated as part of a project. In addition, where the bridge deck is structurally sound but its width is inadequate (i.e., the bridge is functionally deficient), the bridge deck may be rehabilitated solely to widen the bridge deck. Bridge deck widening may then require work to the superstructure and/or substructure.
6. Bridge Deck Repair. The existing bridge deck is structurally adequate, but partial and full-depth repairs are required and an overlay is necessary to improve rideability and to maintain the integrity of the deck.
7. Bridge Rails/Transitions. For reconstructed bridges or rehabilitated bridge decks, the existing bridge rails and approaching guardrail-to-bridge-rail transitions may need upgrading to meet current Department criteria. For existing bridges to remain in place within the project limits, the Bureau of Bridges and Structures will evaluate the adequacy of the existing bridge rail to determine if it should be upgraded. The roadway designer will evaluate the adequacy of the existing approaching bridge rail transition for needed upgrading. See Chapter 38 for more information on guardrail-to-bridge-rail transitions.

Also, for 3R bridge projects, see Sections 49-3 and 50-2.

39-3.01(b) Coordination

This Section clarifies how structure information should be coordinated with the Bureau of Bridges and Structures (BB&S) and with the Bureau of Design and Environment (BDE). This coordination is through the Bridge Condition Report (Section 39-3.02) and the Proposed Structure Sketch. To indicate the bridge information necessary for completion of location study work, this Sketch is included in all Phase I reports. Complete information regarding Bridge Condition Reports can be found in the Bureau of Bridges and Structures manual *BCR Procedures and Practices*.

Bridge Condition Reports (BCR) will ensure that the scope of work proposed in a Phase I report will agree with the design in the final bridge plans. These reports accommodate early structural input into the overall planning process and, as a result, they greatly reduce the need for revisions to approved Phase I reports.

BDE must approve the typical section that shows the proposed clear roadway bridge width as a part of the Proposed Structure Sketch. This concurrence must occur before submission of the BCR by the district to the Bureau of Bridges and Structures.

A BCR and a Proposed Structure Sketch are required for every structure that is within a roadway section covered by a Phase I report or which is the subject of Phase I report by itself. Structures may fall into one of the following categories that would require a BCR or an Abbreviated BCR:

- gap the structure temporarily,
- allow structure to remain in place,
- deck repair and resurface,
- rehabilitate the structure, or
- replace the structure.

Before design approval can be granted on a roadway project that includes structures or on a bridge by itself, the BCRs on all bridges must be approved by the BB&S and concurrence must be received on all Proposed Structure Sketches.

For structures allowed to remain in place within a 3R type highway project, the Illinois Structure Information System—Master Report (S107) may be submitted in lieu of a formal BCR. In addition to the Master Report, the PONTIS Bridge Report for maintenance needs should be submitted.

Structures located within SMART and 3P projects do not require the submittal of a BCR. However, where a structure lies within the limits of such projects, coordination must be initiated with the BB&S before determining resurfacing options across the bridge.

Unless involvement is specifically requested by a district, the Bureau of Bridges and Structures does not evaluate maintenance type work on structures. However, if a project is a deck repair and overlay which is not funded with maintenance funds, it will require the submittal of an

Abbreviated BCR. If the evaluation of the deck leads to a decision to replace the deck, then normal procedures for bridge improvements must be initiated and followed.

The BCR allows BB&S concurrence on the proposed design based on the existing condition of the structure. Upon BB&S review, the Bureau will document agreement with the following geometric and structural factors:

- proposed clear roadway bridge width combined with structural feasibility,
- replacement or reuse of components,
- proposed general configuration features, and
- stage construction possibilities.

The BB&S concurrence relates to the structural adequacy and economic feasibility of the bridge improvement proposal. If appropriate, the economics of any proposal will be investigated at this time. In some instances, environmental factors may preclude economic considerations. Therefore, the Phase I report must contain sufficient information to justify recommendations concerning environmental factors.

39-3.02 Bridge Condition Reports

39-3.02(a) Definition

A Bridge Condition Report is defined as a report to establish the scope of work on the extent of repair, replacement (partial or total), and widening or other improvements. The BCR allows the Bureau of Bridges and Structures to determine the most cost-effective method of correcting the reported structural, geometric, or hydraulic deficiencies and for restoring a bridge to a structurally adequate and functionally serviceable condition.

39-3.02(b) Purpose

A BCR is required for every structure that is within a roadway section addressed in a Phase I report or which is the subject of a Phase I report by itself. The BCR, combined with the Proposed Structure Sketch (Section 39-3.02(d)), allows early structural input into the overall planning process.

Whenever the scope of anticipated rehabilitation work is limited to bridge deck and minor structural repairs without the need for widening or replacement options, only the preparation of an Abbreviated BCR is required. Because the geometrics of the structure will not be altered, this type of work normally will not require a Type, Size, and Location (TS&L) Plan (Section 39-3.04).

39-3.02(c) Applicability

The Bridge Condition Report will provide:

- a description of the physical conditions and deficiencies that mandate repair or replacement,

- a verification of the apparent soundness of any substructure elements recommended for reuse plus the economic advantage gained by their reuse,
- a statement of any geometric or hydraulic improvement requirements, and
- a recommendation for the scope of the proposed work.

The recommended scope of work should address the approximate dimensions of a replacement structure but not so precisely that configuration refinements resulting from subsequent hydraulic, soils, or structural-economic studies are restricted. The format of the BCR required by the BB&S is necessary to enable the Bureau to make accurate structural, economic, and policy decisions for the cost-effective expenditure of bridge rehabilitation funds.

With total structure replacements, a description of the conditions that led to the inclusion of the bridge in the program is usually sufficiently supportive of the replacement recommendation. However, where projects involve extensive repair of bridge components, BCRs must be supported by in-depth field inspection, physical testing, and economic analysis to determine the scope and cost-effectiveness of repairs. Before concurring with the reuse of any substructure elements, the Bureau of Bridges and Structures will verify their capacity to sustain the loads to which they will be subjected in the reconstructed bridge.

The BCR, with its comprehensive recommendation for the proposed scope of work and the support information, is submitted by the district for review and concurrence by the Bureau of Bridges and Structures. After this concurrence is obtained, the memo approving the BCR will be incorporated into or referenced in the Phase I report (see Chapter 12). After all necessary coordination with other agencies has been accomplished, the completed Phase I report and the Proposed Structure Sketch should be submitted to BDE for informational purposes.

39-3.02(d) Proposed Structure Sketches

The bridge information necessary to complete the location/design study phase varies with the complexity and type of project under consideration; however, all bridge projects require the submittal of a Proposed Structure Sketch to the Bridge Planning Section for review and approval. This Sketch should be included or referenced in the Phase I report. For a typical Proposed Structure Sketch, see Figure 39-3.A.

A Proposed Structure Sketch will generally present the following information:

- type of bridge proposed (closed abutments vs. spill-through, existing elements to be reused, etc., but not details such as girder or deck type) and approximate structure length. A preliminary hydraulic analysis may be required to establish the appropriate structure length and vertical profile;

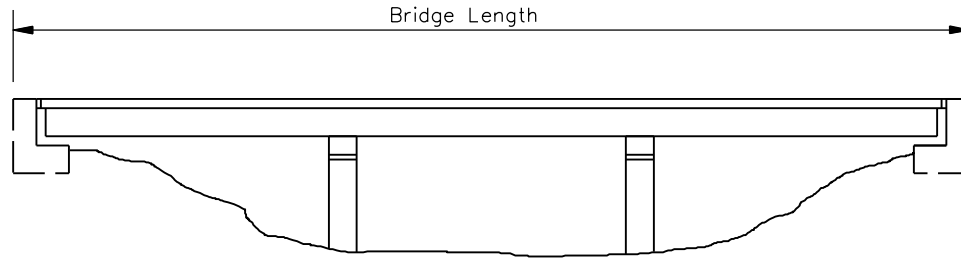

Note: The number and location of piers outside the stream channel, the profile gradeline, and bridge length are subject to refinement in the TSL phase.

ELEVATION
PROPOSED STRUCTURE

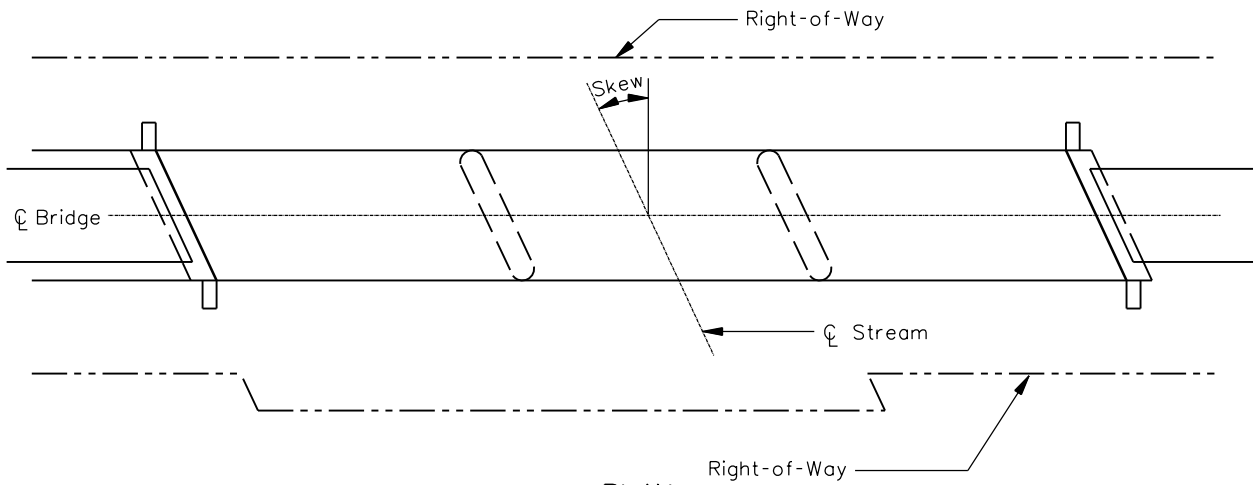

PLAN
PROPOSED STRUCTURE

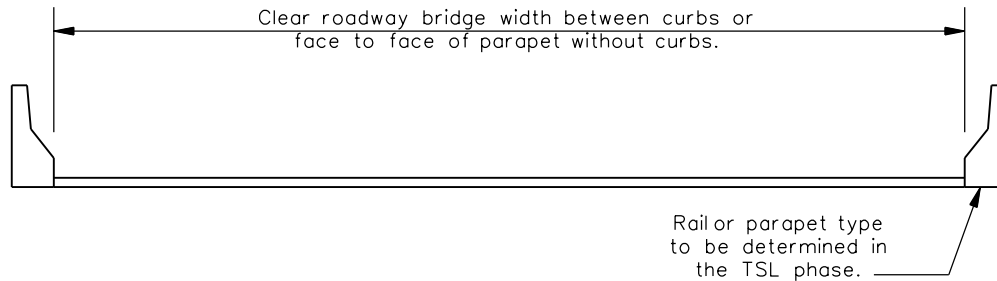

PROPOSED STRUCTURE WIDTH

PROPOSED STRUCTURE SKETCH

Figure 39-3.A

- approximate profile and horizontal alignment and approximate right-of-way or easement widths. The accuracy of the profile will depend upon the nature of right-of-way adjacent to the bridge project. Usually, it will be necessary to establish exact right-of-way requirements only if Section 4(f) property or other very sensitive right-of-way is affected;
- proposed skew angle of feature crossed. See Section 39-4 for further guidance on crossing angles;
- approximate pier locations proposed by the district. Comments on pier location received from the Illinois Department of Natural Resources, U.S. Fish and Wildlife Service, U.S. Army Corps of Engineers, and other affected agencies should be incorporated as appropriate;
- typical section showing the proposed clear roadway bridge width. It is not necessary to show beam locations or type; and
- the need for bikeways across the structure, bicycle railings, and pedestrian railings.

The Proposed Structure Sketch should contain the following note or variation thereof: *“The number and location of piers outside the stream channel, the profile gradeline, and the bridge length are subject to refinement in the TSL phase.”* Care should be taken to make the Proposed Structure Sketch as diagrammatic as possible and no more restrictive to the final design than is necessary to gain design approval.

For rehabilitation, reconstruction, and replacement projects, the information necessary for the location/design study phase is provided in the Bridge Condition Report (BCR). The Proposed Structure Sketch is typically included with the BCR. However, only the Proposed Structure Sketch and memo from the BB&S approving each Bridge Condition Report (if required) need be included in a Phase I report. In addition for each structure location, a few color photographs or prints should be included in the Phase I report as exhibits.

For major stream crossing projects, the determinations made in the location/design study phase on the vertical and horizontal alignment are typically refined such that minor adjustments in the TS&L or design phases will not significantly affect the project impacts. Because of the potentially large variations in structure depths between major river crossing structure types, high and low vertical profile options may need to be addressed. Significant impacts caused by either the high or low profile options might lead to the elimination of certain structure types from further consideration.

Structure type evaluation at this stage should normally be limited to the determination of those structure types that are feasible for the given crossing conditions and within the same general economic range. A detailed evaluation of structure types for major stream crossings is performed during the bridge type study phase.

39-3.03 Preliminary Bridge Investigations

Before initiating Type, Size, and Location (TS&L) Plans for a structure, an investigative procedure that establishes the proper alignment and/or the scope of work to be performed is completed in the Phase I study. This procedure establishes the alignment, develops a profile gradeline, provides an environmental assessment, and addresses those factors affecting the socio-economic conditions and the overall impact of the project. It may also include a proposal for stage construction so that traffic may continue using the route during construction. The results of these procedures and studies are summarized in the Phase I report.

39-3.03(a) Bridge Type Studies

A Bridge Type Study is necessary for the preparation of a TS&L Plan. The study is the process by which the most appropriate structure type for a given location is determined, and it is a compilation of the necessary economic, aesthetic, and site evaluations that lead to that selection. A well-conceived Bridge Type Study will:

- provide hydraulic and geotechnical considerations,
- consider the structure types feasible for the site parameters or environmental commitments,
- provide the reasoning for eliminating or developing particular alternatives, and
- provide cost estimates for all alternatives considered and the rationale for the selection of the structure type chosen.

The Bridge Type Study is typically a part of the planning process that justifies the proposed bridge type and as such is not submitted for review. However, for major river crossings or when requested by BB&S, a bridge type study becomes a formal report requiring approval of the Bridge Planning Engineer before TS&L plan preparation.

39-3.03(b) Selection of a Superstructure System

For Phase I work, the designer should refer to Figure 39-3.B, which provides a list of commonly employed superstructure types; the span ranges for which they are generally applicable; and the approximate construction depth (profile grade to low beam) required for their use. The values provided are general guidelines only and should not be used for detailed TS&L determination.

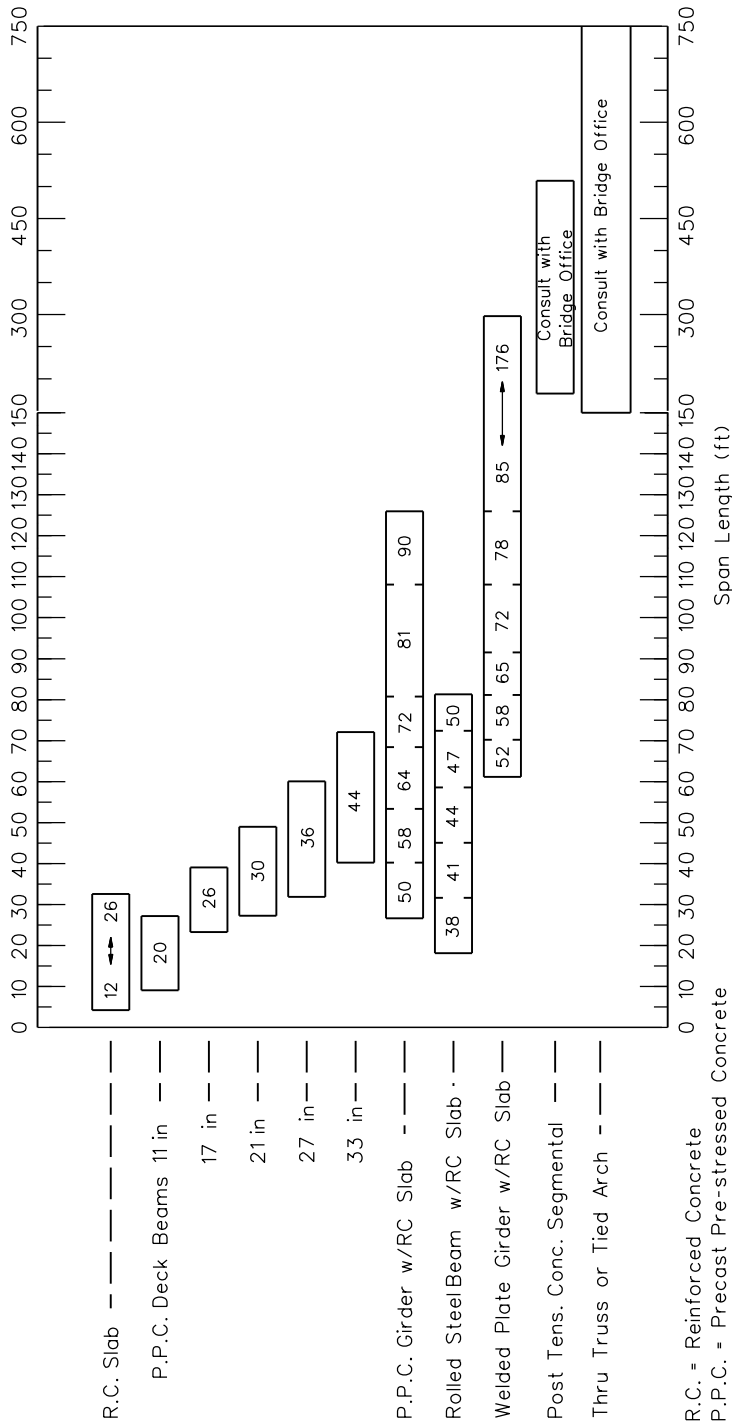

Notes:

- Numbers within bars denote the construction depth in inches (profile grade to low clearance point) required for a simple span structure of charted length with a 40-ft wide, normal crowned bridge roadway, and a future wearing surface allowance of 25 lbs/ft². The values given are general guideline values and should not be used for detailed type, size, and location plans.
- Span lengths for the indicated construction depths may be increased 20% to 25% for continuous beam designs.

CONSTRUCTION DEPTH SELECTION GUIDE
(US Customary)

Figure 39-3.B

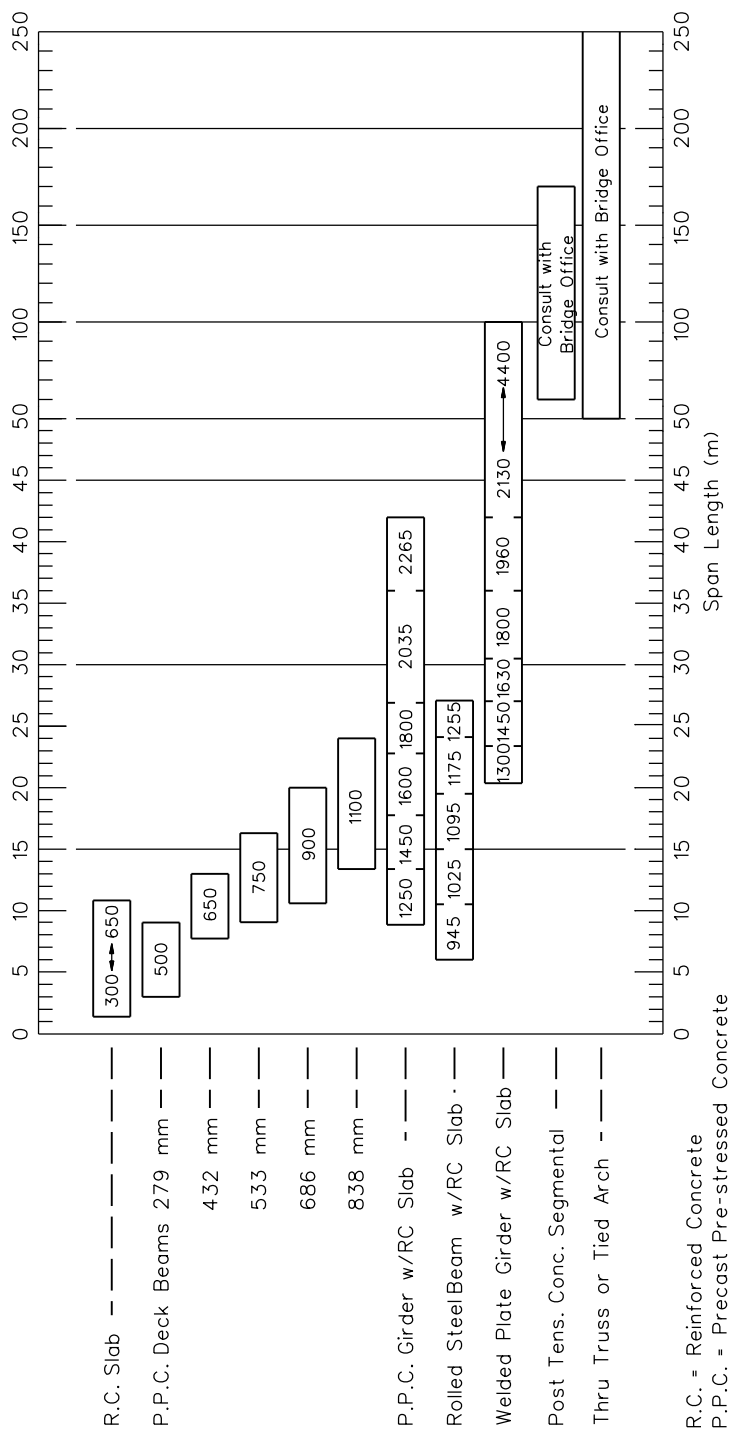

Notes:

1. Numbers within bars denote the construction depth in millimeters (profile grade to low clearance point) required for a simple span structure of charted length with a 12-m wide, normal crowned bridge roadway, and a future wearing surface allowance of 1.2 kN/m². The values given are general guideline values and should not be used for detailed type, size, and location plans.
2. Span lengths for the indicated construction depths may be increased 20% to 25% for continuous beam designs.

**CONSTRUCTION DEPTH SELECTION GUIDE
(Metric)**

Figure 39-3.B

39-3.03(c) Temporary In-Stream Work

As a part of determining the scope of work to be performed, give consideration to anticipated need for temporary in-stream work features for construction of the project (e.g., temporary stream crossings, work pads, temporary bypass channels, cofferdams). This information will need to be described in a work permit submittal to the US Army Corps of Engineers for work involving discharge of dredged or fill material into waters of the United States. To the extent that any needed temporary work features can be anticipated and addresses in the permit submittal for the bridge/culvert, it will avoid the need for having the contractor seek separate permit coverage for the temporary work in the construction phase with the associated potential for delaying construction operations while awaiting receipt of the permit authorization for the temporary work features.

39-3.04 Type, Size, and Location Plans

The bridge planning process encompasses the collection of the applicable site information, its analysis, the application of established policies and practices, and the consideration of reasonable alternatives and their economic evaluations to establish the bridge configuration that is the most cost effective and functionally, structurally, and aesthetically appropriate.

Type, Size, and Location (TS&L) Plans are detailed bridge configuration plans which are used as the basis for the development of construction plans. TS&L Plans are approved by the Bureau of Bridges and Structures only after the processing for approval of a Structure Report including an approved Hydraulics Report, an existing bridge survey, and detailed roadway data. Approved TS&L Plans may be used in lieu of a Proposed Structure Sketch in a Phase I report should their timely development so permit; however, the less detailed Proposed Structure Sketch, developed specifically for the Phase I report, will not be construed to be TS&L Plans.

The Planning Section of the *Bridge Manual* has been developed as a guide and a control for the preparation of TS&L Plans and for the promulgation of policy interpretations of the control documents. In addition, consider the following when preparing TS&L Plans:

- No new structure number should be assigned when a project involves the re-use of any existing bridge element in the rehabilitation.
- For details on Hydraulic Reports, use the *Drainage Manual*.
- A completed Structure Report and Structure Geotechnical Report must accompany any TS&L Plan submittal by a consultant.
- Boring logs are required to be submitted to the Bureau of Bridges and Structures for the development of in-house TS&L Plans.

39-4 BRIDGE SIZING/GEOMETRICS

A variety of factors determine the appropriate size of a bridge under design. Section 39-4 discusses these factors and other geometric design elements pertaining to bridge design (e.g., bridges on horizontal curves, cross slopes). Section 39-5 presents typical sections for bridge overpasses and underpasses. Section 39-6 presents tables of geometric design criteria for bridges on the rural and urban State highway system and for frontage roads.

The design criteria provided in Section 39-4 are applicable to all new or reconstructed bridges on the State highway system, except where specific policy items are governed by other Department directives. See Parts IV, Road Design Elements, and V, Design of Highway Types. Bridge widths for 3R-type improvements are included in Chapters 49 (non-freeways) and 50 (freeways).

39-4.01 Type of Highway Facility

The type of highway facility has a significant impact on bridge size. The highway facility will be defined by its:

- functional classification;
- rural or urban location;
- number of lanes (i.e., two lane or multilane);
- presence of a median (i.e., divided or undivided); and
- operational function (i.e., mainline, ramp, or frontage road).

Part V presents a comprehensive discussion on highway geometric design based on functional classification and rural/urban location. Specifically for bridges, the typical sections in Section 39-5 and the tables of design criteria in Section 39-6 are based on the type of highway facility with appropriate references to Part V, Highway Systems.

39-4.02 Bridge Widths

The bridge width will be determined by:

- the highway type;
- the approaching roadway width;
- the presence of sidewalks and/or bikeways (see Section 39-4.05);
- the presence of auxiliary lanes (e.g., acceleration lanes at interchanges); and
- for divided facilities, whether a single or dual structure is used.

See Sections 39-5 and 39-6 for bridge width criteria and application.

39-4.03 Underpass Width

The roadway section passing beneath a bridge will determine the bridge length in combination with structural design elements (e.g., abutment type). The underpass width will be based on the following roadway design elements:

- the approaching roadway width;
- the presence of sidewalks and/or bikeways (see Section 39-4.05);
- the presence of auxiliary lanes (e.g., acceleration lanes at interchanges); and
- the horizontal clearance to obstructions (i.e., the roadside clear zone).

For high unit cost bridges, the designer should consider locating abutments or piers on the right side of the roadway adjacent to the shoulder where the savings in structure cost could make the required barrier protection cost effective. All reduced clearances below the minimum horizontal clearance requirements must be economically justified and barrier protection must be provided.

The maximum practical horizontal clearance between the left edge of the roadway and pier in the median of divided highways will be realized by placing a single pier at the center of the median. Median piers should have protective barrier where warranted as discussed in Chapter 38.

39-4.04 Vertical Clearances

The vertical clearance for underpassing roadways will significantly impact the size of the overpassing structure. In some cases, the required vertical clearance may also impact the selection of the superstructure type. Sections 33-5, 39-5 and 39-6 and Part V, Highway Systems, presents the Department's vertical clearance criteria for underpassing roadways based on functional classification, project scope, and rural/urban location.

39-4.05 Sidewalks and Bikeways

If pedestrian activity is anticipated, provide sidewalks on both sides of urban structures. The standard sidewalk width on structures is 5 ft (1.5 m). See the *Bridge Manual* for sidewalk details. Also, see Section 48-2.04 for a detailed discussion on sidewalks. In addition, examine the gradeline of the sidewalks for ADA requirements (see Section 58-1). Where wider sidewalks exist on approaching roadways, sidewalk widths greater than 5 ft (1.5 m) can be considered. See the typical urban sections in Section 39-5.

Special sidewalks or bikeways, separated from the roadway by a traffic barrier, may be provided as discussed in Chapter 17. Bikeway widths will be determined from the bikeway design criteria but in no case will the width be less than 5 ft (1.5 m) for a one-way bikeway or 10 ft (3.0 m) for a two-way bikeway across a structure. For geometric combinations, see the typical sections in Chapter 17 and Section 39-5.

39-4.06 Highways Over Railroad

Where a highway bridge overpasses a railroad, the specific horizontal and vertical clearances and the bridge size will be cooperatively determined by the Department and the railroad. The Department's planner/designer shall become acquainted with 92 Ill. Admin. Code 1500.160(c), 23 C.F.R. 646.212(a-2) and (a-3) and the "Appendix to Subpart B of Part 646 – Horizontal & Vertical Clearance Provisions for Overpass and Underpass Structures" prior to any discussions with the railroad. The typical sections in Section 39-5 illustrate the typical minimum geometric design requirements for railroads.

39-4.07 Design Flood Frequency

Design flood frequency is directly related to the ratio of structure capacity to public benefit. A structure which carries large volumes of traffic on a multilane facility is expected to remain in use during extreme flood conditions. To maintain the high level of traffic service afforded by these facilities, a considerable expenditure of funds is justified to provide that service. Conversely, a structure carrying lesser traffic volumes on a lower functional classification facility does not warrant a design based on extreme flood conditions. The *Drainage Manual* and its Appendix contain detailed information on design flood frequencies. Chapter 40 also addresses general drainage issues and procedures.

Because urban highway facilities are intended to accommodate higher traffic volumes at reduced speeds, when compared to rural designs, it is apparent that optimum public benefit requires the assignment of higher flood frequency values for design to provide uninterrupted service for urban bridges. Consideration must also be given to the seriousness of flooding abutting properties that may result in property damage, possible loss of life, and adverse public reaction. Therefore, a flood frequency of 50 years is used for all designs except TWS–2 classifications.

39-4.08 Bridges on Horizontal Curves

Superelevation transitions should be avoided on bridges and their approaches. To achieve this in rural areas, the beginning of a horizontal curve should be a minimum of 400 ft (120 m) from the back of the bridge abutment. In some cases, however, superelevation transitions are unavoidable on urban bridges (e.g., because of right-of-way restraints). Where a curve is necessary on a bridge, the desirable treatment is to place the entire bridge and its approaches on a flat horizontal curve with minimum or no superelevation. In this case, a uniform superelevation rate is provided throughout (i.e., the superelevation transition is neither on the bridge nor its approaches) or the normal crown section is maintained throughout the curve.

Where a bridge is located within a superelevated horizontal curve, the entire bridge roadway is sloped in the same direction and at the same rate across the deck (i.e., the shoulders or gutters and traveled way will be in a planar section). See the typical superelevated sections in Section 39-5. This also applies to the approach traveled way and the approach shoulder pavements. The approach traveled way and approach shoulders are illustrated in the *Highway Standards*.

However, the high-side shoulder on a roadway section off the bridge should slope away from the traveled way at a rate such that the maximum shoulder rollover does not exceed 8.0%. To accomplish the longitudinal shoulder slope transition away from the bridge, the designer should refer to the applicable figure in Section 39-5. See Chapter 32 for more information on horizontal alignment.

39-4.09 Skew Angle

Crossing angles between the mainline and other roadways, railways, or waterways desirably should not be less than 60 degrees (not greater than 30 degree skew). In extreme conditions, crossing angles between waterways and roadways may be 45 degrees and, between intersecting roadways or between roadways and railways, may be 30 degrees (not greater than 60 degree skew). Where these maximums are difficult to meet, consider relocating and/or realigning the intersecting roadways/waterways.

39-4.10 Cross Slopes

The typical sections in Section 39-5 provide the cross slope criteria for bridges. Note that, on tangent sections, the shoulder cross slope on a bridge is flatter (i.e., 1/4"/ft (2%)) than the typical shoulder cross slope on the approaching roadway section (i.e., 1/2"/ft (4%)).

39-4.11 Gradeline on Bridges

Where a bridge is planned for a new construction or reconstruction project and where the bridge is not within the limits of a vertical curve, the designer should strive to provide a minimum longitudinal gradient of 0.50% across the bridge. In addition, where a vertical curve cannot be avoided on the structure, a K value of 167 (51) for drainage should not be exceeded.

39-5 TYPICAL SECTIONS

Section 39-5 presents typical sections for bridges on tangent or with superelevation, for roadways beneath bridges, and for highways passing over railroads. With the exception of cross slopes on bridges, the typical sections do not provide the numerical dimensions for the various cross section elements; i.e., these are nomenclature presentations. See Section 39-6 and the referenced chapters in the *BDE Manual* for the applicable numerical criteria.

Section 39-5 presents the following typical section figures:

- Clear Roadway Width of Bridges for New and Reconstructed Four-Lane Divided Highways (Figure 39-5.A).
- Clear Roadway Width of Bridges for New and Reconstructed Six-Lane Divided Highways (Figure 39-5.B).
- Clear Roadway Width of Bridges for New and Reconstructed Four-Lane Highways with Concrete Barrier (Figure 39-5.C).
- Clear Roadway Width of Bridges for New and Reconstructed Six-Lane Highways with Concrete Barrier (Figure 39-5.D).
- Clear Roadway Width of Bridges for New and Reconstructed Four-Lane Divided Highways with Additional Lane for Acceleration or Deceleration (Figure 39-5.E).
- Clear Roadway Width of Single-Lane Ramp Structures (Figure 39-5.F).
- Clear Roadway Width of Bridges for New and Reconstructed Rural Two-Lane Highways (Figure 39-5.G).
- Clear Roadway Width of Superelevated Bridges on Multilane Divided Highways (Figure 39-5.H).
- Clear Roadway Width of Superelevated Bridges on Multilane Highways with Concrete Barrier (Figure 39-5.I).
- Clear Roadway Width of Superelevated Bridges on Rural Two-Lane Highways (Figure 39-5.J).
- Clear Roadway Width of Bridges for New and Reconstructed Urban Highways with Raised-Curb Median (Figure 39-5.K).
- Clear Roadway Width of Bridges for New and Reconstructed Urban Highways with Bikeways (Figure 39-5.L).
- Clear Roadway Width of Bridges for New and Reconstructed Two-Lane Urban Highways (Flush/Traversable Median) (Figure 39-5.M).

- Clear Roadway Width of Superelevated Bridges on Urban Highways with Raised-Curb Median (Figure 39-5.N).
- Clear Roadway Width of Superelevated Bridges on Urban Highways with Flush/Traversable Median (Figure 39-5.O).
- Clear Roadway Width of Superelevated Bridges on Two-Lane Urban Highways (Figure 39-5.P).
- Clearances for Bridges over Divided Highways (Figure 39-5.Q).
- Clearances for Bridges over Two-Lane Highways (Figure 39-5.R).
- Highway Grade Separation over Railroad (Figure 39-5.S).

See the *Bridge Manual* for more details on bridge design.

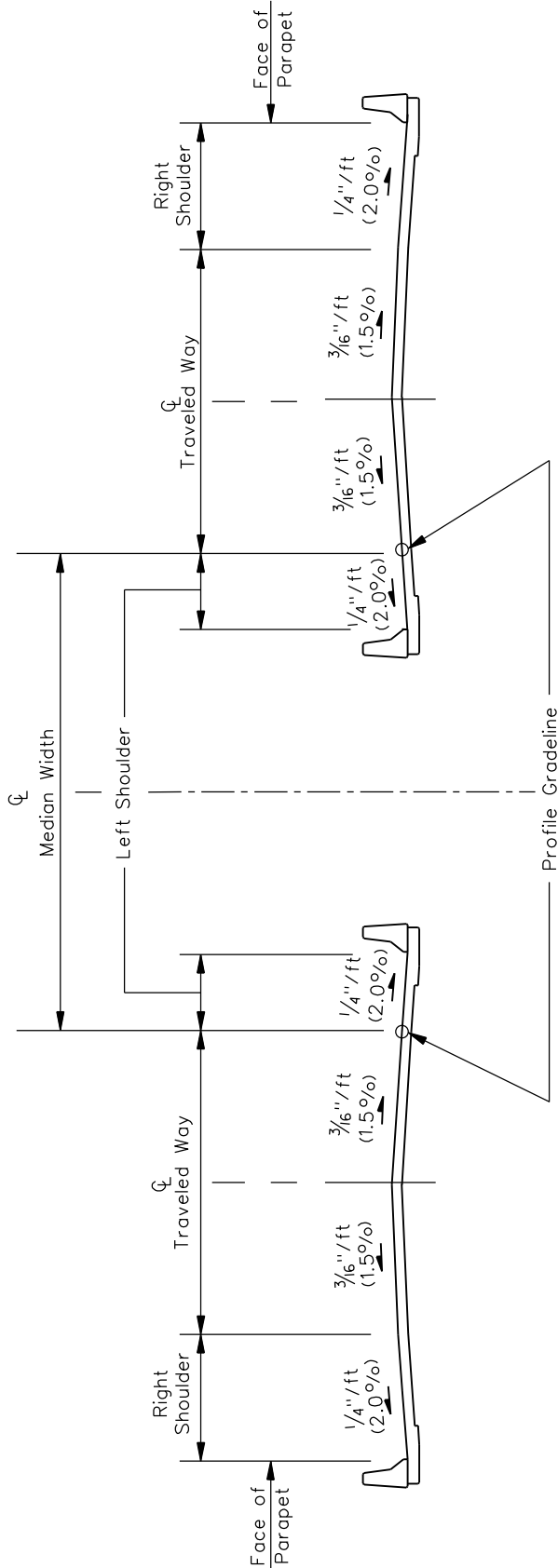

Note: See Figure 39-6A and 39-6.C.

CLEAR ROADWAY WIDTH OF BRIDGES FOR NEW AND RECONSTRUCTED FOUR-LANE DIVIDED HIGHWAYS

Figure 39-5.A

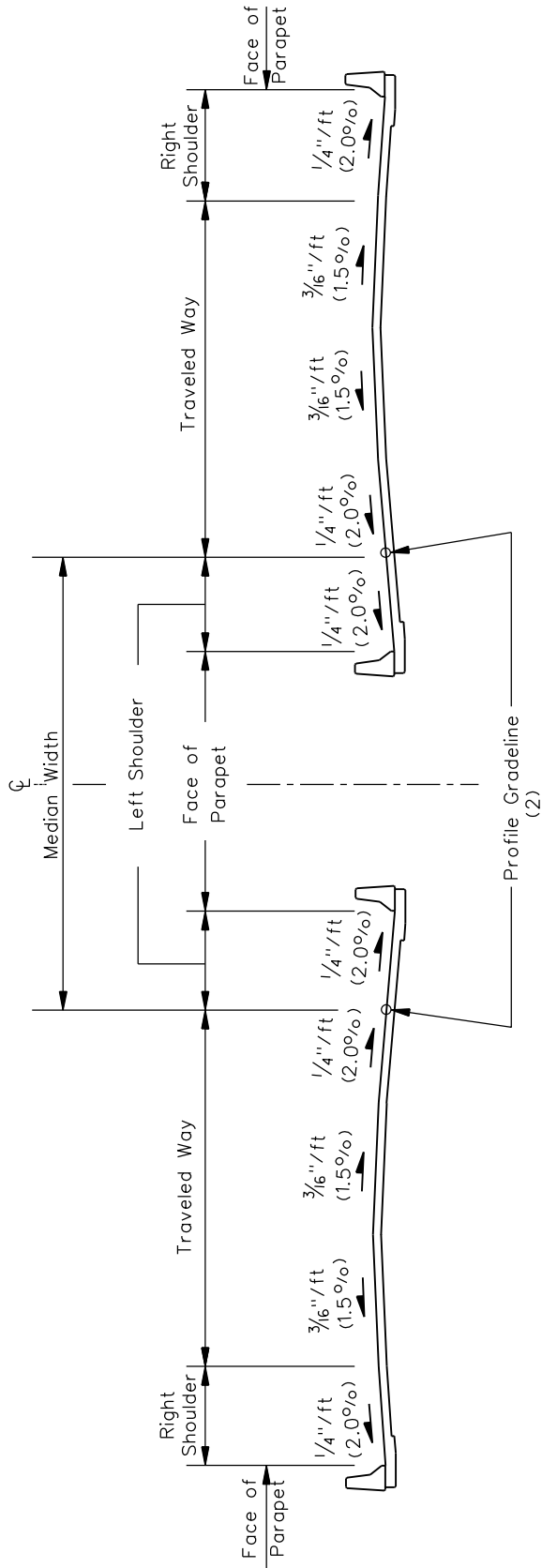

Notes:

1. See Figures 39-6.A and 39-6.C.
2. Profile gradeline is set at the location shown above where the approach traveled way is initially designed for three lanes in each direction.

CLEAR ROADWAY WIDTH OF BRIDGES FOR NEW AND RECONSTRUCTED SIX-LANE DIVIDED HIGHWAYS

Figure 39-5.B

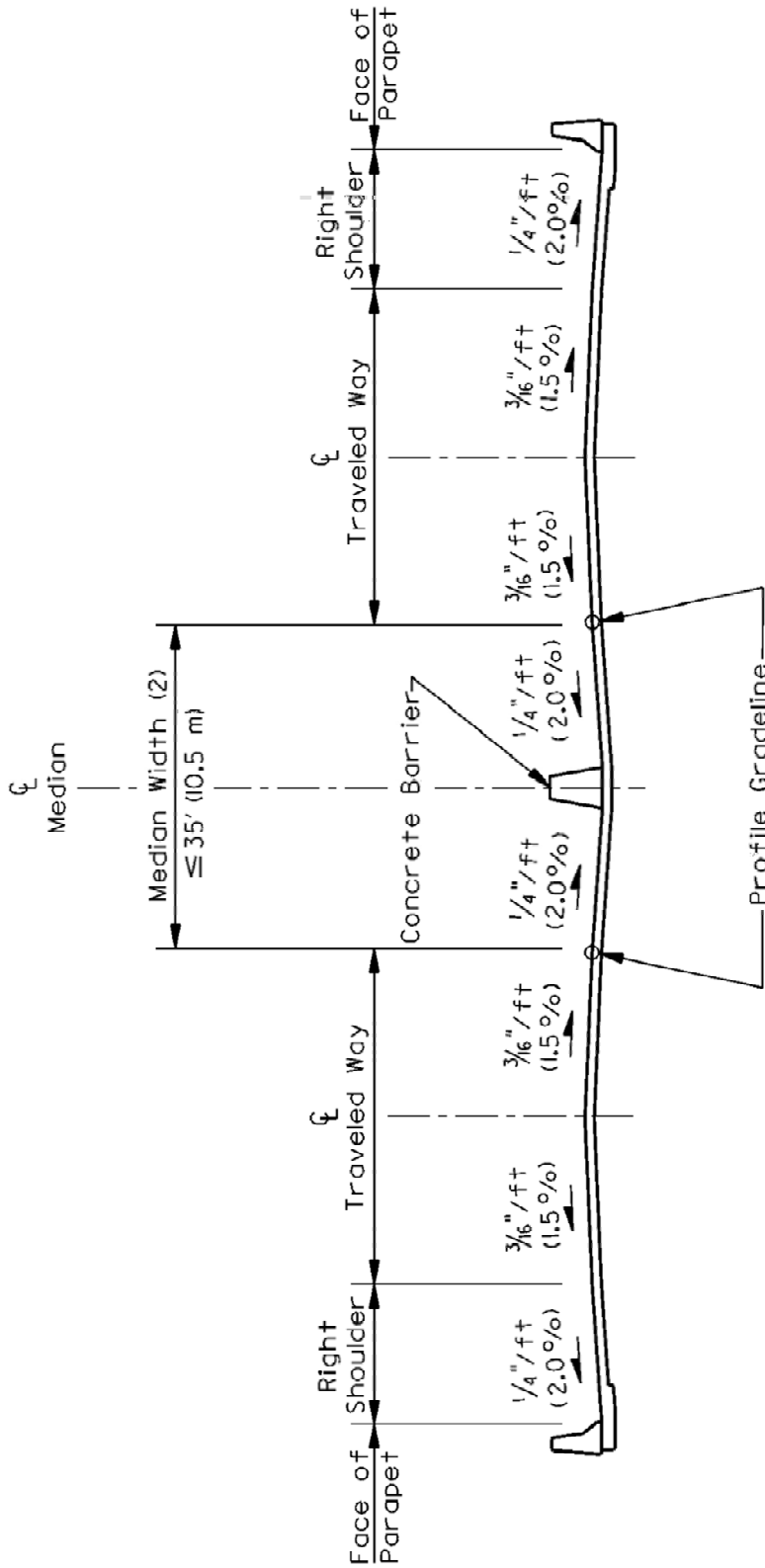

Notes:

1. See Figures 39-6.A and 39-6.C.
2. In all cases, the median width on the approach roadway and the median on the bridge structure must be similar.

CLEAR ROADWAY WIDTH OF BRIDGES FOR NEW AND RECONSTRUCTED FOUR-LANE DIVIDED HIGHWAYS WITH CONCRETE BARRIER

Figure 39-5.C

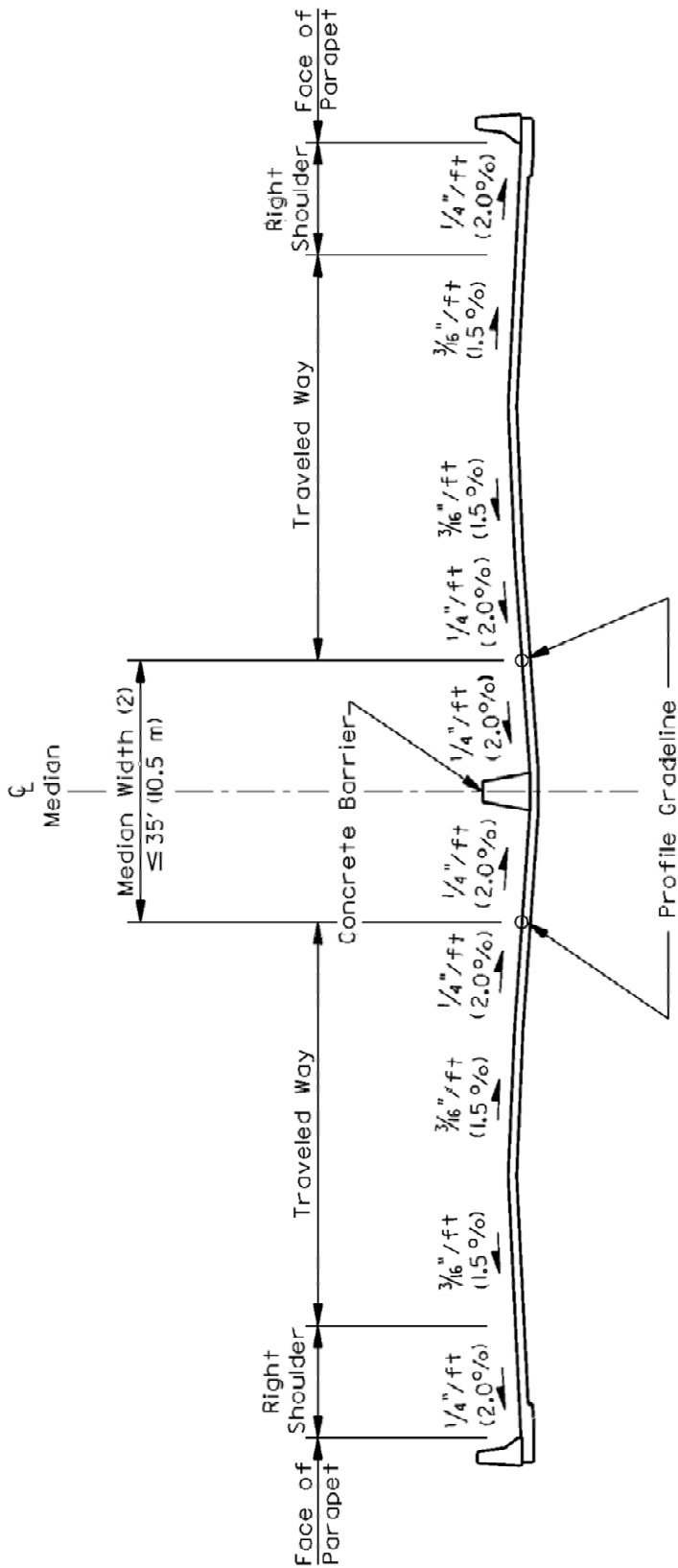

Notes:

1. See Figures 39-6.A and 39-6.C.
2. In all cases, the median width on the approach roadway and the median on the bridge structure must be similar.

CLEAR ROADWAY WIDTH OF BRIDGES FOR NEW AND RECONSTRUCTED SIX-LANE DIVIDED HIGHWAYS WITH CONCRETE BARRIER

Figure 39-5.D

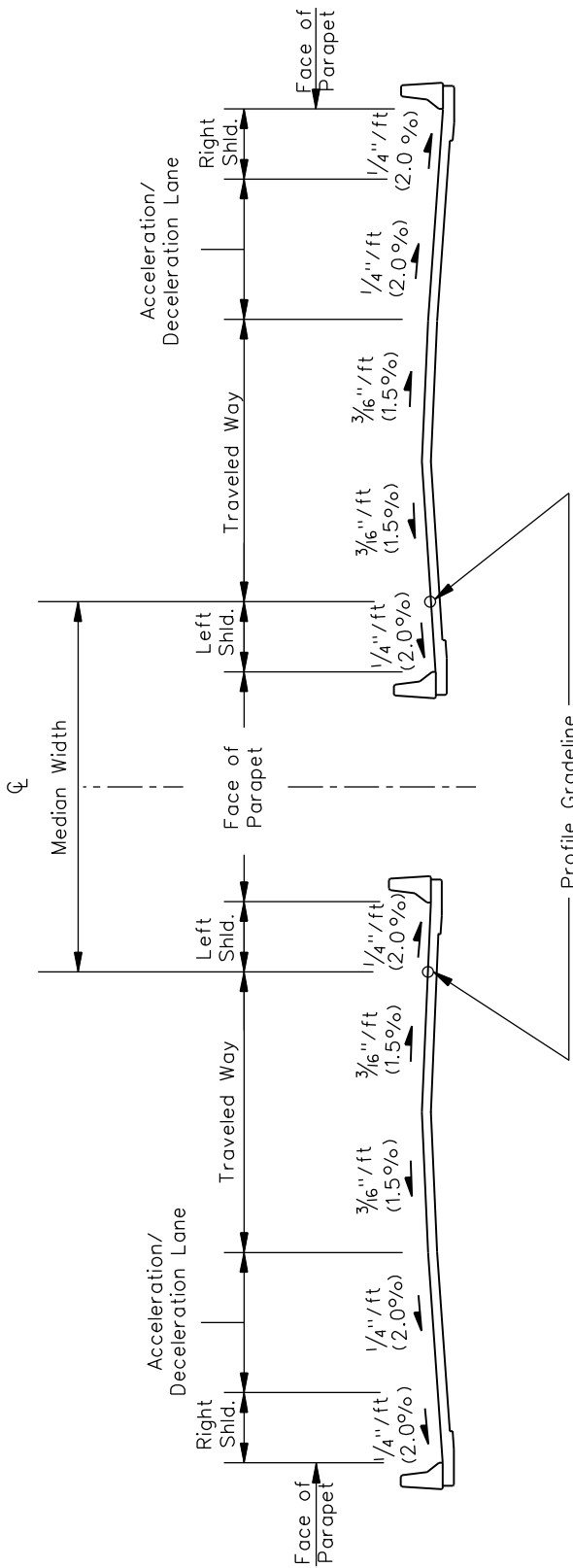

Notes:

1. See Figures 39-6.A and 39-6.C.
2. Where an exit terminal lies within the limits of a bridge, the cross slope of the standard exit terminal must be modified to fit the cross slope of the bridge deck. In this case, the designer should use a minimum uniform cross slope of 1/4" / ft (2%) on the terminal or, if the mainline is on a curve to the right, the designer should use the superelevation rate of the mainline for the terminal cross slope, but not greater than 5/8" / ft (5%). In both cases, the cross slope is measured perpendicular to the edge of the mainline pavement. See Section 37-6.

CLEAR ROADWAY WIDTH OF BRIDGES FOR NEW AND RECONSTRUCTED FOUR-LANE DIVIDED HIGHWAYS

Figure 39-5.E

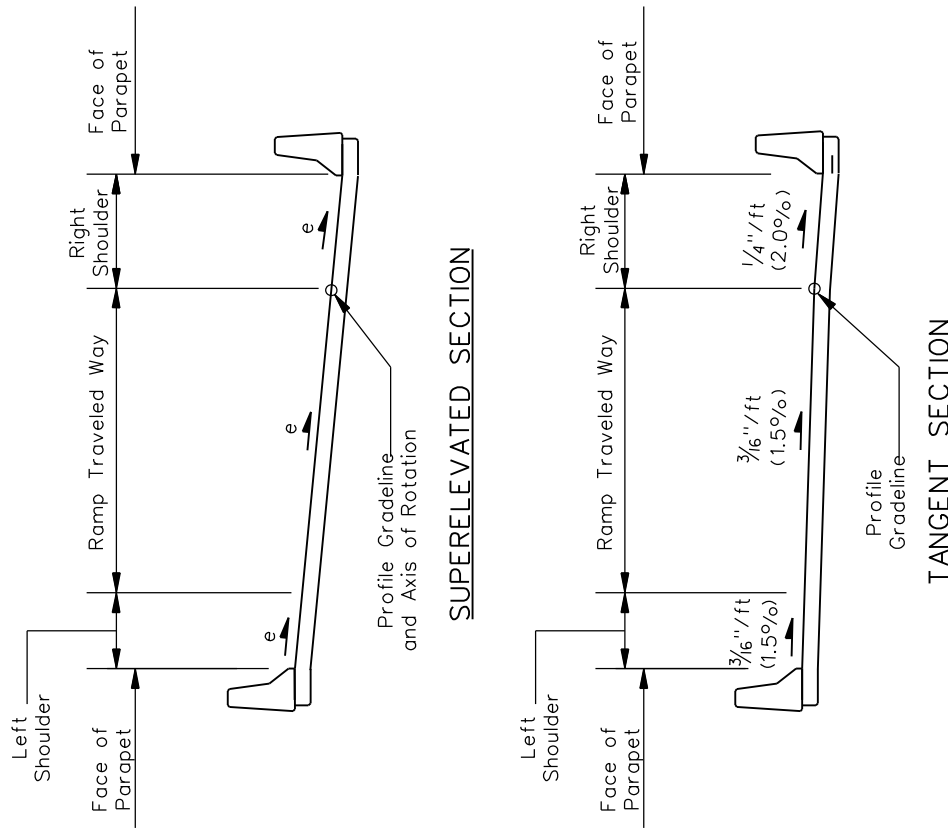

Notes:

1. See Section 37-4 for width criteria.
2. See Note 2. on Figure 39-5.H for roadway shoulder transition to superelevated bridge.

CLEAR ROADWAY WIDTH OF SINGLE-LANE RAMP STRUCTURES

Figure 39-5.F

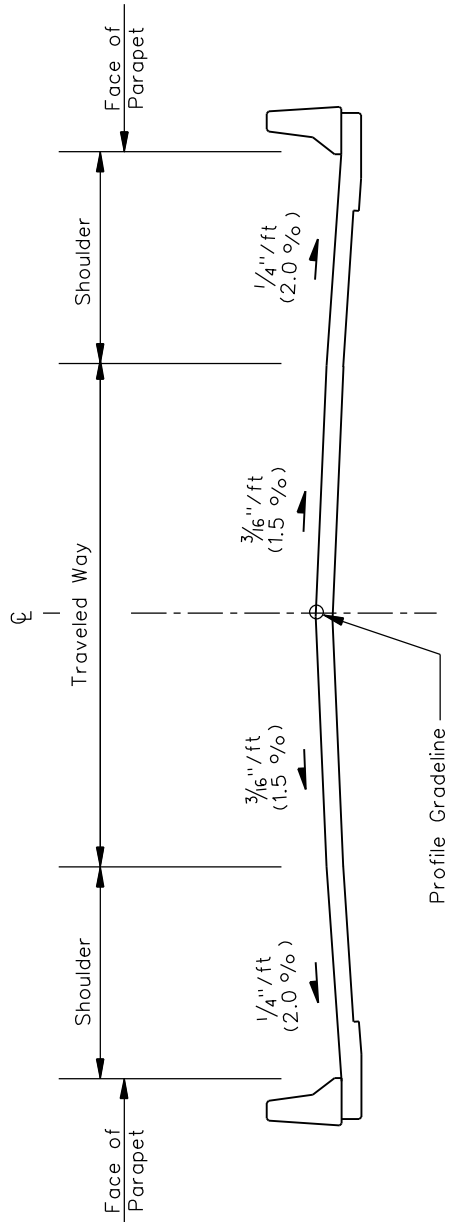

Note: See Figures 39-6.A and 39-6.B.

CLEAR ROADWAY WIDTH OF BRIDGES FOR NEW AND RECONSTRUCTED RURAL TWO-LANE HIGHWAYS

Figure 39-5.G

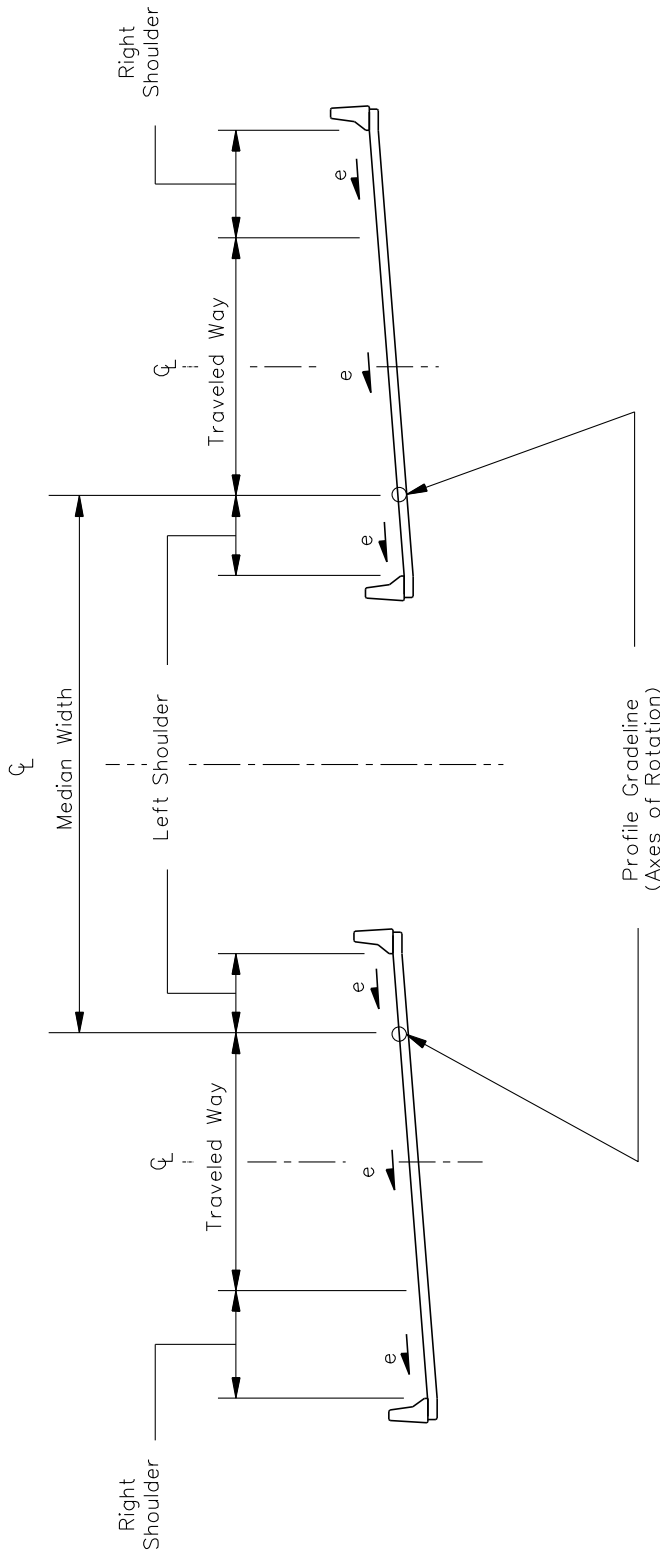

Notes:

1. See Figures 39-6.A and 39-6.C.
2. Where a bridge lies within a horizontal curve with superelevation, the shoulder on the high side of the bridge (starting just off the end of the bridge approach shoulder pavement) will be gradually transitioned into the design slope of the shoulder on the approaching roadway. Also see the Highway Standards. This transition should be accomplished by providing a maximum relative longitudinal difference in gradient of 0.40% between the edge of the traveled way and the outside edge of the shoulder. Also see Chapter 32.

**CLEAR ROADWAY WIDTH OF SUPERELEVATED BRIDGES
ON MULTILANE DIVIDED HIGHWAYS**

Figure 39-5.H

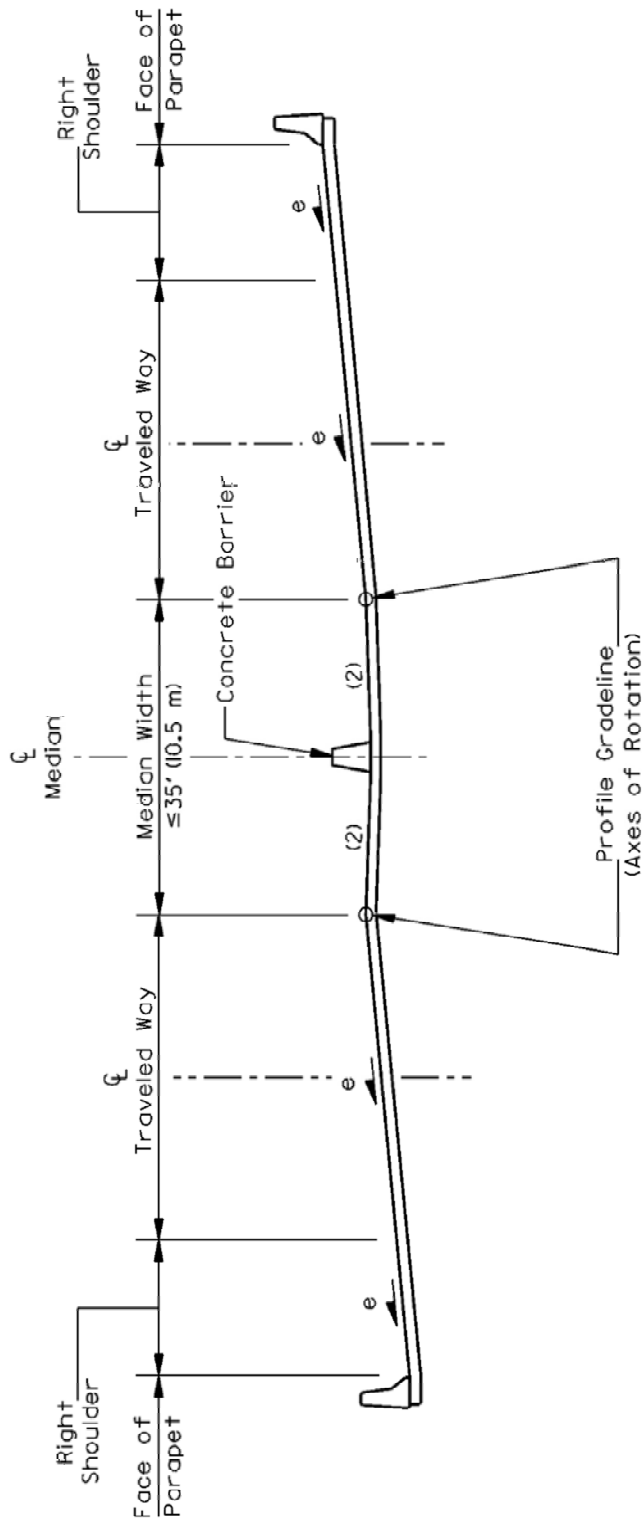

Notes:

1. See Figures 39-6.A and 39-6.C.
2. The usual shoulder cross slope on structure with this type median is 1/4"ft (2%). However, the crossover crown between the traveled way and median shoulder should not exceed 6%.
3. Where a bridge lies within a horizontal curve with superelevation, the shoulder on the high side of the bridge (starting just off the end of the bridge approach shoulder pavement) will be gradually transitioned into the design slope of the shoulder on the approaching roadway. Also see the Highway Standards. This transition should be accomplished by providing a maximum relative longitudinal difference in gradient of 0.40% between the edge of the traveled way and the outside edge of the shoulder. Also see Chapter 32.

CLEAR ROADWAY WIDTH OF SUPERELEVATED BRIDGES ON MULTILANE HIGHWAY WITH CONCRETE BARRIER

Figure 39-5.I

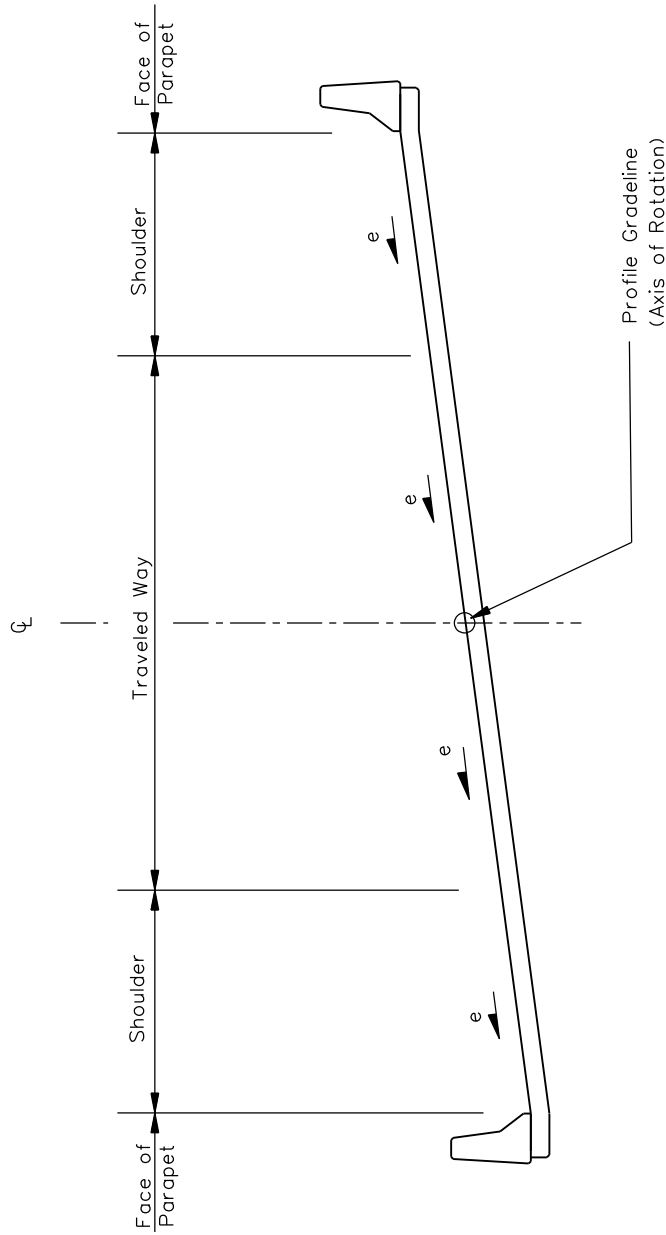

Notes:

1. See Figures 39-6.A and 39-6.B.
2. Where a bridge lies within a horizontal curve with superelevation, the shoulder on the high side of the bridge (starting just off the end of the bridge approach shoulder pavement) will be gradually transitioned into the design slope of the shoulder on the approaching roadway. Also see the Highway Standards. This transition should be accomplished by providing a maximum relative longitudinal difference in gradient of 0.40% between the edge of the traveled way and the outside edge of the shoulder. Also see Chapter 32.

CLEAR ROADWAY WIDTH OF SUPERELEVATED BRIDGES ON RURAL TWO-LANE HIGHWAYS

Figure 39-5.J

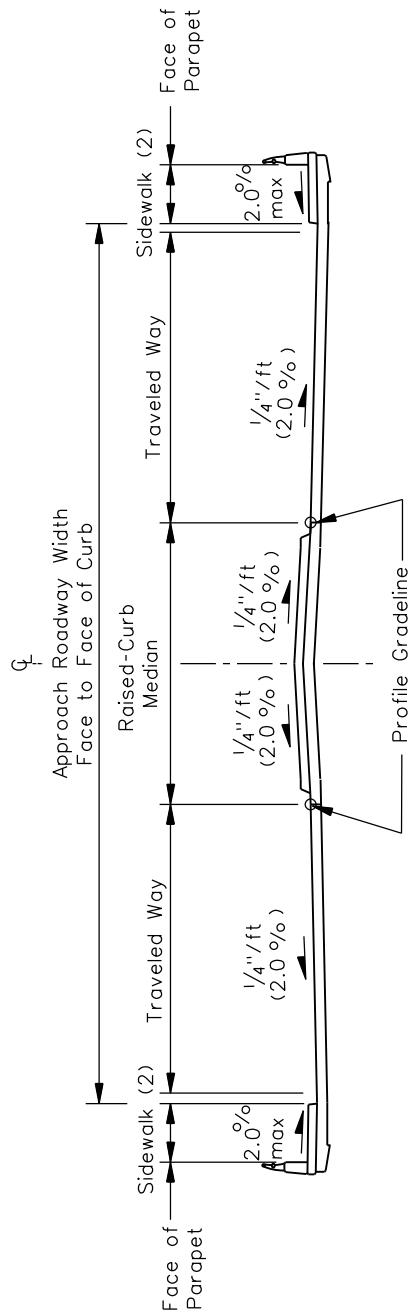

Sidewalk — Both Sides

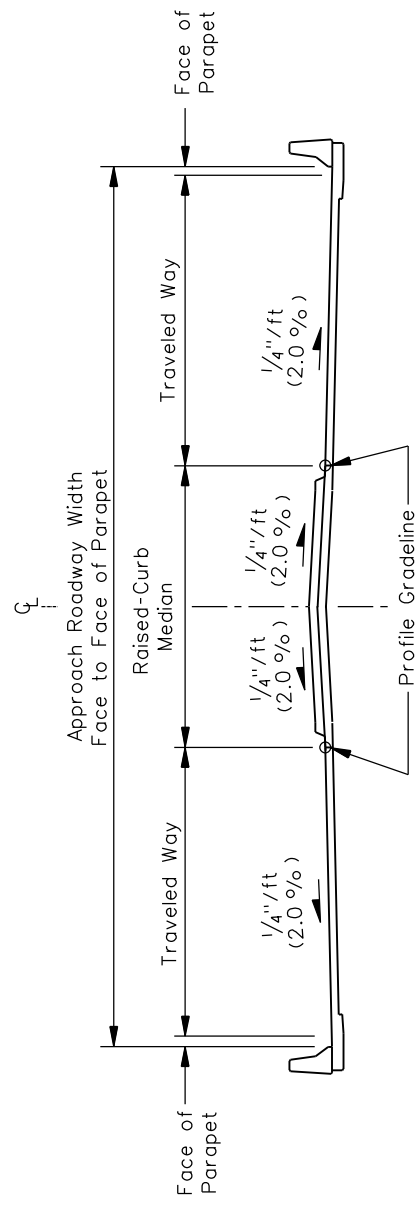

Sidewalk Not Provided

Note: See Figure 39-6.C. Raised sidewalks without physical separation may only be used with posted limits of 40 mph or lower.

CLEAR ROADWAY WIDTH OF BRIDGES FOR NEW AND RECONSTRUCTED URBAN HIGHWAYS WITH RAISED-CURB MEDIAN

Figure 39-5.K

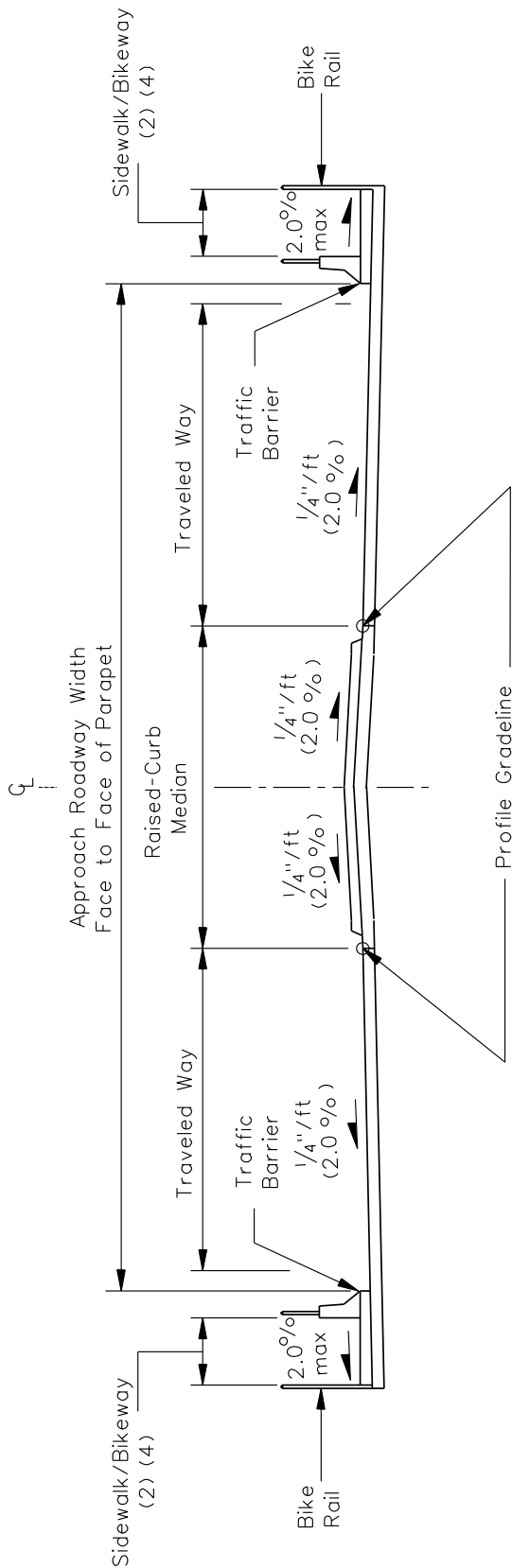

Notes:

1. See Figure 39-6.C and Chapter 17. The configuration shown is most typically applied for pedestrian accommodation at higher speeds. If a side path is provided on one or both sides, design the clear width and parapets for the path in accordance with Chapter 17 guidance. In those cases the side path will be directly on the deck rather than raised as illustrated.
2. Where a flush/traversable median is used on the approach, a raised-curb median may be used across the structure where bridge decks are subject to frequent icing conditions.
3. This template for separation of sidewalks may be considered where there are vehicular posted speed limits of 45 mph or greater, or high pedestrian volumes or a concentration of elementary school children present at lower posted speeds. Always provide separation in conjunction with a two-way side path.

CLEAR ROADWAY WIDTH OF BRIDGES FOR NEW AND RECONSTRUCTED URBAN HIGHWAYS WITH BIKEWAYS

Figure 39-5.L

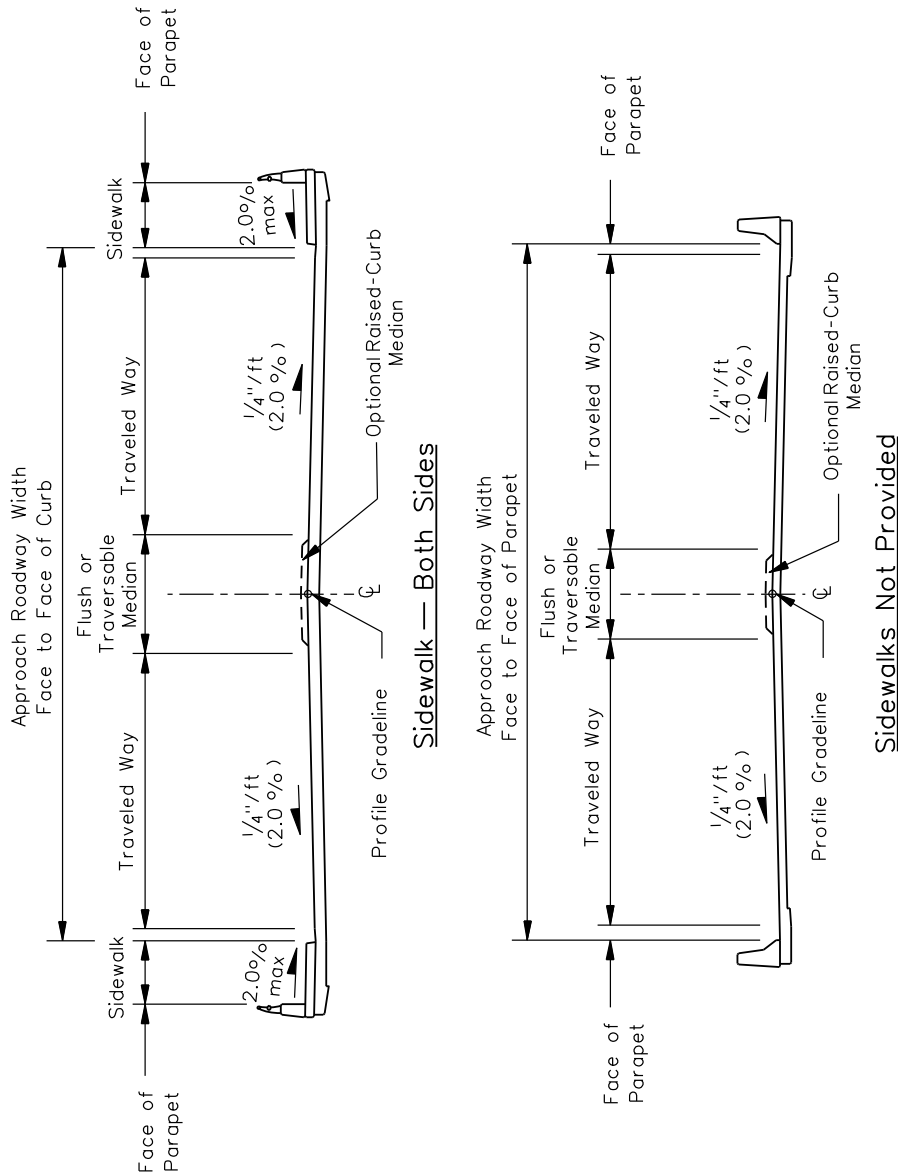

Notes:

1. See Figure 39-6.C and Section 48-2. Raised sidewalks without physical separation may only be used with posted limits of 40 mph or lower.
2. Where a flush/traversable median is used on the approach, a raised-curb median may be used across the structure where bridge decks are subject to frequent icing conditions.

**CLEAR ROADWAY WIDTH OF BRIDGES FOR NEW AND RECONSTRUCTED TWO-LANE URBAN HIGHWAYS
(Flush/Traversable Median)**

Figure 39-5.M

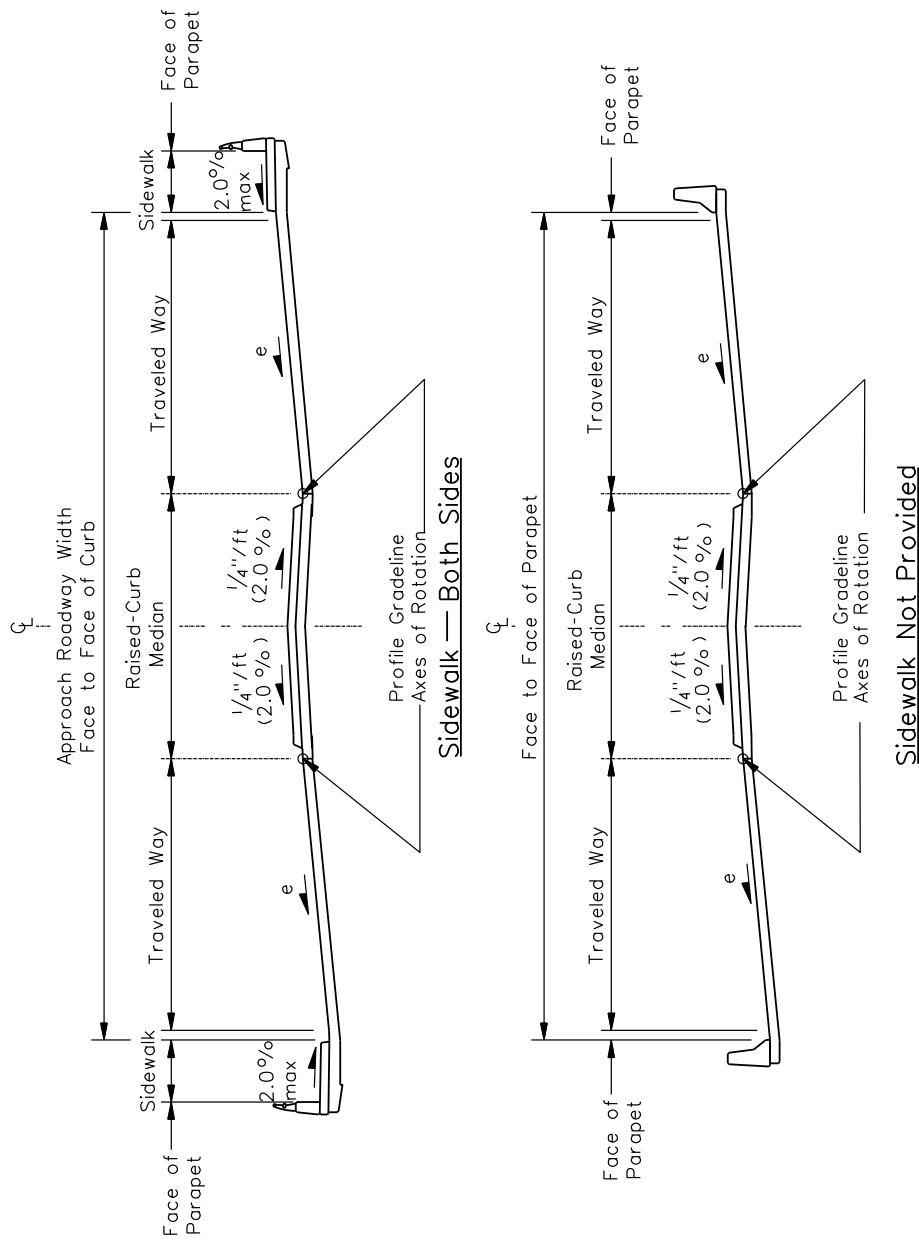

Notes:

1. See Figure 39-6.C and Section 48-2. Raised sidewalks without physical separation may only be used with posted limits of 40 mph or lower.
2. Where an urban bridge lies within a horizontal curve with superelevation, the gutter on the high side of the bridge (starting just off the end of the bridge approach pavement) is gradually transitioned into the design slope of the gutter on the approaching roadway. See the Highway Standards. This transition should be accomplished by providing a maximum relative longitudinal difference in gradient of 0.50% between the edge of the traveled way and the flow line of the gutter. Also see Chapter 32 and Section 48-5.

CLEAR ROADWAY WIDTH OF SUPERELEVATED BRIDGES ON URBAN HIGHWAYS WITH RAISED-CURB MEDIAN

Figure 39-5.N

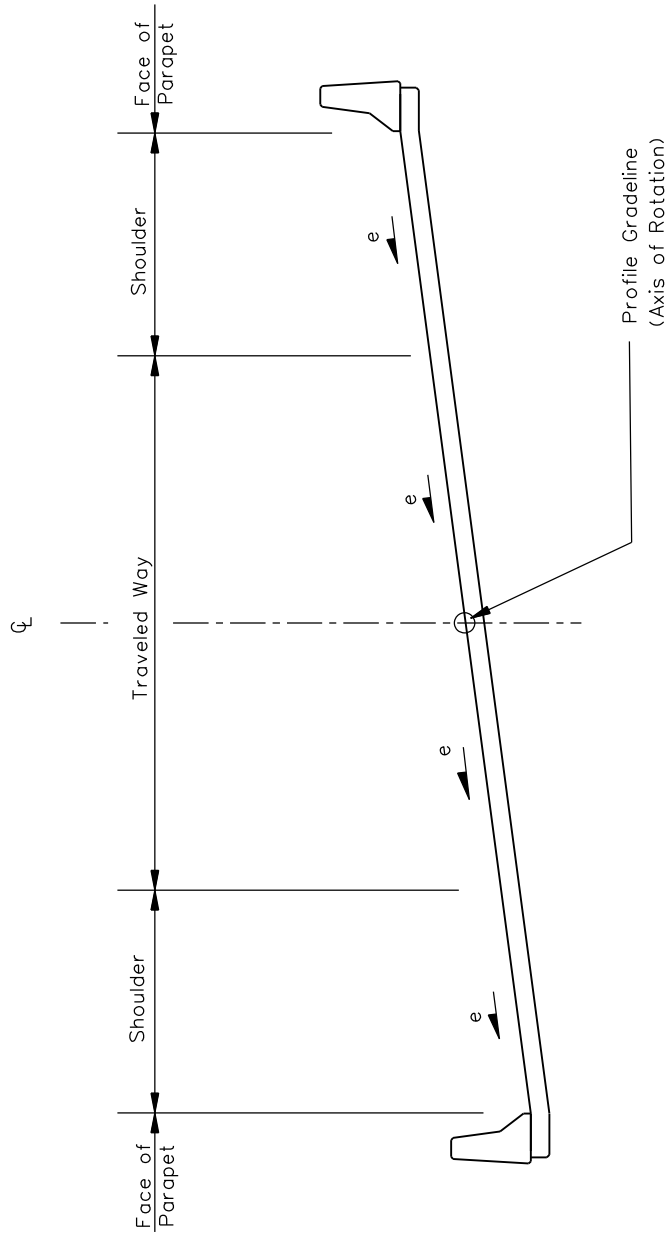

Notes:

1. See Figures 39-6.A and 39-6.B.
2. Where a bridge lies within a horizontal curve with superelevation, the shoulder on the high side of the bridge (starting just off the end of the bridge approach shoulder pavement) will be gradually transitioned into the design slope of the shoulder on the approaching roadway. Also see the Highway Standards. This transition should be accomplished by providing a maximum relative longitudinal difference in gradient of 0.40% between the edge of the traveled way and the outside edge of the shoulder. Also see Chapter 32.

CLEAR ROADWAY WIDTH OF SUPERELEVATED BRIDGES ON RURAL TWO-LANE HIGHWAYS

Figure 39-5.J

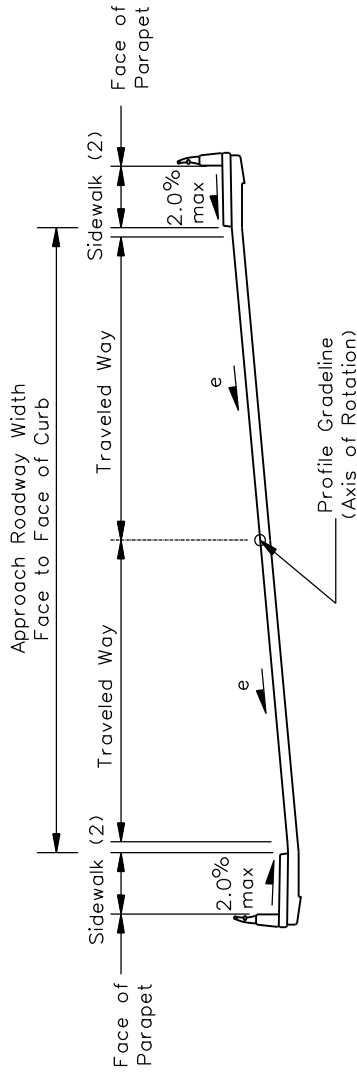

Sidewalk — Both Sides

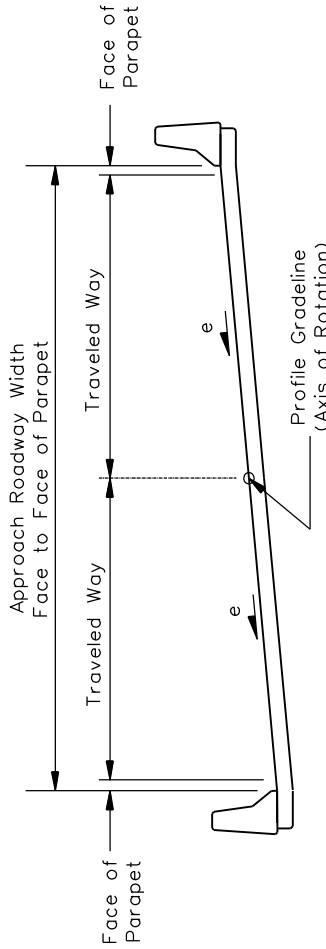

Sidewalk Not Provided

Notes:

1. See Figure 39-6.C and Section 48-2. Raised sidewalks without physical separation may only be used with posted limits of 40 mph or lower.
2. Where an urban bridge lies within a horizontal curve with superelevation, the gutter on the high side of the bridge (starting just off the end of the bridge approach pavement) is gradually transitioned into the design slope of the gutter on the approaching roadway. See the Highway Standards. This transition should be accomplished by providing a maximum relative longitudinal difference in gradient of 0.50% between the edge of the traveled way and the flow line of the gutter. Also see Chapter 32 and Section 48-5.

CLEAR ROADWAY WIDTH OF SUPERELEVATED BRIDGES ON TWO-LANE URBAN HIGHWAYS

Figure 39-5.P

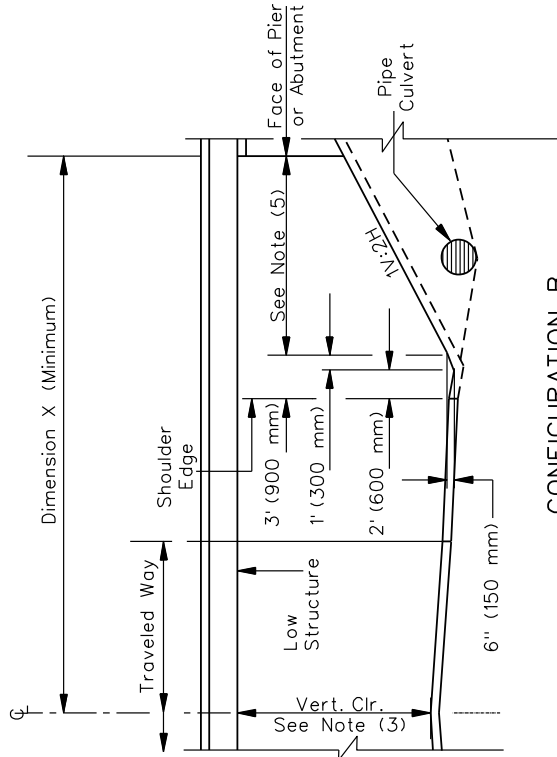

CONFIGURATION A

Notes:

1. Locate the upstream traffic end of a through pipe culvert outside the clear zone of the near edge of traveled way.
2. All horizontal dimensions are right-angle dimensions.
3. Locate the minimum clearance point at the least clearance point above the usable roadway under, including stabilized shoulders.
4. Where $DS \geq 60$ mph (100 km/h), distance is equal to 14 ft (4.2 m). For $DS < 60$ mph (100 km/h), distance is equal to 10 ft (3.0 m).
5. Where $DS \geq 50$ mph (80 km/h), distance is equal to 10 ft (3.0 m). For $DS < 50$ mph (80 km/h) distance is equal to 6 ft (1.8 m).

DS: Design Speed

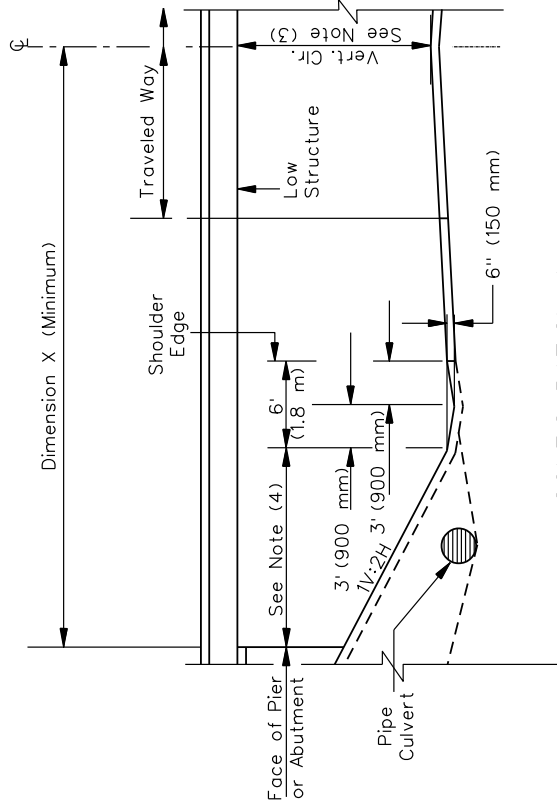

CONFIGURATION B

Functional Classification of Underpassing Highway	Current ADT or 20-Year DHV	Config.	X (Min.)	Minimum Vertical Clearance
Rural Principal Arterial or Minor Arterial*	All ADT's	A	42' (12.8 m)	16'-6" (5.0 m) (new) 16'-0" (4.9 m) (reconst)
Local Road or Collector	DHV over 400	A	36' (11.0 m)	14'-9" (4.5 m)
Local Road or Collector	DHV 200-400	A	36' (11.0 m)	14'-9" (4.5 m)
Local Road or Collector	DHV 100-200	B	30' (9.0 m)	14'-9" (4.5 m)
Local Road or Collector	ADT 250-400	B	28' (8.5 m)	14'-9" (4.5 m)
Local Road or Collector	ADT < 250	B	23' (7.0 m)	14'-9" (4.5 m)
Frontage Road A	ADT over 2000	A	40' (12.0 m)	16'-0" (4.9 m)
Frontage Road B	ADT ≥ 750	A	32' (10.0 m)	14'-9" (4.5 m)
Frontage Road B	ADT < 750	B	30' (9.0 m)	14'-9" (4.5 m)
Frontage Road C	ADT < 400	B	23' (7.0 m)	14'-9" (4.5 m)

For marked highways functional classified as collectors, use the arterial criteria.

CLEARANCES FOR BRIDGES OVER TWO-LANE HIGHWAYS

Figure 39-5.R

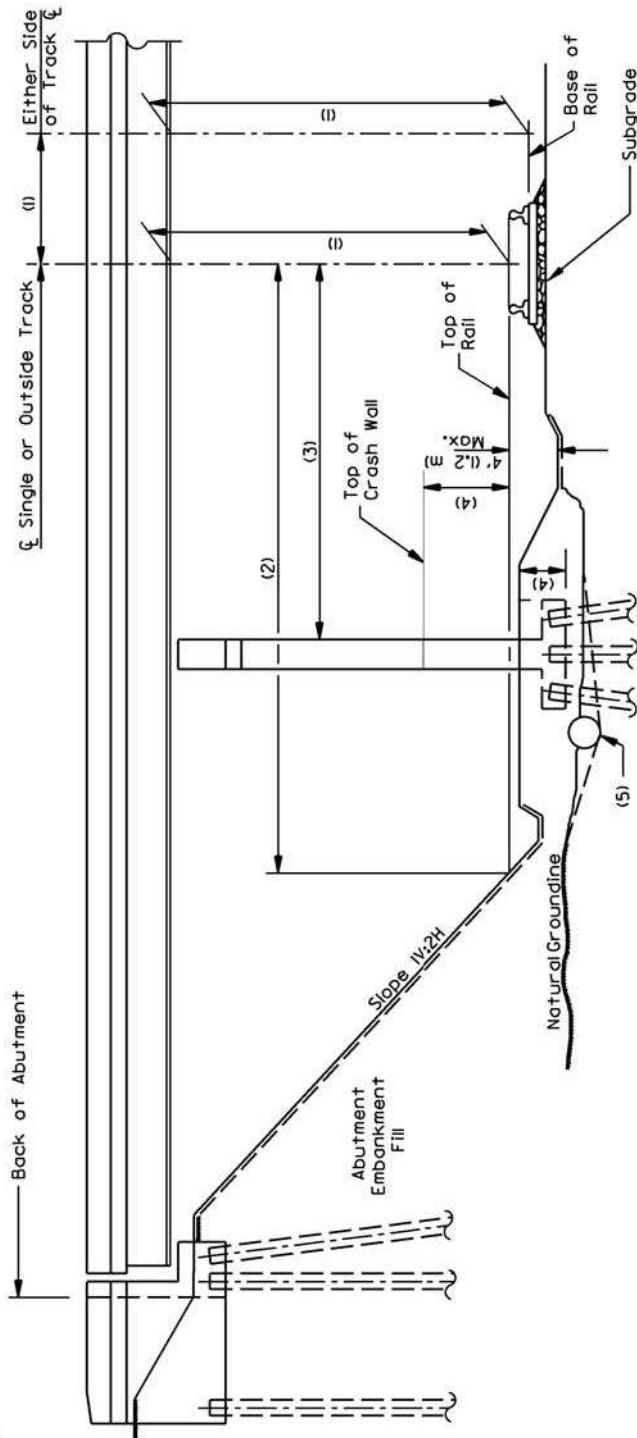

Typical section at right angle to track.

HIGHWAY GRADE SEPARATION OVER RAILROAD

FIGURE 39-5.S

Footnotes for Figure 39-5.S

For multiple track facilities, all dimensions apply to the centerline of the outer tracks. All horizontal dimensions are measured perpendicular to the railroad tracks.

- (1) *A vertical clearance of not less than 23 ft-0 in. (7.0 m) above the top of rail shall be provided for all new or reconstructed highway bridges constructed over a railroad track. Beginning at a point in the centerline of track, 23 ft-0 in. (7.0 m) above the top of the rail, the vertical clearance line shall extend thence horizontally each way to a point 9 ft, 0 in. (2.7 m) from the centerline of the track, from which points the horizontal clearance lines shall extend vertically downward to points level with the base of the rail. Illinois Commerce Commission may permit a lesser clearance if it determines that the 23 ft-0 in. (7.0 m) clearance standard cannot be justified based on engineering, operational, and economic conditions. The existing vertical clearance or 21 ft-6 in. (6.6 m), whichever is greater, is permitted for bridge rehabilitation projects that do not require pier and/or cap replacement, girder removal and/or replacement, and/or widening of the existing piers or pier caps. (92 Ill. Admin. Code 1500.160).*
- (2) *A cross section with a horizontal distance of 20 ft-0 in. (6.1 m) measured at right angles from the centerline of track at the top of rails, to the face of the embankment slope, is permitted. The 20 ft-0 in. (6.1 m) may be increased at individual structure locations as appropriate to provide for drainage if justified by a hydraulic analysis or to allow adequate room to accommodate special conditions, such as where heavy and drifting snow is a problem. The railroad must demonstrate that this is normal practice to address these conditions in the manner proposed. This dimension may be increased by up to 8 ft (2.5 m) on one side only, as may be necessary for off-track maintenance equipment, provided adequate horizontal clearance is not available in adjacent spans and where justified by the presence of an existing maintenance road or by evidence of future need for such equipment. (92 Ill. Admin. Code 1500.160).*
- (3) *Piers should be placed at least 9 ft-0 in. (2.8 m), measured from the nearest point along the edge of the pier, horizontally from the centerline of the track and preferably beyond the drainage ditch. (Appendix to Subpart B of Part 23 C.F.R. 646).*
- (4) *Crash walls for piers from 12 ft to 25 ft (3.6 m to 7.6 m) clear from the centerline of track shall have a minimum height of 6 ft (1.8 m) above the top of the rail. Piers less than 12 ft (3.6 m) clear from the centerline of track shall have a minimum crash wall height of 12 ft (3.6 m) above the top of the rail. The crash wall shall be at least 2 ft, 6 in. (760 mm) thick and at least 12 ft-0 in. (3.6 m) long. When two or more columns compose a pier, the crash wall shall connect the columns and extend at least 1 ft (300 mm) beyond the outermost column parallel to the track. The crash wall shall extend at least 4 ft-0 in. (1.2 m) below the lowest surrounding grade. (Volume 2 Chapter 8 Section 2.1.5 of AREMA Manual for Railway Engineering).*
- (5) *Intercepted drainage along railroad embankment shall be accommodated with a minimum 3 ft (900-mm) diameter culvert or carried along highway embankment.*

39-6 TABLES OF DESIGN CRITERIA

Figure 39-6.A presents the Department's design criteria for new or reconstructed bridges on the rural State highway system. Figure 39-6.B presents the Department's criteria for new or reconstructed bridges on rural frontage roads. Figure 39-6.C presents the Department's criteria for new or reconstructed bridges on the urban State highway system.

Classification	Principal Arterial Highway System or NHS			Minor Arterial System		
	Freeway ⁽³⁾	Expressway ⁽³⁾	Two-Lane Highway	Four-Lane Highway ⁽³⁾	Two-Lane Highway	
Highway Type	Freeway ⁽³⁾	Expressway ⁽³⁾	Two-Lane Highway	Four-Lane Highway ⁽³⁾	Two-Lane Highway	
Manual Reference	Figure 44-5.A	Figure 45-4.A	Figure 47-2.J	Figure 47-3.C	Figure 47-2.K	
Design Hourly Volume	One-Way DHV		One-Way DHV Under 2050	Two-Way DHV Under 850 ⁽⁴⁾	One-Way DHV Under 2525	Two-Way DHV Under 1050 ⁽⁴⁾
	1950 to 2900	Under 1950				
Clear Roadway Bridge Widths (Face-to-Face of Parapets) ⁽⁵⁾⁽⁶⁾⁽⁷⁾⁽⁸⁾	Dual 56'	Dual 40'	Dual 38' or 40'	44'	Dual 36' or 38'	32'
Minimum Width of Bridges (Face-to-Face of Parapets) Allowed to Remain in Place ⁽⁶⁾⁽⁹⁾	Dual 56'	Dual 38'	Dual 36' w/24' traveled way 34' w/22' traveled way	40' w/24' traveled way 38' w/22' traveled way	Dual 36' w/24' traveled way 34' w/22' traveled way	32' w/24' traveled way 30' w/22' traveled way
Minimum Design Flood Frequency	50-year					
Minimum Clearance Above Design High-Water Elevation	2' ⁽¹⁰⁾⁽¹¹⁾			2' ⁽¹¹⁾		
Design Live Load	HS-20 ⁽¹²⁾					
Vertical Clearance for Structures Over Highways ^{(14) (15)}	16'-0" min. Reconstruction/ 16'-9" New ⁽¹⁵⁾ Construction		16'-0" Reconstruction/16'-6" New Construction ^{(13) (15)}			
	See Figures 33-5.A, 39-5.Q and 39-5.R					
Horizontal Clearance for Structures Over Highways	See Figures 33-5.A, 39-5.Q and 39-5.R					
Vertical and Horizontal Clearance over Railroads	See Figure 33-5.A and 39-5.S					

**DESIGN CRITERIA FOR NEW OR RECONSTRUCTED⁽¹⁾ BRIDGES
(Rural State Highway System⁽²⁾)
(US Customary)**

Figure 39-6.A

Classification	Principal Arterial Highway System or NHS			Minor Arterial System		
	Freeway ⁽³⁾	Expressway ⁽³⁾	Two-Lane Highway	Four-Lane Highway ⁽³⁾	Two-Lane Highway	
Highway Type	Freeway ⁽³⁾	Expressway ⁽³⁾	Two-Lane Highway	Four-Lane Highway ⁽³⁾	Two-Lane Highway	
Manual Reference	Figure 44-5.A	Figure 45-4.A	Figure 47-2.J	Figure 47-3.C	Figure 47-2.K	
Design Hourly Volume	One-Way DHV		One-Way DHV Under 2050	Two-Way DHV Under 850 ⁽⁴⁾	One-Way DHV Under 2525	Two-Way DHV Under 1050 ⁽⁴⁾
	1950 to 2900	Under 1950				
Clear Roadway Bridge Widths (Face-to-Face of Parapets) ⁽⁵⁾⁽⁶⁾⁽⁷⁾⁽⁸⁾	Dual 16.8 m	Dual 12.0 m	Dual 11.4 m or 12.0 m	13.2 m	Dual 10.8 m or 11.4 m	9.6 m
Minimum Width of Bridges (Face-to-Face of Parapets) Allowed to Remain in Place ⁽⁶⁾⁽⁹⁾	Dual 16.8 m	Dual 11.4 m	Dual 10.8 m w/7.2 m traveled way 10.2 m w/6.6 m traveled way	12.0 m w/7.2 m traveled way 11.4 m w/6.6 m traveled way	Dual 10.8 m w/7.2 m traveled way 10.2 m w/6.6 m traveled way	9.6 m w/7.2 m traveled way 9.0 m w/6.6 m traveled way
Minimum Design Flood Frequency	50-year					
Minimum Clearance Above Design High-Water Elevation	600 mm ⁽¹⁰⁾⁽¹¹⁾			600 mm ⁽¹¹⁾		
Design Live Load	MS-18 ⁽¹²⁾					
Vertical Clearance for Structures Over Highways ^{(14) (15)}	4.9 m min. Reconstruction/ 5.1 m New ⁽¹⁵⁾ Construction		4.9 m Reconstruction/5.0 m New Construction ^{(13) (15)}			
	See Figures 33-5.A, 39-5.Q and 39-5.R					
Horizontal Clearance for Structures Over Highways	See Figures 33-5.A 39-5.Q and 39-5.R					
Vertical and Horizontal Clearance over Railroads	See Figures 33-5.A and 39-5.S					

**DESIGN CRITERIA FOR NEW OR RECONSTRUCTED⁽¹⁾ BRIDGES
(Rural State Highway System⁽²⁾)
(Metric)**

Figure 39-6.A

Footnotes for Figure 39-6.A

- (1) *Implies reconstruction of a significant length of existing highway either on new location or on existing ROW. For reconstruction of relatively short intermittent highway segments within a project, the design criteria used, where cost-safety effective, should be consistent with the adjacent highway design, but not less than that allowed to remain in place.*
- (2) *For marked highways functionally classified as Collectors, use the Arterial criteria.*
- (3) *Volumes calculated with PHF = 1.0; adjust for local peak hour factors (PHF).*
- (4) *Based on 100% MUTCD passing sight distance; adjust for actual percentage. See Chapter 31 for the assumed truck percentage.*
- (5) *On freeways where truck traffic exceeds 250 DDHV, see Figure 44-5.A for the use of 12 ft (3.6 m) shoulders.*
- (6) *Bridge widths for bridge rehabilitation projects are discussed in Chapters 49 and 50.*
- (7) *Bridge widths are normally defined as the sum of the approach traveled way width and approach paved shoulder width.*
- (8) *For reconstruction projects, where the minimum required right or left shoulder widths on a structure can only be obtained with the addition of new beams and substructure, a cost-safety evaluation should be made to determine the appropriateness of providing the required width. Significant decreases of the required widths should not be considered.*
- (9) *Implies elements allowed to remain in place without a design exception approval when cost-effective and when safety record is satisfactory.*
- (10) *For new freeway or expressway construction, the bottom of the superstructure shall not be below the all time high-water elevation.*
- (11) *For reconstruction projects, the proposed low superstructure should not be below the existing superstructure unless 2 ft (600 mm) of clearance is achieved. Any proposed clearance less than 2 ft (600 mm) above design high-water elevation must be accompanied by a request for a design exception.*
- (12) *For the Interstate System, provisions shall be made for the Alternate Military Loading.*
- (13) *Use 14 ft-9 in. (4.5 m) for local roads and unmarked collector roads.*
- (14) *The minimum required vertical clearance must be available over the traveled way and any paved shoulders.*
- (15) *A vertical clearance of 17 ft-3 in. (5.25 m) shall be provided for through trusses, overhead signs, and pedestrian overpasses.*

CLASSIFICATION	FRONTAGE ROADS		
MANUAL REFERENCE	Figure 44-2.H		
TYPE	A	B	C
Horizontal Clearance	See Figure 39-5.R		
Clear Roadway Bridge Widths (Face-to-Face Parapets)	40' (30')	34' (28')	28' (26')
Minimum Design Flood Frequency	30-year	25-year	20-year
Minimum Clearance Above Design High-Water Elevation	2' ⁽²⁾		
Design Live Load	HS-20		
Vertical Clearance for Structures Over Frontage Roads	See Figure 33-5.A, 39-5.R		
Vertical Clearance Over Railroad	See Figures 33-5.A and 39-5.S		

⁽¹⁾ Minimum design criteria for existing geometric design elements allowed to remain in place are shown in parentheses.

⁽²⁾ For structures allowed to remain in place, the low superstructure should not be lower than the design high-water elevation without a design exception.

**BRIDGE DESIGN CRITERIA FOR NEW CONSTRUCTION AND RECONSTRUCTION⁽¹⁾
(Rural Frontage Roads)
(US Customary)**

Figure 39-6.B

CLASSIFICATION	FRONTAGE ROADS		
MANUAL REFERENCE	Figure 44-2.H		
TYPE	A	B	C
Horizontal Clearance	See Figure 39-5.R		
Clear Roadway Bridge Widths (Face-to-Face Parapets)	12.0 m (9.0 m)	10.2 m (8.4 m)	8.4 m (7.8 m)
Minimum Design Flood Frequency	30-year	25-year	20-year
Minimum Clearance Above Design High-Water Elevation	600 mm ⁽²⁾		
Design Live Load	MS-18		
Vertical Clearance for Structures Over Frontage Roads	See Figure 33-5.A, 39-5.R		
Vertical Clearance Over Railroad	See Figures 33-5.A and 39-5.S		

- (1) *Minimum design criteria for existing geometric design elements allowed to remain in place are shown in parentheses.*
- (2) *For structures allowed to remain in place, the low superstructure should not be lower than the design high-water elevation without a design exception.*

**BRIDGE DESIGN CRITERIA FOR NEW CONSTRUCTION AND RECONSTRUCTION⁽¹⁾
(Rural Frontage Roads)
(Metric)**

Figure 39-6.B

Arterial Highways and Streets												
Classification	FW-6	FW-4	EX-6 Construction	EX-6 Reconstruction	EX-4 Reconstruction	OWS-4	OWS-3	OWS-2	TWS-6	TWS-4	TWS-2	
Highway Type												
Manual Reference	Figure 44-5.A		Figure 45-4.B		Figure 48-6.B		Figure 48-6.A					
Design Hourly Volume	One-Way DHV ⁽³⁾		One-Way DHV									
Clear Roadway Bridge Widths (Face-to-Face of Parapets or Curbs) ⁽⁴⁾⁽⁵⁾⁽⁶⁾	Under 3700	Under 2500	3850	2850	1900	Over 1850	1300-1850	Under 1300	2050-2900	1250-2050	Under 1250	
	56'	40'	56'	56'	38' - 40'	52'	40'	30'	76' plus median width	52' plus median width	30'	
Minimum Design Flood Frequency	50 Years											
Minimum Clearance Above Design High-Water Elevation	2' ⁽⁷⁾⁽⁸⁾											
Design Live Load	HS-20 ⁽⁹⁾											
Vertical Clearance for Structures Over Highways ⁽¹⁰⁾⁽¹¹⁾⁽¹²⁾	16'-0" minimum Reconstruction/ 16'-9" New Construction		16'-0" Reconstruction/ 16'-6" New Construction			14'-9"					See Figures 33-5.A, 39-5.Q, and 39-5.R	
	See Figures 33-5.A and 39-5.Q		See Figure 39-5.R									
Horizontal Clearance for Structures Over Highways	Provide a 3' minimum clearance from edge of traveled way to face of pier or abutment; 5' desirable. Provide a 9" high curb adjacent to pier or abutment.											
Vertical and Horizontal Clearance Over Railroads	See Figures 33-5.A and 39-5.S											

FW = Freeway EX = Expressway OWS = One-Way Street TWS = Two-Way Street

**DESIGN CRITERIA FOR NEW OR RECONSTRUCTED⁽¹⁾ BRIDGES
(Urban State Highway System⁽²⁾)
(US Customary)**

Figure 39-6.C

Classification	Arterial Highways and Streets										
	FW-6	FW-4	EX-6 Construction	EX-6 Reconstruction	EX-4 Reconstruction	OWS-4	OWS-3	OWS-2	TWS-6	TWS-4	TWS-2
Highway Type	Figure 44-5.A	Figure 45-4.B	Figure 45-4.B	Figure 45-4.B	Figure 45-4.B	Figure 48-6.B	Figure 48-6.B	Figure 48-6.B	Figure 48-6.A	Figure 48-6.A	Figure 48-6.A
Manual Reference	One-Way DHV ⁽⁸⁾	One-Way DHV ⁽⁸⁾	One-Way DHV ⁽⁸⁾	One-Way DHV ⁽⁸⁾	One-Way DHV ⁽⁸⁾	One-Way DHV	One-Way DHV	One-Way DHV	Two-Way DHV	Two-Way DHV	Two-Way DHV
Design Hourly Volume	Under 3700	Under 2500	3850	2850	1900	Over 1850	1300-1850	Under 1300	2050-2900	1250-2050	Under 1250
Clear Roadway Bridge Widths (Face-to-Face of Parapets or Curbs) ⁽⁴⁾⁽⁵⁾⁽⁶⁾	16.8 m	12.0 m	16.8 m	16.8 m	11.4 m-12.0 m	15.6 m	12.0 m	9.2 m	22.8 m plus median width	15.6 m plus median width	9.2 m
Minimum Design Flood Frequency	50 Years										
Minimum Clearance Above Design High-Water Elevation	600 mm ⁽⁷⁾⁽⁸⁾										
Design Live Load	MS-18 ⁽⁹⁾										
Vertical Clearance for Structures Over Highways ⁽¹⁰⁾⁽¹¹⁾⁽¹²⁾	4.9 m minimum Reconstruction/ 5.1 m New Construction	4.9 m Reconstruction/ 5.0 m New Construction	See Figures 39-5.Q and 39-5.R								
Horizontal Clearance for Structures Over Highways	See Figure 33-5.A and 39-5.Q										
Vertical and Horizontal Clearance Over Railroads	See Figure 39-5.R										
	Provide a 1.0-m minimum clearance from edge of traveled way to face of pier or abutment; 1.5 m desirable. Provide a 225-mm high curb adjacent to pier or abutment.										
	See Figures 33-5.A and 39-5.S										

FW = Freeway EX = Expressway OWS = One-Way Street TWS = Two-Way Street

DESIGN CRITERIA FOR NEW OR RECONSTRUCTED⁽¹⁾ BRIDGES
(Urban State Highway System⁽²⁾)
(Metric)

Figure 39-6.C

Footnotes for Figure 39-6.C

- (1) *Implies reconstruction of a significant length of existing highway either on new location or on existing ROW. For reconstruction of relatively short intermittent highway segments within a project, the design criteria used, where cost-safety effective, should be consistent with the adjacent highway design, but not less than that allowed to remain in place.*
- (2) *For marked highways functionally classified as Collectors, use the Arterial criteria. For other streets on the unmarked State-maintained system, see the Bureau of Local Road and Streets Manual.*
- (3) *Volumes calculated with PHF = 1.0; adjust for local peak hour factor (PHF).*
- (4) *On freeways where truck traffic exceeds 250 DDHV, see Figure 44-5.A for the use of 12 ft (3.6 m) right shoulders.*
- (5) *Bridge widths for bridge rehabilitation projects are discussed in Chapters 49 and 50.*
- (6) *For urban bridges requiring sidewalks, the width of the sidewalks is 5 ft (1.5 m) unless a wider width is specified by the district.*
- (7) *For new freeway or expressway construction, the bottom of the superstructure will not be below the all time high-water elevation.*
- (8) *For reconstruction projects, the proposed low superstructure will not be below the existing superstructure unless a 2 ft (600 mm) clearance is achieved. Any proposed clearance less than 2 ft (600 mm) above design high-water elevation must be accompanied by a request for a design exception.*
- (9) *For the Interstate System, provisions will be made for the Alternate Military Loading.*
- (10) *The minimum required vertical clearance must be available over the traveled way and any paved shoulders.*
- (11) *For reconstructed urban arterials, existing structures with a vertical clearance of 14 ft 0 in (4.3 m) may be allowed to remain in place. For a freeway or expressway passing through a highly developed urban area, a 15 ft 0 in (4.5 m) vertical clearance may be provided if a circumferential route is designated around the urbanized area and if the circumferential route has a minimum vertical clearance of 16 ft 0 in (4.9 m).*
- (12) *A vertical clearance of 17 ft 3 in (5.25 m) shall be provided for through trusses, overhead signs, and pedestrian overpasses.*

Chapter Forty

GENERAL DRAINAGE PROCEDURES

BUREAU OF DESIGN AND ENVIRONMENT MANUAL

Chapter Forty

GENERAL DRAINAGE PROCEDURES

This Chapter provides guidance on the drainage requirements of projects designed for the State highway system. It discusses the division of responsibility between the districts and the Central Office, general drainage policies, design criteria, and the content of drainage studies for various project types.

The *IDOT Drainage Manual* provides a detailed discussion on drainage policies and procedures to be used on all design projects. This Chapter refers to the *IDOT Drainage Manual* extensively to direct the reader to specific areas of interest.

40-1 ADMINISTRATION

40-1.01 Responsibilities

The Hydraulics Unit of the Bureau of Bridges and Structures is responsible for all drainage functions completed within the Offices of Program Development and Highways Project Implementation. In District 1, the Hydraulic Engineer and support staff are located in the Bureau of Programming. In Districts 2 through 9, the Hydraulic Engineer and support staff are located in the Bureau of Program Development.

The Hydraulics Unit of the Bureau of Bridges and Structures is responsible for the development and administration of the roadway, culvert, and bridge drainage policies used by the Offices of Program Development and Highways Project Implementation within IDOT. The districts are responsible for initiating drainage and hydraulic studies, coordinating and monitoring drainage work performed by consultants, completing Phase I reports, and ensuring that the appropriate policies and procedures are followed throughout project development. Chapter 1 of the *IDOT Drainage Manual* provides a comprehensive description of drainage responsibilities of the Central Office and the districts.

40-1.02 General Overview

The critical impact of drainage decisions and their influence on plan preparation, implementation, and operation requires a continuous consideration of drainage features throughout project development. Typically, project development occurs in two phases, and drainage is a principal feature of both phases.

Drainage Studies are one of several types of Phase I studies, which are then incorporated into the Phase I report that is used to make and document design decisions. On major construction projects, it may also be necessary to prepare an Environmental Impact Statement, which uses the findings of a Drainage Study. On most projects, the district Hydraulic Engineer and the

Operations Field Engineer will examine drainage issues during Phase I and recommend needed improvements or identify items that require evaluation.

Drainage Studies are completed during Phase I to identify the drainage needs and/or problems associated with highway projects. They also provide an excellent coordination tool to consider and document local agency concerns, regulations, and needs. The complexity of the drainage study during Phase I depends on the type of project under study.

For highways on a new location, which require a Design Report or Combined Report, the Drainage Study examines the overall drainage patterns of the area, and the Study identifies the location, type, and relative size of drainage structures required for each alignment. This includes such structures as bridges, culverts, storm drains, ditches, pumping stations, or other special structures. The Study may be rather complex and assist in setting the alignment and profile of the proposed highway project. The Study will also address any special drainage problems that may be encountered by a specific alignment or any problems precipitated by a proposed alignment. The completed Drainage Study for projects on new alignment becomes a technical report to the Design Report or Combined Report.

A 3R project could involve investigating:

- the need to widen and deepen existing highway ditches;
- the hydraulics of existing bridges and culverts;
- flooding problems; and
- storm sewer capacities or the need for new storm sewers and the need for compensatory or detention storage or larger outflow facilities.

See Figure 40-1.A, which summarizes the type of drainage information needed for projects.

Type of Work Type of Project	Phase I (Location/Design Studies)	Phase II (Preparation of Construction Plans)
1. Freeway or expressway construction on new alignment.	Prepare Drainage Study that documents the overall drainage plan for project and indicates preliminary culvert sizes, highwater elevations for proposed bridges, areas of sheet flow, width of ditches for detention storage, etc. Document results in Drainage Study.	Use Drainage Study to develop a Drainage Report for project.
2. Freeway or expressway reconstruction on existing alignment.	Determine if existing drainage facilities can adequately accommodate storm water and what changes may be needed. Document results in Drainage Study. Check with field maintenance engineers and local agencies for any flooding problems. The preparation of Hydraulic Reports are necessary in this Phase.	Use Preliminary Drainage Study to develop a Drainage Report for project. Urban freeways/expressways will have the most potential for significant drainage changes.
3. Expressway construction along existing alignment.	Prepare Drainage Study that documents the overall drainage plan for project and indicates culvert sizes, highwater elevations for existing and proposed bridges, areas of sheet flow, width of ditches for detention storage, location of any gutters and storm sewers in restricted ROW areas, etc. Document results in Drainage Study. Because of existing bridges, multiple box culverts, and other special drainage problems along an existing route, this type of project will require the preparation of Hydraulic Reports. The Hydraulic Report will be submitted in conjunction with each Bridge Condition Report.	Use Drainage Study to develop a Drainage Report for projects. In highly urbanized areas, the drainage investigations required in Phase I may be quite extensive with little work remaining to be done in Phase II.
4. Reconstruction of existing urban arterial or collector streets.	Prepare Drainage Study that documents the overall drainage plan for project and indicates preliminary storm sewer sizes, preliminary culvert sizes, highwater elevations for any bridges, detention storage needed, main outflow storm sewer locations, pump stations, etc. Document results in Drainage Study.	Use Drainage Study to develop a Drainage Report for projects. In highly urbanized areas, the drainage investigations required in Phase I may be quite extensive with little work remaining to be done in Phase II.

TYPICAL DRAINAGE INFORMATION
(Projects on the State Highway System)

Figure 40-1.A

Type of Work Type of Project	Phase I (Location/Design Studies)	Phase II (Preparation of Construction Plans)
5. Reconstruction of existing rural arterial or collector highways including any bypass around a community (could include major realignments in both the horizontal and vertical planes).	Prepare Drainage Study that will document the overall drainage plan for project. Study should indicate culvert sizes, highwater elevations for bridges, areas of sheet flow, width and depth of ditches for detention storage, etc. Document results in Drainage Study. Check with field operations engineers for any flooding problems. The preparation of Hydraulic Reports should be completed in this Phase.	Use Drainage Study to develop a Drainage Report for project. If Hydraulic Reports are not prepared in Phase I, they will have to be prepared in this Phase.
6. All 3R projects.	Check with field operations engineers and local agencies for any flooding problems. Examine the need to deepen ditches to improve highway drainage. If flooding problems occur in urban areas, determine and document causes and recommend solutions. If bridges or large box culverts exist within project, Hydraulic Reports may be prepared during this phase of work in conjunction with each Bridge Condition Report and then submitted for review and approval to the Bureau of Bridges and Structures (BB&S) or the District.	From information documented in approved Phase I Report, the designer submits a TS&L drawing to the BB&S for each major drainage structure. The approved TS&L drawing is then used to prepare the final plans for the drainage structure.
6a. Superstructure replacement on existing piers and abutments.	Project could be part of roadway improvement or a stand-alone project. Requirements as described above for Item 6 will apply.	Requirements as described above for Item 6 will apply.
6b. Complete structure replacement on existing alignment.	Project could be part of roadway improvement or a stand-alone project. Project could involve a runaround detour over waterway that would require a special hydraulics analysis. Requirements as described above for Item 6 will apply.	Requirements as described above for Item 6 will apply.
6c. Existing box culvert or bridge replaced with a multiple-barreled box culvert.	Project could be part of roadway improvement or a stand-alone project. Requirements as described above for Item 6 will apply.	Requirements as described above for Item 6 will apply.

**TYPICAL DRAINAGE INFORMATION
(Projects on the State Highway System)**

**Figure 40-1.A
(Continued)**

40-2 STUDIES

40-2.01 Introduction

Drainage Studies and Hydraulic Reports are investigations of the existing and proposed drainage patterns and the hydraulic performance of highway drainage structures. These drainage investigations are a vital component in the design of every highway project. Runoff, ponding of water, and the adequacy of the outlet must be addressed early in the project development stage to ensure that projects are designed through a process that involves consideration and balancing of a number of factors including:

- flood hazards to highway users and neighboring property owners,
- legal considerations,
- functional needs,
- environmental and social concerns,
- local stormwater management ordinances,
- costs, and
- other site conditions.

The analyses listed below are commonly conducted as a part of both a Drainage Study and a Hydraulic Report:

- hydrologic analysis;
- hydraulic analysis;
- engineering evaluation of selected alternatives; and,
- addressing Illinois Department of Natural Resources, Office of Water Resources (IDNR-OWR) permitting requirements.

The detail of analysis for either study is commensurate with the scope of work and the hydraulic risk associated with the drainage facility and other economic, engineering, social, or environmental concerns. Chapter 2 of the *IDOT Drainage Manual* provides a complete description of Drainage Studies and Hydraulic Reports.

40-2.02 Drainage Studies

A Drainage Study includes the hydraulic investigation and analysis of minor drainage facilities such as roadside and median ditches, detention ponds, storage pipes, storm sewers, and single barrel culverts. The Drainage Study becomes the basis for judging the adequacy of existing facilities, improvements needed, compliance with existing policies and standards, consideration of local stormwater management ordinances, and coordination with other agencies. The Study will typically include the analysis and evaluation of all applicable drainage features within the project reach. In District 1, the Drainage Study is completed during Phase I. However, the Drainage Study is often completed during Phase II work in Districts 2 through 9. The detailed

hydraulic analysis for major drainage structures such as bridges, multi-barrel culverts, and pumping stations are contained in a separate Hydraulic Report. Where a Hydraulic Report is required, it is completed in Phase I in all districts, and the Drainage Study summarizes the findings.

The Drainage Study must begin with an investigation of existing drainage patterns to establish a basis for judging the adequacy of drainage features included in the highway project and to identify the drainage parameters that will be encountered by the highway project. Address the following specific items:

- an evaluation of floodplain impacts,
- permitting requirements,
- identification of all drainage paths,
- highest known water levels,
- reports of flooding of both adjacent property and the highway facility, and
- outlet conditions.

The Drainage Study should also identify the general type, size, and location (including right-of-way requirements) of all highway drainage facilities necessary to accommodate local conditions and design requirements, and it should contain the complete hydraulic analysis of the proposed design.

Where the project involves the replacement or rehabilitation of an existing facility, the Drainage Study should document the adequacy of the existing system during past storm events. This will include consideration for erosion and sediment control of ditches and drainage structures, storm sewer capacities, and locations of pavement flooding and adjacent property flooding. The need for drainage improvements on rehabilitation projects is determined from the investigation of existing conditions and the evaluation of problems or inadequacies encountered. A theoretical hydraulic analysis is performed to determine the proposed changes.

However, if the theoretical analysis indicates the need for major changes but the Drainage Study reveals that no problems have been encountered during past flood events, the theoretical analysis may be determined by the engineer to be overly conservative and not representative of local conditions. The experience of problems with the existing facility, as identified by district Operations personnel, adjacent property owners, or local agencies that maintain State Routes by agreement is normally required to justify major drainage improvements to existing facilities on 3R projects.

When the final Drainage Study is scheduled to be completed with Phase II work, a Preliminary Drainage Study is prepared in Phase I. This Study defines existing drainage features and identifies the type and relative size of drainage structures required to complete the project. The Preliminary Drainage Study should contain mapping or USGS quadrangle maps that identify drainage patterns, adjacent land usage, and the location of affected structures. The Study should include a centerline profile, an adjacent groundline profile, existing and proposed roadway templates, right-of-way or easement requirements, and the relative size and configuration of existing and proposed drainage structures. It should identify known problems such as pavement

flooding, ditch erosion, bridge or culvert scour, concerns of other agencies, and complaints by property owners.

The Preliminary Drainage Study, when finalized and approved, becomes the Drainage Report for the project. The final Drainage Report should identify all changes made to the preliminary study affecting the number, type, size, and location of drainage structures.

40-2.03 Hydraulic Reports

A Hydraulic Report is similar to a Drainage Study, except that it typically focuses on a single structure location because of the greater volume of computations and support data required for the structure involved. Hydraulic Reports are required for bridges, multiple-barrel culverts, single-barrel culverts that are identified by the district as requiring a special study, pumping stations, and all special or unusual drainage structures. For all projects where the structural design will be reviewed by the district Hydraulic Engineer, Hydraulic Reports must be prepared and submitted to the Central Office with the submittal of a Bridge Condition Report. The content of a Hydraulic Report is similar to a Drainage Study in that it includes an evaluation of existing conditions, hydraulic calculations of the proposed design, details of structure type and size, and all supporting data. Bridge and culvert crossings should also be investigated for problems associated with scour and siltation, debris and ice blockage, stream alignment, highwater clearances, headwater and tailwater elevations, and complaints of flooding.

Early in the Hydraulic Report preparation, it should be determined if the project will require a construction permit from the IDNR, Office of Water Resources. See Chapter 28. If a permit is required, the type of permit and the permit requirements should be identified, and the proposed design must be evaluated for those requirements. Where local conditions dictate a higher design standard than the permit requirement, the Hydraulic Report must identify and document these conditions in accordance with the Floodplain Encroachment Policy in Section 1-302 of the *IDOT Drainage Manual*. The jurisdictional limits and the permit requirements of the Office of Water Resources are described in Section 1-400 of the *IDOT Drainage Manual*. The design decisions of projects that do not require a construction permit should be based on a cost evaluation of alternatives which satisfy the project design criteria, local site conditions, legal requirements, and project objectives. These conditions and decisions must also be documented in accordance with the Floodplain Encroachment Policy.

40-3 DESIGN CONSIDERATIONS

40-3.01 Introduction

Section 40-3 addresses the types of design considerations that relate to the drainage aspects of a highway project. There are often numerous design features that will satisfy the design objectives of the project and, therefore, many tasks and requirements must be considered during the early phases of project development to ensure the selection of the most cost-effective and beneficial design features.

Coordination among the various Central Bureaus and the district is a very important function. Also, notification of proposed projects must be made to other agencies and the public, and the permits and regulations of other agencies applicable to the project should be identified and documented as soon as practical. Often project delays are due to the legal process. Problems that may arise during design, construction, or maintenance should be considered in Phase I studies.

The above factors and other considerations may not always allow items to be separated into the planning phase and the design phase. Often, there will be overlap, and sometimes the separation of work between the phases will be indistinct. Therefore, it is essential that the design concepts developed in Phase I be evaluated for their constructability. This includes right-of-way needs, because this consideration reduces the likelihood that Phase I decisions will be revisited during Phase II. When Phase II work is allowed to proceed before Phase I studies are complete, many problems are exacerbated and conflicts between the various parties and schedules often occur. The district is responsible for coordination and guidance on these issues. This ensures that project schedules are maintained.

40-3.02 Storm Drainage Facilities

40-3.02(a) General

Highway storm drainage facilities collect stormwater runoff and convey it along and/or away from highway right-of-way to adequately drain the roadway and minimize the potential for flooding and the erosion to properties adjacent to the right-of-way. Stormwater includes the runoff from precipitation falling within the right-of-way and the surface runoff from adjacent properties which flows into the roadside ditches or the storm drainage system. Storm drainage facilities consist of curbs, gutters, inlets, storm drains, ditches, and culverts. The placement and hydraulic capacities of storm drainage structures and conveyances should be designed to avoid/minimize damage to adjacent property and to secure a low degree of risk of traffic interruption by flooding. Interruption by flooding should commensurate with the importance of the road, the design traffic service requirements, and available funds.

There are two basic types of roadway sections to be considered for pavement drainage—a rural section and a curbed section. A rural section consists of a crowned pavement that drains laterally to the shoulders and down the embankment slope to a roadside ditch or that continues as sheet flow down slope from the right-of-way. The ditches are sloped to carry the runoff to the nearest

natural outlet. A curbed section consists of a sloped pavement that drains to a curb and gutter system. The curb and gutter channels the flow to a series of inlets which capture the runoff and outlet into a storm drain. Both section types may include a median to separate traffic. The rural section is normally more cost effective and is the section of choice where other factors are equal, because it allows the unhindered drainage of the pavement without concern for encroachment on the traveled way. Costs of the rural section include wider right-of-way, longer/wider cross drainage structures, and the maintenance costs of mowing, debris pickup, and ditch erosion repairs. Curbed sections are required in urban settings where sidewalks, storefronts, residential lawns, and/or intersections do not allow room for roadside ditches and the wider right-of-way required for a rural section. The policies and procedures for the design of storm drain systems are presented in Chapter 8 of the *IDOT Drainage Manual*.

40-3.02(b) Rural Cross Sections

Because rural sections usually require wider right-of-way, the scheduling of widening or reconstruction projects must include sufficient time for the purchase of additional right-of-way and the right-of-way requirements must be determined early in project development. Actual right-of-way required is determined by roadway geometrics and drainage needs. Existing drainage conditions and the design highwater elevation plus the freeboard requirements (see Chapter 1 of the *IDOT Drainage Manual*) may control the roadway profile. Basic geometrics with consideration of key drainage elements are established first and then detailed drainage needs and type and size of drainage facilities are determined. These are based on the roadway geometrics and the runoff from adjacent properties. If drainage problems are encountered, it may be necessary to review geometric design decisions and/or to use special drainage structures.

Drainage considerations for rural sections include the discharge to be carried, typical ditch sections and gradients, ditch erosion protection requirements, and suitable outlet conditions. The source of discharge must consider the width of pavements, appurtenant vegetation and/or paved areas of the right-of-way, and adjacent property. Ditch sections must conform to acceptable side slopes and depth to accommodate errant vehicles and mowing equipment. The width, depth, and gradient of ditches may need adjustment to accommodate the design discharge and minimum depth requirements. Chapter 9 of the *IDOT Drainage Manual* presents complete design procedures for roadside ditches.

40-3.02(c) Curbed Cross Sections

Curbed sections are normally more expensive than rural sections because of the number of appurtenant structural items involved. These include the curb and gutter section, inlets, laterals, storm drains, manholes, and outlet structures. A major consideration in the design of a curbed section is the location of the main storm drain. Locations outside the pavement structure are preferred because they provide easier access for maintenance and repairs, and they do not involve the expense of special backfill required for storm drains placed beneath the pavement structure. However, potential conflicts with utilities must be fully evaluated and often will influence the location of storm drains. The most cost-effective design is determined by an analysis considering a balance of sizes, slopes, and depths of storm drains that satisfy the storm drain policies and drainage needs of the project. Chapter 34 discusses the drainage of selected

medians (raised-curb, traversable, or flush). The drainage of each median considers the traffic safety concerns with additional cross flow, and it also considers minimizing ice melt flowing onto and refreezing on the traveled way.

Inlet types are selected from the *IDOT Highway Standards* based on the location and situation to be served by the inlet. Spacing of inlets is determined by analysis to control the spread of water onto the traveled way and at predetermined locations such as at sag vertical curves, intersections, and pedestrian cross walks. These details are normally addressed during Phase II work.

The Drainage Study prepared with Phase I work must address proposed hydraulic improvements for existing conditions such as the conversion of open ditches to a storm drainage system including the suitability of outfalls, pumping stations, and detention basins. Both the functionality and constructability of these changes must be addressed, and impacts such as right-of-way needs, environmental impacts, agency coordination, and permit requirements considered.

40-3.02(d) Joint Participation

Many highway projects involve joint participation in both the use and funding of storm drain systems. Joint participation normally involves a municipality or a county in conjunction with the Department. This may result in either the State connecting to a local agency storm drain because there is no other feasible outlet or the local agency tying into a State storm drain. The possibility of joint participation should be determined early in project development to allow an investigation of the full area to be served by the system and a determination of the storm drain size. Also, adequate time must be allowed for negotiations and development of an agreement between the Department and the local agency involved. Chapter 5 of the *BDE Manual* discusses the policies on Joint Participation.

40-3.03 Stormwater Management

Stormwater management is defined as the control of runoff to satisfy a predetermined objective. The Department's policy on stormwater management is found in the Department's *Storm Water Management Plan*. The basic objective is to ensure that runoff from a highway project does not result in any detrimental effects to upstream or downstream property and flooding conditions. The primary tool in reducing runoff for stormwater management is detention storage; however, it is also possible to reduce runoff rates by lengthening flow paths, flattening slopes, and using open ditches instead of enclosed storm drains. Where storage is necessary, it may be provided in any one of several locations (e.g., medians, roadside ditches, open basins, oversized storm drains). A roadway project may involve a combination of storage features and methods to reduce runoff.

Stormwater management considerations in accordance with Department policies must be analyzed on all projects to ensure that drainage problems are not increased and all legal obligations are satisfied. The stormwater management ordinances of local agencies must also be considered and incorporated into a project design when feasible and cost-effective.

40-3.04 Bridges and Culverts

Highways which cross a watercourse are often referred to as a transverse encroachment. The cross drainage to the highway, whether by swale, stream, or river system, must be carried across the highway to preserve the natural and existing drainage courses. A hydraulic investigation and analysis of both the upstream and downstream reaches of the watercourse is necessary to determine the best location, size, and elevation of the proposed crossroad structure, whether a culvert or a bridge. The investigation should ensure that any highway structure or roadway embankment that encroaches on or crosses the floodplain of a watercourse will not cause a significant adverse effect to the floodplain and will be capable of withstanding the flood flow with minimal damage. The analysis should also clearly indicate the path and approximate elevations of flow and existing conditions at any location where water comes to or leaves a proposed project. To ensure that adequate attention is provided to this aspect of design, all construction plans submitted for approval shall show the magnitude, frequency, and pertinent water surface elevations for the design flood, the 100-year flood, and the overtopping or 500-year flood for all structures in accordance with the criteria in the *IDOT Drainage Manual*.

Where hydraulic structure sizes can affect the selection of alignments or grades, a detailed hydraulic analysis should be performed with Phase I work, and included in a Hydraulic Report. Likewise, 3R projects that have experienced hydraulic problems (severe scour, inundation, debris, flooding complaints, etc.) require a detailed hydraulic analysis in Phase I to identify any necessary countermeasures or drainage features that should be incorporated into the design. This is pursuant to the policy on Documentation of Floodplain Encroachment Designs in Section 1-302 of the *IDOT Drainage Manual*. Abbreviated Hydraulic Reports can be completed for some minor projects which have no impact on the hydraulic performance as described in Section 1-303.

Proposed designs for replacement bridge and culvert structures may be considered acceptable for hydraulic design during location studies provided the proposed replacement does not cause more restriction to flood flows than the existing structure and provided the existing structure will not cause significant flood damage during a normally anticipated flood event up to and including the 100-year frequency flood. A Hydraulic Report is required to verify that these conditions are met.

The selection of a bridge versus a culvert structure will be based on a cost comparison of equal hydraulic alternatives considering acceptable levels of backwater, structure clearance, debris and ice, foundation stability, overtopping flows, scour potential, and local site conditions. The normal break point for considering a culvert alternative is approximately 300 ft² (28 m²) of opening; however, site conditions will allow the use of larger culverts in some situations. The bridge and culvert alternatives must reasonably conform to the shape of the stream channel section to minimize the occurrence of siltation. Consideration of construction staging and the benefits of precast versus cast in place (culvert or bridge) may also influence the selection of structure type.

Projects involving a Regulatory Floodplain of the IDNR-OWR must consider the compensatory storage requirements of the permit rules. Any fill material placed in a designated floodway must be compensated for at the approximate elevation of the fill. If a highway fill is placed between the normal water elevation and the 10-year flood elevation, it must be compensated for between the

normal and 10-year elevation. Likewise, for fill material placed between the 10-year and the 100-year flood elevations, this must be compensated for between the 10-year and 100-year flood elevations. The Drainage Study must address the issue of compensatory storage and identify suitable locations for providing adequate storage.

The policies and procedures for the hydraulic design of culverts are presented in Chapter 6 and those for bridges are presented in Chapter 7 of the *IDOT Drainage Manual*.

40-3.05 Longitudinal Encroachments

Longitudinal encroachments are those where the highway is within the boundary of the stream and its floodplain and runs along the stream approximately parallel to the floodplain. This contrasts with a transverse encroachment which crosses the channel from one side of the floodplain to the other. The policies and procedures for flood plain encroachments are in Section 1-302 and Chapter 3 of the *IDOT Drainage Manual*.

Avoid longitudinal encroachments, especially those that encroach upon the floodway. Where a longitudinal encroachment cannot be avoided, the degree of encroachment should be minimized. Longitudinal encroachments can have a critical impact on floodplain conveyance and storage requiring additional right-of-way and excavation for compensatory storage and enhancement of conveyance sections. Where required, compensatory storage will be provided in accordance with Section 40-3.04. Environmental and highway impacts must be evaluated and mitigated. Highway impacts include overtopping flows, erosive velocities, accumulation of debris, and migrating channel bends. The obvious disadvantages of an encroaching location are the increased flood risk, potential for damaging the highway, cost to protect the facility, environmental impacts, and permit requirements.

40-3.06 Pump Stations

Stormwater pump stations are necessary to remove stormwater from highway sections that cannot be drained by gravity. Because of high costs and the potential problems associated with pump stations, their use is recommended only where other systems are not feasible. Where operation and maintenance costs are capitalized, a considerable expenditure can be justified for a gravity system.

Pump station design presents the designer with a challenge to provide a cost-effective drainage system that meets the needs of the project. Considerations in pump station design include:

- location,
- wet-pit vs. dry-pit,
- type of pumps,
- number and capacity of pumps,
- pump cycling sequence,
- peak flow vs. storage,
- force main vs. gravity,

- above grade vs. below grade,
- site and location of receiving water,
- outlet restrictions,
- monitoring systems,
- backup systems, and
- maintenance requirements.

The procedures recommended for the hydraulic design of pumping stations are found in Chapter 13 of the *IDOT Drainage Manual*.

40-3.07 Pipe Culverts and Storm Sewers

Section 40-3.07 establishes design guidelines for the use of pipe culverts and storm sewers.

40-3.07(a) Diameter Limitations

The following limitations apply:

1. Reinforced Concrete Pipe may be used for diameters up to 108 in. (2700 mm) and equivalent, round sizes up to 72 in. (1800 mm).
2. Corrugated Steel Pipe may be used for diameters up to 144 in. (3600 mm) and equivalent, round sizes up to 120 in. (3000 mm).
3. Corrugated Aluminum Alloy Pipe may be used for diameters up to 120 in. (3000 mm) and equivalent, round sizes up to 120 in. (3000 mm).
4. Polyvinyl Chloride (PVC) Pipe and Corrugated PVC Pipe with a Smooth Interior may be used for diameters up to 36 in. (900 mm). PVC Profile Wall Pipe may be used for diameters up to 48 in. (1200 mm).
5. Polyethylene (PE) Pipe may be used for diameters up to 48 in. (1200 mm).

40-3.07(b) End Treatments

For all pipe culverts, with the exception of entrance culverts, a non-plastic end treatment must be specified. An end treatment for entrance culverts, which can protect the culvert ends from being crushed and allow for proper grading of the transverse slopes, will be at the designers' option.

40-3.07(c) pH Limitations

When the soil pH levels are outside the range of 5 to 9, the designer should consult the Central Bureau of Materials for the appropriate material type to use.

40-3.07(d) Class of Pipe Culverts and Storm Sewers

The classes of pipe culverts and storm sewers are defined in Figures 40-3.A and 40-3.B. In the plans, the designer should specify the appropriate pipe class and allow the contractor to bid the

most cost effective material type. To specify, any one particular material type must be examined as a design exception and supported by proper justification.

Figure 40-3.A presents the class of pipe culvert to be specified for specific conditions. See Section 542 of the *Standard Specifications for Road and Bridge Construction* for a listing of pipe materials allowed in each class.

Figure 40-3.B presents the class of storm sewer to be specified for specific conditions. See Section 550 of the *Standard Specifications for Road and Bridge Construction* for a listing of pipe materials allowed in each class.

Conditions	Class
Entrances, regardless of ADT; and Roadways with ADT < 4000	D
Roadways with $4000 \leq \text{ADT} < 10000$	C
Roadways with ADT ≥ 10000	A

PIPE CULVERT CLASSES

Figure 40-3.A

Conditions	Class
Roadways with ADT < 10000; or pipe location is > 12 ft (3.6 m) from the edge of traveled way	B
Roadways with ADT ≥ 10000 and pipe location is ≤ 12 ft (3.6 m) from the edge of the traveled way	A

STORM SEWER CLASSES

Figure 40-3.B

40-3.07(e) Minimum Permissible Diameter of Pipe Culverts and Storm Sewers

Figure 40-3.C presents the minimum permissible diameter for pipe culverts.

The minimum permissible size for storm sewer is 12 in. (300 mm). However, the *IDOT Drainage Manual* contains additional information on sizing and a discussion of possible exceptions.

Functional Class	Minimum Diameter
Entrances	15 in. (375 mm)
All roadways except arterials	18 in. (450 mm)
All arterials	24 in. (600 mm)

MINIMUM PERMISSIBLE DIAMETER FOR PIPE CULVERTS

Figure 40-3.C

40-4 DOCUMENTATION

40-4.01 Introduction

The definition of hydrologic and hydraulic documentation as used in this chapter is the compilation and preservation of the design and related details and all pertinent information on which the design and decisions were based. Appropriate documentation for the design of any hydraulic facility is essential because of:

- the importance of public safety;
- justification of expenditure of public funds;
- future reference by engineers (when improvements, changes, or rehabilitations are made to the highway facilities);
- information leading to the development of defense for litigation;
- public information;
- IDNR-OWR rule and regulatory conformance (where appropriate); and
- local agency concerns/criticism.

Documentation permits evaluation of the performance of structures after flood events to determine if the structures performed as anticipated or to establish the cause of unexpected performance, if such is the case. In the event of a failure, documentation may aid in the identification of contributing factors that can be avoided or mitigated to prevent recurring damage after repairs or reconstruction.

The documentation shall include drainage area and other maps, field survey information, source references, photographs, methodology, engineering calculations and analyses, other data, and flood history including narratives from newspapers and individuals such as highway maintenance personnel and local residents who witnessed or had knowledge of a significant flood event.

There are three basic types of documentation that shall be considered—preconstruction, design, and construction or operation. The following discusses each type:

1. Preconstruction. This documentation includes the following if available or within the constraints of the project:
 - aerial photographs;
 - contour mapping;
 - watershed map or plan including:
 - + flow directions,
 - + watershed boundaries,
 - + watershed areas, and

- + natural storage areas;
 - surveyed data reduced to include:
 - + existing hydraulic facilities;
 - + existing horizontal and vertical controls;
 - + profiles (roadway, channel, driveways); and
 - + cross sections (roadway, channels, faces of structures);
 - flood insurance studies and FEMA maps;
 - Natural Resources Conservation Service soil maps;
 - field trip report(s) which may include:
 - + video cassette recordings,
 - + audio tape recordings,
 - + still camera photographs,
 - + movie camera films, and
 - + written analysis of findings with sketches; and
 - reports from other agencies (local, State, or Federal), IDOT personnel, newspapers, and abutting property owners.
2. Design. This documentation includes all information used to justify the design, including:
- reports from other agencies,
 - drainage study,
 - hydrological report,
 - hydraulic report, and
 - permits and approvals.
3. Construction/Operation. This documentation includes:
- plans;
 - revisions;
 - as-built plans and subsurface borings;
 - photographs; and
 - record of operation during flood events, complaints, and resolutions.

It is important to prepare and maintain, in a permanent file, the as-built plans for every drainage structure to document subsurface foundation elements (e.g., footing types, (driven) tip elevations). There may be other information that should be included or may become evident as the design or investigation develops.

40-4.02 Purpose

The major purpose of providing good documentation is to define the design procedure that was used and to show how the final design and decisions were determined. Documentation should be viewed as the record of reasonable and prudent design analysis based on the best available technology. Documentation can provide the following:

- evidence that reasonable and prudent actions were, in fact, taken;
- identification of the situation at the time of design;
- documentation that rationally accepted procedures and analyses were used at the time of the design which were commensurate with the perceived site importance and flood hazard;
- identification of the criteria and considerations used in design and evidence that they were adhered to;
- a continuous site history to facilitate future reconstruction;
- the file data necessary to quickly evaluate any future site problems that might occur during the facilities' service life;
- an expedition of plan development by clearly providing the reasons and rationale for specific design decisions; and
- identification and an explanation for design variations from standard policy, practice, and procedures.

40-4.03 Documentation Procedures

A complete hydrologic and hydraulic design and analysis file for each drainage feature shall be maintained by the Section responsible for design approval. Figure 40-4.A provides a tabulation of the items to be included in the documentation file for the various types of drainage facilities. Although the Department's documentation requirements for existing and proposed drainage facilities are similar, the data retained for existing facilities are often slightly different than that for proposed facilities. The intent is not to limit the data to only those items listed except to establish a minimum requirement consistent with the hydraulic design procedures as outlined in the *IDOT Drainage Manual*.

Documentation of hydraulics analyses and studies for pump stations and bridges are included in the approved Hydraulic Reports. These reports are retained in the district files and/or in the Bureau of Bridges and Structures files. Documentation of hydraulic analyses and studies for culverts are included in the Hydraulic Reports approved by the districts and retained in district files.

Other drainage studies and analyses prepared during Phase I become part of the Phase I report(s) and are retained in the district and in the Bureau of Design and Environment.

Detailed design calculations for drainage work, prepared during Phase II, are placed in the district files for each project.

If circumstances are such that the drainage facility is sized by other than normal procedures or if the size of the facility is governed by factors other than hydrologic or hydraulic factors, a narrative summary detailing the design basis shall appear in the documentation file. Additionally, include the file items not listed in Figure 40-4.A but which are useful in understanding the analysis, design information, findings, and final recommendations. The preparer should initial and date all calculations, methods used, and work. Identify the engineer (P.E.) who directed or completed the work.

Item	Bridges	Culverts	Open Channels	Roadside & Median Ditches	Storm Drains	Pump Stations
Criteria and assumptions	X	X	X	X	X	X
Contributing watershed area size and identification of source (map name, etc.)	X	X	X	X	X	X
Design frequency and decision for selection	X	X	X	X	X	X
Hydrologic discharge and hydrograph estimating method and findings	X	X	X	X	X	X
Flood frequency curves to include design, 100-year, and the overtopping or 500-year flood discharge hydrographs and any historical floods when applicable	X	X	X			
Expected level of development in upstream watershed over the anticipated life of the facility (include sources of and basis for these development projections)	X	X	X	X	X	X
Field reconnaissance	X	X	X	X	X	X
Design, 100-year, and overtopping or 500-year high-water for natural, existing, and proposed conditions (include 10-year frequency on regulated streams)	X	X	X			
Cross sections used in the design high-water determination	X	X	X	X		
Roughness coefficient assignments	X	X	X	X		
Observed high-water, dates, and discharges	X	X	X			
Copies of all computer analyses (hard copy and disk)	X	X	X	X	X	X
Complete Drainage Study or Hydraulic Report (when required)	X	X	X	X	X	X
Roadway geometry (plan and profile)	X	X	X	X	X	X
Potential flood hazards to adjacent properties	X	X	X	X	X	X
Structure plan with waterway information table	X	X				
Type of culvert entrance condition		X				
Culvert performance curves		X				
Allowable headwater elevation and basis for its selection or related probable damage	X	X				X
Stage discharge curve for natural, existing, and proposed conditions to include the depth and velocity measurements or estimates and locations for the design, 100-year, and 500-year or overtopping floods (include scour calculations where appropriate)	X	X	X	X		X
Permit requirements	X	X	X			

ITEMS TO BE INCLUDED IN DOCUMENTATION FILES

Figure 40-4.A

Item	Bridges	Culverts	Open Channels	Roadside & Median Ditches	Storm Drains	Pump Stations
Policy waivers	X	X	X	X	X	X
Regulatory or flood insurance studies	X	X	X			
Energy dissipation calculations and designs for outlet appurtenances		X				
Copies of standard computation sheets	X	X		X	X	
Information on the method used for design water surface determinations	X	X	X	X		
Water surface profiles through the reach for the design, 100-year, and any historical floods	X	X	X	X		X
Design or analysis of materials proposed for the channel bed and banks	X	X	X	X		
Energy dissipation calculations and designs			X	X		
Explanation of selected ditch section and gradient				X		
Layout of ditch capacity and storage (if required)				X		
Layout of complete drainage system			X	X	X	X
Special considerations at outlet		X	X	X	X	X
Computations for gutter capacity, pavement encroachment, inlet spacing, and by-pass flow					X	
Information concerning outfalls, existing storm drains, and other design considerations				X	X	X
A schematic indicating storage and storm drain system layout (type and size)				X	X	X
Identification of flood route					X	X
Inflow design hydrograph from drainage area to pump						X
Stage storage calculations					X	X
Starting sequence and elevations						X
Pump dimensions						X
Pump sizes and operations						X
Pump calculations						X
Mass curve routing						X

ITEMS TO BE INCLUDED IN DOCUMENTATION FILES

Figure 40-4.A
(Continued)

Chapter Forty-one

CONSTRUCTION SITE
STORM WATER
POLLUTION CONTROL

BUREAU OF DESIGN AND ENVIRONMENT MANUAL

Chapter Forty-one
CONSTRUCTION SITE STORM WATER POLLUTION CONTROL

Table of Contents

<u>Section</u>	<u>Page</u>
41-1 INTRODUCTION.....	41-1.1
41-1.01 Background	41-1.1
41-1.02 Purpose, Scope, and Organization.....	41-1.1
41-1.03 Acronyms.....	41-1.1
41-1.04 Regulatory Framework	41-1.2
41-1.04(a) Federal Requirements	41-1.2
41-1.04(b) State Requirements and IDOT Responsibilities.....	41-1.2
41-1.04(c) Applicability and Exemptions	41-1.4
41-1.05 Typical Construction Activity Related Pollutants	41-1.5
41-1.05(a) Overview	41-1.5
41-1.05(b) Erosion and Sedimentation.....	41-1.6
41-1.05(c) Types of Erosion	41-1.6
41-1.06 The BMP Approach/Limitations to Addressing Water Quality Problems	41-1.6
41-1.07 Notice of Intent (NOI).....	41-1.7
41-1.07(a) BDE 2342 (Stormwater Pollution Prevention Plan).....	41-1.7
41-1.07(b) Erosion and Sediment Control Details	41-1.7
41-1.07(c) BDE 2342a (Contractor Certification Statement).....	41-1.8
41-1.07(d) Supporting Documentation	41-1.8
41-2 EROSION CONTROL PRACTICES (STABILIZATION).....	41-2.1
41-2.01 Vegetation	41-2.1
41-2.01(a) Incorporate Existing Vegetation	41-2.1
41-2.01(b) Establish New Vegetation	41-2.2
41-2.02 Mulch, Erosion Control Blankets, and Turf Reinforcement Mats.....	41-2.3
41-2.02(a) Straw Mulch (Mulch Methods 1 and 2)	41-2.5
41-2.02(b) Hydraulic Mulch (Mulch Method 3).....	41-2.6
41-2.02(c) Compost Combined With Binder/Stabilizer (Mulch Method 4)	41-2.6
41-2.02(d) Erosion Control Blankets and Turf Reinforcement Mats	41-2.8

Table of Contents
(Continued)

<u>Section</u>		<u>Page</u>
41-2.03	Soil Binders (Stabilization Polymers).....	41-2.9
41-2.04	Concentrated Flow Controls	41-2.11
	41-2.04(a) Diversion Dikes, Drainage Swales, and Lined Ditches ..	41-2.11
	41-2.04(b) Slope Drains	41-2.13
41-2.05	Outlet Protection Controls	41-2.14
	41-2.05(a) Velocity Dissipaters.....	41-2.14
41-2.06	Erosion Control Reference Table	41-2.16
41-3	SEDIMENT CONTROL PRACTICES (CONTAINMENT).....	41-3.1
41-3.01	Perimeter Controls.....	41-3.1
	41-3.01(a) Perimeter Vegetated Buffers.....	41-3.1
	41-3.01(b) Perimeter Silt Fence Barriers	41-3.3
	41-3.01(c) Perimeter Straw Bale Barriers.....	41-3.4
	41-3.01(d) Perimeter Rolled Barriers.....	41-3.5
41-3.02	Inlet Controls	41-3.5
	41-3.02(a) Drop Inlet Filter Bags	41-3.5
	41-3.02(b) Drop Inlet Silt Fence Barriers	41-3.6
	41-3.02(c) Drop Inlet Straw Bale Barriers.....	41-3.6
	41-3.02(d) Drop Inlet Rolled Barriers.....	41-3.7
	41-3.02(e) Drop Inlet Prefabricated Barriers	41-3.8
	41-3.02(f) Above Grade Drop Inlet Filters	41-3.9
	41-3.02(g) Pipe (Culvert) Inlet Vegetated Buffers	41-3.9
	41-3.02(h) Pipe (Culvert) Inlet Silt Fence Barriers.....	41-3.10
	41-3.02(i) Pipe (Culvert) Inlet Straw Bale Barriers	41-3.10
41-3.03	Temporary Ditch and Slope Checks.....	41-3.11
	41-3.03(a) Aggregate Ditch Checks	41-3.11
	41-3.03(b) Prefabricated Ditch Checks	41-3.14
	41-3.03(c) Rolled Barrier Slope Checks.....	41-3.14
41-3.04	Sediment Traps and Basins	41-3.15
	41-3.04(a) Sediment Traps.....	41-3.15
	41-3.04(b) Sediment Basins	41-3.17
41-3.05	Flocculant Polymers/Treatment Chemical.....	41-3.20

Table of Contents
(Continued)

<u>Section</u>	<u>Page</u>
41-3.05(a) Batch Treatment	41-3.20
41-3.05(b) Flow-Through Treatment (Flocculent Logs, Polymer Treated Structures).....	41-3.21
41-3.06 Entrance/Exit Controls.....	41-3.22
41-3.06(a) Stabilized Construction Entrance/Exits	41-3.22
41-3.06(b) Tire Wash Stations.....	41-3.23
41-3.07 Sediment Control Reference Table	41-3.24
41-4 GUIDANCE ON THE NPDES PERMIT NUMBER ILR10.....	41-4.1
41-4.01 Definitions.....	41-4.1
41-4.02 Notice of Intent	41-4.2
41-4.03 BDE 2342 (SWPPP).....	41-4.2
41-4.03(a) SWPPP Signature Page.....	41-4.3
41-4.03(b) SWPPP Notes.....	41-4.3
41-4.03(c) Part I. Site Description	41-4.4
41-4.03(d) Part II. Waters of the US	41-4.5
41-4.03(e) Part III. Water Quality.....	41-4.5
41-4.03(f) Part IV. Temporary Erosion and Sediment Controls	41-4.11
41-4.03(g) Part V. Other Conditions	41-4.14
41-4.03(h) Part VI. Permanent (i.e., Post-Construction) Storm Water Management Controls.....	41-4.15
41-4.03(i) Part VII. Additional Practices Incorporated from Local Ordinance(s).....	41-4.15
41-4.03(j) Part VIII. Unexpected Regulated Substances/ Chemical Spill Procedures.....	41-4.16
41-4.03(k) Part IX. Contractor Required Submittals	41-4.16
41-4.03(l) Part X. Maintenance	41-4.18
41-4.03(m) Part XI. Inspections.....	41-4.18
41-4.03(n) Part XII. Incidence of Noncompliance (ION)	41-4.19
41-4.03(o) Part XIII. Corrective Actions.....	41-4.20
41-4.03(p) Part XIV. Retention of Records.....	41-4.20
41-4.03(q) Part XV. Failure to Comply	41-4.20
41-4.03(r) Part XVI. Keeping the SWPPP (“Plan”) Current.....	41-4.20
41-4.03(s) Part XVII: Notifications	41-4.21
41-4.03(t) Part XVIII. Notice of Termination	41-4.21
41-5 REFERENCES.....	41-5.1

Chapter Forty-one

CONSTRUCTION SITE STORM WATER POLLUTION CONTROL

41-1 INTRODUCTION

41-1.01 Background

Storm water runoff occurs naturally as part of the hydrologic cycle. Site development alters the drainage characteristics and patterns of the landscape through increased imperviousness, restructured contours, altered soils and vegetation, etc. These impacts include changes to the quantity, quality, and timing of storm water being discharged from the altered landscape; increased flooding; and increased concentrations of pollutants in lakes, rivers, streams, and reservoirs. For decades, these impacts have been addressed using storm water detention facilities designed to capture and detain runoff from the site post construction.

Recently, however, more focus has been given to improving the quality of storm water being discharged during the construction process. Significant pollutant loads have been shown to contribute to the degradation of water quality during site development due to the temporary vulnerability of the exposed soils to erosion before permanent stabilization is achieved.

41-1.02 Purpose, Scope, and Organization

Chapter 41 provides guidance in meeting State and Federal requirements for controlling pollution of waterways, the roadway and associated rights-of-way, adjacent properties, and sensitive environmental resources (e.g., floodplain, wetlands and riparian areas, habitat of threatened and endangered species) during highway construction projects. Comprehensive pollution prevention involves thorough planning and proper selection, implementation, and maintenance of pollution prevention best management practices (BMPs) that are designed to reduce or eliminate the introduction of target pollutants from construction sites to receiving waters. Design information is provided to assist in the BMP selection process. Section 41-4 provides guidance for developing the design portion of a site-specific Storm Water Pollution Prevention Plan (SWPPP), as per National Pollutant Discharge Elimination System (NPDES) requirements.

41-1.03 Acronyms

BDE. Bureau of Design and Environment

BMP. Best Management Practice

ECB. Erosion Control Blanket

ECP. Erosion Control Practice

ESCP. Erosion and Sediment Control Plan

FEMA. Federal Emergency Management Agency

IDOT. Illinois Department of Transportation

IEPA. Illinois Environment Protection Agency

ISTHA. Illinois State Toll Highway Authority

IWPA. Interagency Wetlands Policy Act

MS4. Municipal Separate Storm Sewer System

NOI. Notice of Intent

NPDES. National Pollutant Discharge Elimination System

PAM. Polyacrylamide

RR. Rip Rap

SCP. Sediment Control Practices

Standard Specifications. *Standard Specifications for Road and Bridge Construction*

STD. Standard Drawing

SWPPP. Storm Water Pollution Prevention Plan (Form BDE 2342)

TRM. Turf Reinforcement Mat

USEPA. United States Environment Protection Agency

41-1.04 Regulatory Framework

41-1.04(a) Federal Requirements

The National Pollutant Discharge Elimination System (NPDES) is a Federal program, under Section 402 of the *Clean Water Act*, designed to improve the quality of the nation's surface water resources. The NPDES program controls water pollution by regulating the discharge of pollutants into waters of the United States. The NPDES program is administered by the US Environmental Protection Agency (USEPA) or authorized States.

One component of the NPDES program targets storm water discharges from municipal and industrial sites, including discharges associated with construction activities. The program seeks to reduce pollutants found in storm water runoff by prohibiting the discharge of pollutants unless a NPDES permit is obtained and the site maintains compliance with the permit conditions.

41-1.04(b) State Requirements and IDOT Responsibilities

In Illinois, the NPDES storm water permitting program is administered by the Illinois Environmental Protection Agency (IEPA). IEPA issues two general NPDES permits for the discharge of storm water — ILR10 and ILR40 (see Appendix A). The ILR10 is a general permit that provides requirements for storm water discharges from construction site activities that meet or exceed the threshold for permit applicability (e.g., one acre of disturbed land area), while the ILR40 is a general permit for storm water discharges from small municipal separate storm sewer systems (MS4). Individual NPDES permits may be required by IEPA for extensive construction activities that discharge to critical receiving waters or as otherwise deemed necessary by IEPA.

This Chapter provides design guidance for pollution prevention strategies consistent with the requirements of the ILR10 general permit. Individual permits may require design guidance beyond the scope of this Chapter. Meeting the conditions of the general permits covered within Chapter 41 tend to cost less and require less effort than individual permits.

The main components of the ILR10 permit are the required preparation of a SWPPP (Form BDE 2342) (See Section 41-4) and submittal of a Notice of Intent (NOI). The SWPPP identifies potential sources of pollution associated with the construction site activity and describes the pollution prevention BMPs that will be used to reduce the likelihood of those pollutants being discharged from the site. The NOI includes a brief description of the project, estimates of the number of acres (hectares) of the site on which soil will be disturbed, and a certification that a SWPPP will be prepared prior to the start of construction.

The ILR40 permit requires operators of small MS4s to develop a Storm Water Management Program for the management of storm water within their jurisdiction. The term MS4 has a broad application that applies to universities, local sewer districts, hospitals, military bases, parks, and prisons, as well as State departments of transportation and municipally owned storm sewer systems. The *Code of Federal Regulations* defines a MS4 as a conveyance or a system of conveyances, which includes roads with drainage systems, municipal streets, catch basins, curbs, gutters, ditches, man-made channels, or storm drains that are owned or operated by a State, city, town, borough, county, parish, district, association, or other public body.

While IDOT is not a municipality, its extensive storm sewer system functions similarly to the MS4s of small municipalities and, therefore, requires coverage under the NPDES ILR40 permit. IDOT's Storm Water Management Program (Plan) has been developed and is maintained by the Department's Storm Water Committee. This plan addresses the following six minimum control measures:

1. public education and outreach on storm water impacts,
2. public involvement/participation,
3. illicit discharge detection and elimination,
4. construction site storm water runoff control,
5. post-construction storm water management in new development and redevelopment, and
6. pollution prevention/good housekeeping for municipal operations.

Upon submittal of a NOI, any MS4 covered by the ILR40 permit is also granted automatic coverage under the ILR10 for the discharge of storm water associated with construction site activities. The permittee must comply with the requirements of the ILR10 for all construction projects.

The focus of Chapter 41 is to address construction and post-construction site storm water runoff control (Minimum Control Measure #4 and #5, respectively). Regarding these minimum control

measure, the ILR40 permit states that the Plan must include the development and implementation of, at a minimum:

1. an ordinance or other regulatory mechanism to require erosion control practices (ECP) and sediment control practices (SCP) and sanctions to ensure compliance to the extent allowable under State or local law;
2. requirements for construction site operators to implement appropriate ECPs and SCPs;
3. requirements for construction site operators to control waste (e.g., discarded building materials, concrete truck washout, chemicals, litter, sanitary waste at the construction site) that may cause adverse impacts to water quality;
4. require all regulated construction sites to have a SWPPP that meets the requirements of Part IV of the NPDES permit ILR10 including management practices, controls, and other provisions at least as protective as the requirements contained in the *Illinois Urban Manual*.
5. procedures for site plan review that incorporate consideration of potential water quality impacts and review of individual preconstruction site plans to ensure consistency with local sediment and erosion control requirements;
6. procedures for receipt and consideration of information submitted by the public; and
7. procedures for site inspections and enforcement of control measures.

Sections 41-2 and 41-3 provide guidance on selection and implementation of ECPs and SCPs. Section 41-4 provides guidance for developing a SWPPP for IDOT construction projects. The nature and extent of the control measures should be appropriate to address the specific conditions involved and the measures must be properly maintained to ensure continued effective operation.

41-1.04(c) Applicability and Exemptions

IDOT must comply with the requirements of the current ILR10 permit or individual permit for all applicable State highway projects. Provided the proposed project meets the ILR10 permit applicability criteria, IDOT submits a NOI and develops and implements a SWPPP for applicable projects. Unless notified by IEPA to the contrary, IDOT is authorized to discharge storm water from construction sites 30 days after the date the NOI is received by IEPA. This requirement should be considered when developing a construction schedule for time-sensitive projects. ILR10 permit applicability extends to storm water discharges associated with construction activities on sites that:

1. disturb 1 acre (0.4 ha) or more of total land area;

2. disturb less than 1 acre (0.4 ha) of total land but are part of a larger common plan of development or sale if the larger common plan will ultimately disturb one or more acres (0.4 ha or more hectares) of total land area; or
3. disturb less than 1 acre (0.04 ha) of total land and are designated by IEPA to have the potential for contribution to a violation of water quality standards or significant contribution of pollutants to waterways. This includes waters designated by the IEPA as “impaired waters” pursuant to Section 303(d) of the *Clean Water Act*; see Section 26-21. This designation may be determined during the process of acquiring a water quality certification.

Construction projects not meeting any of the above and those that do not involve clearing and grubbing, excavation, stockpiling of topsoil, borrow, or construction of embankments will generally not require a SWPPP or Erosion and Sediment Control Plan sheets (ESCP). However, the design is to include any applicable pollution prevention BMPs necessary to minimize the potential for pollutants to enter IDOT’s MS4 or other waters of the State. The following projects are examples of construction activities that will not require development of a SWPPP or ESCP:

- installation of lighting, signage, traffic signals, or guardrails;
- herbicide application;
- pavement marking;
- seal coating;
- bituminous resurfacing;
- pavement patching; and
- planting of woody landscaping materials.

41-1.05 Typical Construction Activity Related Pollutants

41-1.05(a) Overview

Construction activities involving earthwork (e.g., clearing and grubbing, grading, importing fill material, utility installation) disturb the soil that when the protective vegetation is removed the soil becomes exposed and vulnerable to excessive erosion. This makes the sediment the most common pollutant associated with construction activities. Sediment can be detrimental to aquatic life by interfering with photosynthesis, respiration, growth, reproduction, and oxygen exchange in waterways. In addition, sediment particles can transport other pollutants that are attached to them including nutrients, trace metals, and hydrocarbons. Sediment particles (e.g., silts, clays) are the primary components of total suspended solids, a common water quality parameter.

Construction activities involving building materials, vehicular use, and landscaping have the potential to contribute pollutants to storm water. Common pollutants related to these construction activities include vehicle fluids, curing compounds, solvents, paints, emulsions, oil and grease, metals, organics, pesticides, nutrients, trash, debris, and floatables, as well as other miscellaneous waste.

41-1.05(b) Erosion and Sedimentation

Erosion is the process of soil particle detachment from the land surface by the forces of wind, water, or gravity. After the soil particles have been detached (eroded), the suspended soil particles in transport are referred to as sediment. Sedimentation occurs where suspended sediment settles out and is deposited. Note that gravels and sands tend to drop out of suspension more rapidly than finer particles (e.g., silts, clays) due to differences in size, density, and shape.

Where soil is cleared or disturbed, erosion occurs at a much higher rate due to direct exposure to erosive forces (e.g., raindrop impacts, sheet erosion, rill erosion). Land clearing disturbances can also alter the natural structure of soil and weaken the reinforcing matrix of plant roots and organic compounds. USEPA estimates that unprotected construction sites can experience erosion at over one hundred times the natural rate. As result, primary emphasis should be placed on ECPs as they are preventative source controls, while SCPs are secondary measures designed to contain sediment after it is in transport, preventing it from leaving the site.

41-1.05(c) Types of Erosion

1. Erosion from Raindrop Impact. The dislodgement of soil particles by falling raindrops is a primary agent of erosion, particularly on soils with sparse vegetative cover. Individual soil particles can be splashed over 1.5 ft (500 mm) in height and 5 ft (1.5 m) to the side.
2. Sheet Erosion. Splashed soil particles are moved in a semi-suspended layer uniformly over the land surface. The distance of sheet flow depends on slope, soil roughness, type of vegetative cover, and rainfall intensity.
3. Rill and Gully Erosion. As runoff concentrates, tiny channels form that are termed rills. Rill erosion is the form that produces the greatest amount of soil loss worldwide. Rills are channels small enough to be smoothed by normal tillage. As the runoff accumulates in the rills, they erode further, causing gullies to form. Gullies are so large that they cannot be smoothed by normal tillage. The rate of rill erosion can easily be one hundred times greater than that of sheet flow, and the rate of gully erosion can easily be one hundred times greater than rill erosion. Due to the significant amount of sediment generated by rill and gully erosion, these types of erosion must be given top priority for elimination, reduction, and control.

41-1.06 The BMP Approach/Limitations to Addressing Water Quality Problems

The goal of the Department's NPDES Storm Water Permit Program is to improve water quality by reducing the amount of pollutants in storm water runoff that are conveyed to receiving waters. The Department's program is using the BMP approach to meet this goal.

A pollution prevention BMP is a technique, measure, or structural control that is used for a given set of site conditions to manage the rate, quantity, and quality of storm water runoff in a cost-effective manner. No single BMP can address all pollutants associated with construction activities. Sections 41-2 and 41-3 explore two categories of BMPs — ECPs and SCPs. Independently, these BMPs serve different purposes. Erosion control is a preventative strategy that uses techniques to stabilize the soil, thereby minimizing the occurrence of erosion. Sediment control is a backup strategy that incorporates structural measures to contain sediment on site in the event that erosion does occur. While functionally different, these BMPs should be selected and implemented in a complimentary manner in order to maximize pollution prevention effectiveness.

Each type of BMP has certain limitations based on drainage area served, available land space, cost, pollutant removal efficiency, as well as a variety of site-specific factors (e.g., soil types, slopes, depth of groundwater table). Careful consideration of these factors is necessary in order to select the appropriate BMP or group of BMPs for a particular location. The success of the program relies on the assumption that proper implementation of appropriate pollution prevention BMPs will achieve and maintain applicable water quality standards and protect designated uses. However, additional measures (e.g., treatment of polluted runoff) may be required in the future if these BMPs fall short of the program goals.

Chapter 41 provides guidance for selecting appropriate BMPs to mitigate water pollution as a result of construction activities. Designers are to use the IDOT specification listed for each BMP. If an IDOT specification is not listed, use the associated *Illinois Urban Manual* specification to develop a special provision for the project.

Section 41-4 provides guidance for completing the design portion of the SWPPP (BDE 2342).

41-1.07 Notice of Intent (NOI)

IEPA requires all Notices of Intent (NOIs) to be submitted online through the Central Data Exchange (CDX). Instructions on applying through the CDX platform and can be found on the IEPA website.

The following documents are required for the NOI:

41-1.07(a) BDE 2342 (Stormwater Pollution Prevention Plan)

BDE 2342 comprises the majority of the required “Contents of Plan” from the ILR10 permit. This form is the narrative portion of the SWPPP.

41-1.07(b) Erosion and Sediment Control Details

This plan sheet is discussed in Section 63-4.09 and serves as the site map described in the ILR10 permit.

41-1.07(c) BDE 2342a (Contractor Certification Statement)

BDE 2342a identifies the contractor and every subcontractor for the project. In addition, this form certifies the contractors and all subcontractors will comply with the requirements of the ILR10 permit.

41-1.07(d) Supporting Documentation

The following additional documents are also required as part of the NOI:

41-1.07(d)1 *Threatened and Endangered Species Clearance*

To obtain documentation that can be uploaded into the IEPA CDX system for threatened and endangered species, the district should utilize BDE 2710 (See Section 27-1.05(a)1) or submit the Natural Resource Review (NRR).

41-1.07(d)2 *Section 106 Clearance*

To obtain documentation that can be uploaded into the IEPA CDX system for Section 106 resources, see Section 27-1.05(a)2.

41-2 EROSION CONTROL PRACTICES (STABILIZATION)

All erosion control practices (ECP) selected should consider seasonal influences on BMP effectiveness, installation, and maintenance throughout the duration of the project. For example, stabilization practices that may be effective in the summer may not be sufficient for the winter season (e.g., vegetation establishment).

41-2.01 Vegetation

Vegetation-related BMPs are some of the most effective and economic methods of soil stabilization. Vegetative cover protects soils from raindrop impacts, rill and sheet erosion, and wind erosion. Vegetation also provides a reduction in velocities, valuable filtration and adsorption of pollutants, and can reduce runoff volumes by enhancing infiltration.

41-2.01(a) Incorporate Existing Vegetation

1. Definition and Purpose. Measures taken to use existing vegetation as part of erosion control throughout construction activities. The purpose of this practice is to preserve areas that have value for erosion control.
2. Applications. Existing vegetation is appropriate for the following applications:
 - projects where grading can be phased,
 - projects where existing vegetation can be temporarily preserved and used for erosion control,
 - areas along the perimeter of the site, and
 - areas where upstream tributary sheet flow enters the site.
3. Design Considerations.
 - Minimize disturbance along the project where no construction activity is planned or will occur at a later stage/phase/date. If greater than 10 acres (4 ha) are to be disturbed at any one time to properly construct a project, a special provision will be required to modify Section 280.03 of the *Standard Specifications*.
 - Construction activities, heavy equipment, vehicular traffic, or storage of construction materials are prohibited within the vegetated areas designated for erosion control.
 - Use of existing vegetation for erosion control requires planning and may limit the area available for construction activities.

- See Sections 59-6.03 and 59-6.04 for further information on incorporating existing vegetation for erosion control.
4. Specifications. See Sections 201 and 280 of the *Standard Specifications*.

41-2.01(b) Establish New Vegetation

1. Definition and Purpose. Establishing temporary or permanent vegetative cover to stabilize disturbed or exposed areas in order to reduce erosion from these areas and create a landscape that enhances soil permeability and the filtering of runoff pollutants.
2. Applications.
 - a. Temporary. Temporary locations include the following:
 - all cleared, non-vegetated, or sparsely vegetated soil surfaces where vegetative cover is necessary for less than one year (e.g., diversions, dams, temporary sediment basins, temporary road banks, topsoil stockpiles, any other exposed areas of a construction site);
 - sites that will not be brought to final grade within seven days or are likely to be re-disturbed;
 - cut and fill slopes under construction;
 - soil storage areas and stockpiles; and
 - where development of cover or nursery crops are necessary to assist with establishment of perennial grasses.
 - b. Permanent. Permanent locations include the following:
 - disturbed areas where long-lived vegetative cover is needed to stabilize the soil,
 - rough graded areas that will not be brought to final grade for a year or more,
 - final graded or cleared areas where permanent vegetative cover is needed to stabilize the soil, and
 - drainage channels or waterways designed to be protected with channel liners.

3. Design Considerations.

- Rapidly growing annuals and legumes are recommended examples of temporary vegetation for disturbed soils.
- Erosion may occur during the establishment stage; therefore, areas that fail may need to be re-seeded or seeded in conjunction with additional stabilization practices; see Section 41-2.02.
- Consider the state of the project as the growing season ends.
- Perform seeding during the appropriate season in order to ensure rapid establishment of vegetation. Sufficient moisture conditions may not be present at time of seeding to support timely germination of the seed. If unusually dry (drought) conditions are predicted, a special provision for supplemental watering may need to be included in the contract.
- Sod can provide a quick, but relatively expensive, method for establishing vegetation.
- For seeding and sodding design guidance, see Section 59-7, Section 280.04(f) of the *Standard Specifications*, and Figure 41-2.A.
- Calculate the quantity of temporary erosion control seeding for weekly seeding of estimated acreage (hectares) of disturbance.
- In the event that temporary or permanent vegetation cannot be established prior to winter shutdown, include erosion control measures (e.g., installation of mulch or ECBs on any exposed soil, slopes, and around the perimeter of the site) in the contract. Also, include measures to maintain these areas over the winter.

4. Specifications. See Sections 250, 252, and 280 of the *Standard Specifications*.

41-2.02 Mulch, Erosion Control Blankets, and Turf Reinforcement Mats

Mulch, erosion control blankets, and turf reinforcement mats are ECPs that can be employed in situations requiring stabilization of exposed soils before and during establishment of vegetation. These BMPs protect against raindrop impact and enhance vegetative establishment by retaining soil moisture, preventing erosion and seed washout, controlling weedy species, and protecting seeds from wildlife consumption. See Figure 41-2.A for appropriate applications.

Treatment	Recommended Use	Flow Velocity for Ditch (ft/sec)	Max. Slope Gradient (V:H)	Approx. C Factor ¹ at Max. Grade	Approx. Max. Shear Stress (lbs/sq ft)
Sod	Stabilizing slopes, shallow channels, exposed soil	2 - 7 (0.6-2.1 m/s)	1:4	0.01	1.0 - 3.0 (47.8-143.6 Pa)
Straw Mulch (Method 1)	Stabilizing flat areas	N/A	1:10	0.90	N/A
Stabilized Straw Mulch (Method 2)	Stabilizing slopes and exposed soil	N/A	1:4	0.25	N/A
Hydraulic Mulch (Method 3)	Stabilizing slopes and exposed soil	N/A	1:3	0.25	N/A
Compost w/ Stabilizer (Method 4)	Stabilizing slopes and exposed soil	N/A	1:4	0.25	N/A
ECB	Stabilizing slopes, channels, exposed soil	2 - 7 (0.6-2.1 m/s)	1:3	0.15	1.5 (71.8 Pa)
Heavy Duty ECB	Stabilization of slopes, mulches, and areas to be vegetated; suitable for low flow channel stabilization and steeper slopes	2 - 7 (0.6-2.1 m/s)	1:2	0.25	2.25 (107.7 Pa)
TRM	Long term stabilization and reinforcement of vegetation, especially in highly erosive, hydraulic conditions	7 - 22 (2.1-6.7 m/s)	1:3 or steeper	Varies	10.0 (478.8 Pa)
Hard Armament	Where other practices are inadequate, and for highly erosive, concentrated flows or steep slopes	22+ (6.7+ m/s)	1:2 or steeper	Varies	12.0+ (574.6+ Pa)

¹ C Factor = ratio of soil loss from protected slope to ratio of soil loss from unprotected slope in large-scale testing, per ECTC and ASTM Standards. Used to compare the effects of different soil management techniques on erosion.

² Adapted from ECTC Standard Specifications for Rolled Erosion Control Products.

SUMMARY OF DITCH LINING AND SLOPE TREATMENTS²

Figure 41-2.A

41-2.02(a) Straw Mulch (Mulch Methods 1 and 2)

1. Definition and Purpose. Application of straw fibers to exposed soil as a protective, insulating layer. Straw mulch stabilizes exposed soil and slopes from erosive forces (e.g., wind, water), promotes retention of soil moisture, and encourages the establishment of vegetation.
2. Applications. Consider the following for straw mulch applications:
 - appropriate for disturbed areas that require temporary protection until permanent stabilization is achieved;
 - on slopes 1V:10H and flatter, appropriate with straw mulch alone;
 - on slopes 1V:4H and flatter, appropriate with stabilized straw mulch;
 - not for use in areas of concentrated flow; and
 - in combination with seeding strategies; see Section 41-2.01(b).
3. Design Considerations.
 - Straw mulch may be used for immediate stabilization (unlike hydraulic mulch that requires a drying time).
 - The use of straw mulch may be limited by seasonal availability.
 - The potential exists for introduction of unwanted species.
 - If using a straw blower, disturbed areas should be accessible to vehicles and spreading equipment.
 - If wind or displacement by traffic is a potential problem, straw mulch will need to be anchored; see Mulch Method 2 in Section 251 of the *Standard Specifications*.
 - Straw mulches are biodegradable and should be replaced if decomposition has compromised the stabilizing properties of the product.
4. Specifications. See Section 251 of the *Standard Specifications*.

41-2.02(b) Hydraulic Mulch (Mulch Method 3)

1. Definition and Purpose. Application of degradable fibers or hydraulic matrix combined with a stabilizing tackifier. Hydraulic mulches insulate exposed soils and slopes from erosive forces (e.g., wind, water), promote retention of soil moisture, and encourage establishment of vegetation.
2. Applications. Consider the following for hydraulic mulch applications:
 - appropriate for disturbed areas that require temporary protection until permanent stabilization is achieved;
 - appropriate for areas where there will be re-disturbance following an extended period of inactivity;
 - appropriate for areas where straw mulch is ineffective due to wind, slopes, or ground surface;
 - appropriate for low traffic areas;
 - not appropriate for slopes steeper than 1V:3H; and
 - not to be applied to frozen ground.
3. Design Considerations.
 - Hydraulic mulch typically requires 12 to 24 hours to dry before product is effective, so other erosion control practices (e.g., straw mulch, erosion control blankets, turf reinforcement mats) should be implemented when immediate stabilization is required.
 - A second application may be required in order to remain effective for an entire season, so additional quantities may need to be included in plans.
4. Specifications. See Section 251 of the *Standard Specifications*.

41-2.02(c) Compost Combined With Binder/Stabilizer (Mulch Method 4)

1. Definition and Purpose. Application of compost combined with a performance additive designed to bind/stabilize the compost and prevent erosion of soil during turf establishment.
2. Applications. Consider the following for compost combined with binder/stabilizer applications:

- appropriate for disturbed areas that require temporary protection until permanent stabilization is achieved,
- appropriate for areas where there will be re-disturbance following an extended period of inactivity,
- appropriate for areas where vegetative establishment may be hindered by hard ground surface or poor soil nutrient content,

- not appropriate for slopes steeper than 1V:4H (see Section 41-2.02), and
 - do not use in areas of concentrated flow.
3. Design Considerations. Where practical, track (compact) perpendicular to contours on the slope using a bulldozer before applying compost combined with binder/stabilizer.
 4. Specifications. See Section 251 of the *Standard Specifications*.

41-2.02(d) Erosion Control Blankets and Turf Reinforcement Mats

Erosion Control Blankets (ECB) and Turf Reinforcement Mats (TRM) are manufactured BMPs consisting of nets and textiles. These products provide effective and immediate stabilization of slopes and channels before, during, and after the establishment of vegetation. ECBs and TRMs enhance the development of vegetation and TRMs provide for permanent reinforcement.

1. Definition and Purpose. The placement of ECBs and TRMs stabilize disturbed soil and protect from wind and water erosion. The purpose of this practice is to protect the soil surface from raindrop impacts and overland flow during the establishment of grass or other vegetation and to reduce soil moisture loss due to evaporation.
2. Applications. ECBs and TRMs are appropriate for the following applications:
 - generally used on steep slopes (e.g., 1V:3H and steeper) or soils with a high erosion hazard rating, as determined by USDA Soil Survey;
 - areas inaccessible to other BMPs;
 - channels to be vegetated;
 - slopes and shorelines adjacent to waterways or environmentally sensitive areas;
 - adjacent to shoulders where traffic may blow away other mulches; and
 - areas free from large rocks that could damage or affect the performance of the product.
3. Design Considerations.
 - ECBs and TRMs provide immediate stabilization of disturbed soil regardless of temperature and precipitation, unlike other erosion control practices that require an ideal temperature or curing time in order to become effective (e.g., hydraulic mulches, soil binders).
 - Blankets and mats are generally not suitable for excessively rocky sites.

- When used adjacent to shoulders, the blanket should extend through the ditch line or 25 ft (7.5 m) from the edge of pavement, whichever is greater, in order to mitigate blowing conditions caused by traffic.
- ECBs are biodegradable and should be replaced if decomposition has compromised the stabilizing properties of the product.
- Unlike ECBs designed to biodegrade, some TRMs may be considered semi-permanent or permanent and, therefore, may be implemented in situations requiring long-term stabilization (e.g., longer than one growing season).
- See Figure 41-2.A to determine the proper ECB or TRM to be used.

4. Specifications. See Section 251 of the *Standard Specifications*.

41-2.03 Soil Binders (Stabilization Polymers)

Soil binders consist of spray-on chemical soil amendments designed to provide temporary soil stabilization in low-traffic areas. Some soil binders may be incorporated into the soil medium after their effective use has expired, so they are useful in short-term situations where further disturbance will soon occur (e.g., on stockpiles or areas soon to be graded/paved). Soil binders are composed of chemical blends that penetrate the topsoil and bind the soil particles together, thereby, minimizing wind and runoff erosion. They are used to stabilize the soil and as an erosion control agent. See Figure 41-2.B for appropriate applications.

Attributes	Plant Material Based (Short Lived)	Plant Material Based (Long Lived)	Polymeric Emulsion Blends	Cementitious-Based Binders
Resistance to Leaching	High	High	Low to Moderate	Moderate
Resistance to Abrasion	Moderate	Low	Moderate to High	Moderate to High
Compatibility with Existing Vegetation	Good	Poor	Poor	Poor
Mode of Degradation	Biodegradable	Biodegradable	Photodegradable/ Chemically Degradable	Photodegradable/ Chemically Degradable
Liquid/Powder	Powder	Liquid	Liquid/Powder	Powder

Adapted from California Department of Transportation BMP Handbook.

PROPERTIES OF SOIL BINDERS FOR EROSION CONTROL

Figure 41-2.B

1. Definition and Purpose. Water soluble polyacrylamide (PAM) or other comparable compounds that are applied to exposed soils. Soil binders provide temporary protection from wind and water erosion in low traffic areas.
2. Applications. Consider the following for soil binders applications:
 - appropriate for areas requiring short-term temporary stabilization;
 - appropriate for areas where grading activities will soon resume;
 - appropriate for temporary stabilization of cut and fill areas and on stockpiles;
 - appropriate for tacking wood fiber or straw;
 - appropriate for where over-spray onto the traveled way, sidewalks, lined drainage channels, and existing vegetation can be avoided;
 - where appropriate, in areas supporting existing vegetation (review product specifications for compatibility);
 - appropriate for soils made up primarily of fine silts, clay, and colloids;
 - not suitable for areas receiving concentrated flow;
 - not suitable for frozen soil conditions or when surface ice is present;
 - not suitable for slopes greater than 1V:3H as a stand-alone practice; and
 - not suitable for areas with pedestrian or vehicular traffic.
3. Design Considerations.
 - Soil binders may require a curing time of up to 24 hours, so other erosion control practices (e.g., straw mulch, ECBs, TRMs) should be implemented when immediate stabilization is required.
 - Because cationic PAM is toxic to aquatic life, only anionic PAM may be used.
 - Stabilization effectiveness increases if PAM is combined with the application of seed and mulch.
 - Soil binders are temporary in nature and may need reapplication. Reapplication is considered maintenance and should be included as a special provision.
 - Some soil binders may not perform well with low relative humidity or in low temperatures. Refer to manufacturer's suggested optimal ambient conditions.

- Under rainy conditions, some agents may become slippery or leach out of the soil.
- Soil binders do not have the capabilities of organic mulches to insulate the soil or retain soil moisture; see Section 41-2.02(d).

4. Specifications.

- District Special Provision will be required.
- Refer to manufacturer's specification for particular product.

41-2.04 Concentrated Flow Controls

Concentrated flow control BMPs prevent erosion by redirecting potentially erosive flows along a stabilized path and away from areas that have not yet been stabilized.

41-2.04(a) Diversion Dikes, Drainage Swales, and Lined Ditches

1. Definition and Purpose. Temporary berm of compacted soil with an excavated channel at the upstream toe or temporary drainage ditches (e.g., vegetated, reinforced). Diversion dikes, drainage swales, and lined ditches are designed to divert and convey clean or sediment laden water from upstream tributary areas away from construction activities and exposed soil; see Figure 41-2.C.

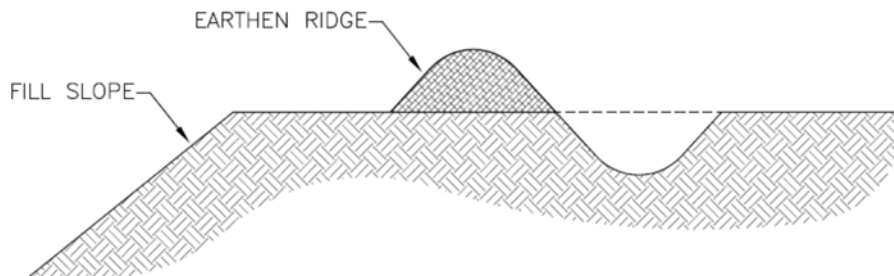

DIVERSION DIKE AND DRAINAGE SWALE

Figure 41-2.C

2. Applications. Diversion dikes, drainage swales, and lined ditches are appropriate for the following applications:

- upslope of disturbed areas (including cut or fill slopes) to prevent surface runoff from entering,
- across slopes to reduce slope length,
- on the down slope side of a construction site to prevent sediment-laden runoff from leaving the site by diverting it to sediment trapping facilities and stabilized outlets, and
- to intercept runoff from paved surfaces.

3. Design Considerations.

- Acquisition of additional right-of-way for diversions may be necessary and may require more time and additional permits.
- Ensure that concentrated flow controls do not become barriers to the movement of construction equipment.
- Design all concentrated flow controls to safely convey the 10-yr, 24-hr storm event.
- Ensure diverted runoff from undisturbed areas is conveyed and discharged to undisturbed areas at non-erosive velocities.
- The minimum height of diversion dikes and berms should be twice the height of the outlet pipe diameter.
- Ensure concentrated flow controls are stabilized prior to use to prevent erosion of exposed soils; see Sections 41-2.02(d) and 41-2.02.
- Consider the additional earthwork costs to remove berms at the end of the project when designing concentrated flow controls.
- Concentrated flow controls are not suitable as sediment-trapping devices.
- It may be necessary to use other soil stabilization and sediment controls in conjunction to prevent scour (e.g., temporary ditch checks); see Section 41-3.03.
- Controls should be constructed of soils that are not easily eroded.
- All ditch, swale, and diversion outlets should be sufficiently stabilized; see Sections 41-2.03(b) and 41-2.05(a).

4. Specifications.

- District Special Provision will be required.
- See ISTHA Standard Drawing K1.

Note: Use IDOT pay items when incorporating ISTHA Standards.

41-2.04(b) Slope Drains

1. Definition and Purpose. A flexible tubing or rigid pipe, generally used in conjunction with a diversion dike or channel, to convey concentrated runoff down the face of a cut or fill slope without causing erosion on or at the base of the slope; see Figure 41-2.D.

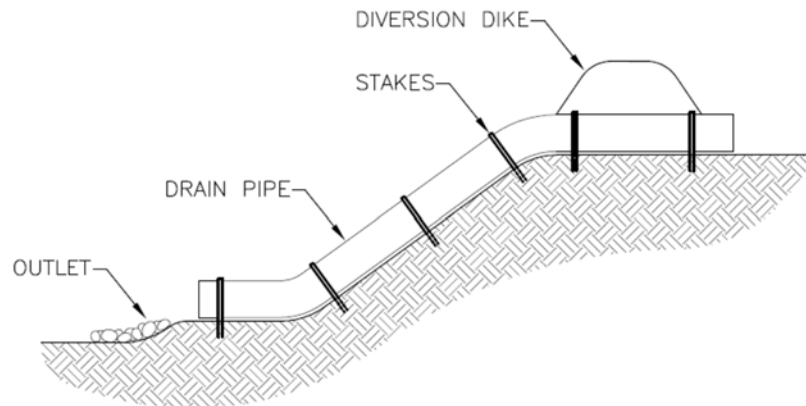

SLOPE DRAIN

Figure 41-2.D

2. Applications. Slope drains are appropriate for the following applications:
 - where concentrated flow of surface water must be conveyed down a slope without erosion,
 - where runoff is intercepted upstream of a newly graded cut or fill section that has not achieved permanent stabilization, and
 - as an emergency spillway for a sedimentation basin.
3. Design Considerations.
 - The maximum allowable drainage area is 1.5 acres (0.61 ha) per 18 in (457 mm) slope drain. Ensure pipe sizes are adequate to convey flows from upstream tributary area without overtopping impoundment structures (e.g., diversion dikes, silt fence).
 - The maximum slope of slope drains is generally limited to 1V:2H, as energy dissipation below steeper slopes is difficult.

- For areas larger than 1.5 acres (0.61 ha) or slopes steeper than 1V:2H, it may be necessary to use aggregate-lined channels or additional drains; See Section 283 of the *Standard Specifications*.
- Severe erosion may result if slope drain fails.
- Install reinforced stakes and cables at least every 10 ft (3 m) to secure conduit.
- To prevent stress and failure, install drains perpendicular to slope contours.
- Place slope drains on compacted soil that is covered with Class B geotextile filter fabric.
- Slopes drains should always drain directly, or indirectly to sediment traps or sedimentation basins; see Section 41-3.04.
- Protect the area around inlet with appropriate inlet sediment controls and outlet area with velocity dissipater; see Sections 41-3.02 and 41-2.05(a).

4. Specifications.

- District Special Provision will be required.
- See ISTHA Standard Drawing K1.

Note: Use IDOT pay items when incorporating ISTHA Standards.

41-2.05 Outlet Protection Controls

Outlet protection controls prevent erosion by slowing the velocity of concentrated flows. These measures are to be employed wherever concentrated flows are conveyed at erosive velocities (e.g., in steep swales, at pipe outlets); See Figures 41-2.E and 41-2.F.

41-2.05(a) Velocity Dissipaters

1. Definition and Purpose. An area or apron of rock, concrete rubble, or gabions placed at the outlet of a drainage system, intended to prevent erosion and reduce velocity of the storm water outflow.
2. Applications. Use velocity dissipaters where the discharge velocity and energy at an outlet will cause erosion to the receiving channel or area, including:
 - outlets of pipes, drains, culverts, slope drains, diversion ditches, swales, and channels (concentrated flows);
 - outlets carrying a continuous flow of water;

- outlets subject to short, intense flows;
- outlets to sedimentation basins; and
- points where lined channels discharge to unlined channels or natural waterways.

IDOT Gradation	Maximum Rock Size (lb)*	Equivalent Diameter (spherical) (in) *	Minimum Bedding Thickness (in)	Minimum Thickness (in)
RR-3	50 (22.5 kg)	10 (300 mm)	—	8 (200 mm)
RR-4	150 (67.5 kg)	15 (400 mm)	6 (150 mm)	16 (400 mm)
RR-5	400 (180 kg)	21 (500 mm)	8 (200 mm)	22 (600 mm)
RR-6	600 (270 kg)	24 (600 mm)	10 (250 mm)	26 (700 mm)
RR-7	1000 (450 kg)	28 (700 mm)	12 (300 mm)	30 (800 mm)

* Assumes a minimum specific gravity of 2.450 and minimum unit weight of 153 lb/ft³ (2,450 kg/m³).

ROCK RIPRAP SIZE AND THICKNESS

Figure 41-2.E

Culvert Diameter (in)	Minimum Tailwater				Maximum Tailwater			
	Max Conduit Velocity = 5 fps (1.5 mps)		Max Conduit Velocity = 10 fps (3.1 mps)		Max Conduit Velocity = 5 fps (1.5 mps)		Max Conduit Velocity = 10 fps (3.1 mps)	
	IDOT Gradation	Apron Length (ft)	IDOT Gradation	Apron Length (ft)	IDOT Gradation	Apron Length (ft)	IDOT Gradation	Apron Length (ft)
12 (0.3 m)	RR-3	10 (3.1 m)	RR-3	12 (3.7 m)	RR-3	12 (3.7 m)	RR-3	15 (4.6 m)
18 (0.5 m)	RR-3	14 (4.3 m)	RR-4	16 (4.9 m)	RR-3	12 (3.7 m)	RR-3	16 (4.9 m)
24 (0.6 m)	RR-3	16 (4.9 m)	RR-4	20 (6.1 m)	RR-3	14 (4.3 m)	RR-4	17 (5.2 m)
30 (0.8 m)	RR-3	18 (5.5 m)	RR-4	22 (6.7 m)	RR-3	16 (4.9 m)	RR-4	20 (6.1 m)
36 (0.9 m)	RR-4	20 (6.1 m)	RR-5	24 (7.3 m)	RR-3	16 (4.9 m)	RR-4	22 (6.7 m)
48 (1.2 m)	RR-4	24 (7.3 m)	RR-6	28 (8.5 m)	RR-4	20 (6.1 m)	RR-4	24 (7.3 m)
60 (1.5 m)	RR-5	32 (9.8 m)	RR-6	36 (10.9 m)	RR-4	22 (6.7 m)	RR-5	26 (7.9 m)
72 (1.8 m)	RR-6	40 (12.2 m)	RR-6	44 (13.4 m)	RR-5	24 (7.3 m)	RR-5	29 (8.8 m)

96 (2.4 m)	RR-7	50 (15.2 m)	RR-7	54 (16.5 m)	RR-5	26 (7.9 m)	RR-5	32 (9.8 m)
---------------	------	----------------	------	----------------	------	---------------	------	---------------

Notes:

1. If tailwater depth from the pipe invert is less than half of diameter of the pipe, then minimum tailwater conditions exist. Otherwise, maximum tailwater conditions exist.
2. Adapted from the Illinois Urban Manual.

**MINIMUM IDOT ROCK SIZES AND APRON LENGTH FOR
MAXIMUM AND MINIMUM TAILWATER CONDITIONS**

Figure 41-2.F

3. Design Considerations.

- Velocity dissipaters are not adequate to stabilize discharges occurring at the top of a cut or a slope steeper than 1V:10H; see Section 41-2.04.
- Large storms may wash away rock or concrete, leaving the area susceptible to erosion.
- Consider using a riprap-stilling basin or plunge pool where velocities exceed 10 fps (3 mps) or where the velocity requires an apron of an excessive length.
- Riprap, gabions, or slope mattresses placed over filter fabric are the general materials used to provide temporary outlet protection. See Figure 41-2.C.

4. Specifications. See Sections 281 and 284 of the *Standard Specifications*.

41-2.06 Erosion Control Reference Table

Figure 41-2.G references all ECPs discussed in Section 41-2. This figure may be used by the designer as a supplemental tool to ensure that all BMP options have been considered. Note that multiple BMPs may be required from each category in order to provide comprehensive stabilization of the site.

ECP Category	Specific ECP	Appropriate Application	Section
Vegetation	Incorporate Existing Vegetation	Wherever feasible	41-2.01(a)
	Establish New Vegetation	All projects where temporary or permanent stabilization is required; when existing vegetation is removed	41-2.01(b)
Mulch, ECBs and TRMs	Straw, Hydraulic, and Compost Mulches	Temporary stabilization; concurrent with seeding or turf establishment	41-2.02
	ECBs and TRMs	Stabilization of slopes, mulches, and areas to be vegetated; suitable for channel stabilization	41-2.02(d)
Soil Binders	Plant-Material Based, Polymeric Emulsion Blends, and Cementitious-Based Binders	Short- to long-term stabilization of low traffic areas (cut/fill areas, stockpiles, areas to be graded soon)	41-2.03
Concentrated Flow Controls	Diversion Dikes	Upslope and down slope of disturbed areas and across slopes where runoff must be intercepted	41-2.04(a)
	Drainage Swales	Upslope and down slope of disturbed areas, adjacent to paved areas	41-2.04(a)
	Lined Ditches	Upslope and down slope of disturbed area, across slopes, where erosive conditions may exist	41-2.04(a)
	Slope Drains	Where concentrated flows must be conveyed down an unstable slope	41-2.04(b)
Outlet Protection Controls	Velocity Dissipaters	All outlets and points of discharge, where lined channels drain to unlined channels	41-2.05(a)

EROSION CONTROL PRACTICES REFERENCE TABLE

Figure 41-2.G

41-3 SEDIMENT CONTROL PRACTICES (CONTAINMENT)

Sediment-laden waters generated on-site should be routed through at least one sediment control practice (SCP) prior to discharge. In some instances, multiple SCPs will be necessary to protect against the discharge of suspended sediment. Install all SCPs in combination with ECPs, using a treatment train approach.

41-3.01 Perimeter Controls

Perimeter control BMPs are methods of containing sediment within the boundaries of the project site. Where containing sediment on site, always install perimeter controls in conjunction with ECPs. Do not use perimeter control as a stand-alone BMPs. Perimeter control BMPs prevent the discharge of sediment by filtering and dissipating the energy of sediment laden sheet flow runoff. Consider all site characteristics when selecting appropriate perimeter control BMPs.

41-3.01(a) Perimeter Vegetated Buffers

1. Definition and Purpose. An existing or proposed area of vegetation designed to remove sediment and other pollutants and enhance infiltration of surface runoff. See Figure 41-3.A.

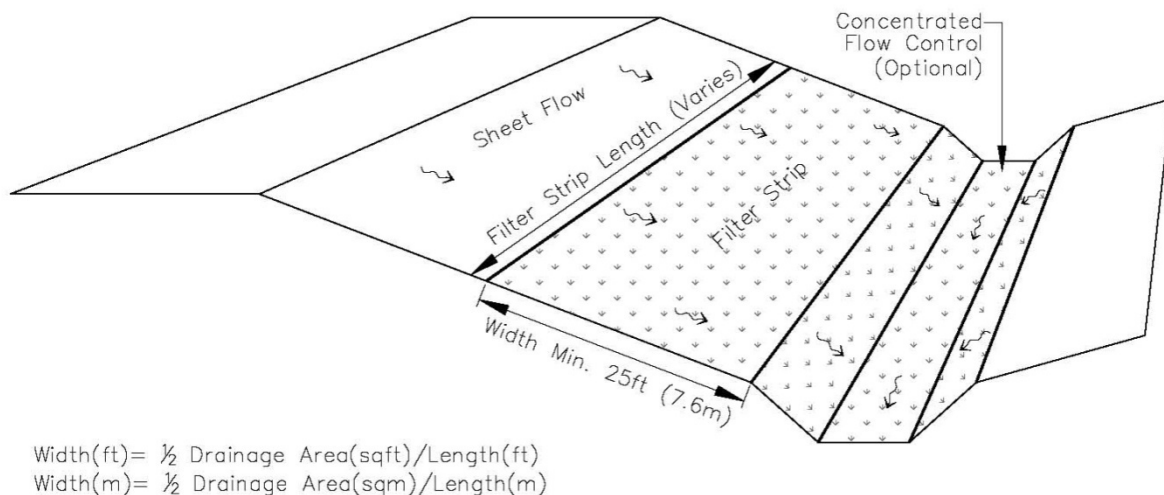

VEGETATION BUFFERS

Figure 41-3.A

2. Applications. Preservation of existing vegetated buffers should always be considered. Perimeter vegetated buffers are appropriate for the following applications:

- projects where grading can be phased and vegetation can be temporarily preserved and used for sediment control;
- urban areas where surface runoff is discharged as sheet flow;
- adjacent to roadways, parking lots, and other impervious surfaces to filter runoff before discharge to storm sewers, swales, and waterways; and
- areas where upstream tributary sheet flow enters site.

3. Design Considerations.

- Vegetation selection varies depending on climate, soil type, topography, land use, available light (e.g., shade tolerance), aesthetics, and planned use of the area.
- The maximum drainage area to a vegetated buffer should be 5 acres (2 ha).
- Vegetated buffer slope should be 1V:6H or flatter if used as a stand-alone perimeter control.
- The width (e.g., dimension parallel to flow path) of the vegetated buffer can be calculated using the equation:

$$\text{Width (ft (m))} = \text{Half of the Drainage Area to Buffer} \div \text{Buffer Length}^*$$

* *Buffer length is the dimension perpendicular to the flow path.*

- The minimum width (e.g., dimension parallel to flow) should be 25 ft (7.62 m).
- Vegetation should be established prior to runoff being directed onto it from impervious areas. If this is not possible, install sodding in the buffer area.
- Avoid concentrated flows through the vegetated buffer. If potential exists for concentrated flows, employ other sediment control measures upstream of the buffer.
- Locate protection measures at the boundary of the existing or proposed vegetated buffer area or 1 ft (300 mm) outside the perimeter of the leaf canopy if a stand of trees is to be protected.
- Install all required protection measures prior to the commencement of any site development activity. Protective measures should remain in place year round and in working, functional order until all site development activities have ceased or the surrounding area has been stabilized.

- Prohibit construction activities, heavy equipment, vehicular traffic, or storage of construction materials within the vegetated buffer area.

4. Specifications.

- See Sections 250, 252, and 280 of the *Standard Specifications*.
- Where existing vegetation is used, delineate the area as a “No Intrusion Area” on the ESCP sheets and note the area in the SWPPP. Temporary fencing and/or signage can be used to delineate this BMP.
- Where proposed vegetation is to be used, note the timing of the installation in the SWPPP. A schedule will be required to designate the widths of vegetation to be used as a buffer.
- See *Illinois Urban Manual* STD 835 (Filter Strip).
- See *Illinois Urban Manual* STD IL-535.

Note: Use IDOT pay items when incorporating Illinois Urban Manual Standards.

41-3.01(b) Perimeter Silt Fence Barriers

1. Definition and Purpose. A temporary permeable barrier of entrenched filter fabric used to contain sediment within a site. Perimeter silt fence barriers promote sedimentation of sheet-flow runoff prior to discharge from the construction site. They intercept and detain small amounts of sediment resulting from disturbed areas (e.g., construction sites) and prevent sediment from leaving the site.
2. Applications. Perimeter silt fence barriers are appropriate for the following locations:
 - along the perimeter of a project,
 - around temporary soil stockpiles and spoil areas,
 - along perimeter of streams and channels,
 - downslope of exposed erodible soil areas, and
 - below the toe of exposed and erodible slopes.
3. Design Considerations.
 - Do not install silt fence barriers in areas of concentrated flow (e.g., streams, channels, drain inlets).
 - Do not use silt fence barriers as mid-slope protection on slopes steeper than 1V:4H; see Section 41-3.03.
 - Do not install silt fence barriers where ponding water behind the silt fence may cause flooding or fence failure.

- Silt fence barriers should not make dips that intercept slope contours because flows will be concentrated and blowouts may occur.
- The maximum drainage area for sheet-flow runoff to a silt fence should not exceed 0.5 acre per 100 ft (0.2 ha per 30 m) of fence.
- Install silt fence barriers with a “J”-Hook at intervals of at least 200 ft (61 m).

4. Specifications.

- See Section 280 of the *Standard Specifications*.
- See IDOT Highway Standard 280001.

Note: Contractor will have choice of materials unless a District Special Provision is included.

41-3.01(c) Perimeter Straw Bale Barriers

1. Definition and Purpose. A temporary barrier of entrenched and anchored straw bales used to contain sediment within a site. Perimeter straw bale barriers promote sedimentation of sheet-flow runoff prior to discharge from a construction site.

2. Applications. Perimeter straw bale barriers are appropriate for the following locations:

- along the perimeter of a project,
- around temporary soil stockpiles and spoil areas,
- down-slope of exposed erodible soil areas, and
- below the toe of exposed and erodible slopes.

3. Design Considerations.

- Do not install straw bale barriers in areas of concentrated flow (e.g., streams, channels).
- This control can only be used for installations less than three months, because straw bales tend to rapidly degrade.
- Straw bales can introduce non-native, undesirable plants.
- The maximum drainage area for sheet-flow runoff to a straw bale barrier should not exceed 0.5 acre per 100 ft (0.1 ha per 30 m) of barrier.

4. Specifications.

- See Section 280 of the *Standard Specifications*.
- See IDOT Highway Standard 280001.

Note: Contractor will have choice of materials unless a District Special Provision is included.

41-3.01(d) Perimeter Rolled Barriers

1. Definition and Purpose. Rolled and bound wood excelsior or equivalent placed around the site perimeter or stockpiles. Rolled barriers decrease the velocity and erosive force of sheet flows, and contain sediment by detaining and filtering runoff.
2. Applications. Perimeter rolled barriers are appropriate for the following locations:
 - along the perimeter of a project;
 - around temporary stockpiles and spoil areas;
 - at the top, face, and toe of erodible and exposed slopes;
 - at grade breaks on erodible and exposed slopes; and
 - down slope of any exposed soil areas.
3. Design Considerations. Install rolled excelsior barriers at the same elevation (e.g., along the same contour line) to prevent erosion.
4. Specifications.
 - See Section 280 of the *Standard Specifications*.
 - See ISTHA Standard Drawing K1.

Note: Contractor will have choice of materials unless a District Special Provision is included.

41-3.02 Inlet Controls

Inlet controls prevent the movement of sediment and other pollutants into the storm sewer network. Consider all site and storm sewer characteristics when selecting an appropriate BMP. Sheet flow draining to drop inlets and shallow concentrated flow draining to culvert inlets require different methods of treatment, so it is important to select a BMP best suited to accommodate the expected velocity, shear stress, and sediment load of site runoff.

41-3.02(a) Drop Inlet Filter Bags

1. Definition and Purpose. A manufactured inlet filtration bag that is custom-fitted for insertion under virtually any type of drop drainage structure casting. An inlet filter can significantly reduce the ingress of sediment into the storm sewer system.
2. Applications. Drop inlet filter bags are appropriate for the following locations:

- inlets within paved areas, and
 - drop inlets receiving runoff from 0.5 acre (0.2 ha) or less.
3. Design Considerations. Common curb-and-gutter and parking lot installations are available. The designer should ensure availability before specifying in other locations.
 4. Specifications. See Section 280 of the *Standard Specifications*.

41-3.02(b) Drop Inlet Silt Fence Barriers

1. Definition and Purpose. A temporary silt fence secured around a drop inlet. Silt fence barriers impound water behind the barrier allowing sediment to drop out before the water enters the inlet.
2. Applications. Drop inlet silt fence barriers are appropriate for the following applications:
 - only for drop inlets in unpaved areas where the base of barrier can be trenched; and
 - for relatively small, flat areas (e.g., less than 1 acre (0.4 ha) per inlet; flatter than 5% slopes) with shallow sheet flows not exceeding 1 cfs (0.03 cms).
3. Design Considerations.
 - Slopes immediately surrounding silt fence barrier should not exceed 1% and must remain accessible for removal of accumulated sediment.
 - Verify flooding will not impact surrounding land.
4. Specifications.
 - See Section 280 of the *Standard Specifications*.
 - See IDOT Highway Standard 280001.

Note: Contractor will have choice of materials unless a District Special Provision is included.

41-3.02(c) Drop Inlet Straw Bale Barriers

1. Definition and Purpose. A sediment control barrier consisting of entrenched and staked straw bales surrounding a drop inlet. Straw bale barriers impound water behind the barrier allowing sediment to drop out before the water enters the inlet.
2. Applications. Drop inlet straw bale barriers are appropriate for the following applications:

- only for drop inlets in unpaved areas; and
- in relatively small, flat areas (e.g., less than one acre per inlet; flatter than 5% slopes) with shallow sheet flows not exceeding 0.5 cfs (0.01 cms).

3. Design Considerations.

- Straw bale barriers are effective for three months or less.
- Slopes immediately surrounding straw bale barrier should not exceed 1% and must remain accessible for removal of accumulated sediment.
- Straw bales can introduce non-native, undesirable plants.

4. Specifications.

- See Section 280 of the *Standard Specifications*.
- See IDOT Highway Standard 280001.

Note: Contractor will have choice of materials unless a District Special Provision is included.

41-3.02(d) Drop Inlet Rolled Barriers

1. Definition and Purpose. Rolled and bound wood excelsior or equivalent surrounding a drop inlet. Rolled barriers impound water behind the barrier allowing sediment to drop out before the water enters the inlet.
2. Applications. Drop inlet rolled barriers are appropriate for the following applications:
 - around drop inlets in unpaved areas, especially where other inlet controls are not feasible; and
 - in relatively small, flat areas (e.g., less than one acre (0.4 ha) per inlet; flatter than 5% slopes) with shallow sheet flows not exceeding 0.5 cfs (0.01 cms).
3. Design Considerations.
 - Rolled barriers should be staked and trenched in to a depth of 3 in (762 mm) to prevent displacement by high flows.
 - Slopes immediately surrounding rolled barrier should not exceed 1% and must remain accessible for removal of accumulated sediment.

4. Specifications.

- District Special Provision will be required.
- See ISTHA Standard Drawing K1.

Note: Use IDOT pay items when incorporating ISTHA Standards.

41-3.02(e) Drop Inlet Prefabricated Barriers

1. Definition and Purpose. Manufactured, temporary sediment control barriers constructed of geosynthetic fabric and foam or equivalent. Drop inlet prefabricated barriers are installed around drop inlets in order to intercept and pond sediment-laden runoff prior to entering the storm sewer. Ponding the water reduces the velocity of any incoming flow and allows most of the suspended sediment to settle and be intercepted. After the water height reaches the top of the barrier, it flows over the dike and into the inlet.
2. Applications. Drop inlet prefabricated barriers are appropriate for the following applications:
 - in relatively small, flat areas (e.g., less than one acre (0.4 ha) per inlet; flatter than 5% slopes) with shallow sheet flows not exceeding 0.5 cfs (0.01 cms); and
 - where temporary upstream ponding will not adversely affect roadways or construction.
3. Design Considerations
 - Slopes immediately surrounding prefabricated barrier should not exceed 1% and must remain accessible for removal of accumulated sediment.
 - Place prefabricated barriers directly around the perimeter of the inlet.
 - Place two full sections against opposite sides of the inlet, and extend both sections beyond the drop sides of the inlet.
 - Where multiple barriers are installed, the sleeve end of fabrics should overlap at the joints and ends and be stapled to prevent bypass of storm water.
 - Prefabricated barriers can be cleaned, moved, and reused multiple times.
4. Specifications. District Special Provision required.

41-3.02(f) Above Grade Drop Inlet Filters

1. Definition and Purpose. Filter fabric-covered, polyethylene-framed barriers that are installed over area drains. Above grade inlet filters protect storm drains from ingress of sediment during construction activities.
2. Applications. Above grade drop inlet filters are appropriate for the following applications:
 - only for drop inlets in sump conditions;
 - for relatively small, flat areas (e.g., one acre (0.4 ha) or less) draining to each inlet; and
 - where sediment laden water is capable of clogging conventional inlet filters.
3. Design Considerations. None.
4. Specifications. See BDE Special Provision for “Above Grade Inlet Filter” (to be incorporated into Section 280 of *Standard Specifications* at a later date).

41-3.02(g) Pipe (Culvert) Inlet Vegetated Buffers

1. Definition and Purpose. A preserved or created area of vegetation at a culvert inlet that filters runoff prior to drainage. A vegetated buffer helps prevent sediment, mulch, and other pollutants from entering the storm sewer system before permanent seeding has become established in the tributary area of the storm inlet.
2. Applications. Pipe (culvert) inlet vegetated buffers are appropriate for the following applications:
 - in areas surrounding pipe inlets, especially culverts; and
 - in conjunction with other SCPs; see Section 41-3.04.
3. Design Considerations.
 - Ensure all feasible efforts are used to preserve existing vegetative buffers during construction.
 - See Section 41-3.01(a) for sizing of vegetated buffers. The minimum length is 25 ft (7.62 m).
 - Designate vegetative buffers as no entry areas by use of signage and/or temporary fence.
 - If removal of existing vegetation cannot be avoided, sod may be used as a buffer. Place the sod level with the surrounding ground surface and extend it at least 25 ft (7.62 m) from inlet.

4. Specifications.

- See Sections 250, 252, and 280 of the *Standard Specifications*.
- Where existing vegetation is used, delineate the area as a “No Intrusion Area” on the ESCP sheets. Also, note this area in the SWPPP. Temporary fencing and/or signage can be used to delineate this BMP.
- Where proposed vegetation is used, note the timing of the installation in the SWPPP. Include a schedule to designate the widths of vegetation to be used as a buffer.
- See *Illinois Urban Manual* practice STD 862 (Inlet Protection-Sod Filter).
- See *Illinois Urban Manual* STD IL-562.

Note: Use IDOT pay items when incorporating Illinois Urban Manual Standards.

41-3.02(h) Pipe (Culvert) Inlet Silt Fence Barriers

1. Definition and Purpose. A temporary permeable barrier of entrenched filter fabric used to protect a pipe inlet. A pipe (culvert) inlet silt fence barrier promotes the deposition of sediment from sediment-laden runoff prior to discharge from the construction site.
2. Applications. Use a pipe (culvert) inlet silt fence barrier for sediment control around pipe and culvert inlets where other methods of inlet protection and sediment control cannot be implemented in a timely manner. See Sections 41-3-.02(g), 41-3.03, and 41-3.04.
3. Design Considerations. Filter fabric may cause storm water backup and flooding of adjacent areas.
4. Specifications.
 - See Section 280 of the *Standard Specifications*.
 - See IDOT Highway Standard 280001.

41-3.02(i) Pipe (Culvert) Inlet Straw Bale Barriers

1. Definition and Purpose. A temporary barrier consisting of entrenched straw bales placed at a pipe inlet. Pipe (culvert) inlet straw bale barriers promote sedimentation and filtration of runoff prior to discharge from the construction site.
2. Applications. Use pipe (culvert) inlet straw bale barriers for short term (e.g., less than three months), sediment control around pipe and culvert inlets where other methods of inlet protection and sediment control cannot be implemented in a timely manner. See Sections 41-3-.02(g), 41-3.03, and 41-3.04.

3. Design Considerations.

- Straw bales may cause storm water backup and flooding of adjacent areas.
- Straw bales decompose and disintegrate rapidly; therefore, may be inefficient and expensive to maintain.
- Straw bales can introduce unwanted plant species and can contribute organic matter to waterways if improperly installed.

4. Specifications. See Section 280 of the *Standard Specifications*.

41-3.03 Temporary Ditch and Slope Checks

41-3.03(a) **Aggregate Ditch Checks**

1. Definition and Purpose. A small rock barrier constructed perpendicular to the flow path in drainage ditches and swales. Aggregate ditch checks reduce the velocity of surface water, which reduces scouring and allows sedimentation to occur. Ditch checks also promote infiltration where suitable soils are present.
2. Applications. Aggregate ditch checks are appropriate for the following applications:
 - most economical choice for steep swales or ditches with velocities exceeding 4.9 ft/s (1.5 m/s),
 - during the establishment of grassy-linings in swales or ditches (both temporary and permanent), and
 - in temporary swales where erosion control lining is not warranted due to their short service time.
3. Design Considerations.
 - Maximum recommended drainage area to each ditch check should not exceed 10 acres (4 ha).
 - Maximum spacing between the ditch checks should be such that the toe of the upstream ditch check is at the same elevation as the top of the rock at the center of the downstream ditch check; see Figure 41-3.B.
 - If scouring occurs on downstream side of aggregate ditch check, install ECBs, or TRMs to prevent further erosion; see Section 41-2.02.

% Slope	Height at Center/Overflow Pt. of Ditch Check (ft)	Spacing of Ditch Check (ft)
8%	1.0 (0.3 m)	13 (3.9 m)
	1.5 (0.5 m)	20 (6.1 m)
	2.0 (0.6 m)	26 (7.9 m)
7%	1.0 (0.3 m)	14 (4.27 m)
	1.5 (0.5 m)	21 (6.40 m)
	2.0 (0.6 m)	28 (8.5 m)
6%	1.0 (0.3 m)	17 (5.2 m)
	1.5 (0.5 m)	26 (7.9 m)
	2.0 (0.6 m)	34 (10.4 m)
5%	1.0 (0.3 m)	20 (6.1 m)
	1.5 (0.5 m)	30 (9.1 m)
	2.0 (0.6 m)	40 (12.2 m)
4%	1.0 (0.3 m)	25 (7.6 m)
	1.5 (0.5 m)	38 (11.6 m)
	2.0 (0.6 m)	50 (15.2 m)
3%	1.0 (0.3 m)	33 (10.1 m)
	1.5 (0.5 m)	50 (15.2 m)
	2.0 (0.6 m)	66 (20.1 m)
2%	1.0 (0.3 m)	50 (15.2 m)
	1.5 (0.5 m)	75 (22.9 m)
	2.0 (0.6 m)	100 (30.5 m)
1% and below	1.0 (0.3 m)	100 (30.5 m)
	1.5 (0.5 m)	150 (45.7 m)
	2.0 (0.6 m)	200 (60.9 m)

Notes:

1. For applications not addressed in this figure, spacing should be equal to the height of ditch check divided by the slope. This ensures that the base of the upstream check is at the same elevation as the crest of the downstream check.
2. Adapted from the Illinois Urban Manual.

SPACING OF TEMPORARY DITCH CHECKS

Figure 41-3.B

- Aggregate ditch checks are not recommended for slopes greater than 20%. When steeper than 20%, stabilize channels and drain to a SCP; see Section 41-2.03(a) and Section 41-3.04.

4. Specifications. See Sections 28 and 283 of the *Standard Specifications*.

41-3.03(b) Prefabricated Ditch Checks

1. Definition and Purpose. Manufactured temporary ditch checks are placed perpendicular to flow in shallow drainage ditches. The purpose of temporary ditch checks is to reduce the velocity of flowing water, thereby, reducing scour and channel erosion, encouraging deposition of sediment and filtration, and promoting infiltration where suitable soils are present.
2. Applications. Prefabricated ditch checks are appropriate for the following applications:
 - in shallow swales or ditches with slopes less than 8%,
 - during establishment of vegetation, and
 - in temporary swales where erosion control lining is not warranted due to short service time.
3. Design Considerations.
 - Product should not cause flooding of adjacent areas or roadways.
 - Place ditch checks perpendicular to the flow path.
 - Space ditch checks according to Figure 41-3.B.
4. Specifications. See Section 280 of the *Standard Specifications*.

41-3.03(c) Rolled Barrier Slope Checks

1. Definition and Purpose. Rolled and bound wood excelsior or equivalent placed on the face of slopes, installed perpendicular to the flow path. Slope checks decrease the velocity and erosive force of sheet flows by reducing slope length and contain sediment near its source by detaining and filtering runoff.
2. Applications. Roller barrier slope checks are appropriate for the following applications:
 - at the top, face, and toe of erodible and exposed slopes;
 - at grade breaks on erodible and exposed slopes;
 - down slope of any exposed soil areas; and
 - not to be used on steep slopes susceptible to slumping or creeping.

3. Design Considerations.

- Rolled barriers should be staked and trenched in to a depth of 3 in (762 mm) to prevent displacement by high flows.
- Space rolled barriers in accordance with the following:
 - + slope inclination of 1V:4H or flatter = 20 ft (6.1 m) apart,
 - + slope inclination of 1V:4H to 1V:2H = 15 ft (4.6 m) apart, and
 - + slope inclination 1V:2H or greater = 10 ft (3.0 m) apart.
- Install temporary slope checks at the same elevation (along the same contour line) to prevent erosion.

4. Specifications.

- District Special Provision will be required.
- See ISTHA Standard Drawing K1.

Note: Use IDOT pay items when incorporating ISTHA Standards.

41-3.04 Sediment Traps and Basins

These sediment controls use excavated or impounded areas to temporarily detain sediment-laden water to promote settling of suspended particles prior to discharge. The outlets of these sediment controls should be stabilized (see Sections 41-2.04 and 41-2.05) so that treated water does not become re-contaminated, and should receive secondary treatment by means of inlet control BMPs (see Section 41-3.02) prior to drainage to a storm sewer. Designs should allow for adequate retention time to ensure maximal sedimentation for the anticipated sediment loads.

41-3.04(a) Sediment Traps

1. Definition and Purpose. A small, temporary ponding area either excavated or impounded by embankments. A sediment trap detains runoff for a sufficient period of time to allow sediment to drop out of suspension prior to discharge through a stabilized spillway. These practices are optimal for draining small disturbed areas comprised of coarse textured soils.
2. Applications. Sediment traps are appropriate for the following applications:
 - for removal of medium to large-sized sediment particles (e.g., sands, coarse silts). For finer textured soils (e.g., silts, clays), see Section 41-3.04(b);
 - at the outlets of small disturbed soil areas draining less than 5 acres (2 ha). If the contributing drainage area is greater than 5 acres (2 ha), see Section 41-3.04(b);

- for installations lasting less than 18 months;
- as a supplemental control to provide additional protection for waterways and drainage systems;
- at the perimeter of the site, at the outlet of any runoff conveyance that will discharge sediment-laden water, or along the flow path of runoff being conveyed through the site;
- where failure of the sedimentation trap will not result in injury, loss of life, damage to homes, buildings, roads, or other public infrastructure or service utilities; and
- not in live waterways or streams.

3. Design Considerations.

- Design the sediment trap to provide enough storage to accommodate the settling process (e.g., live storage) in addition to the accumulated sediment (e.g., dead storage).
- Live storage volume should, at a minimum, accommodate 3600 ft³ of runoff per acre (101.9 m³ per ha) tributary to each sediment trap.
- Design the dead storage to store the estimated sediment load generated from the site over the duration of the construction period. Ensure it is below the permeable fill.
- Total storage may consist of only live detention storage; however, a more frequent schedule for sediment removal will be required.
- Larger surface areas provide more effective settling than smaller areas.
- Larger length-to-width ratios provide protection against short-circuiting; therefore, the length of the trap should be at least twice the width as measured from inlet to outlet.
- If trap is formed by an embankment, maximum height should not exceed 5 ft (1.5 m).
- Side slopes should be no steeper than 1V:2H and be stabilized with vegetation, ECB, or TRM; see Section 41-2.02.
- Sediment should be removed and trap restored to original dimensions when accumulation reaches ½ the design depth of dead storage. If only live storage is used, then sediment should be removed after each sediment generating storm event.

- For situations where particle size or wind turbulence impedes settling within recommended timeframe, chemical treatment may be considered; see Section 41-3.05(b).
- Multiple traps and/or additional volume may be required to accommodate site-specific rainfall and soil conditions.
- Outlet design should ensure sediment is contained and erosion of outlet does not occur. Outflows should discharge to fully stabilized channels at non-erosive velocities; see Section 41-2.05.
- For outlets with a discharge point onto or cut into natural ground, the outlet width (ft (m)) should be equal to six times the drainage area (acres (ha)). If an embankment is used, the outlet should be at least 1 ft (300 mm) below the top of the embankment.
- For outlets consisting of a coarse aggregate and riprap section, locate the stone at the low point of the trap and extend vertically to 1 ft (300 mm) below the top of the embankment. Place coarse aggregate (CA-3) on the upstream side of outlet, separated by filter fabric from riprap (RR-3) on downstream side of outlet; see Section 41-3.03(a). Outlet width (ft (m)) should be equal to six times the drainage area (acres (ha)).
- Provide a maintenance access-way for sediment removal and disposal.
- Sediment traps require construction safety fencing around perimeter.

4. Specifications.

- District Special Provision and detailed drawing will be required.
- See ISTHA Standard Drawing K1.
- See *Illinois Urban Manual* practice STD 960 (Temporary Sediment Trap).
- See *Illinois Urban Manual* STD Drawing IL-660 (Temporary Sediment Trap) as a plan sheet.

Note: Use IDOT pay items when incorporating ISTHA and Illinois Urban Manual Standards.

41-3.04(b) Sediment Basins

1. Definition and Purpose. A temporary ponding basin (i.e., larger than a Sediment Trap), either excavated or impounded by earthen embankments with a controlled release. A sedimentation basin detains runoff for a sufficient period of time to allow sediment to

drop out of suspension prior to discharge through a control structure. These practices are optimal for draining large disturbed areas comprised of finer textured soils.

2. Applications. Sediment basins are appropriate for the following applications:

- for removal of medium to small sized sediment particles (e.g., silts, clays);
- at the outlets of large disturbed soil areas;
- generally for areas between 5 and 10 acres (2 and 4 ha), but not for drainage areas greater than 75 acres (30 ha);
- at the perimeter of the site, at the outlet of any runoff conveyance that will discharge sediment-laden water, or along the flow path of runoff being conveyed through the site;
- where sediment basins are to remain in place after construction is completed as permanent structures (e.g., for storm water detention purposes);
- where failure of the sedimentation basin will not result in injury, loss of life, damage to homes, buildings, roads, or other public infrastructure, or service utilities; and
- not in live waterways or streams.

3. Design Considerations.

- Design the basin to provide enough storage to accommodate the settling process (live storage) in addition to the accumulated sediment (dead storage).
- Multiple basins and/or additional volume may be required to accommodate site-specific rainfall and soil conditions.
- Design the live storage volume for the runoff from a 2-year, 24-hour storm event draining into the basin under maximum runoff conditions, or 3600 ft³ of runoff per acre (101.9 m³ per ha) tributary to the basin, whichever is greater.
- Dead storage should be sized to store the estimated sediment load generated from the site over the duration of the construction period, or 3600 ft³ of runoff per acre (101.9 m³ per ha) tributary to the basin, whichever is greater.
- Ensure the dead storage is below the permeable fill.
- Larger surface areas provide more effective settling than smaller areas.
- Larger length-to-width ratios provide protection against short-circuiting; therefore, the length of the basin should be at least twice the width as measured from inlet to outlet.

- Basin should have a minimum depth of 3 ft (900 mm) and a maximum of 5 ft (1.5 m) in order to maximize safety and efficiency.
- Side slopes should be no steeper than 1V:2H and be stabilized with vegetation, ECB, or TRM; see Section 41-2.02.
- Sediment should be removed and basin restored to original dimensions when accumulation reaches $\frac{1}{2}$ the design depth of dead storage.
- Calculate the elevation of sediment cleanout level and clearly mark the level on the riser.
- Sediment clean-out level should never exceed 1 ft (300 mm) below the top of riser.
- For situations where particle size or wind turbulence impedes settling within recommended timeframe, chemical treatment may be considered; see Section 41-3.05.
- Basin sizes may be limited based on available right-of-way.
- In restrictive right-of-way areas, the basin may be designed to store 1800. ft³ per acre (125 m³ per hectare) of contributing drainage area.
- Where reduced sized basins will be used, more frequent clean out intervals will be required.
- Design the outlet to drain the basin within 24 to 72 hours in order to provide adequate time for sediment to settle out of suspension and protection against mosquito concerns.
- Recommended outlet types are a single orifice outlet or a perforated riser.
- Outlet should consist of corrugated metal, high-density polyethylene (HDPE) or reinforced concrete riser pipe with dewatering holes.
- Attach an anti-vortex device and trash rack to the top of the riser to prevent the discharge of floatables and to protect outlet from obstruction.
- Minimize erosion using stabilization controls (e.g., ECB) at the inlet and outlet using velocity dissipation devices; see Section 41-2.05.
- The design should include features to accommodate overflow or bypass flows that exceed the design storm event.
- The overflow should consist of an open spillway over undisturbed material or properly compacted fill and be appropriately stabilized with vegetation or riprap.

- The level portion of the spillway at the highest elevation in the channel (control section) should be a minimum of 20 ft (6.1 m) in length.
- Provide a maintenance access-way for sediment removal and disposal.
- The perimeter of the basin requires construction safety fencing.

4. Specifications.

- See Section 280 of the *Standard Specifications*.
- ISTHA Standard Drawing K1 for basin dewatering details.

Note: Use IDOT pay items when incorporating ISTHA Standards.

41-3.05 Flocculant Polymers/Treatment Chemical

Per the ILR10 permit, when flocculants are used on a Department project the following shall be documented in BDE 2342 (SWPPP):

- Identify the use of all flocculants or treatment chemicals at the site;
- Dosage of treatment chemicals shall be identified along with any information from any Material Safety Data Sheet;
- Describe the location of all storage areas for chemicals. Include any information from the manufacturer's specifications;
- Treatment chemicals must be stored in areas where they will not be exposed to precipitation; and
- The SWPPP must describe procedures for use of treatment chemicals and staff responsible for use/application of treatment chemicals must be trained on the established procedures.

41-3.05(a) Batch Treatment

1. Definition and Purpose. The process of applying chemical compounds to sediment-laden bodies of water (e.g., sediment traps, sedimentation basins) to reduce turbidity by causing fine sediments to settle out. The compounds are generally buffered alum, polyacrylamide (PAM), and ferric chloride (or ferrous sulfate), which promote settling of fine, suspended particles through the process of flocculation. Flocculation occurs when small, charged soil particles become attached to the chemical compounds and aggregate into larger masses, which then settle out of suspension.
2. Applications. Batch treatment is appropriate for the following applications:

- where turbid discharges cannot be avoided using other SCPs, see Section 41-3.05; and
- only in conjunction with other sedimentation controls, see Section 41-3.04.

3. Design Considerations.

- Anionic PAM is the most commonly used treatment for flocculation of suspended colloids, clays, and metals. PAM is soil specific and should, therefore, be tested on soils and water from the site to ensure adequate performance.
- Do not use cationic PAM, which is highly toxic to aquatic life.
- Perform toxicity and pH testing to ensure that flocculants meet water quality standards.
- Dilute granular flocculants in water to form stock solutions, which is applied hydraulically to the water surface.
- Flocculation effectiveness is highly dependent on the compound being thoroughly dissolved and mixed with the turbid water.
- In general, application rate should yield 1 ppm in the final volume. The application rate is specific to runoff constituents, site conditions, and flocculent compounds.

4. Specifications.

- District Special Provision will be required.
- Refer to manufacturer's specification for chosen product.

41-3.05(b) Flow-Through Treatment (Flocculent Logs, Polymer Treated Structures)

1. Definition and Purpose. The process of bringing concentrated flows (e.g., diversion channels, dewatering discharges, ditches, swales) of sediment-laden runoff in contact with flocculent-treated materials in order to promote settling of suspended particles; see Section 41-3.05(a).
2. Applications. Flow-through treatments are appropriate for the following applications:
 - where turbid discharges cannot be avoided by sole use of other SCPs, see Section 41-3.04;
 - turbid discharges associated with dewatering, pipe discharges, channelized or concentrated flow paths, storm sewer conveyance and collection systems, temporary diversions, and bypass channels; and

- only for concentrated flows draining to a sediment trap or sedimentation basin, see Section 41-3.04.

3. Design Considerations.

- Semi-hydrated polymer blocks (e.g., floc logs) may be placed within sediment-laden concentrated flow paths as a “pretreatment” to remove fine, suspended solids (e.g., silts, clays, colloids) prior to discharge to a sediment trap or sediment basin.
- Effluent from flow-through treatments should not drain directly into natural water bodies or storm sewer.
- Anionic PAM is the most commonly used treatment for flocculation of suspended colloids, clays, and metals. PAM is soil specific and should, therefore, be tested on soils and water from the site to ensure adequate performance.
- Do not use cationic PAM, which is highly toxic to aquatic life.
- Flocculation effectiveness is highly dependent on the compound being thoroughly dissolved and mixed with the turbid water.
- Perform toxicity and pH testing to ensure that flocculants meet water quality standards.
- Securely stake flocculent logs and other polymer-treated structures along the flow path based upon manufacturers’ specifications and site characteristics.

4. Specifications.

- District Special Provision will be required.
- Refer to manufacturer’s specification for chosen product.

41-3.06 Entrance/Exit Controls

Entrance/exit control BMPs prevent the tracking of sediment attached to equipment and vehicles offsite. The design of entrance/exit control measures will depend upon the site conditions. Generally, these BMPs are not a pay item as the contractor is required to install and maintain per NPDES permits. If the district feels the necessity to require this item in a specific location, a District Special Provision will be required.

41-3.06(a) Stabilized Construction Entrance/Exits

1. Definition and Purpose. A stabilized pad of coarse aggregate, underlain with geotextiles or a commercially available prefabricated unit designed to vibrate accumulated sediment from tires and under chassis. BMPs are located at any point where traffic will be entering

and leaving a construction site. Stabilized construction entrances and exits reduce or eliminate the tracking of sediment (e.g., mud, dirt) onto public right-of-way or streets by construction vehicles.

2. Applications. At all points of construction ingress/egress where sediment can be tracked onto public roads.
3. Design Considerations.
 - Stabilized construction entrances can be expensive to construct and maintain, so it will be necessary to limit the number of access points to the construction site.
 - Design stabilized entrances and exits for the heaviest vehicles and equipment loads.
 - Construct stabilized entrances and exits on level or slightly sloping ground.
 - Aggregate entrances and exits may require periodic top dressing.
 - Route runoff from the entrance through a sediment-trapping device.
 - If site conditions are such that the entrance does not remove sufficient amounts of sediment from vehicle and equipment tires, then tire washing may also be required; see Section 41-3.06(b).
 - A temporary pipe culvert may be needed beneath the entrance as to not impede ditch or surface flow towards the entrance.
4. Specifications.
 - Generally not a pay item as the contractor is required to install and maintain per NPDES permits. If the district feels the necessity to require this item in a specific location, include a District Special Provision.
 - See *Illinois Urban Manual* practice STD 930 (Stabilized Construction Entrance).
 - See *Illinois Urban Manual* STD Drawing IL-630 (Stabilized Construction Entrance Plan) as a plan sheet.

Note: Use IDOT pay items when incorporating Illinois Urban Manual Standards.

41-3.06(b) Tire Wash Stations

1. Definition and Purpose. A designated area where sediment may be washed from equipment tires and chassis prior to exiting the site via a stabilized construction exit. Sediment is collected in a receptacle and disposed of at an approved location. Tire wash stations reduce or eliminate the tracking of sediment (e.g., mud, dirt) onto public right-of-

way or streets by construction vehicles and ensure appropriate discharge of sediment-laden wash water.

2. Applications. Tire wash stations are appropriate for the following applications:

- on sites where conditions are such that a stabilized construction entrance alone does not remove all sediment from vehicle and equipment tires; and
- in combination with grated wash rack (e.g., cattle guard).

3. Design Considerations.

- Wash stations require a supply of wash water.
- Where wash areas are used, provide a construction entrance with two lanes (e.g., to avoid having incoming vehicles drive through the wash area) or have a turnout area.
- Drain wash water away from the construction entrance and adjacent pavement towards a sediment trapping facility; see Section 41-3.04.
- If wash rack is used, have the manufacturer design the wash rack to handle the heaviest anticipated traffic loads.

4. Specifications.

- Generally not a pay item as the contractor is required to install and maintain per NPDES permits. If the district feels the necessity to require this item in a specific location, include a District Special Provision. Ensure the wash area has a stabilized construction entrance.
- See *Illinois Urban Manual* practice STD 930 (Stabilized Construction Entrance).
- See *Illinois Urban Manual* STD Drawing IL-630 (Stabilized Construction Entrance Plan) as a plan sheet.

Note: Use IDOT pay items when incorporating Illinois Urban Manual Standards.

41-3.07 Sediment Control Reference Table

Figure 41-3.C summarizes the SCPs that were discussed in Section 41-3. The figure may be used by the designer as a supplemental tool to ensure that all BMP options have been considered. It should be noted that multiple BMPs may be required from each category in order to provide comprehensive sediment management on the site.

SCP Category	Specific SCP	Appropriate Application	Section
Perimeter Controls	Perimeter Vegetated Buffers	Filtration of all overland sheet flow before discharge to storm sewer, swales, or State waters.	41-3.01(a)
	Perimeter Silt Fence Barriers	Along perimeter of construction sites, streams, channels, and stockpiles; at toe of slopes.	41-3.01(b)
	Perimeter Straw Bale Barriers	Along perimeter of construction sites, streams, channels, and stockpiles; at toe of slopes.	41-3.01(c)
	Perimeter Rolled Barriers	Along perimeter of site, on face and toe of slopes, at grade breaks on exposed soils.	41-3.01(d)
Inlet Controls	Drop Inlet Filter Bags	Drop inlets at grade, especially in paved areas.	41-3.02(a)
	Drop Inlet Silt Fence Barriers	Drop inlets draining up to 1 acre (0.4 ha) of flat land, inlets receiving less than 1 cfs (0.03 cms) shallow sheet flow.	41-3.02(b)
	Drop Inlet Straw Bale Barriers	Drop inlets draining up to 1 acre (0.4 ha) of flat land, inlets receiving less than 0.5 cfs (0.01 cms) shallow sheet flow.	41-3.02(c)
	Drop Inlet Rolled Barriers	Drop inlets draining up to 1 acre (0.4 ha) of flat land, inlets receiving less than 0.5 cfs (0.01 cms) shallow sheet flow.	41-3.02(d)
	Drop Inlet Prefabricated Barriers	Drop inlets draining up to 1 acre (0.4 ha) of flat land, inlets receiving less than 0.5 cfs (0.01 cms) shallow sheet flow.	41-3.02(e)
	Above Grade Inlet Filters	Drop inlets draining small up to 1 acre (0.4 ha) during construction.	41-3.02(f)
	Pipe (Culvert) Inlet Vegetated Buffers	Open grated culvert inlets in areas undergoing permanent seeding, areas up to 1 acre (0.4 ha).	41-3.02(g)
	Pipe (Culvert) Inlet Silt Fence Barriers	Only when timely inlet protection and sediment control by other methods is not possible.	41-3.02(h)
	Pipe (Culvert) Inlet Straw Bale Barriers	Only when timely inlet protection and sediment control by other methods is not possible.	41-3.02(i)

SEDIMENT CONTROL PRACTICES REFERENCE TABLE

Figure 41-3.C

SCP Category	Specific SCP	Appropriate Application	Page
Temporary Ditch and Slope Checks	Aggregate Ditch Checks	In small open swales or ditches with a tributary area of 10 acres (4 ha) or less, steep swales or ditches with velocities exceeding 4.9 ft/s (1.5 m/s), during the establishment of grassy-linings in temporary or permanent swales or ditches.	41-3.03(a)
	Prefabricated Ditch Checks	In shallow swales or ditches with slopes less than 8%, during establishment of vegetation, in temporary swales where erosion control lining is not warranted due to short service time.	41-3.03(b)
	Rolled Barrier Slope Checks	Along the face of erodible and exposed slopes.	41-3.03(c)
Sedimentation Controls	Sediment Traps	Where sediment laden water is discharged from small areas (<5 acres (<2 ha)); supplemental treatment.	41-3.04(a)
	Sediment Basins	Where sediment laden water is discharged from large areas (>5 acres (>2 ha)); supplemental treatment.	41-3.04(b)
Flocculent Polymers	Batch Treatment	Where extreme turbidity exists and where sediment basin alone is insufficient.	41-3.05(a)
	Flow-Through Treatment	As pretreatment for sediment-laden water before draining to sediment trap or sediment basin.	41-3.05(b)
Entrance/Exit Controls	Stabilized Construction Entrance/Exits	All points of site egress/ingress.	41-3.06(a)
	Tire Wash Stations	Where stabilized entrances/exits are not sufficient to remove all sediment.	41-3.06(b)

SEDIMENT CONTROL PRACTICES REFERENCE TABLE

Figure 41-3.C
(Continued)

41-4 GUIDANCE ON THE NPDES PERMIT NUMBER ILR10

The National Pollutant Discharge Elimination System (NPDES) permit Number ILR10 is a general permit issued by the Illinois Environmental Protection Agency (IEPA) to authorize storm water discharges from Department construction projects that disturb one (0.4 ha) or more acres of land either as a single project or a group of projects under a common development plan.

The authority for this permit comes from the United States Environmental Protection Agency (USEPA) which has delegated the IEPA to issue NPDES permits under Section 402 of the Clean Water Act.

The ILR10 has numerous components that the Department must comply with, and those components are discussed below.

41-4.01 Definitions

1. 303(d) listed receiving water. 303(d) refers to Section 303(d) of the Clean Water Act where impaired streams are listed by the IEPA.
2. Impaired Stream. An Impaired stream is a waterway listed on the IEPA Section 303(d) List due to nonattainment of applicable water quality standards and/or designated uses. Listing a waterway as impaired is a requirement for developing a Total Maximum Daily Load for a specific pollutant for that waterbody.
3. Biologically Significant Stream. A stream that has a Biological Stream Rating System score of "A" either for Diversity or Integrity based on data from at least two taxonomic groups. These streams are unique resources in the State and are considered to be the highest quality streams.
4. Designated Use. The designated use of a water body includes aesthetic quality, aquatic life, fish consumption, indigenous aquatic life, primary contact (i.e. recreation), and public and food processing water supply.
5. Incidence of Noncompliance (ION). An ION occurs when during an inspection, a violation of the SWPPP is observed, or for any violation of any condition of this permit. The ION (which is a IEPA form) addresses the noncompliance with a corrective action and is submitted to the IEPA. In itself, the ION is not a punitive action (See Part IV (D)(4)(e) of the IRL10).
6. Final Stabilization. Final stabilization means that all soil disturbing activities at the site have been completed and either of the two following conditions have been met:
 - a. a uniform (e.g. evenly distributed, without large bare areas) perennial vegetative cover with a density of 70 percent of the native background vegetative cover for the area has been established on all unpaved areas and area not covered by permanent structures, or

- b. equivalent permanent stabilization measures (such as the use of riprap, gabions, or geotextiles) have been employed.
7. Municipal Separate Storm Sewer System (MS4). An MS4 is conveyance or system of conveyances that is:
 - owned by a state, city, town, village, or other public entity that discharges to waters of the U.S.,
 - designed or used to collect or convey stormwater (e.g., storm drains, pipes, ditches),
 - not a combined sewer, and
 - not part of a sewage treatment plant, or publicly owned treatment works (POTW).
8. Notice of Intent (NOI). The NOI is a package of information submitted to the IEPA and essentially declares that the project is covered under the ILR10. Contents of the NOI are described in Part II. C of the ILR10.
9. Notice of Termination (NOT). The NOT serves to notify the IEPA that Final Stabilization has been reached for the project.
10. Steep slope. A steep slope is defined as a slope that has a slope gradient of 1V:3H or steeper.
11. Total Maximum Daily Load (TMDL). A TMDL is the greatest amount of a given pollutant that a water body can receive without violating water quality standards and designated uses.

41-4.02 Notice of Intent

The Notice of Intent (NOI) is a notice to the IEPA that a Department project meets the conditions of the ILR10 permit. The Department utilizes the following forms and plans to comply with the NOI requirements.

- BDE 2342 Storm Water Pollution Prevention Plan (SWPPP)
- BDE 2342a Contractor Certification Statement
- Erosion and Sediment Control Detail (See Section 63-4.09)

41-4.03 BDE 2342 (SWPPP)

BDE 2342 is broken down into the following parts:

1. Part I. Site Description

2. Part II. Waters of the US
3. Part III. Water Quality
4. Part IV. Temporary Erosion and Sediment Controls
5. Part V. Other Conditions
6. Part VI. Permanent (i.e., Post- Construction) Storm Water Management Controls
7. Part VII. Additional Practices Incorporated from Local Ordinance(s)
8. Part VIII. Unexpected Regulated Substances/Chemical Spill Procedures
9. Part IX. Contractor Required Submittals
10. Part X. Maintenance
11. Part XI. Inspections
12. Part XII. Incidence of Noncompliance
13. Part XIII. Corrective Actions
14. Part XIV. Retention of Records
15. Part XV. Failure to Comply
16. Part XVI. Keeping the SWPPP (“Plan”) Current
17. Part XVII. Notifications
18. Part XVIII. Notice of Termination

Each of these parts will be explained below

Note: Parts I through VII are filled out during Design. Parts VIII to XVIII are the responsibility of either the Contractor or Construction.

41-4.03(a) SWPPP Signature Page

The first page of BDE 2342 is the signature page. The form shall be signed by a representative of the Department delegated by the Regional Engineer to approve the SWPPP.

41-4.03(b) SWPPP Notes

This section provides information in relation to preparing the SWPPP as well as requirements for the Notice of Intent (NOI).

41-4.03(c) Part I. Site Description

This first section describes the nature and scope of the project.

1. Describe the project location; include latitude and longitude, section, town, and range.

2. Describe the nature of the construction activity or demolition work

3. Describe the intended sequence of major activities which disturb soils for major portions of the site (e.g. clearing, grubbing, excavation, grading, on-site or off-site stockpiling of soils, on-site or off-site storage of materials).

4. The total area of the construction site is estimated to be _____ acres.
5. The total area of the site estimated to be disturbed by excavation, grading or other activities is _____ acres.

6. Below, determine an estimate of the runoff coefficient of the site after construction activities are completed and existing data describing the soil or the quality of any discharge from the site (See Drainage manual)

7. Provide the existing data describing the soil or the quality of any discharge from the site.

8. Erosion and Sediment Control Plan (i.e., ILR10 site map) is included in the contract.
 Yes No

9. List all soils found within project boundaries; include map unit name, slope information, and erosivity.

10. List of all MS4 permittees in the area

Note: For sites discharging to an MS4, a separate map identifying the location of the construction site and the location where the MS4 discharges to surface water must be included.

41-4.03(d) Part II. Waters of the US

The following section discuss any Waters of the US in the project area. These are waters that fall under Federal jurisdiction of the Clean Water Act of 1972.

1. List the nearest named receiving water(s) and ultimate receiving waters.

2. Are wetlands present in the project area?

Yes No

If yes, describe the areal extent of the wetland acreage at the site.

3. Natural buffers:

For any storm water discharges from construction activities within 50 feet of a Waters of the United States, except for activities for water-dependent structures authorized by a Section 404 permit, the following shall apply:

(i) A 50-foot undisturbed natural buffer between the construction activity and the Waters of the United States has been provided

Yes No; and/or

(ii) Additional erosion and sediment controls within that area has been provided

Yes No; and Describe:

41-4.03(e) Part III. Water Quality

41-4.03(e)1 *Water Quality Standards Background*

Water Quality Standards are set by the Illinois Pollution Control Boards. These standards are published in Title 35: Environmental Protection, Subtitle C: Water Pollution, Chapter 1: Pollution Control Board, Part 302 Water Quality Standard. This publication should be reviewed as there are general use waters, which apply to all waterways, and specific standards that apply to certain waterways, such as Lake Michigan Basin as well as descriptions of other chemicals not described below.

41-4.03(e)2 *Definitions*

1. Acute Toxicity means the capacity of any substance or combination of substances to cause mortality or other adverse effects in an organism resulting from a single or short-term exposure to the substance.

2. Adverse Effect means any gross or overt effect on an organism, including reversible histopathological damage, severe convulsions, irreversible functional impairment, and lethality, as well as any non-overt effect on an organism resulting in functional impairment or pathological lesions that may affect the performance of the whole organism, or that reduces an organism's ability to respond to an additional challenge.
3. Chronic Toxicity means the capacity of any substance or combination of substances to cause injurious or debilitating effects in an organism that result from exposure for a time period representing a substantial portion of the natural life cycle of that organism, including the growth phase, the reproductive phases, or such critical portions of the natural life cycle of that organism.
4. Criterion means the numerical concentration of one or more toxic substances derived in compliance with the procedures in Subpart F that, if not exceeded, would assure compliance with the narrative toxicity standard of Section 302.210.
5. "Early Life Stages" of fish means the pre-hatch embryonic period, the post-hatch free embryo or yolk-sac fry, and the larval period, during which the organism feeds. Juvenile fish, which are anatomically similar to adults, are not considered to be an early life stage.
6. "Hardness" means a water quality parameter or characteristic consisting of the sum of calcium and magnesium concentrations expressed in terms of equivalent milligrams per liter as calcium carbonate. Hardness is measured in compliance with methods specified in 40 CFR 136, incorporated by reference in 35 Ill. Adm. Code 301.106.
7. "Mixing Zone" means a portion of the waters of the State identified as a region within which mixing is allowed under Section 302.102(d).
8. "Thermocline" means the plane of maximum rate of decrease of temperature with respect to depth in a thermally stratified body of water.
9. "Total Residual Chlorine" or "TRC" means those substances that include combined and uncombined forms of both chlorine and bromine and that are expressed, by convention, as an equivalent concentration of molecular chlorine. TRC is measured in compliance with methods specified in 40 CFR 136, incorporated by reference in 35 Ill. Adm. Code 301.106.
"Toxic Substance" means a chemical substance that causes adverse effects in humans, or in aquatic or terrestrial animal or plant life. Toxic

substances include those substances listed in 40 CFR 302.4, incorporated by reference in 35 Ill. Adm. Code 301.106, or any "chemical substance" as defined by the Illinois Chemical Safety Act [430 ILCS 45]

10. "ZID" or "Zone of Initial Dilution" means a portion of a mixing zone, identified pursuant to Section 302.102(e), within which acute toxicity standards need not be met.

41-4.03(e)3 *General use Standards*

The following are general use water quality standards from the Illinois Pollution Control Board.

- pH
- Phosphorus
- Dissolved Oxygen
- Radioactivity
- Numeric Standards for Chemical Constituents
- Fecal Coliform
- Other Toxic Substances
- Temperature
- Total Ammonia Nitrogen

Below, in BDE 2342, is a table of common chemicals used on Department construction sites as referenced in Standard Specifications for Road and Bridge Construction. This table is not an exhaustive list. Each contract should be reviewed for other chemicals that could cause an issue with Water Quality if spilled and those additional chemicals shall be added to the table as appropriate.

1. Water Quality Standards

As determined by the Illinois Pollution Control Board, Illinois waters have defined numeric limits of pollutants under the umbrella term "Water Quality Standards." In the following table are commonly used chemicals/practices used on a construction site. These chemicals if spilled into a waterway, could potentially contribute to a violation of a Water Quality Standard. If other chemicals that could contribute a violation of a Water Quality Standard, add as needed,

<input type="checkbox"/>	Fertilizer (check as appropriate)	<input type="checkbox"/>	
<input type="checkbox"/>	Nitrogen	<input type="checkbox"/>	Petroleum (gas, oil, kerosene, hydraulic oil / fluids)
<input type="checkbox"/>	Phosphorous, and/or	<input type="checkbox"/>	Wastewater for concrete washout station
<input type="checkbox"/>	Potassium	<input type="checkbox"/>	Coal Tar Pitch Emulsion
<input type="checkbox"/>	Herbicide	<input type="checkbox"/>	Other (Specify)

Table 41-4.A Common chemicals/potential pollutants used during construction

Comparing the general use water quality standards and Table 41-4A. we can see that phosphorus and nitrogen used as a fertilizer per Article 250.04 in the spec book could be two chemicals that can cause an issue if allowed to enter a waterway. However, both fertilizers are applied as a dry product and the likelihood of a spill is low and is reinforced by the Department’s Pollution Prevention practices as described in the Department’s ILR40 permit.

After determining if any chemicals can pose an issue if spilled into a waterway, the following check boxes can be filled out in the SWPPP.

If no boxes are checked in the table above, check the following box:

There are no chemicals on site that will exceed a Water Quality Standards if spilled.

If any of the boxes are checked in the table, check the following box and statement:

There are chemicals on site that if spilled could potentially cause an exceedance of a Water Quality Standard. The Department shall implement Pollution Prevention/Good Housekeeping Practices as described in the Department’s ILR40 Discharge for Small Municipal Separate Storm Sewer Systems (MS4) reiterated below and Part VIII. Unexpected Regulated Substances/Chemical Spill Procedures:

The following discusses pollution prevention practices utilized by the Department.

Pollution Prevention

The Department will design, and the contractor shall, install, implement, and maintain effective pollution prevention measures to minimize the discharge of pollutants from construction activities. At a minimum, such measures must be designed, installed, implemented, and maintained to:

- a) Minimize the discharge of pollutants from equipment and vehicle washing, wheel wash water, and other wash waters. Wash waters must be treated in a sediment basin or alternative control that provides equivalent or better treatment prior to discharge;
- b) Minimize the exposure of building materials, building products, construction wastes, trash, landscape materials, fertilizers, pesticides, herbicides, chemical storage tanks, deicing material storage facilities and temporary stockpiles, detergents, sanitary waste, and other materials present on the site exposed to precipitation and to storm water;
- c) Minimize the discharge of pollutants from spills, leaks and vehicle and equipment maintenance and repair activities and implement chemical spill and leak prevention and response procedures;
- d) Minimize the exposure of fuel, oil, hydraulic fluids, other petroleum products, and other chemicals by storing in covered areas or containment areas. Any chemical container with a storage of 55 gallons or more must be stored a minimum of 50 feet from receiving waters, constructed or natural site drainage features, and storm drain inlets. If infeasible due to site constraints, store containers as far away as the site permits and document in your SWPPP the specific reasons why the 50-foot setback is infeasible and how the containers will be stored;
- e) The contractor is to provide regular inspection of their construction activities and Best Management Practices (BMPs). Based on inspection findings, the contractor shall determine if repair, replacement, or maintenance measures are necessary in order to ensure the structural integrity, proper function, and treatment effectiveness of structural storm water BMPs. Necessary maintenance shall be completed as soon as conditions allow to prevent or reduce the discharge of pollutants to storm water or as ordered by the Engineer. The Engineer shall conduct inspections required in Section XI Inspections, and report to the contractor deficiencies noted. These Department conducted inspections do not relieve the contractor from their responsibility to inspect their operations and perform timely maintenance; and
- f) In addition, all IDOT projects are screened for Regulated Substances as described in Section 27-3 of the BDE Manual and implemented via Section 669: Removal and Disposal of Regulated substances in the Standard Specifications for Road and Bridge Construction.

Approved alterations to the Department's provided SWPPP, including those necessary to protect Contractor Borrow, Use and Waste areas, shall be designed, installed, implemented and maintained by the Contractor in accordance with IDOT Standard Specifications Section 280.

2. 303(d) Impaired Waterways

Note: Information on 303(d) impaired waterways can be found at the following website: [IEPA 2020/2022 Integrated Report Web App \(Interactive Map\)](#)

Does the project area have any 303(d) impaired waterways with the following impairments?

- suspended solids
- turbidity, and or
- siltation.

Yes No

If yes, list the name(s) of the listed water body and the impairment(s)

303(d) waterbody	Impairment(s)

In addition, It is paramount that the project does not increase the level of the impairment(s) described above. Discuss which BMPs will be implemented to reduce the risk of impairment increase:

3. Total Maximum Daily Load (TMDL)

Note: Information on TMDL's can be found on the IEPA's website

Does the project include any receiving waters with a TMDL for sediment, total suspended solids, turbidity or siltation?

Yes No

If yes, List TMDL waterbodies below and describe associated TMDL)

TMDL waterbody	TMDL

Provide a description of the erosion and sediment control strategy that will be incorporated into the site design that is consistent with the assumptions and requirements of the TMDL:

If a specific numeric waste load allocation has been established that would apply to the project's discharges, provide a description of the necessary steps to meet that allocation:

41-4.03(f) Part IV. Temporary Erosion and Sediment Controls

The following section of the SWPPP provides an overview of erosion and sediment control practices implemented for the project and ILR10 permit requirements for these practices.

Stabilization efforts must be initiated within 1 working day of cessation of construction activity and completed within 14 days. Areas must be stabilized if they will not be disturbed for at least 14 calendar days. Exceptions to this time frame include:

- (i) Where the initiation of stabilization measures is precluded by snow cover, stabilization measures must be initiated as soon as practicable,
- (ii) On areas where construction activities have temporarily ceased and will resume after 14 days, a temporary stabilization method can be used (temporary stabilization techniques must be described), and
- (iii) Stabilization is not required for exit points at linear utility construction site that are used only episodically and for very short durations over the life of the project, provided other exit point controls are implemented to minimize sediment track-out.

Additionally, a record must be kept with the SWPPP throughout construction of the dates when major grading activities occur, when construction activities temporarily or permanently cease on a portion of the site, and when stabilization measures are initiated.

At a minimum, controls must be coordinated, installed and maintained to:

1. Minimize the amount of soil exposed during construction activity;
2. Minimize the disturbance of steep slopes;
3. Maintain natural buffers around surface waters, direct storm water to vegetated areas to increase sediment removal and maximize storm water infiltration, unless infeasible;
4. Minimize soil compaction and, unless infeasible, preserve topsoil

Note: For practices below, consult relevant design criteria in Section 41-2 and Section 41-3 and maintenance criteria in the Erosion and Sediment Control Field Guide for Construction.

1. Erosion Control

The following are erosion control practices which may be used on a project (place a check by each practice that will be utilized on the project, add additional practices as needed):

<input type="checkbox"/>	Mulch	<input type="checkbox"/>	Temporary Turf Cover Mixture (Class 7)
<input type="checkbox"/>	Erosion Control Blanket	<input type="checkbox"/>	Turf Reinforcement Mat
<input type="checkbox"/>	Geotextile Fabric	<input type="checkbox"/>	Permanent seeding (Class 1 – 6)
<input type="checkbox"/>	Preservation of existing vegetation	<input type="checkbox"/>	Other (specify)
<input type="checkbox"/>	Sodding	<input type="checkbox"/>	Other (specify)
		<input type="checkbox"/>	Other (specify)

2. Sediment Control

The following sediment control devices will be implemented on this project:

<input type="checkbox"/>	Ditch Checks	<input type="checkbox"/>	Perimeter Erosion Barrier
<input type="checkbox"/>	Inlet and Pipe protection	<input type="checkbox"/>	Rolled Excelsior
<input type="checkbox"/>	Hay or Straw bales	<input type="checkbox"/>	Urethane foam/geotextiles
<input type="checkbox"/>	Silt Filter Fence	<input type="checkbox"/>	Other (specify)
<input type="checkbox"/>	Above grade inlet filters (fitted)	<input type="checkbox"/>	Other (specify)
<input type="checkbox"/>	Above grade inlet filters (non-fitted)	<input type="checkbox"/>	Other (specify)
<input type="checkbox"/>	Inlet filters	<input type="checkbox"/>	Other (specify)

3. Structural Practices:

Provided below is a description of structural practices that will be implemented:

<input type="checkbox"/>	Aggregate Ditch	<input type="checkbox"/>	Rock Outlet Protection
<input type="checkbox"/>	Articulated Block Revetment Mat	<input type="checkbox"/>	Stabilized Construction Exits
<input type="checkbox"/>	Barrier (Permanent)	<input type="checkbox"/>	Stabilized Trench Flow
<input type="checkbox"/>	Concrete Revetment Mats	<input type="checkbox"/>	Sediment Basin
<input type="checkbox"/>	Dewatering Filtering	<input type="checkbox"/>	Sediment Trap
<input type="checkbox"/>	Gabions	<input type="checkbox"/>	Slope Walls
<input type="checkbox"/>	In-Stream or Wetland Work	<input type="checkbox"/>	Storm Drain Inlet Protection
<input type="checkbox"/>	Level Spreaders	<input type="checkbox"/>	Other (Specify)
<input type="checkbox"/>	Paved Ditch	<input type="checkbox"/>	Other (Specify)
<input type="checkbox"/>	Permanent Check Dams	<input type="checkbox"/>	Other (Specify)
<input type="checkbox"/>	Precast Block Revetment Mat	<input type="checkbox"/>	Other (Specify)
<input type="checkbox"/>	Riprap	<input type="checkbox"/>	Other (Specify)
<input type="checkbox"/>	Retaining Walls	<input type="checkbox"/>	Other (Specify)

4. Polymer Flocculants

Note: Polymer Flocculants may only be used by district special provision. If used for a project, the following must be adhered to and described below:

- Identify the use of all polymer flocculants at the site.
- Dosage of treatment chemicals shall be identified along with any information from any Material Safety Data Sheet.
- Describe the location of all storage areas for chemicals.
- Include any information from the manufacturer's specifications.
- Treatment chemicals must be stored in areas where they will not be exposed to precipitation.
- The SWPPP must describe procedures for use of treatment chemicals and staff responsible for use/application of treatment chemicals must be trained on the established procedures.

41-4.03(g) Part V. Other Conditions

The following describes requirements for dewatering as described in the ILR10 permit. In addition, dewatering is addressed on the following form: BC 2259 Storm Water Pollution Plan and Sediment Control Inspection Report

1. Dewatering

Will dewatering be required for this project?

Yes No

If yes, the following applies:

- Dewatering discharges shall be routed through a sediment control (e.g., sediment trap or basin, pumped water filter bag) designed to minimize discharges with visual turbidity;
- The discharge shall not include visible floating solids or foam;
- The discharge must not cause the formation of a visible sheen on the water surface, or visible oily deposits on the bottom or shoreline of the receiving water. An oil-water separator or suitable filtration device shall be used to treat oil, grease, or other similar products if dewatering water is found to or expected to contain these materials;
- To the extent feasible, use well-vegetated (e.g., grassy or wooded), upland areas of the site to infiltrate dewatering water before discharge;
- You are prohibited from using receiving waters as part of the treatment area;

- To minimize dewatering-related erosion and related sediment discharges, use stable, erosion-resistant surfaces (e.g., well-vegetated grassy areas, clean filler stone, geotextile underlayment) to discharge from dewatering controls. Do not place dewatering controls, such as pumped water filter bags, on steep slopes (15% or greater in grade);
- Backwash water (water used to backwash/clean any filters used as part of storm water treatment) must be properly treated or hauled off-site for disposal;
- Dewatering treatment devices shall be properly maintained; and
- See Part XI (Inspections) for inspection requirement.

41-4.03(h) Part VI. Permanent (i.e., Post-Construction) Storm Water Management Controls

Provided below is a description of measures that may be installed during the construction process to control volume and therefore the amount pollutants in storm water runoff that can occur after construction operations have been completed.

Practices may include but are not limited to the following:

- Aggregate ditch checks;
- bioswales,
- detention pond(s),
- infiltration trench;
- retention pond(s),
- open vegetated swales and natural depressions,
- treatment train (sequential system which combine several practices).
- Velocity dissipation devices (See Structural Practices above)

Describe these practices below:

41-4.03(i) Part VII. Additional Practices Incorporated from Local Ordinance(s)

In some instances, an additional practice from a local ordinance may be included in the project. If so, describe below (Note: the Department is not subject to local ordinances)

41-4.03(j) Part VIII. Unexpected Regulated Substances/Chemical Spill Procedures

When Unexpected Regulated Substances or chemical spills occur, Article 107.19 of the Standard Specifications for Road and Bridge Construction shall apply. In addition, it is the contractor's responsibility to notify the Engineer in the event of a chemical spill into a ditch or waterway, the Engineer will then notify appropriate IEPA and IEMA personnel for the appropriate cleanup procedures.

41-4.03(k) Part IX. Contractor Required Submittals

Prior to conducting any professional services at the site covered by this plan, the Contractor and each subcontractor responsible for compliance with the permit shall submit to the Resident Engineer a Contractor Certification Statement, BDE 2342A.

1. The Contractor shall provide a construction schedule containing an adequate level of detail to show major activities with implementation of pollution prevention BMPs, including the following items:

- Approximate duration of the project, including each stage of the project
- Rainy season, dry season, and winter shutdown dates
- Temporary stabilization measures to be employed by contract phases
- Mobilization time-frame
- Mass clearing and grubbing/roadside clearing dates
- Deployment of Erosion Control Practices
- Deployment of Sediment Control Practices (including stabilized construction entrances and exits to be used and how they will be maintained)
- Deployment of Construction Site Management Practices (including concrete washout facilities, chemical storage, refueling locations, etc.)
- Paving, saw-cutting, and any other pavement related operations
- Major planned stockpiling operation
- Time frame for other significant long-term operations or activities that may plan non-storm water discharges as dewatering, grinding, etc.
- Permanent stabilization activities for each area of the project

2. During the pre-construction meeting, the Contractor and each subcontractor shall provide, as an attachment to their signed Contractor Certification Statement, a discussion of how they will comply with the requirements of the permit in regard to the following items and provide a graphical representation showing location and type of BMPs to be used when applicable:

- Temporary Ditch Checks - Identify what type and the source of Temporary Ditch Checks that will be installed as part of the project. The installation details will then be included with the SWPPP.
- Vehicle Entrances and Exits - Identify type and location of stabilized construction entrances and exits to be used and how they will be maintained.
- Material Delivery, Storage and Use- Discuss where and how materials including chemicals, concrete curing compounds, petroleum products, etc. will be stored for this project. Specifically, any chemical stored in a 55 gallon drum provided by the contractor.
- Stockpile Management - Identify the location of both on-site and off-site stockpiles. Discuss what BMPs will be used to prevent pollution of storm water from stockpiles.
- Waste Disposal - Discuss methods of waste disposal that will be used for this project.
- Spill Prevention and Control - Discuss steps that will be taken in the event of a material spill.
- Concrete Residuals and Washout Wastes - Discuss the location and type of concrete washout facilities to be used on this project and how they will be signed and maintained.
- Litter Management - Discuss how litter will be maintained for this project (education of employees, number of dumpsters, frequency of dumpster pick-up, etc.).
- Vehicle and Equipment Fueling - Identify equipment fueling locations for this project and what BMPs will be used to ensure containment and spill prevention.
- Vehicle and Equipment Cleaning and Maintenance - Identify where equipment cleaning and maintenance locations for this project and what BMPs will be used to ensure containment and spill prevention.
- Dewatering Activities - Identify the controls which will be used during dewatering operations to ensure sediments will not leave the construction site.

Additional measures indicated in the plan.

41-4.03(l) Part X. Maintenance

It will be the Contractor's responsibility to attain maintenance guidelines for any manufactured BMPs which are to be installed and maintained per manufacture's specifications. However, when requested by the Contractor, the Resident Engineer will provide general maintenance guides (e.g., IDOT Erosion and Sediment Control Field Guide) to the Contractor for the practices associated with this project. Any damage or undermining shall be repaired immediately.

Below, describe procedures to maintain in good and effective operating conditions:

41-4.03(m) Part XI. Inspections

Qualified personnel shall inspect disturbed areas of the construction site that have not been finally stabilized, structural control measures, and locations where vehicles enter or exit the site at least once every seven calendar days and within 24 hours of the end of a storm or by the end of the following business or workday that is 0.50 inches or greater or equivalent snowmelt (except as allowed for Frozen Conditions).

In addition, all areas where storm water typically flows within the site should be inspected periodically to check for evidence of pollutants entering the drainage system, as well as all locations where stabilization measures have been implemented to ensure they are operating correctly.

Inspections shall be documented on the form BC 2259 (Storm Water Pollution Prevention Plan Erosion Control Inspection Report).

The Erosion and Sediment Control Field Guide for Construction Inspection shall be consulted as needed.

Dewatering Inspections:

For site(s) discharging dewatering water, an inspection during the discharge shall be done once per day on which the discharge occurs and record the following in a report within 24 hours of completing the inspection:

- (i) The inspection date;
- (ii) Names and titles of personnel performing the inspection;
- (iii) Approximate times that the dewatering discharge began and ended on the day of inspection;
- (iv) Estimates of the rate (in gallons per day) of discharge on the day of inspection;
- (v) Whether or not any of the following indications of pollutant discharge were observed at the point of discharge: a sediment plume, suspended solids, unusual color, presence of odor,

decreased clarity, or presence of foam; and/or a visible sheen on the water surface or visible oily deposits on the bottom or shoreline of the receiving water.

Frozen Conditions

Inspections may be reduced to once per month when all construction activities have ceased due to frozen conditions. Weekly inspections will recommence when construction activities resume, either temporarily or continuously, or if there is 0.5" or greater rain event, or a discharge due to snowmelt occurs.

Flooding or unsafe conditions

Areas that are inaccessible during required inspections due to flooding or other unsafe conditions must be inspected within 72 hours of becoming accessible.

41-4.03(n) Part XII. Incidence of Noncompliance (ION)

The Department shall notify the appropriate Agency Field Operations Section office by email as described on the IEPA ION form, within 24 hours of any incidence of noncompliance for any violation of the storm water pollution prevention plan observed during any inspection conducted, or for violations of any condition of this permit.

The Department shall complete and submit within 5 days an "Incidence of Noncompliance" (ION) report for any violation of the storm water pollution prevention plan observed during any Inspection conducted, or for violations of any condition of this permit. Submission shall be on forms provided by the IEPA and include specific information on the cause of noncompliance, actions which were taken to prevent any further causes of noncompliance, and a statement detailing any environmental impact which may have resulted from the noncompliance. Corrective actions must be undertaken immediately to address the identified non-compliance issue(s).

Illinois Environmental Protection Agency

Division of Water Pollution Control Compliance Assurance Section

1021 North Grand Avenue East

Post Office Box

19276

Springfield, Illinois

62794-9276

41-4.03(o) Part XIII. Corrective Actions

Corrective actions must be taken when:

- A storm water control needs repair or replacement;
- A storm water control necessary to comply with the requirements of this permit was never installed, or was installed incorrectly;
- Discharges are causing an exceedance of applicable water quality standards; or
- A prohibited discharge has occurred.

Corrective Actions must be completed as soon as possible and documented within 7 days in an Inspection Report or report of noncompliance. If it is infeasible to complete the installation or repair within 7 calendar days, it must be documented in the records why it is infeasible to complete the installation or repair within the 7 day timeframe and document the schedule for installing the storm water control(s) and making it operational as soon as feasible after the 7-day timeframe. In the event that maintenance is required for the same storm water control at the same location three or more times, the control must be repaired in a manner that prevents continued failure to the extent feasible, and it must be documented the condition and how it was repaired in the records. Alternatively, it must be documented why the specific reoccurrence of this same issue must continue to be addressed as a routine maintenance fix.

41-4.03(p) Part XIV. Retention of Records

The Department must retain copies of the SWPPP and all reports and notices required by this permit, records of all data used to complete the NOI to be covered by this permit, and the Agency Notice of Permit Coverage letter for at least three years from the date that the permit coverage expires or is terminated. The permittee must retain a copy of the SWPPP and any revisions to the SWPPP required by this permit at the construction site from the date of project initiation to the date of final stabilization. Any manuals or other documents referenced in the SWPPP must also be retained at the construction site.

41-4.03(q) Part XV. Failure to Comply

Failure to comply with any provisions of this Storm Water Pollution Prevention Plan will result in the implementation of a National Pollutant Discharge Elimination System/Erosion and Sediment Control Deficiency Deduction against the Contractor and/or penalties under the Permit ILR10 which could be passed on to the contractor (See Article 105.03 Conformity with Contract)

41-4.03(r) Part XVI. Keeping the SWPPP ("Plan") Current

IDOT shall amend the plan whenever there is a change in design, construction, operation, or maintenance, which has a significant effect on the potential for the discharge of pollutants to Waters of the United States and which has not otherwise been addressed in the plan or if the plan proves to be ineffective in eliminating or significantly minimizing sediment and/or pollutants

identified under paragraph Part II. Water Quality or in otherwise achieving the general objectives of controlling pollutants in storm water discharges associated with construction site activity.

In addition, the plan shall be amended to identify any new contractor and/or subcontractor that will implement a measure of the plan. Amendments to the plan may be reviewed by the IEPA the same manner as the SWPPP and Erosion and Sediment Control Plan (ESCP) submitted as part of the Notice of Intent (NOI). The SWPPP and site map must be modified within 7 days for any changes to construction plans, storm water controls or other activities at the site that are no longer accurately reflected in the SWPPP.

In addition, the NOI shall be modified using the CDX system for any substantial modifications to the project such as:

- address changes,
- new contractors,
- area coverage,
- additional discharges to Waters of the United States, or
- other substantial modifications (e.g. addition of dewatering activities).

The notice of intent shall be modified within 30 days of the modification to the project,

41-4.03(s) Part XVII: Notifications

In addition to the NOI submitted to IEPA, all MS4 permittees identified in Part I. Site Description shall receive a copy of the NOI.

41-4.03(t) Part XVIII. Notice of Termination

Where a site has completed final stabilization and all storm water discharges from construction activities that are authorized by this permit are eliminated, the permittee must submit a completed Notice of Termination (NOT) that is signed in accordance with ILR10 permit.

Method of Measurement: NPDES Compliance shall not be measured for payment separately. Measurement for payment for Temporary Erosion and Sediment Control shall be in accordance with Section 280 or as otherwise provided in the contract. Permanent BMPs necessary to comply with this provision shall be measured for payment in accordance with their respective provisions in the contract.

Basis of Payment: NPDES Compliance shall not be paid for separately. Payment for Temporary Erosion and Sediment Control shall be in accordance with Section 280 or as otherwise provided in the contract. Permanent BMPs necessary to comply with this provision shall be paid for in accordance with their respective payment provisions in the contract.

41-5 REFERENCES

1. *BMP Handbook*, California Department of Transportation.
2. *Construction Manual*, Illinois Department of Transportation.
3. *Drainage Manual*, Illinois Department of Transportation.
4. *Erosion and Sediment Control Field Guide for Construction Inspection*, Illinois Department of Transportation.
5. *Highway Standards*, Illinois Department of Transportation.
6. *Illinois Urban Manual*, Association of Illinois Soil and Water Conservation Districts (AISWCD).
7. *Standard Specifications for Road and Bridge Construction*, Illinois Department of Transportation.
1. *BMP Handbook*, California Department of Transportation.

Chapter Forty-two

RESERVED

BUREAU OF DESIGN AND ENVIRONMENT MANUAL

Chapter Forty-two
RESERVED

Chapter Forty-three
HIGHWAY SYSTEMS

BUREAU OF DESIGN AND ENVIRONMENT MANUAL

Chapter Forty-three
HIGHWAY SYSTEMS

Table of Contents

<u>Section</u>	<u>Page</u>
43-1 FUNCTIONAL CLASSIFICATION SYSTEM.....	43-1.1
43-1.01 General	43-1.1
43-1.01(a) Definitions.....	43-1.1
43-1.01(b) Background.....	43-1.1
43-1.01(c) Relationship to Roadway Design	43-1.1
43-1.02 General Functional Classification Categories	43-1.2
43-1.03 Rural Functional Classification Categories	43-1.3
43-1.03(a) Principal Arterial System.....	43-1.3
43-1.03(b) Minor Arterials.....	43-1.4
43-1.03(c) Collector Roads.....	43-1.4
43-1.03(d) Local Roads	43-1.5
43-1.04 Urban Functional Classification Categories	43-1.6
43-1.04(a) Principal Arterial System.....	43-1.6
43-1.04(b) Minor Arterials.....	43-1.7
43-1.04(c) Collector Streets	43-1.8
43-1.04(d) Local Streets.....	43-1.8
43-1.05 Illinois System.....	43-1.9
43-2 URBAN SUBCATEGORIES	43-2.1
43-2.01 General	43-2.1
43-2.02 Urban	43-2.1
43-2.03 Suburban.....	43-2.2
43-2.03(a) Closed Suburban	43-2.2
43-2.03(b) Open Suburban.....	43-2.3
43-3 FEDERAL-AID FUNDING CATEGORIES.....	43-3.1
43-3.01 National Highway System.....	43-3.1
43-3.02 Surface Transportation Program	43-3.2
43-3.03 Highway Bridge Program	43-3.2

Table of Contents
(Continued)

<u>Section</u>	<u>Page</u>
43-4 HIGHWAY JURISDICTIONS.....	43-4.1
43-4.01 State Highway System	43-4.1
43-4.02 County Road System	43-4.1
43-4.03 Municipal Street System.....	43-4.1
43-4.04 Township/Road District System.....	43-4.2
43-4.05 Other Systems.....	43-4.2
43-5 NATIONAL TRUCK NETWORK.....	43-5.1
43-5.01 National Legislation.....	43-5.1
43-5.02 State Legislation	43-5.1

Chapter Forty-three

HIGHWAY SYSTEMS

The proper application of road design criteria depends in part on the various highway system classifications that have been developed, especially the functional classification system. Chapter 43 discusses these highway systems, which include the:

- functional classification system,
- urban subcategories,
- Federal-aid funding categories,
- highway jurisdictions, and
- the National Truck Network.

43-1 FUNCTIONAL CLASSIFICATION SYSTEM

43-1.01 General

43-1.01(a) Definitions

Functional classification is the process by which highways and streets are grouped into classes or systems based on the character of service they are intended to provide.

Urban areas are those places identified by the U.S. Bureau of Census as having a population of 50,000 or more (urbanized areas) or 5,000 or more but less than 50,000 (small urban areas); all places outside of urbanized and small urban areas are rural areas. The urban area boundaries are established by the State, in cooperation with the Metropolitan Planning Organizations (MPOs) and other appropriate local officials. The boundaries must be approved by FHWA.

43-1.01(b) Background

The *Intermodal Surface Transportation Efficiency Act (ISTEA) of 1991* required that every State functionally reclassify its public roads and streets. The database is also used to identify routes for the National Highway System (NHS), for administering the Federal-aid programs, and for assessing the extent, conditions, and performance of the highway system. Figure 43-1.A presents the Department's functional classification terminology.

43-1.01(c) Relationship to Roadway Design

The functional classification concept is one of the most important determining factors in roadway design. The concept recognizes that the public highway network in Illinois serves two basic and often conflicting functions—access to property and travel mobility. Each road or street will

Rural	Urban
Principal Arterial System <ul style="list-style-type: none"> • Interstates • Other Principal Arterials (OPA) Minor Arterials* Collector Roads <ul style="list-style-type: none"> • Major Collectors* • Minor Collectors Local Roads	Principal Arterial System <ul style="list-style-type: none"> • Interstates • (Non-Interstate) Freeways and Expressways • Other Principal Arterials (OPA) Minor Arterials Collector Streets Local Streets

* Upgrade rural Minor Arterial to Urban OPA and upgrade rural Major Collector to urban Minor Arterial when these routes enter an urbanized area.

IDOT FUNCTIONAL CLASSIFICATION TERMINOLOGY

Figure 43-1.A

provide varying levels of access and mobility, depending upon its intended service. The overall objective of the functional classification system, when viewed in its entirety, is to yield an optimum balance between its access and mobility functions. When achieved, the benefits to the traveling public will be maximized.

The functional classification system provides the foundation for highway planning functions and the framework for determining the geometric design of individual roadways and streets. Once the function of the highway facility is defined, the designer can select an appropriate design speed, roadway width, roadside safety elements, amenities, and other design values. All of Part V and much of Part IV of this *Manual* are based upon this systematic concept to determining roadway design.

Before initiating project work, the designer should review the most recent highway functional classification maps for the proposed project in the district or in the Central Office.

43-1.02 General Functional Classification Categories

The following identifies the basic characteristics of the three general categories within the functional classification system:

1. Arterial. Arterial highways are generally characterized by their ability to quickly move relatively large volumes of traffic, but often with restricted capacity to serve abutting

properties. The arterial system typically provides for high travel speeds and the longest trip movements. The rural and urban arterial systems are connected to provide continuous through movements at approximately the same level of service.

2. Collector. Collector routes are characterized by a relatively even distribution of access and mobility functions. Traffic volumes and speeds are typically lower than those of arterials.
3. Local. All public roads and streets not classified as arterials or collectors are classified as local roads and streets. Local roads and streets are characterized by the many points of direct access to adjacent properties and the relatively minor value in accommodating mobility. Speeds and volumes are usually low and trip distances short.

The following sections more explicitly describe the characteristics of these three general categories for rural and urban areas.

43-1.03 Rural Functional Classification Categories

43-1.03(a) Principal Arterial System

The rural principal arterial system provides connections between the major urban areas and OPAs and provides a level of service suitable for statewide or interstate travel. The system provides integrated, continuous movements without the need for stub connections. The rural principal arterial system is divided into the following subcategories:

1. Interstates. The Interstate system consists of a connected rural network of continuous routes designated as part of the National System of Interstate and Defense Highways. They are fully access controlled and constructed for higher design speeds. All Interstates are required components of the National Highway System (NHS) (see Section 43-3).
2. Other Principal Arterials (OPAs). These facilities consist of a connected rural network of continuous routes having the following designations and characteristics:
 - serve to interconnect various regions of the State not served by the Interstate system with either a non-Interstate freeway, expressway (partial access control), or high-type two-lane highway;
 - should connect with routes of the same functional classification in adjacent States;
 - should provide a design with high overall travel speeds and with minimum interference to through movements; and
 - could be part of the National Highway System (NHS); however, note that not all OPAs are on the NHS (see Section 43-3).

43-1.03(b) Minor Arterials

Rural minor arterials should form a network having the following characteristics:

- should form an integrated network of routes connecting to the OPAs and should provide interregional or intercounty service. Stub sections are seldom justified;
- should interconnect and serve areas of the State not served by the principal arterial system;
- should connect with routes of the same function in adjacent states;
- are located at such intervals to provide an average spacing of approximately 12 miles to 15 miles (20 km to 25 km) between all arterial routes;
- should serve virtually all county seats and small towns with populations of 1,000 or more or equivalent type traffic generators; and
- should provide a design with relatively high overall travel speeds with minimum interference to through movements. Partial access control should be considered and investigated on these routes as they approach urbanized areas.

43-1.03(c) Collector Roads

The rural collector road system generally includes those routes where the predominant travel distances are shorter than trips on arterial routes, but greater than the short trips characteristic of the local road system. To more clearly define the characteristics of rural collector roads, these facilities have been subdivided into two separate functional classifications:

1. Major Collectors. These are characterized as follows:
 - provide service to any county seats not on an arterial route;
 - serve the more important intracounty or intraregional travel corridors not served by higher route classifications;
 - serve larger towns not directly served by higher route classifications nor other traffic generators of equivalent intracounty importance. Such routes link nearby larger cities or other routes of higher classification;
 - serve most small towns with populations of 500 or more. Such small towns are either served by a major collector or higher classified route;
 - form an integrated network; however, stub sections are not uncommon. Consolidated school districts, shipping points, recreational areas, or other equivalent traffic generators can be used to justify the inclusion of such stubs in this classification;

- are located at intervals with an average spacing between collectors and other routes with higher classifications of approximately 6 miles to 10 miles (10 km to 15 km); and
- provide all-weather service for reliable and safe travel, considering both access and mobility.

2. Minor Collectors. These are characterized as follows:

- provide service to any remaining small communities with populations of 100 or more and which are not served by a higher classified route;
- are located at intervals, consistent with population density, to collect traffic from local roads and to connect all developed areas within a reasonable distance from a collector route. The average spacing between minor collectors and other routes with higher classifications should be approximately 3 miles to 6 miles (5 km to 10 km);
- include more stub sections than the major collector classification; and
- are designed for relatively reliable and year-around safe travel, with more emphasis on property access than mobility.

Projects for improvements on roads with a rural minor collector functional classification are not eligible for Surface Transportation Program (STP) funds.

43-1.03(d) Local Roads

The roads functionally classified as rural local roads generally have the following characteristics:

- constitute the rural mileage not designated as part of higher classifications;
- serve primarily to provide access to abutting property and connections to higher classified routes;
- provide service to motorists who travel relatively short distances as compared to collectors or other higher classified routes;
- commonly include stub sections; and
- reflect minimal design criteria with primary consideration to access needs.

Projects for improvements on roads with a rural local road functional classification are not eligible for Surface Transportation Program (STP) funds.

43-1.04 Urban Functional Classification Categories

43-1.04(a) Principal Arterial System

In general, the urban principal arterial system carries the highest traffic volumes and accommodates the greatest trip lengths. Because of the nature of the travel served by this system, almost all fully and partially access-controlled facilities will be part of the principal arterial system. However, this system is not restricted to access-controlled routes. To preserve the identification of access-controlled facilities, the principal arterial system is segregated as follows:

1. Interstates. The Interstate system consists of a connected urban network of continuous routes designated as part of the National System of Interstate and Defense Highways. They are fully access controlled and constructed for higher design speeds. All Interstates are required components of the National Highway System (NHS); see Section 43-3.
2. Non-Interstate Freeways and Expressways. Non-Interstate freeways and expressways may be connecting links in the urban area, and they may be extensions of rural OPAs. These routes may traverse the urban area from one boundary to another or may simply connect to another connecting link. Also, non-Interstate freeways and expressways may provide access to circumferential routes around the city or provide links to the central city. Additional links may be necessary to provide system continuity in urbanized areas with a population greater than 50,000.

Non-Interstate freeways and expressways consist of facilities that have the following general characteristics:

- should serve traffic coming from rural other principal arterials or other traffic with interregional demand;
 - should provide continuity within the urban area and for all rural freeways and expressways that intercept the urban boundary;
 - serve the major economic activity centers of an urban area, the highest traffic volume corridors, or the longest regional and intra-urban trips; and
 - should carry a high proportion of the total urban area travel on a minimum of mileage (kilometers) and should serve the major portion of trips entering and leaving the urban area and the majority of through movements desiring to bypass the central city.
3. Other Principal Arterials. These routes consist of a connected urban network of continuous routes having the following designations and characteristics:
 - provide service to, through, or around urban areas from rural minor arterial routes and may be connecting links;

- serve generally as an extension of a rural minor arterial highway and could be an expressway design, a major two-way city street, or a one-way couple system;
- may warrant management of access to the highway;
- serve long distance traffic within a city by connecting major regional activity centers not served by connecting links;
- in urbanized areas (50,000 population or greater), should provide for significant urban and suburban travel demands. Such trips would be between central business districts and outlying residential areas, between major inner city communities, or between major suburban centers;
- in urbanized areas, are located at spacings which are closely related to the trip-end density characteristics of specific portions of the urban area. The spacing may vary from 1 mile (1.5 km) between routes in the densely developed central business district areas to 6 miles (10 km) or more in the sparsely developed urban fringes;
- in smaller urban areas (under 50,000 but greater than 5,000 population), may be limited in the number and extent of routes. The importance of such routes is primarily to serve the central business district and to accommodate through travel at an appropriate level of service;
- could be part of the National Highway System (NHS) (see Section 43-3) and/or a Strategic Regional Arterial (SRA) route in District 1 (see Chapter 46); however, it should be noted that not all OPAs are on the NHS; and
- provide for an integrated network serving the entire urban area.

43-1.04(b) Minor Arterials

When compared to the principal arterial system, urban minor arterials may provide lower travel speeds and accommodate shorter trip lengths and lower traffic volumes, but they provide more access to property. These routes have the following general characteristics:

- interconnect and supplement the urban principal arterial system;
- provide service for trips of moderate length and at a somewhat lower level of mobility than urban principal arterial routes;
- may carry local bus routes and provide intracommunity continuity (but will not, for example, penetrate neighborhoods);
- may be urban extensions of rural major collector routes; and

- considered together with all urban arterial routes, are located from 2 miles to 3 miles (3 km to 5 km) between routes in suburban fringes and as close as 1 mile (1.5 km) in fully developed areas. Within the central business district, a spacing of 650 ft to ½ mile (200 m to 800 m) is typical.

43-1.04(c) Collector Streets

In urban areas, collector streets serve as intermediate links between the arterial system and points of origin and destination. These facilities typically have the following characteristics:

- provide both access and traffic circulation within residential neighborhoods and commercial and industrial areas;
- may penetrate residential neighborhoods or commercial/industrial areas to collect and distribute trips to and from the arterial system;
- in the central business district, may include the streets which are not classified as arterials;
- have spacing of routes dependent on the density of development. In fully developed areas, spacing together with higher classifications should provide approximately ½ mile (800 m) between routes and, within the central business district, a spacing of 650 ft to ½ mile (200 m to 800 m); and
- may be urban extensions of rural minor collector routes.

43-1.04(d) Local Streets

The streets functionally classified as urban local streets generally have the following characteristics:

- constitute the urban mileage (kilometers) not designated as part of a higher classification,
- serve primarily to provide direct access to abutting land and higher order systems,
- offer the lowest level of mobility and usually contain no bus routes, and
- discourage through traffic movements.

Projects for improvements on streets with an urban local street functional classification are not eligible for Surface Transportation Program (STP) funds.

43-1.05 Illinois System

The percent of miles (kilometers) traveled nationally in each category is documented in the US DOT/Federal Highway Administration manual *Highway Functional Classification—Concepts, Criteria and Procedures*. Current Illinois statistics are published annually in *Illinois Travel Statistics*. In addition, roadway information is collected on all public highways and is stored on computer files as documented in the *Roadway Information and Procedure Manual*. The Illinois Roadway Information System (IRIS) is used to compile information for two principal reasons:

- to determine if a specific project is eligible for a certain type of funding, and
- to assist in prioritizing highway improvement needs.

43-2 URBAN SUBCATEGORIES

43-2.01 General

The functional classification system described in Section 43-1 is divided into urban and rural categories. However, the “urban” designation is not sufficiently specific to determine the appropriate roadway design. The urban design classification is divided into “suburban” and “urban” based on the extent of roadside development. These categories are further subdivided as discussed in the following sections. This refinement to the highway design process allows the project to be tailored to the constraints of the surrounding environment. The following briefly discusses these urban subcategories.

43-2.02 Urban

Urban areas are those places identified by the US Bureau of Census having a population of 5,000 or more. For design purposes, urban areas are further subdivided as follows:

1. Central Business Districts (CBD). On streets in the CBD or downtown area, abutting building development often prohibits space for off-street parking and entrances for individual businesses. Right-of-way is usually very limited. The streets may include high-density commercial or residential development (e.g., apartment complexes, row houses). Access to property is the primary function of the street network in CBDs. The designer often must select the cross-sectional criteria that will fit into the existing right-of-way. Pedestrian and bicycle considerations may be as important as vehicular considerations, especially at intersections.

Because of the high density of development in CBD areas, the distinction between the functional classes (local, collector, arterial) becomes less significant in design. The primary distinction among the three functional classes is often the relative traffic volumes and, therefore, the number of lanes needed. As many as half of the intersections may be signalized; posted speed limits typically range between 25 mph and 30 mph.

2. Fringe Area/Outlying Business District (FRNG/OBD). These areas generally have off-street parking and driveway entrances that usually are quite numerous. Right-of-way may be restricted and will typically limit the practical options for roadway improvements. The extent of roadside development will have a significant impact on the selected speeds of drivers. Pedestrian and bicycle activity is common and warrants significant consideration in design.

Local and collector streets in FRNG/OBD areas typically have posted speed limits between 30 mph and 45 mph. The frequency of signalized intersections is substantially higher than in suburban areas. An arterial in FRNG/OBD areas will often have strip commercial development along its roadside, and posted speed limits will range between 40 mph and 45 mph.

43-2.03 Suburban

These areas connote a degree of development greater than that of a rural area, but less than that of an urban area. The predominant character of the surrounding environment is usually residential, but it may also include a considerable number of commercial establishments and a few industrial parks. On suburban roads and streets, drivers usually have considerable freedom of maneuverability; nonetheless, they must devote some of their attention to entering and exiting vehicles. Roadside development is characterized by low to moderate density. Pedestrian and bicycle activity is usually not a design factor. Right-of-way may be available for roadway improvements.

Local and collector streets in suburban areas are typically located in residential areas, but may also serve a commercial area. Posted speed limits typically range between 30 mph and 45 mph. The majority of intersections will have stop or yield control, but there will be an occasional traffic signal. A typical suburban arterial will have strip commercial development and perhaps a few residential properties. Posted speed limits usually range between 35 mph and 50 mph, and there will be a few signalized intersections along the arterial.

Suburban areas are further divided into two subclassifications (closed and open). For definition, the area adjacent to urban conditions is noted as “closed suburban” and the area adjacent to rural conditions as “open suburban.” Some judgment is necessary to define the boundaries between these two suburban subclassifications, as described below.

43-2.03(a) Closed Suburban

Closed suburban areas will generally follow urban policies for capacity and lane requirements and will generally have the following characteristics:

- combination of intermittent strip development, intermittent street network, and open-space segments;
- some high-volume traffic generators;
- isolated signalized intersections;
- some two-way and four-way stop-controlled intersections;
- outside curb and gutter cross sections with a closed drainage system;
- average posted speeds of 35 mph to 45 mph;
- high potential for considerable land development within approximately five years following the highway improvement; and
- adherence to restricted spacing for route access.

43-2.03(b) Open Suburban

Open suburban designs will generally follow the rural policies for capacity purposes and lane requirements and will generally have the following characteristics:

- no established street network;
- local road intersections spaced at approximately 1320 ft – 1600 ft (400 m – 500 m) apart;
- some residential and small commercial properties;
- generally free-flowing traffic on mainline roadways;
- average posted speeds of 45 mph to 50 mph;
- with depressed medians, the cross section usually includes outside shoulders and outside ditch drainage;
- good potential for considerable land development within about 10 to 15 years following the highway improvement; and
- adherence to ¼ mile (400 m) spacing for route access.

Figure 43-2.A presents the relationship between urban and suburban subcategories for design. Figure 43-2.B schematically illustrates the general type of cultural development and roadway networks within suburban areas.

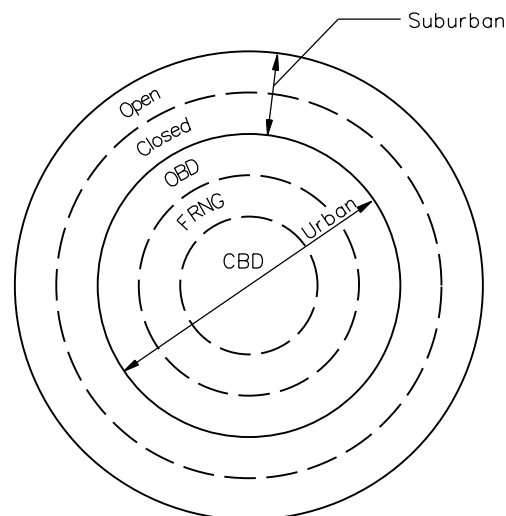

**URBAN AND SUBURBAN CATEGORIES
(For Design)**

Figure 43-2.A

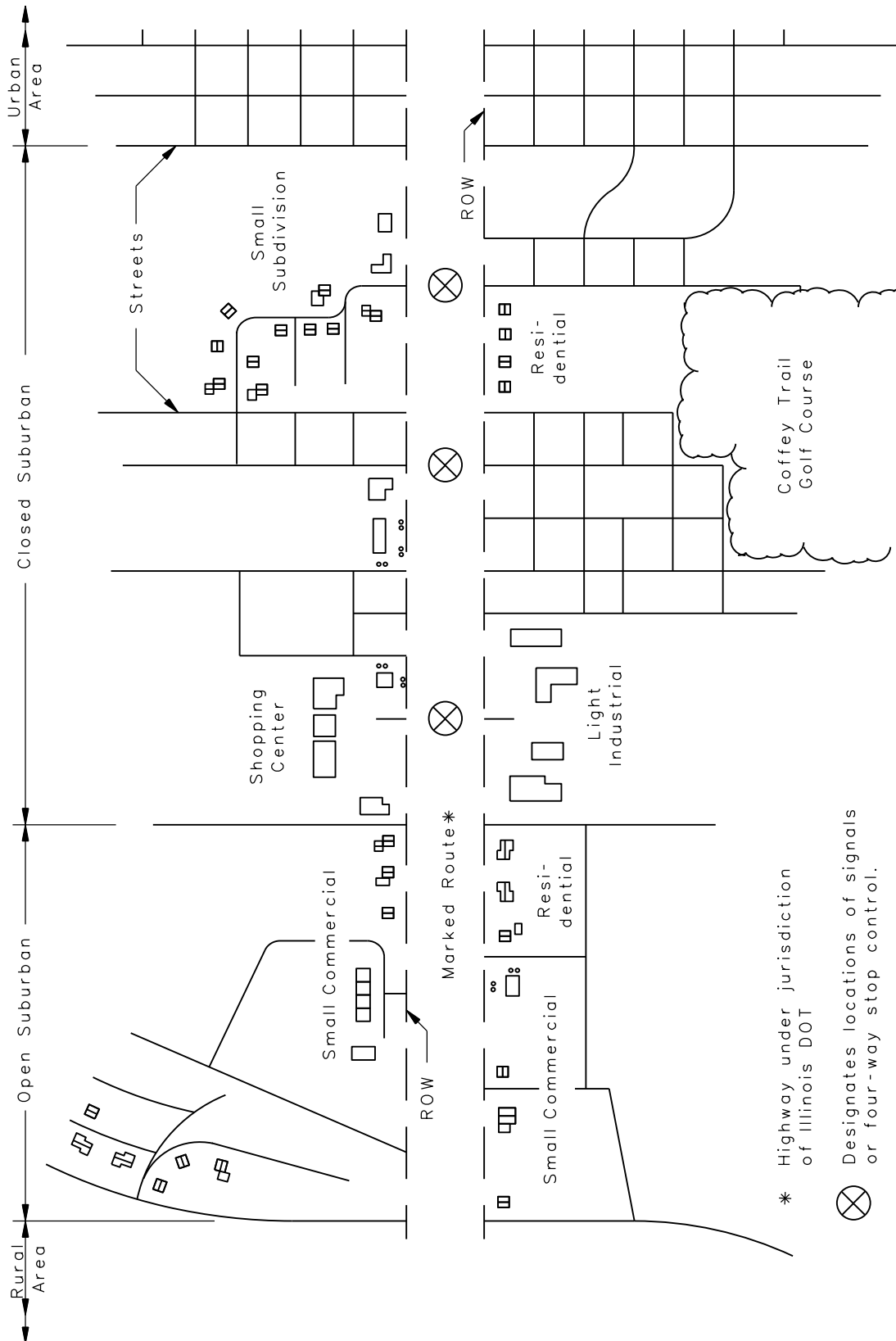

* Highway under jurisdiction of Illinois DOT

⊗ Designates locations of signals or four-way stop control.

INTERSECTION SIGHT DISTANCE CONTROLS

Figure 43-2.B

43-3 FEDERAL-AID FUNDING CATEGORIES

There are three basic Federal-aid funding categories:

- the National Highway System (NHS),
- the Interstate System, and
- the Surface Transportation Program (STP).

Funding options for projects or improvements should be identified because some roadway functional classification categories are not eligible to receive STP funding (e.g., all rural and urban local roads and streets).

43-3.01 National Highway System

The National Highway System (NHS) is a network of principal arterial routes identified as essential for international, interstate, and regional commerce and travel, national defense, and the transfer of people and goods to and from major intermodal facilities. It consists of selected Other Principal Arterials, the Strategic Highway Network (STRAHNET), major STRAHNET connectors, and selected major intermodal connectors. The NHS represents approximately 4% to 5% of the total public road mileage in the United States. Specifically, the NHS includes the following subsystems (note that in a few cases a specific highway route may be on more than one subsystem):

1. Interstate. The current Interstate system of highways retains its separate identity within the NHS. There are also provisions to add mileage to the existing Interstate subsystem.
2. (Selected) Other Principal Arterials (OPA). These are selected highways in rural and urban areas that provide access between an arterial and a major port, airport, public transportation facility, or other intermodal transportation facility.
3. Strategic Highway Network (STRAHNET). This is a network of highways that are important to the United States' strategic defense policy and which provide defense access, continuity, and emergency capabilities for defense purposes. In Illinois, the STRAHNET is the entire marked Interstate system (including toll facilities marked as Interstate routes).
4. Major Strategic Highway Network (STRAHNET) Connectors. These are roads and highways that provide access between major military installations and highways that are part of the Strategic Highway Network (Interstate system).
5. Major Intermodal Connectors. These are selected streets and highways (primarily in urban areas) that provide access between another NHS designated route (Interstate or OPA) and a designated major port, airport, public transportation facility, freight facility, or other intermodal transportation facility.

The NHS (with the exception of the major intermodal connectors) was approved by the *National Highway System Designation Act* in 1995. As of January 1, 1997, the major intermodal connectors are pending formal approval.

To properly manage the NHS, ISTEA initially mandated that each State highway agency develop and implement several management systems and one monitoring system for those facilities on the NHS. These include management systems for pavements, bridges, traffic congestion, safety, public transportation facilities/equipment, traffic monitoring, and intermodal transportation facilities/systems. However, the *NHS Act* of 1995 has relaxed the requirements for these management systems.

43-3.02 Surface Transportation Program

The Surface Transportation Program (STP) is a block-grant program that provides Federal funds for any public road not functionally classified as a rural minor collector or a rural or urban local road/street. The basic objective of the STP is to provide Federal-aid for improvements to facilities not considered to have significant national importance and to minimize the Federal requirements for funding eligibility. The Federal funds allocated to the STP are comparable to those funds previously designated for use on the former Federal-aid primary, Federal-aid urban, and Federal-aid secondary systems. The functional classification of a route is a major factor in determining eligibility for Federal-aid. In addition, bridge projects are eligible for STP funds on any public road. Transit capital projects are also eligible under the STP program.

43-3.03 Highway Bridge Program

The Highway Bridge Program (HBP), formerly known as the Highway Bridge Rehabilitation and Replacement Program, provides funds for eligible bridges located on any public road. The HBP is the cornerstone of FHWA's efforts to correct, on a priority basis, deficient bridges throughout the nation.

HBP funds can be used for total replacement or for rehabilitation. HBP funds can also be used for a nominal amount of roadway approach work to tie the new bridge in with the existing alignment or to tie in with a new gradeline. HBP funds cannot be used for long approach fills, causeways, connecting roadways, interchanges, ramps and other extensive earth structures.

43-4 HIGHWAY JURISDICTIONS

The network of public highway and streets in Illinois has been divided into several jurisdictional systems: —the State, County, Municipal, and Township/Road District highway systems. Jurisdiction is defined as the authority and obligation to administer, control, construct, maintain, and operate a highway subject to the provisions of the *Illinois Highway Code*.

Jurisdictional transfers are usually initiated by an agency that identifies a need for an improvement of a specific roadway or structure; however, certain transfers of jurisdiction can occur without an improvement. Negotiations for a jurisdictional transfer of State unmarked routes should begin when an improvement is being formulated and should be documented with a letter of intent (accepting or refusing the jurisdictional transfer) and signed by the local agency. Subsequently, a Joint Agreement with all affected agencies (State, county, and/or municipality) must be executed before the jurisdictional transfer occurs. For more information, refer to Section 14 of the Office of Planning and Programming's "Multi-Year Guidelines" (updated annually), the Central Bureau of Local Roads and Streets' publication, *Jurisdictional Transfer Guidelines for Highways and Street Systems*, and Chapter 5 of the *BDE Manual*.

43-4.01 State Highway System

The State highway system consists of all highways under the jurisdiction of the Illinois Department of Transportation. This system contains all Interstate highways, all other marked State and US routes, and some unmarked routes. In general, the marked routes are the most important highways in the State, carry the greatest traffic volumes, and operate at the highest speeds. The Department uses either a combination of Federal funds and State funds or State-only funds for improvements on the State highway system.

43-4.02 County Road System

The county governments are responsible for all roads within their boundaries that are not on the State or township/road district highway systems and are not the responsibility of the incorporated municipalities within the county. IDOT is responsible for administering Federal funds that are available for highway improvements on eligible county routes and the rehabilitation of bridges carrying county roads over the State system. The maintenance responsibilities for these structures can vary and depends on the terms of the structure maintenance agreement.

43-4.03 Municipal Street System

The municipal system includes public roads and streets within the corporate limits of municipalities, except those on the Federal, State, county and toll highway systems. The extension of these routes outside the corporate limits, but still within an urbanized or small urban area, is the responsibility of the county. IDOT is responsible for administering Federal funds that are available for improvements on eligible municipal streets.

43-4.04 Township/Road District System

The township/road district system consists of all remaining rural (outside corporate limits and outside urban area boundaries) routes, excluding other jurisdictions described in Section 43-4.05.

43-4.05 Other Systems

These include other private routes under the jurisdiction of other State agencies (e.g., Illinois Department of Natural Resources), Federal agencies, and the toll authorities or toll commissions. A route may also have joint jurisdictional responsibility (e.g., county and State).

43-5 NATIONAL TRUCK NETWORK

43-5.01 National Legislation

The *Surface Transportation Assistance Act* (STAA) of 1982 required the U.S. Secretary of Transportation, in cooperation with the State highway agencies, to designate a national network of highways to allow the passage of trucks of specified minimum dimensions and weight. The objective of the STAA was to promote uniformity throughout the nation for legal truck sizes and weights on a National Truck Network. The Network includes all Interstate highways and significant portions of the former Federal-aid primary system (before the 1991 ISTEA) built to accommodate large-truck travel. In addition, the STAA required that “reasonable access” be provided along other designated routes for STAA vehicles to travel from the National Truck Network to terminals and to facilities for food, fuel, repair, and rest and, for household goods carriers, to points of loading and unloading.

43-5.02 State Legislation

As a result of STAA, the Illinois legislature passed Public Act 83-12, which permits larger and heavier trucks on Illinois highways. As a result, a “Designated State Truck Route System for Large Vehicles and Combinations” was developed and implemented. This system governs the mobility and accessibility of these vehicles and is illustrated on a State map issued annually by the Central Bureau of Operations.

In 1995, additional State legislation was passed governing the length of tractor/semitrailer units. This legislation allows even longer trucks on most State highways. See Section 36-1 for the critical design vehicles corresponding to the appropriate truck route classes within the Designated State Truck Route System.

Chapter Forty-four

RURAL AND URBAN FREEWAYS (New Construction/Reconstruction)

BUREAU OF DESIGN AND ENVIRONMENT MANUAL

HARD COPIES UNCONTROLLED

Chapter Forty-four
RURAL AND URBAN FREEWAYS

Table of Contents

<u>Section</u>	<u>Page</u>
44-1 GENERAL	44-1.1
44-1.01 Establishing A Freeway	44-1.1
44-1.02 Design Studies	44-1.2
44-2 DESIGN ELEMENTS	44-2.1
44-2.01 Design Speed	44-2.1
44-2.02 Alignment	44-2.1
44-2.03 Cross Sections	44-2.2
44-2.03(a) Lane and Shoulder Widths	44-2.2
44-2.03(b) Typical Sections	44-2.3
44-2.04 Medians	44-2.3
44-2.04(a) General	44-2.3
44-2.04(b) Median Crossovers	44-2.3
44-2.05 Frontage Roads/Service Drives	44-2.11
44-2.05(a) General	44-2.11
44-2.05(b) Design Criteria	44-2.11
44-2.05(c) One-Way/Two-Way	44-2.17
44-2.05(d) Outer Separation	44-2.17
44-2.06 Lane Drops	44-2.20
44-2.07 Roadside Safety	44-2.23
44-2.08 Branch Connections/Major Forks	44-2.23
44-2.09 Overhead Signing	44-2.23
44-3 OTHER DESIGN FEATURES	44-3.1
44-3.01 Access Control	44-3.1
44-3.01(a) General	44-3.1
44-3.01(b) Access Control Line	44-3.1
44-3.02 HOV Lanes	44-3.9
44-3.02(a) General	44-3.9
44-3.02(b) Types of HOV Lanes	44-3.9
44-3.02(c) Design	44-3.13

Table of Contents
(Continued)

<u>Section</u>	<u>Page</u>
44-3.03 Lighting	44-3.15
44-3.04 Landscaping.....	44-3.16
44-4 INTERCHANGES/GRADE SEPARATIONS	44-4.1
44-4.01 Interchanges	44-4.1
44-4.02 Grade Separations	44-4.1
44-4.02(a) Justification	44-4.1
44-4.02(b) Design.....	44-4.2
44-4.03 Feasibility Analysis.....	44-4.6
44-4.03(a) Procedure	44-4.6
44-4.03(b) Example Problem.....	44-4.10
44-5 TABLES OF DESIGN CRITERIA.....	44-5.1
44-6 SINGLE INTERSTATE ROUTING FOR SELECTED URBAN AREAS.....	44-6.1
44-7 REFERENCES.....	44-7.1

Chapter Forty-four

RURAL AND URBAN FREEWAYS

Freeways are functionally classified as Principal Arterials and are constructed with full control of access. Freeways are intended to provide high levels of safety and efficiency in moving high volumes of traffic at high speeds. The operational efficiency, capacity, safety, and cost of the highway facility are largely dependent upon its design. Chapter 44 provides guidance in the design of freeways including specific design criteria, frontage roads, lane drops, justification for grade separations, access control along the freeway, and safety. Information that is also applicable to freeways is included in the following chapters:

- Chapter 11 discusses the procedures for determining the freeway location.
- Chapter 15 discusses interchange type and design studies.
- Chapters 31, 32, 33, 34, and 39 provide guidance on the geometric design elements that are also applicable to freeways.
- Chapter 35 provides guidelines for access control along interchange crossroads. It also discusses the procedures for preparing access control plans.
- Chapter 37 discusses the type, location, and design of interchanges.
- Chapter 38 provides guidelines on roadside safety issues that are also applicable to freeways.

44-1 GENERAL

44-1.01 Establishing a Freeway

Highways are established as freeways where they either comprise a portion of a system (e.g., National System of Interstate and Defense Highways) or where there is a need for access control over the entire or a portion of the highway. According to 605 ILCS 5/8-101 of the *Illinois Highway Code*, once it has been determined to control the access on a particular highway, it will be necessary to designate and establish the highway as a freeway. This action is initiated after the design of the freeway is approved and once approval is received on environmental reports.

When establishing a freeway, the district will need to prepare an Order Establishing a Freeway; see Chapter 12. The Order Establishing a Freeway is a legal declaration made by the Department designating a highway as a freeway and delineating the extent of the freeway. The Order contains a legal description of the freeway referenced to section corners, townships, and ranges. The Order must also include the limits along the mainline and specific limits on all crossroads at interchanges. The Order Establishing a Freeway is approved by the Secretary of the Department and attested by the Director of Program Development.

In addition to filing an Order Establishing a Freeway, the district should also consider filing a Corridor Protection Map. The procedures for this process are discussed in the *Land Acquisition Policies and Procedures Manual*.

44-1.02 Design Studies

Chapter 11 discusses the procedures for designing the freeway's alignment and profile through a corridor. When developing a freeway alignment, first determine the type and location of interchanges. Then develop the freeway alignment between the interchanges. Other factors that determine the freeway alignment include:

- the location of grade separations, including major river crossings;
- access control along the freeway and along interchange crossroads;
- topography;
- environmental restrictions; and
- property lines and right-of-way restrictions.

44-2 DESIGN ELEMENTS

44-2.01 Design Speed

Figures 44-5.A, 44-5.B, and 44-5.C provide the range of design speeds for freeways. This range is dependent upon whether the project is rural or urban, new construction or reconstruction, or if the design element can remain in place. See Figures 44-5.B and 44-5.C and Figure 50-2.B for guidance on curves to remain-in-place.

44-2.02 Alignment

Designed for high-volume and high-speed operations, freeways should have smooth-flowing horizontal and vertical alignments. Proper combinations of curvature, tangents, grades, variable median widths, and separate roadway elevations all combine to enhance safety and aesthetics of freeways. When laying out freeway alignments, consider the following guidelines:

1. Horizontal Alignment. Consider the following guidelines when laying out the horizontal alignment:
 - Use large radius curves.
 - Only use minimum radii where it is necessary due to restricted conditions.
 - Avoid alignments that require superelevation transitions on bridges or bridge approach slabs. See Section 32-3.07 for additional guidance on the location of horizontal curves near bridges.
2. Vertical Alignment. Even though the profile may satisfy all design controls, the use of minimum criteria may appear forced and angular. Therefore, with freeways, use values greater than the minimum criteria to produce a smoother, more aesthetically pleasing alignment.
3. Horizontal and Vertical Combinations. Consider the relationship between horizontal and vertical alignments simultaneously to obtain a desirable condition. Chapter 33 discusses this relationship in detail and its effect on aesthetics and safety.
4. Freeway River Crossings. During the development of freeways, the alignment may need to cross major rivers or streams. In selecting the location for a bridge site, consider the following guidelines:
 - a. Crossing Angle. Cross the river at a nearly right angle to minimize the length of the main span.
 - b. Bluffs. If a bluff exists adjacent to the river, attempt to locate one of the abutments on a bluff closest to the river. This will minimize the overall length of the bridge and, therefore, reduce the cost of the structure.

- c. River Bends. Avoid locating the bridge on a bend in the river. Locating a bridge on a bend may result in unnecessarily long spans and may increase the chance of the main river piers being hit by barges.
 - d. Freeway Alignment. Examine how the freeway alignment will tie into the ends of the bridge. Approach horizontal and vertical alignments can significantly improve the aesthetics of the bridge location. Make every effort to avoid placing horizontal curves and superelevation transitions on the bridge.
 - e. Foundation Conditions. Investigate the soil conditions at each bridge abutment and the depth of bedrock at each pier location. Poor foundation conditions may limit possible bridge sites.
 - f. Existing Structures. Existing structures may limit the location of a new bridge. Provide sufficient separation between structures to avoid logjams during spring flooding, ice jams in the winter, accommodate barge traffic, and ease construction.
 - g. Environmental Considerations. Avoid or minimize environmentally or historically sensitive areas wherever practical in conjunction with the above guidelines.
5. Interchanges. When developing the alignment and profile of freeways near proposed interchanges, see Section 37-2.14 for detailed guidelines.
 6. Climbing Lanes. For most freeways, climbing lanes will not be warranted. However, if the drop in the level of service is significant, a climbing lane may be required. Section 33-3 discusses the warrants and design criteria for climbing lanes.

44-2.03 Cross Sections

44-2.03(a) Lane and Shoulder Widths

Section 44-5 provides the minimum lane and shoulder widths for freeways. Under very restricted conditions and with an approved design exception, the designer may consider the following:

1. Widths. Lane widths of 11 ft (3.3 m) may be acceptable for reconstruction projects.
2. Shoulders to Travel Lanes. Converting shoulders to travel lanes for additional capacity through short sections may reduce congestion-related crashes. However, converting shoulders to travel lanes for several miles (kilometers) generally does not reduce crashes. Where shoulders are converted to travel lane(s), use of the left shoulder is preferable to the right shoulder.
3. Shoulder Widths. Where reduced shoulder widths are provided, consider incorporating the following mitigation factors:

- adding advisory and regulatory signing,
- constructing frequent emergency pull-outs,
- using changeable overhead message signs,
- providing continuous lighting,
- incorporating truck-lane restrictions, and/or
- setting up dedicated service patrols and other incident management measures.

44-2.03(b) Typical Sections

Figures 44-2.A through 44-2.F illustrate typical cross sections for various freeway designs. Figure 44-2.G illustrates two options for converting a freeway from two lanes in each direction to four lanes in each direction.

44-2.04 Medians

44-2.04(a) General

Freeway medians should be as wide as economic, operational, and environmental considerations will permit. See for Section 34-3 for guidance on medians. Freeways generally have depressed medians in rural areas and in urban areas where right-of-way is restricted, flush medians with concrete barriers. Section 44-5 provides the minimum median width criteria for freeways. Median widths of 100 ft (30 m) or more allow for the development of independent alignments.

For reconstruction projects with narrow medians, a median barrier usually will be required between the roadways. See Section 38-7 for guidelines for median barrier selection and warrants.

44-2.04(b) Median Crossovers

Permanent crossovers are only provided on freeways for emergency and/or maintenance purposes. During the development of the design study, the district should coordinate with the Bureau of Operations, the State Police, and the district maintenance personnel to determine where crossovers will be required. For guidance on determining the location and design of crossovers, see the Bureau of Operations *Manual of Maintenance Policies*.

For guidance on retaining construction median crossovers, see Section 55-2.12.

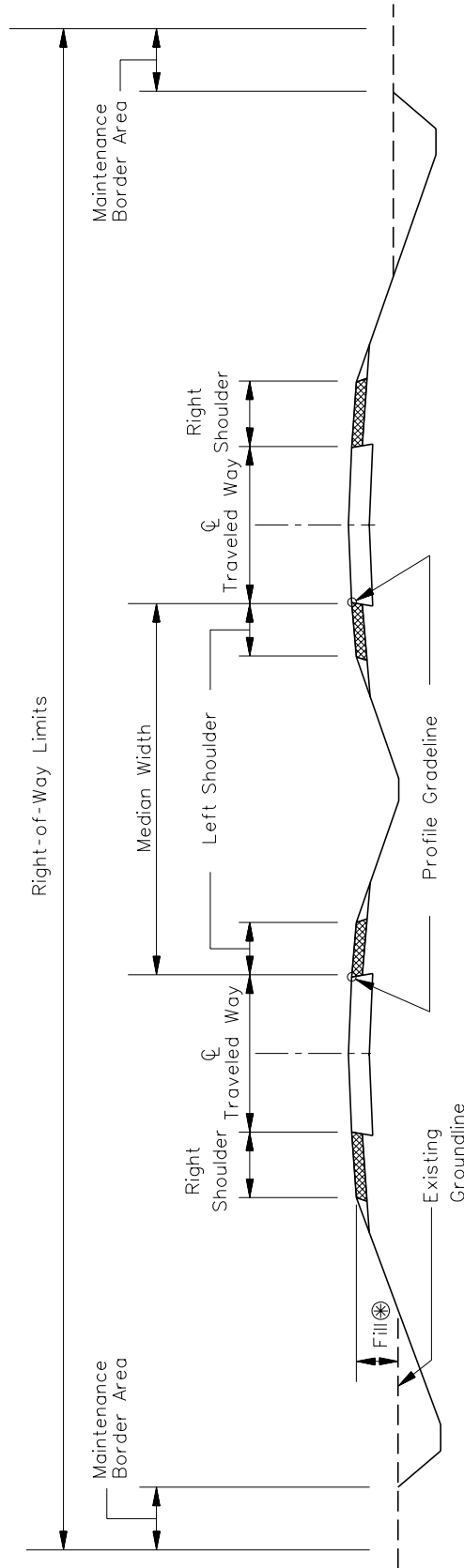

⊕ Roadway should be approximately 3' (1.0 m) above the existing ground line.

**TYPICAL SECTION FOR FOUR-LANE FREEWAY
(Depressed Median)**

Figure 44-2.A

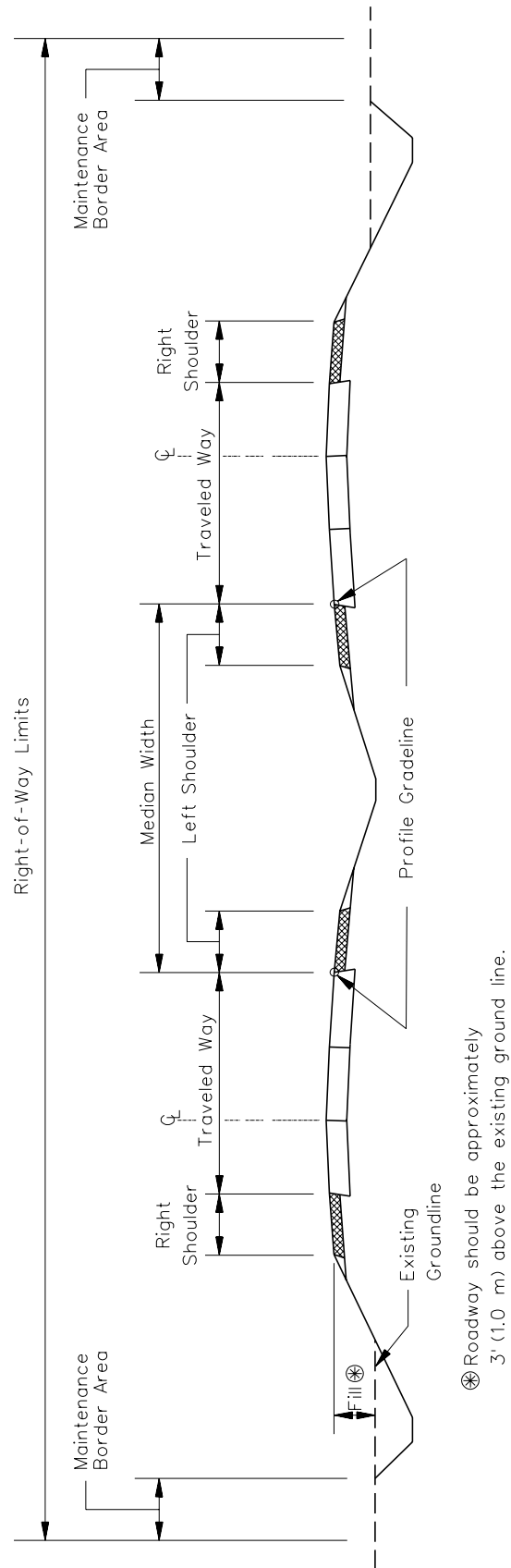

**TYPICAL SECTION FOR SIX-LANE FREEWAY
(Depressed Median)**

Figure 44-2.B

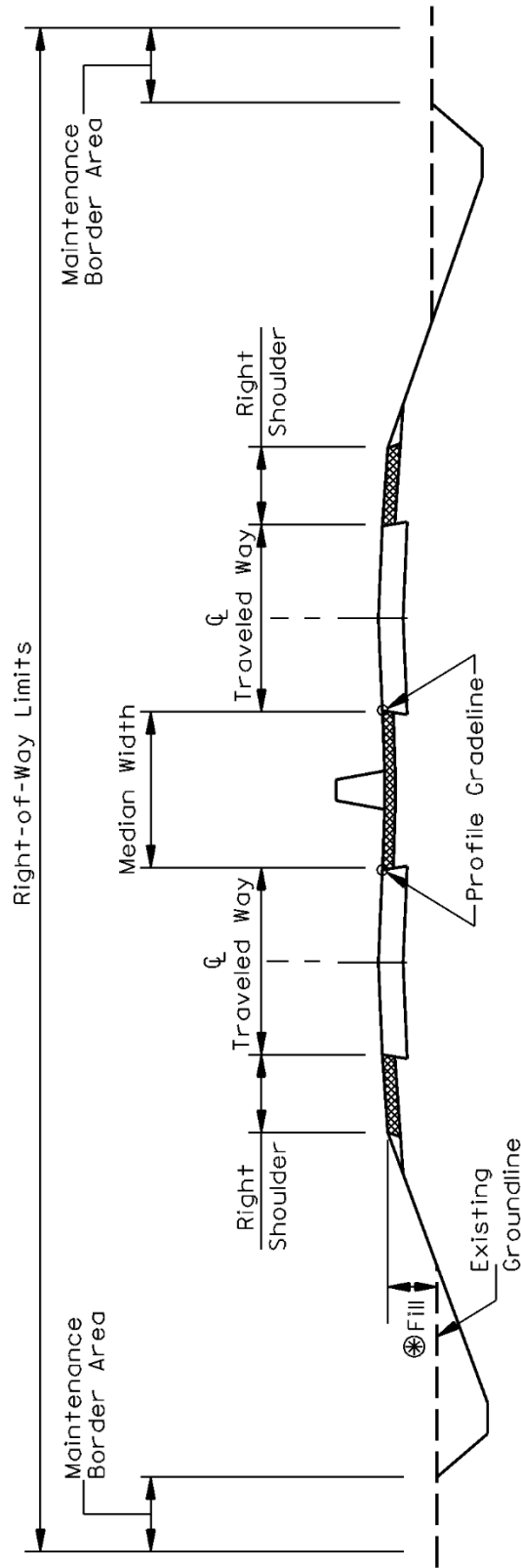

⊗ Roadway should be approximately 3' (1.0 m) above the existing ground line.

**TYPICAL SECTION FOR FOUR-LANE FREEWAY
(Flush Concrete Barrier Median)**

Figure 44-2.C

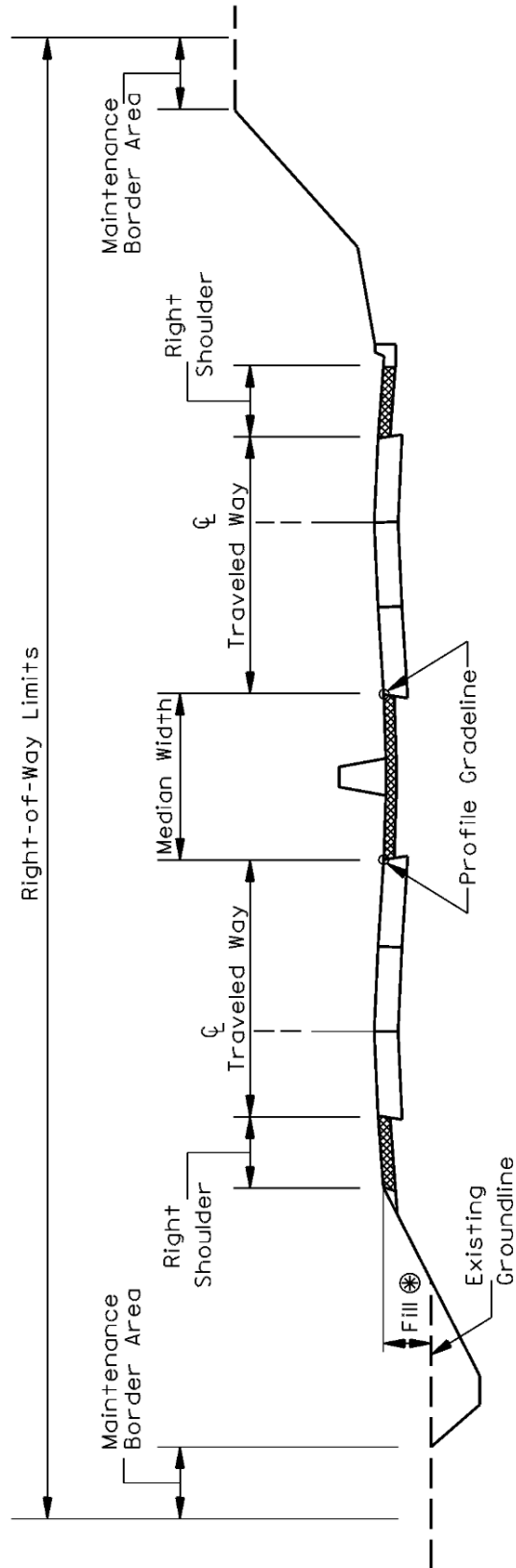

⊗ Roadway should be approximately 3' (1.0 m) above the existing ground line.

**TYPICAL SECTION FOR SIX-LANE FREEWAY
(Flush Concrete Barrier Median)**

Figure 44-2.D

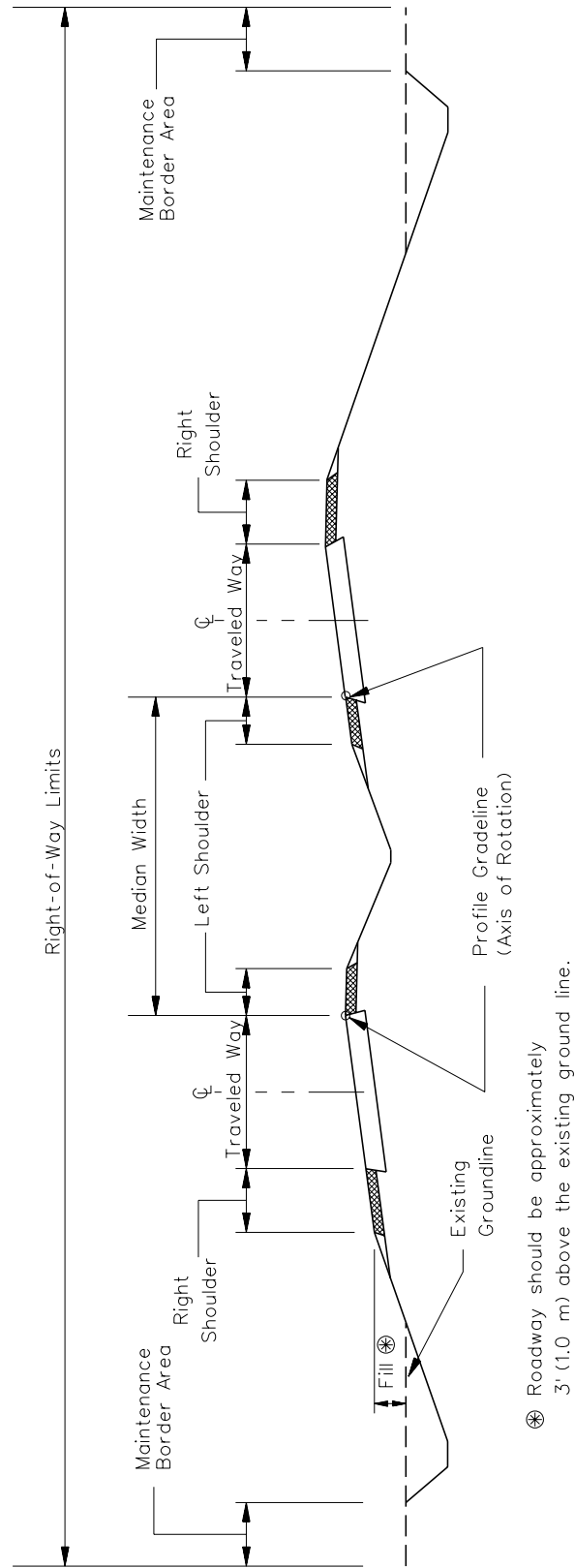

**TYPICAL SECTION FOR SUPERELEVATED FREEWAY
(Depressed Median)**

Figure 44-2.E

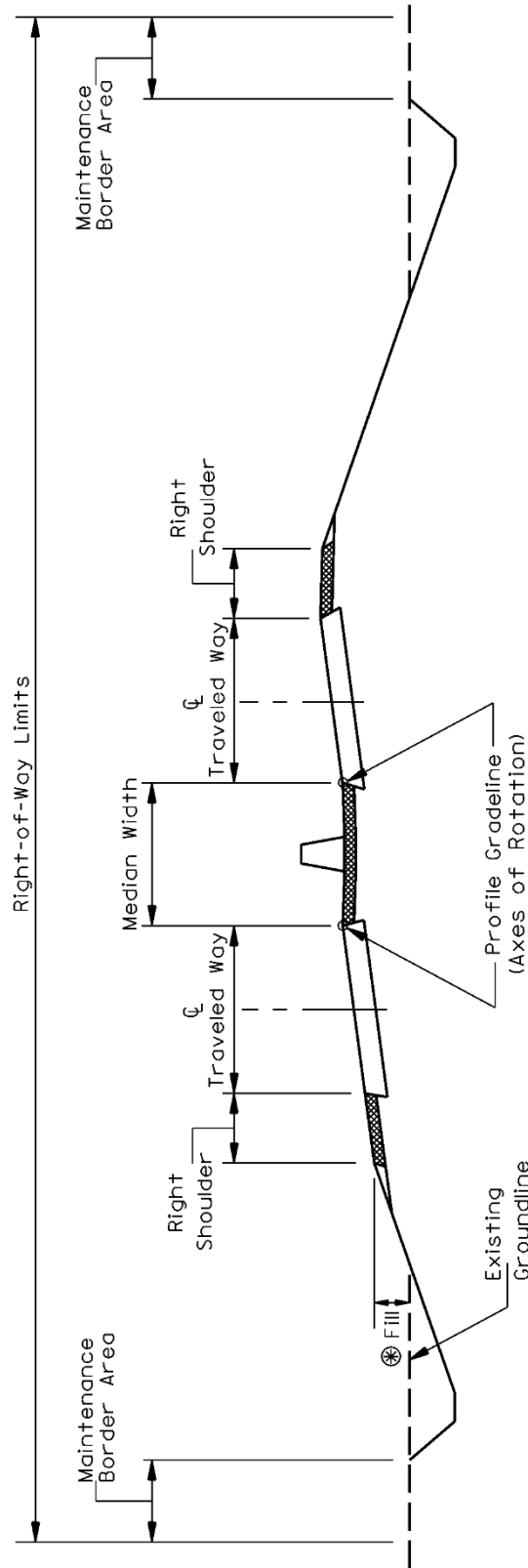

⊗ Roadway should be approximately 3' (1.0 m) above the existing ground line.

**TYPICAL SECTION FOR SUPERELEVATED FREEWAY
(Flush Concrete Barrier Median)**

Figure 44-2.F

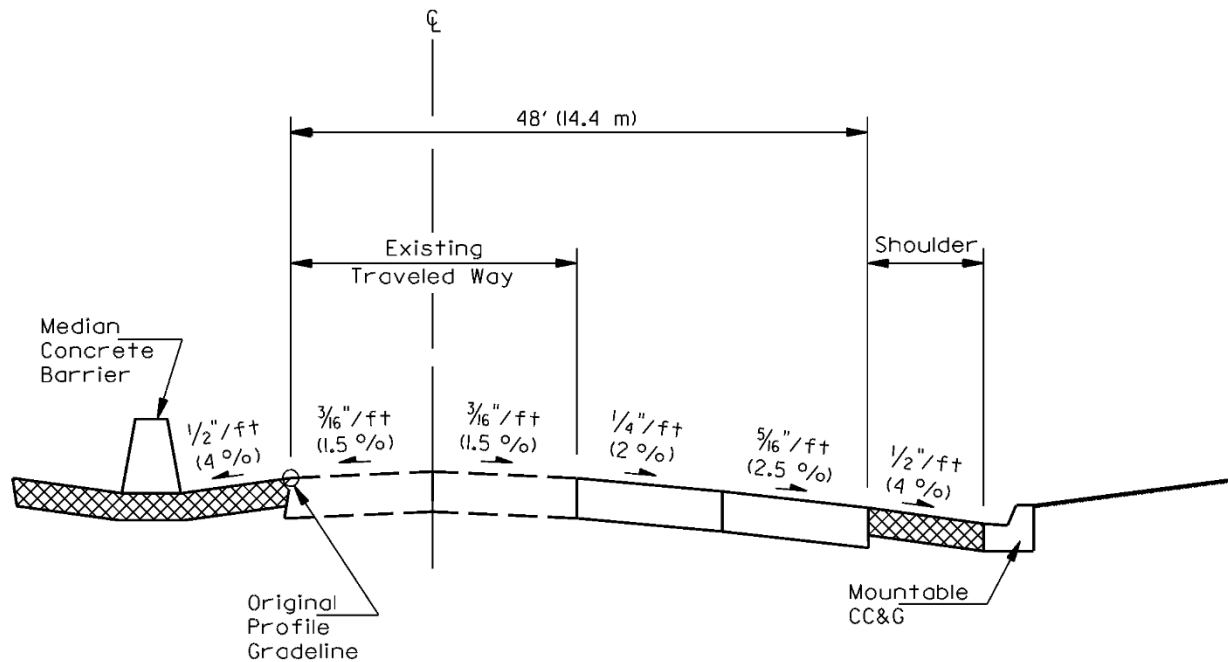
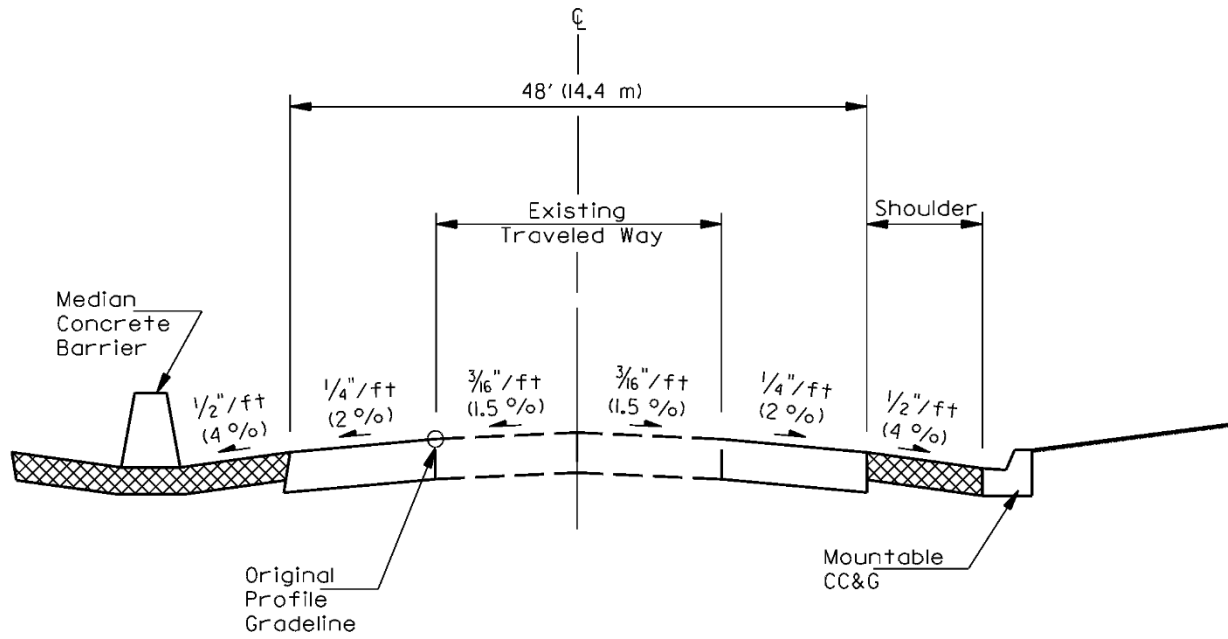

CONVERTING TWO-LANES TO FOUR-LANES IN EACH DIRECTION

Figure 44-2.G

44-2.05 Frontage Roads/Service Drives

44-2.05(a) General

A frontage road is a public street or road, adjacent to, and normally located parallel to a freeway or expressway and connected to a public street or road at both ends. Its purpose is to maintain local road continuity and to provide for controlling of access. Frontage roads serve numerous functions, depending on the type of facility served and the character of the surrounding area. They may be used to control access to the facility, to function as a street serving adjoining property, and to maintain circulation of traffic on each side of the freeway. Frontage roads segregate local traffic from the higher speed through traffic and serve driveways of residences and commercial establishments along the freeway. Connections between the freeway and frontage roads are provided at interchanges. Thus, the flow of the freeway traffic is unaffected by subsequent development. To determine the location of frontage roads at crossroads, see Figures 44-3.B and 44-3.D, Chapter 36, and the access control figures in Chapter 35.

Service drives, as opposed to frontage roads, connect with a public street or road at one end only and normally are constructed to provide access to properties that would otherwise be landlocked or denied access. Service drives adjacent to freeways are usually constructed when an investigation reveals that the cost of construction and right-of-way is less than the cost of mitigation of damages to the properties. Because maintenance of a service drive may become the responsibility of the State, maintenance costs will also need to be considered in the economic analysis.

44-2.05(b) Design Criteria

The selection of the appropriate design criteria is based on the type and ADT of the frontage road, see Figures 44-2.H and 44-2.I. Once the frontage road type has been determined, the appropriate design speed, lane and shoulder widths, etc., can be selected. When designing the frontage road alignment, consider the following:

- In rural areas, design the horizontal curvature according to Chapter 32.
- In urban areas, design the horizontal curvature according to Chapter 48.
- Where horizontal curves approach and tie into a crossroad, see the guidelines in Section 36-1.05(b) for reducing the superelevation rate near the intersection.

For service drives, the design functional classification should be a local road or street. For service drives where the current ADT is 10 or less and the drive serves a single property, a minimum surface width of 12 ft (3.6 m) may be used. Where the ADT is greater than 10 or the drive serves more than one property or is relatively long, consider providing a surface width of 16 ft (5.0 m) or wider to permit passing of opposing vehicles. A roadway surface of a higher type than typically used may be provided when replacing an existing facility in kind.

Design Controls	Design Element	Manual Section	Frontage Road Type			
			A	B	C	
Design Elements	Design Forecast Year	31-4.02	Current	Current	Current	
	Design Service Volume	31-4.03	>2000 ADT	400-2000 ADT	<400 ADT	
	* Design Speed (1)(2)	31-2	55 mph (50 mph)	50 mph (40 mph)	40 mph (30 mph)	
	Access Control	35-2	None	None	None	
	Level of Service	31-4.04	C	B	B	
	* Traveled Way Width (2)	34-2.01	24' (22')	22'	20'	
	* Shoulder Width	34-2.02	8' (6')	6' (4')	4' (2')	
	Auxiliary Lanes	34-2.03	1'	1'	—	
	Cross Slope	Lane Width		12'	11'	N/A
		Shoulder Width		4'	4'	N/A
Clear Zone	* Travel Lane	34-2.01	3/16"/ft	3/16"/ft	3/16"/ft	
	Shoulder	34-2.02	1/2"/ft - 3/4"/ft	1/2"/ft - 3/4"/ft	1/2"/ft - 3/4"/ft	
Roadway Slopes	Cut Section	38-3	(3)	(3)	(3)	
		Front Slope (2)	34-4.03	1V:6H (1V:4H)	1V:6H (1V:4H)	1V:6H (1V:4H)
				4.0' (2.0')	4.0' (2.0')	4.0' (2.0')
	Ditch Bottom Width (2)(4)		1V:3H	1V:3H	1V:3H	
		Back Slope (5)		—	—	
	Side Slopes	Rock Cut		—	—	
		Fill Section (6)	34-4.02	1V:4H to Clear Zone 1V:2H Max. to Toe of Slope	1V:4H to Clear Zone 1V:2H Max. to Toe of Slope	1V:3H to Clear Zone 1V:2H Max. to Toe of Slope
	Bridges	New and Reconstructed Bridges	N/A	HS-20	HS-20	HS-20
			39-6	40'	34'	28'
			N/A	H-15	H-15	H-15
Existing Bridges to Remain in Place		39-6	30'	28'	26'	
		39-4	16'-0" (9b)	14'-9" (9b)	14'-9" (9b)	
* Vertical Clearance (Frontage Road Under) (9a)		49-6.09	Overhead Signs/ Pedestrian Bridges	14'-0"	17'-3" (9b)	
* Vertical Clearance (Frontage Road over Railroad)	33-5		New 23'-0"	Existing: 21'-6"		
39-4.06						

*Controlling design criteria (see Section 31-8).

**GEOMETRIC DESIGN CRITERIA FOR RURAL FRONTAGE ROADS
(New Construction/Reconstruction)
(US Customary)**

Figure 44-2.H

Design Element		Manual Section	Frontage Road Type			
			A	B	C	
Design Controls	Design Forecast Year	31-4.02	Current	Current	Current	
	Design Service Volume	31-4.03	>2000 ADT	400-2000 ADT	<400 ADT	
	*Design Speed (1)(2)	31-2	90 km/h (80 km/h)	80 km/h (60 km/h)	60 km/h (50 km/h)	
	Access Control	35-2	None	None	None	
Cross Section Elements	Level of Service	31-4.04	C	B	B	
	*Traveled Way Width (2)	34-2.01	7.2 m (6.6 m)	6.6 m	6.0 m	
	*Shoulder Width	34-2.02	2.4 m (1.8 m)	1.8 m (1.2 m)	1.2 m (600 mm)	
	Auxiliary Lanes	Paved		300 mm	300 mm	
Lane Width			3.6 m	3.3 m	N/A	
Cross Slope	Shoulder Width	34-2.03	1.2 m	1.2 m	N/A	
	*Travel Lane	34-2.01	1.5%	1.5%	1.5%	
Roadway Slopes	Shoulder	34-2.02	4%-6%	4%-6%	4%-6%	
	Clear Zone	38-3	(3)	(3)	(3)	
	Cut Section	Front Slope (2)		1V:6H (1V:4H)	1V:6H (1V:4H)	1V:6H (1V:4H)
		Ditch Bottom Width (2)(4)	34-4.03	1.2 m (600 mm)	1.2 m (600 mm)	1.2 m (600 mm)
Back Slope (5)			1V:3H	1V:3H	1V:3H	
Bridges	Rock Cut	34-4.05	—	—	—	
	Fill Section (6)	34-4.02	1V:4H to Clear Zone	1V:4H to Clear Zone	1V:3H to Clear Zone	
			1V:2H Max. to Toe of Slope	1V:2H Max. to Toe of Slope	1V:2H Max. to Toe of Slope	
	New and Reconstructed Bridges	N/A	MS-18	MS-18	MS-18	
Existing Bridges to Remain in Place	*Structural Capacity	39-6	12.0 m	10.2 m	8.4 m	
	*Clear Roadway Width (7)					
*Vertical Clearance (Frontage Road Under) (9a)	*Structural Capacity	N/A	MS-13.5	MS-13.5	MS-13.5	
	*Clear Roadway Width (8)	39-6	9.0 m	8.4 m	7.8 m	
	New and Replaced Overpassing Bridges	39-4	4.9 m (9b)	4.5 m (9b)	4.5 m (9b)	
*Vertical Clearance (Frontage Road over Railroad)	Existing Overpassing Bridges	49-6.09		4.3 m		
	Overhead Signs/ Pedestrian Bridges	33-5		5.25 m (9b)		
		39-4.06	New: 7.0 m Existing: 6.6 m			

*Controlling design criteria (see Section 21.8)

**GEOMETRIC DESIGN CRITERIA FOR RURAL FRONTAGE ROADS
(New Construction/Reconstruction)
(Metric)**

Figure 44-2.H

Design Controls	Design Element	Manual Section	Frontage Road Type			
			A	B	C	
Design Controls	Design Forecast Year	31-4.02	Current	Current	Current	
	Design Service Volume	31-4.03	>2000 ADT	400-2000 ADT	<400 ADT	
	*Design Speed (1)	31-2	≥ 30 mph	≥ 30 mph	Min.: 30 mph	
	Access Control	35-2	None	None	None	
	Level of Service	31-4.04	C	B	B	
Cross Section Elements	*Surface Width	34-2.01	30'	30'	28'	
	Outside Curb Type & Width	34-2.04	B6.24 CC&G	B6.24 CC&G	Type B Gutter	
	Auxiliary Lanes	Lane Width	34-2.03	12'	11'	N/A
		Outside Curb Type & Width		B6.12 CC&G	B6.12 CC&G	N/A
	Cross Slope	34-2.01	1/4"/ft	1/4"/ft	1/4"/ft	
	Sidewalk Width	48-2.04	5' with Buffer Strip Behind Curb	5' with Buffer Strip Behind Curb	5' with Buffer Strip Behind Curb	
Roadway Slopes	Clear Zone	38-3	(3)	(3)	(3)	
	Side Slopes	Cut Section (Curbed)	34-4.04	—	—	
		Rock Cut	34-4.05	—	—	
	Bridges	Fill Section (Curbed)	34-4.02	—	—	
		New and Reconstructed Bridges	N/A	HS-20	HS-20	HS-20
Existing Bridges to Remain in Place		39-6	30'	30'	30'	
Bridges	*Vertical Clearance (Frontage Road Under) (9a)	39-6	H-15	H-15	H-15	
			30'	28'	26'	
	*Vertical Clearance (Frontage Road over Railroad)	33-5	16'-0" (9b)	14'-9" (9b)		
				17'-3" (9b)		
39-4.06	New: 23'-0" Existing: 21'-6"					

*Controlling design criteria (see Section 31-8). f-f = face of curb to face of curb e-e = edge of traveled way to edge of traveled way

**GEOMETRIC DESIGN CRITERIA FOR URBAN FRONTAGE ROADS
(New Construction/Reconstruction)
(US Customary)**

Figure 44-2.I

Design Element		Manual Section	Frontage Road Type		
			A	B	C
Design Controls	Design Forecast Year	31-4.02	Current	Current	Current
	Design Service Volume	31-4.03	>2000 ADT	400-2000 ADT	<400 ADT
Cross Section Elements	*Design Speed (1)	31-2	≥ 50 km/h	≥ 50 km/h	Min.: 50 km/h
	Access Control	35-2	None	None	None
	Level of Service	31-4.04	C	B	B
	*Surface Width	34-2.01	9.2 m f-f	9.2 m f-f	8.4 m e-e
Roadway Slopes	Outside Curb Type & Width	34-2.04	B15.60 CC&G	B15.60 CC&G	Type B Gutter
	Auxiliary Lanes	34-2.03	3.6 m	3.3 m	N/A
	Outside Curb Type & Width		B15.30 CC&G	B15.30 CC&G	N/A
	Cross Slope	34-2.01	2%	2%	2%
Bridges	Sidewalk Width	48-2.04	1.5 m with Buffer Strip Behind Curb	1.5 m with Buffer Strip Behind Curb	1.5 m with Buffer Strip Behind Curb
	Clear Zone	38-3	(3)	(3)	(3)
	Side Slopes	34-4.04	—	—	—
	Side Slopes	34-4.05	—	—	—
Bridges	Fill Section (Curbed)	34-4.02	—	—	—
	*Structural Capacity	N/A	MS-18	MS-18	MS-18
	*Clear Roadway Width (7)	39-6	9.2 m	9.2 m	9.2 m
	*Structural Capacity	N/A	MS-13.5	MS-13.5	MS-13.5
	*Clear Roadway Width (8)	39-6	9.0 m	8.4 m	7.8 m
	*Vertical Clearance (Frontage Road Under) (9a)	39.4	4.9 m (9b)	4.5 m (9b)	4.5 m (9b)
Bridges	Existing Overpassing Bridges	33-5	—	4.3 m	—
	Overhead Signs/ Pedestrian Bridges		—	—	—
Bridges	*Vertical Clearance (Frontage Road over Railroad)	39-4.06	New: 7.0 m	Existing: 6.6 m	Existing: 6.6 m

*Controlling design criteria (see Section 31-8). f-f = face of curb to face of curb e-e = edge of traveled way to edge of traveled way

**GEOEMTRIC DESIGN CRITERIA FOR URBAN FRONTAGE ROADS
(New Construction/Reconstruction)
(Metric)**

Figure 44-2.1

- (1) Design Speed. To determine the minimum design speed to remain in place, see Section 45-2.02.
- (2) Remain In Place. Minimum design criteria allowed to remain in place for existing design elements are shown in parenthesis.
- (3) Clear Zone. The clear zone will vary according to design speed, traffic volumes, side slopes, and horizontal curvature.
- (4) Ditch Bottom Width. Provide a wider outside ditch bottom where detention storage of storm water is a consideration.
- (5) Back Slope. Where the height of cut exceeds 10 ft (3 m), consider using a 1V:2H back slope beyond the clear zone. Also, for heights greater than 30 ft (9 m), consider the use of benching.
- (6) Fill Slope. For fill heights greater than 30 ft (9 m), use a 1V:2H uniform slope with a roadside barrier. Also, for heights greater than 30 ft (9 m), consider the use of benching.
- (7) New and Reconstructed Bridge Widths. Clear roadway bridge widths are measured from face to face of parapets or rails. Bridge widths are normally defined as the sum of the approach traveled way width and the width of the paved shoulders.
- (8) Existing Bridge Widths to Remain in Place. Clear roadway bridge widths are measured from face to face of parapets or rails. Implies elements allowed to remain in place without a design exception approval when cost effective and when safety record is satisfactory.
- (9) Vertical Clearance (Frontage Road Under).
 - a. The clearance must be available over the traveled way and any paved shoulders.
 - b. Table value includes allowance for future overlays.

GEOMETRIC DESIGN CRITERIA FOR RURAL/URBAN FRONTAGE ROADS
(New Construction/Reconstruction)

Footnotes to Figures 44-2.H and 2.I

44-2.05(c) One-Way/Two-Way

Two-way frontage roads are used in suburban or rural areas where the adjoining street system is so irregular or so disconnected that one-way operation would introduce considerable added travel distance and cause undue inconvenience. Two-way frontage roads are also used in many urban situations.

From an operational and safety perspective, one-way urban frontage roads are preferred to two-way. One-way operations may inconvenience local traffic to some extent, but the advantages in reducing vehicular and pedestrian conflicts at intersecting streets often fully compensates for this inconvenience. Two-way frontage roads at high-volume, urban intersections may complicate crossing and turning movements. Off ramps (e.g., slip ramps) joining two-way frontage roads should not be used because of the potential for wrong-way entry. See Section 37-5.02 for the design of one-way frontage roads with slip ramps.

44-2.05(d) Outer Separation

The area between the traveled way of the freeway and a frontage road or street is designated as the outer separation distance. This separation functions as a buffer between the through traffic on the freeway and the local traffic on the frontage road. This separation also provides space for shoulders, drainage, and ramp connections to or from the through facility where slip ramps are used. The wider the outer separation, the less influence local traffic will have on the freeway through traffic. Wider separations also lend themselves to landscape treatments that enhance the appearance of both highways and the adjoining property. In urbanized areas, wide separations may also be used for noise walls or noise berms.

The width of an outer separation is based upon the sum of the shoulder widths for the freeway and frontage road, an appropriate border area, and earth slopes. On curvilinear alignments, also consider the clear zone along the outside of horizontal curves when determining the width of the border area. Figure 44-2.J illustrates a typical separation between a rural freeway and frontage road where both roadways have the same profile elevation. The width of this outer separation would have to be increased accordingly for differences in roadway profile elevations. Figure 44-2.K illustrates two typical separations between an urban freeway and a frontage road.

At interchanges, connect the frontage road with the crossroad outside of the access control limits as shown in Chapter 35. For grade separated crossings, the frontage road is typically flared out to account for geometric restrictions (e.g., sight distance restrictions, embankments). This design is illustrated in Figures 44-3.B, 44-3.D, and 36-1.F. Figure 36-1.G also illustrates where the frontage road passes under the crossroad and is connected to the crossroad with a buttonhook design.

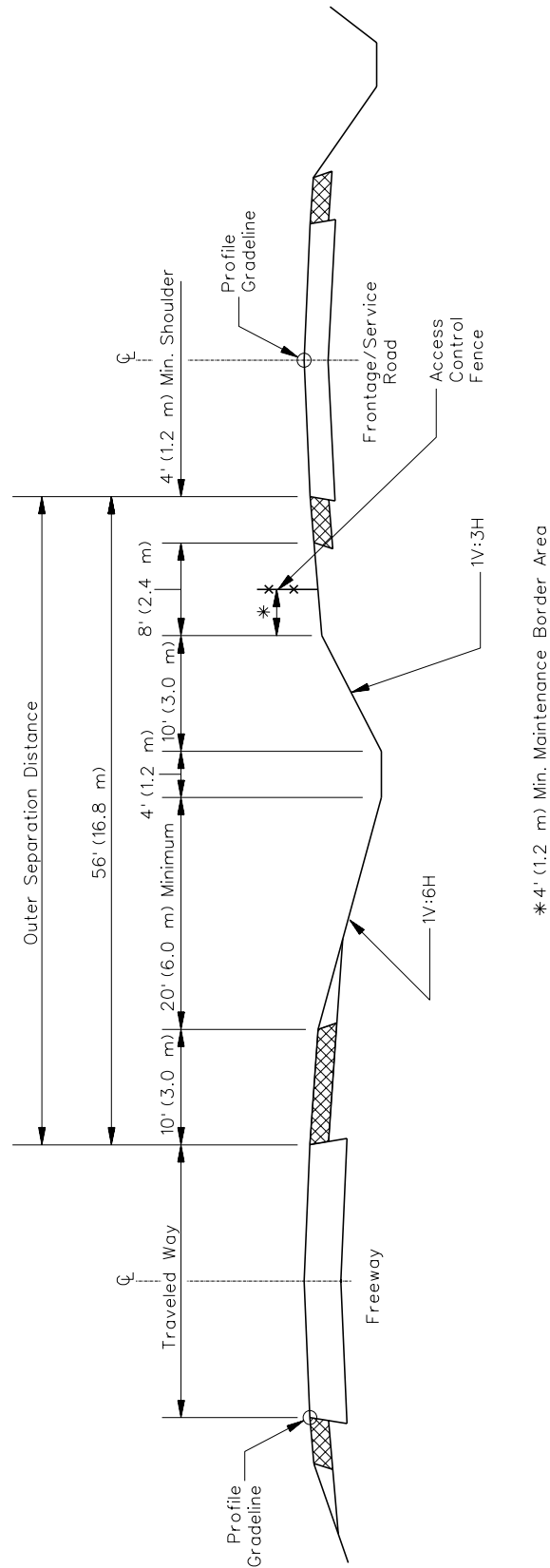

Note: Both roadways are assumed to be at the same profile elevation.

TYPICAL CROSS SECTION FOR RURAL OR SUBURBAN OUTER SEPARATION

Figure 44-2.J

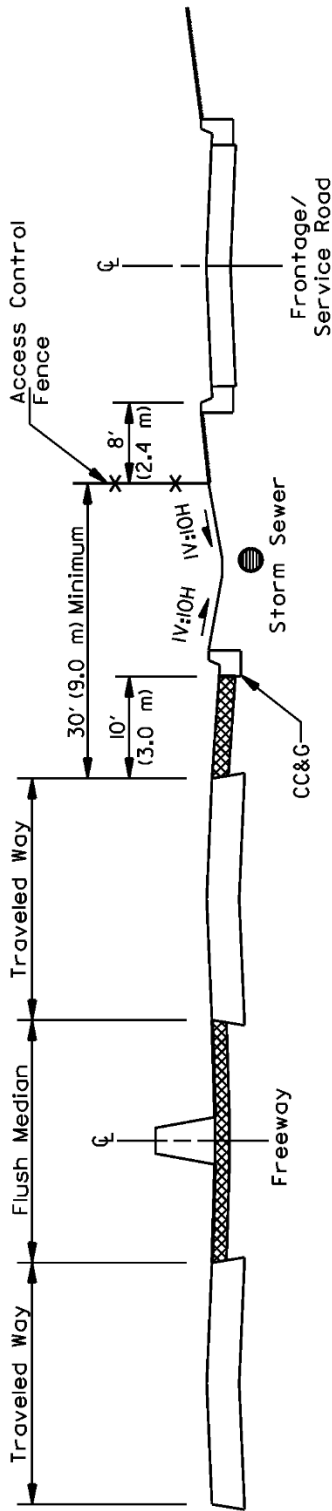

30 ft (9.0 m) OUTER SEPARATION

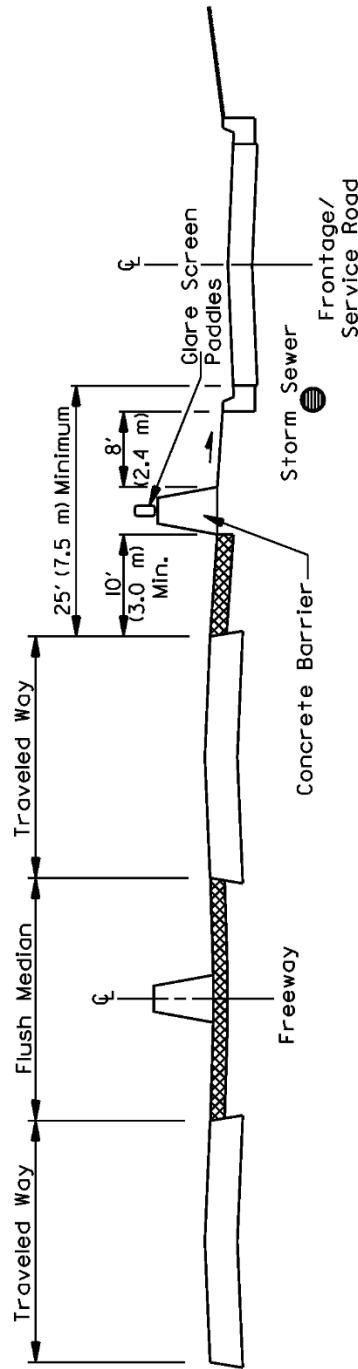

25 ft (7.5 m) OUTER SEPARATION

TYPICAL CROSS SECTION FOR URBAN OUTER SEPARATION
(Restricted ROW Conditions)

Figure 44-2.K

44-2.06 Lane Drops

Freeway lane drops, where the basic number of lanes is reduced, should normally occur on the freeway mainline away from any other turbulence (e.g., interchange exits and entrances). Figure 44-2.L illustrates the recommended design of a lane drop beyond an interchange where there is a high probability of no additional through lanes being needed on the freeway in the near future. Where the addition of a through lane is highly likely in the near future (i.e., four to six years), consider providing a median or left-side lane drop; see Item 4 below. Because left-side lane drops do not meet normal driver expectations, provide advance supplemental signing, longer taper lengths, and 12 ft (3.6 m) wide paved left shoulders beyond the area of the proposed lane drop. In addition, consider the following criteria when designing a freeway lane drop:

1. Location. The following discusses the appropriate locations for lane drops:
 - a. Rural. Desirably, the lane drop should occur approximately 2000 ft–3000 ft (600 m–900 m) beyond the end of a standard entrance terminal. This distance allows for adequate signing and driver adjustments from the interchange, but yet is not so far downstream that drivers become accustomed to the number of lanes and are surprised by the lane drop. A lane drop should not occur on a horizontal curve or where other signing is required (e.g., an upcoming exit).
 - b. Urban. Where interchanges are closely spaced, it may be necessary to drop a freeway lane at an exit. This decision is made on a case-by-case basis and an evaluation of operations of the traffic volume exiting versus the through traffic volume. It is preferable to drop the freeway lane at a major divergence or two-lane exit rather than at a single-lane exit. Lane drops at exit ramps are further discussed in Section 37-6.
2. Tapers. The minimum taper length at the end of a lane drop is 840 ft (250 m).
3. Sight Distance. Decision sight distance (DSD) should be available to any point within the entire lane transition. See Section 31-3.02 for applicable DSD values. This criterion would favor, for example, placing a freeway lane drop within a sag vertical curve rather than just beyond a crest or at a location where the freeway lies on an upgrade.
4. Right-Side versus Left-Side Drop. Right-side freeway lane drops are preferred due to the merging of slower vehicles and normal driver expectations. In the situation where the left lane is to be continued in the median in the future, the right-side lane drop is still preferred. In this case, the mainline is designed for a right-side lane drop and the traveled way is shifted through a set of flat reverse curves. Figure 44-2.M illustrates this design.
5. Shoulders. Maintain the full-width right shoulder through a right-side lane drop. If a left-lane drop is used, maintain the full 10 ft or 12 ft (3.0 m or 3.6 m) paved left shoulder for a distance of 350 ft (100 m) beyond the lane drop. This will provide a recovery area for those drivers who missed the lane drop.
6. Lane Addition. Figure 44-2.M illustrates a typical example for adding a lane to a freeway.

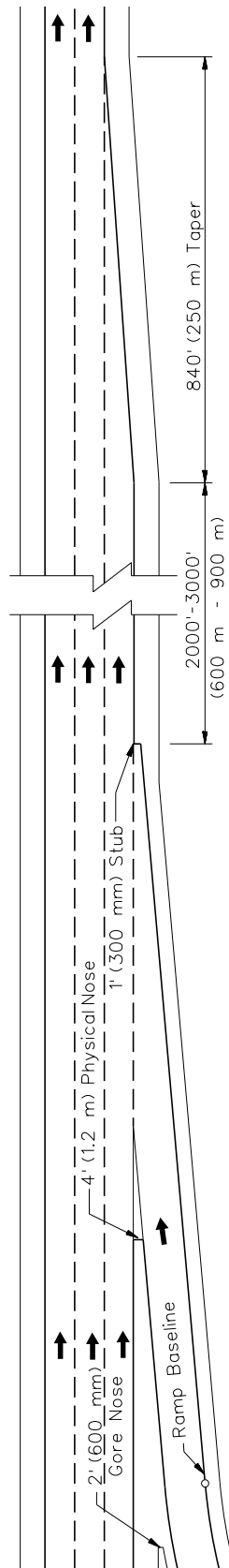

**TYPICAL FREEWAY LANE DROP
(Right Side)**

Figure 44-2.L

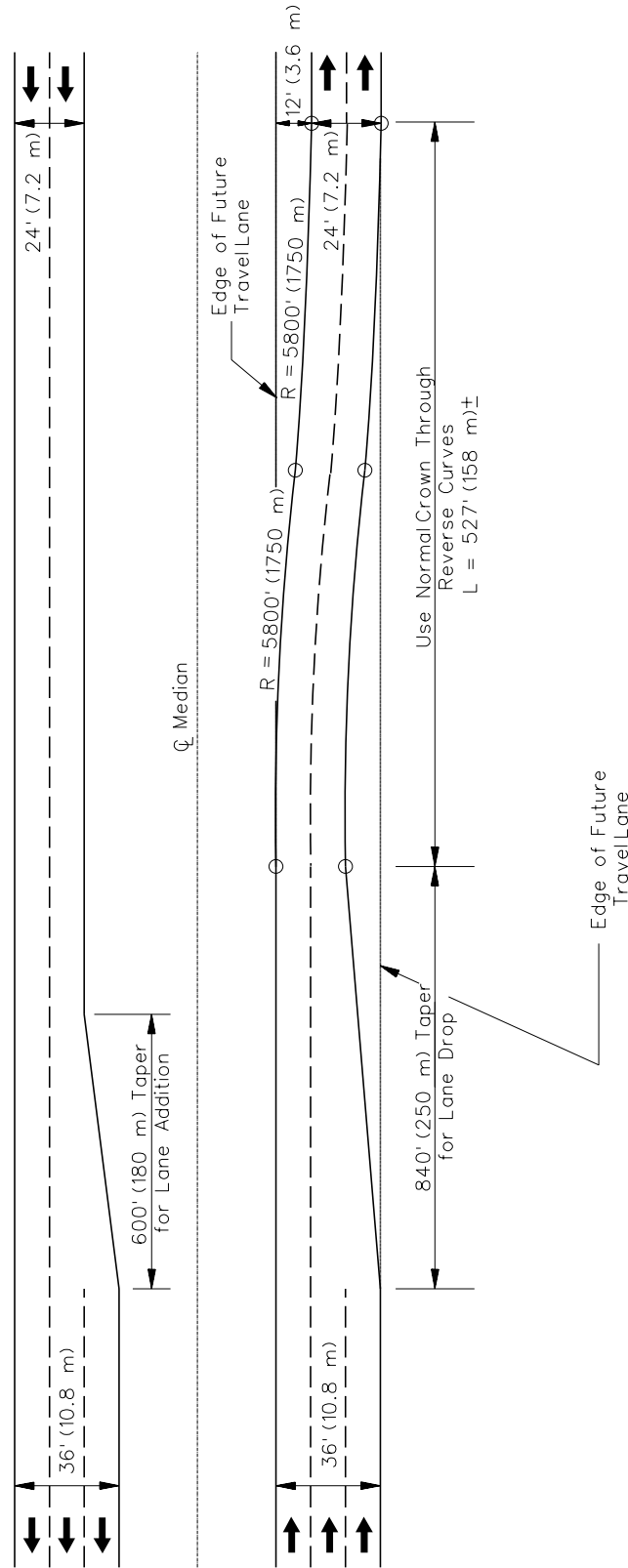

**TYPICAL FREEWAY LANE DROP AND ADDITION
(Median Lanes to be Continued in the Future)**

Figure 44-2.M

44-2.07 Roadside Safety

Chapter 38 discusses the design of clear zones, roadside barriers, breakaway sign supports, median barriers, and impact attenuators that are also applicable to freeways. In addition, the following criteria will apply to freeways:

1. Curbs. Curbing should not be used on freeways. However, where deemed necessary, only use M-4.24 (M-10.60) curb and gutter. Do not locate the curb and gutter any closer than the outer edge of the shoulder.
2. Utilities. Utility easements running parallel to the freeway should be outside the access control line. Generally, provide access to these easement strips from outside of the freeway right-of-way. This includes both the freeway mainline and ramps.
3. Landscaping. Proper landscaping of the freeway can contribute to the safe operation of the freeway by indicating changes in road and ramp alignments, reducing glare from oncoming vehicles, and controlling snow drifting. Plan the landscaping so that when it matures it will not become an obstacle itself or will not restrict sight distance.

44-2.08 Branch Connections/Major Forks

Where two freeways diverge or converge, a major divergence or convergence design will be required. Section 37-6 provides the design criteria for major diverges and converges.

44-2.09 Overhead Signing

Proper interchange operations depend partially on the compatibility between its geometric design and the traffic control devices at the interchange. Freeway signing should be planned concurrently with the geometric design. The proper application of signs and pavement markings increases the clarity of the path to be followed and the safety and operational efficiency of the freeway. For many freeways, overhead signing is used to increase this clarity. Due to sight distance limitations and spacing logistics, signing along a highway segment also impacts the minimum acceptable spacing between adjacent interchanges. Section 37-2.16 provides minimum distances between interchange terminals based on operational and signing requirements. For additional information on the use of overhead signing, the designer should review the *Illinois MUTCD* and/or contact the Bureau of Operations.

44-3 OTHER DESIGN FEATURES

44-3.01 Access Control

44-3.01(a) General

A controlled access highway is defined as a highway where the right of owners or occupants of abutting land to access, light, air, or view, in conjunction with a highway design, is controlled by a public authority. For freeways, the access is controlled by the Department and is limited to interchanges. Direct access to property along the freeway is prohibited. Indirect access may be provided to these properties by means of frontage or service roads constructed adjacent and parallel to the freeway or by existing roads that intersect other public roads, which then connect to an interchange. Section 37-1 discusses the Department's criteria for adding or changing access points (interchanges) along the freeway.

44-3.01(b) Access Control Line

The extent of access control on any freeway is indicated by the access control line. This line is placed on the access control plans included with a Phase I engineering report and on the right-of-way and construction plans. It clearly delineates the extent of access control and provides a permanent record. The access control line is defined as a line established by the Department across which ingress to or egress from a freeway is prohibited. This line is generally coincident with or parallel to the right-of-way line of the normal roadway section and is continuous along the freeway. The access control line must assume various configurations at grade separation structures and bridges and, is extended along those highways interchanging with the freeway. Access control along the crossroad provides for smooth flow of traffic and proper signing distances. The following access control criteria will apply to freeways:

1. Interchanges. Chapter 35 presents the Department's access control criteria along interchange crossroads.
2. Grade Separated Structures. The access control lines at grade separation structures (without an interchange) must be located to permit the movement of traffic over or under the freeway and preclude direct access to the freeway. The locations of access control lines at grade separation structures are indicated in Figures 44-3.A through 44-3.F.
3. Bridges and Culverts. The location of the access control line at bridges and at culverts, having a clear height of 6 ft (1.8 m) or greater or a definite stream channel will necessitate fencing being installed around the culvert wing wall. This is illustrated in Figure 44-3.G. Where the culvert has a clear height less than 6 ft (1.8 m) and no definite stream channel, the access control line is continuous as illustrated in Figure 44-3.H.

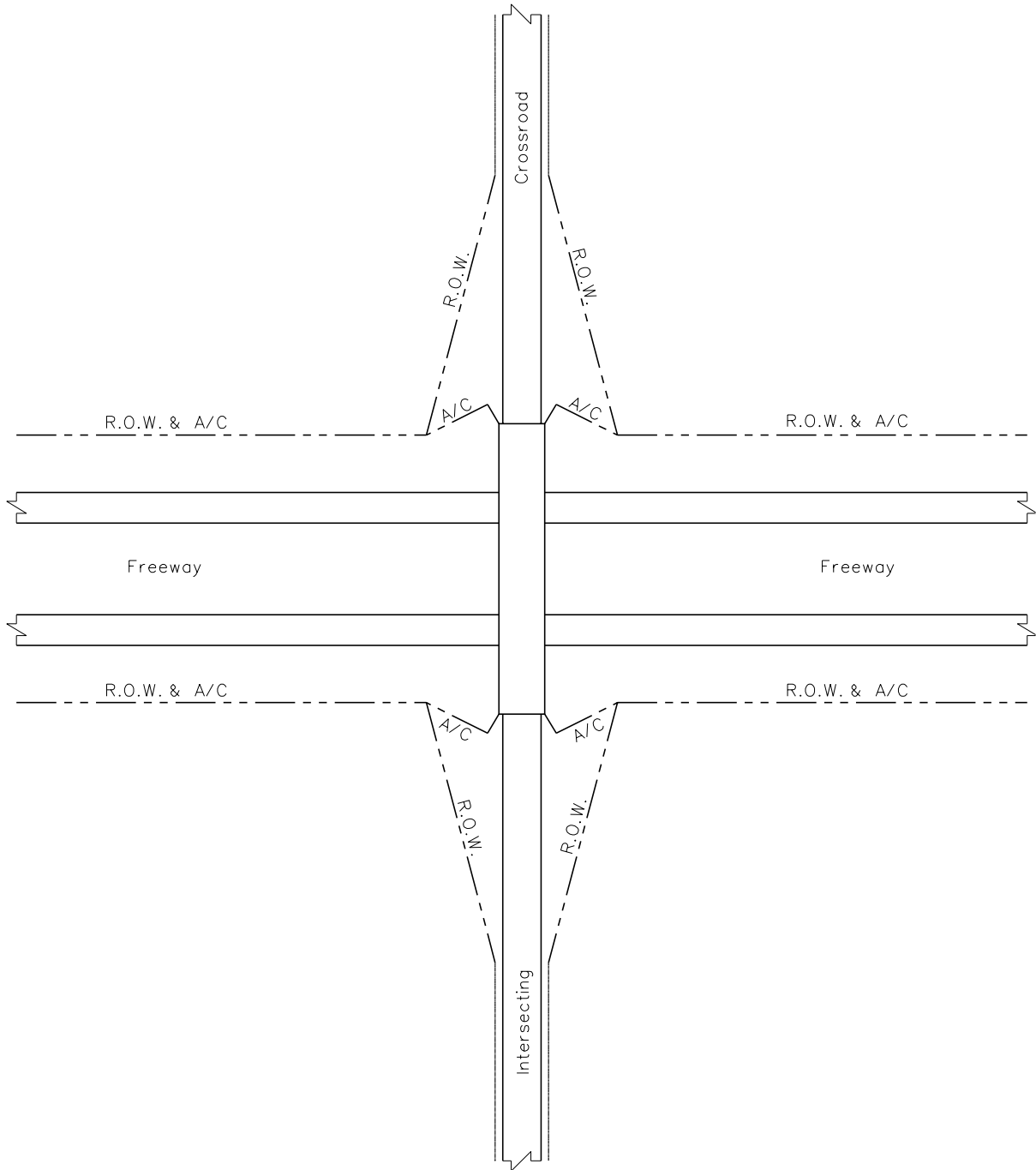

**FREEWAY UNDER INTERESECTING CROSSROAD
(Without Frontage Roads)**

Figure 44-3.A

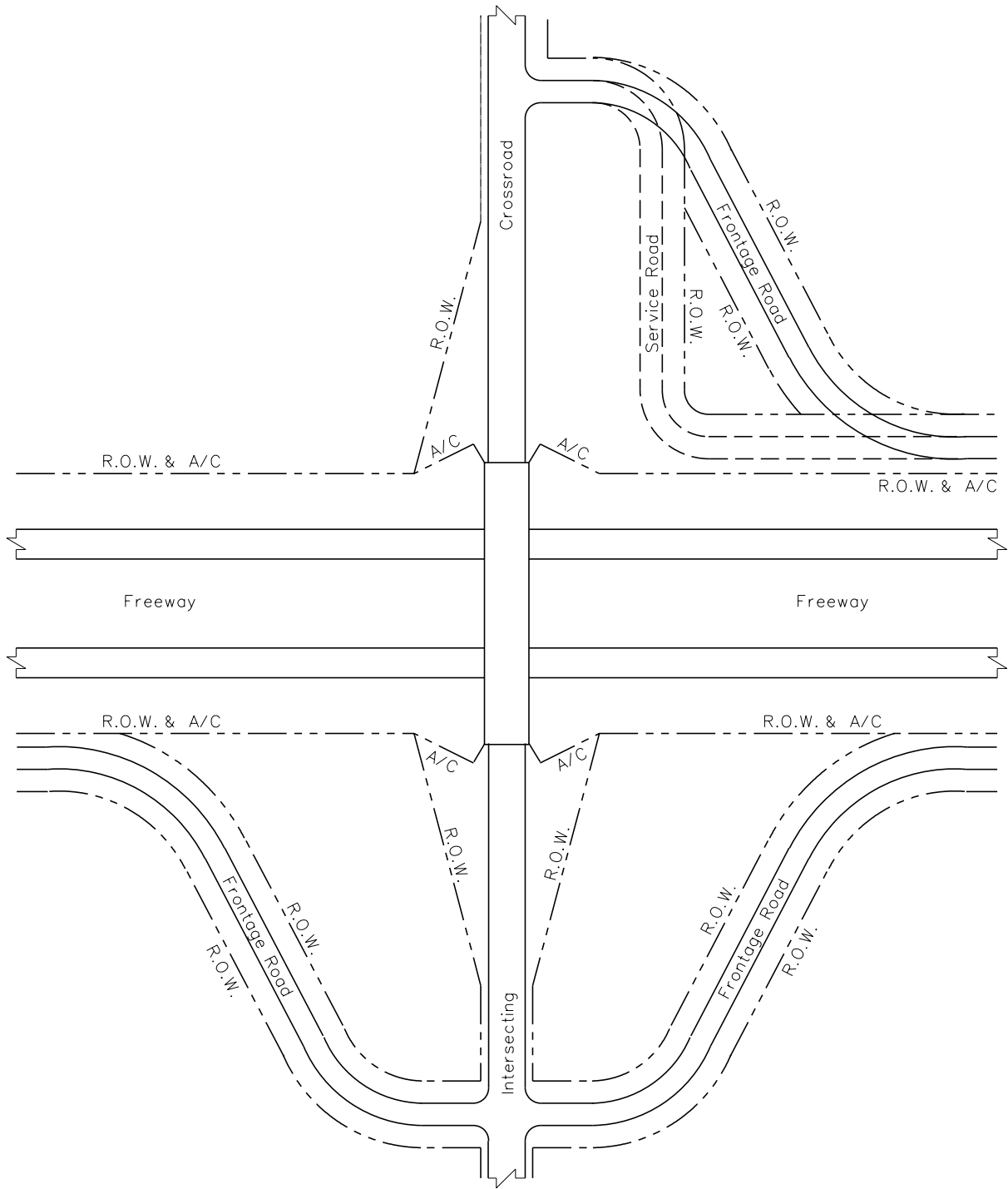

**FREEWAY UNDER INTERESECTING CROSSROAD
(With Frontage Roads or Service Drive)**

Figure 44-3.B

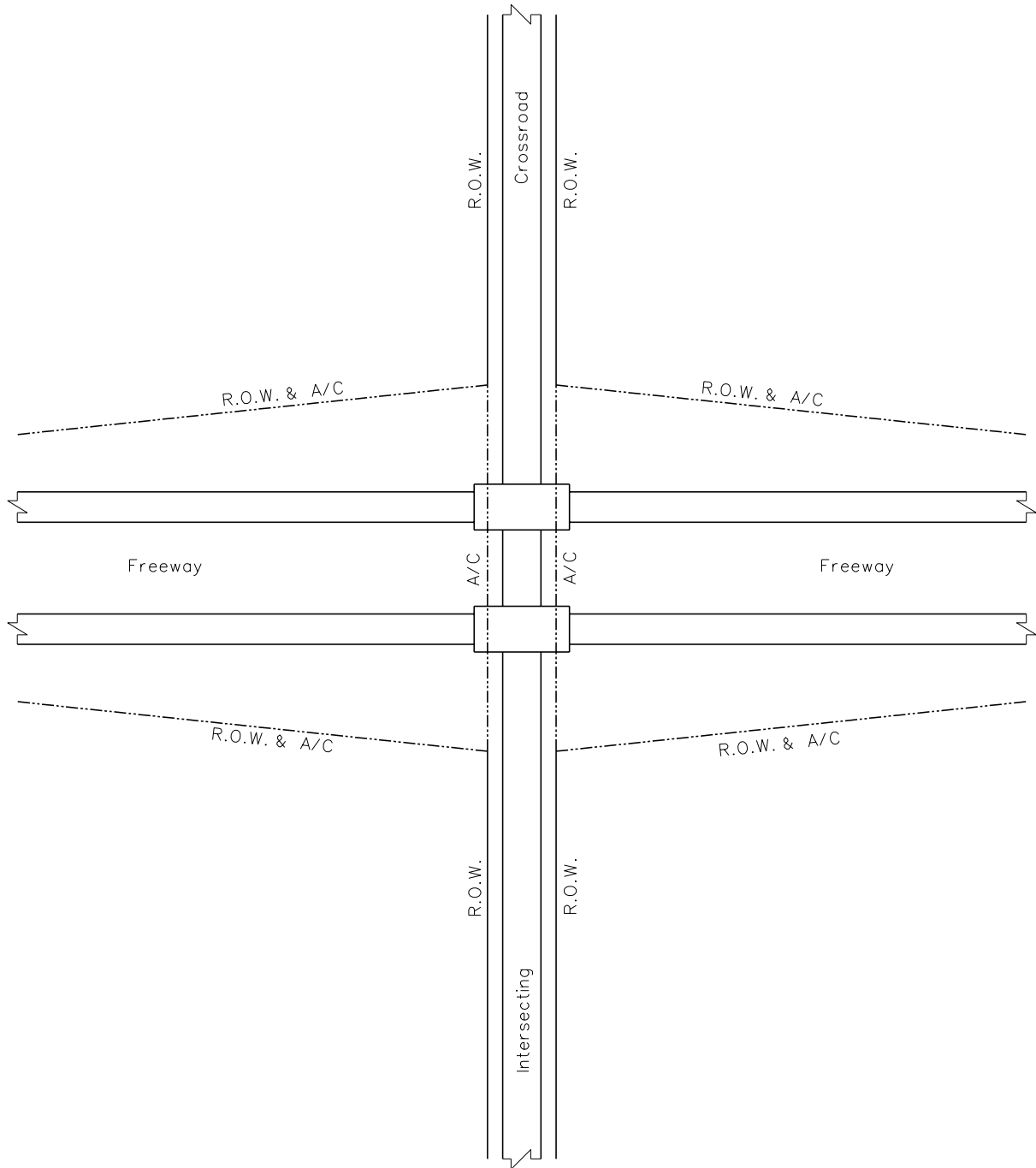

**FREEWAY OVER INTERESECTING CROSSROAD
(Without Frontage Roads)**

Figure 44-3.C

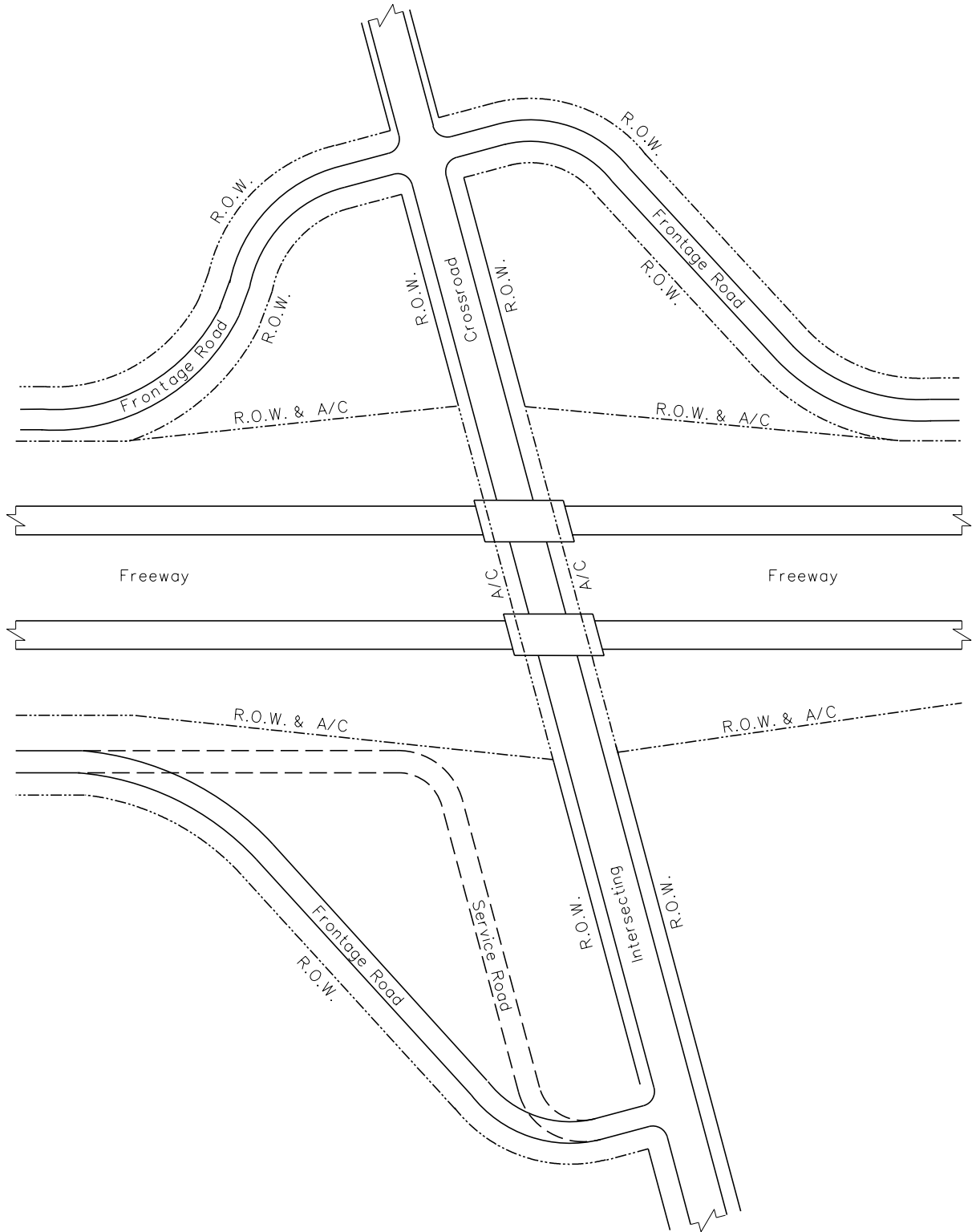

**FREEWAY OVER INTERSECTING CROSSROAD
(With Frontage Roads or Service Drive)**

Figure 44-3.D

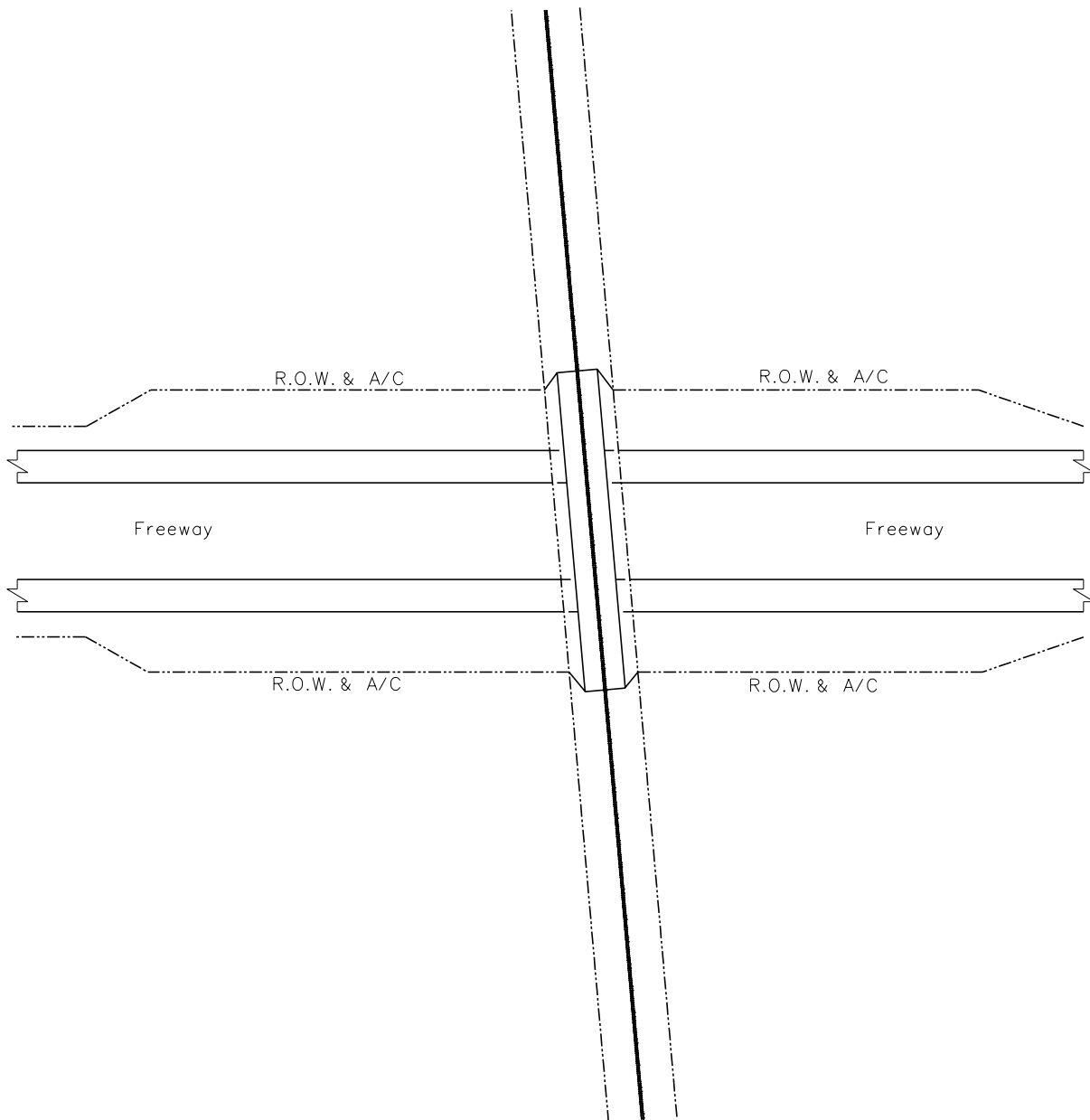

FREWAY UNDER RAILROAD

Figure 44-3.E

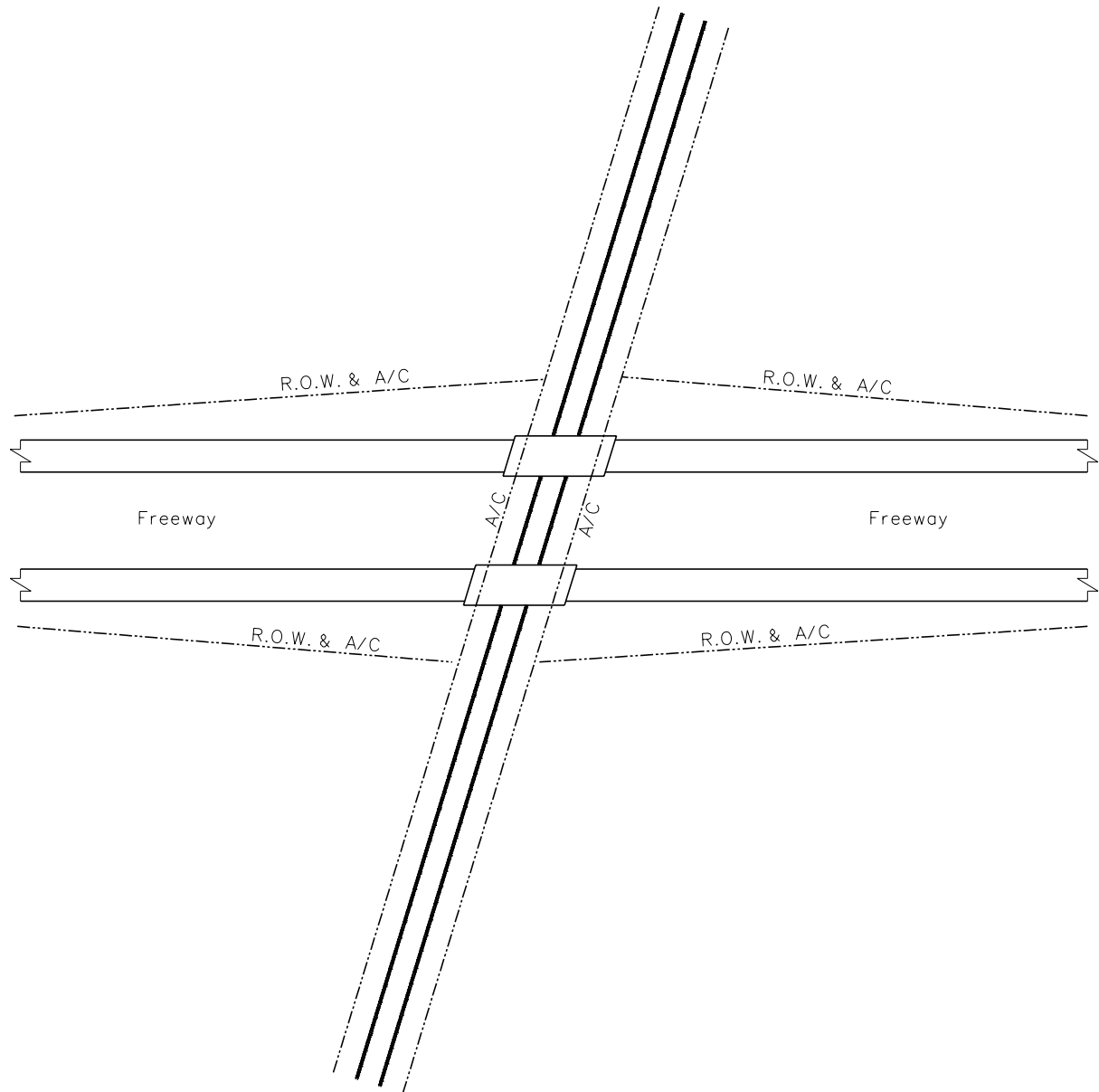

FREWAY OVER RAILROAD

Figure 44-3.F

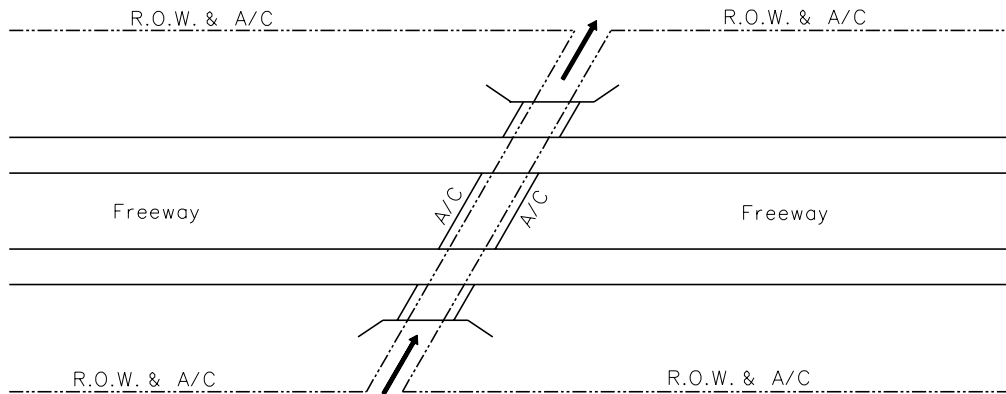

**ACCESS CONTROL AT BRIDGES AND CULVERTS
(6 ft (1.8 m) or Larger)**

Figure 44-3.G

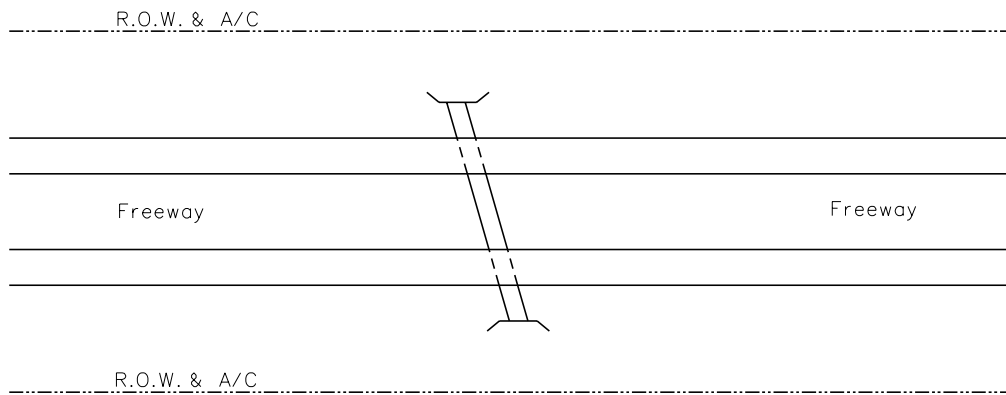

**ACCESS CONTROL AT BRIDGES AND CULVERTS
(Less Than 6 ft (1.8 m))**

Figure 44-3.H

44-3.02 HOV Lanes

44-3.02(a) General

High occupancy vehicle (HOV) lanes are those dedicated, for a portion of the day, to provide priority treatment for HOV's (e.g., carpools, vanpools, buses). HOV facilities provide efficiencies for maximizing person flow while minimizing overall person delay. Therefore, in general, HOV lanes are congestion-dependent improvements and produce substantial benefits where extreme congestion occurs regularly on freeways. HOV facilities should be considered in these situations to encourage motorist to shift from single occupancy vehicles (SOV) to high occupancy vehicles.

Management of HOV operations may be accomplished by a range of technological and manpower means. The level of control needed will depend upon the user demand, system size, HOV lane type, geometric design, hours of operation, and operational costs. Surveillance, communications, and control are vital components with respect to, 2+ versus 3+ occupancy requirements, incident management strategies, and enforcement requirements. HOV facilities should be part of a complete ridesharing program that includes the provision of support facilities and programs (e.g., park-and-ride lots, park and pool lots), and information services to facilitate both bus and rideshare needs.

44-3.02(b) Types of HOV Lanes

Within an existing freeway corridor, there are at least three types of HOV lanes—separated roadway, concurrent-flow lane, and contra-flow lane. These are illustrated in Figure 44-3.I and are further discussed as follows:

1. Separated HOV Roadway. Figures 44-3.J and 44-3.K illustrate separated HOV facilities. Consider the following:
 - a. Location. Separated HOV roadways may be located in the median of the freeway, adjacent to the freeway, or on an independent alignment depending on available space. Consideration should be given to factors such as traffic operations in interchange areas and ramps, access to intermodal facilities, access to and from the facility, and traffic management during construction.
 - b. Design Criteria. Design criteria for separated HOV roadways are typically high by the very nature of the commitment of funds and time to implement and are considered a long-term solution.
 - c. Enforcement. The enforcement needs for a barrier-separated HOV facility can be lessened somewhat because access along the facility is largely controlled at selected breaks in the barrier, as a result, violators are deterred.

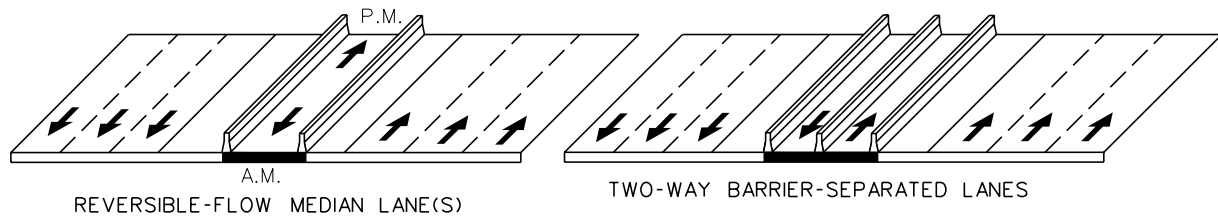

BARRIER SEPARATED ROADWAY

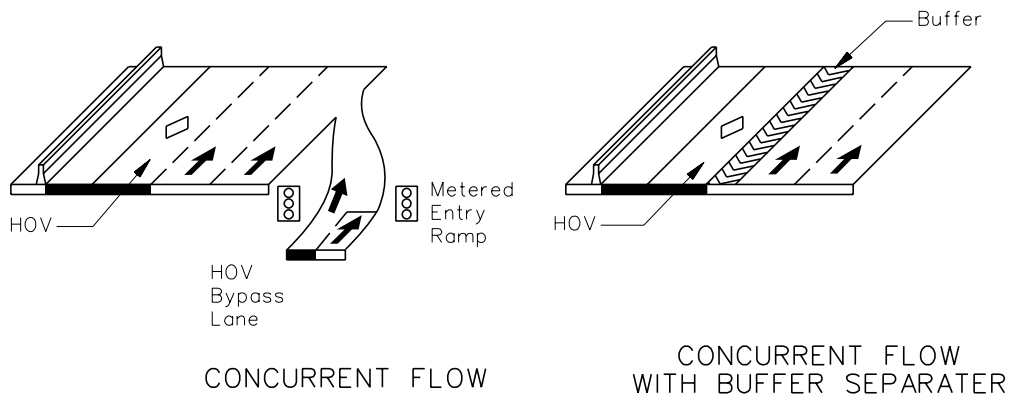

CONCURRENT FLOW

CONCURRENT FLOW WITH BUFFER SEPARATER

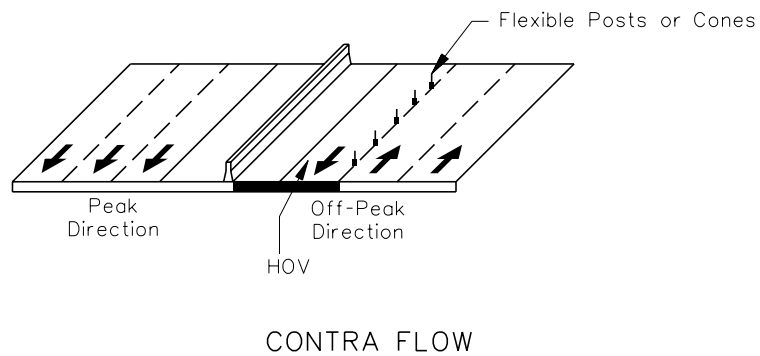

CONTRA FLOW

HOV CONCEPTS

Figure 44-3.I

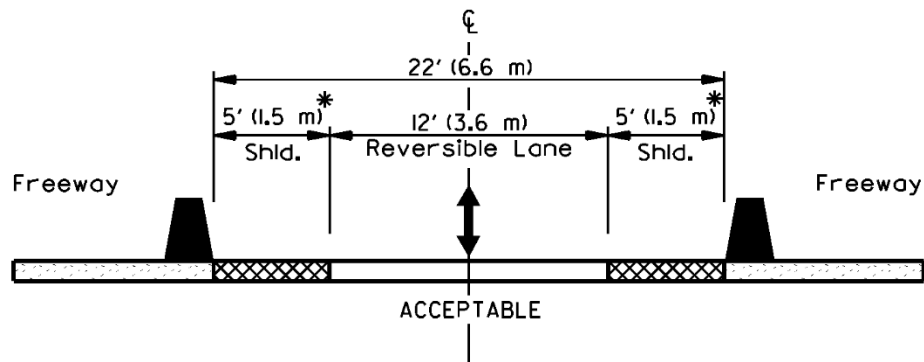
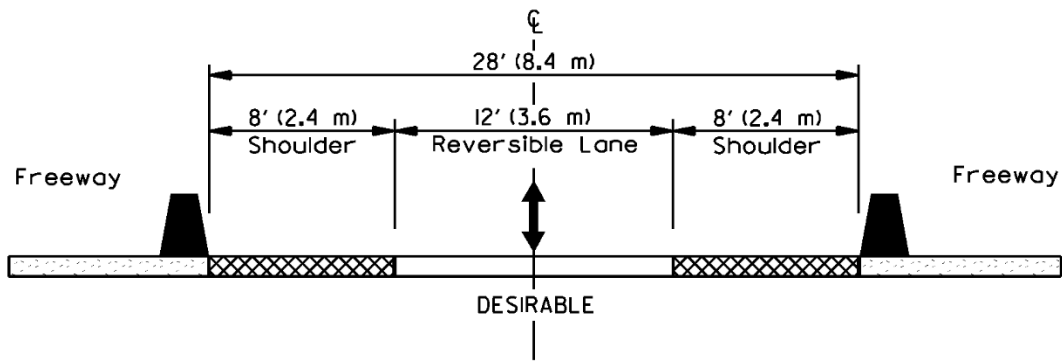

* Lateral clearances may be combined to provide a single 8' (2.4 m) shoulder on one side or the other.

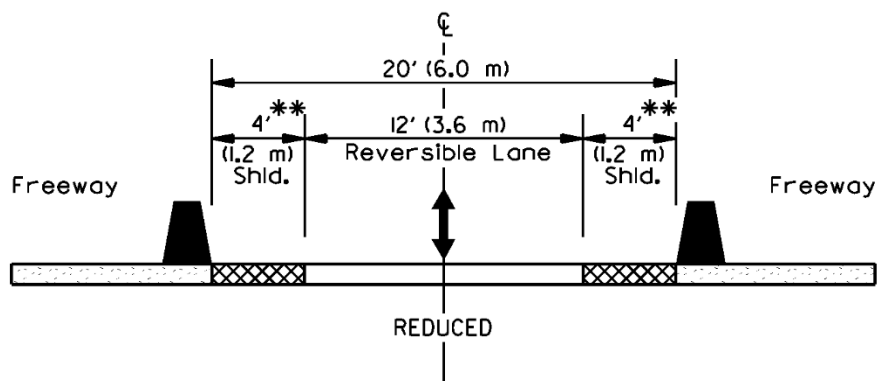

** Lateral clearances may be combined to provide a single 6' (1.8 m) shoulder on one side or the other.

**BARRIER SEPARATED HOV FACILITY CROSS SECTIONS
(Single-Lane Reversible Flow)**

Figure 44-3.J

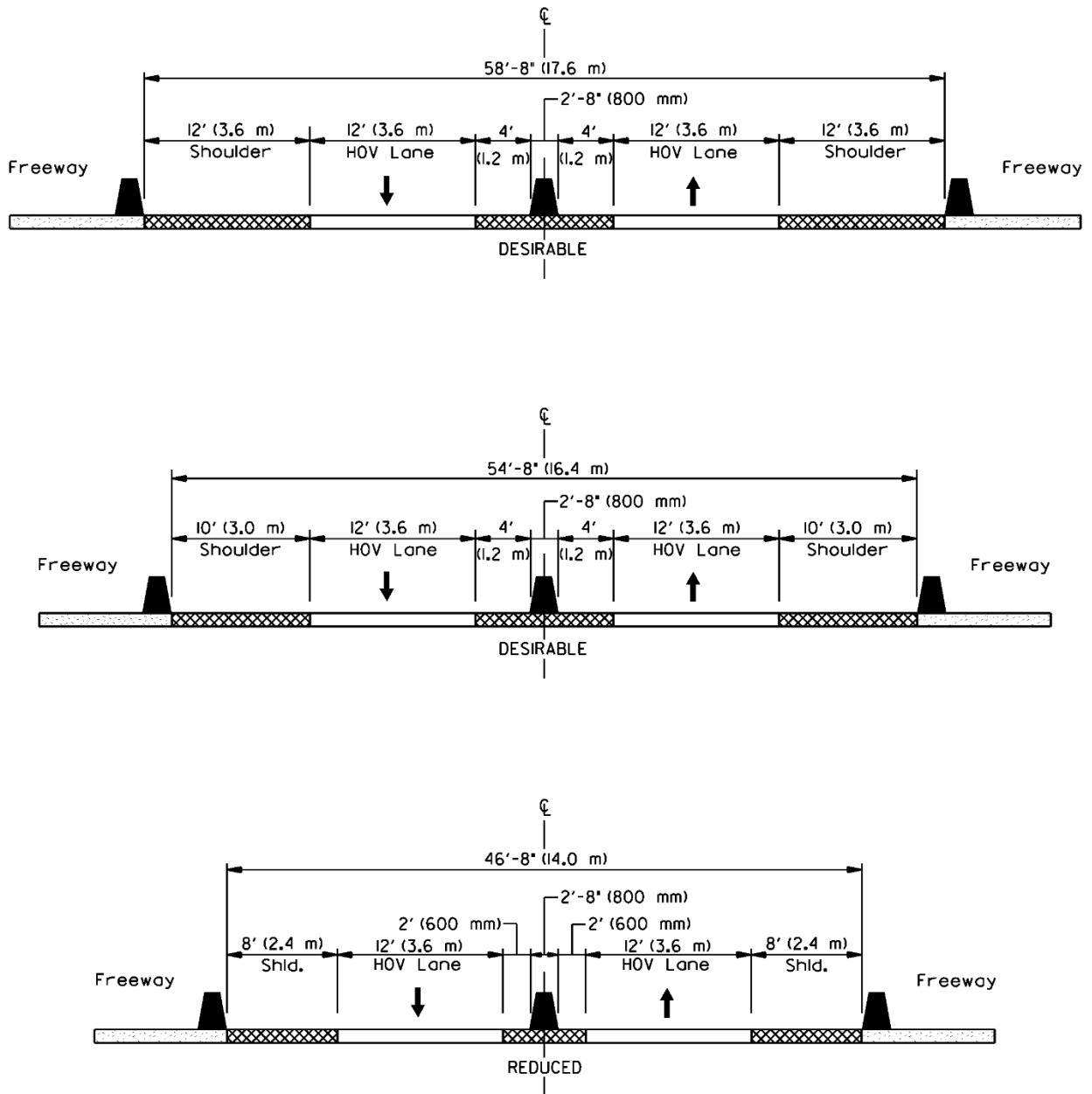

**BARRIER SEPARATED HOV FACILITY CROSS SECTIONS
(Two-Way Flow)**

Figure 44-3.K

- d. Access. Entering and exiting from an HOV to an interchange requires weaving across mixed-flow traffic lanes. To avoid this friction, access may be provided directly to the HOV, which can save users additional travel time. Ramps can be dropped down/up from a crossroad (low speed) or with a fly-over ramp (high speed).
2. Concurrent-Flow HOV Lanes. In contrast to barrier-separated facilities, concurrent-flow HOV lanes provide no more than a paint stripe or painted buffer adjacent to the through lanes; see Figure 44-3.L. Concurrent-flow HOV lanes can be implemented as interim retrofit by reducing the inside shoulder width and widening shoulders over time to enhance safety. Consider the following:
 - a. Access. Concurrent-flow HOV lanes provide for frequent access and are suited for HOV operations that can revert back to general purpose lanes while barrier separated facilities are more applicable to 24-hour HOV operation.
 - b. Enforcement. The lack of a physical barrier and ease of access increases the need for enforcement when compared to a separated HOV roadway; therefore, design treatments for enforcing concurrent flow HOV's is critical. Where a minimum 10 ft (3.0 m) wide shoulder cannot be provided contiguously adjacent to the HOV lane, enforcement will be difficult and violators may reach such proportions that HOV's may lose their time savings. Where narrow inside shoulders exist, it is possible to accommodate enforcement pockets by narrowing the median shoulder on alternating sides of the center barrier.
 - c. Incident Management. Incident management for HOV's are normally handled in the same manner as applied to freeways. Narrow inside shoulders also require real-time incident response.
 3. Contra-flow Lanes. Contra-flow lanes provide an exclusive lane for HOV's traveling in the peak direction by removing a lane from service in the off-peak direction in cases where the level of service will not be seriously affected; see Figure 44-3.I. Contra-flow lanes are often reserved for buses only; however, vanpools and taxis have been successfully introduced through special training and licensing.

44-3.02(c) Design

When designing HOV lanes, consider the following:

1. HOV Types. Section 44-3.02(b) discusses the common HOV types used by the Department.
2. Design Criteria. In general, the same criteria for urban freeways also apply to HOV facilities (e.g., 12 ft (3.6 m) lanes, horizontal alignment, vertical alignment, cross slopes). Urban freeway criteria are presented in Section 44-5.

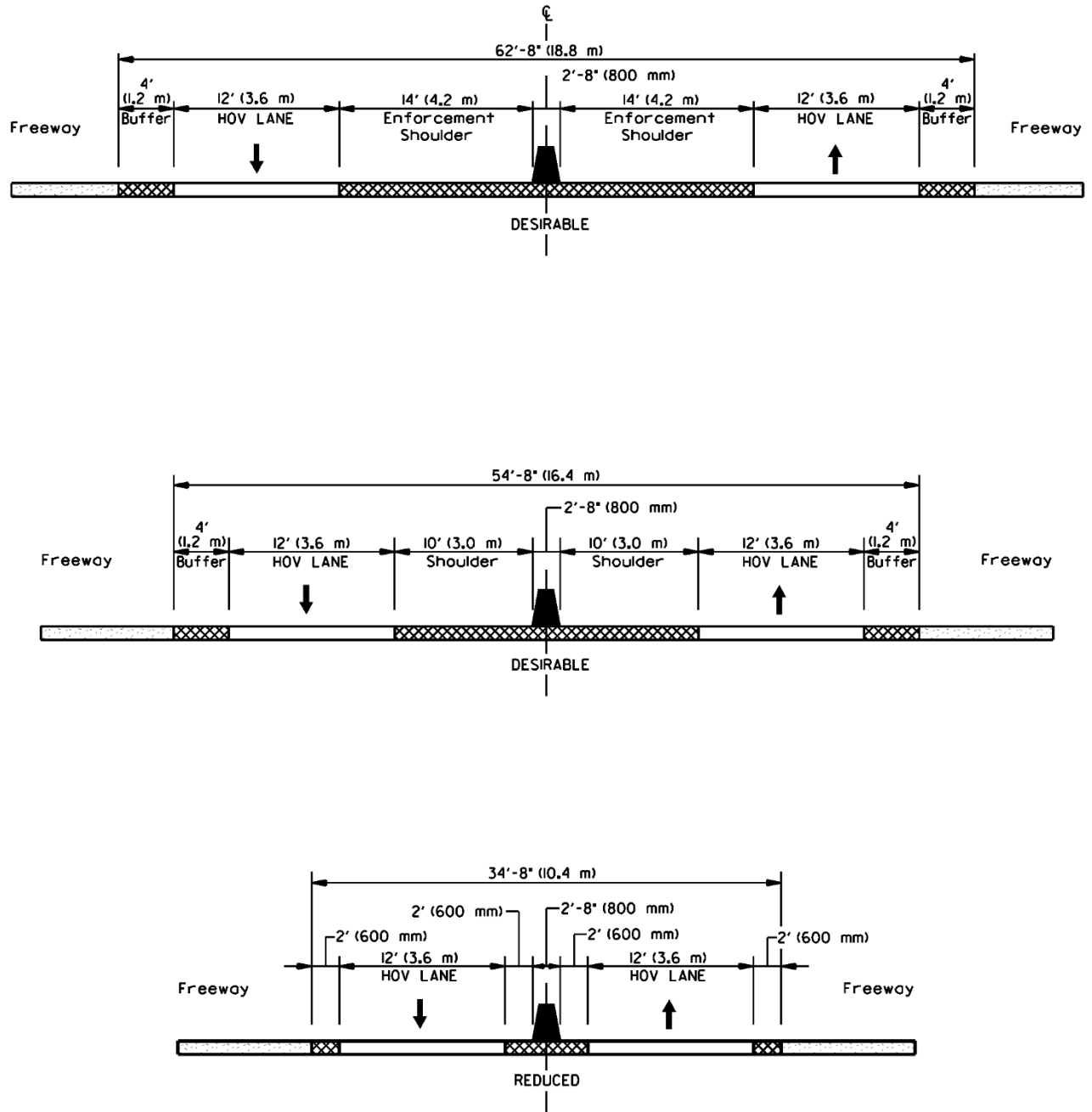

**BARRIER SEPARATED HOV FACILITY CROSS SECTIONS
(Two-Way Concurrent Flow)**

Figure 44-3.L

3. Shoulder Widths. Where barrier separated HOV facilities are provided (e.g., two-way flow), desirably at least one shoulder next to the HOV lane should be 10 ft (3.0 m) wide for emergency stops and at a minimum 8 ft (2.4 m). At a minimum, provide 2 ft (600 mm) offset to the median barrier.
4. Sight Distance. Where concrete barrier is used to separate the HOV lanes from adjacent and/or opposing lanes, give special consideration to any sight distance restrictions that may be caused by a concrete barrier through horizontal curves.
5. Separation. Where an HOV lane is adjacent to the through freeway lanes (i.e., no median barrier), desirably provide a 2 ft to 4 ft (600 mm to 1.2 m) buffer, or spatial separation, between the HOV lane and adjacent through lane. In general, it is more desirable to provide a narrow right-side clearance between the HOV lane and the through traffic lanes plus a wide left-side shoulder than to have a wide common shoulder as the buffer. The wide left shoulder also facilitates enforcement, which is key to the success of an HOV facility.
6. Access Ramps. Access to the HOV lane will vary according to the type of HOV facility used and space available. Access may be obtained by shared ramps, dedicated access ramps, and/or slip ramps from the mainline or crossroads. In general, design HOV ramps using the same criteria as for interchange ramps. However, consider the following:
 - a. Design Vehicle. The design vehicle for HOV lanes will typically be a bus. The absence of trucks may allow for narrower widths and reduced vertical clearances.
 - b. Signing. Advance signing and pavement markings are critical to ensure proper operation of the HOV ramps.
7. Incident Management. Special consideration must be given to incident management to ensure the HOV facility continues to operate after an incident (e.g., crash, disabled vehicle).
8. Additional Guidance. For additional guidance on determining candidate HOV freeway segments and design of HOV lanes, see the AASHTO publication *Guide for the Design of High-Occupancy Vehicles*.

44-3.03 Lighting

Nighttime traffic volumes, nighttime crashes, and geometric complexity will significantly influence the need for freeway lighting. In addition to the following, Chapter 56 provides further guidance on highway lighting:

1. Urban. Urban freeways with closely spaced interchanges and substantially developed adjacent areas are generally illuminated. The geometric and traffic complexities are such that drivers need to detect and react to conditions 500 ft to 1200 ft (150 m to 350

- m) in front of their vehicle. Also, vehicle headlamps cannot be relied on to provide adequate lateral visibility on very wide roadways.
2. Suburban. On suburban freeways without lighting, a reduction in visual sensitivity due to transient adaptation effects can also result from the spillover of lighting from adjacent development. This ambient illumination is distracting to the driver, causes veiling glare, and reduces attention to freeway signs. In areas where the surrounding areas are brightly illuminated, freeway lighting is typically warranted.
 3. Rural. In rural areas, lighting is sometimes deemed justified at interchanges, especially those with complex geometry or multiple merging traffic points. Energy availability and routine maintenance costs are important factors that influence the decisions to provide a lighting system.
 4. Interchanges. Because interchanges have the greatest probability for traffic conflict requiring quick driver decisions, lighting at high-density, complex freeway interchanges can be a useful tool with a high potential for crash reduction. Two designs of interchange lighting systems are commonly warranted—complete interchange lighting and partial interchange lighting. Complete interchange lighting provides considerably better driver performance and traffic operations than partial interchange lighting. Partial interchange lighting is sometimes used based on the premise that it provides some of the benefits attributable to complete interchange lighting at a lower operating cost. In partial interchange lighting, only the freeway gore area, major changes in ramp alignment, and the area where the ramp joins the crossroad are lighted.

44-3.04 Landscaping

The highway should be designed to blend into its environment, see Chapter 59. This may involve landscaping the roadside, either during the construction or later as an improvement. Proper use of landscaping can contribute to the safe operation of freeways by reducing glare from oncoming vehicles, indicating changes in road and ramp alignments, and controlling snow drift. At the same time, ensure that any additions do not sacrifice available operational and safety features. Also, consider the following guidelines:

- Locate tree and shrub plantings so that adequate sight distance will be maintained when mature growth is achieved.
- Give special consideration to selecting flora that will not mature into large or multiple trunks that can halt or snag a vehicle.
- Plant small trees at least 10 ft (3 m) away from other small trees and breakaway devices (e.g., sign supports) to reduce the possibility of a vehicle striking two objects at essentially the same time.
- Do not plant trees and shrubbery in front of barriers and other safety devices.

- Before planting trees on the inside of a curve, consider the restriction they might impose on the sight distance, especially when they mature.

44-4 INTERCHANGES/GRADE SEPARATIONS

On fully access-controlled facilities, each intersecting highway must be terminated, rerouted, or provided with a grade separation or interchange. The importance of the continuity of the crossing road, the feasibility of alternative routes, traffic volumes, construction costs, environmental impacts, etc., must be evaluated to determine which option is the most cost effective.

44-4.01 Interchanges

Section 37-1 discusses several guidelines that must be considered in determining whether or not an interchange should be provided. In general, interchanges are provided on freeways at:

- all freeway-to-freeway crossings;
- all marked highways, unless determined inappropriate; and
- other highways based on the anticipated demand for regional access.

Section 37-1 also discusses the procedures for adding or revising an interchange access point to the freeway system.

44-4.02 Grade Separations

44-4.02(a) Justification

For each crossroad along the freeway, which is not an interchange, a determination must be made whether the crossroad should be closed, rerouted, or provided with a grade separation. This justification is made primarily by comparing the respective cost and social factors for each alternative. Section 44-4.03 discusses the process for determining the feasibility of closing a facility or providing a grade separation. Although cost is a primary factor, also review the following considerations:

1. Operations. Grade separations should be of sufficient number and adequate capacity to accommodate crossroad traffic, traffic diverted to crossroads from other roads and streets terminated by the freeway, and the traffic generated by access connections to and from the mainline.
2. Rural/Urban Locations. In rural areas, the location of grade separation structures is determined by the access and feasibility study. For urban areas, usually grade separation structures are provided every three to four blocks for continuity.
3. Local Considerations. Closing the crossroad can have a significant effect on local users and the overall local road system integrity, due primarily to changes in travel patterns. These may include:
 - a. School Bus Routes. The effect of a road closure on the bus route system can be two-fold. There may be an increase in the operating cost due to longer buses routes and an increase in the travel time for school children.

- b. Emergency Personnel. The financial effect of the longer detour route on emergency vehicles is generally not a concern. However, the extra response time could adversely affect the health and safety of local citizens.
- c. Mail Routes. Mail delivery is normally a minor consideration. Although there may be extra financial burdens, these are generally minor because most routes can be rearranged.
- d. Businesses/Farms. Evaluate access to businesses and farms to ensure that these operations can continue without severe economic hardship. For businesses, the road closure can significantly affect their deliveries and the number of customers they receive (e.g., customers may be unwilling to travel the extra distance). For farmers, the road closure may require the transportation of large, slow-moving farm equipment along busy alternative facilities.
- e. Social Factors. Parks, churches, cemeteries, public facilities, and other areas or buildings of social concern generally cannot be relocated. Limited access to these facilities may create undue hardship if a specific road is closed.
- f. Land Use Planning. Consider future land use within a suburban environment to ensure adequate access and reciprocity factors are available.

44-4.02(b) Design

When designing grade separations, the following guidelines will be applicable:

1. Design Criteria. Section 33-5, Chapter 39, and Part V, Highway Systems, provide geometric design criteria for structures including clear roadway bridge widths, vertical clearances, horizontal clearance, shoulder widths, etc.
2. Over versus Under. The decision on whether the freeway should be over or under the crossroad is normally dictated by topography and cost. If the topography does not favor one profile over the other, use the following guidelines to decide which highway should cross over the other:
 - a. Cost-Effectiveness. The designer should consider which alternative will be more cost effective to construct. Some elements to consider are the amount of embankment and excavation required, span lengths, angle of skew, gradients, sight distances, alignment, vertical clearances, constructability, traffic control, right-of-way, drainage, soil conditions, and construction costs.
 - b. Classification. Select the alternative that provides the highest design level for the mainline road. Typically, the crossroad has a lower design speed and, therefore, the minor road can be designed with steeper gradients, lesser roadway widths, steeper side slopes, etc.
 - c. Future Crossings. Plan future crossings and/or structures as overpasses over the mainline. Overpasses are easier to install and will be less disruptive to the freeway when they are constructed in the future.

3. Vertical Clearance. The allowable vertical clearance for rural and urban interstate projects is 16 ft 09 in for new construction/reconstruction. For urban interstates within the single routing with a 16 ft 09 in vertical clearance, 15 ft 00 in is permitted. Refer to the figures in Section 44-6 for maps of single routing in the urban areas of Peoria, the Quad Cities, the Metro-east St. Louis, and the Chicago metropolitan. See Figure 33-5.A for vertical clearance requirements. If these vertical clearances cannot be met, a design exception must be sought. Refer to Section 31-7.04(c) for directions to process a design exception for vertical clearances over interstates.
4. Horizontal Distance. The distance required for adequate design of a grade separation depends on the design speed, the roadway gradient, and the amount of rise or fall necessary to affect the separation. Figure 44-4.A can be used during Phase I to quickly determine whether a grade separation is feasible for a given set of conditions, what gradients may be involved, and what profile adjustments may be necessary on the crossroad. Also, carefully study sight distance requirements because these will often dictate the required horizontal distance along the crossroad. When using Figure 44-4.A, consider the following:
 - a. Minimum Horizontal Distances. The plotted lines on Figure 44-4.A are derived assuming the same approach gradient on each side of the structure. However, values of "D" from the figure also are applicable to combinations of unequal gradients. Distance "D" is equal to the length of the initial vertical curve, plus one-half the central vertical curve, plus the length of tangent between the curves. Lengths of vertical curves are based on the stopping sight distance. However, longer vertical curves are desirable from an aesthetic and safety standpoint. Conversely, longer curve lengths may be costlier due to increased earthwork quantities. However, these additional costs may be a less important consideration if crossroads or access points exist near the grade separation structure.
 - b. Maximum Gradient. The lower terminal point of each gradient line on Figure 44-4.A, marked by a small symbol, indicates the distance where the tangent between the curves is zero and below which a design for the given grade is not feasible (i.e., a profile condition where the minimum central and end curves for the gradient would overlap).
 - c. Restricted Gradients. For the usual profile rise or fall required for a grade separation ("H" of 25 ft (7.5 m) or less), do not use gradients greater than 3% for a design speed of 70 mph (110 km/h), 4% for 60 mph (100 km/h), 5% for 50 mph (80 km/h), and 6% for 40 mph (60 km/h). For values of "H" less than 25 ft (7.5 m), use flatter gradients.
 - d. Relationship. For a given "H" and design speed, distance "D" is only shortened a negligible amount by increasing the gradient. However, the distance "D" varies to a greater extent for a given "H" and "G" with respect to the design speed.

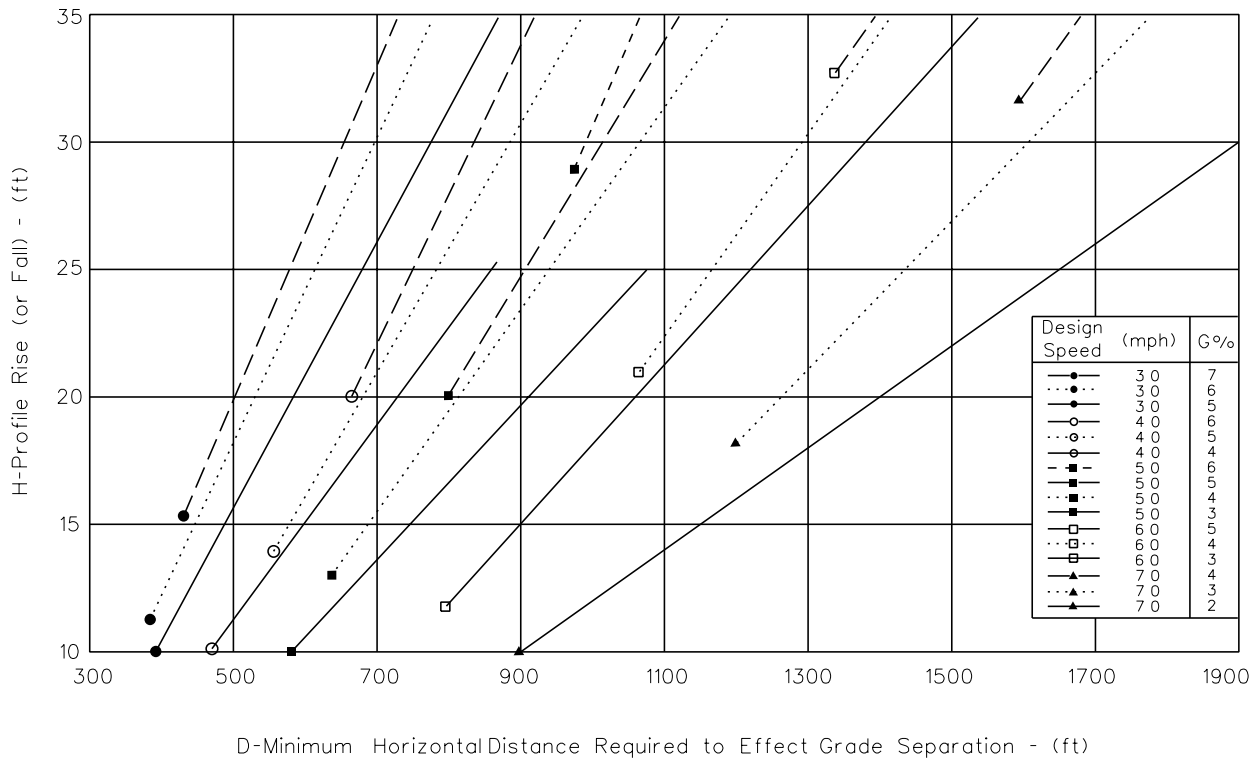

Note: Symbols on ends of lines indicate the point below which the grade is not feasible, necessitating the use of next flatter curve.

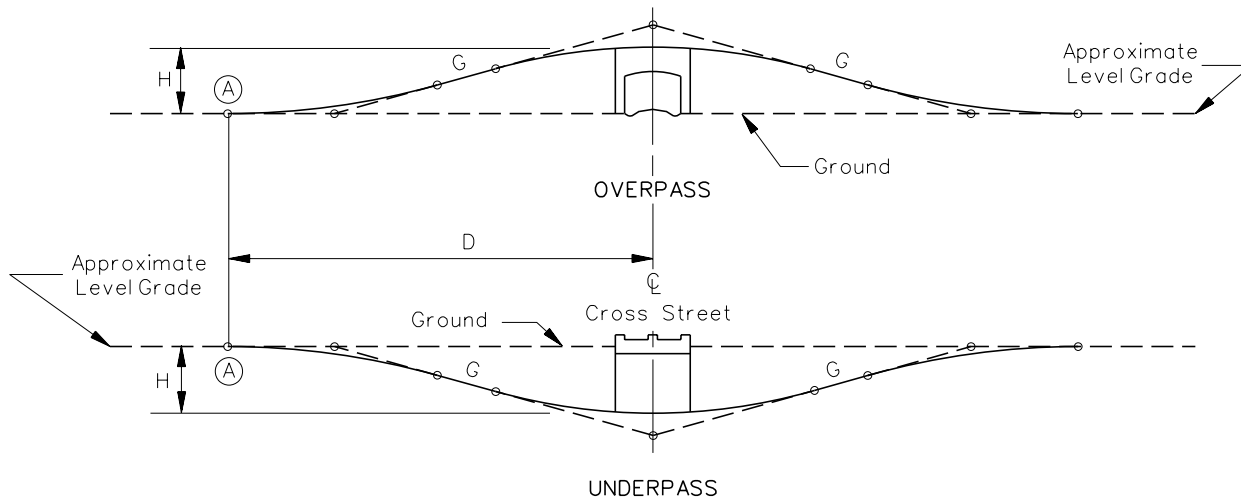

GRADE SEPARATION DETERMINATION (US Customary)

Figure 44-4.A

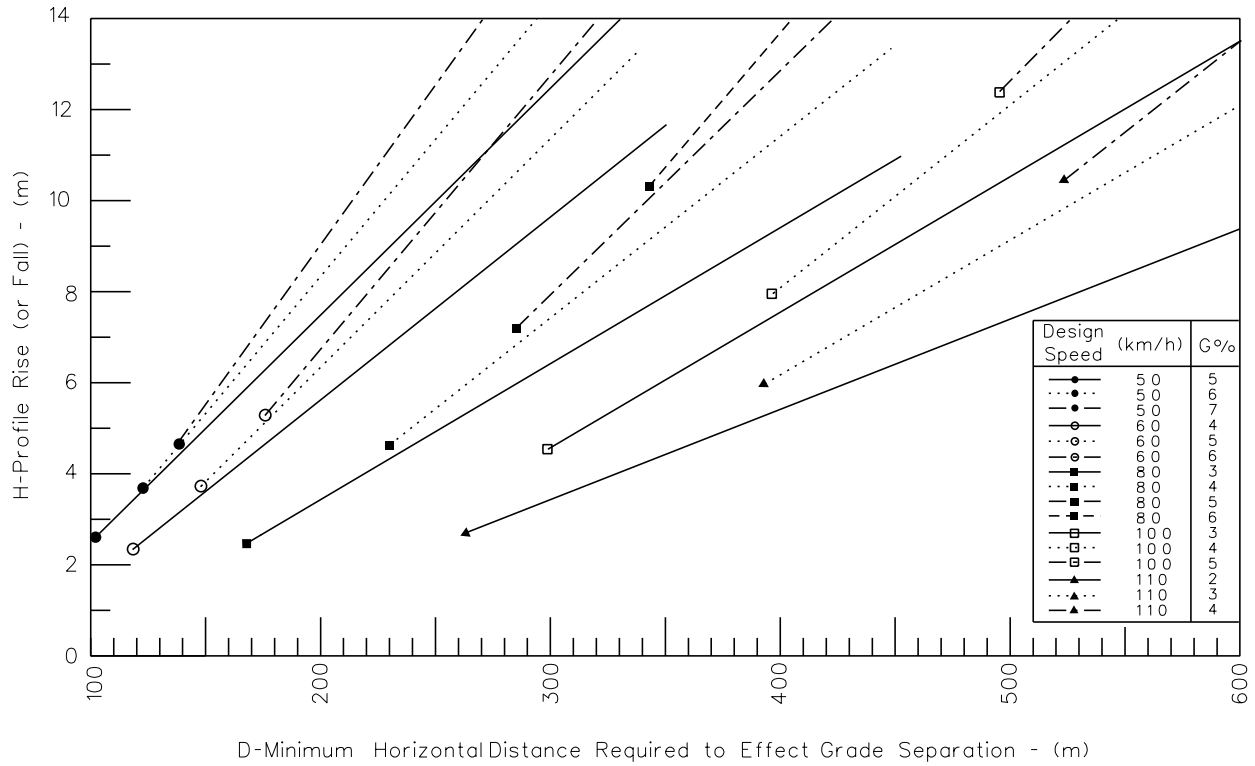

Note: Symbols on each line indicate the point below which the grade is not feasible, necessitating the use of the next flatter grade.

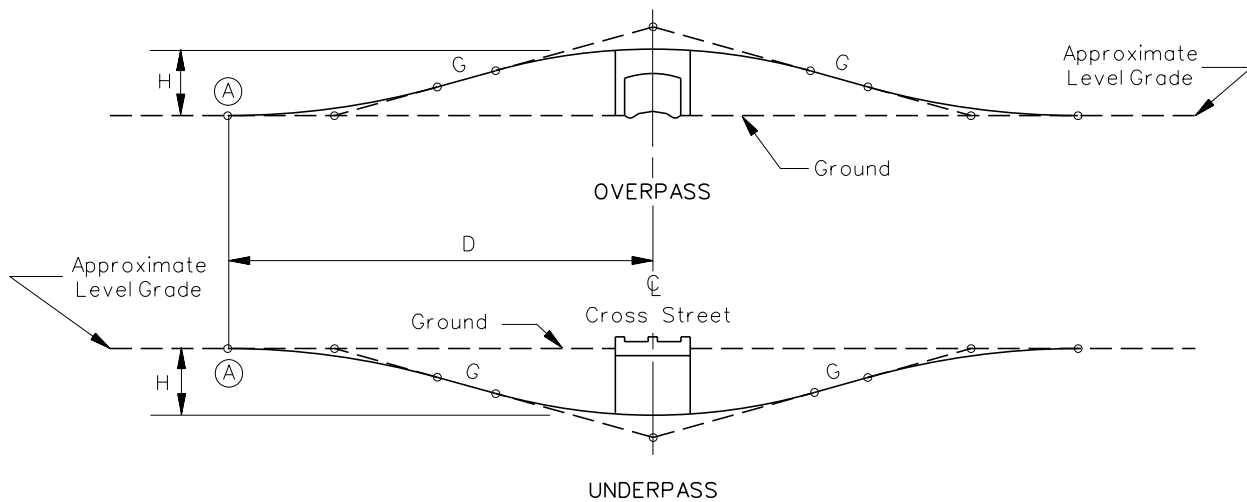

GRADE SEPARATION DETERMINATION (Metric)

Figure 44-4.A

- e. Elevation. Considering the vertical clearance and structural depth, an elevation distance of “H” is typically between 23 ft and 25 ft (7.0 m and 7.5 m) for the grade separation of two highways. “H” is typically the same for a freeway under a railroad. For a railroad facility under a freeway, “H” is typically 30 ft to 31 ft (9.2 m to 9.4 m).
- f. Design Speed. To provide additional safety at rural grade separations where the crossroad passes over the freeway, consider designing the crest vertical curve with a design speed of 55 mph (90 km/h) or greater.

44-4.03 Feasibility Analysis

44-4.03(a) Procedure

When determining the feasibility of closing a crossroad or providing a grade separation on the crossroad, a cost analysis must be completed. This will include comparing the additional road user costs for closing the facility against the amortized annual cost of building a grade separation. The following steps will apply in making this analysis:

1. Data Gathering. The first step is to gather all the necessary data for the cost analysis. This includes a map showing the location of other possible crossings, traffic volumes, construction costs, unit prices, service life for various construction elements, possible detour routes, length of alternative routes, a field review of the area, and possibly meeting with farmers, businessmen, the local postmaster, and local school officials.
2. Road Closure. The cost of the road closure is based on the increase in cost for road users to travel the additional distance to reach their destination. The computation of these costs is based on traffic volumes, distribution of vehicular types (e.g., passenger cars, trucks, buses), additional detour distance, and variable operating costs. Figure 44-4.B provides a form that can be used in the road closure analysis. The following steps will apply to Figure 44-4.B:
 - a. Traffic Volume/Composition. Use the latest data available for traffic volumes and vehicle composition. For local roads, this information can be obtained from the district and/or Chicago Area Transportation System. Adjust the traffic volumes for the design year (e.g., 20 years). For most analyses, the crossroad traffic will typically be the single most important element in influencing the cost analysis for grade separations.
 - b. Alternative Route Distances. Determine the most practical route that will be taken and measure these distances from a local map. The most practical route will typically be obvious. However, in some cases, it may be beneficial to talk with the appropriate local officials (e.g., county officials, emergency personnel, local school district).

NAME OF CROSSROAD: _____ FREEWAY ALTERNATIVE: _____

A. GENERAL CONDITIONS:

1. Traffic on crossroads (ADT _____) _____
2. School buses (daily trips/max. extra distance per trip if closed) _____
3. Mail Route (max. extra distance per day if closed) _____
4. Emergency Vehicles (max. extra distance if closed) _____
5. Approximate Road User Cost (per mile (kilometer)):
 PV - _____; SU - _____; MU - _____.
6. Approximate Vehicular Traffic Distribution (%):
 PV - _____; SU - _____; MU - _____.

B. ALTERNATIVE TRAFFIC ROUTE IF ROAD IS CLOSED: _____



C. ROAD USER COSTS:

DAILY COST IF ROAD IS CLOSED								
Point	Distance mile (km)	PV ADT ()	Cost/mile (Cost/km)	SU ADT ()	Cost/mile (Cost/km)	MU ADT ()	Cost/mile (Cost/km)	Daily Cost
Totals:								
DAILY COST IF ROAD IS OPEN								
1. Daily Increase in Road User Costs:								\$
2. Annual Increase in Road User Costs (Item 1 x 365):								\$

**JUSTIFICATION FOR GRADE SEPARATION STRUCTURE
(Part 1)**

Figure 44-4.B

- c. Road User Costs. Road user costs are based on the variable operating cost of operating a vehicle. Do not include the fixed (ownership) costs. The latest road user costs can be obtained from BDE. Variable operating costs consist of:
- nonscheduled repairs and maintenance,
 - gasoline,
 - oil,
 - tires,
 - gasoline tax (State and Federal),
 - oil tax (Federal),
 - tire tax (Federal), and
 - parking and tolls.
- d. Alternative Route Costs. The daily road user costs for the alternative route can be determined by multiplying each vehicular cost per mile (kilometer) by the distance of the detour. Do this for each vehicular type and add the total costs together.
- e. Open Road Costs. Determine the daily road user costs for each vehicular type assuming the road will remain open by multiplying the distance of the existing route by the road user costs.
- f. Final Costs. Determine the increase in road user costs by subtracting the non-detoured costs from the road closure costs. Multiply this number by 365 to determine the annual cost.
3. Grade Separation Structure. For comparison purposes, determine the annualized costs for constructing the grade separation. These include right-of-way acquisition, construction costs, and other mitigating items (e.g., environmental factors). Figure 44-4.C provides a form that may be used to determine these annualized costs. The following steps apply to Figure 44-4.C:
- a. Base Cost. Estimate quantities or use a generalized quantity (e.g., cost per square foot (square meter) of bridge deck, cost per square foot (square meter) of pavement). Use these quantities in conjunction with the average weighted unit prices to develop the overall grade separation costs. Also, include the cost for any necessary mitigation measures (e.g., relocating businesses, environmental factors, wetland mitigation, compensatory storage) that may be involved with providing a grade separation. Chapters 12, 64, and 65 provide additional guidance in determining quantities and cost estimates for Phase I reports.
- b. Service Life. Determine the service life for the various construction items. These can be found in Chapter 11.

NAME OF CROSSROAD: _____

FREEWAY ALTERNATIVE: _____

Item	Qty	Unit Cost	Total Cost	Service Life	Amort. Factor	Annual Cost
Right-of-Way acre (ha)						
Tree Removal acre (ha)						
Highway Grade Structure						
1. Grading						
a. Earth Excavation yd ³ (m ³)						
b. Embankment yd ³ (m ³)						
2. Drainage Culverts ft (m)						
3. Pavement						
a. _____ Surface Course ft ² (m ²)						
b. _____ Base Course ft ² (m ²)						
c. _____ Shoulders ton (ton)						
4. Structure _____ o-o _____ ft ² (m ²)						
Guardrail ft (m)						
Roadside Improvement						
1. Seeding acre (ha)						
2. Landscaping (L.S.)						
Miscellaneous						
TOTAL COST IF ROAD IS KEPT OPEN						

o-o = out to out width

Annual Increase in Road User Costs if Road is Closed \$ _____

Annual Grade Separation Cost if Road is Kept Open..... \$ _____

Proposed Roadway Cross Section:

Recommendation and Comments:

**JUSTIFICATION FOR GRADE SEPARATION STRUCTURE
(Part 2)**

Figure 44-4.C

- c. Annual Costs. Amortization factors are based on the service life of the construction item and the assumed discount rate for capital improvements, typically 3% or 4%. Amortization factors are available in most engineering economic textbooks. Annualized costs are computed by multiplying the base or total cost of the various construction elements by the amortization factor for capital recovery.
 - d. Total Costs. Sum the annual costs for each element to determine the total annual cost for providing the grade separation.
4. Comparison. Compare the annual road user costs from Step 2 with the annual grade separation costs determined in Step 3. If the value from Step 3 is larger, then the grade separation is not cost effective. If the value from Step 2 is larger, then the grade separation is considered cost effective.
 5. Miscellaneous Considerations. If a structure is justified based on costs, then no other analysis will be required. However, if the closure cost to road users is less than the cost of the grade separation structure, then consider the factors listed in Section 44-4.02(a).
 6. Summary Sheet. Figure 44-4.D can be used to summarize the results for all the crossings of each alternative affected by the proposed freeway.

44-4.03(b) Example Problem

The following is an example calculation to determine whether to close a crossroad or provide a grade separation over a new freeway.

Example 44-4.1

- Given: New Rural Freeway
 Design Year Crossroad Traffic Volumes — 80 ADT (2022)
 Traffic Distribution — 90% passenger cars, 10% SU vehicles
 Existing Route Length — 1.74 miles
 Alternative Route Length — 5.16 miles
 Variable Operating Costs — passenger cars - \$0.31/mile, SU - \$1.05/mile, MU -
 \$1.21/mile
 Discount Factor — 4%
 Proposed Roadway Cross Section — 20 ft traveled way, 3 in Class I Surface, 8
 in Aggregate Base, 4 ft Earth Shoulders
- Problem: Determine whether to close the crossroad (TR79) or provide a grade separation.
- Solution: Use the procedures in Section 44-4.03(a).

Step #1: Gather data. Quantities for the grade separation are shown in Figure 44-4.F.

Step #2: Determine the cost for closing the road. These calculations are shown in Figure 44-4.E. The extra distance for the detour is 3.42 miles. The average annual cost for closing the road is \$37,675.

Step #3: Determine the cost for the grade separation structure. Service lives for the various construction items can be found in Chapter 11 and are shown in the table. Amortization factors for a 4% discount rate can be obtained from an engineering economics textbook. Use the capital recovery factor. The annual cost for providing a grade separation is \$38,776. These calculations are shown in Figure 44-4.F.

Step #4: Comparing the annual grade separation costs (\$38,776) against the road closure cost (\$37,675), the grade separation cannot be justified economically.

Step #5: The road closure would cause significant delays to school bus and emergency vehicle travel times; see Section 44-4.02(a). When considering these factors and the closeness of the annual costs (i.e., less than 5%), a grade separation can be justified for this location.

Step #6: This process would be completed for each crossroad that intersects with the freeway to determine if a grade separation structure should be provided or the road closed. The results can be summarized in a table similar to Figure 44-4.D. In some cases, it may be appropriate to propose building a frontage road or service drive between two adjacent roads.

NAME OF CROSSROAD: TR 79 over FAP 406 FREEWAY ALTERNATIVE: A & B

A. GENERAL CONDITIONS:

- | | |
|--|-----------------------|
| 1. Traffic on crossroads (ADT 2022) | <u>80</u> |
| 2. School buses (daily trips/max. extra distance per trip if closed) | <u>2 min/14 miles</u> |
| 3. Mail Route (max. extra distance per day if closed) | <u>16 miles</u> |
| 4. Emergency Vehicles (max. extra distance if closed) | <u>8 miles</u> |
| 5. Approximate Road User Cost (per mile):
PV - <u>\$0.31/mile</u> ; SU - <u>\$1.05/mile</u> ; MU - <u>\$1.21/mile</u> . | |
| 6. Approximate Vehicular Traffic Distribution (%):
PV - <u>90</u> ; SU - <u>10</u> ; MU - <u>0</u> . | |

B. ALTERNATIVE TRAFFIC ROUTE IF ROAD IS CLOSED: TR 79 to TR 87 to TR 79 to TR 106

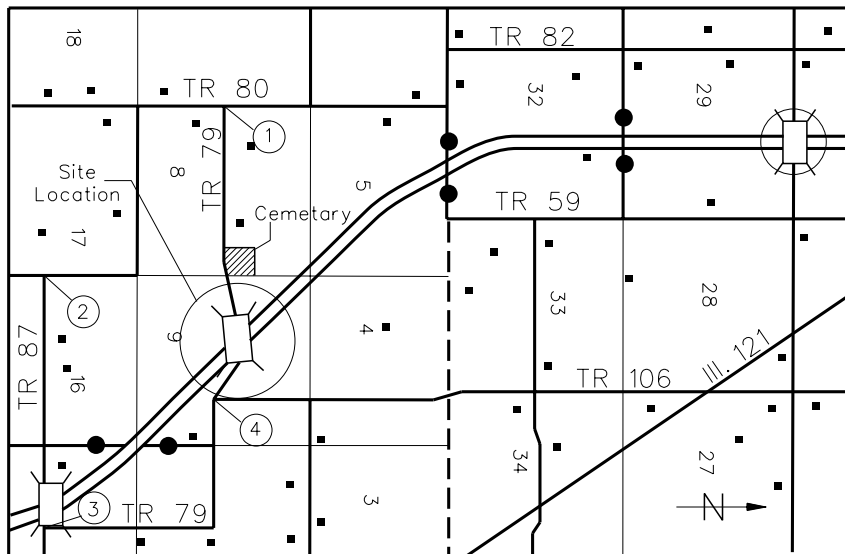

C. ROAD USER COSTS:

DAILY COST IF ROAD IS CLOSED								
Point	Distance (mile)	PV ADT (2022)	Cost/Mile	SU ADT (2022)	Cost/Mile	MU ADT (2022)	Cost/Mile	Daily Cost
1-2	1.87	72	0.31	8	1.05			55.60
2-3	1.55	72	0.31	8	1.05			47.62
3-4	1.74	72	0.31	8	1.05			53.45
Totals:	5.16							156.67
DAILY COST IF ROAD IS OPEN								
1-4	1.74	72	0.31	8	1.05			53.45
1. Daily Increase in Road User Costs:								\$ 103.22
2. Annual Increase in Road User Costs (Item 1 x 365):								\$ 37,675

**JUSTIFICATION FOR GRADE SEPARATION STRUCTURE
(Example 44-4.1)**

Figure 44-4.E

NAME OF CROSSROAD: TR79 over FAP 406

FREEWAY ALTERNATIVE: A & B

Item	Qty	Unit Cost	Total Cost	Service Life (years)	Amort. Factor	Annual Cost
Right-of-Way (acre)	11.50	2300	26,450	100	0.04081	1079
Tree Removal (acre)						
Highway Grade Structure						
1. Grading						
a. Earth Excavation (yd ³)	22,900	3.80	87,020	50	0.04655	4051
b. Embankment (yd ³)	—					
2. Drainage Culverts (ft)	263	71.63	18,839	40	0.05052	952
2@ 36 in (125 ft, 138 ft)						
3. Pavement						
a. 3 in Class I Surface Course (ft ²)	44,300	0.60	26,580	25	0.06401	1701
b. 8 in Aggregate Base Course (ft ²)	44,300	0.93	41,199	25	0.06401	2637
c. Earth Shoulders (ton)						
4. Structure 32 ft (0-0) x 230 ft (ft ²)	7360	76.00	559,360	50	0.04655	26,038
Guardrail (ft)	575	15.25	8769	20	0.07358	645
Roadside Improvement						
1. Seeding (acre)	6.55	3197	20,940	50	0.04655	975
2. Landscaping (L.S.)	L.S.	15,000	15,000	50	0.04655	698
Miscellaneous						
TOTAL COST IF ROAD IS KEPT OPEN			\$804,157			\$38,776

o-o = out-to-out width

Annual Road User Cost if Road is Closed \$ 37,675

Annual Grade Separation Cost if Road is Kept Open..... \$ 38,776

Proposed Roadway Cross Section:

Recommendation and Comments:

**JUSTIFICATION FOR GRADE SEPARATION STRUCTURE
(Example 44-4.1)**

Figure 44-4.F

44-5 TABLES OF DESIGN CRITERIA

Figures 44-5.A, 44-5.B, 44-5.C, and 44-5.D present the Department's design criteria for freeway projects. The designer should realize that some of the cross section elements included in the figures (e.g., flush concrete barrier median) are not automatically warranted in the project design. The values in the figures only apply after the decision has been made to include the element in the highway cross section.

Design Element		Manual Section	Rural One-Way DHV: 2300 - 3400 (1) Urban One-Way DHV: 2800 - 4300 (1)	Rural One-Way DHV: Under 2300 (1) Urban One-Way DHV: Under 2800 (1)	
Design Controls	Design Forecast Year	31-4.02	20 Years		
	*Design Speed	31-2	Rural: 75 mph (2) Urban: 60 mph		
Cross Section Elements	Access Control	35-1	Full Control		
	Level of Service	31-4.04	Rural: B Urban: C (3)		
	*Traveled Way Width	Right	34-2.01	2 @ 36'	2 @ 24'
		Total Width		10'	10'
	Shoulder Width	Paved	34-2.02	10' (4)	10' (4)
		Total Width		10'	8'
	Auxiliary Lanes	Paved		10' (5)	6'
		Lane Width	37-2.05	12'	
	Cross Slope	Shoulder Width		Right: 10' Left: 8' (Minimum)	
		*Travel Lane	34-2.01	3/16"/ft for lanes adjacent to crown (6)	
Median Width	Shoulder	34-2.02	1/2"/ft		
	Depressed		Minimum: 60'	Minimum: 56'	
Clear Zone	Flush (Concrete Barrier)	34-3	23' (7)	20' (7)	
		38-3		(8)	
Roadway Slopes	Cut Section	Front Slope	1V:6H		
		Ditch Bottom Width	4' (9)		
	Back Slope	Back Slope	1V:3H (10)		
		Rock Cut			
Fill Section	Rock Cut	34-4.05			
	Fill Section	34-4.02	1V:6H to Clear Zone; 1V:3H max. to Toe of Slope (11)		
Bridges	Median Slopes	34-3	1V:6H		
	New and Reconstructed Bridges	*Structural Capacity	N/A	HS-20	
		*Clear Roadway Width (12)	39-6	56' (13)	40'
	Existing Bridges to Remain in Place	*Structural Capacity	N/A	HS-20	
		*Clear Roadway Width (14)	39-6	56'	38'
	*Vertical Clearance (Freeway Under) (15a)	New and Replaced Overpassing Bridges (15b)	39-4	16'-9" (15c)	
Existing Overpassing Bridges			16'-0" (15c)		
Overhead Signs/ Pedestrian Bridges		33-5	17'-3" (15b)		
*Vertical Clearance (Freeway over Railroad)	39-4.06		23'-0"		

* Controlling design criteria (see Section 31-8).

GEOMETRIC DESIGN CRITERIA FOR FREEWAYS
(New Construction/Reconstruction)
(US Customary)

Figure 44-5.A

Design Element		Manual Section	Rural One-Way DHV: 2300- 3400 (1) Urban One-Way DHV: 2800 - 4300 (1)	Rural One-Way DHV: Under 2300 (1) Urban One-Way DHV: Under 2800 (1)	
Design Controls	Design Forecast Year	31-4.02	20 Years		
	* Design Speed	31-2	Rural: 120 km/h (2)	Urban: 100 km/h	
Cross Section Elements	Access Control	35-1	Full Control		
	Level of Service	31-4.04	Rural: B	Urban: C (3)	
	* Traveled Way Width	Right	34-2.01	2 @ 10.8 m	2 @ 7.2 m
				3.0 m	3.0 m
		Left		3.0 m (4)	3.0 m (4)
				3.0 m (5)	2.4 m
	Shoulder Width	Total Width		3.6 m	1.8 m
		Paved			
		Total Width			
	Auxiliary Lanes	Lane Width			
Shoulder Width			Right: 3.0 m	Left: 2.4 m (Minimum)	
Cross Slope	*Travel Lane	34-2.01	1.5% for lanes adjacent to crown (6)		
	Shoulder	34-2.02	4%		
Median Width	Depressed	34-3	Minimum: 18 m	Minimum: 17 m	
	Flush (Concrete Barrier)		7.0 m (7)	6.0 m (7)	
Clear Zone		38-3	(8)		
Roadway Slopes	Cut Section	Front Slope	1V:6H		
		Ditch Bottom Width	1.2 m (9)		
		Back Slope	1V:3H (10)		
	Rock Cut		—		
		Fill Section	1V:6H to Clear Zone; 1V:3H max. to Toe of Slope (11)		
Median Slopes		1V:6H			
Bridges	New and Reconstructed Bridges	N/A	MS-18		
	Existing Bridges to Remain in Place	* Structural Capacity	16.8 m (13)	12.0 m	
		* Clear Roadway Width (12)			
	* Vertical Clearance (Freeway Under) (15a)	* Structural Capacity	N/A	MS-18	
		* Clear Roadway Width (14)		16.8 m	11.4 m
		New and Replaced Overpassing Bridges (15b)		5.1 m (15c)	
	Overpassing Bridges	Existing		4.9 m (15c)	
Overhead Signs/ Pedestrian Bridges			5.25 m (15b)		
* Vertical Clearance (Freeway over Railroad)		33-5	7.0 m		
		39-4.06			

* Controlling design criteria (see Section 31-8).

**GEOMETRIC DESIGN CRITERIA FOR FREEWAYS
(New Construction/Reconstruction)
(Metric)**

Figure 44-5.A

- (1) Traffic Volumes. The design hourly volumes (DHV) are calculated assuming base conditions (except for 16% heavy vehicles) and a PHF = 1.0. Adjust these values using local factors.
- (2) Design Speed. In rolling terrain, a minimum design speed of 60 mph (100 km/h) may be considered with study and justification.
- (3) Level of Service. In major urban areas, a level of service D may be considered with study and justification.
- (4) Shoulder Width (Right). Where the directional distribution of trucks exceeds 250 DDHV, consider providing a 12 ft (3.6 m) paved shoulder.
- (5) Shoulder Width (Left). Where there are three or more lanes in one direction and the directional distribution of trucks exceeds 250 DDHV, consider providing a 12 ft (3.6 m) paved shoulder.
- (6) Travel Lane Cross Slope. For each additional lane away from the crown lanes, increase the cross slope by 1/16"/ft (0.5%) per additional lane up to a maximum of 5/16"/ft (2.5%).
- (7) Flush Median Width. Consider providing wider medians where required for snow storage.
- (8) Clear Zone. The clear zone will vary according to design speed, traffic volumes, side slopes, and horizontal curvature.
- (9) Ditch Bottom Width. Provide a wider outside ditch bottom where detention storage of storm water is a consideration.
- (10) Back Slope. Where the height of cut exceeds 10 ft (3 m), consider using a 1V:2H back slope beyond the clear zone. Also, for heights greater than 30 ft (9 m), consider the use of benching.
- (11) Fill Slope. For fill heights greater than 30 ft (9 m), use a 1V:2H uniform slope with a roadside barrier. Also, for heights greater than 30 ft (9 m), consider the use of benching.
- (12) New and Reconstructed Bridge Widths. Clear roadway bridge widths are measured from face to face of parapets or rails. Bridge widths are normally defined as the sum of the approach traveled way width and the width of the paved shoulders.
- (13) Bridge Width. Where the directional distribution of trucks exceeds 250 DDHV, consider providing 12 ft (3.6 m) right and left shoulders. Total width equals 60 ft (18.0 m).
- (14) Existing Bridge Widths to Remain in Place. Clear roadway bridge widths are measured from face to face of parapets or rails. Implies elements allowed to remain in place without a design exception approval when cost effective and when safety record is satisfactory.
- (15) Vertical Clearance (freeway under).
 - a. The clearance must be available over the traveled way and any paved shoulders.
 - b. Make allowances to maintain 16 ft-0 in (4.9 m) minimum vertical clearance in anticipation of future overlays.
 - c. In urban areas, a 15 ft 0 in (4.5 m) clearance may be used where a single routing interstate with a 16 ft 0 in (4.9 m) clearance is available. See Section 44-6 for maps of the single routing in urban areas of Illinois.

GEOMETRIC DESIGN CRITERIA FOR FREEWAYS (New Construction/Reconstruction)

Footnotes to Figure 44-5A

Design Element		Manual Section	Rural One-Way DHV: 2300 - 3400 (2)	Rural One-Way DHV: Under 2300 (2)	
Design Controls	Design Forecast Year	31-4.02	20 Years		
	*Design Speed	31-2	70 mph (3)		
	Access Control	35-1	Full Control		
	Level of Service	31-4.04	B		
Cross Section Elements	*Traveled Way Width	34-2.01	2 @ 36'	2 @ 24' (4)	
	Shoulder Width	Right	10'	10'	
		Left	10' (5)	10' (5)	
	Auxiliary Lanes	Total Width	8'	6'	
		Paved	8' (6)	4'	
	Cross Slope	Lane Width	11'		
		Shoulder Width		Right: 10' Left: 4' (Minimum)	
	Median Width	*Travel Lane	34-2.01	3/16"/ft for lanes adjacent to crown (7)	
		Shoulder	34-2.02	1/2"/ft to 3/4"/ft	
	Clear Zone	Depressed	34-3	Minimum: 54' (8)	Minimum: 50' (8)
Flush (Concrete Barrier)		38-3	22' (9)	18'-6" (9)	
Roadway Slopes	Cut Section	Front Slope	1V:4H		
		Ditch Bottom Width	2.0' (11)		
		Back Slope	1V:3H (12)		
	Rock Cut	34-4.05	—		
	Fill Section	34-4.02	1V:4H to Clear Zone; 1V:3H max. to Toe of Slope (13)		
Bridges	Median Slopes	34-3	1V:4H		
	Existing Bridges to Remain in Place	*Structural Capacity	N/A	HS-20	
		*Clear Roadway Width (14)	39-6	54'	38'
	*Vertical Clearance (Freeway Under) (15a)	Existing Overpassing Bridges	39-4	16'-0" (15c)	
Overhead Signs/Pedestrian Bridges		33-5	17'-00" (15b)		
*Vertical Clearance (Freeway over Railroad)		39-4.06	21'-6"		

* Controlling design criteria (see Section 31-8).

GEOMETRIC DESIGN CRITERIA FOR EXISTING CROSS-SECTION ELEMENTS TO REMAIN IN PLACE ON RURAL FREEWAYS⁽¹⁾
 (Reconstruction)
 (US Customary)

Figure 44-5.B

Design Element		Manual Section	Rural One-Way DHV: 2300 - 3400 (2)	Rural One-Way DHV: Under 2300 (2)	
Design Controls	Design Forecast Year	31-4.02	20 Years		
	* Design Speed	31-2	110 km/h (3)		
	Access Control	35-1	Full Control		
	Level of Service	31-4.04	B		
Cross Section Elements	* Traveled Way Width	34-2.01	2 @ 10.8 m	2 @ 7.2 m (4)	
	Shoulder Width	Right	3.0 m	3.0 m	
		Paved			
	Shoulder Width	Total Width	3.0 m (5)	3.0 m (5)	
		Paved	2.4 m	1.8 m	
	Auxiliary Lanes	Lane Width	2.4 m (6)	1.2 m	
		Shoulder Width		3.3 m	
	Cross Slope	* Travel Lane		Right: 3.0 m Left: 1.2 m (Minimum)	
		Shoulder		1.5% for lanes adjacent to crown (7)	
	Median Width	Depressed		4% to 6%	
Flush (Concrete Barrier)		34-3	Minimum: 16.2 m (8) 6.7 m (9)	Minimum: 15 m (8) 5.5 m (9)	
Clear Zone		38-3	(10)		
Roadway Slopes	Cut Section	Front Slope	1V:4H		
		Ditch Bottom Width	600 mm (11)		
	Back Slope	Back Slope	1V:3H (12)		
		Rock Cut			
Fill Section	Fill Section	34-4.02	1V:4H to Clear Zone; 1V:3H max. to Toe of Slope (13)		
		34-3	1V:4H		
Bridges	* Structural Capacity		MS-18		
		* Clear Roadway Width (14)	16.2 m	11.4 m	
	* Vertical Clearance (Freeway Under) (15a)	Existing Overpassing Bridges	39-4	4.9 m (15c)	
		Overhead Signs/ Pedestrian Bridges	33-5	5.2 m (15b)	
* Vertical Clearance (Freeway over Railroad)		39-4.06	6.6 m		

* Controlling design criteria (see Section 31-8).

GEOMETRIC DESIGN CRITERIA FOR EXISTING CROSS-SECTION ELEMENTS TO REMAIN IN PLACE ON RURAL FREEWAYS⁽¹⁾ (Reconstruction) (Metric)

Figure 44-5.B

- (1) Design Criteria. The minimum cross-section elements in this figure are allowed to remain in place for reconstruction of an existing freeway provided it is cost effective and the safety record is satisfactory.
- (2) Traffic Volumes. The design hourly volumes (DHV) are calculated assuming base conditions (except for 16% heavy vehicles) and a PHF = 1.0. Adjust these values using local factors.
- (3) Design Speed. Existing alignment elements may be allowed to remain in place, provided the comfortable operating speed for level and rolling terrain is a minimum of 65 mph (105 km/h) and 60 mph (100 km/h) respectively.
- (4) Traveled Way Width. In existing 22' (6.7 m) traveled way width may be allowed to remain with concurrence of a design exception.
- (5) Shoulder Width (Right). Where the directional distribution of trucks exceeds 250 DDHV, consider providing a 12 ft (3.6 m) paved shoulder.
- (6) Shoulder Width (Left). Where there are three or more lanes in one direction and the directional distribution of trucks exceeds 250 DDHV, consider providing a 12 ft (3.6 m) paved shoulder.
- (7) Travel Lane Cross Slope. For each additional lane away from the crown lanes, increase the cross slope by 1/16"/ft (0.5%) per additional lane up to a maximum of 5/16"/ft (2.5%).
- (8) Depressed Median Width. Median width based on paved shoulder width 1V:6H median slope, and 2 ft (600 mm) ditch bottom width.
- (9) Flush Median Width. Only use flush medians with concrete barrier where right-of-way or topography restricts the use of a depressed median. Consider providing wider medians where required for snow storage.
- (10) Clear Zone. The clear zone will vary according to design speed, traffic volumes, side slopes, and horizontal curvature.
- (11) Ditch Bottom Width. Provide a wider outside ditch bottom where detention storage of storm water is a consideration.
- (12) Back Slope. Where the height of cut exceeds 10 ft (3 m), consider using a 1V:2H back slope beyond the clear zone. Also, for heights greater than 30 ft (9 m), consider the use of benching.
- (13) Fill Slope. For fill heights greater than 30 ft (9 m), use a 1V:2H uniform slope with a roadside barrier. Also, for heights greater than 30 ft (9 m), consider the use of benching.
- (14) Existing Bridge Widths to Remain in Place. Clear roadway bridge widths are measured from face to face of parapets or rails. Implies elements allowed to remain in place without a design exception approval when cost effective and when safety record is satisfactory.
- (15) Vertical Clearance (Freeway Under).
 - a. The clearance must be available over the traveled way and any paved shoulders.
 - b. Make allowances to maintain 16 ft-0 in (4.9 m) minimum vertical clearance in anticipation of future overlays.
 - c. In urban areas, a 15 ft 0 in (4.5 m) clearance may be used where a single routing interstate with a 16 ft 0 in (4.9 m) clearance is available. See Section 44-6 for maps of the single routing in urban areas of Illinois.

**GEOMETRIC DESIGN CRITERIA FOR EXISTING CROSS-SECTION ELEMENTS
TO REMAIN-IN-PLACE ON RURAL FREEWAYS
(Reconstruction)
Footnotes to Figure 44-5.B**

Design Element		Manual Section	Urban One-Way DHV: 2800 - 4300 (2)	Urban One-Way DHV: Under 2800 (2)	
Design Controls	Design Forecast Year	31-4.02	20 Years		
	*Design Speed	31-2	60 mph (3)		
Cross Section Elements	Access Control	35-1	Full Control		
	Level of Service	31-4.04	C (4)		
	*Traveled Way Width	34-2.01	2 @ 36'	2 @ 24' (5)	
	Shoulder Width	Right	34-2.02	10'	10'
		Left		10' (6)	10' (6)
	Auxiliary Lanes	Total Width	37-2.05	8'	6'
		Paved		8' (7)	4'
	Cross Slope	Lane Width	34-2.01	11'	
		Shoulder Width		Right: 6' Left: 4' (Minimum)	
	Median Width	*Travel Lane	34-2.02	3/16"/ft for lanes adjacent to crown (8)	
Shoulder		1/2"/ft to 3/4"/ft			
Clear Zone	Depressed	34-3	Minimum: 42' (9)	Minimum: 40' (9)	
	Flush (Concrete Barrier)		16' (10)	18'-6" (10)	
Roadway Slopes	Cut Section (12)	34-4.03	(11)		
			Front Slope	1V:4H	
			Ditch Bottom Width	2.0'	
	Side Slopes	Back Slope	34-4.05	1V:3H (13)	
		Rock Cut			
Median Slopes	Fill Section	34-4.02	1V:4H to Clear Zone; 1V:3H max. to Toe of Slope (14)		
			1V:4H		
Bridges	Existing Bridges to Remain in Place	N/A	HS-20		
	*Structural Capacity				
	*Vertical Clearance (Freeway Under) (16a)	*Clear Roadway Width (15)	39-6	54'	38'
		Existing Overpassing Bridges		16'-0" (16c)	
		Overhead Signs/ Pedestrian Bridges		17'-00" (16b)	
	*Vertical Clearance (Freeway over Railroad)		39-4.06	21'-6"	

* Controlling design criteria (see Section 31-8)

GEOMETRIC DESIGN CRITERIA FOR EXISTING CROSS-SECTION ELEMENTS TO REMAIN IN PLACE ON URBAN FREEWAYS⁽¹⁾
 (Reconstruction)
 (US Customary)

Figure 44-5.C

Design Element		Manual Section	Urban One-Way DHV: 2800 - 4300 (2)	Urban One-Way DHV: Under 2800 (2)	
Design Controls	Design Forecast Year	31-4.02	20 Years		
	*Design Speed	31-2	100 km/h (3)		
Cross Section Elements	Access Control	35-1	Full Control		
	Level of Service	31-4.04	C (4)		
	*Traveled Way Width	34-2.01	2 @ 10.8 m	2 @ 7.2 m (5)	
	Shoulder Width	Right		3.0 m	3.0 m
		Left		3.0 m (6)	3.0 m (6)
	Auxiliary Lanes	Total Width		2.4 m	1.8 m
		Paved		2.4 m (7)	1.2 m
	Cross Slope	Lane Width		3.3 m	
		Shoulder Width		Right: 1.8 m Left: 1.2 m (Minimum)	
	Median Width	*Travel Lane	34-2.01	1.5% for lanes adjacent to crown (8)	
Shoulder		34-2.02	4% to 6%		
Clear Zone	Depressed	34-3	Minimum: 12.8 m (9)	Minimum: 12.0 m (9)	
	Flush (Concrete Barrier)	38-3	4.8 m (10)	5.5 m (10)	
Roadway Slopes	Cut Section (12)	Front Slope	(11)		
		Ditch Bottom Width	1V:4H		
	Back Slope	Back Slope	34-4.03	600 mm	
		Rock Cut		1V:3H (13)	
	Fill Section	34-4.05			
Median Slopes	34-4.02	1V:4H to Clear Zone; 1V:3H max. to Toe of Slope (14)			
Bridges	Existing Bridges to Remain in Place	34-3	1V:4H		
		N/A	MS-18		
	*Vertical Clearance (Freeway Under) (16a)	*Structural Capacity	39-6	16.2 m	11.4 m
		*Clear Roadway Width (15)	39-5	4.9 m (16c)	
	*Vertical Clearance (Freeway over Railroad)	33-5	5.2 m (16b)		
	39-4.06	6.6 m			

* Controlling design criteria (see Section 31-8)

GEOMETRIC DESIGN CRITERIA FOR EXISTING CROSS-SECTION ELEMENTS TO REMAIN IN PLACE ON URBAN FREEWAYS⁽¹⁾ (Reconstruction) (Metric)

Figure 44-5.C

- (1) Design Criteria. The minimum cross-section elements in this figure are allowed to remain in place for reconstruction of an existing freeway provided it is cost effective and the safety record is satisfactory.
- (2) Traffic Volumes. The design hourly volumes (DHV) are calculated assuming base conditions (except for 16% heavy vehicles) and a PHF = 1.0. Adjust these values using local factors.
- (3) Design Speed. With restricted conditions, a minimum design speed of 55 mph (90 km/h) may be considered to remain-in-place with study and justification. Also, consider the existing posted speed limits.
- (4) Level of Service. In major urban areas, a level of service D may be considered on a reconstruction project with study and justification.
- (5) Traveled Way Width. In existing 22 ft (6.7 m) traveled way width may be allowed to remain with concurrence of a design exception.
- (6) Shoulder Width (Right). Where the directional distribution of trucks exceeds 250 DDHV, consider providing a 12 ft (3.6 m) paved shoulder.
- (7) Shoulder Width (Left). Where there are three or more lanes in one direction and the directional distribution of trucks exceeds 250 DDHV, consider providing a 12 ft (3.6 m) paved shoulder.
- (8) Travel Lane Cross Slope. For each additional lane away from the crown lanes, increase the cross slope by 1/16"/ft (0.5%) per additional lane up to a maximum of 5/16"/ft (2.5%).
- (9) Depressed Median Width. Median width based on 1V:4H median slope, and 2 ft (600 mm) ditch bottom width (3 – Lanes/Direction) or 4ft. (1.2 m) ditch bottom width (2-Lanes/Direction).
- (10) Flush Median Width. Only use flush medians with concrete barrier where right-of-way or topography restricts the use of a depressed median. Consider providing wider medians where required for snow storage.
- (11) Clear Zone. The clear zone will vary according to design speed, traffic volumes, side slopes, and horizontal curvature.
- (12) Cut Section. In restricted right-of-way, the typical design will have mountable curb and gutter behind the shoulder and an enclosed drainage system.
- (13) Back Slope. Where the height of cut exceeds 10 ft (3 m), consider using a 1V:2H back slope beyond the clear zone. Also, for heights greater than 30 ft (9 m), consider the use of benching.
- (14) Fill Slope. For fill heights greater than 30 ft (9 m), use a 1V:2H uniform slope with a roadside barrier. Also, for heights greater than 30 ft (9 m), consider the use of benching.
- (15) Existing Bridge Widths to Remain in Place. Clear roadway bridge widths are measured from face to face of parapets or rails. Implies elements allowed to remain in place without a design exception approval when cost effective and when safety record is satisfactory.
- (16) Vertical Clearance (Freeway Under).
 - a. The clearance must be available over the traveled way and any paved shoulders.
 - b. A 15 ft 0 in (4.5 m) clearance may be used where a single routing interstate with a 16 ft 0 in (4.9 m) clearance is available.
 - c. In urban areas, a 15 ft 0 in (4.5 m) clearance may be used where a single routing interstate with a 16 ft 0 in (4.9 m) clearance is available. See Section 44-6 for maps of the single routing in urban areas of Illinois.

**GEOMETRIC DESIGN CRITERIA FOR EXISTING CROSS-SECTION ELEMENTS
TO REMAIN-IN-PLACE ON URBAN FREEWAYS
(Reconstruction)
Footnotes to Figure 44-5.C**

Design Element	Manual Section	Design Speed		
		60 mph	70 mph	75 mph
* Stopping Sight Distance (1)	31-3.01	570'	730'	820
Decision Sight Distance (2)	31-3.02	Rural: 990' Urban: 1280'	1105'	1180'
* Minimum Radii	32-2.03	$e_{max} = 6\%$ (New)	Desirable: > 3000' Minimum: 2040'	Desirable: > 3000' Minimum: 2500'
		$e_{max} = 8\%$ (Reconstruction)	Minimum: 1200' (3)	Minimum: 1810' (3)
* Superlevation Rates	32-3	New: $e_{max} = 6\%$ Reconstruction: $e_{max} = 8\%$ (3)		
* Horizontal Sight Distance	32-4	(4)		
* Vertical Curvature (K-values)	33-4	Crest	247	312
		Sag	136	181
* Maximum Grade (5)	33-2.02	Level	New: 3%	Remain in Place: 4%
		Rolling	New: 4%	Remain in Place: 5%
Minimum Grade	33-2.03	Rural	Desirable: 0.5% Minimum: 0.0% (with Special Ditching)	
		Urban	Desirable: 0.5% Minimum: 0.3% (with Curb and Gutter) (6)	

* Controlling design criteria (see Section 31-8).

- (1) Stopping Sight Distance. Table values are for passenger cars on level grade.
- (2) Decision Sight Distance. Table values are for the avoidance maneuver (speed/path/direction change).
- (3) Minimum Radii/Superlevation Rates. Values are only allowed for remain-in-place elements.
- (4) Horizontal Sight Distance. For a given design speed, the necessary middle ordinate will be determined by the radius of curve and the required sight distance.
- (5) Maximum Grade.
 - a. Rural. With wide medians where two roadways are on independent alignments, downgrades may be 1% steeper.
 - b. Urban. Grades 1% steeper may be used for restricted conditions.
- (6) Minimum Grades. Where curb and gutter is required due to restricted right-of-way, use M-4.24 curb and gutter and locate it no closer than the outer edge of shoulder.

**ALIGNMENT CRITERIA FOR FREEWAYS
(US Customary)**

Figure 44-5.D

Design Element	Manual Section	Design Speed	
		100 km/h	110 km/h
*Stopping Sight Distance (1)	31-3.01	185 m	216 m
Decision Sight Distance (2)	31-3.02	Rural: 315 m Urban: 400 m	330 m
*Minimum Radii	e _{max} = 6% (New) e _{max} = 8% (Reconstruction)	Desirable: > 1000 m Minimum: 437 m	Desirable: > 1000 m Minimum: 560 m
		394 m (3)	501 m (3)
*Superelevation Rates	32-3	New: e _{max} = 6%	Reconstruction: e _{max} = 8% (3)
*Horizontal Sight Distance	32-4	(4)	
*Vertical Curvature (K-values)	Crest	52	74
	Sag	45	55
*Maximum Grade (5)	Level	New: 3% Remain in Place: 4%	
	Rolling	New: 4% Remain in Place: 5%	
Minimum Grade	Rural	Desirable: 0.5% Minimum: 0.0% (with Special Ditching)	
	Urban	Desirable: 0.5% Minimum: 0.3% (with Curb and Gutter) (6)	

* Controlling design criteria (see Section 31-8 and Form BDE 31-8).

- (1) Stopping Sight Distance. Table values are for passenger cars on level grade.
- (2) Decision Sight Distance. Table values are for the avoidance maneuver (speed/path/direction change).
- (3) Minimum Radii/Superelevation Rates. Values are only allowed for remain-in-place elements.
- (4) Horizontal Sight Distance. For a given design speed, the necessary middle ordinate will be determined by the radius of curve and the required sight distance.
- (5) Maximum Grade.
 - a. Rural. With wide medians where two roadways are on independent alignments, downgrades may be 1% steeper.
 - b. Urban. Grades 1% steeper may be used for restricted conditions.
- (6) Minimum Grades. Where curb and gutter are required due to restricted right-of-way, use M-10.60 curb and gutter and locate it no closer than the outer edge of shoulder.

**ALIGNMENT CRITERIA FOR FREEWAYS
(Metric)**

Figure 44-5.D

44-6 SINGLE INTERSTATE ROUTING FOR SELECT URBAN AREAS

The integrity of the Interstate System for national defense purposes shall be maintained to meet AASHTO policy as stated in AASHTO's "A Policy on Design Standards - Interstate System." IDOT requires vertical clearances on new construction/reconstruction Interstate sections in rural areas and single routing through or around urban areas to be no less than 16 ft 09 in (5.1 m). The clear height of structures over other urban interstate routes shall not be less than 15 ft 00 in (4.5 m). This clearance is required over the full roadway width (travel lanes and usable shoulders), including ramps and collector-distributor roadways within Interstate-to-Interstate interchanges.

The FHWA allows a minimum 16 ft 00 in (4.9 m) in rural areas and along the single routing in urban areas. The minimum vertical clearance in other urban areas shall be no less than 14 ft 00 in (4.3 m). The extra clearance IDOT requires allows for future overlays. The urban areas in Illinois where single routing occurs and the figures showing maps of the routing are:

- the Chicago urban area¹; Figure 44-6.A
- Metro-east St. Louis urban area; Figure 44-6.B
- Peoria urban area, Figure 44-6.C
- Quad Cities; and Figure 44-6.D

The Federal Highway Administration (FHWA) and the Surface Deployment and Distribution Command Transportation Engineering Agency (SDDCTEA), previously the Military Traffic Command Transportation Engineering Agency, have cooperated to meet the demands of the military traffic on the Interstate System, particularly in the area of vertical clearance. The coordination and reporting with the SDDCTEA on all design exceptions for vertical clearance is to ensure the Department of Defense is aware of the locations of nonstandard clearances on the Interstate System in the event a defense emergency arises. The military continues to have a need for the 16-ft (4.9m) clearance. While the size of future equipment that may use the Interstate System is unknown, the SDDCTEA needs to ensure options remain for the routing of military equipment.

1. The map for the Chicago metropolitan area is the most current available. The SDDCTEA have added the section of I-355 between I-80 and I-55 to the single routing since this map was released.

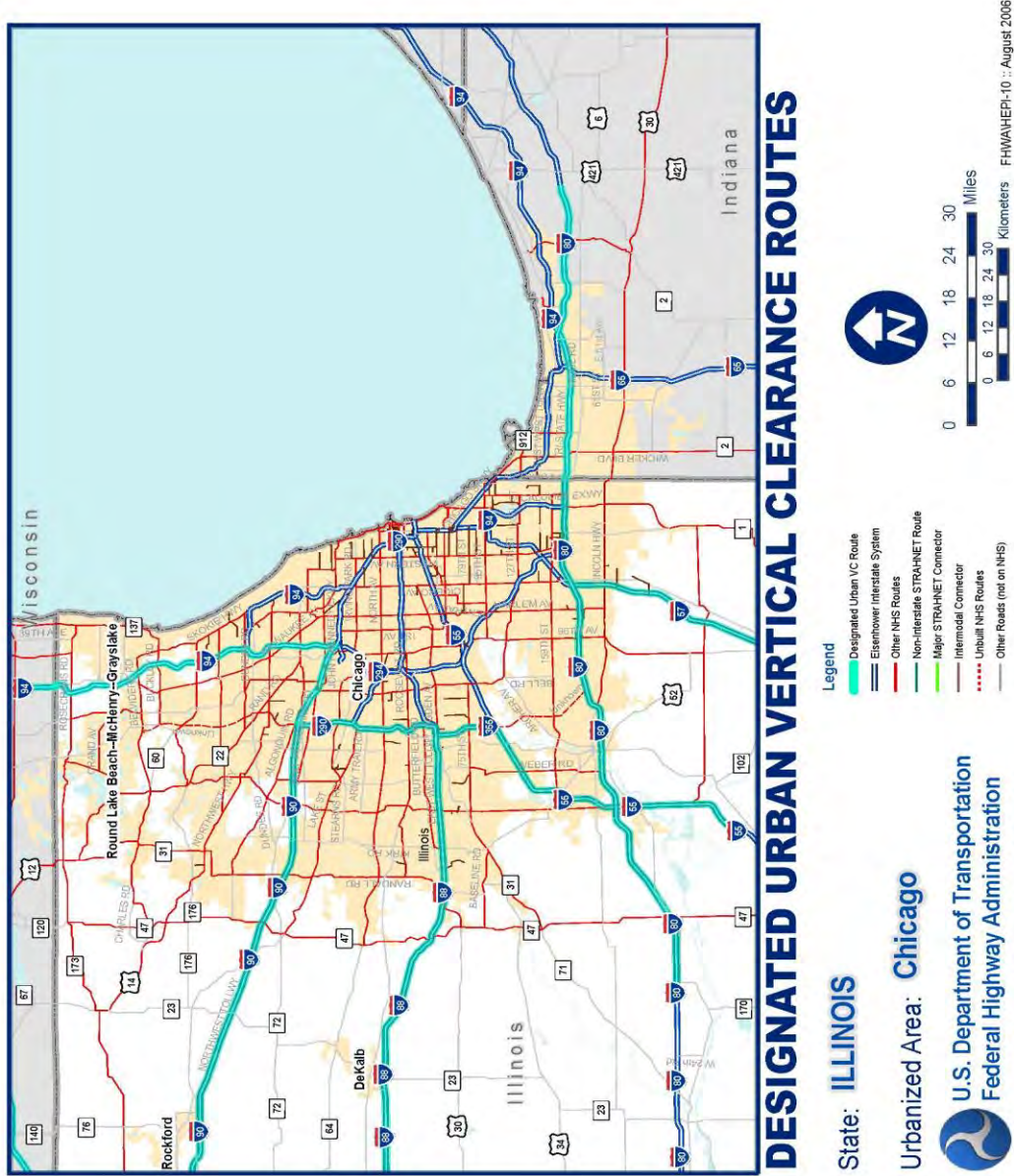

SINGLE INTERSTATE ROUTING FOR THE CHICAGO URBAN AREA

FIGURE 44-6.A

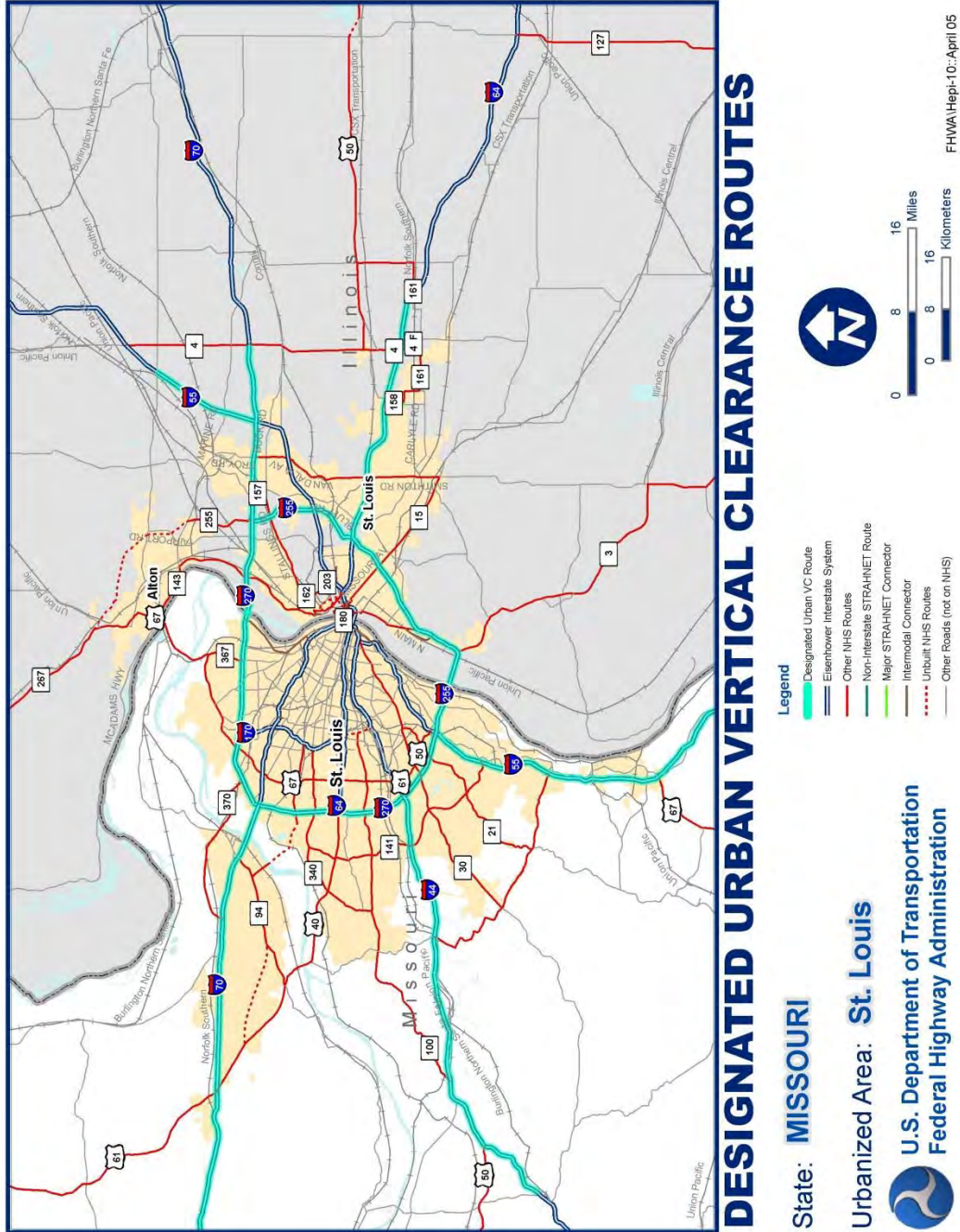

SINGLE INTERSTATE ROUTING FOR THE METRO-EAST URBAN AREA

FIGURE 44-6.B

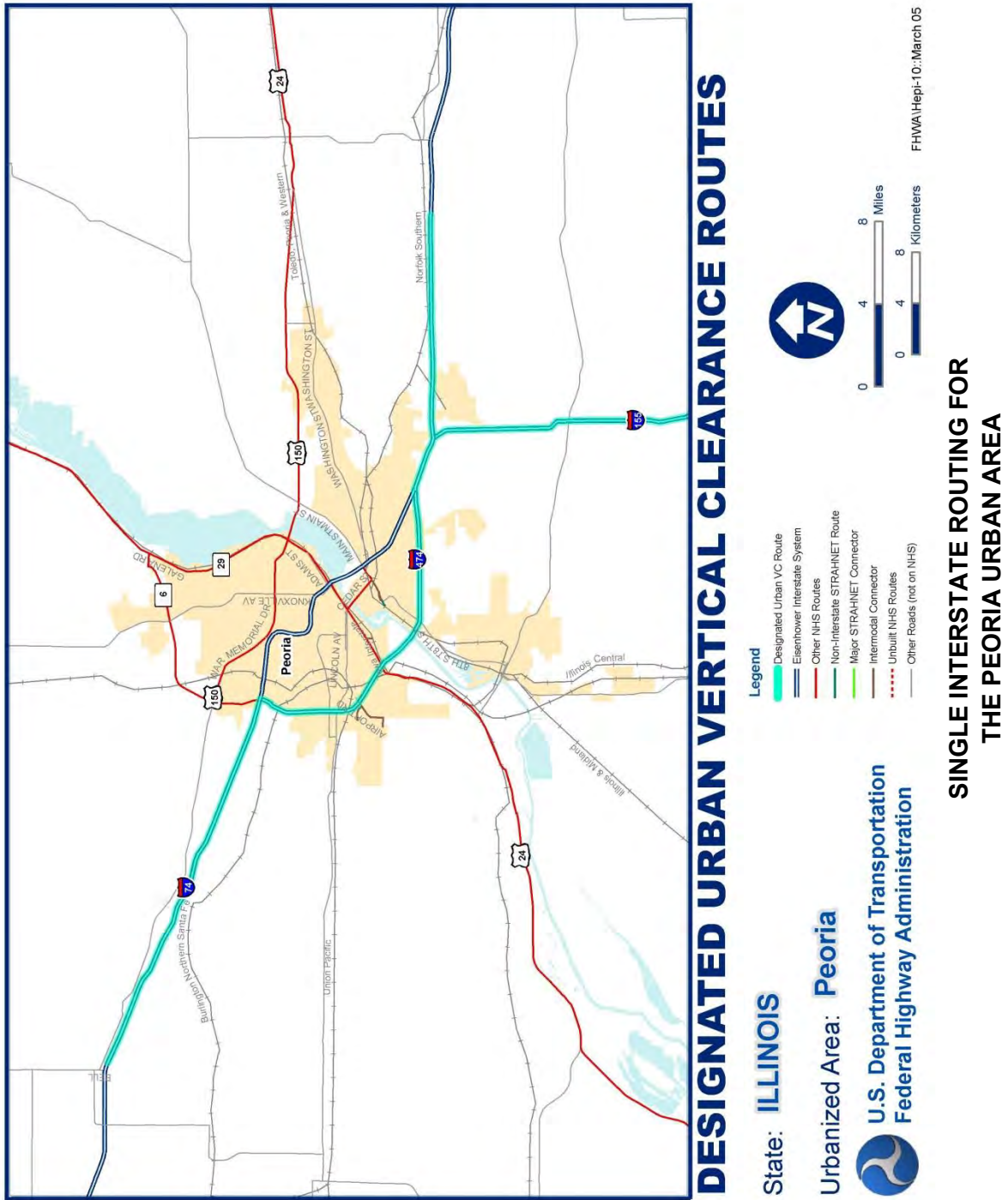
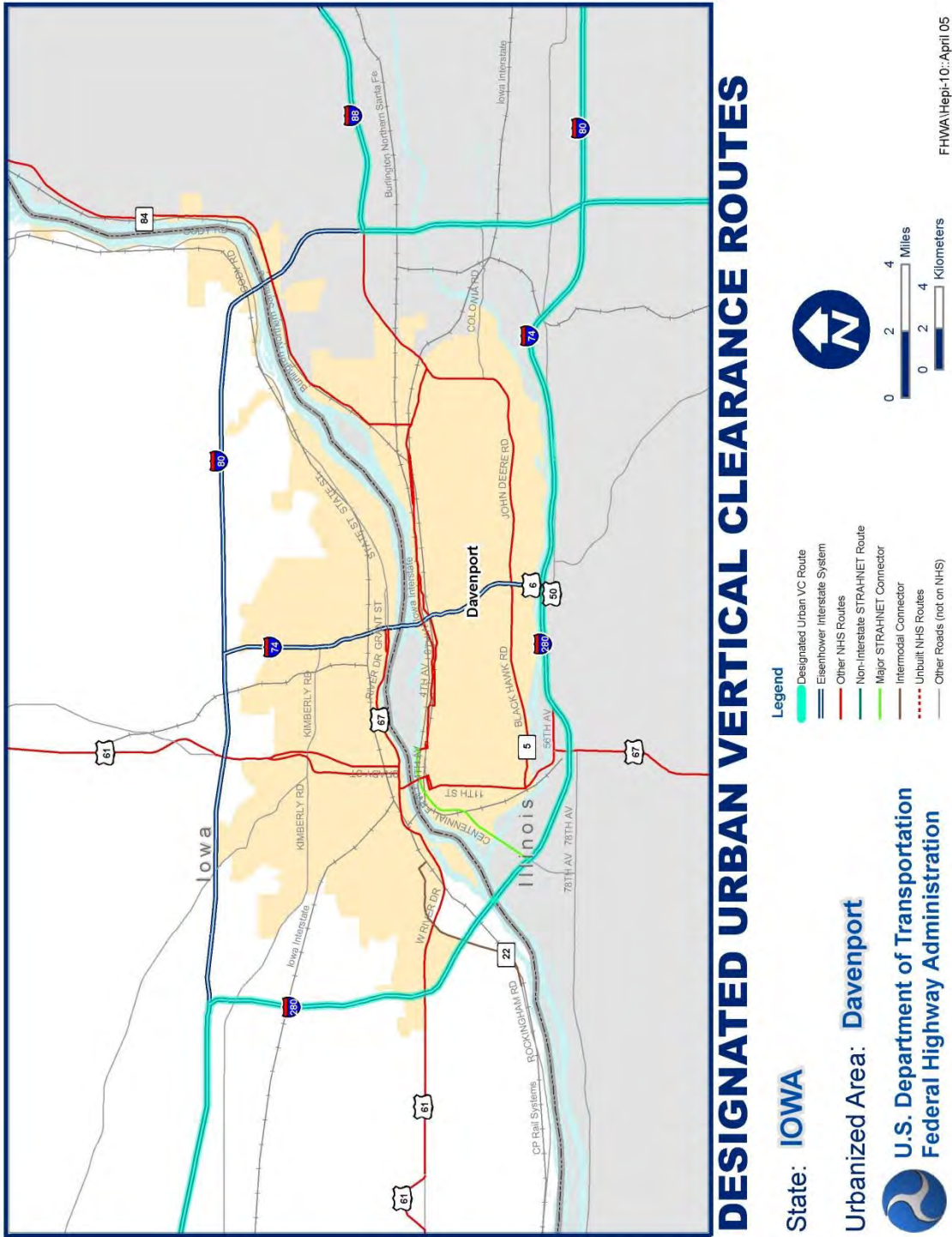

FIGURE 44-6.C



DESIGNATED URBAN VERTICAL CLEARANCE ROUTES

State: **IOWA**

Urbanized Area: **Davenport**



SINGLE INTERSTATE ROUTING FOR THE QUAD CITIES URBAN AREA

FIGURE 44-6.D

FHWA\Hep1-10:April 05

44-7 REFERENCES

1. *A Policy on Geometric Design of Highways and Streets*, AASHTO, 2011.
2. *A Policy on Design Standards — Interstate System*, AASHTO, 2005.
3. *Manual on Uniform Traffic Control Devices*, FHWA, ATSSA, AASHTO, and ITE, 2009.
4. *Highway Safety Design and Operations Guide*, AASHTO, 1997.
5. NCHRP Synthesis 185, *Preferential Lane Treatments for High-Occupancy Vehicles*, Transportation Research Board, 1993.
6. *Guide for the Design of High-Occupancy Vehicle Facilities*, AASHTO, 2004.
7. *Roadside Design Guide*, AASHTO, 2011.

Chapter Forty-five

EXPRESSWAYS
(New Construction/Reconstruction)

BUREAU OF DESIGN AND ENVIRONMENT MANUAL

Chapter Forty-five
EXPRESSWAYS (New Construction/Reconstruction)

Table of Contents

<u>Section</u>	<u>Page</u>
45-1 GENERAL	45-1.2
45-1.01 Design Studies	45-1.2
45-1.02 Establishing An Expressway	45-1.2
45-1.03 Crossroads.....	45-1.2
45-1.03(a) Interchanges/Intersections	45-1.2
45-1.03(b) Grade Separations	45-1.3
45-2 GEOMETRIC DESIGN FEATURES	45-2.1
45-2.01 Design Speed	45-2.1
45-2.02 Alignment.....	45-2.1
45-2.03 Typical Sections.....	45-2.2
45-2.04 Access Control.....	45-2.2
45-2.05 Intersections.....	45-2.8
45-2.06 Medians	45-2.9
45-2.06(a) General.....	45-2.9
45-2.06(b) Crossover Spacing.....	45-2.9
45-2.07 Future Public Road or Street Connections	45-2.11
45-2.08 Frontage Roads/Service Drives.....	45-2.11
45-2.09 Entrances.....	45-2.14
45-2.09(a) Agricultural and Residential Entrances.....	45-2.14
45-2.09(b) Entrances Other Than Agricultural or Residential.....	45-2.16
45-3 OTHER DESIGN FEATURES	45-3.1
45-3.01 Lane Transitions.....	45-3.1
45-3.02 Median Width Transitions.....	45-3.6
45-3.03 Underdrains	45-3.6
45-3.04 Mailboxes.....	45-3.6
45-4 TABLES OF DESIGN CRITERIA.....	45-4.1
45-5 REFERENCES.....	45-5.1

Chapter Forty-five

EXPRESSWAYS

(New Construction/Reconstruction)

Expressways are functionally classified as Other Principal Arterials and are constructed with partial control of access. Expressways are intended to provide high efficiency, safety, and move high volumes of traffic at high speeds. The operational efficiency, capacity, safety, and cost of the highway facility are largely dependent upon its design. Intersections are an integral feature of an expressway design. Chapter 45 provides guidance in the design of expressways including specific design criteria, frontage roads, median openings, service drive connections, public road connections, and transitions. Information that is also applicable to expressways is included in the following chapters:

- Chapter 11 discusses the design of expressway alignment and profile.
- Chapter 14 discusses intersection design studies.
- Chapter 15 discusses interchange type and design studies.
- Chapters 31, 32, 33, 34, and 39 provide guidance on the geometric design elements that are also applicable to expressways.
- Chapter 35 provides guidelines on the access control around interchanges and intersections on expressways. It also discusses the procedures for preparing access control plans.
- Chapter 36 provides information on the design of intersections including left- and right-turn lanes, channelization, and intersection sight distance. Certain alternative intersection types can often be considered along expressway facilities; see 36-1.03(b).
- Chapter 37 discusses the type, location, layouts, and design of interchanges.
- Chapter 38 provides guidelines on roadside safety issues.
- Chapter 44 discusses the procedures for designing freeways, which require full control of access. New-alignment expressway bypasses may include sections with full control of access.

45-1 GENERAL

45-1.01 Design Studies

Chapter 11 discusses the procedures for determining the location of expressways within a corridor. Factors that determine an expressway alignment include:

- existing roadway alignment (many rural expressways will involve constructing a travel way adjacent and parallel to an existing two-lane highway);
- logical and effective locations for proposed interchanges;
- locations of structures over railroads, streams, and river crossings;
- access control along the expressway and crossroads at interchanges and intersections;
- access to property and right-of-way restrictions;
- topography; and
- environmental restrictions.

45-1.02 Establishing An Expressway

When a highway is designated and designed as an expressway, the district must prepare and file an Order Establishing a Freeway sometime after receiving design approval but before construction plans are finalized. The details of this procedure are discussed in Chapter 12. The Order must include the access control limits along the mainline, the location of access breaks for field and private entrances, and the limits of access control along each crossroad.

In addition to filing an Order Establishing a Freeway, the district should also consider filing a Corridor Protection Map. The procedures for this process are described in the *Land Acquisition Policies and Procedures Manual*.

45-1.03 Crossroads

With expressways crossroads usually remain open and are designed as intersections, but also consider opportunities to relocate lower-volume routes. At some locations, a grade separation and/or interchange may be proposed at a crossroad. The following Sections provide guidance for making these decisions.

45-1.03(a) Interchanges/Intersections

For rural expressways, full-access or alternative-access intersections are provided with most public crossroads. When reconstructing urban expressways, limit the number of such

connections and space them according to Section 45-2.06(b). Chapter 36 provides the design criteria for intersections that are also applicable to expressways.

Accurate traffic projections based on reasonable estimates of local and regional growth are very important in the planning of expressways. Over-estimation of growth may result in excessive right-of-way acquisition for unnecessary interchanges; underestimation of growth can create future operational concerns at the at-grade intersections. Interchanges may be constructed or planned at state marked routes or high-volume county highways. Apply the following guidelines in decision making:

- Consider constructing an interchange initially where traffic signals are expected to be warranted within nine years of construction.
- Where projected traffic volumes show a warrant for traffic signals within 10 to 20 years, initially provide a traditional or alternative intersection. Depending on the analysis of future operations, consider a design that can be adapted to accommodate a future interchange. This will include purchasing the access rights for approximately 1000 ft to 1200 ft (300 m to 350 m) along each leg of the crossroad.
- If traffic signals are not warranted within the 20-year design life, construct a two-way stop-controlled traditional or alternative intersection.
- Where a low-volume marked route exists within 2 miles (3 km) of another parallel marked route or high-volume crossroad, consider relocating the low-volume route and only provide one interchange to serve both routes.

Signalized intersections along high-speed roadways can create safety concerns in part because drivers do not expect them. Therefore, when an interchange is not appropriate, a two-lane roundabout should be considered when signal warrants are met at any time within the 20-year design period. Consider the safety of all users in assessing a two-lane roundabout design option wherever two-way stop control will not be effective in handling projected traffic volumes and where local constraints or costs make an interchange impractical. Although roundabouts will increase travel time slightly versus a free-flow mainline condition, the resulting safety benefits as well as operational improvements for side road traffic and non-motorized users can often be substantial.

45-1.03(b) Grade Separations

Grade separations should be considered at all railroad crossings, sites where terrain contours favor the separation of grades, and at high-volume crossroads near an urbanized area where the crossroad connects with a marked route.

45-2 GEOMETRIC DESIGN FEATURES

45-2.01 Design Speed

Figures 45-4.A and 45-4.B provide the range of design speeds for expressways between 50 mph (80 km/h) and 70 mph (110 km/h). Most expressways are classified as rural and will have a 70 mph (110 km/h) design speed. Existing geometric design features may be allowed to remain in place in accordance with Section 45-2.02. For additional guidance on selecting design speeds for existing facilities, see Chapter 49 and consider the following:

- whether a new or existing alignment is proposed for the expressway,
- access restrictions and the level of access control that can be achieved,
- whether signalized intersections will be required initially or in the future, and
- construction costs.

45-2.02 Alignment

Expressways should have smooth-flowing horizontal and vertical alignments. Proper combinations of curvature, tangents, grades, and median types all combine to enhance the safety and aesthetics of expressways. When designing expressway alignments, consider the following:

1. Horizontal Alignment. In rural areas, use curve radii which yield consistent superelevation (SE) rates in the range of 3-4%. SE rates in this range are efficient, meet driver expectations, and minimize the design challenges at intersections/entrances.

Also design alignments to avoid SE transitions on bridges or bridge approach slabs. In urbanized areas where right-of-way is restricted, it may not be practical to avoid SE transition on bridges. See Section 32-3.07 for guidance on the location of horizontal curves near bridges.

Existing horizontal curves may remain in place provided they have a comfortable operating speed within 10 mph (15 km/h) of the design speed if there is no historical pattern of crashes within the curves. See Section 49-3 for guidance on comfortable operating speeds.

2. Vertical Alignment. For the vertical alignment, use design values in the “desirable” range to produce a smooth, aesthetically pleasing alignment. For existing alignments, the following will apply:
 - a. Sag Vertical Curves. Existing sag vertical curves may remain in place if they have a design speed within 20 mph (30 km/h) of the design speed if there is no historical pattern of crashes.
 - b. Crest Vertical Curves. Existing crest vertical curves may remain in place if they have a design speed within 15 mph (25 km/h) of the design speed if there is no historical pattern of crashes.

3. Horizontal and Vertical Combinations. Consider the relationship between horizontal and vertical alignments simultaneously to obtain a desirable condition. Chapter 33 discusses these relationships and their effect on aesthetics and safety.

45-2.03 Typical Sections

The tables in Section 45-4 provide the minimum criteria for lane widths, shoulder widths, median widths, and other cross section elements that should be used on expressways. Figures 45-2.A through 45-2.E illustrate schematic typical sections for various expressway designs.

45-2.04 Access Control

Access to expressways must be located at points that will enable vehicles to enter and exit without creating undue safety concerns. The controls governing the location of access points have some degree of flexibility to meet traffic needs, to fit terrain features, and to be cost effective. Locating access points must be done within the purpose and intent of partial access control. As part of locating access points designers must address safety performance and operational concerns with a goal of allowing mainline traffic to flow without excessive delay.

The types of access allowed on expressways (e.g., partial control, full control on new bypasses, entrances) are discussed throughout Section 45-2 and Chapter 35. Any major access changes should be discussed at district coordination meetings with both BDE and FHWA. When expressways are not on the National Highway System (NHS) exceptions to Department access criteria are reviewed and handled by BDE.

Chapter 35 provides the procedures for preparing access control plans during Phase I studies.

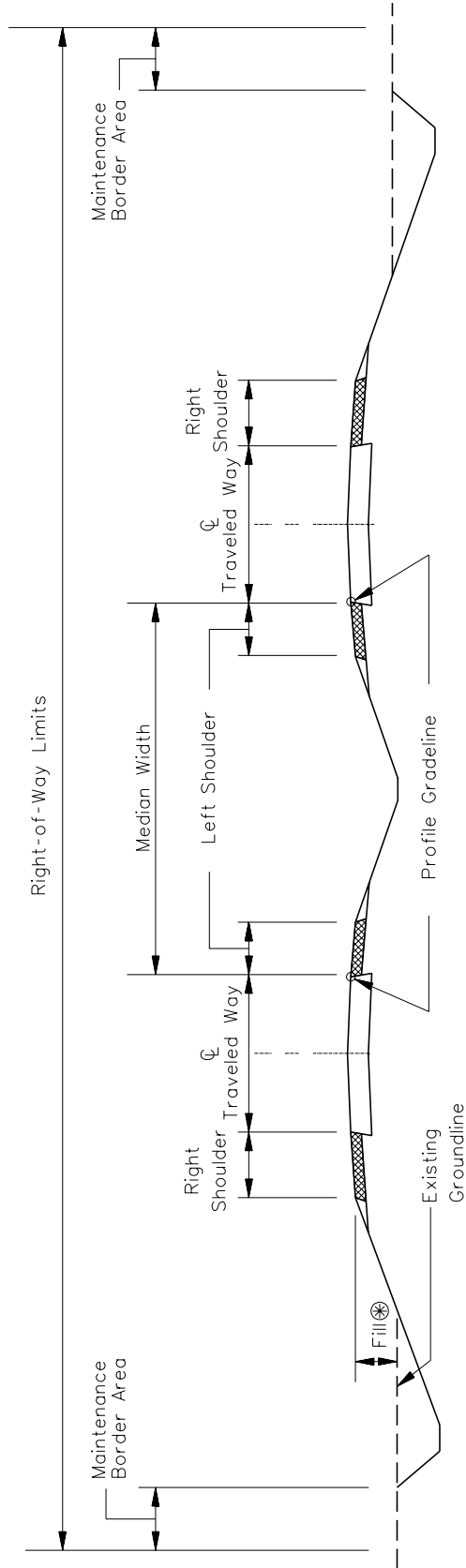

⊕ Roadway should be approximately 3' (1.0 m) above the existing ground line.

**TYPICAL SECTION FOR RURAL EXPRESSWAY
(New Alignment)**

Figure 45-2.A

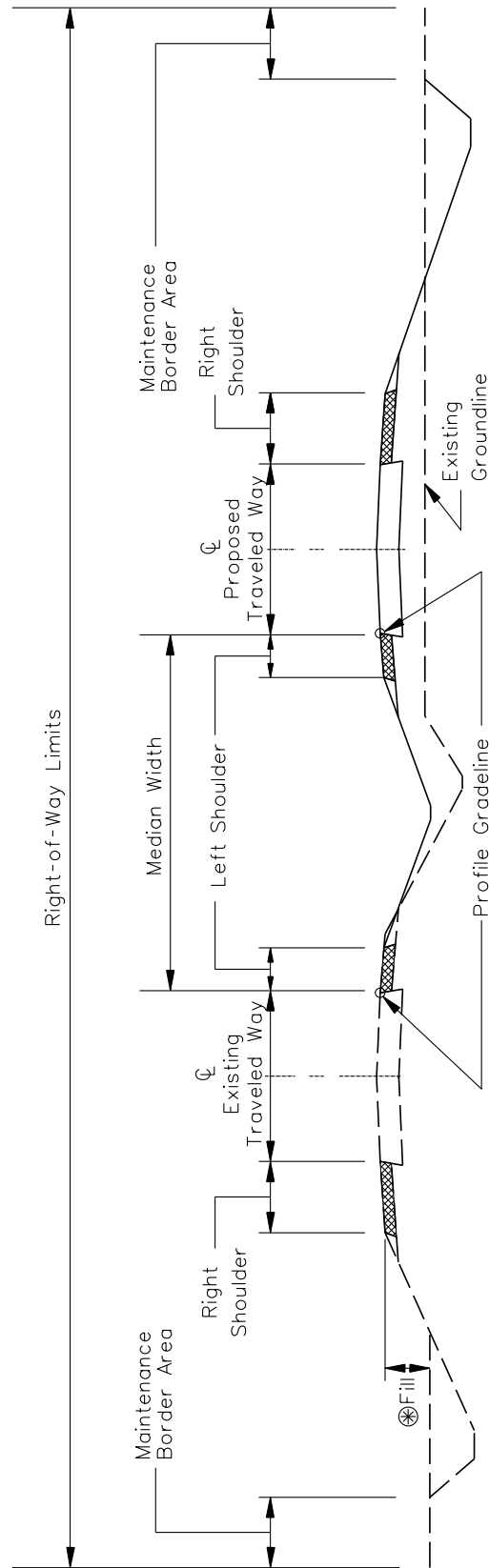

⊗ Roadway should be approximately 3' (1.0 m) above the existing ground line.

TYPICAL SECTION FOR RURAL EXPRESSWAY USING EXISTING ROADWAY

Figure 45-2.B

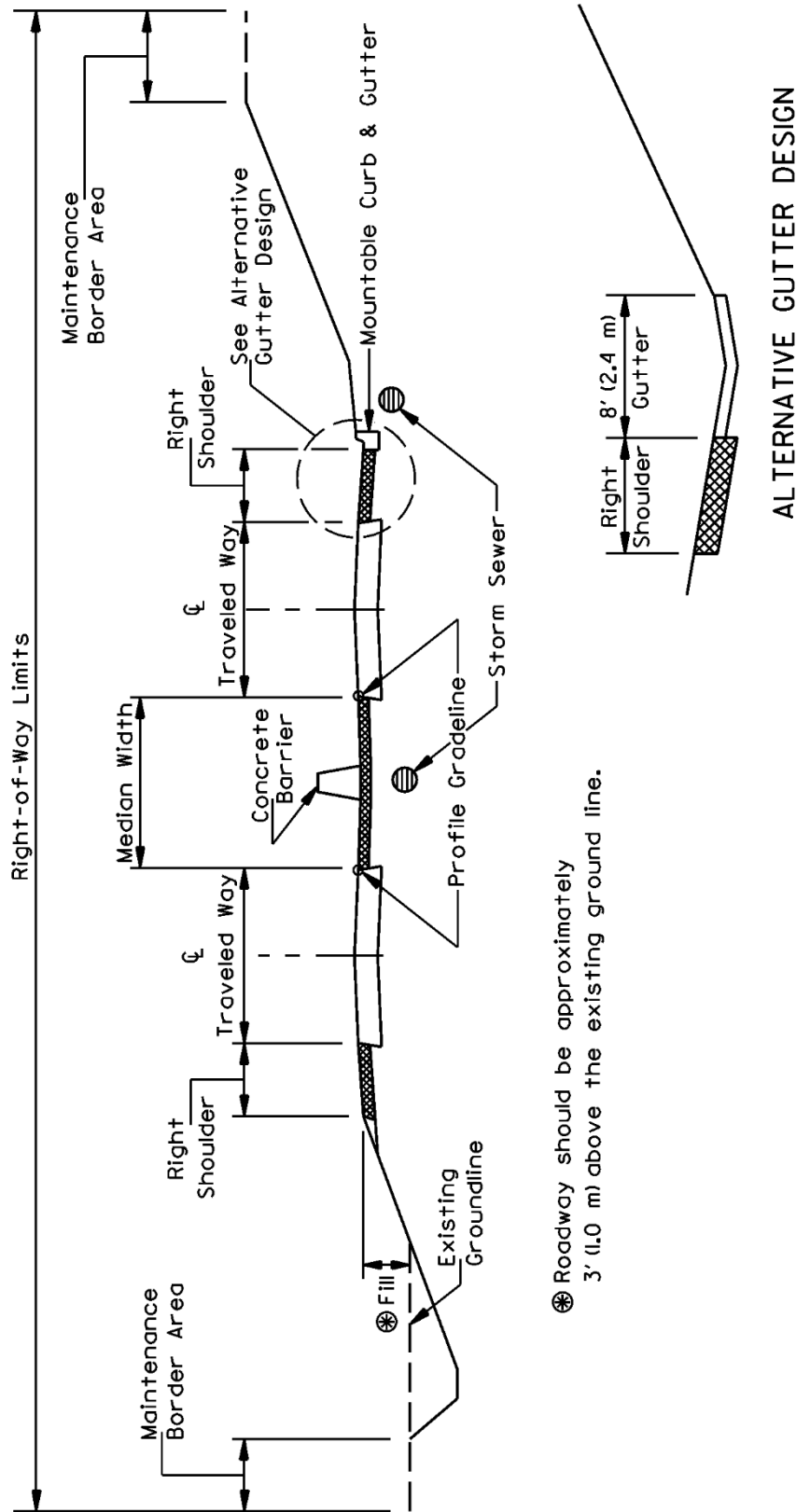

⊗ Roadway should be approximately 3' (1.0 m) above the existing ground line.

TYPICAL SECTION FOR URBAN EXPRESSWAY
(Flush Median with Concrete Barrier)

Figure 45-2.C

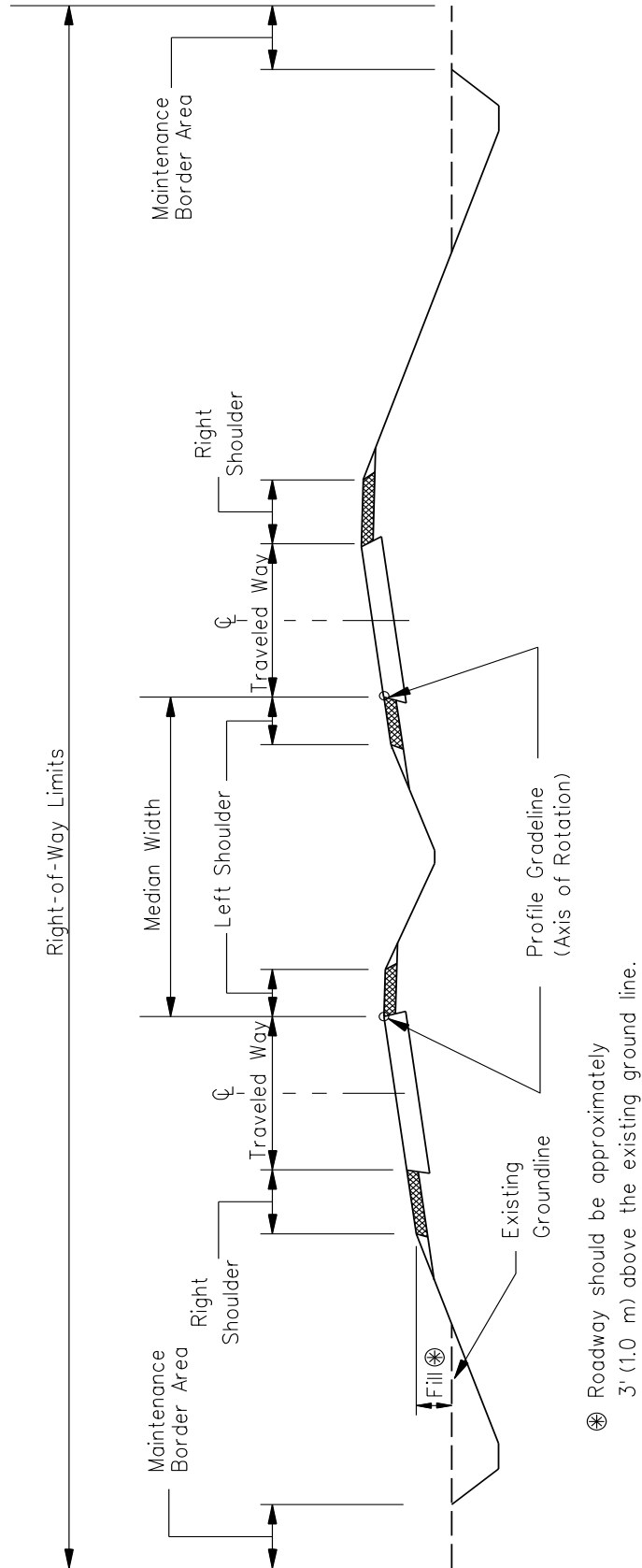

**TYPICAL SECTION FOR SUPERELEVATED EXPRESSWAY
(Depressed Median)**

Figure 45-2.D

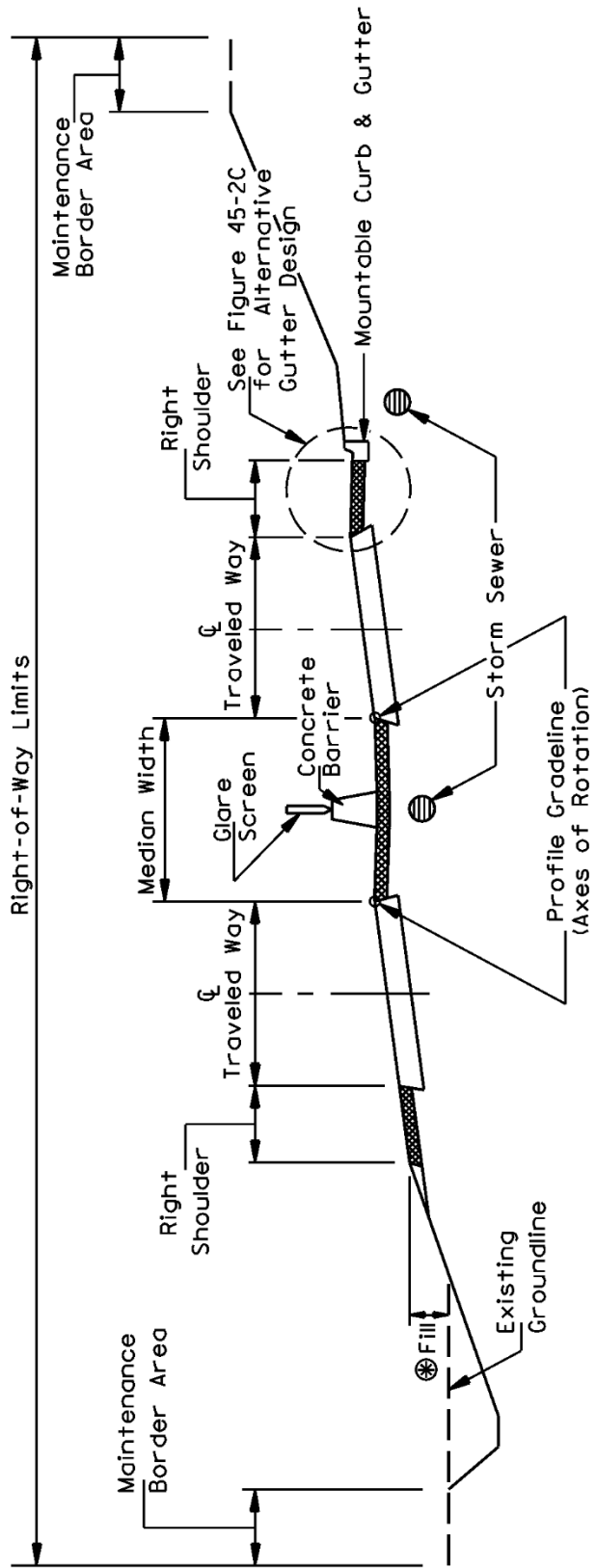

TYPICAL SECTION FOR SUPERELEVATED EXPRESSWAY
(Flush Median with Concrete Barrier)

Figure 45-2.E

45-2.05 Intersections

Chapter 36 provides the criteria for the design of intersections. In addition, the following will apply to expressways:

1. Definitions. The following definitions will apply to the crossroad:
 - a. Major Public Roads. These are facilities with ADT's of 1500 or greater.
 - b. Minor Public Roads. These are facilities with ADT's less than 1500.
2. Turn Lane Warrants. In addition to the turn lane warrants presented in Section 36-3.01, the following will apply to expressways:
 - a. Left-Turn Lanes. Provide left-turn lanes at all public road intersections and at any other locations where U-turns regularly occur.
 - b. Right-Turn Lanes. Provide right-turn lanes at all major public road intersections and at minor public road intersections where the ADT is greater than or equal to 250. At minor public road intersections where the ADT is less than 250, the use of right-turn lanes will be determined on a case-by-case basis.
3. Tapered Offset Left-Turn Lanes. For the design of tapered offset left-turn lanes, see Section 36-3.03(c).
4. Parallel Left-Turn Lanes. For the design of parallel left-turn lanes without an offset, see Section 36-3.03(b). Safety concerns arise with this type of design if they could create visibility constraints with opposing left-turning traffic.
5. Signalized Intersections. Signalized intersections on expressways typically are used only in urban and suburban areas. Due to the safety concerns presented by their "unexpected stop" conditions other options should always be considered. Provide interchanges where traffic signals are warranted; see Section 45-1.03(a). Also investigate alternative intersection designs that may best address operational and safety concerns; see Section 36-1.03(b).
6. Superelevation of Intersections. See Section 36-1.05(b) for intersection details on curves.
7. Design Speeds. In rural areas, use a 70 mph (110 km/h) design speed to design turn lanes on the expressway at major public road intersections and a 50 mph (80 km/h) design speed for turn lanes at minor public roads. In urban areas, use the mainline design speed, typically 50 mph (80 km/h) and also consider storage requirements to determine overall turn-lane lengths.
8. Lighting. Consider providing partial lighting at all major intersections. See Chapter 56 for information on highway lighting.

45-2.06 Medians

45-2.06(a) General

Expressway medians should be as wide as economic, operational, and environmental considerations will permit. Consider the following in the design of medians:

1. Median Selection. Section 34-3 discusses the purpose of medians, types of medians, and guidelines for their selection. Rural expressways generally will have depressed medians. In more urbanized areas where right-of-way is restricted, flush medians with concrete median barriers are typically used. Raised curb medians may only be used where design speeds will be 45 mph (70 km/h) or less, so they are rarely used along expressways.
2. Widths. Section 45-4 provides the minimum median width criteria. The designer should note the following:
 - Median widths of at least 50 ft (15 m), and preferably 64 ft (19 m), are recommended where a large number of trucks are turning or crossing.
 - In rural areas, median widths of 100 ft (30 m) or more may be appropriate when using independent alignments and based on engineering or aesthetic goals. These wider medians accommodate two-stage left turns and typically will not create operational or safety issues if well signed and marked.
 - Provide minimum 50 ft (15 m) wide medians where school buses may store within the median when performing left turning and crossing movements.
3. Median Openings. Section 36-4.04 provides the criteria for designing and laying out the median openings (crossovers) that are provided for full access intersections.
4. Median Barriers. Within narrow medians where the design speed is greater than or equal to 50 mph (80 km/h) a median barrier is required between the directional roadways. See Section 38-7 for guidelines on median barriers. Also, see Figure 36-3.M for how to terminate a median barrier at intersections.
5. Illustrations. Figures 45-2.A and 45-2.B illustrate a typical depressed median. Figure 45-2.C illustrates a typical flush median with a concrete median barrier.

45-2.06(b) Access and Crossover Spacing and Design

Paved median openings (crossovers) for U-turns, crossing and full-access entering/exiting movements along expressways should be constructed only where operationally necessary and where adequate sight lines can be provided. Initial and future crossover locations should be discussed and determined, to the extent practicable, during project planning stages and shown in a Phase I report. Provide the minimum number of median openings necessary to serve the existing road network during the initial construction. Additional crossovers may be considered

later as the need arises. In addition to crossovers at many township roads, most county highways, and most State highways, crossovers may also be considered:

- to permit full access to and from frontage roads and public service drives;
- to minimize the adverse travel from agricultural or residential entrances;
- where property, held under one ownership and used for farming, is severed by an expressway, and;
- to accommodate U-turn movements, often in conjunction with RCUT or other alternative intersections. Where U-turns are expected, median widths of less than 64 ft (19 m) will require the inclusion of outside “loon” areas to allow for tractor-semitrailer movements.

Space median crossovers on expressways according to the following:

1. Rural New Alignment. Space median crossovers, including those for intersecting public highways, an average of 1 mile (1600 m) as measured between adjacent intersections. However, closer spacing may be provided for severed farm tracts.
2. Rural Existing Alignment. Where the new roadway is constructed parallel and adjacent to the existing highway, the average crossover spacing may be reduced to ½ mile (800 m). A detailed study and analysis should document any recommendation to reduce the average spacing to ½ mile (800 m).
3. Urban New Alignment. Where a rural expressway is extended into an urbanized area and where a bypass alignment is feasible, design the bypass with full control of access. This eliminates cross traffic conflicts, stopping through traffic due to traffic signals, lower running speeds, and the potential for rear-end and right-angle crashes.
4. Urban Existing Alignment. Where an expressway design has been extended from a rural area through a developing urban area with restricted right-of-way and where reconstruction of an existing arterial is proposed to six lanes, space median crossovers on the average ¼ mile to ½ mile (400 m to 800 m) apart. Where reconstruction of an existing arterial is proposed to four lanes, space median crossovers no closer than 500 ft (150 m) and desirably 1320 ft to 1800 ft (400 m to 550 m) apart. At these distances, consider closing some median openings and only allowing right in and right out on the side street. Signalized intersections will exist and signal progression must be considered and investigated for the above designs.
5. Interchanges. The location of the first median crossover beyond the end of an interchange entrance ramp terminal will be dependent on the design speed of the expressway. See Chapter 35 for the applicable spacing criteria.
6. Near Bridges. Do not locate crossovers within 750 ft (225 m) of overhead bridge structures or within 750 ft (225 m) from the ends of mainline bridges. Provide adequate stopping sight distance on each side of the proposed crossover.

45-2.07 Future Public Road or Street Connections

Chapter 605 ILCS 5/8-107 of the *Illinois Highway Code* allows the Department, county, or municipality to give, withhold consent, or fix conditions on any request for connecting a new highway or other public way to an expressway. When reviewing a request for public road connections to an expressway, consider the following:

1. **Applications**. Permit applications must be presented by and issued in the name of the local public agency that will be responsible for the maintenance of the facility upon completion of construction. For a determination of financial responsibilities with public road connections, see the Department's *Joint Agreements Policy and Procedure Manual*.
2. **Spacing**. Limit the connections according to the median crossover spacing requirements noted in Section 45-2.06.
3. **System Design**. Evidence must be presented that the proposed public road or public service drive will become an integral part of an existing or definitely planned public road system. The access should not be merely a provision for internal circulation within a particular property.
4. **Access**. See Chapter 35 to determine location of the first point of access allowed along a proposed new connection. According to the *Illinois Highway Code*, the Department is authorized to define these first points of access adjacent to an expressway considering safety and traffic operations.

45-2.08 Frontage Roads/Service Drives

Access to expressways from frontage roads and public service drives is only permitted opposite median crossovers and should be designed according to Figures 45-2.H and 45-2.I. Space median crossovers according to Section 45-2.06(b). For expressways, the following definitions apply:

1. **Frontage Roads**. A public street or road normally located alongside of and parallel to an expressway. Its purpose is to maintain local road continuity and to provide for access. A frontage road is connected to public roads or streets at both ends. In some cases, it may be connected to a public road at one end and the expressway at the other.
2. **Service Drive**. Similar to a frontage road except that a service drive is normally connected to a public road or street at only one end. A private service drive is one that is maintained by the property owner(s) served.

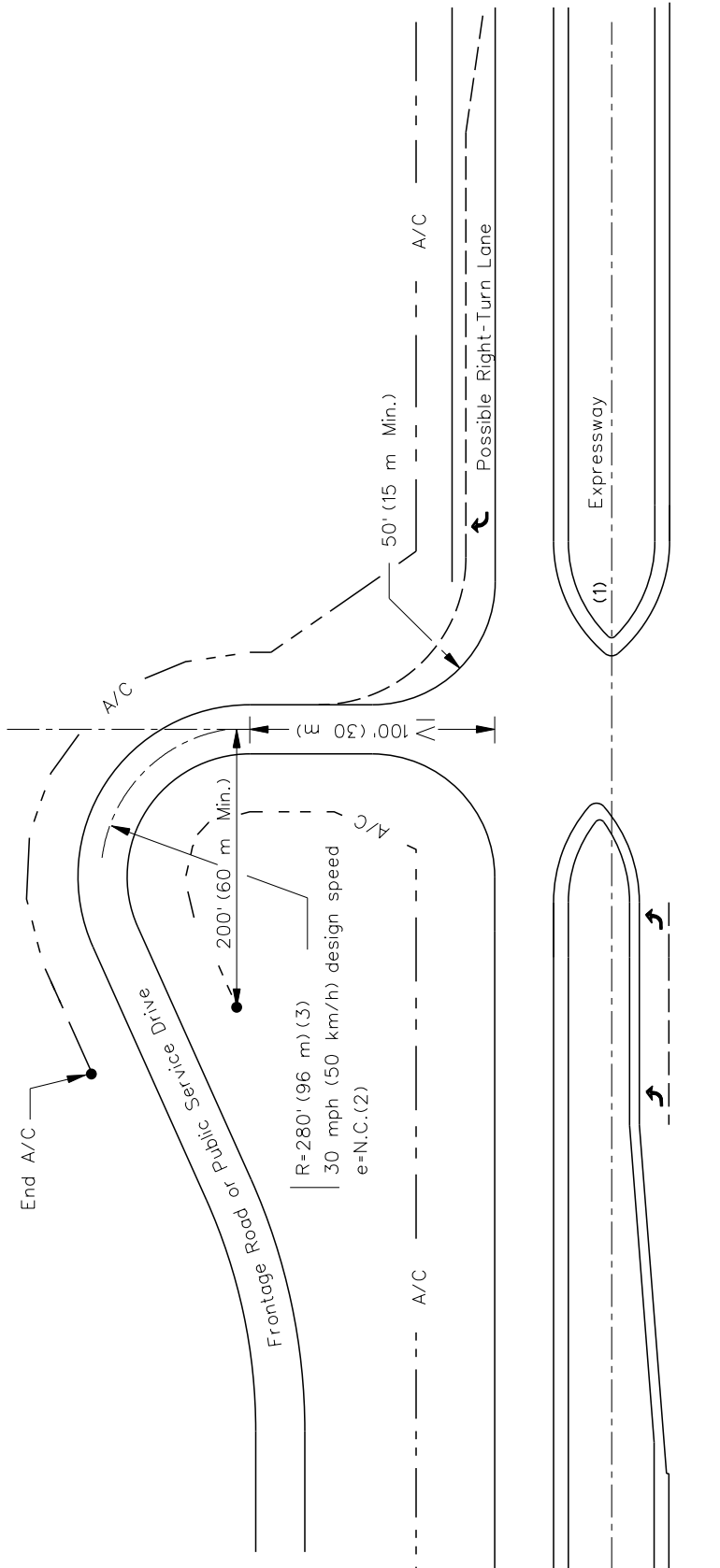

Notes:

1. With a median crossover as shown typically include a left turn lane. There may be a need to add a loon area for U-turn movements opposite the left-turn lane. Considerations in determining design details include the expected number of U-turns per day, safety, and the level of service on the expressway in the design year.
2. Use AASHTO Method 2 for the distribution of superelevation on curves; see Section 48-5. Normal crown is 3/16" /ft (1.5%).
3. If physical space is not available to provide a 280 ft (96 m) radius, use as large of radius as practical, but not less than the minimum radius required for the selected design vehicle. If the radius is selected for the design vehicle, widen the pavement through the curve to accommodate the design vehicle.

TYPICAL FRONTAGE ROAD OR PUBLIC SERVICE DRIVE DESIGN AT AN ACCESS POINT

Figure 45-2.H

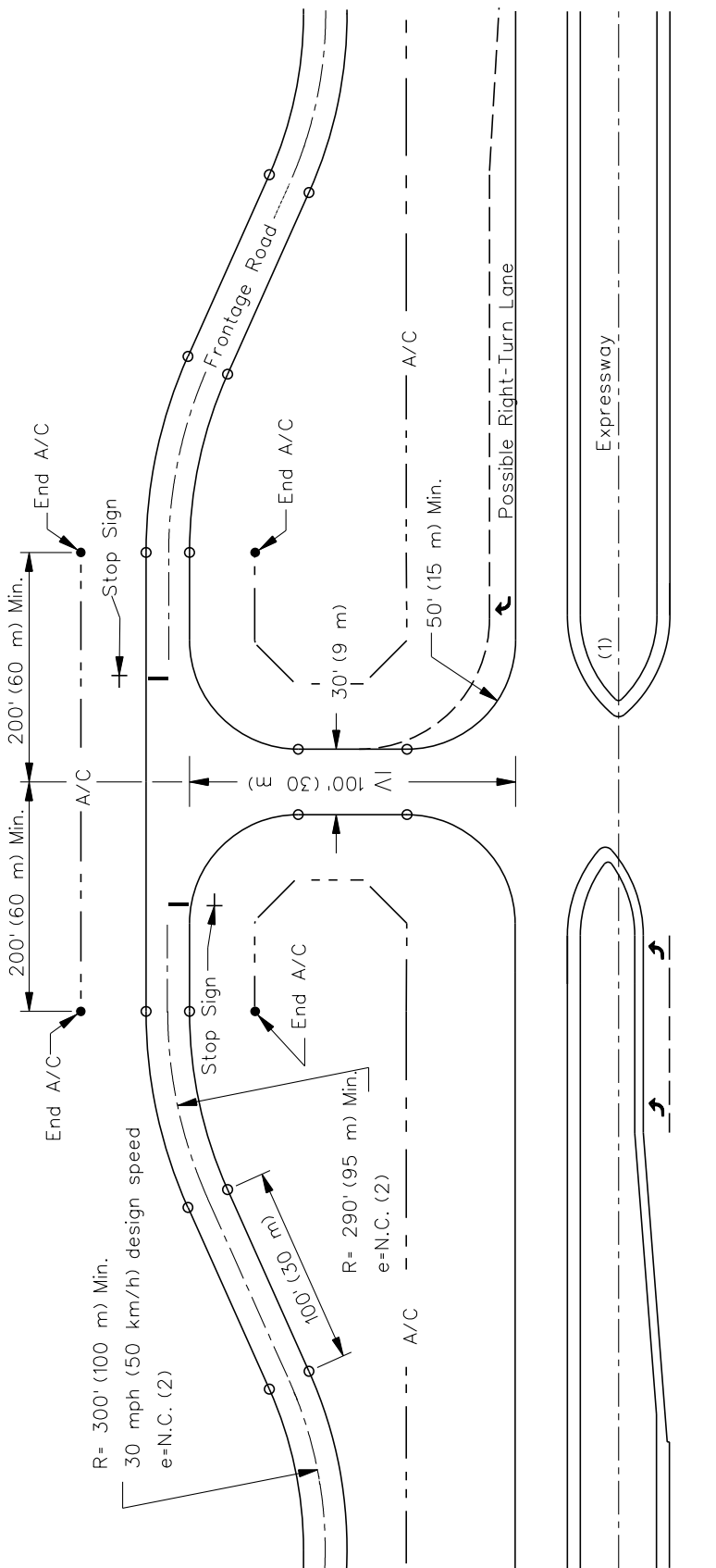

Notes:

1. With a median crossover as shown typically include a left turn lane. There may be a need to add a loon area for U-turn movements opposite the left-turn lane. Considerations in determining design details include the expected number of U-turns per day, safety, and the level of service on the expressway in the design year.
2. Use AASHTO Method 2 for the distribution of superelevation on curves; see Section 48-5. Normal crown is 3/16" /ft (1.5%).

TYPICAL FRONTAGE ROAD DESIGN AT AN ACCESS POINT

Figure 45-2.1

The design criteria for frontage roads and public service drives adjacent to freeways as presented in Section 44-2.05 also applies to these facilities along expressways. In addition, Figure 45-2.J illustrates a cross section view with a service drive adjacent to an expressway where restricted right-of-way conditions exist.

45-2.09 Entrances

45-2.09(a) Agricultural and Residential Entrances

Direct access may be provided to an expressway from an abutting property if it is used solely for farming purposes or for one single-family residence. For these locations, only consider points of direct access where other means of access require unreasonable adverse travel, have excessive construction costs or damages, and where the point of direct access will not interfere with the operational safety of the expressway. Agricultural and single residential entrances are subject to the following specific restrictions:

1. Interchanges. See Chapter 35 to determine the required spacing of an entrance from the end of the speed change taper of an interchange ramp. The calculated composite distances are also provided in Chapter 35.
2. Median Crossovers. Do not provide an entrance within 300 ft (90 m) of a median crossover if the entrance is not located directly opposite the crossover.
3. Number and Spacing. Limit the number and spacing of agricultural or residential entrances to a desirable average of one per $\frac{1}{4}$ mile (400 m) on each side of the expressway. The minimum distance between two residential entrances on the same side of an expressway should be 500 ft (150 m). Where practical, consider combining two or more entrances into one service drive.
4. Field Entrances. Where a field entrance exists to an agricultural property and where the property extends to a nearby public road, make every effort to relocate the field entrance to the adjacent public road.
5. Suburban Entrances. In rare cases, additional entrances to an expressway can be approved on a case-by-case basis by a highway permit. Specifically this may occur where an expressway traverses areas that are "suburban" in nature, has a 50 mph (80 km/h) design speed, and traverses abutting land with development that is not sufficient to warrant continuous frontage roads.. Such access must incorporate a design similar to that of a service drive as a future consideration.
6. Design. Design entrances for agricultural or residential purposes according to the criteria in the *Handbook for the Policy on Permits for Access Driveways to State Highways* (92 Illinois Administrative Code 550).

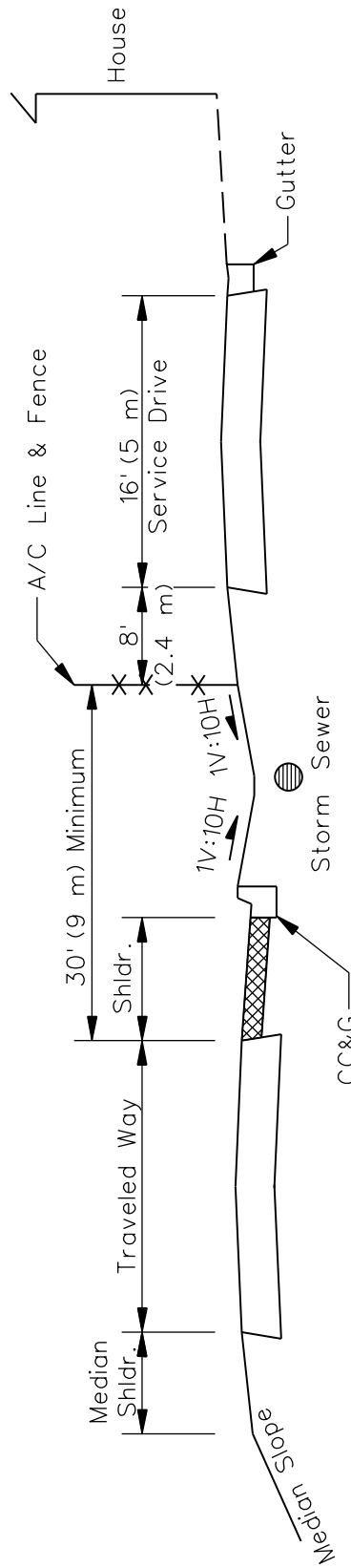

SERVICE DRIVE ADJACENT TO EXPRESSWAY
(Restricted Right-of-Way Conditions)

Figure 45-2.J

45-2.09(b) Entrances Other Than Agricultural or Residential

All land uses other than agricultural or single-dwelling residential are considered commercial. Direct access from commercial developments to an expressway is not permitted. The suburban access allowance may provide an occasional exception as noted in the previous section. Plan for indirect access to commercial properties via adjacent crossroads, service drives, or frontage roads.

45-3 OTHER DESIGN FEATURES

45-3.01 Lane Transitions

Careful consideration must be provided to the design of transitions from multilane facilities to two-lane facilities. These are complex decision-making areas for a driver who may not be expecting the lane reduction and lane shift. Therefore, decision sight distance should be provided to and throughout the transition area. When designing transitions, consider the following:

1. Transitions on Tangent. Desirably, lane transitions should be designed on a tangent section. This can be accomplished by the following:
 - a. Centered on Existing Roadway. Figure 45-3.A illustrates three designs for transitioning from four lanes to two lanes. The proposed pavements are centered about the centerline of the existing traveled way. The bottom drawing illustrates a transition to a raised-curb median, the middle drawing to an existing 40 ft (12.2 m) wide depressed median extended, and the top drawing to a proposed 50 ft (15 m) wide depressed median.
 - b. Existing Roadway on Left. Figure 45-3.B provides three designs where the new roadway is added to the right of the existing roadway. The bottom drawing illustrates a transition to a raised-curb median, the middle drawing to an existing 40 ft (12.2 m) wide depressed median extended, and the top drawing to a proposed 50 ft (15 m) wide depressed median.
 - c. Existing Roadway on Right. Figure 45-3.C provides three designs where the new roadway is added to the left of the existing roadway. The bottom drawing illustrates a transition to a raised-curb median, the middle drawing to an existing 40 ft (12.2 m) wide depressed median extended, and the top drawing to a proposed 50 ft (15 m) wide depressed median.
 - d. Raised-Curb Median. In Figures 45-3.A, 45-3.B, and 45-3.C, the bottom drawings illustrate a transition to a 30 ft (9.5 m) raised-curb median. Only use this design where the design speed is 45 mph (70 km/h) or less.
 - e. Transition Radii. At the design speed, a motorist can make a comfortable lane shift of 12 ft (3.6 m) in approximately three seconds of travel time. The transition design radii of 3820 ft (1165 m) shown in Figures 45-3.A, 45-3.B, and 45-3.C satisfies this criterion for all expressway design speeds; see Figure 45-3.D. With a 45 mph (70 km/h) design speed and restricted right-of-way, the reverse curves may be designed with a minimum radius of 2085 ft (620 m).

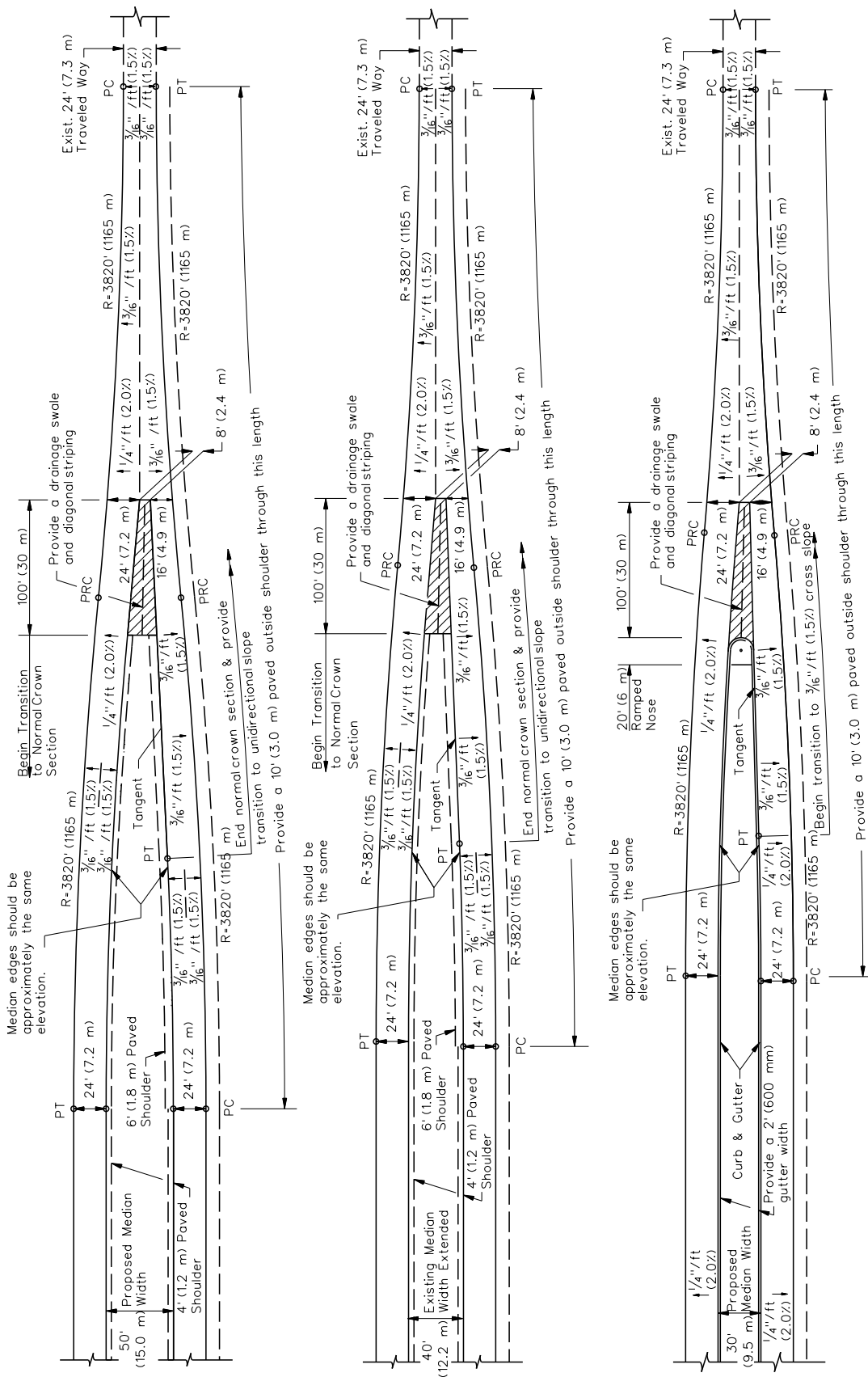

LANE TRANSITION DESIGNS ON TANGENT SECTION FROM FOUR TO TWO LANES (Centered on Existing Traveled Way)

Figure 45-3.A

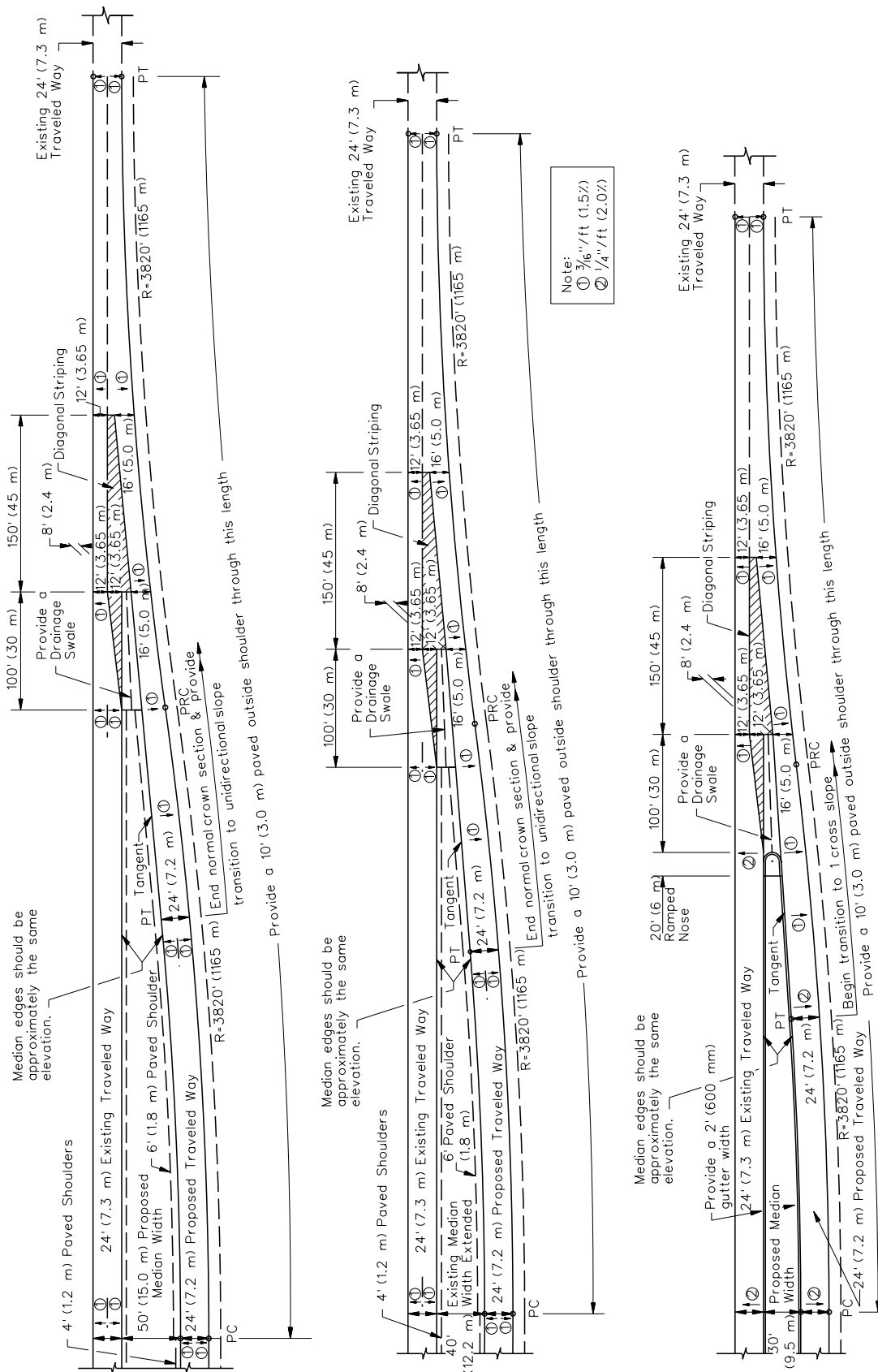

LANE TRANSITION DESIGNS ON TANGENT SECTION FROM FOUR TO TWO LANES (Existing Roadway on Left)

Figure 45-3.B

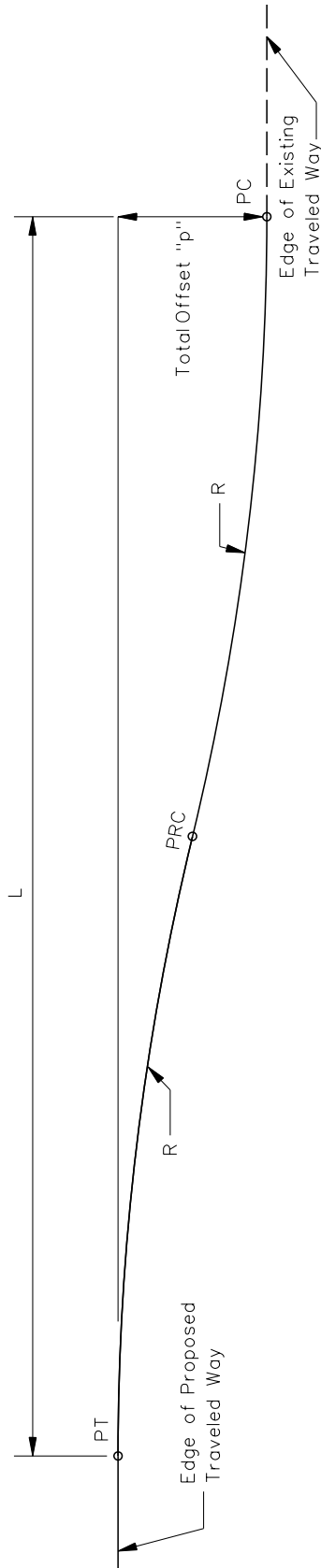

$$L = \sqrt{4pR - p^2}$$

Where: L = Reverse curve length, ft (m)
 R = Radii of reverse curves, ft (m)
 p = Total offset, ft (m)

US Customary		Metric	
R = 3820 ft		R = 1165 m	
Total Offset "p" (ft)	Reverse Curve Length "L" (ft)	Total Offset "p" (m)	Reverse Curve Length "L" (m)
74	1060.78	22.20	320.872
64	986.83	19.40	298.502
54	906.75	16.70	278.465
37	750.99	11.05	226.651
32	698.52	9.65	211.893
27	641.74	8.30	196.492

LANE TRANSITIONS

Figure 45-3.D

2. Transitions on Curve. Where the transition is on a curve, the crossover crown line is an important design consideration. In going from two lanes to the separation of the lanes with a median, the crossover algebraic difference should be no greater than 5% for design speeds greater than or equal to 60 mph (100 km/h) and 6% for design speeds less than or equal to 55 mph (90 km/h).

Figure 45-3.E illustrates an example of a curved-lane transition where the new roadway is added to the outside of an existing curve. Figure 45-3.F illustrates an example of a curved-lane transition where the new roadway is added to the inside of the curve.

45-3.02 Median Width Transitions

Figures 45-3.E and 45-3.F illustrate the geometric criteria for median width transitions. When designing median width transitions, consider the following:

1. Outside a Horizontal Curve. Where the added roadway for the proposed expressway is located on the outside of an existing horizontal curve, provide the alignment transition to the uniform median width on one end of the proposed horizontal curve only (i.e., either up or downstream). The alignment of the transition should be gradual unless intersections, critical right-of-way, etc., require a shorter transition to the project design median width.
2. Inside a Horizontal Curve. Where the added roadway for the proposed expressway is located on the inside of an existing horizontal curve, design the proposed horizontal curve to fit into the back and forward tangents. This design may provide for a variable width median through the two adjacent horizontal curves.

45-3.03 Underdrains

Where there is a significant drainage problem, consider providing underdrains along an existing roadway or raising the elevation of the existing roadway to eliminate the drainage and stability problems.

45-3.04 Mailboxes

With typical 10 ft (3.0 m) wide right shoulders, separate mailbox turnouts will not be required along expressways. Place the mailbox post 2 ft (600 mm) minimum from the edge of the paved shoulder. Locating mailboxes such that they require the crossing of the expressway median by a pedestrian is discouraged; the issue may be addressed on a case-by-case basis.

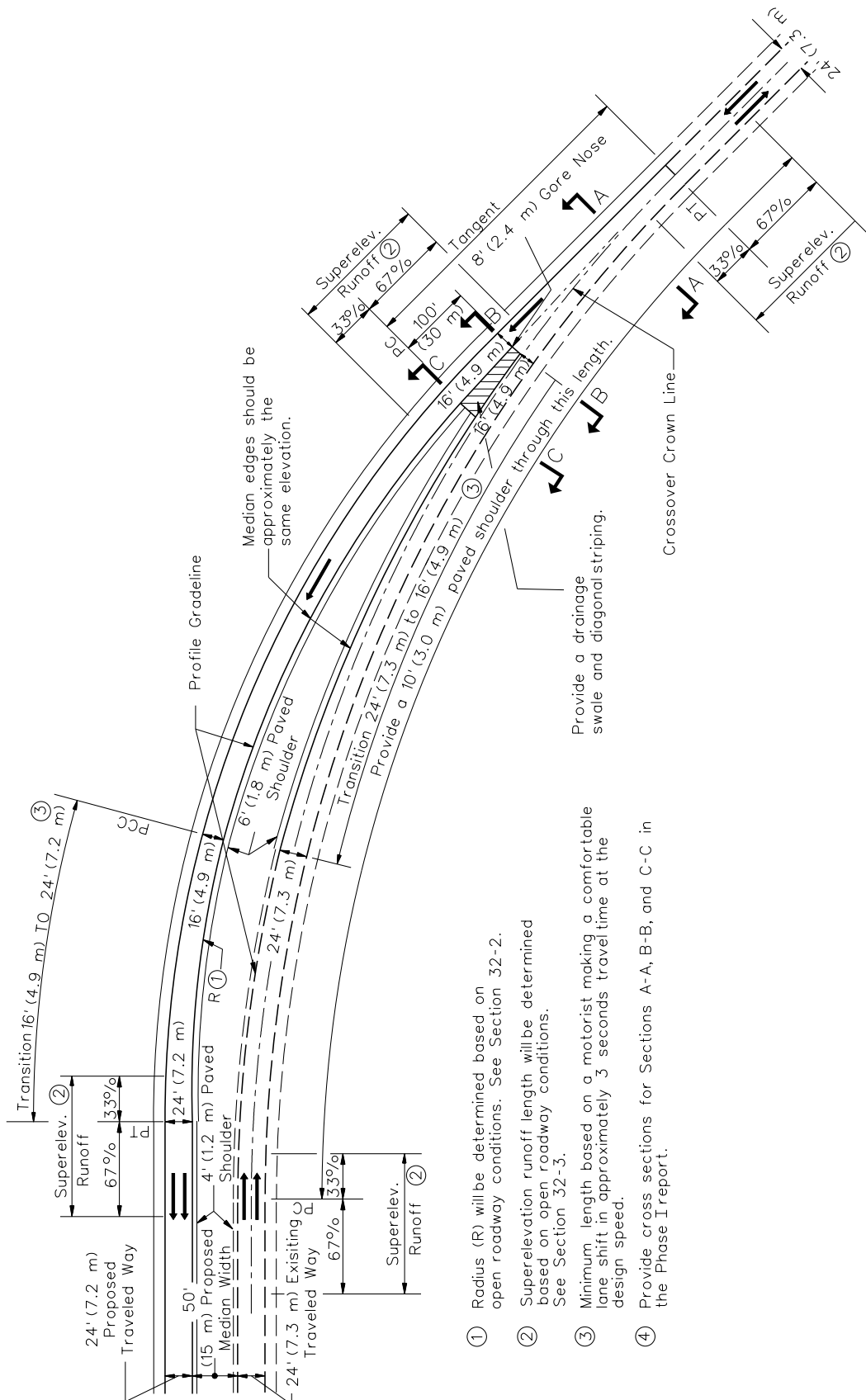

- ① Radius (R) will be determined based on open roadway conditions. See Section 32-2.
- ② Superelevation runoff length will be determined based on open roadway conditions. See Section 32-3.
- ③ Minimum length based on a motorist making a comfortable lane shift in approximately 3 seconds traveltime at the design speed.
- ④ Provide cross sections for Sections A-A, B-B, and C-C in the Phase I report.

**LANE TRANSITION DESIGN ON CURVE FROM FOUR TO TWO LANES
(New Roadway Outside)**

Figure 45-3.E

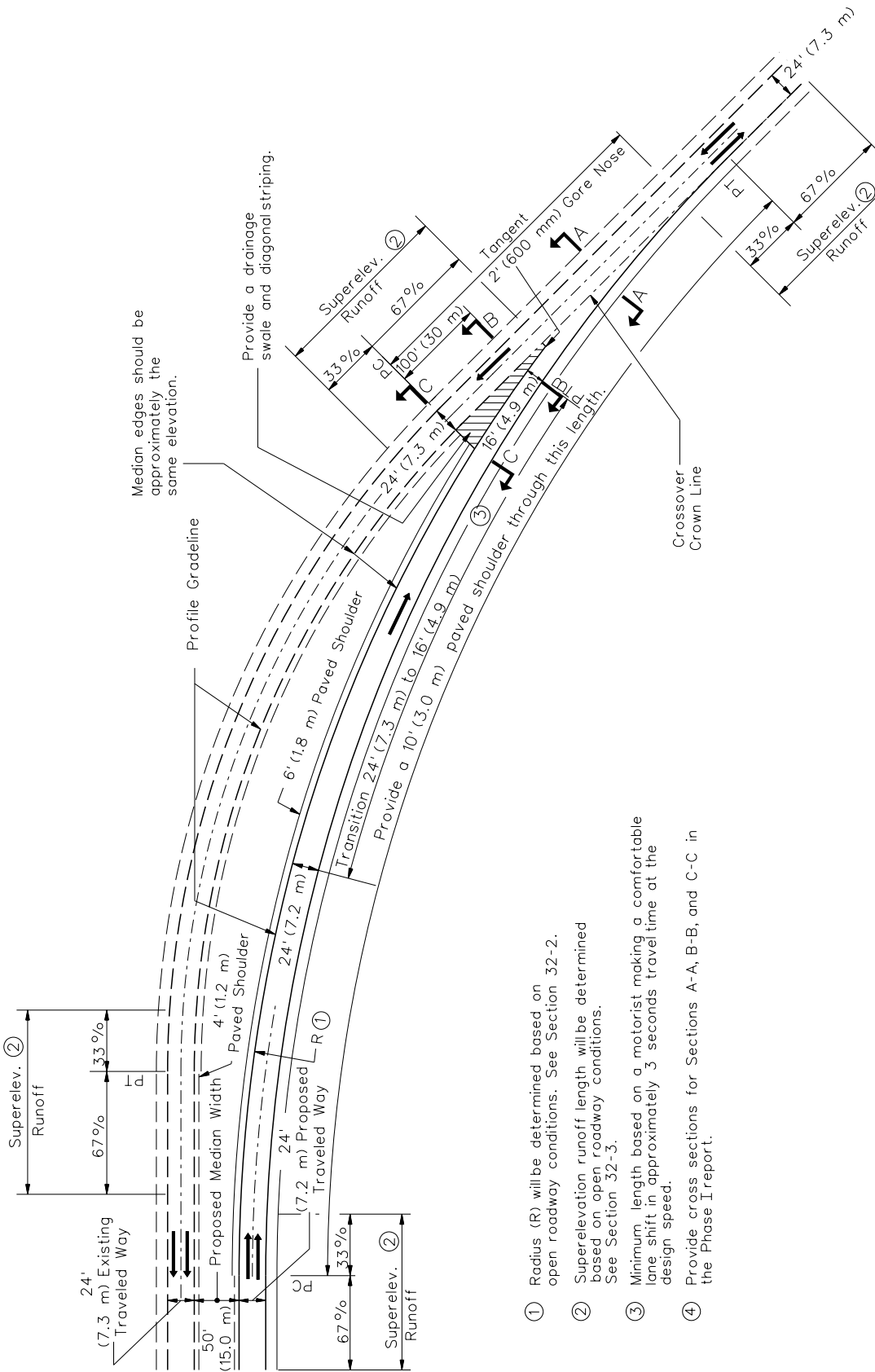

**LANE TRANSITION DESIGN ON CURVE FROM FOUR TO TWO LANES
(New Roadway Inside)**

Figure 45-3.F

- ① Radius (R) will be determined based on open roadway conditions. See Section 32-2.
- ② Superlevation runoff length will be determined based on open roadway conditions. See Section 32-3.
- ③ Minimum length based on a motorist making a comfortable lane shift in approximately 3 seconds travel time at the design speed.
- ④ Provide cross sections for Sections A-A, B-B, and C-C in the Phase I report.

45-4 TABLES OF DESIGN CRITERIA

Figures 45-4.A, 45-4.B, and 45-4.C present the Department's design criteria for expressway projects. Note that these figures also provide criteria for an existing roadway elements allowed to remain in place. The designer should realize that some of the cross section elements included in the figures (e.g., raised-curb median) are not automatically warranted in the project design. The values in the figures only apply after the decision has been made to include the element in the highway cross section.

Design Element		Manual Section	New Lanes (1a) One-Way DHV: Under 2400 (2)	Existing Lanes (1b) One-Way DHV: Under 2400 (2)	
Design Controls	Design Forecast Year	31-4.02	20 Years	20 Years	
	* Design Speed	31-2	70 mph (3a)	70 mph (3b)	
Cross Section Elements	Access Control	35-1	Partial Control (4)	Partial Control (4)	
	Level of Service	31-4.04	B	B	
	* Traveled Way Width	34-2.01	2 @ 24'	2 @ 22'	
	Shoulder Width	Right	34-2.02	10'	8'
		Paved		10'	8'
	Total Width	Total Width	34-2.02	6' (5)	4'
		Paved		4'	4'
	Auxiliary Lanes	Lane Width	37-2.05	12'	12'
		Shoulder Width	37-2.05	4' (Paved)	4' (Paved)
	Cross Slope	* Travel Lane	34-2.01	3/16"/ft for lanes adjacent to crown (6)	3/16"/ft for lanes adjacent to crown (6)
Shoulder		34-2.02	1/2"/ft	1/2"/ft	
Median Width	Depressed	34-3	Minimum: 50'	Minimum: 40' (7)	
	Flush (Concrete Barrier)		22' (8)	Minimum: 20' (8)	
Clear Zone		38-3	(9)	(9)	
		38-3	1V:6H	1V:4H	
Roadway Slopes	Cut Section	34-4.03	4' (10)	2'-0" (10)	
			Back Slope	1V:3H (11)	1V:3H (11)
	Rock Cut	34-4.05	—	—	
	Fill Section	34-4.02	1V:6H to Clear Zone; 1V:3H max. to Toe of Slope (12)	1V:4H to Clear Zone; 1V:3H max. to Toe of Slope (12)	
Bridges	Median Slopes	34-3	1V:6H	1V:5H	
	New and Reconstructed Bridges	N/A	HS-20	HS-20	
	Existing Bridges to Remain in Place	* Structural Capacity	39-6	38' - 40'	38' to 40'
		* Clear Roadway Width (13)	N/A	HS-20	HS-20
	* Vertical Clearance (Expressway Under) (15a)		39-6	36' with 24' Traveled Way (14b)	34' with 22' Traveled Way (14b)
* Vertical Clearance (Expressway over Railroad)	New and Replaced Overpassing Bridges (15b)	39-4	16'-6"	16'-6"	
	Existing Overpassing Bridges		16'-0"	16'-0"	
	Overhead Signs/ Pedestrian Bridges	33-5	New: 17'-3" (15b)	Existing: 16'-9"	
		39-4.06	23'-0"	23'-0"	

* Controlling design criteria (see Section 31-8).

**GEOMETRIC DESIGN CRITERIA FOR RURAL EXPRESSWAYS
(New Construction/Reconstruction) (US Customary)**

Figure 45-4.A

Design Element		Manual Section	New Lanes (1a) One-Way DHV: Under 2400 (2)	Existing Lanes (1b) One-Way DHV: Under 2400 (2)	
Design Controls	Design Forecast Year	31-4.02	20 Years	20 Years	
	* Design Speed	31-2	110 km/h (3a)	110 km/h (3b)	
Cross Section Elements	Access Control	35-1	Partial Control (4)	Partial Control (4)	
	Level of Service	31-4.04	B	B	
	* Traveled Way Width	34-2.01	2 @ 7.2 m	2 @ 6.6 m	
	Shoulder Width	Right	34-2.02	3.0 m	2.4 m
		Left		3.0 m	2.4 m
	Auxiliary Lanes	Total Width	37-2.05	1.8 m (5)	1.2 m
		Paved		1.2 m	1.2 m
	Cross Slope	Lane Width	34-2.01	3.6 m	3.6 m
		Shoulder Width		1.2 m (Paved)	1.2 m (Paved)
	Median Width	* Travel Lane	34-2.02	1.5% for lanes adjacent to crown (6)	1.5% for lanes adjacent to crown (6)
Shoulder		4%		4%	
Clear Zone	Depressed	34-3	Minimum: 15 m	Minimum: 12 m (7)	
	Flush (Concrete Barrier)		7.0 m (8)	Minimum: 6.0 m (8)	
Roadway Slopes	Cut Section	34-4.03	(9)	(9)	
			Front Slope	1V:6H	1V:4H
	Side Slopes	Ditch Bottom Width	34-4.05	1.2 m (10)	600 mm (10)
		Back Slope		1V:3H (11)	1V:3H (11)
		Rock Cut		—	—
Median Slopes	Fill Section	34-4.02	1V:6H to Clear Zone; 1V:3H max. to Toe of Slope (12)	1V:4H to Clear Zone; 1V:3H max. to Toe of Slope (12)	
	Structural Capacity		1V:6H	1V:5H	
Bridges	New and Reconstructed Bridges	N/A	MS-18	MS-18	
	Existing Bridges to Remain in Place	* Clear Roadway Width (13)	11.4 m - 12.0 m	11.4 m - 12.0 m	
		* Structural Capacity	MS-18	MS-18	
	* Vertical Clearance (Expressway Under) (15a)	* Clear Roadway Width (14a)	39-6	10.8 m with 7.2 m Traveled Way (14b)	10.2 m with 6.6 m Traveled Way (14b)
		New and Replaced Overpassing Bridges (15b)		5.0 m	
		Existing Overpassing Bridges		4.9 m	
* Vertical Clearance (Expressway over Railroad)	33-5		New: 5.25 m (15b) Existing: 5.1 m		
	39-4.06		7.0 m		

* Controlling design criteria (see Section 31-8).

**GEOMETRIC DESIGN CRITERIA FOR RURAL EXPRESSWAYS
(New Construction/Reconstruction) (Metric)**

Figure 45-4.A

- (1) Design Criteria.
- a. When upgrading an existing two-lane highway to a four-lane expressway, use the criteria in the new lanes column for the design of the new roadway and median.
 - b. The criteria in this column are the minimum cross-section elements allowed to remain in place for reconstruction of an existing roadway provided it is cost effective and safety record is satisfactory.
- (2) Traffic Volumes. The design hourly volumes (DHV) are calculated assuming base conditions (except for 8% heavy vehicles) and a PHF = 1.0. Adjust these values using local factors. For volumes exceeding the listed DHV, use the *Highway Capacity Manual* to determine the applicable number of travel lanes.
- (3) Design Speed.
- a. In rolling terrain, a minimum design speed of 60 mph (100 km/h) may be considered with study and justification.
 - b. To determine the minimum design speed allowed to remain, see Section 45-2.02.
- (4) Access Control. Bypasses around a community should be fully access controlled if the installation of traffic signals is likely at any intersection during the 20-year design period.
- (5) Shoulder Width (Left). In most cases, left shoulders should be 6 ft (1.8 m) wide. This allows for the use of 1V:6H slopes in the median. However, if the 20-year level of service approaches Level C, then consider an 8 ft (2.4 m) wide left shoulder and decrease the median slopes to 1V:5H.
- (6) Travel Lane Cross Slope. For each additional lane away from the crown lanes, increase the cross slope by 1/16" /ft (0.5%) per additional lane up to a maximum of 5/16" /ft (2.5%).
- (7) Depressed Median Width. Median width based on 1V:5H median slopes and existing 2 ft (600 mm) ditch bottom width.
- (8) Flush Median Width. In rural areas, only use flush medians with concrete barrier where right-of-way or topography restricts the use of a depressed median. Consider providing wider medians where required for snow storage.
- (9) Clear Zone. The clear zone will vary according to design speed, traffic volumes, side slopes, and horizontal curvature. To achieve the proper clear zone for restricted right-of-way conditions, see Figure 34-4D.
- (10) Ditch Bottom Width. Provide a wider outside ditch bottom where detention storage of storm water is a consideration.
- (11) Back Slope. Where the height of cut exceeds 10 ft (3 m), consider using a 1V:2H back slope beyond the clear zone. Also, for heights greater than 30 ft (9 m), consider the use of benching.
- (12) Fill Slope. For fill heights greater than 30 ft (9 m), use a 1V:2H uniform slope with a roadside barrier. Also, for heights greater than 30 ft (9 m), consider the use of benching.
- (13) New and Reconstructed Bridge Widths. Clear roadway bridge widths are measured from face to face of parapets or rails. Bridge widths are normally defined as the sum of the approach traveled way width and the width of the paved shoulders.

**GEOMETRIC DESIGN CRITERIA FOR RURAL EXPRESSWAYS
(New Construction/Reconstruction)**

Footnotes Figure 45-4.A

- (14) Existing Bridge Widths to Remain in Place.
- a. Clear roadway bridge widths measured from face to face of parapets or rails. Implies elements allowed to remain in place without a design exception when cost effective and when safety record is satisfactory.
 - b. Bridges with total lengths greater than 250 ft (75 m) or any span longer than 120 ft (36 m) typically should have a clear roadway bridge width of 38 ft (11.4 m) or 40 ft (12.0 m).
- (15) Vertical Clearance (Expressway Under).
- a. The clearance must be available over the traveled way and any paved shoulder.
 - b. Table value includes allowance for future overlays.

**GEOMETRIC DESIGN CRITERIA FOR RURAL EXPRESSWAYS
(New Construction/Reconstruction)**

Footnotes Figure 45-4.A (Continued)

Design Element		Manual Section	Construction (Ex-6) One-Way DHV: 4400 (1)	Reconstruction (Ex-6) One-Way DHV: 3700 (1)	Reconstruction (Ex-4) One-Way DHV: 2450 (1)	
Design Controls	Design Forecast Year	31-4.02	20 Years	20 Years	20 Years	
	* Design Speed	31-2	Minimum 60 mph (2)	Minimum 50 mph	Minimum 50 mph	
	Access Control	35-1	Full Control (3a)	Partial Control (3b)	Partial Control (3b)	
	Level of Service	31-4.04	C	C	C	
Cross Section Elements	* Traveled Way Width	34-2.01	2 @ 36'	2 @ 36' (4a)	2 @ 24' (4b)	
	Shoulder Width	Right	10'	10'	10'	
		Paved	10'	10'	10'	
		Total Width	10'	10'	6'	
	Auxiliary Lanes	Paved	10'	10'	4'	
		Lane Width	12'	12'	12'	
	Cross Slope	Shoulder Width	4'	4'	4'	
		* Travel Lane (5a)	34-2.01	3/16" /ft for lanes adjacent to crown	3/16" /ft for lanes adjacent to crown (5b)	3/16" /ft for lanes adjacent to crown (5b)
		Shoulder	34-2.02	1/2" /ft	1/2" /ft to 3/4" /ft (6b)	1/2" /ft to 3/4" /ft
		Depressed	34-3	Minimum: 52' (6a)	22' (7b)	Minimum: 44' (6c)
Median Width	Flush (Concrete Barrier) (7a)	45-2.06	N/A	22' - 30' (8)	22' - 30' (8)	
	Raised-Curb	38-3	(9)	(9)	(9)	
Clear Zone	Front Slope	34-4.03	1V:6H	1V:6H	1V:6H	
	Ditch Bottom Width (10)		4'	4'	4'	
	Back Slope (11)		1V:3H	1V:3H	1V:3H	
	Cut Section	34-4.04	1V:20H for 10'; 1V:4H to Top of Slope	1V:20H for 10'; 1V:4H to Top of Slope	1V:20H for 10'; 1V:4H to Top of Slope	
Side Slopes	Cut Section (Curbed)	34-4.05	—	—	—	
	Rock Cut		—	—	—	
	Fill Section (12)	34-4.02	1V:6H to Clear Zone; 1V:3H Max. to Toe of Slope	1V:6H to Clear Zone; 1V:3H Max. to Toe of Slope	1V:6H to Clear Zone; 1V:3H Max. to Toe of Slope	
Median Slopes	Depressed	34-3	1V:6H	1/2" /ft (Flush)	1V:5H	
	Raised-Curb	45-2.06	N/A	3/16" /ft	3/16" /ft	
New and Reconstructed Bridges	* Structural Capacity	N/A	HS-20	HS-20	HS-20	
	* Clear Roadway Width (13)	39-6	56'	56'	38' - 40'	
	* Structural Capacity	N/A	N/A	HS-20	HS-20	
Existing Bridges to Remain in Place	* Clear Roadway Width	39-6	N/A	(14)	(14)	
	New and Replaced Overpassing Bridges (15b)		16'-6"	16'-6"	16'-6"	
	Existing Overpassing Bridges (15a)	39-4	N/A	16'-0" (15c)	16'-0" (15c)	
* Vertical Clearance (Expressway Under) (15a)	Overpassing Bridges					
	Overhead Signs/ Pedestrian Bridges	33-5	New: 17'-3" (15b)	Existing: 16'-9"		
* Vertical Clearance (Expressway over Railroad)		39-4.06		23'-0"		

* Controlling design criteria (see Section 31-8).

**GEOMETRIC DESIGN CRITERIA FOR URBAN AND SUBURBAN EXPRESSWAYS
(New Construction/Reconstruction) (US Customary)**

Figure 45-4.B

Design Element		Manual Section	Construction (Ex-6) One-Way DHV: 4400 (1)	Reconstruction (Ex-6) One-Way DHV: 3700 (1)	Reconstruction (Ex-4) One-Way DHV: 2450 (1)	
Design Controls	Design Forecast Year	31-4.02	20 Years	20 Years	20 Years	
	* Design Speed	31-2	Minimum 100 km/h (2)	Minimum 80 km/h	Minimum 80 km/h	
	Access Control	35-1	Full Control (3a)	Partial Control (3b)	Partial Control (3b)	
	Level of Service	31-4.04	C	C	C	
Cross Section Elements	* Traveled Way Width	34-2.01	2 @ 10.8 m	2 @ 10.8 m (4a)	2 @ 7.2 m (4b)	
	Shoulder Width	Right	3.0 m	3.0 m	3.0 m	
		Left	3.0 m	3.0 m	3.0 m	
	Auxiliary Lanes	Lane Width	3.0 m	3.0 m	1.8 m	
		Shoulder Width	3.6 m	3.6 m	1.2 m	
	Cross Slope	* Travel Lane (5a)	34-2.01	1.5% for lanes adjacent to crown	1.5% for lanes adjacent to crown (5b)	1.5% for lanes adjacent to crown (5b)
		Shoulder	34-2.02	4%	4% to 6%	4% to 6%
	Median Width	Depressed	34-3	Minimum: 16.0 m (6a)	(6b)	Minimum: 13.2 m (6c)
		Flush (Concrete Barrier) (7a)	45-2.06	7.0 m	7.0 m (7b)	7.0 m (7b)
	Clear Zone	Raised-Curb	38-3	N/A	7.0 m - 9.5 m (8)	7.0 m - 9.5 m (8)
Cut Section		34-4.03	(9)	(9)	(9)	
Roadway Slopes	Cut Section	Front Slope	1V:6H	1V:6H	1V:6H	
		Ditch Bottom Width (10)	1.2 m	1.2 m	1.2 m	
	Side Slopes	Back Slope (11)	1V:3H	1V:3H	1V:3H	
		Cut Section (Curbed)	34-4.04	1V:20H for 3.0 m: 1V:4H to Top of Slope	1V:20H for 3.0 m: 1V:4H to Top of Slope	1V:20H for 3.0 m: 1V:4H to Top of Slope
Median Slopes	Rock Cut	34-4.05	—	—	—	
	Fill Section (12)	34-4.02	1V:6H to Clear Zone; 1V:3H Max. to Toe of Slope	1V:6H to Clear Zone; 1V:3H Max. to Toe of Slope	1V:6H to Clear Zone; 1V:3H Max. to Toe of Slope	
Bridges	New and Reconstructed Bridges	Depressed	34-3	1V:6H	1V:5H	
		Raised-Curb	45-2.06	N/A	1.5%	
	Existing Bridges to Remain in Place	* Structural Capacity	N/A	MS-18	MS-18	
		* Clear Roadway Width (13)	39-6	16.8 m	16.8 m	11.4 - 12.0 m
* Vertical Clearance (Expressway Under) (15a)	* Structural Capacity	N/A	N/A	MS-18	MS-18	
	* Clear Roadway Width	39-6	N/A	(14)	(14)	
	New and Replaced Overpassing Bridges (15b)	39-4	5.0 m	5.0 m	5.0 m	
* Vertical Clearance (Expressway over Railroad)	Overpassing Bridges Existing	33-5	N/A	4.9 m (15c)	4.9 m (15c)	
	Overhead Signs/ Pedestrian Bridges	39-4.06	New: 5.25 m (15b)	Existing: 5.1 m	7.0 m	

* Controlling design criteria (see Section 31-8).

GEOMETRIC DESIGN CRITERIA FOR URBAN AND SUBURBAN EXPRESSWAYS (New Construction/Reconstruction) (Metric)

Figure 45-4.B

- (1) **Traffic Volumes.** The design hourly volumes (DHV) are calculated assuming base conditions (except for 8% heavy vehicles) and a PHF = 1.0. Adjust these values using local factors. For volumes exceeding the listed DHV, use the *Highway Capacity Manual* to determine the number of travel lanes.
- (2) **Design Speed.** With restricted urban conditions, a minimum design speed of 55 mph (90 km/h) may be considered with study and justification.
- (3) **Access Control.**
- Where an expressway design has been extended from a rural area and is planned to bypass an urbanized area on new alignment, the bypass route should be developed with full control of access.
 - Where an expressway design has been extended from a rural area through a developing urban area with restricted ROW, median crossovers according to Section 45-2.06. Signalized intersections also will exist and signal progression must be considered and investigated.
- (4) **Traveled Way Width.** For existing pavements to remain, the following minimum widths will be allowed:
- Expressway Six Lanes (EX-6) — 2 @ 33 ft (10.0 m)
 - Expressway Four Lanes (EX-4) — 2 @ 22 ft (6.6 m)
- (5) **Travel Lane Cross Slope.**
- For each additional lane away from the crown lanes, increase the cross slope by 1/16" /ft (0.5%) per additional lane up to a maximum of 5/16" /ft (2.5%).
 - For raised-curb medians (proposed design speed \leq 45 mph (70 km/h)) the cross slope of the two travel lanes adjacent to the median is 1/4" /ft (2%) sloped away from the median. Where a third or outside lane is added to the traveled way in conjunction with a raised-curb median, the cross slope of the third lane will be 5/16" /ft (2.5%).
- (6) **Depressed Median Width.**
- Median width based on 10 ft (3.0 m) left shoulders, 1V:5H median slopes, 3 ft (900 mm) ditch depth, and 2 ft (600 mm) ditch bottom width.
 - Right-of-way usually not available for a depressed median.
 - Desirably, the median width should be 50 ft (15.0 m). The median width of 44 ft (13.2 m) is based on a 1V:5H median slope and 2 ft (600 mm) ditch bottom width.
- (7) **Flush Median Width.**
- Provide a wider outside ditch where detention storage of storm water is a consideration.
 - Where dual left-turn lanes are required, use a 30 ft (9.5 m) to 36 ft (10.5 m) wide median and provide a crashworthy end treatment on the CMB. See Figure 36-3M.

GEOMETRIC DESIGN CRITERIA FOR URBAN AND SUBURBAN EXPRESSWAYS
(New Construction/Reconstruction)

Footnotes Figure 45-4.B

- (9) Clear Zone. The clear zone will vary according to design speed, traffic volumes, side slopes, and horizontal curvature. To achieve the proper clear zone for restricted right-of-way conditions, see Figure 34-4D.
- (10) Ditch Bottom Width. Provide a wider outside ditch bottom where detention storage of storm water is a consideration.
- (11) Back Slope. Where the height of cut exceeds 10 ft (3 m), consider using a 1V:2H back slope beyond the clear zone. Also, for heights greater than 30 ft (9 m), consider the use of benching.
- (12) Fill Slope. For existing slopes to remain in place, see Figures 34-4A or 34-4B. For fill heights greater than 30 ft (9 m), use a 1V:2H uniform slope with a roadside barrier. Also, for heights greater than 30 ft (9 m), consider the use of benching.
- (13) New and Reconstructed Bridge Widths. Assumes roadway approach adjacent to bridge has median shoulders. Clear roadway bridge widths are measured from face to face of parapets or rails. Bridge widths are normally defined as the sum of the approach traveled way width and the width of the paved shoulders. See Figure 39-5K for more information on urban bridges.
- (14) Existing Bridge Widths to Remain in Place. Clear roadway bridge widths are measured from face to face of parapets or rails. Implies elements allowed to remain in place without a design exception approval when cost effective and when safety record is satisfactory. See Figures 39-5.A and 39-5.B.
- (15) Vertical Clearance (Expressway Under).
- The clearance must be available over the traveled way and any paved shoulders.
 - Table value includes allowance for future overlays.
 - A 15 ft 0 in (4.5 m) clearance may be used where an alternative route is available with a 16 ft 0 in (4.9 m) clearance.

GEOMETRIC DESIGN CRITERIA FOR URBAN AND SUBURBAN EXPRESSWAYS (New Construction/Reconstruction)

Footnotes Figure 45-4.B (Continued)

Design Element	Manual Section	Design Speed			
		50 mph	55 mph	60 mph	70 mph
*Stopping Sight Distance (1)	31-3.01	425'	495'	570'	730'
Decision Sight Distance (2)	31-3.02	Urban: 1030'	Urban: 1135'	Rural: 990' Urban: 1280'	Rural: 1105'
Intersection Sight Distance	36-6	—	—	—	—
*Minimum Radii	$e_{min} = 6\%$ (3a) $e_{max} = 8\%$ (3b)	835	1065	1335'	Desirable: $\geq 3000'$ Minimum: 2045' (3)
*Superelevation Rate (4)	32-3	New: $e_{min} = 6\%$ Reconstruction: $e_{min} = 6\%$ or 8%			
*Horizontal Sight Distance	32-4	(5)			
*Vertical Curvature (K-values)	Crest	84	114	151	247
	Sag	96	115	167	181
*Maximum Grade	Level	New: 4% (6a)	New: 3% (6a)	New: 3% (6a)	New: 3% (6b)
	Rolling	New: 5% (6a)	New: 4% (6a)	New: 4% (6a)	New: 4% (6b)
Minimum Grade	33-2.03	Des: 0.5% Min: 0.3% (with Curb & Gutter) (7)		Des: 0.5% Min: 0.3% (with Curb & Gutter) (7)	Des: 0.5% Min: 0.0% (with Special Ditching)

* Controlling design criteria (see Section 31-8)

- (1) Stopping Sight Distance. Table values are for passenger cars on level grade.
- (2) Decision Sight Distance. Table values are for the avoidance maneuver (speed/path/direction change).
- (3) Minimum Radii.
 - a. An e_{max} of 6% may be used for both new and reconstruction projects.
 - b. In rural areas, existing horizontal curves with a maximum superelevation rate of 8% may remain if the radius is 1815 ft or more and there is no history of crashes.
- (4) Superelevation Rate. See Section 32-3 for superelevation rates based on e_{max} , design speed, and radii of horizontal curves. For horizontal curves to remain in place, an e_{max} of 8% in rural areas and 6% in urban areas may be considered to remain in place. Where a crossroad intersection lies within the limits of an expressway horizontal curve, see Figure 36-1.E for the maximum superelevation rates allowed on the expressway.
- (5) Horizontal Sight Distance. For a given design speed, the necessary middle ordinate will be determined by the radius of curve and the required sight distance.
- (6) Maximum Grade.
 - a. Grades 1% steeper may be used for restricted conditions or to remain in place.
 - b. For existing roadways to remain, a maximum of a +4% on upgrades and -5% on downgrades may be retained.
- (7) Minimum Grades. Where curb and gutter is required due to restricted right-of-way, use M-4.24 curb and gutter and locate it no closer than the outer edge of shoulder.

**ALIGNMENT CRITERIA FOR EXPRESSWAYS
(US Customary)**

Figure 45-4.C

Design Element	Manual Section	Design Speed			
		80 km/h	90 km/h	100 km/h	110 km/h
*Stopping Sight Distance (1)	31-3.01	129 m	156 m	185 m	216 m
Decision Sight Distance (2)	31-3.02	Urban: 315 m	Urban: 360 m	Rural: 315 m Urban: 400 m	Rural: 330 m
Intersection Sight Distance	36-6	—	—	—	—
*Minimum Radii	$e_{max} = 6\%$ (3a)	252 m	336 m	437 m	Desirable: ≥ 1000 m Minimum: 560 m (3)
	$e_{max} = 8\%$ (3b)	—	—	—	505 (3b)
*Superelevation Rate (4)	32-3	New: $e_{max} = 6\%$ Reconstruction: $e_{max} = 6\%$ or 8%			
*Horizontal Sight Distance	32-4	(5)			
*Vertical Curvature (K-values)	Crest	26	37	52	71
	Sag	30	37	45	54
*Maximum Grade	Level	New: 4% (6a)	New: 3% (6a)	New: 3% (6a)	New: 3% (6b)
	Rolling	New: 5% (6a)	New: 4% (6a)	New: 4% (6a)	New: 4% (6b)
Minimum Grade	33-2.03	Des: 0.5% Min: 0.3% (with Curb & Gutter) (7)	Des: 0.5% Min: 0.3% (with Curb & Gutter) (7)	Des: 0.5% Min: 0.3% (with Curb & Gutter) (7)	Des: 0.5% Min: 0.0% (with Special Ditching)

* Controlling design criteria (see Section 31-8)

- (1) Stopping Sight Distance. Table values are for passenger cars on level grade.
- (2) Decision Sight Distance. Table values are for the avoidance maneuver (speed/path/direction change).
- (3) Minimum Radii.
 - a. An e_{max} of 6% may be used for both new and reconstruction projects.
 - b. In rural areas, existing horizontal curves with a maximum superelevation rate of 8% may remain if the radius is 502 m or more and there is no history of crashes.
- (4) Superelevation Rate. See Section 32-3 for superelevation rates based on e_{max} , design speed, and radii of horizontal curves. For horizontal curves to remain in place, an e_{max} of 8% in rural areas and 6% in urban areas may be considered to remain in place. Where a crossroad intersection lies within the limits of an expressway horizontal curve, see Figure 36-1.E for the maximum superelevation rates allowed on the expressway.
- (5) Horizontal Sight Distance. For a given design speed, the necessary middle ordinate will be determined by the radius of curve and the required sight distance.
- (6) Maximum Grade.
 - a. Grades 1% steeper may be used for restricted conditions or to remain in place.
 - b. For existing roadways to remain, a maximum of a +4% on upgrades and -5% on downgrades may be retained.
- (7) Minimum Grades. Where curb and gutter is required due to restricted right-of-way, use M-10.60 curb and gutter and locate it no closer than the outer edge of shoulder.

**ALIGNMENT CRITERIA FOR EXPRESSWAYS
(Metric)**

Figure 45-4.C

45-5 REFERENCES

1. *A Policy on Geometric Design of Highways and Streets*, AASHTO, 2018.
2. NCHRP Report 375, *Median Intersection Design*, TRB, 1995.
3. *Highway Safety Design and Operations Guide*, AASHTO, 1997.
4. *Flexibility in Highway Design*, FHWA 1997.
5. *Roadside Design Guide*, AASHTO, 2011

Chapter Forty-six

**STRATEGIC REGIONAL
ARTERIALS**

(New Construction/Reconstruction)

BUREAU OF DESIGN AND ENVIRONMENT MANUAL

Chapter Forty-six
STRATEGIC REGIONAL ARTERIALS
(New Construction/Reconstruction)

Table of Contents

<u>Section</u>	<u>Page</u>
46-1 GENERAL	46-1.1
46-1.01 Objectives for a SRA System.....	46-1.1
46-1.02 SRA Route Definitions.....	46-1.2
46-1.03 Spacing of SRA's.....	46-1.2
46-1.04 Coordination with Local Land Use Plans	46-1.2
46-1.05 SRA Planning	46-1.3
46-1.05(a) Objectives.....	46-1.3
46-1.05(b) Implementation Process	46-1.3
46-2 URBAN SRA ROUTES	46-2.1
46-2.01 General Roadway Features	46-2.1
46-2.02 Geometric Design Elements.....	46-2.1
46-2.02(a) Median Type	46-2.1
46-2.02(b) Additional Lanes	46-2.1
46-2.02(c) Horizontal and Vertical Clearances	46-2.4
46-2.03 Access Management.....	46-2.4
46-2.04 Intersections.....	46-2.5
46-2.05 Railroad Grade Separations	46-2.7
46-2.06 Interchanges	46-2.7
46-2.07 Drainage.....	46-2.7
46-2.08 Removal of On-Street Parking	46-2.7
46-2.09 Traffic Control Devices	46-2.8
46-2.09(a) Traffic Signals	46-2.8
46-2.09(b) Stop Sign Removal	46-2.9
46-2.09(c) Pavement Markings.....	46-2.9
46-2.09(d) Driver Information Systems	46-2.9
46-2.10 Trucks	46-2.9
46-2.11 Transit.....	46-2.9
46-2.11(a) Improvements	46-2.9
46-2.11(b) Local Bus Service.....	46-2.10
46-2.11(c) HOV Lanes	46-2.10
46-2.12 Pedestrians and Bicyclists.....	46-2.13
46-2.13 Environmental Considerations	46-2.13

Table of Contents
(Continued)

<u>Section</u>		<u>Page</u>
46-2.14	Right-of-Way	46-2.13
46-2.15	Tables of Design Criteria.....	46-2.13
46-3	SUBURBAN SRA ROUTES	46-3.1
46-3.01	General Roadway Features	46-3.1
	46-3.01(a) General.....	46-3.1
	46-3.01(b) Bypass Facilities.....	46-3.1
46-3.02	Geometric Design Elements.....	46-3.1
	46-3.02(a) Median Types	46-3.1
	46-3.02(b) Additional Lanes	46-3.6
	46-3.02(c) Vertical Clearances	46-3.6
46-3.03	Access Management.....	46-3.6
46-3.04	Intersections.....	46-3.8
46-3.05	Railroad Grade Separations	46-3.9
46-3.06	Interchanges	46-3.10
46-3.07	Drainage.....	46-3.10
46-3.08	Removal of On-Street Parking	46-3.10
46-3.09	Traffic Control Devices	46-3.11
	46-3.09(a) Traffic Signals	46-3.11
	46-3.09(b) Warrants for Traffic Signals	46-3.11
	46-3.09(c) Overhead Signing	46-3.11
	46-3.09(d) Stop Sign Removal	46-3.11
	46-3.09(e) Pavement Markings.....	46-3.12
	46-3.09(f) Driver Information Systems	46-3.12
46-3.10	Trucks	46-3.12
46-3.11	Transit.....	46-3.12
	46-3.11(a) Improvements	46-3.12
	46-3.11(b) Express Bus Service	46-3.13
46-3.12	HOV Lanes.....	46-3.13
46-3.13	Pedestrians and Bicyclists.....	46-3.13
46-3.14	Environmental Considerations	46-3.13
46-3.15	Right-of-Way Acquisition and Corridor Protection.....	46-3.14
46-3.16	Tables of Design Criteria.....	46-3.14

Table of Contents
(Continued)

<u>Section</u>	<u>Page</u>
46-4 RURAL SRA ROUTES.....	46-4.1
46-4.01 General Roadway Features	46-4.1
46-4.01(a) General.....	46-4.1
46-4.01(b) Bypass Facilities.....	46-4.1
46-4.02 Geometric Design Elements.....	46-4.1
46-4.02(a) Median Types	46-4.1
46-4.02(b) Additional Lanes.....	46-4.4
46-4.02(c) Vertical Clearances	46-4.4
46-4.03 Access Management.....	46-4.4
46-4.04 Intersections.....	46-4.5
46-4.05 Railroad Grade Separations	46-4.6
46-4.06 Interchanges	46-4.6
46-4.07 Drainage.....	46-4.6
46-4.08 Frontage Roads.....	46-4.7
46-4.09 Traffic Control Devices	46-4.7
46-4.09(a) Traffic Signals	46-4.7
46-4.09(b) Overhead Signing	46-4.7
46-4.09(c) Stop Sign Removal	46-4.7
46-4.09(d) Pavement Markings.....	46-4.7
46-4.10 Transit.....	46-4.8
46-4.10(a) Improvements	46-4.8
46-4.10(b) Express Bus Service	46-4.8
46-4.11 Pedestrians and Bicyclists.....	46-4.8
46-4.12 Environmental Considerations	46-4.8
46-4.13 Right-of-Way	46-4.8
46-4.14 Tables of Design Criteria.....	46-4.8
46-5 REFERENCES	46-5.1

Chapter Forty-six

STRATEGIC REGIONAL ARTERIALS (New Construction/Reconstruction)

Strategic Regional Arterials (SRA's) are a network of highways designed to accommodate long-distance regional traffic, to complement a region's major transit and highway facilities, and to supplement the freeway system. The Department's SRA concept was originally developed for Northeastern Illinois and is presented in the IDOT publication *Strategic Regional Arterial Design Concept Report "Operation Green Light."* However, this concept could apply to other cities and regions throughout the State.

Many of the Department's existing arterials can be incorporated into a SRA system. SRA's may have widely varying characteristics. Existing rights-of-way, roadway features, land use, and access differ from route to route, and also may change from one segment of a route to another. Chapter 46 provides guidance in the planning and design of strategic regional arterials including specific design criteria and techniques encountered on SRA routes, which should be applied throughout the system. Information also applicable to SRA's is included in the following chapters:

- Chapters 31, 32, 33, 34, and 39 provide guidance on the geometric design elements that are applicable to SRA's.
- Chapter 36 provides information on the design of intersections including left- and right-turn lanes, channelization, and intersection sight distance.
- Chapter 37 discusses the type, location, and design of interchanges.
- Chapter 38 provides guidelines on roadside safety.

46-1 GENERAL

46-1.01 Objectives for a SRA System

The SRA System is designed to:

- improve regional mobility by providing a comprehensive network of arterial routes designed to carry significant volumes of long distance traffic across a region,
- complement a region's major transit and highway facilities by providing access for regional trips on these facilities, and
- supplement the regional freeway system.

46-1.02 SRA Route Definitions

Within the overall SRA network, there are significant differences in the roadway environment that determine how the different types of routes (urban, suburban, and rural) may function in the system. The information in Chapter 46 has been segregated accordingly. For SRA application, the following defines the characteristics for these designations:

1. Urban Routes. Urban areas are defined as those with densities over 5 households per acre (12 households per hectare) in the design year. SRA routes located in densely urbanized areas typically are existing facilities with minimal potential for roadway expansion. However, improvements can be made to intersections, local transit facilities, and low structural clearances.
2. Suburban Routes. Suburban areas are defined as those with densities between 0.5 to 5 households per acre (1 and 12 households per hectare) in the design year. For routes in developing suburban areas, the major concerns are preservation of right-of-way, additional lanes on roadways, new connections to improve route continuity, and operational improvements (e.g., signal coordination).
3. Rural Routes. Rural areas are defined as those with densities less than 0.5 households per acre (1 household per hectare) in the design year. In rural areas, the major issues are the preservation of right-of-way and controlled access on bypasses to emphasize the movement of through traffic and the accommodation of future needs.

46-1.03 Spacing of SRA's

Spacing of routes on the SRA system is based upon the projected levels of future travel demand within the different parts of a region. In northeastern Illinois, the spacing should range from about 3 miles (5 km) apart in the most densely areas to about 9 miles (15 km) apart in rural areas. Spacing for other parts of the State will be determined on a case-by-case basis.

46-1.04 Coordination with Local Land Use Plans

For the SRA system to successfully accomplish its objectives, coordinated planning with each local jurisdiction is necessary along the routes. Local planning and development policies, particularly the arrangement of land uses adjacent to the arterial street and type of access, will greatly affect the ability of the facility to fulfill its function of carrying long-distance traffic. Also right-of-way protection will need to be coordinated with local planning and development agencies. Dedication or preservation of right-of-way on the SRA routes through the local development process is an effective means of protecting needed right-of-way to provide for future roadway improvements. Land use planning techniques can also encourage use of alternative modes of transportation, with policies favorable to mixed-use development.

Because SRA routes create a regional network, the impact of planning and development decisions crosses local boundaries. The need for cooperation among local governments and

regional transportation agencies in coordinating land development with planned SRA improvements is important whether or not a formal framework is established.

46-1.05 SRA Planning

46-1.05(a) Objectives

Development of comprehensive, long-range plans for a SRA network is necessary in order to implement a SRA system. These plans will identify both short-range and long-range improvements for each of the SRA routes. The following objectives may be used as a guide in the planning process:

- Determine the types of roadway improvements needed for each route including additional lanes, signalization, and interchanges.
- Identify and protect needed rights-of-way.
- Manage access to SRA routes to improve through traffic movement and reduce conflicts.
- Coordinate land use and development projects with transportation improvements.
- Identify ways to accommodate the growth in commercial traffic.
- Accommodate necessary bicycle and pedestrian travel on or near the SRA route corridors.
- Identify potential environmental concerns.

The long-term plans are intended to be specific to each SRA route. However, this does not preclude consideration during the planning process of alternative segments on a route where warranted by circumstances. Also, the planning process should address the fact that not all transportation needs can be provided within the right-of-way of an SRA route, and that some types of travel may be better provided on parallel facilities.

46-1.05(b) Implementation Process

The SRA planning process has two parts:

- The first part consists of developing recommended design features and techniques for the SRA route. Chapter 46 provides the criteria that should be considered when developing route specific plans.
- The second part consists of preparing specific route studies for each SRA route. The studies will recommend both comprehensive short-range and long-range improvements for each route, through the work program; see Figure 46-1.A.

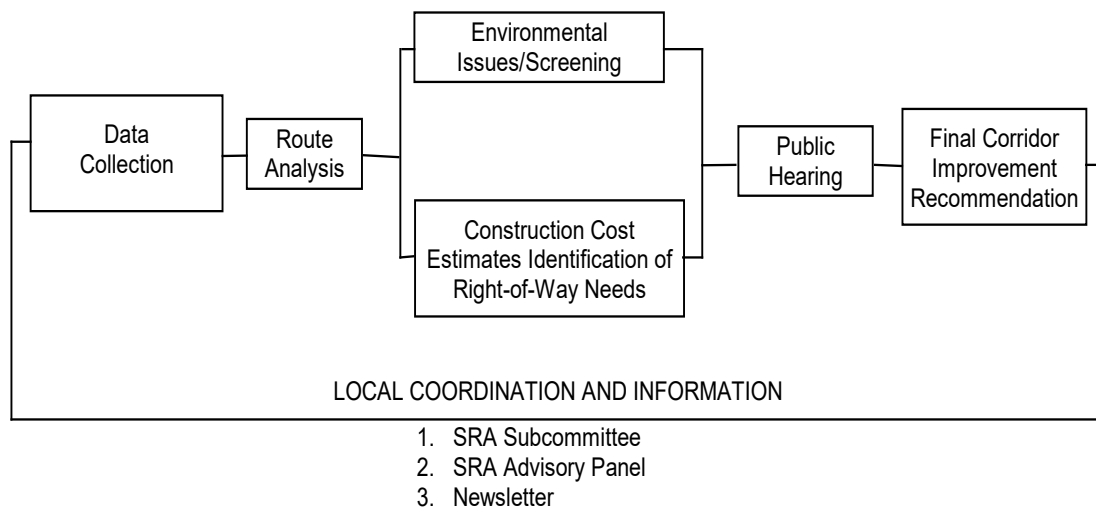

THE SRA ROUTE STUDIES WORK PROGRAM

Figure 46-1.A

The principal activities in the route studies work program are:

1. Data Collection/Evaluation. The SRA planning process is designed to efficiently use available data. For each route, data is assembled from right-of-way information, roadway plans, traffic volume projections, transit information, bicycle usage, adjacent development characteristics, crash data, environmental studies, and other sources, and is analyzed to establish current conditions, constraints, and improvement needs.
2. Route Analysis. Possible improvements for the SRA route are determined by incorporating the recommended design features in specific configurations for each segment of the overall route. These configurations include alternative designs and techniques where necessary to accommodate local conditions or constraints. The timing of the recommended improvements, whether long-range or short-range, are also identified.
3. Environmental Issues/Screening. While the SRA planning process does not include detailed environmental assessments or analysis of specific mitigation measures, a screening process will identify significant environmental conditions along each route. Use the results of this process to evaluate improvement alternatives, and also to serve as an early indicator of environmental issues for future design studies.
4. Construction Cost Estimates/Identification of Right-of-Way Needs. Prepare construction cost estimates for each route segment, both for short-range and long-range improvements. Also identify right-of-way needs to accommodate the recommended long-range improvements.

5. Local Involvement and Coordination. Throughout the SRA route planning process, the involvement of local and regional agencies is an important consideration; see Section 46-1.04. Information and coordination efforts include forming Advisory Panels for each SRA route, which will work with IDOT during the planning process. A regular newsletter for each Panel will inform members about the SRA program and ongoing route studies. A public hearing in an open-house format will also be conducted for each route.

6. Final Route Improvement Plan/Report. As the final step in the planning process, prepare a report for each SRA route to document the recommended improvements and findings.

As planning for each route is completed, the design concepts will be used to help program the scope and timing for improvements along that route. For State routes, once an SRA improvement is included in the IDOT Five-Year Program, the process of implementation follows the process shown in Figure 46-1.B.

Pre-Phase I (SRA Route Studies)	Phase I Reports	Phase II	Phase III	Phase IV
<u>Planning</u> 1. Data Collection 2. Test Alternatives 3. Local Coordination 4. Environmental Screening 5. Recommend Improvements 6. Public Meetings	<u>Preliminary Design</u> 1. Preparation of Preliminary Plans 2. Public Involvement 3. Environmental Studies/Mitigation 4. Public Meetings	<u>Final Design</u> 1. Preparation of Contract Plans 2. Community Coordination 3. Environmental Mitigation	<u>Construction</u> 1. Implementation 2. Community Coordination	<u>Post Construction</u> 1. Environmental Monitoring 2. Land Development/ Access

THE SRA IMPLEMENTATION PROCESS FOR ROUTES UNDER IDOT JURISDICTION

Figure 46-1.B

46-2 URBAN SRA ROUTES

46-2.01 General Roadway Features

Urban SRA's are proposed with two or more lanes in each direction divided by a flush median. Measures to increase mobility will typically be associated with traffic signal systems, changes to access, and removal of parking rather than widening or other new construction. Figure 46-2.A illustrates the typical plan view design configuration for an urban SRA. Figure 46-2.B illustrates a desirable cross section for an urban SRA. For an illustration of a superelevated section, see Chapter 48. Where right-of-way or other restrictions do not allow the configuration in Figure 46-2.A, the designer may consider the following:

1. One-Way Arterial Pairs. One-way arterial pairs can dramatically increase the capacity of a roadway by reducing turning movements and conflicts. The one-way pairs should be within close proximity to each other. This concept is generally feasible in urban areas where right-of-way for increasing capacity is limited and where closely spaced parallel streets are available.
2. Reversible Lanes. In areas where there is substantial commuter traffic and a directional bias to the traffic corresponding to the time of day, reversible lanes may be considered. Lane control signals and other traffic control features will be required.

46-2.02 Geometric Design Elements

46-2.02(a) Median Type

The presence of a median on urban SRA routes will provide protection for left-turning vehicles at cross streets, direct turning movements to desired locations, and reduce opposing traffic conflicts. The typical design is a flush median with an 11 ft (3.3 m) width. A flush median delineated with thermoplastic or painted markings offers a measure of median control in urban areas where limited right-of-way is available and where numerous access points exist.

46-2.02(b) Additional Lanes

On urban SRA routes, there is often little right-of-way available for roadway widening. Additional lanes generally can only be added by using the existing pavement (e.g., converting a parking lane to a travel lane). Section 46-2.08 discusses the removal of on-street parking.

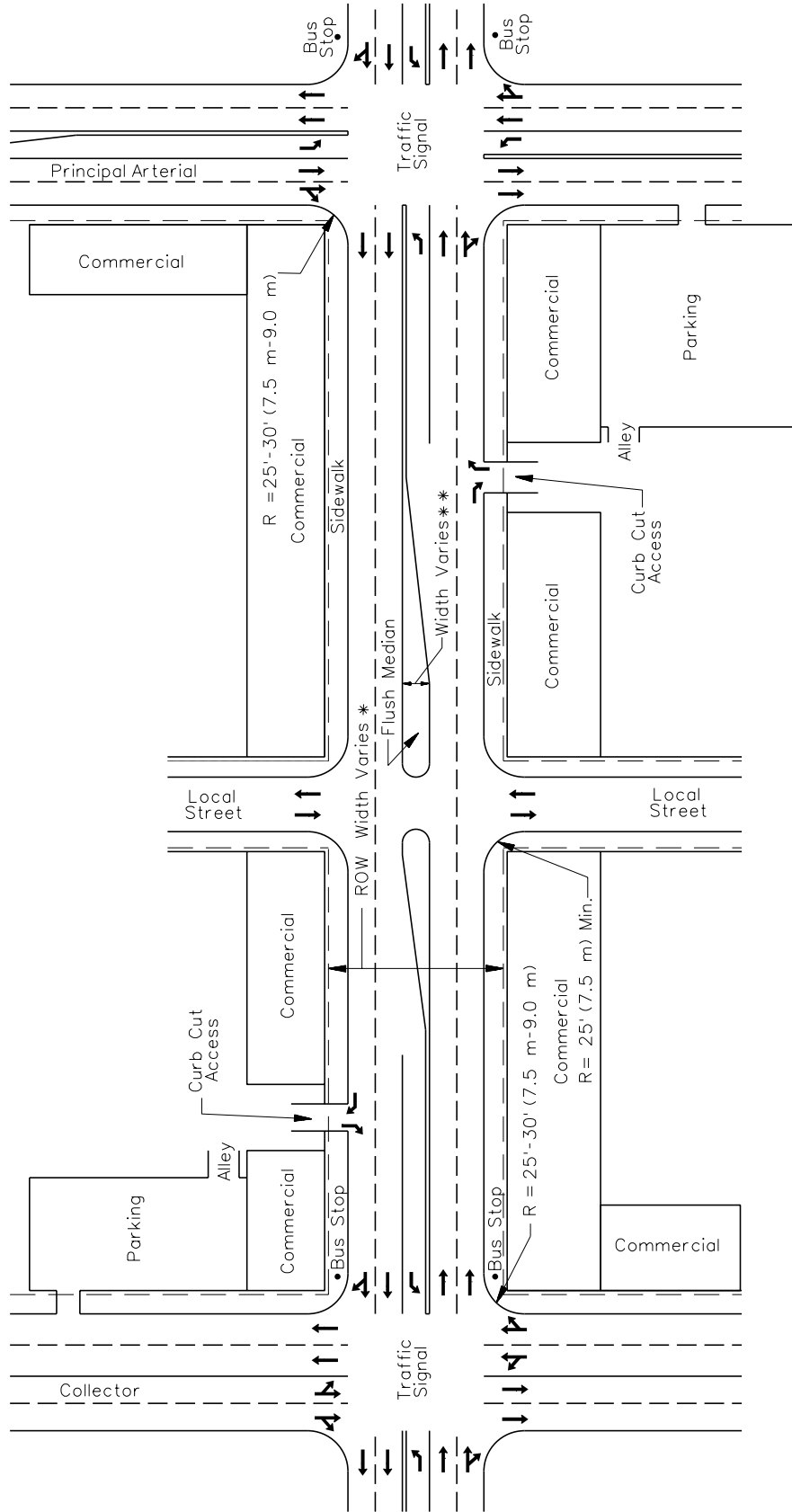

* If no bus/HOV only lanes are required, ROW is typically 82 ft to 87 ft (25 m to 26.5 m) assuming a flush left-turn lane.
 ** If an 11 ft (3.3 m) wide flush median cannot be obtained due to restricted ROW, then consider and investigate a one-way arterial pair.

**TYPICAL URBAN SRA ROUTE
 (Two-Block Segment)**

Figure 46-2.A

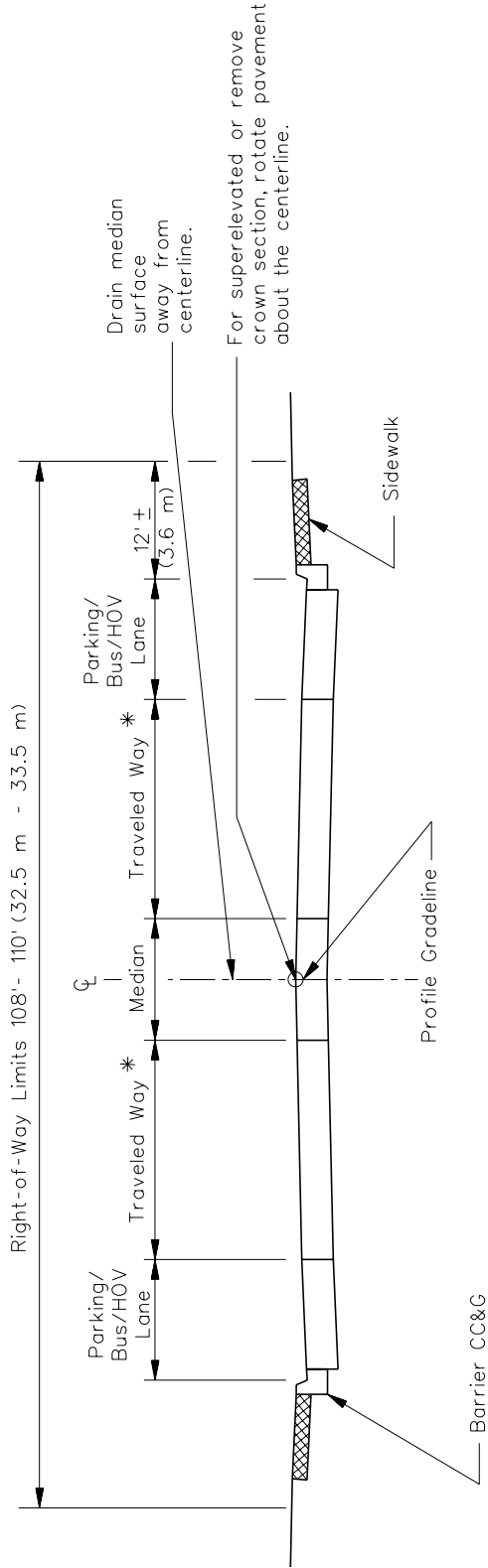

* Where it is desirable to accommodate bicycle demand and ROW is not restricted, an additional width may be added to each direction of the traveled way for bicycles.

**DESIRABLE URBAN SRA CROSS SECTION
(With HOV/Bus Lanes)**

Figure 46-2.B

46-2.02(c) Horizontal and Vertical Clearances

The vertical clearances for urban SRA routes are presented in Figures 33-5.A and 46-2.E. Because most urban SRA's are existing routes, vertical clearances may need to be increased to provide for the unrestricted movement of large vehicles. Bridges that do not provide a minimum of 14 ft 09 in (4.50 m) clearance above the roadway are candidates for modification. Bridges which provide a vertical clearance of 14 ft 00 in (4.25 m) may remain in place, but should be considered for reconstruction or other means to achieve a minimum vertical clearance of 14 ft 09 in (4.50 m). Where the SRA route is an underpass, the recommended method to increase the vertical clearance is to lower the roadway through milling, raising the pier height, reconstructing the bridge, or other methods. Carefully evaluate potential drainage and utility problems where these methods are proposed.

Horizontal clearances along urban SRA routes should provide 1.5 ft (500 mm) from face of curb to an obstruction. Bridge railings and abutments are typically the two most important items to check concerning horizontal clearances. See Section 38-3 for additional guidance. Obstructions (e.g., utility poles) within this clearance should be modified or reconstructed, if feasible.

46-2.03 Access Management

The use of access management techniques is one of the most important concepts implemented on the SRA system. Length of travel time and driver safety are influenced by the number and configuration of access points to the SRA. Each driveway and cross street reduces mobility and safety. Where this may be a problem, consider the following techniques:

1. Eliminate Local Street Access. To improve operations, evaluate closing some local low-volume streets. This is generally not considered a problem where the typical urban street pattern is (8 to 12 streets per mile (5 to 8 streets per km)). Do not close streets that serve as collectors. Where streets are closed, maintain access for pedestrians and bicyclists, where practical.
2. Restricting Curb Cuts. Where curb-cut access is allowed along urban SRA routes, it is preferable that only right-in and right-out turns be permitted. This will prevent left-turn movements from and onto the SRA across through traffic lanes. An example of this design is shown in Figure 46-2.C. This is especially important where a left-turn lane cannot be provided. Another desirable feature is to minimize the number of access points by eliminating or consolidating curb cuts. However, because it is impractical to eliminate all curb cuts, the most beneficial way to increase the efficiency of through movements is to provide for a center-turn lane on the urban SRA. This design feature will remove turning traffic from through lanes.

Chapter 35 provides further guidance on access management techniques that are also applicable to urban SRA routes.

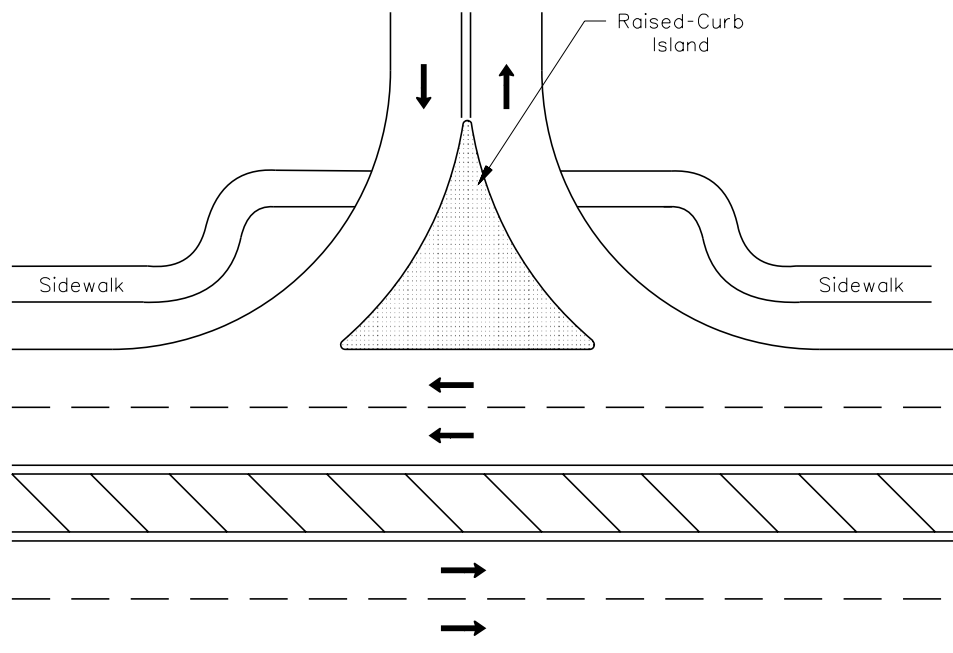

Note: Where ROW is restricted, favor ingress maneuvers over egress maneuvers.

DRIVEWAY CHANNELIZATION (Right-In and Right-Out Only)

Figure 46-2.C

46-2.04 Intersections

In addition to Chapter 36, the following is applicable to intersections on urban SRA routes:

1. Turn Lanes. Section 36-3 provides the warrants and design criteria for turn lanes. Where turn lanes are provided, maintain at least two through lanes in each direction. In addition, the following will apply:
 - a. Left-Turn Lanes. Provide left-turn lanes at all signalized intersections. Where a left-turn lane cannot be provided on the SRA to local streets, discourage or prohibit the left turns.
 - b. Right-Turn Lanes. Where pavement width is available, include right-turn lanes where warranted. It is recommended that parking on the approach and far side of the intersection be prohibited within 100 ft (30 m) of all major intersections to allow for a right-turn lane.
 - c. Dual Left-Turn Lanes. Where there are high left-turn volumes and available right-of-way, dual left-turn lanes are recommended to alleviate congestion. If used, operate dual left-turn lanes using the “protected only” phasing. For access

management, separate the dual left-turn lanes and the turn lane taper from opposing through lanes by a raised-curb median; see Chapters 35 and 36.

2. Turning Radii. Insufficient turning radii for trucks can significantly affect capacity at an intersection. Small radii may require large trucks to slow down to maneuver through the turn, encroach in opposing lanes, or encroach onto the curb. Design the curb radii to meet the expected design vehicle. Intersection design vehicles are discussed in Section 36-1.08. However, do not indiscriminately apply turning radii improvements to urban intersections. Frequently, in urban areas there are heavy pedestrian volumes and shallow setbacks for buildings. Only propose turning radii improvements after a determination that the existing sidewalk width and adequate pedestrian capacity can be maintained.
3. Approaches. Intersections on urban routes with more than four approaches can cause operational problems. To alleviate this problem, consider one of the following options:
 - close one of the approaches;
 - install a roundabout;
 - convert one of the approaches to one-way operation going away from the intersection;
 - provide an extremely short signal timing on one of the approaches to reduce the desirability of the approach; or
 - relocate the excess approaches away from the intersection. This is the most desirable option. However, right-of-way requirements usually make this option difficult to implement.
4. Medians. Where a median cannot be provided on the SRA route, movements between the local streets and the SRA may be restricted to the right-in/right-out.
5. Capacity. At intersections where capacity is limited and volumes are high, left-turn restrictions and the elimination of signalized turn phases may be necessary. This will increase the capacity on the SRA route and reduce intersection conflicts. Alternative routes or access will be required for the affected movements. In some instances, limiting left-turn movements during peak periods on the SRA route may be beneficial to through roadway operations. This alternative is appropriate at locations where turn lanes are not available.
6. Pavement Markings. Chapter 36 and the *Illinois MUTCD* provide information on pavement markings at channelized intersections.
7. Pedestrians. Where pedestrians are required to cross wide intersections, raised-curb center islands of sufficient size and width can provide a refuge area for pedestrians.

46-2.05 Railroad Grade Separations

Grade separations at railroads provide the greatest capacity and safety on an SRA route. However, limited right-of-way and economic considerations in urban areas may restrict the use of grade separations to isolated locations. Protection of sufficient right-of-way is critical where a grade separation is recommended. Design criteria for grade separations are discussed in Chapter 44.

46-2.06 Interchanges

In urban areas, right-of-way and economic feasibility tend to restrict the use of interchanges. However, where the intersection peak-hour level of service in the design year is expected to be E or F, consider providing an interchange. Where interchanges are provided, the single point urban diamond interchange or compressed diamond interchange are recommended to fit into existing right-of-way limitations. Chapter 37 provides further guidance on the selection of interchange types.

Under certain conditions, consider providing a U-turn movement at the cross street as discussed in Section 37-3.04. This design allows the exiting driver access to the opposing frontage road without passing through the signalized intersection on the cross street.

Where an interchange is proposed at the intersection of two SRA routes, give priority for the grade-separated structure to the route with the higher traffic volume.

Evaluate upgrading existing incomplete interchanges to provide for all movements (e.g., half diamonds, partial cloverleaves). Traffic conditions and directional flows that existed at the time of initial construction may have significantly changed. In addition to providing all movements, evaluate widening existing structures, lengthening storage bays for left-turning vehicles, adding right-turn lanes, and interconnecting traffic signals to improve traffic progression along the SRA route.

46-2.07 Drainage

Drainage problems are intensified in urban areas where high runoff coefficients are often combined with storm drainage systems of inadequate capacity. The *IDOT Drainage Manual* provides guidance for the design and construction of all drainage improvements. Chapter 48 illustrates a more efficient means to reduce the flow of water from the high side to the low side of a superelevated urban horizontal curve.

46-2.08 Removal of On-Street Parking

Although on-street parking is typically permitted on portions of urban SRA routes, it can significantly affect the capacity of the route and may constitute a safety hazard as drivers enter and exit parking spaces. Where practical, consider permanently removing the on-street parking or restricting it during peak hours. However, before pursuing these actions, there should be

sufficient off-street parking available, and the route should meet one or more of the following conditions:

- there are less than two travel lanes in each direction and there is insufficient room to provide two through lanes within the existing cross section,
- the projected level of service is expected to be D or worse during peak hours,
- there are high number of crashes attributed to the on-street parking (e.g., 5 crashes per year per 10,000 ADT), and/or
- there is a need for a median where none currently exist.

If adequate off-street parking exists in public or private lots and garages, eliminate the on-street parking. If the existing parking inventory is not adequate to absorb those vehicles currently parked on the street, consider adjacent parcels (vacant or non-vacant) of land in the vicinity that could be developed for additional off-street parking.

46-2.09 Traffic Control Devices

46-2.09(a) Traffic Signals

Interconnect all traffic signals on urban SRA routes into signal networks or signal systems. Signal networks are beneficial in urban areas where grid patterns of signalized intersections, parallel one-way SRA routes, or intersecting SRA routes exist. The network should establish a priority of the through movement for the SRA route. Where an urban SRA route is not located in a grid pattern of signalized intersections, or where numerous other signals are too close to establish a network, then signals along the SRA should be interconnected into a system to provide for progression of traffic.

Time all signal networks and signal systems on urban SRA routes for optimal progression based on a traffic engineering study. When timing traffic signals on urban SRA routes, a peak-hour level-of-service D is the lowest level-of-service acceptable for the SRA through lanes. This may require turning movements and cross streets to operate at a lower level-of-service, or this could require the use of one-way arterial pairs.

The use of a lagging left-turn signal phase (i.e., the left-turn phase comes after the through phase) can improve signal synchronization. Progression bandwidths, which control the time available during which all vehicles can progress through a series of signals, can be increased with lagging left-turn phasing. However, use this type of phasing at T-intersections or intersections that only allow left turns during a protected phase. Do not use lagging left turns where left turns are permitted during the permissive green phase.

In many urban areas pretimed traffic signals are commonly used. If pretimed traffic signals that are not tied into the network are encountered along urban SRA routes, consider replacing them with fully actuated signals.

Chapter 57 and the Bureau of Operations *Policies and Procedures Manual* provide additional information on traffic signals.

46-2.09(b) Stop Sign Removal

Stop sign control for traffic movements on an SRA route is inconsistent with giving priority to the SRA through movement. Therefore, remove any stop signs on the urban SRA route. However, before removal, it will be necessary to conduct a traffic engineering study to determine the appropriate traffic control at the location for both the SRA route and the intersecting cross street.

46-2.09(c) Pavement Markings

Because of their durability and visibility, only use high-type pavement markings on SRA routes. High-type pavement markings include thermoplastic, epoxy, and pre-formed plastics. Also consider including raised pavement markers on SRA routes. Although street lighting is prevalent in the urban environment, raised pavement markers introduce an element of safety to the SRA route during inclement weather. Space raised pavement markers according to the criteria in the Bureau of Operations *Policies and Procedures Manual* and the *IDOT Highway Standards*.

46-2.09(d) Driver Information Systems

In addition to providing signs and pavement markings to guide motorists, furnishing motorists with information on congestion, construction, or other incidents that may affect their trip is important. Driver information systems may include variable or fixed message signing, radio and television traffic reports, newspaper articles, and brochures.

46-2.10 Trucks

Preferably, locate all loading and unloading areas off the SRA route. This may be accomplished by improving alley access, moving loading areas to nearby side streets, providing a central mid-block loading area, etc. Where off-street loading options are not available, one option is to remove or restrict on-street parking. Locate these unloading zones away from intersections so that right-turning traffic can use the curb lane at the intersection.

46-2.11 Transit

46-2.11(a) Improvements

There are numerous transit techniques that may be implemented to improve the operations of an urban SRA route. Some of these include:

1. Ridesharing. Carpools and vanpools are the most common form of ridesharing.

2. High Occupancy Vehicle (HOV) Lanes. This application is discussed in Section 46-2.11(c).
3. Transit Contra-Flow Lanes. This option allows transit vehicles to travel in the reverse direction from the general traffic in a reserved transit lane. This may be applicable if there is reserve capacity available in the non-peak direction. A physical barrier may be required to separate the bus lane from the opposing lanes.
4. Passenger Facilities. Consider providing passenger facilities that make it easier and safer to use transit facilities.
5. Signal and Intersection Improvements. Consider providing signal and intersection improvements that improve the transit operations (e.g., signal preemption, larger turning radii).

46-2.11(b) Local Bus Service

On urban SRA routes that accommodate bus routes, consider transit service enhancements to determine their potential for relieving traffic congestion. This may include the following:

1. Removing Parking. One option is to remove parking from the curb lane, with strict enforcement of parking restrictions, allowing the curb lane to be used as a HOV/bus lane (i.e., through or turning); see Section 46-2.08.
2. Bus Stops. Bus stop turnouts are generally not considered practical on urban SRA routes. However, review the location and spacing of bus stops, passenger amenities, and signal preemption to determine if improvements can be made. Major objectives would be to eliminate stops if there are more than one per block and to eliminate conflicts with right turns. Where the blocks are short, as in central business districts, stops could be located at every other block.
3. Exclusive Lanes. One strategy to improve travel times is to establish exclusive lanes for buses and high-occupancy vehicles during the morning and evening peak travel periods. The SRA route must have at least three traffic lanes in each direction. Section 46-2.11(c) provides further information on the suitability of HOV lanes in urban areas. A companion measure is to minimize access points next to an exclusive lane by eliminating curb cuts wherever practical.

46-2.11(c) HOV Lanes

High occupancy vehicle (HOV) lanes designated for buses, car pools, vanpools, and bicyclists may be appropriate in selected areas with high levels of transit ridership and ridesharing activity. There also should be adequate capacity to accommodate traffic in general use lanes. The following criteria and conditions are applicable outside the central business district for an HOV lane along the curb or median. The HOV lane should not involve major new construction or right-of-way acquisition (i.e., the existing pavement should be used). The facility should be

designed primarily for buses, although car pools, van pools, and bicyclists should also be encouraged. One or more of the following conditions should apply and all of the following criteria should be met before an HOV lane is implemented:

1. **Conditions.** One or more of the following conditions should be met:
 - a. **High Level of Usage (Curb Lane).** Route segments should have an existing or projected transit ridership of at least 1200 one-way passengers in the peak hour. A curb HOV lane should be used almost exclusively by buses. Existing or projected bus volumes should be 15 to 40 vehicles one-way in the peak hour. Figure 46-2.B illustrates a cross sectional view with a HOV/bus lane adjacent to a curb.
 - b. **High Level of Usage (Median Lane).** Route segments should have an existing or projected usage of 2400 one-way passengers or rideshare occupants in the peak hour. A higher demand threshold has been established for a median HOV lane to reflect the potential for higher costs and operational problems associated with implementation. Figure 46-2.D illustrates bus lane treatments within the median. Where used, general vehicular traffic should only be allowed to make left turns at other SRA routes.
2. **Criteria.** All of the following criteria must be met:
 - a. **Reduce Total Person Delay.** There should be a net reduction in the average travel time per person for all users of the route.
 - b. **Minimal Disruption to Traffic Operations.** It must be feasible to institute left-turn restrictions and signalization adjustments necessary for HOV operations with only minimal disruption to traffic flow in the general use lanes.
 - c. **No Peak-Hour On-Street Parking or Loading.** For implementation of a curb HOV lane, it must be feasible to prohibit parking and loading and unloading in the curb lane; see Section 46-2.08.
 - d. **More than the Minimum Number of Travel Lanes.** In urban areas, three through lanes should exist in each direction where one lane can be assigned for HOV use. This provides for the minimum of two through lanes to be maintained unless the situation warrants changing the street into a one-way arterial pair.

46-2.12 Pedestrians and Bicyclists

Safe movement and accessibility are key issues for bicyclists and pedestrians. Urban SRA corridors are likely to experience bicyclists and a high volume of pedestrians, which may significantly impact the capacity and operations of the SRA route. One advantage of urban routes is that there typically are close parallel routes that may be considered for bicycle and pedestrian routes. Identify these parallel facilities as bicycle routes so that the SRA routes can

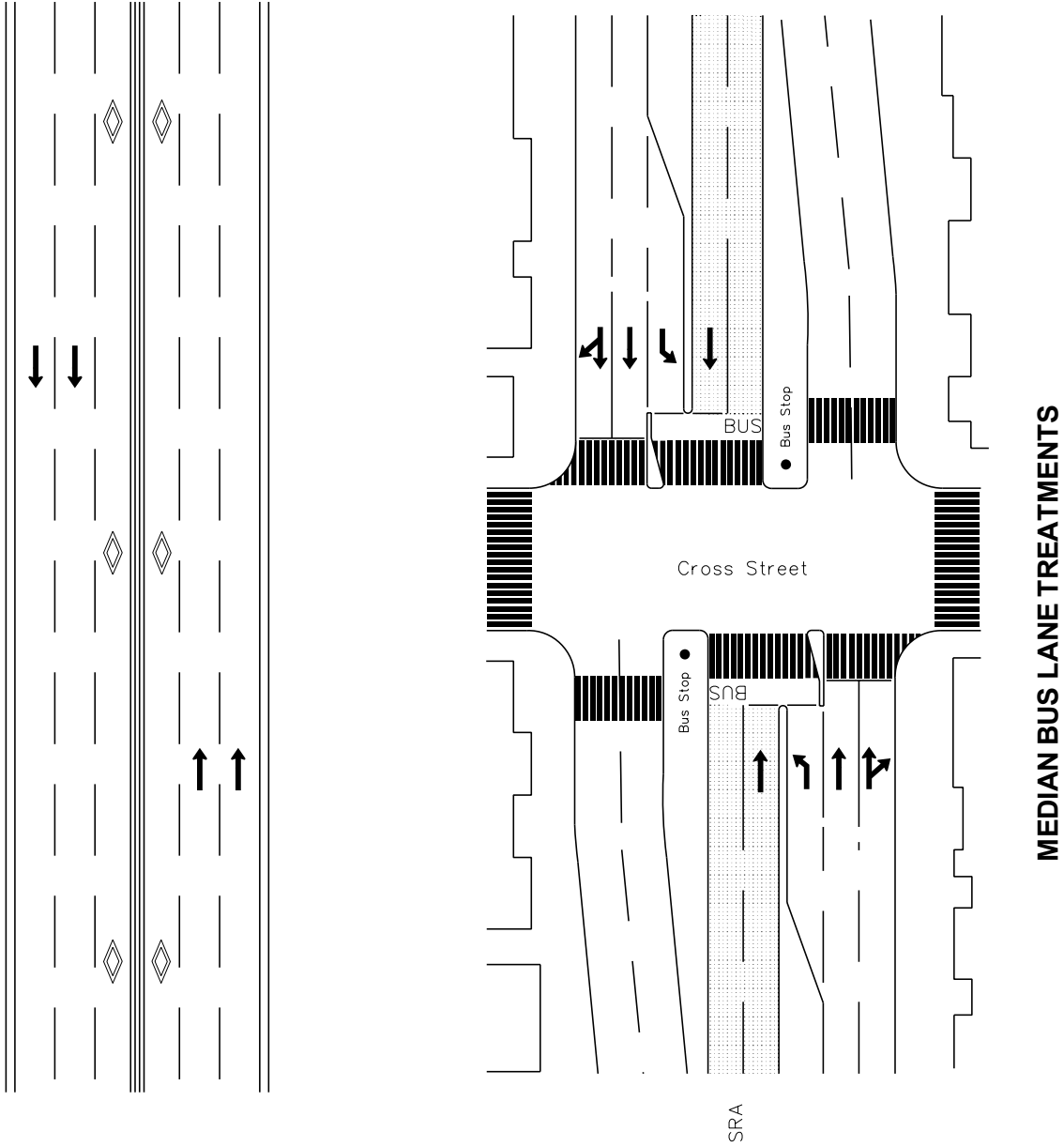

Figure 46-2.D

MEDIAN BUS LANE TREATMENTS

be reserved for vehicular traffic. At major obstacles (e.g., river crossings, canals, railroad bridges, limited access facilities), ensure that adequate provisions are available so that pedestrians and bicyclists have access across these barriers. Chapter 17 provides additional information for bicycle and pedestrian facilities. Chapter 58 provides information on accessibility requirements.

46-2.13 Environmental Considerations

The environmental analysis component of the SRA planning process is primarily an inventory of existing conditions. The inventory identifies those environmental resources in the corridor and probable impacts based on roadway improvements. Environmental assessments will be performed during the Phase I design work. These are discussed in Part III “Environmental Procedures” of this *Manual*.

46-2.14 Right-of-Way

Where there is restricted right-of-way, it is generally not feasible to provide the desirable urban SRA cross section as shown in Figure 46-2.B. In restrictive right-of-way locations, the designer should consider implementing one or more of the following options:

- providing a minimum of two through lanes in each direction,
- only allowing left turns from the SRA route at major intersections,
- consolidating and restricting intermediate access points,
- restricting on-street parking,
- restricting on-street loading and unloading zones,
- developing a one-way arterial pair, and/or
- considering alternative right-of-way acquisitions.

Where feasible, purchase additional right-of-way which allow improvements to the overall cross section of the SRA or to major intersections.

46-2.15 Tables of Design Criteria

Figure 46-2.E presents the Department’s design criteria for new construction and reconstruction of urban strategic regional arterial projects. Figure 46-2.F provides the alignment criteria for urban SRA routes. The designer should realize that some of the cross section elements included in the figure (e.g., HOV/bus lanes) are not automatically warranted in the project design. The values in the figure only apply after the decision has been made to include the element in the highway cross section.

Design Element		Manual Section	Desirable Design Values
Design Controls	Design Forecast Year	31-4.02	20 Years
	*Design Speed	31-2	30 mph – 40 mph (1)
Cross Section	Access Control	46-2.03	Managed Access
	Level of Service	31-4.04	Northeast Illinois: D Elsewhere: C
	On-Street Parking	46-2.08	Not Recommended
	Traffic Signals	46-2.09	Spaced at ¼ mile increments
	*Traveled Way Width	34-2.01	2 @ 24' (2)
	Auxiliary Lanes	34-2.03	Single Left & Right: 12', Min.: 11' Dual Lefts: 24', Min.: 22'
	Median Width	34-3.03	B-6.12 or B-6.24 CC&G 11', 12', 14' (3)
	Parking Lane Width	48-2.05	Des.: 10', Min.: 8' (4)
	Bicycle Lane Width (Shared)	46-2.12	Min.: 13' Outside Lane
	Outside Curb Type and Width	34-2.04	B-6.24 CC&G
Roadway Slopes	Cross Slope	34-2.01	1/4"/ft for Median and Two Lanes Adjacent to Median (5)
	Sidewalk Width	48-2.04	10' Adjacent to Curb
	Clear Zone	38-3	(6)
Bridges	Side Slopes	34-4.04	—
	Median Slopes	34-4.05	—
	New and Reconstructed Bridges	34-4.02	—
	Existing Bridges to Remain in Place	34-3	1/4"/ft
Bridges	*Structural Capacity	N/A	HS-20
	*Clear Roadway Width (7)	39-6	52' plus Median Width
	*Structural Capacity	N/A	HS-20
	*Clear Roadway Width (8)	39-6	48' without Medians or Sidewalk
	New and Replaced Overpassing Bridges (9b)	39-4	14'-9"
	Existing Overpassing Bridges (9a)	33-5	14'-0" (9c)
	Overhead Signs/ Pedestrian Bridges	33-5	17'-3" (9b)
	*Vertical Clearance (SRA over Railroad)	39-4.06	New: 23'-0" Existing: 21'-6"

* Controlling design criteria (see Section 31-8).

GEOMETRIC DESIGN CRITERIA FOR URBAN STRATEGIC REGIONAL ARTERIALS (SRA)
(New Construction/Reconstruction)
(US Customary)

Figure 46-2.E
 (1 of 2)

Design Element		Manual Section	Desirable Design Values	
Design Controls	Design Forecast Year	31-4.02	20 Years	
	* Design Speed	31-2	50 km/h - 60 km/h (1)	
	Access Control	46-2.03	Managed Access	
Cross Section	Level of Service	31-4.04	Northeast Illinois: D Elsewhere: C	
	On-Street Parking	46-2.08	Not Recommended	
	Traffic Signals	46-2.09	Spaced at 400 m Increments	
	* Traveled Way Width	34-2.01	2 @ 7.2 m (2)	
	Auxiliary Lanes	Lane Width	34-2.03	Single Left & Right: 3.6 m, Min.: 3.3 m Dual Lefts: 7.2 m, Min.: 6.6 m
		Curb Type and Width		B-15.30 or B-15.60 CC&G
	Median Width	Flush/TWLT	34-3.03	3.3 m, 3.6 m, 4.0 m (3)
	Parking Lane Width		48-2.05	Des.: 3.0 m, Min.: 2.4 m (4)
	Bicycle Lane Width (Shared)		46-2.12	Min.: 4.0 m Outside Lane
	Outside Curb Type and Width		34-2.04	B-15.60 CC&G
Cross Slope	* Travel Lanes	34-2.01	2.0% for Median and Two Lanes Adjacent to Median (5)	
Sidewalk Width		48-2.04	3.0 m Adjacent to Curb	
Clear Zone		38-3	(6)	
Roadway Slopes	Side Slopes	Cut Section (Curbed)	34-4.04	—
		Rock Cut	34-4.05	—
		Fill Section (Curbed)	34-4.02	—
	Median Slopes	Flush	34-3	2%
Bridges	New and Reconstructed Bridges	N/A	MS-18	
	Existing Bridges to Remain in Place	* Clear Roadway Width (7)	39-6	15.6 m plus Median Width
		* Structural Capacity	N/A	MS-18
	* Vertical Clearance (SRA Under) (9a)	* Clear Roadway Width (8)	39-6	14.4 m without Medians or Sidewalk
		New and Replaced Overpassing Bridges (9b)	39-4	4.5 m
		Existing Overpassing Bridges		4.3 m (9c)
* Vertical Clearance (SRA over Railroad)	Overhead Signs/ Pedestrian Bridges	33-5	5.25 m (9b)	
		39-4.06	New: 7.0 m Existing: 6.6 m	

* Controlling design criteria (see Section 31-8).

**GEOMETRIC DESIGN CRITERIA FOR URBAN STRATEGIC REGIONAL ARTERIALS (SRA)
(New Construction/Reconstruction)
(Metric)**

**Figure 46-2.E
(1 of 2)**

- (1) Design Speed. The 30-mph (50-km/hr) design speed should only be used in central business districts.
- (2) Traveled Way Width. If right-of-way is restricted, 11 ft (3.3 m) travel lanes may be used (i.e., 2 @ 22 ft (6.6 m)).
- (3) Flush Median Width. Use 14 ft (4.0 m) if there is a significant number of trucks making left turns. If a 11 ft (3.3 m) wide flush median cannot be provided due to restricted right-of-way, consider the use of a one-way arterial pair.
- (4) Parking Lane Width. If the parking lane will be used as a travel lane or bus/HOV lane during peak hours or may be converted to a travel lane in the future, provide a 12 ft (3.6 m) width. The width of the parking lane includes the gutter width.
- (5) Travel Lane Cross Slope. For parking/bus/HOV lanes, the cross slope is 5/16" /ft (2.5%).
- (6) Clear Zone. For curbed facilities, the minimum horizontal clearance to an obstruction is 1.5 ft (500 mm) measured from the face of curb.
- (7) New and Reconstructed Bridge Widths. Clear roadway bridge widths are measured from face to face of outside curbs or parapets walls. Urban bridge widths are normally defined as the sum of the approach traveled way widths, the width of the median, and the width of gutters. A sidewalk or bikeway will result in additional bridge width. For sidewalks proposed on bridge, add 10 ft (3.0 m) to each side of bridge.
- (8) Existing Bridge Widths to Remain in Place. Clear roadway bridge widths are measured from face to face of outside curbs or parapet walls. Implies elements allowed to remain in place without a design exception approval when cost effective and when safety record is satisfactory. Provide at least one sidewalk across the bridge.
- (9) Vertical Clearance (SRA Under).
 - a. The clearance must be available over the traveled way and median where a flush median is used.
 - b. Table value includes allowance for future overlays.
 - c. The 14 ft 0 in (4.3 m) clearance may be allowed to remain in place with consideration for reconstructing to a clearance of 14 ft 9 in (4.5 m).

GEOMETRIC DESIGN CRITERIA FOR URBAN STRATEGIC REGIONAL ARTERIALS (SRA)
(New Construction/Reconstruction)
(Footnotes)

Figure 46-2.E
(2 of 2)

Design Element	Manual Section	Design Speed	
		30 mph	40 mph
* Stopping Sight Distance (1)	31-3.01	200'	305'
Decision Sight Distance (2)	31-3.02	620'	825'
Intersection Sight Distance (3)	36-6	335'	445'
* Minimum Radii (4)	$e_{max} = 4\%$	250'	535'
* Superelevation Rate (5)	48-5	$e_{max} = 4\%$	
* Horizontal Sight Distance	32-4	(6)	
* Vertical Curvature (K-values)	Crest	19	44
	Sag	37	64
* Maximum Grade	33-2.02	7%	7%
Minimum Grade	33-2.03	Des: 0.5% Min: 0.3% (with Curb and Gutter)	

* Controlling design criteria (see Section 31-8):

- (1) Stopping Sight Distance. Table values are for passenger cars on level grade.
- (2) Decision Sight Distance. Table values are for the avoidance maneuver on urban streets (speed/path/direction change).
- (3) Intersection Sight Distance. Table values are for passenger cars. See Section 36-6 for trucks.
- (4) Minimum Radii. Values shown are for a 4% superelevation rate. For a normal crown section, the minimum radii are 335 ft and 765 ft for design speeds of 30 mph and 40 mph respectively.
- (5) Superelevation Rate. See Section 48-5 for superelevation rates based on e_{max} , design speed, and radii of horizontal curves.
- (6) Horizontal Sight Distance. For a given design speed, the necessary horizontal sight line offset will be determined by the radius of curve and the required sight distance.

ALIGNMENT CRITERIA FOR URBAN STRATEGIC REGIONAL ARTERIALS (SRA)
(US Customary)

Figure 46-2.F

Design Element	Manual Section	Design Speed	
		50 km/h	60 km/h
*Stopping Sight Distance (1)	31-3.01	64 m	83 m
Decision Sight Distance (2)	31-3.02	195 m	235 m
Intersection Sight Distance (3)	36-6	105 m	126 m
*Minimum Radii (4)	48-5	86 m	135 m
*Superelevation Rate (5)	48-5	$e_{max} = 4\%$	
*Horizontal Sight Distance	32-4	(6)	
*Vertical Curvature (K-values)	Crest	7	11
	Sag	12	17
*Maximum Grade	33-2.02	7%	7%
Minimum Grade	33-2.03	Des: 0.5% Min: 0.3% (with Curb and Gutter)	

* Controlling design criteria (see Section 31-8).

- (1) Stopping Sight Distance. Table values are for passenger cars on level grade.
- (2) Decision Sight Distance. Table values are for the avoidance maneuver on urban streets (speed/path/direction change).
- (3) Intersection Sight Distance. Table values are for passenger cars. See Section 36-6 for trucks.
- (4) Minimum Radii. Values shown are for a 4% superelevation rate. For a normal crown section, the minimum radii are 116 m and 189 m for design speeds of 50 km/h and 60 km/h respectively.
- (5) Superelevation Rate. See Section 48-5 for superelevation rates based on e_{max} , design speed, and radii of horizontal curves.
- (6) Horizontal Sight Distance. For a given design speed, the necessary horizontal sight line offset will be determined by the radius of curve and the required sight distance.

ALIGNMENT CRITERIA FOR URBAN STRATEGIC REGIONAL ARTERIALS (SRA)
(Metric)

Figure 46-2.F

46-3 SUBURBAN SRA ROUTES

46-3.01 General Roadway Features

46-3.01(a) General

The recommended design for suburban SRA's is three lanes in each direction divided by a raised-curb median. Initially, provide a minimum of two travel lanes in each direction. Reserve sufficient right-of-way to allow for the recommended design. Figure 46-3.A illustrates a plan view design configuration for a suburban SRA. Figure 46-3.B illustrates the initial and recommended cross sections for a suburban SRA. For an illustration of a superelevated section, see Figure 45-2.G.

46-3.01(b) Bypass Facilities

Certain suburban SRA routes are characterized by relatively lengthy segments of roadway that connect suburban central core areas. Frequently, these suburban central cores feature traffic capacity constraints (e.g., narrow right-of-way, minimal setbacks, numerous curb cuts, traffic signals). The recommended suburban SRA route (i.e., typical section of six through lanes and an 18 ft, 22 ft, or 30 ft (5.5 m, 7.0 m, or 9.5 m) median width) generally will not be attainable through such suburban cores. Therefore, it may be advantageous to designate a bypass route for the SRA around these central core areas. Bypass routes should be designated on parallel facilities reasonably close to the original SRA route and must be clearly signed as such. Bypass routes may be designed to work in tandem with the originally designated SRA or may become the solely designated SRA. In either case, the travel demands of the area and stipulated level-of-service requirements should be met where a bypass route is proposed.

Due to the extent of suburban development, it is recommended that bypass routes usually be designated on existing roads. Only consider construction of a new roadway where large tracts of undeveloped land or unused rights-of-way exist. In this case, provide a facility with partial access control.

46-3.02 Geometric Design Elements

46-3.02(a) Median Types

When selecting and designing medians for suburban SRA routes, consider the following:

1. General. If a proposed suburban SRA route presently consists of only a four-lane cross section (two through lanes in each direction) in a restrictive right-of-way location, it is recommended that emphasis be placed upon the construction of an 18 ft (5.5 m) median to separate left-turning vehicles from the through stream of traffic. If no additional right-of-way is available for a median, only permit left turns at major intersections or consider the feasibility of creating one-way arterial pairs.

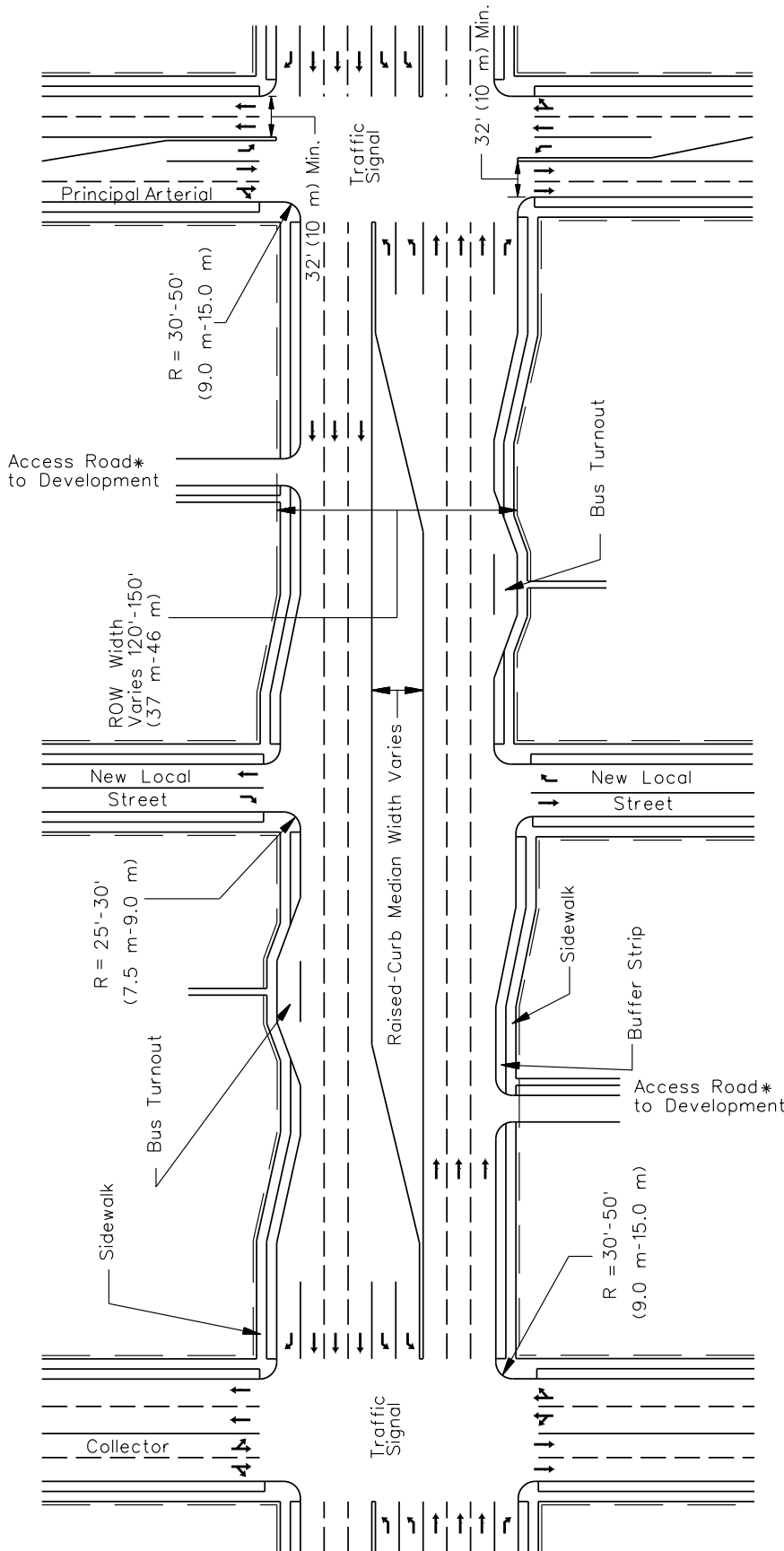

* After an investigation of need, consider providing a separate right-turn lane on the SRA into the development.

Note: See Section 36-1.08 for selection of design vehicles.

TYPICAL SUBURBAN SRA ROUTE
(1/2 mile (800 m) Segment)

Figure 46-3.A

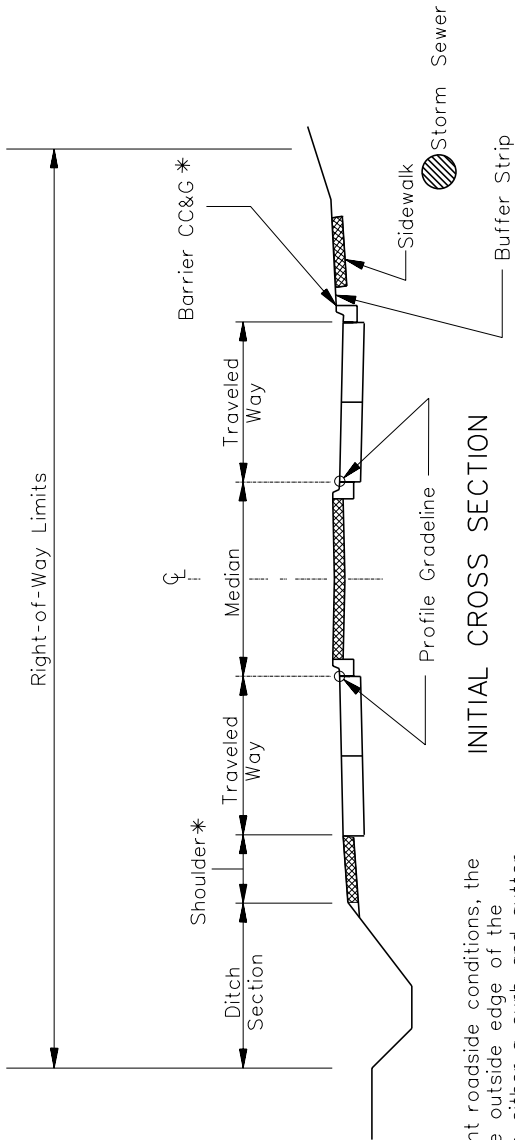

* Depending on adjacent roadside conditions, the initial design along the outside edge of the traveled way may be either a curb and gutter section or a ditch section.

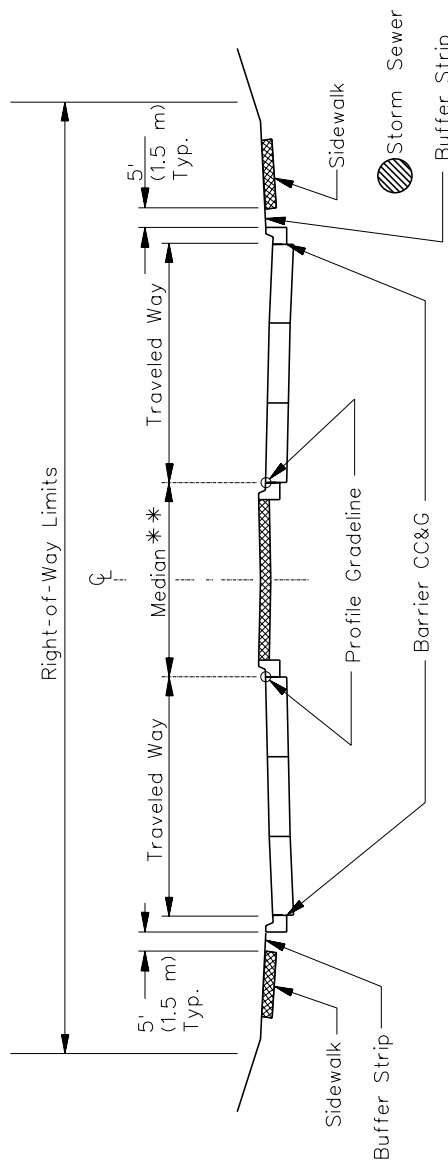

** Under certain conditions, a 48' (14.5 m) wide median may be considered along the street. See Section 46-3.02(a).

**SUBURBAN SRA CROSS SECTION
(Initial and Recommended)**

Figure 46-3.B

2. Raised-Curb Median. It is recommended that all suburban SRA routes be constructed with barrier-curb medians, but barrier-curb is required adjacent to dual left-turn lanes. The raised-curb median will prohibit left-turning vehicles at minor cross streets and driveways, direct turning movements to desired locations, and reduce opposing traffic conflicts. Because raised-curb medians control the location of left turns from the street, there may be the need to allow occasional U-turn movements at certain signalized intersections along the SRA route. These movements can provide access to both sides of the roadway while limiting crossing maneuvers at mid-block locations. Signal timing must be adjusted to provide the additional left-turn signal time needed for the U-turns.

The desirable median width on suburban SRA routes is 22 ft (7.0 m) where unsignalized intersections will exist. The 22 ft (7.0 m) width allows for the storage of most passenger vehicles in the median at unsignalized intersections for crossover movements or for left turns from the side street onto the SRA. If no unsignalized intersections will exist on a segment of the SRA or where right-of-way is restricted, the median width can be reduced to 18 ft (5.5 m) where single left-turn lanes are provided. However, if it is determined that dual left-turn lanes are needed, the minimum median width is 30 ft (9.5 m).

Under some circumstances, it may not be practical to use a raised-curb median. In these cases, consider providing a flush or traversable TWLTL design.

3. U-Turn Crossovers with Raised-Curb Medians. On some high-volume suburban SRA routes, the volume of left turns at many intersections may cause reduced traffic flow for through movements. Also, there may be a considerable demand for U-turn movements by large trucks serving businesses and industry along the route. If sufficient right-of-way is available, an alternative strategy is to not allow left turns at major intersections, but instead provide for a U-turn movement beyond the intersection. The benefits are increased capacity on the SRA route and simplified intersection phasing. An example of this concept is shown in Figure 46-3.C.

Only use this concept where it can be provided continuously for a distance of 3 miles to 5 miles (5 km to 8 km) and where the proposed median is at least 50 ft (14.5 m) wide. Provide a B-6.24 (B-15.60) curb and gutter along the median and mound the median with earth. The mounded earth median may be landscaped along the centerline.

Use a WB-55 (WB-17) design vehicle for the design of the U-turn movement. Provide a 10 ft (3.0 m) wide outside stabilized shoulder with curb and gutter along the right edge of shoulder adjacent to the U-turn lane; see Figure 46-3.C.

4. TWLTL Medians. In areas where there are numerous access points along an existing roadway (e.g., commercial areas), continuous two-way left-turn lanes may increase mobility and reduce conflicts. This design may be considered in suburban areas where there are numerous existing access points and where other solutions to control access (e.g., frontage roads, access closures, raised-curb medians) cannot be implemented. Chapters 34 and 48 provide guidance on flush and traversable TWLTL.

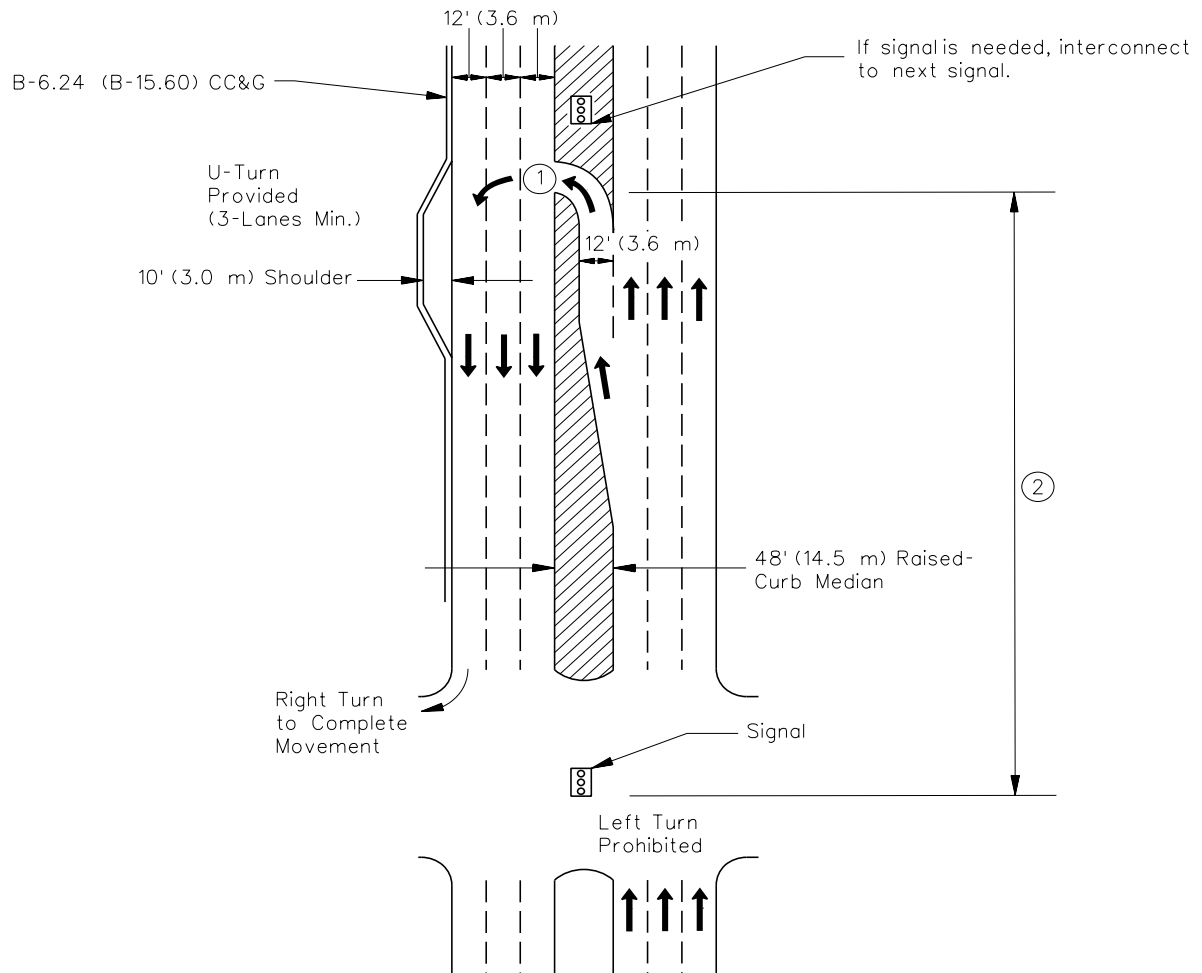

Notes:

1. Use the WB-55 (WB-17) design vehicle for the design of the U-turn movement.
2. The minimum distance is dependent on the design speed of the street, left-turning volumes, and space needed for advance guide signs.

U-TURN CROSSOVERS WITH A RAISED-CURB MEDIAN

Figure 46-3.C

46-3.02(b) Additional Lanes

Some proposed suburban SRA routes may presently consist of a four- or five-lane pavement section through residential or commercial areas with minimal setbacks. It may not be feasible to obtain the additional right-of-way required for expansion into the recommended roadway cross section at these locations.

46-3.02(c) Vertical Clearances

The vertical clearances for suburban SRA routes are presented in Figure 46-3.E. Where practical on existing routes, vertical clearances may need to be increased to provide for the unrestricted movement of large vehicles. Bridges that do not provide a minimum of 14 ft 9 in (4.5 m) vertical clearance above the roadway are candidates for modification. Bridges which provide a vertical clearance of 14 ft 00 in (4.25 m) may remain in place, but should be considered for reconstruction or other means to achieve a minimum vertical clearance of 14 ft 9 in (4.5 m). Where the SRA route is an underpass, the recommended method to increase the vertical clearance is to lower the roadway through milling, raising the pier height, reconstructing the bridge or other methods. Carefully evaluate potential drainage and utility problems where these methods are proposed.

46-3.03 Access Management

The use of access management techniques is one of the most important concepts implemented on the SRA system. The number and configuration of access points to a suburban SRA route influence length of travel time and driver safety. Each driveway and cross street reduces mobility and safety. To improve access management, consider the following techniques:

1. Eliminate Local Street Access. To improve operations, consider closing some low-volume minor roads and local streets. The feasibility of terminating or rerouting the minor route will depend on local street traffic volumes, emergency vehicle response times, and the availability of alternative routes.
2. Restrict Curb Cuts. To improve mobility and safety on the suburban SRA route, consider the following restrictions:
 - a. Sideroad Access. Where a parcel of property has access available from a side street, only allow access from the non-SRA route.
 - b. Directional Movements. Where curb-cut access is allowed along a suburban SRA route, it is preferable that only right-in and right-out turns be permitted. This will prevent left-turn movements onto the SRA across through traffic lanes. An example of this design is shown in Figure 46-2.C.
 - c. Consolidating Access Points. In suburban areas where numerous curb-cut access points are present, it is recommended that the access be consolidated into single points at a desirable spacing of 500 ft (150 m) between access points.

This is illustrated in Figure 46-3.D. The properties should be interconnected through the use of cross-access easements.

- d. **Left-Turn Restrictions.** Discourage left-turn movements from the SRA into curb-cut access points. However, where this prohibition may not be feasible, increase the length of the turn-lane storage to accommodate left-turn queues during peak hours.
3. **Develop Internal Access.** Where new development or redevelopment occurs adjacent to a suburban SRA, it is desirable to provide internal circulation roads within the development. Design the circulation roads to accommodate not only automobiles, but delivery trucks, transit, and bicycles. Also, provide sidewalks within the development. If a signal and median crossover are warranted at the new access point, the spacing should not be less than $\frac{1}{4}$ mile (400 m) to an adjacent signal.

Access management principles should be coordinated among communities along each suburban SRA route. Chapter 35 provides further guidance on access management techniques that are also applicable to suburban SRA routes.

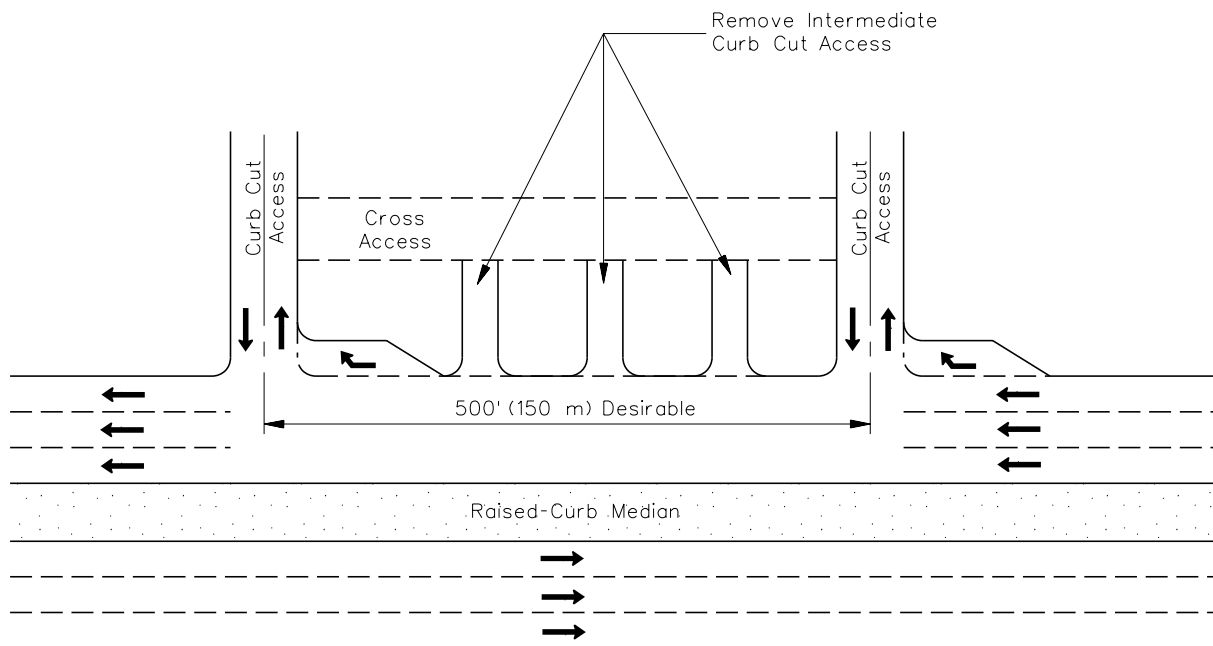

**CONSOLIDATED ACCESS
(Suburban SRA)**

Figure 46-3.D

46-3.04 Intersections

In addition to Chapter 36, the following is applicable to intersections on suburban SRA routes:

1. Turn Lanes. Section 36-3 provides the warrants and design criteria for turn lanes. Where developing turn lanes, it is important to maintain at least two through lanes in each direction. In addition, the following will apply:
 - a. Left-Turn Lanes. Provide left-turn lanes at all intersections. It is recommended that the turn lanes be offset to provide increased sight distance to opposing traffic. See Section 36-3.03 for the design of offset left-turn lanes.
 - b. Right-Turn Lanes. Provide right-turn lanes where warranted.
 - c. Dual Left-Turn Lanes. Where there are high left-turn volumes, consider providing dual left-turn lanes to alleviate congestion where the single left-turn lane storage length is inadequate (e.g., 350 ft (100 m)). Phasing for the dual left-turn lanes must operate under the “protected only” phasing. For access management, separate the dual left-turn lanes and the left turn taper from opposing through lanes by a raised-curb median; see Chapters 35 and 36. Within a suburban environment where development is eminent, provide a 30 ft (9.5 m) wide median to allow for future flexibility at major entrances with dual left-turn lanes.
2. Turning Radii. Insufficient turning radii for trucks can significantly affect capacity at an intersection. Small radii may require large trucks to slow down to maneuver through the turn, to encroach into opposing lanes, or encroach onto the curb. Design the curb radii to meet the expected design vehicle, typically a WB-50 (WB-15). Review turning radii improvements for their impacts on pedestrians and adjacent development. Design vehicles are discussed in Section 36-1.08.
3. Approaches. Intersections on suburban routes with more than four approaches can cause operational problems. To alleviate this problem, consider one of the following options:
 - close one of the approaches,
 - convert one of the approaches to one-way operation going away from the intersection,
 - provide an extremely short signal timing on one of the approaches to reduce the desirability of the approach, or
 - relocate the excess approaches away from the intersection; this is the most desirable option.
4. Channelization. In suburban locations, the recommended cross section consists of three through lanes in each direction, dual left-turn lanes, and exclusive right-turn lanes. To reduce the wide expanses of intersections, use center channelization and consider the

use of corner islands to direct the flow of vehicles through the intersection. Channelization also can be effective at intersections where approaches are not at or close to 90° angles. At these locations, channelization and corner islands can help guide motorists through the unusual turning movements that are often required. Chapter 36 provides guidance on the design of channelized intersections.

5. New Intersections. It is recommended that intersections with new local roads be restricted to right-in/right-out movements. A raised-curb median will restrict left-turn movements from the SRA to the local road, left-turn movements from the local road onto the SRA, and through movements on the local road across the SRA. However, alternative routes and emergency vehicular response times must be evaluated.
6. Intersection Lighting. All suburban SRA to SRA route intersections should have appropriate intersection lighting. See Chapter 56 for information on highway lighting.
7. Capacity. At intersections where capacity is limited and volumes are high, left-turn restrictions and the elimination of signalized turn phases may be necessary. This will increase the capacity on the SRA route and reduce intersection conflicts. Alternative routes or access will be required for the affected movements. In some instances, limiting left-turn movements to off-peak periods on the SRA route may be beneficial to through roadway operations.

46-3.05 Railroad Grade Separations

Providing a grade separation over an intersecting railroad can increase capacity and safety. However, the feasibility of this type improvement is dependent upon projected traffic volumes, roadway characteristics, posted speed, duration and volume of rail movements, and the amount of right-of-way available for overpass construction.

Evaluate all at-grade railroad intersections with suburban SRA routes for a potential grade separation. Preference for grade separation construction may be given to freight rail crossings where delays due to the length of freight trains are considerably longer than at crossings for passenger rail lines. However, the requirement for grade separations at commuter rail lines is important because peak rail and roadway traffic always coincide. Additional factors to assess include the proximity of the rail line to adjacent arterial intersections, access requirements, right-of-way availability, and projected traffic volumes on the suburban SRA.

At all locations where railroad grade separations are not feasible, investigate the use of constant warning time warning devices. Constant warning time (CWT) devices adjust the downtime of the gates based on the speed of the train. This helps reduce excessive delays to vehicular traffic caused by gates being down when trains are not present. This type of device can also recognize when a train is stopped. This can be beneficial where a train station is near an at-grade rail crossing. In some cases, it may be a more conservative design to have a simple DC circuit instead of the CWT circuitry. This proposal should be reviewed by someone who is knowledgeable in both crossing circuitry and train operations at the specific location.

46-3.06 Interchanges

Consider constructing an interchange if the projected level of service of an intersection in the design year is E or F using conventional improvements. Intersections that operate at level-of-service D or better generally are not candidates for interchange construction, unless unsafe geometric design features (e.g., excessive intersection skew) are present. Chapters 37 and 45 provide further guidance for interchange warrants and interchange design.

Suburban SRA routes are frequently characterized by a limited right-of-way availability. Interchange types that require the least amount of right-of-way (e.g., single point urban diamond, compressed diamond) are considered the most appropriate for suburban SRA routes. See Chapter 37 for further information.

For an intersection of two suburban SRA routes and where sufficient right-of-way is available, consider providing a cloverleaf interchange design. The advantage of this interchange type over the diamond interchange is that both intersecting facilities have uninterrupted through movements.

Under certain conditions, a U-turn movement could be added to a compressed diamond interchange between a suburban SRA route and a lower class/volume cross street. The underpass U-turn lane allows SRA vehicles to access an opposing frontage road without passing through signalized intersections on the cross streets. Figure 37-3.G illustrates this design.

All suburban SRA interchanges should have lighting. However, the lighting should not create “light pollution” problems from spillover into nearby residential areas.

46-3.07 Drainage

On suburban SRA routes, roadway drainage generally will consist of an enclosed system. During roadway reconstruction for lane additions or intersection widening, evaluate the existing drainage system for capacity or flooding problems. Any improvements to the existing drainage system must meet the criteria in the *IDOT Drainage Manual*.

46-3.08 Removal of On-Street Parking

On-street parking is currently permitted on some portions of SRA routes in suburban areas. On-street parking can significantly affect the capacity of the SRA route and may constitute a safety hazard as drivers enter and exit parking spaces. Where practical, consider permanently removing the on-street parking or restricting it during peak hours. Section 46-2.08 provides criteria for removal of on-street parking on urban SRA routes. This is also applicable to a suburban SRA route with one exception — if the level-of-service on the suburban SRA route is C or worse, consider removing the on-street parking.

46-3.09 Traffic Control Devices

46-3.09(a) Traffic Signals

Section 46-2.09 provides information on traffic signals for urban areas. In addition, the following applies to traffic signals in suburban areas:

1. **Signal Type.** Provide fully actuated traffic signals at all signalized intersections.
2. **Signal Interconnection.** Where feasible, interconnect all signalized intersections with a spacing of ½ mile (800 m) or less into signal systems. The interconnection is used to provide signal coordination and vehicular progression along the SRA route. Synchronize all signal systems along suburban SRA's for vehicular progression based on a traffic engineering study.
3. **Spacing.** If a signal is warranted at a local road or street, the spacing should not be less than ¼ mile (400 m) to an adjacent signal, but ½ mile (800 m) spacing is preferred.
4. **Bus Preemption.** All signalized intersections on suburban SRA routes should be capable of priority preemption for express bus service. This preemption capability should only be used to keep buses on schedule. Coordinate the preemption by buses with vehicular progression along the SRA route.
5. **Level of Service.** The goal of the traffic signal timing along suburban SRA routes is to achieve a level-of-service C or better for the arterial through lanes. To achieve this, it may be necessary to lower the level-of-service for the turning movements and cross streets to maximize the through movements on the SRA.

46-3.09(b) Warrants for Traffic Signals

Install traffic signals on SRA routes where the signal warrants in the *Illinois MUTCD* are met.

46-3.09(c) Overhead Signing

All suburban SRA-to-SRA route intersections should have advance overhead signing with route numbers and/or street names and, where appropriate, regional destinations. The lettering should be large enough to read at a distance of 350 ft to 400 ft (100 m to 125 m).

46-3.09(d) Stop Sign Removal

Stop sign control for traffic movements on an SRA route is inconsistent with giving priority to the SRA through movement. Therefore, remove stop signs from the through lanes of a suburban SRA route. However, it will be necessary to conduct a traffic engineering study to determine the appropriate traffic control at the location for both the SRA route and the intersecting cross street.

46-3.09(e) Pavement Markings

Because of their durability and visibility, only use high-type pavement markings on suburban SRA routes. High-type pavement markings include thermoplastic, epoxy, and pre-formed plastics. Also, include raised pavement markers on suburban SRA routes. Space raised pavement markers according to the criteria in the Bureau of Operations *Policies and Procedures Manual* and the *Highway Standards*. In addition, place reflectors on top of the raised-curb median.

46-3.09(f) Driver Information Systems

In addition to providing signs and pavement markings to guide motorists, it may be necessary to furnish information on congestion, construction, or other incidents which may affect their trip. Driver information systems may include variable or fixed message signing, radio and television traffic reports, newspaper articles, and brochures.

46-3.10 Trucks

Locate all loading and unloading areas off the suburban SRA street.

46-3.11 Transit**46-3.11(a) Improvements**

Techniques associated with mass transit that may be applicable in certain suburban situations are described in Section 46-2.11. For suburban areas, it will also be necessary to improve transit station accessibility using one or more of the following techniques:

1. Actuated Traffic Signals. Transit station usage is extremely intensive during peak periods. Incorporating traffic signals on the SRA or connecting streets with phasing and timings that are responsive to the varying levels of traffic during the day will make transit stations more accessible and reduce delays. If new traffic signals are proposed at transit stations, they should meet the established traffic volume warrants and criteria for spacing of signals.
2. Turn Lanes. To maximize through traffic movements for vehicles not wishing to access transit stations, provide channelized right- and left-turn lanes for vehicles turning into transit stations. If demand is sufficient, provide dual left- and/or right-turn lanes. Appropriate storage bay lengths for turning vehicles must also be implemented.
3. Park and Ride Lots. Investigate providing parking for commuters. If a potential parking lot site is judged too far from the transit station, then parking in this area could be free or at a greatly reduced rate to encourage use. Another option is to provide satellite lots with free shuttle buses to the stations. Preferential parking stalls nearest to transit stations could be designated for High Occupancy Vehicles. Also, provide secure bicycle

parking at transit stations. Include left- and right-turn lanes at the entrance to the facility to enhance safety.

4. Transit Access. If substantial parking for a transit station is located on the opposite side of a SRA route, consider providing appropriate access for pedestrians.

46-3.11(b) Express Bus Service

Bus service on suburban SRA routes should be limited to express buses that are equipped with priority signal preemption capability that can be deployed when they are running behind schedule. However, coordinate the bus preemption with existing vehicular progression along the SRA route.

Design stops as bus turnouts; see Chapter 58. Walkways to stops of intersecting services will facilitate transfers and promote safety. Near-side and far-side bus stop configurations should be planned to minimize distances between connecting lines.

46-3.12 HOV Lanes

High occupancy vehicle (HOV) lanes designated for buses, carpools, and vans may be appropriate in selected areas with high levels of transit ridership and ridesharing activity. Note that there should also be adequate capacity to accommodate traffic in the general use lanes.

46-3.13 Pedestrians and Bicyclists

On suburban SRA routes, more options are available for accommodating pedestrian and bicycle access than in urban areas. For example, although right-of-way availability is still a critical issue, dense development immediately adjacent to the roadway is not as common an occurrence as in urban areas. Provisions for bicyclists and pedestrians may be accommodated within the SRA right-of-way itself. In suburban situations, alternative parallel routes may not always be available.

Access across major obstacles (e.g., river crossings, railroads, limited access facilities) or barriers will be accommodated by the SRA if alternative access is not feasible. The choice of how to provide access within the SRA corridor is determined on a case-by-case basis. Under all situations, the goal is to provide a continuous system of bicycle and pedestrian routes. Chapter 17 provides guidance on the design of bicycle and pedestrian facilities. Chapter 58 provides information on accessibility requirements.

46-3.14 Environmental Considerations

The environmental analysis component of the SRA planning process is primarily an inventory of existing conditions. The inventory identifies those environmental resources in the corridor and probable impacts based on roadway improvements. Environmental assessments will be

performed during Phase I design work. These are discussed in Part III “Environmental Procedures” of this *Manual*.

46-3.15 Right-of-Way Acquisition and Corridor Protection

A major goal of the SRA planning process is to identify and protect future right-of-ways that are needed to construct the recommended roadway design configuration. Suburban right-of-ways may adjoin both developed and undeveloped properties. During Phase I studies, local governments should be contacted and encouraged to work with roadway jurisdictional agencies. This will ensure that adequate right-of-way is provided for suburban SRA routes in the approval process for new developments. Local governments should review their building setback requirements to ensure that all new building construction is outside the recommended SRA right-of-way widths. This will protect the right-of-way for future roadway expansion.

See the Bureau of Land Acquisition’s *Manual of Policies and Procedures* for information on corridor protection procedures.

46-3.16 Tables of Design Criteria

Figure 46-3.E presents the Department’s design criteria for new construction and reconstruction of suburban strategic regional arterial projects. Figure 46-3.F provides the alignment criteria for suburban SRA routes. The designer should realize that some of the cross section elements included in the figure (e.g., TWLTL widths) are not automatically warranted in the project design. The values in the figure only apply after the decision has been made to include the element in the highway cross section.

Design Element		Manual Section	Desirable Design Values	
Design Controls	Design Forecast Year	31-4.02	20 Years	
	* Design Speed	31-2	45 mph	
	Access Control	46-3.03	Managed Access	
	Level of Service	31-4.04	C or D (1)	
	On-Street Parking	46-3.08	Not Recommended	
	Traffic Signals	46-3.09	Spaced at 1/2 mile increments	
	* Traveled Way Width	34-2.01	Initial: 2 @ 24' Recommended: 2 @ 36' Single Left & Right: 12' Dual Lefts: 24' B-6.12 or B-6.24 CC&G	
	Auxiliary Lanes	34-2.03	18', 22', 30' (2a) Flush: 12' or 14' (2b) Traversable: 16'	
	Median Width	34-3	Min.: 10' (3) Min.: 13' Outside Lane B-6.24 CC&G	
	Parking Lane Width	48-2.05		
Cross Sections	Bicycle Lane Width (Shared)	46-3.13		
	Outside Curb Type and Width	34-2.04	1/4"/ft for Two Lanes Adjacent to Median (4) Initial Stage Construction: 1/2"/ft 5' with Buffer Strip Behind Curb	
	Cross Slope	34-2.01		
	Shoulder	46-3.02		
	Sidewalk Width	48-2.04		
	Clear Zone	38-3	(5)	
	Roadway Slopes	Cut Section (Uncurbed) (6)	Front Slope	1V:6H
			Ditch Bottom Width	4'
			Back Slope	1V:3H
		Fill Section (Curbed)	Cut Section (Curbed)	34-4.04
Rock Cut			34-4.05	
Concrete Median Surface			34-4.02	
Median Slopes	TWLT	34-3	3/16"/ft 1/4"/ft 5/8"/ft towards C&G	
	Mounded with Grass		HS-20	
	*Structural Capacity	N/A		
Bridges	New and Reconstructed Bridges	39-6	52' plus Median Width (two lanes each direction) 76' plus Median Width (three lanes each direction)	
	Existing Bridges to Remain in Place	*Clear Roadway Width (7)	N/A	
		*Structural Capacity	39-6	HS-20 48' plus Median Width
	*Vertical Clearance (SRA Under) (9a)	*Clear Roadway Width (8)	39-4	14'-9"
		New and Replaced Overpassing Bridges (9b)		14'-0" (9c)
		Existing Overpassing Bridges	33-5	New: 17'-3" (9b)
*Vertical Clearance (SRA Over Railroad)	39-4.06		New: 23'-0" Existing: 21'-6"	

* Controlling design criteria (see Section 31-8)

GEOMETRIC DESIGN CRITERIA FOR SUBURBAN STRATEGIC REGIONAL ARTERIALS (SRA)
(New Construction/Reconstruction)
(US Customary)

Figure 46-3.E
 (1 of 2)

Design Element		Manual Section	Desirable Design Values	
Design Controls	Design Forecast Year	31-4.02	20 Years	
	*Design Speed	31-2	70 km/h	
	Access Control	46-3.03	Managed Access	
	Level of Service	31-4.04	C or D (1)	
Cross Sections	On-Street Parking	46-3.08	Not Recommended	
	Traffic Signals	46-3.09	Spaced at 800 m Increments	
	*Traveled Way Width	34-2.01	Initial: 2 @ 7.2 m Recommended: 2 @ 10.8 m	
	Auxiliary Lanes	34-2.03	Single Left & Right: 3.6 m Dual Lefts: 7.2 m B-15.30 or B-15.60 CC&G	
	Median Width	34-3	5.5 m, 7.0 m, 9.5 m (2a) Flush: 3.6 m or 4.0 m (2b) Traversable: 5.0 m	
	Parking Lane Width	48-2.05	Min.: 3.0 m (3)	
	Bicycle Lane Width (Shared)	46-3.13	Min.: 4.2 m Outside Lane	
	Outside Curb Type and Width	34-2.04	B-15.60 CC&G	
	Cross Slope	34-2.01	2% for Two Lanes Adjacent to Median (4)	
	Sidewalk Width	46-3.02	Initial Stage Construction: 4%	
Roadway Slopes	Clear Zone	48-2.04	1.5 m with Buffer Strip Behind Curb	
	Cut Section (Uncurbed) (6)	38-3	(5)	
		Front Slope	34-4.03	1V:6H
		Ditch Bottom Width		1.2 m
	Side Slopes	Back Slope		1V:3H
		Cut Section (Curbed)	34-4.04	—
		Rock Cut	34-4.05	—
	Median Slopes	Fill Section (Curbed)	34-4.02	—
		Concrete Median Surface		1.5%
		TWLT		2.0%
Bridges	Mounded with Grass		5.0% towards C&G	
	*Structural Capacity		MS-18	
	New and Reconstructed Bridges		15.6 m plus Median Width (two lanes each direction) 22.8 m plus Median Width (three lanes each direction)	
	Existing Bridges to Remain in Place		MS-18	
	*Clear Roadway Width (7)		1.4 plus Median Width	
	*Structural Capacity		4.5 m	
	*Clear Roadway Width (8)		4.3 m (9c)	
	New and Replaced Overpassing Bridges (9b)		5.25 (9b) m	
	*Vertical Clearance (SRA Under) (9a)			
	Existing Overpassing Bridges			
Overhead Signs/ Pedestrian Bridges				
*Vertical Clearance (SRA Over Railroad)				
			New: 7.0 m Existing: 6.6 m	

* Controlling design criteria (see Section 31-8)

GEOMETRIC DESIGN CRITERIA FOR SUBURBAN STRATEGIC REGIONAL ARTERIALS (SRA)
(New Construction/Reconstruction)
(Metric)

Figure 46-3.E
 (1 of 2)

- (1) Level of Service. For signal timing on suburban SRA routes, provide a LOS C for the arterial through lanes, which may allow a lower level of service for the cross streets or turning lanes.
- (2) Median Width.
 - a. Raised-Curb. Where there is a U-turn demand for large trucks and undeveloped right-of-way is available, consider a median width of at least 50 ft (14.5 m) with curb and gutter.
 - b. TWLTL Width. Use 14 ft (4.0 m) if there is a significant number of trucks making left turns.
- (3) Parking Lane Width. If the parking lane will be used as a travel lane or bus/HOV lane during peak hours or may be converted to a travel lane in the future, provide a 12 ft (3.6 m) width. The width of parking lane includes the gutter width.
- (4) Travel Lane Cross Slope. For the third lane away from the median, increase the cross slope by 1/16" /ft (0.5%).
- (5) Clear Zone. For curbed facilities, the horizontal clearance to an obstruction is 1.5 ft (500 mm) measured from the face of curb.
- (6) Cut Section (Uncurbed). In some cases, the initial construction of a suburban SRA may involve only providing two lanes in each direction with a shoulder and an outside ditch section. See Figure 46-3.B.
- (7) New and Reconstructed Bridge Widths. Clear roadway bridge widths are measured from face to face of outside curbs or parapet walls. Suburban bridge widths are defined as the sum of the approach traveled way width, the width of the median, and the width of gutters.
- (8) Existing Bridge Widths to Remain in Place. Clear roadway bridge widths are measured from face to face of outside curbs or parapet walls. Implies elements allowed to remain in place without a design exception approval when cost effective and when safety record is satisfactory. Sidewalks must be carried across both sides of the, bridge. Approach width shown assumes initial stage construction of only two lanes in each direction.
- (9) Vertical Clearance (SRA Under).
 - a. The clearance must be available over the traveled way and flush median.
 - b. Table value includes allowance for future overlays.
 - c. A 14 ft 0 in (4.3 m) clearance may be allowed to remain in place with consideration for reconstruction to a clearance of 14 ft 9 in (4.5 m).

GEOMETRIC DESIGN CRITERIA FOR SUBURBAN STRATEGIC REGIONAL ARTERIALS (SRA)
(New Construction/Reconstruction)
(Footnotes)

Figure 46-3.E
(2 of 2)

Design Element	Manual Section	Design Speed
* Stopping Sight Distance (1)	31-3.01	45 mph
Decision Sight Distance (2)	31-3.02	360'
Intersection Sight Distance (3)	36-6	800'
* Minimum Radii (4)	48-5	500'
* Superelevation Rate (5)	48-5	715'
* Horizontal Sight Distance	32-4	$e_{max} = 4\%$
* Vertical Curvature (K-values)	Crest	(6)
	Sag	61
* Maximum Grade	33-2.02	79
Minimum Grade	33-2.03	6%

Des: 0.5% Min: 0.3%
(with Curb and Gutter)

* Controlling design criteria (see Section 31-8)

- (1) Stopping Sight Distance. Table values are for passenger cars on level grade.
- (2) Decision Sight Distance. Table values are for the avoidance maneuver on suburban streets (speed/path/direction change).
- (3) Intersection Sight Distance. Table values are for passenger cars. See Section 36-6 for trucks.
- (4) Minimum Radii. Value shown is with a 4% superelevation rate. For a normal crown section, the minimum radius is 1040 ft.
- (5) Superelevation Rate. See Section 48-5 for superelevation rates based on e_{max} , design speed, and radii of horizontal curves.
- (6) Horizontal Sight Distance. For a given design speed, the necessary horizontal sight line offset will be determined by the radius of curve and the required sight distance.

ALIGNMENT CRITERIA FOR SUBURBAN STRATEGIC REGIONAL ARTERIALS (SRA)
(US Customary)

Figure 46-3.F

Design Element	Manual Section	Design Speed
* Stopping Sight Distance (1)	31-3.01	70 km/h
Decision Sight Distance (2)	31-3.02	105 m
Intersection Sight Distance (3)	36-6	235 m
* Minimum Radii (4)	$e_{max} = 4\%$	146 m
* Superelevation Rate (5)	48-5	203 m
* Horizontal Sight Distance	48-5	$e_{max} = 4\%$
* Vertical Curvature (K-values)	32-4	(6)
	Crest	17
	Sag	23
* Maximum Grade	33-2.02	6%
Minimum Grade	33-2.03	Des: 0.5% Min: 0.3% (with Curb and Gutter)

* Controlling design criteria (see Section 31-8).

- (1) Stopping Sight Distance. Table values are for passenger cars on level grade.
- (2) Decision Sight Distance. Table values are for the avoidance maneuver on suburban streets (speed/path/direction change).
- (3) Intersection Sight Distance. Table values are for passenger cars. See Section 36-6 for trucks.
- (4) Minimum Radii. Value shown is with a 4% superelevation rate. For a normal crown section, the minimum radius is 297 m.
- (5) Superelevation Rate. See Section 48-5 for superelevation rates based on e_{max} design speed, and radii of horizontal curves.
- (6) Horizontal Sight Distance. For a given design speed, the necessary horizontal sight line offset will be determined by the radius of curve and the required sight distance.

**ALIGNMENT CRITERIA FOR SUBURBAN STRATEGIC REGIONAL ARTERIALS (SRA)
(Metric)**

Figure 46-3.F

46-4 RURAL SRA ROUTES

46-4.01 General Roadway Features

46-4.01(a) General

The recommended design for rural SRA's is to construct two or three lanes in each direction separated by a wide depressed median. The wide median will allow the addition of future through lanes in the median with minimum disruption to highway users and surrounding development. The facility may include two-way frontage roads on both sides of the mainline highway. Sufficient right-of-way should be reserved initially to allow for the recommended design. Figure 46-4.A illustrates a plan view design configuration for a rural SRA with frontage roads. Figure 46-4.B illustrates the recommended cross section for a rural four-lane SRA. Initial stage construction and bypass routes around communities would not involve the use of frontage roads. For an illustration of a superelevated section, see Figure 45-2.E.

46-4.01(b) Bypass Facilities

Many rural SRA routes are characterized by relatively lengthy segments of roadway that connect existing communities. A rural SRA route that approaches a community may better serve the concept of regional mobility if it bypasses the town. There are two options to consider for rural SRA routes at a community. One is to designate an existing highway through the town as the planned SRA route, and the other is to construct a new bypass facility. Only consider the construction of a bypass facility where there are large tracts of undeveloped land or unused rights-of-way. Also, every effort should be made to use the rights-of-way of existing roadways for the bypass alignment. As a minimum, any bypass facility should be designed with partial access control; see Chapter 45. Where full access control can be obtained, the bypass should be designed accordingly; see Chapter 44.

46-4.02 Geometric Design Elements

46-4.02(a) Median Types

When providing medians on rural SRA routes, consider the following:

1. Type. Typically, use a depressed median on rural SRA routes. This median type will provide space for left-turning vehicles at crossroads, direct turning movements to desired locations, reduce opposing traffic conflicts, and allow for high operating speeds.
2. Width. For rural SRA routes, the minimum width is 50 ft (15 m). Where there is a high probability of need for three lanes in each direction in the future, use a 74 ft (22.2 m) wide median initially. However, where right-of-way is restricted, a 50 ft (15 m) wide median may be used initially where six lanes will be required in the future. The median can be converted to a 26 ft (7.8 m) wide median with a concrete median barrier.

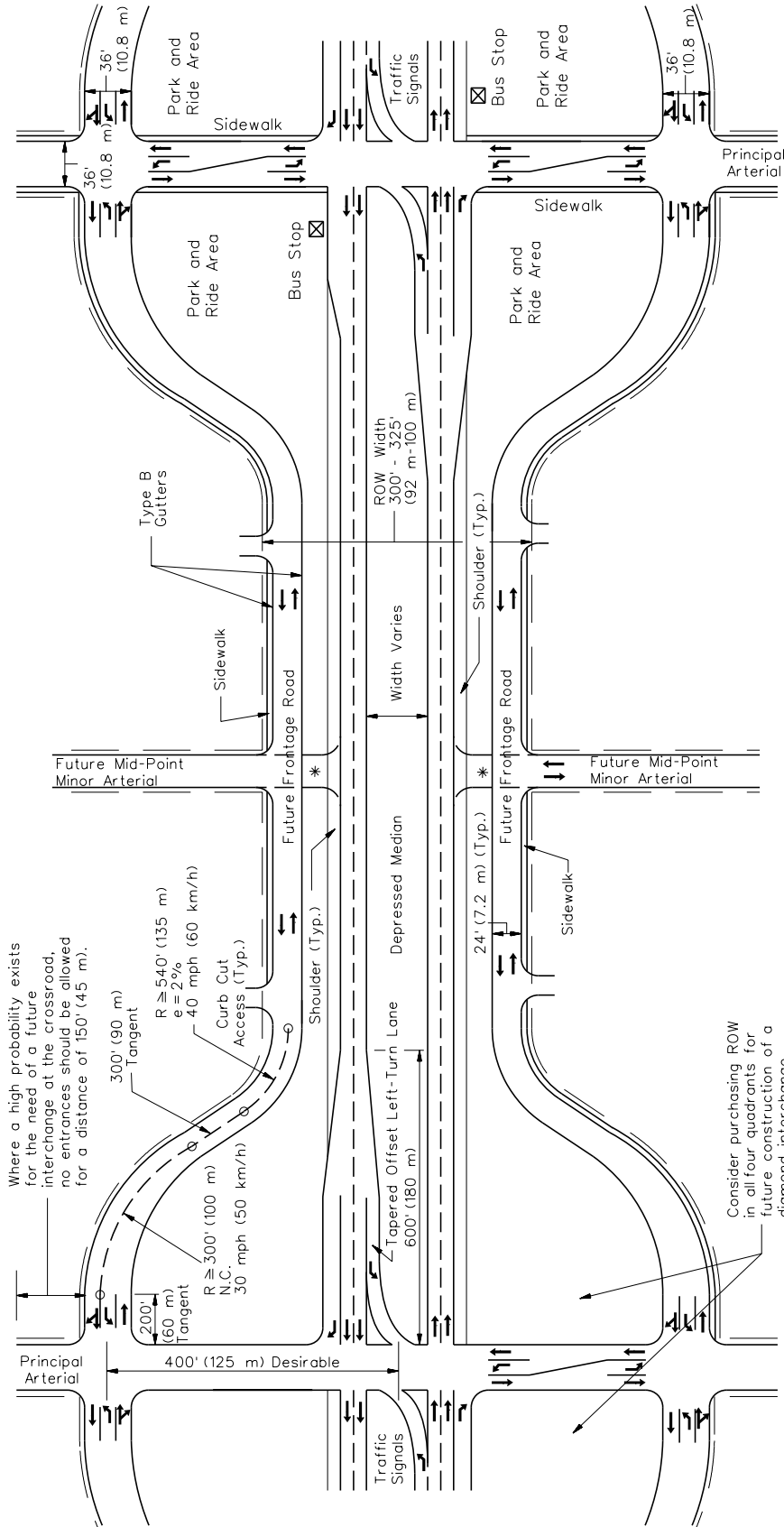

* Before frontage roads are constructed, the mid-point minor arterial may be connected directly to the mainline and provided with right-in and right-out turns.

Note: See Section 36-1.08 for selection of appropriate design vehicle.

**TYPICAL RURAL SRA ROUTE WITH FRONTAGE ROADS
(1 mile (1.6 km) Segment)**

Figure 46-4.A

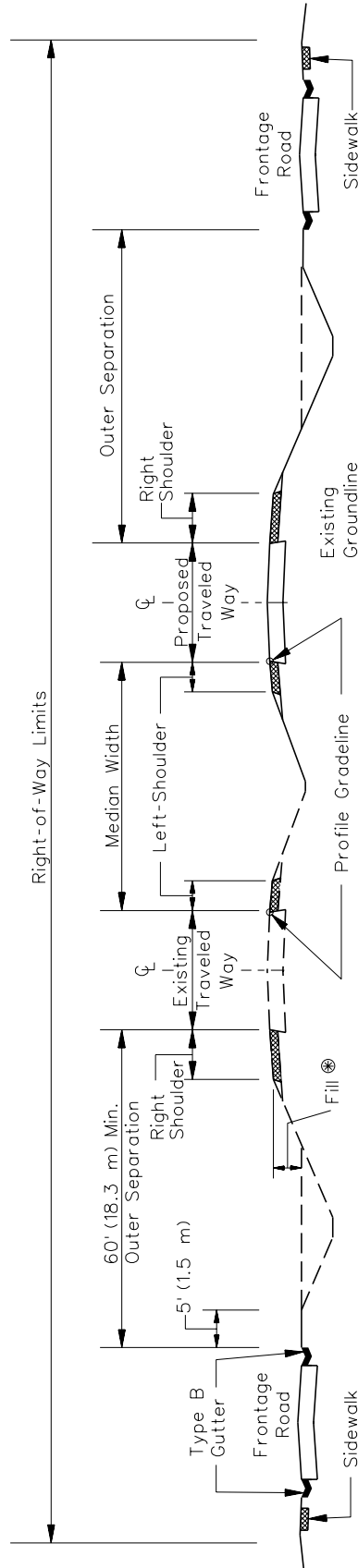

⊗ Existing roadway should be approximately 3' (1.0 m) above the existing ground line. If not, raise the elevation of the existing roadway in the design of the project. See Section 33-6.04.

Note: Initial construction usually will not include frontage roads.

**RURAL SRA CROSS SECTION
(Typical Design with Frontage Roads)**

Figure 46-4.B

3. Median Crossovers. Only permit median crossovers at major intersections. Space these crossovers at intervals of 1 mile (1.5 km) or greater. Where local access to a crossroad is severely restricted or will cause significant delay for a large number of turning vehicles, crossovers may be reduced to ½ mile (800 m) intervals. However, do not use this spacing extensively along rural SRA routes. The intent of rural SRA routes is to give priority to through movements and provide for high operating speeds.
4. Flush Median with Concrete Median Barrier (CMB). This median type may be used where right-of-way is restricted; see Figure 36-3.M and Section 34-3.03.

46-4.02(b) Additional Lanes

On rural SRA routes, the desirable design is to provide sufficient right-of-way to allow two lanes in each direction with a depressed median and two-way frontage roads on each side. Where future capacity is required, a third lane can be constructed in the median.

The usual design to complete the multilane cross section is to provide a depressed median adjacent to an existing roadway and to construct a new roadway parallel to the existing lanes; see Figure 46-4.B. In some cases, it may be more appropriate to center all new construction about the centerline of the existing pavement. However, this would require all new pavements and a close examination of construction phasing for the maintenance of traffic flow.

46-4.02(c) Vertical Clearances

The vertical clearances for rural SRA routes are presented in Figure 46-4.C. Where practical on existing routes, vertical clearances may need to be increased to provide for the unrestricted movement of large vehicles. Existing bridges that do not provide a minimum of 16 ft 6 in (5.0 m) vertical clearance above the roadway are candidates for modification. Bridges which provide a vertical clearance of 16 ft 00 in (4.9 m) may remain in place, but should be considered for reconstruction or other means to achieve a minimum vertical clearance of 16 ft 6 in (5.0 m). Where the SRA route is an underpass, the recommended method to increase the vertical clearance is to lower the roadway through milling, raising the pier height, reconstructing the bridge, or other methods. Carefully evaluate potential drainage and utility problems.

46-4.03 Access Management

Sections 46-2.03 and 46-3.03 provide guidance on access management techniques that are also applicable to rural SRA routes. In addition, consider the following:

1. Frontage Roads. Because of the potential hazards introduced by intermittent access points, the most desirable form of access management is to provide two-way frontage roads along the SRA route. If the frontage roads are not constructed initially, consider providing sufficient right-of-way for incorporation of future frontage roads.

Where the frontage road is flared out at an intersection, do not allow development to occur within the interior area of the “jughandle.” This area may be an appropriate location for park-and-ride lots; see Figure 46-4.A. Protection of this area will also allow the construction of a diamond interchange in the future.

2. **Minor Road Access.** The high speeds on rural SRA routes can make intersections with minor side roads potentially hazardous. Signalization is not recommended due to the delays that would be created on the rural SRA route. Desirably, terminate access to the minor road at the frontage road. If this is not practical, the next option is only to allow right-in and right-out maneuvers on the SRA route.

46-4.04 Intersections

In addition to Chapter 36, the following is applicable to intersections on rural SRA routes:

1. **Turn Lanes.** Section 36-3 provides the warrants and design criteria for turn lanes. In addition, the following will apply:
 - a. **Left-Turn Lanes.** Provide tapered offset left-turn lanes at all signalized and major intersections. Use a parallel, left-turn lane design at minor road intersections where an intermediate median crossover is proposed.
 - b. **Right-Turn Lanes.** In general, provide right-turn lanes at all intersections.
 - c. **U-Turn Crossovers.** Where a crossover is required for U-turns, provide a parallel left-turn lane design into the crossover. The left-turn lane may be designed for 50 mph (80 km/hr) design speed.
2. **Turning Radii.** Insufficient turning radii for trucks can significantly affect the capacity of an intersection. Design the right- and left-turning radii to meet the expected design vehicle. Intersection design vehicles and truck routes are discussed in Section 36-1.08.
3. **Channelization.** To reduce the wide expanses of intersections, use corner islands to direct the flow of right-turning vehicles through the intersection. Channelization also can be effective at intersections where approaches are not at or close to 90° angles. At these locations, channelization and corner islands can help guide motorists through unusual turning movements. Section 36-3 illustrates typical design features that should be used at rural SRA intersections.
4. **New Intersections.** Where new local roads are proposed, restrict them to right-in/right-out movements. The depressed median will restrict left-turn movements from the SRA to the local road, left-turn movements from the local road to the SRA, and through movements on the local road across the SRA. However, alternative routes and emergency vehicular response times must also be evaluated and may result in the design of a median crossover. When frontage roads are provided, remove these minor roads from the SRA route and tee them into the frontage road; see Figure 46-4.A.

5. Intersection Lighting. All major intersections should have appropriate intersection lighting. See Chapter 56 for information on highway lighting.

46-4.05 Railroad Grade Separations

Where there is one or more trains per day crossing a rural SRA, consider providing for a future structure over the railroad. The feasibility of this type of improvement is dependent upon projected traffic volumes, roadway characteristics, posted speed, duration and volume of rail movements, and the amount of right-of-way available for overpass construction. Right-of-way should be protected at all rural SRA routes that will cross railroads at-grade.

In general, do not provide a grade-separation structure for frontage roads adjacent to the rural SRA route. Instead, flare the frontage roads out an appropriate distance from SRA grade-separation structure so that sight lines along the tracks are not blocked by the embankment and structure.

46-4.06 Interchanges

Right-of-way should be protected at all major intersections with rural SRA routes for eventual interchange construction. This will help to eliminate most signalized intersections and improve safety and mobility. Right-of-way is typically available at rural SRA crossroads to construct a diamond interchange; see Chapter 37. Where right-of-way is restricted, consider using a single point urban diamond or compressed diamond interchange. Figure 46-4.A shows the typical design of how frontage roads are flared out at major intersections initially, and how they might be incorporated into an interchange design.

If two intersecting rural SRA routes have unusually high projected traffic volumes and where sufficient right-of-way is available, consider providing a cloverleaf interchange design. The projected level of service on both routes should be level D or lower with conventional improvements before this option is considered. The route with the highest projected volumes should be considered to have the priority movement. The crossover of the lower priority route should have a design speed of 60 mph (100 km/hr) through the interchange.

All rural SRA interchanges should have lighting. However, lighting should not create “light pollution” problems from spillover into nearby residential areas.

46-4.07 Drainage

On rural SRA routes, open ditches will be used to accommodate roadway drainage. Design of ditches and drainage appurtenances must meet the criteria in the *IDOT Drainage Manual*. Outside ditches should be at least 6 ft (1.8 m) wide to provide for extra detention storage and adequate clear zone.

46-4.08 Frontage Roads

Frontage roads may be appropriate along rural SRA routes to separate slower local traffic from the higher speed through traffic on the SRA route and to reduce the number of conflict points. The most desirable option is to provide two-way frontage roads on both sides of the rural SRA route. Direct access to the SRA route should only occur at major crossroad intersections. Design criteria for frontage roads are presented in Chapter 44. Between major intersections, the total SRA right-of-way should be approximately 300 ft to 350 ft (90 m to 100 m). At intersections, flare the frontage road out approximately 400 ft (125 m) to create separate intersections on the crossroad between the frontage road and the rural SRA; see Figure 46-4.A. This spacing will also allow for signal coordination.

46-4.09 Traffic Control Devices**46-4.09(a) Traffic Signals**

Provide fully actuated traffic signals at all signalized intersections on rural SRA routes. Chapter 57 and the Bureau of Operations *Policies and Procedures Manual* provide additional information on traffic signals.

46-4.09(b) Overhead Signing

All rural SRA-to-SRA route intersections should have advance overhead signing with route numbers and/or road names and, where appropriate, regional destinations. The lettering should be large enough to read at a distance of 400 ft to 500 ft (125 m to 150 m).

46-4.09(c) Stop Sign Removal

Stop sign control for traffic movements on an SRA route is inconsistent with giving priority to the SRA through movement. Therefore, remove all stop signs from the through lanes of a rural SRA route. However, it will be necessary to conduct a traffic engineering study to determine the appropriate traffic control at the location for both the SRA route and the intersecting crossroad.

46-4.09(d) Pavement Markings

Because of their durability and visibility, only use high-type pavement markings on rural SRA routes. High-type pavement markings include thermoplastic, epoxy, and pre-formed plastics. Include raised pavement markers and delineators on rural SRA routes. Raised pavement markers introduce an element of safety to the SRA route during inclement weather. Space raised pavement markers and delineators according to the Bureau of Operations *Policies and Procedures Manual* and the *IDOT Highway Standards*.

46-4.10 Transit

46-4.10(a) Improvements

Techniques associated with mass transit that may be applicable in certain rural situations are described in Section 46-2.11. For rural areas, it will also be necessary to improve transit station accessibility as discussed in Section 46-3.11. Ridesharing is a common approach to transit in rural areas. The “jughandle” design of the frontage road at major crossroad intersections typically provides adequate locations for park-and-ride facilities; see Figure 46-4.A.

46-4.10(b) Express Bus Service

Bus service on rural SRA routes should be limited to express buses that are equipped with priority signal preemption capability that can be deployed when they are running behind schedule. However, coordinate the bus preemption with existing vehicular progression along the SRA route. Bus stop locations generally should be located off the rural SRA route on side roads or park-and-ride lots. Space these stops at approximately 5 mile (8 km) intervals. Where it is impractical to locate bus stops off the SRA route, design bus turnouts and stops according to the criteria in Chapter 58.

46-4.11 Pedestrians and Bicyclists

The criterion for pedestrians and bicyclists presented in Section 46-3.13 is also applicable for rural SRA routes.

46-4.12 Environmental Considerations

The environmental analysis component of the SRA planning process is primarily an inventory of existing conditions. The inventory identifies those environmental resources in the corridor and probable impacts based on roadway improvements. Environmental assessments will be performed during the Phase I design work. These are discussed in Part III “Environmental Procedures” of this *Manual*.

46-4.13 Right-of-Way

Section 46-3.15 provides guidance for protecting future right-of-way needs which is also applicable to rural SRA routes. Also the *Illinois Highway Code*, 605 ILCS 5/4-510 provides guidance on the use of protective right-of-way buying as it applies to existing alignments.

46-4.14 Tables of Design Criteria

Figure 46-4.C presents the Department’s design criteria for new construction and reconstruction of rural strategic regional arterial projects. Figure 46-4.D presents the alignment of criteria for

rural SRA routes. The designer should realize that some of the cross section elements included in the figure (e.g., flush median with concrete barrier) are not automatically warranted in the project design. The values in the figure only apply after the decision has been made to include the element in the highway cross section.

Design Element		Manual Section	Desirable Design Values	
Design Controls	Design Forecast Year	31-4.02	20 Years	
	* Design Speed	31-2	60 mph	
	Access Control Level of Service	35-1 31-4.04	Managed Access (1) C	
	On-Street Parking		Not Allowed	
Cross Section	Traffic Signals	46-4.09	Spaced at 1 mile increments	
	* Traveled Way Width	34-2.01	Initial: 2 @ 24' (2) Recommended: 2 @ 36'	
	* Shoulder Width	Right		10'
		Left		10'
	Auxiliary Lanes	Total Width Paved		6' (3)
		Total Width Paved		4'
	Median Width	Lane Width		Single Left & Right: 12'
		Shoulder Width		4' (Paved)
		Depressed Flush (Concrete Barrier)		Minimum: 50'
	Parking Lane Width	TWLT		22' (4)
Bicycle Lane Width			N/A	
Cross Slope	*Travel Lane		N/A	
	Shoulder		Use 10' Paved Shoulder	
Clear Zone	Sidewalk Width		3/16"/ft for Lanes Adjacent to Crown (5)	
	Clear Zone		1/2"/ft	
Roadway Slopes	Cut Section	Front Slope	5' Adjacent to Frontage Road with 5' Buffer Strip (6)	
		Ditch Bottom Width	1V:6H	
		Back Slope	4' (7)	
	Rock Cut	Fill Section		1V:3H (8)
		Depressed		1V:4H to Clear Zone: 1V:3H max. to Toe of Slope (9)
	Median Slopes	Flush		1V:6H or 1V:5H
		*Structural Capacity		1/2"/ft
	New and Reconstructed Bridges	*Clear Roadway Width (10)		HS-20
		*Structural Capacity		38' - 40'
	Existing Bridges to Remain in Place	*Clear Roadway Width (11)		HS-20
New and Replaced Overpassing Bridges (12b)			34' with 22' Traveled Way	
* Vertical Clearance (SRA Under) (12a)	Existing Overpassing Bridges		16'-6"	
	Overhead Signs/Pedestrian Bridges		16'-0"	
* Vertical Clearance (SRA Over Railroad)			17'-3" (12b)	
			New: 23'-0" Existing: 21'-6"	

* Controlling design criteria (see Section 31-8).

GEOMETRIC DESIGN CRITERIA FOR RURAL STRATEGIC REGIONAL ARTERIALS (SRA)
(New Construction/Reconstruction)
(US Customary)

Figure 46-4.C
 (1 of 2)

Design Element		Manual Section	Desirable Design Values	
Design Controls	Design Forecast Year	31-4.02	20 Years	
	* Design Speed	31-2	100 km/h	
	Access Control	35-1	Managed Access (1)	
	Level of Service	31-4.04	C	
Cross Section	On-Street Parking		Not Allowed	
	Traffic Signals	46-4.09	Spaced at 1.6 km Increments	
	* Traveled Way Width	34-2.01	Initial: 2 @ 7.2 m (2) Recommended: 2 @ 10.8 m	
	* Shoulder Width	Right		3.0 m
		Left		3.0 m
	Auxiliary Lanes	Total Width Paved		1.8 m (3)
		Total Width Paved		1.2 m
	Median Width	Lane Width	34-2.03	Single Left & Right: 3.6 m
		Shoulder Width		1.2 m (Paved)
	Parking Lane Width	Depressed	34-3	Minimum: 15 m
Flush (Concrete Barrier)			7.0 m (4)	
TWTL		46-4.06	N/A	
		48-2.05	N/A	
Bicycle Lane Width		46-4.11	Use 3.0-m Paved Shoulder	
			1.5% for Lanes Adjacent to Crown (5)	
Cross Slope	* Travel Lane	34-2.01	4%	
	Shoulder	34-2.02	4%	
Sidewalk Width		58-1.06	1.5 m Adjacent to Frontage Road with 1.5-m Buffer Strip	
		38-3	(6)	
Roadway Slopes	Clear Zone		1V:6H	
			1.2 m (7)	
	Side Slopes	Cut Section	34-4.03	1V:3H (8)
		Back Slope		
	Median Slopes	Rock Cut	34-4.05	
		Fill Section	34-4.02	1V:4H to Clear Zone; 1V:3H max. to Toe of Slope (9)
Bridges	Depressed		1V:6H or 1V:5H	
	Flush	34-3.03	4%	
	* Structural Capacity	N/A	MS-18	
	* Clear Roadway Width (10)	39-6	11.4 m - 12.0 m	
	* Structural Capacity	N/A	MS-18	
	* Clear Roadway Width (11)	39-6	10.2 m with 6.6-m Traveled Way	
* Vertical Clearance (SRA Under) (12a)	New and Replaced Overpassing Bridges (12b)	39-4	5.0 m	
	Existing Overpassing Bridges		4.9 m	
	Overhead Signs/Pedestrian Bridges	33-5	5.25 m (12b)	
* Vertical Clearance (SRA Over Railroad)		39-4.06	New: 7.0 m Existing: 6.6 m	

* Controlling design criteria (see Section 31-8).

GEOMETRIC DESIGN CRITERIA FOR RURAL STRATEGIC REGIONAL ARTERIALS (SRA)
(New Construction/Reconstruction)
(Metric)

Figure 46-4.C
 (1 of 2)

- (1) Access Management. Direct access to the SRA route will be controlled by future two-way frontage roads. Where bypass routes are proposed around communities, the bypass desirably should be fully access controlled or, at a minimum, partially access controlled.
- (2) Traveled Way Width. Existing 22 ft (6.6 m) width may remain in place.
- (3) Left Shoulder Width. Consider providing a 8 ft (2.4 m) shoulder width and 1V:5H median slopes where level of service is approaching "C."
- (4) Flush Median Width. Only use flush medians with CMB where right-of-way or topography restricts the use of a depressed median. Consider providing wider medians where required for snow storage.
- (5) Travel Lane Cross Slope. For the additional lane away from the crown lanes, increase the cross slope by 1/16" /ft (0.5%).
- (6) Clear Zone. The clear zone will vary according to design speed, traffic volumes, side slopes, and horizontal curvature. For restricted right-of-way conditions, see Figure 34-4.D.
- (7) Ditch Bottom Width. Provide a wider outside ditch bottom where detention storage of storm water is a consideration.
- (8) Back Slope. Where the height of cut exceeds 10 ft (3 m), consider using a 1V:2H back slope beyond the clear zone. Also, for heights greater than 30 ft (9 m), consider the use of benching.
- (9) Fill Slope. For fill heights greater than 30 ft (9 m), use a 1V:2H uniform slope with a roadside barrier along the shoulder. Also, for fill heights greater than 30 ft (9 m), consider the use of benching.
- (10) New and Reconstructed Bridge Widths. Clear roadway bridge widths are measured from face to face of parapets or rails. Bridge widths are normally defined as the sum of the approach traveled way width and the width of the paved shoulders.
- (11) Existing Bridge Widths to Remain in Place. Clear roadway bridge widths are measured from face to face of parapets or rails. Implies elements allowed to remain in place without a design exception approval when cost effective and when safety record is satisfactory.
- (12) Vertical Clearance (SRA Under).
 - a. The clearance must be available over the traveled way and any paved shoulders.
 - b. Table value includes allowance for future overlays.

**GEOMETRIC DESIGN CRITERIA FOR RURAL STRATEGIC REGIONAL ARTERIALS (SRA)
(New Construction/Reconstruction)**

**Footnotes to Figure 46-4.C
(2 of 2)**

Design Element	Manual Section	Desirable Speed
* Stopping Sight Distance (1)	31-3.01	60 mph
Decision Sight Distance (2)	31-3.02	570'
Intersection Sight Distance (3)	36-6	990'
* Minimum Radii	32-2.03	665'
* Superelevation Rate (4)	32-3	1330'
* Horizontal Sight Distance	32-4	$e_{max} = 6\%$
* Vertical Curvature (K-values)	Crest	(5)
	Sag	151
* Maximum Grade (6)	Level	3% New Construction
	Rolling	4% New Construction
	Minimum Grade	0.5% Minimum 0.0% (with Special Ditching)

* Controlling design criteria (see Section 31-8)

- (1) Stopping Sight Distance. Table values are for passenger cars on level grades.
- (2) Decision Sight Distance. Table values are for the avoidance maneuver on rural road (speed/path/direction change).
- (3) Intersection Sight Distance. Table values are for passenger cars turning right or left from a stopped condition. A wide median is assumed on the rural SRA for left turns from the crossroad. See Section 36-6 for trucks.
- (4) Superelevation Rate. See Section 32-3 for superelevation rates based on e_{max} , design speed, and radii of horizontal curves. For horizontal curves to remain in place, an e_{max} of 8% may be considered to remain in place for a design speed of 60 mph. Where a crossroad intersection lies within the limits of a horizontal curve, see Figure 36-1.D for the maximum superelevation rates allowed on the SRA curve.
- (5) Horizontal Sight Distance. For a given design speed, the necessary horizontal sight line offset will be determined by the radius of curve and the required sight distance.
- (6) Maximum Grades. For existing roadways to remain in place, a maximum of +4% on upgrades and -5% on downgrades may be retained.

**ALIGNMENT CRITERIA FOR RURAL STRATEGIC REGIONAL ARTERIALS (SRA)
(US Customary)**

Figure 46-4.D

Design Element	Manual Section	Desirable Speed
* Stopping Sight Distance (1)	31-3.01	100 km/h
Decision Sight Distance (2)	31-3.02	185 m
Intersection Sight Distance (3)	36-6	315 m
* Minimum Radii	32-2.03	209 m
* Superlevation Rate (4)	32-3	437 m
* Horizontal Sight Distance	32-4	$e_{max} = 6\%$
* Vertical Curvature (K-values)	Crest	(5)
	Sag	52
* Maximum Grade (6)	Level	45
	Rolling	3% New Construction
Minimum Grade	33-2.02	4% New Construction
	33-2.03	0.5% Minimum 0.0% (with Special Ditching)

* Controlling design criteria (see Section 31-8)

- (1) Stopping Sight Distance. Table values are for passenger cars on level grades.
- (2) Decision Sight Distance. Table values are for the avoidance maneuver on rural road (speed/path/direction change).
- (3) Intersection Sight Distance. Table values are for passenger cars turning right or left from a stopped condition. A wide median is assumed on the rural SRA for left turns from the crossroad. See Section 36-6 for trucks.
- (4) Superlevation Rate. See Section 32-3 for superlevation rates based on e_{max} , design speed, and radii of horizontal curves. For horizontal curves to remain in place, an e_{max} of 8% may be considered to remain in place for a design speed of 100 km/h. Where a crossroad intersection lies within the limits of a horizontal curve, see Figure 36-1.D for the maximum superlevation rates allowed on the SRA curve.
- (5) Horizontal Sight Distance. For a given design speed, the necessary horizontal sight line offset will be determined by the radius of curve and the required sight distance.
- (6) Maximum Grades. For existing roadways to remain in place, a maximum of +4% on upgrades and -5% on downgrades may be retained.

ALIGNMENT CRITERIA FOR RURAL STRATEGIC REGIONAL ARTERIALS (SRA)
(Metric)

Figure 46-4.D

46-5 REFERENCES

1. *A Policy on Geometric Design of Highways and Streets*, AASHTO, 2011.
2. *Strategic Regional Arterial: Design Concept Report*, IDOT, February 1994.
3. SRA Access Management Policy, District 1 Bureau of Traffic, IDOT, 1998.
4. *Guide for the Design of High Occupancy Vehicle Facilities*, AASHTO, 2004.

Chapter Forty-seven

RURAL TWO-LANE/MULTILANE
STATE HIGHWAYS
(New Construction/Reconstruction)

BUREAU OF DESIGN AND ENVIRONMENT MANUAL

Chapter Forty-seven
RURAL TWO-LANE/MULTILANE STATE HIGHWAYS
(New Construction/Reconstruction)

Table of Contents

<u>Section</u>	<u>Page</u>
47-1 GENERAL	47-1.1
47-2 TWO-LANE HIGHWAYS.....	47-2.1
47-2.01 General.....	47-2.1
47-2.02 Typical Sections	47-2.1
47-2.03 Passing Sight Distance.....	47-2.1
47-2.03(a) Design Derivation.....	47-2.1
47-2.03(b) Applications.....	47-2.7
47-2.04 Passing Lanes	47-2.7
47-2.04(a) General	47-2.7
47-2.04(b) Warrants	47-2.8
47-2.04(c) Design.....	47-2.8
47-2.05 Two-Way, Left-Turn Lanes (TWLTL).....	47-2.12
47-2.06 Tables of Design Criteria	47-2.12
47-3 MULTILANE HIGHWAYS	47-3.1
47-3.01 General.....	47-3.1
47-3.02 Design Speed	47-3.1
47-3.03 Typical Sections	47-3.1
47-3.04 Tables of Design Criteria	47-3.2
47-4 REFERENCES.....	47-4.1

Chapter Forty-seven

RURAL TWO-LANE/MULTILANE STATE HIGHWAYS (New Construction/Reconstruction)

Chapter 47 provides guidance in the design of rural two-lane principal arterials, multilane minor arterials, two-lane minor arterials, and collectors on the State highway system. Information that is also applicable to these facilities is included in the following chapters:

- Chapter 11 discusses the procedures for determining the facility location.
- Chapter 14 discusses intersection design studies.
- Chapters 31, 32, 33, 34, and 39 provide guidance on geometric design elements that are also applicable to these facilities.
- Chapter 35 provides guidelines for access control along interchange crossroads and intersections. It also discusses the procedures for preparing access control plans.
- Chapter 36 provides information on the design of intersections including left- and right-turn lanes, channelization, and intersection sight distance.
- Chapter 38 provides guidelines on roadside safety issues.
- Chapter 45 discusses the procedures for designing expressways.

47-1 GENERAL

Construction of new two-lane State highways, full reconstruction of long segments of existing two-lane State highways, or new construction of rural multilane State highways without access control are no longer common highway designs in Illinois. Instead, existing two-lane highways are more commonly improved using 3R guidelines (Chapter 49) or upgraded to a four-lane expressway design with partial access control (Chapter 45).

47-2 TWO-LANE HIGHWAYS

47-2.01 General

The minimum design for a State route is a two-lane, two-way highway. In some areas of the State, the two-lane highway system carries a large portion of the rural traffic. Many of these highways are located near major urbanized areas and are experiencing rapid growth in traffic.

The following describes some of the more common situations where new construction or reconstruction projects might be proposed for a two-lane highway improvement:

- realigning of an existing low-speed horizontal curve;
- raising the profile gradeline of a roadway to remedy flooding problems;
- providing a bypass around a small community;
- modifying the vertical profile or improving an intersection to enhance safety;
- upgrading a major route (i.e., arterial or collector) approaching an urbanized area where the current ADT is 5000 or greater, and where there is a small probability of traffic growth warranting four lanes in 20 years; and/or
- increasing passing opportunities to break up platoons and to reduce delay.

47-2.02 Typical Sections

Figures 47-2.A and 47-2.B illustrate typical schematic cross sections for two-lane highways. The tables in Section 47-2.06 provide the minimum criteria for lane widths, shoulder widths, and other cross section elements that should be used on rural two-lane highways.

47-2.03 Passing Sight Distance

47-2.03(a) Design Derivation

Passing sight distance considerations are limited to two-lane, two-way highways. On these facilities, vehicles may overtake slower moving vehicles, and the passing maneuver must be accomplished on a lane used by opposing traffic.

The minimum passing sight distance for two-lane highways is determined from the sum of four distances as illustrated in Figure 47-2.C. Figure 47-2.D and the following provides the basic assumptions used to develop passing sight distance values for design:

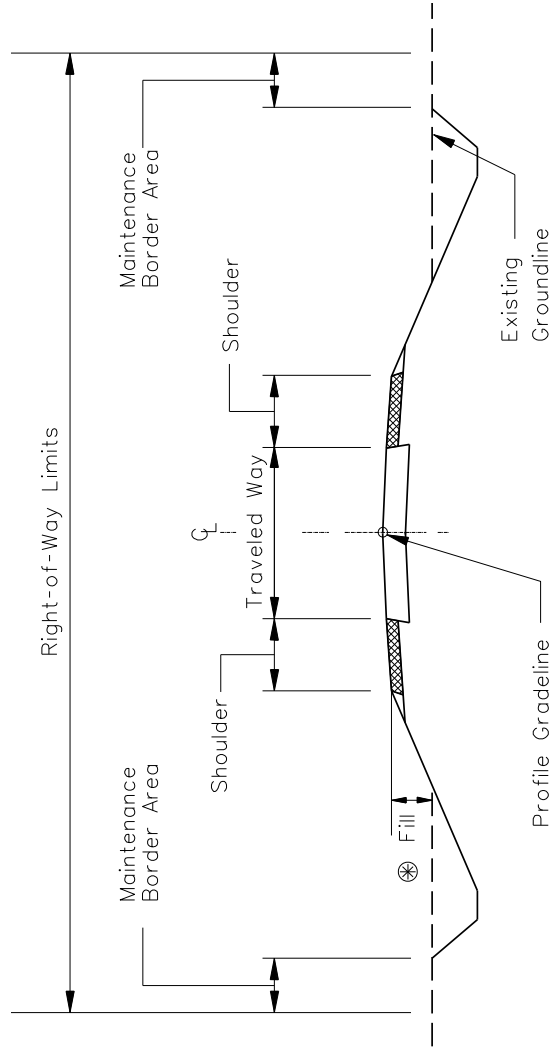

⊗ Roadway should be approximately 3' (1.0 m) above the existing ground line. See Section 33-6.04

TYPICAL TANGENT SECTION FOR RURAL TWO-LANE HIGHWAYS

Figure 47-2.A

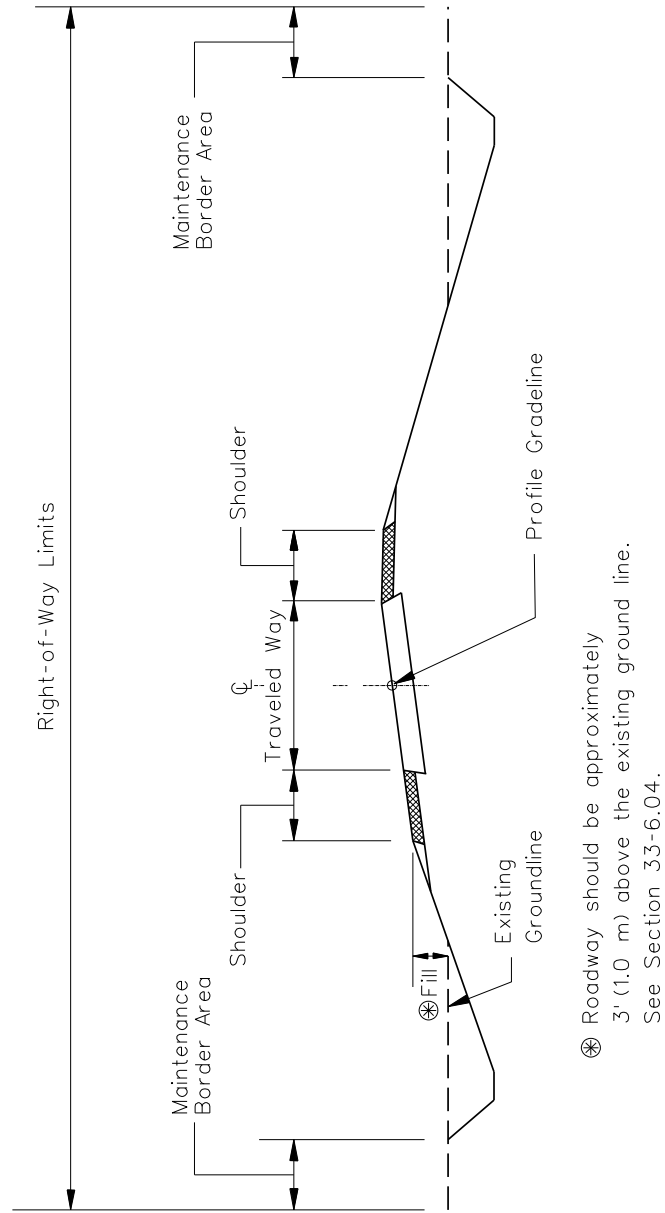

TYPICAL SECTION FOR SUPERELEVATED RURAL TWO-LANE HIGHWAYS

Figure 47-2.B

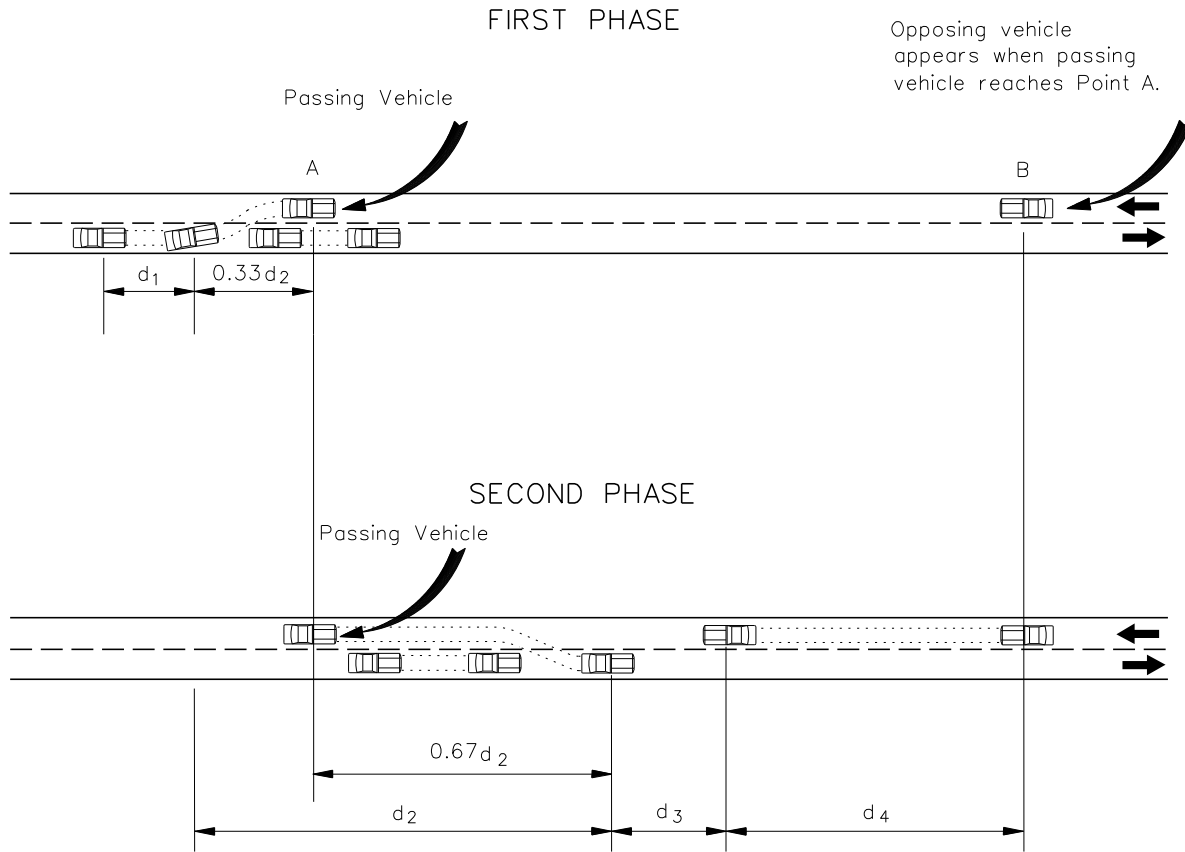

Note: The Illinois MUTCD definition for passing sight distance uses only the second phase of signing and pavement markings distances.

**ELEMENTS OF PASSING DISTANCE
(Two-Lane Highways)**

Figure 47-2.C

Design Speed (mph)	US Customary					Metric				
	Assumed Speeds (mph)		Passing Sight Distance (ft)		Design Speed (km/h)	Assumed Speeds (km/h)		Passing Sight Distance (m)		
	Passed Vehicle	Passing Vehicle	Calculated	Rounded for Design		Passed Vehicle	Passing Vehicle	Calculated	Rounded for Design	
20	18	28	706	710	30	29	44	200	200	
25	22	32	897	900	40	36	51	266	270	
30	26	36	1088	1090	50	44	59	341	345	
35	30	40	1279	1280	60	51	66	407	410	
40	34	44	1470	1470	70	59	74	482	485	
45	37	47	1625	1625	80	65	80	538	540	
50	41	51	1832	1835	90	73	88	613	615	
55	44	54	1984	1985	100	79	94	670	670	
60	47	57	2133	2135	110	85	100	727	730	
65	50	60	2281	2285						
70	54	64	2479	2480						

Note: See Figure 33-4.D for K-values for passing sight distances for passenger cars on crest vertical curves.

MINIMUM DESIGN PASSING SIGHT DISTANCE
 (Assumes Entire Maneuver is Completed)

Figure 47-2.D

1. Initial Maneuver Distance (d_1). This is the distance traversed during the perception and reaction time and during the initial acceleration to the point of encroachment on the left lane. For the initial maneuver, the overtaken vehicle is assumed to be traveling at a uniform speed, and the passing vehicle is accelerating at a rate from 1.41 mph/sec to 1.47 mph/sec (2.25 km/h/sec to 2.37 km/h/sec). The average speed of the passing vehicle is assumed to be 10 mph (15 km/h) greater than the overtaken vehicle. Use Equation 47-2.1 to determine d_1 :

$$d_1 = 1.47t_1 \left(v - m + \frac{at_1}{2} \right) \quad \text{(US Customary) Equation 47-2.1}$$

$$d_1 = \frac{t_1}{3.6} \left(v - m + \frac{at_1}{2} \right) \quad \text{(Metric) Equation 47-2.1}$$

where:

- t_1 = time of initial maneuver, sec
- a = average acceleration, mph/sec (km/h/sec)
- v = average speed of passing vehicle, mph (km/h)
- m = difference in speed of passed vehicle and passing vehicle, mph (km/h)

2. Distance of Passing Vehicle in Left Lane (d_2). This is the distance traveled by the passing vehicle while it occupies the left lane. Use Equation 47-2.2 to determine d_2 :

$$d_2 = 1.47 vt_2 \quad \text{(US Customary) Equation 47-2.2}$$

$$d_2 = \frac{vt_2}{3.6} \quad \text{(Metric) Equation 47-2.2}$$

where:

- t_2 = time passing vehicle occupies the left lane, sec
- v = average speed of passing vehicle, mph (km/h)

3. Clearance Distance (d_3). This is the distance between the passing vehicle at the end of its maneuver and the opposing vehicle. Based on various studies, this clearance distance at the end of the passing maneuver is assumed to be between 100 ft and 250 ft (30 m and 75 m).

4. Opposing Vehicle Distance (d_4). This is the distance traversed by an opposing vehicle during the time the passing vehicle occupies the left lane. As shown in Figure 47-2.C, the opposing vehicle appears after approximately one-third of the passing maneuver (d_2) has been accomplished. The opposing vehicle is assumed to be traveling at the same speed as the passing vehicle. Therefore, $d_4 = 0.67 d_2$.

47-2.03(b) Applications

Figure 47-2.D shows the minimum passing sight distance for design on two-lane, two-way highways. These distances allow the passing vehicle to safely complete the entire passing maneuver. These values are not the same as those values presented in the *Illinois MUTCD* for the placement of no-passing zone stripes. The *Illinois MUTCD* values are based on different operational assumptions (i.e., distance for the passing vehicle to abort the passing maneuver). The designer should also realize that the highway capacity adjustment in the *Highway Capacity Manual* for two-lane, two-way highways is based on the *Illinois MUTCD* criteria for marking no-passing zones. It is not based on the percent of passing sight distance as calculated from the *AASHTO A Policy on Geometric Design of Highways and Streets* and shown in Figure 47-2.D.

On rural new construction/reconstruction projects, the designer should attempt to provide passing sight distance over the length of the project consistent with the percentages shown in Figure 47-2.E. In determining the percentages, each passing sight distance segment should be greater than 800 ft (240 m). It is generally not cost effective to make significant improvements to the horizontal and vertical alignment solely to increase the available passing sight distance.

Appreciable upgrades can increase the sight distances required for safe passing maneuvers. Where these upgrades are encountered in the design of the project, take this into account when selecting the appropriate passing sight distances.

Passing sight distance is measured from a 3.5 ft (1080 mm) height of eye to a 3.5 ft (1080 mm) height of object. Figure 33-4.D presents the K-values for crest vertical curves based on passing sight distances and these eye and object heights. This 3.5 ft (1080 mm) height of object allows 9 in (225 mm) of a typical passenger car to be seen by the opposing driver.

47-2.04 Passing Lanes

47-2.04(a) General

Passing lanes are defined as short added lanes which are provided in one or both directions of travel on a two-lane, two-way highway to improve passing opportunities. They present a relatively low-cost type of improvement for traffic operations by breaking up traffic platoons and reducing delay on facilities with inadequate passing opportunities.

Terrain	Minimum Percent Passing Sight Distance		
	Arterials	Collectors	Local
Level	60%	50%	40%
Rolling	40%	30%	20%

**GUIDELINES FOR PERCENT PASSING DISTANCE
(Rural)**

Figure 47-2.E

Truck-climbing lanes are one type of passing lane used on steep grades to provide passenger cars with an opportunity to pass slow-moving vehicles. The warrant and design criteria for truck-climbing lanes are discussed in Chapter 33. Procedures for developing the climbing lane capacity analysis are also shown in Chapter 33.

Passing lanes may serve to improve safety on a segment of two-lane highway. Three-lane roadways may be considered an intermediate solution to the ultimate expansion to a four-lane highway. The various methods of providing the third lane are shown in Figure 47-2.F.

47-2.04(b) Warrants

Passing lanes other than truck-climbing lanes may be warranted on two-lane facilities where passing opportunities are not adequate. Passing lanes also may be warranted, based on an engineering study that includes judgment, operational experience, and a capacity analysis. The use of a passing lane will be determined on a case-by-case basis. For more information on passing lane warrants, see the FHWA publication *Low Cost Methods for Improving Traffic Operations on Two-Lane Roads*, Report No. FHWA-IP-87-2.

47-2.04(c) Design

1. Capacity Analysis. *Low Cost Methods for Improving Traffic Operations on Two-Lane Roads* presents approximate adjustments that can be made to the capacity methodology in the *Highway Capacity Manual*. These adjustments can be used to estimate the level-of-service benefits from adding passing lanes to two-lane facilities.
2. Spacing. When passing lanes are provided to improve the overall traffic operations over a length of roadway, they should be constructed systematically at regular intervals. Typical spacing for passing lanes may range from 3 miles to 10 miles (5 km to 15 km). Actual spacing of passing lanes will depend on the traffic volumes, right-of-way availability, and existing passing opportunities.
3. Location. When determining where to locate passing lanes, the designer should consider the following factors:
 - a. Costs. Locate passing lanes to minimize costs. Rough terrain will generally increase the costs for construction of passing lanes.
 - b. Appearance. The passing lane location should appear logical to the driver. The value of passing lanes is more obvious to the driver at locations where passing sight distances are restricted or where opposing volumes are significant.
 - c. Horizontal Alignment. Avoid locating passing lanes on highway sections with low-speed horizontal curves.

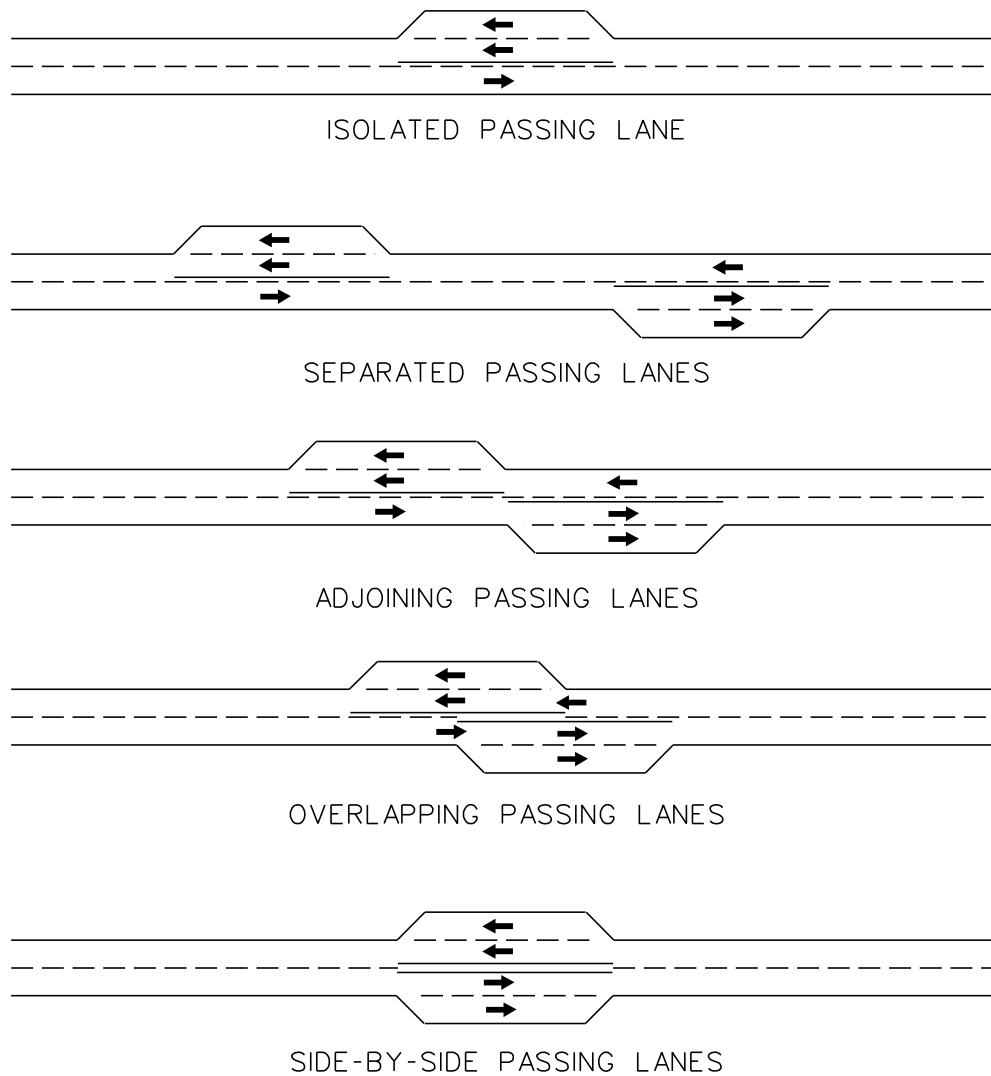

TYPICAL CONFIGURATIONS FOR PASSING LANES

Figure 47-2.F

- d. Vertical Alignment. Where practical, construct passing lanes on a sustained upgrade. The upgrade will generally cause a greater speed differential between slow moving vehicles and passing vehicles. However, passing lanes in level terrain still should be considered where the demand for passing opportunities exceeds supply.
- e. Sight Distance. Locate the passing lane where there will be adequate sight distance to both the entrance and exit tapers of the additional lane. Because of sight distance concerns, do not locate exit tapers just beyond a crest vertical curve.
- f. Intersections. Use special care when designing passing lanes through intersections and high-volume commercial entrances.
- g. Structures. Avoid placing passing lanes where structures (e.g., large culverts, bridges) will restrict the overall width of the traveled way, passing lane, and shoulders.
- h. Alternative Configurations. See Figure 47-2.F for various configurations of passing lanes.
4. Widths. Passing lane widths should be the same width as the adjacent travel lane width. Paved shoulder widths next to the passing lane should be a minimum of 4 ft (1.2 m).
5. Tapers. Design passing lanes by providing an additional lane to the right side of the traveled way; see Figure 47-2.G. Develop the additional lane with an entrance taper of 25:1. For the exit taper, the most commonly used taper rate is 50:1. However, where a location warrants an extended length of taper, the following equation may be used:
- $$L = WS \quad \text{(US Customary) Equation 47-2.3}$$
- $$L = 0.6WS \quad \text{(Metric) Equation 47-2.3}$$
- where:
- L = length of taper, ft (m)
- W = width of passing lane, ft (m)
- S = design speed, mph (km/h)
6. Length. The length of the passing lane will be determined by traffic volumes, length of the platoon, location of major intersections, geometrics, and distances between successive passing opportunities. The optimal length of passing lanes is usually between ½ mile and 1 mile (1 km and 1.5 km). At a minimum, passing lanes should not be less than 1000 ft (300 m) long. On the other hand, passing lane lengths greater than 1 mile (1.5 km) tend to have diminishing reductions in platooning per unit length.

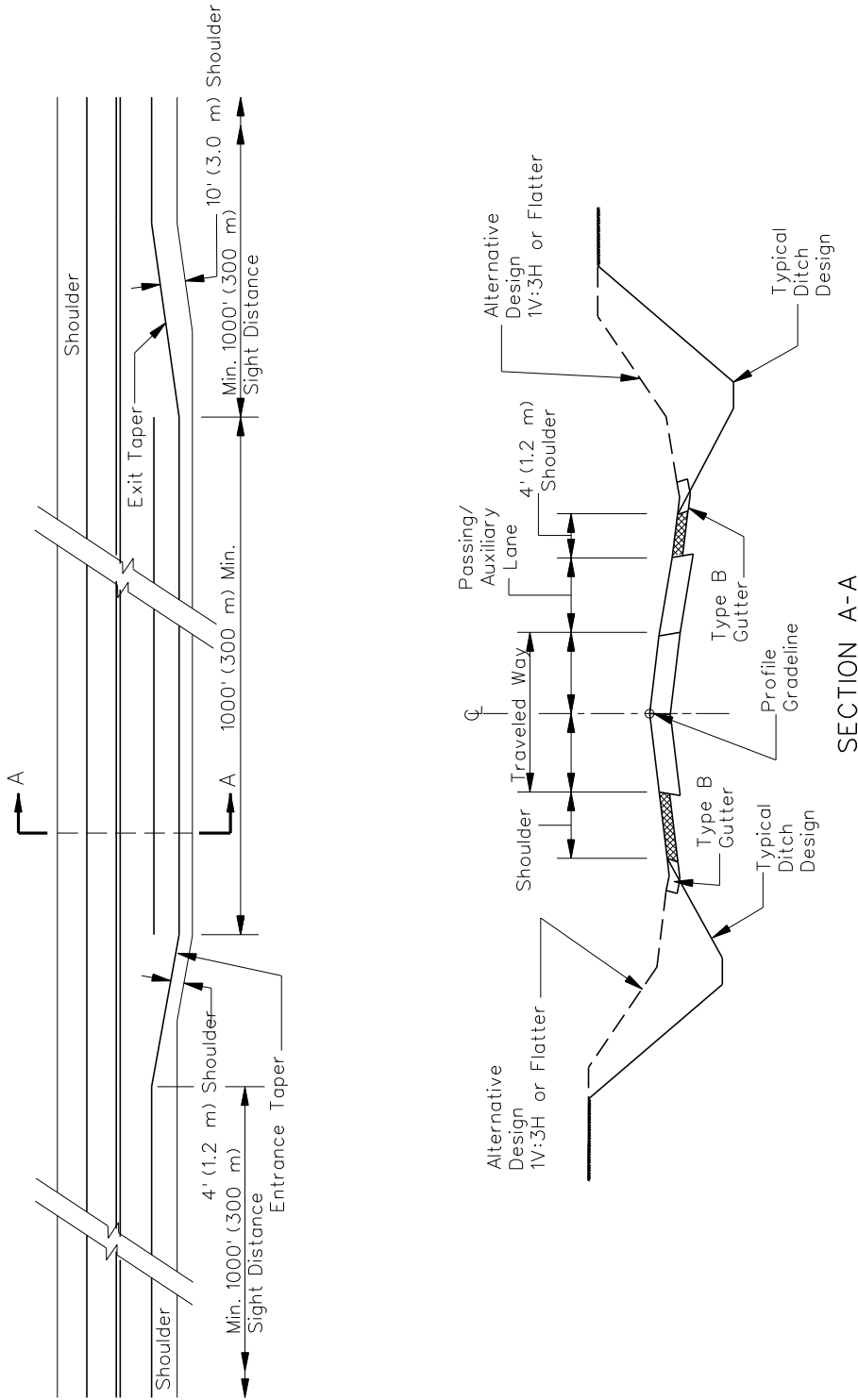

Note: For final signing and pavement markings, contact the Bureau of Operations.

TYPICAL DESIGN LAYOUT FOR ONE DIRECTION PASSING LANE

Figure 47-2.G

7. Typical Design Layout. Figure 47-2.G illustrates a typical design for a passing lane in one direction. Advance signing is necessary to indicate to drivers that passing opportunities exist ahead (e.g., PASSING LANE 1/2 MILES AHEAD). Coordinate the final signing and pavement marking placement with the Bureau of Operations.
8. Typical Sections. Figure 47-2.G illustrates a cross section design for one directional passing lanes and Figure 47-2.H illustrates side-by-side passing lanes.
9. Four-Lane Sections. Short segments of a four-lane cross section, designated as side-by-side passing lanes in Figure 47-2.F, may be constructed along a two-lane highway to break up platoons, to provide the desired frequency of safe passing zones, and to eliminate interference from low-speed vehicles. These sections may be advantageous in rolling terrain, where the alignment is winding, or where the profile includes critical grades in both directions. The decision to use a short four-lane segment, as compared to using a three-lane option, should be based on long-range planning objectives for the facility, the availability of right-of-way, the existing cross section, topography, and the desire to reduce platooning and passing problems.

Provide sufficient sight distance (e.g., 1000 ft (300 m)) in the transition area from the two-lane section to the four-lane section to allow a driver to anticipate the passing opportunity. Four-lane sections of 1 mile to 1.5 miles (1.5 km to 2.5 km) in length are usually sufficient to dissipate most queues formed by slow vehicles and terrain conditions.

47-2.05 Two-Way, Left-Turn Lanes (TWLTL)

TWLTL may be appropriate at isolated rural locations, where the highway is transitioning into a suburban or urban area having sizable left-turn volumes, or where there are several closely spaced driveways. Rural facilities will typically consist of a three-lane cross section illustrated in Figure 47-2.I. For posted speeds greater than 45 mph, exercise caution in designing the TWLTL. See Sections 48-4 and 34-3 for TWLTL design criteria.

47-2.06 Tables of Design Criteria

Figures 47-2.J through 47-2.L present the Department's design criteria for rural two-lane principal arterials, two-lane minor arterials, and two-lane collectors. Note that Figures 47-2.J, 47-2.K, and 47-2.L also provide criteria for existing design elements allowed to remain in place. The designer should realize that some of the cross section elements included in the figures (e.g., TWLTL) are not automatically warranted in the project design. The values in the figures only apply after the decision has been made to include the element in the highway cross section.

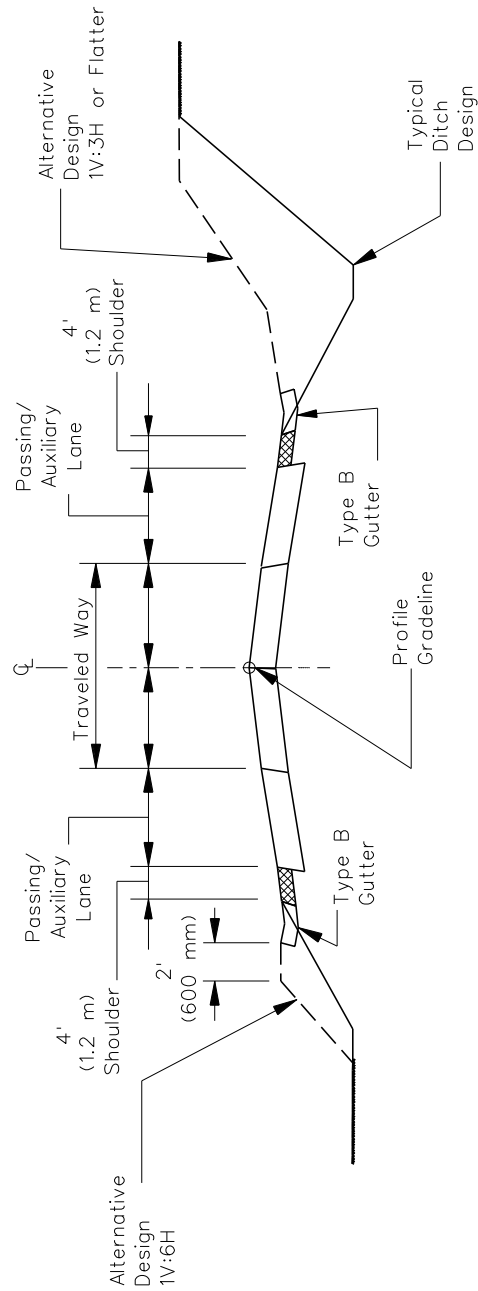

TYPICAL SECTION FOR FOUR-LANE PASSING SEGMENT

Figure 47-2.H

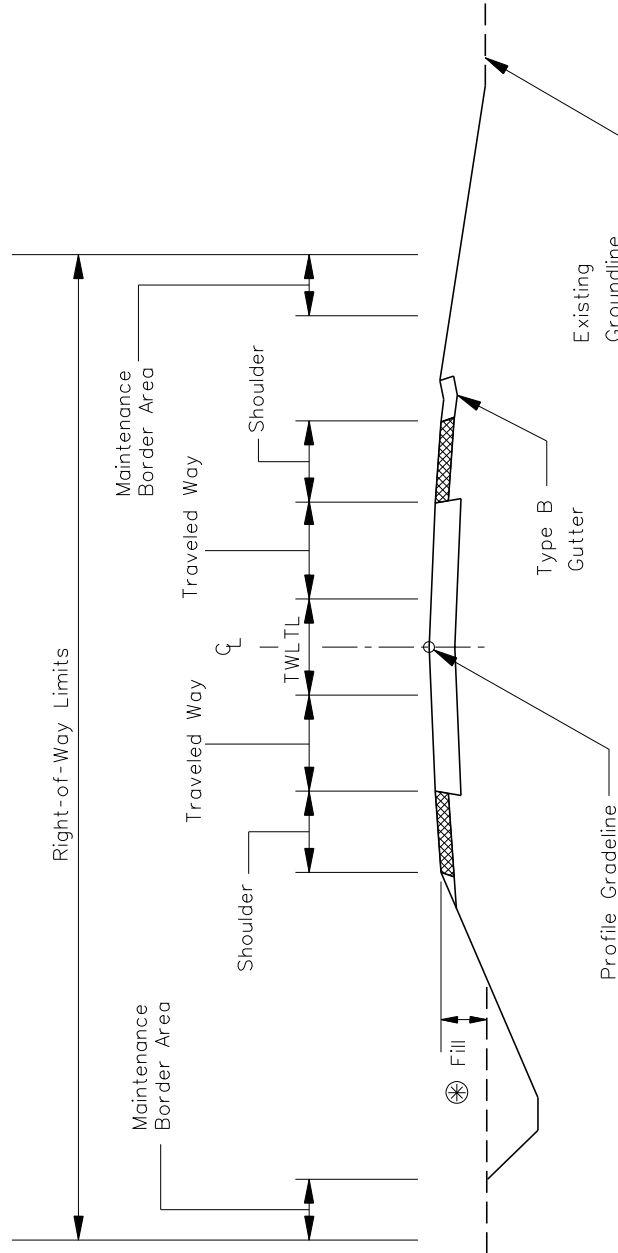

⊗ Roadway should be approximately 3' (1.0 m) above the existing ground line. See Section 33-6.04.

TYPICAL RURAL SECTION WITH TWLTL

Figure 47-2.I

Design Element		Manual Section	New Construction/Reconstruction Two-Way DHV: Under 650 (2)	Elements to Remain-In-Place (1) Two-Way DHV: Under 600 (2)	
Design Controls	Design Forecast Year	31-4.02	20 Years	20 Years	
	* Design Speed	31-2	70 mph (3a)	60 mph (3b)	
Cross Section Elements	Access Control	35-1	Controlled by Regulation (4)	Controlled by Regulation	
	Level of Service	31-4.04	B	B	
	* Traveled Way Width	34-2.01	24'	22'	
	* Shoulder Width	Total Width	34-2.02	10'	8'
		Paved		10'	8'
	Auxiliary Lanes	Lane Width	34-2.03	12'	11'
		Shoulder Width		4' (Paved)	4' (Paved)
	Flush/TWL TL Widths		34-3.03	14'	12'
		* Travel Lane	34-2.01	3/16" /ft (5)	3/16" /ft (5)
	Cross Slope	Shoulder	34-2.02	1/2" /ft	1/2" /ft to 3/4" ft
Clear Zone		38-3	(6)	(6)	
Roadway Slopes	Cut Section	Front Slope	1V:6H	1V:4H	
		Ditch Bottom Width	4' (7)	2'-0" (7)	
		Back Slope	1V:3H (8)	1V:3H (8)	
	Rock Cut	34-4.05	—	—	
Bridges	New and Reconstructed Bridges	Fill Section	1V:6H to Clear Zone; 1V:3H max. to Toe of Slope (9)	1V:4H to Clear Zone; 1V:3H max. to Toe of Slope (9)	
		* Structural Capacity	HS-20	N/A	
	Existing Bridges to Remain in Place	* Clear Roadway Width (10)	39-6	44'	N/A
		* Structural Capacity	N/A	N/A	HS-20
	* Vertical Clearance (Arterial Under) (12a)	* Clear Roadway Width (11) New and Replaced Overpassing Bridges Existing Overpassing Bridges Overhead Signs/ Pedestrian Bridges	39-6	N/A	38' - 40'
* Vertical Clearance (Arterial over Railroad)		39-4.06	16'-6" (12b) 16'-0" New: 17'-3" (12b) 23'-0"		

* Controlling design criteria (see Section 31-8).

GEOMETRIC DESIGN CRITERIA FOR RURAL TWO-LANE PRINCIPAL ARTERIALS
(New Construction/Reconstruction)
(US Customary)

Figure 47-2.J

Design Element		Manual Section	New Construction/Reconstruction Two-Way DHV: Under 650 (2)	Elements to Remain-in-Place (1) Two-Way DHV: Under 600 (2)	
Design Controls	Design Forecast Year	31-4.02	20 Years	20 Years	
	* Design Speed	31-2	110 km/h (3a)	100 km/h (3b)	
Cross Section Elements	Access Control	35-1	Controlled by Regulation (4)	Controlled by Regulation	
	Level of Service	31-4.04	B	B	
	* Traveled Way Width	34-2.01	7.2 m	6.6 m	
	* Shoulder Width	Total Width	34-2.02	3.0 m	2.4 m
		Paved		3.0 m	2.4 m
	Auxiliary Lanes	Lane Width	34-2.03	3.6 m	3.3 m
		Shoulder Width		1.2 m (Paved)	1.2 m (Paved)
	Flush/TWLT Widths		34-3.03	4.2 m	3.6 m
		* Travel Lane	34-2.01	1.5% (5)	1.5% (5)
	Cross Slope	Shoulder	34-2.02	4%	4% to 6%
Clear Zone		38-3	(6)	(6)	
Roadway Slopes	Cut Section	Front Slope	1V:6H	1V:4H	
		Ditch Bottom Width	1.2 m (7)	600 mm (7)	
		Back Slope	1V:3H (8)	1V:3H (8)	
	Rock Cut	34-4.05	—	—	
	Fill Section	34-4.02	1V:6H to Clear Zone; 1V:3H max. to Toe of Slope (9)	1V:4H to Clear Zone; 1V:3H max. to Toe of Slope (9)	
Bridges	New and Reconstructed Bridges	N/A	MS-18	N/A	
	Existing Bridges to Remain in Place	* Clear Roadway Width (10)	13.2 m	N/A	
		* Structural Capacity	N/A	MS-18	
	* Vertical Clearance (Arterial Under) (12a)	* Clear Roadway Width (11)	39-6	N/A	MS-18
		New and Replaced Overpassing Bridges		5.0 m (12b)	
		Existing Overpassing Bridges	39-4	4.9 m	
* Vertical Clearance (Arterial over Railroad)	Overhead Signs/ Pedestrian Bridges	33-5	New: 5.25 m (12b)		
		39-4.06	7.0 m		

GEOMETRIC DESIGN CRITERIA FOR RURAL TWO-LANE PRINCIPAL ARTERIALS
(New Construction/Reconstruction)
(Metric)

Figure 47-2.J

- (1) Design Criteria. The criteria in this column are the minimum cross-section elements allowed to remain in place provided it is cost effective and the safety record is satisfactory.
- (2) Traffic Volumes. The design hourly volumes (DHV) assumes base conditions (except for 8% heavy vehicles) and a PHF = 1 for LOS shown. Adjust these values according to the actual factors.
- (3) Design Speed.
 - a. In rolling terrain, a minimum design speed of 60 mph (100 km/h) may be considered with study and justification.
 - b. To determine the minimum design speed allowed to remain in place, see Section 45-2.02.
- (4) Access Control. For bypass routes on new alignment, design the roadway with partial access control.
- (5) Cross Slopes. Cross slopes for auxiliary lanes should be 1/16"/ft (0.5%) greater than the adjacent travel lane.
- (6) Clear Zone. The clear zone will vary according to design speed, traffic volumes, side slopes, and horizontal curvature.
- (7) Ditch Bottom Width. Provide a wider outside ditch bottom where detention storage of storm water is a consideration.
- (8) Back Slope. Where the height of cut exceeds 10 ft (3 m), consider using a 1V:2H back slope beyond the clear zone. Also, for heights of cut greater than 30 ft (9 m), consider the use of benching.
- (9) Fill Slope. For fill heights greater than 30 ft (9 m), use a 1V:2H uniform slope with a roadside barrier. Also, for heights greater than 30 ft (9 m), consider the use of benching.
- (10) New and Reconstructed Bridge Widths. Clear roadway bridge widths are measured from face to face of parapets or rails. Bridge widths are normally defined as the sum of the approach traveled way width and the width of the paved shoulders. See Figure 39-6.A.
- (11) Existing Bridge Widths to Remain in Place. Clear roadway bridge widths measured face to face of parapets or rails. Implies elements allowed to remain in place without a design exception when cost effective and when safety record is satisfactory. See Figure 39-6.A.
- (12) Vertical Clearance (Arterial Under).
 - a. The clearance must be available over the traveled way and any paved shoulders.
 - b. Table value includes an additional allowance for future overlays.

GEOMETRIC DESIGN CRITERIA FOR RURAL TWO-LANE PRINCIPAL ARTERIALS
(New Construction/Reconstruction)

Footnotes for Figure 47-2.J

Design Element		Manual Section	New Construction/Reconstruction Two-Way DHV: Under 1050 (2)	Elements to Remain-In-Place (1) Two-Way DHV: Under 975 (2)	
Design Controls	Design Forecast Year	31-4.02	20 Years	20 Years	
	*Design Speed	31-2	60 mph (3a)	60 mph (3b)	
Cross Section Elements	Access Control	35-1	Controlled by Regulation (4)	Controlled by Regulation	
	Level of Service	31-4.04	C	C	
	*Traveled Way Width	34-2.01	24'	22'	
	*Shoulder Width	Total Width	34-2.02	10'	8'
		Paved		4'	4'
	Auxiliary Lanes	Lane Width	34-2.03	12'	11'
		Shoulder Width		4' (Paved)	4' (Paved)
	Flush/TWLT Widths		34-3.03	14'	12'
		*Travel Lane	34-2.01	3/16"/ft (5a)	3/16"/ft (5)
	Cross Slope	Shoulder	34-2.02	1/2"/ft (5b)	1/2"/ft to 3/4" ft (5b)
		38-3	(6)	(6)	
Roadway Slopes	Cut Section	Front Slope	1V:6H	1V:4H	
		Ditch Bottom Width	4' (7)	2'-0" (7)	
		Back Slope	1V:3H (8)	1V:3H (8)	
	Side Slopes	34-4.05	—	—	
	Rock Cut	34-4.02	1V:6H to Clear Zone; 1V:3H max. to Toe of Slope (9)	1V:4H to Clear Zone; 1V:3H max. to Toe of Slope (9)	
Bridges	New and Reconstructed Bridges	*Structural Capacity	HS-20	N/A	
		*Clear Roadway Width (10)	32'	N/A	
	Existing Bridges to Remain in Place	*Structural Capacity	N/A	N/A	
		*Clear Roadway Width (11)	N/A	HS-20	
	*Vertical Clearance (Arterial Under) (12a)	New and Replaced Overpassing Bridges	39-4	16'-6" (12b)	30' - 32'
		Existing Overpassing Bridges		16'-0"	
Overhead Signs/ Pedestrian Bridges		33-5	New: 17'-3" (12b)		
*Vertical Clearance (Arterial over Railroad)	39-4.06		23'-0"		

* Controlling design criteria (see Section 31-8).

GEOMETRIC DESIGN CRITERIA FOR RURAL TWO-LANE MINOR ARTERIALS
 (New Construction/Reconstruction)
 (US Customary)

Figure 47-2.K

Design Element		Manual Section	New Construction/Reconstruction Two-Way DHV: Under 1050 (2)	Elements to Remain-In-Place (1) Two-Way DHV: Under 975 (2)	
Design Controls	Design Forecast Year	31-4.02	20 Years	20 Years	
	*Design Speed	31-2	100 km/h (3a)	100 km/h (3b)	
	Access Control	35-1	Controlled by Regulation (4)	Controlled by Regulation	
	Level of Service	31-4.04	C	C	
Cross Section Elements	*Traveled Way Width	34-2.01	7.2 m	6.6 m	
	*Shoulder Width	Total Width	3.0 m	2.4 m	
		Paved	1.2 m	1.2 m	
	Auxiliary Lanes	Lane Width	3.6 m	3.3 m	
		Shoulder Width	1.2 m (Paved)	1.2 m (Paved)	
	Flush/TWL TL Widths	34-3.03	4.2 m	3.6 m	
	Cross Slope	*Travel Lane	34-2.01	1.5% (5a)	1.5% (5a)
		Shoulder	34-2.02	4% (5b)	4% to 6% (5b)
	Clear Zone		38-3	(6)	(6)
				1V:6H	1V:4H
Roadway Slopes	Cut Section	Front Slope	1.2 m (7)	500 mm (7)	
		Ditch Width	1V:3H (8)	1V:3H (8)	
		Back Slope	—	—	
	Rock Cut	34-4.05	—	—	
	Fill Section	34-4.02	1V:6H to Clear Zone; 1V:3H max. to Toe of Slope (9)	1V:4H to Clear Zone; 1V:3H max. to Toe of Slope (9)	
Bridges	New and Reconstructed Bridges	N/A	MS-18	N/A	
	Existing Bridges to Remain in Place	*Structural Capacity	39-6	9.6 m	N/A
		*Clear Roadway Width (10)	N/A	N/A	MS-18
	*Vertical Clearance (Arterial Under) (12a)	*Structural Capacity	39-6	N/A	9.0 m – 9.6 m
		*Clear Roadway Width (11)			
		New and Replaced Overpassing Bridges	39-4	5.0 m (12b)	
		Existing Overpassing Bridges		4.9 m	
*Vertical Clearance (Arterial over Railroad)	33-5	New: 5.25 m (12b)			
	39-4.06	7.0 m			

* Controlling design criteria (see Section 34.8)

**GEOMETRIC DESIGN CRITERIA FOR RURAL TWO-LANE MINOR ARTERIALS
(New Construction/Reconstruction)
(Metric)**

Figure 47-2.K

- (1) Design Criteria. The criteria in this column are the minimum cross-section elements allowed to remain in place provided it is cost effective and the safety record is satisfactory.
- (2) Traffic Volumes. The design hourly volumes (DHV) assumes base conditions (Except for 8% heavy vehicles) and a PHF = 1 for LOS shown. Adjust these values according to the actual factors.
- (3) Design Speed.
- In rolling terrain, a minimum design speed of 55 mph (90 km/h) may be considered with study and justification.
 - To determine the minimum design speed allowed to remain in place, see Section 45-2.02.
- (4) Access Control. For bypass routes on new alignment, design the roadway with partial access control.
- (5) Cross Slopes.
- Traveled Way. Cross slopes for auxiliary lanes should be 1/6"/ft (0.5%) greater than the adjacent travel lane.
 - Shoulder. Where an aggregate shoulder is part of the shoulder width, slope the aggregate portion of the shoulder at 3/4"/ft (6%).
- (6) Clear Zone. The clear zone will vary according to design speed, traffic volumes, side slopes, and horizontal curvature.
- (7) Ditch Bottom Width. Provide a wider outside ditch bottom where detention storage of storm water is a consideration.
- (8) Back Slope. Where the height of cut exceeds 10 ft (3 m), consider using a 1V:2H back slope beyond the clear zone. Also, for heights of cut greater than 30 ft (9 m), consider the use of benching.
- (9) Fill Slope. For fill heights greater than 30 ft (9 m), use a 1V:2H uniform slope with a roadside barrier. Also, for heights greater than 30 ft (9 m), consider the use of benching.
- (10) New and Reconstructed Bridge Widths. Clear roadway bridge widths are measured from face to face of parapets or rails. Bridge widths are normally defined as the sum of the approach traveled way width and the width of the paved shoulders. See Figure 39-6.A.
- (11) Existing Bridge Widths to Remain in Place. Clear roadway bridge widths measured face to face of parapets or rails. Implies elements allowed to remain in place without a design exception when cost effective and when safety record is satisfactory. See Figure 39-6.A.
- (12) Vertical Clearance (Arterial Under).
- The clearance must be available over the traveled way and any paved shoulders.
 - Table value includes an additional allowance for future overlays.

GEOMETRIC DESIGN CRITERIA FOR RURAL TWO-LANE MINOR ARTERIALS
(New Construction/Reconstruction)

Footnotes for Figure 47-2.K

Design Element		Manual Section	New Construction/Reconstruction Two-Way DHV: Under 1050 (2)	Elements to Remain-In-Place (1) Two-Way DHV: Under 975 (2)	
Design Controls	Design Forecast Year	31-4.02	20 Years	20 Years	
	*Design Speed	31-2	60 mph (3a)	60 mph (3b)	
Cross Section Elements	Access Control	35-1	Controlled by Regulation (4)	Controlled by Regulation	
	Level of Service	31-4.04	C	C	
	*Traveled Way Width	34-2.01	24'	22'	
	*Shoulder Width	Total Width	34-2.02	8'	6'
		Paved		4'	2'
	Auxiliary Lanes	Lane Width	34-2.03	12'	11'
		Shoulder Width		4' (Paved)	4' (Paved)
	Flush/TWLT Widths	*Travel Lane	34-3.03	14'	12'
		Shoulder	34-2.01	3/16"/ft (5a)	3/16"/ft (5a)
	Cross Slope		34-2.02	1/2"/ft (5b)	1/2"/ft to 3/4"/ft (5b)
		38-3	(6)	(6)	
Roadway Slopes	Clear Zone		1V:6H	1V:4H	
			4' (7)	2'-0" (7)	
	Cut Section	Front Slope		1V:3H (8)	1V:3H (8)
		Ditch Bottom Width		—	—
	Back Slope		34-4.05	—	—
Rock Cut			1V:4H to Clear Zone; 1V:3H max. to Toe of Slope (9)	1V:4H to Clear Zone; 1V:3H max. to Toe of Slope (9)	
Bridges	New and Reconstructed Bridges		HS-20	N/A	
		*Structural Capacity		N/A	
		*Clear Roadway Width (10)	32'	N/A	
	Existing Bridges to Remain in Place	*Structural Capacity	N/A	N/A	HS-20
		*Clear Roadway Width (11)	39-6	N/A	30' - 32'
	*Vertical Clearance (Collector Under) (12a)	New and Replaced Overpassing Bridges	39-4	14'-9" (12b)	
		Existing Overpassing Bridges		14'-0"	
		Overhead Signs/ Pedestrian Bridges	33-5	New: 17'-3" (12b)	
	*Vertical Clearance (Collector over Railroad)	39-4.06	23'-0"		

* Controlling design criteria (see Section 31-8).

GEOMETRIC DESIGN CRITERIA FOR RURAL TWO-LANE COLLECTORS
(New Construction/Reconstruction)
(US Customary)

Figure 47-2.L

Design Element		Manual Section	New Construction/Reconstruction Two-Way DHV: Under 1050 (2)	Elements to Remain-In-Place (1) Two-Way DHV: Under 975 (2)	
Design Controls	Design Forecast Year	31-4.02	20 Years	20 Years	
	*Design Speed	31-2	100 km/h (3a)	100 km/h (3b)	
	Access Control	35-1	Controlled by Regulation (4)	Controlled by Regulation	
	Level of Service	31-4.04	C	C	
Cross Section Elements	*Traveled Way Width	34-2.01	7.2 m	6.6 m	
	*Shoulder Width	Total Width	2.4 m	1.8 m	
		Paved	1.2 m	600 mm	
	Auxiliary Lanes	Lane Width	3.6 m	3.3 m	
		Shoulder Width	1.2 m (Paved)	1.2 m (Paved)	
	Flush/TWL/TL Widths	34-3.03	4.2 m	3.6 m	
	Cross Slope	*Travel Lane	34-2.01	1.5% (5a)	1.5% (5a)
		Shoulder	34-2.02	4% (5b)	4% to 6% (5b)
	Clear Zone		38-3	(6)	(6)
				1V:6H	1V:4H
Roadway Slopes	Cut Section	Ditch Bottom Width	1.2 m (7)	600 mm (7)	
		Back Slope	1V:3H (8)	1V:3H (8)	
		Rock Cut	—	—	
	Fill Section	34-4.05	1V:4H to Clear Zone; 1V:3H max. to Toe of Slope (9)	1V:4H to Clear Zone; 1V:3H max. to Toe of Slope (9)	
Bridges	New and Reconstructed Bridges	N/A	MS-18	N/A	
	Existing Bridges to Remain in Place	*Clear Roadway Width (10)	9.6 m	N/A	
		*Structural Capacity	N/A	MS-18	
	*Vertical Clearance (Collector Under) (12a)	*Clear Roadway Width (11)	39-6	N/A	9.0 m – 9.6 m
		New and Replaced Overpassing Bridges	39-4	4.5 m (12b)	
		Existing Overpassing Bridges		4.3 m	
	*Vertical Clearance (Collector over Railroad)	Overhead Signs/ Pedestrian Bridges	33-5	New: 5.25 m (12b)	
			39-4.06	7.0 m	

* Controlling design criteria (see Section 31-8).

**GEOMETRIC DESIGN CRITERIA FOR RURAL TWO-LANE COLLECTORS
(New Construction/Reconstruction)
(Metric)**

Figure 47-2.L

- (1) Design Criteria. The criteria in this column are the minimum cross-section elements allowed to remain in place provided it is cost effective and the safety record is satisfactory.
- (2) Traffic Volumes. The design hourly volumes (DHV) assumes base conditions (except for 8% heavy vehicles) and a PHF = 1 for LOS shown. Adjust these values according to the actual factors.
- (3) Design Speed.
 - a. In rolling terrain, a minimum design speed of 55 mph (90 km/h) may be considered with study and justification.
 - b. To determine the minimum design speed allowed to remain in place, see Section 45-2.02.
- (4) Access Control. For bypass routes on new alignment, design the roadway with partial access control.
- (5) Cross Slopes.
 - a. Traveled Way. Cross slopes for auxiliary lanes should be 1/16"/ft (0.5%) greater than the adjacent travel lane.
 - b. Shoulder. Where an aggregate shoulder is part of the shoulder width, slope the aggregate portion of the shoulder at 3/4"/ft (6%).
- (6) Clear Zone. The clear zone will vary according to design speed, traffic volumes, side slopes, and horizontal curvature.
- (7) Ditch Bottom Width. Provide a wider outside ditch bottom where detention storage of storm water is a consideration.
- (8) Back Slope. Where the height of cut exceeds 10 ft (3 m), consider using a 1V:2H back slope beyond the clear zone. Also, for heights of cut greater than 30 ft (9 m), consider the use of benching.
- (9) Fill Slope. For fill heights greater than 30 ft (9 m), use a 1V:2H uniform slope with a roadside barrier. Also, for heights greater than 30 ft (9 m), consider the use of benching.
- (10) New and Reconstructed Bridge Widths. Clear roadway bridge widths are measured from face to face of parapets or rails. Bridge widths are normally defined as the sum of the approach traveled way width and the width of the paved shoulders. See Figure 39-6.A.
- (11) Existing Bridge Widths to Remain in Place. Clear roadway bridge widths measured face to face of parapets or rails. Implies elements allowed to remain in place without a design exception when cost effective and when safety record is satisfactory. See Figure 39-6.A.
- (12) Vertical Clearance (Collector Under).
 - a. The clearance must be available over the traveled way and any paved shoulders.
 - b. Table value includes an additional allowance for future overlays.

GEOMETRIC DESIGN CRITERIA FOR RURAL TWO-LANE COLLECTORS (New Construction/Reconstruction)

Footnotes for Figure 47-2.L

Design Element	Manual Section	Design Speed	
		60 mph	70 mph
* Stopping Sight Distance (1)	31-3.01	570'	730'
Passing Sight Distance	47-2.03	2135'	2480'
Decision Sight Distance (2)	31-3.02	990'	1105'
Intersection Sight Distance (3)	36-6	665'	775'
* Minimum Radii	$e_{max} = 6\%$	Desirable: $\geq 3000'$ Minimum: 1330'	Desirable: $\geq 3000'$ Minimum: 2040'
* Superelevation Rate (4)		$e_{max} = 6\%$	
* Horizontal Sight Distance (5)	32-3 32-4	(5)	
* Vertical Curvature (K-values)	Crest	151	247
	Sag	136	181
* Maximum Grade (6)	Level	New: 3%	
	Rolling	New: 4%	
Minimum Grade	33-2.03	Desirable: 0.5% Minimum: 0.0% (with Special Ditching)	

* Controlling design criteria (see Section 31-8).

- (1) Stopping Sight Distance. Table values are for passenger cars on level grade.
- (2) Decision Sight Distance. Table values are for the avoidance maneuver (speed/path/direction change).
- (3) Intersection Sight Distance. Table values are for passenger cars for assumed conditions described in Figure 36-6.E. See Section 36-6 for trucks.
- (4) Superelevation Rate. See Section 32-3 for superelevation rates based on e_{max} , design speed, and radii of horizontal curves. For horizontal curves to remain in place, an e_{max} of 8% may be considered to remain in place. Where a crossroad intersection lies within the limits of a mainline horizontal curve, see Figure 36-1.E for the maximum superelevation rates allowed on the mainline curve.
- (5) Horizontal Sight Distance. For a given design speed, the necessary horizontal sight line offset will be determined by the radius of curve and the required sight distance.
- (6) Maximum Grade. Grades 1% steeper may be allowed to remain in place for existing roadways.

**ALIGNMENT CRITERIA FOR RURAL TWO-LANE HIGHWAYS
(US Customary)**

Figure 47-2.M

Design Element	Manual Section	Design Speed	
		100 km/h	110 km/h
* Stopping Sight Distance (1)	31-3.01	185 m	216 m
Passing Sight Distance	47-2.03	670 m	730 m
Decision Sight Distance (2)	31-3.02	315 m	330 m
Intersection Sight Distance (3)	36-6	209 m	230 m
* Minimum Radii	$e_{max} = 6\%$	Desirable: ≥ 1000 m Minimum: 437 m	Desirable: ≥ 1000 m Minimum: 560 m
* Superlevation Rate (4)	32-3	$e_{max} = 6\%$	
* Horizontal Sight Distance (5)	32-4	(5)	
* Vertical Curvature (K-values)	Crest	52	71
	Sag	45	54
* Maximum Grade (6)	Level	New: 3%	
	Rolling	New: 4%	
Minimum Grade	33-2.03	Desirable: 0.5% Minimum: 0.0% (with Special Ditching)	

* Controlling design criteria (see Section 31-8).

- (1) Stopping Sight Distance. Table values are for passenger cars on level grade.
- (2) Decision Sight Distance. Table values are for the avoidance maneuver (speed/path/direction change).
- (3) Intersection Sight Distance. Table values are for passenger cars for assumed conditions described in Figure 36-6.E. See Section 36-6 for trucks.
- (4) Superlevation Rate. See Section 32-3 for superlevation rates based on e_{max} , design speed, and radii of horizontal curves. For horizontal curves to remain in place, an e_{max} of 8% may be considered to remain in place. Where a crossroad intersection lies within the limits of a mainline horizontal curve, see Figure 36-1.E for the maximum superlevation rates allowed on the mainline curve.
- (5) Horizontal Sight Distance. For a given design speed, the necessary horizontal sight line offset will be determined by the radius of curve and the required sight distance.
- (6) Maximum Grade. Grades 1% steeper may be allowed to remain in place for existing roadways.

**ALIGNMENT CRITERIA FOR RURAL TWO-LANE HIGHWAYS
(Metric)**

Figure 47-2.M

47-3 MULTILANE HIGHWAYS

47-3.01 General

New rural four-lane highways with depressed medians and without access control are not a common highway design in Illinois. For construction or reconstruction projects, the following are descriptions of some of the more likely situations where a four-lane highway design might be proposed:

1. SRA Routes. Where rural routes are designated as Strategic Regional Arterials (SRA). See Chapter 46 for the details of SRA design.
2. Suburban Areas. Where highways are located in an open-suburban area, where reconstruction is required to satisfy capacity demands, and where a design speed of 50 mph (80 km/h) is desired. These highways will most likely be classified as either a minor arterial or as a collector route. Chapter 43 discusses open-suburban guidelines, and Chapter 34 provides general cross section information.
3. Passing Lanes. Where passing lanes are needed in both directions on a two-lane highway and right-of-way and topography favor using a four-lane section. Also, more desirable traffic operations can be accomplished by designing a four-lane section which consists of side-by-side passing lanes; see Figure 47-2.F.

47-3.02 Design Speed

The selected design speed depends on the type of proposed project and on the following:

1. Rural SRA. Where an arterial route is designated as a rural SRA, the desirable design speed for new and existing roadways is 60 mph (100 km/h). To determine the minimum elements allowed to remain in place in conjunction with the design speed, see Section 45-2.02.
2. Open Suburban Area. Where a route is proposed for reconstruction in an open-suburban area and a high-speed design is preferred, use a rural-type cross section with a 50 mph (80 km/h) design speed. See Section 34-3.04(c) for the median design details and Figure 47-3.C for other geometric elements.
3. Passing Lanes. Where a two-lane highway requires additional passing opportunities and side-by-side passing lanes are proposed, provide a design speed of 60 mph (100 km/h) or greater. See Section 47-2.04 for design details.

47-3.03 Typical Sections

Figures 47-3.A and 47-3.B illustrate typical schematic cross sections for rural multilane highways. The tables in Section 47-3.04 provide the minimum criteria for lane widths, shoulder widths, median widths, and other cross section elements.

47-3.04 Tables of Design Criteria

Figures 47-3.C and 47-3.D present the Department's design criteria for rural multilane highways. Note that Figure 47-3.C also provides criteria for an existing roadway to remain in place. The designer should realize that some of the cross section elements included in the figures (e.g., flush concrete barrier) are not automatically warranted in the project design. The values in the figures only apply after the decision has been made to include the element in the highway cross section.

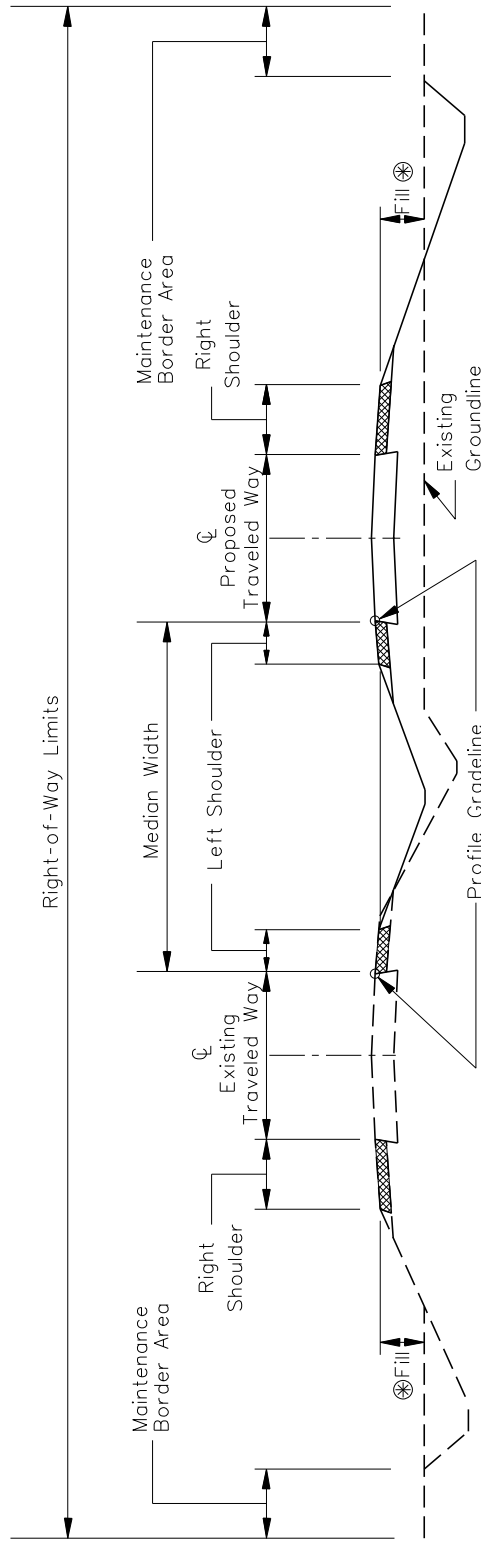

⊗ Existing roadway should be approximately 3' (1.0 m) above the existing ground line. If not, raise the elevation of the existing roadway in the design of the project. See Section 33-6.04.

Note: See Figure 45-2.C for design of flush medians with concrete barrier.

**TYPICAL TANGENT SECTION FOR RURAL MULTILANE HIGHWAYS
(Depressed Median)**

Figure 47-3.A

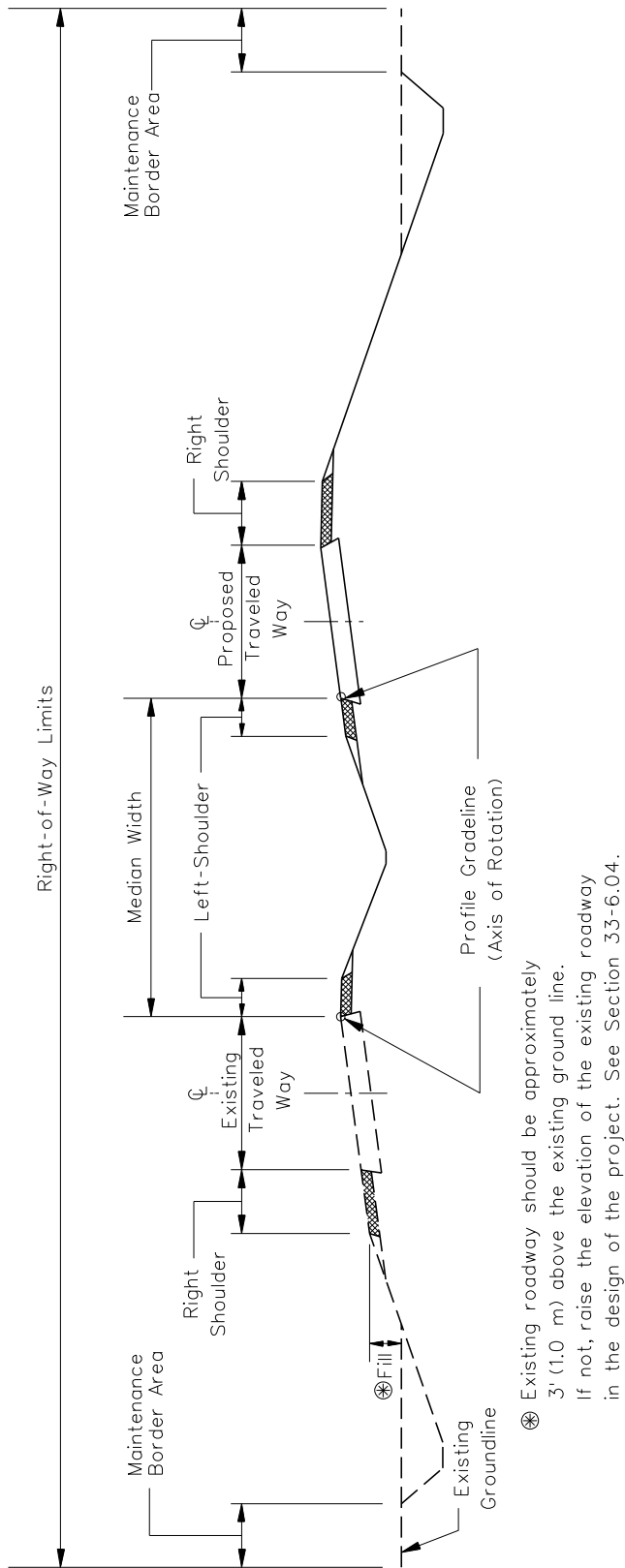

Note: See Figure 45-2.F for design of flush medians with concrete barrier.

**TYPICAL SECTION FOR SUPERELEVATED RURAL MULTILANE HIGHWAYS
(Depressed Median)**

Figure 47-3.B

Design Controls		Design Element		Manual Section	New Lanes (1a) One-Way DHV: Under 2525 (2)	Existing Lanes (1b) One-Way DHV: Under 2375 (2)
Design Controls	Design Forecast Year			31-4.02	20 Years	20 Years
	* Design Speed			31-2	50 mph or 60 mph	50 mph or 60 mph (3)
Design Controls	Access Control			35-1	Controlled by Regulation (4)	Controlled by Regulation (4)
	Level of Service			31-4.04	C	C
Cross Section Elements	* Traveled Way Width			34-2.01	2 @ 24'	2 @ 22'
	Shoulder Width	Right	Total Width	34-2.02	10'	8'
		Left	Total Width		Minimum 8'	8'
	Auxiliary Lanes	Lane Width		34-2.03	4'	4'
		Shoulder Width			12'	11'
	Cross Slope	* Travel Lane		34-2.01	4' (Paved)	4' (Paved)
		Shoulder			3/16"/ft for lanes adjacent to crown (6)	3/16"/ft for lanes adjacent to crown (6)
	Median Width	Depressed		34-3	1/2"/ft	1/2"/ft to 3/4"/ft
		Flush (Concrete Barrier)			Desirable: 50' Minimum: 44' (7a)	Minimum: 40' (7b)
	Clear Zone	Flush (Concrete Barrier)		38-3	22' (8)	Minimum: 20' (8)
Depressed		(9)	(9)			
Roadway Slopes	Cut Section	Front Slope	34-4.03	1V:6H	1V:4H	
		Ditch Bottom Width		4' (10)	2'-0" (10)	
		Back Slope		1V:3H (11)	1V:3H (11)	
	Side Slopes	Rock Cut	34-4.05			
		Fill Section		1V:4H to Clear Zone; 1V:3H max. to Toe of Slope (12)	1V:4H to Clear Zone; 1V:3H max. to Toe of Slope (12)	
Median Slopes	Depressed	34-3	1V:9H to 1V:5H	1V:5H		
	Flush		1/2"/ft	1/2"/ft		
Bridges	New and Reconstructed Bridges	*Structural Capacity	N/A	HS-20	HS-20	
	Existing Bridges to Remain in Place	*Clear Roadway Width (13)	39-6	36'	36'	
		*Structural Capacity	N/A	HS-20	HS-20	
	* Vertical Clearance (Arterial Under) (15a)	*Clear Roadway Width (14a)	39-6	36' with 24' Traveled Way (14b)	34' with 22' Traveled Way (14b)	
New and Replaced Overpassing Bridges (15b)		39-4		16'-6"		
Existing Overpassing Bridges (15a)				16'-0"		
* Vertical Clearance (Arterial over Railroad)	Overhead Signs/ Pedestrian Bridges	33-5		New: 17'-3" (15b) Existing: 16'-9"		
			39-4.06		23'-0"	

* Controlling design criteria (see Section 31-8).

GEOMETRIC DESIGN CRITERIA FOR RURAL FOUR-LANE MINOR ARTERIALS
(New Construction/Reconstruction)
(US Customary)

Figure 47-3.C

Design Element		Manual Section	New Lanes (1a) One-Way DHV: Under 2525 (2)	Existing Lanes (1b) One-Way DHV: Under 2375 (2)	
Design Controls	Design Forecast Year	31-4.02	20 Years	20 Years	
	*Design Speed	31-2	80 km/h or 100 km/h	80 km/h or 100 km/h (3)	
Cross Section Elements	Access Control	35-1	Controlled by Regulation (4)	Controlled by Regulation (4)	
	Level of Service	31-4.04	C	C	
	*Traveled Way Width	34-2.01	2 @ 7.2 m	2 @ 6.6 m	
	Shoulder Width	Right	34-2.02	3.0 m	2.4 m
		Paved		2.4 m	
	Total Width	Right	34-2.02	Minimum 2.4 m	2.4 m
		Paved		1.8 m (5)	
	Auxiliary Lanes	Total Width	34-2.03	1.2 m	1.2 m
		Paved		3.6 m	
	Cross Slope	Lane Width	34-2.01	1.2 m (Paved)	1.2 m (Paved)
Shoulder Width		1.5% for lanes adjacent to crown (6)			
Median Width	*Travel Lane	34-2.02	4%	4% to 6%	
	Shoulder		Desirable: 15 m Minimum: 13.2 m (7a)		
Clear Zone	Depressed	34-3	7.0 m (8)	Minimum: 12 m (7b)	
	Flush (Concrete Barrier)		Minimum: 6.0 m (8)		
Roadway Slopes	Cut Section	38-3	(9)	(9)	
			Front Slope	1V:6H	
	Ditch Bottom Width	34-4.03	1.2 m (10)	600 mm (10)	
			Back Slope	1V:3H (11)	
	Rock Cut	34-4.05	—	—	
			Fill Section	1V:4H to Clear Zone; 1V:3H max. to Toe of Slope (12)	
Median Slopes	Depressed	34-3	1V:6H to 1V:5H	1V:4H to Clear Zone; 1V:3H max. to Toe of Slope (12)	
	Flush		4%	1V:5H	
Bridges	New and Reconstructed Bridges	N/A	MS-18	MS-18	
	Existing Bridges to Remain in Place	*Structural Capacity	10.8 m	10.8 m	
		*Clear Roadway Width (13)	N/A	MS-18	
	*Vertical Clearance (Arterial Under) (15a)	*Structural Capacity	39-6	MS-18	MS-18
*Clear Roadway Width (14a)		10.8 m with 7.2 m Traveled Way (14b)		10.2 m with 6.6 m Traveled Way (14b)	
*Vertical Clearance (Arterial over Railroad)	New and Replaced Overpassing Bridges (15b)	39-4	5.0 m	5.0 m	
	Existing Overpassing Bridges		4.9 m	4.9 m	
*Vertical Clearance (Arterial over Railroad)	Overhead Signs/ Pedestrian Bridges	33-5	New: 5.25 m (15b)	Existing: 1.5 m	
	Overhead Signs/ Pedestrian Bridges		7.0 m	7.0 m	

* Controlling design criteria (see Section 31-8).

GEOMETRIC DESIGN CRITERIA FOR RURAL FOUR-LANE MINOR ARTERIALS
(New Construction/Reconstruction)
(Metric)

Figure 47-3.C

- (1) Design Criteria:
- a. When upgrading an existing two-lane highway to a four-lane facility, use the criteria in the new lanes column for the design of the new roadway and median.
 - b. The criteria in this column are the minimum cross-section elements allowed to remain in place for reconstruction of an existing roadway provided it is cost effective and safety record is satisfactory.
- (2) Traffic Volumes. The design hourly volumes (DHV) assumes base conditions (except for 8% heavy vehicles) and a PHF = 1.0. Adjust these values using local factors.
- (3) Design Speed. To determine the minimum design speed allowed to remain, see Section 45-2.02.
- (4) Access Control. Investigate and consider providing partial access control; see Sections 45-2.06 through 45-2.09. Bypasses around a community should be fully access controlled if the installation of traffic signals is likely at any intersection during the 20-year design period.
- (5) Shoulder Width (Left). In most cases, left shoulders should be 6 ft (1.8 m) wide. This allows for the use of 1V:6H slopes in the median. However, if the 20-year level of service approaches Level C, then consider a 8 ft (2.4 m) wide left shoulder, and decrease the median slopes to 1V:5H.
- (6) Travel Lane Cross Slope. For each additional lane away from the crown lanes, increase the cross slope by 1/16"/ft (0.5%) per additional lane up to a maximum of 5/16"/ft (2.5%).
- (7) Depressed Median Width.
- a. Median width based on 1V:5H median slopes, 2 ft (600 mm) ditch width, 3 ft (900 mm) ditch depth, and 6 ft (1.8 m) left shoulders.
 - b. Median width based on 1V:5H median slopes, existing 2 ft (600 mm) ditch width, 3 ft (900 mm) ditch depth, and 4 ft (1.2 m) left shoulders..
- (8) Flush Median Width. Only use flush medians with CMB where right-of-way or topography restricts the use of a depressed median. Consider providing wider medians where required for snow storage.
- (9) Clear Zone. The clear zone will vary according to design speed, traffic volumes, side slopes, and horizontal curvature.
- (10) Ditch Bottom Width. Provide a wider outside ditch bottom where detention storage of storm water is a consideration.
- (11) Back Slope. Where the height of cut exceeds 10 ft (3 m), consider using a 1V:2H back slope beyond the clear zone. Also, for heights greater than 30 ft (9 m), consider the use of benching.
- (12) Fill Slope. For fill heights greater than 30 ft (9 m), use a 1V:2H uniform slope with a roadside barrier. Also, for heights greater than 30 ft (9 m), consider the use of benching.

GEOMETRIC DESIGN CRITERIA FOR RURAL FOUR-LANE MINOR ARTERIALS
(New Construction/Reconstruction)

Footnotes for Figure 47-3.C

- (13) New and Reconstructed Bridge Widths. Clear roadway bridge widths are measured from face to face of parapets or rails. Bridge widths are normally defined as the sum of the approach traveled way width and the width of the paved shoulders. See Figure 39-6.A.
- (14) Existing Bridge Widths to Remain in Place:
- a. Clear roadway bridge widths measured from face to face of parapets or rails. Implies elements allowed to remain in place without a design exception when cost effective and when safety record is satisfactory. See Figure 39-6A.
 - b. Bridges with total lengths greater than 250 ft (75 m) or any span longer than 120 ft (36 m) typically should have a clear roadway bridge width of 38 ft (11.4 m) or 40 ft (12.0 m).
- (15) Vertical Clearance (Arterial Under).
- a. The clearance must be available over the traveled way and any paved shoulder.
 - b. Table value includes allowance for future overlays.

**GEOMETRIC DESIGN CRITERIA FOR RURAL FOUR-LANE MINOR ARTERIALS
(New Construction/Reconstruction)**

**Footnotes for Figure 47-3.C
(Continued)**

Design Element	Manual Section	Design Speed	
		50 mph	60 mph
*Stopping Sight Distance (1)	31-3.01	425'	570'
Decision Sight Distance (2)	31-3.02	750'	990'
Intersection Sight Distance (3)	36-6	555'	665'
*Minimum Radii	32-2.03	Desirable: $\geq 3000'$ Minimum: 835'	Desirable: $\geq 3000'$ Minimum: 1330'
*Superelevation Rate (4)	32-3	$e_{max} = 6\%$	
*Horizontal Sight Distance (5)	32-4	(5)	
*Vertical Curvature (K-values)	Crest	84	151
	Sag	96	136
*Maximum Grade (6)	Level	New: 6%	New: 3%
	Rolling	New: 7%	New: 4%
Minimum Grade	33-2.03	Des: 0.5% Min: 0.0% (with Special Ditching)	

* Controlling design criteria (see Section 31-8)

- (1) Stopping Sight Distance. Table values are for passenger cars on level grade.
- (2) Decision Sight Distance. Table values are for the avoidance maneuver (speed/path/direction change).
- (3) Intersection Sight Distance. Table values are for passenger cars turning right or left from a stopped condition. A wide median is assumed on the multilane facility for left turns from the crossroad.
- (4) Superelevation Rate. See Section 32-3 for superelevation rates based on e_{max} design speed, and radii of horizontal curves. For horizontal curves to remain in place, an e_{max} of 8% may be considered to remain in place. Where a crossroad intersection lies within the limits of a mainline horizontal curve, see Figure 36-1.E for the maximum superelevation rates allowed on the mainline curve.
- (5) Horizontal Sight Distance. For a given design speed, the necessary horizontal sight line offset will be determined by the radius of curve and the required sight distance.
- (6) Maximum Grade. Grades 1% steeper may be allowed to remain in place for existing roadways.

**ALIGNMENT CRITERIA FOR RURAL FOUR-LANE MINOR ARTERIALS
(US Customary)**

Figure 47-3.D

Design Element	Manual Section	Design Speed	
		80 km/h	100 km/h
* Stopping Sight Distance (1)	31-3.01	129 m	185 m
Decision Sight Distance (2)	31-3.02	230 m	315 m
Intersection Sight Distance (3)	36-6	167 m	209 m
* Minimum Radii	$e_{max} = 6\%$	Desirable: ≥ 1000 m Minimum: 252 m Desirable: ≥ 1000 m Minimum: 437 m	
* Superelevation Rate (4)	32-3	$e_{max} = 6\%$	
* Horizontal Sight Distance (5)	32-4	(5)	
* Vertical Curvature (K-values)	Crest	26	52
	Sag	30	45
* Maximum Grade (6)	Level	New: 6%	New: 3%
	Rolling	New: 7%	New: 4%
Minimum Grade	33-2.03	Des: 0.5% Min: 0.0% (with Special Ditching)	

* Controlling design criteria (see Section 31-8)

- (1) Stopping Sight Distance. Table values are for passenger cars on level grade.
- (2) Decision Sight Distance. Table values are for the avoidance maneuver (speed/path/direction change).
- (3) Intersection Sight Distance. Table values are for passenger cars turning right or left from a stopped condition. A wide median is assumed on the multilane facility for left turns from the crossroad.
- (4) Superelevation Rate. See Section 32-3 for superelevation rates based on e_{max} , design speed, and radii of horizontal curves. For horizontal curves to remain in place, an e_{max} of 8% may be considered to remain in place. Where a crossroad intersection lies within the limits of a mainline horizontal curve, see Figure 36-1.E for the maximum superelevation rates allowed on the mainline curve.
- (5) Horizontal Sight Distance. For a given design speed, the necessary horizontal sight line offset will be determined by the radius of curve and the required sight distance.
- (6) Maximum Grade. Grades 1% steeper may be allowed to remain in place for existing roadways.

**ALIGNMENT CRITERIA FOR RURAL FOUR-LANE MINOR ARTERIALS
(Metric)**

Figure 47-3.D

47-4 REFERENCES

1. *A Policy on Geometric Design of Highways and Streets*, AASHTO, 2011.
2. *Low-Cost Methods for Improving Traffic Operations on Two-Lane Roads: Informational Guide*, Report No. FHWA-IP-87-2, FHWA, 1987.
3. *Highway Capacity Manual 2010*, Transportation Research Board, 2010.
4. NCHRP 605 *Passing Sight Distance Criteria*, TRB, 2008.

Chapter Forty-eight

URBAN HIGHWAYS AND STREETS (New Construction/Reconstruction)

BUREAU OF DESIGN AND ENVIRONMENT MANUAL

Chapter Forty-eight
URBAN HIGHWAYS AND STREETS
(New Construction/Reconstruction)

Table of Contents

<u>Section</u>	<u>Page</u>
48-1 GENERAL	48-1.1
48-1.01 Functional Classification	48-1.1
48-1.02 Closed and Open Suburban Designations	48-1.1
48-2 GENERAL DESIGN ELEMENTS	48-2.1
48-2.01 Design Speed	48-2.1
48-2.02 Median Types	48-2.1
48-2.03 Typical Sections	48-2.1
48-2.04 Sidewalks	48-2.10
48-2.05 Parking	48-2.11
48-3 RAISED-CURB MEDIANS	48-3.1
48-3.01 General	48-3.1
48-3.02 Four Lanes with Median	48-3.1
48-3.03 Six Lanes with Median	48-3.1
48-4 FLUSH OR TRAVERSABLE TYPE MEDIANS	48-4.1
48-4.01 TWLTL Guidelines	48-4.1
48-4.02 Design Criteria	48-4.2
48-4.02(a) Median Width	48-4.2
48-4.02(b) Intersection Treatment	48-4.4
48-4.02(c) Curbing	48-4.4
48-4.02(d) Traversable TWLTL	48-4.4
48-4.03 Railroad Crossings	48-4.6
48-5 HORIZONTAL ALIGNMENT	48-5.1
48-5.01 General Application	48-5.1
48-5.02 General Superelevation Considerations	48-5.1
48-5.03 Horizontal Curves	48-5.3
48-5.03(a) Design Procedures	48-5.3
48-5.03(b) Maximum Superelevation Rate	48-5.3
48-5.03(c) Minimum Radii	48-5.3
48-5.03(d) Minimum Radii with Retain Normal Crown or Superelevate at Normal Crown	48-5.3

Table of Contents
(Continued)

<u>Section</u>		<u>Page</u>
	48-5.03(e) Superelevated Curves.....	48-5.7
	48-5.03(f) Maximum Deflection Without Curve.....	48-5.8
48-5.04	Superelevation Development.....	48-5.8
	48-5.04(a) Transition Length	48-5.8
	48-5.04(b) Axis of Rotation.....	48-5.9
48-5.05	Typical Designs	48-5.10
48-6	TABLES OF DESIGN CRITERIA.....	48-6.1
48-7	REFERENCES	48-7.1

Chapter Forty-eight

URBAN HIGHWAYS AND STREETS (New Construction/Reconstruction)

Chapter 48 provides guidance in the design of urban highways and streets. Information that is also applicable to these facilities is included in the following chapters:

- Chapter 14 discusses intersection design studies.
- Chapters 31, 32, 33, 34, and 39 provide guidance on the geometric design elements that are also applicable to these facilities.
- Chapter 36 provides information on the design of intersections, including left- and right-turn lanes, channelization, and intersection sight distances.
- Chapter 38 provides guidelines on roadside safety issues.
- Chapter 58 provides guidelines for off-street parking facilities.

48-1 GENERAL

48-1.01 Functional Classification

Urban highways and streets can be functionally classified as arterials, collectors, and local streets. Most of the State's urban facilities are arterials; however, there are some urban collectors on the State System. Practical improvements to urban collectors usually are more consistent with objectives pursued under the 3R program, which are presented in Chapter 49. For urban collector streets, planning and programming goals only occasionally include new construction and reconstruction of these highways for significant lengths such as between urban destinations. For criteria on new construction and reconstruction of urban collectors and local streets, the designer is referred to the *Bureau of Local Roads and Streets Manual* and AASHTO *A Policy on Geometric Design of Highways and Streets* for guidance.

Chapter 48 presents new construction and reconstruction criteria for urban and suburban arterials.

48-1.02 Closed and Open Suburban Designations

To better designate appropriate design criteria, the Department has divided its functional classifications into rural, suburban, and urban. Chapter 43 discusses the distinction among these area types. The suburban classification has been further subdivided as open or closed. These are defined in Chapter 43.

48-2 GENERAL DESIGN ELEMENTS

48-2.01 Design Speed

The most common design speed for urban streets is 30 mph (50 km/hr). In relatively undeveloped locations in urban or closed suburban areas and where economics, environmental conditions, and signal spacing permits, consider using a minimum design speed of 40 mph (60 km/hr). Design speeds of 45 mph to 50 mph (70 km/hr to 80 km/hr) are common in open suburban areas.

48-2.02 Median Types

Section 34-3 discusses the various medians that are used in urban and suburban areas and guidelines for selecting medians and widths. In addition, for medians in suburban and urban arterials, the designer should consider the following:

1. Flush/Traversable Medians. These median types may be used in both the urban and suburban areas in conjunction with curb and gutter along the outside edges of the traveled way. For most applications, the flush two-way left-turn lane (TWLTL) should be used. However, in larger metropolitan areas, a traversable TWLTL may be used. Section 48-4 further discusses the use of both types of TWLTL.
2. Depressed Medians. In open suburban areas, a depressed median may be used. This design is typically used with left shoulders and where the design speed is 50 mph (80 km/hr). Section 34-3.03 and Chapter 47 provide further guidance on depressed medians.
3. Raised-Curb Medians. Usually, a raised-curb median is proposed in suburban and urban areas where managed access to the street and control of left-turn movements are desired. Section 34-3.03 provides guidance on the selection and design of raised-curb medians. Figure 48-3.A discusses the advantages and disadvantages of raised-curb medians as compared to TWLTL medians. Chapter 36 illustrates typical treatments for left-turn lanes within raised-curb medians.

48-2.03 Typical Sections

Figures 48-2.A through 48-2.H present the typical cross sections for the various urban facilities. For a typical six-lane urban arterial with a raised-curb median; see Figure 34-3.B. Give consideration to safe accommodation of pedestrians and bicyclists during the development of the project. Chapter 17 provides detailed guidelines for these issues.

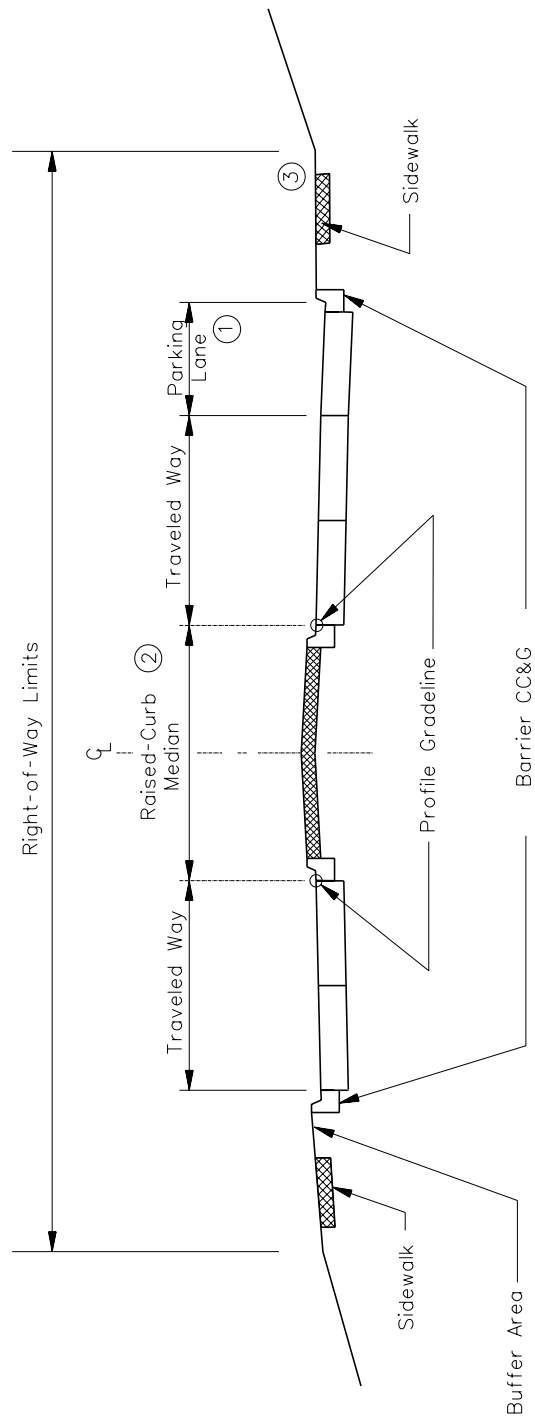

**TYPICAL TANGENT SECTION FOR URBAN ARTERIALS
(Raised-Curb Median)**

Figure 48-2.A

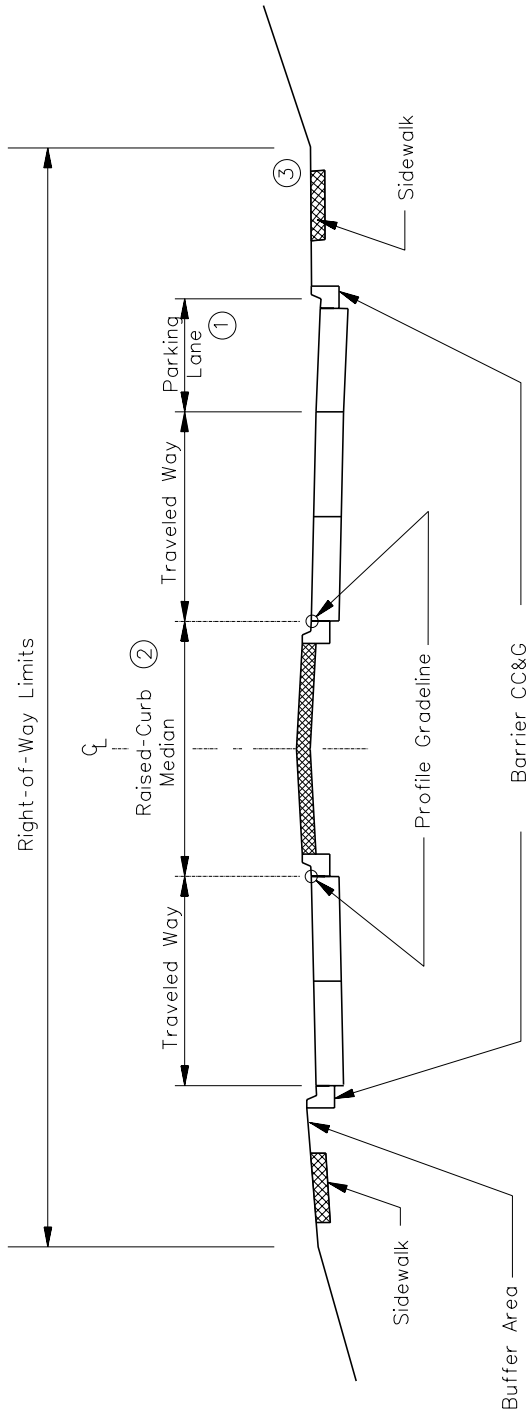

Notes:

- 1. Consider off-street parking.
- 2. See Figure 34-3.B for slope of gutters along the median.
- 3. See Section 34-4 for alternative slope designs behind the sidewalk.

**TYPICAL TANGENT SECTION FOR URBAN ARTERIALS
(Raised-Curb Median)**

Figure 48-2.B

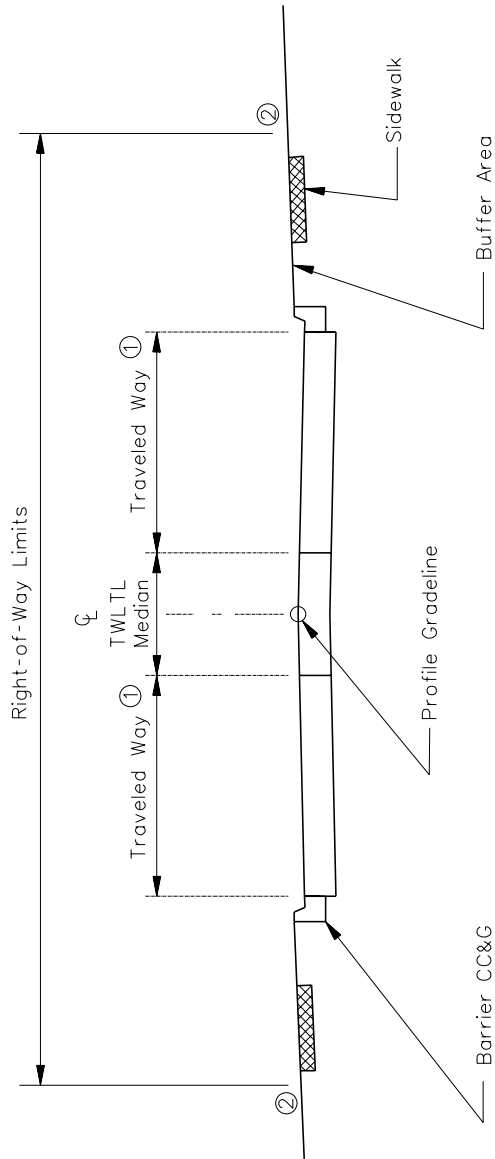

Notes:

1. Traveled ways may be either one or two lanes.
2. See Section 34-4 for alternative slope designs behind the sidewalk.

**TYPICAL TANGENT SECTION FOR URBAN ARTERIALS
(TWLTL)**

Figure 48-2.C

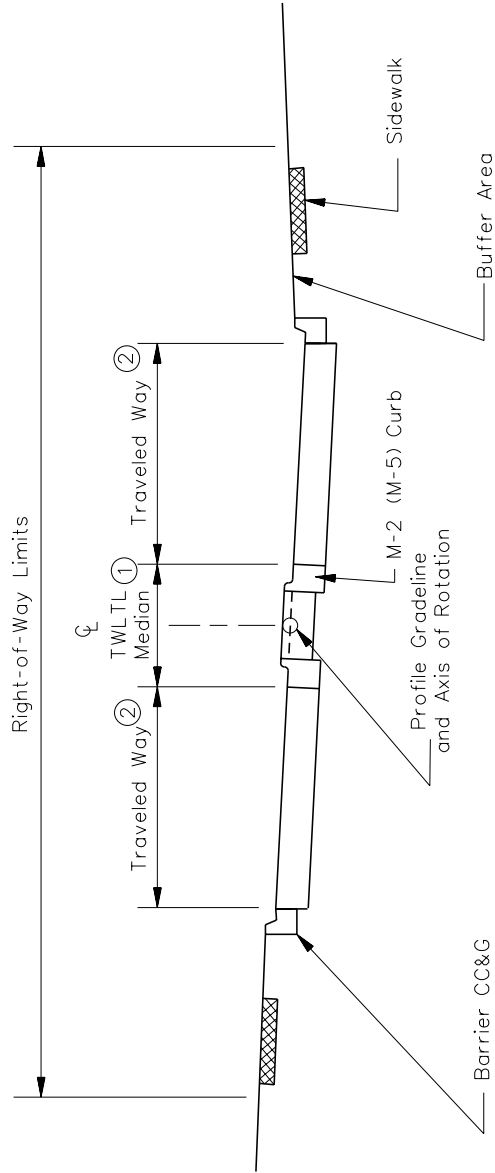

Notes:

1. Within the limits of the horizontal curve, use Type M-2.12 (M-5.30) Concrete Curb & Gutter along the median edges to control drainage.
2. Traveled ways may be either one or two lanes.

TYPICAL SUPERELEVATED SECTION FOR URBAN ARTERIALS (TWLTL)

Figure 48-2.D

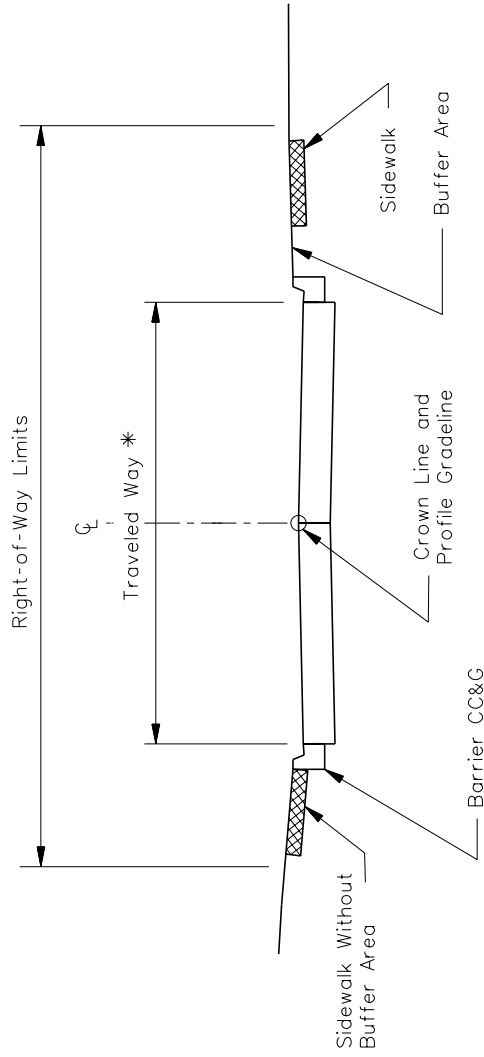

** The traveled way may have two-way or one-way traffic.*

**TYPICAL TANGENT SECTION FOR URBAN ARTERIALS
(Two-Lanes Without Parking)**

Figure 48-2.E

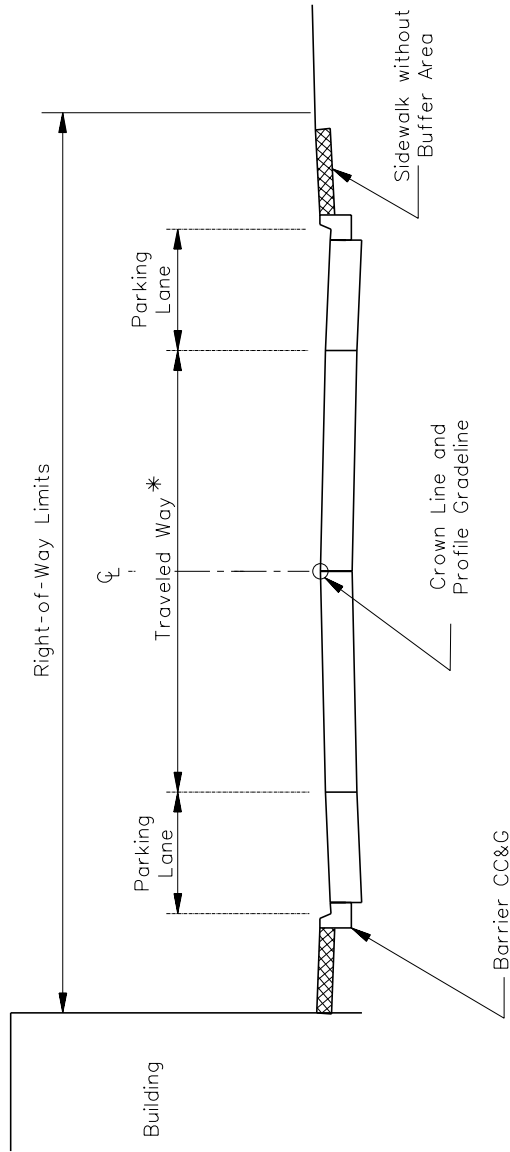

**The traveled way may have two-way or one-way traffic.*

Note: For consistency, see Figures 48-2.E, 48-2.G, and 48-2.H.

**TYPICAL TANGENT SECTION FOR URBAN ARTERIALS
(Two-Lanes With Parking Both Sides)**

Figure 48-2.F

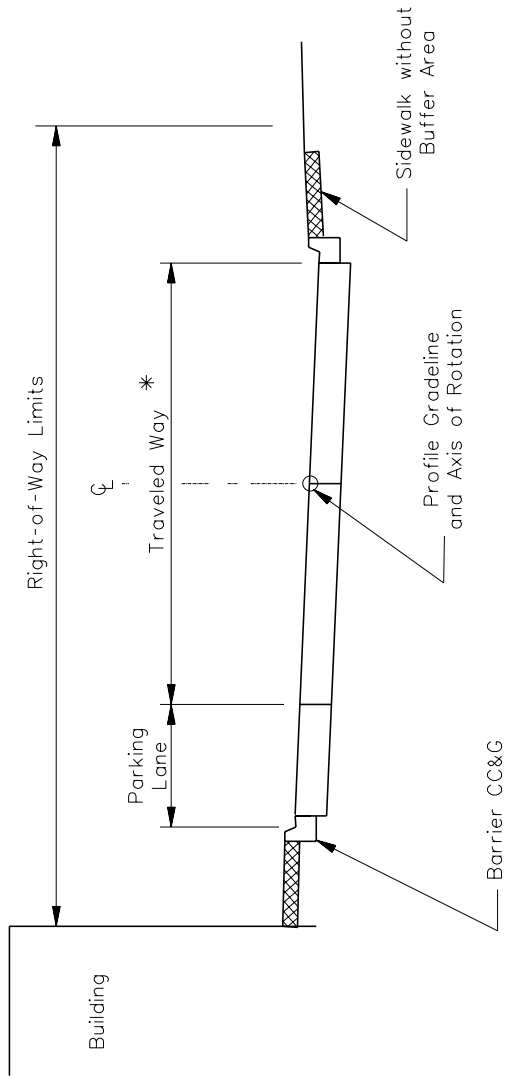

** The traveled way may have two-way or one-way traffic.*

**TYPICAL TANGENT SECTION FOR URBAN ARTERIALS
(Two-Lanes With Parking on One Side)**

Figure 48-2.G

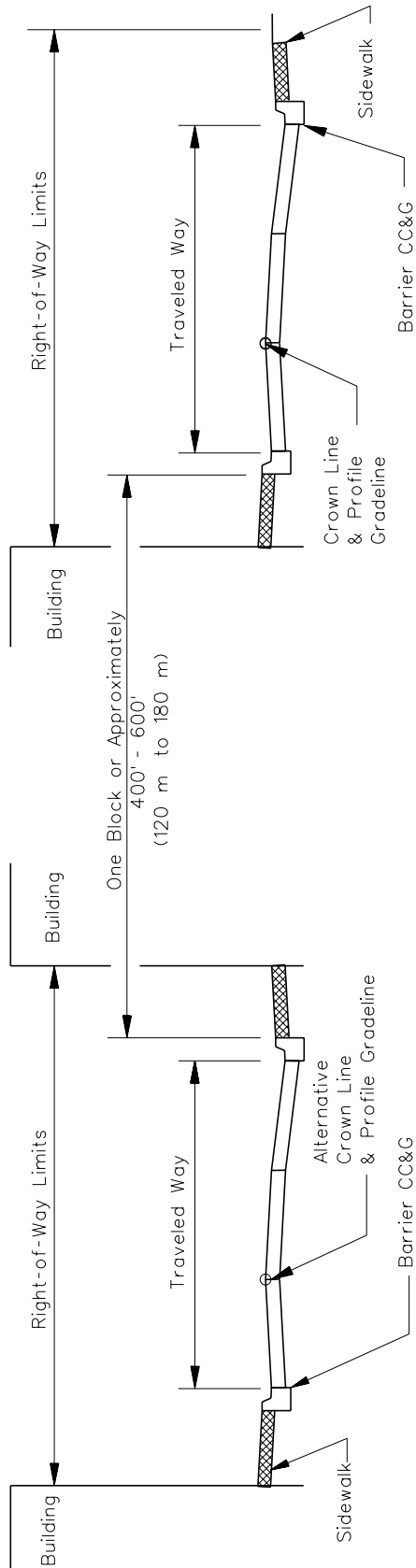

**TYPICAL TANGENT SECTION FOR ONE-WAY COUPLE ON URBAN ARTERIALS
(Three-Lanes in Each Direction)**

Figure 48-2.H

48-2.04 Sidewalks

Sidewalks are considered integral parts of the urban environment. In these areas, most travelers begin and end their trip as pedestrians; and many short trips are made without a vehicle, especially in the context of a dense urban core. When planning and designing sidewalks, the designer should consider the following:

1. Warrants. In general, if pedestrian activity is evident or anticipated, provide sidewalks along all curbed suburban and urban facilities. Extend all sidewalks to logical termini. If sidewalks are not provided in the initial design, grading should be completed so that sidewalks can be added in the future. The designer should confer with local officials.
2. Widths. A typical sidewalk is 5 ft (1.5 m) wide. If no buffer area is provided, the sidewalk should be 7 ft (2.0 m) wide to accommodate any appurtenances that may be included in the sidewalk; see Item #4 below. High pedestrian volumes may warrant greater widths in business areas and school zones. In these cases, a detailed capacity analysis may be required to determine the sidewalk width. Use the *Highway Capacity Manual* for this analysis.
3. Buffer Areas. If the available right-of-way is sufficient, provide a buffer area between the back of curb and sidewalk. These areas provide space for snow storage, utilities, and allow a greater separation between vehicles and pedestrians. The buffer area should be 2 ft to 3 ft (600 mm to 900 mm) wide to be effective and wider if practical. Buffer areas may also be used for the placement of roadside appurtenances.
4. Appurtenances. Where a buffer area cannot be provided, the designer must consider the impact of roadside appurtenances within the sidewalk (e.g., mailboxes, fire hydrants, parking meters, utility poles) as these elements typically reduce the usable width of the sidewalk and interfere with pedestrian activity. Typically, a 1 ft (300 mm) minimum width is provided between the sidewalk and right-of-way line. Utility poles usually can be located behind the sidewalk in this area providing a clear sidewalk width.
5. CBD Areas. In central business districts, the entire area between the back of curb and the front of buildings is fully paved as a sidewalk.
6. Accessibility. The design of the sidewalk (e.g., sidewalk width, cross slope, longitudinal grade, curb ramps) along public rights-of-way must meet the ADA criteria presented in Chapter 58.
7. Bridges. In general, if there is or expected to be pedestrian activity across a bridge, include sidewalks on both sides of the bridge. On long bridges, it may be more cost effective to provide a single sidewalk on one side. However, a safe crossing must be provided in advance of the bridge if there is evidence of pedestrian activity on both sides of the roadway. See Chapter 39 for typical sections.

48-2.05 Parking

For most urban projects, the designer must evaluate the demand for parking. Desirably, these parking needs will be accommodated by providing off-street parking facilities. Chapter 58 provides information on the design and layout of off-street parking facilities. When providing on-street parking along urban streets, the designer should evaluate the following:

1. Warrants. Do not introduce any new parking lanes along State highways. On-street parking reduces capacity, impedes traffic flow, and may produce undesirable traffic operations or may increase the crash potential. On State reconstruction projects, consider removing parking lanes. Removal of existing or revising existing on-street parking configurations will require coordination and concurrence with local officials and adjacent businesses. Chapter 58 discusses the procedures and guidelines for replacing on-street parking with off-street parking.
2. Local Agreements. Prior to implementation of parking on a project, the State will enter into a joint agreement with the municipality; see Chapter 5. The municipality will be required to maintain the parking lane and adopt and enforce an appropriate parking ordinance or provide copies of an existing ordinance in effect. Attach the ordinance to the joint improvement agreement as an exhibit and make a part thereof prior to execution of the agreement on behalf of the State. Enforcement of the ordinance is understood to include erection and maintenance of any necessary NO PARKING or PARALLEL PARKING ONLY signs.
3. Configurations. There are two basic types of on-street parking — parallel and angle parking. These are illustrated in Figure 48-2.1.
4. Design Considerations.
 - a. Department Authority. The *Illinois Vehicle Code* authorizes the Department to determine the propriety of diagonal parking upon routes under its jurisdiction. Section 11-1304(c) of the *Code* states:

Local authorities may permit angle parking on any roadway, except that angle parking shall not be permitted on any federal-aid or state highway unless the Department has determined the roadway is of sufficient width to permit angle parking without interfering with the free movement of traffic.
 - b. Capacity. Parallel parking is the preferred arrangement where street space is limited and traffic capacity is a major factor. Where angle parking is provided, the overall level of service for the facility preferably should be not less than C.

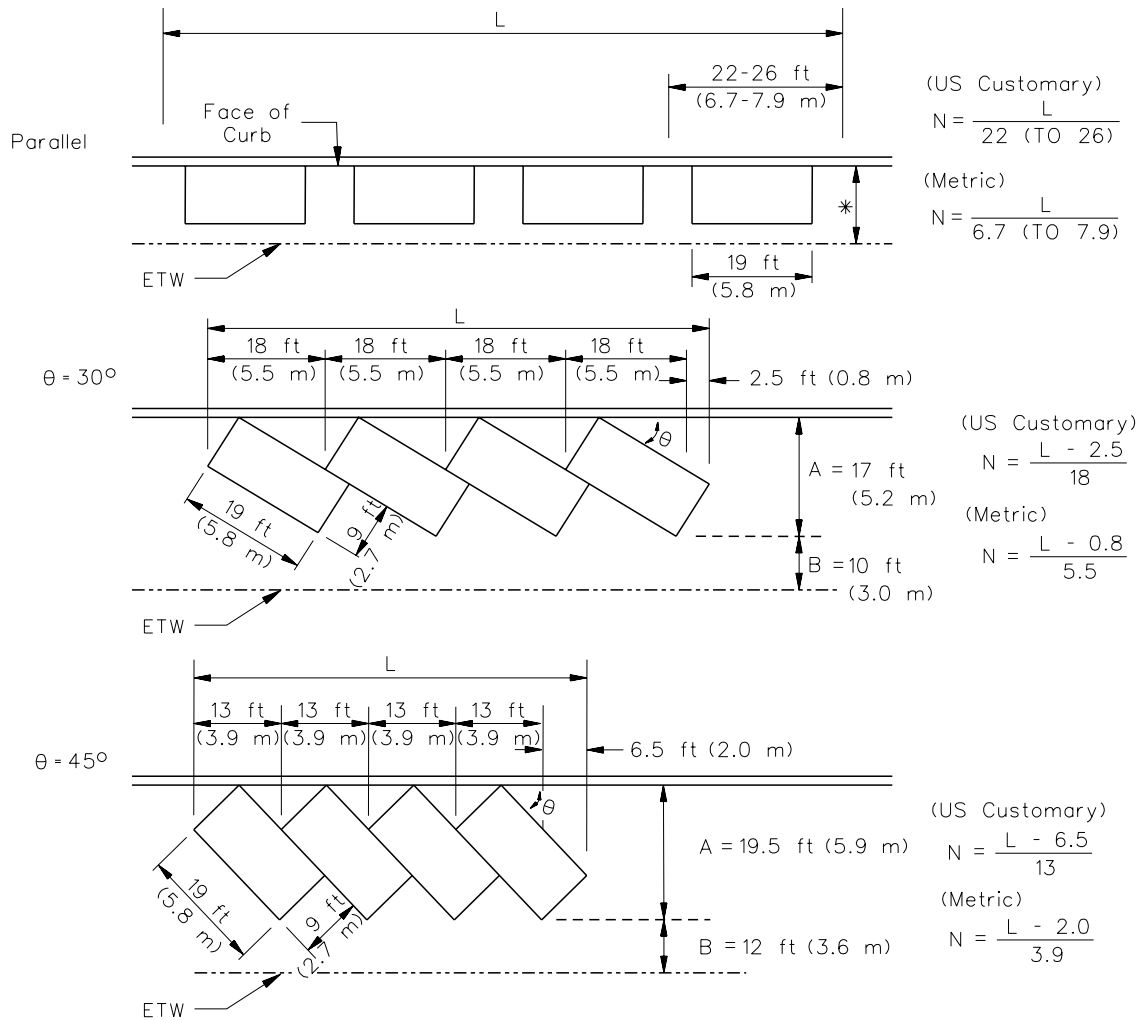

* See Figures 48-6.A and 48-6.B for parallel parking lane widths.
See Chapter 49 for 3R widths.

$A + B = \text{Parking Width for Angle Parking.}$

- Key:
- L = given curb length with parking spaces
 - N = number of parking spaces over distance L
 - A = required distance between face of curb and back of stall, assuming that bumper of parked car does not extend beyond curb face.
 - B = clear distance needed for a parked vehicle to back out of stall while just clearing adjacent parked vehicles.

ETW = Edge of Traveled Way

CURB PARKING CONFIGURATIONS

Figure 48-2.1

- c. Number of Spaces. Angle parking provides more spaces per linear foot (meter) than parallel parking, but requires a greater cross street width.
 - d. Angle. Angle parking should be 45° or less.
 - e. Backing Maneuver. Angle parking requires the driver to back into the traveled way when sight distance may be restricted by adjacent parked vehicles. This maneuver may surprise an approaching motorist. As indicated in Figure 48-2.I, the parked car will require a certain distance “B” to back out of its stall. Whether or not this is a reasonably safe maneuver will depend upon the number of lanes in each direction, lane widths, operating speeds, traffic volumes during peak hours, parking demand, and turnover rate of parked vehicles.
 - f. Crashes. After analyzing backing maneuver space, angle parking may be considered to remain if there is no history of crashes relating to the existing angle parking.
 - g. Trucks. If the truck traffic on the facility is 10% or more of the ADT, angle parking should be removed.
 - h. Agreement. The agreement with local officials must include provisions for monitoring and maintaining the angle parking after the project is completed to determine if safety or capacity problems develop as traffic volumes increase.
5. Stall Dimensions. Figure 48-2.I provides the width and length criteria for parking stalls of various configurations. The figure also indicates the number of stalls that can be provided for each parking configuration for a given curb length. The surface widths in Figures 48-6.A and 48-6.B assume parallel parking on one or both sides of the street.
 6. ADA Requirements. Chapter 58 presents the accessibility requirements for on-street parking for persons with disabilities.
 7. Location. When locating parking spaces, the designer should consider the following:
 - Parking is prohibited within 20 ft (6.1 m) of any crosswalk.
 - Prohibit parking within 10 ft to 16 ft (3 m to 5 m) of the beginning of the curb radius at mid-block driveway entrances.
 - Parking is prohibited within 50 ft (15.2 m) of the nearest rail of a highway/railroad crossing.
 - Parking is prohibited within 15 ft (4.6 m) of a fire hydrant.
 - Parking is prohibited within 30 ft (9.1 m) on the approach leg to any intersection with a flashing beacon, stop sign, or traffic control signal.
 - Parking is prohibited on bridges or within a highway tunnel.

- Prohibit parking from areas designated by local traffic and enforcement regulations (e.g., near school zones, loading zones, bus stops). See local ordinances for additional information on parking restrictions.
- Check intersection sight distance to side roads.
- Eliminate parking across from a T intersection.

48-3 RAISED-CURB MEDIANS

48-3.01 General

Figure 48-3.A presents advantages and disadvantages of raised-curb medians as compared to TWLTL medians. Section 34-3.03 provides guidance on the selection and design of raised-curb medians.

48-3.02 Four Lanes with Median

The most common typical section with raised-curb medians is two lanes in each direction separated by the curbed median; see Figures 48-2.A and 48-2.B.

48-3.03 Six Lanes with Median

Where traffic volumes indicate a need for three lanes in each direction, the recommended median design is a raised-curb. See Figure 34-3.B for a typical cross section design. Where there is a need for dual left turns, the minimum width of the median is 30 ft (9.5 m). Where major intersections are closely spaced and there is a need for dual lefts at most intersections, provide the 30 ft (9.5 m) median width along the entire street.

Where a five-lane facility exists and traffic volumes (ADT > 40,000) and/or capacity analysis warrants a six-lane design, consider providing a traversable type median with M-2 (M-5) curb. Prior to incorporating the M-2 (M-5) curb median into the design, evaluate the following:

1. Concentrated Left-Turn Movements. With raised-curb medians, left-turn movements are concentrated at the intersections, thereby reducing the overall conflict areas of the facility. However, drivers are forced to make all left turns at the intersections, which may overload the capacity of the intersections, increase driver travel time, and may create the need for U-turns at intersections.
2. Businesses. Business owners may perceive an adverse effect when a raised-curb median is proposed. See NCHRP 395 *Capacity and Operations Effects of Midblock Left-Turn Lanes* for guidance on the effects of curbed medians.
3. Opposing Gaps. Six-lane facilities contain high-traffic volumes that limit opportunities for left-turns across the opposing traffic. NCHRP 395 discusses the consequences of these movements on the facility.
4. Merging Gaps. Entering a six-lane facility with an M-2 (M-5) curbed median from a non-signalized side access point provides a considerable challenge for the driver. Upwards of nine different movements may need to be observed by the driver at any given time. Where M-2 (M-5) curbed facilities are justified, the TWLTL can be used as a waiting area before a gap occurs and a merge can take place. For additional concerns, see NCHRP 330 *Effective Utilization of Street Width on Urban Arterials*.

Advantages	Disadvantages
<ol style="list-style-type: none"> 1. Provides an area for left-turn maneuvers. 2. Discourages arbitrary crossings of the median. 3. Reduces the number of vehicular conflict points. 4. Allows for better access management along the street increasing safety performance. 5. Provides a positive and safer separation between opposing traffic flows. 6. Provides a median refuge area for pedestrians. 7. Provides a location for traffic control devices (e.g., signs, signals, lighting). 8. Provides an open space for aesthetic considerations and stormwater management. 9. Provides for enhanced traffic flow and reduces conflicts. 	<ol style="list-style-type: none"> 1. Increases travel time and delay for many left-turning vehicles. 2. Restricts direct access to adjoining properties. 3. Installation and maintenance costs are higher. 4. Can create an over concentration of turns at median openings. 5. Indirect routing may be required. 6. May restrict access for emergency vehicles (e.g., fire, police, ambulance). 7. Lack of operational flexibility. 8. When accidentally struck, curb may cause a driver to lose control of the vehicle. 9. A minimum median width of 22 ft (7 m) is needed to accommodate U-turns or to shadow stopped passenger cars in the median when turning left or crossing through a median opening from a side street.

ADVANTAGES AND DISADVANTAGES OF RAISED-CURB MEDIANS

Figure 48-3.A

48-4 FLUSH OR TRAVERSABLE TYPE MEDIANS

48-4.01 Two Way Left Turn Lane Guidelines

The applicability of a two-way left-turn lane (TWLTL) is a function of the traffic conditions that result from the adjacent land use. Evaluate the area to determine the relative attractiveness of a flush median as compared to a raised-curb median. For example, a TWLTL may perpetuate more strip development. When this is not desirable, use a raised-curb median. For additional information on the use of a TWLTL design or flush alternating left-turn lanes along a street, see NCHRP 395 *Capacity and Operational Effects of Midblock Left-Turn Lanes* and Figures 34-3.C and 34-3.D. Also consider the following guidelines:

1. General. Only provide TWLTL in:
 - areas with a high number of existing driveways per mile (km) (e.g., 30-60 driveways total per mile (20-40 driveways total per km) on both sides of street);
 - areas of existing high-density commercial development;
 - areas with substantial mid-block left turns; and/or
 - areas where space is not available for raised-curb median widths and a need for left-turn lanes exists.
2. Highway Type. Two-lane and four-lane undivided urban or suburban arterials are the most common candidates for the implementation of a TWLTL design. Once these streets are reconstructed, they are commonly referred to as three-lane and five-lane facilities, respectively.
3. Traffic Volumes. Traffic volumes and the percent of left turns in each direction are a significant factor in the consideration of a TWLTL. Use a 20-year design for traffic volumes. As general guidance, consider the following:
 - a. Two-Lane Facilities. On existing two-lane roadways, a TWLTL design will often be advantageous for traffic volumes between 5,000 and 14,000 ADT.
 - b. Four-Lane Facilities. On existing four-lane undivided highways, a TWLTL will often be advantageous for traffic volumes between 10,000 and 40,000 ADT. The 40,000 ADT value assumes left-turn percentages less than or equal to 30%.
 - c. Six-Lane Facilities. The decision on whether to provide a TWLTL or a raised-curb median will be determined on a case-by-case basis. See Section 48-3.03 for guidance.
 - d. Pedestrians. Pedestrian crossing volumes are also a consideration because of the large paved area that must be traversed when a TWLTL is present (i.e., no pedestrian refuge exists). There may be significant delays for vehicles at signalized intersections to accommodate pedestrians having to cross the

highway in one movement. A raised-curb median may provide a refuge area for pedestrians to cross the highway in two movements.

4. Speed. The design speed of an urban street is a major factor in TWLTL applications. Experience indicates that design speeds from 25 mph to 45 mph (40 km/hr to 70 km/hr) will properly accommodate TWLTL operations. For design speeds higher than 45 mph (70 km/hr), the use of TWLTL is not recommended.
5. Crash History. On urban or suburban arterials without medians, traffic conflicts often result because of a significant number of mid-block left turns combined with significant opposing traffic volumes. This may lead to a disproportionate number of mid-block, rear-end, and/or sideswipe crashes. The inclusion of a median for left turns is likely to reduce these types of crashes. Review and evaluate the available crash data to determine if disproportionately high numbers of these crashes are occurring.
6. Advantages and Disadvantages. Figure 48-4.A summarizes some of the advantages and disadvantages of a TWLTL median design.

48-4.02 Design Criteria

48-4.02(a) Median Width

Existing highways that warrant the installation of a TWLTL are often located in areas of restricted right-of-way, and conversion of the existing cross section may be difficult. To obtain the TWLTL width, the designer may have to consider the following:

- reducing the width of existing through lanes and analyzing side road radius returns,
- eliminating existing parking lanes and reconstructing curb and gutter and sidewalks,
- eliminating existing shoulders and ditches,
- eliminating existing buffer areas behind curbs and reconstructing curb and gutter and existing sidewalks,
- acquiring additional right-of-way to expand the pavement width by the amount needed for the TWLTL and sidewalks, and/or
- removing an existing raised-curb median.

See Sections 34-3.03 and 34-3.04 for further guidance on medians.

Advantages	Disadvantages
<ol style="list-style-type: none"> 1. Provides an area for left-turn maneuvers. 2. Reduces circuitous travel distance and delay for left-turn vehicles. 3. Permits direct access to adjoining properties. 4. Provides separation between opposing traffic flows. 5. Eliminates the median island fixed object. 6. Provides temporary refuge for disabled vehicles. 7. Serves as temporary lane for emergency, maintenance, and construction activities. 8. Can be used as a reversible lane during peak hours. 9. Can be used to increase emergency vehicle efficiency. 10. Requires less right-of-way for left turns as compared to raised-curb medians. 	<ol style="list-style-type: none"> 1. Does not provide a pedestrian refuge area. 2. Does not guarantee unidirectional use at high-volume intersections unless left-turn bays are outlined with curb and gutter. 3. Allows numerous traffic conflict points to remain with no restrictions. 4. Allows for unrestricted development and turning movements along a street. 5. Cannot be used in areas where sight distance is restricted along the street. 6. Adds to drainage problems on the low side of superelevated horizontal curves. 7. May promote higher running speeds where proposed with paved outside shoulders and ditch sections. 8. May require reconstruction of intersections.

ADVANTAGES AND DISADVANTAGES OF FLUSH OR TRAVERSABLE TWLTL MEDIANS

Figure 48-4.A

48-4.02(b) Intersection Treatment

At intersections with public roads, consider the following:

1. Side Streets/Major Entrances. At intersections, convert the TWLTL to an exclusive left-turn lane and omit the pavement markings through the intersection. However, where turning volumes to minor streets are low, it will not be necessary to convert the TWLTL markings to an exclusive left-turn lane.
2. Turning Volumes. The left-turn demand into intersecting side streets is a factor in determining the appropriate length of the left-turn lane. As a general rule in urban areas, the minimum storage length will govern the length of left-turn lanes; see Section 36-3.02.
3. Minimum Length of TWLTL. The TWLTL should have sufficient length to operate properly, and the type of intersection treatments will determine the length of the TWLTL. Typically, the minimum length will be 650 ft to 1000 ft (200 m to 300 m) (one block long). The final decision on the length of the TWLTL will be based on site conditions.
4. Operational/Safety Factors. Provide proper signing and stopping sight distance at the beginning and end of each TWLTL. Where a number of turning movements are expected into and out of entrances located close to a major intersection, it is desirable to design a raised-curb median (M-6 (M-15)) into the segment of the exclusive left-turn lane; see Figure 34-3.D.

48-4.02(c) Curbing

In urban and suburban areas where a TWLTL is used, provide curb and gutter along the outside edges of the traveled way.

48-4.02(d) Traversable TWLTL

On most highways and streets, the TWLTL will be a flush design with the adjacent travel lanes. See Figures 34-3.D and 48-2.C. Where traffic volumes and mid-block left turns are unusually high, a traversable TWLTL median with a Type M-2.12 (M-5.30) Concrete Curb and Gutter may be a more appropriate design option. Figure 48-4.B illustrates the typical design for a traversable TWLTL. The M-2 (M-5) curb is used to delineate the edges of the TWLTL and traffic is allowed to turn left across the median. Also, where a horizontal curve with superelevation is proposed along a street with a flush TWLTL, use the Type M2.12 (M-5.30) Concrete Curb and Gutter along the median edges of the curve to improve drainage; see Figure 48-2.D.

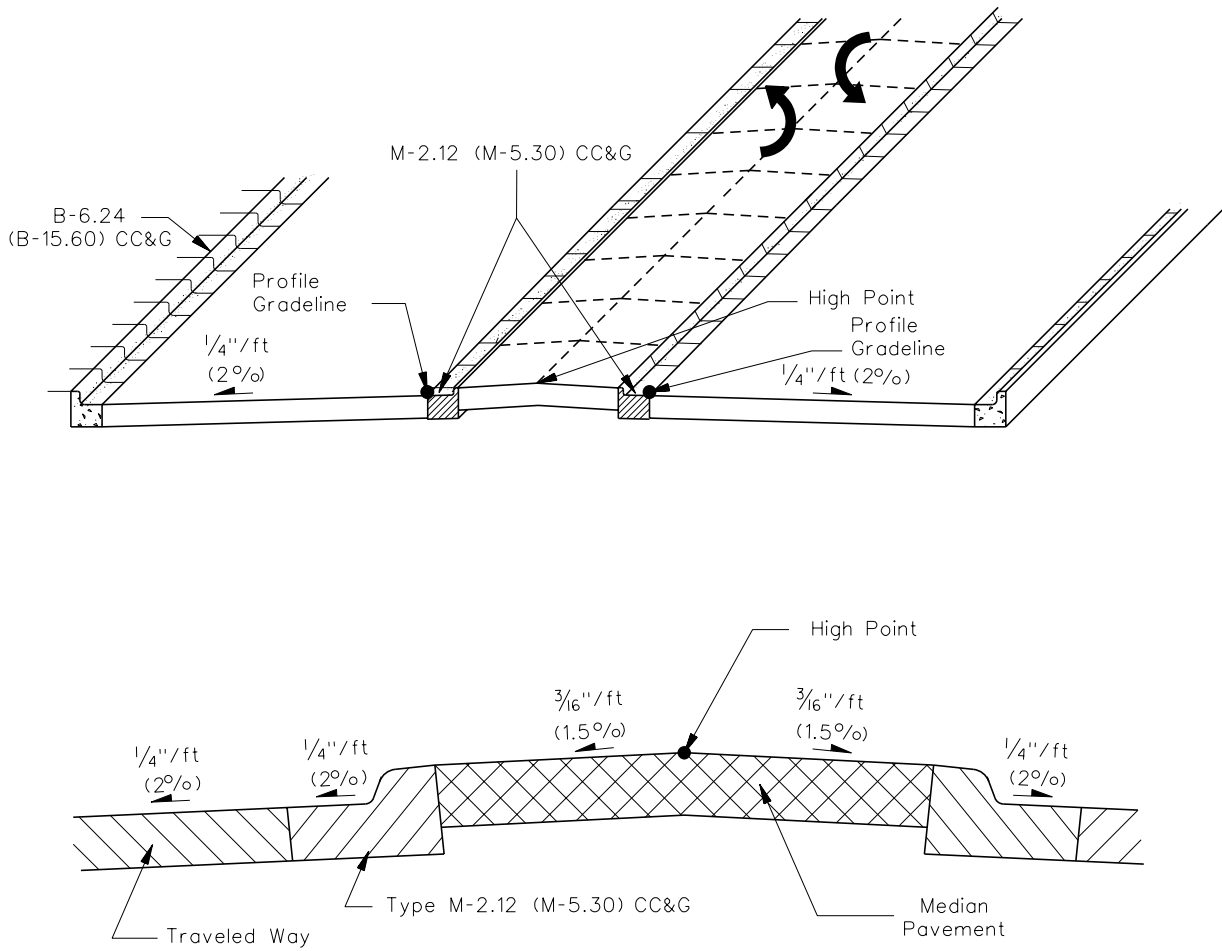

Note: Drain the median surface away from the high point of the median.

TYPICAL TRAVERSABLE TWLTL CROSS SECTION

Figure 48-4.B

48-4.03 Railroad Crossings

TWLTs are not extended across a highway/railroad grade crossing. Terminate the TWLTL 150 ft to 200 ft (45 m to 60 m) in advance of the crossing and provide a raised-curb median adjacent to the railroad; see Figure 7-3.E. In addition, the designer should coordinate the design with the Bureau of Operations.

48-5 HORIZONTAL ALIGNMENT

48-5.01 General Application

For urban and suburban streets and highways, the application of horizontal alignment criteria will depend on several factors. Figure 48-5.A summarizes the application of horizontal alignment criteria to urban facilities. The remainder of Section 48-5 specifically discusses the application to low-speed urban streets ($V \leq 45$ mph (70 km/hr)).

48-5.02 General Superelevation Considerations

For low-speed urban streets, the operational conditions and physical constraints are significantly different than those on rural highways and high-speed urban highways. The following lists some of the characteristics of low-speed urban streets that often complicate superelevation development:

1. Roadside Development/Intersections/Driveways. Built-up roadside development is common adjacent to low-speed urban streets. Matching superelevated curves with many driveways, intersections, sidewalks, etc., creates considerable complications. For example, this may require reconstructing the profile on side streets, and re-grading parking lots, lawns, etc., to compensate for the higher elevation on the high side of the superelevated curve.
2. Non-Uniform Travel Speeds. On low-speed urban streets, travel speeds are often non-uniform because of frequent signalization, stop signs, vehicular conflicts, etc. It is undesirable for traffic to stop on a superelevated curve, especially when snow or ice is present.
3. Limited Right-of-Way. Superelevated curves often result in more right-of-way impacts than would otherwise be necessary. Right-of-way is often restricted along low-speed urban streets.
4. Wide Pavement Areas. Many low-speed urban streets have wide pavement areas because of the number of traffic lanes, the use of a flush-type median, or the presence of parking lanes. In general, the wider the pavement area, the more complicated is the development of superelevation.
5. Surface Drainage. Proper cross slope drainage on low-speed urban streets can be difficult even on sections with a normal crown. The minimum longitudinal gradient on a street with curb and gutter is 0.30%. A curve with superelevation (or remove crown) and/or where a flush-type median is proposed introduces another complicating factor unless special features are designed into the median. See Figure 48-2.D, which illustrates the use of Type M-2.12 (M-5.30) Concrete Curb and Gutter to control drainage.

Land Use Category*	Design Speed	Design Assumptions	e_{max}	BDE Manual References
Urban ¹	$V \leq 45$ mph ($V \leq 70$ km/hr)	Low-Speed Urban Streets	4.0%	Section 48-5
Closed Suburban	$V = 40$ or 45 mph ($V = 60$ or 70 km/hr)	Low-Speed Urban Streets	4.0%	Section 48-5
Open Suburban Likely to Become Closed Suburban within next 10 years	$V = 45$ mph ($V = 70$ km/hr)	Low-Speed Urban Streets	4.0%	Section 48-5
	$V = 50$ mph ($V = 80$ km/hr)	Open Roadway Conditions	4.0%	Chapter 32
Open Suburban Likely to Remain Suburban for next 10-15 yrs	$V = 45$ mph ($V = 70$ km/hr)	Low-Speed Urban Streets	4.0%	Section 48-5
	$V = 50$ or 55 mph ($V = 80$ or 90 km/hr)	Open Roadway Conditions	6.0%	Chapter 32
Urban SRA	$V = 30$ or 40 mph ($V = 50$ or 60 km/hr)	Low-Speed Urban Streets	4.0%	Section 48-5
Suburban SRA	$V = 45$ mph ($V = 70$ km/hr)	Low-Speed Urban Streets	4.0%	Section 48-5

* See Sections 48-1.02 and 43-2 for definitions.

Note: ¹ If an exit ramp connects to a facility where low-speed urban street conditions apply and if the intersection is stop or signal controlled, then the last horizontal curve on the exit ramp should be designed assuming low-speed urban street conditions.

HORIZONTAL ALIGNMENT APPLICATIONS IN URBAN/SUBURBAN AREAS

Figure 48-5.A

48-5.03 Horizontal Curves

48-5.03(a) Design Procedures

Because of the unique operational conditions for low-speed urban streets, it is appropriate to use a modified theoretical basis for horizontal alignment criteria when compared to open-roadway conditions. Specifically, the use of AASHTO Method 2 to distribute superelevation and side friction. This Method assumes maximum design side friction is used before any superelevation is introduced. The practical benefit is that most horizontal curves can be designed with little or no superelevation on low-speed urban streets when compared to the criteria for open roadway conditions in Chapter 32. See the AASHTO publication *A Policy on Geometric Design of Highways and Streets* for a further discussion on Method 2.

48-5.03(b) Maximum Superelevation Rate

For new construction projects, use $e_{\max} = 4.0\%$ for low-speed urban streets. For urban reconstruction projects, existing horizontal curves can remain in place with a superelevation rate up to 6%. However, the use of 6% on a low-speed urban street is a Level Two design exception as discussed in Section 31-7. See Section 36-1.05(b) for a discussion on superelevation for intersections on curves.

48-5.03(c) Minimum Radii

Figure 48-5.B presents the minimum radii for various design speeds for low-speed urban streets. These values should only be used where highly restricted right-of-way conditions exist.

48-5.03(d) Minimum Radii with Retain Normal Crown or Superelevate at Normal Crown

In urban areas, restricted right-of-way conditions usually exist. The radii for superelevation rates of -6% to +6% are shown in Figure 48-5.C. The -2% line provides the minimum curve radii for which a normal crown of $\frac{1}{4}$ in/ft (2%) should be retained. For radii and design speeds between the -2% line and +2% line, provide a superelevation of 2.0%. For radii and design speeds above the +2% line, superelevate at the indicated rate.

US Customary					
V = Design Speed (mph)	e _{max}	f _{max}	e _{max} + f _{max}	Calculated Radius (R _{min}) (ft)	Radii Rounded for Design (ft)
20	4.0%	0.27	0.31	86.0	90
25	4.0%	0.23	0.27	154.3	155
30	4.0%	0.20	0.24	250.0	250
35	4.0%	0.18	0.22	371.2	375
40	4.0%	0.16	0.20	533.3	535
45	4.0%	0.15	0.19	710.5	710
Metric					
V = Design Speed (km/hr)	e _{max}	f _{max}	e _{max} + f _{max}	Calculated Radius (R _{min}) (m)	Radii Rounded for Design (m)
30	4.0%	0.28	0.32	22.1	25*
40	4.0%	0.23	0.27	46.7	50*
50	4.0%	0.19	0.23	85.6	86
60	4.0%	0.17	0.21	135.0	135
70	4.0%	0.15	0.19	203.1	203

* Value rounded up to provide an additional factor of safety for trucks.

$$R_{\min} = \frac{v^2}{15(e_{\max} + f_{\max})} \quad (\text{US Customary})$$

$$R_{\min} = \frac{v^2}{127(e_{\max} + f_{\max})} \quad (\text{Metric})$$

MINIMUM RADII ON LOW-SPEED URBAN STREETS

Figure 48-5.B

Also, Figure 48-5.C provides a visual means to select a curve and pavement cross-slope with a higher factor of safety than normally would be used for a certain design speed (i.e., providing a curve and/or superelevation rate with a higher theoretical design speed). This is a useful function provided by the format of the graph for designing horizontal curves at the fringes of urbanized areas. When motorists first enter the edge of an urbanized area, they normally take a few seconds to slow down to the posted urban speed limit, and as a result, it is desirable to provide a higher factor of safety for this speed transition area in conjunction with horizontal curves to the left. With the most common horizontal curve design being one with a normal crown section, the factor of safety can easily be increased by sloping the entire traveled way at the rate of the normal crown slope. Using this design feature thereby minimizes excessive lateral accelerations for inbound motorists.

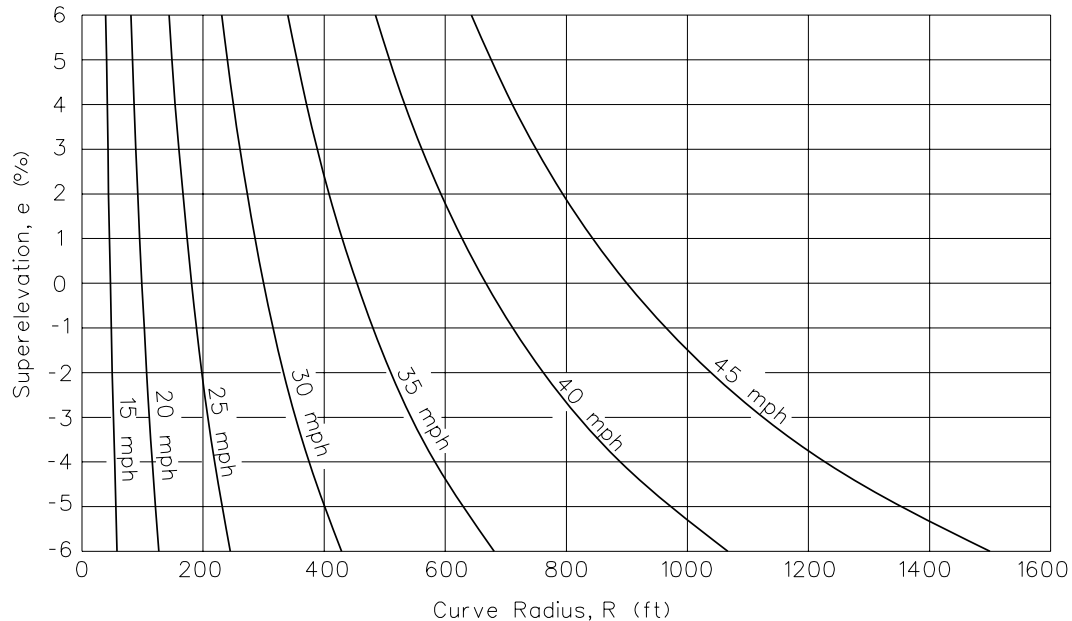
**Notes:**

- ① The Figure provides a range of design speeds and superelevation rates that apply to a selected curve radius.
- ② AASHTO Method 2 is used to distribute superelevation and side-friction for low-speed urban street conditions. Therefore, the basic point-mass equation applies:

$$R = \frac{V^2}{15(e + f_{\max})}$$

Where: R = curve radius, ft

V = design speed, mph

e = assumed superelevation rate, decimal

f_{\max} = assumed maximum side-friction factor for selected design speed (see Figure 48-5.B), decimal

- ③ For curves between the -2% and +2% lines, consider removing the crown slope through the curve. This will ensure that maximum comfortable side friction is not exceeded due to a negative slope in one direction of travel. It will also minimize potential rollover of trucks (on dry pavement) with low rollover thresholds and minimize possible skidding of trucks with smooth tires on polished, wet pavement surfaces. On a tangent section, a low-speed urban street normally should be sloped away from the curbed median or centerline of the roadway (5-lane flush) at a minimum cross-slope rate of 1/4 "/ft.

**SUPERELEVATION RATES
(Low-Speed Urban Streets)
(US Customary)**

Figure 48-5.C

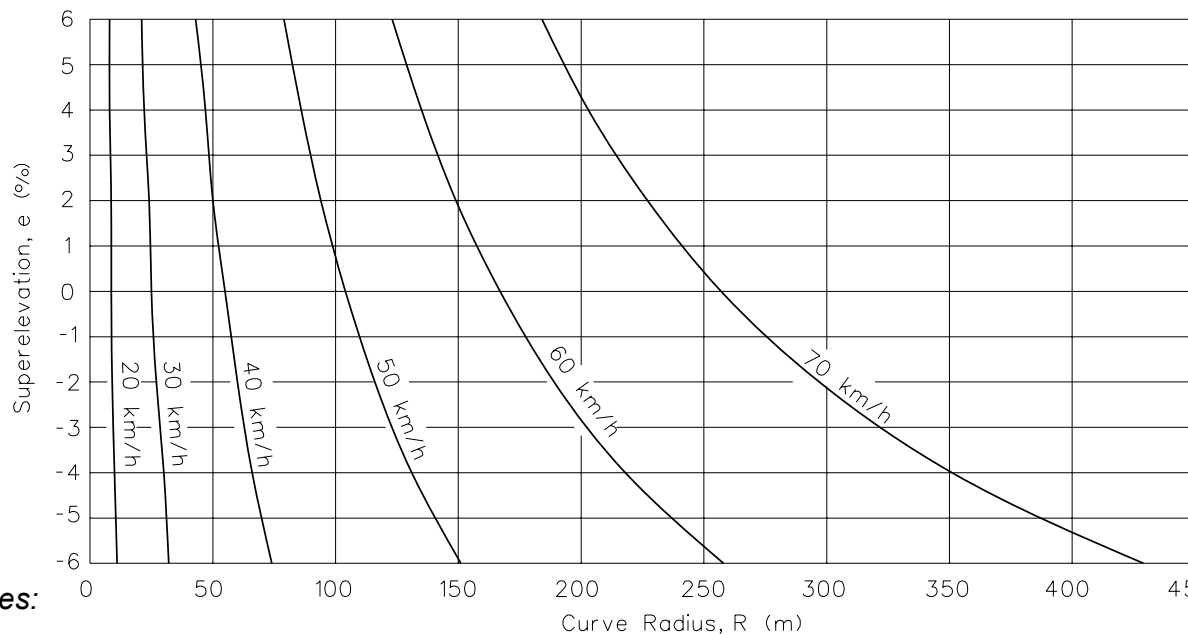

Notes:

- ① The Figure provides a range of design speeds and superelevation rates that apply to a selected curve radius.
- ② AASHTO Method 2 is used to distribute superelevation and side-friction for low-speed urban street conditions. Therefore, the basic point-mass equation applies:

$$R = \frac{V^2}{127(e + f_{\max})}$$

Where: R = curve radius, m

V = design speed, km/hr

e = assumed superelevation rate, decimal

f_{\max} = assumed maximum side-friction factor for selected design speed (see Figure 48-5.B), decimal

- ③ For curves between the -2% and +2% lines, consider removing the crown slope through the curve. This will ensure that maximum comfortable side friction is not exceeded due to a negative slope in one direction of travel. It will also minimize potential rollover of trucks (on dry pavement) with low rollover thresholds and minimize possible skidding of trucks with smooth tires on polished, wet pavement surfaces. On a tangent section, a low-speed urban street normally should be sloped away from the curbed median or centerline of the roadway (5-lane flush) at a minimum cross-slope rate of 2%.

**SUPERELEVATION RATES
(Low-Speed Urban Streets)
(Metric)**

Figure 48-5.C

48-5.03(e) Superelevated Curves

Figure 48-5.C allows the designer to select a curve with superelevation where a radius to retain normal crown or remove crown slope cannot be achieved.

* * * * *

Example 48-5.02(1)

Given: 22 ft raised-curb median with 24 ft traveled ways in each direction
Design speed = 40 mph
Radius = 800 ft
Cross slope of traveled way = 1/4"/ft (2.0%) in each direction

Problem: Determine if superelevation is needed.

Solution: Figure 48-5.C indicates the assumed design speed can be achieved with an adverse crown slope of up to approximately -2.5%. If the normal crown is maintained throughout the curve, the worst-case superelevation rate in one direction is -2.0%. Therefore, the normal crown can be maintained, and the horizontal curve will provide for the assumed design speed.

Example 48-5.02(2)

Given: Two-lane, two-way street at 30 ft f-f
Design speed = 40 mph
Radius = 650 ft
Cross slope of traveled way = 1/4"/ft (2.0%) in each direction

Problem: Determine if superelevation is needed.

Solution: Figure 48-5.C indicates the assumed design speed can be achieved with a 0% cross slope. The normal crown would provide a rate of -2.0% for the worst-case condition in one direction. The -2.0% will accommodate a vehicular speed of approximately 38 mph. Also the footnote in Figure 48-5.C states that any set of conditions between the -2% and +2% lines should be superelevated at the rate of the normal crown slope. Therefore, the curve should have a superelevation rate of +2.0% across the entire traveled way.

Example 48-5.02(3)

Given: Five-lane section with flush TWLTL
Design speed = 40 mph
Radius = 550 ft (restricted ROW conditions)
Cross slope of traveled way = 1/4"/ft (2.0%)

Problem: Determine if superelevation is needed.

Solution: Figure 48-5.C yields a rate of 4.0%, which is the maximum allowable rate for new construction. Therefore, the entire traveled way should be transitioned and superelevated at this rate. Because this is a five-lane section, use Type M-2.12 Concrete Curb and Gutter on both median edges of the horizontal curve for improved drainage.

* * * * *

48-5.03(f) Maximum Deflection Without Curve

It may be appropriate to omit a horizontal curve where very small deflection angles are present. As a guide, the designer may retain deflection angles of about 1° or less on low-speed urban streets. For these angles, the absence of a horizontal curve should not affect aesthetics.

48-5.04 Superelevation Development

48-5.04(a) Transition Length

The superelevation transition length is the distance required to transition the traveled way from a normal crown section to the full design superelevated section. The superelevation transition length is the sum of the tangent runout distance and superelevation runoff length. See Section 32-3. The following applies to low-speed urban streets:

1. Calculation. Section 32-3 presents the methodology for calculating the superelevation runoff and tangent runout for open roadway conditions. This methodology also applies to superelevation transition lengths on low-speed urban streets. Figure 48-5.D presents superelevation runoff lengths (L_1) and tangent runout lengths (TR) for a two-lane urban street, assuming the axis of rotation is about the roadway centerline; i.e., the width of rotation is one travel lane (13 ft (4.0 m)). See Section 32-3 for guidelines on determining modifications to the superelevation transition distance where the width of rotation is more than one travel lane. Include the plot of the pavement edges in the construction plans to ensure a smooth profile design. See Section 63-4.07(b).
2. Portion of Superelevation Runoff Prior to Curve. Typically, 67% of the superelevation runoff length will be placed on tangent and 33% on curve. Exceptions to this practice may be necessary to meet field conditions. Generally, the accepted range is 60%-80% on tangent and 40%-20% on curve.

US Customary								
Design Speed (mph)	Superelevation Transition Lengths							
	e ≤ 2.5%		3.0%		3.5%		4.0%	
	L ₁ (ft)	TR (ft)	L ₁ (ft)	TR (ft)	L ₁ (ft)	TR (ft)	L ₁ (ft)	TR (ft)
20	44	35	53	35	62	35	70	35
25	47	37	56	37	65	37	75	37
30	50	40	59	40	69	40	79	40
35	52	42	63	42	73	42	84	42
40	56	45	67	45	78	45	89	45
45	60	48	72	48	84	48	96	48
Metric								
Design Speed (km/hr)	Superelevation Transition Lengths							
	e ≤ 2.5%		3.0%		3.5%		4.0%	
	L ₁ (m)	TR (m)	L ₁ (m)	TR (m)	L ₁ (m)	TR (m)	L ₁ (m)	TR (m)
30	13	11	16	11	19	11	21	11
40	14	11	17	11	20	11	23	11
50	15	12	18	12	22	12	25	12
60	17	13	20	13	23	13	27	13
70	18	15	22	15	25	15	29	15

**SUPERELEVATION TRANSITION LENGTHS FOR TWO-LANE STREETS
(Low-Speed Urban Streets with 13 ft (4.0 m) Lanes)**

Figure 48-5.D

48-5.04(b) Axis of Rotation

On low-speed urban streets, the axis of rotation for horizontal curves is as follows:

1. Two-Lane Facilities. The axis of rotation is typically about the centerline of the roadway.
2. Multilane Facilities (Median Width ≤ 16 ft (5.0 m)). The axis of rotation is typically about the centerline of roadway or median.
3. Multilane Facilities (Median Width > 16 ft (5.0 m)). The axis of rotation is typically about the two median edges.

Low-speed urban streets may also present special problems because of the presence of two-way, left-turn lanes; turning lanes at intersections; intersections with major crossroads; drainage; etc. For these reasons, the axis of rotation may be determined on a case-by-case basis.

48-5.05 Typical Designs

See Figures 48-5.E and 48-5.F for typical multilane designs on low-speed urban streets that illustrate the superelevation transitions. See Figure 32-3.J for superelevation transitions on two-lane streets.

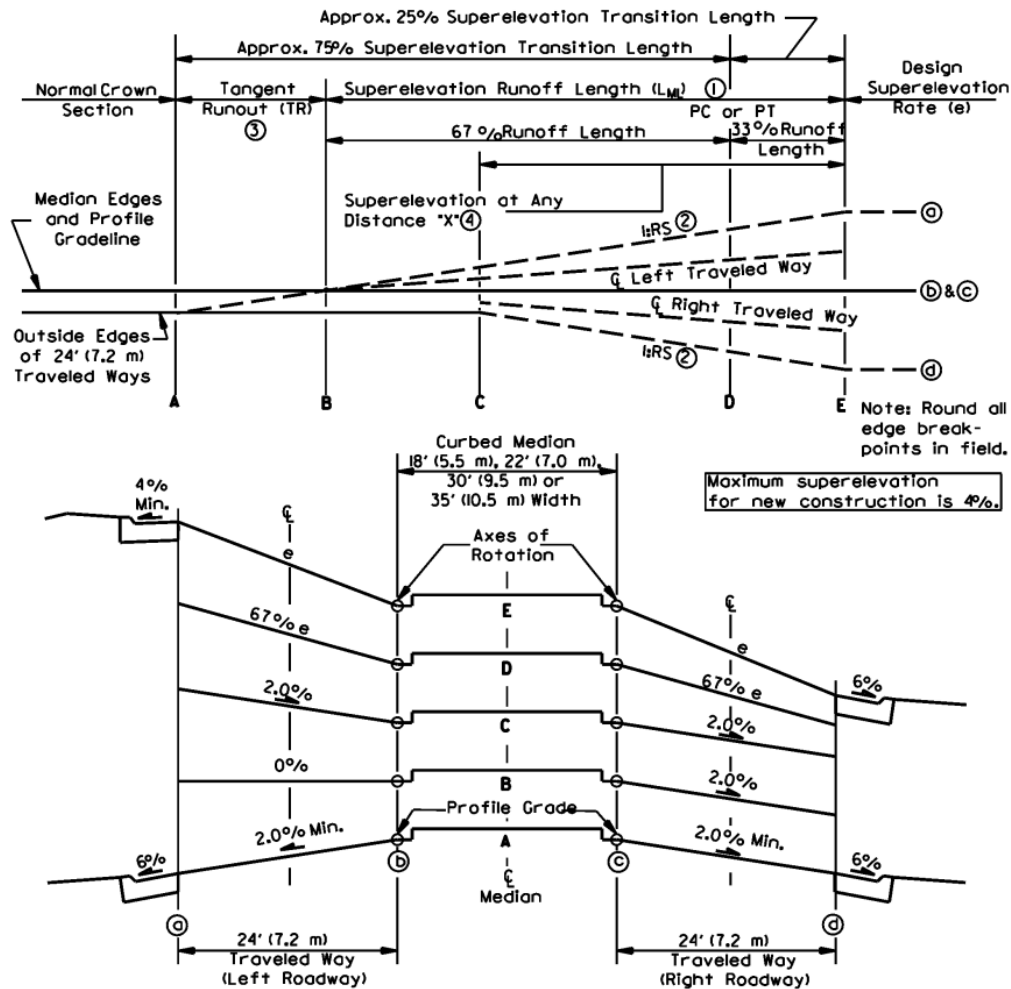

① $L_{ML} = L_1 \times C$. See Section 32-3.02(b) for multilane superelevation runoff calculations.

$$\textcircled{3} TR_{ML} = \frac{S_{normal}}{e} (L_{ML})$$

② The relative gradient of the superelevation runoff (G_{SR} , decimal) is:

$$G_{SR} = \frac{24e}{L_{ML}} \quad (\text{US Customary})$$

④ Superelevation rate (e) at any distance up to full superelevation attainment:

$$G_{SR} = \frac{7.2e}{L_{ML}} \quad (\text{Metric})$$

$$0.02 + \frac{G_{SR} \times \text{Distance "X"}}{24} \quad (\text{US Customary})$$

$$RS = \frac{1}{G_{SR}}$$

$$0.02 + \frac{G_{SR} \times \text{Distance "X"}}{7.2} \quad (\text{Metric})$$

**AXIS OF ROTATION ABOUT EDGE OF CURBED MEDIAN
(Four-Lane Divided Highway With Curbed Median Widths of
18', 22', 30' or 35' (5.5, 7.0, 9.5 or 10.5 m))**

Figure 48-5.E

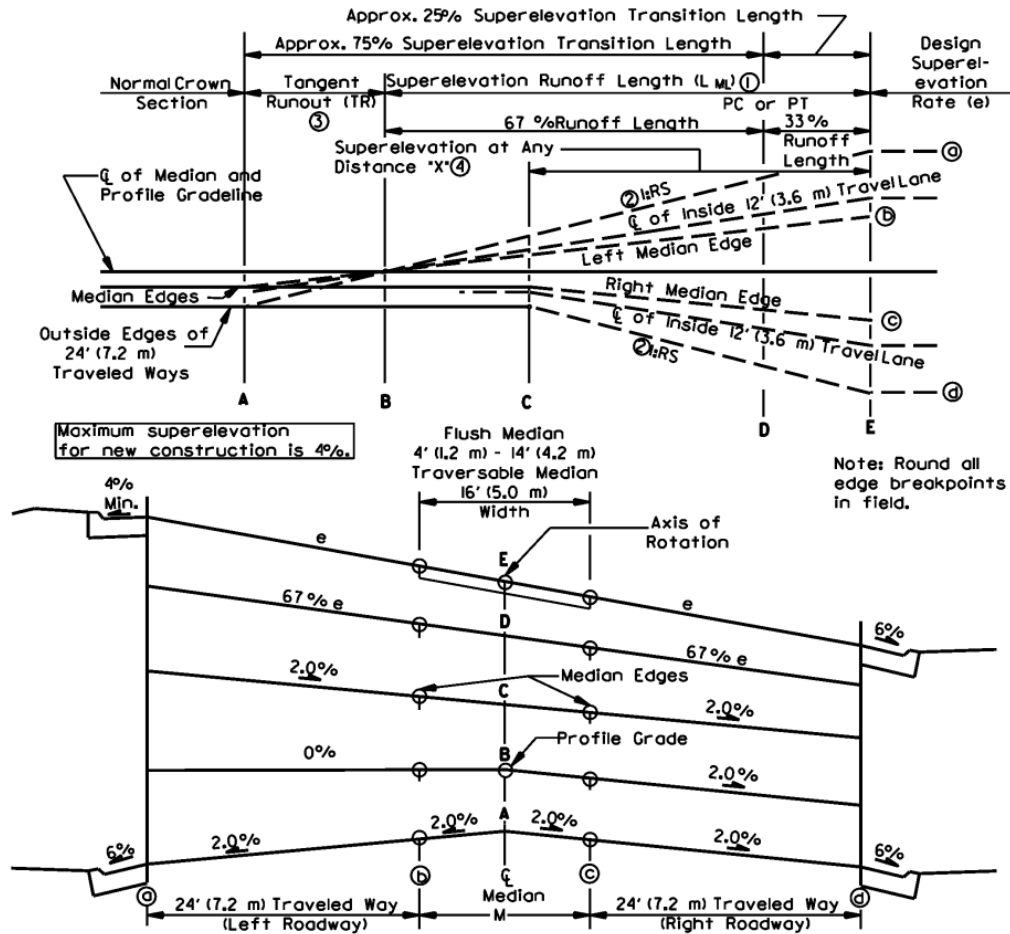

Maximum superlevation for new construction is 4%.

Note: Round all edge breakpoints in field.

① $L_{ML} = L_1 \times C$. See Section 32-3.02(b) for multilane superlevation runoff calculations.

The relative gradient of the superlevation runoff (G_{SR} , decimal) is:

$$G_{SR} = \frac{e(7.2 + M/2)}{L_{ML}} \quad (\text{US Customary})$$

$$\textcircled{2} \quad TR_{ML} = \frac{S_{\text{normal}}}{e} (L_{ML}) \quad (\text{Metric})$$

$$RS = \frac{1}{G_{SR}}$$

$$\textcircled{3} \quad G_{SR} = \frac{e(24 + M/2)}{L_{ML}}$$

④ Superlevation rate (e) at any distance up to full superlevation attainment:

$$\frac{G_{SR} \times \text{Distance "X"}}{(24 + M/2)} \quad (\text{US Customary})$$

$$\frac{G_{SR} \times \text{Distance "X"}}{7.2 + M/2}$$

**AXIS OF ROTATION ABOUT CENTERLINE OF FLUSH/TRAVERSABLE MEDIAN
(Four-Lane Highway with Flush Median 4' (1.2 m) – 14' (4.2 m) or Multi-Lane Highway with
a 16' (5.0 m) Traversable Median using (M-2.12 (M-5.30))**

Figure 48-5.F

48-6 TABLES OF DESIGN CRITERIA

Figures 48-6.A, 48-6.B, and 48-6.C provide the criteria for urban streets with raised-curb medians, two-way left-turn lane medians, and one-way streets. Where it has been decided that the cross section design should be a depressed median with outside shoulders (i.e., open suburban area), use the criteria presented in Chapter 47 for rural four-lane arterials.

The designer should realize that some of the cross section elements included in the figures (e.g., TWLTL) are not automatically warranted in the project design. The values in the figures only apply after the decision has been made to include the element in the highway cross section.

Design Element		Manual Section	Two-Way DHV 2900-2050 (1)	Two-Way DHV 2050-1250 (1)	Two-Way DHV < 1250 (1)	
Design Controls	Highway Type	—	TWS-6	TWS-4	TWS-2	
	Design Forecast Year	31-4.02	20 Years	20 Years	20 Years	
	* Design Speed (2a)	48-2.01	30 mph – 45 mph	30 mph – 50 mph (2b)	30 mph – 40 mph	
	Access Control	35-1	Consider Managed Access	Consider Managed Access	Consider Managed Access	
Cross Section Elements	Level of Service (3)	31-4.04	C	C	C	
	On-Street Parking (4)	48-2.05	Not Recommended	Not Recommended	Not Recommended	
	* Surface Width	Without Parking		2 @ 38' e-f	2 @ 26' e-f	30' f-f
		With Parking - 1 Side (5)	34-2.01	1 @ 38' e-f 1 @ 46' e-f	1 @ 26' e-f 1 @ 34' e-f	36' f-f
	Auxiliary Lanes	With Parking - 2 Sides (5)		2 @ 46' e-f	2 @ 34' e-f	44' f-f
		Lane Width				
	Curb Type and Width		34-2.03	Single Left & Right: 12', Min.: 11' Dual Lefts: 24', Min.: 22'		
	Shared Lane (Bicycle & Motor vehicles) (7)			B-6.12 or B-6.24 CC&G (6)		
	Cross Slope	* Travel Lanes	Chp. 17	Min.: 14'	Min.: 14'	Min.: 14'
		Auxiliary Lanes	34-2.01	1/4"/ft for Two Lanes Adjacent to Median (8a)	1/4"/ft for Two Lanes Adjacent to Median	1/4"/ft for Lanes Adjacent to Crown (8b)
Outside Curb Type & Width		34-2.04	B-6.24 CC&G	B-6.24 CC&G	B-6.24 CC&G	
Median Width	Flush/TWLT		12' - 14' (9)			
	Traversable TWLTL	34-3	16'		N/A	
	Raised-Curb		18', 22', 30'		N/A	
Depressed						
Sidewalk Width		48-2.04	5' with Buffer Strip Behind Curb (10)	5' with Buffer Strip Behind Curb (10)	5' with Buffer Strip Behind Curb (10)	
		38-3				
Roadway Slopes	Clear Zone	34-4.04				
	Cut Section (Curbed)	34-4.05				
	Rock Cut	34-4.02				
Median Slopes	Fill Section (Curbed)					
	Concrete Surface/Traversable		3/16"/ft	3/16"/ft	N/A	
	Flush/TWLT Surface	34-3	1/4"/ft	1/4"/ft	N/A	
Grass Surface		5/8"/ft (Towards C&G)	5/8"/ft (Towards C&G)	N/A		

TWS = Two-Way Street, e-f = edge of median to face of curb, f-f = face of curb to face of curb

* Controlling design criteria (see Section 31-8).

GEOMETRIC DESIGN CRITERIA FOR SUBURBAN/URBAN TWO-WAY ARTERIALS
 (New Construction/Reconstruction)
 (US Customary)

Figure 48-6.A
 (1 of 4)

Design Element		Manual Section	Two-Way DHV 2900-2050	Two-Way DHV 2050-1250	Two-Way DHV < 1250	
Bridges	Highway Type	—	TWS-6	TWS-4	TWS-2	
	New and Reconstructed Bridges	* Structural Capacity	HS-20	HS-20	HS-20	
		* Clear Roadway Width (11)	39-6	76' plus Median Width	52' plus Median Width	30'
	Existing Bridges to Remain in Place	* Structural Capacity	N/A	HS-20	HS-20	
		* Clear Roadway Width (12)	39-6	70' plus Median Width	48' plus Median Width	28'
	* Vertical Clearance (Arterial Under) (13a)	New and Replaced Overpassing Bridges	39-4	14'-9" (13b)		
		Existing Overpassing Bridges		14'-0" (13c)		
		Overhead Signs/ Pedestrian Bridges	33-5	New: 17'-3" (13b)		
	* Vertical Clearance (Arterial over Railroad)	39-4.06	23'-0"			

* Controlling design criteria (see Section 31-8).

GEOMETRIC DESIGN CRITERIA FOR SUBURBAN/URBAN TWO-WAY ARTERIALS
 (New Construction/Reconstruction)
 (US Customary)
FIGURE 48-6.A
 (2 of 4)

Design Element		Manual Section	Two-Way DHV 2900-2050 (1)	Two-Way DHV 2050-1250 (1)	Two-Way DHV < 1250 (1)	
Design Controls	Highway Type	—	TWS-6	TWS-4	TWS-2	
	Design Forecast Year	31-4.02	20 Years	20 Years	20 Years	
	* Design Speed (2a)	48-2.01	50 km/h - 70 km/h	50 km/h - 80 km/h (2b)	50 km/h - 60 km/h	
	Access Control	35-1	Consider Managed Access	Consider Managed Access	Consider Managed Access	
Cross Section Elements	Level of Service (3)	31-4.04	C	C	C	
	On-Street Parking (4)	48-2.05	Not Recommended	Not Recommended	Not Recommended	
	* Surface Width	Without Parking		2 @ 11.4 m e-f	2 @ 7.8 m e-f	9.2 m f-f
		With Parking - 1 Side (5)	34-2.01	1 @ 11.4 m e-f 1 @ 13.8 m e-f	1 @ 7.8 m e-f 1 @ 10.2 m e-f	10.8 m f-f
	Auxiliary Lanes	With Parking - 2 Sides (5)		2 @ 13.8 m e-f	2 @ 10.2 m e-f	13.2 m f-f
		Lane Width	34-2.03	Single Left & Right: 3.6 m, Min.: 3.3 m	Dual Lefts: 7.2 m, Min.: 6.6 m	6.6 m
	Shared Lane Width (Bicycle & Motor Vehicles (7))	Curb Type and Width		B-15.30 or B-15.60 CC&G (6)		
		* Travel Lanes	Chap. 17	Min.: 4.3 m	Min.: 4.3 m	Min.: 4.3 m
	Cross Slope	Auxiliary Lanes	34-2.01	2% for Two Lanes Adjacent to Median (8a)	2% for Two Lanes Adjacent to Median	2% for Lanes Adjacent to Crown (8b)
		Outside Curb Type & Width	34-2.04	B-15.60 CC&G	B-15.60 CC&G	B-15.60 CC&G
Median Width	Flush/TWLT			3.6 - 4.2 m (9)		
	Traversable TWLTL	34-3	New: 5.0 m	Reconstruction: 4.88 m	N/A	
	Raised-Curb		5.5 m, 7.0 m, 9.5 m		N/A	
Sidewalk Width	Depressed					
	Clear Zone	48-2.04	1.5 m with Buffer Strip Behind Curb	1.5 m with Buffer Strip Behind Curb	1.5 m with Buffer Strip Behind Curb	
Roadway Slopes	Side Slopes	38-3	(10)	(10)	(10)	
		34-4.04	—	—	—	
	Median Slopes	34-4.05	—	—	—	
		34-4.02	—	—	—	
		34-3	1.5%	1.5%	N/A	
Roadway Slopes	Flush/TWLT Surface		2%	2%	N/A	
	Grass Surface		5% (Towards C&G)	5% (Towards C&G)	N/A	

TWS = Two-Way Street, e-f = edge of median to face of curb, f-f = face of curb to face of curb

* Controlling design criteria (see Section 31-8).

**GEOMETRIC DESIGN CRITERIA FOR SUBURBAN/URBAN TWO-WAY ARTERIALS
(New Construction/Reconstruction)
(Metric)**

Figure 48-6.A
(1 of 4)

Design Element		Manual Section	Two-Way DHV 2900-2050	Two-Way DHV 2050-1250	Two-Way DHV < 1250	
Bridges	Highway Type	—	TWS-6	TWS-4	TWS-2	
	New and Reconstructed Bridges	N/A	MS-18	MS-18	MS-18	
	Existing Bridges to Remain in Place	39-6	22.8 m plus Median Width	15.6 m plus Median Width	9.2 m	
	* Vertical Clearance (Arterial Under) (13a)	* Structural Capacity	N/A	MS-18	MS-18	MS-18
		* Clear Roadway Width (12)	39-6	21.0 m plus Median Width	14.4 m plus Median Width	8.6 m
	* Vertical Clearance (Arterial over Railroad)	New and Replaced Overpassing Bridges	39-4		4.5 m (13b)	
		Existing Overpassing Bridges			4.3 m (13c)	
	Overhead Signs/ Pedestrian Bridges	33-5		New: 5.25 m (13b)		
		39-4.06		7.0 m		

* Controlling design criteria (see Section 31-8).

GEOMETRIC DESIGN CRITERIA FOR SUBURBAN/URBAN TWO-WAY ARTERIALS
 (New Construction/Reconstruction)
 (Metric)

FIGURE 48-6.A
 (2 of 4)

- (1) Traffic Volumes. The design hourly volumes (DHV) are calculated using a PHF = 1.0; adjust these values using local peak-hour factors.
- (2) Design Speed.
- a. Consider using a minimum 40 mph (60 km/hr) design speed in relatively undeveloped areas where economics, environmental conditions, and signal spacing permit. The statutory speed limits in urbanized areas is 30 mph. Before the posted speed limit can be increased, complete an engineering study (Phase I report) and a speed study.
 - b. Only consider the 50 mph (80 km/hr) design speed in open-suburban areas. Do not place curb and gutter adjacent to the edges of the traveled way.
- (3) Level of Service. In major urban areas, a level of service D may be considered with study and justification.
- (4) Minimum Street Width. The minimum width of a two-way, two-lane street is set at 30 ft (9.2 m) f-f which allows two-way traffic to pass a stalled vehicle.
- (5) Parking Lane Width. The desirable width of the parking lane is 10 ft (3.0 m) and includes the 2 ft (600 mm) gutter width. The minimum width is 8 ft (2.4 m) e-f.
- (6) Gutter Width. Under restricted conditions, the gutter width adjacent to the edge of the turn lane may be narrowed or eliminated adjacent to a 12 ft (3.6 m) lane and narrowed adjacent to a 11 ft (3.3 m) lane.
- (7) Shared Lane Width. Width of a shared lane for motor vehicle and bicyclist use shall be 14 ft (4.3 m) minimum to allow for vehicle passing of bicycles while staying within the lane.
- (8) Cross Slope.
- a. For the third lane away from the median, increase the cross slope by 1/16" /ft (0.5%).
 - b. For reconstruction projects, an existing 3/16" /ft (1.5%) cross slope may remain-in-place.
- (9) TWTL Median Width. Use a minimum 13 ft (4.0 m) wide median width if there are a significant number of trucks making left turns.
- (10) Clear Zone. For curbed facilities, the minimum horizontal clearance to an obstruction is 1.5 ft (500 mm), measured from the face of curb.

GEOMETRIC DESIGN CRITERIA FOR SUBURBAN/URBAN TWO-WAY ARTERIALS
(New Construction/Reconstruction)

Footnotes for Figure 48-6.A
(3 of 4)

- (11) New and Reconstructed Bridge Widths. Clear roadway bridge widths are measured from face to face of outside curbs or parapet walls. Urban bridge widths are defined as the sum of the approach traveled way widths, the width of the gutters, and the width of the median. A sidewalk or bikeway will result in additional bridge width. For proposed sidewalks on a bridge, add 5 ft (1.5 m) to each side of the bridge. Parking is prohibited on bridges.
- (12) Existing Bridge Widths to Remain in Place. Clear roadway bridge widths are measured from face to face of outside curbs or parapet walls. At least one sidewalk must be carried across the bridge. Add a minimum 5 ft (1.5 m) for the sidewalk width.
- (13) Vertical Clearance (Arterial Under).
- a. The clearance must be available over the traveled way and flush or traversable median.
 - b. Table value includes allowance for future overlays.
 - c. A 14 ft 0 in (4.3 m) clearance may be allowed to remain in place with consideration for reconstruction to a clearance of 14 ft 9 in (4.5 m).

GEOMETRIC DESIGN CRITERIA FOR SUBURBAN/URBAN TWO-WAY ARTERIALS
(New Construction/Reconstruction)

Footnotes for Figure 48-6.A
(4 of 4)

Design Element		Manual Section	One-Way DHV >1850 (1)	One-Way DHV 1850-1300 (1)	One-Way DHV < 1300 (1)	
Design Controls	Highway Type	—	OWS-4	OWS-3	OWS-2	
	Design Forecast Year	31-4.02	20 Years	20 Years	20 Years	
Cross Section Elements	*Design Speed (2)	48-2.01	30 mph – 40 mph	30 mph – 40 mph	30 mph – 40 mph	
	Access Control	35-1	Consider Managed Access	Consider Managed Access	Consider Managed Access	
	Level of Service (3)	31-4.04	C	C	C	
	On-Street Parking	Without Parking	48-2.05	Not Recommended	Not Recommended	Not Recommended
		With Parking - 1 Side (5)	34-2.01	52' f-f	40' f-f	30' f-f (4)
	With Parking - 2 Sides (5)	60' f-f		48' f-f	36' f-f	
	Auxiliary Lanes	Lane Width	34-2.03	68' f-f	56' f-f	44' f-f
		Curb Type and Width (6)		Des.: 12' Min.: 11'	Des.: 12' Min.: 11'	Des.: 12' Min.: 11'
	Shared Lane (Bicycle & Motor Vehicle) (7)	*Travel Lanes (8)	Chp. 17	B-6.12 or B-6.24 CC&G	B-6.12 or B-6.24 CC&G	B-6.12 or B-6.24 CC&G
		Auxiliary Lanes		Min.: 14'	Min.: 14'	Min.: 14'
Cross Slope	Auxiliary Lanes	34-2.01	3/16" /ft for Lanes Adjacent to Crown	3/16" /ft for Lanes Adjacent to Crown	1/4" /ft for Lanes Adjacent to Crown	
	Outside Curb Type & Width		34-2.03	—	—	—
Roadway Slopes	Side Slopes	48-2.04	5' with Buffer Strip Behind Curb (9)	5' with Buffer Strip Behind Curb	5' with Buffer Strip Behind Curb	
		38-3	(9)	(9)	(9)	
		34-4.04	—	—	—	
Roadway Slopes	Side Slopes	34-4.05	—	—	—	
		34-4.02	—	—	—	
		34-4.02	—	—	—	

OWS = One-Way Street, f-f = face of curb to face of curb

* Controlling design criteria (see Section 31-8).

GEOMETRIC DESIGN CRITERIA FOR SUBURBAN/URBAN ONE-WAY ARTERIALS
 (New Construction/Reconstruction)
 (US Customary)

Figure 48-6.B
 (1 of 3)

Design Element		Manual Section	One-Way DHV > 1850 (1)	One-Way DHV 1850-1300 (1)	One-Way DHV < 1300 (1)
Bridges	Highway Type	—	OWS-4	OWS-3	OWS-2
	New and Reconstructed Bridges	N/A	HS-20	HS-20	HS-20
	*Structural Capacity	39-6	52'	40'	30'
	*Clear Roadway Width (10)	N/A	HS-20	HS-20	HS-20
	Existing Bridges to Remain in Place	39-6	48'	37'	28'
	*Structural Capacity			14'-9" (12b)	
	*Clear Roadway Width (11)			14'-0" (12c)	
	New and Replaced Overpassing Bridges	39-4			
	Existing Overpassing Bridges				
	*Vertical Clearance (Arterial Under) (12a)	33-5		New: 17'-3" (12b)	
Overhead Signs/ Pedestrian Bridges	39-4.06		23'-0"		
*Vertical Clearance (Arterial over Railroad)					

* Controlling design criteria (see Section 31-8).

GEOMETRIC DESIGN CRITERIA FOR SUBURBAN/URBAN ONE-WAY ARTERIALS
 (New Construction/Reconstruction)
 (US Customary)

Figure 48-6.B
 (2 of 3)

Design Element	Manual Section	One-Way DHV >1850 (1)	One-Way DHV 1850-1300 (1)	One-Way DHV < 1300 (1)
Highway Type	—	OWS-4	OWS-3	OWS-2
Design Forecast Year	31-4.02	20 Years	20 Years	20 Years
* Design Speed (2)	48-2.01	50 km/h - 60 km/h	50 km/h - 60 km/h	50 km/h - 60 km/h
Access Control	35-1	Consider Managed Access	Consider Managed Access	Consider Managed Access
Level of Service (3)	31-4.04	C	C	C
On-Street Parking	48-2.05	Not Recommended	Not Recommended	Not Recommended
* Surface Width	Without Parking	15.6 m f-f	12.0 m f-f	9.2 m f-f (4)
	With Parking - 1 Side (5)	18.0 m f-f	14.4 m f-f	10.8 m f-f
	With Parking - 2 Sides (5)	20.4 m f-f	16.8 m f-f	13.2 m f-f
	Lane Width	Des.: 3.6 m Min.: 3.3 m	Des.: 3.6 m Min.: 3.3 m	Des.: 3.6 m Min.: 3.3 m
Auxiliary Lanes	34-2.03	B-15.30 or B-15.60 CC&G	B-15.30 or B-15.60 CC&G	B-15.30 or B-15.60 CC&G
Shared Lane (Bicycle & Motor Vehicle) (7)	Chp. 17	Min.: 4.3 m	Min.: 4.3 m	Min.: 4.3 m
Cross Slope	34-2.01	1.5% for Lanes Adjacent to Crown	1.5% for Lanes Adjacent to Crown	2% for Lanes Adjacent to Crown
Auxiliary Lanes	34-2.03	—	—	—
Outside Curb Type & Width	34-2.04	B-15.60 CC&G	B-15.60 CC&G	B-15.60 CC&G
Sidewalk Width	48-2.04	1.5 m with Buffer Strip Behind Curb	1.5 m with Buffer Strip Behind Curb	1.5 m with Buffer Strip Behind Curb
Clear Zone	38-3	(9)	(9)	(9)
Roadway Slopes	Cut Section (Curbed)	—	—	—
	Rock Cut	—	—	—
	Fill Section (Curbed)	—	—	—

OWS = One-Way Street; f-f = face of curb to fact of curb

* Controlling design criteria (see Section 31-8).

**GEOMETRIC DESIGN CRITERIA FOR SUBURBAN/URBAN ONE-WAY ARTERIALS
(New Construction/Reconstruction)
(Metric)**

**Figure 48-6.B
(1 of 3)**

Design Element		Manual Section	One-Way DHV > 1850 (1)	One-Way DHV 1850-1300 (1)	One-Way DHV < 1300 (1)	
Bridges	Highway Type	—	OWS-4	OWS-3	OWS-2	
	New and Reconstructed Bridges	N/A	MS-18	MS-18	MS-18	
	Existing Bridges to Remain in Place	*Clear Roadway Width (10)	39-6	15.6 m	12.0 m	9.2 m
		*Structural Capacity	N/A	MS-18	MS-18	MS-18
	*Vertical Clearance (Arterial Under) (12a)	*Clear Roadway Width (11)	39-6	14.4 m	11.1 m	8.6 m
		New and Replaced Overpassing Bridges	39-4	4.5 m (12b)		
		Existing Overpassing Bridges		4.3 m (12c)		
	*Vertical Clearance (Arterial over Railroad)	Overhead Signs/ Pedestrian Bridges	33-5	New: 5.25 m (12b)		
			39-4.06	7.0 m		

* Controlling design criteria (see Section 31-8).

**GEOMETRIC DESIGN CRITERIA FOR SUBURBAN/URBAN ONE-WAY ARTERIALS
(New Construction/Reconstruction)
(Metric)**

Figure 48-6.B
(2 of 3)

- (1) Traffic Volumes. The design hourly volumes (DHV) are calculated using a PHF = 1.0; adjust these values using local peak-hour factors.
- (2) Design Speed. Consider using a minimum 40 mph (60 km/hr) design speed in relatively undeveloped areas where economics, environmental conditions, and signal spacing permit. The statutory speed limits in urbanized areas is 30 mph. Before the posted speed limit can be increased, complete an engineering study (Phase I report) and a speed study.
- (3) Level of Service. In major urban areas, a level of service D may be considered with study and justification.
- (4) Minimum Street Width. The minimum width of a two-lane street is set at 30 ft (9.2 m) f-f which allows two lanes of traffic to pass a stalled vehicle.
- (5) Parking Lane Width. The desirable width of the parking lane is 10 ft (3.0 m) and includes the 2 ft (600 mm) gutter width. The minimum width is 8 ft (2.4 m) e-f.
- (6) Gutter Width. Under restricted conditions, the gutter width adjacent to the edge of the turn lane may be narrowed or eliminated adjacent to a 12 ft (3.6 m) lane and narrowed adjacent to a 11 ft (3.3 m) lane.
- (7) Shared Lane Width. Width of a shared lane for motor vehicle and bicyclist use shall be 14 ft (4.3 m) minimum to allow for vehicle passing of bicycles while staying within the lane.
- (8) Cross Slope. For each additional lane away from the crown lanes, including auxiliary lanes, increase the cross slopes by 1/16" /ft (0.5%) up to a maximum of 3/16" /ft (2.5%).
- (9) Clear Zone. For curbed facilities, the minimum horizontal clearance to an obstruction is 1.5 ft (500 mm), measured from the face of curb.
- (10) New and Reconstructed Bridge Widths. Clear roadway bridge widths are measured from face to face of outside curbs or parapet walls. Urban bridge widths are defined as the sum of the approach traveled way widths and width of the gutters. A sidewalk or bikeway will result in additional bridge width. For sidewalks on a bridge, add 5 ft (1.5 m) to each side of the bridge. Parking is prohibited on bridges.
- (11) Existing Bridge Widths to Remain in Place. Clear roadway bridge widths are measured from face to face of outside curbs or parapet walls. At least one sidewalk must be carried across the bridge. Add a minimum 5 ft (1.5 m) for the sidewalk width.
- (12) Vertical Clearance (Arterial Under).
- The clearance must be available over the traveled way.
 - Table value includes allowance for future overlays.
 - A 14 ft 0 in (4.3 m) clearance may be allowed to remain in place with consideration for reconstruction to a clearance of 15 ft 0 in (4.5 m).

**GEOMETRIC DESIGN CRITERIA FOR SUBURBAN/URBAN ONE-WAY ARTERIALS
(New Construction/Reconstruction)**

**Footnotes for Figure 48-6.B
(3 of 3)**

Design Element	Manual Section	Design Speed			
		30 mph	40 mph	45 mph	50 mph
* Stopping Sight Distance (1)	31-3.01	200'	305'	360'	425'
Decision Sight Distance (2)	31-3.02	620'	825'	800'	890'
Intersection Sight Distance (3)	36-6	335'	445'	500'	555'
* Minimum Radii	$e_{max} = 6\%$ (open-roadway)	N/A	N/A	N/A	835'
	$e_{max} = 4\%$ (open-roadway)	N/A	N/A	N/A	930'
	$e_{max} = 4\%$ (low speed)	250'	535'	710'	N/A
* Superlevation Rate	48-5/32-3	$e_{max} = 4\%$ (4a)			$e_{max} = 6\%$ or 4% (4b)
* Horizontal Sight Distance	32-4	(5)			
* Vertical Curvature (K-values)	Crest	19	44	61	84
	Sag	37	64	79	96
* Maximum Grade	Level	8%	7%	6%	4%
	Rolling	9%	8%	7%	5%
Minimum Grade	33-2.02	Desirable: 0.5% Minimum: 0.3% (with Curb and Gutter)			

* Controlling design criteria (see Section 31-8).

Footnotes:

- (1) Stopping Sight Distance. Table values are for passenger cars on level grades.
- (2) Decision Sight Distance. Table values 30 mph and 40 mph are for the avoidance maneuver on an urban street (speed/path/direction change) and for 45 mph and 50 mph for a suburban street.
- (3) Intersection Sight Distance. Table values are for passenger cars. See Section 36-6 for trucks.
- (4) Superlevation Rate:
 - a. For reconstruction projects with a design speed ≤ 45 mph, a maximum superlevation rate of 6% may remain in place.
 - b. The superlevation rate of 6% only may be used in open suburban areas.
- (5) Horizontal Sight Distance. For a given design speed, the necessary middle ordinate will be determined by the radius of curve and the required sight distance.

ALIGNMENT CRITERIA FOR SUBURBAN/URBAN ARTERIALS
(New Construction/Reconstruction)
(US Customary)

Figure 48-6.C

Design Element	Manual Section	Design Speed			
		50 km/h	60 km/h	70 km/h	80 km/h
* Stopping Sight Distance (1)	31-3.01	64 m	83 m	105 m	129 m
Decision Sight Distance (2)	31-3.02	195 m	235 m	235 m	270 m
Intersection Sight Distance (3)	36-6	105 m	126 m	146 m	167 m
* Minimum Radii	$e_{max} = 6\%$ (open-roadway)	N/A	N/A	N/A	255 m
	$e_{max} = 4\%$ (open-roadway)	N/A	N/A	N/A	280 m
	$e_{max} = 4\%$ (low speed)	90 m	135 m	205 m	N/A
* Superlevation Rate	48-5/32-3	$e_{max} = 4\%$ (4a)			
* Horizontal Sight Distance	32-4	(5)			
* Vertical Curvature (K-values)	Crest	7	11	17	26
	Sag	12	17	23	30
* Maximum Grade	Level	8%	7%	6%	4%
	Rolling	9%	8%	7%	5%
Minimum Grade	33-2.02	Desirable: 0.5% Minimum: 0.3% (with Curb and Gutter)			

* Controlling design criteria (see Section 31-8).

Footnotes:

- (1) Stopping Sight Distance. Table values are for passenger cars on level grades.
- (2) Decision Sight Distance. Table values 50 km/h and 60 km/h are for the avoidance maneuver on an urban street (speed/path/direction change) and for 70 km/h and 80 km/h for a suburban street.
- (3) Intersection Sight Distance. Table values are for passenger cars. See Section 36-6 for trucks.
- (4) Superlevation Rate:
 - a. For reconstruction projects with a design speed ≤ 70 km/h, a maximum superlevation rate of 6% may remain in place.
 - b. The superlevation rate of 6% only may be used in open suburban areas.
- (5) Horizontal Sight Distance. For a given design speed, the necessary middle ordinate will be determined by the radius of curve and the required sight distance.

**ALIGNMENT CRITERIA FOR SUBURBAN/URBAN ARTERIALS
(New Construction/Reconstruction)
(Metric)**

Figure 48-6.C

48-7 REFERENCES

1. *A Policy on Geometric Design of Highways and Streets*, AASHTO, 2011.
2. *Highway Capacity Manual 2010*, Transportation Research Board, 2010.
3. *Parking Principles*, Special Report No. 125, Highway Research Board, 1971.
4. "Two-Way Left-Turn Lanes: State-of-the-Art Overview and Implementation Guide," *Transportation Research Record 681*, TRB, 1978.
5. *Effective Utilization of Street Width on Urban Arterials*, NCHRP Report 330, 1990.
6. "Accident Comparison of Raised Median and Two-Way Left-Turn Lane Median Treatments," Transportation Research Board 1239, TRB, 1989.
7. "Are Raised Medians Safer Than Two-Way Left-Turn Lanes?" *ITE Journal*, December 1994.
8. *Multilane Design Alternatives for Improving Suburban Highways*, NCHRP Report 282, 1986.
9. *Median Intersection Design*, NCHRP 375, 1995.
10. *Capacity and Operational Effects of Midblock Left-Turn Lanes*, NCHRP Report 395, September 1997.
11. *Relationship of Operating Speed to Roadway Geometric Design Speed*, FHWA RD-96-024, FHWA, December 1996.
12. *Highway Standards*, current edition.

Chapter Forty-nine

3R GUIDELINES FOR RURAL AND URBAN HIGHWAYS (Non-Freeways)

BUREAU OF DESIGN AND ENVIRONMENT MANUAL

Chapter Forty-nine
3R GUIDELINES FOR RURAL AND URBAN HIGHWAYS
(Non-Freeways)

Table of Contents

<u>Section</u>	<u>Page</u>
49-1 INTRODUCTION.....	49-1.1
49-2 GENERAL.....	49-2.1
49-2.01 Background.....	49-2.1
49-2.01(a) Federal 3R Regulations	49-2.1
49-2.01(b) Special Report 214.....	49-2.1
49-2.01(c) FHWA Technical Advisory T5040.28.....	49-2.1
49-2.02 Objectives	49-2.2
49-2.03 Application	49-2.3
49-2.04 3R Project Evaluation.....	49-2.3
49-3 TWO-LANE RURAL ARTERIAL HIGHWAYS.....	49-3.1
49-3.01 Application	49-3.1
49-3.02 Design Speed	49-3.1
49-3.03 Roadway Cross Section Elements	49-3.1
49-3.04 Horizontal Alignment.....	49-3.1
49-3.04(a) General.....	49-3.1
49-3.04(b) Radius of Curvature/Superelevation.....	49-3.4
49-3.04(c) Treatment of Existing Horizontal curves	49-3.7
49-3.04(d) Superelevation Transition Lengths	49-3.9
49-3.04(e) Traveled Way/Shoulder "Rollover"	49-3.10
49-3.04(f) Summary	49-3.10
49-3.05 Vertical Alignment.....	49-3.11
49-3.05(a) Crest Vertical Curves	49-3.11
49-3.05(b) Sag Vertical Curves	49-3.11
49-3.05(c) Maximum Grades.....	49-3.12
49-3.06 Intersections.....	49-3.12
49-3.06(a) Superelevation Rate Changes Through Intersections ...	49-3.12
49-3.06(b) Stop-Controlled Approaches on Horizontal Curves	49-3.12
49-3.06(c) Sideroad Approach Grades.....	49-3.12
49-3.06(d) Sideroad Turning Radii	49-3.12
49-3.06(e) Intersection Sight Distance (ISD)	49-3.13
49-3.07 Roadside Treatment and Highway Appurtenances.....	49-3.13

Table of Contents
(Continued)

<u>Section</u>	<u>Page</u>
49-3.07(a) General	49-3.13
49-3.07(b) Earth Slopes	49-3.13
49-3.07(c) Clear Zones	49-3.13
49-3.07(d) Guardrail	49-3.15
49-3.07(e) Culverts.....	49-3.19
49-3.07(f) Sign and Light Supports	49-3.22
49-3.07(g) Trees.....	49-3.22
49-3.07(h) Concrete Signal Bases.....	49-3.22
49-3.07(i) Curbs	49-3.22
49-3.07(j) Traffic Control Devices	49-3.22
49-3.07(k) Mailbox Turnouts	49-3.22
49-3.07(l) Lighting and Landscaping	49-3.22
49-3.07(m) Above-Ground Utilities	49-3.22
49-3.07(n) Airports	49-3.22
49-3.07(o) Other.....	49-3.22
49-3.08 Railroad Crossings and Signals	49-3.23
49-3.09 Bridges.....	49-3.23
49-3.09(a) Bridge Condition Reports/Structure Sketches	49-3.23
49-3.09(b) Scope of Work	49-3.24
49-3.09(c) Criteria for Bridges to Remain in Place.....	49-3.24
49-3.09(d) Criteria for Improved Bridges	49-3.25
49-3.09(e) Vertical Clearance.....	49-3.25
49-4 URBAN ARTERIAL HIGHWAYS AND STREETS.....	49-4.1
49-4.01 Application	49-4.1
49-4.02 Scope of Work	49-4.1
49-4.03 Design Speed	49-4.1
49-4.04 Roadway Cross Section Elements	49-4.2
49-4.05 Capacity	49-4.2
49-4.06 Diagonal Parking.....	49-4.2
49-4.07 Horizontal Alignment.....	49-4.2
49-4.07(a) V = 50 mph (80 km/h).....	49-4.2
49-4.07(b) V ≤ 45 mph (70 km/h).....	49-4.2
49-4.08 Vertical Alignment	49-4.5
49-4.09 Intersections.....	49-4.5
49-4.09(a) Turning Radii.....	49-4.5
49-4.09(b) Curb Cuts/Ramps	49-4.6
49-4.09(c) Intersection Sight Distance (ISD)	49-4.6

Table of Contents
(Continued)

<u>Section</u>	<u>Page</u>
49-4.10	Roadside Treatment and Highway Appurtenances..... 49-4.6
49-4.11	Railroad Crossings and Signals 49-4.6
49-4.12	Bridges..... 49-4.7
	49-4.12(a) Bridge Condition Reports/Structure Sketches 49-4.7
	49-4.12(b) Criteria for Bridges to Remain in Place..... 49-4.7
	49-4.12(c) Criteria for Improved Bridges 49-4.7
	49-4.12(d) Vertical Clearance..... 49-4.7
49-5	HIGH-SPEED, MULTILANE HIGHWAYS (WITHOUT ACCESS CONTROL)..... 49-5.1
	49-5.01 General 49-5.1
	49-5.02 Shoulders..... 49-5.1
	49-5.03 Medians/Posted Speed 49-5.1
49-6	UNMARKED ROUTES ON THE STATE HIGHWAY SYSTEM 49-6.1
	49-6.01 General 49-6.1
	49-6.02 Design Speed 49-6.2
	49-6.03 Roadway Cross Section Elements 49-6.2
	49-6.04 Horizontal Alignment 49-6.2
	49-6.04(a) Radius of Curvature/Superelevation..... 49-6.2
	49-6.04(b) Traveled Way/Shoulder "Rollover" 49-6.2
	49-6.05 Vertical Alignment 49-6.4
	49-6.05(a) Crest Vertical Curves 49-6.4
	49-6.05(b) Sag Vertical Curves 49-6.4
	49-6.05(c) Maximum Grades..... 49-6.4
	49-6.06 Intersections..... 49-6.4
	49-6.06(a) Superelevation Rate Changes Through Intersections ... 49-6.4
	49-6.06(b) Stop-Controlled Approaches on Horizontal Curves 49-6.5
	49-6.06(c) Sideroad Approach Grades 49-6.5
	49-6.06(d) Sideroad Turning Radii 49-6.5
	49-6.06(e) Intersection Sight Distance..... 49-6.5
	49-6.07 Roadside Treatment and Highway Appurtenances..... 49-6.5
	49-6.07(a) General 49-6.5
	49-6.07(b) Earth Slopes 49-6.5
	49-6.07(c) Clear Zones 49-6.6
	49-6.07(d) Guardrail 49-6.7

Table of Contents
(Continued)

<u>Section</u>		<u>Page</u>
	49-6.07(e) Culverts.....	49-6.7
	49-6.07(f) Mailbox Turnouts	49-6.7
	49-6.07(g) Lighting and Landscaping	49-6.7
	49-6.07(h) Other.....	49-6.7
49-6.08	Railroad Crossings and Signals	49-6.8
49-6.09	Bridges.....	49-6.8
	49-6.09(a) Bridge Condition Reports/Structure Sketches	49-6.8
	49-6.09(b) Scope of Work	49-6.8
	49-6.09(c) Criteria for Bridges to Remain in Place.....	49-6.8
	49-6.09(d) Criteria for Improved Bridges	49-6.10
	49-6.09(e) Vertical Clearance.....	49-6.10
49-7	REFERENCES.....	49-7.1

Chapter Forty-nine

3R GUIDELINES FOR RURAL AND URBAN HIGHWAYS (Non-Freeways)

49-1 INTRODUCTION

Section 31-6 identifies four project scopes of work:

- new construction;
- reconstruction;
- 3R (resurfacing, restoration, rehabilitation) (non-freeways); and
- 3R (resurfacing, restoration, rehabilitation) (freeways).

The applicable chapters in Parts IV and V present the Department's design criteria that apply to new construction and reconstruction projects. For these projects, the designer often has the liberty of designing the highway to meet the most desirable and stringent criteria possible. Therefore, exceptions to these criteria should be relatively rare.

Highways constructed to meet nationally recognized design criteria provide measurable advantages for the motoring public. The safety, comfort, and convenience of modern highways present strong incentives for funding programs based on ideal design considerations. However, available finances do not always permit the reconstruction of existing highways to an ideal level. A comparison of Statewide needs demonstrates that, with available revenues, the problem must be addressed not only at a project level but on a system-wide basis.

Therefore, the design of projects on existing highways must be viewed from a different perspective. These projects are often initiated for reasons other than geometric design deficiencies (e.g., pavement deterioration), and they often must be designed within restrictive right-of-way, financial limitations, and environmental constraints. As a result, the design criteria for new construction and reconstruction are often not attainable without major and, frequently, unacceptable adverse impacts. At the same time, however, the Department must exercise the opportunity to make cost-effective, practical improvements to the geometric design of existing highways and streets.

For these reasons, the Department has adopted revised limits for geometric design values for projects on existing highways that are, in many cases, lower than the values for new construction/reconstruction. These criteria are based on a sound, engineering assessment of the underlying principles behind geometric design and on how the criteria for new construction/reconstruction can be legitimately modified to apply to existing highways without sacrificing highway safety.

Chapter 49 presents the Department's criteria for 3R projects on rural and urban highways (non-freeways), and Chapter 50 presents the criteria for 3R freeway projects. These criteria are intended to find the balance among many competing and conflicting objectives. These include the objective of improving Illinois' existing highways; the objective of minimizing the adverse impacts of highway construction on existing highways; and the objective of improving the greatest number of miles (kilometers) within the available funds.

As a summary, Chapter 49 presents 3R criteria for:

- two-lane rural arterial highways (other than freeways) (Section 49-3);
- urban arterial highways and streets (other than freeways) (Section 49-4);
- high-speed, multilane highways (other than freeways) (Section 49-5); and
- rural unmarked collector or local routes on the State highway system (Section 49-6).

This chapter is not applicable to projects that are generally considered to be resurfacing-only type projects (e.g., maintenance overlays,) or fall under the Pavement Preservation Policy (3P).

49-2 GENERAL

49-2.01 Background

49-2.01(a) Federal 3R Regulations

The *Federal-aid Highway Act* of 1976 amended the term “construction” to permit Federal-aid funding of resurfacing and widening and resurfacing of existing rural and urban pavements with or without revision to the horizontal or vertical alignment or other geometric features. The 1982 *Surface Transportation Assistance Act* stipulated that resurfacing, rehabilitation, and restoration (3R) projects be constructed to standards to preserve and extend the service life of highways and enhance safety.

On June 10, 1982, the FHWA issued its Final Rule entitled *Design Standards for Highways; Resurfacing, Restoration and Rehabilitation of Streets and Highways Other Than Freeways*, which adopted a flexible approach to the geometric design of 3R projects. In the Final Rule, FHWA determined that it was not practical to adopt 3R design criteria for nationwide application. Instead, each State can develop its own criteria and/or procedures for the design of 3R projects, subject to FHWA approval, to tailor its design criteria according to the conditions that prevail within that State. This approach is in contrast to the application of geometric design criteria for new construction and reconstruction, for which the AASHTO *A Policy on Geometric Design of Highways and Streets* provides nationwide criteria for application.

49-2.01(b) Special Report 214

In 1987, the Transportation Research Board published Special Report 214 *Designing Safer Roads; Practices for Resurfacing, Restoration and Rehabilitation*. The *Surface Transportation Assistance Act* of 1982 mandated this study. The objective of the TRB study was to examine the safety cost-effectiveness of highway geometric design criteria and to recommend minimum design criteria for 3R projects on non-freeways. The final TRB report (SR 214) presented specific numerical criteria for the geometric design of 3R projects for the following elements:

- lane and shoulder widths,
- horizontal curvature and superelevation,
- crest vertical curvature,
- bridge width,
- side slopes, and
- pavement cross slopes.

The SR 214 information has been considered, where appropriate, for the Department’s criteria and procedures for 3R projects.

49-2.01(c) FHWA Technical Advisory T5040.28

Pursuant to its adoption of SR 214, FHWA issued on October 17, 1988, Technical Advisory T5040.28 “Developing Geometric Design Criteria and Processes for Non-Freeway RRR Projects.” The purpose of the Advisory is to provide guidance on developing or modifying

criteria for the design of Federal-aid, non-freeway 3R projects. The information from the Technical Advisory has been considered, where appropriate, for the Department's criteria and procedures for 3R projects.

49-2.02 Objectives

From an overall perspective, the 3R program is intended to improve the greatest number of highway miles (kilometers) within the available funds for highway projects. Improve is meant to apply to all aspects that determine a facility's serviceability, including:

- the structural integrity of the pavement, bridges, and culverts;
- the drainage design of the facility to, among other objectives, minimize ponding on the highway, to protect the pavement structure from failure, and to prevent roadway flooding during the design-year storm;
- from a highway capacity perspective, the level of service provided for the traffic flow;
- the adequacy of access to abutting properties;
- the geometric design of the highway to safely accommodate expected vehicular speeds and traffic volumes;
- the roadside safety design to reduce, within some reasonable boundary, the adverse impacts of run-off-the-road vehicles; and
- the traffic control devices to provide the driver with critical information and to meet driver expectancies.

These objectives are competing for the limited funds available for 3R projects on existing highways. The Department's goal is to realize the greatest overall benefit from the available funds. Therefore, on individual projects, some compromises may be necessary to achieve the goals of the overall highway program. Specifically for geometric design and roadside safety, the balance is between what is desirable (new construction/reconstruction) and what is practical for the specific conditions of each highway project.

Therefore, based on these objectives, the Department has adopted and FHWA has approved its policy for the geometric design of 3R projects. These objectives are summarized as follows:

1. 3R projects are intended to extend the service life of the existing facility and to return its features to a condition of structural or functional adequacy. This includes providing smoother riding surfaces and structurally improving bridges.
2. 3R projects are intended to enhance highway safety. Safety improvements should be selected to support the State's Strategic Highway Safety Plan (SHSP) and "Zero Fatalities" goal. To accomplish this, identified "Five Percent" locations, and other locations and conditions that present cost-effective opportunities to reduce fatal and

severe injury crashes must be identified and examined in order to apply 3R funds effectively. 3R projects are intended to incorporate cost-effective, practical improvements to the geometric design of the existing facility. This includes increasing roadway and bridge widths.

49-2.03 Application

The design policies and criteria in Chapter 49 apply to 3R projects on existing facilities within the general constraints of the existing alignment and right-of-way. If the purpose and scope of the project is intended to replace or expand the facility, then Chapter 49 is not appropriate, and reconstruction policies will apply. For definitions and application to new construction and reconstruction projects, see Section 31-6.

49-2.04 3R Project Evaluation

Sections 49-3 through 49-6 present the specific geometric design and roadside safety criteria that will be used to define the scope of 3R projects. In addition, the designer should consider several other factors and conduct applicable technical evaluations using appropriate Department units as may be necessary. The potential evaluations are discussed below:

1. Conduct Field Review. The district will normally conduct a thorough field review of the proposed 3R project to ascertain the appropriateness of 3R criteria and on-site conditions and their effects on project development decisions. Other personnel should accompany the designer as appropriate, including district scoping, safety, environmental, Operations, Project Implementation, Bureau of Safety Programs and Engineering, Bureau of Design and Environment, and FHWA (on applicable Interstate projects or project included in a FHWA specific project PoDI plan (see Section 4-2), etc. Objectives of the field review should be to collect relevant field data, to identify potential safety problems, and to determine the need for safety improvements to the facility.
2. Document Existing Geometrics. The designer will normally review the most recent as-built highway plans and combine this with the field review to determine the existing geometrics within the project limits. The review includes lane and shoulder widths, horizontal and vertical alignment, intersection geometrics, and the roadside safety design. A field survey may also be needed to verify certain geometric features.
3. Safety Analysis. Conduct a project safety analysis as described in Chapter 11-2.02(f) for each 3R project.
4. Crash Data. Crash data and analysis of the data are critical to the identification of problem areas. The Phase I engineering report shall include the identified Five Percent Report (FPR) Location evaluations and schematic collision diagrams.

The designer shall evaluate the last three years of crash data available, identify over-represented crash trends, and propose appropriate countermeasures. The Phase I

engineering report shall include schematic collision diagrams and recommendations based on an analysis for all crash patterns throughout a proposed project. The diagrams should show the location and type of crashes for the previous three years.

5. Early Coordination for Right-of-Way (ROW) Acquisition. ROW acquisitions are sometimes required for 3R projects. Therefore, determine the improvements that will be incorporated into the project design as early as feasible and initiate the ROW process.
6. Pavement Condition. 3R projects are often programmed because of a significant deterioration of the pavement structure. The extent of deterioration will influence the decision on whether a project can be designed using the 3R design criteria or whether it should be designed using new construction/reconstruction criteria. In addition, all 3R projects shall include a pavement surface that meets the Department's skid resistance criteria. See Chapter 53 for the Department's policies, procedures, and criteria for the rehabilitation of existing pavements.

Whenever the proposed pavement improvement is major, it may be practical to include significant geometric improvements (e.g., lane and shoulder widening) in the project design. However, the proper level of geometric improvement is often determined by many additional factors other than the extent of pavement improvement. These include available right-of-way, environmental studies, traffic volumes, crash experience, and available funds for the project. Therefore, it may be appropriate for the 3R project to include, for example, full-depth pavement reconstruction and minimal geometric improvement, if supported by safety studies and the operational objectives of the 3R program.

7. Geometric Design of Adjacent Highway Sections. The designer should examine the geometric features and operating speeds of highway sections adjacent to the 3R project. This will include investigating whether or not any highway improvements are in the planning stages. The 3R project should provide design continuity with the adjacent sections. This involves a consideration of factors such as driver expectancy, geometric design consistency, and proper transitions between sections of different geometric designs.
8. Continuity of Design. Consistency is an important factor to be considered in the development of 3R projects. 3R projects are based on current traffic; however, consider the probable future traffic to ensure the appropriate use of 3R policies. Avoid the use of design changes that violate driver expectancy regarding width, curvature, or other roadway features, as practical. Continuity of design may justify constructing certain highway elements to higher or lower design criteria than normally prescribed.
9. Physical Constraints. The physical constraints within the limits of the 3R project may determine what geometric improvements are practical and cost-effective. These include topography, adjacent development, right-of-way, utilities, and environmental constraints. Identified safety countermeasures relative to impacts and costs should be considered and an appropriate balance achieved.

10. Traffic Control Devices. All signing and pavement markings on 3R projects shall meet the criteria of the *Illinois Manual on Uniform Traffic Control Devices*. The Bureau of Operations is responsible for selecting and locating the traffic control devices on the project. The designer should work with the Bureau to identify possible geometric and safety deficiencies that will remain in place (i.e., no improvement will be made).
11. Bridges Within Project Limits. One or more bridges may be within the limits of a 3R project. If bridge improvement is needed, it may be performed prior to, simultaneous with, or deferred from highway projects in accordance with the priorities established in the applicable sections of Chapter 49 (e.g., Section 49-3.09 for rural arterials).

Highway bridge improvement includes all work necessary for the improvement of existing rural or urban bridges to be consistent with 3R objectives for increased safety, improved operating conditions, and structural adequacy. Bridge improvement could include complete replacement of a bridge when no other cost-effective means of meeting these criteria are feasible. For definition and clarification, a bridge constructed at a different location or an existing bridge requiring replacement of all elements as a part of a 3R project is designated as a replacement rather than a new bridge. New bridge designations are reserved for new construction/reconstruction projects because they generally are subject to different width requirements than replacement bridges.

12. Design Exceptions. The use of lower design criteria than described in Chapter 49 will require approval from BDE and, where applicable, FHWA. Where exceptions to these criteria are necessary, they should be processed according to the procedures described in Section 31-8.
13. Spot Improvements. Recently completed spot improvements (e.g., safety or bridge projects) may be considered for omission from 3R projects. The proposed limits of an omission should be identified, and all applicable features within the limits of the spot improvement should be discussed at district coordination meetings and included in the Phase I engineering report. These reports should also discuss the omissions to ensure that they are treated in accordance with 3R policies. Any exceptions to the 3R criteria within omissions shall be identified and addressed in accordance with the 3R procedures.

49-3 TWO-LANE RURAL ARTERIAL HIGHWAYS

49-3.01 Application

Section 49-3 is applicable to resurfacing, rehabilitation, and restoration (3R) projects on the State highway system that are:

- marked two-lane rural arterials,
- marked two-lane rural highways functionally classified as collectors,
- unmarked two-lane rural arterials, or
- expressways (project-by-project basis).

49-3.02 Design Speed

The typical design speed for rural arterial 3R projects is 55 mph (90 km/h), or the regulatory speed, whichever is less.

49-3.03 Roadway Cross Section Elements

Figure 49-3.A presents design criteria for roadway cross section elements for 3R projects on rural two-lane arterial highways. The proposed improvements are primarily related to existing roadway widths and traffic volumes.

49-3.04 Horizontal Alignment

49-3.04(a) General

Engineering judgment and/or a cost-effectiveness evaluation will reveal the need for improvements to the horizontal alignment within a 3R project. In general, improvements to existing horizontal alignment and/or superelevation should be considered if a specific problem is identified. Examples include:

- a disproportionate number of run-off-the-road crashes,
- a disproportionate number of multi-vehicle crashes at curve sites, and/or
- the presence of a major intersection within a horizontal curve.

The evaluation of potential improvements will include the consideration of existing curvature, speed, traffic volumes, truck volumes, right-of-way and utility impacts, environmental impacts, driver expectancy, construction costs, etc.

Current ADT	EXISTING Traveled Way WIDTHS		
	18 ft – 20 ft (5.48 m - 6.10 m)	22 ft (6.71 m)	24 ft (7.32 m)
3000 or more ⁽¹⁾	PROPOSED IMPROVEMENT WIDTHS		
	<u>Traveled Way</u> • WRS to 24 ft (7.2 m) • Stripe for 24 ft (7.2 m)	<u>Traveled Way</u> • RS • Stripe for 22 ft (6.6 m)	<u>Traveled Way</u> • RS • Stripe for 24 ft (7.2 m)
	<u>Width of Shoulder Construction</u> • Construct 3 ft (900 mm) paved + 3 ft (900 mm) aggregate wedge ⁽²⁾	<u>Width of Shoulder Construction</u> • Construct 3 ft (900 mm) paved + 4 ft (1.2 m) aggregate wedge ⁽²⁾	<u>Width of Shoulder Construction</u> • Construct 3 ft (900 mm) paved + 3 ft (900 mm) aggregate wedge ⁽²⁾
2999 to 1000	<u>Traveled Way</u> • WRS to 26 ft (7.8 m) • Stripe for 24 ft (7.2 m)	<u>Traveled Way</u> • RS • Stripe for 22 ft (6.6 m)	<u>Traveled Way</u> • RS • Stripe for 24 ft (7.2 m)
	<u>Width of Shoulder Construction</u> • Construct 1 ft (300 mm) paved ⁽⁴⁾ + 3 ft (900 mm) aggregate wedge	<u>Width of Shoulder Construction</u> • Construct 1 ft (300 mm) paved ⁽³⁾⁽⁶⁾ + 4 ft (1.2 m) aggregate wedge	<u>Width of Shoulder Construction</u> • Construct 1 ft (300 mm) paved ⁽⁶⁾ + 3 ft (900 mm) aggregate wedge
Less than 1000	<u>Traveled Way</u> • WRS 18 ft – 24 ft (5.48 m to 7.2 m) and stripe for 22 ft (6.6 m) • RS 20 ft (6.10 m) and stripe for 20 ft (6.0 m)	<u>Traveled Way</u> • RS • Stripe for 20 ft (6.0 m)	<u>Traveled Way</u> • RS • Stripe for 22 ft (6.6 m)
	<u>Width of Shoulder Construction</u> • Construct 1 ft (300 mm) paved ⁽⁴⁾ + 3 ft (900 mm) aggregate wedge • Construct 1 ft (300 mm) paved ⁽⁵⁾⁽⁶⁾ + 3 ft (900 mm) aggregate wedge	<u>Width of Shoulder Construction</u> • Construct 1 ft (300 mm) paved ⁽⁵⁾ + 3 ft (900 mm) aggregate wedge	<u>Width of Shoulder Construction</u> • Use 1 ft (300 mm) paved + 3 ft (900 mm) aggregate wedge

WRS = Widening and Resurfacing
 RS = Resurfacing Only

Note: See next page for footnotes.

**ROADWAY CROSS SECTION ELEMENTS
 (3R Projects — Two-Lane Rural Arterials)**

Figure 49-3.A

Notes to Figure 49-3.A.

- (1) Roadway widths less than 34 ft (10.3 m) generally will be widened to meet one of the following widths depending on the width of the existing traveled way:

Existing Traveled Way Width	Pavement/Striped Width	Proposed Shoulder Width	Total Roadway Width After Construction
22 ft (6.71 m)	22 ft (6.7 m/6.6 m)	8 ft (2.4 m)	38 ft (11.5 m)
18 ft – 20 ft (5.48 m - 6.10 m)	24 ft (7.2 m/7.2 m)	8 ft (2.4 m)	40 ft (12.0 m)
24 ft (7.32 m)	24 ft (7.3 m/7.2 m)	8 ft (2.4 m)	40 ft (12.0 m)

The paved shoulder will be 3 ft (900 mm) wide, and the remainder will be an aggregate wedge as noted in Figure 49-3.A except as modified by Note (2).

In some cases, widening an existing roadway to only 34 ft or 36 ft (10.3 m or 10.9 m) may be permitted, depending on the existing traveled way width and right-of-way conditions. Where the existing traveled way is 22 ft or 24 ft (6.7 m or 7.3 m) wide, the construction of 6 ft (1.8 m) shoulders may be considered if such a proposed roadway width can reasonably be accommodated within the existing right-of-way, and a 38 ft to 40 ft (11.5 m to 12.1 m) roadway will require additional right-of-way.

- (2) Use an aggregate wedge for part of the shoulder on roadways with a current ADT up to 5000. For roadways where the current ADT is more than 5000, the aggregate wedge will be replaced by a minimum aggregate thickness of 6 in. (150 mm) (minimum design considered as stabilized aggregate). Where the stabilized width of shoulder construction from Figure 49-3A is less than the proposed shoulder width in Footnote (1), the proposed width of the aggregate wedge or stabilization should be increased to include the remaining shoulder width. See the Highway Standards for details.
- (3) Where resurfacing is proposed on a Class II Designated Truck Route or where the ADT of multiple-unit trucks exceeds 250, the paved shoulder should be increased to 2 ft (600 mm) wide, and the width of aggregate wedge should be decreased by 1 ft (300 mm).
- (4) The 1 ft (300 mm) paved shoulder width is constructed as an integral part of the pavement widening. See the Highway Standards for details.
- (5) Where an unusually high number of multiple-unit trucks are present or anticipated (e.g., coal hauling routes) on a highway, the designer may consider providing 11 ft (3.3 m) travel lanes with resurfacing or 11 ft (3.3 m) travel lanes with widening and resurfacing and striping for 1 ft (300 mm) paved shoulders in both cases. For an existing 20 ft (6.1 m) traveled way, the designer may consider the option of only resurfacing the traveled way and constructing 2 ft (600-mm) paved shoulders.
- (6) All 1 ft (300 mm) wide paved shoulders under "Proposed Improvement Widths" which are not an integral part of the widening should be 6 in. (150 mm) thick. See the Highway Standards for details.

49-3.04(b) Radius of Curvature/Superelevation

It is often impractical and unnecessary to correct horizontal curves on 3R projects to meet new construction/reconstruction criteria for the minimum radius of curvature. Consequently, existing horizontal curves should be evaluated to determine if an existing horizontal curve should remain in place; if there is a need for providing more superelevation on a curve; or if the curve must be reconstructed. Reconstruction should be considered only if at least one of the following conditions is met:

1. Safety analysis indicates a problem at the curve site.
2. The comfortable operating speed of an existing horizontal curve is more than 15 mph (25 km/h) below the 3R design speed (or posted or regulatory speed if less than 55 mph (90 km/h)). This assumes an increased superelevation rate cannot reduce this difference. Figure 49-3.B should be used to determine the comfortable operating speed of an existing curve. This figure is based on AASHTO's Method 2 for the distribution of superelevation and side friction.

Comfortable operating speed is defined as the speed at which a motorist can drive an existing horizontal curve and still feel comfortable traversing the curve. In all cases, maximum comfortable side friction (f) is assumed. See Section 32-2.

If it is determined to reconstruct a curve to meet the minimum radius criteria, the curve typically should be reconstructed to meet all horizontal alignment details for new construction/reconstruction (e.g., superelevation rate, superelevation transition lengths, distribution of superelevation runoff between tangent and curve) as discussed in Chapter 32.

If it is determined to retain an existing curve based on the above criteria, the designer still may be able to cost effectively improve other details of the horizontal curve. The following are potential improvements:

1. Improve the frictional characteristics of the roadway with a new pavement surface.
2. Increase the superelevation rate by specifying a tapered overlay.
3. Improve the superelevation transition length.
4. Specify wider lanes throughout the curve and use paved shoulders. Also, add reflectorized pavement markers to the centerline.

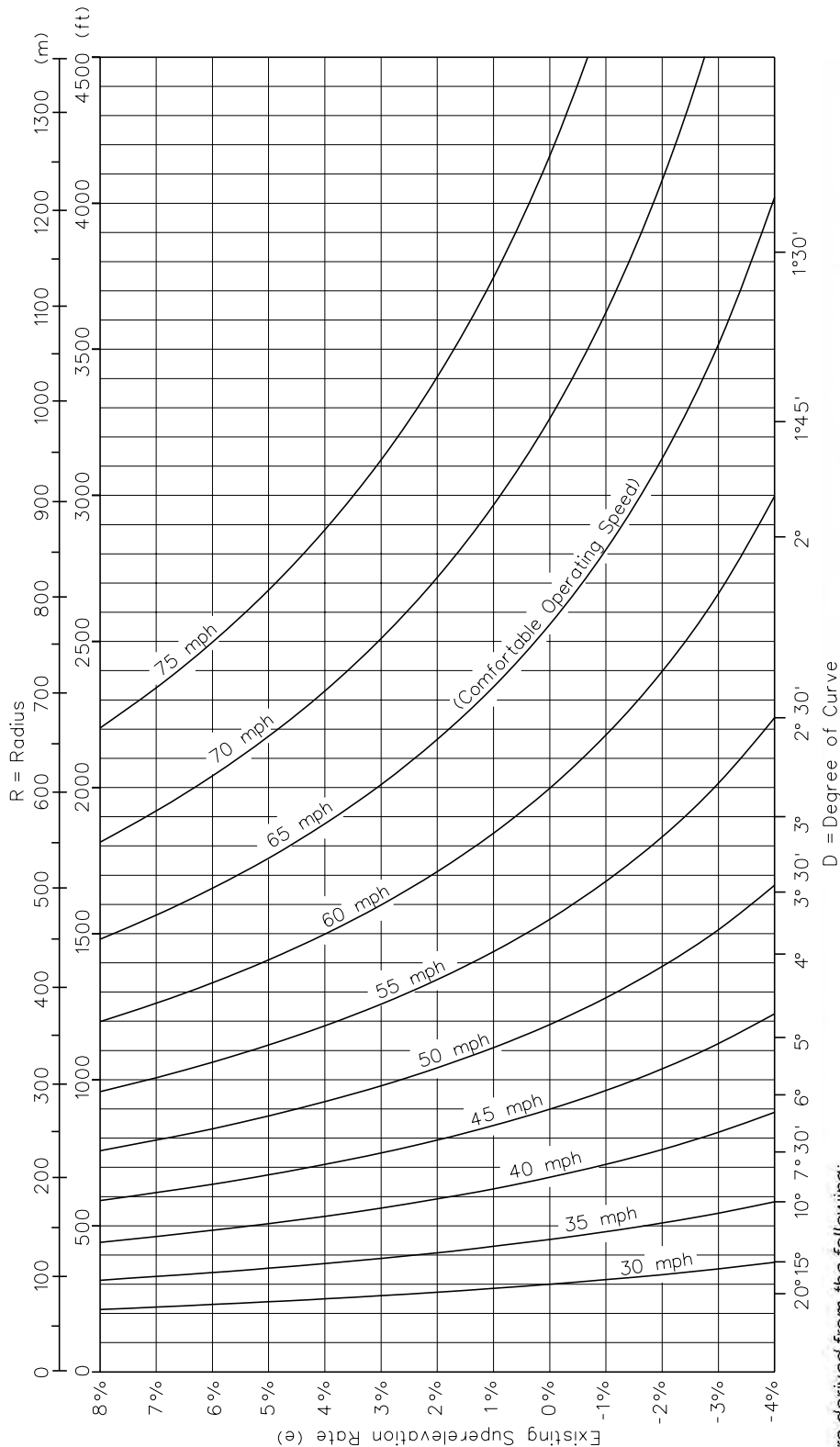

Figure derived from the following:

1. Use AASHTO Method 2 for the distribution of superelevation and side friction.

$$R = \frac{V^2}{15(e + f_{max})}$$
 where V = mph and R = ft. (US Customary)
2. Assume design speed and use f_{max} for selected design speed in all cases.

$$R = \frac{V^2}{127(e + f_{max})}$$
 where V = km/h and R = m. (Metric)
3. Assume different values of "e" and calculate values for "R" on graph for each speed.

HORIZONTAL CURVATURE ALLOWED TO REMAIN IN PLACE FOR 3R NON-FREEWAY PROJECTS

Figure 49-3.B

Notes on How To Use Figure 49-3.B

1. *Figure 49-3.B. applies to all rural highways (open-roadway conditions) and to all urban highways and streets.*
2. *Obtain existing curve radius and the surveyed superelevation rate. Plot point on graph and determine comfortable operating speed for existing conditions. TRB Special Report 214 and FHWA Technical Advisory T5040.28 (October 17, 1988) both are used as references for 3R work. They may be referenced for further information.*
3. *If existing conditions do not provide a sufficiently high speed, then increase the superelevation rate up to a maximum of 8% to increase the comfortable operating speed on the curve.*
4. *If increasing the superelevation rate up to 8% does not provide a sufficiently high comfortable operating speed to allow a curve to remain in place, then the designer shall consider realigning the curve. The following applies:*
 - a. *The preferred alternative is to upgrade the curve (using new construction criteria) to the appropriate design speed for the given functional classification. This is accomplished by using AASHTO Method 5 for superelevation rates and for the calculation of curve radii. See Section 32-2.*
 - b. *In certain cases, a second alternative for reconstruction may be considered for curve realignment. This might occur where environmental issues become critical, where right-of-way is determined to be highly restricted, or where a major at-grade intersection falls within the limits of the curve and the curve radius cannot be increased due to alignment restrictions. The maximum superelevation rate typically used on curves at a major crossroad intersection is 4%. In this case, the designer may determine the appropriate radius by using AASHTO Method 2 for superelevation and side-friction distribution. Figure 49-3.B values would apply.*

49-3.04(c) Treatment of Existing Horizontal curves

The basic objectives for improving operating speeds on horizontal alignment of rural type highways with ADTs of 1000 or more are:

- to determine if a horizontal curve can remain in place by increasing superelevation up to a maximum of 8% which, in turn, will provide a comfortable operating speed of 40 mph (65 km/h) or greater;
- to retain existing horizontal curves adequate for comfortable operating speeds of 40 mph – 50 mph (65 km/h – 80 km/h) by increasing the superelevation rate;
- to determine appropriate superelevation rates on horizontal curves adequate for speeds greater than 50 mph (80 km/h); and
- to realign horizontal curves not adequate for a 40 mph (65 km/h) comfortable operating speed when the design speed is 55 mph (90 km/h).

Regulatory Speed on Adjacent Tangents is 50 mph (80 km/h) or Greater and Current ADT >1000

1. Radius Less Than 460 ft (140 m). The following applies:
 - a. Realign horizontal curve according to functional classification of highway and use appropriate design speed criteria (see applicable chapter in Part V) or, in some cases, use Figure 49-3.B to determine curvature. See the footnotes for Figure 49-3.B for determination of cases.
 - b. If the proposed realignment lies along a highway with a lower current traffic volume, a 60 mph (100 km/h) design speed may be considered for the realignment if this is compatible with the remainder of the route.
 - c. The following design features will apply to any realignments:
 - The traveled way should be 24 ft (7.2 m) wide, and the lanes should be striped 12 ft (3.6 m) wide through the curve.
 - The shoulders should be 8 ft (2.4 m) wide. The minimum paved shoulder will be 1 ft (300 mm) wide, and an aggregate wedge will be provided adjacent to the paved shoulder. Stabilization could be wider to be compatible with the remainder of the project.
 - Front slopes generally should be 1V:4H, but they may vary in relationship to prevailing slopes throughout the project and/or adjacent roadway sections. Back slopes generally should not be steeper than 1V:3H.

2. Radius 460 ft to 750 ft (140 m to 230 m). The following applies:
- a. Retain existing horizontal curvature and use an 8% superelevation rate.
 - b. Find comfortable operating speed from Figure 49-3.B and post with an advisory speed as follows:
 - For 40-42 mph (64–68 km/h) operating speeds, post curve at 40 mph.
 - For 43-47 mph (69–76 km/h) operating speeds, post curve at 45 mph.
 - For 48-50 mph (77–80 km/h) operating speeds, post curve at 50 mph.
 - For operating speeds greater than 50 mph (80 km/h), no posting is required.
 - c. The following design features will apply to horizontal curves in this category:
 - Lanes should be a minimum of 12 ft (3.6 m) wide through the curve.
 - The minimum paved shoulder widths are 1 ft (300 mm) on the outside and 3 ft (900 mm) on the inside of the curve. Stabilization could be wider to be compatible with the remainder of the project.
 - A minimum stopping sight distance for 50 mph (80 km/h) should be considered across the inside of the curve. See Section 32-4.
 - Where the district determines that the truck volumes are high, consider using 13 ft (4.0 m) lanes through the curve. Curve widening on the inside generally is preferable.
 - Reflectorized pavement markers should be placed along the centerline of the curve.
3. Radius Greater than 750 ft (230 m). The following applies:
- a. Superelevate curve in accordance with Figure 49-3.B to accommodate the tangent regulatory speed.
 - b. The following design features will apply to horizontal curves in this category:
 - Use a minimum of 12 ft (3.6 m) lanes.
 - The minimum paved shoulder widths are 1 ft (300 mm) on the outside and 3 ft (900 mm) on the inside of the curve. Stabilization could be wider to be compatible with the remainder of the project.
 - A minimum stopping sight distance for 55 mph (90 km/h) should be considered across the inside of the curve. See Section 32-4.
 - Reflectorized pavement markers should be placed along the centerline of the curve.

Regulatory Speed on Adjacent Tangents is 45 mph (75 km/h) or Less in Rural Areas or Where Rural Cross Sections Exist

1. If the comfortable operating speed using an 8% superelevation rate equals at least 30 mph (50 km/h) ($R = 250$ ft (75 m)), then the horizontal curve may be retained. Appropriate advisory speeds shall be posted.
2. For curves with radii of 250 ft to 600 ft (75 m to 180 m), use an 8% superelevation rate to accommodate the tangent regulatory speed. Refer to Figure 49-3.B and post the appropriate advisory speed.
3. For curves with radii greater than 600 ft (180 m), superelevate the curve to accommodate the tangent regulatory speed by using an e_{\max} up to 6%. Refer to Figure 49-3.B.

Regulatory Speed on Adjacent Tangents is 50 mph (80 km/h) or Greater and Current ADT < 1000

1. If the comfortable operating speed using an 8% superelevation rate equals at least 35 mph (60 km/h) ($R = 350$ ft (106 m)), then the horizontal curve may be retained. Appropriate advisory speeds shall be posted.
2. For curves with radii of 350 ft to 750 ft (106 m to 230 m), use an 8% superelevation rate to accommodate the tangent regulatory speed. Refer to Figure 49-3.B and post the appropriate advisory speed.
3. For curves with radii greater than 750 ft (230 m), superelevate the curve by using Figure 49-3.B to accommodate the tangent regulatory speed.

49-3.04(d) Superelevation Transition Lengths

The length of superelevation transition consists of two parts — the length of superelevation runoff and the length of tangent runoff. For a discussion of superelevation development, see Section 32-3.

When the regulatory speed on an adjacent tangent is 50 mph (80 km/h) or greater and the radius of the curve is greater than 750 ft (230 m), a desirable superelevation transition length of 230 ft (70 m) should be used. The minimum superelevation transition length should be approximately 200 ft (60 m).

For all other speed and curve combinations in a rural area, a desirable superelevation transition length of approximately 200 ft (60 m) should be used. The minimum superelevation transition length should be approximately 150 ft (45 m).

For new construction and reconstruction projects, the Department's practice is to provide 67% of the superelevation runoff on tangent and 33% on curve. However, due to the nature of 3R projects, the location of superelevation runoff lengths with respect to the PC and PT may vary,

and strict compliance with this runoff ratio is not mandatory. Where reverse curves may restrict the distribution of the runoff, a ratio of 50% on tangent and 50% on curve may be used for the superelevation runoff.

49-3.04(e) Traveled Way/Shoulder “Rollover”

Through horizontal curves where the proposed or remaining shoulder width is 6 ft (1.8 m) or wider, the maximum rollover (algebraic difference between slopes) at the intersection of the traveled way and shoulder should not be greater than 10%. Where the shoulder width is 4 ft (1.2 m) or less, the maximum rollover may be 12%. Where 1 ft (300 mm) wide paved shoulder strips are used, the rollover should occur at the edge of the paved shoulder rather than at the traveled way edge for ease of construction.

49-3.04(f) Summary

Figure 49-3.C summarizes the horizontal curve criteria for 3R projects on rural arterial facilities.

Existing Comfortable Operating Speed on Curve	Posted Speed of 45 mph or Less on Adjacent Tangents	Posted Speed of 50 mph or Higher on Adjacent Tangents		Existing Comfortable Operating Speed on Curve
		<1000 ADT	>1000 ADT	
< 30 mph	Reconstruct	Reconstruct	Reconstruct	< 30 mph
30 mph	Improve Superelevation and Post Advisory Speed	Improve Superelevation and Post Advisory Speed	Improve Superelevation and Post Advisory Speed	30 mph
35 mph				35 mph
40 mph				40 mph
45 mph	Improve Superelevation	Improve Superelevation	Improve Superelevation	45 mph
50 mph	Not Applicable			Improve Superelevation
> 50 mph				

SUMMARY OF HORIZONTAL CURVE POLICY

Figure 49-3.C

49-3.05 Vertical Alignment

49-3.05(a) **Crest Vertical Curves**

The following will apply:

<u>Current ADT</u>	<u>Treatment</u>
1000 or more	<p>All existing crest curves which are not within 15 mph (25 km/h) of the posted or regulatory speed, as determined from the available stopping sight distance (SSD), will be upgraded by one of the following options:</p> <ul style="list-style-type: none"> • flatten the crest curve within the existing right-of-way to satisfy 55 mph (90 km/h) (desirable) or 45 mph (70 km/h) (minimum) SSD; or • flatten the crest curve by using additional right-of-way to satisfy a 50 mph to 55 mph (80 km/h to 90 km/h) SSD; or • flatten the crest curve with sufficient additional right-of-way to satisfy the SSD design speed for reconstruction criteria. A 60 mph (100 km/h) design speed may be considered on low-volume highways. • Where a structure lies on a crest curve, flatten the approaches to a SSD design speed using reconstruction criteria. In addition through the limits of the reconstructed embankment, the improved shoulder width should be a minimum of 8 ft (2.4 m). <p>The designer should consider sight distances, intersection influences, overall safety, the need for road closures, detours, stage construction, and especially the prevailing vertical alignment in evaluating the above alternatives. Such an analysis will allow designers to determine the most practical alternative for flattening crest vertical curves.</p>
Less than 1000	<p>Crest curves may be retained where the stopping sight distance on the vertical curve is no more than 20 mph (30 km/h) less than the posted or regulatory speed but not less than a 30 mph (50 km/h) available stopping sight distance.</p>

49-3.05(b) **Sag Vertical Curves**

For all traffic volumes, sag vertical curves generally may be retained except for sags that include a structure requiring a complete replacement. In this case, the designer shall consider and investigate upgrading the sag vertical curve to meet a SSD design speed using reconstruction criteria versus allowing the profile to remain in place.

49-3.05(c) Maximum Grades

Existing mainline grades are acceptable; i.e., flattening grades usually is not within the scope of a 3R project.

49-3.06 Intersections**49-3.06(a) Superelevation Rate Changes Through Intersections**

Superelevation rates less than that specified for the preceding horizontal alignment may be used through certain intersections because of significant intersection conflicts and when supported in the Phase I engineering report. Refer to Figure 36-1D for guidance. Agreement should be reached with the District Operations Engineer on the appropriate advisory speed to be posted for the curve and noted in the Phase I engineering report.

49-3.06(b) Stop-Controlled Approaches on Horizontal Curves

For curved, stop-controlled approaches on State-marked routes or collector route intersections, with arterial highways, it is desirable to provide as flat an alignment as practical (with lower superelevation rates), even though traffic is operating at lower speeds than on comparable non-stop approaches. On a project-by-project basis, the benefits of higher superelevation rates for high operating speeds (during clear weather or wet pavement conditions) versus the benefits of lower superelevation for low operating speeds (during icy pavement conditions) should be carefully considered when selecting an appropriate superelevation rate. Where curve flattening is not practical, an existing curve may be retained when it will accommodate a comfortable operating speed of at least 30 mph (50 km/h) with 8% superelevation. The minimum radius in this case is 250 ft (75 m).

49-3.06(c) Sideroad Approach Grades

All connecting sideroad approaches should be examined for drainage away from the arterial route. The gradeline on the sideroad should normally drain away from the intersected arterial highway for 50 ft to 100 ft (15 m to 30 m) or, at a minimum, to the ditch line of the arterial highway. The minimum sideroad gradeline should be approximately -1.0% from the intersected State highway, and the maximum gradeline is -4.0%. Where the arterial highway is on a horizontal curve, use a maximum of -2.0% on the sideroad connection to minimize rollover at the edge of traveled way. When marked or unmarked crosswalks exist or are proposed across the intersection, roadway approach grade values more restrictive than those shown in this Section may be necessary to achieve accessibility standards. See Sections 58-1.10 and 36-1.06 for more information.

49-3.06(d) Sideroad Turning Radii

For rural arterial 3R projects, the design vehicle used for sideroad turning radii may be site specific with justification. See Section 36-1 for guidance in the selection of a design vehicle considering functional classification.

49-3.06(e) Intersection Sight Distance (ISD)

At rural, public road intersections with a stop condition on the sideroad, provide 600 ft (180 m) of sight distance for the stopped approach in both the left and right directions along the arterial highway. Use a 12 ft (3.5 m) distance from the edge of traveled way to the driver's eye. Approval of a Level Two design exception will be required for the retention of less sight distance. In addition, the posting of a warning sign may be appropriate on the arterial highway.

49-3.07 Roadside Treatment and Highway Appurtenances**49-3.07(a) General**

The intent of these guides is to perform cost-effective work that may reduce the number and severity of run-off-the-road crashes. Remove or shield obstacles within the clear zone, including protrusions that extend more than 4 in. (100 mm) above the ground line, where cost effective.

49-3.07(b) Earth Slopes

Other than specifically described in Section 49-3, existing parallel slopes should generally remain. Where existing right-of-way permits significant slope flattening or where grading within existing right-of-way is necessary, the designer should consider flattening earth slopes, particularly at horizontal curves.

Where considerable new right-of-way is required, front slopes should be 1V:4H or flatter and back slopes 1V:3H or flatter, but slopes may vary in relationship to prevailing conditions throughout the project and/or adjacent highway sections. Reconstructed ditch bottoms should be at least 2 ft (600 mm) wide and 3 ft (900 mm) deep.

Transverse slopes within the right-of-way shall be regraded to be not steeper than 1V:4H.

49-3.07(c) Clear Zones

For rural arterials other than at horizontal curves, clear zone widths (measured from the edge of traveled way) should be in accordance with Figure 49-3.D.

It may be warranted to expand the roadway clear zone on the outside of relatively sharp horizontal curves. This addresses the increased potential of motorists running off the roadway at curves. Figure 49-3.E presents the clear zones at horizontal curves.

Regulatory Approach Speed and ADT	Proposed Ditch Cross Section ⁽¹⁾	Clear Zone
50 mph (80 km/h) or greater and ADT > 1000	Traversable	18 ft (5.5 m) or ROW line ⁽²⁾
	Non-Traversable	18 ft (5.5 m) or Toe of Back Slope ⁽²⁾
All Others		12 ft (3.6 m) or Non-Traversable Ditch ⁽²⁾

Notes:

- (1) *A traversable ditch cross section is one where the following configuration applies: 1V:4H front slopes, 2 ft (600 mm) wide ditch bottom, and 1V:3H back slopes. If any of these minimum criteria are not satisfied, the ditch cross section is considered non-traversable.*
- (2) *Use whichever is less.*

**CLEAR ZONES ON TANGENT SECTIONS
(3R Rural Arterial Projects)**

Figure 49-3.D

Regulatory Approach Speed mph (km/h)	Comfortable Operating Speed on Curve, Range in mph (km/h)	Proposed Ditch Cross Section ⁽¹⁾	Clear Zone ⁽²⁾
50 (80)	35-50 (55 – 80)	Traversable	25 ft (7.5 m) ⁽³⁾
50 (80)	35-50 (55 – 80)	Non-traversable	25 ft (7.5 m) or Toe of Back Slope ⁽⁴⁾
55 (90)	35-55 (55 – 90)	Traversable	25 ft (7.5 m) ⁽³⁾
55 (90)	35-55 (55 – 90)	Non-traversable	25 ft (7.5 m) or Toe of Back Slope ⁽⁴⁾

Notes:

- (1) *A traversable ditch cross section is one where the following configuration applies: 1V:4H front slopes, 2 ft (600 mm) wide ditch bottom, and 1V:3H back slopes. If any of these minimum criteria are not satisfied, the ditch cross section is considered non-traversable.*
- (2) *Clear zone values apply only to the outside of horizontal curves. For regulatory approach speeds less than 50 mph (80 km/h) or for comfortable operating curve speeds greater than those shown in the figure, use the roadway clear zones in Figure 49-3.D.*
- (3) *Use ROW line if it is less than 25 ft (7.5 m) from edge of traveled way.*
- (4) *Use whichever is less.*

**CLEAR ZONES ON OUTSIDE OF HORIZONTAL CURVES
(3R Rural Arterial Projects)**

Figure 49-3.E

49-3.07(d) Guardrail

The designer should carefully analyze all existing guardrail installations to determine if the guardrail should be removed or upgraded in accordance with Section 38-6 and the following:

1. Guardrail Removal. Remove guardrail that is not warranted. An existing guardrail installation should be removed when a life-cycle benefit to cost analysis shows this is preferable to updating, and maintaining the guardrail. Benefit to cost analysis may be done using the Roadside Safety Analysis Program (RSAP), provided by AASHTO, or by using the benefit-cost tool developed to support the Highway Safety Improvement Program (HSIP) referenced in Safety Policy 1-06.
2. Guardrail Upgrading. Existing guardrail that is warranted may remain in place if it meets the all of the following:
 - a. Guardrail installed using Highway Standard 630001-06 or earlier may remain in place if all of the following are met:
 - Safety analysis does not show a pattern of severe crashes related to the existing guardrail.
 - There is no loss of steel section from rusting of the steel rail, posts, or other structural components.
 - The system does not have structural damage (e.g., buckled/kinked elements, torn elements, holes). These criteria may be evaluated in light of guidelines adopted by the Department for acceptable elements.
 - Weathering steel guardrail may not remain.
 - The system must have 6 in. (150 mm) wood or approved plastic blockouts.
 - Slope from the edge of pavement to the face of rail must be 1:10 or flatter, or may be obtained by regrading if this can be done without violating any other of these requirements.
 - Height to the top of rail must be between 27 $\frac{3}{4}$ in. (705 mm) and 30 in. (760 mm) measured at the face of rail.
 - May not have any washers (e.g., "Plate Washer F" on some old Highway Standards) under bolt heads holding the rail at posts.
 - All other structural details are as shown on *Highway Standard* 630001-06. Post lengths may be confirmed from the Highway Standard in effect at the time of installation of the existing guardrail.

- b. For guardrail installed under *Highway Standard* 630001-07 or later:
- There is no loss of steel section from rusting of the steel rail, posts, or other structural components.
 - The system does not have structural damage (e.g., buckled/kinked elements, torn elements, holes). This criterion may be evaluated in light of guidelines adopted by the Department for acceptable elements.
 - Weathering steel guardrail may not remain.
 - The system must have 12 in. (300 mm) wood or approved plastic blockouts.
 - Slope from the edge of pavement to the face of the rail must be 1:10 or flatter.
 - Height to the top of the rail must be 28 in. (710 mm) to 32 in. (810 mm) measured at the face of the rail.
 - All other functional details as shown on the current *Highway Standard* 630001 are provided. Items such as adjusting holes are not considered functional.
3. End Sections. Ensure all guardrail end sections for existing guardrail meets the approved lists of devices in force in December 2006, or subsequent versions appropriate for later *Highway Standards* for guardrail. Ensure all transitions from guardrail to bridge rails or to structures meet the *Highway Standards* in effect in December 2006, or subsequent versions appropriate for later *Highway Standards* for guardrail.
4. Length of Need. Use the length-of-need criteria in Section 38-6.01 to determine the sufficiency of the existing length of guardrail based on the posted speed. Upgrade existing guardrail that is deficient in length by more than 10 percent to provide a proper length of need. Guardrail less than 10 percent deficient may remain in place unless crash data shows that the additional length will reduce crash severity. Also, provide the proper length of need if placement of a new crashworthy terminal is required. Where practical, the designer should shorten the required length of need by tapering the barrier away from the traveled way. In addition, where an intersecting sideroad, driveway, or field entrance interferes with the placement of the length of need of continuous guardrail at a bridge approach, the relocation of the sideroad, driveway, or field entrance should receive preference over reducing guardrail length.

5. New Guardrail Installation. New guardrail should be installed in accordance with Section 38-6 and:
 - at bridge approaches where none exists,
 - at departure ends of two-way bridges,
 - in accordance with the culvert criteria (Section 49-3.07(e)),
 - at locations where the warrants are satisfied in accordance with Figure 49-3.F and the use of the hierarchy of preferences results in a guardrail application.
6. Short-Radius Guardrail. Where practical, roadside safety should be upgraded at locations where short-radius guardrail is present or considered. See Section 38-6.09 for guidance on short-radius guardrail. Short-radius guardrail occurs when the radius is 150 ft (45 m) or less and is usually associated with a side road or entrance.
7. Departure Ends of Two-way Bridges. Due to the extreme hazard posed by the end of a bridge parapet, shielding of the departure end must be provided, even when the bridge parapet end is outside the clear zone for the opposing direction traffic. To determine the required length of need for the departure end, refer to Section 38-6.01.
8. Cable Barrier. Determine the installation of new or disposition of existing cable-guard or cable barrier from special studies. If it appears desirable to use cable barrier for roadside hazards, see Section 38-6.02. Also, contact the Bureau of Safety Programs and Engineering regarding other possible uses on a case-by-case basis.

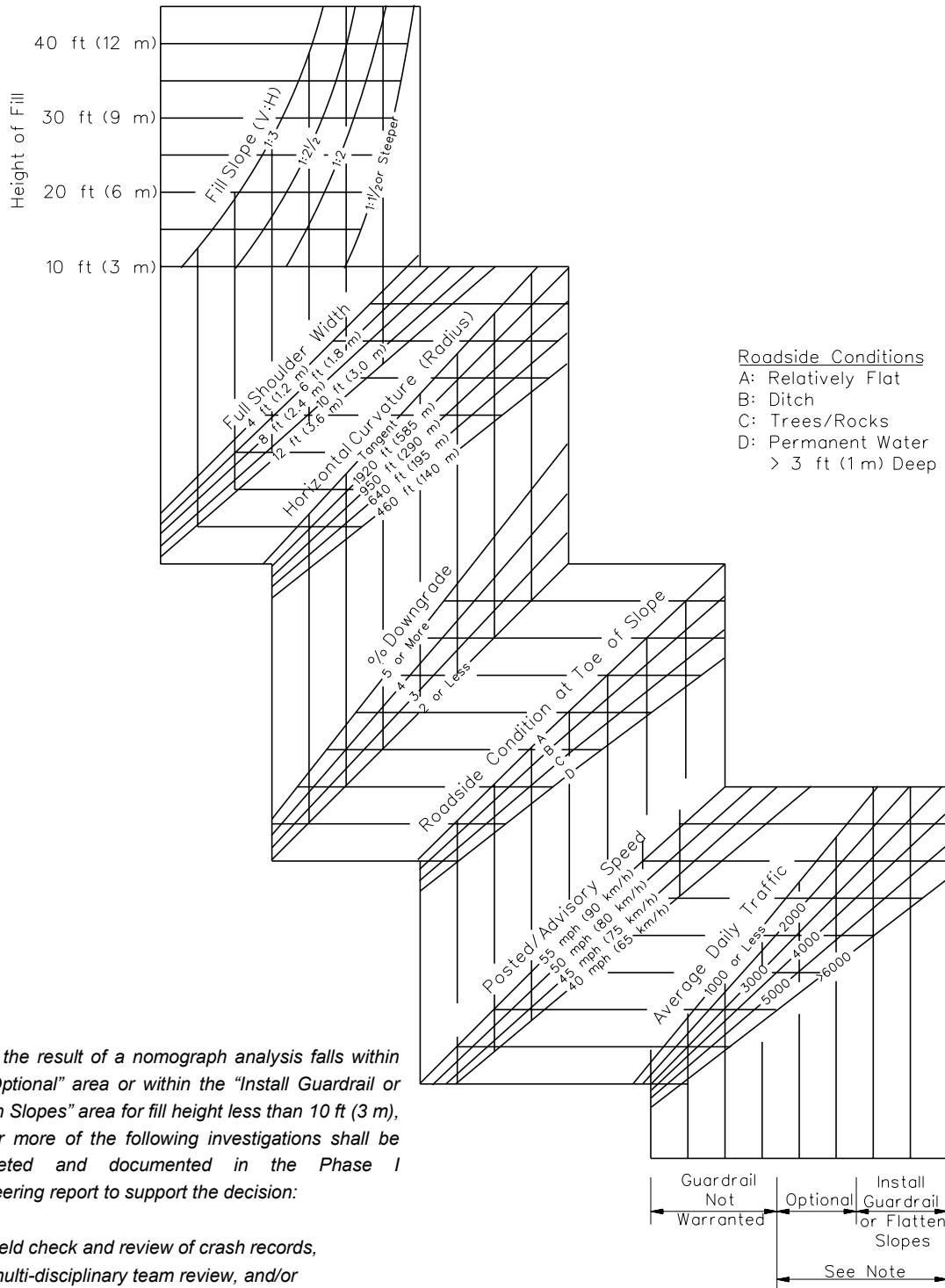

Note: When the result of a nomograph analysis falls within the "Optional" area or within the "Install Guardrail or Flatten Slopes" area for fill height less than 10 ft (3 m), one or more of the following investigations shall be completed and documented in the Phase I engineering report to support the decision:

- field check and review of crash records,
- multi-disciplinary team review, and/or
- cost-effective economic analysis.

**GUARDRAIL WARRANTS FOR 3R PROJECTS
(Arterial Routes)**

Figure 49-3.F

49-3.07(e) Culverts

For the Department's practices for the roadside safety treatment of both cross-drainage and parallel drainage structures, see Section 38-4.06(b). For the determination of guardrail warrants for non-traversable culverts on 3R projects, Figure 49-3.G may be used in lieu of analytical calculations found in Chapter 38.

An example of how to transition the re-graded front slope at the culvert to the steeper existing front slopes on both the approach and departure ends of the culvert is shown in Figure 49-3.H.

The designer should reference Section 3-500, "Construction/Reconstruction and Maintenance of Sideroad and Street Intersections with State Highways," of the Bureau of Operations' *Maintenance Policy Manual* for additional guidance.

49-3.07(f) Sign and Light Supports

Posts or poles used to support signs or lights to remain within the clear zone should be breakaway. Wood sign supports may be modified to properly reduce the cross sectional area or replaced with breakaway supports.

49-3.07(g) Trees

Trees maturing to a diameter greater than 4 in. (100 mm), unless shielded by a protective device required for other purposes, shall be removed within the clear zone. Trees on back slopes that are not likely to be impacted by vehicles may generally remain in place. In cases where unusual specimens are in jeopardy, guardrail or attenuator protection may be considered as an alternative to removal; see Chapter 59.

49-3.07(h) Concrete Signal Bases

Concrete signal bases (Type B) within the clear zone and extending higher than 4 in. (100 mm) above the ground line shall be removed, and standard supports with frangible bases installed where appropriate. Note: Mast arm signal supports cannot have frangible bases.

49-3.07(i) Curbs

Curbs higher than 4 in. (100 mm) within the shoulder area should be removed where posted speeds are greater than 45 mph. The proper placement of traffic control devices shall be reviewed before considering the removal of corner island curbs where such devices are located. Curb removal is not intended to include intermittent center channelizing islands separating two-lane, two-way traffic and supplemented by illumination. Reflectorizing devices should be placed on curbs in accordance with the Bureau of Operations practices to improve delineation.

49-3.07(j) Traffic Control Devices

All traffic control devices shall conform to the *Illinois Manual on Uniform Traffic Control Devices*.

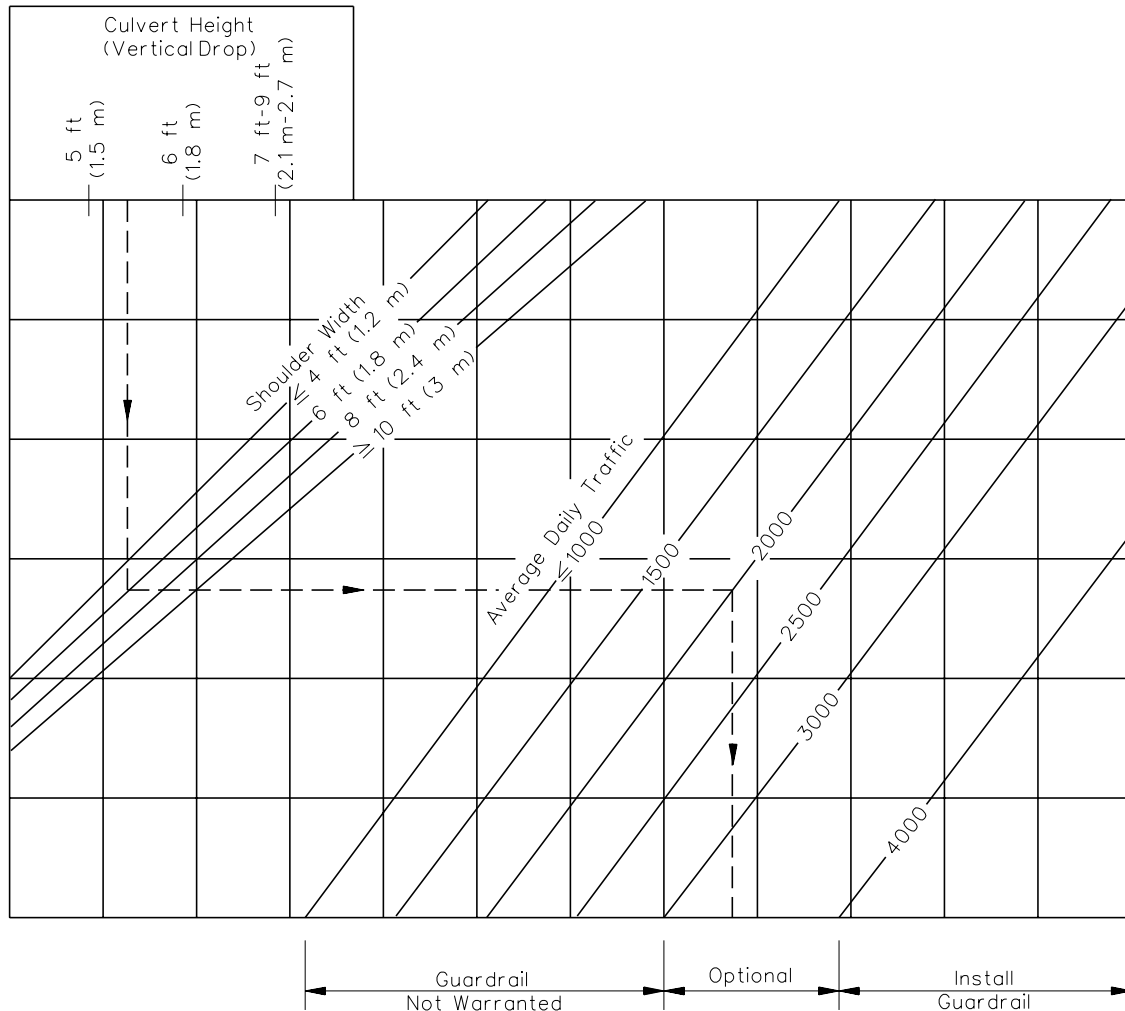

Notes:

1. This nomograph supplements, but does not supersede Figure 49-3.F.
2. Culvert height includes the earth cover immediately above the culvert if it increases the “drop-off.” Where the culvert height is 10 ft (3.0 m) or greater, guardrail is warranted. Follow the hierarchy of preferences in Section 38-4.06(b) for cross road culverts.
3. When the result of a nomograph analysis falls within the “optional” area, one or more of the following investigations shall be completed and documented in the Phase I engineering report to support the decision:
 - field check and review of alignment and crash records,
 - multi-disciplinary team review, and/or
 - cost-effective economic analysis.

3R GUARDRAIL WARRANTS FOR NON-TRAVERSABLE CULVERTS

Figure 49-3.G

FS = Front Slope
D = Ditch Bottom
BS = Back Slope

Combined ditch section
according to Section 49-3.07(b)

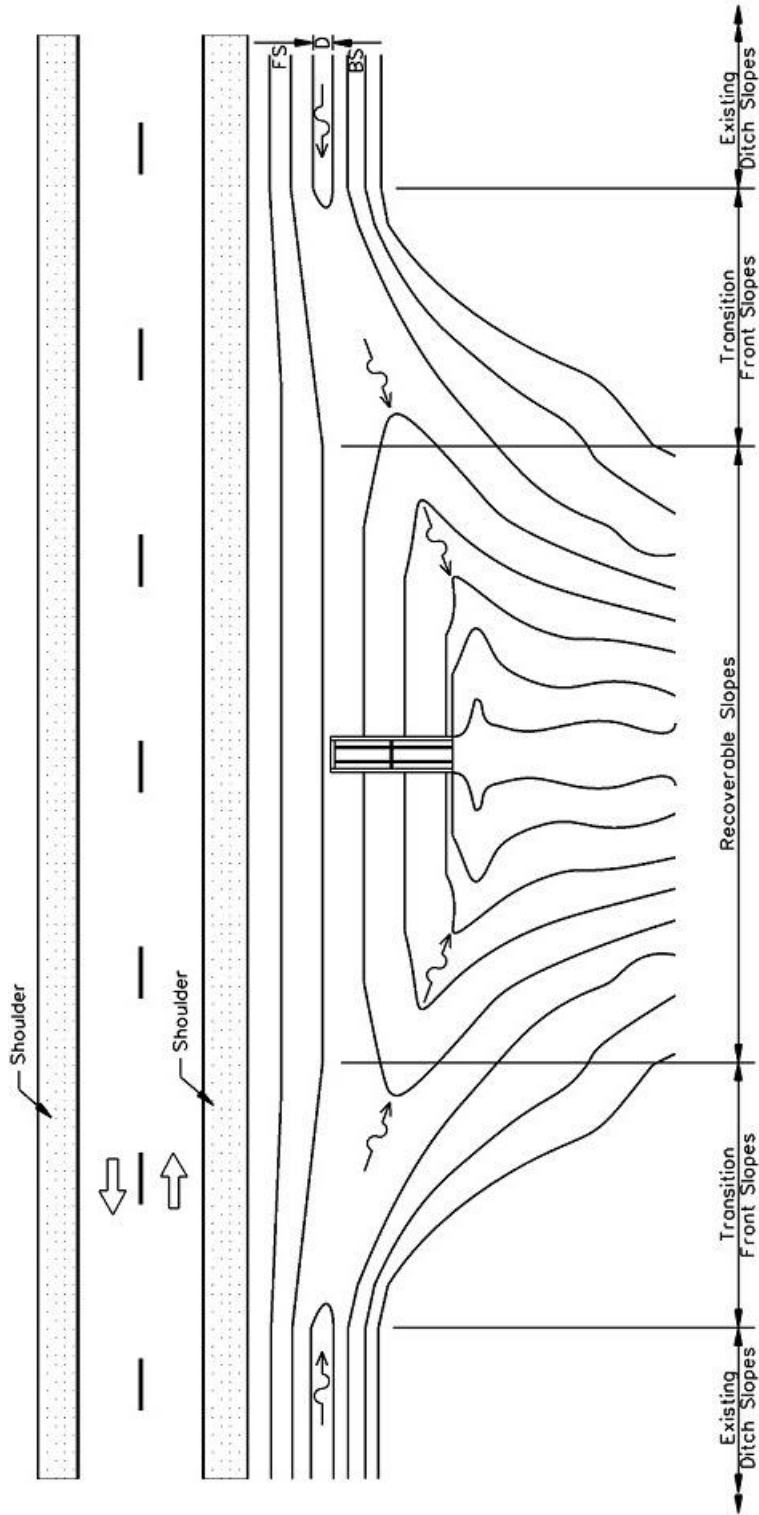

REGRAIDING PLAN FOR EXTENDED CULVERTS
(3R Rural Arterial Projects)
Figure 49-3.H

49-3.07(k) Mailbox Turnouts

The design and construction of mailbox turnouts should be in accordance with the criteria in Chapter 58 and the *Highway Standards*. Where appropriate, the designer should discuss the mailbox supports considered hazardous and within the clear zones with the property owners:

- to inform the owner of the potential severity of the support, such as the results of pertinent research and tests as reported in the TRB Paper “The Rural Mailbox – A Little Known Hazard”;
- to inform the owner of the possibility of personal liability; and
- to request the owner to change the support to reduce the potential seriousness of the hazard. Changed supports will be consistent with the designs contained in *AASHTO Roadside Design Guide*.

49-3.07(l) Lighting and Landscaping

Installation of lighting to improve operations and/or safety should be considered in accordance with the guides in Chapter 56. Generally, landscaping should be directed toward replacing appropriate existing plants and turf removed or damaged by construction and, where practical, planting for safety or erosion control purposes. See Chapter 59.

49-3.07(m) Above-Ground Utilities

Where practical, above ground utility facilities should not be allowed to remain inside the clear zone, except where protected by devices required for other purposes. Existing utility facilities may generally remain:

- where located beyond non-traversable ditch cross sections, or
- where right-of-way is so narrow that the maximum adjustment possible within the existing right-of-way is minimal and considered impractical.

Where regrading of the back slopes is necessary for a significant length within the area of utility facilities, the utilities should be relocated according to the Bureau of Operations’ publication *Accommodation of Utilities on Right-of-Way of the Illinois State Highway System*. See Section 6-1.02 for other publications.

49-3.07(n) Airports

Near airports, the erection of any signs, trusses, light supports, structures, etc., 15 ft (4.5 m) or higher than the roadway, shall be coordinated with Aeronautics. Such obstructions and under what conditions they may apply to clear zone heights are described in Chapter 11.

49-3.07(o) Other

There may be other non-Department-owned objects within the desired clear zone that may be roadside obstacles. Accordingly, they should also be evaluated.

49-3.08 Railroad Crossings and Signals

Railroad crossings and signals should be upgraded prior to or concurrent with 3R projects. When work on existing railroad crossings, new crossings, protection devices, structures, etc., requires coordination of planning with railroad companies and/or the Illinois Commerce Commission, the results of these activities should be included in the Phase I engineering report. Also, coordinate, as necessary, with the IDOT Bureau of Rail in the Office of Intermodal Project Implementation to ascertain the status of affecting railroad improvements or abandonments; see Chapter 7.

Where the existing railroad crossing surface is in good condition and will remain, the roadway overlay shall be tapered to match the existing crossing profile. If required by current practices, the crossing surface outside the traveled way should consist of bituminous or other approved material.

Locate the crossing warning signal devices in accordance with current safety requirements and upgrade if not in conformance with State guidelines as discussed in Chapter 7 and in the IDOT publication *Requirements for Railroad/Highway Grade Crossing Protection*. Any other associated work performed must also meet State guidelines.

If, as an exceptional case, there will be a significant lapse of time in the relocation of railroad warning signal devices, the widened pavement should be constructed up to the crossing. Offsets to the existing warning signal devices should temporarily consist of tapered edge lines and diagonal pavement markings. If the location of the existing warning signal devices precludes this treatment, taper the widened pavement to the existing pavement width at or near the signal location.

Plans showing required changes in railroad facilities should be prepared in time to enable agreement negotiations to be concluded so that railroad work may proceed concurrently with that of the highway contract. The appropriate offices, on a project-by-project basis, shall approve variances to this procedure. See Chapter 7.

49-3.09 Bridges

49-3.09(a) Bridge Condition Reports/Structure Sketches

A Bridge Condition Report (BCR) and a Proposed Structure Sketch are required for every structure within a roadway section covered by a Phase I engineering report or when a bridge itself is the reason for preparing a Phase I engineering report. In advance of submitting the BCR and Proposed Structure Sketch to the Bureau of Bridges and Structures (BB&S) for review and concurrence, a typical section that shows the proposed clear roadway bridge width is approved by BDE. Before design approval can be granted, all BCRs shall be approved by the BB&S and concurrence also must be received on all Proposed Structure Sketches.

A Bridge Condition Report also is required for a bridge proposed to remain in place. This will ensure that the bridge meets the minimum requirements for width, safety, and structural

capacity. However, the Illinois Structure Information System-Master Report (R107) may be substituted for a Bridge Condition Report.

See Section 39-3.02 for more information on Bridge Condition Reports.

49-3.09(b) Scope of Work

Bridges on existing two-lane rural arterials will be rehabilitated to correct operational, structural, and/or significant safety deficiencies.

Bridges meeting the criteria in Section 49-3.09(c) will remain in place. Improvement of deficient bridge rails and curb sections and deck repair and resurfacing, when appropriate, should be performed concurrently with a 3R highway project.

Bridges not meeting the criteria for bridges to remain in place will be improved. They shall meet the criteria for improved bridges as discussed in Section 49-3.09(d). Bridges with clear roadway bridge widths less than the improved pavement widths for the appropriate volumes (see Section 49-3.03) should be improved concurrently with a 3R highway project or deferred for a period of no more than one year from the completion of the highway project.

The improvement of bridges with clear roadway bridge widths equal to or greater than the specified traveled way width, but less than those required to remain in place, and bridges with insufficient structural capacity may be deferred; however, they should be included in the Multi-Year Improvement Program (MYP). Bridges included in the MYP and classified as narrow (i.e., those having clear widths less than 2 ft (600 mm) wider than the required lane width) should be protected and delineated in accordance with Figure 49-3.I and the Bureau of Operations "Policy on Delineation of Narrow Bridges."

Improvement of deficient rails and/or curb sections, as described in Section 49-3.09(c) for an interim period, should be completed concurrently with a 3R highway project.

49-3.09(c) Criteria for Bridges to Remain in Place

Bridges on existing two-lane rural arterials will remain in place according to the following guidelines:

The clear roadway bridge width is equal to or greater than the values in Column I of Figure 49-3.J. The clear roadway bridge width will be measured between the faces of rails or curbs when curb removal is not practical.

The main supporting elements of the bridge including the bridge deck are structurally sound and capable of carrying an HS-20 (MS-18) structural design loading without exceeding 65% of the strength of any member.

Structurally sound bridge decks with poor riding quality that could jeopardize the safety of the motorist or cause undue discomfort should be repaired and resurfaced; however, resurfacing may not be extended across decks without appropriate repair and waterproofing or when the bridge cannot safely carry the additional dead load resulting from the resurfacing.

49-3.09(d) Criteria for Improved Bridges

Minimum clear roadway bridge widths for improved bridges are provided in Figure 49-3.J. These widths will be applicable on all bridge rehabilitation projects:

- that utilize structurally sound elements of the existing bridge,
- that involve total replacement of all elements of the existing bridge, and/or
- that involve replacement bridges on short relocations.

When the Bridge Condition Report indicates deck replacement is necessary, the structure shall be widened to the extent possible without requiring substructure additions. Necessary repairs to or replacement of superstructure elements will be permitted. However, the minimum widths shown in Column I of Figure 49-3.J shall not be violated.

Bridge roadway widths resulting from the optimum use of prefabricated modular deck units may exceed those widths designated in Column II. The minimum clear roadway bridge width on marked routes will be 32 ft (9.6 m). Structural design loading for improved bridges shall be HS-20 (MS-18).

The hydraulics of proposed bridge improvements shall be analyzed to determine the capacity to accommodate floods for the frequencies shown in Column III of Figure 49-3.J. Bridges also shall be evaluated for a base 100-year flood.

Where the existing vertical alignment is maintained and there is no history of serious hydraulic deficiencies, the existing bridge waterway opening for the improved bridge may be retained. However, the designer must evaluate backwater effects of vertical realignments or minor reductions in openings.

49-3.09(e) Vertical Clearance

The minimum vertical clearance for bridges to remain in place is 14 ft (4.3 m). Economics may dictate exceptions.

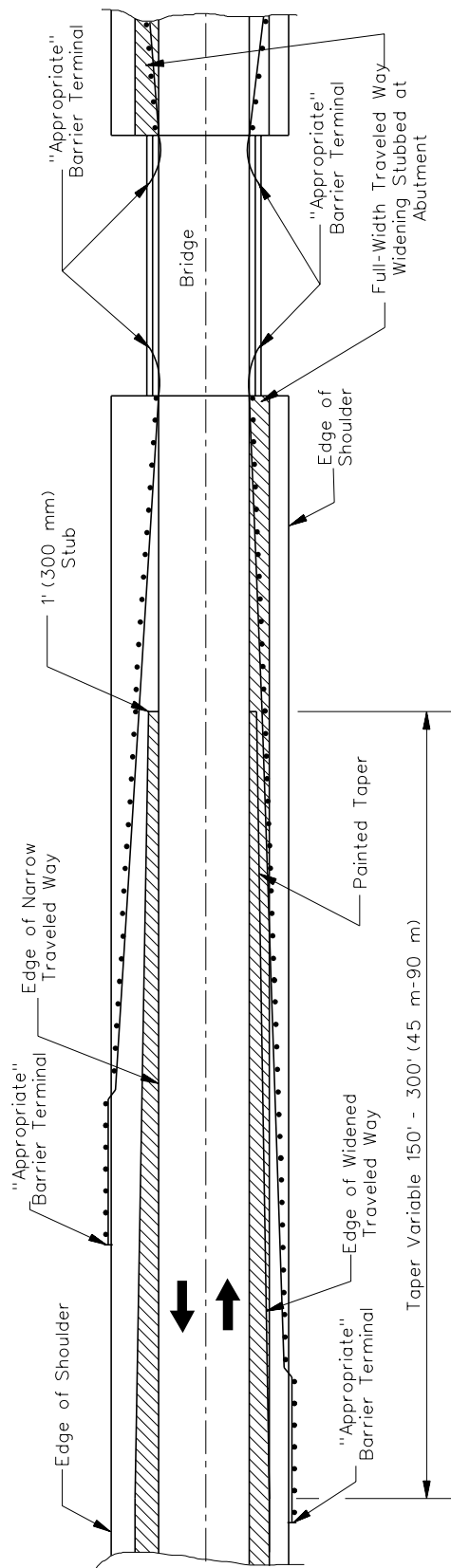

Notes:

1. *Guardrail requirement will be as determined from the length of need criteria in Section 38-6.*
2. *The "Appropriate" Barrier Terminal should be selected using the guidelines set forth in Section 38-6.*
3. *If the use of the "Appropriate" Barrier Terminal results in a roadway clear width less than that given in Section 49-3.03, a Traffic Barrier Terminal, Type 10 and 25 ft (7.6 m) of Type B guardrail may be substituted for the above terminal.*
4. *Guardrail will be installed on a 1:25 taper from the bridge end rail to the shoulder edge, then parallel to the shoulder until the length of need is fulfilled.*
5. *Signing, object markers, and delineation will be as specified by the Bureau of Operations.*
6. *See Chapter 38 and the Highway Standards for more information.*

WIDENING AT NARROW BRIDGES

Figure 49-3.1

Current ADT	Column I	Column II	Column III
	Minimum Width of Bridges to Remain in Place	Width of Improved Bridges ⁽²⁾	Design Flood Frequency
Greater than 5000	Improved Traveled Way Width ⁽¹⁾ Plus 6 ft (1.8 m)	40 ft (12.0 m) ⁽³⁾	50 yr.
5000 to 3000	Improved Traveled Way Width ⁽¹⁾ Plus 6 ft (1.8 m)	36 ft (10.8 m) ⁽⁴⁾	50 yr.
2999 to 1000	Improved Traveled Way Width ⁽¹⁾ Plus 4 ft (1.2 m)	32 ft (9.6 m)	50 yr.
Less than 1000	Improved Traveled Way Width ⁽¹⁾ Plus 2 ft (600 mm)	32 ft (9.6 m)	50 yr.

Notes:

- (1) *The improved traveled way widths refer to the striped widths in Figure 49-3.A.*
- (2) *These clear roadway widths will be considered the minimum widths for safety and the maximum widths for cost effectiveness. For minor arterials, an existing 32 ft (9.6 m) may remain.*
- (3) *When the striped widths plus stabilized shoulders are less than 38 ft (11.5 m), a clear roadway bridge width of 36 ft (10.8 m) may be provided. A stabilized shoulder is defined as a paved shoulder and/or an aggregate shoulder at least 6 in. (150 mm) thick.*
- (4) *Clear roadway bridge widths less than 36 ft (10.8 m) may be approved, on an exception basis, when all of the following conditions exist:*
 - *The width of the existing or improved striped width plus stabilized shoulders, located between logical termini, will not be equal to or greater than 36 ft (10.8 m).*
 - *Projected traffic growth is minimal.*
 - *The proposed clear roadway bridge width will be consistent with the width of other bridges to remain in place along the roadway section. In addition, no upgrading of the roadway is contemplated within the foreseeable future.*
 - *Existing and projected truck traffic is moderate (10% or less of ADT).*
- (5) *If an exception to a bridge width is warranted, the Phase I engineering report shall document the basis (minutes from a coordination meeting) for proposing and selecting the lesser width. However, for bridges located on the arterial system, the minimum clear roadway bridge width for improved bridges shall be no less than 32 ft (9.6 m).*

3R RURAL PRINCIPAL ARTERIAL BRIDGE CROSS SECTION ELEMENTS⁽⁵⁾**Figure 49-3.J**

49-4 URBAN ARTERIAL HIGHWAYS AND STREETS

49-4.01 Application

Section 49-4 is applicable to resurfacing, rehabilitation, and restoration (3R) projects on the State highway system that are:

- urban arterials,
- marked urban highways or streets functionally classified as collectors, or
- expressways (project-by-project basis).

49-4.02 Scope of Work

A 3R project on an urban arterial highway or street may include work such as lane widening, the addition of auxiliary lanes, channelization, median installation, revision of median type, median widening, resurfacing in conjunction with appropriate widening, new or replaced curb and/or gutter, curb ramps to meet the accessibility criteria, pavement markings, landscaping, lighting, and any associated utility adjustments. Except for relatively short sections, 3R work does not include the addition of continuous through lanes that change the basic number of lanes throughout the project.

Other than widening the traveled way, much of this work may also be included in resurfacing only projects. Widening and resurfacing or resurfacing only, in general, should also include any associated improvements necessary to ensure adequate structural support for the new pavement. Widening and resurfacing and resurfacing of parking lanes, replacement of curbs and gutters, sidewalk construction/ replacement, curb ramps to meet accessibility criteria, and other work performed on municipally maintained facilities will be subject to State policy on joint participation improvements as discussed in Chapter 5.

Where considerable amounts of right-of-way will be acquired along a significant length of the project to accommodate widening and resurfacing, most geometric design criteria should be in accordance with the reconstruction requirements of the applicable chapters in this *Manual* (e.g., Chapter 48). Some highway elements may be designed to criteria consistent with restricted site conditions and 3R objectives.

49-4.03 Design Speed

Design speeds for 3R projects on urban and suburban arterials may be the regulatory speed limit when appropriate. A regulatory speed of 45 mph is the maximum design speed where (1) a two-way left-turn (TWLT) lane is allowed in the street/highway design, and (2) continuous curbing is used along either edge of the traveled way.

49-4.04 Roadway Cross Section Elements

For uncurbed urban and suburban arterial facilities, the criteria in Section 49-3.03 for rural facilities will apply. Typical practice is to resurface existing curbed pavements with through lanes of 10 ft (3.0 m) or wider (e-e) or turning lanes (e-f), TWLT lanes (e-e), and 8 ft (2.4 m) (e-f) or wider parking lanes without widening except on Designated Truck Routes (DTR). On DTR routes, prepare special studies to support retaining through lanes less than 11 ft (3.3 m) (e-e) wide.

Where widening will be accommodated within the existing right-of-way or where right-of-way acquisition is minimal, the cross section elements may be consistent with site conditions. Under these conditions, through and TWLT lanes may be striped as 11 ft (3.3 m) and other auxiliary lanes may be 10 ft (3.0 m) wide. Parking lanes may be 8 ft (2.4 m) wide.

49-4.05 Capacity

Design capacities, at a minimum, should be adequate for current traffic at a level of service D.

49-4.06 Diagonal Parking

Parking (existing or proposed) should generally be parallel and adjacent to the curb. Diagonal parking may be permitted to remain if a brief engineering analysis of the existing angle parking is included in the Phase I engineering report and the analysis clearly demonstrates that there will be no adverse effect on street capacity and safety. The analysis must describe parking characteristics, crash history, and an observation of street operations and potential problems. See Chapter 48 for more information.

49-4.07 Horizontal Alignment**49-4.07(a) $V = 50$ mph (80 km/h)**

Where the design speed equals 50 mph (80 km/h), the horizontal alignment criteria in Section 49-3.04 for rural arterials will apply to urban arterial 3R projects.

49-4.07(b) $V \leq 45$ mph (70 km/h)

For low-speed ($V \leq 45$ mph (70 km/h)) urban streets, the designer will use Figure 49-4.A to determine the acceptability of existing horizontal curves. Where a horizontal curve will be improved (i.e., flatten the radius and/or increase the superelevation), the designer will also use Figure 49-4.A for the reconstructed horizontal curve.

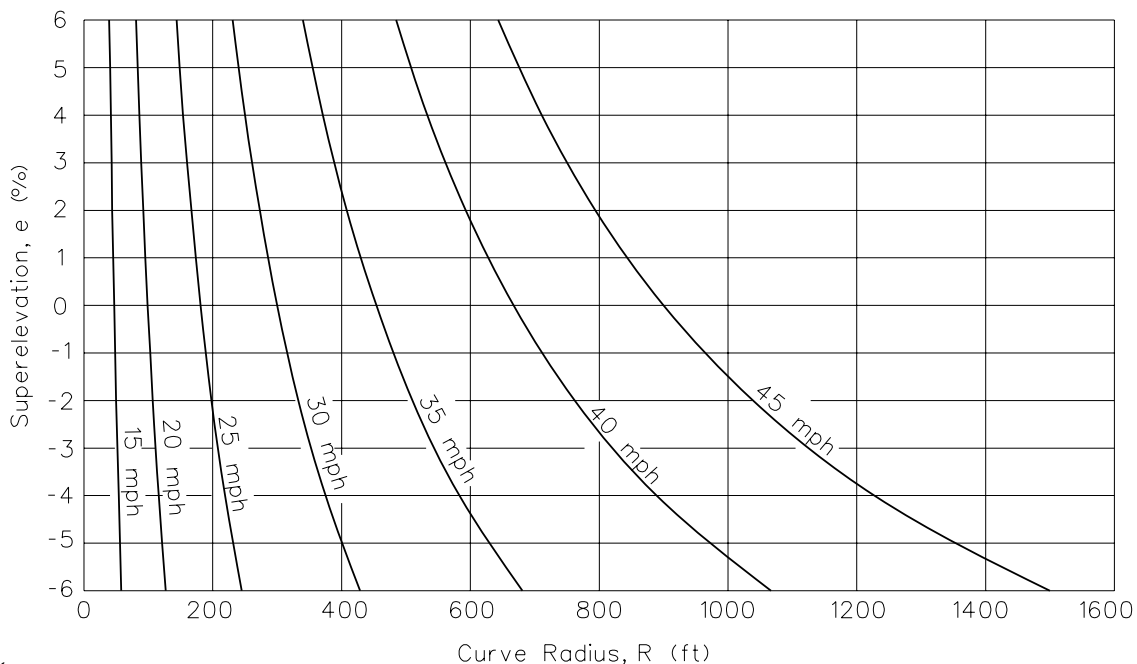

Notes:

1. The figure provides a range of operating speeds and superelevation rates that are used to determine an acceptable curve radii.
2. AASHTO Method 2 is used to distribute superelevation and side friction for low-speed urban streets. Therefore, the basic point-mass equation applies:

$$R = \frac{V^2}{15 (e / 100 + f_{max})}$$

Where:

- R = curve radius, ft
- V = speed, mph
- e = actual superelevation rate, percent
- f_{max} = assumed maximum side-friction factor (see Figure 48 5.B) for selected speed, decimal

3. For curves that fall between the -2% and +2% lines, remove the adverse crown slope through the curve. This will ensure that the maximum comfortable side-friction factor is not exceeded due to a negative slope in one direction of travel. It will also minimize potential rollover of trucks (on dry pavement) with low rollover thresholds and minimize possible skidding of trucks with smooth tires on polished, wet pavement surfaces.
4. The maximum superelevation rate for new construction is 4%. For reconstruction and 3R, a maximum rate of 6% may be considered to remain in place.

**HORIZONTAL CURVES TO REMAIN IN PLACE
(Low-Speed Urban Streets)
(US Customary)**

Figure 49-4.A

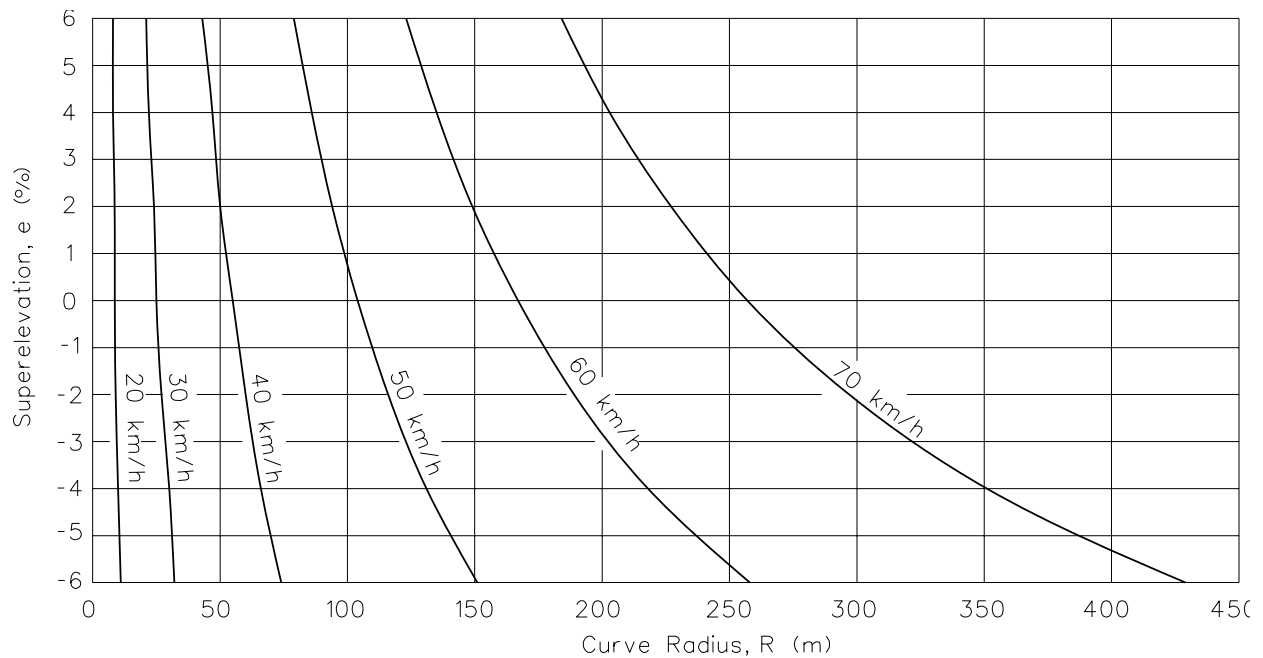
**Notes:**

1. The figure provides a range of curves in feet (meters) operating speeds and superelevation rates that are used to determine a comfortable operating speed acceptable curve radii.
2. AASHTO Method 2 is used to distribute superelevation and side friction for low-speed urban streets. Therefore, the basic point-mass equation applies:

$$R = \frac{V^2}{127 (e / 100 + f_{max})}$$

Where:

- R = curve radius, ft
- V = speed, mph
- e = actual superelevation rate, percent
- f_{max} = assumed maximum side-friction factor (see Figure 48 5.B) for selected speed, decimal

3. For curves that fall between the -2% and +2% lines, remove the adverse crown slope through the curve. This will ensure that the maximum comfortable side-friction factor is not exceeded due to a negative slope in one direction of travel. It will also minimize potential rollover of trucks (on dry pavement) with low rollover thresholds and minimize possible skidding of trucks with smooth tires on polished, wet pavement surfaces.
4. The maximum superelevation rate for new construction is 4%. For reconstruction and 3R, a maximum rate of 6% may be considered to remain in place.

**HORIZONTAL CURVES TO REMAIN IN PLACE
(Low-Speed Urban Streets)
(Metric)**

Figure 49-4.A

The basic objective for improving conditions on the existing horizontal alignment of low-speed urban streets ($V \leq 45$ mph (70 km/h)) is to retain the existing alignment and to check for comfortable operating speeds by using Figure 49-4.A. This figure assumes the use of AASHTO Method 2 for the distribution of side-friction and superelevation to determine the appropriate superelevation rates in conjunction with existing radii and posted speeds. See Section 48-5 for more information.

49-4.08 Vertical Alignment

The vertical alignment criteria in Section 49-3.05 for rural arterials will apply to urban arterial 3R projects.

49-4.09 Intersections

The intersection criteria in Section 49-3.06 for rural arterials generally will apply to urban arterial 3R projects. In addition, the following will apply.

49-4.09(a) Turning Radii

In urbanized areas, right-turn maneuvers at intersections are critical for two reasons. One is the speed at which the design vehicle can make a right turn from the main road onto a side street; the second is how much encroachment, assuming the selected design vehicle, will occur into opposing lanes when the design vehicle makes a right turn onto the main road. For right turns at urban intersections, the following guidelines should be considered for 3R projects:

1. Simple radii of 15 ft to 25 ft (4.5 m to 7.5 m) are adequate for a passenger car design vehicle. These radii may be retained on existing side streets where:
 - very few trucks are expected to turn into the side street,
 - encroachment by a single unit or tractor/semitrailer unit into opposing lanes of the main road is acceptable, or
 - a parking lane is present and parking is restricted a sufficient distance from the intersection thereby providing a larger area for a right-turn maneuver.
2. Where practical, use a simple radius of 30 ft (9 m) or a two-centered curve at all major intersections and at all minor intersections with some frequency of truck turning volumes. This design will provide for the single-unit vehicle and the occasional tractor/semitrailer unit.
3. At intersections where tractor/semitrailer combinations and buses turn frequently, provide a simple radius of 40 ft (12 m) or more or a two-centered curve.

49-4.09(b) Curb Cuts/Ramps

Curb cuts/ramps shall meet the accessibility criteria in Chapter 58.

49-4.09(c) Intersection Sight Distance (ISD)

At urban, public road intersections with a two-way stop condition or at signalized intersections where right-turn-on-red is allowed, provide ISD along the arterial for the regulatory or posted speed. Use a distance of 14.4 ft (4.4 m) from the edge of the traveled way to the eye of the stopped motorist. See Chapter 36 for details on ISD.

49-4.10 Roadside Treatment and Highway Appurtenances

Clear zones along urban arterials are as follows:

1. Where the arterial is curbed, no obstacles should be located closer than 1.5 ft (500 mm) from the face of curb. This distance is not considered a clear zone, but an operational offset. Make every effort to provide the clear zones of a rural cross section. Where parallel parking lanes are included, a 1 ft (300 mm) clearance to the face of curb may be considered.
2. Where the arterial has a rural cross section, minimum clear zone widths should be:
 - 18 ft (5.5 m) or the non-traversable ditch if less, where the regulatory speed is equal to 50 mph (80 km/h);
 - 10 ft (3 m) where the regulatory speed is 45 mph (75 km/h); or
 - the shoulder width where the regulatory speed is 40 mph (65 km/h) or less.
3. For the treatment of roadsides and highway appurtenances other than described above, as appropriate for the cross section, refer to Section 49-3.07.
 - Where pedestrian traffic is significant, breakaway sign and light supports should not be used.
 - Where the removal of trees may adversely affect the roadside environment, these trees should be removed only when necessary for reasons of safety.

49-4.11 Railroad Crossings and Signals

The criteria in Section 49-3.08 for rural arterials will apply to urban arterial 3R projects.

49-4.12 Bridges**49-4.12(a) Bridge Condition Reports/Structure Sketches**

The information in Section 49-3.09(a) for rural arterials will apply to urban arterial 3R projects.

49-4.12(b) Criteria for Bridges to Remain in Place

Urban bridges may remain in place:

- where they meet the structural requirements for rural bridges (see Section 49-3.09(c)) including those requirements for decks and bridge rails;
- where the clear roadway bridge width is sufficient to accommodate the number of approach lanes; and
- where the clear roadway bridge width includes traffic lanes 10 ft (3 m) or wider.

For urban bridges, bridge deck repairs similar to those cited for rural bridges may be undertaken. However, bituminous resurfacing carried across bridge decks is restricted as with rural bridges.

49-4.12(c) Criteria for Improved Bridges

Urban bridges that do not meet the criteria to remain in place should be improved. Such improvements shall include the following:

- The bridge shall meet the structural requirements of improved rural bridges (refer to Section 49-3.09(d)).
- The bridge shall accommodate the number of lanes and the median on the approach roadways.
- The bridge shall provide lane widths equal to those on the roadway approaches but not less than 11 ft (3.3 m).

Parking lanes on the approach roadways usually are not carried across urban bridges.

49-4.12(d) Vertical Clearance

The minimum vertical clearance for bridges to remain in place is 14 ft (4.3 m). Economics may dictate exceptions.

49-5 HIGH-SPEED, MULTILANE HIGHWAYS (WITHOUT ACCESS CONTROL)

49-5.01 General

High-speed, multilane highways are those facilities where the regulatory speed is 50 mph (80 km/h) or higher. In general, for 3R projects, the design will be determined on a project-by-project basis. Section 49-5 provides some guidance on the design of these projects.

49-5.02 Shoulders

If bituminous shoulders do not exist, the designer should include a minimum 1 ft (300 mm) bituminous strip adjacent to each edge of the traveled way. For ADT's over 10,000, the designer should consider the use of 3 ft (900 mm) bituminous right shoulders for each roadway.

49-5.03 Medians/Posted Speed

During the preparation of the Phase I engineering report for 3R work on high-speed, multilane highways, the designer should evaluate the design of the existing median relative to the existing and proposed posted speeds. Although it is necessary to provide an unencumbered median of appropriate width on new and reconstructed high-speed, multilane highways, this is not unconditionally required for 3R projects. On these projects, the need for a median, a median barrier, and/or appropriate median width is primarily based on cost and safety-effectiveness.

To determine whether adjustments should be made to the median design and/or posted speed, the following factors should be examined:

1. ADT. Lower ADT's provide lower exposure to and probability of crashes and operational problems. ADT's less than 10,000 are considered low because this is near the threshold of a four-lane warrant.
2. Safety Analysis. Conduct a project safety analysis as described in Section 11-2.02(f) for each 3R project.
3. Speed. Because these high-speed facilities are posted either at 50 mph or 55 mph, it generally is not effective to simply reduce the posted speed by 5 mph or 10 mph, respectively. However, if other factors strongly suggest a posted speed of 45 mph or less, the facility would then be rehabilitated using 3R criteria for rural arterials (Section 49-3) or 3R criteria for urban arterials (Section 49-4).
4. Intersections. Frequent and closely spaced intersections suggest a potential for crashes involving left-turning vehicles. This may be especially true where no median exists or where a narrow median exists that does not allow the development of separate left-turning lanes. At intersections that exhibit a significant number of crashes due to the absence of left-turn lanes, consider designing channelization at those intersections. Also, investigate the need to add right-turn lanes.

5. Other Factors. Multilane highways should be closely examined for design and operational continuity. Evaluate the influences of speed and cross section due to adjacent sections, length of project, alignment, and current and future potential for abutting land development.

49-6 UNMARKED ROUTES ON THE STATE HIGHWAY SYSTEM

49-6.01 General

The following general information applies to unmarked rural collector and local highways on the State highway system:

1. Application. Section 49-6 is applicable to resurfacing, rehabilitation, and restoration (3R) projects that meet all of the following:
 - the facility is eligible for Federal funding,
 - the facility is an unmarked route, and
 - the facility is on the State highway system.

In addition, proposed improvements to unmarked routes are usually initiated only after an agreement is reached with a local agency for a jurisdictional transfer of the route. See Section 43-4.

If the purpose and scope of the project is intended to replace or expand the facility, then Section 49-6 is not appropriate, and reconstruction criteria will apply.

2. Exceptions. Where these criteria will result in improvements that are inconsistent with adjacent sections or are not cost and safety-effective, the actual treatment implemented will be on the basis of a special study and evaluation.
3. Local System. Where the route is also on the local system and it is unclear which policies should be used, the district should coordinate the proposed improvements with the Central Office and, subsequently, with either the county or municipality.
4. Jurisdictional Transfers. On unmarked routes, the districts should negotiate jurisdictional transfers preferably before improvement projects are included in the program. However, when improvements are proposed, any additional work that exceeds the 3R criteria, primarily undertaken to minimize future maintenance costs and ease the jurisdictional transfer, should be carefully evaluated for long-range cost effectiveness.
5. Ditches. Drainage improvements or restoration by ditch cleaning should be performed as necessary to extend the service life of the pavement and to minimize inundation of the pavement and adjacent properties. Suitable portions of the excavated material may be used for embankment and shoulders.
6. Safety Analysis. Conduct a project safety analysis as described in Section 11-2.02(f) for each 3R project. This analysis will guide selection of cost-effective countermeasures for medians and other project locations.

49-6.02 Design Speed

The typical design speed for rural projects on unmarked routes on the State highway system is 55 mph (90 km/h) or the regulatory speed whichever is less. Design speeds for urban and suburban areas may be the regulatory or posted speed limit. A posted speed of 45 mph is the maximum speed where: 1) a TWLT lane is used in the street/highway design, and 2) continuous curbing is used to delineate the edges of the traveled way.

49-6.03 Roadway Cross Section Elements

Figure 49-6.A presents criteria for roadway cross sections for 3R projects on rural unmarked routes on the State highway system.

49-6.04 Horizontal Alignment**49-6.04(a) Radius of Curvature/Superelevation**

An existing horizontal curve may remain in place if its comfortable operating speed is not more than 15 mph (25 km/h) less than the regulatory speed for the highway but not less than 30 mph (50 km/h). Appropriate advisory speed signs will be used on horizontal curves where the comfortable operating speed is more than 5 mph (10 km/h) less than the regulatory speed.

Superelevation rates for horizontal curves on rural facilities to remain in place shall be commensurate with the comfortable operating speed of the curve using a maximum rate of 8%. See Figure 49-3.B for guidance on curves to remain in place.

49-6.04(b) Traveled Way/Shoulder “Rollover”

Through horizontal curves, the maximum rollover (algebraic difference between slopes) at the traveled way/shoulder intersection should not be greater than 10% where the proposed (or remaining) shoulder width is 6 ft (1.8 m) or wider. Where the shoulder width is 4 ft (1.2 m) or less, the maximum rollover may be 12%. Where 1 ft (300 mm) paved shoulders are used, the rollover should occur at the edge of the paved shoulder rather than at the traveled way edge for ease of construction.

	Current ADT			
	Under 400	400-999	1000-3000	Over 3000
Width of Traveled Way ⁽¹⁾	18 ft (5.4 m)	22 ft (6.6 m)	22 ft (6.6 m)	24 ft (7.2 m)
Width of Shoulder ⁽²⁾	2 ft (600 mm)	4 ft (1.2 m)	4 ft (1.2 m)	6 ft (1.8 m)
Shoulder Type	Turf ⁽⁴⁾ or Aggregate Wedge ⁽⁵⁾		Aggregate Wedge ⁽³⁾⁽⁵⁾	

Notes:

- (1) *Resurfacing only: Traveled way widths may be reduced by 2 ft (600 mm), but the traveled way width shall not be less than 18 ft (5.4 m).*
- (2) *For rural cross sections, shoulder width includes a 1 ft (300 mm) wide paved strip for either a resurfacing or resurfacing and widening project.*
- (3) *Use full-width, 6 in. (150 mm) thick aggregate shoulders for ADTs over 5000 in addition to the 1 ft (300 mm) wide shoulder strip. For definition purposes, a stabilized shoulder will be aggregate of 6 in (150 mm) minimum thickness.*
- (4) *Turf will consist of compacted, stable, roadway embankment or granular material capable of supporting growth and will not contain a high percentage of organic or unstable material.*
- (5) *The width of the aggregate wedge will be 3 ft (900 mm) or equal to the width of the usable shoulder if less than 3 ft (900 mm). The minimum wedge thickness will equal the depth of resurfacing at the edge of traveled way and tapering to zero.*

ROADWAY CROSS SECTION ELEMENTS
(3R Projects on Unmarked Routes on the State Highway System)

Figure 49-6.A

49-6.05 Vertical Alignment

49-6.05(a) Crest Vertical Curves

The following will apply:

Current ADT
1000 or more

Treatment

All existing crest curves which are not within 15 mph (25 km/h) of the posted or regulatory speed, as determined from the available stopping sight distance (SSD), will be upgraded by one of the following options:

- flatten the crest curve within the existing right-of-way to satisfy 55 mph (90 km/h) (desirable) or 45 mph (70 km/h) (minimum) SSD; or
- flatten the crest curve by using additional right-of-way to satisfy a 50 mph to 55 mph (80 km/h to 90 km/h) SSD.

The designer should consider sight distances, intersection influences, overall safety, the need for road closures, detours, stage construction, and especially the prevailing vertical alignment in evaluating the above alternatives. Such an analysis will allow designers to determine the most practical alternative for flattening crest vertical curves.

Less than 1000

Crest curves may be retained if adequate for 20 mph (30 km/h) less than the posted or regulatory speed but not less than a 30 mph (50 km/h) available SSD.

49-6.05(b) Sag Vertical Curves

Sag curves generally may be retained.

49-6.05(c) Maximum Grades

On 3R non-freeway projects, the existing roadway grades are acceptable; i.e., flattening grades is not within the scope of a 3R project on unmarked highways.

49-6.06 Intersections

49-6.06(a) Superelevation Rate Changes Through Intersections

Superelevation rates less than that specified for the preceding horizontal alignment may be used through certain intersections because of significant intersection conflicts and when supported in the Phase I engineering report. Refer to Figure 36-1E for guidance. Agreement should be reached with the District Operations Engineer on the appropriate advisory speed to be posted for the curve and noted in the Phase I engineering report.

49-6.06(b) Stop-Controlled Approaches on Horizontal Curves

On curved, stop-controlled approaches to the unmarked route, the existing superelevated cross section generally is left in place.

49-6.06(c) Sideroad Approach Grades

Where considerable amounts of additional right-of-way are required, geometric design criteria should be in accordance with applicable new construction/reconstruction policies where practical. Some elements may be consistent with site conditions when based on special study and analysis results.

All connecting sideroad approaches should be examined for drainage away from the unmarked route. The gradeline on the sideroad should normally drain away from the intersecting unmarked highway for 50 ft to 100 ft (15 m to 30 m) or, at a minimum, to the ditch line of the unmarked highway. If the sideroad profile is reconstructed, the minimum sideroad gradeline should be approximately -1.0% from the intersecting unmarked highway, and the maximum gradeline is -4.0%. Where the unmarked highway is on a horizontal curve, use a maximum of -2.0% on the sideroad connection to minimize rollover at the traveled way edge.

49-6.06(d) Sideroad Turning Radii

The design vehicle used for sideroad turning radii may be site specific with justification. Refer to Section 36-1 for guidance in the selection of design vehicles based on functional classification.

49-6.06(e) Intersection Sight Distance

At rural, public road intersections with a stop condition on the sideroad, provide 465 ft (140 m) of sight distance for the stopped approach in both the left and right directions along the free-flowing highway. Use a 12 ft (3.5 m) distance from the edge of the traveled way to the driver's eye.

49-6.07 Roadside Treatment and Highway Appurtenances**49-6.07(a) General**

The intent of these guides is to perform cost-effective work that may reduce the number and severity of run-off-the-road crashes. Remove or shield obstacles within the clear zone, including protrusions that extend greater than 4 in. (100 mm) above the groundline, where cost effective.

49-6.07(b) Earth Slopes

Other than specifically described in Section 49-6, existing earth slopes should generally remain. Where existing right-of-way permits significant slope flattening or where grading within existing right-of-way is necessary, the designer should consider flattening earth slopes, particularly at horizontal curves.

49-6.07(c) Clear Zones

On unmarked routes on the State highway system, clear zone widths (measured from the traveled way edge) should be in accordance with Figure 49-6.B.

Roadway Criteria		Ditch Cross Sections ⁽¹⁾	Clear Zone
On Tangent	Regulatory Speed 50 mph (80 km/h) or greater and ADT Greater than 1000	Traversable	13 ft (4.0 m) or ROW Line ⁽²⁾
		Non-Traversable	13 ft (4.0 m) or Toe of Back Slope ⁽²⁾
	All Others	-	10 ft (3.0 m)
On Curve ⁽³⁾	Comfortable Operating Speed less than 50 mph (80 km/h)	Traversable	20 ft (6.0 m) or ROW Line ⁽²⁾
		Non-Traversable	20 ft (6.0 m) or Ditch Line ⁽²⁾
	Comfortable Operating Speed 50 mph (80 km/h) or greater	Same as tangent Clear Zone above	

Notes:

- (1) *Traversable ditch cross sections are those with at least 1V:4H front slopes, 1V:3H back slopes, and 2 ft (600 mm) wide ditch bottom. If any of these criteria are not satisfied, the ditch cross section is considered non-traversable.*
- (2) *Use whichever is less.*
- (3) *Clear zone values apply only to the outside of curve. Tangent clear zone values apply to inside of curve. Use Figure 49-3.B to determine comfortable operating speed.*

CLEAR ZONES
(3R Projects on Unmarked Routes on the State Highway System)

Figure 49-6.B

49-6.07(d) Guardrail

The criteria provided in Section 49-3.07(d) for the treatment of guardrail and locations warranting guardrail will also apply to unmarked routes on the State Highway System. However, any reference to Figure 49-3.F in Section 49-3.07(d) should be read as Figure 49-6.C.

49-6.07(e) Culverts

The criteria present in Section 49-3.07(e) for the treatment of culverts will also apply for unmarked routes on the State Highway System. For jurisdictional transfer projects, end treatments of cross road culverts will be in accordance with the *Bureau of Local Roads and Streets Manual* or the end treatments described in 49-3.07(e).

49-6.07(f) Mailbox Turnouts

The design and construction of mailbox turnouts should be in accordance with the *Highway Standards*, BLR-24.

49-6.07(g) Lighting and Landscaping

Installation of lighting to improve operations and/or safety should be considered in accordance with the guidelines in the *Bureau of Local Roads and Streets Manual*. Generally, landscaping should be directed toward replacing appropriate existing plants and turf removed or damaged by construction and, where practical, planting for safety or erosion control purposes. See Chapter 59.

49-6.07(h) Other

Section 49-3.07 presents criteria for rural arterials for the following roadside elements:

- sign and light supports,
- trees,
- concrete signal bases,
- curbs,
- traffic control devices,
- mailbox supports, and
- above-ground utilities.

These criteria apply to 3R projects on unmarked routes on the State Highway System.

49-6.08 Railroad Crossings and Signals

The criterion in Section 49-3.08 for rural arterials also applies to unmarked routes on the State Highway System.

49-6.09 Bridges**49-6.09(a) Bridge Condition Reports/Structure Sketches**

The information in Section 49-3.09(a) for rural arterials also applies to unmarked routes on the State Highway System.

49-6.09(b) Scope of Work

Bridges on unmarked routes on the State Highway System will be rehabilitated to correct operational, structural, and significant safety deficiencies and will be subject to the following conditions:

1. The roadway template is not anticipated to be widened beyond the proposed bridge cross section within the next 20 years.
2. Where an existing bridge is not of sufficient width to remain in place, it may be gapped within the project limits if its future rehabilitation or replacement is committed as staged construction to be completed within the next five years. No bridge will be gapped for more than one year if the clear roadway bridge width is less than the approach traveled way width.
3. Hazard panels and appropriate pavement markings will be required for all bridges which remain in place and which are narrower than the improved traveled way width; see Figure 49-3.1.

49-6.09(c) Criteria for Bridges to Remain in Place

Bridges on rural unmarked routes on the State Highway System will remain in place provided that the clear roadway bridge width is equal to or greater than the values given in Figure 49-6.D and that the structural capacity is met.

The designer should repair, retrofit, or replace any rails on bridges to remain in place that could be easily penetrated by a passenger vehicle, that show evidence of crash damage, that are in questionable condition, or that contain irregularities that could cause intolerable vehicular decelerations. If replaced, rails and their connections to the deck shall be designed to meet current AASHTO strength and safety performance standards.

Curb sections that project horizontally more than 9 in. (225 mm) but less than 3 ft (900 mm) from the face of rail will be removed or new rail elements installed in accordance with the standards for bridge rail retrofit.

Structurally sound bridge decks with poor riding quality that could jeopardize the safety of the motorist or cause undue discomfort should be repaired and resurfaced; however, resurfacing

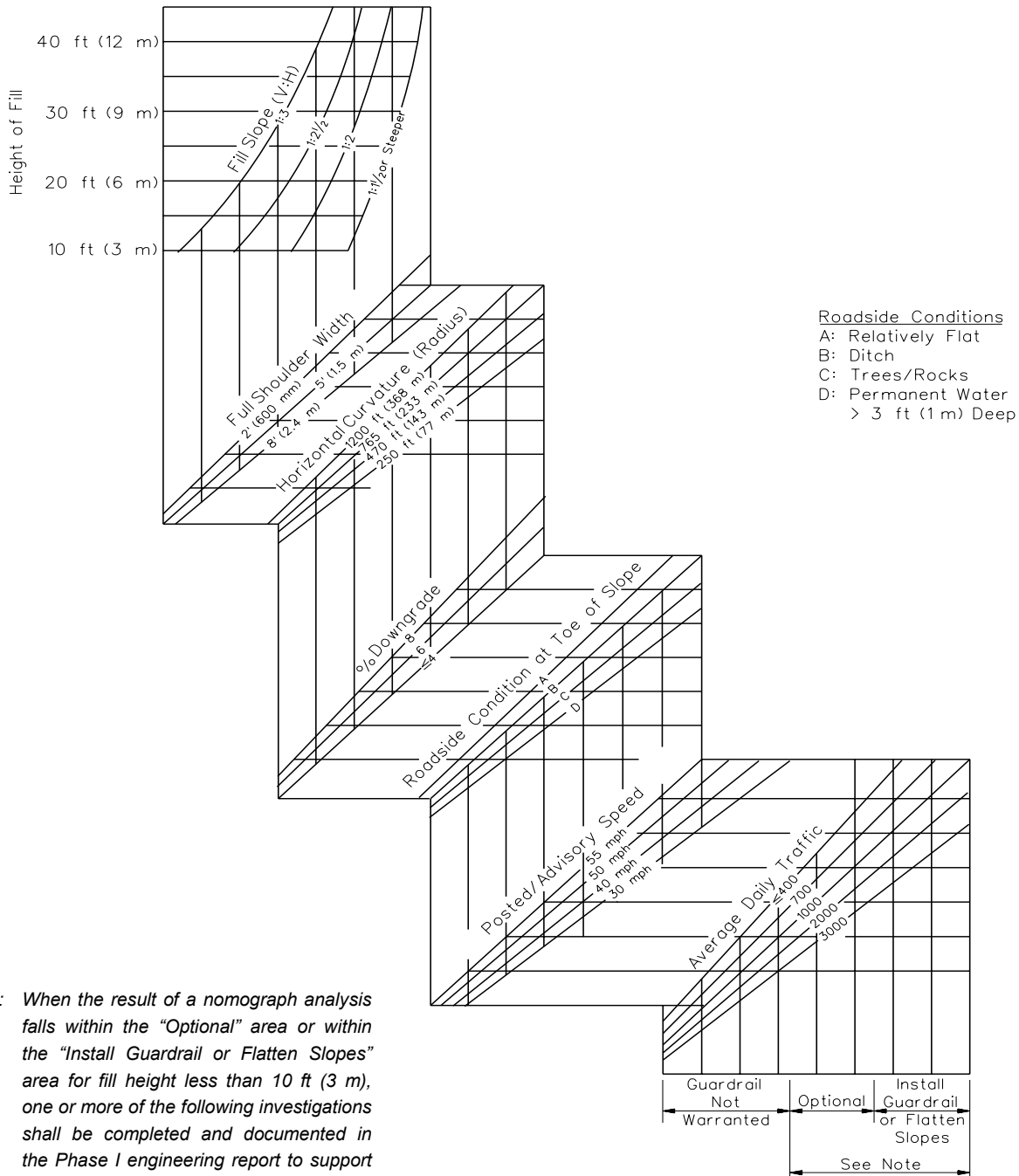

Note: When the result of a nomograph analysis falls within the "Optional" area or within the "Install Guardrail or Flatten Slopes" area for fill height less than 10 ft (3 m), one or more of the following investigations shall be completed and documented in the Phase I engineering report to support the decision:

- field check and review of crash records,
- multi-disciplinary team review, and/or
- cost-effective economic analysis.

**GUARDRAIL WARRANTS FOR 3R PROJECTS
 (On Unmarked Routes on the State Highway System)**

Figure 49-6.C

may not be extended across decks without appropriate repair and waterproofing or when the bridge cannot safely carry the additional dead load resulting from the resurfacing.

49-6.09(d) Criteria for Improved Bridges

All rehabilitated or replaced bridges will be constructed to a clear roadway width equal to the values in Figure 49-6.E. The widths assume a rural type cross section approaching the bridge.

49-6.09(e) Vertical Clearance

The minimum vertical clearance for bridges to remain in place over an unmarked route is 14 ft (4.3 m). Economics may dictate exceptions.

Current ADT ⁽²⁾	Current ADT	Current ADT	Current ADT
Under 400	400 - 999	1000 - 3000	Over 3000
Clear Roadway Bridge Width ⁽³⁾			
20 ft (6.0 m)	22 ft (6.6 m)	24 ft (7.2 m)	28 ft (8.4 m)

Notes:

- (1) *In all cases, except as noted in (2) below, the bridge to remain in place shall have a structural capacity of H-15 (MS-13.5) loading.*
- (2) *When the current ADT is less than 75, a bridge with a structural capacity of H-10 (MS-9) loading will be acceptable if it meets the width criteria.*
- (3) *Between rails or between curbs if the curb projects more than 9 in. (225 mm) beyond the face of the rail.*
- (4) *In no case will the bridge be narrower than the approach traveled way.*

3R WIDTHS OF BRIDGES TO REMAIN IN PLACE ⁽¹⁾⁽⁴⁾
(On Unmarked Routes on the State Highway System)

Figure 49-6.D

Current ADT		
Under 3000	3000 to 4999	5000 and Over
Clear Roadway Bridge Width		
28 ft (8.4 m)	32 ft (9.6 m)	36 ft (10.8 m)

3R WIDTHS OF IMPROVED BRIDGES
(On Unmarked Routes on the State Highway System)

Figure 49-6.E

49-7 REFERENCES

1. Special Report 214, *Designing Safer Roads: Practices for Resurfacing, Restoration and Rehabilitation*, Transportation Research Board, 1987.
2. *A Policy on Geometric Design of Highways and Streets*, AASHTO, 2011.
3. *Roadside Design Guide*, AASHTO, 2011.
4. "Are the Criteria for Setting Advisory Speeds on Curves Still Relevant?," by Mashrur Chowdbury, Davey Warren, Howard Bissell, Sunil Taori, ITE Journal, February 1998.
5. NCHRP Report 350, *Recommended Procedures for the Safety Performance Evaluation of Highway Features*, Transportation Research Board, 1993.
6. *Manual for Assessing Safety Hardware*, AASHTO, 2016.

Chapter Fifty

3R GUIDELINES FOR FREEWAYS

BUREAU OF DESIGN AND ENVIRONMENT MANUAL

Chapter Fifty
3R GUIDELINES FOR FREEWAYS

Table of Contents

<u>Section</u>	<u>Page</u>
50-1 GENERAL	50-1.1
50-1.01 Background	50-1.1
50-1.02 Objectives	50-1.1
50-1.03 Approach	50-1.2
50-1.04 Documentation	50-1.3
50-1.04(a) Phase I Report	50-1.3
50-1.04(b) Contract Provisions	50-1.4
50-2 GEOMETRIC DESIGN.....	50-2.1
50-2.01 Design for Original Construction	50-2.1
50-2.02 Design Speed	50-2.1
50-2.03 Design Traffic Volumes.....	50-2.1
50-2.04 Horizontal Curves	50-2.2
50-2.05 Vertical Alignment.....	50-2.2
50-2.05(a) Vertical Curves.....	50-2.2
50-2.05(b) Vertical Clearances	50-2.2
50-2.06 Bridges.....	50-2.4
50-2.06(a) Bridge Condition Reports/Structure Sketches	50-2.4
50-2.06(b) Safety Analysis for Bridges.....	50-2.4
50-2.06(c) Bridges to Remain in Place	50-2.4
50-2.06(d) Bridge Replacement/Rehabilitation.....	50-2.5
50-2.07 Interchanges	50-2.5
50-2.08 Median Crossovers.....	50-2.6
50-2.08(a) Permanent	50-2.6
50-2.08(b) Temporary (for Construction)	50-2.6
50-3 ROADSIDE SAFETY	50-3.1
50-3.01 General	50-3.1
50-3.01(a) Objective.....	50-3.1
50-3.01(b) Safety Reviews	50-3.1
50-3.01(c) Applicability	50-3.1

Table of Contents
(Continued)

<u>Section</u>	<u>Page</u>
50-3.02 Structures.....	50-3.2
50-3.02(a) Bridge Rehabilitation	50-3.2
50-3.02(b) Piers/Abutments.....	50-3.2
50-3.02(c) Overhead Bridge Structures.....	50-3.4
50-3.02(d) Overhead Bridge Cones.....	50-3.4
50-3.03 Drainage Structures.....	50-3.6
50-3.03(a) Cross Drainage Structures	50-3.6
50-3.03(b) Cost-Effective Analyses	50-3.6
50-3.03(c) Raised Median Inlets.....	50-3.6
50-3.04 Sign Supports.....	50-3.6
50-3.04(a) Wood Posts.....	50-3.6
50-3.04(b) Steel Posts.....	50-3.6
50-3.04(c) Concrete Foundations.....	50-3.7
50-3.04(d) Sign Foundations	50-3.7
50-3.05 Light Standards.....	50-3.7
50-3.06 Trees.....	50-3.7
50-3.07 Gutter and Combination Curb and Gutter	50-3.8
50-3.08 Slopes for Earth Ditch Checks and Permanent Median Crossovers	50-3.8
50-3.09 Guardrail.....	50-3.9
50-3.10 Impact Attenuator Devices	50-3.10
50-3.11 Concrete Barrier Walls	50-3.10
50-3.12 Chain Link Fence.....	50-3.10
50-3.13 Crossroads.....	50-3.10

Chapter Fifty

3R GUIDELINES FOR FREEWAYS

Chapter 50 presents the Department's geometric and roadside safety design guidelines for 3R projects on existing freeways. However, these 3R freeway guidelines should not be substituted for sound engineering judgment. See Chapter 44 for the application of design criteria to new construction/ reconstruction freeway projects.

50-1 GENERAL

50-1.01 Background

The Department began construction of its freeway system in the 1950's. The system has introduced a level of mobility and safety for the traveling public that was unattainable without its special features, including full control of access, wide roadway widths, and high design speeds.

The freeway system requires repair and upgrading which exceeds the limits of normal maintenance. In general, these capital improvements are referred to as 3R freeway projects (resurfacing, restoration, rehabilitation). As with non-freeway 3R projects (Chapter 49), it is often impractical to fully apply new construction/reconstruction criteria to 3R freeway projects without some qualifications. Freeway 3R projects reflect economics and safety relative to their design until full design criteria can be applied; i.e., reconstruction.

50-1.02 Objectives

The objective of a 3R freeway project is, within practical limits, to restore the freeway to its original service or to improve it to meet current demands. This objective applies to all aspects of the freeway's serviceability, including:

- structural adequacy,
- drainage,
- slope and embankment stability,
- level of service for the traffic flow,
- geometric design,
- roadside safety, and
- traffic control.

These objectives are competing for the limited funds available for 3R projects on existing freeways. The Department's responsibility is to realize the greatest overall benefit from the available funds. This is accomplished by:

- recognizing that most 3R freeway projects are typically initiated to make a specific improvement (e.g., pavement rehabilitation) to the existing freeway (i.e., 3R freeway projects are not intended to fully upgrade or reconstruct the facility);
- defining the project scope of work to ensure that the project accomplishes the specific objective as identified at project initiation but does not expand into a full reconstruction project; and
- selectively evaluating and implementing geometric and roadside safety design improvements to the freeway which are a cost-effective expenditure of the Department's highway construction funds.

50-1.03 Approach

The Department's approach to the design of 3R freeway projects is to evaluate and selectively improve the existing geometrics. This is summarized as follows:

1. Nature of Improvement. Identify the specific improvement intended for the 3R project. For example, design improvements might include:
 - pavement rehabilitation/resurfacing/restoration,
 - upgrade roadside safety,
 - increase the length of one or more acceleration lanes at an interchange,
 - eliminate a weaving area at an interchange,
 - widen an existing bridge as part of a bridge rehabilitation project, and/or
 - improve bridge structural adequacy.
2. Selecting Design Criteria. This Chapter addresses 3R freeway projects. If reconstruction is needed to address an identified operational or safety element, the designer will use the new construction/reconstruction criteria in Chapter 44.
3. Design Considerations. Identify and evaluate any design deficiencies that may be precipitated by the freeway improvement. For example:
 - The installation of a concrete barrier may restrict horizontal sight distance.
 - A pavement overlay may require the adjustment of roadside barrier heights or reduce the vertical clearance to below the Department's allowable criteria.
4. Safety Analysis. Identify other geometric and roadside safety design deficiencies within the project limits. Conduct a crash analysis when determining any other improvements that can be practically included without exceeding the intended project scope of work. For example, if a concrete barrier is constructed, it is reasonable to correct any superelevation deficiencies to full standards at the same time, because superelevation corrections in the future may require major modifications to the wall.

5. Project Evaluation. Section 49-2.04 discusses project evaluation for 3R non-freeway projects. This includes, for example, crash data, pavement condition, geometric design consistency, and traffic control devices. As applicable, these evaluation objectives also apply to 3R freeway projects.
6. Design Exceptions. The discussion in Section 31-7 on design exceptions applies equally to the geometric design of 3R freeway projects.

50-1.04 Documentation

50-1.04(a) Phase I Report

A Phase I engineering report shall be prepared and, when required due to funding type or design exceptions, transmitted to FHWA through BDE. See Chapters 11 and 12 for a detailed discussion. The report should be brief and should contain at least the following:

1. Reasons for Project Initiation.
2. Description of Existing Conditions. Before determining the scope of the proposed 3R freeway project, an analysis of the existing conditions is necessary. Provide a fact sheet indicating project length, design and posted speed, current ADT and percentage of trucks, CRS values, etc. From as-built plans and as verified by a field survey, the following should be determined:
 - existing roadway, structure, and interchange geometrics;
 - general pavement distress or failure mode;
 - specific areas of failure;
 - presence of underdrains and pipe drain headwalls;
 - location and performance level of existing roadside safety appurtenances; and
 - locations of existing shallow roadside ditches.
3. Proposed Scope of Work. Provide a brief description of the proposed scope of work. This description must include at least the following items:
 - a Sketch Map showing the location of the proposed improvement, the limits of the proposed work, and any omissions;
 - a typical cross section showing the proposed resurfacing thickness, shoulder widths, pavement and shoulder cross slopes, side slopes, bridge widths; and
 - exceptions from policy resurfacing thicknesses. This will also include justification for the exceptions as discussed in Chapter 53.
4. Estimated Cost for the Proposed Improvement.

5. Categorical Exclusion. The applicable Group for Categorical Exclusions should be identified in the Phase I engineering report (see Chapter 23) plus any required special reports (see Chapter 26). The certification statement is not needed for Group I projects.
6. Other. The Phase I engineering report should document any other special reports such as;
 - justification for requests for exceptions from design policies,
 - discussion of Five Percent Report Locations or other over-represented crash locations and proposed countermeasures,
 - proposed geometric revisions and superelevation corrections,
 - vertical clearances,
 - condition of existing structures, and
 - environmental concerns.

50-1.04(b) Contract Provisions

In addition to providing the various contract documents needed for the 3R freeway project (see Part VII “Plan and Contracts”), the contract should contain provisions for the following items:

1. Markers. The contract should provide for the removal, storage, and replacement of all edge-of-shoulder-mounted delineators and milepost markers that will interfere with construction. When the field survey indicates missing or damaged delineators or markers, the contract should provide for a pay item for replacement. See the *Highway Standards* for placement requirements for delineators. For milepost markers, consult the Bureau of Operations.
2. Bridge Approach Shoulders. The bridge approach shoulders should be surveyed to determine the need for any corrective work if settlement has occurred. See Chapter 53.
3. Erosion. For existing foreslopes that have a history of erosion problems, consider the selective use of Shoulder Inlet and Curb. See the *Highway Standards*. However, barrier (vertical) curbs shall not be used and the placement of any curbs in front of guardrails should be avoided. See Section 50-3 and Chapter 38.

50-2 GEOMETRIC DESIGN

In general, the Department's geometric design criteria for new construction/reconstruction also apply to 3R freeway projects. See Parts IV "Roadway Design Elements" and V "Design of Highway Types." However, the designer must still make certain decisions, and there is some flexibility that can be applied. This is discussed in the following sections.

50-2.01 Design for Original Construction

A specific geometric design element on an existing freeway may not meet the Department's current criteria but did meet the criteria at the time of original construction. In these cases, the design criteria used for horizontal and vertical alignment and traveled way; shoulder and median width can remain in place if they met the AASHTO freeway design criteria in effect at the time of original construction or inclusion into the Interstate system.

50-2.02 Design Speed

The existing posted speed limit will be acceptable as the minimum design speed for the 3R freeway project. However, check with the Bureau of Operations to determine if the existing posted speed limit is likely to change after project completion. For metric projects, consider that the design speed of the project may be in metric and that the posted speed limit will be in English. Figure 50-2.A provides the conversion that will apply to 3R freeway projects.

50-2.03 Design Traffic Volumes

Some design elements on 3R freeway projects will require the selection of the DHV (e.g., level of service) or ADT (e.g., roadside clear zones). The current ADT shall be used unless geometric or structural improvements are made. Use the traffic for 20 years beyond the date of completion for these items.

Posted Speed Limit (mph)	Minimum Design Speed (km/hr)	
	(mph)	(km/hr)
50	50	80
55	55	90
60	60	100
65	65	110
70	70	110

**DESIGN SPEED
(3R Freeway Projects)**

Figure 50-2.A

50-2.04 Horizontal Curves

Mainline horizontal curves should have minimum superelevation rates equal to those allowed to remain in place as shown in Figure 50-2.B. If the required minimum superelevation rates are not met, provide additional resurfacing thickness or milling to correct the superelevation to the rate for the required comfortable operating speed. See Section 49-3 for more information on the use of Figure 50-2.B.

Where the curve occurs beneath an existing overhead structure, the additional thickness may cause the vertical clearance to become less than that required, and appropriate adjustments will be required. See Section 50-2.05.

All ramp superelevation rates should be corrected to the full superelevation rates for new construction. See Chapter 37.

50-2.05 Vertical Alignment**50-2.05(a) Vertical Curves**

Analyze vertical curves to determine if they meet the criteria found in Section 33-4. If not, determine if operational or safety problems exist at the location. Where no operational or safety hazard is present, the curve may remain in place.

50-2.05(b) Vertical Clearances

The minimum vertical clearance for 3R rural interstate projects is 16 ft 00 in. The allowable vertical clearance for 3R urban interstate projects is 16 ft 00 in for single routing around urban areas. For urban interstates within the single routing 15 ft 00 in is permitted. If these vertical clearances cannot be met, a design exception must be sought.

Refer to Section 31-7.04(c) for directions to process a design exception for vertical clearances over interstates. The urban areas in Illinois where single routing occurs are:

- Peoria,
- Quad Cities,
- Metro-east St. Louis area, and
- the Chicago metropolitan area.

Maps of the single interstate route for these urban areas are shown in the figures in Section 44-6.

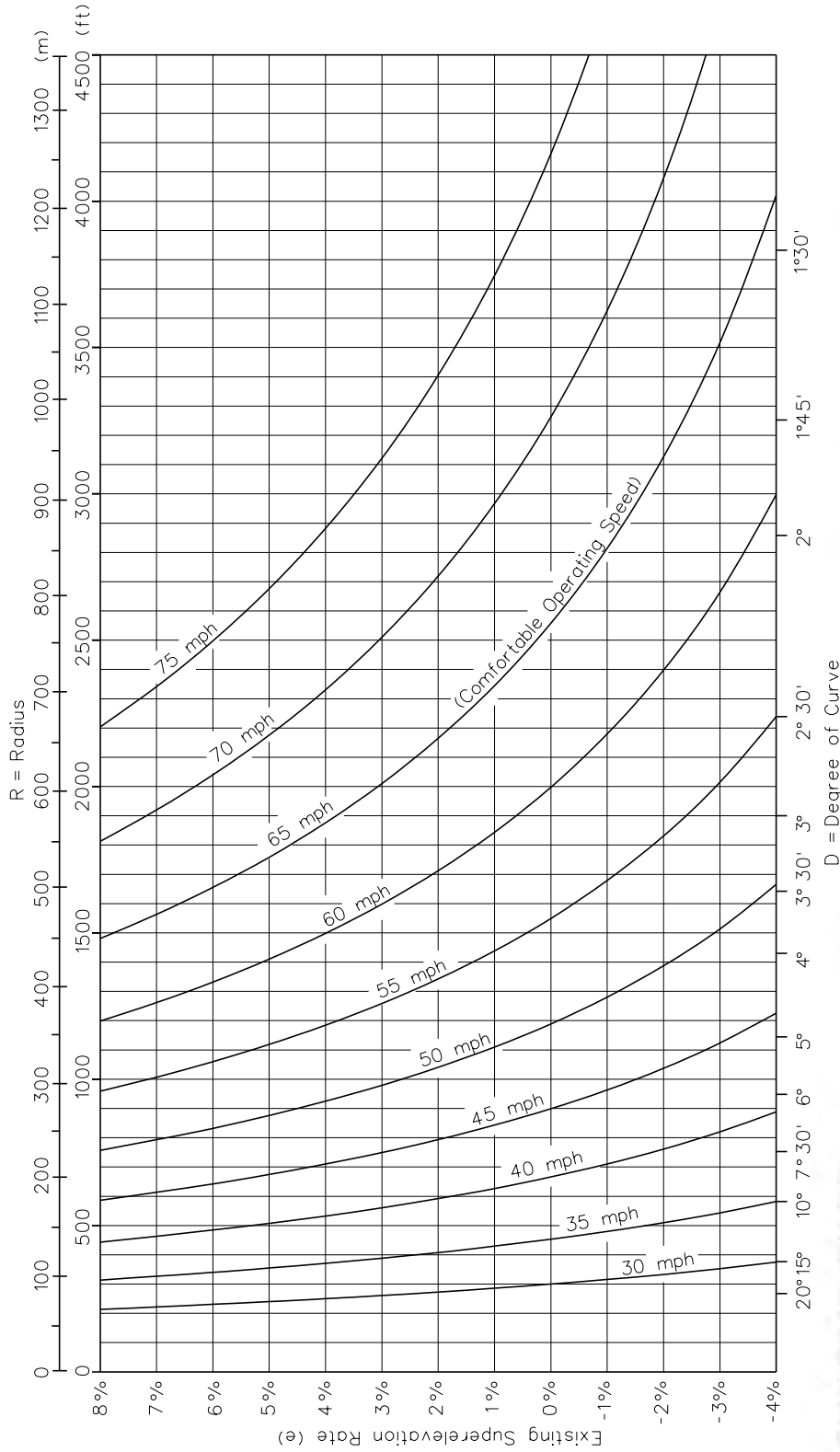

Figure derived from the following:

1. Use AASHTO Method 2 for the distribution of superelevation and side friction.

$$R = \frac{V^2}{15(e + f_{max})}$$
 where $V = \text{mph}$ and $R = \text{ft}$. (US Customary)
2. Assume design speed and use f_{max} for selected design speed in all cases.
3. Assume different values of "e" and calculate values for "R" on graph for each speed.

$$R = \frac{V^2}{127(e + f_{max})}$$
 where $V = \text{km/h}$ and $R = \text{m}$. (Metric)

HORIZONTAL CURVATURE ALLOWED TO REMAIN IN PLACE FOR 3R FREEWAY PROJECTS

Figure 50-2.B

50-2.06 Bridges

Because of the high traffic volumes usually involved, bridges on six-lane or greater facilities must be examined on a case-by-case basis whenever 3R type work is performed. For structures on four-lane facilities, the following will apply to the geometric design criteria for bridges within the limits of 3R freeway projects.

50-2.06(a) Bridge Condition Reports/Structure Sketches

A Bridge Condition Report (BCR) and a Proposed Structure Sketch are required for every structure within a roadway section covered by a Phase I engineering report or when a bridge itself is the reason for preparing a Phase I engineering report. Before design approval can be granted, the BCR's must be approved by the Bureau of Bridges and Structures. In addition, the Bureau of Design and Environment must approve the typical section.

A Bridge Condition Report also is required for a bridge proposed to remain in place. This will ensure that the bridge meets the minimum requirements for width, safety, and structural capacity. However, the Illinois Structure Information System-Master Report (R107) may be substituted for a Bridge Condition Report.

50-2.06(b) Safety Analysis for Bridges

Narrow mainline, interchange, and ramp bridges within the project limits must first be analyzed to determine if widening is necessary to address a high-crash experience or other operational problems. This analysis will include a review of crash data for the previous four years and, if necessary, a field check by the district, FHWA, BDE, Bureau of Safety Engineering, and Bureau of Bridges and Structures. If it is determined that the overall safety of the roadway will be enhanced, include the widening of the bridge within the 3R project or schedule the work no later than one year following the letting of the highway project, unless an extension of time is approved by FHWA.

50-2.06(c) Bridges to Remain in Place

A 3R freeway project may be primarily intended, for example, to improve the pavement condition over several miles (kilometers). A bridge or several bridges may be within the limits of the 3R project. Desirably, the bridge widths will equal the full approach roadway width, including paved shoulders. However, this may not be the case. If the existing bridge is structurally sound and if it meets the Department's design loading structural capacity, an analysis should be performed to determine the cost effectiveness of improving the geometrics of the bridge. However, geometric deficiencies and/or adverse crash experience at the bridge may warrant widening the bridge as part of the 3R project. Design exceptions are required for bridge widths that do not meet Department criteria; see Chapter 31.

50-2.06(d) Bridge Replacement/Rehabilitation

3R freeway projects may include bridge replacements or bridge rehabilitation work and, in some cases, this may be the entire project scope of work. The following will apply to the geometric design of these projects:

1. Horizontal and Vertical Alignment. An existing bridge may have an alignment that does not meet the Department's current criteria. For bridge replacement projects, the designer should evaluate the practicality of realigning the bridge to meet the applicable alignment criteria for new construction/reconstruction (Chapters 32 and 33). For bridge rehabilitation projects, it is unlikely to be cost effective to realign the bridge to correct any alignment deficiencies.
2. Width. When the Bridge Condition Report indicates deck replacement is necessary, widen the structure to the extent possible without requiring substructure additions. Necessary repairs to or replacement of superstructure elements will be permitted. In no case shall the structure be made narrower than the existing width. The bridge width should equal the full approach roadway width, including paved shoulders, as determined by the criteria in Chapter 44. Capacity analyses could determine the need for auxiliary lanes and/or the need for wider shoulders. For example, if the predicted volume of trucks exceeds 250 DHV, the future shoulder width on the approach should be 12 ft (3.6 m). Because freeway bridges represent major economic investments with lengthy design lives, it may be warranted to provide the wider widths as part of a bridge replacement or rehabilitation project.

As another example, a capacity analysis may indicate the need for an additional through lane to meet the level-of-service criteria for the design year. The decision may be made to widen the bridge as part of the replacement/rehabilitation project. Until the roadway approach is widened, it may be necessary to indicate with pavement markings or temporary barriers that the additional width on the bridge cannot be used by through traffic.

3. Length. The length of the freeway bridge determines the cross section of the crossroad passing beneath the freeway. Therefore, if practical, the freeway bridge should be designed to accommodate any future widening of the underpassing roadway. This may involve an assessment of the potential for further development in the general vicinity of the underpass.
4. Roadside Safety. See Section 50-3.01.

50-2.07 Interchanges

A 3R freeway project may include proposed geometric design improvements at an existing interchange. The work may be to rehabilitate the entire interchange or to make only selective improvements to the interchange geometrics. Chapter 37 will be used to design the interchange element.

50-2.08 Median Crossovers

50-2.08(a) Permanent

Close or correct all existing median crossovers that do not meet the requirements of Section 3-400 *Median Crossovers on the Fully Access Controlled Highways*, of the Bureau of Operations Maintenance Policy Manual or for which a variance has not been granted by the Bureau of Operations and FHWA. When the field survey indicates locations of unauthorized median crossovers, the contract should provide for the installation of 4 in. x 4 in. (100 mm x 100 mm) wood posts to discourage intrusions.

Use the following for bituminous surfaces for these crossovers:

1. New Crossovers. Provide an 8 in (200 mm) of BAM meeting the requirements of the *Standard Specifications for Road and Bridge Construction*.
2. Existing Crossovers. If the existing crossover has a minimum thickness of 6 in (150 mm) of aggregate surface, grade the aggregate to a uniform cross section and cover with 3 in. (75 mm) of Bituminous Concrete, Superpave, or 3 in. (75 mm) of BAM meeting the requirements of the *Standard Specifications for Road and Bridge Construction*. If the minimum thickness of aggregate is less than 6 in. (150 mm), reconstruct the crossover to meet the requirements for new crossovers.

See also Section 50-3.08 for guidance on slopes for permanent median crossovers.

50-2.08(b) Temporary (for Construction)

A cost savings may be realized if some construction crossovers remain in place after the project is completed. Because these crossovers are designed to carry freeway traffic, they are often constructed with a high-type pavement that adds to the cost. If the pavement is removed, it may eventually have to be rebuilt to accommodate another project. If the crossover had remained in place, it could have been reused.

The following are examples where it may be advisable to leave temporary crossovers in place:

1. At Major River Crossings. At these locations, there is usually only one location where a crossover can be placed, and any future work will require the rebuilding of the same configuration.
2. Locations Where Physical Constraints Exist. In some instances, factors such as sight distance limitations, closely spaced structures, nearby interchanges, or elevation differences between lanes limit where a crossover can be built. At times, even though the projects may be at different locations, the location of a crossover is set by these limitations.
3. When Future Work is Planned in the Same Area. If structure work is scheduled for one year and roadway work anticipated within the next five years, the same crossover may be

used for both projects. Another example is a series of structures that are rehabilitated during a multi-year program.

Where these and similar situations are encountered, the designer should consider leaving the temporary crossovers in place after the project is completed. Provisions must be included in the contract to close the crossover during the time it is not in use. Discuss these provisions at a regular district coordination meeting and obtain FHWA and Central Office concurrence.

50-3 ROADSIDE SAFETY

50-3.01 General

50-3.01(a) Objective

Although ideally the roadside should be totally forgiving to those motorists who run off the roadway, geometrics, terrain, right-of-way, and economic considerations often render this impractical on existing freeways. Therefore, the objective should be to use the available highway funds to provide the most cost-effective design. This objective will require the designer to identify hazardous features and to determine:

- which hazards should be redesigned to be made traversable,
- which hazards should be removed or relocated,
- which hazards should be shielded with an appropriate barrier, and
- which hazards are not cost effective to redesign and therefore should remain untreated.

Section 50-3 provides the designer with guidelines for recognizing these hazards and provides suggested countermeasures for 3R freeway projects. Other approved countermeasures may be substituted where maintenance, operational, or other considerations are involved. Also, although some hazards may not require treatment according to these guidelines, specific circumstances may be such that treatment is necessary.

Recurring crash locations or over-represented crashes shall be identified early in the preliminary stages of plan preparation and appropriate action included in the plans to ameliorate the cause of these crashes. A recurring crash location is defined as any location that appears on the Five Percent Report Location for any two out of three-year period in the five years prior to plan preparation.

Any item identified as requiring treatment by these guidelines may remain untreated if that item is shielded by a roadside barrier required for some other hazard. In addition, some hazards may be allowed to remain just inside the clear zone when there are other similar hazards just outside the clear zone that do not require treatment and if the crash experience for the facility does not indicate a problem with the type of hazard involved.

50-3.01(b) Safety Reviews

It is not possible to include all hazards in any one set of guidelines. Therefore, a safety or plan-in-hand field review with representatives from the district, FHWA, and BDE may be required at the request of FHWA. Contact BDE for guidance on hazards not covered in Section 50-3.

50-3.01(c) Applicability

Chapter 38 presents Department criteria on roadside safety design for new construction/reconstruction. These apply to 3R freeway projects except as modified in Section 50-3.

50-3.02 Structures

50-3.02(a) Bridge Rehabilitation

If deck replacement is not necessary, treat any substandard bridge rails (which are defined as rails which were designed prior to the 1989 AASHTO *Standard Specifications for Highway Bridges*) on mainline, interchange, and ramp structures as discussed below. Rails built to the 1965 and later specifications essentially meet the 1989 specifications and may remain in place with prior approval:

1. Metal Handrails Mounted on Safety Curbs. Corrective action for handrails in this category is:
 - to remove the curb and rail and retrofit with an F-shaped parapet providing the greatest shoulder width practical without the addition of superstructure beams, or
 - to retrofit using a metal rail as shown in the *Highway Standards*.

The decision on which type of retrofit will be employed will be based on an economic analysis combined with maintenance and performance considerations.

2. Metal Handrail Mounted on a Vertical Face Concrete Parapet (Constructed on a Concrete Safety Curb). No corrective action is recommended for handrails in this category where the concrete safety curb is less than 9 in. (230 mm) wide. Where the safety curb is more than 9 in. (230 mm) wide, remove the curb and rail and retrofit with an F-shaped parapet or provide a metal retrofit rail as in Item #1.
3. Concrete Parapets with General Motors Barrier Configuration. Although this configuration may not have the same optimum redirective capability as the New Jersey configuration, it is considered acceptable. Therefore, no corrective action is recommended.
4. Wide Safety Curbs. For mainline, ramp, and interchange structures with rails not considered substandard but with safety curbs greater than 9 in. (230 mm) wide, remove the curb and existing rail and retrofit with an F-shaped parapet or a metal retrofit rail as in Item #1.

Bridges that have handrails that do not fit into these categories should be referred to BDE and Bureau of Bridges and Structures for analysis and remedial treatment.

If deck replacement is not necessary and the structure has previously been treated with a metal retrofit rail, no further action is required.

50-3.02(b) Piers/Abutments

Correct or shield any piers or abutment walls located within the clear zone, which are unshielded or improperly shielded, in accordance with the following criteria:

1. Piers and Abutment Walls Located 0 ft to 2 ft (0 mm to 600 mm) from the Shoulder Edge.
If the pier is not shielded by any device, provide the proper length of need of guardrail and attachment with a Traffic Barrier Terminal, Type 6 or Type 6B. If a concrete barrier wall is present or planned along the median, modify the existing crash wall by filling in the gaps between the columns with concrete to a height of the Standard concrete barrier and attach to the pier with a Traffic Barrier Terminal, Type 6 or Type 6B. If a concrete barrier wall is not present or planned along the median, modify the existing crash wall by filling in the gaps between the columns with concrete to a height of 36 in. (915 mm) and attach to the pier with a Traffic Barrier Terminal, Type 6 or Type 6B.

If the pier is shielded by existing guardrail that provides proper anchorage to the pier, see Section 50-3.09, provide the proper length of need guardrail for a minimum 25 ft (7.6 m) clear zone to prevent errant vehicles from becoming trapped between the beams and the slopewall.

See Section 38-6.06 for more information on terminal treatments.

2. Piers and Abutment Walls Located 2 ft to 4 ft (600 mm to 1.2 m) from the Edge of Shoulder.
If the pier or wall is unshielded, provide a proper guardrail treatment. This treatment will include Type B rail 25 ft (7.6 m) in advance of and along the front of the hazard.

If the hazard is shielded by existing guardrail, add posts, where necessary, to provide Type B rail as above and a runout length sufficient for a 25 ft (7.6 m) clear zone as in Item #1.

3. Piers and Abutment Walls Located 4 ft (1.2 m) or More from the Shoulder Edge. Treat unshielded piers as follows:

- If the foreslope is steeper than 1V:6H, the guardrail should be located at the shoulder line.
- If the foreslope is between 1V:6H and 1V:10H, place the guardrail 4 ft (1.2 m) from the pier or abutment wall provided there will be at least 12 ft (3.6 m) between the shoulder hinge point and the rail. Otherwise, place the guardrail at the shoulder line.
- If the foreslope is or can be graded to 1V:10H or flatter, place the guardrail 4 ft (1.2 m) from the structure.
- Consider other options (e.g., sand barrels or other appropriate NCHRP 350 or MASH crash TL-3 tested devices) if space permits and the placement requirements of Section 38-8.05(d) can be obtained.

If there is existing guardrail at least 4 ft (1.2 m) from the structure, provide the proper runout length. If it is less than 4 ft (1.2 m) from the structure, install additional posts to provide 25 ft (7.6 m) of Type B rail in advance of the structure and along the front of the structure.

For overhead grade separation structures with vertical face abutments 30 ft (9 m) from the edge of traveled way, no remedial treatment is warranted. However, concrete headwalls or ditch drainage pipe projecting through the bridge cone, parallel to the mainline, should be cost evaluated for remedial treatment where necessary.

50-3.02(c) Overhead Bridge Structures

Guidelines for upgrading overhead bridge structures and roadways that cross the freeway at locations other than interchanges are as follows:

1. In general, all upgrading should be in accordance with existing 3R guidelines for the roadway classification of the overhead facility. See Chapter 49 or *Bureau of Local Roads and Streets Manual*.
2. Guardrail to remain in place shall be upgraded with the addition of posts and/or blockouts to provide minimum 6 ft 3 in. (1905 mm) post spacing. Also provide a proper connection to the bridge.
3. Repair, retrofit, or replace any rails on bridges that:
 - can be easily penetrated by an “average” vehicle (usually assumed to be a full-size domestic passenger car),
 - show evidence of crash damage,
 - are in questionable condition, or
 - contain irregularities that could cause intolerable vehicular decelerations.

If replaced, rails and their connections to the deck shall meet current AASHTO strength and functional requirements. Because of the high potential for severe crashes if a vehicle penetrates a rail and lands on the freeway, retrofit or replace all substandard rails where the current ADT is greater than 750 or 50 MUs per day.

4. Remove any curb sections that project more than 9 in (230 mm) but less than 3 ft (915 mm) from the face of the rail or install new retrofit rail elements to shield the curb where the ADT is greater than 400 or 40 MUs per day.

50-3.02(d) Overhead Bridge Cones

The following presents guidelines for upgrading safety features on existing overhead bridge cones with 1V:2H side slopes located within the clear zone of the freeway.

Examine the cones and, if needed, modify the toe of the slope to prevent bumper penetration by errant vehicles. Using the roadway foreslopes and the bridge cone slope in the severity index curve in Figure 50-3.A, a severity index greater than 1.0 indicates that remedial filling and grading at the toe of the bridge cone may be warranted.

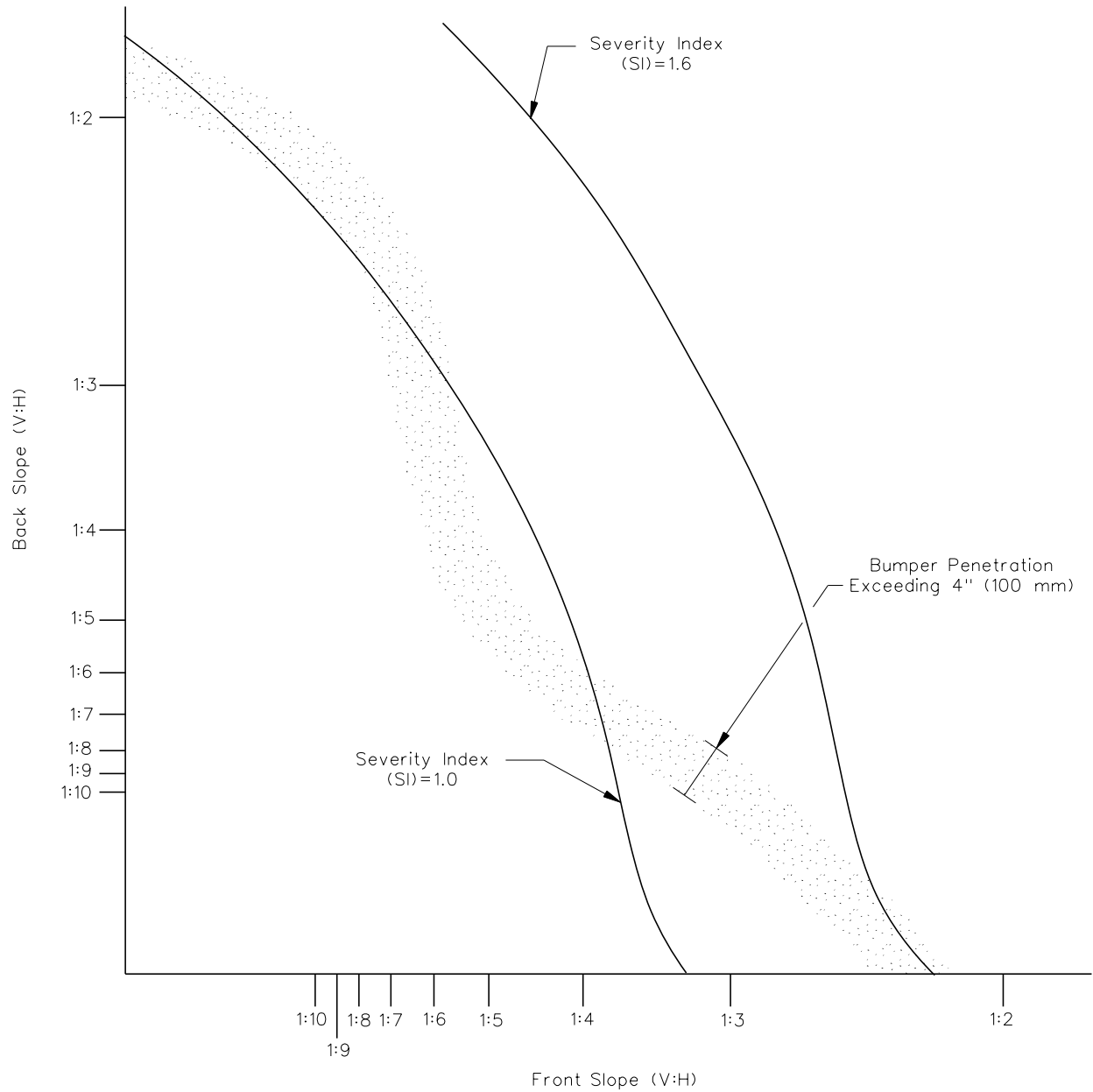

Note: Severity Index and bumper penetration contours based on 12 in. (300 mm) ditch, 60 mph (95 km/hr), and 25 degree encroachment angle.

SEVERITY INDICES FOR ROADSIDE DITCHES

Figure 50-3.A

50-3.03 Drainage Structures**50-3.03(a) Cross Drainage Structures**

When evaluating existing cross drainage pipe structures, see Section 49-3.07(e) and the criteria presented in Section 38-4.06(b).

50-3.03(b) Cost-Effective Analyses

For all culverts greater than 36 in. (915 mm) in diameter more than 30 ft (9 m) from the edge of traveled way, prepare a cost-effective analysis to determine if a safety treatment is warranted. See Section 38-4.03 for Department policies on cost-effective analyses.

50-3.03(c) Raised Median Inlets

Replace raised median inlets with flush inlets as follows:

1. If the median is less than 65 ft (19.5 m) wide, replace all raised inlets.
2. For medians 65 ft (19.5 m) wide and greater, replace raised inlets only where the ADT is greater than 20,000.

50-3.04 Sign Supports**50-3.04(a) Wood Posts**

Treat all wood posts as follows:

1. Drill or notch 6 in. x 6 in. (150 mm x 150 mm) wood posts at a point 4 in. (100 mm) above the ground to reduce the cross sectional area to that for an S4S 4 in. x 6 in. (100 mm x 150 mm) post. The direction of drilling must be perpendicular to the roadway and the notches must be on the backside of the post.
2. No more than two posts may be used in a 7 ft (2.1 m) wide path. If more than two posts are within a 7 ft (2.1 m) path, remove the posts or relocate the signs.

50-3.04(b) Steel Posts

Steel posts that are not breakaway shall be made breakaway unless shielded by guardrail required for other hazards. Also, all supplemental signs below the fuse plate shall be mounted such that they will not affect the breakaway action of the post.

50-3.04(c) Concrete Foundations

Concrete foundations for steel posts located within the clear zone must have no portion of the foundation or stub projection extending 4 in. (100 mm) or more above the grade. Regrading, or removal and replacement, is required for all foundations where the projection exceeds 4 in. (100 mm).

50-3.04(d) Sign Foundations

Treat all cantilever and sign truss foundations as follows:

1. Shield foundations located within the clear zone as in Section 50-3.02(b). Upgrade any existing guardrail used to shield foundations to current standards. An impact attenuator system may be used in lieu of a barrier.
2. Foundations located 30 ft (9 m) or more from the edge of traveled way do not require remedial treatment.

50-3.05 Light Standards

The following applies:

1. Concrete foundations for other than tower lighting must not project more than 4 in. (100 mm) above the grade; otherwise, regrade or remove and replace the foundation.
2. Install breakaway bases for unshielded light poles other than tower lights. Use non-breakaway poles:
 - on urban freeways where there is a possibility that the pole may fall on an area with high pedestrian traffic, and
 - in rest areas and weigh stations.
3. Treat tower lights as in Section 50-3.04(d). Impact attenuator systems may be used in lieu of barrier.

50-3.06 Trees

Remove all trees within the clear zone that, at maturity, will be 4 in. (100 mm) or greater in diameter. Also, remove trees that restrict proper sight distance or trees located immediately behind breakaway devices (e.g., sign supports, light poles).

50-3.07 Gutter and Combination Curb and Gutter

Treat non-traversable gutter sections and raised barrier curbs as discussed below. Non-traversable gutters are those gutters that could snag a wheel or cause other violent vehicular reactions if traversed by an errant vehicle. Raised barrier curb for this purpose is defined as any curb which will be greater than 3 in. (75 mm) in height after any resurfacing on the project is placed. Corrective work on gutters or curbs may also require revisions to existing drainage structures. If these revisions will result in excessive costs, the designer may consider rebuilding the curb or gutter as traversable.

The following applies to gutters and combination curb and gutter:

1. Remove any non-traversable gutter sections at the edge of traveled way or shoulder, or modify to make them traversable.
2. Remove any raised curb in exit gore area, and level the gore.
3. The removal of raised curb at the edge of shoulder, 1 ft (300 mm) in front of guardrail, and in entrance gore areas is not cost effective when modifications are also required to drainage structures. If no extensive regrading or modification to drainage structures is required, the designer should consider its removal.
4. Remove all curbs greater than 2 in. (50 mm) high in advance of impact attenuator systems or guardrail terminals. If curb is required for drainage or delineation in advance of the impact attenuator or terminal, use a Type M-2 (M-5) curb.

50-3.08 Slopes for Earth Ditch Checks and Permanent Median Crossovers

The following applies:

1. Slopes (No Inlet Boxes). Regrade all existing earth ditch checks and median crossovers without inlet boxes to provide a 1V:10H slope. Note that regrading existing ditch checks may create a condition where motorists may use the ditch check as an illegal crossover. Place 4 in. x 4 in. (100 mm x 100 mm) wood posts in these areas to discourage illegal crossings. See Section 50-3.04(a) for wood post spacing.
2. Slopes (With Inlet Boxes). Treat all existing ditch checks and median crossovers with inlet boxes as follows:
 - If the median width is less than or equal to 42 ft (12.8 m) and the slope of the inlet box is 1V:4H, regrade the ditch check to 1V:10H and install a new inlet box for all ADT's over 50,000. 1V:4H ditch checks may remain if the ADT is less than 50,000.
 - If the median width is 44 ft (13.4 m) or greater, 1V:4H ditch checks may remain in place for all ADT's.

- If the existing inlet box is 1V:6H or flatter, no treatment is necessary regardless of median width or ADT.

Remove any existing ditch checks that are not essential.

50-3.09 Guardrail

Identify and correct all guardrail deficiencies for all ADT. The designer should carefully analyze all existing guardrail installations to determine if the guardrail should be removed or upgraded in accordance with Section 38-6 and the following:

1. Guardrail Removal. An existing guardrail installation should be removed when a life-cycle benefit to cost analysis shows this is preferable to updating, and maintaining the guardrail. Roadside Safety Analysis Program (RSAP), provided by AASHTO, is one tool available for this analysis.
2. Guardrail Upgrading. Follow the analysis in Section 49-3.07(d) to determine whether existing guardrail may remain.
3. End Sections. Ensure all guardrail end sections for existing guardrail meets the approved lists of devices in force in December 2006, or subsequent versions appropriate for later *Highway Standards* for guardrail. Ensure all transitions from guardrail to bridge rails or to structures meet the *Highway Standards* in effect in December 2006, or subsequent versions appropriate for later *Highway Standards* for guardrail.
4. Insufficient Length. Use the length-of-need criteria in Section 38-6.01 to determine the sufficiency of the existing length of guardrail based on the posted speed. Upgrade existing guardrail that is deficient in length by more than 10% to provide a proper length of need. Guardrail less than 10% deficient in length may remain in place unless crash data shows that the additional length will reduce crash severity. Also, provide the proper length of need if placement of a new crashworthy terminal is required. Where practical, the designer should shorten the required length of need by tapering the barrier away from the traveled way.
5. Roadside Cable Barrier. Conduct special studies to determine the installation of new or disposition of existing cable-guard or cable barrier. If it appears desirable to use cable barrier for roadside hazards, see Section 38-6.02. Contact the Bureau of Safety Engineering regarding other possible uses on a case-by-case basis.
6. Cable Median Barrier. See Section 38-07 for guidance. For adjustment of existing cable median barrier, contact the Bureau of Safety Engineering.
7. Median Guardrail at Dual Structures. If the guardrail in the median does not meet MASH or NCHRP 350, the following corrective treatment is appropriate:
 - Use an appropriate MASH or NCHRP 350 device.

- Remove the non-compliant guardrail and treat the opening between the bridges as a non-traversable roadside obstacle with sufficient length of shoulder-mounted Steel Plate Beam Guardrail, Type A preferably, flared as shown in Figure 38-6.X. For the approach end of the guardrail, provide an appropriate crashworthy end treatment, and provide the appropriate connection to the bridge.
8. Gaps. Unless unusual circumstances dictate otherwise, remove any gaps that are less than 200 ft (60 m) in length between warranted guardrail by installing new guardrail.
 9. Re-Grading. Where the remedial treatment recommendation is to add a roadside barrier or impact attenuator system, re-grade the slope of the approach to the barrier or system to be 1V:10H or flatter. This grading shall be sufficient to also provide for a 1V:10H or flatter slope in advance of the barrier or system for a vehicle leaving the roadway at a 5-degree to 10-degree angle.

50-3.10 Impact Attenuator Devices

The following applies:

1. Evaluate any existing impact attenuator devices for conformity with the criteria in Section 38-8. If the array or configuration is inappropriate for the obstacle being shielded, implement any needed modification.
2. Shield any obstacle that warrants an impact attenuator device, which presently has none, with an appropriate system; see Section 38-8.

50-3.11 Concrete Barrier Walls

Correct the approach ends of concrete barrier walls which terminate in the clear zone with an appropriate MASH Test Level 3 end treatment.

50-3.12 Chain Link Fence

Where the ADT is greater than 30,000, modify all lengths of chain link fence located near the edge of the clear zone with a top rail which is susceptible to impact by errant vehicles (either on the mainline or adjacent roadways) by replacing the top rail with tension wire. Replace the top rail for all chain link fence located immediately adjacent to the traveled way for all ADTs.

50-3.13 Crossroads

Upgrade all crossroads, both at interchange and non-interchange locations, for safety within the limits of the original Interstate funding. The safety work will meet the 3R guidelines for the classification of roadway involved. See Chapter 49 and the Bureau of Local Roads and Streets policies. Provide special attention to ramp terminals, and consider improving the turning radii

where there is evidence of the design vehicle encroaching on opposing traffic lanes or curbs.
See Chapter 37.

50-4 REFERENCES

1. *Roadside Design Guide*, AASHTO, 2011.
2. *A Policy on Geometric Design of Highways and Streets*, AASHTO, 2018.
3. NCHRP Report 350, *Recommended Procedures for the Safety Performance Evaluation of Highway Features*, Transportation Research Board, 1993.
4. *Illinois Highway Standards*, current edition.
5. *Manual for Assessing Safety Hardware*, AASHTO, 2016.
6. NCHRP Report 711, *Guidelines for Selection, Use, and Maintenance of Cable Barrier Systems*, Transportation Research Board, 2012.

Chapter Fifty-one

RESERVED

BUREAU OF DESIGN AND ENVIRONMENT MANUAL

Chapter Fifty-one
RESERVED

Chapter Fifty-two

RESERVED

BUREAU OF DESIGN AND ENVIRONMENT MANUAL

**Chapter Fifty two
RESERVED**

Chapter Fifty-three

PAVEMENT PRESERVATION AND REHABILITATION STRATEGIES

BUREAU OF DESIGN AND ENVIRONMENT MANUAL

Chapter Fifty-three
PAVEMENT PRESERVATION AND REHABILITATION STRATEGIES

Table of Contents

<u>Section</u>	<u>Page</u>
53-1 GENERAL	53-1.1
53-1.01 Scope of Chapter	53-1.1
53-1.02 Definitions	53-1.2
53-2 PAVEMENT MANAGEMENT METHODOLOGIES	53-2.1
53-2.01 Selection of Pavement Management Methodology.....	53-2.1
53-2.02 Maintenance Methodologies	53-2.1
53-2.03 Pavement Preservation Methodologies	53-2.2
53-2.04 Rehabilitation Methodologies	53-2.2
53-2.05 Pavement Replacement Methodology.....	53-2.2
53-2.06 Pavement Information Needed for Treatment Selection	53-2.5
53-2.07 Pre-Treatment Activities and Other Factors.....	53-2.5
53-2.07(a) Pre-Treatment Activities	53-2.5
53-2.07(b) Secondary Considerations	53-2.5
53-2.07(c) Additional Design Features	53-2.6
53-2.08 Exception Requests	53-2.7
53-2.08(a) TAMP Category Selection Exception Requests.....	53-2.7
53-2.08(b) Overlay Policy Exception Requests.....	53-2.7
53-2.08(c) Exception Request Submittals	53-2.7
53-3 PAVEMENT PRESERVATION TREATMENT SELECTION GUIDELINES	53-3.1
53-3.01 Identify Feasible Preservation Treatments	53-3.1
53-3.02 Select Appropriate Preservation Treatment.....	53-3.1
53-3.03 Pavement Preservation Treatments	53-3.5
53-3.04 Other Factors	53-3.5
53-3.04(a) Shoulders Versus Mainline.....	53-3.5
53-3.04(b) Pavement Markings and Raised Reflective Pavement Markers.....	53-3.5
53-3.04(c) Rumble Strips	53-3.5
53-3.04(d) Surface Preparation	53-3.5
53-3.04(e) Pavement Markings	53-3.6
53-3.04(f) Timing Treatment Application.....	53-3.6
53-4 PAVEMENT REHABILITATION TREATMENT SELECTION GUIDELINES.....	53-4.1
53-4.01 Select Appropriate Pavement Rehabilitation Treatment	53-4.1

Table of Contents
(Continued)

<u>Section</u>		<u>Page</u>
53-4.02	Minor Pavement Rehabilitation Treatments.....	53-4.2
	53-4.02(a) Standard HMA Overlay	53-4.2
	53-4.02(b) Bonded Concrete Overlay on Asphalt (BCOA).....	53-4.2
53-4.03	Major Rehabilitation Treatments.....	53-4.9
	53-4.03(a) HMA Designed Overlay.....	53-4.9
	53-4.03(b) Structural Concrete Overlay (SCO).....	53-4.9
53-4.04	HMA Design Guidelines	53-4.10
	53-4.04(a) Minimum HMA Lift Thickness.....	53-4.10
	53-4.04(b) HMA Mixture Requirements Table	53-4.10
	53-4.04(c) ESAL Calculation	53-4.13
	53-4.04(d) Design Compactive Effort.....	53-4.14
	53-4.04(e) Asphalt Binder Selection	53-4.15
	53-4.04(f) Friction Aggregate.....	53-4.16
	53-4.04(g) Longitudinal Joint Sealant	53-4.20
53-5	TREATMENT SUMMARIES	53-5.1
53-5.01	Flexible and Composite Pavement Preservation Treatment Summaries.....	53-5.2
53-5.02	Rigid Pavement Preservation Treatment Summaries	53-5.12
53-5.03	Minor Rehabilitation Treatment Summaries.....	53-5.18
53-5.04	Major Rehabilitation Treatment Summaries.....	53-5.21
53-5.05	Pre-Treatment Activity Summaries	53-5.23
53-5.06	Additional Design Feature Summaries	53-5.29
53-6	REFERENCES.....	53-6.1

Chapter Fifty-three

PAVEMENT PRESERVATION AND REHABILITATION STRATEGIES

53-1 GENERAL

53-1.01 Scope of Chapter

The Illinois Transportation Asset Management Plan (TAMP) was developed and implemented consistent with the requirements established by 23 U.S.C. 119 and 23 CFR 515. The pavement management aspects of the TAMP are documented in this chapter as well as in the Pavement Management and Evaluation Manual.

This chapter focuses on the preservation and rehabilitation aspects of the pavement life cycle shown in Figure 53-1.A and should be used in conjunction with the Pavement Management and Evaluation Manual. Guidance is given to allow the user to:

- select the proper pavement management methodology,
- gather pavement information,
- identify feasible treatment alternatives,
- select the appropriate treatment, and
- develop the design of the selected treatment.

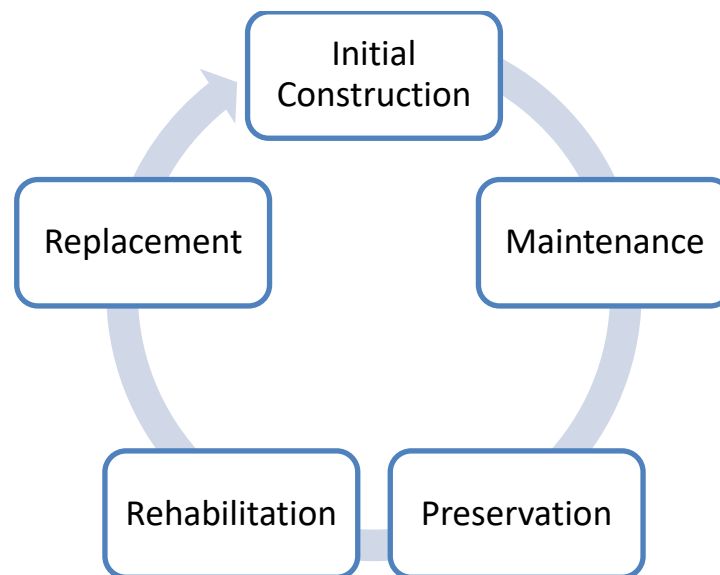

Pavement Life Cycle

Figure 53-1.A

Pavement design/replacement information is found in Chapter 54. Information previously contained in Chapter 52 has been integrated into this chapter. Contract maintenance program requirements are available in Chapter 12 of the Bureau of Operations Maintenance Policy Manual.

The pavement treatments outlined in this chapter are for pavements on the state system and local pavements on the National Highway System (NHS). Preservation and rehabilitation treatments for local agency pavements off the NHS should be developed using Chapters 45 and 46 of the Bureau of Local Roads and Streets Manual.

53-1.02 Definitions

1. Binder Course. One or more layers of a hot-mix asphalt (HMA) overlay or full-depth pavement structure. A surface course or wearing course must be placed over this course to protect it from environmental effects and provide appropriate friction characteristics.
2. Composite Pavement. A pavement structure consisting of a portland cement concrete (PCC) slab overlaid with HMA. The PCC slab may be either a newly constructed base course or an existing jointed PCC or continuously reinforced concrete pavement.
3. Condition Rating Survey (CRS). The primary pavement performance metric used by the Illinois Department of Transportation (IDOT) to quantify the condition of its pavement assets. CRS values range from 9.0 to 1.0, with 9.0 representing a newly constructed, rehabilitated, or preserved pavement and a 1.0 representing a pavement at the end of its service life.
4. Continuously Reinforced Concrete Pavement (CRCP). A rigid pavement structure having continuous longitudinal reinforcement. The continuous reinforcement is achieved by overlapping the longitudinal steel reinforcing bars.
5. Designed HMA Overlay. A hot-mix asphalt overlay consisting of two or more lifts intended to mitigate the effects of underlying structural distresses and provide a stable wearing surface over an existing pavement.
6. Flexible Pavement. A pavement structure whose surface and principle load distributing component is a combination of HMA binder and surface layers, and potentially coarse aggregate layer(s). These pavements may include both conventional flexible and full-depth HMA pavements.
7. Full-Depth Hot-Mix Asphalt Pavement. A flexible pavement structure that uses HMA throughout the entire thickness (binder course and surface course layers).
8. Jointed Plain Concrete Pavement (JPCP). A rigid pavement structure without reinforcing steel that uses doweled joints for effective load transfer at the transverse joints which are typically spaced at 15 ft (4.6 m). This pavement type is the Department's default rigid pavement and is shown on Highway Standard 420101.

9. Jointed Reinforced Concrete Pavement (JRCP). A rigid pavement that uses distributed steel reinforcement and transverse contraction joints. This pavement type was discontinued in the late 1980s.
10. Major Rehabilitation. A strategy of placing an overlay with substantial thickness on a pavement in poor condition. These treatments restore serviceability and slow the propagation of underlying structural distresses with an anticipated service life of 10 to 15 years.
11. Minor Rehabilitation. A strategy of either placing an overlay with nominal thickness or recycling the existing HMA on a pavement in fair condition. These treatments reduce or eliminate functional distresses and restore serviceability with an anticipated service life of 10 to 15 years.
12. National Highway System (NHS). The NHS consists of the highway routes and connections to transportation facilities that serve major population centers, international border crossings, ports, airports, public transportation facilities, and other intermodal transportation facilities and other major travel destinations; meets national defense requirements; and serves interstate and interregional travel and commerce.
13. Pavement Field Investigation (PFI). A method of analyzing the existing pavement to determine the appropriate pavement management methodology and/or treatment selection.
14. Pavement Performance. The trend of pavement condition indices over time with respect to traffic and environmental effects.
15. Pavement Preservation. A cost-effective strategy of placing either a non-structural surface or proactive maintenance treatment on a pavement to extend service life at fair or good condition.
16. Pavement Structure. The combination of granular or stabilized subbase and pavement layers (flexible or rigid) which support the traffic load and distribute it to the subgrade.
17. Predicted CRS. The projected CRS value corresponding to the program year in which the treatment will be placed. This value is calculated annually by the Bureau of Programming.
18. Pre-Treatment Activity. An activity (e.g., milling, patching, etc.) that is used to correct a specific distress to improve the pavement condition, enabling the use of a treatment from another category (e.g., improve from standard overlay to pavement preservation).
19. Proactive (Preventive) Maintenance. A strategy of placing a minimal treatment at an early stage of service life in order to prevent deterioration or associated distresses and maintain the condition of the pavement. Preventive maintenance is a cost-effective means of extending the useful life of a pavement.
20. Ramp. A roadway that connects two or more legs at an interchange and includes at least one ramp terminal section. Roadways that connect two legs of freeway and are

continuations of mainline lanes or arise from tapers designed for high-speed operation are not considered ramps but are considered part of the mainline for structural design.

21. Reactive (Routine) Maintenance. Work that is performed in reaction to an event, season, or overall deterioration to restore serviceability of a pavement until a rehabilitation treatment can be constructed. This work includes that which is performed by State Operations forces and as part of the Contract Maintenance program.
22. Rehabilitation. A strategy of either recycling the HMA or placing a layer of HMA or PCC over a pavement in poor to fair condition.
23. Rigid Pavement. A pavement structure whose surface and principle load distributing component is a PCC slab (e.g., JPCP, CRCP, JRCP).
24. Rubblized PCC Pavement. Rubblization is a replacement alternative in which the existing PCC pavement is broken (in-place) into small pieces and compacted to create a uniform base for the new pavement.
25. Standard HMA Overlay. A hot-mix asphalt overlay consisting of two lifts to mitigate the effects of functional distresses and provide a stable wearing surface over an existing pavement.
26. Surface Course (Wearing Course). The top layer of an HMA pavement or overlay which resists skidding, traffic abrasion, and the disintegrating effects of the environment.
27. Surface Treatment. A non-structural, full-width wearing course. Examples include: cape seal, chip seal, micro-surfacing, and slurry seal.
28. Traffic Factor (TF). The total number of 18-kip equivalent single-axle load applications (ESALs) to the design lane anticipated during the design period, expressed in millions. It is used as an equivalency factor for mixed traffic loads.

53-2 PAVEMENT MANAGEMENT METHODOLOGIES

53-2.01 Selection of Pavement Management Methodology

The life cycle of pavements as defined in the TAMP includes initial construction, maintenance, preservation, rehabilitation, and replacement. Initial construction is not covered in this chapter. Figures 53-2.A and 53-2.B illustrate the relationship between the four major categories of treatments discussed here (maintenance, preservation, rehabilitation, and replacement), typical treatments representative of actions taken in those categories, and the CRS range in which those typical treatments are most applicable. These categories are only the initial step and further evaluation may warrant a change in either the category or specific treatment.

Pavement maintenance and preservation are the first levels of treatment. Pavement maintenance is briefly discussed in Section 53-2.02. The pavement preservation methodology is described in detail in Section 53-3. Once the pavement has deteriorated beyond the point where preservation is cost-effective, pavement rehabilitation should be utilized. The complete description of pavement rehabilitation methodology is provided in Section 53-4. As presented above, pavement replacement becomes necessary when pavement rehabilitation is no longer cost-effective. This methodology is discussed in detail in Chapter 54. However, Interstates with ADT < 15,000 and non-Interstates with ADT < 3,000 may receive a major rehabilitation treatment in lieu of Replacement.

Once the appropriate treatment category is determined, the process of matching pavements and treatments includes the following general steps:

- Gather pavement information,
- Identify feasible preservation treatments, and
- Select the most appropriate preservation treatment.

Additional information on activities necessary for final selection of a treatment strategy is contained in the Pavement Management and Evaluation Manual.

53-2.02 Maintenance Methodologies

Maintenance can take the form of preventive (proactive) or routine (reactive). Proactive maintenance activities are included in the pavement preservation category. Reactive maintenance activities are included in the Contract Maintenance program which is administered by the Central Bureau of Operations.

Proactive maintenance is a subcategory of pavement preservation and includes those activities used to prevent water and incompressible material infiltration, surface oxidation, and other environmental factors. These treatments are applied soon after initial construction or rehabilitation and can be reapplied as needed throughout the pavement's life cycle.

When a pavement segment is in need of treatment but cannot be brought into the annual or multi-year program, reactive maintenance can be used as a stop-gap measure to maintain the roadway

in a serviceable condition until the program can accommodate the proper treatment for the project. Reactive maintenance is addressed through the contract maintenance program which may be used to supplement the maintenance work effort of state forces and is limited to repair and restoration of immediate needs. The contract maintenance program operates under guidelines issued by the Central Bureau of Operations.

53-2.03 Pavement Preservation Methodologies

Pavement preservation treatments are lower cost, non-structural treatments used to extend the surface life of a pavement before the roadway reaches a condition that requires rehabilitation. These treatments are a cost-effective means of increasing the overall service life of a pavement by addressing functional surface distresses before they progress to a structural issue. Matching the right preservation treatment with the right pavement calls for an awareness of the current condition of the pavement in terms of the types of distresses present as well as their severities. It also helps to understand the typical performance of the pavement in its location and considering how it's used.

In some cases, the best strategy will consist of a combination of pre-treatment activities and preservation strategies in order to address a pavement's current and expected performance.

Details on pavement preservation strategies are provided in Section 53-3.

53-2.04 Rehabilitation Methodologies

Rehabilitation consists of improvements made to an existing pavement section that has progressed beyond the limitations of pavement preservation treatments. These strategies remove surface distresses that develop in flexible pavements due to aging and exposure to environmental effects, such as block cracking, raveling, and weathering, as well as reduces the impacts of structural distresses caused by repeated loadings or loss of support. In concrete pavements, pavement rehabilitation consists of the addition of one or more layers of either hot-mix asphalt (HMA) or portland cement concrete (PCC) to address functional or structural distresses and restore ride quality and/or safety. Details on rehabilitation strategies are provided in Section 53-4.

53-2.05 Pavement Replacement Methodology

Once a pavement has insufficient load carrying capacity and can no longer be cost-effectively rehabilitated, the entire pavement structure should be replaced. When selecting this treatment methodology, a complete design and life-cycle cost analysis (LCCA) shall be performed according to Chapter 54 to determine the most cost-effective pavement type.

Category	Subcategory	Treatments	Service Life	Predicted CRS
Do Nothing			N/A	7.6-9.0
Preservation (Section 53-3)	Proactive Maintenance	Crack and Joint Filling, Crack and Joint Sealing, Diamond Grinding, Diamond Grooving, Longitudinal Joint Sealing (Concrete)	2 - 5	> 6.0
	Low	Micro-Surfacing	3 - 7	6.6-7.5
	High	Longitudinal Joint Partial-Depth Repair, SMART Overlay, Ultra-Thin Bonded Wearing Course, Load Transfer Restoration (Transverse Cracking - Concrete) ⁽¹⁾	7 - 12	5.5 - 6.5
Rehabilitation (Section 53-4)	Minor	Bonded Concrete Overlay on Asphalt ⁽²⁾ , Standard HMA Overlay	10 - 15	4.6-5.4
	Major	Designed HMA Overlay, Structural Concrete Overlay (Requires an exception) ⁽¹⁾	10 - 15	4.0-4.5
Replacement ⁽³⁾ (Chapter 54)		Replacement of complete pavement structure, New Pavement (HMA or PCC) over Rubblized PCC, Unbonded Concrete Overlay	30-40	< 4.0
Contract Maintenance	Reactive Measures	See Contract Maintenance Program Guidelines ⁽⁴⁾	Varies	< 5.5 ⁽⁵⁾

Notes:

- (1) Treatment will require an experimental feature according to Construction Memo 02-2.
- (2) Bonded Concrete Overlay on Asphalt is limited to pavements with a rigid traffic factor less than or equal to 7.5.
- (3) Interstates with ADT < 15,000 may receive a major rehabilitation treatment in lieu of replacement.
- (4) Low Preservation treatments may be used as a stop-gap measure. High Preservation activities of Full-depth Repairs and Longitudinal Joint Partial-Depth Repair are allowed as Reactive Measures. HMA Surface Mill and Replacement will be approved on a case-by-case basis.
- (5) For localized failures, any CRS value may be considered (patching, centerline failures, intermittent locations of surface repairs).

Interstate TAMP Category Selection Criteria - Pavements

Figure 53-2.A

Category	Subcategory	Treatments	Service Life	Predicted CRS
Do Nothing			N/A	7.6-9.0
Preservation (Section 53-3)	Proactive Maintenance	Crack and Joint Filling, Crack and Joint Sealing, Diamond Grinding, Diamond Grooving, Longitudinal Joint Sealing (Concrete)	2 - 5	> 6.0
	Low	Cape Seal, Chip Seal (A-1, A-2, A-3), Half-SMART, Micro-Surfacing	3 - 7	6.6 - 7.5
	High	Longitudinal Joint Partial-Depth Repair, Hot In-Place Recycling ⁽¹⁾ , SMART Overlay, Ultra-Thin Bonded Wearing Course, Load Transfer Restoration (Transverse Cracking - Concrete) ⁽¹⁾	7 - 12	5.0 - 6.5
Rehabilitation (Section 53-4)	Minor	Bonded Concrete Overlay on Asphalt ⁽²⁾ , Cold In-Place Recycling (Requires a Design Exception) ⁽¹⁾ , Standard HMA Overlay	10 - 15	4.1 - 4.9
	Major	Designed HMA Overlay, Structural Concrete Overlay (Requires an exception) ⁽¹⁾	10 - 15	3.5 - 4.0
Replacement ⁽³⁾ (Chapter 54)		Replacement of complete pavement structure, New Pavement (HMA or PCC) over Rubblized PCC, Unbonded Concrete Overlay	30-40	< 3.5
Contract Maintenance	Reactive Measures	See Contract Maintenance Program Guidelines ⁽⁴⁾	Varies	< 5.0 ⁽⁵⁾

Notes:

- (1) Treatment will require an experimental feature according to Construction Memo 02-2.
- (2) Bonded Concrete Overlay on Asphalt is limited to pavements with a rigid traffic factor less than or equal to 7.5.
- (3) Projects with ADT < 3,000 may receive a Major Rehabilitation treatment in lieu of Replacement.
- (4) Low Preservation treatments may be used as a stop-gap measure. High Preservation activities of Full-depth Repairs and Longitudinal Joint Partial-Depth Repair are allowed as Reactive Measures. HMA Surface Mill and Replacement will be approved on a case-by-case basis.
- (5) For localized failures, any CRS value may be considered (patching, centerline failures, intermittent locations of surface repairs).

Non-Interstate TAMP Category Selection Criteria - Pavements

Figure 53-2.B

53-2.06 Pavement Information Needed for Treatment Selection

Good treatment selection is guided by understanding as much as possible about the overall pavement structure, such as pavement type, overall pavement age and age of surface, traffic volumes, and pavement typical sections and materials. Much of this information is currently found in several databases within IDOT. The databases are identified in detail in the Pavement Management and Evaluation Manual. Once IDOT's Enterprise Asset Management System (EAMS) is implemented, it will allow data from multiple databases to be viewed in one central location and evaluated comprehensively.

Knowing the existing pavement structure and materials properties can be very useful to determine which treatment(s) will work best with the current structure and how the pavement section might perform in the future. Depending on the methodology being considered, a pavement field investigation (PFI) may be required. Details on the requirements for PFIs can be found in the Pavement Management and Evaluation Manual.

53-2.07 Pre-Treatment Activities and Other Factors

When determining final treatment selection, all aspects of the project must be considered to ensure a comprehensive approach, which will maximize performance. These include pre-treatment activities, secondary considerations, and additional design features.

53-2.07(a) Pre-Treatment Activities

When pavement preservation and rehabilitation treatments are being determined, pre-treatment activities can be used to eliminate or reduce distresses that are prohibiting the use of specific treatments and/or to improve the performance of the chosen treatment. The following pre-treatment activities, summarized in Section 53-5.05, may be considered based on the existing pavement type and results of the PFI.

- Cold Milling / Fine Milling
- Full-Depth CRCP Patches (Class A)
- Full-Depth Dowelled Patches (Class B)
- Full-Depth Undowelled Patches (Class C and Class D)
- Partial-Depth Patches
- Longitudinal Crack Repair

53-2.07(b) Secondary Considerations

Other factors that should be considered when making the final selection include ADA ramps, ADT, traffic control operations, constraints (e.g., bridge clearances, ramps, side slopes), condition of adjacent pavements, and costs. Job limits shall be extended to include intersections within 500 feet of paving and other improvement project termini for the inclusion of bicycle and pedestrian features. Job limits shall be extended to include intersections within 500 feet of paving and other

improvement project termini for the inclusion of bicycle and pedestrian features. Improvements within the scope of Chapter 17 Part 1.02 should be considered. Normal project termini should remain in place.

53-2.07(c) Additional Design Features

While developing the scope of a project, the pavement section needs to be reviewed to determine if any additional design features will require attention, while the preservation or rehabilitation treatment is being constructed. The following additional design features, summarized in Section 53-5.05, should be evaluated to determine if they are still functioning properly.

1. Pipe Underdrains. Pavement distress can be accompanied by pumping of the subbase and subgrade material. For this reason, it is important to evaluate the need for underdrain installation. As part of a rehabilitation or replacement project, pipe underdrains should be installed on the Interstate System and other freeway facilities that are designed to Interstate criteria, if they have not been previously installed. Although pipe underdrains are not mandatory on non-Interstate primary facilities, they can be very useful where existing drainage problems exist. Pipe underdrains should be installed prior to patching unless there are valid reasons to do otherwise.

See the *Highway Standards* for underdrain installation details for Interstate highways. Depending on the type of underdrain material specified, it may be necessary to adjust the depth of the underdrain to accommodate outfall drainage into existing shallow roadside ditches. Ensure the depth is sufficient to prevent overstressing the underdrain material. Generally, pipe will not be overstressed if the trench depth is 24 in. or greater. Consult the Engineer of Pavement Technology in the Bureau of Research for guidance if it is necessary to place pipe in shallower trenches. If deep roadside ditches or high fills are encountered, consider shifting the locations of pipe drain laterals to avoid outfall onto the long steep slopes. Replace any aggregate outlets of existing outfall pipe drains with concrete headwall outlets. If pipe underdrains have been installed on a previous contract, investigate to determine the need for cleaning or repairing the underdrain system.

2. Expansion and Terminal Joints. Expansion joints on PCC pavements and overlays of PCC pavements should be visually inspected to determine if they are in working order. If patching is an integral part of the rehabilitation strategy, closed expansion joints should be re-established regardless of the type of patching that is specified.

Existing lug systems and/or wide flange beam terminal joints on CRCPs and overlays of CRCPs and should be closely inspected to determine if the joint is working properly both at the beam and at the expansion joint between the beam and the bridge approach or jointed pavement. In addition, the flange of the beam should be inspected for signs of fatigue cracking. When a terminal joint is determined to be non-functioning, contact the Pavement Design Engineer in the Bureau of Research for assistance in selecting a treatment strategy.

53-2.08 Exception Requests

If the district would like to deviate from the TAMP category selection criteria or the overlay policies contained in Chapter 53, an exception request will be required.

53-2.08(a) TAMP Category Selection Exception Requests

If the pavement investigation report indicates that a deviation from the category recommended by Figures 53-2.A or 53-2.B or a rehabilitation treatment recommended by Figure 53-4.A is the best alternative, a TAMP category selection exception request will be required when the project is entering the first three years of the multi-year program. Examples of TAMP category selection exception requests include:

- When Figure 53-2.A or Figure 53-2.B recommends replacement, however, the pavement evaluation indicates that rehabilitation is a better alternative.
- When Figure 53-4.A recommends minor rehabilitation, however the pavement evaluation indicates major rehabilitation is a better alternative.

53-2.08(b) Overlay Policy Exception Requests

An overlay policy exception request is required when either a lift thickness(es) would deviate from Figure 53-4.J in either the standard or designed overlays, or when there is preference to use a single lift instead of two lifts for an HMA overlay. This exception request must be submitted prior to the project entering the annual program.

53-2.08(c) Exception Request Submittals

All exception requests shall be submitted to the Asset Management Engineer in the Bureau of Programming, and the documentation shall include the following information:

1. Length and Limits of Project/Limits of Request. If the condition of the section is variable, clearly define the limits of the distressed areas that require additional thickness by station or log mile rather than requesting additional thickness over the entire project. Include the key route inventory number and the key route mileposts.
2. Traffic. Document traffic volumes including breakdown of passenger vehicles, single-unit trucks, and multiple-unit trucks.
3. Pavement History. Include the date of construction, pavement cross-section data, date and description of previous rehabilitations, current and historical CRS ratings, and distress history.
4. Pavement Investigation Report.

- a. Existing Condition. Include the type, severity, and frequency of distress (including photos); directional differences, faulting measurements; rutting measurements; and estimated patching quantities.
 - b. Core Data. When core data is required, photos and descriptions of the cores and information on the quantity and location should be included. When available, additional information on the material characteristics of those cores should also be provided, such as: densities (%), conditioned split tensile strength (psi), and strip rating (numeric rating).
5. Calculations and Estimates. Include all relevant supporting calculations and cost estimates.
 6. Other. Include any other supporting evidence and test data and photographs.

Based on the type of exception request, content of the submittal, and the total length of the project, a joint review with the district, the Asset Management Engineer in the Bureau of Programming, and the Engineer of Pavement Technology in the Bureau of Research may be warranted.

53-3 PAVEMENT PRESERVATION TREATMENT SELECTION GUIDELINES

53-3.01 Identify Feasible Preservation Treatments

When identifying the appropriate pavement preservation treatment for candidate projects, analyze the type and severity of pavement distresses present on the pavement, as well as other relevant collected information, to match pavement and project characteristics with treatment capabilities. Figures 53-3.A, 53-3.B, and 53-3.C can then be used to help identify feasible preservation treatments for flexible, composite, and rigid pavements. These figures provide guidance for treatment selection based upon attributes such as distresses and their level of severity, ride, friction, traffic levels, and relative costs. They relate a single distress or other characteristic to a single treatment; where there are multiple distresses, examine the appropriate treatment(s) to address each distress type. Then, use the recommended treatment(s) in combination with engineering judgment to make a final treatment selection.

Note that this process is not expected to result in the identification of a single treatment that is appropriate for a given set of site conditions; rather it is much more likely that there will be a number of feasible treatments that address those conditions. Therefore, there is at least one more step in the treatment selection process.

53-3.02 Select Appropriate Preservation Treatment

The selection of the most appropriate preservation treatment includes considering the various constraints on a project that affect treatment selection. The following list identifies some of the project constraints that should be considered when selecting the most appropriate preservation treatment.

- Availability of qualified contractors,
- Availability of quality materials,
- Time (of year) of construction,
- Initial costs,
- Ride quality (i.e., International Roughness Index),
- Pavement noise,
- Facility downtime, and
- Surface friction.

The effects of these constraints vary from project to project and should be reviewed for each project when finalizing treatment selection. Contact the Bureau of Research if assistance is needed in evaluating various treatment options to address constraints.

Pavement Conditions	Severity Levels	Proactive Maintenance		Low Preservation Treatments ¹					High Preservation Treatments ¹			
		Crack & Joint Filling/ Sealing	Diamond Grinding	Long. Jt. Micro-surfacing	Cape Seal ²	Chip Seal ²	Half-SMART ²	Micro-surfacing ³	Long. Jt. PD Repair	HIR ²	SMART Overlay	UTBWC
Alligator/ Fatigue Cracking	L1	R	R	N/A	R**	R**	R**	R**	N/A	R	R	R
	L2, L3, L4	NR	NR	N/A	NR	NR	NR	NR	N/A	NR	NR	NR
Block Cracking	M1, M2	R	R	N/A	R	R	R	R	N/A	R	R	R
	M3	R	R	N/A	NR	NR	NR	NR	N/A	R	R	R
	M4	NR	NR	N/A	NR	NR	NR	NR	N/A	NR	NR	NR
"Stable" Rutting	≤ 0.13	R	R	N/A	R	R	R	R	N/A	R	R	R
	≤ 0.25	NR	NR	N/A	NR	NR	NR	R	N/A	R	R	R
Joint Reflection and Transverse Cracking	O1, O2, O3	R	R	N/A	R**	R**	R**	R**	N/A	R	R**	R
	O4	R	R	N/A	NR	NR	NR	NR	N/A	R	R	NR
	O5	NR	NR	N/A	NR	NR	NR	NR	N/A	NR	NR	NR
Overlaid Patch Reflective Cracking	P1, P2, P3	R	R	N/A	R**	R**	R**	R**	N/A	R	R**	R
	P4	R	R	N/A	NR	NR	NR	NR	N/A	R	R	R
	P5	NR	NR	N/A	NR	NR	NR	NR	N/A	NR	NR	NR
Longitudinal / Center of Lane Cracking	Q1	R	R	N/A	R**	R**	R**	R**	N/A	R	R**	R
	Q2, Q3	R	R	N/A	NR	NR	NR	NR	N/A	R	R	NR
	Q4, Q5	NR	NR	N/A	NR	NR	NR	NR	N/A	NR	NR	NR
Reflective Widening Crack	R1	R	R	N/A	R**	R**	R**	R**	N/A	R	R**	R
	R2, R3	R	R	N/A	NR	NR	NR	NR	N/A	R	R	F*
	R4, R5	NR	NR	N/A	NR	NR	NR	NR	N/A	NR	NR	NR
Longitudinal Joint Deterioration ⁴	S1, S2	R	R	R	R**	R**	R**	R**	R	R	R**	R*
	S3, S4	NR	NR	R	NR	NR	NR	NR	R	F	R	F
Edge Cracking	T1	R	R	N/A	R**	R**	R**	R**	N/A	R	R**	R
	T2	R	R	N/A	F*	F*	F*	F*	N/A	F*	F*	F*
	T3, T4	NR	NR	N/A	NR	NR	NR	NR	N/A	NR	NR	NR
Permanent Patch Deterioration	U1	R	R	N/A	R**	R**	R**	R**	N/A	R	R**	R
	U2	F*	F*	N/A	F*	F*	F*	F*	N/A	R	R	F*
	U3, U4	NR	NR	N/A	NR	NR	NR	NR	N/A	NR	NR	NR
Weathering/ Raveling	W1, W2	NR	NR	N/A	R	R	R	R	N/A	R	R	R
	W3	NR	NR	N/A	R*	R*	R*	NR	N/A	R	R	R
	W4	NR	NR	N/A	NR	NR	NR	NR	N/A	NR	NR	NR
Reflective D-Cracking	X1	N/A	N/A	N/A	R	R	R	R	N/A	R	R	R
	X2, X3	NR	NR	N/A	NR	NR	NR	NR	N/A	NR	NR	NR
Friction	Poor	NR	NR	N/A	R	R	R	R	N/A	R	R	R
ADT	< 5,000	R	R	R	R	R	R	R	R	R	R	R
	5,000 – 10,000	R	R	R	NR	NR	NR	R	R	R	R	R
	> 10,000	R	R	R	NR	NR	NR	R	R	NR	R	R
Relative Cost	(\$ to \$\$\$)	\$	\$	\$\$	\$\$	\$\$	\$\$	\$\$	\$\$	\$\$\$	\$\$\$	\$\$\$

- R - Recommended treatment. Care must be taken to ensure all critical distress types are addressed by selected treatment.
- R* - Recommended treatment when used with milling prior to treatment.
- R** - If milling is not included as a mitigating activity, crack sealing is recommended one year prior to treatment.
- F - Feasible treatment but depends upon other project constraints including other existing distresses.
- F* - This is a localized distress and should be treated locally while other distress types present should dictate choice of global treatment.
- NR - Treatment is not recommended to correct the specified pavement condition.
- N/A - Distress does not impact treatment selection.
- 1 - Full-Depth and Partial-Depth patching only allowed as a mitigating activity. A maximum of 0.50 percent will be allowed with any preservation treatment.
- 2 - Treatment not allowed on Interstate pavements.
- 3 - ADT ≤ 25,000 use 1-pass; ADT > 25,000 use 2-pass
- 4 - If only distress present, use indicated treatments. If other distresses are present, use the treatment that addresses the distresses across the full lane.

TREATMENT SELECTION GUIDELINES FOR FLEXIBLE PAVEMENTS

Figure 53-3.A

Pavement Conditions	Severity Levels	Proactive Maintenance		Low Preservation Treatments ¹					High Preservation Treatments ¹			
		Crack & Joint Filling/ Sealing	Diamond Grinding	Long. Jt. Micro-surfacing	Cape Seal ²	Chip Seal ²	Half-SMART ²	Micro-surfacing ³	Long. Jt. PD Repair	HIR ²	SMART Overlay	UTBWC
Alligator/ Fatigue Cracking	L1	R	R	N/A	R**	R**	R**	R**	N/A	R	R	R
	L2, L3, L4	NR	NR	N/A	NR	NR	NR	NR	N/A	NR	NR	NR
Block Cracking	M1, M2	R	R	N/A	R	R	R	R	N/A	R	R	R
	M3	R	R	N/A	NR	NR	NR	NR	N/A	R	R	R
	M4	NR	NR	N/A	NR	NR	NR	NR	N/A	NR	NR	NR
"Stable" Rutting	≤ 0.13	R	R	N/A	R	R	R	R	N/A	R	R	R
	≤ 0.25	NR	NR	N/A	NR	NR	NR	NR	N/A	R	R	R
Joint Reflection and Transverse Cracking	O1, O2, O3	R	R	N/A	R**	R**	R**	R**	N/A	R	R**	R
	O4	R	R	N/A	NR	NR	NR	NR	N/A	NR	NR	NR
	O5	NR	NR	N/A	NR	NR	NR	NR	N/A	NR	NR	NR
Overlaid Patch Reflective Cracking	P1, P2, P3	R	R	N/A	R**	R**	R**	R**	N/A	R	R**	R
	P4	R	R	N/A	NR	NR	NR	NR	N/A	R	R	R
	P5	NR	NR	N/A	NR	NR	NR	NR	N/A	NR	NR	NR
Longitudinal / Center of Lane Cracking	Q1	R	R	N/A	R**	R**	R**	R**	N/A	R	R**	R
	Q2, Q3	R	R	N/A	R**	NR	R*	NR	N/A	R	R	R*
	Q4, Q5	NR	NR	N/A	NR	NR	NR	NR	N/A	NR	NR	NR
Reflective Widening Crack	R1	R	R	N/A	R**	R**	R**	R**	N/A	R	R**	R
	R2, R3	R	R	N/A	NR	NR	NR	NR	N/A	R	R	F*
	R4, R5	NR	NR	N/A	NR	NR	NR	NR	N/A	NR	NR	NR
Longitudinal Joint Deterioration ⁴	S1, S2	R	R	R	R**	R**	R**	R**	R	R	R**	R*
	S3, S4	NR	NR	R	NR	NR	NR	NR	R	F	R	F
Edge Cracking	T1	R	R	N/A	R**	R**	R**	R**	N/A	R	R**	R
	T2	R	R	N/A	F*	F*	F*	F*	N/A	F*	F*	F*
	T3, T4	NR	NR	N/A	NR	NR	NR	NR	N/A	NR	NR	NR
Permanent Patch Deterioration	U1	R	R	N/A	R**	R**	R**	R**	N/A	R	R**	R
	U2	F*	F*	N/A	F*	F*	F*	F*	N/A	R	R	F*
	U3, U4	NR	NR	N/A	NR	NR	NR	NR	N/A	NR	NR	NR
Weathering/ Raveling	W1, W2	NR	NR	N/A	R	R	R	R	N/A	R	R	R
	W3	NR	NR	N/A	R*	R*	R*	NR	N/A	R	R	R
	W4	NR	NR	N/A	NR	NR	NR	NR	N/A	NR	NR	NR
Reflective D-Cracking	X1	N/A	N/A	N/A	R	R	R	R	N/A	R	R	R
	X2, X3	NR	NR	N/A	NR	NR	NR	NR	N/A	NR	NR	NR
Friction	Poor	NR	NR	N/A	R	R	R	R	N/A	R	R	R
ADT	< 5,000	R	R	R	R	R	R	R	R	R	R	R
	5,000 – 10,000	R	R	R	NR	NR	NR	R	R	R	R	R
	> 10,000	R	R	R	NR	NR	NR	R	R	NR	R	R
Relative Cost	(\$ to \$\$\$)	\$	\$	\$\$	\$\$	\$\$	\$\$	\$\$	\$\$	\$\$\$	\$\$\$	\$\$\$

R - Recommended treatment. Care must be taken to ensure all critical distress types are addressed by selected treatment.
 R* - Recommended treatment when used with milling prior to treatment.
 R** - If milling is not included as a mitigating activity, crack sealing is recommended one year prior to treatment.
 F - Feasible treatment but depends upon other project constraints including other existing distresses.
 F* - This is a localized distress and should be treated locally while other distress types present should dictate choice of global treatment.
 NR - Treatment is not recommended to correct the specified pavement condition.
 N/A - Distress does not impact treatment selection.
 1 - Full-Depth and Partial-Depth patching only allowed as a mitigating activity. A maximum of 0.50 percent will be allowed with any preservation treatment.
 2 - Treatment not allowed on Interstate pavements.
 3 - ADT ≤ 25,000 use 1-pass; ADT > 25,000 use 2-pass
 4 - If only distress present, use indicated treatments. If other distresses are present, use the treatment that addresses the distresses across the full lane.

TREATMENT SELECTION GUIDELINES FOR COMPOSITE PAVEMENTS

Figure 53-3.B

Pavement Conditions	Distress Levels	Proactive Maintenance Treatments				High Preservation Treatments ¹	
		Crack Sealing	Joint Resealing	Diamond Grinding ²	Diamond Grooving	LTR ³	UTBWC
D-cracking	A1, A2	R	N/A	NR	NR	NR	R
	A3	NR	N/A	NR	NR	NR	R
	A4, A5	NR	N/A	NR	NR	NR	NR
Transverse Cracking	B1, B2	R	R	NR	NR	NR	R
	B3	R	R	NR	NR	NR	NR
	B4, B5	NR	NR	NR	NR	NR	NR
Transverse Joint Deterioration	C1, C2	R	R	R	NR	R	R
	C3, C4	NR	NR	NR	NR	NR	NR
Centerline Deterioration	D1	R	R	NR	NR	NR	R
	D2, D3	NR	NR	NR	NR	NR	NR
Longitudinal Cracking	E1, E2	R	R	NR	NR	NR	R
	E3, E4	NR	NR	NR	NR	NR	NR
Edge Punchouts (CRCP)	F1	R	N/A	F	NR	NR	R
	F2, F3	NR	NR	NR	NR	NR	NR
Faulting	≤ 0.15	NR	NR	NR	NR	NR	NR
	> 0.15	NR	NR	R*	NR	R	NR
Corner Breaks (JPCP)	H1	N/A	N/A	N/A	NR	N/A	R
	H2, H3	NR	NR	NR	NR	NR	NR
Map Cracking and Scaling	I1	NR	NR	R	NR	NR	R
	I2	NR	NR	R	NR	NR	R
	I3	NR	NR	R	NR	NR	R
Popouts/High Steel	J1, J2, J3	NR	NR	NR	NR	NR	F**
Permanent Patch Deterioration	K1	R	R	F**	F**	NR	R
	K2, K3, K4	NR	NR	NR	NR	NR	NR
Roughness (High IRI)	IRI > 140 in/mi	NR	NR	R	NR	F*	F
Friction	Poor	NR	NR	R	R	N/A	R
Relative Cost	(\$ to \$\$\$\$)	\$	\$	\$\$	\$\$	\$\$\$	\$\$

R - Recommended treatment. Care must be taken to ensure all critical distress types are addressed by selected treatment.
 R* - Recommended when used in conjunction with LTR.
 F - Feasible treatment but depends upon other project constraints including other existing distresses.
 F* - Feasible treatment if poor ride is a result of undoweled joints or faulted transverse (mid-slab) cracking.
 F** - Other distress types should dictate choice of treatment.
 NR - Treatment is not recommended to correct the specified pavement condition.
 N/A - Distress does not impact treatment selection.
 1- Full-Depth and Partial-Depth patching will only be allowed as a mitigating activity. A maximum of 0.50 percent will be allowed.
 2 - If intermittent bump grinding, no additional activity necessary. Large areas of > 100 ft in length require diamond grooving.
 3 - LTR (Load Transfer Restoration) is normally used in combination with diamond grinding.

TREATMENT SELECTION GUIDELINES FOR RIGID PAVEMENTS

Figure 53-3.C

53-3.03 Pavement Preservation Treatments

Available and commonly used pavement preservation treatments are summarized in this section by TAMP subcategory (proactive maintenance, low preservation, high preservation). Further details regarding the treatments are available in the *IDOT Standard Specifications*, supplemental specifications, and special provisions. One-page treatment summaries may be found in Section 53-5 and include additional detail on each treatment. Utilize the guidance contained there to select the final treatment.

53-3.04 Other Factors

There are several other factors that must be addressed during the selection and/or design of various pavement preservation techniques.

53-3.04(a) Shoulders Versus Mainline

Pavement preservation treatments may be different between mainline and shoulders. Some spray applications that are not allowed for high-speed mainline sections may be used on shoulders since that is not the travel lane.

53-3.04(b) Pavement Markings and Raised Reflective Pavement Markers

All pavement markings, except latex paint, shall be removed prior to placement of a preservation treatment. Review all pavement sections for the presence of raised reflective pavement markers (RRPMs) prior to treatment placement for edge-to-edge treatments. RRPMs cannot be masked to protect and leave in place. All treatments will require removal and replacement of RRPMs.

53-3.04(c) Rumble Strips

Care shall be taken to avoid reducing the effectiveness of existing rumble strips when applying pavement preservation treatments.

53-3.04(d) Surface Preparation

Pavement preservation treatments are thin compared to a traditional two-lift HMA overlay and certain existing conditions will negatively impact their performance if not addressed. These conditions include, but are not limited, to the following.

1. Existing Pavement Markings. Some pavement preservation treatments require complete removal of all pavement markings before placement (e.g., thermoplastic, paint). When designing a project, review construction requirements of the selected treatment to determine if this work is required.

2. Roughness. Most thin preservation treatments will not improve a rough ride, unless multiple applications are used. Even then, there are limitations to how much roughness can be corrected. Bumps greater than 0.5 in. (12.5 mm) (measured using a 16-ft [4.9 m] straightedge) should be ground off prior to construction, unless the project includes surface milling or recycling. If excessive bump grinding would be required, consider treating the entire surface with fine milling.
3. Insufficient Cross Slope. Preservation treatments are not thick enough to adjust pavement cross slope when it is needed. If a pavement needs cross slope improvements, this should be accomplished by milling.
4. Cracking. Medium and high severity cracks will reflect through a preservation treatment. Proactive crack sealing should be completed at least 3 months prior to the placement of the treatment to minimize difficulties in constructing the treatment. If considering as a pre-treatment activity before pavement preservation, investigate the possibility of performing a sealing contract in the previous construction season. The sealant should be flush with or slightly below the surface of the pavement to minimize bleed-through.

53-3.04(e) Pavement Markings

A period of several days of good drying weather is necessary prior to the placement of permanent markings on various flexible pavement preservation treatments. Review each treatment specification to determine how much time is needed. Temporary markings of water-based paint or foil-backed tape will be necessary until permanent markings can be applied.

53-3.04(f) Timing Treatment Application

The weather limitations for the selected treatment must be considered when determining the letting date. Some treatments have small ranges of dates and/or temperatures in which they can be constructed. Schedule the letting at a time to avoid late season paving to promote proper cure of the treatment prior to the onset of winter.

53-4 PAVEMENT REHABILITATION TREATMENT SELECTION GUIDELINES

53-4.01 Select Appropriate Pavement Rehabilitation Treatment

Figure 53-4.A provides the decision tree for initial selection of the rehabilitation treatment based on the surface type of pavement and the presence of high severity structural distresses. Use this figure in conjunction with the PFI data as described in the Pavement Management and Evaluation Manual to make a final determination of rehabilitation subcategory (minor or major rehabilitation). Once the final subcategory has been established, utilize the guidance in the one-page treatment summaries to select the final treatment.

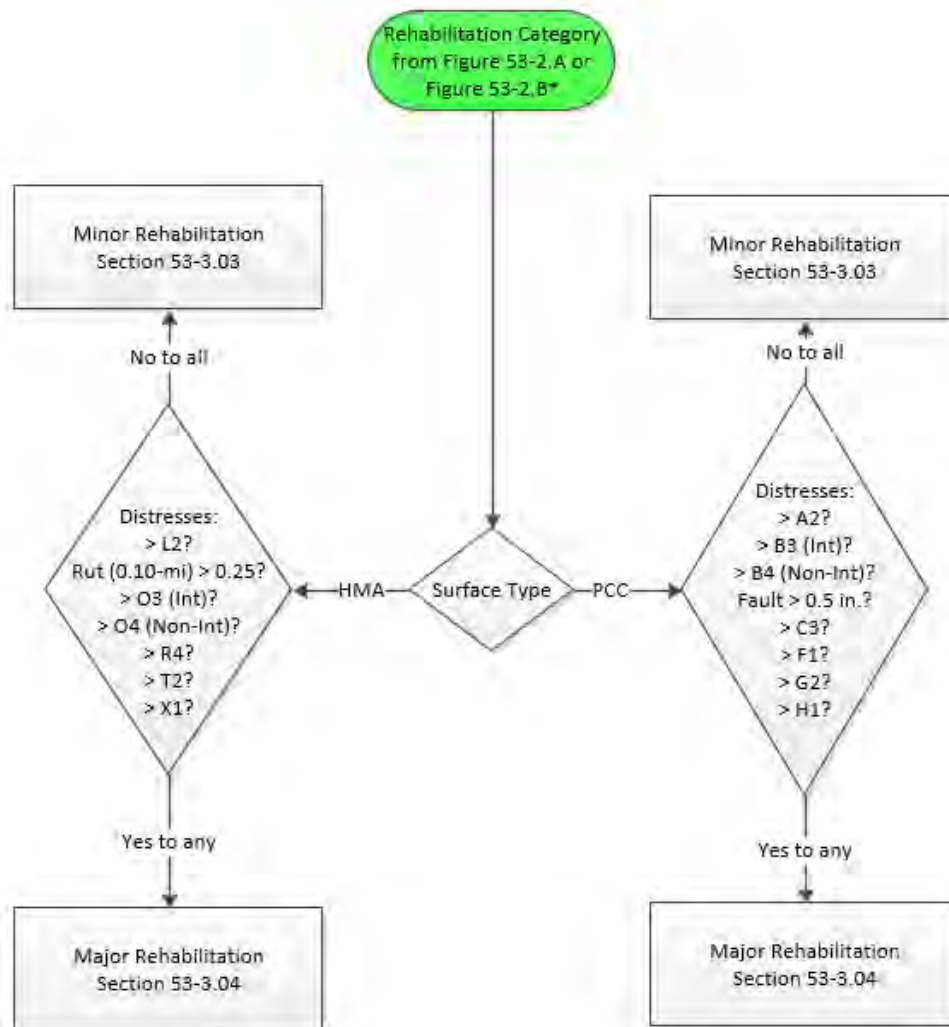

* Note: Thickness for Pavement Rehabilitation Treatments does not apply to the Contract Maintenance Program. Contract Maintenance thicknesses will typically be 1.5-2.0 inches.

REHABILITATION TREATMENT SELECTION

Figure 53-4.A

53-4.02 Minor Pavement Rehabilitation Treatments

A rehabilitation strategy normally is developed and targeted to address specific deficiencies with a particular pavement type. The strategy usually will be a combination of a rehabilitation treatment and one or more mitigating activities that, when completed, will correct deficiencies (i.e., functional failure, structural failure, or both) in the most cost-effective manner. The following pages provide brief descriptions of the pavement rehabilitation treatments typically used by the Department. Use these descriptions to better understand each rehabilitation treatment's purpose and application when developing alternative rehabilitation strategies.

Minor rehabilitation options include standard HMA overlays and bonded concrete overlays on asphalt (BCOA).

1. For a Standard HMA Overlay, use the appropriate thickness guidelines presented in Section 53-4.02(a). HMA mixture design criteria must be met as outlined in Section 53-4.04.
2. When a BCOA is selected, the overlay should follow the guidelines in Section 53-4.02(b).

53-4.02(a) Standard HMA Overlay

If the projected CRS value for the pavement section is within the range for minor rehabilitation according to Figure 53-4.A and the PFI concurs, a standard HMA overlay may be selected.

1. Milling. For HMA-surfaced pavements, the milling depth should remove the entire existing surface lift. When determining milling depth, avoid milling within 0.50 in. of an HMA lift line or within 1.0 in. above underlying PCC whenever possible to eliminate scabbing.

If there are constraints such as curb and gutter or other profile limits, take pavement cores to better define milling depth and required HMA lift thickness.

2. Number of Lifts. Full-depth HMA pavements may use a single lift of 2.00 in. (50 mm). All other pavement types will require the use of two lifts; however, a single 2-in. (50-mm) lift may be requested as an overlay policy exception according to Section 53-2.08.
3. Thickness. The resurfacing thickness for standard HMA overlays shall be according to the following.
 - a. Interstates. Two lifts with a total thickness of 3.00 to 4.25 in.
 - b. Other State Maintained Highways. Two lifts with a total thickness of 2.00 to 2.75 in. Bare PCC will require a minimum total thickness of 2.50 in.

53-4.02(b) Bonded Concrete Overlay on Asphalt (BCOA)

A bonded concrete overlay on asphalt is a rehabilitation strategy that involves a 3.0 in. to 6.0 in. portland cement concrete overlay over an existing HMA surface. The BCOA procedure does not apply to concrete thickness greater than 6.0 in. For thicker concrete slab designs, an unbonded

concrete overlay, which is a pavement replacement option, should be considered. This alternative rehabilitation strategy shall apply to Class I, II, III, and IV pavements, but shall not be used when the traffic factor (based on the rigid pavement equations) exceeds 7.5.

The BCOA treatment requires bonding between the new PCC surface and the underlying HMA as well as selecting slab sizes to balance the number of joints with debonding potential and increased slab stresses.

The successful application of BCOA requires a thorough field evaluation of the existing pavement, as well as close attention to profile, elevation, pavement cross section, and utility adjustments. See the bonded concrete overlay on asphalt pavement evaluation information contained in the Pavement Management and Evaluation Manual for more details.

The existing pavement surface shall be milled to correct the longitudinal and transverse profile, remove surface irregularities, and to maintain an acceptable cross-slope. Milling will also promote better bonding between the HMA and new PCC layer. The existing HMA layer, or remaining HMA after milling, shall be a minimum of 2.5 in. thick. If the remaining HMA does not meet this requirement, mill the entire HMA layer and replace with 2.5 in. new HMA to provide a good surface for the new concrete.

If a portion of the BCOA in excess of 5% will be bonded directly to bare concrete, brick, or other old slabs of concrete, this rehabilitation method shall not be used. This 5% limitation allows for existing concrete patches or other existing pavement features. Construction may be hindered by complicated geometrics, utility obstructions, traffic demand, and condition of the existing pavement.

To ensure good performance, synthetic macrofibers are specified for all BCOA projects. Synthetic macrofibers increase the structural capacity of concrete overlays by increasing the concrete material toughness. Additionally, synthetic microfibers are used to minimize the effects of plastic shrinkage cracks.

1. Procedures. All proposed BCOA projects must be submitted to the Bureau of Research for approval. The request should be documented in a “BCOA Project Request Report” and should include the following:
 - Preliminary and detailed pavement investigations, including performance testing of the existing HMA surface to remain in place,
 - existing and proposed cross sections,
 - existing and projected traffic information,
 - construction sequencing and proposed traffic control,
 - a document summarizing why the BCOA option is preferred over other rehabilitation alternatives.

Guidelines regarding the items to be included in the report and other BCOA design details are provided in the following sections. The designer should review all requirements and conduct preliminary calculations to check for feasibility before proceeding with detailed assessments.

2. Identify Design Considerations. There are several design issues that must be considered before submitting a BCOA rehabilitation proposal for review and approval. Issues that the designers should accommodate for prior to design submission for review are as follows:
 - a. Design Period. The design period to be used for this rehabilitation strategy is 15 years.
 - b. Drainage Considerations. Maintaining proper drainage through design and during construction is important. During construction, maintaining drainage is especially critical for projects that include an inlay. Repairing inadequate surface, subsurface, and/or lateral drainage may be required in certain locations prior to placement of a BCOA.
 - c. Thickness Design and Joint Spacing. Using macrofibers in the mix, the bonded concrete overlay thickness design is based on the traffic factor, the underlying HMA thickness, and the panel size. The concrete thickness shall be 3.0 in. to 6.0 in. with 0.50 in. increments allowed.

The traffic factor shall be determined according to the applicable equation for each pavement class using the equations in Section 54-4.01(g). Based on the traffic factor, the thickness of the underlying HMA material, and panel size, the bonded concrete overlay thickness may be determined either from Figures 53-4.B through 53-4.I or by using a computer program which is available from BDE: www.dot.il.gov/desenv/pdp.html.

This program allows the designer to input the traffic factor, the thickness of the underlying HMA material, panel size, and macrofibers residual strength to calculate the bonded concrete overlay thickness. The result from the program is rounded up to the nearest 0.50 in.

The thicknesses shown in Figures 53-4.B through 53-4.I were calculated using the computer program with the following default values as design inputs:

Elastic Modulus of HMA Layer (E_{AC}) = 350,000 psi
 Elastic Modulus of PCC Overlay or Inlay (E_C) = 3,600,000 psi
 Modulus of Rupture (MOR) = 750 psi
 Residual strength (F_{150}) = 150 psi
 Modulus of Subgrade (k) = 100 pci
 Coefficient of Thermal Expansion (CTE) = 5.5×10^{-6} in./in./°F
 Percent of Panels with Cracking (P_{cr}) = 20%
 Reliability Factor (R) = 85%
 Temperature Gradient (ΔT) = -1.4 °F/in.
 Occurrence of Temperature Gradient (% Time) = 58%

A key to the successful application of BCOA is longitudinal and transverse jointing. These joints are saw cut into hardened concrete to relieve stresses due to drying and thermal shrinkage as well as curling. The joints should be laid out on a regular pattern for both longitudinal and transverse directions (to form panels) based on the spacing used to determine the thickness. No skewed joints will be allowed.

Transverse and longitudinal joints should be laid out to match existing joints, utility obstructions, and geometrics of the existing pavement when PCC pavement is exposed during milling. When feasible, longitudinal joints should be laid out to avoid the wheelpath areas of the traveling lanes. Typically, this means 6 ft slab sizes should be selected to avoid longitudinal contraction joints in the wheelpath that occur with 4 ft panel sizes. The layout of all transverse and longitudinal joints should be detailed on the plan sheets.

The cost of sawing may significantly influence the cost of the BCOA. A thicker overlay may be more economical than a thinner one because the greater thickness may increase the joint spacing, resulting in less sawing.

The following list defines the variables shown in Figures 53-4.B through 53-4.I.

F_{150}	=	Residual Strength (psi) calculated at a net deflection of $L/150$ (L = span length) or 3 mm in accordance with ASTM C1609-12.
h_{ac}	=	Thickness of existing remaining HMA after milling.
h_c	=	Thickness of new bonded concrete overlay.
L	=	Maximum joint spacing in the longitudinal and transverse directions.

- d. Final Finish. Locations with a posted speed limit greater than 40 mph shall use a Type A final finish. All other locations shall use a rough broom final finish struck perpendicular to the direction of traffic flow in lieu of a Type B final finish. The rough broom finish shall be used across the entire surface area of the PCC surface.
- e. Traffic Control. The control of traffic through the project must be considered and well established prior to time of construction. The best alternative for traffic control is to completely close the project to traffic. This alternative may be difficult for urban projects; however, somewhat easier for rural projects. If closure to traffic is not possible, traffic control must be established that will effectively move traffic through the project with minimal disruption to construction operations and traffic flow. Traffic control that can be left unattended overnight must be anticipated for each stage of construction.
- f. Construction Staging. Construction staging for a bonded concrete overlay on asphalt project must be considered with respect to the construction timeframe and traffic flow through the project. The project must be staged in such a way that continuous traffic flow will be maintained. Construction staging must also consider

the geometrics of the project and any lane to lane drop off restrictions that may be present with the overlay thickness.

A PCC traffic opening strength of 550 psi flexural or 3,000 psi compressive is required. The current PCC mix design specified may obtain the opening strength in as little as three days if properly proportioned. If the BCOA must be opened to traffic in a shorter time frame, consult the District Materials Office for an acceptable high-early-strength PCC mixture. The risk of excessive shrinkage and debonding increases at higher cement contents and with thinner slabs.

3. Request for Review and Approval. Upon completion of the BCOA analysis, a completed “BCOA Project Request Report” should be submitted to the Bureau of Research for review and approval. Contact the Engineer of Pavement Technology in the Bureau of Research for an example of a “BCOA Project Request Report.”

If the program is used in lieu of Figures 53-4.B through 53-4.I to determine the thickness, the BCOA Project Request Report must include screenshots of the program indicating the inputs used for the design.

With Synthetic Fibers ($F_{150} = 20\%$)		
Design Parameters		BCOA Thickness, h_c (in.)
Traffic Factor $L = 48$ in.	Traffic Factor $L = 72$ in.	
---	---	3
≤ 0.065	---	3.5
≤ 0.7	---	4
≤ 5	≤ 0.05	4.5
≤ 5	≤ 0.27	5
≤ 5	≤ 1.2	5.5
≤ 5	≤ 4.5	6

BCOA THICKNESSES WHERE $h_{ac} = 2.5$ in.

Figure 53-4.B

With Synthetic Fibers ($F_{150} = 20\%$)		
Design Parameters		BCOA Thickness, h_c (in.)
Traffic Factor $L = 48$ in.	Traffic Factor $L = 72$ in.	
≤ 0.025	---	3
≤ 0.25	---	3.5
≤ 2.5	≤ 0.02	4
≤ 5	≤ 0.12	4.5
≤ 5	≤ 0.6	5
≤ 5	≤ 2.5	5.5
≤ 5	≤ 5	6

BCOA THICKNESSES WHERE $h_{ac} = 3.0$ in.

Figure 53-4.C

With Synthetic Fibers ($F_{150} = 20\%$)		
Design Parameters		BCOA Thickness, h_c (in.)
Traffic Factor $L = 48$ in.	Traffic Factor $L = 72$ in.	
≤ 0.14	---	3
≤ 1.3	≤ 0.011	3.5
≤ 5	≤ 0.06	4
≤ 5	≤ 0.35	4.5
≤ 5	≤ 1.5	5
≤ 5	≤ 5	5.5

BCOA THICKNESSES WHERE $h_{ac} = 3.5$ in.

Figure 53-4.D

With Synthetic Fibers ($F_{150} = 20\%$)		
Design Parameters		BCOA Thickness, h_c (in.)
Traffic Factor $L = 48$ in.	Traffic Factor $L = 72$ in.	
≤ 1	---	3
≤ 5	≤ 0.042	3.5
≤ 5	≤ 0.21	4
≤ 5	≤ 1.1	4.5
≤ 5	≤ 4.5	5
≤ 5	≤ 5	5.5

BCOA THICKNESSES WHERE $h_{ac} = 4.0$ in.

Figure 53-4.E

<i>With Synthetic Fibers ($F_{150} = 20\%$)</i>		
Design Parameters		BCOA Thickness, h_c (in.)
Traffic Factor $L = 48$ in.	Traffic Factor $L = 72$ in.	
≤ 5	≤ 0.037	3
≤ 5	≤ 0.19	3.5
≤ 5	≤ 0.86	4
≤ 5	≤ 4	4.5
≤ 5	≤ 5	5

BCOA THICKNESSES WHERE $h_{ac} = 4.5$ in.

Figure 53-4.F

<i>With Synthetic Fibers ($F_{150} = 20\%$)</i>		
Design Parameters		BCOA Thickness, h_c (in.)
Traffic Factor $L = 48$ in.	Traffic Factor $L = 72$ in.	
≤ 5	≤ 0.22	3
≤ 5	≤ 0.95	3.5
≤ 5	≤ 4.2	4
≤ 5	≤ 5	4.5

BCOA THICKNESSES WHERE $h_{ac} = 5.0$ in.

Figure 53-4.G

<i>With Synthetic Fibers ($F_{150} = 20\%$)</i>		
Design Parameters		BCOA Thickness, h_c (in.)
Traffic Factor $L = 48$ in.	Traffic Factor $L = 72$ in.	
≤ 5	≤ 1.5	3
≤ 5	≤ 5	3.5

BCOA THICKNESSES WHERE $h_{ac} = 5.5$ in.

Figure 53-4.H

<i>With Synthetic Fibers ($F_{150} = 20\%$)</i>		
Design Parameters		BCOA Thickness, h_c (in.)
Traffic Factor $L = 48$ in.	Traffic Factor $L = 72$ in.	
≤ 5	≤ 5	3

BCOA THICKNESSES WHERE $H_{ac} = 6.0$ IN.

Figure 53-4.I

53-4.03 Major Rehabilitation Treatments

Major Rehabilitation treatment options include Designed HMA Overlays and Structural Concrete Overlays (SCO).

1. For a Designed HMA Overlay, use the appropriate thickness guidelines presented in Section 53-4.03(a). HMA mixture design criteria must be met as outlined in Section 53- 4.04.
2. SCO is still considered experimental by the Department. Selection of this treatment as the rehabilitation method must be approved by the Bureau of Research. Design thickness and specification development for the overlay shall also be coordinated through the Bureau of Research.

53-4.03(a) HMA Designed Overlay

If the projected CRS value for the pavement section is within the range for major rehabilitation according to Figure 53-4.A and the PFI results concur, an HMA Designed Overlay may be selected as the rehabilitation treatment.

1. Milling. For HMA-surfaced pavements, consult the Pavement Investigation Report to determine the appropriate milling depth. When determining milling depth, avoid milling either within 0.50 in. of a HMA lift line or within 1.0 in. above underlying PCC whenever possible to eliminate scabbing. If proposed milling thickness exceeds the new overlay thickness, contact the Bureau of Research to confirm residual pavement structure and final milling thickness.
2. Number of Lifts. All pavement types will use a minimum of two lifts.
3. Thickness. A thickness design procedure is still under development. Until the procedure is completed, HMA Designed Overlays will use the following default thicknesses.
 - a. Interstates. 5.00 in.
 - b. Other State Maintained Highways. 3.75 in.

The mixture gradations and lift thicknesses shall be selected from Figure 53-4.J.

53-4.03(b) Structural Concrete Overlay (SCO)

When a pavement section has experienced structural deterioration with a high frequency of working cracks, an HMA overlay may not be the best option due to the propensity for reflective cracking. At this point, the best option is a SCO. The SCO consists of placing a non-reinforced layer of PCC pavement that is sawed both longitudinally and transversely to create panels.

This treatment utilizes an interlayer that serves as a bond breaker over an existing distressed pavement which insulates the overlay from the underlying distresses. If the pavement has been previously resurfaced with HMA, the surface may be milled to correct profile irregularities and use

the remaining existing HMA overlay as the interlayer. If the pavement is bare PCC, an interlayer shall be placed as a bond breaker.

Pavements that have high severity structural distresses (e.g., frequent, high severity transverse cracking) are suited for this treatment to reduce the potential for reflective cracking in the overlay.

This treatment has had limited use and is still considered experimental. The district must work with the Bureau of Research to design the PCC thickness, interlayer type and thickness, and joint spacing for the SCO.

Use of the SCO requires an experimental feature according to Construction Memo 02-2 and approval by the Bureau of Research. Contact the Engineer of Pavement Technology in the Bureau of Research for additional information on use and design of this treatment.

53-4.04 HMA Design Guidelines

These guidelines apply to all HMA construction.

53-4.04(a) Minimum HMA Lift Thickness

The mixture gradations and lift thicknesses shall be selected from Figure 53-4.J.

Mixture Gradation	Type of Lift	Minimum Compacted Lift Thickness (in.)
IL 4.75	Binder only	0.75 – Over HMA Surface 1.00 – Over PCC Surface
IL-9.5FG	Surface or Binder	1.25
IL-9.5, IL-9.5L	Surface or Binder	1.50
SMA-9.5	Surface or Binder	1.50
SMA 12.5	Surface or Binder	2.00
IL-19.0, IL 19.0L	Binder only	2.25

LIFT THICKNESS REQUIREMENTS FOR HMA OVERLAYS

Figure 53-4.J

53-4.04(b) HMA Mixture Requirements Table

Figure 53-4.K was designed to accommodate HMA mixtures and is required to be completed and inserted into the General Notes of the project plans for each HMA mixture application specified.

The following HMA mixture requirements are applicable for this project:

Location(s):	
Mixture Use(s):	
PG:	
Design Air Voids:	
Mixture Composition:	
Friction Aggregate:	
Mixture Weight:	
Quality Management Program:	
Sublot Size:	
Material Transfer Device (Required?)	

HMA MIXTURE REQUIREMENTS TABLE

Figure 53-4.K

Use the following guidelines to complete the table in Figure 53-4.K:

1. Location(s). Specify, by route number or stationing, the location(s) where the mix will be placed.
2. Mixture Use(s). Corresponds to the generic description of the mixture(s) (i.e., surface course, binder, base course, shoulders, etc.). On full-depth projects, specify the lift (e.g., “full-depth, lower binder,” “full-depth, top binder,” or “full-depth, surface”).
3. PG. Specify the Performance-Graded (PG) binder for the mixture, including polymer modified asphalt binder (e.g., PG64-28, SBS-PG64-28, PG70-22, SBS-PG70-22). The PG binder grade shall be specified without consideration of RAP and/or RAS addition. Obtain the required PG binder designation from the District Materials Engineer.
4. Design Air Voids. Specify the target air void content for the mixture. For example, “4.0% @ $N_{design} = 50$ ”, “4.0% @ $N_{design} = 70$ ”, etc. All HMA mixtures will typically require 4.0% air voids; however, the N_{design} number will change. Obtain the N_{design} number from the District Materials Engineer.
5. Mixture Composition. Specify the aggregate gradation for the mixture design:
 - IL-19.0 – binder.
 - IL-19.0L – low volume binder.
 - IL-9.5 – surface or binder.
 - IL-9.5L – low volume surface.
 - IL-9.5FG – fine-graded surface or binder.

- IL-4.75 – binder.
 - SMA-12.5 – surface or binder.
 - SMA-9.5 – surface or binder.
6. Friction Aggregate. Specify the aggregate to be used to meet surface course friction requirements (i.e., Mixture C, Mixture D, Mixture E, Mixture F). Because there are no friction requirements for binder courses, leave this entry blank when specifying binder courses. Refer to Section 53-4.04(f) for additional information.
7. Mixture Weight. Specify the unit weight used to determine the plan quantities for HMA surface course. Use 112.0 lb/sq yd/in. thickness as the unit weight for typical standard mixes using natural aggregate. For a specialty mix design, such as those using synthetic aggregates with differing unit weights (e.g., air-cooled blast furnace slag (light) or steel slag (heavy)), the designer should consult the District Materials Engineer to determine the anticipated unit weight.
8. Quality Management Program. Specify which quality management program will be used for each mixture use listed in Item 2 above. If the same mixture has two QMPs, each QMP should be in separate columns in the mixture requirements table. Options include: Pay-For-Performance (PFP), Quality Control for Performance (QCP), and Quality Control/Quality Assurance (QC/QA).
- a. PFP. PFP utilizes pay adjustments based upon percent within limits statistical calculations. PFP should be specified for interstate, freeway and expressway resurfacing; and full-depth pavement projects having a minimum quantity of 8,000 tons per mix. PFP may also be considered for smaller projects where a more accurate measure of quality is desired. PFP should not be used on:
- incidental surfacing (e.g., driveways, entrances, minor sideroads, and side road returns);
 - temporary pavements;
 - shoulders, unless they are used as auxiliary lanes;
 - patching;
 - turn lanes less than 500 ft in length; or
 - shared-use paths or bike lanes unless paved with the mainline pavement.
- b. QCP. QCP utilizes step-based pay adjustments and should be specified for:
- mainline mixture quantities between 1,200 and 8,000 tons; or
 - shoulder applications that are greater than 8 feet wide and having quantities of 1,200 tons and greater.
- QCP should not be used on:
- incidental surfacing (e.g., driveways, entrances, minor sideroads, and side road returns);
 - temporary pavements;

- patching;
 - turn lanes less than 500 ft in length; or
 - shared-use paths or bike lanes unless paved with the mainline pavement.
- c. QC/QA. The use of QC/QA is limited to:
- mixtures with quantities less than 1,200 tons,
 - shoulders placed with a road widener, and
 - patching or incidental surfacing (e.g., entrances, minor sideroads).
9. Sublot Size. The sublot size for QCP and PFP will typically be 1,000 tons. On rare occasions, the sublot size may be reduced to lower the payment risk for smaller tonnage projects. Sublot size is not applicable when the QC/QA quality management program is used.
10. Material Transfer Device (MTD). Indicate whether or not the use of an MTD is required by placing either a “Yes” or a “No” in the box. MTDs are required for interstate HMA resurfacing and full-depth HMA contracts. For full-depth HMA contracts, an MTD is used for constructing all lifts of the pavement. MTDs may also be required in other types of HMA paving at the district’s discretion.

MTD have specific restrictions regarding travel on structures. The designer shall submit information to the Bureau of Bridges and Structures identifying the structures that will be crossed by a Category I MTD. The Bureau of Bridges and Structures will analyze the structures to verify that it has the capacity to safely carry an emptied Category I MTD and will provide the designer with recommendations. The recommendations provided by the Bureau of Bridges and Structures will identify any structure, which due to general deterioration or insufficient load carrying capacity, cannot be crossed by an emptied Category I MTD. The plans shall include notice to the contractor of special requirements and restrictions for structures that cannot be crossed by an emptied Category I MTD.

53-4.04(c) ESAL Calculation

Use Section 54-2.01(c) and Section 54-5.01(g) to calculate ESALs for the design lane. To select the PG binder and design compactive effort (N_{design}), the ESAL value, equivalent to the Traffic Factor (TF), is calculated according to the equations in Figure 54-5.B. Use a Design Period (DP) of 20 years. In this application, the calculation is purely to determine the mixture design parameters; actual pavement/thickness design may require a different design period and/or TF calculation. Minimum structural design traffic levels should be ignored for mixture design purposes.

It is recommended that each district designate a single individual to coordinate ESAL calculations. In instances where major routes cross district borders, it is recommended that the ESAL counts be confirmed between districts.

53-4.04(d) Design Compactive Effort

The design compactive effort is expressed as an N_{design} number, which is selected based on the estimated 20-year ESAL loading of the traffic lane.

Figure 53-4.L lists the design compactive effort (N_{design}) required for the different levels of traffic loading and describes the typical roadway application. Consult the District Materials Engineer for the appropriate N_{design} value.

Design ESALs (millions) (20-yr. Design)	N_{ini}^1	N_{des}	N_{max}^1	Typical Roadway Application
< 0.3	5	30	42	Roadways with very light traffic volume such as local roads, county roads, and city streets where truck traffic is prohibited or at a very minimal level. (Considered local in nature; not regional, intrastate, or interstate.) Special purpose roadways serving recreational sites or areas may also be applicable.
0.3 to 3	6	50	74	Includes many collector roads or access streets. Medium-trafficked city streets and the majority of county roadways.
3 to 10	7	70	107	Includes many two-lane, multi-lane, divided, and partially or completely controlled access roadways. Among these are medium-to-highly trafficked streets, many state routes, US highways, and some rural Interstates.
> 10	8	90	141	Includes Interstates, both urban and rural in nature. Special applications such as truck-weighting stations or truck-climbing lanes on two-lane roadways may also be applicable to this level. May also include the class of roadways in the row above which have a high amount of truck traffic.

¹ N_{ini} and N_{max} are for informational purposes only. It is recommended the air voids at N_{ini} be greater than 11% to avoid mix tenderness. Also, air voids at N_{max} should be greater than 2% to prevent premature rutting.

DESIGN COMPACTIVE EFFORT FOR VARIOUS TRAFFIC CONDITIONS

Figure 53-4.L

53-4.04(e) Asphalt Binder Selection

Selection of Performance-Graded (PG) binders is based on temperature and traffic conditions. Figure 53-4.M lists the appropriate PG binders for use with all HMA mixtures. Consider the following when selecting the asphalt binder:

1. Polymer Modified PG Binders. Where polymer modifiers are required, designate “SBS” in front of the PG binder requirements in the General Notes table. The following grades of asphalt binder must be polymer modified: PG 64-28, PG 70-22, PG70-28, PG76-22, and PG76-28.

2. Overlays of PCC or Composite Pavements. Overlays of PCC or composite pavements should use the grades shown in Figure 53-4.M for a standard traffic level. Adjustments to this grade are dependent upon conditions such as slow moving traffic, high ESALs, or standing traffic. These modifications should be made for the corresponding N_{design} number and/or ESAL number. The appropriate asphalt binder grade should then be reported on the General Notes table of the plans.
3. Full-Depth HMA Pavements or Overlays of Full-Depth HMA Pavements. Full-depth HMA pavements or overlays of full-depth HMA pavements should be designed using the PG binders shown in Figure 53-4.M. The appropriate binder grade should be reported on the General Notes table of the project plans.

53-4.04(f) Friction Aggregate

An HMA surface course must be specified for each rehabilitation/resurfacing project. Section 11-2.02(f) gives safety analysis procedures to determine risks contributing to substantive safety problems.

Before the appropriate mix is selected, determine whether or not pavement surface friction is contributing to a substantive safety problem at the site. Presence of “wet pavement” crashes alone is not sufficient, as other risks related to wet weather may be present. For example, inadequate warning signage or visibility of stop or maneuver areas, unexpected geometric conditions, rutting, lack of surface drainage, inadequate pavement cross slope, or excess spray from vehicle tires may be more important than surface friction for locations of wet pavement crashes. Review of crash reports including narratives and sketches, site reviews during wet conditions, and surface friction testing should be included in an analysis of wet pavement crashes. Pavement friction testing may be requested according to the Bureau of Research Pavement Technology Advisory- “Testing Pavement Friction” (PTA-T3), <http://idot.illinois.gov/Assets/uploads/files/Transportation-System/Research/Pavement-Technology-Advisories/Testing-and-Data-Collection-Series/PTAT3.pdf>.

If the segment demonstrates a pattern of wet pavement crashes, identification of the risks contributing to the crash pattern will help to indicate the appropriate countermeasures, possibly including improved positive guidance, geometric changes, surface to full-depth repairs of rutting, improved drainage or cross slope, or improved surface texture (pavement grooving) or resurfacing with appropriate friction aggregate.

Type of HMA Pavement	Layer	Illinois N _{design} Number	Design ESALs ⁽¹⁾ (million)	PG Binder Grade ⁽²⁾⁽³⁾		
				Traffic Loading Rate		Standing ⁽⁷⁾
				Standard ⁽⁴⁾	Slow ⁽⁵⁾ or High ESALs ⁽⁶⁾	
IL-4.75	Surface ⁽⁶⁾ and Binder	50	≤ 10	SBS PG 70-22	SBS PG 70-22	SBS PG 70-22
			> 10	SBS PG 76-22	SBS PG 76-22	SBS PG 76-22
SMA Overlay of PCC or Composite Pavement	Surface and Binder	50	≤ 10	SBS PG 76-22	SBS PG 76-22	SBS PG 76-22
			> 10	SBS PG 76-22	SBS PG 76-22	SBS PG 76-22
SMA for Full-Depth Pavement and Overlays of Full-Depth Pavement	Surface and Binder	50	≤ 10	SBS PG 76-28	SBS PG 76-28	SBS PG 76-28
			> 10	SBS PG 76-28	SBS PG 76-28	SBS PG 76-28
Overlay of PCC or Composite Pavement	Surface or Binder	30	≤ 0.3	PG 58-22	PG 64-22	PG 64-22
			> 0.3 to 3	PG 64-22	SBS PG 70-22	SBS PG 76-22
		70	> 3 to 10	PG 64-22	SBS PG 70-22	SBS PG 76-22
			> 10	SBS PG 70-22	SBS PG 70-22	SBS PG 76-22
Districts 1-6 Full-Depth Pavement and Overlays of Full-Depth Pavement	Surface and Top Binder	All	All Levels	SBS PG 64-28 ⁽⁸⁾	SBS PG 70-28	SBS PG 76-28
	Lower Binder	All	All Levels	PG 64-22	PG 64-22	PG 64-22
Districts 7-9 Full-Depth Pavement and Overlays of Full-Depth Pavement	Surface and Top Binder	All	All Levels	PG 64-22 ⁽⁸⁾	SBS PG 70-22	SBS PG 76-22
	Lower Binder	All	All Levels	PG 64-22	PG 64-22	PG 64-22

PG BINDER GRADE SELECTION - ALL APPLICATIONS

Figure 53-4.M (1 of 2)

1. *Design ESALs are the anticipated project traffic level expected on the design lane over a 20-year period. Regardless of the actual design life of the roadway, determine the design ESALs for 20 years and choose the appropriate N_{design} level.*
2. *The binder grade provided in the table is based on the recommendations given in Illinois-Modified AASHTO M 323, Table 1, "Binder Selection on the Basis of Traffic Speed and Traffic Level."*
3. *Consider increasing the high temperature grade by one grade and/or use polymer modified binder within 2,500 ft upstream of the exit terminal stub to 2,500 ft downstream of the entrance stub at weigh stations.*
4. *Standard Traffic - where the average traffic speed is greater than 43 mph.*
5. *Slow Traffic - where the average traffic speed ranges from 12 mph to 43 mph.*
6. *High ESALs – where ESALs are > 30 million.*
7. *Standing Traffic - where the average traffic speed is less than 12 mph.*
8. *For pavements with a posted speed limit \leq 30 mph.*
9. *Consider increasing the high temperature grade by one grade for ESALs 10 to 30 million.*

PG BINDER GRADE SELECTION - ALL APPLICATIONS

Figure 53-4.M (2 of 2)

It is not desirable to specify short, closely spaced segments of special high-quality friction mixes (i.e., patchwork surfacing). If a higher-quality friction mix treatment is required at more than one

location on a project and the distance between locations is less than 1,000 ft, the gaps should also be treated with the higher-quality mix. Also, if the special treatment is required on more than 50 percent of the project, it should be used throughout the entire project.

Four surface course mixtures have been developed that will provide adequate skid resistance for various Average Daily Traffic (ADT) levels: Mixtures C, D, E, and F. Figure 53-4.N designates the ADT levels allowable for each of the surface course mixtures.

It is expected that the application of friction aggregate according to Figure 53-4.N will address most pavement friction needs. However, some conditions create friction demands exceeding typical conditions anticipated by this tabulation. Examples include locations where problem identification shows a pattern of wet pavement related crashes and one of the following conditions:

- on grades exceeding 3.5%;
- locations with a heavy commercial vehicle (HCV) volume (Single Units plus Multiple Units) exceeding 400 per day and equal to 25% or more of the total ADT (Note – 25% HCV represents about 15% of State System mileage);
- locations that are shadowed or otherwise tend to remain wet for an extended time compared to typical locations; or
- other sites where similar friction demands or pavement conditions exist. At such locations, the Mixture designation may be increased by one step (e.g., from Mixture D to Mixture E).

Number of Lanes in Both Directions	Frictional Requirements (ADT)			
	Mixture C	Mixture D	Mixture E	Mixture F
≤ 2	≤ 5,000	> 5,000	N/A	N/A
4	≤ 5,000	5,001 to 25,000	25,001 to 100,000	> 100,000
≥ 6	N/A	5,001 to 60,000	60,001 to 100,000	> 100,000

Note: ADT levels are for the expected year of construction.

FRictional Requirements for Surface Mixtures

Figure 53-4.N

53-4.04(g) Longitudinal Joint Sealant

Longitudinal Joint Sealant improves the performance of centerline and lane-to-lane joints of full-depth HMA pavements and HMA overlays. The specific lifts of HMA that will receive the sealant must be identified on the plans.

- Full-Depth HMA Pavements – under the surface lift and under the top binder lift
- Two-Lift Interstate HMA overlays – under both the surface and binder lifts
- Two-Lift Non-interstate HMA overlays – under the surface lift
- Single-Lift HMA Overlays – under the surface lift.

53-5 TREATMENT SUMMARIES

The following section contains one-page summaries of all pavement preservation treatments (proactive, low, and high), rehabilitation treatments (minor and major), pre-treatment activities, and other design considerations.

53-5.01 Flexible and Composite Pavement Preservation Treatment Summaries

FLEXIBLE AND COMPOSITE PAVEMENT PRESERVATION TREATMENT (PROACTIVE MAINTENANCE)	
Name:	Crack/Joint Filling
Application:	
System:	Interstates and Non-Interstates
Pavement Type(s):	Full-Depth HMA and Composite Pavements
Distress Type(s):	Relates to both Functional and Structural Failures
Purpose.	Crack filling is effective at reducing or delaying moisture damage, further deterioration, roughness, and rutting. However, crack/joint filling can also have a negative impact on roughness and friction.
Treatment Description.	Crack filling is the process of placing material into non-working cracks to substantially reduce the infiltration of water and to reinforce the adjacent pavement. Crack filling is characterized by minimal crack preparation and the use of lower quality bituminous filler materials.
Pavement Conditions Addressed.	Adds no structural benefit, but does reduce moisture infiltration through cracks. Only practical if extent of cracking is minimal and if there is little to no structural cracking.
Application Limitations.	These treatments are not recommended when structural failures exist (e.g., extensive fatigue cracking, high-severity rutting) or if there is extensive pavement deterioration or little remaining life. Crack filling is appropriate for non-working (e.g., longitudinal, block) cracks 0.25 in. (6 mm) to 1.0 in. (25 mm) wide.
	Non-working cracks narrower than 0.25 in. (6 mm) that do not exhibit spalling should not be filled. These cracks generally do not penetrate through the surface course nor do they pose a source of pavement deterioration. The practice of filling this type of crack by the method of pouring filler on the pavement surface is seldom of value. Perform a crack analysis to determine whether crack filling would be effective.
Letting/Construction Considerations.	The project letting date should be selected to target construction during cool, dry weather conditions. Application during cool weather will allow for expanded crack widths.
Traffic Considerations.	Performance is not significantly affected by varying ADT or truck levels. However, improper installation can permit the filler to fail.
Special Considerations/Comments:	Crack filling may have negative effects. Undesirable visual impacts may occur, which include tracking of filling material by tire action, obscuring lane markings, and adversely affecting friction/skid resistance. Crack filling may result in a rougher pavement surface when the filler material is forced out of the cracks during warm months.
Performance Period.	2 to 4 years.

FLEXIBLE AND COMPOSITE PAVEMENT PRESERVATION TREATMENT (PROACTIVE MAINTENANCE)	
<u>Name:</u>	Crack/Joint Sealing
<u>Application:</u>	
System:	Interstates and Non-Interstates
Pavement Type(s):	All Pavements
Distress Type(s):	Relates to both Functional and Structural Failures
<u>Purpose.</u>	Crack/joint sealing is effective at reducing or delaying moisture damage, further crack deterioration, roughness, and rutting. However, crack/joint sealing can also have a negative impact on roughness and friction.
<u>Treatment Description.</u>	Crack/joint sealing is the process of placing higher-quality material into “working” cracks (i.e., those that open and close with changes in temperature) and construction joints in order to reduce water infiltration into a pavement. In contrast to crack “filling,” crack sealing requires crack routing and uses higher quality sealant materials. Thermosetting and thermoplastic materials are both used for crack/joint sealing.
<u>Pavement Conditions Addressed.</u>	Adds no structural benefit, but does reduce future intrusion of incompressible materials, water, and soluble chemicals (e.g., salts, brines) into the cracks/joints. It is only practical if extent of cracking is minimal and if there is little to no structural cracking.
<u>Application Limitations.</u>	These treatments are not recommended where structural failures exist (e.g., extensive fatigue cracking, high-severity rutting) or if there is extensive pavement deterioration or little remaining life. Crack/joint sealing is appropriate for cracks and joints 0.25 in. to 0.75 in. (6 mm to 19 mm) wide. Non-working cracks narrower than 0.25 in. (6 mm) that do not exhibit spalling should not be routed and sealed. These cracks generally do not penetrate through the surface course nor do they pose a source of pavement deterioration. The practice of routing and sealing this type of crack can increase pavement roughness without gaining any benefit.
<u>Letting/Construction Considerations.</u>	The project letting date should be selected to target construction during cool, dry weather conditions. Application during cool weather will allow for expanded crack widths.
<u>Traffic Considerations.</u>	Performance is not significantly affected by varying ADT or truck levels. However, improper installation can cause the sealant to fail.
<u>Special Considerations/Comments:</u>	Crack/joint sealing may result in a rougher pavement surface when the sealant material is forced out of the cracks during warm months. Sealing is best accomplished several months in advance of any other maintenance surface applications. If sealing quantities become excessive, the district may want to consider a higher level treatment.
<u>Performance Period.</u>	2 to 8 years.

FLEXIBLE AND COMPOSITE PAVEMENT PRESERVATION TREATMENT (LOW PRESERVATION)	
Name:	Cape Seal
Application:	
System:	Non-Interstates
Pavement Type(s):	Full-Depth HMA and Composite Pavements
Distress Type(s):	Relates to Functional Failures
Purpose. A cape seal combines a chip seal with micro-surfacing to provide a smooth, quiet wearing surface at a lower cost than an HMA overlay.	
Treatment Description. The treatment consists of a chip seal, followed within a few days by a micro-surfacing treatment to cover the chips and seal them in.	
Pavement Conditions Addressed. Cape seal can be used to address longitudinal, transverse, and block cracking; friction loss; raveling/weathering (remove loose material); minor roughness; low- to medium-severity bleeding; and moisture infiltration. Adds no structural capacity. It is somewhat effective at sealing medium-severity fatigue cracks in comparison with other treatments.	
Application Limitations. Not recommended for pavements with the following conditions: structural deficiency, unsealed cracks > 0.25 in. (6 mm) wide, medium- to high-severity alligator cracking, many potholes, rutting > 1 in. (25 mm) deep, and very rough surface.	
Letting/Construction Considerations. The project letting date should be selected to target construction between May 1 and August 31.	
Traffic Considerations. This treatment is not recommended for ADT greater than 10,000. Temporary pavement markings are required until permanent markings are applied. Because the application of the micro-surfacing removes the hazard of loose chips, the final surface of the cape seal leaves no concerns. However, keep traffic to slower speeds on high-volume or high-speed roadways until the chip seal portion has cured properly and/or it is covered by the micro-surfacing.	
Special Considerations/Comments: Give special consideration to raised reflective pavement markers and bump grinding prior to treatment placement.	
Performance Period. 4 to 7 years.	

FLEXIBLE AND COMPOSITE PAVEMENT PRESERVATION TREATMENT (LOW PRESERVATION)	
<u>Name:</u>	Chip Seal (Bituminous Surface Treatment)
<u>Application:</u>	
System:	Non-Interstates
Pavement Type(s):	Full-Depth HMA and Composite Pavements
Distress Type(s):	Relates to Functional Failures
<u>Purpose.</u>	Chip Seals, also known as Bituminous Surface Treatments (BSTs), are effective at improving poor friction, inhibiting raveling, correcting minor roughness and bleeding, and sealing the pavement surface.
<u>Treatment Description.</u>	Asphalt emulsion is applied directly to the pavement surface followed by the application of aggregate chips, which are then immediately rolled to imbed chips. Application rates depend upon aggregate gradation and maximum size. This treatment can be applied in multiple layers (e.g., double chip seals) and in combination with other surface treatments. For sections with ADT > 1,000, a fog seal shall be included with the treatment.
<u>Pavement Conditions Addressed.</u>	Chip seals can be used to address longitudinal, transverse, and block cracking; raveling/weathering (remove loose material); friction loss; minor roughness; low-severity bleeding; and moisture infiltration. Adds no structural capacity. The flexible, impermeable HMA surface helps reduce cracking and is somewhat effective at sealing medium-severity fatigue cracks in comparison with other treatments.
<u>Application Limitations.</u>	Chip seals are not recommended for pavements with structural deficiency, cracks greater than 0.25 in. (6 mm) wide, medium- to high-severity alligator cracking, many potholes, rutting greater than 1 in. (25 mm) deep, and very rough surface.
<u>Letting/Construction Considerations.</u>	The project letting date should be selected to target construction between May 1 and August 31.
<u>Traffic Considerations.</u>	With special design and proper placement, chip seals can perform well on high-volume roads. However, its use is sometimes limited to lower-speed, lower-volume roads because of the propensity for loose chips to crack windshields. This treatment is not recommended for ADT greater than 10,000. Use lightweight aggregate to help minimize claims. Flaggers may be needed at crossing intersections to control traffic.
<u>Special Considerations/Comments:</u>	Temporary pavement markings are required until permanent markings are applied. Give special consideration to raised reflective pavement markers and bump grinding prior to treatment placement. Additional information is available from the BLRS Report, <i>Seal Coats (Oil & Chipping)</i> .
<u>Performance Period.</u>	Single seals (A-1): 4 to 6 years; double seals (A-2): 5 to 7 years; triple seals (A-3): 6 to 8 years.

FLEXIBLE AND COMPOSITE PAVEMENT PRESERVATION TREATMENT (LOW PRESERVATION)	
Name:	Half-SMART Overlay
Application:	
System:	Non-Interstates
Pavement Type(s):	Full-Depth HMA and Composite Pavements
Distress Type(s):	Relates to Functional Failures
Purpose. Placing a combination of HMA binder and a chip seal is a viable option for improving surface friction, profile, crown, and cross slope.	
Treatment Description. Half-SMART overlays consist of placing a nominal 0.75 in. (19 mm) layer of HMA binder followed by a chip seal. Only place this treatment on a previously resurfaced pavement that is not in need of significant repair and is in good condition.	
Pavement Conditions Addressed. Half-SMART overlays are applicable for low-severity cracking; raveling/weathering (remove loose material), friction loss, low-severity flushing/bleeding, and low-severity block cracking (may perform better with additional milling). Half-SMART overlays may also be used to correct minor rutting (depths less than 0.25 in. (6 mm)).	
Application Limitations. Half-SMART overlays are not recommended where there are structural failures (e.g., fatigue cracking), extensive pavement deterioration, or if there is high-severity thermal cracking. If this treatment is being placed to correct rutting, evaluate the pavement to determine if the rutting is stable. Do not use half-SMART overlays on pavements that have unstable rutting due to stripping in the existing asphalt layers.	
Letting/Construction Considerations. The project letting date should be selected to target construction of the chip seal portion between May 1 and August 31.	
Traffic Considerations. Use of the Half-SMART overlay is sometimes limited to lower-speed, lower-volume roads because of the chip seal layer, which has the propensity for loose chips to crack windshields. This treatment is not recommended for ADT greater than 10,000. Lightweight aggregate can be used to help minimize claims. Flaggers may be needed at crossing intersections to control traffic.	
Special Considerations/Comments. Repair localized distressed areas prior to the placement of the overlay. If milling is not used in conjunction with the Half-SMART overlay, give special consideration to bump grinding prior to treatment placement.	
Consider using IL-9.5FG or IL-4.75 gradations for the binder lift to promote better performance.	
Performance Period. 5 to 7 years.	

FLEXIBLE AND COMPOSITE PAVEMENT PRESERVATION TREATMENT (LOW PRESERVATION)	
<u>Name:</u>	Micro-Surfacing
<u>Application:</u>	
System:	Interstates and Non-Interstates
Pavement Type(s):	Full-Depth HMA and Composite Pavements
Distress Type(s):	Relates to Functional Failures
<u>Purpose.</u> Micro-surfacing is effective at correcting or inhibiting raveling and oxidation of the pavement surface, improving surface friction, sealing the pavement surface, and filling minor surface irregularities and average wheel ruts up to 0.25 in. (6 mm) deep over the entire project. Projects with isolated rut depths up to 1.25 in. (30 mm) deep may be addressed with a rut filling mix prior to full-width placement of the micro-surfacing.	
<u>Treatment Description.</u> Applied in a process similar to slurry seals, micro-surfacing consists of a mixture of latex-modified emulsified asphalt, mineral aggregate, mineral filler, water, and additives. Micro-surfacing material is mixed in specialized, compartmented, self-powered trucks and placed on the pavement using an augured screed box.	
<u>Pavement Conditions Addressed.</u> Micro-surfacing may be used to address block, transverse, and longitudinal cracking; raveling/weathering (remove loose material), bleeding, minor roughness, friction loss, and moisture infiltration.	
<u>Application Limitations.</u> Micro-surfacing is not recommended when the pavement contains structural failures (e.g., significant fatigue cracking), high-severity thermal cracking, or extensive pavement deterioration.	
<u>Letting/Construction Considerations.</u> The project letting date should be selected to target construction between May 1 and October 15.	
<u>Traffic Considerations.</u> Micro-surfacing is very successful on both low-and high-volume roadways. However, avoid areas of heavy truck turning or downgrade locations as there is a high potential for early damage.	
<u>Special Considerations/Comments:</u> Give special consideration to raised reflective pavement markers and bump grinding prior to treatment placement. All RRPMs shall be removed prior to placing micro-surfacing. Covering or masking RRPMs is not permitted.	
Centerline/Longitudinal Joint micro-surfacing is permitted on full-depth HMA pavements and composite pavements. This treatment should only be considered if the distress is at low severity and limited to close proximity of the joint. If a pavement has three or more lanes and all longitudinal joints are in need of a longitudinal joint micro-surfacing, caution shall be used due to the potential for water to be trapped in the center lane(s) during heavy rain events. If the pavement has multiple distresses that would benefit from a full-lane micro-surfacing treatment, it is best to use that in lieu of treating only the longitudinal joints.	
<u>Performance Period.</u> 4 to 7 years.	

FLEXIBLE AND COMPOSITE PAVEMENT PRESERVATION TREATMENT (HIGH PRESERVATION)	
Name:	Longitudinal Joint Partial-Depth Repair
Application:	
System:	Interstates and Non-Interstates
Pavement Type(s):	Full-Depth HMA and Composite Pavements
Distress Type(s):	Relates to Functional and Structural Failures
Purpose.	The partial-depth removal and replacement of the longitudinal joint is a viable option for addressing raveling and spalling of the joint due to high permeability and reduces the potential for moisture infiltration into the pavement structure.
Treatment Description.	This treatment consists of milling a 2- to 3-ft (600- to 900-mm) strip of the surface lift, centered over the longitudinal joint, and replacing with new HMA mix.
Pavement Conditions Addressed.	Longitudinal Joint Partial-Depth Repair can be used to address low to medium severity longitudinal joint deterioration.
Application Limitations.	This treatment is allowed if longitudinal joint deterioration is the only distress. If other distresses are present, a full-width treatment should be considered.
Letting/Construction Considerations.	None.
Traffic Considerations.	Performance is not affected by different ADT or percent trucks.
Special Considerations/Comments:	When determining milling depth, it is recommended to mill 0.5 in. (13 mm) greater than the existing lift thickness to ensure all material is removed, which will minimize the potential for scabbing.
Performance Period.	7 to 10 years.

FLEXIBLE AND COMPOSITE PAVEMENT PRESERVATION TREATMENT (HIGH PRESERVATION)	
<u>Name:</u>	Hot In-Place Recycling
<u>Application:</u>	
System:	Non-Interstates
Pavement Type(s):	Full-Depth HMA and Composite Pavements
Distress Type(s):	Relates to Functional Failures
<u>Purpose.</u>	Hot In-Place Recycling (HIR) is effective at correcting surface distresses that are limited to the top 1 in. to 2 in. (25 mm to 50 mm). Examples include rutting, corrugations, raveling, flushing/bleeding, loss of surface friction, minor thermal cracking, and minor load-associated cracking.
<u>Treatment Description.</u>	HIR is a process of correcting HMA pavement surface distress by softening the existing surface with heat, mechanically loosening the pavement surface, mixing the loosened surface material with recycling agent, aggregate, rejuvenators, or HMA, and relaying the recycled material without removing it from the site. Different HIR processes include surface recycling (e.g., heater scarification), repaving, and remixing.
<u>Pavement Conditions Addressed.</u>	HIR is effective at correcting surface distresses that are limited to the top 1 in. to 2 in. (25 mm to 50 mm). Examples include rutting, corrugations, raveling, flushing, loss of surface friction, and minor thermal and load-associated cracking.
<u>Application Limitations.</u>	As the HIR equipment is relatively wide and long, short road sections, particularly in urban settings, are not suitable for HIR treatment.
	This treatment must be approved by BDE and will require an experimental feature study according to Construction Memorandum 02-2. Good HIR candidates have no structural failures, limited variation in the existing HMA mix, no paving fabrics or interlayers in the anticipated treatment depth plus 25%, no deep ruts greater than one-half of the anticipated HIR treatment depth, and no large stone mixes. The presence of rubber in the surface lift, rubberized seal coats, and some crack fillers require special attention in the mix design process.
<u>Letting/Construction Considerations.</u>	The project letting date should be selected to target construction when the air temperature is moderate (i.e., 50°F (10°C) or above). HIR pavement can remain tender for a number of days. Do not allow this treatment to remain exposed over the winter season without a surface treatment or HMA overlay as the final wearing surface.
<u>Traffic Considerations.</u>	HIR is appropriate for very low to high traffic conditions. Only use the heater-scarification process for low volume traffic. The remixing and repaving processes can be used on high traffic volume roads.
<u>Special Considerations/Comments:</u>	Remove crack sealant prior to the HIR operation to reduce flash fires or excessive blue smoke from the treatment placement.
<u>Performance Period.</u>	6 to 15 years, depending on method of HIR.

FLEXIBLE AND COMPOSITE PAVEMENT PRESERVATION TREATMENT (HIGH PRESERVATION)	
<u>Name:</u>	Surface Maintenance at the Right Time (SMART) Overlay
<u>Application:</u>	
System:	Interstates and Non-Interstates
Pavement Type(s):	Full-Depth HMA and Composite Pavements
Distress Type(s):	Relates to Functional and Structural Failures
<u>Purpose.</u>	The combination of cold milling and the application of a Surface Maintenance at the Right Time (SMART) overlay is a viable option for improving rideability, surface friction, profile, crown, and cross slope.
<u>Treatment Description.</u>	SMART overlays may be continuous or intermittent and consist of placing a 1.50 in. (38 mm) (1.75 in. (44 mm) for F-mix) single-pass overlay on a previously resurfaced pavement that is not in need of significant repair and is in good condition. For Full-Depth HMA pavements, the single lift is 2.00 in. (50 mm) thick. If the SMART overlay is applied at the correct time, it can delay serious distresses, extend the life of the pavement, and decrease the overall cost.
<u>Pavement Conditions Addressed.</u>	SMART Overlay can be used to address low-severity alligator cracking, stable rutting ≤ 0.25 in. (6 mm), medium-severity longitudinal and transverse cracking, medium-severity raveling/weathering, and medium-severity block cracking.
	Cold milling is recommended to reduce pavement irregularities and to produce a uniform surface or to correct cross slope. Milling is required where: (1) rutting is continuous and, in isolated areas, exceeds 0.25 in (6 mm), (2) the CRS block cracking distress level is M3, and/or (3) CRS distress level W3 is present. Milling need not be continuous throughout the section.
<u>Application Limitations.</u>	SMART overlays are not allowed on bare PCC pavements.
<u>Letting/Construction Considerations.</u>	None.
<u>Traffic Considerations.</u>	Performance is not affected by different ADT or percent trucks.
<u>Special Considerations/Comments.</u>	During Phase I, the district shall review the project according to the requirements in Chapter 12 of this manual.
	Repair localized distressed areas prior to the placement of the overlay. If milling is not used in conjunction with the SMART overlay, give special consideration to bump grinding prior to treatment placement.
	Raised Reflective Pavement Markers shall be removed and replaced.
<u>Performance Period.</u>	7 to 10 years.

FLEXIBLE AND COMPOSITE PAVEMENT PRESERVATION TREATMENT (HIGH PRESERVATION)	
Name:	Ultra-Thin Bonded Wearing Course
Application:	
System:	Interstates and Non-Interstates
Pavement Type(s):	All Pavements
Distress Type(s):	Relates to Functional and Structural Failures
<p>Purpose. An ultra-thin bonded wearing course (UTBWC) is an alternative to chip seals, micro-surfacing, or thin HMA overlays as it effectively addresses minor surface distresses and increases surface friction.</p> <p>Treatment Description. A UTBWC is formed in one pass with the application of a heavy, polymer-modified asphalt emulsion tack coat and a gap-graded, polymer-modified, 0.75 in. to 0.9 in. thick HMA layer.</p> <p>Pavement Conditions Addressed. This treatment is applicable for low-severity cracking (high severity can be addressed with cold milling), raveling/weathering (remove loose material), high-severity friction loss, low-severity roughness, and low-severity flushing/bleeding. Retards fatigue cracking, but is not suited for rutted pavements.</p> <p>Application Limitations. Ultra-thin bonded wearing courses are not recommended where structural failures exist (e.g., significant fatigue cracking, deep rutting) or if there is high-severity thermal cracking. They also are not appropriate where there is extensive pavement deterioration or little remaining life.</p> <p>Letting/Construction Considerations. The project letting date should be selected to target construction when the air temperature is moderate (i.e., 50°F or above).</p> <p>Traffic Considerations. It is capable of withstanding high ADT volumes and truck traffic better than other thin treatments.</p> <p>Special Considerations/Comments: Give special consideration to bump grinding prior to treatment placement. Patching quantities should be included to repair localized structural problems prior to overlay application.</p> <p>Avoid using on pavements with heavy turning movements or bus stops.</p> <p>Performance Period. 7 to 12 years.</p>	

53-5.02 Rigid Pavement Preservation Treatment Summaries

RIGID PAVEMENT PRESERVATION TREATMENT (PROACTIVE MAINTENANCE)	
Name:	Crack Sealing
Application:	
System:	Interstates and Non-Interstates
Pavement Type(s):	All Rigid Pavements
Distress Type(s):	Relates to both Functional and Structural Failures
Purpose. Crack sealing is effective at reducing or delaying moisture damage, further crack deterioration, roughness, and rutting. However, crack sealing can also have a negative impact on roughness and friction.	
Treatment Description. Crack sealing is an operation involving thorough crack preparation and placement of high-quality materials into or over candidate cracks to significantly reduce moisture infiltration and to retard the rate of crack deterioration. Sealed cracks in PCC pavements deteriorate less and contribute less to the overall deterioration of the pavement. PCC cracks are typically sealed with thermosetting bituminous materials.	
Pavement Conditions Addressed. Crack sealing is effective at sealing low- or medium-severity transverse or longitudinal cracks where the crack width is ≤ 0.5 in. (13 mm). Full-depth working transverse cracks typically experience substantial movement; therefore, it is recommended that these cracks be sealed to reduce water and incompressibles.	
Application Limitations. Crack sealing is most effective when performed on PCC pavements that exhibit minimal structural deterioration and in which the cracks are not showing other significant distress (e.g., faulting, spalling). Do not use crack sealing where there are unpatched pavement blowups, rocking slabs, pumping of water or fines through the crack, or full-depth punchouts. In these instances, use full-depth patching as a mitigating activity.	
Letting/Construction Considerations. The project letting date should be selected to target construction during cool, dry weather conditions. Application during cool weather will allow for expanded crack widths.	
Traffic Considerations. Performance is not significantly affected by varying ADT or truck levels, but sealant should be allowed to cure before opening to traffic.	
Special Considerations/Comments: Crack sealing may result in a rougher pavement surface when the sealant material is forced out of the cracks during warm months. If sealing quantities become excessive, the district may want to consider a higher level treatment.	
Performance Period. 4 to 8 years.	

**RIGID PAVEMENT PRESERVATION TREATMENT
(PROACTIVE MAINTENANCE)**

Name: Diamond Grinding

Application:

System: Interstates and Non-Interstates
Pavement Type(s): All Rigid Pavements
Distress Type(s): Relates to Functional Failures

Purpose. Diamond grinding is effective at removing joint faulting and other surface irregularities to restore a smooth-riding surface and increase pavement surface friction.

Treatment Description. Diamond grinding is the removal of a thin layer of concrete (generally up to about 0.25 in. (6 mm)) from the surface of the pavement, using special equipment outfitted with a series of closely spaced, diamond saw blades.

Pavement Conditions Addressed. Diamond grinding is used to remove joint faulting and other surface irregularities to restore a smooth-riding surface, increase pavement surface friction, and reduce noise.

Application Limitations. If the average faulting over the section is > 0.15 in. (4 mm) or other signs of structural failure (e.g., mid-panel cracks, corner breaks) exist, diamond grinding is not appropriate. The presence of materials-related distresses (e.g., D-cracking, ASR) may also preclude the use of diamond grinding. Soft aggregate will wear much quicker and require more frequent grinding.

Letting/Construction Considerations. None.

Traffic Considerations. Grinding may be used to remove faulting, which, if the mechanism is not addressed, can reoccur due to the continued application of truck traffic. If used to restore friction to a polished pavement (due to vehicle traffic), heavy volumes of traffic may cause the problem to recur.

Special Considerations/Comments: Note that diamond grinding is a surface repair method because it corrects the existing faulting and wear of PCC pavements. It does nothing to correct pavement distress mechanisms. Therefore, grinding usually is performed in combination with other rehabilitation methods to both repair certain pavement distresses and prevent their recurrence.

Performance Period. 8 to 15 years.

**RIGID PAVEMENT PRESERVATION TREATMENT
(PROACTIVE MAINTENANCE)**

Name: Diamond Grooving

Application:

System: Interstates and Non-Interstates
Pavement Type(s): All Rigid Pavements
Distress Type(s): Relates to Functional Failures

Purpose. Diamond grooving is effective at increasing wet-pavement friction and reducing splash and spray in identified problem areas.

Treatment Description. Diamond grooving is the process of cutting narrow, discrete grooves in the PCC surface to reduce hydroplaning and wet-pavement crashes in localized areas. Grooving can be performed in both the longitudinal and transverse directions, but is more commonly performed longitudinally.

Pavement Conditions Addressed. Grooving is conducted to increase wet-pavement friction and reduce splash and spray. Diamond grooving is conducted in localized areas of a project where wet-pavement crashes have historically been a problem (e.g., curves, intersections).

Application Limitations. In general, candidate pavements for grooving should be structurally and functionally sound.

Letting/Construction Considerations. None.

Traffic Considerations. Performance is not affected by varying ADT or truck levels.

Special Considerations/Comments: Clearly indicate the areas to be grooved on the project plans. The entire lane area should be grooved; however, allowance should be made for small areas that were not grooved because of pavement surface irregularities. Grooving is most commonly performed longitudinally due to ease of construction; however, if the district would like to place the grooving transversely, the Bureau of Research should be contacted for assistance. This treatment can be used in conjunction with diamond grinding.

Performance Period. Remaining service life of the pavement structure.

**RIGID PAVEMENT PRESERVATION TREATMENT
(PROACTIVE MAINTENANCE)**

Name: Longitudinal Joint Sealing

Application:

System: Interstates and Non-Interstates
Pavement Type(s): All Rigid Pavements
Distress Type(s): Relates to both Functional and Structural Failures

Purpose. Joint sealing helps keep moisture out of the pavement layers and incompressibles out of joints, which reduces spalling.

Treatment Description. Sealing longitudinal joints in PCC pavements is intended to minimize the infiltration of surface water into the underlying pavement structure and to prevent the intrusion of incompressibles into the joint.

Pavement Conditions Addressed. Joint sealing is effective in addressing low or medium severity joint spalling.

Application Limitations. Longitudinal joint sealing is most effective when performed on PCC pavements that exhibit minimal structural deterioration. Base material selection on the expected time until next treatment.

Letting/Construction Considerations. The project letting date should be selected to target construction during cool, dry weather conditions. Application during cool weather will allow for expanded crack widths.

Traffic Considerations. Performance is not affected by different ADT or percent trucks.

Special Considerations/Comments: Joint sealing is necessary when the existing sealant has deteriorated to the point that it readily allows water and incompressibles to enter the joint. The primary cause of sealant failure is improper installation (e.g., not preparing joint sidewalls, getting bonding).

Performance Period. 4 to 8 years for hot-poured asphalt sealant; approximately 8 years for silicone sealant.

**RIGID PAVEMENT PRESERVATION TREATMENT
(HIGH PRESERVATION)**

Name: Load Transfer Restoration

Application:

System: Interstates and Non-Interstates
Pavement Type(s): Jointed Plain Concrete Pavements
Distress Type(s): Relates to Functional and Structural Failures

Purpose. Load transfer restoration, also known as dowel bar retrofit, is effective at mitigating medium severity transverse joint deterioration and faulting by re-establishing load transfer across the joint. This treatment should only be used on transverse joints.

Treatment Description. Load transfer restoration is the addition or replacement of dowel bars across a transverse joint. A gang saw is used to grind slots across the joints, a bar is placed in each slot, and then the slot is filled with a non-shrink grout. Once cured, the transverse joint is re-established and diamond grinding is performed to remove faulting, if present.

Pavement Conditions Addressed. This treatment should be used when the concrete pavement is in good condition and the only distresses are faulting and transverse joint deterioration.

Application Limitations. If significant faulting, other signs of structural failure (e.g., mid-panel cracks, corner breaks), or materials-related distresses (e.g., D-cracking, ASR) are present, load transfer restoration is not appropriate.

Letting/Construction Considerations. None.

Traffic Considerations. None.

Special Considerations/Comments: Contact the Bureau of Research for the latest special provision.

Performance Period. 8 to 15 years.

**RIGID PAVEMENT PRESERVATION TREATMENT
(HIGH PRESERVATION)**

Name: Ultra-Thin Bonded Wearing Course

Application:

System: Interstates and Non-Interstates
Pavement Type(s): All Rigid Pavements
Distress Type(s): Relates to Functional and Structural Failures

Purpose. An ultra-thin bonded wearing course (UTBWC) effectively addresses minor surface distresses and increases surface friction.

Treatment Description. A UTBWC is formed in one pass with the application of a heavy, polymer-modified asphalt emulsion tack coat and a gap-graded, polymer-modified, 0.75 in. to 0.9 in. thick HMA layer.

Pavement Conditions Addressed. This treatment is applicable for low-severity D-Cracking, ASR, transverse cracking, and/or longitudinal joint deterioration; medium-severity transverse joint deterioration and/or longitudinal cracking; and surficial cracking such as map cracking and popouts/high steel.

Application Limitations. Ultra-thin bonded wearing course is not recommended where structural failures exist (e.g., significant D-cracking, ASR, excessive permanent patch deterioration) or where there is extensive pavement deterioration or little remaining life.

Letting/Construction Considerations. The project letting date should be selected to target construction when the air temperature is moderate (i.e., 50°F or above).

Traffic Considerations. It is capable of withstanding high ADT volumes and truck traffic better than other thin treatments.

Special Considerations/Comments: Give special consideration to bump grinding prior to treatment placement. Patching quantities should be included to repair localized structural problems prior to overlay application.

Avoid using on pavements with heavy turning movements or bus stops.

Performance Period. 7 to 12 years.

53-5.03 Minor Rehabilitation Treatment Summaries

PAVEMENT REHABILITATION TREATMENT (MINOR)	
<u>Name:</u>	Bonded Concrete Overlay on Asphalt (BCOA)
<u>Application:</u>	
System:	Interstates and Non-Interstates
Pavement Type(s):	HMA-Surfaced Pavements
Distress Type(s):	Relates to Functional and Structural Failures
<u>Purpose.</u> BCOA is suitable for HMA pavements that have a history of rutting and/or shoving. Intersections, with stopping, starting, standing, and turning actions of vehicles, are an example. Other roadways with volumes and types of vehicles that rapidly rut HMA pavements are also good candidates for BCOA.	
<u>Treatment Description.</u> A BCOA consists of placing 3.0 in. to 6.0 in. (75 mm to 150 mm) of PCC pavement over an existing distressed HMA pavement surface. The existing HMA is first milled to correct profile irregularities and provide a surface for bonding the overlay.	
<u>Pavement Conditions Addressed.</u> BCOA is effective in treating low- to medium-severity alligator cracking, rut depth < 0.25 in. (6 mm), low- to medium-severity transverse cracking, and low- to medium-severity reflective widening cracking.	
<u>Traffic Considerations.</u> The best alternative for traffic control is to completely close the project to traffic. This alternative may be difficult for urban projects; however, somewhat easier for rural projects.	
<u>Special Considerations/Comments.</u> Currently, this rehabilitation strategy is only allowed when the traffic factor does not exceed 7.5. If the district is interested in using this treatment on a project with a higher traffic factor, they must work with the Bureau of Research to design the thickness and joint spacing for the BCOA. Contact the Engineer of Pavement Technology in the Bureau of Research for additional information on design.	
Bare concrete or brick areas included in the rehabilitation area should not exceed 5% of the total area. The HMA layer shall be at least 2.50 in. (63 mm) thick. Consider complicated geometrics, utility obstructions, traffic demand, frequency of at-grade and overhead structures, and condition of the existing pavement when selecting this rehabilitation type.	
<u>Performance Period.</u> 10 to 15 years.	

PAVEMENT REHABILITATION TREATMENT (MINOR)

Name: Cold In-Place Recycling

Application:

System: Non-Interstates
Pavement Type(s): Full-Depth HMA and Composite Pavements
Distress Type(s): Relates to Functional and Structural Failures

Purpose. Cold In-Place Recycling (CIR) is very effective at correcting distresses contained in the top 3 in to 6 in. (75 mm to 150 mm) of the pavement surface. Examples include poor friction and roughness, bleeding, raveling, rutting, and poor cross slope.

Treatment Description. Cold in-place recycling (CIR) is an in-situ process used to recycle the top 3 in to 6 in. (75 mm to 150 mm) of an existing HMA pavement to restore integrity of a flexible pavement layer. As the name suggests, the recycling process is conducted without the addition of heat. During the CIR process, the reclaimed asphalt pavement (RAP) is sized, mixed with additives (e.g., asphalt binder, emulsion, rejuvenator, virgin aggregate), and re-laid. The recycled pavement is then typically resurfaced with a surface treatment or HMA overlay. Note that the compacted thickness will be 5 to 10 percent thicker than the depth milled.

Pavement Conditions Addressed. CIR is effective where cracking is limited to the surface layers; profile, crown, and cross slope problems; poor ride quality and surface friction; rutting, corrugations, and bumps; raveling; and flushing/bleeding. This treatment may be used when transverse cracking level is O4 and the age of surface is greater than 12 years.

Application Limitations. This treatment must be approved by BDE and will require an experimental feature study according to Construction Memorandum 02-2. CIR is not an appropriate treatment for pavements with major or extensive structural deficiencies (e.g., severe alligator cracking, severe structural rutting) or distresses deeper than the CIR depth. CIR may also be difficult to conduct on steep grades, tightly curved roads, or on roads with many utility appurtenances.

Letting/Construction Considerations. The project letting date should be selected to target construction when the air temperature is moderate (i.e., 50°F (10°C) or above). CIR pavement can remain tender for a number of days. Do not allow this treatment to remain exposed over the winter season without a surface treatment or HMA overlay as the final wearing surface.

Traffic Considerations. CIR is most often used on secondary and low volume roads. This treatment is not recommended for ADT greater than 10,000.

Special Considerations/Comments: Remove and replace areas of weak material with suitable patching material prior to recycling to reduce the risk of the cold-planing machine or other CIR equipment breaking through the pavement. If excessive concrete patches are present at the pavement surface, this treatment should not be used.

Performance Period. 5 to 13 years.

PAVEMENT REHABILITATION TREATMENT (MINOR)

Name: Standard Hot-Mix Asphalt (HMA) Overlay
(Formerly known as the Policy Resurfacing Program)

Application:

System: Interstates and Non-Interstates
Pavement Type(s): All Pavements
Distress Type(s): Relates to All Functional and Limited Structural Failures

Purpose. Standard HMA Overlays are used to reduce or eliminate distresses and restore serviceability on a pavement in fair to poor condition.

Treatment Description. Standard HMA Overlays consist of placing two lifts of HMA, unless otherwise noted. The mixture gradation and thickness shall be specified according to Section 53-4.03(a). HMA mixture design criteria must be met as outlined in Section 53-4.04.

Pavement Conditions Addressed. Standard HMA Overlays are effective in treating low- to medium-severity alligator cracking, rut depth < 0.25 in. (6 mm), low- to medium-severity transverse cracking, and low- to medium-severity reflective widening cracking.

Traffic Considerations. Roadway segments with extremely high multiple unit counts may want to consider a Stone-Matrix Asphalt mixture.

Special Considerations/Comments. If the district wants to use an alternative thickness range (increased or decreased) or a single lift, an exception request must be submitted to the Asset Management Engineer to coordinate with the Engineer of Pavement Technology for approval.

For existing HMA-surface pavements, cold milling and inlay may be used in conjunction with a Standard HMA Overlay to maintain existing grade elevation or gain clearance under overhead structures. More information on cold milling is available in the pre-treatment activity summaries (Section 53-5.05).

Performance Period. 10 to 15 years.

53-5.04 Major Rehabilitation Treatment Summaries

PAVEMENT REHABILITATION TREATMENT (MAJOR)							
<u>Name:</u>	Designed HMA Overlay (Formerly known as Structural Overlay)						
<u>Application:</u>	<table style="width: 100%; border: none;"> <tr> <td style="padding-right: 20px;">System:</td> <td>Interstates and non-Interstates</td> </tr> <tr> <td>Pavement Type(s):</td> <td>All Pavements</td> </tr> <tr> <td>Distress Type(s):</td> <td>Relates to All Functional and Structural Failures</td> </tr> </table>	System:	Interstates and non-Interstates	Pavement Type(s):	All Pavements	Distress Type(s):	Relates to All Functional and Structural Failures
System:	Interstates and non-Interstates						
Pavement Type(s):	All Pavements						
Distress Type(s):	Relates to All Functional and Structural Failures						
<u>Purpose.</u> Designed HMA overlays are used to restore serviceability and slow the propagation of underlying structural distresses on a pavement in poor condition.							
<u>Treatment Description.</u> Designed HMA overlays consist of placing two or more lifts of HMA. The mixture gradation and thickness shall be specified according to Section 53-4.04(a). HMA mixture design criteria must be met as outlined in Section 53-4.04(b).							
<u>Pavement Conditions Addressed.</u> For Interstate CRS values ≥ 4.0 and non-Interstate CRS values ≥ 3.5 , designed HMA overlays may be effective in treating infrequent high-severity alligator cracking, high-severity transverse cracking, and high-severity reflective widening cracking.							
<u>Traffic Considerations.</u> Roadway segments with extremely high multiple unit counts may want to consider a Stone-Matrix Asphalt mixture.							
<u>Special Considerations/Comments.</u> For existing HMA-surface pavements, cold milling and inlay may be used in conjunction with a designed HMA overlay to maintain existing grade elevation. More information on cold milling is available in the pre-treatment activity summaries (Section 53-5.05).							
If milling depth is greater than designed overlay thickness, an exception request must be submitted according to Section 53-2.08.							
<u>Performance Period.</u> 10 to 15 years.							

PAVEMENT REHABILITATION TREATMENT (MAJOR)

Name: Structural Concrete Overlay (SCO)

Application:

System: Interstates and Non-Interstates
Pavement Type(s): All Pavements
Distress Type(s): All Functional and Structural Failures

Purpose. The Structural Concrete Overlay (SCO) is designed to span underlying structural distresses while minimizing the potential for random cracking of the PCC slab.

Treatment Description. SCOs consist of placing a non-reinforced layer of PCC pavement over an existing distressed pavement. This treatment is sawed both longitudinally and transversely to create panels.

If the pavement has been previously resurfaced with HMA, the surface may be milled to correct profile irregularities. If the pavement is bare PCC, an interlayer shall be placed as a bond breaker between the existing PCC pavement and the SCO.

Pavement Conditions Addressed. Pavements that have high severity structural distresses (e.g., frequent, high severity transverse cracking) are suited for this treatment to reduce the potential for reflective cracking in the overlay.

Traffic Considerations. The best alternative for traffic control is to completely close the project to traffic. This alternative may be difficult for urban projects; however, somewhat easier for rural projects.

Special Considerations/Comments. This treatment has had limited use and is still considered experimental. The district must work with the Bureau of Research to design the PCC thickness, interlayer type and thickness, and joint spacing for the SCO.

Use of the SCO requires an experimental feature according to Construction Memo 02-2 and approval by the Bureau of Research. Contact the Engineer of Pavement Technology in the Bureau of Research for additional information on use and design of this treatment.

Performance Period. 12 to 15 years.

53-5.05 Pre-Treatment Activity Summaries

PRE-TREATMENT ACTIVITY SUMMARY	
<u>Name:</u>	Cold Milling / Fine Milling
<u>Application:</u>	
Pavement Type(s):	HMA Pavements, Composite Pavements
Distress Type(s):	Relates to both Functional Failures and Structural Failures
<u>Description and Purpose:</u>	Cold milling and fine milling are effective at mitigating functional distresses and providing a smoother surface by removing vertical deformations. It can also be used to restore proper grades and cross-slopes on existing pavement.
	Cold milling involves the removal of part or all of an existing HMA surface to prepare an HMA surface for an HMA overlay or SMART overlays. Milling depth should match what is required to remove the entire HMA surface lift. Deeper milling may be required based on the findings of a pavement investigation report or project constraints.
	Fine milling, which uses modified milling equipment, is used in preparation for a preservation treatment. Contact the Bureau of Research for the current version of the fine milling special provision.
<u>Special Considerations/Comments:</u>	
	Some rehabilitation treatments require a minimum thickness of HMA for construction purposes. See Section 53-4 for requirements.

PRE-TREATMENT ACTIVITY SUMMARY

Name: Full-Depth CRCP Patches (Class A)

Application:

Pavement Type(s): CRCP, HMA Overlaid CRCP

Distress Type(s): Structural Failures

Description and Purpose:

Class A patching consists of removing the failed pavement area and patching it with a full-depth, continuously reinforced PCC patch. Where CRCP facilities are to be patched, it is important to make every attempt to maintain the integrity of the continuous reinforcement. A decision that the pavement distress is so severe that continuity cannot be maintained must be justified by district field testing and subsequent review by the Central Office. In some cases, previous contracts or maintenance activities may have resulted in the use of non-tied PCC or HMA patches being placed on a CRCP facility. Such patches should be replaced with Class A patches when rehabilitation is justified. Obtain BDE approval prior to specifying other than Class A patching for CRCP facilities. Refer to the *Highway Standards* for Class A patching details. The minimum Class A patch dimensions will be a length of 4.50 ft and a width that includes half the width of the travel lane.

Special Considerations/Comments:

It is not desirable to create the large number of closely spaced joints in a pavement that would result from placing a large number of closely spaced patches. The minimum distance between patches is 15 ft. If less than 15 ft of existing pavement will remain, the entire area between the two patches should be removed and replaced.

For all Class A patching projects, review previous plans to determine the locations of any lug systems or wide-flange beam terminal joints.

PRE-TREATMENT ACTIVITY SUMMARY

Name: Full-Depth Dowelled Patches (Class B)

Application:

Pavement Type(s): JPCP, JRCP, HMA Overlaid JPCP, and HMA Overlaid JRCP

Distress Type(s): Structural Failures

Description and Purpose:

Class B patching consists of removing the failed pavement area and patching it with a full-depth dowelled PCC patch. For highways on the State system, including Interstate facilities, that have sound JPCP/JRCP and less than 2% of previously placed undowelled patching, specify Class B patching regardless of whether or not the pavement will be overlaid. Class B patching also should be specified on other low-ADT routes that have existing load transfer and sound plain concrete pavements with no previously placed undowelled patches. In general, use dowelled patches on sound JPCP/JRCP. Specify undowelled patching if field testing indicates that the concrete is so unsound as to preclude the use of Class B patching. Refer to the *Highway Standards* for Class B patching details. The minimum Class B patch dimensions will be a length of 6 ft and a width that includes the full width of the travel lane.

Special Considerations/Comments:

It is not desirable to create the large number of closely spaced joints in a pavement that would result from placing a large number of closely spaced patches. The minimum distance between patches is 6 ft. If less than 6 ft of existing pavement will remain, the entire area between the two patches or between a patch and the existing joint should be removed and replaced.

PRE-TREATMENT ACTIVITY SUMMARY

Name: Full-Depth Undowelled Patches (Class C and Class D)

Application:

Pavement Type(s): HMA Pavements, JPCP, JRCP, and HMA Overlaid JPCP/JRCP

Distress Type(s): Structural Failures

Description and Purpose:

Undowelled patching may consist of either Class C or Class D patches. Class C patching consists of removing the distressed pavement area and patching it with an undowelled PCC patch. Class D patching consists of removing the distressed pavement area and replacing it with an HMA patch. Specify "Pavement Patching" to permit the contractor the option of using either PCC or HMA unless there exists a justifiable reason to specify one or the other. If a particular patch material is specified, document the basis for the material selection in the district project files.

Special Considerations/Comments:

Use the following guidelines when specifying either Class C or Class D patching:

1. PCC Pavements. Undowelled patching for PCC pavements should only be specified when field testing indicates that the concrete is so unsound as to preclude the use of Class A or B patching.
2. Full-Depth HMA Pavements. Class D patching shall be specified for all full-depth HMA pavements.
3. Level of Existing Patching. Undowelled patches also may be specified if there exists 2% or more of previously placed undowelled patching and the undowelled patches are in good condition and performing well.
4. Emergency Patching. Except in an emergency, Class D patching should not be specified on the Interstate System or on any supplemental freeway constructed to Interstate criteria. On such facilities, replace emergency Class D patches with permanent Class A, B, or C patches as soon as practical.
5. Full-Depth Patching. Where the multiple unit (MU) traffic is greater than 200 ADT, the minimum dimensions for full-depth patches will be a length of 4 ft and a width of half the travel lane. Where the MU traffic is 200 ADT or less, the minimum patch dimensions for full-depth patches will be as shown in the *Highway Standards* for Class C and Class D patches.

PRE-TREATMENT ACTIVITY SUMMARY

Name: Partial-Depth Patches

Application:

Pavement Type(s): All Pavement Types

Distress Type(s): Structural and Functional Failures

Description and Purpose:

Partial-Depth patching is effective at removing distresses that are primarily in the top portion of the pavement (e.g., isolated unstable rutting, spalling of joints in a PCC pavement, distresses limited to the HMA portion of a composite pavement, etc.). This activity typically uses HMA patching material, but some applications may warrant using PCC patching material.

Special Considerations/Comments:

Areas for partial-depth patching shall be clearly identified on the plans using a detail or note near typical sections or clear typical sections to note milling depth in relation to the cross-sectional layers. For example, the removal depth can include only HMA, or the removal depth can include a combination of HMA and deteriorated concrete.

When patching an HMA or composite pavement, the minimum partial-depth patch size will be 4 ft by 4 ft at the necessary depth. If using HMA patching material, lift thickness requirements shall be followed to ensure good performance of the patch. Mixture requirements, lift thickness, and placement methods are determined by whether or not the patch will be resurfaced.

When patching a bare PCC pavement, the minimum partial-depth patch size will be 2 ft by 2 ft at a depth of 2 to 4 inches. If PCC patching material is used, all joints within patches shall be reestablished to prevent random cracking.

PRE-TREATMENT ACTIVITY SUMMARY

Name: Longitudinal Crack Repair

Application:

Pavement Type(s): All PCC and HMA Overlaid PCC Pavements

Distress Type(s): Structural Failures

Description and Purpose:

Longitudinal crack repair is a cost-effective method of prolonging the service life of a pavement which has distress along a longitudinal crack while the rest of the pavement is sound. The recurring special provision for Portland Cement Concrete Partial Depth Hot-Mix Asphalt Patching shall be used for this work.

Many CRC pavements exhibit longitudinal cracking with severe spalling and D-cracking adjacent to the cracks. The cost of placing a full-depth patch at these locations would be prohibitive. Instead, the crack can be milled to a depth of 2 in. to 3 in. with a width of 12 in. to 24 in. The milled area can then be filled with a HMA mixture without a need to overlay the pavement. This method can also be used to repair high severity longitudinal cracks in JPCP/JRCP and reflective cracks in HMA overlays.

In lieu of milling, the longitudinal crack may be sealed with an asphalt mastic product. If interested in this option, contact the Bureau of Research for the special provision.

Special Considerations/Comments:

When using this method on bare PCC pavements, it is important to limit the depth of the milling to just above the depth of the reinforcing steel so as not to damage the steel.

53-5.06 Additional Design Feature Summaries

ADDITIONAL DESIGN FEATURE SUMMARY	
Name:	Expansion Joints
Application:	Pavement Type(s): PCC Pavements, Composite Pavements Distress Type(s): Relates to both Functional Failures and Structural Failures
Description and Purpose: Expansion joints should be visually inspected to determine if they are in working order. If patching is an integral part of the rehabilitation strategy, closed expansion joints should be re-established regardless of the type of patching that is specified.	
Special Considerations/Comments: Consider the following guidelines when re-establishing expansion joints: <ol style="list-style-type: none">1. <u>Jointed Pavements</u>. Consider the following for JPCP and JRCP:<ol style="list-style-type: none">a. <u>Dowelled Patches</u>. Where the pavement requires patching at or near a closed expansion joint, a new joint should be established using a dowelled expansion patch as shown in the <i>Highway Standards</i> for Class B patches. If the joint is closed, but does not require patching, an expansion joint may be formed by sawing the pavement and filling the saw cut with a preformed expansion joint filler material that meets the <i>Standard Specifications</i> for expansion joints.b. <u>Non-Dowelled Joints</u>. If other than dowelled patches are required and if the pavement is not being resurfaced, a new expansion joint may be formed by sawing the pavement and filling the saw cut with a preformed expansion joint filler material that meets the <i>Standard Specifications</i>.2. <u>CRC Pavements</u>. If a CRC pavement is being patched with a Class A patch, whether or not the pavement is being resurfaced, existing expansion joints should be re-established using a saw cut filled with preformed expansion joint filler material that meets the <i>Standard Specifications</i> for expansion joints.	

ADDITIONAL DESIGN FEATURE SUMMARY

Name: Lug Areas/Pressure Relief Joints

Application:

Pavement Type(s): CRC Pavements, HMA Overlaid CRC Pavements

Distress Type(s): Relates to both Functional Failures and Structural Failures

Description and Purpose:

Lug systems are typically located just prior to the approach pavement of a structure. When developing patching contracts, consult previous plans to determine actual locations.

Lug areas that do not show signs of tilting or other similar distresses should not be cut free. If they have previously been cut free and there is no sign of tilting, the continuity of the pavement should be restored through the use of a Class A patch.

Special Considerations/Comments:

If signs of tilting exist and the pavement surface over the lug area is excessively rough, a 4 in. wide pressure relief joint that is filled with a preformed expansion joint filler material should be provided 150 ft from the lug area. The entire lug system should be subsealed to fill voids, and the area over the lug should be resurfaced to complete the leveling process.

In extreme cases, the lug system should be removed and replaced with a lug system or wide flange beam expansion joint as shown in the *Highway Standards*.

ADDITIONAL DESIGN FEATURE SUMMARY

Name: Pipe Underdrains

Application:

Pavement Type(s): All Pavements

Distress Type(s): Relates to both Functional Failures and Structural Failures

Description and Purpose:

Drainage is an important pavement rehabilitation consideration. Water is a fundamental variable in most problems associated with pavement performance and is directly or indirectly responsible for many pavement distresses. A drainage survey may indicate that pipe underdrains are required to control one or more sources of water in the pavement, thus increasing pavement serviceability and life. Subsurface drainage systems should be designed and constructed with long-term performance and maintenance goals in mind, including periodic inspections to check performance.

Special Considerations/Comments:

The moisture that infiltrates the pavement/shoulder joint usually is the only moisture that can be readily drained. A benefit to installing retrofit pipe underdrains is that it will minimize the potential to trap moisture in the slab/base interface. A properly designed and constructed longitudinal edge drain system can, in some cases, improve the long-term load-carrying and distribution properties of the base and subgrade materials. Note that underdrains by themselves cannot restore a pavement that is structurally inadequate.

ADDITIONAL DESIGN FEATURE SUMMARY

Name: Wide-Flange Beam Terminal Joints

Application:

Pavement Type(s): CRC Pavements, HMA Overlaid CRC Pavements

Distress Type(s): Relates to both Functional Failures and Structural Failures

Description and Purpose:

Wide-Flange Beam Terminal Joints are typically located just prior to the approach pavement of a structure. When developing patching contracts, consult previous plans to determine actual locations.

Existing wide flange beam terminal joints should be closely inspected to determine if the joint is working properly both at the beam and at the expansion joint between the beam and the bridge approach or jointed pavement. In addition, the flange of the beam should be inspected for signs of fatigue cracking.

Special Considerations/Comments:

If the pavement in the area of these joints or the beam itself show signs of distress, special patching details may be required. Contact the BDE for assistance in preparing plans for the proper remedial treatment.

53-6 REFERENCES

1. *Guide for the Design of Pavement Structures*, American Association of State Highway and Transportation Officials, Washington, DC., 1993.
2. *Modern Pavement Management*, Haas, R., W. R. Hudson, and J. Zaniewski, Krieger Publishing Company, Malabar, FL., 1994.
3. FHWA-RD-03-031 *Distress Identification Manual for the Long-Term Pavement Performance Program*, Miller, J. S. and W. Y. Bellinger, Federal Highway Administration, Washington, DC., 2003.
4. FHWA-NHI-04-171 *Pavement Preservation: Design and Construction of Quality Preventive Maintenance Treatments*, Peshkin, D. G., T. E. Hoerner, K. D. Smith, J. E. Bruinsma, and S. B. Seeds, NHI Course 131103, Reference Manual, National Highway Institute, Federal Highway Administration, Washington, DC., 2004.
5. *Seal Coats (Oil & Chipping)*, BLRS Technology Transfer Center (T²), IDOT, 2006.

Chapter Fifty-four
PAVEMENT DESIGN

BUREAU OF DESIGN AND ENVIRONMENT MANUAL

Chapter Fifty-four
PAVEMENT DESIGN

Table of Contents

<u>Section</u>	<u>Page</u>
54-1 GENERAL	54-1.1
54-1.01 Scope of Chapter	54-1.1
54-1.02 Definitions	54-1.1
54-1.03 Pavement Design Methodologies	54-1.6
54-1.03(a) Mechanistic	54-1.6
54-1.03(b) Modified AASHTO	54-1.6
54-1.04 Selection of Design Methodology, Pavement Type, and Design Criteria	54-1.7
54-1.05 Intersections	54-1.12
54-1.05(a) High-Stress Intersections	54-1.12
54-1.05(b) Distress Treatment at Other Intersections	54-1.12
54-1.05(c) Side Road Approaches	54-1.13
54-1.06 Interchange Ramps	54-1.13
54-1.07 Rest Areas	54-1.14
54-1.08 Weigh Stations	54-1.14
54-2 BASIC DESIGN PARAMETERS (MECHANISTIC)	54-2.1
54-2.01 Development of Design Procedures	54-2.1
54-2.01(a) General	54-2.1
54-2.01(b) Design Period	54-2.1
54-2.01(c) Structural Design Traffic	54-2.1
54-2.01(d) Mixed-Traffic Axle Loadings	54-2.4
54-2.01(e) Heavily Loaded Vehicles and High Volume Truck Routes	54-2.5
54-2.01(f) Roadbed Soils	54-2.5
54-2.02 Structural Design	54-2.10
54-2.03 Limitations and Requirements	54-2.10
54-2.03(a) General	54-2.10
54-2.03(b) Adherence to Specifications	54-2.10
54-2.03(c) Structural Design Traffic	54-2.10
54-2.03(d) Terminal Service Level	54-2.11

Table of Contents*(Continued)*

<u>Section</u>		<u>Page</u>
	54-4.02(f) Subbase Type and Thickness	54-4.18
	54-4.02(g) Designating Structural Information on Plans.....	54-4.18
	54-4.02(h) Joints and Concrete Lug End Anchorages	54-4.18
	54-4.02(i) Typical Sections.....	54-4.18
	54-4.02(j) Surface Finish.....	54-4.18
54-4.03	Unbonded Concrete Overlay.....	54-4.19
	54-4.03(a) Limitations.....	54-4.19
	54-4.03(b) Application of Design Method.....	54-4.19
	54-4.03(c) Pavement Type and Thickness	54-4.19
	54-4.03(d) Special Considerations/Comments	54-4.19
54-5	STRUCTURAL DESIGN OF FLEXIBLE PAVEMENTS.....	54-5.1
54-5.01	Mechanistic.....	54-5.1
	54-5.01(a) Limitations.....	54-5.1
	54-5.01(b) Minimum Material Quality.....	54-5.1
	54-5.01(c) Asphalt Binder Selection	54-5.1
	54-5.01(d) Application of Design Method.....	54-5.1
	54-5.01(e) Design Period	54-5.2
	54-5.01(f) Equivalency Factors.....	54-5.2
	54-5.01(g) Traffic Factor.....	54-5.3
	54-5.01(h) Improved Subgrade.....	54-5.3
	54-5.01(i) Thickness Design Process for Full-Depth HMA.....	54-5.3
	54-5.01(j) Use of Limiting Strain Criterion Design Cross-Section...	54-5.12
	54-5.01(k) Designating Structural Design Information on Plans.....	54-5.13
	54-5.01(l) Shoulder Type/Design.....	54-5.13
	54-5.01(m) Design Example.....	54-5.13
	54-5.01(n) Typical Sections.....	54-5.13
54-5.02	HMA Pavement (Full-Depth) on Rubblized PCC Pavement	54-5.18
	54-5.02(a) Application of Design Method.....	54-5.18
	54-5.02(b) Review of the Existing Pavement Structure.....	54-5.18
	54-5.02(c) Design Issues	54-5.21
54-6	STRUCTURAL DESIGN OF COMPOSITE PAVEMENTS.....	54-6.1
54-6.01	Application of Design Method.....	54-6.1
54-6.02	Design Period	54-6.2
54-6.03	Equivalency Factors.....	54-6.2
54-6.04	Traffic Factors	54-6.2
54-6.05	Composite Pavement Structural Number	54-6.2
54-6.06	Thickness Design Equations	54-6.5

Table of Contents
(Continued)

<u>Section</u>		<u>Page</u>
54-6.07	Minimum Design Requirements	54-6.6
54-6.08	Designating Structural Design Information on Plans.....	54-6.7
54-6.09	Design Example	54-6.7
54-7	PAVEMENT SELECTION ANALYSIS	54-7.1
54-7.01	Introduction	54-7.1
54-7.02	Selection Basis	54-7.1
54-7.03	Life-Cycle Activities	54-7.2
54-7.04	Cost Estimating.....	54-7.6
54-7.05	Life-Cycle Cost Analysis.....	54-7.6
54-8	PAVEMENT DESIGN SUBMITTALS	54-8.1
54-8.01	Submittal Requirement.....	54-8.1
54-8.02	Submittal Content.....	54-8.1
54-8.03	Shelf-Life of Approved Pavement Designs	54-8.2
54-9	DESIGN EXAMPLES	54-9.1

Chapter Fifty-four

PAVEMENT DESIGN

54-1 GENERAL

54-1.01 Scope of Chapter

Following the AASHTO Road Test Project, IDOT assessed the results and performed additional research to develop practical applications of the findings that would be applicable to all marked and all unmarked routes on the State highway system. In the late 1980's and early 1990's, mechanistic design concepts were investigated and developed into our first procedures using the actual stresses and strains from traffic to design our pavements. Since that time, extensive research, monitoring, and evaluation have occurred resulting in refinements in the late 2000s. As a result, the following structural pavement design methodologies were developed or updated for inclusion in Chapter 54:

- mechanistic design of rigid pavements,
- modified AASHTO design of rigid pavements (CRCP only),
- design procedures for unbonded concrete overlays,
- mechanistic design of flexible pavements,
- mechanistic design of flexible pavements over rubblized PCC pavements, and
- modified AASHTO design of composite pavements.

A flowchart is presented in Chapter 54 (Figure 54-1.A) that will assist in determining the appropriate structural pavement design methodology, pavement type, and design criteria. In addition to providing an analytical approach to structural pavement design, Chapter 54 presents an analytical method for selecting the most economical pavement design that can be expected to meet structural design requirements. The pavement design submittal serves as documentation to substantiate the recommendation of pavement type and thickness.

The pavement design procedures outlined in this chapter are for pavements on the state system only. The procedures in this chapter are inappropriate for non-state agency pavements and/or parking lots. Designs for local agencies should be developed using Chapter 44 of the BLRS Manual.

54-1.02 Definitions

The following definitions are typically used in pavement design:

1. Base Course. The layer(s) of material placed on a subbase or a subgrade to support the surface course.

2. Class I Roads and Streets. Roads and streets designed as a facility, or as part of a future facility, with four or more lanes, and all one-way streets with structural design traffic greater than 3,500 ADT.
3. Class II Roads and Streets. Roads and streets designed as a two-lane facility with structural design traffic greater than 2,000 ADT, and all one-way streets with structural design traffic less than 3,500 ADT.
4. Class III Roads and Streets. Roads and streets with structural design traffic between 750 ADT and 2,000 ADT.
5. Class IV Roads and Streets. Roads and streets with structural design traffic less than 750 ADT.
6. Composite Pavement. A pavement structure having an HMA surface overlaying a PCC slab of relatively high bending resistance that serves as the principal load distributing layer. The PCC slab may be either a newly constructed base course or an existing rigid or composite pavement that is to be resurfaced.
7. Composite Pavement Structural Number (SN_c). An index number derived from an analysis of traffic and roadbed soil conditions that is used to determine the thickness of HMA surface and PCC base course, if required, for a composite pavement.
8. Construction Year Traffic. Construction year traffic is the ADT for the year the facility is to be opened to traffic.
9. Continuously Reinforced Concrete Pavement (CRCP). A rigid pavement structure having continuous longitudinal reinforcement. The continuous reinforcement is achieved by overlapping the longitudinal steel reinforcing bars.
10. Design HMA Microstrain. The design HMA microstrain is the tensile strain at the bottom of the HMA pavement layer used in the design of mechanistic flexible pavements.
11. Design E_{HMA} (HMA Mixture Modulus). The design E_{HMA} is the HMA mixture modulus in the pavement that corresponds to the design pavement HMA mixture temperature. E_{HMA} is selected from Figure 54-5.D and is based on the relationship between the design HMA mixture temperature and the asphalt binder type (i.e., PGXX-22 or PGXX-28) used in the design of mechanistic flexible pavements.
12. Design Lane. The lane carrying the greatest number of SU and MU vehicles for which the pavement section thickness will be based.
13. Design Pavement HMA Mixture Temperature. The design temperature of the HMA mixture to be used in the design of mechanistic flexible pavements is based on the pavement's geographical location. See Figure 54-5.C.

14. Design Period. The number of years that a pavement is to carry a specific traffic volume and retain a serviceability level at or above a designated minimum value.
15. Design Subgrade Support Rating (SSR). The design SSR is the rating of the subgrade support under mechanistically designed pavements. There are three classes of SSR: poor, fair, and granular. SSR is determined by the district geotechnical engineer and documented in the project soils report.
16. Equivalency Factor. A numerical factor that expresses the relationship of a given axle load to another axle load in terms of its effect on the serviceability of a pavement structure. In pavement design, all axle loads are equated in terms of an equivalent number of repetitions of an 18-kip, equivalent single-axle load (ESALs).
17. Existing Traffic. Existing traffic is the existing ADT of the facility.
18. Flexible Pavement. An HMA pavement structure which maintains intimate contact with and distributes loads to the subgrade which depends upon aggregate interlock, particle friction, and cohesion for stability.
19. Flexible Pavement Structural Number (SN_F). An index number derived from an analysis of traffic and roadbed soil conditions which may be converted to a flexible pavement thickness for modified AASHTO through the use of suitable factors related to the types and strengths of material being used within the pavement structure.
20. Full-Depth HMA Pavement. A flexible pavement structure that uses HMA throughout the entire thickness (binder course and surface course layers).
21. Future Traffic. Future traffic is the ADT of the facility at the end of the design period, typically 20 years.
22. Illinois Bearing Ratio (IBR). The IBR is a measure of the support provided by the roadbed soils or by unbound granular materials under modified AASHTO designed pavements or composite pavements. The IBR test procedure is a modification of the California Bearing Ratio (CBR) procedure and is a soaked laboratory test.
23. Improved Subgrade. A subgrade which has been modified with lime, by-product lime, cement, or other approved material or, alternatively, has been removed and replaced with aggregate.
24. Integral Curb and Gutter. A curb and gutter which is paved monolithically with the pavement. It is used to reduce edge stresses.
25. Jointed Plain Concrete Pavement (JPCP). A rigid pavement structure that uses doweled joints at 12 ft or 15 ft nominal intervals.
26. Jointed Reinforced Concrete Pavement (JRCP). A rigid pavement that uses distributed steel reinforcement and transverse contraction joints.

27. Limiting Strain Criterion Design Thickness. The full-depth HMA pavement thickness at which the tensile strain at the bottom of the HMA is reduced to such a level that fatigue is no longer a factor in the design. This thickness need not be exceeded.
28. Mechanistic Pavement Design. A structural pavement design procedure used to determine fatigue life based on actual conditions, including stresses, strains, and deflections. It can be used to suit any local condition and material.
29. Multiple-Unit (MU) Vehicles. MU vehicles include truck tractor semi-trailers, full trailer combination vehicles, and other similar combinations.
30. Passenger Vehicles (PV). PVs include automobiles, pickup trucks, vans, and other similar two-axle, four-tire vehicles.
31. Pavement Performance. The trend of pavement serviceability with respect to repetitive vehicular load applications.
32. Pavement Structure. The combination of subbase, base course, and surface course placed on a subgrade to support the traffic load and distribute it to the roadbed.
33. Present Serviceability Index (PSI). A number derived by formula for estimating the serviceability rating from measurements of certain physical features of the pavement.
34. Present Serviceability Rating (PSR). The mean value of the independent subjective ratings by members of a special panel for the AASHO Road Test as to the serviceability of a section of the highway.
35. Pumping. The ejection of foundation material through joints or cracks or along edges of rigid slabs due to vertical movements of the slab under traffic.
36. Ramp. A roadway that connects two or more legs at an interchange and includes at least one ramp terminal section. Roadways that connect two legs of freeway, and that are continuations of mainline lanes, or arise from tapers designed for high-speed operation are not considered ramps, but are considered part of the mainline for structural design.
37. Rigid Pavement. A pavement structure whose surface and principal load distributing component is a PCC slab of relatively high bending resistance (e.g., JPCP, CRCP, JRCP).
38. Roadbed. That portion of the highway within the side slopes that is graded and prepared as a foundation for the pavement structure and shoulders.
39. Serviceability. The ability of a pavement, at the time of observation, to serve automobile and truck traffic.

40. Single-Axle Load. The total load transmitted by all wheels whose centers may be included between two parallel transverse vertical planes 40 in. apart, extending across the full width of the vehicle.
41. Single-Unit (SU) Vehicles. SU vehicles include two- or three-axle trucks and buses having six tires.
42. Structural Design Traffic. The ADT that is estimated for the year that represents one-half of the design period which is then classified into PV, SU, and MU vehicles and assigned to the design lane to determine a traffic factor.
43. Subbase. The layer(s) of material (e.g., HMA, CAM II) placed on the subgrade to support the base course or, in the case of rigid pavements, the PCC slab.
44. Subgrade. The finished grade of earthwork upon which the pavement structure (i.e. the subbase, base course, surface course, or pavement slab) and shoulders are constructed. Due to the poor soils in Illinois, the subgrade is typically improved (see Improved Suggrade definition).
45. Surface Course. One or more layers of a pavement structure designed to accommodate the traffic load, the top layer of which resists skidding, traffic abrasion, and the disintegrating effects of climate. The top layer is sometimes called the “wearing course”.
46. Tandem-Axle Load. The total load transmitted to the road by two or more consecutive axles whose centers may be included between two parallel vertical planes spaced more than 40 in. but not more than 96 in. apart, extending across the full width of the vehicle.
47. Tied Curb and Gutter. A PCC curb and gutter, which is tied with reinforcing steel to the pavement. It is used to reduce pavement edge stresses.
48. Tied Shoulder. A PCC stabilized shoulder tied with reinforcing steel to the pavement. It is used to reduce pavement edge stresses.
49. Time-Traffic Exposure Factor. A numerical factor applied to the pavement design term indicated by the AASHO Road Test pavement performance equations (rigid and flexible) to modify the equations to be more representative of the behavior of pavements serving under similar conditions but over periods of time more typical of regular service life.
50. Traffic Factor (TF). The total number of 18-kip equivalent single-axle load applications (ESALs) to the design lane anticipated during the design period, expressed in millions. It is used as an equivalency factor for mixed traffic loads.
51. Untied Shoulder. Any shoulder which does not provide edge support. The shoulder may consist of earth, aggregate, HMA, or other materials.

54-1.03 Pavement Design Methodologies

54-1.03(a) Mechanistic

Since the completion of the AASHO Road Test Project, the Department has developed many new highway materials and procedures to improve pavement construction. This effort has resulted in improved material usage, construction procedures, and pavement designs which, although common practice today, were neither envisioned nor included in design procedures at the time of the AASHO Road Test. Therefore, to supplement the AASHO Road Test Project and better address modern pavement design, mechanistically based structural pavement design procedures were developed using structural mechanical analysis, computer modeling, and actual performance and response of existing pavement sections.

Mechanistic pavement design procedures are applicable to JPCP designs with nominal 12-ft or 15-ft panels and full-depth HMA designs with HMA surface and binder. The procedures use the actual stresses, strains, and deflections experienced by the pavement to determine its expected fatigue life. Factors that are considered in mechanistic designs include:

- design HMA strain,
- design pavement HMA mixture temperature,
- design HMA mixture modulus (E_{HMA}),
- subgrade support ratio (SSR),
- design reliability of 95% (HMA and PCC),
- degree of PCC edge support,
- degree of PCC base erosion,
- PCC joint spacing, and
- PCC stresses.

See Section 54-1.02 for definitions of these factors.

The "IDOT Mechanistic Pavement Design and Life-Cycle Cost Analysis" spreadsheet (BDE 5401) is used to perform the design calculations and is available on the IDOT website.

54-1.03(b) Modified AASHTO

The modified AASHTO design procedures are based on the AASHO Road Test pavement performance equations, which correlate performance of test sections with pavement design, the magnitude and configuration of the axle load, and the number of axle-load applications. The AASHTO equations are necessarily limited to the following factors:

- physical environment of the Road Test Project,
- materials used in the test pavements,
- range of pavement thicknesses included in the experiments,
- axle loads used and number of axle-load applications experienced,

- specific times and rates of application of the test traffic,
- construction techniques employed, and
- climatic cycles experienced during construction and testing of the experimental facility.

To apply the AASHTO equations in design, it is necessary to make certain assumptions and extrapolations based on experience and engineering judgment. In developing the design procedures, modifications were made to the AASHTO equations to reflect the effect of the following variations on pavement performance:

- mixed truck and passenger car traffic axle loadings when compared with controlled traffic axle loadings in the AASHTO Road Test,
- pavements subjected to traffic over longer periods of time when compared to the two years of traffic in the AASHTO Road Test, and
- variations in the support strengths of the roadbed soils.

Variations in climatic conditions as they exist from one part of the State to another and particularly between the extreme northern and extreme southern portions undoubtedly affect pavement performance. The relative effects of these variations on pavement performance, however, are not sufficiently distinguishable at the present time to be taken into account in pavement structural design. Therefore, in developing the modified AASHTO structural design procedures, climatic effects were considered only on a state-wide basis.

Currently, the modified AASHTO design procedure is only used for CRCP, unbonded CRC overlays, and composite pavements. Composite pavements include HMA surfacing for both existing PCC pavements and new PCC base courses.

54-1.04 Selection of Design Methodology, Pavement Type, and Design Criteria

Figure 54-1.A presents a flowchart that will help to determine the appropriate structural pavement design methodology, pavement type, and design criteria. In general, the mechanistic structural pavement design methodology will be used for all projects involving new pavement construction, replacement of existing pavements, and widening greater than or equal to 6 ft. In addition to the above requirements, the following will apply:

1. **New Construction/Replacement Projects.** For new construction/replacement projects, the pavement selection will be based on a life-cycle cost analysis (see Section 54-7). This procedure uses a 45-year life cycle, a 3% discount rate, and a comparison of pavement types based on annualized costs.

For pavement replacement projects, supplemental designs such as unbonded concrete overlay and full-depth HMA pavement over rubblized PCC will be added to the comparison with mechanistic designs for new rigid and flexible pavements to determine the most appropriate and economical strategy.

If the economic analysis does not result in one design being more than 10% cheaper than the others, the pavement selection will be based upon an alternate pavement

bidding process. The criteria and requirements shown below must be met/followed for use of the alternate pavement bidding process.

- a. Project Criteria. The following criteria must be met for a project to be considered for the alternate pavement bidding process.
 - The project length must be 2 lane-miles or more in length. Pavement projects less than 2 lane-miles in length may be developed for alternate bids with approval by the Bureau of Research. A standard lane-mile is defined as pavement 12 ft wide and 1 mile in length. Full-depth paved shoulder widths that have the same pavement type as the mainline should be proportionally included when calculating the overall project length in lane-miles [compared to 12-ft lane width].
 - Projects involving widening cannot be considered for the alternate pavement bidding process.
 - Life cycle costs for both the rigid and flexible designs must be based on a 45-year analysis with equal pavement design life.
 - Traffic and construction staging for all pavement designs are considered an equal cost and therefore not included in the analysis.
- b. Project Requirements. The following requirements must be completed for preparing a project for the alternate pavement bidding process.
 - Plans for all projects with alternate pavements should contain typical cross-sections and multiple sets of quantities. One set will contain all items that are common for all pavement designs. The remaining sets will contain those items exclusive to the a particular design. Typical sections for each alternate pavement design, including station limits and all side road connections, must be presented in the contract plans. All pay items for alternate pavements must be in square yards for the entire pavement surface.
 - The profile grade should always be designed for the thickest pavement design. The Contractor is responsible for maintaining the profile grade shown on the plans for the selected pavement with no additional compensation.
 - Projects using lime modification for the improved subgrade must be scheduled for letting such that the subgrade improvement and placement of the pavement is completed in the same construction season. If the letting date is too late in the year to meet this requirement, the project start date needs to be delayed until the following construction season.
 - Crossroad structures should be designed to accommodate a minimum cover based on the thickest pavement design.
 - Cost adjustment special provisions which tend to benefit one alternative (e.g. Bituminous Materials Cost Adjustment) cannot be included in an

alternate bidding project. Other cost adjustments which are of equal benefit (e.g. Fuel Cost Adjustment and Steel Cost Adjustment) should be included.

While alternate bidding is generally advantageous, circumstances occasionally arise which cause one pavement type to be preferred over the other. In such cases, the district can submit documentation to the Bureau of Research of the preferred pavement type and the reason(s) alternate bidding is not advantageous. The Pavement Selection Committee can then be convened to determine the final pavement design. Refer to Section 54-7.05 for more information on the Pavement Selection Committee.

2. Widening Projects Involving Resurfacing. For projects involving widening greater than or equal to 6 ft in width, where the existing pavement and widening are to be resurfaced, the following will apply.

- The thickness of resurfacing over the existing pavement should be determined first according to the Department's policy.
- The mechanistic pavement design procedure will then be used to determine the total thickness of pavement required for the full-depth HMA pavement widening. The thickness of the resurfacing will be subtracted from the total thickness to determine the thickness of the additional binder required.
- Procedures contained in Section 54-6 will be used to design the PCC base course thickness of the composite pavement alternative. The thickness of the HMA surface and top lift of binder over the PCC base course will be equal to that determined for the resurfacing of the existing pavement.
- The designer should review and consider the ability of the pavement to be matched in-kind. It is possible that the new pavement thickness is thinner than the original pavement and subsequent rehabilitations. The designer should review the cross-section to determine if drainage paths will be impacted or other factors exist that could lead to performance problems if a thinner section is placed next to a thicker section.
- The selection of the pavement type will then be based on first cost.

3. Widening Projects Not Involving Resurfacing. For projects involving widening greater than or equal to 6 ft in width, where the existing pavement and widening are not to be resurfaced, the following will apply:

- The mechanistic structural pavement design procedures will be used to determine the required thickness for both the rigid and full-depth HMA pavement alternatives.
- The designer should review and consider the ability of the pavement to be matched in-kind. It is possible that the new pavement thickness is thinner than the original pavement and subsequent rehabilitations. The designer should review the cross-section to determine if drainage paths will be impacted or other

factors exist that could lead to performance problems if a thinner section is placed next to a thicker section.

- The selection of the pavement type will then be based on first cost.
4. Special Considerations of Mechanistic Designs. The design charts used in the mechanistic design methodology provide several options for both rigid and flexible pavement designs. The following special considerations apply to mechanistic designs:
- a. Rigid Pavement Designs. Unless prior approval to use untied shoulders has been granted by the the Bureau of Research or if stabilized shoulders are not required, the rigid pavement design curve for the 12 ft lane with tied concrete shoulders will be used for determining the design thickness. If the rigid option is selected, plans will be prepared based on the thickness obtained with the 12 ft lane.
 - b. Flexible Pavement Designs. For flexible pavements, the designer must select the appropriate asphalt binder grade(s) (i.e., PG XX-22 or PG XX-28) for the lower binder, upper binder, and surface lifts. This information is then included on the HMA Mixture Table in the plans. However the design thickness of the overall pavement is only based upon the asphalt binder grade of the lower binder which is PG 64-22 for all districts according to Figure 53-4.M. This is the only binder grade which should be used in the actual design.

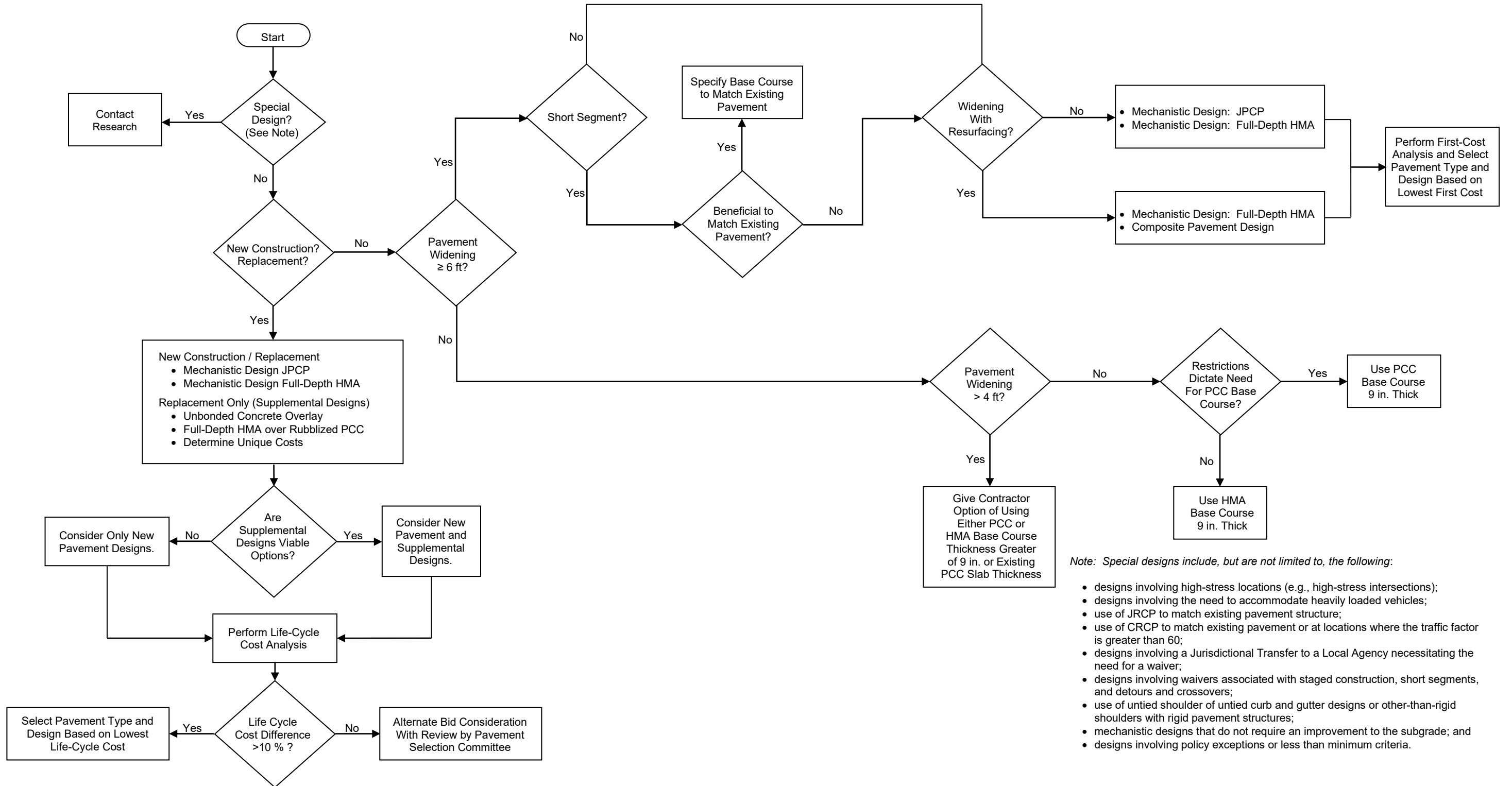

FLOWCHART FOR SELECTION OF DESIGN METHODOLOGY, PAVEMENT TYPE, AND DESIGN CRITERIA

Figure 54-1.A

54-1.05 Intersections

The type of pavement material selected for intersections will depend upon the existing pavement type and the volume and type of vehicles crossing or turning at the intersection. The following sections discuss the type and application of pavement materials typically used at intersections.

54-1.05(a) High-Stress Intersections

High-stress intersections are defined as those under stop control, either signal or signage, that have one or more of the following conditions:

- The approach grade on any stop-controlled leg of the intersection is greater than or equal to 3.5%.
- The design lane MU ADT is greater than or equal to 200 vehicles.
- The MU ADT for turning vehicles on any one lane of the intersection is greater than or equal to 200 vehicles. This also applies to sharp turning movements that are not under stop control.

Pavement types for high-stress intersections are limited to either of the following materials:

- PCC, or
- HMA $N_{\text{design}} \geq 90$ with polymer-modified binders.

Use these materials a minimum of 150 ft back from the location of the stop bar. The maximum length normally will be the length of the turn lane plus the taper. A greater length is permitted if a capacity study indicates a greater queue length.

If an existing intersection exhibits rutting and shoving of the HMA surface material, consider complete replacement rather than resurfacing the intersection.

54-1.05(b) Distress Treatment at Other Intersections

Intersections not meeting the criteria in Section 54-1.05(a) are not considered high-stress intersections. Nevertheless, they may exhibit, or have the potential to exhibit, pavement distress similar to that exhibited at high-stress intersections.

At intersections that do not meet high-stress criteria where the existing pavement type is bare PCC, PCC may be used if the improvement consists of minor widening without resurfacing.

Those intersections that are not considered high-stress but have an HMA pavement type exhibiting distress (e.g., rutting, shoving) should be investigated to determine the cause. Procedures outlined in the Pavement Management and Evaluation Manual should be used to determine the suitability of the existing HMA pavement. If the existing material is found to be unsuitable, remove and replace the unstable material prior to resurfacing. If the investigation indicates a stable mixture but experience indicates a problem with flexible or composite

pavements, consider obtaining an exception to the criteria presented in Section 54-1.05(a). Example conditions which may allow an exception include the following:

- MU ADT less than 200 if all are required to stop or if the approach speed is greater than 40 mph.
- MU ADT less than 200 if the majority are fully loaded at intersections near warehouse facilities, landfills, grain elevators, etc.
- High levels of SU vehicles that are primarily fully loaded hauling vehicles (e.g., grain trucks, concrete trucks, coal trucks). In this case, the designer should add the SU ADT to the MU ADT.
- Demonstrated and repeated history of pavement life significantly below 15 years with shoving of an HMA overlay related to tight turning movements.

The above exceptions also apply to intersections not exhibiting distress if the intersection is being constructed or replaced. Any exception request needs Bureau of Research approval. Requests to use PCC pavement for intersections that are not high-stress and do not require an exception will be submitted for approval through the normal pavement selection process.

54-1.05(c) Side Road Approaches

The following will apply to the placement of pavement material at side road approaches:

- For side road approaches that have a surface type lower than HMA, surface the approach with HMA to the right-of-way line or to 50 ft beyond the edge of the traveled way, whichever is less.
- For side road approaches that have a surface equal to or greater than HMA, surface the approach with HMA to at least the edge of shoulder.

54-1.06 Interchange Ramps

The following will apply to the structural pavement design of interchange ramps:

1. Design Methodology. Use the mechanistic structural pavement design methodology for interchange ramp projects, regardless of whether or not the ramps are to be newly constructed, replaced, or widened. The minimum traffic criteria are given in Figure 54-1.B. Other pavement design methodologies (e.g., modified AASHTO designs, composite pavement designs) are rarely used for interchange ramp designs and will require Bureau of Research approval.
2. Ramp Pavement Type. Use a pavement type for interchange ramps that is the same as that of the contract being let for the mainline, except that ramps connected to entrance or exit ramp terminals shall be jointed PCC pavement if rigid pavement is used for the mainline.

3. Design Considerations. Typically, it is necessary to perform a structural pavement design for interchange ramps that is independent of that for the mainline pavement. Give adequate consideration to the requirements of high-stress locations during design.

54-1.07 Rest Areas

Design the rest area exit and entrance ramps, roadways, shoulders, and parking areas for the greater of: 1) the actual projected mainline 2-way ADT in the design year using $P=16\%$ and $S=M=25\%$, or 2) the interstate/freeway minimums assuming lane distribution of $P=32\%$ and $S=M=45\%$. Use a pavement type for rest areas that is the same as that of the contract being let for the mainline, except use jointed PCC pavement if rigid pavement is used for the mainline. The concentration of heavy trucks braking on the ramps and inner roadways and the sharp turning maneuvers to enter parking stalls require these facilities to be considered high-stress locations. If HMA is used for the pavement material, it may require a polymer modified asphalt binder and/or special mixture design. See Sections 54-1.05(a) and 54-1.06 for additional information. Design the shoulders to the same thickness and material as the pavement as shown in Figure 16-1.H.

54-1.08 Weigh Stations

Design the weigh station ramps and detention parking area to provide the same structural capacity as the adjacent freeway. Weigh stations are, by definition, high-stress locations for pavement design purposes. When flexible or composite pavements are selected, apply modifications to the HMA mixtures to the driving lane pavements beginning 2,500 ft upstream of the exit ramp terminal stub, and downstream to a point 2,500 ft beyond the entrance ramp terminal stub, as well as throughout all pavements in the weigh stations and ramps. See Section 54-1.05(a) for additional information.

Crossroad	Design Traffic Criteria	Lane Distribution Criteria	Traffic Factor Equation	
			Rigid	Flexible
Interstate or Freeway	Actual Ramp Traffic Projection for Design Year	PV = SU = MU = 100% in Design Lane of Ramp (assuming a 1-lane ramp)	54-4.1	54-5.1
	Greater of: Interstate/ Freeway Minimum Traffic (Figure 54-2C)			
Other State Marked Route or Unmarked Route	Actual Ramp Traffic Projection for Design Year	Same distribution as used for the Design Lane of the Crossroad (Figure 54-2B)	54-4.1	54-5.1
	Greater of: Marked Route Minimum Design Traffic (Figure 54-2C)			

¹ Use the highest traffic factor of any ramp at a given interchange for all ramps at that interchange.

DESIGN TRAFFIC CRITERIA FOR INTERCHANGE RAMPS¹

Figure 54-1.B

54-2 BASIC DESIGN PARAMETERS (Mechanistic)

54-2.01 Development of Design Procedures

54-2.01(a) General

See Section 54-1.03(a) for a brief discussion of the mechanistic structural pavement design methodology.

54-2.01(b) Design Period

The level of traffic and type of facility to be constructed affect the selection of the design period. Generally, it is desirable to design highway pavements to carry traffic without necessitating the need for major rehabilitation for a period of 20 years. However, it may be advantageous to design lesser roadways (e.g., frontage roads) for shorter periods. Use the following guidelines when selecting an appropriate design period:

1. New Construction/Pavement Replacement Projects. For new construction/pavement replacement projects, see the following sections for the appropriate design period:
 - Rigid Pavement: Mechanistic Design — Section 54-4.01(e),
 - Rigid Pavement (CRCP only): Modified AASHTO Design — Section 54-4.02(b),
 - Flexible Pavement: Mechanistic Design — Section 54-5.01(e), or
 - Composite Pavement Design: Modified AASHTO Design — Section 54-6.02.
2. Widening Projects. Use the following guidelines when selecting the design period for widening projects:
 - a. Widening Without Resurfacing. Use a design period of 20 years.
 - b. Widening With Resurfacing. Use the Department's policy for the thickness of the resurfacing. Use a design period of 20 years for the total thickness of the widening.

54-2.01(c) Structural Design Traffic

Structural design traffic is an estimate, based on ADT, of the volume of PV, SU, and MU vehicles that will be in the design lane in the year that is one-half the design period from the established date of construction. For example, if the design period is 20 years, the structural design traffic will be projected for the year which is 10 years from the established date of construction. In all IDOT pavement design procedures, structural design traffic is used to calculate a traffic factor (i.e., a factor representing the anticipated traffic load in the design lane on the pavement structure). However, the procedures and equations used to calculate the traffic factor differ among pavement types (rigid pavements or flexible pavements). Use the following procedures to determine structural design traffic:

1. Estimate ADT of PV, SU, and MU Vehicles. Vehicular classification and traffic volume projections for structural design traffic are based on available traffic data (i.e., ADT). ADT

and vehicular classification data for various roadway classes may be obtained from published IDOT traffic maps. Contact the district Programming Section for traffic data. If traffic data is unavailable or if published data is dated or does not appear to reflect known conditions or field observations (e.g., land uses, directional distributions), traffic volume and classification studies may be needed to establish a representative base of existing conditions. Factors that compound annual growth typically are used in traffic projections. Other methodologies may apply. It is important to consider any future land development or land use changes that may affect the volume or composition of traffic that will use the facility. If vehicular classification data is not available for Class III or Class IV facilities, use the percentages in Figure 54-2.A to estimate the number of PV, SU, and MU vehicles from ADT. Also, give consideration to the potential impacts of heavily loaded vehicles, especially in areas near mines, grain elevators, factories, and river ports. It may be necessary to specifically design for such vehicles (see Section 54-2.01(e)).

Facility Class	Percent of Total ADT		
	PV	SU	MU
Class III	88%	7%	5%
Class IV	88%	9%	3%

**VEHICULAR CLASSIFICATION FOR STRUCTURAL DESIGN TRAFFIC
(Class III and Class IV Facilities)**

Figure 54-2.A

2. Assign Traffic to Design Lane. Although the sum of the PV, SU, and MU vehicular volumes determined in Step 1 represents the total ADT that will be carried by the highway facility in the year of the projection, the structural design of the pavement will be based on the lane which carries the greatest number of SU and MU vehicles (i.e., the design lane). Use the distribution factors in Figure 54-2.B to estimate the number of PV, SU, and MU vehicles that will be in the design lane. Use the total two-way ADT for multilane facilities when calculating the structural design traffic as the distribution factors account for directional traffic and the percentage of vehicles in the design lane. For example, if the total projected ADT for a rural 4-lane facility determined in Step 1 includes 300 MU vehicles, the estimated number of MU vehicles in the design lane will be 135 (i.e., $300 \cdot 0.45$). Note that the design lane distribution factors in Figure 54-2.B are based on previous traffic studies under average conditions. Unusual traffic control or design features may influence lane usage (e.g., lane restrictions of commercial vehicles, relatively close interchange spacing). Give consideration to such factors before applying the distribution factors in Figure 54-2.B. Adjustments may be necessary. Contact the Bureau of Research for additional guidance.

Number of Facility Lanes	Percent of Total Vehicular Class Volume (ADT) in Design Lane					
	Rural			Urban		
	PV	SU	MU	PV	SU	MU
2 or 3*	50%	50%	50%	50%	50%	50%
4	32%	45%	45%	32%	45%	45%
≥ 6	20%	40%	40%	8%	37%	37%

*One-way roads and streets.

DESIGN LANE DISTRIBUTION FACTORS FOR STRUCTURAL DESIGN TRAFFIC

Figure 54-2.B

- Determine Actual Structural Design Traffic. Steps 1 and 2 above are used to estimate the actual structural design traffic. The actual structural design traffic is used to calculate an actual traffic factor, which is a number representing an estimate of the total ESALs that will be in the design lane on the pavement structure during the design period. Unless other minimum criteria apply (e.g., see Item 4), this traffic factor will be used to design the entire pavement structure. In all IDOT pavement design methodologies it is necessary to calculate an actual traffic factor. There are two different sets of traffic factor equations, one for rigid and composite pavements and one for flexible pavements. Section 54-4.01(g) applies to rigid mechanistic, rigid modified AASHTO, and composite pavement designs. Section 54-5.01(g) applies to flexible pavement designs using either the mechanistic or modified AASHTO methodologies.
- Determine Minimum Structural Design Traffic. The concept of using minimum structural design traffic to determine a minimum traffic factor applies only to mechanistic pavement designs. The minimum traffic factor is a factor that represents a minimum threshold below which the Department will not permit lesser pavement designs and is based on a set of minimum SU and MU vehicular volumes which are obtained from Figure 54-2.C. Figure 54-2.C applies to mechanistic designs of both rigid and flexible pavements. To obtain the minimum structural design traffic, enter Figure 54-2.C and select the set of minimum SU and MU vehicular volumes for the type of facility being designed, regardless of actual design traffic. Use the procedures discussed in Step 2 to distribute the minimum volumes obtained from Figure 54-2.C and determine the number of SU and MU vehicles in the design lane. The SU and MU vehicles assigned to the design lane will be used to calculate the minimum traffic factor. The minimum traffic factor is calculated in the same manner as the actual traffic factor calculated in Step 3. The only difference is that minimum, not projected actual, traffic volumes are used. The greater of the two traffic factors, actual or minimum, will be used to perform the mechanistic design of the pavement structure. Note that mechanistic designs of flexible pavements for unmarked routes have an overriding absolute minimum traffic factor of 0.5. For example, if the actual traffic factor calculated in Step 3 is less than the calculated minimum traffic factor, and the calculated minimum traffic factor is less than 0.5, the absolute minimum traffic factor of 0.5 will be used in the mechanistic design of the flexible pavement.

Facility Type	PV ①	SU ①	MU ①
Class I Interstates and Freeways	0	500	1500
Class I Other Marked State Routes	0	250	750
Class II, III, and IV Marked State Routes	0	250	750
Class I, II, III, and IV Unmarked State Routes	Use Actual Volumes ②		

Notes:

- ① *The minimum vehicular class volumes presented in Figure 54-2.C are given as ADT (i.e., two-way traffic) and must be assigned to the design lane using the procedures described in Step 2 in Section 54-2.01(c).*
- ② *Mechanistic designs of flexible pavements have an overriding absolute minimum traffic factor of 0.5. See Step 4 in Section 54-2.01(c).*

**MINIMUM VEHICULAR CLASS VOLUMES FOR STRUCTURAL DESIGN TRAFFIC
(Mechanistic Design: Rigid and Flexible Pavements)**

Figure 54-2.C

54-2.01(d) Mixed-Traffic Axle Loadings

To evaluate the effects of mixed-traffic axle loadings on pavement performance, a system was developed to convert these loadings into a traffic factor. The traffic factor represents the total number of 18-kip ESALs, expressed in millions, that a given pavement may be expected to carry throughout its entire service life.

In developing this system, equivalency factors for various groupings of single-axle and tandem-axle loadings were determined from the AASHO Road Test equations, statewide weigh survey data, and classification counts at weigh stations. The equivalency factor for any given single-axle or tandem-axle load expresses the number of 18-kip single-axle load applications that is equivalent in effect upon pavement performance to one application of the given axle load.

In determining the number of 18-kip ESALs that represents one application of each of the three classes of vehicles (i.e., PV, SU, and MU), consideration must be given to the differences in average axle weights of both SU and MU trucks operating on various highways (e.g., high volume major highways with heavy commercial truck traffic, low volume farm-to-market highways). Highways were divided into four general classifications to reflect these differences in average axle loads. Because rigid and flexible pavements respond differently to axle loadings, the equivalency factors reflect these differences. The 18-kip equivalencies per vehicular classification for Class I through Class IV roads and streets are presented in this chapter for each design methodology.

In areas that include mines, grain elevators, factories, river ports, and landfills, the impacts of heavily loaded SU and MU vehicles may become significant. See Section 54-2.01(e) for additional information on designing for heavily loaded vehicles.

54-2.01(e) Heavily Loaded Vehicles and High Volume Truck Routes

The equivalency factors for SU and MU vehicles that are incorporated in the IDOT pavement design methodologies presented in this chapter assume that traffic on the roadway is a typical mix of fully loaded, partially loaded, and empty vehicles. See Section 54-2.01(d) for additional information on equivalency factors for mixed-traffic axle loadings. Highway sections in some areas of the State provide access to businesses that utilize fully loaded trucks. Using typical SU and MU equivalency factors often will result in an inadequately designed pavement section. It only requires an increase in gross vehicle weight of approximately 10% to double the resulting damage to the pavement. Failure to consider the effects of heavily loaded vehicles can reduce pavement life significantly, in some cases by as much as one-half. It is therefore important to seriously evaluate pavement designs that will accommodate heavily loaded vehicles.

Typically, operations that involve moving bulk commodities and hauling large quantities of materials to and from ports and other locations use heavily loaded vehicles. Such operations may include mining operations, grain terminals, factories, river ports, landfills, etc. In general, designs should be adjusted where heavily loaded vehicles comprise 10% or more of the design truck traffic. The designer should refer to the Bureau of Research document *Pavement Technology Advisory PTA-D1: Designing for Heavily Loaded Vehicles*. If needed, contact the Bureau of Research for assistance in analysis of traffic and pavement sections.

When determining the type of pavement to be constructed, first calculate the rigid traffic factor. Projects with a rigid traffic factor greater than 60 should typically use continuously reinforced concrete pavement as discussed in Section 54-4.02(a). If a district has a project with a rigid traffic factor greater than 60 and another pavement type is desired (e.g., match adjacent cross-sections, ease of construction, etc.), the Bureau of Research must approve the design.

54-2.01(f) Roadbed Soils

Subsurface exploration is an essential part of the engineering survey for highway location and design. It includes soils investigation, sampling, testing, identification, and distribution with respect to the horizontal and vertical alignment of the highway. USDA county soils reports often are used in preliminary geotechnical investigations and in developing soil sampling surveys. Roadbed soil types, problem areas, recommendations, and corrective measures are compiled by the geotechnical engineer in the project geotechnical report, which will become a project design document for incorporation in the project plans and specifications. Consider the following guidelines when evaluating the need for subgrade improvements:

1. Importance of Subgrade Stability. Subgrade stability plays a critical role in the construction and performance of a pavement. Pavement performance is directly related to the physical properties of the roadbed soils and the materials used in the pavement structure. Subgrade stability is a function of a soil's strength and its behavior under repeated traffic loadings. Both properties significantly influence pavement construction operations and the long-term performance of the pavement structure. The pavement subgrade should be sufficiently stable to:
 - prevent excessive rutting and shoving during construction;

- provide uniform support for placement and compaction of pavement layers;
 - minimize impacts of excessive volume change and frost;
 - limit pavement resilient (i.e., rebound) deflections to acceptable limits; and
 - restrict permanent deformation during pavement service life.
2. Department Policy. A subgrade that provides a stable working platform will minimize rutting and moisture related problems resulting in effective construction and a smoother pavement. Department policy was established to ensure that the pavement subgrade, in situ or improved, will provide a stable working platform for all pavement construction. Most Illinois soils are not capable of providing a subgrade that meets the criteria for a stable working platform. Although the negative effects of less satisfactory soils can, to some degree, be reduced by increasing pavement structure thickness, it usually is necessary to treat in situ soils to ensure adequate subgrade support for construction equipment operations and for the placement and compaction of pavement layers. At a minimum, it is required that a 12 in. improved subgrade layer be provided. Where in situ soils are found to be inadequate such that the 12 in. improved subgrade layer will not provide a stable working platform, the designer should include provisions to address the need for deeper treatment or removal and replacement per the *IDOT Subgrade Stability Manual*).
3. Design Considerations. Mechanistic structural pavement designs will provide structurally adequate pavements that are suited to local conditions and material selection. The mechanistic design methodology for both rigid and flexible pavement types assumes that a stable subgrade is present (in situ or improved) and that, if improved, the subgrade is constructed with the highest quality material. The subgrade, however, is not given additional credit during design nor is the cost of providing an improved subgrade included in the pavement selection process. If it is determined that an improved subgrade layer is needed to provide a stable working platform, no change will be made to the subgrade support rating that is used during design (see Item 4). For additional design guidance on providing a stable working platform, see the *IDOT Subgrade Stability Manual*. Provisions must be made for the entire thickness of the binder to be completed in a single construction season once the improved subgrade layer is in place. The Department has experienced repeated springtime pavement failures during construction of partially completed sections that have been exposed to winter conditions. Provisions for staging/completion may need to be used to prevent large sections of partially completed pavement being abandoned due to winter shutdown.

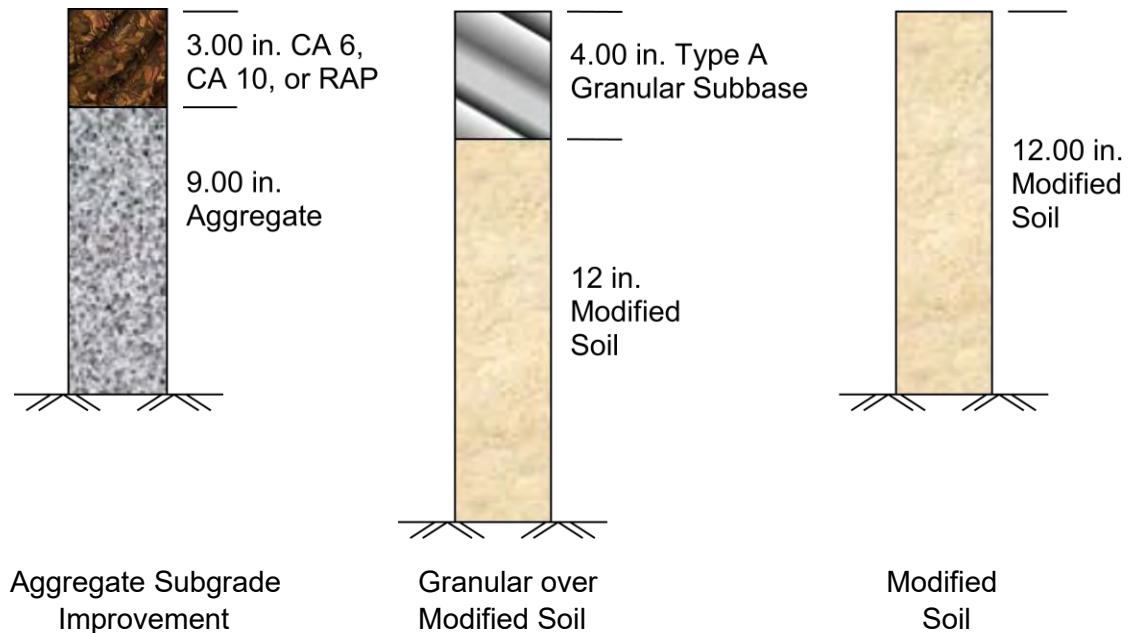

**TREATMENT OPTIONS FOR IMPROVED SUBGRADE
(Mechanistic Design: Rigid and Flexible Pavements)**

Figure 54-2.D

4. Soils Evaluation (Subgrade Support Rating — SSR). Mechanistic pavement design procedures require that subgrade support ratings be determined for the project's in situ soils. These SSR values will be used to design the pavement structure. SSRs are based on information provided in the project geotechnical report. There are three SSR categories (i.e., poor, fair, and granular). Based on the percent clay, silt, and sand found in the in situ soil, SSR values are obtained from Figure 54-2.E. Note that Figure 54-2.E already assumes a high-water table and appropriate frost penetration. All project soils will be evaluated by the district geotechnical engineer to determine and verify what, if any, subgrade treatment is needed. It also is the responsibility of the geotechnical engineer to provide the designer with SSRs and their application limits within the project. Each SSR in the soils report will represent the average soil conditions within the specified limits of the project. For small projects, in the absence of laboratory tests, SSR values may be estimated using USDA county soils reports.

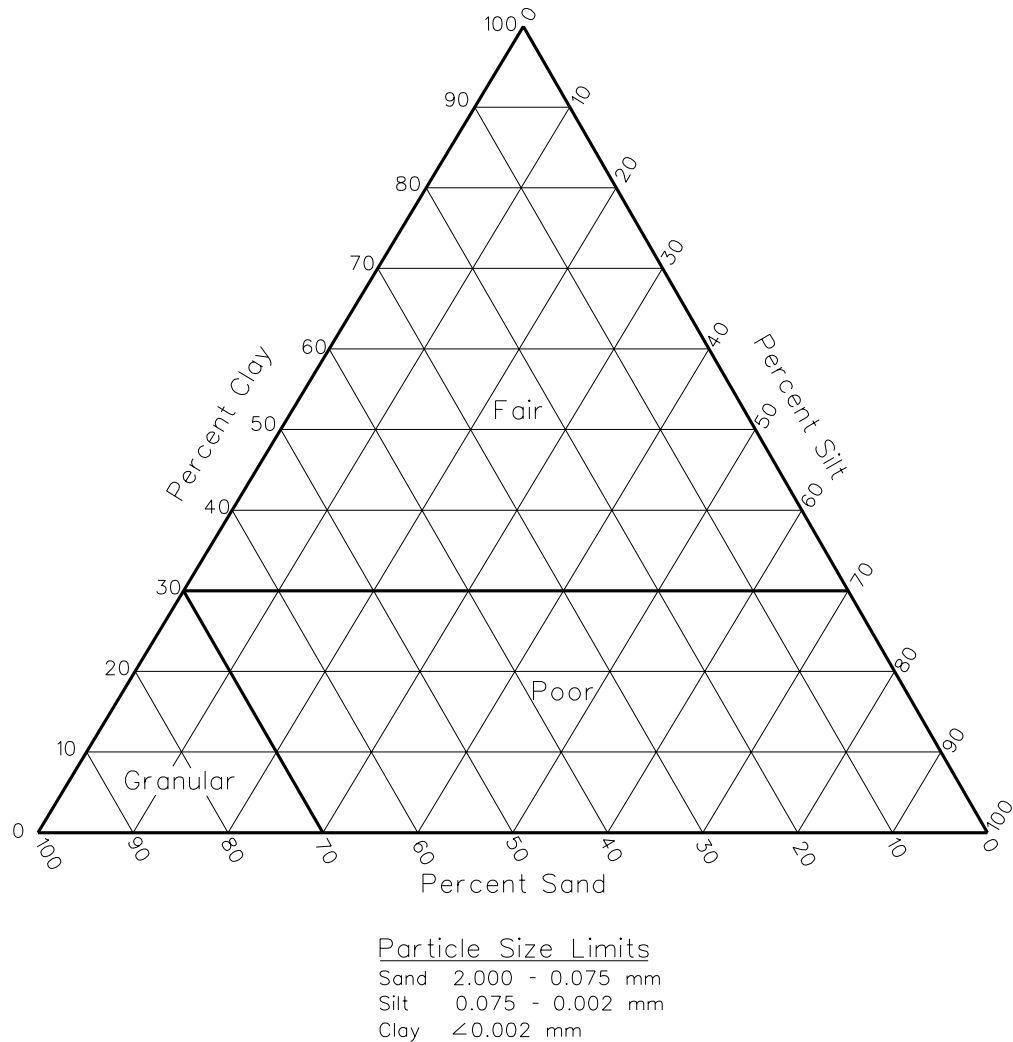

**SUBGRADE SUPPORT RATING (SSR)
(Mechanistic Design)**

Figure 54-2.E

5. Policy Deviations. Typical Illinois soils have poor to fair SSR values and require an improved subgrade layer. Although infrequent, an in situ soil (e.g., granular) may be found at a project location that will provide a stable working platform without improvement. Where marginally adequate soils are found, the district geotechnical engineer may recommend something less than a 12 in. thick improved subgrade layer. On the other hand, the geotechnical report may recommend a thicker improved subgrade layer. Where an improved subgrade layer is needed to provide a stable working platform, any deviation from the 12 in. thickness criteria must be supported by the geotechnical engineer,

documented in the project geotechnical report, and approved by the Bureau of Research. In such cases, ensure that supporting conclusions and recommendations are adequately documented in the pavement design submittal.

6. Subgrade Improvement Alternatives. Where the in situ soil has an SSR value of either poor or fair, the subgrade shall be improved to the required depth using the allowable alternatives shown in Figure 54-2.D.

Consider the following when selecting from these alternatives:

- a. Typical Treatment. Where required, lime modification typically is used for the improved subgrade layer.
- b. Non Lime-Reactive Soils. Where in situ soils are found to not react with lime or by-product lime (e.g., organic and sandy soils), cement or fly ash modification typically is used for the improved subgrade layer. Laboratory testing may be required to determine the ability of cement or fly ash to be used as a modifier.
- c. Urban Areas. For dust control in urban areas, granular material may be specified for the improved subgrade layer.
- d. Granular Material Availability. If granular material is readily available, the district may elect to specify aggregate subgrade improvement in lieu of typical treatments. This decision will be made on a case-by-case basis.
- e. Alternatives Analysis. For the subgrade treatments being considered, determine the appropriate construction parameters for the subgrade alternatives analysis. This may include the following:
 - required thickness of the improved subgrade layer;
 - percentage of lime, by-product lime, fly ash, or cement required; and/or
 - required depth of undercut and granular backfill.

Base the decision for selecting the subgrade treatment on factors that include material availability, constructability, economics, permanence of treatment, and pavement performance benefits. Select the alternative for the improved subgrade layer that is best suited for the project.

7. Embankment Settlement. Underlying soils can settle under the weight of a newly constructed embankment resulting in differential settlement and/or embankment failures. The settlements are expensive to fix and can result in pavement dips. For all classes of roads and streets, construction should be sequenced to assure that earthwork is completed during one construction season and that paving is initiated the next. If this cannot be accomplished with some degree of certainty, include special provisions in the contract that will assure adequate embankment settlement prior to subsequent pavement layers being placed. Consult the district geotechnical engineer for guidance in preparing such special provisions.

54-2.02 Structural Design

To select the proper type and thickness of mainline pavement for a particular project, first determine the following:

- the volume and composition of traffic to be carried by the pavement,
- the length of time the pavement is to service this traffic,
- the strength characteristics of the subgrade soils and pavement materials, and
- the minimum quality of service to be provided by the pavement during its lifetime.

See Section 54-1.06 for information on pavement designs for interchange ramps. Pavement designs for rest areas and weigh stations are discussed in Sections 54-1.07 and 54-1.08, respectively.

54-2.03 Limitations and Requirements

54-2.03(a) General

The procedures that are presented in this chapter will allow the designer to select an economically optimal pavement design that is most capable of carrying the anticipated traffic. To ensure that the selected design is both practical and adequate, the following sections present policy limitations and requirements that must be considered.

54-2.03(b) Adherence to Specifications

The design procedures that are presented in this Chapter are based on the assumption that material requirements, mixture designs, and construction procedures and controls will be in accordance with current IDOT specifications and practices. To ensure satisfactory performance, the strengths of structural components that are assumed during design must be achieved during construction. These strengths should be shown on the cover sheet or typical cross-sections of the plans, along with the structural design traffic; the percentage breakdown of the structural design traffic for PV, SU, and MU vehicles; the percentage of these vehicles in the design lane; and the SSR or IBR values of the roadbed soils. See Section 63-4.05 for additional information on placing structural design traffic on plans.

54-2.03(c) Structural Design Traffic

The equations used to convert structural design traffic into 18-kip ESALs are based on an average distribution of vehicle types and axle loadings and are directly applicable to most roads and streets. However, cases will arise in which these equations should not be used, and a special analysis will be necessary. One such case would be that involving a highway adjacent to an industrial site where the commercial vehicles entering and leaving the site generally travel empty in one direction and fully loaded in the other. Contact the Bureau of Research for assistance. It will be necessary for the district to furnish the structural design traffic and weight and classification count data in sufficient detail to permit a determination of the distribution of commercial vehicle types and the single-axle and tandem-axle loadings within each type. See Section 54-2.01(e) for additional information on designing for heavily loaded vehicles.

54-2.03(d) Terminal Service Level

At the end of the design period, the serviceability level of the pavement can be expected to have been reduced to a value of 2.5 for Class I roads and streets and to 2.0 for Class II, Class III, and Class IV roads and streets, and the pavement should be considered eligible for rehabilitation. The design period may or may not be the actual service life of the pavement. The actual service life may be longer or shorter than the design period depending upon the conditions under which the pavement actually serves and the conditions assumed for the design. Highly significant are the differences between the structural design traffic and the actual traffic carried by the pavement, and the difference between the design terminal serviceability level and the actual serviceability level at which the pavement is structurally upgraded.

54-3 BASIC DESIGN PARAMETERS (Modified AASHTO)**54-3.01 Development of Design Procedures****54-3.01(a) General**

See Section 54-1.03(b) for a brief description of the modified AASHTO design procedures.

54-3.01(b) Design Period

Section 54-2.01(b) applies to the modified AASHTO design procedures.

54-3.01(c) Structural Design Traffic

Section 54-2.01(c) applies to the modified AASHTO design procedures, except for the requirement of calculating a minimum traffic factor based on minimum structural design traffic.

54-3.01(d) Mixed-Traffic Axle Loadings

Section 54-2.01(d) applies to the modified AASHTO design procedures.

54-3.01(e) Heavily Loaded Vehicles

Section 54-2.01(e) applies to the modified AASHTO design procedures.

54-3.01(f) Roadbed Soils

Section 54-2.01(f) does not apply to the modified AASHTO design procedures. The following material specifically relates to the modified AASHTO design methodology.

An A-6 (9-13) type of roadbed soil was used throughout the entire embankment of the AASHO Road Test Project. Because only one soil type was taken into consideration in the AASHO Road Test, it was necessary to modify the AASHO Road Test equations so that pavement thicknesses could be developed for other soil types. The modification makes use of the Illinois Bearing Ratio (IBR) of the soil, which is the only soil support value normally determined by the Department for modified AASHTO designs. Other soil strength test procedures can be used provided that the test results can be directly correlated with those obtained by the IBR test procedure.

The IBR selected for use in design should represent a minimum value for the soil to be used. Preferably, laboratory tests should be made on four-day soaked samples of the soils to be used in construction. It is recommended that a soil survey be made prior to all construction; however, when test data are not available, use the values presented in Figure 54-3.A.

Soil Classification	IBR
A-1	20
A-2-4, A-2-5	15
A-2-6, A-2-7	12
A-3	10
A-4, A-5, A-6	3
A-7-5, A-7-6	2

SUGGESTED IBR VALUES FOR VARIOUS SOIL CLASSIFICATIONS

Figure 54-3.A

Pavement performance is directly related to the physical properties and the support capacity of the materials used in the pavement structure and of the roadbed soils. The effect of less satisfactory soils, to some degree, can be reduced by increasing the thickness of the pavement structure, but it may be necessary to take other steps to ensure adequate pavement performance. The problems that can be encountered because roadbed soils are subject to permanent deformation, excessive volume changes, excessive deflection and rebound, frost susceptibility, and non-uniform support from wide variations in soil types within the State should be recognized in the design stage. Corrective measures should be included in the plans and in the special provisions for any and all small isolated areas of unsatisfactory soils. If such areas contain soils that are unsatisfactory for roadbed construction, the soils should be either removed and replaced with satisfactory soils or granular material or improved in-place with a suitable stabilizing agent. If such soils are unsatisfactory only from the standpoint of having an IBR less than the minimum selected for design, consider the following treatments:

- remove and replace with soils or granular material at or above the minimum value,
- remove and replace with additional subbase material to a depth that will compensate for the deficiency in support strength, or
- improve the material in-place with a suitable stabilizing agent.

See the IDOT *Subgrade Stability Manual* for further guidance.

54-3.02 Structural Design

Section 54-2.02 applies to the modified AASHTO design procedures.

54-3.03 Limitations and Requirements

54-3.03(a) General

Section 54-2.03(a) applies to the modified AASHTO design procedures.

54-3.03(b) Adherence to Specifications

Section 54-2.03(b) applies to the modified AASHTO design procedures.

54-3.03(c) Structural Design Traffic

Section 54-2.03(c) applies to the modified AASHTO design procedures.

54-3.03(d) Terminal Service Life

Section 54-2.03(d) applies to the modified AASHTO design procedures.

54-4 STRUCTURAL DESIGN OF RIGID PAVEMENTS

54-4.01 Mechanistic

54-4.01(a) Limitations

Jointed plain concrete pavement (JPCP) thickness designs may be obtained for thicknesses up to 12 in. and for traffic factors up to approximately 100. For traffic factors above 60, CRCP should typically be used, see Section 54-4.02 for design procedures. The use of doweled joints will be required for pavement thicknesses that are 7 in. and greater on all Class I, Class II, and Class III roads and streets and Class IV marked roads and streets. Doweled joints will not be required for Class IV unmarked roads and streets. Recommended dowel diameters are given in Figure 54-4.A. If designs for traffic factors greater than 100 or for pavement thicknesses greater than 12 in. are desired, contact the Bureau of Research.

Pavement Thickness (T) (inches)	Nominal Dowel Diameter (inches)
10 and greater	1.5
8.01 thru 9.99	1.25
8 and less	1

RECOMMENDED DOWEL DIAMETERS

Figure 54-4.A

54-4.01(b) Application of Design Method

The mechanistic design procedures for rigid pavements enable the designer to determine the type and thickness of PCC pavement that are required to carry a specified volume and composition of traffic for a designated period of time while retaining minimum serviceability. Use the procedures presented in Section 54-4.01(j) to determine pavement type and thickness and provide a subbase in accordance with Section 54-4.01(h).

54-4.01(c) Edge Support Conditions

The mechanistic design methodology gives the designer the option of selecting from the following two-edge support conditions:

1. Tied Shoulder. The tied shoulder condition consists of a 12 ft paved lane that is tied with reinforcing steel to a PCC shoulder or curb and gutter.
2. Untied Shoulder. Any 12 ft pavement that is not positively tied with reinforcing steel to the shoulder or curb and gutter is considered an untied shoulder condition. An untied shoulder may consist of earth, aggregate, or HMA materials.

The selection of edge support has a pronounced effect on edge stresses and pavement thickness. Department policy dictates exclusive use of tied shoulders, unless otherwise approved by the Bureau of Research.

54-4.01(d) Joint Spacing Limitations

Joint spacing between panels may need to vary to accommodate adjacent pavements, drainage structures, etc. See the *Highway Standards* for typical designs. The mechanistic design procedures may be used to design pavement thickness for a nominal panel length of 15 ft, except Class IV unmarked roads and streets may use 12-ft joint spacing. The panel length may be adjusted ± 3 ft to accommodate discontinuities in pavement cross-section (e.g., intersections, medians). If designs for longer panel sections are required to match existing pavements, contact the Bureau of Research.

54-4.01(e) Design Period

The design period for all rigid pavements is typically 20 years.

54-4.01(f) Equivalency Factors

Section 54-2.01(d) describes the use of equivalency factors to convert mixed-traffic loadings to 18-kip ESAL applications. Equivalency factors for rigid pavements are presented in Figure 54-4.B. The factors in Figure 54-4.B were used to develop the traffic factor equations discussed in Section 54-4.01(g).

54-4.01(g) Traffic Factor

The traffic factor is the projected total 18-kip ESALs, expressed in millions, to be carried by the design lane during the design period. Based on the class of the facility, select the appropriate equation from Figure 54-4.C to calculate the traffic factor for rigid pavement designs. See Section 54-2.01(c) for information on structural design traffic.

Facility Class	18-kip ESAL Applications Per Vehicle		
	PV	SU	MU
Class I	0.0004	0.394	1.908
Class II	0.0004	0.372	1.554
Class III and IV	0.0004	0.355	1.541

EQUIVALENCY FACTORS (Rigid Pavements)

Figure 54-4.B

Facility Class	Traffic Factor Equation	Equation Number
Class I	$TF=DP \left[\frac{(0.15 \cdot P \cdot PV) + (143.81 \cdot S \cdot SU) + (696.42 \cdot M \cdot MU)}{1 \times 10^6} \right]$	Equation 54-4.1
Class II	$TF=DP \left[\frac{(0.15 \cdot P \cdot PV) + (135.78 \cdot S \cdot SU) + (567.21 \cdot M \cdot MU)}{1 \times 10^6} \right]$	Equation 54-4.2
Class III and Class IV	$TF=DP \left[\frac{(0.15 \cdot P \cdot PV) + (129.58 \cdot S \cdot SU) + (562.47 \cdot M \cdot MU)}{1 \times 10^6} \right]$	Equation 54-4.3

where:

- PV, SU, MU* = structural design traffic expressed as the number of PV, SU, and MU vehicles.
P, S, M = percent of PV, SU, and MU in the design lane expressed as a decimal.
DP = design period — typically 20 years.

TRAFFIC FACTOR EQUATIONS (Rigid Pavements)

Figure 54-4.C

54-4.01(h) Improved Subgrade and Subbase Type and Thickness

Thicknesses determined through the mechanistic design process assume that an adequate construction platform exists at the time of construction and it will perform adequately over the life of the pavement. The platform consists of an improved subgrade, and subbase when necessary. The requirements for the improved subgrade and subbase are as follows:

1. Improved Subgrade. The improved subgrade provides a stable construction platform for placement of the subsequent courses. All classes of roads and streets shall have an improved subgrade of the required thickness according to Section 54-2.01(f).
2. Subbase. The subbase serves two purposes. First, the subbase provides a separation layer between the rigid pavement and pumpable subgrade soils. Second, the subbase is there to resist erosion of the fine-graded soils during the service life of the pavement.

Treatment options for improved subgrade and requirements for subbase type and thickness are shown in Figure 54-4.D.

54-4.01(i) Designating Structural Information on Plans

See Section 63-4.05 for information on designating structural information on plans.

Facility Type	Subbase ①		Improved Subgrade Type ② ③
	Type	Minimum Thickness (inches)	
Class I Interstate / Freeway Other Marked Routes Unmarked Routes (TF ≥ 2.0) Unmarked Routes (0.7 < TF < 2.0) Unmarked Routes (TF ≤ 0.7)	HMA or PCC Stabilized HMA or PCC Stabilized HMA or PCC Stabilized Not required Not required	4 4 4 n/a n/a	ASI, GM, or MS ASI, GM, or MS ASI, GM, or MS ASI, GM ④ ASI, GM, or MS
Class II Marked Routes Unmarked Routes (TF ≥ 2.0) Unmarked Routes (0.7 < TF < 2.0) Unmarked Routes (TF ≤ 0.7)	HMA or PCC Stabilized HMA or PCC Stabilized Not required Not required	4 4 n/a n/a	ASI, GM, or MS ASI, GM, or MS ASI, GM ④ ASI, GM, or MS
Class III Marked Routes Unmarked Routes (TF ≥ 2.0) Unmarked Routes (0.7 < TF < 2.0) Unmarked Routes (TF ≤ 0.7)	HMA or PCC Stabilized HMA or PCC Stabilized Not required Not required	4 4 n/a n/a	ASI, GM, or MS ASI, GM, or MS ASI, GM ④ ASI, GM, or MS
Class IV Marked Routes Unmarked Routes (TF ≥ 2.0) Unmarked Routes (0.7 < TF < 2.0) Unmarked Routes (TF ≤ 0.7)	HMA or PCC Stabilized HMA or PCC Stabilized Not required Not required	4 4 n/a n/a	ASI, GM, or MS ASI, GM, or MS ASI, GM ④ ASI, GM, or MS

Notes:

- ① For urban sections containing curb and gutter and a storm sewer system, the designer may omit the stabilized subbase when an ASI or GM improved subgrade is used, regardless of the traffic factor.
- ② Improved Subgrade Types include:
 ASI - Aggregate Subgrade Improvement (minimum of 12 in.)
 GM – Granular over Modified Soil (4 in. CA 6 or CA 10 over 12 in. Modified Soil)
 MS – Modified Soil (minimum of 12 in.)
- ③ The minimum thickness of improved subgrade shall be according to Section 54-2.01(f).
- ④ Modified Soil may be used for the improved subgrade if a minimum 4-in. stabilized subbase is used.

**MINIMUM STRUCTURAL DESIGN REQUIREMENTS
 (Rigid Pavement: Mechanistic Design)**

Figure 54-4.D

54-4.01(j) Thickness Design Procedure

For a mechanistic design of a rigid pavement, use the following steps to determine thickness:

1. **Determine Traffic Factor.** Use the following procedures to determine the traffic factor:
 - a. Determine the facility class (e.g., Class I, II, III, or IV).
 - b. Determine the actual structural design traffic as described in Section 54-2.01(c).
 - c. Determine the minimum structural design traffic as described in Section 54-2.01(c) and Figure 54-2.C.
 - d. Based on the facility class, select the appropriate traffic factor equation from Figure 54-4.C.
 - e. Calculate the actual traffic factor.
 - f. Calculate the minimum traffic factor.
 - g. Compare the actual traffic factor to the minimum traffic factor and use the greater of the two as the traffic factor for design.
2. **Determine the SSR.** Determine the SSR as described in Section 54-2.01(f) (e.g., poor, fair, granular).
3. **Determine the Edge Support.** Determine the edge support condition to analyze as discussed in Section 54-4.01(c) (e.g., tied shoulder).
4. **Determine the PCC Thickness.** Use one of the following two procedures to determine the PCC thickness depending on the route class:
 - a. For all Class I, II, III, and IV marked roads and streets, and for Class I, II, and III unmarked roads and streets, use the following procedures:
 - (1) Based on the SSR (e.g., poor, fair, granular) determined in Step 2, select the appropriate rigid pavement mechanistic design chart from the following:
 - SSR = Poor, use Figure 54-4.E;
 - SSR = Fair, use Figure 54-4.F; or
 - SSR = Granular, use Figure 54-4.G.
 - (2) Within the design chart, select the curve that represents the edge support condition, either tied or untied.
 - (3) Enter the chart along the horizontal axis with the traffic factor determined in Step 1.

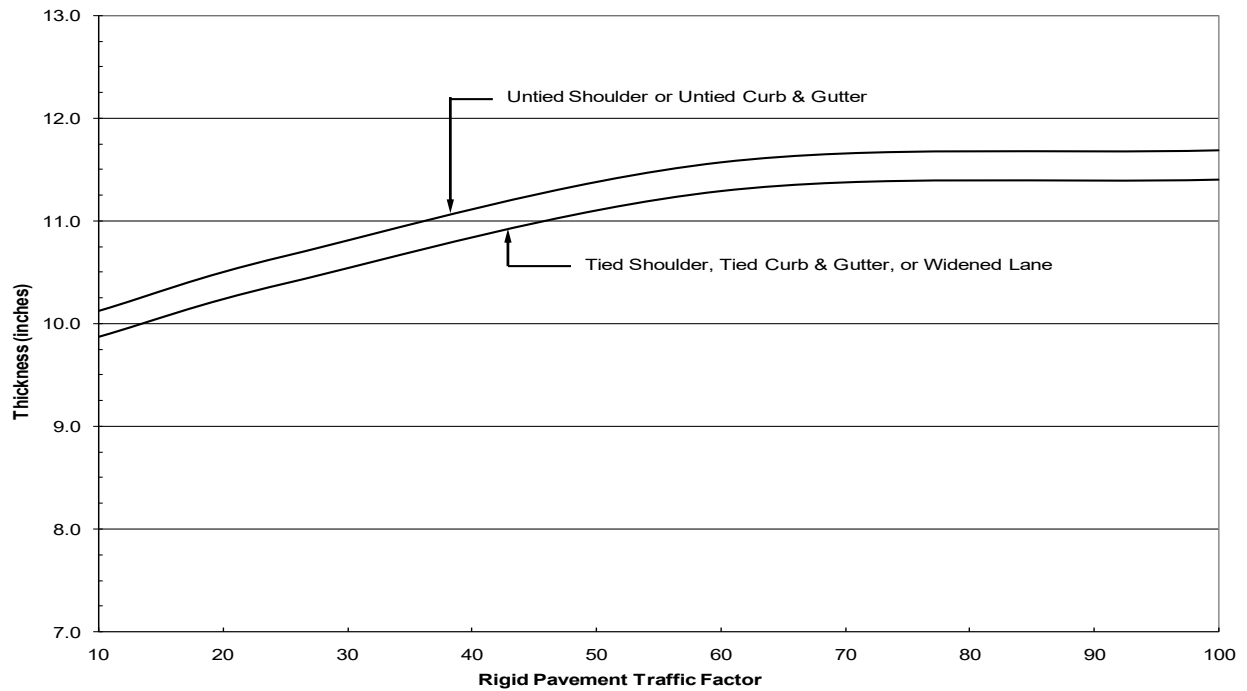
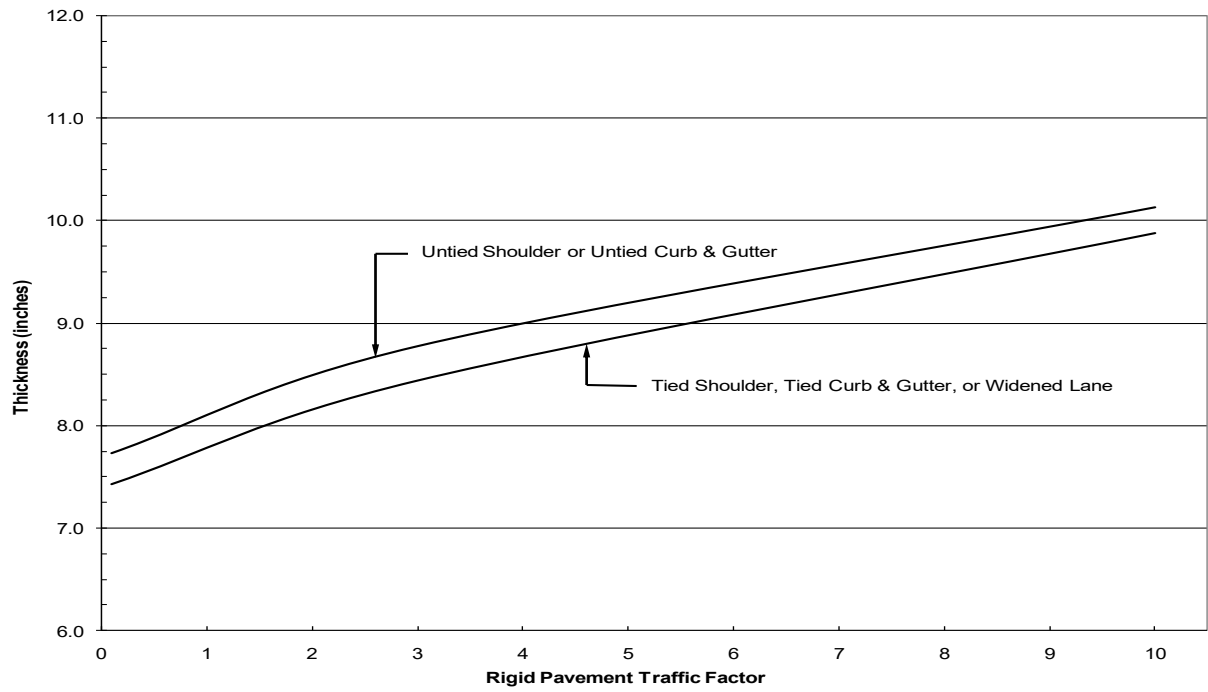

Note: Use of untied shoulder design requires Bureau of Research approval.

**RIGID PAVEMENT DESIGN CHART
(Mechanistic Design: SSR = Poor)**

Figure 54-4.E

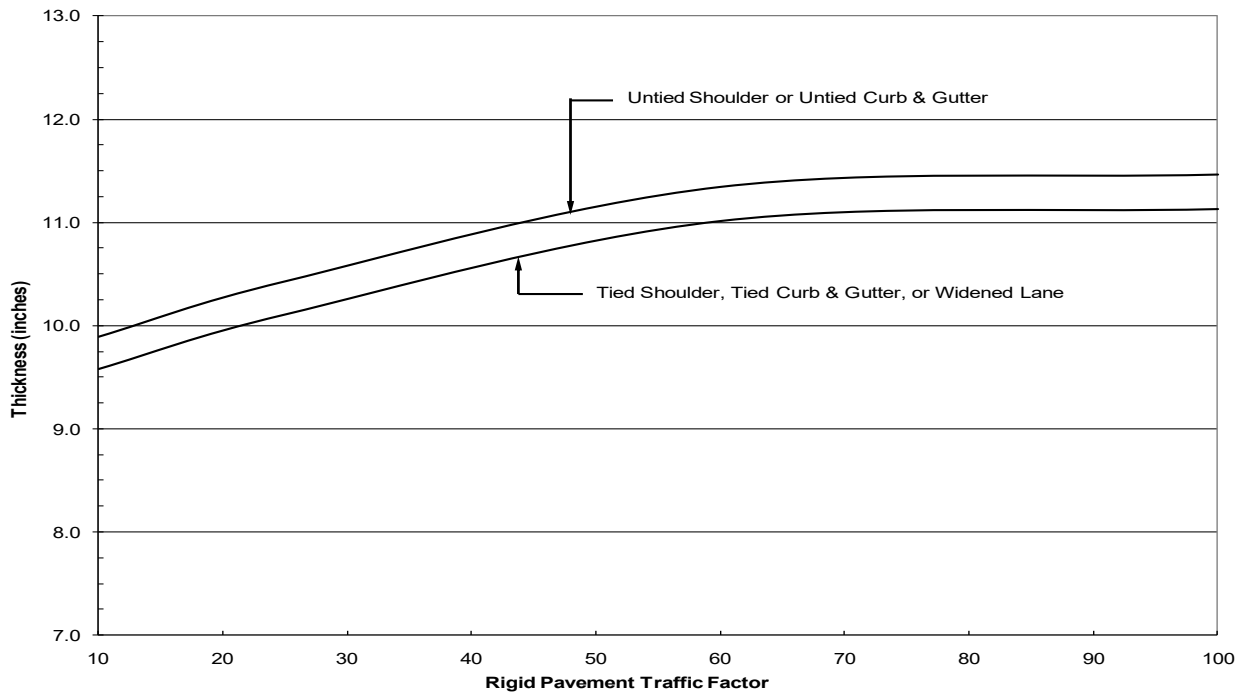
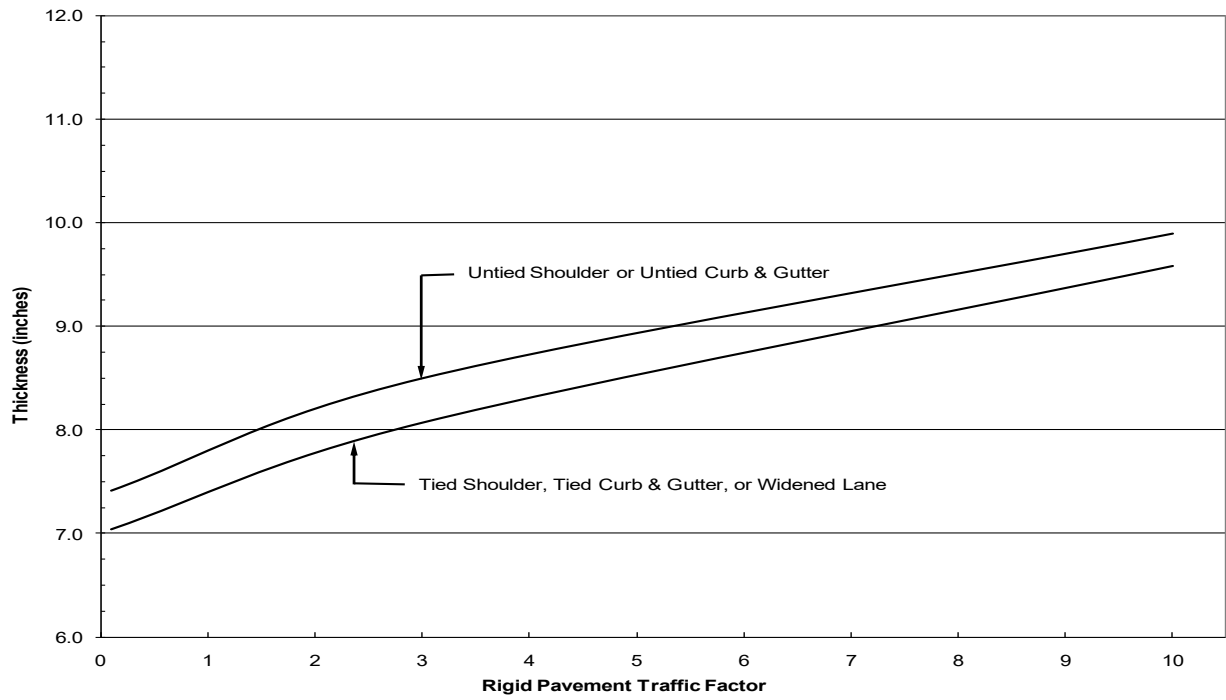

Note: Use of untied shoulder design requires Bureau of Research approval.

**RIGID PAVEMENT DESIGN CHART
(Mechanistic Design: SSR = Fair)**

Figure 54-4.F

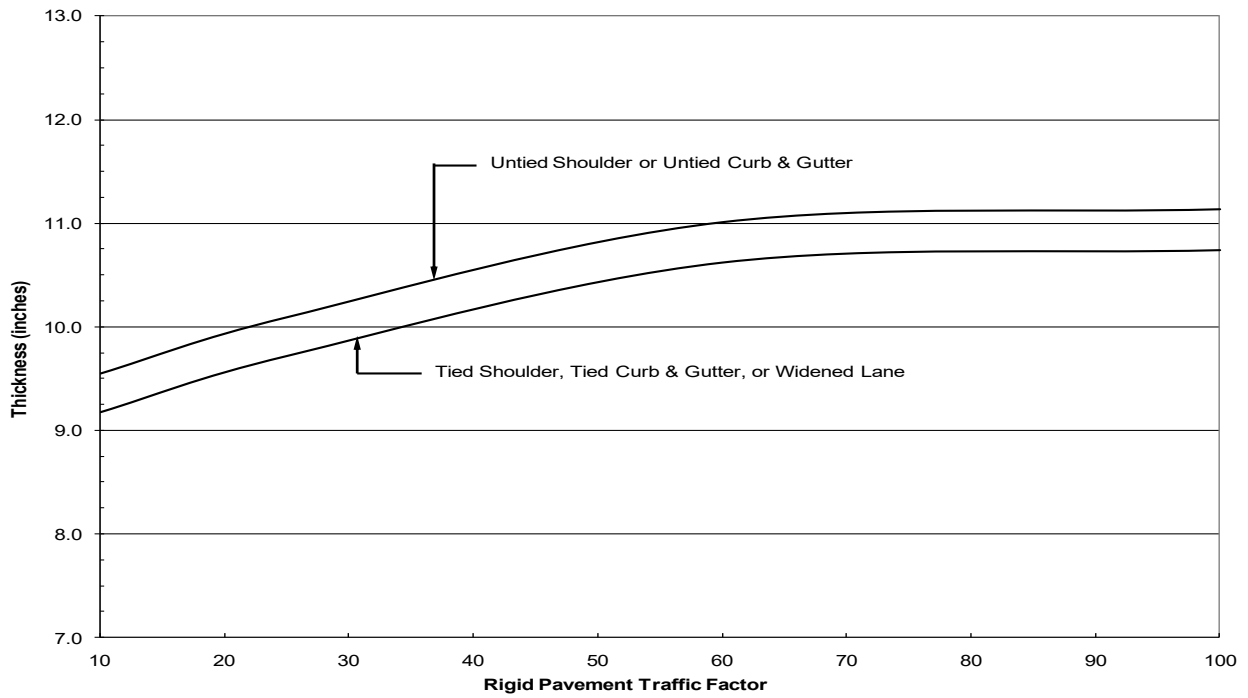
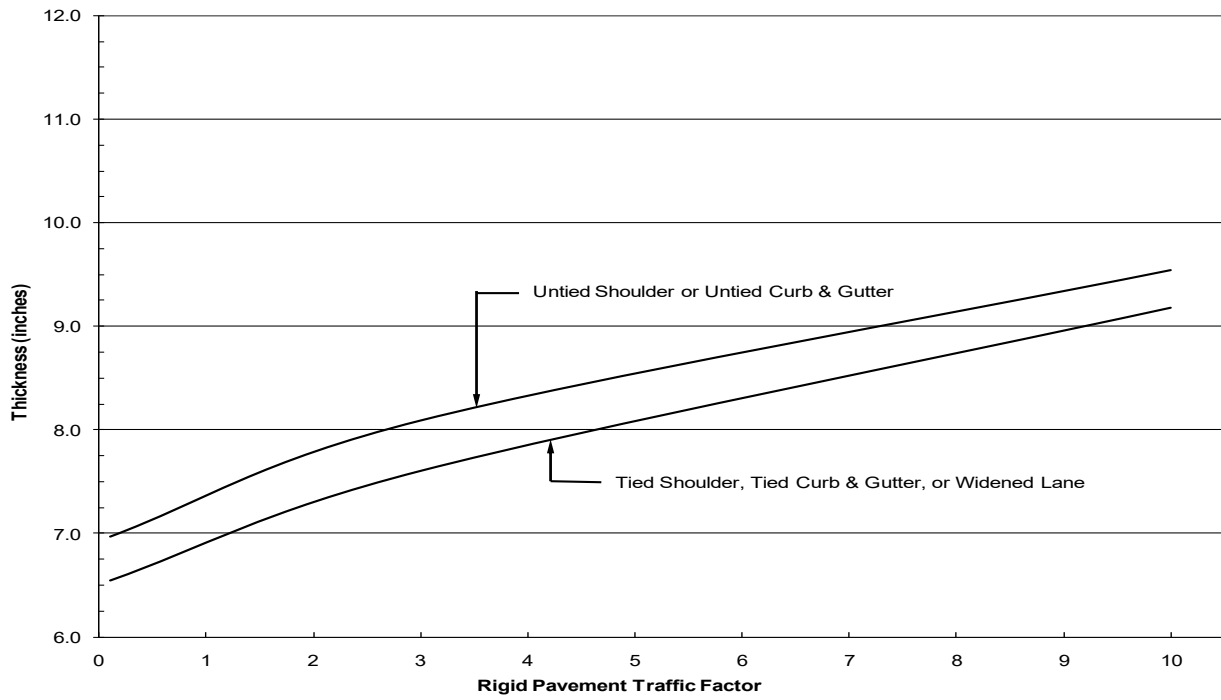

Note: Use of untied shoulder design requires Bureau of Research approval.

**RIGID PAVEMENT DESIGN CHART
(Mechanistic Design: SSR = Granular)**

Figure 54-4.G

- (4) Move up vertically until the curve selected in Step a.(2) is intersected.
 - (5) From the point of intersection, move left horizontally until the vertical axis is intersected.
 - (6) Read the thickness from the chart's vertical axis.
 - (7) Round the thickness up to the nearest 0.25 in.
- b. For Class IV Unmarked Routes, use the following procedures:
- (1) Determine the thickness according to Figure 54-4.H using the standard case of untied shoulders, no subbase, poor subgrade ($k=50$ psi/in.), panel length of 12 ft, and no dowels.

Traffic Factor	Thickness
0.025	6.75
0.05	7.00
0.10	7.25
0.50	7.50
1.00	7.75
2.00	8.00

**PCC PAVEMENT THICKNESS
CLASS IV UNMARKED ROADS AND STREETS**

Figure 54-4.H

- (2) Adjust the pavement thickness according to Figure 54-4.I to account for differences in the cross-section from the standard case.

Option Different from Standard Case	Thickness Adjustment (inches)
Tied Concrete Shoulders	- 0.25
4 in. Granular Subbase	none
4 in. Stabilized Subbase	- 0.25
15 ft Slab Length	+0.50
Fair Subgrade ($k = 100$ psi/in.)	- 0.25
Good Subgrade ($k = 200$ psi/in.)	- 0.50

**THICKNESS ADJUSTMENTS FOR
CLASS IV UNMARKED ROADS AND STREETS**

Figure 54-4.I

54-4.01(k) Shoulder Type/Design

For new construction or pavement replacement rural projects, use a tied rigid shoulder with all mechanistic rigid pavement designs. The thickness of the shoulder will either match the pavement thickness or vary uniformly from the pavement thickness to a 6 in. minimum at the outside edge.

54-4.01(l) Design Example

See Section 54-9 for a design example.

54-4.01(m) Typical Sections

Figures 54-4.J through 54-4.L illustrate typical rural and urban pavement sections of rigid designs for various types of highway facilities.

54-4.01(n) Joint Placement

The proper placement of pavement joints greatly affects the overall performance of the pavement. Where joints are not properly designed, uncontrolled cracking can occur. Features that can affect joint spacing are turn lanes, drainage blockouts, medians, intersecting side streets, etc. This is especially true at large intersections. It is imperative that the designer and the construction engineer pay particular attention to joint placement in these areas.

Designers should provide jointing details in the plans, and construction engineers should make every effort to follow the joint layout. In many cases, it will be necessary to adjust the normal 15 ft spacing used by IDOT to accommodate other features. Joint spacing may be adjusted ± 3 ft to match joints in intersecting pavements and/or to accommodate pavement discontinuities (e.g., drainage castings, median noses). In some cases, it also may be possible to adjust the location of pavement discontinuities so that they are located at a normal joint position. The American Concrete Pavement Association has published a bulletin entitled *Intersection Joint Layout*. Although this bulletin should not be construed as an IDOT policy or standard, it does contain helpful information on jointing intersections and can serve as a design reference.

The designer and construction engineer also must be aware of planned staged construction and its effect on joint layout. Where adjacent lanes are to be constructed in stages, it is important to plan the layout of the joints before any pavement is placed. Occasionally, new pavement is constructed adjacent to existing pavement that was designed using a different joint type and spacing. When this occurs, the designer must make provisions in the plans to match existing joints. A detailed joint survey prior to plan preparation can help eliminate problems during construction and throughout the life of the pavement.

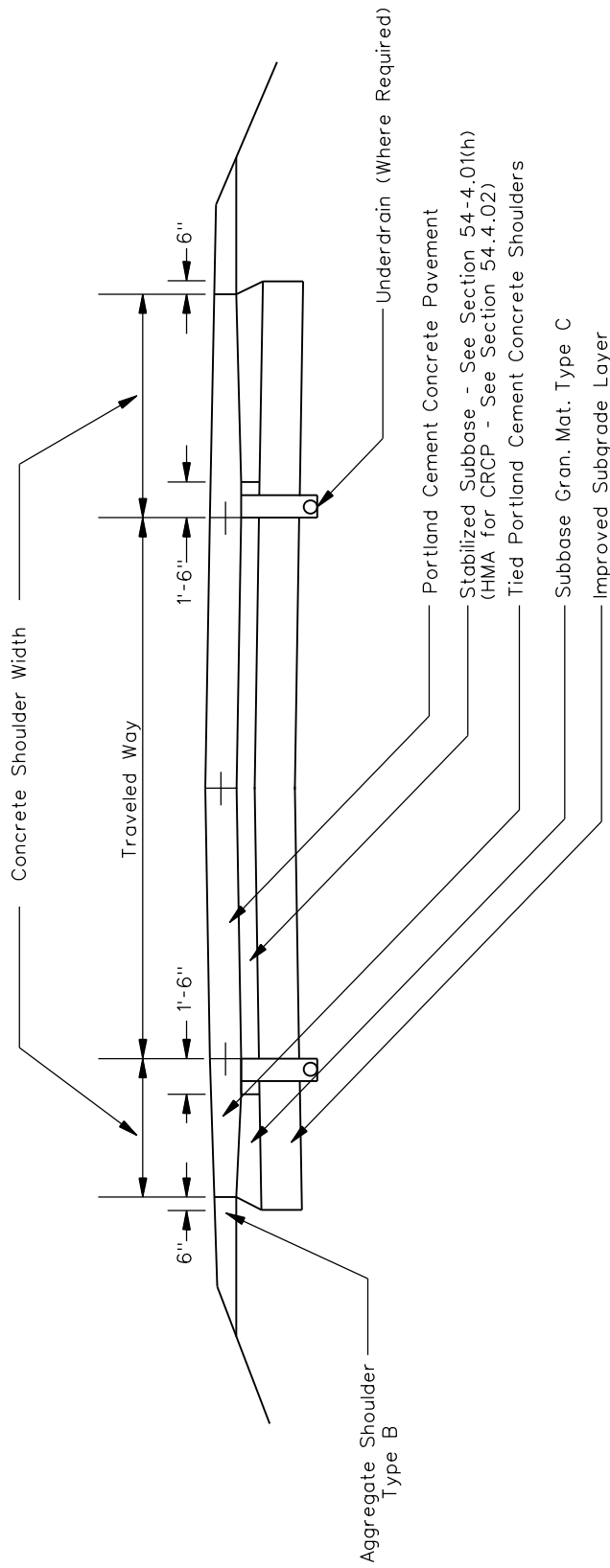

TYPICAL RURAL SECTION: RIGID DESIGN WITH TIED SHOULDER
(Trunk, Major Highways, Area Service Highways)

Figure 54-4.J

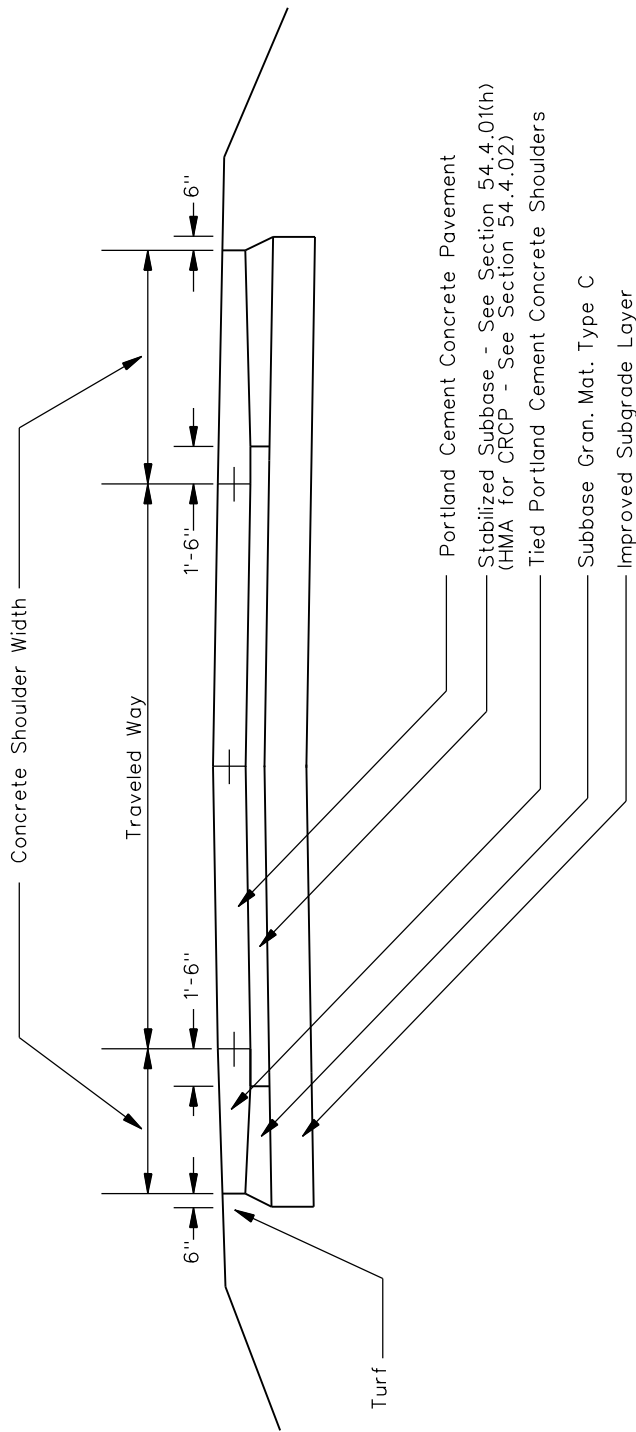

TYPICAL RURAL SECTION: RIGID DESIGN WITH TIED SHOULDER
(Collectors, Land Access Highways)

Figure 54-4.K

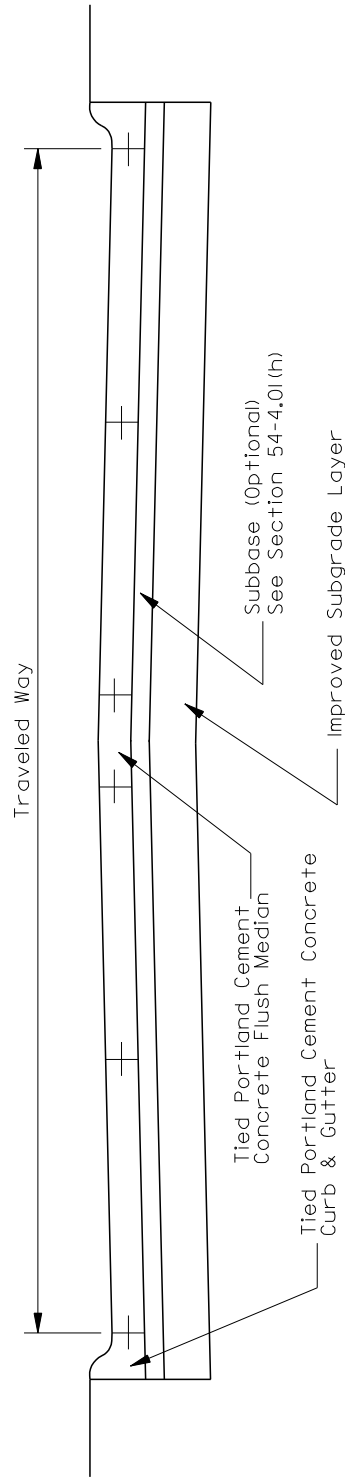

Note: Raised median with tied PCC curb and gutter may be used in lieu of a flush median.

TYPICAL URBAN SECTION: RIGID DESIGN WITH TIED CURB AND GUTTER
Figure 54-4.L

54-4.01(o) Surface Finish

The surface finish of a pavement provides skid resistance for the traveling public. The type of finish is dictated by the posted speed limit. As the posted speed limit increases, so does the need for higher skid resistance. The type of surface finish shall be indicated on the plans according to the following guidelines:

- Final finishing (of surfaces) on highways with posted speed limits in excess of 40 mph will be a Type A final finish as outlined in the *Standard Specifications for Road and Bridge Construction*.
- Final finishing (of surfaces) on highways with posted speed limits not exceeding 40 mph will be a Type A or Type B final finish as outlined in the *Standard Specifications for Road and Bridge Construction*.

54-4.02 Modified AASHTO**54-4.02(a) Application of Design Method**

The modified AASHTO design procedures are used for new CRCP and unbonded concrete overlays using CRCP. These procedures are also used to match existing CRCP. Use the procedures presented in Section 54-4.02(e) to determine pavement type and thickness and provide a subbase in accordance with Section 54-4.02(f). CRCP designs should typically be used if the rigid traffic factor is greater than 60. CRCP designs for projects with rigid traffic factors greater than 60 will not require LCCA.

54-4.02(b) Design Period

Section 54-4.01(e) applies to modified AASHTO designs for rigid pavements.

54-4.02(c) Equivalency Factors

Section 54-4.01(f) applies to modified AASHTO designs for rigid pavements.

54-4.02(d) Traffic Factors

Section 54-4.01(g) applies to modified AASHTO designs for rigid pavements.

54-4.02(e) Pavement Type and Thickness

For a modified AASHTO design of a rigid pavement, use the following steps to determine thickness:

1. Determine Traffic Factor. Use the following procedures to determine the traffic factor:
 - a. Determine the facility class (e.g., Class I, II, III, or IV).

- b. Determine the actual structural design traffic as described in Section 54-3.01(c). Note that the minimum traffic as described in Section 54-2.01(c) does not apply to the modified AASHTO design.
 - c. Based on the facility class, select the appropriate traffic factor equation from Figure 54-4.C.
 - d. Calculate the actual traffic factor for design.
2. Determine the IBR. Determine the IBR as discussed in Section 54-3.01(f).
3. Determine the CRCP Thickness. Use the following procedures to determine the CRCP thickness:
- a. Based on the facility class determined in Step 1a, select the appropriate design nomograph from the following:
 - Class I Facilities; use Figure 54-4.M; or
 - Class II, III, and IV Facilities; use Figure 54-4.N.
 - b. Within the nomograph, project a line from the traffic factor determined in Step 1 through the IBR of the roadbed soil determined in Step 2 and intersect the CRCP pavement type and thickness axis of the nomograph.
 - c. Read the CRCP thickness from the point of intersection on the nomograph and round the thickness up to the nearest 0.25 in.
 - d. If design inputs produce values which exceed the chart's, the design's parameters should be forwarded to the Bureau of Research for design.

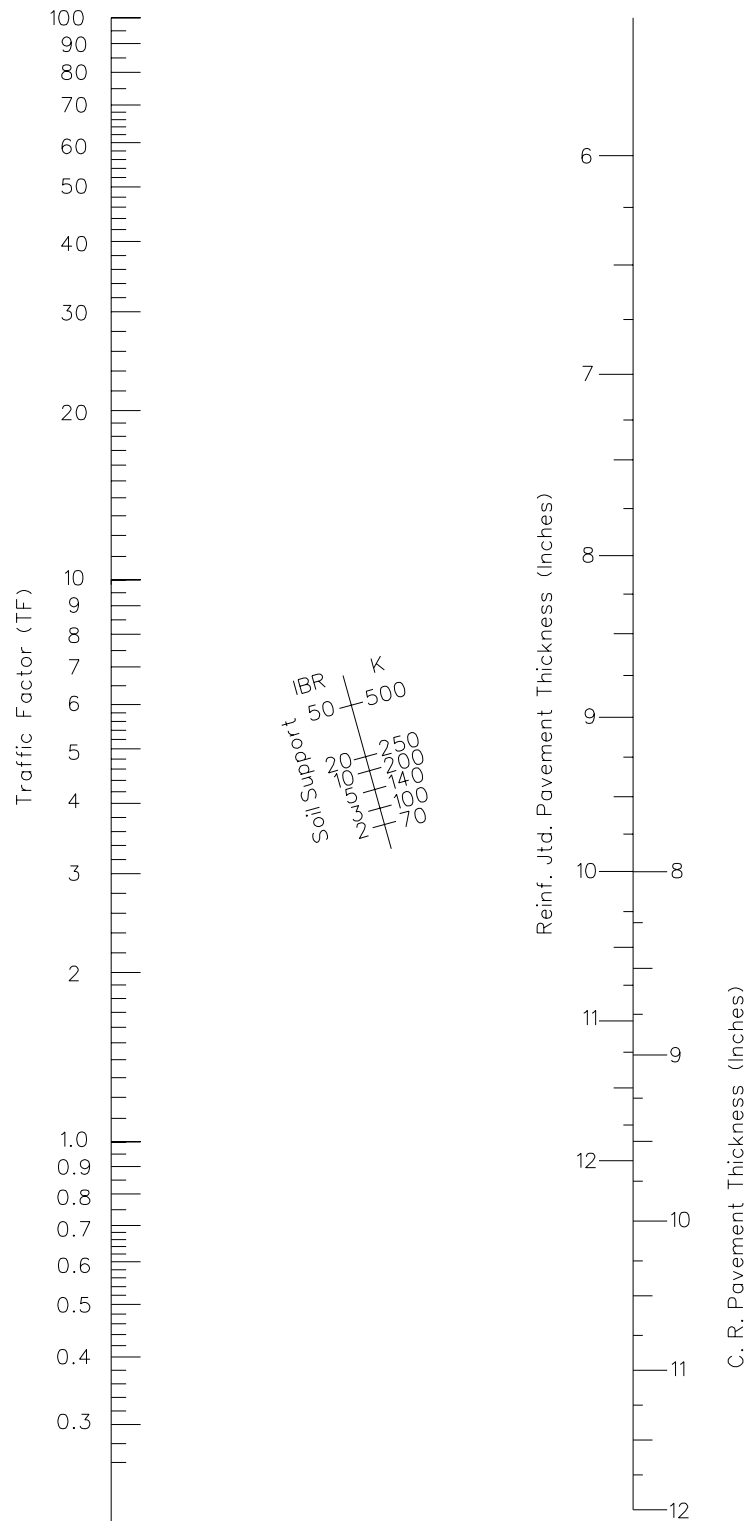

RIGID PAVEMENT DESIGN NOMOGRAPH
 (Modified AASHTO Design: Class I Facilities: CRCP)
 (Note: Ignore the Reinf. Jtd. Pavement thickness scale, it is not used.)

Figure 54-4.M

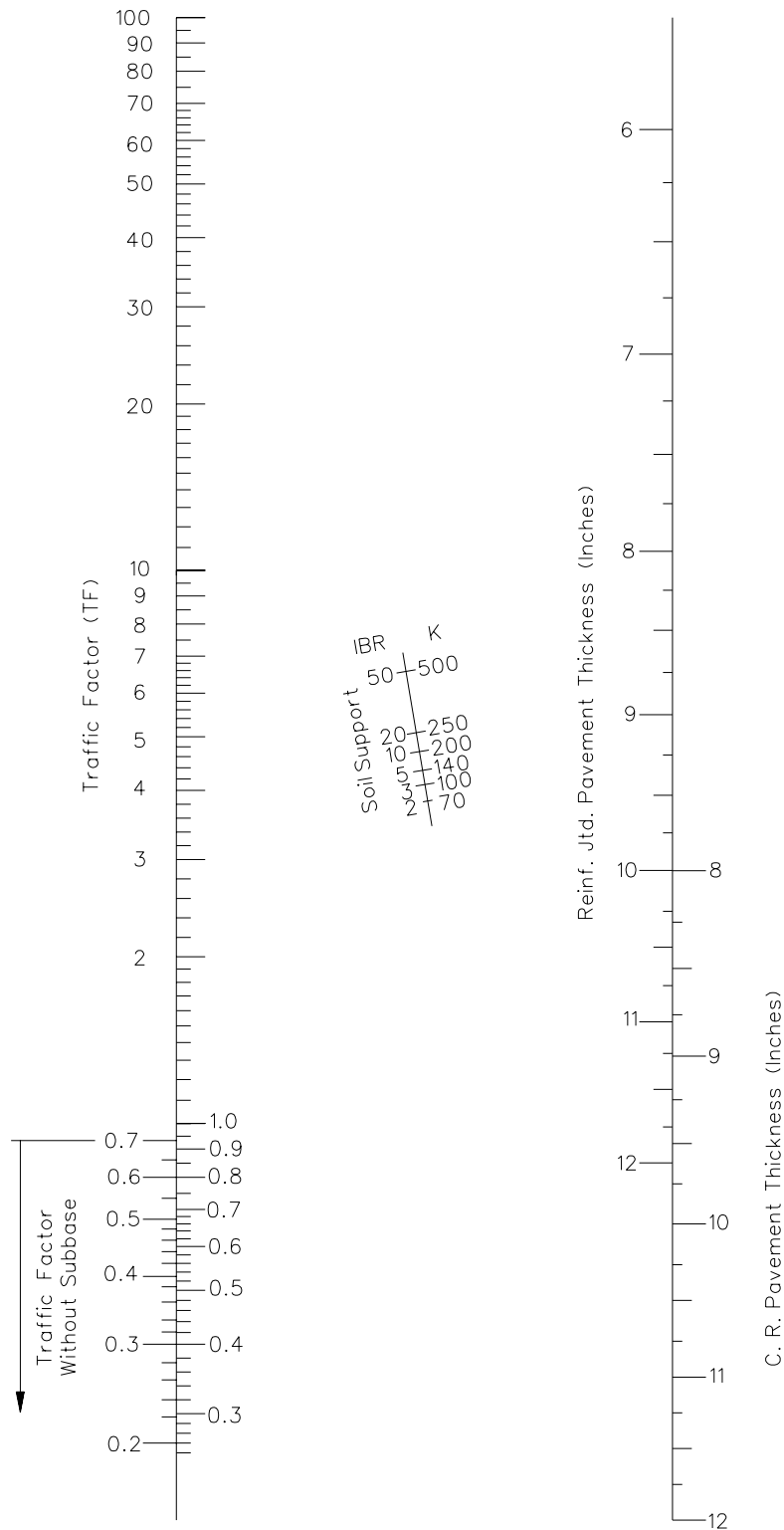

RIGID PAVEMENT DESIGN NOMOGRAPH
(Modified AASHTO Design: Class II, III, and IV Facilities: CRCP)
(Note: Ignore the Reinf. Jtd. Pavement thickness scale, it is not used.)

Figure 54-4.N

54-4.02(f) Subbase Type and Thickness

Section 54-4.01(h) applies to modified AASHTO designs for rigid pavements, except the stabilized subbase shall be constructed of HMA for CRCP.

54-4.02(g) Designating Structural Information on Plans

See Section 63-4.05 for information on designating structural information on plans.

54-4.02(h) Joints and Concrete Lug End Anchorages

The following guidelines should be used when CRCP is placed between structures that are in close proximity to each other.

Where the slab length of CRCP between bridges or other pavement types is less than 1,500 ft, use a doweled expansion joint. Where the slab length is between 1,500 ft and 2,000 ft, contact the Bureau of Research. For sections of CRCP longer than 2,000 ft, use a lug system. A wide-flange beam terminal may be used in place of a lug system.

54-4.02(i) Typical Sections

See Section 54-4.01(m) for typical rural and urban pavement sections of rigid designs for various types of highway facilities.

54-4.02(j) Surface Finish

See Section 54-4.01(o) for guidance on the type of surface finish that is required.

54-4.03 Unbonded Concrete Overlay

54-4.03(a) Limitations

Unbonded concrete overlays (UCOs) have a proven history in Illinois. Research in Illinois has shown that UCOs are a viable alternative to complete removal and replacement when a pavement has deteriorated beyond the point that a standard patch and overlay will not perform. However, some pavements may not be the best candidates for UCOs. Pavements with existing HMA and/or undoweled PCC patches are not good candidates. The UCO is not able to bridge over unstable slabs or rocking or pumping patches. UCOs are not experimental; however, use of this type of pavement requires approval from the Bureau of Research using economic justification.

54-4.03(b) Application of Design Method

A UCO consists of an existing concrete pavement, an interlayer, and a JPCP or CRCP overlay. The overlay relies on minimal structural contribution from the existing pavement and the two layers function independently. The existing pavement acts as the subbase. The interlayer separates the two pavements and retards reflective cracking in the overlay. HMA is an effective interlayer. A minimum HMA interlayer thickness of 4 in. is recommended.

54-4.03(c) Pavement Type and Thickness

When designing a UCO, use the same design parameters for design period, traffic factors, and pavement thickness as shown in Section 54-4.02 for rigid pavements. If using a CRCP, determine the UCO thickness by calculating the thickness of a new CRCP and subtracting 1 in.

Though several other States use JPCP pavements for UCOs, the Department does not have any experience with designing or constructing a UCO with that type of pavement. If the district is interested in using a JPCP for the UCO, the project will require assistance from Bureau of Research for the design of the overlay and an experimental feature according to Construction Memorandum 02-2.

54-4.03(d) Special Considerations/Comments

Due to the increase in pavement elevation, the following must be considered: the grade/elevation of mainline structures, vertical clearances at overhead structures, and adjustments of earth front-slopes. These issues may involve exceptions to policy which must be approved by the FHWA, BDE, or Bridges and Structures. Terminal treatments (e.g., lug systems, wide-flange beams, and special treatments that taper into existing sections) may need to be detailed to connect the adjacent pavement or bridge section to the overlay.

Contact the Bureau of Research for assistance in developing UCO designs (i.e., overlay and interlayer thickness requirements, UCO thickness, terminal treatments). The suitability of a UCO depends on many factors, and each set of conditions warrants an individualized design. Costs must be considered on a case-by-case basis. Rural sections without overhead structures are ideal locations for UCOs because vertical clearance will not become an issue.

54-5 STRUCTURAL DESIGN OF FLEXIBLE PAVEMENTS

54-5.01 Mechanistic

54-5.01(a) Limitations

Thickness designs may be obtained for traffic factors ranging from 0.5 to approximately 100 and for pavement thicknesses ranging from 6 in. to 18 in. However, the absolute minimum traffic factor of 0.5 will control the design thickness at the lower limits and the Limiting Strain Criterion Design Thickness will control the maximum design thickness. Limiting Strain Criterion Design thicknesses will only be allowed on those projects for which the design thickness calculated in Figures 54-5.F, 54-5.G, or 54-5.H exceeds the thickness shown in Figure 54-5.I.

54-5.01(b) Minimum Material Quality

The mechanistic full-depth HMA design procedures require, and are limited to, the use of HMA surface and binder courses with 4% air voids. HMA (4% voids, $N_{\text{design}} \geq 90$) mixtures will be specified for Interstates and freeways. HMA (4% voids, $N_{\text{design}} \leq 70$) mixtures may be specified for all other highway classifications. Any combination of surface course and binder course may be used to total the design HMA thickness. However, for the purpose of providing the most economical design, a surface course thickness of 2 in. should be used for new construction (see Section 54-5.01(i)). If there is any question as to the use of any HMA mixture in the procedure, contact the Bureau of Materials. The HMA mixture design criteria must be met as outlined in Section 53-4.04.

54-5.01(c) Asphalt Binder Selection

The mechanistic design procedures give the designer the option of selecting an appropriate asphalt binder type within the limits of current IDOT policy. The designer should be aware that in northern Illinois the use of a softer asphalt binder will reduce the effects of thermal cracking. On lower volume roads, a softer asphalt binder may be desired to reduce weathering and raveling and improve durability. On high volume roads and in areas of slower moving or standing loads, a stiffer asphalt binder should be used. In some cases, it may be desirable to use one asphalt binder grade for the binder course and another asphalt binder grade for the surface course. Where more than one asphalt binder grade is used, the design thickness will be based on the grade used for the lower binder course. Information on design asphalt binder grade selection is provided in Section 53-4.04(e). The design asphalt binder grade will be provided by the district and will be noted on the plans.

Project location and traffic volume are the main factors affecting the performance of HMA pavements. Consult with the district materials engineer to determine the proper asphalt binder grade.

54-5.01(d) Application of Design Method

The mechanistic design procedures enable the designer to determine the material types and thicknesses for the various layers of a flexible pavement that are required to carry a specified

volume and composition of traffic for a designated period of time while retaining a serviceability level at or above a selected minimum value. Use the procedures presented in Section 54-5.01(i) to determine the thickness design for full-depth HMA pavement.

54-5.01(e) Design Period

The design period for all Class I and Class II roads and streets and for Class III State primary highways is typically 20 years. Other Class III and all Class IV roads and streets may be designed for less than 20 years.

54-5.01(f) Equivalency Factors

Section 54-2.01(d) describes the use of equivalency factors to convert mixed-traffic loadings to 18-kip ESAL applications. Equivalency factors for flexible pavements are given in Figure 54-5.A. These equivalency factors have been used to develop the equations presented in Section 54-5.01(g).

Facility Class	18-kip ESAL Applications Per Vehicle		
	PV	SU	MU
Class I	0.0004	0.363	1.322
Class II	0.0004	0.307	1.056
Class III and IV	0.0004	0.299	1.053

EQUIVALENCY FACTORS (Flexible Pavements)

Figure 54-5.A

54-5.01(g) Traffic Factor

The traffic factor is the projected total 18-kip ESALs, expressed in millions, to be carried by the design lane during the design period. Figure 54-5.B presents the traffic factor equations that should be used for flexible pavement designs.

Facility Class	Traffic Factor Equation	Equation Number
Class I	$TF=DP \left[\frac{(0.15 \cdot P \cdot PV) + (132.50 \cdot S \cdot SU) + (482.53 \cdot M \cdot MU)}{1 \times 10^6} \right]$	Equation 54-5.1
Class II	$TF=DP \left[\frac{(0.15 \cdot P \cdot PV) + (112.06 \cdot S \cdot SU) + (385.44 \cdot M \cdot MU)}{1 \times 10^6} \right]$	Equation 54-5.2
Class III and Class IV	$TF=DP \left[\frac{(0.15 \cdot P \cdot PV) + (109.14 \cdot S \cdot SU) + (384.35 \cdot M \cdot MU)}{1 \times 10^6} \right]$	Equation 54-5.3

where:

DP = design period in number of years.

PV, SU, MU = structural design traffic expressed as the number of PV, SU, and MU vehicles.

P, S, M = percent of PV, SU, and MU in the design lane expressed as a decimal.

**TRAFFIC FACTOR EQUATIONS
(Flexible Pavements)**

Figure 54-5.B

54-5.01(h) Improved Subgrade

The improved subgrade serves as a stable construction platform for placement of the subsequent layers of HMA pavement. All classes of roads and streets shall have an improved subgrade of the required thickness according to Section 54-2.01(f). Treatment options for improved subgrade are shown in Figure 54-2.D.

54-5.01(i) Thickness Design Process for Full-Depth HMA

For a mechanistic design of a flexible pavement, use the following steps to determine thickness:

1. Determine Traffic Factor. Use the following procedures to determine the traffic factor:
 - a. Determine the facility class (e.g., Class I, II, III, or IV) and the design period (see Section 54-5.01(e)).
 - b. Determine the actual structural design traffic as described in Section 54-2.01(c).

- c. Determine the minimum structural design traffic as described in Section 54-2.01(c) and shown in Figure 54-2.C.
 - d. Based on the facility class, select the appropriate traffic factor equation from Figure 54-5.B.
 - e. Calculate the actual traffic factor.
 - f. Calculate the minimum traffic factor.
 - g. Compare the actual traffic factor to the minimum traffic factor and select the greater of the two. Compare the resulting traffic factor to 0.5. If less than 0.5, use 0.5 as the absolute minimum traffic factor for design.
2. Determine the SSR. Determine the SSR as described in Section 54-2.01(f) (e.g., poor, fair, granular).
 3. Determine the Asphalt Binder Grade. Determine the asphalt binder grade for the lower binder, upper binder, and surface lifts as discussed in Section 54-5.01(c).
 4. Determine the HMA Mixture Temperature. Use the following steps to determine the HMA mixture temperature:
 - a. On Figure 54-5.C, identify and mark the location where the pavement section will be constructed.
 - b. Using the temperature contours on Figure 54-5.C, interpolate the temperature and round up to the nearest 0.5°F at the marked location, except that the minimum HMA mixture temperature will be 73°F.
 5. Determine HMA Mixture Modulus (E_{HMA}). Use the following procedures to determine the HMA mixture modulus (E_{HMA}) for pavement design:
 - a. Along the horizontal axis of Figure 54-5.D, locate the value of the HMA mixture temperature determined in Step 4.
 - b. Move up vertically and intersect the curve that represents the asphalt binder grade for the lower binder lifts determined in Step 3.
 - c. Move left horizontally from the point of intersection on the asphalt binder grade curve and intersect the vertical axis of the HMA mixture modulus (E_{HMA}).
 - d. At the point of intersection with the vertical axis, read the HMA mixture modulus (E_{HMA}) and round the value to the nearest 10 ksi. This will be the HMA mixture modulus for use in the design of the flexible pavement thickness (see Figures 54-5.F, 54-5.G, or 54-5.H).

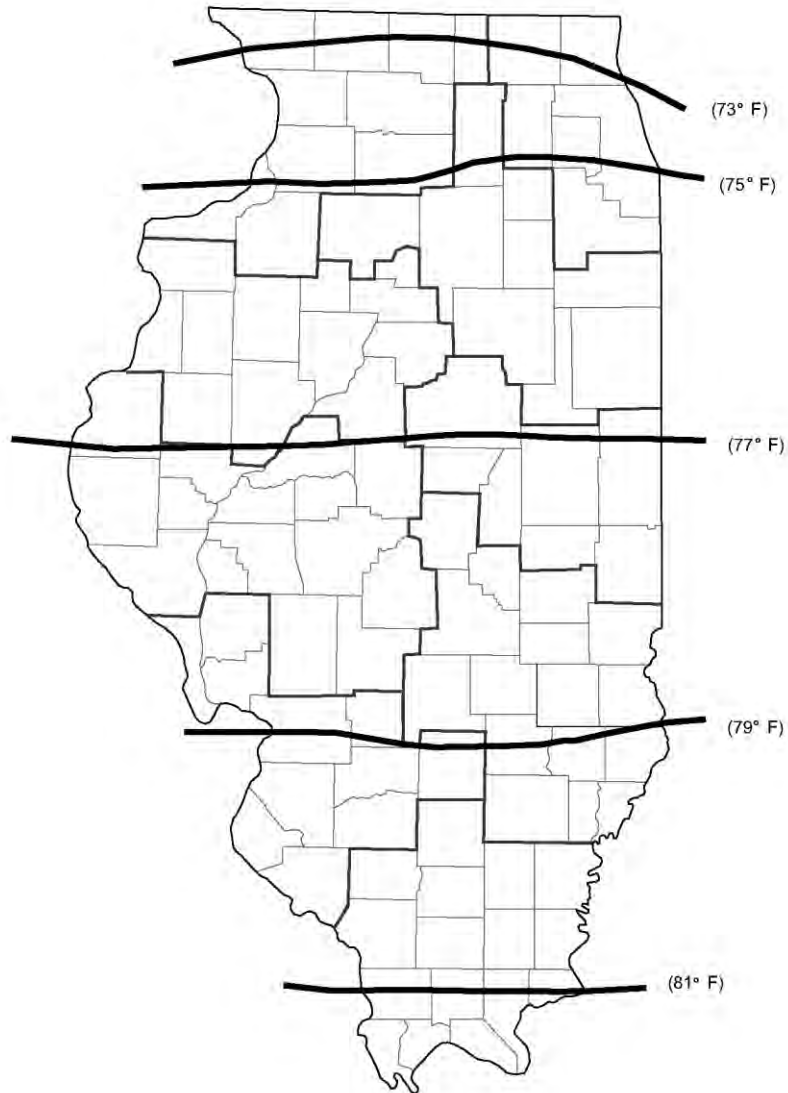

Note: The minimum design HMA mixture temperature will be 73°F.

**HMA MIXTURE TEMPERATURE
(Mechanistic Design: Flexible Pavement)**

Figure 54-5.C

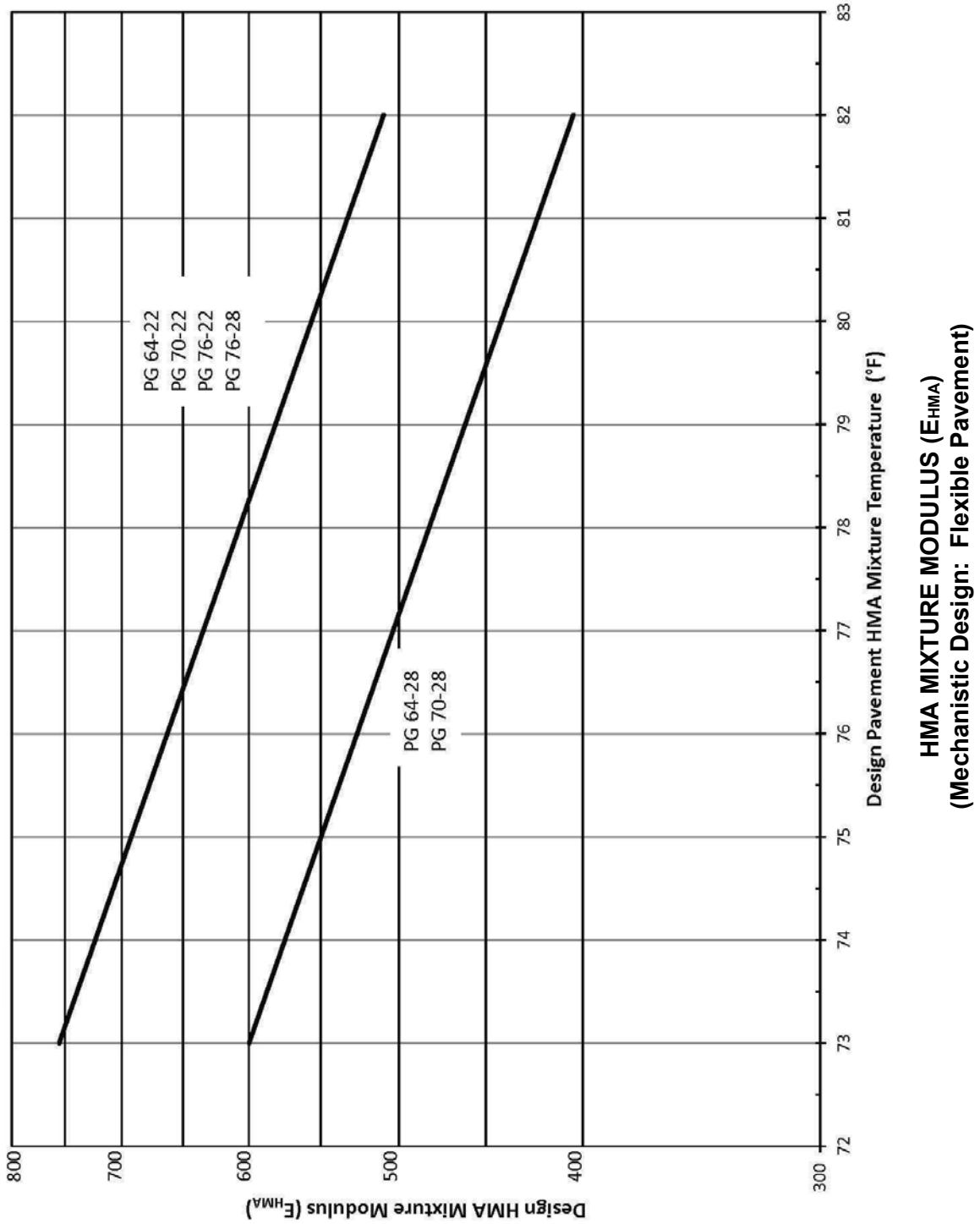
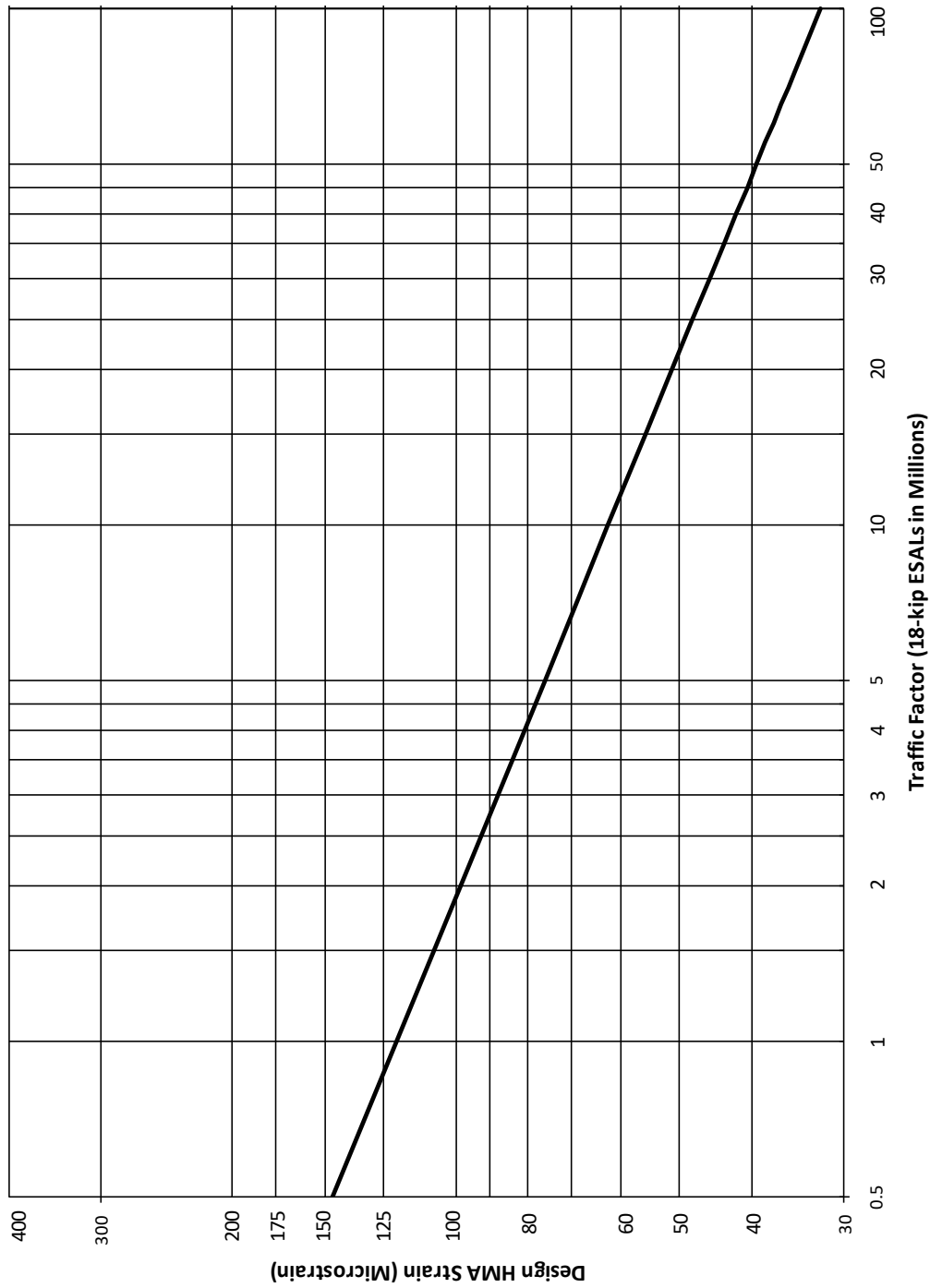
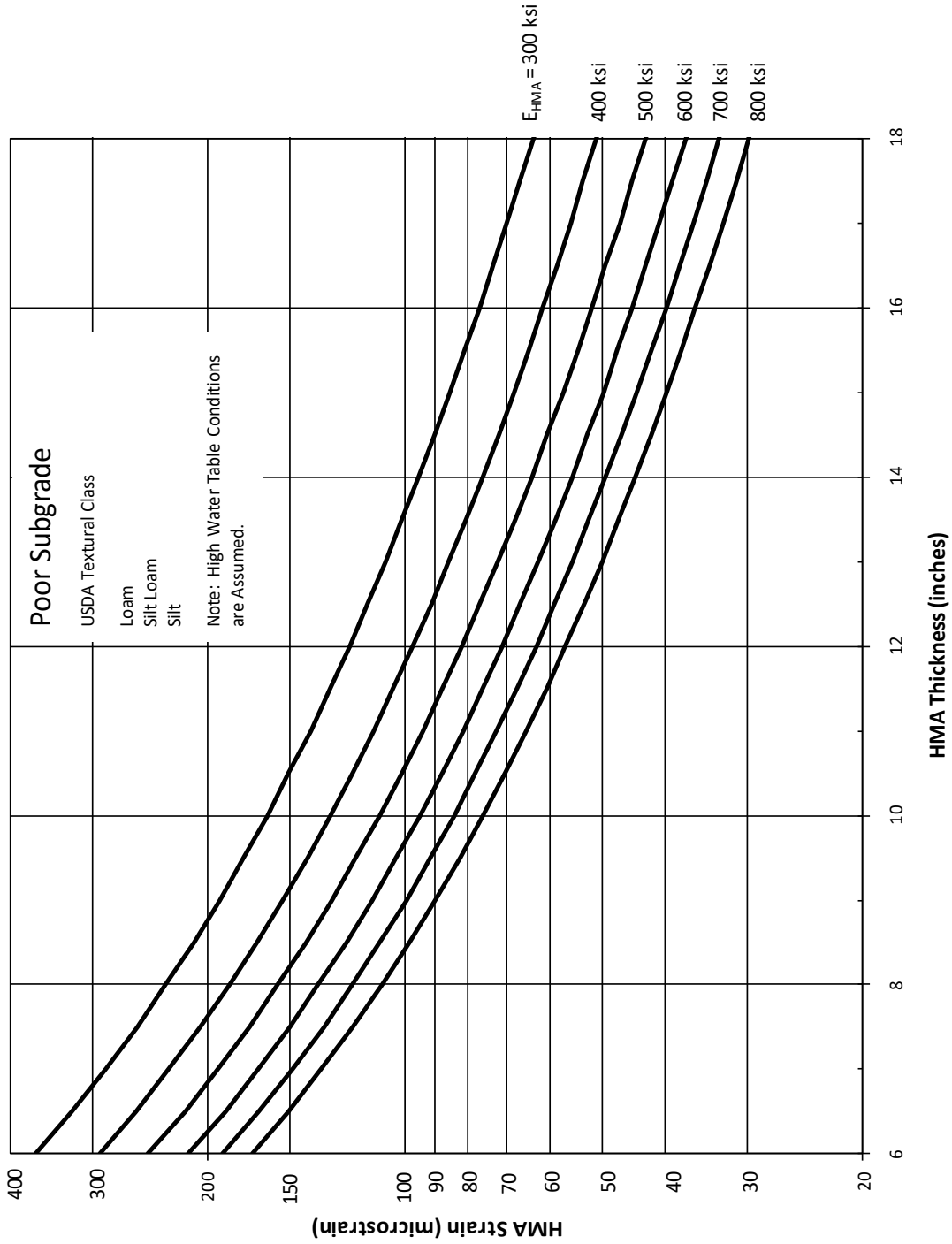

Figure 54-5.D



DESIGN HMA STRAIN
(Mechanistic Design: Flexible Pavement)

Figure 54-5.E



HMA THICKNESS DESIGN CHART
(Mechanistic Design: Flexible Pavement: SSR = Poor)

Figure 54-5.F

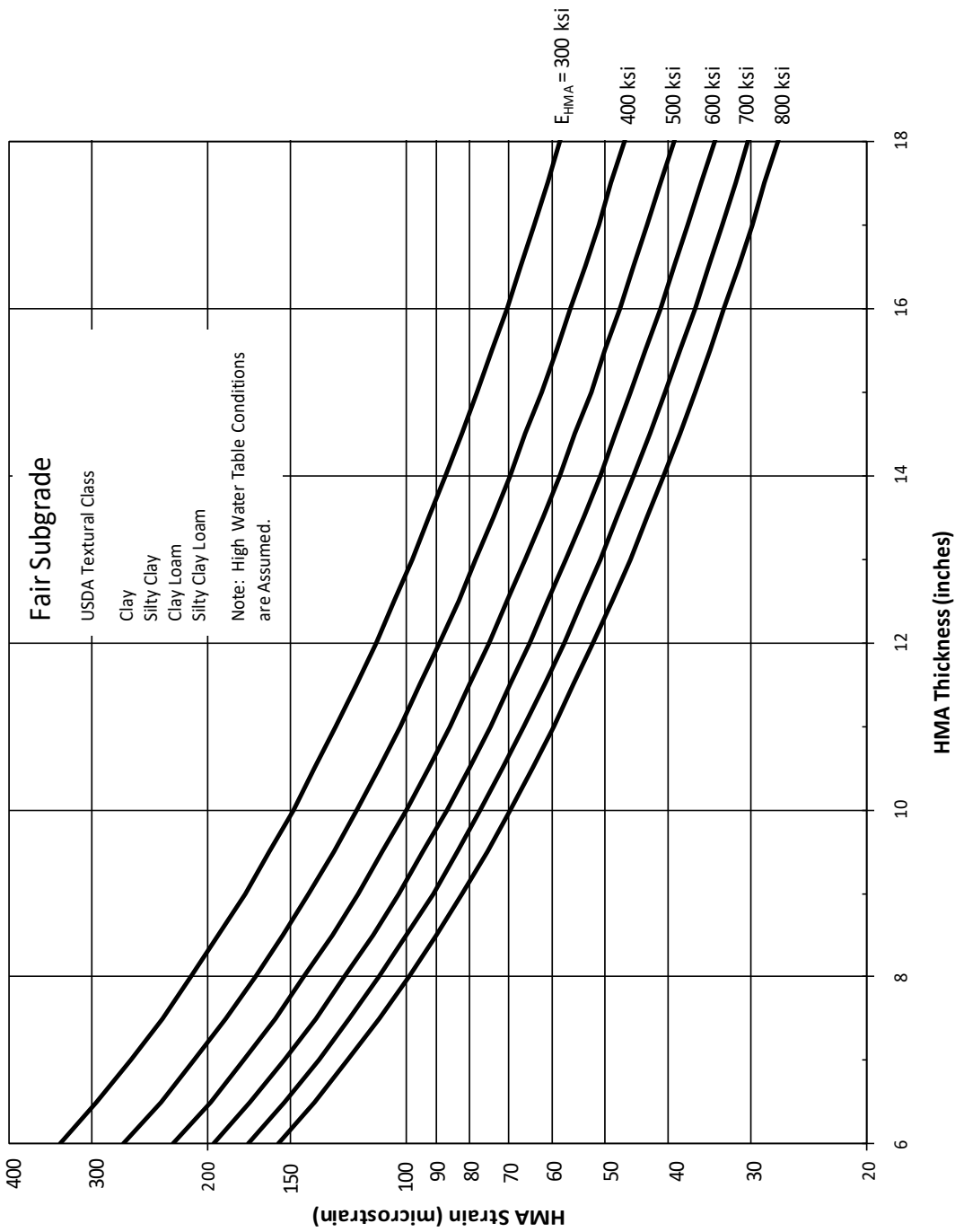

HMA THICKNESS DESIGN CHART
(Mechanistic Design: Flexible Pavement: SSR = Fair)

Figure 54-5.G

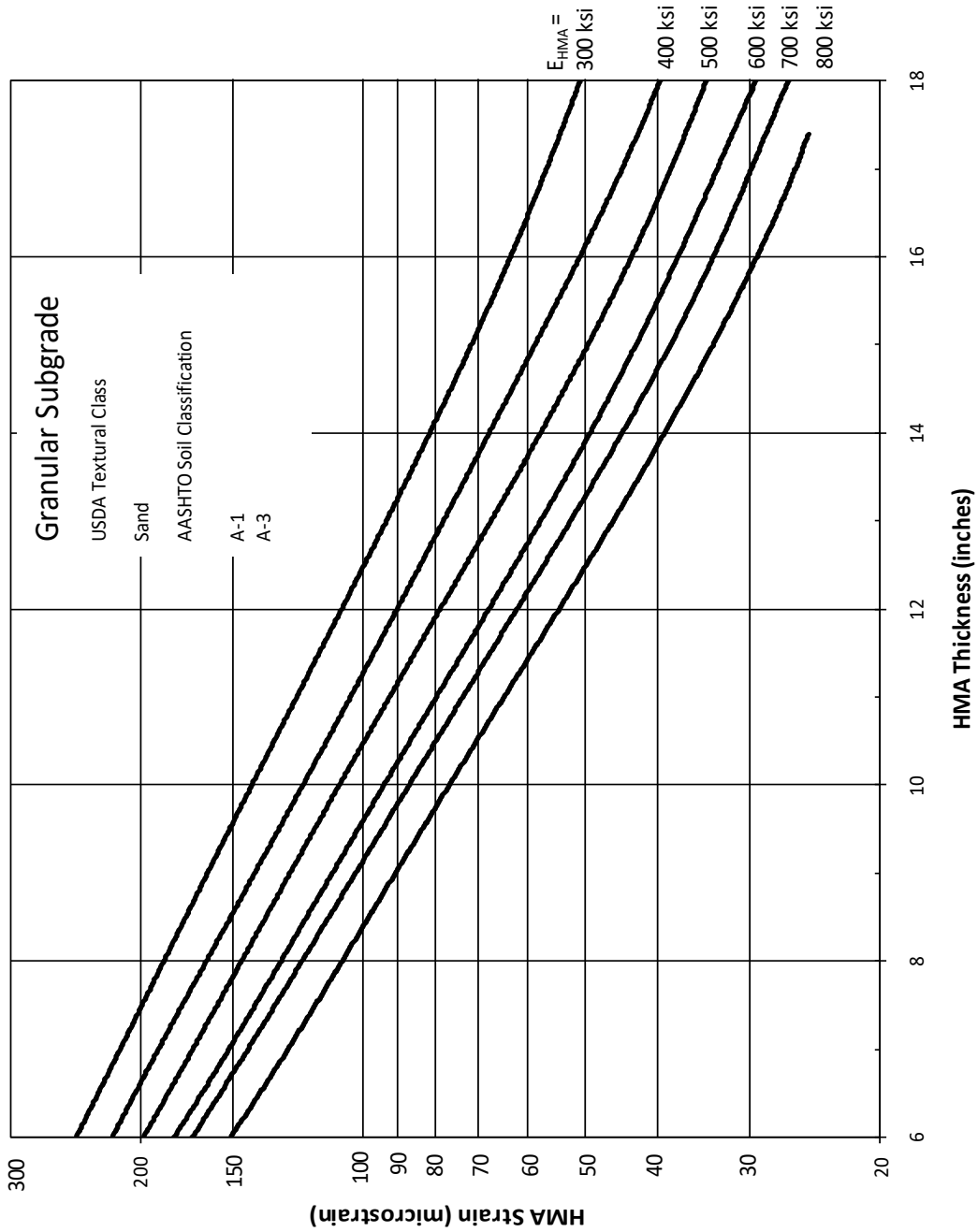

HMA THICKNESS DESIGN CHART
(Mechanistic Design: Flexible Pavement: SSR = Granular)

Figure 54-5.H

6. Determine Design HMA Strain. Use the following procedures to determine the design HMA strain:
 - a. Along the horizontal axis of Figure 54-5.E, locate the value of the traffic factor determined in Step 1.
 - b. Move up vertically and intersect the curve.
 - c. Move left horizontally from the point of intersection on the curve and intersect the vertical axis of the design HMA strain (i.e., microstrain).
 - d. At the point of intersection with the vertical axis, read the design HMA strain and round the value to the nearest unit microstrain. This will be the HMA strain to use in the design of the flexible pavement thickness (see Figures 54-5.F, 54-5.G, or 54-5.H).

7. Determine Pavement Thickness. Use the following procedure to determine the pavement thickness:
 - a. Using the SSR determined in Step 2 (e.g., poor, fair, granular), select from Figures 54-5.F, 54-5.G, or 54-5.H, the one chart that represents the SSR for use in design.
 - b. On the chart selected in Step 7a, there is a set of six curves that represents HMA mixture moduli (E_{HMA}) from 300 ksi to 800 ksi. Using the value of E_{HMA} that was determined in Step 5, interpolate and draw a parallel curve that will represent the HMA mixture modulus for use in design.
 - c. Along the left vertical axis of the selected chart, locate the value of the design HMA strain determined in Step 6.
 - d. Move right horizontally and intersect the design E_{HMA} curve interpolated and drawn in Step 7b.
 - e. Move down vertically and intersect the horizontal axis of the selected chart.
 - f. Read the thickness from the point of intersection on the horizontal axis and round this value up to the nearest 0.25 in. This will be the total thickness for the pavement design.
 - g. Use the following guidelines to determine the proper surface course thickness for full-depth pavements:
 - New or replaced pavements where the pavement selection is based on life-cycle costs will have a surface course thickness of 2 in.
 - Additional lanes, pavement widening, and short replacement segments where the pavement selection is based on first cost will have a surface

course thickness equal to the surface course thickness of the resurfacing if the adjacent pavement is being resurfaced. Otherwise, the surface course will be 2 in.

8. Limiting Strain Criterion Design Thickness Check. Use the following procedure to check the thickness determined in Step 7 against the limiting strain criterion design thickness for the project location.
 - a. Determine the limiting strain criterion design thickness for the project location from Figure 54-5.1 and round up to the nearest 0.25 in.

If PG64-28 or PG70-28 is used in the lower binder lifts, add 1.00 in. of thickness to the value obtained from Figure 54-5.1 and round up to the nearest 0.25 in.
 - b. Compare the value obtained in Step 8a against the value obtained in Step 7 and select the lower value as the final design thickness.
9. Surface Friction Aggregate. See Section 53-4.04(f) for guidance on the selection of the appropriate surface friction aggregate.

The use of an SMA surface course for projects with design TF greater than 10 is encouraged.

54-5.01(j) Use of Limiting Strain Criterion Design Cross-Section

Per Section 54-5.01(i), the surface course thickness for limiting strain criterion designs should be 2 in.

Limiting strain criterion designs should only need surface renewal throughout their design life. Material selection and attention to construction are critical to ensure that the design assumptions are met. Limiting strain criterion designs must incorporate the following mixture characteristics and construction requirements.

1. Mix Characteristics. The use of an SMA surface course is encouraged.
2. Construction Requirements.
 - Positive Dust Control-The use of positive dust control is required.
 - MTD-The use of a Material Transfer Device is required.
 - Auger-Paver Mainframe Extensions-The use of mainframe extensions in addition to auger extensions is required.
 - Tack Coats-The use of tack coats on all HMA lifts is required. Specify use of polymer tack coats on the top two lifts and non-polymer tack coats on all other lifts.

- Joint Construction-The use of echelon or full-width paving is required for all lifts. For situations where this is not possible, longitudinal joint sealant is required at the centerline joint under the surface lift and under the top binder lift.

Potential increases to costs as a result of material selection and improved construction requirements must be factored into the life-cycle cost analysis discussed in Section 54-7.

54-5.01(k) Designating Structural Design Information on Plans

See Section 63-4.05 for information on designating structural design information on plans.

54-5.01(l) Shoulder Type/Design

Use flexible shoulders with flexible pavement designs. The shoulder should be of constant thickness to a depth determined by the designer, but should not be less than 8 in. Give particular consideration to the need to provide a greater-than-minimum shoulder thickness along heavily traveled truck routes.

54-5.01(m) Design Example

See Section 54-9 for a design example.

54-5.01(n) Typical Sections

Figures 54-5.J through 54-5.L illustrate typical rural and urban pavement sections of flexible designs for various types of highway facilities.

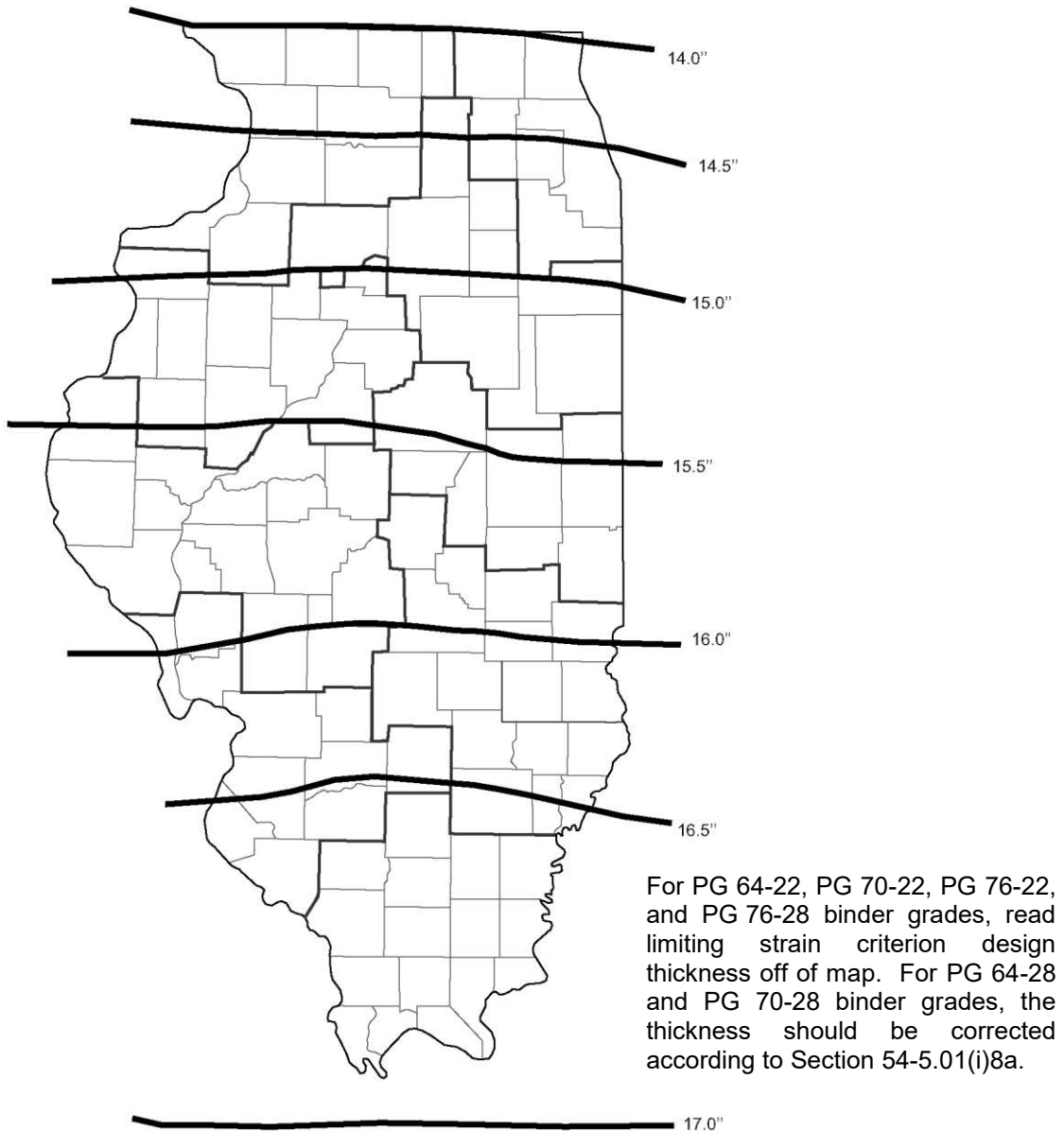

Note. Thickness values based upon Mean Monthly Pavement Temperature at 4 in. depth correlated to July Mean Monthly Air Temperature, axle load of 20,000 lb, strain of 70 $\mu\epsilon$, and E_{Ri} of 2 ksi.

**MAXIMUM PAVEMENT THICKNESS
(Limiting Strain Criterion Design: Flexible Pavement)**

Figure 54-5.I

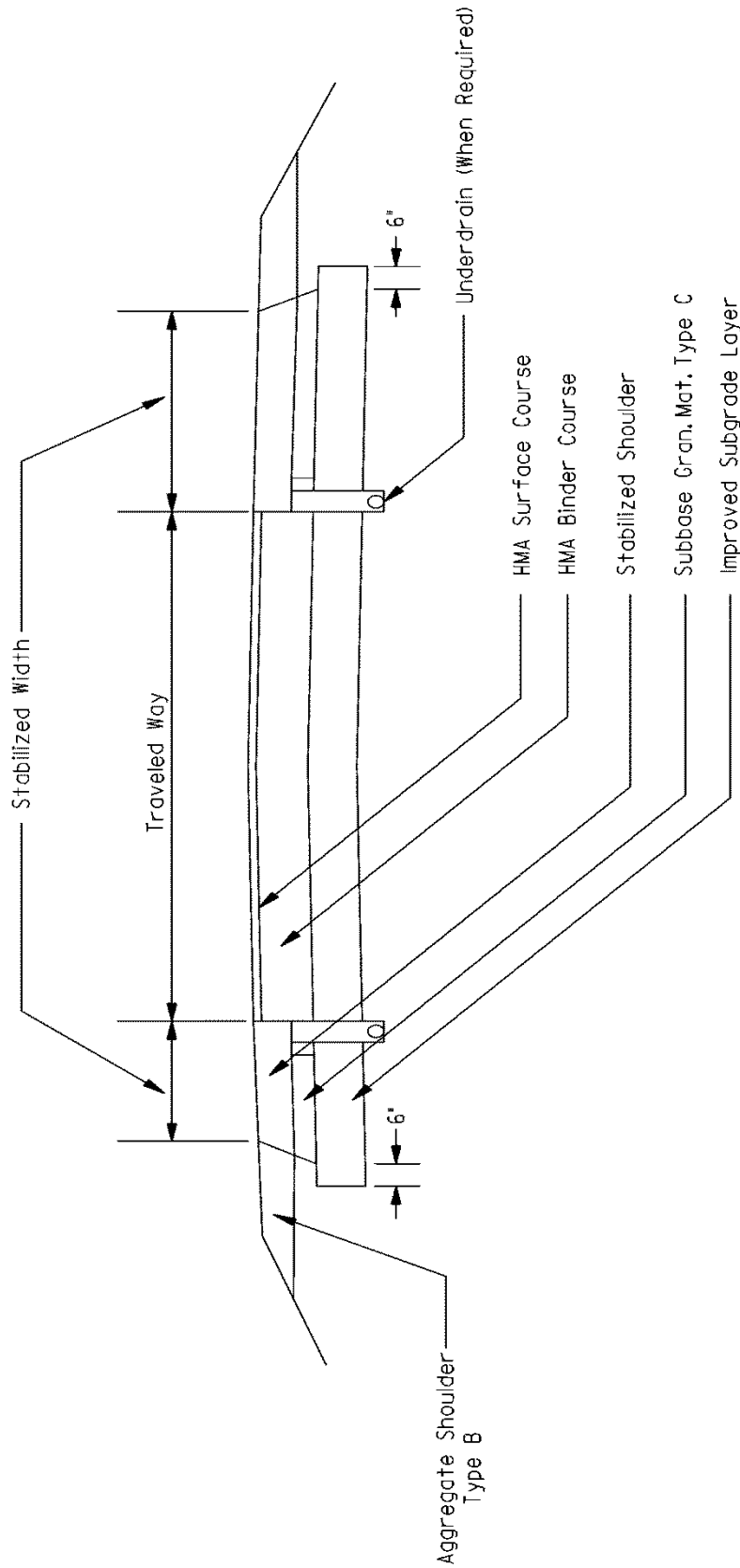

TYPICAL RURAL SECTION: FULL-DEPTH HMA DESIGN
(Trunk, Major Highways, Area Service Highways)

Figure 54-5.J

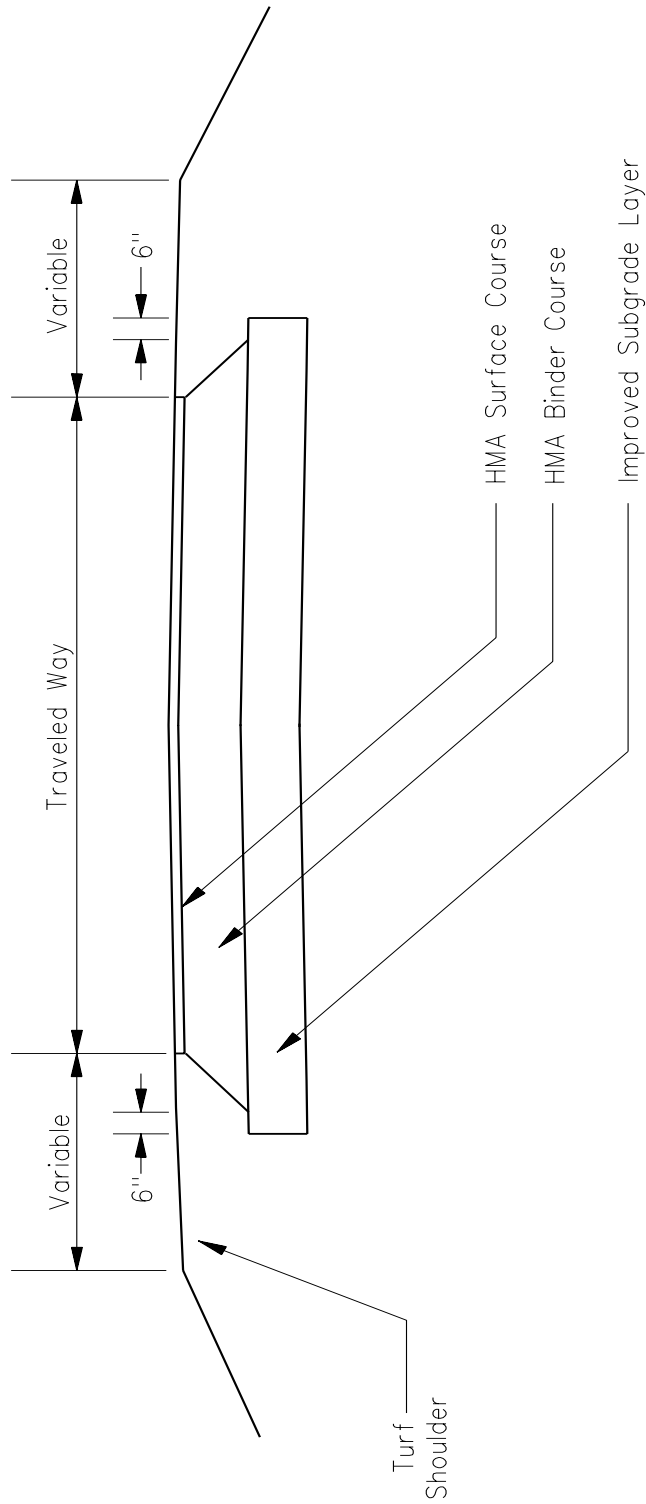

**TYPICAL RURAL SECTION: FULL-DEPTH HMA DESIGN
(Collectors, Land Access Highways)**

Figure 54-5.K

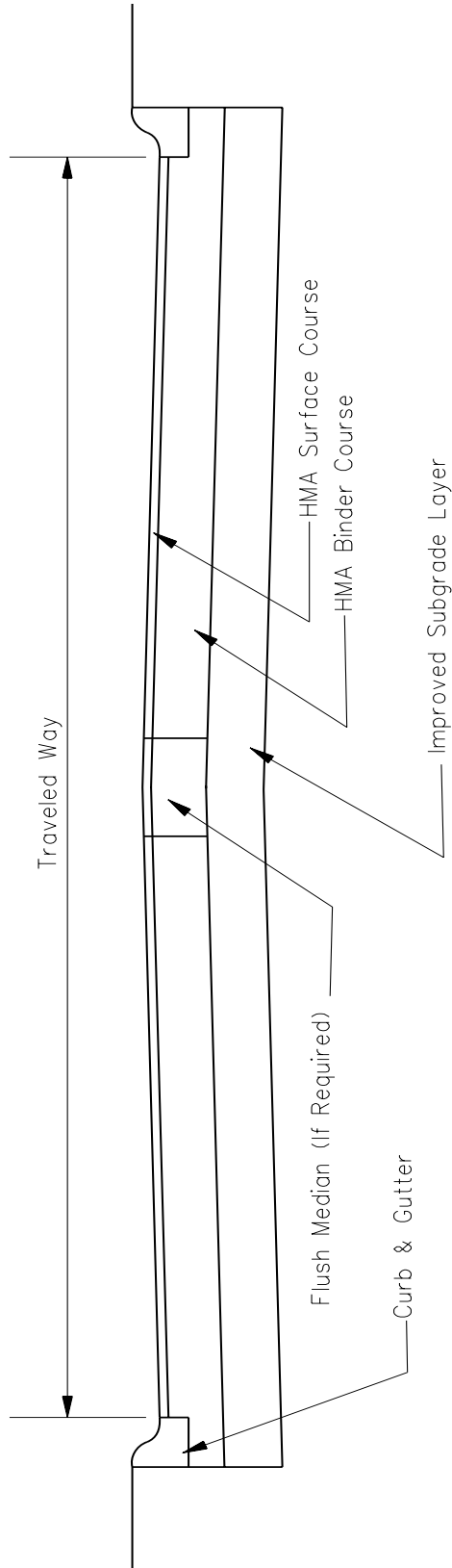

Note: Raised median with curb and gutter may be used in lieu of a flush median.

TYPICAL URBAN SECTION: FULL-DEPTH HMA DESIGN

Figure 54-5.L

54-5.02 HMA Pavement (Full-Depth) on Rubblized PCC Pavement

54-5.02(a) Application of Design Method

The following procedures are to be used to determine the appropriate full-depth HMA pavement thickness to be placed over rubblized PCC pavement. Rubblization is an alternative to complete removal and replacement in which the existing PCC pavement is broken (in-place) into small pieces and compacted to create a uniform base for the new full-depth HMA pavement.

These guidelines encompass the evaluation of an existing pavement structure to determine if the section can support the rubblizing process, as well as the design and construction steps needed to successfully use this option. The use of rubblizing requires close attention to subgrade support. This technique requires sufficient thickness of the rubblized pavement and subbase structure to protect the subgrade during construction operations.

54-5.02(b) Review of the Existing Pavement Structure

The selection of HMA pavement (full-depth) on rubblized PCC pavement as a viable alternative should be the result of a thorough investigation of the existing pavement structure and subsurface conditions. This technique requires adequate support from the subgrade, subbase, and rubblized pavement for each of the various construction activities. If conditions exist that would result in extensive removal and replacement of the existing pavement, or the subgrade is weak and would result in construction problems, the designer should consider other options.

1. Preliminary Soils Review. Before ordering an extensive subgrade investigation, the designer should contact the district's geotechnical engineer to discuss the proposed rubblizing section. From the typical pavement sections, soil maps, and typical Immediate Bearing Values (IBVs) of soils in the area, the designer and geotechnical engineer should determine if the rubblized section will protect the subgrade, as outlined in the Department's *Subgrade Stability Manual*.

If the rubblized pavement will not provide adequate cover for potentially soft subgrades, rubblizing should not be considered as an option. Rubblizing destroys the slab action of the PCC pavement; and if an unstable subgrade is encountered, the pavement section may require expensive change orders during construction.

If it appears that the pavement can be rubblized, then a detailed pavement and subsurface investigation is needed to verify constructability of the pavement.

2. Detailed Pavement and Subsurface Investigation. After passing a preliminary review, a detailed investigation of the existing pavement and subsurface conditions should be conducted and a report prepared to specifically address the following points:
 - condition/thickness of PCC slab and HMA overlay(s) (if present);
 - subbase condition and thickness (if present);
 - subgrade IBV from Dynamic Cone Penetrometer (DCP) tests;

- subgrade soil samples (if needed for further evaluation);
- survey of existing drainage conditions;
- shoulders' ability to carry traffic while under construction;
- identification of locations where pavement removal and replacement, or alternative rehabilitation is recommended; and
- subgrade stability during rubblization.

The district's geotechnical engineer should develop a coring, DCP, and soil sampling plan for the section. If the total thickness of existing concrete and base (i.e. stabilized subbase and/or granular layers) exceeds 12 in. and rubblizing Method I will be used, then DCP testing is optional. In general, a minimum of two cores per lane-mile should be taken. Core locations should be in representative cut and fill locations, and staggered between lanes. Additional coring and testing may be needed to define limits of weak subgrade areas.

The condition of any recovered stabilized material should be noted as being sound (intact and like new), slightly deteriorated (20% or less unsound or missing material), or deteriorated (more than 20% unsound or missing material). The overall condition of the subbase should be reported as a percentage of cores in each of these groups (i.e., 60% – sound, 30% – slightly deteriorated, and 10% – unsound).

After the core is removed, the DCP should be run in the hole for subgrade IBV. It is preferable to record single blow increments, to a depth of approximately 30 in. below the bottom of the pavement. If a granular base exists, the DCP may be driven through it and the depth determined from the change in IBV. A 6-lb to 8-lb soil sample should be taken and stored in an air-tight container for later testing if required. Forms BC 334 and BBS 2640 shall be used for documentation.

After the field survey is complete, typical IBVs should be developed, along with cross section data and condition of each layer. The data from each test location should be presented in table form including depth, penetration, and calculated IBV.

For the 12 in. of subgrade directly below the pavement, additional analysis is required. The top of the subgrade is broken into two layers, from 0 in. to 6 in. and 6 in. to 12 in. The average IBV is determined for each layer and plotted on Figure 54-5.M, using the pavement cross-section information. Once the data is plotted, a determination should be made as to what type of rubblizing method should be specified.

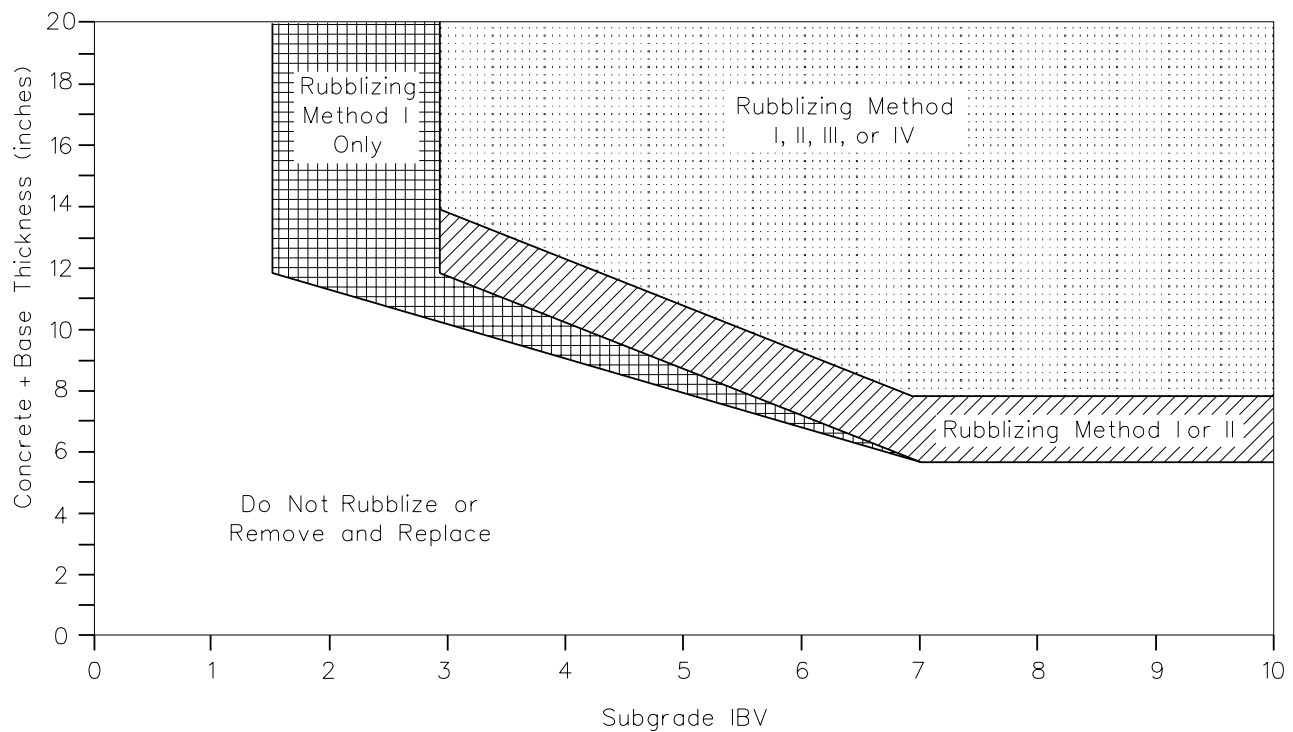

SUBGRADE RUBBLIZING GUIDE

Figure 54-5.M

For very limited areas of very soft subgrades, the designer may remove and replace the pavement, omit rubblizing, or perform a cracking and seating operation so the pavement can bridge weak subgrade areas where undercutting is not cost-effective. These areas should be identified on the plans. If it is found that several short or a few substantial segments of the project require rubblizing omissions, or removal and replacement of the pavement, then rubblization is not a viable alternative.

The pavement and subsurface investigation report should include the following:

- existing typical pavement section(s),
- core soundness and condition,
- summarized results of subsurface investigation,
- data plotted on Subgrade Rubblizing Guide (Figure 54-5.M),
- number and locations of transitions to meet mainline structures,
- clearances for overheads,
- utilities and culverts,
- location of any buildings or structures within 50 ft of the rubblization, and
- location and condition of underdrains.

54-5.02(c) Design Issues

The following design issues must be considered before the project can be submitted for review and approval:

1. Equipment Selection. A pavement breaker and self-propelled rollers are the major equipment necessary to rubblize a PCC pavement. The pavement breaker should be selected to meet the project's needs with respect to traffic control, staging, and subgrade support limitations. The following equipment characteristics should be considered when making a decision on breaker selection:

- a. Method I—Multi-Head Breaker (MHB). The MHB is a self-propelled unit with multiple drop-hammers mounted at the rear of the machine. The hammers are set in one or two rows, and strike the pavement approximately every 4.5 in. The hammers have variable drop heights and variable cycling speeds.

The equipment has the ability to break pavement up to 13 ft wide, in one pass. The rate of production depends on the type of base/subbase material, and is approximately 1.0 lane-mile per day.

The Z-pattern steel grid roller, a vibratory roller with a grid pattern, must be used in conjunction with the MHB to complete the breaking process. A Z-pattern grid is attached transversely to the drum surface. This roller further breaks flat and elongated material into more uniform pieces. The vibratory roller is self-propelled, with a minimum gross weight of 10 tons.

Method I should be specified if there is any question of the rubblized section's ability to support construction equipment. The rubblized section and subgrade still must be able to support compaction equipment and loaded trucks without rutting or dislodging the rubblized PCC pavement.

The MHB should be specified if the roadway is to remain open to traffic and encroachment into the adjacent lane cannot be accommodated. Encroachment of the MHB into the adjacent lane is similar to the rolling operation of HMA paving.

The paving operation may work directly behind the breaking operation, in such a manner that the lane may be rubblized and overlaid for opening to traffic at the end of the day.

Caution should be used if buildings are within 50 ft of the rubblizing operation, especially in an urban setting. Buildings that may be sensitive to vibration should be identified in the project report, with an alternative method of localized pavement breaking recommended. Alternative breaking methods (e.g., skid steer mounted jack hammer) should be considered or pavement rubblizing omitted near vibration sensitive buildings.

Underground utilities and drainage structures must be identified for protection. An omission in the breaking operation may be required over utilities and drainage structures. These omitted areas shall be broken with an alternative breaking method.

- b. Method II—Resonant Frequency Breaker with High Flotation Tires. This method uses a resonant frequency breaker with tires, which have pressures below 60 psi. This allows operation on pavement sections that are thinner or have soft subgrades.

A resonant frequency breaker is a self-propelled unit that uses high frequency, low amplitude impacts with a shoe force of 2,000 lb to fracture the PCC pavement. The shoe, or hammer, is located at the end of a pedestal, which is attached to a beam and counter weight. The breaking principle is that low amplitude, high frequency resonant energy is delivered to the concrete slab, resulting in high tension at the top. This causes the slab to fracture on a shear plane, inclined at about 35 degrees from the pavement surface. The shoe, beam size, operating frequency, loading pressure, and speed of the machine can all be varied.

The breaking begins at the centerline and proceeds to the outside edge of the pavement. The breaking pattern is approximately 8 in. wide, and requires 18 to 20 passes to break a 12 ft lane width. The rate of production depends on the type of base/subbase material, and is about 1.0 lane-mile per day.

The resonant breaker has very heavy wheel loads of 20,000 lb. The broken pavement, shoulder, and subgrade must be adequate to support multiple passes of the equipment. The resonant breaker encroaches 3 ft to 5 ft into the adjacent lane to rubblize pavement near the centerline. The pavement section/shoulder must be structurally adequate for traffic to be moved 7 ft to 8 ft from the centerline and onto the shoulder. The use of the resonant breaker is best suited on roads that can be closed to traffic and support the breaker's weight.

The resonant breaker produces limited vibrations. Caution should be used with vibration sensitive buildings that are within 10 ft of the rubblizing operation.

Utilities or culverts within 6 in. of the PCC pavement bottom need to be protected, as described in Method I.

- c. Method III—Resonant Frequency Breaker. This is the same basic machine as in Method II. However, it does not utilize the high flotation tires. This results in limiting usage as shown in Figure 54-5.M.
- d. Method IV—Breaking Device Not Specified. This method can be specified if Methods I, II, and III could be used without restrictions to subgrade support, traffic, staging, or structures as noted above.

2. Drainage Considerations. The Department's longitudinal underdrain policy (see Section 53-2.07(c)1.) should be followed. Installation of new underdrains is strongly recommended. At a minimum, sag areas of vertical curves must be addressed. French drains, which are capable of draining the entire depth of the section, are acceptable for isolated areas. Existing underdrains that will remain in place shall be thoroughly investigated to ensure that they are functioning properly. For sections where underdrains will not be installed, the designer should consider limiting the amount of time the rubblized pavement may be left without an overlay, to minimize delays from rain saturation.
3. Priming. The rubblized surface should be overlaid without priming. Priming adds an extra step and curing period, which delays construction with no benefit to the finished product.
4. HMA Overlay Thickness Design. Use the following procedure to determine the HMA overlay thickness.
 - a. Overlay Thickness Design Based on Actual Traffic. The designer should determine the required Traffic Factor (TF) needed for the design period (see Section 54-5.01(g)) using a recommended design period of 20 years. Design periods less than 10 years should not be considered. Asphalt binder grade for the HMA overlay is selected according to Section 53-4.04(e) using the requirements for a full-depth HMA pavement (Figure 53-4.M). The thickness of the HMA overlay needed on top of the rubblized section is determined using Figure 54-5.N. All designs are rounded up to the next 0.25 in. The design thickness, as a function of HMA mixture modulus and traffic factor, is determined as follows:
 - Determine the HMA mixture modulus (E_{HMA}) using the procedure described in Section 54-5.01(i)5.
 - Using the TF and E_{HMA} determined above, obtain the design thickness using Figure 54-5.N. An overall maximum thickness of 15 in. applies regardless of TF.
 - Determine the limiting strain criterion design thickness for the project location from Figure 54-5.O and round up to the nearest 0.25 in. If PG 64-28 or PG 70-28 is used in the lower binder lifts, add 1.00 in. of thickness to the value obtained from Figure 54-5.O. Compare the values obtained from Figures 54-5.N and 54-5.O and select the lower value as the final design thickness.

- b. Minimum HMA Overlay and Lift Thicknesses. The minimum HMA overlay thickness for rubblized pavement is 6 in. The first lift of the overlay should be 3 in. to 4 in. This thickness allows good compaction on and minimizes dislodging of the rubblized base. The surface lift should be 2 in. For pavement overlays that are 7 in. or less, surface lifts of 1.5 in. are allowable. Contact the Bureau of Materials if first lifts less than 3 in. are desired.

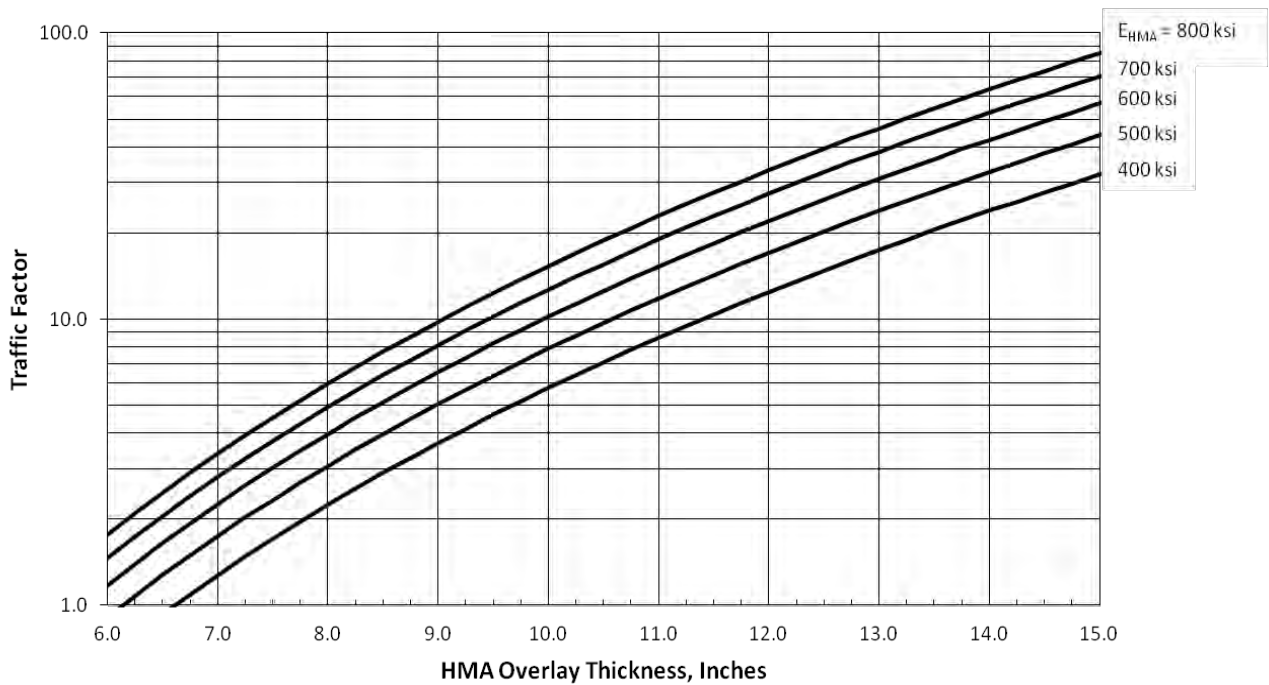

HMA OVERLAY THICKNESS FOR RUBBLIZED PAVEMENTS

Figure 54-5.N

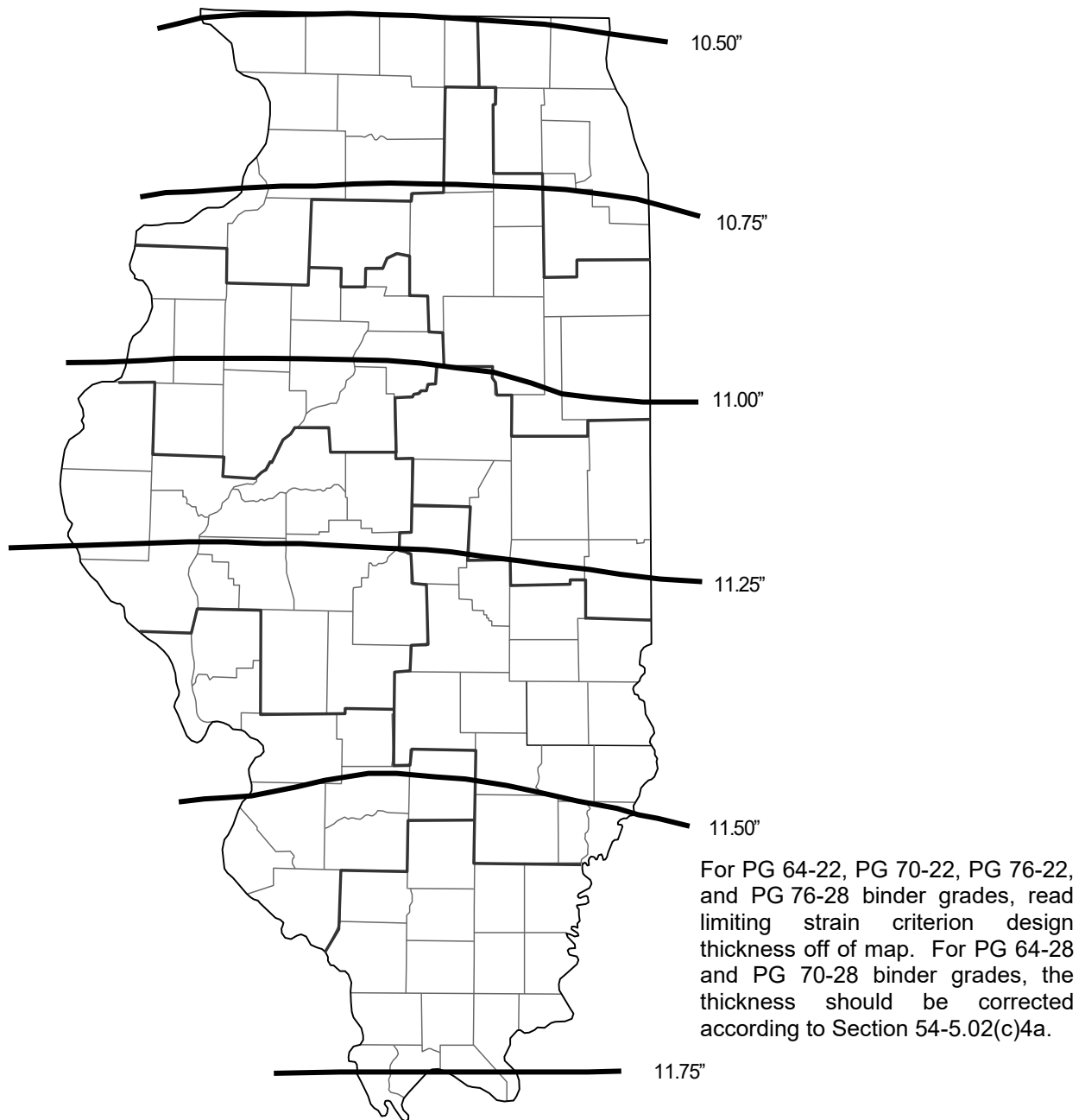

Note. Thickness values based upon Mean Monthly Pavement Temperature at 4 in. depth correlated to July Mean Monthly Air Temperature, axle load of 20,000 lb, strain of 70 $\mu\epsilon$.

**MAXIMUM PAVEMENT THICKNESS
(Limiting Strain Criterion Design: HMA Overlay of Rubblized PCC Pavement)**

Figure 54-5.O

5. Traffic Control. Traffic may be maintained during much of the construction process. The road may be used after the installation of underdrains and the milling of any existing HMA overlay. The safety of open trenches, lane to lane drop-offs, high shoulders, and the condition of the exposed pavement surface should be considered when determining if the road can be reopened to traffic.

No traffic (including unnecessary construction traffic) should be allowed on the fractured pavement surface once the breaking operation begins. All HMA binder lifts should be paved before traffic is allowed onto the section. If staging requires that the pavement be opened to traffic before all the binder layers are in place, contact the Bureau of Research to review the structural impacts.

Edge differentials in elevation of rubblized pavements can be substantially greater than standard overlays, and may require additional traffic control measures. The designer should evaluate the overall design and traffic staging to determine if any additional traffic control may be required. The designer should also evaluate differentials in elevation if milling to bare pavement is needed.

6. Specification of Material Transfer Devices (MTDs). The use of MTDs on the rubblized base must be evaluated on a case-by-case basis, due to the weights and axle configurations of the equipment. Contact the Bureau of Research to perform an analysis.

7. Construction Sequence. The general sequence of construction should be as follows:

- Install underdrains or French drains, as required.
- Remove any existing HMA overlay to the staged width.
- Remove and replace any existing unsound HMA repair materials.
- Rubblize the pavement.
- Compact the broken pavement.
- Pave the binder lifts of the HMA overlay.
- Allow traffic on sections that have adequate thickness, as shown on the plans (if needed).
- Pave the surface of the HMA overlay.

8. Other Design Issues. Any HMA material on the pavement from pothole patching may be left in place. If there are any full-depth HMA patches in the section, soundness of the patch material should be determined. HMA patches should be rated in the same manner as subbase in Section 54-5.02(b). Visually indeterminate patches may be investigated with a limited coring program. If an HMA patch is unsound, the material should be removed. When traffic is maintained during the patching operation, the

replacement material should be a Class C or D patch. If concrete is the replacement material, it shall be rubblized.

If the unsound patch is greater than 10 sq ft, HMA binder mixture shall be used. When the road is closed to traffic and the unsound patch is less than or equal to 10 sq ft, the replacement material may otherwise be aggregate. The aggregate shall be a Class D Quality (or better) crushed stone, crushed slag, crushed concrete, or crushed gravel meeting a CA 6 or CA 10 gradation; according to Section 1004 of the *Standard Specifications*.

Partial-depth HMA patches may be left in place during rubblization. If partial-depth patches prevent proper breaking of the PCC pavement, a skid steer loader (with a jack hammer attachment or similar device) may be used to complete breaking in these areas.

The rubblizing process will increase the pavement width 1 in. to 3 in. per 2-lane width, and encroach slightly into the underdrain trench. This has not caused performance problems with sand trench and pipe type underdrains to date. If the resonant breaker is used, the driving of heavy wheel loads directly over the underdrain trench should be avoided as much as possible. Wheel loads directly over the underdrain trench are of less concern if the existing shoulder is in sound condition.

54-6 STRUCTURAL DESIGN OF COMPOSITE PAVEMENTS

54-6.01 Application of Design Method

The design procedures for composite pavements enable the designer to select:

- the thickness of HMA surface needed to structurally rehabilitate an existing rigid or composite pavement, or
- the thickness of both HMA surface and PCC base course for a new composite pavement.

The resulting composite pavement will be capable of carrying a specified volume and composition of traffic for a designated period of time while retaining a serviceability level at or above a selected minimum value.

The composite design method assumes that the existing rigid or composite pavement has reached the end of its design life and is in need of structural rehabilitation. If the existing pavement has not reached the end of its design life, as may be the case when a resurfacing is being designed in conjunction with a lane addition, higher strength coefficients than those discussed in Section 54-6.06 may be appropriate. Such cases should be referred to the Bureau of Research.

Application of the composite design method involves the following steps:

1. Determine Traffic Factor. Use the following procedures to determine the traffic factor:
 - a. Determine the facility class (e.g., Class I, II, III, or IV).
 - b. Determine the actual structural design traffic as described in Section 54-2.01(c).
 - c. Based on the facility class, select the appropriate traffic factor equation from Figure 54-4.C.
 - d. Calculate the actual traffic factor to use in design.
2. Determine the IBR. Determine the IBR of the roadbed soil (see Section 54-3.01(f)).
3. Determine the Structural Number (SN_C). Determine the composite pavement structural number (SN_C) using the appropriate design nomograph for the facility class (i.e., Figure 54-6.A for Class I facilities or Figure 54-6.B for Class II, III, and IV facilities).
4. Determine Thickness. Select the appropriate equation from Section 54-6.06 as follows:
 - first resurfacing, use Equation 54-6.1;
 - second resurfacing, use Equation 54-6.2; or
 - new composite pavement, use Equation 54-6.3.

Using the appropriate equation and Figure 54-6.C, calculate the thickness of surface and base course, if applicable. Round the thickness(es) up to the nearest 0.25 in. For pavements that are in need of a third resurfacing, see Section 54-6.06.

5. Compare with Minimum Criteria. Compare the calculated thickness(es) with the minimum requirements presented in Figure 54-6.D. Use the larger of the values for design.

54-6.02 Design Period

The design period for all composite pavements is typically 20 years. See Section 54-3.01(b).

54-6.03 Equivalency Factors

Section 54-3.01(d) describes the use of equivalency factors to convert mixed-traffic loadings to 18-kip ESAL applications. Because the main structural layer of a composite pavement is a rigid slab, the equivalency factors are the same as for rigid pavement (see Section 54-4.02(c)).

These equivalency factors have been used to develop the traffic factor equations discussed in Section 54-6.04.

54-6.04 Traffic Factors

The traffic factor is the projected total 18-kip ESALs, expressed in millions, to be carried by the design lane during the design period. Because the main structural layer of a composite pavement is a rigid slab, the equivalency factors are the same as for rigid pavement (see Section 54-6.03). The traffic factor equations discussed in Section 54-4.02(d) also apply to composite pavement designs.

54-6.05 Composite Pavement Structural Number

Having calculated the traffic factor, only the IBR of the roadbed soil (see Section 54-3.01(f)) is needed to determine the composite pavement structural number. The composite pavement structural number (SN_c) is obtained by projecting a line through the traffic factor and the IBR of the roadbed soil on the appropriate design nomograph, either Figure 54-6.A for Class I facilities or Figure 54-6.B for Class II, III, and IV facilities.

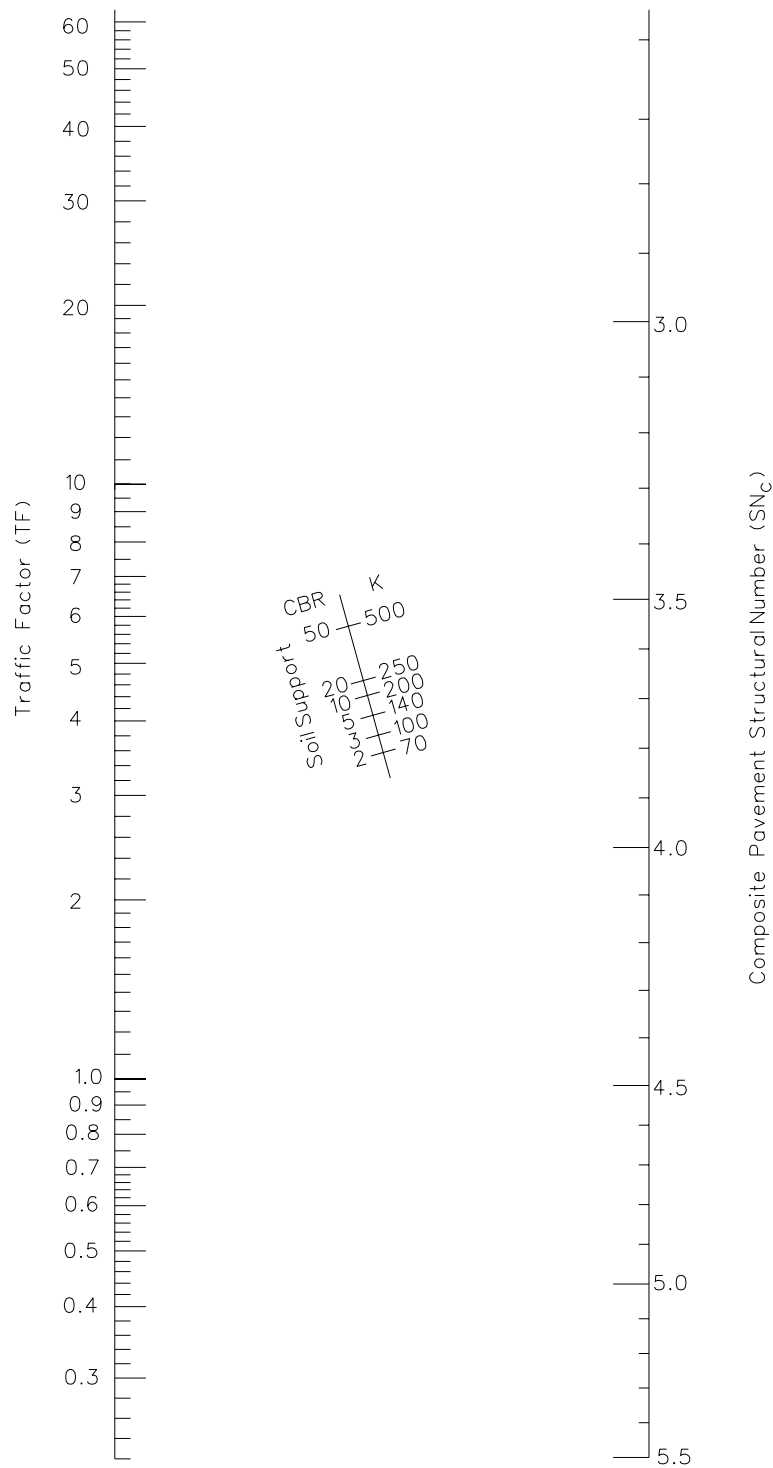

**COMPOSITE PAVEMENT DESIGN NOMOGRAPH
(Class I Facilities)**

Figure 54-6.A

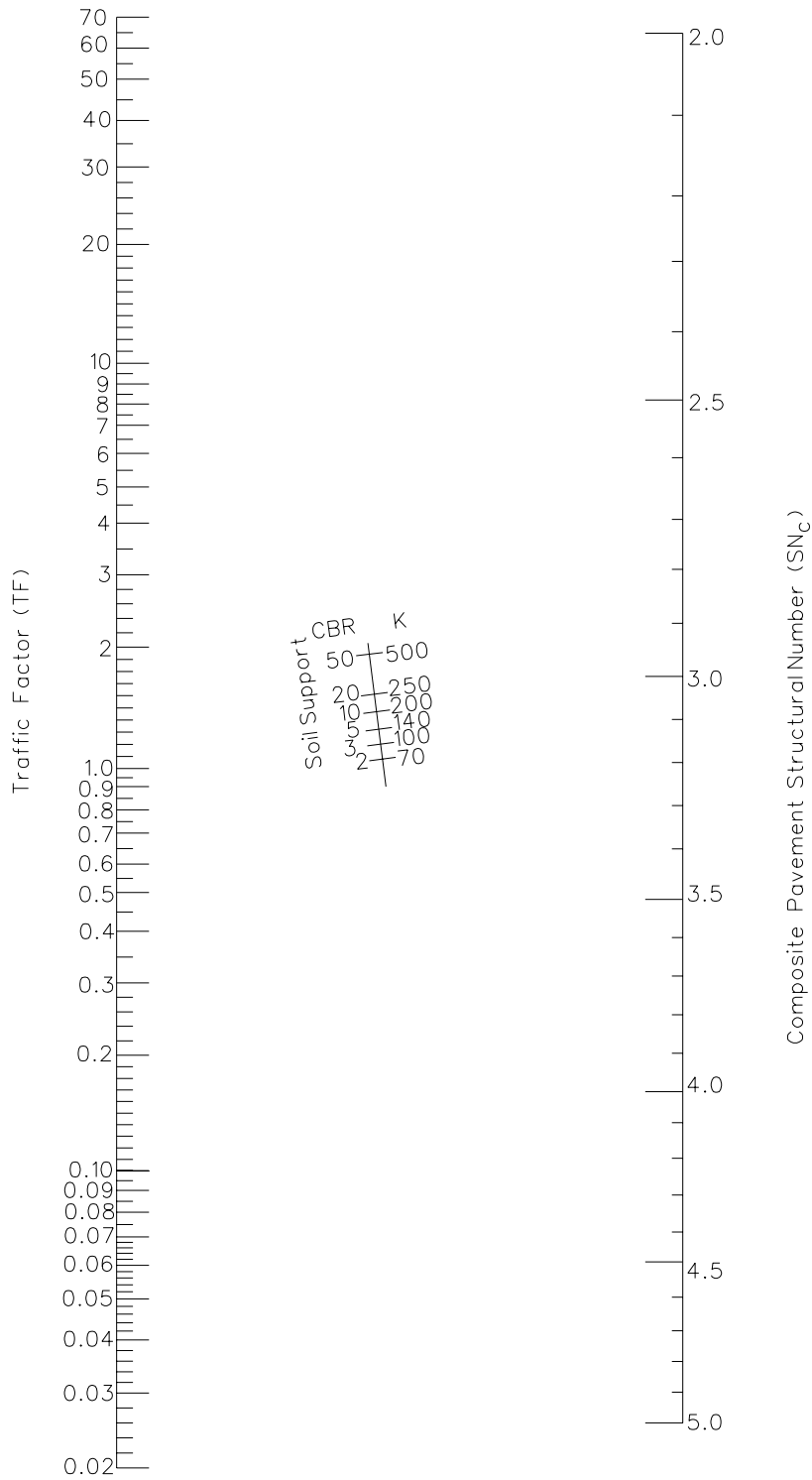

**COMPOSITE PAVEMENT DESIGN NOMOGRAPH
(Class II, III, and IV Facilities)**

Figure 54-6.B

Pavement Cross Section (inches)	Equivalent Thickness (D _c) (inches)
10 – 10 – 8 – 10 – 10	9.75
9 – 9 – 7 – 9 – 9	8.75
9 – 7 – 9	7.71
9 – 9 – 6.5 – 9 – 9	8.50
9 – 6 – 9	7.06
8 – 8 – 6 – 8 – 8	7.75
7 – 8 – 7	7.00

**EQUIVALENT THICKNESS (D_c) FOR EXISTING NON-UNIFORM PCC PAVEMENTS
(Composite Pavement Design)**

Figure 54-6.C

Facility Class	HMA Surface Course	PCC Base Course Minimum Thickness (inches)
Class I	Use Policy Thickness unless otherwise approved. See Section 53-4.04(a).	8
Class II		7
Class II State Primary		7
Class II All Others		6
Class IV		6

**MINIMUM DESIGN REQUIREMENTS FOR COMPOSITE PAVEMENTS
(Composite Pavement Design)**

Figure 54-6.D

54-6.06 Thickness Design Equations

The composite pavement structural number (SN_C), an abstract number related to the strength required of the total pavement structure, is a summation of layer thicknesses multiplied by their corresponding strength coefficients. Three design equations incorporate the composite pavement structural number as follows:

1. First Resurfacing. For the initial HMA surfacing over an existing rigid pavement, use the following equation:

$$D_s = \frac{SN_C - 0.26D_C}{0.40} \quad \text{Equation 54-6.1}$$

2. Second Resurfacing. For a second HMA surfacing over an existing resurfaced rigid pavement, use the following equation:

$$D_s = \frac{SN_C - 0.25D_E - 0.17D_C}{0.40} \quad \text{Equation 54-6.2}$$

3. New Composite Pavement. For the design of a new composite pavement, use the following equation:

$$SN_C = 0.40 D_S + 0.33 D_B \quad \text{Equation 54-6.3}$$

where: SN_C = composite pavement structural number
 D_S = thickness of HMA policy overlay (inches)
 D_C = equivalent thickness of existing PCC slab (inches)
 D_E = thickness of existing HMA surface (inches)
 D_B = thickness of new PCC base course (inches)

Note that the above equations do not include provisions for a third resurfacing. Pavements that are in need of a third resurfacing for structural reasons often are badly deteriorated and may no longer be functioning as a rigid pavement. Contact the Bureau of Research for guidance in selecting the appropriate strength coefficients for such pavements.

In the case of an existing JRCP/JPCP of uniform thickness, the equivalent thickness of the PCC slab (D_C) is the actual slab thickness. For a CRCP, D_C is the slab thickness multiplied by 1.25. Figure 54-6.C presents the equivalent thickness (D_C) of the non-uniform PCC pavements formerly constructed by the Department.

Use Equation 54-6.3 to develop designs for totally new composite pavements composed of an HMA surface and a PCC base course. The application of this pavement design procedure is restricted as follows:

- to changes in horizontal or vertical alignment for short segments of rural pavement,
- to lane additions,
- to replacement of short segments of urban pavement, and
- as an option to flexible base materials.

Equation 54-6.3 requires determination of two unknowns (i.e., the surface and the base course thicknesses). To develop a design, it becomes necessary, therefore, to assume the thickness of one pavement component and compute the required thickness of the other. In most cases, it will be best to initially assume the surface course thickness. The surface course thickness selected should be the standard policy resurfacing thickness or the thickness of the resurfacing being placed on the adjacent pavement.

54-6.07 Minimum Design Requirements

The composite design procedures are used to analyze PCC slabs that are surfaced with high-type HMA and are therefore limited to HMA surfacing materials that meet the requirements of the *Standard Specifications* for HMA. To ensure practical and adequate designs, adhere to the minimum criteria presented in Figure 54-6.D for composite pavements.

54-6.08 Designating Structural Design Information on Plans

See Section 63-4.05 for information on designating structural design information on plans.

54-6.09 Design Example

See Section 54-9 for a design example.

54-7 PAVEMENT SELECTION ANALYSIS

54-7.01 Introduction

The life-cycle activities for mechanistically designed pavements that are presented in this section were developed by a panel of Department experts who have experience in the areas of design, construction, materials, and maintenance of Illinois pavements. The expert group established rehabilitation, patching, and maintenance strategies for a 45-year analysis period for typical rigid and flexible pavements.

A framework for data collection has been established to gather actual data on maintenance activities and costs. As these data are collected, appropriate modifications to the life-cycle strategies will be made where needed.

54-7.02 Selection Basis

The selection of pavement design alternatives is based on the following criteria:

1. Widening Projects. Pavement design alternatives for widening projects are evaluated based on a first-cost analysis. The alternative with the lowest first cost is selected for construction.
2. New Construction/Pavement Replacement Projects. Pavement design alternatives for new or replaced pavements are evaluated based on a life-cycle cost analysis. The analysis will consider the following alternatives:
 - a. New Construction Projects. The analysis for a new pavement shall consider mechanistic designs for rigid and flexible pavements. If the difference in life-cycle costs between alternatives is greater than 10%, the alternative with the lowest life-cycle cost is selected for construction.

If the difference in life-cycle costs is 10% or less, the selection will be based upon the alternate pavement bidding process described in Section 54-1.04. However if the project does not fit the criteria for alternate pavement bidding, or one pavement type is preferable, the project will be referred to the Pavement Selection Committee. If the Committee agrees alternate pavement bidding is not appropriate, the Committee will select the pavement type.

- b. Replacement Projects. The analysis for a replaced pavement shall consider new pavement mechanistic designs for rigid and flexible pavements; as well as supplemental pavement designs for unbonded JPC/CRC overlay and full-depth HMA pavement on rubblized PCC pavement. When developing the supplemental designs, the designer shall review the criteria provided in Sections 54-4.03 and 54-5.03 to determine which supplemental designs are viable options.

When comparing the new pavements designs to the viable supplemental designs, the life-cycle cost analysis must include costs that are unique to this type of comparison. For example, the cost of removing the existing pavement must be added to the new pavement alternatives and the cost of preparing the existing pavement, additional earthwork, etc. must be added to the supplemental designs. If the difference in life-cycle cost between one alternative and the others is greater than 10%, then that alternative with the lowest life-cycle cost is selected for construction.

If the difference in life-cycle costs is 10% or less, the selection will be based upon the alternate pavement bidding process described in Section 54-1.04 with only those alternatives within the 10% being taken forward to bidding. However if the project does not fit the criteria for alternate pavement bidding, or one pavement type is preferable, the project will be referred to the Pavement Selection Committee. If the Committee agrees alternate pavement bidding is not appropriate, the Committee will select the pavement type.

3. Waivers. Although the guidelines presented in Item 1 and Item 2 will apply in most cases, a waiver based on issues related to policy, Local Agency requests, or constructability may need to be considered. Such cases will be referred to the Bureau of Research for approval.

54-7.03 Life-Cycle Activities

Figures 54-7.A through 54-7.C present the maintenance and rehabilitation activities during 45 years of service. Figure 54-7.A illustrates the activities for mechanistically designed JPCPs and unbonded JPC overlays. Figure 54-7.B illustrates the activities for CRCPs and unbonded CRC overlays. Figure 54-7.C illustrates the activities for mechanistically designed full-depth HMA pavements and full-depth HMA pavements on rubblized PCC pavements.

ACTIVITY 1 — YEAR 10
<ul style="list-style-type: none"> • 0.10% Class B Pavement Patching
ACTIVITY 2 — YEAR 15
<ul style="list-style-type: none"> • 0.20% Class B Pavement Patching
ACTIVITY 3 — YEAR 20
<ul style="list-style-type: none"> • 2.0% Class B Pavement Patching • 0.50% Class C Shoulder Patching • 100% Longitudinal Shoulder Joint Routing & Sealing • 100% Centerline Joint Routing & Sealing
ACTIVITY 4 — YEAR 25
<ul style="list-style-type: none"> • 3.0% Class B Pavement Patching • 1.0% Class C Shoulder Patching
ACTIVITY 5 — YEAR 30
<ul style="list-style-type: none"> • 4.0% Class B Pavement Patching • 1.5% Class C Shoulder Patching • Standard HMA Overlay of Pavement and Shoulder (see Sections 53-4.02(a) and 53-4.04(a) for thickness)
ACTIVITY 6 — YEAR 35
<ul style="list-style-type: none"> • 100% Longitudinal Shoulder Joint Routing & Sealing • 100% Centerline Joint Routing & Sealing • 50% Random Crack Routing & Sealing (see Note) • 40% Reflective Transverse Crack Routing & Sealing • 0.10% Partial-Depth Pavement Patching (Mill & Fill Surface - Interstates; Mill & Fill 2.50 in. - Non-Interstates)
ACTIVITY 7 — YEAR 40
<ul style="list-style-type: none"> • 0.50% Class B Pavement Patching • 100% Longitudinal Shoulder Joint Routing & Sealing • 100% Centerline Joint Routing & Sealing • 60% Reflective Transverse Crack Routing & Sealing • 50% Random Crack Routing & Sealing (see Note) • 0.50% Partial-Depth Pavement Patching (Mill & Fill Surface - Interstates; Mill & Fill 2.50 in. - Non-Interstates)

Note: For random crack routing and sealing, assume 100 ft/station/lane.

**MAINTENANCE AND REHABILITATION ACTIVITY SCHEDULE
JOINTED PLAIN CONCRETE PAVEMENT
AND UNBONDED JOINTED PLAIN CONCRETE OVERLAY**

Figure 54-7.A

ACTIVITY 1 — YEAR 10
<ul style="list-style-type: none"> • 0.10% Class A Pavement Patching
ACTIVITY 2 — YEAR 15
<ul style="list-style-type: none"> • 0.20% Class A Pavement Patching
ACTIVITY 3 — YEAR 20
<ul style="list-style-type: none"> • 0.50% Class A Pavement Patching • 100% Longitudinal Shoulder Joint Routing & Sealing • 100% Centerline Joint Routing & Sealing
ACTIVITY 4 — YEAR 25
<ul style="list-style-type: none"> • 0.75% Class A Pavement Patching • 0.50% Class C Shoulder Patching
ACTIVITY 5 — YEAR 30
<ul style="list-style-type: none"> • 3.0% Class A Pavement Patching • 1.0% Class C Shoulder Patching • Standard HMA Overlay of Pavement and Shoulder (see Sections 53-4.02(a) and 53-4.04(a) for thickness)
ACTIVITY 6 — YEAR 35
<ul style="list-style-type: none"> • 100% Longitudinal Shoulder Joint Routing & Sealing • 100% Centerline Joint Routing & Sealing • 50% Random Crack Routing & Sealing (see Note) • 0.10% Partial-Depth Pavement Patching (Mill & Fill Surface)
ACTIVITY 7 — YEAR 40
<ul style="list-style-type: none"> • 100% Longitudinal Shoulder Joint Routing & Sealing • 100% Centerline Joint Routing & Sealing • 50% Random Crack Routing & Sealing (see Note) • 0.50% Class A Pavement Patching • 0.50% Partial-Depth Patching (Mill & Fill Surface)

Note: For random crack routing and sealing, assume 100 ft/station/lane.

**MAINTENANCE AND REHABILITATION ACTIVITY SCHEDULE
CONTINUOUSLY REINFORCED CONCRETE PAVEMENT
AND UNBONDED CONTINUOUSLY REINFORCED CONCRETE OVERLAY**

Figure 54-7.B

ACTIVITY 1 — YEAR 5
<ul style="list-style-type: none"> • 100% Longitudinal Shoulder Joint Routing & Sealing • 100% Centerline Joint Routing & Sealing • 50% Random/Thermal Crack Routing & Sealing (see Note) • 0.10% Partial-Depth Pavement Patching (Mill & Fill Surface)
ACTIVITY 2 — YEAR 10
<ul style="list-style-type: none"> • 100% Longitudinal Shoulder Joint Routing & Sealing • 100% Centerline Joint Routing & Sealing • 50% Random/Thermal Crack Routing & Sealing (see Note) • 0.50% Partial-Depth Pavement Patching (Mill & Fill Surface)
ACTIVITY 3 — YEAR 15
<ul style="list-style-type: none"> • 2.00 in. Milling - Pavement & Shoulder • 1.0% Partial-Depth Pavement Patching (Mill & Fill Additional 2.00 in.) • 2.00 in. HMA Overlay - Pavement & Shoulder
ACTIVITY 4 — YEAR 20
<ul style="list-style-type: none"> • 100% Longitudinal Shoulder Joint Routing & Sealing • 100% Centerline Joint Routing & Sealing • 50% Random/Thermal Crack Routing & Sealing (see Note) • 0.10% Partial-Depth Pavement Patching (Mill & Fill Surface)
ACTIVITY 5 — YEAR 25
<ul style="list-style-type: none"> • 100% Longitudinal Shoulder Joint Routing & Sealing • 100% Centerline Joint Routing & Sealing • 50% Random/Thermal Crack Routing & Sealing (see Note) • 0.50% Partial-Depth Pavement Patching (Mill & Fill Surface)
ACTIVITY 6 — YEAR 30
<p>Interstate Standard Design:</p> <ul style="list-style-type: none"> • 2.00 in. Milling - Pavement Only • 2.0% Partial-Depth Pavement Patching (Mill & Fill Additional 2.00 in.) • 1.0% Partial-Depth Shoulder Patching (Mill & Fill Surface) • 3.75 in. HMA Overlay Pavement • 1.75 in. HMA Overlay Shoulder <p>Other State Maintained Route Standard Design:</p> <ul style="list-style-type: none"> • 2.00 in. Milling - Pavement & Shoulder • 2.0% Partial-Depth Pavement Patching (Mill & Fill Additional 2.00 in.) • 1.0% Partial-Depth Shoulder Patching (Mill & Fill Additional 2.00 in.) • 2.25 in. HMA Overlay Pavement & Shoulder <p>All Limiting Strain Criterion Designs:</p> <ul style="list-style-type: none"> • 2.00 in. Milling - Pavement & Shoulder • 2.0% Partial-Depth Pavement Patching (Mill & Fill Additional 2.00 in.) • 1.0% Partial-Depth Shoulder Patching (Mill & Fill Additional 2.00 in.) • 2.00 in. HMA Overlay - Pavement & Shoulder

**MAINTENANCE AND REHABILITATION ACTIVITY SCHEDULE
FULL-DEPTH HMA PAVEMENT
AND FULL-DEPTH HMA PAVEMENT ON RUBBLIZED PCC PAVEMENT**

Figure 54-7.C

ACTIVITY 7 — YEAR 35
<ul style="list-style-type: none"> • 100% Longitudinal Shoulder Joint Routing & Sealing • 100% Centerline Joint Routing & Sealing • 50% Random/Thermal Crack Routing & Sealing (see Note) • 0.10% Partial-Depth Pavement Patching (Mill & Fill Surface)
ACTIVITY 8 — YEAR 40
<ul style="list-style-type: none"> • 100% Longitudinal Shoulder Joint Routing & Sealing • 100% Centerline Joint Routing & Sealing • 50% Random/Thermal Crack Routing & Sealing (see Note) • 0.50% Partial-Depth Pavement Patching (Mill & Fill Surface)

Note: For random/thermal crack routing and sealing, assume 110 ft/station/lane.

**MAINTENANCE AND REHABILITATION ACTIVITY SCHEDULE
FULL-DEPTH HMA PAVEMENT
AND FULL-DEPTH HMA PAVEMENT OVER RUBBLIZED PCC PAVEMENT**

**Figure 54-7.C
(Continued)**

54-7.04 Cost Estimating

The estimation of unit prices of all major pay items must be documented and must be based upon the anticipated quantities for the contract. Contact the BDE for the Department's procedures for cost estimation.

54-7.05 Life-Cycle Cost Analysis

The life-cycle cost analysis for new construction/pavement replacement type projects is performed using the "IDOT Mechanistic Pavement Design and Life-Cycle Cost Analysis" spreadsheet (BDE 5401). The analysis is based on the following equation which annualizes the costs of initial construction and life-cycle activities amortized over the 45-year service life of the pavement. A discount rate of 3% is used to determine annual costs and no adjustment for inflation is required.

$$A = D + M + CRF_n [C + R_1(PWF_{n1}) + R_2(PWF_{n2}) + \dots + R_n(PWF_{nn})] \quad \text{Equation 54-7.1}$$

where: A = total annual cost per mile

D = annual administrative and overhead cost per mile (assumed to be equal for all pavement types; therefore, do not include in analysis)

M = total annual maintenance cost per mile (assumed to be equal for all pavement types; therefore, do not include in analysis)

CRF_n = capital recovery factor for year n calculated as follows (see Figure 54-7.D):

$$= \frac{i(1+i)^n}{(1+i)^n - 1} \quad \text{Equation 54-7.2}$$

i = discount rate (assumed to be 0.03 (i.e. 3%))

n = year within analysis period in number of years after initial construction

C = initial construction cost per mile

R₁ = first rehabilitation cost per mile

R₂ = second rehabilitation cost per mile

R_n = nth rehabilitation cost per mile

PWF_{nn} = present worth factor for the nth number of years after initial construction that the nth rehabilitation activity is performed, calculated as follows (see Figure 54-7.D):

$$= \frac{1}{(1+i)^{nn}} \quad \text{Equation 54-7.3}$$

n₁ = number of years after initial construction that the first rehabilitation activity is performed

n₂ = number of years after initial construction that the second rehabilitation activity is performed

n_n = number of years n after initial construction that the nth rehabilitation activity is performed

If the difference in life-cycle cost between one alternative and the others is greater than 10%, select the alternative with the lowest life-cycle cost. If the difference in life-cycle costs is 10% or less, the selection will be based upon the alternate pavement bidding process described in Section 54-1.04 with only those alternatives within the 10% being taken forward to bidding. However if the project does not fit the criteria for alternate pavement bidding, or one pavement type is preferable, the project will be referred to the Pavement Selection Committee. If the Committee agrees alternate pavement bidding is not appropriate, the Committee will select the pavement type.

The Pavement Selection Committee consists of five Department personnel (i.e., three from the Central Office and two from the district). Regional Engineers, Deputy Directors, and other high-ranking personnel are excluded from the Committee. Committee meetings usually are held by conference calls. Factors that are considered by the Committee during the selection process are documented in the *AASHTO Guide to Design of Pavement Structures*. Committee deliberations are considered confidential and only the Committee's recommendation as to the final pavement selection is recorded.

n	CRF_n^{①②}	PWF_n^{①③}
5	--	0.8626
10	--	0.7441
15	--	0.6419
20	--	0.5537
25	--	0.4776
30	--	0.4120
35	--	0.3554
40	--	0.3066
45	0.04079	--

Notes:

- ① Factors in Figure 54-7.D are applicable only for a discount rate of 3% (i.e., $i = 0.03$).
- ② See Equation 54-7.2.
- ③ See Equation 54-7.3.

CAPITAL RECOVERY AND PRESENT WORTH FACTORS

Figure 54-7.D

54-8 PAVEMENT DESIGN SUBMITTALS

54-8.01 Submittal Requirement

Pavement designs for projects involving new construction, pavement replacement, or widening greater than or equal to 6 ft will be submitted to the Bureau of Research for approval if the project involves:

- more than 4,750 sq yds of pavement;
- more than \$500,000 in pavement costs (see 20 ILCS 2705/2705-590);
- high stress intersections, experimental pavements, or special designs;
- exceptions to policy; or
- an expired pavement design (see Section 54-8.03).

Once approved, pavement designs will be posted on the IDOT website for public information. Approved pavement designs shall also be included in the Phase I project report or file.

54-8.02 Submittal Content

All pavement design submittals will include the following items:

1. Transmittal Memorandum. Include a memorandum of transmittal with the submittal. The memorandum should include information such as the route, section, county, description of the project, the district's recommendation for the pavement design, and the basis for that recommendation.
2. Location Map. Include a location map of the subject improvement showing the limits of the pavement work.
3. Typical Sections. Include typical sections for the proposed pavement types and for any special or unusual pavement treatment. Typical sections should include information detailing the number of lanes, shoulders, curbs and gutters, and other information as appropriate. Usually, only one typical section is required.
4. Subgrade Stability Chart. If the soil condition is found to be fair or granular, include the subgrade stability chart used in the analysis. Also, include documentation for any unusual soil conditions that affect pavement design (e.g., laboratory test results). If the soil is found to be poor, it is not necessary to include detailed information to substantiate this fact as this is the assumed condition.
5. Design Calculations. For most submittals, simply include a copy of the "IDOT Mechanistic Pavement Design and Life-Cycle Cost Analysis" spreadsheet (BDE 5401). For designs not covered by the spreadsheet (e.g. composite pavement designs), include all design calculations and assumptions (e.g., traffic factor calculations, thickness calculations, thickness nomographs and related charts).

6. Economic Analysis. For most submittals, simply include the life-cycle cost analysis portion of spreadsheet BDE 5401. For designs based upon a first-cost analysis, include all calculations and assumptions related to the economic analysis. For special designs, an economic analysis is not required.
7. Unit Cost Sheets. Provide unit cost computation sheets that document the unit costs used for each major pay item involved in each of the economic designs. The unit costs must be based on the total anticipated quantities of the major pay items involved for the entire contract section.
8. Other Information. Include adequate documentation that describes any unusual factors affecting design or that influenced the pavement selection (e.g., construction staging, high-stress locations, Local Agency requests, unusual traffic volumes, traffic count summary sheets, memoranda from other District Bureaus, etc.).

54-8.03 Shelf-Life of Approved Pavement Designs

To ensure the department is using relevant data in the design and selection of pavements as required by the Department of Transportation Law, 20 ILCS 2705/2705-590, the approval of a pavement design will expire after 5 years.

To avoid having a pavement design expire in close proximity to a project's anticipated construction letting date, the submittal of pavement designs for approval should be coordinated with the letting date; or the design should be updated and re-submitted for approval sufficiently in advance of the letting date.

54-9 DESIGN EXAMPLES

The following examples illustrate typical IDOT pavement designs:

* * * * *

Example 54-9.1

Given: New rural 4-lane State highway in central Sangamon County
 ADT (Design Year Traffic) PV = 17,225 SU = 360 MU = 360
 Subgrade Support Rating (SSR) = Poor
 Asphalt Binder Type = PG64-22

Because this involves new construction, it will be necessary to perform both a rigid and flexible mechanistic design. See Figure 54-1.A.

Solution:

Step 1: Determine the actual traffic factor using Equations 54-4.1 and 54-5.1.

$$\begin{aligned} & \text{TF}_R \text{ (Actual)} \\ \text{TF}_{R(A)} &= 20 \frac{(0.15 \cdot 0.32 \cdot 17,225) + (143.81 \cdot 0.45 \cdot 360) + (696.42 \cdot 0.45 \cdot 360)}{1 \times 10^6} \\ &= 2.74 \end{aligned}$$

$$\begin{aligned} & \text{TF}_F \text{ (Actual)} \\ \text{TF}_{F(A)} &= 20 \frac{(0.15 \cdot 0.32 \cdot 17,225) + (132.50 \cdot 0.45 \cdot 360) + (482.53 \cdot 0.45 \cdot 360)}{1 \times 10^6} \\ &= 2.01 \end{aligned}$$

Step 2: Check minimum traffic factor.

$$\begin{aligned} & \text{TF}_R \text{ (Minimum)} \\ \text{TF}_{R(M)} &= 20 \frac{(143.81 \cdot 0.45 \cdot 250) + (696.42 \cdot 0.45 \cdot 750)}{1 \times 10^6} \\ &= 5.02 \end{aligned}$$

$$\begin{aligned} & \text{TF}_F \text{ (Minimum)} \\ \text{TF}_{F(M)} &= 20 \frac{(132.50 \cdot 0.45 \cdot 250) + (482.53 \cdot 0.45 \cdot 750)}{1 \times 10^6} \\ &= 3.56 \end{aligned}$$

Because the minimum traffic results in a higher traffic factor, use the minimums.

Step 3: Determine the pavement HMA mixture temperature from Figure 54-5.C and round up to the nearest 0.5 degree. See Figure 54-9.A.

$$\text{HMA Mix Temperature} = 78.0^\circ\text{F}$$

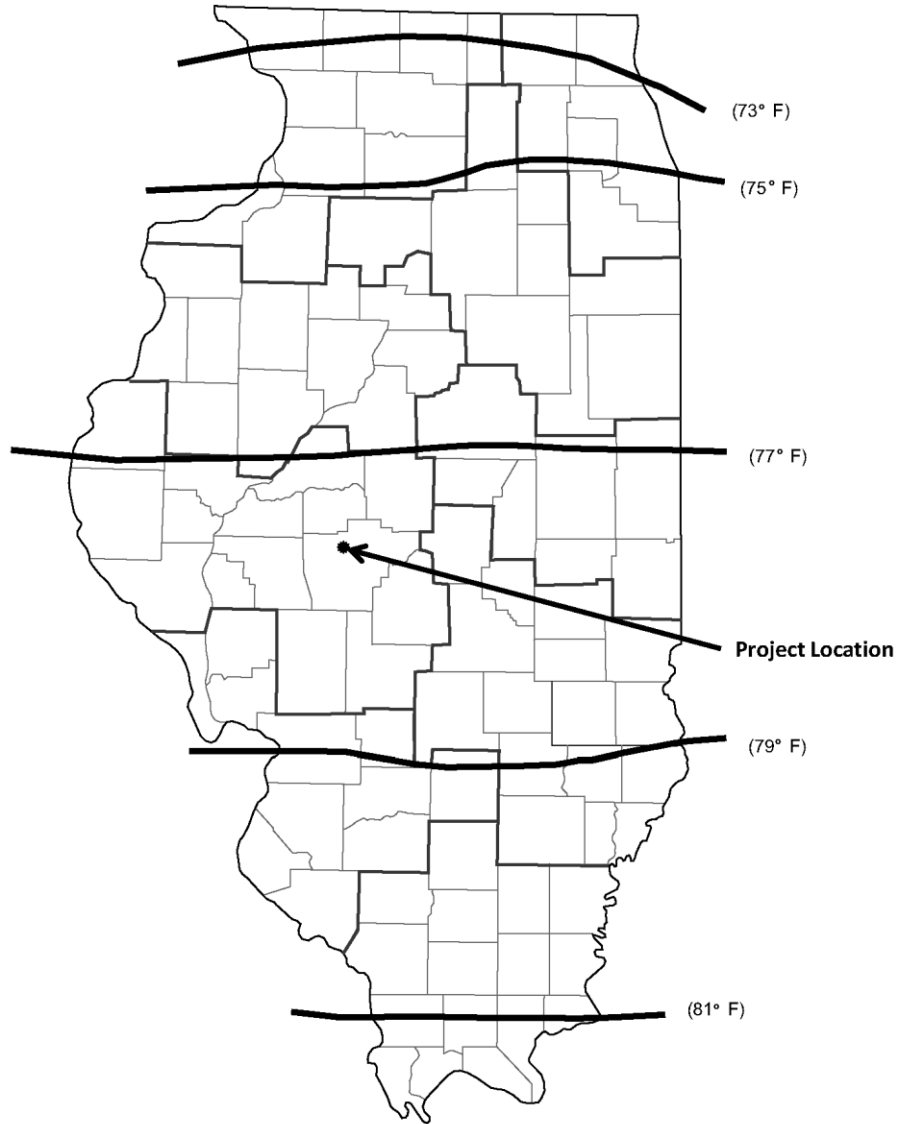

Note: The minimum design HMA mixture temperature will be 73°F.

**HMA MIXTURE TEMPERATURE
(Mechanistic Design: Flexible Pavement)**

Figure 54-9.A

Step 4: Determine Design E_{HMA} from Figure 54-5.D and round to nearest 10. See Figure 54-9.B.

$$\text{Design } E_{HMA} = 610 \text{ (i.e., 607 rounded to 610)}$$

Step 5: Determine the Design HMA strain using the $TF_{F(M)}$ and Figure 54-5.E. See Figure 54-9.C.

$$\text{Design HMA strain} = 84$$

Step 6: Using the Design E_{HMA} and the Design HMA strain, determine the flexible thickness from Figure 54-5.F for a poor subgrade and round up to the nearest 0.25 in. See Figure 54-9.D.

$$\text{Thickness} = 10.75 \text{ in. (i.e., 10.74 in. rounded up to 10.75 in.)}$$

Step 7: Determine the limiting strain criterion (LSC) design thickness from Figure 54-5.I and round up to the nearest 0.25 in. See Figure 54-9.E.

LSC Thickness = 16.00 in. (i.e., 15.78 in. rounded up to 16.00 in.) is greater than standard design thickness – use HMA thickness of 10.75 in.

Step 8: Using the $TF_{R(M)}$ and Figure 54-4.E for a poor subgrade, determine the rigid thickness. Round up to the nearest 0.25 in. See Figure 54-9.F.

$$\text{Thickness} = 9.00 \text{ in. for tied shoulder (i.e., 8.87 in. rounded up to 9.00 in.)}$$

Results: For the design thickness, use a 10.75 in. full-depth HMA pavement or a 9.00 in. JPCP with tied PCC shoulders. A 45-year life-cycle cost analysis must be performed to determine the pavement type.

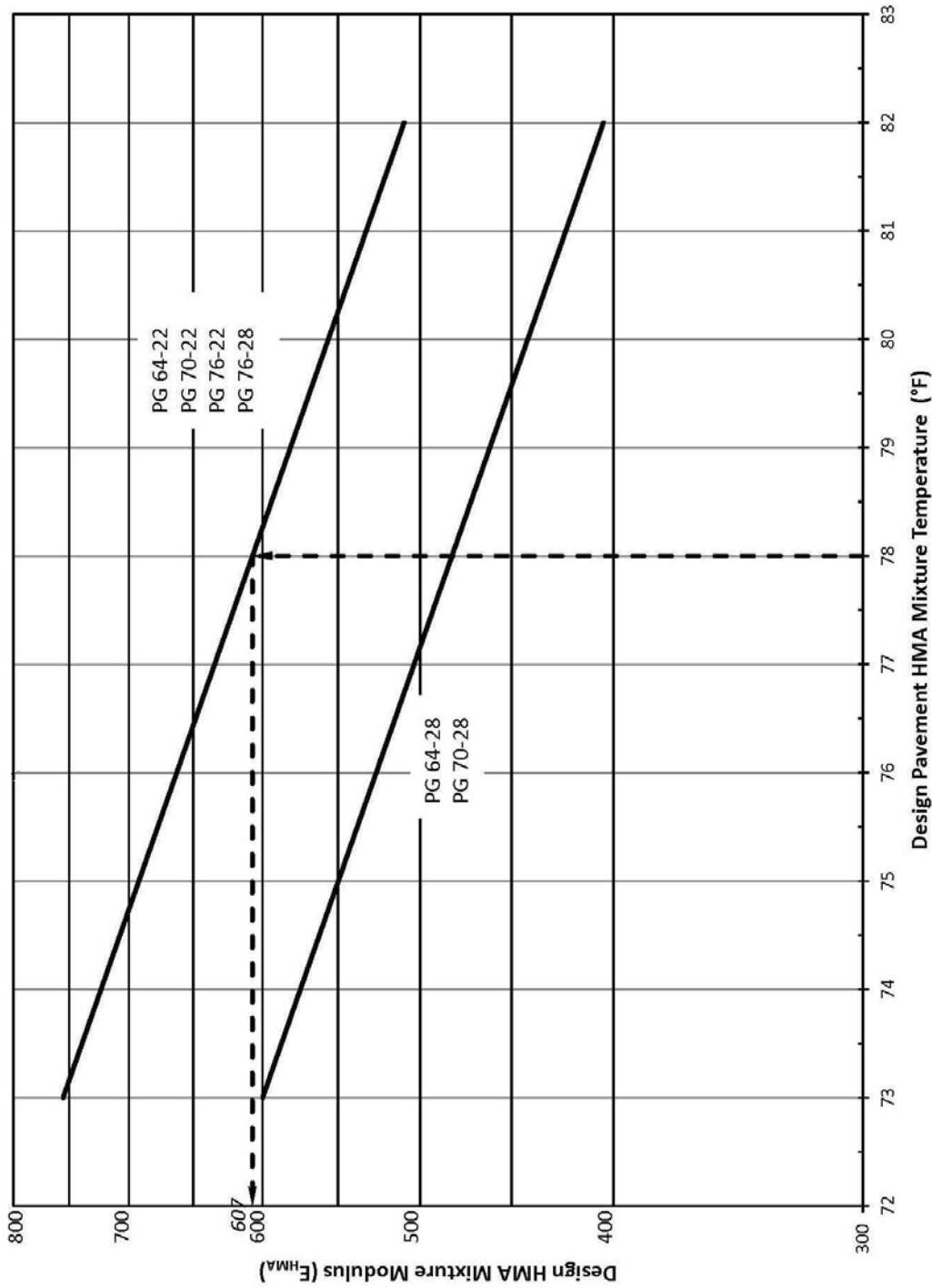

HMA MIXTURE MODULUS (E_{HMA})
(Mechanistic Design: Flexible Pavement)

Figure 54-9.B

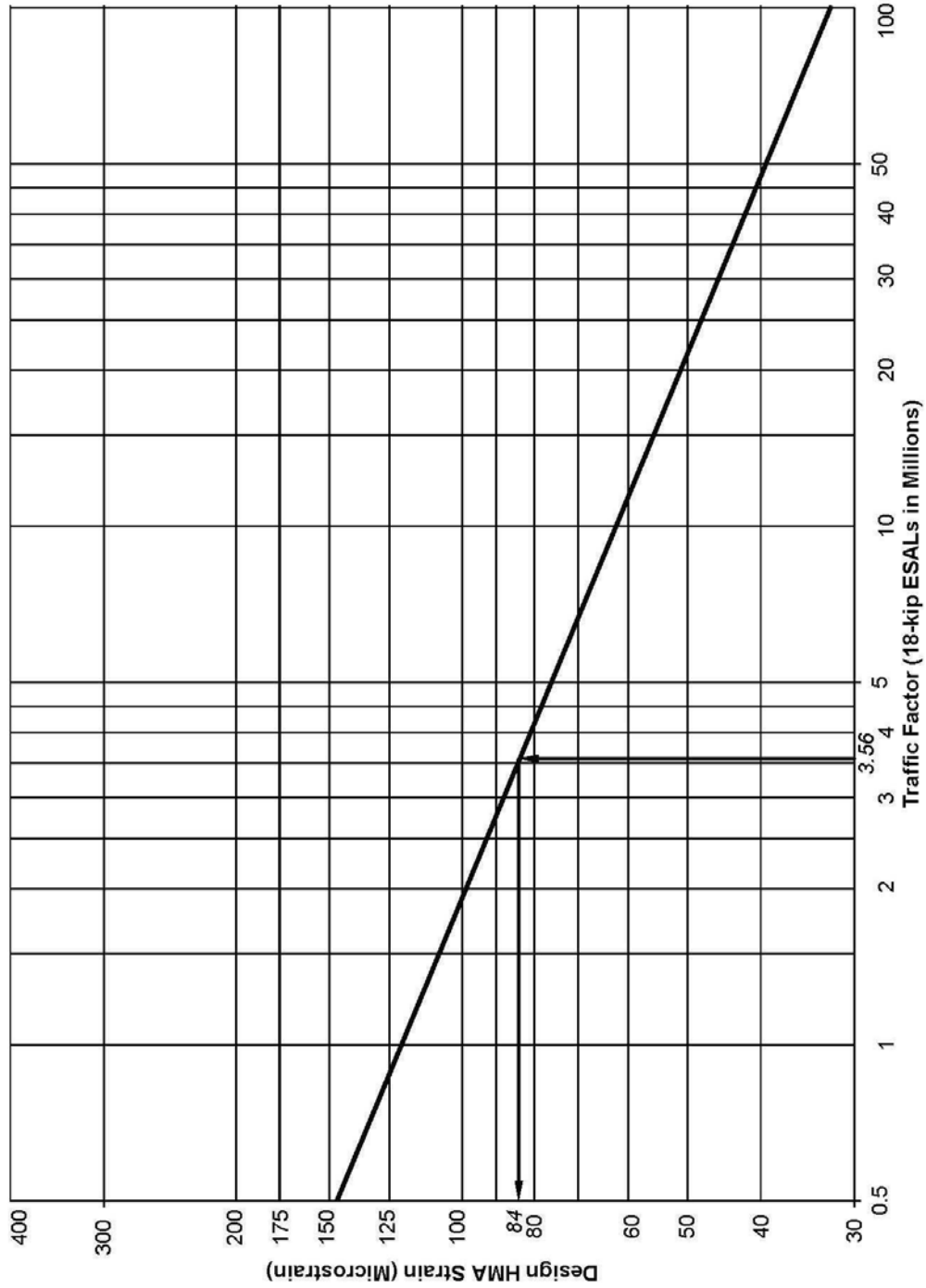

DESIGN HMA STRAIN
(Mechanistic Design: Flexible Pavement)

Figure 54-9.C

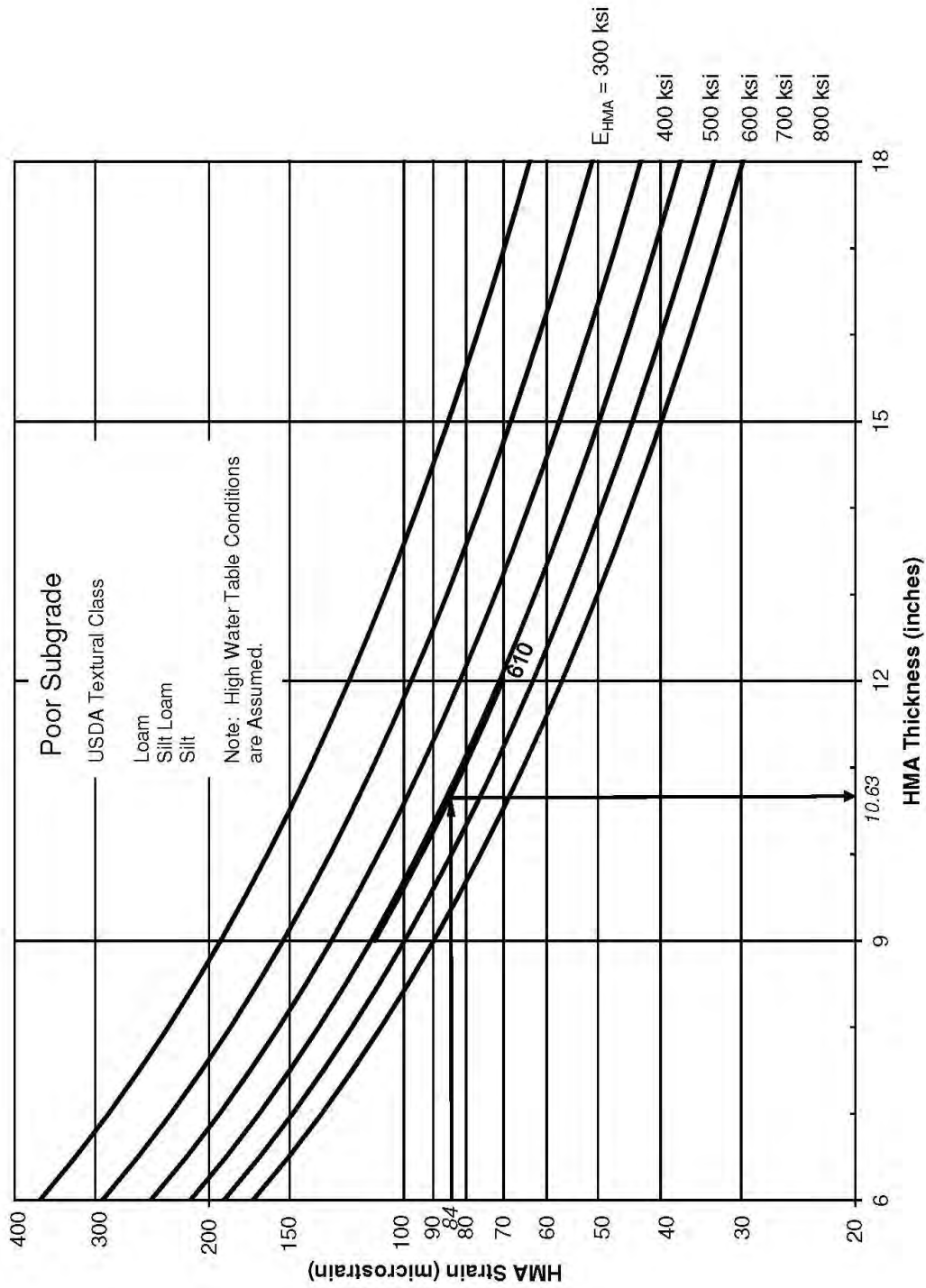

HMA THICKNESS DESIGN CHART
(Mechanistic Design: Flexible Pavement: SSR = Poor)

Figure 54-9.D

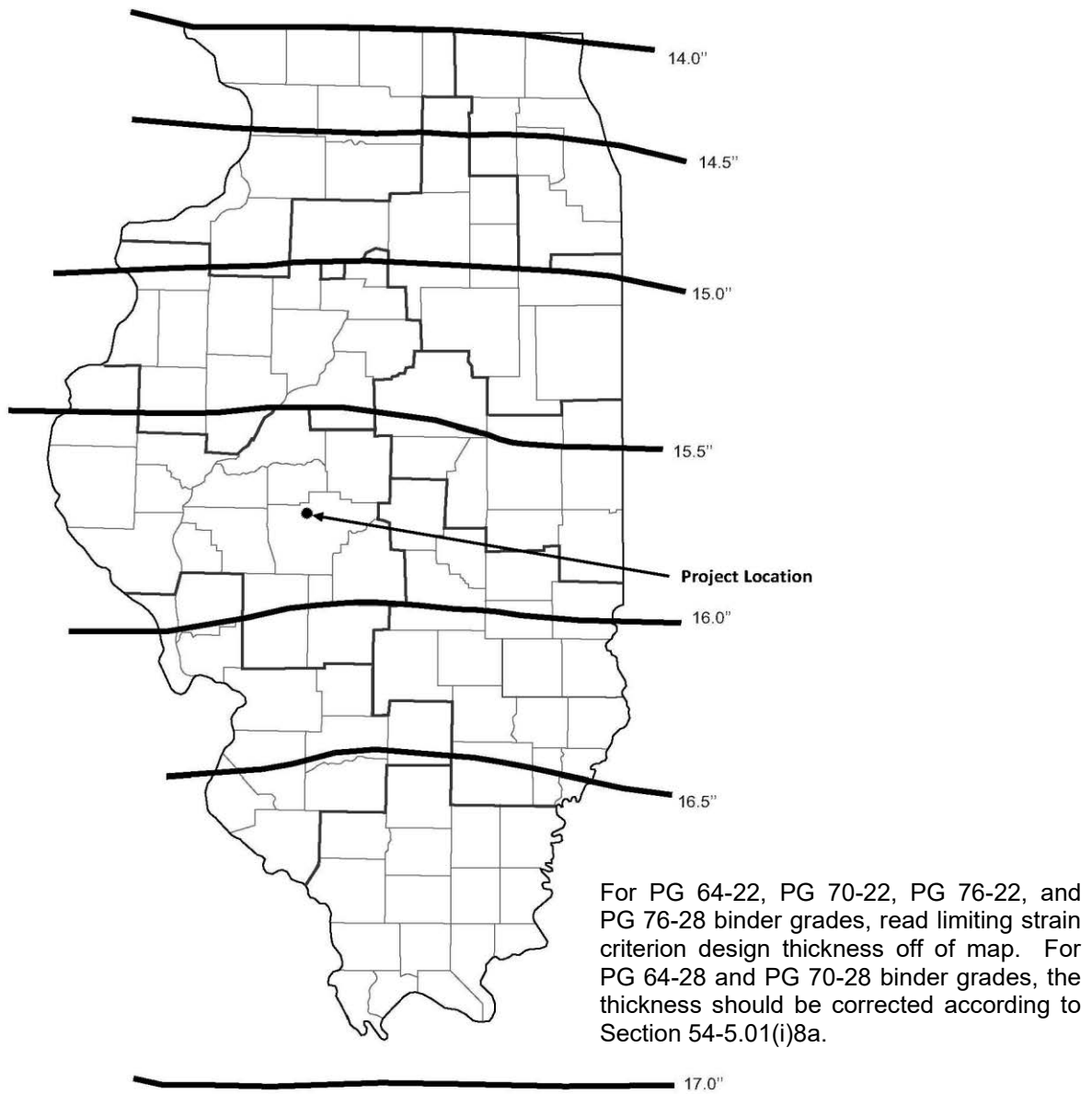

Note: Thickness values based upon Mean Monthly Pavement Temperature at 4 in. depth correlated to July Mean Monthly Air Temperature, axle load of 20,000 lb, strain of 70 $\mu\epsilon$ and E_{Ri} of 2 ksi.

**MAXIMUM PAVEMENT THICKNESS
(Limiting Strain Criterion Design: Flexible Pavement)**

Figure 54-9.E

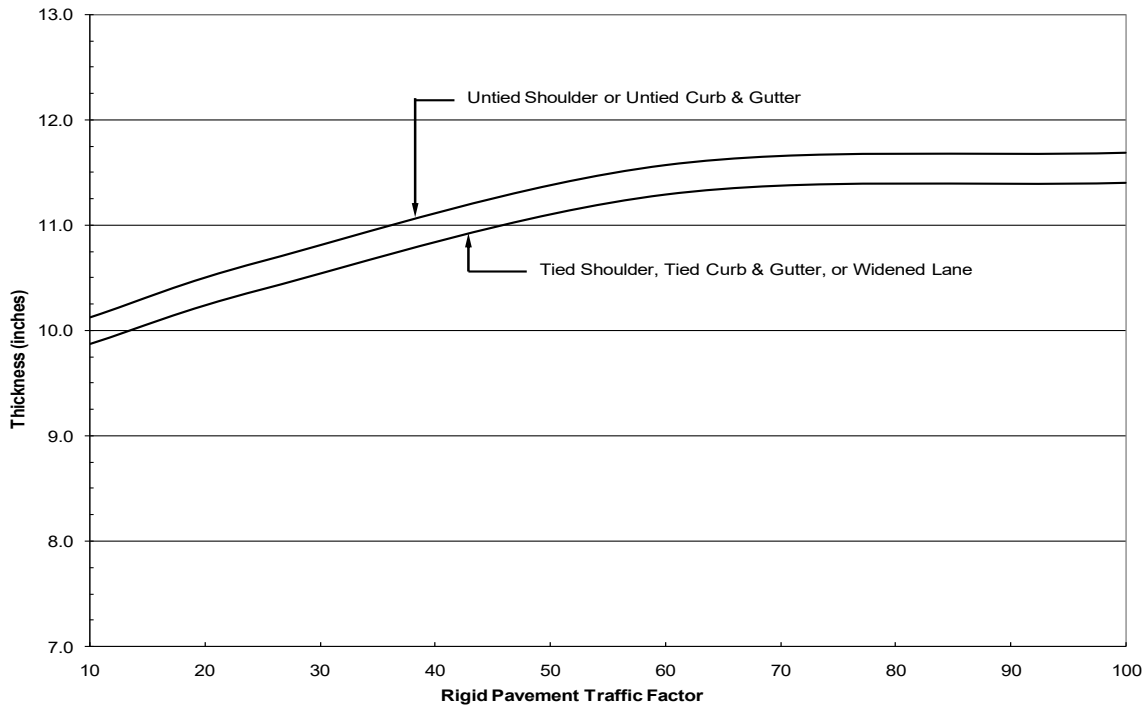
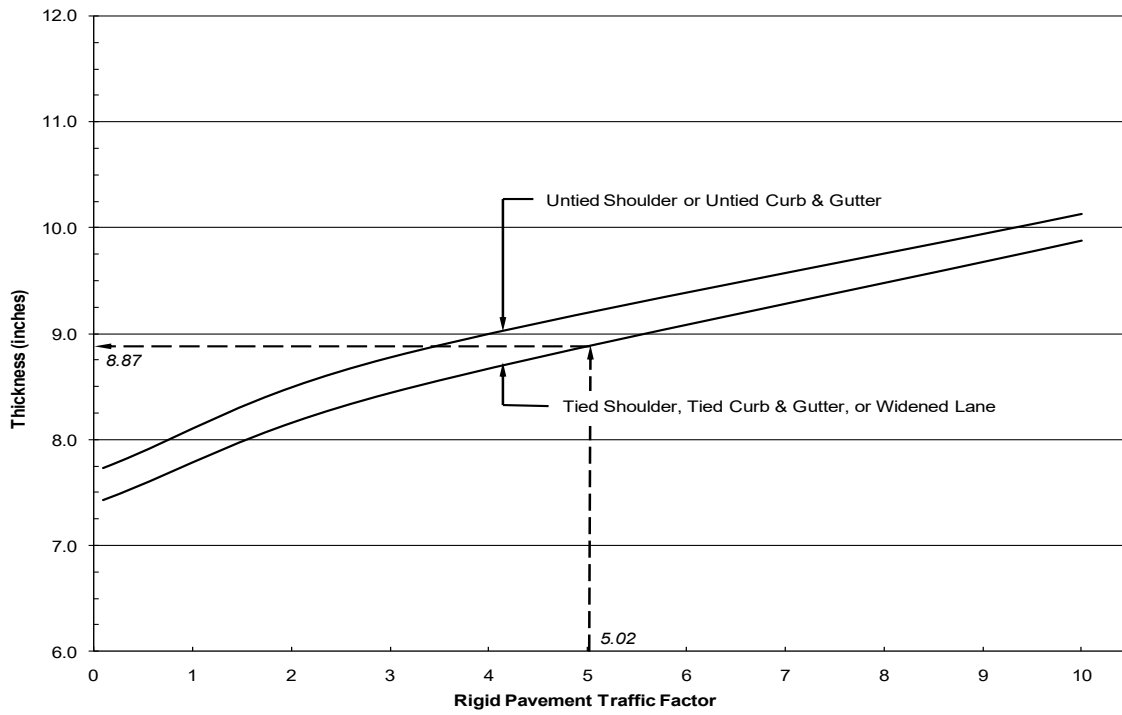

Note: Use of untied shoulder design requires Bureau of Research approval.

**RIGID PAVEMENT DESIGN CHART
(Mechanistic Design: SSR = Poor)**

Figure 54-9.F

Example 54-9.2

Given: Existing 2-lane rural State highway in central Sangamon County
 being widened to 4 lanes – 12 ft widening each side (with resurfacing)
 ADT (Design Year Traffic) PV = 17,225 SU = 360 MU = 360
 Subgrade Support Rating = Poor IBR = 4
 Asphalt Binder Type = PG 64-22

Because the design requires widening with resurfacing, the solution will involve preparing a mechanistic flexible design and a composite design. See Figure 54-1.A.

Solution:

Step 1: The mechanistic flexible design will be the same as in Example 54-9.1.

Step 2: Determine the composite design. A minimum traffic factor does not apply so the actual traffic factor will be used.

$$TR_{R(A)} = 2.74 \text{ (from Example 54-9.1)}$$

From Figure 54-6.A, determine the composite pavement structural number (SN_C).

$$SN_C = 3.55 \text{ (See Figure 54-9.G)}$$

Using Equation 54-6.3, determine the layer thickness:

$$SN_C = 0.40 D_S + 0.33 D_B$$

$$D_B = \frac{3.55 - (0.4 \bullet 2.5)}{0.33}$$

$$D_B = 7.72 \text{ in. From Figure 54-6.D, minimum thickness is 8 in.}$$

Results:

Mechanistic Flexible: 10.75 in. Full-Depth Flexible using PG64-22
 12 in. Improved Subgrade

Composite Design: 2.5 in. HMA Surface Course
 8 in. PCC Base Course

A first-cost economic analysis must be performed to determine the pavement type.

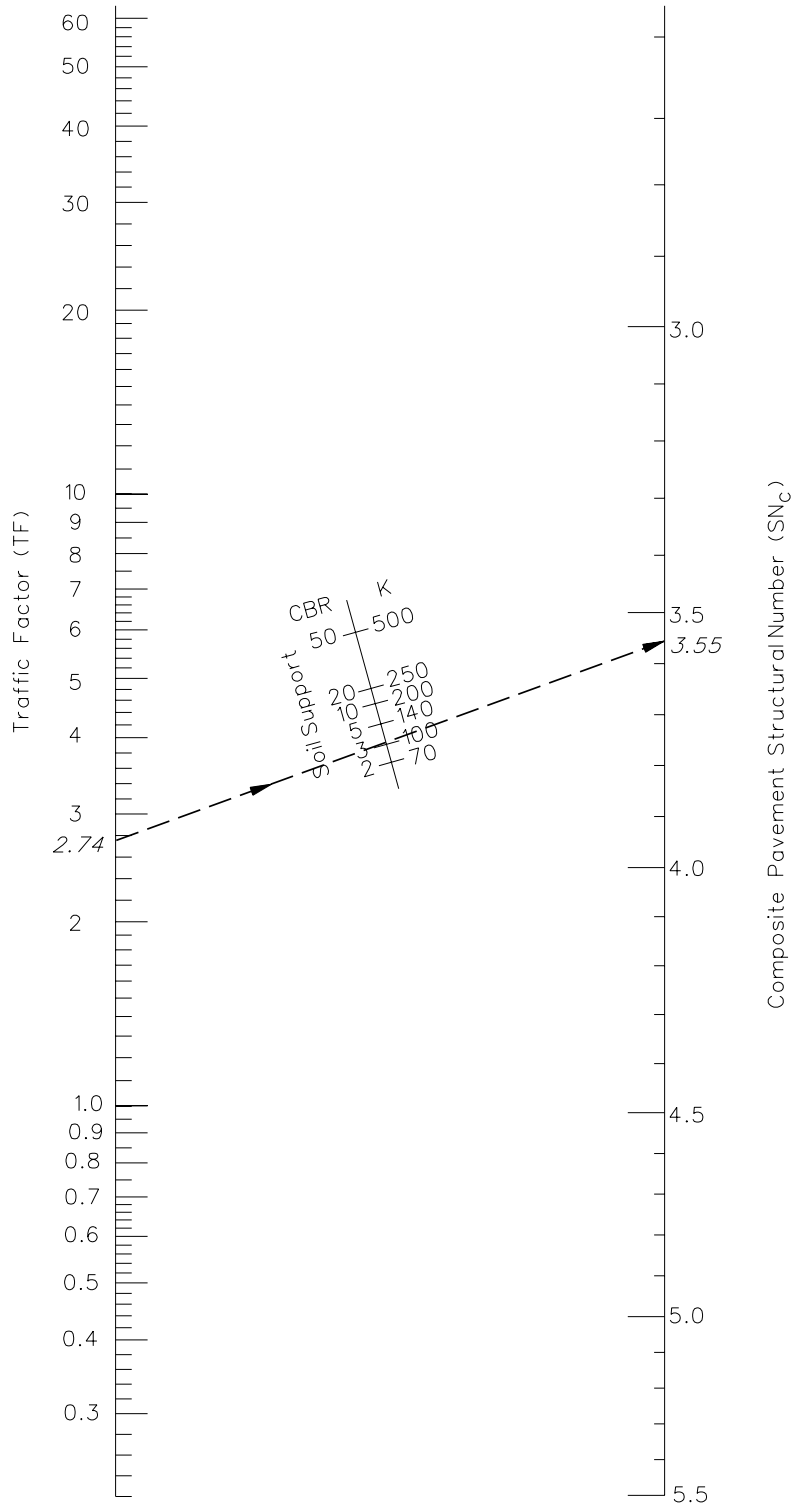

**COMPOSITE PAVEMENT DESIGN NOMOGRAPH
(Class I Facilities)**

Figure 54-9.G

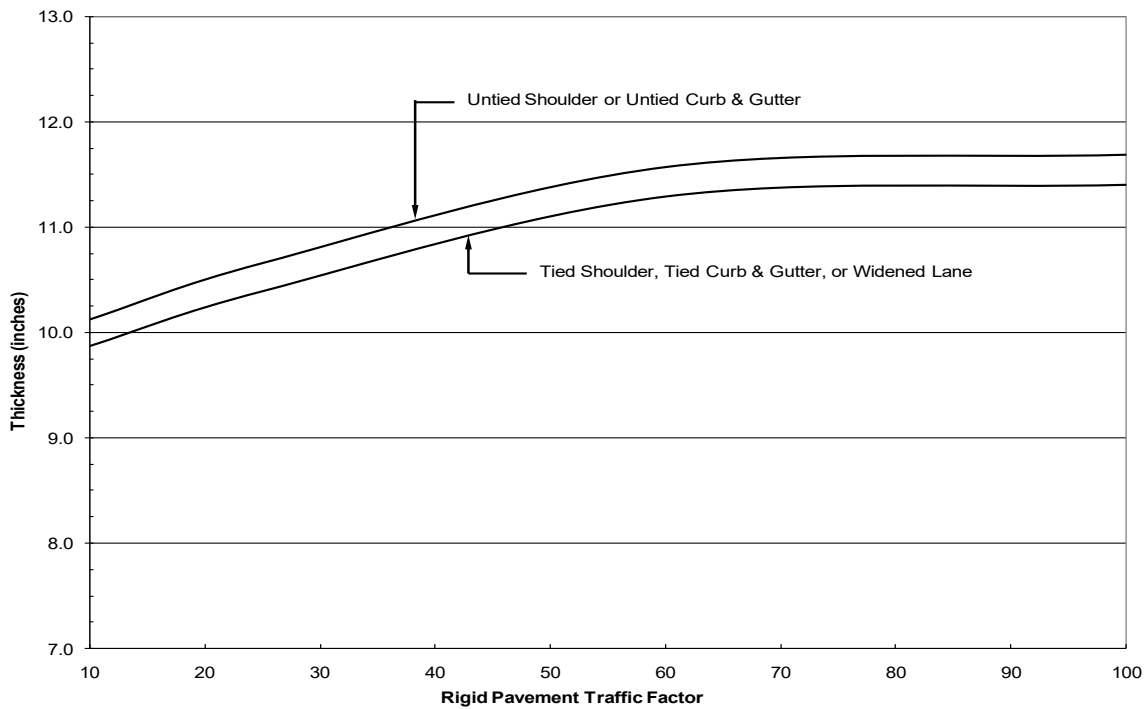
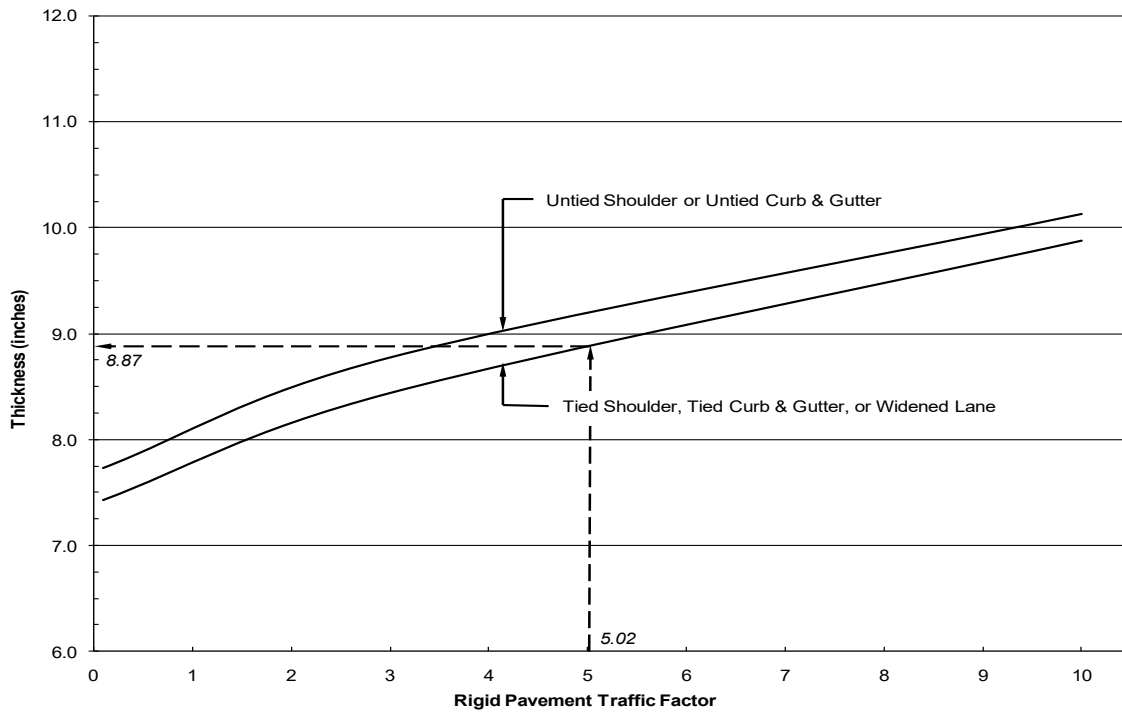

Note: Use of untied shoulder design requires Bureau of Research approval.

**RIGID PAVEMENT DESIGN CHART
(Mechanistic Design: SSR = Poor)**

Figure 54-9.F

Example 54-9.2

Given: Existing 2-lane rural State highway in central Sangamon County
 being widened to 4 lanes – 12 ft widening each side (with resurfacing)
 ADT (Design Year Traffic) PV = 17,225 SU = 360 MU = 360
 Subgrade Support Rating = Poor IBR = 4
 Asphalt Binder Type = PG 64-22

Because the design requires widening with resurfacing, the solution will involve preparing a mechanistic flexible design and a composite design. See Figure 54-1.A.

Solution:

Step 1: The mechanistic flexible design will be the same as in Example 54-9.1.

Step 2: Determine the composite design. A minimum traffic factor does not apply so the actual traffic factor will be used.

$$TR_{R(A)} = 2.74 \text{ (from Example 54-9.1)}$$

From Figure 54-6.A, determine the composite pavement structural number (SN_C).

$$SN_C = 3.55 \text{ (See Figure 54-9.G)}$$

Using Equation 54-6.3, determine the layer thickness:

$$SN_C = 0.40 D_S + 0.33 D_B$$

$$D_B = \frac{3.55 - (0.4 \bullet 2.5)}{0.33}$$

$$D_B = 7.72 \text{ in. From Figure 54-6.D, minimum thickness is 8 in.}$$

Results:

Mechanistic Flexible: 10.75 in. Full-Depth Flexible using PG64-22
 12 in. Improved Subgrade

Composite Design: 2.5 in. HMA Surface Course
 8 in. PCC Base Course

A first-cost economic analysis must be performed to determine the pavement type.

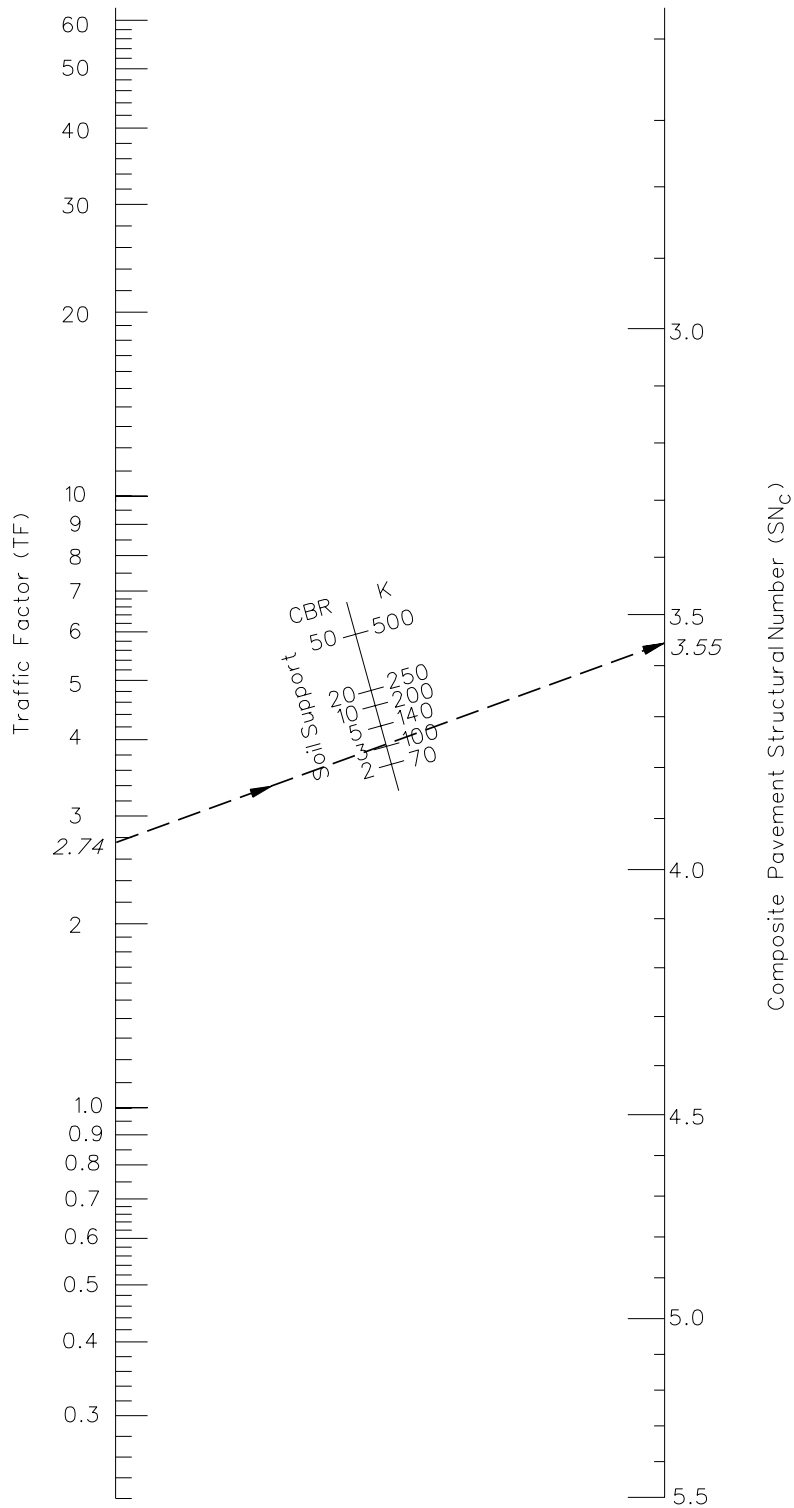

**COMPOSITE PAVEMENT DESIGN NOMOGRAPH
(Class I Facilities)**

Figure 54-9.G

Chapter Fifty-five

**WORK ZONE
TRAFFIC CONTROL**

BUREAU OF DESIGN AND ENVIRONMENT MANUAL

Chapter Fifty-five
WORK ZONE TRAFFIC CONTROL

Table of Contents

<u>Section</u>	<u>Page</u>
55-1 PLAN DEVELOPMENT	55-1.2
55-1.01 Transportation Management Plan	55-1.2
55-1.02 Transportation Management Plan Content	55-1.3
55-2 DESIGN CONSIDERATIONS	55-2.1
55-2.01 Constructability	55-2.2
55-2.01(a) Worksite	55-2.2
55-2.01(b) Construction Design	55-2.2
55-2.01(c) Economic/Business	55-2.3
55-2.01(d) Pedestrians/Bicyclists	55-2.3
55-2.02 Geometrics and Work Zone Design Speed	55-2.4
55-2.03 Lane/Shoulder Widths	55-2.4
55-2.04 Drop-Off Exposure	55-2.5
55-2.05 Transition Taper Rates	55-2.5
55-2.06 Sight Distance	55-2.5
55-2.07 Horizontal Curvature	55-2.8
55-2.08 Vertical Curvature	55-2.8
55-2.09 Cut and Fill Slopes	55-2.8
55-2.10 Pavement Design	55-2.11
55-2.11 Temporary Bridges	55-2.11
55-2.12 Crossovers to Remain in Place	55-2.12
55-3 DESIGN RECOMMENDATIONS	55-3.1
55-3.01 Lane/Shoulder Closures	55-3.1
55-3.02 Two-Way Traffic on Divided Highways	55-3.2
55-3.03 Runaround Detours	55-3.5
55-3.04 Local Route Detours	55-3.9
55-3.05 Stage Construction of Two-Lane, Two-Way Bridges	55-3.11
55-3.06 Stage Construction of Multilane Bridges	55-3.12
55-3.07 Reduced Traffic Control for Road Closed to Through Traffic	55-3.12
55-3.08 Interstate Work Zones	55-3.12
55-4 ROADSIDE SAFETY	55-4.1
55-4.01 Positive Protection	55-4.1
55-4.02 Appurtenance Types	55-4.3
55-4.02(a) Guardrail	55-4.3

Table of Contents
(Continued)

<u>Section</u>		<u>Page</u>
	55-4.02(b) Temporary Traffic Barrier	55-4.3
	55-4.02(c) End Treatments	55-4.5
	55-4.02(d) Glare Screens	55-4.5
55-4.03	Design/Layout	55-4.6
55-5	WORK ZONE TRAFFIC CONTROL DEVICES	55-5.1
55-5.01	Highway Signs	55-5.1
	55-5.01(a) General	55-5.1
	55-5.01(b) Speed Limit Signing	55-5.1
	55-5.01(c) Guide Signs	55-5.1
	55-5.01(d) Portable Changeable Message Signs	55-5.2
	55-5.01(e) Arrow Boards	55-5.3
55-5.02	Channelization Devices	55-5.3
55-5.03	Pavement Markings	55-5.4
	55-5.03(a) Types	55-5.4
	55-5.03(b) Application	55-5.5
55-5.04	Traffic Signals	55-5.5
	55-5.04(a) Location	55-5.5
	55-5.04(b) Application	55-5.6
55-5.05	Highway Lighting and Nighttime Construction	55-5.6
	55-5.05(a) Types	55-5.6
	55-5.05(b) Warrants	55-5.7
	55-5.05(c) Lighting for Nighttime Construction	55-5.7
55-6	REFERENCES	55-6.1

Chapter Fifty-five

WORK ZONE TRAFFIC CONTROL

Highway construction often disrupts the normal flow of traffic and may pose safety hazards to motorists, bicyclists, pedestrians, and workers. Therefore, to mitigate potential operational and safety problems, IDOT requires that a Transportation Management Plan (TMP) be prepared for highway construction projects to consider work zone impacts upon the traveling public.

A Traffic Control Plan (TCP) is a plan to safely guide traffic through a construction project through the use of traffic control devices and project coordination. The TCP focuses on the mobility and protection of traffic within the construction zone. The TCP, part of the TMP, may range in scope from very detailed design plans and special provisions; to the incorporation of Special Provisions, Recurring Special Provisions, and/or Contract Special Provisions; or to merely referencing the *Highway Standards*, *Standard Specifications*, and detailing their use and location.

Chapter 55 provides the necessary information to develop a well-conceived TCP that minimizes the adverse effects of traffic disruption and hazards. This chapter draws heavily on the reader's knowledge of the work zone criteria in Part 6 of the *Illinois Manual on Uniform Traffic Control Devices* (ILMUTCD), *Highway Standards*, and *Standard Specifications*. Work zone traffic control practices and motorist driving patterns are constantly changing and these publications are kept as current as practical.

The key for effective traffic control is consistency. By providing traffic control consistently throughout the State, drivers will recognize the significance of the devices used and react accordingly. When problems or unique situations arise in the development of the traffic control plan, the designer should consult with the District Traffic Control Supervisor. This position is the district contact responsible for resolving unique work zone traffic control issues. Information also applicable to the maintenance and protection of traffic through work zones is included in the following chapters:

- Chapter 13 discusses IDOT's Work Zone Safety and Mobility Rule and provides guidelines for selecting the appropriate traffic control strategy and preparation of a Transportation Management Plan.
- Chapters 31, 32, 33, and 34 provide guidance on the geometric design elements that are also applicable to work zones.
- Chapter 38 provides guidelines on roadside safety.
- Chapter 57 provides guidance on permanent pavement markings, highway signing, and traffic signals.
- Chapter 58 provides guidance on highway lighting.

- Chapter 63 provides guidelines on the preparation of construction plans, including construction and traffic control sheets.
- Chapter 66 provides information and guidelines on the preparation of *Standard Specifications*, *Special Provisions*, *Recurring Special Provisions*, *Contract Special Provisions*, and *Highway Standards*.

55-1 PLAN DEVELOPMENT

55-1.01 Transportation Management Plan

Each Phase I report should contain a TMP that provides the preferred overall strategy for accommodating traffic during construction. The TMP should provide an initial, proposed strategy for addressing traffic control through a work zone (e.g., detour, runaround, crossovers). For many projects, the TMP will not only address the alternatives confined to the project site, but may also address the impact traffic will have on the entire corridor. The earlier in the design process potential traffic control problems are identified, the earlier solutions can be developed and incorporated into the overall project.

Chapter 13 provides guidance on the issues that should be considered during the preparation of the TMP. The goals that directly impact design and planning are:

1. Safety. When analyzing work zone safety measures, consider the following:
 - zero worker fatalities for traffic-related work zone crashes,
 - reduce the number of motorist fatalities in traffic-related work zone crashes by 10% each year with the eventual goal of eliminating all fatalities,
 - eliminate crashes and resulting fatalities and serious injuries caused by queuing, and
 - reduce the number of work zone crashes by 5% from each prior year.
2. Mobility. Consider the following:
 - delays caused by work zones should not exceed more than 5 minutes per mile (3 minutes per km) of project length with a maximum of 30 minutes above the normal recurring traffic delay, and
 - queues caused by work zones should be no more than 1.5 miles (2.5 km) beyond pre-existing queues.

Even if the TMP has been fully developed in the Phase I report and has satisfied the goals, the designer should check to ensure the TMP is still applicable. This is especially true for projects that may have been several years in the development process. If the TMP needs to be modified, present the project at a coordination meeting. If the TMP is acceptable and satisfies

the delay and queuing goals, then the development of the final plans for Phase II can be prepared. If the goals are not met, then submit a “Request for Exception to Compliance” to the Bureau of Safety Programs and Engineering for further approval; see Chapter 13.

If the project is on a significant route and did not require a Phase I report, or if the TMP was not completely developed in Phase I, then a TMP should be developed in accordance with Chapter 13 to address safety and mobility goals.

If the project did not require a project report and the project is not on a significant route, it will be the designer’s responsibility to prepare a TMP in Phase II consistent with the requirements presented in this chapter and Chapter 13.

55-1.02 Transportation Management Plan Content

The TMP should include the preferred traffic control method for accommodating traffic during construction and the expected work zone impacts. Depending on whether a project is on a significant route or not, a TMP can have the following three components:

1. Traffic Control Plan (TCP). A TCP is a plan to safely guide traffic through a construction project through the use of traffic control devices and project coordination. The TCP focuses on the mobility and protection of traffic within the work zone.
2. Transportation Operations Plan (TOP). A TOP is a plan that consists of strategies that mitigate work zone impacts through the use of improved transportation operations and management of the transportation system.
3. Public Information Plan (PIP). A PIP is a plan that consists of strategies to inform those affected road users including the surrounding community of the expected impact of a project, of changing conditions, and available travel options.

A TCP is required on all IDOT highway projects. A TOP and PIP are required on projects designated as significant routes, but should be considered on all projects. See Chapter 13 for guidance on significant routes.

Figure 55-1.A illustrates the format and required opening paragraphs for the TCP that are placed in the special provisions. Include these paragraphs, or similar paragraphs, on every project. See Chapter 66-1.03 for additional guidance on preparation of the special provisions.

Traffic Control Plan

Effective 1985 Revised 1/2/97

9-107T1-97

Traffic control shall be according to the applicable sections of the Standard Specifications for Road and Bridge Construction, the guidelines contained in the Illinois Manual on Uniform Traffic Control Devices for Streets and Highways, the Supplemental Specifications, these Special Provisions, and any special details and highway standards contained herein and in the plans.

Special attention is called to Articles 107.09 and 107.14 of the Standard Specifications for Road and Bridge Construction and the following traffic control related (1) Highway Standards; (2) Supplemental Specifications and Recurring Special Provisions; and (3) Other Special Provisions which are included in this contract:

1. Standards: *(List applicable traffic control standards)*
2. Supplemental Specifications and Recurring Special Provisions:
(List titles of applicable Recurring Specs which relate to traffic control)
3. Special Provisions: *(List titles of traffic control related special provisions)*

**SPECIAL PROVISIONS FOR CONSTRUCTION PROJECTS
(Sample Format)**

Figure 55-1.A

55-2 DESIGN CONSIDERATIONS

The objective of the traffic control plan (TCP) is to provide an implementation strategy that will minimize the adverse effects of traffic disruption on motorists, pedestrians, and bicyclists and provide a safe work area for workers. The following sections present design criteria that apply to temporary crossovers on divided highways, existing roadways through work zones, and detours specifically designed for construction projects (e.g., crossovers, runarounds). These criteria do not apply to detours over existing routes, which are presented in Section 55-3.04.

Consider the following engineering elements when developing the TCP:

1. Geometrics. The TCP should provide adequate facilities for drivers to maneuver safely through the construction area, day or night. The design should avoid frequent and abrupt changes in roadway geometrics (e.g., lane narrowing, lane drops, transitions that require rapid maneuvers). Section 55-2 presents the geometric design criteria applicable to work zones.
2. Roadside Safety. Motorist, pedestrian, bicyclist, and worker safety is a high priority element of any TCP and should be an integral part of each phase of the construction project (i.e., planning, design, and construction). Section 55-4 addresses the roadside safety issues typically encountered during construction.
3. Highway Capacity. The TCP should, where practical, provide the capacity necessary to maintain an acceptable level-of-service for the traveling public. This may require converting shoulders to travel lanes, eliminating on-street parking, constructing temporary lanes, limiting lane closures to hours when the capacity can be maintained, or expanding public transportation. Section 13-3.02(b) provides further information on highway capacity issues.
4. Special Traffic Control Devices. Special traffic control devices not included in the *Highway Standards* are included in the TCP to safely direct vehicles through or around the work zone. Coordinate the selection and location of these special traffic control devices with the Bureau of Safety Programs and Engineering and the Bureau of Operations. Section 55-5 provides guidance on the selection and location of traffic control devices in work zones.
5. Overhead Lighting. The designer should maintain existing overhead lighting and, on a case-by-case basis, consider the need for supplemental roadway lighting at potentially hazardous sites within the work area. Section 55-5.05 discusses the use of work zone lighting.

55-2.01 Constructability**55-2.01(a) Worksite**

Evaluate the construction sequence of the proposed TCP to identify any safety, operational, or logistical problems and to facilitate the timely completion of the project. Special attention must be focused on provisions for contractor accessibility to the work site, the delivery and storing of materials, and worker parking. Consider a worksite delivery plan for complex projects (e.g., turnouts in temporary longitudinal traffic barrier for delivery trucks to accelerate and decelerate safely into and out of the traffic flow).

Some of the elements that should be evaluated include:

- the maneuverability of traffic through the horizontal and vertical alignment during all construction phases;
- the separation of opposing traffic, workers, equipment, and other hazards;
- the work areas that will be used for equipment maneuverability and construction inspection;
- oversize and overweight load requirements for construction; and
- the access points to work and material storage sites.

55-2.01(b) Construction Design

Several construction options are available that may reduce construction time or modify the time of construction. These options allow flexibility in planning the work to allow the TMP to better meet safety and mobility goals. Consider the following:

- the use of special materials (e.g., quick-curing concrete that can support vehicular loads within hours after placement);
- the use of special designs (e.g., using precast box culverts instead of cast-in-place box culverts or bridges);
- special scheduling requirements that will reduce traffic disruptions (e.g., working at night and during off-peak hours);
- project phasing that will allow traffic to use the facility prior to project completion; and
- contractor cost incentives/disincentives for early/late completion of construction for facilities with a high ADT; see Section 66-2.04.

55-2.01(c) Economic/Business

Review the TCP to ensure that it does not restrict access to businesses during peak periods. Consider access for large trucks to businesses for deliveries or from manufacturers that generate high truck traffic. Review the discussion for a Public Information Plan in Section 13.4.

55-2.01(d) Pedestrians/Bicyclists

The safe accommodation of pedestrians/bicyclists through the work zone should be addressed early in project development. Whenever possible, work should be done in a manner that does not disrupt existing pedestrian/bicycle facilities; however when such disruption is necessary, the MUTCD requires alternate routes to be provided. Further, the alternate routes shall be detectable and shall include accessibility features consistent with the features present in the existing facility.

Consider the following guidelines when addressing pedestrian/bicycle accommodation through work zones:

1. **Separation.** Physically separate pedestrians/bicyclists and vehicles where practical.
2. **Construction.** Plan the construction so the disruption of pedestrian/bicycle facilities will occur in the shortest practical time or during non-peak times.
3. **Detours.** Pedestrian detours should be avoided since pedestrians rarely observe them, and the cost of providing an accessible detour might outweigh the cost of maintaining the existing access route. When detours are used, they should be designed to minimize adverse travel and the number of pedestrian street crossings.
4. **Temporary Sidewalks.** Where temporary sidewalks are provided, consider the following:
 - a. **Width.** The width of temporary sidewalks should be equal to the existing sidewalk; however the minimum continuous clear width will be 4 ft (1.2 m). Wider sidewalks should be considered where there are high pedestrian volumes. For temporary sidewalks with clear widths less than 5 ft (1.5 m), a 5 ft x 5 ft (1.5 m x 1.5 m) passing space should be provided at least every 200 feet (60 m).
 - b. **Surface.** The surface of temporary sidewalks must be firm, stable and slip resistant. If the temporary sidewalk is to remain-in-place for more than four weeks, provide a 2 in (50 mm) Portland cement or asphalt surface. The material selection should be at the contractor's option. For temporary sidewalks to remain-in-place less than four weeks, a 3 in (75 mm) compacted aggregate surface may be provided.

55-2.02 Geometrics and Work Zone Design Speed

The TCP should provide adequate facilities for drivers to maneuver safely through the construction area, day or night. The design should avoid frequent and abrupt changes in roadway geometry (e.g., lane narrowing, lane drops, transitions that require rapid maneuvers). The work zone design speed applies to the design of the geometric elements through the work zone. It does not apply to the regulatory speed limits that are used for posting the speed limit through the work zone and construction site.

When selecting the work zone design speed, consider the following factors:

1. Posted Speed Limit. The work zone design speed should reflect the following:
 - the existing posted speed limit of the facility before construction begins,
 - the anticipated posted speed limit through the work zone, and
 - the posted speed limit of the facility immediately prior to the work zone.

The work zone design speed normally should not be more than 10 mph (15 km/h) below the posted speed limit prior to construction. Speed reductions greater than 10 mph (15 km/h) may be warranted by the complexity of the work zone; see the Bureau of Operations "Policy on Establishing and Posting Speed Limits on the State Highway System."

2. Urban/Rural. Work zone design speeds in rural areas are generally higher than those in urban areas. This is consistent with the typically fewer constraints in rural areas (e.g., less development).
3. Terrain. Lower work zone design speeds may be applicable for rolling terrains. This is consistent with the typically higher construction costs as the terrain becomes more rugged.
4. Traffic Volumes. For some facilities, the work zone design speed may vary according to the traffic volumes (i.e., use higher design speeds as traffic volumes increase).

See the Bureau of Operations "Policy on Establishing and Posting Speed Limits on the State Highway System" for further guidance on regulatory and work zone speed limits.

55-2.03 Lane/Shoulder Widths

In general, avoid reductions in the roadway cross section width through the construction and work zones. However, this is often not practical given the constraints of the project. When determining lane and shoulder widths in work zones, consider the following guidelines:

1. Divided Highways. For freeways and other divided highways, desirably use 12 ft (3.6 m) wide lanes; but as a minimum, maintain an 11 ft (3.3 m) lane width with 2 ft (600 mm) wide right and left shoulders. Under restrictive urban conditions, a 10 ft (3.0 m) lane width may be considered if an alternative detour route is provided for wide vehicles.

2. Undivided Highways. For undivided highways, maintain a minimum 10 ft (3.0 m) lane width and 1-ft (300-mm) wide shoulders.
3. Single-Lane Facilities. For single-lane roadways that are less than 14 ft (4.2 m) wide, evaluate the need for an alternative wide-load detour route. Ensure the wide-load detour is adequately marked in advance of the work zone.
4. Runarounds. Figure 55-3.C provides the minimum roadway widths for runarounds.
5. Temporary Crossovers. In addition to the above minimum criteria for lane widths, Section 55-3.02 presents the minimum lane widths for the crossover portion.
6. Options. In most cases, it will be more desirable to reduce the shoulder widths versus reducing the traveled way width.

55-2.04 Drop-Off Exposure

A drop-off is defined as an elevation difference between lanes or the edge of the traveled lane and shoulder as traversed by the wheel of a motor vehicle. Changes in elevation along highways present exposure of risk for highway users, especially vulnerable users (e.g., motorcyclists). Exposure can be limited by reducing speed, increasing lateral distance to the drop-off, providing a transition, or installing a barrier.

Refer to the most current Bureau of Safety Programs and Engineering's Policy Memorandum BSE-04 for guidance on mitigating longitudinal drop-offs.

55-2.05 Transition Taper Rates

Lane closures, lane width reductions, and lane shifts require the use of transition tapers to safely maneuver traffic around the encroaching restriction. These taper rates are shown in Figure 55-2.A., Figure 55-2.B and Figure 55-2.C and illustrate the minimum taper lengths for various taper applications in work zones (e.g., lane closures, lane shifts). The *Highway Standards* also present the minimum taper lengths for various taper applications in construction zones (e.g., lane closures, lane shifts). Use the design speed when selecting the appropriate taper rate.

55-2.06 Sight Distance

When considering sight distance in work zones, review the following:

1. Approaches. For the approach to the first physical indication of the work zone, the sight distance available to the motorist should be desirably based on the decision sight distance criteria provided in Section 31-3 and, at a minimum, on the stopping sight distance criteria provided in Section 31-3.

2. Construction Site. Through the construction site itself, ensure that at least the minimum stopping sight distance is available to the driver at all times.
3. Design Features. The location of many design features are often dictated by construction operations. Locate lane closures and transitions where the approaching driver has decision sight distance available to the lane closure.
4. Horizontal Curves. For horizontal curves in the work zone, check the horizontal clearance (i.e., the middle ordinate) of the horizontal curve using its radius and the minimum stopping sight distance for the work zone design speed; see Section 32-4.

Design Speed	Taper Rate
50 mph (80 km/h) or less	50:1
55 mph (90 km/h)	55:1
60 mph (100 km/h)	60:1
65 mph (110 km/h)	65:1

Note: $L = W \times \text{Taper Rate}$,

where: $L = \text{minimum taper length, ft (m)}$
 $W = \text{width, ft (m)}$

TAPER RATES FOR LANE REDUCTIONS/CLOSURES

Figure 55-2.A

Type of Taper	Taper Length
<u>Upstream Tapers</u>	
Merging Taper	L Minimum
Shifting Taper*	0.5 L Minimum
Shoulder Taper	0.33 L Minimum
Two-way Traffic Taper	100 feet (30 m) Maximum
<u>Downstream Tapers (Optional)</u>	100 feet (30 m) per lane

*May be used for determining buffer zone length.

Notes:

1. Length "L" is determined from Figure 55-2.C.
2. Figure 55-2.E illustrates the various taper types.

TAPER LENGTH CRITERIA FOR CONSTRUCTION ZONES

Figure 55-2.B

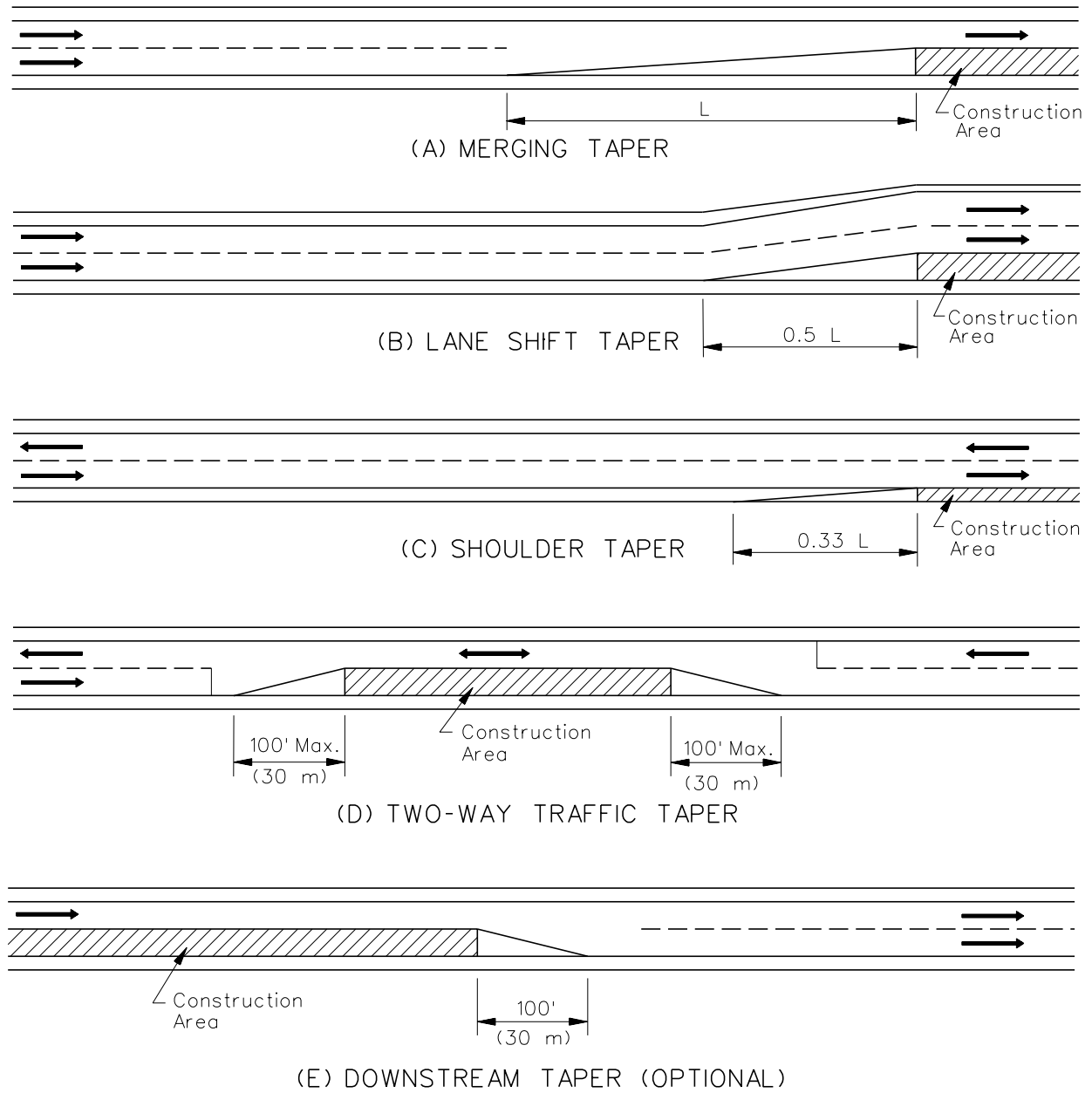

Note: Length "L" is determined from Figure 55-2.C.

**TAPER LENGTH CRITERIA FOR CONSTRUCTION ZONES
(Application)**

Figure 55-2.C

55-2.07 Horizontal Curvature

Design the horizontal curvature using the selected design speed for the work zone (Section 55-2.02) and AASHTO Method 2 for distributing superelevation and side friction to determine the radius and superelevation rate of the horizontal curve. In this Method, superelevation is introduced only after the maximum allowable side friction has been reached. When compared to AASHTO Method 5, this approach typically results in no superelevation on flatter curves (i.e., maintaining the normal crown through the curve) and reduced rates of superelevation on the majority of other curves. Figure 55-2.F provides the minimum radii for retention of the normal crown section for horizontal curves through work zones based on AASHTO Method 2 and a typical cross slope of $\frac{1}{4}$ in/ft (2%). Figure 55-2.G allows the designer to determine the proper combination of curve radius and superelevation rate to meet the work zone design speed where the normal section cannot be retained. For other horizontal curvature elements (e.g., superelevation transition lengths), the criteria presented in Chapter 32 are applicable to work zones, as practical.

Where it is necessary to use the shoulder as a travel lane in the work zone, the shoulder cross slope may create a problem on horizontal curves; i.e., the shoulder slope may need to be modified for superelevation based on Figure 55-2.G, although the traveled way portion can retain the normal crown section through the curve based on Figure 55-2.F. Consider one or more of the following options to alleviate this problem:

- rebuild the shoulders to provide a cross slope equal to that of the adjacent travel lane;
- install advisory speed plate signs for the horizontal curve based on Figure 55-2.G;
- install rumble strips in advance of the temporary travel lane on the shoulder;
- restrict large vehicles (e.g., trucks, buses) from using the temporary travel lane; and/or
- detour large vehicles to other facilities.

55-2.08 Vertical Curvature

Design sag vertical curves in work zones using the selected work zone design speed and the comfort criteria presented in Section 33-4. The comfort criteria are based on the comfort effect of change in vertical direction through a sag vertical curve due to the combined gravitational and centrifugal forces. In general, riding through a sag vertical curve is considered comfortable when the centripetal acceleration does not exceed 1 ft/s^2 (0.3 m/s^2).

55-2.09 Cut and Fill Slopes

Where practical, design temporary cut and fill slopes to meet the design criteria presented in Chapter 34. However, for work zones, 1V:3H front slopes may be used where there is sufficient clear zone available at the bottom of the slope; see Section 55-4.03. The use of steeper front slopes may be considered on a case-by-case basis but may require the installation of roadside barriers or vertical panels.

US Customary			
Work Zone Design Speed, V	f_{max} (Open-Roadway Conditions)	Normal Crown Section Minimum Radii, R_{min} (e = -1.5% to -2%)	Superelevated Section
20 mph	0.27	105 ft	See Figure 55-2.G
25 mph	0.23	200 ft	
30 mph	0.20	335 ft	
35 mph	0.18	510 ft	
40 mph	0.16	760 ft	
45 mph	0.15	1040 ft	
50 mph	0.14	1390 ft	
55 mph	0.13	1835 ft	
60 mph	0.12	2400 ft	
65 mph	0.11	3130 ft	
Metric			
Work Zone Design Speed, V	f_{max} (Open-Roadway Conditions)	Normal Crown Section Minimum Radii, R_{min} (e = -1.5% to -2%)	Superelevated Section
30 km/h	0.28	27 m	See Figure 55-2.G
40 km/h	0.23	60 m	
50 km/h	0.19	116 m	
60 km/h	0.17	189 m	
70 km/h	0.15	297 m	
80 km/h	0.14	420 m	
90 km/h	0.13	580 m	
100 km/h	0.12	787 m	
110 km/h	0.11	1059 m	

Notes:

1. Curve Radii. Radii for both Figures 55-2.F and 55-2.G are calculated from the following equation:

$$R = \frac{V^2}{15(e + f)} \quad (\text{US Customary}) \qquad R = \frac{V^2}{127(e + f)} \quad (\text{Metric})$$

Values for design in Figure 55-2.F have been rounded to the nearest 5 ft (1 m) increment.

2. Normal Crown Section. The data in the above chart is provided based on the normal crown section being maintained throughout the horizontal curve (to the left), a superelevation rate of -2%, and assuming a typical cross slope of 1/4 in/ft (2%). Therefore, the R_{min} column with e = -2% presents the minimum radii that can be used when retaining the normal section through the horizontal curve.

**MINIMUM RADII FOR HORIZONTAL CURVES RETAINING NORMAL CROWN SECTION
(Work Zones)**

Figure 55-2.D

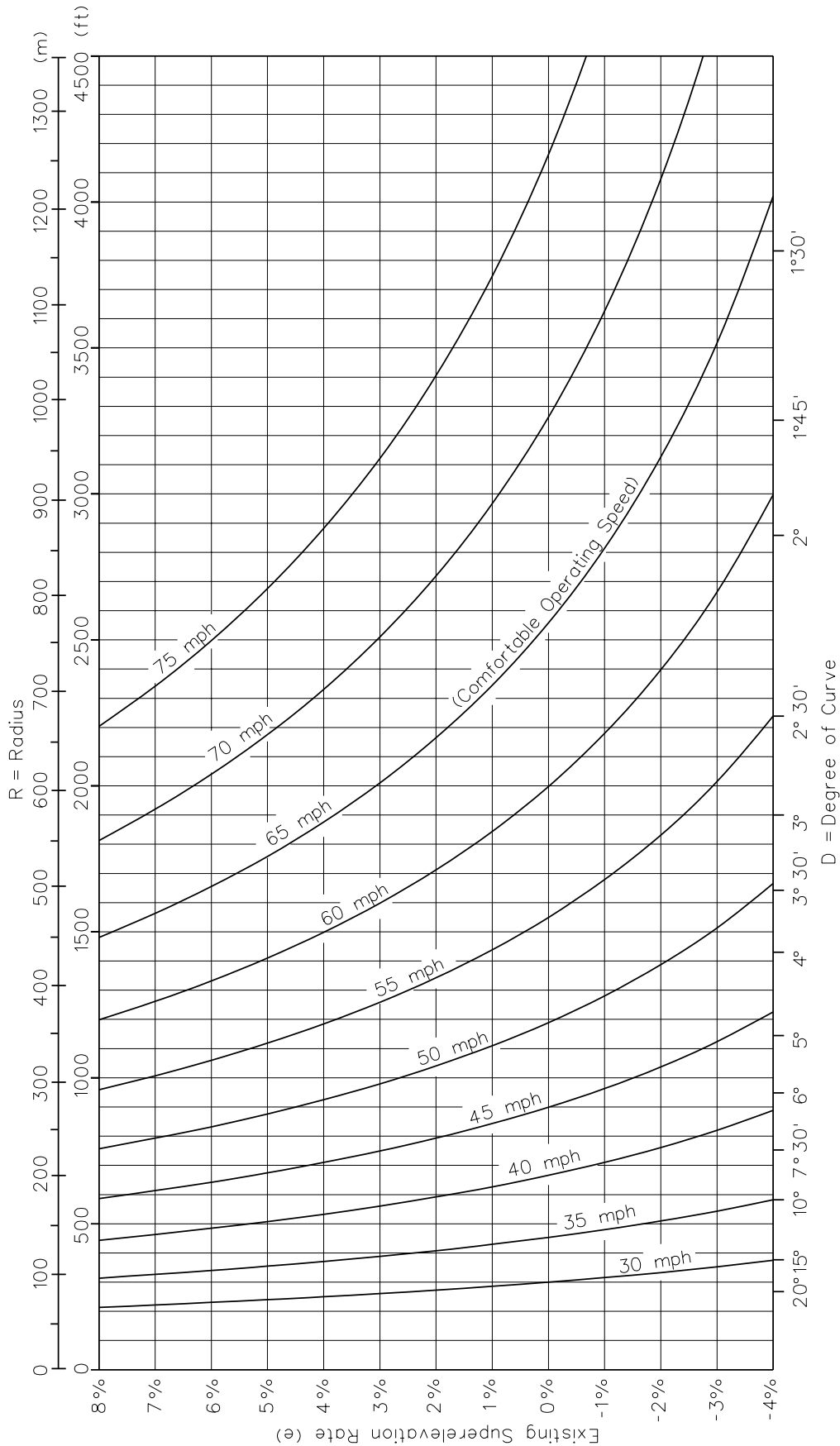

**MINIMUM RADII AND SUPERELEVATION RATES FOR HORIZONTAL CURVES
(Work Zones)**

Figure 55-2.E

- Although detours rarely involve excavation (i.e., cut), 1V:3H cut slopes are generally acceptable in place of the flatter slopes presented in Chapter 34. The use of slopes steeper than 1V:3H for cut depths less than 10 ft (3.0 m) may be acceptable under restrictive conditions. Soil conditions in cut sections will require an investigation to determine their stability.

The anticipated traffic volumes and the length of time the detour will be in place should be weighed in determining final cut and fill slopes. In all cases, stable embankment material must be used and placed according to the *Standard Specifications*.

55-2.10 Pavement Design

The pavement design objective for crossovers, runarounds, local route detours, etc., is to provide, as practical, maintenance-free pavement for its intended life. Note that the pavement for crossovers and runarounds needs to support the expected truck traffic through the work zone. An indication of the required pavement depth can be obtained by preparing a structural pavement design according to Chapter 54 and by using a minimum design period of three years for a single-season detour or five years for over-the-winter detour. The final pavement thicknesses will be based upon a pavement design analysis and previous district experience with similar detour conditions (e.g., soil types, seasons of detour use, truck volume, initial cost, restoration costs).

Typically, crossovers and runarounds are designed using a hot-mix asphalt surface. In high-volume situations, it may be advisable to use full-depth hot-mix asphalt on the detour. Medium-volume situations may warrant a stabilized granular base or an aggregate base with a hot-mix asphalt surface course. In low-volume situations, an aggregate base with some type of surface treatment (e.g., oil and chip) may be an acceptable design to provide maintenance-free pavement. A minimum thickness of 8 in (200 mm) is recommended for aggregate bases and a minimum 3 in (75 mm) of Superpave or Class B is recommended where a HMA surface course is used. As an alternative, a non-reinforced concrete pavement may be used. If non-reinforced concrete pavement is used, investigate the practicality of using lesser quality, local materials in the concrete. Long-term performance is usually not critical in these situations. If the detour will be used through winter, then a HMA surface is recommended.

55-2.11 Temporary Bridges

Where a temporary bridge is required and complete plans for the temporary bridge are not furnished, specify in the traffic control plans or special provisions the general location, roadway width, distance to be spanned, required load capacity, and any other known pertinent design features for the temporary bridge. This information will allow the contractor to bid and submit plans for the Engineer's approval after an award is made, as specified in the *Standard Specifications*.

In special cases, where the district determines the situation dictates a special design, the district may include in the project plans complete design plans for the temporary bridge. Upon request,

the Bureau of Bridges and Structures will prepare these. However, because most contractors are equipped with precast bridge elements and can readily bid and furnish temporary bridges that will meet the Department's criteria, keep the preparation of these special designs by the Department to a minimum.

55-2.12 Crossovers to Remain in Place

A cost savings may be realized if some crossovers on freeway projects are left in place after the project is completed. Because these crossovers are designed to carry Interstate traffic, they are constructed with a high-type pavement that adds to the cost. If crossovers are left in place, this cost may be partially recovered as a cost savings to future construction. Crossovers also leave options open for emergency construction and remain available for future transportation operations plans, including incident management.

Crossovers left in place must be closed with positive separation when not in use, unless the opening is designed to be left open and an exception is obtained from FHWA. Consult the *AASHTO Roadside Design Guide* for information on the design, cost, and maintenance of openings in median barriers for openings in crossovers.

The following are some examples where it may be advisable to leave temporary crossovers in place:

1. Major River Crossings. At these locations, there is usually one preferred location where a crossover can be placed and any future work would require the rebuilding of the same configuration.
2. Locations With Physical Constraints. In some instances, certain factors (e.g., sight distance problems, closely spaced structures, nearby interchanges, elevation differences between lanes) limit where a crossover can be built. Even though projects may be at different locations, the location of a crossover may be set by these limitations.
3. Future Projects in Same Area. If structure work is scheduled for one year and roadway work anticipated in the next five years, the same crossover may be used for both projects. Another example would be a series of structures that are rehabilitated over several years.

When encountering situations as outlined above, the designer should:

- give consideration to leaving the temporary crossovers in place after the project is completed,
- include provisions in the contract to close the crossover during the time it is not in use,
- discuss these provisions at the regular coordination meeting, and
- obtain FHWA and Central Office concurrence.

55-3 DESIGN RECOMMENDATIONS

The following are specific design recommendations for lane and shoulder closures, two way traffic on divided highways, runaround detours, local route detours, stage construction of two lane two way bridges and multilane bridges, reduced traffic control for road closure, and Interstate work zones.

55-3.01 Lane/Shoulder Closures

Lane and/or shoulder closure is often the most common type of traffic control. The *Highway Standards* provide several Traffic Control Standards for lane and shoulder closures. In addition, consider the following:

1. Traffic Control Devices. Section 55-5 and the *Highway Standards* provide Department criteria for the placement of traffic control devices.
2. Speeds. See the Bureau of Operations “Policy for Establishing and Posting Speed Limits on the State Highway System” for guidance on posting speeds in work zones.
3. Tapers. Lane closures, lane width reductions and lane shifts require the use of transition tapers to safely shift traffic around the encroaching restriction. Section 55-2.05 and the *Highway Standards* provide the criteria for taper rates and lengths for work zones.
4. Lane Widths. Section 55-2.03 provides the Department’s criteria for reduced lane widths.
5. Sight Distance. Desirably, provide decision sight distance to the beginning of the lane closure or transition; see Sections 31-3.02, 32-4, and 33-4.
6. Lane Closure Length. Keep the length of a lane closure to a minimum so that motorists are not passing long sections of closed lanes where no work activity is occurring.
7. Roadside Safety. Do not use roadside barriers as transition devices. Where temporary roadside barriers are used, provide sufficient distance between the channelization devices and the roadside barrier to allow an errant motorist to safely return to the traveled way. Roadside barriers (e.g., temporary concrete barrier) may be used as channelization devices beyond the taper. When shifting traffic next to roadside barriers, the shy distance, as discussed in Section 38-6.02, desirably should be provided.
8. Bridges. Sections 55-3.05 and 55-3.06 discuss the criteria for lane closures on bridges.
9. Interstate Projects. Section 55-3.08 discusses additional factors to consider on Interstate projects.

55-3.02 Two-Way Traffic on Divided Highways

Because of the higher traffic volumes and higher speeds on multilane facilities, use special care in the design of these work zones. In these cases, safety considerations are usually more important than costs. In addition to Traffic Control Standard 701416, the following provides several design considerations for this application:

1. Design Speed. The design speed should be no more than 10 mph (15 km/h) below the posted speed limit before the construction zone. See the Bureau of Operations “Policy for Establishing and Posting Speed Limits on the State Highway System” for guidance on posting speeds in work zones.
2. Length. The optimum segment length of two-way traffic on divided highways is less than 4 miles (6 km). Where segments exceed 4 to 5 miles (6 to 8 km), operational efficiency may be reduced as traffic backs up behind slower vehicles.
3. Sight Distance. Adequate sight distance should be provided for motorists approaching the crossover. Desirably, this should be decision sight distance. For additional guidance, see Sections 31-3.02, 32-4, and 33-4. Traffic should not be diverted over to other lanes at locations not clearly visible to approaching motorists (e.g., near bridges, at crest vertical curves).
4. Interchanges. For interchanges, consider the following:
 - a. Access. Desirably, maintain access to all interchange ramps even if the work space is in the lane adjacent to the ramps. Additional crossovers for the purpose of maintaining full interchange access may be required. If interchange access is not feasible or presents a capacity problem, close the ramp and provide detour signing for alternative routes. The designer should review the safety aspects and conduct a capacity analysis to determine the appropriate action.
 - b. Local Coordination and Emergency Services. Where ramp closures are deemed necessary, conduct early coordination with local officials and emergency service having jurisdiction over the affected crossroads or streets. Use newspapers, radio, television, and changeable message signs to alert commuting motorists.
 - c. Deceleration and Acceleration Lengths. Ensure that sufficient deceleration and acceleration distances are maintained where there is work in the vicinity of interchange ramps. If this is not practical, additional traffic control devices or ramp closure may be required.
5. Crossovers. Because of the unexpected movements, special care must be given to the design of crossovers. Temporary concrete barriers and the excessive use of traffic control devices cannot compensate for a poor geometric design of crossovers. Consider the following when designing crossovers:
 - a. Design Speed. The crossover should have a design speed that is no more than 10 mph (15 km/h) below the posted speed limit before the construction zone.

- b. Transitions. Tapers for lane drops should not be contiguous with the crossover (i.e., provide a buffer area between the lane closure and the crossover). See Section 55-2.05 for acceptable taper rates and lengths.
 - c. Width. For one-lane, one-way operations, the lane width through the crossover portion should be 16 ft (5.0 m) with 2-ft (600-mm) wide left and right shoulders. For multilane and/or multidirectional operations, each lane width should be 12-ft (3.6-m) wide with 2 ft (600 mm) left and right shoulders.
 - d. Pavement Design. Section 55-2.10 presents guidelines for determining the pavement design of the crossover.
 - e. Roadside Safety. Provide a clear recovery area or buffer area adjacent to the crossover prior to the work zone.
 - f. Crossovers to Remain In Place. Under some circumstances, it may be cost effective to retain the crossover after the project has been complete. See Section 55-2.12 for additional guidance.
6. Roadside Safety Appurtenances. Where traffic is diverted onto the opposing roadway, consider the effect this will have on the operational characteristics of roadside safety appurtenances. For example, existing trailing ends of unprotected bridge rails may require an approach guardrail transitions or impact attenuators, or blunt guardrail end terminals may require protection with an acceptable end treatment if these appurtenances are within the work zone clear zone. Appurtenances are discussed in Section 55-4.02 and chapter 38 for additional guidance.
 7. Signing. In addition to the signing shown in the Highway Standards, include signing prior to the crossover to indicate the length of the two-way, two-lane section. In addition, provide signing within the two-lane section to indicate the remaining distance of the two-lane section (e.g., NEXT X MILES). Place this sign below the two-way traffic signs.
 8. Channelization Devices. Traffic Control Standards 701416 and 701431 present the general criteria for the placement of channelization devices within and between crossovers. Temporary longitudinal traffic barriers, barricades or drums may be used to channel traffic within the crossovers. Between crossovers, temporary longitudinal traffic barrier is used to separate traffic between the crossovers except as discussed below. Signs, centerline striping, and raised pavement markers, either alone or in combination, are not considered separation devices. Consider the following:
 - a. Short-Duration Projects (120 Consecutive Hours or Less). Type II barricades or drums may be used as separators. Cones may be used for daylight only operations.
 - b. Longer-Duration Projects (Greater than 120 Consecutive Hours). Use temporary longitudinal traffic barrier on all projects other than those listed in Item c. below.

- c. Urban (Typically Posted Speed 40 mph or less). Cones, drums, barricades, or tubular markers may be used as separators for urban projects. Under special circumstances (e.g., winter work), it may be necessary to omit devices to allow for snow removal.
 - d. Ramps. Where ramps or side roads intersect a two-lane, two-way operation, special traffic-accommodation details must be developed. Consult the Bureau of Operations for guidance in these situations.
9. Nighttime Safety for Crossovers. Positive guidance is needed in crossovers. Consider the use of temporary highway lighting, or wet reflective pavement markings within the crossover in addition to other traffic control measures and devices.
- a. Lighting. Consider providing temporary highway lighting where the crossover will be in place for longer than three weeks and one or more of the following conditions exist:
 - Existing continuous highway lighting will be removed because of the construction activities at or adjacent to the proposed median crossover.
 - The median crossover will be located adjacent to a lighted interchange.
 - The absence of highway lighting will contribute to an already less than desirable condition (e.g., inadequate sight distance, inadequate geometrics) required by existing conditions that will not allow an adequate design through the median crossover.
 - The crossover will be used on a roadway section having an ADT of 10,000 or more.

The crossover should be capable of safe operations during blackouts caused by construction activities, adverse weather, or traffic crashes.

See Chapter 56 and/or contact BDE for details on the lighting design. The request for the lighting design should include the:

- location of power source,
 - location of any existing lighting units,
 - geometrics of proposed median crossovers, and
 - length of time it is anticipated that the temporary lighting will be required.
- b. Wet Reflective Pavement Markings. Consider the use of wet reflective pavement markings for crossovers that meet the following conditions:
 - temporary highway lighting is impractical due to cost or geometrics; and
 - adverse geometrics, complexity of the crossover, or previous experience indicate a need for greater positive guidance to the motorist.

10. Emergency Access. Work with local emergency service agencies to ensure access throughout the project. It is important that police, fire, ambulance, and towing services have access without having to travel excessive adverse miles.

55-3.03 Runaround Detours

In addition to the criteria in the *Highway Standards*, runarounds and specially built detours should meet the geometric and roadside safety criteria presented in Sections 55-2 and 55-4 and the following guidelines:

1. Layout. Figure 55-3.A illustrates a typical layout for a runaround detour. Figure 55-3.B illustrates typical cross sections for a runaround detour.
2. Design Speed. The runaround should have a design speed that is no more than 10 mph (15 km/h) below the posted speed limit before the construction zone.
3. Width. At a minimum, provide a 22 ft (6.6 m) traveled way width. If there are significant multiple-unit trucks to affect the design, use the traveled way widths presented in Figure 55-3.C. Also, provide a minimum 2 ft (600 mm) shoulder on each side.
4. Pavement Design. Section 55-2.10 presents guidelines for determining the pavement design.
5. Horizontal Alignment. Desirably, the horizontal curve connecting the runaround to the existing roadway should be sufficiently flat so that superelevation will not be required. See Section 55-2.07 for the design of horizontal curves in work zones.
6. Vertical Alignment. See Section 55-2.08 for the minimum vertical curvature criteria that may be used on runarounds.
7. Sight Distance. Design the runaround to meet the sight distance criteria in Section 55-2.06. Check to ensure that adequate sight distance is available through the horizontal and vertical curves.
8. Traffic Control Devices. Traffic Control Standard 701331 and the Standard Specifications provide the minimum criteria for placement of traffic control devices prior to and through the runaround. Temporary rumble strips, reflectors, and/or additional warning devices may be required where unusual site conditions warrant and/or where the design speed on the runaround is more than 15 mph (25 km/h) less than the approach posted speed.

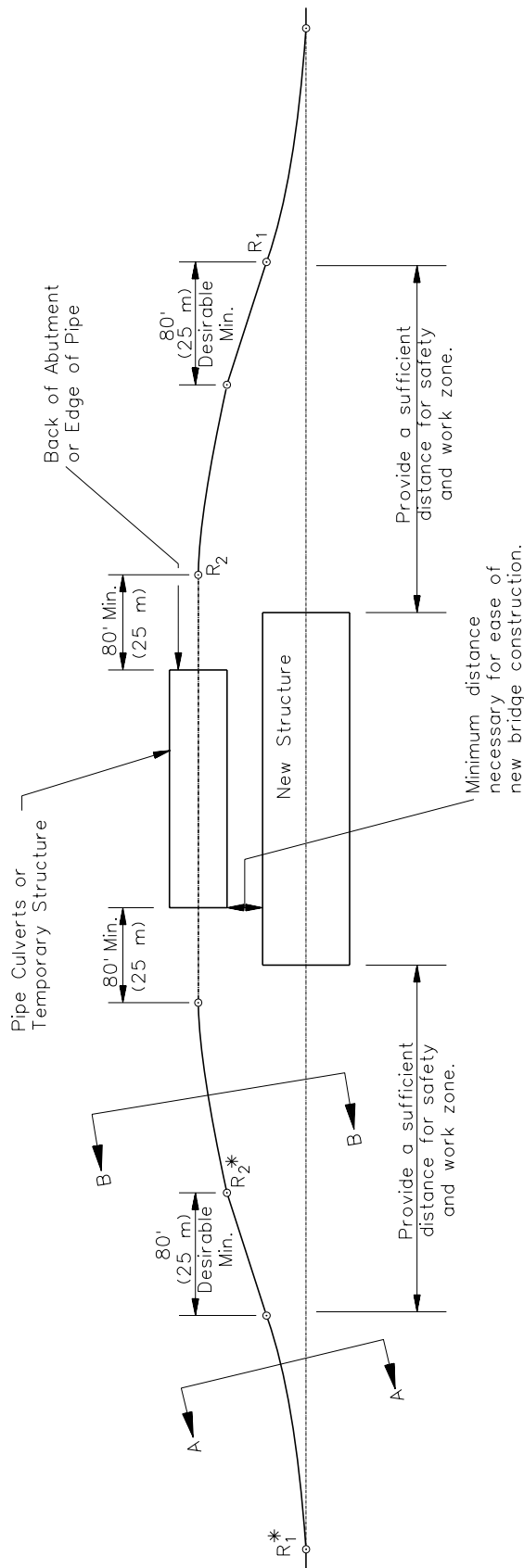

*See Section 55-2.07.

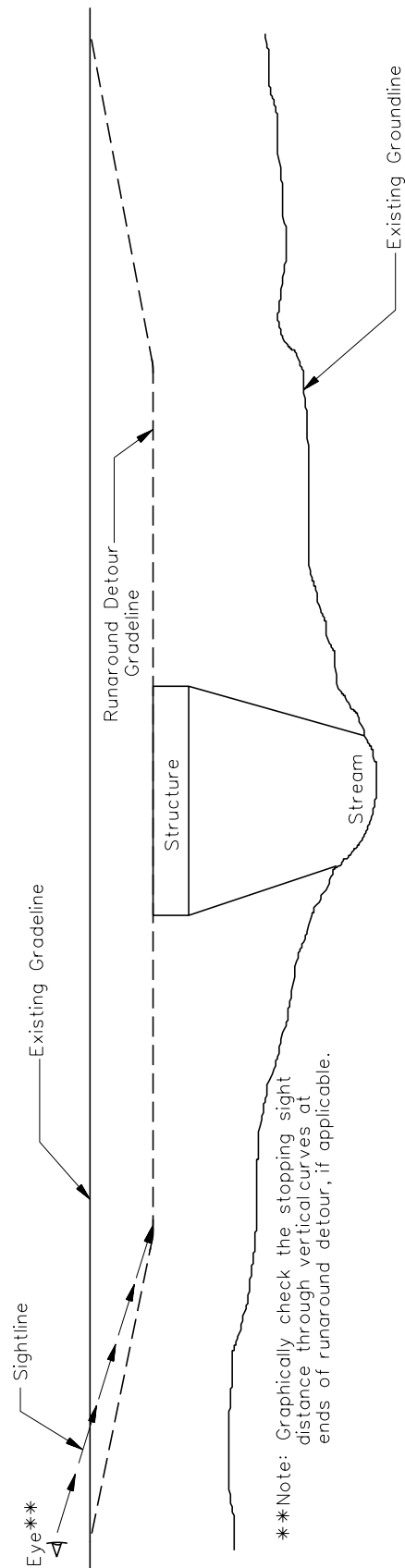

TYPICAL RUNAROUND LAYOUT

Figure 55-3.A

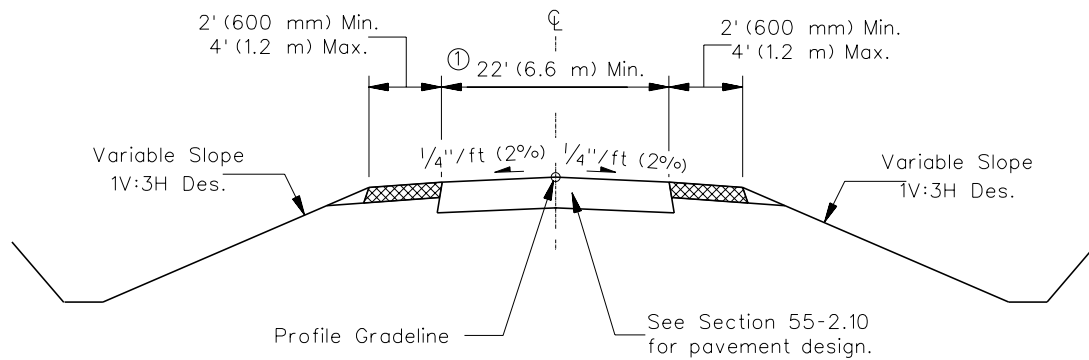

Section A - A

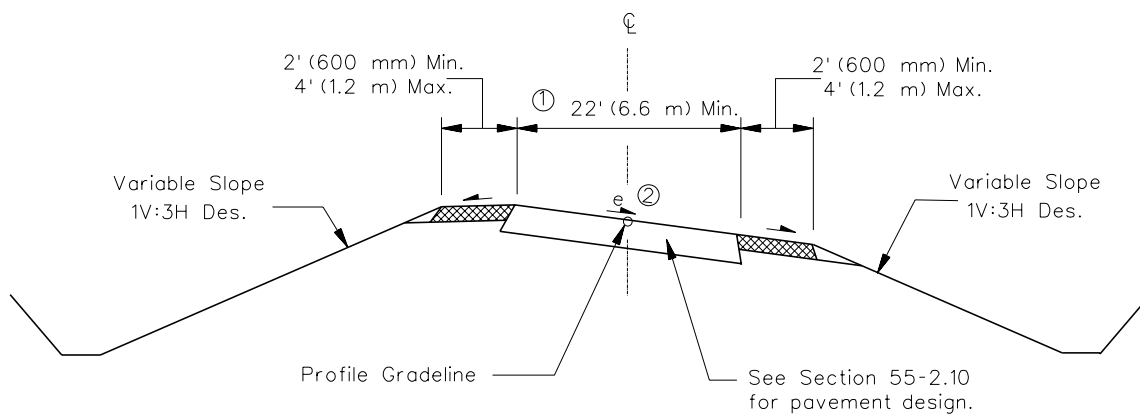

Section B - B

- Where there are significant multiple-unit trucks, see Figure 55-3.C for traveled way widths.
- See Section 55-2.07 for superelevation design.

TYPICAL CROSS SECTIONS FOR RUNAROUND DETOUR

Figure 55-3.B

US Customary			
Roadway Width (ft)			
Radius on Inner Edge of Traveled Way (ft)	Traffic Condition		
	A	B	C
150	26	29	32
200	26	28	30
300	25	28	29
400	25	27	28
500	22	22	22
Tangent	22	22	22
Metric			
Roadway Width (m)			
Radius on Inner Edge of Traveled Way (m)	Traffic Condition		
	A	B	C
50	7.9	8.8	9.5
75	7.7	8.5	8.9
100	7.6	8.3	8.7
125	7.6	8.2	8.5
150	6.6	6.6	6.6
Tangent	6.6	6.6	6.6

Note:

Traffic Condition A — Predominantly P vehicles, but some consideration for SU vehicles.

Traffic Condition B — Sufficient SU vehicles to govern design, but some consideration for semitrailer vehicles (5%-10% SU and 0%-3% semitrailer vehicles).

Traffic Condition C — Sufficient semitrailer vehicles to govern design (over 3% semitrailer vehicles).

**RUNAROUND DETOUR ROADWAY WIDTHS
(Two-Way, Two-Lane Operations)**

Figure 55-3.C

9. Bridges. Temporary structures should be at least 2 ft (600 mm) wider than the approach runaround roadway. Provide appropriate roadside safety protection at the ends of temporary bridges. Design waterway openings based on the criteria of the Bureau of Bridges and Structures.
10. Ditches. Where construction of a runaround detour is over an existing ditch that involves minimal cuts and fills, undercut the ditch by a minimum of 2 ft (600 mm) to remove any unstable material. However, each site must be examined on a project-by-project basis to determine if additional excavation will be required.
11. Side Slopes. For large streams or rivers, the runaround may be in a cut section. Ensure that adequate sight distance is available through the cut section. For additional guidance on side slopes, see Section 55-2.09.

55-3.04 Local Route Detours

Once it has been determined to use a local road as a detour, the designer should consider the following guidelines for local route detours:

1. Widths. Figure 55-3.D presents the minimum and desirable traveled way and roadway widths for a local route detour. These widths are based on the expected average daily traffic during the detour and the detour posted speed.
2. Intersections. Existing rural intersections may need to be converted from a yield or a no-control intersection to a stop-controlled intersection. Note that local drivers may be accustomed to using the route without stop conditions. Therefore, provide adequate advance warning of the new stop condition.
3. Pavement Design. The pavement design of existing local routes may need to be upgraded to meet the increased traffic and truck volumes. See Section 55-2.10 to determine the acceptable pavement design for local detour routes.
4. Agreements. Before a local road can be used as a detour, a Joint Agreement or Letter of Understanding must be executed with the local officials having jurisdiction over the road. This will require conducting a joint inspection with the officials prior to construction to determine the existing condition of the road and reaching an agreement on plans for restoration of the local route to an acceptable condition after the detour is removed. See Chapter 5 for further guidance on agreements.

US Customary									
Detour Posted Speed (mph)		Current ADT Under 400		Current ADT 400-999		Current ADT 1000-2999		Current ADT 3000-5000	
		Traveled Way (ft)	Roadway Width (ft)	Traveled Way (ft)	Roadway Width (ft)	Traveled Way (ft)	Roadway Width (ft)	Traveled Way (ft)	Roadway Width (ft)
30-35	Min.	18	22	18	24	20	24	22	26
	Des.	—	—	20	24	22	26	24	28
Over 35		18	22	18	24	22	26	24	28
Metric									
Detour Posted Speed (mph)		Current ADT Under 400		Current ADT 400-999		Current ADT 1000-2999		Current ADT 3000-5000	
		Traveled Way (m)	Roadway Width (m)	Traveled Way (m)	Roadway Width (m)	Traveled Way (m)	Roadway Width (m)	Traveled Way (m)	Roadway Width (m)
30-35	Min.	5.4	6.6	5.4	7.2	6.0	7.2	6.6	7.8
	Des.	—	—	6.0	7.2	6.6	7.8	7.2	8.4
Over 35		5.4	6.6	6.0	7.2	6.6	7.8	7.2	8.4

MINIMUM TRAVELED WAY AND ROADWAY WIDTHS

Figure 55-3.D

5. **Bridges.** Examine all structures on the local detour route to ensure that they are structurally adequate to accommodate the expected traffic and truck volumes. When determining the structural adequacy, consider the following:
 - a. **Widths.** Where two-way operation is proposed, the minimum horizontal clearance for structures to remain in place along the detour route is 24 ft (7.2 m). Where low truck volumes are anticipated (i.e., where semitrailers are less than 5% and SUs are less than 10% of ADT) and expected traffic volume on the detour route is less than 1,000 ADT, the minimum horizontal clearance that may remain is 22 ft (6.6 m).
 - b. **One-Lane Bridges.** Where it has been determined that it is feasible to retain a one-lane bridge on a local route detour, ensure that the appropriate traffic control devices and signing are provided to delineate the transitions and bridge.
 - c. **Design Load.** Where the load-carrying capacity of a structure on the detour route is questionable, request the Bureau of Bridges and Structures to analyze the structure to determine if it is acceptable. In some cases, it may be necessary to specify weight restrictions (e.g., load limit, one truck at a time) for the bridge. However, where feasible, avoid specifying weight restrictions. When it is not feasible to use a bridge for truck traffic, provide a marked alternative truck route.

- d. New Structures. Where an existing structure does not meet either the load limit requirements and/or width requirements necessary to remain in place, a new structure should be provided and designed according to the bridge policies in the *Bureau of Local Roads and Streets Manual*. Design traffic will be the current ADT on the local route rather than the ADT on the route during its use as a detour. If this is not feasible, provide a marked alternative truck route.
6. Ditches. To improve drainage and increase subgrade stability, existing ditches may need to be cleaned and deepened before the new pavement structure is built.
7. Roadside Safety. Review the local route to determine if new or upgrading existing roadside safety hardware is necessary. Any improvements to the existing roadside protection should be consistent with the local road classification, the temporary nature of the detour route, and the detour design speed. For additional guidance, see Section 55-4 and Chapter 38.

55-3.05 Stage Construction of Two-Lane, Two-Way Bridges

Traffic Control Standards 701316 and 701321 present the general traffic control criteria for stage construction on a two-lane, two-way structure (i.e., alternating traffic using one lane). In addition to the *Highway Standards*, consider the following guidelines:

1. Maximum Distance. Figure 55-3.E presents the recommended maximum closure distance, excluding tapers, that should be considered for this operation. Where longer distances are necessary, evaluate additional methods to improve operations.
2. Width. Section 55-2.03 presents the minimum widths that should be considered for one-lane roadways.
3. Structure Type. Section 13-2.02(b) contains guidelines for stage construction of various structure types.
4. Temporary Traffic Signals. The required method for alternating traffic across the structure is with temporary traffic signals. Section 55-5.04 and the Standard Specifications provide the criteria for these traffic signals.
5. Rumble Strips. Consider providing temporary rumble strips and/or additional warning devices in addition to the standard traffic control devices where there is restricted alignment and/or sight distance.
6. Temporary Bridge Rails. Under some circumstances, it will be necessary to provide temporary bridge rails, temporary concrete barriers, or temporary concrete barriers on the structures. Before using temporary concrete barrier across a structure, consult with the Bureau of Bridges and Structures to ensure the bridge deck can adequately support the barriers. Request the details for temporary bridge rails or temporary concrete barriers on the structure from the Bureau of Bridges and Structures.

Detour ADT	Recommended Maximum Distance
> 8000	300 ft to 500 ft (100 m to 150 m)
≥ 5000 to ≤ 8000	500 ft to 800 ft (150 m to 250 m)
< 5000	800 ft to 1000 ft (250 m to 300 m)

**RECOMMEND MAXIMUM DISTANCE FOR STAGE CONSTRUCTION
(Bridges)**

Figure 55-3.E

55-3.06 Stage Construction of Multilane Bridges

In addition to Traffic Control Standard 701401, consider the following guidelines when using stage construction on multilane bridges:

1. Widths. See Section 55-2.03 for the minimum lane widths allowed.
2. Traffic Control Devices. In addition to the criteria presented in the Highway Standards, consider providing additional traffic control devices (e.g., wing barricades, regulatory speed signs, changeable message signs) where there are high-traffic volumes and/or restricted geometric conditions.

55-3.07 Reduced Traffic Control for Road Closed to Through Traffic

Where a highway or bridge is closed to through traffic, the *Illinois Highway Code* allows the Department to specify alternative procedures, if desired, for flagging and controlling the local traffic through the work zone. The designer must specify the option for reduced traffic control in the plans and provide the average daily local traffic in the contract, otherwise the contractor will be required to provide the same level of traffic control within the section of road closed to through traffic as would be required for open-highway conditions.

The Department's criteria in the *Standard Specifications* for reduced traffic control are based on the expected traffic volumes through the work zone. The designer will be responsible for determining these traffic volumes and incorporating this information within the traffic control plans. The estimated traffic volumes may vary at different locations within the work zone or during separate construction phases. For these situations, list the expected traffic volumes for each location and/or phase. This will allow the contractor to adjust the traffic control accordingly.

55-3.08 Interstate Work Zones

Incorporate the following items, as appropriate, into traffic control plans for Interstate projects involving lane closures:

1. Communication with Motorists. To inform motorists of possible backups, delays, closures, etc., review Section 13-3.02 for on-site strategies.
2. Other Traffic Control Device Requirements. In addition to the criteria presented in Section 55-4, provide extra attention to the following:
 - a. Lighting. Provide temporary lighting at all Interstate crossovers for two-way, two-lane operations; see Chapter 56 and/or contact BDE for details on the lighting design. The request for the lighting design should include the:
 - location of power source,
 - location of any existing lighting units,
 - geometrics of proposed median crossovers, and
 - length of time it is anticipated that the temporary lighting will be required.
 - b. Temporary Longitudinal Traffic Barriers. Use temporary longitudinal traffic barrier to separate two-way, two-lane traffic and to extend work space as required for positive protection. See Section 55-4.01 for positive protection guidelines.
 - c. Guide Signs. In two-way, two-lane operations include signing with the distances remaining in the two-lane section (e.g., NEXT X MILES). This can reduce motorist frustration level. Place this sign below the two-way traffic signs.
 - d. Review. If the TCP is not part of a TMP that will be reviewed by the Bureau of Safety Programs and Engineering, request the Bureau of Operations to review the traffic control plans prior to advertisement to ensure the above requirements are met.
3. Reducing Lane Closures. Develop the traffic control plan so that lane closures can be kept to a minimum. Consider the following to reduce the time and length of lane closures and to meet mobility goals.
 - a. Overnight Closures. Where practical, specify the use of Traffic Control Standard 701406 (Daylight Work Only) versus Traffic Control Standard 701401 (Overnight Closures). Resurfacing, shoulder work, most underdrains, and moving work can be accomplished under Standard 701406. Do not allow contractors to use Standard 701401 in lieu of Standard 701406 at their expense.
 - b. Time Restrictions. Consider the scheduling strategies listed in Section 13-3.04.
 - c. Special Provisions. Figure 55-3.F provides a sample Special Provision that may be used for lane closures to limit the number of days of lane closure by the contractor.

Lane closures under Traffic Control Standard 701401, except those for structure repairs, shall be limited to a total of a. lane closure days. A day is defined as any day or portion thereof including Saturdays, Sundays, and Holidays, in which a lane closure is in effect. If more than one closure is in effect simultaneously, a day will be charged against each individual lane closure in determining the number of lane closure days used. When adverse weather prevents work from being performed, a day will not be charged.

If quantities for the following pay items are increased, days for lane closures will be increased at the following daily rates:

<u>Pay Item</u>	<u>Daily Rate</u>
-----------------	-------------------

b.

Increases in lane closure days will only be allowed for the specified pay items and at the specified rates. No additional increases will be considered.

If the Contractor fails to open all lanes to traffic within the lane closure days allowed, the Contractor shall be liable to the Department in the amount of \$ c. for each full or partial day of overrun not as a penalty but as liquidated damages. These damages shall be in addition to any liquidated damages charged in accordance with Article 108.09.

Any additional cost to comply with these provisions shall be included in the cost of Traffic Control and Protection, Standard 701401.

Notes to the designer:

- a. The total days should be calculated using those pay items that require overnight closures (e.g., concrete patching, shoulder reconstruction). Items such as resurfacing, bituminous patching, pipe underdrains, cold milling, etc., can typically be done using Standard 701406 and the lanes opened at the end of each day. Once the applicable pay items are determined, working days can be calculated using daily production rates; see Section 66-2.03 Working days would then be multiplied by 7/5 to obtain the calendar days.
- b. List the pay items and daily rates used to determine the total days here.
- c. The daily road user delay cost can be determined according to Section 66-2.04. The length used should be the estimated lane closure length; normally this would be 5 miles (8 km) for concrete patching and 3 miles (5 km) for other operations.

SPECIAL PROVISION FOR STANDARD 701401 LANE CLOSURES

Figure 55-3.F

55-4 ROADSIDE SAFETY

Through a work zone, drivers are often exposed to numerous hazards (e.g., restrictive geometrics, construction equipment, opposing traffic). A total elimination of work zone hazards is impractical. Therefore, the designer must devote special attention to reducing a motorist's exposure to potential hazards. The following sections offer roadside safety criteria that apply only to the roadside elements within the work zone. These criteria do not apply to detours over existing routes.

55-4.01 Positive Protection

Positive protection devices are the devices that contain and/or redirect errant vehicles and meet the crashworthiness evaluation criteria contained in NCHRP Report 350 or the Manual on Assessing Safety Hardware (MASH). This can include approved longitudinal barriers or truck/trailer-mounted attenuators (TMA). Positive protection devices shall be considered in work zone situations that place workers at increased risk from motorized traffic and where positive protection devices offer the highest potential for increased safety for workers and road users.

Desirably, the designer should consider traffic control designs that do not require the use of positive protection, while both minimizing the hazard exposure and maximizing the separation of workers and traffic. However, in many work zones, positive protection is needed.

Positive protection is required for the following conditions where work is conducted under traffic:

1. Mobile Operations. Mobile operations are defined as work that moves intermittently or continuously (at approximately 1 mph (1.6 km/h), a walking pace). A mobile operation may be accomplished using the following:
 - a. Multi-lane Highways. Mobile operations on multi-lane highways may be accomplished using a stationary standard lane closure as shown in the *Highway Standards* (or *IDOT Work Site Protection Manual* for IDOT employees) where the lane is closed using signing, arrow boards, and channelizing devices. If such a stationary standard lane closure is not used, then positive protection devices (e.g., TMA) shall be used to close the lane in advance of the workers. The use of additional signing would be dependent upon the normal posted speed limit, and the duration and length of the work, and will be in accordance with the *Illinois Manual on Uniform Traffic Control Devices* (ILMUTCD).
 - b. Two-lane, Two-way Highways. Mobile operations on two-lane highways will require the use of a positive protection device (e.g., TMA) in advance of the work.

TMA's are acceptable for limited daily work hours consistent with the *IDOT Work Site Protection Manual*.

2. Stationary Operations. Stationary operations are defined as work that occupies a location for more than one hour. In these cases, the work would require a lane closure in accordance with an appropriate *Highway Standard*.

Positive protection devices will be required for stationary operations conducted under traffic in areas that offer no means of escape from motorized traffic (e.g., tunnels, bridges, bridge painting, narrow medians). For multi-lane and two-lane two-way highways, please see additional guidance below regarding use of temporary longitudinal traffic barriers:

- Multi-lane highways with work that occupies a location for more than 24 hours, or requires multiple days/nights setups exceeding 24 hours to complete, will require the use of temporary longitudinal traffic barriers.
- Two-lane two-way highways with work that occupies a location for more than four days per stage will require the use of temporary longitudinal traffic barriers.

Additionally, for long duration stationary locations, with high speed and workers near a traffic lane:

Temporary longitudinal traffic barriers will be required for stationary operations where the normal posted speed limit is 45 mph or greater, the duration of the stationary operation is two weeks or more, and workers are present within one lane width of the open traffic lane, except when the project is outside of an urban area and the annual average daily traffic (AADT) is less than 2400 vehicles.

The following are locations where the designer should consider using positive protection:

- exposed ends of temporary concrete barriers;
- untreated guardrail ends in two-way, two-lane operations;
- bridge piers;
- bridge rail or parapet ends;
- structure foundations (e.g., bridge falsework, sign foundations);
- excavations and rock cuts;
- gap in median between dual bridges;
- excessive pavement edge and shoulder drop-offs (see Figures 55-2.A and 55-2.B); and
- other locations where construction will increase the potential hazards of existing conditions.

Consider the following factors when assessing the need for positive protection:

- duration of construction activity,
- traffic volumes (including seasonal and special event fluctuations),
- nature of hazard,
- length and depth of drop-offs,

- work zone design speed,
- highway functional class,
- length of hazard,
- proximity between traffic and construction workers,
- proximity between traffic and construction equipment,
- adverse geometrics which may increase the likelihood of run-off-the-road vehicles,
- two-way traffic on one roadway of a divided highway,
- transition areas at crossovers, and
- lane closures or lane transitions.

Other factors may apply, and the above list is not considered all inclusive.

Positive protection devices shall be used in accordance with the *Highway Standards*, *ILMUTCD*, manufacturers' requirements, NCHRP Report 350 or MASH, and the most current Bureau of Safety Programs and Engineering Policy Memorandum BSE-04. See Section 55-4.02 for more information. Their use provides greater protection for workers than normal channelizing devices; however, workers should be aware of the limitations of positive protection devices.

When developing the Transportation Management Plan, designers should take emergency situations into consideration. Emergency situations and traffic incidents should consider use of positive protection devices in accordance with Chapter 6 of the *ILMUTCD*. Incidents lasting more than 24 hours should be evaluated for appropriate use of positive protection devices.

55-4.02 Appurtenance Types

In addition to Chapter 38 and the *Highway Standards*, the following sections provide additional information on the roadside safety appurtenances used by the Department in work zones.

55-4.02(a) Guardrail

Temporary guardrail installations must meet the permanent installation criteria in Chapter 38 and the *Highway Standards*, except as modified in Section 55-4.02(c). For short-term construction projects, the installation of a new temporary guardrail is usually not practical.

55-4.02(b) Temporary Longitudinal Traffic Barrier

Temporary longitudinal traffic barrier provides protection by separating motorists from the construction site and/or opposing traffic. Temporary longitudinal traffic barrier may consist of temporary concrete barrier (TCB) or shifting, portable, or movable barrier systems.

When considering temporary longitudinal traffic barrier, evaluate the following:

1. Purpose. The primary functions of temporary longitudinal traffic barrier are:
 - to prohibit traffic from entering work areas (e.g., excavations, storage sites);

- to protect workers and pedestrians;
 - to separate two-way traffic;
 - to shield construction elements (e.g., bridge falsework, exposed objects); and
 - to protect motorists from hazards in the clear zone.
2. **Flare Rates.** Temporary longitudinal traffic barrier located along a tapered alignment should be flared at the rates shown in Figure 55-4.A using the selected work zone design speed. If field conditions are such that these flare rates cannot be used, then consider using a flare rate between 4:1 and 8:1. The length of the taper will be determined based on the length of need requirements; see Section 55-4.03. The approaching end of the temporary longitudinal traffic barrier along the tapered alignment should desirably extend to a point beyond the construction clear zone. Under restrictive conditions, however, the designer may reduce this offset to the outside edge of the shoulder with an applicable end treatment.

3. Work Zone Design Speed	Flare Rate
45 mph (70 km/h) and above	12:1
Less than 45 mph (70 km/h)	8:1

TEMPORARY LONGITUDINAL TRAFFIC BARRIER FLARE RATES

Figure 55-4.A

4. **End Treatment.** Shield the approach end of temporary longitudinal traffic barrier with an approved end treatment meeting the requirements of NCHRP Report 350 or MASH, regardless of placement within or outside of the clear zone. Place all end treatments on level ground 1:10 or flatter.
5. **Test Level.** The application of temporary longitudinal traffic barrier must match the test level of the product. Consult the *AASHTO Roadside Design Guide*, NCHRP Report 350 or MASH, and the Bureau of Safety Programs and Engineering for further guidance.
6. **Offset and Deflection.** Check the expected deflection of the temporary longitudinal traffic barrier against the proposed use. The deflection should not allow the barrier to fall from a drop-off or bridge deck, or intrude into oncoming traffic. However, some barriers, including temporary concrete barriers, may be pinned to reduce deflection. Contact the Bureau of Safety Programs and Engineering for information on temporary longitudinal traffic barrier deflection data or potential barrier systems to be considered for use. Also, see the most current Bureau of Safety Programs and Engineering Policy Memorandum BSE-04 for guidance on pinning and anchoring when using temporary concrete barrier. Contact the Bureau of Bridges and Structures for guidance on anchoring barriers to bridge decks.

55-4.02(c) End Treatments

Locate any unprotected approach guardrail end (e.g., at breaks for crossovers, emergency vehicle access, or contractor access) at or beyond the construction clear zone or shield it with an appropriate end treatment. Shield the approach end of a temporary traffic barrier as discussed in Section 55-4.02(b). The following discusses several end treatments that can be used:

1. Attenuating Devices. Attenuating devices meeting the requirements of NCHRP Report 350 or MASH are acceptable protective end treatments. They also may be considered at point obstacles (e.g., bridge piers) where space is limited. Contact the Bureau of Safety Programs and Engineering for guidance on attenuating devices available and physical space requirements needed for installation.
2. Guardrail. The treatments for exposed ends of guardrail include:
 - connection to existing barriers,
 - overlapping barriers,
 - using an approved end terminal,
 - attaching an impact attenuator, or
 - burying the end in the backslope.
3. Sand Barrels. Sand barrels are commonly used to protect the driver from point obstacles (e.g., bridge piers, temporary longitudinal traffic barrier ends). Due to the size of the array, sand barrels should only be used outside of the traveled way (e.g., on shoulders, in medians). Arrays vary according to the obstacle width and the design speed. The Highway Standards illustrate typical sand barrel applications; however, the designer must confirm that the Highway Standards are applicable to the site. Information on alternative NCHRP Report 350 or MASH approved array arrangements can be obtained from the manufacturers' literature. Also note that single-row arrays are not allowed by IDOT policy. Use attenuating devices for areas with limited allowable width.

55-4.02(d) Glare Screens

Glare screens may be used in combination with temporary longitudinal traffic barrier to reduce headlight glare from opposing traffic. Typical applications in work zones are at crossover transitions and in two-way, two-lane operations. In addition to crossovers, consider providing glare screens where:

- the travel lane is within 2 ft (600 mm) of the barrier,
- a high amount of peripheral ambient light exists,
- there is a high volume of truck traffic, and/or
- the vertical or horizontal alignment of the roadway may create a headlight glare problem.

If glare screens are used on curvilinear alignments, ensure that the glare screen installation will not produce below minimum stopping sight distances. For additional glare screen design criteria, see Section 38-7.05.

55-4.03 Design/Layout

Where practical the designer should locate and design temporary roadside safety appurtenances based on the criteria in Chapter 38 (e.g., deflection distance, length of need). However, it is usually not practical nor cost effective to meet these criteria for permanent installations due to the limited time traffic is exposed to construction hazards and the space constraints that are required during construction. The designer must evaluate the exposure time of the hazard in determining the need for installing a roadside safety appurtenance. The following offers several alternatives that should be considered in designing and locating temporary roadside safety appurtenances within work zones:

1. Work Zone Clear Zones. Applying the clear zone distances from Chapter 38 to work zones is often impractical. Therefore, the Department has developed revised work zone clear zone distances, which are presented in Figure 55-4.B. However, the potentially hazardous conditions typically found within work zones warrant the use of considerable judgment when applying these clear zone distances. Note that it is not necessary to adjust the clear zone values presented in Figure 55-4.B for horizontal curvature.

Treat hazards within the work zone clear zone in the same manner as they would be in a conventional clear zone.

2. Embankment Warrants. Figure 55-4.C presents barrier warrants for embankments in work zones.
3. Length of Need. As with new installations, provide a sufficient distance of full-strength barrier prior to the hazard to minimize the potential for a vehicle to run behind the barrier and impact the hazard. For temporary layouts, the length of need can be determined by using an angle of 10° to 15° from the back of the hazard or from the work zone clear zone distance off the traveled way.
4. Flare Rates. Desirably, flare temporary traffic barrier terminals beyond the traveled way to a point outside of the work zone clear zone. Figure 55-4.A presents the desirable flare rates for barrier based on the selected work zone design speed. Use these flare rates unless documented extenuating circumstances render this impractical (e.g., stop conditions, driveways, intersections).

Approach Posted Speed Limit ⁴	ADT	Front Slopes			Back Slopes		
		1:6 or Flatter	1:5 to 1:4	1:3	1:3	1:5 to 1:4	1:6 or Flatter
		Work Zone Clear Zone Distances (ft)					
35 mph or less	Under 750	4-6	4-6	4-6	4-6	4-6	4-6
	750-1500	6-8	8-10	6-8	6-8	6-8	6-8
	1500-6000	6-8	10	8-10	8-10	8-10	8-10
	Over 6000	10	10-12	10	10	10	10
35 - 50 mph	Under 750	6-8	6-10	4-6	4-6	4-6	6-8
	750-1500	10	10-14	6-8	8-10	8-10	10
	1500-6000	10-12	12-16	8-10	10	10	10-12
	Over 6000	12-14	16-18	10	12	12	12-14
55 mph	Under 750	6-8	10-12	6	6-8	6-8	6-8
	750-1500	10-12	12-16	**	6-8	10-12	10-12
	1500-6000	12-14	16-18	10	10	10-12	12-14
	Over 6000	14-16	16-20*	10-12	12-14	12-14	14-16
60 mph	Under 750	10-12	12-16	6-8	8-10	8-10	10
	750-1500	12-16	16-20*	8-10	10-12	10-12	12-14
	1500-6000	16-18	20-24*	10-12	12-14	12-14	16
	Over 6000	18-20*	22-28*	12-14	16	16	16-18
65 mph	Under 750	12	12-16	6-8	10	10	10
	750-1500	16	18-22*	8-10	12	12	12-14
	1500-6000	18-20*	22-26*	10-12	14-16	14-16	16-18
	Over 6000	18-22*	24-28*	14-16	16-18	16-18	18

* Clear zones may be limited to 18 ft for practicality.

** See procedure in Section 38-3.02(b).

- Notes:
1. All distances are measured from the edge of the traveled way.
 2. For clear zones, the "ADT" will be the total ADT on two-way roadways and the directional ADT on one-way roadways (e.g., interchange ramps and one roadway of a divided highway). Traffic volumes will be the expected traffic volume through the work zone.
 3. The values for "back slopes" only apply to a section where the toe of the back slope is adjacent to the shoulder. See Figure 38-3.B(d). For sections with roadside ditches, see Section 38-3.03.
 4. Approach posted speed limit prior to the work zone.

**WORK ZONE CLEAR ZONE DISTANCES
(US Customary)**

Figure 55-4.B

Approach Posted Speed Limit ⁴	ADT	Front Slopes		Back Slopes		
		1:6 or Flatter	1:5 to 1:4	1:3	1:5 to 1:4	1:6 or Flatter
Work Zone Clear Zone Distances (m)						
35 mph or less	Under 750	1.5-2.0	1.5-2.0	1.5-2.0	1.5-2.0	1.5-2.0
	750-1500	2.0-2.5	2.5-3.0	2.0-2.5	2.0-2.5	2.0-2.5
	1500-6000	2.5-3.0	3.0	2.5-3.0	2.5-3.0	2.5-3.0
35 - 50 mph	Over 6000	3.0	3.0-3.5	3.0	3.0	3.0
	Under 750	2.0-2.5	2.5-3.0	1.5-2.0	1.5-2.0	2.0-2.5
	750-1500	3.0	3.0-4.0	2.0-2.5	2.5-3.0	3.0
55 mph	1500-6000	3.0-3.5	4.0-5.0	2.5-3.0	3.0	3.0-3.5
	Over 6000	4.0	4.5-5.5	3.0	3.5-4.0	4.0
	Under 750	2.5-3.0	3.0-3.5	1.5-2.0	2.0-2.5	2.0-2.5
60 mph	750-1500	3.0-3.5	4.0-4.5	2.0-2.5	3.0	3.0-3.5
	1500-6000	4.0	4.5-5.5	3.0	3.0-3.5	4.0
	Over 6000	4.0-4.5	5.0-6.0*	3.0-3.5	4.0	4.0-4.5
65 mph	Under 750	3.0-3.5	4.0-4.5	2.0-2.5	2.5-3.0	3.0
	750-1500	4.0-4.5	5.0-6.0*	2.5-3.0	3.0-3.5	4.0
	1500-6000	5.0-5.5	6.0-7.5*	3.0-3.5	3.5-4.0	4.5-5.0
65 mph	Over 6000	5.5-6.0*	7.0-8.5*	4.0	4.5-5.0	5.0-5.5
	Under 750	3.5-4.0	4.0-5.0	2.0-2.5	3.0	3.0
	750-1500	4.5-5.0	5.5-7.0*	2.5-3.0	3.5-4.0	4.0
65 mph	1500-6000	5.5-6.0*	6.5-8.0*	3.0-4.0	4.0-4.5	5.0-5.5
	Over 6000	5.5-6.5*	7.0-8.5*	4.0-4.5	5.0-5.5	5.5

* Clear zones may be limited to 5.5 m for practicality.

** See procedure in Section 38-3.02(b).

- Notes:
1. All distances are measured from the edge of the traveled way.
 2. For clear zones, the "ADT" will be the total ADT on two-way roadways and the directional ADT on one-way roadways (e.g., interchange ramps and one roadway of a divided highway). Traffic volumes will be the expected traffic volume through the work zone.
 3. The values for "back slopes" only apply to a section where the toe of the back slope is adjacent to the shoulder. See Figure 38-3.B(d). For sections with roadside ditches, see Section 38-3.03.
 4. Approach posted speed limit prior to the work zone.

**WORK ZONE CLEAR ZONE DISTANCES
(Metric)**

Figure 55-4.B

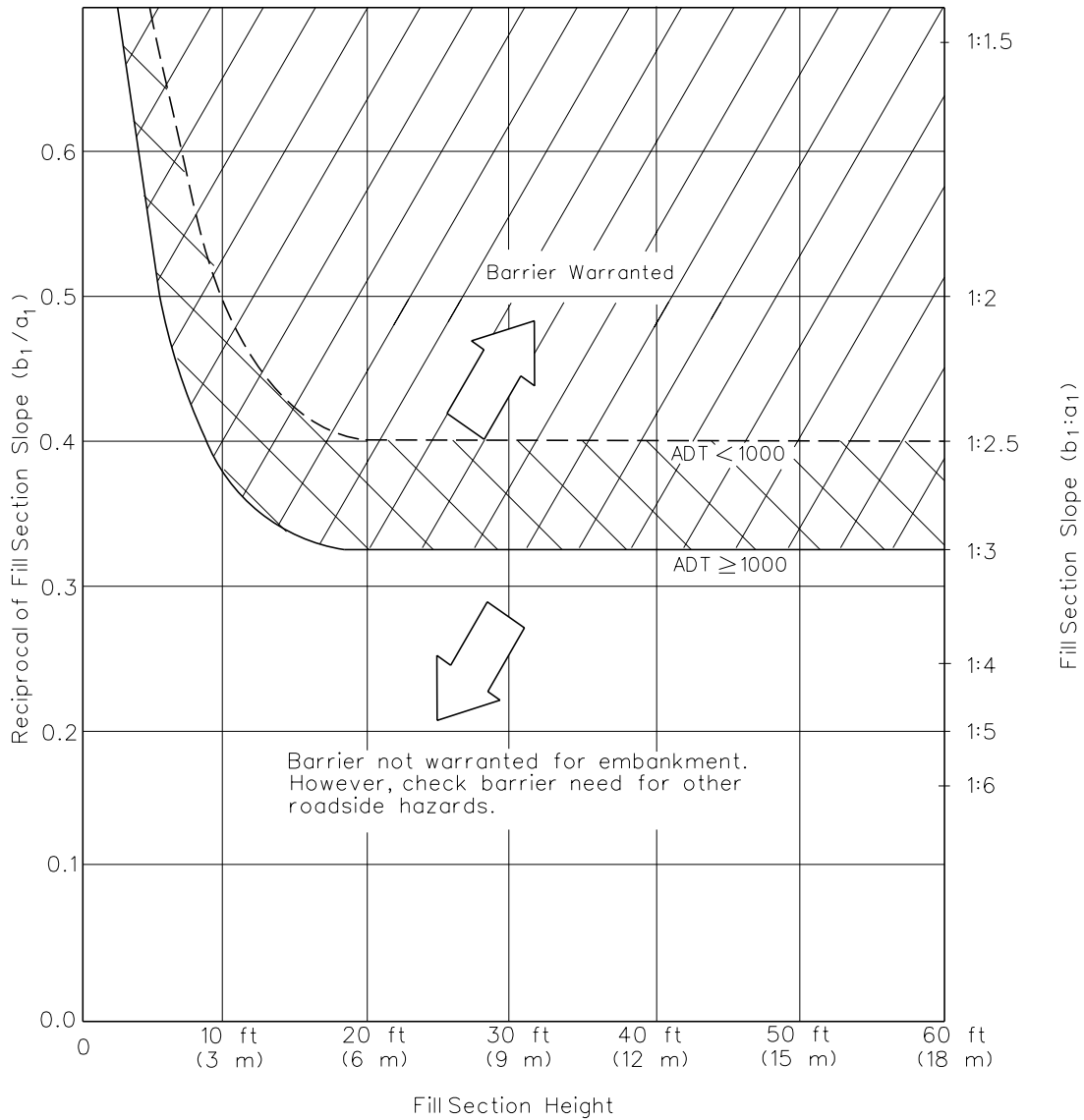

Note: Points which fall on the lines do not warrant a barrier.

**BARRIER WARRANTS FOR EMBANKMENTS
(Work Zones)**

Figure 55-4.C

5. Openings. Avoid openings in the barriers. Where openings are necessary, provide a NCHRP Report 350 or MASH approved end treatment at the barrier ends and proper signing.
6. Sand Barrels. Sand barrel arrays for temporary installations are the same as for permanent installations, except for the shielding of the hazard. Permanent sand barrel installations require a minimum 30 in (750 mm) offset between the hazard and the outside edge of the sand barrel array. For temporary installations, this distance can be reduced to 15 in (375 mm) where a greater offset would cause unacceptable interference with traffic. The preferable alternative is to use an attenuator system.

55-5 WORK ZONE TRAFFIC CONTROL DEVICES

The proper use of traffic control devices is critical to both public and worker safety and has been proven to significantly reduce crashes in work zones. The district Bureau of Operations will be responsible for the selection and design of traffic control devices. This section provides supplemental information on these devices and presents specific Department policies and procedures.

55-5.01 Highway Signs

55-5.01(a) General

In construction zones, regulatory signs are used to temporarily override an existing mandate or prohibition (e.g., reduced speed limit). Warning signs are used in advance of the construction area to indicate potentially hazardous conditions, and guide signs are used at various locations to inform drivers of detour routes, destinations, and points of interest.

In general, the *Highway Standards*, the *Standard Specifications*, and Part 6 of the *Illinois Manual of Uniform Traffic Control Devices* (ILMUTCD) provide the Department's criteria for the design, application, and placement of these signs in construction zones. In addition, the designer should review the applicable sections for permanent signs in Chapter 57 of the *BDE Manual*, the Bureau of Operation's *Policies and Procedures Manual*, and the *ILMUTCD*.

55-5.01(b) Speed Limit Signing

Signs are used to alert the traveling public of the speed limit within a work zone. The signs must comply with *the Highway Standards* for the work zone speed limit to be enforceable. The Work Zone Speed Limit Sign is the regulatory sign that is used to establish the speed limit in a construction or maintenance zone, as well as legally establish the zone for enforcement and fines. Use the Bureau of Operations "Policy on Establishing and Posting Speed Limits on the State Highway System" to establish speed limits in work zones.

The work zone speed limit will be determined based on the work zone design speed, traffic volumes, construction work type, geometrics, project length, etc. Where there is no lane closure or apparent hazard, maintain the existing speed limit.

See the *Standard Specifications* and *Highway Standards* for details on sign placement.

55-5.01(c) Guide Signs

The references in Section 57-1.02 provide the Department's criteria for the design, application, and placement of guide signs. The following provides supplemental information on the use of guide signs in construction zones:

1. Panel Signs. Guide signs are typically warranted in construction zones and on alternative routes where temporary route changes are necessary. For example, the designer may consider using large panel signs or changeable message signs for ramp and lane closures (e.g., “Ramp 2A Closed, Use Ramp 2B,” “Ramp 4A Closed May 9”).
2. Other. Standard route markings, street name signs, special information signs, directional, and detour signs may also be warranted based on the particular work on the facility.

55-5.01(d) Portable Changeable Message Signs

Portable changeable message signs (PCMS) are very effective in communicating the construction zone information to the general public. The use of PCMS will be determined on a project-by-project basis based on road alignment, traffic routing, or other situations requiring advance warning and information.

PCMS can be an effective temporary traffic control device when used appropriately. However, PCMS should not replace any of the signing required by IDOT policy or the *ILMUTCD*. The positive effect of PCMS may be diminished if the device is overused. PCMS should not be employed when they do not add any value to the total traffic control plan.

For all facilities, the following are some typical applications where the PCMS device may be effectively used in construction zones:

- to provide advance notice of upcoming construction;
- where significant traffic queuing and delays are expected;
- where changes in road alignment or surface conditions are present;
- to provide advance notice of ramp, lane, or road closures;
- incident management;
- a change in construction activities (e.g., bridge beam placement, change in alignment);
- to notify or direct motorists to alternative routing; and
- to provide additional information on high-volume, urban projects.

Messages shown on PCMS signs should convey current conditions and as up to date information to the traveling public as possible, especially for incident management. On projects where numerous PCMS signs will be used, the designer should plan for locations and messages to be used on the signs. PCMS messages should be limited to two, with a maximum of three phases. PCMS messages must be carefully planned to be short, understandable, and have “news value” to the motorist. Do not provide information that is redundant to static signing.

PCMS signs are required to be remote programmable. Include provisions for monitoring and changing the messages as necessary to provide current information. Investigate new and emerging technologies for monitoring and changing the messages that can be done by computer in the district, field office, or from a remote location.

See the FHWA *Portable Changeable Message Sign Handbook* and the *ILMUTCD* for specific information on the placement, operation, acceptable messages, and acceptable abbreviations for PCMS.

55-5.01(e) Arrow Boards

In some construction areas, arrow boards are used to supplement conventional traffic control devices. They are used as directional information to assist in merging traffic. The *Highway Standards* and Part 6 of the *ILMUTCD* provide the Department's criteria for the placement, design, and application of arrow boards.

55-5.02 Channelization Devices

The *Highway Standards*, the *Standard Specifications*, and Part 6 of the *ILMUTCD* provide the Department's criteria for the selection, application, and placement of channelization devices. Part 6 of the *ILMUTCD* and the *Highway Standards* also illustrate several typical application diagrams for the use of these devices.

There are numerous types of channelization devices available, each having its specific application in construction operations (e.g., crossovers, runarounds, lane closures, road closures, two-lane, two-way operations). Avoid mixing devices, as it may be confusing to the driver. The following channelization devices are typically used by IDOT in construction zones:

1. Barricades:
 - a. Type I Barricades, Type II Barricades, and Vertical Barricades. Type I or Type II barricades or vertical barricades may be used for channelization or to delineate a specific condition. Vertical barricades are not to be used for lane closure tapers or as check barricades.
 - b. Type III Barricades. Types III barricades are used for road and lane closures.
 - c. Directional Barricades. Directional Barricades may only be used in merging and shifting tapers.
2. Drums. Drums are most commonly used in a linear series to channelize traffic.
3. Cones. Traffic cones are channelization devices used only during daylight hours.
4. Tubular Markers. Also known as flexible delineators, these devices are used to channelize traffic, including the division of opposing lanes of traffic, and to delineate the edge of pavement drop-off, in lieu of drums where space is limited. Tubular markers have less visible area than other devices. Therefore, only use tubular markers where space restrictions do not allow for the use of more visible devices.

5. Vertical Panels. These devices are used to channelize traffic in lieu of drums where space is limited but are not used for the division of opposing lanes of traffic. Vertical panels have less visible area than other devices. Therefore, only use vertical panels where space restrictions do not allow for the use of more visible devices.
6. Temporary Longitudinal Traffic Barriers. Only use temporary longitudinal traffic barriers where positive protection is desired; do not use based on channelization needs. If used, locate the temporary longitudinal traffic barrier behind and in conjunction with other supporting channelization devices, delineators, and/or pavement markings. Section 55-4.02(b) provides information on the application and placement of temporary traffic barrier. Delineators, reflectors, and steady-burning lamps may be required by the *Highway Standards* or *Standard Specifications*.
7. Reflectors. Reflectors provide retro-reflection from headlights and are supplemental devices that may be used to indicate the roadway alignment and the intended path through a construction zone, or to delineate hazards within the construction zone. Reflectors are commonly installed on delineator posts or on channelizing devices such as barrier wall, guardrail, or curbs.

These channelization devices are used extensively in work zones to warn drivers of work activities in or near the traveled way, to protect workers in the area, and to guide drivers and pedestrians safely through and around the work zone. Because each construction project differs, the selection, application, and location of these devices should be determined on a project-by-project basis.

55-5.03 Pavement Markings

The *Highway Standards* and Part 6 of the *ILMUTCD* provide the Department's criteria for the selection, application, and placement of pavement markings in work zones. The *Standard Specifications* provide additional information on pavement markings. Also, review Section 57-3 for applicable information on permanent pavement markings. The following sections provide supplemental guidelines to these sources.

55-5.03(a) Types

The following types of pavement markings are typically used by IDOT in work zones:

1. Temporary Paint. Quick-drying paint is a low-cost, temporary pavement marking that may be used on construction projects. To improve reflectivity, glass beads are required. The Department does not normally allow the use of temporary paint markings on final pavement surfaces.
2. Temporary Raised Pavement Markers. In high-volume locations, the designer may consider using raised temporary pavement markers as a supplemental device to improve delineation through the work zone. Typical locations include lane lines, gore

areas, and other areas where there are changes in the alignment (e.g., lane closures, lane shifts). For lane lines, temporary raised pavement markers are placed mid-point in the gap (i.e., every 40 feet (12 m)). For tapers, gore markings, lane transitions, etc., space the raised markers at 20-ft (6 m) intervals. Temporary raised pavement markers must be removed prior to placing of the next pavement course.

3. Temporary Pavement Marking Tape. Temporary pavement marking tape is an excellent material choice where there are changes to the traffic pattern during construction (e.g., lane shifts, crossover switches). Temporary tape can be easily and quickly installed and, when necessary, easily removed. One disadvantage is that this tape tends to move and/or breakup under heavy traffic volumes. Black tape is also available to temporarily remove lane lines. Wet reflective tape should be considered to improve guidance in long term work zones, poorly lit locations, and high volume areas.
4. Thermoplastic Markings. Thermoplastic markings are generally used in construction zones only if traffic volumes are high and the traffic pattern will be in place for a long duration (e.g., over one year).
5. Temporary Rumble Strips. Temporary rumble strips are used on high-speed, stop conditions to warn motorists of the impending change. The Highway Standards illustrate the typical layout for temporary rumble strips with a lane closure.

55-5.03(b) Application

The application of pavement markings in work zones depends on facility type, project duration, project length, and anticipated traffic volume. The *Standard Specifications* provide the criteria for the use of pavement markings in work zones.

55-5.04 Traffic Signals

55-5.04(a) Location

The use of temporary traffic signals in work zones will be determined on a project-by-project basis. Use the warrant criteria for permanent installations in Section 57-4 of the *BDE Manual* to assist in determining if a temporary traffic signal is warranted. However, use the actual traffic volumes expected during construction for the warrant analysis. Common locations where temporary signal installations may be used include:

- intersections where an existing signal must be maintained,
- existing non-signalized intersections and driveways where construction patterns and volumes now warrant a signal,
- at a temporary haul road or other temporary access points, and

- at crossroad/ramp intersections where there is an increase in traffic or there is a decrease in capacity due to the construction.

Temporary signals are required at long-term, one-lane, two-way traffic operations (e.g., stage bridge construction).

55-5.04(b) Application

Consider the following:

1. Design. Determine the impacts a construction activity has on existing signal operations and attempt to maximize the level-of-service. For example, consider:
 - re-timing or re-phasing the signal to compensate for changes in traffic volume, mix, or patterns and for changes in lane designations or intersection approach geometrics; or
 - physically relocating poles or adjusting signal heads to maintain compliance with the ILMUTCD.

Section 57-4 and Part 4 of the *ILMUTCD* provide design information on traffic signals.

2. Bridges. The Highway Standards require a temporary signal installation for a bridge lane closure. However, in some situations, the use of a flagger may be more cost effective.
3. Plan Sheets. Show all temporary signal installations on the Stages of Construction and Traffic Control Sheets.

55-5.05 Highway Lighting and Nighttime Construction

55-5.05(a) Types

The designer should maintain existing overhead lighting and, on a case-by-case basis, consider the need for supplemental roadway lighting at potentially hazardous sites within the work area.

Give special consideration to lighting of the traveled way during construction. Construction activities present unexpected road geometry, alignment, and hazards to the motoring public. The designer should maintain existing overhead lighting, and consider the need for supplemental roadway lighting at potentially hazardous sites within the work area.

The following lighting devices are used in construction areas:

- hazard identification beacons,
- steady-burning warning lamps,
- flashing warning lights,
- floodlights, and
- conventional highway lighting.

55-5.05(b) Warrants

Hazard identification beacons and warning lights are typically used to supplement signs, barriers, and channelization devices and emphasize specific signs, hazard areas, and the desired travel path. The warrants for these lighting devices should meet the criteria in Part 6 of the *ILMUTCD* and the *Highway Standards*.

For conventional highway lighting, the need for temporary lighting will be determined on a project-by-project basis. Maintain the existing highway illumination on all projects unless discontinuance of the highway illumination is specifically permitted. Review the warrants presented in Chapter 56 for permanent highway lighting to assist in determining the need for temporary lighting. Consider the use of temporary lighting at construction areas with the following characteristics:

- high-traffic volumes;
- high-traffic speeds;
- heavy queuing or congestion;
- areas with complicated traffic maneuvers (e.g., freeway crossovers, intersections); and
- other areas where hazardous locations may exist.

If existing light standards are removed or shut off during construction, consider providing temporary lighting until permanent light standards are reinstalled. In construction areas, the Department typically uses high-pressure sodium lamps mounted on temporary wood posts. However, the designer may wish to consider using portable lighting as an option. Chapter 56 provides additional information on the design of highway lighting.

55-5.05(c) Lighting for Nighttime Construction

Night construction presents additional challenges to both the contractor and the motoring public. The contractor needs adequate light to perform the work in a safe and efficient manner, and the motoring public requires additional guidance to safely transition the night work zone environment. As well, the motoring public must be protected from glare. Floodlights or other supplemental lighting may be used to illuminate the work area during night operations (e.g., flagger stations, equipment crossings, areas requiring supplemental lighting) and are the responsibility of the Contractor.

55-6 REFERENCES

1. *Standard Specifications for Road and Bridge Construction*, IDOT.
2. *Highway Standards*, IDOT.
3. *Traffic Policies and Procedures Manual*, Bureau of Operations, IDOT, 1992.
4. *Illinois Manual on the Uniform Traffic Control Devices (ILMUTCD)*, IDOT.
5. *A Policy on Geometric Design of Highways and Streets*, AASHTO, 2018.
6. *Roadside Design Guide*, AASHTO, 2011.
7. *Highway Capacity Manual 7th Edition*, Transportation Research Board, 2022.
8. *Policy on Establishing and Posting Speed Limits on the State Highway System*, Bureau of Operations, IDOT, 2015.
9. *National Cooperative Highway Research Program (NCHRP) Report 350, "Recommended Procedures for the Safety Performance Evaluation of Highway Features"*, Transportation Research Board, 1993.
10. *Manual on Accessing Safety Hardware (MASH)*, AASHTO, 2016.

Chapter Fifty-six
HIGHWAY LIGHTING

BUREAU OF DESIGN AND ENVIRONMENT MANUAL

Chapter Fifty-six
HIGHWAY LIGHTING

Table of Contents

<u>Section</u>	<u>Page</u>
56-1 GENERAL	56-1.1
56-1.01 Responsibilities	56-1.1
56-1.02 Definitions	56-1.1
56-2 GUIDELINES FOR JUSTIFYING HIGHWAY LIGHTING.....	56-2.1
56-2.01 Analyzing Highway Lighting Needs.....	56-2.1
56-2.02 Freeways.....	56-2.1
56-2.02(a) Continuous Freeway Lighting	56-2.2
56-2.02(b) Complete Interchange Lighting	56-2.3
56-2.02(c) Partial Interchange Lighting	56-2.3
56-2.02(d) Crossroad Ramp Terminal Lighting	56-2.4
56-2.03 Streets and Highways Other Than Freeways.....	56-2.4
56-2.04 Rest Areas.....	56-2.6
56-2.05 Weigh Stations	56-2.6
56-2.06 Bridge Structures and Underpasses.....	56-2.6
56-2.07 Tunnels	56-2.7
56-2.08 Roundabouts.....	56-2.7
56-2.09 Other Locations.....	56-2.8
56-2.10 Highway Sign Illumination	56-2.8
56-2.11 Navigation and Obstruction Lighting	56-2.8
56-2.12 Transition Lighting.....	56-2.8
56-2.13 Roadway Reconstruction.....	56-2.9
56-2.14 Municipal and Residential Street Lighting	56-2.9
56-2.15 Ornamental Lighting	56-2.9
56-2.16 Lighting for Nighttime Construction	56-2.9
56-2.17 Temporary Lighting	56-2.9
56-2.18 Replacement Lighting.....	56-2.10
56-3 MATERIALS AND EQUIPMENT	56-3.1
56-3.01 Foundations and Mounting.....	56-3.1
56-3.02 Pole Bases	56-3.1
56-3.03 Poles.....	56-3.3
56-3.04 Arms.....	56-3.3
56-3.05 Luminaires.....	56-3.3
56-3.05(a) Light Sources.....	56-3.3
56-3.05(b) Optical System	56-3.4
56-3.05(c) Driver.....	56-3.4

Table of Contents

(Continued)

<u>Section</u>		<u>Page</u>
	56-3.05(d) Housing	56-3.4
56-3.06	Other Materials and Equipment	56-3.4
56-3.07	Electric Service.....	56-3.5
56-4	LIGHTING PROJECTS.....	56-4.1
56-4.01	Determine Classifications and Justify Need	56-4.1
56-4.02	Assemble Information	56-4.1
56-4.03	Prepare Preliminary Plans.....	56-4.2
56-4.04	Electrical and Mechanical Unit Central Office Design Package and Review	56-4.3
56-4.05	Field Review.....	56-4.3
56-4.06	Final Plan Preparation/Contract Award.....	56-4.4
56-5	LIGHTING DESIGN.....	56-5.1
56-5.01	Methodologies.....	56-5.2
	56-5.01(a) Illuminance.....	56-5.2
	56-5.01(b) Luminance	56-5.2
56-5.02	Computerized Design	56-5.5
56-5.03	Design Process	56-5.5
56-5.04	Design Considerations	56-5.6
	56-5.04(a) Roadway Classification.....	56-5.6
	56-5.04(b) Area Classification.....	56-5.7
	56-5.04(c) Pedestrian Activity Classification	56-5.7
	56-5.04(d) Pavement Classification	56-5.8
	56-5.04(e) Illuminance and Luminance Design Levels	56-5.8
	56-5.04(f) Luminaire Characteristics	56-5.9
	56-5.04(g) Voltage Drop Determination	56-5.17
56-5.05	Other Design Considerations	56-5.17
	56-5.05(a) Roadside Safety Considerations	56-5.17
	56-5.05(b) Foundation, Pole Mounting, and Structural Considerations	56-5.22
	56-5.05(c) Other Considerations.....	56-5.23
56-5.06	HIGH-MAST LIGHTING DESIGN	56-5.24
56-6	REFERENCES	56-6.1

Chapter Fifty-six

HIGHWAY LIGHTING

56-1 GENERAL

The general purpose of roadway lighting is to provide improved safety, security, and aesthetics for the various users of the roadway and associated facilities. Lighting enables the driver to recognize the geometry and condition of the roadway at extended distances, thereby simplifying the driving task at night. This, in turn, increases driver visual comfort and reduces driver fatigue, which contributes to highway safety.

Due to the large and diverse volume of highway lighting information, it would be impractical for this Chapter to present a complete design guide. Instead, the intent is to provide the user with a synopsis of the highway lighting design process and to present Illinois Department of Transportation (IDOT) criteria, policies, and procedures on this issue.

56-1.01 Responsibilities

Each district is responsible for the highway lighting projects within their respective jurisdictions (e.g., information gathering, plan preparation). See Chapter 63 for additional information on plan preparation.

The district will contact the Electrical and Mechanical Unit in the Central Office to design the project lighting. If it is mutually decided to have the project lighting designed by a consultant, a pre-design discussion will be held with the consultant to outline the lighting design parameters for the project.

The consultant lighting design criteria must be submitted and approved by the Electrical and Mechanical Unit before lighting plans are prepared. The district will submit all consultant preliminary and final lighting plans to the Central Office for review and approval by the Electrical and Mechanical Unit. See Chapter 11 for additional information on the local agency highway lighting improvement projects that must be submitted for review.

District 1 is responsible for highway lighting projects within their jurisdiction. This includes both lighting design and plan review for approval.

56-1.02 Definitions

The following definitions are for a common understanding of terms in the lighting field; consult listed references for detailed definitions:

1. Average Initial Illuminance. The average level of horizontal illuminance on the pavement area of a traveled way at the time the lighting system is installed, when luminaires are new

- and clean; expressed in average footcandles (lux) for the pavement area. See definition of Illuminance.
2. Average Maintained Horizontal Illuminance (E_{ave}). The average level of horizontal illuminance on the roadway pavement when the output of the lamp and luminaire is diminished by the light loss factor (LLF); expressed in average footcandles (lux) for the pavement area; see definition for LLF.
 3. Beacon Lighting. One or two luminaires that will identify the presence of an isolated intersection or potential conflict with other traffic and physical features and will serve as a warning or marker.
 4. Bikeway. Any road, street, path, or way that in some manner is specifically designated as being open to bicycle travel, regardless of whether such facilities are designated for the exclusive use of bicycles or are to be shared with other transportation modes.
 5. Candela (cd). A measure of the luminous intensity of a light source as seen by the eye (a.k.a., "candle"). For example, because the eye is less sensitive to blue light than to green light, a blue light source must radiate more power in watts (W) than a green light source if the two are to have the same luminous intensity. Most light sources have different luminous intensities when viewed from different directions and so the luminous intensity for a light source may vary with the angle at which it is viewed (1 cd = 1 cp).
 6. Candela per Square Meter (cd/m^2). The metric unit of luminance (photometric brightness) that is equal to the uniform luminance of a perfectly diffusing surface emitting or reflecting light at the rate of one lumen per square meter (lm/m^2) or the average luminance of any surface emitting or reflecting light at that rate (1 cd/m^2 = 0.2919 fl).
 7. Candlepower (cp). The luminous intensity in a specific direction; expressed in candelas (cd). It is no indication of the total light output (1 cp = 1 cd).
 8. Conflict Area. An area of a roadway where the motorist's special attention is required in order to interpret the functional features and/ or activities of the roadway, in order to make a decision on their driving routine. It is that area which encompasses all of the conflict points.
 9. Correlated Color Temperature (CCT). Relates to the color appearance of a white LED. CCT is defined in degrees Kelvin. A warm light is around 2700K, moving to neutral white at around 4000K, and cool white is 5000K or more. Commercially available light sources usually range from 2200 K to 6500 K. CCT values are used by the lighting industry to give specifiers a general indication of the apparent "warmth" or "coolness" of the light emitted by the source.
 10. Disability Glare. Glare resulting in reduced visual performance and visibility. It often is accompanied by discomfort. See definitions for Discomfort Glare and Glare.
 11. Discomfort Glare. Glare producing discomfort. It does not necessarily interfere with visual performance or visibility; see definition for Glare.

12. Driver. The power supply used to supply voltage and current to an LED system for operation per the luminaire design goals.
13. Equipment Factor (EF). Light loss factors that are not dependent on time, relate mostly to the characteristics of the specific equipment selected. While some may not be correctable, it is possible that one more may have an important effect upon the light level produced. Care should be taken in selecting equipment appropriate to the service conditions.
14. Footcandle (fc). The US Customary unit of measurement for illuminance on a surface one square foot (ft²) in area where there is uniformly distributed a light flux of one lumen (lm) (1 fc = 10.76 lx).
15. Footlambert (fl). The US Customary unit of luminance (photometric brightness) equal to the uniform luminance of a perfectly diffusing surface emitting or reflecting light at the rate of one lumen per square foot (lm/ft²) or the average luminance of any surface emitting or reflecting light at that rate (1 fl = 3.426 cd/m²).
16. Glare. The optical sensation produced by luminance within the visual field that is sufficiently greater than the luminance to which the eyes are adapted and causes annoyance, discomfort, or loss in visual performance and visibility. See definitions for Disability Glare and Discomfort Glare.
17. House Side. The horizontal direction away from the roadway or behind the nadir of the luminaire. See definitions for Street Side and Nadir.
18. Isolux Diagram. A diagram plotted on any appropriate set of coordinates to show all points on a surface where the illuminance is the same, represented by a series of isolux line curves.
19. Illuminance. The density of the luminous flux, lumen (lm), incident on a surface. It is the quotient of the luminous flux by the area of the surface, ft² (m²) when the latter is uniformly illuminated. It is measured in footcandles (lux). Footcandle (fc) and lux (lx) are units of illuminance expressed in lumens (lm) per square foot (ft²) and lumens per square meter (m²), respectively.
20. LED Array or Module. An assembly of LED packages (components), or dies on a printed circuit board or substrate, possibly with optical elements and additional thermal, mechanical, and electrical interfaces that are intended to connect to the load side of an LED driver. Power source and ANSI standard base are not incorporated into the device. The device cannot be connected directly to the branch circuit.
21. LED Lamp. An assembly comprised of LED packages (components) or LED arrays (modules), LED driver, ANSI standard base and other optical, thermal, mechanical and electrical components. When integrated with an ANSI standard lamp-holder (socket), the device is intended to connect directly to the branch circuit.
22. LED Light Engine. An integrated assembly comprised of LED packages (components) or LED arrays (modules), LED driver, and other optical, thermal, mechanical and electrical

- components. The device is intended to connect directly to the branch circuit through a custom connector compatible with the LED luminaire for which it was designed and does not use an ANSI standard base.
23. Light Emitting Diode (LED). A semiconductor device (p-n junction device) that converts electrical energy directly into incoherent optical radiation when forward biased. Their energy band gaps can span the ultraviolet, visible, or infrared wavelength regions. Also known as a chip, diode or die, it conducts electric current in one direction only. LEDs are typically created from formulations of III-V compounds (combinations of elements from columns III and V in the periodic table).
 24. Light Loss Factor (LLF). A factor used in a lighting calculation after a given period of time and under given conditions. It takes into account temperature and voltage variations, dirt accumulation on luminaire surfaces, lamp lumen depreciation, maintenance procedures, equipment and driver variations ($LLF = \text{Lamp Lumen Depreciation (LLD)} \cdot \text{Luminaire Dirt Depreciation (LDD)} \cdot \text{Equipment Factor (EF)}$).
 25. Luminaire Depreciation Factor (LLD). A depreciation factor that indicates the decrease in a light sources's initial lumen output over time. For design calculations, the initial lamp lumen value is reduced by LLD to compensate for the anticipated lumen reduction. See definition for Maintenance Factor.
 26. Light Standard (Pole). A vertical structural support provided with the necessary internal attachments for wiring and the external attachments for the bracket arm and luminaire.
 27. Longitudinal Roadway Line (LRL). A line along the roadway parallel to the curb or shoulder line. See definition for Transverse Roadway Line.
 28. Lumen (lm). The unit of luminous flux. It is equal to the flux through a unit solid angle (steradian), from a uniform point source of one candela (cd), or to the flux on a unit surface, all points of which are at unit distance from a uniform point source of one candela.
 29. Luminaire. A complete lighting unit consisting of LED-based light emitting elements and a matched driver together with parts to protect the light emitting elements. The LED driver is the power regulator for the system. The LED based light emitting elements may take the form of LED packages (components), LED arrays (modules), LED Light Engine, or LED lamps. The LED luminaire is intended to distribute light to the target area and to connect directly to a branch circuit.
 30. Luminaire Dirt Depreciation Factor (LDD). A depreciation factor that indicates the expected reduction of a luminaire's initial lumen output due to the accumulation of dirt on or within the luminaire over time. See definition for Light Loss Factor.
 31. Luminance. The luminous intensity, candela (cd), of any surface in a given direction per unit of projected area, ft^2 (m^2), of the surface as viewed from that direction. It is measured in footlamberts (candelas per square meter).

32. Luminous Efficacy (lm/W). The quotient of the luminous flux (lm) emitted by the total light source power input. It is expressed in terms of lumens per watt (lm/W).
33. Luminous Efficiency (%). The ratio of the total luminous flux emitted by a luminaire to that emitted by the bare light source.
34. Luminous Intensity. See definition of Candela.
35. Lux (lx). The metric unit of illuminance on a surface one square meter (m²) in area on which there is uniformly distributed light flux of one lumen (lm), or the illuminance produced on a surface where all points are at a distance of one meter (m) from a uniform point source of one candela (cd) (1 lx = 1 lm/m² = 0.0929 fc).
36. Mounting Height. The vertical distance between the roadway surface and the center of the light source in the luminaire.
37. Nadir. The vertical axis that passes through the center of the luminaire light source.
38. Overhang. The horizontal distance between a vertical line through the nadir of a luminaire and the edge of traveled way or edge of the area to be illuminated.
39. Partial Lighting. Partial lighting refers to lighting installed at the decision areas of isolated interchanges and intersections whereby it provides visibility of potential conflicts with other traffic and physical features.
40. Pedestrian Crosswalk. An area designated by pavement markings for pedestrians to cross the roadway.
41. p-n Junction. The actual junction of the two types of semiconductor materials used in the construction of the LED die.
42. Setback. The horizontal distance between the face of a light pole and the edge of traveled way.
43. Spacing. The distance in feet (meters) between successive light poles.
44. Street Side. The horizontal direction toward the roadway from the nadir of the luminaire. See definition of House Side.
45. Transverse Roadway Line (TRL). Any line across the roadway that is perpendicular to the curb or shoulder line. See definition of Longitudinal Roadway Line.
46. Uniformity Ratio. Uniformity ratios are calculated as follows: the average-to-minimum ratio is determined by dividing the average luminance or illuminance of all grid points by the grid point having the lowest value; the maximum-to-minimum ratio (applies to luminance only) is determined by dividing the grid point having the highest luminance value in a calculation grid by the grid point with the lowest luminance value in the calculation grid.

47. Utilization Curve. A plot of the quantity of light falling on the horizontal surface both in front (street side) and behind (house side) the luminaire. It shows only the percent of bare lamp lumens that fall on the horizontal surface and is plotted as a ratio of width of area to mounting height of luminaire.
48. Veiling Luminance. A luminance superimposed on the retinal image which reduces its contrast. It is this veiling effect produced by bright sources or areas in the visual field that results in decreased visual performance and visibility.

56-2 GUIDELINES FOR JUSTIFYING HIGHWAY LIGHTING

Providing lighting for all highway facilities is neither practical nor cost effective. It is generally IDOT's practice only to provide highway lighting where justified based on sound engineering judgment and on the criteria, warranting guidelines presented in the American Association of State Highway and Transportation Officials (AASHTO) publication *Roadway Lighting Design Guide*, NCHRP Report No. 152 *Warrants for Highway Lighting*, and as set forth herein.

The Department will assess the economic feasibility of lighting on roadway projects and prioritize potential lighting projects. A location that appears to justify lighting does not necessarily obligate the Department to provide funding. Local agencies may provide lighting within their respective jurisdictions provided they find sufficient benefit in the forms of convenience, safety, policing, community promotion, public relations, etc., to participate in an appreciable percentage of the cost of, or wholly finance, the installation, maintenance, operation, and energy needs of the lighting facilities; see Chapter 5.

For a highway lighting facility to be considered for funding by IDOT, the lighting system must be both economically feasible and justified based on the applicable criteria presented in the following sections. The impacts of local conditions (e.g., frequent fog, ice, snow, roadway geometry, ambient lighting, sight distance, signing) should also be considered when analyzing highway lighting needs.

56-2.01 Analyzing Highway Lighting Needs

The AASHTO publication *Roadway Lighting Design Guide* presents an empirical approach to analyzing highway lighting needs with primary application to freeway-type facilities. The principal considerations are vehicular traffic volume, interchange spacing (i.e., an indicator of the relative frequency of vehicular traffic maneuvers), land development and artificial lighting conditions in the area surrounding the freeway, and the night-to-day crash ratio. The effect of these factors on driver visibility should be considered in the lighting needs analysis.

A supplemental approach to analyzing highway lighting needs, based primarily on an analytical evaluation of driver information, is published in NCHRP Report No. 152 *Warrants for Highway Lighting*. This publication has application to both urban-type facilities (e.g., streets, arterials, intersections) and freeway-type facilities (e.g., Interstates). In urban areas where the analyst may find difficulty in applying the AASHTO empirical approach, Report No. 152 offers an alternative approach for analyzing highway lighting needs. Additional information for analyzing partial interchange lighting is available in NCHRP Report No. 256.

56-2.02 Freeways

Use the criteria presented in the following sections when analyzing the lighting needs for State-maintained freeway facilities.

56-2.02(a) Continuous Freeway Lighting

Continuous lighting consists of all mainline and direct connections and provides for complete lighting of all associated interchanges. Lighting may be provided through high-mast facilities, conventional, or both. Continuous freeway lighting (CFL) should be considered under the following conditions:

1. Freeway Volume. On those freeway sections in and near cities where the current average daily traffic (ADT) is 30,000 or more, CFL should be considered.
2. Interchange Spacing. CFL should be considered where three or more successive interchanges are located with an average spacing of 1.5 miles (2.5 km) or less, and adjacent areas outside the right-of-way are substantially urban in character.
3. Land Development/Lighting Conditions. Consider CFL where, for a length of 2 miles (3 km) or more, the freeway passes through a substantially developed suburban or urban area where one or more of the following conditions exist:
 - local traffic operates on a complete street grid having some form of street lighting, parts of which are visible from the freeway;
 - the freeway passes through a series of developments (e.g., residential, commercial, industrial areas, civic areas, colleges, parks, terminals), which include facilities (e.g., roads, streets, parking areas, yards) that are lighted;
 - separate cross streets, with and without connecting ramps, occur with an average spacing of 0.5 miles (1 km) or less, some of which are lighted as part of the local street system; or
 - freeway cross-section elements (e.g., median, shoulders) are substantially reduced in width below desirable criteria in relatively open country.
4. Night-To-Day Crash Ratio. CFL should be considered where the night-to-day ratio of crash rates is at least 2.0 or higher than the statewide average for all unlighted similar sections, and a study indicates that lighting may be expected to result in a significant reduction in the night crash rate. The number of nighttime crashes should also be evaluated.
5. Local Agency Needs. CFL should be considered where the local agency finds sufficient benefit in the forms of convenience, safety, policing, community promotion, public relations, etc., to pay an appreciable percentage of the cost of, or wholly finance, the installation, maintenance, and operation of the lighting facilities. See Chapter 5 for additional information on local agencies' lighting responsibilities.
6. Local Conditions. CFL should be considered where local conditions (e.g., frequent fog, ice, snow, roadway geometry, ambient lighting, sight distances, or frequent advertising signing) could justify lighting.

56-2.02(b) Complete Interchange Lighting

Complete interchange lighting (CIL) consists primarily of lighting the freeway's through traffic lanes within the interchange area, the traffic lanes of all ramps, the acceleration and deceleration lanes, all ramp terminals, and the crossroad between the outermost ramp terminals. Consider CIL at interchanges under the following conditions:

1. Ramp Volume. CIL should be considered where the total current ADT ramp traffic entering and exiting the freeway within the interchange area exceeds 10,000 for urban conditions, 8000 for suburban conditions, or 5000 for rural conditions.
2. Crossroad Volume. Consider CIL where the current ADT on the crossroad exceeds 10,000 for urban conditions, 8000 for suburban conditions, or 5000 for rural conditions.
3. Land Development/Lighting Conditions. Consider CIL at locations on unlighted freeways where existing substantial commercial or industrial development, which is lighted during hours of darkness, is located in the immediate vicinity of the interchange, or where the crossroad approach legs are lighted for 0.5 miles (1 km) or more on each side of the interchange.
4. Night-to-Day Crash Ratio. CIL should be considered where the night-to-day ratio of crash rates within the interchange area is at least 1.5 or higher than the statewide average for all unlighted similar sections, and a study indicates that lighting may be expected to result in a significant reduction in the night crash rate. The number of nighttime crashes should also be evaluated.
5. Local Agency Needs. CIL should be considered where the local agency finds sufficient benefit in the forms of convenience, safety, policing, community promotion, public relations, etc., to pay an appreciable percentage of the cost of, or wholly finance, the installation, maintenance, and operation of the lighting facilities. See Chapter 5 for additional information on lighting responsibilities of local agencies.
6. Continuous Freeway Lighting. Provide CIL at interchanges where continuous freeway lighting is provided; see Section 56-2.02(a).

56-2.02(c) Partial Interchange Lighting

Partial interchange lighting (PIL) generally is a lighting configuration that defines lighting for the decision-making areas. It consists of a few luminaires located in the vicinity of all ramp terminals. The usual practice is to light those general areas where the exit and entrance ramps connect with the through traffic lanes of the freeway and generally those areas where the ramps intersect the crossroad. Consider PIL at interchanges under the following conditions:

1. Ramp Volume. Consider PIL where the total current ADT ramp traffic entering and exiting the freeway within the interchange area exceeds 5000 for urban conditions, 3000 for suburban conditions, or 1000 for rural conditions.

2. Freeway Volume. Consider PIL where the current ADT on the freeway through traffic lanes exceeds 25,000 for urban conditions, 20,000 for suburban conditions, or 10,000 for rural conditions.
3. Night-to-Day Crash Ratio. PIL should be considered where the night-to-day ratio of crash rates within the interchange area is at least 1.25 or higher than the statewide average for all unlighted similar sections, and a study indicates that lighting may be expected to result in a significant reduction in the night crash rate. The number of nighttime crashes should also be evaluated.
4. Local Agency Needs. PIL should be considered where the local agency finds sufficient benefit in the forms of convenience, safety, policing, community promotion, public relations, etc., to pay an appreciable percentage of the cost of, or wholly finance, the installation, maintenance, and operation of the lighting facilities. See Chapter 5 for additional information on local agencies' lighting responsibilities.
5. Continuous Freeway Lighting. Consider PIL where continuous freeway lighting is justified, but not initially installed. See Section 56-2.02(a). The freeway section should be in or near a city where the current ADT is 30,000 or more, or the interchange should be among three or more successive interchanges located with an average spacing of 1.5 miles (2.5 km) or less with adjacent areas outside the right-of-way being substantially urban in character.
6. Complete Interchange Lighting. Where complete interchange lighting is justified, but not initially fully installed, a partial lighting system, which exceeds the normal partial installation in number of lighting units, is considered to be justified; see Section 56-2.02(b).

NCHRP Report No. 256 *Partial Lighting of Interchanges* provides additional information on analyzing the need for partial interchange lighting.

56-2.02(d) Crossroad Ramp Terminal Lighting

Lighting of the crossroad ramp terminal should be considered regardless of traffic volume where the crossroad ramp terminal design of freeway interchanges incorporates raised channelizing or divisional islands, where there is poor sight distance, or roadway alignment constitutes curvature or severe slopes.

56-2.03 Streets and Highways Other Than Freeways

Urban and rural conditions, traffic volumes (both vehicular and pedestrian), intersections, turning movements, signalization, channelization, and varying geometrics are factors that should be considered when determining the lighting needs of streets and highways other than freeways. Consider the following when assessing the lighting needs of such State-maintained facilities. NCHRP Report No. 152 *Warrants for Highway Lighting* provides additional information analyzing the need for lighting.

1. Facilities with Raised Medians. Consider highway lighting along sections of State-maintained facilities that have raised medians.
2. Major Urban Arterials. Consider highway lighting along all major arterials that are located in urban areas.
3. Intersections. Consider intersection lighting at rural intersections that meet any one of the following conditions:
 - there are 2.4 or more crashes per million vehicles in each of three consecutive years;
 - there are 2.0 or more crashes per million vehicles per year and 4.0 or more crashes per year in each of three consecutive years;
 - there are 3.0 or more crashes per million vehicles per year and 7.0 or more crashes per year in each of two consecutive years;
 - the intersection is signalized and in the past year the day-to-night crash ratio is at least 1.25 or higher than the Statewide average for similar signalized intersections;
 - substantial nighttime pedestrian volume exists;
 - less than desirable alignment exists on any of the intersection approaches;
 - intersection approach roadway leg has less than the required Safe Sight Stopping Distance (SSSD) at the intersection;
 - the intersection is an unusual type requiring complex turning maneuvers;
 - commercial development exists in the vicinity, which causes high nighttime traffic peaks;
 - distracting illumination exists from adjacent land development; and/or
 - there exists recurrent fog or industrial smog in the area.

Isolated intersections located within the fringe of corporate limits that are suburban or rural in character may be illuminated at the State's expense provided they meet the above criteria. Every effort should be made to have the local agency accept ownership of the system after installation and assume all operational and maintenance costs. See Chapter 5 for additional information on lighting responsibilities of local agencies.
4. High-Conflict Locations. Consider lighting along roadway sections with high vehicle-to-vehicle interactions (e.g., sections with numerous driveways, where driveway separation is less than one SSSD, significant commercial or residential development, driveways with larger percentage of turning traffic, large complex intersection with more than one turning

lane in one direction, intersection with raised medians, high percentage of trucks). Lighting generally improves traffic safety and efficiency at such locations.

5. Complex Roadway Geometry. Consider lighting at spot locations in rural areas where the driver is required to pass through a roadway section with complex or substandard geometry.
6. Night-to-Day Crash Ratio. Lighting should be considered at locations or sections of streets and highways where the night-to-day ratio of crash rates is higher than the statewide average for similar locations, and a study indicates that lighting may be expected to significantly reduce the night crash rate.
7. Local Agency Needs. Lighting should be considered where the local agency finds sufficient benefit in the forms of convenience, safety, policing, community promotion, public relations, etc., to pay an appreciable percentage of the cost of, or wholly finance, the installation, maintenance, and operation of the lighting facilities. See Chapter 5 for additional information on lighting responsibilities of local agencies.
8. Pedestrian Sidewalk. Consider lighting the sidewalk along the roadway section. Properly designed highway lighting may provide adequate pedestrian lighting without the need for supplemental or separate sidewalk lighting.

56-2.04 Rest Areas

Provide lighting at rest areas that offer complete rest facilities (e.g., comfort station, information kiosk, picnic areas). Illuminate all areas within the facility that have pedestrian activities (e.g., parking areas, immediate area of building). Provide lighting at rest area ramps, gore areas, other decision points, and traffic conflict areas.

56-2.05 Weigh Stations

Provide lighting and overheight detectors at all permanent truck weigh stations. Illuminate the weighing area, parking areas, speed change lanes, ramps, and gore areas.

56-2.06 Bridge Structures and Underpasses

Because of their typical configuration and length-to-height ratio, underpasses generally have good daylight penetration and do not require supplemental daytime lighting. Underpass lighting generally is installed to enhance driver visibility after daylight hours. When the underpass length-to-height ratio approaches 10:1, it usually is necessary to analyze specific geometry and roadway conditions, including vehicular and pedestrian activity, to determine the need for supplemental daytime lighting. For more information on daytime lighting see the *Recommended Practice: Lighting Roadway and Parking Facilities, RP-8* produced by the American National Standards Institute (ANSI) and by the Illuminating Engineering Society (IES).

On highways that are not continuously lighted, consider providing underpass lighting where frequent nighttime pedestrian traffic exists through the underpass or where unusual or critical geometry exists within or on an approach to the underpass.

Provide underpass lighting on all highways that are continuously lighted. Favorable positioning of conventional highway luminaires adjacent to a relatively short underpass often can provide adequate illumination within the underpass without a need to provide supplemental lighting. If this action is considered, ensure that shadows cast by the conventional luminaires do not become a visibility problem within the underpass.

56-2.07 Tunnels

Provide lighting for tunnels to create adequate roadway visibility necessary for safe and efficient traffic operation. Daytime tunnel lighting is recommended when driver visibility requirements are not satisfied without the use of a daytime lighting system to supplement natural daylight. Visibility requirements vary considerably with such items as:

- portal to portal tunnel length (i.e., short or long);
- tunnel portal design;
- geometry of tunnel and its approaches;
- vehicular and pedestrian traffic characteristics;
- treatment of pavement, portal, interior, and environmental reflective surfaces;
- climate and orientation of tunnel; and
- visibility objectives to provide for safe and efficient tunnel operation.

The AASHTO publication *Roadway Lighting Design Guide* provides tunnel lighting guidelines. For additional tunnel lighting requirements, consult the *ANSI/IES RP-8*.

56-2.08 Roundabouts

Provide lighting at roundabouts, including rural roundabouts, as recommended by the AASHTO publication *Roadway Lighting Design Guide*. Additional lighting requirements are outlined in *ANSI/IES RP-8*.

Lighting should be located in consideration of the following:

- Lights should be located so that they provide good illumination on the approach nose of splitter islands, at all conflict areas where traffic is entering the circulating stream, and at all places where the traffic streams separate to exit the roundabout.
- Particular attention should be given to the lighting of the pedestrian crossing areas.
- Avoid placing light poles within splitter islands, on the central island, or on the right-hand perimeter immediately downstream of an exit point.

56-2.09 Other Locations

Provide lighting for pedestrian crosswalks and all pedestrian underpass and pedestrian tunnel facilities. In addition, lighting for the following facilities will be considered on a case-by-case basis:

- commuter park-and-ride lots,
- bike paths,
- pedestrian walkways, and
- pedestrian overpasses.

56-2.10 Highway Sign Illumination

Overhead highway signs fitted with long-lasting, highly reflective sheeting may be adequately illuminated by vehicular headlights. Signs with non-reflective lower grade sheeting must be externally illuminated by a direct light source. Roadway lighting adjacent to signs does not provide adequate intensity to meet the requirements for external sign illumination.

Provide sign illumination where background (roadway and/or non-roadway) lighting obscures the legend of the sign or the sign is not adequately visible by vehicular headlights. In urban areas with high-ambient lighting, the external illumination of overhead sign panels generally is warranted.

External lighting for all other overhead sign panels along lighted highway facilities will be illuminated on a case-by-case basis. See *ANSI/IES RP-8* for additional information on when to light signs. Also, apply the requirements of this manual when designing lighting for sign panels.

56-2.11 Navigation and Obstruction Lighting

Highway structures over navigable waterways require waterway obstruction warning luminaires in accordance with US Coast Guard requirements. The district or Electrical and Mechanical Unit in the Central Office will coordinate with the Coast Guard. Design navigable waterway obstruction lighting in accordance with the US Coast Guard Bridge Administration Manual COMDTINST M16590.5C, *Bridge Lighting and Other Signals* and the *Code of Federal Regulations*, 33 CFR 118.

Any need for aviation obstruction warning luminaires on highway structures will be coordinated with the Federal Aviation Administration (FAA) by the district or Electrical and Mechanical Unit in the Central Office. For information on lighting for navigable airspace obstructions, consult the FAA Advisory Circular AC 70/74602-1L *Obstruction Marking and Lighting*.

56-2.12 Transition Lighting

Consider transition lighting, to allow sufficient time for eye adaptation, for traffic lanes emerging from a lighted area with very high lighting levels. For additional information, consult the ANSI/IES RP-8.

56-2.13 Roadway Reconstruction

Existing highway lighting shall be evaluated for upgrade to meet current Department highway lighting criteria on roadway reconstruction projects. Contact the Electrical and Mechanical Unit in the Central Office for additional information.

56-2.14 Municipal and Residential Street Lighting

IDOT will not participate in highway lighting on facilities located within an incorporated area except as described in Sections 56-2.02, 56-2.03, and Chapter 5.

56-2.15 Ornamental Lighting

At the request of a local agency, ornamental lighting may be permitted by the Department on a State-maintained facility if the minimum requirements of the Department and ANSI/IES RP-8 are met and the local agency is 100% responsible for construction funding, ownership, electrical energy, and maintenance of such lighting both during and after construction. Special lighting requirements regarding light trespass and glare must also be satisfied. Contact the Electrical and Mechanical Unit in the Central Office for additional information on ornamental lighting requirements.

56-2.16 Lighting for Nighttime Construction

Ensure lighting for nighttime construction activities, either mobile or stationary, is provided and included in all plans. Ensure the lighting design does not impair motorist visibility and meets ANSI/IES RP-8 glare and light trespass requirements. This should be done to help provide for the overall on-site safety of the workers and by making them more visible to motorists where construction is adjacent to traffic. Nighttime lighting also benefits the quality of the construction work. For more information on work zones see Chapter 13.

56-2.17 Temporary Lighting

Consider temporary highway lighting in construction zones requiring complex traffic maneuvers (e.g., crossovers) and where existing lighting will be removed, relocated, or altered by construction operations. Temporary roadway lighting shall meet ANSI/IESNA RP-8 requirements for lighting, glare, and light trespass. Also, ensure the temporary roadway lighting is designed to meet roadside safety issues (e.g., clear zone setback) in accordance with Chapter 38.

56-2.18 Replacement Lighting

Consider a new roadway lighting design where existing lighting facilities are being replaced on a complete lighting circuit basis or in its entirety. With the exception of spot replacements, large portions of lighting facilities replaced through maintenance or construction operations shall be reevaluated from a lighting design standpoint to ensure lighting facilities are upgraded to meet current Department lighting criteria, including ANSI/IES RP-8 requirements.

This is especially important with older facilities that were installed with a different light source than is currently used, wiring methods, etc. Contact the Electrical and Mechanical Unit in the Central Office for additional information on the replacement of existing lighting facilities.

56-3 MATERIALS AND EQUIPMENT

Because luminaires, electrical devices, and support structures change rapidly with new developments, this section presents an overview rather than an absolute requirement for lighting equipment and materials. The *Standard Specifications, Supplemental Specifications and Recurring Special Provisions, Highway Standards*, and Bureau of Design and Environment (BDE) Special Provisions provide additional details on lighting equipment and materials that are required for IDOT projects. Figure 56-3.A illustrates the various components of a typical highway lighting structure.

56-3.01 Foundations and Mounting

In conventional highway lighting applications, luminaire assemblies generally are attached to davit or mast-arm poles mounted along the roadway either on ground foundations or atop bridge parapets or barriers. Foundations for conventional light poles may be either concrete or steel helix foundations and are constructed from typical designs. However, concrete foundations for light towers in high-mast lighting applications require special designs and soil analyses to determine adequate foundation depth. Depending on factors such as roadside location, most conventional light poles will be mounted on frangible devices (breakaway supports). Attach light poles that are mounted atop parapets and barriers or behind guardrail to foundations with high-strength, non-breakaway bolts. Use special vibration isolating materials to mount light poles on bridges. Where feasible at signalized intersections, a roadway luminaire may be mounted on a combination mast-arm assembly and pole using approved combination structures.

Luminaires installed in underpasses and tunnels are either attached to the wall or suspended from vibration-dampening pendants at the edge of the travel lanes. Light sources that are used to externally illuminate overhead sign panels typically are fastened to the truss or cantilever support structure.

Waterway and aviation obstruction warning luminaires are attached to the structures representing the hazard. Ensure the location and installation of warning luminaires for waterway and aviation also meet the requirements of Section 56-2.11.

56-3.02 Pole Bases

Light poles may be attached to one of several types of bases (e.g., transformer base, breakaway couplings, anchor base). Selection is governed by project need and material suitability. A very important distinguishing characteristic of the pole base is whether it is classified by the Federal Highway Administration (FHWA) as an acceptable breakaway support. If the pole represents a roadside hazard, it shall be mounted on a breakaway support. Section 56-5.05 provides some design guidance on this issue (see Chapter 38 for additional guidance). The following briefly describes a typical pole configuration used by the Department:

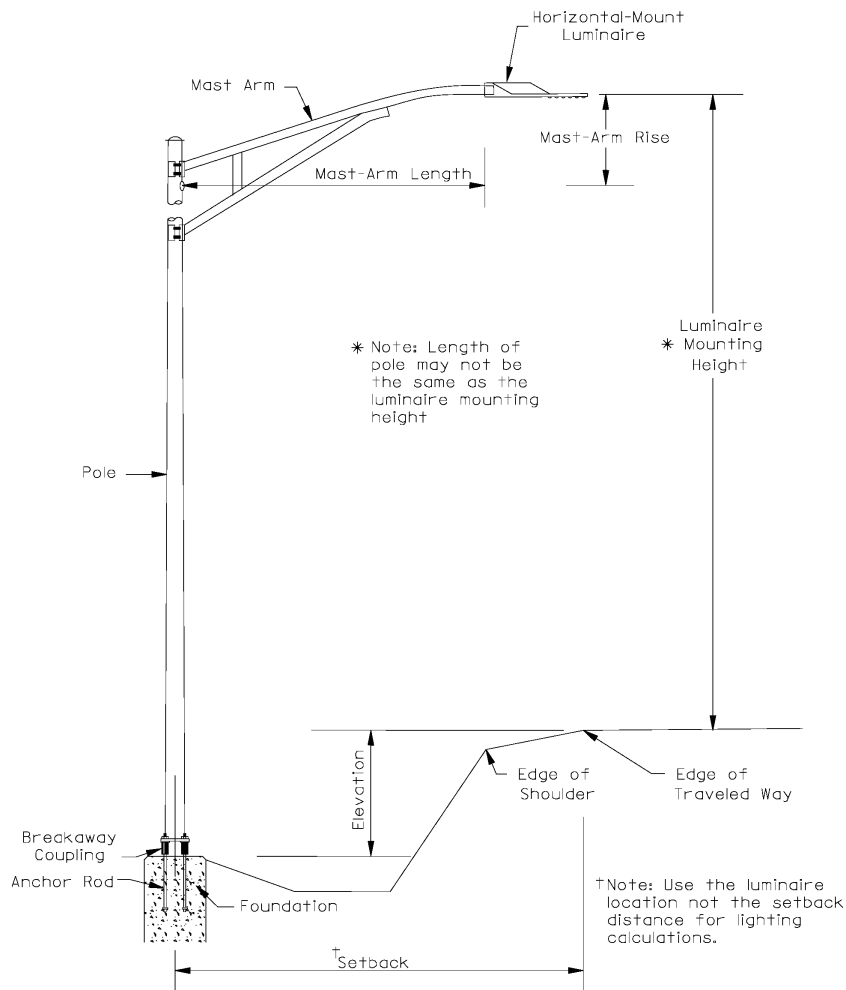

Note: Single mast-arm luminaire shown for illustrative purposes. For other luminaire mounting types, see the Highway Standards and Standard Specifications.

TYPICAL HIGHWAY LIGHTING STRUCTURE

Figure 56-3.A

1. **Breakaway Coupling.** Breakaway couplings are connectors or sleeves that are designed to shear when the pole is hit by an errant vehicle. The bottom of each coupling (device) is threaded onto a foundation anchor rod, and the pole is attached to the top of the coupling. Four couplings are used with each pole. All wiring at the pole base will have simultaneous quick disconnect fuse holders.
2. **Frangible Transformer Base.** The frangible transformer base consists of a cast aluminum apron between the foundation and the base of the pole. It is designed to deform and break away when hit by an errant vehicle. All wiring inside the base will have quick disconnect fuse holders.
3. **Anchor Base.** The pole is mounted on leveling nuts and the bolts attach directly to the foundation. The anchor base is not classified by the Department as a breakaway support.

56-3.03 Poles

Light poles for conventional highway lighting applications support luminaire mounting heights ranging from approximately 30 ft to 50 ft (9.1 m to 15.2 m). Light towers for high-mast lighting applications generally range from 80 ft to 160 ft (24.4 m to 48.8 m) and are designed in multiple sections. Ornamental light poles used for local streets generally range in height from 10 ft to 30 ft (3.0 m to 9.1 m).

56-3.04 Arms

Depending on the particular application, luminaires may be mounted on single and/or double mast arms or davit arms at the top of the pole. The use of an arm places the light source closer to the traveled way while allowing the pole to be located further from the edge of the traveled way. Arms longer than 15 ft (4.5 m) require special approval.

56-3.05 Luminaires

Luminaires consist of a light source or optical assembly inside a housing with electrical components to start and regulate the light source. The following sections provide some general information on the basic components of the luminaire.

56-3.05(a) Light Sources

Light emitting diodes (LEDs) shall be used for roadway lighting unless permission is obtained from the Department for a different light source. The local agency shall request this permission from the district in writing and ensures the request demonstrates the ability of the alternative light source to light the roadway to the requirements of this Chapter without additional luminaires and increased cost.

56-3.05(b) Optical System

The following provides a general discussion on the optical system components of LED luminaires:

1. Light Source. LED is the light source used in highway applications and it is defined in Section 56-1.02. The Department uses a correlated color temperature (CCT) for LED roadway lighting of not more than 4,000 degrees Kelvin.
2. LED Package. An assembly of one or more LED dies that includes wire bond or other type of electrical connections, possibly with an optical element and thermal, mechanical, and electrical interfaces. Power source and ANSI standardized base are not incorporated into the device. The device cannot be connected directly to the branch circuit.
3. Lens. The lens is made of a transparent material, usually UV stabilized plastic or glass, which covers and protects the LED package. The lens controls and directs the light emitted.

56-3.05(c) Driver

Luminaires used in highway lighting applications have a built-in driver. The driver is a device comprised of a power source and LED control circuitry designed to operate an LED light source by regulating power to the LED, thereby controlling the brightness or intensity of the LED. However, the driver system converts the supply voltage to a dc voltage and provides a dc output current to the LED while maintaining the current at a constant level/output over variable supply voltage ranges.

56-3.05(d) Housing

The housing integrates the LED optical assembly, driver, and hardware to connect to the power supply, heat management elements, and other associated devices into a self-contained unit. The housing is designed to seal the unit against the entry of dust, moisture, and insects. Housings are generally designed to accommodate access for maintenance, but this access is typically not for field adjustment (i.e., light direction and distribution). The housing is generally cast aluminum or stainless steel.

56-3.06 Other Materials and Equipment

There are numerous other materials and equipment that are used in a highway lighting system (e.g., quick disconnect fuse holders, controllers, photocells, surge arresters, raceways, ground rods, cabling, transformers, conduit, hand holes, pull boxes). The use and specification of these ancillary items will depend on the highway lighting application and may vary on a project-by-project basis.

56-3.07 Electric Service

Electric services shall be a low voltage (0-600V) grounded system delivered to the roadway right-of-way. The service and equipment shall be grounded in accordance with the NEC. The service transformer, typically supplied by the electric utility shall deliver secondary voltages of single-phase 120/240V or 240/480V and, with Department approval, shall be 3-phase voltages of 120/208V or 277/480V.

56-4 LIGHTING PROJECTS

The following provides a general discussion with regard to the preparation of a roadway lighting design in the State (excluding District 1).

1. Responsibilities. Each District is responsible for highway lighting projects installed under contract in their respective jurisdictions. Typically, the District will initiate a lighting project by submitting the project scope, timeframe, warrants, and all supporting information to the Electrical and Mechanical Unit in the Central Office for review. See Section 56-4.02 for a list of required supporting information.
2. Approvals. The Consultant's lighting design criteria must be submitted and approved before lighting plans are prepared. The Consultant's preliminary and final lighting plans shall be submitted to the Electrical and Mechanical Unit for review and approval.
3. Plan Preparation. The District shall provide to the Consultant all information necessary to develop the lighting plan sheets showing the overall project with roadway and area classifications. Base plan information showing roadway geometry shall include: pavement, shoulder, and median widths at frequent intervals; roadway stationing; locations of roadway features; all utilities; the height and location of all overhead conflicts; and the location of existing and proposed utility service points.
4. Final Design Package. The final design package shall include pole locations, luminaire locations with orientation, electrical distribution, wiring diagrams, voltage-drop calculations, luminaire performance tables, lighting calculations with roadway classifications, and special provisions.

Alternatively, and with approval from the Central Office, the District may request the Electrical and Mechanical Unit to prepare the design package.

56-4.01 Determine Classifications and Justify Need

Determine the roadway classification, pedestrian area classification, pavement classification, and environmental conditions. A mutual determination will be made between the district and the Electrical and Mechanical Unit in the Central Office regarding the classification of any interchange or freeways as urban, suburban, or rural. The district will initiate a lighting project by submitting the warrants and all supporting data to the Central Office for review. Highway lighting projects that are justified may be incorporated into the annual improvements program.

56-4.02 Assemble Information

The district assembles all necessary information needed for a lighting project and forwards it to the Electrical and Mechanical Unit in the Central Office or the lighting design consultant. This may include:

- identifying current lighting design policies, preferences, and procedures;

- gathering all necessary roadway and bridge plan and profile sheets and any special detail sheets (e.g., as-built plans for existing lighting, as applicable);
- determining existing and proposed utility locations;
- discussing special considerations with the highway or bridge designer;
- determining existing and proposed roadway cross-sections, plan and profile, construction staging, and right-of-way lines;
- conducting field reviews with photographic inventory;
- establishing the need for temporary lighting, as applicable;
- contacting local officials for local projects;
- contacting and coordinating with the local electrical utility for electric service;
- determining existing and proposed signalized intersections with detailed information on any combination traffic signal and lighting structures;
- noting areas sensitive to light trespass (e.g., soybean fields);
- determining the location of advance warning beacons, changeable message boards, or other devices that may be affected by roadway lighting;
- contacting the FAA for any possible height restrictions on lighting facilities due to airports in the vicinity;
- identifying the need for other lighting needs (e.g., aviation and/or waterway obstruction warning luminaires, overhead sign lighting, bike paths); and
- noting any other special considerations that may affect the lighting design (i.e., location of light poles due to drainage).

56-4.03 Prepare Preliminary Plans

The district will submit to the Electrical and Mechanical Unit in the Central Office or the lighting design consultant the plan sheets showing the overall project with roadway and area classifications including other pertinent information to justify chosen classification and criteria. Ensure that the plans include:

- information gathered in Section 56-4.02 as appropriate;
- stationing at appropriate 100 ft (30 m) intervals and stationing of noses and tangent points of ramps which are formed by the roadway proper and not by the shoulder;

- pavement, shoulder, and median widths at frequent intervals;
- all roadway features which may affect the stationing or setback of poles (e.g., guardrail, barrier median, barrier curb, signs exceeding 50 ft² (4.5 m²), driveways, culverts, railroads, pipelines);
- the approximate height and location of any power and telephone lines along and over the roadway;
- the location of power poles from which service may be obtained;
- if combination signals and lighting are present or proposed, the stationing and offset of the traffic signal poles, the arm length and mounting height of luminaires, the type and wattage of luminaire, and the location of the power pole and control cabinet; and
- lighting calculations in an electronic format with all the supporting data.

Electronic plans are preferred over paper copies. Show existing and proposed roadway geometry and basic plan information as noted above. Also, furnish as-built plans of existing lighting facilities, as applicable. In addition, copies of any available sample calculations, plans, notes, schedules, and pay quantities may provide further clarification for the lighting designer.

56-4.04 Electrical and Mechanical Unit Central Office Design Package and Review

The district will communicate the project scope, configuration details, and timeframe for a lighting design to the Electrical and Mechanical Unit in the Central Office. Upon receipt of the request from the district, the Electrical and Mechanical Unit will design the lighting for the project and send the design package to the district. The design package will include the location of poles and luminaires, the electrical distribution and control system design, and associated special provisions. The Electrical and Mechanical Unit also will furnish wiring diagrams and drawings of equipment, foundations, and electrical details, as applicable. The plans and special provisions will be returned to the district for CADD drafting and completion as final contract documents.

When a consultant is used by the district to complete the design, the preliminary and final plans will be submitted to the Electrical and Mechanical Unit in the Central Office for review and approval.

56-4.05 Field Review

Prior to finalizing plans, the district or the lighting design consultant will conduct a field review to determine if pole and luminaire locations will interfere with existing or proposed underground, at-grade, and aerial utilities and/or roadway structures. The district will notify the Electrical and Mechanical Unit in the Central Office of any conflict that would cause modification to the design. For high-mast lighting designs, ensure that borings are taken for soil analyses to ascertain the correct foundation depth at each tower location.

56-4.06 Final Plan Preparation/Contract Award

The district and/or the lighting design consultant will prepare the final plans, specifications, and estimates and submit them to the BDE for processing and contract award. See Chapter 63 for information on plan preparation and Chapter 66 for information on contract processing.

56-5 LIGHTING DESIGN

When designing a highway lighting system, there are numerous factors to consider. This Section presents design considerations commonly encountered in highway lighting designs and presents IDOT’s criteria, policies, and procedures on these issues. Figure 56-5.A presents typical highway lighting design parameters used by the Department.

TYPICAL IDOT HIGHWAY LIGHTING DESIGN PARAMETERS^{1, 3}	
LLF (i.e., EF • LLD • LDD)	0.70
Percent of Voltage Drop Allowed	20% maximum ²
Typical Parameters for Conventional Lighting (Interstate, Expressway, or Rural State Routes)	Aluminum or Steel Pole; Davit or Mast-Arm; Single or Twin-Arm Mounting; 45 ft (13.7 m) Mounting Height; LED Horizontal Mount Luminaire; Breakaway Supports where Justified.
Typical Pavement Classification	Class R3
Typical IES Luminaire Classification for Conventional Highway Lighting	Full Cutoff (FC).
Typical Luminaire Pole Arrangement	Staggered, Opposite, or Median Mounted.

1. Values or equipment other than what is shown in the table must be approved by the Electrical and Mechanical Unit.
2. For high mast towers with motorized lowering devices shall not exceed 5%.
3. Ensure all lighting designs conform to current recommended values in ANSI/IES/RP-8 for the selected roadway and pedestrian activity areas.

TYPICAL IDOT HIGHWAY LIGHTING DESIGN PARAMETERS

Figure 56-5.A

56-5.01 Methodologies

The Illuminating Engineering Society (IES) has been a leader in developing illuminance and luminance methodologies for the design of roadway lighting. These methodologies have been documented and acceptable results are provided in the ANSI/IES RP-8. The levels defined in ANSI/IES RP-8 are minimum acceptable levels and the design approach shall achieve, but not significantly exceed these levels. Ensure calculated lighting levels do not exceed the levels for the next higher roadway and pedestrian classification.

In most cases it is a good practice, and will be required in consultant submittals, to consider both illuminance and luminance design. Luminance shall be used for design and illuminance will be used for field verification. Illuminance shall be used where luminance calculations are not applicable (see ANSI/IES RP-8 for applicability of each method). Both of these methodologies require the designer to consider veiling luminance and limit the ratio to the values listed in Figures 56-5.B and 56-5.C. The following sections briefly describe each of the available design methodologies.

56-5.01(a) Illuminance

The illuminance methodology is the oldest and simplest to employ. The illuminance methodology is used to determine the combined amount of luminous flux reaching critical pavement locations from contributing luminaires (i.e., a measure of light quantity) and to calculate how uniformly the luminaires' combined luminous flux is horizontally distributed over the pavement surface (i.e., a measure of light quality).

An inherent disadvantage of the illuminance methodology was that it only accounts for incident light and does not assess the effect on visibility due to reflected light from an object or surface. This sensation is known as "brightness". Objects are distinguished by contrast from their difference in brightness. To address some visibility concerns, "Veiling Luminance Ratio" was added to the illuminance methodology. Illuminance designs consider the average maintained horizontal illumination (E_{avg}), or quantity of light, and the uniformity ratio, or quality of light. See Section 56-1.02 for the definition of uniformity ratio (E_{avg}/E_{min}).

56-5.01(b) Luminance

The luminance methodology is used to simulate driver visibility by assessing the quantity and quality of light reflected by the pavement surface to the motorist's eye from contributing luminaires. Assumptions are made regarding the spatial positioning of the driver's eye, and luminance values are calculated at grid points over the pavement surface.

Roadway Facility Classification ^④	Area Classification	Pedestrian Activity Area ^③	Average Maintained ^① ^⑤ Horizontal Illuminance (E _{avg}) Footcandle (Lux)			Uniformity Ratio (E _{avg} /E _{min})	Veiling Luminance Ratio (L _{vmax} /L _{avg})
			Pavement Classification ^④				
			R1	R2 & R3	R4		
Freeway ^②	Class A Class B		0.6 (6)	0.8 (9)	0.7 (8)	3:1	0.3
			0.4 (4)	0.6 (6)	0.5 (5)		
Expressway ^②	Commercial Intermediate Residential	High	1.0 (10)	1.4 (14)	1.3 (13)	3:1	0.3
		Medium	0.8 (8)	1.2 (12)	1.0 (10)		
		Low	0.6 (6)	0.8 (9)	0.7 (8)		
Major	Commercial Intermediate Residential	High	1.2 (12)	1.7 (17)	1.5 (15)	3:1	0.3
		Medium	0.9 (9)	1.3 (13)	1.1 (11)		
		Low	0.6 (6)	0.9 (9)	0.8 (8)		
Collector	Commercial Intermediate Residential	High	0.8 (8)	1.2 (12)	1.0 (10)	4:1	0.4
		Medium	0.6 (6)	0.9 (9)	0.8 (8)		
		Low	0.4 (4)	0.6 (6)	0.5 (5)		
Local	Commercial Intermediate Residential	High	0.6 (6)	0.9 (9)	0.8 (8)	6:1	0.4
		Medium	0.5 (5)	0.7 (7)	0.6 (6)		
		Low	0.3 (3)	0.4 (4)	0.4 (4)		
Alleys	Commercial Intermediate Residential		0.4 (4)	0.6 (6)	0.5 (5)	6:1	0.4
			0.3 (3)	0.4 (4)	0.4 (4)		
			0.2 (2)	0.3 (3)	0.3 (3)		
Surround	The Surround shall be illuminated at a level of 80% of that of the traveled way. See ANSI/IES RP-8 for further information.						
Walkways/ Bikeways and Intersections ^③	See ANSI/IES RP-8 and LP-2 for recommended criteria and specific treatments.						
Rest Areas and Weigh Stations							
Ramp Gores & Interior Roadways	All		0.4 (4)	0.6 (6)	--	3:1 to 4:1	0.4
Parking & Major Activity Areas	All		0.8 (8)	1.1 (11)	--		
Minor Activity Areas	All		0.4 (4)	0.5 (5)	--	6:1	

Notes:

1. Average illuminance on the traveled way.
2. Both mainline and ramps.
3. Facilities adjacent to a vehicular roadway shall use the illuminance levels and uniformity ratios for that roadway as recommended in ANSI/IES RP-8.
4. See Section 56-5.04 for definitions of roadway facility, area, and pavement classifications. Use either Column 2 or Column 3 in the tables to best describe the location to be lighted.
5. The illuminance values given are minimum maintained averages. Higher levels than shown in the tables may be justified, consult ANSI/IES RP-8 and the AASHTO Roadway Lighting Design Guide for details.

IDOT ILLUMINANCE DESIGN CRITERIA

Figure 56-5.B

Road and Area Classification			Average Luminance L_{avg} (cd/m^2)	Uniformity Ratio L_{avg}/L_{min} (Maximum Allowed)	Uniformity Ratio L_{max}/L_{min} (Maximum Allowed)	Veiling Luminance Ratio L_{Vmax}/L_{avg} (Maximum Allowed)
Roadway	Area Classification	Pedestrian Area Classification				
Freeway Class A	N/A		0.6	3.5	6.0	0.3
Freeway Class B	N/A		0.4	3.5	6.0	0.3
Expressway	Commercial	High	1.0	3.0	5.0	0.3
	Intermediate	Medium	0.8	3.0	5.0	0.3
	Residential	Low	0.6	3.5	6.0	0.3
Major	Commercial	High	1.2	3.0	5.0	0.3
	Intermediate	Medium	0.9	3.0	5.0	0.3
	Residential	Low	0.6	3.5	6.0	0.3
Collector	Commercial	High	0.8	3.0	5.0	0.4
	Intermediate	Medium	0.6	3.5	6.0	0.4
	Residential	Low	0.4	4.0	8.0	0.4
Local	Commercial	High	0.6	6.0	10.0	0.4
	Intermediate	Medium	0.5	6.0	10.0	0.4
	Residential	Low	0.3	6.0	10.0	0.4

IDOT LUMINANCE DESIGN CRITERIA

Figure 56-5.C

In theory, luminance is a good measure of visibility; however, the results of using the luminance methodology in highway lighting applications are greatly affected by the reflectance characteristics of the pavement surface, both now and in the future. Factors affecting pavement reflectivity include initial surface type, pavement deterioration, resurfacing material type, assumptions regarding weather conditions, etc. It is difficult to predict or control these factors. Luminance design parameters include average maintained luminance (L_{avg}), minimum luminance (L_{min}), maximum luminance (L_{max}), maximum veiling luminance (L_{Vmax}), and ratios of L_{avg} to L_{min} , L_{max} to L_{min} , and L_v to L_{avg} .

56-5.02 Computerized Design

The highway lighting design process is an iterative process that is quite effectively implemented by computer. If criteria are not initially satisfied, it will be necessary to change design parameters (e.g., pole spacing, mounting height, luminaire wattage, luminaire distribution) until an acceptable alternative is found. This process will be repeated until the design is optimized to meet the selected criteria.

For computerized designs prepared by outside consultants, the consultant will provide a complete lighting design file in electronic format. The level of precision for calculations shall be in accordance with ANSI/IES TM-34. All lighting calculations shall be performed in Lighting Analysts, AGI32 lighting design software.

56-5.03 Design Process

The following briefly describes the processes used in any highway lighting design:

1. Select Lighting Equipment. Select the lighting equipment and associated design parameters that will be used for the project. This will include items such as luminaire mounting height, pole setback, light source, lamp wattage, etc. It will be necessary to make some initial assumptions during preliminary design. Design parameters then may be iteratively changed to meet the highway lighting criteria.
2. Select Luminaire Arrangement. Select an appropriate luminaire arrangement for the project. This will depend on local site conditions and engineering judgment. Alternative arrangements may need to be considered. The lighting design software will create the required output based on the input criteria.
3. Luminaire Spacing. Typically, luminaire spacing required to satisfy the project specific design criteria will be determined by the lighting design software.
4. Check Uniformity. Once luminaire spacing has been determined, check the uniformity of light distribution and compare this value to the lighting criteria selected in Step #1. Adjust design parameters and recalculate as necessary to meet criteria.
5. Select Optimum Design. Because computerized design is relatively quick and easy, modify key design parameters (e.g., luminaire photometry, location, mounting height) to develop and test several alternative designs. It generally is not good engineering practice to consider only one design, even if found to satisfy the lighting criteria. There often are several alternatives that will work. Optimize and select the most cost-effective and if possible, minimum maintenance design.

Typically, do not terminate a lighting project just before an intersection. Consider motorist decision points and potential pedestrian interaction when evaluating how far to extend the limits of lighting.

56-5.04 Design Considerations

When selecting design criteria for a lighting project, it is necessary to determine classifications for the roadway facility, the area the roadway traverses, and the pavement type that best fit the descriptions contained in ANSI/IES RP-8 and the AASHTO *Roadway Lighting Design Guide*. Do not use the classifications of other publications. The following sections discuss these classifications for the purpose of highway lighting design only.

56-5.04(a) Roadway Classification

Use the following definitions to classify roadway facilities for IDOT highway lighting projects:

1. Freeway. A divided major highway with full control of access and with no crossings at grade.
2. Expressway. A divided major arterial highway for through traffic with full or partial control of access and generally with interchanges at major crossroads. Expressways for non-commercial traffic within parks and park-like areas generally are known as parkways.
3. Major. The part of the roadway system that serves as the principle network for through traffic flow. The routes connect areas of principle traffic generation and important rural highways entering the city.
4. Collector. The distributor and collector roadways serving traffic between major and local roadways. These are roadways used mainly for traffic movements within residential, commercial, and industrial areas.
5. Local. Roadways used primarily for direct access to residential, commercial, industrial, or other abutting property. They do not include roadways carrying through traffic. Long local roadways generally will be divided into short sections by the collector roadway system.
6. Alley. A narrow public way within a block, generally used for vehicular access to the rear of abutting properties.
7. Sidewalk. Paved or otherwise improved areas for pedestrian use, located within public street right-of-way, which also contains roadways for vehicular traffic.
8. Pedestrian Way. Public sidewalks for pedestrian traffic generally not within rights-of-way for vehicular traffic roadways. Included are skywalks (pedestrian overpasses), subwalks (pedestrian tunnels), walkways giving access to park or block interiors, and crossings near centers of long blocks.
9. Bicycle Lane. Any facility that explicitly provides for bicycle travel.

56-5.04(b) Area Classification

For IDOT lighting projects, use the following definitions to classify the area in which the roadway traverses. These definitions match the *AASHTO Roadway Lighting Design Guide*. These definitions do not match the ANSI/IES RP-8 classifications, which are based on pedestrian activity areas.

1. Commercial. That portion of a municipality in a business development where ordinarily there are large numbers of pedestrians and a heavy demand for parking space during periods of peak traffic or a sustained high pedestrian volume and a continuously heavy demand for off-street parking space during business hours. This definition applies to densely developed business areas outside of, as well as those that are within, the central part of a municipality.
2. Intermediate. That portion of a municipality that is outside of a downtown area but generally within the zone of influence of a business or industrial development, often characterized by a moderately heavy nighttime pedestrian volume and a somewhat lower parking turnover than is found in a commercial area. This definition includes densely developed apartment areas, hospitals, public libraries, and neighborhood recreational centers.
3. Residential. A residential development or mixture of residential and commercial establishments, characterized by few pedestrians and a low parking demand or turnover at night. This definition includes areas with single-family homes, townhouses, and/or small apartments. Regional parks, cemeteries, and vacant lands are also included.

56-5.04(c) Pedestrian Activity Classification

The magnitude of pedestrian volume is nearly always related to the abutting land use. Three classifications of pedestrian activity areas during nighttime hours and the types of land use with which they are typically associated are given below. These definitions match the ANSI/IES RP-8 classifications, which are based on pedestrian activity, not the *AASHTO Roadway Lighting Design Guide*:

1. High Pedestrian Activity Areas. Commercial areas in urban environments can have high nighttime pedestrian activity. It is important to provide lighting systems that will increase the visibility of pedestrians. Since the visual environment is much more cluttered, and a high probability for detection of pedestrians is required, the use of both horizontal and vertical illuminances is recommended for design.
2. Medium Pedestrian Activity Areas. Intermediate areas have moderate nighttime pedestrian activities. These areas might typically be those near community facilities such as libraries and recreation centers. Safety for the pedestrian and providing guidance to primary travel ways are key elements in the design of a lighting system in these areas.

3. Low Pedestrian Activity Areas. The lighting system in residential areas can allow both driver and pedestrian to visually orient in the environment, detect obstacles, identify other pedestrians, read street signs, and recognize landmarks.

Consult ANSI/IES RP-8 for the method used in taking pedestrian counts and the associated pedestrian count that corresponds with these conflict areas.

56-5.04(d) Pavement Classification

The following definitions classify the pavement type of the roadway facility. These pavement classifications have mean luminance coefficient Q_0 . For IDOT lighting projects, the designer should use a reflectance value for slightly specular asphalt (R3) to be conservative and account for a current or future asphalt overlay of the roadway.

1. Class R1 and ($Q_0 = 0.10$). Class R1 pavement has a mostly diffuse mode of reflectance. R1 pavements include portland cement concrete road surfaces and asphalt road surfaces with a minimum of 12% of the aggregates composed of artificial brightener (e.g., Synopal) aggregates (e.g., labradorite, quartzite).
2. Class R2 and ($Q_0 = 0.07$). Class R2 pavement has a mixed diffuse and specular mode of reflectance. R2 pavements include asphalt road surfaces with an aggregate composed of a minimum of 60% gravel with a size greater than 0.40 in. (12 mm).
3. Class R3 and ($Q_0 = 0.07$). Class R3 has a slightly specular mode of reflectance. R3 pavements include asphalt road surfaces, both regular and carpet seal coats, with dark aggregates (e.g., trap rock, blast furnace slag) and exhibit a rough texture after some months of use. Class R3 pavement represents typical asphalt highways and is used on most highway lighting projects.
4. Class R4 and ($Q_0 = 0.08$). Class R4 pavement has a mostly specular mode of reflectance. R4 includes asphalt road surfaces with a very smooth texture.

56-5.04(e) Illuminance and Luminance Design Levels

Design criteria for highway lighting projects vary according to the roadway, area, and pavement classification. Figures 56-5.B and 56-5.C present the illuminance and luminance design criteria used by the Department. In addition to these figures, consider the following:

1. Crossroads at Interchanges. Lighting levels on crossroad approaches should not be reduced through an interchange area. If existing crossroad lighting currently is deemed inadequate, consider upgrading the lighting to current criteria to ensure safe and efficient traffic operation.
2. Partial Interchange Lighting. Where partial interchange lighting is provided, luminaires should be located to best light the through lanes and speed change lanes at diverging and

merging locations. The design controls of basic level of lighting and uniformity should be subordinated to overall lighting of the roadway area at these locations.

3. Bridge Structures and Underpasses. Underpass lighting level and uniformity ratios should duplicate, to the extent practical, the lighting levels on the adjacent facility. On continuously lighted freeways and lighted interchanges, the lighting of bridges and overpasses should be at the same level as the adjacent roadway.
4. Transition Lighting. Transition lighting is a technique intended to provide the driver with a gradual reduction in lighting levels and glare when leaving an illuminated area. The designer should consider transition lighting if a study of the specific conditions at a location indicates a need. The designer may also want to consider extending delineation beyond the last luminaire for traffic lanes emerging from a lighted area. This will provide an additional measure of effectiveness. Visual adaptation occurs more quickly when approaching a lighted area and therefore no transition lighting is typically required.
5. Temporary Lighting. The temporary lighting generally shall be designed to the levels and uniformities of the proposed permanent lighting system except where existing lighting is used as temporary lighting.
6. Navigation and Obstruction Lighting. The lighting criteria and locations for waterway and aviation obstruction luminaires will be based on the requirements of the US Coast Guard and the Federal Aviation Administration, respectively.
7. Other Locations. Where lighting is justified for other facilities not covered under this section, consult the references in 56-6 and for additional information on lighting criteria, contact the Electrical and Mechanical Unit in the Central Office.

56-5.04(f) Luminaire Characteristics

Figure 56-5.D illustrates the common terms used in defining and mounting luminaires (e.g., mounting height, overhang). The following sections discuss design issues related to luminaires.

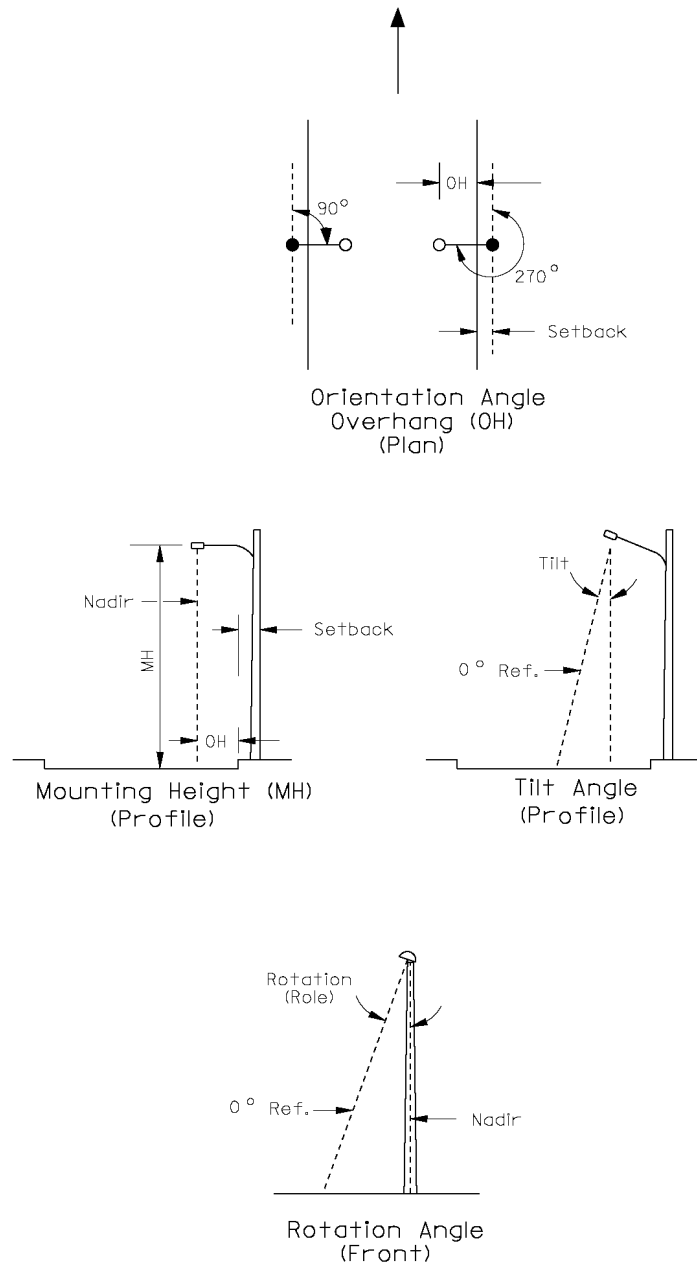

LUMINAIRE GEOMETRY

Figure 56-5.D

56-5.04(f)1 *Light Distribution*

Light distribution is a major factor in highway lighting design. It affects the selection of luminaire mounting height, placement, and arrangement. Specific photometric data and light distribution sheets are available from each luminaire manufacturer. Manufacturers typically classify their luminaire products based on the IES luminaire classification system. This system uses a three part approach to define luminaire distribution — the lateral beam width, vertical angle of maximum candlepower, and the degree of glare control.

The following briefly describes this classification system:

1. Lateral Light Distribution. There are various classifications of lateral light distribution. The selection of a particular lateral light distribution is dependent upon the luminaire mounting height and application. The following defines each type:
 - a. Short Distribution (S). The maximum candlepower strikes the roadway surface between 1 and 2.25 mounting heights from the luminaire. The theoretical maximum luminaire spacing, using the short distribution, is 4.5 mounting heights.
 - b. Medium Distribution (M). The maximum candlepower is between 2.25 and 3.75 mounting heights from the luminaire. The theoretical maximum luminaire spacing is 7.5 mounting heights. Medium distribution is commonly used in highway applications.
 - c. Long Distribution (L). The maximum candlepower is between 3.75 and 6.0 mounting heights from the luminaire. The theoretical maximum luminaire spacing is 12 mounting heights.

From a practical standpoint, the medium distribution is predominantly used in highway practice, and the spacing of luminaires normally does not exceed five to six mounting heights. Short distributions are not used extensively for reasons of economy, because extremely short spacing is required. At the other extreme, the long distribution is not used to any great extent because the high beam angle of maximum candlepower often produces excessive glare.

2. Transverse Light Distribution. There are seven classifications for transverse light distribution. The following provides application guidelines for each luminaire type:
 - a. Type I. The Type I luminaire is placed in the center of the roadway or area where lighting is required. It produces a long, narrow, oval-shaped lighted area. Some types of high-mast lighting are considered a modified form of Type I.
 - b. Type I - 4-Way. This luminaire type is located over the center of the intersection and distributes the lighting along the four legs of the intersection.
 - c. Type II. The Type II luminaire is placed on the side of the roadway or edge of the area to be lighted. It produces a long, narrow, oval-shaped lighted area, which is usually applicable to narrower roadways.

- d. Type II - 4-Way. This luminaire type is placed at one corner of the intersection and distributes the light along the four legs of the intersection.
 - e. Type III. The Type III luminaire is placed on the side of the roadway or edge of the area to be lighted. It produces an oval-shaped lighted area and is usually applicable to medium width roadways.

A Type III distribution is where the street side segment of the half-maximum-intensity isointensity trace within the longitudinal range where the point of maximum intensity falls (S, M, or L), lies partly or entirely beyond the 1.75 MH street side LRL, but does not cross the 2.75 MH street side LRL; see Figure 56- 5.E.
 - f. Type IV. The Type IV luminaire is placed on the side of the roadway or the edge of area to be lighted. It produces a wider, oval-shaped lighted area and is usually applicable to wide roadways.
 - g. Type V. The Type V luminaire is located over the center of the roadway, intersection, or area to be lighted. It produces a circular, lighted area. Type V often is used in high-mast lighting applications.
3. Control of Distribution. IES has developed a Luminaire Classification System for Outdoor Luminaires (LCS). This system provides information regarding the lumen distribution within solid angles of specific interest. These are identified as primary solid angles identified as: Forward Light, Back Light, and Uplight. Each of these primary solid angles are further divided into 10 secondary solid angles.

Based on the luminaire lumen output in the various Back light, Uplight, and Glare zones, the luminaire is assigned a BUG rating. This rating can be used as a means of evaluating and comparing luminaires for inclusion in a lighting design. A BUG rating may be used to evaluate luminaire optical performance related to the potential for light trespass, sky-glow, and high-angle brightness control.

A plan view of the theoretical light distribution (i.e., theoretical roadway coverage) and schematics of the intended application of each type of IES luminaire are illustrated in Figure 56-5.E.

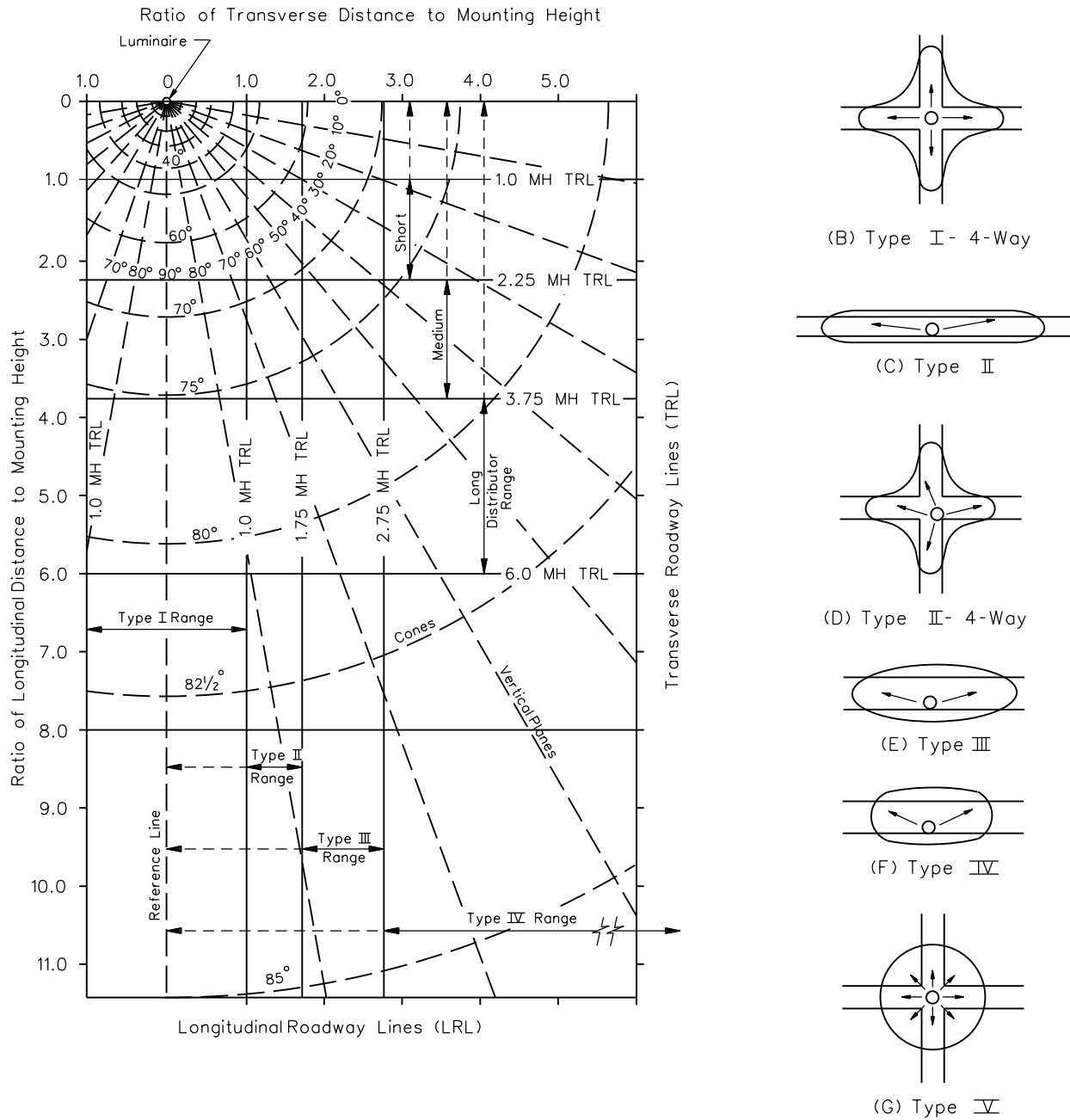

PLAN VIEW OF ROADWAY COVERAGE FROM LUMINAIRES

Figure 56-5.E

A system of backlight, upright, and glare (BUG) ratings has been derived from the IES Luminaire Classification System (LCS). For additional information on the LCS and BUG ratings, consult the *Luminaire Classification System for Outdoor Lighting*, IESNA TM-15.

Use only the photometric data with the proper shield, if the project requires luminaire shielding. Do not use the photometric data without the appropriate shield for projects with shields.

56-5.04(f)2 *Mounting Heights*

Higher mounting heights used in conjunction with higher wattage luminaires enhances lighting uniformity and typically reduces the number of light poles needed to produce the same illumination level. In general, higher mounting heights tend to produce a more cost-effective design. For practical and aesthetic reasons, the mounting height should remain constant throughout the system. The manufacturer's photometric data is required to determine an appropriate mounting height. Typical mounting heights used by the Department for conventional highway lighting purposes range from 30 ft to 50 ft (9.1 m to 15.2 m). Mounting heights for light towers are typically 80 ft (24 m) or greater.

56-5.04 (f)3 *Coefficient of Utilization*

The coefficient of utilization is the ratio of the luminous flux (lm) from a luminaire received on the pavement surface to the rated lumens emitted by the luminaire. A utilization curve is used to obtain a luminaire's coefficient of utilization (CU). Manufacturers typically provide utilization curves and isolux diagrams with each of their respective luminaire products. Figure 56-5.F illustrates a sample utilization curve. The utilization curve relates to the luminaire rather than to the light source. The ratio of transverse distance over luminaire mounting height provides the percentage of bare lamp lumens that are utilized. If the luminaire is placed over the traveled way (i.e., over the pavement), the total lumen utilization is determined by adding the percentages from the street side and curbside (i.e., house-side) light from the coefficient of utilization curve (furnished by the luminaire manufacturer). In essence, the utilization curve defines how much of the total lumen output reaches the area being lighted.

56-5.04(f)4 *Light Loss Factors*

The efficiency of a luminaire decreases over time. The designer must estimate this decrease to properly estimate the light available at the end of the luminaire's serviceable life. The following briefly discusses these factors:

1. Luminaire Lumen Depreciation Factor (LLD). As the luminaire progresses through its serviceable life, the lumen output decreases. This is an inherent characteristic of all light sources. The initial lumen value is adjusted by a lumen depreciation factor to compensate for the anticipated lumen reduction. This assures that a minimum level of illumination will be available at the end of the assumed life (i.e., after lumen depreciation has occurred). The depreciation factor varies, but for all luminaire calculations, a value of 90% shall be used.

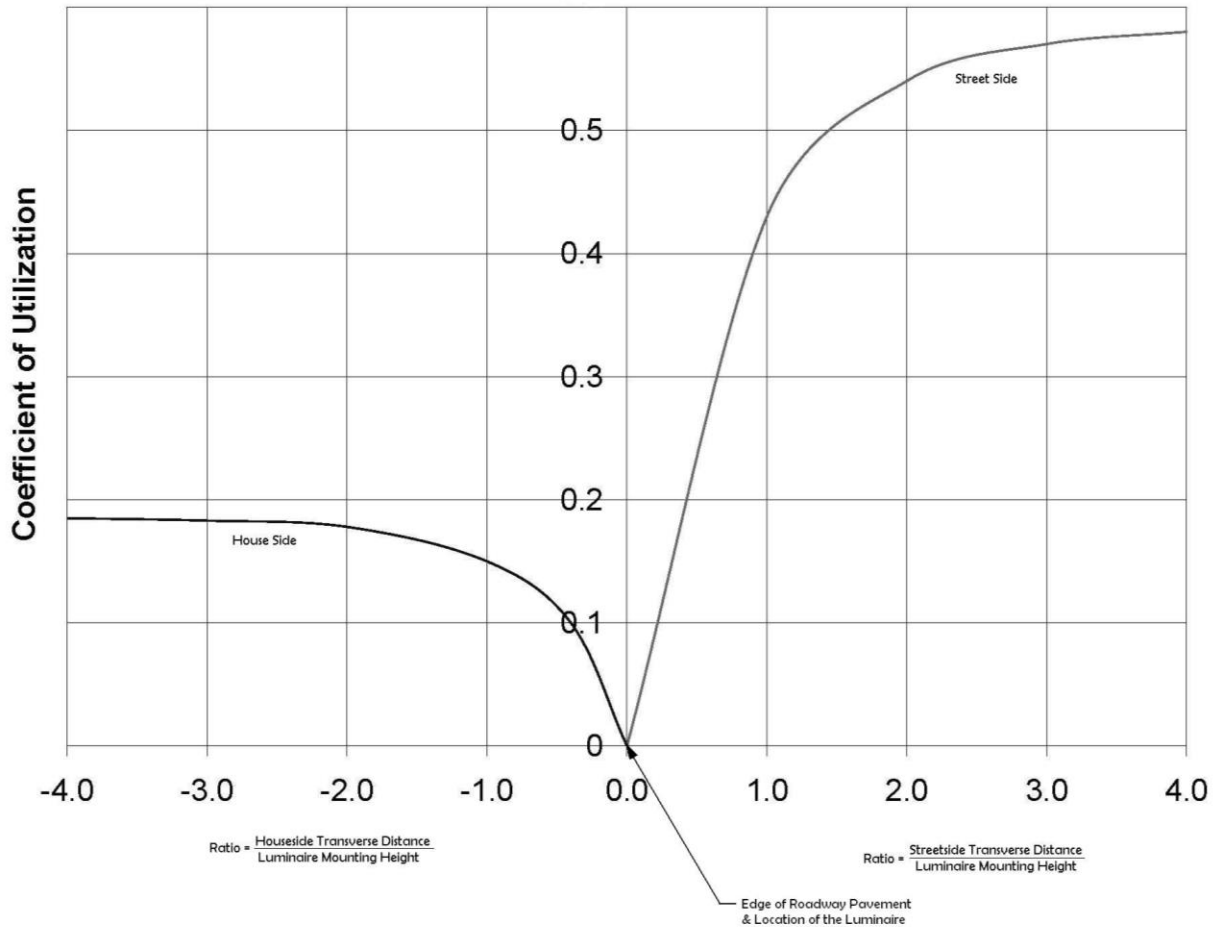

Note: The utilization curve will vary with each manufacturer and luminaire type.

SAMPLE UTILIZATION CURVE

Figure 56-5.F

2. Luminaire Dirt Depreciation Factor (LDD). Dirt on the exterior and interior of the luminaire, and to some extent on the light source itself, reduces the amount of light reaching the pavement. Various degrees of dirt accumulation may occur depending upon the area where the luminaire is located. Industrial areas, automobile exhaust, diesel trucks, dust and other environments all affect the dirt accumulation on the luminaire. Higher mounting heights, however, tend to reduce the vehicle-related dirt accumulation. The relationship between the ambient environment and the expected

level of dirt depreciation over time is shown in Figure 56-5.G. The depreciation factor used in calculations shall be 80%.

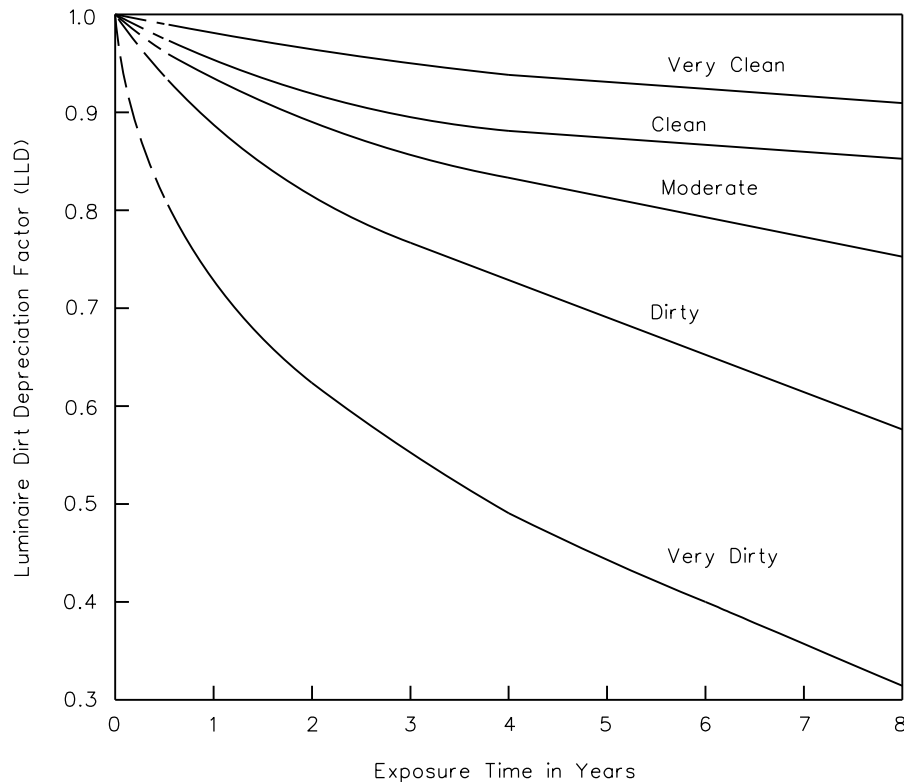

Notes:

1. **VERY CLEAN** - No nearby smoke or dust-generating activities and a low ambient contaminant level. Light traffic. Generally limited to residential or rural areas. The ambient particulate level is not more than 150 micrograms per cubic meter.
2. **CLEAN** - No nearby smoke or dust-generating activities. Moderate to heavy traffic. The ambient particulate level is not more than 300 micrograms per cubic meter.
3. **MODERATE** - Moderate smoke or dust-generating activities nearby. The ambient particulate level is not more than 600 micrograms per cubic meter.
4. **DIRTY** - Smoke or dust plumes generated by nearby activities may occasionally envelope the luminaires.
5. **VERY DIRTY** - As above, but the luminaires are commonly enveloped by smoke or dust plumes.

ROADWAY LUMINAIRE DIRT DEPRECIATION CURVE

Figure 56-5.G

3. Equipment Factor (EF). Allows for variations inherent in the manufacture and operation of the equipment (i.e., luminaire, system voltage, voltage drop). It is generally assumed to be 95%.
4. Light Loss Factor (LLF). The light loss factor is the combination of factors used to denote the reduction of the illumination for a given area after a period of time compared to the initial illumination on the same area. It is the product of the luminaire lumen depreciation factor (LLD), the luminaire dirt depreciation (LDD) factor, and the equipment factor (EF) (i.e., $LLF = LLD \cdot LDD \cdot EF$).

56-5.04(f.5) Luminaire Arrangement

Figure 56-5.H illustrates typical luminaire arrangements for conventional highway lighting designs. Use the calculation points provided in ANSI/IES RP-8, Figure A4.

56-5.04(g) Voltage Drop Determination

The typical power supply circuit to the highway lighting controller is 120/240 V or 240/480 V, single-phase, three-wire, 60-cycle alternating current. The branch lighting circuit consists of two conductors and an insulated (green) equipment grounding conductor. The luminaires are connected on both sides of the circuit to obtain 240V or 480V across the driver. Use Figure 56-5.I to determine the voltage drop between two adjacent luminaires.

56-5.05 Other Design Considerations

56-5.05(a) Roadside Safety Considerations

Light poles should be installed so that they will not present a roadside hazard to the motoring public. However, the physical roadside conditions often dictate their placement. It is important to recognize this limitation. Overpasses, sign structures, guardrail, roadway curvature, right-of-way, gore clearances, proximity to roadside obstacles, and lighting equipment limitations are all physical factors that can limit the placement of light poles. The designer also must consider factors such as roadway and area classification, design speed, posted speed, safety, aesthetics, economics, and environmental impacts. In addition, there should be adequate right-of-way, driveway control, and utility clearance. Consider the following when determining the location of light poles:

1. Clear Zone. Where practical, place light poles outside the roadside clear zone, and as far from the traveled way as consistent with good lighting design. See Chapter 38 for additional information on roadside clear zone.

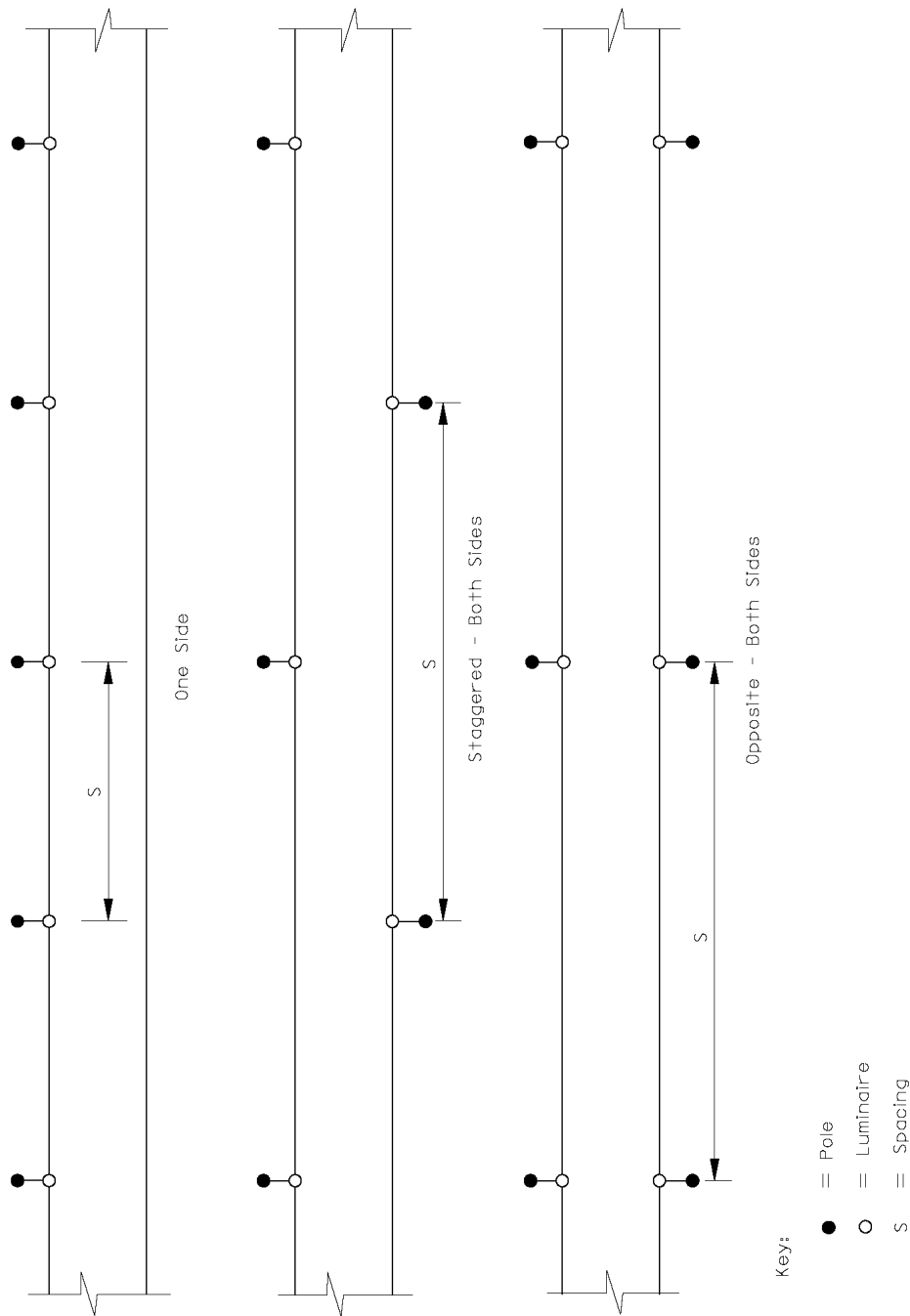

**TYPICAL LUMINAIRE ARRANGEMENTS FOR CONVENTIONAL
HIGHWAY LIGHTING DESIGN**

Figure 56-5.H

AMPS^①		
Watts	240 Volts	480 Volts
Obtain from manufacturer	Value	Value/2

Wire Size AWG	Circuit Resistance ohms/100 ft (ohms/100 m)	Wire Size AWG	Circuit Resistance ohms/100 ft (ohms/100 m)
14	0.326 (1.0700)	2	0.0201 (0.0661)
12	0.205 (0.673)	1	0.0160 (0.0524)
10	0.129 (0.4226)	1/0	0.0127 (0.0415)
8	0.0809 (0.2653)	2/0	0.0101 (0.0329)
6	0.0510 (0.1671)	3/0	0.00797 (0.02610)
4	0.0321 (0.1053)	4/0	0.00626 (0.02050)

Notes:

1. Consult manufacturer’s data for specific characteristics of the luminaire and driver.
2. Voltage drop is determined using the following equation:

$$V_d = 2 \cdot D \cdot I \cdot R \quad (\text{For single-phase circuits with minimal impedance.})$$

where:

V_d = voltage drop (volts)

D = distance in hundreds of ft (m). See Note 3.

I = current (amperes). Use nominal, full-load current – published by the luminaire manufacturer

R = resistance in ohms/100 ft (ohms/100 m). See Note 4.

3. Distance is the circuit length from controller-to-pole or from pole-to-pole for the segment of circuit being analyzed, measured in hundreds of feet (meters).
4. DC resistances listed in table above are based upon stranded copper conductor at 167 °F (75 °C) operating temperature with an insulated covering and located in conduit. Reference source: Table 8 “Conductor Properties,” Chapter 9 of the National Electrical Code.
5. Total voltage drop at end of a conductor run shall not exceed 20%. See 56-5.06 for voltage drop requirements for HIGH-MAST TOWERS.

VOLTAGE DROP BETWEEN LUMINAIRES

Figure 56-5.1

2. Breakaway Supports. Unless located behind or on top of a roadside barrier, wall, guardrail or crash cushion, which are necessary for other safety-related reasons, conventional light poles placed within the roadside clear zone will be mounted on FHWA-approved breakaway supports. Poles outside the clear zone also should be mounted on breakaway supports where there is a possibility of them being struck by errant vehicles. Be aware that falling poles and mast arms may endanger bystanders (e.g., pedestrians, bicyclist, motorists). Consider the following during design:

a. When to use Non-Breakaway Supports. In areas where pedestrians, bicyclists, or building structures and windows may be struck by falling poles or mast arms after a crash, evaluate the relative risks of mounting the light pole on a breakaway support. Examples of locations where the hazard potential to pedestrian traffic would be greater include:

- transportation terminals,
- sports stadiums and associated parking areas,
- tourist attractions,
- school zones, or
- central business districts and local residential neighborhoods where the posted speed limit is 30 mph (50 km/hr) or less.

In these locations, use non-breakaway supports. Other locations that require the use of non-breakaway supports, regardless of the pedestrian traffic volume, are rest areas and weigh station parking lots and combination traffic signal/light poles.

b. Breakaway Support Stub. Substantial remains of breakaway supports shall not project more than 4 in. (100 mm) above a line between the straddling wheels of a vehicle on 60 in. (1.5 m) centers. The line connects any point on the ground surface on one side of the support to a point on the ground surface on the other side, and it is aligned radially or perpendicular to the centerline of the roadway. Breakaway supports, including those placed on roadside slopes, must not allow impacting vehicles to snag on either the foundation or any substantial remains of the support. Surrounding terrain may need to be graded in order to permit vehicles to pass over any non-breakaway portion of the installation that remains in the ground or rigidly attached to the foundation. The specified limit on the maximum stub height lessens the possibility of snagging the undercarriage of a vehicle after a support has broken away from its base and minimizes vehicle instability if a wheel hits the stub. The necessity of this requirement is based on field observations. Application of the clearance requirement is illustrated in Figure 56-5.J.

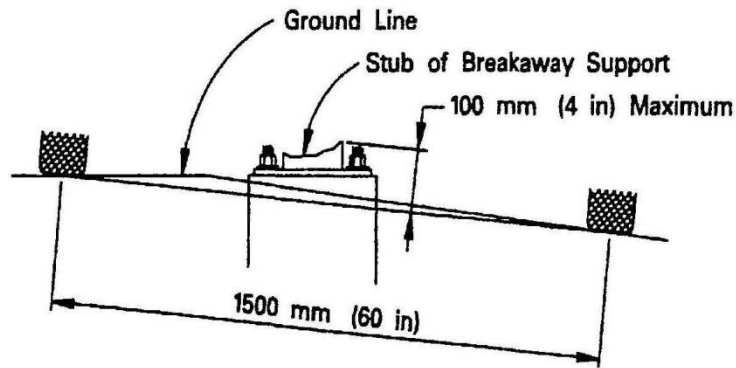

STUB HEIGHT REQUIREMENTS

Figure 56-5.J

- c. Wiring. All light poles that require breakaway supports will be served by underground wiring and designed with simultaneous quick disconnect fuse holders.
 - d. Light Towers. Light Towers used in high-mast lighting applications will be mounted on non-breakaway supports. Also, towers shall be located outside the roadside clear zone as far as consistent with good lighting design unless protected by guardrail, barriers, or crash cushions; see Chapter 38.
 - e. Bridge Parapets and Concrete Barriers. Where poles are mounted atop bridge parapets and concrete barriers, they will be mounted on non-breakaway supports.
3. Gore Areas. Where practical, locate light poles outside the gore areas of exit and entrance ramps. Generally, lighting support should not be placed within the clear zone of the gore area.
 4. Horizontal Curves. Place light poles on the inside of sharp curves and loops. Where poles are located on the inside radius of superelevated roadways, provide sufficient lateral clearance to avoid being struck by trucks.
 5. Maintenance. When determining pole and luminaire locations, consider the hazards that will be encountered while performing maintenance on the lighting equipment. Use the criteria provided in Chapter 38 to design and place light poles in conjunction with roadside barriers. Consider the following additional guidelines:
 - a. Placement. Where a roadside barrier is provided, place all light poles behind the barrier.
 - b. Deflection. Light poles placed behind a roadside barrier should be offset by at least the deflection distance of the barrier; see Chapter 38. This will allow the barrier rail to deflect without hitting the pole.

- c. Concrete Barriers. Light poles that are protected by a rigid or non-yielding barrier do not require a breakaway support.
 - d. Impact Attenuators. Do not locate light poles within the functional operation of any impact attenuator or other safety device.
6. Protection Features. In most cases protection features (e.g., barriers) should not be added for the primary purpose of protecting a light pole.

56-5.05(b) Foundation, Pole Mounting, and Structural Considerations

The *Standard Specifications, Highway Standards* and the electrical detail sheets provide pole mounting details and details for foundation materials, depth, width, reinforcing, etc. When designing lighting systems, also consider the following:

1. Foundation Height Relative to Final Grade. For other than light towers, ensure pole foundations are no more than 0.5 in. (13 mm) higher than the high edge of the surrounding final grade and in compliance with Figure 56-5.J. This permits proper drainage around the foundation and reduces the likelihood of the foundation intensifying a collision. The foundation also is less likely to be destroyed during a collision. When located within the clear zone, ensure that the foundation and fractured breakaway support does not protrude more than 4 in. (100 mm) above the finished grade within a 5 ft (1.5 m) chord as noted in 56-5.05(a)2(c) above. See Chapter 38 for additional information on clear zones.
2. Metal Foundations. The steel (i.e., helix screw-in type) foundation is one that is commonly used by the Department for conventional light poles. This foundation is placed in undisturbed earth using a clockwise rotation similar to a common screw. The metal tube is typically 8-5/8 in. (220 mm) in diameter and 6 ft to 8 ft (1.8 m to 2.4 m) long. Shorter lengths may be appropriate for foundations in areas with shallow bedrock. The metal foundation will accommodate poles with 11.5 in. and 15 in. (292 mm and 381 mm) bolt circles for luminaire mounting heights up to 50 ft (15.2 m).
3. Light Tower Foundations. Foundations for light towers used in high-mast lighting applications typically require specialized designs and soil surveys to ensure adequate support. A 4-ft (1.2-m) diameter reinforced concrete foundation, to a depth as required by the soils analysis, usually is adequate for towers accommodating 80 ft to 110 ft (24.4 m to 33.5 m) luminaire mounting heights. The top 18 in. (450 mm) of the foundation is formed. Below this depth, ensure that the foundation is poured monolithically against the undisturbed earth of the bored hole. Specify the foundation depth on the lighting plans. Additionally, include a level concrete work pad at the base of the tower.
4. Foundations for Temporary Lighting. Foundations for temporary lighting will be determined on a case-by-case basis. This may include direct embedment of wood poles to a depth of from 5.5 ft (1.7 m) for 30 ft (9.1 m) poles, to 12 ft (3.6 m) for 65 ft (19.8 m) poles. The use of butt base anchors also may be considered. However, locate these supports outside the clear zone; see Section 56-5.05(b) for more details.

5. Pole Mounting on Parapets. Poles for bridge lighting typically are mounted on specially designed concrete parapet sections. Mounting design includes the necessary non-breakaway, high-strength bolts, leveling plate, and vibration isolation pad and washers.
6. Structural Design. Poles will be designed and fabricated to meet or exceed AASHTO requirements as documented in *Standard Specifications for Structural Supports for Highway Signs, Luminaires, and Traffic Signals* and NCHRP Report 411. See the *IDOT Standard Specifications, and the Highway Standards* for the appropriate design criteria (e.g., wind loading, luminaire weight, and effective projected area).

56-5.05(c) Other Considerations

In addition to the items discussed in the previous sections, consider the following when designing the highway lighting system:

1. Signs. Place light poles to minimize interference with the driver's view of the roadway and any highway signs. Luminaire locations should not seriously detract from the legibility of signs at night.
2. Structures. Place light poles sufficiently away, generally at least one mounting height, from overhead bridges and sign structures to minimize glare and distracting shadows on the roadway surface.
3. Trees. Insufficiently pruned trees can cause shadows on the roadway surface and reduce the luminaire's effectiveness. Design the pole/luminaire with a height and mast-arm length to negate such adverse effects.
4. Criteria. Consult the authority having jurisdiction of the lighting for design criteria and standards prior to design.
5. Navigable Airspace. Where lighting projects are being considered in close proximity to an active airfield or airport, consider the impact the height of the light pole has on navigable airspace during and after construction. For additional information, consult the FAA Advisory Circular AC 70/7460-2J *Proposed Construction or Alteration of Objects that May Affect the Navigable Airspace*.
6. Luminaire Shielding. Avoid external shielding of luminaires. If external shielding is used, ensure the shields have been tested to achieve the necessary light control and designed to prevent rotation and misalignment. The lighting design must incorporate the correct photometry that accurately depicts the luminaire with the shields in place.
7. Combination Traffic Signal/Light Pole. The use of combination traffic signal structures that have a roadway luminaire top attachment generally improve roadside safety. They should be used, where practical, to eliminate a light pole adjacent to a traffic signal structure. Place combination poles beyond the pedestrian crosswalk to allow pedestrian visibility in silhouette.

8. Light Trespass. Lighting can have considerable impact on crops and must be considered when lighting is installed in rural areas.
9. Environmental. Roadway lighting shall be designed to the extent possible to protect the environment including night skies, fauna, and flora from the potentially undesirable effects from stray light. See ANSI/IES LP-11, *Environmental Considerations for Outdoor Lighting*.

56-5.06 HIGH-MAST LIGHTING DESIGN

In general, the design of high-mast lighting systems follows the same design procedures as discussed elsewhere in Section 56-5. In addition, consider the following:

1. Light Source. IDOT-owned and maintained lighting systems typically use a high lumen output LED luminaire. The number of luminaires required will be determined by the area to be lighted. As a general starting point, it can be assumed that six luminaires will be used per pole.
2. Mounting Heights. Mounting heights in high-mast lighting applications range from 80 ft to 160 ft (24.3 m to 48.8 m). Greater mounting heights require more luminaires to maintain illumination levels. However, greater heights allow for fewer poles and provide better light uniformity. As a general starting point, it can be assumed that mounting heights of 80 ft to 100 ft (24.3 m to 30.5 m) will be used.
3. Location. In determining the location of light towers, review the plan and profile view of the area to determine the critical areas requiring lighting. In selecting tower locations, consider the following:
 - a. Critical Areas. Locate light towers so that the highest localized levels of illumination fall within the critical traffic areas (e.g., freeway/ramp junctions, ramp terminals, merge points).
 - b. Roadside Safety. Locate light towers outside the roadside clear zone and a sufficient distance from the roadway so that the probability of a collision is virtually eliminated; see Chapter 38.
 - c. Signs. Locate light towers so that they are not within the driver's direct line of sight to highway signs.
4. Design. Use point-by-point calculations to evaluate luminance, illuminance, and veiling luminance levels. Calculation grids must be placed at appropriate locations to analyze these levels. Consult the Electrical and Mechanical Unit in the Central Office for assistance to make these determinations.

Adjust luminaires, pole locations, and other variables, as needed, to ensure that the minimum-maintained illumination is provided, and the uniformity ratio has been satisfied. Give consideration to adjacent land use during the analysis. Ensure the design minimizes glare and maintains light control away from adjoining property.

5. Navigable Airspace. Where lighting projects are being considered in close proximity to an active airfield or airport, consider the impact the height of the light tower has on navigable airspace during and after construction.
6. Voltage Drop. The voltage drop at any high-mast tower shall not exceed 5%.

56-6 REFERENCES

1. *Recommended Practice: Lighting Roadway and Parking Facilities*, ANSI/IES RP-8, American National Standards Institute/Illuminating Engineering Society;
2. *Technical Memorandum: Luminaire Classification System for Outdoor Luminaires*, ANSI/IES TM-15, American National Standards Institute/Illuminating Engineering Society;
3. *Roadway Lighting Design Guide*, American Association of State Highway and Transportation Officials;
4. *National Electrical Code*, National Fire Protection Association;
5. *National Electrical Safety Code*, American National Standards Institute/Institute of Electrical and Electronics Engineers;
6. *Standard Specifications for Structural Supports for Highway Signs, Luminaires and Traffic Signals*, American Association of State Highway and Transportation Officials;
7. *Structural Supports for Highway Signs, Luminaires, and Traffic Signals*, National Cooperative Highway Research Program Report No. 411, Transportation Research Board;
8. *Roadside Design Guide*, American Association of State Highway and Transportation Officials;
9. *Standard Specifications for Road and Bridge Construction*, Illinois Department of Transportation;
10. *Supplemental Specifications and Recurring Special Provisions*, Illinois Department of Transportation;
11. *BDE Special Provisions*, Illinois Department of Transportation;
12. *Highway Standards*, Illinois Department of Transportation;
13. *Warrants for Highway Lighting*, National Cooperative Highway Research Program Report No. 152, Transportation Research Board;
14. *Partial Lighting of Interchanges*, National Cooperative Highway Research Program Report No. 256, Transportation Research Board;
15. *Illinois Manual on Uniform Traffic Control Devices (ILMUTCD)*, Illinois Department of Transportation;
16. US Coast Guard Bridge Administration Manual COMDTINST M16590.5C, *Bridge Lighting and Other Signals*;

17. *Code of Federal Regulations*, CFR Title 33, Part 118;
18. FAA Advisory Circular AC 70/7460-1L *Obstruction Marking and Lighting*;
19. *FHWA Lighting Handbook*, Federal Highway Administration; and
20. *Technical Memorandum: Calculation Procedures and Specification Criteria for Lighting Calculations*, ANSI/IES TM-34.
21. *Lighting Practice: Environmental Considerations for Outdoor Lighting*, ANSI/IES LP-11.
22. *Lighting Practice: Designing Quality Lighting for People in Outdoor Environments*, ANSI/IES LP-2.
23. *Recommended Practice: Lighting Exterior Applications*, ANSI/IES RP-43.
24. *Technical Memorandum: Description, Measurement, and Estimation of Sky Glow*, ANSI/IES TM-37.
25. *Technical Memorandum: Standard Format for the Electronic Transfer of Luminaire Optical Data*. ANSI/IES TM-33.

Chapter Fifty-Seven
TRAFFIC CONTROL DEVICES

BUREAU OF DESIGN AND ENVIRONMENT MANUAL

Table of Contents
(Continued)

Section		Page
	57-3.05(c) Crosswalks	57-3.4
	57-3.05(d) Lane-Use Control Markings.....	57-3.4
	57-3.05(e) Multiple Turn Lanes.....	57-3.4
57-3.06	Interchanges	57-3.4
57-3.07	Miscellaneous Marking Applications.....	57-3.5
	57-3.07(a) Special Markings.....	57-3.5
	57-3.07(b) Truck-Climbing Lanes	57-3.5
	57-3.07(c) Two-Way, Left-Turn Lanes (TWLTL).....	57-3.5
	57-3.07(d) School Crossings	57-3.5
	57-3.07(e) Highway-Railroad Grade Crossings	57-3.6
	57-3.07(f) Bicycle Facilities.....	57-3.6
	57-3.07(g) Rest Areas/Weigh Stations	57-3.6
	57-3.07(h) On-Street Parking	57-3.6
57-4	TRAFFIC SIGNALS.....	57-4.1
57-4.01	Responsibilities	57-4.1
	57-4.01(a) State Projects.....	57-4.1
	57-4.01(b) Local Projects	57-4.1
57-4.02	References.....	57-4.1
57-4.03	Definitions	57-4.2
57-4.04	Traffic Signal Warrants.....	57-4.3
	57-4.04(a) New Traffic Signals	57-4.3
	57-4.04(b) Existing Traffic Signals.....	57-4.3
	57-4.04(c) Proposed Volumes.....	57-4.3
57-4.05	Traffic Signal Needs Study	57-4.4
57-4.06	Traffic Signal Operation.....	57-4.5
	57-4.06(a) Pretimed Operation	57-4.5
	57-4.06(b) Semi-Actuated Operation	57-4.6
	57-4.06(c) Fully Actuated Operation.....	57-4.6
	57-4.06(d) Pedestrian Control	57-4.7
	57-4.06(e) Special Operation	57-4.7
57-4.07	Traffic Detectors.....	57-4.7
	57-4.07(a) Detector Operation.....	57-4.7
	57-4.07(b) Inductive Loop Detector	57-4.7
	57-4.07(c) Preformed Loop Detector	57-4.8
	57-4.07(d) Video Image Detector	57-4.8

Table of Contents
(Continued)

Section		Page
	57-4.07(e) Pedestrian Detectors.....	57-4.8
	57-4.07(f) Bicycle Detectors	57-4.8
57-4.08	Traffic Signal Mounting.....	57-4.9
57-4.09	Placement of Traffic Signal Equipment.....	57-4.9
57-4.10	Traffic Signal Phasing	57-4.12
	57-4.10(a) Phasing Types	57-4.12
	57-4.10(b) Left-Turn Phases	57-4.12
57-4.11	Traffic Signal Timing	57-4.13
	57-4.11(a) Pretimed Control	57-4.13
	57-4.11(b) Basic-Actuated Control	57-4.16
	57-4.11(c) Advanced-Design Actuated Control	57-4.17
	57-4.11(d) Actuated Control with Large Detection Areas	57-4.21
57-4.12	Computer Software	57-4.22
57-4.13	Signal System Design	57-4.23
	57-4.13(a) System-Timing Parameters.....	57-4.23
	57-4.13(b) Advantages of Traffic Signal Systems.....	57-4.23
	57-4.13(c) System Types	57-4.24
	57-4.13(d) Communications Techniques	57-4.26

Chapter Fifty-Seven

TRAFFIC CONTROL DEVICES

57-1 GENERAL

57-1.01 Context

57-1.01(a) Illinois Manual on Uniform Traffic Control Devices (ILMUTCD)

The *ILMUTCD* consists of the national *MUTCD* and the Illinois supplement to the *MUTCD*. The *ILMUTCD* information is divided into four categories — standard, guidance, option, and support. Use these categories to determine the appropriate application for the various traffic control devices. The *ILMUTCD* defines these categories as follows:

1. Standard. These are mandatory actions that are required without exception or with exceptions so noted under the standard heading. Typical phrases include shall, shall mean, shall be satisfied, shall consist, etc.
2. Guidance. This category is considered to be advisory usage, recommended but not mandatory. Deviations are allowed where engineering judgment indicates the need. Typical phrases include should, should be, should be considered, should be given, etc.
3. Option. This category includes procedures and devices that are allowed but carry no recommendations or mandate. The designer is free to use or refrain from their use. Typical phrases include may, may be used, may be considered, etc.
4. Support. This category includes all introductory or explanatory language. It may occur before, within, or after any of the above categories. Typical phrases include is, are, warrants, considered, required, etc.

57-1.01(b) IDOT Application

In reference to the *ILMUTCD* categories, the Department has adopted the following positions:

1. Standard. The designer must meet the conditions of the *ILMUTCD*.
2. Guidance. The designer will follow the *ILMUTCD* with very few exceptions. For situations where it is impractical to follow “guidance” criteria, the designer must obtain Departmental approval.
3. Option. The designer should make every reasonable effort to follow the *ILMUTCD* criteria. For situations where it is impractical to follow “option” criteria, Departmental approval is necessary.

57-1.02 References

For information on traffic control device material specifications, design, and application criteria, review the applicable publications listed below:

1. *Illinois Manual on Uniform Traffic Control Devices (ILMUTCD) which consists of both the national MUTCD and the Illinois supplement to the MUTCD*, FHWA and IDOT;
2. *Bureau of Operations Traffic Policies and Procedures Manual*, IDOT;
3. *Standard Specifications for Road and Bridge Construction*, IDOT;
4. *Highway Standards*, IDOT;
5. *Standard Highway Signs*, IDOT;
6. *Sign Structures Manual*, IDOT;
7. *Fabrication of Highway Signs Policy*, IDOT;
8. *A Policy on Geometric Design of Highways and Streets*, AASHTO;
9. *Roadside Design Guide*, AASHTO;
10. *Standard Specifications for Structural Supports for Highway Signs, Luminaires, and Traffic Signals*, AASHTO;
11. *Manual of Steel Construction*, AISC;
12. *Standard Highway Signs and Markings*, FHWA;
13. *Traffic Engineering Handbook*, ITE;
14. *Manual of Transportation Engineering Studies*, ITE;
15. *Manual of Traffic Signal Design*, ITE;
16. *Equipment and Materials Standards*, ITE;
17. *Preemption of Traffic Signals At Or Near Active Warning Railroad Grade Crossings*, ITE;
18. *Traffic Signal Installation and Maintenance Manual*, ITE;
19. *Traffic Signing Handbook*, ITE;
20. *Traffic Detector Handbook*, FHWA;
21. *Official Wire and Cable Specifications Manual*, IMSA;
22. *Traffic Control Systems*, NEMA;

23. *Traffic Controller Assemblies*, NEMA;
24. *Highway Capacity Manual*, TRB; and
25. National, State, and Local Electrical Codes and Manufacturer's Literature.

57-2 HIGHWAY SIGNING

57-2.01 Responsibilities

The responsibilities for elements of highway signing projects are as follows:

1. Structural Design. The Bureau of Operations and the Bureau of Bridges and Structures are jointly responsible for establishing Department criteria for the design of structural supports for traffic control devices (e.g., breakaway bases for large signs).
2. Location and Legend. The district Bureau of Operations is responsible for the legends and the initial placement of highway signs, based on proper conveyance of information to the motorist. The roadway designer will review the location of highway signing to ensure that it is compatible with the roadway design. Final design, location, legends, and any changes should be approved and coordinated with the Bureau of Operations.
3. Soil Borings. Projects with large or overhead signs typically will require soil borings. The district is responsible for taking the soil borings.
4. Plan Preparation. The district Bureau of Operations is responsible for preparing or reviewing the highway signing detail sheets to be included in the plans. See Chapter 63 for additional information on plan preparation.

57-2.02 References

For additional information on highway signing material specifications, design, and application criteria, review the applicable publications listed in Section 57-1.02.

57-2.03 Sign Placement

57-2.03(a) **General**

Placement criteria for highway signs next to and/or over the roadway is documented in the *Bureau of Operations Traffic Policies and Procedures Manual* and the *ILMUTCD*. Additional guidance can be found in the publications listed in Section 57-1.02 and Chapter 38. Uniform placement of highway signing, although desirable, is not always practical because highway alignment and other factors often dictate a more advantageous location. When determining sign locations, consider the following guidelines:

1. Special Locations. Normally, signs should be placed on the right side of the roadway. Under certain circumstances, however, signs may be placed on channelizing islands, overhead structures, or on the left side of the roadway along sharp, right-hand curves, or on the left side of multi-lane highways.
2. Dual Signing. Consider dual signing on one-way or divided roadways (i.e., on both sides of the traveled way) for additional emphasis where a single sign may not provide adequate

- warning and where roadway geometry or other factors (e.g., multiple lanes, trucks, parked vehicles) may cause a single sign to be obscured.
3. Geometric Design. Coordinate sign placement and geometric design as early as practical during project planning and design. A geometric design may need to be revised if it does not accommodate adequate sign placement.
 4. Overhead Lane Control. Where lane control is desired, place signs directly over the affected lane. For additional information, see the *Bureau of Operations Traffic Policies and Procedures Manual, ILMUTCD*, and the publications listed in Section 57-1.02.
 5. Nighttime Visibility. Locate signs to optimize their nighttime visibility.
 6. Field Conditions. Adherence to desired placement is not always practical. Adjust sign locations to accommodate actual field conditions and try to avoid the following problem areas:
 - at short sags in the roadway,
 - beyond the crest of a vertical curve,
 - where a sign would be obscured by parked cars,
 - where a sign would create an obstruction for pedestrians or bicyclists,
 - where a sign would obscure visibility of hazardous locations,
 - where the visibility of a sign would be impaired by overhead illumination,
 - where a sign would be vulnerable to roadside splatter or snow from plowing operations, and/or
 - at locations close to foliage where the sign face may be covered or the foliage should be removed.
 7. Longitudinal Placement. In some cases, signs can be shifted longitudinally without compromising their intended purpose. This may improve their visibility and enhance safety. However, it is vital to stay within the guidelines of the *ILMUTCD*.
 8. Sign Groups. In general, signs are mounted individually on supports. However, it may be necessary to erect a sign grouping (e.g., route markings). Consider wind loading, driver ability to read and comprehend information, and breakaway criteria when designing sign groups.
 9. Lateral Clearance. The *Bureau of Operations Traffic Policies and Procedures Manual, ILMUTCD*, and the publications in Section 57-1.02 provide the criteria for the lateral clearance of signs. In addition, see Section 57-2.04.

57-2.03(b) Placement of Advance Warning Signs

Warning signs are used to warn drivers of potentially hazardous conditions on or adjacent to the roadway. They are placed in advance of the conditions to which they apply. Warning signs should be used sparingly. Use of warning signs at non-hazardous locations tends to cause non-compliance of all signing. If the distances in Chapter 2C of the *ILMUTCD* cannot be met, then consider other measures to attract the motorist's attention to the sign (e.g., flashing beacons, distance plates).

57-2.04 Roadside Safety

For roadside safety applications, the following will apply to highway signs:

1. Design. The *Illinois Highway Standards and Sign Structures Manual* contain the Department's details for structural supports for traffic control devices.
2. Ground-Mounted Sign Supports. Supports for ground-mounted signs shall be made breakaway or yielding. All signs must have breakaway supports, whether within or outside the clear zone. Where practical, locate signs behind a roadside barrier that is warranted for other reasons. Provide adequate clearance to the back of the guardrail post to accommodate the barrier's dynamic deflection (see Section 38-6). In addition, do not place breakaway sign supports in drainage ditches where erosion and freezing might affect the proper operation of the support. It is also possible that an errant vehicle entering the ditch will be inadvertently guided into the support. If placed on a back slope, offset these supports at least 5 ft (1.5 m) from the toe of the back slope of the ditch.

57-2.05 Overhead Signs

In addition to the requirements covered in the *ILMUTCD*, consider the following guidelines for overhead signing applications:

1. Lane Control. Consider using overhead signs where the message is applicable to a specific lane. If the sign is placed over the lane, lane use can be made significantly more effective, especially in areas where channelization does not meet the driver's expectations and where additional guidance is required for unfamiliar drivers. Locate overhead signing in advance of the intersection. Lane control signing may be located on the signal mast arm where justified by sight conditions.
2. Driver Unfamiliarity. Consider overhead signing in areas where there is a high volume of unfamiliar drivers.
3. Visibility. Use overhead signs where traffic or roadway conditions are such that an overhead mounting is necessary for adequate visibility (e.g., vertical or horizontal curves, closely spaced interchanges, two or more through lanes in one direction). In addition, consider the visual acuity of elderly drivers.

4. Divergent Roadways. Place overhead signs in advance of and/or at a divergence from a heavily traveled roadway (e.g., at a ramp exit where the roadway becomes wider).
5. Exits. Consider the application of overhead signing where non-uniform exit maneuvers exist (e.g., left-hand or multi-lane exit ramps).
6. Interchanges/Intersections. Use overhead signs at complex interchanges where driver confusion is exhibited, where interchanges are closely spaced, at Interstate-to-Interstate interchanges and/or where there are lane drops on the exit ramp or mainline within the interchange. Consider overhead signing also on the approach to intersections of two major arterial streets.
7. Trucks. Signs may be mounted overhead where there is a significant number of large trucks.
8. Limited Right-of-Way. Use overhead signs where there is limited space for signs on the roadside (e.g., narrow right-of-way).
9. Roadside Development. Consider overhead signs at locations where roadside development seriously detracts from the effectiveness of roadside signs.
10. Uniformity. Signs should be mounted overhead for consistency with other signs on a given section of highway.
11. Overhead Sign Supports. All overhead signs will use non-breakaway supports. Within the clear zone, these structures should be protected with a roadside barrier or, where applicable, with an impact attenuator. In addition, consider placing overhead signs on bridges to eliminate the need for supports. Consult the Bureau of Operations and the Bureau of Bridges and Structures for guidance.

57-2.06 Vertical Clearance

New installations of overhead signs will require a minimum vertical clearance of 17 ft 3 in. (5.25 m) above the roadway and shoulders. Existing overhead signs may have a vertical clearance of 16 ft 9 in. (5.10 m).

57-3 PERMANENT PAVEMENT MARKINGS

57-3.01 Responsibilities

The designer is responsible to provide for the initial placement of pavement markings (e.g., striping, symbols) and the development of the pavement marking detail sheets for insertion into the plans. The district Bureau of Operations will review the pavement marking details and should provide any specific district striping details. The designer will incorporate the pavement marking details into the final highway plans.

57-3.02 References

For additional information on permanent pavement marking material specifications, design, and application criteria, review the applicable publications listed in Section 57-1.02.

57-3.03 Line Types

Line types vary depending on their application. See the *Bureau of Operations Traffic Policies and Procedures Manual*, *ILMUTCD*, and the publications listed in Section 57-1.02 for specific application criteria. Consider the following when developing pavement marking details for permanent roadway application:

1. Reflectorization. Pavement markings must be retroreflective.
2. Color. Pavement markings will be either white or yellow conforming to the standard highway color specifications. For example, word and symbol markings, crosswalk lines, most channelization lines, stop lines, parking space lines, and all lane lines will be white in color. Center lines, no-passing barrier lines, and medians will be yellow.
3. Material. See Department Policy TRA-14, "Guidelines for the Use of a Pavement Marking Materials on State Highways." The material used will be determined by the district Bureau of Operations.
4. Orientation and Style. Line types will vary in thickness and width; will be oriented in a longitudinal, transverse, or diagonal configuration; and will be striped as either single or double lines in a solid, broken, or dotted pattern.

57-3.04 Traveled Way Markings

The following sections present typical traveled way marking applications. Guidelines for line size, color, and placement can be found in the *ILMUTCD* and the *Bureau of Operations Traffic Policies and Procedures Manual*.

57-3.04(a) Center Lines

Center lines are used to separate vehicles traveling in opposite directions. Locate center lines on either side of a longitudinal pavement joint as required by the *IDOT Standard Specifications*. This will minimize the need for remarking after a joint-sealing operation.

57-3.04(b) Lane Lines

Lane lines are used to separate lanes of traffic traveling in the same direction. Use a broken white line for two or more lanes in the same direction. A solid white line may be used to discourage lane changes (e.g., approaches to signalized intersections). To facilitate future maintenance operations, offset all lane lines from longitudinal construction joints as required by the *IDOT Standard Specifications*.

57-3.04(c) Edge Lines

Edge lines are used to delineate the edge of traveled way. Left-hand edge lines are median lines, except on one-way streets, and are discussed further in Section 57-3.04(d). Where the application of a right-hand edge line is justified, use a solid white line.

57-3.04(d) Median Lines

Median lines are required on all multilane divided highways. Provide gaps at all intersections and median crossovers.

57-3.04(e) Channelizing Lines

Channelizing lines are used to separate traffic movement into definitive paths to facilitate safe and orderly movement. Channelizing lines may be used to separate traffic traveling in the same direction (e.g., gore areas). Channelizing lines also may be used to emphasize a flush or raised-curb median.

57-3.04(f) Transitions

Where transitions are necessary, pavement markings are used to guide the motorist through the transition area. See the *Bureau of Operations Traffic Policies and Procedures Manual* and the *ILMUTCD* for the applicable taper rate and length criteria at transitions (e.g., auxiliary lane tapers, beginning taper for left- and right-turn lanes, Interstate exits).

57-3.04(g) No-Passing Lines

A no-passing line is a special type of center line; see Section 57-3.04(a). Place a solid yellow line adjacent to the lanes that warrant the no-passing restriction. Provide no-passing lines along

vertical and horizontal curves and elsewhere on two-lane facilities where the driver's line-of-sight is less than the minimum passing sight distance criteria presented in the *ILMUTCD*. The values presented in the *ILMUTCD* should not be confused with the passing sight distances presented in the AASHTO publication *A Policy on Geometric Design of Highways and Streets* which are geometric design criteria based on an assumption that a passing vehicle will be able to complete its passing maneuver. The minimum passing sight distance criteria presented in the *ILMUTCD* are sufficient to allow a passing vehicle to abort its passing maneuver. See Chapter 32 and Chapter 33, respectively, for horizontal and vertical curve design criteria. Conduct a review of successive no-passing zones to ensure that the roadway section will be properly striped (e.g., eliminating less than minimum gaps).

57-3.04(h) Raised Reflective Pavement Markers

Raised reflective pavement markers are used to supplement standard pavement markings. Guidelines are provided in Department Policy TRA-14, "Guidelines for the Use of Pavement Marking Materials on State Highways" where minimum ADT's and other conditions suggest appropriate placement. They should not be used in locations where lighting causes them to be ineffective.

57-3.05 Intersections

Chapter 36 discusses intersection design. The following sections present typical intersection pavement marking applications. See the *ILMUTCD* and the *Bureau of Operations Traffic Policies and Procedures Manual* for line size, color, and placement guidelines.

57-3.05(a) Stop Lines

The stop line is a transverse line that is used to indicate where the desired vehicular stopping point is located. Under certain circumstances, the location of the stop line may be adjusted to fit field conditions. For example, where turning trucks are known to encroach into the opposing lane, place the stop line outside the area of frequent encroachment. On multilane facilities that intersect the crossroad at an angle, it may be appropriate to stagger the stop line for each lane. This consideration is especially important at signalized intersections, which may have substantial clearance times. Consult the Bureau of Operations and the district Geometrics Engineer for additional guidance.

57-3.05(b) Channelizing Markings

Channelizing markings are used to emphasize the appropriate direction of travel. Depending on their use, they may be either white or yellow solid lines.

57-3.05(c) Crosswalks

An engineering study should be used to determine the need for proper location of crosswalks. Typical locations where marked crosswalks are used include:

- points of significant pedestrian concentration,
- signalized or unsignalized intersection approaches, and
- traffic stops that channelize pedestrians into identified corridors.

The crosswalk must encompass all curb ramps to satisfy the accessibility criteria; see Chapter 58.

57-3.05(d) Lane-Use Control Markings

At multilane approaches to intersections, it is often necessary to mark the intersection approach to designate the permitted movements through the intersection. This is especially important at intersections that have complex geometrics and multi-phase signal operations (e.g., exclusive turn lanes, drop lanes, dual left-turn lanes). Consider using lane-use control markings at the following locations:

- where the number of lanes approaching an intersection do not continue through to the opposite side of the intersection (e.g., auxiliary turn lanes);
- at major signalized intersections;
- where there exists an abnormal traffic pattern for an intersection approach; or
- where there is a possibility of confusion at an intersection or unusual conditions prevail.

57-3.05(e) Multiple Turn Lanes

At intersections that have multiple turn lanes (e.g., dual left-turn lanes), a series of single dotted lines may be used to guide the turning traffic through the intersection. The radius of the dotted line as extended through the intersection should be sufficient to accommodate the turning radius of the design vehicle and should be installed in accordance with the *ILMUTCD*.

57-3.06 Interchanges

Use pavement markings at interchanges to properly guide the motorist on and off of the high-speed facility (e.g., exit and entrance ramps, gore areas). See the *Bureau of Operations Traffic Policies and Procedures Manual, ILMUTCD*, and the specific application criteria for pavement markings at interchanges. Chapter 37 provides the criteria for interchange design.

57-3.07 Miscellaneous Marking Applications

57-3.07(a) Special Markings

Special markings (e.g., words, symbols, arrows) are used to guide, warn, and regulate traffic. Where used in a regulatory setting, these special markings are used to supplement the appropriate regulatory signing. Typical applications of special markings include:

- lane-use control at multilane intersections;
- highway-railroad grade crossings;
- school crossings;
- stop-controlled intersections;
- two-way, left-turn lanes;
- interchange ramps;
- one-way roadways;
- word markings; and
- directional arrow markings.

See the references in Section 57-1.02 for design and application criteria for special markings.

57-3.07(b) Truck-Climbing Lanes

For facilities with truck-climbing lanes, provide a broken white lane line between the normal travel lane and the climbing lane. Transition the edge line to the outside edge of the climbing lane. See the *Bureau of Operations Traffic Policy and Procedures Manual* for additional pavement marking application criteria for truck-climbing lanes.

57-3.07(c) Two-Way, Left-Turn Lanes (TWLTL)

On TWLTL's, the center lane is reserved for the exclusive use of a bi-directional, left-turn movement. The TWLTL is designed to harbor left-turning vehicles in the median area until a gap in the opposing traffic stream becomes available. The *Bureau of Operations Traffic Policies and Procedures Manual* and the *ILMUTCD* provide the pavement marking application criteria for two-way, left-turn lane facilities.

57-3.07(d) School Crossings

Mark school crossings according to the criteria presented in the *ILMUTCD*. See the publications in Section 57-1.02 for additional criteria. Pavement markings for school crossings should be used only with the appropriate signing. The proper signing should be in place, if practical, at the time the pavement markings are placed.

57-3.07(e) Highway-Railroad Grade Crossings

Place pavement markings in advance of railroad-highway grade crossings according to the criteria in the *ILMUTCD*. See the publications in Section 57-1.02 for specific design and application criteria.

57-3.07(f) Bicycle Facilities

Broken lines for bicycle paths should have a 1 to 3 ratio (e.g., 3 ft (1 m) segment with a 9 ft (2.7 m) gap). A solid yellow centerline may be appropriate on path approaches to an intersection to discourage passing and help increase bicyclist awareness of the intersection. Use solid white lines to separate bicycles from traffic if they share a common facility. Use the bike symbol, as defined in the *ILMUTCD*, where a separate bike lane is provided on a roadway. See the references in Section 57-1.02 for specific design and application criteria for bicycle facilities. Chapter 17 provides additional information on pavement markings for bicycle facilities. Green pavement markings may be used as a traffic control device to clarify for all users the locations where bicyclists are expected to operate. These markings are supplemental to the other pavement markings that are required for the designation of a bicycle lane. When used, green pavement marking can be installed under a MUTCD Interim Approval, and therefore locations are tracked, and performance reported. Green pavement markings should be limited primarily to within intersections and on intersection approaches where bicyclists and other roadway traffic would have potentially conflicting weaving or crossing movements. Refer to Section 17-2. for further discussion.

57-3.07(g) Rest Areas/Weigh Stations

For the design, marking, and striping criteria for rest areas and weigh stations, see Chapter 16, the Bureau of Operations *Traffic Policies and Procedures Manual* and the *ILMUTCD*.

57-3.07(h) On-Street Parking

Where used, on-street parking should be marked a sufficient distance back from an intersection so as not to obscure, or otherwise diminish, sight distance at the intersection and to minimize interference with the flow of vehicles and pedestrians. The publications in Section 57-1.02 provide additional guidance on on-street parking.

57-4 TRAFFIC SIGNALS

57-4.01 Responsibilities

57-4.01(a) State Projects

The following will apply to traffic signals on State projects:

1. Signal Design. The district will be responsible for the design of the traffic signal and for preparing the traffic signal detail sheets to be included in the plans. The district also will coordinate with any involved local agency to ensure that the selected traffic signal equipment can be maintained by that agency.
2. Structure Design. The central office Bureau of Operations and the Bureau of Bridges and Structures are jointly responsible for establishing the Department criteria for the design of traffic signal structural supports.
3. Review. The central office Bureau of Operations is available to assist and review the traffic signal plans.
4. Road Designer. The road designer will be responsible for reviewing the location of the traffic signal equipment (e.g., controller cabinet, signal supports) to ensure that they are compatible with the roadway design.
5. Signal Phasing and Timing. The district will be responsible for preparing the signal phasing and timing designs for the traffic signal.
6. Agreements. The district will be responsible for preparing any necessary agreements between the State and the local agency for the operation and maintenance of the traffic signal; see Chapter 5.

57-4.01(b) Local Projects

Where a local agency places a traffic signal on a State or Federal route or where an exit or entrance ramp intersects with a local facility, the Department will be responsible for reviewing the plans to ensure that they are in conformance with Department criteria. The local agency will be responsible for design of the traffic signal and for preparing the traffic signal detail sheets. Ensure there is an agreement with the local agency regarding the installation, maintenance, and other aspects of the proposed improvement.

57-4.02 References

For additional information on traffic signal equipment and material specifications, design, and application criteria, review the applicable publications listed in Section 57-1.02.

57-4.03 Definitions

The following list of definitions supplements those found in the various references of commonly used terms in traffic signal design:

1. Active Grade Crossing Warning System. The flashing signals, with or without warning gates, together with the necessary control equipment used to inform road users of the approach or presence of trains at highway-railroad grade crossings.
2. Approach. All lanes of traffic moving toward an intersection or a mid-block location from one direction, including any adjacent parking lane(s).
3. Call. The result of the actuation of a vehicle or pedestrian detector.
4. Network. A geographical arrangement of intersecting roadways.
5. Platoon. A group of vehicles or pedestrians traveling together as a group either voluntarily or involuntarily because of traffic signal controls, geometrics, or other factors.
6. Ramp Control Signal (Ramp Meter). A traffic control signal installed to control the flow of traffic onto freeways at entrance ramps and freeway-to-freeway connections.
7. Right-of-Way (Assignment). Permitting vehicles and/or pedestrians to proceed in a lawful manner in preference to other vehicles or pedestrians by the display of signal indications.
8. Signal Installation. The traffic signal equipment, signal heads and their supports, and associated electrical circuitry at a particular location.
9. Signal Section. The assembly of a signal housing, lens, and light source with necessary components and supporting hardware to be used for providing one signal indication.
10. Signal System. Two or more traffic control signal installations operating in coordination.
11. Steady (Steady Mode). The continuous illumination of a signal indication for the duration of an interval, phase, or consecutive phases. The steady mode is used when a signalized location is operated in a stop-and-go manner.
12. Visibility-Limited Signal Indication. A type of signal face, signal section, or signal indication designed to restrict the visibility of a signal indication from the side, or to limit the visibility of a signal indication to a certain lane or number of lanes or to a certain distance from the stop line.

57-4.04 Traffic Signal Warrants

57-4.04(a) New Traffic Signals

The investigation of the need for a traffic signal includes an analysis of factors related to the existing operations and safety at the study location and the potential to improve these conditions, and the applicable factors contained in the following traffic signal warrants from Section 4C of the *ILMUTCD*.

- Warrant 1, Eight-Hour Vehicle Volume
- Warrant 2, Four -Hour Vehicle Volume
- Warrant 3, Peak Hour
- Warrant 4, Pedestrian Volume
- Warrant 5, School Crossing
- Warrant 6, Coordinated Signal System
- Warrant 7, Crash Experience
- Warrant 8, Roadway Network
- Warrant 9, Intersection near a Grade Crossing

If none of the warrants are satisfied, then a traffic signal should not be considered at the study location. Furthermore, the satisfaction of one or more of the warrants does not in itself justify the installation of a traffic signal. An engineering and traffic study of the site's physical characteristics and traffic conditions is necessary to determine whether a traffic control signal installation is justified at a particular location.

57-4.04(b) Existing Traffic Signals

If it is obvious that an existing traffic signal meets one or more of the traffic signal warrants, then no special documentation will be required.

The Phase I report should document whether the existing signals should be removed or retained based on the following as well as other supporting information:

- number of warrants met,
- expected development and traffic growth on intersecting streets,
- signal progression with adjacent signals, and
- crash potential due to either retention or removal of the signal.

Include a traffic count data sheet to verify that signal warrant(s) are or are not met in the appendix of the phase I project report.

57-4.04(c) Proposed Volumes

For new intersections or where proposed intersection improvements for large developments will significantly increase traffic volumes, traffic signals may be justified where the 8-hour vehicle

volume three years after construction exceeds the values required for Warrant 1. The three-year time frame should be increased in the event of staged development. The 8-hour vehicle volume may be considered as 55% of the projected 30th maximum hour volume. See the *ILMUTCD* for additional guidance.

57-4.05 Traffic Signal Needs Study

Although one or more of the warrants presented in *ILMUTCD* may be satisfied, the results of a thorough engineering and traffic study of the site's physical characteristics and traffic conditions may indicate that the installation of a traffic signal is not the most prudent choice. A traffic signal should not be installed unless an engineering study indicates that installing the device will improve the overall safety and/or operation of the intersection. In addition to the *ILMUTCD* traffic signal warrants, consider the following factors:

1. Crash Experience. Consider alternative solutions to crash-related problems (e.g., removing parking, using advance warning signs or larger signs).
2. Geometrics. The intersection's geometric design can affect the efficiency of the traffic signal. Traffic signal installations at poorly aligned intersections may, in some cases, increase driver confusion and reduce the overall efficiency of the intersection. If practical, properly align the intersection to adequately accommodate turning lanes, through lanes, etc. See Chapter 36 for the geometric design criteria of intersections.
3. Costs. The installation and maintenance of traffic signals can be very expensive. A cost-effectiveness analysis may be necessary to determine if the benefits from the reduction in crashes and delays will actually exceed the costs associated with signalization.
4. Location. Consider the intersection relative to the adjacent land use type and density (e.g., urban, suburban, rural) and the potential for future development in the study area. Also consider the location of the intersection within the context of the overall transportation system (e.g., isolated locations, interrelated operations, functional classification). Normally, isolated locations are intersections where the distance to the nearest signalized intersection or potential future signalized intersection is greater than 0.5 mile (800 m).
5. Approach Geometrics and Volumes. For the purpose of comparing intersection conditions to the warrants, lanes added on major streets within 300 ft (90 m) of the intersection should not be considered as approach lanes unless a significant volume of traffic enters the streets within the added lane (e.g., ramp connection).
6. Temporary Signals. The need for temporary traffic signals will be determined on a case-by-case basis. These installations are typically considered for construction and maintenance projects. Use the warrants for permanent signal installations as guidelines to determine temporary signal needs. As practical, design temporary traffic signals consistent with the design criteria for permanent signal installations.

7. Design Year. Consider the design year during the study and assess the potential for future expansion at the intersection (e.g., construction of additional approach lanes).
8. Removal of Confusing Advertising Lights. Advertising lights, or other similar devices located adjacent to the roadway, that are similar in color to traffic signal indications, often can be mistaken for traffic signal control, interfere with the effectiveness of a traffic signal, and possibly contribute to driver confusion and crashes. Where this appears to be a problem, contact the property owner and local officials to explain the problem and possible solutions.
9. Provisions for Future Installations. Consider the future needs of the study location. Assess the anticipated traffic growth and future operational requirements of the signalized location during planning and design, as practical, so that later modifications can be readily incorporated, and total labor and material costs minimized. Traffic signal equipment should be specified with some degree of operational flexibility to accommodate future needs. This is illustrated by the following examples:
 - a. If predicted traffic growth is likely to require a left-turn lane in the future, the design should accommodate this future need (e.g., equipment, phasing, circuitry, pole mounting).
 - b. If a street will be widened or an intersection will be reconstructed in the foreseeable future, consider either a temporary signal or, if possible, an installation that conforms to the proposed final layout.
 - c. If a need for a signal interconnect or additional phases can be foreseen, then provisions for these situations should be incorporated in the initial design.

57-4.06 Traffic Signal Operation

A traffic signal controller is an electronic device mounted in a cabinet for controlling the sequence and phase duration of the traffic signal. Right-of-way is assigned by either energizing or de-energizing the green indication. See the *Standard Specifications for Road and Bridge Construction, Bureau of Operations Traffic Policies and Procedures Manual* and the *ILMUTCD* for specifications, design, and application criteria of traffic signal controllers. The following sections provide general information on the various controller operations.

57-4.06(a) Pretimed Operation

A pretimed operation uses a fixed, consistent predetermined cycle length. There can be several different timing programs based on the time-of-day and/or day-of-week. A pretimed operation is best suited where traffic volumes and patterns are consistent from day-to-day (e.g., downtown areas), where variations in volumes are predictable, and where control timing can be preset to accommodate variations throughout the day.

57-4.06(b) Semi-Actuated Operation

Semi-actuated operation is based on vehicular detection from one or more approaches, but not on all approaches. Typically, vehicular detectors (e.g., loop detectors) are placed only on the minor approaches where traffic is light and sporadic. The major approaches are kept in the green phase until a vehicle on the minor approach is detected. If there is a demand on the minor approach and the minimum green time for the major approach has elapsed, the right-of-way then will be given to the minor approach. To accommodate various fluctuations on the minor approach, the minor approach is given enough time to clear one vehicle with additional time added for each new detection up to the maximum green time. Once the minor approach demand has been satisfied or when the maximum green time has been reached, the right-of-way then is returned to the major approach and the cycle begins again. If there is no minor approach demand, the major approach will remain in the green phase indefinitely.

Typical locations for semi-actuated operation include:

- school crossing intersections,
- on access routes to industrial areas or shopping centers,
- on access routes to recreational areas or sport centers,
- on cross streets with poorly spaced signals along the major route, and
- on cross streets with minimal traffic volumes.

57-4.06(c) Fully Actuated Operation

A fully actuated operation has detection devices on all approaches to the signalized intersection. The green interval for each street or phase is determined on the basis of volume demand. Continuous traffic on one street is not interrupted by a detector actuation from the side street until a gap in the traffic appears or when the preset maximum green time has elapsed. Once the minor street demand has been satisfied, right-of-way typically is returned to the major street whether or not a major street detection has been registered. Under heavy demand on all approaches, the intersection tends to operate as a pretimed signal.

A fully actuated operation is an appropriate design choice:

- at isolated locations where volumes on intersection legs are approximately equal with sporadic and varying traffic distribution,
- at locations where traffic signal control is warranted for only brief periods of the day,
- at locations where turning movements are heavy during specific time periods but are light at other times, and
- at high-speed locations where there is a need to avoid “dilemma zone” problems; see Section 57-4.11(c).

57-4.06(d) Pedestrian Control

The traffic signal controller is equipped to safely assign intersection right-of-way to various combinations of both vehicular and pedestrian traffic movements. This flexibility allows the designer to accommodate a pedestrian demand at the intersection by phasing and timing pedestrian WALK and DON'T WALK intervals. These intervals can be either pretimed or actuated by a pedestrian push button; see Section 57-4.07(e). Depending on the intersection design, bicyclists may negotiate the intersection either as a pedestrian or as part of the rolling traffic flow. See Section 57-4.07(f) for additional information on bicycle detection.

57-4.06(e) Special Operation

There are several specialty operations that may be used in a traffic signal design (e.g., flashing mode, signal preemption for emergency and non-emergency priority vehicles, and at highway-railroad grade crossings). These operations should be determined on a case-by-case basis.

57-4.07 Traffic Detectors

The efficient operation of a traffic-actuated signal installation depends greatly upon the proper design and placement of traffic detectors. See the applicable references in Section 57-1.02 for specifications, design, and application criteria for traffic detectors. The following sections provide general information on the various detector types.

57-4.07(a) Detector Operation

The primary purpose of a traffic detector is to detect the presence of a motor vehicle, bicyclist, or pedestrian or to detect the passage of a moving vehicle. The detector actuation is transmitted to the controller which adjusts the signal indications accordingly. There are many types of detector devices available. The inductive loop detector generally is accurate and is preferred because it can be used for passage or presence detection, vehicular counts, and vehicular speed determination.

57-4.07(b) Inductive Loop Detector

An inductive loop detector design consists of two or more turns of wire embedded below the pavement surface. As a vehicle passes over the loop, it disrupts the magnetic field associated with the current running through the wire. This disruption is recorded by a detector amplifier and is transmitted to the controller as a vehicular detection. The advantages of loop detectors are that they can:

- detect vehicles in both presence and passage modes,
- be used for vehicular counts and speed determinations, and
- be easily designed to meet various site conditions.

A major disadvantage of the loop detector is that it is very vulnerable to pavement surface irregularities (e.g., potholes and cracks), which can cause breaks in the loops.

57-4.07(c) Preformed Loop Detector

The preformed loop detector consists of a detector wire sealed with asphalt rubber or waterproof flexible sealant inside a conduit made of heavy-duty reinforced rubber hose or rigid plastic. This detector may be placed on a base course and covered by a bituminous or concrete surface course. This detector may also be placed within a concrete slab by attaching it to the reinforcing steel and pouring the concrete slab, encasing the detector. The preformed loop detector works the same way as the inductive loop detector.

Preformed loop detectors should be considered in situations where saw-cutting of pavement is impractical or impossible, such as in bridge decks or gravel road approaches to signalized intersections. This detector should be considered for use in concrete pavement because of pavement cracking associated with sawed loops.

57-4.07(d) Video Image Detector

The video image detector consists of one or more video cameras and an automatic control unit. The control unit detects a vehicle by comparing the images from the camera(s) to those stored in memory. The detector can work in both the presence and passage modes. This detector also allows the images to be used for counting and vehicular classification. Special housings are required to protect the camera from environmental elements. This detector should be considered for use with concrete pavement because of pavement cracking associated with sawed loops. Early models experienced problems during adverse weather conditions (e.g., wind, fog, rain, snow); however, recent versions have eliminated many of these problems.

57-4.07(e) Pedestrian Detectors

The most common pedestrian detector is the pedestrian push or call button. The push buttons, as “operable parts”, shall meet the requirements of Section R403 of the Draft *Public Right-of-Way Accessibility Guidelines* (PROWAG) and Part 4 of the ILMUTCD. Locate pedestrian call buttons so that they comply with *Americans with Disabilities Act* (ADA) requirements.

57-4.07(f) Bicycle Detectors

The two most common devices for bicycle detection include:

1. Pedestrian Push-Button Detector. With the push-button detector, the bicyclist must stop and push the detector button for the controller to record the call. This may require the bicyclist to leave the roadway and proceed on the sidewalk to push the detector button.

2. Inductive-Loop Detector. The inductive-loop detector (e.g., quadrupole) can detect the bicycle without the bicyclist's interaction. To ensure detection, the bicyclist should be guided directly over the loop wire. A problem with using inductive loop(s) for bicycle detection is that they require a significant amount of metal to be activated. Today's bicycle designs tend to use a substantial amount of non-metallic, man-made materials to increase their strength and reduce their weight. This substantially has reduced the amount of material that can be detected in bicycles.

57-4.08 Traffic Signal Mounting

Under most circumstances, traffic signals typically are mounted on mast arms that are placed on the far side of the intersection. This allows better location and alignment of signal heads for various lane configurations. In addition, the rigid mounting also allows for better control of the signal heads under wind-loading conditions. On mast arm mounted signals, provide one signal head per lane of traffic.

Under certain circumstances, pedestal- or post-mounted signals may be used (e.g., left-turn signal in median). See the IDOT publications in Section 57-1.02 for application and placement criteria on post-mounted signals in medians.

Under some temporary situations (e.g., temporary traffic signals in construction zones), signal heads may be mounted on span wires. Some problems with using span wire designs include:

- they do not provide enough rigidity under wind-loading conditions,
- the signal faces are difficult to see on narrow streets,
- pedestrians have difficulty seeing the signal faces, and
- installations are often considered to be aesthetically displeasing.

Consequently, span wire designs typically are not used for permanent installations. See the applicable references in Section 57-1.02 for specifications on mounting materials and for design and application criteria for typical traffic signal mounting.

57-4.09 Placement of Traffic Signal Equipment

In general, the designer has limited options available in determining acceptable locations for the placement of signal pedestals, signal poles, pedestrian detectors, and controllers. Considering roadside safety, place these elements as far from the roadway as practical. However, due to visibility requirements, limited mast-arm lengths, limited right-of-way, restrictive geometrics, or pedestrian requirements, traffic signal equipment often must be placed relatively close to the traveled way. Consider the following when determining the placement of traffic signal equipment:

1. Clear Zones. If practical, the placement of traffic signals on new construction and reconstruction projects should meet the clear zone criteria presented in Section 38-3.
2. Controller. In determining the location of the controller cabinet, consider the following:

- a. The controller cabinet should be placed in a position so that it is unlikely to be struck by an errant vehicle. It should be placed outside of the clear zone, if practical.
 - b. The controller cabinet should be located where it can be easily accessed by maintenance personnel.
 - c. The controller cabinet should be placed so that a technician working in the cabinet can see the signal indications in at least one direction.
 - d. The controller cabinet should be located where the potential for water damage is minimized.
 - e. The controller cabinet should not obstruct intersection sight distance.
 - f. The power service connection should be reasonably close to the controller cabinet.
3. Pedestrians. All new and altered pedestrian signals including those used in conjunction with pedestrian hybrid beacons (PHB) shall include accessible pedestrian signals (APS) with push buttons. If the signal pole must be located in the sidewalk, it shall be placed in a location that minimizes pedestrian conflict. In addition, the signal pole shall not restrict access to curb ramps or reduce the sidewalk width below minimum; see Chapter 58.
 4. Layout. Figure 57-4.A illustrates a typical urban traffic signal pole installation.

See the *Bureau of Operations Traffic Policies and Procedures Manual, ILMUTCD*, and the applicable references in Section 57-1.02 for specific IDOT criteria for the placement of traffic signal equipment (e.g., placement of signals in medians, use of near-right signals).

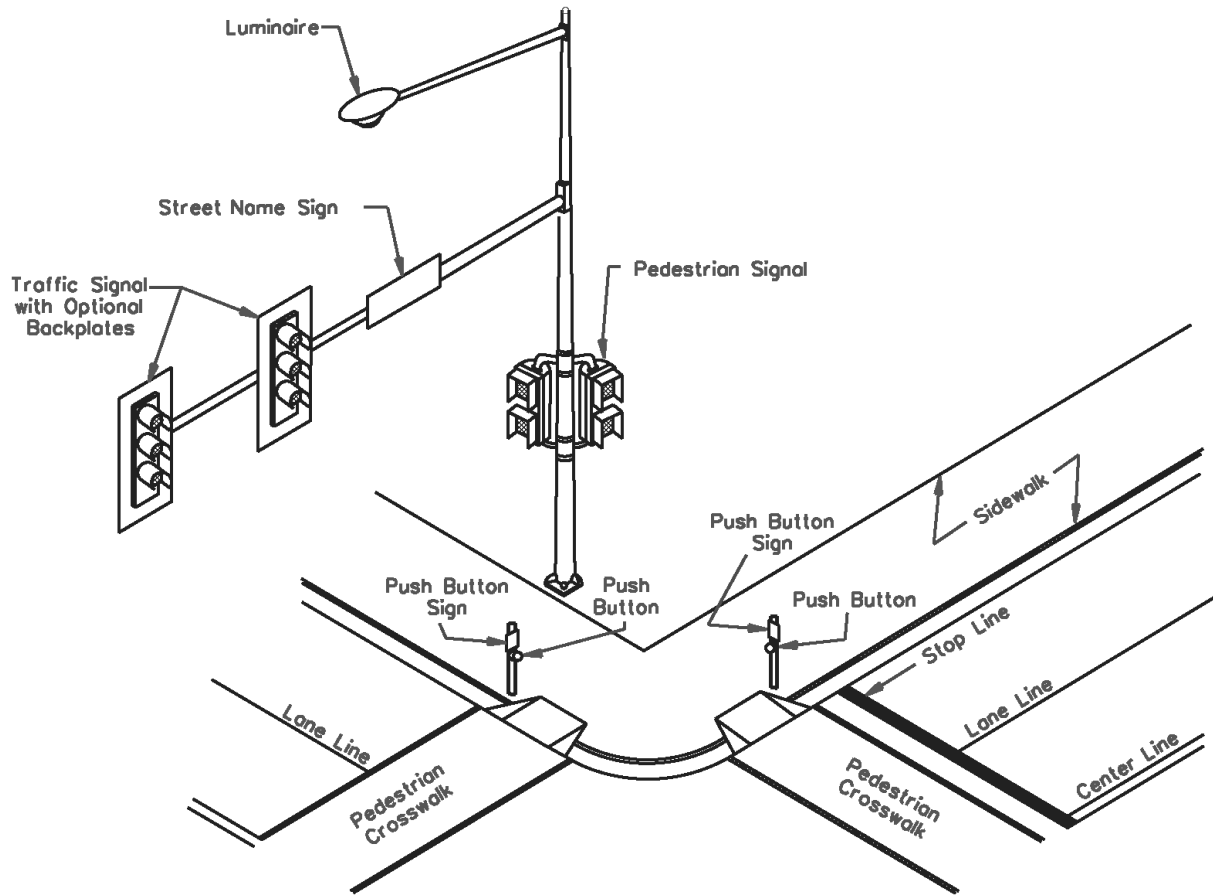

TYPICAL TRAFFIC SIGNAL POLE INSTALLATION

Figure 57-4.A

57-4.10 Traffic Signal Phasing

The district Bureau of Operations is responsible for determining the signal phasing plan. The selected phase designation diagram must be included in the traffic signal details and should identify the roadway preferentially. The following sections provide information on signal phasing.

57-4.10(a) Phasing Types

A traffic phase is defined as the part of the signal cycle allocated to any combination of traffic movements receiving the right-of-way simultaneously during one or more intervals. A phase includes the green, yellow change, and red clearance intervals. Each cycle can have two or more phases. As the number of non-overlapping phases increases, the total vehicular delay at the intersection will increase due to the lost time of starting and clearing each phase. Strive to use the minimum number of phases practical that will accommodate the existing and anticipated traffic demands. As necessary, conduct a capacity analysis to determine if the proposed phasing is appropriate. The following presents typical applications of various phase operations:

1. Eight-Phase Operation. An eight-phase operation provides the maximum efficiency and minimum conflict for high-volume intersections with heavy turning movements. Left-turn lanes should be provided on all approaches. It is most appropriate for actuated control with detection on all approaches. The eight-phase operation allows for the skipping of phases or selection of alternate phases depending upon traffic demand. The *Highway Standards* illustrate a typical eight-phase operation. An eight-phase operation uses the NEMA dual-ring controller.
2. Other Phases. For other phase operations (e.g., six-phase operations), the eight-phase operation can be used by eliminating the non-applicable phases from the sequence.

Highway Standard 857001 illustrates the movements that typically should be assigned to the various numbered phases. As a general rule, on four- and eight-phase operations, the through movements are assigned to the even-numbered phases, and the left turns are assigned to the odd-numbered phases.

The signal controller permits control of each individual phase. Each phase is programmed as a single-entry operation in which a single phase can be selected and timed alone if there is no demand for service in a non-conflicting phase. Dual entry programming may be used to allow timing of concurrent phasing when a demand for a conflicting phase does not exist.

There are several computer programs available that can assist the designer in determining the appropriate phasing requirements; see Section 57-4.12.

57-4.10(b) Left-Turn Phases

The most commonly added phases are for left turns (i.e., left-turning vehicles are given a green arrow without any conflicting movements). Left-turn phases can be either a leading left, where the protected left turn precedes the opposing through movements, or a lagging left, where the

left-turn phase follows the opposing through movements. The decision on when to use either a leading-left or a lagging-left turn will be determined on a case-by-case basis. In most situations, the preferred practice is to use the leading left. Leading pedestrian intervals may necessitate the use of lagging lefts which in turn may require further modifications to left turn phasing such as protected-only or flashing yellow arrows. The district Bureau of Operations should be contacted for further information and guidance. Figure 57-4.B provides a comparison for each left-turn phase alternative.

Not all signalized intersections will require a separate left-turn phase. The decision on when to provide an exclusive left-turn phase is dependent upon such factors as traffic volumes, delays, and crash history. Its use will be determined on a site-by-site basis. For intersections with exclusive left-turn lanes, consider the following guidelines when determining the need for a left-turn phase:

1. **Capacity.** Consider a left-turn phase where the demand for left turns exceeds the left-turn capacity of the approach lane.
2. **Delay.** Consider a left-turn phase where the delay time for left-turning vehicles is excessive for four hours during an average day. Delay is considered excessive when left-turning vehicles are delayed for more than two complete signal cycles.
3. **Miscellaneous.** In addition to capacity and delay guidelines, consider intersection geometrics, total volume demand, crash history, posted speeds, etc.

57-4.11 Traffic Signal Timing

57-4.11(a) Pretimed Control

Consider the following guidelines when developing signal timing for pretimed signals:

1. **Phases.** Keep the number of phases to a minimum. Each additional phase reduces the effective green time available for the movement of traffic flows (i.e., increased lost time due to starting delays and clearance intervals). Adding concurrent phases, if feasible, will normally enhance capacity.
2. **Cycle Lengths.** Short cycle lengths yield the best performance by providing the lowest average delay, provided the capacity of the cycle to serve the vehicles is not exceeded. In general, consider the following relative to cycle lengths:
 - a. **Delay.** For two-phase operations, shorter cycle lengths generally produce the shortest delays.
 - b. **Capacity.** Longer cycle lengths will accommodate more vehicles per hour if there is a constant demand during the entire green period on each approach. Longer cycle lengths have higher capacity because, over a given time period, there are fewer starting delays and clearance intervals.

Leading-Left-Turn Phase	
Advantages	Disadvantages
<ul style="list-style-type: none"> • Minimizes conflicts between left-turn and opposing straight through vehicles by clearing the left-turn vehicles through the intersection first. • Drivers tend to react quicker than with lagging-left operations. 	<ul style="list-style-type: none"> • Left-turning vehicles completing their movement may delay the beginning of the opposing through movement when the green is exhibited to the stopped opposing movement. • Opposing movements may make a false start in response to the movement of the vehicles given the leading green.
Lagging-Left-Turn Phase	
Advantages	Disadvantages
<ul style="list-style-type: none"> • Both directions of straight through traffic start at the same time. • Approximates the normal driving behavior of vehicular operators. • Provides for vehicle/pedestrian separation as pedestrians usually cross at the beginning of straight through green or several seconds ahead of straight through green where a leading pedestrian interval (LPI) is used. • Where pedestrian signals are used, pedestrians have cleared the intersection by the beginning of the lag- green interval. • Cuts off only the platoon stragglers from adjacent interconnected intersections. 	<ul style="list-style-type: none"> • Left-turning vehicles can be trapped during the left-turn yellow change interval as opposing through traffic is not stopping as expected which can lead to crashes.

COMPARISON OF LEFT-TURN PHASE ALTERNATIVES

Figure 57-4.B

3. Green Intervals. The division of the cycle into green intervals will be approximately correct if made proportional to the critical lane volumes for the signal phases. The critical lane volumes can be determined quickly by using the Planning Methodology from the *Highway Capacity Manual*. In addition, check the green interval against the following:
 - a. Pedestrians. If pedestrians will be accommodated, check each green interval to ensure that it is not less than the minimum green time required for pedestrians to cross the respective intersection approaches plus the initial walk interval time.
 - b. Minimum Lengths. In general, relative to driver expectations, major movements should not have green intervals that are less than 15 seconds. Exceptions to this may be appropriate for turn phases.
4. Capacity. For intersection approaches with heavy left turns, the capacity of an intersection should be checked to determine the need for a separate left-turn lane; see Section 57- 4.10.
5. Phase Change Interval. Check each phase change and clearance interval (yellow and all-red) to ensure that approaching vehicles can either come to a stop or clear the intersection during the change interval.
6. Coordination. Traffic signals within 0.5 mile (800 m) of each other should be coordinated together in a system. Section 57-4.13 further discusses signal system coordination.
7. Field Adjustments. All signal-timing programs should be checked and adjusted in the field to meet the existing traffic conditions.

When determining appropriate cycle and interval lengths, consider the following:

1. General. Cycle lengths generally should fall within the following ranges:
 - Two-Phase Operations — 50 - 80 seconds.
 - Three-Phase Operations — 60 - 100 seconds.
 - Four-Phase Operations — Minimum 80 seconds.
2. Phase Change Interval. The yellow change interval advises drivers that their phase has expired, and that they should stop prior to the stop line or allows them to enter the intersection if they are too close to stop. The yellow change interval should be followed by a red-clearance interval (all-red phase) of sufficient duration to permit traffic to clear the intersection before conflicting traffic movements are released. The equation for calculating phase change intervals is found in the *Bureau of Operations Traffic Policies and Procedures Manual*.

There are several software programs available to assist in determining the most efficient design. Section 57-4.12 discusses several of these programs.

57-4.11(b) Basic-Actuated Control

Actuated-control designs are somewhat different than that of pretimed control. The design of actuated control is basically a trade-off process to optimize the location of vehicular detection to provide safe operation, but yet provide controller settings that will minimize the intersection delay. The compromises that must be made among these conflicting criteria become increasingly difficult to resolve as approach speeds increase. The following discusses some of the design considerations for actuated controls.

Basic-actuated control with passage detection is limited in application to isolated intersections with fluctuating or unpredictable traffic demands and low approach speeds. Basic-actuated control can be employed using either semi-actuated or full-actuated operation.

Because of the small area covered by the small-loop detector and its location from the stop line, this type of detection typically is used with controllers that have a locking memory feature for detector calls (i.e., the controller retains the detector actuation made during yellow and red intervals and when an arriving vehicle did not receive enough green time to reach the intersection).

When developing the signal timing plan and establishing detector locations for basic-actuated control, consider the following:

1. Minimum Assured Green (MAG). Although there is no timing adjustment labeled MAG on the controller, the designer still must calculate the MAG. The minimum green time is composed of the initial green interval plus one vehicle extension. Long minimum greens should be avoided. For snappy operation, the minimum assured green normally should be between 10 and 20 seconds for any major movement. Base the actual value selected on the time it takes to clear all possible stored vehicles between the stop line and the detector. If the MAG is too short, the stored vehicles may be unable to reach the stop line before the signal changes. Use Equation 57-4.1 to calculate MAG:

$$\text{MAG} = 3.7 + 2.1n \quad (\text{Greenshield's Formula}) \quad (\text{Equation 57-4.1})$$

where: MAG = minimum assured green, s

n = number of vehicles per lane which can be stored between the stop line and the detector

Where pedestrians must be accommodated, a pedestrian detector (e.g., APS with push button) should be provided. Ensure that the timing will be sufficient for the pedestrian to cross the intersection. The minimum times for pedestrians, as discussed in Section 57-4.11(a) for pretimed signals, is also applicable to actuated systems.

2. Initial Green. The initial green setting is simply the MAG, usually minus one vehicular extension. Typically, the initial green should be limited to a maximum of 10 seconds.
3. Detector Placement. Set the detector setback distance equal to the time required for the typical vehicle to stop before entering the intersection. The vehicular passage time

typically is used to determine this placement. Use the posted speed of the approach roadway to determine the appropriate setback.

4. Maximum Green Interval. This is the maximum time the green should be held for the green phase, given detection from the side street. Typically, for light to moderate traffic volumes, the signal should “gap out” before reaching the maximum green time. However, for periods with heavy traffic volumes, the signal rarely may gap out. Therefore, a maximum green interval is set to accommodate the waiting vehicles. The maximum green interval can be determined assuming a pretimed intersection. It may be somewhat longer to allow for peaking.
5. Change and Clearance Interval. Determine these intervals in the same manner as for pretimed signals.
6. Left-Turn Lanes. Left-turn lanes should be treated like side streets with semi-actuated control. Use short allowable gaps and minimum greens times. The designer must be careful of vehicles which may enter the left-turn lane beyond the detector. Presence detectors should be used at the stop line.
7. Intermediate Traffic. Where vehicles can enter the roadway between the detector and intersection (e.g., driveways, side parking) or where a vehicle may be traveling so slow that it does not clear the intersection in the calculated clearance time, the signal controller will not register their presence. A presence detector at the stop line may be required to address these situations; see Section 57-4.11(d).

57-4.11(c) Advanced-Design Actuated Control

Advanced-design actuated control usually is used at isolated intersections with fluctuating or unpredictable traffic demands and high-speed approaches. An advanced-design actuated control is one that has a variable initial interval. It can count waiting vehicles beyond the first and can extend the initial interval to meet the needs of the number of vehicles actually stored between the stop line and the detector. As with basic-actuated control, the small-area detection requires that the controller have a locking memory.

The timing for advanced-design actuated control requires a significant amount of judgment. Therefore, field adjustments often are required after the initial setup. The following discusses several considerations in the signal timing and detector placement:

1. Detector Placement. For high-speed approaches, locate the detector in advance of the dilemma zone as illustrated in Figure 57-4.C. This typically will place the detector about 5 seconds of passage time from the intersection. The speed selected should be the posted speed of the approach roadway. Figure 57-4.D provides the appropriate detector setback distances for various combinations of passage times and approach speeds. Figure 57-4.D also provides the passage times that are appropriate for various other types of actuated controls.



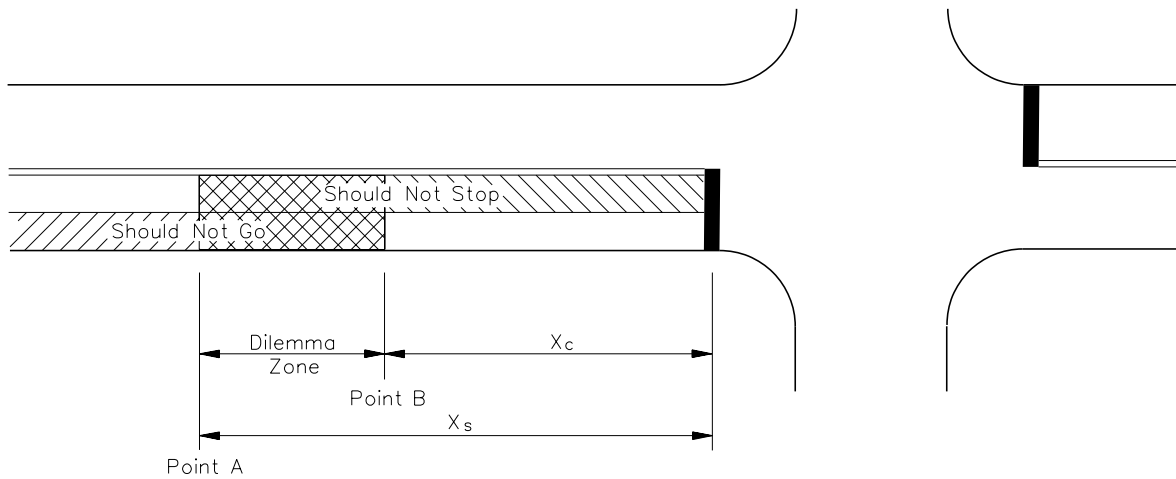

2. Minimum Initial. Because the controller can count the number of vehicular arrivals, the minimum initial time only should be long enough to meet driver expectancy. Typically, the minimum initial interval is set at eight to fifteen seconds for through movements and five to seven seconds for left turns.
3. Variable Initial. The variable initial is the upper limit to which the minimum initial can be extended. It must be long enough to clear all vehicles that have accumulated between the detector and the stop line during the red. The variable initial is determined in the same manner as the minimum assured green for basic-actuated control; see Section 57-4.11(b).
4. Number of Actuations. The number of actuations is the number of vehicles that can be accommodated during the red that will extend the initial green to the variable initial limit. This is a function of the number of approach lanes, average vehicle length, and lane distribution. It should be set based on the worst-case condition (i.e., vehicles are stored back to the detector).
5. Passage Time. The passage time is the time required for a vehicle to pass from the detector to the stop line. This typically is based on the posted speed of approach roadway.
6. Maximum Green. The maximum green should be set the same as for basic-actuated control; see Section 57-4.11(b).

**Notes:**

1. X_c = Maximum distance upstream of stop line from which a vehicle can clear the intersection during the yellow change interval.
2. X_s = Minimum distance from stop line where the vehicle can stop completely after the beginning of the yellow change interval.
3. At "Point A," 90% of the drivers will decide to stop at the onset of the yellow indication while 10% of the drivers will continue through the intersection.
4. At "Point B," 10% of the drivers will decide to stop at the onset of the yellow indication while 90% of the drivers will continue through the intersection.
5. For further information on dilemma zones, see FHWA Traffic Detector Handbook.

DILEMMA ZONE**Figure 57-4.C**

DETECTOR SETBACK DISTANCE — ft (m)							
Approach Posted Speed (mph)	Passage Time in Seconds from Detector to Stop Line						
	1	2	3	4	5	6	7
20	29 (9.0)	58 (17.5)	87 (26.5)	116 (35.5)	145 (44.0)	174 (53.0)	196 (59.5)
25	36 (11.0)	78 (24.0)	108 (33.0)	144 (44.0)	180 (55.0)	216 (66.0)	252 (77.0)
30	44 (13.5)	88 (27.0)	132 (40.0)	176 (53.5)	220 (67.0)	264 (80.5)	308 (94.0)
35	51 (15.5)	102 (31.0)	153 (46.5)	204 (62.0)	255 (77.5)	306 (93.0)	357 (109.0)
40	59 (18.0)	118 (36.0)	177 (54.0)	236 (72.0)	295 (90.0)	354 (108.0)	413 (126.0)
45	66 (20.0)	132 (40.0)	198 (60.5)	264 (80.5)	330 (100.5)	396 (121.0)	462 (141.0)
50	73 (22.5)	146 (44.5)	219 (67.0)	292 (89.0)	365 (111.5)	438 (133.5)	511 (156.0)
55	81 (24.5)	162 (49.5)	243 (74.0)	324 (99.0)	405 (123.5)	486 (148.0)	567 (173.0)
60	88 (27.0)	176 (53.5)	264 (80.5)	352 (107.5)	440 (134.0)	528 (161.0)	616 (188.0)
65	95 (29.0)	190 (58.0)	285 (87.0)	380 (116.0)	475 (145.0)	570 (173.5)	665 (203.0)

Legend		Basic Controllers		Variable Initial Only
		Density		Dilemma Zone

DETECTOR SETBACK DISTANCES

Figure 57-4.D

7. Allowable Gap. The density feature in controllers permit a gradual reduction of the allowable gap to a preset minimum gap based on one or more cross-street traffic parameters — time waiting, cars waiting, and/or density. Generally, time waiting has been found to be the most reliable and usable. As time passes after a conflicting call, the allowable gap time is gradually reduced. The appropriate minimum gap setting will depend on the number of approach lanes, the volume of traffic, and the various times of day. Fine-tuned adjustments will need to be made in the field.

8. Change and Clearance Interval. Determine these intervals in the same manner as for pretimed signals.

57-4.11(d) Actuated Control with Large Detection Areas

Large area detectors are used in basic-actuated control in the “non-locking” memory mode and with the initial interval and vehicular extension set at or near zero. This is referred to as the loop occupancy control (LOC). Large area detectors are used in the presence mode, which holds the vehicle call for as long as the vehicle remains over the loop. One advantage of large area detectors is that they generally reduce the number of false calls due to right-turn-on-red vehicles. With large area detectors, the length of the green time is determined by the time the area is occupied. However, a minimum green time of eight to fifteen seconds should be provided for driver expectancy. The following discusses several applications for LOC:

1. Left-Turn Lanes. An LOC arrangement is appropriate for left-turn lanes where left turns can be serviced on a permitted green or yellow change or where vehicles can enter the left-turn lane beyond the initial detector. Consider the following when using the LOC for left turns:
 - To ensure that the driver is fully committed to making the left turn, the initial loop detector may need to be installed beyond the stop line to hold the call.
2. Through Lanes (Low-Speed Approaches). On low-speed approaches, the dilemma zone protection generally is not considered a significant problem. The length of detection area and controller settings are determined based on the desired allowable gap. For example, assuming a 30 mph (48 km/hr) approach speed and three-second desired allowable gap, the length of LOC area is calculated to be as follows:

$$\frac{30 \text{ mi}}{\text{h}} \times \frac{5280 \text{ ft}}{\text{mi}} \times \frac{\text{h}}{3600 \text{ s}} \times 3\text{s} = 132 \text{ ft} \quad (\text{US Customary}) \text{ Equation 57-4.2}$$

$$\frac{48 \text{ km}}{\text{h}} \times \frac{1000 \text{ m}}{\text{km}} \times \frac{\text{h}}{3600 \text{ s}} \times 3\text{s} = 40 \text{ m} \quad (\text{Metric}) \text{ Equation 57-4.2}$$

By subtracting the vehicular length 20 ft (6 m) from the length of LOC area, the required length of detection area then is 112 ft (34 m). If a typical loop layout is 45 ft (13.7 m) long; then, for a 30 mph (48 km/hr) approach speed, the vehicular extension setting should be set at 1.5 seconds to provide the three-second gap. The vehicular extension setting of 1.5 seconds for a 30 mph approach speed was calculated as follows:

$$\frac{112 \text{ ft} - 45 \text{ ft}}{\frac{30 \text{ mi}}{\text{h}} \times \frac{5280 \text{ ft}}{\text{mi}} \times \frac{\text{h}}{3600 \text{ s}}} = 1.5 \text{ s}$$

If the initial interval is set at zero and the vehicular extension is between zero and one second then, under light traffic conditions, a green as short as two or four seconds may occur. Check to determine if there are pedestrians or bicyclists present; if so, provide the minimum green times for their crossings. Also consider driver expectancy. Generally, drivers for major through movements expect a minimum green interval of eight to fifteen seconds.

3. Through Lanes (High-Speed Approaches). For high-speed approaches, it generally is not practical to extend the LOC beyond the dilemma zone (five seconds of passage time back from the stop line). To cover the dilemma zone problem, an extended-call detector is placed beyond the dilemma zone. This detector is used in a non-locking mode. The time extension is based on the time for the vehicle to reach the LOC area. Intermediate detectors may be used to better discriminate the gaps.

There are several concerns with using the LOC concept for high-speed approaches. Some of these concerns include the following:

- The allowable gap generally is higher than the normally desired 1.5 to 3 seconds. The controller's ability to detect gaps in traffic is impaired substantially. As a result, moderate traffic routinely will extend the green to the maximum setting — an undesirable condition.
- For high-speed approaches, LOC designs only should be used if the route is lightly traveled (e.g., 8,000 to 10,000 ADT). High-speed approaches with heavy volumes are served better with density control. The intersection of a high-speed artery with a low-speed crossroad might be served better by using density control on the artery and LOC for the crossroad.

57-4.12 Computer Software

There are numerous software programs available to assist the designer in preparing traffic signal designs and timing plans. New programs, as well as updates to existing programs, are being continuously developed. The current Highway Capacity Manual and the following website, <http://ops.fhwa.dot.gov/trafficanalysisitools/index.htm>, are recommended for aid in selecting the appropriate analysis tool. The following programs are the most widely used for signal timing and optimization:

1. Highway Capacity Software. The Highway Capacity Software (HCS) replicates the procedures described in the *Highway Capacity Manual*. It is a tool that greatly increases productivity and accuracy, but it should be used only in conjunction with the *Highway Capacity Manual* and not as a replacement for it. HCS is the software required by IDOT for intersection and interchange capacity analyses.
2. Synchro. Synchro provides interactive time-space diagrams for arterials. It can be used to optimize signal splits, cycle lengths, phase orders, and offsets. Outputs include vehicle delay, level of service, queue length, queuing penalty, stops, fuel usage, and dilemma vehicles.
3. SIDRA. IDOT requires the current version of **S**ignalized (and unsignalized) **I**ntersection **D**esign and **R**esearch **A**id (SIDRA) for capacity analyses of roundabouts. SIDRA closely follows the methods used in the *Highway Capacity Manual* (HCM), which IDOT requires for computing highway capacity analyses. SIDRA software also includes alternative tools for applications beyond the ability of the HCM.

Most of these software programs can be purchased from McTrans Center, Trafficware LTD., or from Strong Concepts. SIDRA can be purchased directly from the software manufacturer. Many of these software programs can be used for either the network operating systems or stand-alone operating systems.

57-4.13 Signal System Design

As traffic volumes continue to grow, installing coordinated signal systems is an important consideration for improving traffic flow. By coordinating two or more traffic signals together, the overall capacity of the facility can be increased significantly. As compared to constructing additional lanes, coordinating traffic signals is a relatively inexpensive method of improving capacity because it reduces vehicular delay with minimal disruption to the highway system. Although not a capacity panacea, the use of a coordinated traffic signal system could satisfy the needs of highway users for many years. Generally, traffic signals that are within 0.5 mile (800 m) of each other are good coordination candidates. The following sections present application guidelines for traffic signal systems.

57-4.13(a) System-Timing Parameters

The basic system-timing parameters used in a coordinated system include:

1. Cycle. The period of time in which pretimed control (or actuated control, with demand on all phases) displays a complete sequence of signal indications. In most systems, the cycle length is common to all intersections operating together and is called the background cycle.
2. Split. The proportioning of the cycle length among the various phases of the local controller.
3. Offset. The time relationship determined by the difference between a specific point in the local signal sequence (typically the beginning of the major street green interval) and a system-wide reference point.
4. Time-of-Day/Day-of-Week. The time-of-day/day-of-week system selects system timing plans based on a predefined schedule. The timing plan selection may be based not only on the time-of-day but also on the day-of-week and week-of-year. Some systems permit the selection of plans based upon a specific day of the year.
5. Traffic Responsive. Traffic-responsive systems implement timing patterns based on varying traffic conditions in the street. Most traffic-responsive systems select from a number of predeveloped timing plans.

57-4.13(b) Advantages of Traffic Signal Systems

A primary objective of installing a traffic signal system is to develop a good progression of traffic. Some advantages of providing good traffic progression are as follows:

1. Operational and Environmental Benefits. Traffic signal systems reduce fuel consumption, pollutant emissions, and vehicle operating costs.
2. Increase In Capacity. A higher level of traffic service is provided in terms of higher overall speed and reduced number of stops. Traffic will flow more smoothly and an improvement in level of service often results.
3. Speed Uniformity. The speed of vehicles will be more uniform because there will be no incentive to travel at excessively higher speeds to make a green signal indication that is not in step. On the other hand, the slow driver is encouraged to speed up to avoid having to stop for a red-signal indication.
4. Crash Reduction. Fewer crashes will result because platoons of vehicles will arrive at each traffic signal at a green signal indication, thereby reducing the possibility of red-signal violations and rear-end collisions. Naturally, if there are fewer occasions when a red-signal indication is displayed to a majority of motorists, there is less likely to be crashes than can be attributed to due to driver inattention, brake failure, slippery pavement conditions, and other similar factors.
5. Greater Traffic Control Obedience. Greater obedience to signal indications will be obtained from both motorists and pedestrians. This results because motorists will aggregate in platoons of closely-spaced vehicles due to their desire to ride the “green wave” produced by the coordinated signals. Pedestrians will remain at curbside during the passage of each platoon and realize a sufficient gap between platoons to safely cross.
6. Greater Use of Arterial Streets. Through traffic will tend to remain on arterial streets rather than shifting their route over to parallel minor streets.

57-4.13(c) System Types

There are several different methodologies available to coordinate traffic signals. Most of these take advantage of computer technology. As new signal controllers, computers, and software are developed, the design of coordinated traffic signal systems will continue to improve. These systems should match existing systems and/or be coordinated with nearby systems as practical. The following briefly describes several types of traffic signal coordination systems:

1. Interconnected Time-of-Day System. The interconnected time-of-day system is applicable to both pretimed and actuated control, in either a grid system or along an arterial system. The typical configuration for this type of system includes a field-located, time clock-based master controller generating pattern selection and synchronization commands for transmission along a cable interconnect. Local intersection coordination equipment interprets these commands and implements the desired timing.
2. Time-Base-Coordinated Time-of-Day System. Time-base coordination often is used as a backup for computerized signal systems. Operationally equivalent to the interconnected time-of-day system, this type of system uses accurate time-keeping techniques to

maintain a common time of day at each intersection without physical interconnection. Time-base coordination is tied to the 60 Hz AC power supply, with a battery backup in case of a power failure.

Time-base coordination allows for the inexpensive implementation of a coordinated signal system because the need for a cable interconnect is eliminated. However, time-base systems require periodic checking by maintenance personnel, because the 60 Hz reference from the power company sometimes is inconsistent. In addition, power outages sometimes affect only portions of a system, resulting in drift between intersections that continue to operate on power company lines and those that maintain time on a battery backup.

3. Adaptive or Traffic-Responsive Arterial Systems. The traffic-responsive arterial system normally is used with semi-actuated controllers along an arterial. The field located system master selects predetermined cycle lengths, splits, and offsets based upon current traffic flow measurements. These selections are transmitted along a cable interconnect to the slave controllers at the local intersections.

Cycle lengths are typically selected based on volume (and sometimes occupancy) level thresholds on the arterial; the higher the volumes, the longer the cycle length. Splits frequently are selected based on the side-street volume demands, and offsets are selected by determining the predominant direction of flow along the arterial.

System sampling detectors, located along the arterial, transmit data back to the master controller along the interconnect cable. Most current systems have the capability to implement plans on a time-of-day basis as well as through the use of traffic-responsive techniques.

4. Distributed-Master (Closed-Loop) Systems. The distributed-master (frequently called closed-loop) system advances the traffic-responsive arterial system one step further by adding a communications link between the field-located master controller and an office-based microcomputer. Most systems are designed to interface with a standard personal computer over dial-up telephone lines or fiber optic lines. This connection is established only when the field master is generating a report or when the operator is interrogating or monitoring the system. With proper equipment, several systems can share a single office-based microcomputer.

The system permits the maintenance of the complete controller database from the office. The controller's configuration data, phase and timing parameters, and coordination patterns can be downloaded directly from the office.

The distributed-master system provides substantial remote monitoring and timing plan updating capabilities for only a minor increase in cost — typically, only the expense of the personal computer and the monthly costs of a standard business telephone line. Graphics displays usually are provided to assist in monitoring the system.

57-4.13(d) Communications Techniques

Systems other than time-base-coordinated systems require some type of communications medium to maintain synchronized operation between intersections. Two primary communications options are available. One is to employ hardwired communications through leased telephone lines, fiber optics, or direct wiring. A second option, which has been unreliable in some cases, is to utilize the through-the-air frequencies of radio communications and cellular telephone equipment. The requirements for the communications network depend on the needs of the system. Therefore, decisions on an appropriate communications technique will be made on a case-by-case basis.

Chapter Fifty-eight
SPECIAL DESIGN ELEMENTS

BUREAU OF DESIGN AND ENVIRONMENT MANUAL

Chapter Fifty-eight
SPECIAL DESIGN ELEMENTS

Table of Contents

<u>Section</u>	<u>Page</u>
58-1 ACCESSIBILITY STANDARDS	58-1.1
58-1.01 General.....	58-1.1
58-1.01(a) Referenced Accessibility Standards	58-1.1
58-1.01(b) Scoping Requirements - New Construction, Added Elements, and Alterations	58-1.1
58-1.01(c) Maintaining Accessibility During Construction.....	58-1.3
58-1.02 Buildings and Facility Sites.....	58-1.3
58-1.03 Bus Stops.....	58-1.4
58-1.04 Parking	58-1.4
58-1.04(a) Off-Street Parking.....	58-1.4
58-1.04(b) On-Street Parking.....	58-1.5
58-1.05 Accessible Route	58-1.8
58-1.05(a) Definition	58-1.8
58-1.05(b) Selecting Accessible Routes.....	58-1.8
58-1.06 Sidewalks	58-1.8
58-1.07 Stairs	58-1.10
58-1.08 Ramps.....	58-1.11
58-1.09 Curb Ramps and Crosswalks	58-1.12
58-1.09(a) Responsibility for Construction of Curb Ramps	58-1.13
58-1.09(b) Design and Construction of Curb Ramps.....	58-1.13
58-1.09(c) Detectable Warning Surfaces.....	58-1.15
58-1.09(d) Accessible Pedestrian Signals/Pushbuttons	58-1.16
58-1.09(e) Crosswalks.....	58-1.16
58-1.10 Roadway Approach Grades.....	58-1.17
58-1.11 Pedestrian Overpasses and Underpasses	58-1.17
58-1.12 Rest Areas.....	58-1.18
58-2 OFF-STREET PARKING.....	58-2.1
58-2.01 Park-and-Ride Lots	58-2.1
58-2.01(a) Location	58-2.1
58-2.01(b) Layout.....	58-2.2

Table of Contents*(Continued)*

<u>Section</u>		<u>Page</u>
58-2.02	Replacement Parking Guidelines.....	58-2.3
58-2.03	Design Elements.....	58-2.4
58-3	BUS STOPS AND TURNOUTS.....	58-3.1
58-3.01	Location.....	58-3.1
	58-3.01(a) Bus Stops.....	58-3.1
	58-3.01(b) Bus Turnouts.....	58-3.1
	58-3.01(c) Selection.....	58-3.3
58-3.02	Design.....	58-3.3
	58-3.02(a) Bus Stops.....	58-3.3
	58-3.02(b) Bus Turnouts.....	58-3.3
	58-3.02(c) Bus Stop Pads.....	58-3.6
	58-3.02(d) Bus Shelters.....	58-3.6
58-4	FENCING.....	58-4.1
58-4.01	General.....	58-4.1
	58-4.01(a) Location.....	58-4.1
	58-4.01(b) Fence Types.....	58-4.1
58-4.02	Freeways (Fully Access Controlled).....	58-4.2
58-4.03	Expressways (Partial Access Control).....	58-4.3
58-4.04	Protective Fencing on Highway Overpasses.....	58-4.4
	58-4.04(a) General.....	58-4.4
	58-4.04(b) Evaluation of Need.....	58-4.4
	58-4.04(c) Pedestrian Bridges.....	58-4.4
58-4.05	Fencing or Safety Devices on Top of Retaining Walls.....	58-4.4
58-5	MAILBOX TURNOUTS.....	58-5.1
58-5.01	Location.....	58-5.1
58-5.02	Design Features.....	58-5.5
	58-5.02(a) Typical Designs.....	58-5.5
	58-5.02(b) Special Designs.....	58-5.8
58-5.03	Mailbox Supports.....	58-5.9

Table of Contents
(Continued)

<u>Section</u>		<u>Page</u>
58-6	RECREATIONAL ROADS.....	58-6.1
58-7	SEALING OF ABANDONED WATER WELLS.....	58-7.1
58-8	SURVEY MARKERS AND MONUMENTS.....	58-8.1
58-8.01	Right-of-way Markers.....	58-8.1
58-8.02	Permanent Survey Markers.....	58-8.1
58-8.03	Permanent Survey Ties.....	58-8.2
58-8.04	Land Survey Monuments.....	58-8.2
58-9	REFERENCES.....	58-9.1

Chapter Fifty-eight

SPECIAL DESIGN ELEMENTS

58-1 ACCESSIBILITY STANDARDS

58-1.01 General

58-1.01(a) Referenced Accessibility Standards

Section 504 (49 CFR 27) of the Rehabilitation Act of 1973 (29 U.S.C. 794), the Illinois Environmental Barriers Act, 410 ILCS 25/1, and Title II (28 CFR 35) of the Americans with Disabilities Act (ADA) of 1990 (42 U.S.C. 12131) prohibit discrimination on the basis of disability by public entities. To that end, the following sections present guidance which is intended to ensure the Department's newly constructed facilities, and existing facilities being altered, are accessible to individuals with disabilities. The guidance is generally based on information presented in the *2010 ADA Standards for Accessible Design* and the *Illinois Accessibility Code*. However, for situations in the public right of way that are not specifically or adequately addressed by either of the above standards, the guidance is taken from information presented in the *Draft Public Rights-of-Way Accessibility Guidelines (Draft PROWAG)*.

Where other agencies or local codes require criteria which exceed the above referenced standards, then the stricter criteria may be required. This will be determined on a case-by-case basis.

58-1.01(b) Scoping Requirements - New Construction, Added Elements, and Alterations

When determining the scope of an improvement, the following categories of action must be considered.

1. New Construction. Newly constructed facilities shall fully comply with the applicable accessibility requirements.
2. Added Elements. Elements added to existing facilities shall fully comply with the applicable accessibility requirements. However, where elements are added to existing facilities but the pedestrian circulation path serving the added elements is not altered, the pedestrian circulation path is not required to be altered if out of compliance. For example, if a new bench is installed on an existing sidewalk that has a cross slope exceeding 2 %, the sidewalk is not required to be altered to reduce the cross slope because the bench is installed on the sidewalk.
3. Alterations. Alterations are changes to an existing facility that affect or could affect pedestrian access, circulation, or use. Alterations include: resurfacing, rehabilitation, reconstruction, historic restoration, or changes or rearrangement of structural parts or elements of a facility as well as the various roadway surface treatments listed as such in

Figure 58-1.A. Note: The surface treatments listed under the heading “Maintenance” in Figure 58-1.A are not considered alterations and thus do not trigger the need to address ADA.

Altered elements, spaces, or facilities shall comply with the applicable accessibility requirements to the maximum extent practicable within the scope of the project. This typically means that alterations must be fully compliant; however, there are exceptions.

- Existing Physical Constraints. Where existing physical constraints make it impracticable for altered elements, spaces, or facilities to fully comply with the applicable accessibility requirements, compliance is required to the extent practicable within the scope of the project. Existing physical constraints include, but are not limited to, underlying terrain, right-of-way availability, underground structures, adjacent developed facilities, drainage, or the presence of a notable natural or historic feature.
- Alterations to Qualified Historic Facilities. Where the State Historic Preservation Officer or Advisory Council on Historic Preservation determines that compliance with a requirement would threaten or destroy historically significant features of a qualified historic facility, compliance shall be required to the extent that it does not threaten or destroy historically significant features of the facility.
- Transitional Segments. Transitional segments used to connect new, added, or altered elements to existing unaltered elements shall comply to the extent practicable.

One other requirement for alterations is they shall not decrease or have the effect of decreasing the accessibility of a facility or an accessible connection to an adjacent building or site.

The issue of whether resurfacing constitutes an alteration within the scope of Section 504 of the Americans with Disabilities Act (ADA) was at the heart of a court case in Philadelphia, PA (*Kinney v. Yerusalim*, 9 F.3d 1067 (3d Cir. 1993), cert. denied, 511 U.S.C. 1033 (1994)). The plaintiffs argued that the City of Philadelphia violated the ADA when the City only installed curb cuts when work on the City streets otherwise affected the curb or sidewalk and not during resurfacing projects. The City did not dispute the requirement that the regulations mandate the installation of curb cuts when the City “alters” a street. The City protested the notion that resurfacing of a street constituted an alteration. The judgment determined an alteration occurs when the usability of a facility is affected, and, if affected, the alteration should apply to all users. Further an interpretation of the guidelines determined interdependency between the street and its curbs. If a street is to be altered to make it more usable for the general public, it also must be made more usable for those with ambulatory disabilities thus requiring installation or upgrading of curb ramps.

The basis for the various roadway surface treatments listed in Figure 58-1.A to be classified as either alterations or maintenance is discussed in joint technical assistance issued by the U.S. Department of Justice and the U.S. Department of Transportation. A

copy of the joint technical assistance can be found on the FHWA's website: http://www.fhwa.dot.gov/civilrights/programs/doj_fhwa_ta.cfm.

ALTERATIONS	
<ul style="list-style-type: none"> • Addition of New Layer of Asphalt • Cape Seals • Hot In-Place Recycling • Microsurfacing / Thin-Lift Overlay 	<ul style="list-style-type: none"> • Mill & Fill / Mill & Overlay • New Construction • Open-graded Surface Course • Rehabilitation and Reconstruction
MAINTENANCE (i.e. not alterations)	
<ul style="list-style-type: none"> • Chip Seals • Crack Filling and Sealing • Diamond Grinding • Dowel Bar Retrofit • Scrub Sealing • Slurry Seals 	<ul style="list-style-type: none"> • Fog Seals • Joint Crack Seals • Joint Repairs • Pavement Patching • Spot High-Friction Treatments • Surface Sealing

ALTERATIONS VS MAINTENANCE

Figure 58-1.A

Where accessibility requirements cannot be fully met within the scope of an alteration project, the barriers to full compliance must be documented as well as the measures taken to meet compliance to the maximum extent practicable; see Chapter 31. The non-compliant element must be added to the transition plan inventory. If too many ADA elements cannot be made compliant within the scope of the project, the scope of the project must be increased to achieve a higher level of compliance.

58-1.01(c) Maintaining Accessibility During Construction

During construction, accessibility must be maintained consistent with the features present in the existing facility. If a project is being constructed in stages, the designer may need to provide for the reconstruction of certain curb ramps at different times to maintain accessibility. In other cases, temporary facilities may need to be developed and included in the construction plans. See Section 55-2.01(d) for additional discussion on accommodating pedestrians/bicyclists in a traffic control plan.

58-1.02 Buildings and Facility Sites

For accessibility criteria in buildings, airport terminals, rest areas, weigh stations, and transit stations; and the sites on which they are located, use the accessibility criteria set forth in the *2010 ADA Standards for Accessible Design* and/or the *Illinois Accessibility Code*. These documents contain the accessibility requirements for interior building features including rest rooms, drinking

fountains, elevators, telephones, etc.; as well as exterior features including parking, stairs, ramps, and walkways.

58-1.03 Bus Stops

Bus stops and shelters shall comply with Section R308 of the Public Rights-of-Way Access guidelines (PROWAG). If benches are provided, they shall comply with Section R212.6 of PROWAG. Detectable warning surfaces are required at the boarding platform for bus stops; however, since a boarding platform is defined as having a height greater than 6 in. (150mm), detectable warnings are not required at bus stops with curb heights of 6 in. (150mm) or less.

58-1.04 Parking

58-1.04(a) Off-Street Parking

The following criteria apply to off-street parking:

1. Minimum Number. Figure 58-1.B provides the criteria for the minimum number of accessible spaces.
2. Location. Accessible parking spaces and accessible passenger loading zones that serve a particular building shall be the spaces or zones closest to the nearest accessible entrance on an accessible route. In separate parking structures or lots that do not serve a particular building, locate the accessible parking spaces on the shortest possible circulation route to an accessible pedestrian entrance of the parking facility. In buildings with multiple access entrances with adjacent parking, accessible parking spaces may be dispersed and located closest to the accessible entrances.
3. Signage. Designate the accessible parking spaces with ground-mounted signs as shown in the *ILMUTCD* as sign number R7-8 with sign number R7-1101 ("Fine" placard) below. The signs shall not be obscured by a vehicle parked in the space.
4. Dimensions. Accessible parking spaces shall be a minimum 16 ft (4.9 m) wide including an 8 ft (2.4 m) access aisle; see Figure 58-1.C. Two accessible parking spaces shall not share a common access aisle. Parking access aisles shall blend to common level with an accessible route and should be diagonally striped pursuant to the Illinois Vehicle Code, 625 ILCS 5/11-1301.8. Parked vehicular overhangs shall not reduce the clear width of an accessible circulation route.
5. Passenger Loading Zones. Passenger loading zones shall provide an access aisle at least 60 in. (1.5 m) wide and 20 ft (6.1 m) long adjacent and parallel to the vehicular pull-up space. If there are curbs between the access aisle and the vehicular pull-up space, provide a curb ramp that complies with Section 58-1.09. Vehicular standing spaces and access aisles shall be essentially level. Surface slopes shall preferably be 1.5% but shall not exceed 2% in both directions.

58-1.04(b) On-Street Parking

Where on-street paid or time-limited parking is provided and designated in areas zoned for business uses, the on-street parking design should meet the following accessibility criteria:

1. Number of Spaces. Figure 58-1.B provides the criteria for the required number of on-street accessible spaces.
2. Location. On-street accessible parking spaces should be located where the street has the least crown and grade and close to key destinations. Spaces should also be located nearest the point of sidewalk access (see access aisles below).
3. Access Aisles. For a parallel parking space and where the width of the adjacent sidewalk or available right-of-way exceeds 14.0 ft (4.3 m), a 60 in. (1.5 m) wide access aisle shall be provided at street level the full length of the parking space and shall connect to a pedestrian access route. This is illustrated in Figure 58-1.D. The access aisle shall not encroach into the vehicular travel lane. An access aisle is not required where the width of the adjacent sidewalk or the available right-of-way is less than or equal to 14.0 ft (4.3 m). When an access aisle is not provided, the parking spaces shall be located at the end of the block.
4. Signing. Designate the accessible parking spaces with ground-mounted signs as shown in the ILMUTCD as sign number R7-8 and include the appropriate “Fine” placard below. Locate these signs so they are visible from a driver’s seat.
5. Curb Ramps. If there are curbs next to an on-street accessible parking space, provide a curb ramp complying with Section 58-1.09. Accessible parking spaces adjacent to intersections may be served by the sidewalk curb ramp at the intersection, provided that the path of travel from the access aisle to the curb ramp is within the pedestrian crossing area.

Total No. of Parking Spaces	Minimum Number of Accessible Spaces
1 to 25	1
26 to 50	2
51 to 75	3
76 to 100	4
101 to 150	5
151 to 200	6
201 to 300	7
301 to 400	8
401 to 500	9
501 to 1000	2% of total
1001 and over	20 plus 1 for each 100 over 1000

Notes:

- a. If one or more passenger loading zones are provided, then at least one passenger loading zone shall comply with Item # 5 in Section 58-1.04(a).*
- b. Parking spaces for side-lift vans are accessible parking spaces and may be used to meet the requirements of this Section.*
- c. The total number of accessible parking spaces may be distributed among closely spaced parking lots, if greater accessibility is achieved.*

MINIMUM NUMBER OF ACCESSIBLE PARKING SPACES

Figure 58-1.B

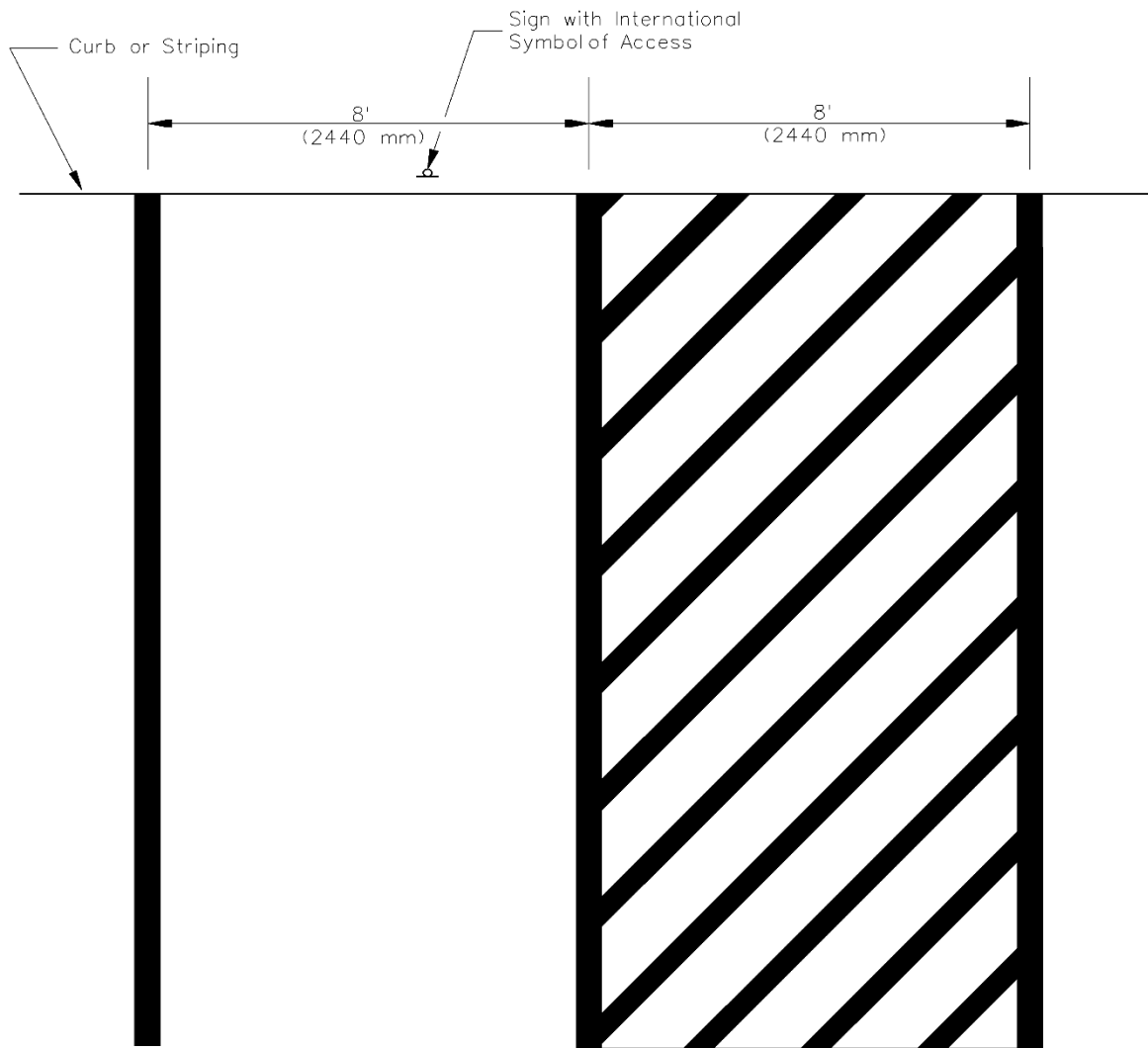

**ACCESSIBLE PARKING SPACE DIMENSIONS
(Off-Street Parking)**

Figure 58-1.C

58-1.05 Accessible Route

58-1.05(a) Definition

An accessible route is a continuous, unobstructed path connecting all accessible elements and spaces. Interior accessible routes may include corridors, floors, ramps, elevators, lifts, and clear floor space at fixtures. Exterior accessible routes may include sidewalks, parking access aisles, curb ramps, crosswalks at vehicular ways, pedestrian overpasses and underpasses, ramps, and lifts.

58-1.05(b) Selecting Accessible Routes

At buildings and facility sites (airport terminals, rest areas, weigh stations, transit stations, etc.), at least one accessible route shall be provided within the boundary of the site from public transportation stops, accessible parking, accessible passenger loading zones, and public streets or sidewalks to the accessible route for the building they serve. The accessible route shall, to the maximum extent feasible, coincide with the route for the general public.

Within the public right-of-way, all routes are held to the accessible standard.

58-1.06 Sidewalks

Section 48-2.04 presents the Department's warrants and design criteria for sidewalks. The following represents the accessibility criteria:

1. Width. The typical sidewalk width is 60 in. (1.5 m). The minimum width is 48 in. (1.2 m).
2. Passing Spaces. If the sidewalk has less than 60 in. (1.5 m) clear width, then passing spaces at least 60 in. by 60 in. (1.5 m by 1.5 m) shall be located at reasonable intervals not to exceed 200 ft (60 m). A T-intersection between two walks is an acceptable passing space such that the T-intersection consists of a 60 in. by 60 in. (1.5 m by 1.5 m) passing space. Paved driveways may also provide acceptable passing space in residential areas such that the area of the driveway used for passing does not have a cross slope perpendicular to the direction of travel greater than 2%.
3. Surface. All sidewalk surfaces shall be stable, firm, and slip resistant. The vertical alignment of the surface should be flush and free of abrupt changes. However, changes in level up to ¼ in. (6 mm) are allowed without treatment. Changes in level between ¼ in. and ½ in. (6 mm and 13 mm) shall be beveled with a slope no greater than 1:2. Changes greater than ½ in. (13 mm) are not allowed.
4. Horizontal Openings. Horizontal openings in gratings and joints shall not exceed ½ in. (13 mm) in the dominant direction of travel. Elongated openings in gratings shall be placed so the long dimension is perpendicular to the dominant direction of travel. Where possible, gratings should be located outside the pedestrian path of travel.

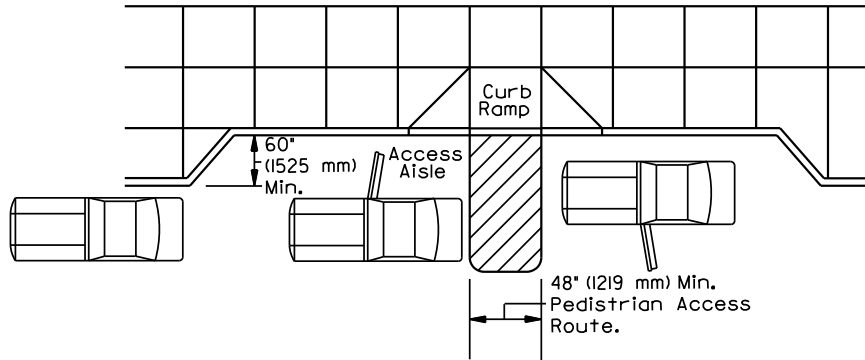

(a) Double Accessible Parking Space with Curb Ramp.

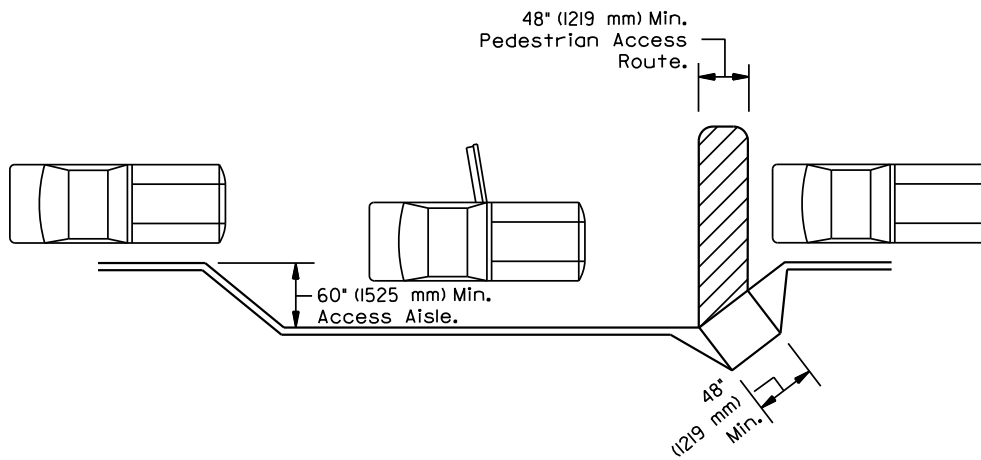

(b) Single Accessible Parking Space with Curb Ramp.

**ACCESSIBLE PARKING
(On-Street Parking)**

FIGURE 58-1.D

5. Running Slope. For sidewalks located within the street or highway right-of-way, the running slope shall not exceed the general grade established for the adjacent street or highway. For sidewalks located outside of such right-of-way, the running slope shall be 5% maximum.
6. Cross Slope. The sidewalk cross slope shall not exceed 2%. However, to allow for some variation during construction and maximize the accessibility of the sidewalk, a cross slope in the range of 1.0% to 1.5% should be used. Where driveways or alleys intersect with sidewalks, give design priority to the sidewalk cross slope rather than to the grade of the driveway or alley. This may require regrading the driveway or realigning the sidewalk. Figure 58-1.E shows one example.
7. Protruding Objects. Objects projecting from walls (e.g., signs, telephones, canopies) with their leading edges between 27 in. (685 mm) and 80 in. (2.0 m) above the finished sidewalk shall not protrude more than 4 in. (100 mm) into any portion of the sidewalk. Freestanding objects mounted on posts or pylons may overhang their mountings up to a maximum of 12 in. (305 mm) when located between 27 in. (685 mm) and 80 in. (2.0 m) above the sidewalk or ground surface. Protruding objects less than 27 in. (685 mm) or greater than 80 in. (2.0 m) may protrude any amount provided that the effective clear width of the sidewalk is maintained. Where the vertical clearance is less than 80 in. (2.0 m), provide a barrier to warn persons with visual impairments.
8. Separation. Sidewalks will be separated from roadways by curbs, planted parkways, or other barriers, which will be continuous except where interrupted by driveways, alleys, or connections to accessible elements.
9. Curb Ramps/Crosswalks. Curb ramps and crosswalks must comply with the criteria in Section 58-1.09.
10. Bridges. Bridges can present special problems for meeting the above sidewalk criteria. Due to geometric restraints of the facility being crossed, special treatments may be required; consult with BDE and the Bureau of Bridges and Structures.

58-1.07 Stairs

Stairs shall not be part of an exterior accessible route because they cannot be safely negotiated by individuals with mobility impairments. Where stairs are located within the public right-of-way in conjunction with an accessible route, they must comply with Section 504 of the *2010 ADA Standards for Accessible Design*, which includes the provision of handrails.

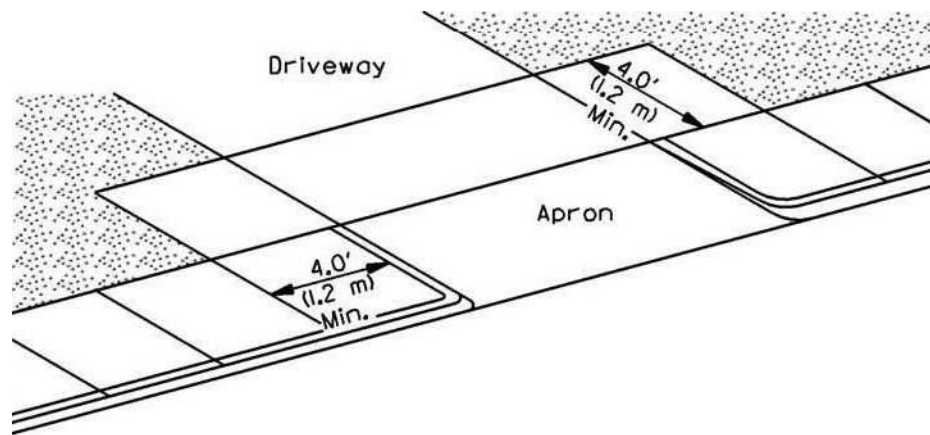

SIDEWALKS AT DRIVEWAY APRONS

Figure 58-1.E

58-1.08 Ramps

Portions of sidewalks whose running slope exceed 5% and are not following the general grade of an adjacent street or highway are typically considered ramps (Note: These ramps are different from curb ramps; see Section 58-1.09 for curb ramps. The following represents the accessible criteria for ramps:

1. **Running Slope and Rise.** Ramps shall have a running slope greater than 5% up to an 8.3% maximum. The maximum rise for any single ramp run shall be 30 in. (760 mm). For elevation differences greater than 30 in. (760 mm), a series of ramps and landings must be used. Ramps to be constructed on existing building/facility sites or inside existing buildings/facilities may have a running slope which exceeds 8.3% within the rise limitations shown in Figure 58-1.F, if space limitations dictate.
2. **Width.** The minimum clear width of a ramp in the public right-of-way shall be 48 in. (1.2 m). The minimum clear width of a ramp for a building/facility site shall be 36 in. (915 mm). Where handrails are provided, the clear width is measured between inside edge of the rails.
3. **Landings.** Ramps shall have level landings (preferably sloped 1.5% and no greater than 2% in both directions) at the bottom and top of each run and shall have the following features:
 - The landing shall be at least as wide as the widest ramp run leading to the landing.
 - The landing length shall be a minimum of 60 in. (1.5 m).

- If ramps change direction at landings, the minimum landing size shall be 60 in. by 60 in. (1.5 m by 1.5 m).
4. **Handrails.** If a ramp run has a rise greater than 6 in. (150 mm) or a length greater than 72 in. (1.8 m), it shall have handrails on both sides. See the applicable accessible guidelines for additional handrail criteria.
 5. **Cross Slope and Surfaces.** The cross slope of ramp surfaces shall not exceed 2%; however to allow for some variation during construction and maximize the accessibility, a cross slope in the range of 1.0% to 1.5% should be used. Ramp surfaces shall comply with the criteria for "Surface" of sidewalks; see Section 58-1.06.
 6. **Edge Protection.** Each side of ramp runs and ramp landings shall have edge protection. Edge protection may be either an extended ramp surface or a curb/barrier. An extended ramp surface shall extend 1 ft (300 mm) beyond the inside face of the handrail. A curb/barrier shall prevent a 4 in. (100 mm) sphere from passing under the handrail.
 7. **Outdoor Conditions.** Outdoor ramps and their approaches shall be designed so that water will not accumulate on walking surfaces.

Running Slope	Maximum Rise
> 8.3% but ≤ 10% (> 1:12 but ≤ 1:10)	6 in. (150 mm)
> 10% but ≤ 12.5% (> 1:10 but ≤ 1:8)	3 in. (75 mm)

Note 1: These dimensions may only be used when space limitations will not fit a standard ramp.

Note 2: Running slopes steeper than 12.5% (1:8) are not allowed.

**ALLOWABLE EXCEPTIONS TO STANDARD RAMP DIMENSIONS
(Existing Sites, Buildings, and Facilities)**

Figure 58-1.F

58-1.09 Curb Ramps and Crosswalks

A curb ramp shall connect sidewalks at each pedestrian street crossing or crosswalk. For the purpose of this section, a pedestrian crosswalk is defined as that portion of a highway or street ordinarily included within the prolongation or connections of lateral lines of sidewalks at intersections. It also includes any portion of a highway or street distinctly indicated as a crossing

for pedestrians by lines or other markings on the surface. It does not include such prolonged or connecting lines from an alley across a street.

58-1.09(a) Responsibility for Construction of Curb Ramps

The determination by the Department whether to construct or modify curbs and/or curb ramps is dependent upon two issues: scope of the project and jurisdiction.

1. Scope. If curbs or crosswalks will be altered as part of the State project and there is sidewalk leading up to the crosswalk, the Department will construct/reconstruct curb ramps within the scope of the project. If the curb ramps cannot be made fully compliant within the scope of the project, they must be made compliant to the maximum extent practicable and such decision documented/approved on the ADA Statement of Maximum Extent Practicable form (BDE 3101). Section 58-1.01(b) and Figure 58-1.A further discuss the types of projects that are considered alterations. See Section 31-7 for guidance on requesting approval for compliance to the maximum extent practicable and the processing of BDE 3101.
2. Jurisdiction. If curbs or crosswalks will not be altered as part of a project and the Department does not have jurisdiction over the curbs, provisions for curb ramps will be the responsibility of local governments. Where curbs and crosswalks will not be altered but the Department does have jurisdiction over the curbs, curbs and inaccessible curb ramps will be reconstructed as part of the project to the maximum extent practicable.

Jurisdiction will be determined by the existence and provisions of maintenance agreements. Where written maintenance agreements do not exist, contact the Bureau of Local Roads and Streets (BLRS) or use the BLRS publication *Jurisdictional Transfer Guidelines* as the initial basis to determine the applicable jurisdictional responsibility of the highway and its elements.

58-1.09(b) Design and Construction of Curb Ramps

Curb ramps shall meet the following criteria:

1. Crosswalks. Curb ramps at marked crossings shall be wholly contained within the markings, except when flared sides are provided. The flared sides of a curb ramp may be outside of the crosswalk. At unmarked crosswalks, place the curb ramp within the area that would reasonably be expected to be used as a crosswalk.
2. Diagonal Curb Ramps. Avoid using a diagonal curb ramp whenever practical due to its effect on the crosswalk width and the indirect path of travel it induces. It is preferable to use two perpendicular curb ramps or a depressed corner rather than a diagonal curb ramp.
3. Raised-Curb Medians. Where a raised-curb median exists within a crosswalk, depress the median to the level of the crosswalk. Provide detectable warning surfaces behind the back of each curb if the median opening is greater than 6 ft measured between the back

of curbs (See the *Highway Standards*). Another option is to provide curb ramps on both sides of the median and a minimum level landing area 60 in. (1.8 m) by 60 in. (1.8 m) between the ramps. A level landing area shall be provided at the upper end of each ramp if the median curb ramps are not in-line.

4. Pedestrian Signals. The location of the curb ramp must be consistent with the operation of pedestrian-actuated traffic signals, if present.
5. Cross Slope. The maximum cross slope of curb ramps shall be 2%. However at pedestrian street crossings without yield or stop control, and at midblock pedestrian street crossings, the cross slope of curb ramps shall be permitted to equal the street or highway grade; see Section 58-1.09(e) for the U.S. Access Board's interpretation of what constitutes yield or stop control. This means there may be some twist in the cross slope of the curb ramp itself or in the portion of sidewalk between the bottom of the curb ramp and the back of curb (i.e. a lower landing) if it exists. Best practices are to: 1) provide a lower landing and limit the twist to the landing or 2) limit the twist to the lower part of the curb ramp; while in either case keeping the rate of change gradual enough to ensure the stability of a person in a wheelchair.
6. Running Slope. The running slope of a curb ramp within the public right-of-way shall be 8.3% maximum. However, in situations where applying this maximum grade would cause the length of the curb ramp to become excessive (e.g. longer than 25-30 ft), the length of the curb ramp can be fixed at 15 ft (4.6 m) and a grade steeper than 8.3% can be used. This exception is commonly known as the "15 ft Rule" and is intended to mitigate the problem of "chasing" a steep sidewalk grade.

The running slope of a curb ramp within a building or facility site shall not exceed 8.3% (1:12). However in existing buildings/sites with space limitations, the running slope may exceed 8.3% (1:12) and comply with Figure 58-1.F.
7. Flared Sides. Where a pedestrian circulation path crosses the curb ramp (that is where pedestrians can approach the curb ramp from the side), flared sides shall be provided. The flared sides shall be sloped a maximum of 10% measured parallel to the curb line. The flared sides are not considered part of the ramp width or the pedestrian access route.
8. Width. The clear width of curb ramps within the public right-of-way shall be 48 in. (1.2 m) minimum (excluding any flared sides). The clear width of a curb ramp within a building or facility site shall be 36 in. (0.915 m) minimum.
9. Grade Breaks. Grade breaks at the top and bottom of curb ramp runs shall be perpendicular to the direction of the ramp run. Grade breaks are not permitted on the surface of ramp runs or their turning spaces. Surface slopes that meet at grade breaks shall be flush.
10. Turning Spaces. The requirements for turning spaces vary depending upon the type of curb ramp as follows:

- a. Perpendicular Curb Ramps. A turning space shall be provided at the top of a perpendicular curb ramp and shall be permitted to overlap other turning spaces and clear spaces. The slope of the turning space shall be 2% maximum in both directions. The size of the turning space shall be 48 in. x 48 in. (1.2 m x 1.2 m) minimum unless the space is constrained at the back of the sidewalk. When constrained the size shall be 48 in. x 60 in. (1.2 m x 1.5 m) minimum with the 60 in. (1.5 m) dimension provided in the direction of the ramp run.
 - b. Parallel Curb Ramps. A turning space shall be provided at the bottom of a parallel curb ramp and shall be permitted to overlap other turning spaces and clear spaces. The slope of the turning space shall be 2% maximum in both directions. The size of the turning space shall be 48 in. x 48 in. (1.2 m x 1.2 m) minimum unless the space is constrained on two or more sides. When constrained the size shall be 48 in. x 60 in. (1.2 m x 1.5 m) minimum with the 60 in. (1.5 m) dimension provided in the direction of the pedestrian street crossing.
 - c. Blended Transitions. If the running slope of either of the curb ramp types listed above is 5% or less, they are then technically classified as a blended transition. Turning spaces are not required for blended transitions.
11. Surface. The surface of a curb ramp shall be stable, firm, and slip resistant.
 12. Detectable Warnings. Detectable warnings shall be according to Section 58-1.09(c)
 13. Clear Spaces. Beyond the bottom grade break of curb ramps and blended transitions, a clear space 48 in. x 48 in. (1.2 m x 1.2 m) minimum shall be provided within the width of the pedestrian street crossing and wholly outside the parallel vehicle travel lane. These spaces are provided by default with parallel curb ramps and perpendicular curb ramps that align with the crosswalk. For skewed/diagonal perpendicular curb ramps, care must be exercised to ensure this space is provided.

58-1.09(c) Detectable Warning Surfaces

Detectable warning surfaces are required at curb ramps, blended transitions, medians and pedestrian refuge islands, at-grade railroad crossings, transit platform edges, and other locations where pedestrians are required to cross a hazardous vehicular way. Where pedestrian access routes cross alleys and commercial entrances, detectable warnings are only required if traffic control devices (e.g., yield signs, stop signs, or signals) are present at the alley/entrance.

Detectable warnings surfaces consist of truncated domes aligned in a square or radial pattern. The size and spacing of the truncated domes is shown in the various accessibility standards. The color of the detectable warning surface shall contrast visually with adjacent walking surfaces either light-on-dark or dark-on-light. Detectable warning surfaces shall extend 2 ft (610 mm) minimum in the direction of pedestrian travel and for the full width of the walking surface (excluding any flared sides). Other requirements for detectable warnings vary with the application as follows.

1. Curb Ramps, Blended Transitions, and Pedestrian Refuge Islands/Medians. Locate the detectable warning surface as shown in the *Highway Standards*. Note the following tolerances for placement of detectable warning surfaces:

Side Border: Detectable warnings should extend the full width of the walking surface (excluding flared sides) but a border along each side up to 2 in. (50 mm) in width is allowed.

Curb Set-Back: Detectable warnings located at the back of curb should closely align with the curb but a gap up to 6 in. (150 mm) behind the curb is allowed.
2. Rail Crossings. Locate the detectable warning surface on each side of the rail crossing and the edge of the detectable warning nearest the rail crossing shall be 6 ft (1.8 m) minimum and 15 ft (4.6 m) maximum from the centerline of the nearest rail. Where pedestrian gates are provided, place the detectable warning surfaces on the side of the gate opposite the rail.
3. Boarding Platforms and Transit Stops. Detectable warning surfaces at boarding platforms and transit stops for buses and rail vehicles where the edges of the boarding platform are not protected by screens or guards shall be placed at the edge of the platform and extend the full length of the public use areas of the platform. Note: Detectable warning surfaces are not required at bus stops with curb heights of 6 in. (150mm) or less; see Section 58-1.03.
4. Stairs at Building and Facility Sites. Stairs, except those enclosed in stair towers or set to the side of the path of travel, shall have detectable warnings placed at the top of the stairs and for their full width (inside of handrails).

58-1.09(d) Accessible Pedestrian Signals/Pushbuttons

Accessible pedestrian signals (APS) are a special category of pushbuttons which communicate information about pedestrian signal timing in a non-visual format, such as audible tones, speech messages, and/or vibrating surfaces. Without these devices, people of low vision or who are hard of hearing find it difficult to utilize the pedestrian signal system/pedestrian crossing. To ensure the transportation services provided by the Department are accessible to all users, all new and altered pedestrian signals shall be of the accessible type. Furthermore, since pedestrian push buttons are considered an “operable part,” they must be located in accessible locations and within allowable reach ranges of a pedestrian access route. Refer to the Central Bureau of Operations’ document entitled, *OPS-T-13: Policy on Accessible Pedestrian Signals and Pushbuttons for Traffic Signals and Pedestrian Hybrid Beacons*, Section 4E.08 of the *Manual on Uniform Traffic Control Devices*, and *Section R403 of the Draft PROWAG* for detailed information.

58-1.09(e) Crosswalks

Pedestrian street crossings or crosswalks are an integral component of a pedestrian access route and may either be marked or unmarked. The U.S. Access Board guidance allows for varying

maximum crosswalk cross-slopes depending upon whether or not there is “yield or stop control” for approaching vehicular traffic. For the purposes of accessibility requirements, the U.S. Access Board has provided the interpretation that the presence of a yield sign or stop sign constitutes “yield or stop control” on that approach since each and every approaching vehicle must stop or slow considerably. Conversely, a signalized approach to an intersection is not considered to have “yield or stop control” since vehicles may proceed through the intersection at running speed when approaching on a green signal indication. This is an important determination in the design of crosswalk cross slopes. Per current ADA criteria, the maximum cross slope of a crosswalk at an intersection with yield or stop control shall be 2%. The maximum cross slope of a crosswalk at an intersection without yield or stop control shall be 5%. Where the pedestrian access route is contained within a midblock pedestrian street crossing, the cross slope of the pedestrian access route shall be permitted to equal the mainline roadway grade. Where crosswalk cross slopes greater than 2% are allowed by policy it is still important to consider ways to achieve cross slopes as close to 2% as practicable.

For information regarding the placement of parking relative to an existing or proposed crosswalk see Section 48-2.05.

58-1.10 Roadway Approach Grades

Section 58-1.09(e) sets maximum values for the cross slope of pedestrian street crossings (i.e., crosswalks) for locations both with and without yield or stop control. The cross slope of the pedestrian street crossing, where present, is also the approach gradient of the roadway through that crossing and must be designed accordingly. When marked or unmarked crosswalks exist or are proposed, roadway approach grade values in compliance with, or more restrictive than, those shown in Section 36-1.06 may be necessary to achieve accessibility standards.

58-1.11 Pedestrian Overpasses and Underpasses

When deciding where to locate a pedestrian crossing, highway and structural designers must coordinate their efforts to properly address the accessibility considerations. The following are applicable:

1. Warrants. Threshold warrants for considering a pedestrian overpass are dependent on pedestrian volumes, vehicular volumes, and distance to the nearest “safe” alternative crossing. These warrants are determined on a case-by-case basis.
2. Accessible Route. All current and future accessible routes must be identified. If existing routes are inaccessible, the designer must evaluate the likelihood that the routes will be made accessible in the future. This evaluation may lead to the decision to relocate the pedestrian overpass or underpass to another site where accessibility can be more easily provided.

3. Design. The proposed design must meet the *accessible* criteria for stairs, ramps, curb ramps, and sidewalks. Refer to Chapter 17 for additional over- and underpass information.

58-1.12 Rest Areas

The accessibility guidelines referenced in Section 58-1.02 address the features present at rest areas. However, certain features need further clarification:

1. Picnic Areas. Where picnic areas/tables are provided in accessible or common use areas, at least 5%, but not less than one, of the picnic areas/tables shall be accessible. An accessible route shall lead to and through such picnic areas or tables. Signs displaying the international symbol of accessibility should be erected at those locations which include accessible facilities.
2. Separator Islands. Many rest areas include islands to separate passenger vehicle parking areas from truck parking areas. In many cases, individuals with disabilities travel in vehicles that may have to park in the truck parking area. In addition, many tour buses use these areas. Accordingly, provide an opening in the island as discussed for “Raised Curb Medians” in Section 58-1.09(c) to provide accessibility for persons with disabilities. Also, consider special markings or signing to indicate the location of this opening.
3. Parking. Provide the minimum number of accessible parking spaces per Figure 58-1.B in both automobile and truck parking areas. See Chapter 16 for additional design criteria.

58-2 OFF-STREET PARKING

A proposed highway project may incorporate some form of off-street parking. Typical applications may include:

- providing off-street parking to replace on-street parking which will be removed as part of a proposed project;
- the construction of a park-and-ride lot for commuters; or
- the construction of a new rest area or improvement to an existing rest area.

58-2.01 Park-and-Ride Lots

58-2.01(a) Location

Park-and-ride lots may be located in either rural or urban areas to accommodate car-pooling or to provide access to transit terminals. By locating these lots outside of the downtown area, congestion is reduced, parking lot property costs are lowered, and accessibility is improved. The general location and size of park-and-ride lots is normally determined during Phase I. Guidance for site selections can be found in the AASHTO *Guide for the Design of Park-and-Ride Facilities*. Some of the factors that will affect the location of the parking facility include:

1. Site Availability. Park-and-ride lots may consist of publicly owned property, excess State right-of-way, or property used with the permission of private owners. When reviewing sites, consider the long-term availability of the lot.
2. Accessibility. The lot should be convenient to residential areas, bus and rail transit routes, and major highways used by commuters.
3. Visibility. The park-and-ride lot should be visible from the access road.
4. Demand. The lot must be large enough to accommodate the anticipated demand for parking spaces. In addition, sufficient transit service must be available to accommodate the anticipated demand.
5. Congestion. The location should precede any points of congestion on the major commuting highway to maximize its benefits.
6. Capacity. There should be sufficient capacity on connections between the lot and the major commuting highway.
7. Design. The site location must be compatible with the design and construction of the lot. Considerations will include property costs, terrain, drainage, subgrade soil conditions, and available space in relation to the required lot size, visibility, and access.
8. Land Use. The location of the lot should be consistent with the present and future adjacent land use. Consider the lot's visual and other impacts on surrounding areas. Where

necessary, site sizing and design should allow for buffer landscaping to minimize the visual impact.

58-2.01(b) Layout

Consider the following when laying out a park-and-ride facility:

1. **Entrances and Exits.** Locate entrances and exits so that they have the least disruption to existing traffic on the street, allow easy access to and from the lot, and provide the maximum storage space within the lot. In addition, consider the following:
 - a. **Location.** Provide separated entrances and exits whenever practical, preferably on two or more streets. The entrance should be on the “upstream” side of the traffic flow nearest the lot and the exit on the “downstream” side. If separation is not reasonable, the combined entry-exit point should be as close to mid-block as practical.
 - b. **Spacing.** Separate entrances and exits should be at least 150 ft (45 m) apart and 150 ft (45 m) from a public road intersection. Desirably, these distances should be 300 ft (100 m). For lots with less than 150 spaces, these dimensions may be reduced to 100 ft (30 m).
 - c. **Traffic Signals.** If a traffic signal is warranted or is expected in the future, the entrance should be more than 1200 ft (400 m) from an adjacent signal. Ensure that the traffic signal can be interconnected and/or coordinated with the other traffic signals to allow vehicular progression along the route.
 - d. **Storage.** Ensure that there is sufficient storage on the mainline for entering the lot. This may require providing separate left- and/or right-turn lanes. Also, check the exiting traffic to ensure that the exiting queue will not adversely affect the traffic circulation in the lot itself.
 - e. **Design.** Design all entrances and exits for capacity, sight distance, turning radii, acceleration and deceleration lanes, turn lanes, etc., according to the criteria in Chapter 36. The typical design vehicle will be a BUS.
2. **Drop-off/Pick-up Zones.** Drop-off and pick-up zones for buses and autos should be clearly separated from each other and from parking areas to avoid as many internal traffic conflicts as possible. Circulation for drop-off and pick-up facilities should be one-way and adjacent to the terminal loading/unloading area. Angle the parking at 45° towards the loading terminal to allow vehicles to pull through.
3. **Traffic Circulation.** Arrange the traffic circulation to provide maximum visibility and minimum conflict between small vehicles (e.g., autos, taxis) and large vehicles (e.g., large vans, buses). Locate major circulation routes at the periphery of the lot to minimize vehicular-pedestrian conflicts. A counter-clockwise circulation of one-way traffic is preferred. This allows vehicles to unload from the right side.

4. Pedestrian and Bicyclist Considerations. Consider pedestrian and bicycle routes when laying out the commuter lot. Avoid entrance and exit points in areas with high-pedestrian volumes, if practical. Provide sidewalks between the parking areas and the modal transfer points. Locate passenger waiting areas in a central location or near the end of the facility. Maximum walking distances to any loading area should not exceed 1000 ft (300 m). Longer walking distances may require more than one loading area.

Crosswalks should be provided where necessary and be clearly marked and signed. Include signing and pavement markings for all pedestrian and bicycle paths to eliminate indiscriminate movements. In high-volume lots, fencing, barriers, or landscaping may be warranted to channel pedestrians and bicyclists to appropriate crossing points. Crossings at major two-way traffic circulation lanes should have a refuge island separating the travel directions.

Include a bicycle parking area relatively close to the loading area. If a large volume of bicycle traffic is expected, provide a designated bicycle lane to and from the bicycle parking area.

5. Accessibility. Section 58-1 discusses accessibility criteria, which also apply to park-and-ride lots.

58-2.02 Replacement Parking Guidelines

In general, on-street parking should be discouraged due to their inherent hazards and capacity problems. Review the following when considering removing on-street parking:

1. Implementation. Ensure that early involvement coordination is conducted with the affected municipality to determine any significant social, economic, and environmental effects from both parking removal and replacement. Discuss existing parking patterns to determine replacement requirements based on actual needs rather than the existing number of available spaces. This information should be included in the Phase I report, combined with estimated costs for parking replacement. Replacement off-street parking may be let as part of the roadway improvement or as a separate municipal contract.
2. Participation. The Department will provide 100% of all engineering, right-of-way (except where replacement parking is constructed on municipally owned property), and construction costs required to construct alternative (off the State system) parking on a maximum ratio of 1 to 1. Alternative parking can consist of improving adjacent local streets to provide some parallel parking, the construction of off-street parking facilities, or combinations thereof. Construction costs will include those items the Department deems reasonable to provide parking facilities including a paved surface, drainage, lighting, pedestrian walkways, and fencing. The construction and installation of guard and toll collection facilities, metering devices, and parking capacity beyond the maximum replacement ratio will be the municipality's responsibility.

3. Maintenance. Provide an agreement with the municipality which allows them to accept jurisdiction of the parking facility including but not limited to its maintenance, operation, repair, reconstruction, provision of electrical energy for lighting systems, and striping. See Chapter 5 for information on local agreements. The municipality will hold the State harmless from any suits arising from construction, operation, and maintenance of these parking facilities.
4. Right-of-Way. The municipality will be responsible for acquiring all necessary rights-of-way and easements in its own name and will provide the Department with certification that it holds good and sufficient title to these properties. This will include the following:
 - a. Hazardous Waste Survey. The Department will, at its own expense, conduct a survey for potential hazardous wastes and notify the municipality of its acceptance or rejection of the site.
 - b. Site Purchase. The municipality will follow the procedures contained in IDOT's *Land Acquisition Manual* and provide the Department with an estimate of right-of-way costs, including its purchase price plus fees associated with negotiators, appraisals, title evidence, and legal services for each potential parcel. The Department will be allowed to either accept or reject the parcel(s).
 - c. Municipally Owned Site. If the municipality owns the site selected for replacement parking, it will provide the property at no expense to the Department. The cost of clearing the municipally owned property will be the Department's responsibility and will be included in the construction contract.
5. Enforcement. The municipality will be responsible for enacting and enforcing ordinances prohibiting parking at all locations where on-street parking is removed.
6. Ownership. The municipality will, unless otherwise approved by the Department in writing, retain in public trust for a period of at least 20 years, all parking facilities constructed at State expense. If the municipality wishes to remove itself from this agreement, the Department will not unreasonably withhold such approval but will require pro rata compensation for its initial expense in constructing the parking facilities as a condition of its approval.

58-2.03 Design Elements

Consider the following elements in the design of off-street parking lots:

1. Parking Lot Dimensions. Parking stall dimensions vary with the angle at which the parking space is arranged relative to the aisle. Figure 58-2.A provides the design dimensions for 9 ft x 18.5 ft (2.7 m x 5.6 m) parking stalls and shows how stalls may be combined into a parking lot. From a traffic operations standpoint, one-way aisles are desirable and should be designed to provide counterclockwise circulation. When determining parking stall widths, consider the following:

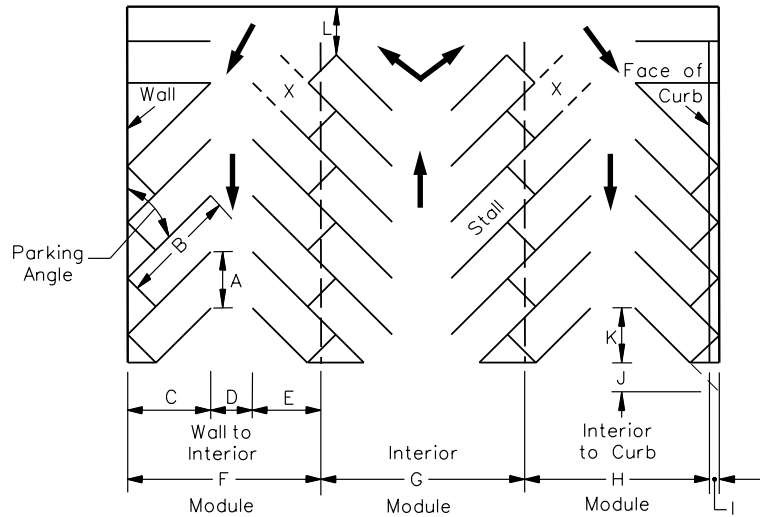

X = Stall not accessible in certain layouts

Parking Layout Dimension for 9 ft x 18.5 ft (2.7 m x 5.6 m) Stalls at Various Lengths

Design Feature	Notation	Parking Angle							
		45° (ft)	45° (m)	60°(ft)	60° (m)	75° (ft)	75° (m)	90° (ft)	90° (m)
Stall width, parallel to aisle	A	12.7	3.9	10.4	3.2	9.3	2.8	9.0	2.7
Stall length of line	B	25.0	7.6	22.0	6.7	20.0	6.1	18.5	5.6
Stall depth to wall	C	17.5	5.3	19.0	5.8	19.5	5.9	18.5	5.6
Minimum aisle width between stall lines	D	12.0	3.7	16.0	4.9	23.0	7.0	26.0	7.9
Stall depth, interior	E	15.3	4.7	17.5	5.3	18.8	5.7	18.5	5.6
Module, wall to interior	F	44.8	13.7	52.5	16.0	61.3	18.7	63.0	19.
Module, interior	G	42.6	13.0	51.0	15.5	61.0	18.6	63.0	2
Module, interior to curb face	H	42.8	13.1	50.2	15.3	58.8	17.9	60.5	19.
Bumper overhang (typical)	I	2.0	0.6	2.3	0.7	2.5	0.8	2.5	2
Offset	J	6.3	1.9	2.7	0.8	0.5	0.2	0.0	18.
Setback	K	11.0	3.4	8.3	2.5	5.0	1.5	0.0	4
Cross aisle, one-way	L	14.0	4.3	14.0	4.3	14.0	4.3	14.0	0.8
Cross aisle, two-way	—	24.0	7.3	24.0	7.3	24.0	7.3	24.0	0.0
									0.0
									4.3
									7.3

- Notes:
1. See Section 58-1 for criteria on the number and dimensions of accessible parking spaces.
 2. If a special section is designated for subcompact vehicles, these stalls can be 8 ft x 15 ft (2.5 m x 4.6 m) for a 90° angle.
 3. Stalls should be wider for commercial parking.
 4. The designer should consider bumper overhang when placing lighting, railing, etc. Therefore, these appurtenances should be placed beyond dimension "I" in the figure.
 5. Two-way traffic in aisles may only be used with a 90° parking angle. Use an aisle width of 26 ft (7.9 m).

**PARKING LOT LAYOUT DIMENSIONS
(9 ft x 18.5 ft (2.7 m x 5.6 m) Stalls)**

Figure 58-2.A

- Typical stall widths (measured perpendicular to the vehicle when parked) range from 8.5 ft to 9.5 ft (2.6 m to 2.9 m).
 - The recommended minimum stall width for self-parking of long-term duration is 9.5 ft (2.6 m).
 - For higher turnover self-parking, a stall width of 9 ft (2.7 m) is recommended.
 - Stall widths at supermarkets and other similar parking facilities, where large packages are prevalent, should desirably be 9.5 ft (2.9 m) or even 10 ft (3.0 m) in width.
2. Bus Loading Areas. Bus loading and unloading areas located adjacent to park-and-ride lots should be designed to provide for continuous counterclockwise circulation and for curb parking without backing maneuvers. The through traffic lanes and the curb loading area should each be 12 ft (3.6 m) wide. Figure 58-2.B provides criteria for the recommended lengths of bus loading areas.
 3. Sidewalk Dimensions. All sidewalks should be at least 5 ft (1.5 m) wide. In loading areas, the width should be 12 ft (3.6 m) or the adjacent sidewalk width plus 7 ft (2.1 m), whichever is greater. The accessibility criteria must be met for all new lots; see Section 58-1.
 4. Cross Slope. To provide proper drainage, the minimum cross slope on a parking lot should be 1%. As a maximum, the cross slope should not exceed 5%. Desirably, design the lot to direct the drainage runoff into existing drainage systems. If water impoundment cannot be avoided along pedestrian routes, bicycle routes, and standing areas, provide drop inlets and underground drainage. In parking areas, design the drainage to avoid standing water. The detailed drainage design for the lot should be prepared using the Department's *Drainage Manual* to determine design frequency, pavement discharge, and capacity of drainage inlets.
 5. Pavements. Minimum pavement design for parking areas in a park-and-ride lot is 3 in. (75 mm) of bituminous concrete on 8 in. (200 mm) of aggregate base. For bus routes, the minimum pavement design should be 5 in. (125 mm) of bituminous concrete on 10 in. (250 mm) of aggregate base. For additional information on pavement designs; see Chapter 54.
 6. Lighting. Desirably, the lot should be lighted for pedestrian safety and lot security. Ensure provisions are considered for lighting supports and power lines. Chapter 56 provides information on the design of lighting.
 7. Shelters. Pedestrian shelters are desirable when loading areas for buses and trains are provided. Their inclusion will be determined on a case-by-case basis. The shelter should provide approximately 5 ft² (0.5 m²) of covered area per person. As a minimum, the shelter should provide lighting, benches, and trash receptacles. Routing information signs and a telephone should also be considered.

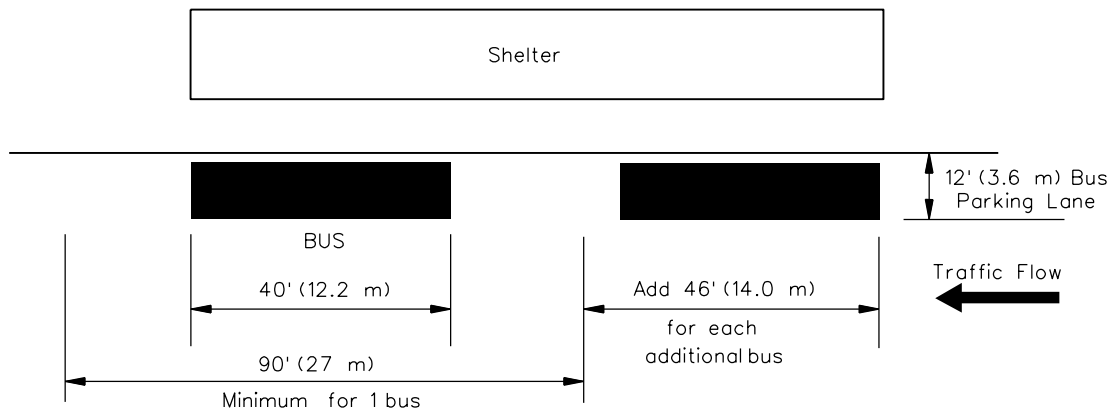

PARALLEL PARKING

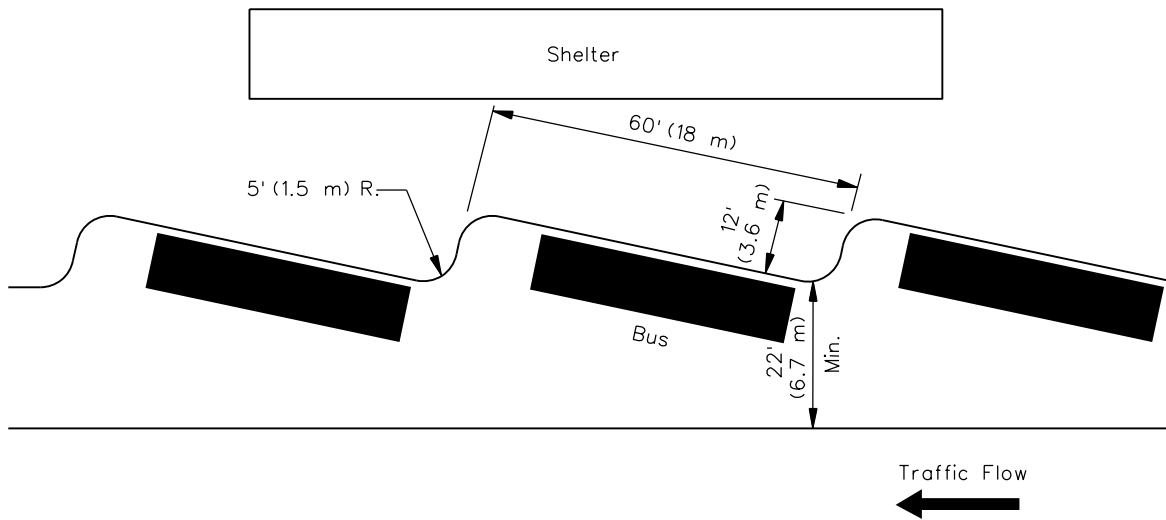

SHALLOW SAWTOOTH PARKING

**RECOMMENDED LENGTHS FOR BUS-LOADING AREAS
(Park-and-Ride Lots)**

Figure 58-2.B

8. Bicycle and Motorcycle Storage. Provide bicycle stalls that allow the use of locking devices. Bicycle stalls are typically 2 ft by 6 ft (600 mm by 1.8 m). Motorcycle stalls are 3 ft by 6 ft (1.0 m by 1.8 m).
9. Traffic Control Devices. Provide signs and pavement markings to direct drivers and pedestrians to appropriate loading zones, bicycle facilities, parking areas, including accessible parking, and entrances and exits. Coordinate the use of traffic control devices with the district Bureau of Operations.
10. Fencing. The need for fencing around a parking lot will be determined on a case-by-case basis.
11. Landscaping. In some locations, consider landscaping to minimize the visual impact of the parking lot. This may include providing a buffer zone around the perimeter of the lot or improving the aesthetics of the lot itself. Desirably, include a 10 ft to 20 ft (3.0 m to 6.0 m) buffer zone around the lot to accommodate vegetation screens. Also, raised-curb islands and parking lot separators provide suitable locations for shrubs and trees. Landscaping should include low maintenance vegetation that does not cause visibility or security problems. See Chapter 59 for guidance on landscaping.
12. Snow Removal. To assist with snow removal and storage, the design should include a 10 ft to 20 ft (3.0 m to 6.0 m) snow shelf around the perimeter of the lot on at least two sides. This area can coincide with the buffer zone around the lot, provided that the entire area is not filled with shrubs or trees. Place any fencing outside the area of the snow shelf. Providing painted islands rather than raised-curb islands can also make it easier to plow snow from the parking lot.

58-3 BUS STOPS AND TURNOUTS

58-3.01 Location

58-3.01(a) Bus Stops

If local bus routes are located on an urban or suburban highway, the designer should consider their impact on normal traffic operations. The stop-and-go pattern of local buses will disrupt traffic flow, but certain measures can minimize the disruption. The location of bus stops is particularly important. These are determined not only by convenience to patrons, but also by the design and operational characteristics of the highway and the roadside environment. If the bus must make a left-turn, for example, do not locate a bus stop in the block preceding the left turn.

There are three basic bus stop designs — far-side or near-side of an intersection, and mid-block. Advantages and disadvantages for each of these bus-stop locations are listed in Figure 58-3.A. In addition, consider the following:

1. Far-Side Stops. For capacity and other reasons, far-side stops are generally preferred to near-side or mid-block bus stops.
2. Near-Side Stops. Near-side stops must be used where the bus will make a right turn at the intersection.
3. Mid-Block Stops. Mid-block bus stops may be considered where right turns at an intersection are high (250 vph in peak hour) and far-side stops are not practical.

58-3.01(b) Bus Turnouts

Interference between buses and other traffic can be reduced significantly by providing bus turnouts. Turnouts remove stopped buses from the through lanes and provide a well-defined user area for bus stops. Consider bus turnouts where the following conditions exist:

- The street provides arterial service with higher speeds (e.g., posted speeds of 35 mph or greater).
- Bus volumes are 10 or more during the peak-hour.
- Passenger volumes exceed 20 to 40 boardings an hour.
- The average bus dwell time generally exceeds 30 seconds per stop.
- During peak-hour traffic, there are at least 250 vehicles per hour in the curb lane.
- Buses are expected to layover at the end of the trip.
- Potential vehicular/bus conflicts warrant the separation of transit and other vehicles.

	Advantages	Disadvantages
Far-Side Stop	<ul style="list-style-type: none"> Minimizes conflicts between right-turning vehicles and buses. Provides additional right-turn capacity by making the curb lane available for traffic. Minimizes sight distance problems on approaches to the intersection. Encourages pedestrians to cross behind the bus. Creates shorter deceleration distances for buses because the bus can use the intersection to decelerate. Results in bus drivers being able to take advantage of the gaps in traffic flow that are created at signalized intersections. 	<ul style="list-style-type: none"> Multiple stopped buses may block the intersection during peak periods. May obscure sight distance for crossing vehicles. May increase sight distance problems for crossing pedestrians. Can cause a bus to stop twice, first for the traffic signal and then for the far-side stop, which interferes with both bus operations and all other traffic. May increase number of rear-end accidents because drivers do not expect buses to stop again after stopping at a red signal. Could result in traffic queued into intersection when a bus is stopped in travel lane.
Near-Side Stop	<ul style="list-style-type: none"> Minimizes interference when traffic is heavy on the far side of the intersection. Allows passengers to access buses closest to crosswalk. The width of the intersection allows easier re-entry into the traffic stream where curb parking is allowed. Eliminates the potential of double stopping. Allows passengers to board and alight while the bus is stopped at a red signal. Provides driver with the opportunity to look for oncoming traffic, including other buses with potential passengers. 	<ul style="list-style-type: none"> Increases conflicts with right-turning vehicles. May result in stopped buses obscuring curbside traffic control devices and crossing pedestrians. May cause sight distance to be obscured for cross vehicles stopped to the right of the bus. May block the through lane during peak period with queuing buses. Increases sight distance problems for crossing pedestrians.
Mid-Block Stop	<ul style="list-style-type: none"> Minimizes sight distance problems for vehicles and pedestrians. May result in passenger waiting areas experiencing less pedestrian congestion. Desirable if a large generator is located mid-block. Less walking for passengers where the distance between intersections is large. May be appropriate where there is a fairly heavy and continuous transit demand throughout the block. 	<ul style="list-style-type: none"> Requires additional distance for no-parking restrictions. Encourages patrons to cross street at mid-block (jaywalking). Increases walking distance for patrons crossing at intersections.

COMPARISON OF BUS STOP LOCATIONS

Figure 58-3.A

- There is a history of traffic and/or pedestrian crashes that can be resolved by a bus turnout.
- Right-of-way width is sufficient to prevent adverse impact on sidewalk pedestrian movements.
- Curb parking is prohibited, at least during peak hours.
- Sight distances prevent traffic from stopping safely behind the bus.
- Appropriate bus signal priority treatment exists at the intersection.
- Other improvements (e.g., widening) are planned for the major roadway.

58-3.01(c) Selection

In general, the municipality or local transit authority will determine the location of the bus stop or bus turnout. However, the designer usually has some control over the best placement of a bus stop or turnout location when considering layout details, intersection design, and traffic flow patterns.

58-3.02 Design

58-3.02(a) Bus Stops

Figure 58-3.B provides the recommended distances for the prohibition of on-street parking near bus stops.

58-3.02(b) Bus Turnouts

Desirably, the total length of a bus turnout will allow for an entrance taper, a deceleration length, a stopping area, an acceleration length, and an exit taper. Figure 58-3.C illustrates the design details for bus turnouts. Providing separate deceleration and acceleration lengths are desirable in open suburban area and on rural arterials and may be provided, wherever feasible. However, common practice is to accept deceleration and acceleration in the through lanes and only build the tapers and stopping area. In addition, consider the following:

1. Far-Side Turnouts. Typically, far-side intersection placement is desirable. Placing turnouts after signal-controlled intersections allows the signal to create gaps in traffic.
2. Near-Side Turnouts. Avoid using near-side turnouts because of conflicts with right-turning vehicles, delays to transit services as buses try to re-enter the traveled way, and obstructions to traffic control devices and pedestrian activities.

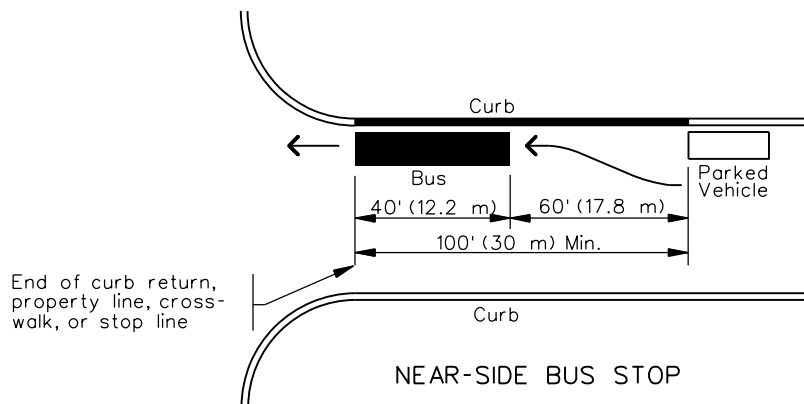
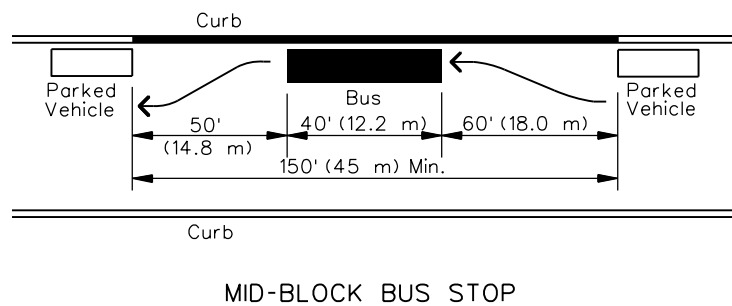
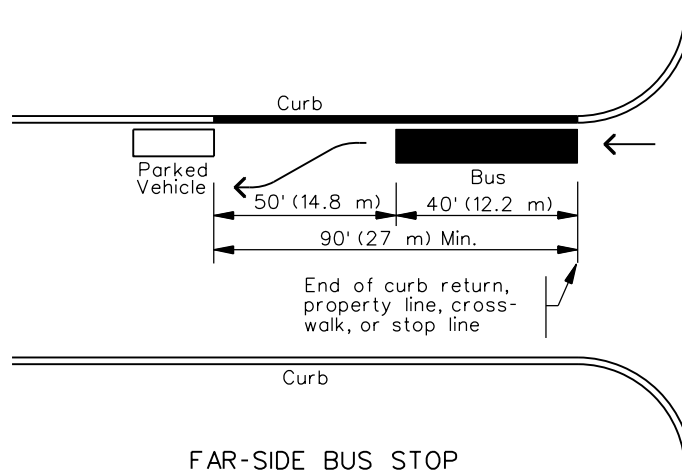

Notes:

1. Where articulated buses are expected to use these stops, add an additional 20 ft (6.0 m) to the bus distances.
2. Provide an additional 50 ft (15 m) of length for each additional bus expected to stop simultaneously at any given bus stop area. This allows for the length of the extra bus (40 ft (12.2 m)) plus 10 ft (2.8 m) between buses.

ON-STREET BUS STOPS

Figure 58-3.B

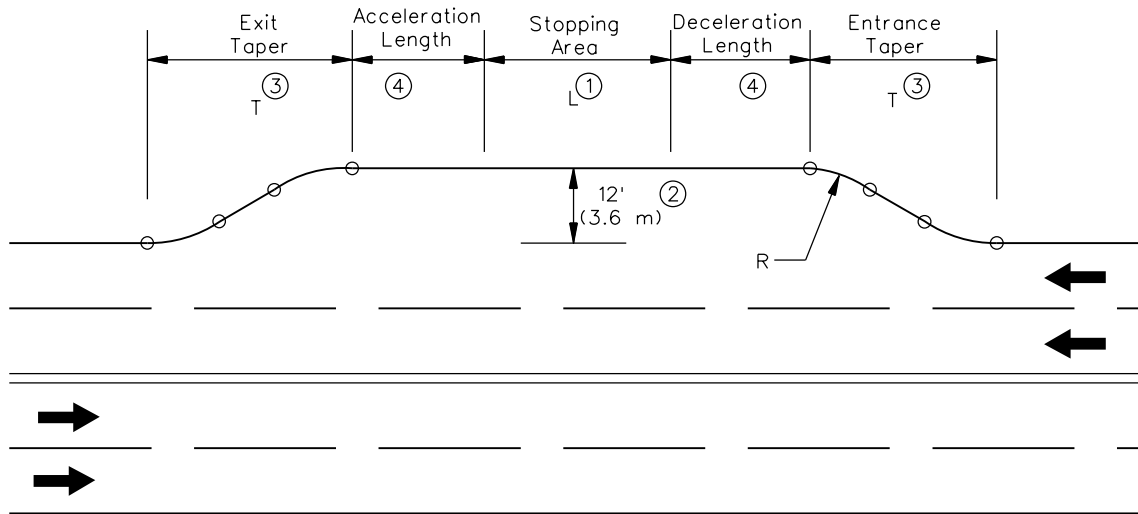

Notes:

- ① Stopping area length consists of 50 ft (15 m) for each standard 40 ft (12.2 m) bus and 70 ft (21 m) for each 60 ft (18.3 m) articulated bus expected to be at the stop simultaneously.
- ② Bus turnout width is desirably 12 ft (3.6 m). For posted speeds under 30 mph, a 10 ft (3.0 m) minimum bay width is acceptable. These dimensions do not include gutter width.
- ③ Suggested taper lengths are listed below. A minimum taper of 5:1 may be used for an entrance taper from an arterial street for a bus turnout while the merging or re-entry taper should not be sharper than 3:1.
- ④ The minimum design for a bus turnout does not include acceleration or deceleration lengths. Recommended acceleration and deceleration lengths are listed below.

Design Speed	Entering Speed*	Acceleration Lengths	Deceleration Lengths **	Suggested Taper Lengths
US CUSTOMARY				
35 mph	25 mph	250 ft	185 ft	170 ft
40 mph	30 mph	400 ft	265 ft	190 ft
45 mph	35 mph	700 ft	360 ft	210 ft
50 mph	40 mph	975 ft	470 ft	230 ft
METRIC				
50 km/hr	35 km/hr	60 m	45 m	45 m
60 km/hr	45 km/hr	105 m	70 m	50 m
70 km/hr	55 km/hr	200 m	105 m	60 m
80 km/hr	65 km/hr	310 m	145 m	70 m

* Desirably, the bus speed at the end of taper should be within 10 mph (15 km/hr) of the design speed of the traveled way.

** Based on a 2.5 mph/sec (4.0 km/hr/s) deceleration rate.

TYPICAL BUS TURNOUT DIMENSIONS

Figure 58-3.C

3. Mid-Block Turnouts. Only use mid-block turnouts in conjunction with major traffic generators.
4. Tapers. Figure 58-3.C provides information on taper lengths that may be used for entrance and exit tapers. To improve traffic operations, use short horizontal curves (100 ft (30 m) radius) on the entry end and 50 ft to 100 ft (15 m to 30 m) curves on the re-entry end. Where a turnout is located at a far-side or near-side location, the cross street area can be assumed to fulfill the need for the exit or entry area, whichever applies.

58-3.02(c) Bus Stop Pads

All new bus stops which are constructed for use with lifts or ramps must meet the accessibility criteria in Section 58-1.

58-3.02(d) Bus Shelters

In general, the municipality or the local transit authority will determine the need for and location of bus shelters. The local transit authority will determine the design of the bus shelter. The designer should ensure that the shelter is accessible, and does not restrict vehicular sight distance, or pedestrian flow.

58-4 FENCING

Fencing is desirable along high-speed highways to protect the driver from unexpected intrusions from outside of the right-of-way line. Fencing deters unauthorized and unsafe entry to the highway by vehicles, pedestrians, or animals. It also reduces the occurrence of objects being dropped or thrown from highway overpasses.

Except where warranted for highway applications, fencing is normally the responsibility of the abutting property owner. Fences may be necessary for retaining livestock, discouraging trespassing, defining property boundaries, or otherwise to keep land use activities within bounds. If private fences are impacted by a highway project, their relocation or disposition is reconciled as part of the right-of-way negotiations and settlement.

58-4.01 General

58-4.01(a) Location

Fencing is typically provided along all segments of fully access controlled facilities; along certain segments of expressways; near schools, playgrounds, and parks; near livestock areas; on some bridges; and between frontage roads and access controlled highways. Fencing is usually erected parallel to the highway centerline. Where right-of-way lines are irregular, the fencing should still be basically parallel to the highway, provided the fencing is within the highway right-of-way. In general, the fence line should coincide with the right-of-way line; however, deviations are acceptable if justified and documented in a Phase I report. Avoid sharp jogs in the fence line to prevent the need for hand mowing. See Section 34-5 and Chapters 35, 44, and 45 for additional guidance on setting right-of-way limits and for the location of access control lines.

58-4.01(b) Fence Types

The following fence types are used by the Department:

1. Woven Wire. This fence type consists of a woven wire mesh and two strands of barbed wire at the top for a total height of 4 ft (1.2 m). It can be placed on either wood or metal posts.
2. Chain Link. Chain link fence consists of an interlocking wire mesh on metal posts. It is typically 4 ft (1.2 m) or 6 ft (1.8 m) high.
3. Existing. Where a portion of an existing fence, which differs from the standard type or height, is to be replaced, the new fence should match the portion of the fence that will remain in place.

All materials and installations must conform to the requirements in the *Illinois Standard Specifications* and the *Highway Standards*.

58-4.02 Freeways (Fully Access Controlled)

The following will apply to fencing along freeways:

1. Warrants. Chain link or woven wire fencing is required along all fully access controlled facilities. Provide continuous fencing along either the right-of-way or access control lines. Also, provide fencing for the entire limits of access control along the crossroad and along the first access connection. However, engineering judgment may dictate exceptions. In addition, where retaining walls, concrete barriers, sound barriers, sight screens, etc., are used, fencing usually is not required to preserve access control. With the appropriate fence inserts, the access-control fencing also may be used as a glare screen between frontage roads and the mainline highway.
2. Location. Fences generally will be located to coincide with the right-of-way line, except for the following:
 - a. Frontage Roads and Service Drives. Where frontage roads or service drives exist or will be constructed, place the fencing between the adjacent roadway and the freeway or ramps. Fencing is normally located outside the clear zone of a freeway; see Figures 44-2.J and 44-2.K. Where access control fencing is located between a frontage road or service drive and the freeway, it is not necessary to provide fencing outside the right-of-way line of the frontage road.
 - b. Structures. Wherever streams, railroads, or grade separations are encountered that prevent the fence from being continued on a straight line, tie the fence to the structure, abutment, or wingwall to ensure that full access control is maintained. See the figures in Section 44-3 for locations of access control lines adjacent to these features. See the *Highway Standards* for the correct application of fencing across stream crossings with culverts.
 - c. Outside Ditches. In relatively flat areas (e.g., across floodplains), it may be desirable to place the access control fence on the front slope of the highway embankment rather than at the right-of-way line. Placing the fence on the front slope eliminates the potential problem of obstructing sheet flow if the fence is placed along the right-of-way line. The obstruction of sheet flow is usually caused by vegetation build-up along the fence and due to field plowing adjacent to the fence.
3. Type of Area. The following will apply:
 - a. Built-Up Areas. Chain link fencing is generally used in urban, suburban, and other similar built-up areas. Use 6 ft (1.8 m) high chain link fence in areas having a high concentration of children (e.g., schools, churches, playgrounds, housing developments). Use 4 ft (1.2 m) high chain link fence in areas adjacent to single-family homes, parks, reservoirs, commercial and industrial properties, etc. The designer must consider the type of impending development adjacent to the highway to determine the appropriate height. This may require a higher fence to be installed initially to preclude replacement a short time later.

- b. Rural Areas. In rural areas where little development is existing or planned, woven wire fencing is typically used.
 - c. Deer Crossings. Where known deer crossings exist, use a woven wire fence with a minimum height of 10 ft (3.0 m). Also, the limits of this fence must be long enough to deter deer from going around the fence. Connect the fence directly to the wingwalls of structures to minimize deer intrusions onto the highway.
4. Construction. Construct access control fencing on the State right-of-way line with the face of the fencing toward the abutting property. Delineate this location on the contract plans. The fence will be maintained by the State.
 5. Gates. Where they are considered necessary for maintenance and operational purposes, gates may be required in the access-control fencing. Limit the number of these gates to an absolute minimum. Only provide gates to allow access for:
 - maintenance to otherwise inaccessible portions of the highway right-of-way, and
 - public utility installations where no other access is available or can be reasonably provided.

All gates must have adequate locking devices to ensure that they are only used by authorized personnel. The district is responsible for maintaining a record of all personnel that possess keys to the locked gates.

58-4.03 Expressways (Partial Access Control)

The following will apply to fencing along expressways:

1. Warrants. Fencing is highly desirable along expressways similar to freeways. At a minimum, existing fencing should be replaced in rural areas and should be considered in built-up residential areas in rural locations. Where it is decided that fencing may be omitted in rural areas, provide informational signs at approximately ¼ mile (400 m) intervals on the right-of-way lines to notify the public that the highway is access controlled. The signs should indicate that the Illinois Department of Transportation may be contacted for any requests for new access points. Also, to minimize future access problems along crossroads, provide fencing along the entire access control limits of each crossroad.
2. Location. The criteria in Section 58-4.02 for freeways also apply to expressways.
3. Type of Area. The criteria in Section 58-4.02 for freeways also apply to expressways with the exceptions noted above in Item 1.
4. Construction. The criteria in Section 58-4.02 for freeways also apply to expressways.

58-4.04 Protective Fencing on Highway Overpasses

58-4.04(a) General

Protective fencing is generally provided wherever there is a potential hazard to highway users resulting from objects being dropped or thrown from overhead crossings, where there is a need to protect pedestrians who cross on the overpass, or where a bikeway is carried across the structure. This fencing is categorized as vertical pedestrian railing, curved bridge fence railing for pedestrians, and bicycle railings. The protective fencing should satisfy the aesthetic consideration of the structure and should be designed in conformance with the latest Department standards. See 92 Ill. Admin. Code 510 for additional guidance. See the *Bridge Manual* for detailed drawings on the different types of protective fencing located on structures and to the typical sections shown in Figures 39-5.L and 39-5.M.

58-4.04(b) Evaluation of Need

The districts will be responsible for determining the need of vertical pedestrian railings or curved bridge fence railings. The vertical railing is desirable in urban areas where there is considerable pedestrian traffic on the bridge. The curved bridge fence railing may also be used in urban areas with considerable pedestrian traffic and where there are reported incidents of objects being thrown or dropped from an overpass or there is the high potential of such events occurring. If fencing is required, the cost apportionment and maintenance requirement will be as discussed in Section 5- 5.02(j).

58-4.04(c) Pedestrian Bridges

Provide protective fencing on all new pedestrian bridges. The cost apportionment will be the same as for the pedestrian crossing itself. The need for protective fencing on existing pedestrian bridges will be determined on case-by-case basis using the guidance discussed in Section 58- 4.04(b).

58-4.05 Fencing or Safety Devices on Top of Retaining Walls

The purpose of a fence or safety device is to alert pedestrians, bicyclists, and/or motorists of a difference in elevation to prevent injury from a fall or vehicular crash. Consider installing a fence or safety device at the top of any wall that is over 1 ft (300 mm) tall if the top of the wall is closer than 2 ft (600 mm) to a sidewalk, trail, parking lot, public common area, or stairway landing. Walls located further away from human or vehicular activity may be higher before a fence is considered necessary. Regardless of the height of the wall, provide a fence or safety device if any activity (e.g., driving, walking, riding a bike, running, or other playground type activities) could result in harm or damage by someone inadvertently going over the wall. A fence or safety device is required when the difference in grade level on either side of the wall is in excess of 4 ft (1.2 m) tall. Consider aesthetics of any fence, especially in urban areas, where the wall and barrier are located adjacent to private property.

58-5 MAILBOX TURNOUTS

Mailboxes and newspaper tubes served by carriers in vehicles may constitute a safety hazard, depending upon the placement of the mailbox and the width of the turnout. Therefore, the designer should make every reasonable effort to replace all non-conforming mailboxes and turnouts with designs that meet the criteria in the IDOT Maintenance Policy 3-100 "Placement of Newspaper Boxes," IDOT Maintenance Policy 3-200 "Construction and Maintenance of Mailbox Turnouts," and Chapter 11 of the AASHTO *Roadside Design Guide*. Mailbox turnouts must be addressed on reconstruction and 3R projects. Where shoulder widths permit on 3P and SMART projects, the designer should address mailbox turnouts. Coordination with the local postmaster and property owner is required for all changes of mailbox locations.

58-5.01 Location

Mailbox turnouts should be placed for maximum convenience to the patron, consistent with safety considerations for highway traffic, the carrier, and the patron. When determining the location of mailboxes, consider the following:

1. Intersections. Placing a mail stop near an intersection will have an effect on the operation of the intersection (e.g., reduction of intersection sight distance, blocked lanes). The nature and magnitude of this impact depends on traffic speeds, volumes on each of the intersecting roadways, the number of mailboxes at the stop, type of traffic control, how the stop is located relative to the traffic control, and the distance the stop is located from the intersection. Figure 58-5.A provides the recommended minimum clearance distances to mailbox stops near intersections. On State highways, many of the above potential problems are alleviated by the use of mailbox turnouts. Where feasible, locate all new turnout installations on the far-right side of an intersection with a public road. However, in some cases the designer may determine that it is preferable to locate the turnout on the near-side of an intersection.
2. Near-Side/Far-Side at Driveways. On rural two-lane highways where a single mailbox installation is required, the near side turnout is preferable because this design allows the postal patron to pull up to the mailbox and then to turn into the driveway without backing up. If there is a need for multiple mailbox installations at one location, the far-side turnout is preferable because all postal patrons except for one can pull into the turnout and then drive out and proceed to their homes; see Figure 58-5.B.
3. Newspaper Boxes. Newspaper boxes are only permitted at mailbox turnouts. Where practical, the newspaper box should be erected on the same post as the mailbox.

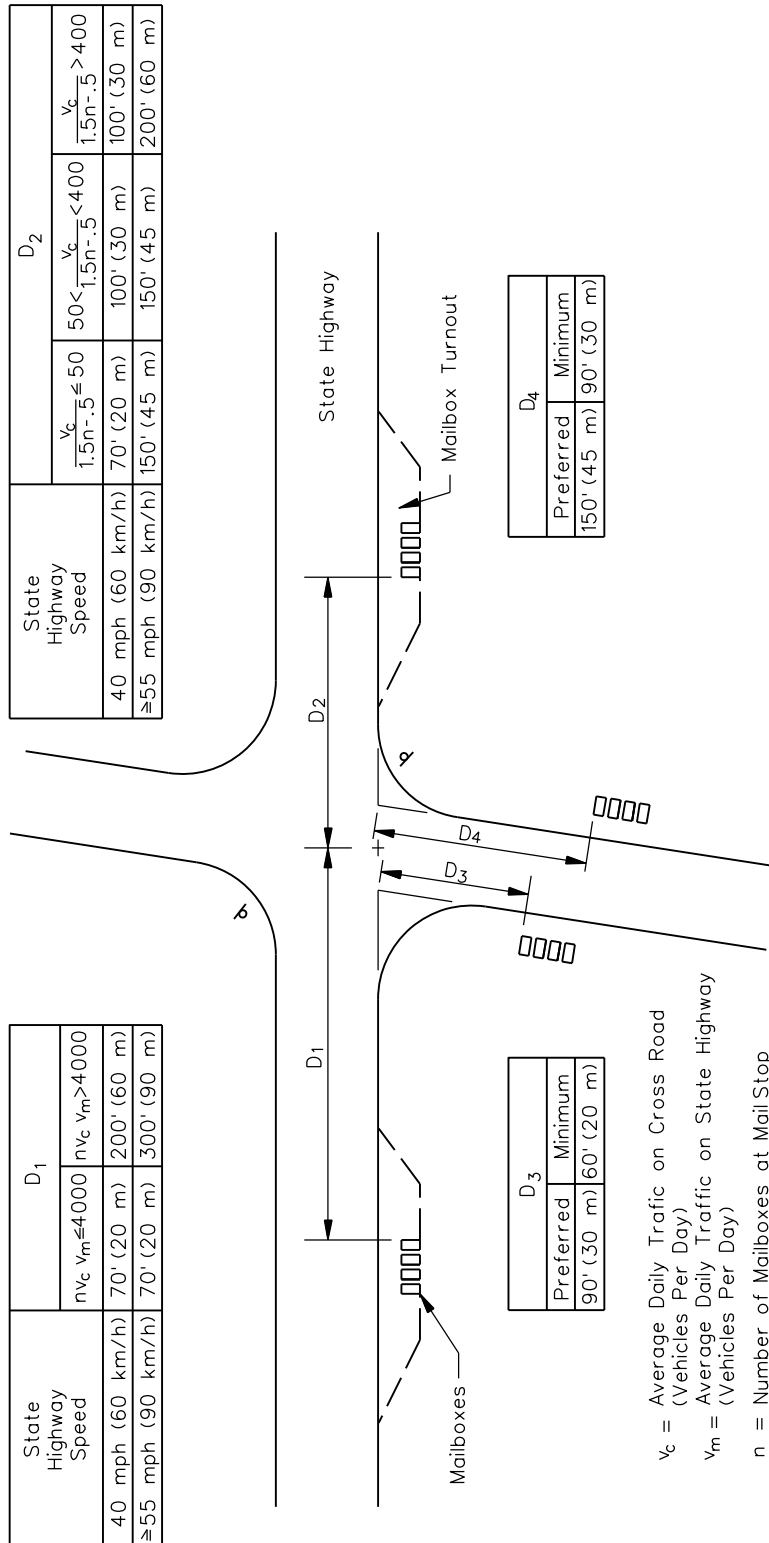

RECOMMENDED MINIMUM CLEARANCE DISTANCES TO MAILBOX STOPS NEAR INTERSECTIONS

Figure 58-5.A

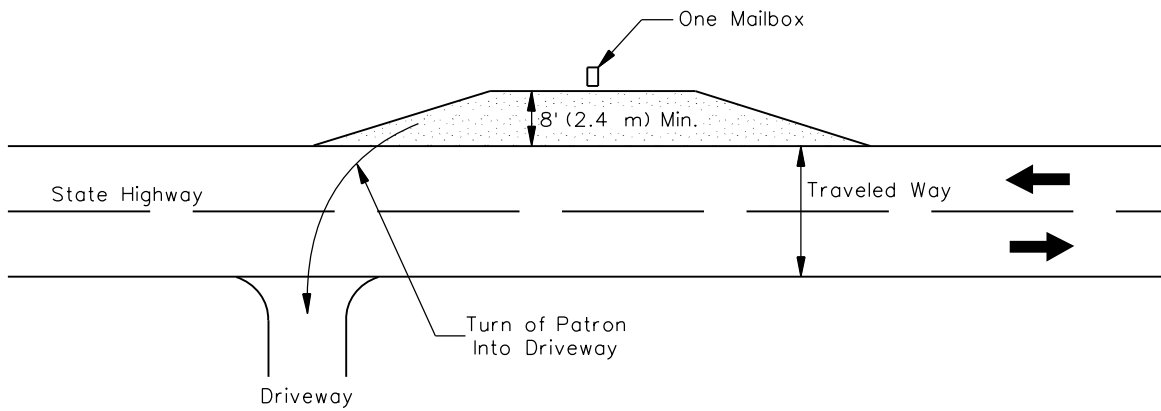

TURNOUT ON OPPOSITE SIDE OF HIGHWAY

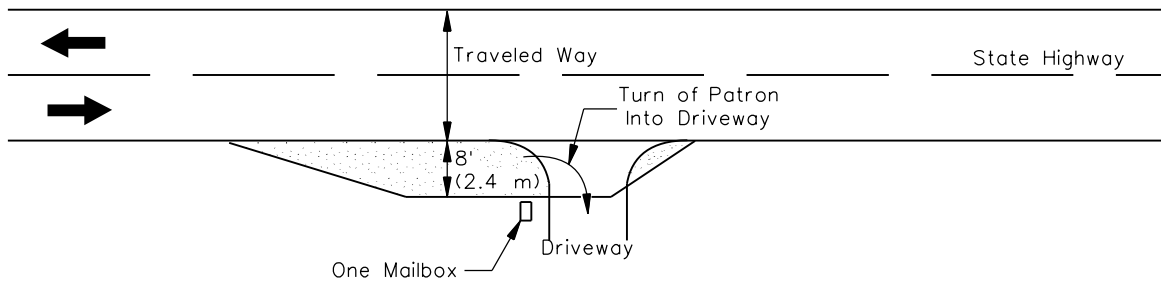

TURNOUT ON NEARSIDE OF DRIVEWAY WITH SINGLE MAILBOX

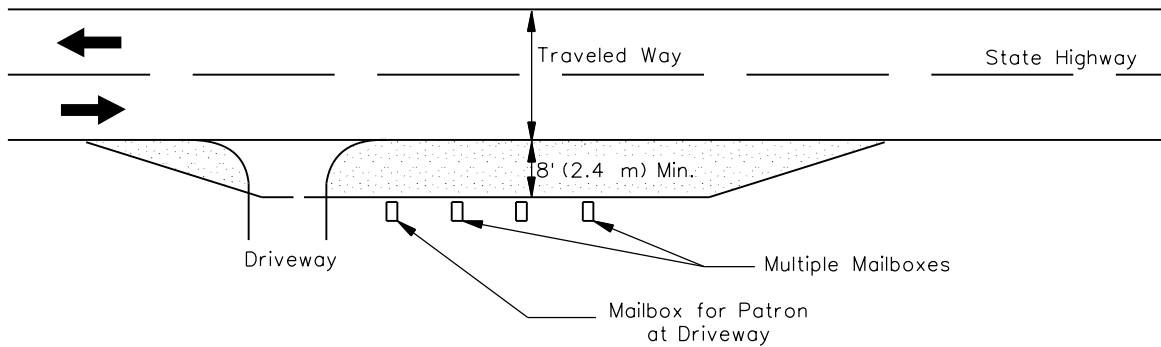

TURNOUT ON FAR SIDE OF DRIVEWAY WITH MULTIPLE MAILBOXES

MAILBOX TURNOUTS AND DRIVEWAYS

Figure 58-5.B

4. Postal Patrons. When determining the location of mailboxes, try to minimize the walking distance to the mailbox site for the patron. It is undesirable to require pedestrians to travel along the shoulder. However, this may be the preferred solution for distances up to 200 ft (60 m) when compared to other alternatives (e.g., constructing a turnout in a deep cut, placing a mailbox turnout just beyond a sharp crest vertical curve (poor sight distance), constructing two or more closely spaced turnouts).
5. Right or Left Side. Only place boxes on the right-hand side of the highway in the direction of travel of the carrier, except on one-way streets where they may be placed on the left-hand side; see Figure 58-5.B.
6. Guardrail. Where a mailbox is installed in the vicinity of an existing guardrail and where practical, place the mailbox support behind the guardrail.
7. High-Speed/High-Volume Facilities. On expressways or other high-speed multilane highways in rural areas, mail delivery usually is accomplished by the mail carrier using the 10 ft (3.0 m) wide paved shoulders for deceleration and as a mailbox turnout area. Where the local postmaster only will agree to deliver mail in one direction and a postal patron is located on the opposite side of the median, it may be necessary to provide a walkway through the median. This is highly undesirable and only should be used as a last resort. Instead, encourage the postal patron to pick up his/her mail at the post office.

As an option to shoulder mail delivery along the route, it may be possible to set up post office box delivery only. However, this change in mail delivery must be agreed to by the postal patrons and the local postmaster.

In some situations, a number of closely spaced houses may have access to a frontage road or service drive rather than direct access to the expressway. In this case, locate the mailboxes on the frontage road or service drive.

8. Suburban/Urban Areas. A potential problem frequently occurs on State highways where a roadway section with shoulder originally existed and where the roadway is reconstructed to a curb and gutter cross section. Previously, the mail carrier would have delivered mail from a vehicle by driving along the shoulder. With the reconstruction to a curb and gutter section, the mail would now have to be delivered by driving on the pavement adjacent to the curb and gutter. Under certain conditions, some mail carriers feel that mail delivery along a curb and gutter roadway has the potential to be hazardous. The factors which could contribute to a potential problem along the street are high-operating speeds, the number of through and turning lanes, and the amount of congestion due to traffic volumes. To alleviate the potential for mail delivery problems where a curb and gutter cross section is proposed, the district should work closely with local postmaster during the development of the project. In many cases, after coordination with a postmaster is completed, Department personnel will determine that the potential for mail delivery problems is minor and no special design features are needed. However, where the potential for mail delivery problems is determined to be significant, it may be possible to modify rural type delivery on streets with curb and gutter by considering the following:

- a. Grouping. Where there are a number of closely spaced houses located along a State highway, it may be desirable to group two, four, or six mailboxes at one location. Due to the possibility of spearing of windshields by the horizontal support, it is desirable to individually mount each mailbox on a separate support. However, it may be acceptable to mount multiple mailboxes on one support if it meets the criteria in Chapter 11 of the AASHTO *Roadside Design*. Figures 58-5.C and 58-5.D illustrate possible placement for groups of mailboxes along urban routes.
 - b. Neighborhood Delivery and Collection Box Unit (NDCBU). Relocate all mailboxes along the block around the corner on a side street by using a NDCBU. However, it should be noted that postal patrons usually do not like this solution in older established neighborhoods.
 - c. Park and Loop Routes. Request the mail carrier to park his/her vehicle on a side street, walk the block, and return to the vehicle.
 - d. Paved Shoulder. Provide a continuous 6 ft (1.8 m) paved shoulder with curb and gutter located behind the shoulder. This alternative is expensive and right-of-way may not be available in many cases. However, this design allows for mail carriers, garbage trucks, and delivery trucks.
9. Problems. Where a satisfactory mail delivery solution cannot be reached between all parties involved, contact the Delivery Programs Support Analysts at one of the U.S. Postal Services' district offices at the following locations:
- For northern Illinois, contact the postal official at (630) 260-5260.
 - For central Illinois, contact the postal official at (708) 563-7360.
 - For southern Illinois, contact the Midwest Area Office in St. Louis at (314) 692-5426.

58-5.02 Design Features

58-5.02(a) Typical Designs

The *Highway Standards* provide the geometric design criteria for rural mailbox turnouts. The designer should also consider the following:

1. Stopping Sight Distance. Ensure that there is sufficient stopping sight distance in advance of the mailbox turnout.

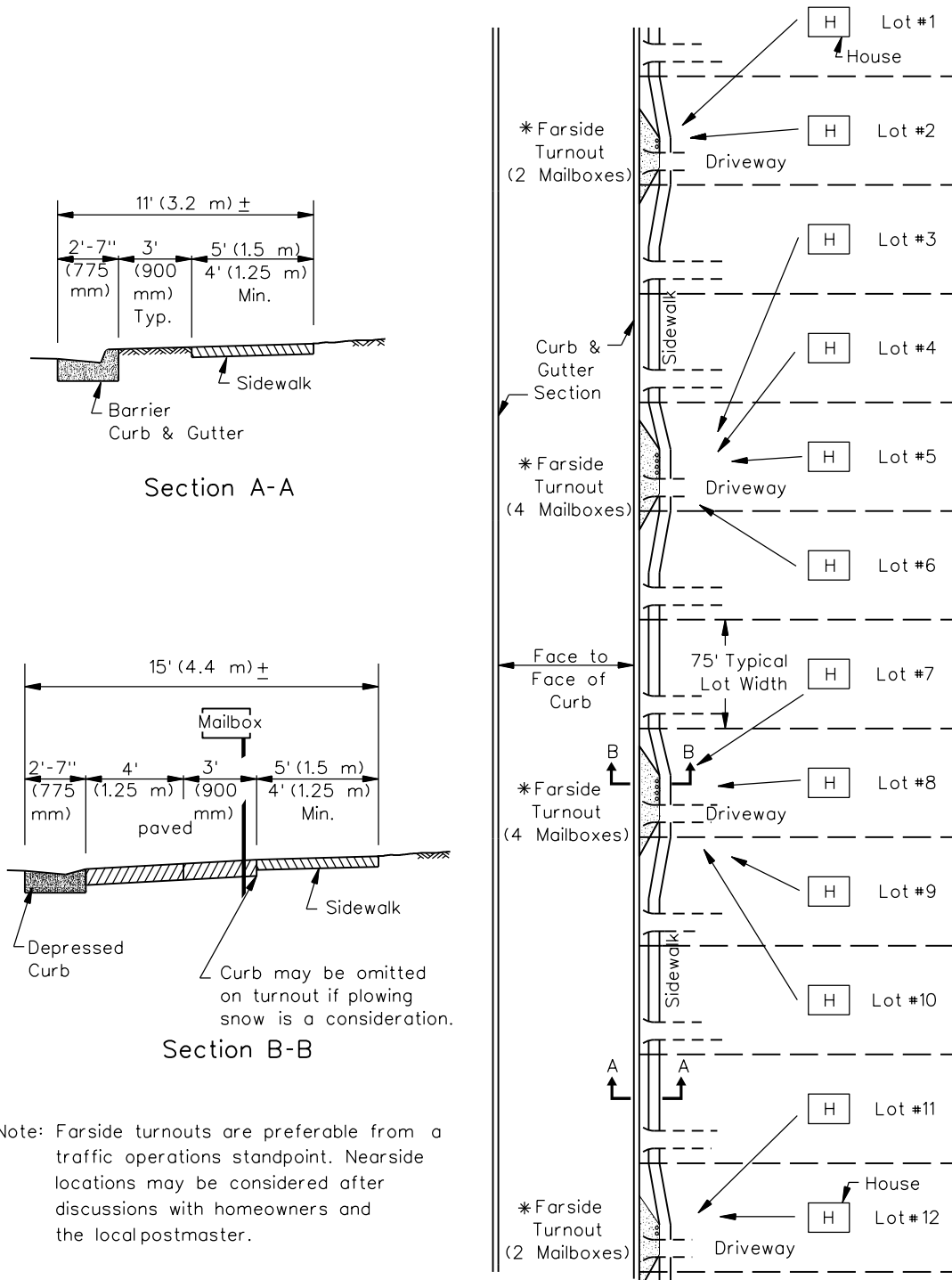

**URBAN MAILBOX TURNOUTS
(Two or Four Mailboxes Grouped Together)**

Figure 58-5.C

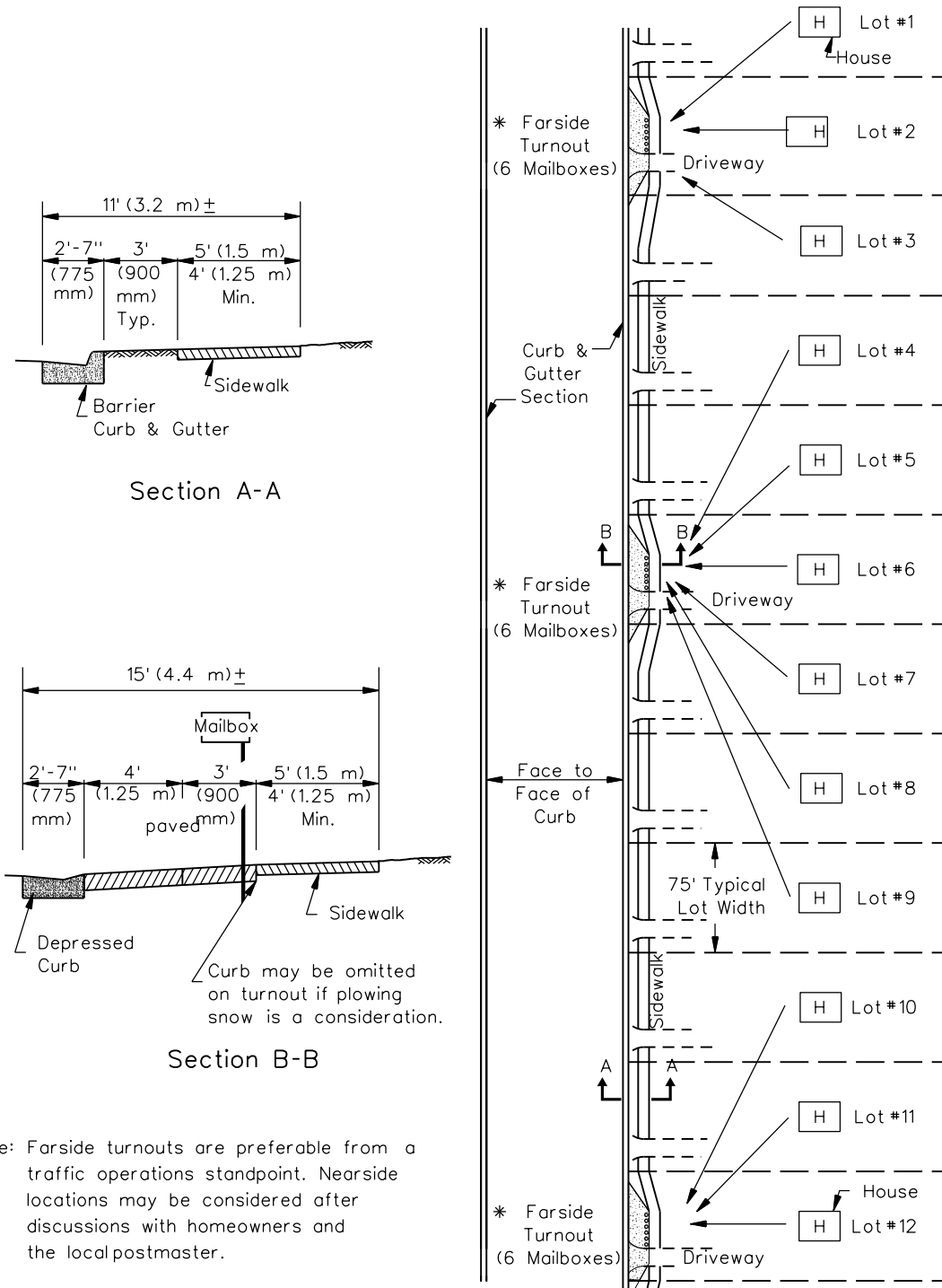

**URBAN MAILBOX TURNOUTS
(Six Mailboxes Grouped Together)**

Figure 58-5.D

2. Width. To ensure stopped vehicles are outside of the traveled way, mailbox turnouts should be at least 8 ft (2.4 m) wide.
3. Narrow Shoulders. Widening and/or resurfacing of highways with limited right-of-way may result in shoulder widths which are too narrow for mailbox turnouts (i.e., less than 8 ft (2.4 m)). In these cases, it will be necessary to widen out the shoulder at the mailbox location to provide the minimum width and, in some cases, installing a sufficient length of pipe culvert to provide for roadside drainage.
4. Surface. Provide an all-weather surface at the turnout. The minimum design should be 6 in. (150 mm) of aggregate or a combination of aggregate and a bituminous surface.
5. Heights. Mailbox heights are usually located so that the bottom of the box is 3 ft (1.0 m) to 4 ft (1.2 m) above the mail stop surface.
6. Mailbox Supports and Attachment Design. For guidance on mailbox posts, supports, and attachments, see the *AASHTO Roadside Design Guide*.
7. Multiple Mailboxes. To reduce the possibility of ramping, multiple mailboxes supports should be separated by a distance at least equal to three-fourths of their height above ground. Due to the number of vehicles using the turnout, desirably the surface should be bituminous. See 58-5.01 for restrictions on multiple mailboxes in a turnout.
8. Neighborhood Delivery and Collection Box Units (NDCBU). NDCBU is a cluster of 8 to 16 locked boxes mounted on a pedestal or within a framework. These clusters can weigh between 100 lbs to 200 lbs (45 kg to 90 kg) and may be a roadside hazard. Consequently, they should be located outside the clear zone in rural areas and preferably on a side street in urban areas. Normally, NDCBU are located in trailer parks, apartment complexes, and new residential subdivisions.

58-5.02(b) Special Designs

Due to the multitude of different conditions, the standard mailbox turnout designs may not always be practical. This is especially true in urban and suburban areas. Therefore, where special agreements have been reached with a local postmaster and where special designs will be needed, provide these details in the Phase I report. These commitments are then carried forward into the contract plans, plan notes, and special provisions.

If during the preparation of the plans it is determined that temporary locations will be required for mail delivery during construction, provide the necessary details in the plans and special provisions. Also, if it is determined that an existing mailbox support which has temporarily been moved is potentially hazardous to traffic, it should be replaced with a suitable support.

58-5.03 Mailbox Supports

During the preparation of the Phase I report, the district is required to address the problem of hazardous mailbox supports. Removal and replacement of mailboxes can be a sensitive issue and should be reviewed with the local postal authorities and the postal patron. The process to determine and achieve compliance on this issue consists of the following:

1. Survey. Conduct an on-site survey to determine whether there are any hazardous mailbox supports within the clear zone of the project. Document these locations in the Phase I report. If there are no hazardous supports on the project, note this in the Phase I report.
2. Notification by Department. If a mailbox box support is determined to be hazardous, the person conducting the field check is required to notify the postal patron. This can be accomplished either through the normal mail service or by placing a postage stamped envelope with a completed form letter enclosed into the patron's mailbox. A sample form letter is shown in Figure 58-5.E and discusses the following issues:
 - potential adverse safety effects,
 - appropriate safety design,
 - potential personal liability, and
 - IDOT's request to change the support to an acceptable design.

Note that the Department contacts postal patrons to remove or replace the support only when a highway is proposed for improvements.

3. Documentation. If an answer is received from the postal patrol, document the following in the project files for Phase II design:
 - the owner's decision to change to a safe mailbox support; or
 - if the owner is undecided, urge the owner to strongly consider a safe support and document all phone conversations or meetings and the results.
4. Notification by Postmaster. If no response is received from a postal patron who has a hazardous mailbox support or if the owner indicates that he/she does not wish to change the support, the district may contact the local postmaster and ask for the postmaster's help in getting the mailbox support removed. If the local postmaster is agreeable, he/she has the authority to notify the patron in writing of the safety hazard of an existing support. Postal regulations require that box supports must bend or break away when struck by a vehicle and that such supports are now readily available for purchase. The local postmaster can give the owner 30 day notice, and if compliance is not achieved, the postmaster has the authority to suspend mail delivery to the box.
5. Phase II Field Reviews. If a hazardous mailbox support is constructed or discovered after design approval, use the above procedures and add the appropriate documentation to the files and reports.

6. Documentation for Construction Personnel. Provide the resident engineer with the correct information on each property owner who has a hazardous mailbox support and what the owner has decided concerning the mailbox support. Also, see Section 58-5.02.

Date _____

 _____ Route _____
 Marked Illinois Route _____
 Section _____

_____ County

Description of Mailbox Support _____

 TO: _____

Dear _____:

It is the intent of the Illinois Department of Transportation to make improvements on the above-described route in the near future. A part of these improvements includes protecting the driving public from roadside hazards. A recent survey of mailbox supports within this project indicates that your mailbox support as described above is a potential hazard to the traveling public and should be changed to meet certain safety requirements.

Each year during Mailbox Improvement Week, the United States Postal Service provides you a pamphlet describing ways to aid the Postal Service in the delivery of your mail. The following is a paragraph, taken from a recent pamphlet, describing the kinds of supports that should be avoided because they can cause serious vehicular damage and personal injury.

“Reports have been received that some mailbox supports are so massive that they are damaging the vehicles and causing serious injuries to people who accidentally strike them. The use of heavy metal posts, concrete posts, and miscellaneous items of farm equipment, such as milk cans filled with concrete, should be avoided. The ideal support is an assembly which, if struck, will bend or fall away from the striking vehicle instead of severely damaging the vehicle and injuring its occupants.”

SAMPLE HAZARDOUS MAILBOX SUPPORT LETTER

Figure 58-5.E

Because your mailbox support is private property, we do not intend to remove or change it to a safer type. However, in the interest of public safety, and to avoid any potential liability if struck by a vehicle, we are requesting that you consider changing the support to a safer type.

Because there are a number of different, safe designs from which to choose, we will be glad to help you select one that you would prefer. At the bottom of this letter, there is a name and telephone number which you can call (collect if you wish) to receive more information about the installation of a safety mailbox support.

If you prefer, you may also ask that someone visit your residence at an agreeable time, during Department working hours, to further explain the safety problems and assist you in selecting an appropriate, safe support. You may arrange this by means of the previously mentioned telephone number or by placing your name and telephone number in the space provided at the bottom on this letter and returning it in the pre-addressed, stamped envelope enclosed for your convenience.

Thank you for your cooperation. We are looking forward to hearing from you so that, together, we can improve highway safety.

Very truly yours,

Regional Engineer

P.S. For more information, please call:

_____ at _____
Name Telephone #

OR

I request that a Department representative call:

_____ at _____
Name Telephone #

SAMPLE HAZARDOUS MAILBOX SUPPORT LETTER

Figure 58-5.E
(continued)

58-6 RECREATIONAL ROADS

Design criteria for recreational roads are applicable to roads in State parks, recreational areas, national forests, and scenic drives. The objective for this type of facility is to provide a safe highway and still retain the aesthetic, ecological, environmental, and cultural amenities of the area.

In the design of recreational roads, consider the following:

1. Design Criteria. For design guidance, see the “Recreational Roads” section in the *AASHTO A Policy on Geometric Design of Highways and Streets*. Strict adherence to highway criteria for these types of roads may be inappropriate and unwarranted. Design speeds are usually low and driver expectancy is such that the reduction of criteria does not produce serious safety concerns. Therefore, the designer must use engineering judgment to ensure that the criteria fit the terrain and expected usage of the highway.
2. Design Vehicle. Depending on the nature of the recreational areas, the most common design vehicle will be a motor home with a boat trailer. Where garbage pickup or other maintenance vehicles are required, an SU may be the appropriate design vehicle. In some situations, only a passenger car may be appropriate. The designer must use engineering judgment to determine the appropriate design vehicle. Use the selected design vehicle to determine lane widths, vertical clearances, intersection designs, etc.

58-7 SEALING OF ABANDONED WATER WELLS

Abandoned water wells located on highway project right-of-way must be properly sealed by a licensed well driller in accordance with the requirements of the *Illinois Water Well Construction Code*, 415 ILCS 30/1 et seq. and *Water Well Construction Code*, 77 Ill. Adm. Code 920.120. When abandoned water wells are identified on proposed project right-of-way during Phase I or Phase II, appropriate provisions shall be included in the contract plans to ensure compliance with the applicable well sealing and notification requirements of the Water Well Construction Code. In addition, any information that the district has available concerning the abandoned well (e.g., location, depth, diameter, type, liner material, etc.) also shall be included in the plans.

58-8 SURVEY MARKERS AND MONUMENTS

58-8.01 Right-of-way Markers

Right-of-way markers are used to delineate the extent of State highway right-of-way. Construction details for right-of-way markers are illustrated in the *Highway Standards*.

Place right-of-way markers at the following locations:

- opposite points of curvature and tangency and opposite the midpoint of curves;
- along tangents so that two markers are always intervisible;
- at each corner of all offsets; and
- at all intersecting roads, except for streets in subdivisions outside of corporate limits.

Indicate the location of all right-of-way markers on the plans. Set the back of the marker flush with the right-of-way line.

Right-of-way markers may be omitted along freeways or controlled access highways where access control fencing is constructed on the right-of-way line. The fence line should be coincident with the right-of-way line (i.e., the back of the posts should be tangent to the right-of-way line). However, use markers for areas where the right-of-way line deviates from the fencing (e.g., grade separations, frontage roads) in compliance with the above requirements.

Do not place markers at the intersections of the right-of-way line with property lines in rural areas except for compliance with the above requirements. The intention of the markers is to delineate right-of-way lines and not to be construed as indicating the dividing line between adjacent property owners.

58-8.02 Permanent Survey Markers

Permanent survey markers are used to delineate the highway centerline. Construction details for permanent survey markers are illustrated in the *Highway Standards*.

Place markers at the PT's and PC's of all horizontal curves and space them along tangents so that two markers are always intervisible. Indicate the location of all markers on the plans.

For two-lane highways, place the Type I markers on the centerline in the pavement. When these highways are resurfaced, the marker should be raised to be flush with the new surface or referenced by means of permanent ties as discussed in Section 58-8.03.

On divided highways, place Type II markers, either precast or site constructed, in the median so that the plaque is flush with the median surface. If the horizontal alignment of the opposing roadways is not concentric, reference the respective roadway centerlines to the survey centerline. The Type II marker may also be used as a permanent benchmark.

58-8.03 Permanent Survey Ties

Permanent survey ties should be used in place of survey markers on highways having bituminous surface treatments and may be used at the option of the Regional Engineer on highways having bituminous concrete surface courses.

The permanent ties must consist of a metal rod or pin embedded in concrete within the highway right-of-way. At least four permanent ties must be provided for each survey point and must be located so that arcs struck from the ties will result in a precise point of intersection. Construction details for permanent survey ties are illustrated in Figure 58-8.A.

58-8.04 Land Survey Monuments

Public Act 79-649 requires that monument records of United States public land survey monuments used as control corners of a survey be filed with the Recorder of Deeds or Registrar of Titles in the county of the survey. Procedures and instructions for the implementation of this *Act* are contained in the *Land Acquisition Policies and Procedures Manual*.

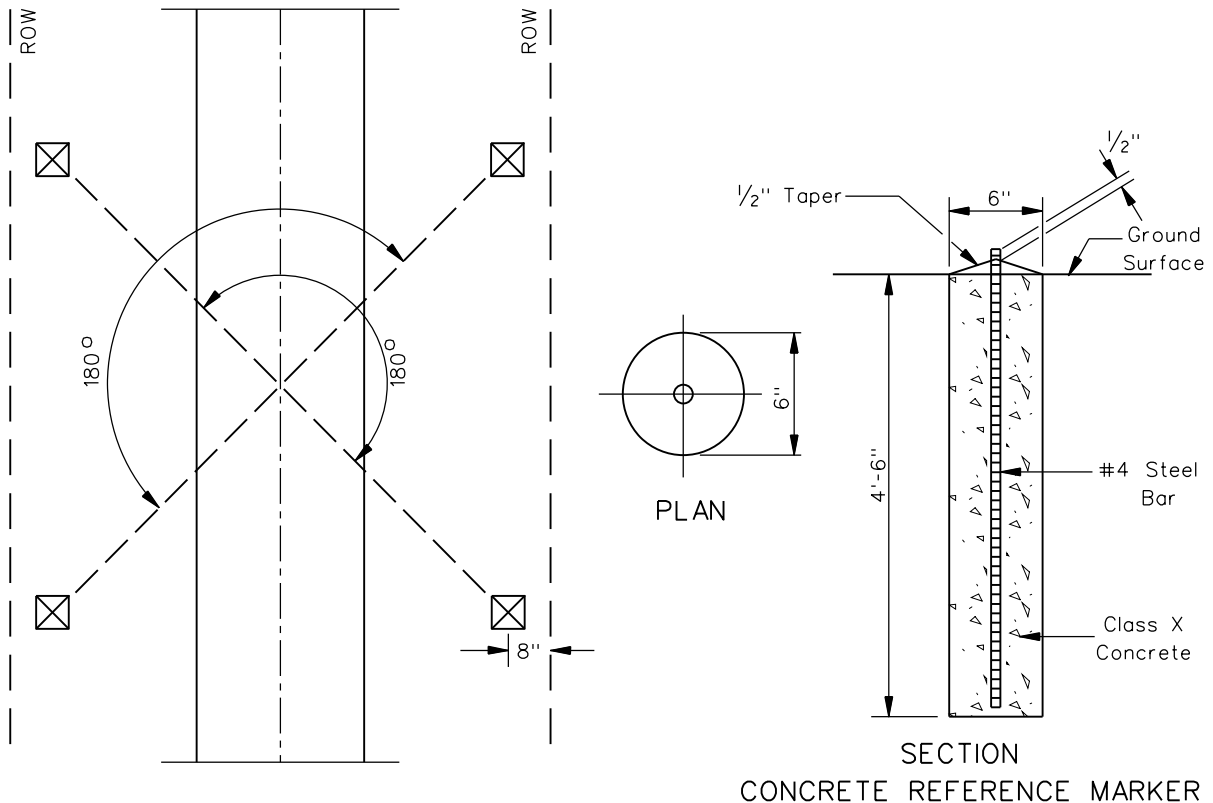

PERMANENT SURVEY TIES

Figure 58-8.A

The provisions of this *Act* require to preserve the U. S. public monuments that are subject to disturbance by the construction of a highway (605 ILCS 5/9-104).

If it is determined during the design stage of a project that a U.S. public land survey monument will be affected by the construction operations, the designer will prepare a Special Provision for inclusion into the contract providing for the preservation of the monument. Clearly indicate in the Special Provision the placement of reference monuments for the location of land survey monuments lowered below the finished grade. The Special Provision should clearly state that the setting of reference monuments, lowering of U.S. public land survey monuments, measuring of distances and angles, and the preparation of the monument record document must be done by or under the supervision of either a contractor-provided or district-provided Illinois Professional Land Surveyor. It is also required that the monument records be filed in accordance with Section 220/7 of the Land Survey Monuments Act, 765 ILCS 220/7.

Proper methods of referencing U.S. public land survey monuments are discussed in the *Land Acquisition Manual*. Monuments referenced as indicated in the *Land Acquisition Manual* need not be placed or marked in the surface of the pavement but must be covered after the monument has been lowered to a level of a minimum of 12 in. (300 mm) below the finished grade. Direct access to monuments under the pavement is not necessary and the installation of monument boxes is not required.

58-9 REFERENCES

1. *Accessibility Guidelines for Building and Facilities*, U.S. Architectural and Transportation Barriers Compliance Board, 1991, 1994, 2004.
2. *Public Right-of-Way Accessibility Guidelines (PROWAG)*, U.S. Access Board
3. *2010 ADA Standards for Accessible Design*, U.S. Department of Justice
4. *2018 Illinois Accessibility Code*, Illinois Capital Development Board
5. *A Policy on Geometric Design of Highways and Streets*, AASHTO, 2018.
6. *Guide for the Design of Park-and-Ride Facilities*, AASHTO, 2004.
7. *Traffic Engineering Handbook*, Institute of Transportation Engineers, 2016.
8. *The Location and Design of Bus Transfer Facilities*, Institute of Transportation Engineers, 1992.
9. *Guidelines for the Location and Design of Bus Stops*, TCRP Report 19, Transportation Research Board, 1996.
10. *Highway Standards*, IDOT.
11. *Standard Specifications for Road and Bridge Construction*, IDOT.
12. *Roadside Design Guide*, AASHTO, 2011.
13. *Land Acquisition Policies and Procedures Manual*, IDOT.
14. *Policy on Accessible Pedestrian Signals and Pushbuttons for Traffic Signals and Pedestrian Hybrid Beacons*, IDOT Central Bureau of Operations, October 18, 2021.

Chapter Fifty-nine
LANDSCAPE DESIGN

BUREAU OF DESIGN AND ENVIRONMENT MANUAL

Chapter Fifty-nine
LANDSCAPE DESIGN

Table of Contents

<u>Section</u>	<u>Page</u>
59-1 OBJECTIVES	59-1.1
59-1.01 General	59-1.1
59-1.02 Effective Design Objectives.....	59-1.1
59-2 AUTHORATIVE BASIS FOR LANDSCAPE DESIGN	59-2.1
59-2.01 Federal Statutes, Regulations, and Policies	59-2.1
59-2.02 Illinois Statutes and Directives.....	59-2.1
59-3 LANDSCAPE DESIGN PRINCIPLES	59-3.1
59-3.01 General	59-3.1
59-3.02 Principles	59-3.1
59-3.03 Application of Principles	59-3.2
59-4 LANDSCAPE DESIGN PROCESS	59-4.1
59-4.01 Determine Management Level	59-4.1
59-4.02 Phase I (Planning).....	59-4.1
59-4.03 Phase II (Design)	59-4.1
59-4.04 Phase III (Construction).....	59-4.1
59-4.05 Phase IV (Operation and Maintenance)	59-4.1
59-5 RESPONSIBILITY FOR PREPARATION OF DESIGN	59-5.1
59-5.01 General	59-5.1
59-5.02 District Landscape Architects/Roadside Manager	59-5.1
59-5.03 District Environmental Unit	59-5.1
59-5.04 BDE Environment Section	59-5.1
59-6 DESIGN FACTORS.....	59-6.1
59-6.01 General	59-6.1
59-6.02 Coordination of the Design Process	59-6.1
59-6.03 Protection of Existing Features.....	59-6.1
59-6.04 Grading and Alignment.....	59-6.2
59-6.05 Erosion Control	59-6.4
59-6.06 Drainage	59-6.4
59-6.07 Visual Quality	59-6.4
59-6.08 Safety.....	59-6.5
59-6.09 Scenic Byways, Rest Areas, Special Projects, and Settings.....	59-6.5

Table of Contents

(Continued)

<u>Section</u>		<u>Page</u>
	59-6.09(a) Scenic Quality Preservation	59-6.5
	59-6.09(b) Auxiliary Facilities.....	59-6.5
	59-6.09(c) Special Designations.....	59-6.6
	59-6.09(d) Roadway Destinations	59-6.6
	59-6.09(e) Historical Influences	59-6.6
	59-6.09(f) Special Designs	59-6.6
59-7	DESIGN ELEMENTS	59-7.1
59-7.01	General	59-7.1
59-7.02	Responsibility	59-7.1
	59-7.02(a) When to Plant	59-7.1
	59-7.02(b) Site Analysis	59-7.2
	59-7.02(c) Function of Plantings.....	59-7.3
	59-7.02(d) Considerations for Plantings	59-7.4
59-7.03	Classification.....	59-7.7
59-7.04	Trees.....	59-7.7
	59-7.04(a) General	59-7.7
	59-7.04(b) Objective	59-7.7
	59-7.04(c) Planning.....	59-7.8
	59-7.04(d) Site Analysis	59-7.8
	59-7.04(e) Design, Plans, and Specifications	59-7.8
59-7.05	Grasses and Forbs.....	59-7.10
	59-7.05(a) General	59-7.10
	59-7.05(b) Seed Classes.....	59-7.11
	59-7.05(c) Planning.....	59-7.12
	59-7.05(d) Site Analysis	59-7.12
	59-7.05(e) Considerations for Planting	59-7.13
	59-7.05(f) Site Preparation.....	59-7.14
	59-7.05(g) Design, Plans, and Specifications	59-7.14
59-7.06	Selective Mowing Stakes	59-7.15
59-7.07	Sodding.....	59-7.15
59-7.08	Perennial Plants	59-7.16
59-7.09	Wetlands	59-7.17
	59-7.09(a) Planning.....	59-7.17
	59-7.09(b) Design.....	59-7.18

Table of Contents
(Continued)

<u>Section</u>		<u>Page</u>
59-7.10	Wildlife Habitat	59-7.20
59-7.11	Planting in Urbanized Areas	59-7.21
59-7.12	Visual Quality	59-7.28
59-7.13	Erosion Control	59-7.28
59-7.14	Architectural Design Elements	59-7.28
59-7.15	Plan Preparation	59-7.29
59-7.16	Highway Related Areas.....	59-7.30
59-7.17	Roadside Seeding in Areas Disturbed By Construction	59-7.30
59-8	REFERENCES.....	59-8.1

Chapter Fifty-nine

LANDSCAPE DESIGN

59-1 OBJECTIVES

59-1.01 General

The Department is responsible for transportation facilities that occupy considerable land area throughout the State. These facilities are developed to be operationally sensitive and a positive economic asset to the State of Illinois through a balanced blend of environmental, economic, aesthetic, and engineering values. This Chapter provides guidance on the implementation of visual and environmentally based aesthetic components of transportation. It also includes procedures for the establishment of components of the physical landscape.

59-1.02 Effective Design Objectives

All design elements and components must be compatible with each other and with the environment into which they are to be introduced. This objective often necessitates the use of materials native to the surroundings. Give consideration to the wide range vegetation zones in Illinois and to the various vegetation types present in the project area when selecting materials.

The objectives of effective landscape design include the following:

- identify social, economic, aesthetic, and environmental effects early enough to permit analysis and consideration while alternatives are being formulated; see Part III, Environmental Procedures;
- involve other agencies and the public in the planning and design decision process early enough to allow their ideas to influence technical studies and final decisions; see Chapter 19;
- use all practical means to restore and enhance the quality of the environment, e.g., consider using native plantings when feasible;
- minimize required maintenance activities after construction; see the *Bureau of Operations Maintenance Policy Manual*; and
- bring together all aspects of the project, including planning, design, construction, and maintenance.

59-2 AUTHORITY BASIS FOR LANDSCAPE DESIGN

59-2.01 Federal Statutes, Regulations, and Policies

Numerous Federal regulations establish the basis for this chapter including:

- 23 U.S.C. 319 “Landscaping and Scenic Enhancement,”
- 23 CFR 752 “Landscape and Roadside Development,”
- *National Environmental Policy Act,*
- *Highway Beautification Act of 1965,*
- *1973 Policy on Operation Wildflower,* and
- SAFETEA-LU – National Scenic Byways Program.

59-2.02 Illinois Statutes and Directives

A number of Illinois statutes and directives also establish basis including:

- Departmental Policy D&E-18 “Preservation and Replacement of Trees,”
- *Illinois Endangered Species Act,*
- *Illinois Interagency Wetlands Policy Act,*
- *Illinois Exotic Weed Act.*

59-3 LANDSCAPE DESIGN PRINCIPLES

59-3.01 General

The establishment of design principles for environmentally based planning, design, construction, and management of the roadside landscape in Illinois is essential.

59-3.02 Principles

The following controlling principles are based upon the conservation of natural resources; creating a facility that is compatible with its surroundings; minimizing future management efforts and expenditures; and producing a high quality, environmentally responsible finished product:

1. Environmental Impact. Where practical, avoid adverse or disruptive impacts to landscape and environmental features on or adjacent to the right-of-way. Where total avoidance of adverse or disruptive impacts is not practical, undertake all reasonable measures to reduce and minimize impacts to these features. If damage or disruption is unavoidable, undertake all reasonable measures to offset damages through mitigation in the project area or other designated areas. Note that the designer cannot recreate or restore natural systems but can utilize native plant materials to represent some of the appearances and functions of the impacted feature; see Part III, Environmental Procedures.
2. Environmentally Sensitive Areas. Consider environmentally sensitive areas and those harboring threatened or endangered species to be a controlling factor in all designs.
3. Use of Native Plants. Emphasize the use of plants native to and grown in Illinois which are appropriate to the site, its planned use, and its future management.
4. Site Compatibility. Design a specific landscape effect that is compatible with the site.
5. Future Management Considerations. Consider the future management plan for the roadside area to be a controlling factor in the planning and design of that area.
6. Sustainable Roadside Environment. Strive to produce a sustainable roadside environment.
7. Visual Quality. Visual appearance and visual unity of the facilities are important components. Recognize that visual quality must be a component in almost all design development and that numerous factors influence the final appearance of the finished project. Durability and appearance are the two items most noticed and commented upon by the traveling public.

59-3.03 Application of Principles

Apply landscape and environmentally based design principles to the full range of highway types, from multi-lane freeways to the rehabilitation and improvement of existing local arterials and rural collector roads. They also apply to all highway components and features including:

- the roadway, i.e., the travel surface itself;
- the roadside, i.e., the remainder of the right of way including any existing natural vegetation and/or plantings;
- ancillary structures, e.g., bridges, culverts, retaining walls; and
- highway appurtenances, e.g., fences, signs, lights, roadside barriers, guardrail, cable barrier (High Tension Cable Barrier), Road Weather Information System (RWIS), traffic controller boxes, and continuous count sites.

The principles also apply to other types of transportation facilities constructed by the Department including public transit, railroad terminals, airports, ferry terminals, and port facilities.

The extent of the application of these principles will depend on the type of project, the environmental resources affected, and the public entities involved.

59-4 LANDSCAPE DESIGN PROCESS

59-4.01 Determine Management Level

Landscape and environmentally based design solutions are initiated in the planning and location phase. It is important, however, that the planned level of management extend into the design, construction, operation, and maintenance of transportation facilities. This is underscored by the likelihood that a large share of future transportation demands will have to be accommodated by upgrading existing facilities while recognizing their management will continue to be limited.

59-4.02 Phase I (Planning)

During the planning and location phase, apply the landscape and environmentally based design principles to assess environmental effects and identify measures to mitigate adverse impacts. Use the principles to help identify landscape features that can be incorporated into project planning and to influence development of alternatives to the proposed action and any environmental commitment.

59-4.03 Phase II (Design)

In the design phase, focus on how each of the principles apply to a particular project, what commitments have been made, and how to incorporate the principles into design plans for such project features as landscaping, environmental impact mitigation measures, support facilities, and associated structures.

59-4.04 Phase III (Construction)

The construction phase ensures that mitigation measures committed to in the design and planning phases are carried out and conditions discovered in the field receive consideration.

59-4.05 Phase IV (Operation and Maintenance)

Finally, the incorporation of landscape and environmentally based design principles into the operation and maintenance of transportation facilities can help to ensure the continued effectiveness of project mitigation measures. Consideration shall be given to the cost of and frequency of maintenance for all design practices.

59-5 RESPONSIBILITY FOR PREPARATION OF DESIGN

59-5.01 General

It is the designer's responsibility to be aware of any aspect of the design which would adversely affect the roadside and to modify such design elements, where necessary, to achieve a harmonious design that meets the criteria for the project. The designer also is responsible for notifying other Bureaus of potential impacts on their respective operations.

59-5.02 District Landscape Architects/Roadside Manager

The Landscape Architect/Roadside Manager in the Bureau of Operations provides the required expertise in landscaping aesthetics, material selection, and visual quality. The Landscape Architect/Roadside Manager advises the designer and reviews design criteria and proposals.

59-5.03 District Environmental Unit

The district Environmental Unit identifies those aspects requiring the input of the Landscape Architect/Roadside Manager in Phase I of the project including commitments regarding wetland mitigation, erosion control, endangered species habitat protection and restoration, and tree replacement or removal. This Unit also identifies the impact of the visual component of noise mitigation structures and notes critical areas adjacent to the project needing protection.

59-5.04 BDE Location and Environment Section

The Location and Environment Section provides expertise and policy directives in environmentally based landscape matters. The Location and Environment Section also reviews design criteria and proposals to ensure conformance with environmental regulations and commitments.

59-6 DESIGN FACTORS

59-6.01 General

Design factors are intended as a guide for the designer to use in developing a solution for a particular project condition. Determine the appropriateness of the design as it applies to given features of the highway environment. Not all factors will apply to most projects, nor will all project situations be covered by those described in this Section.

59-6.02 Coordination of the Design Process

Use the following guidelines to coordinate the design process:

1. Coordination within the Department. During the design process, coordination of many disciplines (e.g., engineering, landscape architecture, roadside maintenance, biology, hydrology) is needed to achieve the proper environmentally based design. This is true not only for large and complex projects but also for small and simple projects. Obtain all available inputs to ensure a coordinated environmentally based design.
2. Coordination with Outside Regulatory Agencies. Where transportation projects involve wetlands, endangered species, Illinois natural areas, nature preserves, historic sites, and culturally sensitive areas or where the planned facility is adjacent to public resources such as streams or forests, the design aspects of the improvement will be coordinated by the central office or the district depending upon the project phase.
3. Coordination with Local Jurisdictions and the General Public. Coordination is best accomplished through the environmental review, public involvement process and/or the Context Sensitive Solutions (CSS) process. The designer is responsible for coordinating with local jurisdictions and abutting landowners adjacent to or affected by the project. Consider the potential impacts to any local management or long range plans. Ensure that aspects of the project are not adverse to broad public values. Early coordination with local jurisdictions and with the general public may provide valuable input to ensure the success of an acceptable design. Coordination at local level includes municipalities, park and forest preserve districts, counties, chambers of commerce, residential and commercial developments, fire and other special districts. Coordination at the general public level may include garden clubs, beautification agencies, and other general public groups with valuable input.

59-6.03 Protection of Existing Features

Certain existing landscape features, whether manmade or natural, should be protected through a process of identification; enhancement, restoration, or preservation; and avoidance or incorporation into the design of the highway improvement. Consider the following when determining the need for protecting existing features:

1. Review Previous Commitments. Review commitments in environmental documents, tree surveys, wetland reports, public hearing records, project reports, and other project documents for those requiring protection during project development and implementation.
2. Statute Protection. Determine which features of the project area are protected by statute. These may include wetlands, endangered species, nature preserves, natural areas, and cultural sites.
3. Cultural Environment. Determine the project's setting or cultural environment, e.g., rural, urban, or in a transitional area. The design should be influenced by the cultural and physical environment adjacent to it and existing features should be protected where practical.
4. Existing vegetation and restoration areas. If native plantings exist in addition to protected areas listed in number 2. above, these areas shall be protected and impacted areas restored to pre-construction conditions.

A variety of techniques may be employed to protect identified resources, including both temporary and permanent measures as appropriate. Consider the following guidelines:

1. Temporary Fencing. Use temporary fencing to protect special waste areas, trees that are not to be disturbed, existing vegetation to remain in critical erosion prone areas (e.g., steep slopes, concentrated flow areas) and areas where it is necessary to prevent stockpiling or construction traffic access. Natural resources (e.g., prairies, woodlands, wetlands) should be protected. Where drainage is flowing from the construction area to these valuable resources, it is usually better to specify perimeter erosion barrier and temporary fencing. The designer should clearly label on the plans the limits of construction and what is to be protected by the temporary fencing.
2. Tree Trunk Protection. Specify tree trunk protection to prevent damage by construction equipment to existing trees located within or along the limits of the construction area.
3. Pruning for Safety and Equipment Clearance. Show pruning of overhanging branches for safety and equipment clearance purposes on the plans.

Note: Trees that require more than 20% of the crown to be pruned should be considered for removal instead of pruning. Pruning in urban areas shall only be conducted by an International Society of Arboriculture (ISA) certified arborist.

59-6.04 Grading and Alignment

That portion of the design process concerning alignment and grading offers the best opportunity to fit the highway into the landscape, thereby avoiding unnecessary environmental impacts and yielding a functional and aesthetically pleasing form. The basic guideline for grading and alignment is the *AASHTO Guide for Transportation Landscape and Environmental Design* and Chapter 33. In addition, consider the following guidelines:

1. Environmental Commitments. During Phase I engineering, ensure that all environmental commitments are reviewed to appropriately influence alignment and grading decisions. These commitments also will serve as controls during Phase II plan preparation.
2. Surrounding Landscape. Give consideration to the surrounding landscape. Blend the alignment and grading to fit the existing topography with minimal visual or physical disruption.
3. Clearing and Construction Limits. Carefully plan the establishment of clearing and construction limits. Consider both existing landscape features and critical areas. No volunteer trees or brush shall be left on ROW or in fence rows when designing landscaping or habitat reconstruction projects. Clearing and tree removal must be specified in accordance with Departmental Policy D&E-18.
4. Plant Survival. Consider the survival potential of existing plantings to be preserved and proposed plantings at the time that grading decisions are made. This is especially critical in confined areas where landscape features, e.g., screening, are proposed. Plant material to remain within the project limits should be properly cared for so that it is alive and in good condition when the project is complete. Consider the following guidelines:
 - a. Root Pruning. Specify root pruning where trenching or excavation is within the root zone of adjacent trees or shrubs to remain in place to prevent ripping up roots.
 - b. Fertilizer Nutrients. Specify fertilizer nutrients for trees and shrubs that will be disturbed by construction but will remain-in-place.
 - c. Supplemental Watering. Specify supplemental watering for trees and shrubs that will be disturbed by construction but will remain-in-place. Watering should begin immediately after root pruning, top pruning, or other construction disturbance.
 - d. Tree Pruning. Specify tree pruning where an entire tree needs to be pruned, to correct structural problems, or improve the overall appearance.
 - e. Temporary Fencing. Specify temporary fencing where protection of existing trees is necessary. At a minimum, place fencing around the drip line of each tree to be protected. However, if space allows, place fencing 5 ft (1.5 m) out from the drip line of each tree to be protected.
 - f. Tree Trunk Protection. Specify tree trunk protection to prevent damage by construction equipment to existing trees located within or along the construction area.
 - g. Reduction in competition. Use a Best Management Practice to reduce the presence of unwanted species and reduce competition with desired species.

59-6.05 Erosion Control

See Chapter 41 for information on Department policy and procedures for erosion and sediment control.

59-6.06 Drainage

Design the drainage of the highway system as part of, and not separate from, the natural hydrology of the environment; see *Drainage Manual* for more information. Consider the following factors during design:

- the environmental impacts of drainage;
- storm sewer management;
- detention/retention basin design;
- how the drainage way is to be designed or altered from its original pattern;
- the affect that the channel lining will have on values such as wildlife, aquatic life, sediment filtration, and water quality; and
- the impact that water retention and/or soil saturation will have on existing or proposed plant material;
- maintenance requirements of drainage features;
- Colonization by invasive species, e.g. Common Reed (*Phragmites australis*).

59-6.07 Visual Quality

A project's visual quality is ensured by encouraging a positive visual change that will improve or enhance the surrounding landscape. Define the visual environment by identifying key views, analyzing resources, depicting the project's proposed appearance, and assessing its visual impacts. Manmade features have been integrated successfully into a large portion of Illinois natural landscape. To better provide for visual quality in a project, evaluate the project's relationship with the following:

- natural landscape elements;
- topographical and physical characteristics;
- ecological influences;
- recreational sites;
- residential areas and their character;
- historical features;
- visual values;
- existing land uses, e.g., industrial, junkyards; and
- existing and proposed project profile.

Review these elements to ensure that visual quality is adequately integrated into the project.

59-6.08 Safety

Safety should be the highest functional goal of every design, and all landscape and environmentally based design principles must be compatible with this criteria. During design, consider the following:

- the location, size, and height of plantings in relation to sight distance, drainage, and clear zones; and
- traffic-calming designs in urban areas; and
- pedestrian safety in areas such as rest areas, transit stations, and bikeways.

59-6.09 Scenic Byways, Rest Areas, Special Projects, and Settings

Existing scenic conditions, auxiliary facilities, special roadway designations, roadway destinations, and historical values of the project area are examples of special conditions which may be present and which may impact the design of a project. Many of these conditions are held in high regard by the public, and their sensitive treatment is essential to a successful project. Ensure that design decisions are compatible with such special conditions. It may be necessary to provide a higher type of design than is normally required.

Designs for special conditions shall be coordinated with the Landscape Architect/Roadside Manager to reduce conflict of Operational activities.

59-6.09(a) Scenic Quality Preservation

The project area may be a designated scenic byway or may possess an outstanding scenic quality that must be preserved as part of the project. This may require special limited grading, aesthetic treatments of highway appurtenances, preservation or enhancement of adjacent features, or other actions to preserve unique aspects of the area. These cases normally require special attention and unique designs to improve the quality and safety of the roadway.

59-6.09(b) Auxiliary Facilities

Auxiliary facilities may be required or desirable as a part of the project, e.g., rest areas, scenic overlooks, roadside tables, scenic vistas. The planning and design of these facilities should be an integral part of the roadway design. Give special attention to site amenities, aesthetics, and environmental values as well as safety and future maintenance.

59-6.09(c) Special Designations

A project area may carry a special designation that sets the route apart as a special experience for the traveler. Examples of these are the Great River Road, Historic US 66, the Lake Michigan Circle Tour, and many similar corridors. It is important to become familiar with the meaning and the special features associated with such designations so that any necessary supportive enhancements can be developed, e.g., opening vistas of the Mississippi River along the Great River Road, providing informational signing along Historic US 66.

59-6.09(d) Roadway Destinations

Certain roadway segments may serve primarily as access to a destination, e.g., state park or historic site. Designers of such segments must be aware of the significance of the site and its surroundings and ensure that the project design is compatible with its destination.

59-6.09(e) Historical Influences

Historical influences may affect the project as a nearby destination, as an adjacent feature, or, in some cases, as a part of the roadway or its appurtenances. Pay particular attention to these influences and prepare the project design to be compatible or harmonize with them. Historical markers, structures, districts, and bridges all may influence the design of a project. Required avoidance of or mitigation of impacts to historical resources usually is identified in early project coordination, but the designer should be alert for any unidentified items. Special consideration may need to be given to landscaping within designated National Register Historic Districts.

59-6.09(f) Special Designs

Various elements of the design may need to be modified from the standard treatment or designed to a higher visual quality standard than the ordinary roadway elements to be compatible with the above special circumstances. Give special consideration to the design of features such as bridges, signing, retaining walls, tree protection, colors and textures of appurtenances, and similar items. Design these treatments to be compatible with their surroundings and with the features that make the segment unique. If questions arise regarding a proper design approach, contact in-house specialists, e.g., district Landscape Architect/Roadside Manager.

59-7 DESIGN ELEMENTS

59-7.01 General

Highway landscape plantings are the living component of the highway design and, through the use of native and non-native materials, provide the means to fully integrate the highway with the surrounding environment. Landscape plantings will serve as functional elements, e.g., erosion control, screening, sound abatement, snow control, in the highway environment.

59-7.02 Responsibility

The district Roadside Development Unit (Landscape Architect/Roadside Manager) has the primary responsibility for determining the plant selection on a site-specific basis for a design project. The district Landscape Architect/Roadside Manager keeps a current preferred plant list for his/her respective district. Consider the following guidelines:

1. Native Plants. Native plants are effective in perpetuating a self-sustaining roadside landscape, increasing biodiversity, reducing maintenance costs, and are more adapted to regional environmental conditions.
2. Non-Native Plants. Non-native plants may be selected for certain results if a native plant cannot be found to achieve the same effect, e.g., color, texture, growth habit, for emphasis or survivability, e.g. de-icing activities.
3. Plant Maintenance. Maintenance is a major consideration in landscape plant selection. Strive to choose those plants that once established require a minimum of maintenance.
4. Ash Trees. Due to Emerald Ash Borer (EAB) in Illinois, no varieties of ash trees (e.g., *fraxinus* spp.) should be planted as this can contribute to the spread of this species.
5. Disease Prevention. The designer should check current guidance on plants susceptible to pests that cause biohazards.

59-7.02(a) When to Plant

Plantings are placed as follows:

- when required by the Phase I report;
- when planting can fulfill one of the “Functions of Planting” as outlined in this chapter;
- when required by law or Department policy;
- when requested by local residents or communities;
- at any location where the local community will assume plant maintenance; and
- where right-of-way agreements indicate that trees will be planted.

59-7.02(b) Site Analysis

The design process begins with the site analysis, which includes the following items:

Determine final contours and cross sections including:

- steep slopes,
- flat areas, and
- drainage features.

Identify adjoining land usage as follows to better blend landscaping with the pre-existing environment:

- urban,
- rural,
- industrial,
- scenic vistas,
- agricultural, and
- natural forested areas.

Consult the USDA Hardiness Zone Maps and analyze native plant communities and climate for the area including:

- local plant types,
- hardiness zone, and
- exposure.

Analyze landscape position as follows:

- upland,
- lowland,
- wetland, and
- floodplain.

This is important because plants are site specific to their environment.

Analyze soil types and structures including the following factors:

- soil types,
- soil textures,
- available moisture,
- drainage,
- fertility, and
- pH.

Ensure plantings are compatible with roadside safety requirements by determining the following:

- clear zones, and
- sight distances.

Because the planned roadside maintenance often dictates the type of planting, determine future maintenance including the following factors:

- scope,
- responsibility,
- future cost,
- mowing requirements,
- burn management requirements,
- chemical weed control, and
- fertilization.

Identify existing features such as the following:

- drainage structures,
- signage and lighting,
- walls,
- roadway and shoulders,
- structures,
- curbs and medians,
- interchanges and intersections,
- alleys,
- driveways,
- fire hydrants,
- utility lines,
- railroad crossings,
- buildings,
- traffic signs and signals, and
- underground utilities.

This is important because these existing features can influence the final design.

59-7.02(c) Function of Plantings

The functions of plantings are as follows:

1. Aesthetics. Planting is one method used to improve the visual quality of the highway system.
2. Screening. Screening undesirable views seen from and toward the highway can be performed with plants.

3. Delineation. Plants may be used to delineate changes in highway alignment. Plants on the outside of curves, at “T” intersections, and at overpasses may aid in directing the motorist. Plants also may be used to frame or form a background for directional signs.
4. Erosion Control. Temporary and permanent plantings may be used to prevent erosion and enhance soil stability.
5. Control of Snow. Living snow fences can reduce maintenance costs, provide increased driver safety, and greatly enhance the appearance of the roadside.
6. Preventing Headlight Glare. Planting can be very effective in screening headlight glare from oncoming vehicles.
7. Environmental Mitigation. Planting may be used for various types of mitigation including various types of buffers, sound barriers, tree replacement requirements, wetland replacement, and providing wildlife habitat.
8. Pollution Control. Planting may be used to attenuate air pollution, dust, and auto emissions.
9. Psychological Considerations. Planting may help to alleviate driver fatigue by changing the driving experience and making it more interesting.
10. Adjacent Landscape Enhancement. Plantings can be used to enhance adjacent landscapes for the better enjoyment of the motorists.

Plant varieties also should be selected for their desirable growth habits, insect and disease resistance, and proven desirable features for highway use.

59-7.02(d) Considerations for Plantings

The functions of plantings are used as the basis for planting shade trees, intermediate trees, shrubs, evergreens, vines, ground covers, and seedlings. Landscape plantings are used to mitigate and replace trees that were removed through highway construction and mitigation for wetland replacement. Installation of landscape plantings are covered in the *Standard Specifications*. Consider the following when designing landscape plans:

1. Hardiness. Select plants for a particular section of roadway based on their climatic and soil requirements. In Illinois, climatic conditions and soil types are favorable to both southern and northern plant groups. Conduct a study of soils, climate, and existing plant growth in the area when planning each planting project. Plant hardiness zones will be as stated in the *Standard Specifications*. Use the USDA Plant Hardiness Zone Map, latest edition, when selecting plant material for any project.
2. Size. The size at which a plant matures will determine the number of plants that will be required in a group planting. The highway speed determines the amount of time a motorist views the planting. Consequently, on higher speed highways, utilize the large group

concept of landscaping in lieu of the individual plant concept. Consider the following guidelines:

- Younger Plants. Younger plants generally establish themselves faster than older plants. As a general practice, specify the smallest size of plants that is consistent with the requirements of the environment.
 - “Balled and Burlapped” Planting. Specify all deciduous trees larger than 1.5 in. (40 mm) in diameter or 5 ft (1.5 m) in height as “balled and burlapped” at the time of planting. Also, specify this method of planting for plants that, according to good horticultural practice, require a ball of earth. It is acceptable to specify container-grown material in lieu of “balled or burlapped” plants as an alternative. The relationship of the plant size to the soil ball size or the container size will be as stated in the *Standard Specifications*.
 - Perennial Plants. Perennial plants can be planted as bulbs, tubers, or container plants. Bulbs and tubers should be of a size large enough to produce a healthy plant and to flower the first year. Container plants should be well rooted in the container. A quart (liter) sized container is usually the smallest size that should be planted on highway projects.
 - Prairie Forbs and Grasses. Prairie forbs and prairie grasses can be planted as root plugs or as seed. The minimum size plug should be 1.25 in. (30 mm) in diameter by 4.25 in. (110 mm) deep.
3. Roadside Safety. Do not locate woody plants with diameters at maturity greater than 4 in. (100 mm) in the clear zone, as defined for new construction. Also, such plants normally should not be planted on the foreslope or in ditches even if outside the clear zone. Curb and gutter is not considered a barrier and clear zone requirements must be applied to these sections of roadway.
 4. Sight Distance. When planting in urban areas, consider potential sight distance problems and the potential for obstructing traffic signals, traffic signs, roadway lighting, railroad signals, etc.
 5. Impact of Tree Roots. Trees with shallow fibrous systems have the ability to damage nearby sidewalks, storm sewers, and pavement.
 6. Fertilizing and Mulching. For survivability and lack of future maintenance, give consideration to fertilizing and mulching all plantings.
 7. Existing Soil. Where practical, use the existing soil in the planting operation. In cases where highway construction has made the condition of the existing soil unsuitable, consider the use of soil amendments or new topsoil. Where soil conditions require topsoil placement to ensure adequate growth, specify the following depth of topsoil for the appropriate areas:

- 8 in. (200 mm) where extensive plantings of wood or perennial plants are proposed, and
 - 24 in. (600 mm) for plantings in landscaped medians.
8. Impacts of Salt. Due to the adverse effect of salt upon plants, give special consideration to the type and location of plants and their proximity to the roadway in those areas of the State where there is extensive snow and ice control.
 9. Agricultural Areas. If planting trees adjacent to agricultural fields, make sure there is enough right-of-way after the tree planting to accommodate any shading from mature trees and minimize impacts to farm machinery, i.e. mobility. Otherwise, do not plant large trees or evergreens on the right-of-way where there is adjacent agricultural land use.
 10. Signage. Do not place plants in a location that will block the view of legally placed advertising signs.
 11. Growth Balance. Every large-scale planting operation should include a small percentage of relatively fast growing short lived trees that will, in a short period of time, provide the overall landscape with some big trees while the slower growing trees mature. This practice will benefit the current motorist as well as the driver of the future.
 12. Blending. Where adjacent land use is wooded, (e.g., parks, forest preserves), use landscape plantings to blend into the existing wooded area and erase the effects of highway construction.
 13. Screening. Landscape plantings are used to screen adjacent properties that have undesirable land usage; to reduce highway noise, dust, etc., reaching adjacent properties; and/or to screen the highway from a residential area or park.
 14. Snow Drifting. Do not plant dense continuous hedges within 40 ft (12 m) of the edge of pavement where they may cause snow to drift onto the pavement.
 15. Permit Planting. All plants placed by permit should be maintained by the person or agency requesting the permit. Removal and/or replacement will be the responsibility of the person requesting the permit.
 16. Harmful Plants. Do not plant poisonous or toxic plants in urban areas. Likewise, plants with thorns are suitable only to rural areas.
 17. Messy Plants. Do not plant trees or shrubs that drop fruit (e.g., crabapples) immediately adjacent to sidewalks or driveways.
 18. Ease of Maintenance. Trees shall be placed a minimum of 20 feet from trunk to trunk to allow mowing between trees. Large trees will require additional spacing based on crown width at maturity. Shrub plantings in rural areas and those used for living snow fence shall be placed to allow mowing between the planting and the ROW line.

59-7.03 Classification

Consider the following groups for planting:

1. Shade Trees. A single-stem, high-headed, deciduous plant that generally grows to a height in excess of 30 ft (9 m).
2. Intermediate Trees. Generally, a multi-stem, deciduous, low, round-headed plant that matures at 30 ft (9 m) or less in height.
3. Shrubs. Low-growing multiple stemmed plants that are either deciduous or evergreen.
4. Evergreen Trees. Tall-growing evergreen plants.
5. Ground Cover and Vines. A colony forming plant less than 1.5 ft (0.5 m) high that has the ability to spread and root itself.
6. Seedlings. Small shade trees, intermediate trees, shrubs, and evergreens that are usually less than 2 years old.
7. Shelterbelts. Also referred to as “living snow fences,” shelterbelts are multiple rows of trees or shrubs planted to provide protection from wind driven snow. There are many advantages to shelterbelts, as compared to snow fences, including roadside beautification, wildlife benefits, little or no maintenance after establishment, and long service life. A disadvantage of shelterbelts is that they may require 5 to 10 years from the time of planting to become effective depending upon their size at the time of planting. Also, use signage to prevent incidental mowing.

59-7.04 Trees

59-7.04(a) General

Departmental Policy D&E-18 provides guidance on the preservation and replacement of trees during the planning, design, and maintenance of facilities on the State highway system.

59-7.04(b) Objective

In determining if the tree replacement is appropriate, consider if the replacement achieves one or more of the following results:

- enhances the scenic quality of the highway,
- provides additional habitat for wildlife,
- results in financial savings from reduced maintenance,
- enhances air quality,
- serves as a deterrent to soil erosion,
- not hinder a driver’s visibility or otherwise create a traffic hazard,

- allows for natural forest revegetation,
- properly mitigate for environmental impacts, and/or
- follows through on a commitment to a regulatory agency, e.g., US Fish and Wildlife Service.

59-7.04(c) Planning

Consider the following when making decisions on trees replacement in the project area:

- clear zones are not affected,
- slope planting blends with adjacent forested areas,
- revegetation of riparian zones around bridges and drainage structures,
- provides screening of undesirable views and objects,
- frames vistas,
- achieve commitments to property owner,
- evergreen trees are highly susceptible to damage from salt or salt spray. Distance from pavement and predominant wind direction should be considered.

59-7.04(d) Site Analysis

Investigate and determine the proper mixture of plant materials best suited for the project area. Use the following to determine the proper selections:

- native plant communities; see Figure 59-7.A;
- landscape type - upland, lowland, bottomland, wetland;
- soil conditions - texture, available moisture, drainage, fertility, pH; and
- climate - hardiness zone, exposure.

59-7.04(e) Design, Plans, and Specifications

Use the following, along with previously gathered information, to develop the final design for tree planting:

- plans and special provisions,
- delineating planting locations,
- plant materials,
- soil amendments, and
- plant care.

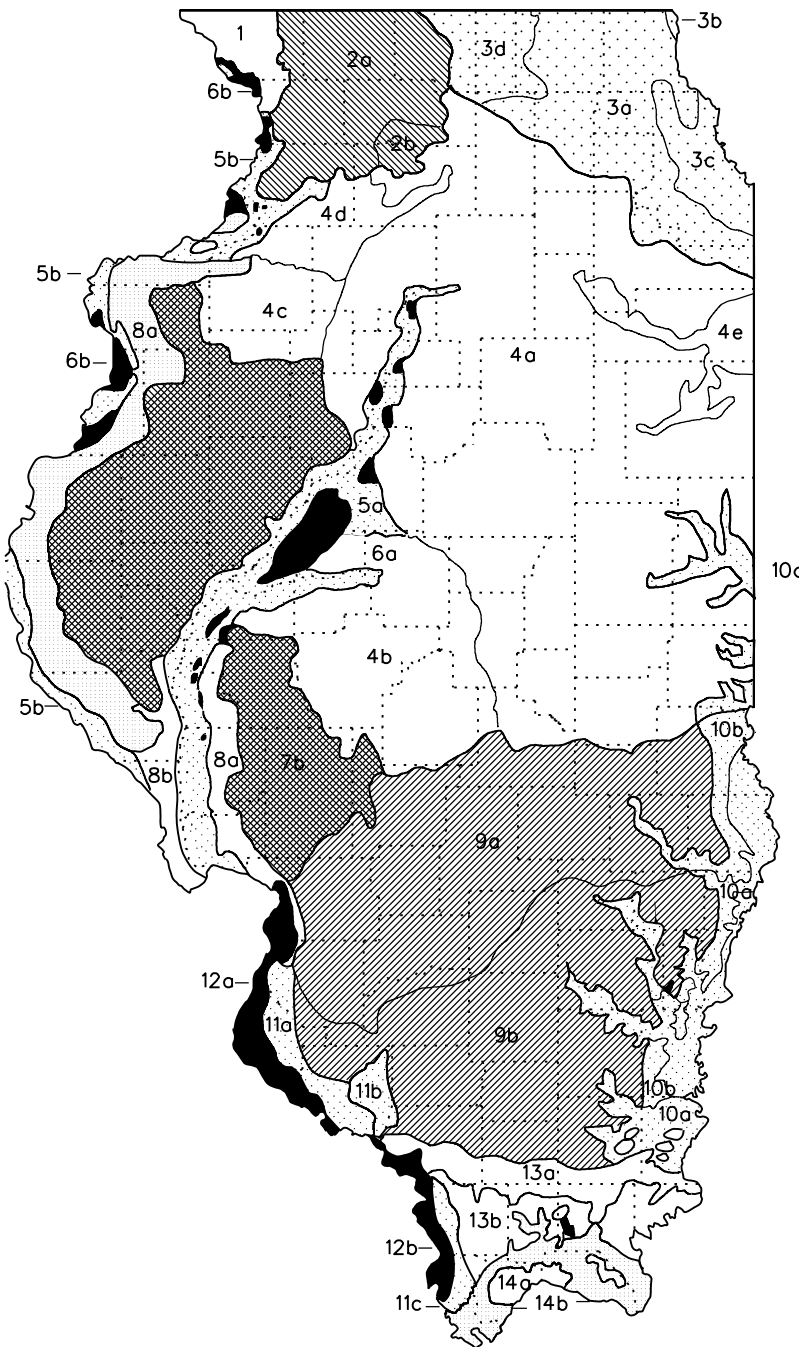

- 1 Wisconsin Driftless Division
- 2 Rock River Hill Country Division
 - a Freeport Section
 - b Oregon Section
- 3 Northeastern Morainal Division
 - a Morainal Section
 - b Lake Michigan Dunes Section
 - c Chicago Lake Plain Section
 - d Winnebago Section
- 4 Grand Prairie Division
 - a Grand Prairie Section
 - b Springfield Section
 - c Western Section
 - d Green River Lowland Section
 - e Kankakee Sand Area Section
- 5 Upper Mississippi River and Illinois River Bottomlands Division
 - a Illinois River Section
 - b Mississippi River Section
- 10c 6 Illinois River and Mississippi River Sand Areas Division
 - a Illinois River Section
 - b Mississippi River Section
- 7 Western Forest-Prairie Division
 - a Galesburg Section
 - b Carlinville Section
- 8 Middle Mississippi Border Division
 - a Glaciated Section
 - b Driftless Section
- 9 Southern Till Plain Division
 - a Effingham Plain Section
 - b Mt. Vernon Hill Country Section
- 10 Wabash Border Division
 - a Bottomlands Section
 - b Southern Uplands Section
 - c Vermillion River Section
- 11 Ozark Division
 - a Northern Section
 - b Central Section
 - c Southern Section
- 12 Lower Mississippi River Bottomlands Division
 - a Northern Section
 - b Southern Section
- 13 Shawnee Hills Division
 - a Greater Shawnee Hills Section
 - b Lesser Shawnee Hills Section
- 14 Coastal Plain Division
 - a Cretaceous Hills Section
 - b Bottomlands Section

NATURAL DIVISIONS OF ILLINOIS

Figure 59-7.A

59-7.05 Grasses and Forbs

59-7.05(a) General

Grasses, grains, legumes, and forbs form the backbone of highway vegetation cover. The large number of species and varieties of vegetative cover may be used for many applications.

Native Grasses. There are numerous species of native Illinois grasses. These grasses are commonly referred to as prairie grasses.

Forbs (Wildflowers). Forbs, commonly referred to as wildflowers, should be native flowering plants that collectively will provide blooms throughout the growing season. They are used for either visual effect, such as in urban areas, to reconstruct habitat along Illinois ROW, or to mitigate environmental impact. If the area is highly visible, consider planting plugs and/or annual species.

Consider the following guidelines when selecting the seed class for the project:

1. Temporary Erosion Control. Temporary erosion control mixtures are seeded to prevent soil from being displaced on a construction project that will be exposing soil. The mixture is spread over all exposed earth to provide a quick cover of the turf that will interrupt the force of rain on the soil and prevent soil from moving. The temporary erosion seed mixture may need to be spread on construction sites numerous times during construction activities. The temporary erosion control mixture also can be combined with a permanent erosion control mixture to provide a nurse crop while the permanent seed is establishing. Use temporary vegetative cover for temporary erosion control at locations where the duration of the turf cover is short term and is expected to prevent loss of soil; see Section 41-2.01(b).
2. Permanent Erosion Control. Permanent vegetative cover is used for permanent erosion control in most highway applications. To achieve a cost-effective permanent cover, select an appropriate seed mix for the landscape conditions and planned maintenance; see Section 41-2.01(b).
3. Weed Control. Good vegetation establishment will minimize weed growth, thereby reducing pesticide requirements.
4. Groomed Appearance. In certain areas, a vegetative cover that can be mowed into a park-like appearance might be most appropriate such as urban settings.
5. Wildlife. Provide a vegetative cover that will enhance and encourage wildlife where appropriate.
6. Diversity. Provide a diverse vegetative cover that will add color, texture, and form to the highway environment. This is important because not only does diversity provide a visual experience, but also breaks up the monotony of the driving task.
7. Sodding. Seed mixtures are most commonly used; however, some instances may call for the use of sodding to provide for the rapid establishment of turf.

59-7.05(b) Seed Classes

The seed classes specified in Section 250 of the *Standard Specifications* are used for specific applications as follows:

- a. Lawn Mixtures (Class 1, 1A, 1B). Lawn mixtures are used in urban settings to create a park-like appearance. This class also includes salt tolerant and low maintenance mixes. Use this class for:
 - all urban reconstruction not covered in Class 2A (below), and/or
 - all projects where the entire right-of-way is not torn up and Bluegrass is the primary existing cover.
- b. Roadside Mixtures (Class 2 and 2A). Roadside mixtures are a hardy mix used in more rural settings where a tougher lower maintenance turf is desired. This class includes a salt-tolerant mix as well. Use Class 2A seeding for:
 - new construction or reconstruction projects of limited access routes in locations intended to be mowed by the Department,
 - all rural reconstruction projects where the entire right-of-way is to be seeded or any situation where grasses (other than Bluegrass) are the primary existing cover, and/or
 - areas adjacent to roads subject to salt spray and/or disposition.
- c. Slope Mixtures (Class 3 and 3A) Slope mixtures are used on slopes usually 3H:1V or greater and are divided in a Northern and Southern mixes.
- d. Native Grass (Class 4, 4A, and 4B). Native grass mixtures can be planted to create specific turf conditions. This class includes mixes with lower growth height (low profile) and a mix typically used for wetland mitigation.
- e. Forb Mixtures (Class 5, 5A, and 5B). These mixtures predominately feature flowering species with mixes including annual, native forbs, or wetland forbs.
- f. Conservation Mixtures (Class 6 and 6A). Conservation mixtures are used for wildlife nesting cover and include salt tolerant mix. These are usually planted at the request of resource agencies. Use caution when considering this class with other seeding classes.
- g. Temporary Turf Cover Mixtures (Class 7). This mix is used to provide a quick growing cover over areas disturbed due to construction and is typically used as part of a project's erosion and sediment control plan. Consider the following when using Class 7:
 - as a temporary cover for areas to be regraded more than a year from the time of seeding, and/or
 - winter shut down.

59-7.05(c) Planning

Because of the splashes of color added to the highway landscape by native wildflowers, place these plantings in areas of high visual impact, e.g., interchanges. Wildflower plantings, although colorful, will still need periodic maintenance. Typical practices might include selective mowing, selective herbicide application, or roadside burning to prevent establishment or undesirable vegetation. Consider future maintenance requirements of the roadside when planning the appropriate planting mixtures.

Wildflower plantings can be placed in stand-alone groupings or combined in a plant community with native grasses to restore part of the native landscape. The advantage of using native species is that they are adapted to the Illinois environment and, therefore, do not require fertilizer nutrients or topsoil.

If native grasses are to be mixed with forb plantings, consult the district Landscape Architect/Roadside Manager for the appropriate mix, because grasses can out-compete forbs. Select grass species that are compatible with forbs. Prairie grasses also may be added to other turf grass mixtures to enhance diversity, erosion control, and aesthetics in the turf area. Consider prairie grasses for use on all new and highway reconstruction projects. These grasses especially can be effective on steep slopes 1V:3H or greater, and where maintenance is limited (e.g., slopes 10 ft (3.0 m) or more in height and 100 ft (30 m) or more in length), due to their deep rooting ability that holds the soil in place. Native grass and forbs mixtures should only be considered in residential areas if a right-of-way fence is present.

Select a location that will maximize the visual impact to the motorist. Examine the highway alignment to determine where to maximize the visual experience with any flowerbeds or grass plantings.

59-7.05(d) Site Analysis

Consider the following guidelines during the analysis:

1. Visual Analysis. Consider the sight line of the motorist when planning any wildflower or native grass establishment. These areas include interchange locations, outsides of curves, gore areas, and back slopes. In urban areas, the view from the surrounding neighborhood as well as the motorist's view must be compatible with existing neighborhood landscapes and coordinated with local municipalities.
2. Landscape Position, Upland, Lowland, Bottomland, and Wetland. Some native grasses and wildflowers are adapted to dry or mesic conditions (prairie) while others require wet or saturated conditions. Consult the district Landscape Architect/Roadside Manager to determine which species are appropriate for a given set of roadside conditions.
3. Soil Conditions. Determine the type of soil and identify the soil's characteristics. Consult soil maps prepared by the Natural Resource Conservation Service for information

regarding project soils. Although native species are adapted to Illinois soil conditions, determining the soil type can dictate the use of a specific species for planting.

59-7.05(e) Considerations for Planting

Consider the following guidelines when planting grasses and forbs (wildflowers):

1. Growth Rate. The native grass and native wildflowers are mostly warm season plants that do not begin their growth until warm weather arrives. Most roadside plantings of native grasses and native wildflowers take 3 to 5 years to show results. The native species spend their initial growth establishing an extensive root system once the seeds germinate, thereby resulting in a longer time frame to show results. Using a temporary seeding might be ideal for high profile areas during this establishment time.
2. Using plugs or container plants of native species can help to accelerate the time between planting and establishment.
3. Applications. Grasses and wildflowers can be used separately or in combination to provide a specific effect or restore a native Illinois landscape. Native roadside plantings offer many benefits to highway managers, motorists, and wildlife. Their thick deep roots anchor the soil and prevent erosion. Native species tolerate a wide range of soil types, climatic conditions, and hydrology making them suitable for most highway conditions. They offer a motorist a rich, aesthetic landscape full of texture and color enhanced by seasonal change. Native-planted roadsides provide habitat for wildlife.

Where it is desirable to eliminate most future mowing, native grasses and forbs are strongly encouraged for the following applications:

- inaccessible areas, e.g., when a creek or similar barrier separates an area from the roadway;
- in wide right-of-way areas;
- interchanges;
- bordering slope walls and retaining walls;
- between the back of guardrail and top of retaining walls in narrow areas; and
- outside access control fencing on rural freeways, (except those immediately adjacent to agricultural land, residential areas, or frontage roads).

Discuss the selection and application of native grasses and forbs with the district Landscape Architect/Roadside Manager.

4. Planting Methods. The method of planting these species ranges from complete seed bed preparation to inter-seeding existing turf. Usually, seed mixtures are selected for planting

grasses and forbs; however, plant plugs may be used to achieve faster results. If plugs are selected (also known as perennial plants), consult the *Standard Specifications* for planting times.

59-7.05(f) Site Preparation

Site preparation may consist of:

- tilling or disking the soil to be seeded;
- application of chemical weed control;
- placement of soil amendments (e.g., fertilizer, lime, compost); and/or
- placement of topsoil.

Where soil conditions require topsoil placement to ensure adequate growth, specify the following depth of topsoil for the appropriate areas:

- 4 in. (100 mm) for use with Seeding Classes 1 and 2 or sodding;
- 12 in. (300 mm) in wetland mitigation areas, or what is required by the Corps of Engineers for the specific project; and
- topsoil is not normally required for seeding Classes 4 and 5. Use compost or coarse sand (usually 2 in. (50 mm) depth) to amend the existing soil where necessary.

For those seed mixtures requiring complete seedbed preparation, placement of a fertilizer is usually required. A fertilizer is not required for native grass mixtures (Class 4, 5 and 6) and for temporary turf cover (Class 7). Agricultural ground limestone may be specified to adjust soil pH. Turf requires a pH of 7.0 to germinate.

1. Seeding. Once the site preparation has been completed, the seed mixture (See Section 59-7.04(b)) is applied. The type of seed mixture will dictate the seeding method to be utilized. Seeding methods are described in the *Standard Specifications*.
2. Mulch, Erosion Control Blanket, and Turf Reinforcement Mats. Mulch, erosion control blankets, or turf reinforcement mats are placed once the seed mixture has been applied to the site. The purpose of mulch is to hold the soil moisture level at the ground surface, prevent displacement of seed, and protect seed from predation. For guidance on choosing the proper mulch, erosion control blanket, or turf reinforcement mat; see Section 41-2.02.

59-7.05(g) Design, Plans, and Specifications

The design plans and specifications should contain the following information:

- type of seed bed preparation,
- delineation of planting locations including selective mowing stakes and signs,
- plant materials required sizes and rates,

- fertilizer requirements (usually only for non-native species),
- mulch requirements and method.

59-7.06 Selective Mowing Stakes

Consider the following guidelines when specifying selective mowing stakes:

1. **Application.** Use selective mowing stakes to delineate areas that are not to be mowed, e.g., areas that contain plants or natural features that need to be protected from mower damage, areas of existing vegetation, areas seeded or planted with trees, shrubs, wildflowers, or prairie plants. Another use of staking would be to delineate mowing lines to create an aesthetic or visual effect.
2. **Placement.** Place selective mowing stakes in a manner as to delineate the mowing boundaries of the feature to be protected or created. Spacing of the stakes will depend upon the size and shape of the area. Use a maximum spacing of 15 ft.
3. When selective mowing stakes are utilized the appropriate habitat sign should be installed at the beginning of each run of mowing stakes and every 200 ft for long straight runs. Increased frequency should be considered for tight curves, e.g., ramps.

59-7.07 Sodding

Appropriate uses of sodding are as follows:

- urban areas with residential or commercial development, e.g., in front of homes, businesses, parks, adjacent to paved shoulders or edges of paved ditches;
- rest areas;
- in front of maintained parks and cemeteries;
- erosion control in ditch bottoms and around culverts; and
- special areas, e.g., channelized medians, around inlets in grassed areas. Small areas which would normally be seeded should be sodded where a large majority of the remainder of the project ($\pm 90\%$) is to be sodded.

Consider the following guidelines when specifying sodding:

1. **Salt Tolerant Sod.** Specify salt tolerant sod in those areas where large quantities of deicing salt are used by maintenance forces, e.g., highly urbanized areas.
2. **Topsoil.** Topsoil is usually required.
3. **Fertilizer.** Fertilizer should be included and incorporated prior to sod installation. Fertilizer requirements are indicated in the *Standard Specifications*.

4. Watering. Specify the number of supplemental waterings. Field adjustments can be made according to season and time of application. Watering rates and requirements are indicated in the *Standard Specifications*.
5. Staking. Specify staking on all slopes of 1V:2H or steeper. Staking requirements are indicated in the *Standard Specifications*.
6. Lime. Consider lime application after a soil pH analysis is taken.

Design considerations for placing sod in ditches are as follows:

1. In urban areas, except expressways, place sodding in ditches with grades of 0.75% to 2.5%.
2. Place sodding in ditches 50 ft (15 m) upstream and downstream from the ends of culverts, unless grades or volume of water flow require a paved ditch, aggregate ditch, or riprap.
3. Place sodding on moderately steep slopes and ditch flow lines where appearances dictate except in continuously flowing ditches or wet ditches.

59-7.08 Perennial Plants

Perennial plants are hardy flowering bulbs, tubers, and herbaceous plants. Perennial non-native flowering plants are often used in the highest visual impact areas, usually in urban areas. Perennial native species often are used more in rural areas. Only specify perennial plants for use when:

- required by commitments in the Phase I report to resource and regulatory agencies and to comply with Federal requirements for wildflower planting,
- requested by local residents or communities, and /or
- needed on any highway to blend the right-of-way into adjacent land uses.

Planting beds containing non-native perennial plants are designed to give the impression of a highly maintained park-like atmosphere. These can be more expensive to establish than other plantings and require intense maintenance. High maintenance ornamental flower beds should only be planted when a local community agrees to accept maintenance of the flower bed. Consider the following for planting perennial plants:

1. Non-Native. Non-native perennial plants require:
 - complete bed preparation,
 - fertilizer,
 - permanent mulch,
 - watering, and
 - a period of establishment.

2. Native. Native perennial plants require:
 - bed preparation or planting in existing turf;
 - mulch, unless planted in existing turf;
 - watering; and
 - a period of establishment.

59-7.09 Wetlands

Use the *Illinois Wetland Restoration and Creation Guide* to assist in the design of wetland mitigation sites and the guidance in the following Sections.

59-7.09(a) Planning

Use the following guidelines when planning wetlands:

1. Project Goals and Objectives. Establish project goals and objectives for wetland compensation in the planning phase of highway development. For compensation that will be provided via wetland restoration or creation, the primary goal is to establish jurisdictional wetlands as defined by current Federal and State criteria. The secondary goal is to restore or create a specific amount (acres (hectares)) and type (emergent, forested) of wetland.

The amount and type of wetland to be replaced is determined by the agency with jurisdiction over the impacts. Compensation ratios to wetlands where a Section 404 permit has been required will be determined by the US Army Corps of Engineers (US ACOE). Some US ACOE district offices allow for compensation ratios as defined in the IDOT Wetland Action Plan (see Appendix A). Currently, wetlands that are considered isolated fall under the jurisdiction of the IDNR and compensation ratios are defined in the Wetland Action Plan.

For the Federal and State goal of no net loss of wetlands, the minimum replacement is 1:1 and the greatest is 5.5:1, replacement to loss. Usually, replacement should be in-kind, but out-of-kind may be justified; see Section 26-8 for more information.

2. Site Selection. Select sites that have a majority of poorly drained soils and that are designated as prior converted by the Natural Resources Conservation Service (NRCS). The NRCS field offices and published soil survey reports can provide information to assist in identifying sites that meet these criteria. If either component of the criteria is not met, there are a number of obstacles that may arise that could block approval of the proposed wetland compensation site. If both criteria are satisfied, planning, design, construction, and maintenance of the planned wetland is much simplified.

Site selection also should include sufficient ground to buffer planned wetlands from adjacent land uses that are not compatible with the establishment of native plant communities. There exist no guidelines, regulatory or scientific, for determining the appropriate amount of buffer to provide. The minimal buffer consists of a 10 ft to 20 ft (3 m to 6 m) belt of upland that is planted with native grasses and forbs. Embankments planted to prairie may be sufficient.

3. Site Assessment. Assess every proposed wetland compensation site both off- and on-site for its possibilities and limitations. Evaluate the site using topographic maps, aerial photography, published soil survey reports, and other existing geographic information. Survey the site for existing vegetation cover types and jurisdictional wetlands. Field-check county soil survey mapping and delineate any hydric soils. Field-check the site's geology and hydrology for confining layers (aquaculdes) and sources of surface water. Note the presence of drain tile blowouts and outlets.

59-7.09(b) Design

Keep designs for planned wetlands simple. Reliance on sophisticated design features to provide hydrology or other attributes will likely increase the margin for failure. Design for low maintenance and utilization of natural systems. Consider the following additional guidelines:

1. Grading. Even the best sites will require some earthwork, e.g., a shallow 1 ft to 2 ft (300 mm to 600 mm) berm may have to be constructed at property boundaries to contain surface water, or earth may have to be moved to enlarge an existing wetland. Excavation for creation of wetlands should extend no deeper than 1 ft to 2 ft (300 mm to 600 mm). Any deeper and side slopes become too steep and erosion and siltation become a problem. The shape or configuration of a wetland should be curvilinear like an oxbow and not geometric.

Although sometimes recommended by regulatory agencies, stockpiling and backfilling topsoil generally is unnecessary for creation of wetlands. Because most substrates can be used as a medium for plant growth, it usually is unnecessary to specify their removal and backfilling with topsoil in the plans and specifications. This practice may be warranted only where soils are very shallow or clayey. In Illinois, most if not all, soils are very deep. Salvaged topsoil may contain a bank of weed seed that should not be used in the planned wetland.

2. Emergent Wetlands. Natural revegetation may be proposed for some exceptional sites. This approach to restoration may be acceptable to the regulatory agencies if it can be demonstrated that a viable seed bank exists in the soils or that there is an adequate source of propagules. A cover crop should be planted in areas proposed for natural revegetation. The cover crop stabilizes the soil and helps control weeds. A recommended crop mix consists of red top at 5.0 lb/acre (5.6 kg/ha). Virginia wild rye at 10 lbs/acre (11.2 kg/ha) may be added to the red top. Never specify agricultural grain or perennial rye as a cover crop. They can alter soil characteristics and impair the growth of desirable wetland plants.

At other sites, the revegetation may have to be accelerated. One to five percent of the surface area of the planned wetland should be planted and the rest seeded to a temporary cover. Tubers, corms, rootstock, etc., are usually set on 1 ft (300 mm) centers; however, the faster a species rate of spreading, the more distance there can be between transplants. Planting areas should be protected from predators. Low netting supported 1 ft to 2 ft (300 to 600 mm) above the mature height of the plants works well.

3. Forested Wetlands. Forested wetlands usually are planted with hardmast producing species as favored by the Federal regulatory agencies. The species of choice include swamp white oak (*Quercus bicolor*), pin oak (*Q. palustris*), pecan (*Carya illinoensis*), and shellbark hickory (*C. laciniosa*). These four species grow naturally throughout Illinois and are commercially available. A cover crop of red top at the rate of 5 lb/acre to 10 lb/acre (5.6 kg/ha to 11.2 kg/ha) should be planted with the trees. Virginia wild rye at the rate of 5 lbs/acres to 10 lb/acres (5.6 kg/ha to 11.2 kg/ha) may be added to the mix. These plants are hydrophytic.

Various methods of tree installation may be used. If bare root seedlings are specified, install a minimum of 560 trees/acre (225 trees/ha). If 3-gallon (11 L) potted material is specified, install a minimum of 70 trees/acre (28 trees/ha). If 1.75 in (45 mm) balled and burlapped material is specified, install a minimum of 30 trees/acre (12 trees/ha). These numbers are consistent with previous practices, but may have to be increased at the request of the Federal regulatory agencies. A goal of 80% survival of all planted trees is usually required as a project goal for forested wetlands. Vegetation between rows should be mowed out completely during the first two growing seasons and then reduced to one mowing pass in a single direction (i.e., north to south or east to west) between rows for the next three growing seasons.

Seeds or acorns may also be proposed for establishment of forested wetlands. A common specification is to plant three seeds or acorns per hole 2 in. to 4 in. (50 mm to 100 mm) deep. Plant one seed or acorn deeper than the other two to deter predation by animals, e.g., squirrels. Each hole is 3 ft (900 mm) on center and rows are 10 ft (3 m) apart.

4. Plants. Use the following guidelines for plants:
 - a. Selection. The best guideline for plant selection is to observe what is growing in similar wetlands near the planned wetland. Select the dominant or common plants in the model wetland for use in the planned one. Select natural associates and group plants by community type.
 - b. Nativity. Plants native to the region always should be specified for use in wetland replacement projects. Where feasible, buy plants from nurseries located within 100 miles (160 km) north or south and 200 miles (320 km) east or west of the compensation site.
 - c. Availability. Take care to specify only those species that are commercially available. Keep plant lists short and simple. Select the more common wetland plants and let nature fill-in with the uncommon species.

- d. Adaptability. Many of our wetland plants, especially the woody ones, are propagated in uplands. Often these plants die in our planned wetlands because they are not adapted to wet conditions. Vegetation must be grown in conditions similar to those in which they will be planted. If this option is not available at the supplying nursery, dormant stock should be planted during the dormant season so that when the plants break dormancy they will develop the necessary structures for survival.

Young woody plant material should be specified because it is not use to growth under ideal conditions and is better able to adapt to wetlands. The survival rate for transplanted containerized plants and seedling plugs is higher than for seed, bare root, and balled and burlapped material.

5. Planting. Consider the following guidelines when planting:

- a. Deconsolidation. Where heavy machinery is used to move earth and create wetland conditions, compacted surface material should be deconsolidated. This is especially true with fine textured (clay) materials or substrates. Site construction plans and specification always should state that before planting, the substrates will be deconsolidated by plowing, discing, rototilling, or ripping. The depth of deconsolidation should be 4 in. to 6 in. (100 mm to 150 mm) for herbaceous material and 12 in. to 18 in. (300 mm to 450 mm) for woody plants.
- b. Planting "In-The-Dry". Wherever practical, plant "in the dry" with most of the water drained from the site. Water may have to be drained from a site mechanically (e.g., through pumping) so that planting "in the dry" may be accomplished and so that planting schedules may be met. Do not plant in standing water. Plantings are more likely to be done properly, and costs will be reduced by as much as a factor of 10.
- c. Bowls. Do not build bowls around planting holes with excess soils. Bowls divert water from the plants during overland flow.
- d. Mulch. Do not mulch plants because mulch will wash or float away.
- e. Stakes and Anchors. Trees and shrubs more than 4 ft (1.2 m) in height should be staked using standard landscape specifications. Where surface water may freeze, trees and shrubs should be wired to anchors. The anchors should be sufficiently deep to prevent plant material from being lifted by ice.

59-7.10 Wildlife Habitat

Wildlife has four basic needs for habitat — food, water, shelter, and space. These needs can be provided through both vegetative and structural components in the landscape design. Consider the following guidelines:

1. Vegetative Cover. Vegetative components of wildlife habitat include:

- a. Conifers. Conifers provide escape cover, winter shelter, and summer nesting sites. Also, the sap, needles, twigs, buds, and seeds are eaten by wildlife.
 - b. Grasses and Legumes. Grasses and legumes provide habitat for ground nesting birds; forage for deer, rabbits, woodchucks, meadow voles, and others; hunting areas for foxes, hawks, kestrels, owls, coyotes, weasels, and skunks; winter cover for pheasants and deer; and winter food for seed-eating winter birds.
 - c. Nectar Plants. Nectar plants typically are provided for hummingbirds, orioles, bees, moths, and butterflies.
 - d. Other. Other vegetative cover include:
 - summer fruit, berry, and cover plants;
 - fall fruit, grains, and cover plants;
 - winter fruits and cover plants; and
 - mast, i.e., plants that produce nuts and acorns.
2. Structural Components. Structural components of wildlife habitat include:
 - nest boxes;
 - dead trees, fallen trees, and perches;
 - brush piles and rock piles;
 - cut banks, cliffs, and caves;
 - dust and grit;
 - salt; and
 - water.

The type of vegetative and structural components of wildlife habitat restoration will be dictated by the species involved, degree of impact, and availability of plant material. A number of published guides exist that list habitat requirements for wildlife species. Consult the district Environmental Coordinator and Landscape Architect/Roadside Manager prior to initiating design.

59-7.11 Planting in Urbanized Areas

Use the following criteria for planting in urbanized areas:

1. Minimum Distance from Intersections, Alleys, and Driveways. The following criteria relates to distances as measured from the property line and along the property lines:
 - a. Intersections. Do not locate trees within 50 ft (15 m) on the near side and 20 ft (6 m) on the far side of the intersection; see Figure 59-7.B. Trees on medians should be located a minimum of 50 ft (15 m) from intersections.
 - b. Alleys. Do not locate trees within 20 ft (6 m) on the near side and 10 ft (3 m) on the far side.

- c. Commercial Driveways. Do not locate trees within 20 ft (6 m) on the near side and 10 ft (3 m) on the far side.
 - d. Residential Driveways. Do not locate trees within 10 ft (3 m).
2. Minimum Distances from Walks, Curbs, Utilities, and Structures. The following criteria applies from face of curb or center of utility to edge of tree, as measured horizontally:
- a. sidewalks and carriage walks — 3 ft (900 mm);
 - b. access of courtesy walks — 5 ft (1.5 m);
 - c. face of curb — 4 ft (1.2 m);
 - d. manholes and catchbasins — 10 ft (3 m);
 - e. fire hydrants — 10 ft (3 m);

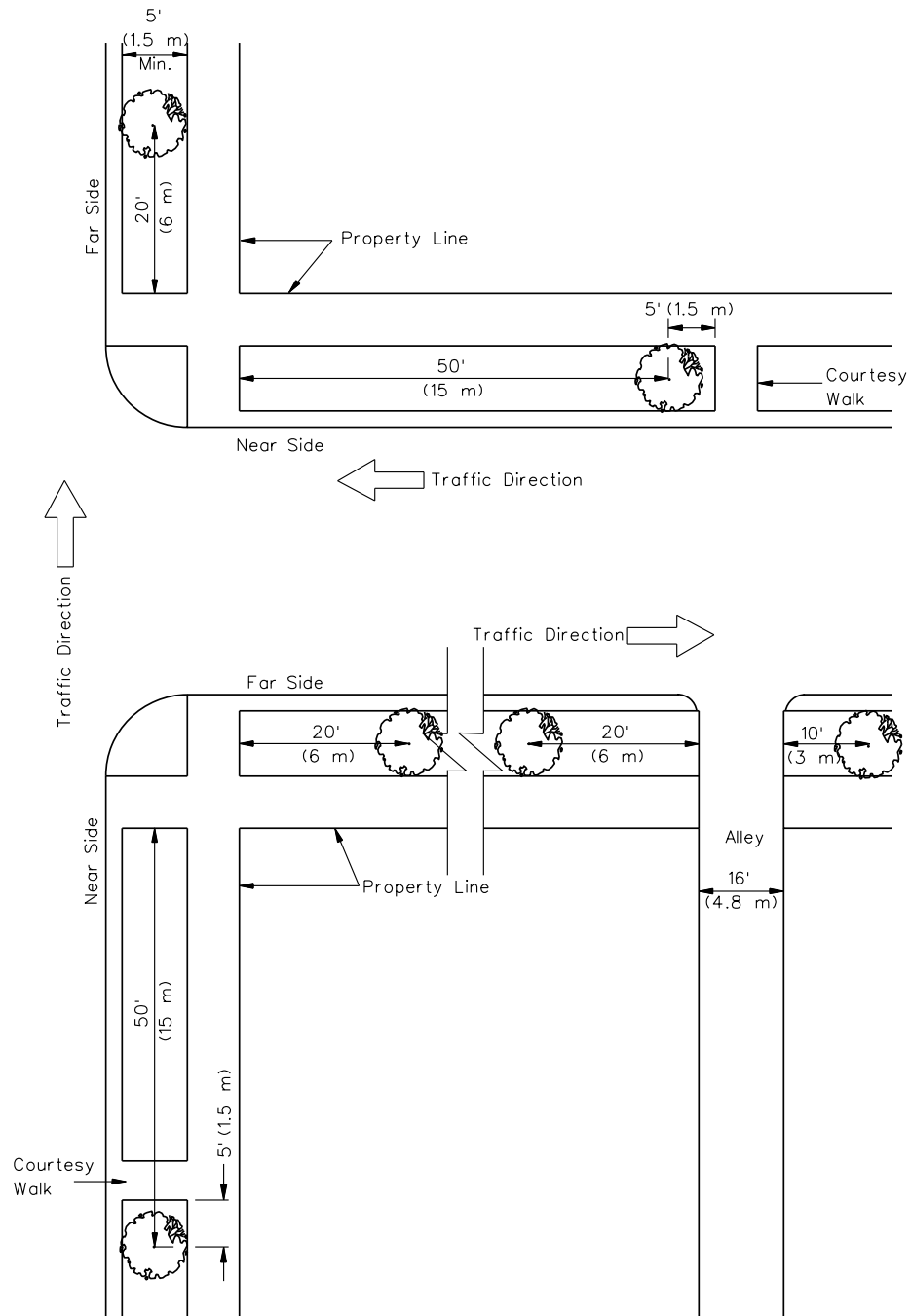

MINIMUM PLANTING DISTANCES FROM INTERSECTIONS

Figure 59-7.B

- underground utility mains and services — 5 ft (1.5 m);
- street lights — see Item 3;
- existing trees — see spacing criteria below;
- overhead wires — no ascending shade trees will be planted under overhead wires or where mature width will reach overhead wires;
- railroad crossings — 100 ft (30 m), written approval from railroad is required to plant within 100 ft (30 m); and
- other structures — 30 ft (9 m) or as directed.

These requirements are for reduced speed urbanized areas and must be adjusted for higher speeds so that clear zone and sight distance requirements are met.

3. Minimum Basal Clearance Between Trees and Structures. Basal clearance is defined as the distance from the center of the tree to the structure or object involved; see Figure 59- 7.C. Minimum basal clearance between trees and between trees and structures located on parkways, medians, or other areas of the right-of-way are as follows:

- Trees with spreading crowns must have a minimum basal clearance of 15 ft (4.5 m).
- Trees with global or pyramidal crowns must have a minimum basal clearance of 12 ft (3.6 m).
- Trees with fastigate or columnar crowns must have a minimum basal clearance of 10 ft (3 m).
- Do not plant trees in areas where basal clearance is less than 10 ft (3 m) without written permission from the district Landscape Architect/Roadside Manager.
- The Department will determine the form classification of a given tree or species of tree; see Figure 59-7.D.
- Select tree species from the approved tree list of the district Landscape Architect/Roadside Manager or from a municipal tree list if it is applicable to the project site.

4. Spacing of Trees Within Parkway. Use the following criteria for spacing of trees within parkways:

- Space trees with spreading crowns at a minimum of 30 ft (9 m).
- Space trees with global or pyramidal crowns at a minimum of 25 ft (7.5 m).

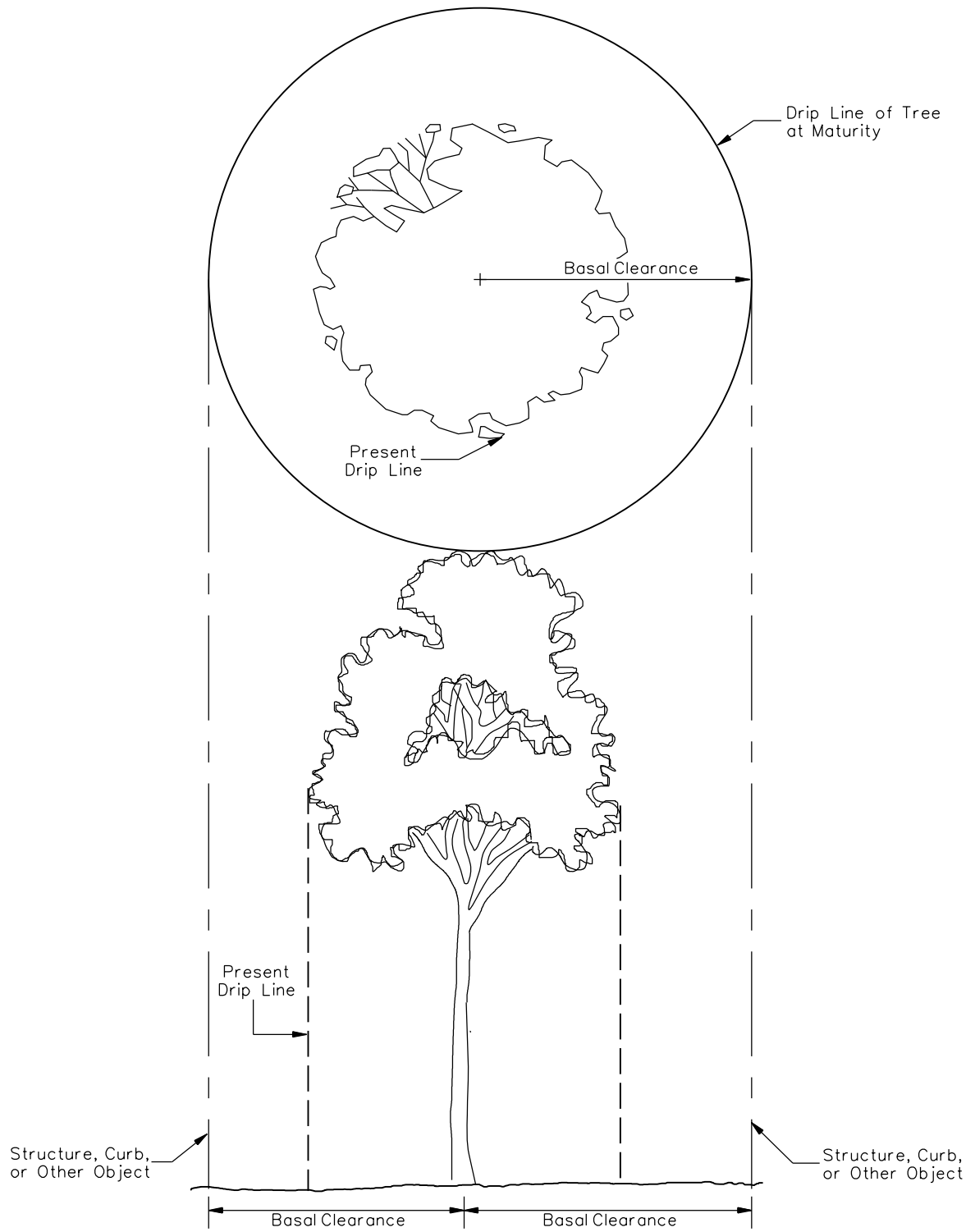

BASAL CLEARANCE

Figure 59-7.C

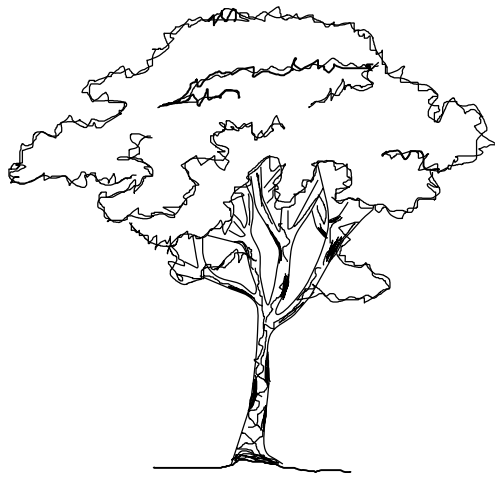

Spreading

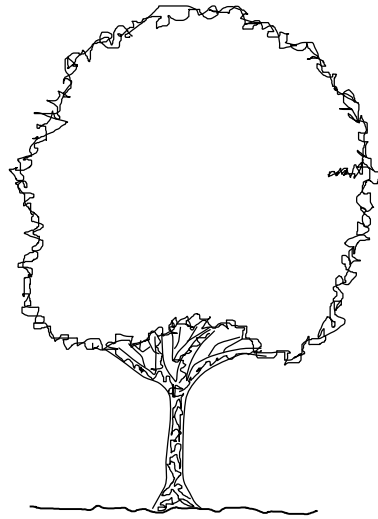

Globe

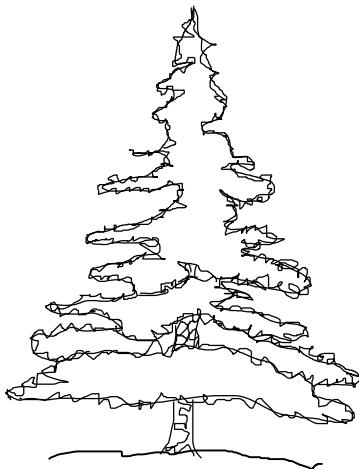

Pyramidal

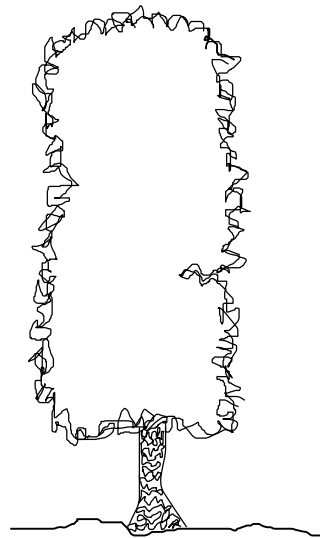

Fastigate

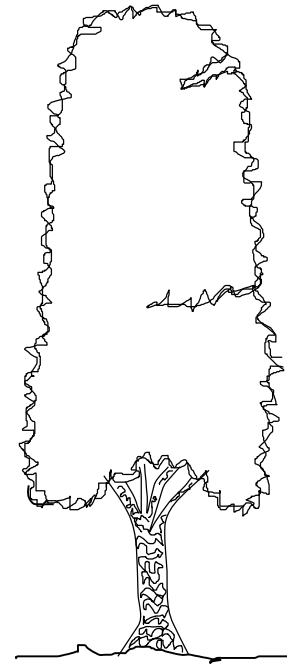

Columnar

REPRESENTATIVE FORM CLASSES

Figure 59-7.D

- Space trees with fastigate or columnar crowns at a minimum distance of 20 ft (6 m).
5. Spacing Between Trees Within Median or Other Right-of-Way Areas. Spacing will follow the same criteria given for spacing between trees within parkways with the following exception: if the median is concrete paving or other hard surface material, obtain written approval for the specific tree planting proposal. Spacing of trees located on other right-of-way must be approved by the district Landscape Architect/Roadside Manager.
6. Width of Parkway, Medians, and Other Public Ways. Landscape designs must be so arranged to provide a sufficiently wide, clear, and safe pedestrian walkway. The required width will in no case be less than 6 ft (1.8 m) wide, measured from a line 1 ft (300 mm) within the right-of-way. Use the following criteria:
- a. Minimum Width of Parkway. Use the following criteria for minimum width of parkways:
 - Do not plant trees on any parkway that is less than 6 ft (1.8 m) in width except when specific permission is granted by the district Landscape Architect/Roadside Manager.
 - Do not plant trees on any commercial or industrial sidewalk or cut-out in a sidewalk that is less than 16 ft (4.8 m) in width, except when specific permission is granted by the district Landscape Architect/Roadside Manager.
 - b. Minimum Width of Medians. Do not plant any trees or shrubs in a median unless a local community agrees to the maintenance of the median. Do not plant trees on any median that is less than 10 ft (3 m) in width, except when specific permission is granted by the district Landscape Architect/Roadside Manager.
 - c. Minimum Width of Other Right-of-Way. Do not plant trees on any right-of-way that is less than 26 ft (7.8 m) in width except when specific permission is granted by the district Landscape Architect/Roadside Manager.
7. Lateral Location of Trees Within Parkway, Medians, and Right-of-Way Areas. Use the following lateral location criteria:
- The lateral location of trees being planted should reflect the ultimate pavement width of arterial streets.
 - Where practical, trees planted in parkways will be planted in the lateral center of the parkway, or as close to it as practicable, unless specifically approved otherwise.
 - Space and locate trees planted according to their crown form, basal clearance, and the recommendations of the district Landscape Architect/Roadside Manager.

- Do not plant trees that will branch lower than 10 ft (3 m) immediately adjacent to sidewalks.
- Do not plant trees that will branch lower than 14 ft (4 m) immediately adjacent to driveways.

In urbanized areas, a maintenance agreement with the local agency is usually required.

59-7.12 Visual Quality

Visual quality is a functional goal that is achieved by conserving existing visual resources and enhancing the built environment through landscape and environmental design. Consider the following factors during design:

- the view from the road and of the road;
- outstanding scenic qualities;
- the color choices for roadside features;
- the location of utilities;
- clear zones, sight lines, and profiles;
- bridge and structure designs;
- number, type, and location of signage; and
- noise mitigation structures.

59-7.13 Erosion Control

See Chapter 41 for information on erosion and sediment control.

59-7.14 Architectural Design Elements

There are a number of architectural design elements that can be incorporated into highway design to make the project compatible with its environment including:

- retaining walls constructed with special finishes, modular block, or stone;
- noise barrier walls;
- sight-screen fences and walls to screen unsightly areas such as junkyards;
- sculptures, graphics, and other special art work;
- guardrails and concrete barriers;
- highway appurtenances including signs, delineators, traffic signals, and control boxes;
- access control fencing;

- bridge designs;
- light poles, historical lighting fixtures, and lighting of tunnels, bridges, and pedestrian sidewalks and trails;
- enhanced light quality and special aesthetic enhancement light for structures, sculptures, flag poles, and other artwork;
- planter boxes;
- bicycle racks;
- bollards and barriers; and
- decorative surface areas including stone surfaces, patterned and/or colored concrete, and precast concrete pavers and natural stone pavers.

59-7.15 Plan Preparation

Provide a copy of the construction plan sheets and cross sections to the district Landscape Architect/Roadside Manager for plant placement/replacement input.

Include the following in the plans:

1. Plant key sheet, including the following information:
 - code numbers with heading of trees, intermediate shrubs, evergreens, seedlings, and wildflowers;
 - scientific name;
 - common name;
 - measured size (include balled and burlapped, container grown, and bare root);
 - key number (optional);
 - each or units;
 - quantity;
 - sheet locations; and
 - general notes, if any;
2. Sheets showing actual location of items on project with key number; and
3. Any standard sheet, e.g., details of hole size, bracing, mulch.

See Chapter 63 for further details.

59-7.16 Highway Related Areas

The transportation system contains supplemental areas and facilities (e.g., bikeways, information centers, weigh stations, rest areas) that are specifically designed for uses other than driving. It is important to understand that these areas and facilities are integral, not separate, features of the highway. Detailed treatment is required to ensure that these areas and facilities provide maximum benefit to the user and blend into or complement the surrounding landscape.

The need for supplemental highway related areas and facilities are evaluated at the inception of the design process. Rest areas, scenic overlooks, and truck weigh stations shall be planned in conjunction with the entire highway system. Other facilities are designed to take advantage of the environment through which the highway passes. Urban streetscape and scenic highways can be either carefully planned and managed or evolve unplanned.

Separate bikeways can exist within the right-of-way. Park-and-ride lots are becoming increasingly important aspects of the highway and must be addressed in evaluating the total highway environment.

As highways and bridges are being reconstructed in response to age, deterioration, and changes in use, similar attention must be paid to the various highway related areas that have been constructed to support the highway system. Consult the AASHTO publication *A Guide For Transportation Landscape and Environmental Design* for considerations involving highway related areas. See Chapter 16 for information on rest areas and weigh stations.

59-7.17 Roadside Seeding in Areas Disturbed By Construction

Since the early 1980's, the Department's decisions on type of cover and plant material for roadside areas have been largely influenced by consideration of the level of maintenance/management anticipated for the areas involved. This practice has helped the Department to achieve a better fit between available funding and manpower resources and the amount of roadside maintenance needed. When allowable as a project cost, experience has shown that where a low level of maintenance/management is desired, native Illinois grasses and other native selections often are the best choice for planting. Furthermore, *Roadside Use of Native Plants* published by the FHWA is guidance that encourages the use of native plants to the project locale where practical. The guidance in this topic clarifies requirements on developing plan specifications for roadside seeding/cover and is intended to maximize the benefits of using native plants.

Use the following procedures in developing seeding/cover specifications for 3R, reconstruction, and new construction projects:

1. Mowing Widths. Consult with the district Landscape Architect/Roadside Managers to determine applicable mowing widths for all projects in accordance with current mowing policies of the Bureau of Operations.
2. Seeding For Mowed Areas. In all areas that Operations' policy stipulates must be mowed for safety of the motoring public, specify the appropriate seeding selections from Classes 1 or 2, depending upon the site conditions and geographical location of the project. The designer should consult the district Landscape Architect/Roadside Manager on the specific seeding selections.
3. Seeding For Areas That Will Not Be Mowed. In those areas that Operations policy stipulates are not to be mowed regularly, specify appropriate seeding selections from Class 4 and Class 5 or, for steep inaccessible slopes, from Class 3. As with specifications for mowed areas, the designer should consult with the district Landscape Architect/Roadside Manager on the selections within these classes for specific circumstances. Do not use Class 4 seeding in ditch bottoms or drainage ways where it would impede the flow of water. In areas that are not to be mowed, plantings within 10 ft (3 m) of the shoulder break/face-of-curb should not exceed a height of 3 ft (1 m) at maturity and should not interfere with sight distances.
4. Seeding for Areas Involving Special Environmental Commitments. For project goals or commitments involving wildflower planting, environmental mitigation, aesthetics, or habitat enhancement the designer should consult with the district Landscape Architect/Roadside Manager on the use of Class 5 or Class 6 seeding.
5. Overseeding/Interseeding on 3R or Reconstruction Projects. On 3R or reconstruction projects, existing turf in unmowed areas and all damaged turf should be overseeded or interseeded in accordance with the specifications using an appropriate class as determined by the district Landscape Architect/Roadside Manager to establish turf that will require little or no regular maintenance.
6. Turf Establishment on New Construction Projects. On new construction projects, turf should be established by conventional methods appropriate to the seeding class as determined by the district Landscape Architect/Roadside Manager.
7. Use of Other Grasses and Forbs. Grasses and forbs other than those in seeding Classes 1 through 6 may be specified for use at the discretion of the district Landscape Architect/Roadside Manager. Any such plants must be appropriate to the location and intended management of the project and, generally, should be species native to the project locale.

59-8 REFERENCES

1. *A Guide for Transportation Landscape and Environmental Design*, AASHTO, 1991
2. *Pollinators and Roadsides: Best management Practices for Managers and Decision Makers*, FHWA, 2016
3. *Roadside Use of Native Plants*, FHWA, 1999.

Chapter Sixty

OTHER DEPARTMENT MANUALS

BUREAU OF DESIGN AND ENVIRONMENT MANUAL

Chapter Sixty
OTHER DEPARTMENT MANUALS

Table of Contents

<u>Section</u>	<u>Page</u>
60-1 GENERAL	60-1.1
60-2 BUREAU OF DESIGN AND ENVIRONMENT	60-2.1
60-2.01 <i>IDOT Coded Pay Items</i>	60-2.1
60-2.02 <i>Standard Specifications for Road and Bridge Construction</i>	60-2.1
60-2.03 <i>Computer Aided Design, Drafting, Modeling and Deliverables Manual</i>	60-2.1
60-2.04 <i>Highway Standards</i>	60-2.2
60-2.05 <i>Survey Manual</i>	60-2.2
60-2.06 <i>Community Impact Assessment Manual</i>	60-2.2
60-3 BUREAU OF BRIDGES AND STRUCTURES	60-3.1
60-3.01 <i>Bridge Manual</i>	60-3.1
60-3.02 <i>Culvert Manual</i>	60-3.1
60-3.03 <i>Prestressed Concrete Manual</i>	60-3.1
60-3.04 <i>Sign Structure Manual</i>	60-3.2
60-3.05 <i>Drainage Manual</i>	60-3.2
60-3.06 <i>Structural Services Manual</i>	60-3.2
60-3.07 <i>Geotechnical Manual</i>	60-3.3
60-3.08 <i>Bridge Manual Design Guides</i>	60-3.3
60-3.09 <i>Bridge Condition Report Procedures and Practices</i>	60-3.4
60-4 BUREAU OF CONSTRUCTION	60-4.1
60-5 BUREAU OF LAND ACQUISITION	60-5.1
60-6 BUREAU OF LOCAL ROADS AND STREETS.....	60-6.1
60-6.01 <i>Local Roads and Streets Manual</i>	60-6.1
60-6.02 <i>Highway Jurisdiction Guidelines for Highway and Street Systems</i>	60-6.1
60-7 BUREAU OF OPERATIONS.....	60-7.1
60-7.01 <i>Traffic Policies and Procedures Manual</i>	60-7.1
60-7.02 <i>Illinois Standard Highway Signs</i>	60-7.1
60-7.03 <i>Illinois Manual for Uniform Traffic Control Devices</i>	60-7.1
<i>Handbook for the Policy on Permits for Access</i>	60-7.2
60-7.04 <i>Driveways to State Highways</i>	60-7.2
60-7.05 <i>Accommodation of Utilities on Right-of-Way of the Illinois</i> <i>State Highway System</i>	60-7.2
60-7.06 <i>Policy on Establishing and Posting Speed Limits on the</i> <i>State Highway System</i>	60-7.2
60-7.07 <i>Maintenance Policy Manual</i>	60-7.3
60-7.08 <i>Pavement Marking Selection Installation & Inspection Manual</i>	60-7.3

Table of Contents
(Continued)

<u>Section</u>	<u>Page</u>
60-7.09 <i>Reporting and Signing of Vertical Clearances and Obstructed Turning Movements</i>	60-7.3
60-8 BUREAU OF MATERIALS	60-8.1
60-8.01 <i>Manual of Test Procedures for Materials</i>	60-8.1
60-8.02 <i>Manual for Materials Inspection</i>	60-8.1
60-9 BUREAU OF SAFETY PROGRAMS AND ENGINEERING.....	60-9.1
60-9.01 <i>Traffic Control Field Manual</i>	60-9.1
60-9.02 <i>Systemic Safety Improvements: Analysis, Guidelines and Procedures Manual</i>	60-9.1

Chapter Sixty

OTHER DEPARTMENT MANUALS

The *Bureau of Design and Environment Manual (BDE Manual)* includes the necessary information on the topics discussed in the *Manual* for the vast majority of roadway projects designed by the districts. However, it does not present all information that may be required by the designer on all projects. For specific projects or for specific project elements, the road designer may need to reference other publications to perform a fully comprehensive analysis of the project. Chapter 60 briefly discusses other publications available within IDOT that are often required by the designer for a roadway project. The designer may also need to review the national highway engineering literature to research a specific problem or to design special elements. Summaries of national publications can be found in the publication catalogs of the various organizations (e.g., AASHTO, ITE, TRB).

60-1 GENERAL

For in-house designers, copies of most documents and publications used in design are available on the Inside IDOT Policy and Research Center Library website or by contacting the IDOT Library. For consultants and other individuals, these documents can be located on the Department's official website.

60-2 BUREAU OF DESIGN AND ENVIRONMENT

In addition to the *BDE Manual*, the various sections of the Bureau of Design and Environment are responsible for maintaining the following documents:

60-2.01 *IDOT Coded Pay Items*

Every pay item has a unique assigned number for data processing. The *IDOT Coded Pay Items* provides a listing of all pay items and numbers used by the Department for a project. These numbers and titles are tied to the *Standard Specifications for Road and Bridge Construction*. Only use these numbers and descriptions in the plans and estimates. Both US Customary and metric pay items are presented in the *IDOT Coded Pay Items*.

Part VII of the *BDE Manual* provides additional information on how to use the *IDOT Coded Pay Items* during plan development.

60-2.02 *Standard Specifications for Road and Bridge Construction*

The *Standard Specifications for Road and Bridge Construction (Standard Specifications)* are the specifications adopted by the Department for work methods, materials, and basis of payment used in construction. The *Standard Specifications* are intended for general repetitive use. They provide Department criteria for:

- bidding,
- awarding the contract,
- the contractor's duties,
- controlling the material quality,
- the contractor's and the Department's legal requirements,
- executing the contract, and
- measuring and paying for construction.

See Section 66-1.02 for more information on the *Standard Specifications*.

60-2.03 *Computer Aided Design, Drafting, Modeling and Deliverables Manual*

The *Computer Aided Design, Drafting, Modeling and Deliverables Manual* provides the policies on the use of Computer Aided Design and Drafting (CADD) software used on Department roadway and structures projects. It defines the following:

- The requirements for CADD files and 3D models used on Department projects, such as file formats and file naming and referencing conventions,
- The deliverables requirements for both 2D and 3D CADD files at various stages of the project lifecycle,
- MicroStation and GEOPAK configuration information,

- Standard software used by the Department,
- CADD Workspace Configuration used by the Department,
- Drafting guidelines to be used on both roadways and structures projects,
- Links to additional resources, district CADD contacts, CADD subscription services, and example roadway and structures construction plans, and
- Various Frequently Asked Questions (FAQ's) concerning CADD.

60-2.04 Highway Standards

The *Highway Standards* provide details for laying out or constructing various design elements that are consistent from project to project (e.g., guardrail, curb and gutter, signs, fencing, landscaping). The *Highway Standards* contain both US Customary and metric units. The *Highway Standards* are developed by BDE in collaboration with other bureaus. See Section 66-1.05 for more information on the *Highway Standards*.

60-2.05 Survey Manual

The *Survey Manual* provides the Department's survey policies and regulations. It includes:

- a discussion of geodetic surveying covering datums, State-plane coordinates, and geodetic surveying;
- design surveys;
- photogrammetric surveys covering accuracy requirements as well as GPS procedures;
- land surveys, which includes a discussion of the public land surveys;
- construction surveys, which includes staking procedures;
- a chapter on safety designed to eliminate crashes and property damage; and
- several appendices with more in-depth discussion of curves, specifications for different types of surveys, survey point codes, and confined space entry policy.

60-2.06 Community Impact Assessment Manual

The purpose of the *Community Impact Assessment Manual* is to present information to be used in socioeconomic or community impact assessments, identify data sources, and aid in the evaluation of alternatives for transportation improvements. This manual is designed to provide accurate, clear, and consistent information to assist IDOT personnel and consultants in completing community/socioeconomic impact documentation. The manual encompasses the socioeconomic or community impacts of the environmental assessment process from initiation of a highway project through the various stages of project development, to the concluding

stages of the preparation of final documentation. In addition, the manual includes suggestions for mitigation and enhancement efforts that may be appropriate for various projects.

60-3 BUREAU OF BRIDGES AND STRUCTURES

The Bureau of Bridges and Structures is responsible for the following documents:

60-3.01 Bridge Manual

The *Bridge Manual* is a compilation of design procedures, plan presentation guidelines, specifications interpretation, standard practices, design details, and base sheets for bridges and other structures. It includes:

- a discussion on the organization of the Bureau of Bridges and Structures;
- plan preparation checklists for TS&L and final plans;
- sample plan sheets;
- a discussion on the Department's bridge planning process;
- preliminary bridge investigation techniques;
- bridge geometric criteria;
- structure rehabilitation techniques;
- utility attachments on structures; and
- design criteria for decks, structural steel, expansion devices, bearings, abutments, piers, piles, embankment and slope walls, and other miscellaneous details.

There are both US Customary and metric versions of the *Bridge Manual*.

60-3.02 Culvert Manual

The *Culvert Manual* is a compilation of design procedures, design charts and tables, standard details, and base plan sheets which are used to aid in the design and detailing of:

- simple-span, reinforced concrete box culverts;
- precast concrete box culverts;
- horizontal cantilever wingwalls;
- vertical cantilever, L-type wingwalls; and
- vertical cantilever, T-type wingwalls.

There are both US Customary and metric versions of the *Culvert Manual*.

60-3.03 Prestressed Concrete Manual

The *Prestressed Concrete Manual* is a compilation of design procedures, design charts and tables, examples, standard details, and base plan sheets that are used to aid in the design and detailing of Illinois standard precast, prestressed concrete bridge beams.

60-3.04 Sign Structure Manual

The *Sign Structures Manual* presents guidelines for the selection of sign supports, sign support design details, and CADD criteria for incorporating traffic signs into the plans. The following types of sign structures are discussed in the *Sign Structures Manual*:

- simple-span sign structures,
- cantilever sign structures,
- bridge-mounted sign structures,
- monotube sign structures,
- break-away wide flange steel sign posts, and
- break-away tubular steel sign posts.

60-3.05 Drainage Manual

The *Drainage Manual* is a compilation of the Department's policies and criteria on drainage and hydraulics for road and bridge projects. The *Drainage Manual* provides guidance on:

- division of responsibility for drainage,
- legal requirements,
- drainage polices,
- permits,
- preparation of drainage studies and hydraulic reports,
- floodplain encroachments,
- hydrology,
- open channel flow,
- culvert hydraulics,
- bridge hydraulics,
- storm sewers,
- roadside ditches,
- erosion and sediment control,
- scour,
- detention storage,
- pumping stations, and
- rules for construction in rivers, lakes, and streams.

60-3.06 Structural Services Manual

The *Structural Services Manual* provides guidance and information on the maintenance and repair of existing structures. It includes information on:

- plan preparation and review responsibilities,
- bridge inspections,

- bridge deck overlays,
- expansion joint replacement,
- longitudinal joint closure,
- bridge rail and parapet repair and replacement,
- deck drains,
- bearing replacements,
- jacking and cribbing,
- pin and link replacement,
- fatigue,
- impact repairs for steel and concrete beams,
- steel and concrete superstructure repairs,
- guidelines for bridge deck repair, and
- substructure repairs.

60-3.07 Geotechnical Manual

The *Geotechnical Manual* addresses the application and treatment of soils and foundations on State projects. It presents guidance and information on:

- geotechnical investigation requirements;
- geotechnical analyses of subgrades, embankments, cut slopes, and foundations;
- recommendations for design problems involving embankments, cut slopes, peat deposits, frost action, drainage, and foundations;
- preparation and submittal of Geotechnical Reports;
- geotechnical engineering aspects for construction;
- the State's geology and pedology;
- laboratory and field testing of soils;
- Illinois' modified testing procedures and methods; and
- geotechnical glossary.

60-3.08 Bridge Manual Design Guides

The *Bridge Manual Design Guides Manual* is a compilation of various design elements on CADD that are commonly found on bridge and other structures projects. The manual provides examples of Type, Size, and Location (TSL) plans that indicate a range of grade separation and stream crossing structures, as well as retaining walls that have been developed to provide planners with a quick reference for bridge planning policy and presentation methods.

60-3.09 Bridge Condition Report Procedures and Practices

This document is a guideline for preparing Bridge Condition Reports for the improvement of roadway structures and was developed to provide the wide range of information necessary to complete reports for various types of bridge projects. The guideline reviews background information, field inspection, and testing (in brief), general analysis procedures and report preparation. Example Bridge Condition Report formats are provided in the document.

60-4 BUREAU OF CONSTRUCTION

The Bureau of Construction is responsible for the *Construction Manual*. The *Construction Manual* expands on the *Standard Specifications for Road and Bridge Construction* and provides guidelines for uniform field inspection and documentation procedures on highway construction. It contains explanatory information on:

- contract administration;
- earthwork;
- landscaping;
- temporary erosion control;
- subgrades, subbases, and base courses;
- surfacing;
- structures including concrete, steel, and timber structures;
- piling;
- reinforcing bars;
- culverts;
- curb and gutter;
- chain link and woven wire fencing;
- traffic control;
- construction memoranda;
- documentation and project procedure guidelines;
- inspection checklists; and
- construction forms and reports.

60-5 BUREAU OF LAND ACQUISITION

The Bureau of Land Acquisition is responsible for the *Land Acquisition Policies and Procedures Manual*. The *Land Acquisition Policies and Procedures Manual* presents information on:

- the organization, functions, and activities of the Bureau of Land Acquisition;
- preparation of right-of-way plans;
- programming of right-of-way projects;
- land surveying criteria;
- development of right-of-way plats;
- legal descriptions for right-of-way;
- guidelines for designing the right-of-way;
- administration of incidental land surveying services;
- policies and procedures for appraisals and appraisal reviews;
- policies and procedures for negotiations;
- policies and procedures for acquisition;
- policies and procedures for property management of State property;
- policies and procedures for relocation assistance and payment program; and
- other miscellaneous Land Acquisition policies and procedures.

60-6 BUREAU OF LOCAL ROADS AND STREETS

The Bureau of Local Roads and Streets is responsible for the following documents:

60-6.01 Local Roads and Streets Manual

The *Local Roads and Streets Manual* replaces the *Administrative Policies and Federal-Aid Procedures Manuals*, used previously.

The *Local Roads and Streets Manual* provides information on:

- the Bureau of Local Roads and Streets' responsibilities for vouchering the State's motor fuel tax funds and township bridge funds to the local agencies;
- local agency (i.e., municipalities, counties, and road districts) responsibilities for maintaining complete records of disbursements, refunds, transfers, and balances involving all State funds transferred to the local agencies;
- design guidelines for local roads and streets including functional classification, engineering analyses, roadway design, traffic control devices, pavement design, bridges and culverts, and hydraulics;
- guidelines for addressing right-of-way acquisitions, railroads, and utilities;
- policies and procedures for preparing plans, specifications, estimates, proposals, contracts, highway system revisions, resolutions, agreements, and other miscellaneous documents;
- letting, award, and construction procedures;
- maintenance administration and operations for local facilities; and
- guidelines and procedures for projects involving Federal funding, including:
 - + environmental analyses and reports;
 - + public involvement guidelines; and
 - + FHWA coordination, review, and approval.

60-6.02 Highway Jurisdiction Guidelines for Highway and Street Systems

The guidelines in the above referenced document summarize highway jurisdiction issues and outline the process required for jurisdictional transfers. The document also addresses vacations and additions to the township and road district system, which may become necessary in the project development process.

| .

60-7 BUREAU OF OPERATIONS

The Bureau of Operations is responsible for the following documents:

60-7.01 *Traffic Policies and Procedures Manual*

The *Traffic Policies and Procedures Manual* presents guidelines for the uniform placement of traffic control devices and the application of traffic control policies and procedures. It contains guidance and information on:

- statutory and administrative requirements for traffic control devices;
- information-gathering procedures and data sources;
- traffic engineering studies and investigations including accident studies, speed studies, warrant studies, observance studies, time and delay studies, and school-zone safety;
- plan preparation including agreements, contracts, specifications, etc., for traffic plans;
- the selection, design, and placement of signing, pavement markings, traffic signals, object markers, delineation, rumble strips, traffic control in work zones, bikeways, and highway and sign lighting, and;
- permits including access control, special vehicular movements, road closures for local celebrations, utilities, snowmobiles on State routes, and other miscellaneous permits.

60-7.02 *Illinois Standard Highway Signs*

The *Illinois Standard Highway Signs* illustrates the layout and design details for the highway signs used by the Department. It includes the MUTCD number, allowable sign sizes, and design details for:

- regulatory signs,
- warning signs,
- construction signs,
- guide signs,
- general information signs,
- motorist services signs,
- civil defense signs, and
- school signs.

60-7.03 *Illinois Manual for Uniform Traffic Control Devices*

The *Illinois Manual for Uniform Traffic Control Devices* (ILMUTCD) consists of the *Illinois Supplement to the MUTCD* and the *FHWA Manual on Uniform Traffic Control Devices* (MUTCD). Note that there is not actually a document entitled the *Illinois Manual for Uniform Traffic Control Devices*. Wherever a publication refers to the *Illinois Manual for Uniform Traffic*

Control Devices, the user should first review the *Illinois Supplement to the MUTCD* and, if it does not address the issue, the user should then use the criteria in the *FHWA Manual on Uniform Traffic Control Devices*. These combined documents address the selection, design, and placement of traffic control devices on State facilities.

The *Illinois Supplement to the MUTCD* presents criteria and guidance specific to Illinois which may vary or which are in addition to the *FHWA MUTCD*. It includes:

- reprint of the applicable sections from the *Illinois Vehicle Code* which pertain to traffic control devices;
- revisions and additions to the *FHWA MUTCD* traffic control devices for signing, pavement markings, traffic signals, construction signing, schools, and railroads; and
- a table of Illinois standard signs.

60-7.04 Handbook for the Policy on Permits for Access Driveways to State Highways

The *Handbook for the Policy on Permits for Access Driveways to State Highways* provides detailed information regarding requirements for the construction or modification of permitted access to State Highways or the access permit process in general. The information in the *Handbook* is governed by the *Illinois Highway Code sections 605 ILCS 5/4-209, 4-210, 4-211 and 4-212*, and *92 Ill. Admin. Code 550*.

60-7.05 Accommodation of Utilities on Right-of-Way of the Illinois State Highway System

The purpose of the above referenced manual is to establish policies and procedures for accommodating utilities on right-of-way of the Illinois State Highway System, which may become necessary for review during project development.

60-7.06 Policy on Establishing and Posting Speed Limits on the State Highway System

The above referenced manual, along with the latest revisions/editions to Chapter 11, Article VI of the *Illinois Vehicle Code*, enumerates the procedures for establishing speed limits on highways under the jurisdiction of the Illinois Department of Transportation (IDOT).

60-7.07 Maintenance Policy Manual

The purpose of the *Maintenance Policy Manual* is to provide a written reference that will enable IDOT personnel to more uniformly maintain the State Highway System. This manual contains:

- Guidelines for completing work activities assigned to the central and district Bureaus of Operations (Bureau of Maintenance in District 1).
- References to policies and procedures governing functions of bureaus, offices, or agencies which have a bearing on highway maintenance operations activities, including the planned activities of roadway and structures designers.
- Information regarding necessary local agency agreements and maintenance obligations on state highway projects with side roads or local participation.

60-7.08 Pavement Marking Selection Installation & Inspection Manual

The above-referenced manual is authorized by Department Policy TRA-14. It serves as both a guideline for selecting optimum pavement marking materials and as a reference for inspecting the installation of pavement markings. The manual is intended for use in design, maintenance, and inspection.

60-7.09 Reporting and Signing of Vertical Clearances and Obstructed Turning Movements

It is necessary to report truck length restrictions for routes where difficulties from load length have occurred due to obstructed turning radii or sag curves with low vertical clearances. Reported truck length restrictions will be utilized, by the central Bureau of Operations, when issuing oversize load permits in order to prevent permitted loads from damaging roadways and becoming entrapped. Additionally, the Illinois Department of Transportation is authorized by the Size, Weight, Load, and Permits law [625 ILCS 5/15-101 *et seq.*, Ch. 15] to issue special permits to allow the operation of vehicles or loads that exceed the legal maximum dimension and weights on highways under Department jurisdiction (Federal and State non-local highways maintained by IDOT). Measurements of vertical clearances are used when issuing these permits. It is therefore necessary that IDOT exercise due diligence in the collection, maintenance, security and reporting of all minimum vertical clearances, measured to overhead obstructions, over all state-maintained roadways.

The intent of the above referenced policy document is to provide uniform signing and reporting procedures for vertical clearances and obstructed turning movements in order to reduce instances of vehicles entrapped on roadways.

60-8 BUREAU OF MATERIALS

The Bureau of Materials is responsible for the following documents:

60-8.01 Manual of Test Procedures for Materials

The above referenced manual presents the Department's criteria for sampling and test procedures for evaluating the following materials for road and bridge construction:

- aggregates,
- hot-mix asphalt, and
- Portland cement concrete.

60-8.02 Manual for Materials Inspection

The above-referenced manual is authorized by Department Policy MAT-11.

This manual is a guide for the inspection of metals, plastics, chemicals, admixtures, and other miscellaneous materials. It generally covers materials that are not soils, hot mix, concrete or aggregates.

60-9 BUREAU OF SAFETY PROGRAMS AND ENGINEERING

The Bureau of Safety Programs and Engineering is responsible for the following documents:

60-9.01 Traffic Control Field Manual

The *Traffic Control Field Manual* is issued for the purpose of the proper application of temporary traffic control devices. The manual has been developed to establish the minimum requirements for work site protection, when traffic control is provided by the Department.

60-9.02 Systemic Safety Improvements: Analysis, Guidelines and Procedures Manual

The Systemic Safety Improvements: Analysis, Guidelines and Procedures Manual explains how to collect crucial safety data that is not readily available, analyze safety data, use available resources to implement strategies effectively and make proactive infrastructure improvements, and to target enforcement and education programs. The information presented in this document will assist in better identifying potential safety performance issues on a roadway system and guide efforts to save lives. Specifically, this document includes the tools necessary for conducting safety analyses, network screening and the systemic approach. These guidelines detail the systemic process which includes collecting and organizing data, obtaining critical values, compiling the results, assessing existing field conditions, and selecting appropriate countermeasures.

Chapter Sixty-one

RESERVED

BUREAU OF DESIGN AND ENVIRONMENT MANUAL

Chapter Sixty-one
RESERVED

Chapter Sixty-two

RESERVED

BUREAU OF DESIGN AND ENVIRONMENT MANUAL

Chapter Sixty-two
RESERVED

Chapter Sixty-three
PLAN PREPARATION

BUREAU OF DESIGN AND ENVIRONMENT MANUAL

Chapter Sixty-three
PLAN PREPARATION

Table of Contents

<u>Section</u>	<u>Page</u>
63-1 GENERAL INFORMATION	63-1.1
63-1.01 Responsibilities	63-1.1
63-1.02 Plan Development Stages	63-1.2
63-1.02(a) Phase II Initiation	63-1.2
63-1.02(b) Preliminary Plan Review	63-1.3
63-1.02(c) Pre-Final Plan Review	63-1.4
63-1.02(d) Final Plan Review	63-1.4
63-1.03 CADD Coordination	63-1.4
63-1.03(a) 3D Modeling Determination	63-1.4
63-1.03(b) Corrections to Plans and Models	63-1.5
63-2 COMPUTERIZED DESIGN	63-2.1
63-2.01 <i>Computer Aided Design, Drafting, Modeling, and</i> <i>Deliverables Manual</i>	63-2.1
63-2.02 Computer Hardware	63-2.1
63-2.03 Computer Software	63-2.1
63-2.04 File Management	63-2.2
63-3 DRAFTING GUIDELINES	63-3.1
63-4 PLAN FORMAT AND COMPOSITION	63-4.1
63-4.01 General	63-4.1
63-4.02 Cover Sheet	63-4.1
63-4.02(a) Sheet Content	63-4.1
63-4.02(b) Section Designation	63-4.5
63-4.03 Index of Sheets, <i>Highway Standards</i> , General Notes, and Commitments	63-4.9
63-4.03(a) Index of Sheets	63-4.10
63-4.03(b) Highway Standards	63-4.10
63-4.03(c) General Notes	63-4.10
63-4.03(d) Sample General Notes	63-4.11
63-4.03(e) Commitments	63-4.11

Table of Contents*(Continued)*

<u>Section</u>		<u>Page</u>
63-4.04	Summary of Quantities	63-4.12
	63-4.04(a) General Layout	63-4.12
	63-4.04(b) Construction Pay Items	63-4.13
	63-4.04(c) Quantity Breakdowns	63-4.14
	63-4.04(d) Schedule of Quantities	63-4.15
63-4.05	Typical Sections	63-4.15
63-4.06	Alignment, Ties, and Benchmarks	63-4.18
63-4.07	Plan and Profile Sheets	63-4.19
	63-4.07(a) General Guidelines	63-4.19
	63-4.07(b) Plan View	63-4.21
	63-4.07(c) Profile View	63-4.26
	63-4.07(d) Surplus Excavation Disposal	63-4.28
63-4.08	Stages of Construction and Traffic Control Sheets	63-4.28
63-4.09	Erosion and Sediment Control Details	63-4.29
63-4.10	Drainage and Utilities Sheets	63-4.30
	63-4.10(a) Existing Information	63-4.30
	63-4.10(b) Proposed Design	63-4.30
	63-4.10(c) General	63-4.31
	63-4.10(d) Plan View	63-4.31
	63-4.10(e) Profile View	63-4.33
63-4.11	Right-of-Way Plan Sheets	63-4.34
63-4.12	Intersection Details	63-4.34
63-4.13	Pavement Marking Details	63-4.35
63-4.14	Special Plans	63-4.35
	63-4.14(a) Landscaping Details	63-4.36
	63-4.14(b) Traffic Signal Plans	63-4.36
	63-4.14(c) Lighting Plans	63-4.36
	63-4.14(d) Structure Plans	63-4.37
	63-4.14(e) Wetland Plans	63-4.37
63-4.15	Special Details	63-4.38
63-4.16	Cross Sections	63-4.39
	63-4.16(a) Procedure	63-4.39
	63-4.16(b) Layout	63-4.39
	63-4.16(c) Plotting Details	63-4.40
63-4.17	Highway Standard Drawings	63-4.43

Table of Contents
(Continued)

<u>Section</u>		<u>Page</u>
63-5	CONSTRUCTION TYPE CODES	63-5.1
63-6	SUGGESTED PLAN PREPARATION CHECKLIST	63-6.1

Chapter Sixty-three

PLAN PREPARATION

Other parts of the *Bureau of Design and Environment Manual (BDE Manual)* provide the designer with uniform criteria and procedures for the design of a highway facility. Incorporate these designs into the roadway plans so that they can be clearly understood by contractors, material suppliers and Department personnel assigned to supervise and inspect the construction of the project. To ensure a consistent interpretation of the plans, individual sheets should have a standard format and content, and the sequence of plan assembly should generally be the same. To provide this consistency, this chapter provides guidelines for the uniform preparation of Phase II plans.

In addition to this chapter, the designer should review:

- Part I of the *BDE Manual* for information on the design process or steps that should be followed in preparing a set of plans,
- Chapter 64 for quantity computations,
- Chapter 65 for cost estimating, and
- Chapter 66 for the contract process.

If problems arise which are not covered in this *Manual*, the designer should consult with the Bureau of Design and Environment personnel as the project progresses to resolve these problems as soon as practical prior to plan completion.

63-1 GENERAL INFORMATION

63-1.01 Responsibilities

The highway designer is responsible for the preparation of Phase II plans. This includes:

- ensuring that the plans are in compliance with the Phase I report, commitments, and agreements;
- ensuring that the survey is properly drafted;
- preparing the plans in the correct format and sequence, and checking for errors and omissions;
- incorporating plan sheets, quantities, and special provisions from other sections/bureaus into the plans;

- calculating the quantities and recording them on the summary of quantities sheet;
- preparing the contract special provisions and supporting documents;
- incorporating appropriate review comments from various other units, bureaus, agencies, etc.;
- requesting the preparation of the construction cost estimate; and
- submitting the plans to the BDE for review, approval, and letting.

63-1.02 Plan Development Stages

The designer is responsible for preparing the plans so that they can be constructed in the field. To ensure the plans are correct and complete, the designer needs to review the Phase I report and the project commitment file. The plans will also be reviewed by others at the preliminary, pre-final, and/or final stages to ensure that they are free from errors and omissions. Chapters 2, 3, and 4 discuss the other activities that are typically involved during the project preparation. The following sections briefly discuss the key stages relative to plan preparation.

63-1.02(a) Phase II Initiation

To properly prepare the plans, the designer must have a well-defined scope of work. The Department's proposed scope of work for a project is defined in the appropriate Phase I report. Part II, Project Development, of the *BDE Manual* discusses how to prepare a Phase I report and what factors should be considered. Part III, Environmental Procedures, discusses the environmental issues that must be addressed.

In addition to the Phase I report, the designer is provided, at the beginning of Phase II, the project commitment file. This file should contain all commitments made to the public and other agencies during the location and environmental study stages of the project. These commitments may include:

- funding arrangements between the Department and local agencies and/or developers, which may include construction costs, signal maintenance, lighting agreements, etc.;
- notification requirements to public agencies, owners, local officials, etc., prior to construction;
- requests for verification of area to be disturbed by the project;
- commitments to owners, public agencies, and/or local officials for plant replacement, removal, or retainage (e.g., trees, shrubs, wetland plants);
- environmental commitments to public agencies, local officials, and/or other groups (e.g., wetland replacement, hazardous material removal);

- relocation, removal, or replacement agreements/requests for existing buildings;
- drainage agreements, including detention areas, culvert locations, ditch construction, etc.;
- relocation, rebuilding, addition, or removal agreements/requests for private and commercial entrances;
- special construction requests (e.g., timing of construction, type of construction, limits of construction);
- existing sign removal and replacement; and/or
- any other special agreements made between the Department and land owners during right-of-way negotiations.

The designer is responsible for maintaining this commitment file and ensuring that these commitments are incorporated into the final plans and agreements. The designer needs to carefully review all minutes of meetings, transcripts of public hearings, and the project study files to ensure all commitments have been listed. If there are any questions, the designer should contact the preparer of the Phase I report. During Phase II, the designer also adds to the file any commitments made to property owners or others affected by the project.

If it is discovered during plan preparation that a change is required to the approved Phase I report or a commitment cannot be met, the designer must immediately notify the Central Office and all appropriate district units so that appropriate action can be taken. Failure to provide the appropriate notification and review may result in project delays.

63-1.02(b) Preliminary Plan Review

This is the best design stage for various other bureaus, sections, agencies, etc., who may have a role in the project to conduct a major review of the plans. This may include a plan-in-hand field review, if deemed necessary. The preliminary plan review will occur after the designer has essentially completed the plans including the cover sheet, plan and profile sheets, detail sheets, cross section sheets, determination of pay items, special provisions, etc. This review may also incorporate the plan sheets from other applicable bureaus. During this stage, the designer should address any utility conflicts and determine if adjustments and/or agreements are necessary. The purpose of the preliminary plan review is to ensure the plans are compatible with the approved Phase I report, are in conformance with the Department's design criteria, and are appropriate for the site. All major content comments must be made during this review period. Incorporation of comments made after this review may require the approval of the Program Development Engineer.

All plan commitments of record should have been incorporated into the preliminary plans. All other bureaus that have made commitments on the project are required to review the preliminary plans to ensure that the plans comply with their commitments.

For complex projects several reviews may be necessary to avoid having to make substantial changes late in the plan preparation process.

63-1.02(c) Pre-Final Plan Review

Pre-final plans are essentially the same as the final plans; i.e., if there are no preliminary review comments, these plans can then be finalized and forwarded to BDE for letting. Prior to this review, the designer should:

- incorporate and/or address all comments made during the preliminary plan review;
- set up a plan-in-hand field review, if necessary; and
- determine the cost participation arrangements (e.g., Federal, State, and local shares).

These cost breakdowns should be noted on the summary of quantities sheet.

Other bureaus and agencies should be given the opportunity to review the pre-final plans to ensure that:

- their comments from the preliminary plan review have been incorporated or addressed in the disposition memorandum,
- the changes to the preliminary draft do not conflict with the bureau's commitments, and
- the plans still conform to the Department's design criteria.

If changes are requested at this point that are desirable, but not mandatory, the Project Engineer determines if they should be incorporated. This will depend on other factors that may preclude them from being added to the plans. If another bureau determines the changes still should be incorporated, an appeal can be made to the Program Development Engineer for their incorporation.

63-1.02(d) Final Plan Review

The purpose of the final plan review is to ensure that reviewer comments from the pre-final plan review have been addressed. Revisions or changes should not be necessary. If changes are deemed necessary, the reviewer should contact the designer directly.

63-1.03 CADD Coordination

63-1.03(a) 3D Modeling Determination

The district Program Development Engineer is ultimately responsible for determining how roadway and structures plans and models are produced. Plans shall be developed using the CADD software and workspace as defined by the IDOT *Computer Aided Design, Drafting, Modeling and Deliverables Manual*.

The district Program Development Engineer shall also define whether three-dimensional (3D) models of road design, structures designs, or both, are required for a project, through discussions with the appropriate district Project Engineer and designer, and with the Structural Design Engineer in the Bureau of Bridges and Structures, respectively. In determining whether or not to develop 3D models for a particular project, the Program Development Engineer considers the following:

- The project's complexity; for small, simple projects it may be more effective to develop two-dimensional (2D) plans only,
- The district designer and/or CADD unit's time availability for the project, and
- The status of district staff's implementation of 3D design and construction practices.

The designer should contact their Project Engineer to discuss overall work and scheduling requirements for each project. If it is determined that 3D modeling will be used for a project, the designer is responsible for contacting the district CADD Manager to discuss the level of detail to be used for 3D models.,

63-1.03(b) Corrections to Plans and Models

The designer is responsible for the information in the plans, CADD files, and the 3D models, and shall insure consistency among all three. Plan review markups received by the designer shall be incorporated to the CADD files in such a way as to preserve the consistency of plans and computer files at all times.

After receiving markups, the designer should check the drawing to ensure that all markups and revisions have been incorporated to the CADD files and models and are reflected in the plan sheets. When checking the revised drawings, the designer should review the new plot against the old plot to ensure that not only the requested revisions were made, but that other changes made using CADD have not adversely affected the drawing and models. The CADD operator may need to adjust features on the sheets and, during this process, mistakes occasionally occur (e.g., accidental deletion of nearby topography, inappropriate movement of dimensions). Designer plan and modeling review is imperative to ensure accuracy and consistency.

63-2 COMPUTERIZED DESIGN

This section briefly discusses the computer hardware and software IDOT uses to prepare contract plans, and where to find additional information regarding the use of CADD on IDOT projects.

63-2.01 Computer Aided Design, Drafting, Modeling and Deliverables Manual

The *Computer Aided Design, Drafting, Modeling and Deliverables Manual* provides the policies and regulations on the use of Computer Aided Design and Drafting (CADD) software used on Department roadway and structures projects. It defines the following:

- The requirements for CADD files and 3D models used on Department projects, such as file formats and file naming and referencing conventions,
- The deliverables requirements for both 2D and 3D CADD files at various stages of the project lifecycle,
- MicroStation and GEOPAK configuration information,
- Standard software used by the Department,
- CADD Workspace Configuration used by the Department,
- Drafting guidelines to be used on both roadways and structures projects,
- Links to additional resources, district CADD contacts, CADD subscription services, and example roadway and structures construction plans, and
- Various other Frequently Asked Questions (FAQ's concerning CADD).

63-2.02 Computer Hardware

All Department computer equipment (e.g., PCs, printers, file servers) have been networked or interconnected. This, along with the use of Bentley's ProjectWise, allows designers across the State to access the same information regardless of their location or which machine they are using. To accomplish this, all project files shall be saved on the Central or district office file servers through ProjectWise. The designer is required to export or check-out the project files from the file server to their PC or workstation at the beginning of each work session. At the end of each work session, the designer is required to import or check-in all project files back to the Central or district office file servers. For instructions on how to acquire files, contact the district CADD Manager.

63-2.03 Computer Software

The Department is presently using and requires the use of Bentley Systems, Inc. software (i.e., MicroStation and GEOPAK) as its computer-aided drafting and design (CADD) package.

All users outside of the Department network should consult with the district Project Manager and/or CADD Manager to determine which version(s) of the software programs are acceptable to the Department. This information is also available on the Department's website. All consultants submitting CADD plans to the Department shall use software versions that are compatible with the Department's, and shall meet all CADD requirements presented in the *Computer Aided Design, Drafting, Modeling and Deliverables Manual*. See the *Computer Aided Design, Drafting, Modeling and Deliverables Manual* for more information on computer software and CADD requirements to be used on Department projects.

63-2.04 File Management

Each project is saved in its own project directory in the Department's ProjectWise database. Individual project documents including sheet files are saved within this directory. To allow others to determine the content of files without the need for opening and reviewing them, the designer shall store and name files in accordance with the *Computer Aided Design, Drafting, Modeling and Deliverables Manual*.

63-3 DRAFTING GUIDELINES

See the IDOT *Computer Aided Design, Drafting, Modeling and Deliverables Manual* for plan sheet drafting guidelines.

63-4 PLAN FORMAT AND COMPOSITION

The designer should prepare the plans as simply as practical. The use of duplicated data and unnecessary cross references should be avoided. The following sections provide additional information on what should be included within each sheet. Section 63-3 provides criteria for drafting the information onto each sheet. Section 63-6 provides a checklist the designer may use when preparing a set of plans.

63-4.01 General

The designer should include the following information on every sheet, except for the *IDOT Highway Standards* included in the back of the plans:

1. Sheet Index Block. Title blocks are provided in the lower right corner (upper right for cover sheet) of sheet cells in the IDOT roadway cell library and contains the following information:
 - project route number(s);
 - section number(s);
 - county the project is located in;
 - total number of sheets for the project, including the cover sheet and excluding the highway standards sheets;
 - sheet number;
 - stationing shown on the sheet, if applicable; and
 - contract number
2. Project Numbers. Project numbers will be determined and placed on the plans by the Central Office.

63-4.02 Cover Sheet

A cover sheet is required for all plans. It identifies the project type, project location, and other pertinent project information, and it authenticates the plans by signatures of approval. A pre-drafted cover sheet is available as a cell in the roadway cell library. This pre-drafted sheet provides the State map, blocks for project approvals, design scales, and other related design information.

63-4.02(a) Sheet Content

The designer should include the following information on the cover sheet:

1. Index of Sheets. If the sheet index is not included as a separate sheet in the plans, locate the index of sheets in the upper left-hand corner of the sheet. If the sheet index is not included on the cover sheet, note the location of the index sheet within the plans in the upper left-hand corner of the sheet. Below the sheet index, list the *IDOT Highway Standards* used on the project. See Section 63-4.03 for more information on the format for listing the sheets and *IDOT Highway Standards*.
2. Title Information. Show the project title information in the top center of the sheet in the following order:
 - the title:

STATE OF ILLINOIS
DEPARTMENT OF TRANSPORTATION
 - project route number and common name;
 - section number; see Section 63-4.02(b);
 - Federal fund type followed by the Federal project number (if Federally funded);

Example: HSIP-XXXX
 - location of improvement (optional);
 - type of improvement;
 - county of project location; and
 - construction job number (“C” number).
3. Planning or Design Number. At the district’s discretion the planning or design job number (P# or D#) may also be listed on the cover sheet. When used, show the number below the sheet index block.
4. State Map. Locate the Illinois State map along the right side of the border. A location symbol is used to show the general location of the project in the applicable county and the general direction of the project (i.e., north-south, east-west). The location symbol can be found in the roadway cell library. This project location map is not required on those projects using the 8.5 in. x 11 in. plan sheets.
5. Scales. Show the graphic scales used for the plan and profile sheets, cross sections, and detail sheets in the lower left-hand side.
6. Contract Number. Show the contract number in the lower left-hand corner of the cover sheet.
7. Layout Map. The layout map is located at the bottom center of the cover sheet. Show only the area necessary to allow the reader to understand where the project is located. The standard scale for rural layout maps is 1 in. = 1 mile (1:60,000 metric) and should be used wherever practical. Select a scale for urban areas that adequately shows the features of the project. A layout map is not required where construction is taking place at several isolated locations (e.g., district wide patching projects).

The layout map should clearly show the following:

- the location of the project roadway in relation to true north, existing roads, cities, towns, major drainage features, railroads, buildings and, where appropriate, the range, township, and Principal Meridian;
- the beginning and ending stations of the project, any station equations, and omissions to the nearest hundredth of a foot (e.g., 0 + 00.01) (thousandth of a meter (e.g., 0 + 000.001));
- the project numbers and stations of as-built projects onto which the project is tied;
- names of any special features (e.g., McHenry Interchange);
- signed route numbers for US, State, and local highways;
- a brief description for separation structures and bridges on the project over 20 ft (6 m). Use a single station number, based on mainline stationing, at the approximate center of each structure. Indicate the length of each structure, structure number, whether it is an overpass or underpass in relation to the main line, and whether it will be constructed under this contract; and
- scale of layout map.

8. Project Length. Show the project gross and net lengths to the nearest thousandth of a mile (kilometer) immediately below the layout map. Show each length on a separate line unless they are the same. The gross length of the project is the length from beginning to end and is calculated as follows:

- For paving, widening, or shoulder projects, show the project termini where the full width begins or terminates.
- For resurfacing projects, show the project termini where the full thickness of resurfacing begins or terminates. However, where two resurfacing projects have overlapping transitions in thickness, the second project should begin at the end station of the first project so that a section will not be shown as unimproved.
- Show the length of a structural project as the centerline distance between the back-to-back of abutments. This length should be constituted as an omission from a paving project.
- Grading sections will normally have the same limits as the paving section with the same basic section designation.
- Measure project lengths for divided highways or one-way facilities along the northbound or eastbound roadway.
- Only show the length for mainline. Do not include the length of improvement along an intersecting side road or street unless the side road improvement is a separate project. If it is a separate project, show separate gross and net lengths.

The net length of the project is the gross length minus any omissions.

9. Project Approval Block. Provide a project approval block in the mid to lower right-hand corner of the sheet. The approval box should include:
- the Regional Engineer’s signature;
 - the Engineer of Design and Environment’s signature;
 - the Director of the Office of Highways Project Implementation’s signature; and
 - the date for each of the above signatures.
- Note. The above signatures may be hand-written (i.e. “wet”), stamped, scanned or computer-generated.
10. Consultant Projects. For consultant design projects, provide the consultant’s company name, professional engineer’s signature, date of their license expiration, and their professional stamp/seal in the lower right-hand corner of the sheet to the left of the State approval box. The engineer’s signature may be hand-written (i.e. “wet”), stamped, scanned or computer-generated.
11. Authority Note. At the very bottom of the lower right-hand corner, include the following statement, “PRINTED BY THE AUTHORITY OF THE STATE OF ILLINOIS.”
12. Utility Information. Information for contacting J.U.L.I.E. is included in the lower left corner of the sheet.
13. Design Designation. For all highway projects involving construction of new pavements, full structural overlays of existing pavements, or structurally designed widenings, the design designation should be shown somewhere on the cover sheet. The design designation is a simple notation to indicate the geometric and structural requirements for the highway. The design designation consists of three basic factors, which is explained with the following example:

Design Designation — 2150(16) Arterial 5.50 (PCC-20)

- a. 2150(16). The first four digits represent the design hourly volume (DHV) that is anticipated for 20 years from the proposed date of construction. The last two digits shown in the parentheses represent the design year (2016). For some minor-type highways, the average daily traffic (ADT) for the year of construction may be used in place of the DHV. In this case, show the construction year in parentheses.
- b. Arterial. This is the highway functional classification.
- c. 5.50 (PCC-20). The first portion (5.50) is the structural design traffic factor (TF). The type of pavement and the structural design period, in years, are indicated in parentheses (PCC-20). The traffic factor represents the summation of equivalent 18 kip single-axle loads, in millions, used to convert mixed traffic to design traffic for the design year. The structural design period also should be included with flexible (HMA) pavement designation. For example, an HMA application would be

designated as (FD-20) with the “FD” indicating a full-depth (HMA) pavement and the number 20 indicating a structural design period of 20 years.

14. Structural Pavement Design Information. Structural pavement design information generally should be included on the typical section sheet, but it may be included on the cover sheet. See Section 63-4.05 for information on the structural pavement design information block.
15. Miscellaneous Information. Include the names and phone numbers for the State project engineer, designer, etc., along the left side of the sheet.

63-4.02(b) Section Designation

Each highway improvement is identified by a section number which denotes the type of work being done and a numbering system indicating the continuity of the original work along the route. On Interstate routes, these numbers must proceed from west to east on even-numbered routes or from south to north on odd-numbered routes. Interstate routes are further typified by a number identifying the county in which the work is being done. In counties where the work will be done on the same route by two districts, the Regional Engineers should confer on section designation to avoid duplication. The section designation should always appear on the cover sheet of the plans and in the sheet index block in the lower right-hand corner of all other plan sheets. The section designation should not exceed 30 characters. Figure 63-4.A shows, alphabetically, the counties by code number, and Figure 63-4.B lists the suffixes used to denote the work type.

Where more than one section of a certain work type occurs within the limits of a basic section number, a second numerical suffix should be added to distinguish between the projects (e.g., 60-5HB-1, 60-5HB-2).

County Section	County	County Code	County Section	County	County Code
1	Adams	001	52	Lee	103
2	Alexander	003	53	Livingston	105
3	Bond	005	54	Logan	107
4	Boone	007	55	McDonough	109
5	Brown	009	56	McHenry	111
6	Bureau	011	57	McLean	113
7	Calhoun	013	58	Macon	115
8	Carroll	015	59	Macoupin	117
9	Cass	017	60	Madison	119
10	Champaign	019	61	Marion	121
11	Christian	021	62	Marshall	123
12	Clark	023	63	Mason	125
13	Clay	025	64	Massac	127
14	Clinton	027	65	Menard	129
15	Coles	029	66	Mercer	131
16	Cook	031	67	Monroe	133
17	Crawford	033	68	Montgomery	135
18	Cumberland	035	69	Morgan	137
19	DeKalb	037	70	Moultrie	139
20	DeWitt	039	71	Ogle	141
21	Douglas	041	72	Peoria	143
22	DuPage	043	73	Perry	145
23	Edgar	045	74	Piatt	147
24	Edwards	047	75	Pike	149
25	Effingham	049	76	Pope	151
26	Fayette	051	77	Pulaski	153
27	Ford	053	78	Putnam	155
28	Franklin	055	79	Randolph	157
29	Fulton	057	80	Richland	159
30	Gallatin	059	81	Rock Island	161
31	Greene	061	82	St. Clair	163
32	Grundy	063	83	Saline	165
33	Hamilton	065	84	Sangamon	167
34	Hancock	067	85	Schuyler	169
35	Hardin	069	86	Scott	171
36	Henderson	071	87	Shelby	173
37	Henry	073	88	Stark	175
38	Iroquois	075	89	Stephenson	177
39	Jackson	077	90	Tazewell	179
40	Jasper	079	91	Union	181
41	Jefferson	081	92	Vermilion	183
42	Jersey	083	93	Wabash	185
43	JoDaviess	085	94	Warren	187
44	Johnson	087	95	Washington	189
45	Kane	089	96	Wayne	191
46	Kankakee	091	97	White	193
47	Kendall	093	98	Whiteside	195
48	Knox	095	99	Will	197
49	Lake	097	X1	Williamson	199
50	LaSalle	099	X2	Winnebago	201
51	Lawrence	101	X3	Woodford	203
				Various	000

COUNTY SECTION AND CODE NUMBERS

Figure 63-4.A

A	Grading
AC	Access Control (A/C) – Frontage Roads or other Features of A/C except Bridges
ACB	Bridges on Frontage Roads
B	Bridges (Complete Structures of Substructures only)
BC	Bridge Cleaning
BDR	Bridge Deck Repair
BDS	Bridge Deck Sealing
BI	Bridge Investigation
BJR	Bridge Joint Repair
BP	Bridge Painting
BR	Bridge Reconstruction or Rehabilitation
BRR	Bridge Repair
BLP	Bicycle Lanes/Paths
BWR	Barrier Wall Repair
BY	Bridge Widening
C	Culverts over 6 ft
CBL	Cable Guardrail
CF	County Funding
CG	Curb and/or Gutter
CJS	Crack and Joint Sealing
CLV	Culvert Repair
CPR	Concrete Pavement Reprofile
CR	Culvert Replacement
CRC	Continuously Reinforced Concrete
CS	City Sections
D	Bridge Floors
DL	Day Labor
DR	Drainage
DM	Building Demolition
E	Steel Erection
ELE	Electrical Repairs (Non-Lighting or Traffic Signals)
EG	Engineering
ES	Engineering Study
F	Steel Fabrication
FNC	Fence Repair or Replacement
G	Gravel or Crushed Stone
GL	Operation Greenlight
GR	Guardrail Repair
FL	Railroad or Roadway Crossing Protection
H	Highway Grade Separation
HB	Highway Grade Separation Structures
HBK	Grade Separation or Interchange Complete with Structures

SUFFIXES FOR WORK TYPES

Figure 63-4.B
(1 of 3)

HF	Bridge Fabrication
HL	Highway Lighting
I	Miscellaneous
ITS	Intelligent Transportation Systems – Installation or Maintenance
J	Guardrail
K	Grade Separation or Interchange Work except Structures
L	Lighting
LA	Land Acquisition
LS	Landscaping
MED	Median Work
MG	Maintenance Garage or Yard
MOW	Mowing
MRK	Pavement Markings, Raised Reflective Pavement Markers
N	Intersection Improvements
NRM	National Recovery Maintenance
NRS	National Recovery System
NW	Noise Wall
P	Painting
PB	Pedestrian Bridge
PCC	Portland Cement Concrete
PP	Pavement Patching
PS	Pump Station
Q	Seal Coat
R	Reconstruction
RA	Rest Area
RCS	Reinforced Concrete Slab (Dry Land Bridge)
RS	Resurfacing
RR	Railroad Crossing
RTR	Roadside Turf Repair
S	Subway Pavement
SA	Structure Grading
SB	Subway (Railroad)
SC	Soil Cement
SCR	Scour Mitigation/Riprap Replacement
SFY	Safety
SG	Signing
SLD	Shielding
SLP	Slope Repair/Erosion Control
SR	Shoulder Reconstruction or Repair
SUR	Traffic Surveillance
SW	Sidewalk/ADA Ramps
SWP	Pavement, Shoulder, or Gutter Sweeping

SUFFIXES FOR WORK TYPES

Figure 63-4.B
(2 of 3)

T	Storm Sewers or Deficient Drainage Correction
TR	Tree Removal
TS	Traffic Signal
V	Viaduct Paving
VB	Viaducts (Railroad)
W	Pavement Widening
WRS	Widening and Resurfacing
WS	Weigh Station
WSP	Weed Spraying
X	Paving Gaps
Y	Widening Shoulders and Ditches
Z	City Pavement

SUFFIXES FOR WORK TYPES

Figure 63-4.B
(3 of 3)

More than one suffix may be used for a single section designation; however, to facilitate the processing of work by the data processing equipment, the section designation must be held to a maximum of 30 characters. For example, where widening and resurfacing are done in one section, indicate it as: "Section (102, 103) (W, RS)." Where widening and resurfacing are separate sections, indicate it as: "Section (102, 103) W, RS."

Within the corporate limits of municipalities, use continuous or consecutive section designations, with the letter "Z" suffix at those locations where the original construction was completed and financed by a municipality or agency other than the State. In addition to the letter "Z" suffix, also add other standard suffix letters indicating the type of improvement.

HMA resurfacing projects by district designation should not contain a reference in the section designation to the type of patching (concrete or HMA) nor should the word "intermittent" be used. Show the section designation as "District (#) HMA Resurfacing (year) — 1, 2, 3" only if the work involved is located on more than three routes. Other special types of projects such as district-wide guardrail installation, weed spraying, etc., should use similar designations. For bridge repair projects involving multiple locations, use "Bridge Repair — (year)" instead of listing each section number.

In the Cook County metropolitan area, the established coordinate system of indicating sections will be acceptable.

63-4.03 Index of Sheets, Highway Standards, General Notes, and Commitments

For most projects, Sheet Two will provide a sheet index, list of *IDOT Highway Standards* used, the general notes, and a list of commitments for the project. The information should be clearly labeled "INDEX OF SHEETS, LIST OF ILLINOIS DOT HIGHWAY STANDARDS, GENERAL

NOTES, COMMITMENTS,” and placed in order from left to right on the sheet, respectively. For small projects, the sheet index and the *IDOT Highway Standards* list may be included on the cover sheet. The general notes and commitments may be shown elsewhere in the plans.

63-4.03(a) Index of Sheets

The index of sheets indicates the major groups of sheets and those subgroups necessary to facilitate locating each item in the plans. Section 63-3.04 provides the proper order for listing the plan sheets and the appropriate subject breakouts.

63-4.03(b) Highway Standards

The list of Highway Standards for each set of plans is unique and is used to indicate which Standards apply to the project. The designer need only provide the list since the actual Highway Standards will be inserted at the Central Office. The Standards should be listed in numerical order and include the appropriate revision number. The revision number should not be included when referencing the Standard number elsewhere in the plans.

63-4.03(c) General Notes

General notes are used to provide the information necessary for plan users to obtain a complete understanding of the plans. Examples of information that general notes should be used to address include:

- descriptions of work to be performed, or items to be removed, by someone other than the contractor;
- instructions for the contractor on items not to be disturbed, or other such commitments for which the contractor needs to be made aware;
- assumed application rates or unit weights used as the bases for plan quantities of surfacing materials; and
- instructions for interpreting the plans.

General notes should be used with restraint and should not be used to emphasize or otherwise address subjects already covered in the *Standard Specifications*, *Supplemental Specifications*, or Special Provisions. General notes should also not be used to create or modify a pay item (a special provision is the best way to do this). Further, all general notes used in a set of plans should be of equal importance so it unnecessary to box-out, embolden, or otherwise highlight any note.

Notes that relate to specific details may be shown on the appropriate sheet (e.g., a specific plan and profile sheet, or detail sheet). Section 63-4.03(d) provides a sample listing of notes that are commonly included within a set of plans.

63-4.03(d) Sample General Notes

The following are samples of general notes used by the Department:

1. 10 FOOT TRANSITIONS SHALL BE USED TO MATCH THE PROPOSED CURB & GUTTER TO THE EXISTING.
2. ALL GUTTER OUTLETS SHALL BE EXTENDED TO THE DITCH FLOW LINE.
3. ALL ELEVATIONS IN THE PLANS ARE BASED UPON THE NORTH AMERICAN VERTICAL DATUM OF 1988 (NAVD88).
4. THE EXISTING BUILDING AT STATION 3+00, 125' RT WILL BE REMOVED BY OTHERS.
5. STORM SEWER WATER MAIN IS TO BE USED AT LOCATIONS WHERE LATERAL SEPARATION BETWEEN THE SEWER AND WATER MAIN IS LESS THAN 10 FEET AND THE WATER MAIN INVERT IS LESS THAN 1.5 FEET ABOVE THE TOP OF THE STORM SEWER.
6. AN HISTORIC STONE ARCH STRUCTURE IS LOCATED AT STATION 135+62. DURING RESURFACING OPERATIONS WITHIN 150 FEET OF THIS STRUCTURE, ALL ROLLERS SHALL BE OPERATED IN STATIC MODE. ALL DENSITY REQUIREMENTS SHALL STILL APPLY.
7. THE CONTACT NAME AND TELEPHONE NUMBER OF THE RAILROAD ENGINEER FOR THE XYZ RAILROAD IS _____.
8. THE BITUMINOUS MATERIAL PRIME COAT QUANTITIES HAVE BEEN DETERMINED USING AN APPLICATION RATE OF 0.10 GAL/SQ YD (0.5 L/SQ M).

63-4.03(e) Commitments

A commitment is a documented obligation or promise, made by a properly authorized representative of the Department, for carrying out a specific action or actions affecting the planning, design, land acquisition, construction, or operation of a highway project. A commitment involves special consideration and action(s) beyond what is routinely required for project development/implementation. Section 63-1.02(a) further describes these commitments. When commitments affect construction operations, the designer includes a brief note describing the commitment – e.g., “TREES RIGHT STATION 11 + 25 ARE TO BE LEFT IN PLACE.”

63-4.04 Summary of Quantities

63-4.04(a) General Layout

The Summary of Quantities (SOQ) sheets summarize all pay items necessary to construct the improvement. It also includes the applicable construction type codes, pay item code numbers, units of measure, total quantities, and quantity breakdown for each section. One or more SOQ sheets typically will be included in each set of plans. Do not show other data on the SOQ sheets (e.g., general notes).

The designer should arrange the pay items in the SOQ, estimates, and schedule of prices so that those with a straight numerical prefix precede those with an alphabetical prefix. It is often necessary to insert additional items after the plans have been prepared. For this reason, items in the summary of quantities and estimate should be double spaced to allow insertion of any further item without disrupting the numerical sequence.

Chapter 64 presents the guidelines for determining plan quantities. When preparing SOQ sheets, it is important that all quantities be calculated and broken down accordingly prior to completing the SOQ sheets. The designer should prepare the SOQ sheets according to the following guidelines:

1. Construction Type Codes. To properly identify the type of construction, the Department uses a coding system based on several elements. These elements are explained in Section 63-5. The applicable construction code should be shown with the appropriate quantity breakdown.
2. Pay Item Code Number. Every pay item has a unique assigned number for data processing. This code number is located in the *IDOT Coded Pay Items*, which is tied to the *IDOT Standard Specifications*. Section 63-4.04(b) describes the Department's coding procedures and how new items can be added. Do not place "dummy" numbers on the SOQ sheets.
3. Description. A descriptive title is applied to every code item. A complete listing of the appropriate titles can be found in the *IDOT Coded Pay Items*. Only these item descriptions should be used on the plans.
4. Unit. The appropriate pay unit should be placed on the sheet after the item description. The *IDOT Standard Specifications* provide the pay units that may be used for each item. Use abbreviations for the units. (Metric units are shown in lower case except for liter (L) and those derived from proper names, e.g., newton (N)).
5. Total Project Quantities. The first column is the total of all breakdown quantities or, for projects with only one construction type code, it may be the only column. For sheets prepared on the computer, the total column will be automatically calculated by the computer. Place all columns for project breakdowns to the right of the total quantity column.

6. Breakdown Quantities. Develop separate project quantities for each of the breakdowns listed in Section 63-4.04(c). If there is only one condition, then additional breakdown columns will not be necessary.
7. Rounding (Total Quantities). Chapter 64 provides the criteria for rounding quantities prior to their incorporation onto the SOQ sheet.
8. Rounding (Breakdown Quantities). Where quantities are expressed in whole units for the total project quantities, it is permissible to round the breakdown quantities to the nearest tenth of a unit (i.e., 0.1).
9. Specialty Items. Certain items of work require specialized knowledge, skills, or equipment that are typically outside the general contractor's expertise (e.g., electrical work, traffic signals, pavement markings on a paving contract, blasting on a bridge contract, paving work on an electrical contract, etc.). Clearly mark Specialty Items in the Summary of Quantities.

63-4.04(b) Construction Pay Items

To permit utilization of the data processing equipment when preparing the Engineer's and detailed estimates; schedule of price sheet for proposals; unit and weighted average prices; and partial, semi-final, and final payment estimates; the designer should ensure that all pay items are number coded and titled appropriately. The appropriate codes and titles are provided in the *IDOT Standard Specifications* and the *IDOT Coded Pay Item Book*. The Specifications and/or special provisions must address the basis of payment for all contract pay items.

Non-standard pay items in the *IDOT Coded Pay Item Book* are noted with an asterisk (*) after the code number and are not covered by the *IDOT Standard Specifications*. Therefore, a special provision, plan note, or detail will be required for clarification. In most cases, it will be possible by writing a special provision to use an existing pay item and its corresponding code number. However, where it is necessary to include coded pay items for a type of work not related to any item in the coded pay item books, list the item last in the summary of quantities and write up a justification for the new item. The designer should then forward the request to the District Estimating Engineer, who reviews it to determine if another item can be used (e.g., by special provision). If not, the District Estimating Engineer requests a new item (and code number) from the Central Office. The Project Management Unit of the Bureau of Design and Environment will assign a new code number and item description.

The code number consists of eight digits (metric - the letter "M" and seven digits). The first three digits indicate the corresponding section in the *IDOT Standard Specifications*. For example, code number 35101500 (M3511500) corresponds to "Section 351. Aggregate Base Course" in the *IDOT Standard Specifications*. The remaining digits of the code number indicate the numerical sequence the number has in the *IDOT Coded Pay Item Book* section.

A number of pay items, contained in the coded pay item books, are identical except for the numerical codes. For example, "Bituminous Materials (Prime Coat)" has code numbers

identifying it according to the type of work being done. The purpose of this is to make possible cost analyses of the various types of work. However, when the quantities are small, the pay items which are identical, except for the numerical code number, should be combined and identified by the code number of the type of work that requires the largest quantity.

63-4.04(c) Quantity Breakdowns

To present the data necessary for cost accounting, the designer must segregate and tabulate the plan quantities for various accounts. Quantity breakdowns will be made on the SOQ sheets in accordance with the following:

1. Construction Type Codes. If a project consists of two or more construction type codes, a breakdown will be required for each code. Section 63-5 describes these codes.
2. Projects. Two or more projects may be combined into one plan set. In this case, separate breakdown columns are required for each project.
3. Funding Appropriations. If the project consists of more than one funding appropriation (e.g., NHI-BRF-320-1()), the quantities will be segregated according to each appropriate funding type.
4. Urban/Rural. Where a Federal and/or State project crosses an urban boundary, provide separate breakdowns for both the urban and rural portions of the project. Urban boundary locations can be obtained from the district programming section.
5. Counties. Where a Federal and/or State project crosses county lines, provide separate breakdowns for the portions in each county. Project termini coincident with county lines should be shown entirely within one county. If the project is in more than three counties, show it as "various counties." For projects that involve bridges that are on the county line, show it in the county designated by the structure number.
6. Joint Agreements. Where there is local participation involved (e.g., city, village, county), breakdown the quantities according to the joint agreement and designate them in the SOQ sheet under a separate heading for each local agency.
7. Traffic Signal Improvements. Where there is one Federal-aid route at two or more locations and local participation is involved, it will be necessary to break down each location and the percentage of participation by each locality. In addition, break down the quantities according to the traffic signal work type.
8. Non-participating Work. Where non-Federal-aid work is included in a Federal-aid project, it should be segregated and identified as such. It is Department policy to consider all maintenance type work (e.g., cleaning storm sewers, cleaning drainage structures) as non-participating, and noted as such.
9. Bridge Approaches. Include bridge approach work with the applicable structure construction-type code.

63-4.04(d) Schedule of Quantities

A tabulation of the quantities may be included after the summary of quantities sheets. These tabulations are highly desirable because they simplify the checking of plans, help the contractor and resident engineer to locate quickly the items in the field, and aid in the determination of final quantities used in the improvement. The tabulations should show the location of the item by station and quantity at each location.

All items not included in the typical section should be considered for tabulation. However, judgment should be used in determining which quantities to tabulate based on continuity of the items or their appearance at relatively few locations. Always tabulate items that are scattered throughout the plans or are located at intermittent locations throughout the improvement (e.g., pipe culverts, structural concrete, reinforcement bars, drainage structures). For items in a schedule of quantities that are shown elsewhere in the plans, place a note to this effect in a conspicuous location near the tabulation. A bill of materials, such as is shown on bridge plans or culvert headwall standards, does not include pay items per se and should not be considered as a duplication in the schedule of quantities.

63-4.05 Typical Sections

One or more typical sections are included in the plans to show details and dimensions for roadway surfaces, bases, subbases, subgrade treatments, shoulders, gutters, curb and gutters, medians, sidewalks, ditches, back slopes, and ROW. When preparing the typical sections, the designer should consider the following:

1. Number of Typical Sections. Provide a separate typical section for each of the following conditions:
 - tangent sections;
 - superelevated sections, show the full superelevated section from PC to PT and note the superelevation transition stations;
 - where there are changes to the pavement structure;
 - where there are changes from a curbed section to a non-curbed section or vice versa;
 - changes in pavement widths, including transitions;
 - changes in pavement cross slopes;
 - cross section changes (e.g., shoulder additions, turn lanes, median changes);
 - driveways and side roads which have a significant length of reconstruction; and

- specially constructed detours; show the proposed ultimate development by the use of dashed lines.
2. Orientation. Orient all typical sections horizontally (landscaped) on the sheet.
 3. Scale. Draw the typical sections to a suitable scale to show all necessary details. The vertical dimension may use a larger scale for clarity.
 4. Order. Show the mainline typical section first, followed by the other sections in the order they appear, in increasing stations, along the mainline.
 5. Titles. Show the name of the road or street to which the typical section applies directly below the typical section number or letter. Alphabetize or number sequentially each typical section.
 6. Station Limits. Always note the station limits for which the typical section applies directly below each typical section. Also include the station limits for back-to-back of abutments.
 7. Cross Section. The typical section cross-section view should show the following elements:
 - the grading template;
 - profile grade line reference, especially where the profile grade line is other than the centerline;
 - surfacing templates for immediate and future development;
 - top widths of surfacing shown to the nearest tenth of a foot (i.e., 0.1 ft) (hundredth of a meter (0.01 m));
 - types of surfacing and thicknesses shown to the nearest $\frac{1}{4}$ of an inch (millimeter); and
 - pavement cross slopes (% or inches/foot – US Customary, % – metric), dimensions, and slopes necessary to define the typical section.
 8. Base Thickness. Show variations in base or subbase thickness due to soil conditions or other reasons in a tabular form and include the station limits for each thickness. In such cases, the typical section only shows the varying thickness.
 9. Notes. Include only the design and construction notes that are pertinent to the specific typical section on the typical section sheet. General notes should be shown on the general notes sheet.
 10. Notations. Where appropriate for clarity, the various typical section elements (e.g., "P.C.C. SIDEWALK 4 in (100 mm)") may be noted using numbers within circles. If this

approach is used, provide a complete legend on each page. Use the same number for each item throughout the typical section sheets.

11. Quantities. Note the applicable material type on the typical section (e.g., “HMA SURFACE COURSE, MIX “D”, N90).
12. Structural Pavement Design Information. Include the structural pavement design information block on the appropriate typical section sheet to allow checking of the pavement design. For those projects that have two or more roadway segments with different design data, provide separate design information blocks for each segment. The project route design information block always should be shown first. For highway grade separations, provide separate design information blocks for each facility. Figure 63-4.C illustrates the recommended format for a structural pavement design information block.

STRUCTURAL DESIGN TRAFFIC:	Year _____
PV = _____	SU = _____ MU = _____
ROAD/STREET CLASSIFICATION:	Class _____
PERCENT OF STRUCTURAL DESIGN TRAFFIC IN DESIGN LANE:	
P = _____	S = _____ M = _____
TRAFFIC FACTOR:	Actual TF = _____ Minimum TF = _____
PG GRADE:	Top Binder = _____ Lower Binder = _____
	Surface = _____
SUBGRADE SUPPORT RATING:	
SSR = _____	(Sta. _____ to _____)
SSR = _____	(Sta. _____ to _____)

*Notes: See Chapter 54 for information on how to determine the appropriate pavement values.
For non-mechanistic designs use IBR in place of SSR.*

RECOMMENDED STRUCTURAL PAVEMENT DESIGN INFORMATION BLOCK

Figure 63-4.C

63-4.06 Alignment, Ties, and Benchmarks

For new pavement, reconstruction, or realignment of the existing pavement, an alignment, tie, and/or benchmark sheet will be required. These sheets are used to locate the construction control points during all phases of construction. In preparing these sheets, the designer should consider the following:

1. Alignment. On complex projects, a separate alignment sheet may be provided showing the existing and proposed horizontal alignment with the appropriate curve data and other pertinent information. For most projects, this information will typically be provided on the plan view sheet.
2. Reference Ties. Reference ties will generally be required on every project. They generally should be combined on one sheet. However, for simple projects, they may be included on the plan sheets. Figures illustrating the reference tie point locations may be

simple or detailed schematics with the appropriate dimensions and tie points identified, including the stationing and applicable control tie (e.g., POT, PI, PT, PC). Show reference ties having locations tied to the mainline first, by increasing station, followed by ties to other lines in the order they appear along the mainline. Clearly identify the feature to which the ties are referenced (e.g., iron pin 18 in. (0.5 m) deep, corner of wall). Tie figures are generally not drawn to scale. If included within the plan view and if too congested with other topography, transfer the tie figure to an insert directly under the point involved. At least three reference ties are required to each point. Note the tie distances to the nearest 0.01 ft (5 mm). The reference ties should be to features that are not affected by construction.

3. **Benchmark Data.** Benchmark tabulations should show the station, location, description, and elevation of each benchmark. Show mainline benchmarks first, followed by benchmarks to other facilities in the order they appear along the mainline. Clearly identify the road or line to which a group of benchmarks is referenced. Show elevations in feet to two decimal places (i.e., 0.01 ft); show elevations in meters to three decimal places (i.e., 0.001 m). Provide a detailed description to locate the benchmark used for the level datum source. The description should include the benchmark location, elevation, number, and any other pertinent information.

63-4.07 Plan and Profile Sheets

The plan and profile sheets are the basic design sheets used by the designer to illustrate the horizontal and vertical alignments and to depict the construction items and the topography necessary for construction. Therefore, the designer must ensure that these sheets are drawn with clarity and are as simple as practical, but still provide the necessary information to construct the project.

63-4.07(a) General Guidelines

The following provides general guidelines for the preparation of the plan and profile sheets:

1. **Views.** For rural and simple urban projects, the Department's practice is to show the plan and profile views on the same sheet. The plan view is presented in the upper half of the sheet with the corresponding profile view presented directly below it. For most urban projects and complex rural projects (e.g., interchanges), the plan and profile views may be shown on separate sheets. Two or more profiles may be shown on the separate profile sheet. Unless necessary for clarity, the proposed improvement should be superimposed onto the existing topography (i.e., do not provide separate views for the existing and proposed improvement).
2. **Sequence of Sheets.** Show the plan and profile sheets for the mainline first in increasing stations. Project stationing progresses from South to North and West to East. Do not interrupt the mainline plan and profile sheets with sheets for other facilities (e.g., side roads, detour roads, frontage roads, railroads) or for other detail sheets (e.g., plan

quantities, general notes, drainage details). Insert and cross reference the plan and profile sheets for other facilities after the mainline sheets in the order they appear along the mainline. For those projects using separate sheets for the plan view and the profile view, place the profiles directly after all the plan view sheets. The profile views should appear in the same order as the plan view sheets.

3. Labeling. It is desirable, but optional, to label all plan and profile sheets in the lower right corner so that the plan user can readily determine what plan and/or profile is being shown (e.g., Route 34 — Stations 10 + 25 to 25 + 00).
4. Sheet Overlap. Use matchlines on each sheet (i.e., the plotting should not overlap the beginning and end of successive sheets).
5. Plotting Limits. In general, plot the survey 500 to 1000 ft (150 m to 300 m) beyond the proposed project limits. Where applicable, provide the station equation between the new and old stationing.
6. Note Orientation. Write all notes and dimensions horizontally from left to right, except for the following:
 - a. Plan Views. The following apply:
 - Dimensions may be written parallel or perpendicular to the element (e.g., property lines, lane widths).
 - Stationing, at 100 ft (50 m) intervals, is placed parallel with the centerline and noted directly beside the tick mark. Intermediate station callouts (e.g., taper termini) should be written perpendicular to the centerline.
 - Curve data is placed radially on the inside of the curve. However, show all curve control points, stationing equations and angles horizontally.
 - Names for specific items may be written parallel with the feature (e.g., street names, river names).
 - b. Profile Views. Elevations for the various features are shown vertically, including the elevation at the stationing intervals.
 - c. Special Considerations. Where limited space for notes and dimensions makes horizontal placement detrimental to the readability of the plans, they may be placed vertically.
7. Use of Notes. Keep notes on plan sheets brief, clear, and consistent. Installations and removals should be noted by station with a brief description. Include detailed descriptions on the general note sheet not on the plan and profile sheets.
8. Drafting Details. See the *IDOT Computer Aided Design, Drafting, Modeling and Deliverables Manual* for the location of the roadway cell library that contains the

topography symbols and additional cells that should be used in preparing plan and profile sheets. The *Computer Aided Design, Drafting, Modeling and Deliverables Manual* also provides additional information on plotting details. The *IDOT Highway Standards* provides the recommended abbreviations that should be used on both roadway and structure plans.

9. Key Maps. If the location of the plan section shown is confusing relative to the rest of the project or does not follow in a logical sequence, provide a “Key Map” or a schematic layout as a guide. Because the purpose of any layout or key map is to simplify otherwise confusing aspects of the plans, keep the level of detail to a minimum. One or more key maps may be required.
10. Bridges. On plans for highway grade separation structures, show the plan and profile views of both roadways.

63-4.07(b) Plan View

The following presents the recommended guidelines for preparing the plan view sheets:

1. Centerline. The following should be noted relative to the centerline:
 - Desirably, the survey line should be the centerline of the proposed facility. Where the two do not coincide, indicate their relationship at the beginning and end of the sheet and at all major control points.
 - On divided highways with independent alignments, the centerlines are generally treated as separate roadways. Note the relationship between the centerlines somewhere on each sheet.
 - Use “tick” marks along the centerline at 100 ft (50 m) intervals. Note the station beside the tick mark.
2. Centerline Layout. When laying out the centerline on the plan sheets, the designer should consider the following:
 - Where an alignment is on a tangent, the centerline or survey line should parallel the profile line and be centered vertically in the plan view.
 - Where the alignment is on a curve, angle the tangents to produce a reasonable balance. Desirably, show the entire curve on the same sheet, even if this requires starting a new sheet and leaving part of the preceding sheet blank. If practical, show the PI on the same sheet.
 - The stationing should progress from left to right (i.e., South to North, West to East).
 - Provide separate survey lines for interchange ramps and rest areas.

3. Scales. For rural facilities, typically use a scale of 1 in. = 50 ft (1:500 metric). For urban facilities, depending upon the complexity of the location and work to be accomplished, use a scale of 1 in. = 20 ft (1:250 metric). Other scales may be used to improve the clarity of the plans or for practical purposes.
4. Horizontal Alignment Data. Chapter 32 presents the criteria for horizontal alignment. The horizontal alignment data should be presented in the plans as follows:
 - a. Horizontal Curve Data. Place the horizontal curve data, including superelevation, on the plan sheet to which it applies. Figure 63-4.D presents the order and rounding accuracy that should be used to present the curve data.
 - b. Superelevation. Show the rate of superelevation on the plan sheets. In the transition portion of superelevated curves, provide superelevation data at 25 ft (10 m) intervals to facilitate construction staking. Elevations of the pavement edges and superelevation rates may be included in a separate table on the plan/profile sheets and/or in special detail sheets. Also, include detailed information and sketches for superelevation transition lengths in the detail sheets.

Simple Curve Data	Accuracy	
	US Customary	Metric
PI	0 + 00.01 (ft)	0 + 000.001 (m)
Δ	00° 00'01"	00° 00'01"
R (existing)	0.01 ft	0.001 m
R (new)	15 ft	5 m
T	0.01 ft	0.001 m
L	0.01 ft	0.001 m
E	0.01 ft	0.001 m
e	0.01%	0.01%
T. R.	1 ft	1 m
S. E. Run	1 ft	1 m
P.C. Sta.	0.01 ft	0.001 m
P.T. Sta.	0.01 ft	0.001 m

**HORIZONTAL CURVE DATA
(Plan Sheets)**

Figure 63-4.D

- c. Curve Points. For all curve control points, show perpendicular lines from the centerline on the inside of the curve. Indicate these control points with small circles, approximately 0.1 in. (2.5 mm) in diameter. Indicate the curve notation (e.g., PC, PT, PI) and station to the nearest hundredth of a foot (i.e., 00 + 00.01)

- (thousandth of a kilometer (i.e., 0 + 000.001)) along the perpendicular line. Also show the coordinates of the control point if a coordinate system has been established for the project.
- d. Deflection Points. Where deflection points are used in place of a horizontal curve, show the deflection angle to the nearest second (i.e., 00° 00' 01"). Also include the coordinates, if available.
 - e. Equations. Equations are used to correct any stationing differences that may occur along the centerline. Show these stationing equations with a small circle on the centerline (0.1 in. (2.5 mm) diameter). Place the station equation at a location on the sheet near the control point and where it can be easily read. Draw a line from the station notation to the point on the centerline.
5. Widths. Note all pavement widths at the beginning and end of each sheet and wherever there is a change in width (e.g., turn lanes, acceleration lanes, truck climbing lane) to the nearest tenth of a foot (meter) (i.e., 0.1 ft (0.1 m)). Individual lane locations are generally not shown on the plan view. They are generally shown on the pavement marking sheets.
 6. Topography. The *Computer Aided Design, Drafting, Modeling and Deliverables Manual* presents the topography features that should be shown on the plan sheet. This includes utility and drainage features, buildings, streams, railroads, wells, and other elements affected by the roadway improvement. Trees and other landscaped elements should be shown graphically. In general, show existing elements with light, dashed lines and proposed elements as darker, solid lines.
 7. North Arrow. Show the appropriate district North arrow on each plan sheet. The roadway cell library provides cells for each district North arrow.
 8. Items to be Removed. Show items within the right-of-way limits that will be removed with cross hatching. Clearly note those items that will be removed by others.
 9. Station Call Outs. Provide station call outs at the following locations:
 - beginning and ending points of the project;
 - match lines with other projects;
 - omissions from paving and station equations;
 - 100 ft (50 m) station increments;
 - horizontal curve points (e.g., PC, PI, PT);
 - beginning and ending points of tapers, including the distance and direction from the centerline;

- construction limit locations and right-of-way breaks, including distance and direction from the centerline for right-of-way breaks;
- curb returns for entrances and intersections, including distance and direction from the centerline;
- entrance locations, including the type, width, and surface material of the entrance;
- special or atypical construction applications that cannot be determined by other means (e.g., short sections of curb and gutter replacement, sidewalk replacement, termini for milling, sign removals);
- side street intersections;
- permanent survey and right-of-way markers, including the distance and direction from the centerline;
- section line ties, right-of-way takes, etc., including the distance and direction from the centerline; and
- other locations where appropriate.

Show all distances from the centerline to the nearest one-half foot (i.e., 0.5 ft) (tenth of a meter (i.e., 0.1 m)) unless greater accuracy is required (e.g., horizontal curve data, right-of-way takes).

10. Utilities and Drainage. In general, separate plan and profile sheets should be provided for all proposed drainage and utilities improvements. These sheets are discussed in Section 63-4.09. Where the drainage or utilities features affect construction, these features may be shown on the plan view (e.g., removal of existing culvert, patching for new utility lines). For these situations, note the type and size of the drainage or utility feature (e.g., 1 ft (300 mm) gas line).
11. Right-of-Way. Where right-of-way acquisition is necessary, consider using separate right-of-way sheets to show this information; see Section 63-4.10. Existing and proposed right-of-way limits, however, are always shown on the plan view. Where separate right-of-way plans are not included, note the following on the plan view:
 - the dimensions of the property to be acquired;
 - station ties to property lines;
 - property ownership lines, parcel numbers, and property owners names;
 - breaks in the right-of-way alignments, including the station and distance from the centerline;

- all temporary and permanent easements necessary to accommodate intersecting roads and streets, access roads, temporary runarounds, detours, drainage areas, material storage areas, slope widenings, utilities, railroads, or other special uses;
 - where the control of access limits do not coincide with the right-of-way limits;
 - location of right-of-way markers; and
 - any pertinent data affecting the cost of the right-of-way (e.g., structures, businesses, access roads, improvements, fences).
12. Access Lines. On projects where the access rights have been or will be acquired, show all approved points of entry to or exit from the traffic lanes. List each approved point of access, other than those by a ramp at an interchange, by entrance centerline station in a tabular form and by symbol at the appropriate point. Show both the control of access line and the right-of-way line even where such lines are coincident. If control of access is accomplished by constructing a frontage road, it will not be necessary to draw in detail the entrances to the frontage road from the property abutting the highway right-of-way. In these cases, show the control of access line between the frontage road and the mainline facility. Show any access points between the frontage road and the mainline facility in detail. If an approved point of access is a temporary measure under stage development, identify it with an appropriate note as to how it will be eliminated in the future.
13. Guardrail. Show the locations for new and existing guardrail on the plan view.
14. Side Roads and Entrances. When showing side roads and entrances on the plan view, the following apply:
- Use light, dashed lines to present existing public roads and entrances.
 - For public facilities, note the route number or street name on the side facility. Label private entrances "Private" or "PE," field entrances "Field" or "FE," and commercial entrances "Commercial" or "CE."
 - Outline commercial entrances in detail with dashed lines to show current usage.
 - Note the type of existing surface material.
 - For intersections with public roads, show the angle of intersection from side road centerline to the mainline centerline.
 - Provide the width of the intersecting facility.
 - Indicate the direction of flow in the drainage ditch with an arrow.

15. Special Details. Where special details are required (e.g., steps, retaining walls, pavement joint repair), note the sheet where the detail can be found. In general, do not include the detail on the plan sheet.
16. Miscellaneous. All features, not listed above, should be labeled and, where necessary, the applicable station called. Also, note the distance and direction from the centerline. Some of these elements may include:
 - sidewalks (e.g., “6 ft (1.8 m) PCC SW, HANDICAPPED RAMP”);
 - curb and gutter (e.g., “COMB. CONC. CURB & GUTTER, TY-B”);
 - special paving instructions (e.g., “CLASS B PVMT PATCH”);
 - special instructions (e.g., “DO NOT REPLACE EXISTING SIDEWALK”);
 - construction done by others (e.g., relocation of utilities); and/or
 - fencing (include size and type).

63-4.07(c) Profile View

The profile should present the existing survey gradeline and proposed improvement profile. The following presents the recommended guidelines for the profile view:

1. Location. The profile typically represents the vertical plane intersecting the finished surface of the pavement wearing course or the top of the subgrade along the centerline of the proposed improvement. Add a note on each profile view to indicate whether the profile grade line represents the pavement surface or the top of the subgrade. Where the profile does not represent the centerline, note its actual location on each profile view.
2. Scales. The profile horizontal scale should use the same scale as the plan view. The vertical profile scale is generally 1" = 5' (1:60) or 1" = 10' (1:120).
3. Existing Ground Line. Plot the existing ground line with a dashed line to the nearest 0.1 ft (0.01 m) and existing pavement surfaces to the nearest 0.01 ft (0.001 m). If the centerline is not on the existing pavement but the existing pavement is nearby, plot the profile of the existing pavement, but do not record the elevations.
4. Vertical Alignment Data. Chapter 33 presents the criteria for vertical alignment. The vertical alignment data should be shown in the plans as follows:
 - a. Vertical Curve Notations. Depict the VPC and VPT on the profile grade line with small circles (approximately 0.1 in. (2.5 mm) in diameter). Use a small triangle for the VPI with short segments of the vertical tangents. VPI notes should provide the VPI station (to the nearest hundredth of a foot — 00 + 00.01 (thousandth of a meter — 0 + 00.001)), the elevation (to the nearest hundredth of a foot — 0.01 ft (thousandth of a meter — 0.001 m)), the vertical curve length (see Comment b. below), and “E” distance — the vertical distance (offset) between the VPI and proposed roadway surface (to the nearest hundredth of a foot — 0.01 ft (thousandth of a meter — 0.001m)). Do not include other vertical curve

information (e.g., K-values, passing sight distances). Place the VPI notes horizontally above the profile for crest curves and below the profile for sag curves. The VPC and VPT stations and notations are generally not recorded.

- b. Vertical Curve Lengths. Round the vertical curve calculations from Chapter 33 to the next highest 50 ft (10 m) increment. The existing vertical curve distance may be shown to the nearest one-half foot (i.e., 0.5 ft) (tenth of a meter (i.e., 0.1 m)).
 - c. Tangent Grades. Show tangent grades along the profile grade line to the hundredth of a percent (i.e., 0.01%). Positive grades should be shown with the “+” prefix and negative grades with the “-” prefix. A “+” prefix indicates that the grade is ascending from left to right.
5. Benchmarks. Show benchmark identifications and elevations along the top of the profile sheet at the approximate location they appear along the centerline (to the nearest hundredth of a foot — 0.01 ft (thousandth of a meter — 0.001 m)). The benchmark number and location should be fully described so that it can be easily located in the field (e.g., “BM #2 — ON NE BOLT OF FH ON NW CORNER OF 1ST AVE AND MAIN ST”).
 6. Elevation Labeling. Note the full stationing along the bottom of the profile sheet at 100 ft (50 m) stations. Show the survey elevations and proposed centerline elevations at 100 ft (25 m) intervals for rural projects and at 50 ft (10 m) intervals for urban projects. For vertical curves, use a closer interval. Show the elevations vertically along the station ordinate line to the nearest hundredth of a foot (i.e., 0.01 ft) (thousandth of a meter (i.e., 0.001 m)). The survey line elevation is to the left of the station ordinate line, and the proposed centerline elevation is to the right of the station ordinate line.
 7. Pavement Edge Profiles. For drainage purposes and other reasons (e.g., superelevation), it may be desirable to also show the left and right pavement edges. Use a different line type to indicate these profiles (e.g., series of dashes and dots). Clearly label each profile line (e.g., “LEFT AND RIGHT PAVEMENT EDGE”).
 8. Undercutting. Only show undercutting on the profile where unsuitable material is being removed. Show this area with crosshatching. Note that the undercutting should only be shown to the top of the subgrade and not to the profile grade line. For each undercut location, note the station locations and the depth of excavation.
 9. Drainage/Utilities Structures. In general, show the drainage and underground utility locations on the drainage profile sheets. However, for small projects with minimal drainage and underground utilities, these items may be shown on the mainline profile. Section 63-4.09 provides the information that should be incorporated.
 10. Ditch Profile Sheets. If no drainage profile sheets are provided, supplemental profile sheets may be provided after the plan and profile sheets to illustrate special ditches and paved ditches. Note the gradient percentage, stationing, beginning and ending elevations, and elevations at all gradient changes. For rural projects, the ditch profiles can be shown on the mainline plan and profile sheets.

11. Bridges. At bridge locations, whether existing or proposed, the profile should include an elevation sketch (to scale) showing the elevations for the abutments, piers, the low vertical clearance point, high water level, and the stream bed.
12. Side Roads. Profiles for side roads may be provided on separate profile sheets or on the cross sections. If separate profile sheets are used, they should be provided after the mainline profile sheets and placed in the order they appear along the mainline. Clearly identify each profile view as to what street or side road the profile view applies. Entrance profiles are typically plotted on the cross sections.
13. Miscellaneous Profiles. Under special circumstances, it may be desirable to provide profiles for tops of curbing, sidewalks, detours, etc. Where these profiles are provided, use a different line type and clearly identify the profile.

63-4.07(d) Surplus Excavation Disposal

The contractor is to dispose of excess waste material, which results from construction operations, off the project right-of-way unless permission is received from the Engineer to place it within the project limits. In many cases it is acceptable to waste this material on the right-of-way when the placement does not adversely affect environmentally sensitive areas, safety, drainage, or aesthetics. When the designer knows that the construction operations will result in excess excavation, find locations within the project limits to place this material.

Consider the following factors when selecting locations:

1. Environmental. The area should not contain wetlands or other environmentally sensitive areas.
2. Drainage. The designer should be certain that drainage will not be adversely affected by any excavation placed on the project.
3. Safety. The wasted material should not create sight distance problems or mounds that could affect a vehicle that has left the roadway.

Areas where it may be permissible to waste this material include flattening front slopes, filling in depressions, interchange infields and in general the area between the top of the back slope and the R.O.W.

The designer should show the areas on the plans and include a schedule showing Station to Station, offset, thickness allowed, and quantity of material that can be wasted. The designer should also include the quantity of material that still needs to be wasted off of the project.

63-4.08 Stages of Construction and Traffic Control Sheets

The strategy for maintaining traffic during the roadway improvement will be described in the Phase I report. For minor projects (e.g., resurfacing, minor widening), the control of traffic can

typically be addressed by referencing the applicable *IDOT Highway Standards*. For complex projects (e.g., major widening, extensive replacement of storm sewers), the designer must develop a more detailed set of traffic control plans, often with stage construction. The designer also must develop traffic control plans for projects with detours, runarounds, or other roadways specifically constructed for traffic control.

Where traffic control plans are required, the designer should use the existing topography plans to lay out the staging. A brief description of each construction stage should be provided. The traffic control sheets should include:

- the temporary roadway horizontal alignment;
- the temporary roadway profile gradeline;
- the temporary pavement needed to maintain traffic;
- the proposed area of construction for each stage;
- the temporary traffic lanes;
- signing for the work zone;
- temporary pavement markings;
- temporary roadside safety layouts;
- typical sections for each construction stage;
- a breakdown of work that should be performed during each stage;
- traffic control standards for each stage; and
- general notes for time frames, closures, etc.

63-4.09 Erosion and Sediment Control Details

Projects which disturb the ground have the potential to displace soil by storm events and typically require erosion and sediment control details to be included in the plans. For minor projects (e.g., SMART and 3P), erosion and sediment control, if needed, can typically be addressed by referencing the applicable *IDOT Highway Standards*, Article 107.23 of the *Standard Specifications for Road and Bridge Construction*, and by specifying the items in schedules.

For complex projects (e.g., 3R Projects) the above still applies and, in addition, an ILR10 NPDES permit (i.e. where the project disturbs more than one acre) may be required. This permit requires an Erosion and Sediment Control Plan that is submitted to and reviewed by the Illinois Environmental Protection Agency (IEPA) and is described as a "site plan" in the ILR10 permit. The following is required to be depicted on the plan:

- Project phases
- drainage patterns and approximate slopes anticipated before and after major grading activities,
- locations where vehicles enter or exit the site and controls to prevent offsite sediment tracking,
- areas of soil disturbance,
- the location of major structural and nonstructural controls identified in the plan,
- the location of areas where stabilization practices are expected to occur,

- locations of on-site or off-site soil stockpiling or material storage,
- surface waters (including wetlands), and
- locations where storm water is discharged to a surface water or Municipal Separate Storm Sewer System (MS4).

Note: For sites discharging to an MS4, a separate map identifying the location of the construction site and the location where the MS4 discharges to surface water must be included.

63-4.10 Drainage and Utilities Sheets

Drainage and utilities plan details are generally required for all jobs where drainage and/or utilities are involved. This includes constructing new drainage systems, expanding existing drainage systems, or adjusting existing drainage structures. Where the existing drainage and utilities are not affected by construction, then separate drainage and utility sheets will not be required.

63-4.10(a) Existing Information

If a Phase I report was completed, the existing drainage and utility information should have already been incorporated onto the existing topography plans and plotted using CADD. If the project does not have a Phase I report, then the information must be added to the plans during plan preparation. Information on the existing drainage can be found in the project survey books. Additional information can be obtained from copies of old plans. To determine existing utility locations, the designer must submit existing and proposed plans to the district utility coordinator. The district utility coordinator forwards the plans to the utility companies impacted by the project to obtain information on the utility locations. This submittal should occur as soon as practical during plan preparation because of the lengthy time frame to obtain utility information from the utility companies. Chapter 6 provides information on coordination with utility companies.

To incorporate the existing drainage information using CADD, provide the survey data to the district designer. The plans marked by the utility companies can also be provided to the district designer for plotting. If the project is not being drafted using CADD, then the information must be plotted manually. Typical symbols have been established for showing drainage and utility information and should be met when preparing the plans. These symbols are provided in the roadway cell library.

63-4.10(b) Proposed Design

Information on drainage design is included in Chapter 40 of the *BDE Manual*, the *IDOT Drainage Manual*, and the *IDOT Drainage Tables for Inlet Spacing*.

The designer should also review the information in the Phase I report. This report provides the locations of drainage outfalls for storm water and notes any drainage problems and the need for permits.

Permits may be required from the Metropolitan Water Reclamation District of Greater Chicago (District 1), the Division of Natural Resources, the Environmental Protection Agency, and the Army Corps of Engineers. The need for a permit is usually based on who has jurisdiction for the drainage outfall and the impact of the improvement on possible flooding and the environment. The designer must always assess the need for a permit for a project even though the Phase I report may not have specified a need. Chapter 28 provides additional information on permits.

63-4.10(c) General

Once the mainline plan and profile sheets have been prepared, the designer should use these sheets to plot the drainage and utility information. If the mainline plan and profiles are provided on separate sheets, then the drainage plan and profile sheets should also be provided on separate sheets. Only the information necessary to construct the drainage and utility items should remain on these sheets. The designer should ensure that the levels of all other superfluous information be turned off.

63-4.10(d) Plan View

The following information should be shown on the drainage plan view sheets:

1. Symbols. The roadway cell library provides the symbols that are used to denote the various utility and drainage lines on the plan view. Provide a legend of these symbols on the first drainage sheet. Legends should also be provided on every sheet if it does not hinder the sheet's clarity. Only use the appropriate abbreviations as presented in the *IDOT Highway Standards*.
2. Culverts. For culverts or cross drains, note the following on the plan view:
 - station locations for the ends, including direction and distance from the centerline;
 - culvert type;
 - pipe size and length;
 - flow direction;
 - skew angle;
 - upstream and downstream flow elevations (to the nearest tenth of a foot — 0.1 ft (hundredth of a meter — 0.01 m));

- end section or headwall type and size; and
 - for existing culverts, the pipe size, material type, and any instructions to the contractor (e.g., “TO REMAIN IN PLACE,” “EXTEND EXISTING CULVERT”).
3. Structures. Structures are shown on the plan sheet with the general details provided in the profile view. Detailed design information will be provided in the structure plans.
4. Storm Systems. Show storm drainage systems or closed drainage systems on the plan view as follows:
- a. Storm Sewer Pipes. Note each run of pipe between manholes, inlets, catch basins, etc., according to its diameter, length (to the nearest tenth of a foot — 0.1 ft) (hundredth of a meter — 0.01 m), and gradient (to the nearest hundredth of a percent — 0.01%) (e.g., “24 in. SS x 20.5 ft @ +1.52%” (“600 mm SS x 6.28 m @ + 1.52%”)).
 - b. Manholes, Catch Basins, Inlets. Provide the following information for these devices:
 - station location and direction and distance from the centerline;
 - the device type;
 - top of grate elevations (to the nearest hundredth of a foot — 0.01 ft (thousandth of a meter — 0.001 m)); and
 - invert elevations for all pipes (to the nearest hundredth of a foot — 0.01 ft (thousandth of a meter — 0.001 m)).

As an option, the designer may provide a numerical symbol for each of the above devices and list the information in a tabular format on the sheet.
 - c. End Sections. Note the type, size, and location offset from centerline for the end section on the plans.
 - d. Existing Facilities. Note the proposed disposition of all existing facilities directly next to the facility or as a general note in the plans (e.g., “MANHOLE TO REMAIN”, “REMOVE OR ABANDON ALL EXISTING CATCH BASINS, INLETS AND MANHOLES”).
5. Ditches. Note special ditch locations with invert elevations at 100 ft (25 m) intervals on the earthwork cross sections and not on the drainage plan sheets.
6. Utilities. Note utility locations on the plan view as follows:
- a. Overhead. Where overhead utilities cross the centerline, note the centerline station where the utility crosses and the type of utility (e.g., telephone, electrical).

- b. Underground. Where underground utilities are within the right-of-way limits, indicate the applicable centerline station, the type of utility, and the size and depth of the utility. All valve boxes, utilities manholes, etc., constructed by the contractor should be noted similarly as discussed for catch basins, manholes, and inlets in comment 4 above.

63-4.10(e) Profile View

The following provides the procedures for presenting the drainage and utility information on the profile view:

1. Profiles. Use the centerline profile where the plan and profile views are provided on the same page. However, where separate profile sheets are provided, provide separate profile views where two or more systems are located longitudinally along the project.
2. Profile and Elevation Labeling. The criteria for labeling the profile and elevations along the profile as presented in Section 63-4.07(c) also apply to drainage profiles.
3. Storm Systems. Show storm drainage systems or closed drainage systems on the profile view as follows:
 - a. Storm Sewer Pipes. Note each run of pipe according to its diameter, type, length (to the nearest tenth of a foot — 0.1 ft (hundredth of a meter — 0.01 m)); and gradient (to the nearest hundredth of a percent — 0.01%) (e.g., “24 in. SS TY-2 85.5 ft @ -0.75%” (“600 mm SS TY-2 26.15 m @ - 0.75%”). The pipe length is determined where all the above information is the same for the pipe. This pipe length may pass through manholes, catch basins, and inlets. If one of the above pieces of information changes, then provide a separate note for the pipe (e.g., where the gradient changes).
 - b. Manholes, Catch Basins, Inlets. The following information should be provided for these devices:
 - station location and direction from the centerline;
 - the device type and size;
 - invert elevations for all pipes leading into and out of the device (to the nearest hundredth of a foot — 0.01 ft (thousandth of a meter — 0.001 m)); and
 - top of casting elevation.List this information vertically along the station ordinate.
 - c. End Sections. All end sections should be shown with the following information:

- station location and direction from the centerline,
 - the device type and size, and
 - outflow elevation at the bottom of the pipe.
4. **Utilities.** The following apply to utilities:
- a. **Work Conducted by IDOT.** Underground utilities being moved or constructed by the Department's contractor should be noted on plan sheets similarly as discussed for storm drainage systems in Comment 3.
 - b. **Work Conducted by Others.** Show only those utilities that are affected by the improvement. Clearly label the affected utility according to its type and size (e.g., 1 in. (25 mm) water main, 3 in (75 mm) gas line).
5. **Ditches.** Note the gradient percentage, stationing, beginning and ending elevations, and elevations at all gradient changes.

63-4.11 Right-of-Way Plan Sheets

Where additional right-of-way is required on the project, the designer should consider including the right-of-way plan sheets (or plat of highways sheets) within the plans. These drawings allow the designer to remove the right-of-way dimensioning from the mainline plan and profile sheets, thereby improving their clarity.

63-4.12 Intersection Details

The designer may be required to provide special plan views of large or complex intersections where the general plan and profile sheets cannot adequately illustrate the horizontal alignment details and elevation controls. Only the necessary information for the geometric layout should be provided (e.g., no topography should be shown). Intersection details generally use a 1-in. = 20-ft (1:250 metric) scale. Some of the elements shown on the intersection detail may include:

- pavement elevations to determine cross road profiles, drainage characteristics, etc.;
- lane widths;
- curb or edge of pavement radii;
- accessible curb ramps;
- turning radii for the left-turning design vehicle;
- location of median noses and islands;
- location of traffic signs (e.g., stop, keep right, one-way);
- location of traffic signal poles, mast-arms, loop detectors, etc.;
- pavement markings; and
- construction joint layout.

Clearly show the name of the intersection on the right side of the detail.

63-4.13 Pavement Marking Details

Pavement marking plans are required for all projects where work on the roadway will disrupt the existing pavement markings and where more detail is required than that shown in the *IDOT Highway Standards*.

It is the designer's responsibility to provide the plan view to the appropriate unit as soon as practical during plan development. The Bureau of Operations may or may not develop the pavement marking details depending on the project type, time constraints, and workload. If the Bureau of Operations does not develop the pavement marking details, the designer will be responsible for developing these details. If the designer develops the details, the pavement marking plans still must be reviewed by the Bureau of Operations.

Copies of the general plan sheets will be used to show the pavement markings. However, only show the proposed improvement. The existing topography, right-of-way, drainage information, etc., should not be shown. This allows the pavement markings to clearly stand out. In developing the pavement markings sheet, the designer should consider the following:

1. Labeling. Pavement markings that are not covered by the *IDOT Highway Standards* must be specified and labeled on the pavement marking sheet.
2. Dimensioning. Provide dimensions for lane and median widths. Show stations for all break points in the pavement markings or use dimension lines to locate and show the lengths of pavement marking lines.
3. Raised Reflectors. In addition to pavement markings, raised reflective pavement markers may be specified on a project. They are normally included on all projects where there is no lighting. Contact the Bureau of Operations to determine where they should be used. Raised reflector locations will not be shown on the pavement marking sheets unless they deviate from the *IDOT Highway Standards*.
4. Large Projects. On very large projects with continuous markings, it may be necessary to show a typical detail of the pavement markings on each sheet.
5. Chicago Projects. District 1 must obtain the details for pavement markings for projects within the City of Chicago. The City of Chicago must review all pavement marking plans within the City.

63-4.14 Special Plans

There are several other bureaus that are responsible for preparing specific details for plans. They are discussed in the following section. The designer will be responsible for providing the plan details to the appropriate bureau. It is important that this information be provided as early as practical to the responsible bureau during plan development to allow time to complete the details and submit them back to the designer for project letting.

63-4.14(a) Landscaping Details

The Phase I report generally includes a statement on landscaping. Whether there is a Phase I report or not, it is the designer's responsibility to ensure landscaping has been considered for a project and that landscaping plans, if required, are included.

Landscaping plans are prepared by the Bureau of Operations. The Bureau provides the designer with landscaping plans, special provisions, pay items, and quantities for incorporation into the final contract. Include schedules of landscaping pay items with other schedules of quantities as discussed in Section 63-4.04(d) along with their botanical and common names clearly shown.

Landscaping details must be coordinated with municipalities, and their input should be considered when preparing the final details. In some cases, local officials may wish to incorporate their own landscaping details into the Department's contract. This can be done by agreement to establish cost participation.

63-4.14(b) Traffic Signal Plans

Traffic signal plans are required on all projects where the project includes new signals, modernization of existing signals, interconnecting signals, or milling the HMA surface at signalized intersections. Milling the HMA surface may damage the existing detector loops in the pavement.

The Bureau of Operations prepares the traffic signal plans and provides the designer with the final plans, special provisions, pay items, and quantities. It is the designer's responsibility to incorporate the traffic signal plans into the final contract.

The designer must provide the Bureau of Operations with the proposed roadway information so the Bureau can prepare its plans in a timely manner. This consist of preparing a 1 in. = 20 ft (1:250 metric) scale intersection plan for all signalized intersections requiring work within the project. The designer should also submit the traffic signal information form to the Bureau of Operations.

63-4.14(c) Lighting Plans

The Phase I report generally includes a statement on lighting. Whether there is a Phase I report or not, it is the designer's responsibility to ensure lighting has been considered for a project and that lighting plans, if required, are included in the final plans. Wherever there is existing lighting on a project, some involvement with proposed lighting work is almost certain.

For all districts except District 1, lighting plans are prepared by the Bureau of Design and Environment Preliminary Engineering Section. In District 1, plans are prepared by the District 1 Bureau of Electrical Operations. The designer will be required to provide the plan view of the project and location of power source as early as practical to the applicable unit to complete its

plans, special provisions, pay items, and quantities. The designer incorporates this information into the final contract.

Lighting on a project may be a municipally maintained system. In this case, the municipality must be contacted to determine the disposition of the lighting after completion of the project. There are two possibilities for preparing municipal lighting plans:

- the municipality performs its own lighting improvements coincident with the roadway work or after the project is completed; or
- the municipality may have IDOT perform the lighting design as part of its project. The Department bills the municipality accordingly by agreement.

If a municipality prepares the lighting plans, these must be submitted for review to the appropriate district for review and approval. The district submits the plans to the appropriate lighting unit. After the plans are approved, the municipality will be responsible for providing IDOT with the final lighting plans, special provisions, pay items, and quantities for incorporation into the final contract.

63-4.14(d) Structure Plans

Structure plans are required for all designs with structural elements including new bridges, bridge replacement, bridge repairs, retaining walls, box culverts (new or extensions to existing), junction chambers, and noise abatement walls.

Most major structure plans are prepared by consultants. The Bureau of Bridges and Structures in the Central Office will be responsible for reviewing and/or preparing the structure plans. The designer must provide the proposed roadway information to whomever is preparing the structural design. It is important to include information on the proposed construction staging in this submittal.

The structural engineer's final plan submittal includes the final plans, special provisions, pay items, and quantities for the designer to incorporate into the final contract plans.

For bridge repairs involving nonstructural work (e.g., repairs to such items as the existing deck, parapets, and deck joints), plan details are typically prepared by the district. A "Bridge Condition Report — Deck Repair" is prepared in the district Bureau of Program Development and it includes recommendations for the type of work that should be performed. Plans for bridge repairs must be submitted to the Bureau of Bridges and Structures at least three months prior to the submittal of the plans for letting in order to allow time for their review.

63-4.14(e) Wetland Plans

For projects that involve restoring or creating wetlands as a part of the environmental mitigation commitments, the designer will be responsible for ensuring the plans and special provisions include appropriate details regarding the wetlands work. This information must address the work necessary to provide the elevations, contours, hydrology, soils, and plants for the type, size, and

location of wetlands to be provided. The type, size, and location of the wetlands will have been agreed upon through consultation with regulatory and natural resource agencies and documented in a written conceptual mitigation plan prepared and approved during Phase I. The plan information should include the overall schedule for the wetlands work, including the relationship to other aspects of project construction. The information should also include a description of any special measures to be implemented during construction to avoid and minimize unnecessary construction-stage impacts to existing wetlands (e.g., placement of geotextile fabric to prevent permanent compaction of wetlands soils) and to correct temporary impacts (e.g., restoration of preconstruction contours, replanting, or reseeding of areas where wetlands vegetation is disturbed or destroyed).

Show the information concerning any manipulation of soils and hydrology that may be necessary for establishing the wetlands on the plan sheets for grading work. Also, show planting information on plan sheets and in the appropriate specifications. Show the schedule of quantities in the same manner as for other pay items.

63-4.15 Special Details

Detail sheets are used for those items that require more specific information than can be adequately described on either the plan or the profile views of the plan and profile sheets. Detail sheets are used to present:

1. Drainage Drawings. Special details are required for those drainage features not provided in the *IDOT Highway Standards*. This may include all special storm sewer layouts, culverts, inlets, catch basins, manholes, and any other drainage appurtenances. The detail sheets should show lengths, sizes, flow line elevations at ends of drainage structures, changes in flow line grade, and/or any other pertinent drainage details.
2. District Details. These are details that have been developed by each district and are generally only applicable to that district. These sheets are in addition to the *IDOT Highway Standards*. The designer should review these sheets prior to developing any new special details. These details are generally already on CADD.
3. Interchange Details. These are the contour maps around an interchange required for computation of the earthwork quantities. These details are in addition to those provided in the plan and profile sheets. They generally do not include any dimensions. Existing contours are shown as dashed lines, and proposed contours as solid lines.
4. Transitions. Details should be provided showing transitions in surface or base course widths. In addition, show the beginning and ending stations and the distance left or right of the centerline to the controlling points, and any other curve data required to construct the transitions.
5. Signing. Signing plans may or may not be included in roadway contracts. The designer is responsible for preparing the signing plans, special provisions, pay items, and quantities for incorporation into the final contract. To determine sign layout and location,

use the criteria in the Bureau of Operations' *Traffic Policies and Procedures Manual*. For sign support design, use the criteria in the Bureau of Bridges and Structures' *Sign Structures Manual*.

6. Special Designs. Additional details may be necessary as plan preparation progresses, which must be developed by the designer (e.g., pavement joint details, superelevation, special guardrail designs, highway/railroad grade crossings). It is important to include sufficient information on these details so that it is clear and understandable for the contractor to accurately bid on the work and for the resident engineer to construct it. However, do not include the code numbers for specific pay items on these sheets.

Clearly label each detail sheet in the sheet description block in the lower right corner of the sheet. The sheet description block should show the name of the detail and the station(s) to which it applies.

63-4.16 Cross Sections

Cross sections provide a graphical representation of the proposed roadway as compared to the existing ground line. Cross sections are generally required on all projects, except those involving resurfacing and/or projects with no earthwork. The following sections present the general guidelines for developing cross section sheets.

63-4.16(a) Procedure

If a Phase I report was prepared, the existing cross sections should have already been developed and may have been plotted using CADD. If the cross sections have not yet been plotted, the designer will be responsible for plotting or having the cross sections plotted. For small projects, the designer may plot the cross sections manually. However, for most projects, the cross sections should be generated using GEOPAK. The designer should review the users' manual for GEOPAK to determine what information can be plotted with this software package.

63-4.16(b) Layout

When laying out cross sections, the following guidelines should be considered:

1. Orientation. Preferably, draw the cross section horizontally (landscaped) on the sheet. If more practical, the cross sections may be drawn vertically (portrait). Draw the cross sections from the bottom of the page to the top in increasing stations.
2. Spacing. Ensure that the spacing between cross sections is such that there is no overlap of the individual cross section figures, especially in areas of large cuts or fills.
3. Intervals. In rural areas, plot the cross sections at 100 ft (25 m) intervals and in urban areas at 50 ft (10 m) intervals. Plot additional cross sections at major grade breaks, culvert crossings, side streets, entrances, and other locations as necessary. Show the

appropriate station for each cross section directly below or to the right of the cross section. For intermediate sections, the cross section may only need to be drawn to the centerline or the profile grade line.

4. **Order.** Provide the mainline cross sections first, in increasing stations. Individual cross sections for minor approaches generally will be shown as half sections at the station they occur along the mainline. Where major construction is conducted for a significant distance along sideroads, frontage roads, ramps, etc., place the cross sections for these facilities after the mainline cross section in the order they appear along the mainline. Clearly label each special cross section sheet to allow the user to identify the actual location of the cross section.
5. **Scales.** The horizontal scale will typically be 1 in. = 5 ft (1:50 metric) or 1 in. = 10 ft (1:100 metric). A larger scale may be used where a greater cross section or height is desired. The vertical scale should always be a 2:1 proportion of the horizontal scale. Show the scales used in the lower right-hand corner of each cross section sheet if not otherwise labeled.
6. **Axis Labeling.** Along the horizontal axis, "0" is placed at the centerline or profile grade line of the existing facility. Label other horizontal axis points left and right of the "0" in at least 10 ft (3.0 m) increments. For the vertical axis, the axis lines are labeled in 5 ft (1.0 m) increments. Show at least two elevation lines. Note the scaling between the horizontal and vertical (i.e., 2:1 proportion).

63-4.16(c) Plotting Details

Generally, plot the cross section slightly beyond the right-of-way line, or slightly beyond the slope intersection of the proposed improvement with the existing ground line. The distance plotted will be determined based on what is beyond the right-of-way or slope limits. Cross sections should be typically plotted using the following guidelines:

1. **Existing Information.** Show all appropriate existing information on the cross section including existing pavement structures. Show these elements with a light, dashed line. The existing roadway centerline is typically centered on the sheet. Some of the existing information that should be shown includes:
 - ground line;
 - pavement structure;
 - drainage structures;
 - all below-ground and major above-ground utilities including sanitary sewers, water lines, electrical lines, gas lines, utility poles, etc.;
 - bridges, buildings, retaining walls, or other structures;

- right-of-way and temporary easement lines; and
 - bodies of water near the right-of-way limits.
2. Proposed Sections. Overlay the proposed cross section template on top of the existing cross section. Show the proposed improvements as dark, solid lines. Some of the proposed cross section elements shown include:
- the centerline, or the profile grade line, if different from the centerline;
 - proposed pavement improvements;
 - pavement structures;
 - all side road and entrance approach adjustments;
 - curb and gutter;
 - sidewalk location and depth;
 - proposed sideslope;
 - special fill material location and depth; and/or
 - other special features (e.g., steps, ramps, retaining walls).
3. Drainage Structures. Plot all drainage structures to scale including inlets, catch basins, and manholes. Label each structure with the following information:
- the station at which the structure is located;
 - the distance from the centerline to the nearest tenth of a foot — 0.1 ft (hundredth of a meter 0.01 m) and direction from the centerline;
 - description and size of the structure; and
 - top and flow line elevations, to the nearest hundredth of a foot — 0.01 ft (thousandth of a meter — 0.001 m).
4. Storm Sewers. Show all storm sewers to the appropriate scale on each cross section. Label the pipe diameter on the first and last cross section of each sheet.
5. Culverts. Where necessary, include culvert profiles at the appropriate station of the cross sections or on separate cross section sheets. Show both the existing ground line and culvert flow lines. Flow line elevations are shown at the ends of the culvert and at changes in grade. Culvert extensions should show the existing culvert flow line in the same line weight as the original ground.

Show dimensions from the centerline to box culvert or pipe culvert ends to the nearest calculated tenth of a foot (i.e., 0.1 ft) (hundredth of a meter (i.e., 0.01 m)). These distances are measured at right angles from the roadway centerline to the ends of the culvert or to breaks in the flow lines. Round culvert lengths to 2 ft (0.5 m) increments. These dimensions should agree with those shown on the plan sheets.

Culvert profiles are not required for culverts under entrances and minor side roads where the flow line of the culvert is the same as the flow line of the mainline ditch.

6. Ditches. Special ditches should also be noted and the flow line elevation shown to the nearest 0.1 ft (0.01 m) on each cross section. Also, show the direction of flow.
7. Utilities. Plot underground and major overhead utilities on the cross section where the utility is located longitudinally within the construction limits or where the utility crosses the existing or new centerline and is located within the construction limits. Some of the utilities that should be shown include water lines, sanitary sewers, gas lines, and major transmission lines. Label the size and type of each utility (e.g., 2 in. (50 mm) gas line) on each cross section.
8. Grading Notes. Show all undercuts for subgrade and unsuitable material (e.g., topsoil, peat) on the cross section. Porous granular material for backfill is also shown as a shaded area. Note the cut and fill amounts, in square yards (square meters), below or next to each cross section. These areas are based on the end areas. Additional grading notes may be added to the cross sections to provide direction to the contractor (e.g., "GRADE TO DRAIN"). Also, show all earthwork for temporary pavements on the cross section.
9. Approaches. Show all approaches (e.g., side roads, streets, entrances) with a separate cross section at the appropriate station. This cross section may only consist of a half section to the centerline or the profile gradeline. Note the approach type, direction from centerline, and station next to the cross section (e.g., "PROFILE P.E. LT. STA. 101 + 44.32" ("PROFILE STA. 267 + 40.32 SOUTH ST")). Label the approach type according to the entrance type (e.g., residential, private, commercial) or street name. Show the approach slope as a percent.
10. Structures. Show all buildings, bridges, or other structures affected by construction on the cross section sheets.
11. Right-of-Way. In general, incorporate all permanent right-of-way lines onto the cross section. Also show temporary right-of-way and easement lines on the cross sections.
12. Labeling. In addition to the above, the cross sections should provide the following information:
 - a. Pavement Elevations. Show the final pavement surface elevation at the profile gradeline to the nearest hundredth of a foot — 0.01 ft (thousandth of a meter, 0.001 m). This elevation should be placed vertically. Other surface elevations as appropriate may be provided (e.g., high and low elevation points for superelevated sections).
 - b. Side Slopes. Label side slopes on each cross section of each sheet. Side slopes are labeled vertical to horizontal as a ratio (e.g., 1V:4H).

- c. Stations. List the cross section stations shown on the sheet in the lower right corner of each sheet. In addition, if cross sections are provided for more than one facility, note the applicable facility name directly with the station listing (e.g., Route 34, Pine St.). Desirably, place this information outside of the cross section grid.
13. Earthwork. Show the earthwork end areas for cuts and fills, above or beside the cross section. For complex projects involving stage construction, list the end areas by stages.

63-4.17 Highway Standard Drawings

The *IDOT Highway Standards* will be the last sheets added to the project. The Central Office will be responsible for adding these sheets to the plans. The sheets added will be based on the listing provided in the Index of Sheets.

63-5 CONSTRUCTION TYPE CODES

Section 63-4.04 discusses the requirements the designer must follow to break down the quantities on the summary of quantities sheet. One of these breakdowns is based on the type of construction. Figure 63-5.A provides the coding system the Department uses for these construction breakdowns.

Code	Type of Construction
0001	Roadway, New Construction Construction of a new roadway that will not replace an existing roadway
0003	Roadway Reconstruction, Capacity Added (through lanes only) Reconstruction of existing pavement, work included but not limited to: <ul style="list-style-type: none"> • Full depth, rubblizing • Small structures and culverts $\leq 20'$ • Drainage improvements
0004	Roadway Reconstruction (No added capacity) Reconstruction of existing pavement, work included but not limited to: <ul style="list-style-type: none"> • Full depth, rubblizing • Small structures and culverts $\leq 20'$ • Drainage improvements
0005	Roadway Resurfacing Maintenance Work to improve serviceability or to provide additional strength to existing roadway, work may include other incidental work in conjunction with resurfacing, work included but not limited to: <ul style="list-style-type: none"> • Mill and fill • System preservation • Resurfacing • SMART, 3P, surface treatments, crack sealing
0006	Restoration and Rehabilitation Work to return existing pavement to a condition of adequate structural support or to a condition adequate for placement of an additional state of construction, work included but not limited to: <ul style="list-style-type: none"> • 3R • Patching • Reworking or strengthening bases or sub-bases • Substantial pavement stabilization <i>prior</i> to resurfacing
0007	Maintenance Relocation Construction of a roadway at a new location that replaces an existing roadway. The new roadway carries all the through traffic with the previous facility closed or retained as a land-service road only.
0008	Bridge, New Construction Construction of a new bridge or culvert that is $> 20'$, and does not replace or relocate an existing bridge.
0010	Bridge Replacement (Added capacity/No added capacity) Total replacement of an existing bridge or culvert that is $> 20'$, with a new structure on existing or new alignment.

0013	<p>Bridge Rehabilitation (Added capacity/No added capacity) Work necessary to restore structural integrity, correct major safety defects, usually resulting in the increase in one or more of the primary condition ratings (deck/super/sub/culverts) bridge must be > 20' with structure number, work includes but not limited to:</p> <ul style="list-style-type: none"> • Superstructure replacement (full/partial) • Deck replacement (full/partial) <ul style="list-style-type: none"> + Full depth replacement significantly more than $\pm 2'$ (than the normal for replacing expansion joints) • Widening of bridge (adding beams/widening substructure) • Jacking superstructure to improve vertical under clearance • Strengthening <ul style="list-style-type: none"> + Significant cover plating + FRP wraps/strips (fixing what has been damaged) + Post-tensioning + Multiple in-kind replacements of primary and secondary structure elements such as beam ends, stringers, diaphragms, cross frames, gusset plates, wind bracing, etc. • Substructure repairs • Upgrade bridge railings • Bearing replacements
0020	<p>Environmental Only</p> <ul style="list-style-type: none"> • Erosion control • noise barriers • Rip rap, channel protection (not at bridge) • Wetland mitigation
0021	<p>Safety Work that provides features or devices to enhance safety, work included but not limited to :</p> <ul style="list-style-type: none"> • Traffic signals • Lighting • Sidewalks, ADA improvements • EVPs • Rumble strips • Guardrails • Pavement markings • Shoulder improvements
0028	<p>Facilities for Bicycle/Pedestrian Trails Sidewalks (utilizing ITEP funds ONLY)</p>
0030	<p>Scenic or Historic Highways Programs</p> <ul style="list-style-type: none"> • For projects related to scenic or historic highway programs • Construction of turnouts, overlooks, viewing areas • Construction of visitor and welcome centers • Designation signs and markers

0031	Landscaping & Other Beautification <ul style="list-style-type: none"> • Beautification • Tree Removal • Weed Spraying
0042	Trainees
0043	Utilities <ul style="list-style-type: none"> • Electrical work, linemen, substations • Storm sewer
0044	Other <ul style="list-style-type: none"> • Building demolition • Overhead sign structures • Pump stations • Retaining wall • Signage • Sweeping • Weigh stations • Work performed on a bridge that carries a railroad over a highway
0047	Bridge Preservation Work that prevents, delays, or reduces deterioration of bridge elements, restores the function of existing bridge, keeps bridge in good condition and extends life for bridges > 20', work includes but not limited to: <ul style="list-style-type: none"> • Deck sealing • Washing • Painting <ul style="list-style-type: none"> + Full removal and repaint + Spot painting and zone painting + Over coating of existing paint system • Deck patching (full/partial) • Expansion joint sealing and replacement (including \pm 2' of concrete deck removal) • Eliminating deck joints • Channel debris removal • Lubricating bearings • Retrofit of fatigue prone details • Column jacketing / FRP wrap of substructures (preserving to prevent damage)
0048	Bridge Protection Work that adds protection against extreme events and provides security countermeasures, work included but not limited to: <ul style="list-style-type: none"> • Installing riprap or other scour countermeasures • Seismic retrofits • Impact protection measures <ul style="list-style-type: none"> + Fenders + Dolphins

	<ul style="list-style-type: none"> + Pier protection cells • Security countermeasures + Fencing + Video monitoring + Fire detection/suppression
0049	Bridge Inspection and Related Training <ul style="list-style-type: none"> • Bridge inspections and evaluations • Bridge inspection training • In-depth/special inspections • Load rating
0050	New Tunnel Construction of a new tunnel that does not replace or relocate an existing tunnel
0051	Tunnel Replacement Total replacement of a tunnel with a new structure constructed with additional lanes in the same general traffic corridor.
0052	Tunnel Rehabilitation For the work required to restore structural integrity of a tunnel, as well as, work necessary to correct major safety defects.
0053	Tunnel Preventative Maintenance Activities that prevent, delay, or reduce deterioration of tunnels or tunnel elements, restore the function of existing tunnels, keep tunnels in good condition and extend their life.
0054	Tunnel Protection Includes impact protection measures, security countermeasures, and protection against extreme events.
0055	Tunnel Inspection and Tunnel Related Training Tunnel inspection and evaluation, including in-depth and other special inspections; tunnel inspection related training
0059	Bridge Resurfacing <ul style="list-style-type: none"> • Microsilica overlays with hydrodemolition or scarification • Latex Overlays with hydrodemolition or scarification • Other hard overlay with/without hydrodemolition or scarification • Concrete wearing surfaces • Thin Polymer Overlays (epoxy w/ broadcast aggregate) • Bituminous Overlays with or without waterproofing membrane

CONSTRUCTION TYPE CODES

Figure 63-5.A

63-6 SUGGESTED PLAN PREPARATION CHECKLIST

Date Completed _____ Route _____
Designer _____ Section _____
County/City _____

Cross off each item as checked and place this form in the project file.

ALL SHEETS

- 1. Complete sheet index block in the lower right-hand corner with the project section number, route number, county, contract number, and sheet numbers.
- 2. Use appropriate symbols, cell library, and abbreviations as noted in the *Computer Aided Design, Drafting, Modeling and Deliverables Manual* and *IDOT Highway Standards*.

COVER SHEET

- 1. Indicate the location of the index of sheets, if not included on the cover sheet.
- 2. Show title information in the top center of the sheet and include:
 - project route number and common name,
 - section designation number,
 - location of improvement,
 - type of improvement,
 - county, and
 - construction job number.
- 3. Below the sheet index block, note the design number.
- 4. Locate the Illinois State map along the right side of the sheet. Also, indicate the project location on the map.
- 5. Show the graphic scales used on plans, profiles, and cross sections in the lower left-hand side of the sheet.
- 6. Provide the contract number in the lower left-hand corner of the sheet.
- 7. Provide a project layout map at bottom center of the sheet. Include on the map:
 - location of project, and north arrow,
 - beginning and end stations,

- all important intermediate stations,
 - prominent features,
 - names for special features,
 - route and street names,
 - description of all structures over 20 ft (6 m),
 - scale of location map,
 - township and range numbers, and
 - equation stations.
8. Provide the project gross and net lengths immediately below the layout map. Only include the mainline distances. Do not include length of intersection improvements.
9. Include the project approval block in lower right-hand corner of the sheet and check to ensure the signatures and dates for the following are included:
- Regional Engineer,
 - Engineer of Design and Environment,
 - Director of the Office of Highways Project Implementation,
 - FHWA Division Administrator, where applicable, and
 - local officials, where applicable.
10. On consultant-designed projects, ensure that the consultant's company name, and the professional engineer's signature, date of their license expiration, and professional stamp are shown beside the State approval box.
11. Ensure that the note "PRINTED BY THE AUTHORITY OF THE STATE OF ILLINOIS" has been included in the lower right-hand corner.
12. Show the information for J.U.L.I.E. or C.U.A.N. somewhere on the cover sheet.
13. Include the design designation notation somewhere on the cover sheet.
14. Include district project engineer/squad leader name in left margin.

INDEX OF SHEETS, HIGHWAY STANDARDS, PLANS NOTES, COMMITMENT
--

- 1. Completely fill out the sheet index.
- 2. Provide a list of all *IDOT Highway Standards* necessary to construct the project. Also, include the revision number.
- 3. Include all applicable general plan notes.
- 4. Include all applicable commitments.

SUMMARY OF QUANTITIES SHEET

- 1. Show the appropriate quantity breakdowns based on the construction and safety work type, project location, funding source, etc.
- 2. Provide the correct pay item code number and description; see Section 63-4.04(b).
- 3. Use the appropriate pay unit; see *IDOT Standard Specifications* for the appropriate metric pay units.
- 4. Fill out the total quantities column.
- 5. Round all quantities in accordance with Chapter 64.
- 6. Provide separate schedule of quantities sheet for as many pay items as practical.

TYPICAL SECTION SHEET

- 1. Ensure that all applicable typical sections are provided.
- 2. Provide the mainline typical sections first, followed by other typical sections as they appear along the mainline.
- 3. Note the title of the typical section and applicable stations directly below the typical section.
- 4. Ensure the following have been included on the typical section:
 - horizontal dimensions rounded to nearest 0.1 ft (0.01 m);
 - vertical dimensions rounded to nearest $\frac{1}{4}$ in. or $\frac{1}{8}$ in. (5 mm or 1 mm) for resurfacing lifts;
 - the profile grade line reference, if different from the centerline;
 - types and depths of surface, base, and subbase courses;
 - side slopes expressed as a ratio of vertical to horizontal distances;
 - cross slopes expressed in inches/foot (US Customary) or percent (metric);
 - percent of superelevation; and
 - all other applicable notations.

- 5. Provide a table of base thickness where the base and subbase depths vary and include the applicable station limits.
- 6. Include all notes applicable to the typical sections.
- 7. Note all applicable pay items on the typical section.
- 8. Include the structural pavement design information.

ALIGNMENT, TIE, AND BENCHMARK SHEET

- 1. Where necessary for complex projects, include a geometric alignment figure. Also, include a coordinate layout sheet for all alignments, sideroads, radius returns, and parking lots.
- 2. Show schematics for reference tie locations that include:
 - the applicable centerline station,
 - the applicable control tie, and
 - the complete description of the features used to determine the tie location.
- 3. Show all mainline reference ties first, followed by those for other facilities.
- 4. Round all reference tie dimensions to the nearest 0.01 ft (5 mm).
- 5. Provide the benchmark data on this sheet and include the following information:
 - centerline station,
 - distance and direction from the centerline,
 - description of location, and
 - benchmark elevation.

PLAN/PROFILE SHEET

PLAN AND PROFILE VIEWS

- 1. Provide the mainline plan and profile sheets first, followed by other plan and profile sheets as they appear along the centerline.
- 2. Plot existing facilities with a light, dashed line and the proposed facilities with a solid, dark line.
- 3. Keep all notes brief, clear, and consistent.

- 4. Desirably, label the applicable stations in the lower right corner on each sheet.

PLAN VIEW

- 5. Show mainline stationing increasing from left to right. Note where the centerline line is not coincident with the survey line.
- 6. Provide tick marks along the centerline at 100 ft (50 m) intervals and note the station.
- 7. Use matchlines on sheet.
- 8. On projects where a coordinate system has been set up, show the coordinates for all control points.
- 9. For rural facilities, use a plan view scale of 1 in. = 50 ft (1:500 metric). For urban facilities, use a plan view scale of 1 in. = 20 ft (1:250 metric).
- 10. For all control points along the centerline, provide a 0.1 in. (2.5 mm) diameter circle on the centerline.
- 11. Place the horizontal curve data on the inside of the curve to which it applies. Present the curve data in accordance with the format and accuracy presented in Figure 63-4.D.
- 12. Include the pavement edge elevations and superelevation rates for superelevated sections.
- 13. Show perpendicular lines from the centerline to the inside of the curve at all curve control points. Indicate the curve control point and station.
- 14. Where deflection angles are used, show the angle to nearest second of a degree. Include coordinates, if available.
- 15. Note all pavement widths at the beginning and end of each sheet and wherever there is a change in pavement width.
- 16. Provide the correct district North arrow on each sheet.
- 17. Ensure station call outs are provided at:
 - beginning and end points of the project,
 - matchlines with other projects,
 - omissions from paving and station equations,
 - 100 ft (50 m) station increments,
 - horizontal curve points,
 - beginning and ending points of tapers,
 - construction limit locations,
 - right-of-way alignment breaks,
 - curb returns for entrances and intersections,

- entrance centerlines,
 - special construction applications,
 - side street intersections,
 - permanent survey and right-of-way markers,
 - section lines, and
 - other necessary locations.
18. In general, do not show utility and drainage information on the plan and profile sheets. Provide this information on the drainage plan and profile sheets.
19. If separate right-of-way sheets are included with the plans, show the existing and proposed right-of-way limits on the plans. If the right-of-way plans are not included with the plans, also incorporate the following:
- dimensions of the properties to be acquired,
 - station ties to property lines,
 - property ownership lines,
 - parcel numbers,
 - property owner names,
 - station locations of right-of-way alignment breaks,
 - temporary and permanent easement locations,
 - points where the control of access does not coincide with the right-of-way line,
 - location of right-of-way markers, and
 - any pertinent data that affects right-of-way costs.
20. Show all approved points of entry or exits across control of access lines.
21. Show the locations for all new and existing guardrail installations.
22. For entrances and side road intersections, show the following:
- the facility with the applicable street name, route number, or entrance type;
 - the existing surface material type;
 - the width of the intersecting facility;
 - for intersections with public roads, the angle of intersection from the side road centerline to the mainline centerline; and
 - direction of ditch drainage.
23. Properly label all additional constructed improvements.

PROFILE VIEW

- 24. Show the profile of the finished surface or top of the subgrade along the centerline for the proposed facility.
- 25. Use the same horizontal scale as shown for the plan view. The vertical scale is typically 1 in. = 5 ft (1:50 metric) or 1 in. = 10 ft (1:100 metric).
- 26. Show the existing ground line to the nearest 0.1 ft (30 mm) and existing pavement surfaces to the nearest 0.01 ft (5 mm).
- 27. Show the vertical curve data above the profile line for crest curves and below the profile line for sag curves. Include the following vertical data for each curve:
 - small triangle at the VPI,
 - small circles (0.1 in (2.5 mm) diameter) at all other vertical curve control points,
 - the VPI station, including short segments of vertical tangents,
 - the vertical curve length,
 - the elevation at the VPI, and
 - the "M" distance between the VPI and roadway surface.
- 28. Show tangent grades to the nearest hundredth of a percent (i.e., 0.01%). Use a "+" prefix for positive grades and "-" prefix for negative grades.
- 29. If not shown on the benchmark sheet, show the benchmark information on the top portion of the profile view.
- 30. Show the elevations for the survey line and proposed centerline vertically every 100 ft (25 m) for rural projects and every 50 ft (10 m) for urban projects. For vertical curves, use a closer interval. The survey elevation is shown to the left of the station ordinate line and proposed centerline elevation to the right.
- 31. Provide additional profiles, where necessary, for:
 - pavement edges,
 - drainage structures,
 - special ditches,
 - side roads, and
 - other situations.
- 32. Show locations of all undercutting for unsuitable materials with cross hatching and show this excavation to the top of subgrade. Note the applicable stations and depth of excavation on the profile sheet.
- 33. For bridges within the project, show elevations for:
 - abutments,

- piers,
- low vertical clearance points,
- the high water level, and
- stream bed.

STAGES OF CONSTRUCTION AND TRAFFIC CONTROL SHEETS

- 1. Determine which *IDOT Highway Standards* are applicable for the traffic control on the project.
- 2. Where necessary, provide plan view sheets showing:
 - temporary roadway horizontal alignment,
 - temporary pavement widths,
 - temporary traffic lanes,
 - proposed construction staging,
 - location of signing for work zones,
 - temporary pavement markings,
 - roadside safety layouts, and
 - general notes for construction, closures, time frames, etc.
- 3. Where necessary, provide the temporary roadway profile grade line on the profile sheet.

EROSION AND SEDIMENT CONTROL DETAILS

- 1. Determine which *IDOT Highway Standards* are applicable for erosion and sediment control on the project.
- 2. Where necessary, provide any commitments or General Notes that relate to erosion and sediment control.
- 3. Where necessary, provide plan view sheets showing:
 - proposed construction staging,
 - location of environmentally sensitive areas,
 - location of erosion and sediment control items, and
 - general notes for construction, pay items, etc.

DRAINAGE AND UTILITIES SHEETS

- 1. For culverts, note the following on the drainage plan view sheet:

- centerline station for the ends,
 - direction and distance of the ends from the centerline,
 - culvert type,
 - pipe size and length,
 - flow direction,
 - skew angle,
 - upstream and downstream flow elevations,
 - end section or headwall type and size, and
 - all applicable construction notes.
2. For storm drainage pipes, show the following:
- Plan View
- each run of pipe between manholes, catch basins, and inlets;
 - pipe diameter and length; and
 - gradient.
- Profile View
- diameter of pipe,
 - type of pipe,
 - length, and
 - gradient.
3. For manholes, catch basins, and inlets, show the following:
- Plan View
- centerline station,
 - direction and distance from centerline,
 - top of grate elevation, and
 - invert elevations for all pipes.
- Profile View
- centerline station,
 - direction from centerline,
 - device type and size,
 - invert elevations for all pipes, and
 - top of casting elevation.
4. For end sections, show the following:

Plan View

- centerline station and offset,
- type, and
- size.

Profile View

- centerline station,
 - direction from centerline,
 - device type and size, and
 - outflow elevation at the bottom of pipe.
5. Note special ditch locations with invert elevations at 100 ft (25 m) intervals on the cross sections. On the profile view note:
- gradient percentage,
 - centerline station,
 - beginning and ending elevations, and
 - elevations at gradient changes.
6. Note all overhead utilities where they cross the centerline and the type of utility.
7. Note all underground utilities within the right-of-way limits affected by the construction with the following:

Plan View

- centerline station,
- direction and distance from the centerline, and
- all applicable elevations.

Profile View

- type and size.

PLANS FROM OTHER UNITS, SECTIONS, AND BUREAUS

Where necessary, the following plan sheets are provided to the designer from other units, sections, and bureaus to be incorporated into the plans:

- 1. Right-of-way plans from the Bureau of Land Acquisition.
- 2. Pavement marking details from the Bureau of Operations. If the Bureau of Operations does not prepare the plans, then the designer should develop the pavement marking details.

- 3. Landscaping details from the Bureau of Operations.
- 4. Traffic signal plans from the Bureau of Operations.
- 5. Lighting plans from the BDE Preliminary Engineering Section or, in District 1, the Bureau of Electrical Operations.
- 6. Structural plans from the Bureau of Bridges and Structures.
- 7. The *IDOT Highway Standards* listed in the sheet index will be incorporated into the plans by the Bureau of Design and Environment for project letting.

DETAIL SHEETS

Where necessary, the following details may be included:

- 1. Intersection details which may include:
 - pavement elevations,
 - lane widths,
 - curb or edge of pavement radii,
 - curb ramps,
 - turning radii for left-turning vehicles,
 - location of median noses and islands,
 - location of traffic signal equipment,
 - location of traffic signs,
 - pavement markings, and
 - construction joint layout.
- 2. Special drainage details that are not covered in the *IDOT Highway Standards* or on the drainage plan and profile sheets.
- 3. District detail sheets.
- 4. Earthwork details for interchanges requiring significant earthwork.
- 5. Transition details where there is a change in the roadway surface or base course width. These details should include:
 - beginning and end stations,
 - distances and direction from the centerline, and
 - all necessary curve data.
- 6. Signing plans, where applicable.

- 7. Wetland plans, where required.
- 8. Any special designs not covered in the *IDOT Highway Standards* or elsewhere in the plans.

CROSS SECTION SHEETS

- 1. Plot rural cross sections at 100 ft (25 m) intervals and urban cross sections at 50 ft (10 m) intervals.
- 2. Plot intermediate cross sections at all major grade breaks, pipe crossings, side streets, entrances, and other locations as necessary.
- 3. Ensure the spacings between cross sections do not overlap.
- 4. The mainline cross sections are placed first, by increasing stations, from the bottom of the sheet to top of the sheet. Provide the cross sections for other facilities after the mainline cross section in the order they appear along the mainline.
- 5. Note the stations of the cross section shown on the bottom of the sheet. Also note the name of the facility to which the cross sections apply.
- 6. Use a horizontal scale of 1 in. = 5 ft (1:50 metric) or 1 in. = 10 ft (1:100 metric). The vertical scale is a 2:1 proportion of the horizontal scale. Show the scales used in the lower right corner of each sheet.
- 7. Plot the existing cross section using a light, dashed line and show the existing:
 - ground line,
 - pavement structure,
 - drainage structures,
 - major utilities,
 - all affected structures,
 - existing and proposed right-of-way and easement lines, and
 - bodies of water near the right-of-way limits.
- 8. Plot the proposed cross section using a dark, solid line and show:
 - centerline (and the profile grade line, if different);
 - proposed pavement structure;
 - all side road and entrances;
 - curb and gutter;
 - sidewalk locations and depth;
 - proposed side slopes;
 - special fill materials;

- all new drainage structures, include the following:
 - centerline station,
 - distance and direction from centerline,
 - description and size of structure,
 - top and flow line elevations;
 - all underground utilities affected by the construction;
 - special ditch elevations and drainage direction;
 - proposed right-of-way and easement lines; and
 - any other special features.
9. Provide the proposed centerline pavement surface elevation vertically on each cross section.
10. Label the side slope on the first and last cross section of each sheet and where there are changes in the slope. Show the side slope using a vertical to horizontal ratio, e.g., 1V:3H.
11. Show the end area cut and fill amounts, in square feet (square meters), above or beside each cross section.
12. Show all undercutting for subgrade and unsuitable material.
13. Show all earthwork for temporary pavements.
14. Provide separate cross sections for all approaches including side roads and entrances, and note the approach type, direction from centerline, and station next to the cross section.

Chapter Sixty-four
QUANTITY COMPUTATIONS

BUREAU OF DESIGN AND ENVIRONMENT MANUAL

Chapter Sixty-four
QUANTITY COMPUTATIONS

Table of Contents

<u>Section</u>	<u>Page</u>
64-1 GENERAL	64-1.1
64-1.01 Guidelines for Preparing Quantity Computations	64-1.1
64-1.02 Computer Estimates	64-1.2
64-1.03 Computation Records	64-1.2
64-1.04 Units of Measurement	64-1.2
64-1.05 Non-Defined Work	64-1.19
64-1.05(a) Lump-Sum Items	64-1.19
64-1.05(b) Items Included in Other Work	64-1.19
64-1.06 Federal Participation in Stockpiling of Salvage Materials	64-1.19
64-2 EARTHWORK COMPUTATIONS	64-2.1
64-2.01 Computer Computations	64-2.1
64-2.02 Manual Computations	64-2.1
64-2.03 Shrink and Swell Factors	64-2.5
64-2.04 Earthwork Considerations	64-2.6
64-2.04(a) Excavation Quantities	64-2.6
64-2.04(b) Earthwork Quantities for Separate Grading and Paving Contracts	64-2.12
64-2.04(c) Bridge Embankment Quantities	64-2.13
64-2.05 Landscaping	64-2.13
64-2.06 Subgrade	64-2.14
64-2.07 Subbase	64-2.14
64-3 PAVEMENT COMPUTATIONS	64-3.1
64-3.01 Bituminous	64-3.1
64-3.01(a) Bituminous Binder and Surface Course	64-3.1
64-3.01(b) Bituminous Materials Applied	64-3.1
64-3.02 Pavement Rehabilitation	64-3.1
64-3.03 Shoulders/Curb and Gutter	64-3.1
64-3.03(a) Shoulders	64-3.1
64-3.03(b) Curb and Gutters	64-3.1

Table of Contents
(Continued)

<u>Section</u>	<u>Page</u>
64-4 MISCELLANEOUS COMPUTATIONS.....	64-4.1
64-4.01 Bridges Deck Slab Repair Quantities	64-4.1
64-4.02 Trench Backfill	64-4.1
64-4.03 Aggregate	64-4.1
64-5 MATHEMATICAL FORMULAS.....	64-5.1

Chapter Sixty-four

QUANTITY COMPUTATIONS

In addition to preparing clear and concise plans, as described in Chapter 63, the designer needs to compile an accurate summary of the project quantities. This information leads directly to the Engineer's Estimate, which combines the computed quantities of work and the estimated unit bid prices. An accurate summary of quantities is critical to prospective contractors interested in submitting a bid on the project. Chapter 64 presents guidelines on calculating quantities for highway construction projects.

64-1 GENERAL

64-1.01 Guidelines for Preparing Quantity Computations

When preparing quantity computations, the designer should consider the following guidelines:

1. Specifications. Cross check all items against the *IDOT Standard Specifications for Road and Bridge Construction* and the Supplemental Specifications to ensure that the appropriate pay items, methods of measurement, and bases of payment are used. If an item is not covered in the *IDOT Standard Specifications* or Supplemental Specifications (i.e., those having an asterisk in the *IDOT Coded Pay Items*), a special provision, plan note or detail must be included in the contract documents to cover the item.
2. Pay Item Code Number. Every pay item has a unique number assigned to it for data processing. This code number is located in the *IDOT Coded Pay Items*. Section 63-4.04 describes the Department coding procedures, description titles, and units of measurement for pay items. Only the official name and description should be used in the contract documents, special provisions, and summary of quantities. Do not include "dummy" code numbers in the plans.
3. Rounding. The quantity of any item provided in the plans should check exactly with the figure on the computation sheets. Indicate any rounding of the raw estimated figures on the computation sheets. Unless stated otherwise, no rounding of the calculations should be done until the value is incorporated into the summary of quantities sheet.
4. Significant Digits. When calculating quantities, carefully consider the implied correspondence between the accuracy of the data and the given number of digits.
5. Multiple Estimates. Some projects will require two or more estimates for work performed under various funding arrangements, construction and safety work types, and area location. Section 63-4.04 describes the various breakdown categories for quantity computations.

6. Cost Estimate. Only use the total values from the summary of quantities sheets to develop the cost estimate. Show all items described in the plans that will be included in the cost estimate on the plan sheets. Chapter 65 provides Department criteria for preparing construction cost estimates. These quantities are used to determine the final Engineer's Estimate.
7. Estimating Forms/Computation Worksheets. Blank copies of the estimating forms and computation worksheets are available from BDE.

64-1.02 Computer Estimates

For most projects, the computer can be used to develop some of the quantity estimates. For small projects, it may be more efficient to manually calculate the quantities for all elements, including earthwork. Each software package used by the Department (e.g., GEOPAK) uses different procedures for determining how and which quantities can be estimated. The designer should give special consideration to how the plans are prepared on the computer (e.g., cell names, levels, processing procedures) to allow the software to determine the quantities.

64-1.03 Computation Records

In preparing the project quantities, prepare a separate computation sheet for each item used on the project. Combine these sheets and bind them with a cover sheet. The preparer will sign or initial and date each sheet. The checker will also be required to sign or initial and date each sheet. Number the sheets and indicate the total number of pages on each sheet (i.e., sheet x of y). Place the code number and pay item on the top of each sheet. Arrange the sheets in code number order (i.e., numerically and then alphabetically).

Check all values obtained through computations or use of standardized tables, preferably on an independent basis. For those pay items where agreements may be reached to make payment on the basis of planned quantities, an independent check should be performed and noted. Note the resolution of any differences between original and check computations. Where computations are performed by computer, an independent check is not required. However, make spot checks of the input and review the computation output sheet for obvious mistakes. Also, sign and date the computer output similarly to hand computation sheets.

Retain the quantity computations within the project file.

64-1.04 Units of Measurement

Estimate the quantities for all contract bid items using the terms and units of measurement presented in the *IDOT Standard Specifications* and the *IDOT Coded Pay Items*. Show the values determined from the computations on the summary of quantities sheet, and elsewhere in the plans. Figure 64-1.A illustrates typical rounding criteria that should be used on the summary of quantities sheet and in the plans. Note that certain elements are rounded based on standard manufacturer sizes.

Item	Measured Unit	Degree of Accuracy
A		
ADJUSTING SANITARY SEWERS	FOOT	1
ADJUSTING WATER SERVICE LINES	FOOT	1
AGGREGATE	TON	1
AGGREGATE (PRIME COAT)	TON	1
AGGREGATE BASE COURSE	CUBIC YARD, TON, SQUARE YARD	1, 1, 1
AGGREGATE BASE REPAIR	TON	1
AGGREGATE SHOULDERS	TON, CUBIC YARD, SQUARE YARD	1, 1, 1
AGGREGATE SURFACE COURSE	SQUARE YARD, CUBIC YARD, TON	1, 1, 1
AGRICULTURAL GROUND LIMESTONE	TON	0.1
ALUMINUM END SECTIONS	EACH	1
ALUMINUM RAILING	FOOT	1
AREA REFLECTIVE CRACK CONTROL TREATMENT	SQUARE YARD	0.5
ASPHALT MODIFIER	GALLON	1
B		
BACKSLOPE DRAINS TYPES 1, 2, AND 3	FOOT	1
BARE COPPER WIRE	FOOT	1
BASE COURSE WIDENING	SQUARE YARD	1
BITUMINOUS BASE COURSE	SQUARE YARD	1
BITUMINOUS CONCRETE BINDER/SURFACE COURSE	TON, SQUARE YARD	1, 1
BITUMINOUS CONCRETE PAVEMENT (FULL-DEPTH)	SQUARE YARD	1
BITUMINOUS MATERIAL APPLIED	GALLON, TON	1, 0.1
BITUMINOUS MATERIALS	GALLON, TON	1, 0.1
BITUMINOUS SHOULDER CURB	FOOT	1
BITUMINOUS SHOULDERS	SQUARE YARD, TON	1, 1
BITUMINOUS SURFACE COAT	SQUARE YARD	1
BITUMINOUS SURFACE REMOVAL	SQUARE YARD	1
BLOTTER AGGREGATE	TON	1
BORROW EXCAVATION	CUBIC YARD	5
BOX CULVERT END SECTIONS	EACH	1
BRIDGE APPROACH PAVEMENT	SQUARE YARD	1
BRIDGE DECK GROOVING	SQUARE YARD	1

QUANTITY ROUNDING CRITERIA — US CUSTOMARY

Figure 64-1.A

Item	Measured Unit	Degree of Accuracy
BRIDGE SEAT SEALER	SQUARE YARD	1
BRIDGE WASHING	EACH	1
C		
CABLE ROAD GUARD REMOVAL	FOOT	1
CABLE ROAD GUARD, SINGLE STRAND	FOOT	1
CALCIUM CHLORIDE APPLIED	TON	0.1
CAST IRON SOIL PIPE	FOOT	1
CAST-IN-PLACE PILE EXTENSIONS	FOOT	0.5
CATCH BASINS	EACH	1
CATCH BASINS TO BE ADJUSTED/RECONSTRUCTED	EACH	1
CEMENT	HUNDRED WEIGHT	1
CHAIN LINK FENCE	FOOT	1
CHAIN LINK GATES	EACH	1
CHANNEL EXCAVATION	CUBIC YARD	1
CLASS A, B, C, D PATCHES	SQUARE YARD	1
CLASS MS CONCRETE	CUBIC YARD	0.1
CLASS SI CONCRETE	CUBIC YARD	0.1
COFFERDAM EXCAVATION	CUBIC YARD	1
COFFERDAMS	EACH	1
COMBINATION CONCRETE CURB AND GUTTER	FOOT	0.5
COMBINATION CURB AND GUTTER REMOVAL	FOOT	1
CONCRETE BARRIER	FOOT	1
CONCRETE BLOCK RIPRAP	SQUARE YARD	1
CONCRETE BOX CULVERTS	CUBIC YARD	0.1
CONCRETE CURB/GUTTER	FOOT	0.5
CONCRETE GLARE SCREEN	FOOT	0.5
CONCRETE HANDRAIL	CUBIC YARD	0.1
CONCRETE HEADWALL REMOVAL	EACH	1
CONCRETE HEADWALLS	CUBIC YARD	0.1
CONCRETE MEDIAN	SQUARE FOOT	1
CONCRETE REMOVAL	CUBIC YARD	0.1

QUANTITY ROUNDING CRITERIA — US CUSTOMARY

Figure 64-1.A
(Continued)

Item	Measured Unit	Degree of Accuracy
CONCRETE STRUCTURES	CUBIC YARD	0.1
CONCRETE SUPERSTRUCTURE	CUBIC YARD	0.1
CONCRETE THRUST BLOCKS	EACH	1
CONDUIT	FOOT	1
CONSTRUCTING TEST STRIP	EACH	1
CONTINUOUSLY REINFORCED PORTLAND CEMENT CONCRETE PAVEMENT	SQUARE YARD	1
CONTROL INSTALLATION	EACH	1
CORRUGATED STRUCTURAL PLATE ARCHES, PIPE ARCHES, PIPE CULVERTS	FOOT	1
COVER COAT AGGREGATE	TON	1
CRACK FILLING	POUND	0.5
CRACK ROUTING (PAVEMENT)	FOOT	1
CURB REMOVAL	FOOT	1
D		
DELINEATORS	EACH	1
DOMESTIC METER VAULTS TO BE MOVED	EACH	1
DOMESTIC WATER SERVICES BOXES TO BE MOVED	EACH	1
DRAINAGE STRUCTURES	EACH	1
DRIVEWAY PAVEMENT REMOVAL	SQUARE YARD	1
DRIVING AND FILLING SHELLS	FOOT	1
DRIVING PILES	FOOT	1
E		
EARTH EXCAVATION	CUBIC YARD	5
EARTH EXCAVATION (WIDENING)	CUBIC YARD	5
EARTH EXCAVATION FOR EROSION CONTROL	CUBIC YARD	5
ELASTOMERIC BEARING ASSEMBLY	EACH	1
ELECTRIC CABLE IN TRENCH	FOOT	1
ELECTRICAL CONDUCTORS IN CONDUIT	FOOT	1
END SECTIONS	EACH	1
ENGINEER'S FIELD LABORATORY	CALENDAR MONTH	1
ENGINEER'S FIELD OFFICE	CALENDAR MONTH	1
EPOXY CRACK SEALING	FOOT	1
EPOXY MORTAR REPAIR	GALLON	1

QUANTITY ROUNDING CRITERIA — US CUSTOMARY

Figure 64-1.A
(Continued)

Item	Measured Unit	Degree of Accuracy
ERECTING STRUCTURAL STEEL	LUMP SUM	1
EROSION CONTROL BLANKET	SQUARE YARD	1
EXCAVATING AND GRADING EXISTING SHOULDER	UNIT	1
EXPANSION BOLTS	EACH	1
EXPANSION TIE ANCHORS	EACH	1
EXPLORATION TRENCH	FOOT	1
F		
FABRIC FORMED CONCRETE REVETMENT MATS	SQUARE YARD	1
FENCE (EROSION CONTROL)	FOOT	1
FIBER MAT	SQUARE YARD	1
FIELD TILE JUNCTION VAULTS	EACH	1
FILLING CATCH BASINS, INLETS, MANHOLES	EACH	1
FILTER FABRIC FOR USE WITH RIPRAP	SQUARE YARD	1
FIRE HYDRANTS TO BE MOVED	EACH	1
FLAP GATE	EACH	1
FLOOR DRAINS	EACH	1
FRAMES AND GRATES	EACH	1
FRAMES AND GRATES TO BE ADJUSTED	EACH	1
FRENCH DRAINS	CUBIC YARD	1
FURNISHED EXCAVATION	CUBIC YARD	5
FURNISHING AND ERECTING DRAINAGE MARKERS	EACH	1
FURNISHING AND ERECTING PRECAST, PRESTRESSED CONCRETE I - BEAMS	FOOT	0.5
FURNISHING AND ERECTING STRUCTURAL STEEL	LUMP SUM, POUND	1, 10
FURNISHING AND PLACING COMPOST	SQUARE YARD	1
FURNISHING AND PLACING TOPSOIL	SQUARE YARD	1
FURNISHING CONCRETE PILES	FOOT	1
FURNISHING STRUCTURAL STEEL	LUMP SUM	1
G		
GABIONS	CUBIC YARD	1
GEOCOMPOSITE WALL DRAIN	SQUARE YARD	1
GEOTECHNICAL FABRIC	SQUARE YARD	1
GLARE SCREEN BLADES	EACH	1

QUANTITY ROUNDING CRITERIA — US CUSTOMARY

Figure 64-1.A
(Continued)

Item	Measured Unit	Degree of Accuracy
GRANULAR EMBANKMENT, SPECIAL	CUBIC YARD, TON	5, 1
GRATES	EACH	1
GRATING FOR CONCRETE FLARED END SECTION	EACH	1
GUARDRAIL REMOVAL	FOOT	1
GUTTER REMOVAL	FOOT	1
H		
HARDWARE	POUND	10
HEAT SCARIFYING	SQUARE YARD	1
I		
INCIDENTAL BITUMINOUS SURFACING	TON	1
INLET BOX, STANDARDS XXXX	EACH	1
INLETS	EACH	1
INLETS TO BE ADJUSTED/RECONSTRUCTED	EACH	1
INSERTION CULVERT LINER	FOOT	1
J		
JOINT OR CRACK FILLING	POUND	10
JOINT OR CRACK ROUTING	FOOT	1
L		
LEVELING BINDER (HAND METHOD)	TON	0.1
LEVELING BINDER (MACHINE METHOD)	TON	1
LIGHT POLE ALUMINUM	EACH	1
LIGHT POLE FOUNDATION	EACH	1
LIGHT TOWER	EACH	1
LIGHT TOWER FOUNDATION	FOOT	0.5
LIME	TON	0.1
LOCATING UNDERGROUND CABLE	FOOT	1
LUG SYSTEM COMPLETE	EACH	1
LUMINAIRE, SODIUM VAPOR	EACH	1
M		
MANHOLES	EACH	1
MANHOLES TO BE ADJUSTED/RECONSTRUCTED	EACH	1
MASONRY REMOVAL	CUBIC YARD	0.1
MEDIAN INLETS	EACH	1

QUANTITY ROUNDING CRITERIA — US CUSTOMARY

Figure 64-1.A
(Continued)

Item	Measured Unit	Degree of Accuracy
MEDIAN REMOVAL	SQUARE YARD	1
MEMBRANE WATERPROOFING	SQUARE YARD	0.5
METAL SHOES	EACH	1
MICRO-SURFACING	SQUARE YARD	1
MIXTURE FOR CRACKS, JOINTS, AND FLANGEWAYS	TON	0.1
MOWING	ACRE	0.25
MULCH METHOD 1, 2, 3	ACRE	0.25
N		
NAME PLATES	EACH	1
NEOPRENE EXPANSION JOINT	FOOT	0.5
P		
PAINTING STEEL RAILING	FOOT	1
PAINTING STRUCTURAL STEEL	LUMP SUM	1
PAVED DITCH	FOOT	1
PAVED DITCH REMOVAL	FOOT	1
PAVED SHOULDER REMOVAL	SQUARE YARD	1
PAVEMENT PATCHING	SQUARE YARD	1
PAVEMENT REINFORCEMENT	SQUARE YARD	1
PAVEMENT REMOVAL	SQUARE YARD	1
PC CONCRETE BRIDGE APPROACH SHOULDER PAVEMENT	SQUARE YARD	1
PCC BASE COURSE	SQUARE YARD	1
PCC BASE COURSE WIDENING	SQUARE YARD	1
PERENNIAL PLANTS	UNIT	1
PERIMETER EROSION BARRIER	FOOT	1
PILE TEST LOADING	EACH	1
PIPE CULVERT REMOVAL	FOOT	1
PIPE CULVERTS	FOOT	1
PIPE DRAINS	FOOT	1
PIPE HANDRAIL	FOOT	0.5
PIPE UNDERDRAINS	FOOT	1
POROUS GRANULAR BACKFILL	CUBIC YARD	1
POROUS GRANULAR EMBANKMENT	CUBIC YARD, TON	1, 1

QUANTITY ROUNDING CRITERIA — US CUSTOMARY

Figure 64-1.A
(Continued)

Item	Measured Unit	Degree of Accuracy
PORTLAND CEMENT CONCRETE DRIVEWAY PAVEMENT	SQUARE YARD	1
PORTLAND CEMENT CONCRETE PAVEMENT	SQUARE YARD	1
PORTLAND CEMENT CONCRETE SHOULDERS	SQUARE YARD	1
PORTLAND CEMENT CONCRETE SIDEWALK	SQUARE FOOT	0.5
PORTLAND CEMENT CONCRETE SURFACE REMOVAL	SQUARE YARD	0.5
PRECAST CONCRETE BOX CULVERTS	FOOT	0.5
PRECAST CONCRETE BRIDGE SLAB	SQUARE FOOT	1
PRECAST REINFORCED CONCRETE FLARED END SECTIONS	EACH	1
PRECAST, PRESTRESSED CONCRETE DECK BEAMS	SQUARE FOOT	1
PREFORMED JOINT SEAL	FOOT	0.5
PREPARATION OF BASE	SQUARE YARD	1
PROCESSING LIME MODIFIED SOILS	SQUARE YARD	1
PROTECTIVE COAT	SQUARE YARD	1
R		
REINFORCEMENT BARS	POUND	10
RELOCATE TEMPORARY CONCRETE BARRIER	FOOT	1
REMOVAL OF EXISTING STRUCTURES	EACH	1
REMOVAL OF EXISTING SUPERSTRUCTURES	EACH	1
REMOVE AND REERECT STEEL PLATE BEAM GUARDRAIL	FOOT	12.5
RIP RAP	SQUARE YARD	1
ROCK EXCAVATION	CUBIC YARD	1
ROCK EXCAVATION FOR STRUCTURES	CUBIC YARD	1
S		
SAND BACKFILL	CUBIC YARD	1
SEAL COAT AGGREGATE	TON, CUBIC YARD	1, 1
SEAL COAT CONCRETE	CUBIC YARD	0.1
SEEDING, INTERSEEDING	ACRE	0.25
SEEDLINGS	UNIT	0.1
SHAPING AND GRADING ROADWAY	UNIT	1
SHRUBS	EACH	1
SIDEWALK REMOVAL	SQUARE FOOT	1
SLOPE WALL	SQUARE YARD	1

QUANTITY ROUNDING CRITERIA — US CUSTOMARY

Figure 64-1.A
(Continued)

Item	Measured Unit	Degree of Accuracy
SODDING	SQUARE YARD	1
STABILIZED SUBBASE	SQUARE YARD	1
STEEL PLATE BEAM GUARDRAIL	FOOT	1
STEEL RAILING	FOOT	1
STORM SEWERS	FOOT	1
STRIP REFLECTIVE CRACK CONTROL TREATMENT	FOOT	1
STRUCTURE EXCAVATION	CUBIC YARD	1
STUD SHEAR CONNECTORS	EACH	1
SUBBASE GRANULAR MATERIAL	SQUARE YARD, CUBIC YARD, TON	1, 1, 1
SUPPLEMENTAL WATERING	UNIT	0.1
T		
TEMPORARY BRIDGE COMPLETE	EACH	1
TEMPORARY CONCRETE BARRIER	FOOT	12.5
TEMPORARY CONCRETE BARRIER TERMINAL SECTION	EACH	1
TEMPORARY PAVEMENT MARKING	FOOT	1
TEMPORARY PAVEMENT MARKING LETTERS AND SYMBOLS	SQUARE FOOT	1
TRAFFIC CONTROL AND PROTECTION STANDARD XXXX	LUMP SUM, EACH	1, 1
TRANSVERSE TERMINAL JOINT COMPLETE	EACH	1
TREE PRUNING	EACH	1
TREE REMOVAL	UNIT, ACRE	1, 0.25
TREES	EACH	1
U		
UNDERGROUND STORAGE TANK REMOVAL	EACH	1
UNIT DUCT	FOOT	1
V		
VINES	EACH	1
W		
WATER	UNIT	0.1
WATER MAIN	FOOT	1
WATER SERVICE LINE	FOOT	1
WATERPROOFING MEMBRANE SYSTEM	SQUARE FOOT	1
WIDE FLANGE BEAM TERMINAL JOINT COMPLETE	EACH	1

QUANTITY ROUNDING CRITERIA — US CUSTOMARY

Figure 64-1.A
(Continued)

Item	Measured Unit	Degree of Accuracy
A		
ADJUSTING SANITARY SEWERS	METER	1
ADJUSTING WATER SERVICE LINES	METER	1
AGGREGATE	TON	1
AGGREGATE (PRIME COAT)	TON	1
AGGREGATE BASE COURSE	CUBIC METER, TON, SQUARE METER	1, 1, 1
AGGREGATE BASE REPAIR	TON	1
AGGREGATE SHOULDERS	TON, CUBIC METER, SQUARE METER	1, 1, 1
AGGREGATE SURFACE COURSE	SQUARE METER, CUBIC METER, TON	1, 1, 1
AGRICULTURAL GROUND LIMESTONE	TON	0.1
ALUMINUM END SECTIONS	EACH	1
ALUMINUM RAILING	METER	0.5
AREA REFLECTIVE CRACK CONTROL TREATMENT	SQUARE METER	0.5
ASPHALT MODIFIER	LITER	1
B		
BACKSLOPE DRAINS TYPES 1, 2 AND 3	METER	0.5
BARE COPPER WIRE	METER	1
BASE COURSE WIDENING	SQUARE METER	1
BITUMINOUS BASE COURSE	SQUARE METER	1
BITUMINOUS CONCRETE BINDER/SURFACE COURSE	TON, SQUARE METER	1, 1
BITUMINOUS CONCRETE PAVEMENT (FULL-DEPTH)	SQUARE METER	1
BITUMINOUS MATERIAL APPLIED	LITER, TON	1, 1
BITUMINOUS MATERIALS	LITER, TON	1, 0.1
BITUMINOUS SHOULDER CURB	METER	1
BITUMINOUS SHOULDERS	SQUARE METER, TON	1, 1
BITUMINOUS SURFACE COAT	SQUARE METER	1
BITUMINOUS SURFACE REMOVAL	SQUARE METER	1
BLOTTER AGGREGATE	TON	1
BORROW EXCAVATION	CUBIC METER	5
BOX CULVERT END SECTIONS	EACH	1
BRIDGE APPROACH PAVEMENT	SQUARE METER	1
BRIDGE DECK GROOVING	SQUARE METER	1

QUANTITY ROUNDING CRITERIA — METRIC

Figure 64-1.A

Item	Measured Unit	Degree of Accuracy
BRIDGE SEAT SEALER	SQUARE METER	1
BRIDGE WASHING	EACH	1
C		
CABLE ROAD GUARD REMOVAL	METER	1
CABLE ROAD GUARD, SINGLE STRAND	METER	1
CALCIUM CHLORIDE APPLIED	TON	0.1
CAST IRON SOIL PIPE	METER	0.5
CAST-IN-PLACE PILE EXTENSIONS	METER	0.1
CATCH BASINS	EACH	1
CATCH BASINS TO BE ADJUSTED/RECONSTRUCTED	EACH	1
CEMENT	HUNDRED WEIGHT	1
CHAIN LINK FENCE	METER	0.5
CHAIN LINK GATES	EACH	1
CHANNEL EXCAVATION	CUBIC METER	5
CLASS A, B, C, D PATCHES	SQUARE METER	1
CLASS MS CONCRETE	CUBIC METER	0.1
CLASS SI CONCRETE	CUBIC METER	0.1
COFFERDAM EXCAVATION	CUBIC METER	1
COFFERDAMS	EACH	1
COMBINATION CONCRETE CURB AND GUTTER	METER	0.1
COMBINATION CURB AND GUTTER REMOVAL	METER	1
CONCRETE BARRIER	METER	1
CONCRETE BLOCK RIPRAP	SQUARE METER	1
CONCRETE BOX CULVERTS	CUBIC METER	0.1
CONCRETE CURB/GUTTER	METER	0.1
CONCRETE GLARE SCREEN	METER	0.1
CONCRETE HANDRAIL	CUBIC METER	0.1
CONCRETE HEADWALL REMOVAL	EACH	1
CONCRETE HEADWALLS	CUBIC METER	0.1
CONCRETE MEDIAN	SQUARE METER	1
CONCRETE REMOVAL	CUBIC METER	0.1
CONCRETE STRUCTURES	CUBIC METER	0.1

QUANTITY ROUNDING CRITERIA — METRIC

Figure 64-1.A
(Continued)

Item	Measured Unit	Degree of Accuracy
CONCRETE SUPERSTRUCTURE	CUBIC METER	0.1
CONCRETE THRUST BLOCKS	EACH	1
CONDUIT	METER	0.5
CONSTRUCTING TEST STRIP	EACH	1
CONTINUOUSLY REINFORCED PORTLAND CEMENT CONCRETE PAVEMENT	SQUARE METER	1
CONTROL INSTALLATION	EACH	1
CORRUGATED STRUCTURAL PLATE ARCHES, PIPE ARCHES, PIPE CULVERTS	METER	1
COVER COAT AGGREGATE	TON	1
CRACK FILLING	KILOGRAM	0.1
CRACK ROUTING (PAVEMENT)	METER	0.5
CURB REMOVAL	METER	1
D		
DELINEATORS	EACH	1
DOMESTIC METER VAULTS TO BE MOVED	EACH	1
DOMESTIC WATER SERVICES BOXES TO BE MOVED	EACH	1
DRAINAGE STRUCTURES	EACH	1
DRIVEWAY PAVEMENT REMOVAL	SQUARE METER	1
DRIVING AND FILLING SHELLS	METER	0.5
DRIVING PILES	METER	0.5
E		
EARTH EXCAVATION	CUBIC METER	5
EARTH EXCAVATION (WIDENING)	CUBIC METER	5
EARTH EXCAVATION FOR EROSION CONTROL	CUBIC METER	5
ELASTOMERIC BEARING ASSEMBLY	EACH	1
ELECTRIC CABLE IN TRENCH	METER	1
ELECTRICAL CONDUCTORS IN CONDUIT	METER	1
END SECTIONS	EACH	1
ENGINEER'S FIELD LABORATORY	CALENDAR MONTH	1
ENGINEER'S FIELD OFFICE	CALENDAR MONTH	1
EPOXY CRACK SEALING	METER	1
EPOXY MORTAR REPAIR	LITER	1
ERECTING STRUCTURAL STEEL	LUMP SUM	1

QUANTITY ROUNDING CRITERIA — METRIC

Figure 64-1.A
(Continued)

Item	Measured Unit	Degree of Accuracy
EROSION CONTROL BLANKET	SQUARE METER	1
EXCAVATING AND GRADING EXISTING SHOULDER	UNIT	1
EXPANSION BOLTS	EACH	1
EXPANSION TIE ANCHORS	EACH	1
EXPLORATION TRENCH	METER	1
F		
FABRIC FORMED CONCRETE REVETMENT MATS	SQUARE METER	1
FENCE (EROSION CONTROL)	METER	1
FIBER MAT	SQUARE METER	1
FIELD TILE JUNCTION VAULTS	EACH	1
FILLING CATCH BASINS, INLETS, MANHOLES	EACH	1
FILTER FABRIC FOR USE WITH RIPRAP	SQUARE METER	1
FIRE HYDRANTS TO BE MOVED	EACH	1
FLAP GATE	EACH	1
FLOOR DRAINS	EACH	1
FRAMES AND GRATES	EACH	1
FRAMES AND GRATES TO BE ADJUSTED	EACH	1
FRENCH DRAINS	CUBIC METER	1
FURNISHED EXCAVATION	CUBIC METER	5
FURNISHING AND ERECTING DRAINAGE MARKERS	EACH	1
FURNISHING AND ERECTING PRECAST, PRESTRESSED CONCRETE I - BEAMS	METER	0.1
FURNISHING AND ERECTING STRUCTURAL STEEL	LUMP SUM, KILOGRAM	1, 10
FURNISHING AND PLACING COMPOST	SQUARE METER	1
FURNISHING AND PLACING TOPSOIL	SQUARE METER	1
FURNISHING CONCRETE PILES	METER	0.5
FURNISHING STRUCTURAL STEEL	LUMP SUM	1
G		
GABIONS	CUBIC METER	1
GEOCOMPOSITE WALL DRAIN	SQUARE METER	1
GEOTECHNICAL FABRIC	SQUARE METER	0.5
GLARE SCREEN BLADES	EACH	1
GRANULAR EMBANKMENT, SPECIAL	CUBIC METER, TON	5, 1

QUANTITY ROUNDING CRITERIA — METRIC

Figure 64-1.A
(Continued)

Item	Measured Unit	Degree of Accuracy
GRATES	EACH	1
GRATING FOR CONCRETE FLARED END SECTION	EACH	1
GUARDRAIL REMOVAL	METER	1
GUTTER REMOVAL	METER	1
H		
HARDWARE	KILOGRAM	10
HEAT SCARIFYING	SQUARE METER	1
I		
INCIDENTAL BITUMINOUS SURFACING	TON	1
INLET BOX, STANDARDS XXXX	EACH	1
INLETS	EACH	1
INLETS TO BE ADJUSTED/RECONSTRUCTED	EACH	1
INSERTION CULVERT LINER	METER	0.5
J		
JOINT OR CRACK FILLING	KILOGRAM	10
JOINT OR CRACK ROUTING	METER	1
L		
LEVELING BINDER (HAND METHOD)	TON	0.1
LEVELING BINDER (MACHINE METHOD)	TON	1
LIGHT POLE ALUMINUM	EACH	1
LIGHT POLE FOUNDATION	EACH	1
LIGHT TOWER	EACH	1
LIGHT TOWER FOUNDATION	METER	0.1
LIME	TON	0.1
LOCATING UNDERGROUND CABLE	METER	1
LUG SYSTEM COMPLETE	EACH	1
LUMINAIRE, SODIUM VAPOR	EACH	1
M		
MANHOLES	EACH	1
MANHOLES TO BE ADJUSTED/RECONSTRUCTED	EACH	1
MASONRY REMOVAL	CUBIC METER	0.1
MEDIAN INLETS	EACH	1
MEDIAN REMOVAL	SQUARE METER	1

QUANTITY ROUNDING CRITERIA — METRIC

Figure 64-1.A
(Continued)

Item	Measured Unit	Degree of Accuracy
MEMBRANE WATERPROOFING	SQUARE METER	0.5
METAL SHOES	EACH	1
MICRO-SURFACING	SQUARE METER	1
MIXTURE FOR CRACKS, JOINTS, AND FLANGEWAYS	TON	0.1
MOWING	HECTARE	0.1
MULCH METHOD 1, 2, 3	HECTARE	0.1
N		
NAME PLATES	EACH	1
NEOPRENE EXPANSION JOINT	METER	0.1
P		
PAINTING STEEL RAILING	METER	1
PAINTING STRUCTURAL STEEL	LUMP SUM	1
PAVED DITCH	METER	1
PAVED DITCH REMOVAL	METER	1
PAVED SHOULDER REMOVAL	SQUARE METER	1
PAVEMENT PATCHING	SQUARE METER	1
PAVEMENT REINFORCEMENT	SQUARE METER	1
PAVEMENT REMOVAL	SQUARE METER	1
PC CONCRETE BRIDGE APPROACH SHOULDER PAVEMENT	SQUARE METER	1
PCC BASE COURSE	SQUARE METER	1
PCC BASE COURSE WIDENING	SQUARE METER	1
PERENNIAL PLANTS	UNIT	1
PERIMETER EROSION BARRIER	METER	1
PILE TEST LOADING	EACH	1
PIPE CULVERT REMOVAL	METER	1
PIPE CULVERTS	METER	0.5
PIPE DRAINS	METER	0.5
PIPE HANDRAIL	METER	0.1
PIPE UNDERDRAINS	METER	0.5
POROUS GRANULAR BACKFILL	CUBIC METER	1
POROUS GRANULAR EMBANKMENT	CUBIC METER, TON	1, 1
PORTLAND CEMENT CONCRETE DRIVEWAY PAVEMENT	SQUARE METER	1

QUANTITY ROUNDING CRITERIA — METRIC

Figure 64-1.A
(Continued)

Item	Measured Unit	Degree of Accuracy
PORTLAND CEMENT CONCRETE PAVEMENT	SQUARE METER	1
PORTLAND CEMENT CONCRETE SHOULDERS	SQUARE METER	1
PORTLAND CEMENT CONCRETE SIDEWALK	SQUARE METER	0.5
PORTLAND CEMENT CONCRETE SURFACE REMOVAL	SQUARE METER	0.5
PRECAST CONCRETE BOX CULVERTS	METER	0.1
PRECAST CONCRETE BRIDGE SLAB	SQUARE METER	1
PRECAST REINFORCED CONCRETE FLARED END SECTIONS	EACH	1
PRECAST, PRESTRESSED CONCRETE DECK BEAMS	SQUARE METER	0.5
PREFORMED JOINT SEAL	METER	0.1
PREPARATION OF BASE	SQUARE METER	1
PROCESSING LIME MODIFIED SOILS	SQUARE METER	1
PROTECTIVE COAT	SQUARE METER	1
R		
REINFORCEMENT BARS	KILOGRAM	10
RELOCATE TEMPORARY CONCRETE BARRIER	METER	1
REMOVAL OF EXISTING STRUCTURES	EACH	1
REMOVAL OF EXISTING SUPERSTRUCTURES	EACH	1
REMOVE AND REERECT STEEL PLATE BEAM GUARDRAIL	METER	3.81
RIP RAP	SQUARE METER	1
ROCK EXCAVATION	CUBIC METER	1
ROCK EXCAVATION FOR STRUCTURES	CUBIC METER	1
S		
SAND BACKFILL	CUBIC METER	1
SEAL COAT AGGREGATE	TON, CUBIC METER	1, 1
SEAL COAT CONCRETE	CUBIC METER	0.1
SEEDING, INTERSEEDING	HECTARE	0.1
SEEDLINGS	UNIT	0.1
SHAPING AND GRADING ROADWAY	UNIT	1
SHRUBS	EACH	1
SIDEWALK REMOVAL	SQUARE METER	1
SLOPE WALL	SQUARE METER	1
SODDING	SQUARE METER	1

QUANTITY ROUNDING CRITERIA — METRIC

Figure 64-1.A
(Continued)

Item	Measured Unit	Degree of Accuracy
STABILIZED SUBBASE	SQUARE METER	1
STEEL PLATE BEAM GUARDRAIL	METER	0.5
STEEL RAILING	METER	0.5
STORM SEWERS	METER	0.5
STRIP REFLECTIVE CRACK CONTROL TREATMENT	METER	1
STRUCTURE EXCAVATION	CUBIC METER	1
STUD SHEAR CONNECTORS	EACH	1
SUBBASE GRANULAR MATERIAL	SQUARE METER, CUBIC METER, TON	1, 1, 1
SUPPLEMENTAL WATERING	UNIT	0.1
T		
TEMPORARY BRIDGE COMPLETE	EACH	1
TEMPORARY CONCRETE BARRIER	METER	3.81
TEMPORARY CONCRETE BARRIER TERMINAL SECTION	EACH	1
TEMPORARY PAVEMENT MARKING	METER	1
TEMPORARY PAVEMENT MARKING LETTERS AND SYMBOLS	SQUARE METER	1
TRAFFIC CONTROL AND PROTECTION STANDARD XXXX	LUMP SUM, EACH	1, 1
TRANSVERSE TERMINAL JOINT COMPLETE	EACH	1
TREE PRUNING	EACH	1
TREE REMOVAL	UNIT, HECTARE	1, 0.1
TREES	EACH	1
U		
UNDERGROUND STORAGE TANK REMOVAL	EACH	1
UNIT DUCT	METER	1
V		
VINES	EACH	1
W		
WATER	UNIT	0.1
WATER MAIN	METER	0.5
WATER SERVICE LINE	METER	0.5
WATERPROOFING MEMBRANE SYSTEM	SQUARE METER	0.5
WIDE FLANGE BEAM TERMINAL JOINT COMPLETE	EACH	1

QUANTITY ROUNDING CRITERIA — METRIC

Figure 64-1.A
(Continued)

64-1.05 Non-Defined Work**64-1.05(a) Lump-Sum Items**

Only use lump sum bid items where the scope of work for the item is clearly defined, and the amount of work has a minimal chance of changing during construction. The *IDOT Standard Specifications* defines which quantities may be estimated as lump sum. Wherever practical, list the quantities for the separate items that will be included within the lump sum item. The list should note that the separate “quantities are for estimating purposes only.” Where there is a significant chance of quantity changes, the work must be bid by the unit and not lump sum. Where lump sum items are used, the total quantity for the project will always equal one.

64-1.05(b) Items Included in Other Work

No item should be shown as incidental to another pay item or the contract. If any item will be included as part of another item, it must be addressed by the specifications or with a special provision. The designer should only include an item of work in another pay item where the scope of work for both is clearly defined and the probability of the quantity of either item changing is minimal. In general, minimize the use of items included in other pay items. It is impossible for bidders, or the Department, to prepare an estimate for a project that contains incidental items for which quantities or the scope of work are indeterminable.

In general, use the applicable pay item for those items that are normally covered in the *IDOT Standard Specifications*. Where the quantities or scope of work items are indeterminate at the time of bidding, these items should be paid for on a force account basis as described in the *IDOT Standard Specifications*.

64-1.06 Federal Participation in Stockpiling of Salvage Materials

The Federal government participates in the cost of salvaging and stockpiling materials, which cannot be reused in the project. This does not apply to material salvaged from Bituminous Surface Removal or Texturing Existing Pavement, which becomes the property of the contractor for future recycling. Stockpile the material either on the project limits or at a State-owned storage site a reasonable distance off the project limits if necessary to prevent a potential roadside safety problem. The amount of participation will be limited to the following:

- If the material can be used on other Federal-aid routes, participation may be obtained for stockpiling the material.
- If the material is to be retained by the contractor, participation may be obtained for salvaging the material provided the special provisions indicate that the salvage value is to be reflected in the contractor’s bid price.
- If the material can be used on non-Federal-aid routes, Federal participation for stockpiling will ordinarily be limited to the dollar amount established by an alternate bid item for contractor disposal.

- If the material has no use, participation will be allowed for the disposal of the material as specified in Article 202.03 of the *Standard Specifications*.

64-2 EARTHWORK COMPUTATIONS

64-2.01 Computer Computations

Earthwork computations for most projects can be determined using the computer and special design software packages (e.g., GEOPAK). Earthwork quantities for small projects, entrances, side roads, ditches, and additional grading features may need to be calculated manually (see Section 64-2.02). For the computer to calculate the mainline earthwork quantities, the following information is typically required:

1. horizontal and vertical roadway alignment;
2. typical sections;
3. terrain data;
4. shrinkage factor;
5. cut and fill slope rates; and
6. identification of sections not to be included (e.g., bridge sections).

The computer provides a listing of the quantities for each station. Include these quantities on the cross sections as described in Section 63-4.16.

64-2.02 Manual Computations

For small projects and to calculate special features on larger projects (e.g., entrances, ditches), it may be necessary to calculate the earthwork quantities manually. Figure 64-2.A provides a sample computation sheet that may be used to develop these quantities. A spreadsheet program may be used in place of these computation sheets. The following steps and examples from Figure 64-2.A illustrate how to use the computation sheet:

1. Station. In rural areas, cross sections are typically plotted and calculated at 100 ft (25 m) intervals and urban areas at 50 ft (10 m) intervals. The intervals shown in Figure 64-2.A are at 50 ft.
2. Grade. Indicate the grade of the profile grade line. Also, indicate if there is a vertical curve and the length of the vertical curve. Figure 64-2.A shows a 500 ft crest vertical curve.
3. Tangent Elevation. This is the grade along the tangent between two VPI's, exclusive of the vertical curve correction. In the example, the tangent elevations are 465.00 ft and 466.00 ft at Stations 4 + 00 and 4 + 50, respectively.
4. Vertical Curve Correction. This is the elevation correction required from the tangent elevation for the vertical curve. Values in this column only will be noted if there is a vertical curve. Chapter 33 illustrates how to calculate the vertical curve corrections. For Station 4 + 00, the correction is 0.12 ft, and for Station 4 + 50, 0.50 ft.

EARTHWORK COMPUTATIONS

Computed By: _____ Date: _____ Route _____ Example _____
 Checked By: _____ Date: _____ Section _____
 Shrinkage Factor _____ 15% _____ County/City _____

(1) Sta. No.	(2) % Grade	(3) Tangent Elev. (ft)	(4) Vert. Curve Corr. (ft)	(5) Grade Elev. (ft)	(6) End Area (ft ²)		(7) Sum of End Area (ft ²)		(8) Distance (ft)	(9) Section Volumes (yd ³)		
					Cut	Fill	Cut	Fill		Cut	Fill	
1 + 50	+2%	460.00	—	460.00	0	0	4	430	50	4	398	
2 + 00	+2%	461.00	—	461.00	4	430	14	1080	50	13	1000	
2 + 50	+2%	462.00	—	462.00	10	650	60	700	50	56	648	
3 + 00	+2%	463.00	—	463.00	50	50	1350	70	50	1250	65	
3 + 50	500 ft Vertical Curve	464.00	VPC	464.00	1300	20	3000	30	50	2778	28	
4 + 00		465.00	0.12	464.88	1700	10	3450	10	50	3194	9	
4 + 50		466.00	0.50	465.50	1750	0	3650	0	50	3380	0	
5 + 00		467.00	1.12	465.88	1900	0	3900	0	50	3611	0	
5 + 50		468.00	2.00	466.00	2000	0	4500	0	50	4167	0	
6 + 00		469.00	3.12	465.88	2500	0	5000	0	50	4630	0	
6 + 50		467.50	2.00	465.50	2500	0	4700	0	50	4352	0	
7 + 00		466.00	1.12	464.88	2200	0	3900	5	50	3611	5	
7 + 50		464.50	0.50	464.00	1700	5	2550	35	50	2361	32	
8 + 00		463.00	0.12	462.88	850	30	1350	110	50	1250	102	
8 + 50		461.50	VPT	461.50	500	80	700	180	50	648	167	
9 + 00		-3%	460.00	—	460.00	200	100	210	145	50	194	134
9 + 50		-3%	458.50	—	458.50	10	45	10	55	50	9	51
10 + 00		-3%	457.00	—	457.00	0	10	0	10	50	0	9
10 + 50	-3%	455.50	—	455.50	0	0						
	(*)	(*)	(*)	(*)								
Total Section Volumes										35,508	2648	
Shrinkage Factor										—	1.15	
Adjusted Volume										35,508	3045	

(*) These columns are optional.

SAMPLE COMPUTATION SHEET

Figure 64-2.A

5. Grade Elevation. This is the actual grade of the profile grade line. For tangent sections, this column is the same elevation as shown in the tangent elevation column. For crest vertical curves, this elevation is determined by subtracting the vertical curve correction from the tangent elevation. For sag vertical curves, this elevation is determined by adding the vertical curve correction to the tangent elevation. For Station 4 + 00, the grade elevation is (465.00 - 0.12 = 464.88 ft) and for Station 4 + 50, (466.00 - 0.50) = 465.50 ft.
6. End Areas. The end areas used to compute the quantities are defined by the ground lines and typical section template (see Figure 64-2.B). After the cross sections have been plotted, determine the areas of cut and fill for each cross section using a planimeter. Include the borrow excavation, waste of unsuitable soils, undercut, rock excavation, trench excavation, and any special excavation or embankment on the section. If topsoil is used on the section, compute the quantity of topsoil. Add the undercut in the cut section to the earth excavation and deduct the topsoil in fill from the embankment quantity. Record the cut and fill areas for each cross section in the “END AREA” columns of the Computation Sheet. Ensure that intermediate cross sections (e.g., culvert location, entrances) are not used for an end section. For the example, the cut end areas for Stations 4 + 00 and 4 + 50 are 1700 ft² and 1750 ft², respectively. The fill end areas are 10 ft² and 0 ft², respectively.
7. Sum of End Areas. The “SUM OF END AREAS” columns are the sum of adjacent cross-section areas for the cut and fill columns. Note that the line in the figure is offset between the two end areas. This line indicates the two areas to be added together. For the example, the sum of cut areas is 3450 ft² and sum of fill areas is 10 ft².
8. Distance. This is the distance between the cross-section interval selected in Comment 1. For the example, this is 50 ft.
9. Section Volumes. Volumes for excavation (cut) and embankment (fill) are determined using the average-end-area formula:

$$V = \left(\frac{A_1 + A_2}{2(27)} \right) (D) \quad \text{(US Customary) Equation 64-2.1}$$

$$V = \left(\frac{A_1 + A_2}{2} \right) (D) \quad \text{(Metric) Equation 64-2.1}$$

where: V = volume, yd³ (m³)

A₁ + A₂ = sum of cut or fill end areas of adjacent sections (from the “Sum of End Areas”), ft² (m²)

D = distance between sections, ft (m)

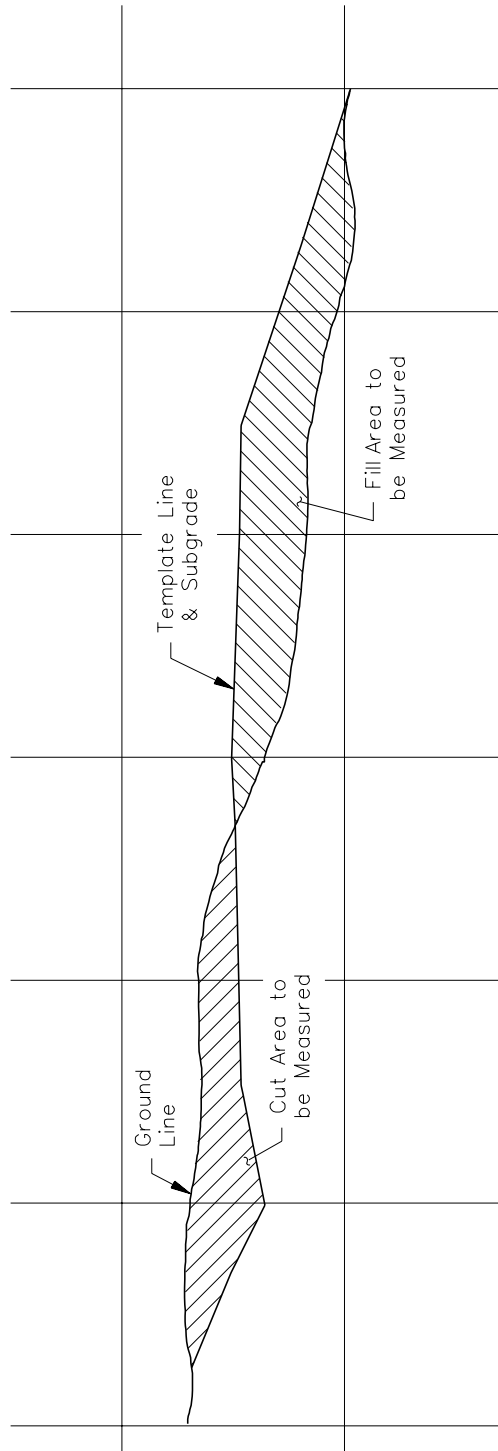

END AREA TEMPLATE

Figure 64-2.B

These values are rounded to the nearest yd^3 (m^3) and recorded in the appropriate cut and fill "SEC. VOLUMES" columns on the Computation Sheet.

For the example, the cut and fill volumes are:

$$\text{Cut: } V = \left(\frac{1700 + 1750}{2(27)} \right) (50) = 3194 \text{ yd}^3$$

$$\text{Fill: } V = \left(\frac{10 + 0}{2(27)} \right) (50) = 9 \text{ yd}^3$$

10. **Total Section Volumes.** This is the sum of the section volumes for both the cut and fill columns. For the example, these are $35,508 \text{ yd}^3$ for cut sections and 2648 yd^3 for fill sections.
11. **Shrinkage Factor.** The total section volumes for fill section must be adjusted by the appropriate shrinkage factor. Section 64-2.03 discusses how to determine the appropriate shrinkage factor. For this example, the shrinkage factor was determined to be 15%. Note for earth fills, the factor is only shown in the fill column.
12. **Adjusted Volume.** This value is determined by multiplying the "TOTAL SECTION VOLUME" by the appropriate "SHRINKAGE FACTOR." For cut sections, the volume is $35,508 \text{ yd}^3$. For fill sections, the 2648 yd^3 is multiplied by 1.15 to obtain the "ADJUSTED VOLUME" ($2648 \times 1.15 = 3045$ cubic yards).

64-2.03 Shrink and Swell Factors

Embankment fill quantities calculated manually or by the computer must be adjusted by the appropriate shrinkage factor to account for the compaction of material, loss from hauling, subsidence of the existing ground caused by the overburden, erosion, and clearing operation. The factors used in the calculations depend on the soil type, quantity to be moved, and engineering judgment. Sand and gravel have smaller shrinkage factors than clay and silt. For rock excavation, it may be necessary to apply an expansion or swell factor. Generally, the shrinkage factor will only be applied to the total fill area (see Section 64-2.02) unless highly variable materials are encountered along the alignment requiring different numerical values.

The use of more than one factor is often necessary to describe the characteristics of the material. The District Geotechnical Engineer will provide guidance in choosing the applicable factor(s) to be used in the calculations. The designer may need to adjust the shrinkage factor to account for the smaller quantities.

64-2.04 Earthwork Considerations**64-2.04(a) Excavation Quantities**

The following procedures establish design guidelines for use of the earthwork pay items:

1. Earth and Rock Excavation. This work consists of excavation and transportation of suitable excavated material to embankment locations throughout the limits of the contract or the excavation, transportation, and disposal of excavated material. This work does not include excavation for structures or channel excavation.

Calculate quantities in the normal manner according to Section 64-2.

If the earth or rock excavation is to be used on the project in an embankment, the suitability and/or stability of the excavated material must be examined. Show the amount of suitable excavated material to be used in embankments in the Earthwork Schedule. The pay item is "Earth Excavation" or "Rock Excavation." If a portion or all of the excavated material is determined to be unsuitable or unstable, calculate the quantity and list it as "Removal and Disposal of Unsuitable Material."

When possible, a shrinkage factor should be determined for the suitable excavation to be used as embankment. The shrinkage factor will determine the final volume of the excavated material once it is compacted within the embankment. This quantity is then used to determine the amount of material either to be wasted or to be hauled in from off-site. Contact the District Materials Engineer concerning the determination of a shrinkage factor. When a shrinkage factor is determined, show the factor in the plans. If no shrinkage factor is determined, assume a shrinkage factor of 25%.

If topsoil is to be excavated and used on the project, include this quantity as "Topsoil Excavation and Placement," but do not include this quantity in the earth excavation quantity. Cross sections should show the different cut quantities.

2. Borrow and Furnished Excavation. Borrow and furnished excavation consists of excavating suitable materials obtained from borrow locations furnished by the contractor and transporting the materials to various locations throughout the limits of the contract.

The only difference between borrow excavation and furnished excavation is the method of measurement as described below:

- a. Borrow Excavation. Borrow excavation is measured in its original position by taking cross sections of the borrow site before the work is started and again after it has been completed. The volume in cubic yards (cubic meters) of material will be computed by the method of average end areas. When possible, also determine the shrinkage factor of the borrow excavation. The shrinkage factor will determine the plan quantity of material to be excavated from the borrow site, which is the pay quantity, that will provide the required volume once it is compacted in the embankment. The District Materials Engineer should be contacted regarding the determination of a shrinkage factor. When a shrinkage

factor is determined it should be shown on the plans. If no shrinkage factor is determined, assume a shrinkage factor of 25%.

- b. Furnished Excavation. Furnished excavation will be determined either by an agreement to plan quantity or by measurement in its final place. For measurement in place, compute the volume of the compacted material in cubic yards (cubic meters) using the average end areas method and then subtract the final pay quantity of earth excavation, rock excavation and other excavation suitable to be used as embankment, adjusted by a shrinkage factor of 25% or as shown on the plans, as discussed above. Also, deduct the excavation quantities included in the cost of other items.

The use of borrow excavation or furnished excavation will be at the designer's discretion; however, the designer should consult with the District Materials Engineer and District Construction Engineer. In determining which pay item to use, consider the following:

- Do not use borrow excavation and furnished excavation on the same project; use one or the other.
 - Furnished excavation should be used:
 - + on projects where a small amount of borrow material is required (<50,000 yd³ (40,000 m³));
 - + on bridge projects, minor realignments, and/or 3R type improvements;
 - + on projects in urbanized areas where borrow may come from many sources;
 - + where no suitable borrow locations are apparent; or
 - + where use of commercial borrow sites or multiple borrow sites are anticipated.
 - Borrow excavation should be used:
 - + on projects where a significant amount of borrow material is required (>50,000 yd³ (40,000 m³)); or
 - + where a borrow site may be readily available.
3. Embankment. This work consists of the construction of embankments by depositing, placing, and compacting earth, stone, gravel, or other materials of acceptable quality above the natural ground or other surface. The materials incorporated are from earth excavation, rock excavation, borrow excavation, furnished excavation, or other sources as mentioned in the contract documents.

Embankment will not be paid for directly, but is considered to be included in the various items of excavation, and their construction included in the unit prices of these items.

4. Topsoil and Compost. This work consists of furnishing, excavating, and placing topsoil, special types of topsoil or compost/topsoil blend.

The use of topsoil on projects is paid for either as “Topsoil Excavation and Placement” or as “Topsoil Furnish and Place.” The designer will decide which pay item(s) to use and should consult with the District Landscape Architect, District Materials Engineer, and District Construction Engineer for assistance. Topsoil excavation and placement involves the use of topsoil obtained from within the project limits. Topsoil furnish and place requires the contractor to obtain topsoil from an off-site location. The use of topsoil within the project limits is encouraged and recommended. In determining contract quantities, on-site material should be used first and, if additional quantities are required, the amount of off-site material should be calculated. Consequently, on some projects both pay items may be used.

The quantity of topsoil excavation and placement is not included in the earth excavation quantity.

5. Earthwork Schedule. Earthwork schedules are shown on all plans involving earthwork pay items. The schedule should show:

- cuts and fills;
- earth and rock excavation quantities;
- removal and disposal of unsuitable material quantities;
- borrow or furnished excavation quality (Note that borrow excavation is calculated in the uncompacted state so a shrinkage factor must be assumed to arrive at this quantity from the known fill required. Furnished excavation is calculated in its final place (i.e., compacted state));
- shrinkage factors for earth excavation and borrow excavation; and
- topsoil excavation and placement, topsoil furnish and place, and/or compost furnish and place quantities.

6. Equations. Consider the following when calculating excavation quantities:

$$\begin{aligned}
 \text{a. Shrinkage Factor (SF)} &= \frac{\text{bank volume} - \text{compacted volume}}{\text{bank volume}} \\
 &= 1 - \frac{\text{compacted volume}}{\text{bank volume}}
 \end{aligned}$$

Where the bank volume is material as it lies in its natural state.

Unless otherwise determined, assume SF = 0.25.

- b. Suitable Excavation is defined to be all earth excavation, rock excavation, and all other on-site excavation that is suitable to be used as embankment for the project.
- c. Use the following to determine the quantity of embankment that will result from the suitable excavation:

$$\text{Excavation to be used as Embankment} = \text{Suitable Excavation} \times (1 - \text{SF})$$

- d. If the quantity of excavation to be used as embankment is less than the embankment quantity required, then use one of the following equations:

$$\text{Furnished Excavation} = \text{Embankment} - (\text{Suitable Excavation} \times (1 - \text{SF}))$$

$$\text{Borrow Excavation} = (\text{Embankment} - (\text{Suitable Excavation} \times (1 - \text{SF}))) / (1 - \text{SF})$$

It is the designer's option on use of the borrow excavation or furnished excavation when off-site material is needed.

7. Examples.

Example 64-2.04(1)

Earthwork Schedule

1 Location	2 Earth Excavation	3 Earth Excavation Adjusted for Shrinkage	4 Embankment	5 Earthwork Balance Waste (+) or Shortage (-)
	Cubic Yard	Cubic Yard	Cubic Yard	Cubic Yard
Sta. 100+00 to 105+00	500	375	100	+275
Sta. 105+00 to 110+00	400	300	100	+200
Sta. 110+00 to 115+00	500	375	200	+175
Side Road A	200	150	300	-150
Total	1600	1200	700	+500

Columns 1, 2, & 4 Location and quantities from cross sections:

Cut = Earth Excavation Fill = Embankment

Column 3 Quantity of earth excavation (cut) adjusted for a shrinkage factor of 25%.

Column 5 Earthwork required:

(-) = Quantity of Fill or Embankment needed (Furnished or Borrow Excavation).

(+) = Quantity to be wasted.

Because the earth excavation quantity is greater than embankment needed the only pay item is for "Earth Excavation," no pay item for "Borrow or Furnished Excavation" is needed.

Pay Item:

EARTH EXCAVATION 1600 cubic yards

Example 64-2.04(2)

Earthwork Schedule

1 Location	2 Earth Excavation	3 Earth Excavation Adjusted for Shrinkage	4 Embankment	5 Earthwork Balance Waste (+) or Shortage (-)
	Cubic Yard	Cubic Yard	Cubic Yard	Cubic Yard
Sta. 320+00 to 325+00	100	75	275	-200
Sta. 325+00 to 330+00	200	150	125	+25
Sta. 330+00 to 335+00	150	112.5	300	-187.5
Side Road X	50	37.5	250	-212.5
Total	500	375	950	-575

Columns 1, 2, & 4 Location and quantities from cross sections:

Cut = Earth Excavation Fill = Embankment

Column 3 Quantity of earth excavation (cut) adjusted for a shrinkage factor of 25%.

Column 5 Earthwork required:

(-) = Quantity of Fill or Embankment needed (Furnished or Borrow Excavation).

(+) = Quantity to be wasted.

Because the earth excavation quantity is not great enough to account for all embankment (fill) needed, additional earth is required from off-site either as borrow or furnished excavation.

Example 64-2.04(3)

Earthwork Schedule

1	2	3	4	5	6	7	8	9
Location	Earth Excavation Cubic Yard	Rock Excavation Cubic Yard	Unsuitable or Unstable Material Cubic Yard	Excavation to be used in Embankment Adjusted for Shrinkage Cubic Yard	Embankment Cubic Yard	Earthwork Balance Waste (+) or Shortage (-) Cubic Yard	Topsoil Excavation and Placement Cubic Yard	Topsoil Furnish and Place Square Yard
Sta. 410+00 to 430+00	3,000		1,000	1,600	10,000	-8,400	600	
Sta. 430+00 to 450+00	2,000	500		2,100	8,000	-5,900	200	300
Sta. 450+00 to 470+00	5,000			4,000	2,000	+2,000	200	400
Frontage Road	1,000			800	5,000	-4,200	300	
Total	11,000	500	1,000	8,500	25,000	-16,500	1,300	700

Shrinkage Factors:

Earth Excavation: 20%
 Rock Excavation: 0%
 Borrow Excavation: 30%

- Column 1 – Location from plans.
- Column 2 – Cut quantities from cross sections, this does not include topsoil excavation.
- Column 3 – Quantities from cross sections.
- Column 4 – Cut material that is determined to be either unstable or unsuitable for use in embankment.
- Column 5 – Earth and rock excavation quantities that are to be used as fill material in embankment. Includes deduction for unsuitable material. Earth excavation shrinkage factor was determined to be 20%. Rock excavation shrinkage factor was determined to be 0%.
- Column 6 – Quantities from cross sections.
- Column 7 – Off-site material needed or material to waste.
- Column 8 – Quantities from cross sections, these quantities are not included in earth excavation or embankment.
- Column 9 – Quantities required from off-site to complete project, quantities are not included in borrow or furnished excavation.

Furnished excavation is measured in its final (compacted) state. Borrow excavation is measured at the borrow site and, therefore, the borrow quantity must allow for shrinkage (assumed 25%). $\text{Borrow} = 575 \text{ yd}^3 / (1 - 0.25) = 766.67 \text{ yd}^3$.

Pay Items:

EARTH EXCAVATION	-	500 cubic yards
FURNISHED EXCAVATION	-	575 cubic yards

or

EARTH EXCAVATION	-	500 cubic yards
BORROW EXCAVATION	-	767 cubic yard

On projects in which cut material is paid for with multiple pay items (e.g., Earth Excavation and Rock Excavation), calculate the total quantity of cut material to determine the quantity of off-site material required for embankment. Each item may have a different shrinkage factor.

On projects in which topsoil is to be paid for, the topsoil quantities are not included in any other pay items (e.g., earth excavation, furnished excavation). First, calculate the total quantity of topsoil needed. Next, calculate the amount of topsoil available within the project limits. If not enough topsoil is available on the project, then the additional amount will be obtained from off-site and paid for as "Topsoil Furnish and Place." A shrinkage factor may be used for topsoil, but is not usually required.

Borrow excavation quantity is $16,500 / (1 - 0.30) = 23,571$ cubic yards. If furnish excavation were used the quantity would be 16,500 cubic yards.

Pay Items:

EARTH EXCAVATION	-	10,000 cubic yards
ROCK EXCAVATION	-	500 cubic yards
REMOVAL AND DISPOSAL OF UNSUITABLE MATERIAL	-	1,000 cubic yards
BORROW EXCAVATION	-	23,571 cubic yards
TOPSOIL EXCAVATION AND PLACEMENT	-	1,300 cubic yards
TOPSOIL FURNISH AND PLACE	-	700 square yards

64-2.04(b) Earthwork Quantities for Separate Grading and Paving Contracts

On grading and paving contracts, the paving contractor may have the problem of either wasting substantial quantities of excess excavation or obtaining borrow to construct the subgrade. Often the plans do not provide the contractor with the proper quantities to adequately estimate the project. To ensure that sufficient quantities are provided, the designer should consider the following:

1. Grading Contracts. For grading contracts, show the grading cross sections parallel to the ultimate pavement and shoulder structure. Occasionally, special conditions may dictate a different grading cross section. For these situations, provide accurate earthwork quantities to construct the final paving cross section in the paving plans.
2. Graded Paving Contracts. For paving contracts on pregraded sections, do not include the earthwork in the cost of paving or use “token” quantities to establish unit prices. determine the earthwork quantities according to one of the following conditions:
 - a. When a grading contract will be completed several months before the advertising of the paving contract, develop new cross sections to establish accurate earthwork quantities.
 - b. When the paving contract will be advertised prior to the completion of the grading contract, accurate earthwork quantities cannot be determined for bidding purposes. For these situations, include the pay item “Shaping and Grading Roadway.”

64-2.04(c) Bridge Embankment Quantities

For determining bridge embankment quantities, the Bureau of Bridges and Structures will only show on the general plan and elevation sheet of the bridge plans the limits of the minimum embankment that must be constructed prior to the construction of the abutments. The road designer is responsible for determining the quantities for the embankment cones and including these quantities in the total earthwork for the project.

The bridge plans will present any pipe culverts under these embankment cones. However, the road designer determines the pipe culvert length and any quantities.

64-2.05 Landscaping

When determining landscaping quantities, the designer should consider the following:

1. Seeding and Sodding. Calculate the area for seeding and sodding by measuring the distance along the slope and not horizontally.
2. Fertilizer Nutrients. To determine the quantity of fertilizer nutrients, multiply the area to be fertilized by the application rate. The designer should check with the District Landscape Architect to determine the proper application rate. Show the selected application rate in the plans, typically in the general notes.
3. Mulch. To determine the quantity of mulch, multiply the area to be mulched by the application rate obtained from the District Landscape Architect. Show the application rate in the plans, typically in the general notes.

64-2.06 Subgrade

Calculate the area of subgrade using the out-to-out width of the paved shoulders. To ensure a proper pavement foundation, add 6 in (150 mm) to each side. If the paved shoulders are bituminous, include an allowance for the 1V:1H slope of the bituminous material before adding the 6 in (150 mm) to each side.

For urban sections with curb and gutter, calculate the subgrade width using the out-to-out distance from the back of curb plus the 6 in (150 mm) extension.

64-2.07 Subbase

To determine the area of subbase under rigid pavements, include an additional 18 in (450 mm) on each side to the pavement width. Where curb and gutter is used with rigid pavements, the extra width will be the curb and gutter width.

64-3 PAVEMENT COMPUTATIONS**64-3.01 Bituminous****64-3.01(a) Bituminous Binder and Surface Course**

Where bituminous binder and surface course pay items are in square yards (square meters), calculate the quantities using the top surface area. For binder course construction without curb and gutter, allow for the 1V:1H side slope of the surface course material before determining the width of the binder course. For binder course construction with curb and gutter on an improved subgrade, allow for the additional thickness required below the curb and gutter.

Where the pay item is in tons, provide an allowance for the extra width required due to the slope of the bituminous material. This allowance is not required for curb and gutter sections.

64-3.01(b) Bituminous Materials Applied

The designer should consult with the District Materials Engineer to determine the proper application rate of material for the type of project being constructed. This rate should be shown on the plans.

64-3.02 Pavement Rehabilitation

When determining quantities for pavement patching, conduct a field inspection immediately prior to the plan submission. Add a growth factor of 10% to 20% if the bids on the project will be received in late summer or fall and there is a likelihood that patching would not be completed until the following spring.

64-3.03 Shoulders/Curb and Gutter**64-3.03(a) Shoulders**

Where the pay item is in square yards (square meters), use the top width of the shoulder to determine the area of shoulders.

64-3.03(b) Curb and Gutters

To determine the length of curb and gutters, measure the length along the gutter flow line. This length is measured across entrances and not around an entrance radius. The curbs in entrances should be included in the area of the entrance. At street returns, measure the curb around the radius of the return.

64-4 MISCELLANEOUS COMPUTATIONS

64-4.01 Bridges Deck Slab Repair Quantities

There may be a lag time between the time of inspection of the deck and the recording of the plan quantities and the start of actual construction. To reduce possible overruns on deck slab repair quantities, inspection of the deck should not occur more than four months prior to taking of bids for work. On projects on which bids are taken in late summer or fall, add a growth factor of 5% to 10% to the measured quantities to allow for the additional winter period between the inspection and the start of construction.

When a project is delayed and the deck(s) are subject to additional winter wear, make an update inspection prior to taking bids for the work. Conduct this updated inspection in the same manner as the initial inspection. The designer is responsible for keeping the records of the dates for all inspections.

Also, to reduce possible overruns, conduct a thorough and complete deck inspection. A detailed visual inspection of the underside of the deck is extremely critical. Time may be saved by not determining the corrosion potential and chloride content of the concrete.

The Department may secure outside consultants to conduct these inspections.

64-4.02 Trench Backfill

Calculate the trench backfill quantities using the trench backfill tables in the *IDOT Construction Manual*.

64-4.03 Aggregate

When calculating the quantity of aggregate required for temporary entrances, temporary lanes, etc., indicate the pay item in tons. Also, include additional quantities for maintenance during time the temporary facility is open to traffic.

64-5 MATHEMATICAL FORMULAS

This section presents mathematical formulas used by IDOT for various quantity determinations.

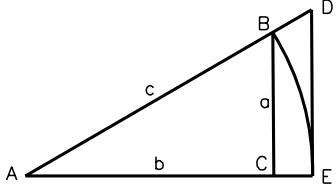
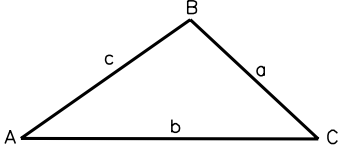
 <p style="text-align: center;">Right Triangle</p>	 <p style="text-align: center;">Oblique Triangle</p>	
Right Triangles		
$\sin A = \frac{a}{c} = \cos B$ $\cos A = \frac{b}{c} = \sin B$ $\tan A = \frac{a}{b} = \cot B$ $a = c \sin A = c \cos B = b \tan A = b \cot B = \sqrt{c^2 - b^2}$ $b = c \cos A = c \sin B = a \cot A = a \tan B = \sqrt{c^2 - a^2}$ $c = \frac{a}{\sin A} = \frac{a}{\cos B} = \frac{b}{\sin B} = \frac{b}{\cos A}$	$\sec A = \frac{c}{b} = \operatorname{cosec} B$ $\operatorname{cosec} A = \frac{c}{a} = \sec B$ $\cot A = \frac{b}{a} = \tan B$	
Oblique Triangles		
Given	Sought	Formula
A, B, a	b, c	$b = \frac{a}{\sin A} \cdot \sin B$ $c = \frac{a}{\sin A} \cdot \sin (A+B)$
A, a, b	B, c	$\sin B = \frac{\sin A}{a} \cdot b$ $c = \frac{a \sin (A + \arcsin (b \sin A / a))}{\sin A}$
C, a, b	$\frac{1}{2}(A + B)$ $\frac{1}{2}(A - B)$	$\frac{1}{2}(A+B) = 90^\circ - \frac{1}{2} C$ $\tan \frac{1}{2}(A - B) = \frac{a - b}{a + b} \cdot \tan \frac{1}{2}(A+B)$
a, b, c	A	<p>Given $s = \frac{1}{2}(a+b+c)$, then :</p> $\sin \frac{1}{2} A = \sqrt{\frac{(s - b)(s - c)}{bc}}$ $\cos \frac{1}{2} A = \sqrt{\frac{s(s - a)}{bc}}$ $\tan \frac{1}{2} A = \sqrt{\frac{(s - b)(s - c)}{s(s - a)}}$ $\sin A = 2 \sqrt{\frac{s(s - a)(s - b)(s - c)}{bc}}$
	Area	$\text{Area} = \sqrt{s(s - a)(s - b)(s - c)}$
c, a, b	Area	$\text{Area} = \frac{1}{2} ab \sin C$

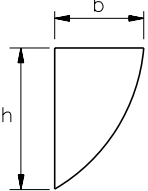
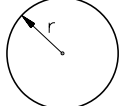
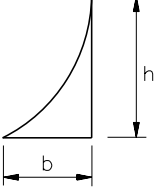
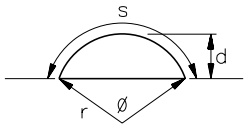
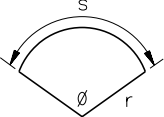
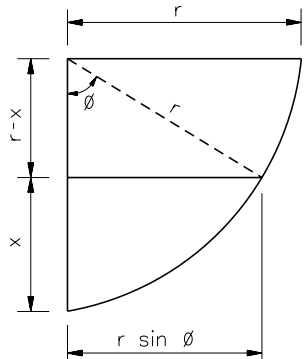
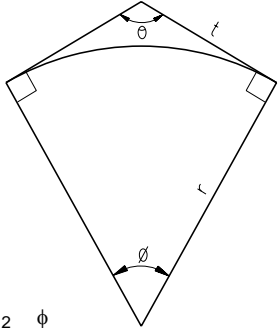
<p>Nomenclature</p> <p>A = total surface area d = distance h = height p = perimeter r = radius s = side (edge) length, arc length V = volume θ = vertex angle, in radians φ = central angle, in radians</p>	<p>Parabola</p>  $A = \frac{2bh}{3}$
<p>Circle</p>  $p = 2\pi r$ $A = \pi r^2 = \frac{p^2}{4\pi}$	 $A = \frac{1}{3}bh$
<p>Circular Segment (1)</p>  $A = \frac{1}{2}r^2(\phi - \sin\phi)$ $\phi = \frac{s}{r} = 2\left(\arccos \frac{r-d}{r}\right)$	<p>Circular Sector</p>  $A = \frac{1}{2}\phi r^2 = \frac{1}{2}sr$ $\phi = \frac{s}{r}$
<p>Circular Segment (2)</p>  $\cos \phi = \frac{r-x}{r}$ <p>Area of Circle Segment</p> $\frac{\phi}{360^\circ} \pi r^2$ <p>Area of Triangle</p> $\frac{1}{2}(r-x)(r \sin \phi)$	<p>External Area</p> <p>Total Area - Area of Circle Segment = External Area</p>  $t = \frac{r}{\tan \frac{\theta}{2}}$ $\phi = 180^\circ - \theta$ $\text{Total Area} = rt = \frac{r^2}{\tan \frac{\theta}{2}}$ $\text{Area of Circle Seg.} = \pi r^2 \frac{\phi}{360}$ $\text{Ext. Area} = r^2 \left[\frac{1}{\tan \frac{\theta}{2}} - \pi \frac{\phi}{360} \right]$

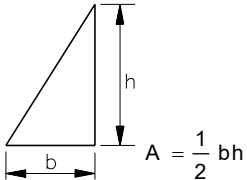
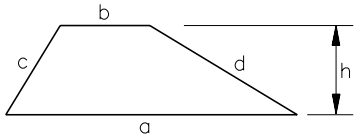
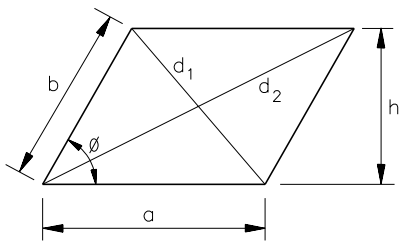
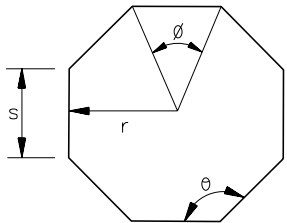
Number of Sides	Name of Polygon	<i>Triangle</i>
3	triangle	 $A = \frac{1}{2} bh$
4	rectangle	
5	pentagon	
6	hexagon	
7	heptagon	
8	octagon	
9	nonagon	
10	decagon	
<p><i>Trapezoid</i></p>  $p = a + b + c + d$ $A = \frac{1}{2} h (a + b)$ <p>The trapezoid is isosceles if $c = d$.</p>		
<p><i>Parallelogram</i></p>  $p = 2 (a + b)$ $d_1 = \sqrt{a^2 + b^2 - 2ab(\cos \phi)}$ $d_2 = \sqrt{a^2 + b^2 + 2ab(\cos \phi)}$ $d_1^2 + d_2^2 = 2 (a^2 + b^2)$ $A = ah = ab(\sin \phi)$ <p>If $a = b$, the parallelogram is a rhombus.</p>	<p><i>Regular Polygon</i> (n equal sides)</p>  $\phi = \frac{2\pi}{n}$ $\theta = \frac{\pi (n - 2)}{n}$ $p = ns$ $s = 2r \left(\tan \left(\frac{\phi}{2} \right) \right)$ $A = \frac{1}{2} nsr$	

Chapter Sixty-five
COST ESTIMATING

BUREAU OF DESIGN AND ENVIRONMENT MANUAL

Chapter Sixty-five
COST ESTIMATING

Table of Contents

<u>Section</u>	<u>Page</u>
65-1 PROJECT ESTIMATES	65-1.1
65-1.01 Project Initiation Estimate	65-1.1
65-1.02 Phase I Estimate	65-1.2
65-1.03 Phase II Estimates	65-1.7
65-1.04 Engineer's Estimate	65-1.7
65-1.04(a) Originating Unit	65-1.8
65-1.04(b) Central Office Project Management Unit	65-1.9
65-1.04(c) Awards Committee	65-1.10
65-2 DISTRICT ESTIMATING PROCEDURES	65-2.1
65-2.01 Responsibilities	65-2.1
65-2.01(a) Designer Responsibilities	65-2.1
65-2.01(b) Estimator Responsibilities	65-2.2
65-2.02 Unit Cost Determinations	65-2.2
65-2.02(a) Historical Data	65-2.2
65-2.02(b) Unit Cost Hybrid Worksheet	65-2.3
65-2.02(c) Unit Cost Detailed Worksheet	65-2.3
65-2.02(d) Lump-Sum Items	65-2.8
65-2.03 Other Duties	65-2.8
65-3 CENTRAL OFFICE PROJECT MANAGEMENT UNIT	65-3.1
65-3.01 Wage Rate Tabulation	65-3.1
65-3.02 Other Duties	65-3.1

Chapter Sixty-five

COST ESTIMATING

To adequately define the project scope and to ensure sufficient construction funds are available, cost estimates are required during the various stages of project development. As the project progresses, the estimates are refined to ensure the project is still cost effective, sufficient funds are available for construction, and the contractor's bid price is reasonable. Chapter 65 discusses the various project estimates that are required and the responsibilities of the district and Central Office estimators.

65-1 PROJECT ESTIMATES

65-1.01 Project Initiation Estimate

The districts and other units are responsible for nominating projects to be included on the Department's Multi-Year Highway Improvement Program. Once a project is nominated, the Office of Planning and Programming is responsible for gathering the necessary information on the project before it can be included on the Program list. One part of this information gathering includes a preliminary cost estimate for construction. These cost estimates are prepared in cooperation with the District Programming Engineer and/or Estimating Engineer.

Once a project has been included on the Department's Multi-Year Program, it may be several years before a Phase I study can be conducted. Consequently, the project initiation cost estimate must be updated annually until the Phase I study has been conducted.

At the time of project initiation, detailed project quantities have not yet been developed. The programmer determines the estimate based on information provided periodically by the estimator, by using broad units of cost (e.g., cost per mile (kilometer), cost per square yard (square meter)), and by reviewing similar, recent projects in the area. Project initiation cost estimates are generally determined according to the following:

1. Roadway Projects. For most highway projects, assume a cost per mile (kilometer) per roadway width. This estimate includes the cost for earthwork, pavement structures, drainage, and other miscellaneous items. Every effort should be made to include all anticipated work items.
2. Structure Projects. For most structural projects, assume a cost per square foot (square meter) based on similar structure types and lengths.
3. Traffic Signal Projects. Estimate traffic signal projects assuming a per intersection installation.
4. Unit Costs. If sufficient quantities are available, use the quantities with the average weighted unit prices to develop the estimate. Add a factor of 10% to 20% to account for minor items.

In addition, the programmer should add the cost for any major features that are beyond the basic assumptions used to develop the estimate. For example, the cost for a major box culvert should be added to the roadway cost per mile (kilometer) estimate.

Based on the proposed scope for the project, the programming engineer determines the unit cost basis considering the following factors:

- geographic location (e.g., urban/rural, State location, district);
- similarity of recent construction projects;
- inflation (adjustments of past prices to reflect the current year);
- reliability of recent construction cost data;
- recent trends in cost of materials, labor, and equipment;
- anticipated difficulty of construction;
- project size relative to size of previous projects;
- proposed project schedule;
- anticipated construction staging;
- right-of-way;
- railroads;
- utilities;
- expected environmental problems (e.g., hazardous wastes, wetlands); and
- engineering judgment.

65-1.02 Phase I Estimate

Once the Phase I study has been completed, the district programming engineer with input from the estimating engineer will work with the Office of Planning and Programming to prepare a more detailed cost estimate for the Phase I report. The programmer and/or estimating engineer preparing the estimate will use the quantities determined during the study. If quantities are not available, the designer should be requested to develop these quantities. If quantities are unavailable and cannot be estimated in a reasonable time frame, use the estimating procedures described in Section 65-1.01 (e.g., cost per mile (kilometer)). For consultant projects, the consultant develops the quantities and determines the unit prices. Department personnel will review and may adjust the consultant's proposed unit prices.

Figure 65-1.A lists the elements that should be estimated and included in the Phase I report for complex projects (e.g., reconstruction or new alignments). Typically, at this stage, not all of the quantities have yet been determined. The designer may include a 10% to 20% contingency factor depending upon engineering judgment for the minor items. Section 65-2 discusses the procedures for developing cost estimates based on quantities. Chapter 12 provides additional information on estimating procedures for Phase I reports. To adequately reflect construction and programming options, it may be necessary to use multiple columns on the estimate form or multiple estimate forms to show the costs for the various alternatives, segments, local participation, and construction breakdowns. In determining the breakdowns, the designer should consider the following:

1. Major Items. List the individual major elements separately (e.g., interchanges, bridges) and clearly identify their location on the estimate.
2. Rehabilitation Projects. On rehabilitation projects, breakdowns may be required for certain construction items because of the potential for specific items to become significant project costs.
3. Two or More Construction Seasons. On complex projects that require more than one construction season to complete, break the project into individual segments that can be completed in one season.
4. Project Funding. Identify construction, right-of-way, utility adjustments, local participation, and consultant PE costs separately to facilitate programming of these items.

Figure 65-1.B illustrates the cost estimate format that should be used for simple projects (e.g., 3R, widening, resurfacing).

Date: _____
 Route: _____
 Section: _____

Designer: _____
 City/County: _____
 Base Year: _____

Work Classification	Estimated Costs in \$1000's					Totals
	Segments					
	1	2	3	4	5	
1. Clear and Grub (Minor removal items and demolition)						
2. Earthwork						
a. Mainline grading and drainage (minor structures)						
b. Frontage road grading and drainage (minor structures)						
3. Pavement						
a. Mainline subbase, base, surface, and shoulders						
b. Frontage road, subbase, base, surface, and shoulders						
4. Grade Separations						
a. Railroads						
b. Highway grade separations, including earthwork and pavement (without ramps). List each separately.						
c. Structure removal						
5. Interchanges (structure, crossroad and ramp earthwork, crossroad and ramp pavements). List each separately. (Do not include mainline grading or pavement.)						
6. Structures						
a. Drainage (major structures)						
b. Walls (retaining or reinforced earth)						
7. Miscellaneous Items						
a. Guardrail, fencing, and lighting						
b. Traffic control						
c. Traffic signals (modernization or new)						
d. Signing						
e. Railroad Crossing Improvements						
f. Field Office and Laboratory						

**COST ESTIMATE FORMAT
 (Complex Projects)**

Figure 65-1.A

Work Classification	Estimated Costs in \$1000's					
	Segments					Totals
	1	2	3	4	5	
8. Other Items						
a. Erosion Control						
b. Landscaping						
c. Rest areas or other amenities						
d. Environmental mitigation						
9. Traffic Management Costs						
a. Crossovers						
b. Temporary roadways						
c. Detours						
10. Subtotal (Categories 1 – 9)						
11. Contingencies (____% of Line 10). (Should not exceed 20%).						
12. Total Construction Cost (Lines 10 and 11)						
13. Right-of-Way						
a. Residential property and relocations						
b. Farm and business property and relocations						
14. Utility Adjustments						
15. *Preliminary Engineering (____% of Line 12)						
16. *Construction Engineering (____% of Line 12)						
17. Total Project Cost (Lines 12 - 16)						
18. Local Participation						

*Note: *If consultant work is anticipated for preliminary engineering or construction engineering, list these items separately in submission of costs for programming purposes.*

**COST ESTIMATE FORMAT
(Complex Projects)**

**Figure 65-1.A
(Continued)**

Date: _____
 Route: _____
 Section: _____

Designer: _____
 City/County: _____
 Base Year: _____

Work Classification	Estimated Costs in \$1000's
1. Clearing; Minor Removal Items	
2. Earthwork	
3. Erosion Control	
4. Drainage	
5. Subbase, Base, Surface, Shoulders	
6. Guardrail, Roadside Safety	
7. Traffic Signals	
8. Detours, Temporary Traffic Control - Roadway	
9. Railroad Crossing Improvements	
10. Field Office and Laboratory	
11. Environmental Mitigation/Incidental Items	
12. Roadway Subtotal (Categories 1-11)	
13. Structure Removal	
14. Major Culverts	
15. Bridges	
16. Structures for Detours and Temporary Traffic Control	
17. Structure Subtotal (Categories 13-16)	
18. Roadway and Structure Subtotal (Lines 12 and 17)	
19. Contingencies (___% of Line 18) (should not exceed 15%)	
20. Total Construction Cost (Lines 18 and 19)	
21. Utility Adjustments	
22. Land Acquisition and Relocations	
23. *Preliminary Engineering (___% of Line 20)	
24. *Construction Engineering (___% of Line 20)	
25. Total Project Cost (Lines 20 - 24)	

*Note: *If consultant work is anticipated for preliminary engineering or construction engineering, list these items separately in submission of costs for programming purposes.*

**COST ESTIMATE FORMAT
 (Project Reports)**

Figure 65-1.B

65-1.03 Phase II Estimates

One or more cost estimates may be prepared during the Phase II project stage. These estimates may include the following:

1. Preliminary Plan Review. At this project stage, a revised cost estimate is generally developed only to determine the appropriate preliminary Disadvantaged Business Enterprises (DBE) requirements. Recommended guidelines for DBE determinations are provided by the Office of Highways Project Implementation and approved by the Office of Business and Workforce Diversity. Under some circumstances, a preliminary plan cost estimate may be prepared to ensure that the program funding is still reasonable and appropriate. At this stage, the plans and major quantities are essentially complete. Therefore, the estimate can be prepared using the methodologies discussed in Section 65-2 (i.e., based on unit prices). The designer will work with the district estimating engineer to develop this estimate. Do not forward this estimate to the Project Management Unit in the Bureau of Design and Environment.
2. Project Scope Change. Whenever the scope of the project changes, the designer will be responsible for obtaining a new construction cost estimate. These estimates are forwarded to the Office of Planning and Programming to revise the Multi-Year Program. Estimates for scope of work changes are typically based on approximate quantities and are determined using the procedures discussed in Section 65-1.02.
3. Project Delay. If there has been a significant delay in the project since it was originally designed and estimated, it may be necessary to update the cost estimate to reflect inflation, new materials, new equipment, contractor workloads, etc.
4. Final Plan Submittal. Prior to submitting the plans to the Central Office for letting, the district estimating engineer prepares a cost estimate based on the final plans. This may be an update of an earlier cost estimate or, for many projects without a Phase I report, this estimate will be the first detailed estimate for the project. This estimate is forwarded to the Project Management Unit in the Bureau of Design and Environment, which will use it to develop the Engineer's Estimate.
5. Engineer's Estimate. The Engineer's Estimate is the official Department estimate for the project. This estimate is prepared by the Project Management Unit in the Bureau of Design and Environment based on the district estimating engineer's estimate. Section 65- 1.04 discusses the procedures for the Engineer's Estimate.

65-1.04 Engineer's Estimate

The Engineer's Estimate provides the Department with a basis for evaluating the bids for highway construction and allows the Department to determine if the low bid price is fair and reasonable for the work involved. This estimate, plus the data used to generate the estimate, is considered confidential and is not for general distribution. Section 65-2 discusses the procedures for

developing the actual cost estimate. The following sections discuss the responsibilities of the various units for the Engineer's Estimate.

65-1.04(a) Originating Unit

Base cost estimates are prepared by the various units where the design originated (e.g., district, county, municipality, consultant). These estimates are submitted to the Engineer of Project Management in the Bureau of Design and Environment for final review and adjustment prior to contract letting. The originating estimator generally prepares the final plan submittal estimate as discussed in Section 65-2. The originating estimator's responsibilities include the following:

1. Quantities. The estimator is responsible for inputting all quantities into the Bureau of Design and Environment's Electronic Contract Management (ECM) System.
2. Unit Prices. The estimator adjusts the unit prices according to the procedures discussed in Section 65-2.
3. Worksheets. The estimator prepares all estimates submitted to the Central Office on hybrid and cost-based worksheets.
4. Data Input. The estimator must input all data into the ECM System prior to the PS&E date, or the project may not be scheduled for the anticipated letting.
5. Local Projects. For local road and bridge projects, the district estimator reviews the local agency estimate and prepares a district estimate. This may be, but is not required to be, an independent estimate. If the difference between the local agency's estimate and district estimate is 5% or less, enter both estimates into the ECM System. If the difference is greater than 5%, contact the local agency and negotiate an acceptable estimate to both parties. If an agreement cannot be reached, notify the Engineer of Project Management. Enter both the district's and local agency's final estimates into the ECM System.
6. Submittals. When submitting the estimate data to the Central Office Project Management Unit, the estimator should note the following:
 - a. Data Transfer. Submit all estimates electronically to the Central Office through the ECM System. In addition, send an electronic file (.pdf) of the backup data and worksheets to the Central Office before the PS&E due date to DOT.DandEEstimates@illinois.gov.
 - b. Approval. All cost estimates must be approved by a district estimator or an estimator-in-training before they can be forwarded to the Central Office Project Management Unit.
7. Revisions. If, after the estimate data has been submitted to the Central Office, the district estimator wishes to revise the estimate, the estimator must consider the following:

- a. Review. Conduct all reviews of the data on-line through the ECM System. The estimate in the ECM System should always be the latest copy of the estimate.
- b. Changes. If an estimate quantity, pay item, and/or unit price is changed on-line, notify the Engineer of Project Management, by email, that a change has been made. The Central Office may be unaware of the change, because on-line changes are nearly impossible to identify.
- c. Due Date. Do not change any estimate on-line less than ten days prior to the letting. If a change is necessary, contact the Engineer of Project Management directly to discuss the change.

The Engineer of Project Management must be notified of any changes to ensure the latest data is transferred to the Department's Electronic Letting Management (ELM) System.

65-1.04(b) Central Office Project Management Unit

After the district submits a cost estimate to the Engineer of Project Management, the Unit responsibilities include the following:

1. Review. The estimator reviews the district's estimate and checks it for errors and/or omissions. If large discrepancies are noted, the Engineer of Project Management contacts the district estimator to discuss and resolve any differences. The Central Office estimator will not review every project cost estimate. For these situations, the district estimate is used as the Engineer's Estimate. However, the Engineer of Project Management will still have final authority for all estimates. Typically, the following estimates will not be reviewed by the Central Office:
 - a. Projects < \$250,000. For all projects less than \$250,000, the estimates prepared by district estimators will be used without review.
 - b. Lighting and Pumping Station Projects. All lighting and pumping station projects from the District 1 Bureau of Electrical Operations that are less than \$250,000 are used without review. For lighting and pumping station projects from Districts 2 through 9, the Electrical and Mechanical Unit in the Bureau of Design and Environment is responsible for reviewing the estimate.
 - c. Local Agency Projects. Local agency estimates may not be reviewed.
 - d. Bridge Projects. For all bridges designed by the Bureau of Bridges and Structures and/or Department consultants, the Bridge Office reviews the estimate for bridge items.
 - e. Bureau of Operations Projects. Estimates prepared by the Central Office Bureau of Operations may be used without review.

2. Opening and Processing the Bids. After the public reading of the bids, the Project Management Unit is responsible for checking the proposals for errors and obtaining computer printouts of itemized unit bid prices. The bid prices of each bidder are reviewed for omissions or extreme differences. If no extreme differences appear, the low bidder meets all criteria and the low bid is within a pre-established award range, the bids are forwarded to the Awards Committee for approval.
3. Rejection of Bids. When the low bid exceeds the pre-established award range, the estimate is reviewed for possible errors. If no errors are found, the rejection process begins, unless special circumstances such as public safety, etc., would be just cause for award.

65-1.04(c) Awards Committee

The Awards Committee is responsible for approving or rejecting the bid. This Committee consists of the following personnel:

- Director of the Office of Highways Project Implementation,
- Engineer of Design and Environment,
- Engineer of Construction,
- Engineer of Local Roads and Streets,
- Engineer of Project Management, and
- Office of Planning and Programming, Program Management

At the conclusion of the Awards meeting, the Engineer of Project Management prepares the official bid letting tabulation and the award memorandum for submittal to the Secretary.

65-2 DISTRICT ESTIMATING PROCEDURES

65-2.01 Responsibilities

65-2.01(a) Designer Responsibilities

Before a detailed cost estimate can be prepared, the designer typically provides the following information to the district estimating engineer:

1. Plans. Provide the estimator with a complete set of plans.
2. Quantities. In addition to providing quantities to the estimator, the designer must provide the following:
 - a. Breakdowns. For those projects with separate breakdowns, separate the quantities for each breakdown category (e.g., construction and safety codes, funding appropriations). These breakdown categories are discussed in Section 63-4.04.
 - b. Lump Sum Items. Provide the estimator with a summary of the individual items within the lump sum item. For example, the list of elements for the lump sum pay item "Traffic Control and Protection Standards" may include the number of barricades, barricade lights, construction signs, arrow boards, temporary guardrail, temporary signals, pavement marking tape, etc.
3. Specifications. Provide the estimator with a copy of the special provisions and a list of all recurring special provisions used in the project.
4. Other Cost Estimates. Several bureaus and sections may prepare their own cost estimates. The designer is responsible for collecting these estimates and forwarding them to the appropriate district or Central Office estimating engineer. The following bureaus or sections may develop their own cost estimate:
 - a. Bureau of Bridges and Structures. The Bureau of Bridges and Structures may provide the cost estimates for bridges, retaining walls, major drainage structures, or any other work designed by the Bureau.
 - b. Bureau of Operations. The Bureau of Operations may provide cost estimates for traffic signals, traffic surveillance, signing, pavement markings, and landscaping projects.
 - c. District 1, Bureau of Electrical Operations. The Bureau of Electrical Operations in District 1 will provide the cost estimates for lighting and pumping stations.
 - d. Other. Other units may provide cost estimates as appropriate.
5. Other. Provide the estimator with any other information that may impact the cost of the project (e.g., special commitments, experimental materials).

65-2.01(b) Estimator Responsibilities

The district estimating engineer reviews the information received from the designer and develops a cost estimate for the project. These estimates are generally formulated using the analyses discussed in Section 65-2.02. For estimates other than the Engineer's Estimate, the district estimating engineer returns the proposed estimate to the requesting party. For the Engineer's Estimate, the district estimating engineer follows the procedures in Section 65-1.04(a).

If for some reason there are project changes after letting, the contractor will request reimbursement for the item at a unit cost. The district Bureaus of Project Implementation and/or Program Development may request the district estimating engineer to review the contractor's proposal to ensure that the unit cost is reasonable. This review is typically conducted in the same manner as reviews for other estimates.

65-2.02 Unit Cost Determinations

The Department uses the Electronic Contract Management (ECM) System and the *Estimates Manual* for developing and managing Department cost estimates. Worksheets are used to determine the cost estimate. These worksheets may be prepared utilizing estimating software, and on Excel spreadsheets. Cost estimates are typically based on the quantities and applicable unit prices. The following sections discuss the basic procedures the Department uses to determine the applicable unit cost for each quantity. The estimator may adjust these procedures depending upon the project parameters. Both the *Estimates Manual* and the ECM System are for internal Department use and are not for general distribution.

65-2.02(a) Historical Data

The unit cost for minor work items are based upon an average price among projects of relative size and scope, utilizing recent unit cost bid tabulations. Adjustments to unit prices may be appropriate based on the factors listed in Section 65-1.01.

The following work types are typically considered minor; i.e., the estimator should use the historical data methodology to determine the unit prices:

- lighting;
- traffic signals;
- signing;
- weed spraying;
- crack routing;
- pavement marking (all types);
- guardrail;
- signing, guardrail maintenance;
- landscaping;
- pipe culverts;
- pipe underdrains and pipe drains;
- manholes, catch basins, inlets, etc.;
- marine construction;
- curb and gutter;
- sidewalk;
- driveway pavement;
- electrical maintenance;
- bridge deck overlay;
- reinforcing steel;
- bridge approach pavement;
- riprap;
- soil stabilization;
- anchors and tiebacks;
- fencing;
- railroad track construction; and
- miscellaneous bridge items (e.g., bearings, deck grooving).

65-2.02(b) Unit Cost Hybrid Worksheet

For intermediate work items, calculate the unit costs using a Unit Cost Hybrid Worksheet . An example for using this Worksheet would be to calculate the unit cost for Furnishing and Erecting Structural Steel (i.e., pounds (kilograms) of steel times dollars per pound (kilogram)). Section 65-1.01 lists several adjustment factors that should be considered when determining the final unit cost. The following are considered intermediate work types for which the estimator should use the Hybrid Worksheet:

- bridge painting,
- bridge cleaning,
- temporary support system, and
- structural steel.

65-2.02(c) Unit Cost Detailed Worksheet

For major work items and where these item quantities exceed the values in Figure 65-2.A, the estimator should calculate the unit cost using a Unit Cost Detailed Worksheet. For quantities less than those shown in Figure 65-2.A, use engineering judgment to determine whether or not to use the Worksheet. The following are considered major work types for which the estimator should use the Detailed Worksheet:

- earth excavation, borrow, and embankment;
- concrete paving, widening, shoulders, and CAM II;
- bituminous paving, widening, shoulders, and BAM;
- aggregate base, shoulders, subbase, and surface;
- patching;

- cold milling;
- hauling;
- traffic control;
- seal coat;
- storm sewers;
- cofferdams;
- concrete structures and concrete box culverts;
- piling;
- structure removal; and
- sweeping.

Work Item	Minimum Quantity	
	US Customary	Metric
Earthwork	5,000 yd ³	5,000 m ³
Aggregate	4,000 tons	3,500 m tons
Bituminous Mixes	2,000 tons	2,000 m tons
PCC Pavement & Bases	5,000 yd ²	4,000 m ²
Cold Milling	20,000 yd ²	17,000 m ²
Class A Patching	400 yd ²	350 m ²
Class B Patching	400 yd ²	350 m ²
Class C Patching	600 yd ²	500 m ²
Class D Patching	600 yd ²	500 m ²
Concrete Box Culverts	150 yd ³	150 m ³
Concrete Superstructures	150 yd ³	150 m ³
Concrete Structures	150 yd ³	150 m ³
Storm Sewers	1,800 ft	550 m
Structure Removal	Anytime in excess of \$25,000 per structure	Anytime in excess of \$25,000 per structure
Cofferdams	Anytime in excess of \$25,000 per cofferdam	Anytime in excess of \$25,000 per cofferdam
Drive and Furnish Piling	2,000 ft	600 m

MINIMUM QUANTITIES FOR UNIT COST DETAILED WORKSHEET

Figure 65-2.A

The Unit Cost Detailed Worksheet requires the estimator to determine the unit prices based on the following factors:

1. Production Rates. The estimator determines the appropriate production rates for the various items on the project. Section 66-2.03 provides typical production rates. Stage construction, congestion, urban work, size of quantity, traffic, seasonal work, expedited work schedule, local restrictions, etc., all affect the production rate. The estimator should consult with district construction personnel, review Means' *Heavy Construction Cost Data*, review the values within Section 66-2.03, and use engineering judgment when determining production rates.
2. Equipment. Equipment costs include ownership expenses to cover such items as depreciation, repairs, taxes, storage costs, fuel, oil, and grease. Equipment costs can be obtained from the *Rental Rate Blue Book*. To obtain any equipment costs not specified, other sources may include manufacturers of the equipment and the Means' *Heavy Construction Cost Data*.
3. Labor. Labor costs vary greatly throughout the State. The estimator must not only determine what types of crafts that will be required, but also the most efficient number of workers in each craft. In determining a unit cost for labor, the estimator considers the efficiency of the local labor, their working agreements, fringe benefits, social security, workers compensation, guarantees of minimum working hours per week, show-up time clauses, liability insurance, and non-working conditions due to mechanical breakdowns or bad weather.

The labor rate used for Federal-aid projects must be at least equal to the Federal prevailing wage rate. The labor rate used for State projects must be at least equal to the Illinois prevailing wage rate. An exception is when the prevailing rates are not provided in a contract. Section 65-3.01 further discusses the wage rate determination.

4. Material. Contact the suppliers directly to obtain quotes for materials. The quoted prices are typically what suppliers hope to receive for their product. The final price the contractor will be required to pay will generally be lower due to competition and negotiations between the contractor and supplier. Such items as discounts for large quantities, early payment or extreme competition on a particular project may vary the final price. The estimator should adjust the quoted prices based on these factors, previous estimates, and engineering judgment.
5. Hauling. The hauling expense is based upon haul distance, truck capacity, load and unload time, driver wage and truck expense, and/or quoted hauling costs.
6. Incidental. Incidental costs cover any items that may or may not be addressed by a particular pay item in a contract. Incidental costs may include:
 - pay items included in other items by specification or special provision;
 - coordination with other contractors;

- “tight” completion dates which demand double shifts;
 - payment of overtime;
 - winter construction;
 - congested work areas;
 - high elevation work;
 - hauling through heavy traffic, frequent railroad crossings, or traffic signals;
 - work not adaptable to the normal equipment used which results in manual labor or renting of special equipment;
 - location of plant sites, including costs of rental and renovation;
 - the season during which the work will be performed;
 - the cost of maintaining traffic including stage construction, flagmen, lights, and barricades; and
 - other outside agencies rules and regulations (e.g., OSHA, EPA).
7. Mobilization. Mobilization costs consist of preparatory work and operations necessary for the movement of personnel, equipment, supplies, and incidentals to the project site; for the establishment of offices, buildings and other facilities necessary for work on the projects; and for all other work or operations that must be performed or costs incurred when beginning work on the project. Mobilization may include delivery and removal of all equipment utilized for a given type of work. This type of mobilization includes loading, unloading, set-up, delivery, and all necessary permits. When determining mobilization costs, the estimator needs to consider the following:
- the same piece of equipment may be utilized for different work types and should only be mobilized once, if practical;
 - the type of operation;
 - how often and when the equipment is used;
 - the types of equipment; and
 - multiple types of mobilization.
8. Overhead. Overhead costs are divided into two classes — general overhead and job overhead. General overhead costs are main office expenses away from the job site, which include salaries and expenses for staff employees, office maintenance, office transportation, expenses of bidding on projects, local contributions to charities, dues to

contractor's associations, interest charges on borrowed capital, and any other expenses considered a part of the firm's general costs of doing business. Job overhead costs include general job supervision, general job supervision expenses, and security. Overhead costs are calculated differently depending upon whether it is equipment, material, labor, or subcontractor work. These differences are defined in the *Estimates Manual*.

9. Profit. Profit mark-up is the amount of money a contracting company retains after it has completed a project and paid all costs for materials, equipment, labor, overhead, taxes, insurance, etc. Profit costs are calculated differently depending upon whether it is for equipment, material, labor, or subcontractor work; see Section 109 of the Standard Specifications and the *Estimates Manual*.
10. Bond. Bond costs are a percentage mark-up of all costs associated with a project. This cost should include both bid bond and performance bond costs.

65-2.02(d) Lump-Sum Items

When lump-sum items appear in the contract, the designer should provide a list of the elements within the lump sum item. However, the estimator should also search the plans and special provisions to determine what materials, procedures, equipment, etc., are involved to construct the item. The unit cost for the lump sum item is then determined by combining the cost for each of the individual items.

65-2.03 Other Duties

The district estimating engineer is also responsible for the following:

1. Pavement Selection Cost Analysis. Providing the designer with the unit costs to be used in pavement selection cost analysis. If the pavement area exceeds 5000 yd² (4000 m²), unit cost sheets must be prepared.
2. Cost Studies. Conducting cost studies for other bureaus within the district, upon request.
3. Agreed Unit Prices. Reviewing agreed unit prices submitted by the contractor to the district Bureau of Project Implementation and recommending acceptance or rejection.
4. Unit Price Tabulation of Bids. Obtaining a copy of the Unit Price Tabulations of Bids for all projects in their district. This information will be made available to the general public for review and should be maintained for the last three years.

65-3 CENTRAL OFFICE PROJECT MANAGEMENT UNIT

The following discusses the duties and responsibilities of the Bureau of Design and Environment Project Management Unit. Section 65-1.04 discusses the Unit's responsibilities for the Engineer's Estimate.

65-3.01 Wage Rate Tabulation

The Project Management Unit is responsible for preparing a tabulation of wage rates for laborers, operating engineers, carpenters, concrete finishers, ironworkers, etc. This tabulation includes the minimum hourly wage rates for these crafts for all Illinois counties, including the fringe benefits in the contract agreement. These rates are determined from contracts between the local unions. This tabulation is updated quarterly and distributed to all district estimators. The Project Coordination and Implementation Section is responsible for maintaining a file, by county, of the current wage rates. Contractors must pay the current prevailing wage rates and all subsequent changes.

Wage rate tabulation is required on all projects. When the advertisement for bids on any contract is for the construction of a project on the Federal-aid system, a wage rate determination is distributed to all bidders 10 days prior to the letting per agreement with the US Department of Labor. When the advertisement for bids on any contract is for State-funded contracts, the wage rates are included in the proposal. Any prevailing wage rate changes for State-funded contracts will be included in the Service Bulletin for the contractor's information.

65-3.02 Other Duties

The Project Management Unit is responsible for the following:

1. Day Labor Projects. Separate estimates are prepared based upon the day labor guidelines and the guidelines of the Project Management Unit. These two estimates are compared to determine the cost effectiveness of day labor versus competitive public bidding.
2. Pavement Selection Cost Analysis. The Project Management Unit reviews the cost of the pavement structural items included in the pavement design study submitted by the district to the Bureau of Design and Environment's Policy and Procedures Section. A detailed cost analysis is made of each structural pavement item submitted in the study. Corrections, if necessary, are made and the file returned to the Policy and Procedures Section.
3. Cost Studies. Cost studies within the realm of the Project Management Unit's expertise are conducted for all divisions and bureaus of the Department upon request.
4. Agreed Unit Prices. If the agreed unit prices initially negotiated between the district Bureaus of Project Implementation and Program Development are unacceptable to the

Central Office Bureau of Construction, the Project Management Unit will review the unit prices and provide a recommendation to the Central Office Bureau of Construction.

5. Incoming Estimates. The Project Management Unit maintains a list of all incoming estimates showing the total cost and data received for use by other internal offices.
6. Price Indices. The Project Management Unit develops and maintains material price indices for Department use in contract price adjustment clauses. Price adjustment clauses are available on steel, fuel and bituminous materials.
7. Federal Highway Administration. The Project Management Unit submits a complete estimate to the FHWA for all non-exempt Interstate projects as defined by the Oversight Committee. On exempt projects, only the total cost is submitted to the FHWA when Federal-aid is involved. However, the estimates should include fund type breakdowns and distances. As contracts are awarded, the Program Support Unit submits the Bid Price Data on FHWA Form PR-2 to FHWA.
8. Construction Breakdown. The Project Management Unit prepares unit price breakdowns by work categories for each contract and submits it to the Bureau of Construction to enable them to determine the bidding capabilities of contractors.
9. Estimates Manual. The Engineer of Project Management is responsible for maintaining, updating, and distributing the *Estimates Manual*.
10. Research. The Engineer of Project Management is responsible for developing new methods of computing unit costs, training, and instructing personnel involved in the art of cost estimating. This may involve seminars with district estimators to instruct and inform the estimators of revised or new methods of estimating and to discuss new equipment, materials, and unit cost items.

Chapter Sixty-six
CONTRACT PROCESSING

BUREAU OF DESIGN AND ENVIRONMENT MANUAL

Chapter Sixty-six
CONTRACT PROCESSING

Table of Contents

<u>Section</u>	<u>Page</u>
66-1 SPECIFICATIONS, SPECIAL PROVISIONS, AND HIGHWAY STANDARDS.....	66-1.1
66-1.01 General.....	66-1.1
66-1.02 Specifications	66-1.1
66-1.02(a) Standard Specifications	66-1.1
66-1.02(b) Supplemental Specifications	66-1.2
66-1.03 Special Provisions	66-1.2
66-1.03(a) General	66-1.2
66-1.03(b) Recurring Special Provisions	66-1.2
66-1.03(c) Contract Special Provisions	66-1.2
66-1.04 Special Provisions Preparation.....	66-1.3
66-1.04(a) Preparation Steps	66-1.3
66-1.04(b) Format.....	66-1.5
66-1.04(c) Guidelines	66-1.5
66-1.04(d) Terminology	66-1.7
66-1.04(e) Unit Abbreviations.....	66-1.9
66-1.04(f) Rules.....	66-1.9
66-1.05 IDOT Highway Standards.....	66-1.11
66-2 SUBMISSION OF PLANS, SPECIFICATIONS & ESTIMATES	66-2.1
66-2.01 District Pre-Letting List	66-2.1
66-2.02 PS&E Submittal	66-2.1
66-2.03 Construction Time Estimates.....	66-2.11
66-2.04 Selecting Contract Time and Project Letting Dates.....	66-2.19
66-2.04(a) Guidance for Selecting Project Letting Dates	66-2.19
66-2.04(b) Selecting the Type of Contract Time.....	66-2.20
66-2.04(c) Increased Use of Completion Date Contracts.....	66-2.22
66-2.04(d) Expanded Use of Lane Rental Contracts.....	66-2.24
66-2.05 Incentive/Disincentive Policy	66-2.24
66-2.05(a) Guidelines for Project Selection	66-2.24
66-2.05(b) Application	66-2.25
66-2.05(c) Amount Determination	66-2.26
66-2.05(d) Determination of Scheduled Completion Date	66-2.27

Table of Contents
(Continued)

<u>Section</u>	<u>Page</u>
66-2.05(e) Limits of Incentive/Disincentive	66-2.27
66-2.05(f) Extension of Contract Time	66-2.27
66-2.05(g) Project Development.....	66-2.27
66-2.05(h) Example Calculations	66-2.28
66-2.05(i) Sample Special Provisions	66-2.30
66-3 PROJECT COORDINATION AND IMPLEMENTATION SECTION	66-3.1
66-3.01 Plan Check-In and Review	66-3.1
66-3.01(a) Program Support Unit	66-3.1
66-3.01(b) Project Development Unit	66-3.1
66-3.02 Final Plan and Proposal Review.....	66-3.3
66-3.02(a) Special Provision Review.....	66-3.3
66-3.02(b) Procedures.....	66-3.3
66-4 PROPOSALS AND CONTRACTS	66-4.1
66-4.01 Transportation Bulletin and Advertising.....	66-4.1
66-4.01(a) Transportation Bulletin	66-4.1
66-4.01(b) Electronic Advertising	66-4.1
66-4.02 Proposals and Plans.....	66-4.1
66-4.02(a) Assembly of Proposal	66-4.1
66-4.02(b) Plans	66-4.1
66-4.02(c) Authorization to Bid	66-4.2
66-4.02(d) Subcontractors and Material Suppliers	66-4.2
66-4.02(e) Bidder's List	66-4.2
66-4.02(f) Addendums to Proposals and Plans	66-4.2
66-4.03 Letting Process.....	66-4.2
66-4.03(a) Receipt of Bids	66-4.2
66-4.03(b) Bid Tabulations	66-4.3
66-4.03(c) Proposal Guaranty Checks and Bid Bonds.....	66-4.3
66-4.03(d) Processing of Bids Received	66-4.3
66-4.03(e) Awards Committee.....	66-4.3
66-4.03(f) Preparation of Contract Prior to Award	66-4.4
66-4.03(g) Award and Rejection.....	66-4.4
66-4.04 Execution of Contracts	66-4.5

Table of Contents
(Continued)

<u>Section</u>		<u>Page</u>
66-4.05	Railroad Insurance	66-4.6
66-4.06	Contractor Services	66-4.6

Chapter Sixty-six

CONTRACT PROCESSING

66-1 SPECIFICATIONS, SPECIAL PROVISIONS, AND HIGHWAY STANDARDS

66-1.01 General

The *Standard Specifications for Road and Bridge Construction* (Standard Specifications), Supplemental Specifications, Recurring Special Provisions, Contract Special Provisions, and plans all are essential parts of the contract. They should complement each other and provide complete instructions for the work to be accomplished. If a discrepancy does exist among these documents, the relationships as described in Article 105.05 of the *Standard Specifications* will apply.

The *Standard Specifications* and Supplemental Specifications are included in the contract documents by the designer by referencing the applicable editions in the first paragraph of the special provision portion of the contract. Recurring Special Provisions are included through the use of a check sheet. Contract Special Provisions are included with the contract documents provided to the contractor.

The *Standard Specifications* and Supplemental Specifications are reviewed by the Specifications Committee which acts in an advisory capacity to the Director of Highways. The Specifications Committee includes permanent representatives from the Bureaus of Bridges and Structures, Design and Environment, Construction, Materials and Physical Research, Operations, and Local Roads, District One, FHWA, and Illinois State Toll Highway Authority. Three seats are also held by the other eight downstate districts on a three-year rotating basis. The chairperson is chosen by the Director of Highways for a four-year term. The Standards and Specifications Engineer in the Bureau of Design and Environment is the recording secretary.

66-1.02 Specifications

66-1.02(a) Standard Specifications

The *Standard Specifications for Road and Bridge Construction* (*Standard Specifications*) are the requirements adopted by the Department for work methods, materials, and basis of payment used in construction. The *Standard Specifications* are intended for general and repetitive use. They provide Department criteria for:

- the scope of work,
- control of work,
- control of materials,
- legal regulations and responsibilities to the public,
- contract prosecution and progress, and

- measurement and payment of contract items.

The *Standard Specifications* are published in book form and are updated every three to four years. Copies of the *Standard Specifications* can be obtained from the Department's website.

66-1.02(b) Supplemental Specifications

Supplemental Specifications are additions, deletions, and/or revisions to the *Standard Specifications*, which have been adopted by the Department since the last printing of the *Standard Specifications*. They are automatically considered part of the *Standard Specifications*.

Supplemental Specifications are printed in book form and are revised each year. Copies of the latest editions can be obtained from the Department's website.

66-1.03 Special Provisions

66-1.03(a) General

Special provisions are additions or revisions to the *Standard Specifications* and the Supplemental Specifications documenting conditions and requirements for special situations. Special provisions are either included in the contract documents or referenced through a check sheet.

66-1.03(b) Recurring Special Provisions

Recurring Special Provisions are special provisions that are commonly used on many projects. Unlike *Standard Specifications* and Supplemental Specifications, Recurring Special Provisions do not require the approval of the Specifications Committee. Recurring Special Provisions are printed with the Supplemental Specifications and inserted into a project by reference (i.e., check sheet). Each district is provided a copy of the check sheet, which contains a list of all the latest Recurring Special Provisions, by the BDE. The designer can obtain the check sheet from the district Program Development Engineer. The designer is responsible for checking the appropriate Recurring Special Provisions for the project and including the check sheet with the contract documents.

66-1.03(c) Contract Special Provisions

Contract Special Provisions are the special provisions the designer includes with the proposal submitted with the plans to BDE. They may include one or more of the following:

1. BDE Special Provisions. BDE Special Provisions are Contract Special Provisions issued for Statewide use. These special provisions are fill-in-the-blank specifications or specifications that are issued between publications of the Recurring Special Provisions. They are issued through BDE effective beginning with a specific letting. All special

provisions effective for a letting are transferred to the districts through the LAN and via email. The designer is responsible for marking the appropriate BDE Special Provisions on the BDE Check Sheet and BDE will insert the paper copy into the proposal for each project.

2. Bridge Special Provisions. Bridge Special Provisions are Contract Special Provisions issued by the Bureau of Bridges and Structures that may have changes from letting to letting. These special provisions may become BDE Special Provisions when no revisions have been made for at least a year. The Bureau of Bridges and Structures is responsible for including the appropriate Bridge Special Provisions into the contract documents for each project.
3. District Special Provisions. District Special Provisions are Contract Special Provisions addressing concerns unique to a district (e.g., material shortages, labor agreements). These special provisions are approved by BDE prior to their repetitive use. The district may also recommend these special provisions for consideration as BDE Special Provisions. The designer is responsible for including the appropriate District Special Provisions into the proposal for each project.
4. Project Specific Special Provisions. Project Specific Special Provisions are Contract Special Provisions written by the designer to address a unique situation on a project. These special provisions should not be used in more than one project. Project Specific Special Provisions are required wherever a project contains work, material, unique sequence of operations, or any other requirements that are necessary for the completion of the project but are not included in the *Standard Specifications*, Supplemental Specifications, Recurring Special Provisions, BDE Special Provisions, or Bridge Special Provisions. These special provisions should not be prepared to personalize the work to the ideas of the designer or to place emphasis on certain aspects of a project. The practice of emphasizing particular procedures and requirements already stated in the *Standard Specifications* is more properly accomplished at the preconstruction conference. The district may recommend these special provisions for consideration as District Special Provisions or BDE Special Provisions. The designer is responsible for writing and including the appropriate Project Specific Special Provisions into the proposal for each project.

66-1.04 Special Provisions Preparation

66-1.04(a) Preparation Steps

The designer should use the following steps when preparing a special provision:

1. Define Need. The designer should review the existing specifications, standards, details, special provisions, and plans to ensure that there is a need for the special provision. If the topic is not adequately covered in one of the other documents, only then should a special provision be prepared.

2. Research. The designer should research the topic so that complete and detailed information is available before writing the special provision. If the designer determines this special provision will be applicable in more than one project, the special provision should be submitted to BDE for consideration as a District Special Provision or BDE Special Provision.
3. Format. Prepare special provisions in the same manner as the *Standard Specifications*. Section 66-1.04(b) presents the format that should be used.
4. Writing the Special Provision. Once all research has been completed, the first draft can then be prepared. The designer may want to review existing special provisions for guidance. The following are several grammatical recommendations for preparing special provisions:
 - a. Wording. Write in the passive voice.
 - b. Sentences. Prepare the special provision using simple language and words. Keep words and sentences short (20 words or less), unless complexity is unavoidable.
 - c. Paragraphs. Limit paragraphs to three or four sentences.
 - d. Terminology. Words should be used consistent with their exact meaning. Use the same word throughout; do not use synonyms. Avoid any words that have a dual meaning. Section 66-1.04(d) presents the recommended terminology that should be used. Omit extraneous words and phrases.
 - e. Pronouns. Avoid the use of pronouns, even if this results in frequent repetition of nouns.
 - f. Punctuation. Carefully consider the punctuation using the minimum number of punctuation marks consistent with the precise meaning of the language. Ensure that the meaning of any sentence is not in doubt.
 - g. Parentheses. Avoid the use of parentheses (). Instead, use commas or rewrite the sentence.
 - h. Numbers. Write all numbers numerically. It is unnecessary to write numbers both in words and figures. Show times and dates numerically. Write fractions as decimals. Decimals less than one should be preceded by the zero.
5. Reviewing. Review the previously completed paragraphs as succeeding ones develop. Where necessary, redraft preceding paragraphs to reflect later thoughts.
6. Submissions. The designer should prepare and distribute the preliminary draft of the special provisions within the district for review and comment as soon as practical. The designer will be responsible for incorporating the reviewers' comments into the final draft.

66-1.04(b) Format

Prepare special provisions in the same format as the *Standard Specifications*. The sections of the special provision that should be addressed, when needed, include:

1. **Description.** Provide a brief narration of the work to be performed with references to specifications, plans, or other special provisions that further define the work. The description usually begins with "This work shall consist of...". Only mention the major aspects of the work.
2. **Materials.** Designate the materials to be used in the work and establish their requirements. Delineate complete specifications of the properties of each material and the test method. References may be made to AASHTO, ASTM, or other recognized specifications. Where a material is already specified in the *Standard Specifications*, reference the appropriate article or section with any necessary changes stated. Do not reproduce a standard specification in its entirety to revise one or two elements.

The use of proprietary specifications is generally prohibited by the Illinois General Statutes. However, the Statutes do allow, under certain conditions, proprietary items to be used. Where the designer has a need for a proprietary specification, contact the Policy & Project Development Section in the Bureau of Design and Environment for guidance.

3. **Equipment.** Designate the equipment to be used in the work and establish its requirements. Where a piece of equipment is already specified in the *Standard Specifications*, reference the appropriate article or section with any necessary changes stated. Do not reproduce a standard specification in its entirety to revise one or two requirements.
4. **Construction Requirements.** Describe the sequence of construction operations or the desired end product. Only use the presentation for the sequence of construction operations if it is critical to achieve the desired result.
5. **Method of Measurement.** Describe the units of measurement for each pay item and where the item will be measured (e.g., in place, in truck, at plant). Designate any modifying factors and other requirements needed to establish a definite measured unit.
6. **Basis of Payment.** Describe the units and the pay item name for which payment will be made. Note the entire pay item name in upper-case letters. Do not include a listing of all elements of the work.

66-1.04(c) Guidelines

In addition to the above sections, the following presents several guidelines the designer should consider when developing special provisions:

1. Completeness. The designer should ensure that the essentials have been included, each requirement is definitive and complete, and the *Standard Specifications* have not been duplicated. The special provision should not be vague.
2. Clarity. To ensure clarity, the designer should:
 - Clearly delineate the method of measurement and basis of payment.
 - Make a clear, concise analysis of the job requirements for general conditions, types of construction, and quality of workmanship. Do not leave the contractor in doubt on what they will be required to do.
 - Give directions, never suggestions.
 - Never assume the contractor knows what is meant.
 - Avoid conflicting or ambiguous requirements. Every specification should have only one meaning.
 - Never conceal difficulties or hazards from the contractor.
3. Conciseness. Each special provision should be as concise as practical. When reviewing the special provision, the designer should consider the following suggestions:
 - Where practical, refer to an existing specification and delineate only the portion changed.
 - Avoid duplications between different special provisions and any related contract documents.
 - Do not give reasons for a specification requirement.
 - Do not provide additional information that is unnecessary for the preparation of bids and the accomplishment of the work.
 - Once stated, do not repeat any instruction, requirement, direction, or information.
 - Use cross references, wherever practical.
 - Write the specification in the positive form (e.g., use “will” instead of “will not”).
 - Do not include instructions to the Department in the specification.
4. Correctness. To ensure that the special provision is written correctly, the designer should review the following:
 - Do not include items that cannot be required or enforced.
 - Ensure that the specification does not punish the contractor or supplier.

- Ensure that the specification does not unintentionally exclude an acceptable product, construction method, or any equipment.
- Ensure that the provision does not change the basic design of the item.
- Do not specify impossibilities. The practical limits of workers and materials must be known and recognized.
- Specify standard sizes and patterns wherever practical.
- Avoid personal whims and pet requirements.
- Ensure that the contractor will not be held responsible for the possible inaccuracy of information furnished by the Department.
- Ensure sufficient attention has been provided to assessing the durability or reliability of the material or procedure discussed. The use of recognized standards should be referenced to ensure that the specified performance or characteristics are achieved. If not, define the testing criteria completely and accurately.
- Make a careful, critical examination of manufacturers' or trade associations' recommendations, and require supporting evidence.
- Requirements should be stringent. A strong requirement can be relaxed more economically, when the need arises. Weak specifications cannot be strengthened without increasing cost and generating claims.
- Ensure that the provision gives directions that are consistent with the standard practice currently used by the Department.

66-1.04(d) Terminology

Phraseology and terminology used in the *Standard Specifications* also should be used in the special provisions. In addition, the designer should consider the following:

1. Abbreviations. Generally, avoid abbreviations. However, they may be used if they are defined and the definitions are consistent with the accepted meanings. Always use the abbreviations for the terms listed in Article 101.01 of the *Standard Specifications*.
2. Amount, quantity. Use "amount" when writing about money only. When writing about measures of volume, use "quantity."
3. Any, all. The word "any" implies a choice and may cause confusion. In place of "any," the term "all" should be used.
4. Article. Capitalize "Article" when referring to an article of the *Standard Specifications*.

5. As per. Do not use “as per”; instead, use “according to.”
6. As shown on the plans. Use “as shown on the plans” instead of “as shown in the plans,” “as detailed on the plans,” “as shown on the detail sheets,” “as shown on the highway standards,” or “as shown on sheet _____ of the plans.”
7. Contractor. Use the word “Contractor” in place of the word “bidder” when writing special provisions for construction. “Bidder” should only be used for proposals. Contractor should always be capitalized.
8. Course. Use “course” for layers, not for “lifts.”
9. Day. Define the type of day to be used (e.g., calendar day, work day).
10. Department. Use “Department” in place of “Illinois Department of Transportation.” Department should always be capitalized. IDOT should not be used in the contract documents.
11. Included In. Use “included in the cost” instead of “incidental to.” The price of all work will be factored somewhere into the contract. Bid prices are generally lower when the contractor knows where to include costs.
12. Pay item. Use “pay item” instead of “bid item.”
13. Proposal. Do not use the word “proposal” when the word “contract” is intended. The term “proposal” only should be used to describe requirements during the bidding process.
14. Said. Do not use “said pipe,” “said aggregates” but, instead, use “the pipe,” “the specified aggregates.”
15. Same. Do not use “same” to replace a pronoun like “it” or “them” standing alone, such as “connected to same,” “specified for same,” or “same will be given consideration.” Rewrite the sentence to clearly describe what is meant.
16. Section. Capitalize “Section” when referring to a section in the *Standard Specifications*.
17. Shall, will. Use the word “shall” when specifying the responsibilities of the contractor. Use the word “will” when specifying the responsibilities of the Department (“we will,” “they shall”).
18. State. The term “State” is preferred over the “State of Illinois” or “Illinois.”
19. Such. Do not end a sentence with the word “such.” “Such” usually means “of this or that kind,” or similar to something stated. Instead, state that which is actually meant, or name the work to be completed or rephrase the sentence.
20. The. Do not eliminate “the” for brevity.

21. Unless Otherwise Specified. Do not use the term “unless otherwise specified.” In special provisions, the designer should know if something will be “otherwise specified.” In the *Standard Specifications* everything can be “otherwise specified” in the plans or through Contract Special Provisions.
22. Unit Price. Use “contract unit price” instead of “contract unit price bid.”

66-1.04(e) Unit Abbreviations

Figure 66-1.A provides a list of unit abbreviations adopted for the Standard and Supplemental Specifications and the Recurring and BDE Special Provisions.

66-1.04(f) Rules

The following is a list of rules adopted for the Standard and Supplemental Specifications and the Recurring and BDE Special Provisions:

1. Do not use hyphens to combine units (e.g., foot pounds would be ft lb not ft-lb). Do not use hyphens between the number and the unit (i.e., use 10 ft versus 10-ft).
2. Use the “/” symbol instead of the word “per” to combine units (e.g., inch per foot would be in./ft).
3. Always write out and do not abbreviate units used within Method of Measurement and Basis of Payment Articles.
4. Write out the words “percent” and “degrees” (i.e., angles) within text, but they may be abbreviated within charts and tables.
5. Write out the words “hour(s)” and “minute(s)” within the text, but they may be abbreviated within charts and tables (except: they will be abbreviated when used in combination with other unit abbreviations (e.g., m/min or ft/min))
6. Numbers within charts and tables are always written as numbers. Numbers associated with an abbreviated unit will also be written as numbers (e.g., 2 m, 8 mph, 32 kPa).

Unit Metric (US Customary)	Abbreviations
<u>Length</u>	
nanometer (thousands of an inch)	nm (mils)
micrometer (thousands of an inch)	μm (mils) or μm (in.)
millimeter (inch)	mm (in.)
meter (foot)	m (ft)
kilometer (mile)	km (mile)
<u>Area</u>	
square meter (square foot)	sq m (sq ft)
square meter (square yard)	sq m (sq yd)
hectare (acre)	ha (acre)
<u>Volume</u>	
liter (gallon)	L (gal)
cubic meter (cubic yard)	cu m (cu yd)
<u>Weight</u>	
gram (ounce)	g (oz)
kilogram (pound)	kg (lb)
metric ton (ton)	metric ton (ton)
<u>Force</u>	
Newton (pound)	N (lb)
kiloNewton (pound)	kN (lb)
<u>Pressure, Stress</u>	
kilopascal (pounds per square inch)	kPa (psi)
<u>Energy, Work</u>	
Joule (foot pound)	J (ft lb)
<u>Torque</u>	
Newton meter (foot pound)	N m (ft lb)
kiloNewton meter (foot pound)	kN m (ft lb)
<u>Speed</u>	
meter per minute (feet per minute)	m/min (ft/min)
kilometer per hour (miles per hour)	km/hr (mph)

UNIT ABBREVIATIONS

Figure 66-1.A
(1 of 2)

Unit Metric (US Customary)	Abbreviations
<u>Temperature</u>	
degrees Celsius (Fahrenheit)	°C (°F)
<u>Electrical</u>	
millivolt	mV
volt	V
kilovolt	kV
kilovoltampere	kVA
millampere	mA
ampere	A
hertz	Hz
watt	W
kilowatt	kW
ohm	ohm

UNIT ABBREVIATIONS

Figure 66-1.A
(2 of 2)

7. For numbers not associated with an abbreviated unit, use the following:
- numbers from zero to ten will be spelled out (e.g., ten hours, two-way radio, seven tires);
 - numbers greater than ten will always be written as numbers (e.g., 12 hours, 50 cycles, 11 percent); and
 - numbers less than one will be written as decimal numbers except inches will be written as fractions (e.g., 0.2 acre, 3/4 in.).

66-1.05 IDOT Highway Standards

The *IDOT Highway Standards* provide details on various design elements that are consistent from project to project. They provide information on how to lay out or construct the various design elements. Design data and/or specifications are not included on the *IDOT Highway Standards*. The designer is responsible for providing the standard number, including revision number, in the Standard Index included in the plans; see Chapter 63.

IDOT Highway Standards are developed by the Bureau of Design and Environment and are approved for general use by the Engineer of Design and Environment. *IDOT Highway*

Standards are developed in collaboration with other bureaus. Districts may submit ideas and details for the *IDOT Highway Standards* to BDE.

Copies of the *IDOT Highway Standards* are available on the Department's website.

66-2 SUBMISSION OF PLANS, SPECIFICATIONS & ESTIMATES

66-2.01 District Pre-Letting List

To consider all improvements that are available for letting, the district will submit to the Engineer of Design and Environment a list of recommended improvements for each scheduled letting. This list will be submitted at least 12 weeks in advance of the scheduled letting date. Identify the improvements by route, section, and county. It is desirable that improvements that are included in the published program be available for letting as early in the calendar year as practical, especially those that will require less than 100 working days and include bituminous work. Letting improvements early also gives the prospective bidders better opportunities to schedule their work and may result in more competitive bidding.

66-2.02 PS&E Submittal

The district must electronically submit the plans, specifications and estimates (PS&E) to the Program Support Unit within the Bureau of Design and Environment by the applicable PS&E deadline for the letting (typically 10-12 weeks before the letting date). Each district has its own folder on the Cosep1\Letting directory with sub-folders for each letting date. Within each letting date sub-folder, there will be a folder for each project on that letting named with the contract number where electronic copies of the following PS&E documents must be submitted:

1. Certification Acceptance/Project Status (Form BDE 488). Complete and include this form to ensure that all applicable Federal/State requirements have been addressed (e.g., right-of-way, utilities, railroads). This form must be signed by both the designer and the Regional Engineer. See Figure 66-2.A for instructions on completing the form.
2. Plans. Include 11"x17" PDF files of the plans after they are signed by the Regional Engineer (note: paper copies of the signed sheet(s) are no longer required as the signature may be hand-written, stamped, scanned or computer-generated). There must be one PDF file for each individual plan sheet as well as one multiple-page PDF file containing all sheets, up to 100 sheets. If there are more than 100 sheets, then additional multiple-page PDF files will be required. Do not include copies of the *IDOT Highway Standards* with the plan submittal as they will be incorporated into the plans by the Bureau of Design and Environment. Print styles, .pltcfgs and pen tables are available in the IDOT CADD Standards folder on every district CADD server to assist the districts in creating PDFs directly in MicroStation that meet these requirements.
3. Contract Special Provisions. Include a Microsoft Word file of the contract special provisions written for the project. Section 66-1.04 discusses the procedures for developing special provisions. Also include a copy of the Recurring Special Provisions check sheet and the BDE Special Provisions check with the applicable special provisions marked.
4. Quantities Estimate. Include the project quantities on Form BDE-213 or Bureau of Design and Environment approved equal. The unit prices are provided to the Central

Office by the district estimating engineer under a separate submittal. Copies of form may be obtained from the Department's website. Chapter 64 provides the procedures for determining plan quantities.

5. Estimate of Time. Determine the expected construction time for the project. Section 66-2.03 provides the Department's guidelines for determining the expected construction time.
6. Permits and Agreements. Include electronic copies of permits, agreements, and other such documents required for the project.

Once all required PS&E documents have been placed in the project folder, send a notification email to: DOT.CO.D&E-Plan&SpecSubmittal.

The above process only applies to the original PS&E submittal. If any revisions or addenda need to be submitted at a later time, those documents and notification of the change(s) must be coordinated directly with the appropriate Regional Field Engineer in BDE except for revisions to structure plans which must be submitted through the Bridge Office. All new and/or revised plan sheet PDFs must follow the same naming conventions as the original submittal.

Top Portion

 Illinois Department of Transportation		Certification Acceptance/ Project Status	
District	Contract No.	Submittal Date	
Functional Classification		Recommended Letting Date	
Route	Marked Rte.	Annual Program No.	
Project		Program Cost	
Section		Population of Urban(ized) Area	
County		State Job No. C-	
Length, Type & Location of Work:			

District - Which district the project is taking place in. If central office is submitting plans for work to be done in a different district, please indicate in which district the project is located

Contract No. - Construction contract number

Functional Classification - Classification by which highways and streets are grouped into classes or systems based on the character of service they are intended to provide (See Chapter 43: Highway Systems for more information). Identifiers to use:

- Interstate
- Freeway or Expressway
- Other Principle Arterial
- Minor Arterial
- Major/Minor Collector

Route -

- FAI: Interstate
- FAP: Primary
- FAS: Secondary
- FAU: Urban

Marked Route - State Bond Issued (SBI) Marked Route. The interstate, state or US route marking or street/road/avenue that is noted for the public on state maps

Project - If Federally funded: fund type prefix + 7 digit federal project number generated from the State Job Number database (SJN).
Examples: NHPP-0JBU(103) or STP-000V(123) or HSIP-BQUJ(586)
Else if State funded: "State" or "Illinois" funded

**BDE 488 Certificate Acceptances/Project Status Instructions
Figure 66-2.A
(1 of 8)**

Section - Section number assigned to the project

County - The County or Counties project is taking place in, if it's greater than 3 counties list "Various" (for Electronic Letting Management (ELM) mainframe allows only 3 counties to be entered)

State Job No. - State Job Number assigned and developed through the State Job Number database (SJN) which should always be the "C" number

- P = Phase 1 – Studies & Environmental work
- D = Phase 2 – Design & Plans
- C = Phase 3 – Construction

Submittal Date - Date submitted to Springfield Central Office

Recommended Letting Date - The letting date project is anticipated to be let on

Annual Program No. – A 9 digit program number generated through Windows Program Planning System (WPPS) database. Identifies how the money is programmed whether it be across multiple fiscal years, single fiscal year, multiple fund types, straight state or federally funded.

Example: 1-76489-0100

If there are multiple program numbers list them all or add to the "Remarks" field at the bottom of the form.

Program Cost - Estimated cost of the project, amount that is programmed in WPPS using the 9 digit program number

Congressional District - List the congressional district/legislative district

Maintenance Responsibility - List who will maintain finished product of the project, typically "State" responsibility (Chicago may have maintenance responsibility for State routes within Chicago)

Population of Urbanized Area - List the population of the area and if it's considered rural or urban use the following:

- Urban = places identified by the US Bureau of Census having a population $\geq 5,000$
 - Urbanized $> 50,000$
 - Small urban areas $> 5,000$ but $< 50,000$
- Rural = places identified by the US Bureau of Census having a population $< 5,000$

More information is provided in Chapter 43: Highway Systems

BDE 488 Certificate Acceptances/Project Status Instructions

Figure 66-2.A

(2 of 8)

Length, Type & Location of Work - • Location must be described in sufficient detail to be identified on a state map.

- Include mileage, municipality, location identified by road to road or street to street
- On bridge jobs state what the structure/culvert is over (route, body of water, RR etc.)
- Include brief description of the type of work
- This information will be used for the service bulletin

Middle of Form

The following will go in numerical order in line with the form.

For reference for the rest of the form, please mark the appropriate statement for each category/descriptor of the project:

- A = Approved, Clear, or Yes;
- R = Required but Not Clear;
- E = Exempt or Not Applicable

If something is not required, then mark (E) or else provide the necessary information requested below. Per each statement one of the three checkboxes should be marked.

1. Plans and Special Provisions - Mark if the statement is true and comply with current policies, and if there are exceptions list them out in the "Remarks" at the bottom of the form

2. Completion Date and Working Days - Use a minimum of 15 working days and use of multiples of 5 days. The completion date should match the completion date as stated in the Special Provisions (SP) and if there are additional working days to the completion date be sure to note them.

3. Design Approval - On projects where design approval is not required, put the date Plans, Specifications, and Estimates (PSE) is signed by the Regional Engineer.

BDE 488 Certificate Acceptances/Project Status Instructions
Figure 66-2.A
(3 of 8)

4. NEPA Category - Check which one applies (i.e., EIS/ROD, EA/FONSI, State CE (using BDE 2301), Federal CE, or State CE (exempt from Phase I report). For the Date of ROD/FONSI/CE box enter the date as described below:
- the date the Regional Engineer or Authorized Designee approved the State CE from BDE 2301 in the Phase I report;
 - For projects that meet the criteria in Section 12-3.10 and are exempt from a Phase I report, the CE determination can be made directly on BDE 488. The date will be the date that the Regional Engineer signs BDE 488. However, for these types of projects to ensure NEPA compliance when Federally funded, the Appendix (Appendix A or B) and the item # must be filled out on this form (see the CE Agreement in Appendix A of the BDE Manual for this information);
 - the date the Federal CE was approved by the FHWA Transportation Engineer (TE);
 - the date of the Finding of No Significant Impact (FONSI) for an EA; or
 - the date of the Record of Decision (ROD) for an EIS.

If a reevaluation was completed, then enter the date of the re-evaluation.

3 classes of environmental signoff:

- EIS/ROD
 - Environmental Impact Statement: know there is a significant impact
 - For More information see Chapter 25 Environmental Impact Statements
- EA/FONSI
 - Environmental Assessment: don't know if there will be a significant impact
 - For more information see Chapter 24 Environmental Assessments
- Categorical Exclusions
 - State Approved CE: No potential for unusual circumstances
 - Federal Approved CE: Potential for unusual circumstances
 - For more information see Chapter 23 Categorical Exclusions

5. ESR/PMA Sequence Number - Project Monitoring Application (PMA) sequence number is required if an Environmental Survey Request (ESR) was submitted to BDE.

6. Natural Resource Review - If an ESR was submitted to BDE for biological and/or wetland resources and a Natural Resource Review was received in response, then mark the 'A' and enter the date of the Natural Resource Review. Please note that the date of the Natural Resource Review must be within two years of the letting date. If it will be more than two years, then district should either ensure there is a valid IDNR review response or request the Natural Resource Unit to update the review.

Note: Submittal of the biological review validation takes a minimum of 3 months to complete, provided no additional coordination or surveys are required.

If an ESR was submitted to BDE for biological and/or wetland resources and a Natural Resource Review was not received, then mark "R". The Natural Resource Review must be received, and all coordination complete prior to letting.

If an ESR was not required to be submitted to BDE for biological, then mark "E."

7. Regulated Substances Evaluation - Choose from one of the following scenarios when an ESR was submitted to BDE for regulated substances evaluation and make the appropriate notation on line 7 of the CA sheet:

- a. If a Level I, II, or III screening was successfully completed, list "BDE 2737" on the line, enter BDE's approval date from the BDE 2737 Regulated Substances Screening form, and mark "A" for approved.
- b. If a Level I, II or III screening was unsuccessful, a Preliminary Environmental Site Assessment (PESA) is required. If results of the PESA identified no recognized environmental conditions (RECs), or if RECs were identified in the PESA but they can be avoided, list "No RECs/Avoided" on the line, enter the date of the PESA report, and mark "A" for approved. Please note that the date of the PESA must be within three years of the PS&E date associated with the project's letting. If it will be more than three years old at the time of the PS&E date, then request the Geologic & Waste Assessment Unit to validate the PESA.
- c. If the Level I, II or III screening was unsuccessful and a PESA was not completed, mark "R" on line 7 for required but not cleared.
- d. If the PESA identified RECs and they could not be avoided, a special provision is required. In this case, list "Special Provision" on the line, enter the date of the BDE special provision final memorandum and mark "A" for approved. Please note that, if a PSI was completed, the date of the PSI must be within five years of the PS&E date associated with the project's letting date. If it will be more than five years old at the time of the PS&E date, then request the Geologic & Waste Assessment Unit to complete a new PSI.
- e. If a PESA was completed, and a special provision was required but was not received, mark "R" for required but not cleared.

If an ESR was not required to be submitted to BDE for regulated substances, then mark "E" for exempt or not applicable.

8. Cultural Resource Review

If an ESR was submitted to BDE for cultural resources, then mark 'A' and enter the date of the Cultural Resource Review

BDE 488 Certificate Acceptances/Project Status Instructions

Figure 66-2.A

(5 of 8)

If an ESR was submitted to BDE for cultural resources and a Cultural Resource Review memorandum was not received, then mark "R". The Cultural Resource Review must be received and all coordination complete prior to letting.

If an ESR was not required to be submitted to Central Office for cultural, then mark "E."

9. Cultural Resource Review - If an ESR was submitted to BDE for cultural resources, then mark 'A' and enter the date of the Cultural Resource Review

If an ESR was submitted to BDE for cultural resources and a Cultural Resource Review memorandum was not received, then mark "R". The Cultural Resource Review must be received and all coordination complete prior to letting.

If an ESR was not required to be submitted to Central Office for cultural, then mark "E."

10. Incidental Take Authorization from IDNR - If the Illinois Department of Natural Resources requested IDOT to obtain an Incidental Take Authorization, it would be noted in the Natural Resource Review memo. If IDNR did not request an Incidental Take Authorization mark "E." If IDNR did request an Incidental Take Authorization and the signed copy has been received, then mark "A." IF IDNR requested an Incidental Take Authorization and the signed copy has not been received then mark "R."

11. TIP (Urbanized Areas)

- Supply the TIP number
- Areas that apply: Beloit, Chicago, Bloomington/Normal, Champaign/Urbana, Decatur, DuBuque, Kankakee, Peoria, Rock Island/Moline, Rockford, St. Louis, and Springfield
- Project must be approved with the funding source and dollar amount before it can go to letting
- If there is a change in the scope of work that would increase the dollar amount substantially the TIP must be amended to reflect this fluctuation in cost

12. Right-of-Way (ROW) Status - Right-of-Way (ROW) is the property that the state owns or needs to acquire to construct a project.

- Check "Exempt" if NO ROW is required.
- Check "Approved" if additional ROW or temporary easements have already been acquired.
- Check "Required" if ROW or temporary easements are necessary but have not been acquired. If ROW is not clear, show the total number of parcels, total number parcels cleared, and total number of parcels NOT cleared.

13. Relocation Status - If required but not approved indicate the type of relocation: Business, residential, farm etc. and status.

**BDE 488 Certificate Acceptances/Project Status Instructions
Figure 66-2.A**

(6 of 8)

14. Joint Agreement (Local Agency) -

- Joint Agreement
 - Indicate who the agreement is with on the line provided
 - Approved means signed by the Local Agency and the Regional Engineer or Central Office
 - Send a copy of Agreement along with plan submittal
 - If not approved, send a copy of the current draft copy
- Letter of Understanding
 - Indicate who the letter is with on the line provided
 - Approved means signed by the Local Agency
- Letter of Intent/Information
 - Indicate who the letter is with on the line provided
 - Approved means sent to the Locals

15. Railroad Agreement (Railroad) -

- Indicate name of Railroad company on the line provided
- Approved means signed by the Railroad and the Central Office
- Must have a plan approval signed by the Railroad

16. Utility Adjustment - Indicate name of Utility on the line provided.

- Add a special provision for status of utilities to be adjusted showing the name and address of utility, location and when the adjustment is to be done
 - Utility Agreements (Company)
- For reimbursable work ONLY
- Indicate name of Utility on the line provided

17. Permits -

- If there are more than one permit required show number on the line provided
- Submit a copy of each permit listed below that is applicable to the project with the plan submittal to Springfield Central Office

Fill in the date the permit was received for each permit that is applicable to the project:

U.S. Corps. Of Engineers 404, and select the appropriate type of permit and date

U.S. Coast Guard permit and date

IDNR Office of Water Resources (OWR) and date

FAA and date

For more information on these permits see Chapter 28: Environmental Permits/Certifications

BDE 488 Certificate Acceptances/Project Status Instructions

Figure 66-2.A

(7 of 8)

- 18. Existing Structure. - Provide existing structure number on the line provided
- 19. Experimental Features Work Plan -
 - Required on all federally funded projects which has any type of Experimental procedures
 - If a work plan is required the district must submit it to Bureau of Materials and they will submit it to FHWA for approval
 - Must be approved before project will go on the letting
- 20. Construction Engineering -
 - Indicate either: state; local agency; consultant
 - IF done by local agency or consultants supply the name on line provided.
- 21. Pavement Design Approval - Pavement Design Approval is required if certain quantities of new pavement are needed, refer to Chapter 11: Phase I Studies for more information.
- 22. Value Engineering Report - Projects estimated at a certain dollar threshold will require a value engineering report, refer to Chapter 11: Phase 1 Studies for more information.
- 23. Work Zone Transportation Management Plan Approval - Plan approval is required if certain safety and mobility thresholds are exceeded, refer to BDE Chapter 13: Work Zone Traffic Management Studies for more information.

Bottom of Form

Remarks: _____

Code: **A** = Approved, Clear, or Yes; **R** = Required but Not Clear; **E** = Exempt or Not Applicable
The above information is certified to be true and correct.

Prepared By: _____
Name Telephone No. Regional Engineer Date

- Remarks: any additional comments or provide extra information as noted above.
- Prepared by: District contact that Central office can contact if there are questions in regard to the information provided on this form.
- Regional Engineer: signature of Regional Engineer or authorized designee.

BDE 488 Certificate Acceptances/Project Status Instructions

Figure 66-2.A
(8 of 8)

66-2.03 Construction Time Estimates

The contract duration is a very important part of the design data that accompanies plan submittals. It is essential that care be exercised in the determination of the working days or completion date. It must be remembered that a severe time requirement imposed upon a contractor will very probably be reflected in the bid prices, and the Department will pay a premium for that particular job when it may not be absolutely necessary. Also, with a provision for liquidated damages, it is extremely important that the designer arrive at a reasonable time limit to alleviate differences between the contractor and the Department.

To determine a feasible time limit, the designer must devote special attention to the sequence of construction operations to determine the order in which the work will progress. Also, sound engineering judgment is necessary to determine which construction operations will overlap to ascertain the days not affecting the total working days. The magnitude of the job is significant; i.e., the contractor for a small resurfacing job will use a much smaller work force than a contractor engaged in a large freeway project. Therefore, it is not probable that the contractor for the small job will be engaged in numerous operations at one time. Another consideration for the designer is the delivery of materials to the job site; e.g., in the case of a grade separation structure, it may be necessary to allow slack time between the completion of the substructure and initiating work on the superstructure due to the time required for fabrication and delivery of the structural steel. Although such determinations cannot always be made with absolute certainty, an estimate must be made to determine a reasonable time limit. If the contract will be placed on a completion date basis, the designer must devote special attention to construction operations that are limited by the *Standard Specifications*.

To determine the contract duration, the number of working days must be estimated. The "Estimate of Time Required," Form BDE 220A, is used to determine working days and should accompany the plan submittal. Copies of the form may be obtained from the Department's website. The number of days required for each item is obtained by dividing each quantity by its respective production rate. Figure 66-2.B provides the production rates for major items. The production rates shown in Figure 66-2.B apply to an average eight-hour work day. Construction production rates in Figure 66-2.B should be reviewed periodically and revisions made for any advancement in equipment output or construction techniques. Use the low rates on small projects and the higher rates on larger projects. For expedited contracts, it will be necessary to adjust the rates for longer working days. For items not contained in Figure 66-2.B, the district may supplement rates from their own design or construction files. The production rates of a single improvement are not conclusive in establishing these rates. Extremely high rates are often reached on a particular project or on any given day in the normal highway improvement but using these rates for the entire project would materially affect the accuracy of the time estimate.

The designer determines the "total days required" and "days not affecting time limit" on Form BDE 220A. These can be ascertained more readily by using a bar diagram, particularly when it is anticipated that many operations will be performed simultaneously or intermittently therefore making them difficult to schedule. In assigning work days, the minimum number used is 15 days and the total number of days assigned is in multiples of five. The number of working days

required must also be calculated for contracts that will be completion date contracts. This will ensure that the completion date is realistic and allow the estimator to make allowances in the unit costs for anticipated overtime and extra crews the contractor may need to meet the completion date. Completion date contracts must be approved by BDE.

Where the major contract items require a tight completion date and it is not necessary for the minor items (e.g., seeding, clean-up) to be included in that date, the designer may use a completion date plus working days. The number of working days allowed after the completion date should be kept to a minimum and only allow minor work to be completed. The designer must clearly state in the Project Specific Special Provisions which items must be completed by the completion date and which items are involved in the working days. Completion date contracts with working days must be approved by BDE.

Major Worktype	Sub Worktype	Description	Unit	Low	High
Bridge	Bridge	Bearing Assembly	each	5	10
Bridge	Bridge	Bridge Deck Concrete Overlay	square yard	200	500
Bridge	Bridge	Bridge Deck Grooving	square yard	500	800
Bridge	Bridge	Bridge Deck Scarification (Cold Milling)	square yard	350	1000
Bridge	Bridge	Bridge Deck Scarification (Hydroblasting)	square yard	175	500
Bridge	Bridge	Concrete Structures	cubic yard	10	25
Bridge	Bridge	Concrete Superstructure	cubic yard	10	30
Bridge	Bridge	Clean & Paint Steel Bridge - SP 10	square foot	1000	2100
Bridge	Bridge	Clean & Paint Steel Bridge - SP 6	square foot	800	1600
Bridge	Bridge	Clean & Paint Steel Bridge - SP 3	square foot	250	550
Bridge	Bridge	Cofferdam (Doesn't apply for major river bridges)	each	0.20	0.50
Bridge	Bridge	Concrete Removal	cubic yard	5	20
Bridge	Bridge	Deck Slab Repair (Full Depth)	square yard	10	25
Bridge	Bridge	Deck Slab Repair (Partial Depth)	square yard	25	50
Bridge	Bridge	Driving Piles	foot	250	500
Bridge	Bridge	Cofferdam Excavation	cubic yard	75	150
Bridge	Bridge	Formed Concrete Repair	square foot	50	100
Bridge	Bridge	Jacking & Cribbing (per beam)	each	5	10
Bridge	Bridge	Precast Concrete Beam Erection	foot	150	325
Bridge	Bridge	Precast Concrete Beams (Fabricate & Furnish)	calendar day	30	120
Bridge	Bridge	Precast Concrete Bridge Deck	square foot	500	800
Bridge	Bridge	Precast Deck Beams	square foot	1000	3000
Bridge	Bridge	Protective Shield	square yard	160	250
Bridge	Bridge	Reinforcement Bars (Substructure)	pounds	4000	6000
Bridge	Bridge	Reinforcement Bars (Superstructure)	pounds	10 000	15 000
Bridge	Bridge	Removal of Existing Concrete Deck	square yard	150	300
Bridge	Bridge	Removal of Existing Substructure	cubic yard	20	40
Bridge	Bridge	Removal of Existing Superstructure	square yard	100	250
Bridge	Bridge	Slope Wall	square yard	25	75
Bridge	Bridge	Structural Steel Erection	foot	150	250
Bridge	Bridge	Structural Steel (Fabricate & Furnish)	calendar day	60	270
Bridge	Bridge	Stud Shear Connectors	each	1000	2500
Bridge	Bridge	Temporary Sheet Piling	square foot	300	1000
Bridge	Bridge	Test Pile	Each	0.5	1
Bridge	Bridge	Waterproofing Membrane System	square yard	100	250
Electrical	Electrical	Conduit in Trench	foot	75	325
Electrical	Electrical	Conduit (Pushed)	foot	30	75
Electrical	Electrical	Controller	each	0.5	1
Electrical	Electrical	Detector Loop	foot	150	300
Electrical	Electrical	Electric Cable	foot	1500	3000
Electrical	Electrical	Electrical Conductors in Conduit	foot	750	1300
Electrical	Electrical	Foundations — Controller, Signal	foot	2	5
Electrical	Electrical	Foundations — Light Poles	foot	10	20
Electrical	Electrical	Foundations — Light Towers	foot	20	25
Electrical	Electrical	Handholes	each	2	4
Electrical	Electrical	Junction Box	each	2	5
Electrical	Electrical	Light Pole	each	4	6
Electrical	Electrical	Light Tower	each	1	2
Electrical	Electrical	Luminaire	each	5	10
Electrical	Electrical	Mast Arm Assembly & Pole	each	2	4
Electrical	Electrical	Raceway for Magnetic Detectors	foot	100	200
Electrical	Electrical	Relocate Existing Traffic Signal Posts	each	2	4
Electrical	Electrical	Service Installation	each	0.5	1

CONSTRUCTION DAILY PRODUCTION RATES — US CUSTOMARY

Figure 66-2.B
(1 of 6)

Major Worktype	Sub Worktype	Description	Unit	Low	High
Electrical	Electrical	Signal Head	each	5	10
Electrical	Electrical	Signal Post (wood or metal)	each	4	8
Electrical	Electrical	Trench & Backfill	foot	75	350
Electrical	Electrical	Unit Duct	foot	550	700
Electrical	Electrical	Unit Duct/without Cable	foot	150	350
Landscape	Landscape	Evergreens	each	20	40
Landscape	Landscape	Excelsior Blanket	square yard	1000	4000
Landscape	Landscape	Intermediate Trees	each	20	40
Landscape	Landscape	Seeding	acre	5	10
Landscape	Landscape	Seedling Trees	each	2000	3000
Landscape	Landscape	Shade Trees	each	20	40
Landscape	Landscape	Shrubs	each	200	400
Landscape	Landscape	Sodding	square yard	1000	1500
Landscape	Landscape	Straw Mulch	ton	10	20
Landscape	Landscape	Vines	each	1000	2000
Landscape	Landscape	Weed Control Spraying	acre	50	100
Roadway	Aggregate	Granular Backfill	cubic yard	300	600
Roadway	Aggregate	Granular Embankment Special	ton	800	1500
Roadway	Aggregate	Gravel or Crushed Stone Base Course	ton	700	1200
Roadway	Aggregate	Gravel or Crushed Stone Shoulders	ton	500	1200
Roadway	Aggregate	Gravel or Crushed Stone Surface Course	ton	700	1200
Roadway	Aggregate	Porous Granular Embankment	cubic yard	400	1000
Roadway	Aggregate	Subbase Granular Materials	ton	700	2000
Roadway	Drainage	Adjust Frames & Grates	each	5	10
Roadway	Drainage	Catch Basins	each	2	5
Roadway	Drainage	Concrete Box Culverts	cubic yard	8	15
Roadway	Drainage	Concrete Headwalls	cubic yard	3	8
Roadway	Drainage	Concrete Gutter	foot	400	1400
Roadway	Drainage	Curb & Gutter	foot	300	1200
Roadway	Drainage	End Sections (Pipe Culvert & Storm Sewer)	each	5	10
Roadway	Drainage	Inlets	each	2	5
Roadway	Drainage	Manholes	each	2	4
Roadway	Drainage	Paved Ditch	foot	200	400
Roadway	Drainage	Pipe Culverts (Depending on size and depth)	foot	100	300
Roadway	Drainage	Pipe Underdrains	foot	1500	7500
Roadway	Drainage	Precast Box Culverts	foot	75	250
Roadway	Drainage	Reinforcement Bars (Culverts)	pound	3000	5000
Roadway	Drainage	Riprap	square yard	100	200
Roadway	Drainage	Storm Sewers (Dependent on size and depth)	foot	75	300
Roadway	Drainage	Trench Backfill	cubic yard	100	200
Roadway	Drainage	Exploration Trench	foot	250	1000
Roadway	Excavation	Embankment	cubic yard	500	10 000
Roadway	Excavation	Borrow Excavation	cubic yard	1000	10 000
Roadway	Excavation	Channel Excavation	cubic yard	200	500
Roadway	Excavation	Earth Excavation (Shoulders & Widening)	cubic yard	500	1000
Roadway	Excavation	Earth Excavation	cubic yard	750	10 000
Roadway	Excavation	Rock Excavation (Ripping or Blasting)	cubic yard	500	2000
Roadway	Excavation	Excavation (Special)	cubic yard	500	1000
Roadway	Excavation	Excavation (Topsoil)	cubic yard	500	1000
Roadway	Excavation	Grading and Shaping Roadway	unit	10	50
Roadway	Excavation	Process Lime Modified Soil	square yard	2000	6500
Roadway	Excavation	Process Lime Stabilized Soil	square yard	2000	6500
Roadway	Excavation	Topsoil Placement	square yard	5000	25 000

CONSTRUCTION DAILY PRODUCTION RATES — US CUSTOMARY

Figure 66-2.B
(2 of 6)

Major Worktype	Sub Worktype	Description	Unit	Low	High
Roadway	Miscellaneous	Chain Link Fence	foot	300	500
Roadway	Miscellaneous	Concrete Barrier	foot	200	400
Roadway	Miscellaneous	Delineators	each	75	150
Roadway	Miscellaneous	Furnishing and Erecting Row Markers	each	10	30
Roadway	Miscellaneous	Noise Abatement Wall	square foot	800	1000
Roadway	Miscellaneous	Steel Plate Beam Guardrail	foot	300	600
Roadway	Miscellaneous	Steel Plate Beam Guardrail Removal	foot	500	800
Roadway	Miscellaneous	Temporary Concrete Barrier Wall	foot	500	1500
Roadway	Miscellaneous	Woven Wire Fence	foot	500	1000
Roadway	Patching	Class A	square yard	50	100
Roadway	Patching	Class B	square yard	50	100
Roadway	Patching	Class C & D	square yard	100	150
Roadway	Patching	Partial Depth Patches	square yard	200	400
Roadway	Paving	Bituminous Concrete Base Course Widening	square yard	500	2000
Roadway	Paving	Bituminous Concrete Binder & Surface Course SuperPave	ton	500	1600
Roadway	Paving	Bituminous Materials	gallon	3000	10 000
Roadway	Paving	Bituminous Pavement Removal & Replacement	square yard	50	100
Roadway	Paving	Bituminous Shoulders	square yard	1500	4500
Roadway	Paving	Bridge Approach Pavement	square yard	50	100
Roadway	Paving	Continuously Reinforced Concrete Pavement	square yard	2000	7000
Roadway	Paving	Bituminous Concrete Pavement (Full depth)	square yard	1000	3500
Roadway	Paving	Bituminous Concrete Surface Removal (1.5 in)	square yard	10 000	60 000
Roadway	Paving	Cracking and Sealing Pavement	square yard	5000	15 000
Roadway	Paving	Level Binder	ton	50	1600
Roadway	Paving	Median Surface (Concrete)	square foot	750	2000
Roadway	Paving	Micro-Surfacing/Lane	mile	1	3
Roadway	Paving	Pavement Fabric	square yard	1200	6000
Roadway	Paving	Pavement Reinforcement	square yard	1500	5000
Roadway	Paving	PC Concrete Base Course	square yard	1500	6000
Roadway	Paving	PC Concrete Base Course Widening	square yard	750	2500
Roadway	Paving	PC Concrete Driveways	square yard	100	150
Roadway	Paving	PC Concrete Pavement	square yard	1500	6000
Roadway	Paving	PC Concrete Pavement (Hinge Joint)	square foot	1500	6000
Roadway	Paving	PC Concrete Sidewalks	square foot	1000	1500
Roadway	Paving	PCC Shoulders	square yard	1200	6000
Roadway	Paving	Protective Coat	square yard	3000	7000
Roadway	Paving	Stabilized Subbase 4"	square yard	3000	10 000
Roadway	Paving	Strip Reflective Crack Control	foot	10 000	20 000
Roadway	Pvt Mk	Paint Pavement Marking (Hand)	foot	500	1000
Roadway	Pvt Mk	Paint Pavement Marking (Truck)	foot	10 000	20 000
Roadway	Pvt Mk	Raised Reflective Pavement Markers	each	100	200
Roadway	Pvt Mk	Thermoplastic Pavement Marking Symbol	square foot	450	900
Roadway	Pvt Mk	Thermoplastic Pavement Marking (Hand)	foot	500	1000
Roadway	Pvt Mk	Thermoplastic Pavement Marking (Truck)	foot	60 000	180 000
Roadway	Removal	Bituminous Surface Removal	square yard	2000	10 000
Roadway	Removal	Curb & Gutter Removal	foot	600	1400
Roadway	Removal	Pavement Grinding	square yard	1000	2000
Roadway	Removal	Pavement Removal	square yard	1000	2000
Roadway	Removal	Sidewalk Removal	square foot	1500	2500
Roadway	Removal	Tree Removal	acre	2	4
Roadway	Removal	Tree Removal (6 to 15 Units Diameter)	units	150	400
Roadway	Removal	Tree Removal (Over 15 Units Diameter)	units	100	300
Signing	Signing	Metal Post	foot	250	400
Signing	Signing	Overhead Sign Foundation	cubic yard	5	16
Signing	Signing	Overhead Sign Structure	foot	25	50
Signing	Signing	Sign Panel	square foot	500	2000
Signing	Signing	Structural Steel Sign Support Non-Breakaway	pound	1000	15 000

CONSTRUCTION DAILY PRODUCTION RATES — US CUSTOMARY

Figure 66-2.B
(3 of 6)

Major Worktype	Sub Worktype	Description	Unit	Low	High
Bridge	Bridge	Bearing Assembly	each	5	10
Bridge	Bridge	Bridge Deck Concrete Overlay	square meter	175	425
Bridge	Bridge	Bridge Deck Grooving	square meter	425	675
Bridge	Bridge	Bridge Deck Scarification (Cold Milling)	square meter	300	850
Bridge	Bridge	Bridge Deck Scarification (Hydroblasting)	square meter	150	425
Bridge	Bridge	Concrete Structures	cubic meter	5	20
Bridge	Bridge	Concrete Superstructure	cubic meter	5	25
Bridge	Bridge	Clean & Paint Steel Bridge - SP 10	square meter	100	200
Bridge	Bridge	Clean & Paint Steel Bridge - SP 6	square meter	75	150
Bridge	Bridge	Clean & Paint Steel Bridge - SP 3	square meter	25	50
Bridge	Bridge	Cofferdam (Doesn't apply for major river bridges)	each	0.20	0.50
Bridge	Bridge	Concrete Removal	cubic meter	4	15
Bridge	Bridge	Deck Slab Repair (Full Depth)	square meter	8	20
Bridge	Bridge	Deck Slab Repair (Partial Depth)	square meter	20	40
Bridge	Bridge	Driving Piles	meter	75	150
Bridge	Bridge	Cofferdam Excavation	cubic meter	60	115
Bridge	Bridge	Formed Concrete Repair	square meter	5	10
Bridge	Bridge	Jacking & Cribbing (per beam)	each	5	10
Bridge	Bridge	Precast Concrete Beam Erection	meter	50	100
Bridge	Bridge	Precast Concrete Beams (Fabricate & Furnish)	calendar day	30	120
Bridge	Bridge	Precast Concrete Bridge Deck	square meter	50	75
Bridge	Bridge	Precast Deck Beams	square meter	90	275
Bridge	Bridge	Protective Shield	square meter	125	200
Bridge	Bridge	Reinforcement Bars (Substructure)	kilograms	1800	2700
Bridge	Bridge	Reinforcement Bars (Superstructure)	kilograms	4500	7000
Bridge	Bridge	Removal of Existing Concrete Deck	square meter	125	250
Bridge	Bridge	Removal of Existing Substructure	cubic meter	15	30
Bridge	Bridge	Removal of Existing Superstructure	square meter	80	200
Bridge	Bridge	Slope Wall	square meter	20	65
Bridge	Bridge	Structural Steel Erection	meter	45	75
Bridge	Bridge	Structural Steel (Fabricate & Furnish)	calendar day	60	270
Bridge	Bridge	Stud Shear Connectors	each	1000	2500
Bridge	Bridge	Temporary Sheet Piling	square meter	25	90
Bridge	Bridge	Test Pile	each	0.5	1
Bridge	Bridge	Waterproofing Membrane System	square meter	80	210
Electrical	Electrical	Conduit in Trench	meter	20	100
Electrical	Electrical	Conduit (Pushed)	meter	10	25
Electrical	Electrical	Controller	each	0.5	1
Electrical	Electrical	Detector Loop	meter	45	90
Electrical	Electrical	Electric Cable	meter	450	900
Electrical	Electrical	Electrical Conductors in Conduit	meter	225	450
Electrical	Electrical	Foundations — Controller, Signal	meter	0.5	1.5
Electrical	Electrical	Foundations — Light Poles	meter	3	6
Electrical	Electrical	Foundations — Light Towers	meter	6	8
Electrical	Electrical	Handholes	each	2	4
Electrical	Electrical	Junction Box	each	2	5
Electrical	Electrical	Light Pole	each	4	6
Electrical	Electrical	Light Tower	each	1	2
Electrical	Electrical	Luminaire	each	5	10
Electrical	Electrical	Mast Arm Assembly & Pole	each	2	4
Electrical	Electrical	Raceway for Magnetic Detectors	meter	30	60
Electrical	Electrical	Relocate Existing Traffic Signal Posts	each	2	4
Electrical	Electrical	Service Installation	each	0.5	1

CONSTRUCTION DAILY PRODUCTION RATES — METRIC

Figure 66-2.B
(4 of 6)

Major Worktype	Sub Worktype	Description	Unit	Low	High
Electrical	Electrical	Signal Head	each	5	10
Electrical	Electrical	Signal Post (wood or metal)	each	4	8
Electrical	Electrical	Trench & Backfill	meter	25	105
Electrical	Electrical	Unit Duct	meter	165	210
Electrical	Electrical	Unit Duct/without Cable	meter	45	105
Landscape	Landscape	Evergreens	each	20	40
Landscape	Landscape	Excelsior Blanket	square meter	825	3350
Landscape	Landscape	Intermediate Trees	each	20	40
Landscape	Landscape	Seeding	hectare	2	4
Landscape	Landscape	Seedling Trees	each	2000	3000
Landscape	Landscape	Shade Trees	each	20	40
Landscape	Landscape	Shrubs	each	200	400
Landscape	Landscape	Sodding	square meter	825	1250
Landscape	Landscape	Straw Mulch	ton	9	18
Landscape	Landscape	Vines	each	1000	2000
Landscape	Landscape	Weed Control Spraying	hectare	20	40
Roadway	Aggregate	Granular Backfill	cubic meter	230	460
Roadway	Aggregate	Granular Embankment Special	ton	725	1360
Roadway	Aggregate	Gravel or Crushed Stone Base Course	ton	635	1100
Roadway	Aggregate	Gravel or Crushed Stone Shoulders	ton	450	1100
Roadway	Aggregate	Gravel or Crushed Stone Surface Course	ton	635	1100
Roadway	Aggregate	Porous Granular Embankment	cubic meter	305	765
Roadway	Aggregate	Subbase Granular Materials	ton	635	1800
Roadway	Drainage	Adjust Frames & Grates	each	5	10
Roadway	Drainage	Catch Basins	each	2	5
Roadway	Drainage	Concrete Box Culverts	cubic meter	6	12
Roadway	Drainage	Concrete Headwalls	cubic meter	2	6
Roadway	Drainage	Concrete Gutter	meter	120	425
Roadway	Drainage	Curb & Gutter	meter	90	365
Roadway	Drainage	End Sections (Pipe Culvert & Storm Sewer)	each	5	10
Roadway	Drainage	Inlets	each	2	5
Roadway	Drainage	Manholes	each	2	4
Roadway	Drainage	Paved Ditch	meter	60	120
Roadway	Drainage	Pipe Culverts (Depending on size and depth)	meter	30	90
Roadway	Drainage	Pipe Underdrains	meter	450	2250
Roadway	Drainage	Precast Box Culverts	meter	20	75
Roadway	Drainage	Reinforcement Bars (Culverts)	kilogram	1350	2275
Roadway	Drainage	Riprap	square meter	80	170
Roadway	Drainage	Storm Sewers (Dependent on size and depth)	meter	20	90
Roadway	Drainage	Trench Backfill	cubic meter	75	150
Roadway	Drainage	Exploration Trench	meter	75	300
Roadway	Excavation	Embankment	cubic meter	375	7650
Roadway	Excavation	Borrow Excavation	cubic meter	750	7650
Roadway	Excavation	Channel Excavation	cubic meter	150	375
Roadway	Excavation	Earth Excavation (Shoulders & Widening)	cubic meter	375	750
Roadway	Excavation	Earth Excavation	cubic meter	575	7650
Roadway	Excavation	Rock Excavation (Ripping or Blasting)	cubic meter	375	1500
Roadway	Excavation	Excavation (Special)	cubic meter	375	750
Roadway	Excavation	Excavation (Topsoil)	cubic meter	375	750
Roadway	Excavation	Grading and Shaping Roadway	unit	10	50
Roadway	Excavation	Process Lime Modified Soil	square meter	1675	5400
Roadway	Excavation	Process Lime Stabilized Soil	square meter	1675	5400
Roadway	Excavation	Topsoil Placement	square meter	4000	21 000

CONSTRUCTION DAILY PRODUCTION RATES — METRIC

Figure 66-2.B
(5 of 6)

Major Worktype	Sub Worktype	Description	Unit	Low	High
Roadway	Miscellaneous	Chain Link Fence	meter	90	150
Roadway	Miscellaneous	Concrete Barrier	meter	60	120
Roadway	Miscellaneous	Delineators	each	75	150
Roadway	Miscellaneous	Furnishing and Erecting Row Markers	each	10	30
Roadway	Miscellaneous	Noise Abatement Wall	square meter	75	100
Roadway	Miscellaneous	Steel Plate Beam Guardrail	meter	90	180
Roadway	Miscellaneous	Steel Plate Beam Guardrail Removal	meter	150	250
Roadway	Miscellaneous	Temporary Concrete Barrier Wall	meter	150	450
Roadway	Miscellaneous	Woven Wire Fence	meter	150	300
Roadway	Patching	Class A	square meter	40	80
Roadway	Patching	Class B	square meter	40	80
Roadway	Patching	Class C & D	square meter	80	125
Roadway	Patching	Partial Depth Patches	square meter	165	335
Roadway	Paving	Bituminous Concrete Base Course Widening	square meter	400	1675
Roadway	Paving	Bituminous Concrete Binder & Surface Course SuperPave	ton	450	1450
Roadway	Paving	Bituminous Materials	liter	13 600	37 850
Roadway	Paving	Bituminous Pavement Removal & Replacement	square meter	40	80
Roadway	Paving	Bituminous Shoulders	square meter	1250	3750
Roadway	Paving	Bridge Approach Pavement	square meter	40	80
Roadway	Paving	Continuously Reinforced Concrete Pavement	square meter	1675	5850
Roadway	Paving	Bituminous Concrete Pavement (Full depth)	square meter	825	2925
Roadway	Paving	Bituminous Concrete Surface Removal (40 mm)	square meter	8350	50 175
Roadway	Paving	Cracking and Sealing Pavement	square meter	4175	12 550
Roadway	Paving	Level Binder	ton	45	1450
Roadway	Paving	Median Surface (Concrete)	square meter	70	185
Roadway	Paving	Micro-Surfacing/Lane	kilometer	1.6	3.2
Roadway	Paving	Pavement Fabric	square meter	1000	5000
Roadway	Paving	Pavement Reinforcement	square meter	1250	4200
Roadway	Paving	PC Concrete Base Course	square meter	1250	5000
Roadway	Paving	PC Concrete Base Course Widening	square meter	625	2000
Roadway	Paving	PC Concrete Driveways	square meter	80	125
Roadway	Paving	PC Concrete Pavement	square meter	1250	5000
Roadway	Paving	PC Concrete Pavement (Hinge Joint)	square meter	1250	5000
Roadway	Paving	PC Concrete Sidewalks	square meter	90	140
Roadway	Paving	PCC Shoulders	square meter	1000	5000
Roadway	Paving	Protective Coat	square meter	2500	5850
Roadway	Paving	Stabilized Subbase 100 mm	square meter	2500	8400
Roadway	Paving	Strip Reflective Crack Control	meter	3000	6000
Roadway	Pvt Mk	Paint Pavement Marking (Hand)	meter	150	300
Roadway	Pvt Mk	Paint Pavement Marking (Truck)	meter	3000	6000
Roadway	Pvt Mk	Raised Reflective Pavement Markers	each	100	200
Roadway	Pvt Mk	Thermoplastic Pavement Marking Symbol	square meter	40	80
Roadway	Pvt Mk	Thermoplastic Pavement Marking (Hand)	meter	150	300
Roadway	Pvt Mk	Thermoplastic Pavement Marking (Truck)	meter	18 300	54 850
Roadway	Removal	Bituminous Surface Removal	square meter	1675	8400
Roadway	Removal	Curb & Gutter Removal	meter	180	425
Roadway	Removal	Pavement Grinding	square meter	835	1675
Roadway	Removal	Pavement Removal	square meter	835	1675
Roadway	Removal	Sidewalk Removal	square meter	140	230
Roadway	Removal	Tree Removal	hectare	0.8	1.6
Roadway	Removal	Tree Removal (6 to 15 Units Diameter)	units	150	400
Roadway	Removal	Tree Removal (Over 15 Units Diameter)	units	100	300
Signing	Signing	Metal Post	meter	75	120
Signing	Signing	Overhead Sign Foundation	cubic meter	4	12
Signing	Signing	Overhead Sign Structure	meter	8	15
Signing	Signing	Sign Panel	square meter	45	185
Signing	Signing	Structural Steel Sign Support Non-Breakaway	kilogram	450	6800

CONSTRUCTION DAILY PRODUCTION RATES — METRIC**Figure 66-2.B**

(6 of 6)

66-2.04 Selecting Contract Time and Project Letting Dates

66-2.04(a) Guidance for Selecting Project Letting Dates

A major Department goal is the delivery of the Highway Improvement Program. Proposed projects should go to letting as soon as practicable within the fiscal year as specified in the annual program. To determine what is practical, the designer must consider the type of work involved, the estimated time of completion, the availability of critical materials, other work in the area, and commitments. Typically, letting dates are chosen to prevent projects from being active through the winter months (December, January, February, and March). Winter construction is usually less productive, more expensive, and more disruptive to the traveling public.

The designer should become familiar with public activities and traffic patterns in the project area early in the Phase I engineering and recommend the best letting date for the project to the district programming engineer that will minimize delays and impacts to the traveling public and adjacent property owners. The designer should have a good idea how long the construction will take from the general scope and size of the project. The majority of projects are estimated to take less than 112 working days or approximately seven months to complete.

If a project (e.g., an eight mile, two-lane, resurfacing job) is estimated to take less than 45 working days to complete, it will be practical to schedule the project for a June letting with a construction start date around the first of August, allowing 45 days for the award of the contract and a completion around the first of November. This assumes no public event clauses are included in the contract (e.g., no lane closures allowed during the Illinois State Fair). Indicate how many working days are anticipated to complete the project in the Estimate of Time Required. The designer should determine the anticipated contract duration knowing when work items can or cannot be completed by the critical schedule of work anticipated, factoring in the contract work time restrictions. If work cannot be completed by the first part of November, the designer should recommend that the project go to a September letting or later and restrict the start of work until the following spring.

Districts prefer to have very small resurfacing projects completed before winter weather and will try for a June or August letting. If the project is scheduled for an August letting, estimate the time to take less than 20 working days, assuming construction starts around the middle of September (allowing 45 days for the Award of the contract) and is completed around the first of November.

The designer should recommend that the project go to a September letting or later and restrict the start of work until the following spring for larger projects (e.g., bridge replacements, bridge rehabilitations) that are estimated to take more than 45 working days. This avoids winter lane closures and the fall letting allows the contractor more time to order and fabricate critical materials ahead before the start of construction. The Department ends up with lower bid prices and more work completed within budget by allowing the contractor more time to order materials and schedule work.

If the designer estimates a project will take between 75 and 112 working days, recommend a November or January letting (possibly with a specific start date) to allow for a full construction season. If the designer estimates a project will take between 45 and 75 working days, target a January, March, or April letting.

On very large projects (e.g., new construction, reconstruction, major bridges) with more than 112 estimated working days (over one year) to complete, the designer must understand the major phases of construction and determine the critical path in order to recommend the appropriate letting date.

For a new bridge on a new alignment, the designer may want to place the project on a June letting to allow the bridge cones to be built in late summer or early fall and bridge work to proceed throughout the winter. For a large urban project, target a November letting to allow for off pavement utility relocations and storm sewers to be completed during the winter without disrupting traffic.

66-2.04(b) Selecting the Type of Contract Time

After estimating the anticipated number of working days to complete a project, the next step is to determine the type of Contract Time for the Completion of Work.

The Department's goal is to use Contract Time for the Completion of Work in all contracts that will minimize inconveniences to the traveling public, but also foster reasonable contract unit bid prices for the proposed work from the contractors.

Figure 66-2.C shows working days per month based on a Working Days Contract versus that for Completion Date (Via Calendar Days) Contract.

WORKING DAYS PER MONTH												
	JAN	FEB	MAR	APR	MAY	JUN	JUL	AUG	SEPT	OCT	NOV	DEC
WORKING DAYS	0	0	0	0	15	17	17	17	16	16	14	0
CALENDAR DAYS	31	28	31	30	31	30	31	31	30	31	30	31

WORKING DAYS PER MONTH

FIGURE 66-2.C

The following explains general uses of each type of Contract Time for the Completion of Work:

1. Working Day Contract. A Working Day Contract is the preferred type of contract. The completion of the contract is set by the specified number of working days allowed in the contract. If the contractor exceeds the specified number of working days, liquidated damages, as specified in the *Standard Specifications*, will be charged until all contract work is completed.

This type of contract is used when work does not need to be completed by a certain date. It allows more flexibility in getting materials ordered and fabricated. The contractor is not dependent on work by others being completed within a reasonable time (e.g., utilities being relocated during construction). The contractor is not charged a working day unless work is performed on a controlling item of work.

2. Completion Date Contract. Use Completion Date Contracts selectively. The latest possible completion of the contract is set by the completion date specified in the contract. If the contractor exceeds the specified completion date, liquidated damages, as specified in the *Standard Specifications*, will be charged until all contract work is completed.

This type of contract does not guarantee the contractor a certain number of workable days; therefore, the contractor is more at risk. Use this type of contract when all project work must be completed by a specific date (e.g., State Fair, special events, farming operations, school start or end dates) or when coordination with other contracts requires work to be completed prior to start of next contract.

3. Completion Date Plus Working Day Contract. Use Completion Date Plus Working Day Contracts when a facility must be open to traffic by a specific date, but all work does not have to be completed by the completion date. The latest possible completion of specified work items in the contract is set by the completion date specified in the contract and it allows a number of working days in the contract to complete the remaining work. If the contractor exceeds the specified completion date or the number of working days allowed, liquidated damages will be assessed.

When this type of contract is specified, the designer must identify the work to be completed by the completion date. The work to be completed during the allowed working days that are weather sensitive and/or require performance or establishment periods (e.g., landscaping, pavement markings) must also be identified.

4. Completion Date (Via Calendar Day) Contract. Use Completion Date (Via Calendar Day) Contracts when the work must be completed in a specific timeframe, not by a specific date. A Completion Date (Via Calendar Day) Contract is a completion date contract with a floating start date. The specified number of calendar days sets a date of project completion at the time the contract is started; therefore, the contractor is not affected by a late award.

Use this type of contract when a specific completion date is not required, but a completion date is necessary to expedite the work once the contract is started.

5. Completion Date (Via Calendar Day) Plus Working Day Contract. Use Completion Date (Via Calendar Day) Plus Working Day Contracts when a facility must be open in a specific timeframe, not by a specific date, but all work does not have to be completed by the completion date. A date of completion is established by the specified number of calendar days in the contract at the time the contract is started and allows a number of working days to complete the remaining work. If the contractor exceeds the specified date of completion or the number of working days allowed, liquidated damages will be assessed.

When this type of contract is specified, the designer must identify the work to be completed by the completion date. The work to be completed during the allowed working days that are weather sensitive and/or require performance or establishment periods (e.g., landscaping, pavement markings) must also be specified.

Use this type of contract when a specific completion date is not required, but a completion date is necessary to expedite the work once the contract is started.

Figure 66-2.D is a matrix summarizing definitions, benefits, weaknesses, and applicability for each type of contract.

66-2.04(c) Increased Use of Completion Date Contracts

As traffic volumes increase, so do the impacts to the motoring public and businesses during construction. To lessen these impacts, the use of Completion Date Contracts is encouraged as well as the use of Incentive/Disincentive specifications.

The provisions for Completion Date Contracts and Completion Date Contracts with Incentive/Disincentive provisions are as follows:

- Use on all multi-lane roadway projects with more than 25, 000 ADT.
- Use on all routes in urban areas where construction has the potential to severely impact the adjacent businesses.
- Consider using on projects where there is a need to control the completion of the project. Projects where completion is anticipated in the fall of the year may require a completion date to help ensure the work is completed and does not extend over the winter period. Large projects that will be let in multiple contracts should contain provisions to keep the overall project on schedule. Use completion dates to avoid conflicts with special events.

	Working Day	Completion Date	Completion Date plus Working Days	Completion Date (Via Calendar Days)	Completion Date (Via Calendar Days) plus Working Days
Definition	Defined in Article 108.04. Contracts specify the number of working days, by Special Provision, it should take for the contractor to complete the work.	Defined in Article 108.05(a). Contracts specify a date, by Special Provision, when the work is to be completed.	Defined in Article 108.05(b). Contracts specify a date, by Special Provision, that major items of work must be completed and allows working days to complete miscellaneous work.	Defined in Article 101.06. Contracts specify the number of calendar days, by Special Provision, to establish the completion date based on when the contract is started.	Defined in Article 101.06. Contracts specify the number of calendar days, by Special Provision, to establish completion date based on when the contract is started and allows working days to complete misc. work.
Benefits	<ul style="list-style-type: none"> Allows the contract to be awarded late (> 45 days) without penalty to the contractor. Bids are generally better because of guaranteed working days. District can delay start without penalty to the contractor. Easier to administer. 	<ul style="list-style-type: none"> Specifies a date when all work must be completed (before special events or before winter). Can prevent contractor from prolonging the work over more than one season. 	<ul style="list-style-type: none"> Specifies a date when the major items of work must be completed (before special events). Working days allow time for miscellaneous work to be completed after the completion date. 	<ul style="list-style-type: none"> Allows the contract to be awarded late (> 45 days) without penalty to the contractor. Can prevent contractor from prolonging the work over more than one season. Completion date is established based on start date. Establishes a date when all work will be completed. 	<ul style="list-style-type: none"> Allows the contract to be awarded late (> 45 days) without penalty to the contractor. Can prevent contractor from prolonging work over more than one season. Completion date is established based on start date. Specifies a date when the major items of work must be completed (before special events)
Weakness	<ul style="list-style-type: none"> No specified date for completion. Charging working days can be subjective. 	<ul style="list-style-type: none"> Possible conflicts due to potential time extension requests. Could result in higher bid prices if expedited schedule is required. Potential for project delays if contract is awarded > 45 days after letting or if contractor rejects. 	<ul style="list-style-type: none"> Possible conflicts due to potential time extension requests but easier to administer than completion date contracts. Could result in higher bid prices if expedited schedule is required. Potential for project delays if contract is awarded > 45 days after letting or if contractor rejects. 	<ul style="list-style-type: none"> Possible conflicts due to potential time extension requests. Could result in higher bid prices if expedited schedule is required. 	<ul style="list-style-type: none"> Possible conflicts due to potential time extension requests. Could result in higher bid prices if expedited schedule is required.
Applicability	<ul style="list-style-type: none"> Preferred type of contract method. Use on contracts that do not have strict dates that the work needs to be completed. 	<ul style="list-style-type: none"> Use on contracts when all project work must be completed by a specific date (e.g., State Fair, special events, farming operations, school start or end dates) or when coordination with other contracts requires all work to be completed prior to start of next contract. 	<ul style="list-style-type: none"> Use when facility needs to be open by a specific date, but all work does not have to be completed. Use when miscellaneous items in the contract are weather sensitive and/or require performance or establishment periods (landscaping, pavement markings, etc.). 	<ul style="list-style-type: none"> Use when you want the work to be completed in a specific timeframe, not by a specific date. 	<ul style="list-style-type: none"> Use when the work is to be completed in a specific timeframe, not by a specific date and when the facility could be open sooner and all work does not have to be completed. Use when misc. items in the contract are weather sensitive and/or require performance or establishment periods (e.g., landscaping, pavement markings).

BENEFITS, WEAKNESSES, AND APPLICABILITY OF EACH CONTRACT TYPE

Figure 66-2.D

66-2.04(d) Expanded Use of Lane Rental Contracts

Lane rental is a contracting technique where the contractor bids the number of days of work requiring lane closures as part of the contract, or the Department sets the number of days that lane closures are allowed. If the contractor finishes early, an incentive is paid. If the contractor exceeds the number of days allowed, a disincentive payment is deducted from the contract for each day the limit is exceeded. This type of contract forces the contractor to schedule resources and perform work in a more timely manner.

Contracts using a lane rental specification should be considered on all high-volume, multi-lane projects (e.g., Interstates, expressways). Complete a traffic capacity analysis for these projects to determine the level-of-service to be anticipated during construction. In addition, complete a queuing analysis to determine the anticipated traffic backups at different times during the day and week. Once a traffic capacity analysis and queuing analysis are complete, a decision may be made on whether or not to use a lane rental specification. If a lane rental specification is used, this information will aid in determining the average road user benefit cost.

Include lane rental specifications for all Interstate and expressway projects. The lane rental specification must apply to the patching operation and may be applied to the whole project. Prepare a traffic capacity analysis and queuing analysis to determine the anticipated back-ups at different times during the day and week. This information is used in determining the average road user benefit cost for purposes of developing the Lane Rental Specification.

66-2.05 Incentive/Disincentive Policy

The term Incentive/Disincentive describes a contract provision, which compensates the contractor a prescribed amount of money for each day identified that critical work is completed ahead of schedule, and assesses a deduction for each day the contractor overruns the schedule. The Incentive/Disincentive clause is used to motivate contractors to complete critical projects by an expedited work schedule on or before a specified date. The use of Incentive/Disincentive provisions should be restricted to those critical projects where it is highly desirable for traffic inconvenience and delays to be minimized. Before an Incentive/Disincentive clause is included in a contract, prior approval must be obtained from BDE. Unique cases not covered in Section 66-2.05(a) may be submitted for review and approval to the BDE.

66-2.05(a) Guidelines for Project Selection

Incentive/Disincentive clauses are intended for those projects where early completion would greatly benefit both the road user and the Department and where ramifications of not meeting the completion date are extreme. Use of Incentive/Disincentive clauses should be limited to projects that involve one or more of the following characteristics:

1. Adverse Effects. High-volume roads/high-volume truck traffic/structures that involve: high road-user cost increases, extended inconveniences, hazards to the motoring public, or severe disruption on adjacent business communities. Lower volume roads and river

structures that involve long adverse travel and area economic impact also may be considered.

2. Timing. Projects that have a direct bearing on the start and/or interruption of progress on major freeways, arterials, or structures may be considered for Incentive/Disincentive (e.g., utility relocations). However, where late completion, not early completion, is the primary concern, the designer should instead consider adding a clause providing for higher liquidated damages based on other Department costs per the *Code of Federal Regulations — Title 23*. A beam fabrication project is an example where late completion may be the primary concern.
3. Urban River Crossings. River structures in or adjacent to central business districts.
4. Night Time Construction. Nighttime construction (rehabilitation and/or resurfacing) on major urban freeways.

66-2.05(b) Application

Incentive/Disincentive clauses can be applied to a single project or to a combination of two or more projects. The following will apply:

1. Single Projects. The Incentive/Disincentive can apply to all or part of the project. The designer should consider the following:
 - a. Entire Project. For projects where the Incentive/Disincentive applies to the entire project, all work must be completed before the Incentive/Disincentive is applied. River structure (rehabilitation or replacement) and urban freeway resurfacing projects are examples of single projects with the Incentive/Disincentive applied to the entire project.
 - b. Project Portion(s). For projects where the Incentive/Disincentive applies to a portion of the work, a completion date is set on the specific portion of the project in which the Incentive/Disincentive is applied, and the remaining work is covered by liquidated damages. For example, an interchange reconstruction project where the primary concern is to restore traffic flow, the Incentive/Disincentive could be applied to only the work necessary to reopen the ramps and the interchange structure to traffic. Miscellaneous items, such as seeding and lighting, are not critical to reopening the roadway and could be completed after the Incentive/Disincentive completion date. These miscellaneous items would be covered by liquidated damages.
2. Multiple Projects. Cooperative Incentive/Disincentives are used to expedite a combination of two or more projects. The cooperative Incentive/Disincentive clause will require that work be completed on all projects before the total Incentive/Disincentive is applied. This type is used where a greater benefit is received by completion of a combination of projects. Adjacent sections of roadway that would provide usable

segments of a freeway would be an example where a cooperative Incentive/Disincentive could be used.

66-2.05(c) Amount Determination

The Incentive/Disincentive amount is the daily rate to compensate the contractor for early completion or assess the contractor for overrunning the completion date. This Incentive/Disincentive amount is based on the sum of the road-user delay cost and liquidated damages and should, in general, be adjusted downward for fiscal responsibility.

The Incentive/Disincentive amount should not exceed a total of road-user delay costs and liquidated damages. On projects where the Incentive/Disincentive amount applies to a portion of a single project, this amount is based only on the road-user delay cost. On projects where the Incentive/Disincentive amount applies to the completion of all work, the amount is based on the sum of road-user delay costs and liquidated damages.

The final costs are determined as follows:

1. Road-User Delay Cost. This cost is based on the change in travel time, number of passengers per vehicle, and an hourly cost per person determined as follows:
 - a. Travel Time. The change in travel time is determined by comparing the travel time through the project under normal conditions versus the estimated travel time through the project or along the designated detour during construction.
 - b. Passengers. The number of passengers per vehicle is assumed to be 1.25, based on research by the Chicago Area Transportation Study.
 - c. Hourly Cost. The hourly cost per passenger is assumed to be \$10.00/hour, based on average earnings issued by the Department of Employment Security.
2. Liquidated Damages. Liquidated damages rates are based on construction engineering costs. Liquidated damages rates are found in Section 108 of the *Standard Specifications* and the Supplemental Specifications.
3. Rate Adjustment. The final daily rate for the Incentive/Disincentive amount should be adjusted downward from the sum of the calculated road-user delay costs and the liquidated damages. When setting the rate, the designer should note the following:
 - a. The Incentive/Disincentive amount must provide a favorable benefit-cost ratio (B/C) of at least 1.0.

$$\frac{B}{C} = \frac{\text{calculated road user delay cost and liquidated damages}}{\text{adjusted road user delay cost and liquidated damages}}$$

- b. The final daily Incentive/Disincentive amount must be large enough to motivate the contractor to work an accelerated schedule.

66-2.05(d) Determination of Scheduled Completion Date

The setting of the completion date is a very important step in the use of Incentive/Disincentive clauses. The completion date must be based on a realistic and expedited work schedule. The work schedule will involve accelerated construction procedures because projects with Incentive/Disincentive clauses are critical projects. Expedited work schedules may involve one or more of the following:

- six-day work week, double shift with night illumination;
- extended work hours with 12 to 14 hours per day;
- expedited work schedule with 228 working days per calendar year; and/or
- multiple work crews in multiple areas.

66-2.05(e) Limits of Incentive/Disincentive

The incentive amount should not exceed five percent of the total construction cost. All Incentive/Disincentive clauses should include an upper limit to the number of days that an incentive will be paid. The incentive payment limit is a maximum of 30 calendar days. These limits are used to protect the Department. Disincentives are not time limited so that the contractor is effectively encouraged to meet the scheduled completion date.

66-2.05(f) Extension of Contract Time

Contract extensions may be granted by the Department as noted in Section 108 of the *Standard Specifications*. Extension of time applies to only the Disincentives. Incentive payments will be based on the completion date in the special provisions regardless of any extension of time. The extension of the completion date for Incentive payments will only be considered where significant extra work is added to the contract due to unforeseen circumstances.

66-2.05(g) Project Development

During the development of Incentive/Disincentive projects, greater attention to plans, specifications, and schedules is required. Omissions or errors in the plans or specifications may result in a claim from the contractor. The plans and specifications should indicate any unusual conditions or restrictions on the contractor. Specifications should clearly delineate the work that must be completed to meet the Incentive requirements.

The preconstruction phase of Incentive/Disincentive projects should include contacts with local officials, police, and/or other agencies to ensure a coordinated effort during the construction phase. A prebid meeting may be necessary to address the special features of an Incentive/Disincentive project.

66-2.05(h) Example Calculations

The following are two examples of how to calculate road-user delay costs and the Incentive/Disincentive rates.

Example 66-2.04(1)

Given: Urban Freeway Rehabilitation
 \$5.0 million construction cost
 60,000 ADT
 Project Length — 1.8 miles
 Average Normal Speed — 55 mph
 Average Construction Speed — 35 mph

Problem: Determine the appropriate Incentive/Disincentive rate for the project.

Solution: Motorist Time (normal conditions) = $\frac{(\text{Project Length}) (\text{ADT})}{\text{Average Normal Speed}}$

$$\text{Motorist Time (NC)} = \frac{(1.8)(60,000)}{55} = 1,964 \text{ hrs}$$

$$\text{Motorist Time (under construction)} = \frac{(1.8)(60,000)}{35} = 3,086 \text{ hrs}$$

$$\text{Motorist Time Lost} = (3,086 \text{ hrs} - 1,964 \text{ hrs}) = 1,122 \text{ hrs}$$

$$\text{Total Road-User Delay Cost} = (1,122 \text{ hrs}) (1.25 \text{ Passengers/Vehicles}) (\$10/\text{hr})$$

$$\text{Total Road-User Delay Cost} = \$14,025.00$$

$$\text{Liquidated Damages Per Specifications} = \$1,800.00$$

$$\text{Calculated Road-User Delay Cost} + \text{Liquidated Damages} = \$14,025.00 + 1,800.00 = \$15,825.00$$

Based on the 5% incentive cap and the 30-day time limit, the maximum incentive is determined as follows:

$$\frac{(\$5,000,000)(0.05)}{30} = \$8,333.33 / \text{day}$$

Therefore, the adjusted road-user delay cost and liquidated damages must be less than \$8,333.33/day. See Section 66-2.04(e).

For this example, the Incentive/Disincentive rate was set at \$8,000/day.

$$\text{The B/C ratio is: } \frac{15,825.00}{8,000.00} = 1.98$$

Example 66-2.04(2)

Given: Rural River Bridge Replacement
 \$3.25 million construction cost
 2,000 ADT
 Project Length — 1 mile
 Detour Length — 20 miles
 Average Normal Speed — 55 mph
 Average Construction Speed — 55 mph

Problem: Determine the appropriate Incentive/Disincentive rate for the project.

$$\text{Solution: Motorist Time (normal conditions)} = \frac{(1.0)(2,000)}{55} = 36.4 \text{ hrs}$$

$$\text{Motorist Time (under construction)} = \frac{(20.0)(2,000)}{55} = 727.3 \text{ hrs}$$

$$\text{Motorist Time Lost} = (727.3 \text{ hrs} - 36.4 \text{ hrs}) = 691 \text{ hrs}$$

$$\text{Total Road-User Delay Cost} = (691 \text{ hrs}) (1.25 \text{ Passengers/Vehicles}) (\$10/\text{hr}) = \$8,638.00$$

$$\text{Liquidated Damages Per Specifications} = \$1,800.00$$

$$\text{Calculated Road-User Delay Cost} + \text{Liquidated Damages} = \$8,638.00 + 1,800.00 = \$10,438.00$$

Based on the 5% incentive cap and the 30-day time limit, the maximum Incentive is as follows:

$$\frac{(\$3,250,000)(0.05)}{30} = \$5,416.67$$

The Incentive/Disincentive rate was set at \$5,400/day.

$$\text{The B/C ratio is: } \frac{10,438.00}{5,400.00} = 1.93$$

66-2.05(i) Sample Special Provisions

The following are two sample special provisions that may be used where Incentive/Disincentive clauses are used in the project. The first is a sample for an Incentive/Disincentive contract where the Incentive/Disincentive applies to the completion of all work. The second is a sample where the Incentive/Disincentive applies to a portion of the contract.

(Sample Special Provision for Entire Project)

Incentive/Disincentive: Effective _____ (DATE) _____

Date of Completion: The Contractor shall schedule his/her operations so as to complete all work and open all the roadway to traffic on or before _____ (DATE) _____. The Contractor shall note that this completion date is based on an expedited work schedule.

Failure to Complete the Work on Time: Should the Contractor fail to complete the work on or before the specified date of completion, or within such extended time allowed by the Department, the Contractor shall be liable to the Department in the amount of _____ (\$) _____, not as a penalty but as liquidated and ascertained damages for each calendar day beyond the date of completion or extended time as may be allowed. Such damages may be deducted by the Department from any monies due the Contractor.

In fixing the damages as set out herein, the desire is to establish a certain mode of calculation for the work because the Department's actual loss, in the event of delay, cannot be predetermined, would be difficult of ascertainment, and a matter of argument and unprofitable litigation. This mode is an equitable rule for measurement of the Department's actual loss and fairly takes into account the loss of use of the roadway if the project is delayed in completion. The Department shall not be required to provide any actual losses to recover these liquidated damages provided herein, as these damages are very difficult to ascertain. Furthermore, no provision of this clause shall be construed as a penalty, as such is not the intention of the parties.

A calendar day is every day on the calendar and starts at 12:00 midnight and ends at the following 12:00 midnight, twenty-four hours later. No payment will be paid for any day less than twenty-four hours.

Incentive Payment Plan: The nature of this project is such that the use of this roadway cannot be safely and efficiently used until all roadway work is essentially complete. On this basis, the Contractor shall be entitled to an Incentive Payment for the completion of all work including clean up as set forth by the date of completion.

The Incentive Payment shall be paid at the rate of _____ (\$) _____ per calendar day for each day of completion prior to _____ (DATE) _____. The maximum payment under this incentive plan will be limited to _____ (#) _____ calendar days.

A calendar day is every day on the calendar and starts at 12:00 midnight and ends at the following 12:00 midnight, twenty-four hours later. No payment will be paid for any day less than twenty-four hours.

(Sample Special Provision for Entire Project)

(Continued)

Should the Contractor be delayed in the commencement, prosecution, or completion of the work for any reason, there shall be no extension of the incentive payment calculation date even though there may be granted an extension of time for completion of the work unless significant extra work is added to the contract by the Department. No Incentive Payment will be made if the Contractor fails to complete the work before the specified date of completion or within such extended time allowed by the Department. Failure of the Contractor to complete all work as required by the contract before (DATE) shall release and discharge the State, the Department and all of its officers, agents, and employees from any and all claims and demands for the payment of any incentive amount or damages arising from the refusal to pay any incentive amount.

If the contract is part of a combination award, no Incentive Payment shall commence on this contract, which is part of the combination until all work on contracts that are part of the combination award has been completed.

(Sample Special Provision for a Portion of the Project)

Incentive/Disincentive Plus Working Days: Effective _____ (DATE)

Date of Completion: The Contractor shall schedule his/her operations so as to complete all work, except as specified below, and open all the roadway to traffic on or before _____ (DATE).

The Contractor shall note that this completion date is based on an expedited work schedule. The Contractor will be allowed _____ (#) working days, after the _____ (DATE) completion date, to complete any remaining planting, seeding, and sodding work.

Failure to Complete the Work on Time: Should the Contractor fail to complete the work on or before the specified date of completion or within such extended time allowed by the Department, the Contractor shall be liable to the Department in the amount of _____ (\$) not as a penalty but as liquidated and ascertained damages for each calendar day beyond the date of completion or extended time as may be allowed. Failure to complete the remaining planting, seeding, and sodding work within _____ (#) working days shall be governed by the provision of Article 108.09 of the Standard Specifications. Such damages may be deducted by the Department from any monies due the Contractor.

In fixing the damages as set out herein, the desire is to establish a certain mode of calculation for the work because the Department's actual loss, in the event of delay, cannot be predetermined, would be difficult of ascertainment, and a matter of argument and unprofitable litigation. This mode is an equitable rule for measurement of the Department's actual loss and fairly takes into account the loss of use of the roadway if the project is delayed in completion. The Department shall not be required to provide any actual losses to recover these liquidated damages provided herein, as these damages are very difficult to ascertain. Furthermore, no provision of this clause shall be construed as a penalty, as such is not the intention of the parties.

A calendar day is every day on the calendar and starts at 12:00 midnight and ends at the following 12:00 midnight, twenty-four hours later. No payment will be paid for any day less than twenty-four hours.

Incentive Payment Plan: The nature of this project is such that the use of this roadway cannot be safely and efficiently used until all specified work is complete. On this basis, the Contractor shall be entitled to an Incentive Payment for the completion of all work as set forth by the date of completion.

The Incentive Payment shall be paid at the rate of _____ (\$) per calendar day for each day of completion prior to _____ (DATE). The maximum payment under this incentive plan will be limited to _____ (#) calendar days.

A calendar day is every day on the calendar and starts at 12:00 midnight and ends at the following 12:00 midnight, twenty-four hours later. No payment will be paid for any day less than twenty-four hours.

(Sample Special Provision for a Portion of the Project)

(Continued)

Should the Contractor be delayed in the commencement, prosecution, or completion of the work for any reason, there shall be no extension of the incentive payment calculation date even though there may be granted an extension of time for completion of the work unless significant extra work is added to the contract by the Department. No Incentive Payment will be made if the Contractor fails to complete the work before the specified date of completion or within such extended time allowed by the Department. Failure of the Contractor to complete all work as required by the contract before *(DATE)* shall release and discharge the State, the Department and all of its officers, agents, and employees from any and all claims and demands for the payment of any incentive amount or damages arising from the refusal to pay any incentive amount.

If the contract is part of a combination award, no Incentive Payment shall commence on this contract which is part of the combination until all work on contracts which are part of the combination award has been completed.

66-3 PROJECT COORDINATION AND IMPLEMENTATION SECTION

The following sections discuss the responsibilities of the Project Coordination and Implementation Section within the Bureau of Design and Environment to advance the plans and special provisions to letting after they have been submitted by the district.

66-3.01 Plan Check-In and Review

66-3.01(a) Program Support Unit

The Program Support Unit duties include the following:

- Checking in all plans submitted to the BDE for letting.
- Verifying that the plans are on the list of recommended projects previously submitted to the Section.
- Checking the CA/Project Status Form. All items listed as “Required” on the CA Form are noted.
- Verifying that the project is programmed and that the scope of work is correct.
- Checking eligibility for projects using bridge funds.
- Determining final funding of the project based on availability of the funds as initially programmed.
- For a project with joint agreements requiring local, private, or other sources of funding, checking the agreements and summary of quantity sheets to ensure that they are consistent and correct.

66-3.01(b) Project Development Unit

The Program Support Unit forwards the plans to the Project Development Unit where the project file folder is set up and the project is sent to the Regional Field Engineer and technicians for review. Plans and special provisions are also sent to appropriate central bureaus for review of bridge, traffic signals, landscaping, and other special items for concurrent reviews.

The technician will prepare the Transportation Bulletin worksheets to advertise the project. The Bulletin worksheet should address the following information:

1. Basic Information. The Transportation Bulletin worksheet must include the following:
 - the contract number, county, section, project number, route, and district;
 - the location and a brief description of the improvement;
 - a summation of the major items of work including the unit of measure and quantity of each; and
 - the working days or completion date and the job number.

2. Improvement Description. In preparing the material for the Bulletin worksheet, describe the basic or main part of the improvement and any other work of major importance. For example, if the improvement is primarily roadway construction but includes major quantities for storm sewers, frontage roads, ramps, pumping stations, box culverts, and bridges, also reference these element descriptions. The description of the location of the improvement should be such that the beginning and ending can be identified on a current Illinois Official Highway Map.
3. Location Description. When describing an improvement in relation to other routes, show the approximate distance to the nearest large city (e.g., on Illinois Route 4 between Illinois Route 104 and FAI Route 72 approximately 2 mi (3 km) southwest of Springfield). Place the corresponding marked route, as shown on a current Illinois Official Highway Map, in parentheses after the designated FA or SBI routes (e.g., FA Route 68 (Illinois Route 4)) and, if the improvement is in an urban area, show the corresponding street name.
4. Bridge Improvements. When describing the replacement of a bridge superstructure, note the face-to-face curb width of the existing and proposed roadway. If the improvement involves two or more independent types of work or if both urban and rural type construction is involved, describe and give the length of each type. Show distances to the nearest hundredth of a mile (thousandth of a kilometer). The Bulletin worksheet description for bridge and structure improvements should give a brief description and location of the improvement similar to that shown on the title sheet of the plans. If approaches are included with the structure contract, list the length, type, and width of the approach. Also list the number of spans, span sizes, and material type.
5. Patching and Resurfacing Improvements. Where patching and resurfacing are included in the same improvement and portions of the patching quantities are outside the limits of resurfacing, list the length of patching outside the resurfacing limits separately. In describing intermittent bituminous resurfacing, show the total length of the improvement and also the net length of resurfacing. When resurfacing is on less than four routes or in less than four counties, show the length, width, type, and location for each route; otherwise, this work may be summarized as "various routes and counties" in the given district.
6. Traffic Signals. If the improvement is for the installation of traffic signals and the number of locations is ten or less, describe each location separately. Where more than ten locations are involved, the description may be summarized (e.g., at 14 intersections on various routes in the north portion of Cook County).

Prior to reviewing a set of plans, the Regional Field Engineer should review the project file folder and determine if the plans are in accordance with the approved scope of work. The engineer will review the plans to determine if they comply with the criteria presented in this *Manual* unless the design file indicates prior approval for deviations.

Due to the complexity and varied nature of highway plans, it is impractical to establish a set of rules which will completely govern a comprehensive review of plans; however, certain features

should always be checked. Figure 66-3.A provides a checklist of items to consider during the review of plans prior to advertisement for letting.

All changes to special provisions and plans (including quantity changes), performed at the Central Office, must be supported with documentation from either the district or their consultant. This documentation will either be in writing or via email and will clearly describe the changes to be made. If the district or their consultant comes to the Central Office to make changes personally, they must document the changes with marked-up sheets or an itemized list. The documentation will then be kept in the contract file until the project is complete.

66-3.02 Final Plan and Proposal Review

66-3.02(a) Special Provision Review

The special provisions are reviewed by the Project Development Unit for compliance with the requirements in Section 66-1.04. For plan reviews, inflexible rules cannot be established for reviewing special provisions. The engineer should be certain that all pay items are covered by the *Standard Specifications*, Supplemental Specifications, Recurring Special Provisions, or Contract Special Provisions, and that on applicable Federal-aid projects FHWA requirements are met. An especially important aspect of special provisions is that they must adequately cover the intended work and that details must be given which will distinguish the equipment or method required to perform the work. Generalities in special provisions are undesirable because they can often lead to misinterpretation and disputes with resultant claims for extra work. The performance of work on a force account basis should be minimized.

66-3.02(b) Procedures

After the special provisions have been reviewed and found satisfactory, return the prints of the plans and special provisions to the district for a final review prior to advertising bids. The memorandum transmitting the plans and special provisions to the district for final review should note significant changes in the plans or special provisions made by the Bureau of Design and Environment.

The Regional Field Engineer prepares the check sheet of appropriate Recurring Special Provisions and attaches the check sheet to the contract. Plans ready for letting are then forwarded for duplicating. Contract Special Provisions are sent to the Project Management Unit where the appropriate State or Federal boilerplate sheets are added which completes the proposal. The proposal is then sent for duplication.

Figure 66-3.B presents the minimum advance time that the Project Development Unit should plan for when preparing a contract for letting.

Date Completed _____
Project No. _____
Checker _____

Route _____
Section _____
County/City _____

- 1. Ensure that the CA/Project Status Form has been completed. If not, return it to the district for completion.
- 2. Ensure that the plans are complete by checking them against:
 - the approved Phase I report;
 - the design criteria presented in the *Bureau of Design and Environment Manual*, except where revised by a design exception;
 - the criteria presented in the Procedural Memoranda;
 - any reports prepared for the project (e.g., soils, pavement, intersection design study); and
 - the plan preparation guidelines presented in Chapter 63 (see Section 63-6 for a plan preparation checklist).
- 3. Ensure the plans and/or special provisions have addressed the maintenance and protection of traffic through construction zones.
- 4. Ensure that the designer has addressed all the issues in the Commitment File somewhere in the plans, special provisions, or agreements.
- 5. Ensure that all applicable units have reviewed the plans and Contract Special Provisions by checking the transmittal memoranda between the designer and the bureaus. For example, the Bureau of Operations should have reviewed the signal plans and the Bureau of Bridges and Structures should have reviewed the structural plans.
- 6. Ensure that the Recurring Special Provision Checklist is included and properly completed.
- 7. Ensure that all applicable Contract Special Provisions have been provided including:
 - Project Specific Special Provisions,
 - District Special Provisions,
 - Bridge Special Provisions, and
 - Inserted Special Provisions.

PLAN REVIEW CHECKLIST

Figure 66-3.A
(1 of 2)

- 8. Check the Contract Special Provisions prepared by the designer to ensure they meet the criteria presented in Section 66-1.04.
- 9. Ensure that all pay items are covered by the *Standard Specifications*, Supplemental Specifications, Recurring Special Provisions, or Contract Special Provisions.
- 10. Copy and distribute the special provisions for review as discussed in Section 66-3.02(b).
- 11. Ensure the designer has completed the quantity estimate sheet and has segregated the quantities according to the criteria presented in Section 63-4.04.
- 12. Ensure that the quantities, coded numbers, and pay items on the plans, summary of quantities, and proposals agree.
- 13. Ensure that the district estimating engineer has forwarded the unit prices to the Project Management Unit.
- 14. Ensure that the Project Management Unit has prepared the Engineer's Estimate.
- 15. Check the designer's construction time estimate to ensure that it is reasonable and complete.
- 16. Prepare the Bulletin worksheet and forward it to the Project Management Unit for copying and distribution.
- 17. Verify with the Program Support Unit that all agreements with utility companies, railroads, local municipalities, etc., are signed prior to letting.
- 18. Verify through the Program Support Unit that all applicable permits have been approved before letting (e.g., Corps of Engineers, Coast Guard, USEPA).
- 19. Verify through the Program Support Unit that any right-of-way acquisitions, easements, agreements, etc., are completed prior to letting.
- 20. Forward all construction documents to the Project Management Unit.

PLAN REVIEW CHECKLIST

Figure 66-3.A
(2 of 2)

Submittal	Minimum Time In Advance Of Letting
PS&E to Federal Highway Administration	6 Weeks
Transportation Bulletin	5 Weeks
Addendums to FHWA (See Chapter 31)	17 Days
Addendums to Contractors	10 Days

**PLANNING SCHEDULE
(Project Development Unit)**

Figure 66-3.B

66-4 PROPOSALS AND CONTRACTS

66-4.01 Transportation Bulletin and Advertising

66-4.01(a) Transportation Bulletin

The Project Development and Implementation Engineer selects the projects that will be on the letting. Bulletin worksheets of projects to be advertised are prepared by the Project Development Unit in the Bureau of Design and Environment or the Central Bureau of Local Roads and Streets. The worksheets are sent to the Contracts Office where they are logged in. Once selected, the Bulletin worksheets are numbered and the Contracts Office prepares a draft of the Transportation Bulletin.

The draft bulletin is emailed to the Office of Planning & Programming and the Office of Finance & Administration for review. Once their concerns, if any, are addressed a revised draft bulletin is emailed to the Chief Contracts Official for final review. A marked-up copy is returned for final processing and posting on the IDOT Internet site.

66-4.01(b) Electronic Advertising

Once the Transportation Bulletin has been prepared, it is published on the IDOT Internet site and emailed a notice to subscribers of the IDOT electronic subscription service at least 21 days before the letting.

66-4.02 Proposals and Plans

66-4.02(a) Assembly of Proposal

As specifications are received from the districts, the Project Development Unit or the Bureau of Local Roads and Streets will review the specifications for accuracy, prepare a copy of the Illinois wage rates (if applicable), and develop the schedule of prices to form the draft proposal. The Contracts Office will prepare a typing package which consists of the cover sheet, certifications, financial disclosure sheets, bidder's employee utilization form, bidder's affidavits (if required), signature sheet, assurances, and the notice-to-bidders sheet. The draft proposal is combined with the typing package to form an original proposal. The proposal is reviewed for accuracy and posted on the IDOT Internet site. Hard copies are processed by the Reproduction Service Unit for internal use.

66-4.02(b) Plans

Plans are received from the districts and reviewed for accuracy by the Project Development Unit. Once reviewed, the plans are posted on the IDOT Internet site. Hard copies are processed by the Reproduction Service Unit for internal use.

66-4.02(c) Authorization to Bid

Authorization to bid is issued to prequalified contractors who have sufficient financial and work ratings that indicate their ability to complete work on which they wish to bid. Requests for authorization to bid (BDE 124) are to be submitted to the Contracts Office. The Bureau of Construction's Prequalification Section reviews the submitted BDE 124. The Prequalification Section analyzes each request for authorization to determine if the contractor has sufficient prequalification. Upon determination of sufficient prequalification, notification is given to the Contracts Office to authorize or deny the contractor to bid.

66-4.02(d) Subcontractors and Material Suppliers

Subcontractors and material suppliers can download proposals and plans from the IDOT Internet site.

66-4.02(e) Bidder's List

As proposals and plans are posted to the IDOT Internet site, a list of contractors receiving authorization to bid is maintained by the Contracts Office. A similar list is maintained for other interested parties (e.g., subcontractors and material suppliers). The bidder's list is updated four times with the final list being available the day before the letting. The lists are available for review on the IDOT Internet site.

66-4.02(f) Addendums to Proposals and Plans

The Program Development Unit will be responsible for making corrections to the original proposal and the original plans. Addenda on local roads projects are handled similarly between the Bureau of Local Roads and Streets and the Contracts Office.

When an addendum will be issued on a project, the Project Development Unit notifies the Contracts Office of the item number and if the correction is on the proposal, plans, or both. The Contracts Office updates the Addendum/Revision Checklist on the IDOT Internet site.

66-4.03 Letting Process**66-4.03(a) Receipt of Bids**

Bids sealed in proposal envelopes are deposited in locked bid boxes, or electronically submitted through the department's EBids system, at the place and time designated in the Transportation Bulletin. Bidders may also submit their bids by mail to the Contracts Office where they are stamped, logged and locked until the time of the letting. After the specified time, no additional bids will be accepted. The bid boxes are unlocked and the bids are sorted by item number. The total amount of each bid, including alternatives and combinations, if any, are marked and then read publicly. A bidder's proposal package is not read at the letting if a bidder has not

been authorized to bid. When bids have been publicly read, they are reviewed for bid bonds or guaranty checks. If proposal guaranty checks are received, they are detached from the bids and submitted to the Contracts Office for further processing. Once this is completed, the bids are then transferred to the Project Development and Implementation Section for further processing.

66-4.03(b) Bid Tabulations

The afternoon of the letting the Contracts Office posts on the IDOT Internet site the "As-Read" Tabulation of bids. These are the bid amounts identified in the bid proposal packages and publically read aloud. After the bids have been reviewed for any calculation errors the Corrected Tabulation of Bids is posted to the IDOT Internet site identifying low bidders and any revised bid totals.

66-4.03(c) Proposal Guaranty Checks and Bid Bonds

A proposal guaranty check or bid bond must accompany each bid, if applicable. If the proposal guaranty check or bid bond is missing or incomplete, the Contracts Office will notify the bidder by letter of the problem and what is required for correction. A copy of the letter is kept in the Chief Contracts Official's letting folder and a note is included in the Letting Status database. Once received, guaranty checks are placed into individual envelopes and locked in a safe. The envelope indicates the contractor's name, item number, check amount, and check number. The guaranty checks of the low and second low bidder are retained in the safe until the contract documents are executed by the Department. The guaranty checks of the low and second low bidders are returned by United Parcel Service (UPS) after the contract is executed. The guaranty checks of the other bidders are returned by the UPS Ground. Bid bonds of the low bidders are retained in the safe until all contracts are executed. After all contracts are executed, the bid bonds are destroyed. A bid bond may be submitted by the low and second low bidder no sooner than 3 working days after the letting as a substitute for the guaranty check.

66-4.03(d) Processing of Bids Received

The Project Development and Implementation Section is responsible for the processing of bids received. All bids are entered into the computer system to be checked for accuracy. Once a low bid has been determined, the system is locked and the low bid is transferred to the Contracts Office for further processing pending the decision of the Awards Committee.

66-4.03(e) Awards Committee

The Awards Committee is responsible for approving or rejecting the bids. This Committee consists of the following personnel:

- Deputy Director of Program Development,
- Engineer of Design and Environment,

- Engineer of Construction,
- Engineer of Project Development and Implementation,
- Engineer of Project Management,
- Chief Contracts Official,
- representative from Bureau of Local Roads and Streets,
- representative from Office of Planning and Programming, and
- representative from FHWA.

At the conclusion of the Awards Committee meeting, the Engineer of Project Management prepares the official bid letting tabulation and the award memorandum for submittal to the Secretary.

66-4.03(f) Preparation of Contract Prior to Award

Once low bids are received in the Contracts Office, they are placed in numerical order by item number. Bids are checked for Form A (Financial Information & Potential Conflicts of Interest Disclosure), Form B (Other Contracts & Procurement Related Information Disclosure), Apprenticeship and Training certification, Doing business in Iran certification and Workforce projection (Form BC-1256), to see if the contractor included the Steel, Bituminous or Fuel Cost Adjustment forms, and check the Signature page. DBE plans (SBE 2025 & 2026) are pulled off and taken to the Bureau of Small Business Enterprises, if applicable. Bidders are checked for delinquent debt. Bids are reviewed by the Chief Procurement Office for registration with the Secretary of State and with the state Board of Elections. Contracts that included a Project Labor Agreement are checked for the Letter of Assent. If any deficiencies are found while the sub-unit is reviewing the bidder's proposal package the bidder is notified by telephone or e-mail of the issue and what is required for correction. A note is included in the Letting Status database of the notification. Subsequently, a contract schedule of prices showing the low bidders unit prices is requested through the Bureau of Design and Environment's Letting Management (ELM) System. The bid, contract schedule of prices, and the original proposal are combined to form a draft contract. The Contracts Office will type two original contracts and two original contract bonds. All original copies of the contract and contract bond, plus the bidder's Federal taxpayer identification sheet, and a copy of insurance requirements, are taken to the Reproduction Service Unit for preparation prior to award.

66-4.03(g) Award and Rejection

Prior to the award or rejection of bids, concurrences may be required. Local agency concurrence for local projects is obtained by the Bureau of Local Roads and Streets. Concurrence may also be required from other State and Federal agencies or other States. This information is obtained by the Program Support Unit and logged by the Contracts Office, when notified. Agreements between the State of Illinois and local agencies, private benefits, and utilities must also be cleared prior to award. DBE utilization plans, if required, must also be approved prior to award. Email notification of approval is received from the Bureau of Small Business Enterprises. Prior to award, the Bureau of Land Acquisition advises the Contracts

Office of the status of the right-of-way concerning projects advertised in the Transportation Bulletin. Also prior to award, any potential conflicts of interest that were noted on Form A (Financial Information & Potential Conflicts of Interest Disclosure) must be cleared by the Procurement Policy Board. After the Chief Contracts Official has determined that all required concurrences, agreements, and right-of-way have been received, the award or rejection letter is prepared by the Contracts Office, approved by the Engineer of Project Development and Implementation, and transmitted to the Deputy Director of Program Development for review. The letter is then forwarded to the Director of Highways for signature. When the award or rejection letter has been signed for the Secretary, it is returned with all correspondence to the Contracts Office for dating, mailing, and distribution. The Contracts Office also notifies the Reproduction Service Unit to mail out the package that was previously prepared that includes an office copy and a bonding company copy of the draft contract package. Additional copies of the draft contract package are sent to the responsible district handling the project and the Bureau of Materials and Physical Research. (Note that when a project is rejected the low bid is filed with the unsuccessful bids.) The award date is entered into the Letting Management (ELM) System; this triggers the contract to pull into the Highway Procurement Policy Review (HPPR) system. The Form A (Financial Information & Potential Conflicts of Interest Disclosure) is attached to the contract information and the Disadvantaged Business Enterprise (DBE) goal is entered for each bidder, the contract is then submitted to the Procurement Policy Board (PPB) for their review and approval. The PPB waiver date is added to the Letting Status database and all emails from the PPB are electronically stored in the Letting folder.

66-4.04 Execution of Contracts

The bidder's Federal taxpayer identification form, contracts, contract bonds, power of attorney, trust agreement forms, and required insurance are reviewed for accuracy and compliance with Department policy. If it is determined the contract documents or the insurance requirements have not been properly executed, the paperwork is returned by mail to the contractor for correction. A copy of the letter is kept in the Chief Contracts Official's letting folder and a note is included in the Letting Status database. When it is determined the paperwork has been properly executed, the contract documents are dated and signed by the Chief Contracts Official (for the Secretary) or the Bureau Chief of Design and Environment (for the Secretary) and the Chief Procurement Officer or designee. If the department is unable to execute the contract the contractor is notified by letter of the problem and allowed to withdraw their bid. A copy of the letter is kept in the Chief Contracts Official's letting folder and a note is included in the Letting Status database. Once fully executed, one copy of the contract is returned to the contractor via the United Parcel Service (UPS) utilizing the UPS tracking system. The original copy is transmitted to the Bureau of Construction for further processing. The State Comptroller's Office receives a copy of the bidder's schedule of prices, certifications, affidavits, signature sheet, and executed contract documents. A certified copy of the contract is sent to the Federal Highway Administration on non-exempt Federal and Interstate projects only.

66-4.05 Railroad Insurance

Railroad insurance is required for projects on or adjacent to railroad right-of-way. Information concerning this requirement can be found in the special provisions of the proposal. The contractor must furnish the Contracts Office with one original policy, one copy of the policy, and a copy of the general, workman's compensation and automobile liability insurance certificate. The original, plus the copy of the general, workman's compensation and automobile liability certificate, are forwarded to the railroad for approval. Approval must be received before the contractor can undertake any work on the railroad or railroad right-of-way. Once approval is received, the contractor and the applicable district are notified by letter that the policy has been approved.

66-4.06 Contractor Services

Prior to each letting, the proposal and plans for each project being advertised in the Transportation Bulletin are available for inspection on the IDOT Internet site. The authorized For Bid and Not For Bid list is also available on the IDOT Internet site. Other services provided to the public are the Pay Item Report and the Pay Item Report with Awarded Prices available on the IDOT Internet site.

As contracts are executed, the Contracts Office prepares a unit price tabulation for the IDOT Internet site. Each individual tabulation will contain the following information — contractors bidding on the project, low bidder, unit prices, and totals. These tabulations are published on the IDOT Internet site approximately once per week.

DISPOSITION OF BDE PROCEDURE MEMORANDA (2002 Manual -2010 Manual)

The following disposition discusses where previously issued Procedure Memoranda have been incorporated into the 2010 BDE Manual or retired.

Memo No.	PM Title	Disposition
1-00	New Series of BDE Procedure Memorandums	See BDE PM 10-01.
2-00	Project Files Documentation	See BDE PM 10-02.
5-07	Value Engineering Program	Incorporated in Section 11-7.03 of the BDE Manual 2010 edition.
6-00	Local Participation in Spot Safety Improvement Projects	See BDE PM 10-03.
8-00	Federal Participation in Stockpiling of Salvage Materials	Incorporated in Section 64-1.06 of the BDE Manual 2010 Edition.
9-00	Surplus Excavation Disposal	Incorporated in Section 63-4.07(d) of the BDE Manual 2010 Edition.
10-01	New Series of BDE Procedure Memorandums	Retired as BDE no longer issues stand-alone Procedure Memoranda.
10-02	Project Files Documentation	Retired as it has been superseded by an update to Record Retention Schedule 12-75.
10-03	Local Participation in Spot Safety Improvement Projects	Retired as its content has been replaced by the Bureau of Safety Engineering Policy Memorandum 1-06, "Highway Safety Improvement Program (HSIP)".
10-04	Architectural and Engineering Report and Negotiation Guidelines for Engineering Agreements and Supplements	Retired as updates to Chapter 8 of the BDE Manual, BDE Form 17-09, and implementation of the Engineering Prequalification and Agreement System (EPAS) have made its content obsolete.
10-05	Compliance with Asbestos Requirements for Highway Bridges	Incorporated in Section 27-4 of the BDE Manual in October 2015.
10-06	Borrow, Use, and Waste Site, and Excess Material Disposition Documentation, Review, and Approval	Incorporated in Section 27-1.03(e) of the BDE Manual 2010 Edition in February 2011.
10-07	Special Waste Procedures	Incorporated in Section 27-2 of the BDE Manual 2010 Edition in February 2011.
15-02	Procedures to Minimize Motorists' Costs and Inconvenience	Incorporated in Chapters 13 and 34 of the BDE Manual 2010 Edition.
16-00	Quality Assurance/Quality Control Guidelines for Work By Consulting Engineers	Incorporated in Section 8-6 of the BDE Manual 2010 Edition.
17-09	Architectural and Engineering Report and Negotiation Guidelines for Engineering Agreements and Supplements	See BDE PM 10-04.

19-08	Procedures for Concurrent NEPA/404 Processes	Incorporated in Section 22-4 and updated NEPA/404 Agreement included in Part III, Appendix A of the BDE Manual 2010 Edition.
23-01	Pavement Patching for Multilane Jointed Plain Concrete Pavement (JPCP), Jointed Reinforced Concrete Pavement (JRCP), Asphaltic Concrete (AC) Overlaid JPCP and AC Overlaid JRCP	Incorporated in Chapter 53 of the BDE Manual 2010 Edition.
26-02A	Compliance with Asbestos Requirements For Highway Bridges	Still active and re-issued as BDE PM 10-05
27-02	Temporary Concrete Barrier	Incorporated in Section 55-4.02 of the BDE Manual 2010 Edition.
28-02	Validity of Special Waste Assessment Results	Incorporated in PM 66-09A, which was incorporated in Section 27-2 of the BDE Manual 2010 edition.
31-03	Incidental Taking Authorization Procedures	Incorporated in Section 26-9.06(h) of the BDE Manual 2010 Edition.
32-03	Changes in 4(f) Applicability for Actions Involving U.S Coast Guard Permits	Incorporated in Section 26-2.04(b) of the BDE Manual 2010 Edition.
33-03	Wetlands Compliance Procedures	Incorporated in Section 26-8 of the BDE Manual 2010 Edition.
34-08	Impact Attenuators (Crash Cushions)	Incorporated in Section 38-8 of the BDE Manual 2010 Edition.
35-05	Detectable Warnings for Curb Ramps, and Other Locations	Incorporated in Section 58-1.09 of the BDE Manual 2010 Edition.
36-08	Roadside Barriers	Incorporated in Sections 38-5 and 38-6 of the BDE Manual 2010 Edition.
37-03	Documenting Microscale Analysis Information	Incorporated in Section 26-14 of the BDE Manual 2010 Edition.
38-04	Errata for the BDE Manual 2002 Edition	Incorporated in the BDE Manual 2010 Edition.
39-08	Median Barriers and Glare Screens	Incorporated in Section 38-7 of the BDE Manual 2010 Edition.
40-04	Addressing Impaired Waters/TMDLs in Project Environmental Documentation	Incorporated in Sections 24-3.02(e), 253.08(j), and 26-21 of the BDE Manual 2010 Edition.
41-08	Delegation of Approval Authorities to Districts	Incorporated in applicable Sections of the BDE Manual 2010 edition.
42-04	Changes in the BDE Manual Guidance on Air Quality and Related Subjects	Incorporated in Sections 24-3.02(e), 253.08(f), and 26-11 of the BDE Manual 2010 Edition.
43-09	Coordination with IDNR on Natural Resource Issues	Incorporated in Sections 22-5.02(b) and 27-1 and updated Coordination Agreement included in Part III, Appendix A of the BDE Manual 2010 Edition.

44-05	Timeframes for Environmental Impact Statements and Environmental Assessments	Incorporated in Sections 24-2 and 25-2 and Timeframes Agreement included in Part III, Appendix A of the BDE Manual 2010 Edition.
46-05	FHWA Section 4(f) Policy Paper and Final Programmatic Section 4(f) Evaluation and Determination for Federal-Aid Transportation Projects That Have a Net Benefit to a Section 4(f) Property	Incorporated in Part III, Appendix A of the BDE Manual 2010 Edition.
47-05	Guidelines for Pavement Preservation	Incorporated in Chapter 52 of the BDE Manual 2010 Edition.
48-06	Design Flexibility and the Stakeholder Involvement Process for Context Sensitive Solutions (CSS)	Incorporated in applicable Sections of the BDE Manual 2010 edition.
49-06	Guidance for Determining De Minimis Impacts to Section 4(f) Resources	Incorporated in Section 26-2.04(d) of the BDE Manual 2010 Edition.
50-06	Final Rule for 23 CFR 772 "Procedures for Abatement of Highway Traffic Noise and Construction Noise"	Incorporated in Section 26-6 of the BDE Manual 2010 Edition.
51-06	Plan, Specification and Quantity Changes	Incorporated in Section 66-3.01(b) of the BDE Manual 2010 Edition.
52-06	Mobile Source Air Toxics	Incorporated in Section 26-13 of the BDE Manual 2010 Edition.
53-06	Design Guidance for Median and Curb Treatments at Railroad Grade Crossings	Incorporated in Sections 7-3.02(f) and 34-2.04 of the BDE Manual 2010 Edition.
54-07	Categorical Exclusion Group II Approval Documentation	Incorporated in Section 24-1.03(c) of the BDE Manual 2010 Edition.
55-07	Wetland Impact Accumulation	Incorporated in Section 26-8.05(c) of the BDE Manual 2010 Edition.
56-08A	Borrow, Use, and Waste Site, and Excess Material Disposition Documentation, Review, and Approval	See BDE PM 10-06
57-08	Use of Commercial and Department Wetland Mitigation Bank Site Credits	Incorporated in Section 26-8.05(c) of the BDE Manual 2010 Edition.
58-08	Existing Public Educational Facility Entrances	Incorporated in Chapter 12 of the BDE Manual 2010 edition.
59-08	Selecting Contract Time and Project Letting Date	Incorporated in Section 66-2.04 of the BDE Manual 2010 Edition.
60-08	Transportation Conformity Project-Level Qualitative Hot-Spot Analysis in PM2.5 and PM10 Nonattainment and Maintenance Areas	Incorporated in Section 26-12 of the BDE Manual 2010 Edition.
61-08	Meeting SAFETEA-LU Section 6002, Context Sensitive Solutions, and NEPA/404 Merger Process Requirements for Environmental Impact Statements	Incorporated in Chapter 3 and Section 25-2 of the BDE Manual 2010 Edition.

62-08	Control of Emerald Ash Borer on Department Owned Lands	Incorporated in Section 59-7.01(a) of the BDE Manual 2010 Edition.
63-08	Local Agency Agreements – Municipality Reimbursements	Incorporated in Section 55-5.03(a) of the BDE Manual 2010 Edition.
64-08	Portland Cement Concrete Inlay or Overlay	Incorporated in Chapter 53 of the BDE Manual 2010 Edition.
65-08	Pipe Culverts and Storm Sewers	Incorporated in Section 40-3.07 of the BDE Manual 2010 Edition.
66-09A	Special Waste Procedures	Incorporated in Section 27-2 of the BDE Manual 2010 Edition prior to the issuance of BDE PM 66-10 which superseded it.
66-10	Special Waste Procedures	See BDE PM 10-07
67-09	Surface Finish for Concrete Pavements	Incorporated in Section 41-4.01(o) of the BDE Manual 2010 Edition.
68-10	Bicycle and Pedestrian Accommodation (Complete Streets)	Incorporated in Chapters 5 and 17 of the BDE Manual 2010 edition.