



State of Illinois
Illinois Department of Transportation

Illinois Department of Transportation

DRAINAGE MANUAL

July 2011



Illinois Department
of Transportation
Bureau of Bridges and Structures

IDOT Drainage Manual

Title Page

Prepared by:

Drainage Manual Committee for IDOT Division of Highways

Agency:

Illinois Department of Transportation

Place of Publication:

Springfield Illinois

2011

STATE OF ILLINOIS	FILE CLASSIFICATION: IDOT Drainage Manual
DEPARTMENT OF TRANSPORTATION BUREAU OF BRIDGES AND STRUCTURES	DRAINAGE MANUAL CHANGE LETTER NO. 11-1
To: All holders of the Drainage Manual	DATE ISSUED: July 31, 2011

The new 2011 IDOT Drainage Manual is now available for download on the IDOT website. It shall replace the 2004 Drainage Manual and Drainage Manual Appendix in its entirety. The 2004 Drainage Manual and Appendix will be archived and retained for reference.

These are some of the major changes incorporated into the 2011 IDOT Drainage Manual.

- Delineated hydraulic duties & responsibilities between District Hydraulics and BBS Hydraulics, including qualification of District Hydraulic Engineer.
- Replaced outdated USGS regression equations with procedures and example for Illinois StreamStats hydrologic method.
- Updated Table 1-305 Design Flood Frequency and Table 4-002 Hydrologic Methods for drainage facilities.
- Expanded HEC-RAS modeling direction for bridge and culvert hydraulics.
- Reflects latest IDOT policy and practices regarding allowable pipe culvert and storm drain materials.
- Reflects latest FHWA methods and procedures from HEC-22 for storm drain analysis, including updated examples.
- Rewrote and expanded regulatory permit information from IEPA, Army Corps and particularly IDNR-OWR Floodway Construction Program.
- Reworked section on linear detention and added new material on roadway, detention and pump station hydrologic analysis.
- Extensive update of National Flood Insurance Program maps and studies along with FEMA information and contacts.
- Incorporates bridge scour developments since 2004:
 - Plan of Action (POA) material and countermeasure designs.
 - Estimating pressure flow scour.
- IDOT & external source or reference materials hyperlinked throughout.
- All 2004 Appendix text folded into Manual or hyperlinked within.

Implementation of the 2011 IDOT Drainage Manual:

The official effective date of this July 2011 edition of the manual is October 1, 2011. However, many of the new policies, practices and procedures have already been put in place by the manual committee since the 2004 update. It is recommended the new manual's policies and procedures be implemented as soon as it becomes practical.

The manual can be found at <http://www.dot.il.gov/bridges/brmanuals.html>. Please note that the file size is very large. If download problems are encountered, please contact Dick Best of BBS at 217/785-2922 or richard.best@illinois.gov.



D. Carl Puzey
Acting Engineer of Bridges and Structures

MO'C

IDOT Drainage Manual

Preface

In 1984, the Director of the Division of Highways established a task force to compile and publish a manual collecting all departmental highway drainage policies and procedures in one publication. The task force was composed of IDOT personnel from three IDOT Central Office bureaus (Bridges & Structures, Design and Location & Environment) and staff from all the nine Districts that included all District Hydraulic Engineers.

A committee was formed in 2000, consisting of the BBS Hydraulics Unit, DHE's and various staff from all 9 districts and two consultants that had previously held the DHE position with IDOT. The committee solicited input from sources such as consultants (ACEC) and Central Office bureaus. The committee rewrote much of the Drainage Manual and released the update in 2004.

Since 2004, there have been several important developments related to hydrology and hydraulic work completed within the Division of Highways. Consequently, the committee reconvened in 2008- with the same representative mix of BBS Hydraulics, District Hydraulics and consultant input- to produce the current manual. The release date for this update is July 2011.

Dedication: to Tom Jungk

In 2004, the committee dedicated this manual to the memory of our friend and colleague, Tom Jungk, who passed unexpectedly in October 2001. Tom was the longtime District Hydraulic Engineer for District 2 in Dixon. He made significant contributions to the original version of this manual and to subsequent revisions. Tom was known for his friendly outgoing personality as well as his knowledge of highway and bridge hydraulics. Tom will long be remembered by those who had the opportunity to work beside him.

IDOT Drainage Manual

Table of Contents

Cover

Title Page

Change Letter

Preface & Dedication

Chapter 1..... *Responsibilities & Policy*

Chapter 2..... *Drainage Studies & Hydraulic Reports*

Chapter 3..... *Floodplain Encroachments*

Chapter 4..... *Hydrology*

Chapter 5..... *Open Channel Flow*

Chapter 6..... *Culvert Hydraulics*

Chapter 7..... *Bridge Hydraulics*

Chapter 8..... *Storm Sewers*

Chapter 9..... *Roadside Ditches*

Chapter 10..... *Scour*

Chapter 11..... *Scour Countermeasures*

Chapter 12..... *Detention Storage*

Chapter 13..... *Pump Stations*

Chapter 14..... *Computer Software*

Glossary



Chapter 1

ACIOP & MOI-DIHODOR

CHAPTER 1- RESPONSIBILITIES & POLICY

- 1-000 GENERAL
 - 1-001 Introduction
 - 1-002 Objectives of Highway Drainage Design
- 1-100 ORGANIZATION & RESPONSIBILITIES
 - 1-101 IDOT Drainage Manual
 - 1-102 Drainage Responsibilities
 - 1-102.01 Central Office \ Bureau of Bridges and Structures
 - 1-102.02 District Office
 - 1-102.03 District Hydraulic Engineer Qualification
- 1-200 LEGAL REQUIREMENTS
 - 1-201 General
 - 1-202 Executive Order & FEMA National Flood Insurance Program
- 1-300 DRAINAGE POLICIES
 - 1-301 Overview
 - 1-302 Floodplain Encroachments
 - 1-302.01 Longitudinal Encroachments
 - 1-302.02 Transverse Encroachments \ Bridges & Culverts
 - 1-302.03 Compensatory Storage
 - 1-303 Documentation of Floodplain Encroachment Designs
 - 1-303.01 Design Risk Assessment
 - 1-303.02 Plan Notation- Waterway Information Table
 - 1-304 Pavement and Bridge Deck Drainage
 - 1-304.01 Pavement Encroachment
 - 1-304.02 Bridge Deck Drainage
 - 1-304.021 Bridge Deck Inlets
 - 1-304.022 Floor Drains
 - 1-304.023 Off-Bridge Inlets
 - 1-304.03 Stormwater Storage
 - 1-305 Design Criteria

1-400	REGULATORY AGENCY PERMITS	
1-401	Introduction	
1-402	Navigable Waters	
1-403	Section 401 Illinois EPA and Section 404 U. S. Army Corps of Engineers	
1-404	Floodway Construction Program \ Illinois Department of Natural Resources- Office of Water Resources	
	1-404.01	IDNR-OWR Permit FAQ's
	1-404.02	IDNR-OWR Regulatory Permit Program
	1-404.03	IDNR-OWR Individual Permit Program
	1-404.04	IDNR-OWR Statewide Permits
		1.404.041 Permanent Construction: Statewide Permits #2 & #12
		1.404.042 Temporary Construction: Statewide Permits #13 & #14
	1-404.05	IDNR-OWR Public Body of Water Permit
1-500	IDOT HIGHWAY ACCESS PERMITS	
1-600	TEMPORARY STRUCTURES	
1-700	REFERENCES	
1-800	ADDENDUMS	
	1-801	Highway Drainage Law
	1-802	Public Act 86-186
	1-803	Draft Rules: Permits for Drainage Outlets

1-000 GENERAL**1-001 Introduction**

The intent and purpose of the IDOT Drainage Manual is to provide a published document that formalizes the drainage policies, procedures and practices to be used by the employees and consultants representing the IDOT Division of Highways. The IDOT Drainage Manual contains the following:

- Drainage policies, procedures and guidance for practices to be utilized in the planning, design, construction and operation of the State highway system.
- Design examples that illustrate the typical application of design procedures, standard practices and common reference materials.
- Delineation of responsibilities between the Central Office and Regional \ District Offices.
- Guidance to ensure the legal obligations and functional needs of the Division of Highways are achieved.

1-002 Objectives of Highway Drainage Design

Drainage structures and their appurtenances, or accompanying features, play a vital role in the operation of the State highway system. Drainage structures account for approximately 30 percent of the highway construction dollar and it is essential that only cost effective structures are utilized.

The objectives of highway drainage design are to blend the highway system into the local environment with minimal negative impact to adjacent property, the stream environment, and to the subject roadway embankment and drainage structures themselves. These objectives are to be accomplished in a cost effective manner, while maintaining public safety and satisfying the Department's legal obligations and functional needs.

1-100 ORGANIZATION & RESPONSIBILITIES

1-101 IDOT Drainage Manual

The Hydraulics Unit within the Central Office Bureau of Bridges and Structures (BBS) is responsible for the development and administration of highway and bridge drainage policies and procedures for the Division of Highways.

The Drainage Manual Committee is currently chaired by the BBS Hydraulics Group Leader and is composed of the nine District Hydraulic Engineers, BBS Hydraulics Unit staff, various District hydraulic staff and two consulting engineers who previously held the position of District Hydraulic Engineer. The Committee is responsible for continually reviewing the status of the Division's highway drainage policies and procedures as contained in the Drainage Manual and making recommendations on revisions or additions.

The Drainage Manual Committee shall meet annually or as need dictates. During the interim between upgrades or revisions to the Manual, users may contact the e-mail inbox bbs.comsuggest@illinois.gov with comments, suggestions or questions. This service collects comments on all BBS issued manuals. BBS Hydraulics will monitor the inbox for input related to this Manual.

1-102 Drainage Responsibilities

The drainage responsibilities of the Division of Highways are divided between the Central Office and nine District Offices located around the State. In 2003, the nine District Offices were further reorganized into five Regions. During that reorganization, District boundaries were revised, resulting in the reassignment of upwards of 20 counties to a different IDOT District office. The current locations and jurisdictional boundaries of both the nine Districts and five Regions are shown in [Figure 1-102](#).

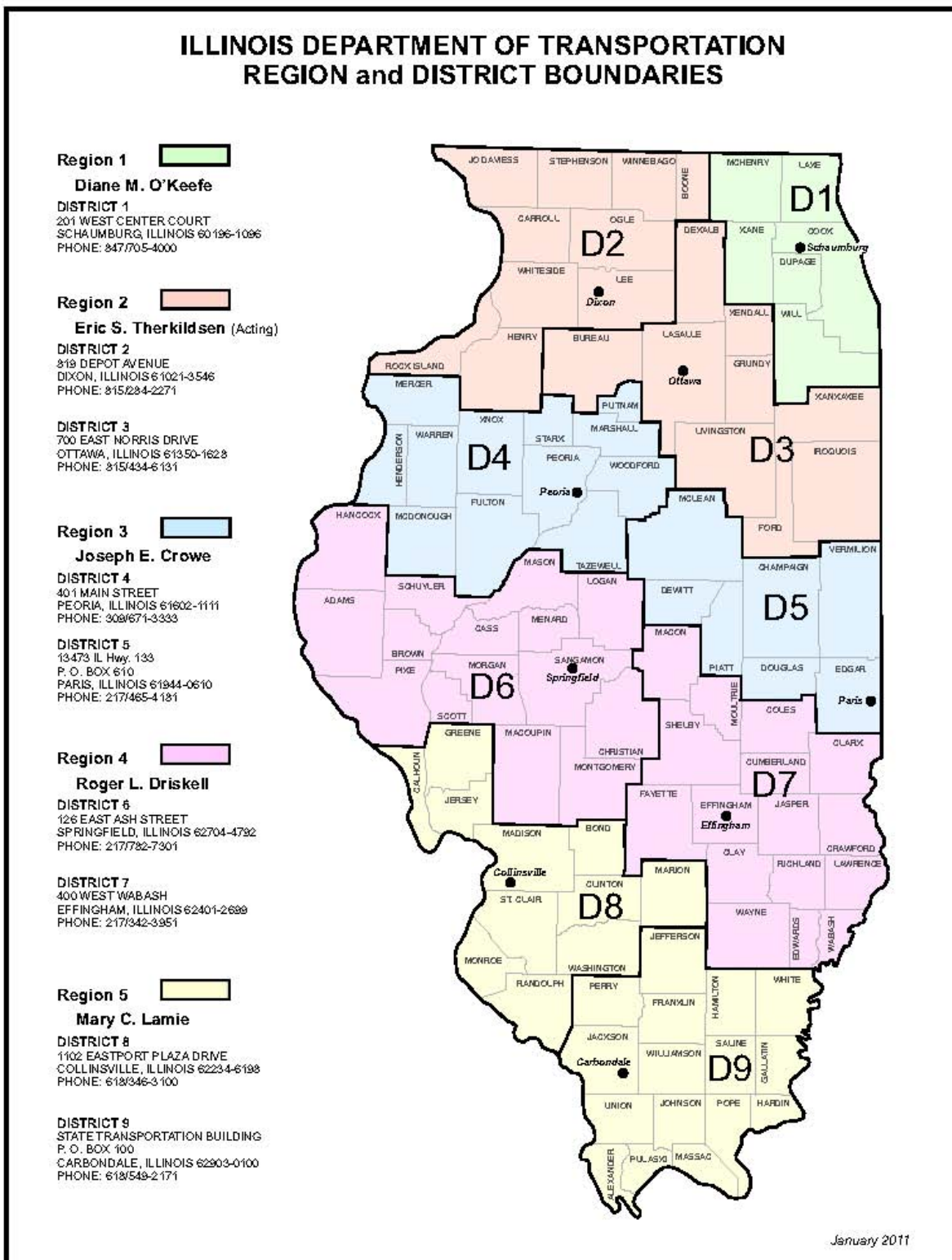

**Region\District Office Locations and Jurisdictional Boundaries
Figure 1-102**

1-102.01 Central Office \ Bureau of Bridges and Structures

The Hydraulics Unit within the Bureau of Bridges and Structures has the responsibility for carrying out the drainage functions of the BBS. There are a handful of exceptions to that blanket statement; the exceptions are noted below.

The primary drainage functions of the BBS include the following:

1. Policy - The Bureau of Bridges and Structures is responsible for the development and implementation of all drainage policies and technical procedures of the Division of Highways.
2. Report Review and Approval – It is the responsibility of the Bureau of Bridges and Structures to review and approve the Hydraulic Report for all pumping stations. It is the responsibility of the Bureau of Bridges and Structures to review and approve the Hydraulic Report for all bridges that fall under BBS approval authority as defined within the June 28, 2004, ADE Memorandum entitled “Delegation of Approval Authority to Districts”. BBS approval authority includes all bridges that require an Individual Permit from the Illinois Department of Natural Resources - Office of Water Resources (IDNR-OWR) and all bridge Hydraulic Reports prepared in-house by non-qualified District Hydraulic Engineers. (See 1.102.03 District Hydraulic Engineer Qualification). For a consultant-prepared Hydraulic Report completed in a non-qualified District, it is the responsibility of BBS to review and approve exceptions to standard policy and procedures **only**. Districts may request BBS review and approval or technical assistance on any Hydraulic Report- bridge or culvert- regardless of which office possesses approval authority. See Figure 1-102.01 Hydraulic Report Milestones for Bridges and Culverts.
3. Illinois Department of Natural Resources Office of Water Resources (IDNR-OWR) Floodway Construction Permits - It is the responsibility of the Bureau of Bridges and Structures to obtain all required construction permits from the OWR for structures designated as BBS responsibility and for any channel changes associated with these structures. See Section 1-404.
4. Permits in Navigable Waters¹ - The Bureau of Bridges and Structures is responsible for obtaining all United States Coast Guard (USCG) permits, for construction or modification of bridges or causeways, under Section 9 of the River and Harbor Act of 1899 and the General Bridge Act of 1946. USCG permits are NOT the responsibility of the Hydraulics Unit; they are handled by the Bridge Planning Unit Chief. See [Section 2 Planning of the IDOT Bridge Manual](#).
5. Approval in Navigable Waters¹ – Plans for bridge repair that permanently alter the navigational clearances or conditions for navigation must be approved by the United States Coast Guard prior to commencing work. Like USCG Permits in Navigable Waters, the Bridge Planning Unit handles approval coordination with the USCG.
6. Technical Advisory Service - The Bureau of Bridges and Structures provides a technical advisory service consisting of the investigation, analysis and solution of difficult drainage problems for the District Offices and the Central Bureaus of Construction, Operations, Local Roads and Streets and Design and Environment.

7. Waiver of Drainage Policy - The Bureau of Bridges and Structures is responsible for the review and approval of District requests for waiver of drainage policy criteria on specific projects for which the BBS has provided review and approval of the Hydraulic Report. Note that whichever office possesses review and approval authority of the HR also assumes responsibility for granting waivers from drainage policy criteria.
8. Legal Support – BBS Hydraulics serves as the Division's authority on drainage matters and provides support to the Chief Counsel's Office and District Offices concerning drainage litigation or complaints.
9. Training - The Bureau of Bridges and Structures coordinates statewide training opportunities related to hydrology and hydraulics using the resources of cooperative agencies, such as the United States Geological Survey (USGS), Natural Resource Conservation Service (NRCS), National Highway Institute (NHI) and the Federal Highway Administration (FHWA).
10. Computer Assistance and Support - The Bureau of Bridges and Structures is responsible for developing and maintaining a computer program base for dissemination and use by the District Offices and Division consultants. The goal is to establish and maintain design and application uniformity with all interfacing offices to expedite the review of computations. The Bureau of Bridges and Structures evaluates the appropriateness of special drainage programs for statewide use. Resolution of computer-related problems, such as application, provision or troubleshooting, is also provided. The types of programs and documentation are covered in [Chapter 14](#).
11. Research Coordination - The Bureau of Bridges and Structures coordinates drainage related research on two levels. The first is a review of the published findings of outside agencies such as FHWA and NCHRP, who do the primary study and documentation. The second is assistance in drainage related research funded by the Division in cooperation with outside agencies, such as USGS, state universities and joint studies with other States. The latter effort is coordinated through the Bureau of Materials and Physical Research and is primarily carried out through the research projects initiated by the Illinois Center for Transportation (ICT). The ICT is IDOT's in-house research arm that involves program affiliation with the UIUC, UIC, other state universities and public agencies that do research in the field of transportation.

Hydraulic Report (HR) Milestones Bridges & Culverts

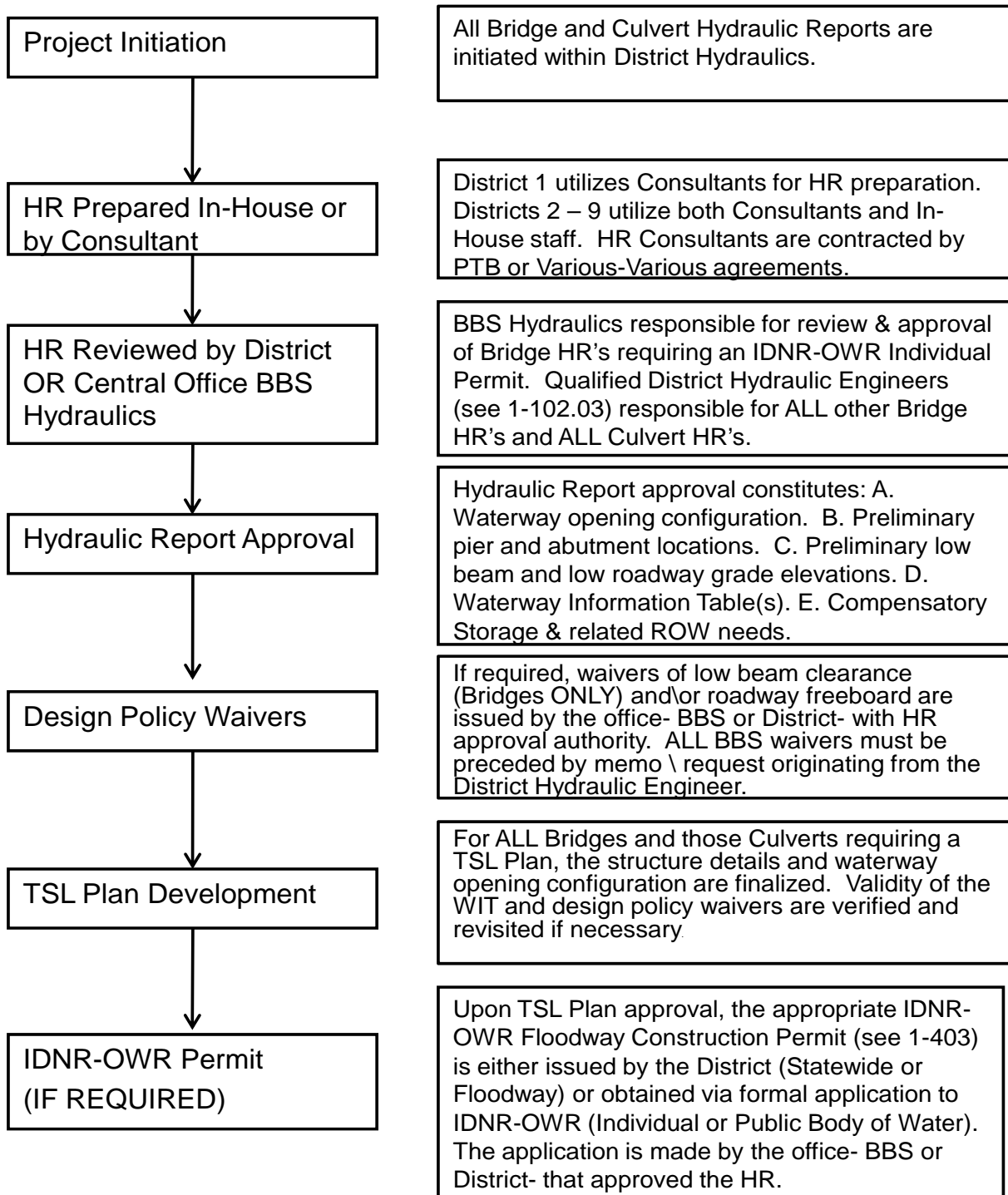

Figure 1-102.01

1-102.02 District Office

District Office drainage responsibilities are different from those of the Central Office in that Districts do not establish policy, develop standards or perform other centralized functions. District drainage functions are generally the responsibility of the District Hydraulic Engineer. This position is located in the Bureau of Programming \ Drainage Section in District One and in the Bureau of Program Development \ Hydraulic Unit in each of the other Districts. In Districts 3, 4, 5, 7 and 9, the position is known as the Bridge and Hydraulics Engineer, because it also encompasses a number of bridge or structurally related responsibilities.

The primary drainage functions of the District Office include the following:

1. Consultant Services - The District Office is responsible for negotiating consultant agreements and for directing consultants in the extent of data collection and analysis required for specific projects. The District is also responsible for monitoring the consultant's work.
2. Location Drainage Studies - The District is responsible for the completion and approval of location drainage studies for highway-related drainage improvements. These studies and Reports may be performed by District personnel or by a consultant under District supervision. The studies are approved in the District or in some cases by the Central Office Bureau of Design and Environment.
3. Hydraulic Reports - The District is responsible for the submittal of Hydraulic Reports and/or Hydraulic Report Data Sheets to the Bureau of Bridges and Structures for all bridge and/or drainage structures requiring Central Office approval. See Figure 1-102.01 Hydraulic Report Milestones for Bridges and Culverts.

The District is responsible for approval of all bridge Hydraulic Reports (HR), except for bridge projects requiring an individual IDNR-OWR permit and/or prepared by District staff in a non-qualified District. For those projects that fall under District approval authority, the Bureau of Bridges and Structures is available for consultation and may provide HR review and approval at the District's request. The District is responsible for the hard copy submittal of Hydraulic Reports to the Bureau of Bridges and Structures for all bridge and/or drainage structures requiring BBS approval. The District should electronically post an informational copy of the Hydraulic Report to the BBS Hydraulics Unit SharePoint site for two types of projects: bridges approved by the District Hydraulic Engineer and culverts requiring structural approval from the BBS. The District is responsible for informing BBS by memorandum of any HR's approved by District Hydraulics and posted to SharePoint.

4. Hydraulic Design - The District is responsible for the hydraulic adequacy of all drainage structures not listed as Central Office responsibility. This includes the hydraulic design of storm sewer systems, roadside and median ditches, erosion control devices, culverts and longitudinal floodplain encroachments which do not include structures. Culverts replacing bridges are included in this responsibility.
5. IDNR-OWR Permits - The District is responsible for obtaining any necessary OWR floodway construction permits for projects described above as District responsibility.

6. Section 401, 404 and Section 10 Permits - The District is responsible for obtaining all necessary Section 401 from the Illinois EPA. The District is responsible for obtaining all necessary 404 and Section 10 Permits from the Corps of Engineers. Refer to [Sections 1-402 and 1-403](#).
- 7a. Waiver of Drainage Policy - For those projects that fall under Central Office hydraulic review responsibility (BBS, Design and Environment, or other CO Bureau) and contain design elements in non-compliance with IDOT drainage policy criteria, the District is responsible for making a written request for a waiver of policy criteria to the appropriate Central Office bureau(s).
- 7b. For those projects that fall under the District hydraulic responsibility, the District is responsible for documenting and approving waivers from policy criteria.
8. IDOT Highway Access Permits - The District is responsible for reviewing applications for highway access permits to ensure that the integrity of the State highway drainage system is maintained and that drainage from developed property does not otherwise affect the operational safety of the State highway system.
9. Technical Advisory Service - The District Hydraulic Engineer provides a technical advisory service on drainage matters to consultants and other Bureaus of the District.
10. Joint Agreements - The District is responsible for the initiation and drafting of joint agreements and submittal to the Central Office for approval, if required.
11. Expert Testimony - The District hydraulic staff provides the District's expert witness testimony for land acquisition and other drainage-related legal activities.
12. District Scour Evaluation Team - The SET in each District (comprised of the Hydraulic Engineer, Bridge Maintenance Engineer and Geotechnical Engineer) is responsible for the scour evaluation of all existing bridges. This responsibility includes the development and implementation of a Plan of Action (POA) at scour critical bridges.
13. United States Coast Guard Approval – Plans for repairs or maintenance to bridges over navigable waters (as defined by the U.S. Coast Guard) which will not result in any permanent reduction to the existing navigational clearances do not require approval from the Coast Guard. However, Approval from the Coast Guard is required for any temporary falsework, scaffolding, cofferdams or bents that will be used to facilitate bridge repairs on structures over navigable waters if these temporary structures will reduce the clearance for navigation. See the booklet *Application for Coast Guard Bridge Permits*¹ for more information and definitions.

1-102.03 District Hydraulic Engineer Qualification

The June 28, 2004, All District Engineers (ADE) Memorandum entitled "Delegation of Approval Authority to Districts", implemented a Division of Highways initiative to delegate more approval authority to the District Offices. Towards that end, the memo created the Qualified District Hydraulic Engineer designation and a process for obtaining the designation. Essentially the process requires the Regional Engineer to present the District Hydraulic Engineer as a candidate for approval by the Director of Highways in the Central Office. As detailed in the ADE memo, candidates must have reached the CEV position classification, demonstrate proven ability to prepare bridge Hydraulic Reports and have taken a variety of training courses. Once Qualification is achieved, the District Hydraulic Engineer gains the approval authority for all bridge Hydraulic Reports, regardless if prepared by the District or if prepared by consultant, except for those projects that require an Individual Permit from IDNR-OWR. Those projects requiring an Individual Permit remain under the approval authority of the Bureau of Bridge and Structures, as summarized in Section 1-102.01, Item 2. This approval authority also carries the responsibility for issuance of IDNR-OWR Statewide Permits and the appropriate waivers from policy criteria.

As of this 2011 update, eight of nine IDOT District Offices have obtained Qualified District Hydraulic Engineer status. These eight Districts possess approval authority for ALL bridge Hydraulic Reports that do not require an Individual Permit from IDNR-OWR. It should be noted that at the request of the District Office, BBS Hydraulics may contribute technical input or provide review and approval for ANY structure Hydraulic Report. Also note that the Qualified designation is subject to internal IDOT review and can be impacted by staffing turnover.

1-200 LEGAL REQUIREMENTS

1-201 General

The Department of Transportation is bound by the common, statutory and constitutional laws of natural drainage, as adopted by Illinois Courts. The basic rule of natural drainage is that the owner of higher ground has an easement to have surface water flow naturally from his land onto the land of the lower owner, and that the owner of the lower land does not have the right to obstruct its flow and cast the water back on the land above.

This rule is to apply to all aspects of highway construction and maintenance, including bridges, culverts, basins, storm sewers, roadway embankments, channel changes and their appurtenances.

The application of this rule in the design of storm sewers and roadside ditches requires that the highway drainage system collect all surface flow, which naturally drains to the right of way. This includes sheet flow, as well as flow in a defined channel. The highway drainage system is to be designed so as not to cast water back onto adjacent upstream properties.

A similar application of this rule is to be followed in the design of bridges and culverts. A detailed hydraulic analysis is required for all bridge and culvert projects to ensure that the completed construction will satisfy the highway objectives and to ensure that all flows which are naturally tributary to the site are considered in the design and are passed on downstream by the structure. As it becomes necessary to replace existing structures, the design must consider legal increases in flow resulting from watershed development that has occurred since the existing structure was built.

For a more complete presentation of legal considerations, see the publication Illinois Drainage Laws: Rights and Responsibilities of Highway Authorities and Land Owners Adjacent to Highways² available at the webpage <http://www.ideals.uiuc.edu/handle/2142/8575>. The paper, Highway Drainage Law³, is provided as Addendum 1-701 at the end of this chapter for additional information. It is a brief synopsis of the three areas of the law that can affect drainage issues or disputes that are commonly encountered in highway engineering.

1-202 Executive Order 2006-05 and FEMA National Flood Insurance Program

The Governor's 2006 Executive Order entitled "Construction Activities in Special Flood Hazard Areas 2006-05", supersedes and replaces Executive Order Number 4 of the same title, issued in 1979 during the Thompson administration. EO 2006-05 defines special flood hazard areas (or floodplains) as areas subject to inundation by the base (Q100) flood event and shown as such on the current FEMA Flood Insurance Study (FIS) Rate Map. The EO requires that the construction activities of the Division of Highways comply with the standards of the State Flood Plain Regulations (IDNR-OWR Regulatory Permit Program) and the National Flood Insurance Program (NFIP), whichever is "applicable". Proper IDOT roadway and structure hydraulic design criteria ensure the overall intent of the EO is met. IDNR-OWR is in concurrence with the IDOT position that compliance with the OWR floodway permit criteria constitutes compliance with the Executive Order 2006-05. The Executive Order is shown here in its entirety.

EO 2006-05 CONSTRUCTION ACTIVITIES IN SPECIAL FLOOD HAZARD AREAS

WHEREAS, the State of Illinois has programs for the construction of buildings, facilities, roads, and other development projects and annually acquires and disposes of lands in floodplains; and

WHEREAS, federal financial assistance for the acquisition or construction of insurable structures in all Special Flood Hazard Areas requires State participation in the National Flood Insurance Program; and

WHEREAS, the Federal Emergency Management Agency has promulgated and adopted regulations governing eligibility of State governments to participate in the National Flood Insurance Program (44 C.F.R. 59-79), as presently enacted or hereafter amended, which requires that State development activities comply with specified minimum floodplain regulation criteria; and

WHEREAS, the Presidential Interagency Floodplain Management Review Committee has published recommendations to strengthen Executive Orders and State floodplain management activities;

NOW THEREFORE, by virtue of the authority vested in me as Governor of the State of Illinois, it is hereby ordered as follows:

1. For purpose of this Order:

A. "Critical Facility" means any facility which is critical to the health and welfare of the population and, if flooded, would create an added dimension to the disaster. Damage to these critical facilities can impact the delivery of vital services, can cause greater damage to other sectors of the community, or can put special populations at risk. The determination of Critical Facility will be made by each agency.

Examples of critical facilities where flood protection should be required include:

Emergency Services Facilities (such as fire and police stations)

Schools

Hospitals

Retirement homes and senior care facilities

Major roads and bridges

Critical utility sites (telephone switching stations or electrical transformers)

Hazardous material storage facilities (chemicals, petrochemicals, hazardous or toxic substances)

Examples of critical facilities where flood protection is recommended include:

Sewage treatment plants

Water treatment plants

Pumping stations

B. "Development" or "Developed" means the placement or erection of structures (including manufactured homes) or earthworks; land filling, excavation or other alteration of the ground surface; installation of public utilities; channel modification; storage of materials or any other activity undertaken to modify the existing physical features of a floodplain.

C. "Flood Protection Elevation" means one foot above the applicable base flood or 100-year frequency flood elevation.

D. "Office of Water Resources" means the Illinois Department of Natural Resources, Office of Water Resources.

E. "Special Flood Hazard Area" or "Floodplain" means an area subject to inundation by the base or 100-year frequency flood and shown as such on the most current Flood Insurance Rate Map published by the Federal Emergency Management Agency.

F. "State Agencies" means any department, commission, board or agency under the jurisdiction of the Governor; any board, commission, agency or authority which has a majority of its members appointed by the Governor; and the Governor's Office.

2. All State Agencies engaged in any development within a Special Flood Hazard Area shall undertake such development in accordance with the following:

A. All development shall comply with all requirements of the National Flood Insurance Program (44 C.F.R. 59-79) and with all requirements of 92 Illinois Administrative Code Part 700 or 92 Illinois Administrative Code Part 708, whichever is applicable.

B. In addition to the requirements set forth in preceding Section A, the following additional requirements shall apply where applicable:

(1). All new Critical Facilities shall be located outside of the floodplain. Where this is not practicable, Critical Facilities shall be developed with the lowest floor elevation equal to or greater than the 500-year frequency flood elevation or structurally dry floodproofed to at least the 500-year frequency flood elevation.

(2). All new buildings shall be developed with the lowest floor elevation equal to or greater than the Flood Protection Elevation or structurally dry floodproofed to at least the Flood Protection Elevation.

(3). Modifications, additions, repairs or replacement of existing structures may be allowed so long as the new development does not increase the floor area of the existing structure by more than twenty (20) percent or increase the market value of the structure by fifty (50) percent, and does not obstruct flood flows. Floodproofing activities are permitted and encouraged, but must comply with the requirements noted above.

3. State Agencies which administer grants or loans for financing development within Special Flood Hazard Areas shall take all steps within their authority to ensure that such development meets the requirements of this Order.

4. State Agencies responsible for regulating or permitting development within Special Flood Hazard Areas shall take all steps within their authority to ensure that such development meets the requirements of this Order.

5. State Agencies engaged in planning programs or programs for the promotion of development shall inform participants in their programs of the existence and location of Special Flood Hazard Areas and of any State or local floodplain requirements in effect in such areas. Such State Agencies shall ensure that proposed development within Special Flood Hazard Areas would meet the requirements of this Order.

6. The Office of Water Resources shall provide available flood hazard information to assist State Agencies in carrying out the responsibilities established by this Order. State Agencies which obtain new flood elevation, floodway, or encroachment data developed in conjunction with development or other activities covered by this Order shall submit such data to the Office of Water Resources for their review. If such flood hazard information is used in determining design features or location of any State development, it must first be approved by the Office of Water Resources.

7. State Agencies shall work with the Office of Water Resources to establish procedures of such Agencies for effectively carrying out this Order.

8. Effective Date. This Order supersedes and replaces Executive Order Number 4 (1979) and shall take effect on the first day of.

Rod R. Blagojevich, Governor

Issued by Governor: March 7, 2006

Filed with Secretary of State: March 7, 2006

For virtually all IDOT construction projects within a floodplain, regardless if the floodplain is regulated (published FIS data is available) or non-regulated, the "applicable" legal and regulatory standard will be the State Flood Plain Regulations. These regulations are the basis for the IDNR-OWR Regulatory Permit Program (also referred to as the State floodway permit program) which is detailed in Section 1-404. That does not mean that FEMA standards and studies play no role in IDOT drainage studies. FIS data is very commonly employed by IDOT for two purposes; first, to demonstrate compliance with IDNR-OWR permit regs and second, as reference information for comparison to IDOT-generated H&H design recommendations. The first purpose is commonly served at bridge and culvert projects over regulated streams in District 1, where FIS models, Q100-event discharges and water surface elevations are routinely employed to obtain IDNR-OWR 3708 Floodway Permits. For those projects both FIS discharges and hydraulic models are utilized to demonstrate 3708 compliance. The second scenario is typically encountered in Districts 2 through 9, where IDNR-OWR does not explicitly and uniformly require utilization of FIS data to demonstrate permit compliance. In that case, IDOT is not

obligated to use the FIS model to support and validate a more detailed and updated model study that is compiled, for example, to assess a roadway longitudinal encroachment in a Location Drainage Study. All floodplain designs in regulated streams- regardless of District location and permit requirements- should at the very least identify the FIS data and published water surface profiles for purposes of comparison to the IDOT H&H analysis. That comparison should include an assessment of the content, completeness and applicability of the methods utilized within the FIS model. It is the Department's intent to recognize all FEMA studies to the degree that they are required for IDNR-OWR regulatory compliance and to the extent that the studies can be effectively used to supplement or improve IDOT H&H analysis and design recommendations.

1-300 DRAINAGE POLICIES

1-301 Overview

The drainage policies of the Division of Highways have been established to provide continuity in the design and operation of the State highway system, to enhance traffic safety, to ensure the use of technically accepted materials and procedures, to provide the most cost effective highway facilities, and to ensure the fulfillment of all legal and regulatory obligations.

Drainage projects (and applicable policies) can be broadly categorized as those that constitute a floodplain encroachment and those that do not. Section 1-302 Floodplain Encroachments distinguishes between the two major types of encroachments. Transverse encroachments consist of roadways that cross from one side of the floodplain to the other, conveying flood flow through bridge or culvert structures. Policy and design criteria for these projects focus on determining and documenting an acceptable level of waterway opening that minimizes flood impact on both IDOT facilities and surrounding properties. Longitudinal encroachments occur along the edges of the floodplain where highway fill or embankment is placed inside the area designated as the floodplain; that is, the area inundated by the Q100 event. Design and policy criteria for these projects centers around addressing the volume of highway embankment or fill placed in the floodplain. Section 1-303 Documentation of Floodplain Encroachment Designs details the study/analysis required to document and justify design recommendations involving floodplain encroachments of both kind.

Section 1-304 Pavement and Bridge Deck Drainage includes drainage elements that do not encroach on the floodplain. The highway stormwater collection system consisting of the pavement, storm drain network, median, roadside ditches, etc., conveys flow originating from both within and beyond the IDOT right-of-way. IDOT policy and design criteria centers on maintaining safe motoring conditions on the pavement. Policy and design recommendations also address flow conditions in the collection system- be it storm drain, roadside ditch, median, etc.- and at the system outlet, where collected flow is discharged into a receiving stream or storm drain system.

Compliance with all policies and their accompanying design criteria compiled in Section 1-305 Design Criteria is essential to ensure the uniformity of the Highway System and the timely preparation and review of plans. However, it is recognized that site specific circumstances may not always be best served by the written policy. In those situations where a waiver from the policy's design criteria is desired, a request for waiver along with proper justification must be submitted to the Bureau of Bridges and Structures or appropriate Central Office Bureau in Springfield for those projects which fall under Central Office authority. The waiver is issued internally to the file by the District for those projects falling under District approval authority.

1-302 Floodplain Encroachments

Drainage facilities of the State highway system must be designed to minimize the flood hazard to the highway system and surrounding property in a cost effective manner and avoid permanent or long lasting environmental damage of any nature to the extent practicable. Designs must be completed in accordance with the provisions of the Federal-Aid Policy Guide and the Governor's Executive Order 2006-05 on "Construction Activities in Special Flood Hazard Areas". Designs must also satisfy any applicable external regulatory requirements such as those summarized within Section 1-400 Regulatory Agency Permits.

1-302.01 Longitudinal Encroachments

Longitudinal encroachments (See Figure 3-101) involve the placement of fill within the limits of the floodplain. They are to be avoided where practicable. If a longitudinal encroachment cannot be avoided, the degree of encroachment should be minimized to the extent practicable.

The scope of longitudinal encroachments can range from minimal (minor volume of fill placed in the flood fringe assessed by inspection as having negligible impact) to a significant volume of fill placed within the channel or floodway. The latter would likely involve a floodplain backwater study and a formal Individual IDNR-OWR permit. Refer to Chapter 3 for detailed design and policy criteria.

Generally, any increase in the 100 year water surface elevation produced by a longitudinal encroachment on a FEMA National Flood Insurance Program (NFIP) regulated floodplain should not exceed the one foot allowed by the Federal NFIP standards. In some cases, particularly in the 6-county area within District 1, the allowable increase is as low as 0.1 ft. for the Q100 event, or 0.0 ft. if sensitive flood receptors lie in the upstream floodplain. For those projects that may impact upstream flood conditions, the project must be supported by the design risk assessment described below and will require a floodway construction permit from IDNR-OWR. See Section 1-404.

1-302.02 Transverse Encroachments \ Bridges and Culverts

Transverse encroachments (Figure 3-101) by their nature cannot be avoided. Crossing the network of the natural surface drainage system does not allow any alternative (except no build) to transverse encroachments by a highway system. Therefore, it is essential that the design selected for transverse encroachments be supported by analysis of design alternatives with consideration given to capital costs, risk and other site specific factors. "Supported" means that the design is either shown to be cost effective or justified on some other engineering basis. The analysis used to develop this support is referred to as a design risk assessment. Justification for the structure size selected for design must be documented in a hydraulic design study report (Hydraulic Report or Location Drainage Study) and retained in the design file.

1-302.03 Compensatory Storage

For all highway projects, it shall be the Division's policy to evaluate the placement of highway fill (encroachment) in the floodplain to determine any resultant effects to upstream and downstream property and flooding conditions. The provision of storage facilities for highway projects shall be based on the findings of the hydraulic analysis and the following requirements and shall apply to the change in flood stage and velocities due to the highway improvement- not to the change in flood stage and velocities resulting from the development of other property.

1. Parallel (or Longitudinal) fill or encroachment of mapped floodplain:

Storage facilities shall be provided whenever fill in the floodplain is proposed and the hydraulic analysis indicates that there is a measurable change in flood stage and/or velocity that will cause or contribute to flood damage.

2. Crossing (or Transverse) fill or encroachment of mapped floodplain:

Storage facilities shall be provided whenever fill in the floodway is proposed and the hydraulic analysis indicates that there is a significant change in flood stage and/or velocity that will cause or contribute to flood damage.

3. Optional Applications for Both Longitudinal and Transverse fill or encroachment of mapped floodplain:
 - (a) Storage facilities may be provided when necessary as part of the IDNR-OWR permit requirements.
 - (b) Storage facilities may be provided at the option of the Regional District Engineer, when it would not otherwise be required by this policy, to satisfy requirements of a local ordinance when it is shown that there will be no significant increase in the IDOT project cost.
 - (c) Floodplain easements may be obtained to reduce the size of the proposed drainage structures or to mitigate the effects of existing facilities.

On Federal-aid projects, Federal funds can only participate in those costs necessary to accommodate the highway facility. The existing highway surface shall be considered the natural condition when evaluating storage requirements. Storage facilities may consist of ditches, storm sewers, pumping stations, depressions, and basins. For guidance in specific situations, contact the District Hydraulic Engineer. Applicable definitions follow:

- Floodplain:** The channel and overbank areas that are inundated by the Q100 event.
- Mapped Floodplain:** Floodplain mapped or delineated for regulatory purposes by the IDNR Office of Water Resources (Regulatory) and/or by the FEMA Flood Insurance Study.
- Floodway:** That portion of the mapped floodplain in\near the channel required to store and convey the floodwater with no measurable increase in stage or velocity. (See Figure 3-102) The floodway is also delineated by OWR and/or FEMA Flood Insurance Study.

1-303 Documentation of Floodplain Encroachment Designs

Hydraulic studies are required for all highway projects involving drainage facilities or floodplain encroachments. Rehabilitation of existing highway facilities often requires the same degree of hydraulic analysis as a new facility. This policy requires the documentation of the decision making process involved in the selection of a floodplain encroachment design based on the results of the hydraulic study and the design risk assessment.

The studies are to consist of a hydraulic analysis involving stage-discharge relationships for the stream system, flow velocity and backwater analysis of alternate designs, and an evaluation of potential flood damage to adjacent property, the stream environment, and the roadway embankment and structure(s). The Hydraulic Report for each project should contain the complete analyses of the above items with conclusions and design recommendations, including items such as waterway opening and configuration, skew, erosion protection, appurtenances such as spur dikes and energy dissipaters, channel modifications, overflow structures, roadway freeboard and bridge clearance. A Hydraulic Report is typically prepared for transverse encroachments. See Section 1-303.02 for direction on bridge and culvert project types that do not require a Hydraulic Report. For longitudinal encroachments, the level of analysis and

documentation is dependent upon the degree of encroachment and impact on the stream system. A Location Drainage Study (LDS) may be needed, per BDE Manual requirements. Chapters 2 and 3 of this manual provide direction for studies related to both transverse and longitudinal encroachments.

1-303.01 Design Risk Assessment

Justification, or support of a drainage feature or design alternative is achieved through the design risk assessment process. The design risk assessment can be included within the Hydraulic Report or Location Drainage Study. The degree of support is to be commensurate with the sensitivity of each site and can range from conducting an economic analysis to simply describing the constraints which justify the design. An economic analysis is a dollars and cents exercise which determines whether a proposed hydraulic structure is cost-effective by demonstrating that an appropriate balance exists between the capital costs and the risk costs attributable to the encroachment. This method of support should be used to the extent that risk is quantifiable. Risk is defined as the consequences associated with the probability of flooding attributable to an encroachment. It includes the potential for property loss and hazard to life during the design life of the highway. An economic analysis demonstrating the cost effectiveness of a design should include considerations for both the design frequency and the 100-year frequency. In some instances, even a lower frequency occurrence may have significant risk costs.

There are many projects where the optimum design is controlled by obvious economic, environmental, or physical constraints. In these situations, a description of the constraint with a statement explaining how the constraint justifies the design, will be sufficient support for the design risk assessment.

Examples of constraints include:

1. Project scope limitations: Rehabilitation of existing structure (including superstructure replacement, deck replacement or repair, roadway widening & culvert extensions)
2. Flood-sensitive development within or adjacent to the floodplain
3. Reservoir and dam crossings
4. Channel stability problems
5. Presence of supercritical flow conditions
6. Roadway overtopping
7. Active channel encroachment
8. Levee overtopping
9. Minimum opening which spans the channel maintaining the natural channel template through the waterway opening
10. Smallest waterway opening that meets acceptable backwater limits
11. Major ice or debris problems or concerns
12. Flood control projects

13. Topography (deep ravine, etc.)
14. Geometrics (navigation clearances, etc.)
15. Foundation issues
16. Multiple use structure (combination stream and grade separation structure, bikepath, animal crossing, etc.)
17. Environmental commitments (threat to endangered species, encroachment on historic sites, wetlands, parks, recreation areas, or wildlife and waterfowl refuges).
18. IDNR Office of Water Resources Permit Criteria ([refer to Section 1-404](#))

1-303.02 Plan Notation – Waterway Information

This policy shall apply to all culverts and bridges located within a base floodplain. A base floodplain is defined as that area adjacent to a stream below the Q100 base flood elevation (BFE), and therefore subject to inundation when flood waters escape from the stream banks. Sheet flow which has not yet reached a stream and is not associated with a defined channel or swale is normally not considered part of a floodplain. Also, roadside ditches and medians which only carry storm water runoff are not considered to be floodplains. However, roadside ditches which are oversized or overdesigned made larger than standard ditches for the purposes of conveying flood waters should be considered part of a floodplain.

The purpose of this policy is to establish guidelines for the waterway information to be shown on bridge and culvert plans.

For structure plans to be designed or reviewed by the Bureau of Bridges and Structures, the waterway information should be displayed in the format shown in [Figure 1-302.02a](#) (bridges), [Figure 1-302.02b](#) (sites with a relief or overflow structure sharing the floodplain) or [Figure 1-302.02c](#) (culverts). Note that [Figure 1-302.02a](#) and [Figure 1-302.02c](#) are IDOT Forms BBS 2730 Waterway Information Table and BBS 2802 Culvert Waterway Information Table, respectively.

Items pertaining to the overtopping flood should be recorded for the flood frequency at which the headwater elevation overtops the low grade elevation of the roadway. (See 1-305 for clarification of the low grade elevation.) When the determination of overtopping is not practicable (the overtopping flood is greater than a 500-year frequency), the overtopping information should be left blank and the information for the maximum calculable flood (500 year) should be listed. See Chapter 2 for directions on completing the Waterway Information Table (WIT).

For culverts which are not structurally designed or reviewed by the Bureau of Bridges and Structures, waterway information may be provided in the Culvert WIT, an abbreviated format ([Figure 1-302.02d](#)) or in a drainage schedule. The choice of WIT, Abbreviated Hydraulic Data Form or drainage schedule is made in the District. The minimum information to be provided in a drainage schedule should include:

1. Drainage area
2. Design waterway opening
3. Design discharge and headwater elevation
4. The 100-year discharge and headwater elevation
5. The overtopping or maximum calculable (whichever is less) frequency, discharge and headwater elevation

The design natural highwater elevation and the 100-year natural highwater elevation should be shown on the elevation view of the plan. The vertical clearance from design natural highwater to the low beam should also be shown on the elevation view of the plan for all bridge structures. The all time highwater elevation, if known, should be shown on the Waterway Information Table.

If the bridge or culvert is designed for non-hydraulic purposes such as a grade separation, pedestrian crossing, etc., it is not necessary to submit hydraulic information for the structure.

There are certain bridge and culvert projects that are structurally reviewed by BBS but still qualify for an exemption from the standard Hydraulic Report and WIT documentation requirements listed above. In addition, there may be some projects which qualify for an exemption from the standard hydraulic requirements. The exemption is to be granted at the discretion of the District Hydraulic Engineer. Those types of projects which may qualify:

1. Bridge deck replacements or repairs where there have been no hydraulic problems with the existing structure. This does not include full superstructure replacements.
2. Replacement or repair of deck beam structures (where there have been no hydraulic issues with the existing structure) without reducing the low beam elevation.
3. Superstructure replacements of high level crossings when the bridge length and vertical clearance are controlled by features other than hydraulics.
4. Widening of the existing superstructure without reducing the low beam elevation.
5. Short Culvert extensions up to 100 percent of original length, but not exceeding 40 ft in length.

The Abbreviated Hydraulic Data Form, shown in [Figure 1-302.02d](#) should be submitted with the Bridge Condition Report for the projects described in 1 through 5, along with documentation of the exemption to the hydraulic requirements. The exemption is not available for projects where identified flooding problems exist or for projects that require an IDNR-OWR floodway construction permit. Additionally, the exemption is not available for projects which include raising the approach roadway profile where overtopping of the roadway presently occurs for the 100 year flood frequency.



Waterway Information Table

Route: _____ Existing SN: _____
 Section: _____ Proposed SN: _____
 County: _____ Waterway: _____
 Date: _____ Prepared by: _____

Existing Overtopping Elev. = _____ at Sta. _____

Drainage Area =		Proposed Overtopping Elev. = _____ at Sta. _____							
Flood	Freq. Yr.	Q Ft ³ /s	Opening - ft ²		Natural H.W.E.	Head - ft.		Headwater Elevation	
			Existing	Proposed		Existing	Proposed	Existing	Proposed
Design									
Base									
Overtop Existing									
Overtop Proposed									
Max. Calc.									

10 YEAR VELOCITY THROUGH EXISTING BRIDGE = _____ ft/s 10 YEAR VELOCITY THROUGH PROPOSED BRIDGE = _____ ft/s

ALL-TIME H.W.E. & DATE:

Scope of Work:

EXISTING STRUCTURE

PROPOSED STRUCTURE

TYPE:
 LENGTH:
 # SPANS:
 LOW BEAM:
 SKEW:
 LOW E.O.P.:

TYPE:
 LENGTH:
 # SPANS:
 LOW BEAM:
 SKEW:
 LOW E.O.P.:

NOTE: PROPOSED STRUCTURE DETAILS ARE PRELIMINARY; SUBJECT TO REFINEMENT IN TSL STAGE.



**Illinois Department
of Transportation**

**MULTIPLE OPENINGS WATERWAY
INFORMATION TABLE**

Route: _____ SN Existing: _____ Computed by: _____ Date: _____
 Section: _____ SN Proposed: _____ Checked by: _____ Date: _____
 County: _____ Waterway: _____
 Station: _____

Drainage Area =		Existing Overtopping Elev. =		Proposed Overtopping Elev. =		at Sta.		at Sta.		
Flood		Discharge (cfs)		Waterway Opening (sq. ft.)		Natural H.W.E.	Head (ft.)		Headwater Elevation	
		Existing	Proposed	Existing	Proposed		Existing	Proposed	Existing	Proposed
10	Main Channel									
	Relief Structure									
	TOTAL									
50	Main Channel									
	Relief Structure									
	TOTAL									
100	Main Channel									
	Relief Structure									
	TOTAL									
Overtopping	Main Channel									
	Relief Structure									
	TOTAL									
500	Main Channel									
	Relief Structure									
	TOTAL									

10 Year Velocity Through Existing Bridge = _____ ft/s

10 Year Velocity Through Proposed Bridge= _____ ft/s

ALL – TIME H.W.E. & Date:

Scope of Work:

EXISTING STRUCTURE

PROPOSED STRUCTURE

TYPE:
 LENGTH:
 # SPANS:
 LOW BEAM:
 SKEW:
 LOW E.O.P.:

TYPE:
 LENGTH:
 # SPANS:
 LOW BEAM:
 SKEW:
 LOW E.O.P.:

NOTE: PROPOSED STRUCTURE DETAILS ARE PRELIMINARY; SUBJECT TO REFINEMENT IN TS&L STAGE.

Printed 02/23/2011

BBS 2804



Illinois Department of Transportation

Culvert Waterway Information Table

Route:
Section:
County:
Station:

S.N. Exist:
S.N. Prop:
Waterway:

Computed by:
Checked by:

Date:
Date:

Drainage Area =		Square Miles		Existing Overtopping Elevation:			ft. @ Sta			
				Proposed Overtopping Evaluation:			ft. @ Sta			
Flood	Frequency Year	Discharge cfs	Waterway Opening (sq. ft.)		Natural H.W.E.	Head (ft.)		Headwater Elev. (ft.)		
			Existing	Proposed		Existing	Proposed	Existing	Proposed	
	10									
Design	50									
Base	100									
OVT(E)										
OVT(P)										
Max Calc	500									

10-Year Outlet Velocity from Existing Structure = fps
 10-Year Outlet Velocity from Proposed Structure = fps

OVT = Overtopping Event
 (E) Existing (P) Proposed

DATUM:
 ALL-TIME H.W.E. & DATE:

SCOPE OF WORK:

EXISTING STRUCTURE

Bridge or Culvert Type:
 Cell Dimensions (W x H):
 # of spans \ cells:
 Length:
 U/S Flowline:
 D/S Flowline:
 Skew:
 Low EOP:

EXISTING DROPBOX

Dimensions:
 Drop:
 Weir Elevation:

PROPOSED STRUCTURE

Culvert Type:
 Cell Dimensions (W x H):
 # of cells:
 Length:
 U/S Flowline:
 D/S Flowline:
 Skew:
 Low EOP:

PROPOSED DROPBOX

Dimensions:
 Drop:
 Weir Elevation:

NOTE(S): _____

ABBREVIATED HYDRAULIC DATA FORM

SN _____ - _____
Route _____
Section _____
County _____
Stream Name _____

Date _____
Completed By _____

NOTE: To be used only for deck repairs or replacement of deck beams w/out lowering of low beam at sites lacking hydraulic issues, superstructure replacements on high level crossings, superstructure widening, and short culvert extensions. Submit Form with Bridge Condition Report.

1. Maximum recorded high water elev. _____ ft. Date _____
2. Does high water inundate the low beam? _____ How often? _____
3. Does high water overtop the approach roadway? _____ How often? _____
4. Low beam elevation _____ ft.
5. Low point on approach roadway. Elev. _____ ft.
6. Has scour occurred under or adjacent to structure? _____
7. Drainage area. _____ sq. mi.
8. Is any particularly valuable property located upstream within possible bridge backwater influence? _____ Describe and list critical upstream flood elevation(s):

9. Have there been any hydraulic problems with the existing structure?

10. Description of proposed improvement. _____

11. Supplemental hydraulic information (available cross sections, plan and profile, photographs, etc.).
12. Comments: _____

Figure 1-302.02d

1-304 Pavement and Bridge Deck Drainage

The State highway system shall be designed to minimize the hazards of stormwater runoff in a cost effective manner considering the safety of the motoring public, the maintenance and operational aspects of the highway system and the damage potential to surrounding property.

The drainage system must be designed to remove stormwater from the pavement and to intercept stormwater from adjacent properties which are naturally tributary to the highway right-of-way. Typically, there is no storage or detention element in the highway drainage system. However, certain design or site circumstances can warrant the provision of detention or storage facilities within the improvement. The drainage system must be maintained and connections to the drainage system by others can only be made when authorized by highway access permit or agreement to ensure that the system continues to operate as designed.

1-304.01 Pavement Encroachment

Inlets and/or catch basins are required at locations needed to collect runoff within the design controls specified below. Inlet locations should first be coordinated with other design features such as sags, crossroad intersections, pedestrian crosswalks, and interception points for concentrated flow from sources outside the pavement.

The following encroachment limitations are the maximum allowable for determining inlet spacing on construction and reconstruction projects and they shall be applied for the design frequency specified in [Table 1-305](#). Encroachment limits specified are onto the traveled lane; spread is the width of flow measured from the curb face. This policy assumes that encroachment widths agree with [BDE Manual](#). Note that encroachment limits for bridge deck drainage are given in [Section 1-304.02](#) and are considerably less than those allowed for roadway sections.

1. Sections with full shoulders (6 ft or more) - no encroachment. Spread is limited to shoulder width.
2. Sections with permanent parking lane - no encroachment. Spread is limited to parking lane.
3. Sections with one lane each direction - allow maximum encroachment of 4 ft except when surface width (face to face) is less than 30 ft, then allow 3 ft encroachment.
4. Sections with two (2) or more lanes in each direction - one half (1/2) traffic lane maximum encroachment, except where traffic volumes exceed maximum specified for level of service (See [BDE Manual](#)), then use maximum encroachment of 4 ft.
5. Sections with three (3) or more lanes each direction with one (1) lane draining to the median - allow maximum encroachment of 4 ft on median side with one half (1/2) traffic lane allowed on outside (right) lane.

The resultant inlet spacing shall not exceed 250 ft and the maximum depth of flow should be limited to 0.35 ft regardless of computed encroachment. The maximum spacing of 250 ft is the distance between successive inlets and represents the maximum desirable spacing needed for maintenance access to clean the connecting storm drain.

1-304.02 Bridge Deck Drainage

Bridge roadway grades should be established recognizing deck drainage. It is desirable that the longitudinal grade be no less than 0.5 percent. In certain circumstances, such as near the crest of vertical curves, grades less than 0.5 percent may not be avoidable; however, efforts should be made to minimize these areas. The IDOT Bridge Manual has considerable direction and information on this topic, including calculation worksheets.

The minimum cross slope should be 1.56 percent (3/16 in/ft). At superelevation transitions where the cross slope reverses from full crown to full superelevation, care should be exercised to avoid impoundments and to eliminate cross road flow.

The spread of gutter flow under a rainfall intensity of 7 inches per hour (roughly Q10 intensity) shall not encroach on the traveled way traffic lane:

- more than 1 ft when the design speed is 50 mph or greater
- more than 3 ft when the design speed is less than 50 mph

The allowable spread of gutter flow on bridge decks is less than that for roadway sections because there is no escape route for errant vehicles.

Wherever practical, bridge deck drains and inlets should be avoided. It is good practice to drain bridge decks to off-bridge inlets where possible and practical.

1-304.021 Bridge Deck Inlets

Inlet boxes are required on bridge decks wherever needed to prevent the gutter flow spread from exceeding the traffic lane encroachment limitations. IDOT employs two types of inlets on bridges; bridge scuppers and a standard 6-inch floor drain. Downloadable PDF files and CADD drawings, or Bridge Base Sheets, are available for all four scupper types and one floor drain from this link: <http://www.dot.il.gov/bridges/bscadd2.html>. Under Superstructure Library, see Drainage Scuppers DS-11, DS-12, DS-12M10 and DS-33 on page 1. See S-I-D on page 2 for the floor drain base sheet.

An inlet\scupper shall be provided at a distance D_i from the high point of the bridge deck and subsequent inlets shall be spaced at distance D_n . Inlets are required in the bridge deck unless the distance from the high point to an off-bridge inlet equals D_i or less.

Theoretical values of D_i and D_n may be determined in accordance with the methods contained in [Section 2 of the Bridge Manual](#). Additional direction is included within Section 3.2.9 Deck Slab Drains & Drainage Scuppers and within Bridge Scupper Placement Design Guide 2.3.6.1.8. To allow for the eventuality of some drains becoming clogged, it is desirable to reduce these theoretical distances by 25 to 50 percent.

For purposes of computing the need for and spacing of inlets, portions of decks on crest vertical curves where the grade is less than 0.5 percent shall be assumed to have a grade of 0.5 percent.

Deck inlets are required at the bottom of any sag vertical curve and, to prevent flow from crossing the deck, immediately ahead of any transverse slope reversals. Also, it is desirable to locate an inlet immediately upstream from deck expansion joints.

Free fall inlets should not be located within 10' of substructure elements. Where discharge from the inlets cannot be allowed to fall free to underlying areas, the inlets should be located directly above downspouts attached to the substructure. Mid-span locations that would result in complex, lengthy piping should be avoided whenever possible.

Special size inlet boxes may be required on steep grades to prevent the flow from jumping the opening and on urban cross sections to prevent the inlet from extending into the traveled way.

1-304.022 Floor Drains

Floor drains (see Figure 1-304e) are vertical, fiberglass or aluminum tubes cast into the deck and extending to below the superstructure. Downloadable PDF files and CADD drawings, or Bridge Base Sheets, are available at this link: <http://www.dot.il.gov/bridges/bscadd2.html>. Under Superstructure Library, see S-I-D on page 2 for the floor drain base sheet.

Bridge decks or portions thereof on vertical tangent grades of less than 0.5 percent should be provided with standard free fall floor drains spaced at 15 ft centers. Free fall floor drains should not be located within 10 ft of substructure elements. When free fall drains are not permitted, a special investigation should be conducted to determine whether to provide an enclosed system or to re-space or omit the drains.

Similar provision should be made on crest vertical curves with K-values of 167 or greater over the portion having a grade of 0.3 percent or less. Crest vertical curves of K less than 167 need not be provided with drains.

Sag curves on bridge decks should be avoided. They create the potential for clogging, standing water, icing; undesirable conditions that can cause excessive encroachment. Where locating the sag on the bridge deck cannot be avoided, floor drains may be more closely spaced than 15 ft centers.

1-304.023 Off-Bridge Inlets

At bridges on uncurbed rural type highways, inlets or other form of positive drainage should be provided in all approach shoulder pavements receiving runoff from the bridge, regardless of the presence or location of deck inlets, except where the grade is less than 0.5 percent and floor drains are provided.

At bridges on urban type curbed highways any gutter flow that would enter the bridge should be intercepted by a roadway inlet immediately ahead of the bridge.

1-304.03 Stormwater Storage

It shall be the Division's policy to evaluate the stormwater runoff characteristics of all highway projects to determine any resultant effects to downstream property and flooding conditions. Stormwaters are those waters which have been precipitated on the land from the sky and which then spread over the surface of the ground where they may appear as puddles, sheet or overland flow, and rills. They may be collected in sewers or artificial ditches constructed for their transport to an outfall. They continue to be stormwaters until they disappear by infiltration or evaporation or until they reach well defined water courses or standing bodies of water. The provision of storage facilities shall apply to the increased runoff due to the highway improvement and not the increase of runoff resulting from the development of other upstream property. The provision of storage facilities for highway projects shall be based on the findings of the hydraulic analysis and

the following warrants or requirements:

1. Diversion
 - (a) Urban- Storage facilities shall be provided whenever diversion is proposed in an urban or built-up area.
 - (b) Rural- Storage facilities shall be provided in rural areas when diversion is proposed and the hydraulic analysis indicates that the diverted flow will cause or contribute to flood damage.

This policy is not intended to encourage the practice of diverting flow. The Division's position on diversion is as stated within Illinois Drainage Laws: Rights and Responsibilities of Highway Authorities and Landowners Adjacent to Highways²:<http://www.ideals.uiuc.edu/handle/2142/8575>

“IN NONAGRICULTURAL LAND USES AND ABSENT LOCAL ORDINANCES SPECIFYING STORM DRAINAGE AND DETENTION REQUIREMENTS, OWNERS OF DOMINANT ESTATES MAY DRAIN THEIR LANDS INTO PUBLIC DRAINS OR ONTO SERVIENT LANDS AS LONG AS THE INCREASED FLOW OF SURFACE WATERS IS CONSISTENT WITH THE POLICY OF REASONABLENESS OF USE. IN SOME CASES, THE DRAINAGE IMPROVEMENT CONTEMPLATED FOR THE DOMINANT ESTATE WILL REQUIRE A PERMIT FROM THE ILLINOIS DEPARTMENT OF TRANSPORTATION OR THE ILLINOIS DEPARTMENT OF NATURAL RESOURCES – OFFICE OF WATER RESOURCES.” AND THE CORPS OF ENGINEERS².”

*“IN THE INTERESTS OF GOOD HUSBANDRY, THE OWNERS OF DOMINANT ESTATES MAY CONSTRUCT OPEN OR COVERED DRAINS ON THEIR OWN LAND FOR AGRICULTURAL PURPOSES, EVEN THOUGH THE FLOW OF DRAINAGE WATER MAY BE INCREASED IN THE WATERCOURSES THAT CARRY THE WATERS FROM THE DOMINANT TO THE SERVIENT ESTATES. THE OWNERS OF THE DOMINANT ESTATES, HOWEVER, MUST DISCHARGE THE WATERS AT THE POINTS WHERE THE WATERS WOULD HAVE ENTERED THE SEVIENT ESTATES NATURALLY. AND THEY GENERALLY MUST NOT CUT OR TILE THROUGH DIVIDES SO AS TO DISCHARGE UPON THE SERVIENT ESTATES WATERS THAT ORIGINATED FROM DIFFERENT WATERSHEDS. LARGE DRAINAGE IMPROVEMENTS MAY REQUIRE A PERMIT FROM THE ILLINOIS DEPARTMENT OF TRANSPORTATION** OR THE ILLINOIS DEPARTMENT OF NATURAL RESOURCES – OFFICE OF WATER RESOURCES. AND THE CORPS OF ENGINEERS. THE AMOUNT AND MANNER OF WATER DISCHARGED UPON THE LOWER OWNER MAY BE SUBJECT TO A “REASONABLENESS” LIMITATION².”*

2. Altered Runoff Characteristics
 - (a) Urban- Storage facilities shall be provided in urban and built-up areas whenever a significant increase in the amount of runoff occurs as a result of increased impermeability, reduced time of concentration, and/or the filling of natural storage areas.
 - (b) Rural- Storage facilities shall be provided in rural areas whenever the hydraulic analysis indicates that flood damage will result from an increase in the amount of runoff occurring as a result of increased impermeability, reduced time of concentration, and/or the filling of natural storage areas.

3. Optional Applications

- (a) Storage facilities may be provided at the option of the District Regional Engineer, when it would not otherwise be required by this policy, to satisfy the requirements of a local ordinance when it is shown that there will be no significant increase in cost to the project.
- (b) Storage facilities may be provided to reduce the size of the proposed drainage structures or to improve the performance of existing facilities.

On Federal-aid projects, Federal funds can only participate in those costs necessary to accommodate the highway facility.

The evaluation of storage requirements should be based on a stormwater runoff frequency which is compatible with the design frequency of the highway facility being drained and checked for a 100-year frequency.

The existing highway surface shall be considered the natural condition when evaluating storage requirements. Storage facilities may consist of pavements and gutter systems, ditches, storm sewers, pumping stations, depressions, parking areas and detention basins. For guidance in specific situations, contact the District Hydraulic Engineer.

1-305 Design Criteria

The Division of Highways has found it necessary to specify certain design criteria to ensure that the highway system consistently meets its functional needs and legal responsibilities. To provide an acceptable standard level of service, the Division employs widely used, pre-established design frequencies which are based on the importance of the transportation facility to the system and the allowable risk for that facility. These design frequencies represent minimum standards. Higher, more stringent standards can be considered and/or implemented where desirable and where adequate justification exists. An example would be utilization of a larger design event for pavement drainage on high volume expressways in District 1. The actual design must also consider the site specific consequences of larger flood events including the 100 year and the overtopping event; the flood frequency at which the low point of the roadway across the floodplain is first overtopped. Specific design frequency requirements for most State highways are shown in [Table 1-305 Design Flood Frequency](#). [Note \(1\) beneath the table details applicable design references for lower class roadways.](#)

For bridges, in addition to the design frequency criteria, it is also required that the bottom of the bridge superstructure (low beam elevation) be at or above the all-time highwater elevation for new freeway and expressway construction. The all-time highwater is the highest water surface elevation reliably observed or recorded. For all bridge projects, it is required that a minimum clearance of two (2) feet be established between **design natural highwater** elevation and the low beam elevation. The natural highwater elevation is an estimate produced by a backwater model such as HEC-RAS. For bridges which do not provide a relatively constant beam clearance above the design natural highwater, such as with roadways on grade across the opening or arched bridge openings, the minimum 2 ft clearance may be applied over the main channel only. There are other instances when it is practical to apply this criteria within the channel limits - where debris and ice are primary considerations - not in the overbank spans where beam clearance is of lesser concern. The low beam policy and design criteria are also applied to superstructure replacements. If the proper application is unclear, the District Hydraulic Engineer or BBS Hydraulic Unit should be consulted.

For culverts and 3-sided bridges, the 2 ft low beam clearance policy described here does NOT apply. However, clearance should be considered for debris concerns at site specific locations.

For bridges, culverts and 3-sided bridges, a minimum roadway freeboard of 3 ft must be established between the **design headwater** (see [Section 7-106](#)) elevation and the lowest pavement elevation within the floodplain. In most cases, the upstream edge of pavement will be controlling, but in some situations (such as superelevation of roadway) the downstream edge of pavement may be the controlling reference point if the design headwater has physical access to the downstream side of the roadway. This point of reference is labeled the “overtopping elevation” on the Waterway Information Table.

Clearance and Freeboard waivers with proper justification, the above low beam clearance and roadway freeboard criteria may be waived if a request for policy waiver is documented, then reviewed and approved by the proper approval authority. For bridge and culvert projects, whichever office possesses Hydraulic Report approval authority - either District or BBS - is also charged with approving the clearance and freeboard waivers. In either case, if the District grants the waiver or if BBS Hydraulics approves a District request for waiver from criteria, the documentation originates within the District.

Direction for documenting or requesting waivers from policy criteria are contained within 7-001.04 Clearance and Freeboard. The nature and scope of IDOT projects that may require policy waivers range from large river systems down to 12” entrance culverts. The direction in Chapter 7 is directed towards the former. Documentation of freeboard waivers for small AR or entrance culverts does not need to meet that same standard. For a very high percentage of these projects, failing to meet the criteria causes no negative ramifications and poses no risk. For minor culvert projects where the scope is fixed and there is clearly no viable, cost effective option that satisfies the 3 ft design roadway criteria, documentation can be limited to a simple file statement to that affect.

FACILITY \ CLASS	Rural State Highway System Principal & Minor Arterial Systems	Urban State Highway System Arterial Highways and Streets	
		All Highway Types except Type TWS-2 with DHV < 1250	Type TWS-2 DHV < 1250
Bridges & Culverts ^{(1) (2)}	50 Year	50 Year	30 Year
Roadway ⁽³⁾	50	50	30
Roadside Ditches *	50	50	30
Ditch Lining	10	10	10
Subways ⁽⁴⁾	50	50	50
Urban Pavements, Inlets & Storm Drains ⁽⁵⁾	10	10	10
TWS-2 = Two-way Street, 2 Lanes * Follow these frequencies for Entrance and Side Road culverts within.			

**Design Flood Frequency
Table 1-305**

- (1.) Marked highways functionally classified as collectors will be designed using these flood frequencies. For design criteria for lower class roadways on the State highway system, see the Bureau of Local Roads & Streets Manual from the IDOT internet site at <http://www.dot.il.gov/blr/manuals/blrmanual.html>. Criteria can vary according to the presence or absence of Federal funding.
- (2.) The waterway openings of bridges and culverts are designed on a flood frequency basis. Where significant damage will be incurred by adjacent property, a higher flood frequency than that indicated in the Table should be considered.
- (3.) The roadway edge of pavement at the low grade point in a floodplain area for highways with a DHV of 100 or more shall be a minimum of 3 ft above design headwater elevation.
- (4.) A 50 year design frequency is used at sag locations for depressed roadways; see Section 8-008.01.
- (5.) Q10 is the minimum standard. High volume expressways or new freeways may require a higher design standard.

1-400 REGULATORY AGENCY PERMITS

1-401 Introduction

Both Federal and State agencies impose drainage related laws or regulations upon IDOT projects. Primarily, these regulations apply to construction activity in channels, floodplains, lakes, ponds and wetlands. The regulations typically take the form of compliance with specific permit requirements or criteria on a project by project basis. These requirements and criteria shape design considerations and constraints for projects ranging from culvert extensions to storm drain outlets to construction of new highways on new alignment. Beyond the planning and design phase impacts, regulatory permits routinely affect construction phase methods and activities. They can also create post-construction commitments related to upkeep or maintenance. Therefore, it is important to recognize, account for and comply with all applicable permits throughout the plan development timeline, from the preliminary stage (Location Drainage Study, Project Report, Hydraulic Report, Type Size & Location Plan, etc.) to final plan preparation.

Section 1-400 identifies the permitting agencies that are frequently encountered by the hydraulic designer in drainage-related projects. It includes links to agency websites that provide more complete information on the respective programs and their jurisdiction, including permit types, detailed rules and F.A.Q.'s. The following sub-sections also delineate responsibility within IDOT for obtaining the respective permit.

The IDOT BDE Manual is an excellent source of further information on permits and certifications that are considered to be of environmental nature, such as the Illinois EPA 401 and the U.S. Army Corps of Engineers 404 permits. Chapter 28 Environmental Permits / Certifications documents the basic information related to these permits, including agency office contacts and the IDOT unit responsible for handling the permit process.

The BDE Manual also includes guidance and direction related to permits that are not addressed in this manual, including the 402 NPDES Point Source and Construction Permits. IDOT documents related to the 402 NPDES Permit such as the Erosion Control Plan and the Stormwater Pollution Prevention Plan (SWPPP) are controlled by the Bureau of Design and Environment or the Bureau of Implementation.

1-402 Navigable Waters

Federal laws under the River and Harbor Act of 1899 provide the permit authority for controlling work in the navigable waters of the United States.

Section 9 of the River and Harbor Act (33 USC 401) prohibits the construction of any dam or dike across any navigable water of the United States without congressional consent and approval of the plans by the Chief of Engineers, U.S. Army Corps of Engineers, and the Secretary of the Army. Section 9 authority with regard to bridges and causeways was transferred to the Secretary of Transportation by the Department of Transportation Act of 1966 (80 Stat. 941, 49 U.S.C. 1165g(6)(A)) and the authority to approve plans and issue permits was delegated to the U.S. Coast Guard¹.

Section 10 of the River and Harbor Act of 1899 (33 U.S.C. 403) prohibits the unauthorized obstruction or alteration of any navigable water of the United States. A Corps of Engineers permit is required for the construction of structures other than a bridge, causeway, excavation or deposition of material in such waters.

The Bureau of Bridges and Structures is responsible for obtaining all required Section 9 permits and the District Office is responsible for obtaining Section 10 permits. For USCG Section 9 permits, [Section 2 of the IDOT Bridge Manual](#) should be consulted for a description of permit requirements and a listing of navigable streams. Permit criteria focuses on the structure's navigational clearance and keeping the navigational channel clear of obstructions. See this link to the USCG permit rules for the 8th District based in St. Louis: <http://www.uscg.mil/d8/WesternRiversBridges/docs/Permit%20Application%20Guide.pdf>

1-403 Section 401 \ Illinois EPA and Section 404 \ U.S. Army Corps of Engineers

The EPA 401 and Corps of Engineers 404 are separate permit programs. However, the two share some common ground in purpose, jurisdiction and permit requirements. For a great percentage of projects, these programs go virtually hand in hand. Permit processing for both has evolved to recognize and capitalize on that relationship.

Navigable waters are defined by the U.S. Army Corps of Engineers to include essentially all rivers, streams, lakes, ponds, and wetlands. The instrument of authorization is a permit, and the Secretary of the Army, acting through the Chief of Engineers, U.S. Army Corps of Engineers (USACE), has responsibility for the administration of the regulatory program. Section 404 of the Federal Water Pollution Control Act Amendments of 1972 (PL92-500, as amended), prohibits the unauthorized discharge of dredged or fill material in navigable waters. The permit controls work limits and construction activities to ensure that no damage or pollution will be attributed to the proposed project. . The responsibility for obtaining all Section 404 permits has been assigned to the District offices. Illinois falls under the jurisdiction of five (5) separate USACE Districts; Chicago, Rock Island, St. Louis, Louisville and Memphis. For Corps District office contacts and IDOT-specific information regarding the 404 Permit, refer to Chapter 28 of the BDE Manual.

The 404 permit is required for a wide variety of projects, including but not limited to:

- Bridge and culvert replacements
- Channel realignment and stabilization
- Placement of riprap or other revetments (bridge scour countermeasures)
- Structure repairs in-stream
- Storm drain outlets

For all projects including structures and roadways that potentially impact wetlands, the 404 permit can affect permanent design features, such as the profile grade line. More typically, the permit impact is on allowable construction activities. The Nationwide Permit is intended to cover most project scopes and typical construction activities. If the terms of the Nationwide Permit cannot be satisfied, then an application for Individual Permit may be required. These applications can affect the letting date. Typically, for structure related projects, the 404 is handled by the District Hydraulics Unit, or Programming Bureau in District 1. The Corps of Engineers sometimes works with local soil conservation districts- particularly in District 1- to ensure construction activities are acceptable and in compliance with the terms of the permit.

For general information on the USACE and their regulatory program, go to:

http://www.usace.army.mil/CECW/Pages/cecwo_req.aspx

The Corps provides a 404 tutorial from this hyperlink:

<http://www.mvk.usace.army.mil/offices/od/odf/avatar/index.html>

The Illinois Environmental Protection Agency (IEPA) prohibits the unauthorized discharge into the waters of the State. The instrument of authorization is the Section 401 water quality certification. This is associated with a Section 404 permit application and is usually done at the same time. The IEPA has conditioned Section 401 water quality certification applicable to certain Nationwide Corps permits. If the IEPA grants Section 401 water quality certification approval through the Section 404 Nationwide Permit, no further action is necessary. In that case, the Section 401 water quality certification will be subject to the IEPA conditions contained in the Section 404 Nationwide Permit approval. If the IEPA denies Section 401 water quality certification through the Section 404 Nationwide Permit, then an Individual Section 401 water quality certification will be required from the IEPA. Projects that need Individual 401 certification will need to complete an application that shows that water quality standards will be met for the project. Projects will also be subject to antidegradation assessment review and development of an antidegradation assessment fact sheet in accordance with water quality standards. The water quality standards regulations are on the internet under 35 Ill. Adm. Code 302 at <http://www.ipcb.state.il.us/documents/dsweb/Get/Document-33354/>. Antidegradation regulations are at 35 Ill. Adm. Code 302.105. The application forms to be filed in a joint application are on the internet at <http://www2.mvr.usace.army.mil/Regulatory/Documents/IllinoisApplicationPacket.pdf>. Additional information regarding 401 certifications is found in the instructions for the joint application form.

For IEPA office contacts and IDOT-specific information regarding the 404 Permit, refer to Chapter 28 of the BDE Manual. The responsibility for obtaining all IEPA 401 Permits has been assigned to the District offices.

1-404 Floodway Construction Program \ Illinois Department of Natural Resources- Office of Water Resources

The Illinois Department of Natural Resources⁴ has the authority, under the Rivers, Lakes and Streams Act, to administer a permit program regulating construction within public bodies of water and within floodways of rivers, lakes and streams of the State of Illinois. IDNR's Office of Water Resources (OWR) has been assigned responsibility for the program. The OWR Regulatory Section consists of two Regulatory Program Sections. The Northeast Illinois office (located in Bartlett) administers the 6-county area around Chicago. The Downstate Section (Springfield) is responsible for floodplain management responsibilities for the other 96 counties in Illinois. Two separate permit programs have been set up by OWR to regulate construction within floodways. They are the Individual Permit program under 615 Illinois Compiled Statutes 5/18f and the Regulatory Program for Regulation of Construction Within Floodways established under 615 ILCS 5/18g. The home page for the IDNR-OWR permit programs is: <http://dnr.state.il.us/owr/ResmanPermitProgs.htm>

The IDNR-OWR program regulates IDOT construction activities in the floodplain by placing limits on proposed flow conditions. Bridges and culverts are the primary affected construction activities, but longitudinal encroachments of the floodplain due to roadway widening or new alignments, channel modifications and other miscellaneous projects sometimes fall under IDNR-OWR jurisdiction. IDNR-OWR jurisdiction includes all watersheds equal to or greater than 1 square mile in urban or urbanizing locations and equal to or greater than 10 square miles for rural locations. Permit rules center around allowable backwater for all events up to and including the Q100 event, so for conveyance structures, the permit's design impact relates primarily to the overall size of effective waterway opening. None of the IDNR-OWR permits dictate structure type- bridges and culverts are subject to identical backwater limitations. Additionally, the permit program does not directly impact or regulate specific design features. For example, bridge backwater is held to certain limits based on project location and the nature of the upstream floodplain, but design

considerations such as low beam clearance, roadway freeboard and pier placement are not addressed specifically in the permit language. Specific design features such as these may impact flow conditions, but their ultimate determination is made entirely within\by IDOT. IDNR-OWR establishes limits or boundaries from within which IDOT has the latitude to employ policies and practices as deemed appropriate.

Refer to [Table 1-403a, b, c and d](#) for summary of permit type, jurisdictional limits and criteria for IDNR-OWR permits.

Permit Type	Illinois Administrative Code; Title 17 Chapter I Subchapter h	Construction Activities Affected	Jurisdictional Limits	Permit Criteria
Individual Floodway	Part 3700	All construction within 100 yr. Floodway (If the Floodway has not been delineated, all Floodplain work must be coordinated with OWR).	Rural > 10 Sq. Mi. Urban > 1 Sq. Mi.	With the ownership of or flood easements on impacted properties these criteria can be exceeded. No induced flood damages (absent contrary evidence the following guidelines apply). New bridges and culverts A. Urban – backwater limits of 0.5 ft. at structure and 0.1 ft. at 1000 ft. upstream. B. Rural – backwater limits of 1.0 ft. at structure and 0.5 ft. at 1000 ft. upstream. Bridge and Culvert Reconstruction A. No more restrictive than existing. B. Certification of no demonstrable flood damages. Longitudinal encroachments – contact OWR for analysis procedures.
SWP #2	Part 3700	Bridges and Culverts	Rural locations D.A. 10-25 Sq. Mi.	New Structures A. Q100 backwater limited to 1.0 ft. at structure and 0.5 ft. at 1000 ft. upstream. Replacement Structures A. Equal or greater waterway opening compared to existing OR Q100 backwater limited to 1.0 ft. at structure and 0.5 ft. at 1000 ft. upstream AND Certification of the existing structure. For both New and Replacement Structures A. Must not involve straightening, enlargement or relocation of existing channel. B. Dual certification by two (2) P.E.'s.
SWP #7	Part 3700	Outfalls	All streams covered by 3700 rules	A. An outfall structure shall not extend beyond existing bank line. B. Velocity of discharge shall not exceed scour velocity of channel soil unless protected. C. Outlets from drainage ditches shall not be opened to a stream until ditch slopes are stabilized. D. Disturbance of streamside vegetation shall be kept to a minimum.
SWP #9	Part 3700	Minor channel protection activities	All streams covered by 3700 rules	A. Channel protection shall not exceed 1000 ft. B. Volume of material placed shall not exceed 2 cubic yards per lineal foot of bank. C. The crosssectional area of the channel shall not be reduced by more than 10%.
SWP #11	Part 3700	Minor maintenance dredging activities	All streams covered by 3700 rules	A. Length of dredging shall not exceed 1000 ft. B. Project shall not include construction of any new channel. C. Cross-sectional area of dredged channel shall conform to natural channel. D. Dredged spoil shall be properly disposed of in accordance with Special Conditions of permit.

Table 1-403a

Permit Type	Illinois Administrative Code; Title 17 Chapter I Subchapter h	Construction Activities Affected	Jurisdictional Limits	Permit Criteria
SWP #12	Part 3700	Bridge and culvert replacements and widenings	All non-public streams covered by 3700 rules	A. Same or larger waterway opening than existing structure. B. No appreciable raising of the approach road (e.g. a resurfacing shall not exceed 3" singularly or cumulatively). C. No straightening, enlargement, or relocation of existing channel except as allowed in SWP #11. D. Certification of no demonstrable flood damages.
SWP #13	Part 3700	Temporary construction activities	All non-public streams covered by 3700 rules	A. The permanent structure must have necessary permits. B. Cannot remain in place more than one construction season. C. Shall not cause erosion or damage to adjacent properties. D. No solid embankments or dams (e.g. without culverts).
SWP #14	Part 3704	Temporary construction activities	All public waters covered by 3704 rules	A. The permanent structure must have necessary permits. B. Use or activity is authorized for no more than seven (7) consecutive days and no more than twice in any 1 year period.
Individual Dams	Part 3702	All new construction or modifications to spillways or embankments beyond day to day maintenance such as mowing or culvert cleaning	All Class I and II dams and Class III dams of a certain size. This group includes all state highways which also serve as dams. OWR should be contacted for a determination on all other roads which also serve as dams.	Examples: <ul style="list-style-type: none"> • Illinois Route 17 in Knox County west of LaFayette, Calhoun Lake Dam • Illinois Route 143 in Madison County west of Highland, Highland Silver Lake Dam • Local Road in Bureau County west of Tiskilwa, Menno-Haven Lake Dam (TWS #1) • Local Road in Christian County west of Edinburg, Lake Sangchris Dam • Local Road in Richland County east of Olney, East Fork Lake Dam • Local Road in Jefferson County east of Mt. Vernon, Lake Jaycee Dam
Individual Public Waters	Part 3704	All construction within a Public Body of Water	All meandered lakes and waterways listed as Public Bodies of Water	A. No obstruction to navigation. B. No creation of private property. C. Benefits to the public interests in the public water must exceed damages. D. The permit criteria of either the 3700 or the 3708 rules also apply, depending on the location. E. Temporary construction features must be permitted (e.g. causeways).

Table 1-403b

Permit Type	Illinois Administrative Code; Title 17 Chapter I Subchapter h	Construction Activities Affected	Jurisdictional Limits	Permit Criteria
Floodway	Part 3708	All construction within a designated floodway	All construction within Regulatory Floodways of Cook, DuPage, Kane, Lake, McHenry, and Will Counties	Bridges and culverts A. Backwater increase limited to 0.1 ft. over existing 100 year flood profile. B. If damages occur for existing conditions backwater must be reduced to point of non-damage or to 0.1 ft. over natural conditions. C. Compensatory storage must be provided for fill placed between the normal water and the 10 year and between the 10 year and 100 year flood profile.
Regional #1	Part 3708	Bridge and culvert reconstruction and modification	All construction within Regulatory Floodways of Part 3708	A. The proposed structure, including approach roads, is no more restrictive than the existing. B. No channel modification is proposed other than that required for transitions. C. On Public Waters, the proposed work is not an obstruction to navigation. D. The existing crossing is not a source of flood damage by calculation or by Regulatory Study. E. The maximum headwater increase is 0.1 ft. over the existing flood profile F. Compensatory storage requirements must be met. G. Transition sections must be used in calculations and design of bridge and culvert openings. H. Backwater impacts of downstream receiving streams must be considered. I. Adjacent construction projects anticipated within the next 5 years must be included in the analysis. J. Any resultant change in the floodway location or profile must have OWR authorization.
Regional #2	Part 3708	Bridge and culvert modification	Within Regulatory Floodways of Part 3708	A. Proposed culvert lengthening or bridge widening does not exceed 12 feet. B. The proposed modification, including approach roads, is no more restrictive than the existing. C. No channel modification is proposed other than that required for transitions. D. On Public Waters, the proposed modification is not an obstruction to navigation. E. Compensatory storage requirements must be met.

Table 1-403c

Permit Type	Illinois Administrative Code; Title 17 Chapter I Subchapter h	Construction Activities Affected	Jurisdictional Limits	Permit Criteria
Regional #3	Part 3708	Minor projects in Regulatory Floodways	Within Regulatory Floodways of Part 3708	<p>Storm and sanitary sewer outfalls and outlet channels</p> <ul style="list-style-type: none"> A. The outfall must not project riverward or lakeward of the existing adjacent natural bank slope or bulkhead. B. Construction of outfalls and outlet channels must not result in an increase in ground elevation in the floodway. C. The outfall or outlet channels must not cause stream erosion at the discharge location. D. The velocity of the discharge shall not exceed the scour velocity of the channel soil, unless channel erosion would be prevented by the use of riprap or other design measures. E. Outlets from drainage ditches shall not be opened to a stream until the ditch is vegetated or otherwise stabilized to minimize stream sedimentation. F. The outlet jet shall not be a hazard to navigation. G. The outlet discharge capacity shall not exceed 1,000 cubic feet per second. H. Bank erosion shall be prevented by aprons, energy dissipaters or drop structures as necessary. I. Disturbance of streamside vegetation shall be kept to a minimum to prevent erosion and sedimentation. All disturbed floodway areas, including the stream banks, shall be restored to their original contours and seeded or otherwise stabilized upon completion of construction. <p>Shoreline and streambank protection</p> <ul style="list-style-type: none"> A. Only the following materials may be utilized: Stone and concrete riprap, steel sheet piling, cellular blocks, fabric formed concrete, gabion baskets, rock and wire mattresses, sand/cement filled bags, geotechnical fabric materials, natural vegetation and treated lumber. B. The length of shoreline or streambank to be protected shall not exceed one thousand (1000) feet. C. All material utilized shall be properly sized or anchored to resist anticipated forces of current and wave action. D. Materials shall be placed in a way which would not cause erosion or the accumulation of debris on properties adjacent to or opposite the project. E. Materials shall not be placed higher than the existing top of bank. F. Materials shall be placed so that the modified cross-sectional area of the channel will conform to that of the natural channel upstream and downstream of the site. In no case shall the cross-sectional area of the natural channel be reduced. The bank may be graded to obtain a flatter slope and to lessen the quantity of material required.

Permit Type	Illinois Administrative Code; Title 17 Chapter I Subchapter h	Construction Activities Affected	Jurisdictional Limits	Permit Criteria (cont.)
Regional #3	Part 3708	Minor projects In regulatory Floodways.	Within Regulatory Floodways of Part 3708	<p>G. If broken concrete is used, all protruding materials such as reinforcing rods shall be cut flush with the surface of the concrete and removed from the construction area.</p> <p>H. Disturbance of vegetation shall be kept to a minimum during construction to prevent erosion and sedimentation. All disturbed areas shall be seeded or otherwise stabilized upon completion of construction.</p> <p>I. In case of seawalls and gabion structures on lakes, the structure shall be constructed at or landward of the water line as determined by the normal pool elevation.</p> <p>J. This regional permit does not authorize filling for the purpose of converting public water to private use.</p> <p>Underground and overhead utilities-see conditions stated in Regional Permit 3 in appendix.</p> <p>Sidewalks, athletic fields, playground equipment, and patios-see conditions stated in Regional Permit 3 in Appendix.</p>

Table 1-403d (Cont.)

1-404.01 IDNR-OWR Permit FAQ

1. What is the significance of the IDNR-OWR Floodway Construction permit to IDOT projects?

Identifying the appropriate IDNR-OWR permit type and developing design recommendations that address permit requirements are integral parts of preliminary hydraulic studies and plans. Regarding project scope and cost, this permit can directly impact the size/length of the structure and the roadway profile grade across the floodplain. Certain OWR permits are self-issued by IDOT for OWR and typically do not impact the project timeline. Other “formal” permit applications to OWR can initiate negotiations and require several months for OWR review and approval. Compliance with all IDNR-OWR permits and their requirements demonstrates that IDOT construction activities are in compliance with State floodplain management statutes. In that respect, the IDNR-OWR permit solidifies IDOT’s longstanding reputation with IDNR and helps to maintain public trust.

2. When does a project require an IDNR-OWR permit?

The project must meet **BOTH** of these qualifiers:

- a. Location falls within a jurisdictional floodway: within the floodway limits of a watershed at or greater than 1 square mile urban and 10 square miles rural. See 1-404.02 IDNR-OWR Individual Permit Program for urban\rural distinction.
- b. Construction activities possessing sufficient potential impact on the upstream floodplain. These activities include but are not limited to:
 - new bridges and culverts
 - highway projects on new alignments
 - replacement bridges and culverts
 - all culvert liner installations & some culvert extensions
 - some bridge superstructure replacements
 - significant roadway encroachments into the floodplain

3. When does a project NOT require an IDNR-OWR permit?

If the watershed is below the jurisdictional limits in FAQ #2, **no IDNR-OWR permit is required**, regardless of project type and scope. Lesser or minor activities are labeled “Exempt activities” by OWR and do **NOT** require a permit. These include routine maintenance and repair that does not reduce the bridge\culvert waterway opening. Longitudinal encroachments that are minimal in scope and by inspection have negligible impact on flow conditions do not require a permit. Activities that take place above the Q100 water surface profile also do **NOT** require an IDNR-OWR permit. See the respective permit criteria and language for applicable and exempt activities.

4. What type of permit covers a new bridge or culvert?

In District 1, 3708 Floodway Rules apply to regulated floodways; those streams with published regulatory (Q100) profiles by FEMA or OWR. For non-regulatory streams in District

1, the designer should coordinate the permit type with District 1 Hydraulics. In Districts 2 through 9, Statewide Permits #2 and #12 are commonly employed. Statewide Permits #2 and #12 essentially allow the proposed conditions to match existing, provided certain conditions are satisfied. Statewide #2 & #12 are not applicable on streams designated by OWR as Public Waters and they are not applicable when the existing structure is a source of potential damages in the upstream floodplain. In Districts 2 through 9, an Individual Permit under the 3700 Rules is typically utilized when Statewide permits are ruled out. For all Districts, bridges and culverts on Public Waters require a formal permit application to OWR; either 3708 Floodway in District 1 or 3704 Public Bodies \ 3700 Individual Permit in Districts 2 through 9.

5. **At one time IDNR-OWR Q100 backwater limits for bridges and culverts were 0.5 ft. urban and 1.0 ft. rural. Are these limits still in place?**

These limits are still part of the Individual Permit and Statewide Permit #2 language, both of which are under OWR 3700 Rules. However, for the most part, the answer is **NO- these limits are no longer routinely applied**. Allowable backwater in District 1 is typically closely tied to existing conditions and to potential for damage in the upstream floodplain. For 3708 Floodway Permits, arbitrary limits such as 0.5 \ 1.0 ft do not apply. Downstate, in Districts 2 through 9 where Statewide Permits #2 and #12 are very commonly employed, allowable backwater is also closely tied to existing conditions and to upstream impacts. For both SWP2 and SWP12, the 0.5 ft. urban or 1.0 ft. rural limits can be exceeded where permissible under IDNR-OWR regulations and where deemed to be acceptable hydraulic design. An Individual Permit under 3700 Rules may utilize the 0.5 \ 1.0 limits, but they can be superseded by OWR's policy of no increase in the Q100 flood profile when the existing structure is the source of potential flood damages.

6. **For bridges and culverts, how do Statewide Permit #2 and Statewide Permit #12 differ?**

SWP 2 covers new and replacement structures, applies to only rural sites, allows the road grade to be raised, requires a dual certification of the hydraulic design by registered P.E.s and allows proposed backwater to exceed existing within certain limits if proposed conditions don't create damages upstream. SWP12 covers only replacement structures, but applies to both rural and urban sites. SWP12 allows for a grade raise above the Q100 profile, requires P.E. certification that the existing structure is not the source of demonstrable flood damage upstream and requires that proposed Q100 conditions match or improve upon existing.

7. **For bridge and culverts, when is compensatory storage (comp storage) required or dictated by an IDNR-OWR permit?**

The 3708 Floodway Permit covering the 6-county area in District 1 requires compensatory storage provisions. No other OWR permit utilized for bridges and culverts specifically requires excavation to compensate for roadway embankment fill placed within the floodplain.

See the IDNR-OWR webpage <http://dnr.state.il.us/owr/ResmanPermitfaq.htm> for additional F.A.Q.s addressing other approvals required for floodway construction (U.S. Army Corps of Engineers, Illinois EPA), definition of the term floodway and OWR contact information.

1-404.02 IDNR-OWR Regulatory Permit Program

The Regulatory Program applies to construction activity in identified floodways within the 6-county Chicago area, or all of IDOT Region 1, District 1, except Chicago city limits. A 1 square mile (or
July 2011

greater) limit of jurisdiction is exercised on these streams. The IDNR-OWR 3708 Rules for Floodway Construction in Northeastern Illinois⁴ (aka, the Floodway Permit) can be found at: <http://dnr.state.il.us/legal/adopted/3708.pdf>

The Regulatory Program's Part 3708 Rules do not apply to construction activity downstate, within IDOT Districts 2 through 9. IDNR's predecessor to Part 3708 is Part 3706-Regulation of Construction Within Floodplains⁴, dated 1979. Part 3706 was implemented in like fashion to 3708; it applied to identified floodplains in the Chicago area. It also covered the lower reach of the Rock River below the mouth of the Green River in District 2. However, Part 3708 has since superceded the older Part 3706 rules. As a result, the lower Rock River has been excluded from the Regulatory Program and is permitted under the Individual Permit Program.

The regulation is based on a 100-year frequency flood profile called the regulatory flood profile. The Q100 profile is also referred to as the base flood elevation, or BFE. This is an established profile computed and published by the Office of Water Resources or contained within a Flood Insurance Study published by the Federal Emergency Management Agency (FEMA) for a county or municipality. The regulatory profile is the source data used to evaluate all permit applications on regulated streams.

The regulatory flood profile includes the backwater effects of existing floodplain obstructions (including bridges and culverts) and permits are issued for roadway and bridge construction which provide waterway openings adequate to pass the regulatory flood with no significant increase in flood stage or which provide compensation for possible damage due to backwater effects. Compensatory storage, or comp storage, shall be provided for any regulatory floodway storage lost due to proposed work from the volume of fill or structures placed. Comp storage is provided for fill placed between the normal water and the Q10 elevations, and between the Q10 and Q100 profiles.

For new and replacement structures, a computed increase in the water surface profile of 0.1 ft above existing conditions is generally considered acceptable unless damages occur. If damages occur for the existing condition, backwater must be reduced to the point of non-damage or to 0.1 ft. above natural conditions.

Construction activities exempt from this permit include bridge/culvert maintenance and repair. Superstructure replacement that does not result in change to the dimensions of the structure is considered non-jurisdictional maintenance and repair. For projects that fall under the review and approval authority of the Bureau of Bridges and Structures, the BBS Hydraulic Unit shall issue the Floodway Permit to District 1 in accordance with IDNR-OWR's Part 3708 Rules and policies. For projects that do not fall under the review and approval authority of the BBS, the District 1 Hydraulics Section issues the Floodway Permit for IDNR-OWR following the same rules and policies. See [Table 1-403c & d](#) for jurisdictional limits and criteria of the Regulatory Program, Part 3708.

Three Regional Permits created in the late 1980's supplement the 3708 Floodway Permit program in the 6-county area. Regional Permits 1 and 2 are IDOT permits created in conjunction with IDNR-OWR. They are administered by IDOT Division of Highways acting as the agent of IDNR-OWR. Regional Permit 1 authorizes bridge and culvert reconstruction and modification projects that are not a source of flood damage. The proposed structure (and approach roads) cannot be more restrictive to normal and flood flows than existing. In addition, RP 1 requires the Regional Engineer to certify that the existing crossing is not a source of flood damage. Regional Permit 2 authorizes limited modification of existing structures; specifying that the amount of proposed culvert lengthening or bridge widening cannot exceed 12 feet. RP1 & RP2 are summarized in [Table 1-403c](#). Regional Permit 3 covers many minor construction activities regulated under the

Part 3708 Rules. Those activities pertaining to highway and bridge hydraulics are contained with Table 1-403d. Regional Permits 1, 2 and 3 are for exclusive use in District 1. RP 1 is typically **NOT** utilized by District 1 due to the existing structure certification requirement listed above. RP 2, however, does have frequent application. For bridge improvements, District 1 employs a summary form to identify the appropriate permit type; typically either Floodway or Regional Permit 2. Note that application of the permit should be coordinated with District 1. See District 1 Form PD0024 "Permit Summary for Floodway Construction in NEIL" through this link to IDOT Forms Management:

<https://insideidot.portal.illinois.gov/prc/FormsManagement/pages/bureau.aspx>

A copy of Regional Permit 3 can be downloaded from the OWR website at this web page:

<http://dnr.state.il.us/owr/ResmanRegionalPermit3.htm>

1-404.03 IDNR-OWR Individual Permit Program

The Individual Permit program of the Office of Water Resources applies to construction activity within the floodplains of all streams and rivers of the State of Illinois except those covered under the Regulatory Program discussed in [Section 1-404.02](#). The OWR Rules for Part 3700-Construction in Floodways of Rivers, Lakes and Streams⁴ can be found at <http://dnr.state.il.us/legal/adopted/3700.pdf> That portion of the rules which most affects bridge and culvert construction is paraphrased as follows:

With the exception of dams, the following jurisdictional limits apply to all man-made flow alterations including bridges, culverts, levees and channel changes:

1. Rural Areas - locations draining 10 or more square miles will require a permit.
2. Urban and Urbanizing Areas - locations draining one or more square miles will require a permit.

Urban and urbanizing areas are those areas of the State where urban development currently exists or can reasonably be expected to occur within a ten-year period. Urban development means residential, commercial or industrial uses in the immediate vicinity of the bridge site, as opposed to scattered farmsteads. Rural areas are the remainder of the State.

Permits are required for new and replacement bridges over streams with drainage areas falling within the above limits. The 3700 Rules list a number of exempt activities that do not require permits, regardless of the crossing location or watershed size. Maintenance of existing bridges and culverts is an exempt activity. Maintenance includes repair, replacement of the superstructure, resurfacing, and minor dredging to restore the waterway opening to the original design cross section. Bridge widening, without pier extension, may also be undertaken without permit. Construction of scour countermeasures at an existing bridge is considered maintenance and repair as long as the effective waterway opening is not significantly reduced. Culvert extensions of up to 100% of the original length, but not exceeding 40 feet in length, may be undertaken without permit. Longer culvert extensions exceeding these limits **AND** culvert liner applications will require a permit since the culvert hydraulics may be significantly affected.

Proposed plans for new bridge and culvert structures will be considered acceptable for hydraulic design purposes provided no significant increase in flood damage potential, without compensation, will be created by the proposed structure. Generally, bridges and culverts which meet the following guidelines for allowable created head will be presumed to cause no significant increase in flood damage potential unless buildings are impacted:

1. In Rural Areas - For all floods up to and including the 100-year frequency discharge, the allowable created head is 1.0 ft at the structure and 0.5 ft at 1000 ft upstream.
2. In Urban and Urbanizing Areas - For all floods up to and including the 100-year frequency discharge, the allowable created head is 0.5 ft at the structure and 0.1 ft at 1000 ft upstream.

The hydraulic designer should keep in mind that meeting the allowable created head limit does not assure that no significant increase in flood damage potential will be created. The flood damage potential at the site should be carefully evaluated and taken into consideration in the design process.

Due to the Regulatory 3708 Program covering District 1 (see 1-404.01) almost all of IDOT's Individual Permit applications to OWR originate in Districts 2 through 9. The Downstate Regulatory Section (Springfield) has been very cooperative in providing preliminary direction and 3700 Rules interpretations to IDOT prior to the formal permit application. Obtaining OWR input prior to or during Hydraulic Report completion contributes to streamlined design work and optimizes the waterway opening for both agencies. This is particularly true for new bridges on new alignments, complex or atypical floodplain modeling or for bridges at highly flood-sensitive locations. Due in part to this early coordination, IDOT has been allowed by the Downstate Section to develop alternatives that demonstrate proposed conditions limit or reduce potential upstream damages to the fullest practical extent, considering physical and economical constraints. This demonstration, or feasibility study, can reduce the proposed bridge length and still produce a waterway opening that is acceptable to OWR and hydraulically adequate by IDOT policy and standards. For those projects where early coordination with OWR could be beneficial, the District Hydraulics staff (and consultant) should work with BBS Hydraulics to obtain OWR's preliminary input.

3700 Rules and OWR policy for Districts 2 through 9 (Downstate Section) allow for the excavation of overbank material beneath the bridge deck in order to maximize the effective waterway opening for a given bridge length. Excavation is allowed to a depth of one-half the channel height. To promote hydraulic efficiency, both vertical and horizontal transitions away from the excavation are required upstream and downstream of the opening. Recommendations for horizontal and vertical transitions are 6:1 and 10:1 respectively. For Individual Permits, IDOT must agree to maintain the excavated opening and transitions; this agreement is handled with a special condition to the permit.

The process of obtaining an Individual Permit from IDNR-OWR is initiated by completion of the Illinois Joint Application Form, aka, the Joint Ap. This is an OWR form available at <http://dnr.state.il.us/owr/ResmanPermitProgs.htm>. The form itself is completed by the consultant or District office. For Hydraulic Reports approved by BBS Hydraulics, the Joint Ap, approved Hydraulic Report and approved TSL Plan are submitted to OWR by BBS. For Hydraulic Reports approved by District Hydraulics- which in this respect are generally culvert projects- the District office submits the same information package directly to OWR.

1-404.04 IDNR-OWR Statewide Permits

The Office of Water Resources has developed several Statewide Permits to authorize construction activities that meet certain terms and conditions. Statewide Permits are applicable in all 9 districts except on waterways designated as 3704 Public Bodies by IDNR-OWR and neither are they applicable to designated 3708 Floodway construction within the 6-county area that constitutes District 1. Note that due to the 3708 exclusion and the degree of urbanization, Statewide Permits are infrequently used in District 1.

Projects meeting the specified conditions are authorized without submittal of a formal Individual Permit application to IDNR-OWR. Statewide Permits are issued by IDOT for IDNR-OWR, and they are issued by the office- either BBS or District Hydraulics- with Hydraulic Report approval authority. For a complete listing of all OWR Statewide Permits, go to <http://dnr.state.il.us/owr/ResmanPermitProgs.htm>. There is no explicit expiration date for Statewide Permits, however, they can be revoked by OWR if the terms and conditions of the permit are not followed.

1-404.041 Permanent Construction: Statewide Permits #2 and #12

Two Statewide Permits pertain to floodway construction of permanent structures; Statewide 12 and Statewide 2.

Statewide Permit No. 12 (SWP12) is entitled Bridge and Culvert Replacement Structures and Bridge Widening. (See Table 1-403b) SWP12 is issued by IDOT at both urban and rural crossings within (i.e., above) OWR's jurisdictional limits; 1 square mile urban and 10 square miles rural.

There are 2 conditions that determine the applicability of the permit to bridge and culvert projects:

1. SWP12 applies to replacement structures only- not to new structures. OWR 3700 Rules define "Bridge or Culvert Reconstruction" (i.e., replacement structures) as total replacement of existing **OR** new alignment within 100 ft. (urban) or 500 ft. (rural) of the existing alignment.
2. SWP12 is applicable **ONLY** when the existing structure is not the cause of demonstrable flood damage; defining demonstrable damage as actual damages observed or recorded, NOT theoretical damages as modeled.

Key SWP12 permit requirements are:

- Certification of the existing structure by a registered P.E. For existing structures that are not the cause of demonstrable upstream flood damage, a certification statement with this language must accompany the permit:

"This is to certify that no demonstrable flood damage has been caused by the existing structure at this location. Our records search revealed that there are no damage claims or complaints concerning the hydraulic adequacy of the existing crossing."
- Replacement structure of equal or greater effective waterway opening than existing. There are no absolute limits imposed upon the Q100 head. Q100 created head in excess of 0.5 ft. (urban) or 1.0 ft. (rural) does NOT eliminate SWP12 from consideration.
- The roadway grade cannot be raised in such a manner that **significantly** affects roadway overtopping conditions for events up to and including Q100. In effect, this tenet means the roadway cannot be raised up if the grade raise would occupy volume below the existing Q100 headwater elevation. However, note that a typical roadway resurfacing lift IS allowable.
- The project shall not involve the straightening, enlargement or relocation of the existing channel except as permitted by Statewide Permit No. 9 Minor Shoreline, Channel and Streambank Protection Activities or Statewide Permit No. 11 Minor Maintenance

Dredging Activities. Excavation of the channel and/or overbank necessary for the effective hydraulic performance of the culvert or bridge is NOT considered straightening, enlargement or relocation.

For bridge and culvert projects, SWP9 and SWP11 address minor channel work intended to reestablish or improve channel alignment with the proposed structure opening. Typically, routine work within the ROW, such as very limited adjustment or shaping of the channel plan form, is done without issuance of SWP9 or SWP11. Work that extends beyond ROW limits, reduces channel flow capacity or calls for streambank protection that is not adjacent to the structure is a candidate for SWP9 or SWP11.

Statewide Permit No. 2 (SWP2) is entitled Construction of Bridge and Culvert Crossings of Streams in Rural Areas. (See Table 1-403b). SWP2 is issued by IDOT for both new **AND** replacement structures (see distinction above) at **rural** crossings within OWR’s jurisdictional limit of 10 square miles. Like SWP12, SWP2 is applicable **ONLY** when the existing structure is not the cause of demonstrable flood damage; demonstrable being defined as actual damages observed or recorded, NOT theoretical damages as modeled. There is a critical difference between SWP2 and SWP12 pertaining to allowable project scope. Unlike SWP12, Statewide 2 allows the roadway grade to be raised up, without restriction on the height or scope of the proposed profile grade across the floodplain.

Key SWP2 permit requirements are:

For a new culvert or bridge crossing:

- Q100 backwater limited to 1 ft. at the structure and 0.5 ft. at a point 1000 ft. upstream.
- There are no buildings or structures in the area impacted by the increases in water surface profile.

Note that OWR 3700 Rules define Bridge or Culvert Reconstruction as total replacement of existing or new alignment within 100 ft. (urban) or 500 ft. (rural) of the existing alignment. Structures exceeding those offsets are considered “new”.

For a replacement culvert or bridge crossing:

- A. Regarding backwater for all events up to and including Q100, no increase over existing conditions.
- OR--**
- B. Q100 backwater limited to 1 ft. at the structure and 0.5 ft. at a point 1000 ft. upstream.

--AND--

The existing structure must be certified by a registered P.E. in the same manner described above for SWP12.

The following requirements apply to both new and replacement structures:

- The project shall not involve the straightening, enlargement or relocation of the existing channel except as permitted by Statewide Permit No. 9 Minor Shoreline, Channel and Streambank Protection Activities or Statewide Permit No. 11 Minor Maintenance Dredging Activities. Excavation of the channel and/or overbank necessary for the effective hydraulic performance of the culvert or bridge is NOT considered

straightening, enlargement or relocation. (See the paragraph after the last SWP12 bullet.)

- Dual certification by two registered P. E.'s in the State of Illinois.
 1. Certified to have been designed by standard hydrologic and hydraulic engineering methods and in compliance with the terms and conditions of SWP2 and the applicable 3700 Rules.
 2. Certified to have been reviewed and found to be in compliance with the terms and conditions of SWP2.

Typically for consultant-prepared Hydraulic Reports, the consultant provides the first certification and the office with approval authority over the Hydraulic Report- either BBS or District Hydraulics- provides the second certification.

1-404.042 Temporary Construction: Statewide Permits #13 and #14

IDNR-OWR distinguishes or categorizes construction in the floodway as either permanent or temporary. Two Statewide Permits regulate temporary construction activities that are needed for bridge and culvert projects. These are Statewide Permit No. 13 and Statewide Permit No. 14.

Statewide Permit No. 13 (SWP13) is entitled Temporary Construction Activities. (See Table 1-403c) SWP13 is issued by IDOT at both urban and rural crossings within (i.e., above) OWR's jurisdictional limits; 1 square mile urban and 10 square miles rural, for all non-Public Body streams outside of the 6-county area in District 1. This includes all sites permitted under the 3700 Rules where permanent structures are covered under SWP2, SWP12, or Individual Permits. SWP13 is evaluated and issued by the District office separately from the permanent structure's Statewide permit.

Statewide Permit No. 14 (SWP14) is entitled Special Uses of Public Waters. (See Table 1-403b) SWP14 is issued by IDOT at Public Bodies of Water under the 3704 Rules. It addresses construction measures such as work causeways, pier cofferdams and other measures that may create potential for damages to upstream properties or impact upon or pose a hazard to recreational activities. Section **1-404.05 IDNR-OWR Public Body of Water Regulation** provides a link to IDNR-OWR's list of designated public body streams and details on the proper use and processing of SWP14.

1-404.05 IDNR-OWR Public Body of Water Regulation

The Illinois Department of Natural Resources maintains permit rules for Part 3704 – Regulation of Public Waters⁴ which can be found at: <http://dnr.state.il.us/owr/resmanpermitprogs.htm>. OWR has designated a number of waterways, canals and lakes around the state as "public waters". These are typically larger streams or systems including all the major rivers in Illinois. Designated public waters were once navigable or have been improved for navigation and opened to public use. A list of the Illinois Public Waters identified by the IDNR Office of Water Resources is on the OWR website and is included as an Appendix of the 3704 Rules. .

Projects that lie nearby or adjacent to a public water- but not within the channel banks of the public body of water itself- can also fall under 3704 jurisdiction. The permit language includes "all bayous, sloughs, backwaters and submerged lands connected to the main channel or body of water during normal flows or stages". OWR has utilized several criteria and/or reference elevations for "normal stage" in order to determine if nearby or adjacent projects should be permitted under the 3704 Rules. These criteria\rationale have included:

1. Normal pool elevation, such as the published water surface elevation behind a lock and dam.
2. 50% exceedance stage- the WSE exceeded 50% of the time period during which stages were recorded. Produced by the U.S. Army Corps of Engineers, this data is available only on the largest rivers in Illinois.
3. Top of channel bank on the public water.
4. Labeling the tributary a "creek channel" and not a slough\backwater, thereby excluding the crossing from the 3704 Rules.

The 3704 Rules do not dictate allowable backwater, per se, for new and replacement bridge and culvert projects. To establish backwater criteria, the appropriate rules are applied; either 3708 Rules for regulated streams in District 1, 3700 Rules for non-regulated streams or waterways in District 1 or 3700 Rules for all public waters in Districts 2 through 9. **ALL** Public Body 3704 permits require a formal application to the appropriate OWR regulatory section.

3704 Rules also list routine maintenance and repair of existing structures under exempt activities, like the 3700 and 3708 Rules. However, per the August 2008 memo from IDNR-OWR to IDOT BBS, **ALL** superstructure replacements on public bodies require formal application for the appropriate 3700 Individual Permit or 3708 Floodway Permit.

3704 Rules regulate both the permanent proposed structure and any temporary construction features placed within the public waters. Temporary features such as causeways and equipment platforms are permitted under Statewide Permit No. 14. SWP14 is the responsibility of the contractor, as described below.

IDOT & CONTRACTOR PROCEDURES

- IDOT must make a formal permit application to IDNR for any permanent bridge or culvert projects within public waters.
- Contractors must draft and post Statewide Permit 14 for temporary construction features placed within public waters. Drawings must be provided to OWR with sufficient detail to identify general location and dimensions of temporary structures. A brief description of purpose and estimated length of time in place should be included for key features. Scheduling should allow for issuance of a 21-day public notice and Statewide 14 permits should identify the permit number issued by IDNR-OWR for the permanent structure.
- Bridge plans for structures over "Public Waters" should be so identified in the title block, and
- A special provision should be included with contract documents stating the contractor's permit responsibilities.

1-500 IDOT HIGHWAY ACCESS PERMIT

No person may perform work in any right of way of a highway under the jurisdiction of the Division without first obtaining an access permit from the Division of Highways. Typically the work in question consists of a physical connection to the highway system in the form of a commercial or private entrance. The physical connection commonly includes a drainage element or outlet; runoff originating from the adjacent property flowing to an IDOT roadway drainage facility such as a storm drain or roadside ditch. In that instance, IDOT review and approval of the analysis and recommendations pertaining to the drainage connection then becomes an integral part of the permit issuance.

The Division has prepared a set of rules which describes the standards and procedures for the issuance of permits for construction projects which affect drainage along highways under the Department of Transportation's jurisdiction. The level of documentation required is described along with the type of bonding. The standards used in determining whether to grant a permit are written to insure the integrity of the highways and to control the amount of downstream discharge of storm waters to a reasonable extent. The conditions to be included in each permit issued are written to insure that the work is performed safely and in a way which will not expose the State to any additional liability.

The "DRAFT" rules titled "Permits for Drainage Outlets" are included as [Addendum 1-803](#). The focal point of the DRAFT rules is the requirement that proposed peak flow from the off-ROW property not exceed the existing peak flow for both the Q10 and Q100 events.

Public Act 86-616, section 9-115.1 of the Illinois Highway Code, was passed by the General Assembly in 1989. It gives highway agencies approval authority over the construction of these drainage facilities, when said facilities are built adjacent to IDOT ROW, either above or below ground:

- Storage facilities which detain or retain water
- Earthen berms

Section 9-115.1 states:

"It is unlawful for any person to construct or cause to be constructed any drainage facility for the purpose of the detention or retention of water within a distance of 10 feet plus one and one-half times the depth of any drainage facility adjacent to the right-of-way of any public highway without the written permission of the highway authority having jurisdiction over the public highway."

"It is unlawful for any person to construct or cause to be constructed any earthen berm such that the toe of such berm will be nearer than 10 feet to the right-of-way of any public highway without the written permission of the highway authority having jurisdiction over the public highway."

Excerpts from the Public Act are contained in [Section 1-802](#), along with the January 30, 1990, memorandum presenting the Act, noting general concerns to be addressed by the reviewing authorities. Also, in [Section 1-802](#) is a memorandum dated May 30, 1990, presenting six cases to be used with the January memorandum for consistency in implementing the Act. A seventh case is presented to show the application for underground detention, along with the presenting memorandum dated February 26, 2003.

Each IDOT District has developed their own process of reviewing and approving the drainage elements of this permit. As you might expect, the number, variety and complexity of access permit submittals varies across the state. The typical drainage connection in DuPage County, for example, dictates a higher level of scrutiny than downstate areas that aren't as urbanized or commercially developed. Accordingly, each District has supplemented the Draft Rules and Public Act 86-186 with their own information and requirements for analysis. District 1 has developed a set of submittal requirements and guidelines for site development and posted supporting documents to the IDOT website. District 1 also utilizes information presented at the 2006 ACEC-IDOT Drainage Seminar as a guide to completing the Permit Checklist. Regarding information posted to the IDOT website, other Districts have followed suit to varying degrees. The applicant should contact the respective District for direction, if needed.

1-600 TEMPORARY STRUCTURES

Bridges and culverts, used as part of a detour runaround, are naturally in service for relatively short time periods and judicious concessions in hydraulic capacity are appropriate. The following information is presented to aid in planning temporary structures:

1. The overall bridge length or waterway opening, but not both, must be specified in the contract documents.
2. When the overall length is specified, the shape of the waterway opening shall be shown on the runaround plan and profile in sufficient detail to assure that the design waterway opening will be provided.
3. The abutment type should be appropriate for the waterway opening size and shape. The end slopes in front of spill through abutments may be 1.5:1 for temporary bridges. When the temporary waterway opening requirements are greater than the opening provided by the main channel section, it may be necessary to use overbank spans.
4. Where waterway opening is specified, the shape of the opening and length of the bridge may be left for determination by the Contractor.
5. Generally, the waterway opening should be specified as the required opening measured along the centerline of the runaround. This opening should provide for the effect of the angle of stream flow on the alignment of the runaround.
6. The runaround bridge should be offset from the proposed bridge such that adequate room for drainage between the pavements is provided.
7. The roadway grade of a temporary runaround should be positioned low enough to allow overtopping when floods exceed the design frequency. A 2' minimum vertical clearance between low beam and design high water is preferred.
8. The waterway opening required for a temporary runaround structure should be based on the same hydraulic considerations and type of analysis as the permanent structure. Consideration should be given to such items as scouring velocities, allowable backwater, flood relief by overtopping, duration of flooding, debris, ice and length of construction.
9. The selection of design frequency should be based on the anticipated length of service of the temporary structure and the flood damage potential upstream. In general, temporary structures which will be in service from one to three months can be designed for a minimum 1-year frequency flood event and structures to be in service longer than three months to one construction season can be designed for a minimum 5-year frequency flood event. For longer than one construction season, contact the Hydraulics Unit of the Bureau of Bridges and Structures. A higher design frequency should be considered for locations which have a high flood damage potential upstream.

Service Life	Design Frequency
1 - 3 Mo.	1 yr
3 Mo. - 1 Const. Season	5 yr
>1 Const. Season	Consult BBS-HYD

10. Consideration should be given to locating the temporary structure downstream from the permanent structure to reduce the tendency for scour in the construction area.
11. U.S. Army Corps of Engineers Section 404 and IDNR- Office of Water Resources Floodway Construction Permits, when required for the permanent structure, will include the temporary structure. In the case of Public Waters, a separate permit is required by IDNR-OWR for the temporary construction; application is typically by the contractor.

1-700 REFERENCES

1. U.S. Coast Guard. *Application for Coast Guard Bridge Permits*. Supplement to Coast Guard Publication COMDT PUB P16591.3B "Bridge Application Guide". June 2001.
2. Donald L. Uchtmann, Carroll J. W. Drablos, Thomas D. Bratschun, and Benjamin A. Jones, Jr. 1986. *Illinois Drainage Laws: Rights and Responsibilities of Highway Authorities and Landowners Adjacent to Highways, Report No. FHWA/IL/UI-212*. Illinois Cooperative Highway and Transportation Series No. 212. Illinois Department of Transportation, UILU-ENG-86-7023. 1986.
3. *Highway Drainage Law, paper*. Presented by Rich Christopher, Illinois Department of Transportation of the Chief Counsel's Office. October 2002.
4. Illinois Department of Natural Resources, Office of Water Resources, Division of Water Resource Management:
 - Part 3700 *Construction in Floodways of Rivers, Lakes and Streams*
 - Part 3704 *Regulation of Public Waters*
 - Part 3706 *Regulation of Construction Within Floodplains*
 - Part 3708 *Floodway Construction in Northeastern Illinois*

1-800 ADDENDUMS

1-801 Highway Drainage Law

[Paper authored by Rich Christopher, former IDOT Deputy Chief Counsel, circa 2002.]

I. Introduction

The legal basis for the resolution of drainage issues between highway authorities and neighboring property owners arises from three sources. These sources are the common law, statutory law, and constitutional law. This paper summarizes each source separately even though an individual problem may need to be resolved by referring to two or all three of the sources.

II. Common Law

The common law is a body of legal precedents adopted by courts in resolving prior disputes. The rules arising from the common law come from tradition and are modified from time to time by the courts based on the particular circumstances of each case and, to some degree, changing times. Generally the common law rules are applied by the Illinois courts when there is no statute which addresses the situation. The common law sometimes has more than one rule to address recurring legal situations. In these cases it's up to each State Supreme Court to choose which rule to follow. Drainage is no exception here. The common law has provided three general approaches or rules to follow. Each rule will be summarized here, along with an explanation of the approach typically followed by Illinois courts.

A. Common Enemy Rule

This rule is based on the principle that surface water interferes with the ability to develop property and can be dealt with any way the owner sees fit. Diversion, repulsion, or alteration in the point of outlet are all fair game subject to certain exceptions. The exceptions are based on certain egregious practices which are viewed as unnecessary or unreasonable. At one time thirty states were following the common enemy rule. There are now only 11 and the District of Columbia that are still using it.

B. The Natural Flow Rule

This rule assumes that lower land is impressed with a natural easement or obligation to accept surface water from higher land. The lower landowner cannot obstruct the flow from the higher land. A corollary to this rule is that surface water may not be diverted from its natural course by changing its point of outlet or by redirecting it to a different drainage basin. The most significant exception to this rule is the "good husbandry" exception which recognizes that some flows can be collected and then discharged at increased rates if this is required by sound agricultural practice. Eighteen states are following some form of this rule.

C. The Reasonable Use Rule

This rule states that each property owner can alter the flow of surface water across his property, even if this causes harm to his neighbors, as long as the harm is reasonable under the circumstances. Instead of following the norms on giving a preference to the higher landowner and prohibiting diversions and changes in points of outlet, each case is based on the relative amounts of harm suffered by the neighboring property owners, the relative

benefits, and how much of the harm could have been avoided. The trend around the country has been for courts to move toward this standard, even if they do not adopt it outright.

D. The Illinois Rule

Illinois is generally considered a natural flow State with some exceptions based on the reasonable use rule. Where neighboring land uses are different, such as agricultural land bordered by a subdivision, Illinois courts will follow the reasonable use rule. This operates as a limitation on the downstream discharge that would have been allowed under the natural flow rule. There is one reported case where the reasonable use rule was applied against a township highway improvement. The township should have known that since there was evidence of local flooding before the improvement, new enlarged ditches were only going to make the problem worse for the downstream property owners. In cases where surface waters are diverted and downstream damage results or a lower property owner obstructs flow causing damage upstream, Illinois courts have not allowed the reasonable use rule to change the natural flow rule. Even though Illinois recognizes the “good husbandry” exception to the natural flow rule, that does not mean that highway agencies have a duty to improve drainage on adjacent farmland. The railroads often argue that they have an exception similar to the “good husbandry” rule for farmers. In fact, the rules are no different for railroads than they are for highways. Compliance with a stormwater management ordinance does not allow a property owner to violate Illinois drainage law.

E. Prescriptive Rights

Sometimes an unlawful diversion or obstruction cannot be remedied if certain criteria are met. Generally if the diversion or obstruction is open, that is easily seen, and continuous for twenty years, it may not be removed. When the diversion or obstruction benefits a public highway, the prescriptive right arises after fifteen years. Prescriptive rights are generally limited to their actual use and usually cannot be enlarged. Diverted flows allowed by prescription cannot be increased. A downstream obstruction allowed by prescription cannot be enlarged. These rights can be acquired *by* public highway authorities but probably cannot be acquired *against* public highway authorities.

III. Statutory Law

There are a number of instances where the Illinois General Assembly has passed laws addressing drainage. The following statutes have direct relation to highways.

A. The Drainage Code (70 ILCS 605)

In 1955 the General Assembly collected all of the old farm drainage laws and consolidated them into one unified code. This code is generally used to establish the rights of farmers and drainage districts, but its provisions affect others as well. Section 2-1 of the Code states that “Land may be drained in the general course of drainage by either open or covered drains.” This is generally regarded as an acknowledgement by the General Assembly that the natural flow rule applies in Illinois.

Section 2-12 states in part as follows:

“The landowner shall not willfully and intentionally interfere with any ditches or natural drains which cross his land in such manner that such ditches or natural drains shall fill or become obstructed with any matter which shall materially interfere with or impede the flow of water.”

This section does not create an obligation on the part of the downstream owner to keep ditches or drains open. It just prevents the downstream owner from doing anything to interfere with drainage. The upstream owner can go on to the downstream owner's land to keep ditches and drains open but is liable for any damage caused.

Section 12-4 addresses highway bridges. This section states as follows:

“Whenever a natural drain or a ditch constructed in the course of natural drainage crosses a public highway, the highway authority shall construct and thereafter keep in repair and maintain a bridge or culvert of sufficient length, depth, height above the bed of the drain or ditch, and capacity to subserve the needs of the public with respect to the drainage of the lands within the natural watershed of such drain or ditch, not only as such needs exist at the time of construction, but for all future time.”

The other side of this rule is also stated in Section 12-4 as follows:

“If a district, by deepening, widening or straightening a natural drain or by changing the established grade, width or alignment of a ditch, removes or threatens to remove the supporting member of a highway bridge the district is liable to the highway authority for the cost of protecting or underpinning such abutment, pier, wingwall or other supporting member.”

B. The Highway Code (605 ILCS 5)

In 1959 the General Assembly collected all of the laws pertaining to public highways, except for the toll highways, and consolidated them into one unified code. Different articles in the Code pertain to township, municipal, county and State highways. In Article 9, there are general provisions which relate to all of these different levels of roads. The general provisions pertaining to drainage follow.

Section 9-101.1 provides in part as follows:

“Whenever the proper highway authority is about to construct or improve the drainage structures of a State highway the highway authority shall meet and consult with the authorities of any municipality adjacent to or through which such highway or road runs. The purpose of such meetings is to work out an agreement with such municipality and all other interested agencies and units of local government as to the extent of such drainage construction or improvement.”

The key words here are meet, consult, and agree. This means that neither side tells the other what to do. Both sides need to do what it takes to come to an agreement. This section also allows the Department to “buy detention” in new subdivisions adjacent to State highways outside Cook County.

Section 9-105 states as follows:

“In constructing a public highway, if a ditch is made at the junction of highways, or at the entrance of gates or other openings of adjoining premises, the highway authorities shall construct good and sufficient culverts or other convenient crossings. New entrance culverts or crossings or additions to existing entrance culverts or crossings along an existing public highway or street where there is a ditch may be made with the consent of the highway authorities, provided the applicant for such entrance, culvert or crossing

constructs at the applicant's expense a good and sufficient culvert or other convenient crossing of the type and size specified by the highway authorities, which structure shall then become the property of the public."

Section 9-107 states as follows:

"Whenever the highway authorities are about to lay a tile drain along any public highway the highway authority may contract with the owners or occupants of adjoining lands to lay larger tile than would be necessary to drain the highway, and permit connection therewith by such contracting parties to drain their lands."

This section only covers voluntary cooperative arrangements between highway authorities and their neighbors. It does not create any obligation for a highway authority to contract with adjacent owners and does not obligate the highway authority to maintain all tiles which cross or run parallel to the highway right of way. It also does not create any obligation for the highway authority to maintain tiles off the highway right of way which do not benefit the highway.

Section 9-109 states in part as follows:

"It is unlawful to construct any bridge or culvert upon any ravine, creek, drainage ditch or river upon a public highway in this State unless such bridge or culvert shall have the capacity of sustaining highway traffic with safety. The fact that any such bridge or culvert does not conform with the specifications of the Department in effect at the time when the contract for such bridge or culvert is let, is prima facie evidence that the bridge or culvert does not have the capacity of sustaining highway traffic with safety."

This provision is apparently directed at accidents caused by flooded roads.

Section 9-111.1 states in part as follows:

"The highway authorities shall from time to time inspect the bridges and culverts on the public highways and streets under their respective jurisdictions which span streams and water courses and shall remove driftwood and other materials accumulated within the right of way at such structure which obstruct the free flow of either low or high water."

Section 9-115.1 states as follows:

"It is unlawful for any person to construct or cause to be constructed any drainage facility for the purpose of the detention or retention of water within a distance of ten feet plus one and one-half times the depth of any drainage facility adjacent to the right-of-way of any public highway without the written permission of the highway authority having jurisdiction over the public highway.

It is unlawful for any person to construct or cause to be constructed any earthen berm such that the toe of such berm will be nearer than 10 feet to the right-of-way of any public highway without the written permission of the highway authority having jurisdiction over the public highway."

This provision was inserted to prevent the construction of detention ponds and other drainage facilities at the edge of the right of way. These facilities can make future widening of the highway much more problematic.

Section 9-117 states in part as follows:

“If any person injures or obstructs a public highway by turning a current of water so as to saturate, wash or damage the same, or by plowing in or across or on the slopes of the side gutters or ditches, or by placing any material in such ditches, or in any way interfering with the free flow of water therein without the permission of the highway authority having jurisdiction over such highway, he shall be guilty of a petty offense.

The highway authority having jurisdiction over such highway, after having given 10 days notice to the owners of the obstruction or person so interfering with the free flow of water in the side gutters or ditches interfering with drainage may fill up any ditch or excavation except ditches necessary for the drainage of an existing farm emptying into a ditch upon the highway, or regrade such side gutters or ditches, and recover the necessary cost from such owner or other person obstructing or damaging such highway.”

This section gives the Department control over the activities of adjacent landowners so it must be used very carefully. This provision is generally not used unless there is real damage to the highway resulting from the adjacent property owner’s conduct.

Section 9-123 states in part as follows:

“No person, firm, corporation, or institution, public or private shall discharge or empty any type of sewage, including the effluent from septic tanks or other sewage treatment devices, or any other domestic, commercial or industrial waste, or any putrescible liquids, or cause the same to be discharged or emptied in any manner into open ditches along any public street or highway, or into any drain or drainage structure installed solely for street or highway drainage purposes.”

C. Groundwater Control (525 ILCS 45)

Prior to 1983 groundwater was considered by the Illinois courts to be the property of the landowner. He could do with it as he saw fit. This rule was changed by the General Assembly in Section 6 of the Water Use Act of 1983. Section 6 states simply as follows:

“The rule of ‘reasonable use’ shall apply to groundwater withdrawals in the State.”

The only reported case which has interpreted this language concerned a homeowner whose well dried up when a drainage ditch next to her home was deepened and enlarged. The court reviewed the legislative history and decided the phrase “reasonable use” in this Act has the same meaning as the doctrine of reasonable use in disputes over the use of water in streams by riparian owners. In those riparian cases each user is entitled to use the resource as long as no other’s use is unreasonably deprived. This means that groundwater is a shared resource. This provision can come into play when a highway ditch affects the levels of an adjacent pond or well. The highway authority is probably not responsible for all damages but can probably be held responsible for damage which could have been avoided by undertaking reasonable precautions.

IV. Constitutional Law

Both the U.S. and Illinois Constitutions provide that private property shall not be taken for public use without the payment of just compensation. This has been interpreted to mean that no one should, as a result of a public improvement, be required to receive surface water on to his land other than what the common law rule in effect would provide for him to receive unless

the property owner is compensated. Normally the highway authority which chooses to put more water on to a neighboring property owner than drainage law allows or proposes to place a drainage structure on to his property will make an offer of compensation. If the offer is rejected, the highway authority will file an eminent domain or condemnation lawsuit to establish the appropriate compensation and take the necessary property rights. If the highway authority goes ahead and causes the damage without paying compensation, the property owner can file an inverse condemnation lawsuit and seek to force the highway authority to institute eminent domain proceedings. Illinois courts have allowed these suits to proceed only when the drainage structure or water permanently occupy the complaining person's property. Occasional unwarranted flooding can be pursued through suits against the Department in the Illinois Court of Claims.

1-802 Public Act 86-186



Illinois Department of Transportation

To: ALL BUREAU CHIEFS AND DISTRICT ENGINEERS
 From: Ralph E. Anderson
 Subject: Transportation Legislation – Public Act 86-616
 Date: January 30, 1990

Public Act 86-616, passed by the 1989 Session of the 86th General Assembly, added a new section (9-115-1) to the Illinois Highway Code which became effective January 1, 1990. The new section, as shown below, gives highway agencies additional approval authority over the construction of drainage facilities which detain or retain water and the construction of earthen berms which are adjacent to highway right-of-way.

Section 9-115.1 – “It is unlawful for any person to construct or cause to be constructed any drainage facility for the purpose of the detention or retention of water within a distance of 10 feet plus one and one-half times the depth of any drainage facility adjacent to the right-of-way of any public highway without the written permission of the highway authority having jurisdiction over the public highway.

It is unlawful for any person to construct or cause to be constructed any earthen berm such that the toe of such berm will be nearer than 10 feet to the right-of-way of any public highway without the written permission of the highway authority having jurisdiction over the public highway.”

Since the legislation provides no standard for review of these facilities it is necessary that the Department establish guidelines to insure consistency and adequacy of implementation. The draft rules on permits for drainage outlets, as contained in the Appendix to the Drainage Manual should be used for enforcement of this new legislation. These rules were written to see to it “... that rights-of-way are maintained and the integrity, operational safety, and primary function of such highways are preserved”.

Drainage facilities which should be included under this new section are all types of retention or detention facilities including those formed by excavation, channelization, levee, or impoundment. To determine whether a drainage facility falls within the provisions of the new law, the depth of the drainage facility shall be taken as the difference in elevation between the bottom of the basin and the 100 year highwater elevation, the natural groundline, or the top of berm or dam whichever is greater.

ALL BUREAU CHIEFS AND DISTRICT ENGINEERS

January 30, 1990

Page 2

The procedures identified in the Drainage Manual should be used to evaluate the hydrologic characteristics of the proposed construction. General concerns to be addressed by the reviewing authorities include the following:

1. That the proposed construction does not inundate or over tax the highway drainage system.
2. That traffic safety is not jeopardized by sight distance constraints caused by berms.
3. Right-of-way needs for highway projects.
4. Stability of roadway embankments.
5. That maintenance responsibilities are not increased.

Specifically, impoundments should not be allowed which will pond water to a depth greater than the roadway.

DGG/kktABC DEpublic act 86-616-2010

cc: Ralph C. Wehner



Illinois Department of Transportation

To: ALL BUREAU CHIEFS AND DISTRICT ENGINEERS
From: Ralph E. Anderson
Subject: Transportation Legislation - Public Act 86-616
Date: May 30, 1990

Reference is made to my memorandum of January 30, 1990, which advised of the passage of Public Act 86-616 which gives highway agencies additional approval authority over the construction of drainage facilities which detain water and the construction of earthen berms which are adjacent to highway right-of-way.

The attached sketches have been prepared to assist in the interpretation of whether a drainage facility or a berm falls within the provisions of the new law. Six situations are presented showing how to measure the depth of the drainage facility and the point of measurement for determining the distance from the right-of-way.

These sketches should be used with the guidelines given in the January 30, 1990 memorandum for consistency in implementing Public Act 86-616.

DGG/kktABC DEpublic act 86-616 1990sketches memo-2010

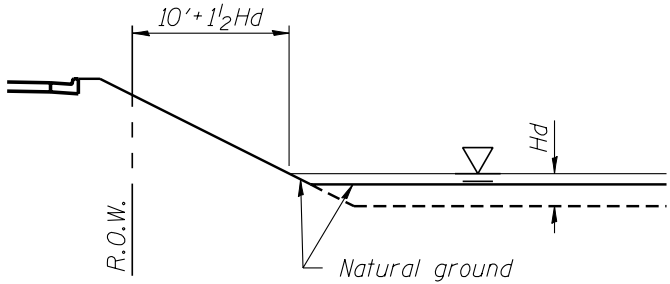

CASE I

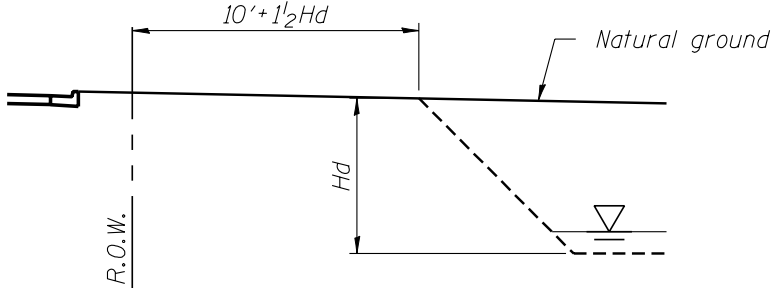

CASE II

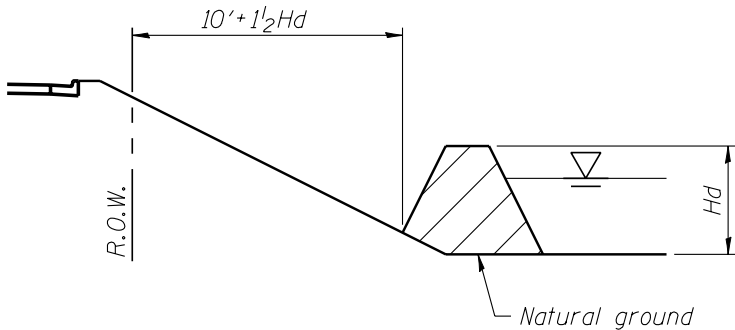

CASE III

DRAINAGE FACILITY & EARTHEN BERM CONSTRUCTED ADJACENT TO THE HIGHWAY R.O.W.

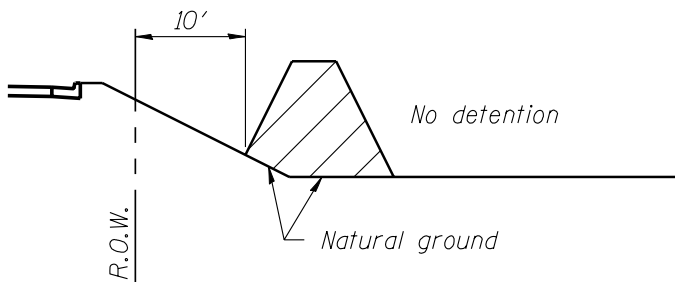

CASE IV

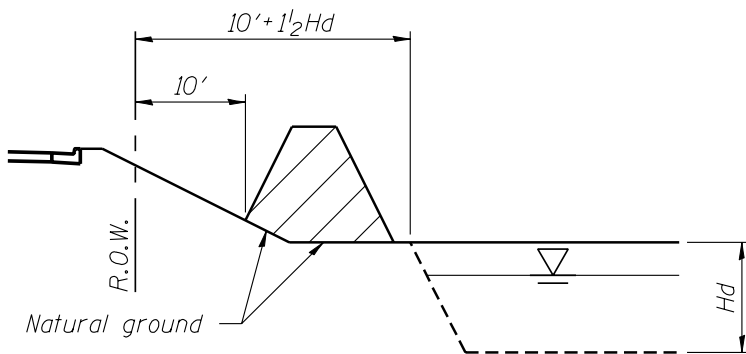

CASE V

Combination berm with no drainage function adjacent to excavation for detention. Both distance criteria are to be applied independently.

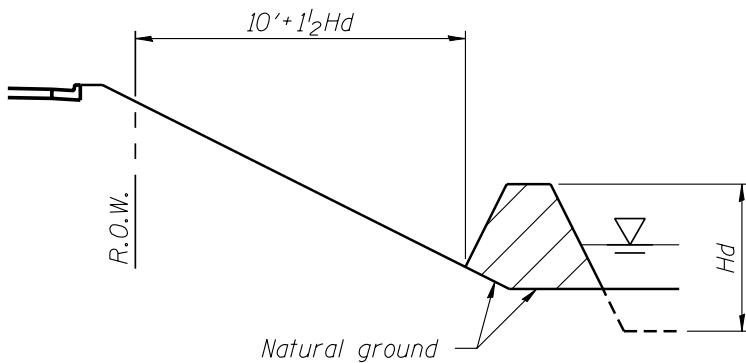

CASE VI

If any portion of berm is being used to detain water, then Hd would be taken from bottom of basin to top of berm and 10' + 1/2 Hd applied to the top of the berm adjacent to R.O.W.

DRAINAGE FACILITY & EARTHEN BERM CONSTRUCTED ADJACENT TO THE HIGHWAY R.O.W.



Illinois Department of Transportation

To: ALL DISTRICT ENGINEERS
From: Ralph E. Anderson
Subject: Transportation Legislation - Public Act 86-616
Date: February 26, 2003

Public Act 86-616, Section 9-115.1 gives highway agencies additional approval authority over the construction of drainage facilities that detain water and construction of earthen berms, which are adjacent to highway right-of-way.

The attached sketches are offered to assist in interpretation of whether a drainage facility or a berm falls within the provisions of the law. The first six cases have been in use since they were first issued in 1990. Case VII is new and is presented to assist in interpretation and to establish a guideline for underground drainage detention facilities. These guidelines are necessary to ensure consistency and adequacy of implementation.

For reference, the memorandum introducing the act dated January 30, 1990, and the memorandum presenting the sketches dated May 30, 1990, are attached.

Section 9-115.1, including all seven case sketches, will be included in the Drainage Manual which is currently undergoing revisions and updating.

Attach.
RLD2003.3/kktADEpublic act 86-616 2003sketches memo-2010

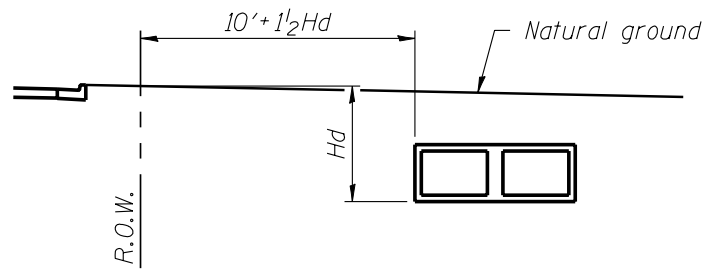

CASE VII

DRAINAGE FACILITY & EARTHEN
BERM CONSTRUCTED ADJACENT
TO THE HIGHWAY R.O.W.

1-803 Draft Rules: Permits for Drainage Outlets

Permits For Drainage Outlets Draft

Section

101	Scope
102	Purpose
103	Definitions
104	Requirement for Permit
105	Permit Application Form
106	Permit Application – Additional Document Required
107	Standards for Permit Issuance
108	Permit Conditions

Section 101 Scope

The rules in this Part establish uniform procedures and standards for construction projects affecting drainage on the right-of-way of all highways under jurisdiction of the Department.

Section 102 Purpose

The rules in this Part are intended to control the use of right-of-way of all highways under the jurisdiction of the Department for drainage of lands of other persons such that rights-of-way are maintained and the integrity, operational safety, and primary function of such highways are preserved.

Section 103 Definitions

The following terms as used in this Part shall have the following meanings:

“Department” mean the Illinois Department of Transportation

“Diversion” mean the deflection of storm or stream waters in such a way that these waters flow into a watercourse to which they are not naturally tributary or that the point of discharge of these waters within a natural watershed is changed.

“Highway Permit Continuous Bond” means a continuous bond which remains in full force and effect as long as permitted drainage facilities occupy the Department’s right-of-way.

“Hydrograph” means a graph showing the rate of discharge of storm or stream waters with respect to time for a specific storm condition.

“Individual Highway Permit Bond” means a performance bond which remains in full force and effect until permitted construction of drainage facilities has been completed and the facilities have remained in acceptable condition for a reasonable period of time as determined by the Department (usually 5 years).

“Person” means any individual, partnership, corporation, association, unit of local government, or agency of State government other than the Department.

“Storm waters” mean those waters which have been precipitated on land or caused to flow on land by irrigation or other artificial means and which then spread over the surface of land

where they may appear as puddles, sheet or overland flow, or rills. "Storm waters" include waters collected in sewers or artificial ditches constructed for their transport to an outlet. Waters continue to be "storm waters" until they reach well defined natural watercourses or standing bodies of water. "Storm waters" do not include stream waters.

"Stream waters" mean those waters which are former storm waters or ground waters which have entered into and flow in well defined natural watercourses including overflow channels and multiple channels.

Section 104 Requirement for Permit

No person may perform work in any right-of-way of a highway under the jurisdiction of the Department without first obtaining a permit from the Department.

Section 105 Permit Application Form

- a) Three signed copies of the Department's Highway Permit form must be filed with the District Office of the Department's Division of Highways which exercises jurisdiction over the area where the work is proposed.
- b) If the land to be drained by the proposed work is held in trust, both the holder(s) of the beneficial interest(s) in the trust, and the trustee(s) must sign as applicants.
- c) The mailing address of each applicant, not the address of the location of the proposed work site, must be provided.
- d) Generally, one permit application will be sufficient for all work to be performed at each work site. When construction is to be performed by more than one contractor, the Department may require a separate application for each contractor's portion of the work.

Section 106 Permit Application – Additional Documents Required

Each application must be accompanied by the following:

- a) An Individual Highway Permit Bond or a Highway Continuous Bond must be executed by a licensed bonding company which names the applicant as principal. The amount and type of the bond shall be based on the amount of work to be done and shall be set by consultation with the Department after initial review of plans for proposed work. Individual Highway Permit Bonds must be furnished by applicants who have no Highway Permit Continuous Bond in effect or by those applicants short-term surety.
- b) Five copies of a drawing shall be enclosed which shows clear and true representation of the proposed work. The following guidelines may be used to assist in preparation of suitable drawing.
 - 1) The work should be accurately located with a mailing address, legal description, and/or the distance to intersecting streets, roads, railroads and streams.
 - 2) The following existing conditions should be depicted:
 - A) Width of pavement and right-of-way;
 - B) Storm drainage scheme;
 - C) Location of curbs, gutters, sidewalks, median, shoulders, ditches, poles, street lights, traffic signals, hydrants, trees, underground mains, underground cables, underground ducts (with dimensions shown from existing pavement); and
 - D) Highway stationing
 - 3) The description of the proposed work should include the following:

- A) Geometrics of driveways, street returns, pavement widening, and parking layouts;
 - B) Lateral and longitudinal location of proposed mains and sewers;
 - C) Profile elevations of all underground installations;
 - D) A detailed internal site plan showing drainage patterns;
 - E) Material specifications showing size, thickness, diameter, weight, gauge, type, class, ect.; and
 - F) All dimensions shown from existing pavement.
- 4) An arrow indicating north, a scale, and the name and telephone number of a person who can answer questions should also be provided.
- c) A United States Geological Survey Quadrangle Map or Northeastern Illinois Planning Commission Flood Map showing the proposed site to approximate scale shall be enclosed.
- d) A vicinity map showing the site location in relation to major intersection roads or streets with distances indicated from property lines to these streets shall be enclosed.
- e) A plan shall be enclosed showing existing topography with contours at intervals adequate to show the following:
- 1) The general direction of flow of storm waters,
 - 2) Existing drainage facilities within the highway right-of-way and along the site frontage, and
 - 3) The general pattern of drainage in the area adjacent to the proposed work site.
- f) A plan shall be enclosed showing proposed site development with a grading plan and proposed drainage facilities.
- g) Calculations of drainage for existing and proposed conditions shall be enclosed showing the rate of runoff for the maximum storm event which can be expected to occur once every ten (10) and one hundred (100) years.
- h) An analysis shall be enclosed including the following if on-site storage of storm waters is included in the applicant's proposed development:
- 1) An inflow-outflow hydrograph,
 - 2) A tabulation or plot of available storage related to stage in basin with verifying cross sections,
 - 3) The rating of the outlet structure,
 - 4) Routing computations,
 - 5) A description and rating of any auxiliary outlet, and
 - 6) A plan of storage basin(s) locating paths of inflow and outflow.
- i) If a natural drainage is being utilized, plotted cross sections and a profile of the drainage course with calculations for stage-discharge relationships shall be enclosed.
- j) Documentation showing that the applicant's proposed development complies with applicable local ordinances shall be enclosed.

Section 107 Standards for Permit Issuance

- a) The permitted work must not hinder the performance of existing or proposed highway drainage facilities, create traffic hazards or unnecessary maintenance responsibilities, or cause or be likely to cause increased liability for the State of Illinois.

- b) Drainage structures to be constructed under or across highways shall conform to the Department's standards for culvert and bridge design, which are available for review at the Department's District Highway Offices, and shall be constructed in accordance with the Department's Standard Specifications for Road and Bridge Construction.
- c) Permit applicants must agree to maintain permitted drainage structures and facilities constructed on their own property and must obtain an ordinance or resolution from a unit of local government accepting jurisdiction and maintenance of drainage structures and facilities other than entrance culverts or crossings or additions thereto constructed on highway rights-of-way. New entrance culverts or crossings shall become the property of the State of Illinois with jurisdiction, control and supervision vested in the Department.
- d) Detention of storm waters must be provided as necessary to satisfy the following:
 - 1) Storm waters which enter the Department's drainage system from developed property must not exceed that which would naturally enter from the naturally tributary area during and immediately after the maximum storm event which can be expected to occur once every ten (10) and one hundred (100) years.
 - 2) Applicant's proposed facilities must be designed and constructed to prevent the overtaxing or otherwise damaging of the Department's drainage system.
 - 3) When any part of the storm waters to be discharged by any of the applicant's facilities into the Department's drainage system constitutes a diversion, the applicant must provide detention facilities of sufficient capacity to limit the flow reaching the Department's drainage system to the rate of flow which would have occurred previously from that portion of the area to be drained which is naturally tributary. Overflow in the course of natural drainage for the diverted flow must be provided.
- e) The outletting of flow which constitutes a diversion will be permitted only when the applicant demonstrates that there is no reasonable alternative to such a diversion, that the applicant's facilities provide storage necessary to prevent any increases in flow over that flow which would have occurred without the diversion, and that the necessary flood or drainage easements have been secured from all property owners who will be affected by such diversion or that the applicant has obtained an ordinance or resolution from a unit of local government agreeing to indemnification of the State of Illinois for said diversion.
- f) A diversion is not permitted when the Department's drainage system is pumped.
- g) Storm waters from the applicant's property must not discharge onto the highway pavement by flowing over curbs or along entranceways.
- h) The applicant must provide a drainage system which collects and discharges all flow which reaches the Department's right-of-way.
- i) Connections to the Department's sewers must be at the manhole or catch basin nearest the applicant's property. If no such structure exists, the applicant must build a structure conforming to the Department's Standard Specifications for Road and Bridge Construction at the point of connection.
- j) The applicant's facilities must prevent sanitary sewage effluent from septic tanks and industrial wastes from discharging on the Department's right-of-way or into any drainage tile or structure which discharges into such right-of-way.
- k) Connections to the Department's drainage system must prevent sedimentation from occurring. Proper staging or the use of siltation basins must be provided to show that sedimentation will not occur.
- l) The applicant shall be responsible for compliance with all other applicable federal, state, and local requirements.
- m) Connections to the Department's roadside ditches must have adequate protective features to prevent erosion and washing of the ditch bottom and banks.
- n) To ensure the maintaining of facilities as designed, the applicant must provide a drainage easement for facilities which include covered drains or detention basins. A drainage

easement must show location, typical cross section, and control elevation along the easement.

Section 108 Permit Conditions

All permits issued pursuant to the rules of this part shall be subject to the following conditions:

- a) The applicant represents all parties in interest and shall furnish material, do all work, pay all costs, and shall in a reasonable length of time restore the damaged portions of the highway to a condition similar or equal to that existing before the commencement of the described work, including any seeding or sodding necessary.
- b) The proposed work shall be located and constructed to the satisfaction of the Department's District Engineer or his duly authorized representative. No revisions or additions shall be made to the proposed work on the right-of-way without the written permission of the Department's District Engineer.
- c) The applicant shall at all times conduct the work in such a manner as to minimize hazards to vehicular and pedestrian traffic. Traffic controls and work site protection shall be in accordance with the applicable requirements of Part 6 (Traffic Controls for Street and Highway Construction and Maintenance Operations) of the Manual on Uniform Traffic Control Devices for Streets and Highways (92 Ill. Adm. Code 546) and with the traffic control plan if one is required elsewhere in the permit. All signs, barricades, flaggers, etc., required for traffic control shall be furnished by the applicant. The work may be done on any day except Sunday, New Year's Day, Memorial Day, Independence Day, Labor Day, Thanksgiving Day, and Christmas Day. Work shall be done only during daylight hours unless the Department determines that night work will be less disruptive to traffic.
- d) The work performed by the applicant is for the bona fide purpose expressed and not for the purpose of, nor will it result in, the parking or servicing of vehicles on the highway right-of-way. Signs located on or overhanging the right-of-way shall be prohibited.
- e) The applicant, his successors or assigns, agrees to hold harmless to the State of Illinois and its duly appointed agents and employees against any action for personal injury or property damage sustained by reason of the exercise of this permit.
- f) The applicant shall not trim, cut, or in any way disturb any trees or shrubbery along the highways without the approval of the Department's District Engineer or his duly authorized representative.
- g) The State reserves the right to make such changes, additions, repairs, and relocations within statutory limits to the facilities constructed under this permit or their appurtenances on the right-of-way as may at any time be considered necessary to permit the relocation, reconstruction, widening, or maintaining of the highway and/or to provide proper protection to life and property on or adjacent to the State right-of-way. However, in the event this permit is granted to construct, locate, operate, and maintain utility facilities on the State right-of-way, the applicant, upon written request by the Department's District Engineer, shall perform such alterations or change of location of the facilities, without expense to the State, and should the applicant fail to make satisfactory arrangements to comply with this request within a reasonable time, the State reserves the right to make such alterations or change of location or remove the work, and the applicant agrees to pay for the cost incurred.
- h) This permit is effective only insofar as the Department has jurisdiction and does not presume to release the applicant from compliance with the provisions of any existing statutes or local regulations relating to the construction of such work.
- i) The construction of access driveways is subject to the rules listed in Permits for Access Driveways to State Highways (92 Ill. Adm. Code 550). If, in the future, the land use of property served by an access driveway described and constructed in accordance with this permit changes so as to require a higher driveway type as defined in those rules, the

owner shall apply for a new permit and bear the costs for such revisions as may be required to conform to those rules. Utility installations shall be subject to the Accommodation of Utilities of Right-of-way (92 Ill. Adm. Code 530).

- j) The applicant affirms that the property lines shown on the attached sheet(s) are true and correct and binds and obligates himself to perform the operation in accordance with the description and attached sketch and to abide by these rules.
- k) Such other special conditions shall be required as necessary to insure compliance with the rules of this Part.

Revised 12-9-84
From DOCO523S



Chapter 2

Dr. Richard S. Tedlow
The Harvard Business School
Boston, MA 02163
USA
Phone: 617 495 6200
Fax: 617 495 6201
E-mail: tedlow@hbs.edu

CHAPTER 2 – DRAINAGE STUDIES AND HYDRAULIC REPORTS

- 2-000 GENERAL
 - 2-001 Introduction
- 2-100 DATA COLLECTION FOR DRAINAGE STUDY
 - 2-101 Purpose
 - 2-102 Initial Information Compiled
 - 2-103 Topographic Mapping
 - 2-103.01 LiDAR
- 2-200 EXISTING DRAINAGE SYSTEM
 - 2-201 General Location Drainage Map
 - 2-202 Existing Drainage Plan
 - 2-202.01 Field Tile
 - 2-202.02 Subway
 - 2-203 Drainage Investigation
 - 2-204 Major Drainage Features
 - 2-205 Local and Other Agency Coordination
- 2-300 PROPOSED DRAINAGE SYSTEM
 - 2-301 Drainage Criteria
 - 2-302 Outlet Evaluation
 - 2-303 Storm Water Detention Analysis
 - 2-304 Right-of-Way Analysis
 - 2-305 Drainage Alternatives
 - 2-306 Floodplain Encroachment Evaluation
 - 2-307 Local and Other Agency Coordination
 - 2-308 Proposed Drainage Plan
 - 2-309 Major Drainage Features

2-400 HYDRAULIC SURVEYS

2-401 Culverts

- 2-401.01 Stream Profile/ Alignment
- 2-401.02 Structure Opening
- 2-401.03 Roadway Profile
- 2-401.04 Floodplain Cross Sections
- 2-401.05 Aerial Surveys
- 2-401.06 LiDAR Surveys
- 2-401.07 Flood Sensitivity
- 2-401.08 Datum Correlation
- 2-401.09 Knowledge of Flooding
- 2-401.10 Data Collection

2-402 Bridges

- 2-402.01 Mapping and Photography
- 2-402.02 Stream Survey Data
- 2-402.03 Existing Structure Information
- 2-402.04 Flood History Information
- 2-402.05 Existing Land Use
- 2-402.06 Estimated Water Surface Elevation (EWSE)

2-500 DRAINAGE STUDIES

2-501 Transmittal Letter

2-502 Title Page

2-503 Index (Table of Contents)

2-504 Text

2-505 Appendix

- 2-505.01 Source Data Reviewed
- 2-505.02 Exhibits

2-506 Addendum

2-600 HYDRAULIC REPORTS

2-601 Hydraulic Report for Waterway Crossings

- 2-601.01 Hydraulic Report Content

2-602 Hydraulic Report for Longitudinal Encroachments

2-603 Hydraulic Report for Pumping Stations

2-000 GENERAL

2-001 Introduction

Drainage studies are investigations of the existing and proposed drainage patterns that affect a section of roadway and/or structure. This includes both transverse and longitudinal drainage. The decision on whether or not a drainage study is required will be made by the District.

A drainage study can be a very effective management tool to achieve the following:

1. Provision of a basis for a determination of drainage costs, right-of-way requirements, and joint participation.
2. Confirmation that drainage matters have been recognized, evaluated, and incorporated into design.
3. Inviting public input into the identification and solution to any existing drainage problems.
4. Documenting the identification and justification of any deviations to design policy for which an exception would be requested.

The intent of the drainage studies and hydraulic reports described in this chapter is to document the hydraulic investigations and recommendations for a roadway improvement or structure replacement/rehabilitation. For structure replacements/rehabilitations and pump stations, please refer to [Section 2-600](#) for additional guidelines concerning hydraulic reports.

The ACEC-Illinois/ IDOT 2006 Drainage Seminar handouts have been used for reference to develop the contents of this Chapter. Efforts have been made to ensure that the Drainage Seminar handouts and the Chapter are consistent and compatible. This Chapter is written to provide the guidelines for preparing drainage studies and hydraulic reports, but should not be construed as a blanket policy covering all situations. The District will be the sole judge of variances from this Chapter for preparing drainage studies.

2-100 DATA COLLECTION FOR DRAINAGE STUDY

2-101 Purpose

In the initial stage of project development, an inquiry and overview should be undertaken to define the type of work needed for a given project. Information from several IDOT Sections such as Programming, Bridges, Maintenance Field Engineers and Field Technicians, Traffic, within the Bureaus of Program Development and Operations should be gathered. This information can then be utilized to ascertain the definitive activities to be accomplished for the drainage study.

2-102 Initial Information Compiled

The Drainage Study shall include the following information, if available:

1. All applicable information available from the Illinois Highway Information System. This system consists of the Illinois Roadway Information System (I.R.I.S.), the Illinois Structure Information System (I.S.I.S), the Geographical Information System (G.I.S.), and the Illinois Railroad Information System (I.R.R.I.S.). In addition, if a structure (defined as being twenty feet or greater in clear span along the highway centerline) is within the defined project limits, a copy of the structure inventory master report should also be obtained.
2. Where available (District 1), the United States Geological Survey (U.S.G.S.) Hydrologic Investigations Atlas prepared in cooperation with the Northeastern Illinois Planning Commission known as NIPC. Portions of District 8 (areas surrounding East St. Louis) have also been mapped and an atlas prepared.
3. Copies of the various plans as they pertain to the drainage features of the highway should be included. This may also require obtaining records from the County Highway Department or the District Bureau of Local Roads and Streets. This data should be retrieved during the development of the Existing Drainage Plan discussed in [Section 2-202](#).
4. Flood Insurance Study (F.I.S.) information that pertains to the project.
5. Initiate coordination with the Bureau of Maintenance/Operations by requesting the identification of flooding problems. In addition, the local agencies are requested by letter to identify flooding problems and to furnish plans and copies of watershed management related studies for the local sewers (storm or combined), local ordinances, topographic mapping, and pertinent drainage system information such as size, inverts, types, locations, and topographic mapping, etc.
6. The District Bureau of Traffic/Operations is requested to furnish permit information. Other watershed-management agency plans are to be obtained from the appropriate agency.
7. Information for Illinois Department of Natural Resources Office of Water Resources (IDNR-OWR) regulated streams is obtained from the IDNR-OWR Regulatory Section, if applicable to the project.

8. The Inventory of Illinois Drainage and Levee District book is reviewed to determine if a Drainage District is present. If the Drainage District is active, a letter requesting information is to be transmitted. If the Drainage District is inactive, the local Soils Conservation District and the Mosquito Abatement District, if applicable, should be contacted to provide any information from their records that pertain to the agricultural drain-tile systems. Other sources of information, such as the County Clerk's Office, may also have information about Drainage Districts.

2-103 Topographic Mapping

After the project scope is approved, and depending upon the intent of the project and the information compiled, the extent of the field survey, and need for topographic mapping will be discussed with the District Chief of Surveys. Computer Aided Drafting and Design (CADD) system is to be used for plotting the topographic mapping. Topographic mapping, if available, should be used as part of the determination as to the type and amount of supplemental survey information that will be required. If topographic mapping is not available, the following criteria should be used as a basis for determining the need for topographic mapping:

1. The highway is to be relocated or constructed on new alignment.
2. Replacement of the pavement and major profile changes in an urbanized area (developed property at least two blocks on each side of the proposed highway improvement) that has been visually inspected and identified as being a problem relative to interpreting the areas that would drain to or away from the highway right of way.
3. Widening the pavement such as from two (2) to four (4) lanes in an urbanized area as previously defined, or in a rural area where volume-sensitive outlets have been identified, such as depressed areas drained by agricultural drain tiles.

In any event, available mapping should be pursued prior to a final decision on which is the most cost-effective type of survey to be conducted (field, topographic mapping, or a combination).

2-103.01 LiDAR

LiDAR (Light Detection And Ranging) is a newer technology from which to obtain topographic information. Airborne collection is one common form. Airborne collection is done with two different platforms, the standard aircraft and the helicopter. The fixed wing aircraft will collect data for large areas on single collection to as little as two (2) foot contour spacing. The current data sets have been checked and found to be accurate to plus or minus 0.4 feet in grass and timber areas to 0.06 feet on paved areas. The helicopter is utilized to collect data at a larger sampling to produce one (1) foot contours. This normally is used for small areas or when there is heavy air congestion. With Airborne LiDAR, a laser is shot towards the ground until it comes into contact with an object, providing that objects position and elevation. One of the biggest advantages is the very small amount of void or obstructed area in the Digital Elevation Model (DEM).

The second type of collection is the Mobile LiDAR. It is mounted on a vehicle and driven down the pavement. The speed driven corresponds with the accuracy required for the project. At forty (40) mile per hour and with proper survey control, the accuracy has been found to be in the range of plus or minus two (2) to three (3) centimeters, which is considered within normal survey accuracy for pavement. This style of collection removes

the need for lane closures to perform surveys on busy roadways, has the data collected in very quick manner, and may display more than just the roadway such as signs, trees, and poles. If so desired, the vehicle can stop and scan the underside of any structure.

Another type of collection is Terrestrial Scanning. With this type there is a scanner mounted on a tripod and the data is collected by moving the setup along the project limits (about every six (6) to seven (7) hundred feet. This method allows the survey crew to work on the shoulders and not on the roadway. It is however, slower than Mobile LiDAR. The accuracy of this type is the highest quality available from LiDAR, normally less than one centimeter. Scanning bridges is one of the major uses for Terrestrial Scanning at this time. Beam seats, bottoms of beams, splice joints, etc. are typical objects that are scanned. Anything that can be seen with the naked eye can be scanned with less than one centimeter accuracy.

Yet another type of collection is Bathymetry. With this type, the topography of the bottom of a river or stream is produced. The data is collected from an echo radar unit mounted to a boat.

Conventional survey data along with the data from all previously mentioned methods can be used individually or merged together to produce a DEM, which can be utilized in CADD or GIS applications. The merging of Airborne LiDAR and Bathymetry is beneficial for Hydraulic Studies, giving far greater accuracy that has been seen in the past.

The point density from these methods can be significantly higher than that of a conventional topographic survey. As such, significant storage capacity and computing power is required.

Several of the Northern Counties in Illinois have LiDAR data available, which was collected via aircraft and are complete county collections. Several counties throughout the State are expected to be available in next few years, with hopes of having the entire state completed in the near future. The following link contains a list of counties for which LiDAR data is currently available and can be downloaded:
<http://www.isgs.uiuc.edu/nsdihome/webdocs/ilhmp/data.html>



2-200 EXISTING DRAINAGE SYSTEM

2-201 General Location Drainage Map

The purpose of a General Location Drainage Map is to illustrate the overall current drainage features which include the delineation of external flow to the highway drainage system.

The General Location Drainage Map is usually a small-scale map, which summarizes the scope of the study to be undertaken. [Figure 2-201a](#) contains the information shown on the study exhibit.

At a minimum, the following information shall be included:

1. Project Limits with project route. The anticipated work on crossroads is to be shown as well as contract omissions, limits of construction, and rehabilitation limits.
2. North Arrow
3. Map Scale
4. Drainage Investigation location by symbol. 
5. Potential Flood Plain Encroachment location by symbol. 
6. Identify structures within the project limits by structure number, pump station number, etc.
7. Identify external sub-areas that drain to cross-drainage structures.
8. Drainage divides, drainage districts, combined sewer areas, local storm-sewer areas, and local governmental boundaries.

Remarks:

The base map for the General Location Drainage Map is a color copy of the USGS Hydrologic Investigations Atlas (HA) or a color copy of the USGS Topographic Quadrangle Map if the HA is not available. See [Figure 2-201a](#).

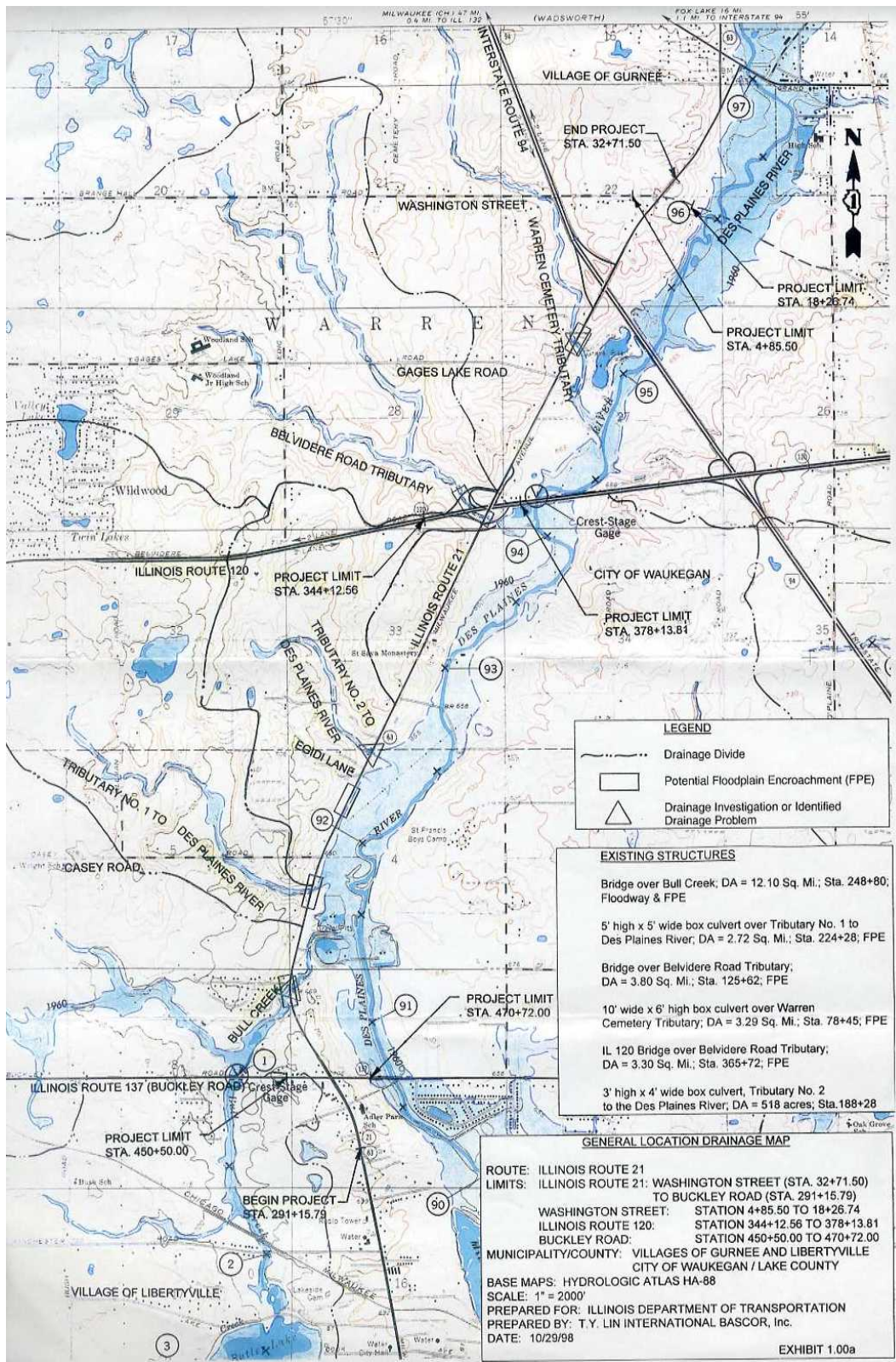

Example General Location Drainage Map
 Figure 2-201a

2-202 Existing Drainage Plan

Depending on the complexity of the improvement, a detailed Existing Drainage Plan may be required. The purpose of the Existing Drainage Plan is to illustrate the current drainage features to the extent necessary to define:

1. The external areas which will drain to cross drainage structures and channels (streams) located within the proposed highway right of way.
2. Sheet and concentrated flow entering the existing highway drainage system.
3. The drainage summits along and adjacent to the highway which include the centerline of the roadway. Plotting of ditch profiles is contingent upon the complexity and availability of mapping, which is a judgment to be made by the Engineer.
4. Existing closed drainage systems, which include local drainage facilities located within the proposed highway right of way (local facilities are to be appropriately labeled).
5. Low flow and flood flow (overflow).
6. Identification of highway outlets.

The extent to which the data previously obtained is used in defining the Existing Drainage Plan is dependent on the following:

- Scope of Work - Rehabilitation, construction which includes added lanes, identified flooding problems, and inadequate outlets.
- Extent of Drainage Improvement - Converting an open to a closed drainage system, separation of sewers, whether or not significant impacts are anticipated due to improved drainage, and the extent to which the existing drainage patterns are or are not to be reinstated to accommodate the proposed improvement.

If the outlets are judged suitable and no known local flooding problems are identified as part of the coordination or during the discussions with the locals and the appropriate District Maintenance/Operations Field Engineer, the improvement would probably not have a significant potential for altering drainage patterns (minor improvement). More than likely, the development of an Existing Drainage Plan would not be required. The Engineer would be responsible for preparing the documentation supporting this determination.

Projects with more involved or significant changes resulting in the conversion from an open to a closed drainage system, sewer separations, diversions, or joint improvements (such as outlet improvements) will normally require the preparation of an Existing Drainage Plan with the appropriate evaluations.

It is to be noted that the exhibit utilized for the Existing Drainage Plan will consist of the detailed topographic mapping. The exhibit must include an interpretation of the ridges and sub-ridges within the study area. Since much of the information shown on the topographic mapping may have been compiled and plotted by others, the mapping should be field verified.

Any discrepancies in the plotted information by others as compared to the data reviewed by the Engineer would be documented in order for the surveyor to initiate a field-verification. The type of discrepancies may include missing cross-culverts, storm sewers, combined sewers, inverts,

Drainage Manual Chapter 2 – Drainage Studies & Hydraulic Reports

discontinuity of system, etc. After the discrepancies are identified and verified by the surveyor, an updated field survey is to be provided to make the necessary revisions.

When the discrepancies identified cannot be resolved, the Engineer is to document and report these discrepancies for further handling. Depending on the sensitivity of the discrepancies, arrangements may be necessary to undertake exploratory investigation. The Engineer is responsible for appropriate documentation such as photographs, dye tests, field report, etc.

It is to be noted that in the case of an obstructed outlet, the presence of a local agency representative may be desirable during the exploratory investigation. These arrangements are to be coordinated with the Bureau of Maintenance/Operations and are to be confirmed in writing.

Outlet conditions for the area being drained are to be clearly depicted on the draft Existing Drainage Plan. It is important that the Engineer ensure the overall area being drained to an outlet is clearly delineated.

The more detailed sub-ridge interpretations are to be included in a working exhibit. This information is essential when developing the Proposed Drainage Plan and is to be used as a working tool by the Engineer.

2-202.01 Field Tile

All field tiles within the existing and proposed right of way should be located within practical limits during the planning stage of a highway improvement. The locations of these tiles are often very difficult to establish, as the outlet pipes may be the only portion of a field tile system which is visible. If the presence of a field tile is known or suspected, the following procedures may facilitate the determination of the location:

1. Contact the landowner, who will usually know if a field tile system exists. He/she will rarely have a map of the system, and will have to rely on memory of where the system was installed. If the system was in place when the property was purchased, the present owner may have little or no knowledge of the tile location. Contacts with previous owners may provide useful information.
2. Some assistance may be obtained from representatives of local drainage districts, soil and water conservation districts, or the United States Natural Resources Conservation Service (U.S.N.R.C.S.).
3. As-built road plans, old survey books, construction files, and permit records should be reviewed for references to field tile.
4. Aerial photographs of the bare soil, taken under certain moisture conditions, may show a slight contrast in color along field tile laterals.
5. The survey party should be alerted to be on the lookout for outlet pipes, vents, inspection wells, or junction boxes. A close inspection in the vicinity of unexplained eroded areas in the sides of creeks or ditches, or near areas that are moist during dry periods, may lead to discovery of hidden outlet pipes.

Drainage Manual Chapter 2 – Drainage Studies & Hydraulic Reports

6. If an outlet pipe is discovered, the remainder of the individual tile may be located by tracking the tile with a probe, or by inserting a metal rod into the tile and following the rod with a magnetic detector.
7. If the approximate location of the tile is known, and the above procedures have proven unsuccessful in locating it, the use of random probing or trenching may be warranted.

2-202.02 Subway

When a subway is identified within the project limits, the major features to be considered in the preliminary evaluation are as follows:

1. The area that presently drains versus the proposed area to be drained to the subway.
2. The condition of the existing pumping station which includes the condition of the wet well and the specific recommendations obtained from the District Bureau of Electrical Operations/Operations.
3. The condition of the existing gravity-drain outlet.
4. The receiving stream/sewer into which the pump station discharges.

2-203 Drainage Investigation

One objective of a Drainage Investigation is to determine if immediate action is required by the Bureau of Maintenance/Operations, or if an improvement is required and if so, who is responsible. Another objective is to determine the Division of Highways responsibility in correcting off highway right-of-way conditions. If action is required by another agency, it may not be pursued at present unless the highway right-of-way is adversely affected. However, the issue should still be discussed at a local coordination meeting.

Drainage investigations are generally categorized as follows:

1. Routine maintenance
2. Highway related
 - a. On-highway right-of-way
 - b. Off-highway right-of-way

Generally, routine maintenance will be identified during project scoping. However, further study may indicate maintenance as the solution. The following is considered routine maintenance and the Engineer should notify the Bureau of Maintenance/Operations in writing of the recommended action to be taken:

1. Erosion and scour that may result in an immediate hazard
2. Debris and silted ditches, including weeds that are contributing to a flooding problem requiring immediate correction

Drainage Manual Chapter 2 – Drainage Studies & Hydraulic Reports

3. Silted or crushed culverts and sewers
4. Silted or crushed driveway culverts

The following would require an evaluation, provided that the problem is highway related and not in an identified floodplain:

1. On-highway right-of-way
 - a. Standing water on the pavement or shoulders
 - b. Flow over the road
 - c. Field tile problems within the highway right of way which may have to be referred to the Bureau of Maintenance/Operations for immediate action
2. Off-highway right-of-way
 - a. Blocked outlet
 - b. Flooding on private properties resulting from landfilling
 - c. Field tile system failure
 - d. Water quality (pollutants)

Problems should be referred to the Bureau of Design/Program Development if they require action such as the installation of underdrains, erosion control, etc. to be incorporated into the preparation of contract plans. It is essential that needed actions be defined for future reference so they can be incorporated during the design phase.

Each location identified as a flooding problem is to be investigated and shown in the Drainage Study. When the drainage investigation is initiated by local input, a copy of the Drainage Investigation is to be sent immediately to the Bureau of Maintenance/Operations for their review, comments and/or corrective action as appropriate. This coordination should be initiated in the early stages. If the problem is correctable by the Bureau of Maintenance/Operations, they should provide a response to the local agency when the corrective action is completed.

During the initial investigation, the Engineer must review all available data and determine if it is adequate for conducting a drainage investigation. If additional information is required, a field meeting with the Maintenance/Operations Field Engineer or other designated representative may be needed. Additional information may include a more detailed survey, development of a plan, or input from local agencies.

Depending on the complexity of the identified flooding problem, it may be necessary to evaluate alternatives and determine the most cost-effective solution. The recommended solution may be included as part of the Proposed Drainage System.

Local coordination will be required in cases where the original highway drainage patterns have been altered by development, landfilling in anticipation of development, illegal dumping, etc. The coordination is to be documented and contained in the Drainage Investigation as a part of the Drainage Study. This should include joint determination with the local agency of right-of-way and local participation in the cost.

Due to the proposed highway improvement, the preliminary drainage concepts may minimize the potential for flooding the highway right of way by providing a curb and gutter with a closed drainage system. As discussed under the Existing Drainage Plan, the identified flooding problem

Drainage Manual Chapter 2 – Drainage Studies & Hydraulic Reports

and the preliminary concepts for correcting the problem will be discussed and contained in the local coordination notes and should be formally provided to the locals.

Joint participation in a sewerred area may be required and shall be in accordance with the policy for sewerred areas contained in [Chapter 5 of the Bureau of Design and Environment \(BDE\) Manual](#).

2-204 Major Drainage Features

This task involves the compilation of data to perform a hydraulic analysis of the existing and proposed conditions for the following major drainage features:

- Bridges
- Culvert Crossings
- Pump Stations
- Reservoirs/Detention Facilities
- Subways
- Channels

The level of hydraulic analysis will depend on the scope of work and project specific conditions of the major drainage feature. The results of the hydraulic analysis will be used to determine if the highway meets design criteria.

2-205 Local and Other Agency Coordination

When the "working documents" are at a suitable stage of completion, the Engineer (in-house staff or consultant) will arrange a meeting with the appropriate local agencies. In addition, the Existing Drainage Plan will be forwarded to the appropriate local agencies for their review prior to the meeting.

The meeting notes with the locals will document the extent that the Existing Drainage Plan is to be refined. This includes substantiation of whether or not there are identified flooding problems or concerns in the identified flood plain. In addition, the local drainage system and outlets contained in the draft Existing Drainage Plan shall be verified. The capacity of the local outlets should be checked against their drainage areas.

To expedite the project, to have effective coordination with the local agencies, and to minimize the number of local meetings, the Engineer should also have developed the preliminary Proposed Drainage Plan concepts for presentation to the locals. The determination of whether or not to discuss the concepts is dependent upon whether or not the preliminary geometrics (horizontal and vertical), which includes typical cross sections, have been provided for review by the Engineer.

If the preliminary Proposed Drainage Plan concepts have been generally developed, this information is also to be made part of the notes as previously discussed. Local input should be obtained relative to 1) storm water management plans and/or sewer separation plans the

Drainage Manual Chapter 2 – Drainage Studies & Hydraulic Reports

community may have that could affect the project, and 2) local ordinances that will affect the project.

The meeting notes are to be furnished to the involved parties for review. Upon receipt of the local comments, the Engineer should update the Existing Drainage Plan and notes as appropriate. Additional discussions and/or correspondence may be required to resolve some issues.

2-300 PROPOSED DRAINAGE SYSTEM

The development of the Proposed Drainage System requires that the Engineer work in close cooperation with the Project Engineer throughout the planning of the facility. At various stages the Engineer will be required to review the geometric information being developed in order to provide drainage criteria, geometric concerns, and right-of-way requirements.

The Proposed Drainage System being developed requires an evaluation of at least the following items:

1. Drainage Criteria
2. Outlet Evaluation
3. Stormwater Detention Analysis
4. Right-of-Way Analysis
5. Drainage Alternatives
6. Floodplain Encroachment Analysis
7. Proposed Drainage Plan

2-301 Drainage Criteria

This task involves documenting that the highway system meets certain design criteria as specified in the IDOT Drainage Manual and the Bureau of Design and Environment Manual. Included in drainage criteria, is geometrics (horizontal and vertical) which deal with low and flood flows, adequate profile grades and curve lengths, reinstatement of drainage patterns and cross drainage structures, closed drainage system versus open drainage system, and underpass conditions.

Any design criteria not met shall be presented at the FHWA coordination meeting.

2-302 Outlet Evaluation

The outlet conditions which have been identified as part of the existing drainage plan are essential to defining the proposed drainage improvement. In the event that the existing outlet is obstructed or otherwise deficient, the appropriate alternatives can be defined and evaluated to determine the most cost-effective solution.

Types of outlets frequently encountered are:

1. stream/river
2. ditch/swale
3. storm sewer
4. combined sewer

5. field tile

Note: Outlets 3, 4, and 5 are usually in conjunction with overland flow which may or may not outlet in the same location.

Generally, storm sewers, combined sewers, and field tiles are sensitive to change in flow rates due to their limited capacity. Increased flow rates could result in either surcharging the system or conversion into overland flow for a given storm frequency. Also, there may be limitations due to invert elevation required to properly drain the roadway (evaluation of raised road vs. improved outlet may be necessary).

Locations that are sensitive to the rate of flow usually require that stormwater detention be provided or alternative outlets be located in conjunction with the highway improvement.

The outlet or area which the outlet drains to may also be a sensitive receptor to volume (i.e., low depression area, whether it is tile supported or not) and/or water quality (i.e., lakes, trout ponds, etc.). Each may need alternative drainage evaluations to assure that measures such as dry wells, diversions to suitable outlets, and specialized construction procedures regarding soil erosion-sedimentation along with the provision of catch basins in highway drainage structures are taken to minimize harm.

It is to be noted that in a sewered area, the existing outlet is the responsibility of the local agency having zoning and building authority.

Therefore, the intent of reinstatement of the Existing Drainage System is contingent upon the effect that the highway improvement could have on the existing outlet.

The highway improvement in a sewered area may be achieved in some cases by minor extensions to the stream because of the minimal change in runoff characteristics. However, in many cases, this is not feasible because of capacity, invert elevation, significant change in runoff characteristics, volume sensitive outlets, or the local agencies desire to improve the outlet.

Where a rural roadway (no curb and gutter) is to be improved to an urban cross section and an outlet is identified as not being adequate, the problem is usually related to the urbanization of the area. Consequently, an unsuitable outlet requires an evaluation to ascertain the most cost-effective solution in accordance with the Department's policies. This will be included in the Drainage Alternatives of the Drainage Study.

2-303 Storm Water Detention Analysis

One of the objectives of a Drainage Study is to identify the right of way necessary to reinstate the drainage patterns. This includes the right-of-way needs relative to providing storage and identifying alternate sites, if applicable. Justification is to be provided in a Drainage Study to support the findings of either providing detention or omitting it.

In the case of a receiving stream/channel the stage-discharge relationship of the stream/channel would be reviewed with respect to the highway area to be drained. In most cases, highway stormwater detention would not be required. As part of this evaluation, the known information relative to the water levels (10, 50 and 100-year) of the receiving stream or the condition of the outfall, such as an enclosed water course, is to be used. If the Waterway Information Table for

Drainage Manual Chapter 2 – Drainage Studies & Hydraulic Reports

existing conditions is predicated on the Flood Insurance Study, appropriate references are to be noted.

The Policy on Storage Requirements for Storm Water Runoff Generated by Highway Improvements, ([Section 1-303](#)), is to be used as a base for analyzing detention requirements. Refer to [Chapter 12](#) for methods of calculating detention requirements.

Detention storage may be provided in one or a combination of the following methods:

1. Altering conveyance system by providing orifice plates, restrictors, etc. within control structures.
2. Parking lanes
3. Pavement (edge and sags)
4. Drainage structures
5. Oversizing storm sewers
6. Providing storage pipe
7. Ditches
8. Open detention ponds
9. Dry wells
10. Medians
11. Interchange Infields

The practicality of oversizing storm sewers is initially investigated by a detention analysis for estimating the amount of storage required for the change in runoff characteristics resulting from the proposed highway improvements.

A schematic drawing is to be prepared to demonstrate how storage is to be reasonably achieved. Refinement is accomplished in the design phase.

The linear nature of highway drainage systems lends itself to a linear storage system. Proposed systems can be economically accomplished by oversizing all or portions of the system for small or moderate storage.

Offsite storage (supplemental or total) may be more cost-effective when inspection and evaluation of the following conditions result in rendering in-line storage infeasible:

1. Topographic limitations (ground cover, side slope outlet inverts)
2. Major utility conflicts
3. Proximity of water mains

Drainage Manual Chapter 2 – Drainage Studies & Hydraulic Reports

4. Unusual soil conditions and slope stability
5. High rock table
6. Groundwater table conditions
7. Conflicts with agricultural tiles

Two conditions of flood frequency are usually subject to evaluation in the development of "in-line" storage:

1. The design frequency of the conveyance system.
2. Base flood flow (100-year flood frequency).

Generally, when conditions result in a closed highway drainage system, the availability and practicality of open detention sites is limited and/or not compatible with the "urban" nature of the area. Oversizing for storage is usually developed for the design frequency, and any additional storage for the 100-year flood frequency should be evaluated. In the event oversizing of pipe is necessary for floods exceeding the design frequency; it would be necessary to check that the storm water runoff can be routed into the storage pipe.

Occasionally, it may be feasible to utilize the highway drainage ditch for storage. Caution is to be exercised in the evaluation to assure that the safety aspects and related costs of protection to both vehicles and pedestrians are considered. Controls relative to the level of "standing water" consist of pavement freeboard, saturation of subgrade and flooding of adjacent properties. The ditch-bottom elevation controls would consist of slope stability, maintenance, ground water, and the significance of the potential hazard.

If detention cannot be cost-effectively achieved by modifying the highway drainage system, it is essential that coordination be initiated with the local agencies regarding the need for a detention facility. The discussions are to be directed to ascertain whether or not the local agency is desirous of a joint improvement, which includes the feasibility of utilizing public rights of way for constructing a new outfall to the receiving stream.

2-304 Right-of-Way Analysis

Coordination must occur throughout the project; however, the main input from the Engineer occurs when the preliminary geometrics are provided for review. The information furnished for review will consist of the proposed roadway geometrics (horizontal and vertical) with the existing and proposed typical cross sections and Bridge Condition Report when appropriate.

Depending on the right-of-way requirements for the particular improvement, additional cross sections may be required. This information is to be requested in order to evaluate the alternatives. The Drainage Study is to include at least the following alternative evaluations, as applicable:

1. Reinstate intercepting swale/ditch within existing right-of-way for proposed geometrics vs. the need for additional right of way.
2. Change nature of ditch from conveyance to collection/interception of flow of storm sewer system.

3. Utilizing the existing highway drainage system.
4. Provide swale/ditch vs. flow over the curb.
5. Provide storm water detention sites.
6. Use of public rights of way or easements for outlets.
7. Change in system type (open vs. closed).
8. Outlet improvements vs. utilizing existing outlets (includes volume-sensitive outlets vs. diversion of increased volume).
9. Design criteria vs. alternatives involving exemption to the design criteria.
10. Alternate roadway profile changes when in a floodplain and overtopping occurs.
11. Alternative horizontal changes in alignment when within the horizontal limits of the floodway.
12. Reinstatement of drainage patterns vs. alternatives resulting from proposed berms (noise barrier walls/berms, subway).
13. Change in runoff characteristics and local participation resulting from parking lanes and sidewalks proposed by locals.

2-305 Drainage Alternatives

This task involves the qualitative analysis of feasible alternative drainage concepts and recommendation of a preferred drainage alternative. The drainage alternatives are identified during the development of the Proposed Drainage Plan. The level of evaluation required is dependent upon the scope and complexity of the project. Items to consider include reinstatement of existing drainage patterns, right of way requirements, consistency with scope of improvement, cost effectiveness, environmental concerns, and compliance to laws and policies. The evaluation of drainage alternatives and the preferred recommendation should be documented in the Drainage Study.

The geometric alternates and/or design variations, which include the preliminary profile and the cross sections (existing and proposed), will be reviewed to ascertain if the drainage patterns can be reestablished. In addition, the proposed right of way will be verified with respect to the typical cross sections and any need for additional right of way will be identified and discussed with the Project Engineer before processing the request.

If required, a preliminary evaluation of any storage requirements using the typical existing and proposed cross sections is to be accomplished at the preliminary stage. The purpose of this determination is to provide information to the Project Engineer regarding right-of-way requirements, especially if the storage cannot be provided by in-line detention (oversized storm sewers). If the detention requirements are developed as preliminary information, they should be further refined when the preferred alternative is selected.

In addition, the Engineer will review the profile of the roadway with respect to the outlet inverts for locations not in an identified flood plain. The purpose of this review is to provide the Project Engineer with recommendations that may retain the use of an outlet to avoid the need for constructing a low-flow system or the purchase of a drainage easement.

2-306 Floodplain Encroachment Evaluation

All projects, which involve Federal and/or State funds, must include an evaluation of all encroachments into the 100-year frequency flood plains. Nearly all encroachments consist of earth fill (embankment) necessary to safely support the highway and the structured protection such as slope walls, retaining walls, riprap, etc. necessary to protect the embankment from the floodwaters. Therefore, when the highway improvement is located within or adjacent to the floodplain, it is necessary to consider the effects that the proposed action (geometric design) would have on the floodplain and also the effects that the floodplain would have to the roadway.

The floodplain may be an important factor in the development of the recommended plan. The Engineer, utilizing the Flood Insurance Study data, will review the design alternatives and/or design variations and evaluate the extent/degree of encroachment. Good judgment is especially essential with respect to the roadway profile.

For a more detailed discussion of the evaluation of Floodplain Encroachments, see [Chapter 3 - Flood Plain Encroachments](#).

2-307 Local and Other Agency Coordination

After the Engineer is satisfied that the Proposed Drainage Plan is consistent with policies, practices, and procedures, arrangements should be made for a meeting or meetings with any affected local agencies.

The recommended drainage plan and the drainage alternatives shall be presented. Notes should be prepared to document the major points discussed at the meeting, including comments or concerns expressed by the local agencies. The solutions should be discussed with the locals with the intent of obtaining their concurrence.

After the meeting, the notes should be reviewed and areas of concern evaluated. The notes and pertinent information that are concurred upon should be furnished to the involved parties for confirmation after the meeting and used as documentation. Additional discussions or correspondence may be required to resolve remaining issues. The assembled documentation should be made part of the Drainage Study.

2-308 Proposed Drainage Plan

The preferred base map is the contour mapping with existing CADD topography and proposed geometric plan superimposed. If base mapping is available in digital format, then the Proposed Drainage Plan should also be prepared in a digital format, although this is not required. If contour mapping is not available, then the base map should be the aerial photography with the proposed geometric plan superimposed. A stand-alone proposed geometric plan is the least preferred base map. The purpose of the Proposed Drainage Plan is to illustrate the proposed drainage features and overall concept to the extent necessary to identify:

Drainage Manual Chapter 2 – Drainage Studies & Hydraulic Reports

- Reinstatement of the existing drainage patterns.
- Sub areas to each outlet.
- Low and overflow (flood) flows.
- Diversions, when unavoidable (shown as cross hatched).
- Potential utility conflicts.
- Maintain, replace or construct storm sewers, crossroad and appurtenant culverts, and special drainage structures.
- Maintain, re-grade, or construct ditches and/or swales.
- Location for proposed storm water detention.

The Proposed Drainage Plan should be developed utilizing the drainage symbols that are consistent with the Existing Drainage Plan tasks. The project limits, project route, crossroads, and streams should be completely identified. The existing right of way and centerline along with the anticipated proposed right of way or drainage easements must also be shown on the base map. Coordinate any missing geometric information or mapping deficiencies with the Project Engineer before the Proposed Drainage Plan is completed.

The Engineer should utilize the Existing Drainage Plan and the templated cross sections to define the proposed tributary areas (sub divides) to each outlet, and to identify diversions. Diversions should be avoided if possible and should only be used as a last resort. The District should carefully consider the downstream impacts, risks, and liabilities before allowing diversions. All outlets, including new outlets (low flow outlets may not be at the same location as the flood flow outlets) should be identified and numbered.

For re-graded ditches, provide beginning and ending stations. Identify proposed ditch and proposed swale locations. For proposed ditches, identify beginning and ending stations and proposed ditch slope. Proposed ditches should be standard ditches or better.

Existing storm sewers to be maintained or abandoned must be identified with beginning and ending stations. Proposed storm sewers are to be designed based on the guidelines described in [Chapter 8, Storm Sewers](#). The size, inverts, and slopes of the proposed storm sewer systems are to be provided on the Proposed Drainage Plan exhibit(s). Plan and profile of the proposed storm sewer runs (not lateral extensions) are required. The Hydraulic Grade Line for the design storm frequency is required to be plotted on the storm sewer profile when restrictors are required in the system. A detailed sketch of any special drainage structure must be provided on the Proposed Drainage Plan or on a separate exhibit.

2-309 Major Drainage Features

This task involves the compilation of data for a hydraulic analysis of the existing and proposed conditions for the following drainage features:

- Bridges

Drainage Manual Chapter 2 – Drainage Studies & Hydraulic Reports

- Major Culvert Crossings
- Pump Stations
- Reservoirs/Detention Facilities
- Subways
- Channels

The level of hydraulic analysis required will depend on the scope of work and project specific conditions of the major drainage feature. The results of the hydraulic analysis will be used to determine if the highway meets design criteria.

If a subway condition exists or is being recommended as the only viable option, special consideration is to be given in the development of the Proposed Drainage Plan. Major concerns are related to the lowering of the roadway profile, increasing the volume of runoff to the underpass by the change in runoff characteristics, and the outlet for an existing pumping station. Any other related concerns that are expressed as part of the coordination with the Central Bureau of Bridges and Structures, or the District Bureau of Maintenance/ Operations are to be fully addressed.

The basic drainage plan is to be laid out to provide the most advantageous system from a hydraulic standpoint (gravity flow versus pump station). If a pump station is required, the major objective is to limit the area draining to the subway by providing a separate gravity system and to provide a berm or other structural measure to limit the runoff to the subway.

The Engineer, after investigating the alternatives to minimize the effect to the subway, coordinates with the Project Engineer relative to impacts for right of way and geometrics. The roadway profile may be used as a structural measure for limiting the area draining to the subway and is to be evaluated in the early stages to minimize the cost incurred.

After compiling the advantages and disadvantages for each alternative including preliminary cost estimates, the preferred alternative is to be reviewed before proceeding with the coordination meeting.

The intent of this coordination meeting is to discuss the compiled evaluations, the alternative pump-station sites, (if any) and the pump-station outlet and storage requirements. Depending on the preferred location of the pump-station outlet, evaluation of alternatives may be required.

For a subway condition, the following are the major points that must be included in a Drainage Study:

1. The roof drainage and conveyance system must be a 50-year design compatible with the subway design.
2. The berms or structural measures utilized to limit the area draining to the subway must be under the control of the Department.
3. The outlet must be under the control of the Department, and the pump station location must offer ingress/egress provisions for the proper maintenance of the facility.

See [Section 2-603](#) for information concerning Hydraulic Reports for pump stations.

2-400 HYDRAULIC SURVEYS

2-401 Culverts

A hydraulic survey is required to determine the essential data of a waterway crossing. A Major Culvert is considered one for which a full Hydraulic Analysis and Report is required. A HEC-RAS analysis would likely be required for this type.

The definition of a Major Culvert as defined by the ACEC-Illinois/ IDOT 2006 Drainage Seminar, Section 3, and District 1 is as follows:

- a) Single or multi barrel culverts with combined end area opening greater than 7.5 sq. ft. or,
- b) Single or multi barrel culverts regardless of combined end area opening when the Major Culvert crossing drains 20 acres or more in an urban area and 200 acres or more in a rural area when the scope of the roadway work is new construction or,
- c) Single or multi barrel culverts regardless of combined end area opening located within an identified base floodplain or flood of record as shown on the General Location Drainage Map.
- d) Any culvert associated with an identified drainage problem.

A Minor Culvert is one that is considered small and that an Abbreviated Hydraulic Analysis would be required or those cases not meeting the criteria as set forth in a-d above for District 1. Win HY-8 would most likely be used to complete this type of Hydraulic Analysis.

A Hydraulic Report is generally not required for minor culverts, but a hydraulic analysis is required with supporting documentation and drainage schedule. Culverts defined as structures by the American Association of State Highway and Transportation Officials (A.A.S.H.T.O.) require a formal Hydraulic Report and associated documentation.

The District Hydraulics Unit will determine which type of analysis is required for each situation.

The Survey Requirements stated below reflect typical culvert locations. It is recognized that judgment must be exercised when unusual circumstances are encountered.

2-401.01 Stream Profile/Alignment

A stream profile shall be taken for a distance of approximately 750 ft upstream and downstream for a minor culvert crossing and at least 1000 ft upstream and downstream for a major culvert crossing. The stream profile should be taken at: the thalweg (lowest point in the XS) a maximum of 100 ft increments so as to accurately define the stream both horizontally and vertically; locations of any other structures along the stream; significant breaks in slope; and any other relevant points of interest as per the discretion with the District during scope development. Scour holes should be defined on the stream profile. Stream alignment should be recorded. For minor culvert crossings this may be only a matter of noting the skew, if the crossing is straight. For major culvert crossings, all meanders should be located with respect to a base line, and approximate channel widths recorded. The locations of all flood plain cross sections should be noted and angles to the base line noted if other than 90 degrees.

2-401.02 Structure Opening

Any upstream and downstream structures should be included. The span and rise, dropbox dimensions (width, height, & depth) if applicable, invert and/or flowline elevations (if different), headwalls should be recorded.

2-401.03 Roadway Profile

A roadway profile shall be taken in the area of the crossing in order to establish the available freeboard and location of potential overtopping. The roadway profile should extend a minimum of 500 ft each side of the crossing in a maximum of 100 ft increments or a minimum of 2 ft vertically above the sag/ low point where the overtopping would occur, if possible. The profile should be taken at the centerline and at the high point of the roadway. On curbed sections, the top of the curb could be the high point. If super-elevated, the high point will be at the edge of pavement, or the edge of shoulder.

2-401.04 Floodplain Cross Sections

A minimum of two floodplain cross sections (including the channel) are required, one upstream and one downstream of a minor culvert crossing. These cross sections should be a good representation of the “typical” floodplain. A minimum of four floodplain cross sections (including the channel) are required, two upstream and two downstream of a major culvert crossing. These cross sections should also be “typical” of the flood plain. If a new highway alignment is proposed, a cross section is required on that alignment. Often channel and floodplain flows are not parallel. In these situations the floodplain cross section should begin perpendicular to the floodplain and continue until the edge of the channel is intersected. At this point the direction of the cross section should change so as to be perpendicular to the channel and the change in direction (angle) should be recorded. Once the opposite edge of the channel is reached the direction of the cross section should again change to be perpendicular with the floodplain. Care should be used as to where the flood plain cross sections are to be taken. They should be located to be representative of the area through which the flood will be conveyed. They should also be taken at constrictions and areas where they are fully expanded. The cross sections should extend until they reach an elevation that will not be overtopped. Since that information may not be known before the survey has been complete, a rule of thumb is to go horizontally to about 2' vertically above low point of roadway. The survey notes of the cross sections should include a description of the ground cover being traversed to enable the analyst to select appropriate "n" values. Photographs of the channel and flood plain serve as a good guide in selecting and documenting "n" values.

2-401.05 Aerial Surveys

If aerial surveys are available, they can be utilized to show the stream alignment, roadway alignment, cross section location and the locations of valuable properties. If the aerial surveys are recent and show one-foot contours, they can be used to extend the cross sections beyond the channel.

2-401.06 LiDAR Surveys

LiDAR is becoming more commonly available throughout the State of Illinois. LiDAR data is available for a handful of Counties and several Counties are in the process of obtaining it in next few years. It too can be used to extend the cross sections beyond the channel. See [Section 2-103](#) for more information regarding LiDAR.

2-401.07 Flood Sensitivity

Note the location and critical flood elevations of upstream and downstream buildings and flood receptors that could be affected by the 100-year flood. This should generally include openings and foundation elevations below the 100-year flood level within the survey limits of the stream floodplain. In urban areas, the survey could be limited to a few critical houses.

2-401.08 Datum Correlation

Include survey datum correlation with other reports such as a Flood Insurance Study datum or reference marks, if available.

2-401.09 Knowledge of Flooding

Local residents and property owners should be interviewed or sent a questionnaire to ascertain any knowledge of flooding events and their frequencies. See [Figure 2-401.09a](#) Important questions to ask include:

1. Period of observation
2. Dates of occurrence
3. Is this in a drainage district
4. Maximum elevation
5. Relative water elevation, upstream and downstream of structure
6. Frequency of flooding
7. Is debris a problem
8. Are ice jams a problem
9. Any recollection of the amount of precipitation during the event
10. Was the roadway overtopped
11. Any change in site conditions
12. Do you have any photographs of flooding



Illinois Department of Transportation
 Division of Highways / Region 2 / District 2
 815 Depot Avenue / Dixon, Illinois / 61021-3500
 Telephone 815/284-2271

PROGRAM DEVELOPMENT
 Hydraulics

September 15, 2005

Mr. John Q. Public
 1000 Main St
 Dixon, IL 60000

Re: Prior Flooding of Rock Creek

Dear Mr. Public:

The Illinois Department of Transportation is working on planned improvement to the US 30 bridge over Rock Creek.

We are required to study potential impacts to the adjacent properties that may result from any improvement. In doing so, we attempt to gather information from the adjacent property owners to learn historical information concerning Rock Creek that may impact our decision making process and our final recommendations.

Please respond to the following questions, as the information provided would be very helpful in improving the result of our study.

Have you seen water from Rock Creek flowing over US 30? Yes ___ No ___

If yes, please provide an approximate date, your opinion as to the event that created this condition and the depth of water over the pavement.

Have you ever noticed or seen the US 30 bridge over Rock Creek blocked with debris or ice flows? Yes ___ No ___

If yes, please provide a description of what was observed. Is this a regular occurrence?

Mr. John Q. Public
 Prior Flooding of Rock Creek
 September 1, 2005
 Page 2

Has your property ever been subject to flooding? Yes ___ No ___

If yes, please provide a description of where and at what height the water was observed. Is this a regular occurrence?

How long have you lived at the residence or had first hand knowledge of any flooding?

What is the highest flow of Rock Creek that you have observed at the bridge?

Are you aware of another person whom we may contact that has knowledge of any prior flooding at this bridge? Yes ___ No ___

If yes, please provide their name, address, and phone number.

Thank you for your time and the information provided.

If you have any questions, please contact Bill McWethy at 815/284-5360.

Sincerely,

Gregory L. Mounts, P.E.
 Deputy Director of Highways,
 Region Two Engineer

By: Ross E. Monk
 Engineer of Program Development

Example Property Owner Questionnaire regarding past flooding
[Figure 2-401.09a](#)

If the Hydraulic Report is prepared by the Consultant, they should use their own letterhead and contact information.

Other possible sources of information are local or State Police, Postal Workers, Area Municipal Maintenance Workers, and IDOT Operations Field Personnel.

2-401.10 Data Collection

The data collection detailed above is only a general recommendation. Some situations may require more data for a proper analysis. [Figure 2-402.02a through 2-402.02e](#) help to detail the preceding items.

2-402 Bridges

This section covers the collection of all desirable survey and field information needed to analyze bridge waterway crossings.

2-402.01 Mapping and Photography

U.S. Geological Survey topographic maps should be acquired for all drainage crossing sites for defining the watershed area, channel slopes, influencing features such as surface storage (ponds, swamps, wetlands, etc.) and flood control structures (reservoirs, levees, etc.). The topographic map provides a convenient means of identifying features which should be investigated more closely in the field such as downstream influences (such as a confluence with a larger stream), for identifying drainage patterns, and making comparisons of similarity and/or diversity with other local watersheds.

Detailed contour mapping is often extremely helpful in identifying flood plain storage pockets, flow patterns, and best structure alignment in watercourses having irregular flood plains or highly meandering channels. These contour maps can be plotted from aerial photography. Floodplain cross sections can be interpreted from aerial contour mapping in less sensitive areas, such as rural areas. In urban (sensitive) areas, ground surveys should be undertaken due to the greater accuracy needed in analyzing potential flood elevations. When an aerial mapping plot is available, the flood plain cross sections should be located on the plot and provided to the surveyor. This provides an excellent guide so that the necessary field survey for channel sections can be accomplished.

Orthophotography mapping, which combines controlled aerial photography with contour mapping on the same sheet, is the preferred form of mapping due to the cultural ground features that are disclosed.

2-402.02 Stream Survey Data

The stream survey shall generally follow, see "Preliminary Guide for Stream and Flood Plain Survey - Typical", ([Figure 2-402.02a](#)). Please note that distances for the stream cross sections are not given in the guide since they are to be taken in locations that represent the channel, structure and floodplain conditions. If contour mapping is available, the stream survey may be limited to channel surveys only. Please note that the downstream or upstream structure may not be a bridge or culvert, but could be a dam or confluence with another stream whose backwater could affect the structure under investigation.

The selection of locations to survey channel cross sections should be made carefully and preferably by the individual responsible for the hydraulic analysis. These locations should provide a typical representation of both the upstream and downstream floodways. These valley cross sections should be normal to the flood flow of both low flow channel and the floodplain. Due to the meandering tendency of most of our stream systems, it is extremely difficult to locate a straight, continuous line, representative section, which is at right angles to both the low flow channel and the floodplain. Proper sectioning of these locations requires surveying across the floodplain at right angles to the contours, then pivoting at the channel bank to shoot at right angles across the channel, and then pivoting again by swinging at right angles to the contours across the floodplain. An alternate procedure is to shoot across the floodplain and channel on a straight line properly recording the skew of the floodplain and channel so that the designer can make the necessary dimensional adjustments in the office. With either procedure, a plan view should be prepared showing the survey base line and the location and orientation of each cross section and the alignment of the roadway and proposed bridge with respect to the stream.

The number of floodplain sections required depends upon the regularity or irregularity of the valley channel; the more irregular channel requiring a greater number of cross-sections. Normally, a minimum of six cross sections (two upstream, two near the site, and two downstream) are required. If the hydraulic analysis will include the computation of a water-surface profile, additional downstream cross sections immediately adjacent to the crossing, as shown in [Figure 2-402.02a](#), are required. The number and location of additional sections will depend on the irregularity of the floodplain valley and local sensitivity to flood damage. To model multiple bridges of different waterway configurations, which are close together, a cross section must be taken between them. This cross section should not be taken along any part of the embankment fill, but should be taken where the natural ground is evident between both embankments. Each section taken should include a description of the

vegetative cover to aid the designer in the selection of appropriate roughness coefficients. Photographs are extremely helpful in this regard.

Many times the flood elevation at a bridge site is controlled well downstream in a narrow part of the valley. If such a valley control section exists, it is extremely important that it is identified and cross sectioned so that a water surface profile can be established from the control. See [Item No. 11 of Section 2-601.01](#), Hydraulic Report Content, for additional comments on surveyed cross sections.

When determining the locations for sections to be taken, two areas to be considered are model requirements and sections that affect the profile. For required sections near the structure, consult the computer program's documentation or [Chapter 7](#). Otherwise, it is recommended to have two sections at approximately 500 ft and 1000 ft upstream and downstream of the structure. The 1000 ft upstream section is recommended in order to check compliance with IDNR-OWR permit policy. Other sections that may also be required are at constrictions of the floodplain, stream junctions, or other structures. [Section 2-402.02](#) gives further guidance about selecting proper locations for cross-sections. If the proposed structure is within the backwater effects of another structure, or the backwater effects of the proposed structure affect another structure, then the analysis must include the other structure. This determination must be made carefully by an individual who is very familiar with the requirements of proper hydraulic modeling.

The streambed profile is another integral part of the field survey. The streambed profile should extend beyond the proposed channel crossing to the limits of the hydraulic survey. See [Figure 2-402.02e Streambed Profile](#). The length of hydraulic survey required is normally 1000 ft both upstream and downstream, with additional cross sections and streambed shots taken as needed to account for tailwater controls created by constricting structures, larger receiving streams or other site specific factors. The streambed survey should also include points between the 100-ft stations as well, to capture the presence of scour holes, beaver dams, cutoff walls, or other such features that do not represent the natural channel bottom. The presence of significant headcutting (degradation) or aggradation along the entire surveyed reach should be noted in the hydraulic survey. The slope generated from the streambed or thalweg profile is one means of estimating the friction slope needed to generate an estimate of normal depth with Manning's Equation. Normal depth is utilized as the tailwater depth for some culvert analyses and as a method of computing the downstream boundary condition (starting water surface elevation) within some HEC-RAS models. Refer to [Section 5-400 Stream Analysis](#) direction regarding the normal depth calculation and for boundary condition options within HEC-RAS modeling.

In addition to streambed elevations, the survey should also record the water surface elevation (WSE) at the time of the survey, date of survey (month, year), along with its corresponding bank elevation, which may be used to calculate the Estimated Water Surface Elevation (EWSE). The EWSE is an estimate of low flow conditions during construction that contributes to both substructure design and construction. [Section 2-402.06 Estimated Water Surface Elevation \(EWSE\)](#) compiles the survey data and additional site information required within the Hydraulic Report.

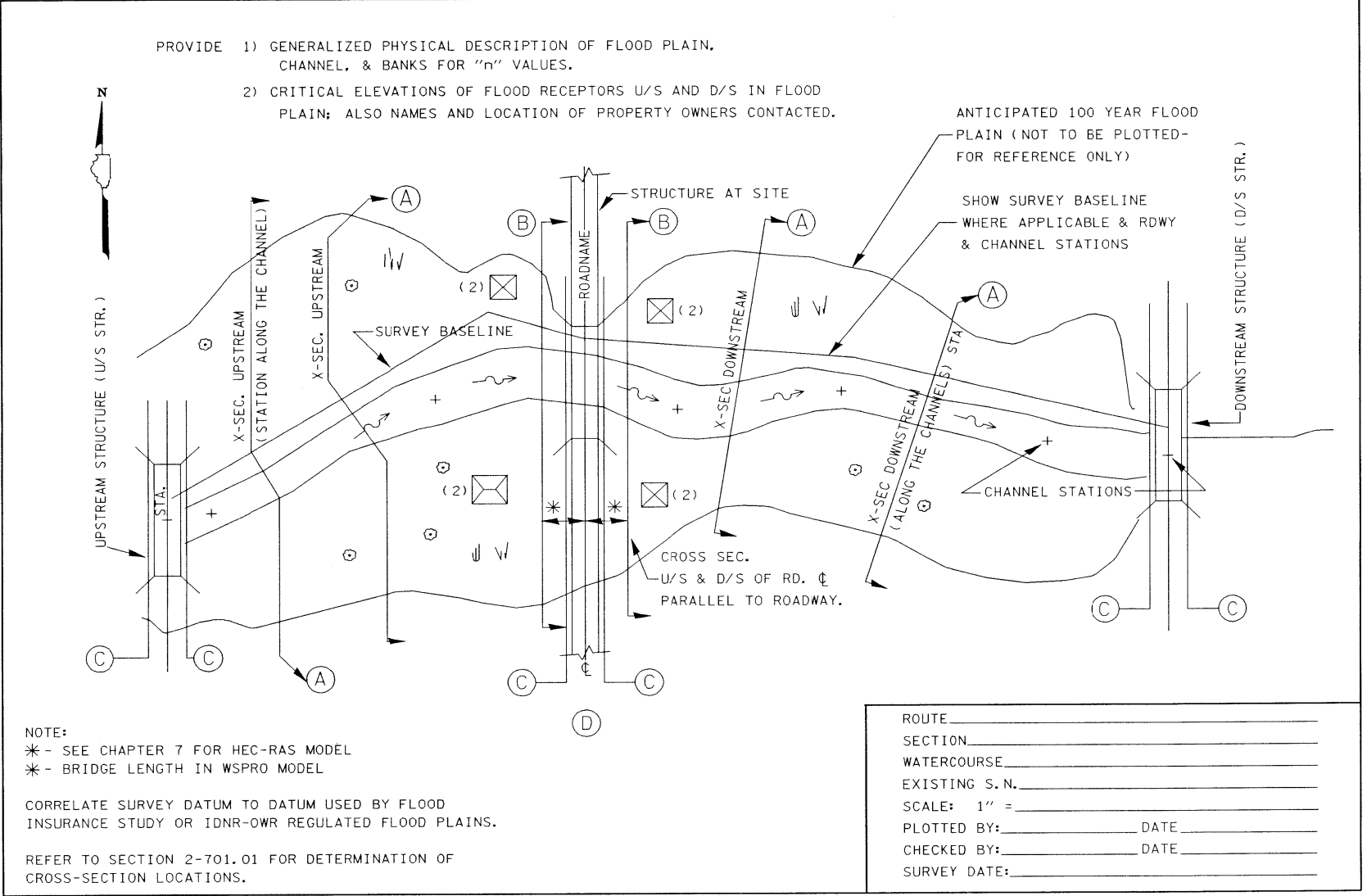

Preliminary Guide for Stream & Flood Plain Survey – Typical
 (to be adjusted for project conditions)
 Figure 2-402.02a

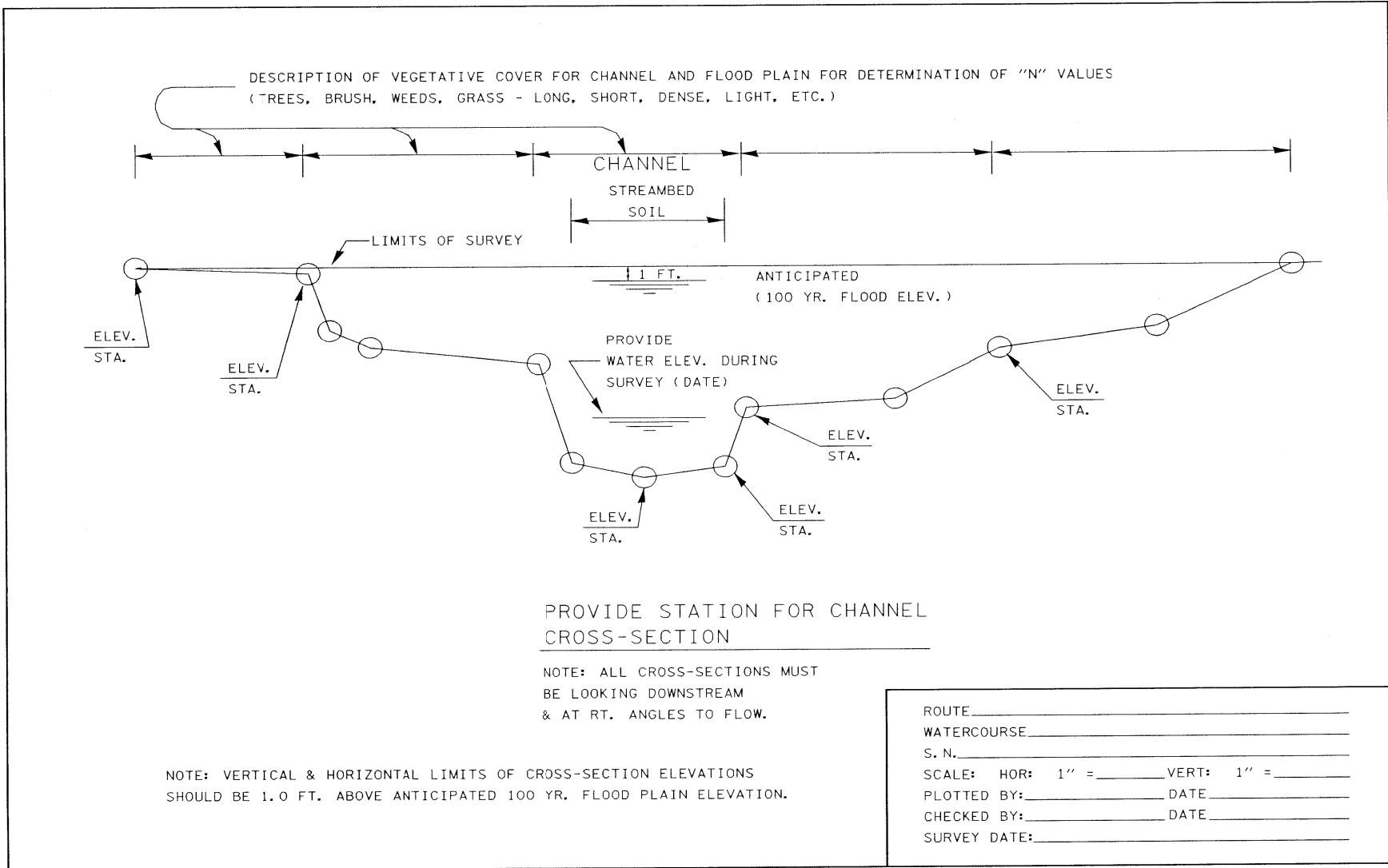

Channel and Flood Plain Cross-Section
(looking downstream)
Figure 2-402.02b

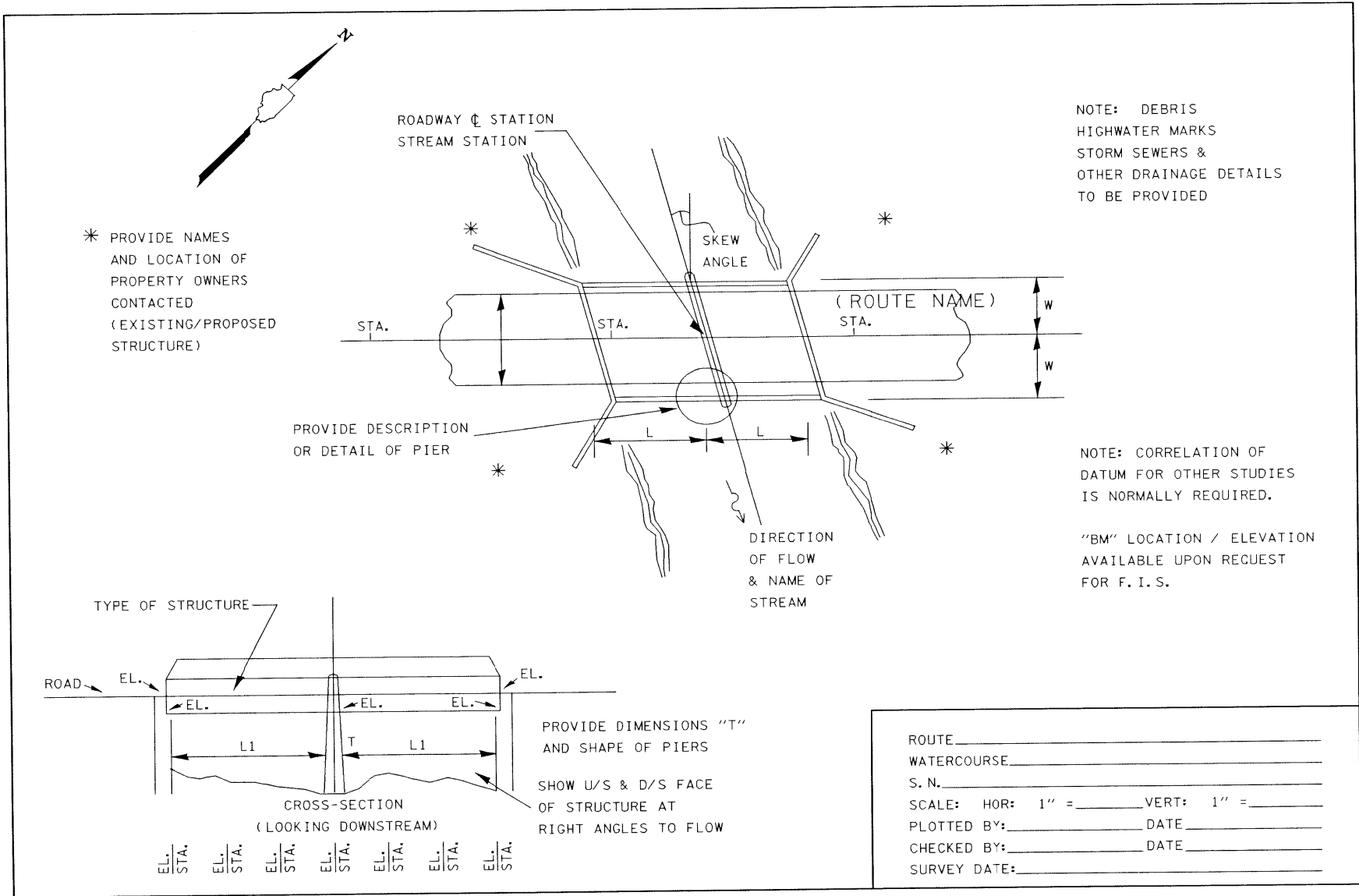

Site Structure and U/S & D/S Structures
Figure 2-402.02c

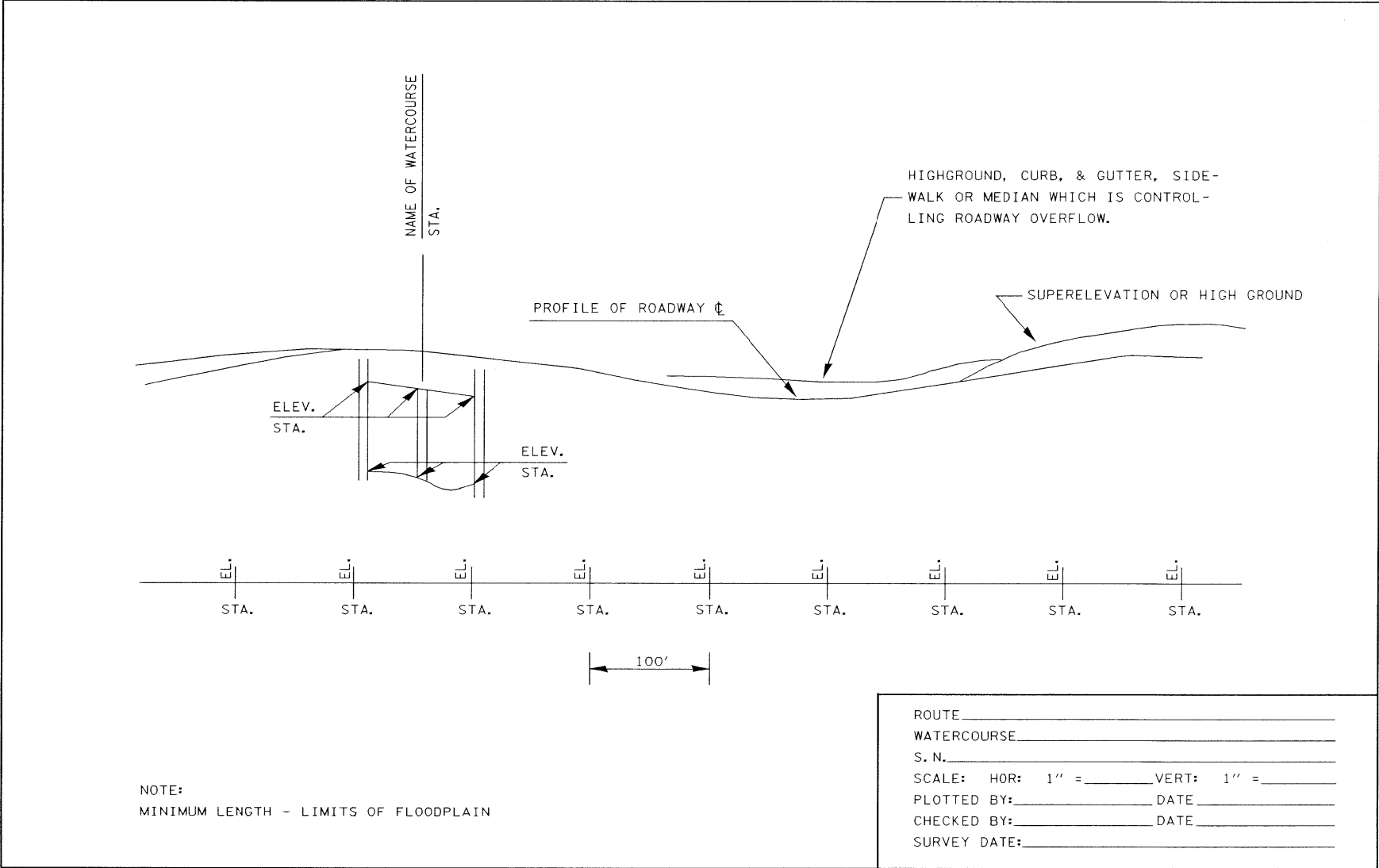

Roadway Profile
Figure 2-402.02d

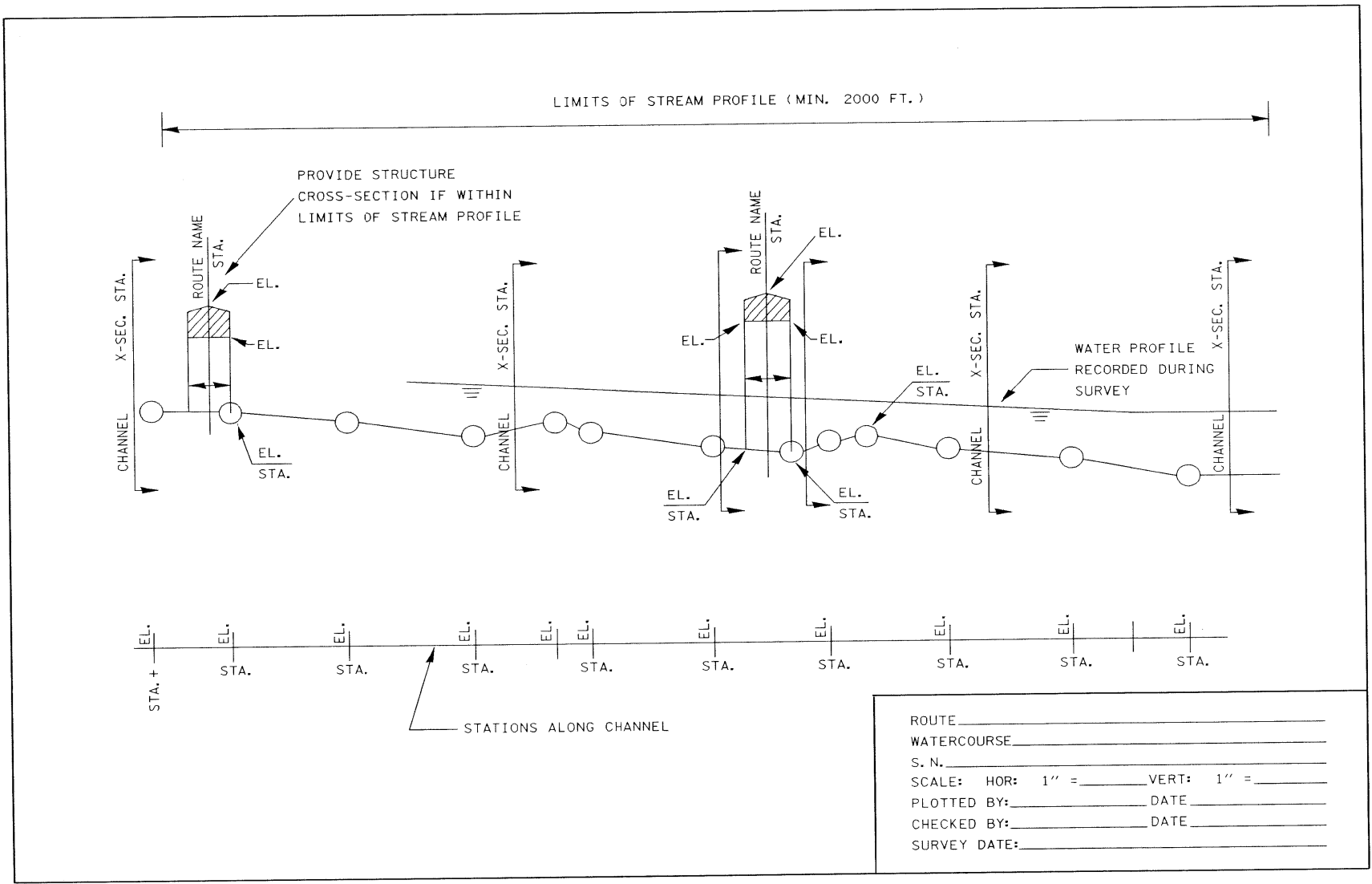

Streambed Profile
Figure 2-402.02e

2-402.03 Existing Structure Information

The survey party should also record the performance of existing structures. Information on existing structures may be obtained from local residents, the District Bureau of Maintenance/Operations, the District Bureau of Local Roads and Streets, or a local agency. This information should be obtained for the adjacent structures upstream and downstream as well as the structure at the site.

Data at existing structures should include the following, if available:

1. Date of construction
2. Major flood events since construction
3. Performance during past floods
4. Scour indicated near the structure
5. Type of material in streambed and banks
6. Condition of structure
7. Alignment and general description of structure
8. Size, shape, and skew of waterway opening
9. Highwater marks on or near the structure or roadway
10. Highwater elevations with datum and dates of occurrence
11. Location and description of overflow areas
12. Photographs
13. Silt and drift accumulation
14. Evidence of headcutting in stream

2-402.04 Flood History Information

A few hours spent interviewing people familiar with the flood history of a stream can result in considerable monetary savings either in initial construction, possible litigation, or future maintenance. Possible sources of information include local residents, school bus drivers, mail carriers, law enforcement officers, and maintenance personnel. Each testimony should identify the individual and state the number of years of observation. See [Figure 2-401.09a](#)

2-402.05 Existing Land Use

The survey data should also include a description of land usage and floodplain developments. Land use descriptions may simply state timber, pasture, wetland, cultivated, or developed residentially or commercially. The description should also include any known or anticipated future changes in the land usage. Buildings within or reasonably adjacent to

Drainage Manual Chapter 2 – Drainage Studies & Hydraulic Reports

the floodplain should be identified as to type, condition, and critical flooding elevation. This information is necessary for the designer to evaluate an allowable backwater for the proposed structure.

2-402.06 Estimated Water Surface Elevation (EWSE)

The EWSE is an estimate of flow depth that is anticipated during construction. The EWSE contributes to several substructure design recommendations made during TSL Plan development. To determine the EWSE, this information needs to be provided in the Hydraulic Report:

- Per Section 2-402.02 Stream Survey Data: water surface elevation, date of survey and top of bank elevation.
- Normal pool elevations. On major rivers where the Corps of Engineers or other agencies regulate and control flow elevations.
- Gage data. Identify the USGS or IDNR gaging station that provides daily flow depths or elevations at or near the subject structure.

The necessary survey data and any other pertinent information (as available) is contained in the HR, but the hydraulic engineer does not compute the EWSE. The EWSE is computed during TSL Plan development by the TSL engineer using this information (Item 21 EWSE Data of [Section 2-601.01](#) Hydraulic Report Content) and the material within [IDOT Bridge Manual Section 2.3.6.4.2](#).

2-500 DRAINAGE STUDIES

The study text and exhibits consist of the compilation of the information assembled in the study process. At various stages during the Drainage Study process, text was prepared to substantiate decisions. This information should be reviewed and the pertinent observations included in the final document. Supplemental text may be required for clarity and to relate the various study items.

The following general format is to be used in the preparation of the final document:

1. Transmittal Letter
2. Title Page
3. Index (Table of Contents)
4. Text
5. Appendix

The study is to be bound (8-1/2" x 11") with exhibits organized into fold outs or marked pockets. Exhibits may be reduced in size, however, a full size exhibit shall be provided under separate cover for documentation purposes.

2-501 Transmittal Letter

The "final" transmittal letter is to include identification of at least the following major items:

- Commitments that may carry into a later Design Phase
- Office of Water Resources permits
- Designs that do not meet standard criteria and an exemption or variance has been applied for and approved

2-502 Title Page

The Title Page should include the following items, the order of this list is not critical:

- Route
- Section
- County
- Existing Structure Number (if applicable/ available)
- Proposed Structure Number (if applicable/ available)
- Job Number
- Contract Number (if available)

Drainage Manual Chapter 2 – Drainage Studies & Hydraulic Reports

- Project Limits or Roadway/ Waterway Crossing (i.e. IL 26 over the Rock River)
- Date Submitted (month, year)
- Name of the individual and Firm who prepared the Drainage Study/ Hydraulic Report (include telephone number and email address. May include company logo if so desired)
- IDOT PTB/ Item Number (for Studies/ Reports submitted by Consultants)

2-503 Index (Table of Contents)

The Table of Contents should generally follow the work item activities undertaken for the specific project.

2-504 Text

The text should comprise a synopsis of text developed earlier with the related work items during the study. The objective is to minimize the text by the effective use of exhibits and to inter-relate the work activities.

2-505 Appendix

The results of various reports, pertinent correspondence, and exhibits would be included in the Appendix.

2-505.01 Source Data Reviewed

All pertinent references that can be readily retrieved should be referenced. Source data that were reviewed, and if lost would be critical to the conclusions of the study, should be made part of the study, if practical. Similar items that were retrieved and can be utilized in the final design should be included in any transmittal of the study.

2-505.02 Exhibits

The supporting exhibits developed with the work items are to be included. Supplemental schematics to illustrate alternatives evaluated for a proposed drainage system should be included.

Although exhibits, such as the existing drainage plan and proposed drainage plan, may be reduced for study presentation; care must be taken that the reduced exhibit is still readable.

2-506 Addendum

The purpose of an Addendum, if required, is to provide a means for updating a drainage study that was previously completed and approved. The basis for an addendum is to modify and document changes resulting from unexpected concerns regarding the preferred plan. However, the changes should be consistent with policy, practices and procedures.

In addition to unexpected concerns, there may be a change in policy, practices and procedures that may require an addendum.

2-600 HYDRAULIC REPORTS

A Hydraulic Report is required to document the Hydraulic Analysis so that a WIT can be produced to show compliance with the regulations and to obtain the necessary Waterway Permits from the applicable Regulatory Agencies.

2-601 Hydraulic Report for Waterway Crossings

Waterway information for all drainage structures designed or reviewed by the Central Office Bureau of Bridges and Structures is to be submitted on the Hydraulic Report Data Sheets (HDS – Form BBS 2800- (<http://www.dot.il.gov/Forms/BBS%202800.docx>)). The data sheets are to be used as a guide for collection of all required information.

Hydraulic Reports are preliminary until approved by the Central Office Bureau of Bridges and Structures or Qualified District Hydraulic Engineer.

2-601.01 Hydraulic Report Content

The Hydraulic Report format and contents should be organized in the following manner to insure a thorough and complete analysis, provide documentation of the design procedures used and show how the final design was determined. The general contents of a Hydraulic Report are as follows:

1. **Title Page** (See [Section 2-502](#) for required content)
2. **Table of Contents** (Tabbed dividers are preferred for each TOC item or Exhibit)
3. **Narrative** - The narrative is essential in assisting the individual responsible for the hydraulic review to become familiar with the project and objectives of the analysis. It should contain the following information:
 - a. Project Description - State what is being done at the site. Is the project a replacement or rehabilitation? Structure number, location, county, route, and waterway.
 - b. Description of Existing Structure and Floodplain - Give a specific description of the existing structure. Describe any other existing structures within the study reach as well as any existing conditions that may affect the hydrologic or hydraulic analysis. This should include a description of the presence of scour, aggradation or degradation. Finally, describe the terrain and ground cover of the floodplain surrounding the structure. Include a statement regarding whether or not the Existing Structure meets the Clearance and Freeboard Policy.
 - c. Field Observations – Give accounts of anything pertinent as seen on the site visit. Ex. Beaver Dams, Highwater Marks, Scour holes, etc.
 - d. Historical Observations/ Records - State if there are high water reports on file for the site. If so, relate the

information listed in these reports. Also state observations noted in field notes, survey notes or high water testimonials from nearby property owners. Discuss items that may explain discrepancies between historical data and computations, such as debris or ice jams. Provide a statement on the validity of any data obtained from other watershed management agency studies. For all models it is strongly recommended that a diligent effort be applied in obtaining an all-time H.W.E. along with the time of its occurrence and if possible a corroborating testimony. Many times this information appears to be overlooked or just not included in the Hydraulic Report. This information may help verify or dispute the highwater elevations when they appear to be unrealistic. The District Maintenance/Operations Office should also be contacted. If no significant flooding has occurred at the subject structure, this should be indicated. If several contacts were made and still no information was gained, then this should also be indicated.

- e. Other Studies & Affected Agencies – Discuss pertinent FIS studies. IDOT recognizes the potential value of an existing FIS or regulatory study. Use of FIS profiles can serve as simply a reference \ comparative tool or they can be used as the basis for design; updated as needed with additional valley cross sections and floodplain encroachments. Their use hinges upon several factors beyond the reliability of the FIS model, including input from local agencies/ municipalities, the Coast Guard, Drainage/ Levee Districts, or Corps Levees and the sensitivity of the upstream floodplain to damages. The primary determinant is OWR: If an Individual OWR Permit is required, it is very likely the FIS discharges and backwater model ([See Section 7-100](#)) will be used as the basis for design and permitting. OWR does accept FIS models that have been modified or improved to reflect current floodplain conditions so the original model may be updated or a new model can be constructed including the FIS as the base data. In Northeastern Illinois (District 1), basing the analysis on a floodprofile that significantly differs from the FIS may require a Letter of Map Revision. To avoid this onerous task, the procedure described in [Section 2-601.01 \(4\)\(j\)](#) can be implemented. If an Individual OWR Permit is not required, the FIS model will likely be used only as a reference/ comparative tool. The OWR Statewide permit program does not require the applicant to utilize the FIS as the basis for hydraulic design but the modeling used to evaluate the project should be approved by IDNR/ OWR.

- f. Datum Correlation - Describe the datum correlation with other reports (such as a flood insurance study) used in the Hydraulic Report and to identify drainage districts. Use high water elevations corresponding to the highway datum on the waterway information table.

- g. Sensitive Flood Receptors Describe sensitive flood receptors and include their low entry elevations in this section. The location of these receptors should also be shown on the plan view drawing. There are sometimes residential structures on the upstream side of the bridge site that are included in the photographs and appear to be at risk of being sensitive flood receptors, yet no mention of them are made in the Hydraulic Report. Again, it is strongly recommended that if there is any risk at all of a structure being a sensitive flood receptor, the elevations be obtained and included in the Hydraulic Report. Even if the structure appears to be at low risk for damage after the bridge hydraulics have been completed, the elevations still should be included in the Hydraulic Report. A highwater testimony may possibly be obtained from the resident occupying the structure. If there are no sensitive flood receptors, then a statement should be made to confirm this.

- h. Hydrologic Methodology - State the method used to determine the discharges in the hydraulic model. Examples may include the [StreamStats](#), stream gauge data, [HEC-1](#), [HEC-HMS](#), [TR-20](#), [Win TR-20](#) or any other approved method. Also give a brief description of the method used and any assumptions made.

- i. Hydraulic Methodology - State what hydraulic software (see [Chapter 14](#)) was used for the analysis, how Manning's "n" values were determined (see [Chapter 5](#)), how cross-sections were obtained, and explain the method of determining the starting water surface elevation. Also give reasons behind the choice made to start the profile. Include any assumptions made in the computer model that a reviewer may not readily see and give the basis of these assumptions. Examples include use of levees or blocked ineffective areas. For bridge HR's, see [Chapter 7](#) for direction regarding HEC-RAS modeling requirements.

- j. Summary of Natural and Existing Hydraulic Analyses - Describe how the natural and existing conditions were analyzed. State how the information given on the Waterway Information Table was obtained within the model. Include supporting calculations showing how various values on the WIT were developed should accompany the WIT. Important parameters include identifying the approach section, created head

calculations, freeboard, clearance, and the waterway area. Describe what impacts the existing bridge has on the natural condition. Discuss the modeling Errors, Warnings, and Notes and how the model was modified to account for them.

- k. Proposed Structure Analysis - Give a physical description of the layout of the proposed structure. This should include a description of abutment and pier types, preliminary span configuration, and low beam elevation. Tell what changes were made to the existing condition to make it the proposed condition. If several alternates were investigated, define each alternate and state why it works or why it fails. State where, within the model, information was obtained for the Waterway Information Table. Discuss the modeling Errors, Warnings, and Notes and how the model was modified to account for them. Evaluate how design criteria for freeboard and clearance are addressed by the proposed structure.
- l. Scour Analysis - State how the scour analysis was performed. This should include a description of where data was obtained, which cross-sections were used, what software or methodology was used for calculations and which scour calculations were performed. Finally, state the acceptability of the results. If needed scour countermeasures can be recommended.
- m. Compensatory Storage - If compensatory storage is required, include a description and location. An exhibit should also be added that contains the storage computations.
- n. Permit Requirements - Identify any permit requirements of the Illinois Department of Natural Resources/Office of Water Resources, IL Environmental Protection Agency, or Corps of Engineers for the project. If the project includes a designated floodway that has a drainage area greater than or equal to one square mile in District 1, the Permit Summary Form should be completed and attached. Also, the narrative should describe how the OWR rules apply to the project along with how the project complies with the rules. A list of navigable waters in Illinois can be found at <http://www.uscg.mil/d9/D9Legal/water/illinois.pdf>. These waters will require a Coast Guard Permit. All Public Bodies of Water as defined in the IDNR/OWR Part 3704 rules require an Individual OWR Permit.
- o. Freeboard/ Clearance - IDOT policy is that a minimum clearance of two (2) feet be established between Design N.H.W.E and the low beam elevation of the bridge structures and that a minimum freeboard of three (3) feet

is established between the Design H.W.E and the edge of pavement of the roadway within the floodplain. (IDOT Drainage Manual, [Section 1-305 - Design Criteria](#)). State if the design meets the Freeboard and Clearance policies and if not which will require a policy waiver and why it could not be met. If applicable, when checking for adequate freeboard and/or clearance at the proposed structure, the 50 year water surface elevation on the downstream river system at the confluence should be checked to see if it is greater than the stream's 50 year natural highwater (for clearance) and design headwater elevation (for freeboard) at the structure. Freeboard and Clearance should be determined from the higher water surface elevation. See [Section 7-001.04](#)

- p. Conclusion - A concluding statement is to be made which identifies the findings of the analysis, gives final recommendations and restates why the proposed structure is a suitable option. Also include a description of any specific items which are essential for the hydraulic performance of the recommended design. Included should be such items as channel or floodplain modification or excavations, transition sections, spur dikes, river training structures, erosion or scour prevention devices, and compensatory storage requirements.

- 4. **Waterway Information Table** - This is perhaps the most important item in the Hydraulic Report and is required as outlined in [Section 1-303.02](#). <http://www.dot.il.gov/Forms/BBS%202730.docx>. More detailed guidelines for completing the Waterway Information Table (WIT) can be found in [Section 1-303.02](#). General guidelines for developing this table are as follows:

- a. When a site is encountered that has been previously modeled in a FEMA Flood Insurance Study (FIS), two waterway information tables may be required. This is due to outdated modeling procedures, data input errors, incorrect structure opening in the FIS model, or considerable changes in water surface elevations after current survey information is added to the FIS model. The first table should be derived directly from the FIS model and labeled as the PERMIT WIT. The second can be based on the original FIS model with the addition of survey information gathered by the modeler and produced using current hydraulic modeling techniques. This table should be labeled as the DESIGN WIT and included in the Hydraulic Report and plans, which is used to determine compliance of the design criteria. The FIS model is also provided in the Hydraulic Report for information and for processing IDNR-OWR permits. The compensatory storage volume should be calculated based on the FIS model.

- b. Include the WSE of major stream/river at the confluence, if there are TW effects on the subject structure from the receiving stream/river (10 yr. and 50 yr.). When there is a possibility of TW influences from a major river or stream, consider that two reach boundary flow conditions may be required for determining the N.H.W.E.: 1) Normal Depth and 2) Known WSE (10 yr. WSE of the major river or stream at the confluence). The higher WSE produced at the U/S face cross section (w/o the structure in place) is entered into the WIT (under N.H.W.E.) for each flow profile. If the NHWE was produced by Run 1 (No TW influences), then compare the created heads of several of the U/S cross sections for Run 1. Enter the largest of those created heads into the HEAD column of the WIT. If the N.H.W.E. was produced by Run 2 (TW influences), then compare the created heads of several of the U/S cross sections for Run 2. Enter the largest of those created heads into the HEAD column of the WIT. Do this for each Flood Profile. Coordinate this type of analysis with the District while developing the project scope.
- c. Values for N.H.W.E., Head, and Headwater Elev. should be rounded to the nearest 0.1 ft. Values for Frequency Year, Discharge, and Waterway Opening should be rounded to the nearest whole number.
- d. DRAINAGE AREA - Drainage Area for subject structure rounded to the nearest 0.1 of a Sq Mi. If the Drainage Area is less than 1 Sq Mi then show in units of acres rounded to the nearest acre.
- e. DISCHARGE (Q) - Typically, these are the 10, 50, 100 & 500 year events. For certain jobs, such as county jobs, the Design High Water Elevation (H.W.E.) is the 30 year. Also, if overtopping occurs before the 500 year, the overtopping event is reported instead of the maximum calculation (Max. Calc.) and the 500 year event is disregarded. For example, the 500 year event is not calculated if there is an overtopping at the 200 year event.
- f. NATURAL HIGHWATER ELEVATION (NHWE) - The natural condition water surface profile is the profile generated by excluding the effects of the subject structure and roadway embankment, but includes D/S impacts. When there are D/S constrictions, levees, etc., an additional run may be needed without any man-made structures in the model. This run is considered as the "Natural" and shows solely the effects of the D/S constriction and its impact on the highway structure. The need for such a run should be coordinated with the

appropriate District staff. The N.H.W.E. to be reported in the Waterway Information Table is the natural water surface elevation at the location of the upstream face of the proposed structure. If a cross-section that is free of the effects of any road or bridge construction is not available at this location, the N.H.W.E. may be interpolated between upstream and downstream cross-sections.

- g. OPENING - The effective waterway opening should be calculated at the upstream face of the structure based on the Natural Highwater Elevation for a given frequency. It should represent actual existing conditions, not as-built or cleaned out. It is determined by calculating the flow area under the Natural High Water Elevation (N.H.W.E.) at the surveyed bridge opening section. It is not based on the Existing H.W.E. or the Proposed H.W.E. This value is not the value you can find in the Hydraulic Software output. It is calculated separately from any Hydraulic Software. Pier area below the N.H.W.E. should be subtracted from the total opening area. An adjustment for improperly skewed piers may be required which will increase the pier area and reduce the net opening.
- h. OVERTOPPING ELEVATION & STATION - This is the minimum elevation that will produce over-the-road flow within the limits of the floodplain. It does not necessarily have to be at the bridge site. If conveyance is allowed in the overbanks, and water can overtop the roadway, then that would be the overtopping station and elevation. The roadway elevation and station for this particular location is shown on the table. Low EOP stands for low edge of pavement elevation along the entire floodplain. Low EOP is the point of reference utilized to determine roadway freeboard provided by the existing or proposed conditions. (See [Table 1-305](#) Design Flood Frequency Table.)
- i. HEADWATER ELEVATION - This is simply a computed value. The Head plus the N.H.W.E.
- j. HEAD - The largest change in computed water surface elevation, comparing the computed water surface elevations from the existing condition and proposed condition to the natural condition for each upstream cross section, is the Created Head. That Created Head is entered into the HEAD column of the Waterway Information Table for each flow profile. Head should not be negative, so use a value of zero if a negative number is computed. Proposed structures that result in headwater less than the Natural HWE for a given

frequency should indicate "0.0" as the head and the headwater elevation will be equal to the NHWE.

- k. **EXISTING & PROPOSED STRUCTURE INFORMATION** - Include type of structure, length, number of spans, low beam elevation and skew with roadway centerline. If culvert is used, include U/S & D/S flowline elevation, drop box dimensions and height of drop, if applicable.



Waterway Information Table

Route: _____ Existing SN: _____
 Section: _____ Proposed SN: _____
 County: _____ Waterway: _____
 Date: _____ Prepared by: _____

Flood	Freq. Yr.	Q Ft ³ /s	Opening - ft		Natural H.W.E.	Head - ft		Headwater Elevation	
			Existing	Proposed		Existing	Proposed	Existing	Proposed
Design									
Base									
Overtop Existing									
Overtop Proposed									
Max. Calc.									

10 YEAR VELOCITY THROUGH EXISTING BRIDGE = _____ ft/s 10 YEAR VELOCITY THROUGH PROPOSED BRIDGE = _____ ft/s

ALL-TIME H.W.E. & DATE:

Scope of Work:

<p style="text-align: center;">EXISTING STRUCTURE</p> <p>TYPE: _____</p> <p>LENGTH: _____</p> <p># SPANS: _____</p> <p>LOW BEAM: _____</p> <p>SKEW: _____</p> <p>LOW E.O.P.: _____</p>	<p style="text-align: center;">PROPOSED STRUCTURE</p> <p>TYPE: _____</p> <p>LENGTH: _____</p> <p># SPANS: _____</p> <p>LOW BEAM: _____</p> <p>SKEW: _____</p> <p>LOW E.O.P.: _____</p>
--	--

NOTE: PROPOSED STRUCTURE DETAILS ARE PRELIMINARY; SUBJECT TO REFINEMENT IN TSL STAGE.

Printed 9/9/10

BBS 2730 (Rev. 08/02/10)

Basic Waterway Table – Bridge
<http://www.dot.il.gov/Forms/BBS%202730.docx>
 Figure 2-601.01a

Drainage Manual Chapter 2 – Drainage Studies & Hydraulic Reports



Culvert Waterway Information Table

Route: _____ S.N. Exist: _____ Computed by: _____ Date: _____
 Section: _____ S.N. Prop: _____ Checked by: _____ Date: _____
 County: _____ Waterway: _____
 Station: _____

Drainage Area =		Square Miles	Existing Overtopping Elevation:		Proposed Overtopping Evaluation:		ft. @ Sta		Headwater Elev. (ft.)	
			Flood Frequency Year	Discharge cfs	Waterway Opening (sq. ft.)		Natural H.W.E.	Head (ft.)		Existing
			Existing	Proposed		Existing	Proposed	Existing	Proposed	
	10									
Design	50									
Base	100									
OVT(E)										
OVT(P)										
Max Calc	500									

10-Year Outlet Velocity from Existing Structure = _____ fps
 10-Year Outlet Velocity from Proposed Structure = _____ fps

OVT = Overtopping Event
 (E) Existing (P) Proposed

DATUM:
 ALL-TIME H.W.E. & DATE:

SCOPE OF WORK:

EXISTING STRUCTURE
 Bridge or Culvert Type:
 Cell Dimensions (W x H):
 # of spans \ cells:
 Length:
 U/S Flowline:
 D/S Flowline:
 Skew:
 Low EOP:

PROPOSED STRUCTURE
 Culvert Type:
 Cell Dimensions (W x H):
 # of cells:
 Length:
 U/S Flowline:
 D/S Flowline:
 Skew:
 Low EOP:

EXISTING DROPBOX
 Dimensions:
 Drop:
 Weir Elevation:

PROPOSED DROPBOX
 Dimensions:
 Drop:
 Weir Elevation:

NOTE(S): _____

Basic Waterway Table - Culvert

<http://www.dot.il.gov/Forms/BBS%202802.docx>

Figure 2-601.01b

- I. Multiple Bridge Analysis - When there is a main structure and an overflow structure, the values reported in the waterway information table are similar, but additional rows are needed so that the discharge and opening area of each individual structure can be reported.

Drainage Manual Chapter 2 – Drainage Studies & Hydraulic Reports



MULTIPLE OPENINGS WATERWAY INFORMATION TABLE

Route: _____ SN Existing: _____ Computed by: _____ Date: _____
 Section: _____ SN Proposed: _____ Checked by: _____ Date: _____
 County: _____ Waterway: _____
 Station: _____

Drainage Area =	Flood	Discharge (cfs)		Waterway Opening (sq. ft.)		Natural H.W.E.	Head (ft.)		Headwater Elevation	
		Existing	Proposed	Existing	Proposed		Existing	Proposed	Existing	Proposed
10	Main Channel									
	Relief Structure									
	TOTAL									
50	Main Channel									
	Relief Structure									
	TOTAL									
100	Main Channel									
	Relief Structure									
	TOTAL									
Overtopping	Main Channel									
	Relief Structure									
	TOTAL									
500	Main Channel									
	Relief Structure									
	TOTAL									

10 Year Velocity Through Existing Bridge = _____ ft/s 10 Year Velocity Through Proposed Bridge = _____ ft/s

ALL – TIME H.W.E. & Date:

Scope of Work:

EXISTING STRUCTURE

PROPOSED STRUCTURE

TYPE: _____ TYPE: _____
 LENGTH: _____ LENGTH: _____
 # SPANS: _____ # SPANS: _____
 LOW BEAM: _____ LOW BEAM: _____
 SKEW: _____ SKEW: _____
 LOW E.O.P.: _____ LOW E.O.P.: _____

NOTE: PROPOSED STRUCTURE DETAILS ARE PRELIMINARY; SUBJECT TO REFINEMENT IN TS&L STAGE.

Printed 4/22/2011

BBS 2804 (02/28/11)

Waterway Table for Multiple Bridge Analysis
 Figure 2-601.01c
<http://www.dot.il.gov/Forms/BBS%202804.docx>

5. Hydraulic Report Data Sheets –

Hydraulic Report Data Sheets

Route: _____ P or D #: _____
 Section: _____ PTP #: _____
 County: _____
 State SW: _____
 Prop SH: _____

General Information

1. Name of the Stream: _____

2. Location of the Structure: Township _____ % of the Range _____ % of Section of the _____ P.M.

3. Hydraulic Report Prepared By: Consultant District

4. Hydraulic Report Approval Authority: District – Post PDF of HR to BBS Hydraulic SharePoint Server BBS Hydraulic - Submit 2 hard copies of HR to BBS Hydraulic

Site Design Data

5. Drainage Area (sq. ft.): _____

6. Highway Classification: Rural Principal Arterial Urban Minor Arterial Other Collector Local

7. Design Frequency: 30 yr. 50 yr. Other _____

8. Number of Waterway Information Tables (WIT): _____
 If more than one, explain: _____

Hydrologic & Hydraulic Analysis

9. Hydrology Modeling (check all that apply): USGS Stream Stats FIS Sage Data Other _____

10. Hydraulic Modeling (check all that apply):
 a. Method: HEC-RAS HEC-2 Other _____
 b. Manning's "n" values determined as per IDOT O&S? Yes No
 If no, explain: _____
 c. Source of Starting WSE: _____
 d. Non-IDOT encroachments in Survey? Yes No
 If yes, are they accounted for? Yes No
 e. Does the "Waterbar Counter"? Yes No
 If yes, list: _____
 f. Were the Expansion/Contraction comes properly addressed? Yes No N/A
 If No or N/A, explain: _____

Printed 6/28/11 Page 1 of 4 BBS 2804 (Rev. 03/10/11)

Page 1

g. What Expansion and Contraction Rates were used? Expansion: _____ (X-1)
 Contraction: _____ (X-1)

ICWR – OWR Floodway Permit

11. Is area experiencing urbanization or expected to urbanize within 10 years? Yes No

12. Are there any sensitive flood receptors located upstream within possible backwater influence? Yes No
 If yes, list and describe critical upstream flood damageable properties and their elevations: _____

13. Is there any history of flooding or overtopping problems? Yes No
 Sources of Observed Highwater: _____

14. Is the structure hydraulically connected to or within the floodway of an ICWR-OWR designated Public Body of Water? Yes No

15. Required ICWR - OWR Permit type:
 Individual SWP #2 Floodway
 None Other _____

Proposed Structure Data

16. Project Scope (check all that apply):
 a. Complete Replacement
 b. Superstructure Replacement
 c. Superstructure Widening; Length of Pier Extension in the water: _____
 d. Bridge Culvert
 e. New Alignment
 f. Downstream Below O&S HWB? Yes No
 g. Profile Raisin

17. If a bridge is proposed, supply:
 Pile line elevation (ft): _____ Abutment type: _____
 Preliminary low beam elevation (ft): _____ Skew (degrees): _____
 Width of deck (ft): _____ Number of spans: _____
 Total length from face to face of abutment (ft): _____

18. If a culvert is proposed, supply:
 Type and size: _____ Length (ft): _____
 Entrance type: _____
 Upstream invert elevation (ft): _____ Skew (degrees): _____
 Downstream invert elevation (ft): _____ Number of spans: _____
 Note: options and question numbers (O&S) which the sections below the "r" sign is applied

19. If a three-sided structure is proposed, supply:
 Pile line elevation (ft): _____ Skew (degrees): _____
 Span (ft): _____ Length (ft): _____
 Height (ft): _____ Number of spans: _____

20. a. Is the IDOT Clearance Policy Met? Yes No NA Value (ft): _____
 b. Is the IDOT Freeboard Policy Met? Yes No NA Value (ft): _____

21. Type of streambed soil: Clay Silt Sand Loam _____

Printed 6/28/11 Page 2 of 4 BBS 2804 (Rev. 03/10/11)

Page 2

22. Scour/Migration Problems: None/Minimal Significant Severe
 Concerns:

Ice Concerns: None/Minimal Significant Severe
 Concerns:

Debris Concerns: None/Minimal Significant Severe
 Concerns:

Countermeasures Proposed:

Existing Structure Data

	Structure USG	Subsidiary Structure	Structure D/S
23. Distance from proposed structure (ft.)			
24. Type of structure:			
25. Low beam elevation:			
26. Flow line elevation:			
27. Maximum known high water elevation:			
28. Date of maximum high water:			
29. Cause (backwater, headwater, etc.):			
30. Does structure vary entire design flood flow? <small>If not, state area of additional waterway opening (ft²)</small>	<input type="checkbox"/> Yes <input type="checkbox"/> No	<input type="checkbox"/> Yes <input type="checkbox"/> No	<input type="checkbox"/> Yes <input type="checkbox"/> No
31. Type and size of existing overflow structure:			
32. Has anyone ever occurred under or adjacent to the structure?			
33. Classify type of scour and/or aggradation / degradation:			

Required Additional Data

34. Deviations from the General Procedures presented in IDOT DM CH 2, CH 6, and CH 7:

35. Information regarding high water from other streams, reservoirs, flood control projects, proposed channel changes, or other sources affecting proposed waterway area:

36. Site Inspection made by: _____ Date _____
 Remarks:

37. Prepared by: _____ Date _____
 Signed (DA/GC): _____ Date _____

Printed 6/28/11 Page 3 of 4 BBS 2000 (Rev. 02/10/11)

Page 3

Hydraulic Report Checklist

The District or Consultant should complete the following checklist before submitting the Hydraulic Report for approval.

- Title Page
- Table of Contents
- Narrative - (as outlined in Section 2-601.01 Item #3)
- Waterway Information Table (WIT) - (as outlined in Section 2-601.01 Item #4)
- Hydraulic Report Data Sheets
- Location Map - should show the subject structure along with nearby location defining landmarks (roads, roads, highways, etc.)
- USGS Hydraulic Investigation Map (Clicknet 1 only)
- Photographs - (Minimum USG & D/S Structure Faces, Up & Down Channel, Up & Down Roadway Access Structure)
- Hydrology (map and calculations)
- Streambed Profile
- Roadway Profile (existing and proposed)
- Cross Section Plots - with plan layout preferably overlaid upon an aerial photo with the structure
- Bridge Opening Plots
- Natural Condition Analysis
- Existing Condition Analysis
- Proposed Condition Analysis
- Scour Analysis - Existing and Proposed Conditions
- Compensatory Storage Calculations (if required)
- Survey Notes (if available, in Electronic Point Files)
- Correspondence Notes
- CD with Project Files (include pdf copy of the Hydraulic Report)

When HEC-RAS modeling is being used, ALL Plans (Structure, Existing, & Proposed) shall be included in ONE Project File.

Printed 6/28/11 Page 4 of 4 BBS 2000 (Rev. 02/10/11)

Page 4

Hydraulic Report Data Sheets

Figure 2-601.01c2

<http://www.dot.il.gov/Forms/BBS%202800.docx>

- Location Map** - Include a copy of a portion of a USGS quadrangle map, county map or any other detailed mapping that shows the subject structure along with upstream and downstream structures and nearby landmarks.
- Photographs** - Original color photographs or color photo printouts of structure's opening, channel, and overbank areas. Include pictures of anything out of the norm.
- Hydrology** - Include data, figures and computations used to calculate discharges for analysis (see Chapter 4). Include a topographic map with the delineated drainage area. If a model such as HEC-HMS is used a model schematic relating the model to the physical features of the watershed it represents should be included. When using [StreamStats](#), Include printouts of the Drainage Area with the flow path and printouts of the necessary variables so that the discharges could be computed as a check. If FIS Flows are being utilized, provide the methodology and date of study.
- Streambed Profile** - Include a graph or plot of the streambed profile within the limits of the surveyed area upstream and downstream from the proposed structure. The profile should include surveyed elevations at approximately 100 ft intervals. An example is shown in [Figure 2-402.02e](#).
- Roadway Profile** - Include a graph or plot of the Roadway Profile. If the proposed is different than the existing, both should be shown. The limits of the profile should extend to the edges of the floodplain. The location of the structure should be labeled. An example is shown in [Figure 2-402.02d](#).

11. **Cross Section Plots** - Include station/elevation cross-section plots to scale of the data from the stream survey for all sections used in the analysis. Customarily they should be oriented looking in the downstream direction. An example is shown in [Figure 2-402.02b](#). Points should be spaced adequately to properly define the channel and overbank areas. If possible, also include contour mapping that shows the location and orientation of these sections. An explanation of why sections were taken may be necessary to justify the section taken. The drawings of these cross-sections should contain the coordinates at each point as well as the sub-area breakdowns with land use description and the respective Manning's "n" values in order to justify the numbers selected. The date of the survey should also be identified on the cross-sections.

12. **Bridge Layout/Plan Drawing Plots –**
 - a. Existing conditions; see [Figure 2-402.02c](#) as an example. The plan should provide all the dimensions needed for the hydraulic analysis.
 - b. Proposed conditions, a plot should be supplied similar to existing conditions. This drawing can be superimposed over the existing bridge drawing if clarity can be maintained.

13. **Bridge Cross Section Plots - Existing Conditions**
 - a. [Figure 2-402.02c](#) provides a generalized opening sketch. All bridge cross-sections plots (also known as bridge faces) should be provided on a scale large enough to show clearly all the surveyed streambed points, the deck/superstructure points the piers points and the road above the bridge. The plots should be provided on a grid background similar to the stream cross-sections. All the information needed to model the opening should be included. These plots should be drawn facing downstream and should have the surveyed water elevation and the date of survey on them.
 - b. Plot of bridge upstream opening superimposed on top of the next upstream cross-section.
 - c. Plot of the bridge downstream opening superimposed on top of the next downstream cross-section.

14. **Bridge Cross Section Plots - Proposed Conditions**
 - a. Plot of proposed upstream opening superimposed over upstream opening.
 - b. Plot of proposed upstream opening superimposed over the next upstream cross-section.
 - c. Plot of proposed downstream opening superimposed over existing downstream opening.
 - d. Plot of proposed downstream opening superimposed over next downstream cross-section.

15. **Hydraulic Analyses** – All hydraulic analyses that support the waterway information tables should include the model printout of the input and output data and the warning list. The HEC-RAS printout is to include also the HEC-RAS layout plot of the cross-sections, the stream profile, the stream cross-sections and the structure cross-sections. These plots should show the 10, 50, 100 and 500 year flood profiles. The printout should include the standard tables and the special bridge and culvert tables.
16. **Scour Analysis** - Include a scour analysis of the 10, 50, 100, and OVT/ 500 yr Flow Events for existing and proposed conditions. This consists of showing all scour computations in the form of hand calculations, spreadsheets, or computer program input and output. The computations should be based on [HEC 18](#), "Evaluating Scour at Bridges" or [Chapter 10](#). The scour analysis should provide calculated contraction scour depth and pier scour depth (if applicable). Also include field observations of the existing presence of scour, aggradation, and degradation. Describe existing and proposed countermeasures.
17. **Riprap Sizing** – Utilizing the Equations in [Chapter 11](#), provide calculations to determine the size of Riprap required. Adjustments may be necessary during the TSL stage of the project.
18. **Permit Summary Form (District 1) – Related Exhibits & Calculations** (<http://www.dot.il.gov/Forms/D1%20PD0024.docx>) – Exhibits to include plan of the road with the floodway and floodplain boundaries scaled from the FIS. Also included are the cross-sections used to calculate the fill and excavation. The cross-sections should show the normal, 10 year and 100 year water elevations and the floodway and floodplain boundaries.
19. **Compensatory Storage** - If compensatory storage is included, include all calculations and preliminary grading plans here.
20. **Survey Notes** - A copy of the field survey notes used for the analysis should be included as an exhibit. Electronic point data should not be included.
21. **EWSE Data** – Compile the survey data and additional site information (as available) required to compute the EWSE. See Section 2-402.06 Estimated Water Surface Elevation (EWSE).
22. **Correspondence Notes** - Include a copy of any communications regarding the hydraulic performance of the structure such as information from local residents and agencies, information from Bureau of Maintenance/ Operations, FHWA coordination meeting minutes, etc.
23. **CD** - Include a CD with the HEC-RAS files as well as any computer programs files used such as Win HY-8, Microstation, etc. files. Include a pdf copy of the Approved Hydraulic Report.

2-602 Hydraulic Report for Longitudinal Encroachments

In the case of highway projects, which parallel streams, the proposed embankment or retaining wall could encroach on the stream floodway. See [Figure 3-101](#). To evaluate the effect of such a longitudinal encroachment, a form of the Hydraulic Report must be developed for the site with stream and channel analyses for the existing and proposed conditions. For this reason the stream, floodplain and highway cross sections must be obtained for the stretch of highway, which encroaches on the stream.

Generally for the longitudinal encroachment, the stream and floodplain cross section is required approximately 1000 feet both upstream and downstream beyond the limits of the encroachments. The number of cross sections within the limits of encroachment is to be determined by the Hydraulic Engineer or consult with the District and OWR. As a bare minimum, cross-sections will be required at the beginning, middle, and end of the encroachment. In addition, template highway cross sections will be required at 100-ft intervals.

The floodplain cross sections, stream cross sections, and proposed roadway improvements will need to be merged together and incorporated in a HEC-RAS model. In the past, OWR has required that the improvements show a Zero Rise or No created head over the existing condition in order to obtain the necessary permits. If any fill material is placed within the floodway below the 100 yr water surface, compensatory storage will be required.

2-603 Hydraulic Report for Pumping Stations

The Hydraulic Report for a Pump Station is reviewed and approved by the Central Bureau of Bridges and Structures. The required information and suggested format are discussed in [Section 13-300](#), Hydraulic Reports, within the Pump Station Chapter.



Chapter 3

st
n
e
m
b
c
a
o
r
c
n
E
n
i
a
l
p
d
o
o
l
F
s
t
h
e
b
c
a
o
r
c
n
E
n
i
a
l
p
d
o
o
l
F

CHAPTER 3 - FLOODPLAIN ENCROACHMENTS

3-000	GENERAL		
	3-001	Introduction	
	3-002	Objectives	
	3-003	Relationship to Phase I Study	
	3-004	Studies	
		3-004.01	Evaluation Process
		3-004.02	Risk Assessment
		3-004.03	Risk Analysis
3-100	FLOODPLAIN ENCROACHMENTS		
	3-101	Types of Encroachments	
		3-101.01	Transverse
		3-101.02	Longitudinal
	3-102	Floodplain Characteristics	
		3-102.01	Floodway
		3-102.02	Flood Fringe
3-200	FLOODPLAIN DATA		
	3-201	Floodplain Identification and Data Collection	
	3-202	Field Examination and Evaluation	
	3-203	Hydraulic Data	
		3-203.01	Transverse Crossings
		3-203.02	Longitudinal Crossings
3-300	HIGHWAY DESIGN IN THE FLOODPLAIN		
	3-301	General	
	3-302	Overtopping Flood	
		3-302.01	General Rule for Setting Level of Flood Protection
		3-302.02	Related Floodplain Hydraulic Analysis
	3-303	Freeboard	
	3-304	Design Variations	
		3-304.01	Alteration of Embankment Slope
		3-304.02	Alteration of Highway Alignment
		3-304.03	Variations of the Typical Roadway Cross Section
	3-305	Maintenance of Traffic During Flood Stage	

	3-305.01	Emergency Vehicular Access and Interruption of Traffic
	3-305.02	Construction Staging/Detour
3-306	Levee Conditions	
3-307	Subway Conditions	
3-400	FLOODPLAIN STORAGE (COMPENSATORY STORAGE)	
3-401	General	
	3-401.01	Transverse Encroachment
	3-401.02	Longitudinal Encroachment
	3-401.03	Depressed Areas
3-402	Storage Site Design	
3-403	Compensatory Storage Design Concepts	
	3-403.01	Storage Excavation in the Floodplain
	3-403.02	Storage by Impoundment
	3-403.03	Storage Incorporated Within Highway Drainage Systems
3-404	Flowages/Flood Easements	
3-500	FLOODPLAIN ENCROACHMENT DOCUMENTATION	
3-600	RELATED DOCUMENTS	
3-601	Procedure for Coordination	
	3-601.01	IDOT Coordination
	3-601.02	Coordination with Federal Emergency Management Agency (FEMA)
3-602	Executive Order 11988	
3-603	Illinois Executive Order	
3-700	REFERENCES	

3-000 GENERAL

3-001 Introduction

This chapter provides guidance for the evaluation/assessment and documentation for different categories of work with respect to floodplain hydraulics to meet policy in Section 1-302 Floodplain Encroachments. This applies to the selection process of the most cost-effective highway (geometric) alternate or design variation when the improvement is located within or adjacent to a 100-year-frequency flood plain.

3-002 Objectives

1. Identify the criteria to be evaluated in the selection of the appropriate highway geometrics.
2. Identify the probable impacts on the floodplain that are to be evaluated by the Hydraulic Engineer.
3. To assure that the Location Floodplain Encroachment is appropriately hydraulically evaluated in accordance with the Illinois Department of Transportation(IDOT), Bureau of Design and Environment(BDE) Manual¹.
4. To provide guidance for assuring that the evaluation includes appropriate coordination with others (i.e., local ordinances, Illinois Department of Natural Resources(IDNR) Office of Water Resources(OWR)as detailed in Section 1-403 office of Water Resources or the IDOT Bridge Manual Section 2.3.9.1, and Federal Emergency National Flood Insurance Program).
5. Encourage that the selected alternate or design variation will minimize or avoid adverse impacts involving the floodplain and identifies the measures to be considered to avoid a significant encroachment finding.

3-003 Relationship to Phase I Study

The highway located in or adjacent to a floodplain should be designed to avoid a significant encroachment whenever practical. It is important that potential encroachments be addressed in the Phase I Study since failing to do so could result in project implementation delays which may result in plan revision, additional right-of-way requirements, additional Phase I Study and/or Phase II Design work, etc.

Establishing alignments depends upon the interrelationships of several variables, including suitable stream crossing locations and gradeline; and is directly influenced by stream alignment, highwater elevations at stream crossings, and the depth of roadway ditch flow for surface drainage. Phase I Study reports should contain preliminary hydrologic and hydraulic analyses where highway drainage structures will significantly affect the design or cost of a project. Assessment of encroachments should be incorporated into the development and analysis of corridor and design alternates so that floodplain impacts will be part of the assessment of social, economic, environmental, and engineering considerations.

Improvements in floodplains should be assessed to determine that no other feasible alternates exist to ensure compliance with and/or resolve conflicts with local agency floodplain regulations. Also, determine if significant flood damage potential for property loss and hazard to life may be

Drainage Manual Chapter 3 – Floodplain Encroachments

increased to such items as subdivisions, agri-business, structures, roads, and sensitive land area; and to identify the need for mitigation of any adverse impacts.

In addition, floodplain encroachments which may result in adverse impacts or significant encroachment, whether they occur by design or inadvertently, may lead to the following consequences, if not mitigated:

- Increased flood damage potential which may also increase the risk of personal injury
- Change in stream velocity which may adversely affect scour, erosion/sedimentation characteristics of the stream
- Increased risk to the failure and/or damage of the highway embankment/structure
- Increased risk to the interruption of emergency vehicular traffic
- Increased risk to the disruption and safety of vehicular traffic
- Increased costs and project delays necessary to incorporate measures to minimize harm

To minimize the effect or to avoid a significant (adverse) effect, the floodplain impact may be a heavily weighted factor in the development of the recommended highway improvement plan.

The hydraulics engineer, project engineer, and environmental coordinator working as a design team, shall establish limits to avoid a significant encroachment and shall investigate alternates and/or design variations for consideration that have the least adverse impact to the floodplain. Once the alternate and/or design variation that is considered to be the preferred action is selected, the mitigation of the adverse impacts, if any, is to be defined and documented.

The hydraulics engineer should assure that the appropriate floodplain data are obtained/developed and should also function as a catalyst to assure that the floodplain hydraulics and associated risks are considered in the development of the recommended design alternate and/or design variations.

3-004 Studies (Refer to [Chart 3-004](#))

Projects which involve federal and/or state funds will include an evaluation of all encroachments into 100-year-frequency floodplains. The results of the evaluation will be documented in the reports prepared for corridor and/or design approval and must be summarized in the projects' environmental documentation¹. The "Floodplain Evaluation Flowchart" ([Chart 3-004](#)) illustrates the flow of tasks that may be involved.

Floodplain studies range from routine evaluations that result in determinations of not significant, by inspection, to more complex evaluations that may include a Risk Assessment for potentially significant encroachments and Risk Analyses for significant encroachments.

Drainage Manual Chapter 3 – Floodplain Encroachments

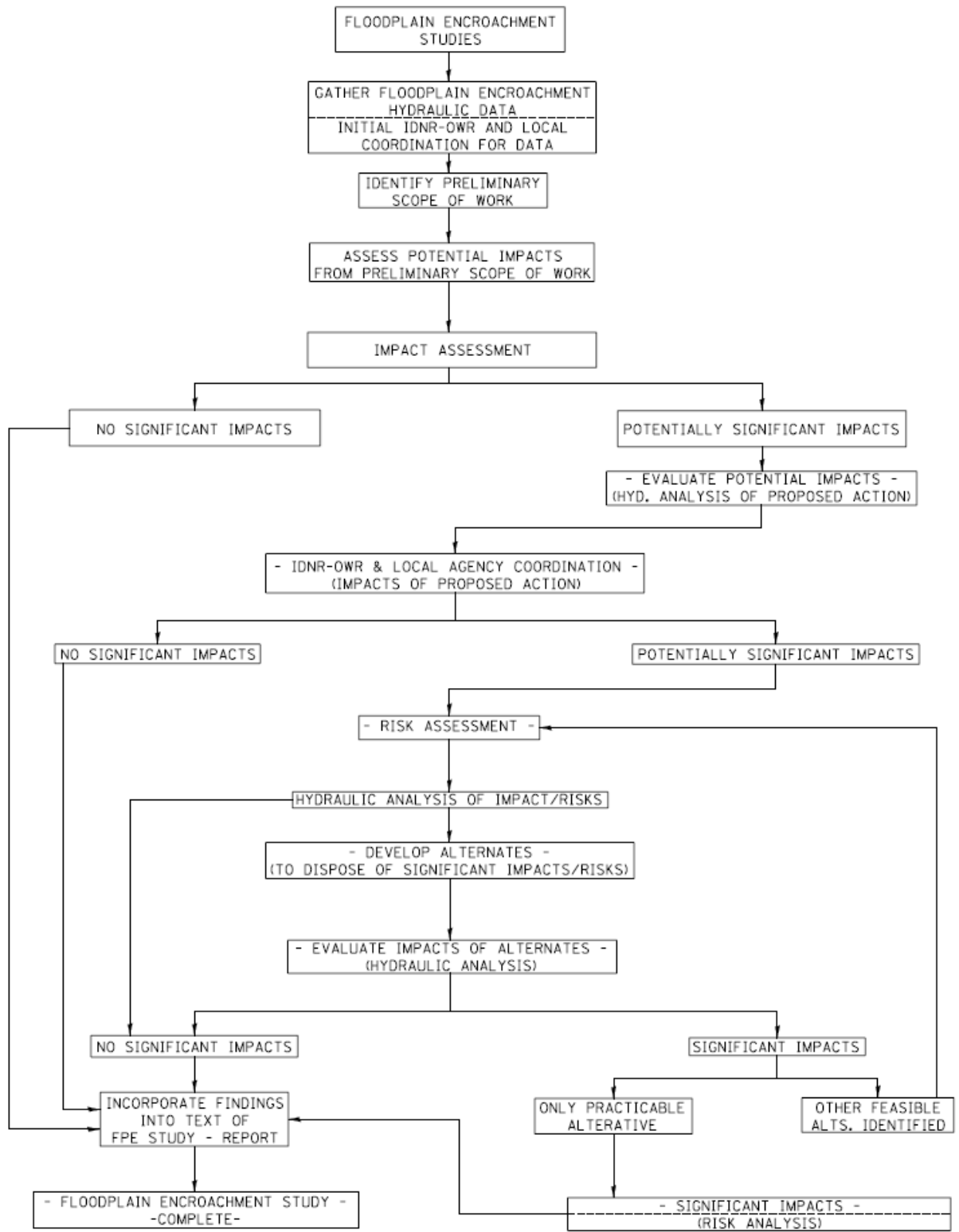

Floodplain Evaluation Flowchart
Chart 3-004

Drainage Manual Chapter 3 – Floodplain Encroachments

3-004.01 Evaluation Process

The evaluation process requires an initial evaluation that consists of review of design alternates/variations, preliminary roadway profile, and cross sections to determine geometric concerns and right-of-way requirements.

The tasks involved in the evaluation include the following:

- Review profile in respect to Flood Insurance Studies(FIS) and evaluate extent/degree of encroachment (if FIS are not available, data would need to be determined).
- Determine appropriateness of proposed action and provide recommendations for revisions to proposed action to avoid a significant encroachment.
- Categorize the action in accordance with the BDE Manual¹, and determine the need for additional detailed hydraulics, if any.

When the initial evaluation results in a determination that additional data are necessary, then it is required to compile data to enable the Hydraulic Analysis to be developed for the existing and perceived proposed conditions for potential transverse (bridge, culvert crossings) and potential longitudinal encroachments ([Section 2-602](#)).

The tasks involved to ensure that the potential Floodplain Encroachment is appropriately hydraulically evaluated in accordance with the BDE Manual¹ for the recommended alternate/profile include:

- Review information previously developed in respect to recommended preliminary alternate and design variations.
- Define constraints that substantiate the hydraulic design variations to be evaluated.
- Evaluate the recommended design variations as necessary to avoid a significant encroachment (this may include consideration of request for exemption from policy).
- Review and consider IDNR-OWR's permit requirements and local ordinances.
- Review results of hydraulic analysis for proposed conditions for consistency with expectations.
- Summarize the impacts and summarize findings in appropriate format.

3-004.02 Risk Assessment

An assessment of the consequences associated with the probability of flooding attributable to an encroachment. It shall include the potential for property loss and hazard to life during the service life of the highway for potentially significant encroachments.

The risk assessment is made during the planning phase for potentially significant encroachments of project development, and it does not take the place of a detailed Hydraulic

Drainage Manual Chapter 3 – Floodplain Encroachments

Report. To ensure thoroughness and consistency in the risk assessment process, project classifications have been established with a description of the level of assessment required (refer to the BDE Manual²). Any detailed hydraulic studies required for the project may be completed during this phase or later during design.

The result from the assessment process is based on recommended frequency and waterway opening commensurate with prevailing criteria. During the course of this endeavor, it may not be feasible to anticipate every alternative. Therefore, it must be recognized that circumstances encountered in final design may warrant some departure from the assessment recommendation.

The risk assessment is intended to provide decision makers with an economic assessment of design alternates and their associated risks. The categorized alternates are analyzed relative to existing conditions with worst case estimates used. The risks are very probabilistic in nature, and it is unlikely that they would reflect actual flood losses for any given year of flood event. The basic purpose of this analysis is to provide the decision maker with a relative risk assessment of the design alternates rather than an estimate of probable flood damages.

Risk Considerations Use the following Risk Considerations to determine the impacts that the designs will have on the floodplain, and identify any lands that can be expected to be subject to flooding or subject to increased frequency of flooding as a result of each design considered.

From [Hydraulic Engineering Circular \(HEC\) No. 17 Section 4⁴](#):

1. *Prescribed minimum design flood criteria as in the case of the Interstate.*
2. *Limitations imposed by roadway geometrics such as maximum or minimum grade lines, site distance, vertical curvature, etc.*
3. *Overtopping frequency of the adjoining roadway. In particular, that section of roadway involving the same watershed under consideration.*
4. *Topographical features such as stream levees, elevation of the watershed divide, and clearances for highways or railroads which are bridged.*
5. *Navigation clearance requirements.*
6. *Floodplain ordinances or other legislative mandates limiting allowable backwater or encroachment on the floodplain.*
7. *Channel stability considerations which would limit velocity or the amount of constriction.*
8. *Ecological considerations such as may exist with wetland or in other sensitive environments.*
9. *Geological or geomorphic conditions or constraints including subsurface conditions.*
10. *Social considerations including the importance of the facility as an emergency evacuation route in time of peril.*

Drainage Manual Chapter 3 – Floodplain Encroachments

11. *Availability of funds to construct the facility. (This item may or may not be a consideration in a first appraisal but could ultimately govern the design selection).⁴*

3-004.03 Risk Analysis

Risk analysis is an economic comparison of design alternatives using expected total costs (construction plus risk costs) to determine the alternative with the Least Total Expected Cost (LTEC) to the public which is required for significant encroachments.

Since the primary objective is to avoid significant encroachment, risk analysis will rarely be used. Before proceeding with any risk analysis, it must be thoroughly demonstrated that there is no other practical alternative to a significant encroachment.

If significant encroachments are found a risk analysis shall be made. A risk analysis presents an implementation of the philosophy that a stream crossing (including the roadway approaches, as well as the drainage components) shall be designed for the "least total expected cost" (LTEC) in terms of annual costs. Risk analysis is the essential ingredient in the LTEC concept.

This concept goes beyond the construction cost comparisons of all of the feasible alternatives as derived from engineering considerations. After a designer has selected the most economical (first cost) design that will handle the runoff for the flood frequency as established by policy, the designer should apply risk analysis procedures to designs that have less flow capacity and involve floodplain encroachment.

The lower capacity designs would reduce the initial cost, but would involve risk of damages to the highway facilities, the stream channel, and the adjacent properties. The "Total Expected Cost" (TEC) to the public during the service life of the highway includes the initial capital investment, expected replacement and repair costs resulting from flood damage, expected user costs from traffic interruptions and detours, and expected highway aggravated flood damages to other property. Engineering analysis and economic analysis (including risk analysis) provide information for selecting a range of design alternates of least total expected cost (LTEC) to the public.

The procedure outlined in [HEC 17⁴](#) shall be followed.

3-100 FLOODPLAIN ENCROACHMENT

A Floodplain Encroachment is any construction, reconstruction, rehabilitation, repair, or improvements undertaken within the limits of the area subject to a flood having a one percent chance of being exceeded in any given year.

Nearly all highway encroachments consist of earth-fill embankments bordered by cross drainage structures sized to pass flood flows within the environmental, economical, and geometric constraints of the location. The volume and necessary configuration of the embankment are functions of the geometric requirements to safely support the highway and the structural measures necessary to protect the embankment from floodwaters (slope walls, retaining walls, riprap, etc.). The length of embankment on transverse encroachments and the horizontal placement on longitudinal encroachments is a direct function of the hydraulic requirements in conjunction with considerations for stream mechanics, soil conditions, geometrics, and environmental constraints.

3-101 Types of Encroachments (Figure 3-101)

There are two types of encroachments, transverse and longitudinal. Each has a varying degree of potential encroachment significance depending on whether or not the encroachment will affect the flood stage either by altering the floodplain conveyance characteristics or by altering the discharges as a result of extensive floodplain storage changes.

3-101.01 Transverse

Transverse encroachments by their nature cannot be avoided. The network of the natural surface drainage system does not allow any alternatives (except - no build) to transverse encroachment by a highway system. Refer to the BDE Manual, Section 40-3.04 Bridges and Culverts² for further discussion.

The vertical alignment is most critical for a transverse crossing with minor emphasis on horizontal alignment and cross-sectional elements. Whereas for longitudinal crossings, the reverse generally applies.

3-101.02 Longitudinal

The longitudinal condition exists wherever the roadway alignment parallels the stream, is located either adjacent or within the floodplain limits, and does not immediately cross the stream. Refer to the BDE Manual, Section 40-3.05 Longitudinal Encroachments² for further discussion.

Horizontal alignment and the positioning of the roadway embankment may be critical to the floodplain conveyance in the situation of involving a potential longitudinal encroachment.

Generally, longitudinal encroachments, especially those which encroach upon the floodway, are to be avoided. When a longitudinal encroachment cannot be avoided, the degree of encroachment should be minimized to the extent practicable.

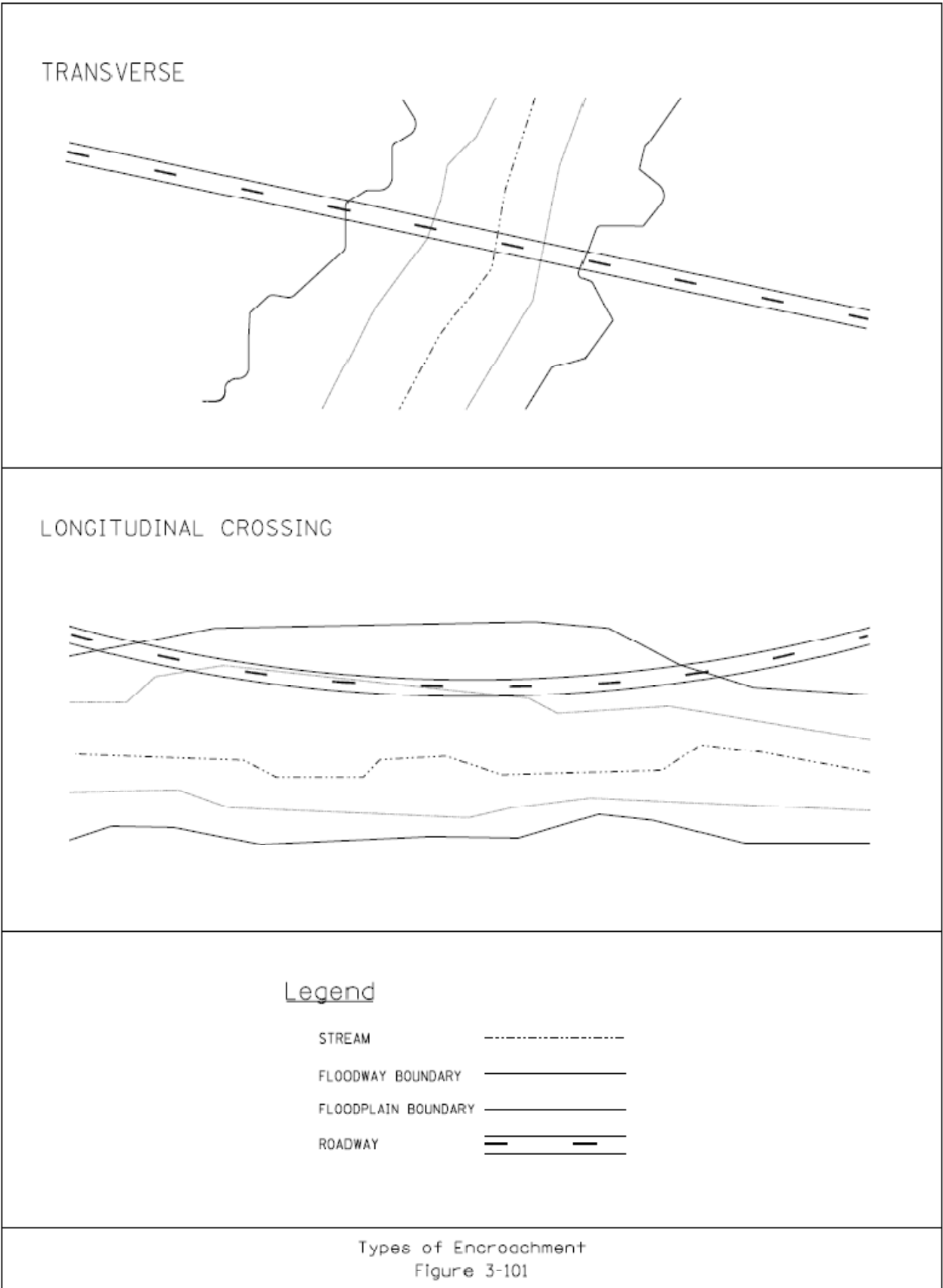

Drainage Manual Chapter 3 – Floodplain Encroachments

3-102 Floodplain Characteristics (Figure 3-102)

Generally the floodplain information utilized to identify and evaluate the encroachment is initially based upon National Flood Insurance Program (NFIP) maps and in some instances on information developed during the evaluation.

3-102.01 Floodway

Floodway may be defined as a portion of the cross-sectional area of the floodplain essential to retain conveyance and storage.

The floodway, as a minimum, generally includes the channel and the area formed by a vertical extension of its banks. The floodway limits may have been expanded to include additional area of the floodplain determined to be necessary for storage (usually a maximum of 90 percent of the floodplain cross-sectional area). The conveyance floodway limits are determined by constraining a given cross-section equally on each side until a specific increase in elevation of flood height is met (usually 0.1 ft).

3-102.02 Flood Fringe

The flood fringe is the portion of the floodplain outside of the floodway.

These outer boundaries of the flood plain are not usually considered essential for conveyance in the floodplain. The flood fringe usually encompasses approximately 10 percent of the floodplain cross sectional area.

By definition, the fill placed within a floodplain outside a floodway would not result in an increase in the flood elevation beyond the set limits due to loss of conveyance. This is a useful concept in determining the effect of the potential encroachment.

Generally, the floodway is regulated by the OWR (subject to drainage area limitation as detailed in Section 1-403 Office of water Resources) and the flood fringe is regulated by the agency having building and zoning authority.

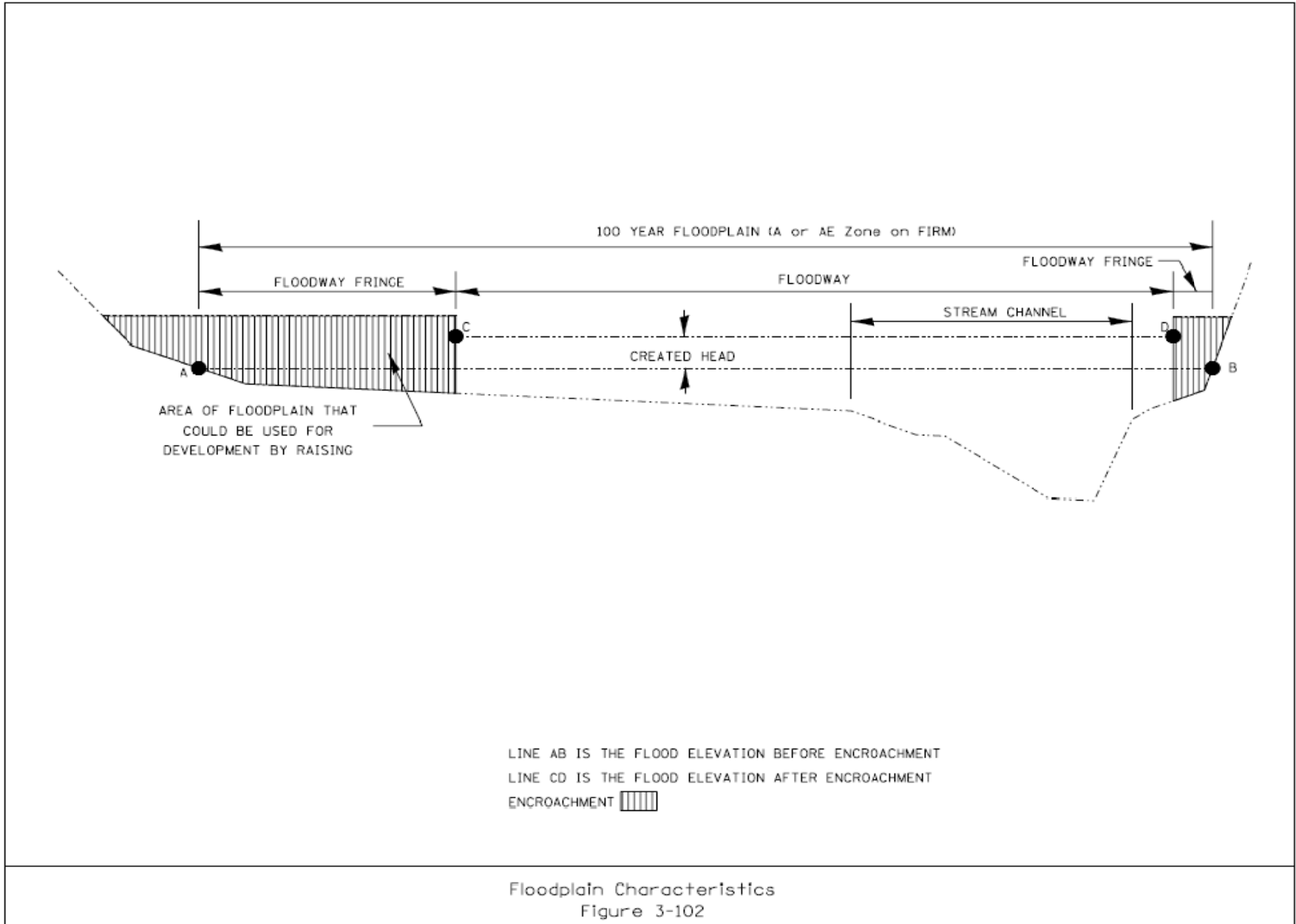

3-200 FLOODPLAIN DATA

3-201 Floodplain Identification and Data Collection

The floodplain data necessary to identify and evaluate the extent of encroachment varies with the project scope and the floodplain sensitivity.

The primary sources of floodplain identification are NFIP maps and studies. These sources and data from other floodplain management agencies may be utilized for initial assessments and/or a base for detailed hydraulic studies for the work to be done within the floodplain.

The data available ranges from approximate flood boundaries to detailed hydraulic analysis of the floodplains that may be sufficient to use as a base for further studies. The data is to be inspected to determine its validity prior to its use as a data base. Coordination with other watershed management agencies and local jurisdictional/agencies may be appropriate.

When information from other sources regarding flood stage elevations is used, the survey base datum must be correlated with the highway survey base datum.

To assure that the data elevations are on the same base, the datum correlation requires that a surveyor provides the information on each survey datum and provides the correction factor. It is suggested that the hydraulic data derived from available information be summarized on the Waterway Information Table with the source of data noted along with any corrections made resulting from the datum correlation.

Using data obtained from these sources or studies, an office analysis of the data should be used to identify potential encroachments on base floodplains. Special note should be made of potential longitudinal encroachments or significant encroachments and conditions that may affect the significance of the encroachment.

For Potentially Significant and Significant Encroachments, detailed Hydraulic Studies would be necessary to provide the floodplain data for the floodplain encroachment evaluation. Additional involvement with local jurisdiction agencies is desirable to obtain additional information and have them involved in the decision making process.

The Hydraulic Studies performed in accordance with procedures contained in the Drainage Manual may require expanded field data to identify sensitive floodplain receptors within the influence of the encroachment. Coordination activities with Federal Emergency Management Agency (FEMA), OWR and Local Jurisdictional Agencies should occur.

Sources of available flood and floodplain information:

1. NFIP maps and studies, which may include:
 - (a) **Flood Boundary and Floodway Map (FBFM)** -- The map furnished the community, for regulatory purposes, the boundaries of the regulatory floodway and the existing 100 year floodplain and 500 year floodplain. This map also shows the location of selected cross sections used in the course of the study. The map shows only that portion of the community where the regulatory floodway has been established. A FBFM is generally derived from a detailed hydraulic study and should provide reasonably accurate information. The FBFM was included with studies

Drainage Manual Chapter 3 – Floodplain Encroachments

prepared before 1986. Since 1986, The FBFM information has been incorporated into the Flood Insurance Rate Map (FIRM)⁶.

- (b) **Flood Insurance Study (FIS)** -- The enumeration, evaluation, and determination of Special Flood Hazard Area (SFHA), and base flood water surface elevations. This study will include a table of regulatory floodway charts and data, and flood boundary and floodway map if the report was prepared before 1986⁶. Engineering methods used to produce the 100 year flood profiles and regulatory floodway are documented in the study report.
- (c) **Flood Insurance Rate Map (FIRM)** -- Official map for communities in which the SFHAs, Base Flood Elevations (BFE) and insurance risk zones applicable to the community have been delineated. This map will show the existing 100 year flood elevation also known as, the BFE or the 1-percent-annual-chance flood. Several areas of flood hazard are commonly identified on the FIRM. One of these areas is the SFHA, which is defined as the area that will be inundated by the flood event having a 1-percent chance of being equaled or exceeded in any given year. The 1-percent-annual-chance flood is also referred to as the "base flood." SFHAs are labeled as Zone A, Zone AO, Zone AH, Zones A1-A30, Zone AE, Zone 99, Zone AR, Zone AR/AE, Zone AR/AH, Zone AR/AO, Zone AR/A1-A30, Zone AR/A, Zone V, Zone VE, and Zones V1-V30. The flood hazard zones of interest to IDOT are Zones A and AE.
Zone A: Areas subject to inundation by the 1-percent-annual-chance flood event. Because detailed hydraulic analyses have not been performed, no BFEs or flood depths are shown. Mandatory flood insurance purchase requirements apply.
Zones AE and A1-A30: Areas subject to inundation by the 1-percent-annual-chance flood event determined by detailed methods. BFEs are shown within these zones. Mandatory flood insurance purchase requirements apply. (Zone AE is used on new and revised maps in place of Zones A1-A30.)⁷
- (d) **Countywide FIRM** -- Countywide FIRMS are being produced which show flooding information for the entire geographic area of a county, including the incorporated communities within the county. As a result, each countywide FIRM becomes the official source of flood risk data for several communities. These newer FIRMS include floodways and floodplain management information not shown on older FIRMS. They also present a simplified, or compressed, set of insurance zone designations.
- (e) **Flood Hazard Boundary Map (FHBM)** -- Maps showing special flood hazard areas of the community. This map is based on existing available information, and generally the 100 year data is not available. The areas are approximate, and no specific elevations or discharge given. A FHBM is generally not based on a detailed hydraulic study and, therefore, the floodplain boundaries shown are approximate and should not be used as a basis for determining the 100 year floodplain for the risk assessment. FHBMs were made in the 1970s and early 1980s as an interim measure until a detailed study could be carried out. FHBMs are still being used where detailed FISs have not been prepared or cannot be justified⁶.

For a tutorial on NFIP map types go to http://www.fema.gov/pdf/floodplain/nfip_sg_unit_3.pdf⁶

2. USGS Water Supply Papers

Drainage Manual Chapter 3 – Floodplain Encroachments

3. USGS Hydrologic Atlases
4. High-water marks established under FIA Programs, or equivalent others
5. U. S. Army Corps of Engineers(USACE), Natural Resources Conservation Service(NRCS)
6. State and Local Flood Control Agencies Division of Water Resources Floodplain Map
7. Land Use Planning Agencies
8. Highway Hydraulic and Drainage Planning Studies
9. Illinois State Water Survey(ISWS)
 - (a) Rainfall Data
 - (b) 100-year Frequency Certified Discharges
 - (c) Illinois Floodplain Information Repository

To obtain FEMA publications:

1. **National Flood Insurance Program Community Status Book**
Effective June 1, 2006, the subscription service for the Community Status Book was discontinued. Please be advised that you can access the book free of charge from <http://www.fema.gov/fema/csb.shtm>
2. **Flood Insurance Study Maps and Reports**
Write to:

Map Service Center
P.O. Box 1038
Jessup, MD 20794-1038

Call the Map Service Center toll-free Monday through Friday 8:00 a.m. to 6:00 p.m. (Eastern Time) at (800) 358-9616

Fax: (800) 358-9620

The Internet ordering address is:
<http://www.msc.fema.gov/webapp/wcs/stores/servlet/info?storeId=10001&catalogId=10001&langId=-1&content=orderCost&title=Ordering%20and%20Cost>

Most counties, communities and Illinois State Water Survey have copies of the FEMA maps and they should be available for inspection through their Floodplain Officers.

To Obtain a Copy of the FIS Hydraulic Model:

1. Review the effective FIRM or FIS report to obtain the full name of the stream for which the hydraulic model is needed and to verify that the stream was studied by detailed methods.
2. If the model is needed for only a section of the stream, review the FIRM or Flood Profiles in the FIS report to identify the limits of that section; the limits can be referenced to roads or other physical features or to floodplain cross sections.
3. Obtain the full name of the community shown on the effective FIRM or FIS report.

Drainage Manual Chapter 3 – Floodplain Encroachments

4. Check with the community map repository to determine whether the hydraulic model needed has been revised.
5. The only FEMA-official repository of complete and final FEMA-effective data is the FEMA Engineering Library, which is operated by a contractor. The Internet address is: http://www.fema.gov/plan/prevent/fhm/st_order.shtm#2

Revision Request Submittal:

All requests for revisions should be prepared using a MT-2 application/certification forms package, entitled "Revisions to National Flood Insurance Program Maps" (FEMA Form 81-89 Series), and the required supporting information. The Internet address for the MT-2 forms is <http://www.fema.gov/library/viewRecord.do?id=1493>.

The complete package should be transmitted to the following address:

LOMC Clearinghouse
6730 Santa Barbara Court
Elkridge, MD 21075

3-202 Field Examination and Identification of Structures Sensitive to Flooding

A field examination should be conducted to verify the accuracy of data collected and analyzed in the preceding phase, and to assist in defining possible alternatives to significant encroachments and longitudinal encroachments. Note the amount and kind of development that exists within the floodplain, the kind of flooding which exists, and whether the proposed highway project and/or alternatives will have an adverse effect on the existing situation. It would also be well to determine whether an existing adverse effect might tend to be perpetuated by the proposed project.

The above may require a rather extensive survey. To appropriately limit what exceptions should be evaluated, the following is suggested:

- Initially inspect available mapping after laying out general limits of floodplain. This will aid in field review and provide a guide to be used by the surveyor.
- Determine the length of stream reach that is being affected by the project being evaluated (i.e., new structure or replacement structure, the reach length attained when the backwater was reduced to 0.1 ft or less).
- Collect the low opening elevation or lowest damageable elevation of the upstream building and structures within the above length and determine if any are subject to flood damage.

Buildings and structures (receptors) that may be sensitive to flooding within the influence of the encroachment are to be identified (usually they are located upstream). This would require the use of an approximate scaled aerial photo, aerial mapping or field survey to locate whether or not the receptor lies within the floodplain. Once identified either by the above process or field review, elevations at which flood damage may occur would be obtained. Note, the Hydraulic Report Data Sheets, may have this information identified, to some degree, under General Information item "7".

Drainage Manual Chapter 3 – Floodplain Encroachments

The sensitive receptors may include:

1. Primary
 - a. Buildings and Structures
 - 1) 1st Floor
 - 2) Basement
 - 3) Windows
 - 4) Window Wells
 - b. Levees
 - c. Other Highways
 - d. Railroads
2. Secondary
 - a. Storm Sewer Outfalls
 - b. Combined Sewer Outfalls
 - c. Sanitary Sewer Manholes
 - d. Septic Fields
 - e. Floor Drains
 - f. Water Well

3-203 Hydraulic Data

Methods of analyses of bridges, culverts, and channels are contained in the corresponding chapters in this Manual.

The hydraulic data for existing and proposed conditions that may be required for assessment of alternates and/or evaluation of the encroachment follows.

3-203.01 Transverse Crossings

- Waterway Information Table at site
- Flood Stage Information at sensitive locations
- Floodplain and channel velocity changes

3-203.02 Longitudinal Crossings

- Flood Stage Information through the site and at sensitive locations.
- Floodplain and channel velocity changes (The above information may be summarized in a table which provides the data of each reference point, i.e., at each station.)

3-300 HIGHWAY DESIGN IN THE FLOODPLAIN

3-301 General

This section identifies roadway features which aid the development of appropriate highway designs in the floodplain.

When the highway improvement is located within or adjacent to the floodplain, it is necessary to consider the effects that the proposed action (geometric design) would have on the floodplain and also the effects the floodplain would have on the roadway.

It may be necessary to develop various alternates which reflect established policies, flood risk damages, OWR's permitting regulations³ (which can be found at <http://dnr.state.il.us/owr/resmanpermitprogs.htm> and consider local requirements/needs. Decisions on the horizontal and vertical alignment and cross sections for the geometric design of the highway may require an in-depth analysis of the effect within the floodplain. Refer to Section 1-302.01 Documentation of Floodplain Encroachment Designs for decision documentation requirements. To minimize the effect or to avoid a significant (adverse) effect, the extent of floodplain encroachment may be a heavily weighted factor in the selection of the geometric plan.

The development of recommended plans may necessarily be supported by risk assessment, especially when the recommended plan results in a variation from policy and would be the basis for requests to the Bureau of Bridges and Structures for approval of design variation.

3-302 Overtopping Flood (Figure 3-302)

The overtopping flood frequency is defined as the frequency at which flood waters first flow over the roadway.

The maximum calculable flood frequency (i.e., 500 year) may be considered the upper limit for evaluating overtopping flood frequency. This identifies both the actual level of service of the roadway and the point at which relief flow is available for the encroachment. Normally, the occurrence of relief flow and the disruption of traffic occur at approximately the same elevation. However, exceptions should be noted, such as curbed sections and superelevation sections where the occurrence of relief flow is at a higher elevation than the pavement.

3-302.01 General Rule for Setting Level of Roadway Flood Protection

The traffic lanes should not be inundated for the design flood frequency as specified in "Design Flood Frequency", [Table 1-305](#). However, when the overtopping flood frequency is controlled by the roadway centerline profile, the edges of the lane would be inundated by the rise of the crown.

It is desirable to develop a roadway profile that does not result in the flooding/inundation of the traffic lanes for the design frequency.

When physical limitations put constraints on the roadway profile and the geometric variation of cross sectional elements, consideration of equating the overtopping flood frequency elevation as close as possible to the inundation level of traffic lanes should be explored. The geometric variation may include modifying the superelevation rate to avoid lowering the low edge (and avoid raising the high edge when located on the downstream side of the highway).

Drainage Manual Chapter 3 – Floodplain Encroachments

Other conditions may result in unfavorable depth of flooding of the traffic lanes. Overtopping is controlled by the superelevated section (worse case is when high edge is downstream side of highway), raised medians (curbed or barrier wall), widening of existing facilities and any other form of downstream barrier such as retaining walls, noise abatement walls, etc.

For rehabilitation projects when the scope of work is basically resurfacing, raising the roadway may result in increased backwater (approximately equivalent to the raise). Increasing the waterway opening may be initially beyond the scope of work. If the overtopping flood frequency meets the design flood frequency, generally the profile should be retained by stripping/resurfacing or by pavement patching. If the overtopping flood frequency is less than the design flood frequency, serious consideration must be given to correcting the deficiency, especially if supported by pavement flooding records

3-302.02 Related Floodplain Hydraulic Analysis

When the overtopping elevation is raised, a change in floodplain hydraulics may occur. A hydraulic evaluation must then be made to determine if an improvement to the floodplain conveyance is necessitated by the proposed conditions. The results of the hydraulic analysis would be summarized on a Waterway Information Table.

Two basic conditions can exist when the establishment of the roadway profile results in overtopping.

1. The flooding/overtopping of the roadway results from downstream conditions. For these conditions it is generally required that the profile must be raised to reduce roadway inundation potential.
2. For a transverse crossing, when the flooding/overtopping of the roadway is a function of the waterway opening, it may be appropriate to enlarge the waterway opening of the cross-drainage structure to reduce the backwater (subject to evaluation of potential increased upstream/downstream flood damage). Another option is to raise the roadway if the initial backwater is reasonable and evaluate whether or not the cross-drainage structure should be enlarged to compensate for loss of flow over the roadway.

Drainage Manual Chapter 3 – Floodplain Encroachments

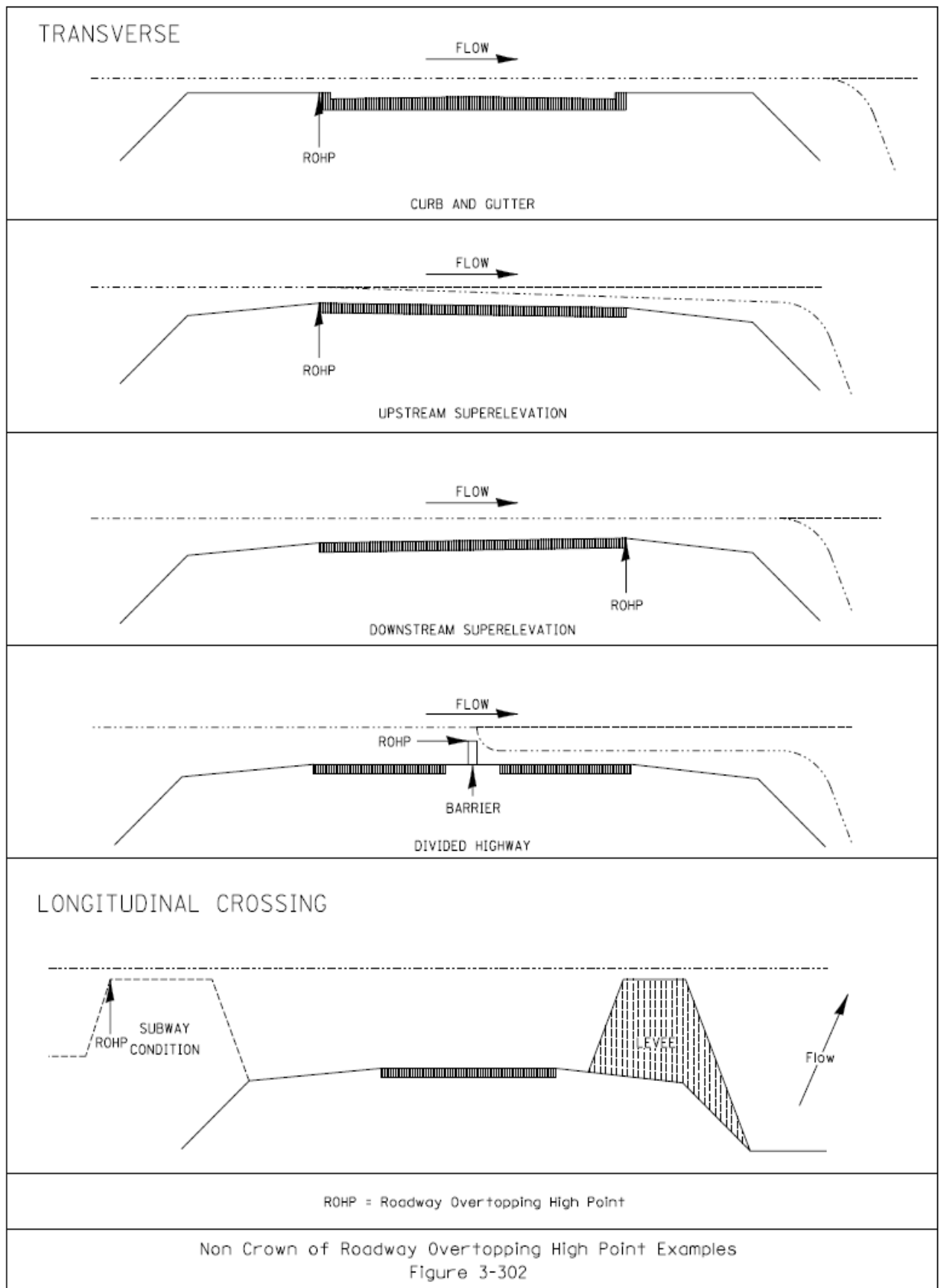

3-303 Freeboard

Drainage Manual Chapter 3 – Floodplain Encroachments

Freeboard is defined as the distance that the roadway is located above a given flood stage.

Table 1-305 Design Flood Frequency states: "*The roadway edge of pavement at the low grade point in a floodplain area for highways with a DHV of 100 or more shall be a minimum of 3 feet above design headwater elevation.*". This criterion is to be met for construction and evaluated for rehabilitation category projects. Often in environmentally sensitive rural areas and urbanized areas it is not feasible to meet the criteria. The reasoning for not meeting the criteria and the evaluation supporting the determination of the recommended freeboard is to be developed as part of the profile studies.

The information reviewed would include:

- "Flood of record" which exceeds the design criteria
- Consequences to upstream properties in the event a major flood occurs
- Safety to traffic
- Embankment and structure failure potential
- Cost-effectiveness of raising the embankment including traffic maintenance
- Right-of-way costs
- Emergency vehicular access
- Utilities
- Access to adjoining properties
- Effect on existing structures and associated costs including need for separate overflow structures
- Extent of fill that encroaches in the floodplain

The evaluation would be utilized in the request to the Bureau of Bridges and Structures for design variation when associated with waterway crossing, bridge, or multi-barrel box.

3-304 Highway Design Variations to Minimize Fill in the Floodplain

The extent of significance of a highway encroachment (usually fill in the floodplain) may be judged based on the amount of embankment that encroaches into the floodway or is in close proximity to it. The design team (refer to [3-003](#)) should explore design variations that minimize the fill in the floodplain without either significantly altering the highway's operational or safety characteristics or significantly increasing costs.

3-304.01 Alteration of Embankment Slopes

Steeper side slopes may be appropriate due to height of fill.

Retaining or slope walls may also be necessary to protect the embankment from scour.

Drainage Manual Chapter 3 – Floodplain Encroachments

3-304.02 Alteration of Highway Alignment

The highway alignment should not be located in the floodplain in a potential longitudinal encroachment situation. Alternate alignments should be developed and evaluated that would avoid the encroachment. In the event the encroachment cannot be avoided, alternates should be further developed/evaluated that would not encroach or at least minimize the encroachment on the floodway. New alignment that results in a longitudinal encroachment should not occur unless there is no other practicable design.

Vertical alignment variations may be appropriate in conjunction with horizontal variations but must be within the constraints for overtopping flood frequency and freeboard established by the design team.

3-304.03 Variations of the Typical Roadway Cross Sections

For existing facilities that are to be widened basically within the right of way, variation of typical roadway cross sections may be appropriate to minimize or avoid a longitudinal encroachment of the floodway. Geometric variations may include reduced lane widths, widening away from the stream, etc. There would rarely be a basis for roadway cross section variations for transverse encroachment although in certain longitudinal applications the variations may be necessary in order to avoid encroachment of the floodway when alignment variations are not feasible due to other adverse impacts.

Drainage Manual Chapter 3 – Floodplain Encroachments

3-305 MAINTENANCE OF TRAFFIC DURING FLOOD STAGE

Highway encroachment of the floodplain should be designed to avoid/minimize damage to adjacent property and to secure a low degree of risk of traffic interruption by flooding. Interruption by flooding should be commensurate with the importance of the road, the design traffic service requirements, and available funds.

3-305.01 Emergency Vehicular Access and Interruption of Traffic

Also to be considered is the Emergency Vehicular Access. Often the need for Emergency Vehicular Access is coincidental with major storm events that may lead to the inundation of the roadway. Therefore, the importance of the facility with respect to the emergency vehicle routes (i.e. fire protection districts, hospitals, etc.) is to be evaluated with respect to the level of flood protection to be afforded to the roadway.

3-305.02 Construction Staging/Detours

The evaluation of construction staging, especially with respect to determining whether the road should be closed during construction, and/or selection of a detour route should consider the susceptibility of the detour route to flooding. Concern being not only in the interruption of traffic, but also in maintaining Emergency Vehicular Access (refer to 3-305.01) during a major flooding event.

3-306 Levee Conditions

The condition where the highway embankment or a portion of it is positioned such that a portion of the longitudinal floodplain lies opposite of the embankment from the stream channel is considered to be a levee condition.

Under normal circumstances there would be structures through the highway embankment that are intended to perpetuate minor stream crossing and/or drain the low lands. During flood stages in the major stream, reverse flow through the structure may occur. Flap gates, check valves or other devices may be installed to provide flood protection from the major stream when in flood stage.

The use of flap gates for highway purposes is limited due to the high costs associated with maintenance and the use is generally discouraged due to the risks of flooding in the event the gate does not function properly.

An alternative to flapgates for backflow protection is the use of check valves. Check valves have no moving parts like hinges and seats to rust or freeze. They can eliminate the operational and maintenance problems such as corrosion of mechanical parts, freezing open or shut, warping, and clogging due to trapped debris. Available sizes of check valves range from 1/2 in. to 96 in. diameter. The estimated service life is 25 to 50 years.

IDOT is receptive to the use of flap gates provided that it is a part of a watershed management plan by others and that the cost of construction, including the maintenance and jurisdiction of such devices, is also by others. In addition, one of the following conditions would need to be met:

1. A local agency constructs the control device off of state right of way.
2. A local agency indemnifies the State (holds harmless) by agreement or passage of a local board resolution when located within the highway right of way.

Drainage Manual Chapter 3 – Floodplain Encroachments

As a levee condition can result in the highway embankment functioning as a dam, care must be taken to assure that the structural integrity of the highway embankment is properly evaluated due to potential differentials of water elevation that may occur under flood stage. Referral of this condition for structural analysis and coordination with the IDNR-OWR Dam Safety section and the USACE may be required. This situation is discussed and very strongly discouraged in the FHWA memorandum “Highway Embankments versus Levees and other Flood Control Structures” dated September 10, 2008 which is available at <http://www.fhwa.dot.gov/engineering/hydraulics/policymemo/20080910.cfm>.

3-307 Subway Conditions

For conditions where a depressed roadway underpass is in a subway condition and located within or adjacent to a floodplain it should be treated similar to a levee condition to assure that the design level of protection is provided.

The level of protection provided should be in accordance with the design flood frequency criteria for subway conditions. The extent to which protection is provided should be carefully evaluated with respect to consequences that would result from flooding due to flood stages that exceed the design frequency.

Normally, freeboard in the range of 3 ft, between design high water elevation and the top of the boundary (or berm), should be provided. Protection from overtopping should consider the depth to which the underpass would flood and the safety of the motorist in the event the boundary (or berm) was overtopped.

3-400 FLOODPLAIN STORAGE (COMPENSATORY STORAGE)

3-401 General

Floodplain storage is a volume of stream flood water stored in a purposely designed excavation or reservoir in or adjacent to the floodplain, controlled by the flood stage, to minimize or eliminate an increase in the stream flood stage that would otherwise result from the proposed displacement of floodwaters by the embankment placed below the base flood level.

As part of a highway project which results in fill being placed within the floodplain, it may either be necessary to provide compensatory floodplain storage to avoid a significant encroachment or appropriate to provide floodplain storage as a by-product of another activity. The placement of highway fill in the floodplain is to be evaluated in accordance with [Section 1-302.03](#), "Compensatory Storage", to determine any resultant effects to upstream and downstream property and flooding conditions. The effects are generally evaluated for the design flood frequency and also for the 100 year flood frequency.

Whether or not an encroachment will "significantly" increase flood stages due to the amount of storage lost is a difficult judgment. Normally, encroachment by highway projects which are usually of the transverse type would have minimal impact, if any, on the floodplain storage.

In Districts 2 through 9, the hydraulic effects of relatively small fills (i.e. less than 200 cu. yd.) are considered to be minimal, if in fact, non-measurable. For this reason (and considering that the analysis would be time-consuming and relatively expensive), it is not necessary to include the effects in the evaluation. In District 1, there is no minimum compensatory storage volume that is considered minimal or negligible. In accordance with IDNR-OWR regulatory requirements, any volume of fill within the floodway is evaluated for compensatory storage provisions.

The extent to which the floodway is encroached upon is usually used as a gage to measure the effect of the fill.

Although it is generally accepted that the filling of the flood fringes by definition should not result in a significant storage loss, there may be critical situations where properties are already subject to flood damages and consequently would be sensitive to flood storage changes. In this case, even minute increases of flood stage may be intolerable, and compensatory storage would be economically justified as a mitigation measure.

3-401.01 Transverse Encroachment

Rarely is the floodplain storage considered to be significantly altered by a transverse encroachment. This is due to the typically relatively minor nature of the potential floodplain storage loss as compared to the total floodplain storage.

3-401.02 Longitudinal Encroachment

Compensatory floodplain storage is more frequently necessary when the encroachment extends into the floodway. The additional alteration of the floodplain cross section designed to compensate for conveyance loss also results in compensatory storage.

3-401.03 Depressed Areas

Drainage Manual Chapter 3 – Floodplain Encroachments

Compensatory floodplain storage may also be considered for highway actions which increase volumes to depressed areas which may or may not be located within an identified floodplain.

Depressed Areas generally are sensitive to changes in volume. They are characteristically drained by either tiles, infiltration or pumping.

The volume change could occur either by fill being placed in the depressed area or by increased volume of runoff that is part of the highway.

Compensatory storage may be necessary to avoid significant damages. Dry wells (depending on soil conditions) or diversion of runoff to a less volume sensitive outlet may also be appropriate options to providing storage.

3-402 Storage Site Design

Floodplain storage facilities may be developed within highway drainage facilities, sites adjacent to the floodplain, impoundments and flowages. In all cases the storage is for floodplain waters and is controlled by the flood level in the floodplain.

Often, compensatory storage can result as a by-product of highway projects in the form of such facilities as borrow pits, wetland replacement, stormwater detention facilities, and modification of the floodway to provide conveyance.

Floodplain storage facilities are characterized, ideally, by less frequent inundation than storm water detention facilities (i.e., floodplain storage facilities are generally not inundated until stream over bank flooding occurs, thereby lending themselves to public multi-purpose use).

The change in volume usually is determined utilizing conventional earthwork computations. The cross sectional area is measured on a floodplain cross section between the flood stage and the ground surface (or permanent impoundment of water). The volume is usually expressed in units of cu. yd. or for larger volumes in acre-ft (area of one acre - one foot deep). It usually is necessary for evaluation purposes to determine the extent of encroachment separately for floodway and the flood fringe.

Coordination - An objective when providing storage is to combine the function of providing replacement storage volume with other facilities and/or combine them with facilities that will have multi-purpose public uses such as parks, forest preserves, and watershed management facilities. Consequently, sites located adjacent to land suitable for multi-purposes and adjacent or within floodplains are ideal.

The site concept should be developed in coordination by the design team and then coordinated with the local jurisdictional agency or agencies and the appropriate Federal agencies (i.e., USACE) and State agencies (i.e., IDNR-OWR).

3-403 Compensatory Storage Design Concepts

Compensatory storage requirements for projects involving a Regulatory Floodplain of the IDNR-OWR are discussed in the BDE Manual, [Chapter 40, Section 40-3.04 Bridges and Culverts](#):²

3-403.01 Storage Excavation in the Floodplain (Figure 3-403)

Drainage Manual Chapter 3 – Floodplain Encroachments

This concept utilizes a site located both adjacent and contiguous to the floodplain and in the vicinity of the encroachments.

The storage volume is achieved by excavating above the normal water elevation. The site is characterized by excavation which has a triangular cross sectional shape which is open towards the channel and is drained gradually as the flood waters recede. The excavation may be on either side of the channel or both.

Sites located within or adjacent to the floodway may serve both to provide the storage volume and also to enhance conveyance characteristics of the floodplain. Generally, excavation should be limited to areas outside of the channel bank(s) and above the ground water table and/or the normal water elevation in the stream (or pool) (1 foot minimum is desirable).

Sites located within or adjacent to the flood fringe may allow more latitude in site design although the area is more susceptible to higher land values. A characteristic of areas outside the flood fringe may result in significant cost increases resulting from removal of overburden. Sites located within the flood fringe of course would not have overburden.

The design of the site should minimize the disturbance of the floodplain environment, i.e. gentle contour to blend in with surrounding terrain with minimal disturbance to vegetation and wildlife is highly desirable.

3-403.02 Storage by Impoundment

This concept is utilized when the site area is limited and additional volume is desired. Additional depth of excavation and/or leveeing forms an impoundment characterized by a trapezoidal cross section shape and inflow and outflow facilities.

Site design considerations including safety would be similar to Detention Sites, (refer to [Chapter 12](#)) and are to be utilized as guidelines. This type of site design may be developed in conjunction with a detention facility for storm water runoff.

This type of facility would rarely be utilized for highway improvements. It is more common to utilize this type of facility for watershed management improvements.

The depth of storage can be increased by either raising the level above the adjacent floodplain or by lowering the bottom below the conventionally drained bottom elevations. This condition can be achieved by lift stations and/or by specially designed conduits that take advantage of their hydraulic efficiency with respect to the floodplain profile.

It is recommended that the inflow design be fixed to allow only the floods of greater frequency to "overflow" to minimize maintenance costs including pumping costs and maximize effectiveness.

3-403.03 Storage Incorporated Within Highway Drainage Systems

This concept is limited to a small volume of compensatory storage due to its relatively high cost. The storage volume may be achieved by modification to the highway drainage system, designed initially for conveyance (with or without stormwater detention).

The modifications usually consist of lowering the inverts and/or enlargement of the highway drainage system below the stream flood level. Conveyance function for stormwater runoff would be retained and compensatory storage would occur as the flood stage rose above the invert.

Drainage Manual Chapter 3 – Floodplain Encroachments

Although ditches may be utilized, care must be exercised so as to neither create a hazard along the roadway nor saturate the roadway base. It is recommended to limit depth of storage to 3 feet or less. It is preferable that storage be provided by widening the ditch designed initially for conveyance rather than deepening it.

For projects of minor nature (i.e., shoulder improvements, safety improvements) it may not be practicable to provide compensatory storage at the site. In particular, hardships may arise from potential environmental impacts such as wetland disturbance, the taking of recreational lands (4f), archeological disturbances, and excessive construction costs associated with providing small amounts of storage (i.e., 200 cu. yd. or less). It would appear to be more prudent to not provide compensatory storage under such circumstances.

This direction is generally applicable in Districts 2 through 9, but does not apply to floodway encroachments in District 1. As noted above in 3-401 General, District 1 projects must satisfy the comp storage requirements contained within IDNR-OWR regulatory permit criteria.

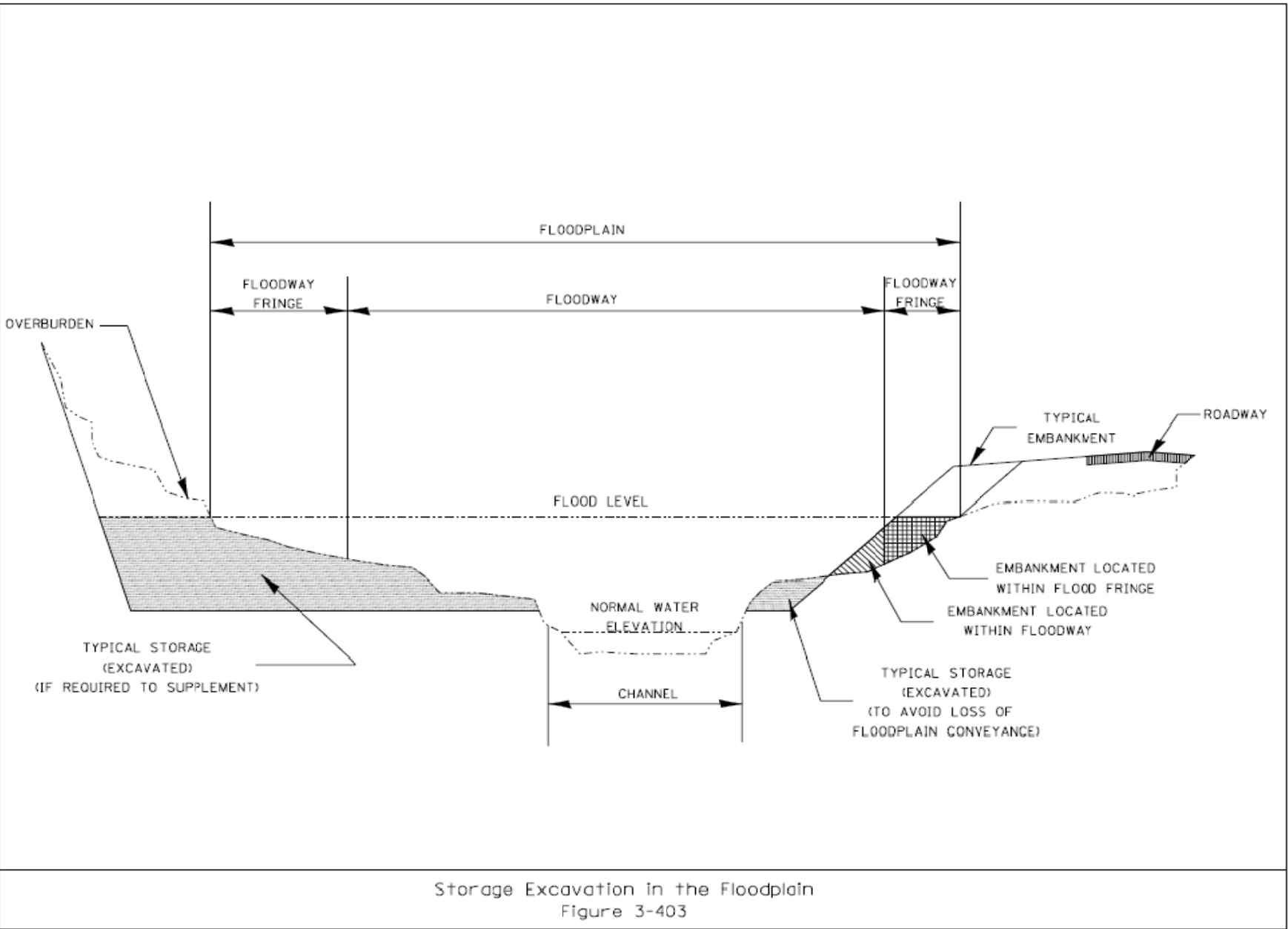

Storage Excavation in the Floodplain
Figure 3-403

Drainage Manual Chapter 3 – Floodplain Encroachments

3-404 Flowages/Flood Easements

The flowage would be defined by the increased level of flood storage and the increase in floodplain area. Storage would be achieved within the temporary impoundment resulting from the change in floodplain storage.

Establishment of a flowage which would alter floodplain limits established by a Flood Insurance Study (FEMA) or by State Regulatory Stream (OWR) normally would place an encumbrance on the affected property owners. Under these circumstances a Flood Easement would need to be acquired.

This concept of providing storage would appear to be limited to Watershed Management Agency projects initiated by others. The flood easements would be obtained by others. The Division of Highways would consider the reduction of a transverse crossing either existing or proposed as part of the plan.

When a flowage/flood easement is being considered the evaluation should include the following:

- Highest & best use of land
- Existing improvements (buildings, utilities, etc)
- Reliability of estimated cost of Flood Easements
- Effect of increased duration of flood stage
- Reliability of floodplain data & documented historical flooding records
- The hydraulic effect on the highway structure
- Effects of changes in future flood stage levels due to external factors
- Effects of properties located within an elevation 1 foot above the flowage level

Information is to be coordinated with the Bureau of Land Acquisition in District 1, or the Land Acquisition Section in the other Districts, to determine the feasibility of obtaining the easement and its cost.

Information is to include:

- Location map for site
- Approximate property lines
- Flood stage boundary elevation and boundary (existing & proposed)
- Data on probable change in flooding depth and duration

3-500 FLOODPLAIN ENCROACHMENT DOCUMENTATION

An assessment should be conducted for each identified Potential Floodplain Encroachment. Guidance regarding information on floodplain encroachments to include in the various reports is discussed in the [BDE Manual¹, Chapter 26, section 26-7, FLOODPLAIN ENCROACHMENTS.](#)

3-600 RELATED DOCUMENTS

3-601 Procedure for Coordination

3-601.01 IDOT Coordination

IDOT coordination policy is stated in the [BDE Manual¹](#), Chapter 26, section 26-7.05(h), [Coordination](#).

3-601.02 Coordination with Federal Emergency Management Agency (FEMA)

A Non-regulatory attachment from the FHWA Federal-Aid Policy Guide, Title 23 Code of Federal Regulations (CFR) 650A:

Procedures for Coordinating Highway Encroachments on Floodplains with Federal Emergency Management Agency (FEMA)⁵

The local community with land use jurisdiction, whether it is a city, county, or state, has the responsibility for enforcing National Flood Insurance Program (NFIP) regulations in that community if the community is participating in the NFIP. Most NFIP communities have established a permit requirement for all development within the base (100 year) floodplain. Consistency with NFIP standards is a requirement for Federal-aid highway actions involving regulatory floodways. The community, by necessity, is the one who must submit proposals to FEMA for amendments to NFIP ordinances and maps in that community should it be necessary. Determination of the status of a community's participation in the NFIP and review of applicable NFIP maps and ordinances are, therefore, essential first steps in conducting location hydraulic studies and preparing environmental documents.

Where NFIP maps are available, their use is mandatory in determining whether a highway location alternative will include an encroachment on the base floodplain. Three types of NFIP maps are published: (1) a Flood Hazard Boundary Map (FHBM), (2) a Flood Boundary and Floodway Map (FBFM), and (3) a Flood Insurance Rate Map (FIRM). A FHBM is generally not based on a detailed hydraulic study and, therefore, the floodplain boundaries shown are approximate. A FBFM, on the other hand, is generally derived from a detailed hydraulic study and should provide reasonably accurate information. The hydraulic data from which the FBFM was derived is available through the regional office of FEMA. This is normally in the form of computer input data cards for calculating water surface profiles. The FIRM is generally produced at the same time using the same hydraulic model and has appropriate rate zones and base flood elevations added.

Communities in the regular program of the NFIP generally have had detailed flood insurance studies performed. In these communities the NFIP map will be a FIRM; and, in the majority of cases, a regulatory floodway is in effect.

Communities in the emergency program of the NFIP usually have not had a detailed flood insurance study completed and, usually, only limited floodplain data is available. In this case, the community NFIP map will be a FHBM, and there will not be a regulatory floodway.

Other possibilities are: (1) the community is not in a FEMA identified flood hazard area and thus there is no NFIP map; (2) a FHBM, FIRM, or FBFM is available, but the community is not participating in the NFIP; (3) a community is in the process of converting from the emergency program to the regular program and a detailed flood insurance study is

Drainage Manual Chapter 3 – Floodplain Encroachments

underway; or (4) a community is participating in the regular program, the NFIP map is a FIRM, but no regulatory floodway has been established. Information on community participation in the NFIP is provided in the "National Flood Insurance Program Community Status Book" which is published bi-monthly for each state and is available through the headquarters of FEMA.

Coordination With FEMA

It is intended that there should be highway agency coordination with FEMA in situations where administrative determinations are needed involving a regulatory floodway or where flood risks in NFIP communities are significantly impacted. The circumstances which would ordinarily require coordination with FEMA are:

1. *A proposed crossing encroaches on a regulatory floodway and, as such, would require an amendment to the floodway map.*
2. *A proposed crossing encroaches on a floodplain where a detailed study has been performed, but no floodway designated and the maximum one foot increase in the base flood elevation would be exceeded.*
3. *A local community is expected to enter into a regular program within a reasonable period and detailed floodplain studies are underway.*
4. *A local community is participating in the emergency program and base flood elevation in the vicinity of insurable buildings is increased by more than one foot. (Where insurable buildings are not affected, it is sufficient to notify FEMA of changes to base flood elevations as a result of highway construction.)*

The draft EIS/EA should indicate the NFIP status of affected communities, the encroachments anticipated, and the need for floodway or floodplain ordinance amendments. Coordination means furnishing to FEMA the draft EIS/EA and, upon selection of an alternative, furnishing to FEMA, through the community, a preliminary site plan and water surface elevation information and technical data in support of a floodway revision request as required. If a determination by FEMA would influence the selection of an alternative, a commitment from FEMA should be obtained prior to the FEIS or FONSI. Otherwise this later coordination may be postponed until the design phase.

For projects that will be processed with a categorical exclusion, coordination may be carried out during design. However, the outcome of the coordination at this time could change the class of environmental processing.

Highway Encroachments Which Are Consistent With Regulatory Floodways In Effect

In many situations it is possible to design and construct highways in a cost-effective manner such that their components are excluded from the floodway. This is the simplest way to be consistent with the standards and should be the initial alternative evaluated. If a project element encroaches on the floodway but has a very minor effect on the floodway water surface elevation (such as piers in the floodway), the project may normally be considered as being consistent with the standards if hydraulic conditions can be improved so that no water surface elevation increase is reflected in the computer printout for the new conditions.

Drainage Manual Chapter 3 – Floodplain Encroachments

Revision Of Regulatory Floodway So That Highway Encroachment Would Be Consistent

Where it is not cost-effective to design a highway crossing to avoid encroachment on an established floodway, a second alternative would be a modification of the floodway itself. Often, the community will be willing to accept an alternative floodway configuration to accommodate a proposed crossing provided NFIP limitations on increases in the base flood elevation are not exceeded. This approach is useful where the highway crossing does not cause more than a one-foot rise in the base flood elevation. In some cases, it may be possible to enlarge the floodway or otherwise increase conveyance in the floodway above and below the crossing in order to allow greater encroachment. Such planning is best accomplished when the floodway is first established. However, where the community is willing to amend an established floodway to support this option, the floodway may be revised.

The responsibility for demonstrating that an alternative floodway configuration meets NFIP requirements rests with the community. However, this responsibility may be borne by the agency proposing to construct the highway crossing. Floodway revisions must be based on the hydraulic model which was used to develop the currently-effective floodway, but updated to reflect existing encroachment conditions. This will allow determination of the increase in the base flood elevation that has been caused by encroachments since the original floodway was established. Alternate floodway configurations may then be analyzed.

Base flood elevation increases are referenced to the profile obtained for existing conditions when the floodway was first established.

Data submitted to FEMA in support of a floodway revision request should include:

1. Copy of current regulatory Flood Boundary Floodway Map, showing existing conditions, proposed highway crossing, and revised floodway limits.
2. Copy of computer printouts (input, computation, and output) for the current 100-year model and current 100-year floodway model.
3. Copy of computer printouts (input, computation, and output) for the revised 100-year floodway model. Any fill or development that has occurred in the existing flood fringe area must be incorporated into the revised 100-year floodway model.
4. Copy of engineering certification is required for work performed by private subcontractors.

The revised and current computer data required above should extend far enough upstream and downstream of the floodway revision area in order to tie back into the original floodway and profiles using sound hydraulic engineering practices. This distance will vary depending on the magnitude of the requested floodway revision and the hydraulic characteristics of the stream.

A floodway revision will not be acceptable if development that has occurred in the existing flood fringe area since the adoption of the community's floodway ordinance will now be located within the revised floodway area unless adversely-affected adjacent property owners are compensated for the loss.

Drainage Manual Chapter 3 – Floodplain Encroachments

If the input data representing the original hydraulic model is unavailable, an approximation should be developed. A new model should be established using the original cross section topographic information, where possible, and the discharges contained in the Flood Insurance Study which establish the original floodway. The model should then be run confining the effective flow area to the currently-established floodway and calibrated to reproduce within 0.10 foot, the "With Floodway" elevations provided in the Floodway Data Table for the current floodway. Floodway revisions may then be evaluated using the procedures outlined above.

Floodway Encroachment Where Demonstrably Appropriate

When it would be demonstrably inappropriate to design a highway crossing to avoid encroachment on the floodway and where the floodway cannot be modified such that the structure could be excluded, FEMA will approve an alternate floodway with backwater in excess of the one-foot maximum only when the following conditions have been met:

- 1. A location hydraulic study has been performed in accordance with Federal-Aid Highway Program Manual (FHPM) 6-7-3-2 "Location and Hydraulic Design of Encroachments on Floodplains" (23 CFR 650, Subpart A), and FHWA finds the encroachment is the only practical alternative.*
- 2. The constructing agency has made appropriate arrangements with affected property owners and the community to obtain flooding easements or otherwise compensate them for future flood losses due to the effects of the structure.*
- 3. The constructing agency has made appropriate arrangements to assure that the National Flood Insurance Program and Flood Insurance Fund do not incur any liability for additional future flood losses to existing structures which are insured under the program and grandfathered in under the risk status existing prior to the construction of the structure.*
- 4. Prior to initiating construction, the constructing agency provides FEMA with revised flood profiles, floodway and floodplain mapping, and background technical data necessary for FEMA to issue revised Flood Insurance Rate Maps and Flood Boundary and Floodway Maps for the affected area upon completion of the structure.*

Highway Encroachment On A Floodplain With A Detailed Study (FIRM)

*In communities where a detailed flood insurance study has been performed but no regulatory floodway designated, the highway crossing should be designed to allow no more than a one-foot increase in the base flood elevation based on technical data from the flood insurance study. Technical data supporting the increased flood elevation should be submitted to the local community and FEMA for their files. Where it is demonstrably inappropriate to design the highway crossing and meet backwater limitations, the procedures outlined under **Floodway Encroachment Where Demonstrably Appropriate** should be followed in requesting a revision of base floodplain reference elevations.*

Highway Encroachment On A Floodplain Indicated On An FHBM

Drainage Manual Chapter 3 – Floodplain Encroachments

In communities where detailed flood insurance studies have not been performed, the highway agency must generate its own technical data to determine the base floodplain elevation and design encroachments in accordance with FHPM 6-7-3-2. Base floodplain elevations should be furnished to the community and coordination carried out with FEMA as outlined previously where the increase in base flood elevations in the vicinity of insurable buildings exceeds one foot.

Highway Encroachment On Unidentified Floodplains

Encroachments which are outside of NFIP communities or NFIP identified flood hazard areas should be designed in accordance with FHPM 6-7-3-2 of the Federal Highway Administration. The NFIP identified flood hazard areas are those delineated on an FHBM, FBFM, or FIRM.⁵

3-602 Executive Order 11988¹

Floodplain Management

HISTORY: May 24, 1977; 42 FR 26951, 3 CFR, 1977 Comp., p. 117; Amended by Executive Order 12148, July 20, 1979; 44 FR 43239, 3 CFR, 1979 Comp., p. 412

[EDITOR'S NOTE: Executive Order 12148 --Federal Emergency Management, July 20, 1979, substituted "Director of the Federal Emergency Management Agency" for "Federal Insurance Administration" in Section 2(d).]

By virtue of the authority vested in me by the Constitution and statutes of the United States of America, and as President of the United States of America, in furtherance of the National Environmental Policy Act of 1969, as amended (42 USC 4321 et seq.), the National Flood Insurance Act of 1968, as amended (42 USC 4001 et seq.), and the Flood Disaster Protection Act of 1973 (Public Law 93-234, 87 Stat. 975), in order to avoid to the extent possible the long and short term adverse impacts associated with the occupancy and modification of floodplains and to avoid direct or indirect support of floodplain development wherever there is a practicable alternative, it is hereby ordered as follows:

Section 1.

Each agency shall provide leadership and shall take action to reduce the risk of flood loss, to minimize the impact of floods on human safety, health and welfare, and to restore and preserve the natural and beneficial values served by floodplains in carrying out its responsibilities for

- (1) acquiring, managing, and disposing of Federal lands and facilities;*
- (2) providing Federally undertaken, financed, or assisted construction and improvements;
and*
- (3) conducting Federal activities and programs affecting land use, including but not limited to water and related land resources planning, regulating, and licensing activities.*

Section 2.

In carrying out the activities described in Section 1 of this Order, each agency has a responsibility to evaluate the potential effects of any actions it may take in a floodplain; to ensure that its planning programs and budget requests reflect consideration of flood hazards and floodplain

Drainage Manual Chapter 3 – Floodplain Encroachments

management; and to prescribe procedures to implement the policies and requirements of this Order, as follows:

(a)

- (1) *Before taking an action, each agency shall determine whether the proposed action will occur in a floodplain for major Federal actions significantly affecting the quality of the human environment, the evaluation required below will be included in any statement prepared under Section 102(2)(C) of the National Environmental Policy Act. This determination shall be made according to a Department of Housing and Urban Development (HUD) floodplain map or a more detailed map of an area, if available. If such maps are not available, the agency shall make a determination of the location of the floodplain based on the best available information. The Water Resources Council shall issue guidance on this information not later than October 1, 1977.*
- (2) *If an agency has determined to, or proposes to, conduct, support, or allow an action to be located in a floodplain, the agency shall consider alternatives to avoid adverse effects and incompatible development in the floodplains. If the head of the agency finds that the only practicable alternative consistent with the law and with the policy set forth in this Order requires siting in a floodplain, the agency shall, prior to taking action,*
 - (i) *design or modify its action in order to minimize potential harm to the floodplain, consistent with regulations issued in accord with Section 2(d) of this Order, and*
 - (ii) *prepare and circulate a notice containing an explanation of why the action is proposed to be located in the floodplain.*
- (3) *For programs subject to the Office of Management and Budget Circular A-95, the agency shall send the notice, not to exceed three pages in length including a location map, to the state and areawide A-95 clearinghouses for the geographic areas affected. The notice shall include:*
 - (i) *the reasons why the action is proposed to be located in a floodplain;*
 - (ii) *a statement indicating whether the action conforms to applicable state or local floodplain protection standards and*
 - (iii) *a list of the alternatives considered.*
Agencies shall endeavor to allow a brief comment period prior to taking any action.
- (4) *Each agency shall also provide opportunity for early public review of any plans or proposals for actions in floodplains, in accordance with Section 2(b) of Executive Order No. 11 514, as amended, including the development of procedures to accomplish this objective for Federal actions whose impact is not significant enough to require the preparation of an environmental impact statement under Section 102(2)(C) of the National Environmental Policy Act of 1969, as amended.*

Drainage Manual Chapter 3 – Floodplain Encroachments

- (b) *Any requests for new authorizations or appropriations transmitted to the Office of Management and Budget shall indicate, if an action to be proposed will be located in a floodplain, whether the proposed action is in accord with this Order.*
- (c) *Each agency shall take floodplain management into account when formulating or evaluating any water and land use plans and shall require land and water resources use appropriate to the degree of hazard involved. Agencies shall include adequate provision for the evaluation and consideration of flood hazards in the regulations and operating procedures for the licenses, permits, loan or grants-in-aid programs that they administer. Agencies shall also encourage and provide appropriate guidance to applicants to evaluate the effects of their proposals in floodplains prior to submitting applications for Federal licenses, permits, loans or grants.*
- (d) *As allowed by law, each agency shall issue or amend existing regulations and procedures within one year to comply with this Order. These procedures shall incorporate the Unified National Program for Floodplain Management of the Water Resources Council, and shall explain the means that the agency will employ to pursue the nonhazardous use of riverine, coastal and other floodplains in connection with the activities under its authority. To the extent possible, existing processes, such as those of the Council on Environmental Quality and the Water Resources Council, shall be utilized to fulfill the requirements of this Order. Agencies shall prepare their procedures in consultation with the Water Resources Council, the Director of the Federal Emergency Management Agency, and the Council on Environmental Quality, and shall update such procedures as necessary.*

Section 3.

In addition to the requirements of Section 2, agencies with responsibilities for Federal real property and facilities shall take the following measures:

- (a) *The regulations and procedures established under Section 2(d) of this Order shall, at a minimum, require the construction of Federal structures and facilities to be in accordance with the standards and criteria and to be consistent with the intent of those promulgated under the National Flood Insurance Program. They shall deviate only to the extent that the standards of the Flood Insurance Program are demonstrably inappropriate for a given type of structure or facility.*
- (b) *If, after compliance with the requirements of this Order, new construction of structures or facilities are to be located in a floodplain, accepted floodproofing and other flood protection measures shall be applied to new construction or rehabilitation. To achieve flood protection, agencies shall, wherever practicable, elevate structures above the base flood level rather than filling in land.*
- (c) *If property used by the general public has suffered flood damage or is located in an identified flood hazard area, the responsible agency shall provide on structures, and other places where appropriate, conspicuous delineation of past and probable flood height in order to enhance public awareness of and knowledge about flood hazards.*
- (d) *When property in floodplains is proposed for lease, easement, right-of-way, or disposal to non-Federal public or private parties, the Federal agency shall*
 - (1) *reference in the conveyance those uses that are restricted under identified Federal, State or local floodplain regulations; and*

Drainage Manual Chapter 3 – Floodplain Encroachments

- (2) *attach other appropriate restrictions to the uses of properties by the grantee or purchaser and any successors, except where prohibited by law; or*
- (3) *withhold such properties from conveyance.*

Section 4.

In addition to any responsibilities under this Order and Sections 202 and 205 of the Flood Disaster Protection Act of 1973, as amended (42 U.S.C. 4106 and 4128), agencies which guarantee, approve, regulate, or insure any financial transaction which is related to an area located in a floodplain shall, prior to completing action on such transaction, inform any private parties participating in the transaction of the hazards of locating structures in the floodplain.

Section 5.

The head of each agency shall submit a report to the Council on Environmental Quality and to the Water Resources Council on June 30, 1978, regarding the status of their procedures and the impact of this Order on the agency's operations. Thereafter, the Water Resources Council shall periodically evaluate agency procedures and their effectiveness.

Section 6.

As used in this Order:

The term "agency" shall have the same meaning as the term "Executive agency" in Section 105 of Title 5 of the United States Code and shall include the military departments; the directives contained in this Order, however, are meant to apply only to those agencies which perform the activities described in Section 1 which are located in or affecting floodplains.

- (a) *The term "base flood" shall mean that flood which has a one percent or greater chance of occurrence in any given year.*
- (b) *The term "floodplain" shall mean the lowland and relatively flat areas adjoining inland and coastal waters including floodprone areas of offshore islands, including at a minimum, that area subject to a one percent or greater chance of flooding in any given year.*

Section 7.

Executive Order No. 11296 of August 10, 1966, is hereby revoked. All actions, procedures, and issuances taken under that Order and still in effect shall remain in effect until modified by appropriate authority under the terms of this Order.

Section 8.

Nothing in this Order shall apply to assistance provided for emergency work essential to save lives and protect property and public health and safety, performed pursuant to Sections 305 and 306 of the Disaster Relief Act of 1974 (88 Stat. 148, 42 U.S.C. 5145 and 5146).

Section 9.

Drainage Manual Chapter 3 – Floodplain Encroachments

To the extent the provisions of Section 2(a) of this Order are applicable to projects covered by Section 104(h) of the Housing and Community Development Act of 1974, as amended (88 Stat. 640, 42 U.S.C. 5304(h)), the responsibilities under those provisions may be assumed by the appropriate applicant, if the applicant has also assumed, with respect to such projects, all of the responsibilities for environmental review, decision making, and action pursuant to the National Environmental Policy Act of 1969, as amended.

*/s/ JIMMY CARTER
THE WHITE HOUSE
May 24, 1977¹*

3-603 Illinois Executive Order

The Governor's Executive Order 2006-05 entitled "Construction Activities in Special Flood Hazard Areas", requires that the construction activities of the Division of Highways comply with the standards of the State Floodplain Regulations (i.e., IDNR-OWR Regulatory Permit Program) and the National Flood Insurance Program; whichever is more stringent. It is the IDOT position that compliance with the OWR floodway permit criteria constitutes compliance with EO 2006-05.

Section 1-202 includes this position statement and the EO in its entirety.

Drainage Manual Chapter 3 – Floodplain Encroachments

3-700 REFERENCES

1. Illinois Department of Transportation. *Bureau of Design and Environment(BDE) Manual: Chapter 26, Section 26-7 FLOODPLAIN ENCROACHMENT.*
2. Illinois Department of Transportation. *Bureau of Design and Environment(BDE) Manual: Chapter 40, General Drainage Procedure.*
3. Illinois Department of Natural Resources, Office of Water Resources. *Division of Water Resource Management:*
 - Part 3700 Construction in Floodways of Rivers, Lakes and Streams;
 - Part 3704 Regulation of Public Waters;
 - Part 3706 Regulation of Construction within Floodplains;
 - Part 3708 Floodway construction in Northeastern Illinois;
 - Part 3720 Rules Establishing Horizontal and Vertical Clearances for Bridges Over the Fox River.
4. United States Department of Transportation, Federal Highway Administration. *Hydraulic Engineering Circular No. 17: Design of Encroachments on Floodplains Using Risk Analysis, 1981.*
5. United States Department of Transportation, Federal Highway Administration: Federal-Aid Policy Guide, NS 23 CFR 650A Attachment 2: Procedures for Coordinating Highway Encroachments on Floodplains with the Federal Emergency Management Agency. <http://www.fhwa.dot.gov/legsregs/directives/fapg/0650asu3.htm>
6. Federal Emergency Management Agency. Managing Floodplain Development Through The National Flood Insurance Program, 1998. <http://www.fema.gov/library/viewRecord.do?id=2108>
7. Federal Emergency Management Agency. Web Site: Answers to Questions about the NFIP; <http://www.fema.gov/business/nfip/fhamr.shtm#76>



Chapter 4

Hydrology

CHAPTER 4 - HYDROLOGY

- 4-000 GENERAL
 - 4-001 Introduction
 - 4-002 Hydrologic Method Selection
- 4-100 HYDROLOGIC METHODS
 - 4-101 USGS Regression Equations
 - 4-101.01 Rural Technique
 - 4-101.011 Example Problem 1
 - 4-101.012 Example Problem 2
 - 4-101.013 StreamStats
 - 4-101.02 Urban Technique
 - 4-101.021 Example Problem 3
 - 4-101.022 Example Problem 4
 - 4-101.03 Application of Gage Data
 - 4-101.031 Site at Gage Location
 - 4-101.032 Example Problem 5
 - 4-101.033 Site near Gage Location
 - 4-101.034 Example Problem 6
 - 4-101.035 Gage Frequency Analysis
 - 4-102 Rational Method
 - 4-102.01 Example Problem 7
 - 4-102.02 Rainfall Intensity Equation
 - 4-103 Natural Resources Conservation Service Method TR20 (Formerly SCS)
 - 4-104 HEC 1/ HEC-HMS
- 4-200 APPLICATION OF RAINFALL DATA TO HYDROLOGIC METHODS
 - 4-201 Introduction
 - 4-202 ISWS Bulletin 70 Rainfall Data
 - 4-203 ISWS Bulletin 70 Rainfall Data: Selecting Rainfall Amounts and Time Distributions
 - 4-203.01 Rainfall Amounts
 - 4-203.02 Time Distributions
 - 4-204 Application of ISWS Bulletin 70 Rainfall Data to Hydrologic Methods
 - 4-204.01 Example Problem 8 – Rational Method
 - 4-204.02 Example Problem 9 – TR-20/ HEC-HMS/ HEC-1
- 4-300 REFERENCES

4-000 GENERAL**4-001 Introduction**

The design of each highway drainage facility requires the determination of discharge-frequency relationships. Some facilities require a determination of a momentary peak flow rate while others require a runoff hydrograph providing an estimate of runoff volume. The momentary peak flow rates are most often used in the design of bridges, culverts, roadside ditches, and small storm sewer systems. Drainage systems involving detention storage, pumping stations and large or complex drainage facilities require the development of a runoff hydrograph.

The Division of Highways uses a very commonly employed set of hydrologic tools that have been considered industry standards for many years. Several of the tools and all of the raw rainfall statistical data that is used to drive these rainfall-runoff simulations have been developed specifically for work in Illinois. The first two sub-sections of Chapter 4 (4-000 and 4-100) identify these tools, explain how the appropriate tool or method can be selected for a given drainage application or project, then provide some background information and technical direction on each of the available methods. Example Problems 1 through 7 illustrate how the equations and methods function and generate typical project solutions. The last sub-section of Chapter 4 (4-200) explains how gage-based rainfall statistics for the entire State of Illinois contained in the Illinois State Water Survey's [Bulletin 70⁵](#) Study are incorporated into IDOT's hydrologic methods. Example Problems 8 and 9 show how [Bulletin 70⁵](#) rainfall data is used to drive Rational Method and hydrograph-based models, respectively.

4-002 Hydrologic Method Selection

The hydrologic equations, methods and numerical models that the Division of Highways utilizes and accepts for drainage-related work are shown below in Table 4-002. The table includes all of the hydrologic tools available for commonly encountered drainage Facilities; labeling or ranking the applicability of each Method on a sliding scale of 1 to 5. For the great majority of IDOT projects or Facilities, a Method identified by the KEY as "1) Standard or Customary" is selected. However, there are projects that due to their complexity, special nature or other complicating site factors are better served by a Method labeled "2) Alternate when 1 is not acceptable" or "3) Preferred for complex facilities or when hydrograph is needed". For projects fitting this description, a comparison of the peak discharge Method (USGS or Rational) with a hydrograph-based method (NRCS or HEC-1/HEC-HMS) may be desirable. The capabilities and limitations of the respective Methods under consideration can also impact selection. This scenario is particularly common for Stream Flow applications (bridges, culverts and channels) on smaller watersheds (under 0.5 sq. mi.) and for culverts listed under the Roadway Design heading. For these projects, as suggested above, a comparison of applicable methods may be desirable. A comparison of Methods may be prudent whenever the initial method selected produces results that are not consistent with past similar analyses/sites or generates discharges that contradict observed or published values. For any project where hydrologic method selection is not a straightforward determination, the hydraulic designer should consult with the District Hydraulic Engineer or appropriate District staff for direction. Ideally this consultation should occur early in project coordination. All projects should include a scoping process that includes selection and agreement on a hydrologic method selection between appropriate Department staff and party performing the analysis.

		METHOD				
		USGS*		Rational	NRCS**	HEC-1/ HEC-HMS
		Rural Eq.	Urban Eq. ***			
Drainage Area Limits		0.03 Sq Mi. to 10K Sq Mi	0.7 to 630 Sq Mi	< 200 Ac.	None	None
FACILITY DESCRIPTION	<i>Stream Flow</i>					
	Bridges	1	1		2,3	2,3
	Large Multi-Cell Culverts	1	1		2,3	2,3
	Channels	1	1		2,3	2,3
	<i>Roadway Design</i>					
	Storm Sewers			1	3	3
	Roadway Ditches			1	3	3
	Median Drains			1	2	3
	Small Across Road (AR) Culverts			1	2	3
	Sideroad Culverts			1	2	3
	Entrance Culverts			1	2	3
	Pumping Stations			4	1	1
	Detention Basins			5	1	1

(*) Note: For Drainage Areas less that 0.5 Sq Mi, see Limitations in Sec. 4-101

(**) Note: NRCS (Formerly SCS) is automated within the WinTR-55 and WinTR-20 software

(***) Note: The USGS Urban Regression Equations may not be acceptable to various permitting agencies and their use should be approved by the Department prior to starting a new project.

KEY

- 1) Standard or Customary Method.
- 2) Alternate when 1 is not acceptable.
- 3) Preferred for complex facilities when a hydrograph is needed.
- 4) Method may be used for preliminary evaluation.
- 5) May be used for small off right-of-way detention systems which will not impact sensitive flood situations.

Hydrologic Methods for Various Highway Drainage Facilities
Table 4-002

4-100 HYDROLOGIC METHODS

4-101 USGS Regression Equations

The Department has adopted the flood frequency equations developed by the U.S. Geological Survey for both bridge and culvert designs.

Flood magnitudes for rural watersheds should be estimated by the flood-frequency equations presented in the publication [Scientific Investigations Report 2004-5103 - "Estimating Flood-Peak Discharge Magnitudes and Frequencies for Rural Streams in Illinois"](#)¹.

Discharge computations for streams which are affected by urbanization should be based on the procedures presented in the U.S. Geological Survey publication [Water-Resources Investigations 79-36 - "Effects of Urbanization on the Magnitude and Frequency of Floods in Northeastern Illinois"](#)². The urban technique should be checked against the USGS Rural Regression Equations ([StreamStats](#)¹) adjusted for urbanization and the higher runoff value should be used when designing within the northeastern boundary shown in [Figure 4-101.02e](#). While this procedure was developed for northeastern Illinois, the effects of urbanization on flood magnitudes may be similar in other parts of Illinois with similar climatic and physiographic characteristics. The procedure can be extended to watersheds which are largely urban and are outside of the study area. However, this should be done with caution and the results should be compared with other methods such as TR-20 or HEC-1/ HEC-HMS.

4-101.01 Rural Technique

The general U.S.G.S. regression equation for rural streams in Illinois is as follows:

$$Q_T = a(TDA)^b (MCS)^c (PermAvg)^d RF(N) \quad (\text{Eq. 4-1a})$$

[For hydrologic regions 1, 3, and 5]

$$Q_T = a(TDA)^b (MCS)^c (\%Water + 5)^d RF(N) \quad (\text{Eq. 4-1b})$$

[For hydrologic regions 2, 6, and 7]

$$Q_T = a(TDA)^b (MCS)^c (BL)^d \quad (\text{Eq. 4-1c})$$

[For hydrologic region 4]

- Annual Maximum Series (AMS)

Where:

Q_T	=	estimated flood quantile, in ft^3 / sec (cfs), for the designated recurrence interval T , in years.
T	=	recurrence interval, years
a, b, c, d	=	coefficients and exponents of the equations for the variables TDA , MSC , PermAvg , BL , and (%Water + 5) , respectively. (See Figure 4-101.01a)
TDA	=	total drainage area, in square miles.
MCL	=	main-channel length, in miles. Used to calculate the MCS.
MCS	=	main-channel slope, in feet per mile.
PermAvg	=	averaged permeability of the watershed, in inches per hour.
BL	=	basin length, in miles.
(%Water + 5)	=	calculated percentage of open water and herbaceous wetland plus a constant 5 percent (to avoid zero values). The unit of the (%Water + 5) term is percent.
RF(N)	=	regional factor for hydrologic region N .

Q _T	a	b	c	d	RF(1)	RF(3)	RF(5)
Regions 1, 3, 5							
Q ₂	22.2	0.749	0.401	-0.224	1.467	1.620	2.128
Q ₅	34.1	0.743	0.437	-0.223	1.563	1.811	2.360
Q ₁₀	41.8	0.74	0.457	-0.224	1.618	1.913	2.476
Q ₂₅	50.8	0.738	0.478	-0.224	1.686	2.030	2.612
Q ₅₀	57.0	0.737	0.491	-0.223	1.738	2.113	2.711
Q ₁₀₀	62.7	0.736	0.503	-0.222	1.790	2.192	2.809
Q ₅₀₀	74.5	0.735	0.527	-0.219	1.917	2.371	3.037
Regions 2, 6, 7					RF(2)	RF(6)	RF(7)
Q ₂	54.7	0.728	0.341	-0.470	1	2.963	3.515
Q ₅	94	0.721	0.374	-0.527	1	3.119	3.281
Q ₁₀	120	0.718	0.393	-0.550	1	3.241	3.226
Q ₂₅	151	0.716	0.413	-0.573	1	3.409	3.217
Q ₅₀	174	0.715	0.426	-0.586	1	3.540	3.236
Q ₁₀₀	195	0.714	0.437	-0.598	1	3.672	3.269
Q ₅₀₀	241	0.714	0.461	-0.619	1	3.980	3.377
Region 4							
Q ₂	49.3	0.734	0.370	-0.006	0	0	0
Q ₅	85.1	0.772	0.406	-0.095	0	0	0
Q ₁₀	111	0.792	0.425	-0.140	0	0	0
Q ₂₅	144	0.812	0.446	-0.183	0	0	0
Q ₅₀	168	0.823	0.46	-0.207	0	0	0
Q ₁₀₀	193	0.833	0.472	-0.228	0	0	0
Q ₅₀₀	250	0.852	0.496	-0.266	0	0	0

Coefficients & Exponents for Equations 4-1a, 4-1b, and 4-1c for USGS Hydrologic Regions 1 - 7.
 (From [SIR 2004-5103¹](#) pgs. 23 and 24)
 Table 4-101.01a

The TDA, MCL, and MCS are determined from topographic maps. TDA is the area contributing to surface runoff. MCL is the distance from the basin divide to the basin outlet along the low-water channel. MCS is determined between the 10 percent point and 85 percent point of the MCL. RF(N) is determined by first selecting the region number from [Figure 4-101.01a](#). Note: If the Regional factor divides are on the drainage basin divide, choose the proper regional factor for the drainage basin you are in. Maps for determining PermAvg can be found in the [SIR 2004-5103¹](#) on pages 17 thru 20. More concise explanations for these variables can be found in the [SIR 2004-5103¹](#) on pages 15 and 16. (%Water +5) values can be obtained from the U.S. Fish and Wildlife Service (USFWS) website at the following link: <http://www.fws.gov/wetlands/Data/Mapper.html>

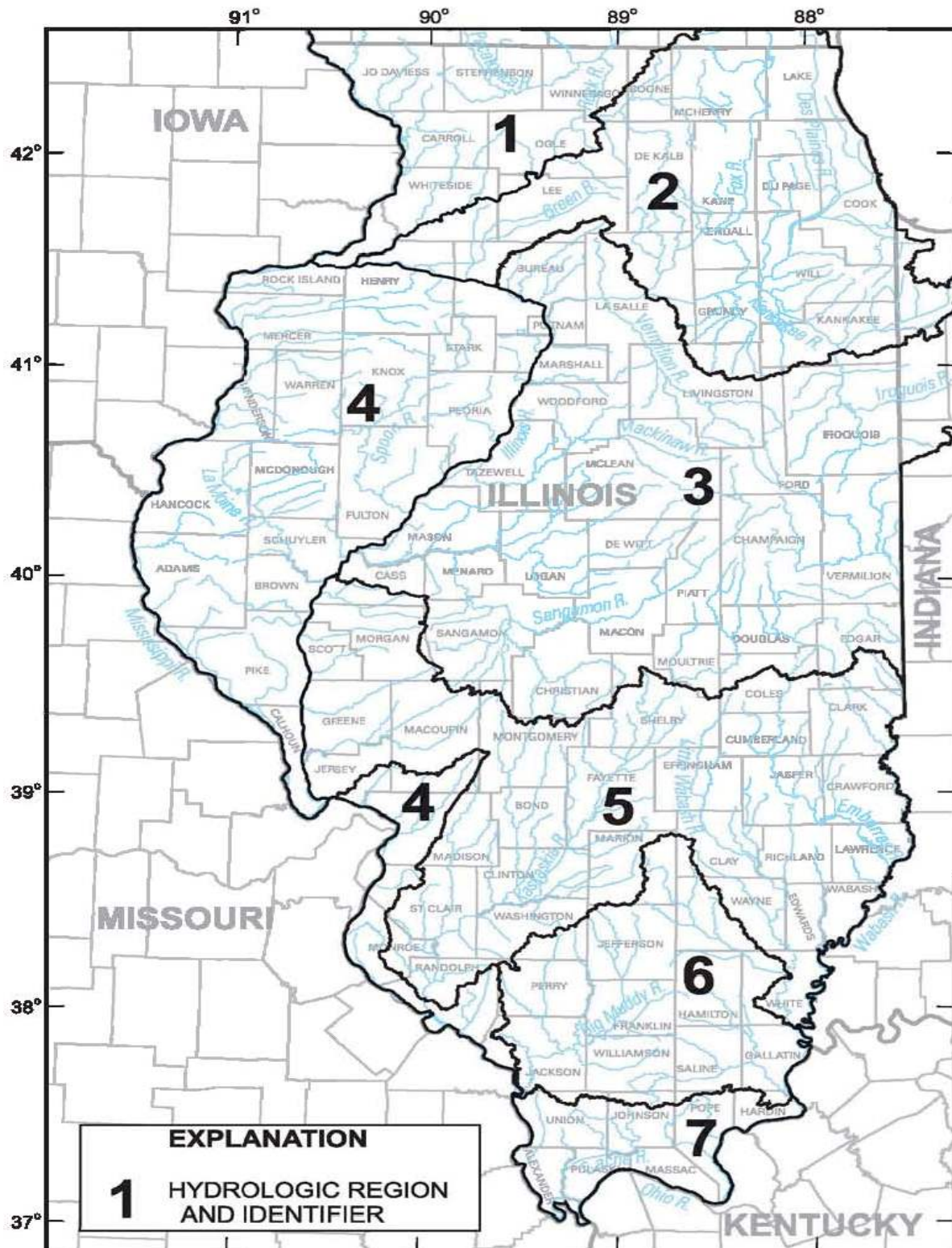

USGS Hydrologic Regions for Flood Frequency Analysis of Rural Streams in Illinois.

([SIR 2004-5103](#)¹ pg. 13, Figure 5)

Figure 4-101.01a

Limits on the use of the USGS Rural Regression Equations.

Explanatory Variables	Units	Minimum Value	Maximum Value
TDA	Sq. Mi.	0.03	9,554
MCS	Ft / Mi.	0.81	317
BL	Mi.	0.3	190
PermAvg	In./ Hr.	0.3	8.0
(%Water+5)	%	5	13
-----		-----	-----

Parameter Space for the Annual Maximum Series Regional Equations in Illinois
[\(SIR 2004-5103¹ pg. 28, Table 8\)](#)
 Table 4-101.01b

The equations are not applicable to streams where peak discharges are appreciably affected by natural or reservoir storage, channel changes, diversions, urbanization, conditions such as karst terrain, bluff-flood plain combinations (streams that traverse the bluff and adjacent flood plain of major rivers), or other unusual conditions that affect flood flow. (Karst terrain consists of irregular topography characterized by sinkholes, streamless valleys, and streams that disappear into the ground).

The USGS [SIR 2004-5103¹](#) report states that the equations are not applicable for the following streams:

- Big Muddy River (Below Rend Lake)
- Cal Sag Channel
- Fox River (Below Chain of Lakes)
- I & M Canal
- Illinois River
- North Shore Channel
- Saline River (below mouth of Cypress Ditch)
- Sanitary and Ship Canal
- South Branch Chicago River

Flood peaks on these rivers are altered by channel improvements, levees, dams, diversion, or interbasin flow. For the Big Muddy, Fox and Illinois Rivers, flood frequencies may be estimated for ungaged sites by interpolation between gaged sites on the basis of drainage area.

Typically, studies are available on these and other larger streams, including Flood Insurance Studies (F.I.S.), IDNR-OWR regulatory studies or Corps of Engineers analyses. When F.I.S. or IDNR-OWR regulatory discharges are available, they often become the benchmark for IDNR-OWR permit purposes. In the absence of an existing study, or at more sensitive locations such as parts of the Chicago metropolitan area, a hydrograph oriented procedure such as [HEC-1 / HEC-HMS](#) or [TR-20](#) may be utilized.

4-101.011 Example Problem 1

Find:

The discharge from a site for a 50-year frequency flood on a rural ungaged stream.

Solution:

1. Determine the size of contributing drainage area (TDA), in sq mi. The area can be planimetered on topographic, county, or other maps suitable for delineating the basin boundary. For this example, assume TDA = 625 sq mi.
2. Determine the slope (MCS), in ft/mi. Slope is based on the difference of elevations divided by distance between points 10 percent and 85 percent of the (MCL) - total distance measured along the low-water channel of the stream from the site to the basin divide. Refer to [Figure 4-101.01b](#) for procedure for determining slope. For this example, assume MCS = 2.5 ft/mi.
3. Determine the region factor (RF(N)) from [Figure 4-101.01a](#) and [Table 4-101.01a](#), respectively. For this example, RF(3) is 2.113.
4. For RF(3), the required variable is PermAvg. For this example, assume PermAvg = 1.3 in/hr. [SIR 2004-5103](#)¹ pages 17 thru 20 would be consulted to determine this value.
5. Compute the Q₅₀ peak discharge from ([Eq. 4-1a](#)).

$$\begin{aligned}
 Q_{50} &= a(TDA)^b (MCS)^c (PermAvg)^d RF(N) \\
 &= (57.0) (625)^{0.737} (2.5)^{0.491} (1.3)^{-0.223} (2.113) \\
 &= 20,479 \text{ cfs}
 \end{aligned}$$

Procedure for Determining the Main Channel Slope, MCS

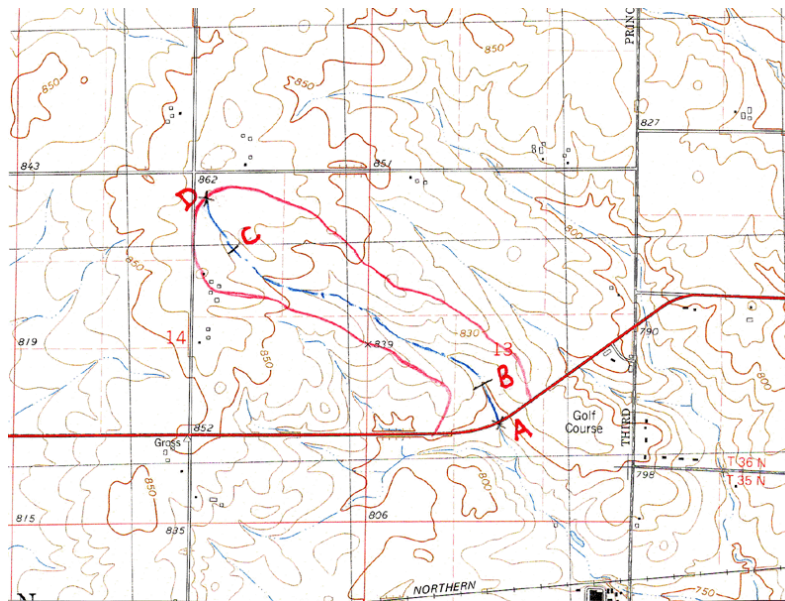

Figure 4-101.01b

1. Measure distance along streamline from the proposed crossing (point A) to a point on the basin divide (point D). If the stream forks, follow the fork that contributes the greater drainage area. This is also known as the Main Channel Length (MCL).
2. Locate point B, which is 10 percent of the distance A to D from the proposed crossing.
3. Locate point C, which is 85 percent of the distance A to D from the proposed crossing (or 15 percent of this distance down from the basin divide).
4. Estimate elevations at points B and C from topographic map.
5. Compute slope in feet per mile by the following formula:

$$MCS = \frac{Elev. C (ft.) - Elev. B (ft.)}{(0.75) MCL} \quad (Eq. 4-2)$$

4-101.012 Example Problem 2

Given:

Distance A to D = 5,800 ft
Distance A to B = 5,800 * 0.10 = 580 ft
Distance C to D = 5,800 * (1 - 0.85) = 870 ft
Elevation at point B = 800 ft (estimated)
Elevation at point C = 856 ft (estimated)

Find:

Main Channel Slope

Solution:

$$\text{MCS} = \frac{856 - 800}{((0.75)(5800))/5280} = 68.0 \text{ ft/mi}$$

4-101.013 StreamStats

As per the memo dated June 5, 2008, "Adoption of the Illinois StreamStats Hydrologic Program", [StreamStats¹](#) is the default method for utilizing the USGS Rural Regression Equations when possible, in lieu of hand computing. StreamStats is a web-based computer program which emulates the procedures outlined in [SIR 2004-5103¹](#). The user must simply click on the desired crossing and the drainage area will be delineated. If the user is in disagreement with the drainage area generated by [StreamStats¹](#), it can be modified. The necessary variables are determined by the program for the delineated area and the discharges calculated.

Tips for using the [StreamStats¹](#) website:

1. Go to: <http://streamstats.usgs.gov/ilstreamstats/>

****Make sure your computer will allow pop ups from this web site****

StreamStats in Illinois - Microsoft Internet Explorer

File Edit View Favorites Tools Help

Address <http://water.usgs.gov/osw/streamstats/illinois.html>

USGS
science for a changing world

Welcome to StreamStats

Best viewed in Internet Explorer 5 or above
Screen resolution of 1152x864 or greater, with pop-up blocker disabled

Illinois

Attention!

The application for this State is based on StreamStats version 2. Please read the new [User Instructions](#) for this application before attempting to use it. The new network navigation and estimating flows based on similar gages, have not yet been implemented in this state. These processes will be added in the near future.

Please help us conserve our server system resources and **close** the Interactive Map window when you are finished using it. Doing so will help ensure system availability for all users. Thank you.

Also, please [bookmark this page](#), rather than the Interactive Map page, since the URL for the interactive map may change in the future.

We want your feedback! Please send any comments or questions that you have on StreamStats to the StreamStats development team at GS-W_StreamStats@usgs.gov.

The report below documents the regression equations that are available in the Illinois StreamStats application for estimating flood-peak discharges of selected recurrence intervals for rural streams in Illinois. The report also describes the methods used to measure the basin characteristics and to develop the equations, and the errors associated with the estimated discharges. Users of the StreamStats application should familiarize themselves with this report before using StreamStats to obtain estimates of streamflow statistics for ungaged sites.

- [Soong, D.T., Ishii, A.L., Sharpe, J.B., and Avery, C.F., 2004, Estimating flood-peak discharge magnitudes and frequencies for rural streams in Illinois: U.S. Geological Survey Scientific Investigations Report 2004-5103, 147 p.](#)

Interactive Map

Improved estimates for an ungaged site can be obtained by use of the drainage-area ratio method when the drainage area for the ungaged site is within ± 50 percent of the drainage area for an upstream or downstream streamgaging station. Methods described on page 24 of the above report can be applied to obtain these estimates. Weighted estimates for streamgaging stations in Illinois can be found in table 1, beginning on page 93 of the above report, or in the StreamStats reports for data-collection stations. The [Data-Collection Stations](#) link to the left explains how to obtain the reports. The National Streamflow Statistics program (NSS) also can be used to compute weighted flood-peak discharges for streamgaging stations and improved estimates for ungaged sites. The NSS can be obtained from <http://water.usgs.gov/software/NSS/>.

javascript:openAGSMap('');

Internet

2. Click on Interactive Map

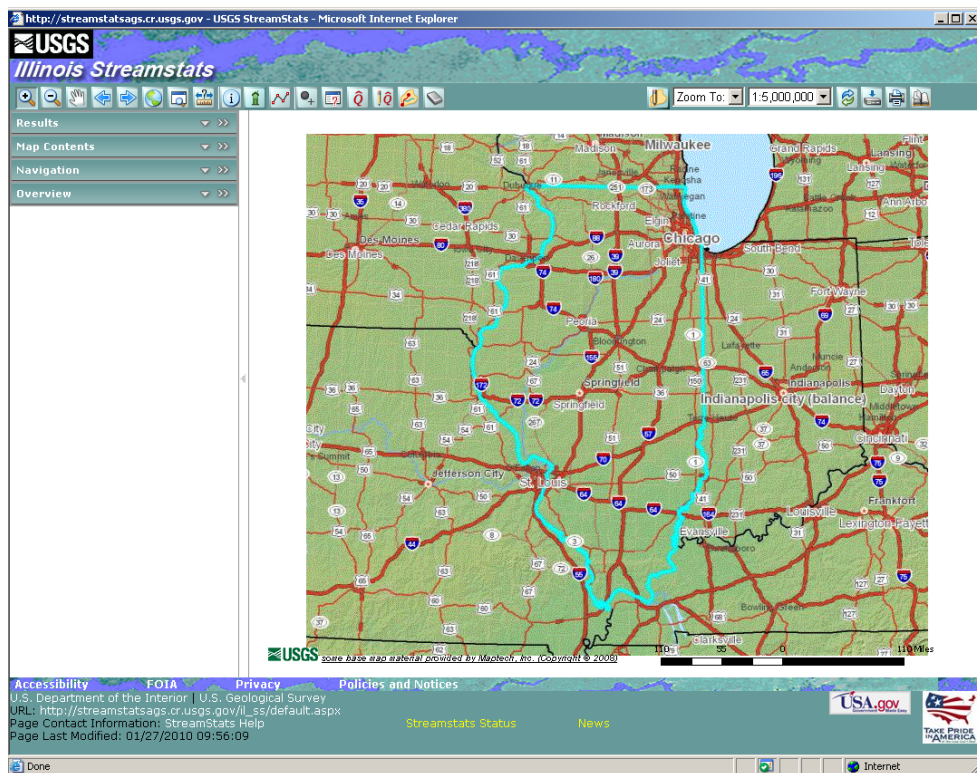

3. Choose the icon with the magnifying glass and the plus sign to zoom in the area where the structure of interest is located



4. Zoom in the area until the scale is at least 1:24,000 to be able to use the tool for watershed delineation

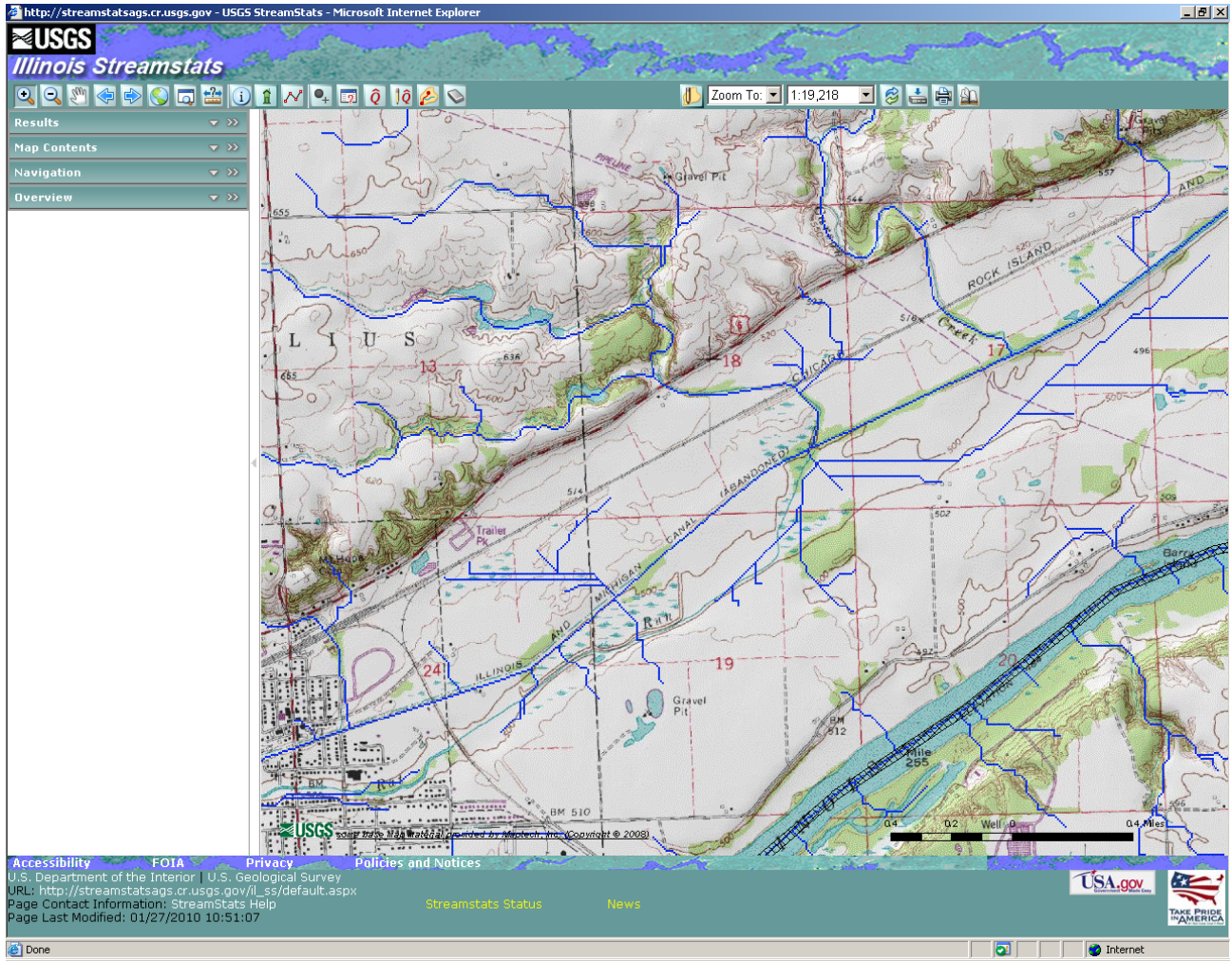

5. Click on the water delineation icon



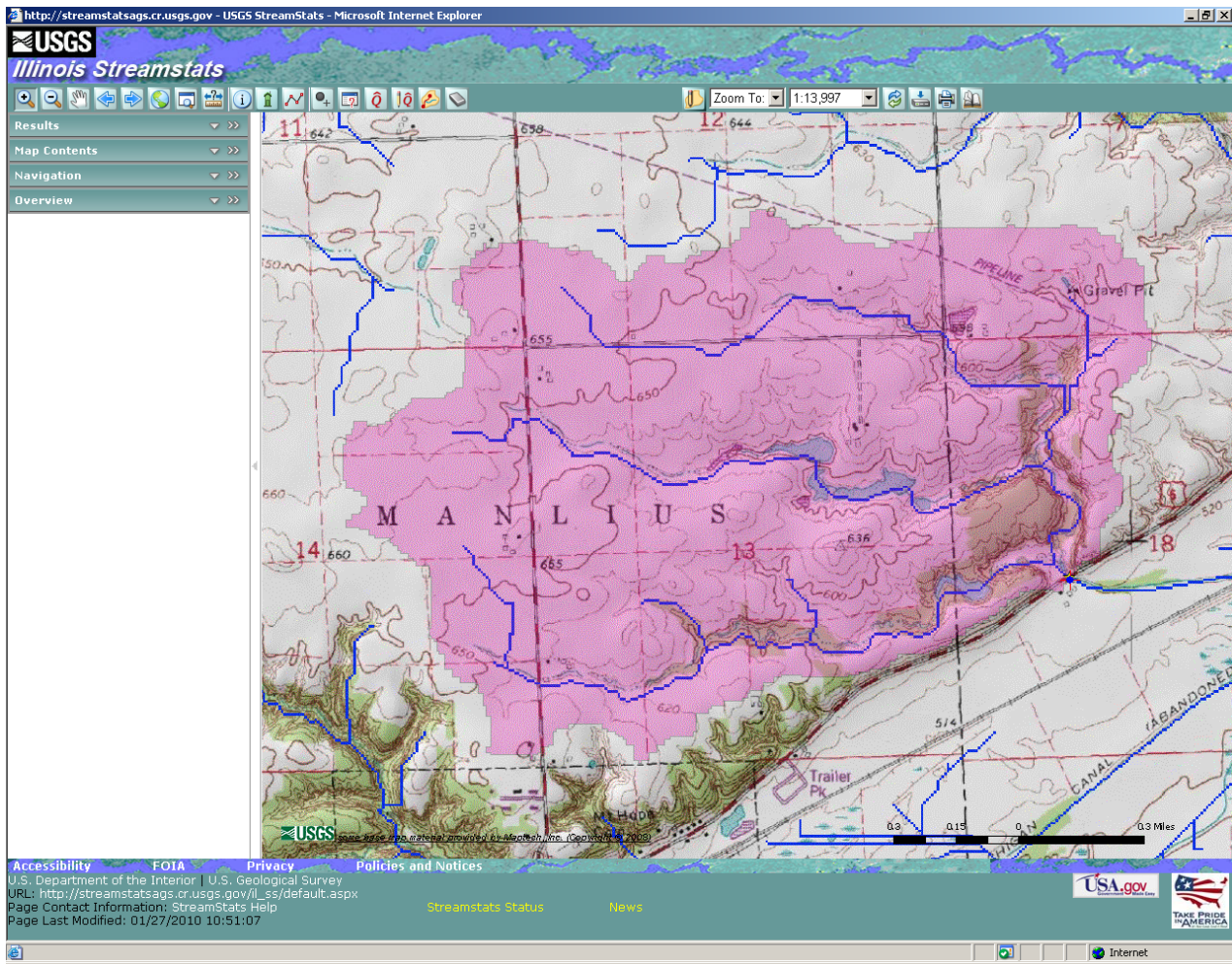

- When the watershed is delineated and if you agree with the delineation, proceed to click on the icon to estimate the flow using the regression equations. (If you do not agree with the basin delineation, refer to step 9.)



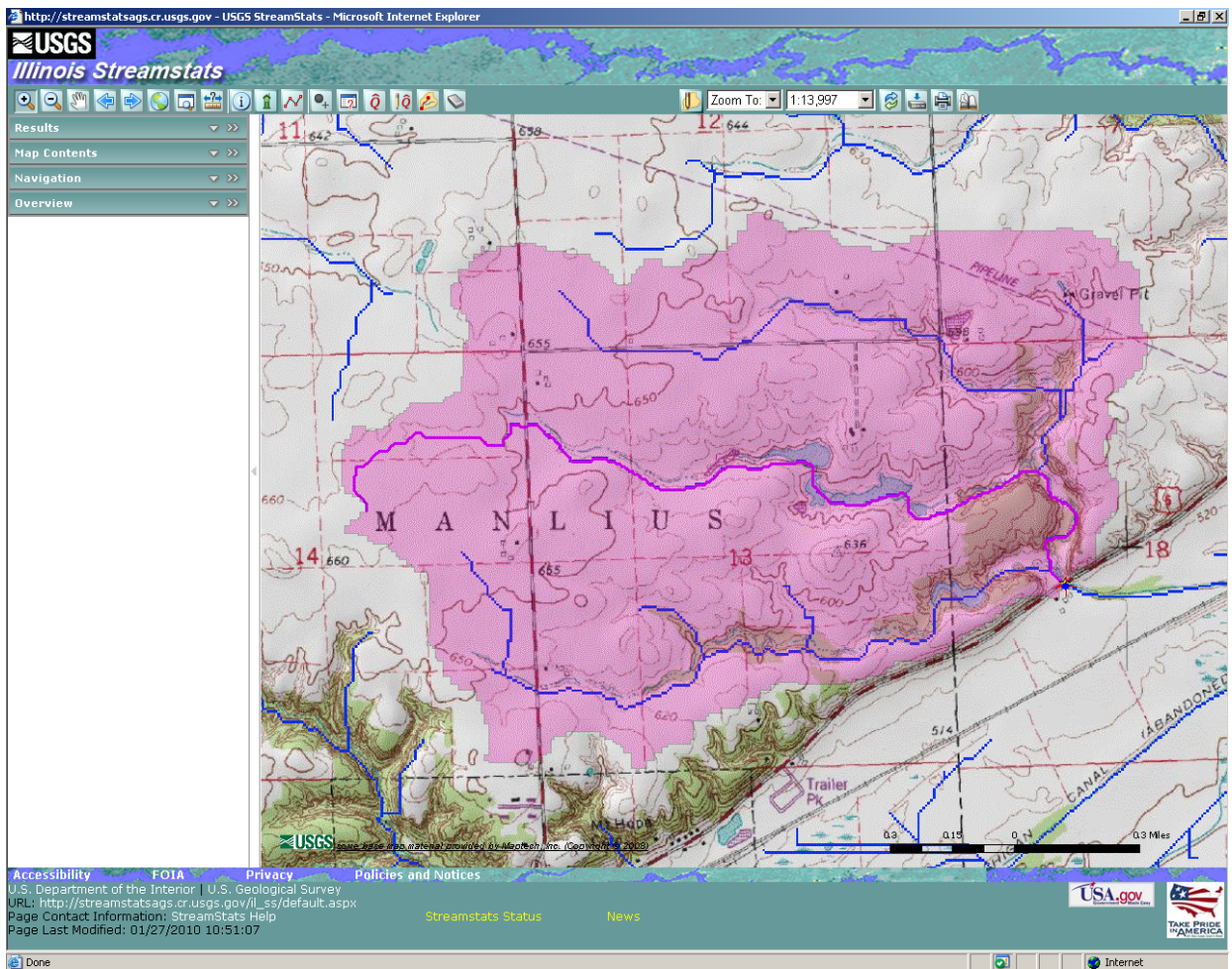

*The flow path will show up in the delineation after the calculation is performed

*A new screen will open with the tabulated characteristics of the basin and the calculated flows

USGS
Illinois Streamstats

Streamstats Ungaged Site Report

Date: Wed Jan 27 2010 10:35:55 Mountain Standard Time
 Site Location: Illinois
 NAD83 Latitude: 41.3321 (41 19 55)
 NAD83 Longitude: -88.5863 (-88 35 10)
 NAD27 Latitude: 41.3321 (41 19 55)
 NAD27 Longitude: -88.5862 (-88 35 10)
 Drainage Area: 1.77 mi²

Peak Flow Basin Characteristics

100% Region 2 AMS (1.77 mi²)

Parameter	Value	Regression Equation Valid Range	
		Min	Max
Drainage Area (square miles)	1.77	0.03	9554
Stream Slope 10 and 85 Method (feet per mi)	56.225	0.81	317
Percent Open Water AND Herb Wetland (percent)	1.509	0	8

Peak Flow Streamflow Statistics

Statistic	Flow (ft ³ /s)	Prediction Error (percent)	Equivalent years of record	90-Percent Prediction Interval	
				Minimum	Maximum
PK2	136	40	2.6	71.3	258
PK5	239	41	3.1	125	456
PK10	314	42	3.8	161	613
PK25	410	45	4.6	203	831
PK50	486	47	5.2	232	1020
PK100	556	49	5.6	257	1200
PK500	728	55	6.2	311	1700

7. Click on the Basin Characteristics icon



*A new window will open: choose the parameters that you would like to be displayed

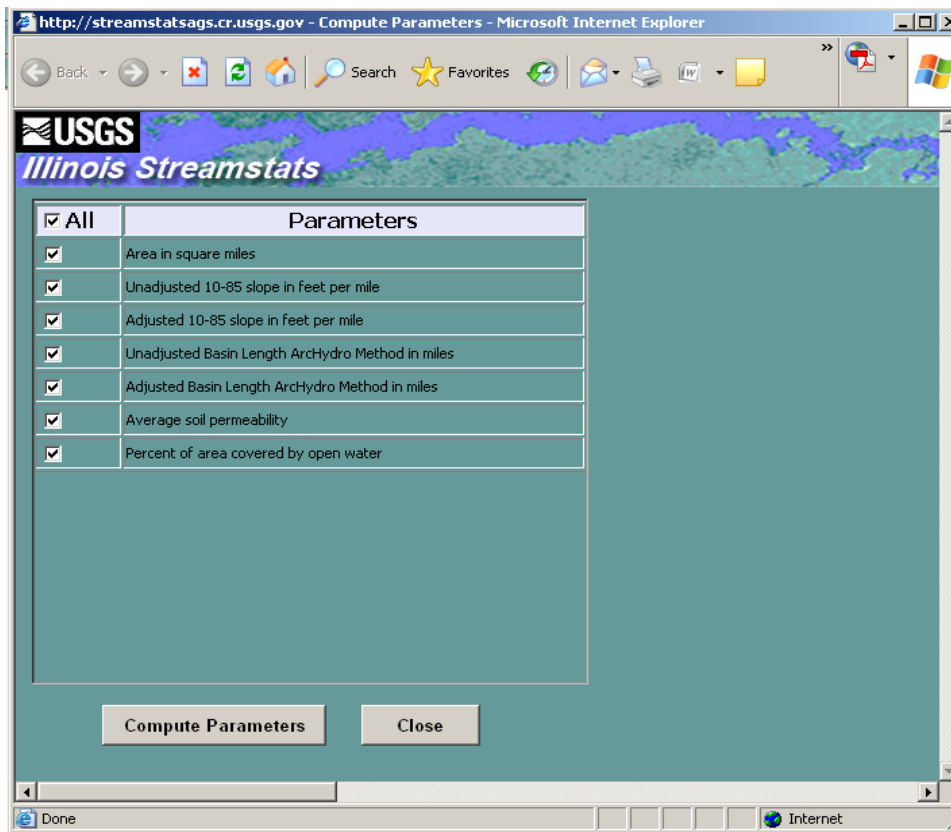

*Press Compute Parameters

Compute Parameters

*The window will display the parameters that were chosen

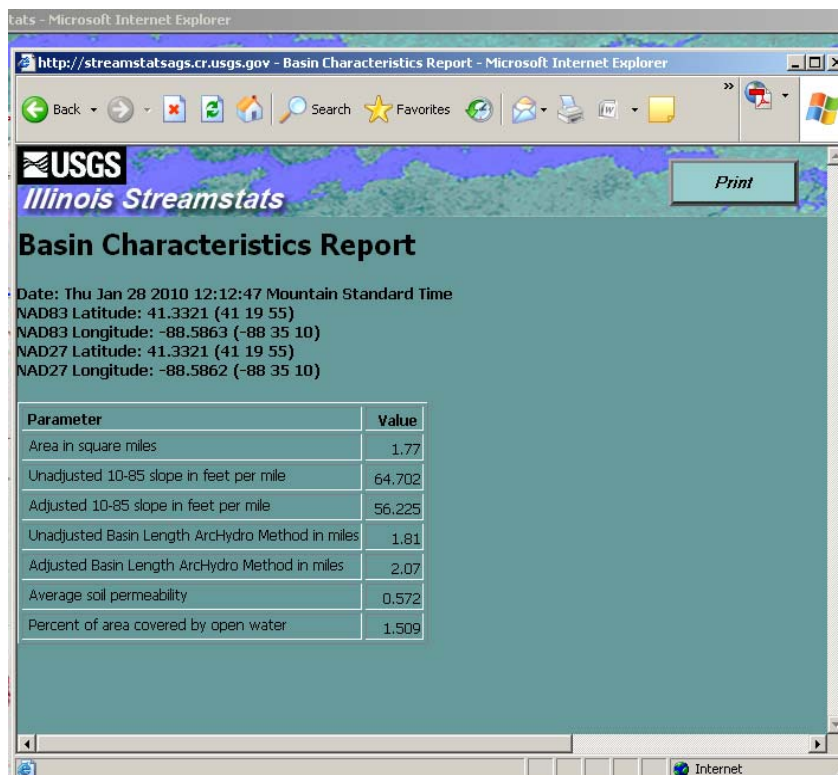

8. To print the drainage area delineation click on the icon with the printer



*A new screen will come up, choose your page size

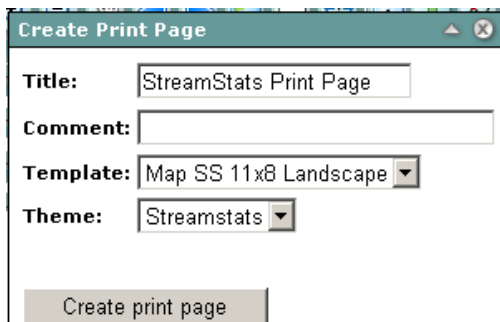

*The print page will be created

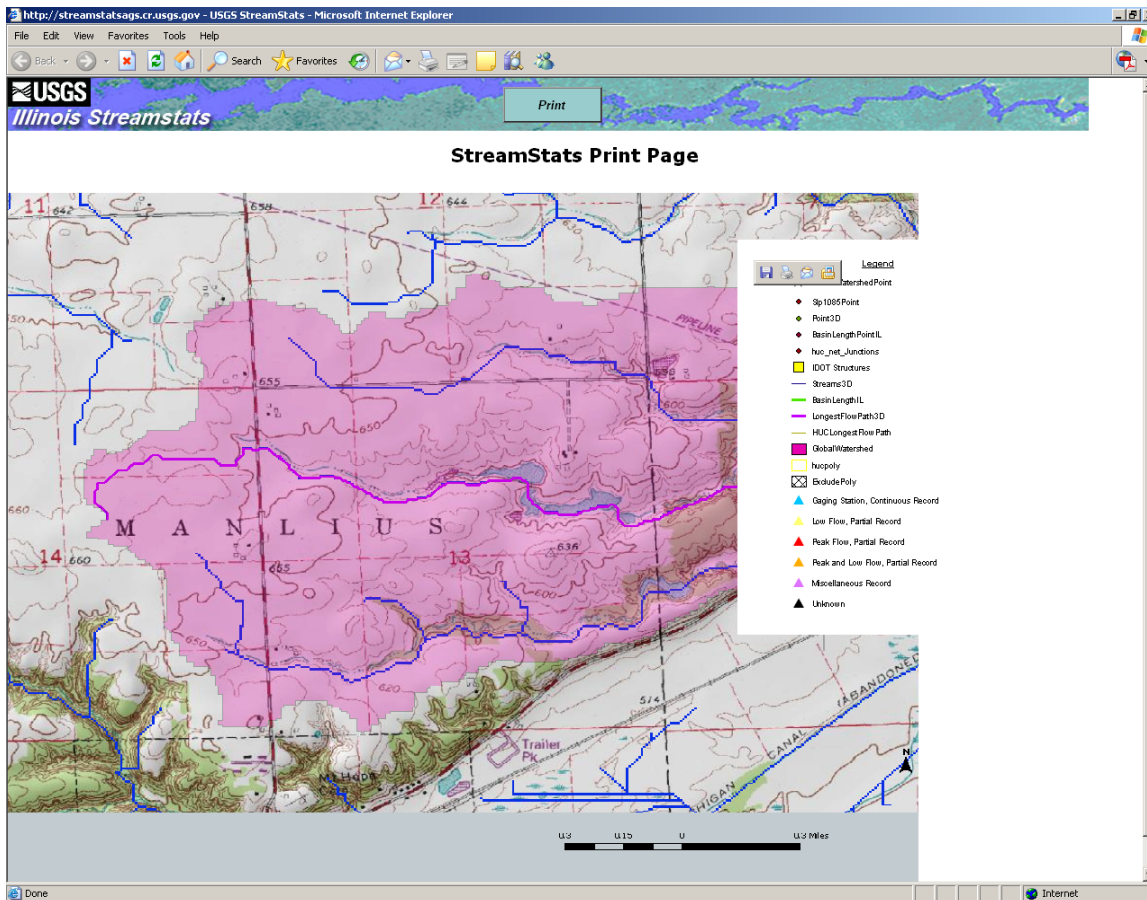

9. If you do not agree with the basin delineation click on the icon that has a pencil and a basin



*A new screen will come up, select if you wish to add or remove area

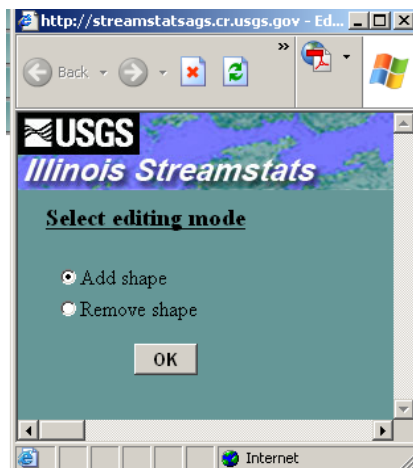

*Once you are done, perform steps 6 thru 8

10. To print any of the site reports just go to file then print.

**** For more details on other icons functions go to user instructions on the left side menu of StreamStats main page****

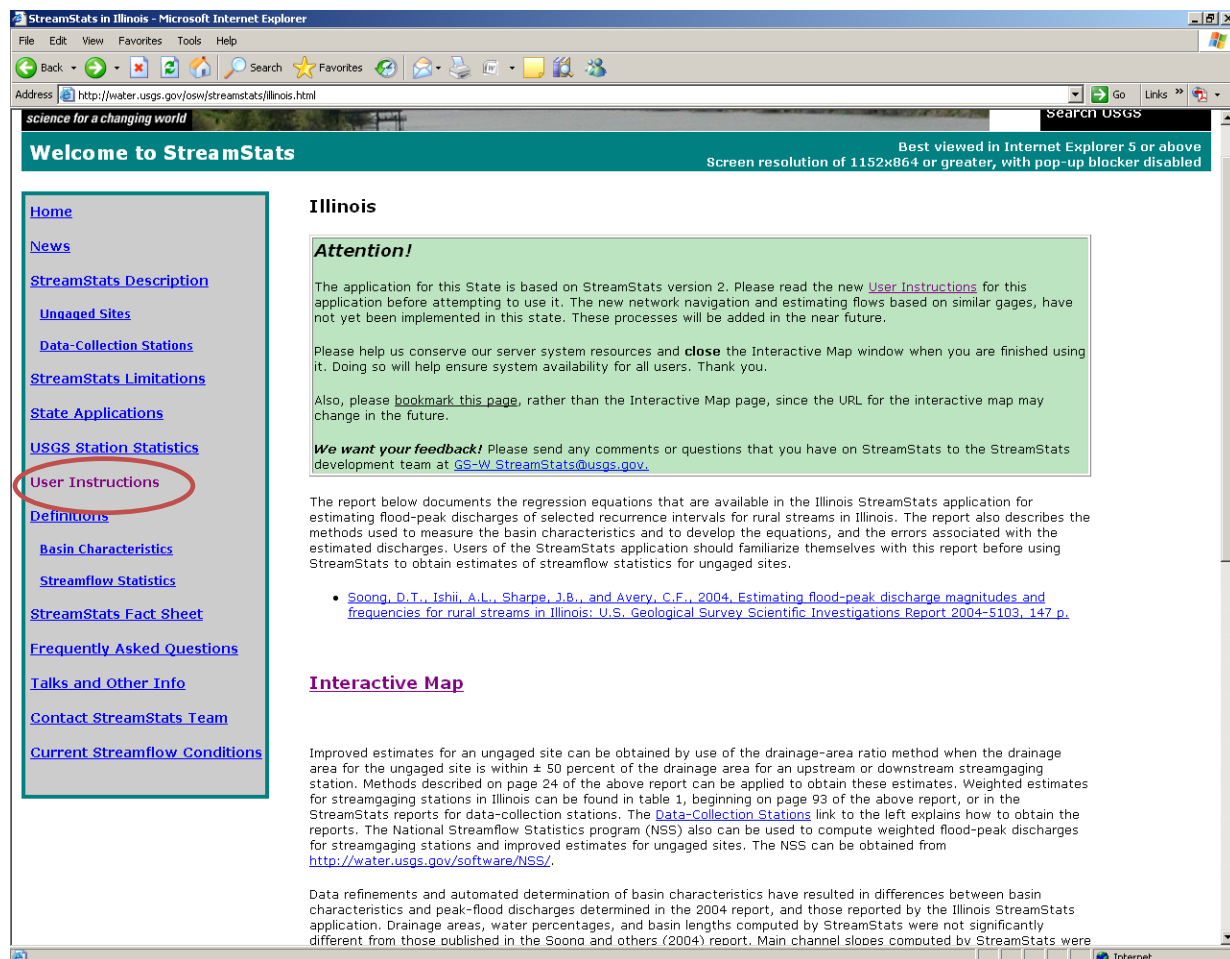

Note: It is very important to check that all the variables given by [StreamStats¹](#) are within the acceptable limits as shown in [Table 4-101.01b](#). To verify them go to: <http://il.water.usgs.gov/pubs/sir2004-5103.pdf> to see the latest report.

For information on how to adjust data for gaged and ungaged sites refer to: Techniques for Estimating Flood-Peak Discharge Magnitude and Frequencies, Annual Maximum Series Regional Equations for Rural, Unregulated Streams.

4-101.02 Urban Technique

The flood-frequency-estimating equations, shown in [Table 4-101.02](#), are to be used to estimate flood-peak discharges on urbanizing watersheds in Northeastern Illinois. The Study Area includes Cook, DuPage, Kane, Kendall, Lake, McHenry, and Will Counties ([Figure 4-101.02e](#)). The equations may be used on watersheds with drainage areas ranging from 0.07 to 630 sq mi., channel slopes from 1.1 to 115 ft/mi and impervious areas from 1 to 39 percent. The equations should not be used on watersheds completely served by underground drainage systems, or to predict flood flows from airports, parking lots or other highly impervious areas. The equations are also not applicable to locations on streams where flood detention reservoirs substantially affect the flood peaks.

The variables used in the equations are drainage area (TDA) in sq mi, main channel slope (MCS) in ft/mi and imperviousness of the watershed area (I_f) expressed as a percentage ($I_f = 100 \times \text{imperviousness area/drainage area}$).

The imperviousness factor is used to quantify the degree of present urbanization, or that projected for future conditions. Impervious areas may be measured directly from aerial photographs, large scale maps or by field surveys.

Any one of the curves shown in [Figures 4-101.02a through d](#) may be used to estimate the percentage of imperviousness. Population and housing data can be obtained from publications of census statistics by the U.S. Census Bureau. Population estimates or projections may be obtained for specific areas from city, county and state planning agencies.

The urban technique should be checked against the USGS Rural Regression Equations ([StreamStats¹](#)) adjusted for urbanization and the higher runoff value should be used when designing within the northeastern boundary shown in [Figure 4-101.02e](#). It has been commonly found that the Rural Regression Equations adjusted for urbanization produce higher values than those from [Table 4-101.02](#)

Flood-Frequency Estimating Equations For
Urbanizing Watersheds in Northeastern Illinois

$Q_2 = 14.7 (TDA)^{0.698} \times (MCS)^{0.241} \times I_f^{0.313}$
$Q_5 = 23.8 (TDA)^{0.682} \times (MCS)^{0.284} \times I_f^{0.255}$
$Q_{10} = 29.8 (TDA)^{0.675} \times (MCS)^{0.305} \times I_f^{0.228}$
$Q_{25} = 37.2 (TDA)^{0.668} \times (MCS)^{0.325} \times I_f^{0.202}$
$Q_{50} = 42.7 (TDA)^{0.664} \times (MCS)^{0.338} \times I_f^{0.186}$
$Q_{100} = 48.0 (TDA)^{0.660} \times (MCS)^{0.349} \times I_f^{0.172}$
$Q_{500} = 60.5 (TDA)^{0.651} \times (MCS)^{0.366} \times I_f^{0.145}$

“Effects of Urbanization on the Magnitude and Frequency of Floods in Northeastern Illinois”
From Water-Resources Investigations 79-36²

Pg 7

Table 4-101.02

July 2011

IMPERVIOUSNESS, IN PERCENTAGE OF LAND AREA

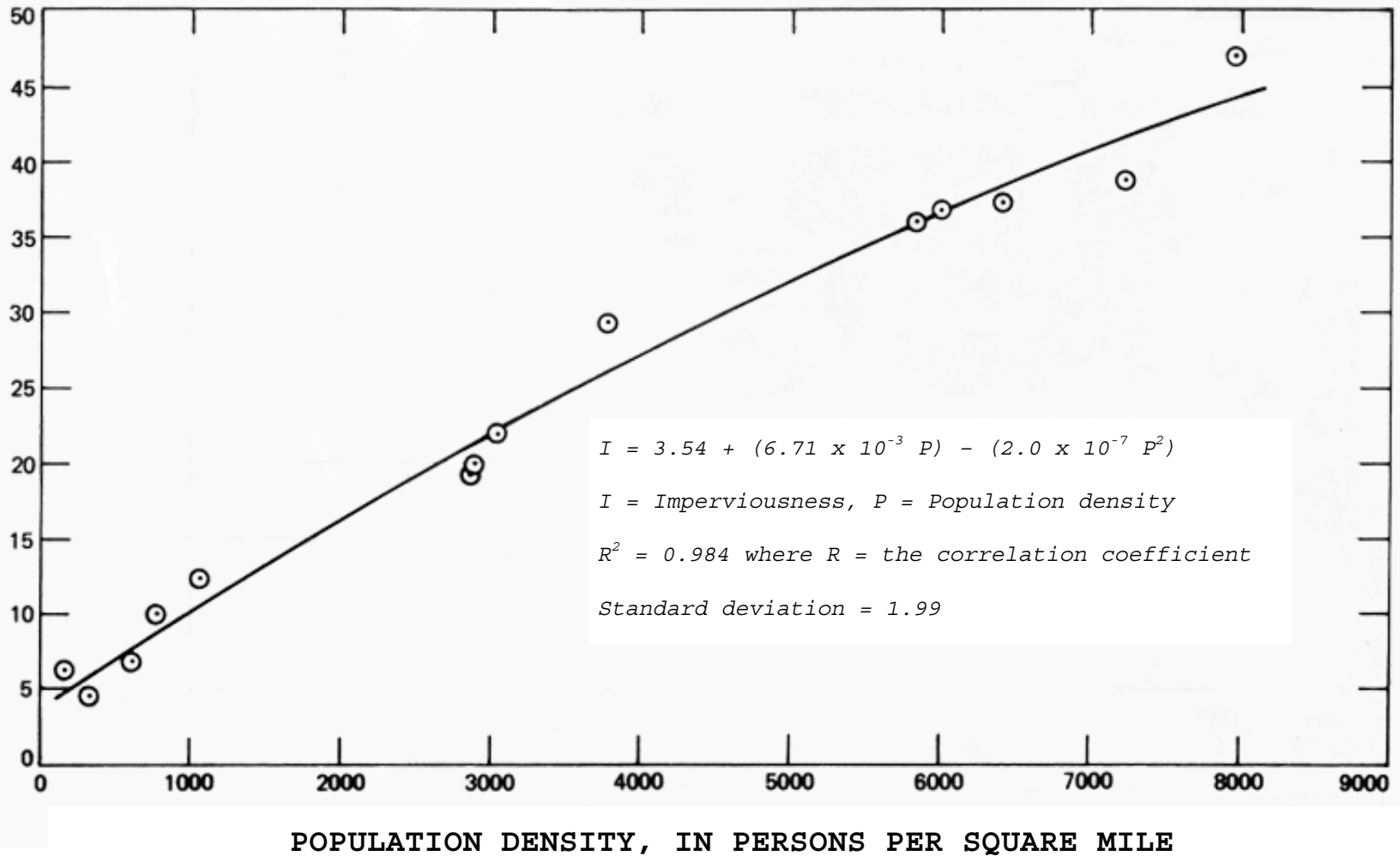

Relationship between Percentage of Imperviousness and Population Density
 From Water-Resources Investigations 79-36²
 “Effects of Urbanization on the Magnitude and Frequency of Floods in Northeastern Illinois”
 Pg 18

Figure 4-101.02a

4 - 23

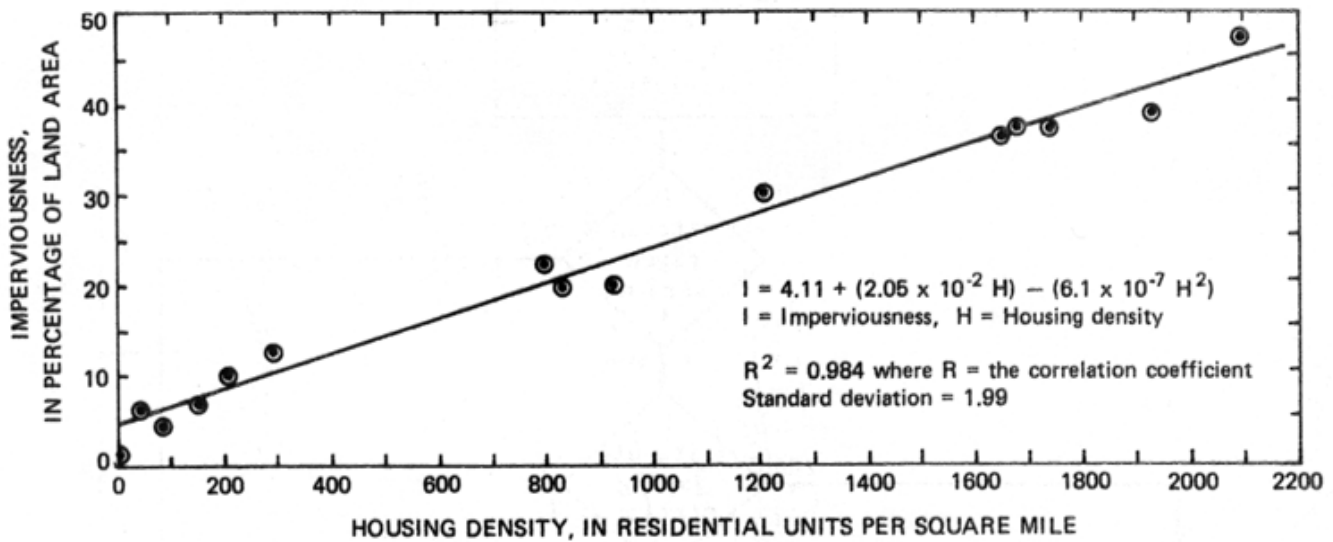

Relationship between Percentage of Imperviousness and Housing Density.

From Water-Resources Investigations 79-36²

“Effects of Urbanization on the Magnitude and Frequency of Floods in Northeastern Illinois”

Pg 19

Figure 4-101.02b

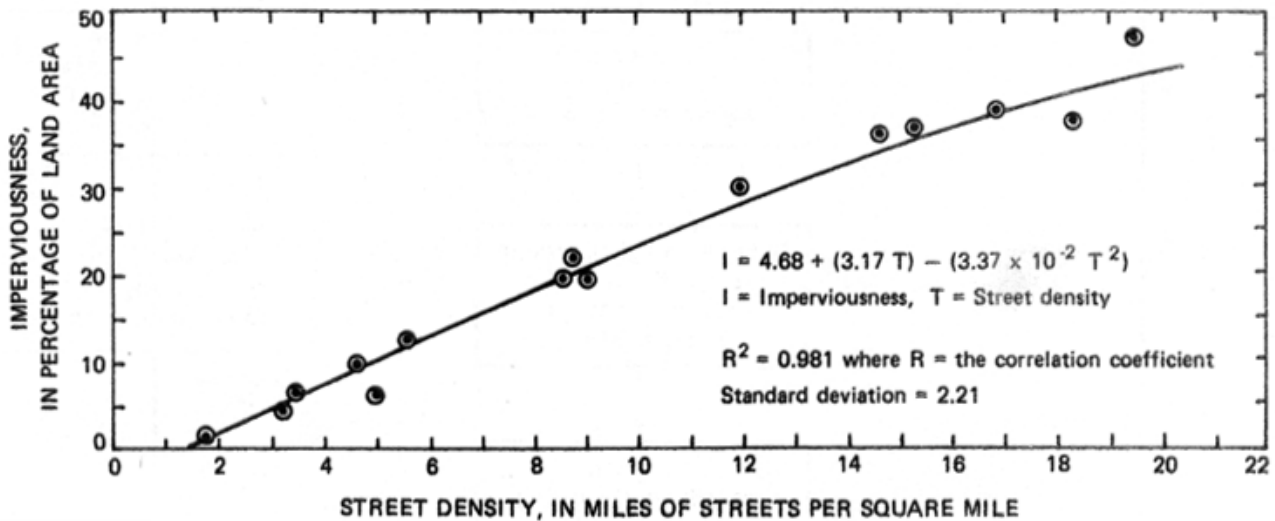

Relationship between Percentage of Imperviousness and Street Density

From Water-Resources Investigations 79-36²

“Effects of Urbanization on the Magnitude and Frequency of Floods in Northeastern Illinois”

Pg 19

Figure 4-101.02c

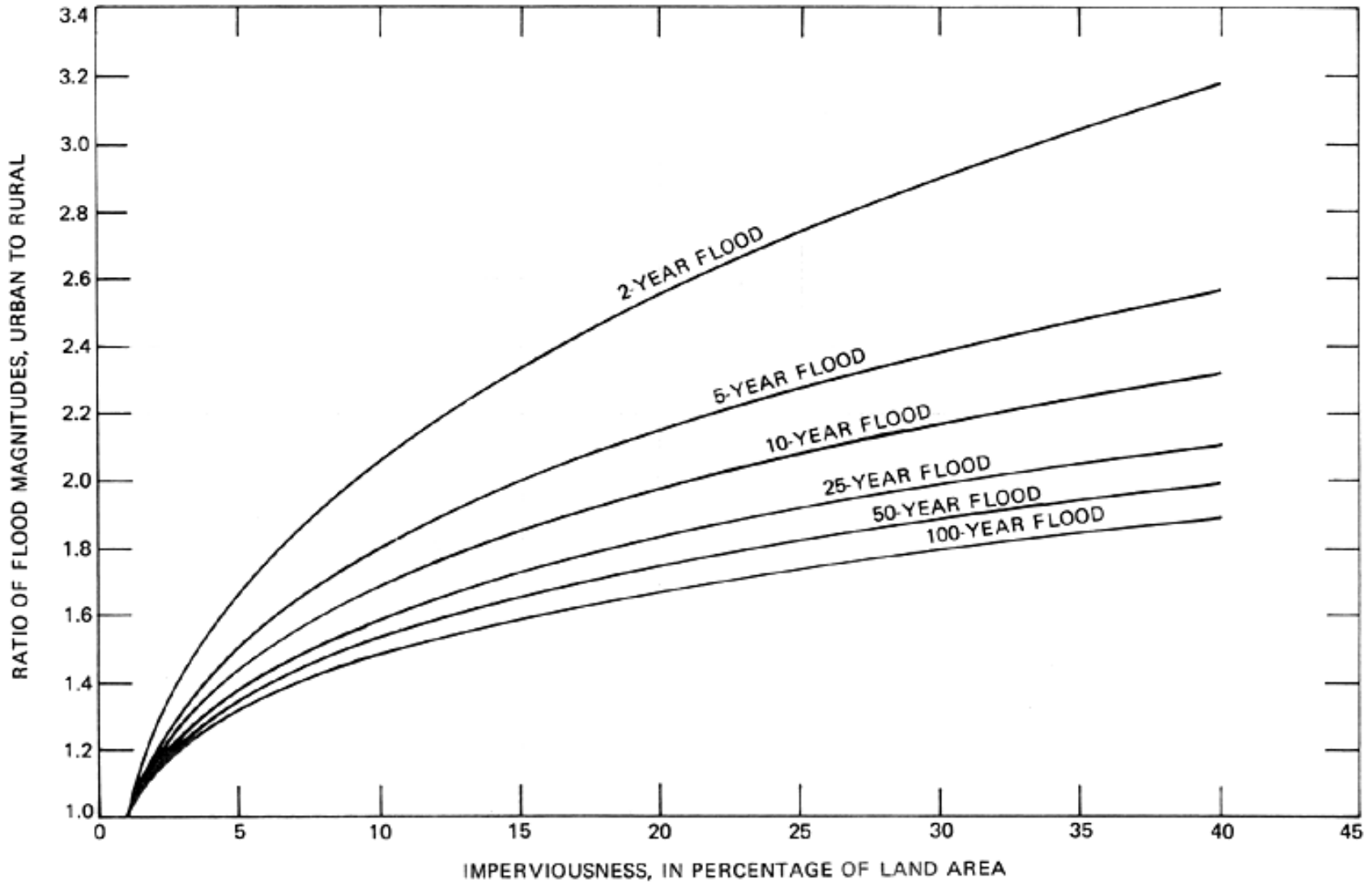

Affect of Urbanization on Flood Magnitudes in Northern Illinois
From Water-Resources Investigations 79-36²

“Effects of Urbanization on the Magnitude and Frequency of Floods in Northeastern Illinois”

Pg 21

Figure 4-101.02d

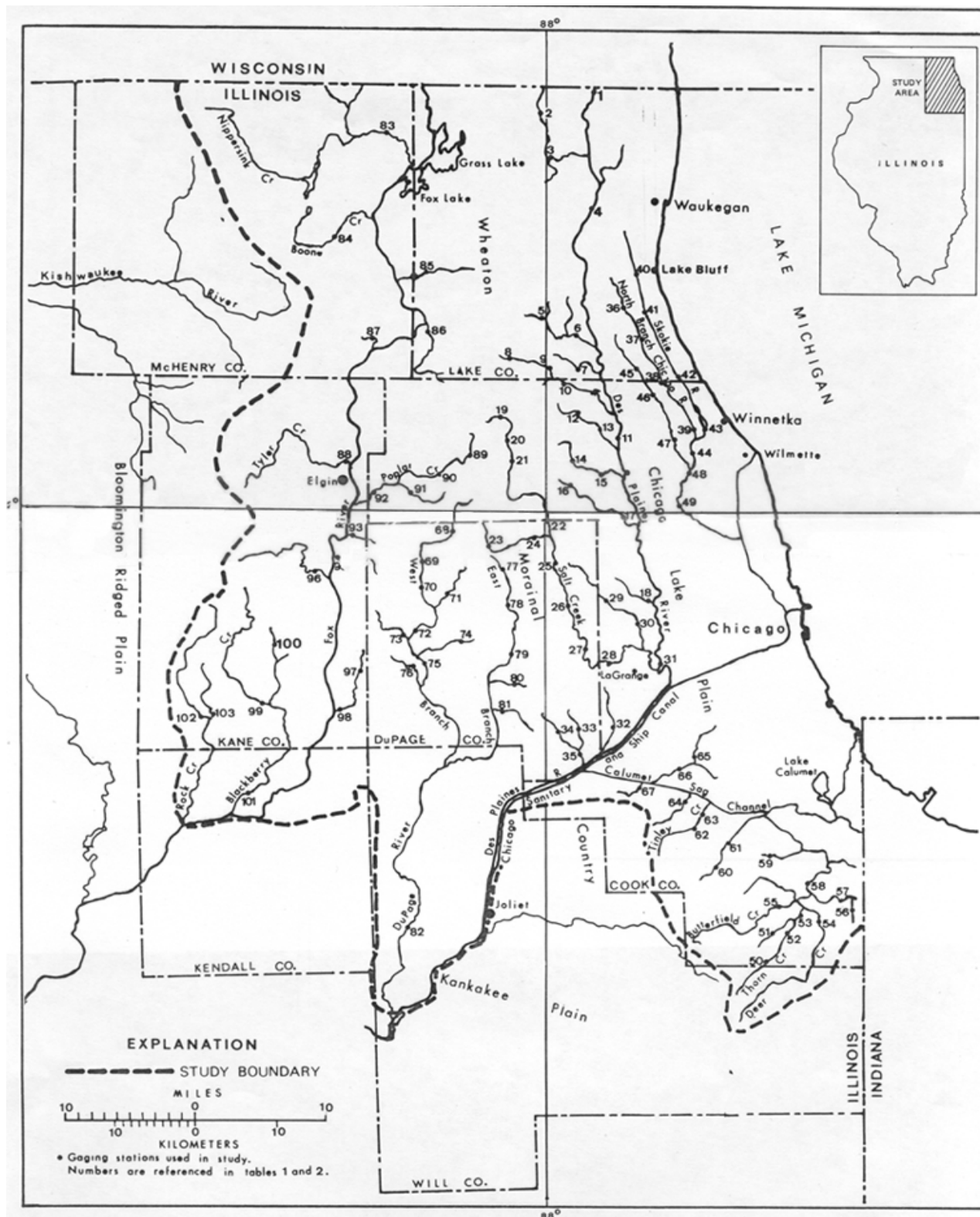

Location of Study Area and Gaging Stations for Urban Technique
 From Water-Resources Investigations 79-36²
 "Effects of Urbanization on the Magnitude and Frequency of Floods in Northeastern Illinois"
 Pgs. 16 & 17
 Figure 4-101.02e

4-101.021 Example Problem 3

Find:

The 50-year flood discharge for use in the design of a bridge opening in Wheaton, DuPage County.

Solution:

1. Determine the size of drainage area (TDA), in sq mi. For this example, assume TDA = 11.22 sq mi.
2. Determine the slope (MCS) in ft/mi. For this example, assume MCS = 15 ft/mi.
3. Determine the percent imperviousness (I_f). The population was estimated at 55,416 based on data by the U.S. Census Bureau (2000). The population density is 4,938.5 persons/sq mi. From [Figure 4-101.02a](#), watershed imperviousness for this site is 33 percent.
4. Substitute into the equation for Q_{50} in [Table 4-101.02a](#).

$$\begin{aligned}
 Q_{50} &= 42.7 TDA^{0.664} MCS^{0.338} I_f^{0.186} \\
 &= (42.7) (11.22)^{0.664} (15.0)^{0.338} (33.0)^{0.186} \\
 &= (42.7) (4.98) (2.50) (1.92) \\
 &= 1,020 \text{ cu ft/sec}
 \end{aligned}$$

Transferability of Urban Study to Other Areas:

Using the curves in [Figure 4-101.02d](#) and the rural equations ([Eq. 4-1 a, b, or c](#) the effects of urbanization in locations outside of the Northeastern Illinois study area ([Figure 4-101.02e](#)) may be estimated.

The following example illustrates how to estimate flood peak discharges on urbanizing watersheds outside of the study area.

4-101.022 Example Problem 4

Find:

The 50-year frequency discharge for IL 15 over Johnson Creek in Fairfield, Wayne County. (SN: 096-2007: Lat 38° 22' 44"; Long -88° 21' 04")

Solution:

1. Determine the size of Drainage Area (TDA), in square miles. Utilizing the electronic U.S.G.S. topographic maps brought into CADD, the TDA was delineated, flooded, and found to be 2.542 sq mi.
2. Determine the Main Channel Slope (MCS) in ft/ mi. Eq. 4-2 was used and calculated to be 24.061 ft/ mi.
3. Determine the *PermAvg* variable in percent. It was determined to be 0.664 inches/ hour.
4. Determine discharge estimate by U.S.G.S. Rural Regression Equations. From Eq. 4-1a $Q_{50} = 57.0 \times (2.542)^{0.737} \times (24.061)^{0.491} \times (0.664)^{-0.223} \times (2.711) = 1,605$ cfs. The user could have utilized [StreamStats](#)¹ to obtain this value and skipped Steps 1 thru 3.
5. Determine the percent imperviousness (I_p). Based on the 2000 Census, the population of Fairfield is 5,421 people. (Note: Use the most current data available.) Since only 2/3 of the town is within the project watershed, the population was accordingly reduced to $5,421 \times 2/3 = 3,614$ people. The population density is $3,614/2.542$ sq mi = 1,422 persons/sq mi. An impervious value of 13 percent was determined from [Figure 4-101.02a](#).
6. Determine the ratio of flood magnitudes, urban to rural, from [Figure 4-101.02d](#) for an impervious value of 13 percent as determined in [step 5](#). For the 50-year flood, the ratio of flood magnitudes is 1.60.
7. Multiply the discharge of 1,605 cu ft/sec in [step 4](#) by the ratio of 1.60 from [step 6](#) to get a final estimate of 2,568 cu ft/sec.

Note: If the urbanized area isn't the full drainage area the correction should only be applied to the percent within the urbanized area.

4-101.03 Application of Gage Data

Many gaging stations exist throughout the State where data can be obtained and used for hydrologic studies. If a project is located near one of these gages and the gaging record is of sufficient length in time; a frequency analysis may be made to aid in estimating future discharges. The most important aspect of an applicable station is the series of annual peak discharges. It is possible to apply a frequency analysis to that data for the derivation of flood-frequency curves. The USGS regression equations presented in [Section 4-101.01](#) and [Section 4-101.02](#) were developed from multiple-regression analyses using basin characteristics and peak stream flow data from gaged sites in Illinois.

Using the following procedure for weighting the gage frequency curves with the regression equation discharges, discharge estimates for bridge and culvert sites on gaged streams may be made. Table 1 of the [SIR 2004-5103](#)¹ presents the discharges from the gage data, regression equations, and the weighted values for the 2, 5, 10, 25, 50, 100, and 500-year frequency occurrences for each of the gaging stations used in the study. [Tables 6 & 7](#), from

[SIR 2004-5103¹](#), presents selected basin characteristics, years of record, equivalent years of record and maximum flood for unregulated rural gaging stations.

4-101.031 Site at Gaged Location

Flood frequency estimates at gaged sites are combinations of the gaging station frequency curve and the equation estimates. The equivalent years of record concept was used to obtain weighted estimates of peak flow at gaged sites using estimates obtained from station records and from the regression equations and is expressed in the following equation:

$$\text{Log } Q_T = \frac{\text{Years of record (log sta. } Q_T) + \text{Eq yrs record (log regional } Q_T)}{\text{Yrs of record} + \text{Eq yrs record}}$$

(Eq. 4-3)

In the equation, station Q_T is obtained from the first line of discharge values in Table 1 of the [SIR 2004-5103¹](#) and converted to a logarithm (log). The years of record are determined from Table 7 - column 2, from the [SIR 2004-5103¹](#). The regional Q_T is computed using the desired regional estimating equation or obtained from the second line of discharge values in Table 1 of the [SIR 2004-5103¹](#), and then transformed into logs. The station equivalent years of record (Eq yrs record) for the equation are also given in Table 6 of the [SIR 2004-5103¹](#). The antilog of the result is the weighted estimate of the station flood discharge.

4-101.032 Example Problem 5

Find:

Compute the weighted 50-year recurrence interval flood at the gaging station 05572000 Sangamon River at Monticello, Illinois:

$$\begin{aligned} \text{Log } Q_{50} &= \frac{\text{Yrs of record (log sta. } Q_{50}) + \text{Eq yrs record (log equation } Q_{50})}{\text{Yrs of record} + \text{Eq yrs record}} \\ &= \frac{90 (\log 17,800) + 5.3 (\log 20,000)}{90 + 5.3} \\ &= \frac{405.357}{95.3} \\ &= 4.25348 \\ Q_{50} &= 17,926 \text{ cuf}t/\text{sec} \end{aligned}$$

For convenience, the weighted estimates for stations have been tabulated in the third line of values in Table 1 of the [SIR 2004-5103¹](#). The Weighting Equation may be used to update the values of [line 3 in Table 1](#), as additional years of record are obtained.

4-101.033 Site Near Gage Location

Estimated flood quantiles can be adjusted at sites upstream or downstream from a gaging station on the same stream, depending on the proximity of the site to the gaging station. If the drainage area of the site in question is within ±50 percent of the drainage area of the gaging station, the estimated flood quantiles can be improved by using the ratio of the areas to compute an adjustment ratio between the regional estimate at the site and the estimate at the gaging station.

Define the adjustment ratio, *ar*:

$$ar = \left| \frac{A_{site}}{A_{gage}} - 1 \right| \times 2, \text{ if } 0.5 < \left| \frac{A_{site}}{A_{gage}} \right| < 1.5 \quad (\text{Eq. 4-4a})$$

$$ar = 1, \text{ otherwise} \quad (\text{Eq. 4-4b})$$

The adjusted Q_T for a site is computed using the equation:

$$Q_T (\text{adjusted, site}) = Q_T (\text{equation, site}) \times ar + Q_T (\text{weighted at gage}) \times (1 - ar) \times (A_{site} / A_{gage}) \quad (\text{Eq. 4-5})$$

4-101.034 Example Problem 6

For this example, assume the site in [Example Problem 1 in Section 4-101.011](#) is located on the Sangamon River downstream from gaging station 05572000 Sangamon River at Monticello, Illinois. The drainage area, from Table 6 of the [SIR 2004-5103¹](#), is 551 sq mi for the gaging station. The procedure is as follows:

First computation:

1-5. Same as [Example 1 in Section 4-101.011](#), site $Q_{50} = 20,479$ cfs

Second computation:

6. Same as [Example 5 in Section 4-101.032](#), gage weighted $Q_{50} = 17,926$ cu ft/sec; or, the weighted Q_{50} may be selected from Table 1, line 3 of the [SIR 2004-5103¹](#) for station 05572000 which is 17,900 cfs.

Third computation:

7. From [Table 1](#), line 2 of the [SIR 2004-5103¹](#) select the Q_{50} that was computed using the regression equation for the station. $Q_{50} = 20,000$ cfs.

8. $\left| \frac{A_{\text{site}}}{A_{\text{gage}}} \right| = \left| \frac{625}{551} \right| = 1.13$ which is between 0.5 and 1.5; therefore, the

following equation should be used.

9.
$$ar = \left| \frac{A_{\text{site}}}{A_{\text{gage}}} - 1 \right| \times 2 = \left| \frac{625}{551} - 1 \right| \times 2 = 0.27$$

10. Compute the adjusted Q_{50} at the site:

$$\begin{aligned} Q_{50}(\text{adjusted,site}) &= Q_{50}(\text{equation,site}) \times ar + Q_{50}(\text{weighted at gage}) \times (1 - ar) \times (A_{\text{site}} / A_{\text{gage}}) \\ &= 20,479 \times 0.27 + 17,900 \times (1 - 0.27) \times (1.13) \\ &= 20,295 \text{ cfs} \end{aligned}$$

This is the best estimate for the ungaged site on the Sangamon River.

The site for which flood-frequency calculations are desired may sometimes be between two gaged sites on the same stream. The 50-percent rule should be applied to determine which gaged site, if any, should be used to make the adjustment. If the ungaged site is within 50 percent of both gaged sites, the frequency calculations for the ungaged site can be made by interpolation of the weighted station values Q_T for each gage site. Again, interpolation should be on the basis of drainage area.

4-101.035 Gage Frequency Analysis

When gage data which includes recorded flows are available, flood flows for a given recurrence interval (such as 1 percent or 100 year) can be estimated by performing a statistical analysis of the flow data. Generally this involves performing a Log-Pearson Type III analysis. One of the most commonly accepted methods of performing this type of evaluation is described in the publication entitled: "[Guidelines for Determining Flood Flow Bulletin 17B, Water Resources Council, September 1981, Revised March 1982³](#)". An analysis such as this can be performed by using a computer program entitled Flood Frequency Analysis (HEC-FFA) that was developed by the US Army Corps of Engineers, Hydraulic Engineering Center (HEC), as well as the program,

HYDRAIN, which was developed by the Federal Highway Administration (FHWA). HEC-FFA is no longer being supported and has been replaced by HEC-SSP (Statistical Software Package).

The three normal statistical parameters which define this method; mean, standard deviation and coefficient of skew are determined from the data sample. In Illinois the coefficient of skew can be estimated from a United States Geological Survey (USGS) publication entitled "[Estimating Generalized Skew of the Log-Pearson Type III Distribution for Annual Peak Floods in Illinois, Water- Resources Investigation Report 86-4008](#)"⁴. This document can be used to determine generalized skew instead of using the generalized skew map found in the "[Guidelines for Determining Flood Flow, Bulletin 17B](#)"³. Generalized skew coefficients reflect data obtained at many locations whereas station skew is only based on the period of record at the stream flow gage station. Station skew can be biased and subject to large sampling errors, especially when computed from short periods of record.

In general a stream flow record of 10 years or more is considered desirable, while another important factor to evaluate is the homogeneity of the gage record. This could involve a review of land use throughout the watershed over the period of time covered by the gage record. "[Guidelines for Determining Flood Flow, Bulletin 17B](#)"³ addresses how to account for these types of issues when analyzing a gage record.

4-102 Rational Method

The Rational Method of determining peak rates of runoff is to be limited to drainage areas of 200 acres or less for the design of the following drainage facilities within the applicable limits described in their respective chapters.

1. Inlets ([Chapter 8](#))
2. Storm Sewers ([Chapter 8](#))
3. Roadside Ditches, & Small Across Road (AR), Sideroad, and Entrance culverts ([Chapter 9](#))
4. Erosion control features ([Chapter 9](#))
5. Small detention facilities ([Chapter 12](#))

The Rational Method is based on the principle that the maximum rate of runoff from a given drainage area occurs at that point in time when all parts of the watershed are contributing to the flow. The rainfall generating the peak flow is assumed to be of uniform intensity for the entire watershed with rainfall duration equal to the time of concentration.

The Rational Method is expressed by the equation:

$$Q = CIA \quad (\text{Eq. 4-6})$$

Where:

- Q = discharge, cuft/sec
- C = runoff coefficient
- I = rainfall intensity, in/hr
- A = drainage area, acres

The runoff coefficient (C) is a dimensionless ratio of rainfall excess to total rainfall and it varies with the topography, land use and surface characteristics of the drainage area. The runoff coefficient is the same for all storms of all recurrence intervals. Watersheds with varying topography, land use, or type of cover require the determination of a weighted (C) value as an average representation of the entire watershed. This may include future widening or add lane highway projects or known private development with site-specific plans. Local storm water management ordinances and any applicable IDOT permit requirements should be included in the considerations.

The runoff coefficients for various types of surfaces are shown in [Table 4-102a](#). The weighted C value is to be based on a ratio of the drainage areas associated with each C value as follows:

$$\text{weighted } C = \frac{A_1 C_1 + A_2 C_2 + A_3 C_3}{A_1 + A_2 + A_3} \quad (\text{Eq. 4-7})$$

Rainfall Intensity (I): Rainfall intensity is the rate of rainfall in in/hr. The Rational Method assumes the rainfall intensity is constant over the entire drainage area and uniform over duration of time equal to the time of concentration. The frequency, or return, period of the computed peak flow is the same as that of the rainfall intensity, (I), i.e., the 10-year event rainfall intensity is assumed to produce the Q_{10} peak flow. The value of (I) for various times of concentration and return periods is obtained from the Intensity-Duration-Frequency or I-D-F curves ([Figures 4-102b through k](#)).

[Figure 4-102a](#), delineates 10 unique climatic sections of Illinois. [Figure 4-102a](#) is taken from [Figure 7](#) page 17 of the ISWS (Illinois State Water Survey) publication entitled “[Frequency Distributions and Hydroclimatic Characteristics of Heavy Rainstorms in Illinois](#)”. This publication is commonly referred to as [Bulletin 70](#)⁵. [Figure 4-102a](#) is used to select the applicable figure among [Figures 4-102b through k](#) for determining rainfall intensity.

[Figures 4-102b through k](#) presents the conversion of tabular data from [Table 13](#) on [pages 29-31](#) of [Bulletin 70](#)⁵ to graphical I-D-F curves. [Figures 4-102 b through k](#) are best-fit curves that provide rainfall intensity for storm durations up to and including 6 hours and for return periods of Q_2 through Q_{100} . The numerical data points from which each curve was constructed are shown in the upper right hand corner of each respective figure. The data points were produced in the manner of this example:

4-102.01 Example Problem 7

Find:

The intensity of a 10 year, 15 minute duration storm in Jo Daviess County in Northwest Illinois.

Solution:

From [Table 13](#) ([page 29](#) of [Bulletin 70](#)⁵), identify the 15-minute storm duration as Storm code 13, and the appropriate Sectional zone code for Jo Daviess County as 1-Northwest. On page 31, the 10 year event for storm code 13, code 1 is 1.25 inches of rainfall. Dividing the 1.25 inches of total rainfall by the 15 min. duration produces an

intensity, (I), equal to 0.0833 in/min. Multiply 0.0833 by 60 to produce a rainfall intensity of 5.0 in/hr., which is the value shown in [Figure 4-102b](#).

Note that the I-D-F curves shown here in [Figures 4-102b through k](#) are derived from [Bulletin 70⁵](#) sectional values for point rainfall.

[Section 4-204](#) of this chapter details the use of [Bulletin 70⁵](#) data with the Rational Method.

Time of concentration T_c : When using the Rational Method, the user must assume that peak flow due to certain rainfall intensity over the watershed is produced by that runoff which accumulates during the time required for the surface runoff from the most remote part of the drainage basin to reach the point of interest. “Most remote” is measured and defined in terms of travel time, not linear distance.

The time of concentration can be obtained by determining the total travel time, (T_c) considering the incremental travel times of overland flow (t_{OF}) (frequently referred to as sheet flow), shallow concentrated flow (t_{SC}) (typically rill or gutter), and open channel flow (t_{OC}). If the total T_c is computed to be less than 5 min., a minimum T_c of 5 minutes is used.

$$T_c = t_{OF} + t_{SC} + t_{OC} \quad (\text{minimum } T_c = 5 \text{ min.}) \quad (\text{Eq. 4-8})$$

Overland Flow. Per the [FHWA's HEC 22, “Urban Drainage Design Manual”⁶](#), overland flow, or sheet flow, is the shallow mass of runoff on a planar surface with a uniform depth across the surface. This usually occurs at the headwater of streams or in the upper portions of smaller watersheds that lack defined channels. Sheet flow is normally characterized by a 2 inch maximum depth of flow. A maximum flow length of 100 ft is allowed. The overland flow travel time can be obtained from the Kinematic Wave Equation, a derivative of Manning’s Equation, expressed as:

$$t_{OF} = \frac{56 L^{0.6} n^{0.6}}{I^{0.4} S^{0.3}} \quad (\text{Eq. 4-9})$$

Where:

- t_{OF} = overland flow travel time, seconds
- L = overland flow length, ft (Max 100 ft)
- n = Manning's roughness coefficient for overland flow ([Table 4-102b](#))
- I = rainfall intensity, in/hr
- s = average slope of flow path, ft/ft

Manning's n values reported in [Table 4-102b](#) were determined specifically for overland flow conditions and is not appropriate for conventional open channel flow.

The Kinematic Wave Equation generally entails a trial and error process using the following steps:

1. Assume a trial value of rainfall intensity (I) for the design year frequency.
2. Find the overland travel time (t_{OF}), using [Figure 4-102l](#) or ([Eq. 4-9](#)).
3. Use (t_{OF}) calculated from [Step 2](#) to find actual rainfall intensity for a storm duration of T_c from the IDF Curves [Figures 4-102 b through k](#) or ([Eq. 4-13](#)) for the design year frequency.
4. Compare the trial and actual rainfall intensities. If they are not equal, additional iterations may be needed using the results from the previous trial as input for the next, to achieve results where the estimated intensity matches the computed intensity within a reasonable range such as 0.1 in/ hr.

Shallow Concentrated Flow. Average velocities for shallow channel flow in rills and gutters can be obtained directly from [Figure 4-102m](#) or from the following equations obtained from the [FHWA publication HDS-2 “Highway Hydrology”](#)⁷, if the MCS of the segment in ft/ft is known.

Paved: $V = 20.3288\sqrt{MCS}$ (Eq. 4-10a)

UnPaved: $V = 16.1345\sqrt{MCS}$ (Eq. 4-10b)

Time of Concentration (t_{SC}) is then calculated by the following:

$$t_{SC} = \frac{L}{3600 * V} \tag{Eq. 4-10c}$$

Where:

- V = velocity, ft/sec
- MCS = Main Channel Slope, ft/ ft
- Q = flow rate, cu ft/sec
- A = area of flow, sq ft
- L = length of flow, ft
- t_{SC} = time of flow, hrs

Alternative procedures for evaluating gutter flow velocities involve use of the modified Manning's Equation (also discussed in [Chapter 8, Storm Sewers](#)) as follows:

$$Q = \left(\frac{0.56}{n}\right) \left(S_x^{1.67}\right) \left(S_L^{0.5}\right) \left(T^{2.67}\right) \tag{Eq. 4-10d}$$

Where:

- Q = flow rate, cu ft/sec
- n = Manning's roughness coefficient ([Table 9-403](#))
- S_x = pavement cross slope, ft/ft
- S_L = longitudinal gutter slope, ft/ft
- T = width of flow spread, ft

Velocity is then determined from the equation:

$$V = \frac{Q}{A} \tag{Eq. 4-10e}$$

Time of Concentration (t_{SC}) is then calculated by the following:

$$t_{SC} = \frac{L}{3600 * V} \tag{Eq. 4-10c}$$

Where:

- V = velocity, ft/sec
- Q = flow rate, cu ft/sec
- A = area of flow, sq ft
- L = length of flow, ft
- t_{SC} = time of flow, hrs

Open Channel Flow: Average velocities for open channel flow can be evaluated using the standard Manning's Equation (Also discussed in [Chapter 5, Open Channel Flow](#)). Bank full conditions should be assumed.

$$V = \left(\frac{1.486}{n} \right) \left(R^{2/3} \right) \left(S^{1/2} \right) \tag{Eq. 4-11}$$

Time of Concentration (t_{OC}) is then calculated by the following:

$$t_{OC} = \frac{L}{3600 * V} \tag{Eq. 4-12}$$

Where:

- V = flow velocity in fps
- n = Manning's roughness coefficient ([Table 9-403](#))
- R = hydraulic radius
- S = longitudinal slope in ft/ft
- L = length of flow, ft
- t_{OC} = time of flow, hrs

Understanding the above parameters, the following procedure is recommended for using the Rational Method.

1. Determine drainage area, general dimensions and character of ground and slope of drainage basin either by field measurement or from suitable maps.
2. Break down different types of surface areas by size and compute overland flow time for each.
3. Add all flow times of controlling reach and enter rainfall intensity chart using the curve for year of design frequency to obtain rainfall intensity (I) in in/hr.
4. Obtain from [Table 4-102a](#), the (C) factor for the various types of surfaces involved and determine the weighted (C).
5. Enter in formula all factors and determine design Q in cu ft/sec.

CLIMATIC SECTIONS IN ILLINOIS

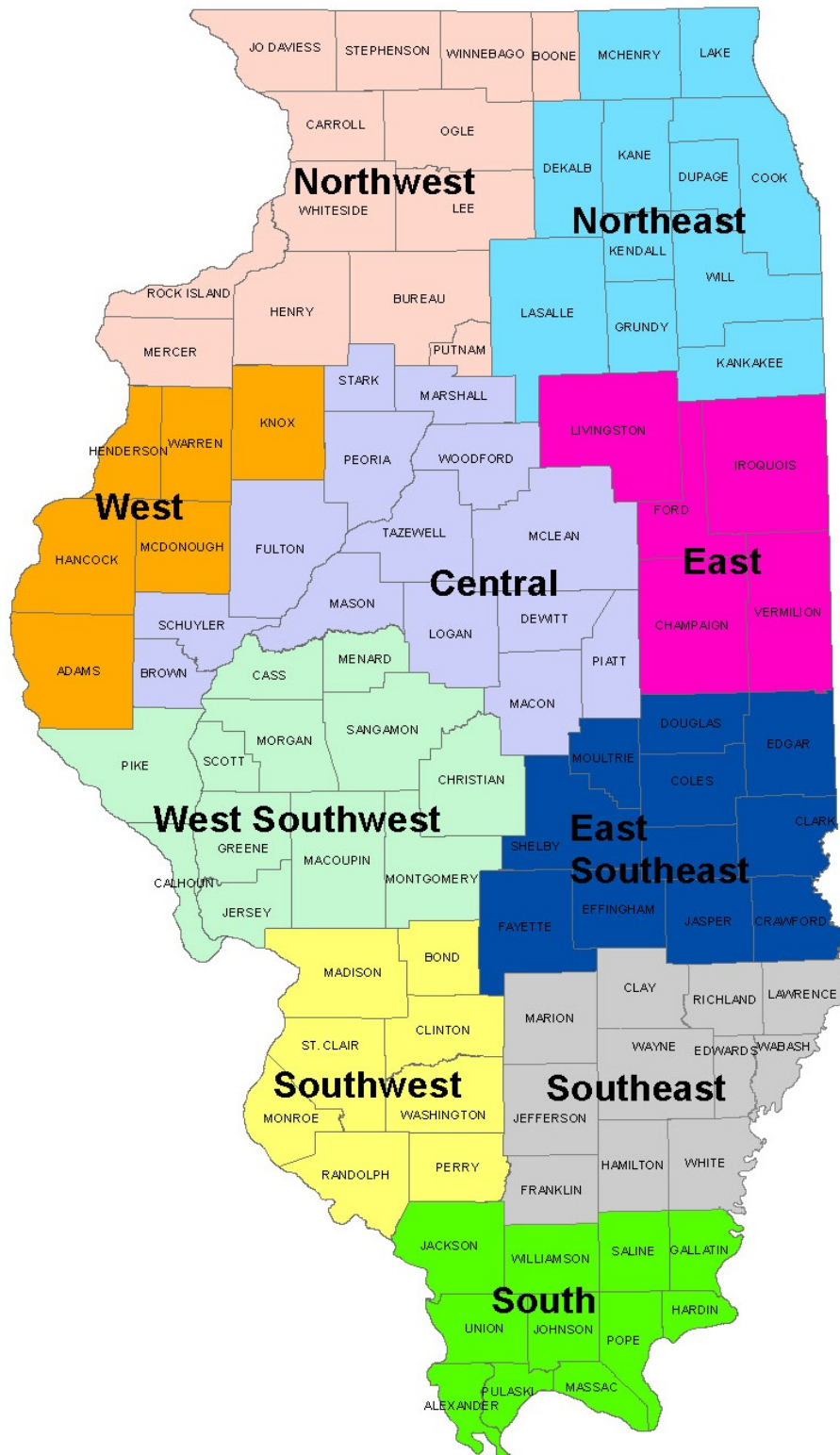

(Bulletin 70⁵ pg. 17, Figure 7)
Figure 4-102a

RAINFALL INTENSITY vs. DURATION

NORTHWEST ILLINOIS

I.S.W.S. BULLETIN-70

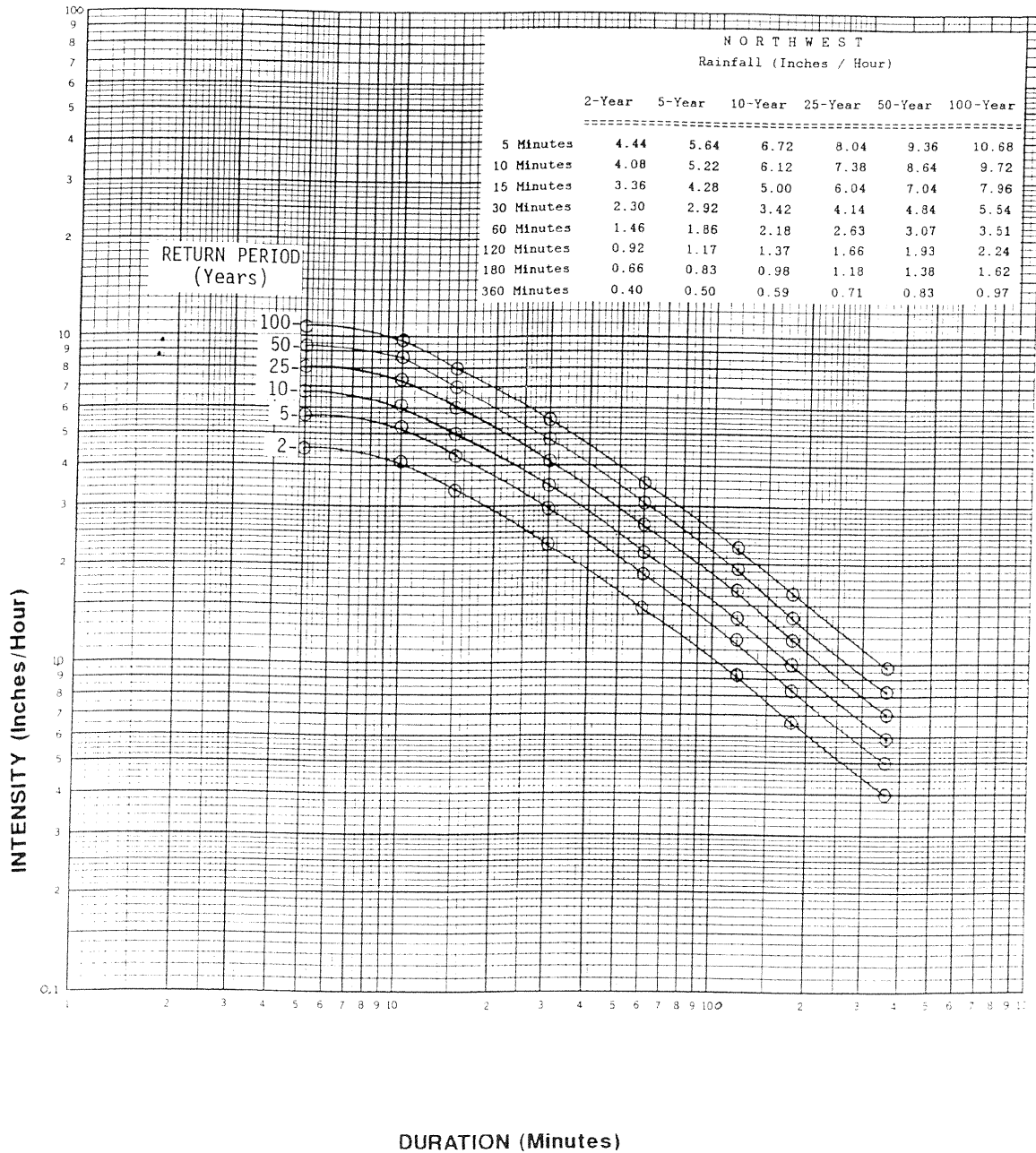

Figure 4-102b

RAINFALL INTENSITY vs. DURATION

NORTHEAST ILLINOIS

I.S.W.S. BULLETIN-70

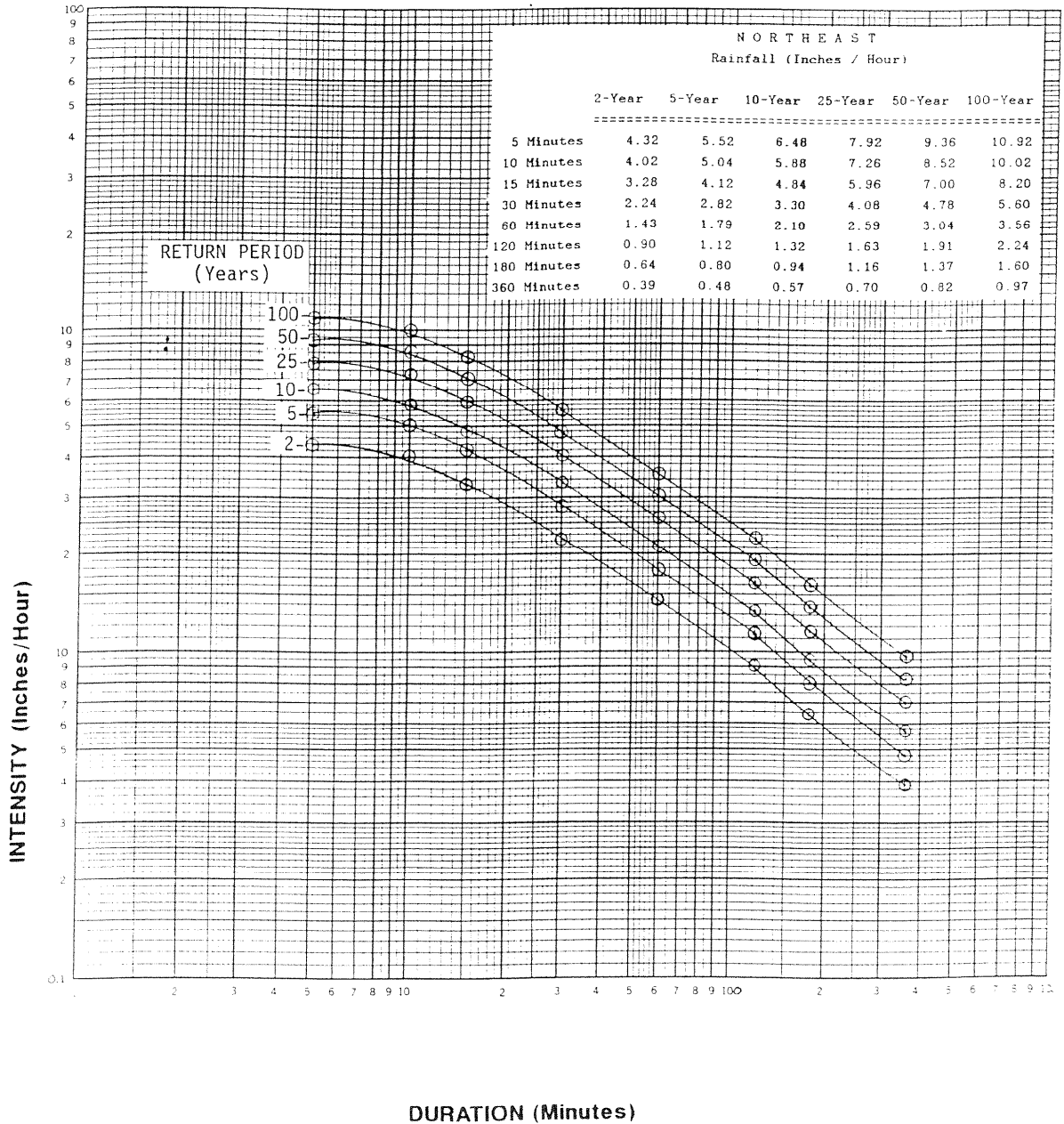

Figure 4-102c

RAINFALL INTENSITY vs. DURATION

EAST ILLINOIS

I.S.W.S. BULLETIN-70

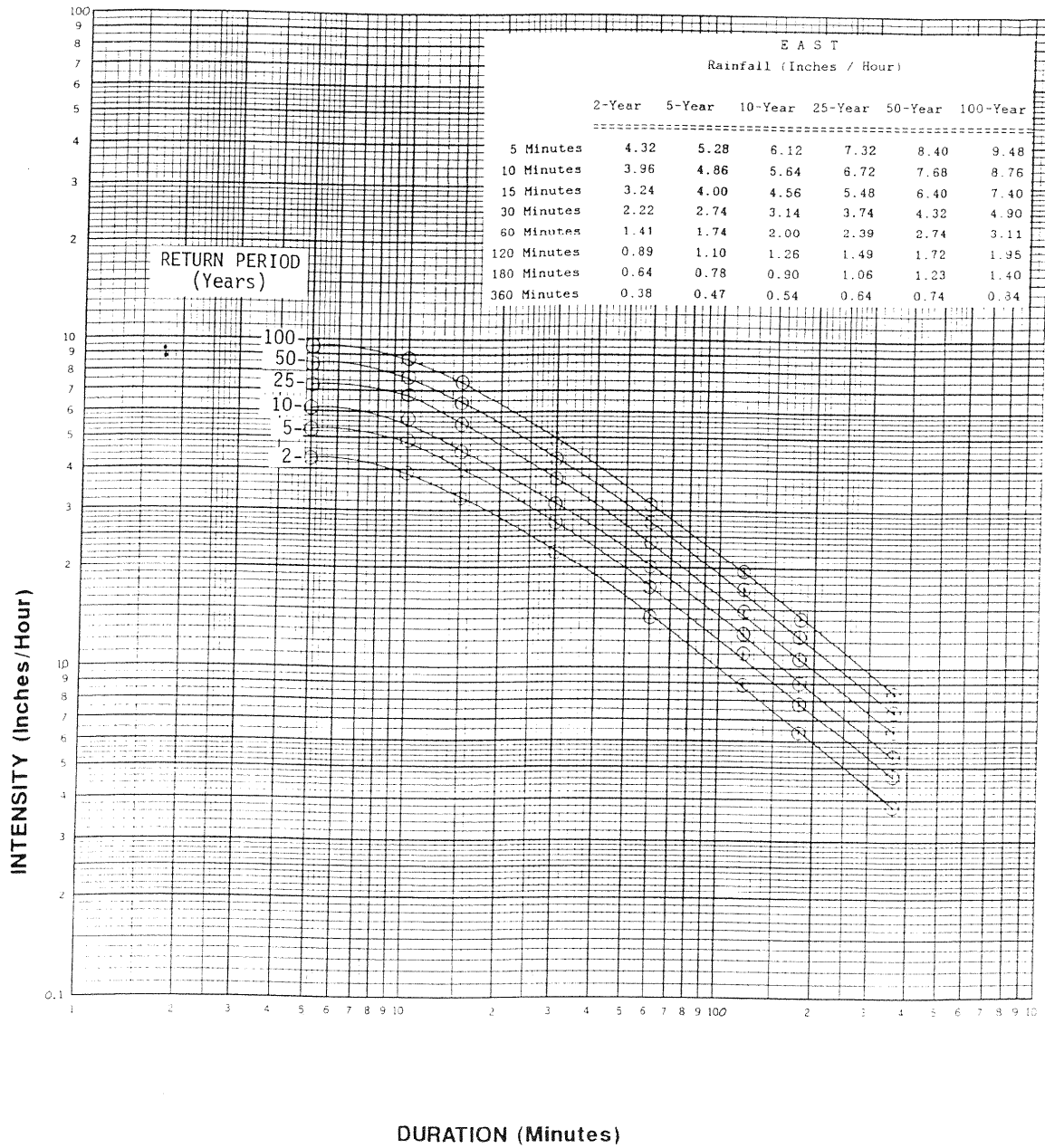

Figure 4-102d

RAINFALL INTENSITY vs. DURATION

WEST SOUTHWEST ILLINOIS

I.S.W.S. BULLETIN-70

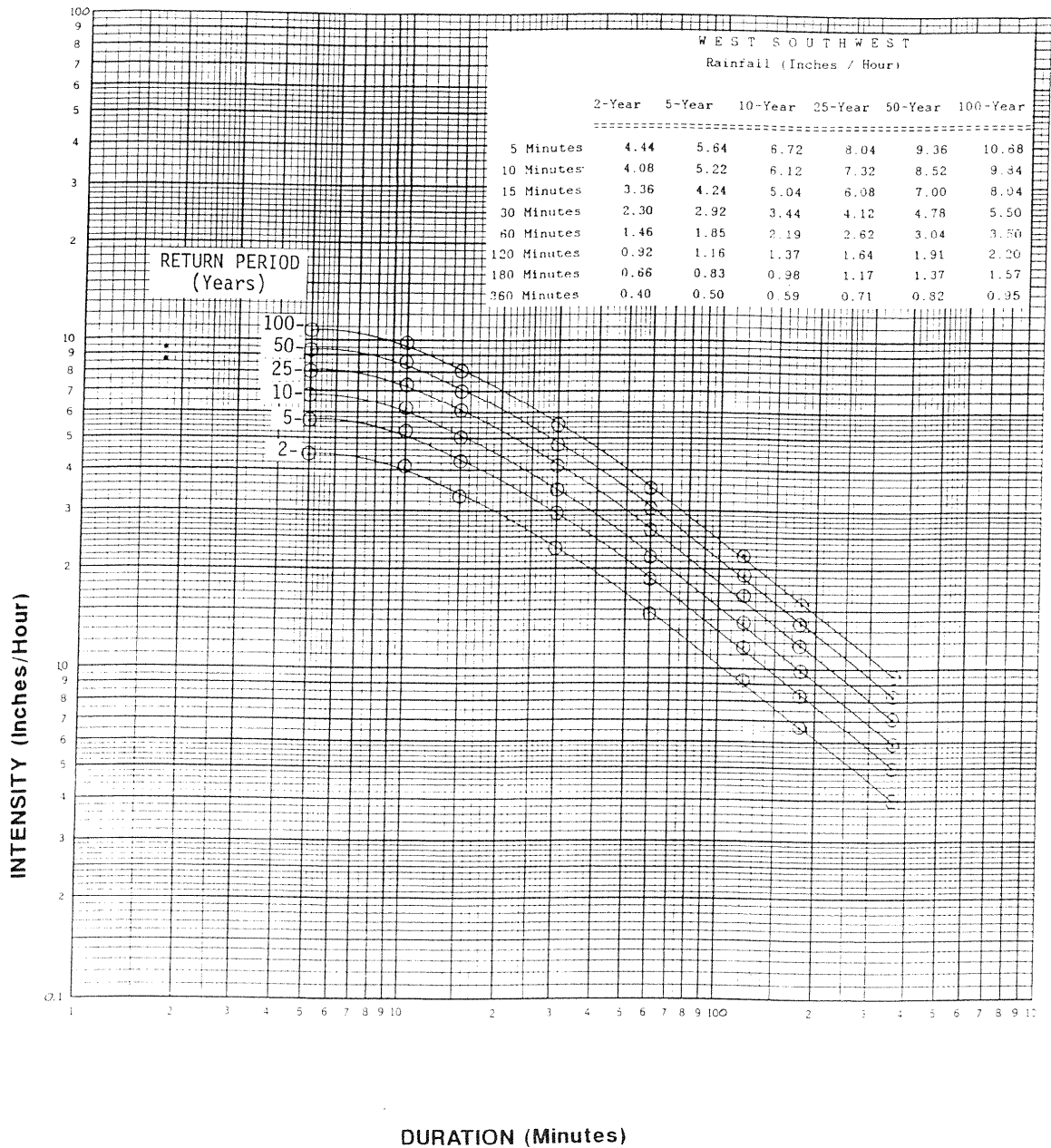

Figure 4-102e

RAINFALL INTENSITY vs. DURATION

WEST ILLINOIS

I.S.W.S. BULLETIN-70

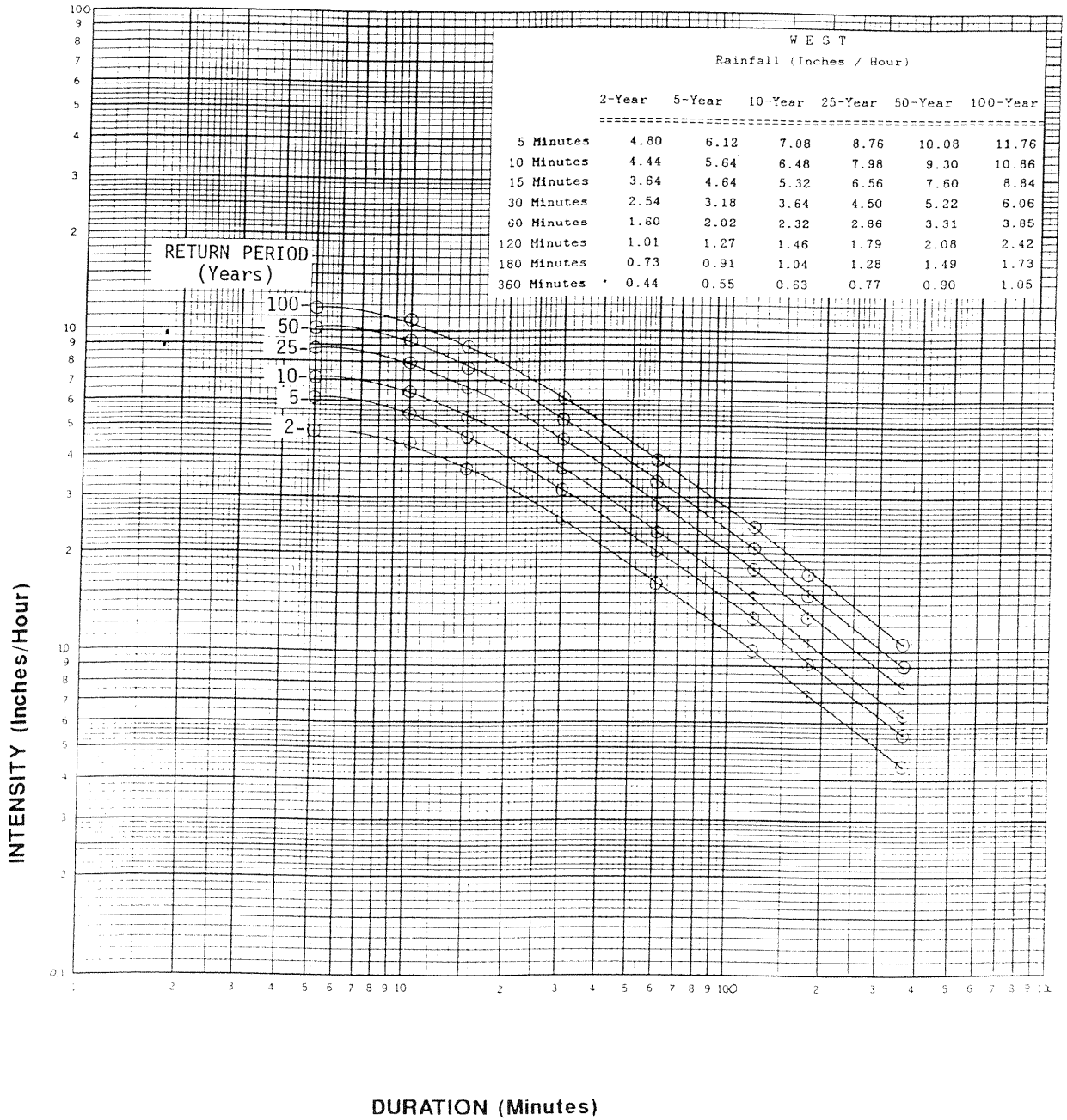

Figure 4-102f

RAINFALL INTENSITY vs. DURATION

CENTRAL ILLINOIS

I.S.W.S. BULLETIN-70

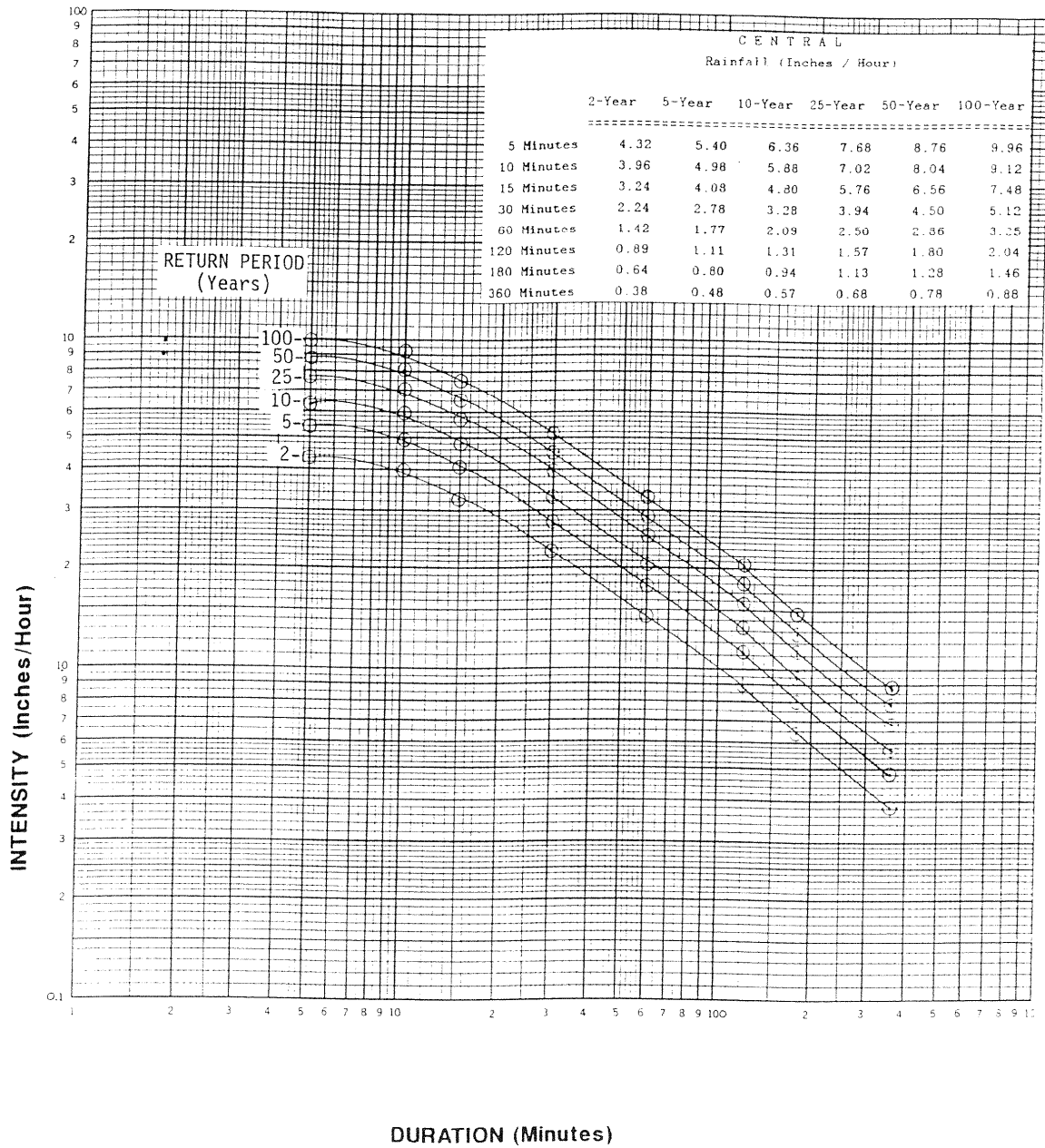

Figure 4-102g

RAINFALL INTENSITY vs. DURATION

SOUTHEAST ILLINOIS

I.S.W.S. BULLETIN-70

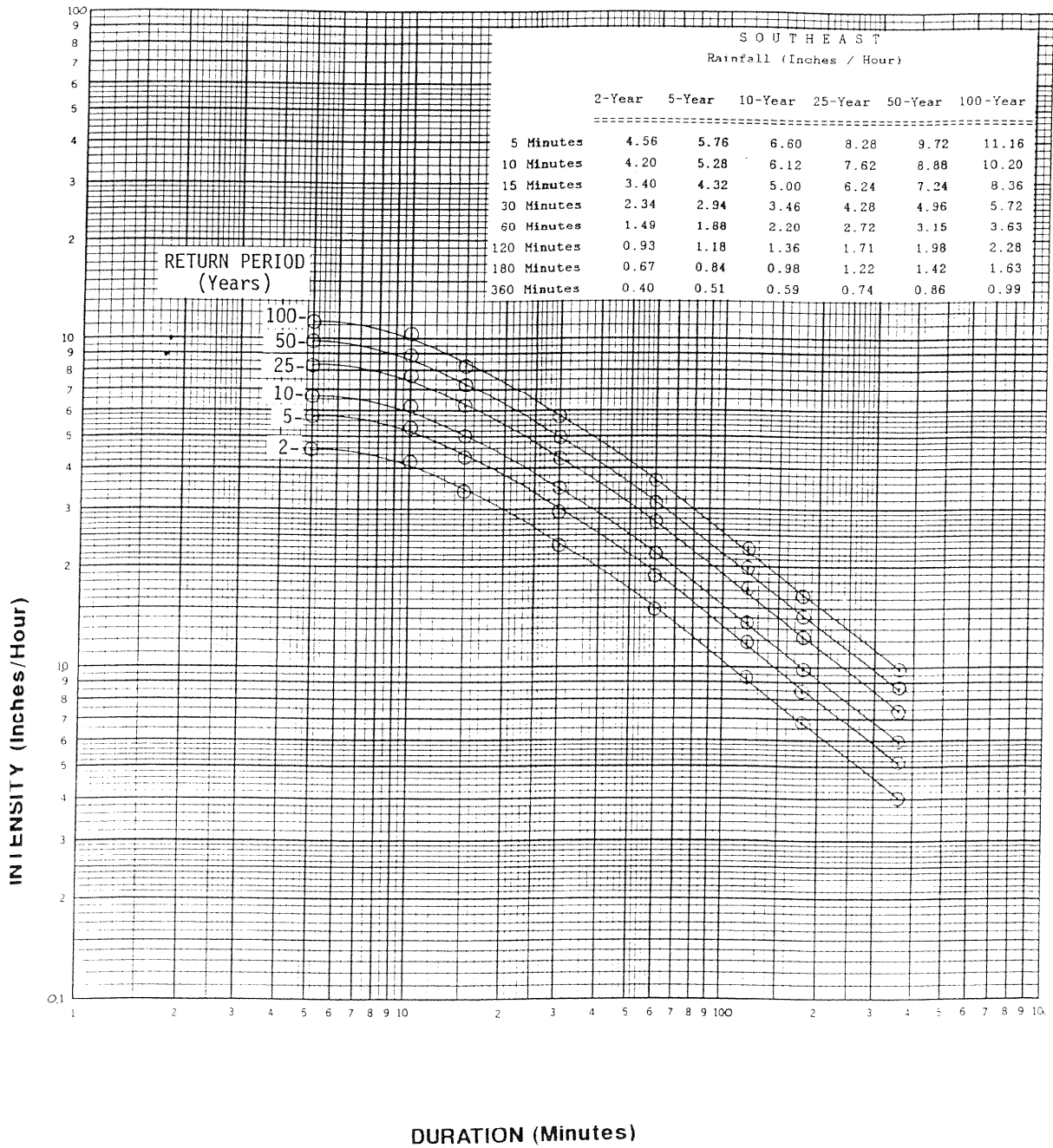

Figure 4-102h

RAINFALL INTENSITY vs. DURATION

SOUTH ILLINOIS

I.S.W.S. BULLETIN-70

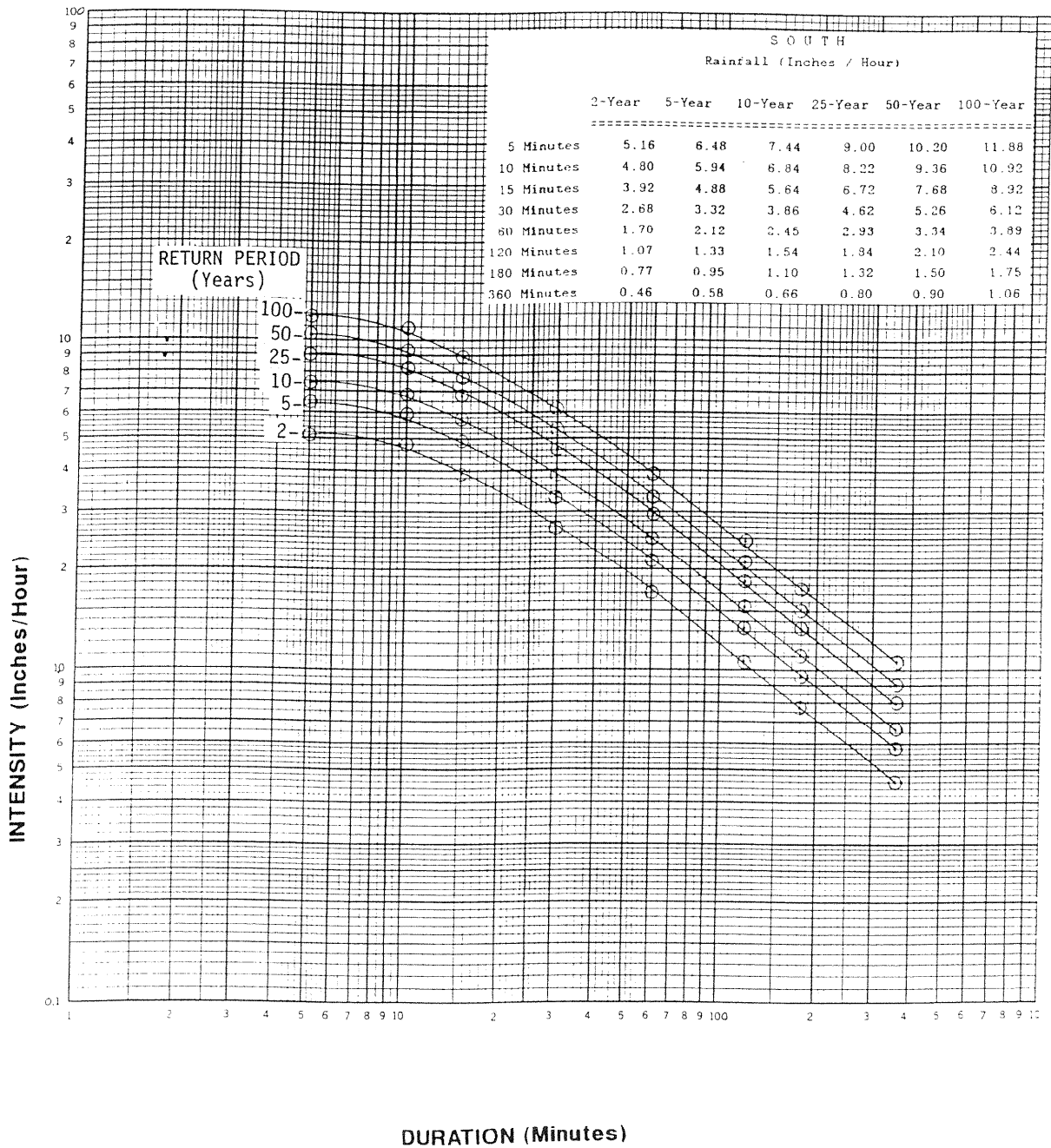

Figure 4-102i

RAINFALL INTENSITY vs. DURATION

EAST SOUTHEAST ILLINOIS

I.S.W.S. BULLETIN-70

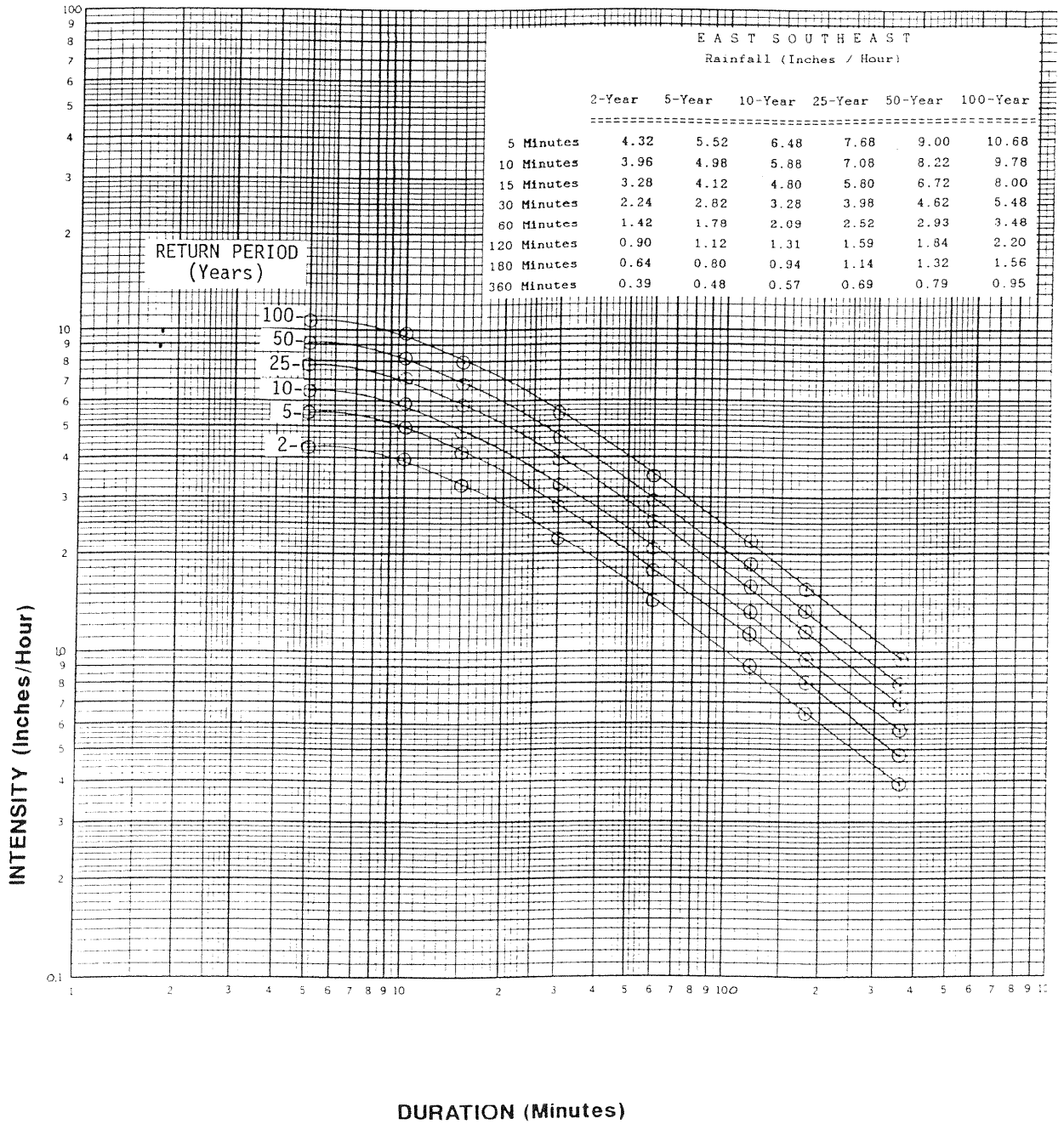

Figure 4-102j

RAINFALL INTENSITY vs. DURATION

SOUTHWEST ILLINOIS

I.S.W.S. BULLETIN-70

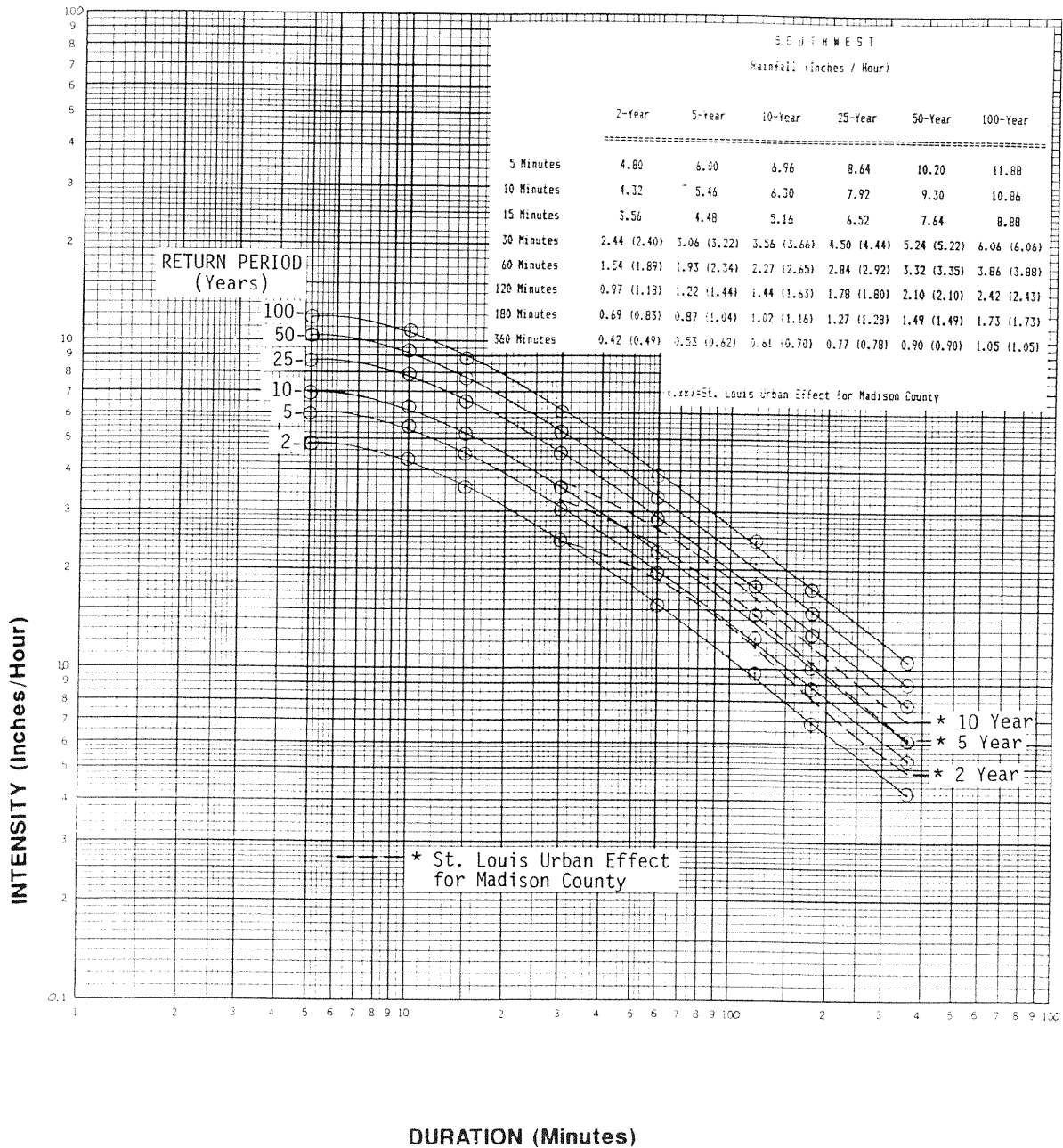

Figure 4-102k

RUNOFF COEFFICIENTS

VALUES OF C - <u>Runoff</u> Rainfall			RUNOFF COEFFICIENT C	
TYPE OF DRAINAGE AREA SURFACES			MIN.	MAX.
ROOFS, slag to metal			0.75	0.95
PAVEMENTS	Asphalt		0.70	0.95
	Concrete		0.80	0.95
	Gravel, from clean and loose to clayey and compact		0.25	0.70
R. R. YARDS			0.20	0.40
EARTH SURFACES	Sand, from uniform grain size, no fines to well graded, some clay or silt	Bare	0.15	0.50
		Light Vegetation	0.10	0.40
		Dense Vegetation	0.05	0.30
	Loam, from sandy or gravelly to clayey	Bare	0.20	0.60
		Light Vegetation	0.10	0.45
		Dense Vegetation	0.05	0.35
	Gravel, from clean gravel and gravel sand mixtures, no silt or clay to high clay or silt content	Bare	0.25	0.65
		Light Vegetation	0.15	0.50
		Dense Vegetation	0.10	0.40
	Clay, from coarse sandy or silty to pure colloidal clays	Bare	0.30	0.75
		Light Vegetation	0.20	0.60
		Dense Vegetation	0.15	0.50
COMPOSITE AREAS	City, business areas		0.70	0.95
	City, dense residential areas, vary as to soil & vegetation		0.50	0.65
	Suburban residential areas, vary as to soil & vegetation		0.35	0.55
	Rural districts, vary as to soil & vegetation		0.10	0.25
	Parks, Golf Courses, etc., vary as to soil & vegetation		0.10	0.35
LAWNS	Sandy soil, flat 2%		0.05	0.10
	Sandy soil, average 2% to 7%		0.10	0.15
	Sandy soil, steep, 7%		0.15	0.20
	Heavy soil, flat 2%		0.13	0.17
	Heavy soil, average, 2% to 7%		0.18	0.22
	Heavy soil, steep 7%		0.25	0.35

Note: Values of C for earth surfaces are further varied by degree of saturation, compaction, surface irregularity and slope, by character of subsoil, and by presence of frost or glazed snow or ice.

Table 4-102a

OVERLAND FLOW MANNING'S n VALUES
 (For use with Kinematic Wave Equation)
 (Used to Calculate ONLY t_{OF})

	<u>Recommended Value</u>	<u>Range of Values</u>
Concrete	.011	.01 - .013
Asphalt	.012	.01 - .015
Bare sand ^a	.010	.010 - .016
Graveled surface ^a	.012	.012 - .030
Bare clay-loam (eroded) ^a	.012	.012 - .033
Fallow (no residue) ^b	.05	.006 - .16
Chisel plow (E1/4 tons/acre residue)	.07	.006 - .17
Chisel plow (1/4 - 1 tons/acre residue)	.18	.07 - .34
Chisel plow (1 - 3 tons/acre residue)	.30	.19 - .47
Chisel plow (F3 tons/acre residue)	.40	.34 - .46
Disk/Harrow (1/4 tons acre residue)	.08	.008 - .41
Disk/Harrow (1/4 - 1 tons/acre residue)	.16	.10 - .25
Disk/Harrow (1 - 3 tons/acre residue)	.25	.14 - .53
Disk/Harrow (3 tons/acre residue)	.30	-- --
No till (1/4 tons/acre residue)	.04	.03 - .07
No till (1/4 - 1 tons/acre residue)	.07	.01 - .13
No till (1 - 3 tons/acre residue)	.30	.16 - .47
Plow (Fall)	.06	.02 - .10
Coulter	.10	.05 - .13
Range (natural)	.13	.01 - .32
Range (clipped)	.08	.02 - .24
Grass (bluegrass sod)	.45	.39 - .63
Short grass prairie ^a	.15	.10 - .20
Dense grass ^c	.24	.17 - .30
Bermudagrass ^c	.41	.30 - .48
Woods	.45	-- --

All values are from Engman (1983), unless noted otherwise.

^aWoolhiser (1975).

^bFallow has been idle for one year and is fairly smooth.

^cPalmer (1946). Weeping lovegrass, bluegrass, buffalo grass, blue gramma grass, native grass mix (OK), alfalfa, lespedeza.

Note: These values were determined specifically for overland flow conditions and is not appropriate for conventional open channel flow calculations. See [Chapter 5](#) of this manual for open channel flow procedures.

Table 4-102b

July 2011

$$t = 0.93 \frac{L^{0.6} n^{0.6}}{I^{0.4} S^{0.3}}$$

EXAMPLE:

GIVEN: S=0.01; n=0.1; L=100FT; I=5 IN/HR
 FIND: t = 7.7 MIN

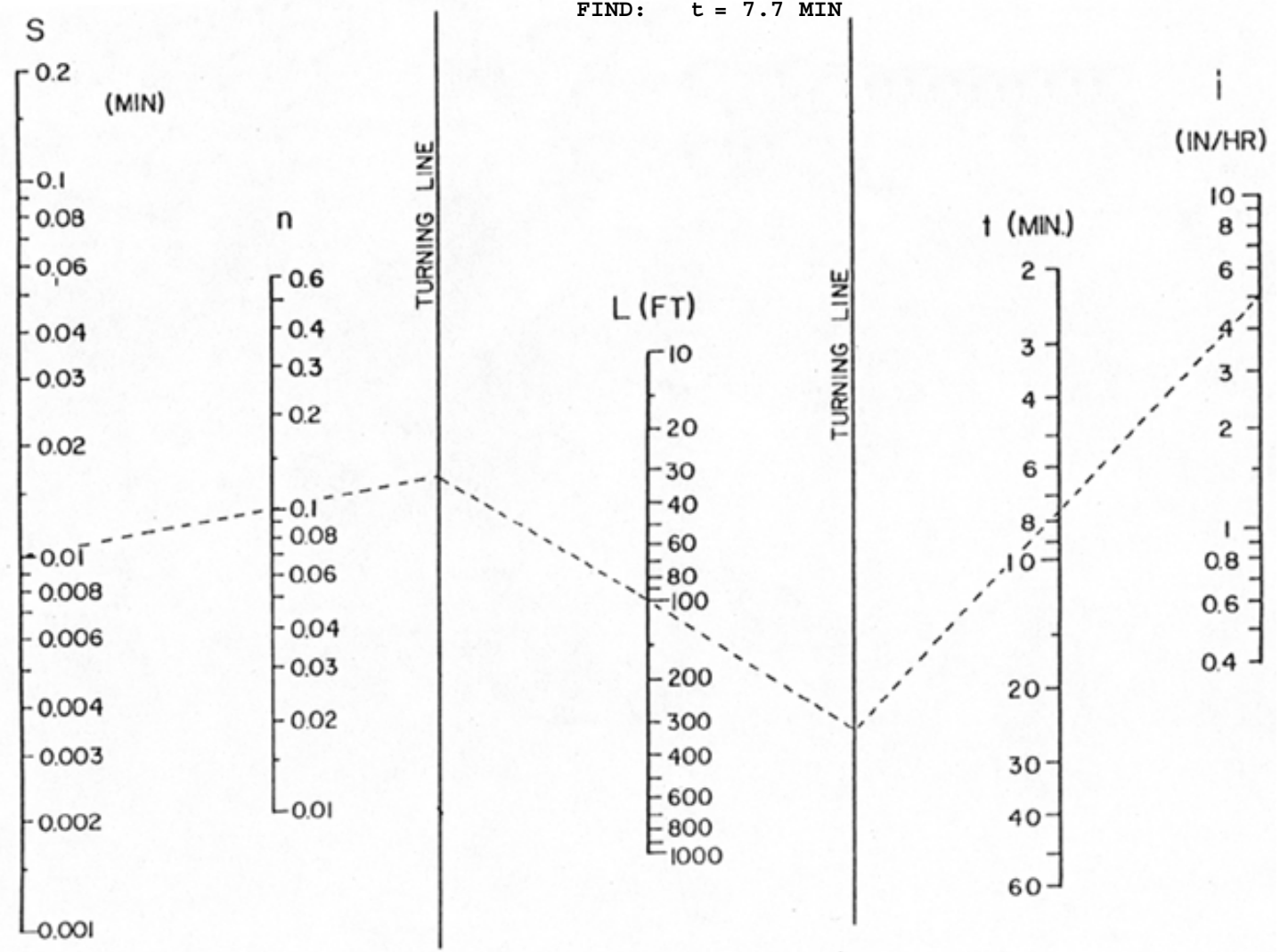

Kinematic Wave Formulation for Determining Time of Concentration
 Figure 4-102I

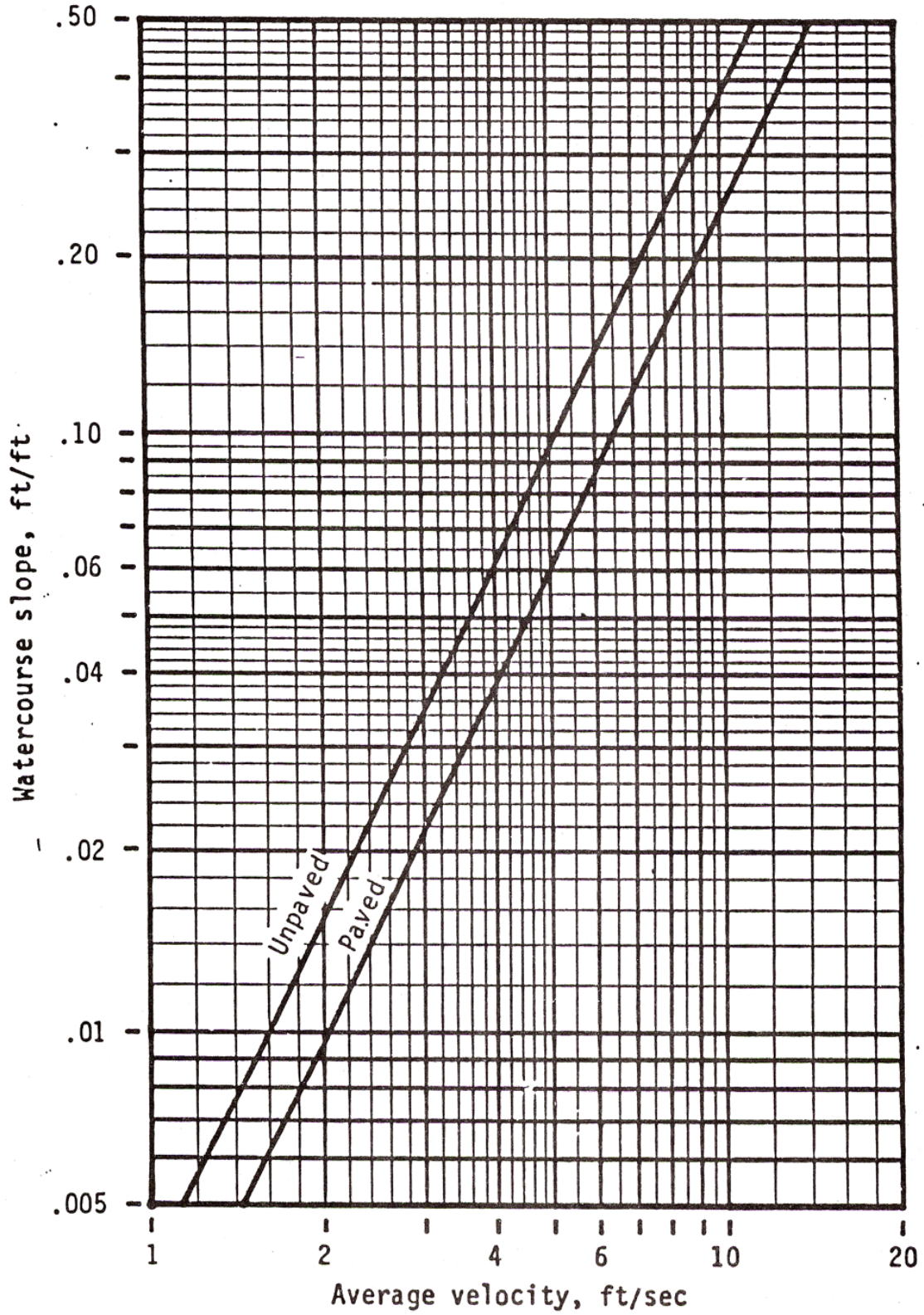

Average Velocities for Estimating Travel Time for Shallow Concentrated Flow.

(From TR-55⁸ pg 3-2)

Figure 4-102m

4-102.02 Rainfall Intensity Equation

The following equation was developed in order to closely replicate the Rainfall Intensity as shown in the I-D-F Curves, [Figures 4-102 b through k](#), in order to help utilize electronic spreadsheets.

$$i = k \frac{[f^2 + a]^x}{[t^2 + b]^y} \quad \text{(Eq. 4-13)}$$

Where:

- i = Rainfall Intensity, (in/ hr)
- t = Duration of Storm or Travel Time, (min)
- f = Recurrence Interval, (yrs)
- k, a, b, x, y are constants

SECTIONAL (ZONE) CODE		k	a	b	x	y
NW	1	24.0312	-2.2525	124.3945	0.1023	0.3443
NE	2	22.4675	-1.6645	126.4786	0.1134	0.3474
W	3	27.1511	-1.1899	137.8761	0.1071	0.3536
C	4	24.5796	-1.4894	137.6923	0.1006	0.3538
E	5	24.7642	-1.8635	139.6292	0.0965	0.3574
WSW	6	28.7763	-0.8261	150.2885	0.1085	0.3790
ESE	7	27.9168	-0.8261	157.0796	0.1084	0.3781
SW	8	24.2962	0.6547	134.4983	0.1200	0.3543
SE	9	23.2134	-0.4695	132.5677	0.1116	0.3437
S	10	28.9940	-1.1910	137.1440	0.1009	0.3544

Table 4-102.02

When comparing Intensity values calculated from Eq. 4-13 with those of produced from [Bulletin 70⁵](#) and shown on the upper right-hand corner of the I-D-F Curves ([Figures 4-102 b through k](#)), the average difference between the two methods ranges from 0.08 in/ hr to 0.21 in/ hr with majority averaging approximately 0.10 in/ hr. That being said, it would be difficult to choose a value from the I-D-F chart with much greater accuracy than Eq. 4-13.; therefore, either method is acceptable. It is the user's preference as which to use.

4-103 Natural Resources Conservation Service Method TR20 (Formerly SCS)

The U.S. Department of Agriculture, Natural Resources Conservation Service, developed TR-20, "Computer Program for Project Hydrology", in the 1960's. A Windows based version of the computer program TR-20 called WinTR-20 can be downloaded from the following link: http://www.wsi.nrcs.usda.gov/products/W2Q/H&H/Tools_Models/WinTR20.html. During the late '90's, SCS became known as the Natural Resources Conservation Service, or NRCS. Although the NRCS has continued to support and develop TR-20 and other SCS software titles, the hydrograph methodology developed by SCS and automated within TR-20 is still referred to as the SCS method. TR-20 estimates runoff volume and runoff hydrographs for the point of interest by generating hydrographs for individual sub-areas, combining them, and routing them through stream lengths and reservoir structures. Factors such as rainfall amount and distribution, runoff curve numbers, time of concentration and travel time are included in the method. TR-20 is acceptable for any size basin.

Table 4-002 lists the suggested applications for this program.

Rainfall input for TR-20 should be taken from Illinois State Water Survey [Bulletin 70⁵](#) data. This 1989 study is the product of extensive research and is the best rainfall data available for Illinois, to date. Direction on the use of [Bulletin 70⁵](#) is provided in [Section 4-204](#). If the site is within the 6-county study Area ([Circular 172⁹](#), pg. 26, [Figure 12](#)), the Isohyetals from [Circular 172⁹](#) ([Figures 13 and 14](#), pages 28 – 31) must be utilized.

TR-20 allows the user to develop runoff hydrographs using the SCS method and four unique rainfall distributions labeled Type I, IA, II, and III. However, when applying [Bulletin 70⁵](#) rainfall data, it is important to use the Huff Rainfall Distributions rather than the SCS (or NRCS) distributions already contained in the program. In general, a critical storm duration analysis should be performed to evaluate peak flow rates. A common practice is to evaluate the 30 min, 1-hr, 3-hr, 6-hr, 12-hr and 24-hr events. This can be done in one run using TR-20. Results should then be tabulated to determine the peak flow or if other durations should be considered.

Important parameters to be computed for input include time of concentration, runoff curve numbers and watershed drainage area. If other watershed parameters are to be represented, information such as stage/storage relationships needs to be developed as well. TR-20 can be used to reflect the impacts of storage in a watershed either through reach or reservoir routing. Reach routing is based on the Muskingum-Cunge method which performs a storage routing and translates the hydrograph through a particular reach. The reach length should be based on whether the reach storage is primarily due to channel or overbank storage. A data table relating elevation, discharge and end area is also required. This table should be representative of the entire reach. Storage routing is performed through the storage indication method and requires a table of elevation, discharge and volume. Flow diversions can also be reflected in TR-20 by computing a rating curve reflecting when flow continues downstream versus what is diverted. The diverted hydrograph can be stored and reinserted into the system at a different location.

The SCS/NRCS runoff curve numbers (CN) are a very common method of estimating excess rainfall runoff. Local soil maps and a determination of land use are needed to compute a CN for a particular watershed. Frequently a composite CN is needed to reflect different land uses within the watershed. The CN are weighted based on land use type. [TR-55](#) provides information and guidance in developing a runoff curve number.

Time of Concentration T_c is also an important parameter which reflects the time it takes for water to travel from the most hydraulically distant portion of the watershed to the outlet. Typically

NRCS has used three types of flow to estimate this parameter. They are based on sheet flow, shallow concentrated flow and channel flow. The subject watershed may exhibit one or all of these types of flow. As can be seen in the discussion of the rational method, this parameter can be estimated by several different techniques. The modeler should keep the physical characteristics of the watershed in mind when determining T_c . [TR-55](#) provides information and guidance in developing a T_c .

[TR-20](#) may be used to analyze bridge openings in the following manner although it is not the preferred method. Although not a level pool, floodplain storage upstream of bridges and culverts can be evaluated by performing hydraulic calculations to develop a stage versus discharge curve. A stage versus storage curve for the structure based on the volume in the upstream reach would also need to be computed. This information is input into [TR-20](#) and the computed flood flows can then be reinserted into a hydraulic model. The hydraulic model usually should start downstream of the structure and be carried upstream so that the results can be compared to the rating curve input into [TR-20](#) to see if there is a reasonable match. This can sometimes be an iterative process but allows backwater effects to be reflected in the [TR-20](#) analysis. Please note that a similar process can be done with [HEC-1 / HEC-HMS](#).

An inflow hydrograph into a pump station can be developed using [TR-20](#); however there is no provision for pump station routing. Therefore, when using [TR-20](#) to evaluate a pump station, the pump station routing can only be performed by hand calculations or with a spreadsheet. Pump Station procedures are more thoroughly discussed in [Chapter 13](#).

It is good practice for the modeler to become familiar with the theory used to develop [TR-20](#) by reading the manual and any other related literature. The NRCS website is a good source of data. Reasonable attempts should be made to calibrate the modeling results by running historical rainfall and comparing the results to gage data or comparing flood elevations derived using the [TR-20](#) flows to high-water marks.

[TR-20](#) and [TR-55](#) were developed with sub-basins no larger than 2,000 acres. Other agencies may have more restrictive requirements as far as the minimum number of sub-basins and the maximum acreage of each sub-basin. There are some assumptions of homogeneity of the land use considered in the method. Subdividing the watershed is the solution. [WinTR-55](#) is not well adapted for the use of the Huff Distribution. It will allow the user to customize only one distribution with one storm event (Ex. 1-hr (First-Quartile Distribution) 50-yr Storm). [WinTR-20](#) will allow all Four Quartile Distributions with virtually an unlimited number of Storm Events. The TY II Distribution produces significantly higher flows than the Huff Distribution. On the order of two to three times larger are not uncommon. This phenomenon may be because the Huff Distribution was developed specifically for Illinois, whereas the TY II Distribution was not. [WinTR-20](#) requires the Huff Distribution to be entered in a particular format. Each Storm Duration has to be entered as its own Rainfall Distribution using the percentages in the appropriate Quartile's Cumulative Percent Storm Rainfall from [Circular 173¹³ Tables 1, 3, and 4](#) with a Time increment equal to $1/20^{\text{th}}$ of the storm Duration. The $1/20^{\text{th}}$ increment is due to the fact that there are 20 increments in given in [Circular 173¹³ Tables 1, 3, and 4](#).



Win TR-20 2-hr (1st Quartile) Storm – Rainfall Distribution

Each Flood Frequency Event has to be entered as its own Storm Analysis using the rainfall depth from [Bulletin 70⁵](#) for the appropriate Zone, Storm Duration, and Frequency Event.

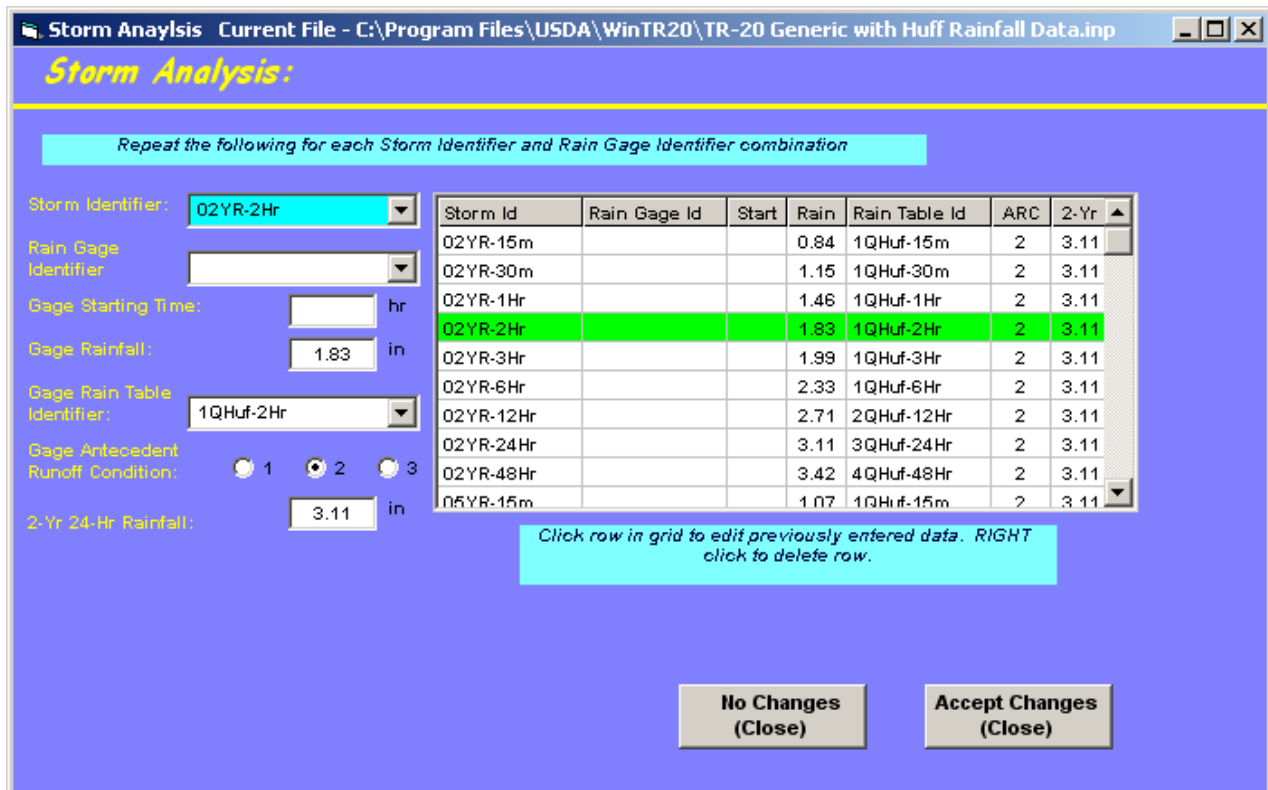

Win TR-20 2-yr, 2-hr (Zone 1 NW) – Storm Analysis

4-104 HEC-1 /HEC-HMS

HEC-HMS was developed by The U.S. Army Corps of Engineers and supersedes HEC-1 (<http://www.hec.usace.army.mil/software/legacysoftware/hec1/hec1-download.htm> - last released in 1998). HEC-HMS is Windows based and can be downloaded from the following link: <http://www.hec.usace.army.mil/software/hec-hms/>. It is also a hydrograph-oriented program with the capability to compute, combine and route hydrographs through a system of sub areas. HEC-1 /HEC-HMS can be utilized for any size basin. Input requirements are similar to TR-20; HEC-1 /HEC-HMS can also fully utilize ISWS [Bulletin 70](#)⁵ rainfall data.

Table 4-002 indicates that HEC-1 /HEC-HMS and TR-20 are the Division of Highways primary models for most projects requiring hydrograph analysis. Again, refer to Chapter 14 for further information on hydrologic models.

HEC-1 /HEC-HMS allow the user to select from several unit hydrograph methods in order to develop runoff hydrographs. These include the NRCS, Snyder, Clark, or Distributed Runoff using Kinematic Wave and Muskingham-Cunge Routing. Of particular interest in Illinois is the Clark Unit hydrograph as parameters for this method have been developed specifically for Illinois. The United State Geological Society (USGS) published [Water Resource Investigations 82-22 entitled, "A Technique for Estimating Time of Concentration and Storage Coefficient Values for Illinois Streams"](#)¹⁰ which provides guidelines for estimating these parameters. A similar report was prepared by the USGS ([Open-File Report 96-474](#)¹¹) for small watersheds in Lake County. This report may also be applicable in other areas of Northeastern Illinois after careful consideration of watershed characteristics. [Water Resource Investigations 00-4184 entitled, "Equations for estimating Clark Unit-hydrograph parameters for small rural watersheds in Illinois"](#)¹² can be used to estimate Clark Unit Hydrograph parameters for small rural watersheds throughout Illinois.

Once a unit hydrograph methodology is selected, a critical storm duration analysis using Huff Rainfall Distributions from [Bulletin 70](#)⁵ should be performed and the results tabulated to determine the peak flow at the point of interest, as is done with TR-20. Precipitation losses are usually estimated using the NRCS curve number (CN) method, which is widely used and accepted. The parameters needed to apply the other loss rate parameters offered in HEC-1 /HEC-HMS are generally not as readily available as they are for the NRCS curve number method (previously explained in TR-20 section).

Additionally, HEC-1 /HEC-HMS has features that allow representation of various kinds of storage routing procedures such as Muskingham-Cunge and Modified-Puls. The modeler should consider which method reasonably represents the characteristics of the study area. Modified-Puls can be applied to very flat streams such as those frequently found in Illinois which exhibit a looped storage effect where a very small bottom slope requires a substantial depth gradient to move the flood flow. Due to the nature of the floodplain, the early stages of a flood primarily enter storage with little change in outflow until the storage is no longer available. Muskingham-Cunge is applicable to a wide range of channel and hydrograph conditions and can account for backwater effects. Reservoir storage can also be represented with HEC-1 /HEC-HMS and the methodology previously described for TR-20 can be used to reflect backwater impacts on flood flows.

Both flow diversions and pumping operations can be simulated in HEC-1 /HEC-HMS. Input tables showing inflow versus diverted flow are needed to represent a flow diversion and both diverted flow or pumped flow can be returned to the system. Several pumps with different on and off elevations can be represented; however, pumps are either on or off and there is no variation in

discharge with head, so that each pump discharges at a constant rate. Final pump station routing should be performed by hand/spreadsheet as a check. Pump Station procedures are more thoroughly discussed in [Chapter 13](#).

It is good practice for the modeler to become familiar with the theory used to develop HEC-1 /HEC-HMS modeling techniques by reading the manual and any other related literature. [The United States Army Corps of Engineering](#) Center's website is a good source of reference material. Reasonable attempts should be made to calibrate the modeling results such as by running historical rainfall and comparing the results to gage data or comparing flood elevations derived using the HEC-1 /HEC-HMS flows to high-water marks.

HEC-HMS also allows the use of the Huff Distribution with virtually no restrictions, unlike [Win TR-55](#). HEC-HMS requires the Huff Distribution to be entered as a Precipitation Gage within the Time-Series Data Component of the program. Each Storm Code is its own Precipitation Gage - (1 Hour storm, 2 Hour storm, etc.). This is because the Time Interval may differ for each Storm Code, depending on number of ordinates entered to replicate the proper Huff Distribution Quartile. A 2-hr Storm using 20 increments yields 6 minute increments (1/20 of 120 minutes).

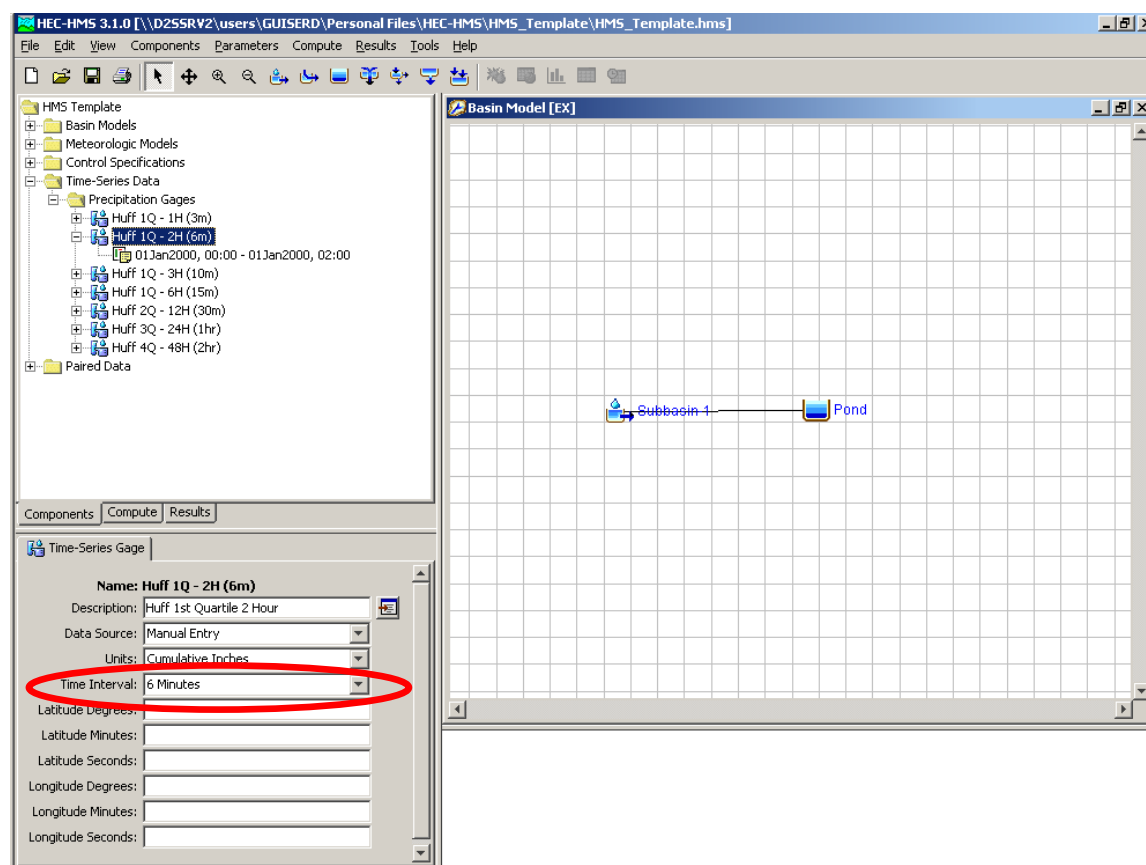

HEC-HMS 2-hr (1st Quartile) Storm – Precipitation Gage

A number of ordinates other than 20 for the Huff Distribution Quartile may be obtained by interpolation. The number of desired ordinates depends on the Time Interval chosen. HEC-HMS has built-in Time Intervals that are chosen from the drop down menu. Those are the only choices available within HEC-HMS. The user cannot directly input a Time Interval.

Determining the number of ordinates required, so that one of the choices from the drop down menu can be utilized, can be determined by dividing the Storm Code by the chosen Time Interval built into HEC-HMS. It is advisable to choose a Time Interval less than that produced with 20 ordinate points, which in turn will assure that the number of ordinates are greater than 20.

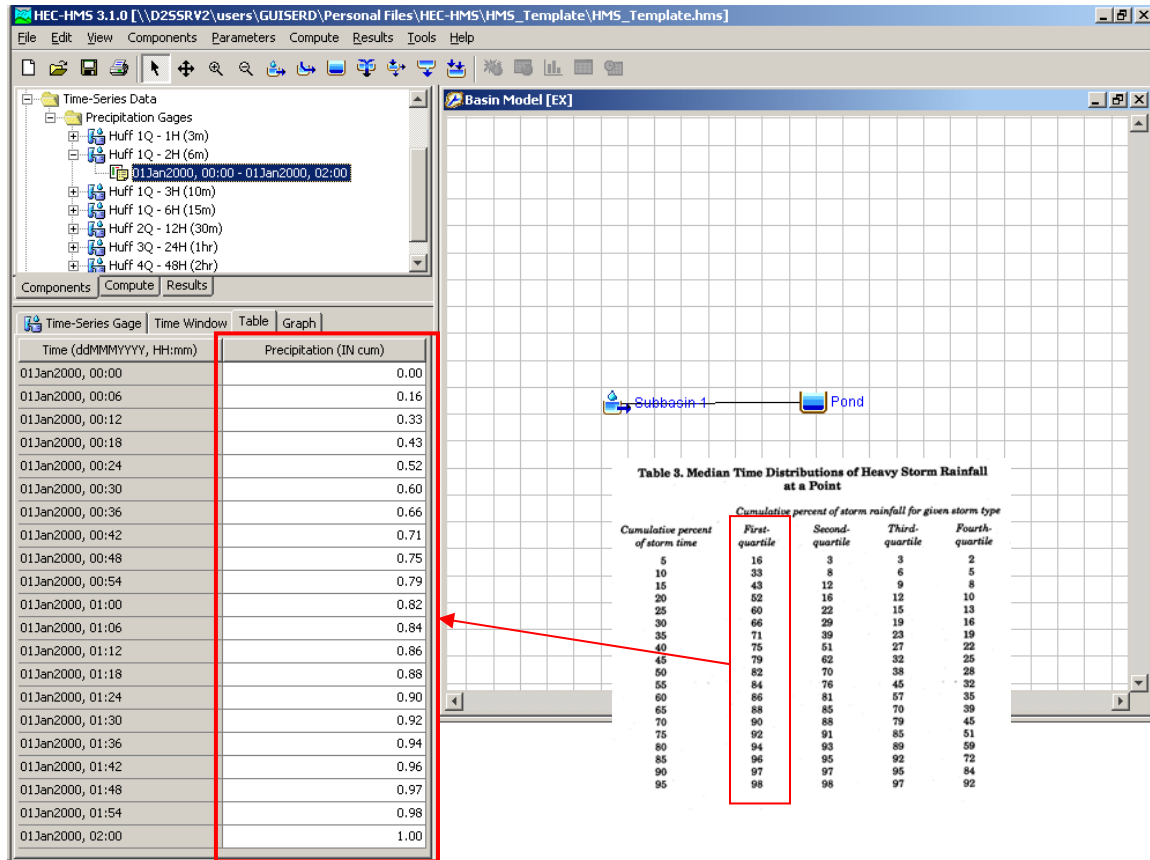

HEC-HMS 2-hr (1st Quartile) Storm – Precipitation Gage

The ordinates from the Huff Distribution are entered as a decimal percentage (from Circular 173¹³, Table 3, pg 14) in the Table Tab in the Precipitation column.

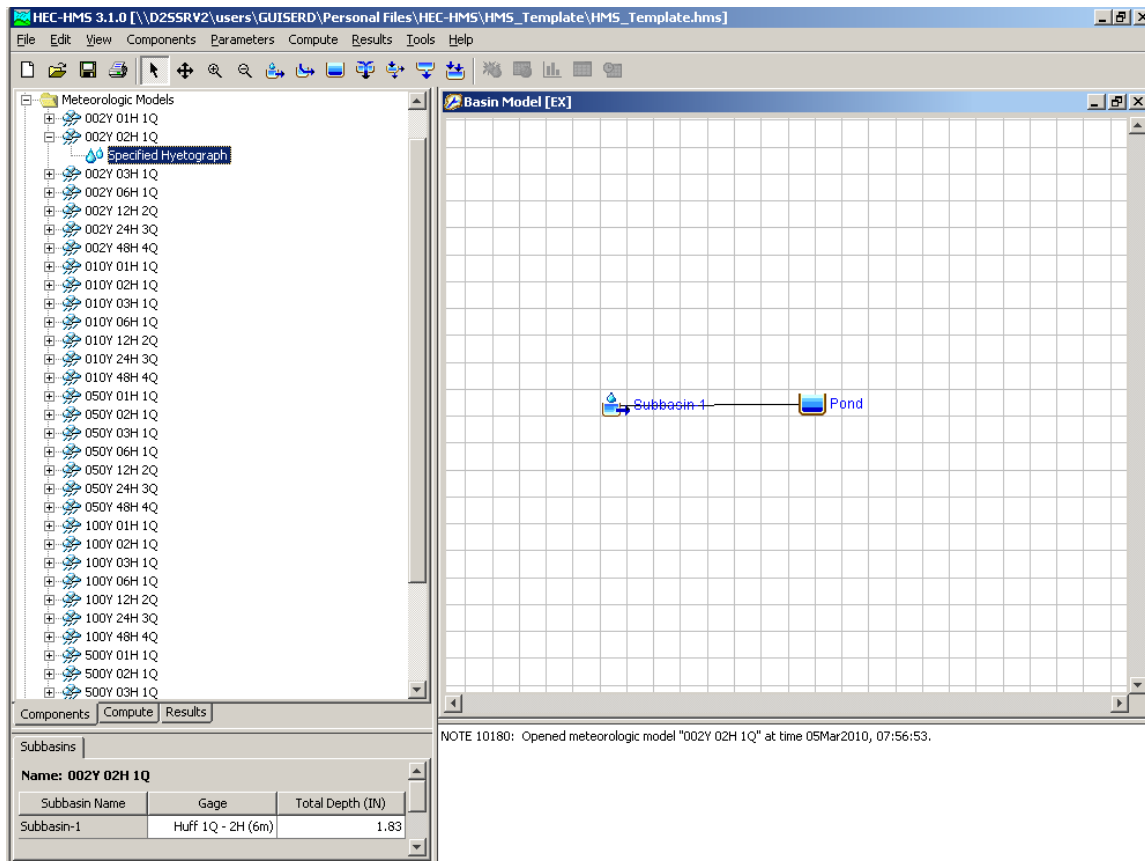

HEC-HMS 2-yr 2-hr Storm (Zone 1 NW) – Meteorologic Model

The appropriate Precipitation Gage is chosen in the Gage column and the rainfall depth for the applicable Zone Code and Storm Code from [Bulletin 70⁵ Table 13](#) is entered in the Total Depth column.

4-200 APPLICATION OF RAINFALL DATA TO HYDROLOGIC METHODS

4-201 Introduction

The USGS [StreamStats](#)¹ Method in Section 4-101.01 uses regression analysis to transpose historical stream gaging data into peak discharge estimates. The website documents the 288 USGS-operated gaging stations around the State of Illinois used for this purpose. [StreamStats](#)¹ is self-contained in the sense that the method does not require the user to import any other sources of data or rainfall information. This section covers methods that differ from [StreamStats](#)¹ in two major respects. First, some of the methods (SCS and HMS) are hydrograph based, meaning they produce a hydrograph of flow versus time for the watershed conditions and storm duration specified by the user. Secondly, Section 4-201 methods are not self-contained. All of them (including the Rational Method) require rainfall data from an external source. That source is the Illinois State Water Survey study ("[Frequency Distribution and Hydroclimatic Characteristics of Heavy Rainstorms in Illinois](#)") commonly referred to as [Bulletin 70](#)⁵, detailed in Sec 4-202.

Hydrologic Method

	Rational	TR-20	TR-55	HEC-1 / HEC-HMS
Calculates Peak Discharge	√	√	√	√
Produces Hydrograph		√	√	√
Critical Duration Analysis		√	*	√
Requires Bulletin 70 Rainfall Data	√	√	√	√

(*) Limited to one User-Defined Distribution with one Storm Event.

(**) The USGS Regression Equations do not require any rainfall data for their calculations.

Table 4-201

4-202 ISWS Bulletin 70 Rainfall Data

In 1989 the ISWS (Illinois State Water Survey) published [Bulletin 70](#)⁵ entitled "Frequency Distribution and Hydroclimatic Characteristics of Heavy Rainstorms in Illinois", by Floyd A. Huff and James R. Angel. The ISWS study contains data and techniques for estimating rainfall amounts and time distributions. In 1990 it was followed by two more ISWS publications. [Circular 172](#)⁹ is a numerical abstract of [Bulletin 70](#)⁵ which contains rainfall frequency distributions for 10 distinct sections of Illinois. [Circular 173](#)¹³ includes time-distribution relationships and is recommended for use in conjunction with [Bulletin 70](#)⁵ data. Together, the three volumes represent a research study utilizing 83 years of gaging data taken from 61 stations around the state. All three publications will be referred to collectively as [Bulletin 70](#)⁵ in this manual.

This larger and longer sampling makes [Bulletin 70](#)⁵ the most complete recent study available for Illinois, leading to its acceptance by a number of agencies around the state. Consequently, this replaces previous rainfall data such as Technical Paper 40 (TP40) and Technical Letter 13

(TL13). Its use is recommended for purposes of estimating runoff with the Department's standard hydrologic procedures; Rational Method, [TR-20](#), and [HEC-1 /HEC-HMS](#).

[NOAA Atlas 14 Volume 2 "Precipitation-Frequency Atlas of the United States"](#)¹⁴ is a more recent study available and contains similar values as [Bulletin 70](#)⁵, but is not preferred since [Bulletin 70](#)⁵ is specific to Illinois, whereas NOAA Atlas 14 Volume 2 encompasses a much broader area - the Ohio River Basin and Surrounding States.

4-203 ISWS Bulletin 70 Rainfall Data: Selecting Rainfall Amounts and Time Distributions

4-203.01 Rainfall Amounts

[Bulletin 70](#)⁵ provides total rainfall (inches) for a storm of given duration and frequency by dividing Illinois into 10 zones ([Fig. 4-102a](#)) of "homogeneous precipitation climate". The point rainfall depths grouped by storm are shown in [Bulletin 70](#)⁵ [Table 13, page 29](#). These average values are referred to as "sectional" values and are adequate for drainage basins that are entirely contained within one zone.

For larger basins that overlap 2 or more sections, the isohyetal mapping in [Figures 3-11, pages 8-25, Circular-172](#)⁹ is recommended. The mapping also reflects point rainfall amounts and details the variation of rainfall across the state for storm durations of 30 minutes and greater.

When the drainage area under study exceeds 10 sq mi, areal reduction factors in [Bulletin 70](#)⁵ [Table 35, Pg. 97](#) should be utilized to reduce the point rainfall amount. This adjustment is needed regardless if the point rainfall is taken from the tables or from the isohyets. If the Drainage Area of the Site is not an exact match to one of the Table's column values, then the areal reduction factor shall be calculated from a Linear Interpolation of the Table values. If the Drainage Area exceeds 400 Sq Mi, it is recommended that rainfall for individual subareas be adjusted using the subarea watershed size and [Table 4-203.01](#), consult IDOT District staff if in doubt.

Relations between Areal Mean and Point Rainfall Frequency Distributions
Ratio of areal to point rainfall for given area

Storm Period (hrs)	10 Sq Mi.	25 Sq Mi.	50 Sq Mi.	100 Sq Mi.	200 Sq Mi.	400 Sq Mi.
0.5	0.88	0.80	0.74	0.68	0.62	0.56
1.0	0.92	0.87	0.83	0.78	0.74	0.70
2.0	0.95	0.91	0.88	0.84	0.81	0.78
3.0	0.96	0.93	0.90	0.87	0.84	0.81
6.0	0.97	0.94	0.92	0.89	0.87	0.84
12.0	0.98	0.96	0.94	0.92	0.90	0.88
24.0	0.99	0.97	0.95	0.94	0.93	0.91
48.0	0.99	0.98	0.97	0.96	0.95	0.94

(From [Bulletin 70⁵](#) Table 35, pg. 97)
Table 4-203.01

Two locations in Illinois require slight deviation from the above procedure:

1. Chicago Metropolitan Area - The six-county Chicago metropolitan area ([Circular 172⁹](#), pg. 26, [Figure 12](#)) located in the Northeast Section (Cook, DuPage, Will, Lake, McHenry, and Kane Counties) was the subject of a special study within [Bulletin 70⁵](#). The authors developed separate rainfall amounts for the six-county area and also for the Chicago urban area proper. Isohyetal maps for both are shown in [Figures 13 and 14](#), pages 28-31 ISWS [Circular-172⁹](#). The isohyets display significant deviation from the average Northeast section values mentioned above. For example, the 50 year, 24-hour isohyetal based rainfall depth in Lake County varies from 5.5 to 7 inches, while the sectional average equals 6.46 inches. Therefore, using the appropriate mapping in the six-county area and the Chicago urban area for all bridges, Large Multi-Cell culverts, pump stations and detention basins is recommended. Sectional values from [Table 13 of Bulletin 70⁵](#) can be utilized for storm sewers, pavement drainage, roadside ditches, and Small Across Road (AR), Sideroad, and Entrance culverts. Sectional values are acceptable for these structures associated with lower discharges, unless local ordinances dictate using the isohyetal mapping.

Note that [Figure 13 and 14](#) mapping applies only to 24-hour duration storms. For other durations ranging from 5 minutes to 72 hours, multiply the isohyetal value by the correct adjustment factor from [Table 2 on Page 32 ISWS Circular-172⁹](#).

2. Madison County - [Bulletin 70⁵](#) also identifies an anomaly around the St. Louis urban area that affects rainfall amounts downwind of the city. Consequently, Madison County rainfall is 12-25 percent higher than typical Southwest section values for certain storm durations. [Table 4 page 35 ISWS Circular-172⁹](#) contains the correct precipitation estimates for those specific events. This table and the dashed line portion of the I-D-F curves [Figure 4-102k](#) are for use in this county only.

CHART A: SUMMARY OF RECOMMENDED RAINFALL DATA

District 1: Isohyetal Mapping (Figures 13 and 14, pages 28-31 ISWS Circular-172⁹) for bridges, Large Multi-Cell culverts, pumping stations, and detention basins. Adjust rainfall for durations other than 24 hours. Sectional values (Table 13 page 29 of Bulletin 70⁵ and Figures 4-102b through k) for storm sewers, pavement drainage, roadside ditches, and Small Across Road (AR), Sideroad, and Entrance culverts only.

Districts 2 - 9: Sectional values (Table 13 pg 29 of Bulletin 70⁵ and Figures 4-102b through k) (See above for Madison County adjustment). Isohyetal mapping only for watersheds which overlap sections.

NOTE: For drainage areas > 10 sq mi in all Districts, utilize the areal reduction factors (Bulletin 70⁵ Table 35, Pg. 97) for both mapping and sectional values. If the Drainage Area of the Site is not an exact match to one of the Table's column values, then the aerial reduction factor shall be calculated from a Linear Interpolation of the Table values.

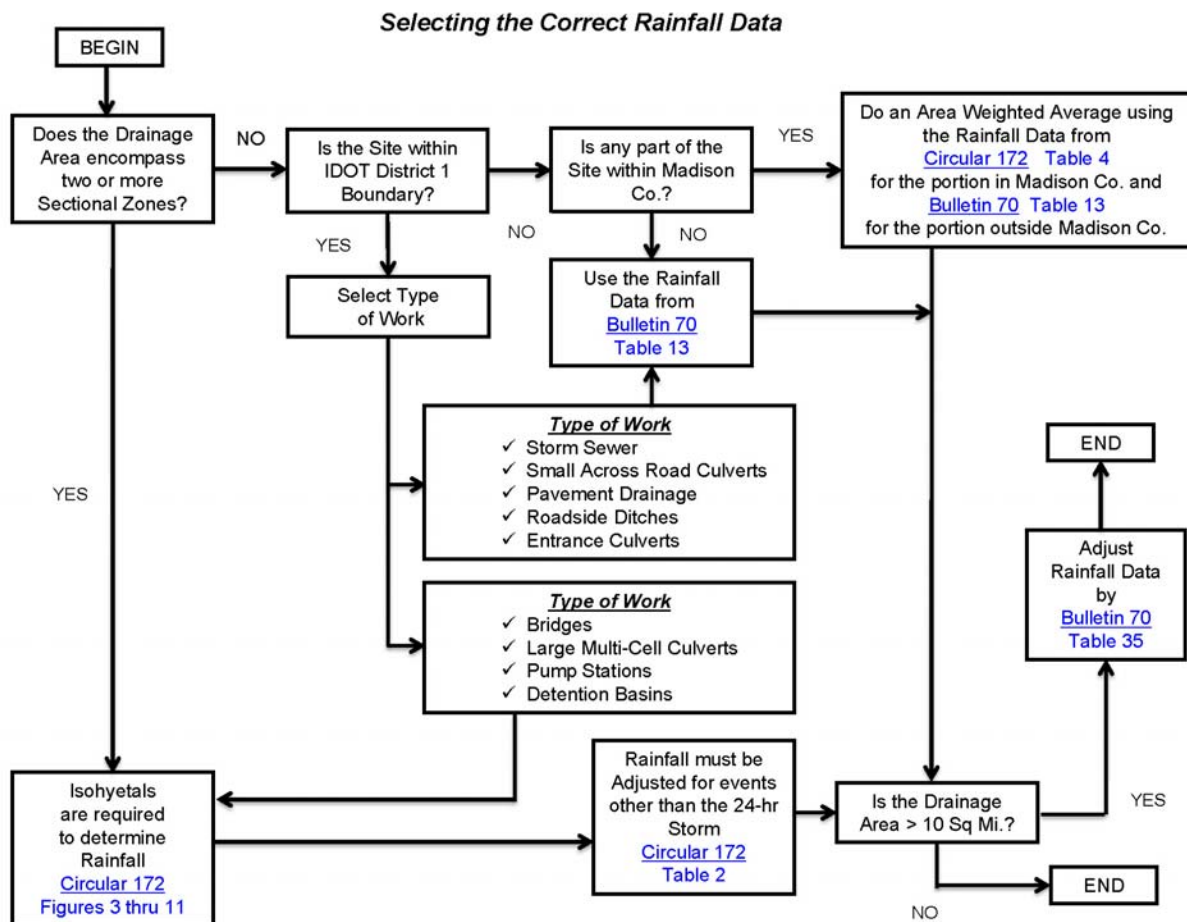

Figure 4-203.01

4-203.02 *Time Distributions*

[Circular 173¹³](#) categorizes storms as 1st, 2nd, 3rd or 4th quartile according to whether the largest percentage of total rainfall occurs in the first, second, third, or fourth quarter of the storm duration. Cumulative percentage values of total rainfall are then plotted against percent of elapsed storm time to form a time distribution.

The appropriate quartile should be based on the particular design duration under consideration. The following chart shows the recommended relationship between duration and quartile type:

CHART B: SELECTION OF QUARTILE TYPE

<u>Quartile Type</u>	<u>Design Storm Duration</u>
1st	≤6 hours
2nd	>6 to ≤12 hours
3rd	>12 to ≤24 hours
4th	> 24 hours

(From [Circular 173¹³](#) pgs 11 & 16)
Table 4-203.02

[Circular 173¹³](#) notes that some storms can fall into any of these 4 quartiles, each of which ultimately generates a unique hydrograph. Considering the uncertainty in computing time of concentration and subsequent design duration, choosing just 1 quartile type could be insufficient. It is suggested that if the design duration is near one of these boundaries, the results from both quartiles be compared and the most critical result be selected for design.

Once the quartile type has been determined, the correct time distribution is based on the drainage area. Refer to [Tables 1 page 10 and Tables 3 and 4 page 14 of Circular 173¹³](#). These tables contain median time distributions which represent the 50 percent probability curve or "average event" within a given quartile. The [Bulletin 70⁵](#) authors recommend these median values for design purposes.

4-204 Application of ISWS Bulletin 70 Rainfall Data to Hydrologic Methods

Rational Method I-D-F curves based upon [Bulletin 70⁵](#) rainfall data are shown in [Figures 4-102 b thru k](#). Using a duration which approximates the time of concentration for the particular watershed, select an intensity for your design frequency. In the Southwest section ([Figure 4-102k](#)), note the dashed lines for certain events in Madison County. All of the values in [Figures 4-102 b thru k](#) are based on sectional rainfall.

TR20 and HEC1/ HEC-HMS Both programs allow user specified rainfall amounts and time distributions in several different combinations. The storm duration can be varied to determine the critical value. This critical duration is usually defined as the duration which creates the maximum discharge for a given frequency. In addition, this critical duration may change with the frequency, depending on the storage characteristics of the basin. Several runs may be needed to estimate the critical duration for each frequency in question.

For some analyses, peak discharge is not the primary concern. Detention basin analysis must also address storage volume requirements for given inflow and outflow hydrographs.

NOTE: [Bulletin 70⁵](#) data does not allow the user to compute the 500 year event directly for any of these methods; rainfall data was not compiled for events greater than the 100 year storm. There are several acceptable methods for determining the 500 year rainfall data:

- 1) Several calculated Q's plotted on a semi-log graph to develop a best fit line placed between the points and extended out to the 500-year event. This is similar to the Log-Pearson Type III plot discussed in section [4-101.035](#). This method will produce the estimated 500 year flow.
- 2) Plotting of a frequency curve of rainfall depths to develop a best fit curve and extended out to the 500-year event. This method will produce the estimated 500 year rainfall depth.
- 3) The Rainfall Intensity Equation ([Eq. 4-13](#)) may also be used. For [TR-20](#), [HEC-1](#), or [HEC-HMS](#), the value calculated from the equation must be converted from an Intensity (in/ hr) to a Depth (in). This can be accomplished by multiplying the Intensity from [Eq. 4-13](#) by the Storm Duration (hrs). This method will also produce the estimated 500 year rainfall depth.

4-204.01 Example Problem 8 (Rational Method)

Given:

Watershed size = 145 ac
Time of concentration $T_c = 2.0$ hr
Design Frequency = 50 years

Find:

The 50-year event Rainfall Intensity using [Bulletin 70⁵](#) data at a site in northern most Kane County.

Solution:

[Figure 4-102a](#) indicates Kane County lies in the Northeast Zone #2. Kane County is within the 6-county Area ([Circular-172⁹](#), pg. 26, [Figure 12](#)); therefore, isohyets are required, instead of choosing the value from [Bulletin 70 Table 13](#). [Figures 13 and 14, pages 28-31 ISWS Circular-172⁹](#) indicates the 50 year, 24-hour event, rainfall is about 6 inches as opposed to 6.46 inches from [Bulletin 70⁵](#). Because the basin is less than 10 sq mi, no areal reduction factor is needed. Since the duration, which is equal to the time of concentration (2 hrs), is not equal to 24 hours, the 6 inch estimate must be adjusted. [Table 2 on Page 32 ISWS Circular-172⁹](#) shows an adjustment factor of 0.58. The 50 year, 2-hour rainfall becomes 6.0 inches x 0.58 = 3.5 inches. Since the Rational Method requires an intensity, $I = 3.5 \text{ in}/2.0 \text{ hr} = 1.75 \text{ in/hr}$.

(The IDF curves of [Figure 4-102b through k](#) were prepared in this same manner, using the sectional values. [Figure 4-102c](#) indicates an intensity of approximately 1.91 in/hr for the 50 year, 2-hour event.)

4-204.02 Example Problem 9 (NRCS or HEC-HMS Method)

Given:

A site in McHenry County near Woodstock has a Drainage Area of 12.2 Sq Mi. A Temporary Pipe needs to be sized to be in service for up to one Construction Season. As per 1-500 Temporary Structures, temporary structures which are to remain in service for three months to one construction season are to be designed for a minimum one-year frequency (Q1) event

Find:

Using [Bulletin 70⁵](#) data and critical duration analysis, determine:

1. Design rainfall amount for the Q1 event.
2. Compare accumulated rainfall 45 minutes into the design event for various storm durations.

Solution:

For this Critical Duration Analysis, the 1, 2, 3, 6, 12, 24, and 48-hour storm durations should be considered. Since this site lies within the 6-county study area ([Circular-172⁹, pg. 26, Figure 12](#)), the use of the isohyets from [Circular 172⁹ pg 30 Figure 14](#) will be required. From the isohyets in [Circular 172⁹ pg 30 Figure 14](#), the 1-year, 24-hour rainfall in McHenry County near Woodstock is 2.42 inches. The isohyets are based on a 24-hour storm event; therefore, the storm durations other than the 24-hour event will have to be adjusted using a reduction factor from [Circular 172⁹ pg 32 Table 2](#).

Storm Duration (hr)	Isohyetal Rainfall (24-hr) (inches)	Adjustment Factor	Adjusted Rainfall (inches)
1	2.42	0.47	1.14
2	2.42	0.58	1.40
3	2.42	0.64	1.55
6	2.42	0.75	1.82
12	2.42	0.87	2.11
24	2.42	1.00	2.42
48	2.42	1.08	2.61

Since the Site Drainage Area is greater than 10 Sq Mi., an Areal Reduction is required. Since the Drainage Area of the Site is not an exact match to one of the Table’s column values from [Bulletin 70⁵ pg 97 Table 35](#), the aerial reduction factor will have to be calculated from a Linear Interpolation of the Table values.

Storm Duration (hr)	Adjusted Rainfall (inches)	Areal Reduction Factor*	Adjusted Rainfall (inches)
1	1.14	0.91	1.04
2	1.40	0.94	1.32
3	1.55	0.96	1.49
6	1.82	0.97	1.77
12	2.11	0.98	2.07
24	2.42	0.99	2.40
48	2.61	0.99	2.58

- Values may need to be interpolated

The storm durations vary; therefore, the correct Quartile will need to be determined from [Table 4-203.02](#) and the appropriate Time Distribution from [Circular 173¹³ pg 14 Table 4](#) applied (Drainage Area is between 10 and 50 Sq Mi.).

Storm Duration (hr)	Quartile
1	1
2	1
3	1
6	1
12	2
24	3
48	4

The Rainfall Amount after 45 minutes for each storm event is desired. It is necessary to determine what percentage is Forty-five minutes (0.75 hrs) for each storm duration.

Storm Duration (hr)	Percentage of Total Storm Duration
1	75.0
2	37.5
3	25.0
6	12.5
12	6.3
24	3.1
48	1.6

The Percentage of Total Storm Duration (shown above) is then used to find the Cumulative Percent of Storm Rainfall from [Circular 173¹³ pg 14 Table 4](#) (shown below in Column 1) to get the Cumulative Percent of Storm Rainfall (shown below in Columns 2 thru 5 depending on the Quartile of the particular Storm event).

Cumulative Percent of Storm Time	1 st Quartile	2 nd Quartile	3 rd Quartile	4 th Quartile
0	0	0	0	0
5	12	3	2	2
10	25	6	5	4
15	38	10	8	7
20	51	14	12	9
25	62	21	14	11
30	69	30	17	13
35	74	40	20	15
40	78	52	23	18
45	81	63	27	21
50	84	72	33	24
55	86	78	42	27
60	88	83	55	30
65	90	87	69	34
70	92	90	79	40
75	94	92	86	47
80	95	94	91	57
85	96	96	94	74
90	97	97	96	88
95	98	98	98	95
100	100	100	100	100

Storm Duration (hr)	Quartile	Percentage of Total Storm Duration	Cumulative Percent of Storm Rainfall *
1	1	75.0	94.0
2	1	37.5	76.0
3	1	25.0	62.0
6	1	12.5	31.5
12	2	6.25	3.75
24	3	3.13	1.24
48	4	1.56	0.63

•Values may need to be interpolated

Storm Duration (hr)	Adjusted Rainfall (inches)	Cumulative Percent of Storm Rainfall	Rainfall Depth after 45 min (inches)
1	1.04	94.0	0.98
2	1.32	76.0	1.00
3	1.49	62.0	0.92
6	1.77	31.5	0.56
12	2.07	3.75	0.08
24	2.40	1.24	0.03
48	2.58	0.63	0.02

To complete the Critical Duration Analysis, the Peak Flow for each storm duration is needed. To do so, the user would input the adjusted rainfall depth (as shown in the chart above column 2) into [TR-20](#), [HEC-1](#), or [HEC-HMS](#) along with the appropriate Time Distribution (Huff).

The sizing of the pipe can be accomplished by incorporating a trial pipe size into the [TR-20](#), [HEC-1](#), or [HEC-HMS](#) model or a stand-alone program such as [WinHY-8](#) using the largest of the Peak flows from the Critical Duration Analysis.

Conclusion:

1) The Design Rainfall Amount for the Q1 event for each Storm Duration are as follows:

Storm Duration (hr)	Design Rainfall Amount (inches)
1	1.04
2	1.32
3	1.49
6	1.77
12	2.07
24	2.40
48	2.58

2) The accumulated Rainfall Amount 45 minutes into the design event are as follows:

Storm Duration (hr)	Rainfall Depth after 45 min (inches)
1	0.98
2	1.00
3	0.92
6	0.56
12	0.08
24	0.03
48	0.02

4-300 REFERENCES

1. U.S. Geological Survey, *Estimating Flood-Peak Discharge Magnitudes and Frequencies for Rural Streams in Illinois*, Scientific Investigations Report 2004-5103. Soong, David T., Ishii, Audrey L., Sharpe, Jennifer B., and Avery, Charles F. 2004. (<http://pubs.er.usgs.gov/usgspubs/sir/sir20045103>)
2. U.S. Geological Survey. *Effects of Urbanization on the Magnitude and Frequency of Floods in Northeastern Illinois*, Water-Resources Investigations 79-36. Allen Jr., Howard E. and Bejcek, Richard M., 1979. (http://il.water.usgs.gov/pubs/wri79_36.pdf)
3. Water Resources Council. *Guidelines for Determining Flood Flow Bulletin 17B*. September 1981, Revised March 1982. (http://water.usgs.gov/osw/bulletin17b/dl_flow.pdf)
4. U.S. Geological Survey. *Estimating Generalized Skew of the Log-Pearson Type III Distribution for Annual Peak Floods in Illinois*. Water-Resources Investigations Report 86-4008. Oberg, Kevin A. and Mades, Dean M. 1987. (http://il.water.usgs.gov/pubs/wrir86_4008.pdf)
5. State Of Illinois Department of Energy and Natural Resources. *Frequency Distributions and Climatic Characteristics of Heavy Rainstorms in Illinois*. Illinois State Water Survey Bulletin 70. Floyd A. Huff and James R. Angel, 1989. (<http://www.isws.illinois.edu/atmos/statecli/PDF/b70-all.pdf>)
6. U.S. Department of Transportation, Federal Highway Administration. *Urban Drainage Design Manual*. Hydraulic Engineering Circular No. 22, September 2009. (<http://www.fhwa.dot.gov/engineering/hydraulics/pubs/10009/10009.pdf>)
7. U.S. Department of Transportation, Federal Highway Administration. *Highway Hydrology*. Hydraulic Design Series No. 2, Second Edition. October 2002. (<http://isddc.dot.gov/OLPFiles/FHWA/013248.pdf>)
8. United States Department of Agriculture Natural Resources Conservation Service. *Urban Hydrology for Small Watersheds*. Technical Release 55, June 1986. (<http://www.cpesec.org/reference/tr55.pdf>)
9. State Of Illinois Department of Energy and Natural Resources. *Frequency Distributions of Heavy Rainstorms in Illinois*. Illinois State Water Survey Circular 172. Floyd A. Huff and James R. Angel, 1989. (<http://www.isws.illinois.edu/pubdoc/C/ISWSC-172.pdf>)
10. U.S. Geological Survey. *A technique for estimating time of concentration and storage coefficient values for Illinois streams*, Water-Resources Investigations Report Open-File Report 82-22. Graf, J.B., Garklavs, G., and Oberg, K.A., 1982. (http://il.water.usgs.gov/pubs/wri82_22.pdf)
11. U.S. Geological Survey. *Equations for Estimating Synthetic Unit-Hydrograph Parameter Values for Small Watersheds in Lake County, Illinois*. Open-File Report 96-474. Melching, C.S., and Marquardt, J.S., 1997. (http://il.water.usgs.gov/pubs/ofr96_474.pdf)

12. U.S. Geological Survey. *Equations for estimating Clark Unit-hydrograph parameters for small rural watersheds in Illinois*. Water-Resources Investigations Report 00-4184. Straub, T.D., Melching, C.S., and Kocher, K.E. 2000. (http://il.water.usgs.gov/pubs/wrir00_4184.pdf)
13. State Of Illinois Department of Energy and Natural Resources. *Frequency Distributions and Climatic Characteristics of Heavy Rainstorms in Illinois*. Illinois State Water Survey Circular 173. Floyd A. Huff, 1990. (<http://www.isws.illinois.edu/atmos/statecli/RF/circular173.pdf>)
14. National Oceanic and Atmospheric Administration. *Precipitation – Frequency Atlas of the United States, Volume 2 Version 3.0*. Geoffrey M. Bonin, Deborah Martin, Bingzhang Lin, Tye Parzybok, Michael Yekta, and David Riley. 2004, Revised 2006. (http://www.nws.noaa.gov/oh/hdsc/PF_documents/Atlas14_Volume2.pdf)
15. U.S. Geological Survey. *Time of concentration and storage coefficient values for Illinois streams*. Water-Resources Investigations Report Open-File Report 82-13. Graf, J.B., Garklavs, G., and Oberg, K.A. 1982. (http://il.water.usgs.gov/pubs/wri82_13.pdf)



Chapter 5

Open Access
Chapter 5
Volume 1
World

CHAPTER 5 – OPEN CHANNEL FLOW

5-000 INTRODUCTION

- 5-001 Definition of Open Channel Flow
- 5-002 Application of Open Channel Flow to Highway Drainage

5-100 HYDRAULIC TERMS OF OPEN CHANNEL FLOW

- 5-101 Specific Energy
- 5-102 Energy Line (Total Energy Head Line)
- 5-103 Steady Flow and Unsteady Flow
- 5-104 Uniform Flow and Non-Uniform (Varied Flow)
- 5-105 Varied Flow
- 5-106 Froude Number
- 5-107 Critical Flow
- 5-108 Subcritical (Tranquil) Flow
- 5-109 Supercritical (Rapid) Flow
- 5-110 Hydraulic Jump

5-200 CLASSIFICATION OF OPEN CHANNEL FLOW

5-300 OPEN CHANNEL EQUATIONS

- 5-301 Manning's Equation
 - 5-301.01 Manning's Roughness Coefficient
 - 5-301.011 Channel Roughness Coefficient
 - 5-301.012 Floodplain Roughness Coefficient
- 5-302 Continuity Equation
- 5-303 Bernoulli Equation

5-400 STREAM ANALYSIS

- 5-401 Analysis by Manning's Equation
- 5-402 Analysis by Standard Step Method of Computation
- 5-403 Stream Analysis by Computer Programs

5-500

EXAMPLE PROBLEMS

5-501

Example Problem 1:

Illustration of Using Manning's Equation to Find Velocity and Discharge in a Channel

5-502

Example Problem 2:

Illustration of the Use of Trial and Error Method to Find the Normal Depth in a Channel

5-503

Example Problem 3:

Stream Analysis by Use of Manning's Equation and the Stage-Discharge Curve

5-600

HIGHWAY STRUCTURES

5-601

Weir Flow

5-602

Levee

5-700

CHANNEL MODIFICATION

5-701

Explanation

5-702

Coordination with Other Agencies

5-703

Guidelines and Requirements for Major Channel Modifications

5-800

REFERENCES

5-000 INTRODUCTION**5-001 Definition of Open Channel Flow**

The concept of open channel flow applies to any conveyance in which flowing water has a free surface subjected only to atmospheric pressure. Since the gage pressure is zero at the water surface, the flow in open channel is produced under the influence of gravity. The energy available is due to the elevation difference from one section to another section of the channel.

5-002 Application of Open Channel Flow to Highway Drainage

This section consists of the fundamental principles of open channel hydraulics, procedures for analysis, and practical examples of open channel flow for both highway drainage facilities and natural channels.

Highway facilities such as a roadside ditch, median, storm sewer, chute, gutter, flume, channel change, spillway, etc. are manmade channels providing a waterway to remove the rainfall runoff from the highway and adjacent areas. These channels may be either lined or unlined. When highways cross the natural channel, the waters carried by the channel must be conveyed in a manner which will minimize the effects of any highway restriction.

In general, the same fundamental hydraulic principles for open channel flow apply to both manmade and natural channels.

5-100 HYDRAULIC TERMS OF OPEN CHANNEL FLOW

5-101 Specific Energy

The specific energy (E) is the sum of the depth of flow (d) measured from the channel bottom and the velocity head ($v^2/2g$) as shown in [Figure 5-101](#).

$$E = d + \frac{V^2}{2g} \quad (\text{Eq. 5-1})$$

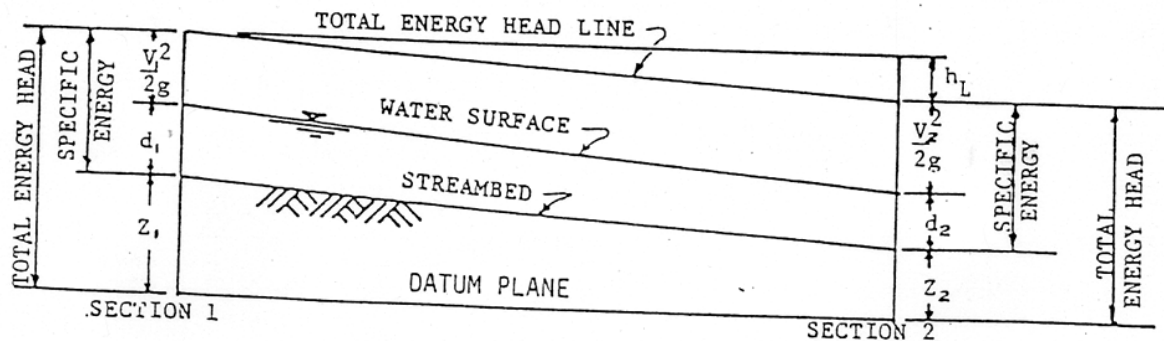

Energy in Open Channel Flow
Figure 5-101

5-102 Energy Line (Total Energy Head Line)

The total energy of flow in any section with reference to some datum is the sum of the elevation head (Z), the depth of flow (d), and the velocity head ($v^2/2g$). The energy from one section to another is represented by a line called the Energy Grade Line or Energy Line as shown in [Figure 5-101](#).

5-103 Steady Flow and Unsteady Flow

Flow in open channels is classified as steady flow or unsteady flow. Steady flow occurs when discharge or rate of flow at any cross section is constant with time. In unsteady flow the discharge or rate of flow varies from one cross section to another with time.

5-104 Uniform Flow and Non-Uniform (Varied) Flow

Uniform flow exists when the channel cross section, roughness, and slope are constant and thus the depth of flow at various points along the channel remains unchanged. Non-Uniform (varied) flow exists when the channel properties vary from section to section and thus the depth of flow changes at various points along the channel.

5-105 Varied Flow

Flow is varied if the depth of flow changes along the length of channel. Varied flow may be further classified as either rapidly or gradually varied. The flow is rapidly varied if the depth changes abruptly over a comparatively short distance such as in a hydraulic jump; otherwise, it is gradually varied.

5-106 Froude Number

The Froude Number is the ratio of the inertial force to that of gravitational force, expressed by the following equation:

$$Fr = \frac{V}{\sqrt{gD}} \quad (\text{Eq. 5-2})$$

$$D = \frac{A}{T} \quad (\text{Eq. 5-3})$$

Where:

- V = mean velocity of flow, ft/sec
- g = acceleration of gravity, ft/sec²
- D = hydraulic depth, ft
- A = cross sectional area of water normal to the direction of flow in the channel, ft²
- T = width of the free surface, ft

5-107 Critical Flow

The critical flow is defined as the condition for which the Froude Number is equal to one. At that state of flow, the specific energy is a minimum for a constant discharge. A specific energy diagram for a constant discharge is developed by plotting specific energy versus depth of flow as shown in Figure 5-107. The specific energy diagram, therefore, indicates the minimum specific energy for a given discharge. A discharge curve is developed by plotting specific energy versus discharge and indicates maximum discharge for a given specific energy as shown in Figure 5-107.

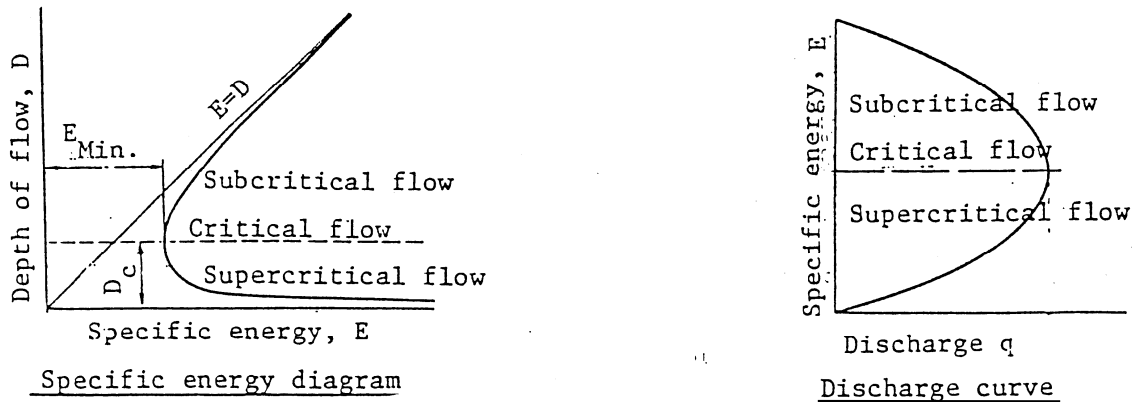

Figure 5-107

5-108 Subcritical (Tranquil) Flow

When the Froude Number is smaller than 1 at a given cross section or point of interest, the state of flow is defined as subcritical or tranquil flow and surface waves propagate upstream as well as downstream. Control of subcritical flow depth is always downstream.

5-109 Supercritical (Rapid) Flow

When the Froude Number is larger than 1 at a given cross section or point of interest, the state of flow is defined as supercritical or rapid flow and surface disturbance can propagate only in the downstream direction. Control of supercritical flow depth is always at the upstream end of the critical flow region.

5-110 Hydraulic Jump

A hydraulic jump occurs when a supercritical flow rapidly changes to subcritical flow as shown on Figure 5-110. The result is usually an abrupt rise of the water surface with an accompanying loss of kinetic energy. The hydraulic jump is an effective energy dissipation device which is often employed to control erosion at highway drainage structures.

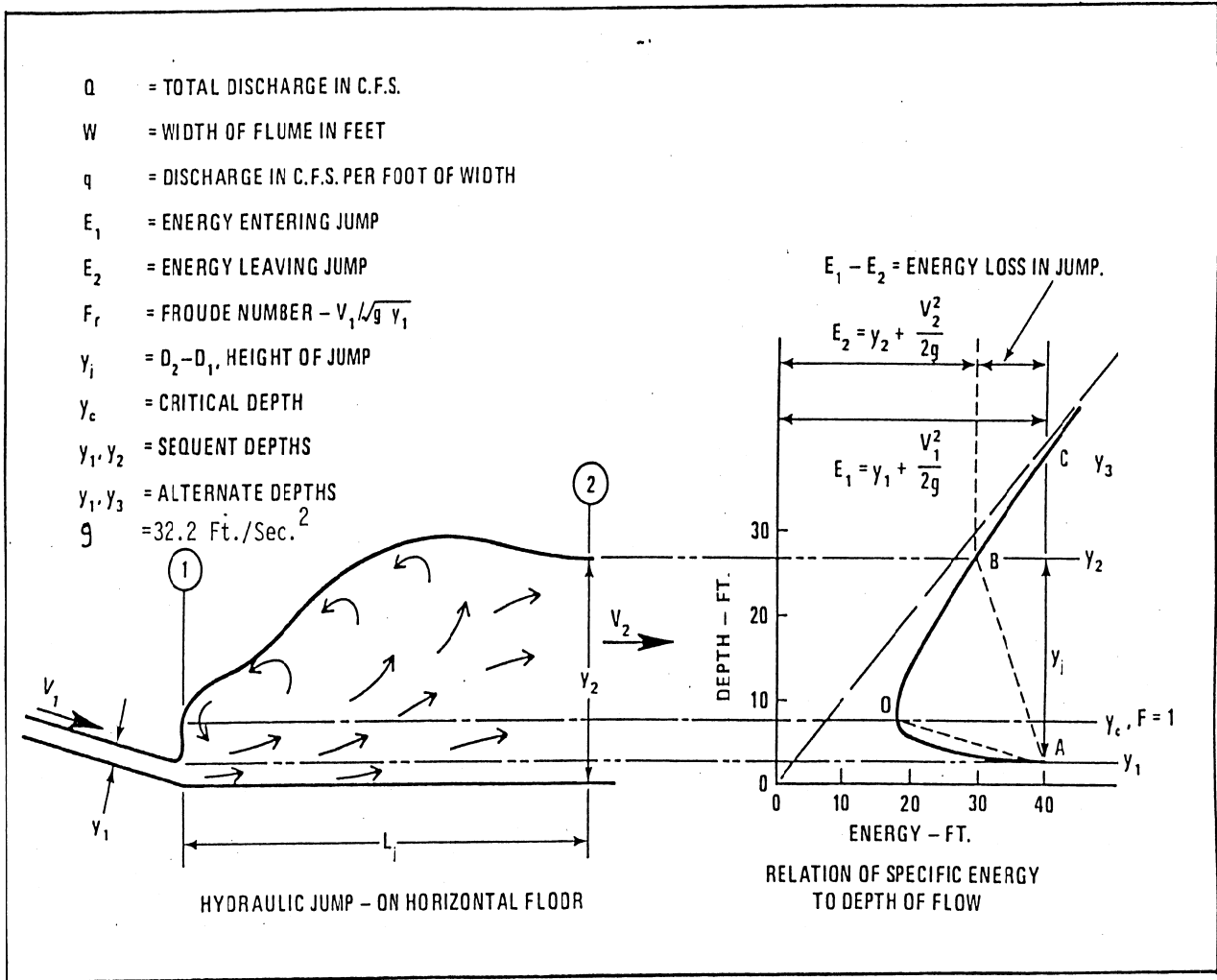

Hydraulic Jump
Figure 5-110

5-200 CLASSIFICATION OF OPEN CHANNEL FLOW

Flow in an open channel can be classified in various ways. It is usually classified as uniform or non-uniform flow, steady or unsteady (varied) flow, and subcritical (tranquil) or supercritical (rapid) flow.

For clarity, the classification of open channel flow can be summarized as follows:

Steady Flow

1. Uniform Flow
2. Non-uniform (Varied) Flow
 - a. Gradually Varied Flow
 - b. Rapidly Varied Flow

Unsteady Flow

1. Unsteady Uniform Flow (Rare)
2. Unsteady Non-Uniform Flow
 - a. Gradually Varied Unsteady Flow
 - b. Rapidly Varied Unsteady Flow

Even though open channel flow can be classified into so many types, the steady uniform and steady non-uniform flow are the most fundamental types of flow treated in Highway Engineering Hydraulics.

5-300 OPEN CHANNEL EQUATIONS

Open channel flow is most commonly analyzed by the use of the Manning's Equation, the Continuity Equation, and the Bernoulli Equation.

5-301 Manning's Equation

A useful tool for estimating capacities of open channel flow under steady uniform condition is Manning's Equation. This equation is also useful for determining the velocities of flow of water in open channels as well as through culverts and storm sewers that are subject only to atmospheric pressure. If the channel cross section, roughness, and slope are fairly constant over a sufficient distance to establish essentially steady uniform flow, Manning's Equation should give reliable results.

The Manning's Equation for velocity of flow in open channels is:

$$V = \frac{1.486}{n} R^{2/3} S^{1/2} \quad (\text{Eq. 5-4})$$

Where:

- V = mean velocity in feet per second, ft/sec
- n = Manning's coefficient of channel roughness
- R = hydraulic radius, ft
- S = slope, the slope of the energy gradeline, ft/ft, which may be parallel to the water surface. When the water surface slope is unknown, the streambed slope is normally used as an estimate.

The selection of the Manning's coefficient n is evaluated generally by observation; however, considerable experience is essential in selecting appropriate n values. The method used to determine Manning's n value is presented in [Section 5-301.01](#). The hydraulic radius is a shape factor that depends only upon the channel dimensions and the depth of the flow. It is defined as the section area of flow A divided by the wetted perimeter of flow P. It is computed by the equation:

$$R = \frac{A}{P} \quad (\text{Eq. 5-5})$$

Another basic equation in open channel hydraulics is the continuity equation:

$$Q = AV \quad (\text{Eq. 5-6})$$

Where:

- Q = discharge, cuft/sec
- A = cross sectional area, sq ft
- V = velocity, ft/sec

By combining Equations 5-4 and 5-6, the Manning's Equation can be used to compute discharge directly:

$$Q = \frac{1.486}{n} AR^{2/3} S^{1/2} \quad (\text{Eq. 5-7})$$

In open channel flow analysis, it is convenient to group the properties particular to the cross section in one term called conveyance K:

$$K = \frac{1.486}{n} AR^{2/3} \quad (\text{Eq. 5-8})$$

and

$$Q = KS^{1/2} \quad (\text{Eq. 5-9})$$

The concept of conveyance K is useful when computing the distribution of overbank flood flows in the stream cross section to that within the channel. Manning's Equation is not to be used for determining highwater elevations in an abnormal section such as a bridge opening.

Aids in the solution of the Manning's Equation:

A nomograph to simplify the solution of Manning's Equation is shown in Figure 5-301. The charts in the Appendix of this Manual (also found in "Design Charts_for Open Channel Flow" prepared by the U.S. Department of Transportation, Federal Highway Administration¹) give a direct and rapid determination of normal depth and normal velocity of flow for the particular cross sections, roughness, slope, and known discharge illustrated on the charts.

The Stage-Discharge curve is often termed the "rating curve" and is portrayed graphically by plotting flow depth versus discharge. From this curve, the Engineer can evaluate flow depths for a wide range of discharges. The cross section, Manning's coefficient, and streambed slope used to compute the stage-discharge relationship must be representative of channel conditions. This relationship curve indicates the flow depth of the channel for any particular discharge or indicates the flow discharge of the channel for any particular depth within the capacity limits of the channel cross section.

NOMOGRAPHIC SOLUTION OF THE MANNING FORMULA

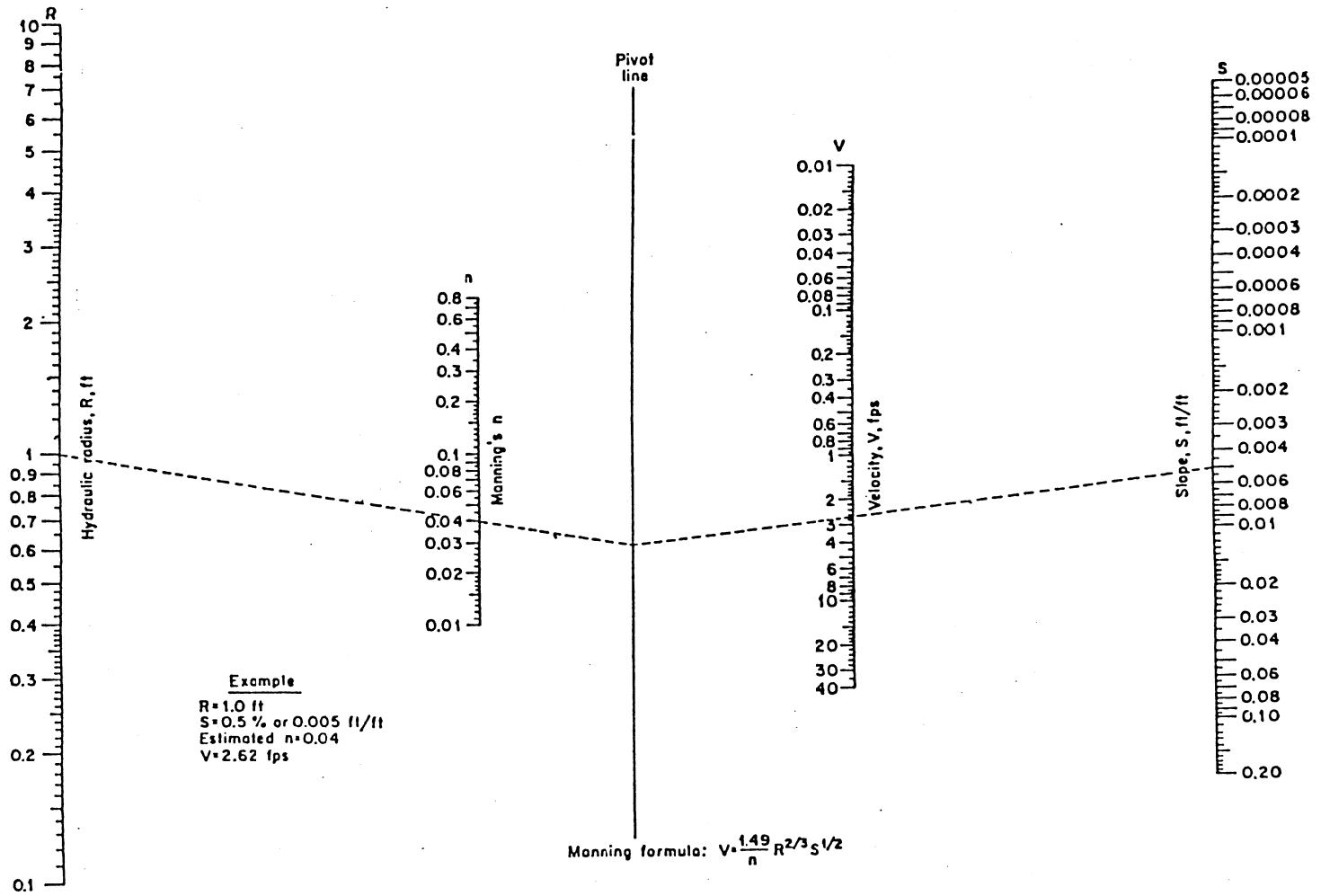

Figure 5-301

5-301.01 Manning's Roughness Coefficient

Values of roughness coefficient n should be assigned after a field inspection of the channel and floodplain. Consideration should be given as to how the channel and floodplain will change through the different seasons of the year. Crop rotation or the amounts of undergrowth in a timbered area are examples of seasonal considerations. In the unique case where there is a known water surface elevation and discharge from an actual flood event, the Manning's n values could be calibrated within reason to match the known event. When it is required to use FEMA flood profiles for permitting purposes, the Manning's n values used to generate the FEMA flood profiles should be used unless there were changes in the floodplain to justify new n values.

The roughness coefficients apply to a longitudinal reach of channel and (or) floodplain. Cross sections are typically divided into subsections at points where major roughness or geometric changes occur. For example, such changes may be at the juncture of dense woods and a pasture or a floodplain and main channel. However, subsections should reflect representative conditions in the reach rather than only at the cross section. A single n value should be assigned to the entire channel at each cross section.

Roughness values for floodplains can be quite different from values for channels. Therefore, roughness values for floodplains should be determined independently from channels. As in the computation of channel roughness, a base roughness n_b is assigned to the floodplain and adjustments for various roughness factors are made to determine the total n value for the floodplain.

A more complete discussion of n values is presented in the "Guide for Selecting Manning's Roughness Coefficient for Natural Channels and Floodplains" by the U.S. Department of Transportation – Federal Highway Administration². Excerpts from this publication are presented in [Section 5-301.011](#) and [5-301.012](#). This publication generally produces higher n values than previously shown in the Drainage Manual which were based on Ven T. Chow Open Channel Hydraulics³ text. The n values from Ven T. Chow's text are valid when used to analyze a roadside ditch (see Table 9-403). However, for channel analysis, n values should be based on the FHWA publications. Following are typical n values derived from the FHWA publications.

Description	Range
Clean, straight, dug channel	0.040 – 0.055
Large channel, width\bank height > 100	0.035 – 0.050
Lawn or pasture, short grass	0.035 – 0.045
Crops	0.060 – 0.080

These numbers would typically be revised upwards as ground cover or flow conditions suggest. For example, a winding, heavily overgrown channel n -value would typically be at 0.055 or higher.

Additional guidance on selecting Manning's n values can be obtained from the report titled "Data Base and Computational Tools to Aid in Determination of Roughness Coefficients of Streams" published by the U. S. Department of the Interior, U. S. Geological Survey⁴. This report (also available at <http://il.water.usgs.gov>) (1) compiles the available roughness coefficient data from all across the world; (2) presents said roughness data along with the associated hydraulic data and photographs in a searchable data base; and (3) provides computational tools that allow the user to interactively calculate roughness coefficients

based on several variables. Roughness coefficients for selected representative streams throughout Illinois also were computed during said study and are presented.

5-301.011 Channel Roughness Coefficient

Although several factors affect the selection of an n value for a channel, the most important factors are the type and size of the materials that compose the bed and banks of the channel and the shape of the channel. The following equation should be used in computing the n value for channels:

$$n = (n_b + n_1 + n_2 + n_3 + n_4)m \tag{Eq. 5-10}$$

Where:

- n_b = a base value of n for a straight uniform, smooth channel in natural materials
- n_1 = a value added to correct for the effect of surface irregularities
- n_2 = a value for variations in shape and size of the channel cross section
- n_3 = a value for obstructions
- n_4 = a value for vegetation and flow conditions
- m = a correction factor for meandering of the channel

Selection of Base n Value (n_b)

In the selection of a base n value for channels, the channel must be classified as a stable channel or as a sand channel. A sand channel is defined as a channel in which the bed has an unlimited supply of sand. [Table 5-301.011a](#) shows base n_b values for various size bed materials in a sand channel.

A stable channel is defined as a channel in which the bed is composed of firm soil, gravel, cobbles, boulders or bedrock and which remains relatively unchanged through most of the range in flow.

[Table 5-301.011b](#) shows the base n_b values for various types of stable channels and floodplains.

Table 5-301.011a
Base n_b Values for Sand Channels

Median size of bed materials Millimeters	Base n_b
0.2	0.012
0.3	0.017
0.4	0.020
0.5	0.022
0.6	0.023
0.8	0.025
1.0	0.026

Table 5-301.011b
Base n_b Values for Stable Channel and Floodplains

Material	Median Size of Bed Material Base n_b		
	<u>Millimeters</u>	<u>Inches</u>	<u>Range</u>
Concrete	-----	-----	0.012-0.018
Rock cut	-----	-----	-----
Firm soil	-----	-----	0.025-0.032
Coarse sand	1-2	-----	0.026-0.035
Fine gravel	-----	-----	-----
Gravel	2-64	0.08-2.5	0.028-0.035
Coarse gravel	-----	-----	-----
Cobble	64-256	2.5-10.1	0.030-0.050
Boulder	>256	>10.1	0.040-0.070

The n_b values selected from [Table 5-301.011a](#) and [Table 5-301.011b](#) are for straight channels of nearly uniform cross-sectional shape. Channel irregularities (n_1), alignment (n_2), obstruction (n_3), vegetation (n_4) and meandering (m) increase the roughness and the value of n must be adjusted accordingly as shown in [Table 5-301.011c](#).

The effects of depth of flow on the selection of n values for channels must be considered. If the depth of flow is shallow in relation to the size of the roughness elements, the n value can be large. The n value generally decreases with increasing depth, except where the channel banks are much rougher than the bed or where dense brush overhangs the low-water channel.

Irregularity (n_1)

Where the ratio of width to depth is small, roughness caused by eroded and scalloped banks, projecting points, and exposed tree roots along the banks must be accounted for by fairly large adjustments. Chow_(1959)³, and Benson and Dalrymple (1967)⁵, showed that severely eroded and scalloped banks can increase n values by as much as 0.02. Larger adjustments may be required for very large, irregular banks having projecting points.

Variation in Channel Cross Section (n_2)

The value of n is not affected significantly by relatively large changes in the shape and size of cross sections if the changes are gradual and uniform. Greater roughness is associated with alternating large and small sections where the changes are abrupt. The degree of the effect of changes in the size of the channel depends primarily on the number of alternations of large and small sections and secondarily on the magnitude of the changes. The effects of sharp ends, constrictions, and side-to-side shifting of the low-water channel may extend downstream for several hundred feet. The n value for a reach below these disturbances may require adjustment, even though none of the roughness-producing factors are apparent in the study reach. A maximum increase in n of 0.003 will result from the usual amount of channel curvature found in designed channels and the reaches of natural channels used to compute discharge.

Obstructions (n_3)

Obstructions such as logs, stumps, boulders, debris, pilings and bridge piers disturb the flow pattern in the channel and increase roughness. The amount of increase depends on the shape of the obstruction, its size in relation to that of the cross section, and the number, arrangement and spacing of obstructions. The effect of obstructions on the roughness coefficient is a function of the flow velocity. When the flow velocity is high, an obstruction exerts a sphere of influence that is much larger than the obstruction because the obstruction affects the flow pattern for considerable distances on each side. The sphere of influence for velocities that generally occur in channels that have gentle to moderately steep slopes is about 3 to 5 times the width of the obstruction. Several obstructions can create overlapping spheres of influence and may cause considerable disturbance, even though the obstructions may occupy only a small part of a channel cross section.

Vegetation (n_4)

The extent to which vegetation affects n depends on the depths of flow, the percentage of the wetted perimeter covered by the vegetation, the density of vegetation below the high-water line, the degree to which the vegetation is flattened by high water, and the alignment of vegetation relative to the flow. Rows of vegetation that parallel the flow may have less effect than rows of vegetation that are perpendicular to the flow. The adjustment values given in [Table 5-301.011c](#) apply to constructed channels that are narrow in width. In wide channels having small depth-to-width ratios and no vegetation on the bed, the effect of bank vegetation is small and the maximum adjustment is about 0.005. If the channel is relatively narrow and has steep banks covered by dense vegetation that hangs over the channel, the maximum adjustment is about 0.03. The larger adjustment values given in [Table 5-301.011c](#) apply only in places where vegetation covers most of the channel.

Meandering (m)

In selecting the value of m , the degree of meandering depends on the ratio of the total length of the meandering channel in the reach being considered to the straight length of the channel reach. The meandering is considered minor for ratios of 1.0 to 1.2, appreciable for ratios of 1.2 to 1.5, and severe for ratios of 1.5 and greater. Meanders can increase the n values as much as 30 percent where flow is confined within a stream channel. The meander adjustment should only be considered when the flow is confined to the channel. There may be very little flow in a meandering channel when there is floodplain flow.

Table 5-301.011c
Factors that Effect Roughness of Channel

Channel Conditions		n value Adjustment <u>1/</u>	Example
Degree of Irregularity (n ₁)	Smooth	0.000	Compares to the smoothest channel attainable in a given bed material.
	Minor	0.001-0.005	Compares to carefully dredged channels in good condition but having slightly eroded or scoured sideslopes
	Moderate	0.006-0.010	Compares to dredged channels having moderate to considerable bed roughness and moderately sloughed or eroded sideslopes.
	Severe	0.011-0.020	Badly sloughed or scalloped banks of natural streams; badly eroded or sloughed sides of canals or drainage channels; unshaped, jagged and irregular surfaces of channels in rock.
Variation in Channel Cross Section (n ₂)	Gradual	0.000	Size and shape of channel cross sections change gradually.
	Alternating occasionally	0.001-0.005	Large and small cross sections alternate occasionally, or the main flow shifts from side to side owing to changes in cross-sectional shape.
	Alternating Frequently	0.010-0.015	Large and small cross sections alternate frequently, or the main flow frequently shifts from side to side owing to changes in cross-sectional shape.

Table 5-301.011c (continued)
 Factors that Effect Roughness of Channel

Channel Conditions		n value Adjustment <u>1/</u>	Example
Effect of Obstruction (n ₃)	Negligible	0.000-0.004	A few scattered obstructions, which include debris deposits, stumps, exposed roots, logs, piers, or isolated boulders, that occupy less than 5 percent of the cross-sectional area.
	Minor	0.005-0.015	Obstructions occupy less than 15 percent of the cross-sectional area and the spacing between obstructions is such that the sphere of influence around one obstruction does not extend to the sphere of influence around another obstruction. Small adjustments are used for curved smooth-surfaced objects than are used for sharp-edged angular objects.
	Appreciable	0.020-0.030	Obstructions occupy from 15 to 50 percent of the cross-sectional area or the space between obstructions is small enough to cause the effects of several obstructions to be additive, thereby blocking an equivalent part of a cross section.
	Severe	0.040-0.050	Obstructions occupy more than 50 percent of the cross-sectional area or the space between obstructions is small enough to cause turbu-lence across most of the cross-section.

Table 5-301.011c (continued)
Factors that Effect Roughness of Channel

Channel Conditions		n value Adjustment <u>1/</u>	Example
Amount of Vegetation (n ₄)	Small	0.002-0.010	Dense growths of flexible turf grass, such as Bermuda, or weeds growing where the average depth of flow is at least two times the height of the vegetation; supple tree seedlings such as willow, cottonwood, arrowseed, or saltcedar growing where the average depth of flow is at least three times the height of the vegetation.
	Medium	0.010-0.025	Turf grass growing where the average depth of flow is from one to two times the height of the vegetation; moderately dense stemmy grass, weeds, or tree seedlings growing where the average depth of flow is from two to three times the height of the vegetation; brushy, moderately dense vegetation, similar to 1 to 2 year old willow trees in the dormant season growing along the banks and no significant vegetation along the channel bottoms where the hydraulic radius exceeds two feet.
	Large	0.025-0.050	Turf grass growing where the average depth of flow is about equal to the height of vegetation; 8 to 10 year old willow or cottonwood trees inter-grown with some weeds and brush (none of the vegetation in foliage) where the hydraulic radius exceeds 2 ft; bushy willows about 1 year old inter-grown with some weeds along sideslopes (all vegetation in full foliage) and no significant vegetation along channel bottoms where the hydraulic radius is greater than 2 feet.
	Very Large	0.050-0.100	Turf grass growing where the average depth of flow is less than half the height of the vegetation; bushy willow trees about 1 year old inter-grown with weeds along sideslopes (all vegetation in full foliage) or dense cat-tails growing along channel bottom; trees inter-grown with weeds and brush (all vegetation in full foliage).

Table 5-301.011c (continued)
Factors that Effect Roughness of Channel

Channel Conditions		n value Adjustment <u>1/</u>	Example
Degree of Meandering <u>1/</u> (Adjustment values apply to flow confined in the channel and do not apply where downvalley flow crosses meanders.) (m)	Minor	1.00	Ratio of the channel length to valley length is 1.0 to 1.2.
	Appreciable	1.15	Ratio of the channel length to valley length is 1.2 to 1.5.
	Severe	1.30	Ratio of the channel length to valley length is greater than 1.5.

1/ Adjustments for degree of irregularity, variations in cross-section, effect of obstructions, and vegetation are added to the base n value before multiplying by the adjustment for meander.

5-301.012 Floodplain Roughness Coefficient

It is usually necessary to determine roughness values for channels and floodplains separately. The makeup of a floodplain can be quite different from that of a channel. The physical shape of a floodplain is different from that of a channel and the vegetation covering a floodplain is typically different from that found in a channel. The following procedure is used for determining an n value for floodplains.

Modified Channel Method

By altering the procedure that was developed for estimating n values for channels, the following equation can be used to estimate n values for a floodplain.

$$n = (n_b + n_1 + n_2 + n_3 + n_4)m \tag{Eq. 5-11}$$

Where:

- n_b = a base value of n for the floodplain’s natural bare soil surface, with nothing on the surface
- n_1 = a value to correct for the effect of surface irregularities on the floodplain
- n_2 = a value for variations in shape and size of the floodplain cross-section assumed to equal 0.0
- n_3 = a value for obstructions on the floodplain
- n_4 = a value for vegetation on the floodplain
- m = a correction factor for sinuosity of the floodplain, equal to 1.0

Using [Equation 5-11](#), the roughness value for the floodplain is determined by selecting a base value of n_b for the natural bare soil surface of the floodplain and adding adjustment factors due to surface irregularity, obstructions and vegetation.

The selection of an n_b value is the same as outlined for channels in the previous section. A description of the major factors follows and [Table 5-301.012](#) gives n value adjustments. The adjustment for cross-section shape and size is assumed to be 0.0. The cross-section of a floodplain is generally subdivided where there are abrupt changes in the shape of the floodplain. The adjustment for meandering is assumed to be 1.0 because there may be very little flow in a meandering channel with there is floodplain flow. In certain cases where the roughness of the floodplain is caused by trees and brush, the roughness value for the floodplain can be determined by measuring the “vegetation density” of the floodplain rather than directly estimating from [Table 5-301.012](#). This is discussed under “Vegetation Density Methods”. Refer to U.S. Department of Transportation, Federal Highway Administration “Guide for Selecting Manning’s Roughness Coefficients for Natural Channels and Flood Plains” listed under Reference in Section 5-800 of this Chapter.

Surface Irregularities (n_1)

Irregularity of the surface of a floodplain causes an increase in the roughness of the floodplain. Such physical factors as rises and depressions of the land surface and sloughs and hummocks increase the roughness of the floodplain. A hummock can be defined as a low mound or ridge of earth above the level of an adjacent depression. A slough is a stagnant swamp, marsh, bog or pond. Shallow water depths, accompanied by an irregular ground surface in pastureland or brushland and by deep furrows perpendicular to the flow in cultivated fields, can increase the n values by as much as 0.02.

Obstructions (n_3)

The roughness contribution of some obstructions on a floodplain, such as debris deposits, stumps, exposed roots, logs, or isolated boulders, cannot be measured directly but must be considered. [Table 5-301.012](#) lists values of roughness for obstructions at different percentages of occurrence.

Vegetation (n_4)

Visual observation, judgement and experience may be used in selecting adjustment factors for the effects of vegetation from [Table 5-301.012](#). Although it is relatively easy to measure the area occupied by tree trunks and other major vegetation, it is much more difficult to measure the area occupied by vegetation such as low vines, briars, grass and crops.

Table 5-301.012
Factors that Effect Roughness of Floodplains

Floodplain Conditions		n value adjustment	Example
Degree of Irregularity (n ₁)	Smooth	0.000	Compares to the smoothest, flattest floodplain attainable
	Minor	0.001-0.005	A floodplain with minor irregularity in shape, a few rises and dips or sloughs may be visible on the floodplain.
	Moderate	0.006-0.010	Has more rises and dips. Sloughs and hummocks may occur.
	Severe	0.011-0.020	The floodplain is very irregular in shape. Many rises and dips or sloughs are visible. Irregular ground surfaces in pastureland and furrows perpendicular to the flow are also included.
Variation of Floodplain Cross Section (n ₂)		0.000	Not applicable.
Effect of Obstructions (n ₃)	Negligible	0.000-0.004	A few scattered obstructions, which include debris deposits, stumps, exposed roots, logs or isolated boulders, occupy less than 5 percent of the cross-sectional area.
	Minor	0.005-0.019	Obstructions occupy less than 15 percent of the cross-sectional area.
	Appreciable	0.020-0.030	Obstructions occupy from 15 to 50 percent of the cross-sectional area.

Table 5-301.012 (continued)
Factors that Effect Roughness of Floodplains

Floodplain Conditions		n value adjustment	Example
Amount of Vegetation (n ₄)	Small	0.001-0.010	Dense growth of flexible turf grass, such as Bermuda, or weeds growing where the average depth of flow is at least two times the height of the vegetation; or supple tree seedlings such as willow, cottonwood, arrowweed, or saltcedar growing where the average depth of flow is at least three times the height of the vegetation.
	Medium	0.011-0.025	Turf grass growing where the average depth of flow is from one to two times the height of the vegetation; or moderately dense stemmy grass, weeds or tree seedlings growing where the average depth of flow is from two to three times the height of the vegetation; brushy, moderately dense vegetation, similar to 1 to 2 year old willow trees in the dormant season.
	Large	0.025-0.050	Turf grass growing where the average depth of flow is about equal to the height of vegetation; or 8 to 10 year old willow or cottonwood trees inter-grown with some weeds and brush (none of the vegetation in foliage) where the hydraulic radius exceeds 2 ft.; or mature row crops such as small vegetables; or mature field crops where depth of flow is at least twice the height of the vegetation.
	Very Large	0.050-0.100	Turf grass growing where the average depth of flow is less than half the height of the vegetation; or moderate to dense brush; or heavy stand of timber with few down trees and little undergrowth with depth of flow below branches; or mature field crops where depth of flow is less than height of the vegetation.
	Extreme	0.100-0.200	Dense bushy willow, mesquite, and saltcedar (all vegetation in full foliage); or heavy stand of timber, few down trees, depth of flow reaching branches.
Degree of Meander (m)		1.0	Not applicable.

5-302 Continuity Equation

One of the fundamental concepts applying to most problems of open channel flow is continuity of flow. Continuity is the fact that no water is gained or lost and no flow is created or destroyed. In other words, the discharge of flow is constant throughout the reach of the channel. This equation is most commonly used to compute velocity in a given cross-section.

The continuity of flow may be expressed as follows:

$$Q = A_1V_1 = A_2V_2 = A_3V_3 = A_nV_n \quad (\text{Eq. 5-12})$$

Where:

- Q = discharge, cuft/sec
- A = cross-sectional area, sqft
- V = velocity, ft/sec

5-303 Bernoulli Equation

The Energy Equation: Open channel flow contains energy in two forms, potential and kinetic. The potential energy is due to the position of the water above some datum, and kinetic energy is due to the velocity of the flowing water. In open channel problems, energy is usually expressed in terms of head. The potential energy head is equal to depth of flow, d plus the depth from channel bottom to some datum, Z. The kinetic energy head is equal to $v^2/2g$.

For open channel flow energy, the law of conservation of energy is represented by the Bernoulli Equation – The Energy Equation:

$$E_1 = E_2$$

$$d_1 + \alpha_1V_1^2 / 2g + z_1 = d_2 + \alpha_2V_2^2 / 2g + z_2 \quad (\text{Eq. 5-13})$$

Its practical use requires a term to account for decrease in total head through friction. This term h_L , when added to the downstream side of the above equation, yields the form of the Bernoulli Equation most frequently used.

This equation is commonly used for computation of the headwater at the inlet of a structure and of the backwater surface profile of a stream.

$$E_1 = E_2 + h_L$$

$$d_1 + \alpha_1V_1^2 / 2g + z_1 = d_2 + \alpha_2V_2^2 / 2g + z_2 + h_L \quad (\text{Eq. 5-14})$$

Where:

- d = depth of Flow, ft
- V = velocity of flow, ft/sec
- g = acceleration due to gravity, ft/sec² (32.2 ft/sec²)
- Z = elevation of the channel bottom, ft
- h_L = head losses, ft
- α_1, α_2 = velocity correction factors, generally assumed to = 1

The above equation states that the total head at any section is equal to the total head at any section downstream, plus intervening head losses, as shown in [Figure 5-303](#).

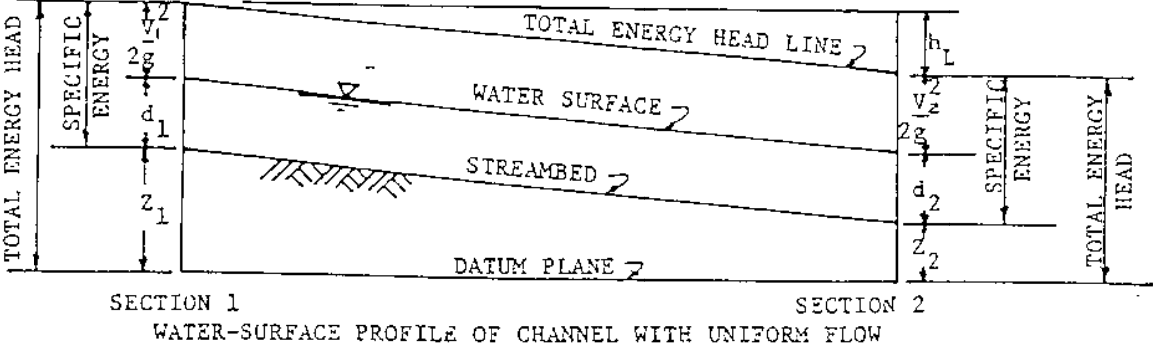

Figure 5-303

5-400 STREAM ANALYSIS

5-401 Analysis by Manning’s Equation

Generally speaking, truly uniform flow rarely exists in either manmade or natural channels. This is due to changes in channel section, slope or roughness causing the depths and average velocities of flow to change from point to point along the channel and the water surface not being parallel to the streambed. For practical purposes in highway engineering, however, the Manning’s Equation and Stage-Discharge curve method can be applied to most stream flow problems by making judicious assumptions.

It should be understood that the results of the procedure are approximate since the flow conditions of a manmade or natural channel are subject to many uncertain factors.

5-402 Analysis by Standard Step Method of Computation

The standard step method of computation is normally the preferred procedure for determining water surface profiles in natural channels. It is usually necessary to collect survey data for a large number of sections to be considered in the computations. This may involve a long reach of the stream and must include the location controlling or most influencing the high water elevations. The procedure involves a step by step computation of the energy balance between each cross-section. The computation must begin at the control section and proceed upstream (for subcritical flow) analyzing the interrelationship of the various hydraulic elements.

A sample computation is provided in “Hydrologic Engineering Methods For Water Resources Development – Volume 6, Water Surface Profiles”, The Hydrologic Engineering Center, Corps of Engineers⁶.

The Standard Step Method of Computation requires an initial estimate of the water surface elevation at the first cross-section. Following are guidelines to help determine the initial water surface elevation:

- On a typical stream when no information from outside sources is available, the initial water surface elevation can be determined using normal depth with the stream slope in the vicinity of the cross-section taken from surveys. Note that when utilizing one of the computer programs described in [Section 5-403](#), the program will determine the initial water surface elevation requiring only that the stream slope be provided.
- When known water surface elevations are available such as from a Flood Insurance Study, the known water surface elevations can be utilized unless flow conditions have clearly changed since the time of the study.
- When the subject stream drains into a much larger stream, two methods of determining the starting water surface elevations must be considered. The first method is to ignore the effect of backwater from the larger receiving stream. The second method is to start the analysis assuming a 10-year frequency backwater elevation from the receiving stream. The method producing the higher water surface elevation should be utilized in the final design.
- When the subject stream drains into a receiving stream with a similar size drainage area, two methods of determining the starting water surface elevations must be

considered. The first method is to ignore the effect of backwater from the receiving stream. The second method is to consider coincidental flooding effects. This would involve starting the analysis using the backwater effect from the receiving stream for similar frequencies. An example would be to analyze the 50-year frequency flood considering a 50-year backwater effect from the receiving stream. The method producing the higher water surface elevations should be utilized in the final design.

- The effect of any downstream obstruction should be considered. An example of this is when the subject stream drains into a reservoir. The reservoir would need to be analyzed to determine its effect on the subject stream.

5-403 Stream Analysis by Computer Programs

There is a number of computer programs available for the analysis of open channel flow. Among the programs utilized by the Illinois Department of Transportation are:

“Water Surface Profile 2” (WSP-2). This program, developed by the Soil Conservation Service of the United States Department of Agriculture, uses the standard step method to calculate backwater. The program computes water surface profiles for open channel flow and provides information on elevation, discharge and flow area for specified points. Head losses are computed at any road restrictions for one bridge opening or up to five different culvert configurations with unlimited multiples of identical configurations. Flow in the channel must be subcritical, steady and gradually varying.

“Water Surface Profiles” (HEC-2). HEC-2 also uses the standard step method to compute backwater. Developed by the Hydrologic Engineering Center, United States Army Corps of Engineers, the program calculates water surface profiles for steady, gradually varied flow for subcritical and supercritical states. Hydraulic information is provided for each input cross-section and the effects of various obstructions such as bridges, culverts, weirs, structures in the floodplain, channel changes and levees on water surface profiles are shown.

“Bridge Waterways Analysis Model” (WSPRO). This program is a digital model developed by the USGS for FHWA for water-surface profile computations. The program is compatible with conventional step-backwater analyses and it provides computations for flow through bridge openings, combined road overflow and bridge opening flow, and multiple waterway openings.

“River Analysis System” (HEC-RAS). This is a program designed as the successor to the U.S. Army Corps of Engineer’s HEC-2, Water Surface Profiles program. The program incorporates the Standard Step Method for Water Surface Profile Computations, Bridge Hydraulics, Hydraulics including the contracted opening method presented in WSPRO, Culvert Hydraulics, Flood Encroachments, Design of open channel flow, analyzing split flow options, and Subcritical and Supercritical flow computations. The program can be used to compute bridge pier and abutment scour following the HEC 18 guidelines. The program is Windows based and uses a Graphical User Interface for file management, data entry and editing, program execution, and output display. It provides easy conversion from English to metric units and vice-versa.

For more detailed information and program examples, see [Chapter 14](#) “Computer Programs”.

5-500 EXAMPLE PROBLEMS

The example problems in this section present step-by-step engineering calculations and design procedures for some problems always present in the highway drainage field. The actual problems may be more complex in the field; therefore, engineering judgement and experience play a very important part in their solutions.

In current practice, computer programs tend to take the place of manual calculation methods, but the computer programs cannot be used successfully unless basic engineering concepts and the solution method are known.

5-501 Example Problem 1: Illustration of Using Manning's Equation to Find Velocity and Discharge in a Channel

This example illustrates the use of Manning's Equation, with the channel properties, to find the mean velocity and discharge in any particular channel cross-section.

Given:

A trapezoidal earth channel lined with grass, straight alignment and uniform section, bottom width of 2 ft., sideslopes 3 to 1, streambed slope 0.003 ft/ft with allowable depth of 3 ft.

Find:

Velocity and discharge

Solution:

- Terms:
 b = bottom width (2 ft)
 d = depth of flow (3 ft)
 Z = sideslope – horizontal/vertical (3:1) = 3/1 = 3
 P = wetted perimeter
 R = hydraulic radius
 n = Manning's n value (0.03) (calculated using Eq. 5-10)
 Q = discharge
 V = velocity
 S = channel slope (0.003 ft/ft)

- Solution of channel properties:

$$A = (b + zd)d = (2 + (3)(3))3 = 33.00 \text{ sq ft}$$

$$P = b + 2d\left(\frac{z^2 + 1}{z}\right)^{1/2} = 2 + (2)(3)\left(\frac{(3)^2 + 1}{3}\right)^{1/2} = 20.97 \text{ ft}$$

$$R = \frac{A}{P} = \frac{33}{21} = 1.571 \text{ ft}$$

$$n = 0.03 \quad \text{New channel properly maintained.}$$

3. Solve velocity by using Manning's Equation

$$V = \frac{1.486}{n} R^{2/3} S^{1/2} = \frac{1.486}{0.03} (1.571)^{2/3} (0.003)^{1/2} = 3.67 \text{ ft/sec}$$

4. Solve discharge

$$Q = AV = (33)(3.67) = 121 \text{ cuft/sec}$$

Discussion:

1. This problem could be solved graphically by using [Figure 5-301](#), with the channel properties as given to find $V = 3.6 \text{ ft/sec}$ and compute $Q = AV = 33 \times 3.6 = 120 \text{ cuft/sec}$.
2. Selection of n depends on the condition of the channel. For an old channel lacking maintenance, a higher n value should be used.

5-502 Example Problem 2: Illustration of the Use of the Trial and Error Method to Find the Normal Depth in a Channel

This example illustrates the use of the trial and error method to find the normal depth with fixed discharge and a particular channel cross-section. Further, use this defined depth to analyze the channel characteristics. Even though the model in this example is simple, the same concepts apply to complex models.

Given:

A trapezoidal channel in earth lined with grass, bottom width 6 ft, sideslope 3:1, $n = 0.03$, streambed slope 0.004 ft/ft, and discharge 180 cuft/sec.

Find:

Depth, velocity and describe this flow

Solution:

1. Terms:
 b = bottom width (6 ft)
 d = depth of flow
 Z = sideslope – horizontal/vertical (3:1) = 3/1 = 3
 P = wetted perimeter
 R = hydraulic radius
 n = Manning's n value (0.03)
 Q = discharge (180 cuft/sec)
 V = velocity
 S = channel slope (0.004 ft/ft)

2. General solution of channel properties.

$$A = (b + zd)d = (6 + 3d)d$$

$$P = b + 2d(z^2 + 1)^{1/2} = 6 + 2d((3)^2 + 1)^{1/2} = 6 + 6.325d$$

$$R = \frac{A}{P}$$

3. Try: $d = 3$ ft

$$A = (6 + (3)(3))3 = 45 \text{ sq ft}$$

$$P = 6 + (6.325)(3) = 25 \text{ ft}$$

$$R = \frac{45}{25} = 1.8 \text{ ft}$$

$$V = \frac{1.486}{n} R^{2/3} S^{1/2} = \frac{1.486}{0.03} (1.8)^{2/3} (0.004)^{1/2} = 4.6 \text{ ft/sec}$$

$$Q = AV = (45)(4.6) = 207 \text{ cuft/sec} \quad \text{too high}$$

- Try: $d = 2.5$ ft

$$A = (6 + (3)(2.5))2.5 = 33.75 \text{ sq ft}$$

$$P = 6 + (6.325)(2.5) = 21.81 \text{ ft}$$

$$R = \frac{33.75}{21.81} = 1.547 \text{ ft}$$

$$V = \frac{1.486}{0.03} (1.547)^{2/3} (0.004)^{1/2} = 4.19 \text{ ft/sec}$$

$$Q = (33.75)(4.19) = 141 \text{ cuft/sec} \quad \text{too low}$$

- Try: $d = 2.8$ ft.

$$A = (6 + (3)(2.8))2.8 = 40.32 \text{ sq ft}$$

$$P = 6 + (6.325)(2.8) = 23.71 \text{ sq ft}$$

$$R = \frac{40.32}{23.71} = 1.7 \text{ ft}$$

$$V = \frac{1.486}{0.03} (1.7)^{2/3} (0.004)^{1/2} = 4.46 \text{ ft/sec}$$

$$Q = (40.32)(4.46) = 180 \text{ cuft/sec} \quad \text{O.K.}$$

Therefore, Depth = 2.8 ft and Velocity = 4.46 ft/sec

4. Describe the flow:

$$\text{Specific Energy } E = d + \frac{V^2}{2g} = 2.8 + \frac{(4.46)^2}{(2)(32.2)} = 3.11 \text{ ft}$$

$$\text{Froude Number } Fr = \frac{V}{(gD)^{1/2}}$$

$$\text{Hydraulic Depth } D = \frac{A}{T}$$

$$D = \frac{40.32}{6 + (2)(2.8)(3)} = 1.768 \text{ ft}$$

$$Fr = \frac{4.46}{((32.2)(1.768))^{1/2}} = 0.59$$

Fr = 0.59 is smaller than 1, the flow is under subcritical (tranquil) flow condition.

5-503 Example Problem 3: Stream Analysis by Use of Manning’s Equation and the Stage-Discharge Curve

This is an example that illustrates stream analysis manually by use of Manning's Equation and the Stage-Discharge curve.

Given:

The channel as shown, channel bed slope 0.002 ft/ft Design $Q_{50} = 5,400$ cuft/sec

Find:

- Normal high water surface elevation of flow, and the velocities of channel and overbank flow.

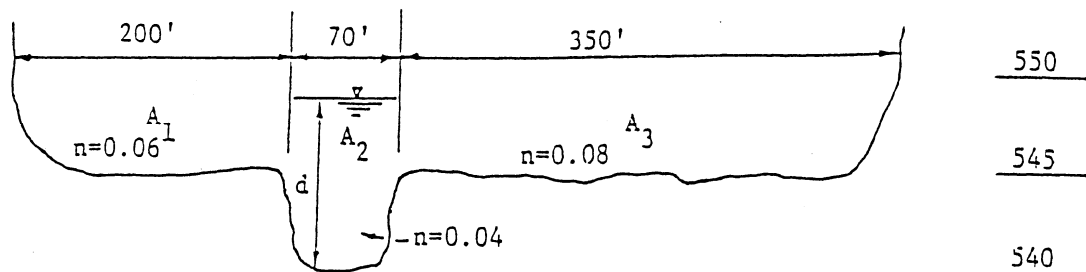

- Develop a Rating Curve or Stage-Discharge curve
- Use Rating Curve to find normal high water surface elevation for 50-year design storm

Solution:

1. Trial and error method:

Try: $d = 2$ ft W.S.E. 542.0 (all flow in channel)

$$A_2 = 140 \text{ sq ft} \quad \text{using planimeter}$$

$$P_2 = 70 + 2 + 2 = 74 \text{ ft}$$

$$R_2 = \frac{140}{74} = 1.89 \text{ ft}$$

$$V_2 = \frac{1.486}{0.04} (1.89)^{2/3} (0.002)^{1/2} = 2.54 \text{ ft/sec}$$

$$Q_2 = (140)(2.54) = 356 \text{ cuft/sec}$$

Try: $d = 5 \text{ ft W.S.E. } 545.0$ (all flow in channel)

$$A_2 = 350 \text{ sq ft}$$

$$P_2 = 70 + 5 + 5 = 80 \text{ ft}$$

$$R_2 = \frac{350}{80} = 4.38 \text{ ft}$$

$$V_2 = \frac{1.486}{0.04} (4.38)^{2/3} (0.002)^{1/2} = 4.45 \text{ ft/sec}$$

$$Q_2 = (350)(4.45) = 1558 \text{ cuft/sec}$$

Try: $d = 6 \text{ ft W.S.E. } 546.0$ (1' depth in overbank)

$$A_1 = 200 \text{ sq ft}$$

$$P_1 = 200 \text{ ft (for a wide floodplain, the width can be used)}$$

$$R_1 = \frac{200}{200} = 1 \text{ ft}$$

$$V_1 = \frac{1.486}{0.06} (1)^{2/3} (0.002)^{1/2} = 1.11 \text{ ft/sec}$$

$$Q_1 = 200(1.11) = 222 \text{ cuft/sec}$$

$$A_2 = 420 \text{ sq ft}$$

$$P_2 = 70 + 5 + 5 = 80 \text{ ft ----- (height of bank is only 5 ft even though water depth is 6 ft)}$$

$$R_2 = \frac{420}{80} = 5.25 \text{ ft}$$

$$V_2 = \frac{1.486}{0.04} (5.25)^{2/3} (0.002)^{1/2} = 5.02 \text{ ft/sec}$$

$$Q_2 = 420(5.02) = 2108 \text{ cuft/sec}$$

$$A_3 = 350 \text{ sq ft}$$

$$P_3 = 350 \text{ ft}$$

$$R_3 = \frac{350}{350} = 1.00 \text{ ft}$$

$$V_3 = \frac{1.486}{0.08} (1)^{2/3} (0.002)^{1/2} = 0.83 \text{ ft/sec}$$

$$Q_3 = 350(0.83) = 291 \text{ cuft/sec}$$

$$Q_T = 222 + 2,108 + 291 = 2,621 \text{ cuft/sec}$$

Try: $d = 7 \text{ ft}$ W.S.E. 547.0 (2 ft depth in overbank)

$$A_1 = 200(2) = 400 \text{ sqft}$$

$$P_1 = 200 \text{ ft}$$

$$R_1 = \frac{400}{200} = 2 \text{ ft}$$

$$V_1 = \frac{1.486}{0.06} (2)^{2/3} (0.002)^{1/2} = 1.76 \text{ ft/sec}$$

$$Q_1 = 400(1.76) = 704 \text{ cuft/sec}$$

$$A_2 = 70(7) = 490 \text{ sq ft}$$

$$P_2 = 70 + 5 + 5 = 80 \text{ ft -----} \quad \text{(height of bank is only 5 ft even though water depth is 7 ft)}$$

$$R_2 = \frac{490}{80} = 6.13 \text{ ft}$$

$$V_2 = \frac{1.486}{0.04} (6.13)^{2/3} (0.002)^{1/2} = 5.56 \text{ ft/sec}$$

$$Q_2 = 490(5.56) = 2,724 \text{ cuft/sec}$$

$$A_3 = 350(2) = 700 \text{ sq ft}$$

$$P_3 = 350 \text{ ft}$$

$$R_3 = \frac{700}{350} = 2 \text{ ft}$$

$$V_3 = \frac{1.486}{0.08} (2)^{2/3} (0.002)^{1/2} = 1.32 \text{ ft/sec}$$

$$Q_3 = 700(1.32) = 924 \text{ cuft/sec}$$

$$Q_T = 704 + 2,724 + 924 = 4,352 \text{ cuft/sec}$$

Try: $d = 8 \text{ ft W.S.E. } 548.0$ (3 ft depth in overbank)

$$A_1 = 600 \text{ ft}$$

$$P_1 = 200 \text{ ft}$$

$$R_1 = \frac{600}{200} = 3 \text{ ft}$$

$$V_1 = \frac{1.486}{0.06} (3)^{2/3} (0.002)^{1/2} = 2.3 \text{ ft/sec}$$

$$Q_1 = 600(2.30) = 1380 \text{ cuft/sec}$$

$$A_2 = 560 \text{ sq ft}$$

$P_2 = 70 + 5 + 5 = 80 \text{ ft}$ (height of bank is only 5 ft even though water depth is 8 ft)

$$R_2 = \frac{560}{80} = 7 \text{ ft}$$

$$V_2 = \frac{1.486}{0.04} (7)^{2/3} (0.002)^{1/2} = 6.08 \text{ ft/sec}$$

$$Q_2 = 560(6.08) = 3,405 \text{ cuft/sec}$$

$$A_3 = 1050 \text{ sq ft}$$

$$P_3 = 350 \text{ ft}$$

$$R_3 = \frac{1050}{350} = 3 \text{ ft}$$

$$V_3 = \frac{1.486}{0.08} (3)^{2/3} (0.002)^{1/2} = 1.73 \text{ ft/sec}$$

$$Q_3 = 1050(1.73) = 1817 \text{ cuft/sec}$$

$$Q_T = 1380 + 3405 + 1817 = 6602 \text{ cuft/sec}$$

Develop Rating Curve using trial depths and calculated total discharges.

2. Rating curve:

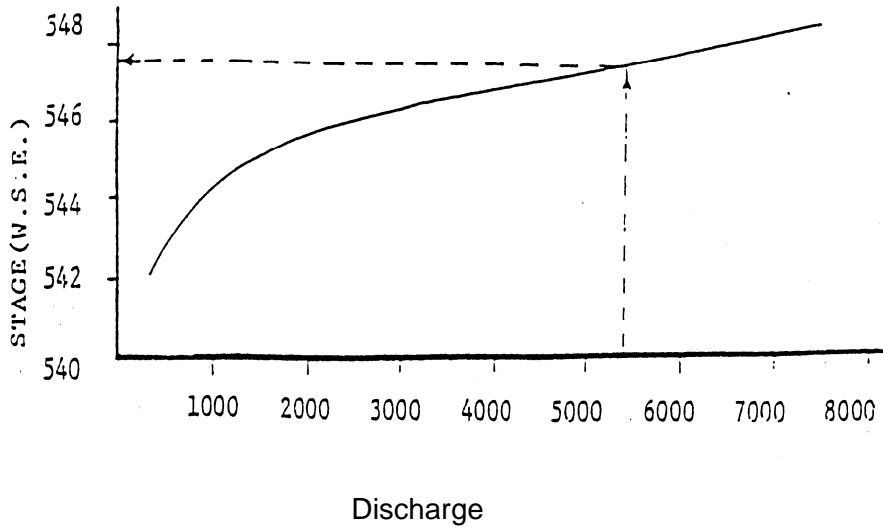

3. Use rating curve and find W.S.E. for 5,400 cuft/sec.

$$\text{W.S.E.} = 547.5, d = 547.5 - 540.0 = 7.5 \text{ ft}$$

Try: $d = 7.5 \text{ ft}$ (2.5 ft depth in overbanks)

$$A_1 = 200(2.5) = 500 \text{ sq ft}$$

$$P_1 = 200 \text{ ft (use width of overbank)}$$

$$R = \frac{500}{200} = 2.50 \text{ ft}$$

$$V_1 = \frac{1.486}{0.06} (2.50)^{2/3} (0.002)^{1/2} = 2.04 \text{ ft/sec}$$

$$Q_1 = 500(2.04) = 1020 \text{ cuft/sec}$$

$$A_2 = 70(7.5) = 525 \text{ sq ft}$$

$$P_2 = 70 + 5 + 5 = 80 \text{ ft -----}$$

(height of bank is only 5 ft even though water depth is 7.5 ft)

$$R = \frac{525}{80} = 6.56 \text{ ft}$$

$$V_2 = \frac{1.486}{0.04} (6.56)^{2/3} (0.002)^{1/2} = 5.82 \text{ ft/sec}$$

$$Q_2 = 525(5.82) = 3,056 \text{ cuft/sec}$$

$$A_3 = 350(2.5) = 875 \text{ sq ft}$$

$$P_3 = 350 \text{ ft}$$

$$R_3 = \frac{875}{350} = 2.5 \text{ ft}$$

$$V_3 = \frac{1.486}{0.08} (2.5)^{2/3} (0.002)^{1/2} = 1.53 \text{ ft/sec}$$

$$Q_3 = 875(1.53) = 1,339 \text{ cuft/sec}$$

$$Q_T = 1,020 + 3,056 + 1,339 = 5,415 \text{ cuft/sec} \quad \text{O.K.}$$

5-600 HIGHWAY STRUCTURES

When highways cross canals and natural channels, the water must be carried by the highway structures and conveyed under the highway. There are several types of waterway crossing structures that are used for highway construction. Culvert and Storm Water flow are introduced in other sections; weir flow will be introduced in this section as follows:

5-601 Weir Flow

The basic weir flow equation is in the following expression:

$$Q = C_f LH^{3/2} C_s / C_f \quad (\text{Eq. 5-15})$$

Where:

- L = the length of inundated roadway, ft
- H = the total head upstream measured above the crown of the roadway, ft
- C_f = coefficient of discharge for free flow
- C_s = coefficient of discharge for submergence

To determine the discharge flowing over a roadway, first enter curve B (Figure 5-601) with H/L and obtain the free flow coefficient of discharge C_f. If the value of H/L is less than 0.15, it is suggested that C_f be read from curve A (Figure 5-601). If submergence is present (e.g., if D/H is > 0.7) enter curve C with the proper value of submergence in percent and read off the submergence factor C_s/C_f. The resulting discharge is determined by substituting values in the equation mentioned above. Where the depth of flow varies along the roadway, it is advisable to divide the inundated section into subsections and compute the discharge over each subsection separately.

The present tendency, for interstate and primary roads, is to construct approach embankments well above the 50-year flood, or record-high flood level. A limit must be set, however, on the length of bridge for economic reasons, which is usually proportioned for about a 50-year flood.

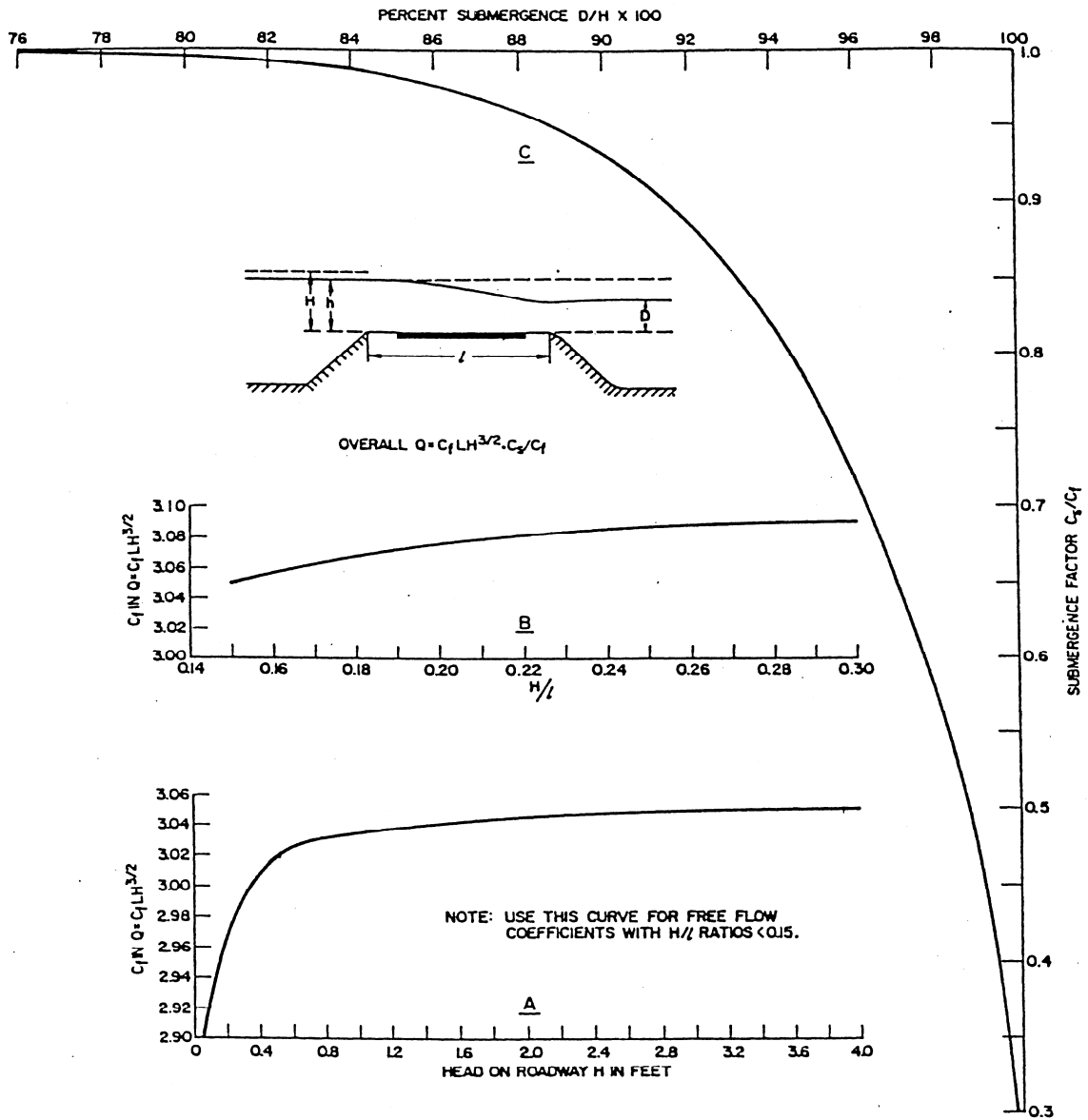

Discharge coefficients for flow over roadway embankment
Figure 5-601

5-602 Levee

A levee is essentially a longitudinal dam erected roughly parallel to a river rather than across its channel. It restricts the channel width by preventing flow on the floodplain, and this results in increased stages in the leveed reach. Channel improvements, which usually accompany levee construction, increase velocity and may offset some or all of this increase. If stages in the leveed reach are increased, stages will also be higher upstream from the leveed reach. Downstream from the leveed area, peak flows will be increased because of lessened channel storage and as a result of the increase in flow velocity. The net result of levee construction depends very much on the physical characteristics of the situation. Usually levee construction and associated flood-mitigation works result in a general increase in flood stages along a river unless reservoirs or extensive channel improvements are provided.

The increase in stage following levee construction has sometimes led to unfortunate consequences. The best program of flood mitigation for a river will be obtained if a master plan is developed at an early date, and if this program reserves a considerable amount of floodplain for a flood channel. Excessive encroachment on the floodplain initiates a cycle of higher stages which leads to levee failure and extensive flood fighting which may offset the economic advantage of protecting more floodplain land from flooding.

When a highway project crosses a levee system, the hydraulic analysis for the crossing design must include the effects of the levee. It is essential that the levee system be inspected to verify that it is continuous without any breaks and that it contains all flood flows until the flow depth reaches the point of overtopping. The survey data for the site must include a profile of the levee top sufficient to identify the elevation and location of overtopping.

The hydraulic analysis to determine the stage-discharge relationship for the levee system should initially include an evaluation of the conveyance characteristics of the channel section inside the levees only. All parts of the floodplain cross-section behind the levees should be omitted from the initial analysis. After the conveyance characteristics and the overtopping frequency of the levee system have been determined, the floodplain section behind the levee system should be evaluated for its conveyance and/or storage characteristics.

5-700 CHANNEL MODIFICATION**5-701 Explanation**

Channel modification is defined as the straightening, enlargement and/or relocation of a river or stream. Channel modification includes any construction which modifies the physical dimensions of the channel. The significant removal of bottom or woody vegetation, or both, is also a form of channel modification.

Channel changes alter the conditions of the natural waterway. Replacing a long sinuous natural channel by a shorter improved channel will increase the channel slope and usually decrease the channel roughness. Both of these changes cause an increase in velocity of the flowing water which sometimes causes damage to the highway embankment near the stream or excessive scour around footings of structures. At other times damage occurs because the stream continues to use the old channel rather than the new because adequate training works are not provided to divert the stream into the new channel. In addition to possible damage to the highway, a major channel change may be detrimental to fish and other aquatic life because of increased velocities, decreased depth of flow and the removal of boulders and irregularities in the channel. Therefore, channel changes of existing streams should be minimized to the fullest extent practical. If a channel change is otherwise unavoidable, a detailed evaluation should be made and documented including consideration of the environment, hydraulic, legal, and geomorphic aspects involved.

The proposed new channel should duplicate the existing stream and floodplain characteristics as nearly as possible. These characteristics should include the stream width, depth, slope, flow regime, sinuosity, pool-riffle ratio, bank cover, sideslopes, flow, and velocity distribution.

The hydraulic analysis should include the one-hundred (100) year frequency flood. It should not increase flood damage outside the limits of the project and should not cause scour and erosion. A rating curve for existing conditions shall be prepared and utilized as the basis of comparison for the proposed design.

5-702 Coordination with Other Agencies

The environmental, fish, wildlife, and water quality considerations involved in channel modification shall be coordinated with appropriate Federal, State, and local agencies as necessary.

The following is a partial listing of agencies commonly involved in the activities which could affect channel modification:

1. U.S. Army – Corps of Engineers
2. U.S. Fish and Wildlife Service
3. Illinois Environmental Protection Agency (IEPA)
4. Illinois Department of Natural Resources – Office of Water Resources (IDNR – OWR)
5. Illinois Department of Natural Resources – Office of Realty and Environmental Assessment
6. Counties, Municipalities

In order to avoid delays in the orderly progression of project development, early coordination with these regulatory agencies provides time for review and allows any necessary modifications to be made.

There are many local regulations such as floodplain ordinances, building codes, and zoning regulations that must be observed in addition to State and Federal permit requirements.

5-703 Guidelines and Requirements for Major Channel Modifications

IDNR Office of Water Resources defines major channel modification as any modification over 500 ft in length as measured along the existing channel. However, if the watershed is below their jurisdiction limit of 1 square mile in an urban area or 10 square miles in a rural area a permit would not be required regardless of channel length.

The guidelines and requirements for major channel modifications are: A major channel modification may be constructed, provided that for any frequency flood from bankfull up to the 100-year frequency flood it would not increase flood damages outside the limits of the project and would not cause scour and erosion. These conditions will generally be presumed to be met if, when evaluated either from a singular or cumulative effects basis:

- a. The water surface profile would not be increased by 0.5 ft or more in rural areas; and 0.1 ft in urban areas anywhere within the project limit if the increase affects any other property owners. This increase can be increased if a flood easement is purchased from all affected property owners.
- b. The average existing channel velocity would not be increased beyond the scour velocity of the predominant soil type at the project site or, for those cases where average existing channel velocity naturally exceeds the scour velocity of the predominant soil type, the increase would be limited to 10 percent.
- c. The proposed channel modification should make a smooth transition at its end points to match into the existing channel.
- d. There is a 10 percent limit on the reduction of overbank storage.
- e. The physical characteristics of the new channel shall match as closely as practical those of the existing channel in length, cross-section, bottom profile and sinuosity.

5-800 REFERENCES

1. U.S. Department of Transportation, Federal Highway Administration. *Design Charts for Open Channel Flow*. Hydraulic Design Series No. 3, August 1961.
2. U.S. Department of Transportation, Federal Highway Administration. *Guide for Selecting Manning's Roughness Coefficient for Natural Channels and Floodplains*. Report No. FHWA-TS-84-204, April 1984.
3. Chow, V. T. *Open-Channel Hydraulics*: New York: McGraw-Hill, 1959.
4. Gary P. Johnson and S. Bridgett Marsh. *Data Base and Computational Tools to Aid in Determination of Roughness Coefficients of Streams*. U.S. Department of the Interior, U.S. Geological Survey, 2001.
5. Benson, M. A. and Dalrymple, Tate. *General field and office procedures for indirect discharge measurements*. U.S. Geological Survey Techniques of Water-Resources Investigations, book 3, Chap. A1, 30p., 1967
6. U.S. Army, Corps of Engineers, Hydrologic Engineer Center. *Hydrologic Engineering Methods for Water Resources Development*. Water Surface Profiles Volume 6, Davis, California.
7. U.S. Department of Transportation, Federal Highway Administration. *Hydraulics of Bridge Waterways*. Hydraulic Design Series No. 1, Second Edition, 1970.



Chapter 6

Copyright © 2011 by
Hybrid
Security

CHAPTER 6 - CULVERT HYDRAULICS

6-000	GENERAL		
6-001	Definition		
6-002	Kind and Size of Culvert		
6-003	Types of Culverts		
6-004	Miscellaneous Information		
6-100	HYDRAULIC ANALYSIS		
6-101	Allowable Headwater		
6-102	Trial Size		
6-103	Headwater Depth		
6-104	Outlet Velocities		
	6-104.01	Example Problem 1 Determining Depth of Flow and Velocity in Inlet Control	
	6-104.02	Example Problem 2 Determining Depth of Flow and Velocity in Outlet Control	
6-105	Information for Waterway Information Table		
6-106	Hydraulic Reports		
6-107	Example Problem 3 Culvert Design Form and HY-8		
6-200	ENERGY DISSIPATION		
6-201	General		
6-202	Light Channel Protection		
6-203	Stilling Basins		
6-204	Impact-type Energy Dissipater		
6-205	Additional Dissipaters		
6-300	DROP STRUCTURES		
6-400	IMPROVED INLETS		
6-500	AUTOMATIC FLAP GATES & CHECK VALVES		
6-600	SAFETY GRATES		
6-700	DEBRIS CONTROL STRUCTURES		

6-800 MISCELLANEOUS

6-801 Application of Three-Sided Structures

6-802 Culvert Liners

6-803 Broken-Back Culverts

6-804 Helical Pipes – “n” Values

6-900 REFERENCES

6-000 GENERAL

6-001 Definition

A culvert is a structure used to convey drainage through a roadway embankment. Culverts come in many shapes, some of the more common shapes include: circular, rectangular, elliptical and arch. The most common materials used are reinforced concrete, steel and aluminum.

This section covers the policies, methods and procedures used in the economic design of culverts for highways and their appurtenances. It is realized that new methods for determining the proper types and sizes of drainage structures are continually being developed; however, the methods outlined in this section shall govern the hydraulic design of all culverts on state highway projects unless otherwise authorized by the Engineer of Bridges and Structures. A comprehensive culvert design will include the type, size, length, slope and shape of the proposed culvert as well as a waterway information table (see [Chapter 1 and Section 6-105](#)).

6-002 Kind and Size of Culvert

The kind and size of culvert permitted is dependent upon location (See [Figure 6-002](#)); however, 15 in. is considered the smallest size practical. Refer to [Section 542 of the IDOT Standard Specifications for Road and Bridge Construction¹](#) and [BDE Procedure Memorandum #65-8²](#) to verify materials permitted. Pipe Culverts shall have a minimum of 6 inches of cover measured from the top of the pipe to the bottom of the pavement and shall meet the minimum fill height requirements as indicated in [Section 542 of the IDOT Standard Specifications for Road and Bridge Construction¹](#). Box Culverts generally require minimal or no cover, but should be designed to the requirements of the [Culvert Manual³](#) as published by the IDOT Bureau of Bridges and Structures. Headwalls or end sections are required for all culverts 24 in or greater in diameter and when deemed necessary for smaller culverts.

TYPE OF IMPROVEMENT	KIND OR CLASS OF DRAINAGE STRUCTURE PERMITTED	MINIMUM PERMISSIBLE DIAMETER
All roadways with ADT \geq 10,000	A	24" – Up to 200' in Length 30" > 200' in Length
All Roadways with 4,000 \leq ADT < 10,000	C	18"
Entrances/Driveway and Roadways with ADT < 4,000	D	15"

*Kind and Size of Culvert Permitted
Figure 6-002*

<u>Class</u>	<u>Material</u>
A	Reinforced Concrete Reinforced Concrete Arch Culvert Reinforced Concrete Elliptical Culvert, Storm Drain, and Sewer Pipe
C	Reinforced Concrete Reinforced Concrete Arch Culvert Reinforced Concrete Elliptical Culvert, Storm Drain, and Sewer Pipe Polyvinyl Chloride (PVC) Pipe Corrugated Polyvinyl Chloride (PVC) Pipe with a Smooth Interior Polyvinyl Chloride (PVC) Profile Wall Pipe – 794 Polyvinyl Chloride (PVC) Profile Wall Pipe – 304 Polyethylene (PE) Pipe with a Smooth Interior Polyethylene (PE) Profile Wall Pipe Aluminized Steel Type 2 Corrugated Culvert Pipe Aluminized Steel Type 2 Corrugated Pipe Arch Precoated Galvanized Corrugated Steel Culvert Pipe Precoated Galvanized Corrugated Steel Pipe Arch Corrugated Aluminum Alloy Pipe Corrugated Aluminum Alloy Culvert Pipe Arch
D	Reinforced Concrete Reinforced Concrete Arch Culvert Reinforced Concrete Elliptical Culvert, Storm Drain, and Sewer Pipe Polyvinyl Chloride (PVC) Pipe Corrugated Polyvinyl Chloride (PVC) Pipe with a Smooth Interior Polyvinyl Chloride (PVC) Profile Wall Pipe – 794 Polyvinyl Chloride (PVC) Profile Wall Pipe – 304 Polyethylene (PE) Pipe with Smooth Interior Polyethylene (PE) Profile Wall Pipe Aluminized Steel Type 2 Corrugated Culvert Pipe Aluminized Steel Type 2 Corrugated Pipe Arch Precoated Galvanized Corrugated Steel Culvert Pipe Precoated Galvanized Corrugated Steel Pipe Arch Corrugated Aluminum Alloy Pipe Corrugated Aluminum Alloy Culvert Pipe Arch Corrugated Polyethylene (PE) Pipe with a Smooth Interior Corrugated Steel Culvert Pipe Corrugated Steel Pipe Arch Bituminous Coated Corrugated Steel Culvert Pipe Bituminous Coated Corrugated Steel Pipe Arch Zinc and Aramid Fiber Composite Coated Corrugated Steel Pipe

This chapter will cover the hydraulic design of the following types of culverts:

- Circular (concrete, corrugated metal and structural plate corrugated metal)
- Box (concrete)
- Elliptical (concrete and corrugated metal)
- Pipe arch (corrugated metal and structural plate corrugated metal)
- Arch (concrete and corrugated metal)
- Structural plate corrugated metal elliptical
- Three-sided structure

This chapter focuses on concrete and metal pipe materials. However, the list of allowable pipe types shown in Section 542 of the [Standard Specifications for Road and Bridge Construction](#)¹ has expanded over recent years, allowing flexible pipe to be utilized in a wider range of conditions. For a given culvert installation, the calculations of headwater and outlet velocity follow the same procedures provided in [Section 6-100 Hydraulic Analysis](#), regardless of pipe or material type. The procedures are taken directly from the FHWA publication entitled [HDS5, Hydraulic Design of Highway Culverts](#)⁵. For the concrete and metal pipe types listed here, the nomographs, tables and charts required for headwater calculations are no longer included at the end of this chapter but can still be obtained from this FHWA publication. For allowable pipe types not listed here – such as plastic pipe – please refer to the [HDS 5](#)⁵ Publication for the analogous information. To automate culvert hydraulic analysis for any allowable pipe material or shape, refer to the software titles recommended in this manual's [Chapter 14 Computer Programs](#).

Pipe wall thicknesses are sometimes needed. Concrete pipe wall thicknesses can be found in the Trench Backfill Tables in the [IDOT Construction Manual](#)¹⁴. Wall thicknesses for corrugated pipes can be found in [IDOT Standard Specifications for Road and Bridge Construction](#)¹ and from manufacturers for Polyvinyl Chloride (PVC) and Polyethylene (PE) pipes.

6-004 Miscellaneous Information

Pipe coatings are usually required on pipe culverts when the culvert must be protected from corrosive material in the flow. [Section 542 of the IDOT Standard Specifications for Road and Bridge Construction](#)¹ contains information on acceptable coatings.

The requirement of waterproofing culverts was discontinued through an IDOT memo on October 4, 1976. The waterproofing was applied to the outside of the culvert prior to backfilling. The problem appeared to be that the protection provided by the waterproofing was difficult to document. With the increased use of precast culverts and three-sided structures, waterproofing may again be an appropriate method of providing additional protection, especially to structures located close to the pavement structure, and should be given consideration. The district's representative should be consulted to determine if waterproofing is appropriate for a particular project.

Pipe uplift can be a problem when a culvert is under inlet control and a large head exists. Uplift can distort the flowline and shape of the culvert and can lead to failure. Pipe culverts projecting from the fill can be most vulnerable to these types of problems. When headwater calculations show that this situation exists, pipe uplift should be considered as a possible source of problems. Placing pipe culverts with conventional headwalls can help anchor the culvert and reduce pipe uplift.

There is some concern about the maximum acceptable velocity in a culvert. The maximum velocity should be based on the amount of sediment transport in the flow or abrasive potential to the culvert ([Figure 6-004](#)), probability of joint displacement and the acceptability of the receiving end to accommodate a large velocity (Refer to [Section 6-200](#)). Culvert manufacturers also have information on recommended velocity limits for their particular products.

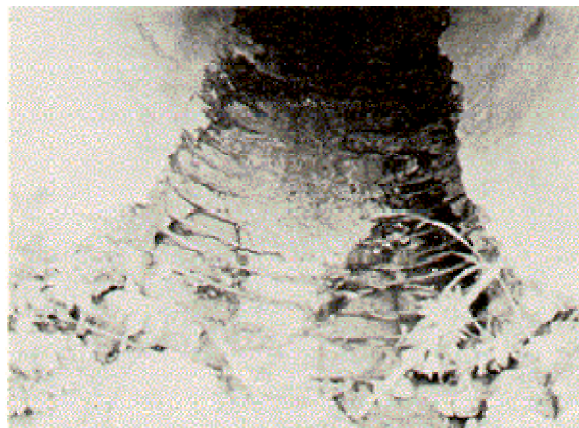

(a)

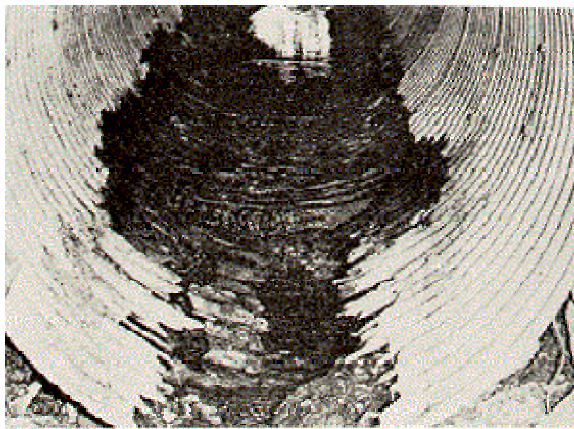

(b)

Figure 6-004

6-100 HYDRAULIC ANALYSIS

Hydraulic analysis consists of determining headwater elevations for alternate culvert sizes to aid in the determination of the most economic design. Each alternative should be evaluated for the 10-year, design, 100-year, and 500-year or overtopping flood frequency. Refer to the charts in the [BDE Manual⁴](#) for the appropriate design year. The design year for most State roadways is 50 years. Refer to [Chapter 1 Section 1-305 Design Criteria](#) for additional guidance or the District for more appropriate guidance. Outlet velocities shall also be computed and the need for erosion protection or energy dissipation assessed.

The culvert designer should recognize that Section 40-3.07 of the [BDE Manual⁴](#) allows the contractor to bid the most cost effective material type for pipe culverts, choosing among the allowable types for pipe class and diameter specified in the contract plans. To accommodate the contractor's selection, the designer has to anticipate that the contractor may choose ANY of the allowable material types for the specified class of culvert. It follows that in order to ensure the as-built installation satisfies design constraints on headwater and outlet velocity, design calculations should utilize an appropriately conservative Manning's roughness n -value from the list of allowable materials within the given class of pipe. The correct approach is dependent on the controlling design flow condition. To satisfy headwater constraints in outlet control flow conditions, design calculations should employ the highest Manning's roughness (n -value) for the pipe types within the specified class. Utilize a range of 0.010 to 0.013 (concrete) for Class A and 0.027 to 0.028 (corrugated metal) for Class C and Class D, noting that n -values varies by pipe diameter for corrugated metal. (See [Figure 6-804b](#)) Analogously, to ensure outlet velocity limits or constraints are satisfied for pipe culverts operating under inlet control flow conditions, design calculations should employ the lowest available Manning's roughness among the material types within the specified class. Utilize 0.010 to 0.013 (concrete) for Class A and 0.009 to 0.011 (PVC) for Class C and Class D. Given this direction, the designer should also anticipate the potential impact of material selection when the estimated design headwaters are on the cusp of inlet and outlet control.

The culvert designer should also recognize another design consideration when a box culvert is specified on the contract plans: the likelihood of a pre-cast versus a cast-in-place box. Pre-cast boxes are haunched and therefore provide reduced openings. The designer needs to assess the potential impact due to reduction of waterway opening, particularly for shallow design flows. The fact that pre-cast boxes are typically square edged can affect the applicable inlet coefficient. The designer shall use the appropriate inlet edge configuration (and loss coefficient) based upon anticipated edge treatment and likely end section selection. The inherent uncertainty of the selected constructed type supports recommending a slightly larger opening than that which is analyzed as "acceptable".

A hydraulic survey is required to determine the essential data of a waterway crossing. A major culvert crossing has previously been defined as one that drains 20 or more acres in an urban area and 200 or more acres in a rural area while a minor culvert crossing is one falling below these parameters. Refer to [Section 6-106 Hydraulic Reports](#) for more guidance on when a Hydraulic Report or culvert analysis for a culvert is needed. The survey shall be completed per the details in [Chapter 2](#), "Drainage Studies and Hydraulic Reports". Engineering judgment must be exercised when unusual circumstances are encountered.

The discharges used in the culvert analysis are to be determined by the appropriate method in [Chapter 4](#), "Hydrology". The hydraulic characteristics of the stream system; design highwater, tailwater and natural stream velocity are to be analyzed using the procedures in [Chapter 5](#), Open Channel Flow.

A slope parallel to the local stream profile is normally selected for a proposed culvert. The invert of all box culverts shall be set a minimum of 3 inches below the existing streambed to allow fish passage during low water. An approximate length of structure should be determined from a review of the proposed typical section or of the existing plans.

The culvert design form in [Figure 6-100a](#) can be used to record the culvert parameters, headwater and velocity calculations for each design alternative using the culvert design charts. The design charts can be found in *Hydraulic Design of Highway Culverts - Hydraulic Design Series No. 5 (HDS 5) by the FHWA*⁵. Refer to [Table 6-100](#) for a list of terminology for the Culvert Design Form. A design example can be found in [Section 6-107](#) and on [Figure 6-107a](#).

If either the natural highwater or the culvert backwater inundates the roadway, relief-flow over the roadway should be determined using the weir flow procedures given in [Chapter 5](#).

[HDS 5 by the FHWA](#)⁵ also has a hand method procedure for determining roadway overtopping and the performance curves for the roadway and the culvert. These procedures can be found in [HDS 5](#)⁵ on pages 38-44. An example problem of these procedures can also be found in [HDS 5](#)⁵ on pages 66 and 67.

There are many computer programs available for the design of culverts. Refer to the computer software chapter ([Chapter 14](#)) of this manual.

In most cases, [HY-8](#)⁷ ([Figure 6-100b](#)) or [HEC-RAS](#)⁶ will be the preferred program for culvert analysis.

There are no hard criteria or rules for selecting the appropriate program; the determination considers several site-specific factors.

[HY-8](#)⁷ tends to be easier to use for this task, and it requires less survey information than [HEC-RAS](#)⁶ to complete the design. [HY-8](#)⁷ is appropriate for designing minor culverts (as defined in [Section 6-100](#)) on smaller watersheds, such as those that lack a well-defined channel near the highway crossing. [HY-8](#)⁷ is also appropriate at those locations where the performance characteristics of the culvert- such as headwater and outlet velocity- are the deciding factors. A [HEC-RAS](#)⁶ model is utilized at major culverts and typically for all multi-cell culverts. When the proposed culvert crossing lies in a hydraulically sensitive floodplain, in a designated Federal Emergency Management Agency (FEMA) Zone A floodplain, or in any watershed large enough to require a floodway construction permit from Illinois Department of Natural Resources – Office of Water Resources (IDNR-OWR), water surface profiles extending upstream of the crossing are required. [HEC-RAS](#)⁶ (or, in District 1, the appropriate FEMA model) is required for those projects. In some cases, the culvert results from [HEC-RAS](#)⁶ will not be reasonable, such as when most or all storm events generate negative created heads. (This anomaly can occur at culverts that severely constrict wide and shallow overbank flow.) In that case, the user should check the culvert results in [HY-8](#)⁷ using a rating curve generated from the natural conditions water surface profile in [HEC-RAS](#)⁶.

The computer models [HEC-RAS](#)⁶ and [HY-8](#)⁷ can also determine roadway overtopping and performance curves. The appropriate culvert and roadway information must be available and correctly entered into the programs.

6-101 Allowable Headwater

Allowable headwater elevation (AHW) is a function of two constraints: regulatory and arbitrary. Regulatory constraints are defined in [Chapter 1, Responsibilities and Policy](#). Arbitrary constraints are clearance restrictions related to pavement elevation, limited elevations because of potential damage to upstream properties, or elevation of drainage divides where if the ditch summit is overtopped the runoff could change watersheds.

6-102 Trial Size

For the first trial size, use the same size as the existing culvert or a nearby structure in the stream. If there is no other structure nearby, select a culvert that has an area in square feet roughly equal to one-fifth the design discharge as a trial size. [Figure 6-102](#) lists areas for various size circular, elliptical and arch culvert pipes. The height of the trial size culvert is typically set at the natural depth of water in the stream for the design discharge.

If a trial size is too large because of limited embankment height or availability of size, multiple barrels may be used by dividing the discharge equally between the number of barrels. Raising the embankment height or the use of pipe arch, elliptical or box culverts with greater width than height should also be considered. Final selection should be based on an economic analysis of hydraulic equivalents.

CULVERT DESIGN FORM

Project <input style="width: 90%;" type="text"/>	Station <input style="width: 80%;" type="text"/>	Designer/Date: <input style="width: 95%;" type="text"/>
	Sheet <input style="width: 15%;" type="text"/> of <input style="width: 15%;" type="text"/>	Reviewer/Date: <input style="width: 95%;" type="text"/>

Method:
 Drainage Area: Stream Slope:
 Channel Shape:
 Routing: Other:

Design Flows / Tailwater

R.I. (years)	Flow (cfs)	TW (ft)
<input style="width: 95%;" type="text"/>	<input style="width: 95%;" type="text"/>	<input style="width: 95%;" type="text"/>
<input style="width: 95%;" type="text"/>	<input style="width: 95%;" type="text"/>	<input style="width: 95%;" type="text"/>

ROADWAY ELEVATION (ft)

EL_{hd} (ft)

EL_{st} (ft) S_o

EL_i (ft)

EL_{ho} (ft)

L_g: S =

S = S_o - FALL / L_o

	Total flow Q (cfs)	Flow / barrel Q/N (ft)	Headwater Calculations											Control head-water elevation (g)	Outlet Velocity	Comments
			Inlet control				Outlet control									
			HW _i /D (2)	HW _i (3)	Fall (3)	EL _{hi} (4)	TW (5)	d _c	$\frac{d_c + D}{2}$	h _a (6)	k _c	H (7)	EL _{ho} (8)			

TECHNICAL FOOTNOTES:

(1) Use Q/NB for box culverts

(2) HW_i/D = HW_i/D or HW_i/D from design charts

(3) Fall = HW_i - (EL_{hd} - EL_{st}); Fall is zero for culverts on grade

(4) EL_{hi} = HW_i + EL_i (invert of inlet control section)

(5) TW based on down stream control or flow depth in channel.

(6) h_a = TW or (d_c + D)/2 WHICHEVER IS GREATER

(7) H = $[1 + K_c + (29r^2L)/R^{1.33}] \sqrt{72g}$

(8) EL_{ho} = EL_o + H + h_a

(9) EL_{hi} or EL_{ho}, whichever is greater

<p>SUBSCRIPT DEFINITIONS:</p> <p>Q. APPROXIMATE #F. STREAMBED AT</p> <p>F. CULVERT FACE CULVERT FACE</p> <p>N. DESIGN HEADWATER N. TAILWATER</p> <p>h_i. HEADWATER IN INLET CONTROL</p> <p>h_a. HEADWATER IN OUTLET CONTROL</p> <p>I. INLET CONTROL SECTION</p> <p>O. OUTLET</p>	<p>Comments/Discussion</p> <div style="border: 1px solid black; height: 80px; width: 95%;"></div>	<p>CULVERT BARREL</p> <p>Size: <input style="width: 80%;" type="text"/></p> <p>Shape: <input style="width: 80%;" type="text"/></p> <p>Material: <input style="width: 80%;" type="text"/></p> <p>Entrance: <input style="width: 80%;" type="text"/></p>
--	---	---

Figure 6-100a

Table 6-100
List of Terms for Culvert Design Form (Figure 6-100)

Q	Total flow or discharge (cuft/sec)
Q/N	Flow or discharge per barrel (cuft/sec)
HW _i /D	Headwater depth above inlet control section in diameters (ft/ft)
HW _i	Headwater depth above inlet control section invert (ft)
Fall	Depression of inlet control section below the streambed (ft)
EL _{hi}	Headwater elevation required for culvert to pass flow in inlet control (ft)
TW	Tailwater depth measured from culvert outlet invert (ft)
d _c	Critical depth (ft)
h _o	Height of hydraulic grade line above outlet invert (ft)
k _e	Entrance loss coefficient
H	Sum of inlet loss, friction loss, and exit loss in a culvert or head (ft)
EL _{ho}	Headwater elevation required for culvert to pass flow in outlet control (ft)
EL _i	Invert elevation at inlet (ft)
EL _o	Invert elevation at outlet (ft)
L	Actual culvert length (ft)
L _a	Approximate length of culvert, including tapered inlet, but excluding wingwalls (ft)
S	Slope of culvert barrel (ft/ft)
S _o	Slope of channel bed (ft/ft)
EL _{hd}	Design headwater or allowable headwater elevation (ft)
EL _{sf}	Stream bed elevation at face of culvert (ft)
D	Interior height of culvert barrel (ft)

Crossing Data - Crossing 1

Crossing Properties
 Name:

Parameter	Value	Units
DISCHARGE DATA		
Minimum Flow	0.00	cfs
Design Flow	0.00	cfs
Maximum Flow	0.00	cfs
TAILWATER DATA		
Channel Type	Rectangular Channel	
Bottom Width	0.00	ft
Channel Slope	0.0000	ft/ft
Manning's n (channel)	0.0000	
Channel Invert Elevation	0.00	ft
Rating Curve	View...	
ROADWAY DATA		
Roadway Profile Shape	Constant Roadway Elevation	
First Roadway Station	0.00	ft
Crest Length	0.00	ft
Crest Elevation	0.00	ft
Roadway Surface	Paved	
Top Width	0.00	ft

Culvert Properties

Culvert 1

Parameter	Value	Units
CULVERT DATA		
Name	Culvert 1	
Shape	Circular	
Material	Concrete	
Diameter	0.00	ft
Embedment Depth	0.00	in
Manning's n	0.0120	
Inlet Type	Conventional	
Inlet Edge Condition	Square Edge with Headwall	
Inlet Depression?	No	
SITE DATA		
Site Data Input Option	Culvert Invert Data	
Inlet Station	0.00	ft
Inlet Elevation	0.00	ft
Outlet Station	0.00	ft
Outlet Elevation	0.00	ft
Number of Barrels	1	

Click on any  icon for help on a specific topic

HY-8 Input Screen
 Figure 6-100b

PIPE CULVERTS AND CORR. STR. PLATE PIPE		ELLIPTICAL PIPE CULVERTS		CORRUGATED STRUCTURAL PLATE PIPE ARCHES		PIPE ARCH CULVERTS			
						CORRUGATED METAL		REINFORCED CONCRETE	
DIAMETER INCHES	AREA SQ. FT.	SPAN X RISE INCHES	AREA SQ. FT.	SPAN X RISE FT. - IN.	AREA SQ. FT.	SPAN X RISE INCHES	AREA SQ. FT.	SPAN X RISE INCHES	AREA SQ. FT.
6	0.2								
8	0.4								
10	0.5								
12	0.8								
15	1.2					17X13	1.1	18X11	1.1
18	1.8	23X14	1.8			21X15	1.6	22X13 1/2	1.6
21	2.4					24X18	2.2	26X15 1/2	2.2
24	3.1	30X19	3.3			28X20	2.8	28 1/2X18	2.8
27	4.0	34X22	4.1						
30	4.9	38X24	5.1			35X24	4.4	36 1/4X 22 1/2	4.4
36	7.1	45X29	7.4			42X29	6.4	43 3/4X26 5/8	6.4
42	9.6	53X34	10.2			49X33	8.7	51 1/8X31 5/16	8.8
48	12.6	60X38	12.9			57X38	11.4	58 1/2X36	11.4
54	15.9	68X43	16.6			64X43	14.3	65X40	14.3
60	19.6	76X48	20.5			71X47	17.6	73X45	17.7
66	23.8	83X53	24.8			77X52	21.3		
72	28.3	91X58	29.5			83X57	25.3	88X54	25.6
78	33	98X63	35	6-1X4-7	22	87X63	31		
				6-4X4-9	24				
				6-9X4-11	26				
84	38	106X68	40	7-0X5-1	28	95X67	35	102X62	34.6
				7-3X5-3	31				
90	44	113X72	46	7-8X5-5	33	103X71	40	115X72	44.5
				7-11X5-7	35				
96	50	121X77	52	8-2X5-9	38	112X75	46	122X77 1/4	51.7
				8-7X5-11	40				
102	57	128X82	59	8-10X6-1	43	117X79	52		
				9-4X6-3	46				
108	64	136X87	66	9-6X6-5	49	128X83	58	138X87 1/8	66.0
				9-6X6-7	52				
114	71	143X92	74	10-3X6-9	55	137X87	64		
				10-8X6-11	58				
120	78	151X97	82	10-11X7-1	61	142X91	71	154X96 7/8	81.8
				11-5X7-3	54				
126	87			11-7X7-5	67				
				11-10X7-7	71				
132	95	166X106	99	12-4X7-9	74				
				12-6X7-11	78				
138	104			12-8X8-1	81				
				12-10X8-4	85				
144	113	180X116	119	13-5X8-5	89				
				13-11X8-7	93				
150	123			14-1X8-9	97				
				14-3X8-11	101				
156	133			14-10X9-1	105				
				15-4X9-3	109				
162	143			15-8X9-5	113				
				15-8X9-7	118				
168	154			15-10X9-10	122				
				16-5X9-11	126				
174	165			16-7X10-1	131				
180	177								

Cross Section Area of Culvert Pipes and Arches
Figure 6-102

6-103 Headwater Depth

Once a trial size has been selected, the headwater depth is determined. Headwater is generally a function of either inlet or outlet conditions. A culvert is said to operate with inlet control when the flow capacity is controlled at the entrance by the depth of headwater and entrance geometry. In outlet control, a culvert's hydraulic performance is determined by the factors governing inlet control as well as the controlling water surface elevation at the outlet and the slope, length and roughness of the culvert barrel. Prediction of the flow condition of a culvert is difficult; therefore, this design method will assume the culvert will flow with the most adverse condition. Following is the procedure for analysis if using the Culvert Design Form and Culvert Design Charts:

1. Check Inlet Control

Using the trial size previously selected and the discharge, find the headwater depth (HW) by using the appropriate inlet control nomograph from [HDS 5⁵](#). Tailwater (TW) conditions are to be neglected in this determination. HW in this case is found by multiplying HW/D, obtained from the nomograph, by the height of the culvert, D (See [Section 6-107](#) for an example).

Note: The approach velocity is assumed to be zero by this procedure. If the average approach velocity is considered significant, the headwater (HW) can be decreased by subtracting the velocity head ($V^2/2g$).

Note: [Hydraulic Design Series No. 5 \(HDS 5\)⁵](#) by the FHWA has inlet and outlet control nomographs for a wide variety of culverts.

2. Check Outlet Control

Using the trial size and design discharges, enter the appropriate outlet control nomograph from [HDS 5⁵](#). These nomographs show length scales with entrance loss coefficients combined and appear as arcs on the nomograph. Values of the coefficient "K_e" for various types of structures and types of entrances are given in [Figure 6-103](#). Even though there is not a direct tie to which value would correspond to the accepted IDOT entrance type, the designer should pick the value that best represents the type of IDOT entrance that would be used, leaning towards the more conservative choice. Other scales on the nomograph are discharge on the left and the diameter or culvert size scale. A turning line or reference line without division marks is provided for solving the two parts of the equation. On the far right is the head scale (H), which is the difference in elevation of the upstream pool level and the water surface at the culvert outlet. The nomograph is used by placing one end of a straight edge on the appropriate length scale at the selected length and the other end at the selected diameter (or area in the case of a box culvert). A small mark is then made on the turning line. Then the straight edge is used to extend a line from the appropriate discharge through the small mark on the turning line to the head scale, where the head, H, is read.

The depth of flow at the outlet is designated as h_o . When the downstream tailwater submerges the culvert outlet, h_o is the depth of the tailwater. For unsubmerged outlet conditions, h_o is the greater of tailwater depth (TW) and the average of critical depth and the culvert height, $(d_c + D)/2$. Values of critical depth are given in the charts from [HDS 5⁵](#). These charts are based on the IDOT accepted method for computing critical depth. The critical depth computed by any computer program used to design culverts,

not listed as an IDOT accepted program, should be checked manually against the charts to ensure that they are approximately the same.

To compute headwater depth above flow line elevation at the culvert entrance, use the equation given below that corresponds to the tailwater condition:

A. Submerged outlet (TW = D or Greater):

$$HW = TW \text{ elevation} + H - \text{Entrance Flow Line Elevation.}$$

B. Unsubmerged Outlet (TW less than D):

$$HW = H + h_o - SL$$

Where SL is slope of the culvert * length of culvert

3. Compare the Headwaters

Compare the headwaters (HW) determined in Steps 1 and 2 (Inlet and Outlet Control). The higher headwater governs and indicates the controlling flow existing under the given conditions for the trial size selected.

If the governing headwater is higher or considerably lower than what is acceptable, a new trial size is selected and the procedures in Steps 1 and 2 are repeated.

<u>Type of Structure and Design of Entrance</u>	<u>Coefficient K_e</u>
• <u>Pipe, Concrete</u>	
Projecting from fill, socket end (groove-end)	0.2
Projecting from fill, sq. cut end	0.5
Headwall or headwall and wingwalls	
Socket end of pipe (groove-end)	0.2
Square-edge	0.5
Rounded (radius = D/12)	0.2
Mitered to conform to fill slope	0.7
*End-Section conforming to fill slope	0.5
Beveled edges, 33.7° or 45° bevels	0.2
Side-or slope-tapered inlet	0.2
• <u>Pipe. or Pipe-Arch. Corrugated Metal</u>	
Projecting from fill (no headwall)	0.9
Headwall or headwall and wingwalls square-edge	0.5
Mitered to conform to fill slope, paved or unpaved slope	0.7
*End-Section conforming to fill slope	0.5
Beveled edges, 33.7° or 45° bevels	0.2
Side-or slope-tapered inlet	0.2
• <u>Box, Reinforced Concrete</u>	
Headwall parallel to embankment (no wingwalls)	
Square-edged on 3 edges	0.5
Rounded on 3 edges to radius of D/12 or B/12 or beveled edges on 3 sides	0.2
Wingwalls at 30° to 75° to barrel	
Square-edged at crown	0.4
Crown edge rounded to radius of D/12 or beveled top edge	0.2
Wingwall at 10° to 25° to barrel	
Square-edged at crown	0.5
Wingwalls parallel (extension of sides)	
Square-edged at crown	0.7
Side-or slope-tapered inlet	0.2

*Note: "End Sections conforming to fill slope," made of either metal or concrete, are the sections commonly available from manufacturers. From limited hydraulic tests they are equivalent in operation to a headwall in both inlet and outlet control. Some end sections, incorporating a closed taper in their design have a superior hydraulic performance. These latter sections can be designed using the information given for the beveled inlet.

*Entrance Loss Coefficients (K_e) from HDS 5
Outlet Control, Full or Partly Full Entrance Head Loss*

$$H_e = K_e (V^2/2g)$$

Figure 6-103

6-104 Outlet Velocities

The outlet velocities and need for channel protection should be determined for each culvert considered. Outlet velocity is calculated using the continuity equation:

$$V = Q/A \quad (\text{Eq. 6-1})$$

Where:

- V = velocity, ft/sec
- Q = discharge, cuft/sec
- A = area, sqft

To compute the area of flow (A), the depth of flow (d) must first be determined.

If a culvert is in inlet control, the depth of flow and the velocity can be found by using Manning's Equation to arrive at the full flow of the culvert and comparing that by means of the hydraulic elements ([Chart 6-104a](#)) to the design flow.

Manning's Equation for velocity of flow:

$$V = \frac{1.486R^{2/3}S^{1/2}}{n} \quad (\text{Eq. 6-2})$$

Where:

- V = mean velocity, ft/sec
- R = hydraulic radius, ft
- S = slope, ft/ft
- n = manning's coefficient

The hydraulic radius R can be found using the following equation:

$$R = \frac{A}{P} \quad (\text{Eq. 6-3})$$

Where:

- P = wetted perimeter, ft

6-104.01 Example Problem 1 *Determining Depth of Flow and Velocity in Inlet Control*

Given:

3 ft diameter concrete culvert
 $Q = 50$ cuft/sec
 $S = 1$ percent
 $n = 0.013$

Find:

Flow depth and Velocity

Solution:

$$R = \frac{A}{P} = \frac{\pi(1.5)^2}{2\pi(1.5)} = 0.75 \text{ ft}$$

$$V = \frac{1.486R^{2/3}S^{1/2}}{n} = \frac{1.486(0.75)^{2/3}(0.01)^{1/2}}{0.013} = 9.4 \text{ ft/sec flowing full}$$

$$Q_f = V_f A = (9.4)(\pi(1.5)^2) = 66.7 \text{ cu ft/sec flowing full}$$

The same data could be obtained using [Chart 6-104b](#).

The percent of full flow discharge is $50/66.4 = 75$ percent. Using the hydraulic elements chart ([Chart 6-104a](#)) we see that 75 percent of full flow discharge corresponds to a depth of 65 percent of full flow depth or $0.65(3) = 1.95$ ft and a velocity of 111% of full flow velocity or $V = 1.11(9.4) \text{ ft/sec} = 10.4 \text{ ft/sec}$.

The same data could be obtained using the spreadsheet given in [Figure 6-104](#) as shown below.

36.00 inches or 3.00 feet
 Depth of Flow = 36 inches
 angle = 180
 c = 0.00
 s = 9.42
 Area = 7.07 sq. ft.
 Wetted Perimeter = 9.42 feet
 Hydraulic Radius = 0.75 feet
 n = 0.013
 Slope = 0.01 ft./ft.
 Computed Velocity = 9.4 fps
 Computed Discharge = 66.7 cfs
 Actual Discharge = cfs
 Actual Velocity = 0.0 fps - based on above area

36.00 inches or 3.00 feet
 Depth of Flow = 23.4 inches
 angle = 107.458
 c = 2.86
 s = 5.63
 Area = 4.86 sq. ft.
 Wetted Perimeter = 5.63 feet
 Hydraulic Radius = 0.86 feet
 n = 0.013
 Slope = 0.01 ft./ft.
 Computed Velocity = 10.4 fps
 Computed Discharge = 50.5 cfs
 Actual Discharge = cfs
 Actual Velocity = 0.0 fps - based on above area

If a culvert is in outlet control, the area of flow is based on the barrel geometry and one of the following:

1. Critical depth if the tail water is below critical depth.
2. The tailwater depth if the tailwater is between critical depth and the top of the barrel.
1. The height of the barrel if the tailwater is above the top of the barrel.

6-104.02 Example Problem 2 *Determining Depth of Flow and Velocity in Outlet Control*

Given:

3 ft diameter concrete culvert
Q = 50 cuft/sec
S = 1 percent
n = 0.013
TW = 2.5 ft

Find:

Flow depth and Velocity

Solution:

Reviewing [Chart 6-107b](#) using Q = 50 cfs and D = 3 ft, we find $d_c = 2.3$ ft. This is less than the tailwater depth of 2.5 ft; therefore, the area of the culvert inundated by 2.5 ft of depth is used in the continuity equation. The area relative to this depth can be estimated using the hydraulic elements chart ([Chart 6-104a](#)). Entering the chart with a depth of flow of $2.5/3 = 83$ percent corresponds to an area of 89 percent of the total.

$$\text{Area of flow} = 0.89(\pi(1.5)^2) = 6.29 \text{ sq ft}$$

Rearranging the continuity equation and using the design discharge and area of flow, the velocity can be calculated:

$$V = Q/A = 50/6.29 = 7.95 \text{ ft/sec}$$

Again, the same data could be obtained using the spreadsheet given in [Figure 6-104](#) as shown below.

36.00	inches or	3.00	feet
	Depth of Flow =	30	inches
	angle =	131.81	
	c =	2.24	
	s =	6.90	
	Area =	6.29	sq. ft.
	Wetted Perimeter =	6.90	feet
	Hydraulic Radius =	0.91	feet
	n =	0.013	
	Slope =	0.01	ft./ft.
	Computed Velocity =	10.7	fps
	Computed Discharge =	67.7	cfs
	Actual Discharge =	50.0	cfs
	Actual Velocity =	7.9	fps - based on above area

A velocity in the range of 5 to 7 ft/sec is usually considered an acceptable outlet velocity. Refer to [Section 6-004](#) for discussion on maximum pipe velocities. The natural channel velocity downstream of the culvert should be computed for each storm event. Outlet protection or energy dissipation should be designed in accordance with [Section 6-200](#). The outlet protection should be designed so that the culvert outlet velocity returns to the normal channel velocity by time the flow leaves the outlet protection.

[Figure 6-104](#) can be used to determine the area of a partially filled circular culvert. The spreadsheet can be recreated using the equations shown. The only input data required is the diameter in inches and the depth of flow in inches.

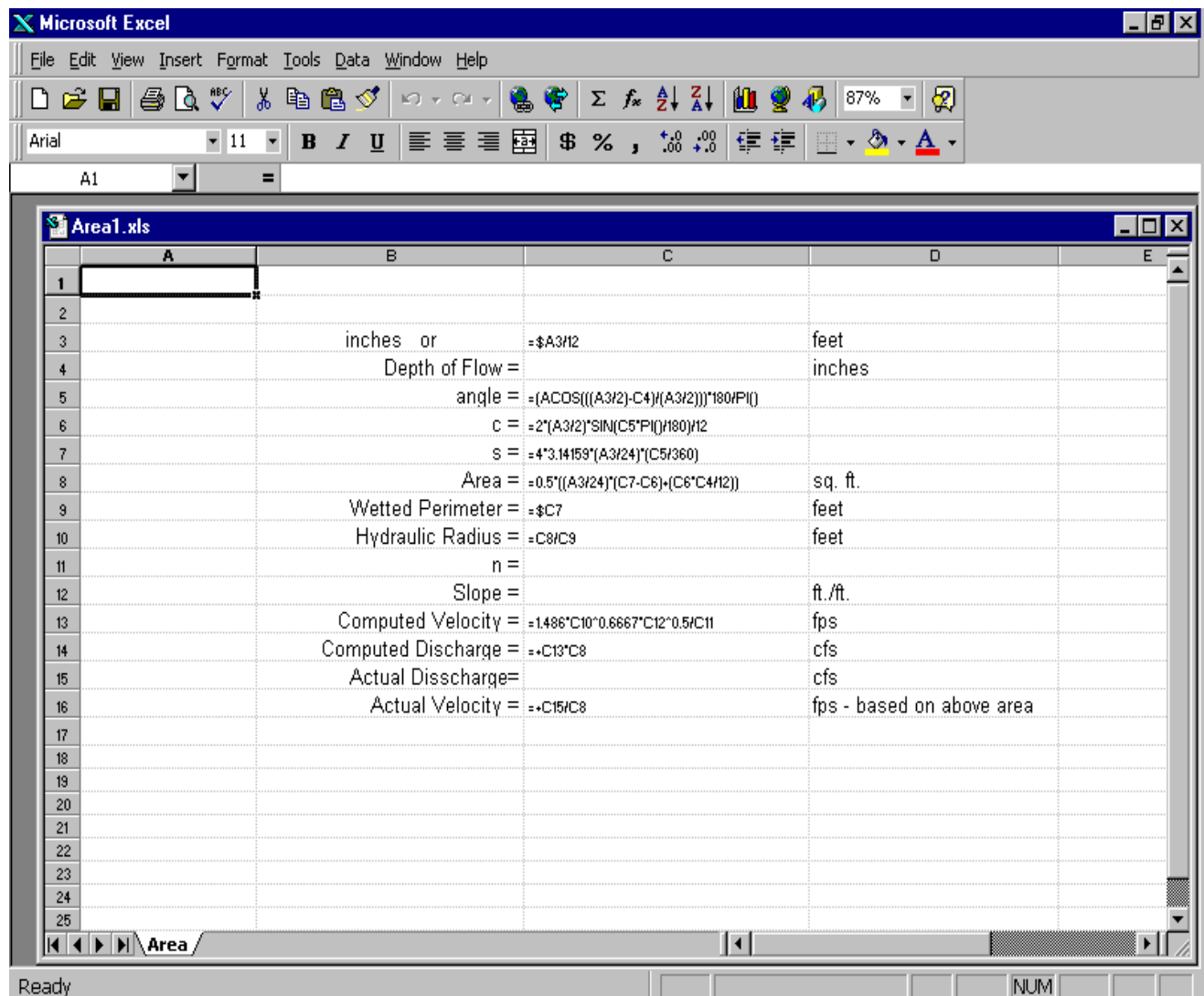
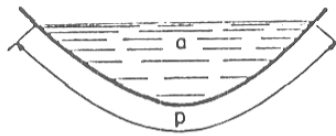

Figure 6-104

The spreadsheet can also be utilized using trial and error to determine velocity and area for a particular discharge. All that is needed is the diameter in inches, the known discharge, the “n” value and the culvert slope.

Most of the same information can be computed using the computer software [Visual Urban \(HY 22\) Urban Drainage Design Programs](#)¹³. This software is available free from the FHWA website listed in [Section 6-200](#).



a = Cross-sectional area of waterway
 p = Wetted perimeter
 $R = \frac{a}{p}$ = Hydraulic radius

SECTION OF ANY CHANNEL

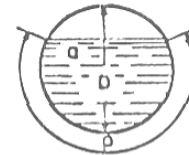

For pipes full or half full

$R = \frac{D}{4}$

SECTION OF CIRCULAR PIPE

- V = Average or mean velocity in feet per second
- $Q = a V$ = Discharge of pipe or channel in cubic feet per second (cfs)
- n = Coefficient of roughness of pipe or channel surface
- S = Slope of Hydraulic Gradient (water surface in open channels or pipes not under pressure, same as slope of channel or pipe invert only when flow is uniform in constant section.

HYDRAULIC ELEMENTS OF CIRCULAR SECTIONS

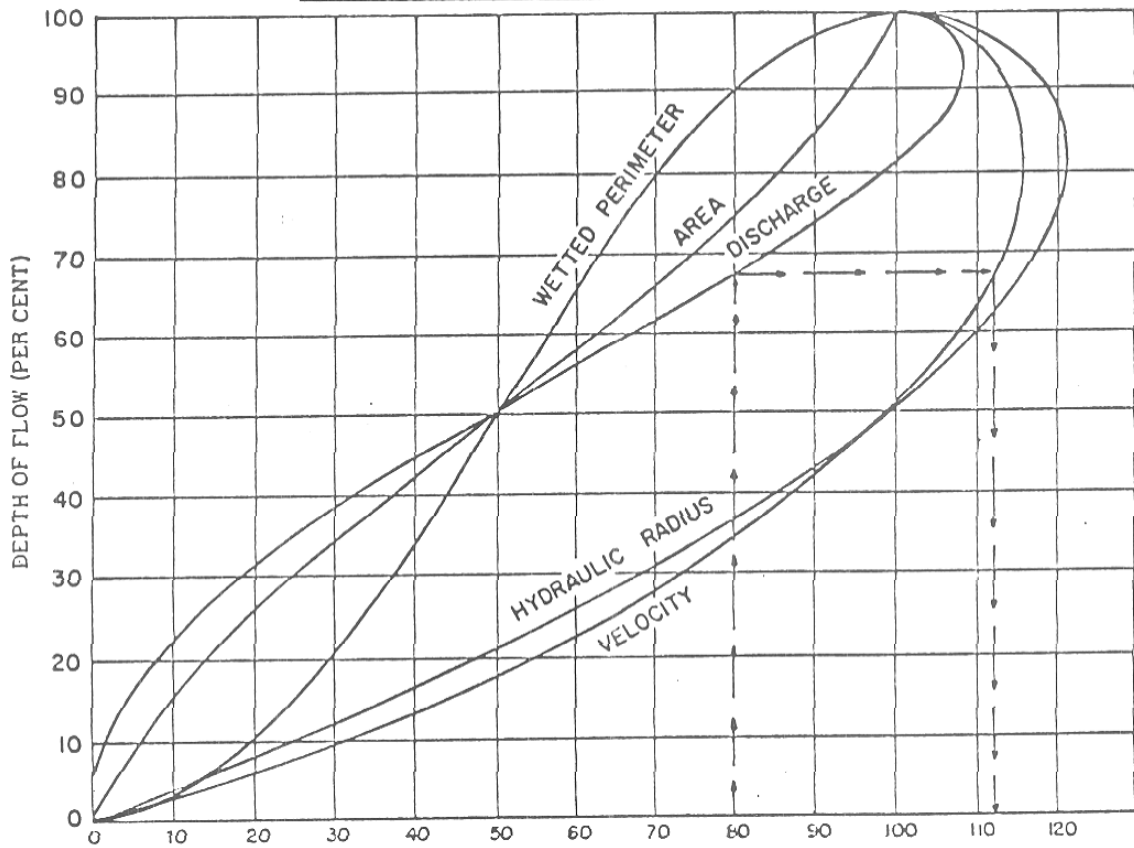

HYDRAULIC ELEMENTS
 PER CENT OF VALUE FOR FULL SECTION (approximate)

EXAMPLE: Given: Discharge = 12 cfs through a pipe which has capacity flowing full of 15 cfs at a velocity of 7.0 ft. per sec. Required to find V for $Q = 12$ cfs therefore, Percentage of full discharge = $\frac{12}{15} = 80\%$. Enter chart at 80% of value for full section of Hydraulic Elements, find $V = 112.5\% \times 7 = 7.9$ ft. per sec.

VALUES OF HYDRAULIC ELEMENTS OF CIRCULAR SECTION
 FOR VARIOUS DEPTHS OF FLOW

Chart 6-104a

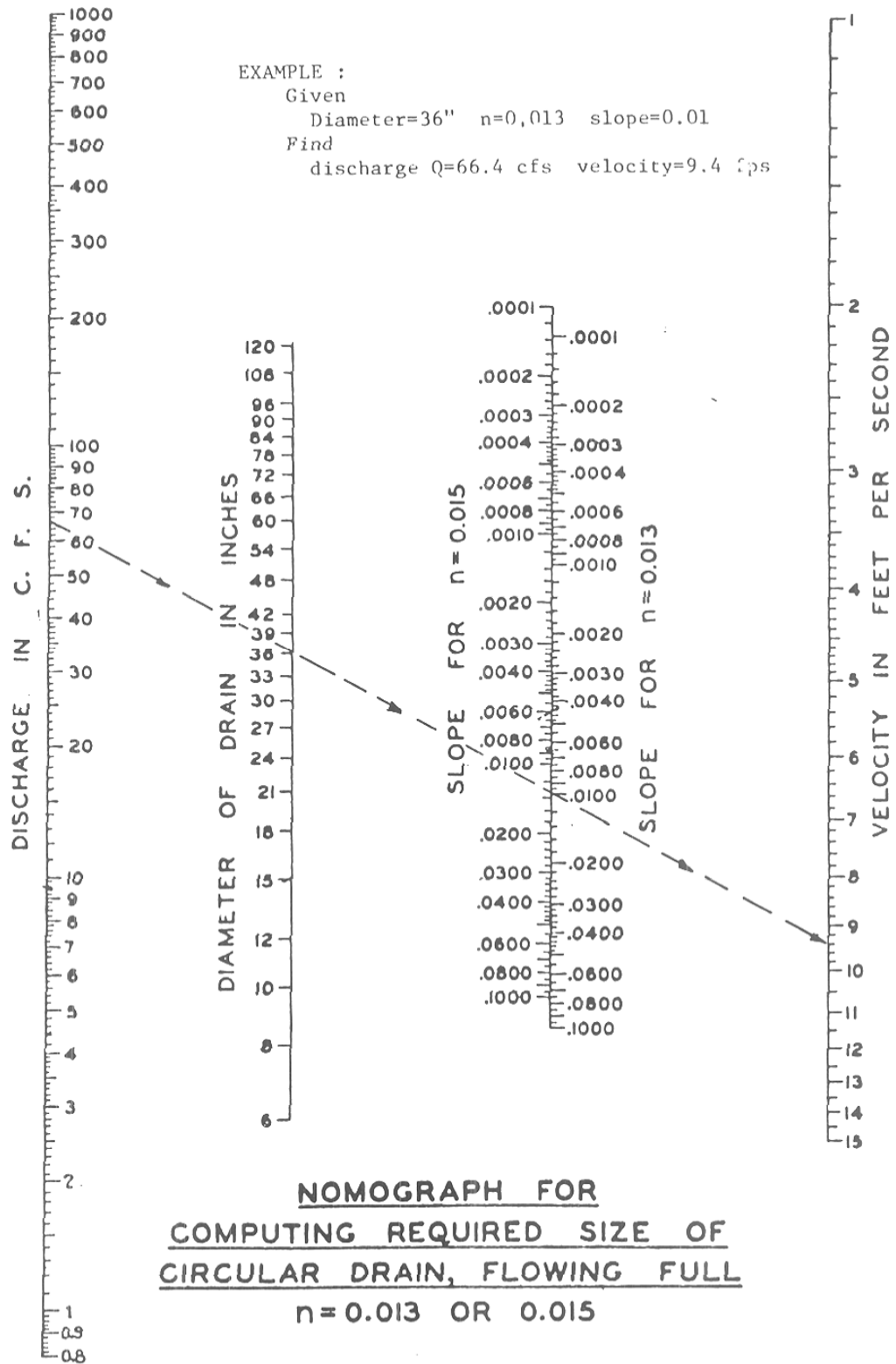

Chart 6-104b

6-105 Information for Waterway Information Table

Hand methods using the Culvert Design Form and the computer program [HY-8⁷](#) determine the controlling headwater elevation for the culvert being analyzed. In the computer program [HEC-RAS⁶](#), the maximum difference between the natural and proposed water surface profiles determines the created head for the culvert being analyzed.

If a Waterway Information (WWI) Table needs to be developed, then the determined controlling headwater elevation from hand methods or [HY-8⁷](#) can be entered directly on the WWI Table as the Headwater Elevation or the created head from [HEC-RAS⁶](#) can be entered directly on the WWI Table as the Head. A natural highwater elevation needs to be determined at the upstream face of the culvert. This is usually accomplished by interpolating the natural water surface profiles between the upstream and the downstream cross sections. This natural highwater elevation is then entered on the WWI Table as the Natural H.W.E. and used to compute the Waterway Opening for the WWI Table at the culvert face below this natural highwater elevation. To get the Head when using hand methods or [HY-8⁷](#), subtract the difference between the Headwater Elevation and the Natural H.W.E. To get the Headwater Elevation when using [HEC-RAS⁶](#), add the Head to the Natural H.W.E.

6-106 Hydraulic Reports

The Districts gained approval for all culverts around 1990. Thus there may be several different schools of thought as to when a Hydraulic Report is required. For example, due to the flood-sensitive nature of most of District 1, a Hydraulic Report is required for all culverts with an equivalent opening equal to or greater than a 42" diameter pipe. In general a Hydraulic Report is required for a culvert:

- When the total clear span is equal to or greater than 20 feet
- If there are potentially sensitive flood receptors upstream of the culvert
- At locations where drainage problems or issues attributed to the existing culvert have been identified.
- If a Floodway Construction Permit will be needed from the Illinois Department of Natural Resources – Office of Water Resources. [See Chapter 1, Section 1-404.](#)
- For a smaller culvert at the direction of the appropriate District.

The Hydraulic Report requires the generation of a Waterway Information Table. See [Chapter 1](#) and [Section 6-105](#) of this chapter for more guidance.

For culverts not requiring a Hydraulic Report, a culvert analysis will still be required to determine that the culvert is appropriately sized. Placing minimal culvert information on the plans such as drainage area, design and 100 year flows and controlling headwater elevations will be useful for future referencing.

6-107 Example Problem 3 - Culvert Design Form and HY-8

Figure 6-107a shows an example of the use of the culvert design form. A trial size of 30 inches was used because a nearby structure in the stream was 30 inches. Inlet control was computed using Chart 6-107a. The tailwater was computed as the depth in the stream at the location of the culvert outlet for the particular storm event. The critical depth was taken from Chart 6-107b. The head used to compute outlet control was determined using Chart 6-107c. These charts are shown here only for this and previous examples. The Hydraulic Design Series No. 5 (HDS 5)⁵ by the FHWA has inlet and outlet control nomographs for a wide variety of culverts. Once inlet and outlet control elevations were computed, the controlling headwater elevation was selected as the higher of the two, in this case inlet control. Once the controlling headwater was determined, the outlet velocity was computed using the procedures outlined in Section 6-104. Since the controlling headwater elevation is above the allowable headwater elevation, a larger culvert was selected.

A 36 inch culvert was selected next and the same procedures outlined above were followed. The controlling headwater elevation was below the allowable, but the outlet velocity warranted outlet protection.

A 42 inch culvert was then selected following the same procedures. The controlling headwater elevation was again below the allowable, but the outlet velocity was not any better. The calculations show that the controlling headwater was not significantly decreased with a larger culvert and outlet protection was still needed.

Therefore, a 36 inch culvert appeared to be adequate at this location, but before a final size was selected the 100-year storm needed to be checked. Computations showed the controlling headwater elevation to be slightly higher than the allowable, but were considered acceptable.

Outlet protection should be designed per Section 6-200.

The same example culvert was analyzed using HY-8⁷. The input screen is shown in Figure 6-107b and the HY-8⁷ analysis results are shown in Figure 6-107c. As can be seen in comparing the hand methods using the culvert design form to the computer model HY-8⁷, the HY-8⁷ has a 0.3' higher controlling headwater elevation and a 0.2 fps higher outlet velocity when comparing the design flow of 50 cfs for the 36" concrete pipe. These differences would be considered insignificant and either method would be considered acceptable. Likely differences can be attributed to rounding errors while using the design charts or assumptions made during HY-8⁷ computer model use. Additional information is required for the HY-8⁷ computer modeling compared to information needed for culvert design form hand method.

Project: <input style="width: 100%;" type="text" value="Example"/>			Station: <input style="width: 100%;" type="text"/>			Designer/Date: <input style="width: 100%;" type="text" value="G.B.M. - 08-08-2002"/>																																	
			Sheet: <input style="width: 20px;" type="text" value="1"/> of <input style="width: 20px;" type="text" value="1"/>			Reviewer/Date: <input style="width: 100%;" type="text"/>																																	
<input checked="" type="checkbox"/> Method: <input style="width: 100%;" type="text" value="S.C.S."/>			<p style="text-align: right; margin-right: 50px;">$s = S_o - FALL/L_o$ $s = 0.01$</p>																																				
<input checked="" type="checkbox"/> Drainage Area: <input style="width: 40px;" type="text" value="20"/> <input checked="" type="checkbox"/> Stream Slope: <input style="width: 40px;" type="text" value="1%"/>																																							
<input checked="" type="checkbox"/> Channel Shape: <input style="width: 100%;" type="text" value="Trapizoidal"/>																																							
<input type="checkbox"/> Routing: <input style="width: 100%;" type="text"/>																																							
Design Flows / Tailwater																																							
R.I. (years)		Flow (cfs)				TW (ft)																																	
<input style="width: 40px;" type="text" value="50"/>		<input style="width: 40px;" type="text" value="50"/>				<input style="width: 40px;" type="text" value="2.5"/>																																	
<input style="width: 40px;" type="text" value="100"/>		<input style="width: 40px;" type="text" value="58"/>				<input style="width: 40px;" type="text" value="2.8"/>																																	
		Total flow Q (cfs)		flow / barrel Q/N (1)		Headwater Calculations								Control head-water elevation		Outlet Velocity	Comments																						
						Inlet control				Outlet control																													
						HW_i/D (2)		HW_i (3)		Fall (3)		EL_{hi} (4)		TW (5)		d_c (6)		$\frac{d_c + D}{z}$ (6)		h_a (6)		k_c (6)		H (7)		EL_{ho} (8)													
Conc 30" Groove End HW		50		--		1.95 4.88		--		97.88		2.5 2.3		2.4 2.5		0.2 3.15		97.65 97.88		10.2		HW Too High																	
Conc 36" Groove End HW		50		--		1.22 3.66		--		96.66		2.5 2.3		2.65 2.65		0.2 1.40		96.05 96.66		10.4		Needs Outlet Prot																	
Conc 42" Groove End HW		50		--		0.93 3.26		--		96.26		2.5 2.2		2.85 2.85		0.2 0.68		95.53 96.26		10.4		Same																	
Conc 36" Groove End HW		58		--		1.42 4.26		--		97.26		2.8 2.5		2.75 2.8		0.2 1.90		96.70 97.26		10.6		Same																	
TECHNICAL FOOTNOTES:																																							
(1) Use Q/NB for box culverts					(2) $HW_i/D = HW_i/D$ or HW_i/D from design charts					(3) Fall = $HW_i - (EL_{hd} - EL_{sf})$; Fall is zero for culverts on grade					(4) $EL_{hi} = HW_i + EL_i$ (invert of inlet control section)					(5) TW based on down stream control or flow depth in channel.					(6) $h_o = TW$ or $(d_c + D)/2$ WHICHEVER IS GREATER					(7) $H = [1 + K_c + (29r^2L)/R^{1.33}]v^2/2g$					(8) $EL_{ho} = EL_o + H + h_o$				
SUBSCRIPT DEFINITIONS:																																							
Q. APPROXIMATE $\frac{1}{2}$ STREAMBED AT					f. CULVERT FACE					h.d. DESIGN HEADWATER					h.i. HEADWATER IN INLET CONTROL					h.o. HEADWATER IN OUTLET CONTROL					I. INLET CONTROL SECTION					o. OUTLET									
															Comments/Discussion																								
															CULVERT BARREL																								
															Size		<input style="width: 100%;" type="text" value="36"/>																						
															Shape		<input style="width: 100%;" type="text" value="Round"/>																						
															Material:		<input style="width: 100%;" type="text" value="Concrete"/>																						
															Entrance:		<input style="width: 100%;" type="text" value="Grooved End in HW"/>																						

Figure 6-107a

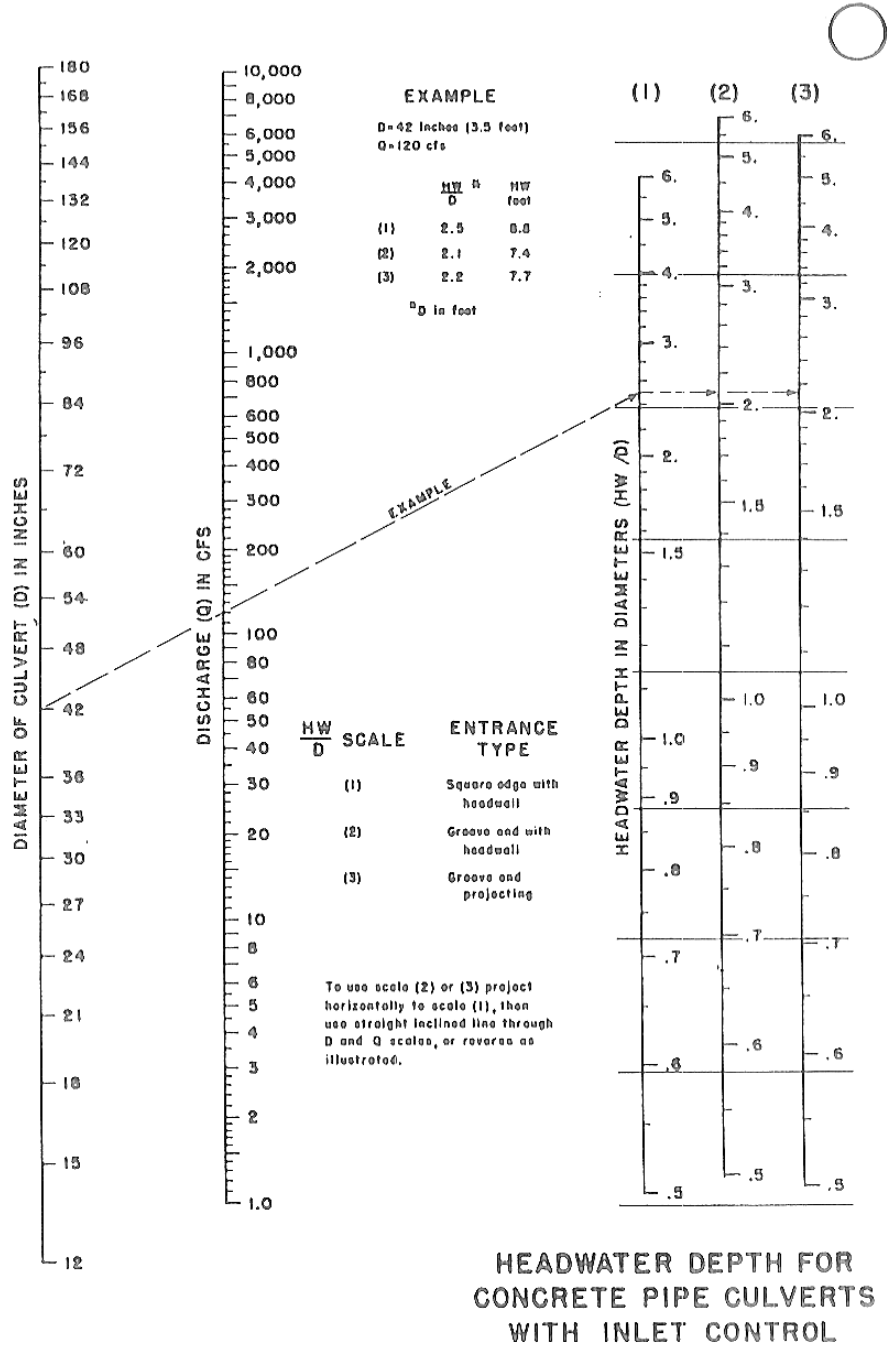
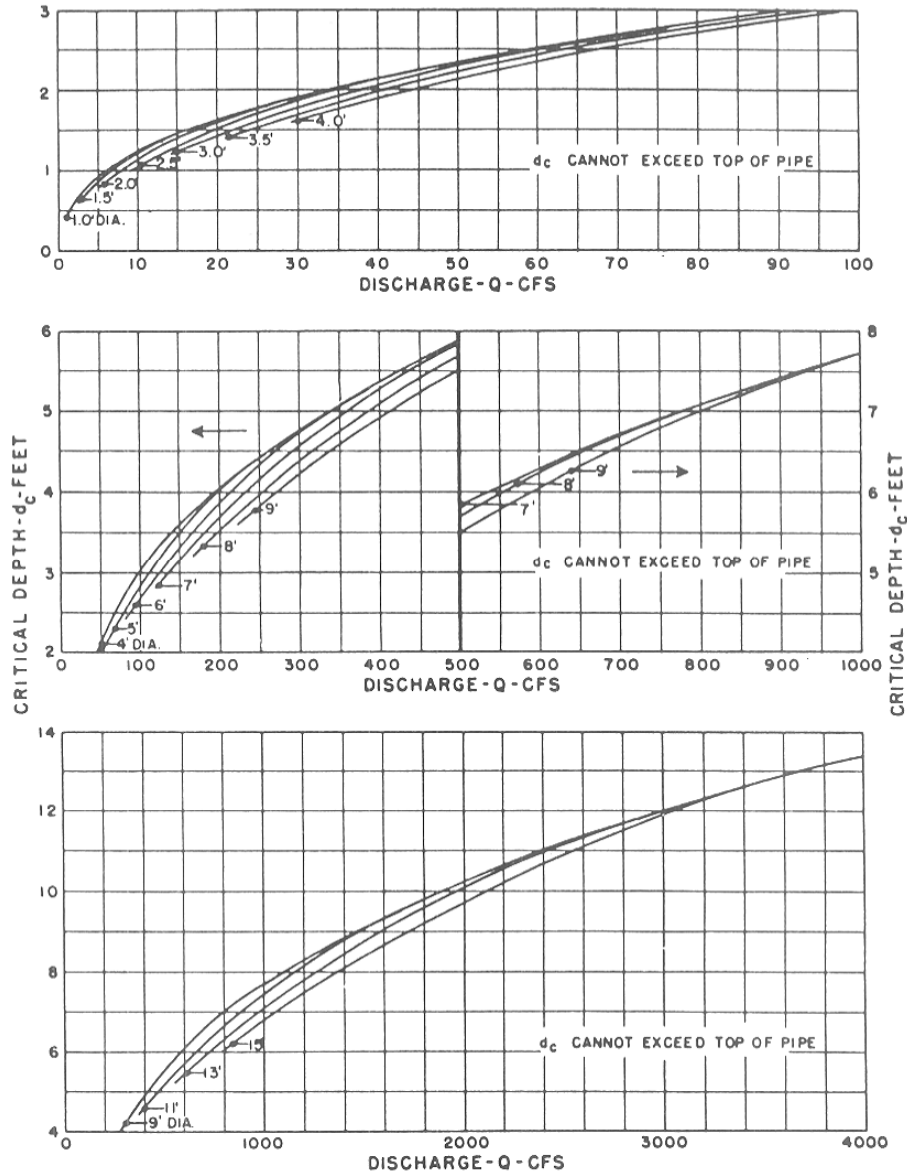
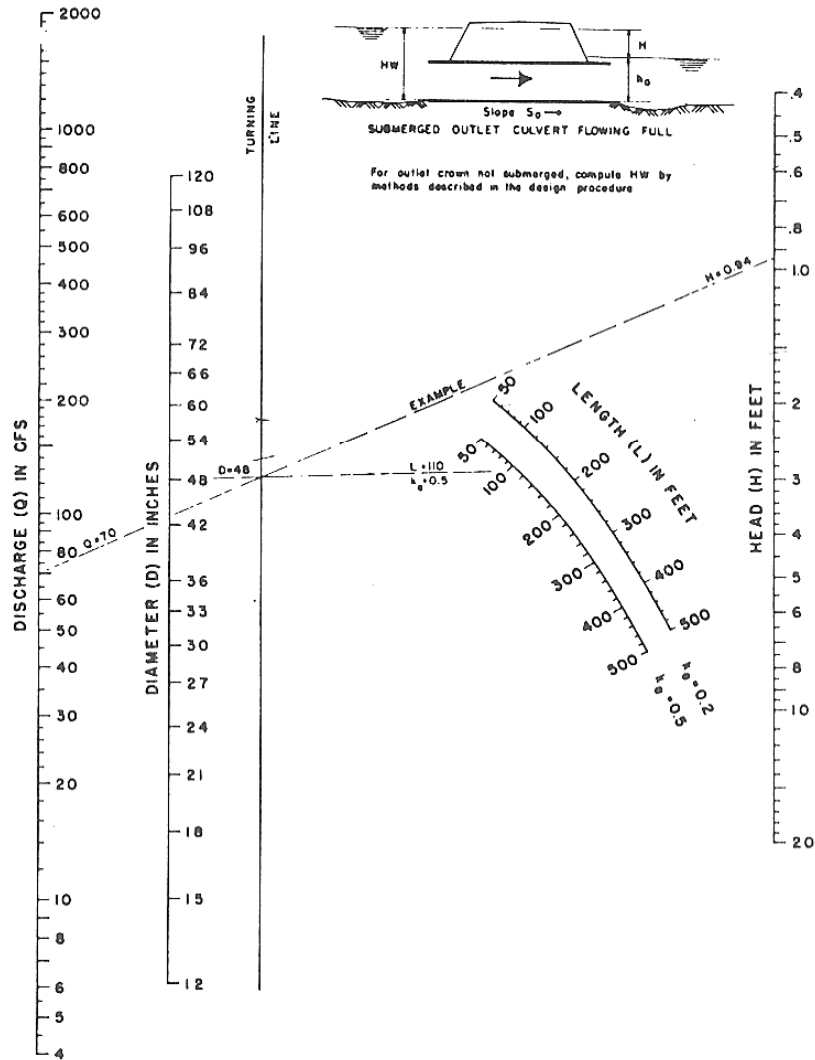

Chart 6-107a



CRITICAL DEPTH
CIRCULAR PIPE

Chart 6-107b



HEAD FOR
CONCRETE PIPE CULVERTS
FLOWING FULL
 $n = 0.012$

Chart 6-107c

Crossing Data - Example

Crossing Properties
Name:

Parameter	Value	Units
DISCHARGE DATA		
Minimum Flow	0.00	cfs
Design Flow	50.00	cfs
Maximum Flow	58.00	cfs
TAILWATER DATA		
Channel Type	Enter Rating Curve	
Channel Invert Elevation	92.00	ft
Rating Curve	Define...	
ROADWAY DATA		
Roadway Profile Shape	Constant Roadway Elevation	
First Roadway Station	0.00	ft
Crest Length	500.00	ft
Crest Elevation	100.00	ft
Roadway Surface	Paved	
Top Width	30.00	ft

Culvert Properties

Culvert 1

Add Culvert
Duplicate Culvert
Delete Culvert

Parameter	Value	Units
CULVERT DATA		
Name	Culvert 1	
Shape	Circular	
Material	Concrete	
Diameter	3.00	ft
Embedment Depth	3.00	in
Manning's n (Top/Sides)	0.0120	
Manning's n (Bottom)	0.0120	
Inlet Type	Conventional	
Inlet Edge Condition	Beveled Edge	
Inlet Depression?	No	
SITE DATA		
Site Data Input Option	Culvert Invert Data	
Inlet Station	0.00	ft
Inlet Elevation	93.00	ft
Outlet Station	100.00	ft
Outlet Elevation	92.00	ft
Number of Barrels	1	

Help Click on any icon for help on a specific topic Energy Dissipation Analyze Crossing OK Cancel

HY-8 Input Screen
Figure 6-107b

HY-8 Analysis Results

Culvert Summary Table - Culvert 1

Culvert Crossing: Example

Total Discharge (cfs)	Culvert Discharge (cfs)	Headwater Elevation (ft)	Inlet Control Depth(ft)	Outlet Control Depth(ft)	Flow Type	Normal Depth (ft)	Critical Depth (ft)	Outlet Depth (ft)	Tailwater Depth (ft)	Outlet Velocity (ft/s)	Tailwater Velocity (ft/s)
0.00	0.00	93.25	0.00	0.00	0-NF	0.00	0.00	0.00	0.00	0.00	0.00
5.80	5.80	94.11	0.86	0.00	1-S2n	0.44	0.62	0.45	0.29	5.90	0.00
11.60	11.60	94.54	1.29	0.00	1-S2n	0.67	0.93	0.67	0.58	7.45	0.00
17.40	17.40	94.91	1.66	0.00	1-S2n	0.86	1.18	0.86	0.87	8.32	0.00
23.20	23.20	95.28	2.03	0.00	1-S2n	1.02	1.39	1.02	1.16	9.06	0.00
29.00	29.00	95.58	2.33	2.33	1-S2n	1.18	1.58	1.22	1.45	9.26	0.00
34.80	34.80	95.88	2.63	2.63	1-S2n	1.32	1.76	1.37	1.74	9.67	0.00
40.60	40.60	96.27	3.02	3.02	5-S2n	1.47	1.91	1.52	2.03	10.06	0.00
46.40	46.40	96.67	3.42	3.42	5-S2n	1.61	2.05	1.67	2.34	10.38	0.00
50.00	50.00	96.97	3.72	3.72	5-S2n	1.70	2.13	1.76	2.50	10.57	0.00
58.00	58.00	97.65	4.40	4.40	5-S2n	1.92	2.28	1.93	2.80	11.21	0.00

*HY-8 Output Report
Figure 6-107c*

6-200 ENERGY DISSIPATION

6-201 General

Scour at culvert outlets is a common occurrence. Velocities at the culvert outlet are usually higher than in the natural channel and can be erosive. Erosion can cause culvert failure and create problems downstream. Remedial measures are often more expensive than anticipating erosive potential and providing suitable protection. Section 9-500 in Chapter 9, Roadside Ditches, offers guidance as to when erosion protection is warranted. Refer to computer software [HY8 Energy – Energy Dissipater Design](#)⁸. This is a program for energy dissipation at culvert outlets. This program is available free from the FHWA website:

<http://www.fhwa.dot.gov/engineering/hydraulics/software.cfm>

Also refer to [Hydraulic Design of Energy Dissipaters for Culverts and Channels, \(HEC 14\)](#)⁹.

Energy dissipation can be expensive and should not be considered the only solution to large outlet velocities. A cost analysis of the various alternatives, such as a larger culvert, should be performed to verify the cost effectiveness of each alternative. All possible options should be investigated before energy dissipation is proposed.

Scour or erosion at a bridge can create the possibility of catastrophic failure. However, since that is typically not the case at culvert structures, the FHWA does not mandate a calculation or evaluation of scour at this structure type. Although not considered a scour evaluation per se, the potential for damaging erosion, channel migration and aggradation/degradation are still addressed within the TSL plan development. This assessment can lead to the inclusion of such design features as riprap placement at one or both ends, cutoff walls, drop structures, energy dissipaters or even a change in structure type. Accordingly, the Design Scour Elevation Table for culverts is not the calculated scour, but instead documents the tolerable loss of stream bed material/riprap that would not impact the factor of safety or performance of the culvert structure and wingwalls. The Design Scour Elevation Table will indicate Upstream and Downstream elevations as shown in [Table 6-201](#).

Design Scour Elevation Table

	Upstream	Downstream
Design Scour Elevation (ft.)		

Table 6-201

The design scour elevation would normally be taken as the bottom of the cut off wall which is usually located at or above the bottom of horizontal L-Type or T-Type wingwalls. When the foundation soils in front of the wall footing are necessary for providing sliding or bearing capacity resistance, the elevation may be increased. In the case of sheeting pile or soldier pile wingwalls, the elevation would be the cutoff wall or the soil elevation assumed in the wall design, whichever is higher.

6-202 Light Channel Protection

The most common method of light channel protection at culvert outlets is a riprapped transition or apron from the culvert outlet to the natural channel. The riprap should have bedding and/or filter fabric under it and should be of sufficient size and depth for the anticipated flow. A length of protection of three times the anticipated velocity in feet per second is commonly used as a rule of thumb.

Another guide is available at the following website from the Natural Resource Conservation Service (NRCS):

<http://www.il.nrcs.usda.gov/technical/engineer/urban/standards/urbst910.html>

6-203 Stilling Basins

Stilling basins are often used to dissipate energy at culvert outlets. [Figure 6-203](#) details the general layout of a riprap stilling basin.

Chapters V and XI of Hydraulic Design of Energy Dissipaters for Culverts and Channels, ([HEC 14](#))⁹, should be consulted to determine the dimensions of a specific riprapped energy basin.

Other types of stilling basins include Supercritical Expansion into Hydraulic Jump Basins – The supercritical expansion into a basin is used to convert depth (potential energy) at the culvert outlet into kinetic energy by allowing the flow to expand, drop or both. This results in a decrease in depth of flow and an increase in both the velocity and Froude number. The higher the Froude number entering the jump, the more efficient the jump and the shorter the basin required.

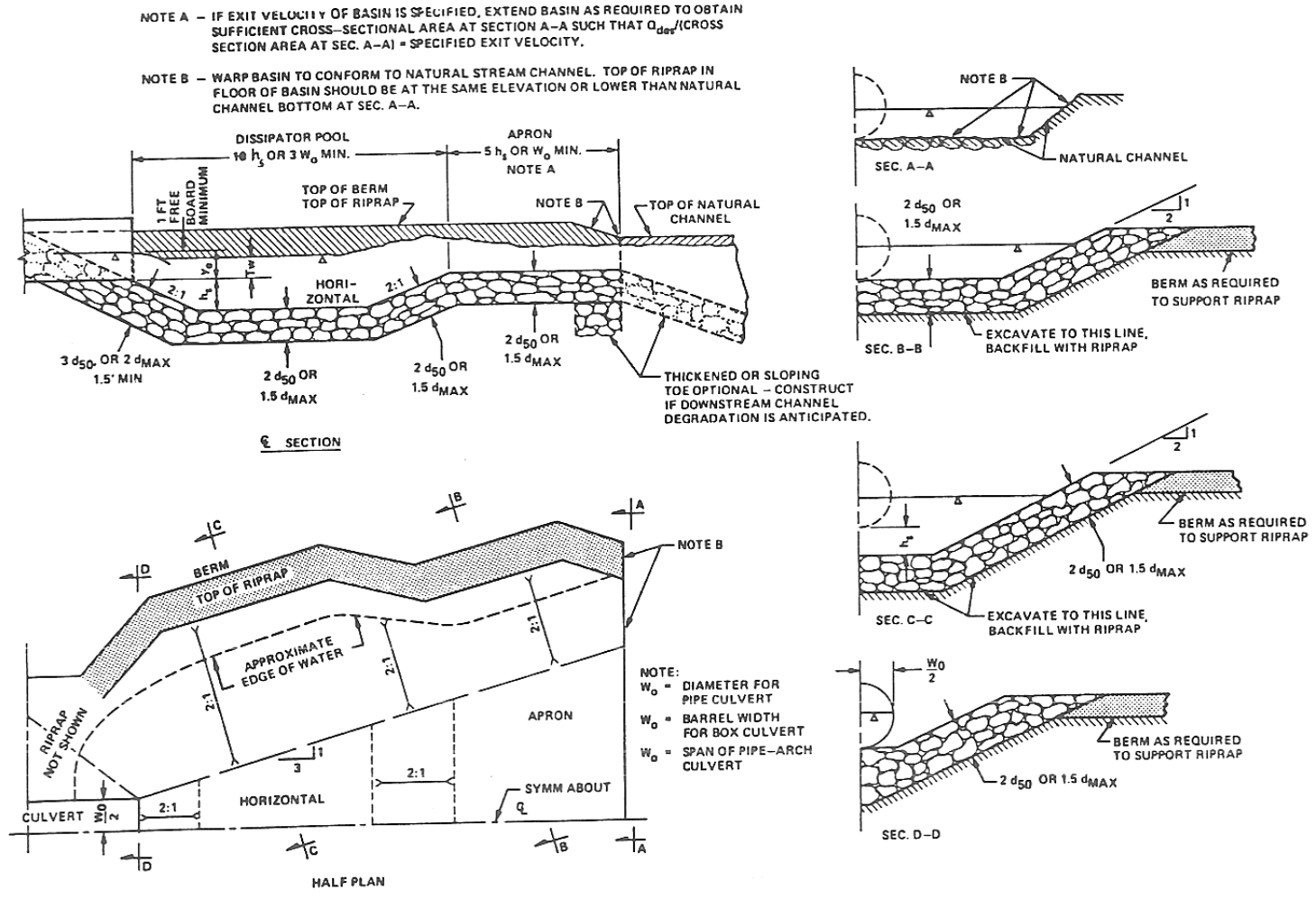

DETAILS OF RIPRAPPED CULVERT ENERGY BASIN

Figure 6-203

6-204 Impact-type Energy Dissipater

Another method of energy dissipation is the impact-type energy dissipater. This dissipater consists of a relatively small box like structure that requires no tailwater, and will handle incoming velocities as great as 30 ft/sec. A table listing critical dimensions for 7 different pipe sizes is shown in [Figure 6-204a](#). A photograph of an impact energy dissipater is shown in [Figure 6-204b](#)

The following procedures and rules pertain to the design of this energy dissipater:

1. Use is limited to entrance velocities that do not exceed 30 ft/sec.
2. The retardance ratio of this type of dissipater is approximately 4.5:1. If the velocity after passing through the dissipater exceeds allowable, consideration should be given to providing rock fill at the end of the dissipater.
3. For pipe grades greater than 15 percent, use an approximately horizontal pipe, two or more diameters long at the outlet end of the pipe.
4. Under certain flow conditions, a hydraulic jump may form in the downstream end of the pipe sealing the exit end. If the upper end of the pipe is also sealed by incoming flow, a vent may be necessary to prevent pressure fluctuation in the system. A vent to the atmosphere having a perimeter about one-sixth the pipe diameter should be installed upstream of the jump.
5. In certain areas, consideration should be given to providing drain tile in the apron so that any entrapped water can seep out of the dissipater, thus avoiding any stagnant water pools.
6. The notches shown in the baffle ([Figure 6-204a](#)) are provided to aid in cleaning the basin after prolonged periods of nonuse. The notches provide concentrated jets of water to clean the basin when it is full of sediment. These notches are not required if cleaning action is not considered necessary.

July 2011

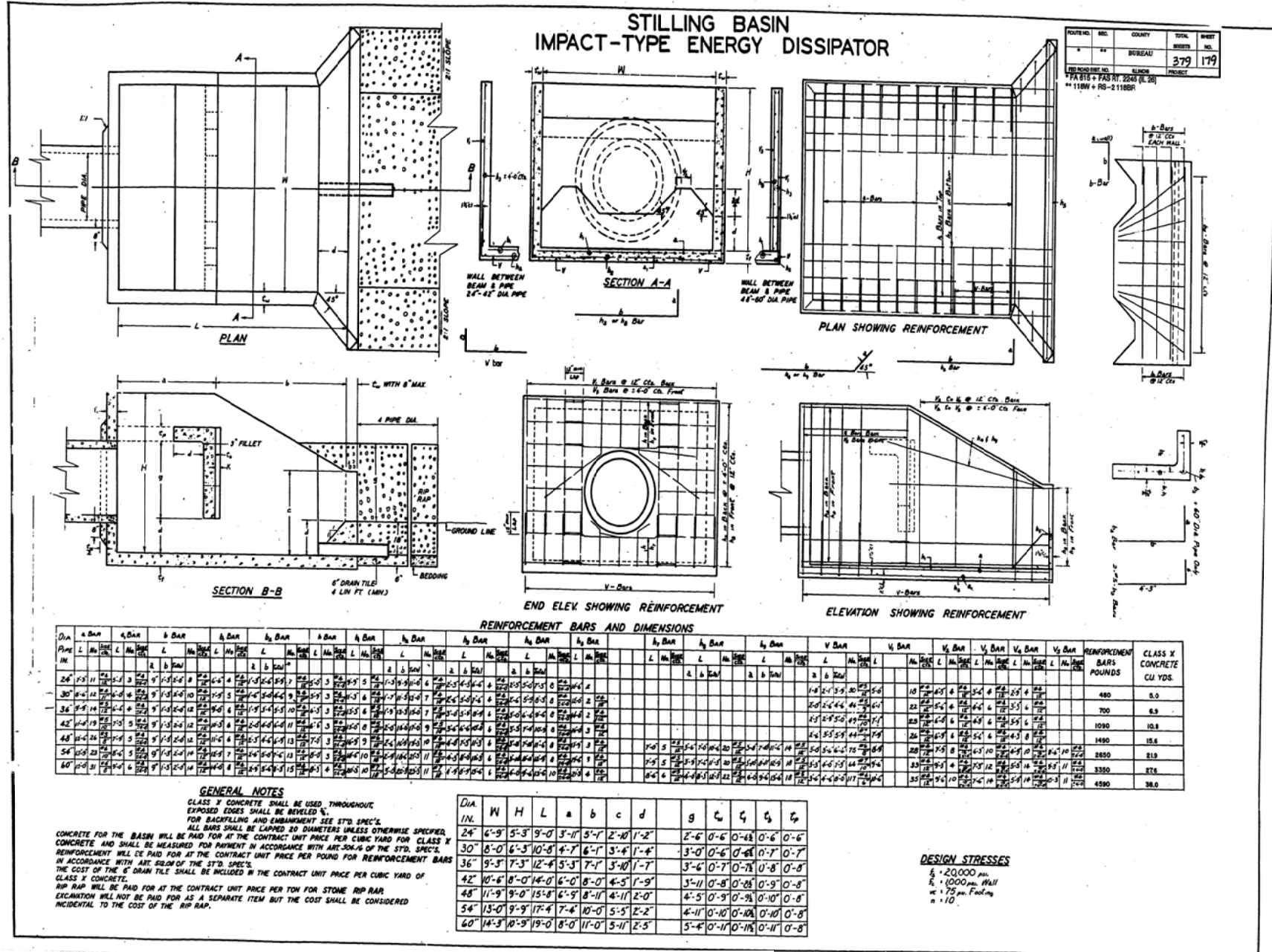

GENERAL NOTES

CLASS X CONCRETE SHALL BE USED THROUGHOUT.
EXPOSED EDGES SHALL BE BEVELED 1/4".
FOR BACKFILLING AND EMBANKMENT SEE STD SPEC'S.
ALL BARS SHALL BE LAPPED 20 DIAMETERS UNLESS OTHERWISE SPECIFIED.
CONCRETE FOR THE BASIN WILL BE PAID FOR AT THE CONTRACT UNIT PRICE PER CUBIC YARD FOR CLASS X CONCRETE. REINFORCEMENT WILL BE PAID FOR AT THE CONTRACT UNIT PRICE PER POUND FOR REINFORCEMENT BARS IN ACCORDANCE WITH ART. 304.14 OF THE STD. SPEC'S. THE COST OF THE 6" DRAIN TILE SHALL BE INCLUDED IN THE CONTRACT UNIT PRICE PER CUBIC YARD OF CLASS X CONCRETE.
RIP RAP WILL BE PAID FOR AT THE CONTRACT UNIT PRICE PER TON FOR STONE RIP RAP. EXCAVATION WILL NOT BE PAID FOR AS A SEPARATE ITEM BUT THE COST SHALL BE CONSIDERED INCIDENTAL TO THE COST OF THE RIP RAP.

6-35

Figure 6-204a



Figure 6-204b

6-205 Additional Dissipaters

Other types of energy dissipation basins are available for use at culvert exits to control flow velocity. Two types of dissipaters are described below:

- **Forced Hydraulic Jump Basin or At Stream Level Structures:** These basins induce a forced hydraulic jump by utilizing blocks, sills or other rough elements to impose exaggerated resistance to flow.
- **Tumbling Flow in Box Culverts and Open Chutes:** Where there is limited right-of-way for an energy dissipater at a culvert outlet, rough elements placed in the culvert barrel may be used to decrease velocities by creating a series of hydraulic jumps in a phenomenon known as tumbling flow.

A combined Forced Hydraulic Jump Basin and Tumbling Flow in Box Culvert is shown in [Figure 6-205a](#) and [Figure 6-205b](#).



Figure 6-205a



Figure 6-205b

6-300 DROP STRUCTURES

Drop structures are often used in agricultural areas as a common structure for both the outlet point for field tile systems and the collection box for surface flow at the beginning of an excavated channel. Drop structures are also used to prevent erosion from migrating upstream by maintaining a flatter slope upstream of a structure. Occasionally, a stream will degrade downstream from an existing across road culvert. In order to protect the highway embankment from sloughing off, a drop structure can be retrofitted, but care must be taken to properly dissipate the energy released by the falling water or the degradation will continue. In addition, care must be taken to securely attach the drop structure or the water forces could separate the retrofitted drop structure from the existing culvert causing continued problems.

Drop structures can also be used to reduce a culvert's slope, thereby reducing velocities. The drop structure should be located at the upstream end of the culvert so that the energy of the falling water may be dissipated within the culvert. The designer should be aware that a drop structure could be a hazard to the traveling public and may warrant protection.

The hydraulic design of a drop structure includes determination of the minimum length of wall required to generate the proper weir flow and the minimum distance between the end wall and the culvert face. Minimum wall length is determined by solving the weir equation ([Equation 6-4](#)) for L. Assuming free flow over the weir, H is set equal to the difference between the natural highwater elevation and the top of the weir. A weir coefficient (C) of 3.0 is normally used for drop box design. Using the design discharge (Q), the minimum length of weir without causing backwater can be solved by:

$$Q = CLH^{1.5} \quad (\text{Eq. 6-4})$$

Where:

- Q = discharge, cuft/sec
- C = weir coefficient
- L = length of weir, ft
- H = head, ft

The length of weir can be adjusted to control the level of backwater by increasing the H value accordingly. If the maximum allowable backwater is 1.0 ft for the 100-year flood, then H for example should be set equal to the difference between an elevation 1.0 ft above the natural highwater and the top of the weir elevation to obtain the minimum acceptable length. The weir length used should include the entire length of the weir whether it is perpendicular or parallel to the flow as would be in a three sided drop structure upstream of a culvert.

The culvert is then sized by conventional methods as outlined in [Section 6-100](#), with the allowable headwater elevation set below the point of submergence of the weir ($0.6d_c$). If the headwater elevation is above this point, the weir will not perform properly and the benefits of having a drop structure will be lost because the culvert will act as an orifice ([Figure 6-300a](#)).

The minimum distance from the end wall to the culvert face is set equal to the width of one culvert barrel. The formulas for the trajectory of water, $y = 1/2gt^2$ and $x = vt$, should also be checked to determine if a greater distance is needed.

Set $y = d_c + D$ (D is the depth of drop at the weir) to determine t from $y = 1/2gt^2$.

The length of trajectory (x), is then determined by multiplying the approach velocity (v) by t , where $x = vt$. The depth d_c would not be the same as the depth of flow H .

For a rectangular section $d_c = q^{2/3}/g^{1/3}$, where $q = Q/L$, and L is the length of weir.

For a non-uniform section, d_c can be solved from $\frac{A^3}{T} = \frac{Q^2}{g}$ where T is the top width of the channel and A is the area of the flow.

More discussion of weirs can be found in [Section 12-200](#) of Chapter 12, Outlet Hydraulics. A photograph of an upstream drop structure is shown in [Figure 6-300b](#).

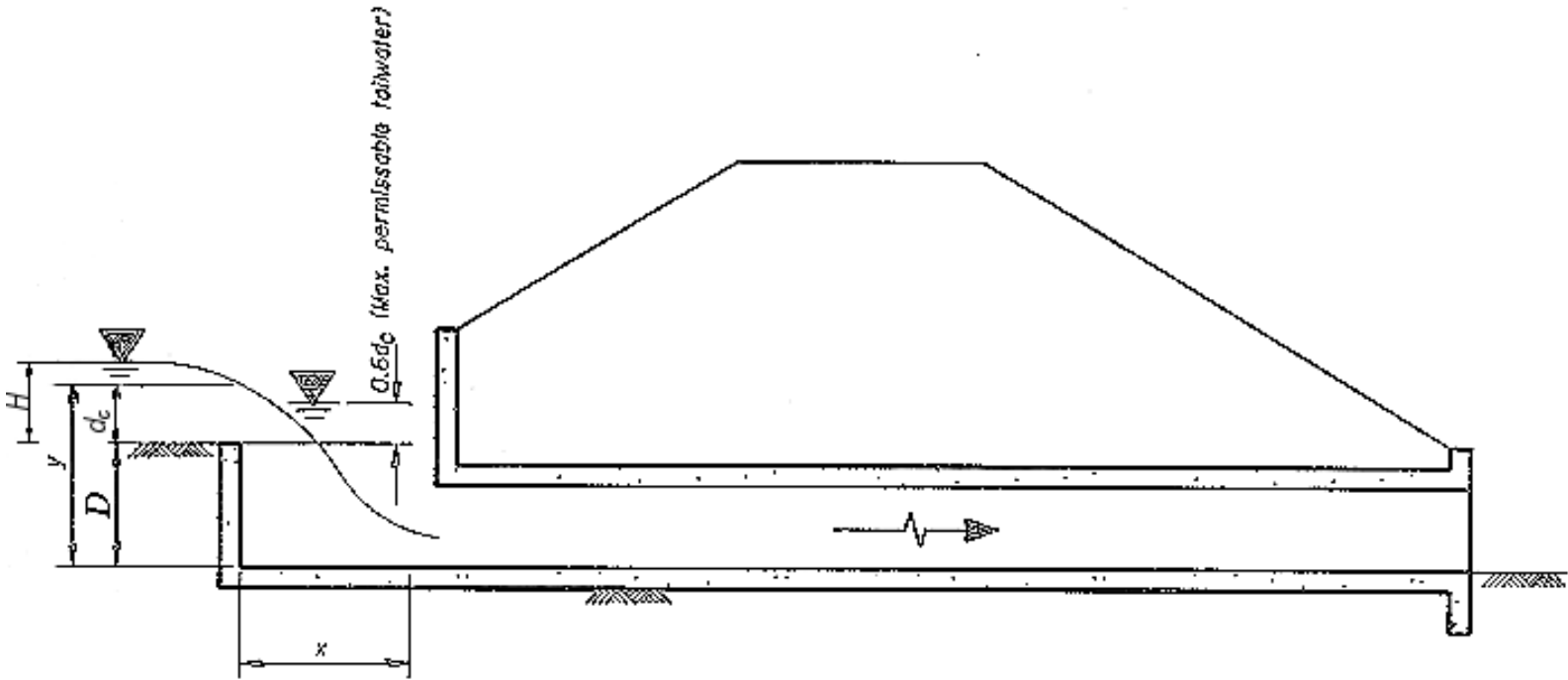

- H = Depth of flow
- y = Depth from the bottom of the drop to the water surface above the drop
- D = Height of the drop
- d_c = Critical depth of the drop
- x = Length of trajectory

Detail of Drop Structure Configuration
 Figure 6-300a



Figure 6-300b

6-400 IMPROVED INLETS

The hydraulic capacity of culverts operating in inlet control is a function solely of inlet configuration and headwater depth. On long culverts, where the difference in headwater found in [Section 6-103](#) is significant (25 percent or more) and the outlet control headwater sufficiently handles design discharges, consideration should be given to using an improved inlet rather than a larger barrel or additional barrels.

Inlet improvements are to be considered for both box and pipe culverts and consist of beveled edges, side tapered inlets and slope taper inlets. Properly designed improved inlets will provide the same hydraulic capacity with a smaller culvert barrel. The extra cost of the improved inlet must be weighed against the savings of a smaller barrel size.

At times, improved inlets may be installed on existing culverts with inadequate flow capacity, thus avoiding replacement of the entire structure or the addition of a parallel structure.

Improved inlets enhance culvert performance by providing a more efficient control section (the throat). Tapered inlets with falls also improve performance by increasing the head on the throat.

Other than the conditions mentioned above, improved inlets should be considered as a last resort due to additional costs and increased maintenance requirements.

The hydraulic design of improved inlets should be performed in accordance with [Hydraulic Design of Highway Culverts, \(HDS 5\)](#)⁵ or the window version of computer software [HY8](#)⁷. For more information, refer to the archived publication [Hydraulic Design of Improved Inlets for Culverts, \(HEC 13\)](#)¹⁰.

A side-tapered inlet has tapered sides while a slope-tapered inlet has tapered bottom and sides. [Figure 6-400a](#) shows a side tapered improved inlet and [Figure 6-400b](#) shows a slope tapered improved inlet.

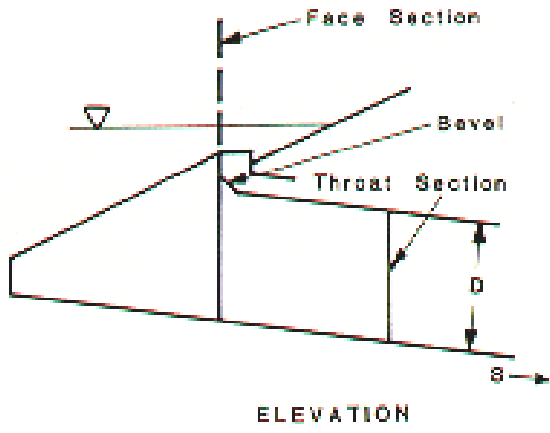

ELEVATION

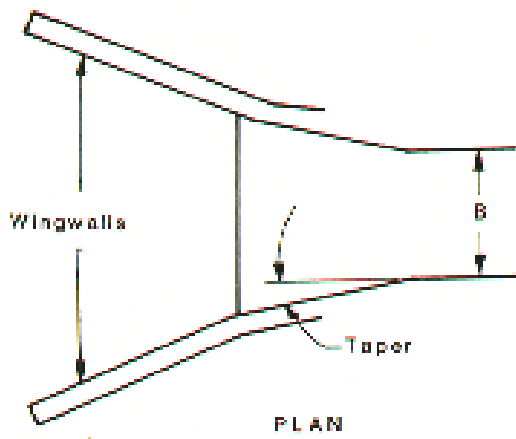

PLAN

Figure 6-400a

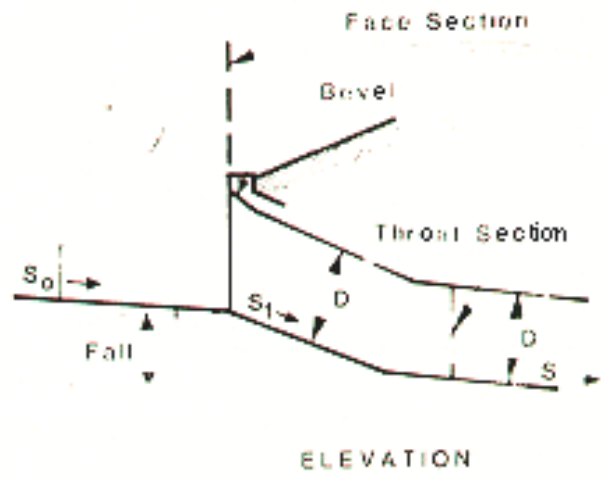

ELEVATION

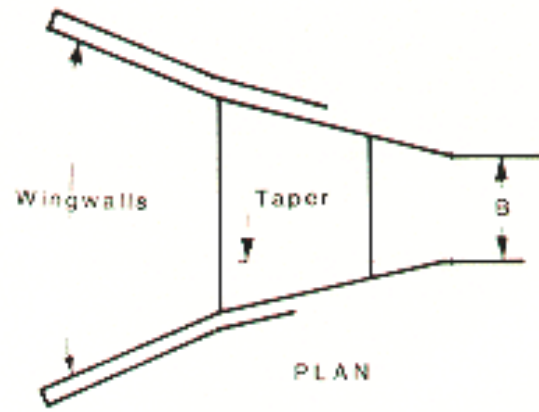

PLAN

Figure 6-400b

6-500 AUTOMATIC FLAP GATES & CHECK VALVES

Automatic flap gates are mechanical devices that can be attached to the outlet end of culverts or storm drains to prevent backflow. These devices are sometimes used when carrying drainage through a levee. [Figure 6-500a](#) shows some of the details and essential dimensions of flap gates. It is necessary to compute head loss at the flap gate and the following equation is one method.

$$h_1 = \frac{4v^2 e^x}{g} \quad (\text{Eq. 6-5})$$

$$x = \frac{-1.15v}{d^{1/2}}$$

where:

- h_1 = head loss, ft
- v = velocity, ft/sec
- d = diameter of the pipe, ft
- g = acceleration of gravity, ft/sec²
- e = natural log base

Check valves are also used for backflow prevention. Check valves are available that require no maintenance due to all-rubber construction. These are totally passive valves, operating solely on line and backpressure. The check valves can seal and close around debris with minimal backpressure. These valves will not warp or freeze and can sit inactive for years and still be ready to provide backflow protection when needed ([Figure 6-500b](#)).

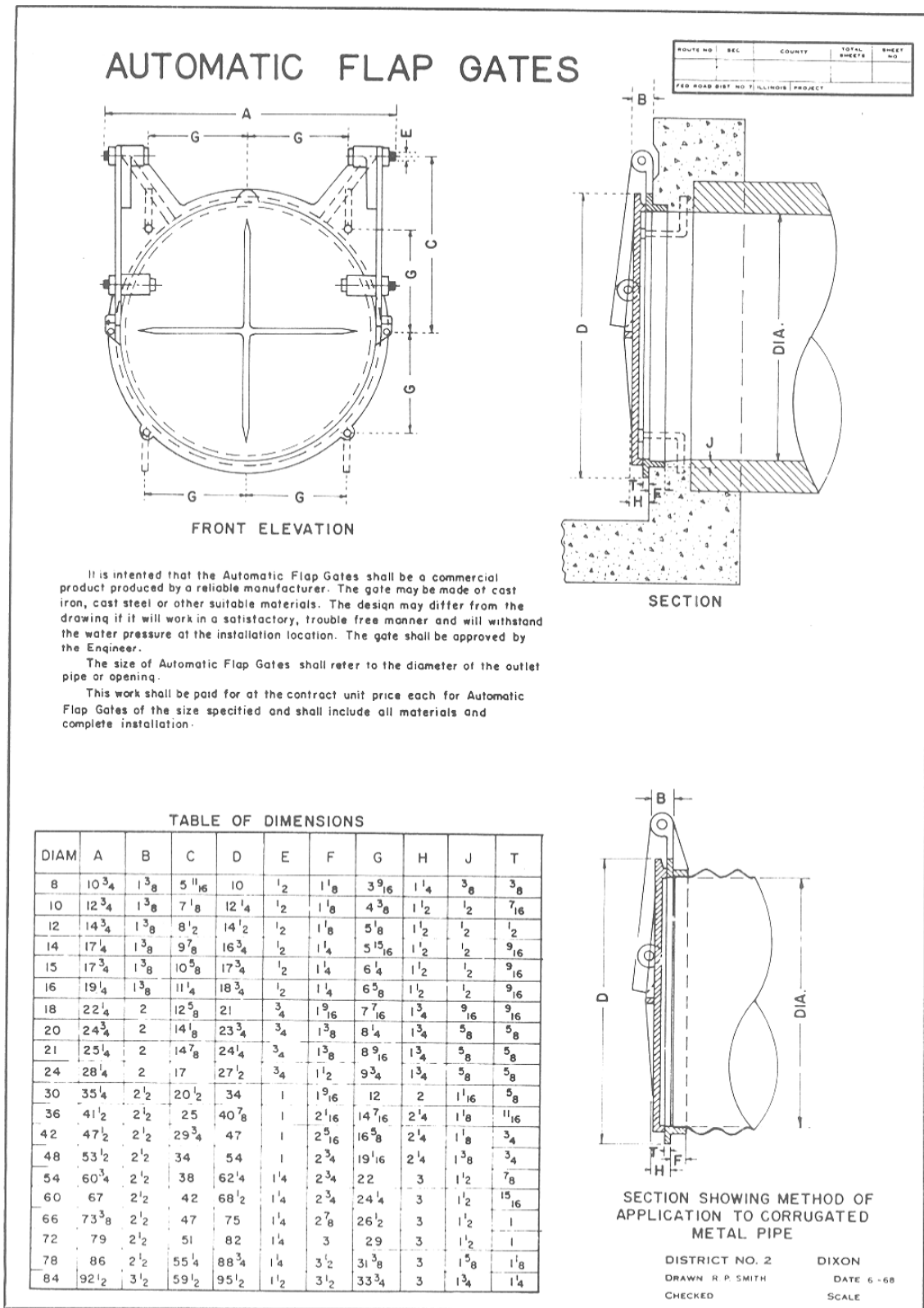

REVISED 10/20/87

73.2

Figure 6-500a



Figure 6-500b

6-600 SAFETY GRATES

Culvert ends within the clear zone can be hazardous to the driving public. If culvert ends within the clear zone are not protected by other means they can be protected with safety grating.

[Chapter 38 of the BDE Manual⁴](#) on Roadside Safety gives guidance on transverse and cross road slopes and recommended treatments when drainage structures are present within the clear zone. Also check with District policy on when safety grate use is warranted. Some Districts still require safety grate use in certain circumstances even though the culvert ends are outside of the clear zone.

Safety grates can catch debris and greatly reduce the hydraulic efficiency of culverts, so their design should be as open as possible. A study done by the Texas Transportation Institute indicates that the bar spacing perpendicular to traffic can be as much as 30 inches and still be effective in improving the safety of a culvert opening. The bars, however, must be of sufficient strength to support an errant vehicle. If there is a high potential for debris, extra consideration should be given to extending the culvert ends beyond the clear zone without grating.

[Figure 6-600](#) shows an example of one such safety grate design.

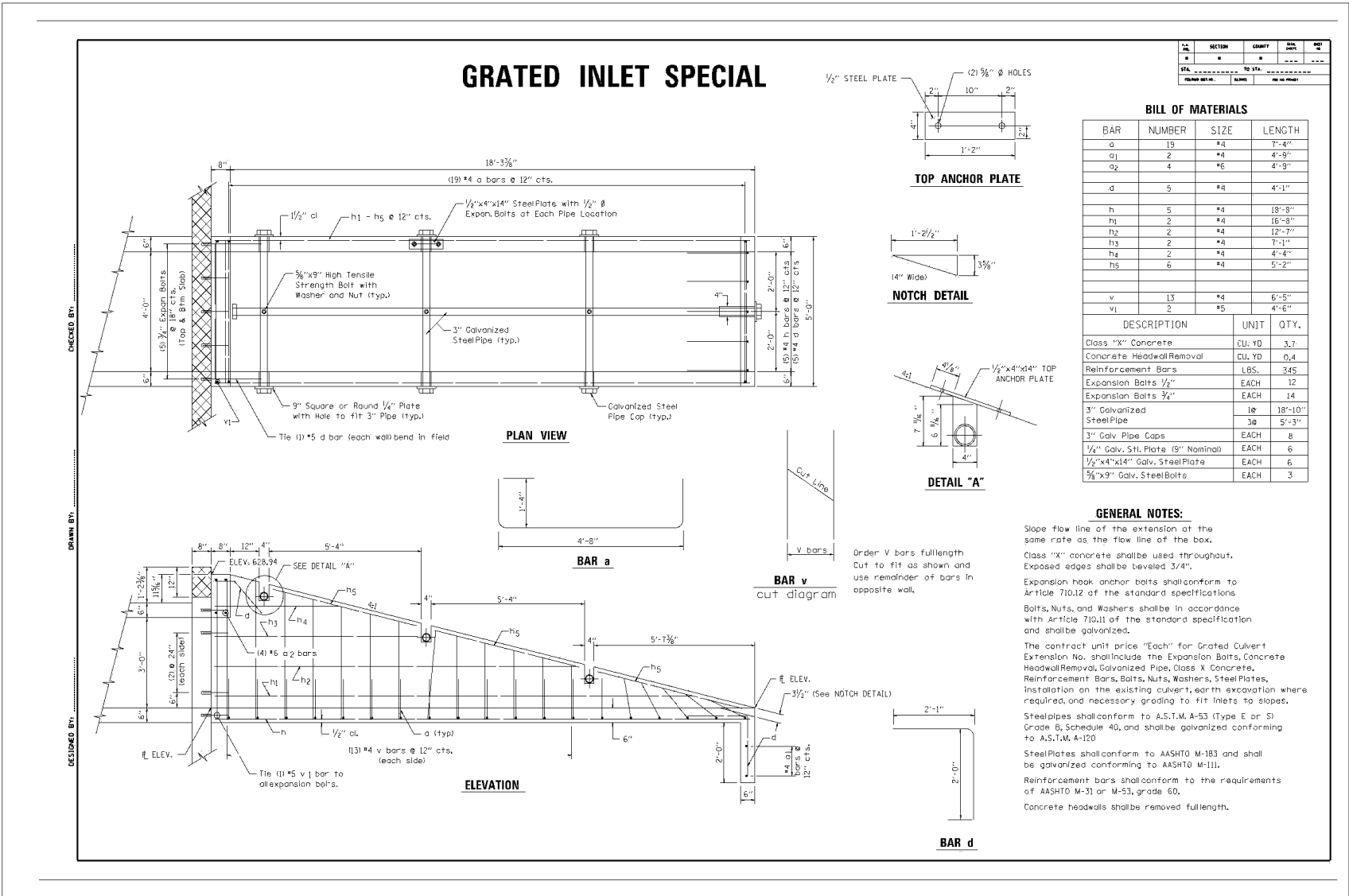

Figure 6-600

6-700 DEBRIS CONTROL STRUCTURES

Debris can be a significant problem at culverts. Debris can accumulate to such an extent that the culvert is rendered useless. Notes should be taken on the watershed land use and degree of any expected debris during site field-checks. If debris is expected to be a problem, consideration should be given to a debris control structure (Figure 6-700). [Hydraulic Engineering Circular Number 9¹¹](#) gives a detailed discussion of types and applications of debris control structures.

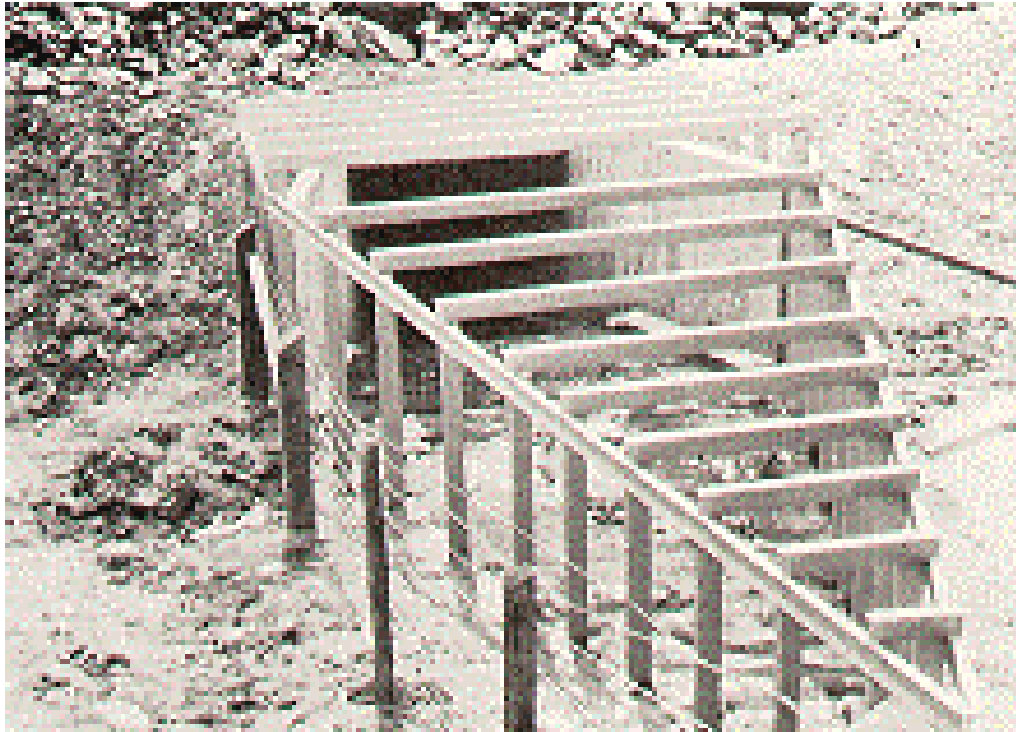

Figure 6-700

6-800 MISCELLANEOUS

6-801 Application of Three-Sided Structures

Three-Sided, precast concrete structures offer a cost-effective, convenient solution for a variety of bridge or culvert needs. The ease and short duration of construction for these structures make them an attractive alternative on certain projects. Three-Sided, precast concrete structures shall be planned and designed according to Section 2.3.11 Culvert and Three Sided Precast Concrete Structure Selection and Section 2.3.11.2 and Subsection 2.3.11.2 Three Sided Precast Concrete Structures of the [Bridge Manual](#)¹².

This type of structure is preferred by many Drainage Districts because of the natural bottom which can be graded.

These structures work best if set on rock or soil with an unconfined compressive strength of 2 tons/sqft or better. This avoids costly footings and possibly the use of cofferdams. To determine whether a three-sided structure is an acceptable alternate during the planning phase, structure borings should be included with the Bridge Condition Report to allow proper evaluation of foundation conditions.

Hydraulic and waterway opening requirements shall be handled similar to any other bridge project and a scour analysis shall be performed.

[HEC-RAS](#)⁶ can model a three-sided structure. Select Conspan Arch under the culvert type drop down menu.

6-802 Culvert Liners

Installation of a liner can be a cost effective alternative to culvert replacement. This is particularly applicable for longer culverts or culverts beneath a large fill. Rigid and flexible pipe culvert liners are available from many manufacturers for structural and non-structural applications. [Section 543 of the IDOT Standard Specifications for Road and Bridge Construction](#)¹ covers insertion lining of existing pipe culverts up to 96 inches inside diameter. Information on different types of liners is available directly from the manufacturers of these products. The designer should ensure that the liner type/diameter physically fits within the existing culvert, allowing for grouting, wall thickness and any caved in or failed segments of the existing structure.

Regarding hydraulic capacity, liners offer smoother materials (plastic or metal) compared to concrete. However, that “gain” in capacity is generally offset by the reduction in opening. Because the net result can be increased headwater and higher outlet velocities, the designer needs to ensure the hydraulic adequacy of the proposed liner installation. As described in [Section 6-100](#), this determination can vary from a Hydraulic Report and HEC-RAS model or HY-8 analysis for larger openings at sensitive locations to a cursory assessment of existing conditions and relative pipe diameters at smaller, less sensitive sites. Due to the nature of liner applications, hydraulic adequacy should focus on headwater impacts and outlet velocity, as opposed to freeboard policy. The primary intent of liner project scope is minimizing roadway impact/closure and cost. Therefore, the 3-foot minimum design criteria is typically waived. However, note that IDNR-OWR does NOT consider culvert liner applications to be an exempt activity. If the watershed falls under IDNR-OWR jurisdiction (see [Section 1-404](#)), 3700 Individual Permit or 3708 Floodway Permit is required. When hydraulic adequacy is not easily assessed, the District Hydraulic Engineer should be consulted to determine the proper level of analysis.

6-803 Broken-Back Culverts

When one or more grade changes occur within the culvert profile, it is called a broken-back culvert. Broken back culverts are usually placed in areas where installing a straight culvert would require large excavations or where other site conditions dictate a break should occur. Broken-back culverts may also be used to reduce outlet velocities when normal outlet velocities are greater than desired. The goal of a broken-back culvert is to transition created supercritical flow to acceptable subcritical flow within the culvert, thereby reducing the potential for scour at the outlet and channel erosion downstream.

Although there are no nomographs available, computer programs are available for design of this type of culvert.

6-804 Helical Pipes – “n” Values

In pipes less than about 6 feet in diameter, helical corrugations may provide lower resistance values than pipes with annular corrugations. This is due to the spiral flow that develops when such pipes flow full. As the pipe size increases, the helix angle approaches 90 degrees, and the Manning's n value approaches the value of pipes with annular corrugations ([Figures 6-804a](#) and [Figures 6-804b](#)).

For partial flow in circular metal pipes with 2-2/3 inch by 1/2 inch helical corrugations, Manning's n value should be 11% higher than that for full flow. In the case of full flow in corrugated metal pipe arches with 2-2/3 inch by 1/2 inch helical corrugations, Manning's n value is the same as an equivalent diameter pipe. Additional information concerning the hydraulic resistance of culvert barrels can be found in [FHWA's HDS 5⁵](#) – Hydraulic Design of Highway Culverts, Appendix B.

Recommended Manning's n Values for Selected Culverts

<u>Type of Culvert</u>	<u>Roughness or Corrugation</u>	<u>Manning's n</u>
Concrete Pipe	Smooth	0.010-0.013*
Concrete Box	Smooth	0.012-0.015
Spiral Rib Metal Pipe	Smooth	0.012-0.013
Corrugated Metal Pipe, Pipe-Arch and Box (Annular and Helical Corrugations--See Figure 6-805b, Manning's n varies with barrel size).	68 by 13 mm 2-2/3 by 1/2 in Annular	0.022-0.027
	68 by 13 mm 2-2/3 by 1/2 in Helical	0.011-0.023
	150 by 25 mm 6 by 1 in Helical	0.022-0.025
	125 by 25 mm 5 by 1 in	0.025-0.026
	75 by 25 mm 3 by 1 in	0.027-0.028
	150 by 50 mm 6 by 2 in Structural Plate	0.033-0.035
	230 by 64 mm 9 by 2-1/2 in Structural Plate	0.033-0.037
Corrugated Polyethylene	Smooth	0.009-0.015
Corrugated Polyethylene	Corrugated	0.018-0.025
Polyvinyl chloride (PVC)	Smooth	0.009-0.011

NOTE: The values indicated in this table are recommended Manning's n design values. Actual field values for older existing culverts may vary depending on the effect of abrasion, corrosion, deflection and joint conditions. Concrete pipe with poor joints and deteriorated walls may have n values of 0.014 to 0.018. Corrugated metal pipe with joint and wall problems may also have higher n values, and in addition, may experience shape changes which could adversely affect the general hydraulic performance of the culvert.

*Figure 6-804a
From HDS 5⁵*

** Modified per IDOT Recommendations*

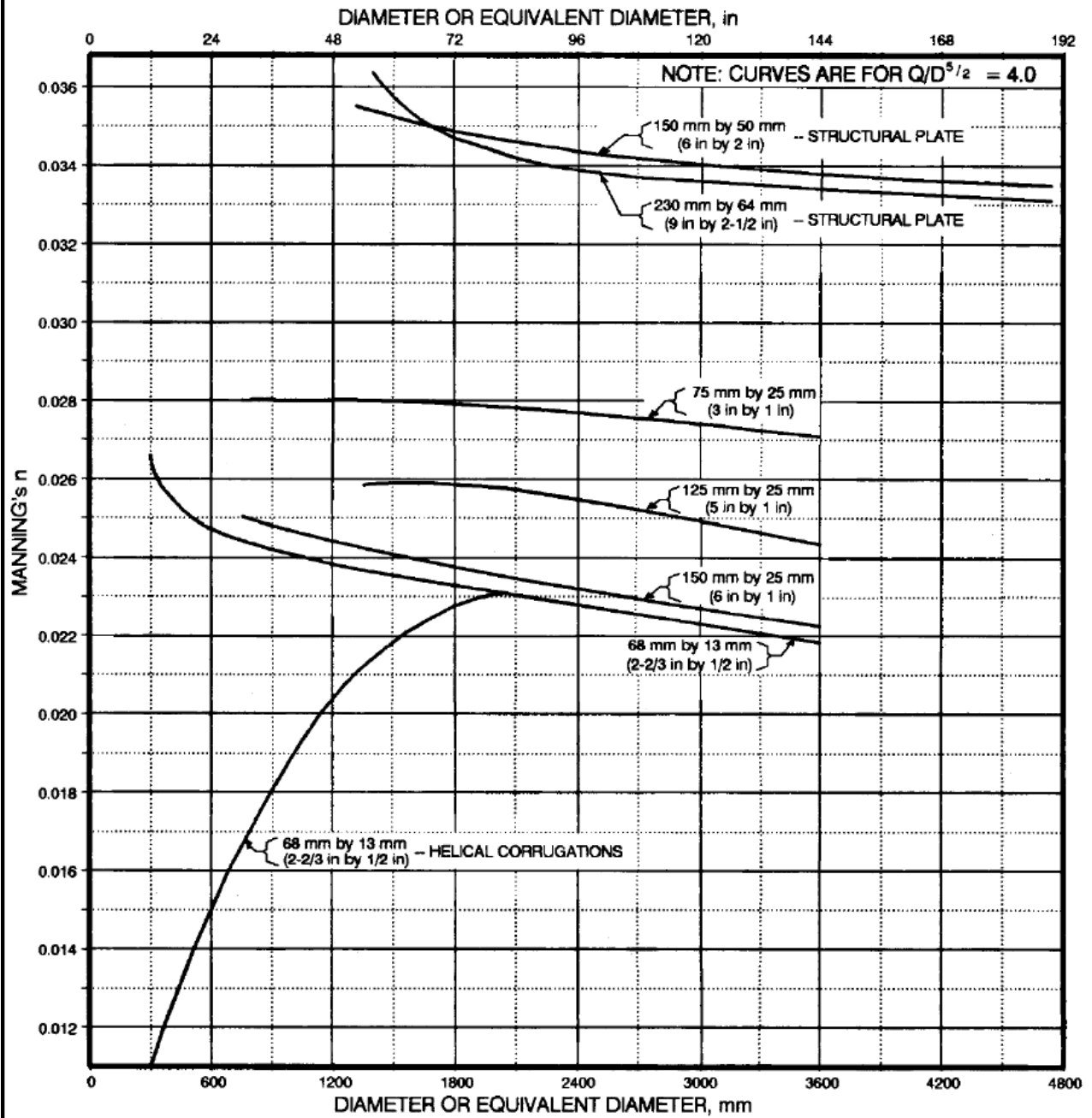

Manning's n Versus Diameter
 For Corrugated Metal Conduits
 Figure 6-804b
 From HDS 5⁵

6-900 REFERENCES

1. Illinois Department of Transportation. *Standard Specifications for Road and Bridge Construction*. Adopted January 1, 2007
2. Illinois Department of Transportation, Bureau of Design and Environment. BDE Procedure Memorandum #65-08. *Pipe Culverts and Storm Sewers* 11/1/08
3. Illinois Department of Transportation, Bureau of Bridges and Structures. *Culvert Manual* June 2000
4. Illinois Department of Transportation, Bureau of Design and Environment. *BDE Manual* 2002
5. U. S. Department of Transportation, Federal Highway Administration. *Hydraulic Design of Highway Culverts*. Hydraulic Design Series No. 5 (HDS 5) Sept 2001, Revised May 2005
6. U.S. Army Corps of Engineers. Hydraulic Engineering Centers River Analysis System (HEC-RAS), Version 4.1
7. U. S. Department of Transportation, Federal Highway Administration. Culvert Hydraulic Analysis Program HY-8, Version 8.7.2
8. U. S. Department of Transportation, Federal Highway Administration. Culvert HY-8 Energy part of Hydraulic Analysis Program HY-8, Version 8.7.2
9. U. S. Department of Transportation, Federal Highway Administration. *Hydraulic Design of Energy Dissipators for Culverts and Channels*. Hydraulic Engineering Circular 14 (HEC 14) July 2006
10. U. S. Department of Transportation, Federal Highway Administration. *Hydraulic Design of Improved Inlets for Culverts*. Hydraulic Engineering Circular 13 (HEC 13) August 1972
11. U. S. Department of Transportation, Federal Highway Administration. *Debris Control Structures*. Hydraulic Engineering Circular 9 (HEC 9) October 2005
12. Illinois Department of Transportation, Bureau of Bridges and Structures. *Bridge Manual* May 2008
13. U. S. Department of Transportation, Federal Highway Administration. Visual Urban (HY-22) Urban Drainage Design Programs 2001
14. Illinois Department of Transportation, Bureau of Project Implementation. *Construction Manual* 2006



Chapter 7

Mathematics
History
Science
Literature
Arts
Social Studies
Health
Physical Education
Foreign Languages
Music
Dance
Career and Technical Education
Special Education
Gifted and Talented
Enrichment
Professional Development
Community Service
Parent Involvement
Student Government
Sports
Clubs
Activities
Extracurricular
Counseling
Mental Health
Substance Abuse
Peer Support
Leadership
Character Education
Civics
Economics
Government
History
Literature
Mathematics
Science
Social Studies
Writing

CHAPTER 7 - BRIDGE HYDRAULICS

7-000 INTRODUCTION

7-001 Design Considerations

- 7-001.01 Headwater and Waterway Opening
- 7-001.02 Velocity
- 7-001.03 Scour and Pier/Abutment Placement
- 7-001.04 Clearance and Freeboard

7-100 BRIDGE BACKWATER MODELING

7-101 Accepted Computer Models

- 7-101.01 HEC-RAS Modeling

7-102 Cross Section Requirements

- 7-102.01 Locations Within the Model & Limits of Effective Flow
 - 7-102.011 WSPRO
 - 7-102.012 HEC-RAS

7-103 Backwater Computational Routines

- 7-103.01 WSPRO
 - 7-103.011 Unconstricted & Constricted Profiles
 - 7-103.012 Flow Classes
- 7-103.02 HEC-RAS
 - 7-103.021 Bridge Modeling Approach Editor

7-104 Adjusting Input Parameters

7-105 Special Bridge Problems

- 7-105.01 Dual Bridges
- 7-105.02 Closely Spaced Bridges
- 7-105.03 Multiple Openings
- 7-105.04 Coincidental Tailwater Conditions

7-106 Natural Highwater and Headwater Elevations

- 7-106.01 Natural Highwater
- 7-106.02 Headwater

7-200 INLET SPACING FOR APPROACH PAVEMENTS AND BRIDGE DECKS

7-300 REFERENCES

7-000 INTRODUCTION

This chapter covers the hydraulic design of bridges and three-sided, pre-cast concrete structures over waterways. Design considerations are outlined and preferred methodologies for completing this hydraulic work are presented. Applicable material from this Manual and other publications will be referenced as sources for further direction.

Certain text has been borrowed verbatim from AASHTO's 1999 Model Drainage Manual¹; text regarding computer modeling is taken from the respective user's manual. The user's manuals are referenced frequently.

The methodology from the FHWA's publication "Hydraulic Design Series No. 1, Hydraulics of Bridge Waterways"² has long been considered an excellent reference source for bridge backwater analysis. However, the "longhand" calculations in [HDS 01](#) that were circa 1970's are no longer utilized for bridge hydraulic analysis and design. The FHWA publication [HDS 01](#) is still available at http://www.fhwa.dot.gov/engineering/hydraulics/library_listing.cfm. [HDS 01](#) remains a valuable reference, but its by-hand application has been supplanted entirely by computer models. See [Chapter 14](#), Computer Software, to obtain [HDS 01](#) and additional FHWA publications and software products.

[HEC-RAS](#) is a computer model from the U.S. Army Corps of Engineers (USACE) Hydraulic Engineering Center. RAS stands for River Analysis System. Introduced in 1995, [HEC-RAS](#) has become the industry and Department's standard computer model for bridge backwater analysis. At that time, [HEC-RAS](#) displaced the [WSPRO](#) model, short for Water Surface PROfiles. Born from a USGS-FHWA partnership, [WSPRO](#) was previously considered the industry standard during the early 1990's. Although [WSPRO](#) has been supplanted by [HEC-RAS](#), [WSPRO](#) direction is still included within Chapter 7 as a reference for projects that require utilization of FIS models or flood profiles that were created using the [WSPRO](#) model. Both [WSPRO](#) and [HEC-RAS](#) are packaged with a number of bridge routines, including scour estimation tools. Refer to [Chapter 10](#) for specific direction on [HEC-RAS](#) scour calculations. Culvert analysis capabilities based on industry-standard methodologies are also contained within each model.

Three-sided bridges or so-called bottomless culverts are considered by the Department to be bridges in regards to plan review and approval, drainage responsibilities and hydraulic design requirements. Typically, the correct hydraulic modeling routine (bridge or culvert) for three-sided bridges is the same routine/method utilized to estimate existing conditions; particularly when proposed flow conditions equate to or approximate existing. This recommended practice brings uniformity to the analysis and resulting design recommendations. It also accounts for potential discrepancies in headwater estimation when comparing standard culvert methodology to one of the [HEC-RAS](#) bridge routines. For comparably sized openings, the standard culvert routine typically estimates less created head than the applicable bridge backwater computation. Recognizing that discrepancy, [HEC-RAS](#) offers a three-sided, pre-cast bridge option within the culvert routine. Of course, the designer should consider site-specific factors that may invalidate the assumptions behind this modeling recommendation and, as stated in [Section 6-800 of Chapter 6](#), consult the Hydraulic Unit of the Bureau of Bridges and Structures or the District Hydraulic Engineer if assistance is required.

Extensive instruction for proper setup and utilization of both [WSPRO](#) and [HEC-RAS](#) is contained here throughout [Section 7-100](#), Bridge Backwater Modeling. Again, the [WSPRO](#) information is provided for reference since all Districts prefer to utilize [HEC-RAS](#). [Section 7-101.01 HEC-RAS](#)

Modeling contains an overview of bridge modeling elements that are vital to the model and the Hydraulic Report. **Sections 7-102** through **Section 7-104** provide detailed direction of the Department's common approach to typical bridge analysis, while **Section 7-105 Special Bridge Problems** suggests modeling techniques for atypical situations that are not encountered at every bridge crossing. Model-specific direction for completing the waterway information table in **Section 7-106** closes out Bridge Backwater Modeling. Additional background information on **WSPRO** and **HEC-RAS** is also available in **Chapter 14**.

Section 7-200 Inlet Spacing for Approach Pavements and Bridge Decks addresses approach roadway and bridge deck drainage. This Manual is **not** the Department's primary source of reference and direction for hydraulic design of approach and deck drainage. Please refer to the **IDOT Bridge Manual, Section 2 "Planning"**³, <https://insideidot.portal.illinois.gov/sites/businessservices/prc/Master%20Documents/Bridge%20Manual.pdf> for specific design practices and procedures that govern the selection and location of scuppers and inlets. **Section 7-200** compiles information sources pertinent to the design, including various chapters within this Manual and the FHWA manual entitled **HEC No. 21, Design of Bridge Deck Drainage**⁴. See http://www.fhwa.dot.gov/engineering/hydraulics/library_listing.cfm.

7-001 Design Considerations

All of the areas discussed below are addressed within the Hydraulic Report prepared during the planning phase (Phase I) of project development. The end product of the planning phase for bridges is another document entitled the Type, Size and Location Plan, or TSL Plan, which is detailed in the **IDOT Bridge Manual, Section 2**³. The TSL Plan incorporates design recommendations derived from the Hydraulic Report and structural/geotechnical findings from several other reports (Structure Report, BCR, SGR) into a layout of the bridge configuration and approach roadway alignment. Along with structural features such as superstructure type and foundation treatment, the TSL further develops and refines hydraulic recommendations affecting the opening geometry. These recommendations include skew, low beam elevation, opening configuration, number \ location of piers and the low point of the roadway profile grade across the floodplain. Ideally, the TSL should closely follow or parallel the Hydraulic Report in the project path. The approved TSL Plan then becomes the basis of final plan preparation within the design phase, and serves as the permit drawings for IDNR-OWR, EPA and U. S. Army Corps of Engineers submittals.

Although listed individually, the design considerations covered within **Section 7-001** are interrelated with each other and also with recommendations made during TSL development. The required bridge opening and configuration are determined within the Hydraulic Report by balancing acceptable velocity and backwater considerations in conjunction with good practices for locating proposed piers \ slopewall toes \ abutments and avoiding any constriction of the natural channel. Most waterway opening designs are controlled by backwater limitations, with the velocity considered acceptable if proposed does not exceed existing and existing velocities have not created erosion or scour issues. average velocities through the opening do not exceed natural channel velocities. The preliminary bridge opening configuration based on the approved Hydraulic Report is refined and finalized during TSL Plan preparation. At some structures, this includes scour countermeasures and/or river training measures as discussed in **Chapters 10 and 11**. The need for countermeasures is based in large part on the foundation treatment, which is also part of TSL Plan development. Low beam clearance and roadway freeboard recommendations based on the Hydraulic Report are impacted by superstructure design, span configuration and the roadway profile determination, which again, are finalized during TSL Plan development.

The following four sections are the chief hydraulic design considerations for a typical replacement structure on an existing alignment. Design considerations for new bridges on new alignment are very similar to those for replacement bridges, except that new structures are generally held to stricter regulatory standards and policy adherence. This is particularly true in regards to backwater, low beam clearance and roadway freeboard. Since projects on new alignment are infrequent, a discussion of the appropriate hydraulic design considerations should precede Hydraulic Report preparation at new crossings.

7-001.01 Headwater and Waterway Opening

Headwater is an increase in the water surface upstream of a structure caused by the subject structure's encroachment on the floodplain ([Section 7-106.02](#)). Headwater (often referred to as backwater) is typically the controlling hydraulic design consideration in determining the required waterway opening. The allowable headwater in the upstream floodplain attributed to the subject structure is a project-specific determination. Of primary concern is the presence of sensitive flood receptors in the form of residential structures or commercial buildings. It has been the Department's longstanding policy to minimize adverse impacts to such structures and to avoid any long term or permanent damage to the extent possible. This means if damageable upstream property is at or below existing Q_{100} headwater, the replacement bridge will not raise the existing backwater profile for all events up to and including the Q_{100} discharge, provided that a larger opening is a feasible alternative. In this situation, strong consideration would be given to an alternative bridge design that would reduce headwater below existing levels. The potential impact of headwater for larger events up to Q_{500} should also be given consideration where practical.

Where damageable property is present upstream, statutory regulation enforced by the Illinois Department of Natural Resources, Office of Water Resources can supersede IDOT policy regarding allowable headwater. As outlined in [Chapter 1, Section 1-404 Floodway Construction Program IDNR-OWR](#), the applicable IDNR-OWR permit rules regulate construction in the floodway by establishing allowable headwater criteria. The headwater limits and applicable permit rules vary throughout the state. Of notable importance is the fact that IDNR-OWR permit criteria changes when the existing structure and approach roadway is the source of flood damage to buildings or structures in the upstream floodplain. In that case, IDNR-OWR has historically held proposed headwater levels for all events up to and including Q_{100} strictly at or very near natural highwater levels; a policy often referred to as "zero rise".

In the absence of valuable upstream property below the existing Q_{100} profile, the applicable IDNR-OWR construction permit is the controlling factor in determining allowable headwater. All crossings with drainage areas at least 1 sq. mi. in urban or urbanizing areas and 10 sq. mi. in rural locations require an IDNR-OWR permit. [Chapter 1, Section 1-404](#) and [Tables 1-404a, b, c, and d](#) provide direction for selection of the appropriate permit type and each permit type's acceptable backwater limits. Summarizing that text; IDOT's most commonly employed OWR permits for bridge replacements are Statewide Permit #2 (SWP2) and Statewide Permit #12 (SWP12). IDNR-OWR established the Statewide Permit program in the 1990's to allow public entities like IDOT, counties and municipalities to certify that a proposed improvement meets OWR rules and policies. This allows IDOT to issue the permit for OWR without making a formal application to IDNR-OWR. SWP12 for replacement structures has no strict backwater limits, per se, but it does require that the proposed waterway opening meet or exceed existing. Again, referring to [Section 1-404](#), SWP2 & 12 are not applicable to streams identified by OWR as Public Bodies, or to those rivers, lakes

and streams within the 6-county area located in Northeastern Illinois for which regulatory floodways have been designated. Note that the 6-county area excludes the City of Chicago.

For locations that do require an IDNR-OWR permit, but do not fall under the Statewide Permit umbrella, IDNR-OWR permits establish definitive limits on allowable backwater profiles for all events up to and including the Q_{100} event. The limits are a function of several project factors; chief among these is the existing backwater profile. The controlling restriction of IDNR's permit regulations is that "no additional damage can be attributed to any proposed encroachment, for any flood frequency up to and including the Q_{100} event, when compared to existing conditions." In this respect, IDOT's policy and practice parallel IDNR's regulatory permit criteria. Again, any bridge backwater impact on damageable upstream property is considered undesirable and would merit the consideration of an alternative design intended to mitigate or eliminate the impact, where practical.

Headwater constraints are not always determined by the presence of damageable upstream property or the applicable IDNR-OWR permit criteria. Bridge projects over watersheds that fall below IDNR-OWR's 1 sq. mi. urban and 10 sq. mi. rural jurisdictional limits do not require a Floodway Construction permit, regardless of project scope, channel realignment or any other appurtenant work. For these bridges without strict limits or site-specific constraints on allowable headwater, the nature of the affected upstream properties and the longevity and performance of the existing opening become the benchmarks for establishing "acceptable" headwater elevations. The proposed opening generally meets or exceeds existing in these situations, and the other hydraulic considerations given in [Section 7-001](#) become the primary design considerations.

Providing a longer or larger replacement bridge is the conventional method of providing additional waterway opening to satisfy backwater constraints. An open, spill-through abutment with riprap-armored slopewalls at a 1V:2H slope is IDOT's standard opening configuration. As [Figure 7-001.01a](#) indicates, armored slopewalls can be placed in-line or flush with natural banks or levees, or, when additional waterway opening is required, abutments can be sufficiently set back from the channel so that slopewalls "toe-in" at natural overbank elevations. (See [Section 7-001.03](#) for additional text on slopewall and riprap toe placement.) As a general rule, slopewalls should not constrict the natural or leveed channel by toeing into the streambed within the limits of the natural channel bottom width. However, slopewalls may be located inside of existing vertical, closed abutment walls in order to shift the bridge opening towards the opposite bank. This shift of the bridge centerline is intended to improve alignment with the channel and generally places one or both abutments in more hydraulically desirable locations. Shifting the opening centerline in this manner is fairly common at smaller structures over streams that have experienced channel migration that can be described as having reached a stable, equilibrium plan form at the crossing.

It is desirable that open, spill-through abutment bridge construction leave the natural channel undisturbed to the extent possible between slopewall toes. Limited channel reshaping and cleaning is generally undertaken during construction, particularly when piers are located near the bank(s). For three-sided bridges, limited channel excavation intended to reshape and transition the natural channel section (both upstream and downstream) to the opening is not uncommon. However, channel excavation on a more extensive scale to provide additional waterway opening, either vertically or laterally in the form of lateral channel widening, has long been considered an unacceptable hydraulic practice. An artificially wide, flat-bottom channel can be expected to refill over time as deposition occurs and the natural channel template is re-established. The classic example of this is observed on existing Interstate bridge plans that indicate a wide, flat bottom width greatly exceeding the natural bottom. In

IDOT's experience with maintaining and improving these structures, we have found that the original, trapezoidal-shaped waterway shown on the plans is typically greatly reduced over time by sediment deposition. The ensuing reduction of effective area, compared to that specified by design, can have a negative impact on both the structure and the upstream floodplain. In addition, channel bottom widening of this type can produce undesirable stream migration that leads to poorly aligned substructure units. Channel excavation is acceptable when channel realignment is required to improve alignment with the bridge opening. In this situation, the excavated channel template typically matches or approximates the existing channel template. Armoring or revetment should be placed along the entire length of the new, realigned channel reach.

Overbank excavation through the bridge opening for purposes of providing additional waterway opening should be distinguished from channel excavation, or channel widening. Overbank excavation is an uncommon practice that should be utilized judiciously, if at all, for the reasons described here. Plan limits of overbank excavation through the bridge opening to a benched, or terraced depth several feet below natural ground typically take the same shape and width as the bridge deck footprint. Since the excavated area is below natural overbank grade, deposition will gradually eliminate the opening over time, albeit at a slower rate than channel excavation. Consequently, this feature should be used only at sites where increasing the overall bridge length or waterway opening any further by conventional means becomes unfeasible or impractical and the potential risk due to lost effective area is acceptable. IDNR-OWR policy also considers overbank excavation to be less than desirable for these same reasons. Overbank excavation is not allowed by IDNR-OWR in District 1. However, in Districts 2 through 9, it is a permissible method for establishing the required bridge opening, but only if adequate transitions to natural ground upstream and downstream of the opening are provided to maintain hydraulic efficiency. To this end, the IDNR-OWR Individual Permit includes special conditions stipulating that IDOT maintain the excavation and the transition areas. In addition, the excavation and the maintenance could require additional ROW purchase or easements. Consequently, the BBS Hydraulics Unit recommends that overbank excavation be employed only as a "last-ditch" effort to comply with IDNR-OWR backwater criteria in situations where it is not feasible to provide additional waterway opening by lengthening the structure or raising the low beam. If overbank excavation is deemed necessary, refer to [Section 1-404.03](#) for minimum horizontal/vertical transition rates to natural ground elevation and further information on the applications of overbank excavation.

*TYPICAL SPILL-THROUGH BRIDGE OPENINGS
(ELEVATION VIEWS)*

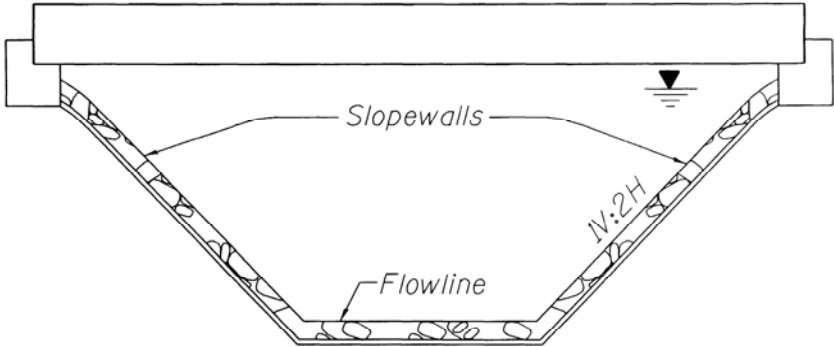

- 1. Riprapped slopedwalls extending to streambed elevation. Riprap blanket is continuous from abutment to abutment.

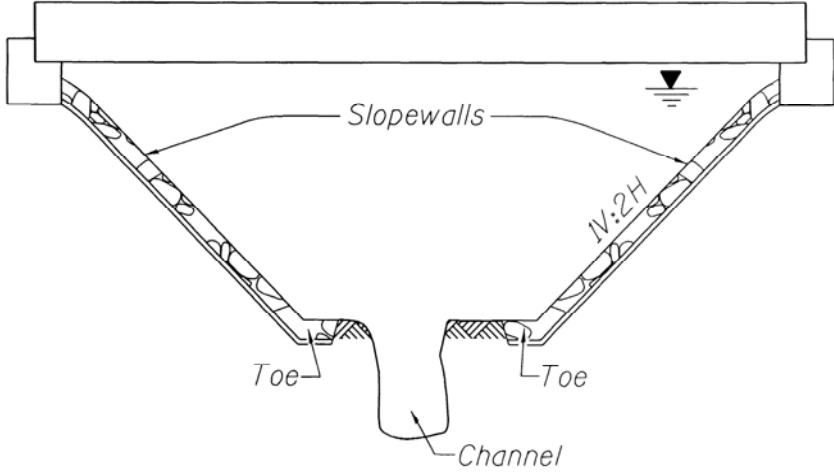

- 2. Riprapped slopedwalls toed into overbank elevations; offset from the channel banks.

Figure 7-001.01a

7-001.02 Velocity

Velocities through the structure shall not damage the highway facility or increase damages to adjacent property. There is no maximum allowable design velocity utilized in practice or policy for bridges- or culverts, for that matter- since soils conditions, stream slope and flow patterns vary significantly from site to site. Generally for proposed bridges, the velocity is considered acceptable if the average velocity through the structure is equal to or less than existing. Performance and longevity of the existing structure are major indicators. A proposed bridge providing more effective waterway opening than the existing structure would normally be considered adequate provided the existing structure has performed favorably. Local velocities, or point velocities, are accounted for in pier orientation and location; two key hydraulic design elements.

As mentioned in the next section, worst-case velocities should be estimated at locations where water surface profiles are influenced or controlled by downstream tailwater. This requires a simulation of what is referred to as the headwater flood. Typically, this means ignoring or neglecting the impact of tailwater created by downstream structures or a larger, receiving stream downstream of the subject structure. The higher velocities generated by the shallower headwater flood should be utilized for design recommendations. Use of the headwater flood for design recommendations is particularly critical on smaller, flashier streams that can peak and recede before the receiving stream peaks.

7-001.03 Scour and Pier/Abutment Placement

Chapter 2 itemizes the scour related work to be performed for the Hydraulic Report. The work is also required for three-sided bridge structures, but not for culverts. This evaluation is primarily based on two FHWA publications: HEC 18⁶, which addresses scour in the vertical plane, and HEC 20⁷, which addresses lateral stream migration. These manuals and a third, HEC 23⁸, “Bridge Scour and Stream Instability Countermeasures”, form the basis of this Manual’s scour direction in Chapters 10 and 11. HEC 18⁶ labels Q_{100} the design event for scour, adding that adequate foundation stability must also be established for the Q_{500} event. In the case of roadway overtopping, the overtopping frequency (if less than Q_{500}) becomes the critical design event for scour and either the Q_{100} or Q_{500} flood is utilized to check stability. Although not the design scour event, scour conditions for Q_{50} are estimated and documented for all proposed bridges.

Water surface profiles used to generate scour parameters should consider the worst case scour conditions when design highwater at the subject structure is controlled or impacted by a receiving stream or constrictive downstream structure(s). That is, scour conditions during the headwater flood (assuming no tailwater influence) should also be analyzed to compare with scour based on the higher water surface profiles represented on the approved waterway information table. Typically, the headwater flood simulation produces higher design velocities and deeper estimated scour depths.

Analysis and existing structure performance in the Hydraulic Report prepared by the District or Consultant is used as the basis for scour related recommendations made during the Planning phase. As suggested in HEC 18⁶, IDOT takes a multi-disciplinary approach to the process. Hydraulic and structural engineers work with District and consultant project engineers to develop preliminary bridge and roadway geometry that

minimizes potential scour within structural and physical constraints. In parallel with this effort, the foundations engineer adjusts estimated scour to reflect soils conditions and determines substructure type and dimensions needed to withstand the adjusted estimated scour depths. The disciplines interact to finalize TSL Plan details relating to scour and stream stability. Scour countermeasures are developed as needed and are based on the discussion in [Chapters 10 and 11](#). Also refer to [Section 2](#) of the [Bridge Manual](#) for more information on scour design.

From a hydraulic perspective, local scour mitigation relates directly to pier skew and orientation to flow. According to IDOT convention, the skew angle refers to the acute angle between a line perpendicular to the roadway centerline and a line drawn parallel with the bridge abutment face. Bridges are typically skewed to align with the upstream channel, with all substructure units built at the same skew. If the channel alignment breaks or bends at the highway crossing, the skew angle is still typically oriented towards the upstream angle of approach, with consideration given to any possible downstream impacts. Piers in or near the channel should align with the channel. If all piers are sufficiently set back from a stable channel that does not approach at 90 degrees to roadway centerline, the bridge may not be skewed to match the channel. Instead, depending on the orientation of overbank flow, the structure may be built at right angles or skewed to better align with overbank flood flow. At sites where the proposed skew angle is not clearly identifiable, the adequacy of the existing structure and existing skew angle should be considered.

In addition to pier orientation, or skew, pier placement is a critical hydraulic feature relating to scour design. It is an IDOT practice to avoid locating piers directly in the channel provided it is structurally and economically feasible to do so. The increased depth, velocity and conveyance associated with channel flow create greater scour potential, particularly when debris or ice problems are present. However, channel piers are obviously necessary for larger streams and rivers that cannot be economically spanned. They are also justifiable at waterways where flow conditions in the channel present no apparent threat to the pier foundation and the pier has no adverse affect on channel stability. Overbank pier locations are typically less critical from a hydraulic viewpoint and are generally dictated by span length constraints. A common structural constraint is the presence of existing substructure units. As detailed in [Section 7-001.01](#), an offset or minimum spacing between the new pier or piles and the existing substructure unit is desirable to avoid placing new foundations within the area of influence around existing units. As a rough rule of thumb, a pier face to pier face offset of 5 to 6 feet is generally sufficient spacing to avoid conflict with existing pier substructures.

As with piers, abutment placement and skew are key determinants in limiting the potential for damaging scour. Standard IDOT features such as the open, spill-through abutment type and rock-armored slopewalls provide built-in scour countermeasures. IDOT's standard bridge configuration features 1V:2H slopewalls that are typically lined with riprap. The typical abutment and slopewall are generally set back from the channel in an overbank area of lower velocity and lesser flow depth when compared to channel conditions. Slopewalls generally toe in at natural overbank elevations, as stated in [Section 7-001.01](#), (See [Figure 7-001.01a](#), View 2) but can toe in at channel bottom elevations as long as the slopewall does not constrict the natural channel template and the natural bottom width is not constricted. If the opposing slopewall toes are relatively close to each other, it is common practice to extend the riprap to cover any unprotected gap and provide continuous protection from abutment to abutment. (See [Figure 7-](#)

001.01a, View 1) Since the toe riprap extends a minimum of 8 ft. horizontally from the slope break, this direction applies to channel bottoms in the 20 to 35 foot range. Note that USACE Regional Permit 38 restricts armoring streambeds and does not allow “closing the gap” between riprap toes in this manner. Dimensions of typical riprap toe detail and flank detail (along upstream and downstream perimeter) at stream crossings are shown in [Figure 2.3.6.3.3-2 of the Bridge Manual](#)³

The starting point for selecting slopewall protection is stone riprap of A4 gradation. This level of protection is considered acceptable for abutments set back from the channel and properly aligned with low velocity flow; particularly when a larger, longer structure is replacing a closed abutment bridge that has performed capably. Some Districts have their own preference for slopewall gradation- for example District 2 employs A5 riprap as their standard gradation. At abutment locations that will experience adverse hydraulic conditions (high velocities, potential for channel migration, turbulent flow, lengthy flood durations, etc.), consideration of a greater level of protection is warranted. That typically means larger riprap, but the designer may consider a different form of revetment offering a greater level of protection.

Regarding placement of proposed abutments at replacement structures, it is desirable from a cost and constructability perspective to sufficiently offset proposed abutments from existing substructure units to avoid major substructure removal costs. As a rule of thumb, at a typical replacement with proposed abutments located behind existing vertical closed abutments at a 90-degree crossing, this offset equates to a minimum 10 to 15 ft spacing from face-to-face of abutment. Placing the new abutment inside of an existing abutment can also be a viable hydraulic option. Again as a non-binding rule of thumb, the offset for locating a new open, spill-through abutment inside a typical existing closed, vertical abutment of zero degree skew is roughly 7 to 8 ft measured face-to-face. These offsets are rough guidelines and therefore are intended for preliminary determinations only. [Section 7-001.01](#) contains additional guidelines addressing abutment and slopewall placement.

As mentioned above, IDOT’s multi-disciplinary approach is intended to account for site factors related to scour evaluation. Hydraulic recommendations are taken into consideration by the BBS Planning Unit engineer, who compares TSL Plan alternatives based on cost and structural constraints. Consequently, ideal or optimal pier/abutment locations identified by the hydraulic engineer are subject to refinement during TSL development.

7-001.04 Clearance and Freeboard

The reference water surface elevations for the determination of low beam clearance and roadway freeboard are design natural highwater and design headwater, respectively. [Section 7-106 Natural Highwater and Headwater Elevations](#) contains descriptions of these parameters and detailed procedures for extracting them from bridge backwater models. Policy regarding minimum standards and direction for determining clearance and freeboard is contained in [Chapter 1, Section 1-305 Design Criteria](#). Policy also requires special clearances for those crossings over navigable streams, as defined by the United States Coast Guard. Refer to [Chapter 1](#) of this manual and the IDOT [Bridge Manual Section 2](#)³ for additional information and a list of USCG permit waterways. Regarding beam clearance, three-sided pre-cast concrete structures are treated like culvert structures in that they are not required to meet the 2-ft minimum criteria over

design highwater. However, the 3-ft roadway freeboard criteria applies to all transverse floodplain encroachments, regardless of structure type.

Structures on a new alignment and major river crossings are generally held strictly to policy criteria or to even more stringent criteria, especially when debris and/or ice are known problems at a specific location. In addition, per [Table 1-305 in Chapter 1](#), for new freeway or expressway structures the proposed low beam should not be placed lower than existing low beam or lower than a reputable, documented all-time highwater mark, unless the policy is met. However, exclusions or waivers are granted from the criteria specified in [Section 1-305](#) under certain circumstances for both replacement and rehabilitation projects. A waiver is possible when the cost of raising the bridge and road grade to elevations required by policy is considered excessive or physical/geometric constraints such as adjacent structures or intersections make meeting the criteria unfeasible. A key consideration is past experience at the site; including the frequency and duration of overtopping events, maintenance or damage costs associated with past flood events, and traffic safety incidents. Factors unrelated to hydraulics such as sensitive adjacent wetlands can make the policy criteria unfeasible. The size of the watershed and the width of the floodplain are to be considered at all sites, in that they directly affect the duration of flooding events and the length of impacted roadway. For those projects under the approval authority of the Bureau of Bridges and Structures (see [Section 1-102.01 Central Office \ Bureau of Bridges and Structures](#), Item 2), it is the District Hydraulic Engineer's responsibility to formally request a waiver of policy from the BBS Hydraulics Unit. That request is typically made after BBS hydraulic review and approval of the proposed opening, so that the waiver process parallels or even follows TSL Plan development. This timeline enables sufficient development and comparison of bridge/roadway geometry alternatives to determine if a waiver is warranted. However, for those projects where the district has satisfactorily studied the viable alternatives and/or identified non-hydraulic constraints such as environmental concerns or impacts to adjacent property owners that will clearly control the beam placement and profile grade, the request for waiver can accompany the Hydraulic Report submittal to BBS. Identification of these types of controlling factors within the Hydraulic Report itself can prevent or deter the expenditure of unnecessary man-hours by bridge and roadway planners.

The above design criteria apply to bridge projects on the State highway system. Local agency design criteria differ in the areas of design frequency, roadway freeboard and bridge clearance. For design criteria of lower class roadways on the State highway system, see the Bureau of Local Roads & Streets Manual⁹ from the IDOT internet site at <http://www.dot.il.gov/blr/manuals/blrmanual.html>. Criteria can vary according to the presence or absence of Federal funding.

7-100 BRIDGE BACKWATER MODELING

This section introduces the Department's accepted software models, and their repertoire of computational routines for bridge analysis. Some of this material is informational, dealing with model capabilities and options. Other parts of the section include recommended techniques specific to single-bridge analyses and other more complex situations. [7-101.01 HEC-RAS Modeling](#) contains items that are critical to developing acceptable hydraulic models. This direction is derived from many years of bridge modeling with these and other models, discussions with involved regulatory agencies such as IDNR and also from extensive training courses through the FHWA's NHI training program, among others. Commonly applied tools and techniques have been assembled here as a compact reference. These techniques are not absolute or unchanging. The user should always exercise judgment to amend or append them as warranted.

7-101 Accepted Computer Models

There are several computer models commonly available for generating flow profiles needed to make hydraulic design recommendations. As stated in the Introduction, [HEC-RAS](#) has become the Department's primary, default model for bridge hydraulics. [HEC-RAS](#) and other models used by the Department on an occasional basis such as [WSPRO](#), [HEC-2](#) and [WSP-2](#) are classified as 1-dimensional, steady flow, step backwater models.

The U.S. Army Corps of Engineers supports and maintains the software. [HEC-RAS](#) and supporting documentation can be downloaded for free from:

<http://www.hec.usace.army.mil/software/hec-ras/hecras-document.html>

The current version is 4.1. These supporting documents are viewable and downloadable at the website:

User's Manual- guide to using [HEC-RAS](#).

Hydraulic Reference Manual¹⁰ – covers theory and data requirements for the hydraulic calculations performed by [HEC-RAS](#). (previously titled Hydraulic Reference Guide)

Applications Guide- examples that demonstrate various aspects of the program.

[HEC-RAS](#) is considered to be the state-of-the-practice for steady flow, 1-D modeling. The [HEC-RAS](#) model/package also has unsteady flow capability, but that feature is not yet being utilized by the Department.

There is one common project type where a model other than [HEC-RAS](#) may be used. For those projects, the hydraulic design is based upon the FIS model (or other published study) or a modification of an existing study driven by updated survey information. This is the case on regulated stream crossings in the 6-county area around Chicago in District 1 when an IDNR-OWR Individual Permit or 3708 Floodway Permit is required. For those projects, IDOT is typically required to use the study discharges and match or very nearly match the published base flood profile- be it a published Flood Insurance Study or other approved certified regulatory study- to satisfy IDNR-OWR permit criteria. Typically, the existing study model is updated with current survey information to include supplemental floodplain sections and all impacting encroachments within the study reach. It is common practice to utilize FIS water surface elevations to start the profile modeling at the furthest downstream section. For bridge projects within the 6-county area around Chicago, District 1 Hydraulics should be involved or consulted to properly utilize the FIS study and modeling on regulatory streams.

The great majority of older FIS regulatory profiles were constructed with one of these three programs; [WSP-2](#), [HEC-2](#) or [WSPRO](#). As stated above, all three are 1-dimensional, steady flow, step backwater models. The following is a brief summary of the origin of each model and the typical application to bridge projects on regulated streams in District 1.

[WSP-2](#) is a Soil Conservation Service model developed in the 1970's. (The SCS is now called the Natural Resources Conservation Service, or NRCS.) [WSP-2](#) is based upon the outmoded, single-section bridge methodology from the FHWA's [HDS No. 1 Manual](#)² (see [Section 7-000](#)). The model is no longer supported by the NRCS. Use of existing [WSP-2](#) modeling should be restricted to insertion of newer floodplain cross sections into the existing model, with project scope limited to minor modifications of the existing structure. Chapter 7 contains limited direction on the theory and use of the model.

[HEC-2](#) was the U.S. Army Corps of Engineers backwater model for many years prior to the development of [HEC-RAS](#). Typically, [HEC-2](#) FIS analyses are brought up to date with current survey information to include supplemental floodplain sections and all impacting encroachments within the study reach. The [HEC-2](#) bridge tools are still considered to produce valid backwater analyses. Although the Corps of Engineers and the HEC no longer support the model, [HEC-2](#) runs can be imported to [HEC-RAS](#). Like [WSP-2](#), limited direction on [HEC-2](#) is included here.

[WSPRO](#)¹¹ was developed by USGS and the FHWA in the 1980's. For many years extending into the 1990's [WSPRO](#) was the state of the practice for 1-D steady flow modeling, supplanting [HEC-2](#) and [WSP-2](#). Like [HEC-2](#), [WSPRO](#) modeling and bridge routines are still considered to be valid for purposes of backwater modeling. [WSPRO](#) models can typically be supplemented with new survey data and be utilized as the basis for IDNR permit modeling.

As the immediate forerunner or predecessor of [HEC-RAS](#), [WSPRO](#) was IDOT's primary bridge backwater model through the mid-1990's. Consequently, the last two Drainage Manual rewrites focused on [WSPRO](#), including technical direction on cross section input requirements, bridge modeling routines and troubleshooting output. Since the last manual update completed in 2004, [HEC-RAS](#) has entirely replaced [WSPRO](#)- except for those District 1 projects mentioned above. The [WSPRO](#) material within this chapter remains valid and consequently is retained for reference purposes. See this link for the USGS research report:

http://www.fhwa.dot.gov/engineering/hydraulics/library_arc.cfm?pub_number=71&id=107

7-101.01 HEC-RAS Modeling

Acceptable [HEC-RAS](#) modeling within a bridge Hydraulic Report involves satisfying three primary areas:

1. Plan Requirements

Chapter 2 describes the details of typical modeling requirements at a given bridge project for the natural, existing and proposed conditions. [HEC-RAS](#) refers to each of these scenarios or simulations as a Plan. Each Plan contains a Geometry file and Steady Flow data. At most bridge locations, there is one natural, one existing and one proposed Plan within the [HEC-RAS](#) Project file. For some projects, due to the presence of site-specific physical elements or design considerations, it may be necessary to model additional natural, existing or proposed Plans within [HEC-RAS](#). For example, a railroad bridge located 300 feet downstream of the subject structure may cause sufficient backwater to increase the tailwater elevation at the subject structure beyond so-called natural depths. In

that case, Plans for modeling natural, existing and proposed conditions both with and without the railroad constriction may be required. Another example involves the presence of potentially damageable structures in the upstream floodplain. Several iterative proposed condition Plans may be needed in order to determine the waterway opening that would eliminate or mitigate damages. The need for additional modeling is generally caused by one or more of these site factors:

- Tailwater effects at the subject bridge due to constriction of the downstream floodplain by bridges, levee systems or other encroachments.
- Tailwater effects at the subject structure due to flooding on a larger downstream system.
- Sensitive flood receptors in the upstream floodplain.
- Inadequate low beam clearance and/or roadway clearance.
- IDNR-OWR Floodway Construction Permit criteria.

These chapter\sections within the Drainage Manual should be utilized to help determine all required [HEC-RAS](#) Plans:

Chapter 1

[1-305 Design Criteria](#) Clearance and freeboard policy and design criteria discussion.

[1-404.03 IDNR-OWR Individual Permit Program](#) For projects requiring an Individual permit from IDNR-OWR, early coordination with IDNR-OWR & IDOT BBS is suggested to identify design constraints and the modeling required to demonstrate permit compliance. Modeling can include a second natural conditions Plan and a feasibility study of proposed alternatives.

Chapter 2

[2-601.01 Hydraulic Report Content](#) Describes natural conditions as defined by IDOT.

Chapter 7

[7-001.01 Headwater and Waterway Opening](#) Discusses design constraints and model requirements related to sensitive flood receptors and IDNR-OWR permit criteria.

[7-105.03 Coincidental Flooding](#) Modeling variable downstream tailwater conditions to account for a receiving stream. Additional [HEC-RAS](#) Plans are needed for design purposes (backwater, clearance, freeboard, scour, etc.) and possibly to satisfy IDNR-OWR worst-case modeling scenarios.

[7-106.01 Natural Highwater](#) Describes natural conditions as defined by IDNR-OWR. (Applicable to projects that require an Individual Permit or 3708 Floodway Permit.)

[7-106.02 Headwater](#) Covers modeling and documentation to account for floodplain encroachments downstream from the subject structure.

Chapter 10

Both existing and proposed condition Plans may need revision or modification to model the worst-case scour conditions. Worst-case typically refers to the highest potential velocities for a given event. This Plan is labeled the “headwater flood”, because all potential tailwater effects from encroachments or receiving streams are removed from the model.

For consultant-prepared Hydraulic Reports, particularly in District 1, the consultant is encouraged to discuss required modeling Plans with District Hydraulics. For all projects requiring an IDNR-OWR Individual Permit, the consultant and or District should confer with BBS Hydraulics to determine the need for early coordination and discussion with IDNR-OWR.

2. Input Parameters

IDOT has utilized [HEC-RAS](#) as the primary model for bridge and floodplain studies since the late 1990's. Over that time period, District and Bridge Office hydraulics staff have developed preferred or required practices and modeling techniques. These are intended to ensure [HEC-RAS](#) work is technically acceptable, per the direction and reference information provided by the Corps of Engineers HEC support group and also the FHWA instruction provided in NHI short course training. These practices and modeling techniques contribute to making the modeling consistent in content and uniformly acceptable to reviewing agencies- particularly IDNR-OWR.

The following input parameters or modeling practices are necessary elements of an acceptable [HEC-RAS](#) model. There is direction available in this manual for most of these items. Among the [HEC-RAS](#) supporting documents listed in [7-101 Accepted Computer Models](#), the Hydraulic Reference Manual is a ready source of technical direction.

Manning's roughness values Channel and overbank n-values should be determined from [Section 5-301.01 Manning's Roughness Coefficient](#).

Downstream boundary conditions A slope-conveyance based (normal depth) water surface elevation must be compared to WSE's that reflect a tailwater impact (if applicable)for a given event. For subcritical regime flood simulation, the downstream boundary condition must account for the presence of floodplain encroachments, tailwater due to coincidental flooding or other impacts that increase flow depth (above normal depth) at the furthest cross section downstream. [7-105.04 Coincidental Tailwater Conditions](#) provides direction for modeling concurrent flooding. For those projects where the FIS water surface is utilized, downstream WSE's are taken directly from or extrapolated \interpolated from the FIS model.

Coefficients of expansion & contraction Values of 0.3 and 0.5 for contraction and expansion, respectively, are routinely used within the cones of contraction\expansion for structure analysis.

Cross section requirements [Chapter 2](#) covers the standard cross section locations for bridge Hydraulic Reports and [7-102 Cross Section Requirements](#) addresses proper cross section locations near bridges using [HEC-RAS](#). The location and number of floodplain cross sections should be consistent across all Geometry files.

Bridge backwater method [7-103.021 Bridge Modeling Approach Editor](#) includes the backwater modeling capabilities available within [HEC-RAS](#). The Hydraulic Reference Guide addresses selection of the appropriate modeling method (or methods) for a given flow condition and bridge\roadway geometry.

Limits of effective flow A valid [HEC-RAS](#) model must utilize limits of effective flow around structures and for any other floodplain element that creates a significant degree of contraction\expansion. [7-102.012 HEC-RAS](#) includes guidelines for establishing and implementing limits of effective flow at typical bridge constrictions. In addition, the model must utilize similar techniques in the floodplain to account for ineffective flow areas or flow that "leaves" the subject reach.

Waterway opening and roadway modeling In addition to the cross sections around the bridge detailed in [7-102.012](#), the model must accurately reflect the geometry of the waterway opening and roadway profile. This includes x,y coordinate data representing the waterway opening configuration, pier blockage, low beam and roadway profile. The roadway profile data must extend to the physical limits of conveyance to properly model overtopping conditions.

Scour Per the [Chapter 2](#) Hydraulic Report requirements, estimates of scour for both existing conditions and proposed conditions are required. See [Chapter 10](#) for direction.

3. Troubleshooting & interpreting output

The modeler needs to do two main things with [HEC-RAS](#) output: first, confirm that the computed water surface profiles are valid, and secondly, extract the pertinent information for completing the Waterway Information Table. Working towards those ends, these tasks are associated with every bridge [HEC-RAS](#) model:

Project & file management All Plans for a given site location must be contained in a list or index of files clearly identified as natural, existing or proposed. Sufficient description can be provided in each Plan filename (and within the Plan Description Box) to clearly identify the variation- such as FIS flow data, tailwater control boundary conditions or IDNR-OWR permit compliant alternative. All Plans within the Hydraulic Report should be included within one [HEC-RAS](#) Project file.

Review output messages [HEC-RAS](#) summarizes errors, warnings and notes for user reference. Notes are generally informational, but errors and warnings should be scrutinized by the user to ensure the input is valid and complete and that the results are reasonable. [Section 7-104 Adjusting Input Parameters](#) also covers revisions to the input file.

Extracting WIT data For purposes of estimating the natural highwater elevation on the Waterway Information Table (WIT), [7-106.01 Natural Highwater](#) contains direction on locating a cross section in the model and how to extract the natural highwater elevation. [7-106.02 Headwater](#) instructs how to extract created head values from the model.

7-102 Cross Section Requirements

Both [HEC-RAS](#) and [WSPRO](#) have model-specific requirements regarding the nature and location of cross sections directly involved in bridge analysis. [Section 7-102.01](#) includes figures illustrating these locations. The text also includes direction regarding survey information and coding techniques such as adjusting the section limits to better represent 1-dimensional flow conditions. The [HEC-RAS](#) Hydraulic Reference Manual has documented guidelines for adjusting these sections to account for areas of ineffective flow created by cones of expansion and contraction located downstream and upstream, respectively, from bridge openings. [Section 7-102.01](#) covers proper modeling techniques to satisfy these guidelines and also contains a brief discussion of some [HEC-RAS](#) features for this purpose.

7-102.01 Locations Within the Model & Limits of Effective Flow

Both [WSPRO](#) and [HEC-RAS](#) require a minimum set of cross sections for bridge analysis. Each model specifies locations for these sections that allow their respective bridge routines to produce valid profiles. These locations are generally unchanging for all single-bridge

analyses, but they may require adjustment if the model includes other bridges or structures over the same stream near the subject crossing. [Section 7-105](#) addresses adjustments for modeling dual bridges and closely spaced bridges.

All bridge backwater analyses in the subcritical flow regime are preceded by the determination of tailwater conditions. Profile construction by step backwater (e.g., energy balance) in the downstream floodplain must produce accurate tailwater elevations which in turn become starting points for estimating losses through the subject structure. To this affect, neither [WSPRO](#) nor [HEC-RAS](#) has any rigid requirements for floodplain cross sections that lie outside of the sections required for bridge analysis. [Chapter 2](#) lays out the typical study reach length, the roadway and floodplain sections needed for bridge hydraulic surveys, and also includes discussion on when this basic grouping should be supplemented with additional sections. The user typically assumes subcritical flow, since almost all design flood conditions within Illinois lie within that regime. Step backwater calculations in subcritical flow regimes start downstream of the subject crossing (at the furthest section downstream) and work in the upstream direction to the limits of survey information. Tailwater at the highway crossing is determined in large part by the starting water surface elevation utilized at the furthest downstream section. [Chapter 5 Open Channel Flow](#) addresses IDOT practices and modeling techniques for determining the starting the water surface profile. [Section 7-105.04](#) and [Section 7-106](#) further expound on developing the natural profile and accounting for downstream tailwater conditions.

Establishing limits of effective flow in [HEC-RAS](#) typically refers to user modification of floodplain sections that are affected by the contraction and expansion of flow caused by bridge constrictions. These areas of flow contraction and expansion immediately upstream and downstream from the structure are often referred to as the cones of influence. Within the computer model, flow top width across affected sections is reduced from a full, natural width to a lesser width in order to represent only the cross-sectional area that conveys flow in the predominant direction of flow. Areas outside of these limits, or outside the cones of influence, are considered to be ineffective when water surface profiles are below specified elevations. The proper section adjustments depend on the model used. Ordinarily, [WSPRO](#) does not require the user to make this type of adjustments around constrictions, while accepted [HEC-RAS](#) application involves adjustments to several sections. Acceptable modeling strategies for both models are covered below.

7-102.011 WSPRO

[Figure 7-102.011](#) establishes the four cross sections needed to perform single-bridge analysis in [WSPRO](#). The figure also includes a road grade section, which becomes the fifth section involved in the analysis when the roadway is overtopped. These 5 sections are entered into the input file in the same order as addressed below. No other sections, other those shown in [Figure 7-102.011](#), are allowed between the EXIT and APPROACH sections. All sections are typically surveyed at the same locations they assume in the model, with the exception of the FULL VALLEY. Since this section is located at the downstream toe of the highway embankment, it can be propagated from the EXIT section, particularly for analysis of shorter bridges in homogeneous, uniformly shaped floodplains.

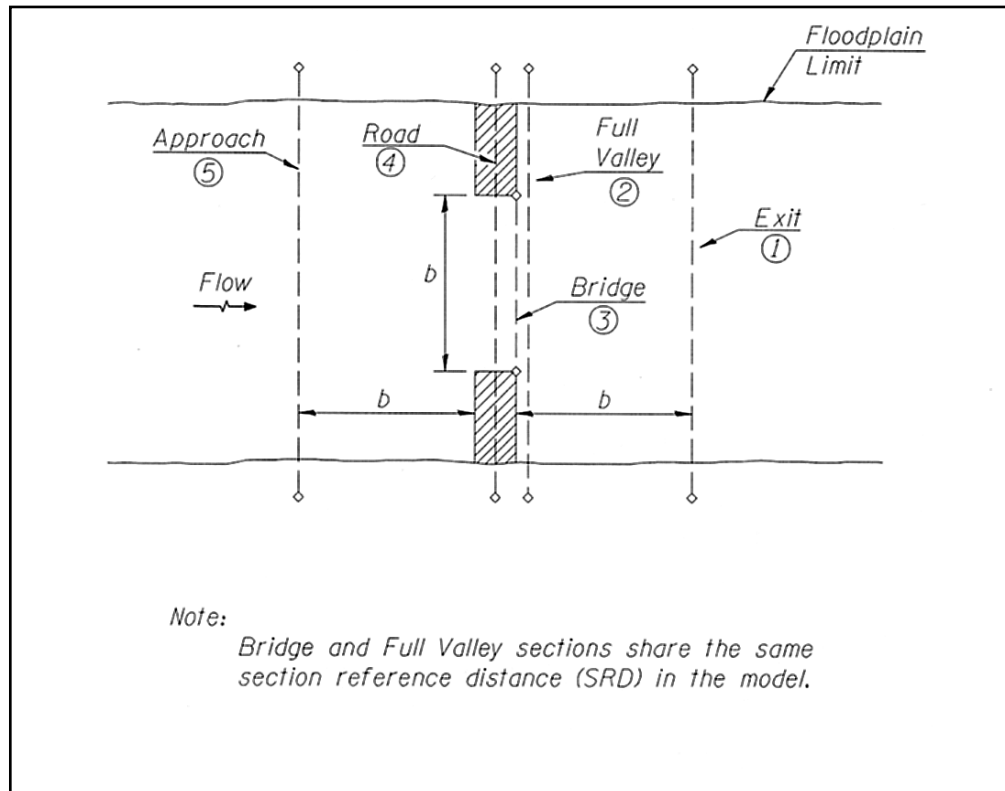

WSPRO: Required Sections for Bridge Analysis
 Figure 7-102.011

1. **EXIT** An unconfined floodplain section located approximately one bridge length downstream of the downstream bridge face.
2. **FULL VALLEY** An unconfined floodplain section located at the toe of the highway embankment. Typically, this section is copied from the surveyed EXIT section and the elevations are adjusted for stream fall. Any skew adjustment of the BRIDGE is also made to this section. The FULL VALLEY is located in the model at the same stream reference distance (SRD) as the BRIDGE section.
3. **BRIDGE** Surveyed cross section of the opening located in the model near the downstream face.
4. **ROAD** A section representing the roadway profile across the limits of the floodplain. WSPRO requires ROAD be located at the bridge centerline, or one-half of the bridge width upstream from the FULL VALLEY and BRIDGE sections. For a tangent roadway section not on a horizontal curve, ROAD consists of X, Y shots along the centerline. For super-elevated pavements, the Y shot represents the elevation at which overtopping begins for its respective roadway station, X. ROAD shares a common horizontal datum with the BRIDGE section. Note the XR header record representing the ROAD section is optional. If roadway overtopping is clearly not a possibility, this section can be excluded.
5. **APPROACH** An unconfined floodplain section located one bridge length from the upstream bridge face. A common horizontal datum is also required between the APPROACH and BRIDGE, or the BP record can be used to establish one.

WSPRO allows for some latitude from the “one bridge length” spacing requirement of the EXIT and APPROACH sections, stating that “a misplacement of the EXIT and APPROACH sections by up to 20 percent will typically have an insignificant effect on the results”. Chapter 4 of the WSPRO User’s Manual¹¹ contains additional direction, particularly regarding the ROAD section.

For a typical WSPRO analysis, the floodplain sections involved in the constricted profile are not adjusted to simulate the contraction/expansion affects of the bridge constriction on flood flow. Since the model’s inception, it has been accepted WSPRO convention to consider the full, divide-to-divide width of available overbank flow at both the EXIT and APPROACH sections to be effective flow for bridge analysis. They are modified, just as any section should be, for lower depressed areas, permanent storage or any part of the cross section that does not convey flow in the predominant direction of flow. However, they are not modified to reflect their relative location within the zones of expansion and contraction attributed to the bridge opening. This convention serves two purposes. First, it allows the model to develop both the constricted and the natural, unconstricted profiles within the same file without the user recoding or revising the input. Secondly, and more importantly, the model’s construction of the constricted profile assumes full-width flow conditions one bridge length upstream and downstream of the constriction. Various flow length and resultant friction loss estimations are built upon or derived from this assumption of full flow at these sections. Again, this convention should not prevent the user from establishing limits of effective flow to improve the simulation, especially when the APPROACH or EXIT sections are very wide and expansive compared to the bridge length. In that situation, or in any case where the user can demonstrate that the limits of effective flow are inside the actual top width for any given section, establishing effective flow limits is an acceptable modeling technique.

7-102.012 HEC-RAS

Figure 7-102.012a illustrates that a minimum of 4 floodplain sections are needed to complete HEC-RAS bridge analysis. The model also fabricates two more sections, BD and BU, located just inside the downstream and upstream bridge face, respectively. Chapter 5 of the HEC-RAS Hydraulic Reference Guide (HRG) contains additional guidelines for locating and modifying each of these sections for effective flow. Appendix B of the HRG¹⁰ also addresses contraction/expansion ratios used in effective flow determination.

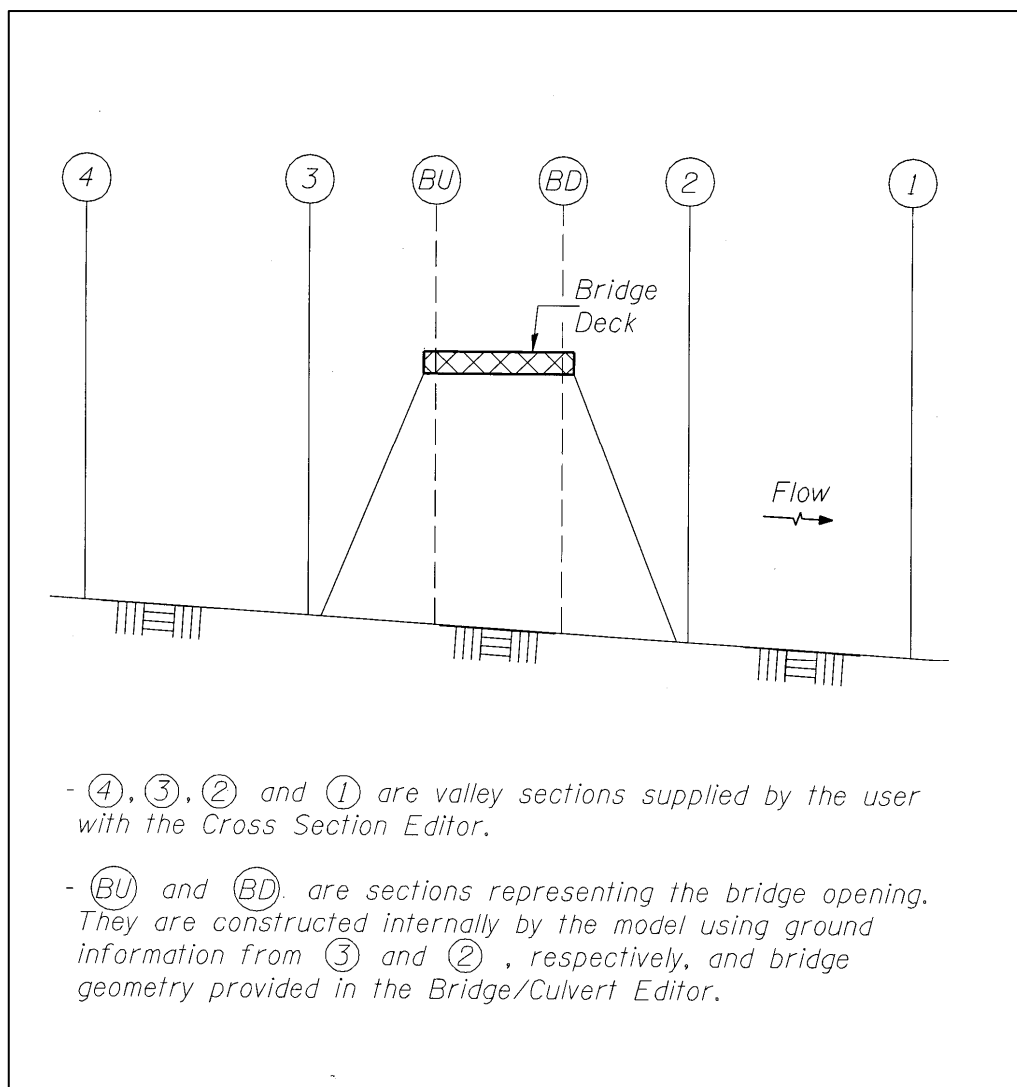

HEC-RAS: Required Sections for Bridge Analysis
Figure 7-102.012a

Sections 1 and 4 are located at areas of full flow; sufficiently removed from the opening so that flow is not affected by the structure. [Figure 7-102.012b](#) is a plan view of a bridge/highway crossing over the floodplain that shows section 4 located at the start of flow contraction and section 1 located at a point where flow has fully expanded to its natural width. Typically, the survey information does not include sections at these precise locations shown here, so the user should propagate or relocate surveyed sections accordingly.

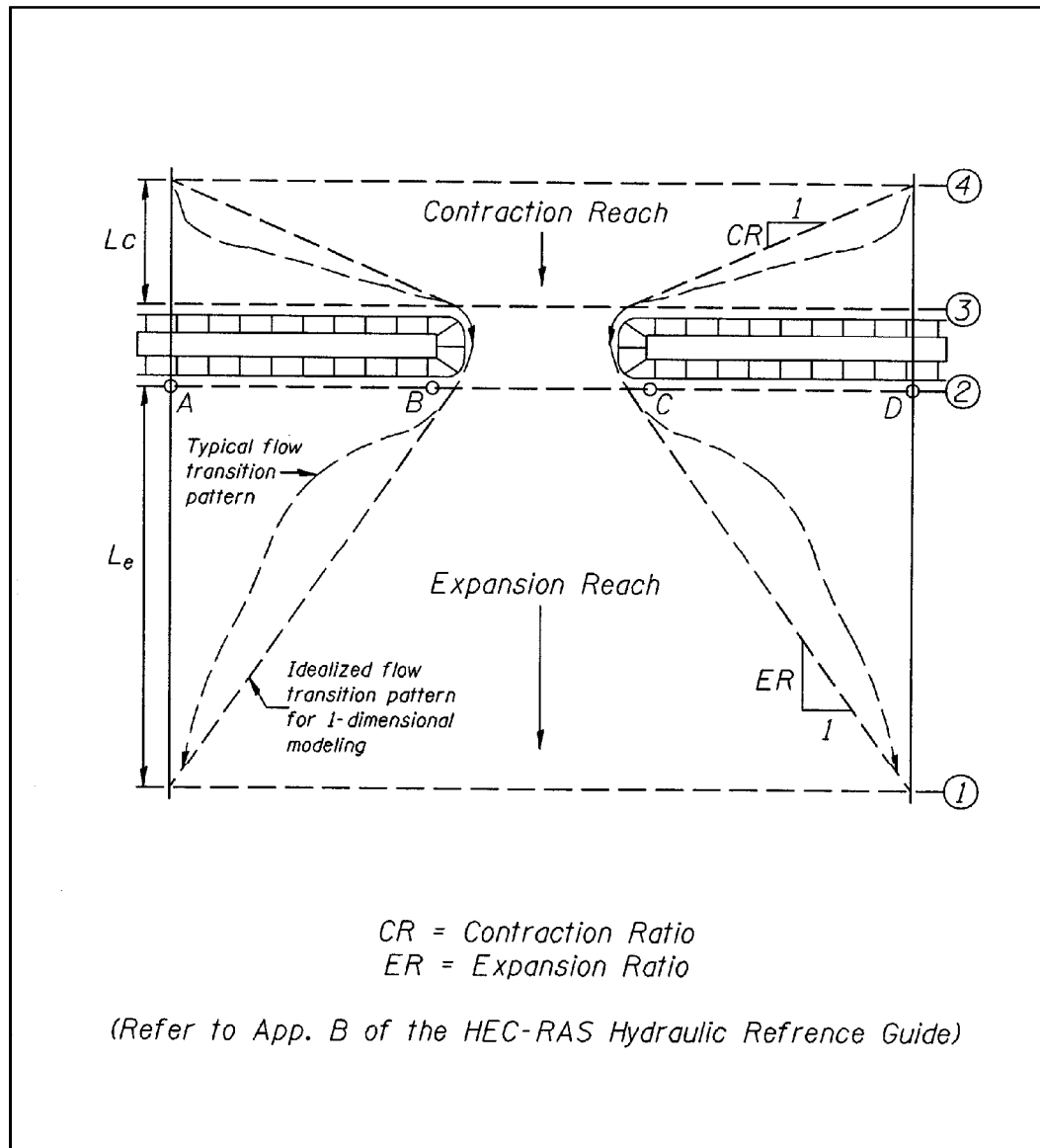

Plan View of HEC-RAS Cross Section Layout for Bridge Modeling
 Figure 7-102.012b

The exact locations of sections 1 and 4 in the model are determined by applying the ratios ER and CR, respectively, as shown in Figure 7-102.012b. Appendix B of the HRG¹⁰ contains tables for determining these ratios, which are dependent on such factors as n-values, stream slope and the degree of constriction. The HRG¹⁰ suggests that 1.0 is a reasonable value for the contraction ratio, CR. However, the expansion ratio, ER, is somewhat more indeterminate and therefore has a greater working range. Table B.2 in the HRG¹⁰ indicates a reasonable value of ER for most IDOT crossings would be 2.0 or lower. Appendix B of the HRG¹⁰ notes that these methods of locating sections 1 and 4 proved valid for asymmetrical floodplains and bridges with vertical abutments. For asymmetrical floodplains, which can also be described as eccentric, the average value of overbank widths AB and CD is utilized to locate distances Lc and Le. It also notes that certain situations such as highly skewed bridges or curving

floodplains were not part of the study that produced these ranges for ratios CR and ER.

Sections 2 and 3 are right at the toe of the highway embankment. The basic package of surveyed sections does not include sections at these locations, so sections 2 and 3 may also be propagated or built from nearby sections. Both sections should utilize the natural channel geometry, not the bridge channel configuration. Since both are adjacent to the bridge opening, flow width for both sections needs to be adjusted to represent only the effective width just downstream and upstream, respectively, of the constriction. Typically, flow limits for sections 2 and 3 are set just outside of the flow width through the bridge itself.

The Hydraulic Reference Guide¹² states the elevations specified for ineffective flow should correspond to elevations where significant flow passes over the bridge. At that elevation and above, the active or effective flow area is greatly expanded.

Sections BU and BD are formulated within [HEC-RAS](#) by combining the bridge geometry (low beam, piers, and slopewall) with the respective bounding cross section. The bridge and roadway geometry are integrated within [HEC-RAS](#) and are coded into the Geometry File starting with the Deck/Roadway Data Editor. Unlike [WSPRO](#), [HEC-RAS](#) requires at least limited roadway data, even if overtopping is not a possibility. The sections BU and BD can be modified by the user to reflect actual geometry under the bridge by using the Internal Bridge Cross Sections option, if significant difference from the bounding cross sections exists.

[HEC-RAS](#) analyses can include surveyed sections (typically those shot one bridge length upstream and downstream) that are within the cones of expansion and contraction. These sections are included in the natural run and should also be coded within the bridge analyses, provided limits of effective flow are identified. Additional sections between 3 and 4 and between 1 and 2 are generally beneficial to the analysis, in that they help to delineate the drawdown curve just upstream or at the constriction and produce a more highly defined backwater curve. This statement is especially true at long structures over wide floodplains, where the spacing between 3 and 4 can be substantial, and at small structures where the affect of drawdown on the backwater curve is more pronounced. Although the location of maximum backwater is typically thought to occur at the point of full-width flow upstream, its location can vary depending on a number of physical factors. The inclusion of additional sections within the bridge cones gives the user more information to compare the natural and bridge-in-place profiles. Additional sections are particularly beneficial when damageable property is present upstream and/or an IDNR-OWR permit is required. [Section 7-106](#) includes additional direction on determining headwater elevations.

7-103 Backwater Computational Routines

Accepted models [WSPRO](#) and [HEC-RAS](#) offer a variety of computational routines for estimating the impact of bridge/highway constrictions on water surface profiles. Each routine constitutes a different method of estimating energy losses through the structure(s), which is the basis for backwater computations. It is generally true that for a particular bridge and roadway alternative, the preferred routine (or routines, in some cases) changes as the flow conditions change. For example, a beams wet, orifice flow condition would typically eliminate the consideration of a low flow, energy balance solution. It follows that the user would select or activate the proper routine

for a given flow condition; even to the point of changing the solution algorithm from the Q_{50} to the Q_{100} event, if changes in flow condition dictate. Within the two models, this is done in slightly different ways.

HEC-RAS allows the user to choose from a menu of backwater solutions that can be simulated within the same analysis, or plan. WSPRO is more labor intensive in this respect, requiring the user to review the initial profile output before fine-tuning the input to activate a different bridge routine and subsequent backwater solution. Available routines from both models are logged in this section, along with instruction and recommendations to assist the user in determining valid backwater profiles.

7-103.01 WSPRO

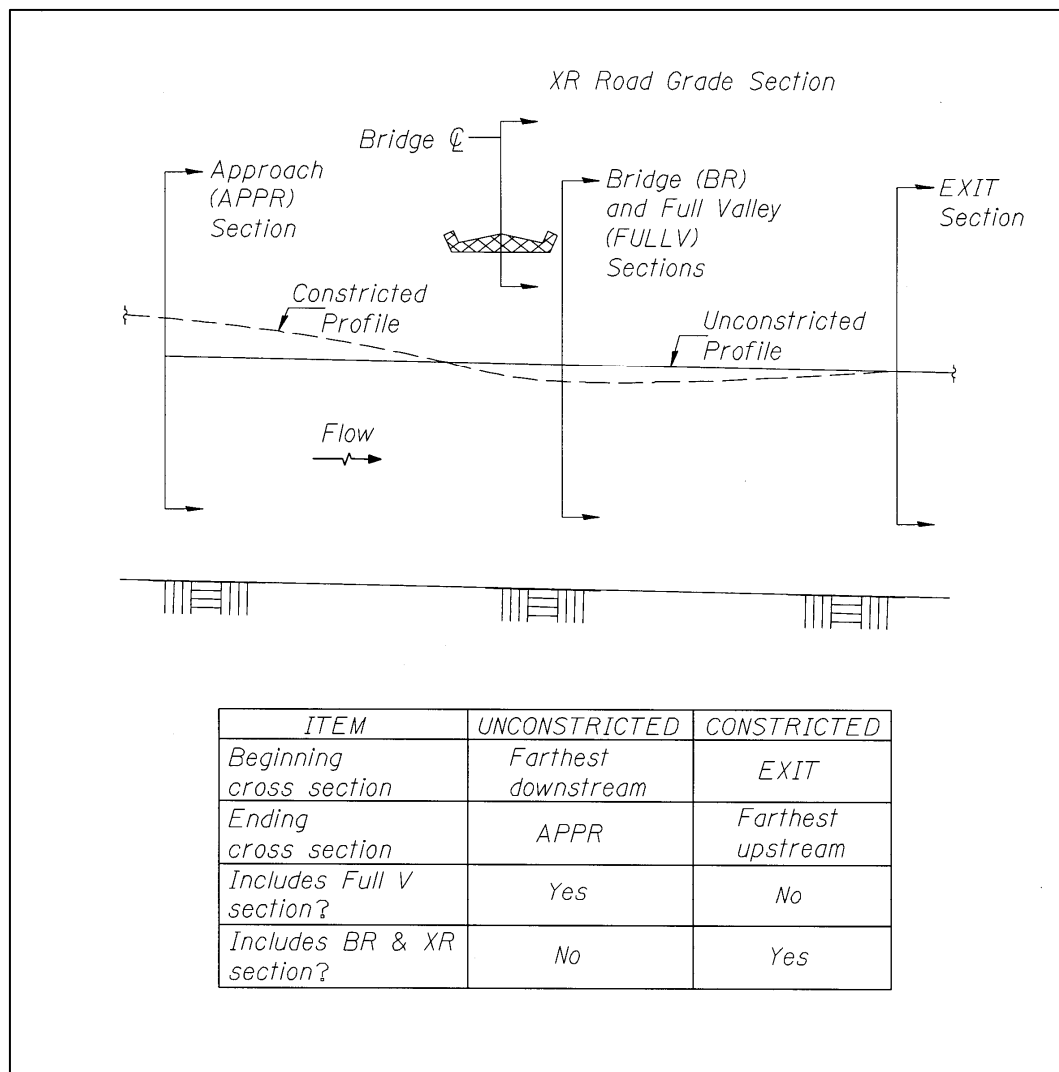

WSPRO: Unstricted and Constricted Profiles
Figure 7-103.011

7-103.011 Unconstricted and Constricted Profiles

As [Figure 7-103.011](#) indicates, the **WSPRO** model produces two separate profiles for each discharge, unconstricted and constricted. The unconstricted profile represents natural conditions without the bridge and roadway. This profile calculation begins at the furthest downstream section and ends at the APPROACH (APPR) section (Refer to [Figure 7-102.011](#) for the cross sections required in bridge analysis and their locations in the model). The second profile generated is the constricted profile, which estimates the backwater created by the bridge and roadway embankment. The constricted profile starts at the EXIT section and extends to the furthest upstream section in the analysis. This calculation omits the FULL VALLEY (FULLV) section and inserts the BRIDGE (BR) and ROAD (XR) sections to represent the bridge opening and profile grade of the roadway respectively. Note that the XR section representing the roadway is optional and can be omitted if there is no possibility of flow over the roadway. Profile solutions at all sections upstream of the APPR section are obtained by the standard step backwater method.

7-103.012 Flow Classes

WSPRO identifies six distinct flow classes, listed in [Figure 7-103.011](#). They refer to the computational methods used to generate the constricted profile at the BRIDGE and APPROACH sections, along with weir flow estimates if the ROAD section is overtopped. Per [Figure 7-103.011](#), constricted profile computations begin at the EXIT section, where the profile starts with a WSEL (water surface elevation) equal to that computed in the unconstricted profile. **WSPRO** bridge analysis always begins the same way, by applying the energy equation between the APPR and EXIT sections flanking the bridge. In [Figure 7-103.012](#), this routine is labeled Flow Class 1, free surface flow without road overflow. In Flow Class 1, the energy equation generates two equations with two unknowns; WSEL at the BR section and WSEL at the APPR section. Initially, the possibility of road overflow is neglected, and all flow is assumed to be passed through the bridge. Key elements in this energy balance are friction losses upstream of the bridge, losses related to the bridge geometry and expansion losses between the BR and EXIT sections. Like the step backwater process between successive floodplain sections, the model uses an iterative solution algorithm. It assumes a trial set of elevations at the two sections of interest, APPR and BR. It then uses the energy balance to generate the WSEL at both of these sections, and compares them to the trial set of elevations. The program allows a maximum of 15 profile iterations to find two successive sets that fall within the solution tolerance. If the WSEL immediately upstream of the bridge, *hus*, remains below both the low beam and the low roadway grade, **WSPRO** will attempt to solve for a Class 1 solution within these 15 iterations. If, at any point in this process, the constricted profile is at or above the low beam ($hus > PFELEV$) or if the roadway is overtopped ($hus > y_{min}$), a different backwater routine is considered from the flow classes listed in [Figure 7-103.012](#) and the iterative process continues.

Flow Classes	Flow Condition at Bridge	Is Roadway Overtopped?	Relative Elevations
①	Free Surface	No ($h_{us} < y_{min}$)	$h_{DS} \& h_{US} < PFELEV$
②	Orifice		$h_{DS} < PFELEV \quad h_{US} > PFELEV$
③	Submerged Orifice		$h_{DS} \& h_{US} > PFELEV$
④	Free Surface	Yes ($h_{us} > y_{min}$)	$h_{DS} \& h_{US} < PFELEV$
⑤	Orifice		$h_{DS} < PFELEV \quad h_{US} > PFELEV$
⑥	Submerged Orifice		$h_{DS} \& h_{US} > PFELEV$

Key:

- WSEL -----Water Surface Elevation
- h_{us} -----WSEL immediately upstream of the bridge.
- h_{DS} -----WSEL immediately downstream of bridge.
- PFELEV---low beam elevation (as coded in BR header record).
- y_{min} -----low point on roadway grade (as coded under XR header record).

Note:

PFELEV replaces the LSEL parameter, which was used in pre-1998 versions.

WSPRO Flow Classes
Figure 7-103.012

WSPRO steps through the flow class hierarchy and selects the appropriate routine for each constricted profile based primarily, but not solely, on these relative elevations.

Output messages document the selection process (see [WSPRO](#)¹¹ User's Manual, Chapter 6) by listing values for the pertinent relative elevations. The messages often indicate that more than one solution was considered along the iterative path to the selected flow class. The flow class number used to build the constricted profile is given within the BR section output.

Flow Class 1 may be described as the default bridge routine. It typically applies to proposed structures on the State system, since IDOT's design policy establishes criteria for minimum low beam clearance and roadway freeboard. Bridge losses in [WSPRO](#) are primarily driven by the gross opening, or bridge length, but are relatively insensitive to total pier blockage or to the opening shape. In addition, the Flow Class 1 solution is very much affected by flow conditions at the upstream APPROACH section. Wide, expansive floodplains with significant overbank conveyance generate a loss contribution that can easily outweigh the impact of small increases in bridge length. In these situations, the user should recognize that backwater is not simply a function of the bridge opening as contraction losses and friction loss upstream of the structure can be inherent within the physical properties of the river system.

Flow classes 2 and 3 both involve pressure flow, or orifice flow. For Flow Class 2, there is beam submergence ($h_{us} > PFELEV$) at the upstream face of the bridge. [WSPRO](#) literature refers to Flow Class 2 as orifice flow and Flow Class 3 as submerged orifice flow because the downstream face is also submerged. In Class 3, both $h_{us} > PFELEV$ and $h_{ds} > PFELEV$. In addition to this qualifier, there is an internal test that triggers either class 2 or 3. [WSPRO](#) computes a ratio of average depth just upstream to hydraulic depth at the bridge (hydraulic depth is the opening area divided by bridge length); a ratio that in effect measures the degree of submergence at the upstream face. So, in addition to beam submergence as measured by these relative elevations, this ratio must be 1.1 or greater to make either of these two flow classes valid. Therefore, the model allows for the possibility that one or both sides of the deck are submerged, but not to a degree of submergence that is sufficient to produce actual pressure flow conditions. In that instance, even with h_{us} and/or h_{ds} above PFELEV, the model reverts to a Flow Class 1 solution.

Flow Classes 4, 5 and 6 are analogous to classes 1, 2 and 3, respectively, with the addition of weir flow over the road. [WSPRO](#) considers all three of these classes as combination flow consisting of two components; flow through the bridge and relief weir flow over the roadway. Class 4 utilizes the Class 1 free surface flow routine for flow through the bridge, while Classes 5 and 6 use the pressure flow routines from 2 and 3, respectively, in the same manner. The initial trial unconstricted profile is still estimated with a low flow (or free surface flow) energy balance solution, which utilizes the entire design discharge. The iterative process described above begins, and Classes 5 or 6 kick in when the WSEL immediately upstream of the bridge submerges the low beam. Concurrently, the model is comparing the WSEL immediately upstream (h_{us}) to the low point on the roadway (y_{min}), as defined under the XR header record. If $h_{us} > y_{min}$, [WSPRO](#) estimates the quantity of weir flow over the road corresponding to h_{us} by applying the standard weir equation. This weir flow component is then subtracted from the design discharge and the remaining discharge is assumed to flow through the bridge opening. [WSPRO](#) uses this remainder between "design Q" and "weir Q" to develop the constricted WSEL's with either the free surface routine (class 4), orifice flow equation (5), or the submerged orifice flow equation (6) in an iterative manner analogous to the solution algorithm for classes 1, 2 and 3. The iterative process is complete when the "bridge flow only" profile at the upstream bridge face matches the elevation used to compute weir flow within an allowable tolerance. The tolerance for

this solution allows for the sum of the combined flow discharges to be within a certain percentage of the design discharge.

It is important for the user to note that in the absence of an XR header record representing the ROAD section, the model cannot simulate over the road flow. Flow classes 4, 5 and 6 can only be utilized when the [WSPRO](#) input file includes the roadway section.

7-103.02 HEC-RAS

[HEC-RAS](#) builds water surface profiles for bridge analyses differently than [WSPRO](#). The model develops one profile for every discharge that includes the bridge and roadway geometry and solves for a single WSEL at each section in the run. [HEC-RAS](#) does not compute an unconfined profile in the same manner that [WSPRO](#) does. Consequently the user must run a separate analysis, or Plan, to build the natural profile upstream of the highway. However, [HEC-RAS](#) offers the user a menu of bridge routines that can all be turned on within the same analysis, potentially reducing the need to revisit input data to activate different backwater solutions. Regarding available bridge routines, the [HEC-RAS](#) model actually utilizes the same equations and solution algorithm as [WSPRO](#) does for a variety of flow conditions. The model is also loaded with the [WSPRO](#) low flow, Class 1 solution, which allows the [HEC-RAS](#) user to duplicate many [WSPRO](#) analyses.

7-103.021 Bridge Modeling Approach Editor

[HEC-RAS](#) lets the user specify which bridge routines the model will utilize during creation of the Geometry File. This allows the user to simulate and view several solutions without changing the bridge/roadway geometry. [Figure 7-103.021](#) displays an example of this pull-down menu box defined as the Bridge Modeling Approach Editor in [HEC-RAS](#).

Bridge Modeling Approach Editor

Add Copy Delete Bridge # 1 ↓ ↑

Low Flow Methods

Use Compute

Energy (Standard Step)

Momentum Coef Drag Cd 2

Yarnell (Class A only) Pier Shape K

WSPRO Method (Class A only) WSPRO Variables

Highest Energy Answer

High Flow Methods

Energy Only (Standard Step)

Pressure and/or Weir

Submerged Inlet Cd (Blank for table)

Submerged Inlet + Outlet Cd 0.8

Max Low Chord (Blank for default)

OK Cancel Help

Elevation to start checking for pressure flow (ft)

Figure 7-103.021

For low flow conditions (water surface below the highest point on the low chord of the bridge opening) the user may select any or all of the four Low Flow Methods. The Editor requires the user to specify the drag coefficient for the Momentum routine, the pier shape coefficient (K value) for Yarnell's equation and a menu of bridge/roadway parameters for the [WSPRO](#) method. (Note the default flow profile for Yarnell and [WSPRO](#) is Class A, denoting subcritical conditions throughout the reach.) This information must be supplied before the model can utilize the method. Turning on the Highest Energy Answer button forces the model to utilize the low flow method that produces the highest estimate of energy losses through the bridge.

For high flow conditions (flows that come into contact with the low chord of the bridge deck and/or overtop the roadway) there are two methods to choose from. For the Pressure and/or Weir method, the coefficient for submerged inlet and outlet must be entered, while the submerged inlet coefficient and maximum low chord have pre-established default values. The model uses the Max Low Chord to begin testing for pressure flow conditions. [HEC-RAS](#) uses essentially the same tests as [WSPRO](#) (see [Section 7-103.01](#) of this chapter) to determine if pressure flow conditions exist and

employs the same equations to generate bridge backwater under orifice flow conditions.

Both the [HEC-RAS User's Manual](#)¹⁰ and particularly the [Hydraulic Reference Guide](#)¹⁰ include excellent background information on all of these routines, including valuable guidance for selecting the appropriate method(s) for various flow situations. Major factors influencing the selection include bridge geometry, pier blockage, flow regime through the opening and the degree of deck/roadway submergence. For the typical structure, IDOT utilizes the Editor as depicted in [Figure 7-103.021](#). The Yarnell equation, which applies to bridges where the majority of energy losses are attributed to the piers, is generally not considered. The other three Low Flow Methods are turned “on”, and the applicability of each method is considered, as is the upstream impact of the respective backwater profiles. In most cases the methods produce relatively similar results and the Highest Energy result can be utilized conservatively for design.

[HEC-RAS](#) documentation suggests that one of the High Flow methods is usually more appropriate than the other for a given discharge and flow depths. For example, the manual suggests a “significant constriction resulting in orifice flow” should utilize the Pressure and/or Weir method. Some of this documentation is built into the model, as it will default to an energy solution if tailwater is high and the roadway is submerged to a certain degree. [HEC-RAS](#) also has a fixed, default solution to a combined flow condition with weir flow over the roadway and free surface flow through the bridge opening (this situation is often described as a perched bridge). In that case, energy is the high flow choice and Yarnell is used to build the low flow profile. When flow conditions do not clearly fall well within the description suggesting one of these two methods, it may be advantageous to run two Plans and study both results.

7-104 Adjusting Input Parameters

When using either [WSPRO](#) or [HEC-RAS](#), there are two common output scenarios that require the user to revisit or troubleshoot the input file. The first occurs when the model is unable to develop the constricted profile through the bridge. Frequently, this occurs on small streams, with steep slopes and closely spaced sections. Steep reaches at or near critical slope may cause the model to default to critical depth at any of the sections involved in the bridge analysis. Critical depth “solutions” are also common when flood flows are at or near bank-full elevation and minor changes in depth cause great variation in flow width between successive sections. Output messages (see Chapter 6 of the [WSPRO User's Manual](#)¹¹ and Chapter 10 of the [HEC-RAS Manual](#)¹²) document the unsuccessful process, culminating in a message stating that profile computations are terminated. In the absence of input coding errors, the problem typically involves major differences in section geometry or conveyance characteristics between sections in close proximity to the bridge in question. Reasonably minor revisions to section shape, subarea breakdown, thalweg elevation, n-values, etc., may allow the solution algorithm to produce a valid profile. Additional sections that reduce the flow length between sections also help enable valid profile solutions.

If the bridge analysis is terminated with roadway overtopping, the problem most likely involves the difficulty in obtaining an accurate estimate of weir flow. Very often in this situation, discharge over the road is overestimated and discharge through the bridge is reduced to a level where an equivalent WSEL upstream for the two flow components is unattainable. Low traffic volume roads on the secondary or local system often display this attribute, particularly when a perched bridge is flanked by low-lying approach pavement. Again, each model provides messages to this effect,

like [WSPRO's](#) message 265: "Road overflow appears excessive". [HEC-RAS](#) recognizes a similar situation by defaulting to the energy equation when the degree of submergence reaches a certain value\percentage. In situations like these, when the model indicates that a very high percentage of flow is overtopping the roadway, the user needs to consider how realistic the flow breakdown is and use judgment to gradually adjust the weir flow component to improve the simulation. The user should also recognize that sufficient tailwater depth and submergence of the roadway can indicate the roadway is not functioning as a weir, but as a conveyance-based floodplain section. Couple this with low flow through the bridge opening and it can be concluded that the bridge and roadway are not acting as a constriction in the conventional sense, but rather as another floodplain cross section. This conclusion would lead to modeling the bridge/roadway as a conveyance section (energy balance solution) with the appropriate effective areas redefined and the bridge superstructure removed from the geometry (Note that [HEC-RAS](#) defaults to this solution when submergence reaches a specified limit; while [WSPRO](#) does not). This type of alternative analysis can then be compared to a conventional analysis and historical results to determine its appropriateness.

Another common scenario causing the user to revisit the input data centers around model sensitivity. In this instance, like the first scenario, the model may be unable to develop the constricted profile. More typically, the model is able to find a solution, but WSEL's are so close to low beam and/or the low road grade that a very slight variation in water surface elevations (i.e., flow conditions) would trigger the selection of a different flow class. The user should recognize that each of the six [WSPRO](#) flow classes and all of the [HEC-RAS](#) routines represent a unique estimate of the impact of the bridge and roadway on the water surface profile. Both models' level of precision is such that small input changes like introducing higher n-values or a flatter starting slope may produce significant changes in natural and headwater elevations. Consequently, some solution(s) may be considered borderline, and there may be a gray area around the "correct" solution. The user should consider each model's sensitivity to key input parameters such as low beam elevation, which essentially controls the elevation above which orifice flow conditions occur. Both models allow the user to explicitly define this testing elevation, and in fact, both models use the same criteria to determine if sufficient submergence exists to create pressure flow conditions. When working with these gray area solutions, the [WSPRO User's Manual](#)¹¹ goes so far as to state the user may "mislead" the model by coding a PFELEV value slightly higher or lower than the actual low chord elevation to dictate the flow class that is computed. This technique will generate multiple solutions with varying backwater estimates. Profiles obtained in this manner need to be studied closely before the user can select one constricted profile for design purposes.

7-105 Special Bridge Problems

Bridge hydraulics are often affected by the presence of other openings in close proximity to the bridge under analysis. Additional openings near the subject bridge complicate the backwater calculations described previously.

The most common scenario involves a nearby bridge or culvert over the same channel. Downstream openings can control tailwater depths at the subject structure and modify "natural" expansion/contraction patterns. Upstream openings generally have a smaller impact, but also influence flow patterns by contracting the natural floodplain. Both of these can affect the water surface profiles at the subject structure.

It is difficult to provide a maximum distance from the subject structure beyond which other structures can be excluded from the analysis. For a typical flat stream reach on a larger watershed, backwater can project upstream for several thousand feet. However, for a small,

steep basin, backwater effects can dissipate over several hundred feet. Judgment should be utilized to ensure that all structures of influence within the reach are surveyed and included in the water surface profile analysis, as described in [Chapter 2](#).

For these situations, the typical "stand-alone" bridge analysis must be modified to include the effects of local structures that span the same channel or share a common floodplain. The modeling techniques required to do this vary depending on the model chosen. [Sections 7-105.01 through 7-105.03](#) provide guidance for applying IDOT accepted models to common situations.

7-105.01 Dual Bridges

Dual bridges are defined as bridges of essentially identical design placed in such close proximity that there is virtually no expansion/contraction of flow between the structures. For example, IDOT typically constructs dual bridges at interstate crossings, many of which have continuous slopewalls between the structures. Due to increased bridge width, backwater resulting from dual bridges is naturally larger than that attributed to a single bridge of identical waterway opening. Yet, created head attributed to dual structures is less than the value resulting from considering two equivalent bridges in series, since there are typically minimal expansion/contraction losses between dual bridges. Normally, dual bridges should be modeled as a single bridge reflecting the total out-to-out width of both structures.

In [WSPRO](#), this means coding an appropriate bridge width on the CD record. The APPROACH section is located one bridge length upstream from the upstream face of the bridge furthest upstream. In terms of section reference distance (SRD) within the model, the APPROACH section will be spaced (1 bridge length) + (1 bridge width) upstream from the common SRD shared by the FULLV and BR sections.

The [HEC-RAS](#) cross section locations shown in [Figure 7-102.012a](#) for a single bridge analysis are still applicable for a dual bridge analysis. For the natural analysis, no section representing the median section between the bridges should be included. [HEC-2](#) is similar to [HEC-RAS](#) in the location of cross sections for a dual bridge analysis.

The [WSP-2](#) model has limited capacity for quantifying the backwater impact of dual bridges since bridge width is not included among the input variables describing the bridge geometry.

7-105.02 Closely Spaced Bridges

"Closely spaced" bridges are not dual structures, but are close enough to each other that backwater from the downstream opening impacts the upstream structure performance. These bridges are spaced such that expansion/contraction of flow does occur, but only to something less than the natural, fully expanded width. An example would be a railroad structure and embankment just downstream of an IDOT crossing. Typically, this situation can be modeled as two bridges in series with some adjustment of the valley sections between openings to account for the lack of full expansion/contraction of flow.

[WSPRO](#) sections are dependent upon the spacing between structures ([Figure 7-105.02](#)). If the spacing between structures is greater than the sum of their respective lengths, then [WSPRO](#) can model two (or more) bridges in one run with little modification. The structures are modeled in succession, following the input and section location conventions for each structure.

For bridges whose spacing is at or near the sum of the two structure lengths, WSPRO coding must be adjusted. One section between bridges serves as both the APPROACH section for the downstream opening and the EXIT section for the upstream opening. Remember that WSPRO does allow some deviation from the “one bridge length” requirement for EXIT and APPROACH.

WSPRO becomes more tedious when two bridges are rather closely spaced; when $W > L_1 + L_2$ as shown in Figure 7-105.02. In that instance, one section cannot serve as both APPROACH and EXIT section without violating the model's cross section location requirements. Then, two separate runs are needed. The first estimates backwater from the downstream bridge while excluding the upstream bridge from the analysis. Valley sections in this run may need to be adjusted to account for the "spur dike" affect of the upstream bridge, which generally constricts the natural floodplain. The second run starts at a valley section between the structures with starting water surface elevations generated by the first analysis.

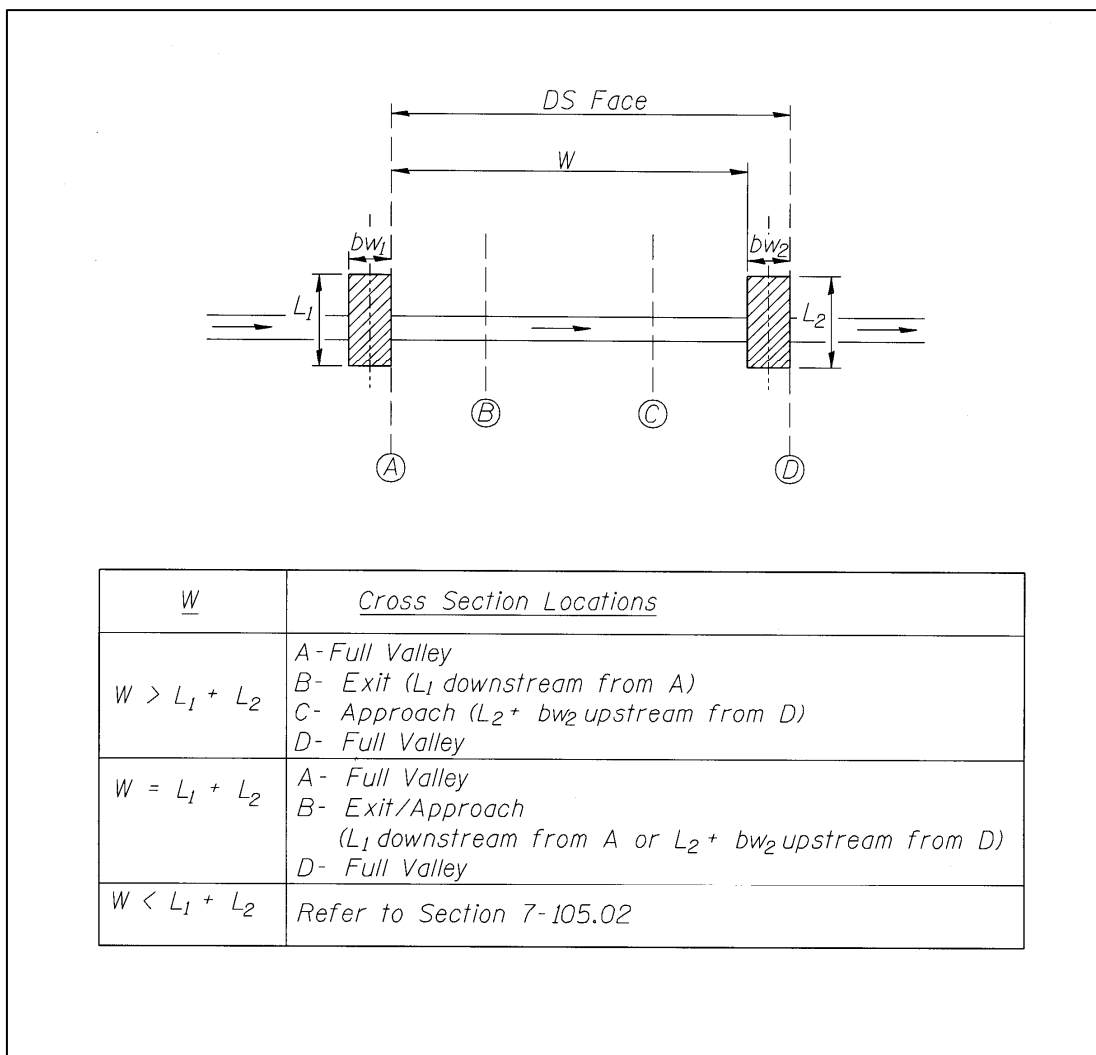

WSPRO Cross Section Locations for Closely Spaced Bridges
Figure 7-105.02

HEC-RAS and **HEC-2** are easier to apply to this situation. There are no specific cross section requirements between bridges, so one surveyed section could suffice. However, the section(s) between openings need to be modified to identify areas of ineffective flow outside expansion/contraction limits and expansion/contraction coefficients may need adjustment.

WSP-2 works in similar fashion as **HEC-RAS** or **HEC-2** when bridges are in series. Obviously, closely spaced bridges dictate closely spaced cross sections, regardless of the model used. Care should be taken with **WSP-2** to ensure that flow between adjacent sections does not violate physical limitations. Since the model provides little output commentary, take steps to ensure your results make good sense; check top widths, conveyance ratios, and changes in the profile between successive sections. **WSP-2** performs a less sophisticated, single section bridge analysis. The limitations of that methodology are accentuated by the presence of additional bridges.

7-105.03 Multiple Openings

The phrase multiple openings refers to two or more openings sharing a common upstream floodplain under flood conditions. Relief, or overflow structures in the overbank accept a portion of the flow in order to improve flow characteristics through the main bridge. Typically, these overflow openings are needed at highway crossings over wide floodplains of fairly large river systems. The key to multiple opening analysis becomes determining the flow breakdown to the respective openings.

WSPRO splits the flow according to the upstream floodplain geometry, spacing between openings, and the respective opening sizes. Individual profiles are generated for each opening until there is reasonable agreement at the upstream APPROACH section. The final product is a common water surface profile for the system, and respective discharges and velocities through each opening. Because the model is analyzing openings separately, it can work with different flow types. For example, the user can model free surface flow through the main bridge while the overflow bridge is in orifice flow.

WSPRO can handle up to 3 openings (with the overflows flanking the main bridge) simultaneously. The overflow openings can be modeled as culverts, but not the main channel structure. All multiple box openings must be represented as a single box and it is recommended that only openings handling 10% or more of the total flow be included in the analysis. Some elimination or consolidation of openings may be required to work within these constraints.

HEC-RAS has two ways to handle this type of problem. The first, more commonly applied method is to use the multiple opening capabilities. The second method is to model the two openings as divided or split flow.

The multiple opening feature in **HEC-RAS** is based upon the **WSPRO** multiple opening routine, with some enhancements. It can handle up to 3 types of openings (bridges, culverts and conveyance areas) and up to 7 openings at any one floodplain crossing. The approach used in **HEC-RAS** is to evaluate each opening as a separate entity. An iterative solution is applied, in which an initial flow distribution is developed based on the percent of flow area in each opening. The computed upstream energies for each opening are compared to see if they are within a specific tolerance. If the difference in energies exceeds the tolerance, the program makes a new estimate of the flow distribution through the openings and repeats the process. This iterative technique continues until either a solution falling within the tolerance is achieved, or a predefined number of iterations are reached.

HEC-RAS also has a second approach for solving a multiple opening problem, a split flow model. This approach models the flow paths of each opening as a separate river reach. This method is more time consuming and requires the user to have a greater understanding of how the flow will separate between openings. The benefit of using this approach is that independent varying water surfaces and energies can be obtained between openings. When modeling divided flow, the user must define the portion of total flow going through each reach. Manual adjustments in the flow distribution are made until the energies from both branches are within a reasonable tolerance. This method requires the user to define the flow path for each opening as a separate reach and should be used only when the user feels that there is a physical feature between the structures that would cause such a division of flow. Both HEC-2 and WSP-2 are much less applicable to multiple opening analyses than either WSPRO or HEC-RAS. HEC-2 use should be limited to normal bridge analysis, since the special bridge record can only specify one trapezoidal opening. Normal bridge analysis works with the standard step energy balance, and it is therefore applicable when all openings are operating under low flow conditions. In this mode, the roadway embankment with multiple openings is modeled as a conveyance section.

WSP-2 cannot be utilized for multiple opening analysis. The model has no documented multiple opening features.

7-105.04 Coincidental Tailwater Conditions

Section 7-106 Natural Highwater and Headwater Elevations discusses how natural and headwater elevations are determined for bridge hydraulic design under a variety of floodplain conditions. The most common floodplain element that complicates the modeling and design is an encroachment across the floodplain downstream from the subject structure. The most typically encountered encroachment is a bridge or culvert roadway or railway stream crossing. This section addresses another common floodplain condition of note that is not covered within Section 7-106; the presence of a receiving stream some distance downstream from the subject structure that impacts or affects the water surface profiles or flood conditions at the subject structure. This is referred to as a tailwater (TW) condition. IDOT bridge hydraulic design must account for the possibility of concurrent or coincidental flooding on both systems.

The first step in accounting for the receiving stream is developing the water surface profile on the subject reach for all events of interest ignoring any possible tailwater influence due to the receiving stream. This analysis is labeled the “natural condition”. It includes downstream floodplain encroachments (bridges, levees, etc.) and typically utilizes normal depth as the starting water surface elevation at the farthest downstream cross section. At the typical bridge crossing, coincidental flooding becomes a factor when flood depth (TW) on the receiving stream for the given event\discharge of interest (Q_{10} , Q_{50} , Q_{100} , Q_{500} or Q_{OVT}) exceeds the water surface elevation at the farthest downstream section for the same respective event\discharge.

The following are elements of bridge hydraulic modeling and design impacted by coincidental flood affects. Included with each element are brief comments on how their determination is affected.

Starting water surface elevation at the most downstream cross section Generally the Q_{10} WSE on the receiving stream is utilized for comparison to normal depth for all events of interest. This approach is standard but other conditions may be modeled or considered as appropriate- such as concurrent equal events (Q_{10} TW w/ Q_{10} event, Q_{50} TW with Q_{50} event,

etc.) for equal-sized watersheds. To simulate the worst case backwater scenario at the subject structure, IDNR-OWR has suggested starting the Q_{10} event on the subject stream with the Q_{100} TW **and** modeling Q_{100} with Q_{10} TW.

Natural highwater The natural condition analysis as described here accounts for the TW affect D\S. That analysis is the source for natural highwater elevations shown on the WIT. Q_{50} natural from the WIT is then compared to Q_{50} TW on the receiving stream. For purposes of applying the design beam clearance policy, the higher of the two elevations controls.

Created head and headwater elevation Existing and proposed bridge and roadway configurations are added to the natural conditions analysis as described here. Created head and headwater elevations on the WIT are determined per the direction in [7-106.02 Headwater](#). Q_{50} headwater elevation from the WIT is then compared to Q_{50} TW on the receiving stream. For purposes of applying the roadway freeboard policy, the higher of the two elevations controls.

The hydraulic designer is encouraged to consult District or BBS Hydraulics for direction for any of these items, but particularly for projects involving IDNR-OWR Individual or 3708 Floodway permits. For those projects, the source of water surface elevations and the modeling requirements can be very site-specific. [Section 2-601.01 Hydraulic Report Content](#) (4b WIT) and [Section 5-400 Stream Analysis](#) also contain applicable direction.

7-106 Natural Highwater and Headwater Elevations

Natural highwater and bridge backwater shown on the waterway information table (WIT) should be determined in a manner consistent from site to site and model to model. The WIT includes three parameters (natural highwater, head and headwater elevation) that quantify the structure's impact on flood profiles. The WIT also documents the effective waterway opening provided by the existing and proposed structures. Per direction in [Section 2-601.01 Hydraulic Report Content](#), natural highwater for all bridge structures should be computed at the upstream bridge face. The waterway opening is the effective bridge opening; i.e., cross-sectional area; below the respective natural highwater elevation for each event. Bridge backwater, or head, is estimated at a representative upstream cross section, typically located at a point of fully expanded flow. [Section 7-106.02 Headwater](#) discusses project factors that may dictate the use of a section other than the point of fully expanded flow (section 1 in [Figure 7-102.012b](#)) for computing created head using HEC-RAS. The head, or created head, is then added to the natural highwater elevation to produce the headwater elevation attributed to the opening. This section provides a description of what constitutes natural highwater and headwater elevations, along with direction for extracting both from computer models.

7-106.01 Natural Highwater

Natural highwater estimated at the upstream face of the bridge structure is taken from what is referred to as the natural condition profile. As explained in [Section 2-402.02 Stream Survey Data](#), the natural profile typically begins 1000 feet downstream from the subject structure, but is extended further downstream to include any man-made or natural floodplain features that influence tailwater conditions at the subject structure. The natural profile shall exclude the subject bridge(s) and roadway embankment, but includes downstream floodplain constrictions; features such as bridges, culverts, roadways, levees/berms, embankments, stormwater control structures, etc. The natural profile also accounts for the tailwater impact due to concurrent or coincidental flood events on receiving streams. See [Section 5-400](#)

[Stream Analysis](#) and [7-105.04 Coincidental Tailwater Conditions](#) for modeling techniques that account for high tailwater on receiving streams.

The natural profile described in this manner is utilized in the process of addressing design constraints regarding low beam clearance and roadway freeboard criteria. Consequently, the natural profile as described here and the ensuing headwater calculations derived from this natural profile shall be the basis of the waterway information table shown on the TSL Plan and design plans. This statement holds true regardless of the need for additional natural condition analyses (described below) required to simulate worst-case scour conditions or to satisfy IDNR-OWR construction permit criteria.

A good percentage of IDOT bridge and culvert crossings are affected by tailwater impacts caused by downstream structures and/or receiving streams, particularly in urban settings. Downstream influences of this nature complicate the determination of what constitutes “natural” conditions at the subject structure. Typically, they create the need for additional analysis (beyond that prescribed in the previous paragraph) for purposes of improving hydraulic/scour design, identifying the “worst-case” headwater conditions, and satisfying IDNR-OWR permit criteria. This additional analysis should include a simulation referred to as the headwater flood; a scenario that assumes the downstream receiving stream is not experiencing coincidental flood conditions. In this scenario, starting water surface elevations on the subject stream are determined according to [Section 5-402](#). Although not utilized for design purposes (e.g., required waterway opening or low beam clearance) per se, the headwater flood is typically the critical flood condition for scour evaluation per [Sections 7-001.02](#) and [7-001.03](#). Variations on the headwater flood scenario may also include the removal of any or all man-made constrictions in the downstream floodplain, depending on their nature, impact and relative permanence. For example, the modeler may want to simulate the removal or expansion of a restrictive railroad structure just downstream of the subject highway embankment. The removal of any or all downstream constrictions should also be modeled with both low tailwater and coincidental flooding if a receiving stream is present. As the next paragraph outlines, a scenario that models flood flows with all man-made bridges and constrictions removed from the downstream floodplain is typically required to demonstrate compliance with IDNR-OWR individual permit criteria.

It should be noted that IDNR-OWR’s definition of natural conditions can vary significantly from IDOT’s working definition stated here. For purposes of regulating construction in the floodplain and in the absence of a regulatory study, they interpret natural conditions as essentially the removal of nearly all man-made constrictions from the floodplain. There has been some leeway in their interpretation. For example, well established, long-term levee systems are generally included in the natural conditions model. However, by comparison with IDOT’s working definition, IDNR-OWR’s definition of the natural profile can produce notably lower natural highwater elevations when constrictions downstream of the subject crossing are present. For projects requiring an Individual Permit from IDNR-OWR at locations within the influence of downstream man-made and/or natural floodplain constrictions, early coordination with IDNR-OWR and BBS Hydraulics is encouraged to discuss and determine appropriate construction of the natural profile.

To summarize, the typical natural profile for IDOT bridge and highway design shown on the approved waterway information table (WIT) accounts for any and all permanent downstream tailwater impacts. The natural profile as described in this manner and the design tailwater elevations on the receiving stream form the basis for clearance and freeboard design considerations. The headwater flood for purposes of scour evaluation assumes low tailwater conditions on the receiving stream and the removal of any downstream constriction(s) that

the user can justifiably neglect. IDNR-OWR's definition of natural conditions more closely resembles the headwater flood scenario than IDOT's working definition. Multiple additional scenarios with and without any downstream constrictions are useful for comparison to the natural condition as defined by IDNR-OWR (for individual or regulatory permit purposes) and also as the basis for estimating the potential "worst-case" created head upstream of the subject structure for any foreseeable tailwater condition. For further direction regarding complex tailwater impacts; particularly for structures requiring an IDNR-OWR individual permit; the user is encouraged to contact the District Hydraulic Staff or the Bridge Office Hydraulics Unit.

Computer models employed by the Department can be utilized to produce natural highwater elevations for the waterway information table according to these guidelines:

WSPRO uses the term "unconstricted profile" to describe the natural profile. As [Figure 7-103.011](#) indicates, this profile excludes the bridge (BR) and roadway (XR) header records that represent the subject crossing. The unconstricted profile provides water surface elevations for the FULLV section located at the downstream face of the bridge and the APPR section ([Figure 7-103.011](#)). Interpolate between these two elevations to determine the natural highwater elevation at the upstream face. The bridge width input from the CD record under the BR header record is the distance from downstream to upstream face. Note that this distance may need to be adjusted for a skewed structure.

HEC-RAS input is more adaptable to this purpose. A surveyed or propagated floodplain section can be located right at the upstream face of the bridge opening. Natural highwater elevations are taken directly from the natural profile at this section. If the natural run does not include a valley section at the upstream face, interpolate a water surface elevation at the upstream face from the two closest bracketing sections.

Again, **HEC-2** is similar to **HEC-RAS**. Natural highwater can be taken from the section at the upstream face or generated at this location in the same manner as with **HEC-RAS**.

In **WSP-2**, the bridge section is considered by the model to be at the roadway centerline. Output at this section (under the TW column) represents the natural highwater elevation at the centerline. This elevation should be adjusted in a manner similar to that described in **WSPRO**. Develop a slope from the profile downstream of the bridge, multiply this by one-half of the bridge width, and add this adjustment to the figure shown in the TW column. The sum represents the natural highwater at the upstream face.

7-106.02 Headwater

The headwater elevation shown on the waterway information table (WIT) is the sum of the natural highwater elevation and created head for the given event. Created head, head loss, or simply "head" as labeled on the WIT, represents an increase in the upstream water surface attributed to the subject structure. The increased depth is the physical manifestation of the energy required to contract flow upstream, pass the design event through the structure/over the roadway and expand flow back to its natural, fully expanded width at some point downstream. Consequently, head loss for a given discharge is primarily a function of waterway opening and the opening configuration/roadway geometry. However, the variety of backwater routines available in **HEC-RAS** and **WSPRO** would suggest it is important to recognize physical and flow-related factors such as floodplain width, ground cover, tailwater depth, flow conveyance distribution across the floodplain or the presence of relief opening provided by overflow structures. In recognition of the many contributing factors, backwater

programs like [WSPRO](#) and [HEC-RAS](#) contain a variety of bridge routines and modeling tools that allow the user to generate the most accurate estimate of created head.

Typically, the subject structure and roadway embankment is inserted into the natural profile to determine created head. Regardless of the model employed or the bridge backwater routine selected, there is an IDOT convention for the cross section location where the estimation of head is typically taken from; that is the upstream section where flow is still considered to be fully expanded. The backwater impact of the structure and roadway embankment is considered to be maximized at or near this section. At the fully expanded section, head for a given event is the difference between the respective water surface elevations generated by the run with bridge and roadway in place and the natural conditions run. Exceptions to this practice are discussed below.

The WIT convention of taking head from the fully expanded section (valley section 4 in [Figures 7-102.012a](#) and [Figure 7-102.012b](#)) is intended to maintain consistent practice around the state, uniformity in IDOT hydraulic design and agreement with IDNR-OWR regulatory policies. However, it should be recognized that created head will not necessarily be maximized at this section. Sections both inside the cone of contraction and upstream of the fully expanded section may register greater created head. The hydraulic engineer should apply judgment to design recommendations when sections other than the fully expanded section produce significantly higher created heads- particularly for projects with roadway overtopping or sensitive upstream floodplains. The maximum created head is shown on the WIT- regardless of section location- and the WIT Q_{50} headwater is utilized for roadway freeboard criteria. However, design recommendations relating to the upstream floodplain should utilize the appropriate headwater elevations. For example, headwater elevations at sections adjacent to buildings or structures in the upstream floodplain may be better indicators of potential damage to sensitive flood receptors. Therefore, it is good practice to estimate and document created head at all sections upstream of the subject structure. The most common application of this information is compliance with IDNR-OWR permit criteria, which includes head limits at two sections (fully expanded section and 1000 feet upstream) and an assessment of potential damages at all upstream sections.

As stated above, the IDOT convention for estimating head shown on the waterway information table (WIT) attributed to the subject structure involves the insertion of the subject structure and roadway into the natural run. However, just as for natural conditions analysis, the presence of downstream constrictions that affect tailwater at the subject structure can complicate the analysis required. Typically, backwater due to downstream constrictions has a cumulative impact on the water surface profile; in that increased tailwater at the subject structure generally translates into increased headwater profiles upstream. It should therefore be recognized that headwater upstream of a less restrictive, non-controlling subject structure may in fact be controlled by more restrictive downstream structure(s). In those situations, it may be necessary to produce additional simulations that produce alternative water surface profiles upstream for purposes of comparison with the typical, conventional estimation of created head and headwater. One common instance where additional modeling is beneficial involves the IDNR-OWR construction permit. Their permit rules allow the applicant to demonstrate created head in various ways, depending on the permit type and the potential for damage to upstream properties. One of those ways involves IDNR-OWR's natural conditions profile, which removes all man-made floodplain constrictions as described in [Section 7-106.01](#). The analysis consists of placing the subject structure and roadway into IDNR's natural run. Since IDNR's natural profile is typically below IDOT's, which includes downstream constrictions, the created head and headwater elevations produced in this scenario should differ from those produced in the conventional manner described here.

It should be noted that the user should also consider the head attributed to the subject structure if it is likely that natural conditions reflected on the WIT could be altered, as mentioned in the previous Section. Common examples would include the scheduled removal or improvement of a downstream structure resulting in reduced tailwater, or the assumption of non-coincidental flooding (low tailwater conditions) on a receiving stream.

In summary, created head on the WIT is typically taken from the section where flow is fully expanded. Consideration and documentation of the backwater impacts at other upstream sections is warranted when valuable properties are present or if an IDNR individual permit is required. Backwater determination for IDNR purposes can differ from IDOT's conventional, working definition. For that purpose, the user may need additional analysis to demonstrate compliance with permit criteria. The user also needs to recognize the potential controlling impact of downstream constrictions and should produce additional analyses as required to improve the hydraulic recommendations at the subject structure. Finally, as with the natural conditions run, the user should consider headwater conditions upstream of the subject structure for any foreseeable scenario that could alter the natural conditions profile, such as the removal of a downstream structure.

Computer models employed by the Department can be utilized to produce created heads for the waterway information table according to these guidelines:

WSPRO provides an estimate of backwater, or created head, at the APPROACH section ([Figure 7-103.011](#)). The model assumes fully expanded flow upstream of the APPROACH section in that the contraction cone begins here, one bridge length upstream. At the APPROACH section, created head is the difference between the unstricted and constricted water surface elevations. This increase in water surface elevation is recorded as head on the WIT. (Note that the **WSPRO** constricted profile extends to the furthest upstream section. However, the unstricted profile shown in [Figure 7-103.011](#) does not extend upstream of the APPROACH section. If the user desires created head estimates at sections further upstream, an additional run with the BRIDGE and ROAD records removed would be needed to produce natural water surface elevations for comparison).

To generate headwater within **HEC-RAS**, the created head should be calculated at the approach section, or cross section 4 ([Figure 7-102.012a](#)). As with **WSPRO**, created head is the difference in water surface elevations at cross section 4 between the natural and bridge-in-place runs. Again, created heads at other upstream sections may exceed the created head at cross section 4 and should be taken into account when meeting IDNR-OWR permit criteria or when upstream property is affected by the higher headwater elevation. To ensure consistency and to develop uniform analyses, etc., head from cross section 4 shall typically be shown on the WIT.

HEC-2 created head is determined in the same way as with **HEC-RAS**; typically it is extracted from the bridge in place run at cross section 4.

Working in **WSP-2**, the created head due to the structure can be taken directly from the HL column on the output table for the bridge section. It represents head loss, or created head at the structure.

7-200 INLET SPACING FOR APPROACH PAVEMENTS AND BRIDGE DECKS

All bridge decks and approach pavements need to be evaluated for proper runoff collection and drainage. This evaluation consists of identifying the need for, type and location of inlets both on the structure itself and within the limits of the approach pavement. Since this evaluation does not contribute to the preliminary determination of the proposed waterway opening and the minimum roadway grade, the work is not included within the scope of the Hydraulic Report. Accordingly, the evaluation of bridge deck drainage is excluded from the itemized list of design considerations in [Section 7-001](#) of this chapter.

Deck drainage evaluation is part of the TSL Plan preparation and is therefore completed or reviewed by the TSL consultant \ Planning Unit within the Bridge Office. Direction for completing the evaluation comes from two primary sources; this Manual and the IDOT Bridge Manual³. The Bridge Manual contains practices and procedures utilized during TSL completion in [Section 2.3.6.1.8 Bridge Deck Drainage](#). [Section 3.16 Design Guides](#) contains the Bridge Scupper Placement design guide, a procedural outline and example for scupper placement. The Bridge Manual material is supplemented by policy and direction within [Chapter 1, Section 1-304.02 Bridge Deck Drainage](#) of this manual. Another useful resource within this Manual is a procedure for estimating pavement runoff and spacing inlets; see [Chapter 8, Section 8-200 Location and Spacing Inlets](#). Finally, an excellent overall reference and source of much of IDOT's general direction is the FHWA's manual entitled [HEC No. 21, Design of Bridge Deck Drainage](#)⁴.

7-300 REFERENCES

1. American Association of State Highway and Transportation Officials (AASHTO). *Model Drainage Manual*. 1999.
2. U. S. Department of Transportation, Federal Highway Administration. *Hydraulics of Bridge Waterways*. Hydraulic Design Series No. 1 (HDS 1), 1978. (<http://www.fhwa.dot.gov/engineering/hydraulics/pubs/hds1.pdf>)
3. Illinois Department of Transportation, Bureau of Bridges and Structures. *Bridge Manual* (<http://www.dot.il.gov/bridges/brmanuals.html>)
4. U. S. Department of Transportation, Federal Highway Administration. *Design of Bridge Deck Drainage*. Hydraulic Engineering Circular 21 (HEC 21), 1993. http://www.fhwa.dot.gov/engineering/hydraulics/library_listing.cfm
5. Illinois Department of Natural Resources, Office of Water Resources. *Floodway Construction in Northeastern Illinois*. Title 17: Conservation, Chapter 1: Department of Natural Resources, Subchapter H: Water Resources, Part 3708, Adopted November 29, 1988. (<http://www.ilga.gov/commission/jcar/admincode/017/01703708sections.html>)
6. U. S. Department of Transportation, Federal Highway Administration. *Evaluating Scour at Bridges*. Hydraulic Engineering Circular 18 (HEC 18), 2001. (<http://isddc.dot.gov/OLPFiles/FHWA/010590.pdf>)
7. U. S. Department of Transportation, Federal Highway Administration. *Stream Stability at Highway Structures*. Hydraulic Engineering Circular 20 (HEC 20), 2001. (<http://isddc.dot.gov/OLPFiles/FHWA/010591.pdf>)
8. U. S. Department of Transportation, Federal Highway Administration. *Bridge Scour and Stream Instability Countermeasures Experience, Selection, and Design Guidance*. Hydraulic Engineering Circular 23, (HEC 23), 2 volumes, 2009. (<http://www.fhwa.dot.gov/engineering/hydraulics/pubs/09111/09111.pdf>)
(<http://www.fhwa.dot.gov/engineering/hydraulics/pubs/09111/09112.pdf>)
9. Illinois Department of Transportation, Bureau of Local Roads and Streets. *Bureau of Local Roads & Streets Manual*, 2005. (<http://www.dot.il.gov/blr/manuals/blrmanual.html>)
10. U. S. Army Corps of Engineers. *HEC-RAS Hydraulic Reference Manual (aka Hydraulic Reference Guide)*. Version 4.1, January 2010. (<http://www.hec.usace.army.mil/software/hec-ras/documents/hydref/>)
11. U. S. Department of Transportation, Federal Highway Administration. *Bridge Waterways Analysis Model (WSPRO) Research Report*, by USGS, July 1986. (<http://water.usgs.gov/admin/memo/SW/sw87.05.html>)

CHAPTER 8 – STORM SEWERS

8-000 GENERAL

- 8-001 Introduction
- 8-002 Pavement Cross Section and Profile
- 8-003 I.E.P.A. Regulations
 - 8-003.01 Horizontal and Vertical Separation
 - 8-003.02 Storm Sewers Crossing Utilities
 - 8-003.03 Storm Sewer Manhole Separation from Water Main
- 8-004 Storage In Storm Sewers
- 8-005 Inverted Siphons
- 8-006 Automatic Flap Gates and Check Valves
- 8-007 Storm Sewer Plan Notation and Layouts
- 8-008 Design Guidelines and Considerations
 - 8-008.01 Design Storm Frequency
 - 8-008.02 Time of Concentration and Discharge
 - 8-008.03 Maximum Highwater
 - 8-008.04 Minimum and Maximum Velocities and Grades
 - 8-008.05 Sizes
 - 8-008.06 Type of Materials
 - 8-008.07 Cover
 - 8-008.08 Location
 - 8-008.09 Run Length
 - 8-008.10 Alignment
- 8-009 General Design Procedure

8-100 STORM SEWER STRUCTURES

- 8-101 Manholes
 - 8-101.01 Location
 - 8-101.02 Maximum Spacing
 - 8-101.03 Types
- 8-102 Pipe Connections
- 8-103 Junction Chambers
- 8-104 Catch Basins

	8-104.01	General
	8-104.02	Types
8-105	Inlets	
	8-105.01	General
	8-105.02	Types
8-200	LOCATION AND SPACING OF INLET STRUCTURES	
8-201	Pavement Encroachment	
8-202	Flow in Gutters	
	8-202.01	Example Problem 1
	8-202.02	Example Problem 2
8-203	Locations	
	8-203.01	Flanking Inlets
8-204	Capacity of Inlets	
	8-204.01	Inlets on Continuous Grade
	8-204.02	Grate Inlets in a Sag
	8-204.03	Curb Opening Inlets
	8-204.04	Slotted Inlets
	8-204.05	Combination Inlets
8-205	Spacing of Inlet Structures	
	8-205.01	The Rational Method
	8-205.02	Determination of First Inlet Location
	8-205.021	Example Problem 3
	8-205.03	Spacing of Successive Inlets
	8-205.031	Example Problem 4
8-300	STORM SEWER DESIGN	
8-301	Introduction	
8-302	Hydraulic Capacity	

8-303	Charts, Nomographs and Tables
	8-303.01 Example Problem 5
8-304	Design Procedures
8-305	Energy Grade Line/Hydraulic Grade Line
	8-305.01 Storm Sewer Outfalls
	8-305.02 Tailwater
	8-305.03 Energy Losses
	8-305.04 Hydraulic Grade Line Computations
	8-305.05 Example Problem 5
	8-305.051 Example Problem 6
8-306	Best Management Practices
8-400	COMBINED AND SANITARY SEWERS
	8-401 Combined Sewers
	8-402 Sanitary Sewers
	8-402.01 General
	8-402.02 Type
	8-402.03 Locations
	8-402.04 Slope
	8-402.05 Manholes
	8-402.06 Sanitary Sewer Plan Notation
8-500	REFERENCES

8-000 GENERAL

8-001 Introduction

This chapter covers the policies, methods, and procedures for designing storm sewer systems to remove storm water from roadway pavements. The policies concerning sanitary sewers and combined sewers will also be discussed in this chapter.

Effective drainage of highway pavement is essential in ensuring traffic safety and maintaining an adequate highway service level. Water on the pavement slows traffic, increases the possibility of hydroplaning and reduces visibility due to splash and spray. Advances in highway design and increased emphasis on highway safety have made the problem of removing storm water from the highway pavement more difficult and costly. Flatter slopes, both transverse and longitudinal, slow the flow of storm water over the pavement and decrease gutter capacities.

There are three main types of sewer systems, which are classified according to the type of service they render. Storm sewers collect storm water. Sanitary sewers carry domestic or industrial sewage and other waste liquids. Combined sewers carry both storm water and sanitary sewage.

8-002 Pavement Cross Section and Profile

Adequate drainage of the pavement surface begins with the selection of pavement cross section and profile. The pavement width, cross slope, and profile control the time it takes for storm water to drain to the gutter section. The gutter cross section and longitudinal slope control the quantity of flow which can be carried in the gutter section. With consideration for drainage, level of service, safety, and economics, the Division of Highways has established standard pavement and gutter sections to be used in certain situations. The roadway profile is normally established by matching the groundline profile or balancing cut and fill sections with consideration made for drainage.

On urban streets with curb and gutter sections, a minimum pavement and/or gutter gradient of 0.30 percent shall be utilized to facilitate roadway drainage and prevent undue encroachment of storm water on highway pavement. AASHTO geometric policy recommends a gradient of 0.30 percent within 50 feet of the level point in a sag or crest vertical curve. When zero grades are encountered, warping of the pavement to provide 0.30 percent gutter slope may be considered. Pavement cross slopes should also be adequate to provide proper drainage. On two lane pavements, a minimum cross slope of 3/16 inch per foot (1.56%) shall be used. On multilane pavements with two or more lanes in each direction, a 1/4 inch/foot (2.08%) cross slope is recommended for outer lanes. The design frequency for storm sewer systems for state highways, freeways, or expressways shall be in accordance with the requirements of [Table 1-305 in Chapter 1](#).

8-003 I.E.P.A. Regulations

The horizontal and vertical separation of a storm sewer line from any existing or proposed water main shall be in accordance with the Illinois Environmental Protection Agency (IEPA) regulations which are given in the IEPA's most current publication "[Illinois Recommended Standards for Sewage Works](#)"¹.

8-003.01 Horizontal and Vertical Separation

Whenever possible, a storm sewer must be at least 10 feet horizontally from any existing or proposed water main.

Should local conditions exist which would prevent a horizontal separation of 10 feet, a storm sewer may be closer than 10 feet to a water main provided that the outside of the water main is at least 18 inches above the outside of the storm sewer and is either in a separate trench or in the same trench on an undisturbed earth shelf located to one side of the storm sewer.

If it is impossible to obtain proper horizontal and vertical separation as described above, both the water main and storm sewer must be constructed with water main quality pipe and joints that comply with 35 Ill. Adm. Code 653.119 and shall be pressure tested in accordance with “AWWA Standard for Installation of Ductile-Iron Water Mains and their Appurtenances²,” for a working pressure equal to or greater than the maximum possible surcharge head to assure water tightness before backfilling.

8-003.02 Storm Sewers Crossing Utilities

Whenever possible, storm sewers crossing water mains shall be laid with the outside of the storm sewer a minimum of 18 inches below the outside of the water main. The vertical separation shall be maintained on each side of the crossing until the horizontal distance from the water main to the storm sewer is at least 10 feet. The crossing shall be arranged so that the sewer joints will be equidistant and as far as possible from the water main joints. Adequate support shall be provided for the water mains to prevent damage resulting from settling of the sewer trench.

Where a storm sewer crosses under a water main and it is not possible to provide an 18-inch vertical separation, the following special construction methods shall be specified:

1. The storm sewer shall either:
 - a. Be constructed with water main quality pipe and joints, complying with 35 Ill. Adm. Code 653.119, pressure tested in accordance with AWWA Standard for Installation of Ductile-Iron Water Mains and their Appurtenances, for a working pressure equal to or greater than the maximum possible surcharge head.
 - b. Be encased in a carrier pipe with sealed ends and joints complying with 35 Ill. Adm. Code 653.119.
2. The water main quality sewer or carrier pipe shall extend on each side of the crossing to a point where the horizontal distance from the outside of the water main to the outside of the storm sewer is at least 10 feet.
3. Point loads between the storm sewer or storm sewer casing and the water main are prohibited.
4. Adequate support shall be provided for the water main to prevent damage resulting from settling of the storm sewer trench.

5. For the required length of the water main quality storm sewer or carrier pipe, omit the select granular cradle and granular backfill to one foot over the crown of the storm sewer and use selected excavated material (Class IV) compacted to 95% of Standard Proctor maximum density. Where it is not possible for a proposed storm sewer to cross under an existing water main, the specifications shall require the construction methods stipulated above and that any select granular backfill above the crown of the water main be removed within the width of the proposed storm sewer trench and be replaced with select excavated material (Class IV) compacted to 95% of Standard Proctor maximum density. Where a proposed storm sewer must cross over a proposed water main, an 18-inch vertical separation shall be maintained.

8-003.03 Storm Sewer Manhole Separation from Water Main

No water pipe shall pass through or come into contact with any part of a storm sewer manhole.

8-004 Storage In Storm Sewers

Some storm sewer projects require the release rate to be controlled. This may be due to the restricted capacity of the existing receiving and/or outfall drainage systems. Where it is not feasible to provide an open detention basin, required storage volumes may be provided by installing larger than needed storm sewer sizes, with restrictors to control release rates.

8-005 Inverted Siphons

An inverted siphon carries flow under obstructions such as sanitary sewers, water mains, or any other structure or utility line, which is in the path of the storm sewer line. The storm sewer invert is lowered at the obstacle and is raised again after the crossing. A minimum of two barrels with 3 feet per second velocity is recommended. The inlet and outlet structures should be designed to keep the normal flow in one barrel to provide the required minimum velocity for self-cleaning and servicing.

8-006 Automatic Flap Gates and Check Valves

Automatic flap gates are generally used at or near storm sewer outlets for preventing the back flowing of the storm sewer system by high tides or high stages in the receiving stream. Automatic flap gates consist of circular and rectangular gates of metal construction that are commercially available in sizes up to 7 feet. Larger gates can be fabricated from plates and structural shapes. Flap gates may be attached to either concrete or corrugated metal pipe. They need regular inspection for removal of any debris from the pipe and outlet chamber, lubrication of hinge pins, and cleaning of seating surfaces. All metal parts of the flap gate should be corrosion resistant. A flap gate should be correctly balanced so that the gate will begin to open under a minimum head differential. [Figure 6-500a](#) shows the details and essential dimensions of automatic flap gates.

Check valves like automatic flap gates are also used for back flow prevention. Since they require minimal maintenance, check valves are preferred to flap gates. [Section 6-500](#) discusses the benefits of check valves. A picture of an installed check valve is shown in [Figure 6-500b](#).

8-007 Storm Sewer Plan Notation and Layouts

All storm sewers, inlets, manholes, catch basins, and other drainage features shall be identified and shown on the plans in accordance with the standard symbols included in the Illinois Department of Transportation Highway Standards³. The necessary construction details and drainage schedules for all storm sewers with all pay items and quantities must be included in the contract plans.

8-008 Design Guidelines and Considerations

Design criteria and considerations define the limiting factors that qualify an acceptable design. Several of these factors, including design and check storm frequency, time of concentration and discharge determination, allowable highwater at inlets and manholes, minimum flow velocities, minimum pipe grades, and alignment are discussed in the following sections.

8-008.01 Design Storm Frequency

The storm sewer conduit is one of the most expensive and permanent elements within storm drainage systems. Storm sewers normally remain in use longer than any other system elements. Once installed, it is very expensive to increase the capacity or repair the line. Consequently, the design flood frequency for projected hydrologic conditions should be selected to meet the need of the proposed facility both now and well into the future.

The design frequency for storm sewer systems for state highways, freeways, or expressways shall be in accordance with the requirements of [Table 1-305 in Chapter 1](#). Pavement and appurtenances are generally designed for a 10-year frequency. However, caution should be exercised in selecting an appropriate storm frequency. Consideration should be given to traffic volume, type and use of roadway, speed limit, flood damage potential, and the needs of the local community. Storm sewers which drain depressed roadways where runoff can only be removed through the storm drainage system should be designed for a minimum 50-year frequency storm. The inlet in the depressed roadway as well as the storm sewer pipe leading from it must be sized to accommodate this additional runoff. This can be done by computing the bypass occurring at each inlet during a 50 year rainfall and accumulating it at the sag point. Another method is to design the upstream system for a 50 year design to minimize the bypass to the depressed roadway. Each case must be evaluated on its own merits and the impacts and risk of flooding at a sag point.

Following the initial design of a storm sewer system, it is prudent to evaluate the major drainage system using a higher check storm. The major drainage system consists of the storm sewer as well as any path that the flow may take outside the storm sewer system for a specified discharge. The check storm is used to evaluate the performance (qualitatively as a minimum, quantitatively if possible) of the storm sewer system and determine if the major drainage system is adequate to handle the flooding from a storm of this magnitude.

8-008.02 Time of Concentration and Discharge

The rate of discharge at any point in the storm drainage system is not the sum of the inlet flow rates of all inlets above the section of interest. It is generally less than this total. The Rational Method is the most common means of determining design discharges for storm drain design. The time of concentration is very influential in the determination of the design discharge using the Rational Method. The time of concentration is defined as the period required for water to travel from the most hydraulically distant point of the watershed to the point of interest. The designer is usually concerned with two different times of concentration:

one for inlet spacing and the other for pipe sizing. The time of concentration for inlet spacing is the time required for water to flow from the hydraulically most distant point of the unique drainage area contributing only to that inlet. Typically, this is the sum of the times required for water to travel overland to the pavement gutter and along the length of the gutter between inlets. If the time of concentration calculates to less than 5.0 minutes for any inlet or storm sewer, a minimum time of concentration of five minutes is used as the duration of rainfall. The time of concentration for each successive inlet should be determined independently in the same manner as was used for the first inlet. The time of concentration for pipe sizing is defined as the time required for water to travel from the most hydraulically distant point in the total contributing watershed to the design point. Typically, this time consists of two components: (1) the time for overland and gutter flow to reach the first inlet, and (2) the time to flow through the storm drainage system to the point of interest.

The flow path having the longest time of concentration to the point of interest in the storm drainage system will usually define the duration used in selecting the intensity value in the Rational Method. Exceptions to the general application of the Rational Method exist. For example, a small, relatively impervious area within a larger drainage area may have an independent discharge higher than that of the total area. This anomaly may occur because of the high runoff coefficient (C value) and high intensity resulting from a short time of concentration. If an exception does exist, it can generally be classified as one of two exception scenarios. The first exception occurs when a highly impervious section exists at the most downstream area of a watershed and the total upstream area flows through the lower impervious area. The second exception exists when a smaller less pervious area is tributary to the larger more pervious area in the same watershed. When either of these two scenarios occurs, two separate calculations should be made. The results of those two calculations should be compared and the larger value of discharge should be used for design. Additional information for performing calculations can be found in the Federal Highway Administration (FHWA) publication "[Hydraulic Engineering circular No. 22, Third Edition⁴](#)" (HEC 22).

8-008.03 Maximum Highwater

Maximum highwater is the maximum allowable elevation of the water surface (hydraulic grade line) at any given point along a storm sewer. These points include inlets, manholes, or any place where there is access from the storm sewer to the ground surface. The calculated water surface elevation must be kept below the top of the inlet grate and at least two feet below the manhole cover. Maximum allowable highwater levels should be established along the storm sewer system prior to initiating hydraulic evaluations.

8-008.04 Minimum Velocity and Grades

A uniform slope is to be maintained between drainage structures, and where feasible the storm sewer should follow the slope of the ground surface to minimize the depth of excavation required. Where the roadway is on a high fill or in a deep cut, the roadway profile may be a more appropriate guide for determining the storm sewer slope. The slope of the storm sewer is the most significant factor in establishing pipe capacity and velocity, and it may be necessary to adjust the slope to satisfy these design constraints. Lower velocities (less than 3 feet per second) will lead to sedimentation and clogging. Higher velocities greater than 10 feet per second may cause erosion of the pipe and manhole walls, which should be consulted with manufacturers to see if erosion control measures are required. Storm sewers with steep grades may require the use of concrete thrust blocks and concrete anchors.

The designer should avoid using a larger pipe than is required to carry the design discharge, unless it is required for detention storage purposes. Larger pipes will allow flatter slopes (hence less excavation) but the resulting lower velocities may lead to clogging in the pipe, particularly during low flow events. The minimum velocity allowed in storm sewer systems is 3 ft/sec. A flatter slope sufficient to maintain a velocity of 2 ft/sec will be permitted only in special cases. All velocities shall be based on the pipe flowing full. Minimum slopes required for a velocity of 3 feet per second can be computed using the Manning's formula. Alternately, values in Table 8-008.04 can be used.

DIAMETER d (inches)	DISCHARGE Q (cfs)	SLOPE (feet per foot)		
		n = 0.012	n = 0.013	n = 0.024
8	1.05	0.0064	0.0075	0.026
10	1.64	0.0048	0.0056	0.019
12	2.36	0.0037	0.0044	0.015
15	3.68	0.0028	0.0032	0.011
18	5.30	0.0022	0.0026	0.0087
21	7.22	0.0018	0.0021	0.0071
24	9.43	0.0015	0.0017	0.0059
27	11.9	0.0013	0.0015	0.0051
30	14.7	0.0011	0.0013	0.0044
33	17.8	0.00097	0.0011	0.0039
36	21.2	0.00086	0.0010	0.0034
42	28.9	0.00070	0.00082	0.0028
48	37.7	0.00059	0.00069	0.0023
54	47.7	0.00050	0.00059	0.0020
60	58.9	0.00044	0.00051	0.0017
66	71.3	0.00038	0.00045	0.0015
72	84.8	0.00024	0.00040	0.0014

Slopes Necessary to Create Minimum Velocity of 3 ft/sec
In Pipes Flowing Full
Table 8-008.04

8-008.05 Sizes

The minimum size for all mainline storm sewers shall be 15 inches. The minimum desirable size for lateral storm sewers is 12 inches, however, under special conditions such as clearance problems, 10 inches and 8 inches will be permitted. Contents of a larger pipe should not discharge into a smaller one as it leads to blocking, except when using detention in the system.

8-008.06 Type of Materials

The type of material permitted for storm sewers shall be as specified in the Illinois Department of Transportation Standard Specifications for Road and Bridge Construction⁵ and compliant with BDE Procedure memorandum 85-08 and BDE Manual⁷ 40-3.07.

The storm sewer designer should recognize that Section 40-3.07 of the BDE Manual allows the contractor to bid the most cost effective material type for pipe storm drains, choosing among the allowable types for the pipe class and diameter specified in the contract plans. To accommodate the contractor’s selection, the designer has to anticipate the contractor may choose any of the allowable material types for the specified n-value from the list of allowable materials within the given class of pipes. For both Class A and B, utilize concrete with roughness ranging from 0.013 to 0.016. In addition to accounting for rougher pipe in this manner, the designer also needs to consider any adverse affects on design features due to the implementation of a smoother, thinner pipe than the concrete pipe assumed in hydraulic design calculations.

Storm sewer class selection shall be based on the following criteria:

STORM SEWER CLASSES

Conditions	Storm Sewer Class
Roadways with ADT < 1,500 or pipe location is > 12 ft. (3.6 m) from the edge of the traveled way	B
Roadways with ADT ≥ 1,500 and pipe location is ≤ 12 ft. (3.6 m) from the edge of the traveled way	A

Changing from one type of storm sewer to another should typically be done at scheduled manholes or junction chambers.

Tables in the Illinois Department of Transportation “Standard Specifications for Road and Bridge Construction”⁵ show the thickness of metal, or class of concrete or clay, which may be used under various fill heights up to 35 ft over the top of the storm sewer pipe. Where fill heights are greater than 35 ft, special design consideration will be necessary.

When elliptical reinforced concrete storm sewer pipe is specified, the class of elliptical pipe used for various storm sewer sizes and heights of fill shall conform to those specified for circular pipe in the Standard Specifications. When pre-coated, fully lined, galvanized corrugated steel pipe arch is specified, the thickness of metal used for the various storm sewer sizes and fill heights shall conform to those specified for corrugated steel pipe arches in the Standard Specifications. The pipe class, and/or thickness, shall be shown in the plans and/or special provisions.

8-008.07 Cover

Both minimum and maximum cover limits must be considered in the design of storm sewer systems. Minimum cover limits are established to ensure the conduits structural stability under live and impact loads. With increasing fill heights, dead load becomes the controlling factor. For highway applications, a minimum cover depth of 3.0 ft should be maintained where possible. In cases where this criterion cannot be met, the storm sewers should be evaluated to determine if they are structurally capable of supporting imposed loads. For all cases, the minimum cover depth from the top of the pipe to top of the subgrade is 12 inches. As indicated above, maximum cover limits are controlled by fill and other dead loads.

8-008.08 Location

Storm sewers are normally located a short distance behind the curb or in the roadway near the curb. It is preferable to locate storm drains on public property. On occasion, it may be necessary to locate storm sewers on private property in easements. The acquisition of required easements can be costly, and should be avoided wherever possible.

When possible, the main storm sewer line shall be located outside the roadway pavement with the inner edge of the trench at least 2 feet from the edges of the proposed pavement, stabilized shoulder, curb, or sidewalk. Where storm sewers are located outside the right of way, a permanent easement must be provided for the construction and maintenance of the storm sewer and its appurtenances. The location of the storm sewer should be based on consideration of all pertinent factors, including comparative costs and availability and accessibility of right of way. The designer should obtain and show on the plans all existing underground utility data which will affect the storm sewer design and every effort should be made to eliminate interference. When a storm sewer or lateral is located under the pavement, the top of the sewer pipe should be at least 12 inches below the bottom of the pavement structure. At other locations, when pipe gradients and ground elevations permit, the minimum cover over a storm sewer should not be less than 3 ft and below the freeze line.

8-008.09 Run Length

The length of individual storm sewer runs is dictated by storm drainage system configuration constraints and structure locations. Storm drainage system constraints include inlet locations, manhole and junction locations, etc. Where straight runs are possible, maximum run length is generally dictated by maintenance requirements. [Section 8-101.02](#) identifies maximum suggested run lengths for various pipe sizes.

8-008.10 Alignment

Where possible, storm sewers should be straight between manholes. However, curved storm sewers are permitted where necessary to conform to street layout or avoid obstructions. For larger diameter storm sewers, deflecting the joints to obtain the necessary curvature is not desirable except in very minor curvatures. Long radius bends are available from many suppliers and are the preferable means of changing direction in pipes 4.0 ft in diameter and larger. The radius of curvature specified should coincide with standard curves available for the type of material being used.

Curved storm sewers are permitted in special cases provided the following requirements are met:

1. Curved Sewers 24 inches in Diameter and Smaller
 - a. Location: Curved alignments should follow the general alignment of streets.
 - b. Curve Type: Only a simple curve design is acceptable.
 - c. Radius of Curvature: The minimum allowable radius of curvature is 300 feet.
 - d. Manholes: Manholes are required at the beginning and end of all curves.

- e. Velocity: The minimum velocity shall be 3 feet per second for full flow conditions and design flow conditions. Erosion evaluation should be conducted where there is a concern about high velocities.
 - f. Joints: Compression joints are required. The ASTM maximum allowable deflection of the pipe joints shall not be exceeded.
2. Curved storm sewers larger than 24 inches in diameter shall meet the requirements of [Section 8-008.10\(1\)](#) except that the joints may be manufactured such that they fit together securely without deflection at the design curvature and the radius of curvature may be less than 300 feet.

If curved storm sewer alignments are contemplated, concrete pipe manufacturer should be consulted regarding manufacturing and installation feasibility as well as availability of proper cleaning equipment for storm sewer maintenance. Many manufacturers have standardized joint configurations and deflections for specific radii.

8-009 General Design Procedure

The design of storm sewers is generally divided into the following operations:

1. The first step is the determination of inlet locations and spacing as outlined in [Section 8-200](#).
2. The second step is the preparation of a plan layout of the storm sewer drainage system establishing the following design data:
 - a. Location of storm sewer
 - b. Direction of flow
 - c. Location of manholes
 - d. Location of existing utilities such as water, gas, sanitary sewers, or underground cables
3. The design of the storm sewer system is then accomplished by determining drainage areas, computing runoff by Rational Method, and computing the hydraulic capacity using Manning's Equation. The Location Drainage Study described in [Chapter 2](#) should be used to confirm drainage boundaries, flow paths and outlet conditions, and to determine the need for special design features to accommodate local drainage requirements.

The storm sewer systems are normally designed for full gravity flow conditions using design frequency discharges. A higher level of design frequency is used for depressed roadways and underpasses where water can be removed only through the storm sewer systems. In these situations, a 50 year frequency design is used to locate the inlets at the sag location and to size the storm sewer line. The maximum encroachment shall not exceed the limitation policies covered under Pavement Encroachment, [Section 1-303.01](#).

If the storm sewer line discharges into a pumping station, the storm sewer is designed for a 50 year storm under gravity flow conditions.

Hydraulic grade lines may be computed for pressure flow conditions. The water surface elevations must be kept below the grates and/or established critical elevations in the system and comply with the other parameters provided in [Section 8-008.03](#).

The design procedure should include the following:

- a. Storm sewer design computations may be made on the forms illustrated in [Section 8-300](#).
- b. All computations and design sheets should be clearly identified. The designer's initials and date of computations should be shown on each sheet. Voided or superseded sheets should be so marked. Data used on one sheet but computed on another sheet should be identified as to origin.

8-100 STORM SEWER STRUCTURES

8-101 Manholes

8-101.01 Location

Manholes are utilized to provide access to continuous underground storm sewers for the purpose of inspection and clean-out, and to permit a change in direction, grade and/or size of sewer. Typical locations where manholes should be specified are:

1. Where two or more storm sewers converge
2. At intermediate points along tangent sections
3. Where pipe size changes
4. Where an abrupt change in alignment occurs
5. Where an abrupt change of the grade occurs

Manholes should not be located in traffic lanes. However, when it is impossible to avoid locating a manhole in a traffic lane, care should be taken to ensure it is not in the normal vehicle tire path.

8-101.02 Maximum Spacing

The maximum spacing of manholes should be in accordance with the following:

Sizes of Pipe (Inches)	Maximum Distance (Feet)
10-24	300
27-36	400
42-54	500
60-up	1000

8-101.03 Types

A Manhole Type A with appropriate frame and lid should be provided when the depth exceeds 4 ft. A cast-in-place junction chamber should be utilized when the general guidelines below cannot be accommodated with a 9' diameter manhole, the largest highway standard.

1. A minimum of one foot shall be maintained between adjacent pipe holes.
2. A minimum of one foot shall be maintained between the top of a pipe hole and the top edge of the manhole.
3. No more than 50% of the circumference of the manhole may be removed to accommodate intersecting pipes.

8-102 Pipe Connections

Pipe tee and wye connections are permitted for connecting lateral lines from pavement inlets to main storm sewer lines, provided the following conditions are met:

1. Manholes are provided at the required intervals.
2. The minimum lateral size is 12 inches or larger.
3. Pre-cast connections are required unless the designer verifies that the structural and hydraulic integrity of the storm sewer is not affected by field connection.

8-103 Junction Chambers

The junction of small sewers is made in manholes. On occasion, junction chambers of special design are required to join two or more converging large size storm sewers. In design, a smooth transition is essential to prevent turbulent flow, which would cause eddies and deposition of solids. Normally, junction chambers should not be utilized when standard manholes or catch basins are suitable.

The hydraulic head losses in junction chambers are explained [in Section 8-300](#).

8-104 Catch Basins**8-104.01 General**

Catch basins are designed to collect surface water. They differ from inlets in that a sump for collection of silt and debris is provided. Catch basin sumps require periodic cleaning to be effective and may become an odor and mosquito nuisance if not properly maintained.

Catch basins should be provided with appropriate frames and grates as provided in the Highway Standards.

8-104.02 Types

1. Catch Basin Type A may be used where a greater sedimentation space is required. Inlet and outlet pipes should have enough cover to provide protection from freezing.
2. Catch Basin Type B is for use at ditches or depressions having substantial tributary areas. Inlet and outlet pipes should be of sufficient depth to provide protection from freezing.
3. Catch Basin Type C may be used in lieu of Inlets Type A, where a small sedimentation space is desirable. However, they should not be used as a receiver of storm water from other inlets.
4. Catch Basin Type D may be used where the sedimentation space required and the tributary area involved, does not warrant the use of a Type A catch basin.

8-105 Inlets**8-105.01 General**

Inlets are drainage structures utilized to collect surface water through grate or curb openings and convey it to storm sewers or direct outlet to culverts and ditches. Inlets should be provided with appropriate frames and grates as specified in the Highway Standards.

An Inlet Type A should be utilized when the sewer pipe diameter is 15 inches or less and the depth of pipe is not more than 4 ft. For larger diameter pipes or where there is both an incoming and outgoing pipe in the inlet, a larger diameter inlet structure, such as Inlet Type B, or a 3 ft, 4 ft or 5 ft diameter catch basin or manhole should be specified. When such a structure is used in a shallow pipe situation, a pre-cast, reinforced concrete flat-slab top, shown in the Highway Standards³, should be used in lieu of the standard conical-top.

8-105.02 Type of Inlets

Inlets used for the drainage of highway surfaces can be divided into four major classes as shown in [Figure 8-105.02](#). These classes are:

1. Grate Inlets - These inlets consist of an opening in the gutter covered by a grate. The design of grate inlets must consider bicycle safety as well as hydraulic efficiency.
2. Curb Opening Inlets - These inlets consist of a vertical opening in the curb covered by a top slab. They generally require a larger structure than grate inlets of equal capacity. Proper design of curb opening inlets on grade must include a depressed gutter section to maintain inlet capacity.
3. Combination Inlets - These inlets consist of both a curb opening and a grate inlet acting as a unit. These inlets are primarily used in sag locations and on flat grades.
4. Slotted Drain Inlets – Drainage inlet composed of a continuous slot built into the top of a pipe, which serves to intercept, collect, and transport the flow. Often used in conjunction with a single grate inlet for clean-out access.

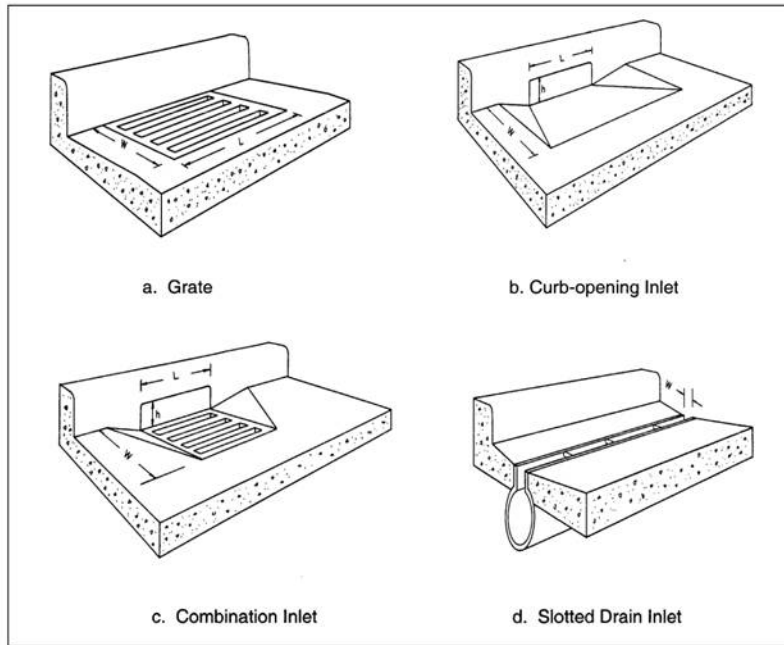

Inlet Types
Figure 8-105.02

8-200 LOCATION AND SPACING OF INLET STRUCTURES

Inlets and/or catch basins are required at locations to collect runoff within the pavement encroachment limitations specified below.

There are a number of locations where inlets/catch basins may be necessary with little regard to contributing drainage area. These locations should be marked on the plans prior to any computations regarding discharge, water spread, inlet capacity, or flow bypass. Examples of such locations are as follows:

- At all low points in the gutter grade
- Immediately upstream of median breaks, entrance/exit ramp gores, cross walks, and street intersections, i.e., at any location where water could flow onto the travelway
- Immediately upstream of bridges (to prevent pavement drainage from flowing onto bridge decks)
- Immediately downstream of bridges (to intercept bridge deck drainage)
- Immediately upstream of cross slope reversals
- Immediately upstream from pedestrian cross walks
- At the end of channels in cut sections
- On side streets immediately upstream from intersections
- Behind curbs, shoulders or sidewalks to drain low area

8-201 Pavement Encroachment

The following encroachment limitations are the maximum allowable for determining inlet spacing on construction and reconstruction projects and they shall be applied for the design frequency specified in [Chapter 1, "Policy for Flood Frequency"](#). Specified Encroachment limits are the allowable encroachment onto the traveled lane. This policy assumes that widths are in accordance with current policies as set forth in the Bureau of Design and Environment Manual.

1. Sections with full shoulders (6 ft or more) - no encroachment. Width of spread is limited to the shoulder width.
2. Sections with permanent parking lane - no encroachment. Width of spread is limited to the parking lane.
3. Sections with one lane each direction - allow a maximum encroachment of 4 ft. EXCEPTION: When the surface width (face to face) is less than 30 ft, allow a maximum encroachment of 3 ft.
4. Sections with two (2) or more lanes in each direction – allow a maximum encroachment of one half (1/2) traffic lane. EXCEPTION: Where traffic volumes exceed the maximum specified for the indicated level of service, as determined from policies included in the Bureau of Design and Environment Manual, allow a maximum encroachment of 4 ft.
5. Sections with three (3) or more lanes in each direction and one (1) lane draining to the median - allow a maximum encroachment of 4 ft on the median side. Allow a maximum encroachment of one half (1/2) traffic lane on the outside (right) lane.
6. When traffic is extremely high, the District may select a more stringent level of protection and allow only a maximum encroachment of 3 ft on the traveled lane.

The maximum depth of flow shall be limited to 0.30 ft, regardless of computed encroachment. Spacing between inlets shall not exceed 250 ft.

8-202 Flow in Gutters

The flow capacity of a gutter depends upon its cross section, longitudinal and transverse slopes and surface roughness.

Gutter cross sections usually have a triangular shape with a cross slope composed of two straight lines: gutter and pavement cross slopes. The total flow is considered in two parts; the flow in gutter and the flow on the pavement adjacent to the gutter. The rate of flow in the gutter and on a pavement section is determined by using a modification of Manning's Equation. The hydraulic radius as used in Manning's Equation does not adequately describe the gutter cross section for flow in triangular gutter sections. This is particularly evident when the top width of the water surface is more than 40 times the depth at the curb. To compute the pavement and gutter flow, the Manning's Equation is integrated for an increment of width across the section and the resulting equation is:

$$Q = \frac{0.56}{n} T^{8/3} S_x^{5/3} S^{1/2} \tag{Eq. 8-1}$$

or

$$Q = \frac{0.56}{n} Z d_g^{8/3} S^{1/2} \tag{Eq. 8-2}$$

Where:

Q = flow rate, cuft/sec

$$Z = \text{reciprocal of the cross slope} = \left(\frac{T}{d_g} \right) = \left(\frac{1}{S_x} \right)$$

n = Manning's coefficient

S = longitudinal slope, ft/ft

d_g = depth of channel at deepest point, ft

T = top width of water surface (spread), ft

S_x = cross slope, ft/ft

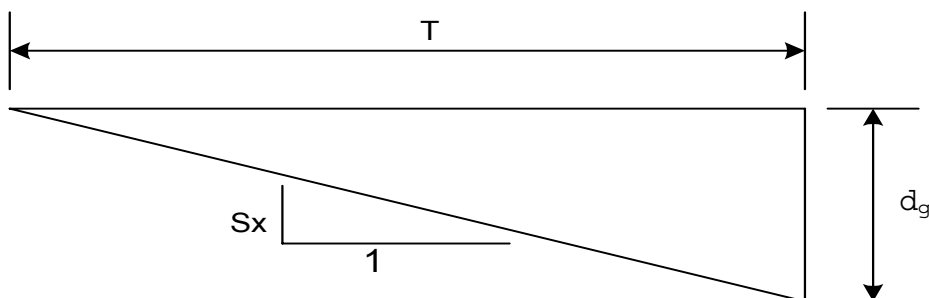

Flow in composite gutter sections may be determined using the following equations.

$$d_p = \frac{T_p}{Z_p} \tag{Eq. 8-3}$$

$$Q_g = 0.56 \frac{Z_g}{n} \left(d_g^{8/3} - d_p^{8/3} \right) S^{1/2} \tag{Eq. 8-4}$$

$$Q_p = 0.56 \frac{Z_p}{n} d_p^{8/3} S^{1/2} \tag{Eq. 8-5}$$

$$Q_T = Q_g + Q_p \tag{Eq. 8-6}$$

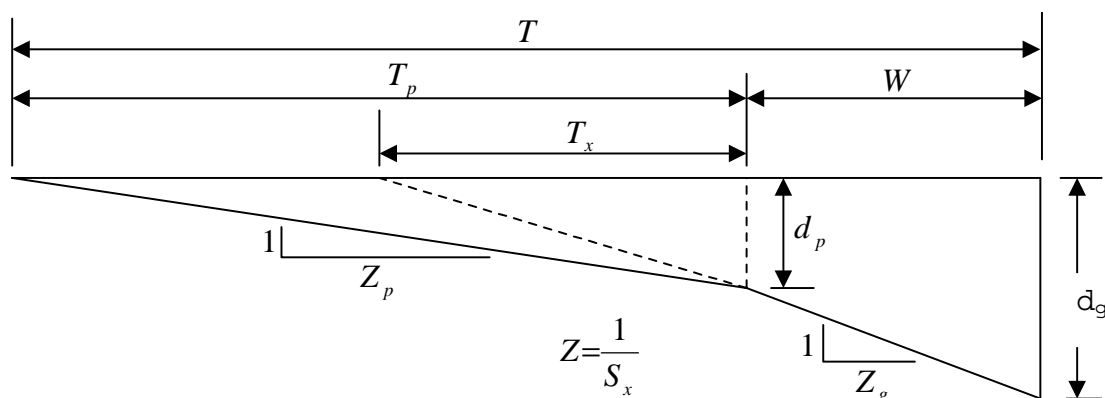

Where:

- T_p = width of spread on pavement, ft
- Q_g = flow in the gutter, cuft/sec
- Q_p = flow on the pavement, cuft/sec

Nomograph solutions of these equations for Q and T are shown in [Figure 8-202a](#) and [8-202b](#). In [Figure 8-202b](#), for values of n other than 0.016, divide the value of Q_n by n . Instructions for use and example problem solutions are provided on the figure. Values of Z for various cross slopes are shown in [Table 8-202](#).

[Figure 8-202c](#) is provided for use with [Figures 8-202a](#) and [8-202b](#) to find the flow in a width of gutter, W , less than the total spread, T . It can be used for either a straight cross slope or a composite gutter slope. The procedure for use of [Figure 8-202c](#) is illustrated in Example 1.

[Figure 8-202d](#) is a direct solution of gutter flow in a composite gutter section.

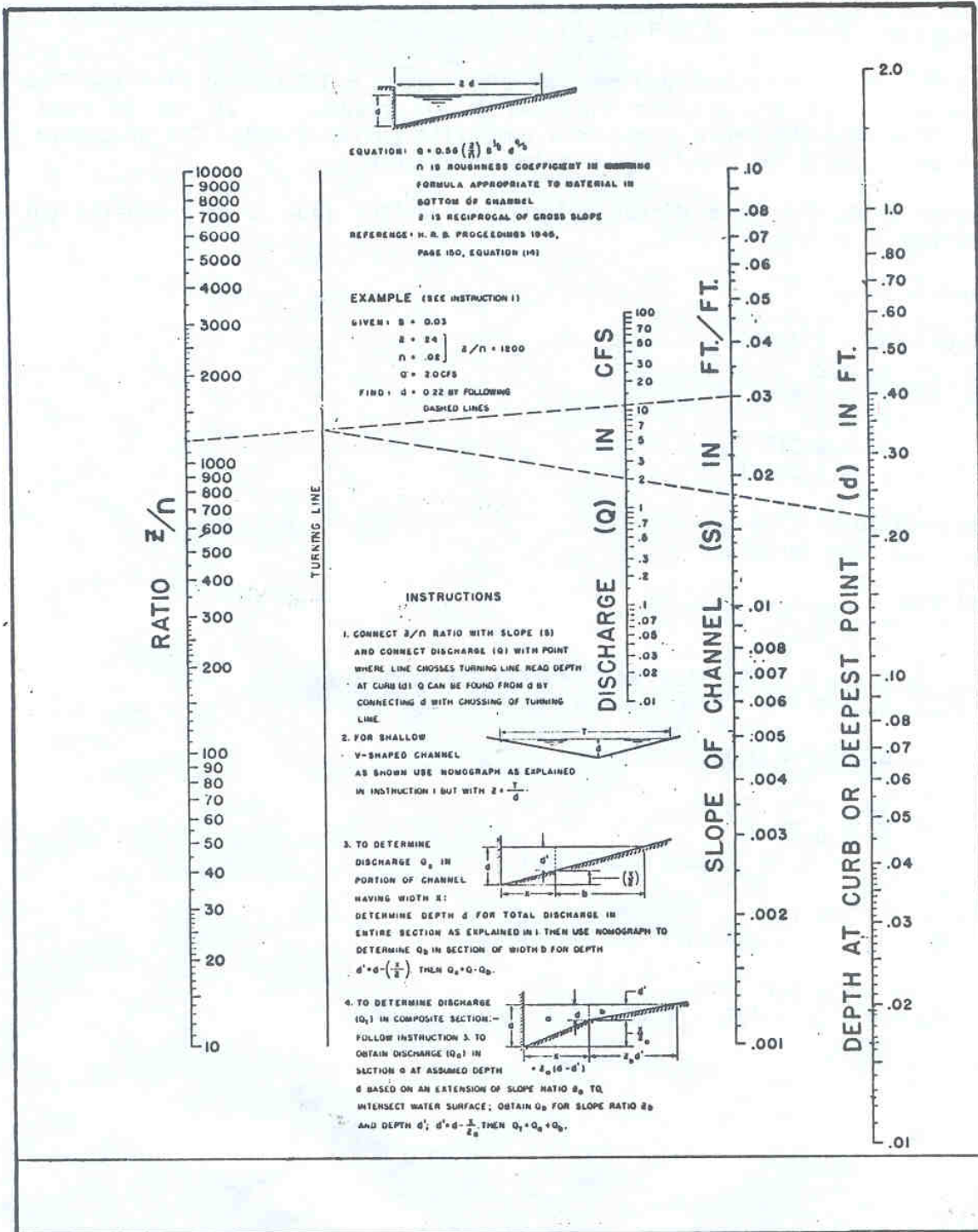

Flow in Triangular Sections
 Figure 8-202a

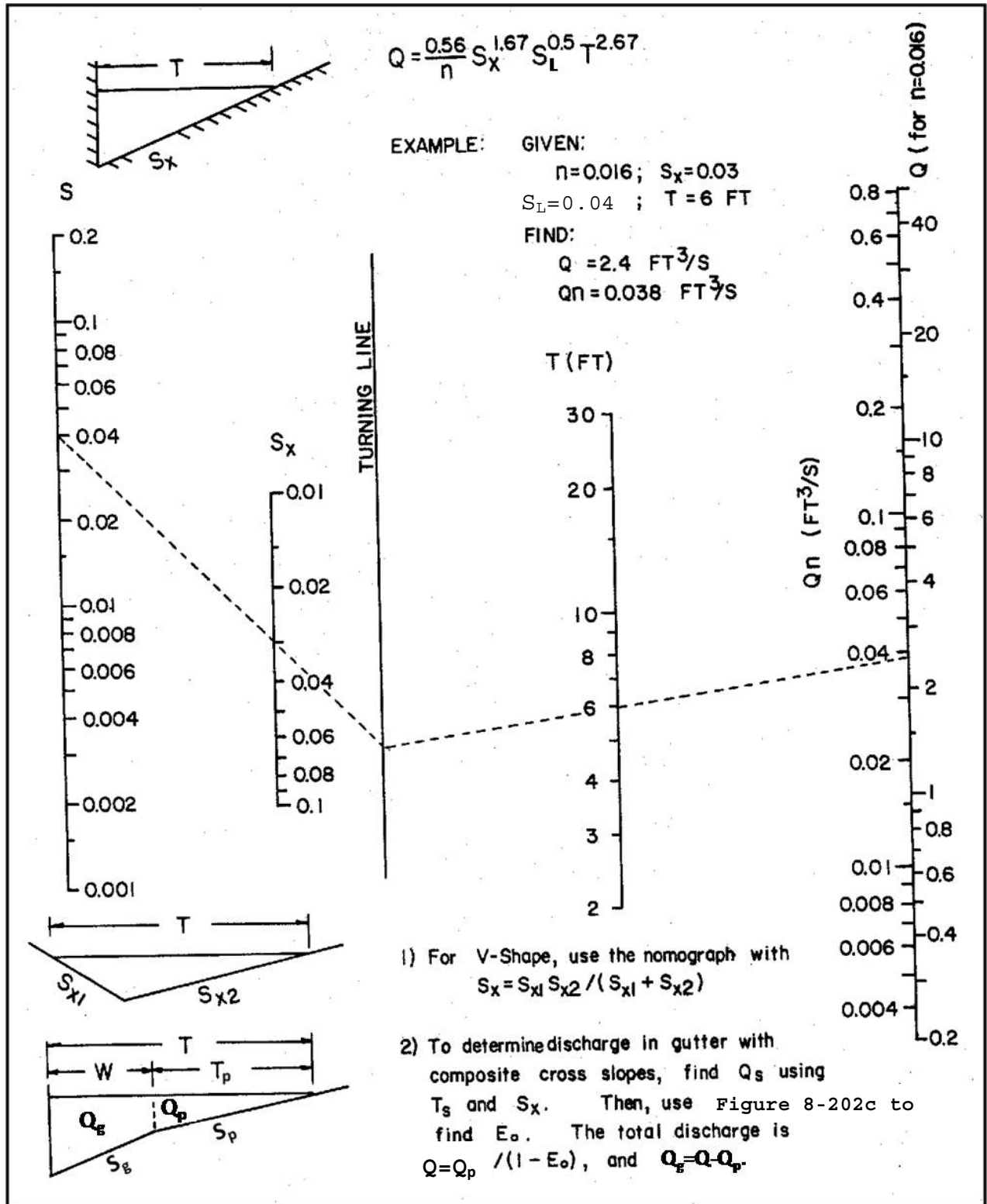

Flow in Triangular Gutter Sections
 Figure 8-202b

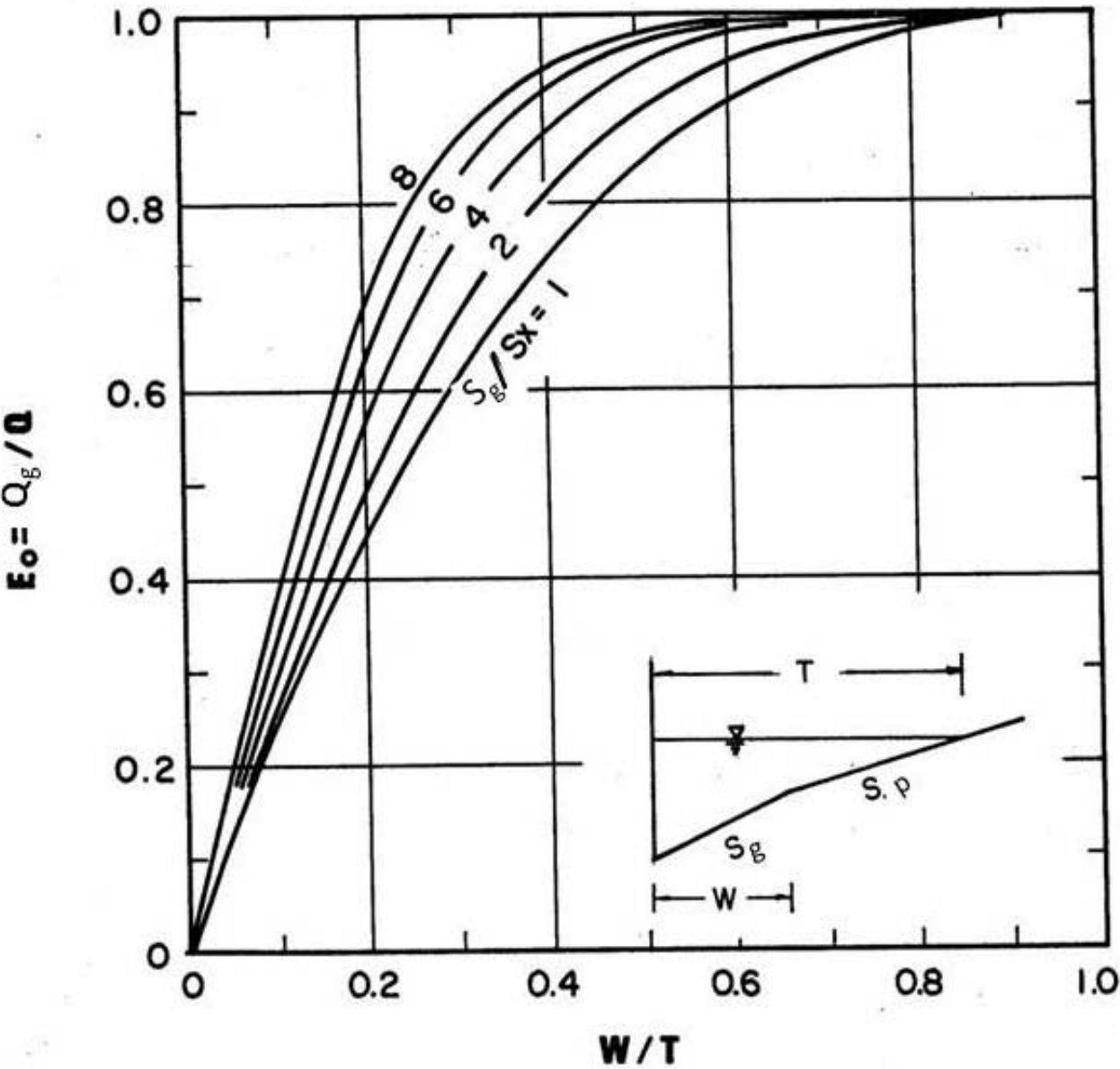

Ratio of Frontal Flow to Total Gutter Flow
Figure 8-202c

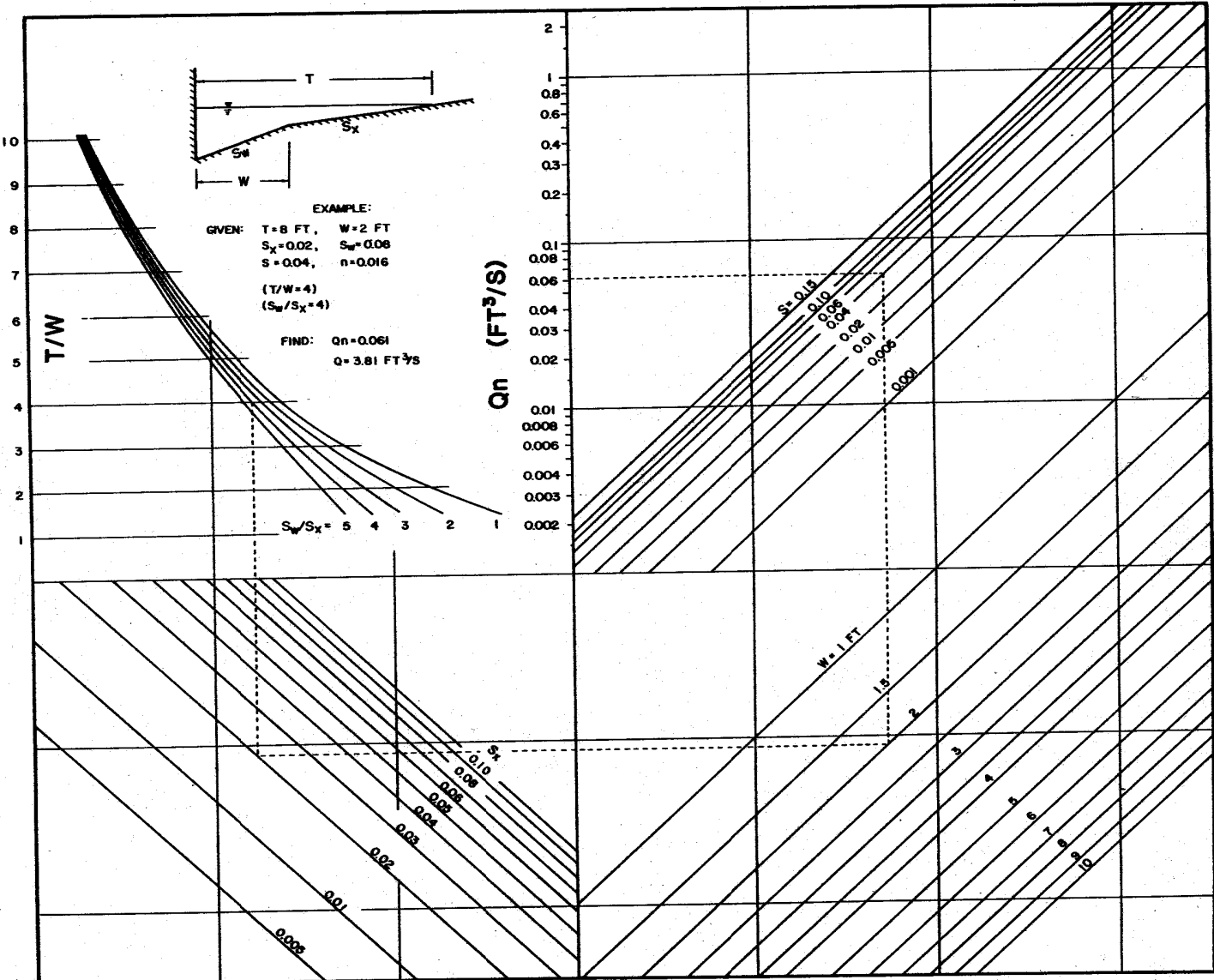

Flow in Composite Gutter Sections
 Figure 8-202d

Z and Z/n values for various cross slopes

in/ft	in/ft	ft/ft	Z	Z/0.012	Z/0.013	Z/0.014	Z/0.015	Z/0.016
1/64	.0120	.0010	1000.0	83,333	78,923	71,429	66,666	62,500
	.0156	.0013	769.2	64,100	59,169	54,943	51,282	48,075
1/32	.0246	.0020	500.0	41,667	38,462	35,714	33,333	31,250
	.0313	.0026	384.0	32,000	29,538	27,429	25,640	24,000
1'16	.0360	.0030	333.3	27,775	25,638	23,807	22,220	20,830
	.0480	.0040	250.0	20,833	19,231	17,957	16,666	15,625
3/32	.0600	.0050	200.0	16,667	15,385	14,286	13,333	12,500
	.0625	.0052	192.0	16,000	14,769	13,714	12,820	12,000
1/8	.0720	.0060	166.7	13,892	12,823	11,907	11,113	10,419
	.0840	.0070	142.9	11,908	10,992	10,207	9,526	8,931
5/32	.0938	.0078	128.0	10,667	9,846	9,143	8,533	8,000
	.0960	.0080	125.0	10,417	9,615	8,929	8,333	7,812
3/16	.1000	.0083	120.5	10,042	9,269	8,607	8,033	7,531
	.1080	.0090	111.1	9,258	8,546	7,936	7,406	6,944
1/4	.1200	.0100	100.0	8,333	7,692	7,143	6,667	6,250
	.1250	.0104	96.00	8,000	7,385	6,857	6,410	6,000
5/16	.1320	.0110	90.90	7,575	6,992	6,493	6,060	5,681
	.1440	.0120	83.33	6,944	6,410	5,952	5,555	5,208
3/8	.1563	.0130	76.80	6,400	5,908	5,486	5,128	4,800
	.1680	.0140	71.43	5,952	5,495	5,102	4,762	4,464
7/16	.1800	.0150	66.67	5,556	5,128	4,782	4,445	4,167
	.1875	.0156	64.00	5,333	4,923	4,571	4,273	4,000
1/2	.1920	.0160	62.50	5,208	4,808	4,464	4,167	3,906
	.2000	.0167	59.88	4,990	4,606	4,277	3,992	3,742
9/16	.2040	.0170	58.82	4,902	4,525	4,201	3,921	3,676
	.2160	.0180	55.56	4,630	4,274	3,969	3,704	3,472
5/8	.2188	.0182	54.86	4,572	4,220	3,919	3,663	3,429
	.2280	.0190	52.63	4,386	4,048	3,759	3,509	3,289
11/16	.2400	.0200	50.00	4,167	3,846	3,571	3,333	3,125
	.2500	.0208	48.00	4,000	3,692	3,429	3,205	3,000
3/4	.2813	.0234	42.67	3,556	3,282	3,048	2,849	2,667
	.2969	.0247	40.42	3,368	3,109	2,887	2,695	2,526
7/8	.3000	.0250	40.00	3,333	3,077	2,857	2,667	2,500
	.3125	.0260	38.40	3,200	2,954	2,743	2,564	2,400
15/16	.3281	.0273	36.57	3,047	2,813	2,612	2,438	2,286
	.3438	.0286	34.94	2,912	2,688	2,496	2,331	2,184
1 1/8	.3600	.0300	33.33	2,777	2,564	2,381	2,222	2,083
	.3750	.0313	32.00	2,667	2,462	2,286	2,137	2,000
1 1/4	.4000	.0333	30.00	2,500	2,308	2,143	2,000	1,875
	.4063	.0339	29.54	2,462	2,272	2,110	1,967	1,846
1 1/2	.4200	.0350	28.57	2,381	2,198	2,041	1,905	1,786
	.4375	.0364	27.43	2,286	2,110	1,959	1,831	1,714
1 5/8	.4688	.0391	25.60	2,133	1,969	1,829	1,704	1,600
	.4800	.0400	25.00	2,083	1,923	1,786	1,667	1,562
1 3/4	.5000	.0417	24.00	2,000	1,846	1,714	1,603	1,500
	.5313	.0443	22.59	1,882	1,738	1,614	1,505	1,412
1 7/8	.5400	.0450	22.22	1,852	1,709	1,587	1,481	1,389
	.5625	.0469	21.33	1,777	1,641	1,524	1,421	1,333
2 1/8	.5938	.0495	20.21	1,684	1,555	1,444	1,347	1,263
	.6000	.0500	20.00	1,667	1,538	1,429	1,333	1,250
2 1/4	.6250	.0521	19.20	1,600	1,477	1,371	1,282	1,200
	.6563	.0547	18.29	1,524	1,407	1,306	1,219	1,143
2 3/8	.6600	.0550	18.18	1,515	1,398	1,299	1,212	1,136
	.6875	.0573	17.47	1,456	1,344	1,248	1,163	1,092
2 1/2	.7000	.0583	17.15	1,429	1,319	1,225	1,143	1,072
	.7188	.0599	16.70	1,392	1,285	1,193	1,112	1,044
2 5/8	.7200	.0600	16.67	1,389	1,282	1,191	1,111	1,042
	.7500	.0625	16.00	1,333	1,231	1,143	1,066	1,000
2 3/4	.7800	.0650	15.38	1,282	1,183	1,099	1,025	961
	.7813	.0651	15.36	1,280	1,182	1,097	1,024	960
3 1/8	.8000	.0666	15.00	1,250	1,154	1,071	1,000	938
	.8125	.0677	14.77	1,231	1,136	1,055	985	923
3 1/4	.8400	.0700	14.28	1,190	1,098	1,020	952	892
	.8438	.0703	14.22	1,185	1,094	1,016	948	889
3 3/8	.8500	.0708	14.12	1,177	1,086	1,009	941	882
	.8750	.0729	13.71	1,142	1,055	979	914	857
3 1/2	.9000	.0750	13.33	1,111	1,025	952	889	833
	.9063	.0755	13.24	1,103	1,018	946	882	828
3 5/8	.9375	.0781	12.80	1,067	985	914	853	800
	.9500	.0792	12.63	1,052	972	902	842	789
4 1/8	.9600	.0800	12.50	1,042	962	893	833	781
	.9688	.0807	12.39	1,032	953	885	826	774

Values of "Z" for Various Cross Slopes
Table 8-202

in/ft	in/ft	ft/ft	Z	Z/0.012	Z/0.013	Z/0.014	Z/0.015	Z/0.016
1	1.000	.0833	12.00	1,000	923	857	800	750
	1.020	.0850	11.76	980	905	840	784	735
	1.080	.0900	11.11	928	855	794	741	694
	1.140	.0950	10.52	877	809	751	701	658
	1.200	.1000	10.00	833	769	714	667	625
2	2.000	.1667	6.000	500	462	429	400	375
	2.400	.2000	5.000	417	385	357	333	312
3	3.000	.2500	4.000	333	308	286	267	250
	3.600	.3000	3.333	278	256	238	222	208
4	4.000	.3333	3.000	250	231	214	200	188
	4.800	.4000	2.500	208	192	179	167	156
5	5.000	.4167	2.400	200	185	171	160	150
	6.000	.5000	2.000	167	154	143	133	125
7	7.000	.5833	1.714	143	132	122	114	107
	7.200	.6000	1.667	139	128	119	111	104
8	8.000	.6667	1.500	125	115	107	100	94
	8.400	.7000	1.428	119	110	102	95	89
9	9.000	.7500	1.333	111	103	95	89	83
	9.600	.8000	1.250	104	96	89	83	78
10	10.00	.8333	1.200	100	92	86	80	75
	10.80	.9000	1.111	93	85	79	74	69
11	11.00	.9167	1.091	91	84	78	73	68
	11.50	.9583	1.044	87	80	75	70	65
12	12.00	1.000	1.000	83	77	71	67	62

Values of "Z" for Various Cross Slopes
Table 8-202 (continued)

8-202.01 Example Problem 1

Given:

$$\begin{aligned} S_g &= 3/4 \text{ inch/ft} = 0.0625 \text{ ft/ft} \\ W &= 2 \text{ ft} \\ S_p &= 1/4 \text{ inch/ft} = 0.0208 \text{ ft/ft} \\ T &= 6 \text{ ft} \\ n &= 0.015 \\ s_L &= 0.04 \text{ ft/ft} \end{aligned}$$

Find:

- Total Flow
- Flow in Gutter

Solution:

$$T_p = T - W = 4 \text{ ft}$$

$$Q_{p,n} = 0.0065 \text{ (Flow in 4 ft section) (Figure 8-202b)}$$

$$Q_p = \frac{Q_{p,n}}{n} = \frac{0.0065}{0.015} = 0.43 \text{ cuft/sec}$$

$$\frac{W}{T} = \frac{2}{6} = 0.33$$

$$\frac{S_g}{S_p} = \frac{0.06}{0.02} = 3.0$$

$$E_0 = 0.75 \text{ (Figure 8-202c)}$$

$$\text{Total Flow} = Q = \left(\frac{Q_p}{1 - E_0} \right) = \frac{0.43}{(1 - 0.75)} = 1.72 \text{ cuft/sec}$$

$$\text{Flow in Gutter} = Q_w = Q - Q_s = 1.72 - 0.43 = 1.29 \text{ cuft/sec}$$

8-202.02 Example Problem 2

The following example illustrates the method of determining the maximum allowable flow in cubic feet per second (Q_T) for the Type B6.24 curb and gutter adjacent to concrete pavement by use of [Equations 8-1 & 8-2](#) or [Figures 8-202a or 8-202b](#).

Given:

Longitudinal slope of pavement = 0.3 percent

Maximum allowable encroachment of water on pavement permitted will be 3 ft

Cross slope of pavement = 3/16 inch/ft = 0.0156 ft/ft

Cross slope of gutter = 3/4 inch/ft = 0.0625 ft/ft

Width of gutter = 2 ft

Manning's n value of pavement and gutter = 0.013

Find

Maximum allowable flow, Q_T

Solution:

$$Q_T \text{ (total)} = Q_p \text{ (pavt)} + Q_g \text{ (gutter)}$$

Determine maximum allowable flow on pavement (Q_p) by use of modified Manning's equation.

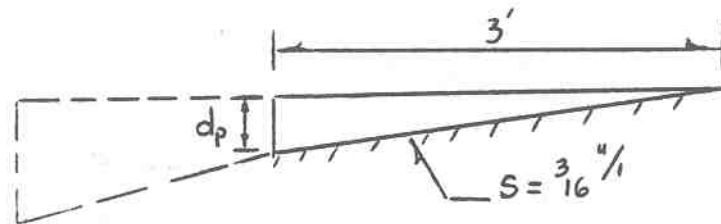

$$Q = 0.56 \frac{Z_p}{n} S_o^{1/2} d^{8/3}$$

where:

Z_p	=	64 from Table 8-202
d_p	=	$T/Z = 3/64 = 0.047$ ft.
n	=	0.013 for concrete

hence

$$Q_p = 0.56 \left(\frac{64}{0.013} \right) (0.003)^{1/2} (0.047)^{8/3} = 0.043 \text{ cuft/sec (pavement)}$$

This can also be computed by the nomograph on [Figure 8-202a](#).

Determine maximum allowable flow in the gutter (Q_g) also by use of modified Manning's Equation.

Since the gutter cross slope of 3/4 in/ft is steeper than the pavement slope, the section used for computation will look as follows:

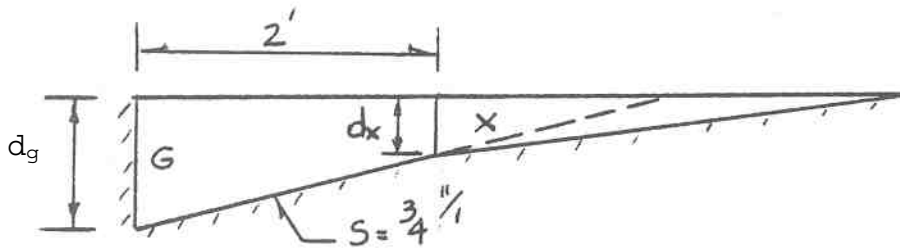

The discharge for the gutter section must be computed in two steps to maintain triangular sections for computation. The discharge computed for Section X (an extension of gutter slope) must be subtracted from the discharge of the total triangular section comprising G and X.

$$d_x = d_p$$

$$Z = 16 \text{ for } s = 3/4 \text{ in/ft}$$

$$Q_x = 0.56 \left(\frac{16}{0.013} \right) (0.003)^{1/2} (0.047)^{8/3} = 0.011 \text{ cuft/sec}$$

Also

$$d_{g+x} = d_x + \frac{2 \text{ ft}}{Z} = 0.047 + 0.125 = 0.172$$

$$Q_{g+x} = 0.56 \left(\frac{16}{0.013} \right) (0.003)^{1/2} (0.172)^{8/3} = 0.345 \text{ cuft/sec}$$

hence

$$Q_g = Q_{g+x} - Q_x$$

$$Q_g = 0.334 \text{ cuft/sec (gutter flow)}$$

Determine maximum allowable flow (Q_T)

$$Q_T = Q_p + Q_g$$

from above

$$Q_T = 0.043 + 0.334$$

$$Q_T = 0.377 \text{ cuft/sec}$$

8-203 Inlet Locations

In general, inlets should be placed at all low points in the gutter grade and at intersections to prevent the gutter flow from crossing traffic lanes of the intersecting road. Inlets are normally placed upgrade from pedestrian crossings to intercept the gutter flow before it reaches the crosswalk. Where pavement surfaces are warped, as at cross streets, ramps, or in transitions between superelevated and normal sections, gutter flow should be picked up before the cross slope direction of the pavement changes in order to lessen water flowing across the roadway and to prevent icing. Inlets at driveway locations should be placed upgrade from driveways.

On continuous grades, inlets should be spaced so as to limit the spread of water to not more than the allowable limit on a through traffic lane during a design frequency storm subject to the maximum spacing of 250 feet.

In a sag vertical curve, a minimum of two inlets should be located, one at the low point and one at 20 to 60 feet from the sag point. The rim of the flanking inlet should not be higher than 0.3 feet above the sag point. In a depressed roadway and underpass, a minimum of three inlets is recommended. Flanking inlets should be located as discussed in the next section. The additional inlets furnish added capacity to allow for flow bypassing the upgrade inlets and provide a safety factor if the sag inlet becomes clogged. The drainage requirement for a depressed roadway differs from a sag vertical curve or a rolled profile as it is designed for a 50-year storm and the ponded water can be removed only through the storm sewer system. Whereas a sag vertical curve is designed for a 10 year frequency and is drained by the storm sewer system where the flood waters can overflow when its depth exceeds the top of curb and/or approach gutter crest elevations.

The close spacing of inlets is a continual problem on extremely flat grades due to redundancy. Two available methods for increasing spacing requirements between inlets are to use slotted drains or a rolling pavement profile.

Where a curbed roadway crosses a bridge, the gutter flow should be intercepted and not be permitted to flow onto the bridge. This is particularly important where freezing temperatures occur. The design criteria for bridge deck drainage is included in [Chapter 1](#) and in the [IDOT Bridge Manual⁶](#).

Stormwater from adjacent properties should not discharge into the highway pavement by flowing over curbs or along entrance ways. If possible, runoff from areas adjacent to the roadway should be intercepted before reaching the pavement. This applies to water that would normally run onto the highway from side streets or from cut slopes and areas beside the pavement. Street inlets are inefficient means for intercepting water and should not be used to intercept the runoff that could have been intercepted by more efficient methods such as swales or structures behind the curb.

8-203.01 Flanking Inlet

Inlets should always be located at the low or sag points in the gutter profile. In addition, it is good engineering practice to place flanking inlets on each side of the low point inlet when in a depressed area that has no outlet except through the system. The purpose of the flanking inlets is to act in relief of the inlet at the low point if it should become clogged or if the design spread is exceeded.

The spacing required for various depths at curb criteria and vertical curve lengths is defined as follows:

$$K = L / (G2 - G1) \tag{Eq. 8-7}$$

where:

L = Length of the vertical curve in feet
 G1, G2 = Approach grades in percent

The AASHTO policy on geometrics specifies maximum K values for various design speeds and a maximum K of 167 considering drainage.

$$X = (74 d K)^{0.5} \tag{Eq. 8-8}$$

where:

X = Maximum distance from bottom of sag to flanking inlet
 d = Depth of water over inlet in bottom of sag
 K = As defined above

Table 8-203.01 is a tabulated solution of Equation 8-8, showing calculated distance from a sag point to flanking inlets in the sag vertical curve when d and K are predetermined.

	K (ft/%)	20	30	40	50	70	90	110	130	160	167
d(ft)											
0.1		12	14	17	19	22	25	28	31	34	35
0.2		17	21	24	27	32	36	40	43	48	49
0.3		21	25	29	33	39	44	49	53	59	60
0.4		24	29	34	38	45	51	57	62	68	70
0.5		27	33	38	43	50	57	63	69	76	78
0.6		29	36	42	47	55	63	69	75	84	86
0.7		32	39	45	50	60	68	75	82	91	93
NOTES:	1. $x = (74dK)^{0.5}$, where x = distance from sag point										
	2. d = depth of ponding at curb										
	3. Drainage Maximum K=167										

Table 8-203.01 Distance to Flanking Inlets in Sag Vertical Curve

8-204 Capacity of Inlets

The hydraulic capacity of inlets determines the rate of water removal from the gutter, as well as the amount of water that can enter the storm sewer system. Inadequate inlet capacity may cause flooding on the roadway, which will create a hazardous situation for the motoring public.

It is important to note that the discussion of inlet capacities neglects the effects of debris and clogging of the various types of inlets. All types of inlets are subject to clogging by debris, with some being more vulnerable than others. Because the attempts to simulate clogging in lab tests have been relatively unsuccessful, comparisons between inlets are based on their unclogged efficiency. Since the amount of debris encountered will vary from location to location, some roadways will have extensive clogging of inlets, while others will not. In general, partial clogging

of inlets will not cause major problems, so allowances for reduced inlet capacity due to debris should not be made unless local experience indicates it is necessary.

For more guidance on the effects of debris on inlet capacity, "Hydraulic Engineering Circular No. 22, Third Edition"⁴ published by the Federal Highway Administration is available through the National Technical Information Service, 5285 Port Royal Road, Springfield, VA 22161. It can also be viewed on the Internet at <http://www.fhwa.dot.gov/bridge/hydpub.htm>.

8-204.01 Inlets on Continuous Grade

The same factors that affect gutter flow will also affect inlet capacity. An inlet capacity depends upon its geometry, the pavement cross slope, longitudinal slope, roughness, total gutter flow, and depth of flow. The depth of water next to the curb is the major factor in the interception capacity of both grate inlets and curb opening inlets. At low velocities, all of the water flowing in the section of gutter occupied by the grate, called frontal flow, is intercepted by grate inlets, and a small portion of the flow along the length of the grate, termed side flow, is intercepted. On steep slopes, only a portion of the frontal flow will be intercepted if the velocity is high, or if the grate is short and splash-over occurs. For grates less than 2 ft long, intercepted side flow is very small.

[Figure 8-204.01a](#) shows the equations necessary for calculating the amount of flow that will be intercepted by an inlet.

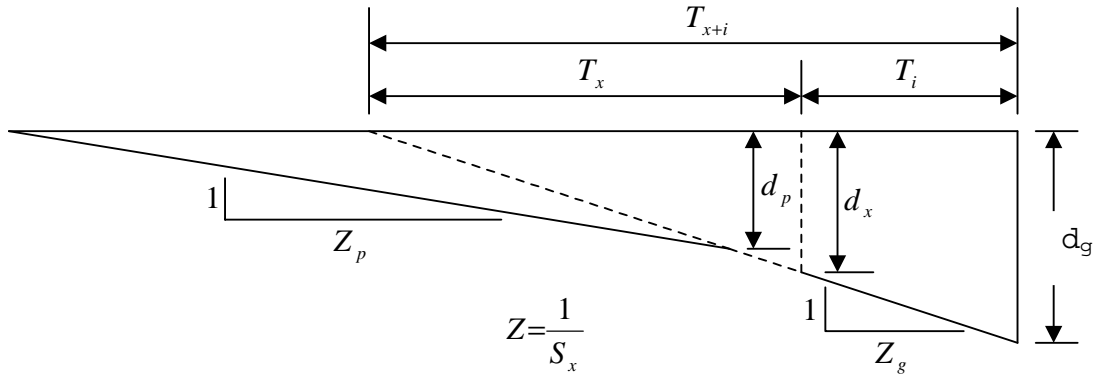

The following equations can be used when the grate width is less than the gutter width. Please note that the intercepted flow is assumed to be the entire flow passing over the width of the grate.

$$d_x = d_g - \frac{T_i}{Z_g} \tag{Eq. 8-9}$$

$$Q_i = 0.56 \frac{Z_g}{n} \left(d_g^{8/3} - d_x^{8/3} \right) S_L^{1/2} \tag{Eq. 8-10}$$

$$Q_b = Q_T - Q_i \tag{Eq. 8-11}$$

Where:

- T_{x+i} = width of spread from curb to the extended projection of the gutter slope to the water surface, ft
- T_i = width of spread over inlet, ft
- T_x = width of spread past from the inlet to the extended projection of the gutter slope to the water surface, ft
- Q_T = total flow in gutter and on pavement, cuft/sec
- Q_i = flow intercepted by grate, cuft/sec
- Q_b = flow bypassing grate, cuft/sec
- d_g = depth of flow in gutter, ft
- d_x = depth of flow at outside edge of inlet grate, ft
- d_p = depth of flow on pavement, ft
- S = longitudinal slope of pavement, ft/ft
- Z_p = reciprocal of cross slope of pavement, ft/ft
- Z_g = reciprocal of cross slope of gutter, ft/ft
- n = manning's roughness coefficient

Equations Utilized in Calculation of Flow Intercepted by Inlets
Figure 8-204.01a

8-204.02 Grate Inlets in a Sag

A grate inlet in a sag operates as a weir up to a certain depth, above this depth the inlet operates under orifice flow. The point where orifice flow begins is dependent on the bar configuration and size of the grate. Weir to orifice flow results in interception capacity less than that computed by either the weir or the orifice equation.

The capacity of grate inlets operating as a weir is:

$$Q_i = CPd^{1.5} \quad (\text{Eq. 8-12})$$

Where:

- C = 3.0 weir coefficient
- P = perimeter of the grate in ft disregarding bars and the side against the curb
- d = average depth of water above grate, ft

and as an orifice is:

$$Q_i = CA(2gd)^{0.5} \quad (\text{Eq. 8-13})$$

Where:

- C = 0.67 orifice coefficient
- A = clear opening area of the grate, sqft
- g = 32.2 ft/sec²

When one is dealing with drainage in a sag location, it is important to remember that all runoff entering the sag must be passed through the inlets. Because of this, clogging of the inlets due to debris can create hazardous ponding conditions on the pavement. As mentioned earlier, it may be necessary to increase the size of the inlet opening where debris blockage has been a problem or could pose a problem in the future. [Figure 8-204.02](#) is a graphical solution of the capacity equations.

An alternative to providing a larger inlet is the placement of a flanking inlet on each side of the sag to provide relief opening in the event the sag inlet becomes clogged or the design spread is exceeded. Flanking inlets are normally located where the gutter invert elevation is 0.2 ft higher than the elevation at the sag. The maximum depth of water over the inlet at the sag point should not be greater than 0.3 ft.

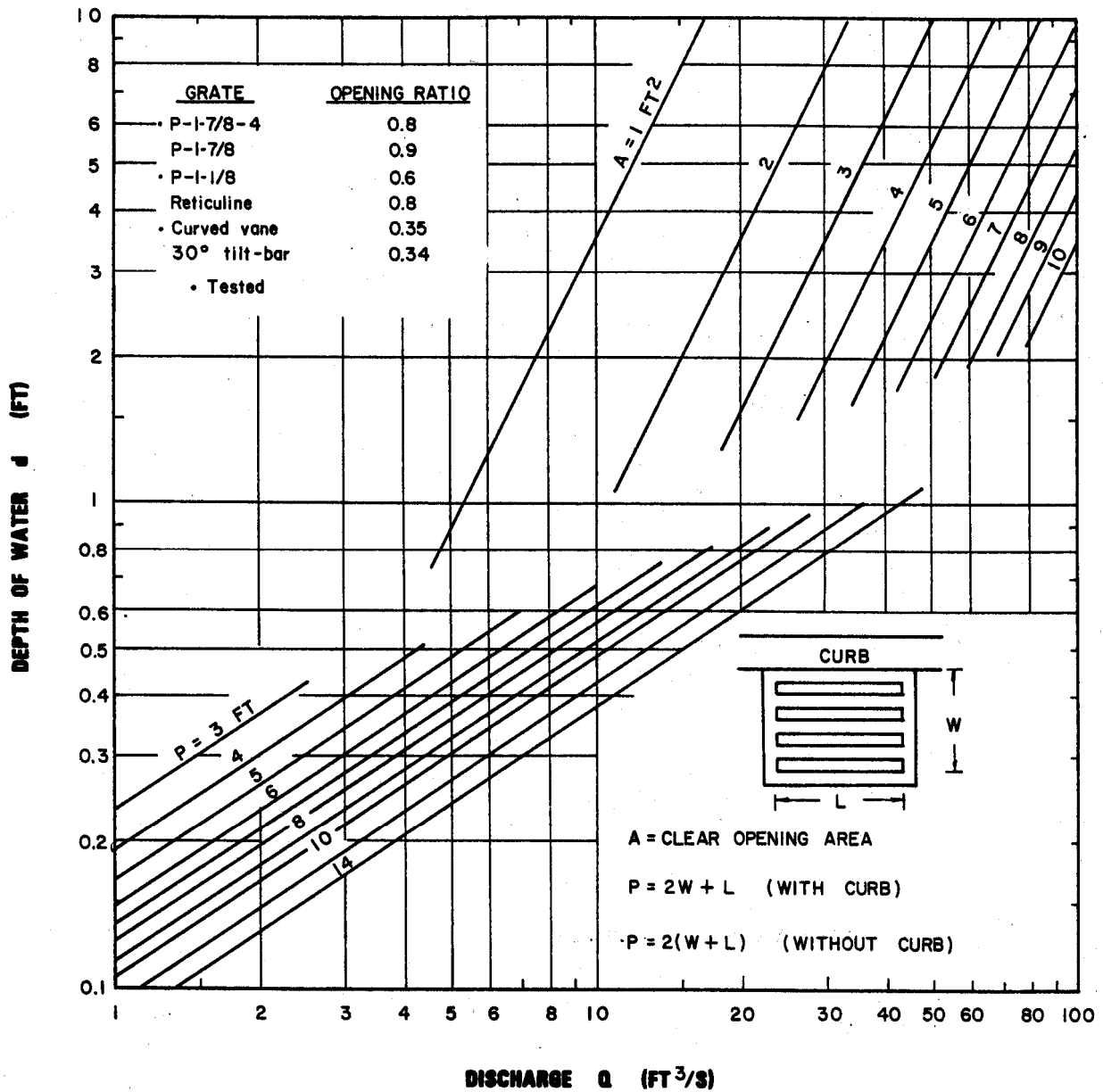

Grate Inlet Capacity in Sump Conditions
 Figure 8-204.02

8-204.03 Curb Opening Inlets⁴

The capacity of a curb-opening inlet in a sag depends on water depth at the curb, the curb opening length, and the height of the curb opening. The inlet operates as a weir to depths equal to the curb opening height and as an orifice at depths greater than 1.4 times the opening height. At depths between 1.0 and 1.4 times the opening height, flow is in transition stage.

Spread on the pavement is the usual criterion for judging the adequacy of a pavement drainage inlet design. It is also convenient and practical in the laboratory to measure depth at the curb upstream of the inlet at the point of maximum spread on the pavement. Therefore, depth at the curb measurements from experiments coincide with the depth at curb of interest to designers. The weir coefficient for a curb-opening inlet is less than the usual weir coefficient for several reasons, the most obvious of which is that depth measurements from experimental tests were not taken at the weir, and drawdown occurs between the point where measurement were made and the weir.

The weir location for a depressed curb-opening inlet is at the edge of the gutter, and the effective weir length is dependent on the width of the depressed gutter and the length of the curb opening. The weir location for a curb-opening inlet that is not depressed is at the lip of the curb opening, and its length is equal to that of the inlet.

The equation for the interception capacity of a depressed curb-opening inlet operating as a weir is:

$$Q_i = C_w (L + 1.8 W) d^{1.5} \tag{Eq. 8-14}$$

where:

$$C_w = 2.3$$

L = length of curb opening, ft

W = lateral width of depression, ft

d = depth at curb measured from the normal cross slope, ft, i.e., $d = T S_x$

The weir equation is applicable to depths at the curb approximately equal to the height of the opening plus the depth of the depression. Thus, the limitation on the use of Equation 8-14 for a depressed curb-opening inlet is:

$$d \leq h + a / 12 \tag{Eq. 8-15}$$

where:

h = height of curb-opening inlet, ft

a = depth of depression, in, as shown in Figure 8-204.03a

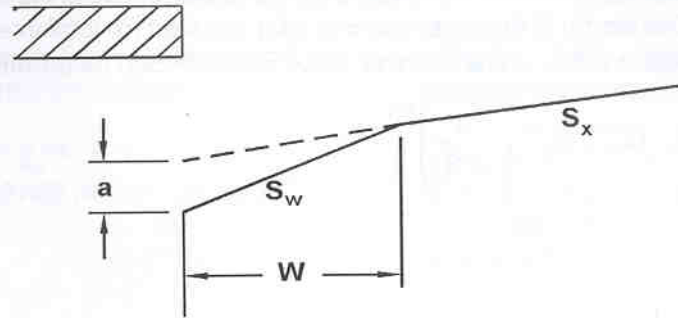

Depressed Curb Opening on Grade
Figure 8-204.03a

Experiments have not been conducted for curb-opening inlets with a continuously depressed gutter, but it is reasonable to expect that the effective weir length would be as great as that for an inlet in a local depression. Use of Equation 8-14 will yield conservative estimates of the interception capacity.

The weir equation for curb-opening inlets without depression becomes:

$$Q_i = C_w L d^{1.5} \tag{Eq. 8-16}$$

Without depression of the gutter section, the weir coefficient, C_w , becomes 3.0. The depth limitation for operation as a weir becomes $d \leq h$.

At curb-opening lengths greater than 12 ft, Equation 8-16 for non-depressed inlet produces intercepted flows which exceed the values for depressed inlets computed using Equation 8-14. Since depressed inlets will perform at least as well as non-depressed inlets of the same length, Equation 8-16 should be used for all curb opening inlets having lengths greater than 12 ft.

Curb-opening inlets operate as orifices at depths greater than approximately 1.4 times the opening height. The interception capacity can be computed by Equation 8-17a and Equation 8-17b. These equations are applicable to depressed and undepressed curb-opening inlets. The depth at the inlet includes any gutter depression.

$$Q_i = C_o h L (2 g d_o)^{0.5} \tag{Eq. 8-17a}$$

or

$$Q_i = C_o A_g \{2g [d_i - (h/2)]\}^{0.5} \tag{Eq. 8-17b}$$

where:

- C_o = orifice coefficient (0.67)
- d_o = effective head on the center of the orifice throat, ft
- L = length of orifice opening, ft
- A_g = clear area of opening, ft^2
- d_i = depth at lip of curb opening, ft

h = height of curb-opening orifice, ft

The height of the orifice in Equations 8-17a and 8-17b assumes a vertical orifice opening. As illustrated in Figure 8-204-.03b, other orifice throat locations can change the effective depth on the orifice and the dimension $(d_i - h/2)$. A limited throat width could reduce the capacity of the curb-opening inlet by causing the inlet to go into orifice flow at depths less than the height of the opening.

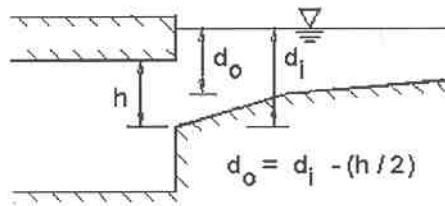

a. Horizontal Throat

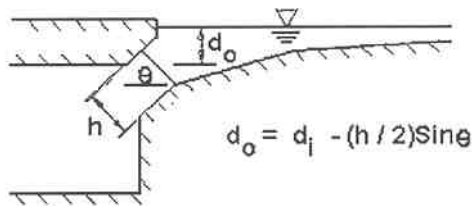

b. Inclined Throat

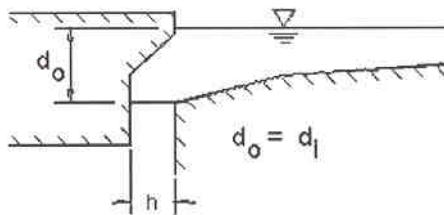

c. Vertical Throat

Curb Opening Inlets
Figure 8-204.03b

8-204.04 Slotted Inlets

Slotted inlets in sag locations perform as weirs to depths of about 0.2 ft, dependent on slot width. At depths greater than about 0.4 ft, they perform as orifices. Between these depths, flow is in a transition stage. The interception capacity of a slotted inlet operating as a weir can be computed by Equation 8-18:

$$Q_i = C_w L d^{1.5} \tag{Eq. 8-18}$$

where:

C_w = weir coefficient; various with flow depth and slot length; typical value is approximately 2.48

L = length of slot, ft)

d = depth at curb measured from the normal cross slope, ft

The interception capacity of a slotted inlet operating as an orifice can be computed by Equation 8-19:

$$Q_i = 0.8 L W (2 g d)^{0.5} \tag{Eq. 8-19}$$

where:

W = width of slot, ft

L = length of slot, ft

d = depth of water at slot for $d > 0.4$ ft, ft

g = 32.16 ft/s²

For a slot width of 1.75 in, Equation 8-19 becomes:

$$Q_i = C_D L d^{0.5} \tag{Eq. 8-20}$$

where:

C_D = 0.94

To conservatively compute the interception capacity of slotted inlets in sump conditions in the transition area, orifice conditions should be assumed. Due to clogging characteristics, slotted drains are not recommended in sag locations.

8-204.05 Combination Inlets

In general, combination inlets of equal length are not desirable for use on a continuous grade where the longitudinal slope of the road is greater than 0.5 percent. The interception capacity of a combination inlet on a continuous grade is not appreciably greater than that of a grate alone. In computing the inlet capacity, the curb opening is neglected and only the grate opening is considered.

The use of combination inlets in a sag is desirable because they can help avoid ponding of water. The curb opening provides a relief opening if the grate should become clogged. The capacity of a combination inlet in a sag is essentially the same as the grate alone in weir flow conditions unless the grate opening becomes clogged. In orifice flow, the capacity is equal to the total capacity of the grate and curb opening.

Combination inlets are also used on flat grades (less than 0.5 percent) where the curb opening provides additional capacity when debris blocks gutter grates due to the low velocities. Tilt bar or vane grates are to be used on grade sections and parallel bar grates are used in sag locations where gutter flow approaches from both directions.

8-205 Spacing of Inlet Structures**8-205.01 The Rational Method**

The Rational Method is used to make the hydrologic analysis for inlet spacing and three major factors govern the rate of flow:

1. The surfaces that compose the drainage area ("C" factor)
2. The rainfall intensity rate depends upon two factors: design frequency and duration time. The design frequency is the period of time in which we expect the design storm event to be exceeded. However, it is possible to have several design events within a single year. On a statistical basis though, the average recurrence of the design storm event is the design frequency. The design frequency concept is essential to a sound and economical design. Duration time is assumed to be equal to the time of runoff concentration. The time of concentration for any area must be estimated and is the sum of the time required for water to move across the pavement or overland to the gutter, plus the time required for flow to move through the length of gutter to the inlet. When the total time of concentration for pavement drainage inlets is less than five minutes, a minimum time of five minutes should be used to estimate the duration of rainfall.
3. Drainage Area - Except in special cases, design drainage areas are composed of more than one type of surface. One exception is where the shoulder or finished grade slopes away from the gutters or the back of curbs. In this case, the width of the drainage area is equal to the sum of the pavement width to the crown of the road plus the width of the gutter.

8-205.02 Determination of First Inlet Location

The location of the first inlet from the crest is found by determining the length of pavement and the area back of curbs sloping toward the roadway which will generate the design runoff. The design runoff is set equal to the maximum allowable flow in the pavement and gutter section as computed above.

On some combinations of drainage areas, it is possible that the maximum rate of runoff will occur from the higher intensity rainfall for periods less than the time of concentration for the total area, even though only a part of the drainage area may be contributing. This might occur where a part of the drainage area is highly impervious and has a short time of concentration while another part is pervious and has a much longer time of concentration. Unless the areas or times of concentration are considerably out of balance, however, the range of accuracy of the method does not warrant checking the peak flow from only a part of the drainage area. For the relatively small drainage areas associated with highway pavement drainage, it can usually be assumed that the longest time of concentration for the drainage area is appropriate for purposes of computing runoff.

On combined drainage areas, the contributing area is assumed to be the product of the length and a constant width and the first inlet location can be calculated as:

$$L = \frac{Q_T \cdot 43560}{CIW} \tag{Eq. 8-21}$$

Where:

- L = distance from the crest, ft
- Q_T = maximum allowable flow when width of conveyance is at its allowable design width (includes encroachment on road), cuft/sec
- C = composite runoff coefficient for contributing area
- W = average width of contributing area, ft
- I = rainfall intensity for design frequency, in/hr

8-205.021 Example Problem 3:

Inlet spacing calculations are required for a Type B.6.24 curb and gutter connected to a 24 ft. wide pavement with finished ground sloping away from back of curbs.

Note: Please refer to Example 2 ([Section 8-202.02](#)) for explanation regarding the computation of Q_T used in this example.

Given:

- C = 0.95
- I = 5.9
- W = 14
- Q_T = 0.377 cuft/sec

Solution:

Determine first inlet location

$$L = \frac{Q_T}{CIW} = \frac{(0.377)(43560)}{(0.95)(5.9)(14)} = 209 \text{ ft}$$

The interval between successive inlets must be adjusted to account for the flow that bypasses the first or previous inlets and the length between inlets can be calculated as:

$$L = \frac{(Q_T - Q_b)43560}{CIW} \tag{Eq. 8-22}$$

Where:

Q_b = the flow that bypasses the first or previous inlet, cuft/sec

8-205.03 Spacing of Successive Inlets

The amount of flow that bypasses an inlet is known as bypass flow. Bypass flow occurs because of lack of inlet capacity or because flow on the pavement is not presented to the inlet opening.

When design flow occurs in a street drainage system, all upstream inlets in the system should contribute bypass flow to the next inlet downstream. Only the inlet located at the low point in the roadway grade should be designed to receive all of the flow that is presented to it.

To complete the above sample problem, assuming a Type 3 frame and grate, the designer must determine the quantity of flow intercepted by the first inlet.

Based on test results by several agencies and grate manufacturers, it can be assumed that at longitudinal pavement slopes less than 1 percent the inlet efficiency is 100 percent since the inlet intercepts all of the flow presented within the width of the inlet. The only carryover which will occur will be from that spread of water beyond the width of the inlet. Since the grate has a cross width of 16-7/8 inches, the quantity of flow intercepted will be that contained in the first 16-7/8 inches of the gutter.

8-205.031 Example Problem 4:

Below is the continuation of Examples 2 and 3 ([Section 8-202.02](#) and [Section 8-205.021](#)). The design parameters for the additional inlet spacing remain the same as shown in Example 2 ([Section 8-202.02](#)) and are repeated below.

Given:

- 3/4 in/ft gutter cross slope with 1/4 in/ft pavement cross slope
- Longitudinal slope = 0.30 percent
- Manning’s n for pavement = 0.013
- Maximum allowable encroachment of water on pavement permitted will be 3 ft

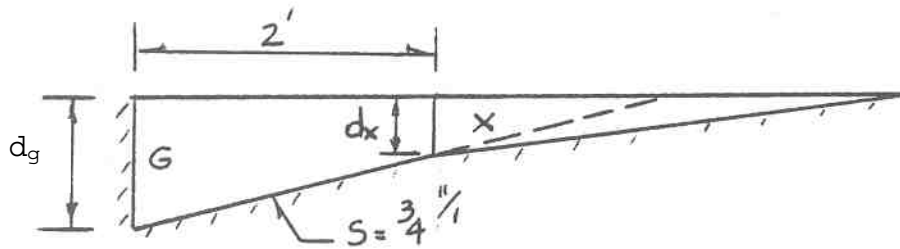

Solution:

$$d_g = 0.172 \text{ ft from solution for gutter flow}$$

$$\text{Then } Q_{g+x} = 0.56 \left(\frac{16}{0.013} \right) (0.003)^{1/2} (0.172)^{8/3} = 0.345 \text{ cuft/sec}$$

Computing Q_x for Section X.

$$d_x = \frac{T}{Z} = \frac{3}{64} = 0.047 \text{ ft}$$

$$Q_x = 0.56 \left(\frac{16}{0.013} \right) (0.003)^{1/2} (0.047)^{8/3} = 0.011 \text{ cuft/sec}$$

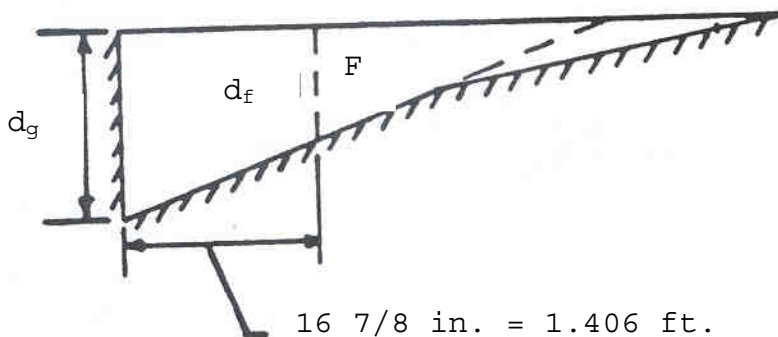

Computing Q_f for Section F.

$$d_f = d_g - \frac{T}{Z} = 0.172 - \frac{1.406}{16} = 0.084 \text{ ft}$$

$$Q_f = 0.56 \left(\frac{16}{0.013} \right) (0.003)^{1/2} (0.084)^{8/3} = 0.051 \text{ cuft/sec}$$

The intercepted flow is then:

$$Q_i = Q_{g+x} - Q_f = 0.345 - 0.051 = 0.294 \text{ cuft/sec}$$

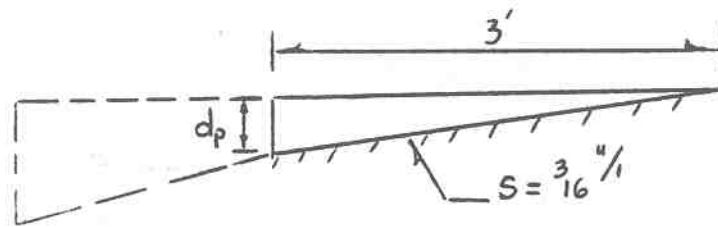

Computing Q_p for pavement flow

$$d_p = d_x = 0.047 \text{ ft}$$

$$Q_p = 0.56 \left(\frac{64}{0.013} \right) (0.003)^{1/2} (0.047)^{8/3} = 0.043 \text{ cuft/sec}$$

The total flow can be determined.

$$Q_T = Q_{g+x} - Q_x + Q_p = 0.345 - 0.011 + 0.043 = 0.377 \text{ cuft/sec}$$

Computing Q_b for bypass flow

$$Q_b = Q_T - Q_i = 0.377 - 0.294 = 0.083 \text{ cuft/sec}$$

The spacing of the second inlet is then dependent upon the drainage area required to contribute the amount of flow intercepted by the first inlet.

Again using the Rational Method:

$$Q = CIA = 0.95(5.9) \left(\frac{14L}{43560} \right) = 0.294 \text{ cuft/sec}$$

Solving for L

$$L = \frac{(0.294)(43560)}{(0.95)(5.9)(14)} = 163 \text{ ft}$$

The minimum spacing of all subsequent inlets is equal to the interval between the first and second inlets as long as the longitudinal and transverse grades as well as the pavement width remain constant. When any one of the variables changes, the maximum allowable flow must be recomputed and a new inlet interval determined for a flow rate equal to the new maximum allowable flow minus the bypass flow from the previous inlet.

8-300 STORM SEWER DESIGN

8-301 Introduction

After the preliminary locations of inlets, connecting pipes, and outfalls with tailwaters have been determined, the next logical step is the computation of the rate of discharge to be carried by each reach of the storm sewer, and the determination of the size and gradient of storm sewer required to convey this discharge. This is done by starting at the upstream reach, calculating the discharge and sizing the storm sewer, then proceeding downstream, reach by reach, to the point where the storm sewer connects with other drains or the outfall. The rate of discharge at any point in the storm sewer is not necessarily the sum of the inlet flow rates of all inlets above that section of storm sewer. It is generally less than this total. The time of concentration is most influential and, as the time of concentration grows larger, the rainfall intensity to be used in the design grows smaller. In some cases, where a relatively large drainage area with a short time of concentration is added to the system, the peak flow may be larger using the shorter time even though the entire drainage area is not contributing. The prudent designer will be alert for unusual conditions and determine which time of concentration controls for each pipe segment. See [Section 8-008.02](#) for a discussion on time of concentration and discharge.

For ordinary conditions, the storm sewer system should be sized on the assumption that it will flow full or practically full under the design discharge but will not flow under pressure head. The Manning's Equation is recommended for capacity calculations. In locations such as depressed sections and underpasses where ponded water can be removed only through the storm sewer system, a 50 year design frequency should be considered to design the storm sewer which drains the sag point. See [Section 8-203](#) and [Section 8-203.01](#) for a discussion on the location of flanking inlets. The main storm sewer downstream of the depressed section should be designed by computing the hydraulic grade line and keeping the water surface elevations below the grates and/or established critical elevations for the design storm.

8-302 Hydraulic Capacity

The most widely used formula for determining the hydraulic capacity of sewers for gravity and pressure flows is the Manning's Equation and it is expressed by the following equation:

$$V = \frac{1.486}{n} R^{2/3} S^{1/2} \quad (\text{Eq. 8-23})$$

Where:

V = mean velocity of flow, ft/sec

R = the hydraulic radius, ft. It is defined as the area of flow divided by the wetted flow surface or wetted perimeter.

S = the slope of the hydraulic grade line, ft/ft

n = Manning's roughness coefficient

In terms of discharge, the above equation becomes

$$Q = \frac{1.486}{n} A R^{2/3} S^{1/2} \quad (\text{Eq. 8-24})$$

Where:

- Q = rate of flow, cuft/sec.
- A = cross sectional area of flow, sqft

For pipes flowing full, the above equations become

$$V_{full} = \frac{0.590}{n} D^{2/3} S^{1/2} \quad (\text{Eq. 8-25})$$

and

$$Q_{full} = \frac{0.463}{n} D^{8/3} S^{1/2} \quad (\text{Eq. 8-26})$$

Where:

- D = diameter of pipe, ft

The Manning's Equation can be written to determine friction losses for pipes as:

$$H_f = \frac{29n^2 LV^2}{2gR^{4/3}} \quad (\text{Eq. 8-27})$$

Equation 8-28 is derived from Equation 8-27 for full flow conditions.

$$H_f = \frac{2.87n^2 V^2 L}{D^{4/3}} \text{ (for full flow)} \quad (\text{Eq. 8-28})$$

Where:

- H_f = total head loss due to friction, ft
- n = Manning's roughness coefficient
- D = diameter of pipe, ft
- L = length of pipe, ft
- V = mean velocity, ft/sec
- R = hydraulic radius, ft
- g = acceleration of gravity = 32.2 ft/sec²

8-303 Charts, Nomographs and Tables

The nomograph solution of Manning's Equation, for full flow in circular storm sewers, is shown in Figures 8-303a through 8-303c. Figure 8-303d through Figure 8-303g have been provided to solve the Manning's Equation for part-full flow in circular section, elliptical section and arch section of storm sewers, respectively. Table 8-303a like Figure 8-303d also can be used to solve the Manning's Equation for part-full flow in circular storm sewers. Table 8-303b provides hydraulic properties of circular pipe.

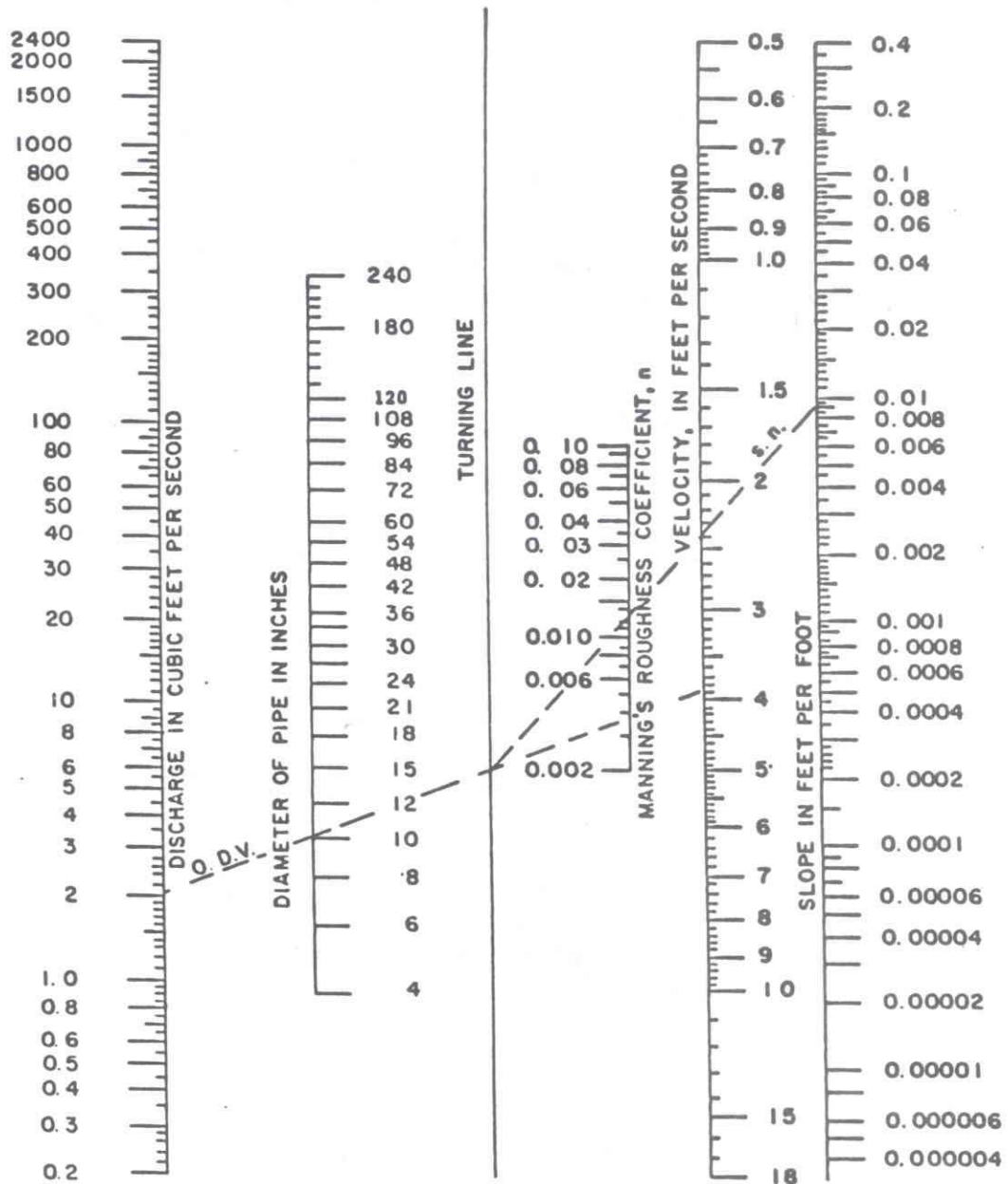

Nomograph for Solution of Manning's Formula for Full Flow in Storm Sewers
Figure 8-303a

Example:- Given discharge $Q = 4.4$ c.f.s.
 friction factor $n = 0.015$
 slope of $0.0060'$ per foot
Find diameter 15 inches and
 velocity of 3.5 ft. per second,
 by following dashed line.

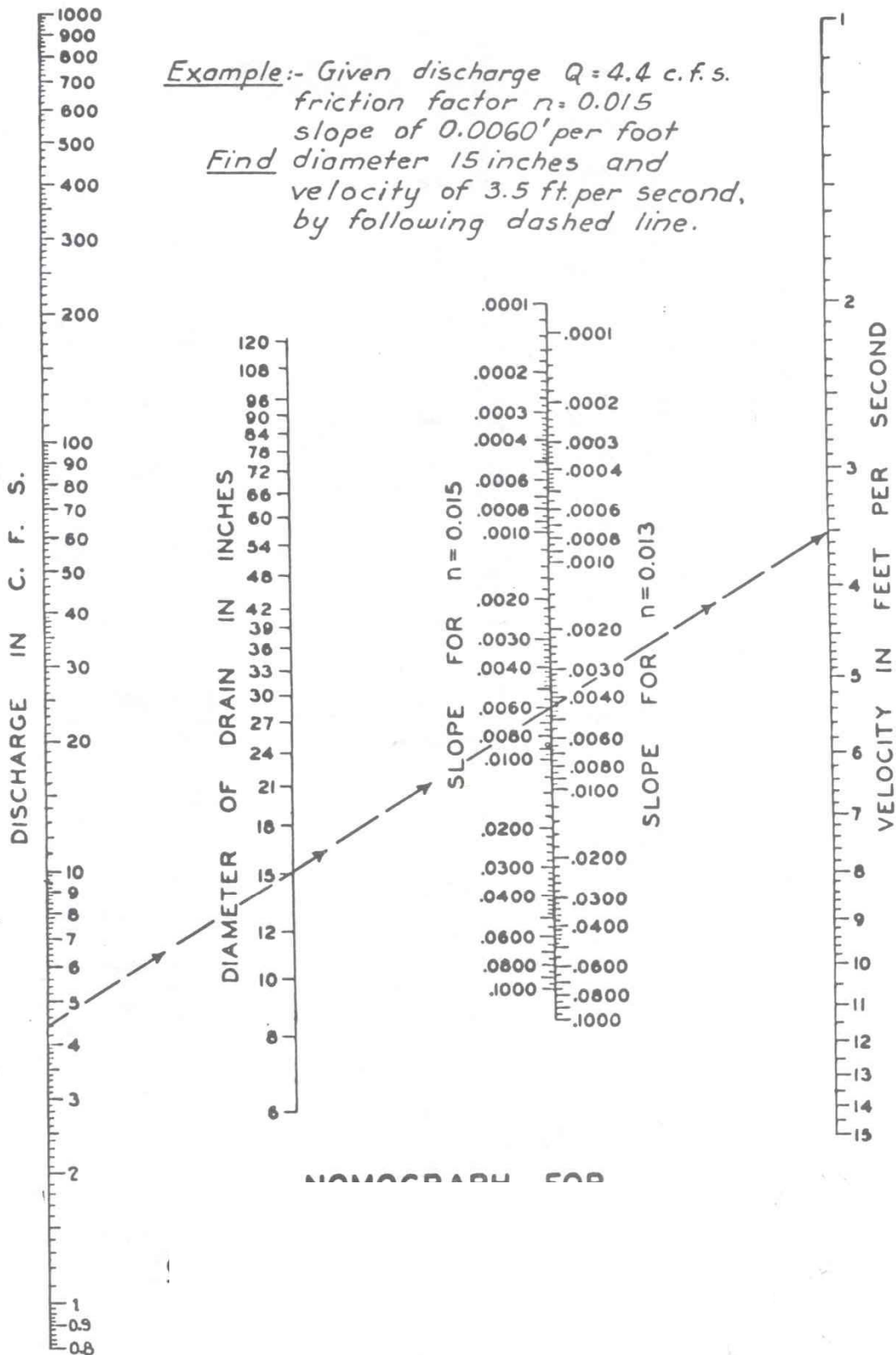

Nomograph for Computing Required Size of Circular Drain, Flowing Full
 ($n = 0.013$ or 0.015)
 Figure 8-303b

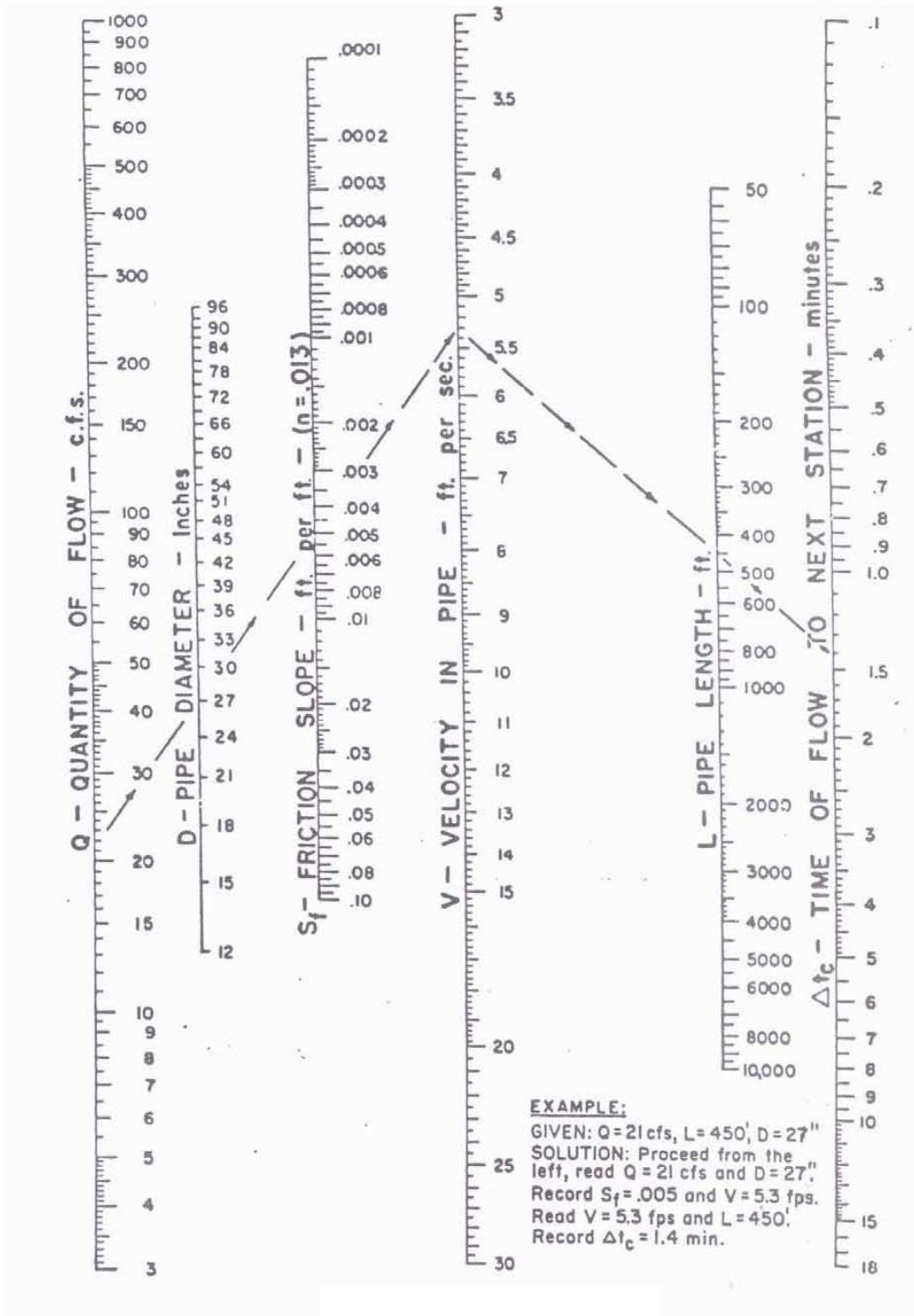

CONCRETE PIPE FULL FLOW NOMOGRAPH

Figure 8-303c

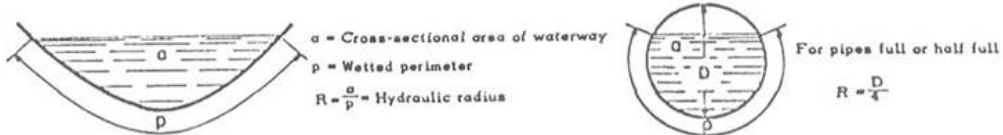

SECTION OF ANY CHANNEL

SECTION OF CIRCULAR PIPE

V = Average or mean velocity in feet per second
 Q = a V = Discharge of pipe or channel in cubic feet per second (cfs)
 n = Coefficient of roughness of pipe or channel surface
 S = Slope of Hydraulic Gradient (water surface in open channels or pipes not under pressure, same as slope of channel or pipe invert only when flow is uniform in constant section.

HYDRAULIC ELEMENTS OF CIRCULAR SECTIONS

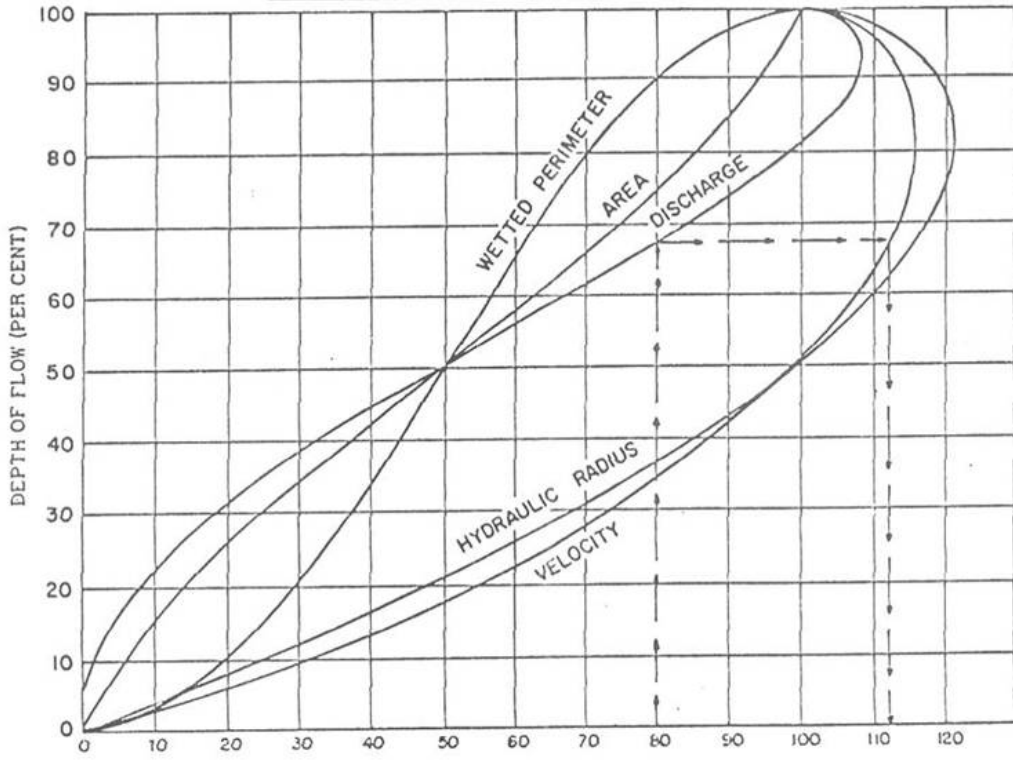

HYDRAULIC ELEMENTS PER CENT OF VALUE FOR FULL SECTION (approximate)

EXAMPLE: Given: Discharge = 12 cfs through a pipe which has capacity flowing full of 15 cfs at a velocity of 7.0 ft. per sec. Required to find V for Q = 12 cfs therefore, Percentage of full discharge = $\frac{12}{15} = 80\%$. Enter chart at 80% of value for full section of Hydraulic Elements, find V = 112.5% x 7 = 7.9 ft. per sec.

VALUES OF HYDRAULIC ELEMENTS OF CIRCULAR SECTION FOR VARIOUS DEPTHS OF FLOW

Figure 8-303d

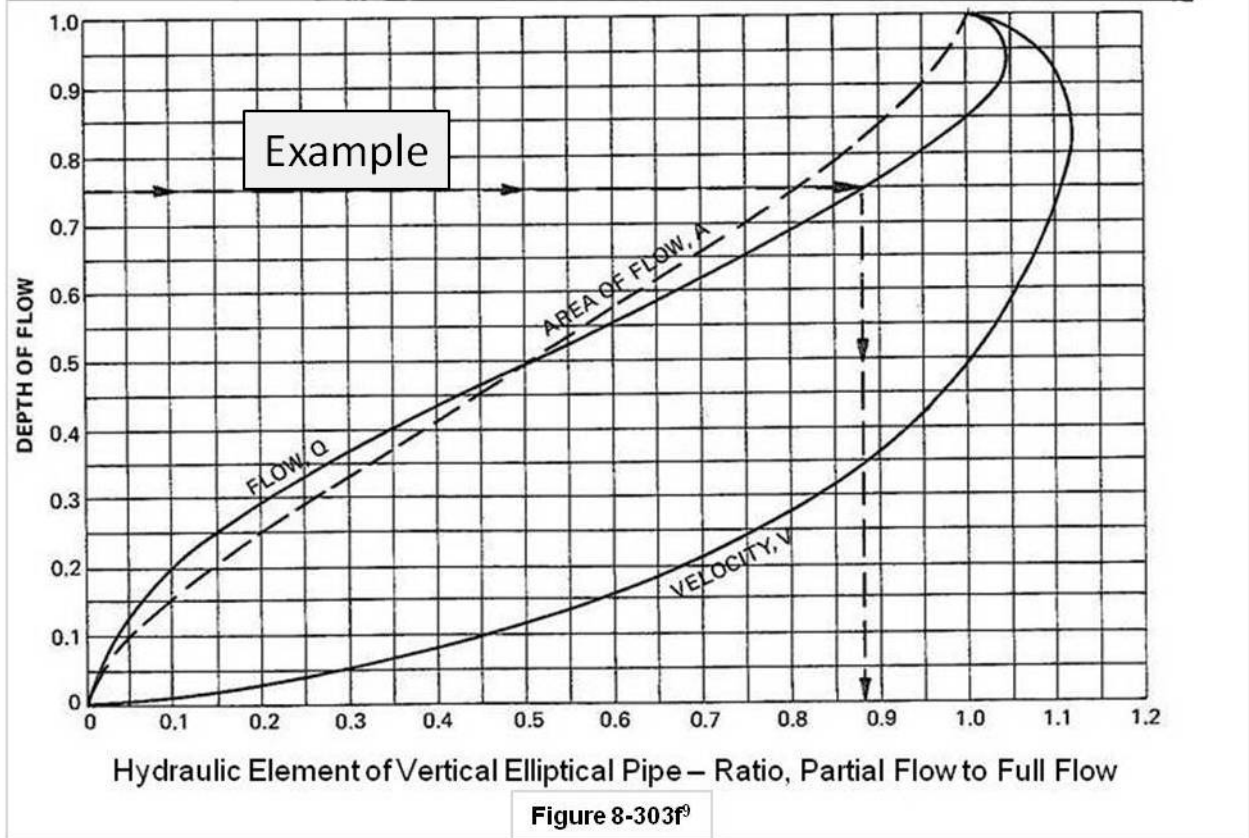
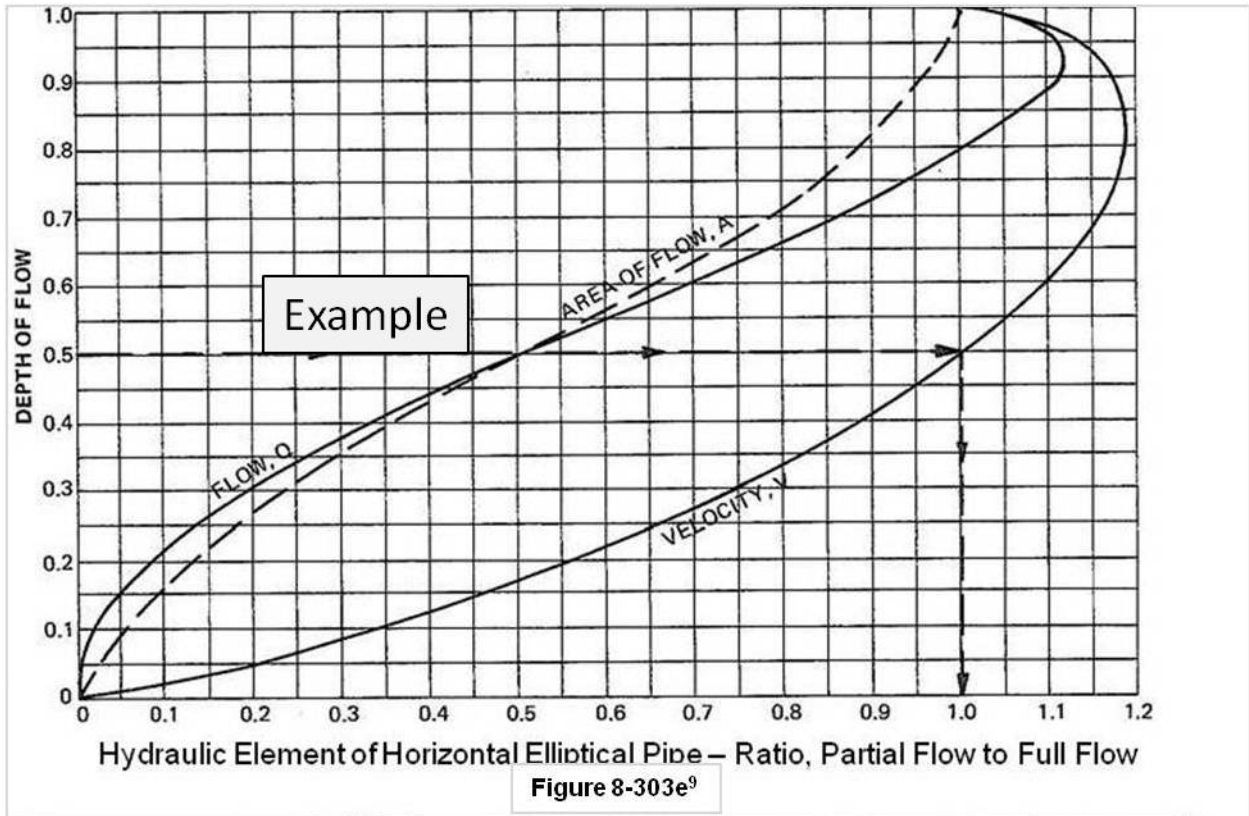

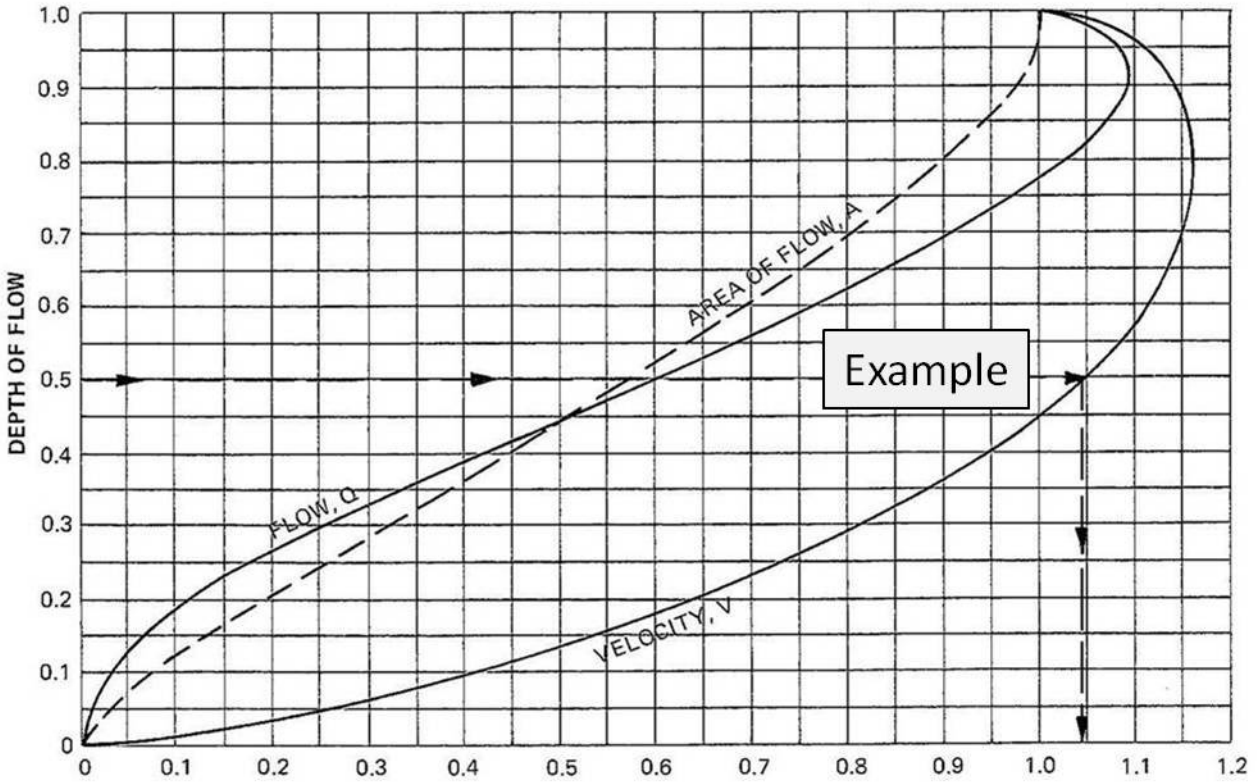

Hydraulic Elements of Arch Pipe – Ratio, Partial Flow to Full Flow
Figure 8-303g⁹

%D	%Q	%V	%A	%D	%Q	%V	%A	%D	%Q	%V	%A
7.06	1	32.1	3.11	43.4	39	93.8	41.6	65.8	77	110.3	69.8
9.80	2	39.6	5.05	44.0	40	94.4	42.4	66.4	78	110.6	70.5
11.9	3	44.7	6.71	44.6	41	95.0	43.1	67.0	79	110.8	71.3
13.7	4	48.8	8.20	45.2	42	95.6	43.9	67.7	80	111.1	72.0
15.2	5	52.1	9.59	45.8	43	96.2	44.7	68.3	81	111.3	72.7
16.6	6	55.0	10.9	46.4	44	96.8	45.5	68.9	82	111.6	73.5
17.9	7	57.6	12.2	47.0	45	97.4	46.2	69.5	83	111.8	74.2
19.1	8	59.9	13.4	47.6	46	97.9	47.0	70.2	84	112.0	75.0
20.3	9	62.0	14.5	48.2	47	98.5	47.7	70.8	85	112.3	75.7
21.4	10	63.9	15.6	48.8	48	99.0	48.5	71.5	86	112.5	76.5
22.4	11	65.7	16.7	49.4	49	99.5	49.2	72.1	87	112.6	77.2
23.4	12	67.4	17.8	50.0	50	100.0	50.0	72.8	88	112.8	78.0
24.3	13	69.0	18.8	50.6	51	100.5	50.7	73.5	89	113.0	78.8
25.3	14	70.5	19.9	51.2	52	101.0	51.5	74.2	90	113.2	79.5
26.2	15	71.9	20.9	51.8	53	101.5	52.2	74.9	91	113.3	80.3
27.0	16	73.3	21.8	52.3	54	101.9	53.0	75.6	92	113.5	81.1
27.9	17	74.6	22.8	52.9	55	102.4	53.7	76.3	93	113.6	81.9
28.7	18	75.8	23.8	53.5	56	102.8	54.5	77.0	94	113.7	82.7
29.5	19	77.0	24.7	54.1	57	103.3	55.2	77.8	95	113.8	83.5
30.3	20	78.1	25.6	54.7	58	103.7	55.9	78.6	96	113.9	84.3
31.1	21	79.2	26.5	55.2	59	104.1	56.7	79.4	97	113.9	85.1
31.9	22	80.2	27.4	55.8	60	104.5	57.4	80.2	98	114.0	86.0
32.6	23	81.2	28.3	56.4	61	104.9	58.1	81.1	99	114.0	86.8
33.4	24	82.2	29.2	57.0	62	105.3	58.9	82.0	100	114.0	87.7
34.1	25	83.1	30.1	57.6	63	105.7	59.6	82.9	101	114.0	88.6
34.8	26	84.0	30.9	58.1	64	106.1	60.3	83.9	102	113.9	89.6
35.5	27	84.9	31.8	58.7	65	106.5	61.1	85.0	103	113.7	90.5
36.2	28	85.8	32.6	59.3	66	106.8	61.8	86.1	104	113.6	91.6
36.9	29	86.6	33.5	59.9	67	107.2	62.5	87.4	105	113.3	92.7
37.6	30	87.4	34.3	60.5	68	107.5	63.2	88.9	106	112.8	94.0
38.2	31	88.2	35.1	61.1	69	107.9	64.0	91.0	107	112.0	95.5
38.9	32	89.0	36.0	61.6	70	108.2	64.7	96.3	107	108.3	98.8
39.5	33	89.7	36.8	62.2	71	108.5	65.4	97.7	106	106.6	99.4
40.2	34	90.4	37.6	62.8	72	108.8	66.2	98.5	105	105.3	99.7
40.8	35	91.1	38.4	63.4	73	109.1	66.9	99.1	104	104.2	99.9
41.5	36	91.8	39.2	64.0	74	109.5	67.6	99.5	103	103.1	99.9
42.1	37	92.5	40.0	64.6	75	109.7	68.3	99.8	102	102.0	100
42.7	38	93.2	40.8	65.2	76	110.0	69.1	99.9	101	101.0	100
								100	100	100	100

Hydraulic Elements in Solving Manning's Equation for Part-Full Flow in Circular Storm Sewers

Table 8-303a

DIAMETER d (inches)	AREA A (Sq. Ft.)	HYDRAULIC RADIUS R (Feet)	K	
			n = 0.012	n = 0.013
8	0.349	0.167	13.1	12.1
10	0.545	0.208	23.6	21.8
12	0.785	0.250	38.6	35.7
15	1.227	0.312	70.1	64.7
18	1.767	0.375	113.8	105.1
21	2.405	0.437	171.5	158.3
24	3.142	0.500	245.1	226.2
27	3.976	0.562	335.3	309.6
30	4.909	0.625	444.3	410.1
33	5.940	0.688	573.7	529.6
36	7.069	0.750	722	666
42	9.621	0.875	1090	1006
48	12.57	1.000	1556	1436
54	15.90	1.125	2131	1967
60	19.64	1.250	2821	2604
66	23.76	1.375	3636	3357
72	28.27	1.500	4587	4234
78	33.18	1.625	5679	5242
84	38.49	1.750	6920	6388
90	44.18	1.875	8321	7681
96	50.27	2.000	9878	8119
102	56.75	2.125	11615	10722
108	63.62	2.250	13526	12486
114	70.88	2.375	15624	14422
120	78.54	2.500	17915	16537
126	86.59	2.625	20397	18829
132	95.03	2.750	23104	21327
138	103.87	2.875	26009	24011
144	113.10	3.000	29133	26894

*Hydraulic Properties of Circular Pipe
Table 8-303b*

8-304 Design Procedures

The design of storm drainage systems is generally divided into the following operations:

- | | |
|--------|--|
| Step 1 | Prepare the plan layout of the storm drainage system establishing the following design data: <ol style="list-style-type: none">a. location of storm sewers;b. direction of flow;c. location of inlet structures for special condition (see Section 8-200); andd. location of existing utilities (e.g., water, gas, underground cables and existing and proposed foundations). |
| Step 2 | Determine drainage areas, runoff coefficients and a time of concentration to the first inlet. Using an Intensity-Duration-Frequency (IDF) curve, determine the rainfall intensity. Calculate the discharge by using the Rational Method, $Q=CIA$. |
| Step 3 | Determine inlet locations and spacing. |
| Step 4 | Size the pipe to convey the discharge by varying the slope and pipe size as necessary. The storm drain systems are normally designed for full gravity-flow conditions using the design frequency discharges. |
| Step 5 | Calculate travel time in the pipe to the next inlet or manhole by dividing pipe length by the velocity. This travel time is added to the time of concentration for a new time of concentration and new rainfall intensity at the next entry point. |
| Step 6 | Calculate the new area (A) and multiply by the runoff coefficient (C), add to the previous (CA), and multiply by the new rainfall intensity to determine the new discharge. Determine the size of pipe and slope necessary to convey the discharge. |
| Step 7 | Continue this process to the storm sewer outlet. Utilize the equations and/or nomographs to accomplish the design effort. |
| Step 8 | Complete the design by calculating the hydraulic grade line as described in Section 8-305.04 . |
| Step 9 | Check the hydraulic grade line to ensure that it meets the design criteria. |

Typical storm sewer computations can be made on forms as illustrated in [Table 8-304](#). The designer should note drainage areas are accumulated from one intercepting point to the next. Laterals will also be used connecting the inlet on one side of the road to the inlet on the other side, which is part of the trunk sewer.

The design of sag inlets at underpasses and depressed roadways is shown in the following example problem.

8-304.01 Example Problem 5

Given:

A roadway with the centerline profile and cross section as shown in [Figure 8-304.01a](#).

Design:

1. Limit the spread on the pavement for a 50 year storm to one half of a lane width.
2. Design a storm sewer system for a ten year storm frequency.

Solution:

The grades are symmetrical about the P.I. of the vertical curve and only one half of a section need be considered. The first inlet is spaced 190 feet from the crest and successive inlets are spaced at 140 foot intervals. Inlets are also placed 20 feet to each side of the sag inlet. (Type 3 frames and grates.)

Computations for the peak flows arriving at the inlets are given in [Table 8-304.01a](#). The pavement encroachment is less than one half of a lane width (6 ft), therefore, the system is satisfactory.

Computations for the design of the storm sewer system are given in the upper half of [Table 8-304.01b](#).

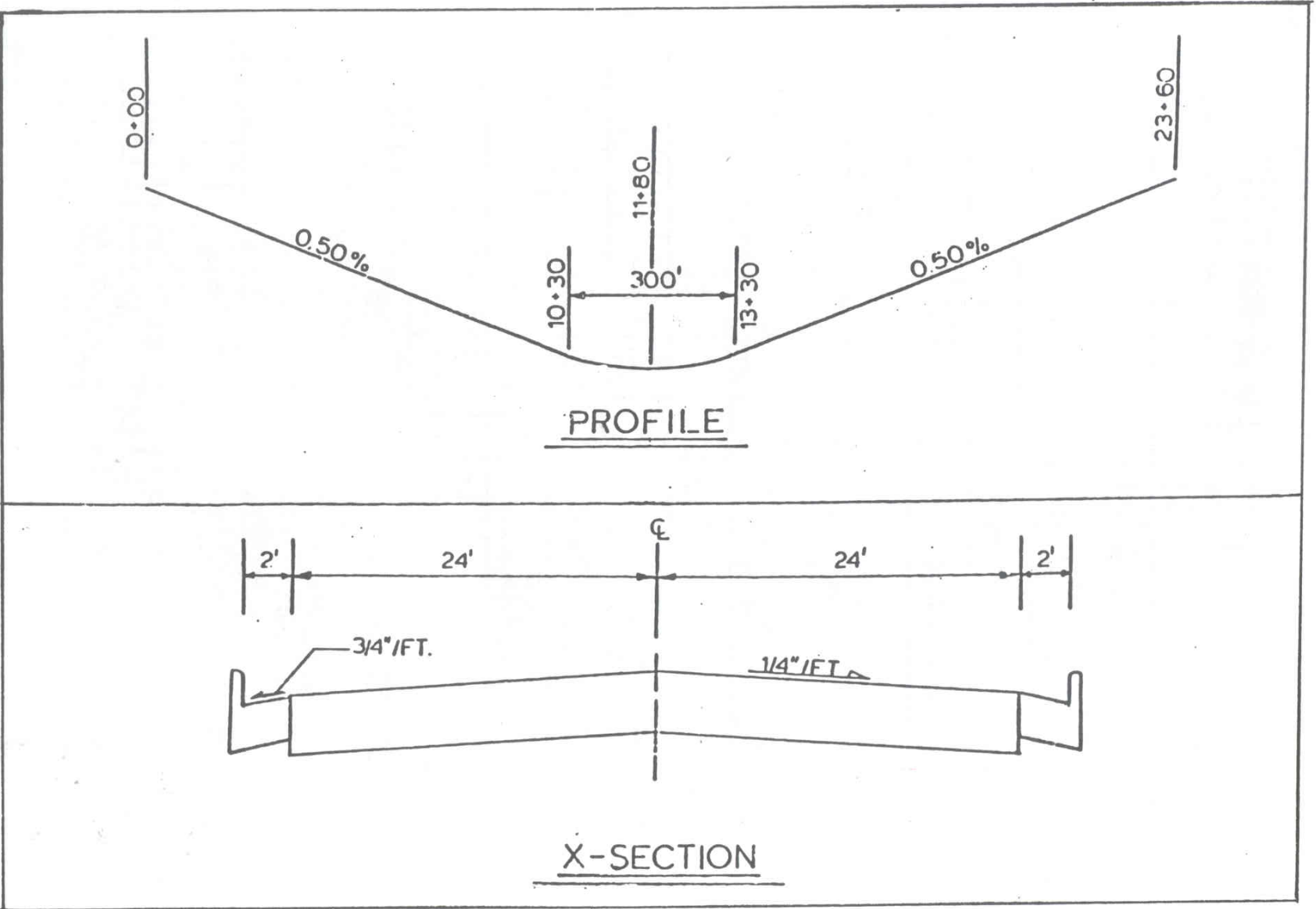

Example Problem Centerline Profile and Cross Section
Figure 8-304.01a

INLET STA.	DIST. (FT.)	% SLOPE	ΔA (Ac.)	C	ΔCA	ΔT _c (MIN)	ΣT _c (MIN)	I (50yr.)	ΔQ (CFS)	Q (CFS)	T (FT.)	Q _{int} (CFS)	Q _{by} (CFS)	
1+90	190	0.50	0.11	0.95	0.10	6.0	6.0	8.05	0.81	0.81	3.7	0.54	0.27	
3+30	140	0.50	0.08	0.95	0.08	1.2	7.2	7.80	0.62	0.89	4.0	0.57	0.32	
4+70	140	0.50	0.08	0.95	0.08	1.2	8.4	7.40	0.59	0.91	4.1	0.59	0.32	
6+10	140	0.50	0.08	0.95	0.08	1.2	9.6	7.05	0.56	0.88	4.0	0.57	0.31	
7+50	140	0.50	0.08	0.95	0.08	1.2	10.8	6.80	0.54	0.85	3.9	0.56	0.29	
8+90	140	0.50	0.08	0.95	0.08	1.2	12.0	6.50	0.52	0.81	3.7	0.54	0.27	
10+30	140	0.50	0.08	0.95	0.08	1.2	13.2	6.25	0.50	0.77	3.6	0.53	0.24	
11+60	130	0.30	0.08	0.95	0.08	1.2	14.4	6.00	0.48	0.72	4.2	0.46	0.26	
11+80	20	0.05	0.01	0.95	0.01	0.2	14.6	5.95	0.06	0.32				
TOTAL @ STA. 11+80											0.64	5.9	0.64	0

Example Problem Peak Flow Computations
Table 8-304.01a

STORM SEWER COMPUTATION SHEET

COMPUTED _____ DATE _____
 CHECKED _____ DATE _____

ROUTE _____
 SECTION _____
 COUNTY _____

EXAMPLE

STATION		LENGTH FEET	DRAINAGE AREA "A" (ACRES)		RUNOFF COEFFICIENT "C"	"A" x "C"		FLOW TIME MIN.		RAINFALL INTENSITY "I" in/hour	TOTAL RUNOFF C.I.A. = Q (c.f.a.)	DIAMETER PIPE inches	CAPACITY FULL c.f.a.	VELOCITY f.p.s.		INVERT ELEV		MANHOLE INVERT DROP	SLOPE OF SEWER ft/ft
FROM	TO		INCREMENT	TOTAL		INCREMENT	TOTAL	TO UPPER END	IN SECTION					FLOWING FULL	DESIGN FLOW	UPPER END	LOWER END		
10 YEAR																			
1+90	3+30	140	0.23	0.23	0.95	0.22	6.0	0.7	5.75	1.27	12"	2.5	3.2	3.2	93.15	92.45		0.005	
3+30	4+70	140	0.17	0.40	0.95	0.38	6.7	0.6	5.55	2.10	12"	2.5	3.2	3.6	92.25	91.55		0.005	
4+70	6+10	140	0.17	0.57	0.95	0.54	7.3	0.6	5.4	2.92	15"	4.6	3.7	3.9	91.35	90.65		0.005	
6+10	7+50	140	0.17	0.74	0.95	0.70	7.9	0.6	5.3	3.71	15"	4.6	3.7	4.1	90.45	89.75		0.005	
7+50	8+90	140	0.17	0.91	0.95	0.86	8.5	0.6	5.2	4.52	15"	4.6	3.7	3.7	89.55	88.85		0.005	
8+90	10+30	140	0.17	1.08	0.95	1.03	9.1	0.5	5.0	5.15	18"	7.6	4.2	4.5	88.65	87.95		0.005	
10+30	11+80	150	0.17	1.25	0.95	1.19	9.6	0.8	5.0	5.95	18"	6.0	3.3	3.3	87.75	87.30		0.003	
11+80	OUTLET		0.18	1.43	0.95	1.36	10.4		4.70	6.3									
										6.30 X 2 = 12.60 CFS (10 YEAR)									
50 YEAR																			
1+90	3+30	140	0.23	0.23	0.95	0.22	6.0	0.7	8.0	1.76	12"	2.5	3.2	3.5				0.005	
3+30	4+70	140	0.17	0.40	0.95	0.38	6.7	0.6	7.9	3.0	12"	2.5	3.2	3.8				0.005	
4+70	6+10	140	0.17	0.57	0.95	0.54	7.3	0.6	7.8	4.2	15"	4.6	3.7	5.2				0.005	
6+10	7+50	140	0.17	0.74	0.95	0.70	7.9	0.5	7.5	5.25	15"	4.6	3.7	4.4				0.005	
7+50	8+90	140	0.17	0.91	0.95	0.86	8.4	0.4	7.3	6.3	15"	4.6	3.7	5.3				0.005	
8+90	10+30	140	0.17	1.08	0.95	1.03	8.8	0.5	7.2	7.4	18"	7.6	4.2	4.8				0.005	
10+30	11+80	150	0.17	1.25	0.95	1.19	9.3	0.5	7.1	8.4	18"	6.0	3.3	4.7				0.003	
11+80	OUTLET		0.18	1.43	0.95	1.36	9.8		6.9	9.4									
										9.4 X 2 = 18.8 CFS (50 YEAR)									

Example Problem Storm Sewer Computation Sheet
 Table 8-304 01h

8-305 Energy Grade Line/Hydraulic Grade Line

The energy grade line (EGL) is a theoretical line that represents the total energy along a channel or conduit carrying water. Total energy includes elevation (potential) head, velocity head and pressure head. The calculation of the EGL for the full length of the system is critical to the evaluation of a storm sewer. In order to develop the EGL it is necessary to calculate all of the losses through the system. The energy equation states that the energy head at any cross section must equal that in any other downstream section plus the intervening losses. The intervening losses are typically classified as either friction losses or form losses such as bend losses, junction losses, and access hole losses. Knowledge of the location of the EGL is critical to the understanding and estimating the location of the hydraulic grade line (HGL). HGL, a measure of flow energy, is determined by subtracting the velocity head ($V^2/2g$) from the EGL.

The hydraulic grade line (HGL) is a line coinciding with the level of flowing water at any point along an open channel. In closed conduits flowing under pressure, the hydraulic grade line is the level to which water would rise in a vertical tube at any point along the pipe. The hydraulic grade line is used to aid the designer in determining the acceptability of a proposed storm drainage system by establishing the elevation to which water will rise when the system is operating under design conditions.

When water is flowing through the pipe and there is a space of air between the top of the water and the inside of the pipe, the flow is considered as open channel flow and the HGL is at the water surface. When the pipe is flowing full under pressure flow, the HGL will be above the crown of the pipe. When the flow in the pipe just reaches the point where the pipe is flowing full, this condition lies in between open channel flow and pressure flow. At this condition the pipe is under gravity full flow and the flow is influenced by the resistance of the total pipe circumference. Under gravity full flow, the HGL coincides with the crown of the pipe.

8-305.01 Storm Sewer Outfalls

All storm sewers have an outlet or outfall where flow from the storm drainage system is discharged. The discharge point can be a natural river or stream, an existing storm drainage system, a roadside ditch, or a channel that is either existing or proposed for the purpose of conveying the storm water away from the highway. The procedure for calculating the energy grade line through a storm drainage system begins at the outfall. Therefore, consideration of outfall conditions is an important part of storm sewer design.

Several aspects of outfall design must be given consideration. These include the flowline or invert elevation of the proposed storm sewer outlet, tailwater elevations, the need for energy dissipation, and the orientation of the outlet structure.

The flowline or invert elevation of the proposed outlet should be equal to or higher than the flowline of the outfall. If this is not the case, there may be a need to pump or otherwise lift the water to the elevation of the outfall.

8-305.02 Tailwater

Evaluation of the hydraulic grade line for a storm drainage system begins at the system outfall with the tailwater elevation. For most design applications, the tailwater will either be above the crown of the outlet or can be considered to be between the crown and critical

depth of the outlet. The tailwater may also occur between the critical depth and the invert of the outlet. However, the starting point for the hydraulic grade line determination should be either the design tailwater elevation or the average of critical depth and the height of the storm sewer conduit, $(d_c + D)/2$, whichever is greater.

An exception to the above rule would be for a very large outfall with low tailwater where a water surface profile calculation would be appropriate to determine the location where the water surface will intersect the barrel. In this case, the downstream water surface elevation would be based on critical depth or the design tailwater elevation, whichever is higher.

If the outfall is a river or stream, it may be necessary to consider the joint or coincidental probability of two hydrologic events occurring at the same time to adequately determine the elevation of the tailwater in the receiving stream. The relative independence of the discharge from the storm drainage system can be qualitatively evaluated by a comparison of the drainage area of the receiving stream to the area of the storm drainage system. For example, if the storm drainage system has a drainage area much smaller than that of the receiving stream, the peak discharge from the storm drainage system may be out of phase with the peak discharge from the receiving watershed. Table 7-3 in HEC 22 provides a comparison of discharge frequencies for coincidental occurrence for a 10-year and 100-year design storm. This table may be used to establish an appropriate design tailwater elevation for a storm drainage system based on the expected coincident storm frequency on the outfall channel.

There may be instances in which an excessive tailwater causes flow to back up the storm drainage system and out of inlets and access holes, creating unexpected and perhaps hazardous flooding conditions. The potential for this should be considered. Flap gates or check valves placed at the outlet can sometimes alleviate this condition; otherwise, it may be necessary to isolate the storm sewer from the outfall by use of a pump station.

8-305.03 Energy Losses

Prior to computing the hydraulic grade line, all energy losses in pipe runs and junctions must be estimated. In addition to the principal energy involved in overcoming the friction in each conduit run, energy is required to overcome changes in momentum or turbulence at outlets, inlets, bends, transitions, junctions, and access holes. The new methodology recommended by FHWA for calculating energy losses in storm sewer access holes has been introduced in "Hydraulic Engineering Circular No. 22, Third Edition" (HEC 22). Relationships for estimating typical energy losses in storm drainage systems are documented in Section 7.1.6 of HEC 22. The application of some of these relationships is included in the design example in Section 7.6 of HEC 22.

8-305.04 Hydraulic Grade Line Computations

This section presents a step-by-step procedure for manual calculations of the hydraulic grade line (HGL) using the energy loss method.

The procedure starts at the outlet end of the storm sewer with an estimate of the tailwater or energy grade line in the receiving water. The procedure then calculates the energy losses in each of the pipe segments working upstream from the outlet to each access hole. Access holes can be interpreted as manholes, catch basins or inlets. The pipe losses are added to the energy grade level obtained from the previous access hole as the energy grade line is calculated. The energy losses involving the access holes or other junction structures are computed separately from the pipe losses and added to the pipe energy level at the outlet

side of the access hole. As the calculations are continued, the inflow pipe exit losses are added to the access hole energy grade line and the procedure is repeated through the next section of the drainage system. Manual calculations of estimating energy losses as introduced in the Third Edition of HEC 22 are time consuming. Computer methods are the most efficient means of calculating the EGL and the HGL. However, it is important that designers understand the analysis process so that they can better interpret the output from computer generated storm sewer design.

The basic procedure for computing the energy grade line remains unchanged; but, the methodology for computing the energy losses occurring within an access hole has been changed. Although the Third Edition of HEC 22 has been published since September 2009, Federal Highway Administration (FHWA) is still working on a compatible computer program. Since public release of the automated HEC 22 is not imminent, the computational steps for manually determining energy losses in this Chapter will not be updated.

Many storm sewer systems are designed to function in a subcritical flow regime. In subcritical flow, pipe and access hole losses are summed to determine upstream EGL levels. In these cases where the inflow pipe is flowing unsubmerged in supercritical flow, FHWA recommends that the exit loss be ignored and the energy grade line in the outlet pipe be determined by adding the velocity head to normal depth plus the invert elevation of pipe. Additionally, because of the difficulty and uncertainty in estimating the velocity for supercritical flow in an access hole, FHWA recommends that the hydraulic grade line, HGL, be conservatively set equal to the energy grade line, EGL, in an access hole.

Hydraulic grade lines are determined by computing head losses from the control point to the first junction and repeating the procedure for each successive junction. The computations for an outlet control system may be tabulated on [Table 8-305.04](#), Hydraulic Grade Line Computation Sheet, using the following procedure:

- Step 1 Enter in Col. 1 the station for the junction immediately upstream of the outflow pipe. Hydraulic grade line computations begin at the outlet and are worked upstream, taking each junction into consideration.
- Step 2 Enter in Col. 2 the outlet water surface elevation if the outlet will be submerged during the design storm or 0.8 diameter plus invert out elevation of the outflow pipe, whichever is greater. (Note: different approach from HEC 22)
- Step 3 Enter in Col. 3 the diameter (D_o) of the outflow pipe.
- Step 4 Enter in Col. 4 the design discharge (Q_o) for the outflow pipe.
- Step 5 Enter in Col. 5 the length (L_o) of the outflow pipe.
- Step 6 Enter in Col. 6 the friction slope (S_f) in ft/ft of the outflow pipe. This can be determined by using the pipe flow figures in [Section 8-306](#), or by using the formula:

$$S_f = \left(\frac{Q}{K} \right)^2 \quad (\text{Eq. 8-29})$$

Where:

S_f = friction slope, ft/ft

$$K = \frac{1.486}{n} AR^{2/3} \quad (\text{Eq. 8-30})$$

Step 7 Multiply the friction slope (S_f) in Col. 6 by the length (L_o) in Col. 5 and enter the friction loss (H_f) in Col. 7. On curved alignments, calculate curve losses by using the formula and add to the friction loss.

$$H_c = 0.002\Delta \frac{V_o^2}{2g} \quad (\text{Eq. 8-31})$$

Where:

Δ = angle of curvature, degrees
 g = 32.2 ft/sec²

Step 8 Enter in Col. 8 the velocity of the flow (v_o) of the outflow pipe.

Step 9 Enter in Col. 9 the contraction loss (H_o) by using the formula:

$$H_o = 0.25 \frac{V_o^2}{2g} \quad (\text{Eq. 8-32})$$

Step 10 Enter in Col. 10 the design discharge (Q_i) for each pipe flowing into the junction, except lateral pipes with inflows of 10 percent or less of the mainline outflow. Inflow must be adjusted to the mainline outflow duration time before a comparison is made.

Step 11 Enter in Col. 11 the velocity of flow (V_i) for each pipe flowing into the junction (for exception, see [Step 10](#)).

Step 12 Enter in Col. 12 the product of Q_i and V_i for each inflowing pipe. When several pipes inflow into a junction, the line producing the greatest Q_i and V_i product is the line which will produce the greatest expansion loss (H_i). (For exception, see [Step 10](#)).

Step 13 Enter in Col. 13 the controlling expansion loss (H_i) using the formula:

$$H_i = 0.35 \frac{V_i^2}{2g} \quad (\text{Eq. 8-33})$$

Step 14 Enter in Col. 14 the angle of skew of each inflowing pipe to the outflow pipe (for exception, see [Step 10](#)).

Step 15 Enter in Col. 15 the greatest bend loss (H_{Δ}) calculated by using the formula:

$$H_{\Delta} = \frac{KV_i^2}{2g} \quad (\text{Eq. 8-34})$$

Where:

K = the bend loss coefficient corresponding to the various angles of skew of the in-flowing pipes.

Step 16 Enter in Col. 16 the total head loss (H_t) by summing the values in Col. 9 (H_o), Col. 13 (H_i), and Col. 15 (H_{Δ}).

Step 17 If the junction incorporates adjusted surface inflow of 10 percent or more of the mainline outflow, i.e., drop inlet, increase H_t by 30 percent and enter the adjusted H_t in Col. 17.

Step 18 If the junction incorporates full diameter inlet shaping, such as standard manholes, reduce the value of H_t by 50 percent and enter the adjusted value in Col. 18.

Step 19 Enter in Col. 19 the FINAL H, the sum of H_f and H_t , where H_t is the final adjusted value of H_t .

Step 20 Enter in Col 20 the sum of the elevation in Col. 2 and the Final H in Col. 19. This elevation is the potential water surface elevation for the junction under design conditions.

Step 21 Enter in Col. 21 the rim elevation or the gutter flow line, whichever is lowest, of the junction under consideration in Col. 20. If the potential water surface elevation exceeds the rim elevation or the gutter flow line, whichever is lowest, adjustments are needed in the system to reduce the elevation of the Hydraulic Grade Line (HGL).

Step 22 Repeat the procedure starting with [Step 1](#) for the next junction upstream.

8-305.041 *Example Problem 6*

Given:

Table 8-305.041a illustrates hydraulic elements of the storm sewers designed for the roadway cross section (Figure 8-305.041a) and roadway plan (Figure 8-305.041b).

Determine:

The hydraulic gradeline (HGL) is to be calculated to evaluate the storm sewer performance.

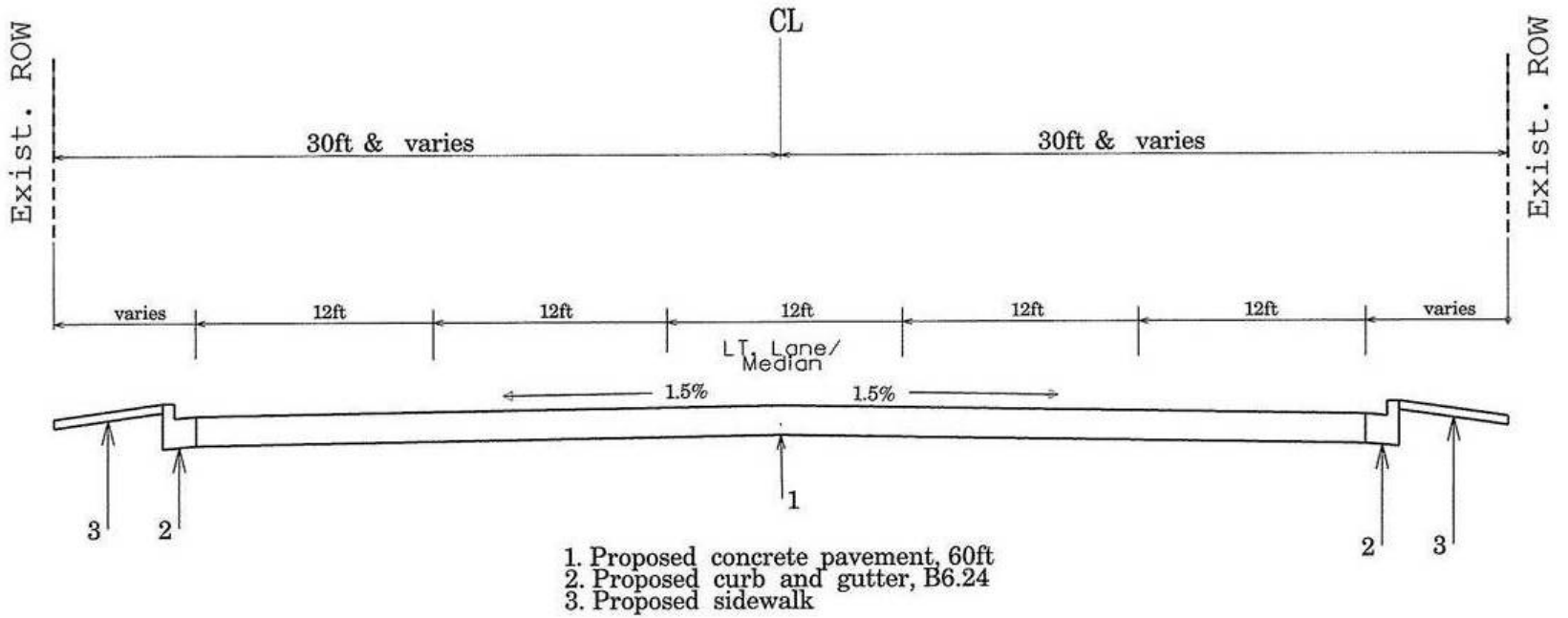

TYPICAL PROPOSED CROSS SECTION

*ILLINOIS ROUTE 120
 Crystal Lake Road to W. of Illinois Route 31*

Figure 8-305.041a

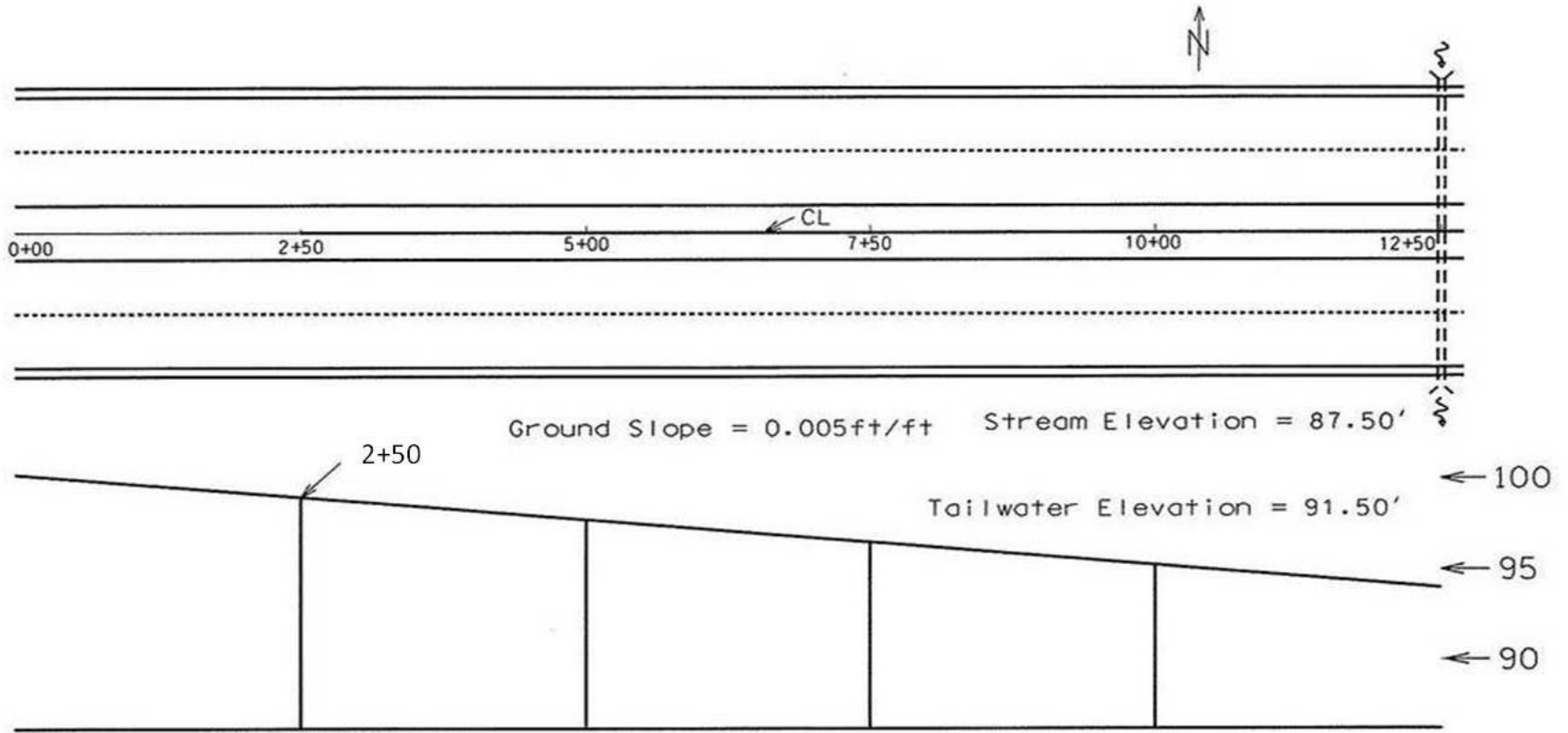

PLAN AND PROFILE
ILLINOIS ROUTE 120
Crystal Lake Road to W. Illinois Route 31

Figure 8-305.041b

Solution:

The solution summary is presented in Table 8-805.041b.

LINE 1

1. Station: first junction upstream of outlet pipe-STA. 10+00
2. Outlet Water Surface Elev: 91.5 ft., 10yr. tailwater depth in stream
3. Do: diameter of outflow pipe=21 inches
4. Qo: design discharge of outflow pipe=8.5 cfs
5. Lo: length of outflow pipe= 250 ft
6. Sfo: friction slope $S_f = (Q/K)^2$, $Q=8.5$, $K=158.3$ from Table 8-306c
 $S_f = (8.5/158.3)^2 = .0029$ ft/ft
7. Hf: friction loss, $H_f = S_f \times L = .0029 \times 250 = 0.725 = 0.73$
8. Vo: since pipe is submerged at outlet, use pipe flowing full at design
 $V_o = Q/A = 8.5/2.405 = 3.53$ fps
9. Ho: contraction loss, $H_o = 0.25(V_o)^2/2g = .25(3.53)^2/64.4 = .048$
10. Qi: flow from inlets at STA. 10+00, adjust inlet inflow for the
 8.1 min. duration of outlet pipe. $I = 6.1$ in/hr, increment of $AXC = 0.35$
 $Q_i = .35 \times 6.1 = 2.1$ cfs
11. Vi: without more information on lateral drain, assume minimum velocity of 3 fps
12. Qi Vi: $3 \times 2.1 = 6.3$
13. Hi: $H_i = 0.35 V_i^2/2g = 0.35 (3)^2/64.4 = 0.049$
14. Angle: the internal inflow pipes are entering at 90°
15. H_{Δ} : $H_{\Delta} = K V_i^2/2g = 0.7 \times 3^2 / 64.4 = 0.098 = 0.1$
16. Ht: $H_t = \text{Column (9)} + \text{Column (13)} + \text{Column (15)} = .05 + .05 + .1 = 0.2$
17. Ht: Since there is no drop inlet into manhole, this column is not used
18. Ht: standard manhole, \therefore reduce Ht by 50%, $H_t = .5 \times .2 = 0.1$
19. Find H: $H = H_f + H_t = 0.73 + 0.1 = 0.83$
20. Water Surface Elev. : $\text{Column (2)} + \text{Column (19)} = 91.5 + .83 = 92.33$ ft.
21. Rim Elev. : surface profile elev. at STA. 10+00=95.0 ft

LINE 2

1. Station: next junction upstream-STA. 7+50
2. Outlet Water Surface Elev. : 92.33 ft from Column (20) Line 1
3. Do: 18", dia. of pipe between STA. 7+50 and STA. 10+00
4. Qo: design discharge of this section is 6.6 cfs
5. Lo: length of sewer between STA. 7+50 and STA. 10+00 is 250 ft
6. Sf: $Sf = (Q/K)^2$, $Q=6.6$, $K= 105.1$ from Table 8-306C
 $Sf = (6.6/105.1)^2 = .0039$ ft/ft
7. Hf: $Hf = Sf \times L = .0039 \times 250 = 0.975 = 0.98$ ft
8. Vo: pipe is still submerged at end of section, use pipe flowing full at design discharge. $Vo = Q/A = 6.6/1.77 = 3.7$ fps
9. Ho: $Ho = 0.25 Vo^2 / 2g = .25 \times (3.7)^2 / 64.4 = .053$ ft
10. Qi: 2.1 cfs, see Line 1, Column (10)
11. Vi: 3 fps, see Line 1, Column(11)
12. QiVi: $2.1 \times 3 = 6.3$ cfs
13. Hi: $Hi = 0.35 Vi^2 / 2g = .35 \times 3^2 / 64.4 = .049$ ft
14. Angle: lateral enters at 90°
15. H_Δ: $H_{\Delta} = K Vi^2 / 2g = 0.7 \times 3^2 / 64.4 = .098 = 0.1$ ft.
16. Ht: $Ht = \text{Column (9)} + \text{Column (13)} + \text{Column (15)} = .053 + .049 + .1 = 0.202 = 0.2$ ft.
17. Ht: no drop inlet
18. Ht: standard manhole, ∴ reduce Ht by 50%, $Ht = .5 \times .2 = 0.1$ ft
19. Final H: $Hf + Ht = .98 + .1 = 1.08$ ft
20. Inlet Water Surface: $\text{Column (2)} + \text{Column (19)} = 92.33 + 1.08 = 93.41$ ft
21. Rim Elev.: surface profile at STA. 7+50=96.5 ft

LINE 3

1. Station: next junction upstream-STA. 5+00
2. Outlet Water Surface: 93.41 ft, from Column 20 Line 2
3. Do: 15", dia of pipe between STA. 5+00 and STA. 7+50
4. Qo: 4.55 cfs, design discharge of this section
5. Lo: 250 ft, length of section from STA. 5+00 to STA. 7+50
6. Sf: $Sf = (Q/K)^2$, $Q = 4.55$ cfs, $K = 64.7$, from Table 8-306C
 $Sf = (4.55/64.7)^2 = .0049$ ft/ft
7. Hf: $Hf = SfxL = .0049 \times 250 = 1.23$ ft
8. Vo: pipe is still submerged at outlet, use pipe flowing full
 $Vo = Qo/A = 4.55/1.23 = 3.7$ fps
9. Ho: $Ho = 0.25 Vo^2/2g = 0.25 (3.7)^2/64.4 = 0.053$ ft
10. Qi: 2.1 cfs, see Line 1, Column (10)
11. Vi: 3 fps, see Line 1, Column (11)
12. QiVi: $2.1 \times 3 = 6.3$
13. Hi: $Hi = 0.35 Vi^2/2g = 0.35 \times 3^2/64.4 = 0.049$ ft
14. Angle: lateral pipe enters at 90°
15. H_Δ: $H_{\Delta} = K Vi^2/2g = .7 \times 3^2/64.4 = 0.1$ ft
16. Ht: $Ht = \text{Column (9)} + \text{Column (13)} + \text{Column (15)} = .053 + .049 + .1 = 0.2$ ft
17. Ht= no drop inlet
18. Ht: standard manhole, ∴ reduce Ht by 50%, $Ht = .5 \times .2 = 0.1$ ft
19. Final H: $Hf + Ht = 1.23 + 0.1 = 1.33$ ft.
20. Inlet Water Surface: $\text{Column (2)} + \text{Column (19)} = 93.41 + 1.33 = 94.74$ ft.
21. Rim Elev.: surface profile at STA. 5+00=97.75 ft.

LINE 4

1. Station: next junction upstream-STA. 2+50
2. Outlet Water Surface: 94.74 ft, from Line 3 Column 20
3. Do: 12", dia. of pipe between STA. 2+50 and STA. 5+00
4. Qo: 2.3 cfs, design discharge of this section
5. Lo: 250 ft, length of section from STA. 2+50 to STA. 5+00
6. Sf: $Sf = (Q/K)^2$; Q= 2.3 cfs, K= 35.7 from Table 8-306C
 $Sf = (2.3/35.7)^2 = 0.0042$ ft/ft
7. Hf: $Hf = Sf \times L = .0042 \times 250 = 1.05$ ft
8. Vo: pipe is still submerged, use pipe flowing full
 $Vo = Qo/A = 2.3/.785 = 2.9$ fps
9. Ho: $Ho = 0.25 Vo^2/2g = 0.25 \times 2.9^2/64.4 = 0.03$ ft
10. Qi: 2.1cfs, see Line 1 Column (10)
11. Vi: 3fps, see Line 1 Column (11)
12. QiVi: $2.1 \times 3 = 6.3$
13. Hi: $Hi = 0.35 Vi^2/2g = .35 \times 3^2/64.4 = 0.049$ ft
14. Angle: lateral pipe enters at 90°
15. H_Δ: $H_{\Delta} = K Vi^2/2g = 0.7 \times 3^2/64.4 = 0.1$ ft
16. Ht: $Ht = \text{Column (9)} + \text{Column (13)} + \text{Column (15)} = .03 + .049 + .1 = 0.179$ ft
17. Ht: no drop inlet
18. Ht: standard manhole, ∴ reduce Ht by 50%, $Ht = .5 \times .179 = .09$ ft
19. Final H: $Hf + Ht = 1.05 + 0.09 = 1.14$ ft
20. Water Surface at Inlet: $\text{Column (2)} + \text{Column (19)} = 94.74 + 1.14 = 95.88$ ft
21. Rim Elev.: surface profile at STA. 2+50=99.0 ft

8-306 Best Management Practices

Best Management Practices (BMPs) are measures implemented to minimize adverse impacts to water quality and water quantity. Water quality and quantity should be managed through a combination of stormwater runoff and drainage collection facilities and the implementation of other BMPs in accordance with state and federal water quality goals of restoring water quality of impaired/degraded streams and minimizing adverse impacts to the downstream aquatic environment. Stormwater outfalls should be protected to prevent scour erosion, to guard the outlet structure, and to minimize the potential for downstream erosion by reducing the velocity and energy of concentrated stormwater flows. Potential BMPs for incorporation into roadway projects generally include, but are not limited to, ditch checks, slope drains, vegetated swales and buffers, outlet protection, detention basin, retention basin, aggregate filter and manufactured devices. BMPs selection must take into consideration of site constraints, anticipated pollutants, sediment and maintenance requirements.

The designer should establish pollutant removal goals then design BMPs that achieve those goals. The U.S. Environmental Protection Agency's National Menu of Storm Water Best Management Practices (<http://cfpub.epa.gov/npdes/stormwater/menuofbmps/index.cfm>), the Illinois Urban Manual (IEPA/USDA, NRCS; latest version), and IDOT BDE Manual, Chapter 59, Landscape Design and Erosion Control should be consulted regarding selection, installation, and maintenance of appropriate BMPs. The multiple benefits of BMPs can be optimized when BMPs are used in an integrated system. None of the individual BMPs provide all of the benefits, but as a system they can.

8-400 COMBINED AND SANITARY SEWERS

8-401 Combined Sewers

Combined sewers collect waste water and storm water from residential, commercial and industrial areas and carry its content, up to a design limit, to the sewage treatment plant. When the combined flows exceed the design capacity, storm water along with waste water, is discharged to surface streams which cause public health and environmental problems and contamination of surface waters. Most of the combined systems were constructed many years ago. In certain urban areas, underground drainage is still provided by combined system. Every effort should be made to avoid discharging highway drainage into such a system. However, if no other alternative is available, the designer should be aware that discharging runoff from the highway improvement within the existing combined sewer service area requires approval of the local municipality. A thorough investigation and study should be made to prevent any overloading of the existing system.

The highway improvement, which is in an existing combined sewer service area, requires approval of the Illinois Environmental Protection Agency (IEPA), Bureau of Water, Water Pollution Control, 1021 North Grand Avenue East, Springfield, Illinois 62794. However, approval is required by the local jurisdiction before it can be evaluated by the IEPA. The District office shall be responsible for submitting plans to the Environmental Protection Agency and obtaining a letter of approval. This letter of approval shall accompany the submittal of any plans, which involve the discharge of highway drainage into a combined sewer, to the Engineer of Design and Environment. The letter of approval will be attached to the submittal of final contract plans and/or certification acceptance to the Federal Highway Administration for Federal-Aid projects.

The existing drainage connections to combined sewers can be maintained on a highway improvement project without approval of the Environmental Protection Agency. However, every effort should be made to limit the discharge rate to the existing conditions. The connection to a combined sewer should be abandoned when a feasible alternative is available.

The policies for cost participation of state and local agency for improvement of combined sewers are included in the IDOT Bureau of Design and Environment Manual.

8-402 Sanitary Sewers

8-402.01 General

Sanitary sewers involved with highway design usually consist of relocating and/or adjusting existing sewer facilities to facilitate the construction of the proposed highway improvement.

The designer should be aware that a permit for alterations of any existing sanitary sewer system must be obtained from the Illinois Environmental Protection Agency, Bureau of Water, Water Pollution Control, 1021 North Grand Avenue East, Springfield, Illinois 62794. However as mentioned in the above text, approval by the local jurisdiction is required before it can be evaluated by the IEPA. Whenever an existing sanitary sewer must be relocated or adjusted, it should be replaced with a pipe having an equivalent capacity and satisfying current structural and specification requirements. Therefore, it is important that the designer first obtain sufficient data to determine the capacity and material of the existing sanitary sewer. All sewer computations are to be made on the standard form shown in [Table 8-402.01](#). The District office shall be responsible for obtaining approval of the Environmental

Protection Agency for adjustment of all sanitary sewers. A copy of the Environmental Protection Agency permit shall accompany the submittal of any plans, which involve sanitary sewer adjustment, to the Bureau Chief of Design and Environment. This permit will be attached to the letter submitting final contract plans and/or certification acceptance to the Federal Highway Administration for Federal-Aid projects.

The hydraulic capacity of the sanitary sewers, flowing full, shall be determined using Manning's Equation. The use of the nomograph chart shown in [Figure 8-303b](#) may be employed for this purpose when the Manning's n value of the pipe is 0.013 or 0.015.

8-402.02 Type

When specifying concrete, clay, or cast iron pipe, the diameter, class or strength, the method of jointing, the type of protective coating and lining, if any, and any special requirements should be stipulated. The pipe should always conform to standard Federal AWWA or ASTM specifications for the type of pipe suitable for the use intended.

Leakage test shall be specified for all sanitary sewer installations. The most current publication "[Standard Specifications for Water and Sewer Main Construction in Illinois](#)" prepared by the Standard Specifications Committee of Illinois for maximum leakage allowances for sanitary sewers shall be consulted.

8-402.03 Locations

Sanitary sewers are generally considered utilities and, as such, their location or relocations shall be in accordance with the requirements of the [BDE Manual, Chapter 6](#)⁷.

Sanitary and combined sewers should be located at least 10 ft horizontally from any existing or proposed water main. If conditions exist which prevent a lateral separation of 10 ft, then the outside of the sewer must be located a minimum 18 inches below the outside of the water main. The sewer should be placed in a trench separate from the water main; however, if they must be placed in the same trench, the water main must be located on an undisturbed earth shelf to one side of the sewer.

Whenever a sanitary or combined sewer crosses a water main, the 18 inch vertical separation must be maintained for that portion of the sewer located within 10 ft of any water main.

If it is impossible to obtain proper horizontal and vertical separation, or it is necessary for a sewer to pass over a water main, both the water main and sewer must be constructed of slip-on or mechanical-joint cast iron pipe, asbestos-cement pressure pipe, prestressed concrete pipe, or PVC pipe meeting water main standards and be pressure tested to maximum expected surcharge head to assure water tightness before backfilling. The encasing of sewers should be avoided since it destroys the ability of the joints to provide flexure and may result in a break in the pipe.

8-402.04 Slope

Sanitary sewers shall be designed and constructed with hydraulic slopes sufficient to give mean velocities, when flowing full, of not less than 2.0 ft/sec.

The following are the minimum slopes (based on Manning's Equation using an "n" value of 0.013) which shall be provided for sanitary sewers.

Sewer Size (Inches)	Minimum Slope (%)
8	0.40
10	0.28
12	0.22
15	0.15
18	0.12
21	0.10
24	0.08
27	0.067
30	0.058
36	0.047
42 or larger	0.035

8-402.05 Manholes

Manholes shall be located at the ends of all lines, at all changes in direction, size, or slope of sewer. Sanitary sewer manholes shall be spaced at distances not greater than 400 ft for sewers 15 inches or less, and 500 ft for sewers 18 inches to 30 inches. Greater spacing may be permitted in larger lines. Standard manholes, Type A, when applicable, will be used for sanitary sewers. However, when it is necessary to drop the elevation of the sewer at a manhole more than 2 ft, the drop shall be made by means of an outside connection similar to that shown in [Figure 8-402.05](#), drop manhole.

8-402.06 Sanitary Sewer Plan Notation

All sanitary sewers and manholes (existing and proposed) are to be identified on the plans. Standard storm sewer symbols shall not be used for sanitary sewers. The complete construction details for all sanitary sewers must be shown on the plans, together with all items and quantities. Manhole schedules may be listed separately for convenience.

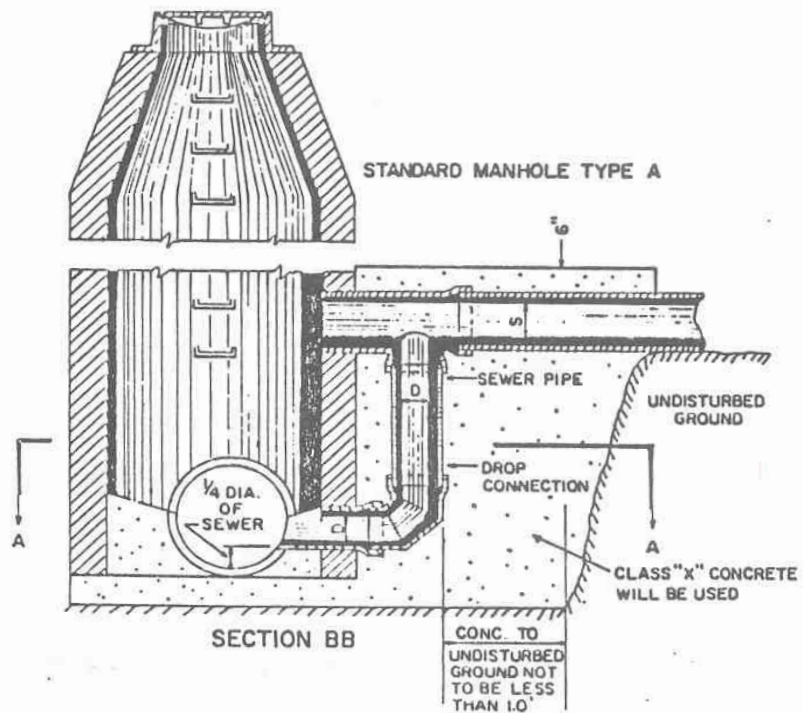

DIAMETER OF RISER OF MANHOLE DROP CONNECTION "D" TO BE OF A DIAMETER ONE STANDARD PIPE SIZE SMALLER THAN THE DIAMETER OF THE SEWER BEING CONNECTED TO THE MANHOLE "S" EXCEPTING THAT NO RISER SHALL BE LESS THAN EIGHT INCHES (8) IN DIAMETER

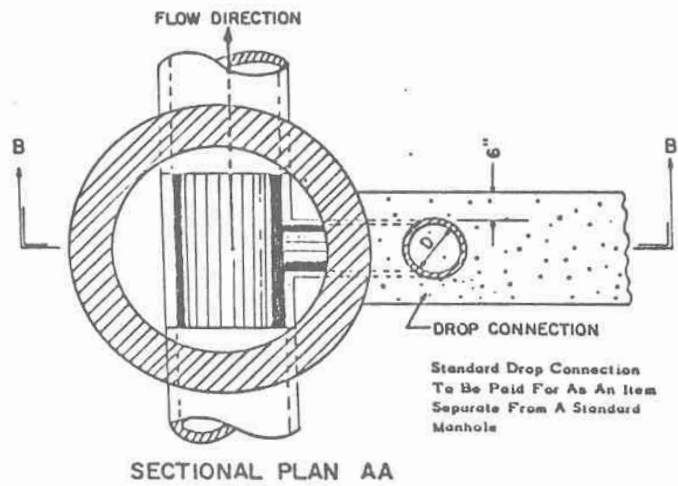

Drop Manhole
Figure 8-402.05

8-500 REFERENCES

1. Illinois Environmental Protection Agency. Part 370, Illinois Recommended Standards for Sewage Works.
2. American Waterworks Association. AWWA Standard for Installation of Ductile-Iron Mains and their Appurtenances. American Wasteworks Association, 6666 Quincy Avenue, Denver Colorado 80235.
3. Illinois Department of Transportation. Highway Standards.
4. U.S. Department of Transportation, Federal Highway Administration. Hydraulic Engineering Circular No. 22, Third Edition. Urban Drainage Design Manual. September 2009
5. Illinois Department of Transportation. Standard Specifications for Road and Bridge Construction. January 2007
6. Illinois Department of Transportation. Bridge Manual.
7. Illinois Department of Transportation. Bureau of Design and Environment Manual.
8. American Concrete Pipe Association. Design Data 37. July 1980
9. American Concrete Pipe Association. Design Data 36. June 1980
10. Standard Specifications for Water and Sewer Main Construction in Illinois. Illinois Society of Professional Engineers, Consulting Engineers Council of Illinois, Illinois Municipal League and The Associated General Contractors of Illinois.
11. Illinois Environmental Protection Agency/USDA Natural Resource Conservation Service. Illinois Urban Manual.
12. U.S. Environmental Protection Agency. National Menu of Storm Water Best Management Practices.



Chapter 9

Northwood Architects
Northwood Architects

CHAPTER 9 - ROADSIDE DITCHES

- 9-000 GENERAL
 - 9-001 Definition
 - 9-002 Constraints
 - 9-003 Runoff Determination
 - 9-004 Hydraulics
 - 9-005 General Design Procedure
- 9-100 DITCH TYPICAL SECTIONS
 - 9-101 General
 - 9-102 Considerations
- 9-200 DITCH PLAN
 - 9-201 General
 - 9-202 Considerations
 - 9-203 Preparation
- 9-300 DITCH GRADIENT DETERMINATION
 - 9-301 General
 - 9-302 Considerations
 - 9-303 Procedure
- 9-400 CAPACITY INVESTIGATION
 - 9-401 General
 - 9-402 Considerations
 - 9-403 Procedure
 - 9-404 Example Problem - Ditch Capacity
- 9-500 DITCH LINING INVESTIGATION
 - 9-501 General
 - 9-502 Considerations
 - 9-503 Procedure
 - 9-504 Example Problems - Ditch Lining

- 9-600 OUTLET TREATMENT
 - 9-601 General
 - 9-602 Modified Discharge
 - 9-603 Modified Velocity of Flow
 - 9-604 Concentration of Sheet Flow
 - 9-605 Water Quality Control

- 9-700 FIELD TILE SYSTEMS
 - 9-701 General
 - 9-702 Location Determination
 - 9-703 Adjustments

- 9-800 SUBSURFACE DRAINS
 - 9-801 General
 - 9-802 Types

- 9-900 REFERENCES

9-000 GENERAL

9-001 Definition

For the purpose of this manual, a roadside ditch is defined as an open channel paralleling the highway embankment within the limits of the highway right of way. It is normally trapezoidal in shape and lined with grass or a special protective lining. Its primary function is to collect runoff from the highway right of way and tributary areas adjacent to the right of way, and to transport this accumulated water to an acceptable outlet point. A secondary function of a roadside ditch is to drain the base of the roadway to prevent saturation and loss of support for the pavement.

For purposes of this Chapter, a standard ditch is defined as trapezoidal shape with a defined bottom width and sideslopes.

9-002 Constraints

Roadside ditches must be designed to conform to the geometric standards applicable to the individual project and the legal requirements and drainage policies included in [Chapter 1](#) of this manual. In general, these ditches should be hydraulically capable of carrying the design runoff in a manner which assures the safety of motorists and minimizes future maintenance requirements, damage to abutting properties, and adverse effects on environmental and aesthetic values.

9-003 Runoff Determination

In order to investigate the capacity and lining needs for ditches, design discharges must be determined. The method used to determine these discharges depends upon the characteristics of the watershed. If the runoff is derived primarily from overland flow, the Rational Method in determining peak rates of runoff is recommended. If one or more defined watercourses contribute a significant portion of the runoff, use of the regression equations developed by the U.S. Geological Survey, the Soil Conservation Service Method, or HEC (Hydraulic Engineering Circular) may be more appropriate. These three methods are discussed in detail in [Chapter 4](#). If the ditch flow is complicated by outflow from storm sewers, field tile or other drains, a special analysis may be required.

Flood frequencies for design of ditches and ditch lining are given in [Table 1-305](#). The use of higher frequencies may be warranted in areas especially sensitive to flooding or erosion.

9-004 Hydraulics

For the purpose of designing roadside ditches, uniform flow conditions can be assumed. Ditch flow is rarely uniform, but the accuracy obtained by the use of complex non-uniform flow calculations is not necessary. Therefore, the discharges and velocities of flow needed to investigate capacity and erosion control requirements for a roadside ditch may be determined using Manning's equation and the general flow formula. The use of these two equations is discussed in detail in [Chapter 5](#). They are reproduced here for easy reference.

Manning's Equation:

$$V = \frac{1.486}{n} R^{2/3} S^{1/2} \quad (\text{Eq. 9-1})$$

General Flow Formula:

$$Q = VA \quad (\text{Eq. 9-2})$$

Where:

- A = area of the ditch section below water surface, sqft
- n = manning's coefficient of roughness
- Q = discharge in cuft/sec
- R = hydraulic radius (cross sectional area/wetted perimeter), ft
- P = wetted perimeter of the ditch, ft
- S = slope (the ditch gradient may be used), ft/ft
- V = mean velocity of flow, ft/sec

Flow charts for select ditch configurations can be found at the link below. These charts were developed based on the above formulas. Each chart contains five variables (n, Q, S, V and depth of flow D). With the roughness coefficient (n) and any other two variables known, the charts allow the remaining two variables to be determined quickly and accurately. If a flow chart is not included for the ditch section being investigated, interpolation between solutions on charts for slightly larger and slightly smaller ditches may give sufficiently accurate results. The two equations may also be used directly to solve for any unknown feature. Repetitive (trial and error) calculations may be required.

If a flow chart is not available for a ditch cross section, which is to be used frequently, it may be desirable to prepare one. Instructions for preparing these charts can be found in the Federal Highway Administration's Design Charts for Open-Channel Flow, Hydraulic Design Series No. 3¹. Computer programs such as FHWA Hydraulic Parameters of Open Channel can also be utilized for ditch design www.fhwa.dot.gov/bridge/hydpub.htm.

9-005 General Design Procedure

Since each project is unique in some manner, there can be no complete step-by-step procedure for designing roadside ditch systems; however, the following six basic steps should normally be included:

1. Determine the standard or typical ditch cross sections for the project.
2. Establish a ditch plan, which shows the proposed ditch flow patterns.
3. Determine the gradients to be used on all proposed ditches.
4. Investigate the capacity of the typical ditch with the proposed gradients and enlarge any ditch found to be inadequate.
5. Determine the limits and degree of protection necessary to prevent erosion in the ditch system.

6. Determine any special measures necessary to prevent adverse effects at and downstream from ditch outlets points.

Note that it may be necessary to make several trial runs through these steps to establish the most suitable ditch system. The least expensive system, which will give satisfactory performance, should be used. These steps are discussed individually in the following sections.

9-100 DITCH TYPICAL SECTIONS

9-101 General

The first step in design of a roadside ditch system is to establish typical or standard ditch cross sections based on applicable geometric policies, with consideration of safety, economy and soils conditions. Normally included on each of these sections is the foreslope, backslope, ditch bottom width and standard depth of ditch for cut locations. Also, refer to [Section 34-4, Roadside Elements, of the BDE Manual](#).

9-102 Considerations

Design features, which should be considered at this stage and as ditch design progresses, include the following:

1. To provide adequate subbase drainage and minimize the effect of freeze-thaw cycles on the pavement structure, the depth of the roadside ditch below the shoulder should be equal to the maximum depth of frost penetration for the locale, but not less than 3 ft.
2. The soils report should be reviewed to determine locations where flatter side slopes or berms will be required for stability, and the limits through which special rock sections will be required.
3. The difficulties associated with establishing and maintaining vegetation on steep slopes must be considered. Slopes steeper than 2:1 will usually require special erosion control measures. In areas of very erosive soils, 2:1 or even flatter slopes may need special attention.
4. Ditches should be designed to facilitate mowing operations, as heavy vegetation in a ditch can significantly reduce its capacity. Mowing equipment cannot drive on slopes steeper than about 2-1/2:1, but can usually mow a narrow strip on one slope while driving on the opposite slope or the shoulder. If wide steep slopes or steep foreslopes and backslopes are proposed, consideration should be given to planting vegetation that does not require mowing.
5. Try to avoid the use of steep side slopes along the frontage of businesses, residences or other maintained properties. In these sensitive areas it is especially desirable to use flat side slopes, rounded and blended with the adjacent terrain.
6. All permanent ditches should be trapezoidal in shape with a bottom width sized according to the appropriate section of the BDE Manual. The bottom width varies according to the type of roadway improvement. For new construction, the bottom ditch width is a minimum 4 ft. Refer to [Figure 34-4c of the BDE Manual](#) for more details. Curved bottom ditches, although ideal for hydraulic and safety purposes, are difficult to build; and triangular ditches are highly susceptible to erosion and easily blocked by debris.
7. When a high steep fill slope is being used, it is desirable to include a berm between the embankment and the roadside ditch to prevent the embankment material from filling in the ditch and to prevent any erosion in the ditch from damaging the

- embankment. Such berms should be at least 6 in. above the overtopping elevation of the backslope, have a width of about one third the embankment height and slope toward the ditch at a rate of about 5 percent. The width and height of the berm should be varied as necessary to provide a smooth berm grade and ditch alignment.
8. If the project includes a cut section within the limits of a horizontal curve in the highway, the use of a flatter backslope on the inside of the curve may be desirable to increase sight distance. The use of flatter backslopes to increase corner sight distance at approaches to intersections should also be considered.
 9. Flattening backslopes or increasing the depths or widths of ditches to generate material for construction of the roadway embankment may be economical in some situations.
 10. A ditch with flatter sideslopes and a wider bottom width is more easily traversed by errant vehicles, and should be used at any location with a history or high probability of run-off-the-road accidents.

9-200 DITCH PLAN

9-201 General

The second step in the design of a roadside ditch system is the establishment of a ditch plan. The completed plan should show the highway alignment, proposed drainage structures, pertinent natural and manmade features and proposed ditch flow patterns for the project. The ditch plan is normally a part of the plan sheets for the improvement; however, separate detailed drawings may be required or a simple sketch may suffice, depending on the complexity of the drainage. The ditch plan for any project should be shown on large-scale contour maps if these maps are available. A sample ditch plan is shown as [Figure 9-201](#).

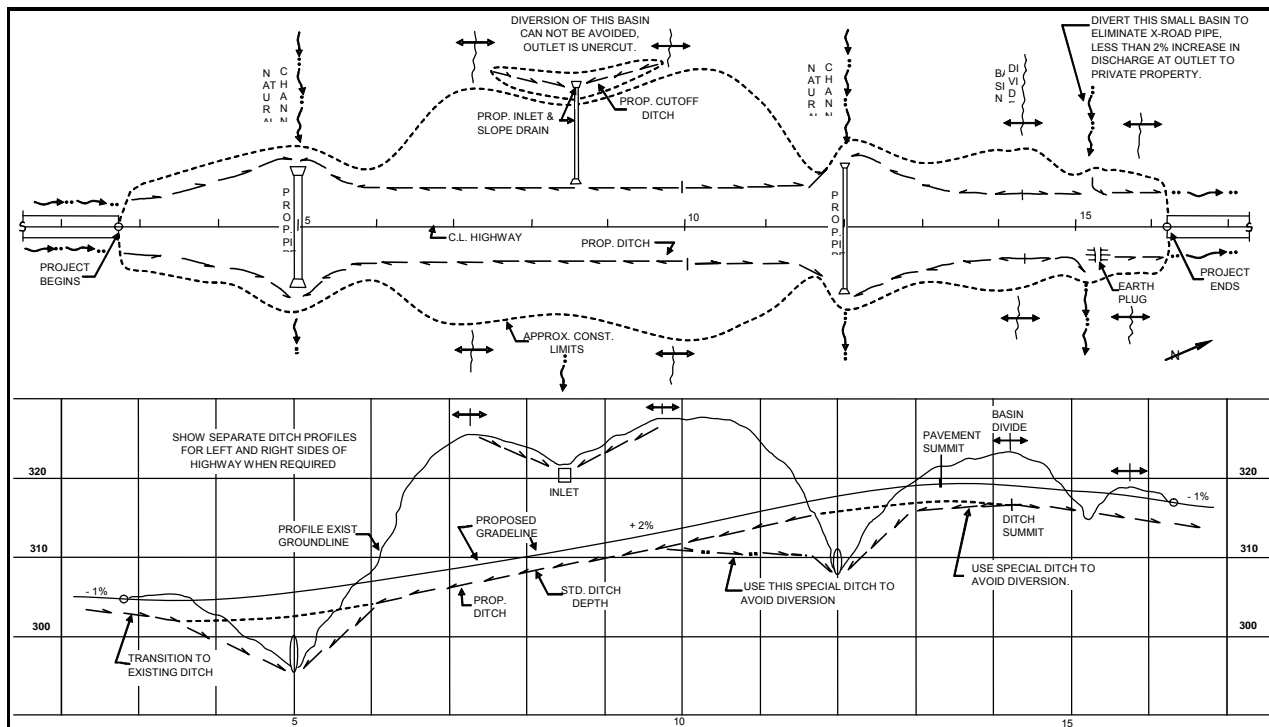

Sample Ditch Plan
Figure 9-201

9-202 Considerations

The following items should be considered during preparation of the drainage plan:

1. In general, ditches should be included continuously along both sides of any highway with a rural cross section to provide controlled drainage and protect adjoining property from flooding, erosion and siltation. Omission of a roadside ditch should only be considered at locations where the highway borders an inundated area, or where the natural ground slopes away from the road and the adjacent area is well vegetated with natural grass or woods.
2. In situations where the natural ground drains toward the top of a high backslope, consideration should be given to providing an interception ditch along the top of the slope to reduce flow and erosion down the face of the slope. If the backslope is 30 ft

or more in height, an intermediate ditch near the mid-slope may be warranted. If feasible, these secondary ditches should be drained away from the highway. If not, their flow should be collected and carried down to the roadside ditch by use of an inlet and pipe, lined ditch or other appropriate system. Such facilities should be designed to remove flow rapidly. Any portion of the system not visible from the highway should be as maintenance free as possible. Because of the high outlet velocities, some type of energy dissipator or other erosion protection is normally required at the outlet point. A typical slope drain is shown in [Figure 9-202](#).

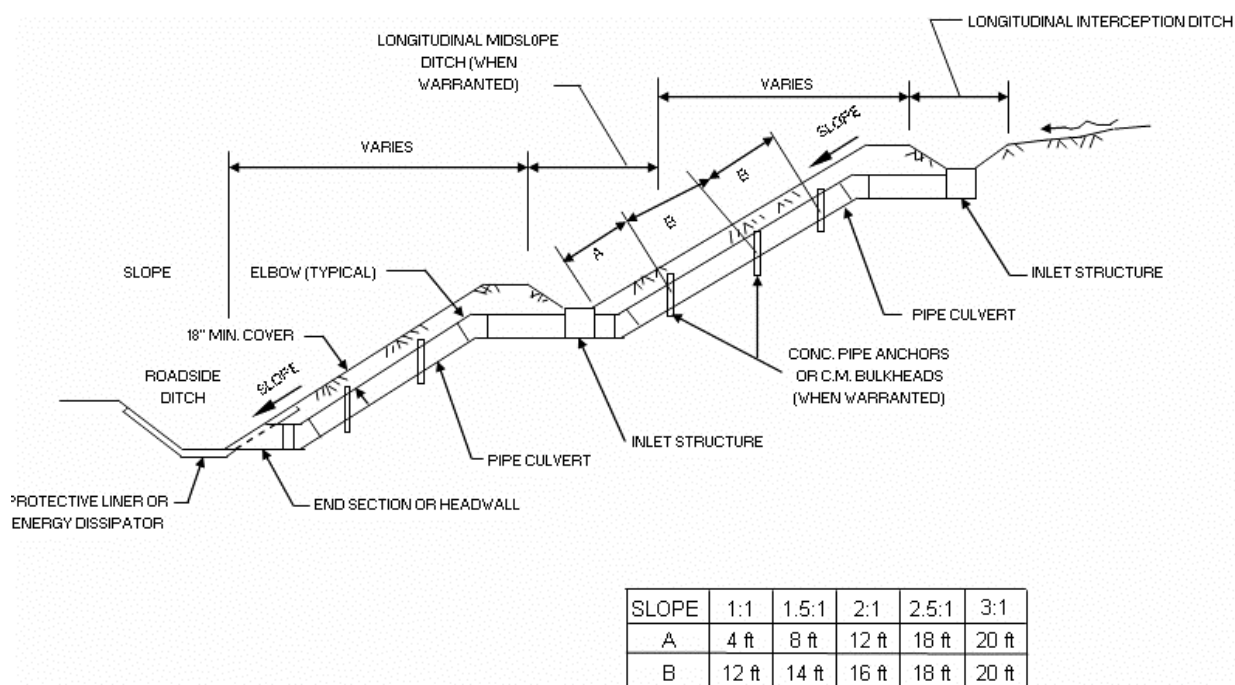

*Typical Slope Drain
Figure 9-202*

3. Every reasonable effort should be made to avoid outletting water onto a lower property that did not originally receive that flow. Before proposing any such diversion, the effects downstream of both the increased flow at the new outlet point and the decreased flow at the original outlet point must be determined and thoroughly evaluated. The advantages of the diversion should be weighed against the probability of causing damage to the downstream properties, adverse public opinion, and/or litigation. The following are situations where some degree of diversion may prove to be warranted:
 - a. When an entrance pipe can be eliminated by summitting the roadside ditch at the entrance.
 - b. When a crossroad culvert can be omitted by collecting the flow from a small basin and carrying it in the roadside ditch to an adjacent basin. In situations where a standard depth ditch undercuts a natural outlet channel and the grade cannot be raised, this type of diversion cannot be avoided.

- c. When a shallower ditch can be used if the ditch summit is located at the crest of the highway profile rather than at a natural basin divide.
- d. Directing the flow away from its natural course can eliminate the need for either excessively flat or very steep and erosive ditch grades.
4. Environmental specialists should be consulted before flow is diverted into or away from wetlands or other environmentally sensitive areas.
5. Sharp changes in the horizontal alignment of roadside ditches should be avoided as they create a point of attack for the flowing water. Required changes in alignment should be made gradually and, if practicable, in a location where the ditch has a mild gradient.
6. To reduce turbulence at the confluence of two ditches or streams, the angle between the two flows should be as small as possible. Any side ditch, which is to discharge into a roadside ditch, should be curved into the ditch in a manner that will reduce the angle of intersection between the two flows.
7. Roadside ditch flow should normally be outletted at every outlet point encountered. Earth median ditch checks, as shown in the Highway Standard, should be used when necessary to prevent bypass of side-hill outlets.

9-203 Preparation

The following basic steps should be used during preparation of the ditch plan:

1. Collect all available survey data, contour maps, drainage studies, and reports and plan drawings for the project.
2. Prepare a plan and profile layout showing the location of the highway, all topography, all proposed culverts, bridges, entrances and intersections, the existing ground profile and the proposed grade of the highway.
3. Determine and plot on the plan the locations of the natural basin divides and all available ditch outlet points along both sides of the highway. Typical outlet points are the upstream ends and outlet channels of proposed culverts, other creeks or swales flowing away from the highway and existing roadside ditches which are to remain in place along intersecting roads, or at the ends of the project. A field review is normally required to accurately locate these features.
4. Layout the proposed roadside ditches to minimize diversion of flow by directing flow away from each basin divide and to the first outlet encountered. During this process, the items discussed in [Section 9-202](#) and any special situations, which might affect the ditch layout, must be considered and evaluated.

9-300 DITCH GRADIENT DETERMINATION**9-301 General**

Ideally, the grade of a roadside ditch should result in flow velocities that do not erode the soil lining nor cause sedimentation. Unfortunately the slope of the natural ground, gradeline of the highway or other natural or manmade features frequently prevent the use of such an ideal grade and the gradient must be established based on economics or other non-hydraulic factors.

9-302 Considerations

The following items should be kept in mind during the process of establishing ditch grades:

1. To minimize ponding and silt accumulation, a grade of at least 0.3 percent should be provided on all roadside ditches. Grades in the range of 0.4 percent to 0.6 percent are usually more desirable. When a grade flatter than 0.3 percent is used, the ditch bottom may remain wet for long periods of time and prevent the establishment of a grass lining and encourage the growth of cattails or other undesirable aquatic vegetation. This is especially true in areas of field tile, underdrains, springs, sand stratum or a high water table. If such a flat grade cannot be avoided, the use of a paved invert, or pipe underdrain should be considered. The paving will increase the velocity of flow to a more desirable level and allow the flowline to be easily re-established if silt accumulation becomes a problem.
2. There is no upper limit on ditch grades; however, the steeper the grade, the greater the expense may be for erosion control requirements. If the designer has some knowledge of the erosion potential of the soil that will line the ditch and can estimate a depth of flow, this table may be used as a guide in selecting an initial ditch grade. It must be kept in mind that the grades shown are based on average conditions. The actual erosion control requirements must be determined by the methods discussed in [Section 9-500](#). The final ditch grade should normally be selected based on a comparison of the costs of erosion control features, earthwork, etc. for various gradients.
3. Do not require deep ditches just for the purpose of maintaining a long uniform ditch grade. Frequent breaks in the grade can usually reduce earthwork and ditch lining costs. The desirable distance between breaks varies with the terrain. In rugged terrain a change in slope every 100 ft may be warranted. In flat land it may be economical to maintain a constant slope for several thousand feet. The length of the ditch that will require lining can sometimes be minimized by concentrating as much of the drop as possible in a short length, preferably near the downstream end of the ditch.

4. A ditch grade, which will require the use of an earth levee to form the ditch backslope, is usually undesirable. The levee could cause ponding or the forming of a second channel outside the levee and might restrict future drainage improvements on the abutting property.
5. The depth of ditches in flood plains subject to backwater should be as shallow as feasible to minimize the depth and duration of standing water in the ditches when flooding occurs.
6. When a roadside ditch is to outlet into a large stream, care must be taken to minimize adverse effects on the flow of the stream and riparian habitat. The normal ditch depth should be maintained to the bank of the stream, and the flow should then be carried down to the low water level of the stream in a shallow ditch or chute with an appropriate lining.

9-303 Procedure

The following basic steps should be used to establish the proposed grades for the roadside ditches:

1. Plot the highway cross sections at appropriate intervals showing the natural groundlines and proposed roadway templates.
2. Plot all above and below ground features which may influence or restrict the ditch design on the cross sections, including any required clearance between these items and the construction limits. Typical features are:
 - a. All right of way limits which are firmly established
 - b. Any trees, shrubs, fences, wells, etc., which are to be preserved
 - c. Any areas restricted for environmental reasons
 - d. All utilities including buried pipes and cables and above ground poles, hydrants, meters, etc.
 - e. Existing drainage facilities, which are to remain in operation including pipes, drains, ditches and field tile. The preservation of field tile systems is discussed in detail in [Section 9-700](#).
 - f. Pertinent geological formations: rock, gravel, highly erosive soils, etc.
3. In areas where special ditches are anticipated, plot all proposed standard depth ditches and the foreslopes and backslopes on the cross sections, in accordance with controls previously established.
4. Determine a suitable grade line for each special ditch. It may be desirable to plot a separate profile of the existing ground line along the proposed ditch and work with this profile and the cross sections to establish the most desirable ditch grade line.

9-400 CAPACITY INVESTIGATION

9-401 General

Each proposed roadside ditch should be investigated to verify that it will provide adequate capacity to carry the peak rate of runoff that is expected to occur with the frequency specified for "ditches" in [Table 1-305](#). Higher frequencies should also be investigated at any location where significant damage will occur if the design flood is exceeded.

9-402 Considerations

The following items should be considered during capacity investigation and the process of establishing ditch bottom widths:

1. A ditch bottom should not be less than 2 ft wide and should be specified as a multiple of one foot.
2. Changes between different ditch cross sections should be made with gradual transitions to avoid the creation of turbulent flow conditions, and to improve the appearance of the finished project. Recommended transition rates are 25 ft per 1 ft change in ditch bottom width, and 100 ft for each change in side slope from 2:1 to 3:1, 3:1 to 4:1, etc.
3. The capacity of a proposed ditch should at least equal the capacity of any natural channel it is to replace, unless the discharge is being reduced significantly.
4. A roadside ditch may be oversized to provide storage for the purpose of either reducing the peak rate of discharge from the ditch or to compensate for a reduction in storage caused by other features of the project. Compensatory and retention storage is discussed in detail in [Chapters 3 and 12](#) of this manual. According to [Section 38-4 of the BDE Manual](#), roadside barrier may be warranted where the permanent ponded depth of water is greater than 2 ft.

9-403 Procedure

The following procedure should be used to check the capacity of a roadside ditch or to determine the required ditch size:

1. Compute the design discharge at the downstream end of the section of ditch being investigated by the methods discussed in [Section 9-003](#).
2. Select a trial size for the ditch at this location (the standard ditch is normally used initially), and assign a roughness coefficient for the finished surface of the ditch. If a lining is proposed, the coefficient should be obtained from [Table 9-403](#).
3. Determine the maximum allowable depth of flow in the ditch. The discharge should be confined within the ditch and provide 1' freeboard below the shoulder of the highway.

4. Check the capacity of this ditch flowing at the previously established gradient by the methods discussed in [Section 9-004](#) and as follows:
 - (a) If a flow chart for the ditch is available, enter this chart with the discharge, roughness coefficient and slope. Read the depth of flow direct and compare it to the allowable depth.
 - (b) If a flow chart is not available, compute the capacity of the ditch flowing at the maximum allowable depth and compare this discharge to the design discharge.
 - (c) In all cases, computer programs and spreadsheets are readily available and provide quick solutions.
5. If the initial ditch is too small, select a larger size or increase the capacity by other means and return to step (2).
6. After an adequate cross section is established at the downstream end of the ditch, the same procedures should be used to investigate the capacity upstream as needed to determine the point at which the ditch size should be changed. There is no set interval at which the capacity of the ditch should be investigated, but it is generally desirable to check either side of points where flow conditions change (such as breaks in the ditch grade or configuration, and points of entrance of concentrated flow) and at intermediate points along any long uniform ditch section. After several locations have been checked, the designer should be able to judge which points should be investigated by comparison to previous locations.

The computation sheet for ditch lining ([Figure 9-503](#)) may be suitable for organization of capacity calculations. This sheet is designed for use with the rational method but can be adapted to other methods of computing runoff if required.

Type of Channel and Description	Minimum	Normal	Maximum
1. Manmade			
a. Earth, straight and uniform			
1. Clean, recently completed	0.016	0.018	0.020
2. Clean, after weathering	0.018	0.022	0.025
3. Gravel, uniform section, clean	0.022	0.025	0.030
4. With short grass, few weeds	0.022	0.027	0.033
b. Earth, winding and sluggish			
1. No vegetation	0.023	0.025	0.030
2. Grass, some weeds	0.025	0.030	0.033
3. Dense weeds or aquatic plants in deep channels	0.030	0.035	0.040
4. Earth bottom and rubble sides	0.028	0.030	0.035
5. Stony bottom and weedy banks	0.025	0.035	0.040
6. Cobble bottom and clean sides	0.030	0.040	0.050
c. Dragline-excavated or dredged			
1. No vegetation	0.025	0.028	0.033
2. Light brush on banks	0.035	0.050	0.060
d. Rock cuts			
1. Smooth and uniform	0.025	0.035	0.040
2. Jagged and irregular	0.035	0.040	0.050
e. Channels not maintained, weeds and brush Uncut			
1. Dense weeds, high as flow depth	0.050	0.080	0.120
2. Clean bottom, brush on sides	0.040	0.050	0.080
3. Same, highest stage of flow	0.045	0.070	0.110
4. Dense brush, high stage	0.080	0.100	0.140
2. Flood plains			
a. Pasture, no brush			
1. Short grass	0.025	0.030	0.035
2. High grass	0.030	0.035	0.050
b. Cultivated areas			
1. No crop	0.020	0.030	0.040
2. Mature row crops	0.025	0.035	0.045
3. Mature field crops	0.030	0.040	0.050
c. Brush			
1. Scattered brush, heavy weeds	0.035	0.050	0.070
2. Light brush and trees, in winter	0.035	0.050	0.060
3. Light brush and trees, in summer	0.040	0.060	0.080
4. Medium to dense brush, in winter	0.045	0.070	0.110
5. Medium to dense brush, in summer	0.070	0.100	0.160
d. Trees			
1. Dense willows, summer, straight	0.110	0.150	0.200
2. Cleared land with tree stumps, no sprouts	0.030	0.040	0.050
3. Same as above, but with heavy growth of sprouts	0.050	0.060	0.080
4. Heavy stand of timber, a few down trees, little undergrowth, flood stage below branches	0.080	0.100	0.120

5. Same as above, but with flood stage reaching branches	0.100	0.120	0.160
--	-------	-------	-------

*Values of the Roughness Coefficient n
(Uniform Flow)
Table 9-403*

9-404 Example Problem - Ditch Capacity

Given:

An unlined trapezoidal ditch with a 2' bottom width, 2:1 sides and a gradient of 0.5 percent (0.005 ft/ft) is proposed to carry a discharge of 95 cuft/sec. The maximum allowable depth of flow has been set at 2.5 ft.

Find:

1. The maximum capacity of this ditch.
2. The bottom width which should be used to meet the depth of flow limitation.

Solution:

1. To solve for the capacity of the ditch, the two equations discussed in [Section 9-004](#) should be combined to derive an equation for direct determination of discharge:

$$Q = \frac{1.486}{n} R^{2/3} S^{1/2} A \tag{Eq. 9-3}$$

The slope (S) is given as 0.005 ft/ft, a roughness factor of 0.03 should be used for an unlined ditch and the area and wetted perimeter of the proposed ditch can easily be computed to be A = 17.50 sqft and WP = 13.18 ft. Therefore, the maximum capacity of the ditch would be:

$$Q = \frac{1.486}{0.03} (17.50/13.18)^{2/3} (0.005)^{1/2} (17.50)$$

= 74.0 cuft/sec (answer)

2. The bottom width, which should be used, can be determined by a trial and error solution of the same equation, as follows:

Try a 3' bottom:

A = 20.00 sqft

WP = 14.18 ft

$$Q = \frac{1.486}{0.03} (20.00/14.18)^{2/3} (0.005)^{1/2} (20.00)$$

= 88.1 cuft/sec (low)

Try a 4' bottom:

A = 22.50 sqft

WP = 15.18 ft

$$Q = \frac{1.486}{0.03} (20.00/15.18)^{2/3} (0.005)^{1/2} (20.00)$$

= 102.4 Cuf/sec (high)

By repetitive trials the exact bottom width would be determined to be 3.483 ft, an accuracy that is not required. Since a ditch bottom width is normally set at some even multiple of 1 ft, it is only necessary to determine the smallest even foot needed to exceed the required capacity -- in this example, 4 ft (answer).

This example can also be solved with commercially available hydraulic software or with available Ditch flow charts from HDS-3.

9-500 DITCH LINING INVESTIGATION

9-501 General

Investigating the need for protective lining is a necessary part of ditch design. If adequate protection is not provided, ditch erosion may occur, maintenance costs increase, and the highway structure may be damaged.

Referencing [HEC-15](#), a flexible lining should be used if the maximum computed shear stress exceeds the permissible shear stress of the grass lining or bare soil. The design storm frequency for ditch lining is a 10 year frequency, also located in [Table 1-305](#). Ditch lining frequencies are purposely lower than those used for other aspects of design, since the additional cost of protecting ditches for velocities of higher frequency floods typically outweigh any resulting reduction in maintenance costs. If lining is required, and established grass will give adequate protection, the ditch should be lined with sod or be seeded and protected with a suitable ditch lining such as a mulch or excelsior blanket (see [Figure 41-2a](#) of the BDE Manual) to protect the bare earth surface until the vegetation becomes established. A lower return period flow, such as a 2 yr return period, is allowable if a transitional lining is to be used. This transitional lining is used until the establishment of permanent vegetation. The table below lists typical permissible shear stresses for various linings.

Taken from Table 2.3 Typical Permissible Shear Stresses for Bare Soil

Lining Category	Lining Type	Permissible Shear Stress (lb/ft ²)			
Bare Soil Cohesive (PI=10)	Clayey sands	0.037-0.095			
	Inorganic silts	0.027-0.11			
	Silty Sands	0.024-0.072			
Bare Soil Cohesive (PI=20)	Clayey sands	0.094			
	Inorganic silts	0.083			
	Silty Sands	0.072			
	Inorganic clays	0.14			
Bare Soil Non-cohesive (PI < 10)	Finer than coarse sand	0.02			
	D ₇₅ <0.05in				
	Fine gravel	0.12			
	D ₇₅ =0.3in				
	Gravel	0.24			
Lining Category	Lining Type	Permissible Shear Stress (lb/ft ²)			
			Temporary	Woven Paper Net	0.15
				Jute Net	0.45
				Single Fiberglass	0.60
				Double Fiberglass	0.85
				Straw with net	1.45
				Curled Wood Mat	1.55
				Synthetic Mat	2.00
			Vegetative	Class A	3.70
				Class B	2.10
Class C	1.00				
	Class D	0.60			

	Class E	0.35
Gravel Riprap	1 in.	0.33
	2 in.	0.67
Rock Riprap	6 in.	2.00
	12 in.	4.00

Various manufacturers will list the product engineering information such as allowable shear stresses, in literature or the respective website.

Retardance Classification of Vegetal Covers (table 4.1 HEC-15)

Retardance Class	Cover	Condition
A	Weeping Love Grass	Excellent stand, tall, average 30 in.
	Yellow Bluestem Ischaaemum	Excellent stand, tall, average 36 in.
B	Kudzu	Very dense growth, uncut
	Bermuda Grass	Good stand, tall, average 12 in.
	Native Grass Mixture (little bluestem, blue gamma, and other long and short Midwest grasses)	Good stand, unmowed
	Weeping lovegrass	Good stand, tall, average 24 in.
	Lespedeza sericea	Good stand, not woody, tall, average 19 in.
	Alfalfa	Good stand, uncut, average 11 in.
	Weeping lovegrass	Good stand, unmowed, average 13 in.
C(TYPICAL IDOT DITCH)	Kudzu	Dense growth, uncut
	Blue Gamma	Good stand, uncut, average 11 in.
	Crabgrass	Fair stand, uncut 10-48 in.
	Bermuda Grass	Good stand, mowed, average 6 in.
	Common Lespedeza	Good stand, uncut, average 11 in.
	Grass-Legume mixture-summer(orchard grass, redtop, Italian ryegrass, and common lespedeza)	Good stand, uncut, average 6-8 in.
	Centipede grass	Very dense cover, average 6 in.
D	Kentucky Bluegrass	Good stand, headed, 6-12"
	Bermuda Grass	Good stand, cut to 2.5 in. height
	Common Lespedeza	Excellent stand, uncut, average 4.5 in.
	Buffalo Grass	Good stand, uncut 3-6 in.
	Grass-Legume mixture-fall,	Good stand, uncut 4-5 in.

	spring(orchard grass, redtop, Italian ryegrass, and common lespedeza)	
	Lespedeza sericea	After cutting to 2 in. height. Very good stand before cutting.
E	Bermuda grass	Good stand, cut height, 1.5 in.
	Bermuda grass	Burned stubble

The basic procedure for design principles

1. Determine discharge, Q, and select channel slope and shape.
2. Select a lining type.
3. Estimate the channel depth, d, and compute the hydraulic radius, R.
4. Estimate Manning’s, n, and resultant, Q, from Manning’s equation.
5. Check if computed Q from step 4 is within 5% of Q from step 1. If not within, estimate a new channel depth and revise steps 4 and 5.
6. Calculate the maximum shear stress, τ_d , determine the permissible shear stress, τ_p , and select a safety factor.
7. Is $\tau_p > SF\tau_d$? If not, the lining is not adequate and a new lining needs to be selected (step 2). Otherwise, the lining is acceptable.

[HEC 15](#) provides design procedures for four major categories of flexible linings:

- Vegetative lining and bare soil design;
- Manufactured lining design (rolled erosion control products (RECP’s) – such as open-weave textiles, erosion control blankets, and turf-reinforcement mats(TRM);
- Riprap, cobble and gravel lining design and;
- Gabion mattress linings.

9-502 Considerations

The following items should be kept in mind during ditch lining investigations:

1. In general, when a lining is required, the lowest cost lining that affords satisfactory protection should be used.
2. Ditch lining should be continued through short gaps in the actual limits of need.
3. In some situations, it may be possible to reduce lining requirements by directing flow away from a new section of ditch until a grass lining has been established in the ditch.
4. Lining, not otherwise required, may be needed at sharp changes in ditch alignment and at any confluence of two or more ditches, as these locations are subject to turbulence and wave action. The lining should be carried well above the depth of flow in these locations to protect against the wave action and splash.
5. At any curve in the ditch alignment, the depth of flow along the outside of the curve will be increased by centrifugal force. For this reason, any required lining should be extended further up the outer slope. If feasible, any required curve in the ditch

alignment should be made in an area where the velocity of flow is very low. [HEC-15 section 3.4](#) has design procedures for flow around a curve/bend.

- Any existing ditches, which are disturbed by the project, must also be investigated for lining needs.

9-503 Procedure

The following procedure should be used to determine ditch-lining requirements:

- Calculate the design discharge, Q , near the upstream end of the section of ditch being investigated using the methods discussed in [Section 9-003](#).
- Select a trial lining type. Initially, the designer may need to determine if a long term lining is needed and whether or not a temporary or transitional lining is required. For the transitional period between construction and vegetative establishment, analysis of the bare soil will determine if a temporary lining is required.
- Estimate the depth of flow, d_i , and compute the hydraulic radius, R . Iterations on steps 3-5 may be required.
- Estimate Manning's, n , and the discharge implied by the estimated n and estimated flow depth values. The discharge, Q_i , is calculated using the Manning's equation.
- Compare the Q_i with Q (design). If Q_i is within 5% of the design Q , then proceed on to step 6. If not, return to step 3 and select a new estimated flow depth d_{i+1} . This can be estimated from the following equation or any other appropriate method.

$$d_{i+1} = d_i \left(\frac{Q}{Q_i} \right)^{0.4} \quad (\text{Eq. 9-4})$$

- Calculate the design shear stress at maximum depth, τ_d

$$\tau_d = \gamma d S_o \quad (\text{HEC-15 Eq. 3.1})$$

where τ_d is the shear stress in the channel at maximum depth (lb/ft^2), γ is the unit weight of water 62.4 lb/ft^3 , d is the depth of flow in the channel (ft), and S_o is the channel bottom slope (ft/ft).

Determine the permissible shear stress, τ_p , and select an appropriate safety factor. The safety factor provides for a measure of uncertainty, as well as for the designer to reflect a lower tolerance for failure by choosing a higher safety factor. Permissible shear stress, τ_p , is

$$\tau_p = SF \tau_d \quad (\text{HEC-15 Eq. 3.2})$$

A safety factor of 1.0 is appropriate in many cases and may be considered the default. Safety factors from 1 to 1.5 may be appropriate where one or more of the following conditions may exist:

- Critical or supercritical flows are expected
- Climatic regions where vegetation may be uneven or slow to establish

- Significant uncertainty regarding the design discharge
 - Consequences of failure are high
7. Compare the permissible shear stress, τ_p , to the calculated design shear stress. If the permissible shear stress is adequate then the lining is acceptable. If the permissible shear stress is inadequate, then return to step 2 and select an alternative lining type with greater permissible shear stress. As an alternative, a different channel shape may be selected that results in a lower depth of flow.

The selected lining is stable and the design process is complete.

8. After the investigation near the upstream end of the ditch is completed, the same procedure should be used to investigate appropriate downstream points as necessary to determine the required types and minimum limits of lining for the entire section of ditch.
9. After the minimum limits of lining are established, each section of lining should be extended downstream a sufficient distance to allow the flow to slow down before it enters the unprotected or less protected ditch. [Table 9-503](#) gives recommended lengths for this transitional lining.

Scouring Slope (%*)	Length of Transition (ft)
0-4	25
4-6	50
6-10	75
Over 10	100

* *A suggested computation sheet for ditch lining, as shown Ditch gradient at the lower end of the section of ditch where lining is required.*

*Transitional Ditch Lining
Table 9-503*

A suggested computation sheet for ditch lining, as shown in ([Figure 9-503](#)) should be used to organize and show the procedures used to determine the lining requirements. This sheet is designed for use with the Rational Method but can be adapted to other methods of determining discharge if necessary.

If the above procedures indicate that extensive lining is required, the drainage plan and ditch gradients should be reviewed to verify that the most economical ditch system is being proposed.

Stability in bends, side slope stability, and composite lining design should be reviewed, but is not presented in this manual. Please refer to [HEC-15](#).

9-504 Example Problems - Ditch Lining

Example 1

Evaluate a new or reconstructed grassed ditch on a trapezoidal ditch for stability. Given:

$$Q = 2 \text{ ft}^3/\text{s}$$

$$B = 2 \text{ ft}$$

$$Z_1 = 3 \text{ ft}$$

$$Z_2 = 4 \text{ ft}$$

$$S_o = 0.003 \text{ ft/ft}$$

Grass stem height, $h = 3 \text{ in (0.25 ft)}$

Cohesive soil, clayey sands with a $PI = 20$

The density-stiffness coefficient, $C_s = 9$ (good condition) from table 4.2.

Step 1. Channel slope, shape and discharge have been given.

Step 2. Proposed lining type is vegetated grass

Step 3. Assume the depth of flow, d_i , in the channel is 0.78 ft. Compute, R .

$$A = Bd + \frac{Z_1 d^2}{2} + \frac{Z_2 d^2}{2} = (2)(0.78) + \frac{(3)(0.78^2)}{2} + \frac{(4)(0.78^2)}{2} = 3.69 \text{ ft}^2$$

$$P = B + d\sqrt{Z_1^2 + 1} + d\sqrt{Z_2^2 + 1} = 2 + 0.78\sqrt{3^2 + 1} + 0.78\sqrt{4^2 + 1} = 7.68 \text{ ft}$$

$$R = \frac{A}{P} = \frac{3.69}{7.68} = 0.48 \text{ ft}$$

Step 4. Estimate Manning's, n , from [equation 2.3 of HEC-15](#). The discharge is calculated using Manning's equation,

$$\tau_o = \gamma R S_o = 62.4(0.48)0.003 = 0.0899 \text{ lb/ft}^2$$

Using [equation 4.1 of HEC-15](#) to determine the grass roughness coefficient, C_n , where $\alpha_1 = 0.237$, a constant. The stem height, h , is given,

$$C_n = \alpha_1 C_s^{0.10} h^{0.528} = (0.237)9^{0.10}0.25^{0.528} = 0.142$$

Using [equation 4.2 of HEC-15](#) to determine Manning's, n , where $\alpha_2 = 0.213$,

$$n = \alpha_2 C_n \tau_o^{-0.40} = (0.213)0.142 (0.0899)^{-0.40} = 0.0793$$

$$Q = \frac{1.49}{n} A R^{\frac{2}{3}} S^{0.5}$$

$$Q = \frac{1.49}{0.0793} (3.69)(0.48)^{\frac{2}{3}}(0.003)^{0.5} = 2.33 \text{ cfs}$$

Step 5. Since this value is more than 5% different from the design flow, we need to go back to step 3 to estimate a new flow depth.

Step 3 (2nd iteration). Estimate a new depth:

$$d_{i+1} = d_i \left(\frac{Q}{Q_i} \right)^{0.4}$$

$$d = 0.78 \left(\frac{2}{2.33} \right)^{0.4} = 0.73 \text{ ft}$$

Compute a new hydraulic radius.

$$A = Bd + \frac{Z_1 d^2}{2} + \frac{Z_2 d^2}{2} = (2)(0.73) + \frac{(3)(0.73^2)}{2} + \frac{(4)(0.73^2)}{2} = 3.33 \text{ ft}^2$$

$$P = B + d\sqrt{Z_1^2 + 1} + d\sqrt{Z_2^2 + 1} = 2 + 0.73\sqrt{3^2 + 1} + 0.73\sqrt{4^2 + 1} = 7.32 \text{ ft}$$

$$R = \frac{A}{P} = \frac{3.33}{7.32} = 0.454 \text{ ft}$$

Step 4 (2nd iteration). Estimate Manning’s, n, from [equation 2.3 of HEC-15](#). The discharge is calculated using Manning’s equation,

$$\tau_o = \gamma R S_o = 62.4(0.454)0.003 = 0.085 \text{ lb/ft}^2$$

C_n = remains the same from first iteration.

Using equation 4.2 of HEC-15 to determine Manning’s, n

$$n = \alpha_2 C_n \tau_o^{-0.40} = (0.213)0.142 (0.085)^{-0.40} = 0.081$$

$$Q = \frac{1.49}{n} A R^{\frac{2}{3}} S^{0.5}$$

$$Q = \frac{1.49}{0.081} (3.33)(0.454)^{\frac{2}{3}}(0.003)^{0.5} = 1.98 \text{ cfs}$$

Step 5. Since this value is within 5% of the design flow, proceed to step 6.

Step 6. The shear stress at maximum depth from [Equation 3.1 of HEC-15](#) is

$$\tau_d = \gamma d S_o$$

$$\tau_d = 62.4(0.73)(0.003) = 0.14 \text{ lb/ft}^2$$

Check $\tau_p = SF\tau_d$

Determine the soil permissible shear stress for cohesive soils from [equation 4.6 of HEC 15](#),

$$\tau_{p\ soil} = (c_1 PI^2 + c_2 PI + c_3)(c_4 + c_5 e)^2 c_6$$

$$\tau_{p\ soil} = ((1.07)20^2 + 14.3(20) + 47.7)(1.42 + (-0.61)0.5)^2(0.0001) = 0.095\ lb/ft^2$$

Table 4.6. Coefficients for Permissible Soil Shear Stress (USDA, 1987)

ASTM Soil Classification ⁽¹⁾	Applicable Range	C ₁	C ₂	C ₃	C ₄	C ₅	C ₆ (SI)	C ₆ (CU)
GM	10 < PI < 20	1.07	14.3	47.7	1.42	-0.61	4.8x10 ⁻³	10 ⁻⁴
	20 < PI			0.076	1.42		48.	1.0
GC	10 < PI < 20	0.0477	2.86	42.9	1.42	-0.61	4.8x10 ⁻²	10 ⁻³
	20 < PI			0.119	1.42		48.	1.0
SM	10 < PI < 20	1.07	7.15	11.9	1.42	-0.61	4.8x10 ⁻³	10 ⁻⁴
	20 < PI			0.058	1.42		48.	1.0
SC	10 < PI < 20	1.07	14.3	47.7	1.42	-0.61	4.8x10 ⁻³	10 ⁻⁴
	20 < PI			0.076	1.42		48.	1.0
ML	10 < PI < 20	1.07	7.15	11.9	1.48	-0.57	4.8x10 ⁻³	10 ⁻⁴
	20 < PI			0.058	1.48		48.	1.0
CL	10 < PI < 20	1.07	14.3	47.7	1.48	-0.57	4.8x10 ⁻³	10 ⁻⁴
	20 < PI			0.076	1.48		48.	1.0
MH	10 < PI < 20	0.0477	1.43	10.7	1.38	-0.373	4.8x10 ⁻²	10 ⁻³
	20 < PI			0.058	1.38		48.	1.0
CH	20 < PI			0.097	1.38	-0.373	48.	1.0

This shear stress is the bare soil (cohesive) permissible shear stress. This will be checked against the design shear stress for the need of a transitional lining (at end of example).

The combined effects of the soil permissible shear stress and the effective shear stress transferred through the vegetative lining, results in a permissible shear stress for the vegetative lining. [Equation 4.7 of HEC-15](#) gives the permissible shear stress on the vegetative lining and is,

$$\tau_p = \frac{\tau_{p\ soil}}{1 - C_f} \left(\frac{n}{n_s}\right)^2 = \frac{0.095}{1 - 0.75} \left(\frac{0.081}{0.016}\right)^2 = 9.7\ lb/ft^2$$

where C_f, Cover Factor is selected from Table 4.5.

Table 4.5. Cover Factor Values for Uniform Stands of Grass

Growth Form	Cover Factor, C _f				
	Excellent	Very Good	Good	Fair	Poor
Sod	0.98	0.95	0.90	0.84	0.75
Bunch	0.55	0.53	0.50	0.47	0.41
Mixed	0.82	0.79	0.75	0.70	0.62

Is $\tau_p \geq SF\tau_d$?

Yes, 9.7 > 1.0(0.14). The permanent vegetative lining is stable. Check if the bare earth will need a transitional lining such as excelsior blanket using a 2 year return design discharge of 0.5 cfs.

Following the preceding steps 1-5, one obtains a depth of d = 0.154 ft, assuming a Manning’s n = 0.016 (Unlined, Bare Soil) from Table 2.1. The calculated design shear stress $\tau_d = \gamma d S_o$, $\tau_d = 62.4(0.154)(0.003) = 0.029$. Is $\tau_{p,soil} \geq SF\tau_d$? Yes, 0.095 > 0.029. The bare soil is stable and would not need a transitional lining before permanent vegetation is established.

Table 2.1. Typical Roughness Coefficients for Selected Linings

Lining Category	Lining Type	Manning's n ¹		
		Maximum	Typical	Minimum
Rigid	Concrete	0.015	0.013	0.011
	Grouted Riprap	0.040	0.030	0.028
	Stone Masonry	0.042	0.032	0.030
	Soil Cement	0.025	0.022	0.020
	Asphalt	0.018	0.016	0.016
Unlined	Bare Soil ²	0.025	0.020	0.016
	Rock Cut (smooth, uniform)	0.045	0.035	0.025
RECP	Open-weave textile	0.028	0.025	0.022
	Erosion control blankets	0.045	0.035	0.028
	Turf reinforcement mat	0.036	0.030	0.024

Example 2

Evaluate a proposed gravel mulch lining on a trapezoidal ditch for stability. Given:

- Q = 15 ft³/s
- B = 2 ft
- Z = 3 ft
- S_o = 0.008 ft/ft
- D₅₀ = 1 in

Step 1. Channel slope, shape and discharge have been given.

Step 2. Proposed lining type is a gravel mulch with D₅₀ = 1 in

Step 3. Assume the depth of flow d_i in the channel is 1.6 ft. Compute, R.

$$A = Bd + Zd^2 = 2(1.6) + 3(1.6)^2 = 10.88 \text{ ft}^2$$

$$P = B + 2d\sqrt{Z^2 + 1} = 2 + 2(1.6)\sqrt{(3^2) + 1} = 12.12 \text{ ft}$$

$$R = \frac{A}{P} = \frac{10.88}{12.12} = 0.898 \text{ ft}$$

Step 4. From Table 2.2, Manning's n = 0.033. The discharge is calculated using Manning's equation,

Table 2.2. Typical Roughness Coefficients for Riprap, Cobble, and Gravel Linings

Lining Category	Lining Type	Manning's n for Selected Flow Depths ¹		
		0.15 m (0.5 ft)	0.50 m (1.6 ft)	1.0 m (3.3 ft)
Gravel Mulch	D ₅₀ = 25 mm (1 in.)	0.040	0.033	0.031
	D ₅₀ = 50 mm (2 in.)	0.056	0.042	0.038
Cobbles	D ₅₀ = 0.10 m (0.33 ft)	-- ²	0.055	0.047
Rock Riprap	D ₅₀ = 0.15 m (0.5 ft)	-- ²	0.069	0.056
	D ₅₀ = 0.30 m (1.0 ft)	-- ²	-- ²	0.080

$$Q = \frac{1.49}{n} AR^{\frac{2}{3}} S^{0.5}$$

$$Q = \frac{1.49}{0.033} (10.88)(0.898)^{\frac{2}{3}}(0.008)^{0.5} = 40.90 \text{ cfs}$$

Step 5. Since this value is more than 5% different from the design flow, we need to go back to step 3 to estimate a new flow depth.

Step 3 (2nd iteration). Estimate a new depth estimate:

$$d_{i+1} = d_i \left(\frac{Q}{Q_i} \right)^{0.4}$$

$$d = 1.6 \left(\frac{15}{40.90} \right)^{0.4} = 1.07 \text{ ft}$$

Compute a new hydraulic radius.

$$A = Bd + Zd^2 = 2(1.07) + 3(1.07)^2 = 5.57 \text{ ft}^2$$

$$P = B + 2d\sqrt{Z^2 + 1} = 2 + 2(1.07)\sqrt{(3^2) + 1} = 8.767 \text{ ft}$$

$$R = \frac{A}{P} = \frac{5.57}{8.767} = 0.635 \text{ ft}$$

Step 4 (2nd iteration). Table 2.2 does not have a 1.07 ft depth so [Equation 6.1 of HEC-15](#) is used for estimating Manning's, n, which is approximately 0.033. The discharge is calculated using Manning's equation:

$$Q = \frac{1.49}{n} AR^{\frac{2}{3}}S^{0.5}$$

$$Q = \frac{1.49}{0.033} (5.57)(0.635)^{\frac{2}{3}}(0.008)^{0.5} = 16.62 \text{ cfs}$$

Step 5 (2nd iteration). Since the discharge is still more than 5% difference, iterate steps 3-5 to obtain a new depth.

Step 3 (3rd iteration). Estimate a new depth estimate:

$$d_{i+1} = d_i \left(\frac{Q}{Q_i} \right)^{0.4}$$

$$d = 1.07 \left(\frac{15}{16.62} \right)^{0.4} = 1.03 \text{ ft}$$

Compute a new hydraulic radius.

$$A = Bd + Zd^2 = 2(1.03) + 3(1.03)^2 = 5.24 \text{ ft}^2$$

$$P = B + 2d\sqrt{Z^2 + 1} = 2 + 2(1.03)\sqrt{(3^2) + 1} = 8.51 \text{ ft}$$

$$R = \frac{A}{P} = \frac{5.24}{8.51} = 0.61 \text{ ft}$$

Step 4 (3rd iteration). [Table 2.2](#) does not have a 1.03 ft depth so Equation 6.1 of HEC-15 is used for estimating Manning’s, n, which is approximately 0.033. The discharge is calculated using Manning’s equation:

$$Q = \frac{1.49}{n} AR^{\frac{2}{3}} S^{0.5}$$

$$Q = \frac{1.49}{0.033} (5.24)(0.616)^{\frac{2}{3}} (0.008)^{0.5} = 15.32 \text{ cfs}$$

Step 5 (3rd iteration). Since this value is within 5% of the design flow, proceed to step 6.

Step 6. The shear stress at maximum depth from Equation 3.1 of HEC-15 is,

$$\tau_d = \gamma d S_o$$

$$\tau_d = 62.4(1.03)(0.008) = 0.51 \text{ lb/ft}^2$$

Check $\tau_p \geq SF\tau_d$

From Table 2.3, permissible shear stress $\tau_p = 0.4 \text{ lb/ft}^2$

Is $\tau_p \geq SF\tau_d$? No, $0.4 < 1.0(0.51)$. The lining is not stable. Go back to step 2 and select an alternative lining type with greater permissible shear stress. Try the next larger size of gravel. If the lining had been stable, the design process would be complete.

Example 3

Evaluate a grass lining for a straight roadside trapezoidal ditch.

Given:

Q = 30 ft³/s

B = 2 ft

Z₁ = 3 ft

Z₂ = 4 ft

S_o = 0.03 ft/ft

Soil: Clayey Sand (SC classification), PI=16, e=0.5

Grass: Fair, mixed, height = 0.61 ft

Step 3. Assume the depth of flow d_i in the channel is 1.0 ft. Compute, R.

$$A = Bd + \frac{Z_1 d^2}{2} + \frac{Z_2 d^2}{2} = 2(1) + \frac{(3)(1)^2}{2} + \frac{(4)(1)^2}{2} = 5.50 \text{ ft}^2$$

$$P = B + d\sqrt{Z_1^2 + 1} + d\sqrt{Z_2^2 + 1} = 2 + (1)\sqrt{3^2 + 1} + (1)\sqrt{4^2 + 1} = 9.285 \text{ ft}$$

$$R = \frac{A}{P} = \frac{5.50}{9.285} = 0.592 \text{ ft}$$

Step 4. Estimate Manning’s n from [equation 2.3 of HEC-15](#).

$$\tau_o = \gamma R S_o = 62.4(0.592)(0.03) = 1.108 \text{ lb/ft}^2$$

Determine a Manning’s n from [equation 4.2 of HEC-15](#)

$$n = \alpha C_n \tau_o^{-0.4},$$

where $\alpha = 0.213$

$$n = \alpha C_n \tau_o^{-0.4} = 0.213(0.20)(1.108)^{-0.4} = 0.0409$$

The discharge is calculated using Manning’s equation,

$$Q = \frac{1.49}{n} A R^{\frac{2}{3}} S^{0.5}$$

$$Q = \frac{1.49}{0.041} (5.50)(0.592)^{\frac{2}{3}}(0.03)^{0.5} = 24.41 \text{ cfs}$$

Step 5. Since this value is more than 5% different from the design flow, we need to go back to step 3 to estimate a new flow depth.

Step 3 (2nd iteration). Estimate a new depth estimate:

$$d_{i+1} = d_i \left(\frac{Q}{Q_i} \right)^{0.4}$$

$$d = 1.0 \left(\frac{30}{24.41} \right)^{0.4} = 1.09 \text{ ft}$$

Compute a new hydraulic radius.

$$A = Bd + \frac{Z_1 d^2}{2} + \frac{Z_2 d^2}{2} = 2(1.09) + \frac{(3)(1.09)^2}{2} + \frac{(4)(1.09)^2}{2} = 6.338 \text{ ft}^2$$

$$P = B + d\sqrt{Z_1^2 + 1} + d\sqrt{Z_2^2 + 1} = 2 + (1.09)\sqrt{3^2 + 1} + (1.09)\sqrt{4^2 + 1} = 9.941 \text{ ft}$$

$$R = \frac{A}{P} = \frac{6.338}{9.941} = 0.638 \text{ ft}$$

Step 4 (2nd iteration). Estimate Manning’s n from [equation 2.3 of HEC-15](#)

$$\tau_o = \gamma R S_o = 62.4(0.638)(0.03) = 1.194 \text{ lb/ft}^2$$

Determine a Manning’s n from [equation 4.2 of HEC-15](#)

$$n = \alpha C_n \tau_o^{-0.4}$$

Where $\alpha = 0.213$

$$n = \alpha C_n \tau_o^{-0.4} = 0.213(0.20)(1.194)^{-0.4} = 0.0397$$

The discharge is calculated using Manning’s equation,

$$Q = \frac{1.49}{n} AR^{\frac{2}{3}} S^{0.5}$$

$$Q = \frac{1.49}{0.0397} (6.338)(0.638)^{\frac{2}{3}}(0.03)^{0.5} = 30.5 \text{ cfs}$$

Step 5 (2nd iteration). Since the discharge is within 5% of the design discharge, proceed to step 6.

Step 6. Determine the maximum shear on channel bottom from [equation 3.1 of HEC-15](#)

$$\tau_d = \gamma d S_o = 62.4(1.09)0.03 = 2.04 \text{ lb/ft}^2$$

Determine the permissible shear stress from [equation 4.6 of HEC-15](#)

$$\tau_{p \text{ soil}} = (c_1 PI^2 + c_2 PI + c_3)(c_4 + c_5 e)^2 c_6 = (1.07(16^2) + 14.3(16) + 47.7)(1.42 + (-0.61)(0.5))^2 0.0001 = 0.0684 \text{ lb/ft}^2$$

[Equation 4.7 of HEC-15](#) is the permissible soil shear stress on vegetation. C_f from [Table 4.5 of HEC 15](#). Say $C_f = 0.75$

$$\tau_p = \frac{\tau_{p \text{ soil}}}{(1 - C_f)} \left(\frac{n}{n_s}\right)^2 = \frac{0.0684}{(1 - 0.75)} \left(\frac{0.0397}{0.016}\right)^2 = 1.68 \text{ lb/ft}^2$$

Since the maximum shear stress, τ_d , on the channel bottom exceeds the permissible soil shear stress, τ_p , the grass lining is unstable. The designer should select an alternative lining with a larger permissible shear stress.

Example 4

Check if a manufacturers Rolled Erosion Control blanket product such as excelsior blanket, is stable given the following information:

- Proposed Ditch Shape: Trapezoidal, B=2.0 ft, Z₁=3 ft, Z₂=4 ft
- Soil: Clayey sand (SC classification), PI=16, e=0.5
- Grass: Fair, mixed, height =0.61ft
- Q = 30 ft³/s, S_o = 0.03 ft/ft

Erosion control Blanket with manufacturer’s performance data of:

$$\tau_l = 3.2 \text{ lb/ft}^2$$

Applied Shear (lb/ft ²)	n value
1.6	0.036
3.2	0.030
6.4	0.028

Step 3. Initial depth is estimated at 1.09 ft

$$A = Bd + \frac{Z_1 d^2}{2} + \frac{Z_2 d^2}{2}$$

$$A = 2.0(1.09) + \frac{3(1.09)^2}{2} + \frac{4(1.09)^2}{2} = 6.338 \text{ ft}^2$$

$$P = B + d\sqrt{Z_1 + 1} + d\sqrt{Z_2 + 1}$$

$$P = 2.0 + (1.09)\sqrt{3.0 + 1} + (1.09)\sqrt{4.0 + 1} = 9.941 \text{ ft}$$

$$R = \frac{A}{P} = \frac{6.338}{9.941} = 0.638 \text{ ft}$$

Step 4. To estimate n, the applied shear stress on the lining is given by [Equation 2.3 of HEC-15](#),

$$\tau_o = \gamma R S_o = 62.4 (0.638)(0.03) = 1.194 \text{ lb/ft}^2$$

Determine Manning’s n from [equation 5.1](#) with support from equation 5.2 and 5.3 of HEC-15.

$$b = -\frac{\sqrt{\ln\left(\frac{n_{mid}}{n_{low}}\right) \ln\left(\frac{n_{up}}{n_{mid}}\right)}}{0.693} = -\frac{\sqrt{\ln\left(\frac{0.030}{0.028}\right) \ln\left(\frac{0.036}{0.030}\right)}}{0.693} = -0.162$$

$$a = \frac{n_{mid}}{\tau_{mid}^b} = \frac{0.030}{3.2^{-0.162}} = 0.0362$$

$$n = a\tau_o^b = .0362(1.194)^{-0.162} = 0.0352$$

$$Q = \frac{1.49}{0.0352} (6.338)(0.638)^{\frac{2}{3}} (0.03)^{\frac{1}{2}} = 34.4 \text{ cfs}$$

Step 5. Check if Q is within 5% of design flow.

$$\% \text{ Difference} = \frac{34.4 - 30}{30} (100) = 14.67 \%$$

We need to determine a new d, and continue from step 3.

Step 3. (Second Iteration) Estimate a new depth

$$d_{i+1} = d_i \left(\frac{Q}{Q_i}\right)^{0.4}$$

$$d = 1.09 \left(\frac{30}{34.4} \right)^{0.4} = 1.03 \text{ ft}$$

Compute a new hydraulic radius

$$A = Bd + \frac{Z_1 d^2}{2} + \frac{Z_2 d^2}{2}$$

$$A = 2.0(1.03) + \frac{3(1.03)^2}{2} + \frac{4(1.03)^2}{2} = 5.787 \text{ ft}^2$$

$$P = B + d\sqrt{Z_1 + 1} + d\sqrt{Z_2 + 1}$$

$$P = 2.0 + (1.03)\sqrt{3.0 + 1} + (1.03)\sqrt{4.0 + 1} = 9.515 \text{ ft}$$

$$R = \frac{A}{P} = \frac{5.787}{9.515} = 0.608 \text{ ft}$$

Step 4. (Second Iteration) estimate n, the applied shear stress on the lining is given by [Equation 2.3 of HEC-15](#),

$$\tau_o = \gamma R S_o = 62.4 (0.608)(0.03) = 1.138 \text{ lb/ft}^2$$

Determine Manning's n from [equation 5.1 of HEC-15](#) using a & b which was previously determined

$$n = a\tau_o^b = .0362(1.138)^{-0.162} = 0.0354$$

$$Q = \frac{1.49}{n} (A)(R)^{\frac{2}{3}}(S_o)^{\frac{1}{2}}$$

$$Q = \frac{1.49}{0.0354} (5.787)(0.608)^{\frac{2}{3}}(0.03)^{\frac{1}{2}} = 30.3 \text{ cfs}$$

Step 5. Check if Q is within 5% of design flow.

$$\% \text{ Difference} = \frac{30.3 - 30}{30} (100) = 1.00 \%$$

Continue to Step 6.

Step 6. The maximum shear on the lining of the channel bottom is,

$$\tau_d = \gamma d S_o = 62.4 (1.03)(0.03) = 1.928 \text{ lb/ft}^2$$

[Equation 5.5](#) gives the permissible shear on the RECP. Note the $\tau_{p \text{ soil}}$ is the same as in example

3 ($\tau_{p \text{ soil}} = 0.0684$).

$$\tau_{p \text{ RECP}} = \frac{\tau_l}{\alpha} \left(\tau_{p \text{ soil}} + \frac{\alpha}{4.3} \right) = \frac{3.2}{0.14} \left(0.0684 + \frac{0.14}{4.3} \right) = 2.308 \text{ lb/ft}^2$$

Is $\tau_p > (SF) \tau_d$

Safety Factor = 1.0

$$2.308 > (1.0)1.928$$

The lining is stable.

Example 5 – Evaluate a riprap lined ditch for stability given:

Slope = 4%
 Q=25 cfs
 B=2 ft
 Z₁=3 ft, Z₂=4 ft.

The basic design procedures for riprap and gravel lining are:

- Step 1. Determine the channel slope, channel shape, and design discharge.
- Step 2. Select a trial D₅₀.
- Step 3. Estimate the depth d_i. For subsequent iterations, a new depth can be estimated from the following equation.

$$d_{i+1} = d_i \left(\frac{Q}{Q_i} \right)^{0.4}$$

Determine the average flow depth d_a, in the channel, where d_a = A/T where T is the top width of water.

Step 4. Estimate Manning’s n and the implied discharge. Calculate the relative depth ratio d_a/D₅₀. If d_a/D₅₀ ≥ 1.5, use [equation 6.1 of HEC-15](#) to calculate Manning’s n. If d_a/D₅₀ ≤ 1.5, use [Equation 6.2 of HEC-15](#) to calculate the Manning’s n. Calculate the discharge using Manning’s equation.

Step 5. If the calculated discharge is within 5% of the design discharge, then proceed to step 6. If not, repeat steps 3-5 and estimate a new flow depth.

Step 6. Calculate the particle Reynolds number using [equation 6.6 of HEC-15](#) and determine Shields parameter and Safety factor values from [Table 6.1](#). If the channel slope is < 5%, calculate the required D₅₀ from [equation 6.8 of HEC-15](#). If the channel slope is > 10%, use [equation 6.11 of HEC-15](#). If the channel slope is between 5% and 10%, use both equations and take the largest value.

Step 7. If the D₅₀ calculated is greater than the trial size in step 2, the trial size is too small and unacceptable. Repeat procedure beginning at step 2 with the new trial value of D₅₀. If the D₅₀ calculated in step 6 is less than or equal to the previous trial size, then the previous trial size is acceptable. However, if the D₅₀ calculated in step 6 is sufficiently smaller than the previous trial size, the designer may select to repeat the design procedure at step 2 with a smaller, more cost effective D₅₀.

Step 2. For this example, determine if RR3 is stable. D₅₀ = 0.82, γ_s = 165 lb/ft².

Step 3. Assume an initial trial depth of 1.23 ft

$$A = Bd + \frac{Z_1 d^2}{2} + \frac{Z_2 d^2}{2}$$

$$A = 2.0(1.23) + \frac{3(1.23)^2}{2} + \frac{4(1.23)^2}{2} = 7.76 \text{ ft}^2$$

$$P = B + d\sqrt{Z_1^2 + 1} + d\sqrt{Z_2^2 + 1}$$

$$P = 2.0 + (1.23)\sqrt{9 + 1} + (1.23)\sqrt{16 + 1} = 10.96 \text{ ft}$$

$$R = \frac{A}{P} = \frac{7.76}{10.96} = 0.708 \text{ ft}$$

$$T = B + dZ_1 + dZ_2 = 2 + 1.23(3) + 1.23(4) = 10.61 \text{ ft}$$

$$d_a = \text{average depth of flow in channel} = \frac{A}{T}$$

$$d_a = \frac{7.76}{10.61} = 0.731$$

Step 4. The relative depth ratio $\frac{d_a}{D_{50}} = \frac{0.731}{0.82} = 0.89$, therefore, use [equation 6.2 of HEC-15](#) to calculate Manning's n.

$$n = \frac{\alpha d_a^{1/6}}{\sqrt{g} f(Fr) f(REG) f(CG)}$$

where the 3 terms in the denominator represent functions of the Froude number, roughness element geometry, and channel geometry.

$$f(Fr) = \left(\frac{0.28Fr}{b}\right)^{\log(0.755/b)} \quad \text{(HEC-15 Eq. 6.3)}$$

$$Fr = \frac{V}{\sqrt{gd_a}} = Fr = \frac{25}{\sqrt{32.2(0.731)}} = 0.664$$

Where b describes the relationship between effective roughness concentration and relative submergence of the roughness bed.

$$b = 1.14 \left(\frac{D_{50}}{T}\right)^{0.453} \left(\frac{d_a}{D_{50}}\right)^{0.814} \quad \text{(HEC-15 Eq. 6.6)}$$

$$b = 1.14 \left(\frac{0.82}{10.61}\right)^{0.453} \left(\frac{0.731}{0.82}\right)^{0.814} = 0.325$$

$$f(Fr) = \left(\frac{0.28(0.664)}{0.325}\right)^{\log(0.755/0.325)} = 0.815$$

$$f(REG) = 13.434 \left(\frac{T}{D_{50}}\right)^{0.492} b^{1.025(T/D_{50})^{0.118}} \quad \text{(HEC-15 Eq. 6.4)}$$

$$f(REG) = 13.434 \left(\frac{10.61}{0.82} \right)^{0.492} 0.325^{1.025} \left(\frac{10.61}{0.82} \right)^{0.118} = 9.96$$

$$f(CG) = \left(\frac{T}{d_a} \right)^{-b} \quad \text{(HEC-15 Eq. 6.5)}$$

$$f(CG) = \left(\frac{10.61}{0.731} \right)^{-0.325} = 0.419$$

Now that we have all of the components of the Manning’s n equation 6.2,

$$n = \frac{\alpha d_a^{1/6}}{\sqrt{g} f(Fr) f(REG) f(CG)} \quad \text{(HEC-15 Eq. 6.2)}$$

$$n = \frac{(1.49)(0.731)^{1/6}}{\sqrt{32.2}(0.815)(9.96)(0.419)} = 0.073$$

Now estimating the discharge,

$$Q = \frac{1.49}{n} AR^{2/3} S^{0.5} = \frac{1.49}{0.073} (7.76)(0.708)^{2/3} (0.04)^{0.5} = 25.16 \text{ cfs}$$

Step 5. Check if Q is within 5% of design flow.

$$\% \text{ Difference} = \frac{25.16 - 25}{25} (100) = 0.64 \%$$

We can continue to step 6.

Step 6. Calculate the Reynolds number.

$$R_e = \frac{V_* D_{50}}{\nu}, \text{ where } V_* = \text{shear velocity, } \nu \text{ is the kinematic viscosity (1.217x10}^{-5} \text{ ft}^2/\text{s at 60 }^\circ\text{F)}$$

$$V_* = \sqrt{gdS} \quad \text{(HEC-15 Eq. 6.10)}$$

$$V_* = \sqrt{32.2(1.23)(0.04)} = 1.26 \text{ ft/s}$$

Calculating the particle Reynolds number,

$$R_e = \frac{V_* D_{50}}{\nu} \quad \text{(HEC-15 Eq. 6.9)}$$

$$R_e = \frac{(1.26)(0.82)}{1.21 \times 10^{-5}} = 85,388.4$$

Linearly interpolating this value of Reynolds number with the values given in [Table 6.1](#) of HEC 15 yields a Shields parameter $F_* = 0.076$

Since the D_{50} is given, determine the permissible shear stress and compare to the design shear stress.

$$\tau_p = F_*(\gamma_s - \gamma)D_{50} \quad \text{(HEC-15 Eq. 6.7)}$$

$$\tau_p = 0.076(165 - 62.4)0.082 = 6.39 \text{ lb/ft}^2$$

Calculating the design shear stress from [equation 3.1 of HEC-15](#),

$$\tau_d = \gamma d S_o = 62.4(1.23)0.04 = 3.07 \text{ lb/ft}^2$$

Comparing the design shear stress to the permissible shear stress shows that the ditch is stable with riprap.

$$\tau_p > (SF) \tau_d$$

$$6.39 > (1)3.07$$

Flexible Ditch Lining Computation (Hec-15)																					
Location	Total Area (acres)	Weighted "C"	Total CxA	Tc (minutes)	Intensity (in/hr)	Discharge Q (cfs)	DITCH SECTION			Area (sq.ft)	Wet Perimeter (ft)	Hydraulic Radius	Ditch Grade (ft/ft)	Flow Depth (ft)	Manning's "n"	Velocity V (ft/sec)	τ_d (lb/ft ²)	Lining Type	Permissible Lining Shear Stress	Stable?	Comments
							A	B	C												
Example 1						2	4	2	3	3.325	7.314	0.455	0.003	0.73	0.081	0.6015	0.1367	Vegetation	0.14	YES	Safety factor = 1
Example 1-bare soil						0.5	4	2	3	0.410	3.165	0.129	0.003	0.16	0.016	1.2207	0.0300	Bare Soil	0.095	YES	SF = 1; transitional lining not required; used a Q2 flow.
Example 2						15	3	2	3	5.243	8.514	0.616	0.008	1.03	0.033	2.8611	0.5142	Gravel	0.4	NO	Safety factor = 1; try larger D ₅₀ gravel mulch
Example 3						30	4	2	3	6.338	9.935	0.638	0.03	1.09	0.039	4.7331	2.0405	Vegetation	0.068	NO	Safety factor = 1; consider wider ditch or riprap lining
Example 4						30	4	2	3	5.773	9.499	0.608	0.03	1.03	0.0354	5.1965	1.9282	RECP	2.308	YES	Safety factor = 1
Example 5						25	4	2	3	7.755	10.955	0.708	0.04	1.23	0.073	3.2237	3.0701	Rock Riprap	6.39	YES	Safety factor = 1

Figure 9-503

9-600 OUTLET TREATMENT

9-601 General

The final step in design of a roadside ditch system is the determination of any required special measures at the points where ditch flow is outletted onto adjacent properties. Construction of a highway will always cause changes in flow conditions at these outlet points. Some of these changes are unavoidable, but others can be avoided or diminished if special facilities are included for that purpose. The decision of whether or not to include such facilities should be based on their cost and the degree of damage, which would be expected to occur on the lower property if they are not included. In general, if the changes in flow conditions will not cause "undue harm" to the downstream property, then expensive corrective measures are probably not warranted. The definition of "undue harm" must be left to the judgement of the designer. The Illinois Drainage Laws: Rights and Responsibilities of Highway Authorities and Landowners Adjacent to Highways³ includes a detailed discussion of drainage rules related to this subject.

Highway improvements most commonly affect the outlet flow in one or more of the following manners:

1. Increased or decreased discharge
2. Increased or decreased velocity of flow
3. Concentration of previously diffused flow
4. Change in the quality of the outlet water

These four subjects are discussed in the following sections.

9-602 Modified Discharge

If it is determined that a proposed ditch system will increase the discharge at an outlet point to an unacceptable level, the designer should first review the ditch system to see if it is feasible to reduce the flow by modifying some feature of the system. A reduction in the size of the area drained, or an increase in either the average permeability of the basin or the time needed for the flow to reach the outlet, would reduce the discharge. If such changes are not feasible, detention or storage facilities may be used to reduce the peak rate of discharge to an acceptable level. Design of these facilities is discussed in [Chapter 12](#). If the increase in flow is due to concentration of previously diffused flow, a solution might be found in [Section 9-604](#).

A proposed improvement may also adversely affect downstream property, such as cropland, wetland, farm pond, etc., by reducing the discharge. This normally would occur only when a diversion of flow was planned. As discussed in [Section 9-202\(3\)](#), the designer should weigh the value of this diversion against the probability of causing damages to the downstream property.

9-603 Modified Velocity of Flow

One of the more common complaints received from lower property owners after a highway project is completed is that a natural channel or swale which had always been stable is now washing away. This erosion is almost always attributable to a high velocity at the outlet point of a culvert

or roadside ditch. In most instances, a proper design could have avoided these problems. The designer should always determine the velocity at each outlet point and investigate its effect on the natural downstream channel by the methods discussed in [Section 9-500](#). If unacceptably high velocities are indicated, corrective measures must be taken. Possible corrective measures include the following:

1. Decrease the discharge. Methods of changing the discharge are discussed in the previous section; however, there is usually no economical method of significantly reducing discharge.
2. Increase the roughness of the ditch lining approaching the outlet. If the necessary reduction in velocity is not too extreme, a lining of riprap or other material with a high resistance to flow may suffice. The required length of the lining should be obtained from [Figure 9-503](#).
3. Decrease the grade of the ditch upstream from the outlet. The length of this flatter grade should at least equal the transition length obtained from [Table 9-503](#).
4. Increase the size of the ditch. Increasing the bottom width or flattening the side slopes of the proposed ditch will reduce the velocity of flow. The ditch should not be significantly larger than the natural downstream channel.
5. Construct an energy dissipater at the outlet point. Design of these facilities is discussed in [Chapter 6](#).
6. Place a protective lining in the natural downstream channel to the end of the anticipated erosion. This could require the acquisition of an extensive temporary easement and approval of the property owner.

It is also possible, but improbable, that a proposed ditch system could result in an outlet velocity too low to keep the downstream channel clean. The velocity could be increased by moving the opposite direction with the measures indicated in items 1 through 4 above.

9-604 Concentration of Sheet Flow

Sheet flow (also called diffused flow, spread flow or overland flow) is defined as surface water that flows over a wide area and is not concentrated in a defined watercourse. When a highway crosses an area of sheet flow, more often than not, the roadside ditches are designed to intercept the sheet flow and concentrate it for easy passage through the highway embankment in one or more culverts. In most cases this concentration and diversion will cause no problems, but in some situations a downstream cropland may be robbed of needed irrigation or an erosion problem may be created at a culvert outlet. The designer should consider such problems and include design features to outlet the discharge in diffused flow when conditions warrant. Methods of accomplishing this diffusion include the following:

1. The degree of concentration can be reduced somewhat by placing equalizer culverts at frequent intervals along the highway, and designing the roadside ditch along the upstream side of the embankment to intercept the sheet flow and distribute it equally to the individual culverts. The discharge from these culverts will usually still be concentrated as it enters the lower property unless one of the following measures is included to further spread the flow.

2. A level concrete weir, paralleling and near the lower right of way line and at the elevation of the highest point of the natural ground, is the most effective and most accurate facility to recreate diffused flow. It is also the most expensive. If the weir is to be constructed as a vertical wall, it must be designed to resist hydrostatic and earth pressures, its base must be set below the frost line and a paved apron may be necessary to prevent erosion along its outside face. If a paved spillway type structure is to be used, a toewall will be needed along the inner edge and the paving should continue down the outer slope to the natural ground. In either case, the area between the embankment and the weir may need to be filled to avoid the creation of a pond and to prevent the structure from being hit by errant vehicles.
3. If the natural ground along the lower property is approximately level, sheet flow may be created to some extent by using dense vegetation or a porous dam to cause the flow to back up and spread until it can seep evenly through the barrier. The porous dam could be a timber or gabion wall or a short levee of evenly graded stone. If the natural ground were not level, a level berm could be constructed at or above the elevation of the high point of the ground, and the vegetation or dam could be placed on this berm.
4. An earth levee with frequent small pipe or trough outlets with the same invert elevation would create some degree of spread flow. The small outlets should be sized for a low discharge, and a large outlet should be provided at a higher elevation to carry the design flood and act as an emergency facility if the smaller drains become plugged.
5. A dam built of hay or straw bales can temporarily slow and spread concentrated flow. The bales must be staked, embedded or otherwise held in place. In some situations, such a dam will last until silt accumulation and volunteer growth creates a level well-vegetated berm that will permanently diffuse the flow.

9-605 Water Quality Control

In highway construction, the primary cause of a change in the quality of water received on a lower property is erosion. Soil is washed from the highway slopes and ditches and carried downstream to the point where the velocity of flow is slow enough to allow sedimentation to occur. This silt can block drainageways, smother lawns and crops, cover topsoil, fill or pollute ponds and lakes and create a general eyesore along the highway. If temporary erosion and siltation control measures are properly applied and permanent drainage and erosion control facilities are properly designed, silt problems can be controlled during construction and will usually cease when construction is completed and vegetation is established. If severely erosive soils are uncovered by the highway project or exist in the upstream basin, sedimentation may be an ongoing problem. If these soils cannot be stabilized by reasonable means, a permanent sediment basin may be needed to trap the silt. This basin should be located immediately downstream from the problem area. The design, construction and maintenance of temporary and permanent erosion and siltation control measures are discussed in detail in [Chapter 10](#). Other pollutants that may be washed onto lower properties include de-icing chemicals, oil, grease and other noxious materials that fall on the pavement. These materials are usually harmless as they become well diluted before they leave the right of way. There is no practical method of removing these materials from the discharge, but the potential for pollution can be reduced by limiting the use of de-icing chemicals to what is actually required, and diverting the flow away from any particularly sensitive areas.

9-700 FIELD TILE SYSTEMS

9-701 General

A field tile system consists of a subsurface network of drains, installed in an agricultural area, whose primary purpose is lowering the water table to a level where it does not interfere with the growth of plant roots. These systems can significantly improve crop yields and minimize the periods when fields can not be traversed with farm equipment due to excess moisture by accelerating the removal of water from the surface and upper portion of soil.

A field tile system represents a significant investment by the property owner, therefore when any portion of a system will be disturbed by highway construction, provisions should be included in the plans to insure the system continues to function in at least its original state of efficiency after construction. Damage payment in lieu of keeping the system operational is not in the Department or property owner’s best interest and should be considered only at locations where there is no other feasible alternative.

Field tile is generally encountered in large level cultivated fields, but may also be found in isolated areas to relieve artesian pressure or drain small depressions in the surface or subsurface barriers to percolation. A field tile system may consist of one or more individual tiles or a series of tiles connected to a main drain. The most common layout patterns are shown in [Figure 9-701](#). The pattern best suited to the terrain and the locations of available outlet points is normally used.

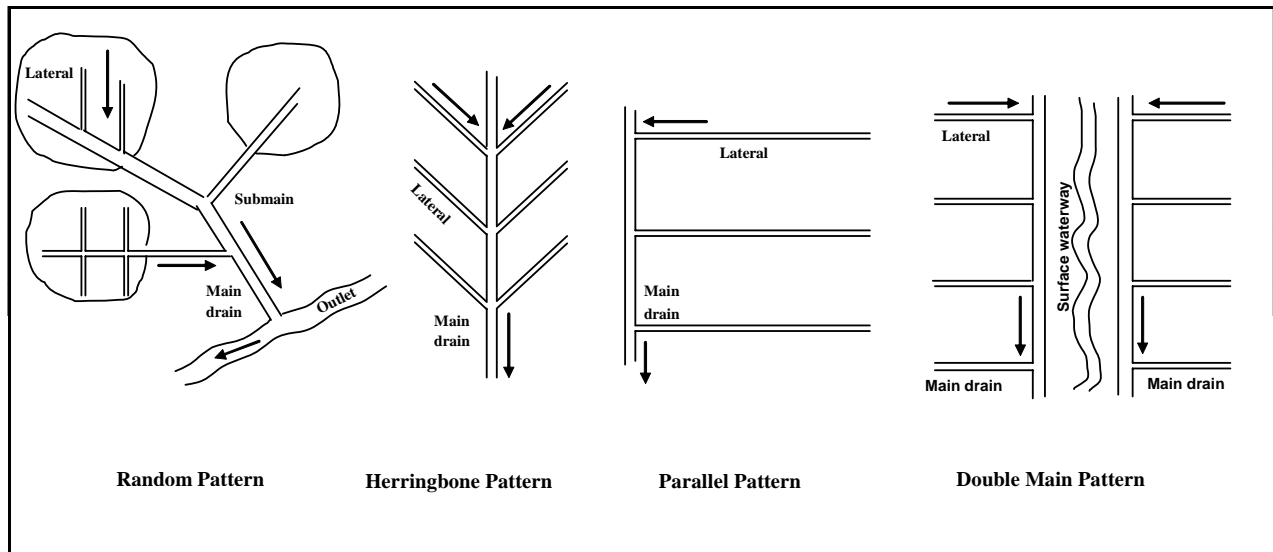

*Basic Field Tile Patterns
Figure 9-701*

The spacing and depth of tile is influenced by the permeability of the soil, the depth to an impermeable barrier, rainfall, topography and other factors. Laterals are commonly placed 2 ft to 5 ft deep and spaced at intervals of 50 ft to 200 ft or greater. The main drains may be at any depth. Older systems utilized clay tile for the laterals and clay, concrete or steel for the main drains. Modern systems are constructed of a variety of materials. Plastic type materials are most commonly used for laterals.

9-702 Location Determination

All field tile within the existing and proposed right-of-way should be located, within practical limits, during the planning stage of a highway improvement. The location of tile is often very difficult to establish, as the outlet pipes may be the only visible portions of a system. If the presence of field tile is known or suspected, the following procedures may facilitate the determination of their location:

1. The landowner should be contacted. The owner may know of the presence of a field tile system, but will rarely possess a map of the system and will rely on memory for an approximate location. If the system was in place when the property was purchased, the present owner may have little or no knowledge of the tile locations. Contacts with previous owners may provide useful information.
2. Assistance may be obtained from representatives of local drainage districts, soil and water conservation districts or the U.S. Soil Conservation Service.
3. As-built road plans, old survey books, construction dead files and permit records should be reviewed for references to field tile.
4. Aerial photography of the bare soil, taken under certain moisture conditions, may show a slight contrast in color along field tile laterals.
5. There have been claims that divining rods have been used to accurately locate field tile systems. The value of divining is a matter of individual judgment.
6. The survey party should be instructed to be on the lookout for outlet pipes, vents, inspection wells or junction boxes. A close inspection of unexplained eroded areas of the sides of creeks or ditches and areas that are moist during dry periods may uncover hidden outlet pipes.
7. If an outlet pipe is discovered, the remainder of the individual tile may be determined by tracking the tile with a probe, or by inserting a metal rod into the tile and following the rod with a magnetic detector.
8. If the approximate location of a tile is known, but the above procedures have proven unsuccessful, the use of random probing or trenching may be warranted.

If a field tile system is known to exist and all reasonable attempts to locate it have failed, consideration should be given to including an item for "Exploration Trench" in the plans. The trench should be excavated along one side of the right-of-way within the limits of the suspected tile location. If pipes are encountered, a trench should be excavated along the opposite right-of-way line to establish the sizes, grades and layout of the system. A reasonable quantity of storm sewer (6 to 10 inches) should be included in the plans for any adjustments required. The specifications should explain the situation and require any adjustments necessary be made as directed by the Engineer. This procedure will likely result in extensive changes to plan quantities, but should minimize cost overruns. If such provisions are not included, the resident engineer should be advised to be alert for field tile during all excavation operations.

9-703 Adjustments

Once the presence of a field tile system has been verified, the most appropriate method of insuring the system’s performance is not impaired must be established. The Illinois Drainage Laws: Rights and Responsibilities of Highway Authorities and Landowners Adjacent to Highways³ list and discusses acceptable practices when field tile is encountered. This manual should be reviewed prior to the design of any field tile facilities. Additional items to be considered are listed below:

1. If the roadside ditches pass over and clear an individual tile or main drain, which crosses the right of way, the pipe should be replaced from right of way line to right of way line with a new pipe. This pipe should be the same size or one size larger than existing and should have sufficient load capacity to withstand the stresses induced by the roadway. An inspection and cleanout facility should be placed just outside each right-of-way line.

2. Field tile is often installed on very flat grades. When replacing tile, care must be taken to avoid creating flat sections that may accumulate sediment. The recommended minimum grades for small drains are shown in [Table 9-703](#). A sediment trap may be required if these grades cannot be obtained.

Minimum Grades of Small Drains				
Inside diameter (inches)	Minimum grades for drains not subject to fine sand or silt		Minimum grades for drains where fine sand or silt may enter	
	Tile	Tubing	Tile	Tubing
	(percent)			
3	0.08	0.10	0.60	0.81
4	0.05	0.07	0.41	0.55
5	0.04	0.05	0.30	0.41
6	0.03	0.04	0.24	0.32

Table 9-703

3. If the roadside ditches pass over and clear a series of parallel laterals, a study should be made to determine if it would be more economical to lower the ditch to intercept the tile, replace each individual tile across the right of way or install a collector pipe paralleling the upstream right of way line to intercept the individual tiles and then carry the combined flow across the right of way in one pipe.

The acceptability of using a collector pipe is contingent upon the availability of a suitable outlet. If the downstream laterals are at approximately the same elevation, the crossroad pipe could be connected to a distribution pipe along the downstream right of way line to redistribute the flow to the individual tiles. The new pipe might also be outletted to a nearby existing main drain, ditch or creek. However, this would very likely create a diversion of flow, and as discussed in [Section 9-202\(3\)](#), a study of the effects of the diversion would be required. Another item to be considered is the fact that whenever a field tile is outletted into an open ditch, the continuous flow from the tile keeps the ditch wet and creates maintenance problems.

4. If the roadside ditch will intercept one or more pipes of a field tile system, these pipes may be outletted into the ditch. As discussed in (3) above, the feasibility of using a collector pipe to allow the use of only one outlet into the ditch should be considered as it is desirable to minimize the number of outlet points. It would also be necessary to consider the diversion and maintenance problems discussed in (3) above.
5. The ends of intercepted tiles, which flow away from the highway, should be plugged with concrete at the right of way line.
6. Where drains are outletted into a roadside ditch, the invert of the drain should be a minimum of 6" above the ditch flowline. A drop of 9 in. to 18 in. is preferred, especially in areas where silt accumulation is anticipated.
7. When small tile is to be outletted into the ditch, concrete pipe should be used for at least the last 4 ft of the pipe.
8. The ends of all outlet pipes should be fitted with a flush end section or other appropriate end treatment. The use of projecting corrugated metal pipes is not recommended. Appropriate erosion control measures should also be included at each outlet point. For smaller pipes, a strip of sod or similar material from the tile outlet down to the ditch flowline may be sufficient. For larger pipes, a mechanical lining across the entire ditch section may be warranted.
9. Rodent shields should be installed at the open ends of all field tiles.
10. If a field tile coincides with the location and elevation of another drainage structure (culvert or storm sewer), the tile may be outletted into the side of the structure. If diversion, maintenance or capacity problems make this undesirable, a junction box could be placed at the intersection and the tile could continue through this box.
11. All field tile pipes placed under the roadway shall be storm sewer of the type specified in [Section 550 of the Standard Specifications](#). If the cover over the pipe will be less than 2 ft, consideration should be given to encasing the pipe in concrete or paving the roadside ditch.
12. All abandoned field tile beneath the roadway, should be removed or crushed. Care should be taken to insure that the tile is definitely abandoned.
13. Provisions should be made for the continued operation of all field tile systems during their reconstruction and during all phases of the highway project.
14. All field tile adjustments should be designed and constructed to be as maintenance free as practical. There should be no rough inner surfaces and all sharp turns and connections should be made with manufactured fittings. If a collector pipe is used, the field tiles should drain into the top or upper portion of this pipe. Inspection and cleanout facilities should be installed as required for proper maintenance of the system.
15. Collector pipes should be adequately sized to carry the combined flow from all tile intercepted. A generally accepted procedure is to size the collector pipe based on the sum of the individual tile flowing full. The upstream portion of the collector pipe should be one size larger than the first lateral intercepted and should be stepped up in size, as needed, as more laterals are intercepted.

Methods for computing discharges from field tiles are not included in this manual but can be found in many publications. The Illinois_Drainage Guide⁴ contains a comprehensive treatment of this subject. Most Illinois offices of the USDA Natural Resources Conservation Service use this publication.

16. All field tile adjustments needed outside the permanent right-of-way should be made by the landowner, with the cost included in the right-of-way settlement or under a separate agreement. The funds for this work should be withheld until the work has been completed and approved by the Department.
17. Maintenance of the portion of the completed field tile system within right-of-way is normally the responsibility of the Department. Whenever feasible, the right of way documents or a separate agreement should be written to transfer this maintenance to the landowner the system serves.
18. The plans shall show the locations, sizes and elevations of all pipes and appurtenances to be installed in the highway improvement as well as all portions of the existing system which have been located. It is desirable to furnish a copy of this information to the landowner for future reference.

9-800 SUBSURFACE DRAINS**9-801 General**

Procedures for analyzing subsurface drainage problems and designing facilities to solve such problems are outside the scope of this manual, but can be found in many textbooks and other publications. Therefore only a cursory discussion of this subject is presented in this manual.

Excessive and uncontrolled subsurface water is a contributing cause of many highway failures. This groundwater can: increase the compressibility of foundation soil and cause excessive settlement; increase the stress level and decrease the shear strength of soil in embankments and slopes and cause landslides; create shear planes and erosion when flowing along the top of sloping impervious layers and cause a wide variety of problems when present in the pavement subgrade.

The purpose of a subsurface drain is to intercept water before it reaches areas where it can cause damage or remove it from such areas. Subsurface drains are commonly used under and/or alongside the pavement to remove infiltrating water and to intercept lateral seepage or water that is rising because of artesian pressure or capillary action. Other applications of these drains include but are not limited to the following:

1. A subsurface drain can be placed along the backslope to intercept and safely drain potentially damaging subsurface flow in much the same manner as cutoff ditches are used to intercept surface flow.
2. These drains can be designed to dewater a mucky area or drain an isolated spring.
3. The water table can be temporarily or permanently lowered over a large area.
4. Sand drains can be used to accelerate the settlement of soft compressible foundation soil by draining water that is squeezed from the soil by the pressure of the embankment.
5. Water that is trapped in trenched-in aggregate shoulders or granular embankments can be safely outletted.
6. Seepage along the top of an impervious layer can be intercepted before it concentrates and breaks through a cut slope or subgrade.

Since there are many variables and uncertainties in actual subsurface conditions, solutions to subsurface drainage problems are best left to personnel trained or experienced in soils engineering. The need for subsurface drains should be determined by the District Geotechnical Engineer and included in the Project Soils Report.

9-802 Types

Some of the more common types of subsurface drains are listed below. The selection of the type of drain to be used in a particular installation should be based on the intended function of the drain, any physical restraints on its installation and economics. Two or more different types of drains used in combination frequently offer the best solution.

1. **French Drain.** This is a fabric wrapped trench, filled with an open graded aggregate. This type of drain is economical and can be used for a variety of purposes. French drains can be outletted by extending the granular material to where it intercepts the ground surface (daylighting) or with a pipe drain. A drywell, or stonewell as it is sometimes referred to, consists of vertical drainage through a perforated well, backfilled with granular material. The bottom of the well is placed within a gravel/permeable stratum.
2. **Drainage Blanket.** This is a thin horizontal layer of open graded aggregate commonly used to prevent the vertical passage of both gravity flow and rising groundwater. Subbase granular material is an example of a drainage blanket. This drain may be outletted by daylighting; however, the thin layer of granular material tends to clog. It is therefore usually best to use a pipe underdrain or French drain to collect and outlet the flow.
3. **Pipe Underdrain.** This may consist of either perforated pipe/tubing or short sections or pipe placed end to end with the joints left open. The openings are covered with a filter material to prevent soil from entering the pipe. In years past, the filter material has been a geotextile fabric. A study is underway to determine an aggregate gradation that can be used with a fabric around the pipe or trench. Underdrains may be used singly or in series to drain wet areas. They are commonly used in conjunction with a French drain or drainage blanket to provide a positive interception and positive outlet, but may be used alone in permeable soils.
4. **Well System.** One or more vertical wells can be drilled to collect groundwater. They are especially adaptable to lowering the water table. These wells can be drained by pumping or through horizontal pipes placed or drilled-in to the bottom of each well when conditions permit. Sand filled wells (sand drains) can be used to remove water from consolidating foundation soils.
5. **Prefabricated Drainage Structure.** This drain consists of a porous plastic core covered with a filter fabric. This material comes in sheets or rolls and can be installed in a horizontal or vertical position to solve many subsurface drainage problems. It can be outletted by daylighting or using a pipe drain.

9-900 REFERENCES

1. U.S. Department of Transportation Federal Highway Administration. *Design Charts for Open Channel Flow*. Hydraulic Design Series 3(HDS 3), August 1961. (<http://www.fhwa.dot.gov/bridge/hds3.pdf>)
2. U.S. Department of Transportation Federal Highway Administration. *Design of Roadside Channels with Flexible Linings (HEC 15)*. Publication No. FHWA-NHI-05-114, September 2005.(<http://www.fhwa.dot.gov/engineering/hydraulics/pubs/05114/index.cfm>)
3. Donald L. Uchtmann, Carroll J. W. Drablos, Thomas D. Bratschun, and Benjamin A. Jones, Jr. *Illinois Drainage Laws: Rights and Responsibilities of Highway Authorities and Landowners Adjacent to Highways*. Illinois Cooperative Highway and Transportation Series No. 212, Illinois Department of Transportation, UILU-ENG-86-7023, Springfield, IL. 1986. (http://www.archive.org/stream/illinoisdrainage00univ/illinoisdrainage00univ_djvu.txt)
4. Drablos, C.J.W. and Moe, R.C. *Illinois Drainage Guide*. Circular 1226, University of Illinois Cooperative Extension Service, 1984.



Chapter 10

SS
C
O
U
R

CHAPTER 10 – SCOUR (2010)

10-000 GENERAL

- 10-001 Introduction
- 10-002 Scope
- 10-003 Background
- 10-004 Design Criteria, Philosophy, and Concepts
- 10-005 IDOT Planning
- 10-006 Total Scour

10-100 AGGRADATION AND DEGRADATION

- 10-101 Introduction
- 10-102 General Aggradation
 - 10-102.01 Causes and Effects of Aggradation*
- 10-103 General Degradation
 - 10-103.01 Causes and Effects of Degradation*
- 10-104 Estimating Long-Term Aggradation and Degradation
 - 10-104.01 Bridge Inspection Records*
 - 10-104.02 Gaging Station Records*
 - 10-104.03 Geology and Stream Geomorphology*
 - 10-104.04 Computer Models*
 - 10-104.05 Total Scour*
 - 10-104.06 Communication to Inspection and Maintenance Personnel*

10-200 GENERAL SCOUR

- 10-201 Introduction
- 10-202 Contraction Scour Conditions
 - 10-202.01 General*
 - 10-202.02 Causes and Effects*
 - 10-202.03 Live-Bed and Clear-Water Contraction Scour*
 - 10-202.04 Contraction Scour Cases*
 - 10-202.05 Computing Live-Bed Contraction Scour*
 - 10-202.06 Computing Clear-Water Contraction Scour*
- 10-203 Pressure Flow Scour
 - 10-203.01 Contraction Scour with Backwater*
- 10-204 Other General Scour
 - 10-204.01 General*
 - 10-204.02 Causes and Effects*

10-205 Contraction Scour Example Problems

10-205.01	Example Problem 1:	Live-Bed Contraction Scour
10-205.02	Example Problem 2:	Alternate Method
10-205.03	Example Problem 3:	Relief Bridge Contraction Scour

10-300 LOCAL SCOUR

10-301 General

10-302 Causes and Effects

10-303 Computing Pier Scour

10-303.01 Local Pier Scour Equation

10-303.02 Complex Pier Scour

10-303.03 Example Problem 1: Scour at a Simple Solid Pier

10-303.04 Example Problem 2: Angle of Attack

10-304 Computing Abutment Scour

10-304.01 General

10-304.02 Abutment Site Conditions

10-304.03 Abutment Skew

10-304.04 Abutment Shape

10-304.05 Designing for Scour at Abutments

10-400 USING HEC-RAS TO COMPUTE SCOUR

10-401 Steady Flow Analysis

10-402 Hydraulic Design – Bridge Scour

10-403 Contraction Scour

10-404 Pier Scour

10-405 Abutment Scour

10-406 Total Bridge Scour

10-407 Summary

10-500 REFERENCES

10-000 - GENERAL

10-001 Introduction

The most common cause of bridge failures is from floods scouring bed material from around bridge foundations. Scour is the engineering term for the erosion caused by water of the soil surrounding a bridge foundation (piers and abutments). It is a common hydraulic process that may occur naturally or be the result of man-induced factors. Scour related damage and maintenance problems can involve costly economic losses that can be prevented or reduced by judicious prior planning and by the use of suitable countermeasures.

Three manuals are currently available to provide guidance for bridge scour and stream stability analyses. They are part of a set of Hydraulic Engineering Circulars (HEC) issued by [FHWA](#). [HEC 18](#), Evaluating Scour at Bridges, contains equations for computing scour depths and designing countermeasures. [HEC 20](#), Stream Stability at Highway Structures, provides a guide for identifying stream instability problems. [HEC 23](#), Bridge Scour and Stream Instability Countermeasures, provides guidelines for the selection and design of appropriate countermeasures to mitigate potential damage to bridges and other highway components at stream crossings. [HEC 18](#) forms the primary basis of the text in this chapter and is an excellent reference for more in-depth information.

10-002 Scope

The object of this chapter is to provide information and guidelines for identifying and computing scour to use in planning for measures to prevent, mitigate or correct hydraulic problems caused by scour. In this chapter the following subjects shall be covered:

1. Types of scour.
2. Conditions/situations that cause scour and their effects on a structure or site.
3. Channel degradation and channel aggradation in relation to scour.
4. Computing total scour with equations from [HEC 18](#).

The HEC 18 methods for predicting scour depths are empirical, based mainly on laboratory research in sand. Limited field data has been collected to verify the applicability and accuracy of the various equations for the range of soil conditions, stream flow conditions, and bridge designs encountered throughout Illinois. It is very possible that these equations, even if used properly, may at times generate overly conservative scour depths. Having stated that, the equations are still the best tools available at this time to predict scour. Consequently, engineering judgment is essential to determining the scour potential at a given site.

10-003 Background

The American Association of State Highway and Transportation Officials ([AASHTO LRFD Bridge Design Specifications; 3rd Edition 2004](#)) has the following requirements to address the problem of stream stability and scour.

1. Hydraulic studies are a necessary part of the preliminary design of a bridge and should include calculated scour depths at the proposed structures.
2. The probable depth of scour shall be determined by subsurface exploration and hydraulic studies. Refer to Section 2.6 in the AASHTO reference noted above and [FHWA \(HEC 18\)](#) for general guidance regarding hydraulic studies and design.
3. In all cases, the pile length shall be determined such that the design structural load may be safely supported entirely below the probable scour depth.

10-004 Design Criteria, Philosophy, and Concepts

Bridge foundations shall be designed to withstand the effects of scour without failing for the worst conditions resulting from floods ranging from the 100-year flood to the 500-year flood, or a smaller flood if it will cause deeper scour depths. Scour at bridge foundations is investigated for two conditions per [AASHTO 2.6.4.4.2 Bridge Foundations](#) and are as follows:

- For the design flood for scour, the streambed material in the scour prism above the total scour line shall be assumed to have been removed for design conditions. The design flood storm surge, tide, or mixed population flood shall be the more severe of the 100-year events or from an overtopping flood of lesser recurrence interval.
- For the check flood for scour, the stability of the bridge foundation shall be investigated for scour conditions resulting from a designated flood storm surge, tide, or mixed precipitation flood not to exceed the 500-year event or from an overtopping flood of lesser recurrence interval. Excess reserve beyond that required for stability under this condition is not necessary. The extreme event limit state shall apply.

If site conditions lend themselves to ice or debris jams with low tailwater conditions, the use of a more severe flood event for either the design or check event may be considered by the engineer.

Guidance in this chapter is based on the following concepts:

1. The foundation should be designed by an interdisciplinary team of engineers with expertise in hydraulic, geotechnical, and structural design. See [Figure 10-005](#).
2. Hydraulic studies of bridge sites are a necessary part of a bridge design. These studies should address both the bridge configuration and the design of the foundations to be safe from scour. The scope of the analysis should be commensurate with the importance of the highway and consequences of failure.
3. Consideration must be given to the limitations and gaps in existing knowledge when using currently available formulas for estimating scour. The designer needs to apply engineering judgment in comparing results obtained from scour computations with available hydrologic, hydraulic and field data to achieve a reasonable and prudent design. Such data should include:
 - a. Performance of existing structures during past floods.
 - b. Effects of regulation and control of flood discharges.
 - c. Hydrologic characteristics and flood history of the stream and similar streams.
 - d. Whether the bridge superstructure is continuous or single span.

4. The principles of economic analysis and experience with actual flood damage indicate that it is almost always cost-effective to provide a foundation that will not fail, even from a very large flood event or superflood. Generally, occasional damage to highway approaches from rare floods can be repaired quickly to restore traffic service. On the other hand, a bridge that collapses or suffers major structural damage from scour can create safety hazards to motorists as well as significant social impacts and economic losses over a long period of time. Aside from the costs to the highway agency of replacing or repairing the bridge and constructing and maintaining detours, there can be significant costs to communities or entire regions due to additional detour travel time, inconvenience, and lost business opportunities. Therefore, a higher hydraulic standard is warranted for the design of bridge foundations to resist scour than is usually required for sizing of the bridge waterway. This concept is reflected in [Figure 10-005](#).

10-005 IDOT Planning

A scour analysis is required for all new bridges, bridge replacements, superstructure replacements, three-sided bridge, and bottomless culvert construction. For other types of bridge repair and rehabilitation and culvert construction, past performance and future projection analysis along with judgment should be considered to determine if a scour analysis should be performed. Please see [Publication No. FHWA-RD-02-078, Bottomless Culvert Scour Study: Phase 1 Laboratory Report dated November 2003](#) for more discussion on bottomless culvert scour.

The flowchart of [Figure 10-005](#) illustrates graphically the interrelationship between [HEC 18](#), [HEC 20](#), and [HEC 23](#) and emphasizes that they should be used as a set. A comprehensive scour analysis or stability evaluation should be based on information presented in all three documents.

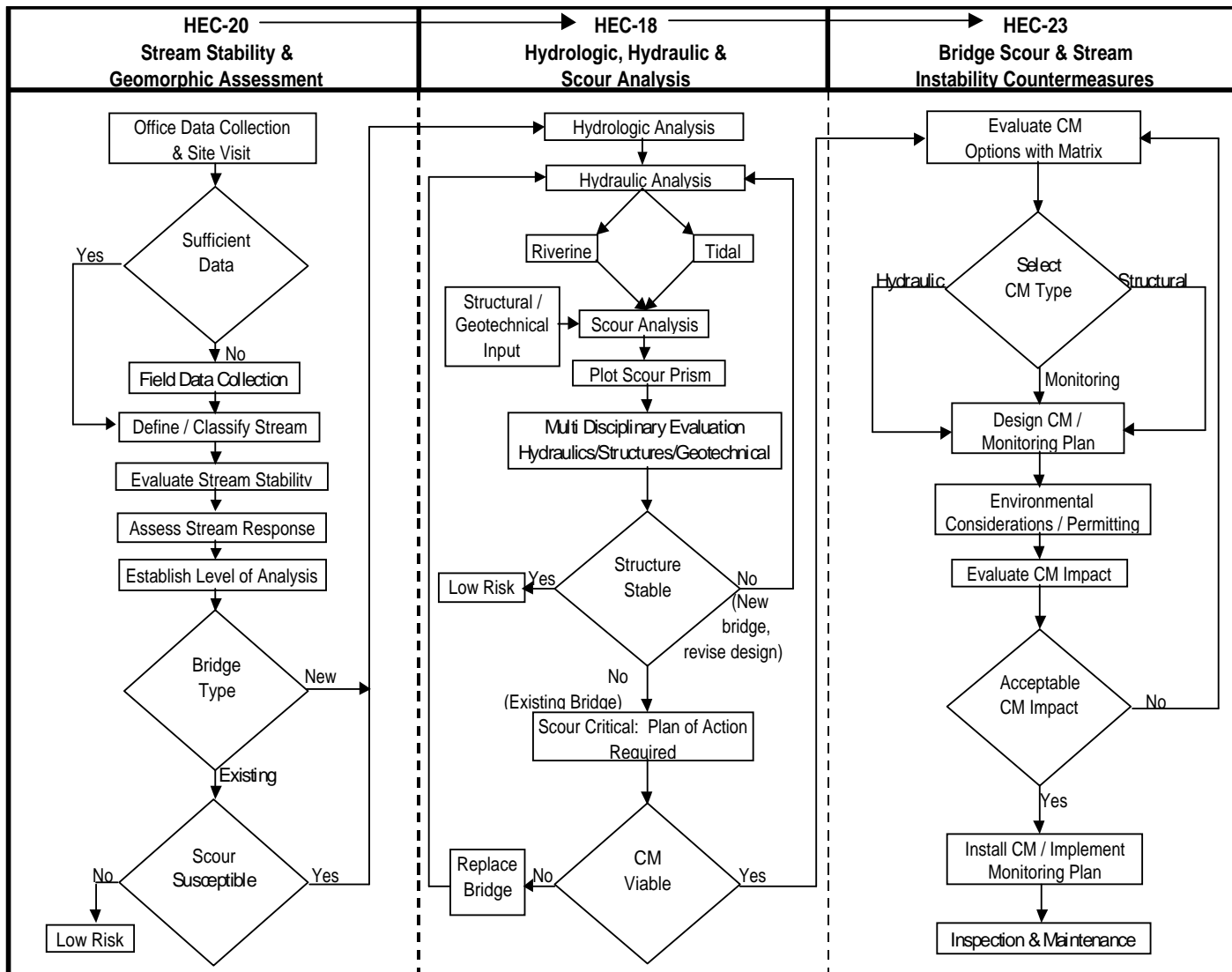

Flowchart for Scour and Stream Stability Analysis and Evaluation
Figure 10-005

In general, scour computations are computed based upon the procedures and recommendations included in [HEC 18](#). Using a complete bridge removal and replacement project in Illinois as an example, the engineer (assuming a consultant) shall prepare the scour analysis and include it in the Hydraulic Report as directed in [Chapter 2](#). The scour analysis may be reviewed after submittal to the IDOT District Office, but the preparer should not rely on any assurance that an additional check will be performed by the Central or District Offices. The raw scour totals are then reviewed by the Foundation & Geotechnical Unit. It should be noted here again that the scour equations included in [HEC 18](#) used to calculate the raw scour depths are the result of physical modeling of bridges over only cohesionless sand-bed streams. The Geotechnical Engineer of Record (typically the author of the Structure Geotechnical Report “SGR”) studies the actual soil and rock types from the soil borings/rock cores and adjusts the theoretical scour depths according to guidelines included in the [IDOT Bridge Manual](#). In addition the Design Scour Elevation Table, showing the adjusted scour elevations, is developed by the Geotechnical Engineer of Record. A discussion on its format is provided within the [IDOT Bridge Manual](#). The Design Scour Elevation Table is included on the final TSL drawing.

The adjusted scour depths are then provided to the Bridge Planning Engineer for analysis. The Bridge Planning Engineer may consider alternatives that will also ensure the foundation is structurally stable without the use of riprap, gabions, or some other type of revetment intended to reduce or mitigate estimated scour. The IDOT Bridge Manual states “use of riprap at piers is allowed if additional alternatives are also employed”. This solution alternative happens on an infrequent basis and is not recommended for new structures as a mitigative practice to raise the foundation. Hydraulic countermeasures intended to protect the pier or stabilize channel alignment cannot be considered absolute safeguards against scour. It is unrealistic to expect these countermeasures to remain stable and in place throughout the service life of a structure. However if this unrecommended countermeasure solution is investigated further as a possible feasible alternative even after considering the risks involved, concurrence from the District Hydraulics Engineer and Geotechnical Engineer are required. **Please note, on federal aid projects FHWA does not allow the use of scour countermeasures for purposes of reducing the foundation design for a new or replacement structure.**

Below is a flowchart (Figure 10-005a) demonstrating the critical path to the final foundation design.

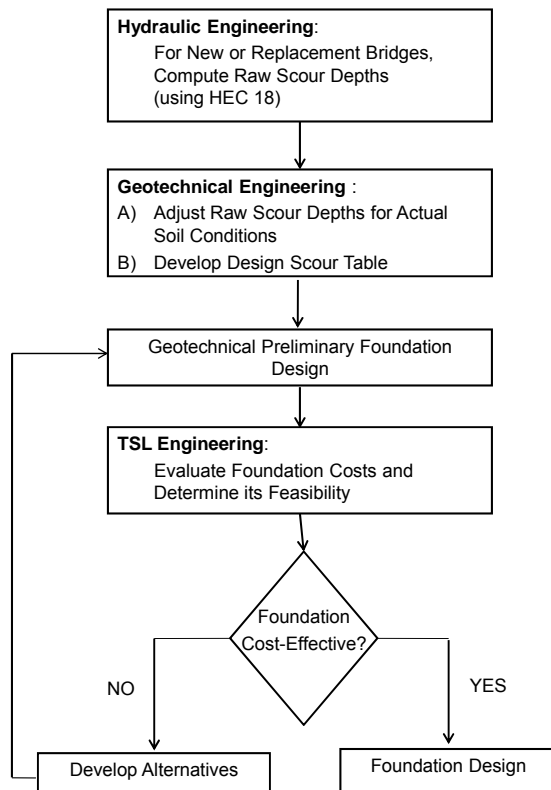

IDOT Scour and Evaluation
Figure 10-005a

10-006 Total Scour

Total scour at a highway crossing is comprised of three components:

1. Long-term aggradation and degradation of the river bed (aggradation is not considered in the cumulative calculated scour depth)
2. General scour at the bridge
 - a. Contraction scour
 - b. Pressure flow scour
 - c. Other general scour
3. Local scour at the piers and abutments
 - a. Pier scour. (includes complex pier analysis if appropriate)
 - b. Abutment scour equations are for the worst case conditions per [Hec 18](#).

These three scour components are added to obtain the total scour at a pier or abutment.

$$\text{TOTAL SCOUR} = \text{DEGRADATION} + \text{GENERAL SCOUR} + \text{LOCAL SCOUR}$$

This equation assumes that each component occurs independent of the other and is the same magnitude for each flood event. This may not be the case. For example, long-term degradation occurs over the design life of the bridge. This degradation may not have occurred for a flood earlier in the life of the bridge. However, considering that all the components are additive provides some conservatism to the design. [Figure 10-006a](#) shows the cumulative effects of the individual scour components that comprise the total scour prism. Please note that abutment scour is shown in this definition sketch. However in Illinois it is a common practice to apply abutment slope protection to reduce the risk of abutment scour particularly for open abutment bridges. The abutment slope protection is the only scour countermeasure that FHWA will allow on new or replacement bridge constructions to reduce or minimize the risk of scour

Even though there are only three scour components, each scour component can consist of one or more subcomponents such in the case of general scour. Each one of these subcomponents is additive and when summed together comprise the total general scour. The current state-of-knowledge recommends that contraction flow scour (horizontal contraction) and pressure flow (vertical contraction) scour should be summed together to develop the total general scour depth. The general scour depth should be added to degradation and then added to each subcomponent of local scour. Local scour subcomponents are not necessarily additive unless the individual scour holes should overlap. When scour holes overlap it is recommended to consider adjusting span lengths such that overlapping does not occur. If adjustment of span lengths is not feasible then judgment is required in assessing the total scour depth.

In addition, lateral migration of the stream must be assessed when evaluating total scour at bridge piers and abutments. Attention should be given to potential scour and the possibility of channel shifts in designing foundations for bridges on floodplains and spans approaching the stream channel. The thalweg in the channel should be considered not to be in a fixed location when establishing founding elevations. The history of a stream and a study of how active it has been can be very useful in making decisions on pile and drilled shaft tip elevations (See Figure 10-006b). **Pier foundations on floodplains should be designed to the same elevation as pier foundations in the stream channel if there is likelihood that the channel will shift its location over the life of the bridge.**

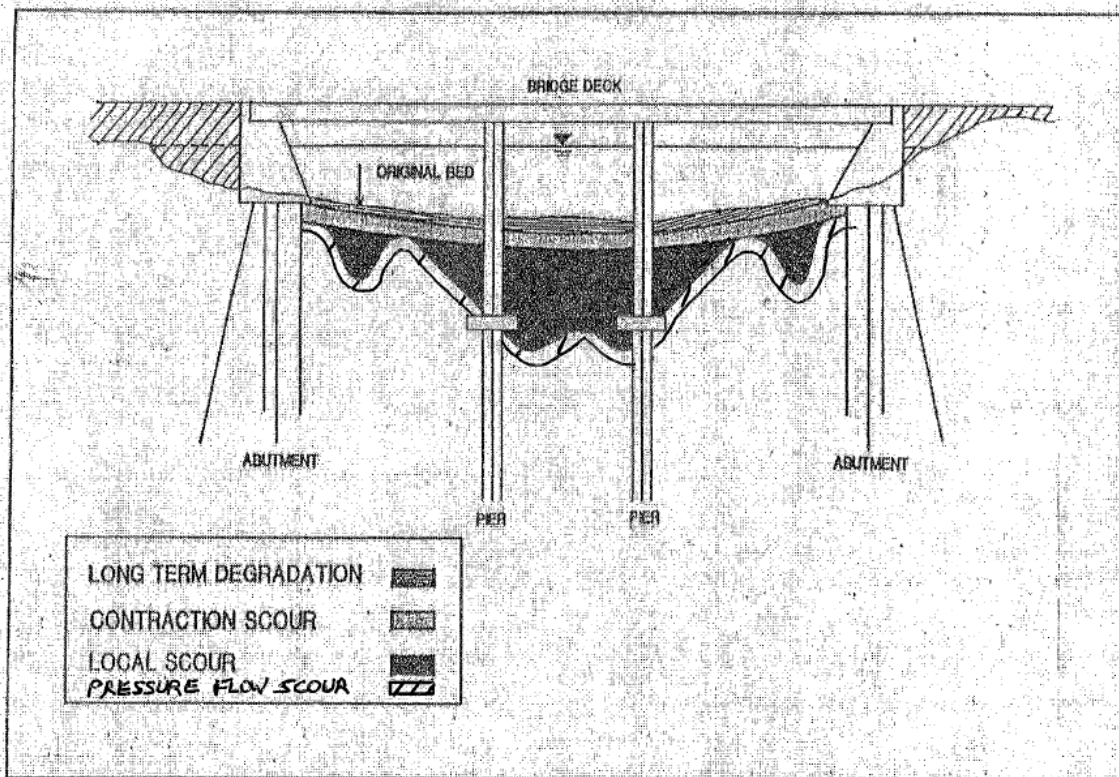

Definition Sketch – Total Scour Prism
Figure 10-600a

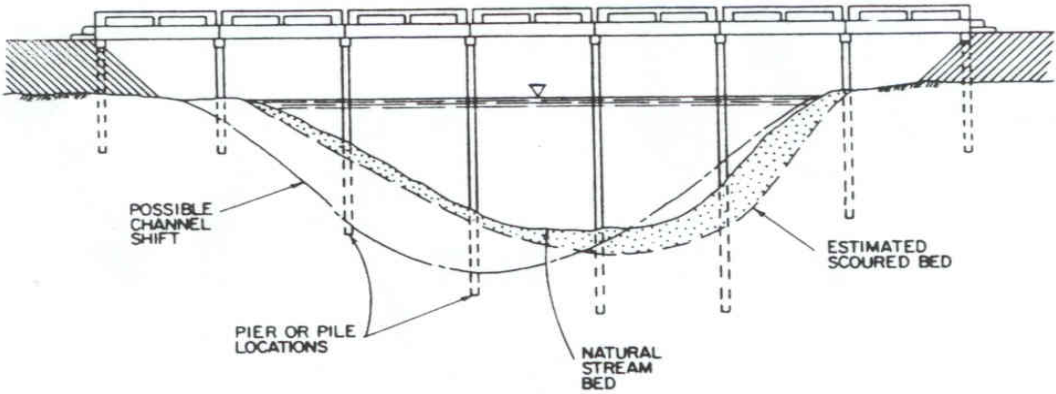

Future Channel Shift
Figure 10-006b

10-100 AGGRADATION AND DEGRADATION

10-101 Introduction

Many streams in Illinois, for engineering purposes, are considered stable due to a state of practical equilibrium throughout long reaches. However, significant changes may be evident over time. Some streams experience natural aggradation and degradation, as well as aggradation caused by man's attempt to improve flow conditions or develop water resources for beneficial use such as levee construction.

Aggradation and degradation are long-term streambed elevation changes due to natural or man-induced causes which can affect the reach of the river on which the bridge is located. Aggradation involves the deposition of material eroded from the channel or watershed upstream of the bridge; whereas, degradation involves the lowering or scouring of the streambed due to a deficit in sediment supply from upstream.

Long-term aggradation and degradation do not include the cutting and filling of the streambed at a bridge that might occur during a runoff event (general and local scour). A stream may cut and fill at specific locations during a runoff event and also have a long-term trend of an increase or decrease in bed elevation over a longer reach of a stream. The problem for the engineer is to estimate the long-term bed elevation changes that will occur during the life of the structure.

A long-term trend may change during the life of the bridge. These long-term changes are the result of modifications to the stream or watershed. Such changes may be the result of natural processes or human activities. The engineer must assess the present state of the stream and watershed and then evaluate potential future changes in the river system. From this assessment, the long-term streambed changes must be estimated.

Procedures for estimating long-term aggradation and degradation at a bridge are presented in [HEC 20](#). This text discusses the factors affecting long-term bed elevation changes and methods available for estimating these changes. A link is provided between long-term degradation to the other components of scour at a bridge site. In the following sections, methods and equations are given for determining the other components of total scour.

Shown below is a qualitative tool ([Figure 10-101](#)) useful in demonstrating the variable changes that are responsible for aggradation and degradation.

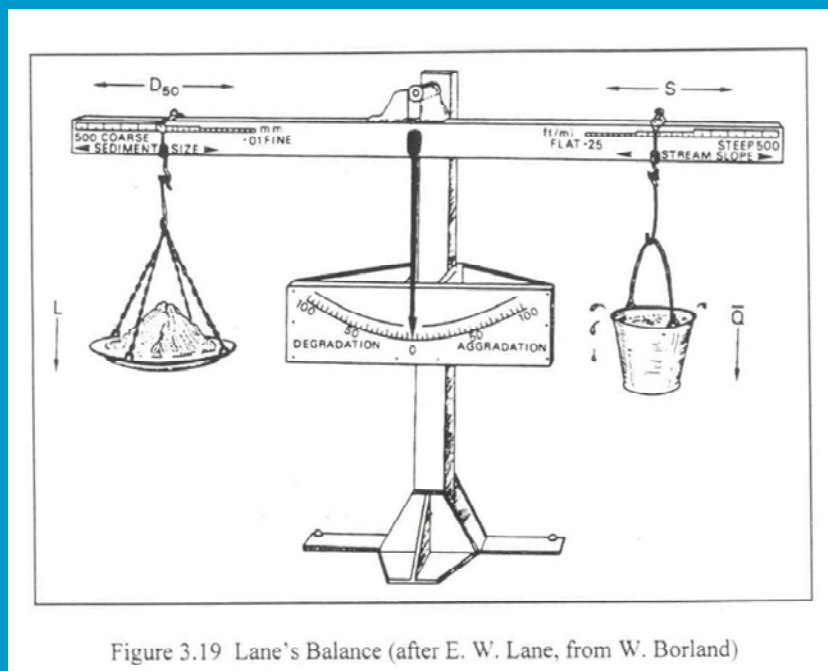

Figure 3.19 Lane's Balance (after E. W. Lane, from W. Borland)

Taken from U.S. Army Corps of Engineers Demonstration Erosion Control Design Manual.

Lane's Balance
Figure 10-101

10-102 General Aggradation

Aggradation by itself in an open channel usually does not pose a problem. However, aggradation does create a problem when it occurs at a bridge site. Aggradation in a channel at a bridge site can raise the streambed to such an extent that the waterway area at the bridge is reduced below the minimum required to convey flood flows. If this situation occurs the following problems could result.

1. The water surface of the channel would rise due to the rise in the streambed and could cause drift to hang up on the lower members of the bridge. This drift would restrict the waterway area under the bridge, therefore increasing the velocity of flow resulting in a scouring action.
2. Reduction of the waterway area could cause a larger percentage of flood flow to encroach on the floodplain, which could result in scour at the abutments or along the embankment.

10-102.01 Causes and Effects of Aggradation

Channel aggradation can be caused by the following conditions.

1. **Clearing of Natural Vegetation:** A floodplain cleared of its natural vegetation; brush or timber, for agricultural or lumbering purposes can cause an increase in sediment supply entering a stream channel. If the

stream flow is unable to carry this additional sediment, aggradation of the channel will result downstream.

2. **Channel Straightening or Alteration:** Channel straightening or alteration that results in degradation of the streambed can cause aggradation of the channel at some point downstream. The excess sediment resulting from degradation could be transported downstream until it encounters a reach of channel with a flatter gradient. Upon reaching the flatter gradient aggradation can occur.
3. **Dams and Reservoirs:** Reservoirs can induce aggradation upstream from the reservoir. As a stream enters a reservoir, which is ponded water, the stream will drop its sediment load forming a delta. This deposition of material in the reservoir will cause the gradient of the upstream channel to flatten. The flattening of the upstream channel will induce aggradation of the channel bed.
4. **Diversion of Clear Water:** The removal of clear water from a stream for irrigation or industrial purposes forces the remaining water to carry the total sediment load in the stream. If the remaining water left in the stream does not have the capacity to transport the sediment load, aggradation of the channel downstream from the diversion site will result.
5. **Main Channel Aggradation:** Aggradation occurring in a main channel may cause aggradation to occur in the channels of its tributaries. If a tributary enters the main channel at a location where aggradation of the main channel has occurred, the channel slope of the tributary will be reduced. The flattening of the tributary channel gradient will induce aggradation in the upstream reaches of the tributary.

10-103 General Degradation

Channel degradation may or may not be restricted to the immediate area of a bridge waterway. If degradation occurs at a bridge waterway, the effects may be similar to those associated with contraction scour. An identifying characteristic of channel degradation is that it affects the channel bed by lowering through a reach of substantial length, usually a length greater than 10 channel widths. Sometimes there can be multiple headcuts or knickpoints that progressively move through the channel reach.

10-103.01 Causes and Effects of Degradation

Channel degradation can be caused by the following conditions:

1. **Channel Straightening or Alteration:** Channel straightening or alteration caused by nature or man that shortens the length of channel may increase the channel slope. An increase in channel slope may result in channel bed degradation. Channel degradation may occur in the length of channel straightened or it may occur upstream from the location of the channel alteration. Due to the possibility of degradation occurring upstream, straightening of a channel downstream from a bridge site may cause degradation of the channel at the bridge site. There is evidence based upon actual field observations that degradation resulting from a channel

alteration will be most rapid during a period shortly following the alteration and will thereafter occur at a decreasing rate.

2. **Augmentation of Stream Flow:** Diversion of additional flow into a channel by constructing drainage ditches in the floodplain or by diversion of an overflow channel into the main channel can increase the magnitude and duration of flow in the main channel to the extent that degradation of the main channel will occur. If the augmentation of stream flow takes place upstream from a bridge, degradation of the channel may occur at the bridge site causing damage to the structure.
3. **Mining of Sand or Gravel:** Streams, especially those flowing in an alluvial channel, continually transport a certain amount of sediment called bedload. The mining of sand or gravel from a channel streambed in quantities that represent a substantial percentage of the stream's bedload will cause the channel to degrade downstream to compensate for the loss of sediment. If a structure is located downstream from a mining operation, degradation of the channel may occur at the structure site. Sand or gravel mining operations may change the channel bed elevation to the extent that there will be an increase in the channel gradient. An increase in channel gradient will increase the erosive ability of the stream resulting in degradation of the channel upstream from the mining operation. Structures located in the area of channel degradation could be affected.
4. **Dams and Reservoirs:** Construction of dams and reservoirs on a stream channel will decrease or remove the sediment load carried by the stream. As a result of this removal, channel degradation downstream from a dam or reservoir can be expected to compensate for the loss of sediment. Structures located downstream from dams or reservoirs can be affected if the channel degradation occurs at the structure site.
5. **Main Channel Degradation:** Degradation occurring in a main channel may cause degradation to occur in the channels of its tributaries. This condition may happen if the tributaries enter the main channel at the location the main channel streambed is degrading.
6. **Watershed Land Use Changes:** Urbanization as well as other land use changes may cause degradation to occur in the stream channel. Urban channels should be investigated for possible degradation because it has been found that many urban streams experience this condition.

10-104 Estimating Long-Term Aggradation and Degradation

To organize an assessment of long-term degradation, a three-level fluvial system approach can be used. The three level approach consists of the following:

1. A qualitative determination based on general geomorphic and river mechanics relationships.

2. An engineering geomorphic analysis using established qualitative and quantitative relationships to estimate the probable behavior of the stream system to various scenarios or future conditions.
3. Physical models or physical process computer modeling using mathematical models to make predictions of quantitative changes in streambed elevation due to changes in the stream and watershed.

Methods to be used in Levels (1) and (2) are presented in [HEC 20](#) and Highways and River Environment (HIRE).

The USACE, USGS, and other Federal and State agencies should be contacted concerning documented long-term streambed variations. If no data exists or if such data requires further evaluation, an assessment of long-term streambed elevation changes for riverine streams should be made using the principles of river mechanics. Such an assessment requires the consideration of all influences upon the bridge crossing, i.e., runoff from the watershed to a stream (hydrology), sediment delivery to the channel (watershed erosion), sediment transport capacity of a stream (hydraulics), and response of a stream to these factors (geomorphology and river mechanics).

Significant morphologic impacts can result from human activities. The assessment of the impact of human activities requires a study of the history of the river, estuary, or tidal inlet, as well as a study of present water and land use and stream control activities. All agencies involved with the river should be contacted to determine possible future changes.

10-104.01 Bridge Inspection Records

The bridge inspection reports for bridges on the stream where a new or replacement bridge is being designed are an excellent source of data on long-term aggradation or degradation trends. Also, inspection reports for bridges crossing streams in the same area or region should be studied. In some Districts the inspection includes taking the elevation and/or cross section of the streambed under the bridge. These elevations are usually referenced to the bridge, but these relative bed elevations will show trends and can be referenced to sea level elevations. Successive cross sections from a series of bridges in a stream reach can be used to construct longitudinal streambed profiles through the reach. Existing bridge plans may also provide insight to a degrading channel, but should not be used as the sole evidence for determining degradation.

10-104.02 Gaging Station Records

The USGS and many State Water Resource and Environmental agencies maintain gaging stations to measure stream flow. In the process they maintain records from which the aggradation or degradation of the streambed can be determined. Gaging station records at the bridge site, on the stream to be bridged, and in the area or region can be used.

Where an extended historical record is available, one approach to using gaging station records to determine long-term bed elevation change is to plot the change in stage through time for a selected discharge. This approach is often referred to as establishing a "specific gage" record.

10-104.03 Geology and Stream Geomorphology

The geology of the area and at the site needs to be studied to determine the erosion and degradation potential at the site. Also, the fluvial geomorphology of the site needs to be studied to determine the potential for long-term bed elevation changes at the bridge site. Quantitative techniques for streambed degradation analysis are covered in detail in [HEC 20](#). These techniques include:

1. Incipient motion analysis
2. Analysis of armoring potential
3. Equilibrium slope analysis
4. Sediment continuity analysis

Sediment transport concepts and equations are discussed in detail in [Highways in the River Environment \(HIRE\)](#).

10-104.04 Computer Models

Areas under severe aggradation or degradation conditions should be evaluated using computer modeling. Refer to [HEC 18](#) for further information.

10-104.05 Total Scour

Using the information available, estimate the long-term bed elevation change at the bridge site for the design life of the bridge. If the estimate indicates that the stream will aggrade, then (1) make note of this fact to inspection and maintenance personnel, and (2) use existing ground elevation as the base for general and local scour. If the estimate indicates that the stream will degrade, use the elevation after degradation as the base elevation for general and local scour. That is, total scour must include the estimated long-term degradation. **Aggradation should not be included in the scour computations.**

10-104.06 Communication to Inspection and Maintenance Personnel

The estimate of long-term aggradation or degradation in the final design should be communicated to inspection and maintenance personnel. This information will aid them in tracking long-term trends and provide feedback for future design and evaluation.

10-200 GENERAL SCOUR

10-201 Introduction

General scour is that scour at the bridge that is neither localized at the foundations or the long-term changes in the stream bed elevation. It is the general decrease in the bed elevation across the bridge opening. General scour may not have a uniform depth across the bridge opening. That is, the scour depth may be deeper in some locations and the scour depth may not return to its original elevation after a flood event.

The most common general scour is contraction scour. Pressure flow scour is also considered general scour and is computed separately and independently from that of contraction scour. Other general scour conditions are for a bridge located over a bend, located upstream or downstream of a confluence with another stream or on a tributary. With a bridge located on a bend, there is deepening of the bed on the outside, possible deposition on the inside and even a chute channel across the point bar. The scour at a bend may be cyclic or may continuously deepen. Cyclic scour is the increase and decrease of the stream bed elevation (cutting and filling) during the passage of a flood.

General scour at a bridge upstream or downstream of a confluence of two streams or on a tributary results from the changes in water and sediment discharge and/or elevation of the bed or water surface elevation between the different streams.

Contraction scour is caused where the bridge opening is smaller than the flow area of the upstream channel and/or floodplain. Pressure flow scour begins to occur when the water surface elevation at the bridge reaches the low chord elevation of the bridge. There are several cases and flow conditions for contraction scour, which will be described later.

10-202 Contraction Scour Conditions

10-202.01 General

The identifying trait of contraction scour which distinguishes it from the other scour components is that contraction scour occurs across all or most of the channel or floodplain width, which may include areas at piers, abutments, or other obstructions to flow. Pressure flow scour holes may also resemble that of horizontal contraction scour. The increased velocities through the opening remove bed material from the channel and any part of the overbank with insufficient ground cover. This scour mechanism is typically cyclic in nature. Material is removed during the rising limb of the hydrograph and can be deposited as the floodwaters recede. Contraction scour differs from streambed degradation in that contraction scour is shorter in length, whereas degradation is longer in length affecting a long reach of channel and is confined to the stream channel.

The principal factor that determines the extent to which a site will experience contraction scour is the overall flow at or through the site, especially during flood flows. This is the primary reason that contraction scour occurs across all or most of the channel or floodplain width.

10-202.02 Causes and Effects

Contraction scour can be the result of the following conditions.

1. **Flow Constrictions:** Flow constriction of a channel is the most common cause of contraction scour. Flow constriction can consist of a highway approach embankment for a bridge site that crosses approximately perpendicular to the floodplain, a longitudinal encroachment of the floodplain, or a levee system paralleling a stream channel or floodplain.

At bridge sites where the approach embankment fill severely constricts the flood flow through the bridge waterway opening, the floodplain flow must move laterally at some point in order to pass through the waterway opening. The point where this lateral movement of the flood flow takes place determines where contraction scour will occur.

- a. If the major portion of the floodplain flow moves laterally to the bridge waterway opening along a reach of channel some length upstream from the bridge site, contraction scour will occur across the entire waterway opening of the bridge.
 - b. If the major portion of the floodplain flow moves laterally to the bridge waterway opening along the approach embankment, severe scour will occur at the abutment and contraction scour will occur downstream from the bridge site.
2. **Channel Straightening or Alteration:** Straightening or altering the channel upstream from a bridge site can change the flow pattern of flood flows entering the bridge waterway opening, causing contraction scour across the waterway opening. In this type of situation, in addition to contraction scour, usually degradation of the streambed will also occur.
 3. **Debris:** Blockage of all or part of an opening by debris at a bridge site will alter the flow pattern through the bridge opening especially during floods. Depending upon the size of debris pile-up, stream flow may be diverted down to pass under the debris or the stream flow may be diverted to pass through a section of the bridge opening that is not blocked by debris. In both cases contraction scour may occur across all or part of the stream channel or floodplain.
 4. **Clearing of Natural Vegetation:** A floodplain cleared of its natural vegetation, brush or timber, may alter the flow pattern during floods by allowing an increase in the concentration and velocity of flow through the floodplain area that has been cleared. Structures located downstream of the cleared floodplain may experience contraction scour as a result of the change in flow. Relief bridges in particular are the types of structures that have been affected by contraction scour as a result of the clearing of floodplains.

10-202.03 Live-Bed and Clear-Water Contraction Scour

Live-bed contraction scour occurs at a bridge when there is transport of bed material in the upstream reach into the bridge cross section. With live-bed contraction scour the area of the contracted section increases until, in the limit, the transport of sediment out of the contracted section equals the sediment transported in.

Clear-water contraction scour occurs when (1) there is no bed material transport from the upstream reach into the downstream reach, or (2) the material being transported in the upstream reach is transported through the downstream reach mostly in suspension and at less than capacity of the flow. With clear-water contraction scour the area of the contracted section increases until, in the limit, the velocity of the flow (V) or the shear stress (t_o) on the bed is equal to the critical velocity (V_c) or the critical shear stress (t_c) of a certain particle size (D) in the bed material.

There are four conditions (cases) of contraction scour at bridge sites depending on the type of contraction, and whether there is overbank flow or relief bridges (Section 10-202.04). Regardless of the case, contraction scour can be evaluated using two basic equations: (1) live-bed scour, and (2) clear-water scour. For any case or condition, it is only necessary to determine if the flow in the main channel or overbank area upstream of the bridge, or approaching a relief bridge, is transporting bed material (live-bed) or is not (clear-water), and then apply the appropriate equation with the variables defined according to the location of contraction scour (channel or overbank).

To determine if the flow upstream of the bridge is transporting bed material, calculate the critical velocity for beginning of motion V_c of the D_{50} size of the bed material being considered for movement and compare it with the mean velocity V of the flow in the main channel or overbank area upstream of the bridge opening. If the critical velocity of the bed material is larger than the mean velocity ($V_c > V$), then clear-water contraction scour will exist. If the critical velocity is less than the mean velocity ($V_c < V$), then live-bed contraction scour will exist. The equation for critical velocity is:

$$V_c = K_u y^{1/6} D^{1/3} \tag{Eq. 10-1}$$

where:

- V_c = critical velocity above which bed material of size D and smaller will be transported, ft/sec
- y = average depth of flow upstream of the bridge, ft
- D = particle size for V_c , ft
- D_{50} = particle size in a mixture of which 50 percent are smaller, ft
- K_u = 11.17

The D_{50} is taken as an average of the bed material size in the reach of the stream upstream of the bridge. It is a characteristic size of the material that will be transported by the stream. Normally this would be the bed material size in the upper one foot of the streambed.

Live-bed contraction scour depths may be limited by armoring of the bed by large sediment particles in the bed material or by sediment transport of the bed material into the bridge cross-section. IDOT typically disregards the armoring effect in the scour calculations. However under this type of armoring condition, according to Hec-18, live-bed contraction

scour at a bridge can be determined by calculating the scour depths using both the clear-water and live-bed contraction scour equations and using the smaller of the two depths.

10-202.04 Contraction Scour Cases

Four conditions (cases) of contraction scour are commonly encountered:

- Case 1. Involves overbank flow on a floodplain being forced back to the main channel by the approaches to the bridge. Case 1 conditions include:
 - a. The river channel width becomes narrower either due to the bridge abutments projecting into the channel or the bridge being located at a narrowing reach of the river ([Figure 10-202.04a](#))
 - b. No contraction of the main channel, but the overbank flow area is completely obstructed by an embankment ([Figure 10-202.04b](#))
 - c. Abutments are set back from the stream channel ([Figure 10-202.04c](#))
- Case 2. Flow is confined to the main channel (i.e., there is no overbank flow). The normal river channel width becomes narrower due to the bridge itself or the bridge site is located at a narrower reach of the river ([Figures 10-202.04d and 10-202.04e](#))
- Case 3. A relief bridge in the overbank area with little or no bed material transport in the overbank area (i.e., clear-water scour) ([Figure 10-202.04f](#))
- Case 4. A relief bridge over a secondary stream in the overbank area with bed material transport (similar to case 1) ([Figure 10-202.04g](#))

Notes:

- 1. Cases 1, 2, and 4 may either be live-bed or clear-water scour depending on whether there is bed material transport from the upstream reach into the bridge reach during flood flows. To determine if there is bed material transport compute the critical velocity at the approach section for the D_{50} of the bed material using equation 10-1 and compare to the mean velocity at the approach section. The approach section should be located sufficiently upstream from the opening that the flow is not affected by the structure but is fully expanded to natural floodplain width. To determine if the bed material will be washed through the contraction, determine the ratio of the shear velocity (V^*) in the contracted section to the fall velocity (ω) of the D_{50} of the bed material being transported from the upstream reach (see the definition of V^* in the live-bed contraction scour equation 10-2). If the ratio is much larger than 2, then the bed material from the upstream reach will be mostly suspended bed material discharge and may wash through the contracted reach (clear-water scour).

2. Case 1c is very complex and is representative of many of the IDOT bridges. The depth of contraction scour depends on factors such as:
 - a. How far back from the bank line the abutment is set.
 - b. The condition of the overbank (is it easily eroded, are there trees on the bank, is it a high bank, etc.).
 - c. Whether the stream is narrower or wider at the bridge than at the upstream section.
 - d. The magnitude of the overbank flow that is returned to the bridge opening.
 - e. The distribution of the flow in the bridge section.
 - f. Other factors.The main channel under the bridge may be live-bed scour; whereas, the set back overbank area may be clear-water scour.

Below is an example of contraction scour in the overbank area.

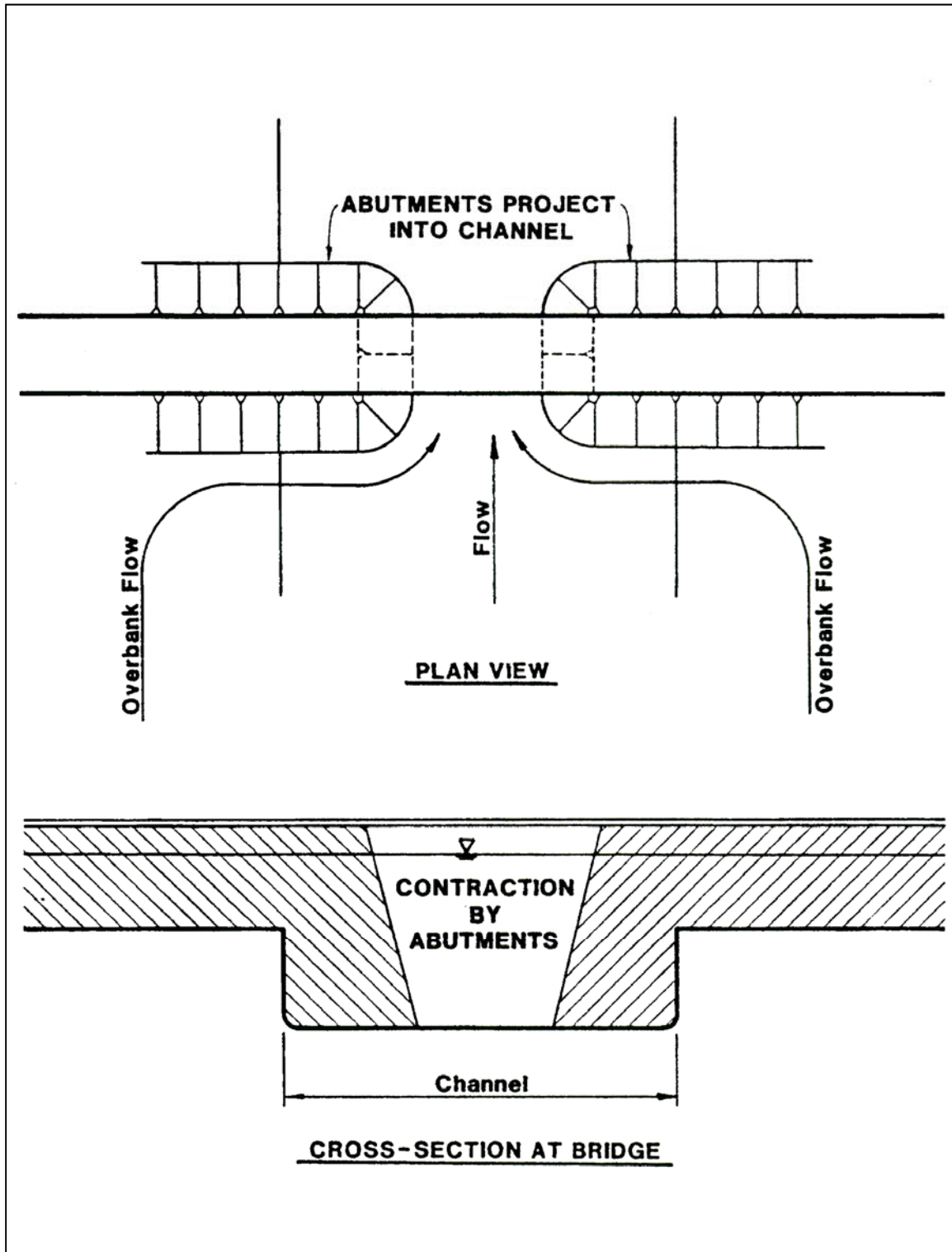

Figure 10-202
Overbank contraction scour hole submerged

WSPRO or HEC-RAS can be used to determine the distribution of flow between the main channel and the setback overbank areas in the contracted bridge opening. However, the distribution of flow needs to be done with care. Studies have shown that conveyance calculations do not properly account for the flow distribution under the bridge.

If the abutment is set back only a small distance from the bank (less than 3 to 5 times the average depth of flow through the bridge), there is the possibility that the combination of contraction scour and abutment scour may destroy the bank. Also, the two scour mechanisms are not independent. Consideration should be given to using a guide bank and/or protecting the bank and bed under the bridge in the overflow area with rock riprap. In Illinois, the common practice is to apply riprap to the abutment slopes to prevent the risk of abutment scour. [FHWA](#) agrees with this practice. See [HEC 23](#) for guidance on designing rock riprap.

3. Case 3 may be clear-water scour even though the floodplain bed material is composed of sediments with a critical velocity that is less than the flow velocity in the overbank area. The reasons for this are there may be vegetation growing part of the year; and if the bed material is fine sediments, the bed material discharge may go into suspension (wash load) at the bridge and not influence contraction scour.
4. Case 4 is similar to case 3, but there is sediment transport into the relief bridge opening (live-bed scour). This case can occur when a relief bridge is over a secondary channel on the floodplain. Hydraulically this is no different from case 1, but analysis is required to determine the floodplain discharge associated with the relief opening and the flow distribution going to and through the relief bridge. This information could be obtained from [WSPRO](#) or [HEC-RAS](#).



Case 1a: Abutments project into channel
Figure 10-202.04a

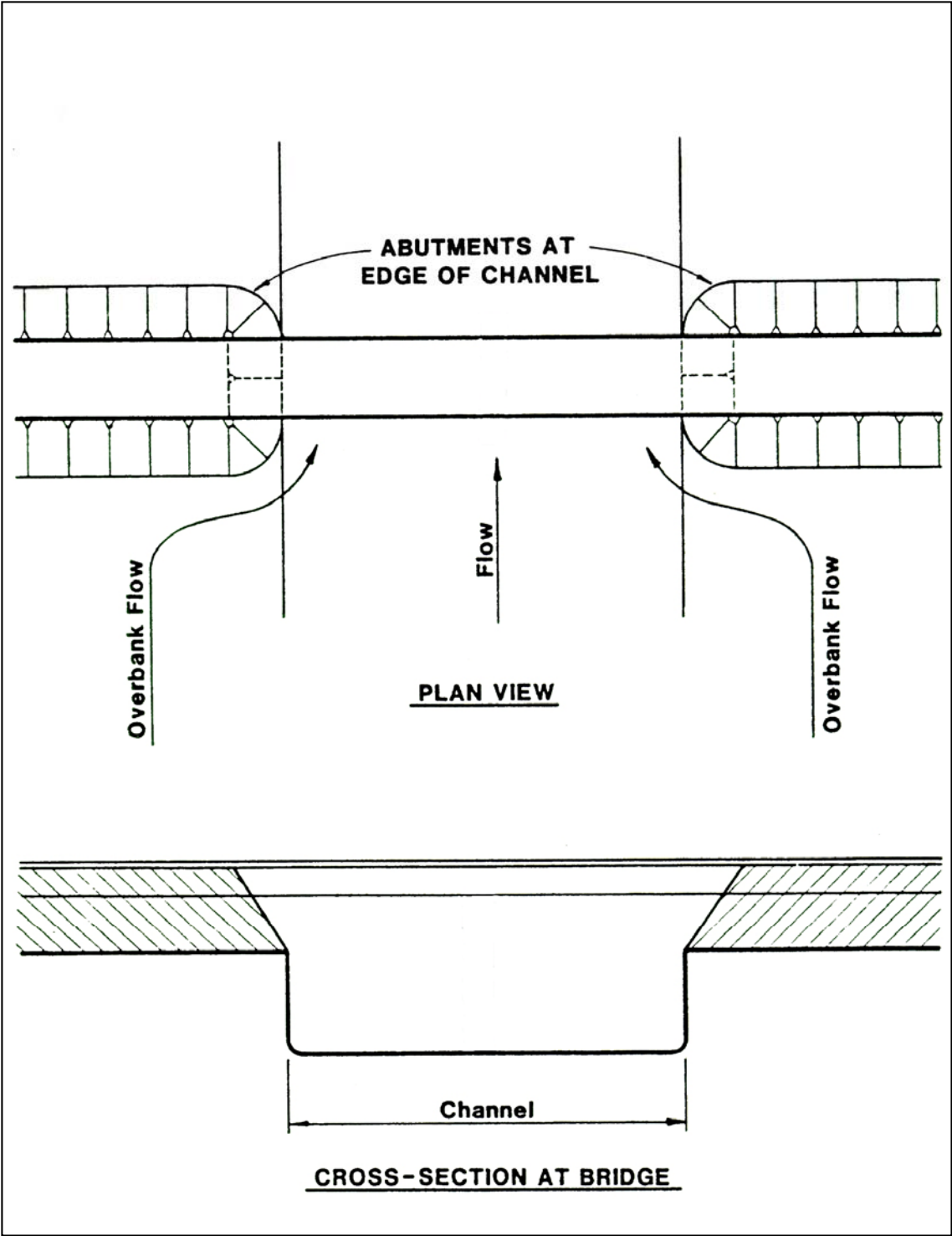

Case 1b: Abutments at edge of channel
Figure 10-202.04b

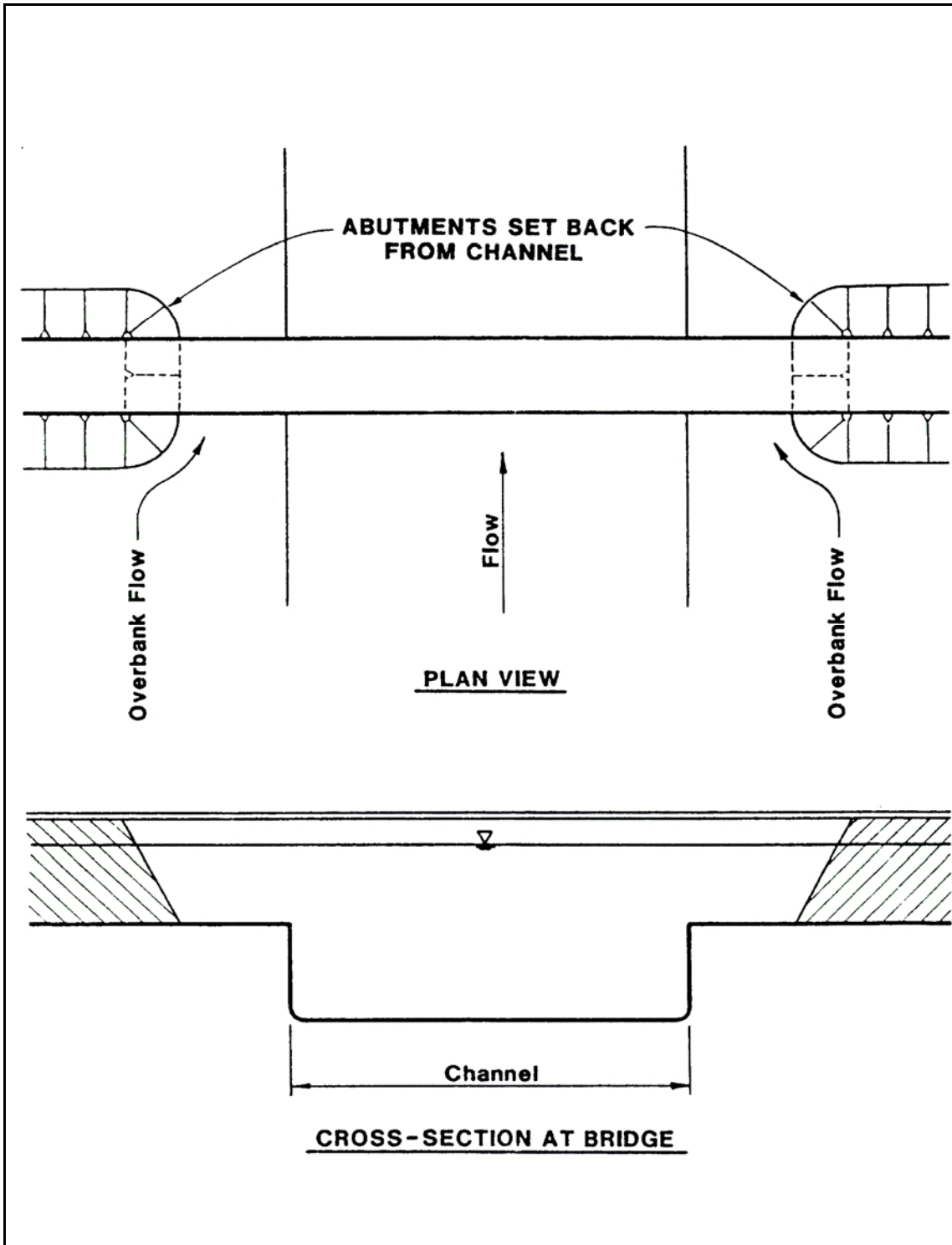

Case 1c: Abutments set back from channel
Figure 10-202.04c

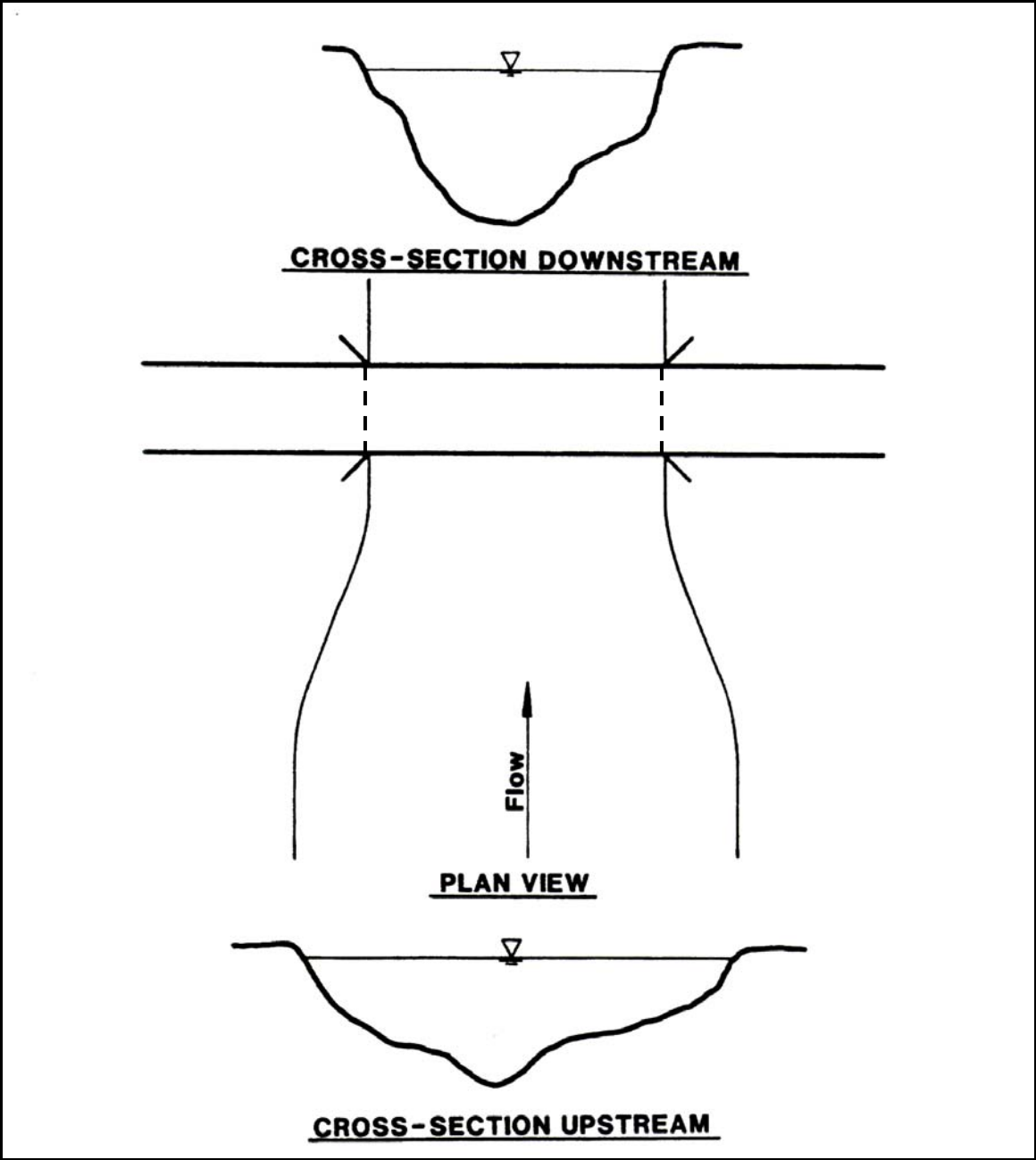

Case 2a: River narrows
Figure 10-202.04d

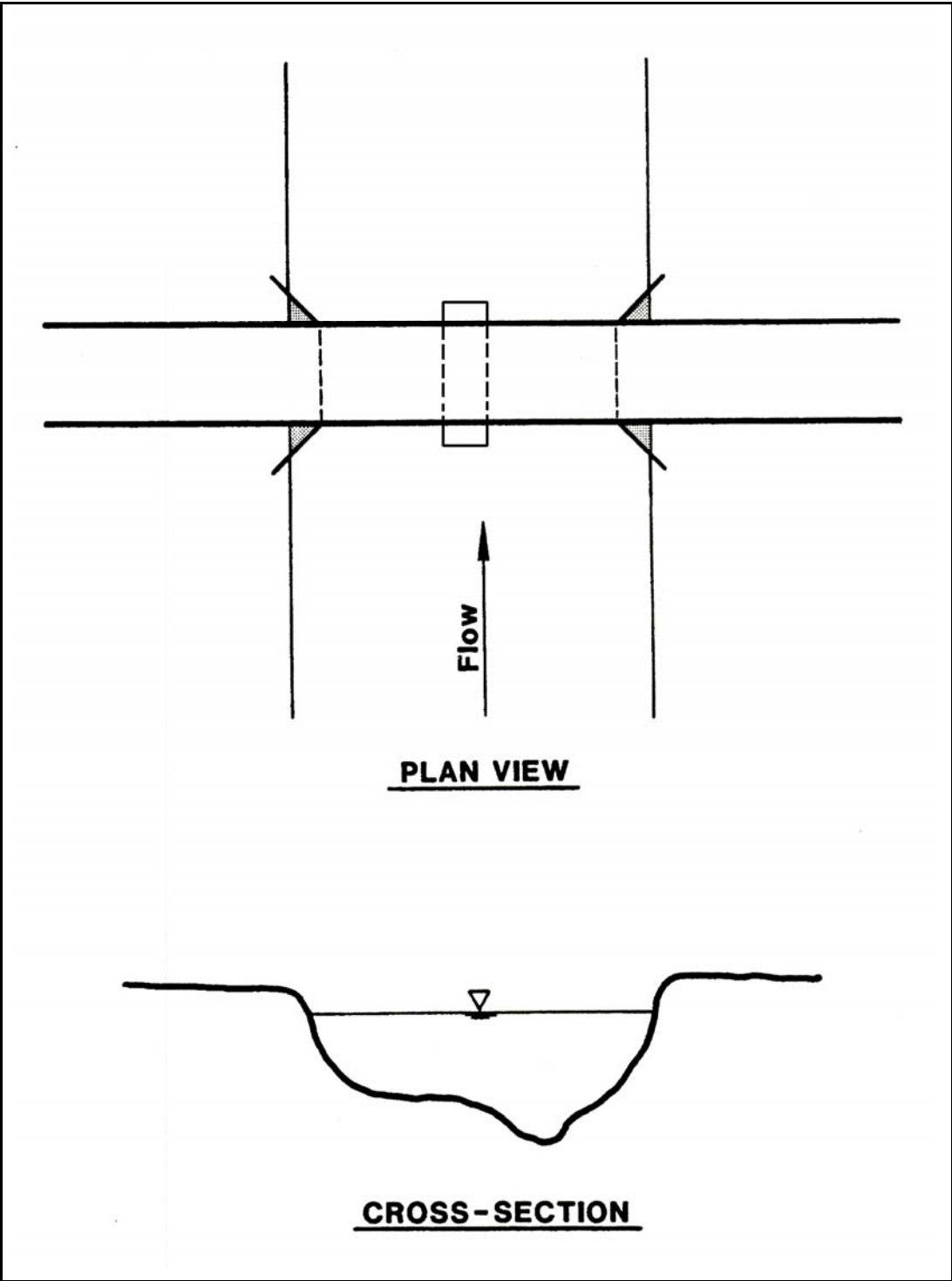

Case 2b: Bridge abutments and/or piers constrict flow
Figure 10-202.04e

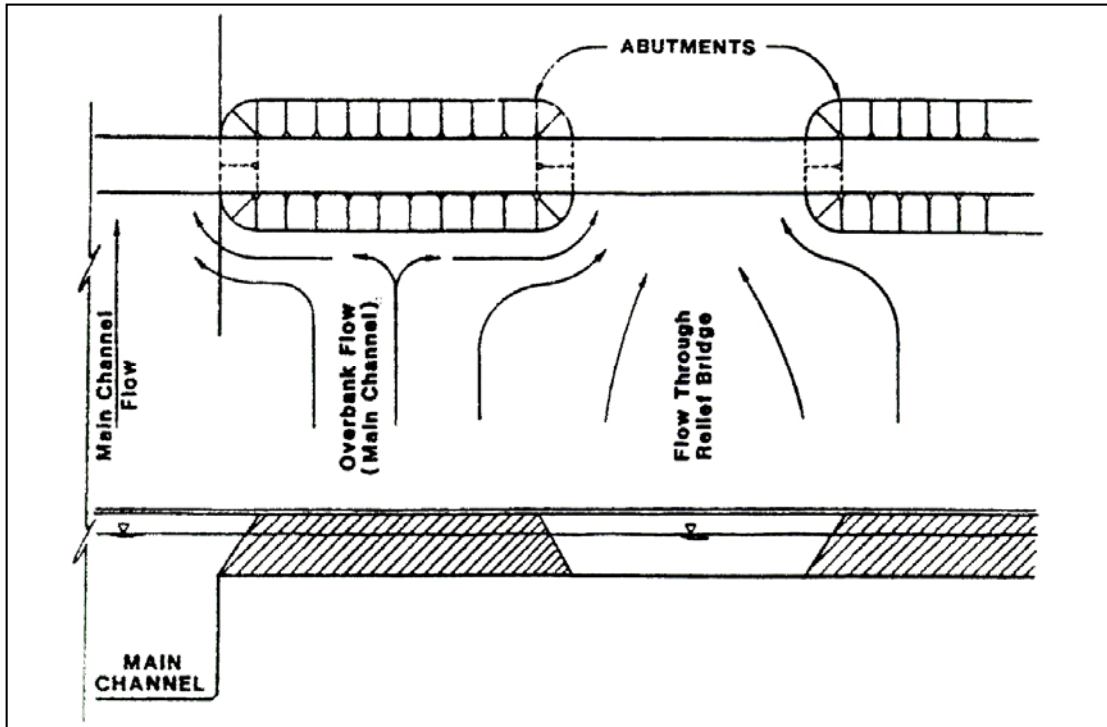

Case 3: Relief bridge over floodplain
Figure 10-202.04f

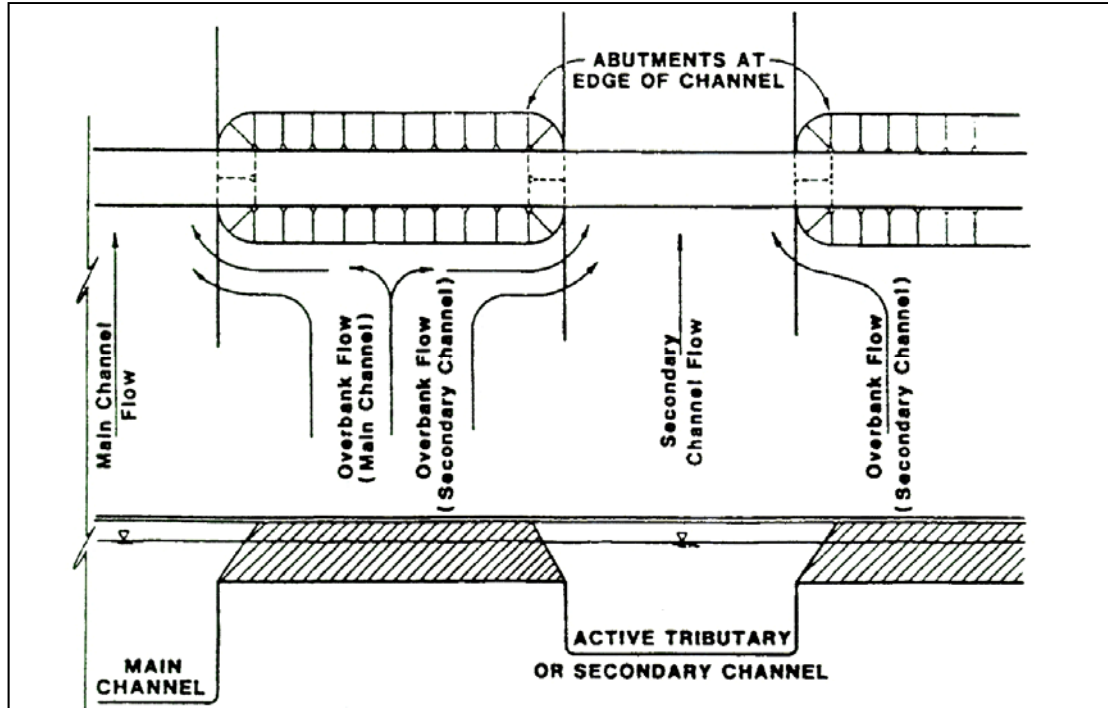

Case 4: Relief bridge over secondary stream
Figure 10-202.04g

10-202.05 Computing Live-Bed Contraction Scour

A modified version of Laursen's 1960 equation for live-bed scour at a long contraction is recommended to predict the depth of scour in a contracted section. The original equation has been modified to eliminate the ratio of Manning's n (see the following note 3). The equation assumes that bed material is being transported from the upstream section.

$$\frac{y_2}{y_1} = \left(\frac{Q_2}{Q_1} \right)^{6/7} \left(\frac{W_1}{W_2} \right)^{k_1} \tag{Eq. 10-2}$$

$$y_s = y_2 - y_0 = (\text{average contraction scour depth}) \tag{Eq. 10-3}$$

where:

- y_1 = Average depth in the upstream main channel, ft
- y_2 = Average depth in the contracted section, ft
- y_0 = Existing depth in the contracted section before scour, ft (see note 7)
- Q_1 = Flow in the upstream channel transporting sediment, cuft/sec
- Q_2 = Flow in the contracted channel, cuft/sec
- W_1 = Bottom width of the upstream main channel that is transporting bed material, ft
- W_2 = Bottom width of the main channel in the contracted section less pier width(s), ft
- k_1 = Exponent determined below

V_* / ω	k_1	Mode of Bed Material Transport
<0.50	0.59	Mostly contact bed material discharge
0.50 to 2.0	0.64	Some suspended bed material discharge
>2.0	0.69	Mostly suspended bed material discharge

Note: IDOT has assumed $k_1 = 0.69$ as a conservative estimate.

- V_* = $(t_o / \rho)^{1/2} = (g y_1 S_1)^{1/2}$, shear velocity in the upstream section, ft/s
- ω = Fall velocity of bed material based on the D_{50} , m/s (Figure 10-202.05)
For fall velocity in English units (ft/s) multiply ω in m/s by 3.28
- g = Acceleration of gravity (32.2 ft/sec²)
- S_1 = Slope of energy grade line of main channel, ft/ft
- t_o = Shear stress on the bed, lb/sqft
- ρ = Density of water (1.94 slugs/cuft)

Notes:

1. Q_2 may be the total flow going through the bridge opening as in cases 1a and 1b. It is not the total flow for case 1c (most IDOT bridges), when abutments are set back from the channel. For case 1c contraction scour must be computed separately for the main channel and the left and/or right overbank areas.
2. Q_1 is the flow in the main channel upstream of the bridge, not including overbank flows.
3. The Manning's n ratio is eliminated in Laursen live-bed equation to obtain equation 10-2. This was done for the following reasons. The ratio can be significant for a condition of dune bed in the upstream channel and a corresponding plane bed, washed out dunes or antidunes in the contracted channel. However, Laursen's equation does not correctly account for the increase in transport that will occur as the result of the bed planing out (which decreases resistance to flow, increases the velocity and the transport of bed material at the bridge). That is, Laursen's equation indicates a decrease in scour for this case, whereas in reality, there would be an increase in scour depth. In addition, at flood flows, a plane bedform will usually exist upstream and through the bridge waterway, and the values of Manning's n will be equal. Consequently, the n value ratio is not recommended or presented in equation 10-2.
4. W_1 and W_2 are not always easily defined. In some cases, it is acceptable to use the top width of the main channel to define these widths. Whether topwidth or bottom width is used, it is important to be consistent so that W_1 and W_2 refer to either bottom widths or top widths.
5. The average width of the bridge opening (W_2) is normally taken as the bottom width, with the width of the piers subtracted.
6. Laursen's equation will over estimate the depth of scour at the bridge if the bridge is located at the upstream end of a natural contraction or if the contraction is the result of the bridge abutments and piers. At this time, however, it is the best equation available.
7. In sand channel streams where the contraction scour hole is filled in on the falling stage, the y_0 depth may be approximated by y_1 . Sketches or surveys through the bridge can help in determining the existing bed elevation.
8. Scour depths with live-bed contraction scour may be limited by coarse sediments in the bed material armoring the bed. Where coarse sediments are present, HEC 18 recommends that scour depths be calculated for live-bed scour conditions using the clear-water scour equation (given in the next section) in addition to the live-bed equation, and that the smaller calculated scour depth be used.
9. When $W_1 \neq W_2$ and boring information has not been acquired, a k_1 factor of 0.69 should be used to provide the most conservative answer. If this provides scour results that appear too deep, boring information should then be collected to obtain a more exact answer.

Fall Velocity of Sand-Sized Particles with Specific Gravity of 2.65 (metric units)

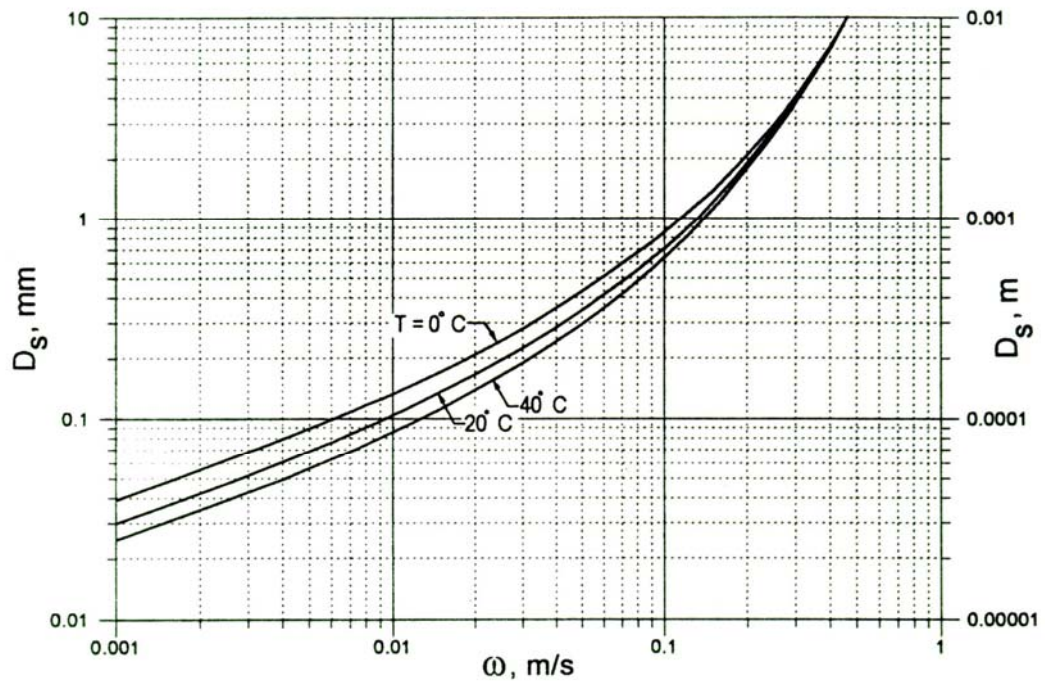

Figure 10-202.05

10-202.06 Computing Clear-Water Contraction Scour

The recommended clear-water contraction scour equation is based on a development suggested by Laursen. The equation is:

$$y_2 = \left(\frac{K_u Q^2}{D_m^{2/3} W^2} \right)^{3/7} \tag{Eq. 10-4}$$

$$y_s = y_2 - y_0 = (\text{average scour depth, ft}) \tag{Eq. 10-5}$$

where:

- y_2 = Average equilibrium depth in the contracted section after contraction scour, ft
- Q = Discharge through the bridge or on the set-back overbank area at the bridge associated with the width W , cuft/sec
- D_m = Diameter of the smallest nontransportable particle in the bed material ($1.25 D_{50}$) in the contracted section, ft
- D_{50} = Median diameter of bed material, ft
- W = Bottom width of the contracted section less pier widths, ft
- y_0 = Average existing depth in the contracted section, ft
- K_u = 0.0077

Equation 10-4 is a rearranged version of equation 10-1.

For stratified bed material the depth of scour can be determined by using the clear-water scour equation sequentially with successive D_m of the bed material layers.

To obtain an estimation of the distribution of the scour depths across a section (say at or downstream of a bend) use WSPRO or HEC-RAS to obtain the velocity of each stream tube and the velocity versus depth equation for clear-water scour to estimate the scour depth in each stream tube. Changes in bed material size across a stream can be accounted for by this method.

10-203 Pressure Flow Scour

Pressure flow scour, which is also denoted as orifice flow or vertical contraction scour, occurs when the water surface elevation at the upstream face of the bridge is greater than or equal to the low chord of the bridge superstructure. Pressure flow under the bridge results from a pile up of water on the upstream bridge face, and a plunging of the flow downward and under the bridge. At higher approach flow depths, the bridge can be entirely submerged with the resulting flow being a complex combination of the plunging flow under the bridge (orifice flow) and flow over the bridge (weir flow).

In many cases, when a bridge is submerged, flow will also overtop adjacent approach embankments. This highway approach overtopping is also weir flow. Hence, for any overtopping situation the total weir flow can be subdivided into weir flow over the bridge and weir flow over the approach. Weir flow over approach embankments serves to reduce the discharge which must pass either under or over the bridge. In some cases, when the approach embankments are lower than the low chord of the bridge, the relief obtained from overtopping of the approach embankments will be sufficient to prevent the bridge from being submerged.

Hydraulic bridge computer models such as [WSPRO](#) and [HEC-RAS](#) are suitable for determination of the amount of flow which will flow over the roadway embankment, over the bridge as weir flow, and through the bridge opening as orifice flow, provided that the top of the highway is properly included in the input data. These models can be used to determine average flow depths and velocities over the road and bridge, as well as average velocities under the bridge. It is recommended that one of these models be used to analyze the scour problem when the bridge is overtopped with or without overtopping of the approach roadway.

With pressure flow, the local scour depths at a pier or abutment can be much larger than for free surface flow with similar depths and approach velocities. The increase in local scour at a pier subjected to pressure flow results from the flow being directed downward towards the bed by the superstructure (vertical contraction of the flow) and by increasing the intensity of the horseshoe vortex. The vertical contraction of the flow can be a more significant cause of the increased scour depth. However, in many cases, when a bridge becomes submerged, the average velocity under the bridge is reduced due to a combination of additional backwater caused by the bridge superstructure impeding the flow and a reduction of the discharge which must pass under the bridge because of weir flow over the bridge and/or approach embankments. As a consequence of this, increases in local scour attributed to pressure flow scour at a particular site may be offset to a degree by the lower velocities.

Limited studies of pressure flow scour have been made in flumes at Colorado State University and FHWA's Turner Fairbank Highway Research Center which indicate that pier scour can be increased 200 to 300 percent by pressure flow. Both studies were for clearwater scour (no transport of bed material upstream of the bridge). Arneson conducted a more extensive study of the pressure flow scour under live bed conditions. FHWA's Turner Fairbank Laboratory and Arneson's study concluded that:

1. Pressure flow scour is a combination of vertical contraction scour and local pier scour.
2. The local pier scour component was approximately the same as the free-surface local pier scour measurements for the same approach flow condition.
3. The two components were additive.

Please see [HEC-18](#) for detailed guidance in computing pressure flow scour. The current state-of-knowledge is that pressure flow scour should be added to contraction flow scour, pier scour, and degradation.

10-203.01 Contraction Scour With Backwater

The live-bed contraction scour equation is derived assuming a uniform reach upstream and a long contraction into a uniform reach downstream of the bridge. With live-bed scour the equation computes a depth after the long contraction where the sediment transport into the downstream reach is equal to the sediment transport out. The clear-water contraction scour equations are derived assuming that the depth at the bridge increases until the shear-stress and velocity are decreased so that there is no longer any sediment transport. With the clear-water equations it is assumed that flow goes from one uniform flow condition to another. Both equations calculate contraction scour depth assuming a level water surface ($y_s = y_2 - y_0$). A more consistent computation would be to write an energy balance before and after the scour. For live-bed the energy balance would be between the approach section and the contracted section. Whereas, for clear-water scour it would be the energy at the same section before and after the contraction scour.

Backwater, in extreme cases, can decrease the velocity, shear stress and the sediment transport in the upstream section. This will increase the scour at the contracted section. The backwater can, by storing sediment in the upstream section, change live-bed scour to clear-water scour.

10-204 Other General Scour

10-204.01 General

Other general scour is normally the easiest scour form to detect since it does not fill in as floodwaters recede, it disturbs streamside vegetation, and the scour occurs above the streambed where it is more easily observed. The rate of movement of this type of scour can vary from inches per year to several hundred feet per flood.

Other general scour should be considered as threatening as bottom scour since it can move sideways quickly to undermine floodplain piers and abutments or to attack the approach roadway embankment.

10-204.02 Causes and Effects

Other general scour changes at a bridge site may be easily recognized, but can be difficult to assess the future magnitude and time rate of change. Other general scour changes are morphological changes such as those imposed on a bridge crossing site by meander migration or bank widening. The movement of meanders can threaten bridge approaches as well as increase scour by changing flow patterns approaching a bridge opening. Bank widening can cause significant changes in the flow distribution and thus the bridge's flow contraction ratio. Meanders that may appear stable are often subject to radical change after the removal of streamside vegetation.

Four steps are used in assessing other general scour.

- Step 1** Determine the fixed bed hydraulics.
- Step 2** Using the findings from the fixed bed hydraulic analysis, history, and site variables, subjectively estimates the future geometry at the bridge site. Where time change data for an encroaching meander is available (rare), relate this data to the expected bridge service life in order to determine the need for the immediate or delayed application or countermeasures -- usually in the form of river training devices.
- Step 3** Where bank widening is apparent use regime theory to try and identify the future channel geometry of the approach section. Channels nearing or in the braided regime are particularly hazardous. With this expected channel width geometry, adjust the approach flow distribution to see if it poses a greater contraction problem than presently exists.
- Step 4** If the stream is found to be changing due to other general scour, then use these changes in devising the worst case scenario for the proposed bridge by determining the most adverse angle of attack or approach flow distributions.

[HEC 20](#) is an excellent reference for assessing channel migration. It also contains design procedures for several common countermeasures. [HEC 23](#) is the primary reference for countermeasure selection and design.

10-205 Contraction Scour Example Problems

10-205.01 Example Problem 1 - Live-Bed Contraction Scour

Given:

The upstream channel width = 322 ft; depth = 8.6 ft
 The discharge is 27,300 cuft/sec and is all contained within the channel. Channel slope = 0.004 (ft/ft)
 The bridge is vertical wall with wing walls, width = 122 ft; with 3 sets of piers consisting of 3 columns 15 inches in diameter resting on concrete piles 16 inches in diameter.
 The bed material size: from 0 to 3 ft the D_{50} is 0.31 mm (0.0010 ft) and below 3 ft the D_{50} is 0.70 mm (0.0023 ft) with a fall velocity of 0.33 ft/sec
 Original depth at bridge is estimated as 7.1 ft

Determine:

The magnitude of the contraction scour depth.

Solution:

1. Determine if it is live-bed or clear-water scour.

Average velocity in the upstream reach

$$V = \frac{27,300}{8.6 \times 322} = 9.86 \text{ ft/sec}$$

For velocities this large and bed material this fine live-bed scour will occur. Check by calculating V_c for 0.7 mm bed material size. If live-bed scour occurs for 0.7 mm it would also be live-bed for 0.3 mm.

$$V_c = K_u Y^{1/6} D^{1/3} = 11.17(8.6)^{1/6}(0.0023)^{1/3} = 2.11 \text{ ft/sec}$$

Live-bed contraction scour is verified.

2. Calculate contraction scour

- a. Determine K_1 for mode of bed material transport

$$V_* = (gY_1 s_1)^{0.5} = (32.2 \times 8.6 \times 0.004)^{0.5}$$

$$= 1.05 \text{ ft/sec}$$

Given: $\omega = 0.33$

$$V_*/\omega = 1.05/0.33 = 3.2; \text{ therefore, } K_1 = 0.69$$

- b. Live-bed contraction scour (equation 10-2)

$$Q_1 = Q_2$$

$$\frac{y_2}{y_1} = \left(\frac{Q_2}{Q_1} \right)^{6/7} \left(\frac{w_1}{w_2} \right)^{k_1}$$

$$\frac{y_2}{8.6} = \left(\frac{27,300}{27,300} \right)^{6/7} \left(\frac{322}{122} \right)^{0.69} = 1.95$$

$$y_2 = 8.6(1.95) = 16.8 \text{ ft from water surface.}$$

$$y_s = 16.8 - 7.1 = 9.7 \text{ ft from original bed surface.}$$

10-205.02 Example Problem 2 – Alternate Method

An alternative approach is demonstrated to calculating V in Problem 1 to determine if scour is clear-water or live-bed. In this method calculate the scour depth using both the clear-water and the live-bed equation and take the smaller scour depth.

- a. Live bed-bed scour depth is 9.7 ft from Problem 1.
 b. Clear-water scour depth (equation 10-4)

$$D_m = 1.25 D_{50} = 1.25(0.0023) = 0.003 \text{ ft}$$

$$y_2 = \left(\frac{K_u Q^2}{D_m^{2/3} W^2} \right)^{3/7} = \left(\frac{0.0077(27,300)^2}{0.003^{2/3}(122)^2} \right)^{0.429} = 67.8 \text{ ft}$$

$$y_s = 67.8 - 7.1 = 60.7 \text{ ft from original bed surface}$$

- c. Live-bed scour (9.7 ft < 60.7 ft). The sediment transport limits the contraction scour depth rather than the size of the bed material.

10-205.03 Example Problem 3 - Relief Bridge Contraction Scour

The 1952 flood on the Missouri River destroyed several relief bridges on Highway 2 in Iowa near Nebraska City, Nebraska. The USGS made continuous measurements during the period April 2 through April 29, 1952. This data set is from the April 21, 1952 measurement (measurement # 1013). The discharge in the relief bridge was 13,012 cuft/sec. The measurement was made on the upstream side of Cooper Creek ditch using a boat and tag line.

Given:

$$Q = 13,012 \text{ cuft/sec}$$

$$W = 300 \text{ ft}$$

$$\text{Area} = 7,604 \text{ sqft}$$

$$V_{avg} = 1.71 \text{ ft/sec}$$

$$Y_0 = 4.2 \text{ to } 5.3 \text{ ft}$$

$$D_{50} = (\text{estimated between } 0.2 \text{ and } 0.3 \text{ mm}) \text{ use } 0.3 \text{ mm as } D_m$$

Clear-water scour because of low velocity flow on the floodplain.

Determine:

Clear-water contraction scour

Solution:

Use equation 10-4

$$D_m = 0.3 \text{ mm} = 0.0010 \text{ ft}$$

$$Y_2 = \left(\frac{K_u Q^2}{D_m^{2/3} W^2} \right)^{3/7} = \left(\frac{0.0077(13,012)^2}{(0.0010)^{2/3}(300)^2} \right)^{3/7} = 22.6 \text{ ft}$$

$Y_2 = 22.6 \text{ ft}$ from the water surface, this compares to 25.3 ft measured at the site.

10-300 LOCAL SCOUR

10-301 General

Local scour at piers is a function of bed material characteristics, bed configuration, flow characteristics, fluid properties, and the geometry of the pier and footing. The bed material characteristics are granular or non-granular, cohesive or non-cohesive, erodible or non-erodible rock. Granular bed material ranges in size from silt to large boulders and is characterized by the D_{50} and a coarse grain size such as the D_{84} or D_{90} size. Cohesive bed material is composed of silt and clay, possibly with some sand that is bonded chemically. Rock may be solid, massive, or fractured. It may be sedimentary or igneous and erodible or non-erodible.

Flow characteristics of interest for local pier scour are the velocity and depth just upstream of the pier, the angle the velocity vector makes to the pier (angle of attack), and free surface or pressure flow. Fluid properties are viscosity, and surface tension that for the field case can be ignored.

Pier geometry characteristics are its type, dimensions, and shape. Types of piers include single column, multiple columns, or rectangular; with or without friction or tip bearing piles; with or without a footing or pile cap; footing or pile cap in the bed, on the surface of the bed, in the flow or under the deck out of the flow. Important dimensions are the diameter for circular piers or columns, spacing for multiple columns, and width and length for solid piers. Shapes include round, square or sharp nose, circular cylinder, group of cylinders, or rectangular. In addition, piers may be simple or complex. A simple pier is a single shaft, column or multiple columns exposed to the flow. Whereas, a complex pier may have the pier, footing or pile cap, and piles exposed to the flow. This section will only direct simple pier analysis and will provide the corresponding examples. **It is recommended that the designer consult HEC 18 when a complex pier scour situation is encountered.**

Local scour at piers has been studied extensively in the laboratory. However there is limited field data. The laboratory studies have been mostly of simple piers, but there have been some laboratory studies of complex piers. Often the studies of complex piers are model studies of actual or proposed pier configurations. As a result of the many laboratory studies, there are numerous pier scour equations. In general, the equations are for live-bed scour in cohesionless sand-bed streams.

All pier foundations should be designed to the maximum scour depth computed for the piers in the channel with the exception of the special case referenced in the Bridge Manual. The depth of the calculated scour may differ in the overbank areas. Channel migration could result in a shift of location of the maximum scour depth.

10-302 Causes and Effects

Local scour can be the result of the following conditions.

1. **Pier Skew:** Pier skew contributes to local scour by reducing the effective waterway opening and by inducing turbulence in the stream flow.

The ratio of pier area to gross area of waterway as discussed in the above topic on pier area also applies to the effect pier skew has on reducing the effective waterway opening. An increase in pier skew is the same as increasing the pier area.

The amount of turbulence in the stream flow caused by the skew of piers varies depending upon the direction of flow as it impacts against the piers.

The direction of flow may change with different types of flow conditions occurring at a site, creating an angle of attack at the pier. The various flow conditions and directions of flow that may contribute to scour are: normal stream flow inside of channel banks, a shift of the stream thalweg or channel with time causing a corresponding shift in direction of stream flow, flood flows that differ in direction from main channel flow, and diversion of overbank flow by approach embankments. Scour at skewed piers is most likely to occur when the direction of flood flow differs in direction from main channel flow and the piers are skewed in the direction of main channel flow.

2. **Pier Spacing:** Close spacing of piers normally used with some short bridges can cause the accumulation of drift between piers or between piers and abutments. The accumulation of drift can restrict the bridge waterway causing a concentration of flow and an increase in velocity against other piers or abutments, resulting in local scour at these locations.
3. **Pier Shape:** Square nose piers can cause local scour by creating localized turbulence of flow that consists of the flow being driven downward into a rolling action that picks up streambed material and transports it away. If the depth of scour extends down to the pier footing, especially a spread footing, the square nose on the footing can increase the scour action in intensity and size.
4. **Approach Embankments:** Approach embankments that project into floodplains can cause local scour at the upstream corners of the embankment or abutment and at piers located near the abutment.

Scour at the upstream corners of the embankment is caused by an extreme concentration of overbank flow entering the bridge waterway opening. The concentration of flow is the result of the overbank flow moving laterally along the approach to the bridge opening.

Local scour may occur at piers located near the abutment due to the embankment constricting the waterway opening with a corresponding increase in concentration and velocity of flow at the piers.

Local scour holes at piers and abutments may overlap one another in some instances. If local scour holes overlap, the scour is indeterminate and may be deeper. The top width of a local scour hole on each side of the pier ranges from 1.0 to 2.8 times the depth of local scour. A top width value of 2.0 times the depth of local scour on each side of a pier is suggested for practical applications.

5. **Abutment Skew:** The skew of an abutment can contribute to local scour at the abutment in the same way as the skew of piers. Information contained in the above topic, Pier Skew, is applicable to abutment skew.
6. **Debris:** Accumulation of drift resulting from low superstructure, pier shape, pier spacing, pier skew or size of waterway opening can cause local scour at piers and abutments by constricting the effective waterway opening or creating localized turbulence of the stream flow.

Constricting the waterway opening may result in an increased concentration of flow with an increase in velocity against a pier or abutment causing a scouring action.

Drift accumulated against a pier will create a localized turbulence of flow and a resulting scouring action similar to that which was discussed for a square nose pier in the above topic, Pier Shape.

7. **Dual Parallel Bridges:** Where two parallel bridges cross a stream, the piers and abutments of the downstream structure may be subject to local scour caused by flow disturbance, change in flow alignment, or an increase in water velocity as a result of conditions at the upstream structure.

The following conditions at the upstream structure may create scouring action at the downstream structure:

- (a) Upstream bridge piers and abutments are aligned at a different angle to the flow or at different locations than the downstream piers and abutments causing a flow disturbance downstream.
- (b) Drift accumulation at the upstream structure causing a deflection of flow or an increase in velocity downstream.
- (c) The waterway opening of the upstream structure is smaller than the downstream structure causing an increase in local flow velocity downstream.

8. **Channel and Floodplain Alterations:** The local scour potential at waterway openings of structures is increased with changes in the flow pattern that may significantly alter the distribution of flow between the stream channel and the floodplain. Changes in flow patterns may be caused by the following conditions:

- (a) Channel alterations upstream that include straightening, enlarging or diversion
- (b) Clearing a floodplain of its natural vegetation
- (c) Earth borrow excavation sites located upstream
- (d) Floodplain encroachments
- (e) Construction of a flood control measure such as a levee system
- (f) Meandering of a channel resulting in lateral movement against a bridge structure

9. **Ice Jams:** Ice jams generally occur at the following natural or manmade locations:

- (a) Where the stream slope flattens
- (b) Where the stream constricts, such as a bridge site
- (c) Where the stream depth lessens
- (d) Where the stream makes a sharp bend
- (e) Where there is an obstruction to flow, such as a bridge pier

As an ice jam grows, especially in depth from the water surface down, it forms a hanging dam that reduces the waterway opening available for stream flow. As the stream tries to force its way through the reduced opening under the ice jam, general scour can occur.

Evaluate the hazards of ice and debris buildup when considering use of multiple pile bents in stream channels. Where ice and debris buildup is a problem, consider the bent a solid pier for purposes of estimating scour. Consider use of other pier types where clogging of the waterway area could be a major problem. Use ice and debris deflectors where appropriate. Below is an example of pier scour (Figure 10-303) that occurred during a June, 2008 flood.



Pier Scour
Figure 10-303

The pier scour hole is submerged. Contraction scour holes in the overbank are also submerged.

10-303 Computing Pier Scour

10-303.01 Local Pier Scour Equation

To determine pier scour, an equation based on the Colorado State University (CSU) equation is recommended for both live-bed and clear-water pier scour. The equation predicts maximum pier scour depths. The equation is:

$$\frac{y_s}{y_1} = 2.0 K_1 K_2 K_3 K_4 \left(\frac{a}{y_1} \right)^{0.65} Fr_1^{0.43} \quad (\text{Eq. 10-7})$$

As a Rule of Thumb, the maximum scour depth for round nose piers aligned with the flow is:

$$y_s = 2.4 \text{ times the pier width (a) for } Fr = 0.8$$

$$y_s = 3.0 \text{ times the pier width (a) for } Fr > 0.8$$

In terms of y_s/a , equation 10.7 is:

$$\frac{y_s}{a} = 2.0 K_1 K_2 K_3 K_4 \left(\frac{y_1}{a} \right)^{0.35} Fr_1^{0.43} \quad (\text{Eq. 10-8})$$

where:

- y_s = Scour depth, ft
- y_1 = Flow depth directly upstream of the pier, ft
- K_1 = Correction factor for pier nose shape from [Figure 10-303.01](#) and [Table 10-303.01a](#)
- K_2 = Correction factor for angle of attack of flow from [Table 10-303.01b](#) or equation 10-9
- K_3 = Correction factor for bed condition from [Table 10-303.01c](#)
- K_4 = Correction factor for armoring by bed material size from equation 10-10
- a = Pier width, ft
- L = Length of pier, ft
- Fr_1 = Froude Number directly upstream of the pier = $V_1/(gy_1)^{1/2}$
- V_1 = Mean velocity of flow directly upstream of the pier, ft/sec
- g = Acceleration of gravity (32.2 ft/sec²)

The correction factor for angle of attack of the flow K_2 is calculated using the following equation:

$$K_2 = \left(\cos \theta + \frac{L}{a} \sin \theta \right)^{0.65} \quad (\text{Eq. 10-9})$$

If L/a is larger than 12, use $L/a = 12$ as a maximum in equation 10-9 and [Table 10-303.01b](#). [Table 10-303.01b](#) illustrates the magnitude of the effect of the angle of attack on local pier scour.

Correction Factor, K_1 , for Pier Nose Shape	
Shape of Pier Nose	K_1
(a) Square nose	1.1
(b) Round nose	1.0
(c) Circular cylinder	1.0
(d) Group of cylinders	1.0
(e) Sharp nose	0.9

Table 10-303.01a

Correction Factor, K_2 , for Angle of Attach, θ , of the Flow			
Angle	L/a=4	L/a=8	L/a=12
0	1.0	1.0	1.0
15	1.5	2.0	2.5
30	2.0	2.75	3.5
45	2.3	3.3	4.3
90	2.5	3.9	5.0

Angle = skew angle of flow
L = length of pier, m

Table 10-303.01b

Increase in Equilibrium Pier Scour Depths, K_3 , for Bed Condition		
Bed Condition	Dune Height m	K_3
Clear-Water Scour	N/A	1.1
Plane bed and Antidune flow	N/A	1.1
Small Dunes	$3 > H > 0.6$	1.1
Medium Dunes	$9 > H > 3$	1.2 to 1.1
Large Dunes	$H > 9$	1.3

Table 10-303.01c

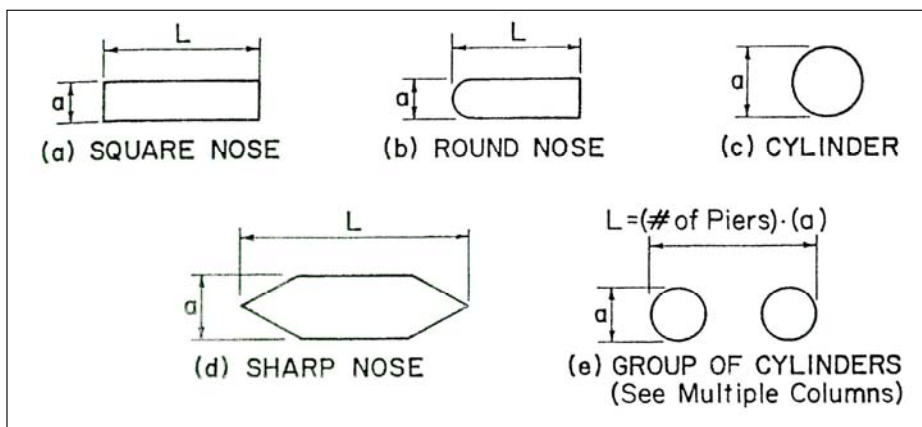

Common pier shapes
Figure 10-303.01

Notes:

1. The correction factor K_1 for pier nose shape should be determined using Table 10-303.01a for angles of attack up to 5 degrees. For greater angles, K_2 dominates and K_1 should be considered as 1.0. If L/a is larger than 12, use the values for $L/a = 12$ as a maximum in Table 10-303.01b and equation 10-9.
2. The values of the correction factor K_2 should be applied only when the field conditions are such that the entire length of the pier is subjected to the angle of attack of the flow. Use of this factor will result in a significant over-prediction of scour if a portion of the pier is shielded from the direct impingement of the flow by an abutment or another pier; or an abutment or another pier redirects the flow in a direction parallel to the pier. For such cases, judgment must be exercised to reduce the value of the K_2 factor by selecting the effective length of the pier actually subjected to the angle of attack of the flow.
3. The correction factor K_3 results from the fact that for plane-bed conditions, which is typical of most bridge sites for the flood frequencies employed in scour design, the maximum scour may be 10 percent greater than computed with equation 10-7. In the unusual situation where a dune bed configuration with large dunes exists at a site during flood flow, the maximum pier scour may be 30 percent greater than the predicted equation value. This may occur on very large rivers, such as the Mississippi. For smaller streams that have a dune bed configuration at flood flow, the dunes will be smaller and the maximum scour may be only 10 to 20 percent greater than the predicted equation value.
4. Piers set close to abutments (for example at the toe of a spill through abutment) must be carefully evaluated for the angle of attack and velocity of the flow coming around the abutment.

The correction factor K_4 decreases scour depths for armoring of the scour hole for bed materials that have a D_{50} equal to or larger than 2.0 mm and D_{95} equal to or larger than 20 mm. The K_4 factor should only be applied to self-armoring streams. The correction factor results from recent research by Molinas and Mueller. Molinas's research for FHWA showed that when the approach velocity (V_1) is less than the critical velocity (V_{c90}) of the D_{90} size of the bed material and there is a gradation in sizes in the bed material, the D_{90} will limit the scour depth. Mueller and Jones developed a K_4 correction coefficient from a study of 384 field measurements of scour at 56 bridges. The equation developed by Jones given in HEC 18 Third Edition should be replaced with the following:

$$\text{If } D_{50} < 2 \text{ mm or } D_{95} < 20 \text{ mm } K_4 = 1$$

$$\text{If } D_{50} \geq 2 \text{ mm and } D_{95} \geq 20 \text{ mm}$$

then

$$K_4 = 0.4(V_R)^{0.15} \tag{Eq. 10-10}$$

$$V_R = \frac{V_1 - V_{icD50}}{V_{cD50} - V_{icD95}} > 0 \tag{Eq. 10-11}$$

$$V_{icD_x} = 0.645 \left(\frac{D_x}{a} \right)^{0.053} V_{cD_x} \tag{Eq. 10-12}$$

$$V_{cD_x} = K_u y_1^{1/6} D_x^{1/3} \tag{Eq. 10-13}$$

where:

- V_{icD_x} = the approach velocity (ft/sec) required to initiate scour at the pier for the grain size D_x (ft)
- V_{cD_x} = the critical velocity (ft/sec) for incipient motion for the grain size D_x (ft)
- y_1 = Depth of flow just upstream of the pier, excluding local scour, ft
- V_1 = Velocity of the approach flow just upstream of the pier, ft/s
- D_x = Grain size for which x percent of the bed material is finer, ft
- K_u = 11.17

While K_4 provides a good fit with the field data the velocity ratio terms are so formed that if D_{50} is held constant and D_{95} increases, the value of K_4 increases rather than decreases. For field data an increase in D_{95} was always accompanied with an increase in D_{50} . The minimum value of K_4 is 0.4.

Please note: IDOT uses a conservative estimate of $K_4=1$.

Flow can be obstructed by substructure elements that include the pier stem, pile caps and footings, and the pile group that can result in additional scour. The various scour producing components are addressed in Hec 18 and the method should be employed when the situation is encountered.

10-303.03 Example Problem 1 - Scour at a Simple Solid Pier

Given:

Pier geometry: $a = 4.0$ ft, $L = 59$ ft, round nose
 Flow variables: $y_1 = 10.2$ ft, $V_1 = 11.02$ ft/sec
 Angle of attack = 0 degrees, $g = 32.2$ ft/sec²
 Froude No. = $11.02/(32.2 \times 10.2)^{0.5} = 0.61$
 Bed material: $D_{50} = 0.32$ mm (0.001 ft), $D_{95} = 7.3$ mm (0.024 ft),
 Bed Configuration: Plane bed.

Determine:

The magnitude of pier scour depth.

Solution:

Use equation 10-7

$$\frac{y_s}{y_1} = 2.0 K_1 K_2 K_3 K_4 \left(\frac{a}{y_1} \right)^{0.65} Fr_1^{0.43}$$

$$\frac{y_s}{y_1} = 2.0 (1.0) (1.0) (1.1) (1.0) \left(\frac{4.0}{10.2} \right)^{0.65} (0.61)^{0.43} = 0.97$$

$$y_s = 0.97(10.2) = 9.9 \text{ ft}$$

10-303.04 Example Problem 2 - Angle of Attack¹

Same as Problem 1 but angle of attack is 20 degrees

Solution:

Use equation 10-9 to compute K_2

$$K_2 = \left(\cos\theta + \frac{L}{a} \sin\theta \right)^{0.65}$$

If L/a is larger than 12, use $L/a = 12$ as a maximum in equation 10-9 and [Table 10-303.01b](#).

$$\frac{L}{a} = \frac{59}{4.0} = 14.8 > 12 \quad \text{use } 12$$

$$K_2 = (\cos 20 + 12 \sin 20)^{0.65} = 2.86$$

$$Y_S = 9.9(2.86) = 28.3 \text{ ft}$$

10-304 Computing Abutment Scour

10-304.01 General

Scour occurs at abutments when the abutment and embankment obstruct the flow. Several causes of abutment failures during post-flood field inspections of bridge sites that have been documented:

1. Overtopping of abutments or approach embankments
2. Lateral channel migration or stream widening processes
3. Contraction scour
4. Local scour at one or both abutments

Abutment damage is often caused by a combination of these factors. Where abutments are set back from the channel banks, especially on wide floodplains, large local scour holes have been observed with scour depths of as much as four times the approach flow depth on the floodplain. As a general rule, the abutments most vulnerable to damage are those located at or near the channel banks.

The flow obstructed by the abutment and approach highway embankment forms a horizontal vortex starting at the upstream end of the abutment and running along the toe of the abutment, and a vertical wake vortex at the downstream end of the abutment (Figure 10-304.01a).

The vortex at the toe of the abutment is very similar to the horseshoe vortex that forms at piers, and the vortex that forms at the downstream end is similar to the wake vortex that forms downstream of a pier. Research has been conducted to determine the depth and location of the scour hole that develops for the horizontal (so called horseshoe) vortex that occurs at the upstream end of the abutment, and numerous abutment scour equations have been developed to predict this scour depth. However, because these equations tend to be overly conservative, they are not presented here. The equations are provided in the HEC 18 manual. These equations are not appropriate for abutments that are protected by armoring.

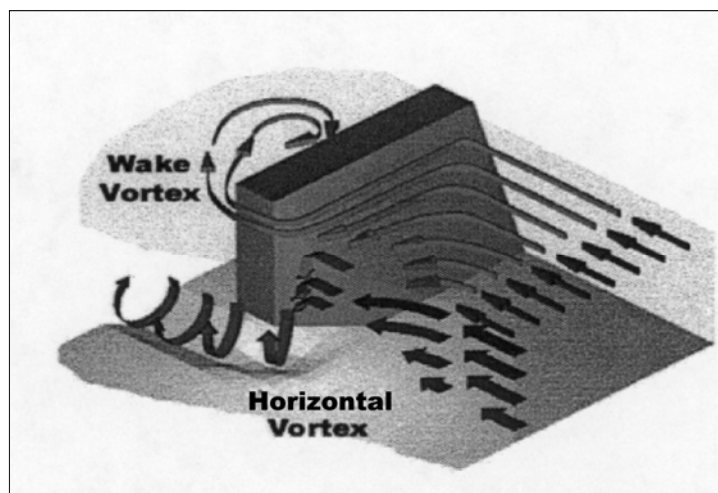

Schematic representation of abutment scour
Figure 10-304.01a

Abutment scour should be approached through prevention during the design phase of a bridge. For IDOT bridges on the state system, the abutment scour calculations are often ignored because of: difficulty in predicting abutment scour depths, the placement of the abutment in the overbank area of the floodplain, the use of spill-thru abutments, and because of the armoring of the spill-thru abutment slopes. The armoring of abutment slopes should extend down to the depth of estimated degradation plus contraction scour. Any deviation from any one or all of these stipulations or unusual site conditions should suggest computing the abutment scour depths. **Also please note that even though FHWA agrees it is reasonable to disregard the abutment scour equations for reasons suggested above, FHWA recommends that the abutment foundations should be designed for any scour (i.e. degradation and contraction scour) that could impact the abutment itself.**

Abutment failures and erosion of the fill also occur from the action of the downstream wake vortex. However, research and the development of methods to determine the erosion from the wake vortex has not been conducted. An example of abutment and approach erosion of a bridge due to the action of the horizontal and wake vortex is shown in Figure 10-304.01b.



Scour of bridge abutment and approach embankment.
Figure 10-304.01b

Figure 10-304.01c below demonstrates one form of abutment scour where the embankment slopes failed, though other scour types (contraction and pressure flow scour) probably contributed to the ultimate scour damage. The flood damage at this bridge was caused by a breached levee on a nearby channel.



Scour of bridge abutment and approach embankment
Figure 10-304.01c

Figure 10-304.01d below shows abutment/contraction scour that happened during a large flood event June of 2008.



Abutment scour looking downstream from the top of the abutment slope
Figure 10-304.01d

The types of failures described above are initiated as a result of the obstruction to the flow caused by the abutment and highway embankment and subsequent contraction and turbulence of the flow at the abutments. There are other conditions that develop during major floods, particularly on wide floodplains, that are more difficult to foresee but that need to be considered in the hydraulic analysis and design of the substructure:

1. Gravel pits on the floodplain upstream of a structure can capture the flow and divert the main channel flow out of its normal banks into the gravel pit. This can result in an adverse angle of attack of the flow on the downstream highway with subsequent breaching of the embankment and/or failure of the abutment.
2. Levees can become weakened and fail with resultant adverse flow conditions at the bridge abutment.
3. Debris can become lodged at piers and abutments and on the bridge superstructure, modifying flow conditions and creating adverse angles of attack of the flow on bridge piers and abutments.

10-304.02 Abutment Site Conditions

Abutments can be set back from the natural stream bank, placed at the bankline or, in some cases, actually set into the channel itself (not recommended). Common designs include stub abutments placed on spill-through slopes, and vertical wall abutments, with or without wingwalls. Scour at abutments can be live-bed or clear-water scour. The bridge and approach road can cross the stream and floodplain at a skew angle and this will have an effect on flow conditions at the abutment. Finally, there can be varying amounts of overbank flow intercepted by the approaches to the bridge and returned to the stream at the abutment. More severe abutment scour will occur when the majority of overbank flow returns to the

bridge opening directly upstream of the bridge crossing. Less severe abutment scour will occur when overbank flows gradually return to the main channel upstream of the bridge crossing.

10-304.03 Abutment Skew

The effect of skew angle is depicted in Figure 10-304.03. Note that for an abutment angled downstream, the scour depth is decreased whereas the scour depth is increased for an abutment angled upstream.

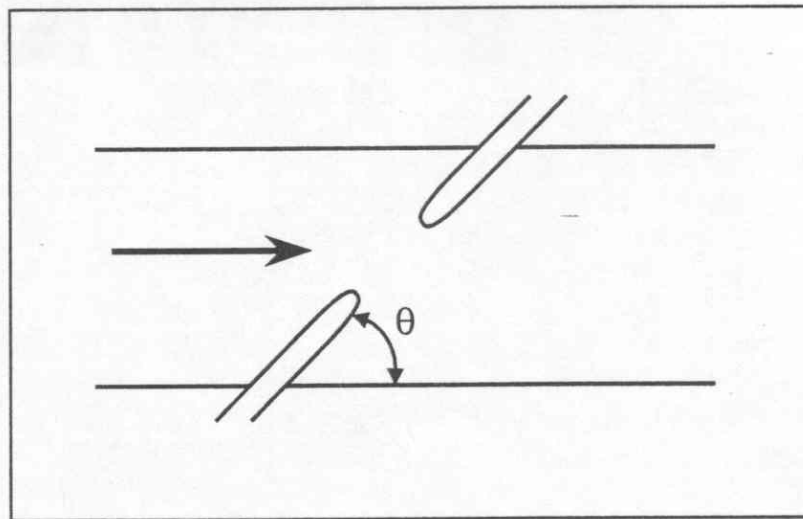

Adjustment of abutment scour depth estimate for skew
Figure 10-304.03

10-304.04 Abutment Shape

There are three general shapes for abutments (Figure 10-304.04):

1. Spill-through abutments. Typical of most of IDOT bridges that are on the state system.
2. Vertical walls without wing walls
3. Vertical-wall abutments with wingwalls

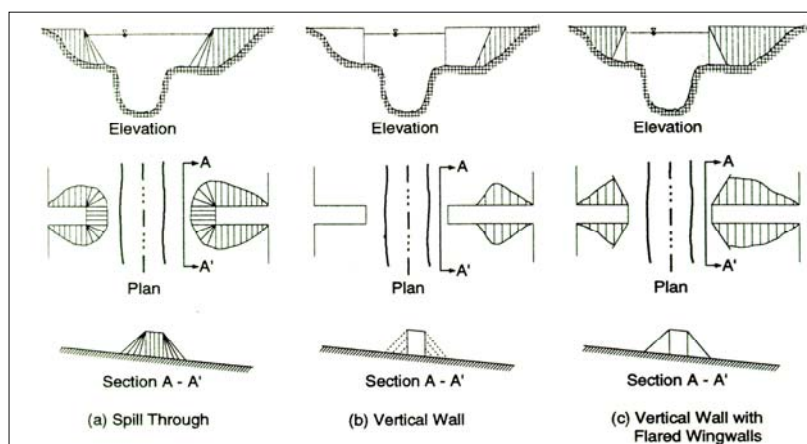

Abutment shapes
Figure 10-304.04

These shapes all have varying angles to the flow. The depth of scour is approximately double for vertical-wall abutments as compared with spill-through abutments. Similarly, scour for vertical wall abutments with wingwalls is reduced to 82 percent of the scour of vertical wall abutments without wingwalls.

10-304.05 Designing for Scour at Abutments

The preferred design approach is to place the abutment on scour resistant rock or on deep foundations. Available technology has not developed sufficiently to provide reliable abutment scour estimates for all hydraulic flow conditions that might be reasonably expected to occur at an abutment. Therefore, engineering judgment is required in designing foundations for abutments. In many cases, foundations can be designed with shallower depths than predicted by the equations given in HEC 18 when they are protected with rock riprap and/or with a guide bank placed upstream of the abutment designed in accordance with guidelines in HEC 23. Cost will be the deciding factor.

Based on lessons learned from field evaluations of damaged abutments, consideration should be given to designing deep foundations (piles and shafts) to support both vertical wall abutments and stub abutments on spill-through slopes for the condition where the approach embankment is breached and all supporting soil around the abutment (including the spill through slope) has been removed (Figure 10-304.02). Piling for abutments should be driven below the elevation of the long-term degradation, stream instability, and contraction scour. In addition, where ice build-up is likely to be a problem, the toe of the spill-through slopes or vertical abutments should be set back from the edge of the channel bank to facilitate passage of the ice.

On wide floodplains or on floodplains with complex conditions which could affect future flood flows (confluences, adverse meander patterns and bends, gravel mining pits, ponding of the flow, levee systems, etc.), additional scour countermeasures such as guidebanks, dikes or revetments should be evaluated for inclusion with the initial bridge construction. The intent

here is to establish a control to maintain a favorable approach flow condition at the abutment even though upstream conditions may change.

Where spread footings are placed on erodible soil, the preferred approach is to place the footing below the elevation of total scour. If this is not practicable, a second approach is to place the tops of footings below the depth of the sum of contraction scour and long-term degradation and to provide scour countermeasures. For spread footings on erodible soil, it becomes especially important to protect adjacent embankment slopes with riprap or other appropriate scour countermeasures. The toe or apron of the riprap serves as the base for the slope protection and must be carefully designed to resist scour while maintaining the support for the slope protection.

10-400 USING HEC-RAS TO COMPUTE SCOUR

10-401 Steady Flow Analysis

After the geometric and steady flow data were entered, the steady flow analysis was performed. First, **Run** and then **Steady Flow Analysis** were selected from the main program window. Then, a *Short ID* was entered as “Plan 01” and a subcritical analysis was selected. Next, **Options** and then **Flow Distribution Locations** were selected from the **Steady Flow Analysis Window**. This activated the **Flow Distribution Editor** as shown in Figure 10-401.

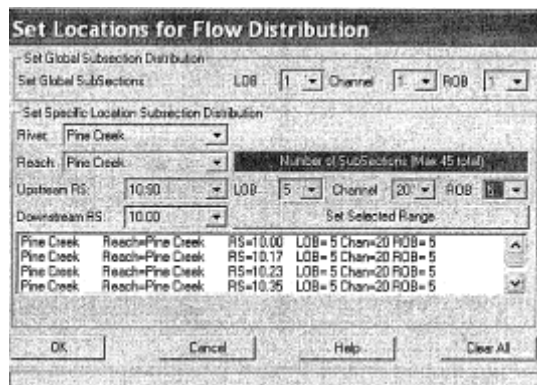

Flow Distribution Editor
Figure 10-401

To perform the bridge scour calculations, the program requires detailed values of the depth and velocity within the cross sections located just upstream from the bridge (cross section 10.37 for this example) and at the approach section (cross section 10.48). Therefore, the modeler is required to set the flow distribution option for these two cross sections. For this example, the flow distributions were selected for the entire river reach. As shown in the Figure 10-401, the left and right overbanks were divided into 5 subsections each, and the main channel was divided into 20 subsections. This will allow the program to produce detailed results of the distribution of depth and velocity at the cross sections.

The number of subsections is dependent upon such factors as the cross section geometry, the bridge opening width, and the number of piers. The modeler should perform the hydraulic calculations with different numbers of subsections to evaluate the impact on the bridge scour results. It is recommended to use fewer subsections; however, an adequate number of subsections is required to determine the hydraulic properties. For this example, the bridge scour calculations were also performed using 20 subsections for the main channel, and no appreciable changes were observed in the scour results. For a further discussion on the flow distribution option, the modeler is referred to chapter 7 of the **Hec-RAS User's Manual** and to chapter 4 of the **Hec-RAS Hydraulic Reference Manual**.

Finally, the flow distribution editor was closed and the data were saved as a plan entitled “Scour Plan 1”. The **Compute** button was then selected to execute the analysis.

At this point, the modeler should review the output from the hydraulic analysis and calibrate the model. It is important to obtain a good working model of the river system before attempting to perform a bridge scour analysis. For this example, the hydraulic analysis included the evaluation of the expansion and contraction reach lengths according to the procedures as outlined in the

Hec-RAS Hydraulic Reference Manual. Finally, after a working model has been developed, the user should evaluate the long-term aggradation or degradation for the river reach and incorporate this analysis into the working model.

10-402 Hydraulic Design – Bridge Scour

After a working model of the river reach is developed and the long-term effects for the river system are evaluated, the modeler can perform the bridge scour computations. The scour computations are performed by selecting **Run, Hydraulic Design Functions, Functions,** and then **Scour at Bridges.** This will activate the **Bridge Scour Editor** as shown in Figure 10-402.

The top of the editor is used to select the River, Reach, River Station, and Profile number for the scour analysis. For this example, the river and reach is Pine Creek, the bridge is located at river station 10.36, and the scour analysis was for the first profile.

The remaining portion of the editor is divided into three areas: input data tabs, a graphic, and a results window. There are three tabs, one for each of the three types of scour computations: contraction, pier, and abutment. The graphic displays the bridge cross section (inside upstream). When the **Compute** button is selected, the scour results will be displayed graphically on the cross section and in tabular format in the results window. The following sections describe the parameters for each of the three data tabs.

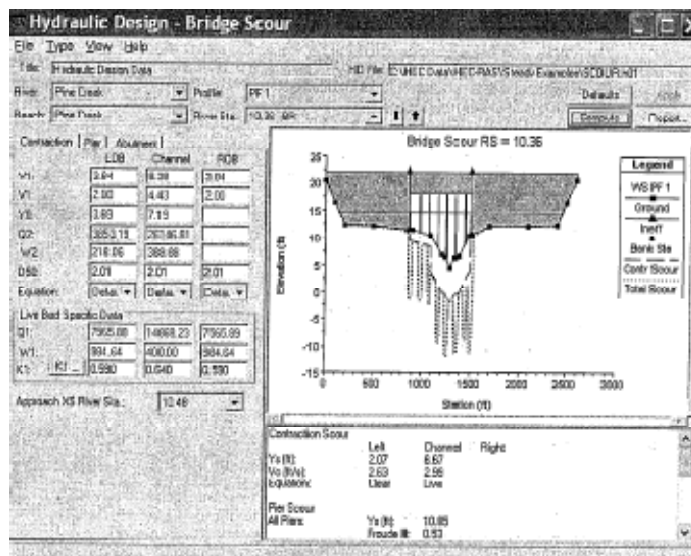

Bridge Scour Editor - Contraction Tab
Figure 10-402

10-403 Contraction Scour

Contraction scour occurs when the flow area of a stream is reduced by a natural contraction or bridge constriction the flow. There are two forms of contraction scour: live bed and clear water. The equations for the contraction scour are presented in chapter 10 of the **Hydraulics Reference Manual** and the variables for the equations are listed on the left side of the contraction tab, as shown in Figure 10-402. Additionally the contraction tab is divided into three columns: for the LOB (left overbank), main channel, and ROB (right overbank). This allows the program to calculate the contraction scour for each of the three areas of the cross section.

When the **Bridge Scour Editor** is activated, the program will search the output file from the hydraulic analysis and fill in the values for the variables on the contraction tab, with appropriate results, as shown in Figure 10-402 (Note: As shown in the figure, the values for Y0, Q2, and W2 are zero for the ROB because the right sloping abutment extended into the main channel).

The user can override any of these values by simply entering in a new value at the appropriate location. For the contraction scour analysis, the user is only required to provide the D_{50} mean size fraction of the bed material, the water temperature for the K1 factor, and select the equation to be used for the analysis.

For this example, the D_{50} was entered as 2.01 mm, for each of the LOB, main channel, and ROB. To enter the water temperature, the **K1** icon was selected and this activated the **K1 Data Editor** as shown in Figure 11.5. As shown in Figure 11.5, the water temperature was entered as 60 F and then the program automatically determined that the K1 value was 0.59, 0.59, and 0.59 for the LOB, main channel, and ROB respectively. This editor was then closed.

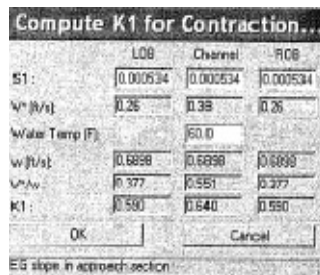

K1 Data Editor
Figure 10-403

Finally, the down arrows adjacent to Equation were selected and the default option was chosen. This informed the program to use either the clear water or the live bed scour equation as determined from equation 10-1 in the **Hydraulic Reference Manual**.

To perform the contraction scour computations, the **Compute** button at the top of the editor was selected. When the calculations were completed, the results appeared in tabular form in the lower right corner of the editor and in graphical form on the bridge cross-section plot, as shown in **Figure 10-402**.

As a review of the results for the contraction scour, the critical velocity (V_c) for the LOB was determined to be 2.63 ft/s. This value is greater than the velocity at the approach section ($V_1 = 2.00$) in the LOB; therefore the clear water scour equation was used for the LOB, as listed in the summary table. Comparatively, the live bed scour equation was used for the main channel because the critical velocity ($V_c=2.99$) was less than the approach section velocity ($V_1=4.43$), in the main channel. Finally, the contraction scour depth (Y_s) was determined to be 2.07 and 6.67 feet for the LOB and main channel, respectively. As a final note, there was no contraction scour in the ROB because the right abutment extended into the main channel. These contraction scour depths are also shown on the graphic display of the bridge cross section in **Figure 10-402**.

10-404 Pier Scour

To enter the data for the pier scour analysis, the Pier Tab was selected. This tab is shown in **Figure 10-404**. As for the contraction scour tab, the program will automatically fill in the

values for the variables from the results of the hydraulic analysis. The user may replace any of these values by changing the value in the appropriate field.

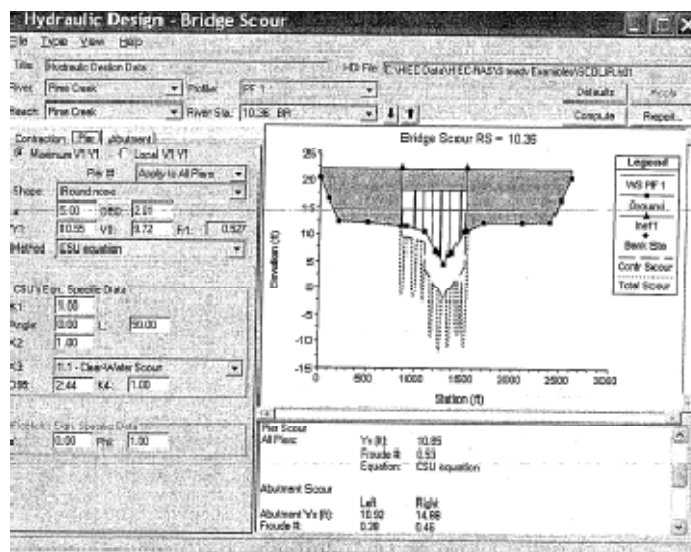

Bridge Scour Editor – Pier Tab
Figure 10-404

For this example, the Maximum V1 Y1 option was selected to inform the program to use the maximum value of the depth and velocity values, as opposed to the values upstream from each pier. Then, Method was selected as the “CSU equation.” Next, the Pier # option was selected as “Apply to All Piers” to inform the program that the data will be used for all of the piers. (The user has the option of entering the data for each individual pier.)

Next, the Shape of the piers was selected as “Round nose” which set the K1 value to be 1.00. Then, the D50 was entered as 2.01 mm. The angle was set to be 0 degrees which set the K2 value to be 1.00. Next, the bed condition was selected as “Clear Water Scour” (this set K3 = 1.1) and the D95 was entered as 2.44 mm.

This completed the required user input and then the **Compute** button was selected. The results were then displayed graphically and in the summary table and showed that the pier scour depth (Ys) was 10.85 feet, as shown in the Figure 11.6. (Note: When the compute button was selected, the program automatically computed all 3 scour depths: contraction, pier, and abutment).

10-405 Abutment Scour

To enter the data for the abutment scour, the **Abutment Tab** was selected and is shown in Figure 11.7. For the abutment scour computations, the program can use either the Froehlich or the HIRE equation. The variables for the equations appear on the left side of the tab and their values for the left and right abutment were automatically obtained from the hydraulic analysis results.

To perform the abutment scour analysis, the user must enter the abutment shape, the skew angle, and select the equation to be used. For this example, the shape (K1) was selected as “Spill-through abutment”. This set the K1 value to be 0.55. Then, the Skew angle was entered as 90 degrees and this set K2 to be 1.00, for both the left and right abutment. Finally, the Equation was selected as “Default”. With this selection, the program will calculate the L/y1 ratio to

determine which equation to use. The modeler is referred to chapter 10 of the **Hydraulic Reference Manual** for a further discussion on the scour equations.

This completed the data entry for the abutment scour and the **Compute** button was selected. The results were then displayed on the graphic and in the summary table, as shown in Figure 10-405. The results show that the HIRE equation was used for both the left and right abutment and the magnitude of the scour was 10.92 and 14.88, respectively. Additionally, the summary table displayed the values of the Froude numbers used for the calculation.

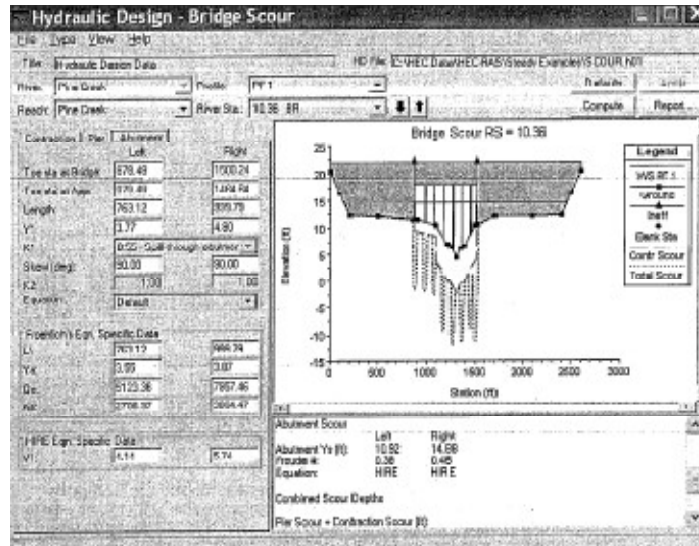

Bridge Scour Editor – Abutment Tab
Figure 10-405

10-406 Total Bridge Scour

The total bridge scour is the combination of the contraction scour and the local scour (pier or abutment). To review the total scour, the user can toggle to the bottom of the summary table. For this discussion, a portion of the summary table is shown as Table 10-406. This table was obtained by selecting **Copy Table to Clipboard** under the **File** menu.

Table 10-406 Summary of Results for Bridge Scour

Contraction Scour

	Left	Channel	Right
Ys:	2.07	6.67	
Eqn:	Clear	Live	Default

Pier Scour

All Piers	Ys=	10.85
	Eqn=	CSU equation

Abutment Scour

	Left	Right
Abutment Ys:	10.92	14.88
Equation:	HIRE	HIRE

Combined Scour Depths

Pier Scour + Contraction Scour

Left Bank:	12.92
Channel:	17.52
Left abut + contr:	12.98
Right abut + contr:	21.55

The first three portions of the table display the results of the contraction, pier, and abutment scour, as discussed previously. The final portion of the table displays the combined scour depths. For this example, the pier and contraction was 12.92 feet (= 10.85 + 2.07) for the left bank and 17.52 feet (= 10.85 + 6.67) for the main channel. Additionally, the total left abutment and contraction scour was 12.98 feet (=10.92 +2.07) and the right abutment and contraction scour was 21.55 feet (=14.90 + 6.67). The contraction scour for the right abutment was the contraction scour for the main channel because the right abutment extended into the main channel.

Finally, the total scour is displayed graphically, as shown in Figure 10-406. (Note: The graphic has been zoomed in to see more detail.) As shown in the legend, the long dashed line represents the contraction scour and the short dashed line portrays the total scour. This graphic was obtained by selecting **Copy Plot to Clipboard** from the **File** menu.

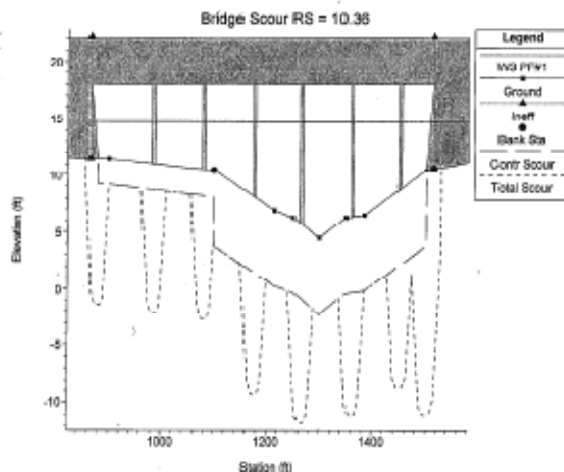

Total Scour Prism
Figure 10-406

10-407 Summary

To perform the bridge scour computations, the user must first develop a model of the river system to determine the hydraulic parameters. Then, the program will automatically incorporate the hydraulic results into the bridge scour editor. The user can adjust any of the values that the program has selected. For each particular scour computation, the modeler is required to enter only a minimal amount of additional data. The results for the scour analysis are then presented in tabular form and graphically. Finally, the user can select **Detailed Report** from the **Bridge Scour Editor** to obtain a table displaying a full listing of all the input data used and the results of the analysis.

10-500 REFERENCES

1. Richardson, E.V., and S.R. Davis. *Evaluating Scour at Bridges, Hydraulic Engineering Circular No. 18, Fourth Edition*. FHWA NHI 01-001. Federal Highway Administration, U.S. Department of Transportation, Washington, D.C. 2001.
2. American Association of State Highway and Transportation Officials. *LRFD Bridge Design Specifications, 3rd Edition*, Washington, D.C. 2004.
3. American Association of State Highway and Transportation Officials. *Highway Drainage Guidelines*. Washington, D.C. 1999.
4. U.S. Army Corps of Engineers. *HEC-RAS (Hydrologic Engineering Center-River Analysis System), Version 4.1*. January 2010.



Chapter 11

www.pearson.com

CHAPTER 11 – SCOUR COUNTERMEASURES

11-000 GENERAL

- 11-001 Introduction
- 11-002 Management Strategies for a Plan of Action
- 11-003 Implicit Design Concepts
- 11-004 Explicit Design Concepts
- 11-005 Inspection and Detection
- 11-006 Scour Monitoring
- 11-007 Selecting Countermeasures

11-100 HYDRAULIC COUNTERMEASURES

11-101 River Training Structures

11-101.01 Transverse Structures

- 11-101.011 Spurs
- 11-101.012 Transverse Dikes
- 11-101.013 Bendway Weirs/Stream Barbs
- 11-101.014 Drop Structures (Check Dams/Grade Control)

11-101.02 Longitudinal Structures

- 11-101.021 Longitudinal Dike
- 11-101.022 Dike
- 11-101.023 Guide Bank

11-101.03 Areal Structures/Treatments

- 11-101.031 Jack or Tetrahedron Field
- 11-101.032 Channelization
- 11-101.033 Flow Relief

11-102 Armoring Countermeasures

11-102.01 Rigid Revetments and Bed Armor

- 11-102.011 Concrete Slopewall
- 11-102.012 Rigid Grout Filled Mattress/
Concrete Fabric Mat
- 11-102.013 Fully Grouted Riprap

	11-102.02	Flexible Revetments or Bed Armor
	11-102.021	Rock Riprap
	11-102.022	Gabions/Gabion Mattress
	11-102.023	Wire Enclosed Riprap Mattress
	11-102.024	Precast Block Revetment Mats/ Articulated Block Mats
	11-102.025	Concrete/Grout Mattress
	11-102.026	Partially Grouted Riprap
	11-102.03	Local Scour Armoring
	11-102.031	Rock Riprap at Piers and Abutments
	11-102.032	Concrete Armor Units
	11-102.033	Grout Filled Bags
	11-102.034	Gabions/Gabion Mattresses
	11-102.035	Partially Grouted Riprap
11-200	STRUCTURAL COUNTERMEASURES	
	11-201	Foundation Strengthening
	11-201.01	Underpinning
	11-201.02	Continuous Spans
	11-201.03	Pumped Concrete/Grout Under Footing
	11-202	Pier Geometry Modifications
	11-202.01	Debris Deflector for Pier
11-300	BIOTECHNICAL COUNTERMEASURES	
11-400	MONITORING	
	11-401	Fixed Instrumentation
	11-402	Portable Instrumentation
	11-403	Visual Monitoring
11-500	REFERENCES	

11-000 GENERAL**11-001 Introduction**

Scour is the erosion of streambed or bank material due to flowing water. Sixty percent of all bridge failures are from hydraulic and stream instability problems that cause scouring of material from bridge foundations. Countermeasures for these problems are defined as features incorporated into a highway-stream crossing system to monitor, control, inhibit, change, delay, or minimize stream scour problems. Considerations in choosing a countermeasure are stream characteristics, construction and maintenance requirements and cost.

New bridges shall be designed for scour by assuming that all streambed material in the computed scour prism has been removed and is not available for bearing or lateral support. Every existing bridge over a waterway shall be evaluated for scour in order to determine if it is scour critical and to define prudent measures to be taken for its protection. A scour critical bridge is one with abutment or pier foundations that are rated as unstable due to observed scour at the bridge site or scour potential as determined from a scour evaluation study. A plan of action, which can include timely installation of scour countermeasures, should be developed for each scour critical bridge. The goal of the plan of action is to provide guidance for inspectors and engineers that can be implemented before, during, and after flood events to protect the traveling public.

This chapter provides guidelines for the selection of scour countermeasures implemented by the Illinois Department of Transportation (IDOT). The details of management strategies for developing a plan of action for a scour critical bridge, selecting countermeasures, countermeasure design concepts, scour monitoring and countermeasure case histories of performance are presented in [Hydraulic Engineering Circular 18 \(HEC 18\)](#) “Evaluating Scour at Bridges”, and [Hydraulic Engineering Circular 23 \(HEC 23\)](#) “Bridge Scour and Stream Instability Countermeasures”. Countermeasures for erosion and sedimentation are also presented in [Chapter 59 of the IDOT Bureau of Design and Environment \(BDE\) Manual 2002](#).

11-002 Management Strategies for a Plan of Action

As mentioned above, when a bridge is found to be scour critical a plan of action shall be developed and implemented. However, while many bridges may be found to be scour critical, the severity of the problem and risk to the traveling public can vary dramatically. As a result, the plan of action management strategy, including such factors as: the urgency of the response, the type and frequency of inspection, the redundancy in the plan, and amount of money and resources allocated to countermeasures (including monitoring); can vary from one scour critical bridge to the next.

For instance, a bridge rated scour critical as a result of a substantial scour hole undermining the foundation found during an underwater inspection, would be of greater concern than a currently stable bridge rated scour critical based on calculations of the theoretical conditions of the 100-year flood. In the first case, the bridge has experienced actual scour and is at risk of failure, whereas in the second case the bridge is not presently at risk, but could develop scour problems in the future. The resulting management strategy for developing and implementing a plan of action would be much more urgent in the first case.

The management strategy may also vary according to the importance of the roadway to the transportation network and may require a risk-based analysis. For example, a bridge with high

average daily traffic (ADT) or one that provides the only access in and out of a given area would be of greater concern than a low ADT bridge or one for which alternate routes or detours are available. Similarly, a bridge that is along an evacuation route or provides access to an airport might also require a different level of response in developing a plan of action.

The management strategy might also vary as a result of other repair or replacement plans. For example, a bridge found to be scour critical but already programmed for replacement in the near future might be treated differently than another bridge that was newer, or not considered for replacement for many years. In the first case, the use of monitoring as a countermeasure might be reasonable until the bridge is replaced. However in the second case a structural countermeasure, at substantially greater cost, would probably be necessary.

[HEC 18](#) provides guidance for developing a comprehensive scour evaluation program. A key element of the program is the identification of scour critical bridges which will be entered into the National Bridge Inventory System (NBIS) using the revised Recording and Coding Guide for the Structure Inventory and Appraisal of the Nation's Bridges¹. Item 113 of the NBIS identifies the current scour critical evaluation.

A template for the Plan of Action to be used on Illinois bridges is [Form BBS 2680](#), available on the IDOT internet webpage.

11-003 Implicit Design Concepts

The following standard design practices provide a minimum level of protection against scour. These are normally sufficient for locations that do not possess deep scour potential. For additional information refer to [Section 7-001.03](#).

1. Sizing the waterway opening for an acceptable level of backwater for both the minimum design flood frequency and the 100-year frequency. This normally results in an average velocity through the structure of 3 to 6 ft/s.
2. Selection of alignment, shape, and location of piers and abutments that accommodate stream flow patterns and thereby reduce the scour potential.
3. The use of spill-through abutments with protected slopewalls instead of vertical abutments.
4. The use of pile supported foundation units that provide protection from shallow scour instead of spread footing foundations.
5. Overtopping road grades and structure freeboard which provide relief opening during extreme flood events.

Each bridge design shall be evaluated by a scour team with expertise in hydraulic, geotechnical, and structural design. This team determines if the implicit, "built-in" features of the structure provide adequate scour protection or if additional measures are required to protect against scour. [HEC 18](#) considers the following to be the primary scour considerations:

1. The degree of uncertainty in the scour prediction.
2. The potential for and consequences of failures².

3. The added cost of making the bridge less vulnerable to scour. Design measures incorporated in the original construction are almost always less costly than retrofitting scour countermeasures.

11-004 Explicit Design Concepts

If the scour team determines that the implicit design features of a new structure provide insufficient scour protection, the design shall incorporate either countermeasures to prevent the scour or a foundation design to provide stability under the anticipated scour conditions.

Total scour should be plotted on a cross section of the bridge opening. Foundation analysis should then proceed assuming all material above the total scour prism has been removed. The design event for scour is the 100-year flood, unless overtopping occurs prior to Q_{100} , in which case the frequency of incipient overtopping becomes the design event. For roadways which are not overtopped, all frequencies up to the 500-year flood should be examined.

HEC 18 suggests that an overdesigned foundation in the form of overdriven piles, deeper footings, etc., is more effective and economical over the long term than armoring a pier. Chapter 2 of HEC 18 contains guidelines for foundation design. A key concern is the footing depth; HEC 18 suggests that the top of the footing may arrest pier scour as long as it is not exposed by degradation and contraction scour.

Armoring (see Section 11-102) generally takes the form of riprap. However, riprap can become unstable over the course of several events, especially if it is undersized or not properly placed. It becomes less attractive at sites with large design discharges and high velocities. Sheet piling may be utilized around the pier, or a cofferdam could be cutoff below streambed and left in place. This option requires less monitoring, but may increase the effective width of obstruction and lead to deeper scour.

Due to the unpredictable nature of stream behavior, it is difficult to design reliable, effective flow control measures such as those detailed in Section 11-101 and Hydraulic Engineering Circular 20 (HEC 20) "Stream Stability at Highway Structures". It is somewhat unrealistic to rely solely on one or more of these flow structures to alleviate damaging flow conditions and thus eliminate scour. Consequently, flow control structures are usually conservatively used in conjunction with an overdesigned foundation or pier armoring.

11-005 Inspection and Detection

IDOT's routine bridge inspections have been expanded to include considerable observation and measurement relating to scour potential. These procedures incorporate the bridge inspection and monitoring techniques detailed in HEC 18. This information is supplemented at critical structures with the Underwater Bridge Element inspection. Inspection records are valuable tools for assessing existing scour potential and validating computed scour for a replacement structure.

The bridge inspections are generally conducted during periods of normal stream flow. However, the greatest potential for scour occurs during flood flows. At some time during flood flows the maximum depth and lateral area of scour will be reached. As the water recedes, or later in time during normal stream flow, these scour areas may be filled by sediment. The ideal time to obtain meaningful scour depth recordings is during flood flows. However, high velocities, turbulent flow, floating debris, increased water depths and murky water make detecting and

measuring scour during floods both difficult and dangerous. Chapter 9 of [HEC 23](#) discusses instruments and techniques for measuring scour.

The following are commonly used methods of detecting and measuring scour:

1. Weighted Line – Also called a sounding line, this is the least expensive method, consisting of a cable with a lead weight at one end marked at set intervals for measuring depth.
2. Rod measurements.
3. Sonar or electronic sounding devices. Mobility of this type of equipment makes its use very advantageous.
4. Wet-suit divers.
5. Soil boring of streambed. From the soil profile, an indication of degradation, aggregation, stream shifting, and filling of scour holes may be determined by the various soil types and layers present. This method may indicate the maximum depth of scour that has occurred at a site.
6. Comparison of channel cross-sections and aerial photography taken at different intervals in time can aid in the determination of the amount and rate of plan form scour.
7. Streambed profiles taken at different time intervals.

As mentioned earlier, scour measurements during floods are difficult. Almost all of the methods listed above cannot be utilized during flood conditions.

11-006 Scour Monitoring

Scour monitoring are activities used to facilitate early identification of potential scour problems. Bridges are usually inspected biennially however more frequent inspections and specific concerns can be addressed in the Plan of Action. Monitoring could also consist of a continuous survey of the scour progress around a bridge foundation by utilizing a fixed monitoring device. The Plan of Action outlines the details of the devices to be used, the frequency for review of data and identification who is conducting the review. Monitoring allows for action to be taken before the safety of the public is threatened by the potential failure of a bridge, based on an elevation determined from the scour evaluation study called the Scour Critical Criteria.

The Plan of Action may outline monitoring activities to take place during an actual flood event. This may be a visual inspection for movement or settlement of the bridge or use of instrumentation to measure scour or water elevation. If a threshold is reached and action is required, the Plan of Action states the action to be taken and the agency, department, position, or person responsible for taking that action.

11-007 Selecting Countermeasures

The functions of countermeasures installed separately at or near a structure are to correct, prevent or control the causes and resulting effects of scour or channel degradation. In many

situations more than one countermeasure may be suitable for use in dealing with a particular scour problem. The following items should be considered in determining what type of countermeasure to use:

1. The function the countermeasure is required to perform – corrective, preventive or control.
2. Relative costs of different countermeasures.
3. Amount of damage a countermeasure is expected or able to sustain in performing its function that would make it acceptable to use.
4. Any unwanted effects, such as inducing new or additional scour at another location, that may occur as a result of installing the countermeasure.
5. The type and frequency of maintenance problems that are associated with a particular countermeasure.

This chapter provides only an outline and a brief discussion of countermeasures and their use. Refer to the [HEC-23](#) manual for further guidance. A wide variety of countermeasures have been used to control channel instability and scour at bridge foundations. The countermeasure matrix¹, presented in Table 2.1 of [HEC-23, Volume 1](#), is organized to highlight the four main groups of countermeasures and identify their individual characteristics. The four main types of countermeasures (hydraulic, structural, biotechnical and monitoring) are grouped based on their functionality with respect to scour and stream instability. The left column of the matrix lists types of countermeasures in groups. In each row of the matrix, distinctive characteristics of a particular countermeasure are identified. The matrix identifies most countermeasures used by DOTs and lists information on their functional applicability to a particular problem, their suitability to specific river environments, the general level of maintenance resources required and which states have experience with specific countermeasures. Finally, a reference source for design guidelines is noted, where available.

Several factors must be considered when selecting a countermeasure. Some of these factors are erosion or scour mechanism, stream characteristics, construction and maintenance requirements, potential for vandalism, and costs. Effectiveness in resolving the erosion or scour problem however is perhaps the most important factor to consider.

New construction should integrate features into the design to minimize the potential for scour. Some existing applications are better addressed by certain countermeasures.

1. **Bank stabilization and meander migration:** bank revetments, spurs, bendway weirs, longitudinal dikes, vane dikes, bulkheads, and channel relocations.
2. **Channel braiding and anabranching:** dikes, guide bank at bridge abutments, revetment on highway fill slopes, and spurs to constrict flow to one channel
3. **Stream degradation:** check dams, drop structures, cutoff walls, drop flumes, longitudinal rock toe-dikes to provide toe protection of steepening banks, and design of deeper bridge foundations.

4. **Stream aggradation:** channelization, debris basins, bridge modification, and maintenance through dredging and clearing of deposited material.
5. **Contraction scour at bridges:** longer bridges, relief bridges on the floodplain, superstructures at elevation above flood stages of extreme events, crest vertical profile on approach roadways for overtopping, elevation of bridge low beam, piers located outside of main channel, revetment on channel banks and slopewalls, and spurs and guide banks on upstream side.
6. **Local scour at bridges:** (1) Abutments: deep foundations or in rock, revetments and riprap, and guide banks at abutments. (2) Piers: deep foundations or in rock, pier shape and orientation to flow, webwalls to eliminate debris collection between columns, riprap, partially grouted riprap, geotextile sand containers, and sheet piling.

The goal in any countermeasure design is to achieve a response which is beneficial to the protection of the highway crossing and to minimize adverse effects either upstream or downstream of the highway crossing. Countermeasures must be inspected periodically after floods to check performance and modify the design, if necessary.¹

11–100 HYDRAULIC COUNTERMEASURES

Hydraulic countermeasures are organized into two groups. River training structures are those primarily designed to modify the flow. Armoring countermeasures resist erosive forces caused by the flow. The performance of hydraulic countermeasures is dependent upon design considerations such as filter requirements and edge treatment, which are discussed in Sections 5.2 and 5.4 of [HEC 23](#).

11-101 River Training Structures

River training structures modify stream flow to mitigate undesirable erosional and/or depositional conditions at a particular location in a river reach. River training structures can be constructed of various material types and are not distinguished by their construction material, but by their orientation to flow. These structures are described as transverse, longitudinal, or areal depending on their orientation to the stream flow.

11-101.01 Transverse Structures

Transverse Structures are countermeasures which project into the flow field at an angle or perpendicular to the direction of flow.

11-101.011 Spurs

A spur can be a pervious or impervious structure projecting from the streambank into the channel. Spurs are used to deflect flowing water away from or to reduce flow velocities in critical zones near the streambank, to prevent erosion of the bank and to establish a more desirable channel alignment or width. The main function of a spur is to reduce flow velocities near the bank, which in turn, encourages sediment deposition due to the reduced velocities. Increased protection of banks can be achieved over time, as more sediment is deposited behind the spurs. Because of this, spurs may protect a streambank more effectively and at less cost than revetments. Furthermore, by moving the location of any scour away from the bank, partial failure of the spur can often be repaired before damage is done to structures along and across the stream.

Spurs are generally used to halt meander migration at a bend. They are also used to channelize wide, poorly defined streams into well-defined channels. The use of spurs to establish and maintain a well-defined channel location, cross section, and alignment in braided streams can decrease the required bridge lengths and consequently the cost of bridge construction and maintenance.

Spur types are classified by their permeability as retarder spurs, retarder/deflector spurs, and deflector spurs. The permeability of spurs is defined simply as the percentage of the spurs which function by diverting the primary flow currents away from the bank. Retarder/deflector spurs are more permeable and function by retarding flow velocities at the bank and diverting flow away from the bank. Retarder spurs are highly permeable and function by retarding flow velocities near the bank. Design Guideline 2 in [HEC-23](#) provides detailed information on design and installation of spurs.

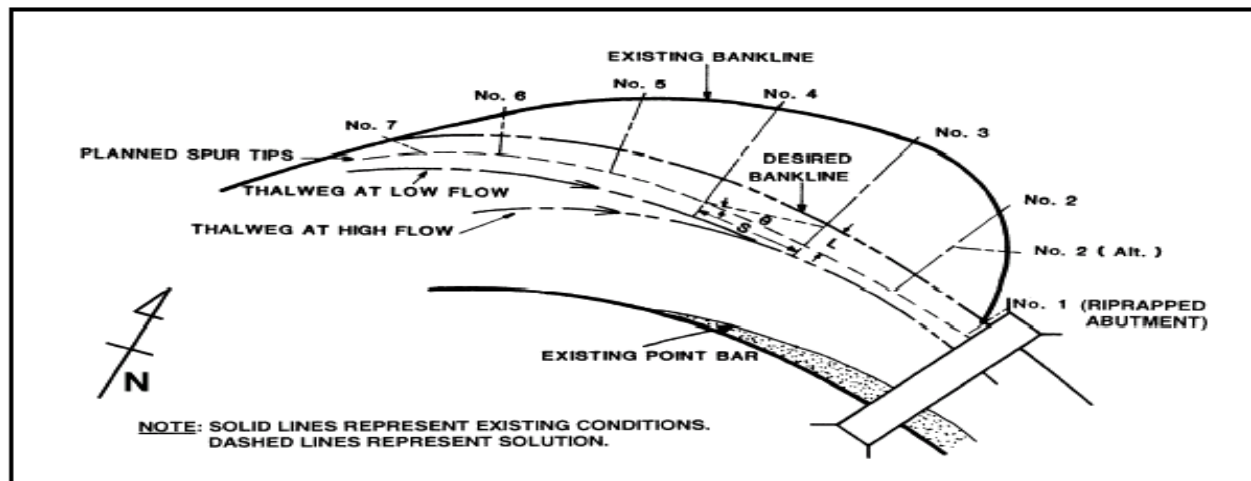

Figure 11-101.011¹
Example of spur design

11-101.012 Transverse Dikes

A transverse dike is a linear structure or spur that projects into a stream channel from the bank for the purpose of altering flow direction by establishing a pre-determined flow direction, inducing deposition, or reducing the flow velocity along the bank.

11-101.013 Bendway Weirs/Stream Barbs

Bendway weirs, also referred to as stream barbs, bank barbs and reverse sills, are low elevation stone sills used to improve lateral stream stability and flow alignment problems at river bends and highway crossings. Bendway weirs are used for improving inadequate navigation channel width at bends on large navigable rivers but are used more often for bankline protection on streams and smaller rivers. The stream barb concept was first introduced in the Soil Conservation Service (now the Natural Resource Conservation Service, NRCS) by Reichmuth³ who has applied these rock structures to many streams in the western United States.

The design concept and appearance of a bendway weir is similar to a stone spur but has significant functional differences. Spurs are typically visible above the flow line and are designed such that flow is either diverted around the structure, or the flow along the bank is reduced as it passes through the structure. Bendway weirs are normally not visible, especially at stages above low water, and are intended to redirect flow by utilizing weir hydraulics over the structure. Flow passing over the bendway weir is redirected so that it passes perpendicular to the axis of the weir and is directed toward the channel centerline. Similar to stone spurs, bendway weirs reduce the velocity of flow near banks, reduce the concentration of currents on the outer bank, and can produce a better alignment of flow through the bend and downstream crossing. Experience with bendway weirs has indicated that the structures do not perform well in degrading or sediment deficient reaches. In Illinois, bendway weirs are constructed from stone, typically during low flow periods for the affected river. Construction methods will vary depending on the size of the river. Design Guideline 1 in [HEC 23](#) gives detailed information on design of bendway weirs.

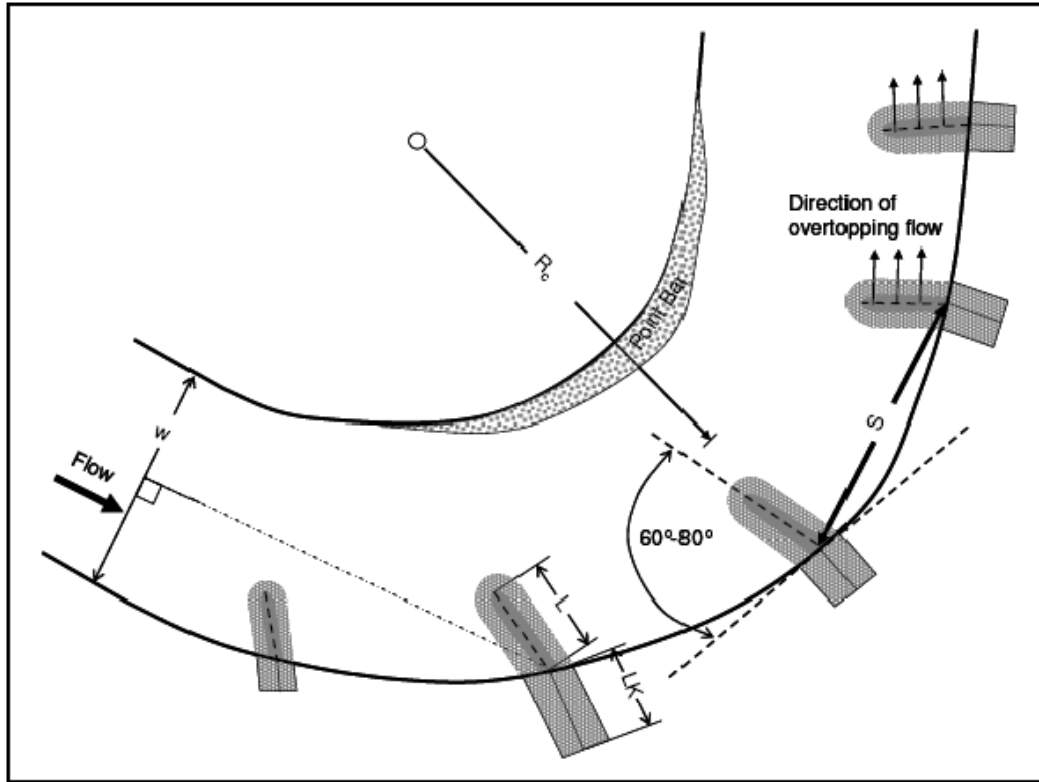

Figure 11-101.013a¹
Bendway Weir typical plan view

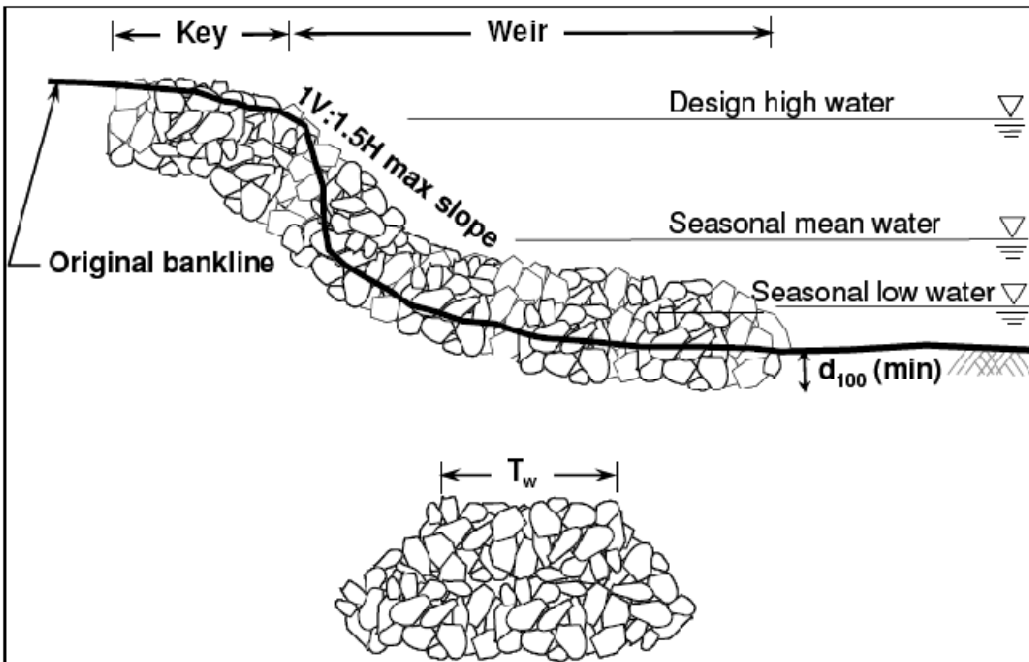

Figure 11-101.013b¹
Bendway Weir typical cross section

11-101.014 Drop Structures (Check Dams/Grade Control)

A check dam or channel drop structure is a low dam, or weir, constructed across a channel for the control of water stage or velocity. It is used downstream of highway crossings to arrest head cutting and maintain a stable streambed elevation in the vicinity of the bridge. Check dams are usually built of rock riprap, concrete, sheet pile, gabions, or treated timber piles. The materials used to construct the structure depend on the availability of materials, the height of drop required, and the width of the channel. Rock riprap and timber pile construction has been most successful on channels having small drops and widths less than 100 ft. Sheet piles, gabions, and concrete structures are generally used for larger drops on channels with widths up to 300 ft. Check dam location with respect to the bridge depends on the hydraulics of the bridge reach and the amount of headcutting or degradation anticipated.

Check dams can initiate erosion of banks and the channel bed downstream of the structure as a result of energy dissipation and turbulence at the drop. This local scour can undermine the check dam and cause failure. The use of energy dissipaters downstream of check dams can reduce the energy available to erode the channel bed and banks. In some cases it may be better to construct several consecutive drops of shorter height to minimize erosion. Concrete lined basins may also be used.

Lateral erosion of channel banks just downstream of drop structures is another adverse result of check dams and is caused by turbulence produced by energy dissipation at the drop, bank slumping from local channel bed erosion, or eddy action at the banks. Bank erosion downstream of check dams can lead to erosion of bridge approach embankments and abutment foundations if lateral bank erosion causes the formation of flow channels around the ends of check dams. The usual solution to these problems is to place riprap revetment on the streambank adjacent to the check dam. The design of riprap is given in Highways in the River Environment (HIRE), [Hydraulic Engineering Circular 11 \(HEC 11\)](#) Design of Riprap Revetment, and USACE (see [HEC 23](#) Design Guideline 4 also).

Erosion of the streambed can also be reduced by placing rock riprap in a preformed scour hole downstream of the drop structure. A row of sheet piling with the top set at or below streambed elevation can keep the riprap from moving downstream. Because of the problems associated with check dams, they should be designed to resist scour by providing for dissipation of excess energy and protection of areas of the bed and the bank which are susceptible to erosive forces. Additional information can be found in Design Guideline 3 of [HEC-23](#).

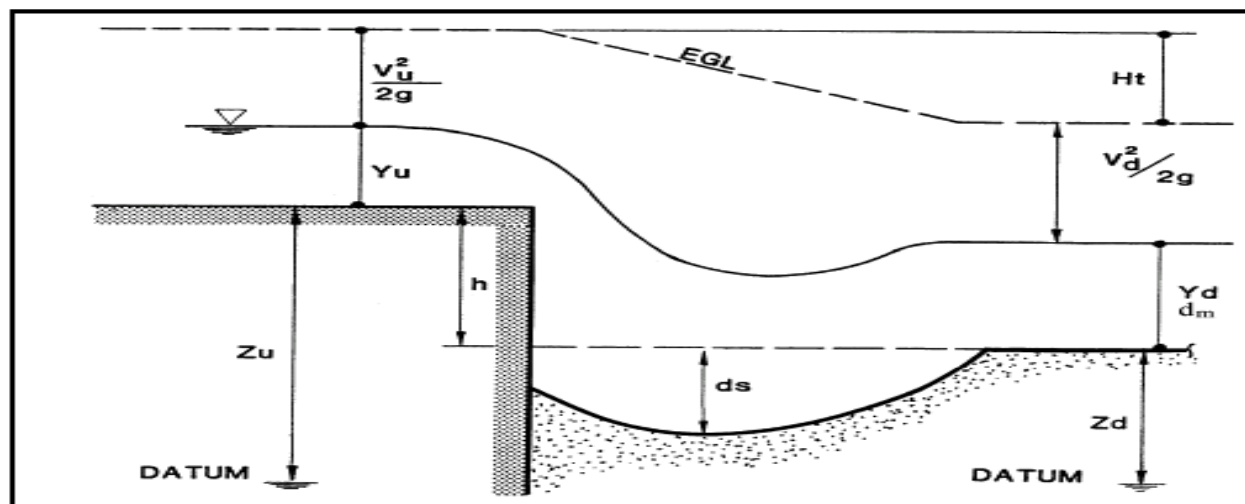

Figure 11-101.014¹
Schematic of a vertical drop caused by a check dam

11-101.02 Longitudinal Structures

Longitudinal river training structures are countermeasures which are oriented parallel to the flow field or along a bankline.

11-101.021 Longitudinal Dike

A longitudinal dike is a permeable or impermeable linear structure located in a channel. It is constructed parallel with the bank usually at the toe of the bank for the purpose of reducing flow velocity, inducing deposition, or to maintain an existing alignment of flow.

11-101.022 Dike

A dike is an impermeable linear structure constructed in the floodplain for the control or containment of overbank flow. Dikes function as a countermeasure by confining channel widths, maintaining channel alignment and by directing or diverting overbank flow in a predetermined direction. Dikes are similar in function to spur dikes at bridge sites, except dikes are usually much longer in length and extend upstream from one or both sides of the bridge opening.

11-101.023 Guide Bank

A guide bank (also referred to as a spur dike) is a straight or outward-curving structure that extends upstream from the approach embankment at either or both sides of a bridge opening, for the general purpose of directing flow through the opening. When embankments encroach on wide flood plains, the flows from these areas must flow parallel to the approach embankment of the bridge opening. These flows can erode the approach embankment. A severe flow contraction at the abutment can reduce the effective bridge opening, which could increase the severity of abutment and pier scour. Guide banks can be used in these cases to prevent erosion of the approach embankment by cutting off the flow adjacent to the

embankment, guiding streamflow through a bridge opening and transferring scour away from abutments to prevent bridge damage caused by abutment scour. The two major enhancements guide banks bring to bridge design are:

1. reduce the separation of flow at the upstream abutment face,–thereby making use of the total bridge waterway area, and
2. reduce abutment scour by decreasing turbulence at the abutment face.

Guide banks can be used on both sand and gravel bed streams. The principle factors to be considered when designing guide banks are their orientation to the bridge opening, plan shape, upstream & downstream length, cross-sectional shape and crest elevation.

Figure 11-101.023 presents a typical guide bank plan view. It is apparent from the figure that without this guide bank, overbank flows would return to the channel at the bridge opening, which can increase the severity of contraction and scour at the abutment. Note, that with the installation of guide banks, the scour holes which would normally occur at the bridge abutments are moved upstream and away from the abutments. Guide banks may be designed at each abutment as shown, or at a single abutment, depending on the amount of overbank or flood plain flow directed to the bridge by each approach embankment.

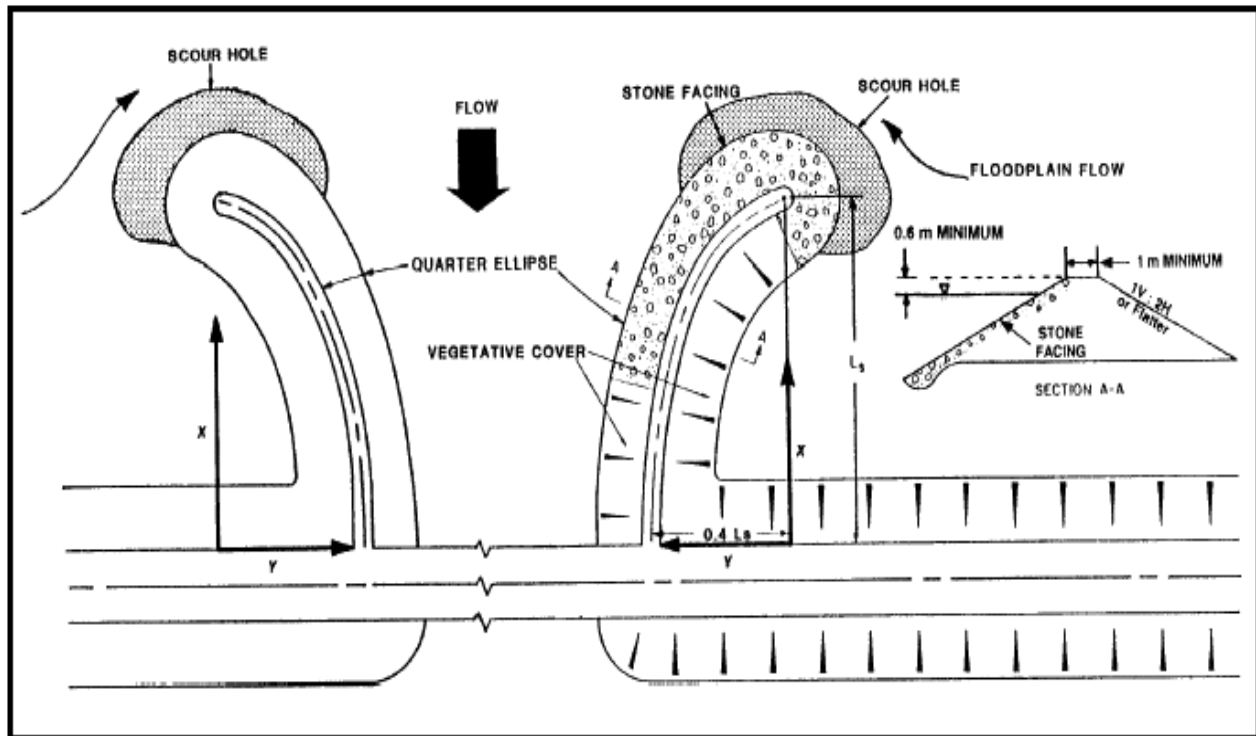

Figure 11-101.023⁴
 Typical guide bank (modified from Bradley)

The goal in the design of a guide bank is to provide a smooth transition and contraction of the streamflow through the bridge opening. Ideally, the flow lines through the bridge opening should be straight and parallel. As with other

countermeasures, the designer should consider the principles of river hydraulics and morphology, and exercise sound engineering judgment. Refer to Design Guideline 15 of [HEC 23](#) for design procedures.

11-101.03 Areal Structures/Treatments

Areal river training structures are countermeasures which cannot be described as transverse or longitudinal when acting as a system. This group also includes countermeasure “treatments” which have areal characteristics, such as channelization, flow relief and sediment detention.

11-101.031 Jack or Tetrahedron Field

A jack is a device that generally has six mutually perpendicular arms rigidly fixed at the center and strung with wire. It is used for flow control and protection of banks against lateral erosion. Jacks may be constructed from steel struts or reinforced concrete.

11-101.032 Channelization

Realignment of the channel for the purpose of altering the flow pattern as it impacts a structure or channel bank may be a solution to the cause of a scour problem. This countermeasure may include the removal of material in the channel such as a sand bar deposit for the purpose of redirecting the flow.

11-101.033 Flow Relief

The addition of spans to a bridge may be used as a countermeasure for the purpose of increasing the waterway opening thereby reducing flow velocities or altering the flow pattern. Raising of the bridge superstructure can be used to increase clearance above highwater in order to prevent debris from lodging on bridge. Another countermeasure in the form of flow relief is modifying the roadway approach embankment to provide for an overflow section that allows for overtopping of the roadway by flood flows. This countermeasure functions most effectively when the depth of overflow at any point along the roadway embankment is minimized. In order to obtain this countermeasure, consideration must be given to protecting the slopes of the embankment, especially the downstream shoulder of the roadway embankment, from erosion. The acceptability of this countermeasure is a function of the traffic volume and desired level of service of the roadway. Construction of a new bridge or culvert overflow structure may be the most expensive but only feasible countermeasure that will function in a particular situation.

11-102 Armoring Countermeasures

Armoring countermeasures resist the erosive forces caused by a hydraulic condition. They do not necessarily alter the hydraulics of a reach, but act as a resistant layer to hydraulic shear stress, providing protection to the more erodible materials underneath. Armoring countermeasures generally do not vary by function, but vary in material type. Armoring countermeasures are classified by two functional groups: revetments and bed armoring or local scour armoring.

Revetments and bed armoring protect the channel bank and/or bed by placement in a blanket

fashion for areal coverage. Revetments and bed armoring can be classified as either rigid or flexible/articulating. Rigid revetments and bed armoring are typically impermeable and do not have the ability to conform to changes in the supporting surface. These countermeasures often fail due to undermining. Flexible/articulating revetments and bed armoring can conform to changes in the supporting surface and adjust to settlement. These countermeasures often fail by removal and displacement of the armor material.

Local scour armoring is used to protect specific individual substructure elements of a bridge from local scour. Generally, the same material used for revetments and bed armoring is used for local armoring, but these countermeasures are designed and placed to resist local velocities created by flow obstructions.

11-102.01 Rigid Revetments and Bed Armor

11-102.011 Concrete Slopewall

Concrete pavement or concrete slopewall consists of four-inch thick concrete reinforced with welded-wire mesh. Concrete anchor walls are usually placed at the top, center and toe of the slopewall. Concrete pavement is an effective countermeasure, if it is thoroughly protected from undermining, especially at the toe and ends.

11-102.012 Rigid Grout Filled Mattress/Concrete Fabric Mat

This type of countermeasure consists of porous, pre-assembled geotextile fabric forms, envelopes or bags which are placed on the surface to be protected and then filled by injection with a high strength mortar or grout. Measures need to be taken to protect the mat against undermining, especially at the toe. Manufacturers should also supply the appropriate Manning's n resistance coefficient for each product. Grout filled mat systems can range from very smooth, uniform surface conditions approaching cast in place concrete in terms of surface roughness, to extremely irregular surfaces exhibiting substantial projections into the flow, resulting in boundary roughness approaching that of moderate size rock riprap.

11-102.013 Fully Grouted Riprap

This type of countermeasure consists of a layer of stone riprap with the spaces between the individual stones filled with a concrete mortar. This type of riprap protection allows for the use of smaller stone and total revetment thickness compared to rock riprap. Construction procedures and specifications in the use of concrete-grouted riprap can be found in the AASHTO Standard Specification for Highway Bridges.

11-102.02 Flexible Revetments or Bed Armor

Flexible revetments include rock riprap, partially grouted rock riprap, rock-and-wire mattresses, gabions, precast articulating concrete blocks and vegetation. Rock riprap adjusts to distortions and local displacement of materials without complete failure of the revetment installation. However, flexible rock-and-wire mattress and gabions may sometimes span the displacement of underlying materials, but usually can adjust to most local distortions. Precast concrete block mattresses are generally stiffer than rock riprap

and gabions and, therefore, do not adjust well to local displacement of underlying materials. References for design guidelines of flexible revetments depend on the type of flexible revetment being used.

11-102.021 Rock Riprap

Riprap, as discussed in this section, is defined as a flexible channel or bank lining consisting of a well-graded mixture of angular rock usually dumped in place. Other types of riprap are “hand-placed” and “keyed or plated” riprap. Hand-placed riprap is carefully placed by hand or a mechanized manner in a definite pattern with voids between the large stone being filled with smaller rock. Plated riprap is placed on the bank with a skip loader tamped into place using a heavy steel plate leaving a smoother surface than dumped riprap. See [HEC 11](#) for more information on each of these types.

Dumped riprap does not mean end dumping from trucks and allowing the material to roll down the slope which can cause size segregation, but instead means the riprap is placed in a manner to prevent segregation by using a crane with a bucket or dragline. Regardless of how it is placed, care should be taken to prevent segregation of the rock mixture. Dumped riprap should form a layer of loose stone where individual stones may move independently to adjust to the movement of the bank material being protected. This minor movement may occur without complete failure of the installation and allows the riprap to be somewhat “self healing” and is one of the main advantages of dumped rock riprap.

Dumped riprap should also be placed on a bank with a benched flat area partway up the slope to allow for protection if the toe should fail. As the bank undercuts, the riprap on the benched flat area will launch into place at the rate at which the toe is eroding.

Riprap is a very effective countermeasure when the area riprapped is of adequate size (length, width, and depth), the riprap is of suitable gradation, and has been installed properly. Stone bedding or a filter blanket is required to prevent erosion of the ground through the interstices of the riprap. Construction procedures and specifications in the use of rock riprap can be found in the [Illinois Department of Transportation's Standard Specifications for Road and Bridge Construction](#) Sections 281 and 282, and standard gradations found from the equivalent weight of riprap particle in Section 1005.01c. Refer to Design Guideline 4 of [HEC-23](#) for sizing and proper placement of riprap revetment.

[Table 11-102.021](#) lists the minimum classes of stone that may be specified on the plans for various construction uses. The class designation represents both a quality (A or B) and a gradation (RR 3, RR 4, RR 5, RR 6, or RR 7) which are defined in Article 1005.01 of the [Standard Specifications](#). The choice of stone gradation shall be based upon hydraulic analysis.

Purpose	Construction Use	Classes	
Erosion Protection: Erosion Scour Stream	Chute Liner	A4, A5, A6, A7	
	Ditch Check	B3, B4	
	Ditch Lining	B3, B4, B5	
	Slope Protection (sheet flow only)	B3, B4	
	Abutment and Pier Protection	A4, A5, A6, A7	
	Outlet Protection: Continuous flow		A3, A4, A5, A6, A7
		Intermittent flow	B3, B4, B5, B6, B7
	Slope Protection	A3, A4, A5, A6, A7	
	Wave Action Protection	A3, A4, A5, A6, A7	
	Riffles	B3, B4, B5	
	Stilling Basin	A4, A5, A6, A7	
	Stream Bank and Bottom Protection	A3, A4, A5, A6, A7	
	Wing Dam	A3, A4, A5, A6, A7	
Sediment Control	Sediment Basin	B1, B2, B3, B4, B5	
Rockfill	Rockfill (Material is used only to fill voids. No erosion protection or sediment control is desired.)	N/A ^{1/}	

^{1/}Rockfill may be shot rock, primary crusher run, or other designated products as approved by the Department.

*Table 11-102.021
Riprap Quality and Gradation*

11-102.022 Gabions/Gabion Mattress

Wire-enclosed rock, or gabion, revetments consist of rectangular wire mesh baskets filled with rock. These revetments are formed by filling pre-assembled wire baskets with rock, and anchoring to the channel bottom or bank (See [IDOT Standard Specifications](#) Section 284). Failure of the wire mesh resulting in the spilling out of the riprap is not uncommon. However the wire mesh allows the gabions to deform and adapt to changes in the subgrade while maintaining stability. Additionally, when compared to riprap, less excavation of the bed is required and smaller, more economical stone can be used. Wire-enclosed rock revetments are generally of two types distinguished by shape:

1. Slope mattresses: In mattress designs, the individual wire mesh units are laid end to end and side to side to form a mattress layer on the channel bed or bank. The gabion baskets comprising the mattress generally have a depth dimension which is much smaller than their width or length.
2. Block gabions: These are, on the other hand, more equidimensional, having depths that are approximately the same as their widths, and of the same order of magnitude as their lengths. They are typically rectangular or trapezoidal in shape. Block gabion revetments are formed by stacking the individual gabion blocks in a stepped fashion.

As revetments, wire-enclosed rock has limited flexibility. They will flex with bank surface subsidence; however, if excessive subsidence occurs, the baskets will span

the void until the stress in the wire strands exceed their tensile strength at which point, the baskets will fail.

Geotextile filters are most commonly used with gabion mattresses in dry conditions. For placement under water, sand-filled geotextile containers made of nonwoven needle punched fabric are particularly effective.

Besides its use as a general bank revetment, wire-enclosed rock in the form of either mattresses or blocks can be used alone as bank toe protection or with some other type of bank revetment protection.

The most common observed failure mechanism of wire basket revetments has been failure of the wire. To avoid this type of failure and washing away of the enclosed rock, it is recommended that wire-enclosed rock revetments not be used on lower portions of the channel bank in environments subject to significant abrasion or corrosion.

An additional failure mechanism has been observed when the wire basket units are used in high-velocity, steep-slope environments. Under these conditions, the rock within individual baskets shift downstream, deforming the baskets as the material moves. The movement of the material within the individual baskets will sometimes result in exposure of filter or base material. Subsequent erosion of the exposed base material can cause failure of the revetment system. For further guidance on placement and design of gabions and gabion mattresses, see Design Guideline 10 of [HEC-23](#).



Fig. 11-102.022¹
Field installation of gabion mattress on streambank

11-102.023 Wire Enclosed Riprap Mattress

Wire enclosed riprap mattress differs from gabions and gabion mattresses in that it is a continuous framework rather than individual interconnected baskets. Steel stakes driven through the mattress anchor it to the embankment. Wire enclosed riprap mattress is used primarily for slope protection, and can be used in conjunction with gabions placed at the toe of slope. Integrity of the wire and protection against corrosion determines the success of this type of countermeasure. For more detailed guidance on wire enclosed riprap mattress see Design Guideline 6 of [HEC-23](#).



*Fig. 11-102.023¹
Wire enclosed riprap used for slope protection*

11-102.024 Precast Block Revetment Mats/Articulated Block Mats

Articulated concrete block systems (ACB's) provide a flexible alternative to riprap, gabions and rigid revetments. These systems consist of preformed units which interlock, are held together by steel rods or cables, or abut together to form a continuous blanket or mat.

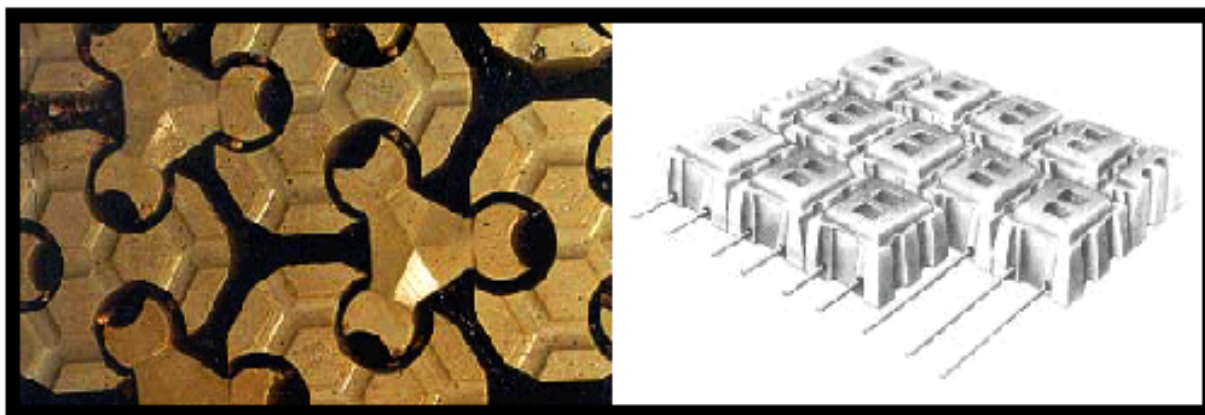

*Figure 11-102.024¹
Articulated block mat/precast block revetment mat*

These systems are typically used for revetments and channel armoring where the mat is placed across the entire channel width and keyed into the abutments or bank protection. Specifications and design guidelines for installation and anchoring of

ABC's are documented in [HEC 11](#) and Design Guideline 8 of [HEC-23](#) (also see [IDOT Standard Specifications for Road and Bridge Construction](#) Section 285). Based upon hydraulic analysis, the designer must specify the following information on plans prepared for IDOT:

Precast Block Revetment Mat

- The size and mass(weight) of the blocks.
- Whether the configuration of the blocks is interlocking or non-interlocking.
- Whether the configuration of the mat is open-cell(has voids) or closed-cell(solid surface).

Articulated Block Revetment Mat

- The size and mass(weight) of the blocks.
- The frequency and depth of mat anchors.
- Whether the configuration of the mat is open-cell(has voids) or closed-cell(solid surface).

Based upon aesthetics, the designer must decide if the finished mat is to be seeded. A suitable filter layer beneath the blocks and in some cases a drainage layer of granular or synthetic material are considered to be an integral component of the overall system.

11-102.025 Concrete/Grout Mattress

Concrete grout mattress is comprised of a double layer of strong synthetic fabric, typically woven nylon or polyester, sewn into a series of pillow-shaped compartments that are connected internally by ducts. The compartments are filled with a concrete grout that flows from compartment to compartment via the ducts. When set, the grout forms a mat made up of a grid of interconnected blocks. Because this type of revetment is fairly specialized, comprehensive technical information on specific mat types and configurations is available from a number of manufactures. Grout mattress revetment is typically used for bridge abutment spill slopes and channel armoring across the entire channel width and keyed into bridge abutments or stream banks. See Design Guideline 9 from [HEC-23](#) for more guidance on the design and installation of concrete/grout mattress.

11-102.026 Partially Grouted Riprap

Partially grouted riprap consists of specifically sized rocks that are placed and grouted together, with the grout filling only 1/3 to 1/2 of the total void space. In contrast to fully grouted riprap, partial grouting increases the overall stability of the riprap installation unit without sacrificing flexibility or permeability. Partially grouted riprap may be used for bank protection as well as a scour countermeasure at piers and abutments, and can be place under water or in the dry. A filter layer, consisting of either a geotextile fabric or a filter of sand and/or gravel, allows for infiltration and exfiltration to occur while providing particle retention. Further information on the design and placement of partially grouted riprap can be found in Design Guideline 12 of [HEC-23](#).

11-102.03 Local Scour Armoring

Local scour armoring is used specifically to protect individual substructure elements of a bridge from local scour. Generally, the same material used for revetments and bed armoring is used for local scour armoring, but these countermeasures are designed and placed to resist local vortices created by obstructions to the flow.

11-102.031 Rock Riprap at Piers and Abutments

The FHWA continues to evaluate how best to design rock riprap at bridge piers and abutments. Present knowledge is based on research conducted under laboratory conditions with little field verification, particularly for piers. If flow turbulence and velocities around a pier are of sufficient magnitude, then large rocks will move over time. Bridges have been lost (Schoharie Creek bridge) due to the removal of riprap at piers resulting from turbulence and high velocity flow. Usually this does not happen during one storm, but is the result of the cumulative effect of a sequence of high flows. Therefore, if rock riprap is placed as scour protection around a pier, the bridge should be monitored and inspected during and after each high flow event to insure stability of the riprap.

- **Sizing Rock Riprap at Piers:** As a countermeasure for scour at piers for existing bridges, riprap can reduce the risk of failure and in some cases could make a bridge safe from scour (see [HEC 18](#), Appendix I for additional guidance). **Riprap is not recommended as a pier scour countermeasure for new or replacement bridges** as foundations and piling shall be designed to extend below expected scour depths. Riprap around a pier should not be heaped in a pile but be placed with the top at or below the elevation of the streambed to minimize maintenance and replacement of stones washed downstream.

Determine the D_{50} size of riprap for use at bridge piers by using the rearranged Isbash equation to solve for stone diameter (in feet, for fresh water)¹:

$$d_{50} = \frac{0.692(V_{des})^2}{(S_g - 1)2g} \tag{Eq. 11-1}$$

where:

- d_{50} = Median stone diameter, ft
- V_{des} = Design velocity on pier, ft/sec
- S_g = Specific gravity of riprap (normally 2.65)
- g = 32.2 ft/sec²

The velocity used in Eq. 11-1 should be representative of conditions in the immediate vicinity of the bridge pier including the constriction caused by the bridge. To determine V , multiply the average channel velocity (Q/A) by factors that are a function of the shape of the pier and its location in the channel:

$$V_{des} = K_1 K_2 V_{avg} \tag{Eq. 11-2}$$

If a velocity distribution is available from stream tube or flow distribution output of a 1-D model or directly from a 2-D model, then only the pier shape coefficient should be used. The maximum velocity in the active channel V_{max} is often used since the channel could shift and the highest velocity could impact any pier.

$$V_{des} = K_1 V_{max} \tag{Eq. 11-3}$$

where:

- V_{des} = Local velocity at pier, ft/sec
- K_1 = Shape factor equal to 1.5 for round-nose piers or 1.7 for square-faced piers
- K_2 = Velocity adjustment factor for location in the channel (ranges from 0.9 for a pier near the bank in a straight reach, to 1.7 for a pier located in the main current of flow around a sharp bend)
- V_{avg} = Channel average velocity at the bridge, ft/sec
- V_{max} = Maximum velocity in the active channel, ft/sec

The equivalent weight of the stone particle based on the diameter is defined by the following relationship.

$$W = 0.85(\gamma_s d^3) \tag{Eq. 11-4}$$

where:

- W = Weight of stone, lb
- γ_s = Density of stone, lb/ft³
- d = Diameter of stone, ft

$$\gamma_s = S_g \gamma_w \tag{Eq. 11-5}$$

where:

- S_g = specific gravity of riprap
- γ_w = density of water, lb/ft³

After determining the weight of riprap particle the standard gradation can be selected from the tables presented in Article 1005.01c of [IDOT's Standard Specifications for Road and Bridge Construction](#). Layout of the riprap and filter should follow these guidelines:

1. Provide a riprap mat width which extends horizontally at least 2 times the width of the pier¹ or 10 feet, whichever is greater, measured from the pier face.

An alternate to 2 times the width of the pier is using the top width of the scour hole in cohesionless bed material from one side of a pier or footing estimated from the following equation in [HEC 18 Chapter 6.8²](#).

$$W = y_s (K + \text{Cot}\theta) \quad (\text{Eq. 11-6})$$

where:

W	=	Topwidth of the scour hole from each side of the pier or footing, ft
y_s	=	Scour depth, ft
K	=	Bottom width of the scour hole related to the scour depth
θ	=	Angle of repose of the bed material ranging from about 30° to 44°

2. Place the top of a riprap mat at the same elevation as the streambed. Placing the bottom of a riprap mat on top of the streambed is discouraged. In all cases where riprap is used for scour control, the bridge must be monitored and inspected after high flows.

It is important to note that it is a disadvantage to bury riprap so that the top of the mat is below the streambed because inspectors have difficulty determining if some or all of the riprap has been removed. Therefore, it is recommended to place the top of a riprap mat at the same elevation as the streambed.

- a) The thickness of the riprap mat should be three stone diameters (D_{50}) or more. In general, the bottom of the riprap blanket should be placed at or below the computed contraction scour depth. Placement of riprap under water warrants an increased thickness by 50%.
- b) A filter layer is typically required for riprap at bridge piers. The filter should terminate 2/3 of the distance from the pier to the edge of the riprap. The minimum thickness of filter should be 4 times the d_{50} of the filter stone or 6 inches, whichever is greater. The filter layer thickness should be increased by 50% when placing under water. In flowing water or for filling an existing scour hole under water, sand-filled geotextile containers provide a convenient method of controlled placement.
- c) The maximum size rock should be no greater than twice the D_{50} size.¹

- **Design Example for Riprap at Existing Bridge Piers**

Riprap is to be sized for an existing 6 ft. diameter circular pier. The velocity was determined to be 6 ft/sec using the continuity equation. The pier is located between the bank and the thalweg on a gradual bend. A velocity multiplier of 1.2 should be used to account for pier location in the channel, since the calculated value represents a cross section average. The computed contraction scour at the pier is approximately 3.9 ft.

Solution procedure:

1. Determine D_{50} and D_{max} for the riprap protection using [Equation 11-1](#):

$$d_{50} = \frac{0.692(KV)^2}{(S_g - 1)2g}$$

$$d_{50} = 0.692 \frac{[(1.5)(1.2)(6)]^2}{(2.65 - 1)(2)(32.2)} = 0.8 \text{ ft}$$

$$d_{max} = 2(0.8) = 1.6 \text{ ft}$$

2. Extent of riprap from edge of pier = $2(6) = \underline{12 \text{ ft}} > 10 \text{ ft}$
3. Depth of riprap from streambed at pier = Contraction Scour = $\underline{3.9 \text{ ft}} > 3d_{50} = 2.4 \text{ ft}$
4. Gradation of the riprap can be determined from [Equation 11-4](#) and Article 1005.01c of [IDOT's Standard Specifications for Road and Bridge Construction](#).
5. A granular or geotextile filter is recommended under the riprap layer. See Design Guidelines 11 and 16 of [HEC-23](#) for guidance in design and placement of the proper filter.

Figure [11-102.031a](#) presents the riprap placement resulting from the design. Additional guidance on riprap design at bridge piers is located in Design Guideline 11 of [HEC-23](#).

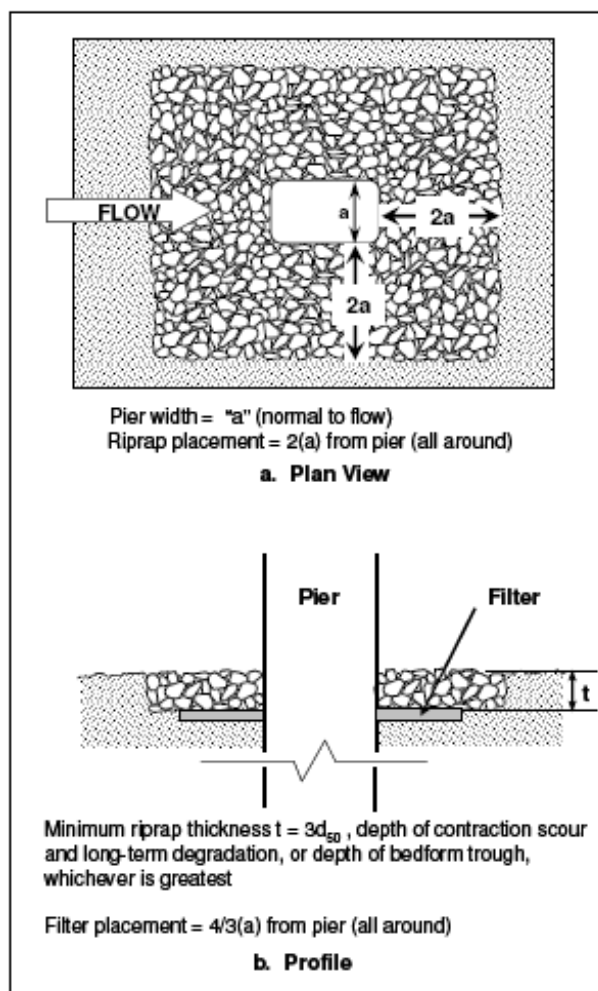

Figure 11-102.031a¹
 Placement of pier riprap

- **Sizing Rock Riprap at Abutments**

Typical spill-through abutments should follow the [IDOT Bridge Manual](#) and [Standard Specifications](#) for riprap protection. The preferred design approach is to place the abutment foundation on scour resistant rock or on deep foundations. Current practice for estimating scour depths at abutments tends to be overly conservative and engineering judgment is required in designing foundations for abutments. For known or expected problem sites, the following riprap sizing design method may be considered for new or existing spill-through abutments. The toe or apron of the riprap serves as the base for the slope protection and must be designed to resist scour while maintaining the support for the slope protection.

For Froude Numbers $(V/(gy))^{1/2} \leq 0.80$, the recommended design equation for sizing rock riprap for spill-through and vertical wall abutments is in the form of the Isbash relationship:

$$\frac{D_{50}}{y} = \frac{K}{(S_s - 1)} \left[\frac{V^2}{gy} \right] \tag{Eq. 11-7}$$

where:

- D₅₀ = Median stone diameter, ft
- V = Characteristic average velocity in the contracted section (explained below), ft/sec
- S_s = Specific gravity of rock riprap
- g = Gravitational acceleration, (32.2 ft/sec²)
- y = Depth of flow in the contracted bridge opening, ft
- K = 0.89 for a spill-through abutment
1.02 for a vertical wall abutment

For Froude Numbers > 0.80, Equation 11-8 is recommended:

$$\frac{D_{50}}{y} = \frac{K}{(S_s - 1)} \left[\frac{V^2}{gy} \right]^{0.14} \tag{Eq. 11-8}$$

where:

- K = 0.61 for spill-through abutments
0.69 for vertical wall abutments

In both equations, the coefficient K is a velocity multiplier to account for the apparent local acceleration of flow at the point of rock riprap failure. Both of these equations are envelope relationships that were forced to predict over 90% of the laboratory data.

A recommended procedure for selecting the characteristic average velocity is as follows:

1. Determine the set-back ratio (SBR) of each abutment. SBR is the ratio of the set-back length to average channel flow depth. The set-back length is the distance from the near edge of the main channel to the toe of abutment.
 - a) If SBR is less than 5 for both abutments ([Figure 11-102.031b](#)), compute a characteristic average velocity, Q/A, based on the entire contracted area through the bridge opening. This includes the total upstream flow, exclusive of that which overtops the roadway. The [HEC-RAS](#) BR Open Velocity located in the Bridge Output table is also appropriate for this step.

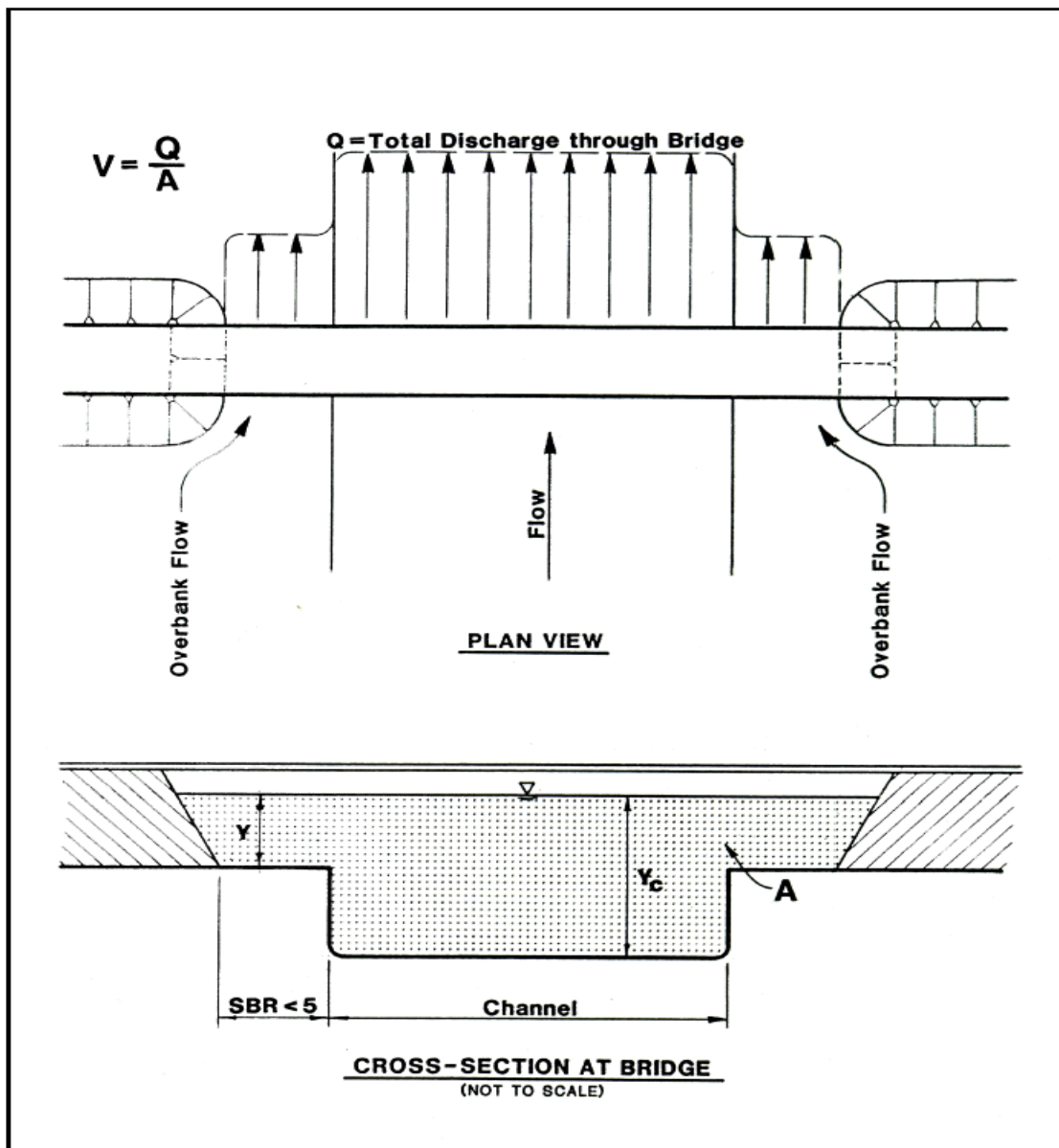

Figure 11-102.031b¹
 Characteristic average velocity for $SBR < 5$

- b) If SBR is greater than 5 for an abutment (Figure 11-102.031c), compute a characteristic average velocity, Q/A , for the respective overbank flow only. Assume that the entire respective overbank flow stays in the overbank section through the bridge opening. This overbank velocity can be found in the cross section output table in [HEC-RAS](#).

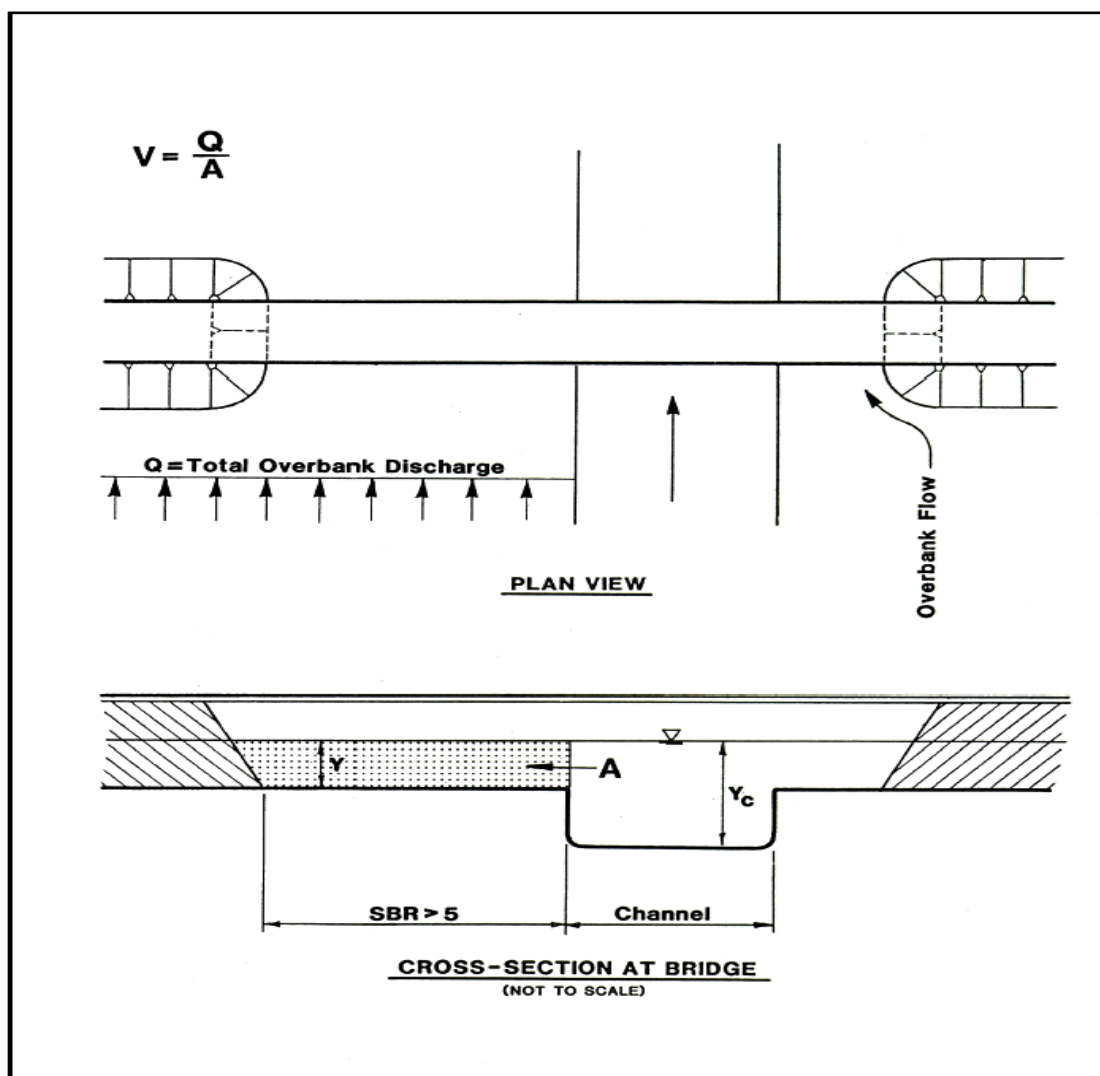

Figure 11-102.031c¹
 Characteristic average velocity for SBR > 5

- c) If SBR for an abutment is less than 5 and SBR for the other abutment at the same site is more than 5 (Figure 11-102.031d), a characteristic average velocity determined from Step 1a for the abutment with SBR less than 5 may be uncharacteristically low. This would, of course, depend upon the opposite overbank discharge as well as how far the other abutment is set back. For this case, the characteristic average velocity for the abutment with SBR less than 5 should be based on the flow area limited by the boundary of that abutment and an imaginary wall and the outer edge of the floodplain associated with that abutment.

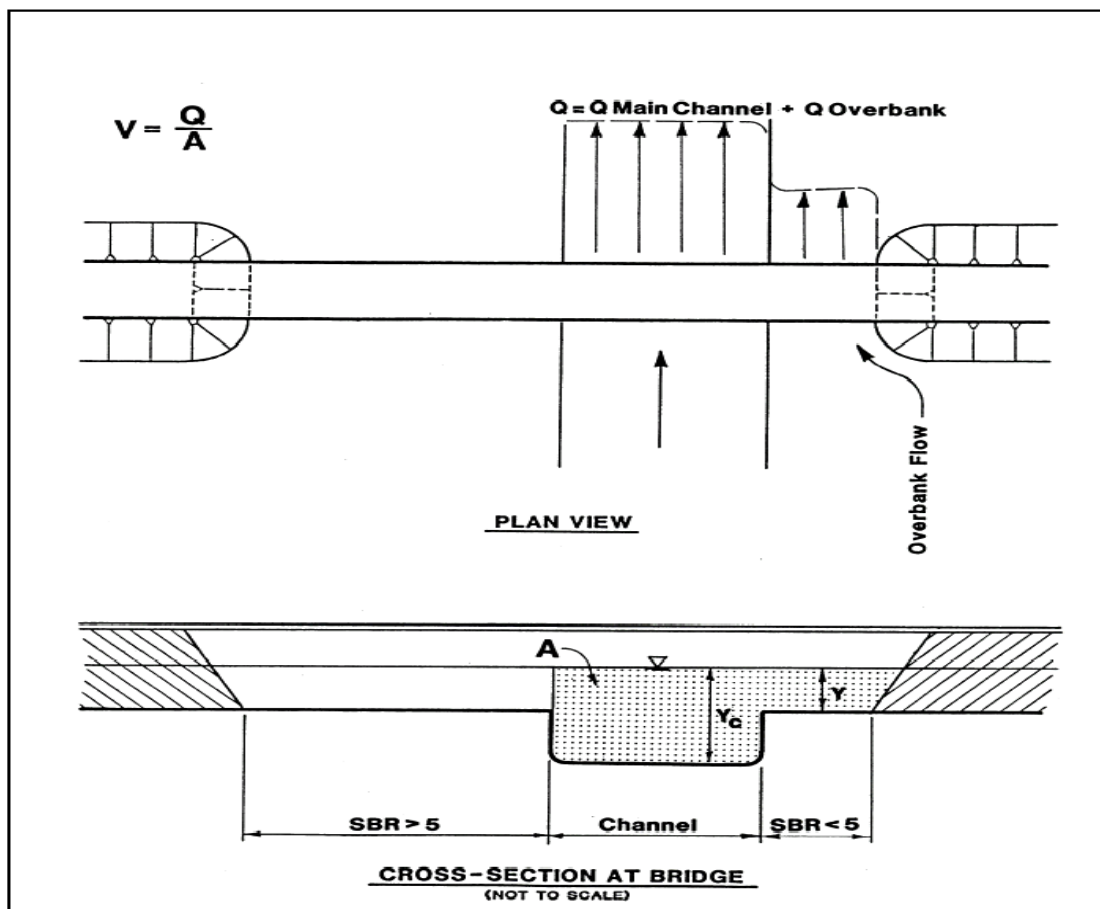

Figure 11-102.031d¹
 Characteristic average velocity for $SBR > 5$ and $SBR < 5$

2. Select characteristic average velocity when applying the SBR method using the following additional criteria.
 - a) Whenever the SBR is less than 5, the average velocity in the bridge opening provides a good estimate for the velocity at the abutment.
 - b) When the SBR is greater than 5, the recommended adjustment is to compare the velocity from the SBR method to the maximum velocity in the channel within the bridge opening and select the lower velocity.
 - c) The SBR method is well suited for estimating velocity at an abutment if the estimated velocity does not exceed the maximum velocity in the channel.
3. Compute rock riprap size based on the Froude number in [Equations 11-7](#) or [11-8](#).
4. Determine extent of rock riprap.

- a) The apron should extend from the toe of the abutment into the bridge waterway a distance equal to twice the flow depth in the overbank area near the embankment, but need not exceed 25 ft. The downstream coverage should extend back from the abutment 2 flow depths or 25 ft. whichever is larger, to protect the approach embankment (Figure 11-102.031e).

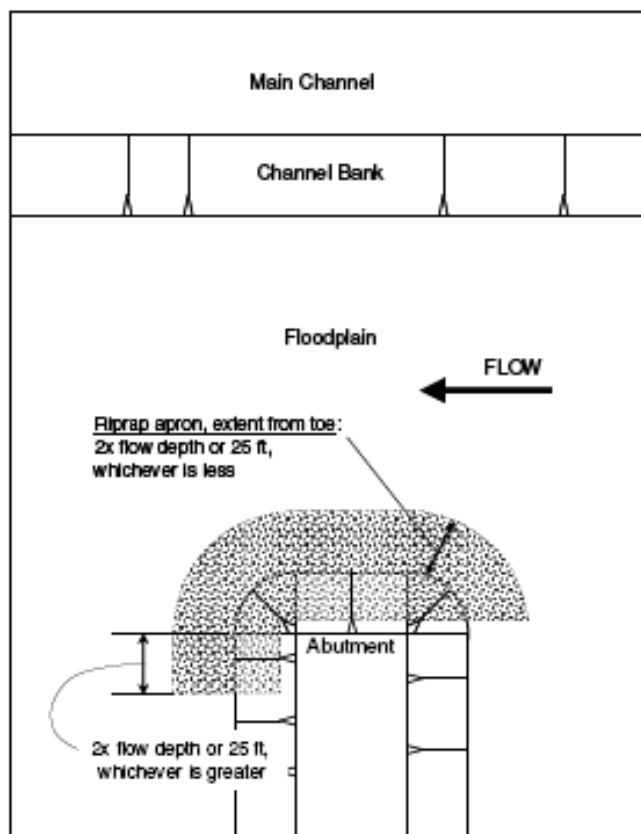

Figure 11-102.031e¹
Plan view of the extension of rock riprap apron

- b) Spill-through abutment slopes should be protected with the rock riprap size, computed from Equations 11-7 or 11-8, to an elevation 2 ft. above expected high water elevation for the design flood.¹
- c) The rock riprap thickness should not be less than the larger of either 1.5 times D_{50} or D_{100} . The rock riprap thickness should be increased by 50% when it is placed under water. The top surface of the apron should be flush with the existing grade of the floodplain⁵ to prevent blocking a significant portion of the floodplain flow depth and generating significant scour around the apron (Figure 11-102.031f).

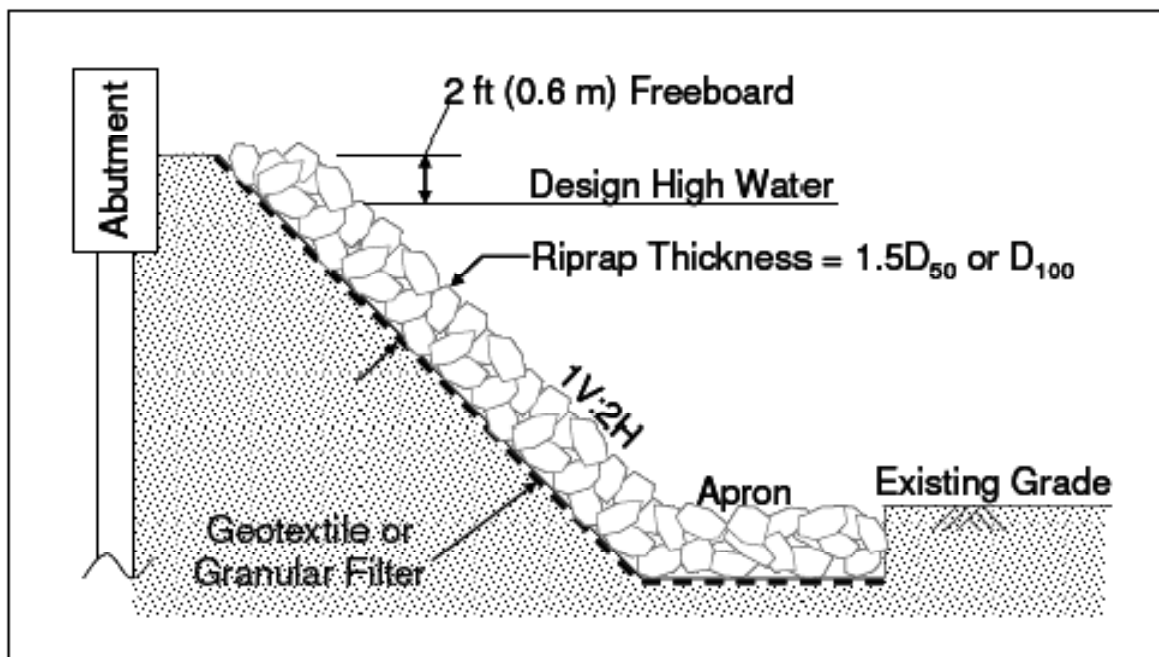

Fig. 11-102.031¹
 Typical cross section for abutment riprap

- d) The rock riprap gradation and need for underlying filter material and bedding requirements are specified in the [IDOT Standard Specifications](#) Section 281.04(a).
- e) It is not desirable to construct an abutment that encroaches into the main channel. If abutment protection is required at a new or existing bridge that encroaches into the main channel, then riprap toe down or a riprap key should be considered.

• **Design Example for Riprap at Bridge Abutments**

Riprap is to be sized for an abutment located on the floodplain at an existing bridge. The bridge is 650 ft. long, has spill through abutments on a 1V:2H side slope and seven equally spaced spans. The left abutment is set back from the main channel 225 ft. Given the following (Table 11-102.031) hydraulic characteristics for the left abutment, size the riprap.

Hydraulic Property	Value	Remarks
y (ft)	2.7	Flow depth adjacent to abutment
Q (cfs)	7,720	Discharge in left overbank
A (ft ²)	613.5	Flow area of left overbank

Table 11-102.031¹
 Example Hydraulic Characteristics for the Left Abutment

Solution procedure:

1. Determine the SBR (set-back distance divided by the average channel flow depth)

$$SBR = \frac{225}{9.7} = 23.2$$

2. Determine characteristic average velocity, V. Abutment is set back more than 5 average flow depths, therefore overbank discharge and areas are used to determine V.

$$V = \frac{Q}{A} = \frac{7720}{613.5} = 12.6 \text{ ft/s}$$

3. Check SBR velocity against main channel velocity

$$V_c = \frac{Q_c}{A_c} = \frac{25,500}{1,977} = 12.89 \text{ ft/s}$$

Velocity in channel is greater than SBR velocity, therefore, use SBR velocity.

4. Determine the Froude number of the flow.

$$Fr = \frac{V}{\sqrt{gy}}$$

where:

V = velocity, ft/sec
 g = acceleration of gravity, ft/sec²
 y = hydraulic depth, ft

$$Fr = \frac{12.6}{\sqrt{(32.2)(2.7)}} = 1.35$$

5. Determine the D₅₀ of the riprap for the left abutment. The Froude number is greater than 0.8, therefore, use [Equation 11-8](#).

$$\frac{D_{50}}{y} = \frac{K}{(S_s - 1)} \left[\frac{V^2}{gy} \right]^{0.14}$$

$$\frac{D_{50}}{2.7} = \frac{0.61}{(2.65 - 1)} \left[\frac{12.6^2}{(32.2)(2.7)} \right]^{0.14} = 0.40$$

$$D_{50} = 0.4(2.7) = 1.1 \text{ ft} = 13 \text{ in}$$

Use Eq. 11-4 to determine the relationship between the diameter and the weight of the median stone particle.

$$W=0.85(\gamma_s d^3)$$

where:

W = weight of stone, lb
 γ_s = density of stone, lb/ft³

$$\gamma_s = S_s \gamma_w$$

where:

S_s = specific gravity of riprap
 γ_w = density of water, lb/ft³
 d = diameter of stone, ft

After determining the weight of riprap particle the standard gradation can be selected from the tables presented in Article 1005.01c of [IDOT's Standard Specifications for Road and Bridge Construction](#). Using $S_s=2.65$ lbs/ft³; $W_{50}=110$ lbs, Grade 5 stone would be used.

6. Determine riprap extent and layout.

Extent into floodplain from toe of slope = $2(2.7) = 5.4$ ft

Vertical extent up abutment slope from floodplain = $2.0 + 2.7 = 4.7$ ft

The downstream face of the embankment should be protected a distance of 25 ft. from the point of tangency between the curved portion of the abutment and the plane of the embankment slope.

Riprap mattress thickness = $1.5(1.1) = 1.7$ ft and not less than D_{100} . Filter fabric is required under 8 in. of either CA 3 or Grade 1 Stone bedding material (From [IDOT Standard Specifications](#) Section 281.04(a) for Grade 5 stone).

11-102.032 Concrete Armor Units

Concrete armor units are man-made 3-dimensional shapes fabricated for soil stabilization and erosion control. These structures have been used in environments where riprap availability is limited or where large rock sizes are required to resist extreme hydraulic forces. They have been used as revetments on shorelines, channels, streambanks, and for scour protection at bridges. Some examples of armor units include Toskanes, A-Jacks[®], tetrapods, tetrahedrons, dolos, and Core-loc[™].

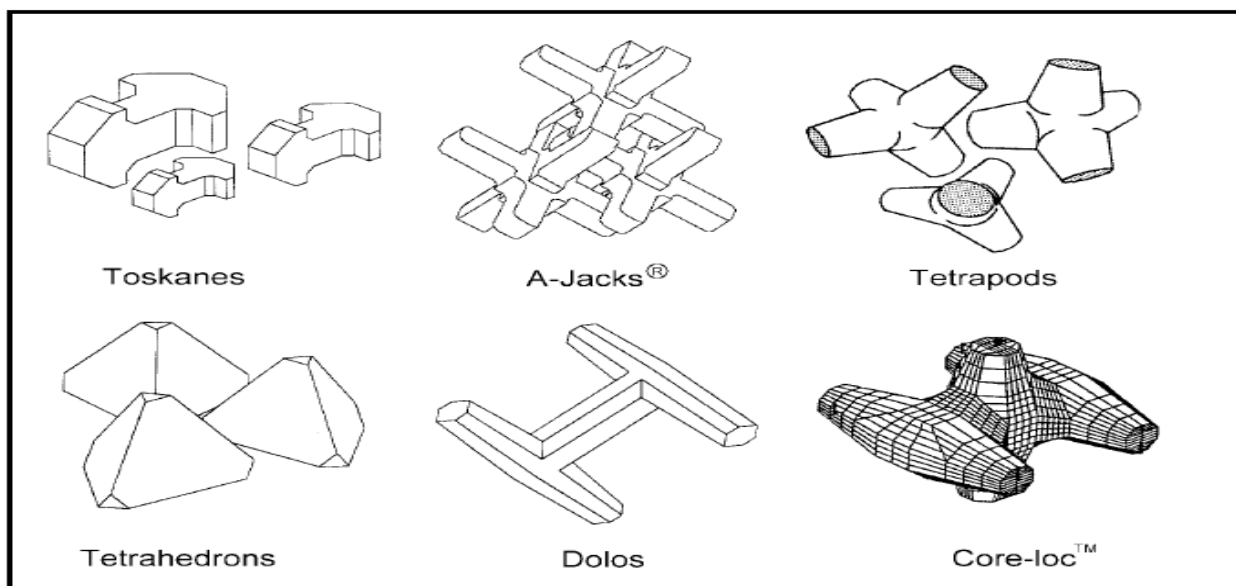

Figure 11-102.032¹
Armor Units

The primary advantage of armor units is that they usually have greater stability than riprap. This is due to the interlocking characteristics of their complex shapes. The increased stability allows for placement on steeper slopes or the use of lighter weight units for equivalent flow conditions as compared to riprap. This is significant when riprap of a required size is not available. Some installations of concrete armor units have failed due to freeze-thaw cycle cracking. Consult with the manufacturer to determine if the units should be submerged under water. See Design Guideline 19 in [HEC 23](#) for more information on layout and installation of concrete armor units.

11-102.033 Grout Filled Bags

Grout filled bags are generally used at bridges to fill in undermined areas around piers and abutments. They are relatively easy to install and can shift to changes in the channel bed to provide effective scour protection. The large bags made of mechanically bonded fabric are filled with granular material to 80% capacity. They can be used as a filter or a stand-alone countermeasure. The flexibility of the fabric and partial filling allows the containers to conform to the channel bed. See [HEC-23](#) Design Guideline 13 for additional information on design and placement of grout filled bags.

11-102.034 Gabions/Gabion Mattresses

Gabion mattresses are containers constructed of wire mesh and filled with rocks. During installation, individual mattresses are connected together by lacing wire or other connectors to form a continuous structure. The wire mesh allows the gabions to deform and adapt to changes in the subgrade while maintaining stability. The obvious benefit of gabion mattresses is that the size of the individual stone used to fill the mattress is smaller than the riprap stone particle that would be used to

withstand the hydraulic forces of a stream. Refer to Design Guideline 10 in [HEC-23](#) for more information.

11-102.035 Partially Grouted Riprap

Partially grouted riprap consists of specifically sized rocks that are placed and grouted together, with the grout filling only 1/3 to 1/2 of the total void space. Partial grouting increases the overall stability of the riprap without sacrificing flexibility or permeability. Design Guideline 12 of [HEC-23](#) supplies detailed information on design and placement of partially grouted riprap around piers and abutments.



Fig. 11-102.035¹
Close-up view of partially grouted riprap

11-200 STRUCTURAL COUNTERMEASURES

Structural countermeasures involve modification of the bridge structure (foundation) to prevent failure from scour. Typically, the substructure is modified to increase bridge stability after scour has occurred or when a bridge is assessed as scour critical. These modifications are classified as either foundation strengthening or pier geometry modifications.

11-201 Foundation Strengthening

Foundation strengthening includes additions to the original structure which will reinforce and/or extend the foundations of the bridge. These countermeasures are designed to prevent failure when the channel bed is lowered to an expected scour elevation, or to restore structural integrity after scour has occurred. Scour may remove material from around and under foundations resulting in void areas and exposed piling under footers.

11-201.01 Underpinning

Underpinning or jacketing may involve one of the following procedures:

1. Filling in scoured area with large riprap and filling voids with sand and gravel. The riprap should be placed so that the top of the riprap is below rather than level with the streambed. If the riprap is exposed, it may create a flow disturbance that will undermine the edges of the riprap or cause scour elsewhere in the bridge waterway.
2. Filling in scoured area with material and placing a concrete apron around the foundation with the top of the apron at or below the streambed elevation.

11-201.02 Continuous Spans

Design and construction of bridges with continuous spans provide a degree of safety against catastrophic failure resulting from substructure displacement caused by scour. Retrofitting a simple span bridge with continuous spans could also serve as a countermeasure after scour has occurred or when a bridge is assessed as scour critical.

11-201.03 Pumped Concrete/Grout under Footing

Sheet piling may be driven around foundation and scoured area and then filled with grout or pumped concrete.

When utilizing any of the above procedures, consideration must be given to the possibility of flow disturbance caused by the countermeasure that may result in another scour problem at the same location or elsewhere in the channel.

11-202 Pier Geometry Modifications

Pier geometry modifications include extending the footings and modifications to pier shape and are used to either reduce local scour at bridge piers or to transfer scour to another location. These modifications are used mainly to minimize local scour.

11-202.01 Debris Deflector for Pier

- **Concrete Fender Debris Deflector:** A structure shaped like half of a cone located at the nose of a pier for the purpose of directing floating debris between the piers.
- **Curtain Wall Between Pier Columns:** Concrete enclosure of multiple column piers or pile bents for the purpose of preventing the debris from lodging between columns.

11-300 BIOTECHNICAL COUNTERMEASURES

Biotechnical countermeasures utilize vegetation to control streambank erosion and facilitate bank stabilization. This countermeasure type can be used independently or in combination with structural countermeasures and primarily in stream restoration and rehabilitation projects. Soft revetments, consisting solely of living plant materials or plant products, are often referred to as bioengineering. The combination of vegetation with structural (hard) elements is classified as biotechnical engineering and biotechnical slope protection. An example of biotechnical slope protection is vegetated riprap.

Biotechnical engineering is a cost-effective, aesthetically and habitat- enhancing solution for bank and channel erosion. However hydraulic or structural countermeasures should be utilized in the immediate vicinity of a bridge or highway structure where failure of the countermeasure could lead to failure of the structure.

Streambank protection consisting of riprap, concrete or other unnatural material lack environmental and aesthetic benefits. Designs that combine vegetation with these materials offer long-term protection with the habitat benefits inherent with the establishment of a healthy riparian buffer. The riprap will resist the hydraulic forces, while roots and branches increase geotechnical stability, prevent soil erosion from behind the system and increase durability. Additionally vegetated riprap creates habitat for both aquatic and terrestrial wildlife.

Figure 11-300 illustrates some construction techniques of vegetated riprap. Additional information on commonly used methods can be located in [HEC 23](#) Chapter 6, Section 6.6.

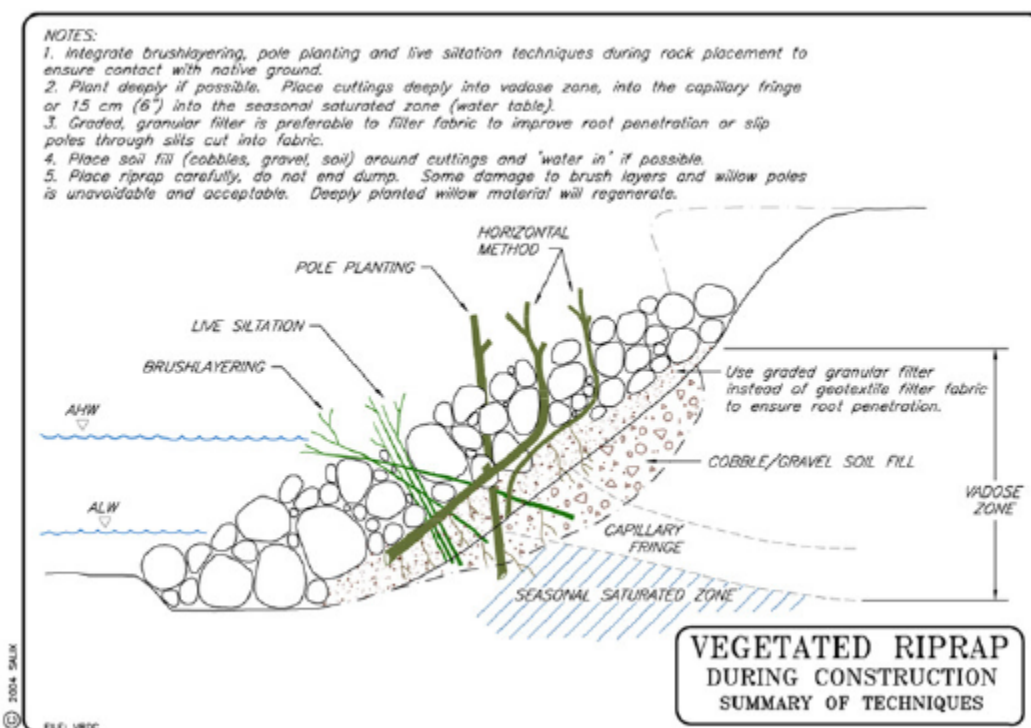

Fig. 11-300
Vegetated riprap – construction techniques⁶

11-400 MONITORING

Early indications of potential scour problems can be detected through monitoring. At a scour critical bridge, monitoring allows for action to be taken before the safety of the public is threatened by the potential failure of the bridge. Monitoring can be accomplished with instrumentation or visual inspection. A well designed monitoring program can be a very cost effective countermeasure for existing bridges. Two types of instrumentation, fixed and portable (see [HEC 23](#), Chapter 9), and visual inspection are used to monitor bridge scour.

11-401 Fixed Instrumentation

Fixed Instrumentation are monitoring devices attached to the bridge structure to detect scour at a particular location. Typically, fixed monitors are located at piers and abutments. The number and location of piers to be instrumented should be defined, as it may be impractical to place a fixed instrument at every pier and abutment on a bridge. Instruments such as sonar monitors can be used to provide a timeline of scour, whereas instruments such as magnetic sliding collars can only be used to monitor the maximum scour depth. Data from fixed instruments can be downloaded manually at the site or can be telemetered to another location. Debris accumulation can affect readings. The most common types of fixed instruments include sonar, sounding rods, buried/driven rods, and float-out devices.

11-402 Portable Instrumentation

Portable Instrumentation are monitoring devices that can be manually carried and used along a bridge and transported from one bridge to another. Portable instruments are more cost effective in monitoring an entire bridge than fixed instruments; however, they do not offer a continuous watch over the structure. The allowable level of risk will affect the frequency of data collection using portable instruments. Typical portable devices include lead-line sounders and sonar devices.

11-403 Visual Monitoring

Visual Monitoring is the standard monitoring practice of inspecting the bridge on a regular interval and increasing monitoring efforts during high flow events (flood watch). Typically, bridges are inspected on a biennial schedule where channel bed elevations at each pier location are taken. The channel bed elevations should be compared with historical cross sections to identify changes due to scour. Channel elevations should also be taken during and after high flow events. If measurements cannot be safely collected during a high flow event, the bridge owner should determine if the bridge is at risk and if closure is necessary. Underwater inspections of the foundations could be used as part of the visual inspection after a flood.

11-500 REFERENCES

1. United States Department of Transportation, Federal Highway Administration. *Bridge Scour and Stream Instability Countermeasures: Experience, Selection and Design Guidance*. Hydraulic Engineering Circular No.23, Third Edition, September 2009.
2. United States Department of Transportation, Federal Highway Administration. *Evaluating Scour at Bridges*. Hydraulic Engineering Circular No. 18, Fourth Edition, May 2001.
3. Reichmuth, D. R. *Living with Fluvial Systems*. Workshop notes, Portland OR, February 23-25, 1993.
4. Bradley, J.N. *Hydraulics of Bridge Waterways*. Hydraulic Design Series No. 1, U.S. Department of Transportation, FHWA, Washington, D.C., 1978.
5. Lagasse, P.F., Clopper, P.E., Zevenbergen, L.W., and Ruff, J.F. *Riprap Design Criteria, Recommended Specifications, and Quality Control*. NCHRP Report 568, Transportation Research Board, National Academies of Science, Washington, D.C., 2006.
6. MuCullah, J.A. and Gray, D. *Environmentally Sensitive Channel- and Bank-Protection Measures*. NCHRP Report 544, Transportation Research Board, National Academies of Science, Washington, D.C., 2005.
7. United States Department of Transportation, Federal Highway Administration. *Stream Stability at Highway Structures*. Hydraulic Engineering Circular No. 20, Third Edition, March 2001.
8. United States Department of Transportation, Federal Highway Administration. *Highways in the River Environment*. February 1990.
9. United States Department of Transportation, Federal Highway Administration. *Design of Riprap Revetment*. Hydraulic Engineering Circular No. 11, March 1989.
10. Illinois Department of Transportation's Standard Specifications for Road and Bridge Construction.
11. Illinois Department of Transportation, Bureau of Bridges and Structures, Bridge Manual.



Chapter 12

Downloaded from <https://www.cambridge.org/core>.
University of Cambridge, on 02 Jun 2020 at 10:00:00, subject to the Cambridge Core terms of use, available at <https://www.cambridge.org/core/terms>.
<https://doi.org/10.1017/9781009051600.012>

CHAPTER 12 - DETENTION STORAGE

- 12-000 GENERAL CONSIDERATION
 - 12-001 Types
 - 12-002 Benefits
 - 12-002.01 Quality
 - 12-002.02 Quantity
 - 12-002.03 Objectives
 - 12-003 Design Criteria
 - 12-003.01 Release Rate and Overflow
 - 12-003.02 Storage
 - 12-003.03 Grading and Depth
 - 12-003.031 Detention
 - 12-003.032 Retention
 - 12-003.04 Outlet Works
 - 12-003.05 Location
- 12-100 GENERAL PROCEDURE
 - 12-101 Data Needs
 - 12-102 Stage-Storage Curve
 - 12-103 Stage-Discharge Curve
 - 12-104 Procedure
- 12-200 OUTLET HYDRAULICS
 - 12-201 Outlet Types
 - 12-202 Sharp Crested Weirs
 - 12-203 Broad Crested Weirs
 - 12-204 V-Notch Weirs
 - 12-205 Orifices
- 12-300 FLOOD ROUTING TECHNIQUES

12-400	STORAGE ROUTING		
12-401	Modified Puls Method		
12-402	Modified Rational Method		
12-403	Example Problems		
	12-403.01	Example Problem 1(Modified Puls Method)	
	12-403.02	Example Problem 2(Modified Rational Method)	
12-500	LINEAR STORMWATER DETENTION		
12-501	Scope		
12-502	Application		
12-503	Storage Volume		
12-504	Example Problems		
	12-504.01	Example Problem 1(Storage Volume in Pipes)	
	12-504.02	Example Problem 2(Oversized Conveyance System)	
12-600	CONSTRUCTION AND MAINTENANCE CONSIDERATIONS		
12-700	PROTECTIVE TREATMENT		
12-800	REFERENCES		

12-000 - GENERAL CONSIDERATION

This chapter is intended to present recommended design procedures and guidelines for use in complying with the requirements of [Section 1-303.03 StormWater Storage](#).

The main purpose of a detention basin is to store excess runoff thus reducing peak discharges downstream. Detention basins should be considered when increased runoff due to highway activities would cause additional damage to downstream property or would worsen flooding conditions. The cost of a detention basin should be compared to other methods of mitigation, such as downstream channel improvements or purchasing flood easements, to determine the most feasible solution.

A detention facility should be designed to project an image acceptable to the public. Multiple use of detention facilities is also a major means of gaining public acceptance for the stormwater management facility. Because an area used for detention of runoff may have other uses; the size, shape and slopes of the detention facility should be compatible with such auxiliary uses of the facility. In addition, the allowable depth of water for the design discharge and the length of time that stored water remains in the facility should also be compatible with other uses of the facility.

The position of the groundwater table may be important in determining the suitability of a site for a detention facility. If a permanent pool is desired and if the base flow is not sufficient, groundwater may be a source for maintaining a permanent pool.

12-001 Types

Urban stormwater storage facilities are often referred to as either detention or retention facilities. For the purposes of this chapter, detention facilities are those that are designed to reduce the peak discharge and only detain runoff for some short period of time. These facilities are designed to completely drain after the design storm has passed. Retention facilities are designed to contain a permanent pool of water. Since most of the design procedures are the same for detention and retention facilities, the term storage facilities will be used in this chapter to include detention and retention facilities. If special procedures are needed for detention or retention facilities, these will be specified.

There are several kinds of detention facilities such as open space basins, parking lots, ponds, rooftops, and oversized storm sewers. Permanent ponds for detention of excess runoff due to highway improvements can be incorporated into the surface drainage system. The ponds should have adequate effective storage volume to accommodate a given frequency of runoff as per highway classifications. Effective volume is the volume that will be above the groundwater table which usually fluctuates seasonally. If a detention pond is designed to have a permanent pool, only the volume above the low level outlet should be considered as effective storage. For detention ponds of 5 acres or greater in surface area, some protection of banks against wave action should be considered. Part of the storage requirements may be supplemented by use of the interchange infields and specially enlarged ditches along the highway.

12-002 Benefits

The use of storage facilities for stormwater management has increased dramatically in recent years. The benefits of storage facilities can be divided into two major control categories of quality and quantity.

12-002.01 Quality

Control of stormwater quality using storage facilities offers the following potential benefits:

- Decrease downstream channel erosion
- Control of sediment deposition
- Improved water quality through stormwater filtration (wet ponds only)

12-002.02 Quantity

Controlling the quantity of stormwater using storage facilities can provide the following potential benefits:

- Prevention or reduction of peak runoff rate increases caused by urban development
- Mitigation of downstream drainage capacity problems
- Recharge of groundwater resources
- Reduction or elimination of the need for downstream outfall improvements
- Maintenance of historic low flow rates by controlled discharge from storage

12-002.03 Objectives

The objectives for managing stormwater quantity by storage facilities are typically based on limiting peak runoff rates to match one or more of the following values:

- Historic rates for specific design conditions (i.e. post-development peak equals pre-development peak for a particular frequency of occurrence)
- Non hazardous discharge capacity of the downstream drainage system
- A specified value for allowable discharge set by a regulatory jurisdiction

For a watershed with no positive outfall, the total volume of runoff is critical and storage facilities are used to store the increases in volume and control discharge rates.

12-003 Design Criteria¹

Storage may be concentrated in large basin wide or regional facilities or distributed throughout an urban drainage system. Possible dispersed or on site storage may be developed in depressed areas in parking lots, road embankments and freeway interchanges, parks and other recreation areas, and small lakes, ponds, and depressions within urban developments. The utility of any storage facility depends on the amount of storage, its location within the system, and its operational characteristics. An analysis of such storage facilities should consist of comparing the design flow at a point or points downstream of the proposed storage site with and without storage. In addition to the design flow, other flows in excess of the design flow that might be expected to pass through the storage facility should be included in the analysis. The design criteria for storage facilities should include:

- Release rate
- Storage volume
- Grading and depth requirements
- Outlet works
- Location

12-003.01 Release Rate and Overflow

Control structure release rates shall approximate pre-developed peak runoff rates in accordance with the Storm Water Storage policy of [Section 1-303.03](#) for IDOT projects and the Highway Access Permit policy of [Section 1-404](#) for private developments requiring an access permit. Multi stage control structures may be required to control the runoff rates of both the high and low frequency rates identified by policy. Design calculations are required to demonstrate that runoff from the designated frequencies are controlled. With these calculations, runoff from intermediate storm frequencies can be assumed to also be adequately controlled.

Flows that exceed the design frequency of the storage facility will overflow. Overflow in the course of natural drainage must be provided.

12-003.02 Storage

Storage volume shall be adequate to attenuate the post-development peak discharge rates to pre-development discharge rates for the storm frequencies designated by policy or capacity depending on what the downstream system is designed for.

Detention facilities such as detention basins typically require 50 year design inflow hydrograph in most highway projects. A lower frequency may be justified in special cases. Highly urbanized detention facilities such as oversized storm sewers in series or in parallel, not associated with pump stations, typically do not require inflow hydrographs in most highway projects. A 10 year or 50 year design storm is often used for oversized storm sewers. The volume of runoff for oversized sewers is typically determined by Section 12-402 Modified Rational Method. The 100 year storm should be routed through the detention basin to determine if there is a chance of a catastrophic failure that may lead to loss of life. If there is a chance that loss of life will occur during a 100 year storm, consideration should be given to increasing the design frequency of the detention basin or providing an early warning system. The 100 year hydraulic Grade line for oversized storm sewers should be plotted as a check to the 100 year storm. Local ordinances should be considered if they dictate a more stringent level of protection.

Storm duration is a critical aspect of detention basin design. A full range of durations should be used during analysis, since duration is the significant parameter in sizing a detention basin. The duration that requires the largest amount of storage should be chosen.

12-003.03 Grading and Depth

The construction of storage facilities usually requires excavation or placement of earthen embankments to obtain sufficient storage volume. Vegetated embankments shall be less than 20 ft in height and shall have side slopes no steeper than 3:1 (horizontal to vertical). Riprap protected embankments shall be no steeper than 2:1. Geotechnical slope stability analysis is recommended for embankment slopes steeper than those given above.

Other considerations when setting depths include flood elevation requirements, public safety, land availability, land value, present and future land use, water table fluctuations, soil characteristics, and maintenance requirements. Aesthetically pleasing features are also important in urbanizing areas.

12-003.031 Detention

Areas above the normal highwater elevations of storage facilities should be sloped at a minimum of 5 percent toward the facilities to allow drainage and to prevent standing water. Careful finish grading is required to avoid creation of upland surface depressions that may retain runoff. The bottom area of storage facilities should be graded toward the outlet to prevent standing water conditions. A minimum 2 percent bottom slope is recommended. A low flow channel constructed across the facility bottom from the inlet to the outlet is recommended to convey flows, and prevent standing water conditions.

12-003.032 Retention

The maximum depth of permanent storage facilities will be determined by site conditions, design constraints, and environmental needs. In general, if the facility provides a permanent pool for water, a depth sufficient to discourage growth of weeds should be considered. A depth of 6 to 8 ft is generally reasonable unless fishery requirements dictate otherwise. Aeration may be required in permanent pools to prevent anaerobic conditions. Where aquatic habitat is required, the cognizant wildlife experts should be contacted for site specific criteria relating to such things as depth, habitat, and bottom and shore geometry.

12-003.04 Outlet Works

Outlet works selected for storage facilities typically include a principal spillway and an emergency overflow, and must be able to accomplish the design functions of the facility. Outlet works can take the form of combinations of drop inlets, pipes, weirs, and orifices. The principal spillway is intended to convey the design storm without allowing flow to enter an emergency overflow. The minimum flood to be used to size the emergency overflow is generally the 100 year flood.

The purpose of emergency overflow is to provide a controlled overflow relief from storm flows in excess of the design discharge for the storage facility. The invert of the spillway at the outfall should be at an elevation 1 to 2 ft above the maximum design storage elevation. It is preferable to have a minimum freeboard of 2 ft. However, for very small impoundments (less than 2 acre surface area) either a minimum of 1 ft of freeboard may be acceptable or a minimum overflow elevation based on the 500 year storm water elevation shall be provided².

12-003.05 Location

In addition to controlling the peak discharge from the outlet works, storage facilities will change the timing of the entire hydrograph. If several storage facilities are located within a particular basin it is important to determine what affects a particular facility may have on combined hydrographs in downstream locations.

12-100 GENERAL PROCEDURE¹

12-101 Data Needs

The following data will be needed to complete storage design and routing calculations.

- Inflow hydrograph for all selected design storms
- Stage-storage curve for proposed storage facility (see [Figure 12-101a](#) below for an example)
- Stage-discharge curve for all outlet control structures (see [Figure 12-101b](#) below for an example)

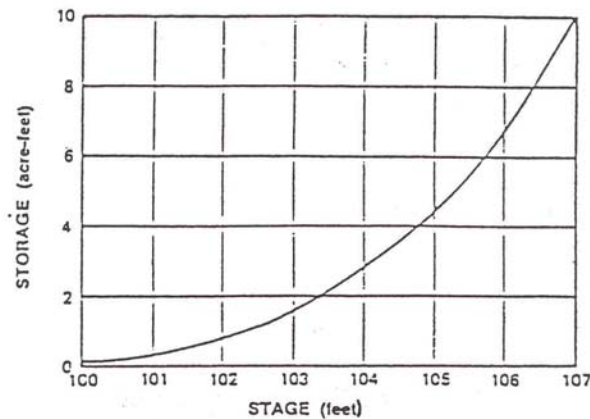

*Example Stage-Storage Curve
Figure 12-101a*

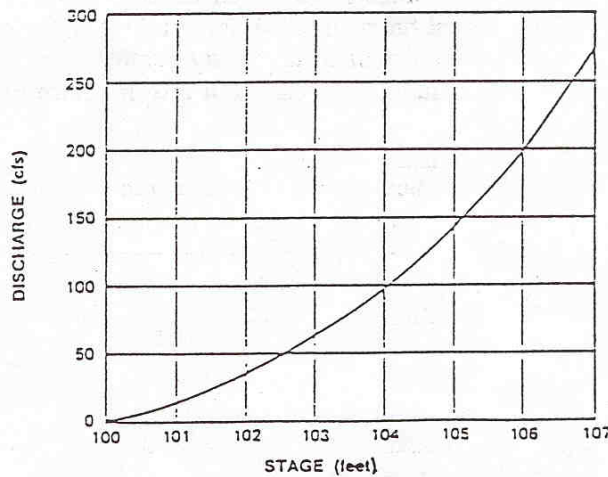

*Example Stage-Discharge Curve
Figure 12-101b*

Using these data, a design procedure is used to route the inflow hydrograph through the storage facility with different basin and outlet geometry until the desired outflow hydrograph is achieved.

12-102 Stage-Storage Curve

A stage-storage curve defines the relationship between the depth of water and storage volume in a reservoir. The data for this type of curve is usually developed using a topographic map and the double-end area frustum of a pyramid or prismatic formulas. The double-end area formula is expressed as:

$$V_{1,2} = \left(\frac{(A_1 + A_2)}{2} \right) d \tag{Eq. 12-1}$$

Where:

- $V_{1,2}$ = storage volume between elevations 1 and 2, cuft
- A_1 = surface area at elevation 1, sqft
- A_2 = surface area at elevation 2, sqft
- d = change in elevation between points 1 and 2, ft

The frustum of a pyramid is expressed as:

$$V = \frac{d \left(A_1 + (A_1 A_2)^{0.5} + A_2 \right)}{3} \tag{Eq. 12-2}$$

Where:

- V = volume of frustum of a pyramid, cuft
- d = change in elevation between points 1 and 2, ft
- A_1 = surface area at elevation 1, sqft
- A_2 = surface area at elevation 2, sqft

The prismatic formula for trapezoidal basins is expressed as:

$$V = LWD + (L + W)ZD^2 + \frac{4}{3}Z^2D^3 \tag{Eq. 12-3}$$

Where:

- V = volume of trapezoidal basin, cuft
- L = length of basin at base, ft
- W = width of basin at base, ft
- D = depth of basin, ft
- Z = side slope factor, ratio of horizontal to vertical

The equations for determining volume in pipes can be found in [Section 12-503 Storage Volume](#).

12-103 Stage-Discharge Curve

A stage-discharge curve defines the relationship between the depth of water and the discharge or outflow from a storage facility. A typical storage facility has two spillways: principal and emergency. The principal spillway is usually designed with a capacity sufficient to convey the design flood without allowing flow to enter the emergency spillway. A pipe culvert, weir, or other appropriate outlet can be used for the principal spillway or outlet.

The emergency spillway is sized to provide a bypass for floodwater during a flood that exceeds the design capacity of the principal spillway. This spillway should be designed taking into account the potential threat to downstream life and property if the storage facility were to fail.

The stage-discharge curve should take into account the discharge characteristics of both the principal and emergency spillways.

12-104 Procedure

A general procedure for using the above data in the design of storage facilities is presented below.

Step 1

Compute inflow hydrograph for runoff from the storm frequencies designated by the policy. Both pre-development and post-development hydrographs are required for the designated design storms.

Step 2

Perform preliminary calculations to evaluate detention storage requirements for the hydrographs from [Step 1](#). If storage requirements are satisfied for runoff from the designated design storms, runoff from intermediate storms is assumed to be controlled.

Step 3

Determine the physical dimensions necessary to hold the estimated volume from [Step 2](#), including freeboard. The maximum storage requirement calculated from Step 2 should be used.

Step 4

Size the outlet structure. The estimated peak stage will occur for the estimated volume from [Step 2](#). The outlet structure should be sized to convey the allowable discharge at this stage.

Step 5

Perform routing calculations using inflow hydrographs from [Step 1](#) to check the preliminary design using the storage routing equations. If the routed post-development peak discharges from the designated design storms exceed the pre-development peak discharges, or if the peak stage varies significantly from the estimated peak stage from [Step 4](#), then revise the estimated volume and return to [Step 3](#).

Step 6

Consider emergency overflow for runoff exceeding design storm and establish freeboard requirements.

Step 7

Evaluate the downstream effects of detention outflow to ensure that the routed hydrograph does not cause downstream flooding problems.

Step 8

Evaluate the control structure outlet velocity and provide channel and bank stabilization if the velocity will cause erosion problems downstream.

This procedure can involve a significant number of reservoir routing calculations to obtain the desired results.

12-200 OUTLET HYDRAULICS¹

12-201 Outlet Types

Sharp-crested weir flow equations for no end contractions, two end contractions, and submerged discharge conditions are presented below, followed by equations for broad-crested weirs, v-notch weirs, and orifices, or combinations of these facilities. If culverts are used as outlets works, procedures presented in the Culvert Chapter should be used to develop stage-discharge data. Slotted riser pipe outlet facilities should be avoided.

12-202 Sharp-Crested Weirs

When the weir length is less than the width of channel, the weir opening is in the form of a notch, with the ends of the notch having sharp edges and causing contractions.

A sharp-crested weir with no end contractions is illustrated in [Figure 12-202a](#). The discharge equation³ for this configuration is;

$$Q = \left(3.27 + 0.4 \left(\frac{H}{H_c} \right) \right) LH^{1.5} \quad (\text{Eq. 12-4})$$

Where:

- Q = discharge, cuft/sec
- H = head above weir crest excluding velocity head, ft
- H_c = height of weir crest above channel bottom, ft
- L = horizontal weir length, ft

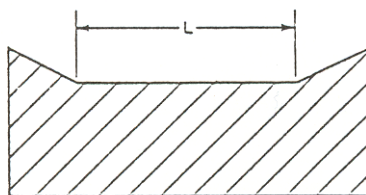

Sharp-Crested Weir No End Contractions
Figure 12-202a

A sharp-crested weir with two end contractions is illustrated in [Figure 12-202b](#) and [Figure 12-202c](#). The discharge equation³ for this configuration is:

$$Q = \left(3.27 + 0.4 \left(\frac{H}{H_c} \right) \right) (L - 0.2H) H^{1.5} \quad (\text{Eq. 12-5})$$

Where: Variables are the same as the preceding equation.

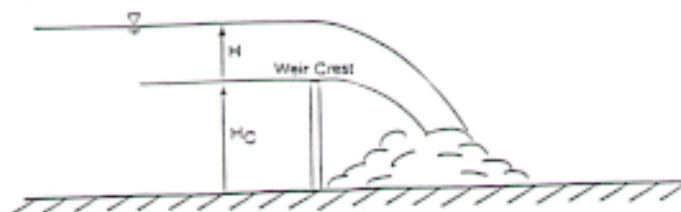

Sharp-Crested Weir and Head with Two End Contractions
Figure 12-202b

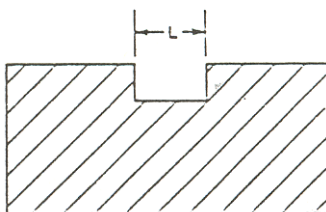

Sharp Crested Weir, Two End Contractions
Figure 12-202c

A sharp-crested weir will be affected by submergence when the tailwater rises above the weir crest elevation. The result will be that the discharge over the weir will be reduced. The discharge equation⁴ for a sharp-crested submerged weir is:

$$Q_s = Q_r \left(1 - \left(\frac{H_2}{H_1} \right)^{1.5} \right)^{0.385} \quad (\text{Eq. 12-6})$$

Where:

- Q_s = submergence flow, cuft/sec
- Q_r = free flow, cuft/sec
- H₁ = upstream head above crest, ft
- H₂ = downstream head above crest, ft

12-203 Broad-Crested Weirs

The equation⁴ generally used for the broad-crested weir is:

$$Q = CLH^{1.5} \quad (\text{Eq. 12-7})$$

Where:

- Q = discharge, cuft/sec
- C = broad-crested weir coefficient
- L = broad-crested weir length, ft
- H = head above weir crest, ft

If the upstream edge of a broad-crested weir is so rounded as to prevent contraction and if the slope of the crest is as great as the loss of head due to friction, flow will pass through critical depth at the weir crest; this gives the maximum C value of 3.087. For sharp corners on the broad-crested weir, a minimum C value of 2.6 should be used. Additional information on C values a function of weir crest breadth and head is given in [Table 12-203⁴](#).

Measured Head, H* (ft)	Breadth of the Crest of Weir (ft)										
	<u>0.50</u>	<u>0.75</u>	<u>1.00</u>	<u>1.50</u>	<u>2.00</u>	<u>2.50</u>	<u>3.00</u>	<u>4.00</u>	<u>5.00</u>	<u>10.00</u>	<u>15.00</u>
0.2	2.80	2.75	2.69	2.62	2.54	2.48	2.44	2.38	2.34	2.49	2.68
0.4	2.92	2.80	2.72	2.64	2.61	2.60	2.58	2.54	2.50	2.56	2.70
0.6	3.08	2.89	2.75	2.64	2.61	2.60	2.68	2.69	2.70	2.70	2.70
0.8	3.30	3.04	2.85	2.68	2.60	2.60	2.67	2.68	2.68	2.69	2.64
1.0	3.32	3.14	2.98	2.75	2.66	2.64	2.65	2.67	2.68	2.68	2.63
1.2	3.32	3.20	3.08	2.86	2.70	2.65	2.64	2.67	2.66	2.69	2.64
1.4	3.32	3.26	3.20	2.92	2.77	2.68	2.64	2.65	2.65	2.67	2.64
1.6	3.32	3.29	3.28	3.07	2.89	2.75	2.68	2.66	2.65	2.64	2.63
1.8	3.32	3.32	3.31	3.07	2.88	2.74	2.68	2.66	2.65	2.64	2.63
2.0	3.32	3.31	3.30	3.03	2.85	2.76	2.27	2.68	2.65	2.64	2.63
2.5	3.32	3.32	3.31	3.28	3.07	2.89	2.81	2.72	2.67	2.64	2.63
3.0	3.32	3.32	3.32	3.32	3.20	3.05	2.92	2.73	2.66	2.64	2.63
3.5	3.32	3.32	3.32	3.32	3.32	3.19	2.97	2.76	2.68	2.64	2.63
4.0	3.32	3.32	3.32	3.32	3.32	3.32	3.07	2.79	2.70	2.64	2.63
4.5	3.32	3.32	3.32	3.32	3.32	3.32	3.32	2.88	2.74	2.64	2.63
5.0	3.32	3.32	3.32	3.32	3.32	3.32	3.32	3.07	2.79	2.64	2.63
5.5	3.32	3.32	3.32	3.32	3.32	3.32	3.32	3.32	2.88	2.64	2.63

* Measured at least 2.5H upstream of the weir

Broad-Crested Weir Coefficient C Values as a Function of Weir Crest Breadth and Head Weir Crest Breadth (ft)
Table 12-203⁴

12-204 V-Notch Weirs

The discharge through a v-notch weir (Figure 12-204) can be calculated from the following equation⁴:

$$Q = 2.5 \left(\tan \left(\frac{\theta}{2} \right) \right) H^{2.5} \tag{Eq. 12-8}$$

Where:

- Q = discharge, cuft/sec
- θ = angle of v-notch, degrees
- H = head on apex of notch, ft

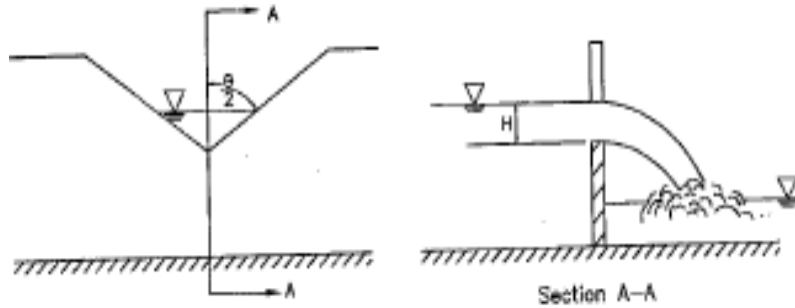

Figure 12-204 V-Notch Weir

12-205 Orifices

When the outlet is small in comparison to the depth of water, the discharge through the orifice can be calculated using the following equation:

$$Q = C_d A \sqrt{2gH} \tag{Eq. 12-9}$$

Where:

- C_d = discharge coefficient (Figure 12-205⁵)
- Q = discharge, cuft/sec
- A = cross section area of orifice, sq ft
- g = acceleration due to gravity, 32.2 ft/sec²
- H = head on orifice, from the centerline of the orifice to the water surface, ft, if the outlet is not submerged; otherwise, H will be the differential head, or difference between the water levels on the upstream and downstream side of the orifice (Figure 12-205a).

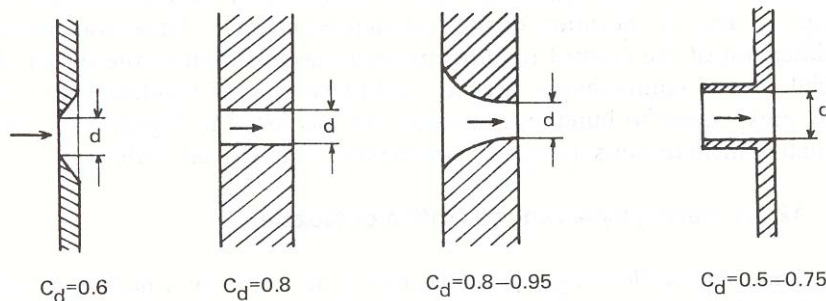

Discharge Coefficient C_d for Different Outlets
Figure 12-205⁵

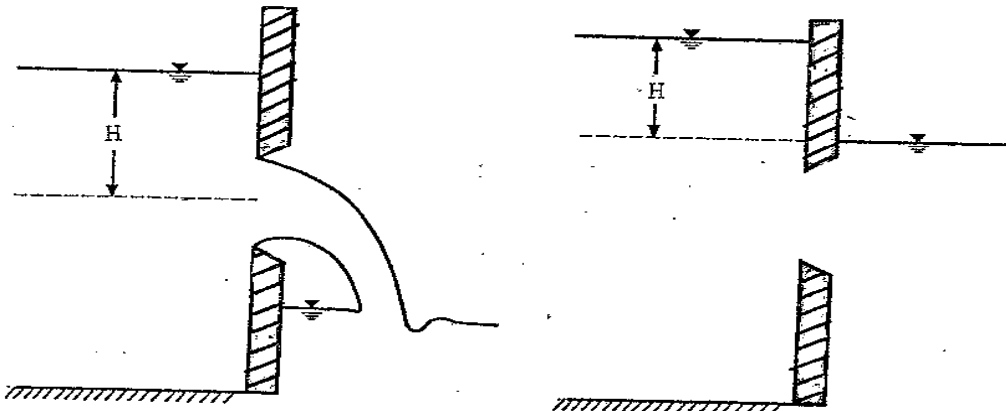

Orifice Flow – Free Outlet

Orifice Flow – Submerged Outlet

Figure 12-205a

12-300 FLOOD ROUTING TECHNIQUES⁶

Flood routing is a process used to predict the temporal and spatial variations of a flood wave through a river or reservoir. The effects of storage and flow resistance are reflected by changes in the hydrograph shape and timing as the flood wave moves from upstream to downstream. In general, routing techniques may be classified into two major categories: hydraulic routing and hydrologic routing.

Hydraulic routing techniques are based on the solution of the continuity equation and the momentum equation for unsteady open channel flow. These differential equations are often referred to as the St. Venant equations or the dynamic wave equations. The solution of these equations defines the propagation of a flood wave with respect to distance along the channel and time.

Continuity Equation

$$q = A \frac{\partial V}{\partial x} + VB \frac{\partial y}{\partial x} + B \frac{\partial y}{\partial t} \quad (\text{Eq. 12-10})$$

Momentum Equation

$$S_f = S_o - \frac{\partial y}{\partial x} + \left(\frac{V}{g}\right) \left(\frac{\partial V}{\partial x}\right) - \left(\frac{1}{g}\right) \left(\frac{\partial V}{\partial t}\right) \quad (\text{Eq. 12-11})$$

Where:

- A = cross sectional flow area
- V = average velocity of water
- x = distance along channel
- B = water surface width
- y = depth of water
- t = time
- q = lateral inflow per unit length of channel
- S_f = friction slope
- S_o = channel bed slope
- g = gravitational acceleration

Hydrologic routing involves a balance of inflow, outflow and volume of storage through the use of the continuity equation. The storage-discharge relation is also required between outflow rates and storage within the reach. In its simplest form, the continuity equation can be written as inflow minus outflow equals the rate of change of storage within the reach.

Continuity Equation

$$I - O = \frac{\Delta s}{\Delta t} \quad (\text{Eq. 12-12})$$

Where:

- I = inflow
- O = outflow

ΔS = storage within a reach

Δt = change in time

Flood routing is used to simulate flood wave movement through river reaches and reservoirs. Most of the flood-routing methods available in TR-20 and [HEC-1](#)/[HEC-HMS](#) are based on the continuity equation and some relationship between flow and storage or stage. These methods are Muskingum, Muskingum-Cunge, Kinematic Wave, Modified Puls, Working R and D, and Level-pool reservoir routing. In all of these methods, routing proceeds on an independent-reach basis from upstream to downstream; neither backwater effects nor discontinuities in the water surface such as jumps or bores are considered.

12-400 STORAGE ROUTING

Detention basin routing can be detailed as in the case of Modified Puls routing where the entire inflow hydrograph is analyzed and a complete outflow hydrograph is produced, or it can be an approximate analysis as in the case of the Rational Method where only the peak discharge is considered. In either case the outflow discharge is dependent on the inflow discharge and the available storage within the detention basin.

A hydrograph producing method is preferable to compute the reduction of discharge through a detention basin due to available storage. There are various hydrologic analysis packages available to calculate the runoff rates and volumes from a watershed. The [HEC-1/HEC-HMS](#) and [TR-20](#) computer models are preferred. If hydrologic models other than [HEC-1/HEC-HMS](#) and [TR-20](#) are to be used, prior approval should be obtained from the IDOT staff.

12-401 Modified Puls Method⁶

The Modified Puls Method or Storage Indication Method applied to reservoirs or detention basins consists of a repetitive solution of the continuity equation. It is assumed that the reservoir water surface remains horizontal; and therefore, outflow is a unique function of reservoir storage. [Equation 12-12](#) can be written in finite-difference form as [Equation 12-13](#). The continuity equation can be manipulated to get both of the unknown variables on the left-hand side of the equation.

$$\frac{S_2 - S_1}{\Delta t} = \frac{1}{2}(I_1 + I_2) - \frac{1}{2}(O_1 + O_2) \quad (\text{Eq. 12-13})$$

$$\frac{S_2}{\Delta t} + \frac{O_2}{2} = \frac{S_1}{\Delta t} + \frac{O_1}{2} - O_1 + \frac{I_1 + I_2}{2} \quad (\text{Eq. 12-14})$$

Where:

- I = inflow
- O = outflow
- S = storage
- Δt = change in time

Since I is known for all time steps, and O_1 and S_1 are known for the first time step, the right hand side of the equation can be calculated. The left-hand side of the equation can be solved by trial and error. This is accomplished by assuming a value for either S_2 or O_2 , obtaining the corresponding value from the storage-outflow relationship, and then iterate until it is satisfied. Rather than resort to this iterative procedure, a value of Δt is selected and points on the storage-outflow curve are replotted as the "Storage-Indication" curve ($S/\Delta t + O/2$ vs. O). This graph allows for a direct determination of the outflow (O_2) once a value of storage-indication ($S_2/\Delta t + O_2/2$) has been calculated from the equation.

12-402 Modified Rational Method

The rational method of determining stormwater detention requirements is based on the equation $Q = CIA$. A description of the variables of this equation along with its limitations can be found in [Chapter 4](#) on Hydrology. The rational method of determining detention is generally used to

determine the volume of stormwater storage needed to compensate for increased runoff due to development. A step by step procedure is as follows:

1. Determine allowable release rate. This is usually equal to the maximum discharge rate under pre-development conditions, and can be determined by applying the equation $Q = CIA$.
2. Determine an after-development runoff coefficient, C .
3. Assume a variety of storm durations and choose the corresponding intensity as shown on the duration intensity charts in [Chapter 4](#) on Hydrology.
4. For each duration assumed and intensity chosen in [Step 3](#), determine a maximum discharge using the after-development runoff coefficient, C , in the equation $Q = CIA$.
5. From each discharge determined in [Step 4](#), subtract the allowable discharge determined in Step 1.
6. Multiply the discharges determined in [Step 5](#) by their corresponding duration to determine the detention needed for each duration storm.
7. The largest value obtained in [Step 6](#) is the volume of detention needed.

Once the volume of detention is determined, a basin and outlet structure is designed such that the required detention volume is provided at an elevation that does not produce discharges in the outlet structure above the allowable. Provision should be provided in the design to allow discharges larger than the design discharge to pass through the detention basin without producing a catastrophic failure.

12-403 Example Problems

12-403.01 Example Problem 1 (Modified Puls Method)

Determine:

The peak rate of discharge, the maximum water level, and the maximum amount of storage required for a detention basin.

Given:

1. The inflow hydrograph and flow rates ([Figure 12-403.01a](#))
2. The stage-storage curve for the storage structure - detention basin ([Figure 12-403.01b](#))
3. The performance curve or stage-discharge curve for the outlet structure ([Figure 12-403.01c](#))
4. The peak rate of discharge should not exceed 36.0 cuft/sec.

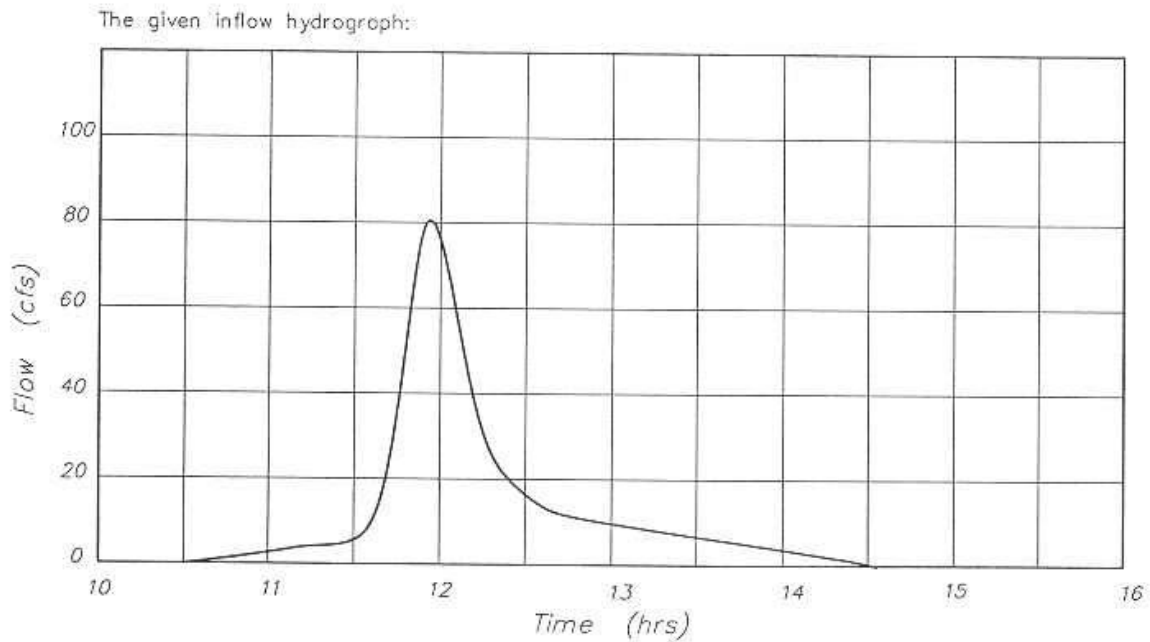

Figure 12-403.01a

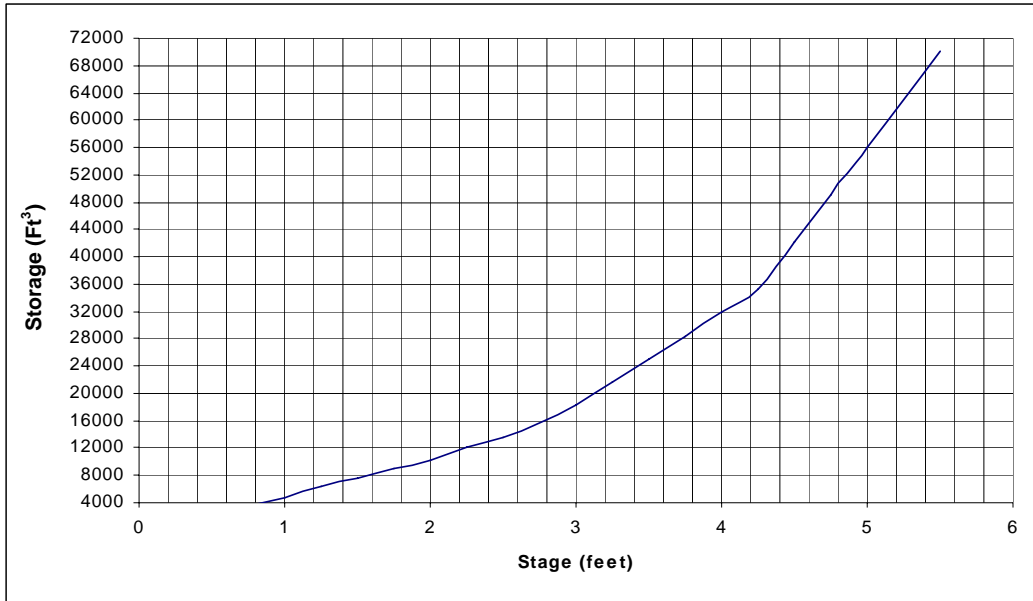

Figure 12-403.01b

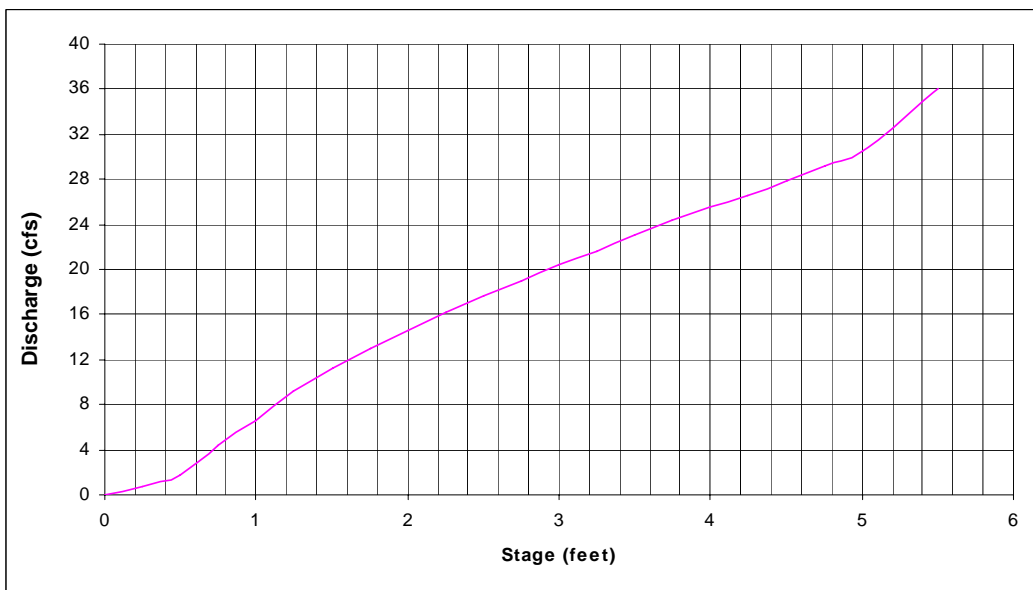

Figure 12-403.01c

Solution:

Step 1: Construct the storage indicator table (Table 12-403.01a):

- Column 2: Obtain from Figure 12-403.01c
- Column 3: Obtain from Figure 12-403.01b
- Column 4: Divide the discharge by 2
- Column 5: Divide the storage by the change in time (normally $\Delta t = 360$ sec). Also, Δt must match time increment used in determining the inflows from the inflow hydrograph.
- Column 6: Determine the storage-indicator value = Column 4 + Column 5

	Elevation (ft)	Discharge, O_2 (cfs)	Storage, S_2 (ft ³)	$\frac{O_2}{2}$	$\frac{S_2}{\Delta t}$	$\frac{S_2}{\Delta t} + \frac{O_2}{2}$
	Col. 1	Col. 2	Col. 3	Col. 4	Col. 5	Col. 6
1	0.00	0.0	0	0	0	0
2	0.25	0.8	1000	0.4	2.8	3.2
3	0.50	1.8	2500	0.9	6.9	7.8
4	0.75	4.4	3600	2.2	10.0	12.2
5	1.00	6.6	4800	3.3	13.3	16.6
6	1.25	9.2	6300	4.6	17.5	22.1
7	1.50	11.2	7600	5.6	21.1	26.7
8	1.75	13.0	9100	6.5	25.3	31.8
9	2.00	14.6	10300	7.3	28.6	35.9
10	2.25	16.2	12000	8.1	33.3	41.4
11	2.50	17.6	13500	8.8	37.5	46.3
12	2.75	19.0	15800	9.5	43.9	53.4
13	3.00	20.4	18300	10.2	50.8	61.0
14	3.25	21.6	21700	10.8	60.3	71.1
15	3.50	23.0	25100	11.5	69.7	81.2
16	3.75	24.4	28300	12.2	78.6	90.8
17	4.00	25.6	31900	12.8	88.6	101.4
18	4.25	26.6	35200	13.3	97.8	111.1
19	4.50	27.9	42200	14.0	117.2	131.2
20	4.75	29.2	49200	14.6	136.7	151.3
21	5.00	30.5	56000	15.3	155.6	170.9
22	5.50	36.0	70000	18.0	194.4	212.4

Table 12-403.01a

Step 2: Graph the discharge versus the storage-indicator number:

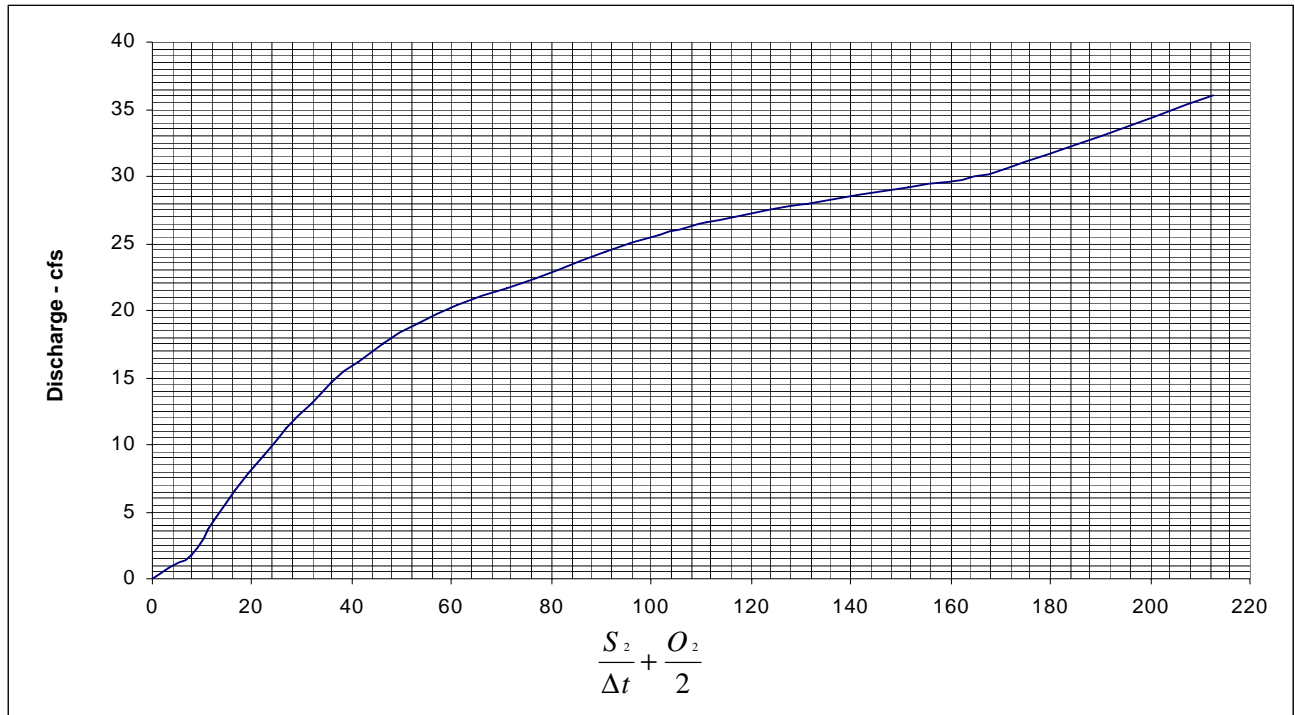

Figure 12-403.01d

Step 3: Graph the storage versus the storage-indicator number:

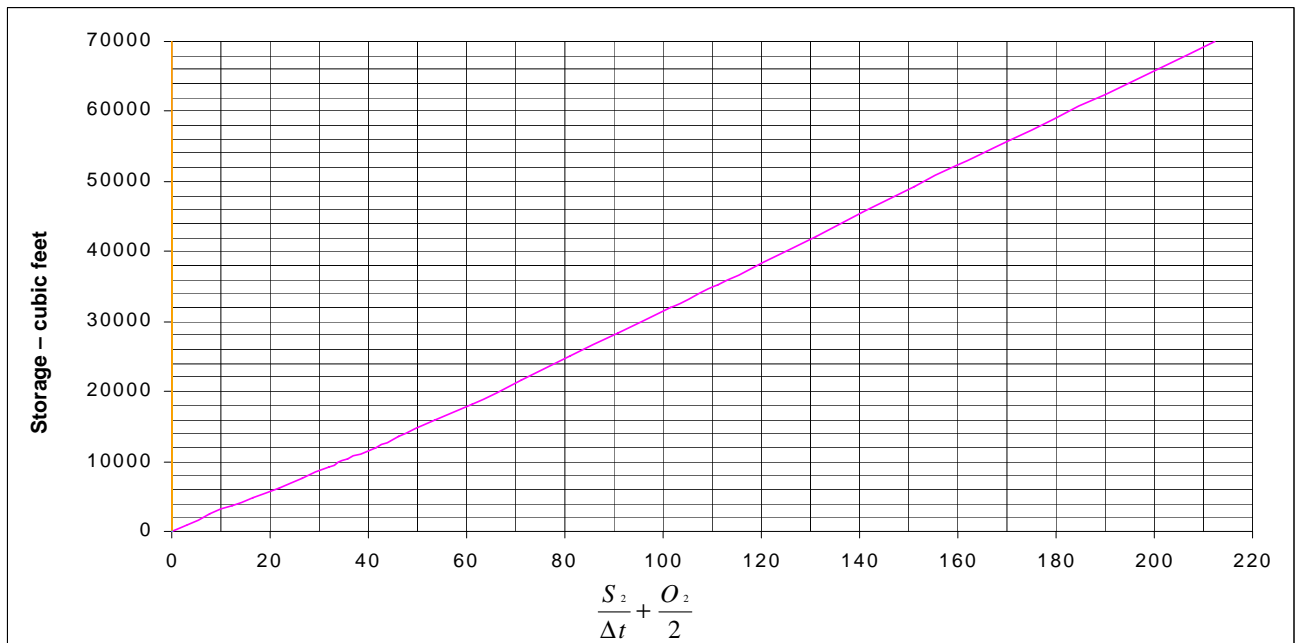

Figure 12-403.01e

Step 4: Develop the routing table (Table 12-403.01b):

- Column 1&2: From inflow hydrograph (Figure 12-403.01a)
- Column 3: Average inflow
- Column 4: Initial value is taken from the storage-indicator curve for the flow of O_1 (column 5). Usually this value is zero.
- Column 5: Initial value of O_1 is assigned. Usually this value is zero.
- Column 6: Column 3 + Column 4 - Column 5
- Column 7: Enter storage indicator curve with $\frac{S_2}{\Delta t} + \frac{O_2}{2}$ value (Column 6) to obtain O_2 (Figure 12-403.01d)

Transpose Column 6 and 7 to Column 4 and 5 for the next line.

	Time, t (hrs.)	Inflow, I (cfs)	$\frac{I_1 + I_2}{2}$	$\frac{S_1}{\Delta t} + \frac{O_1}{2}$	O_1 (cfs)	$\frac{S_2}{\Delta t} + \frac{O_2}{2}$	O_2 (cfs)
	Col. 1	Col. 2	Col. 3	Col. 4	Col. 5	Col. 6	Col. 7
1	10.5	0.0	0	0	0	0	0
2	10.6	0.4	0.2	0	0	0.2	0
3	10.7	1.0	0.7	0.2	0	0.9	0.2
4	10.8	1.4	1.2	0.9	0.2	1.9	0.5
5	10.9	2.0	1.7	1.9	0.5	3.1	0.8
6	11.0	2.6	2.3	3.1	0.8	4.8	1.0
7	11.1	3.2	2.9	4.8	1.0	6.7	1.6
8	11.2	4.0	3.6	6.7	1.6	8.7	2.3
9	11.3	4.2	4.1	8.7	2.3	10.5	2.9
10	11.4	4.4	4.3	10.5	2.9	11.9	4.0
11	11.5	5.2	4.8	11.9	4.0	12.7	4.6
12	11.6	8.0	6.6	12.7	4.6	14.7	5.1
13	11.7	20.0	14.0	14.7	5.1	23.6	9.8
14	11.8	49.0	34.5	23.6	9.8	48.3	18.2
15	11.9	84.4	66.7	48.3	18.2	96.8	25.0
16	12.0	79.0	81.7	96.8	25.0	153.5	29.7
17	12.1	58.0	68.5	153.5	29.7	192.3	32.8
18	12.2	37.0	47.5	192.3	32.8	207	35
19	12.3	25.0	31.0	207	35	203	34.4
20	12.4	20.0	22.5	203	34.4	191.1	32.4
21	12.5	16.4	18.2	191.1	32.4	176.9	31.0
22	12.6	13.6	15.0	176.9	31.0	160.9	30.0
23	12.7	11.6	12.6	160.9	30.0	143.5	29.0

Table 12-403.01b

Step 5: Determine the maximum outflow from the routing table ([Table 12-403.01b](#)):

Maximum discharge = 35 cuft/sec

Step 6: Determine the required storage in the detention basin

List the storage-indicator value corresponding to the maximum outflow:

Storage-indicator value = 207

Using this storage-indicator value, determine the required storage from the storage vs. storage-indicator curve ([Figure 12-403.01e](#)):

Required storage = 67400 cuft

Step 7: Determine the maximum stage from the storage-indicator table ([Table 12-403.01a](#)):

Maximum stage = 5.43 ft

12-403.02 Example Problem 2 (Modified Rational Method)

A 25 acre site is to be developed and the post development outflow rate will be limited to the existing 100 year peak flow rate.

Determine:

1. The required storage using the Modified Rational Method
2. Determine the maximum stage for the required storage

Given:

Location: Northeast Illinois

Drainage Area: $A = 25$ acres

Pre-development: Earth surface, loamy soil with light vegetation

-100 feet of overland flow, $n = 0.15$

-800 feet of shallow concentrated flow

-900 feet of ditch flow, $n = 0.04$

Post-development: Primarily paved surfaces and roof tops

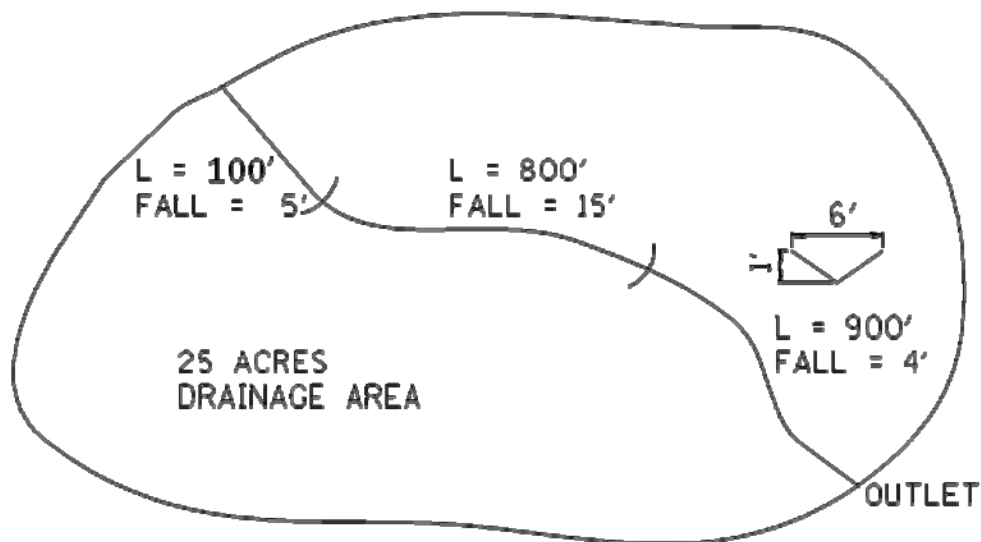

Solution:

Step 1: Calculate the existing peak discharge for the 100 year return period:

Determine the slope of the overland, shallow concentrated and ditch flow sections:

Overland flow slope = $5 \text{ ft}/100 \text{ ft} = 0.03 \text{ ft/ft}$

Shallow concentrated flow slope = 15 ft/800 ft = 0.0188 ft/ft

Ditch flow slope = 4/900 = 0.0044 ft/ft

Determine the existing travel times for the three sections:

Overland flow time (use Manning's kinematic Wave equation iterative process followed per Chapter 4)²:

I = 6.8 in/hr (from [Bulletin 70](#) for 100 year intensity)

$$t_{of} = \frac{56L^{0.6} n^{0.6}}{I^{0.4} S^{0.3}} = \frac{56(100)^{0.6} (0.15)^{0.6}}{(6.8)^{0.4} (0.03)^{0.3}}$$

$$= 378.66 \text{ sec} = 0.10 \text{ hrs}$$

Shallow concentrated flow time (Use average flow velocity from [Figure 102m](#), Drainage Manual):

V = 2.2 ft/sec

$$t_{sc} = \frac{L}{3600v} = \frac{800}{3600(2.2)} = 0.10 \text{ hrs}$$

Ditch flow time (use average flow velocity based on Manning's equation):

$$v = \frac{1.49r^{2/3} s^{1/2}}{n} = \frac{1.49(0.47)^{2/3} (0.0044)^{1/2}}{0.04}$$

$$= 1.5 \text{ ft/sec}$$

Where: $a = 2(1/2)(3)(1) = 3 \text{ sqft}$

$$p_w = 2\left(\sqrt{3^2 + 1^2}\right) = 6.32 \text{ ft}$$

$$r = \frac{a}{p_w} = \frac{3}{6.32} = 0.47$$

$$t_{oc} = \frac{L}{3600v} = \frac{900}{3600(1.5\text{fps})} = 0.17 \text{ hrs}$$

Compute the time of concentration as the summation of travel times:

$$T_C = 0.10 + 0.10 + 0.17 = 0.37 \text{ hrs.}$$

Compute the existing peak runoff:

Existing runoff coefficient, $C = 0.45$

100 Year Intensity (from [Bulletin 70](#), setting the time of concentration equal to the storm duration), $I = 6.8$ in/hr

Peak Runoff, $Q = CIA = 0.45(6.8)(25) = 76$ cuft/sec

Step 2: Compute the maximum storage required using the table below.

- Column 1: Runoff Coefficient based on post development.
- Columns 2&3: Assume a variety of storm durations and choose the corresponding intensities from [Bulletin 70](#).
- Column 4: Drainage area in acres.
- Column 5: Computed by $Q = CIA$ where C is based on post development conditions.
- Column 6: Allowable discharge determined previously.
- Column 7: Column 5 - Column 6
- Column 8: Column 7 x Column 2 adjusted for proper units.

	Runoff Coeff. C	Storm Duration T (min)	Intensity I (in/hr)	Area A (Acres)	Inflow Rate Qi (cfs)	Release Rate Qo (cfs)	Storage Rate (Qi-Qo) (cfs)	Storage (Qi-Qo)T x 60 (cu. ft.)
	Col. 1	Col. 2	Col. 3	Col. 4	Col. 5	Col. 6	Col. 7	Col. 8
1	0.9	5	10.92	25	245.70	76.3	169.40	50820
2	0.9	10	10.02	25	225.45	76.3	149.15	89490
3	0.9	15	8.20	25	184.50	76.3	108.20	97380
4	0.9	20	7.10	25	159.75	76.3	83.45	100140
5	0.9	25	6.30	25	141.75	76.3	65.45	98175
6	0.9	30	5.60	25	126.00	76.3	49.70	89460
7	0.9	40	4.58	25	103.50	76.3	27.20	65280
8	0.9	60	3.56	25	80.15	76.3	3.80	13680
9	0.9	120	2.24	25	63	76.3	0	0

The volume of storage required in cuft = 100140 cuft.

Step 3: Develop a rating curve for the outlet structure to determine the elevation which the storage must be provided below. The outlet structure is a 36 inch concrete pipe with a grooved end and a headwall. Inlet control for the outlet pipe is assumed for the exercise; it is required outlet control be checked for correctness.

Outlet headwater table:

Q (cfs)	HW/D	HW (feet)
30	0.85	2.55
40	1.04	3.12
50	1.20	3.60
60	1.45	4.35
70	1.70	5.10
80	2.00	6.00

Stage-Discharge curve:

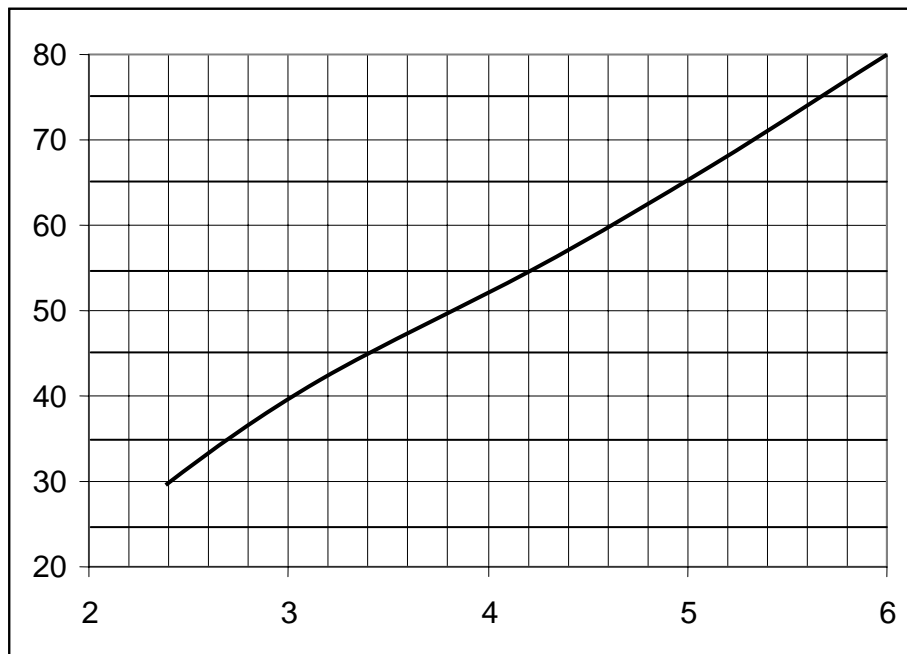

*When release rate = 76 cuft/sec.
The maximum stage for the required storage = 5.6 ft.*

12-500 LINEAR STORMWATER DETENTION**12-501 Scope**

For the purpose of this manual, linear stormwater detention refers to both open and closed drainage systems, initially designed for conveyance and modified to provide the stormwater detention determined to be necessary. The linear nature of highway drainage systems lend themselves to linear storage systems. This can be accomplished by oversizing all or a portion of the drainage system. Conditions may result in rendering linear storage unfeasible. These include topographic limitation, utility conflicts, proximity of water mains, unusual soil conditions, slope stability, high rock table, groundwater table conditions, and conflicts with agricultural tiles. Linear detention, especially storm sewer detention is particularly suited to highway congested areas where surface ponding is prohibited due to the scarcity or high cost of available land.

Generally, when conditions result in a closed highway drainage system, the availability and practicality of open detention sites is limited and/or not compatible with the "urban" nature of the area. Oversizing for storage is usually developed for the design frequency of the conveyance system and the additional storage due to volume increased in the highway right of way for the 100 year flood frequency is normally not required. In the event oversizing of pipe is necessary for floods exceeding the design frequency, it would be necessary to check that the storm water runoff can get to the storage pipe.

Occasionally, it may be feasible to oversize the highway drainage ditch for storage. Caution is to be exercised in the evaluation to assure that the safety aspects and related cost of protection to both vehicles and pedestrians are considered. Controls relative to the level of "standing water" consist of freeboard to pavements, saturation of subgrade and also flooding of adjacent properties. The ditch bottom elevation controls would consist of slope stability, maintenance, ground water and the relativity of the hazard.

The effects that external drainage areas would have on the highway drainage system need to be considered. Since the area outside of the highway right of way is not under the direct control of the Department, it may be prudent to evaluate the merit of an independent highway drainage system in the selection for the conveyance system concept, especially when storm water detention is to be incorporated into the design. Factors to be considered include the nature of the external area, the extent to which it would be subject to soil erosion (and subsequent siltation), and the extent to which the reduced velocities and potential build up of sedimentation would jeopardize the integrity of the conveyance system and increase maintenance costs.

The hydraulics of the receiving system should also be evaluated. The information developed in the design of highway drainage systems should include appropriate information on the peaking characteristics of the recipient of the discharge from the highway drainage system. In urbanized areas the outlet hydraulics may require a complex time consuming analysis that may not be justified in view of the relatively minor cost savings that may result in the design. It may be appropriate to look at the more conservative approach in outlet stage-frequency relationships of assuming that the peaking characteristics occur at the same time thus resulting in a worse case scenario. If a sophisticated study of peaking characteristics would appear to result in significant cost savings, the analysis should be performed.

12-502 Application

Linear storage consists of the drainage system as designed for conveyance that is modified to meet storage requirements and the control structures incorporated into the drainage system for inflow and outflow. Storm sewers designed for conveyance require minimum velocities of 3 feet per second. As sewers are oversized for storm water detention, velocities of 2 feet per second are permissible. For either existing or proposed conveyance systems, auxiliary storage may be utilized for exclusive or supplementary storage. Generally, linear storage systems are either parallel systems or series systems. A schematic of the two systems are shown on [Figure 12-502a](#). It should be recognized that existing conveyance systems can often be salvaged and modified to incorporate additional storage as shown on [Figure 12-502b](#).

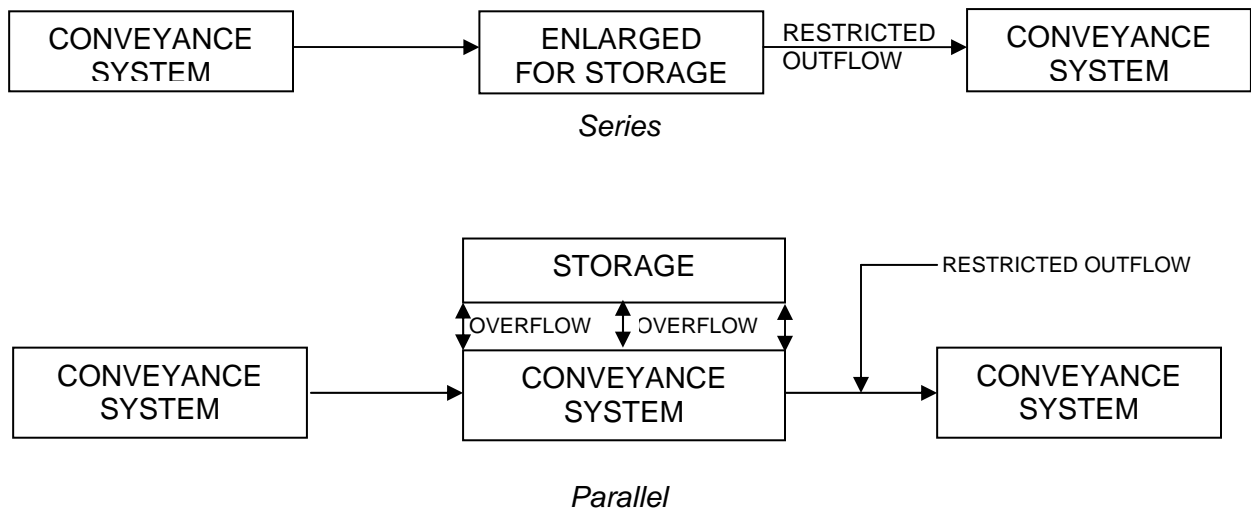

*Series and Parallel Storage Systems
Figure 12-502a*

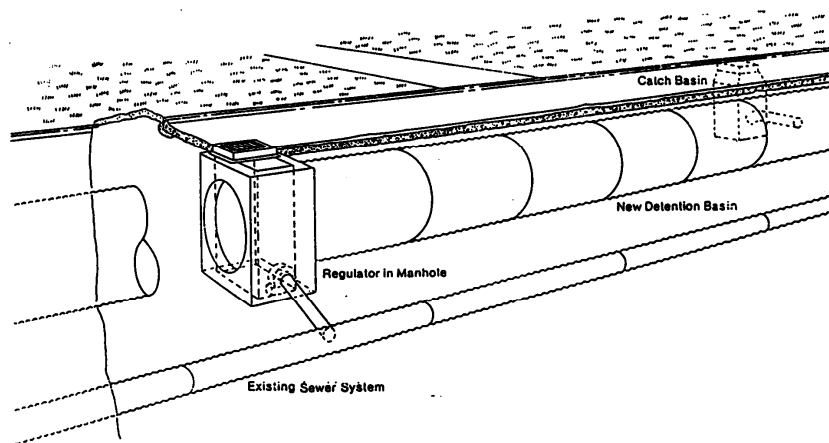

*Storage Utilizing Existing Conveyance System
Figure 12-502b*

A parallel pipe system concept is shown in Figure 12-502c. The Storage pipe has no minimum velocity. Purpose is for storm water storage volume. It must gravity drain out to the conveyance pipe after storage. Desired velocity for conveyance pipe is 3 feet per second. Velocities are based on full flow conditions. However check design flow velocities.

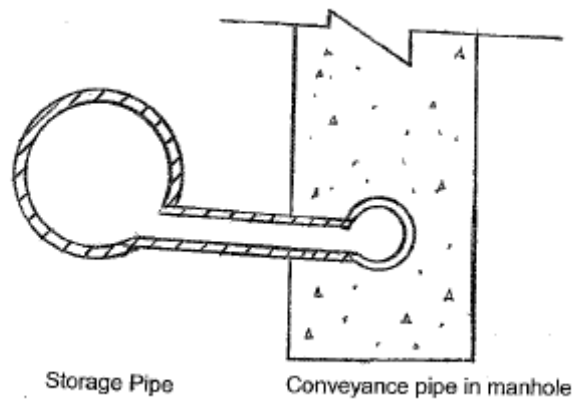

*Parallel Pipe System
Figure 12-502c*

Inflow structures should provide sufficient volume to the system to fully utilize the storage that is available. The design of outflow structures in conjunction with storage systems is critical in the effectiveness of the overall design. The control structure design ranges from utilizing conventional manholes to relatively expensive structures. Properly designed outlet structures should incorporate the following items:

- Overflow facilities to protect highway and adjacent property from flooding
- Hydraulic control elements such as restrictor orifices
- Vehicular and pedestrian safety features
- Accessibility for easy maintenance
- Should control the velocity to avoid siltation

Examples of control structures are shown on [Figure 12-502d](#) through [Figures 12-502g](#).

Typical highway practice for oversized storm sewers is to provide an orifice with a weir overflow for the design storm event (Figure 12-502c). If bypass/offsite flow is brought into the oversized sewer, the orifice should maintain, at a minimum, the existing discharge rate (pre-development) for the entire tributary area.

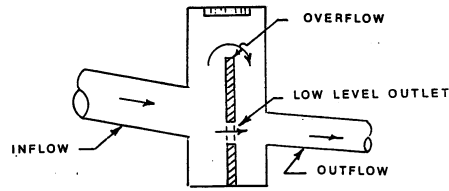

*Storm Sewer Storage
Figure 12-502d*

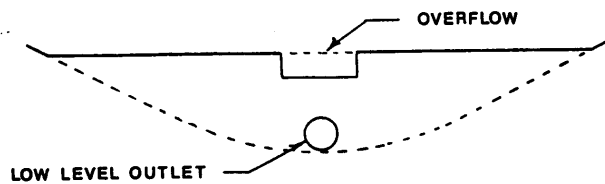

*Ditch Storage
Figure 12-502e*

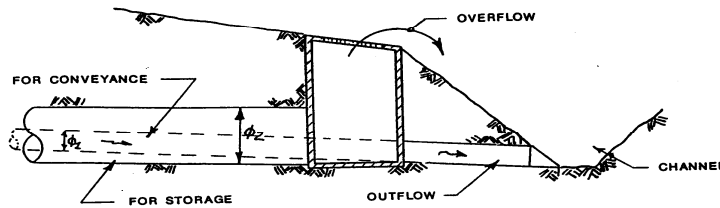

*Storm Sewer Storage to Ditch Flow
Figure 12-502f*

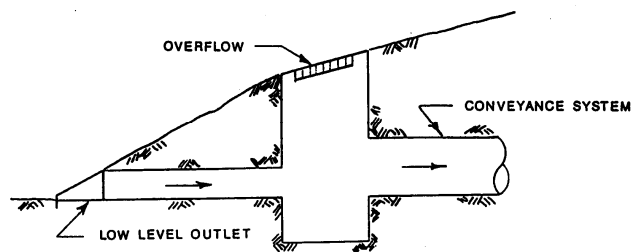

*Ditch Storage to Storm Sewer Flow
Figure 12-502g*

Discharge rates for control structures can be calculated utilizing the proper flow equations (weir, orifice) as discussed in [Section 12-200](#) of this chapter. When calculating the discharge rate, the depth of flow into the receiving system will need to be calculated to determine its backwater effect on the control structure. Discharges for control structures utilizing the orifice equation can be adjusted for backwater conditions by determining the difference in the water surface elevation upstream and the water surface elevation downstream of the orifice or the center of the orifice.

12-503 Storage Volume

The routing procedure through a linear storage system is the same as any of the routing procedures discussed in this chapter. An inflow discharge is calculated, stage-discharge curve is calculated, and stage-storage curve is developed. Since the invert of a linear storage system is sloping to a positive outlet the process of calculating the stage storage relationship is made more complicated. The storage volume in pipes and ditches can be determined by the prismoidal formula.

$$V = \left(\frac{L}{6}\right)(A_1 + A_2 + 4M) \tag{Eq. 12-15}$$

Where:

- V = volume of water in pipe or ditch, cuft
- L = wetted length of pipe or ditch, ft
- A₁ = wetted cross sectional area of lower end of pipe or ditch, sqft
- A₂ = wetted cross sectional area of upper end of pipe or ditch, sqft
- M = wetted cross sectional area of midsection of pipe or ditch, sqft

Table 12-503 shows the hydraulic properties for circular and pipe arch conduits flowing partially full.

Hydraulic Properties of Circular Conduits Flowing Partly Full

d = Depth of Flow
 d_c = Critical depth
 d_m = Mean depth

D = Diameter of pipe
 A = Area of flow
 R = Hydraulic radius
 T = Top width of flow

$\frac{d}{D}$ or $\frac{d_c}{D}$	$\frac{A}{D^2}$	$\frac{R}{D}$	$\frac{T}{D}$	$\frac{d_m}{D}$
1.00	0.7854	0.2500	—	—
0.95	0.7707	0.2865	0.4359	1.7681
0.90	0.7445	0.2980	0.6000	1.2408
0.85	0.7115	0.3033	0.7142	0.9962
0.80	0.6736	0.3042	0.8000	0.8420
0.75	0.6319	0.3017	0.8660	0.7297
0.70	0.5872	0.2962	0.9165	0.6407
0.65	0.5404	0.2882	0.9539	0.5665
0.60	0.4920	0.2776	0.9798	0.5021
0.55	0.4426	0.2649	0.9950	0.4448
0.50	0.3927	0.2500	1.0000	0.3927
0.45	0.3428	0.2331	0.9950	0.3445
0.40	0.2934	0.2142	0.9798	0.2994
0.35	0.2450	0.1935	0.9539	0.2568
0.30	0.1982	0.1709	0.9165	0.2163
0.25	0.1535	0.1466	0.8660	0.1773
0.20	0.1118	0.1206	0.8000	0.1397
0.15	0.0739	0.0929	0.7142	0.1035

Hydraulic Properties of Pipe Arch Conduits Flowing Partly Full

d = Depth of flow
 d_c = Critical depth
 d_m = Mean depth

D = Diameter of pipe
 A = Area of flow
 R = Hydraulic radius
 T = Top width of flow.

$\frac{d}{D}$ or $\frac{d_c}{D}$	$\frac{A}{D^2}$	$\frac{R}{D}$	$\frac{T}{D}$	$\frac{d_m}{D}$
1.00	0.7879	0.2991	—	—
0.95	0.7762	0.3408	0.3489	2.225
0.90	0.7552	0.3549	0.4855	1.555
0.85	0.7283	0.3622	0.5848	1.245
0.80	0.6970	0.3649	0.6637	1.0503
0.75	0.6621	0.3639	0.7288	0.9085
0.70	0.6243	0.3595	0.7837	0.7966
0.65	0.5839	0.3520	0.8303	0.7033
0.60	0.5414	0.3415	0.8700	0.6223
0.55	0.4970	0.3282	0.9037	0.5500
0.50	0.4511	0.3120	0.9320	0.4840
0.45	0.4039	0.2928	0.9555	0.4227
0.40	0.3556	0.2705	0.9755	0.3646
0.35	0.3065	0.2451	0.9889	0.3100
0.30	0.2568	0.2162	0.9967	0.2577
0.25	0.2069	0.1839	0.9967	0.2076
0.20	0.1574	0.1484	0.9815	0.1603
0.15	0.10908	0.11022	0.9477	0.11505

Table 12-503 Hydraulic Properties⁷

In the special case of circular pipe the volume can be determined by the ungula of a cone formula, [Figure 12-503](#), and [Equation 12-16](#).

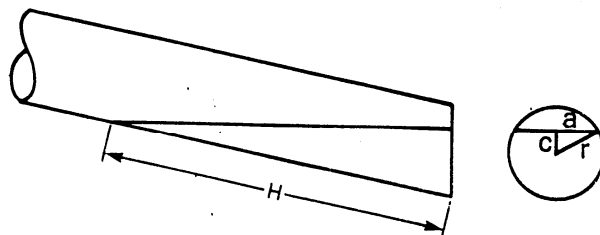

Figure 12-503

$$V = \frac{H \left(\frac{2}{3} a^3 \pm cB \right)}{r \pm c} \tag{Eq. 12-16}$$

Where:

- V = volume of water in pipe, cuft
- H = wetted length of pipe, ft.
- a = 1/2 of the water surface width, ft
- r = radius of pipe, ft.
- c* = distance from center of pipe to water surface, ft
- B = wetted cross sectional area of base, sqft

- *use + when water surface is above center of pipe
- *use - when water surface is below center of pipe

In [Equation 12-16](#) the value of "a" can be calculated as:

$$a = \left(r^2 - c^2 \right)^{0.5} \tag{Eq. 12-17}$$

[Equation 12-16](#) assumes the pipe is on a uniform slope. If this is not the case, use [Equation 12-15](#) and determine the volume of storage for each section of pipe on a uniform slope and sum up the volumes to determine the total volume.

12-504 Example Problems

12-504.01 Example Problem 1 (Storage Volume in Pipes)

Determine:

The volume in a circular pipe given the following:

Given:

Diameter = 5 ft

Slope of pipe is 0.8 percent

Depth of water at the downstream end of the pipe is 4 ft

Solution:

Step 1: Determine the wetted length of pipe by dividing the depth of flow at the downstream end by the slopes.

$$L = \frac{4}{0.008} = 500 \text{ ft}$$

Step 2: Utilizing [Equation 12-15](#)

$$V = \left(\frac{L}{6}\right)(A_1 + A_2 + 4M)$$

A_1 is determined using [Table 12-503](#) knowing $d=4$ ft and $D=5$ ft.

$$\frac{A_1}{D^2} = 0.6736$$

$$A_1 = 0.6736(5)^2 = 16.84 \text{ sqft}$$

$A_2 = 0$ because the depth of flow "d" is 0 at the upper end of the pipe

M is determined using [Table 12-503](#) knowing $d=2$ ft and $D=5$ ft.

$$\frac{M}{D^2} = 0.2934$$

$$M = 0.2934(5)^2 = 7.335 \text{ sq ft}$$

Inserting into [Equation 12-15](#)

$$V = \left(\frac{500}{6}\right)(16.84 + 0 + (4)(7.335))$$

$$V = 3848 \text{ cuft}$$

Step 3: Since this is a circular pipe with uniform slope, the volume can also be determined using [Equation 12-16](#) and [Equation 12-17](#).

$$c = 4 \text{ ft} - 2.5 \text{ ft} = 1.5 \text{ ft}$$

$$r = 2.5 \text{ ft}$$

$$a = (r^2 - c^2)^{0.5}$$

$$a = (2.5^2 - 1.5^2)^{0.5} = 2 \text{ ft}$$

$$V = \frac{H \left(\frac{2}{3} a^3 \pm cB \right)}{r \pm c}$$

Where:

$$H = 500 \text{ ft}$$

$$a = 2 \text{ ft}$$

$c = 1.5 \text{ ft}$, c is positive (depth of flow is above the center of the pipe)

$B = 16.84 \text{ sqft}$ (same as A , in [Equation 12-15](#))

$$V = \frac{500 \left(\left(\frac{2}{3} \right) 2^3 + (1.5)(16.84) \right)}{(2.5 + 1.5)} = 3824 \text{ cuft} \quad (3848 \text{ cuft determined in$$

Step 2)

12-504.02 Problem 2 (Oversized Conveyance System)

Incorporate the following data into the Hydra program in Hydrain to perform hydraulic analysis and design.

Determine:

1. The conveyance system for a 10 year storm frequency
2. Outlet structures to maintain the existing 10 year and 100 year release rates
3. Pipe sizes to meet the storage volume requirement

Given:

- Tributary Area = 1.47 acres
- Existing composite runoff coefficient = 0.78
- Proposed composite runoff coefficient = 0.9
- Existing 10-year Release rate = 4.82 cuft/sec
- Existing 100-year Release rate = 9.21 cuft/sec
- Existing 10 year tailwater elevation at outlet = 48.92 ft
- Required 10-year storage volume = 1779 cuft

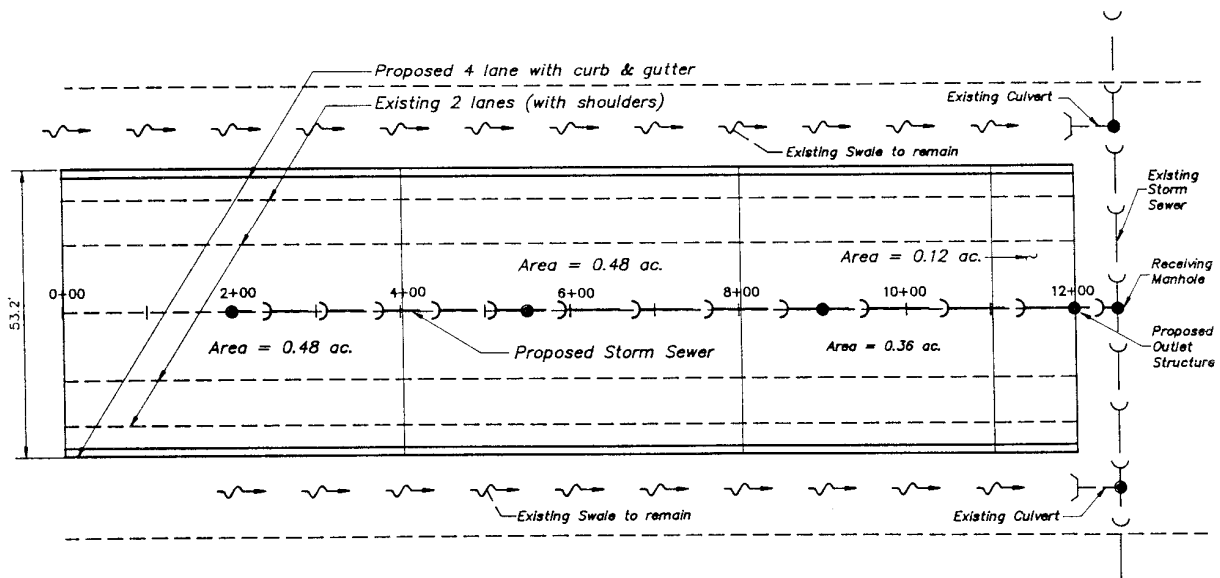

PLAN

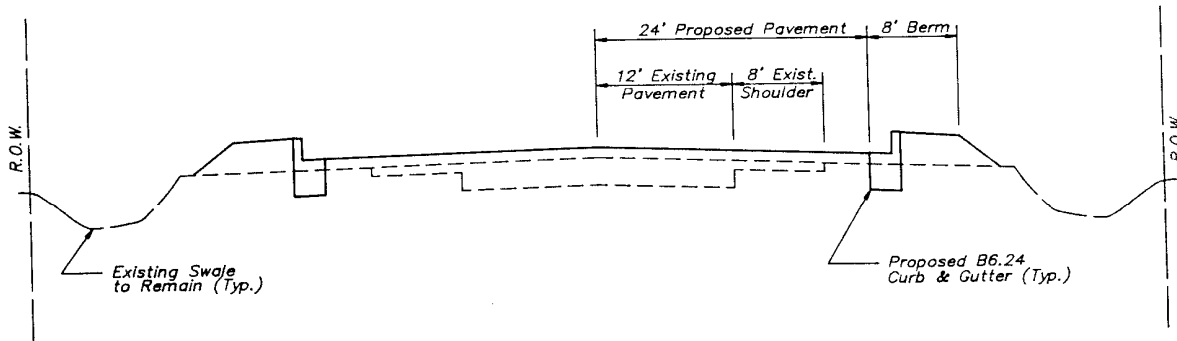

TYPICAL EXISTING & PROPOSED CROSS SECTION

Solution:

Step 1: Design the conveyance system using the 10-year rainfall data from Bulletin 70.

INPUT:

JOB Linear stormwater detention Rational Method Design with Hydraulic Gradeline

SWI 2

PDA 0.013 12 4 3 3 0.005 66

RAI 5,6.5 10,5.88 15,4.84 21,4.2 30,3.3 60,2.1 120,1.32 180,0.94 360,0.69

HGL 1

NEW MAIN TRUNK

REM Junctions 1 to 2 (station 2+00 to 5+50)

STO 0.48 0.90 5.0

PIP 346 63.0 59.0 59.25 54.00

PNC 1 2 4 0 0 0

REM Junctions 2 to 3 (station 5+50 to 9+00)

STO 0.48 0.90 6

PIP 346 59.0 56.0 53.75 50.00

PNC 2 3 4 0 0 0

REM Junctions 3 to 4 (station 9+00 to 12+00)

STO 0.36 0.90 7

PIP 296 56.00 53.5 50.00 47.00

PNC 3 4 4 0 0 0

REM Junction 4 to 5 (station 12+00 to 12+50)

STO .12 0.909 8

PIP 50 53.5 53.0 47.00 46.50

PNC 4 5 0 0 0

END

OUTPUT:

MAIN TRUNK

Link #	Length (ft)	Diam (in)	Invert (ft)	Depth Up/Dn (ft/ft)	Min. Slope (ft)	Velocity Up/Dn (ft/s)	--Flow-- Cover (cfs)	Estimated Act/Full (\$)	Act/Full (\$)	Cost
1	346	12	59.25	.01517	3.8	2.7	5.9	2.81	0.	
			54.00	5.0	5.6	4.39				
2	346	15	53.75	.01084	5.3	3.9	6.1	5.51	0.	
			50.00	6.0	5.5	6.73				
3	296	18	50.00	.01014	6.0	4.4	6.5	7.43	0.	
			47.00	6.5	6.0	10.58				
4	50	18	47.00	.01000	6.5	4.9	6.5	7.94	0.	
			46.50	6.5	5.9	10.50				

Length = 1038. ft Total length = 1038. ft
 Cost = 0. Total Cost = 0.

Hydraulic Gradeline Computations

Link #	stream Node #	Down- Hydraulic Gradeline Elevation	Crown Elev.	Possible Surchage	Ground Elev.	Super- crit.?	Manhole Depth	Loss Coef
1	2	54.72	55.00	N	59.00	Y	1.72	1.95
2	3	50.95	51.25	N	56.00	Y	1.77	1.92
3	4	48.05	48.50	N	53.50	Y	1.78	2.11
4	5	47.49	48.00	N	53.00	Y	.99	.00

Link #	Terminal Node #	Hydraulic Gradeline Elevation	Ground Elevation	Loss Coef.
1	1	60.66	63.00	1.50

NORMAL END OF HYDRA

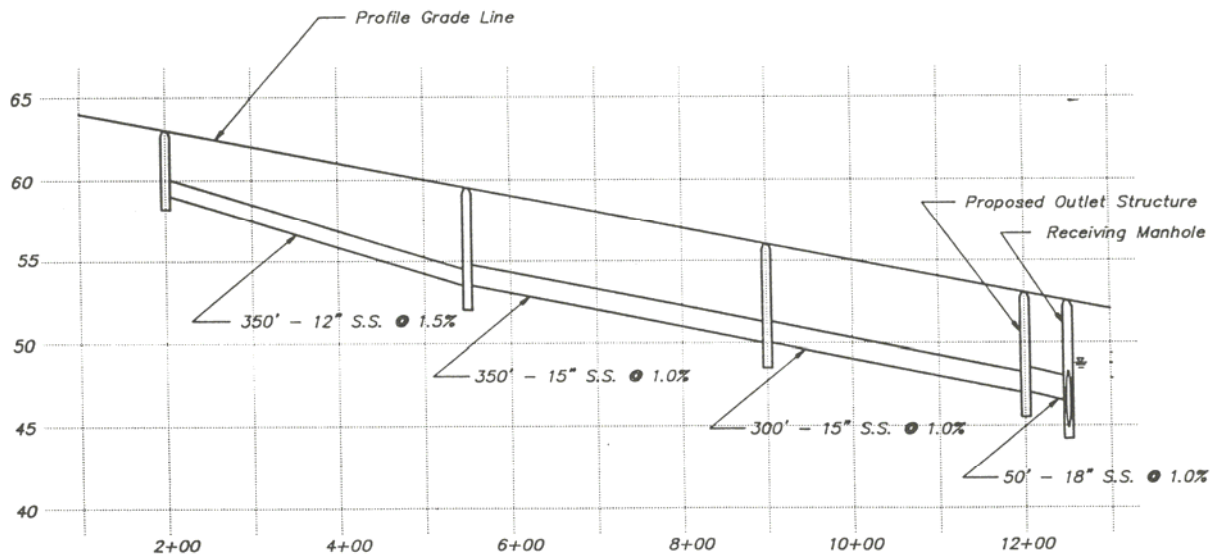

INITIAL CONVEYANCE SYSTEM

CONVEYANCE SYSTEM

Step 2: Design the control structure by sizing the restrictor and overflow weir.

Assume the use of a circular orifice in a sharp edge plate with a minimum diameter of 12 inches.

Note the orifice equation:

$$Q_0 = C_d A \left(2g \left(H + \frac{v^2}{2g} \right) \right)^{1/2}$$

When velocity ≤ 3.0 fps, neglect velocity head, $\left(\frac{v^2}{2g} \right)$

$$Q_0 = C_d A (2gH)^{1/2}$$

Where:

- Q_0 = existing 10-year event discharge rate (4.82 cuft/sec)
- C_d = orifice coefficient ($C_d = 0.61$)
- A = area of the orifice (for 12 inch diameter, $A = 0.785$ sqft)
- g = gravitational acceleration ($g = 32.2$ ft/sec)
- H = created head, ft

Therefore:

$$4.82 = 0.61(0.785)[2(32.2(H))]^{1/2}$$

$$H = 1.57 \text{ ft}$$

Proposed weir elevation = Tailwater elevation + Created head

$$\text{Proposed weir elevation} = 48.92 \text{ ft} + 1.57 \text{ ft} = 50.49 \text{ ft}$$

Calculate the 100-year water surface elevation over the weir:

$$Q_{100\text{yr}} = C_w L H_w^{3/2} + C_d A (2gH_o)^{1/2}$$

Where:

$$Q_{100\text{yr}} = 100 \text{ year release rate (9.21 cuft/sec)}$$

$$C_w = \text{weir coefficient (2.7)}$$

$$L = \text{weir length (4 ft)}$$

$$H_w = \text{head on the weir}$$

$$C_d = \text{orifice coefficient (0.61)}$$

$$A = \text{area of the orifice (12 inch dia. = 0.785 sqft)}$$

$$g = \text{gravitational acceleration (32.2 ft/sec)}$$

$$H_o = \text{head on the orifice}$$

Assume the tailwater elevation between the 10 year and 100 year event is constant.

$H_w = H_o - H$ (H is the head between the tailwater and the top of the proposed weir, previously calculated as 1.57 ft).

Therefore:

$$9.21 = 2.7(4)(H_o - 1.57)^{3/2} + 0.61(0.785)[2(32.2)H_o]^{1/2}$$

$$H_o = 2.06 \text{ ft (By Trial and Error)}$$

$$H_w = 2.06 - 1.57 = 0.49 \text{ ft}$$

$$\text{Water surface elevation at weir} = 50.49 + 0.49 = 50.98 \text{ ft}$$

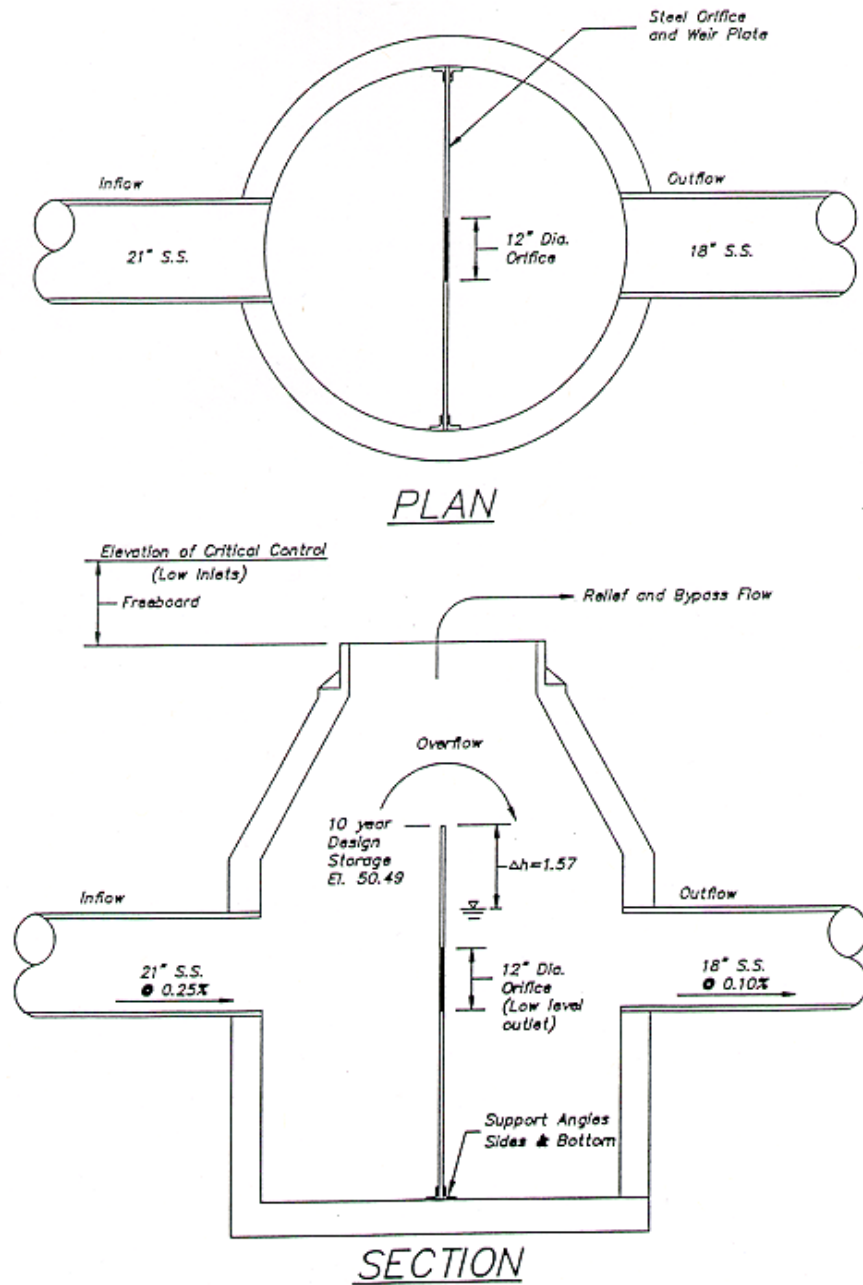

PROPOSED OUTLET STRUCTURE

Step 3: Model conveyance system with the restrictor to see if the storage is adequate.

INPUT:

SWI 2

PDA 0.013 12 4 3 3 0.005 66

RAI 5,6.5 10,5.88 15,4.84 21,4.2 30,3.3 60,2.1 120,1.32 180,0.94
360,0.69

HGL 1

NEW MAIN TRUNK

REM Junctions 1 to 2 (station 2+00 to 5+50)

STO 0.48 0.90 5.0

PIP 346 63.0 59.0 59.25 54.0 -12

PNC 1 2 4 0 0 0

REM Junctions 2 to 3 (station 5+50 to 9+00)

STO 0.48 0.90 6.0

PIP 346 59.0 56.0 53.75 50.00 -15

PNC 2 3 4 0 0 0

REM Junctions 3 to 4 (station 9+00 to 12+00)

STO 0.36 0.90 7.0

PIP 296 56.00 53.5 50.0 47.00 -18

PNC 3 4 4 0 2 0

TWE 50.49

END

OUTPUT:

MAIN TRUNK

Analysis of Existing Pipes

Link	Length (ft)	Diam (in)	Invert (ft)	Depth (ft/ft)	Cover (ft)	Velocity (ft/s)	--Flow-- Up/Dn	-Solutions- Up/Dn	Act/Full (cfs)	Act/Full (cfs)	Load	Remove (in)
1	346	12	59.25	.015	17	3.8	2.7	5.9	2.81	64		

		54.00	5.0	3.9	5.6	4.39		
2	346	15 53.75	.01084	5.3	3.9	6.1	5.51	82
		50.00	6.0	4.6	5.5	6.73		
3	296	18 50.00	.01014	6.0	4.4	6.5	7.43	70
		47.00	6.5	4.9	6.0	10.58		

 Length = 988. ft Total length = 988. ft

Hydraulic Gradeline Computations

Down- Hydraulic

Link #	stream Node #	Gradeline Elevation	Crown Elev.	Possible Surcharge	Ground Elev.	Super- crit.?	Manhole Depth	Loss Coef
1	2	54.72	55.00	N	59.00	Y	1.72	1.95
2	3	50.95	51.25	N	56.00	Y	1.89	1.94
3	4	50.49	48.50	Y	53.50	Y	3.49	.00

Link #	Terminal Node #	Hydraulic Gradeline Elevation	Ground Elevation	Loss Coef.
1	1	60.66	63.00	1.50

NORMAL END OF HYDRA

Step 4: Check Volume

Calculate Storage in the conveyance system with the restrictor.

12 inch pipe - supercritical flow

Depth in pipe = 72 percent (from output)

Area = 76.5 percent (using the Hydraulic Elements Chart, [Figure 8-102d](#))

Volume = $(.765)\pi(.5)^2(346) = 208$ cuft

15 inch pipe - supercritical flow

Depth in pipe = 76 percent (from output)

Area = 81.5 percent

Volume = $(.815)\pi(.625)^2(346) = 346$ cuft

18 inch pipe - surcharged

Depth in pipe = 100 percent (from output)

Volume = $(1.00)\pi(.75)^2(296) = 523$ cuft

Manholes - 3 full manholes and one half manhole

Volume = $3.5(\text{area of manholes})(\text{average depth in manholes}) = 3.5(12.57)(2.21) = 97$ cuft

Total volume = 1174 cf < 1779 cf (required volume)

Step 5: Model the system with oversized pipes and/or adjust inverts.

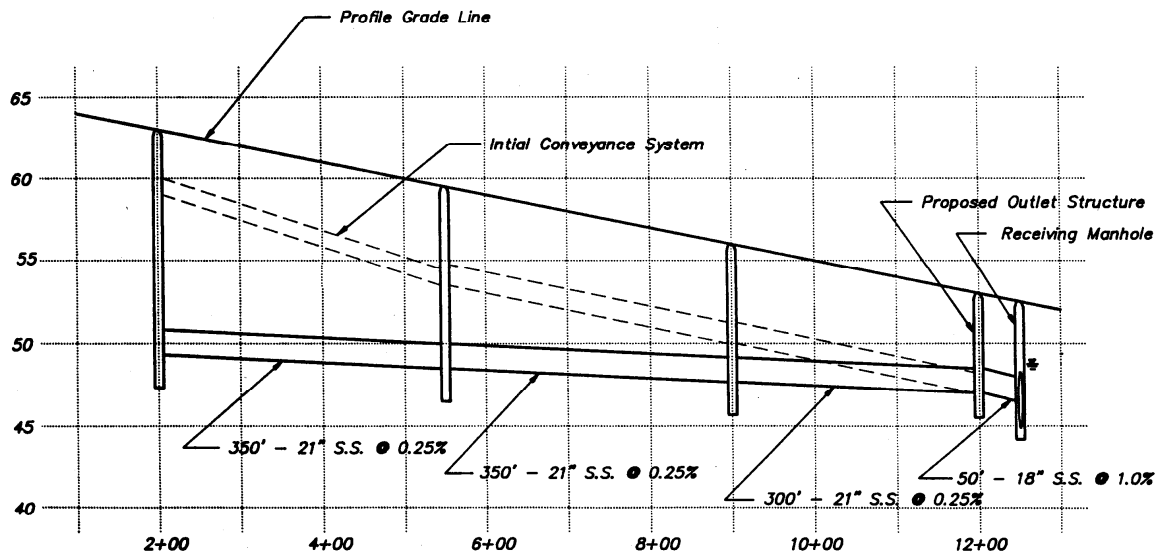

PROPOSED CONVEYANCE & STORAGE SYSTEM

INPUT

SWI 2

PDA 0.013 12 4 3 3 0.005 66

RAI 5,6.5 10,5.88 15,4.84 21,4.2 30,3.3 60,2.1 120,1.32 180,0.94
360,0.69

HGL 1

NEW MAIN TRUNK

REM Junctions 1 to 2 (station 2+00 to 5+50)

STO 1.47 0.78 21.0

PIP 346 63.0 59.0 49.25 48.5 -21

PNC 1 2 4 0 0 0

REM Junctions 2 to 3 (station 5+50 to 9+00)

PIP 346 59.0 56.0 48.50 47.75 -21

PNC 2 3 4 0 0 0

REM Junctions 3 to 4 (station 9+00 to 12+00)

PIP 296 56.00 53.5 47.75 47.00 -21

PNC 3 4 4 0 2 0

TWE 50.49

END

OUTPUT:

***** HYDRA ***** (Version 6.1) *****

MAIN TRUNK Analysis of Existing Pipes

Link	Length (ft)	Diam (in)	Invert (ft)	Depth (ft)	Cover (ft)	Velocity (ft/s)	--Flow-- Up/Dn (%)	-Solutions- Act/Full (cfs)	Load Remove (in)
1	346	21	49.25	.00217	13.8	11.9	3.3	4.82	65
		48.50		10.5	8.6	3.1	7.38		
2	346	21	48.50	.00217	10.5	8.6	3.2	4.61	63
		47.75		8.3	6.4	3.1	7.38		
3	296	21	47.75	.00253	8.3	6.4	3.4	4.41	55
		47.00		6.5	4.6	3.3	7.98		

Length = 988. ft Total length = 988. ft

Hydraulic Gradeline Computations

Link #	stream Node #	Down- Hydraulic Gradeline Elevation	Crown Elev.	Possible Surchage	Ground Elev.	Super- crit.?	Manhole Depth	Loss Coef
1	2	51.48	50.25	Y	59.00	N	2.81	2.23
2	3	50.99	49.50	Y	56.00	N	3.06	2.08
3	4	50.49	48.75	Y	53.50	N	3.49	.00

Link #	Terminal Node #	Hydraulic Gradeline Elevation	Ground Elevation	Loss Coef.
1	1	51.86	63.00	1.50

NORMAL END OF HYDRA

Step 6: Verify if the oversized system has provided the required storage.

Volume of oversized system

Area of 21 inch pipe = 2.41 sqft

Volume in pipes = $346(2.41) + (346)(2.41) + 296(2.41)$
= 2381 cuft

Volume in manholes = $4(12.57)(3.1)=156$ cuft

Total Volume = 2537 cuft > 1779 cuft (required volume)

Step 7: Verify if a minimum velocity of 3 ft/sec can be achieved. A velocity of 2 ft/sec will be permitted only in special cases.

$$V = \frac{Q}{A} = \frac{4.82}{2.41} = 2 \text{ ft/sec}$$

12-600 CONSTRUCTION AND MAINTENANCE CONSIDERATIONS¹

An important step in the design process is identifying whether special provisions are warranted to properly construct or maintain proposed storage facilities. To assure acceptable performance and function, storage facilities that require extensive maintenance are discouraged. The following maintenance problems are typical of urban detention facilities and facilities shall be designed to minimize problems:

- Weed growth
- Grass and vegetarian maintenance
- Sedimentation control
- Bank deterioration
- Standing water or soggy surfaces
- Mosquito control
- Blockage of outlet structures
- Litter accumulation
- Maintenance of fences and perimeter plantings

Proper design should focus on the elimination or reduction of maintenance requirements by addressing the potential for problems to develop. Following are examples of maintenance considerations:

- Both weed growth and grass maintenance may be addressed by constructing side slopes that can be maintained using available power-driven equipment, such as tractor mowers.
- Constructing traps to contain sediment for easy removal or low-flow channels to reduce erosion and sediment transport may control sedimentation.
- Bank deterioration can be controlled with protective lining or by limiting bank slopes.
- Standing water or soggy surfaces may be eliminated by sloping basin bottoms toward the outlet, constructing low-flow pilot channels across basin bottoms from the inlet to the outlet, or by constructing underdrain facilities to lower water tables.
- In general, when the above problems are addressed, mosquito control will not be a major problem.
- Outlet structures should be selected to minimize the possibility of blockage (i.e., very small pipes tend to block quite easily and should be avoided).
- Finally, one way to deal with the maintenance associated with litter and damage to fences and perimeter plantings is to locate the facility for easy access where this maintenance can be conducted on a regular basis.

The principal maintenance problem associated with rooftop detention is removal of debris. This includes tree leaves, paper and other material that accumulates at the rooftop drain heads. If these drains become blocked so that excessive depths of water are ponded on the roof, considerable damage to both structure and building contents can occur from overflows and possible overloading.

When parking lots are used for surface storage of stormwater, it is important to keep the parking lot cleaned of debris to prevent blockage of grated surface inlets and orifice discharge controls. Where it is necessary to permit entry of runoff from adjacent land areas, then areas along the parking lot perimeter should be provided with grass or rock filter strips. This will reduce silt accumulation in the storm sewer and receiving drainage way.

12-700 PROTECTIVE TREATMENT¹

Detention facilities can present a safety hazard, particularly to children who will be naturally drawn to the site regardless of whether or not the site is intended for their use. Semi-permanent grills and bars should be installed on all inlet pipes, particularly if they connect with an underground storm sewer system. Fences should be placed around the edges of inlet and outlet structures or other places where accidental falls may occur. Whenever possible mild bottom slopes should be used along the detention pond.

Protective treatment may be required to prevent entry to facilities that present a hazard to children and, to a lesser extent, all persons. Fences may be required for detention areas where one or more of the following conditions exist:

- Rapid stage increases would make escape practically impossible where small children frequent the area
- Water depths either exceed 2.5 feet for more than 24 hours or are permanently wet and have side slopes steeper than 4:1
- A low-flow watercourse or ditch passing through the detention area has a depth greater than 5 feet or a flow velocity greater than 5 ft/sec
- Side slopes equal or exceed 1.5:1

Guards or grates may be appropriate for other conditions, but in all circumstances heavy debris must be transported through the detention area. In some cases, it may be advisable to fence the watercourse or ditch rather than the detention area.

12-800 REFERENCES

1. AASHTO *Model Drainage Manual*, 3rd Ed 2005.
2. U.S. Department of Transportation, Federal Highway Administration. *Urban Drainage Design Manual Hydraulic Engineering Circular No. 22*. September 2009.
3. Chow, V.T. *Open-Channel Hydraulics*. New York: McGraw-Hill, 1959.
4. Brater, E.F., and H.W. King. *Handbook of Hydraulics*. 6th edition New York: McGraw-Hill, 1976.
5. Stahre, P., and B. Urbonas. *Stormwater Detention*. Englewood Cliffs: Prentice Hall, 1990.
6. U.S. Army Corps of Engineers. *Routing of Floods through River Channels*. March 1960.
7. *Modern Sewer Design 4th Ed 1999*
<http://www.jensenbridge.com/new%20files/pipe/Modern%20Sewer%20Design%20book.pdf>



Chapter 13

Pump
Stat
Con

CHAPTER 13 – PUMP STATIONS

13-000 OVERVIEW

13-001 Introduction

13-002 Philosophy

13-003 Policy

13-100 DESIGN CONSIDERATIONS

13-101 Location

13-102 Hydrology

13-103 Collection System

13-104 Discharge System

13-105 Station Types

13-105.01 Wet-Pit Stations

13-105.02 Dry-Pit Stations

13-106 Trash Racks and Grit Chambers

13-107 Number of Pumps

13-107.01 Main Pumps

13-107.02 Standby/Spare Pumps

13-107.03 Low-Flow Pumps

13-108 Submergence

13-109 Wet Well Design

13-109.01 Cycling Sequence and Volumes

13-109.02 Lowest Pump "OFF" Elevation

13-109.03 Pump "ON" Elevations

13-109.04 Allowable High-Water Elevations

13-110 Stormwater Storage

13-200 ADDITIONAL CONSIDERATIONS

13-201 Construction

13-202 Maintenance

13-203 Retrofitting Stations

13-204 Safety

13-205 Monitoring

CHAPTER 13 – PUMP STATIONS

- 13-300 HYDRAULIC REPORTS
 - 13-301 Introduction
 - 13-302 Hydraulic Report Content
 - 13-303 Hydraulic Report Checklist
 - 13-304 Pump Station Hydraulic Report Data Sheets
- 13-400 DESIGN PROCEDURES
 - 13-401 Introduction
 - 13-402 Pump Station Design Sequence
- 13-500 REFERENCES

13-000 OVERVIEW

13-001 Introduction

Stormwater pump stations are necessary to remove stormwater from highway sections that cannot be drained by gravity. Because of high costs and the potential problems associated with pump stations, their use is recommended only where other systems are not feasible. When operation and maintenance costs are capitalized, a considerable expenditure can often be justified for a gravity system. Alternatives to pumping which may be considered include diversion of flow to some other outfall, changes in roadway profile and/or alignment and changing to a crest instead of a sag design. These and other feasible alternates to pumping should be investigated before conceding to a pumping station design. General guidance and information on various aspects of pump stations can be found in [Hydraulic Engineering Circular No. 24 \(HEC 24\)](#)¹ HighwayStormWaterPumpStationDesign¹, and [HEC 22 Urban Drainage Design Manual](#)² www.fhwa.dot.gov/engineering/hydraulics/.

IDOT currently maintains an inventory of over 60 stormwater pumping stations around the state, the great majority of which are located in urban settings. Over 50 of these stations are situated within Region 1, District 1.

The need can also arise to evaluate an existing pump station. When analyzing an existing station efforts should be made to improve it to the greatest extent possible. This could include better access to the station or improving outlet capacity. Sometimes due to roadway improvements it may be necessary to relocate the station which could allow for the existing station to be used during construction of the new facility. Many techniques provided in this chapter such as mass flow routing are equally applicable for evaluating performance of an existing facility.

13-002 Philosophy

Many stormwater management plans limit the post-development discharge to that which existed prior to the development. To meet this requirement, it is often necessary to provide storage in the system to supplement storage needed for the pump operation.

The mass inflow curve procedure discussed in this document is commonly used when significant storage is provided outside of the wet well. The plotting of the performance curve on the mass inflow diagram gives the designer a good graphical tool for determining storage requirements. The procedure also makes it easy to visualize pump start/stop and run times. If a pump failure should occur, the designer can also evaluate the storage requirement and thus the flooding or inundation that could occur.

When it is determined that a pump station is the most feasible design, efforts should be made to limit the tributary area and the amount of water reaching the station to minimize the required pumping rate. For depressed roadway sections, as much of the upper elevations on the approaches to the sag as possible should be drained to gravity outlets by storm sewers or roadside ditches. The sag should only collect water from that portion of the approaches which cannot be drained by gravity. Similarly, berms can be constructed around a sag section to collect the runoff from higher adjacent property where it can be drained by a ditch or a storm sewer to a gravity outlet.

13-003 Policy

Pump stations shall only be used where a gravity system is not practical or feasible. Pump stations shall be designed in accordance with standards recommended by the Hydraulic Institute (www.pumps.org) and the guidance provided in this Chapter. The Hydraulic Institute (HI) was established in 1917 to serve the pump industry by providing product standards and a forum for the exchange of industry information. The following policies are specific to pump station design:

- The design frequency for pump stations shall be a 50-year flood frequency, but no less than the frequency for the roadway system being drained. The design frequency for storm sewers shall be in accordance with the requirements of [Table 1-305](#) in Chapter 1.
- The starting water surface elevation from the receiving stream must be considered, which is generally assumed a 10-year flood frequency backwater elevation of the receiving stream. It is rare to analyze the 50-year flood considering a 50-year backwater effect from the receiving stream because coincidental flooding effects rarely occur
- Depressed roadway at the pump station must be designed to satisfy the spread criteria limitations of the roadway section being drained, which shall be designed for at least a 50-year flood frequency. Storm sewers which drain depressed roadways where runoff can only be removed through the storm drainage system shall be designed for a minimum 50-year flood frequency.
- The calculated water surface elevation based on a 50-year flood frequency shall have a minimum freeboard of 2-foot below the top of an inlet.
- The calculated water surface elevation based on a 100-year flood frequency must be kept below the top of an inlet at the sag served by a pump station.
- Hydrograph methods such as [HEC1](#), [HEC-HMS](#) and [TR20](#) shall be used to determine the critical duration and the critical hydrologic values. A 50-year design inflow hydrograph is recommended for highway projects. A 100-year storm should be routed through the proposed facility to determine if the proposed facility provides adequate protection for the roadway and adjacent properties.

It is the responsibility of the Bureau of Bridges and Structures to review and approve the Hydraulic Report for all pump stations. A request for a waiver of policy must be processed through and approved by the Bureau of Bridges and Structures. Typically, pump station Hydraulic Reports are not reviewed by the Federal Highway Administration (FHWA). However, if such a request is made by the FHWA at the coordination meeting within the district, the hydraulic report will be forwarded by the Bureau of Bridges and Structures upon completion of review and approval. When preparing a pump station Hydraulic Report coordination should occur early in the process with the District to ensure the development of the report is consistent with District operating procedures and needs.

13-100 DESIGN CONSIDERATIONS**13-101 Location**

Economic and design considerations dictate that the pump station be located relatively near the low point of the highway. Desirably, a frontage road or overpass is available for easy access to the station. The station and access road should be located on high ground so that access can be secured even if the highway becomes flooded. Soil borings should be made during the selection of the site to determine the allowable bearing capacity of the soil and to identify any potential problems.

Architectural and landscaping decisions should be made in the location phase for above-ground stations so that the station will blend into the surrounding community. Following are some considerations that should be used in the location and design of pump stations:

- Modern pump stations can be architecturally pleasing with a minimum increase in cost. Surrounding environmental considerations should be taken into account in the location of the facility.
- Clean functional lines will improve the station's appearance.
- Masonry or a textured-concrete exterior can be very pleasing.
- Screening walls may be provided to hide exterior equipment and break up the lines of the building.
- A small amount of landscaping can substantially improve the overall appearance of the site.
- Ample parking and working areas should be provided adjacent to the station for maintenance and repair vehicles.
- The access to the site should be from state right-of-way.
- The access to the site should be safe for both ingress and egress.
- The site should be visible from the adjacent roadway for safety of the maintenance personnel. Screening and plantings should be minimized.
- The location of the site should be chosen based on proximity to the low point of the roadway being drained, location of the storm sewer system, proximity to the discharge point of the facility, and overall accessibility as outlined elsewhere.
- Right-of-way availability should be considered in the location of the facility.
- If the evaluation is being performed for an existing facility then there will probably need to be an existing condition analysis performed to determine current operating capacity and parameters. This should include an evaluation of the collection system. Facility deficiencies such as pump station access or lack of back-up power should also be identified so potential remedies can be evaluated to determine if adequate right-of-way is available to construct suggested improvements.

13-102 Hydrology

Because of traffic safety and flood hazards, pump stations serving major expressways and arterials are usually designed to accommodate a 50-year storm. It is desirable to check the drainage system for the 100-year storm to determine the extent of flooding and the associated risk. Every attempt should be made to keep the drainage area tributary to the station as small as possible. Avoid future increases in pumping by isolating the drainage area; i.e., prevent off-site drainage from possibly being diverted to the pump station. Hydrologic design should be based on the ultimate development of the area that must drain to the station.

Designers should consider storage, in addition to that which exists in the wet well, at all pump station sites. For most highway pump stations, the high flows of the inflow hydrograph will occur over a relatively short time. Additional storage, skillfully designed, may greatly reduce the peak pumping rate required. An economic analysis can be used to determine the optimum combination of storage and pumping capacity. Because of the nature of the sites where highway-related pump stations are located, it is most often necessary that the storage be located well below normal ground level.

If flow attenuation is required for purposes other than reducing the size of the pump facility and cannot be obtained upstream of the station, consideration may be given to providing the storage downstream of the pump station. This will require large flows to be pumped and, thus, pump installation and operation costs will be higher.

If storage is used to reduce peak-flow rates, a routing procedure must be used to design the system. To determine the discharge rate, the routing procedure integrates three independent elements: the inflow hydrograph, the stage-storage relationship, and the stage-discharge relationship.

13-103 Collection System

Storm sewers leading to the pumping station are usually designed on a minor grade to minimize depth and cost. A minimum grade that produces a velocity of 3 ft/sec in the pipe while flowing full is suggested to avoid siltation problems in the collection system. Minimum cover or local head requirements should govern the depth of the uppermost inlets. When a storm sewer or lateral is located under the pavement, the top of the pipe shall be at least six inches below the bottom of the pavement structure. At other locations, the minimum cover over a storm sewer should not be less than three feet. The inlet pipe should enter the station perpendicular to the line of pumps. The inflow should distribute itself equally to all pumps. Baffles may be required to ensure that this is achieved.

The collector lines should preferably terminate at a forebay or storage box. However, they may discharge directly into the station. Under the latter condition, the conveyance capacity of the collectors and the storage within them is critical to providing adequate cycling time for the pumps and must be carefully calculated.

Using grate inlets as screens to prevent large objects from entering the system and possibly damaging the pumps is recommended. This approach has additional advantages of possibly eliminating costly trash racks and simplifying debris removal because debris can be more easily removed from the roadway than the wet well.

13-104 Discharge System

The discharge piping should be as simple as possible. Pumping systems that lift the stormwater vertically and discharge it through individual lines into a discharge chamber which drains to a gravity storm sewer as quickly as possible are preferred. Individual pump discharge lines are the most cost-effective system for short outfall lengths. Long forced mains should be eliminated to avoid damaging pump reversal that could occur due to potential backup. The effect of stormwater returning to the sump after pumping stops should also be considered and check valves should be installed. Outlet pipes may exit the pumping station either above or below grade. Frost depth shall be considered when deciding the depth of discharge piping. Frozen discharge pipes could exert additional back pressure on pumps.

13-105 Station Types

Basically, there are two types of stations: wet-pit and dry-pit. Because dry-pit stations are as much as 60% more expensive than wet-pit stations, wet-pit stations are recommended. Dry-pit stations may be considered where ease of access for repair and maintenance is a primary concern.

13-105.01 Wet-Pit Stations

In the wet-pit station ([Figure 13-105.01](#)), the pumps are submerged in a wet well or sump with the motors and the controls located overhead. With this design, the stormwater is pumped vertically through a riser pipe. The motor is commonly connected to the pump by a long drive shaft located in the center of the riser pipe. Another type of wet-pit design involves the use of submersible pumps. Because of cooling effect on motors, submersible pumps are the most desirable types. It is recommended that submersible pumps be considered for use in all station designs.

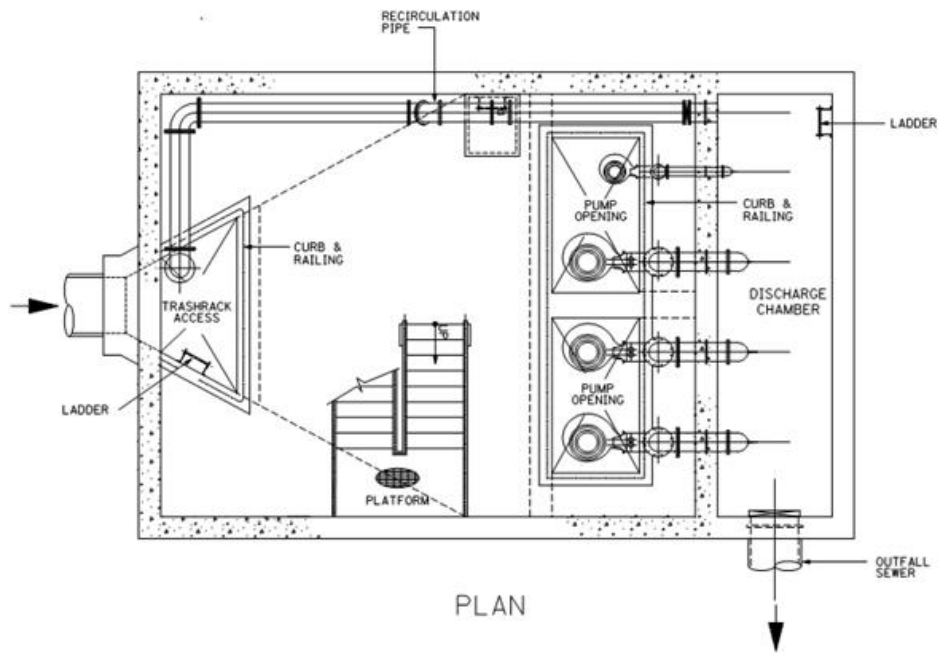

PLAN

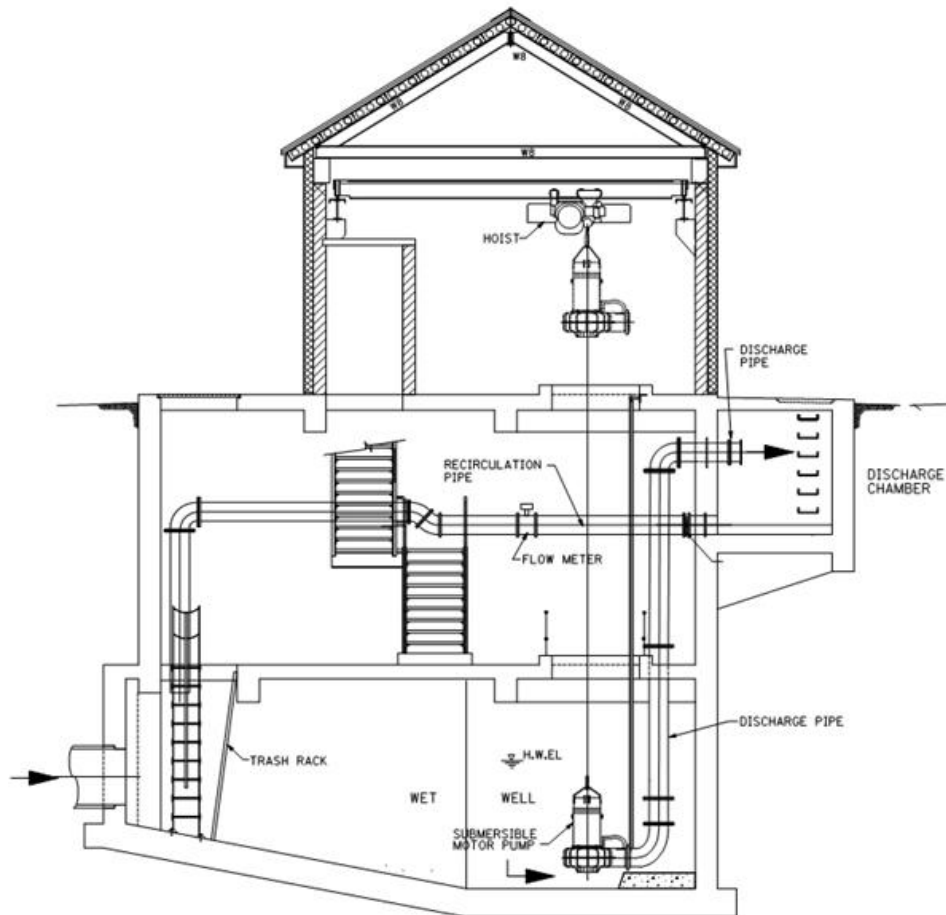

SECTION

Typical Wet-Pit Station
Figure 13-105.01

13-105.02 Dry-Pit Stations

Dry-pit stations ([Figure 13-105.02](#)) consist of two separate chambers: the storage box or wet well and the dry well. Stormwater is stored in the wet well that is connected to the dry well by horizontal suction piping. Centrifugal pumps are usually used. Power is provided by either close-coupled motors in the dry well or long drive shafts with the motors located overhead. The main advantage of the dry-pit station for stormwater is the availability of a dry area for personnel to perform routine and emergency pump and pipe maintenance.

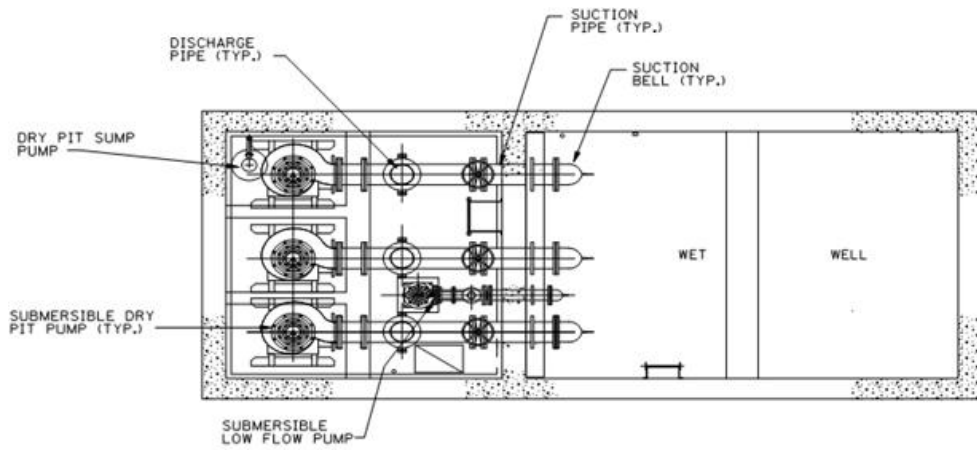

PLAN

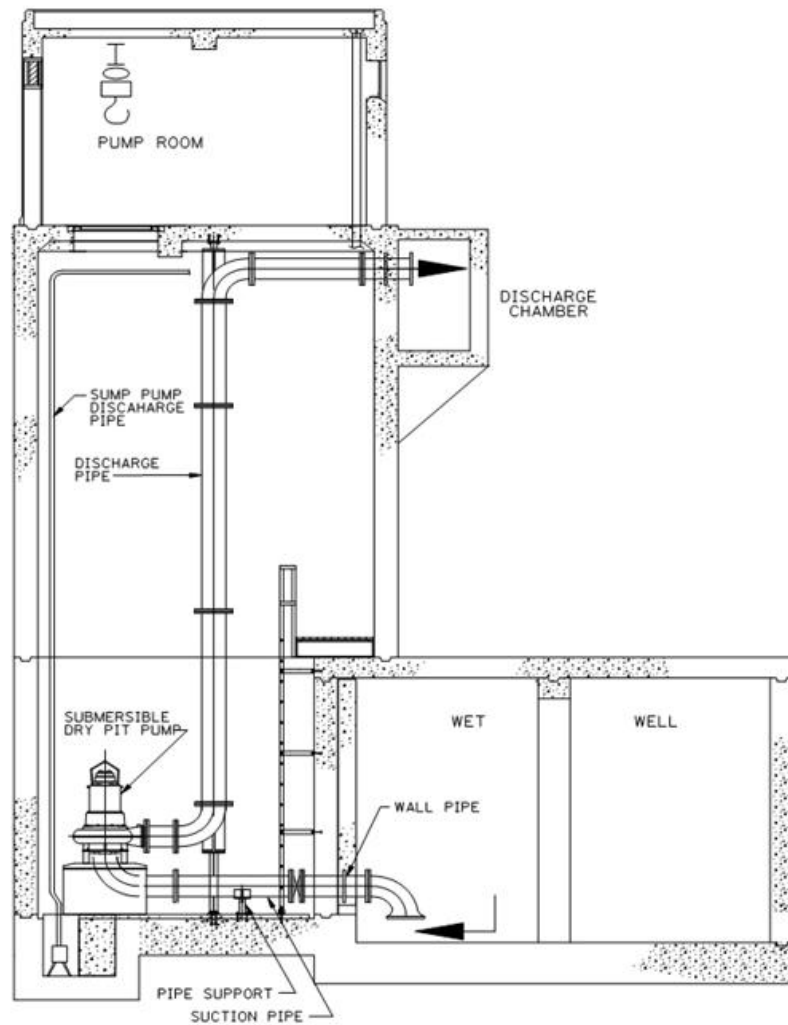

SECTION

Typical Dry-Pit Station
Figure 13-105.02

13-106 Trash Racks and Grit Chambers

Trash racks should be provided at the entrance to the wet well if large debris is anticipated. For stormwater pump stations, simple steel bar screens are adequate. Usually, the bar screens are inclined with bar spacings approximately 1.5 inches. Constructing the screens in modules facilitates removal for maintenance. If the screen is relatively small, an emergency overflow should be provided to protect against clogging and subsequent surcharging of the collection system.

If substantial amounts of sediment are anticipated, a chamber may be provided to catch solids that are expected to settle out. This will minimize wear on the pumps and limit deposits in the wet well. The grit chamber should be designed so that a convenient means of sediment removal is available.

13-107 Number of Pumps*13-107.01 Main Pumps*

The designer will determine the number of pumps needed by following a systematic process defined in this Chapter. However, two to three pumps have been judged to be the recommended minimum. If the total discharge to be pumped is small and the area draining to the station has little chance of increasing substantially, the use of a two-pump station is preferred.

It is recommended that equal-size pumps be used. Identical size and type enables all pumps to be freely alternated into service. This equalizes wear and reduces needed cycling storage. It also simplifies scheduling maintenance and allows pump parts to be interchangeable.

13-107.02 Standby/Spare Pumps

As a general rule, a minimum of twenty percent extra pump station capacity should be provided as stand-by pumping capacity. It is preferred that the standby pump(s) is/are equal to the largest pump in the pump station. This will keep the station more reliable in case of failure or major maintenance of equipment.

13-107.03 Low-Flow Pumps

Low-flow pumps should be considered in each application to alleviate short main pump run times in dry weather flow; keep the level of the wet well low to retain a buffer in the wet well storage; help in the desiltation of the wet well; and provide a means to draw the wet well down to a desirable level for maintenance.

If utilized, the low-flow pump(s) size should be coordinated with the main pump size. Multiple low-flow pumps may be considered for assurance of reliability. If multiple low-flow pumps are chosen, the pumps may be duplexed with separate discharge pipes.

Generally for IDOT facilities low flow pumps are not counted as part of the pump station capacity and are not to be included in the mass flow routing of the pump station. Typically low flow pumps do not operate when a main pump turns on. Coordination with the District on this issue is advisable before performing calculations involving low flow pumps as part of the operation of the station.

13-108 Submergence

Submergence is the depth of water above the pump suction pipe necessary to prevent cavitation and vortexing.

Cavitation occurs when the pressure in the liquid is reduced to the liquid's vapor pressure such that boiling begins to occur, even though the liquid's temperature may not have changed. Cavitation is a hydraulic phenomenon in which vapor bubbles form and suddenly collapse (implode) as they move through a pump impeller. Implosions occur on each of the vanes of the impeller causing excessive noise. The hydraulic effect on the pump is a significant reduction in performance. The mechanical effects can include shock waves and vibration, which may result in damage to the impeller vanes, bearings, and seals.

A vortex can occur at the impeller and may extend to the surface of the liquid. If this occurs, air will be sucked into the pump. The effects can be similar to cavitation with a possible reduction in hydraulic efficiency and increased wear on the pump.

Submergence varies significantly with pump type and speed, atmospheric pressure and inlet bell diameter. This dimension is provided by the pump manufacturer and is determined by laboratory testing. A very important part of submergence is the required net positive suction head (NPSH) because it governs cavitation. The available NPSH should be calculated and compared to the manufacturer's requirement. The designer should use the criterion that creates the higher submergence.

13-109 Wet Well Design

The primary variables for sizing the wet well are the:

- number of pumps,
- pump bell diameter,
- pump bay width,
- minimum distance to trash rack, and
- minimum distance to inlet invert.

The criteria to be considered in wet well design include:

- the floor clearance,
- the minimum distance between an inlet bell and the wall,
- the minimum clearance between adjacent inlet bells,
- the width of partition walls between pumps and the submergence required for the pump bell diameter.

The specific criteria for both circular and rectangular wet wells can be found in HI Pump Standards⁵ by the Hydraulic Institute (HI), from the pump supplier and in [HEC 24 Highway Storm Water Pump Station Design](#)¹.

The wet well size and shape are important factors for both their contribution to available storage and for providing room for proper sizing and layout of pumps. However, the final number and size of pumps is normally not known until the final design phase. Therefore, it becomes necessary to estimate wet well dimensions based on a trial number and size of pumps. It may then be necessary during the design process to increase dimensions to provide additional storage or to accommodate additional pumps. The determination of final sump size and check of

clearance are performed after trial pump selection and sizing procedures. The volume of the wet well is often only a small portion of the total available storage that is used by the system to reduce the required pump capacity and to control the cycling interval of the pumps.

13-109.01 Cycling Sequence and Volumes

Cycling is the starting and restarting of the same pump, the frequency of which must be limited to prevent damage and possible malfunction of the pump. The wet well must be designed to provide sufficient volume for safe cycling, or sufficient volume must be provided outside the wet well. However, to keep sediment in suspension, the wet well should not be oversized. The volume required to satisfy the minimum cycle time is dependent upon the characteristics of the power unit, the number and capacity of pumps, the sequential order in which the pumps operate and whether or not the pumps are alternated during operation.

There are two basic cycling sequences. One will be referred to here as the “common off elevation.” In this sequence, the pumps start at successively higher elevations as required; however, they all stop at the same off elevation. This is advantageous when large amounts of sediment are anticipated. This operation may also cause higher surge pressure (water hammer) in the force mains. The other sequence uses a “successive start/stop” arrangement in which the start elevation for one pump is also the stop elevation for the subsequent pump; i.e., the start elevation for Pump 1 is the stop elevation for Pump 2, the start elevation for Pump 2 is the stop elevation for Pump 3. There are countless variations between these two sequences.

There are also different alternation techniques that reduce the cycling volume requirement and equalize wear on the pumps. They range from simply alternating the first pump to start, to continuously alternating all pumps during operation, a technique referred to as “cyclical running alternation.” Using this technique, each pump is stopped in the same order in which it starts; i.e., the first pump to start will be the first pump to stop.

The table below provides some sample starting sequences for systems with 2 to 4 pumps.

No. of Pumps	First Sequence	Second	Third	Fourth	Fifth
2	1-2	2-1	1-2	2-1	1-2
3	1-2-3	3-1-2	2-3-1	1-2-3	3-1-2
4	1-2-3-4	4-1-2-3	3-4-1-2	2-3-4-1	1-2-3-4

This approach involves assigning a starting order for the pumps (say 1, 2, 3), then after one complete sequence the starting order is rearranged for the next operation (say 3, 1, 2), and so on. Otherwise, the first pump is always the most used and would require more frequent maintenance and repair than the others. Also, this has the effect of increasing cycling time for a given storage volume or reducing the storage requirement for a given cycling time.

13-109.02 Lowest Pump “Off” Elevation

The Hydraulic Institute recommends that the lowest pump “off” elevation be no lower than the invert elevation of the inflow pipe of the main to the wet well, unless plan dimension constraints dictate that the station floor is lowered to obtain the necessary cycling volume

(refer to HEC 24). This recommendation is based on the fact that it is usually less expensive to expand a station’s plan dimensions than to increase its depth. This elevation represents the maximum static pumping head to be used for pumping selection.

13-109.03 Pump “On” Elevations

These should be set at the elevations that satisfy the individual pump cycling volumes (V_x). Starting the pumps as soon as possible by incrementing these volumes successively above the lowest pump-off elevation will maximize what storage is available within the wet well and the collection system. The depth (H_x) required for each volume is computed as follows:

$$H_x = \frac{V_x}{\text{plan area (wet well surface area)}} \quad (\text{Eq. 13-1})^3$$

13-109.04 Allowable High-Water Elevation

The allowable high-water (AHW) elevation in the station should be set such that the water surface elevation at the lowest inlet in the collection system provides a minimum freeboard of two feet below the roadway grate for the design frequency. In addition, the water surface elevation should be above the soffit of the wet well inlet conduit, but safely below the wet well ceiling.

13-110 Stormwater Storage

The total storage capacity that can or should be provided is an important initial consideration in pump station design. The basic principle is that the volume of water beyond the capacity of the pumps must be stored. If a larger part or most of the design storm is allowed to collect in a storage facility, a smaller set of pumps can be utilized. If the discharge rate is to be limited, ample storage is essential.

When it is anticipated that most of the peak flow will be pumped, pump cycling sequences are of great importance. For many of the highway storm drain situations, it has been the practice to store substantial parts of the flow to minimize pumping requirements and outflow piping. The demands on the pumping system are different and thus, additional considerations should be made.

The simplest form of storage is either the enlargement of the storm sewer collection system or the construction of an underground storage facility. For some pump stations, the storage available in the storm sewer collection system may be significant. However, it is often necessary to provide additional storage near the pump station. This may be done by oversizing the storm sewer collection system, providing storage pipes, or designing an underground vault.

The designer should recognize that a balance should be reached between pump rate and storage volume. This will require a trial-and-error procedure used in conjunction with an economic analysis. Pump stations are very costly, and alternatives to minimize total costs need to be considered.

The principles discussed for minimum pump cycling in the design of wet wells should also be considered for larger storage volume development. However, the concern for meeting minimum cycling time will be reduced because the volume of storage is sufficient to prevent these conditions from controlling the pump operation.

The approach used for the design of the pump station will be that associated with the development of an inflow mass curve. In this process, the designer will need to have an inflow hydrograph and a developed stage-storage relationship. Trial pumping systems will be imposed on the inflow mass curve to develop a mass curve routing diagram. The inflow hydrograph is a fixed design component, while the storage and pumping discharge rates are variable. The designer may assign a pumping discharge rate based on downstream capacity considerations, limits imposed by local jurisdictions, etc. It is becoming a common requirement that post-development discharges not exceed predevelopment discharges. This requirement can most often be met with a design that includes storage. With the inflow mass curve and an assigned pumping rate, the required storage can be determined by various trials of the routing procedure.

13-200 ADDITIONAL CONSIDERATIONS³**13-201 Construction**

The method of construction has a major impact on the cost of the pump station. For near continuous operation (e.g., pumping sewage), it has been estimated that construction represents more than 20% of the pump station costs over a 10-year period. With a stormwater pump station operating less frequently, operating costs may be insignificant compared to construction costs. Therefore, the type of construction should be chosen carefully, between caisson constructions, in which the station is usually circular, or open-pit construction. Soil conditions are the primary factor in selecting the most cost-effective alternative.

13-202 Maintenance

Because major storm events are infrequent, a comprehensive, preventive maintenance program should be developed for maintaining and testing the equipment so that it will function properly when needed. Instruments such as hour meters and number-of-starts meters should be used on each pump to help schedule maintenance. Input from maintenance forces should be a continuous process so that each new generation of stations will be an improvement.

13-203 Retrofitting Stations

Retrofitting existing stormwater pump stations may be required when changes to the highway result in an increase of runoff to them. The recommended approach to this problem is to increase the capacity of the station without making major structural changes or to increase the facility storage. The former can be achieved by using a cycling sequence that requires less cycling volume or power units that allow a greater number of starts per hour (i.e., shorter cycling time). Submersible pumps have been used effectively in retrofitting stations because of the flexibility in design and construction afforded by their frequent cycling capability. Other common reasons for the need for retrofit include problems associated with excessive wear and tear and poor performance of the pumps such as:

- Inadequate storage
- Excessive cycling,
- Cavitation,
- Poor distribution of flow to pumps, and
- Excessive head losses in discharge system.

Refer to [HEC 24 Highway Stormwater Pump Station Design¹](#) for a detailed discussion on the cause of problems and appropriate retrofit measures and other correctional actions.

13-204 Safety

All elements of the pump station should be carefully reviewed for safety of operation and maintenance. Ladders, stairwells and other access points should facilitate use by maintenance personnel. Adequate space should be provided for the operation and maintenance of all equipment. Particular attention should be given to guarding moving components such as drive shafts and providing proper and reliable lighting. It may also be prudent to provide air-testing equipment in the station so maintenance personnel can be assured of clean air before entering.

Pump stations may be classified as a confined space, in which case, access requirements and any safety equipment are all defined by code. Pump stations should be designed to be secure from entry by unauthorized personnel and as few windows as possible should be provided.

All electrical equipment including motors should be explosion proof and should be located above the allowable high-water elevation. Even submersible pump motors should be explosion proof because they may not always be submerged. Their control panels should not be in the wet well but in a non-hazardous location.

13-205 Monitoring

Pump stations are vulnerable to a wide range of operational problems from malfunction of the equipment to loss of power. Monitoring systems (e.g., on-site warning lights, remote alarms) can help minimize such failures and their consequences.

Telemetry is an option that should be considered for monitoring critical pump stations. Operating functions may be telemetered from the station to a central control unit. This allows the central control unit to initiate corrective actions immediately if a malfunction occurs. Such functions as power, pump operations, unauthorized entry, explosive fumes and high water levels can be monitored effectively in this manner. Perhaps the best overall procedure to assure the proper functioning of a pump station is the implementation of a regular schedule of maintenance conducted by trained, experienced personnel.

SCADA (Supervisory Control and Data Acquisition) System is used to monitor and control multiple remote process facilities from a central location. Generally computers, which serve as the SCADA master station, are installed in the central control room. Programmable logic controllers (PLC), which serve as SCADA remote terminal units (RTU), are installed at each remote facility. The RTU continuously monitors the process data and statuses and transmits them to the SCADA master at pre-set intervals. The control set points, control logic and control commands may be entered into the RTU or through the SCADA master and the control commands are ultimately executed by the RTU.

The communication media between the SCADA master and the RTU may be microwave and/or VHF radio, leased and/or dial-up telephone lines. Microwave radio is the primary medium for most of the IDOT Pump Stations SCADA system and dial-up telephone lines serve as backup media.

Each RTU has a PLC and a graphic display panel with touch screen, keypad or keyboard for HMI (Human Machine Interface).

Most SCADA master computer systems consist of computer servers with historical data storage, communication modem, alarm printer and report printer. SCADA HMI and report software are installed in the SCADA master for data collection, graphic display, control setpoints and command entries, live and historical data trending, alarm display and report generation.

In IDOT pumping station design, the local RTU/PLC at the pumping station is programmed to perform the following:

- Monitor the water levels in screen chamber, wet well, and discharge chamber with air bubbler system.

- Control operations of main pumps and low flow pumps based on the monitored wet well level/depth of water (step operation) and rising rate of the wet well level (dynamic operation). Typically, the dynamic operation occurs prior to the step operation to handle sudden water inrush or flash flood to a high capacity pump station.
- Monitor the status of main pumps, low flow pumps, discharge gate, recirculation gate and electric power sources as well as fire, combustible gas, power failure, flood and illegal entry alarms.

When reviewing existing pump station SCADA data against various data such as historical plans or updated survey information it is advisable to ensure that the reviewer understands what datum is used for each data set. For example the SCADA may be in reference to the wet pit bottom. The elevation of the bottom would then need to be determined so that it is consistent with the project datum and/or the roadway or collection system survey. This ensures stage-storage relationships pump start/stop elevations, freeboard determinations and all items dependent on a uniform datum are correctly evaluated. If no SCADA data is available all charts tables and exhibits for a Hydraulic Report should be prepared using a consistent datum. Any datum correlations need to be documented within the report.

13-300 HYDRAULIC REPORTS

13-301 Introduction

Hydraulic Reports for all pump stations are to be submitted with Pump Station Hydraulic Report Data Sheets. The data sheets are to be used as a guide for compilation of all required information.

Hydraulic Reports are preliminary until approved by the Central Office Bureau of Bridges and Structures.

13-302 Hydraulic Report Content

The Hydraulic Report format and contents should be organized in the following manner to insure a thorough and complete analysis, to provide documentation of the design procedures used and to show how the final design was determined. All supporting calculations should contain “calculated by” initial with date and “checked by” initial with date. The general contents of a Hydraulic Report are as follows:

1. Title Page ([Section 2-502](#))
2. Table of Contents
3. Narrative - The narrative is essential to assist the engineer responsible for the hydraulic review to become familiar with the project and the objectives of the analysis. It should contain the following information:
 - a. Project Scope and Purpose - Explain what is being done at the site. Briefly describe the major drainage deficiencies. Is the pump station to be constructed or rehabilitated? Is the roadway to be constructed or rehabilitated? Describe why a new pump station is required and how the pump station location is determined.
 - b. Design criteria - Describe criteria that are adopted and if deviation approval is required.
 - c. Description of existing pump station and existing collection system (including detailed references to exhibits and calculation):
 - General watershed description.
 - Description of problems with the existing drainage system that need to be resolved (i.e. flood occurrences, unintended overflows, highwater in the receiving stream etc.).
 - Storm sewers description and adequacy discussion.
 - Outfall system description and adequacy discussion.
 - Description of existing pump station, if applicable, and its capacity adequacy.
 - d. Hydrologic and hydraulic analyses for existing condition (including detailed references to exhibits and calculation):

- Description and justification of the methodologies selected and assumption made within the hydrology model, and the results of the analyses.
 - Description of the pump routing analyses including cycling time, storage availability in the system, and the results of the analyses.
- e. Drainage alternatives (including detailed references to exhibits and calculations):
- General description of each alternative
 - Detailed description of each analyses and results
 - Comparison of the alternatives with regard to advantages and disadvantages
 - Cost Comparison of the alternatives
- f. Conclusions and recommendations for the preferred alternative: Provide conclusions and justify the selected alternative.
4. Hydraulic Report Data Sheets – Complete and include accordingly.
 5. General Location Map – Include a copy of a portion of a USGS quadrangle map or a similar map showing the subject structure location.
 6. Photographs – Original color photographs or color photo printouts to document concerns, abnormalities, or areas associated with hydrologic and hydraulic analyses.
 7. As-Built Pump Station Plans – Include if applicable and available.
 8. Existing Pump Station Operation Data – Include pump performance curve, start and stop elevations for each existing pump, etc.
 9. Roadway Plan and Profile – If the proposed is different than the existing, both should be shown. The limits of the profile should extend to cover the tributary area from one summit to another summit. The location of the pump station, storm sewer collection system and storm sewer discharge system should be shown and labeled.
 10. Roadway Cross-Sections – Include station/elevation cross-section plots of all roadway sections within the area tributary to the pump station, which should be extended as needed to show drainage boundaries.
 11. Receiving System Capacity and Tailwater Elevation – Include and incorporate into the hydraulic analysis.
 12. Hydrologic Analysis – Include data, figures and computations used to calculate discharges. Include a topographic map or a contour map with the delineated drainage area. The information such as drainage boundaries, drainage acreage, CN values, time of concentration with flow path, potential overflow areas towards the pump station, depressed areas for storage, etc. should be clearly indicated on the work map. Duration analysis to determine peak discharges is also required.

13. Storage Volume Calculations and Plots – Include storage required after developing an economic balance between volume and pumping capacity. The storage volume required for the pump operation will include wet-pit in the pump station and additional storage within the drainage system which is below the highest water elevation proposed in the wet-pit.
14. Pump Schedule, Routing Calculations, and Mass Curve Plots – Provide spreadsheets and graphs with all needed volume backup information, such as inflow hydrograph, storage volume, pump operation sequences, etc.
15. Pump Cycling Time Calculations – Verify the system cycling time for proposed conditions to ensure it meets minimum requirements for the pump specified. Include wet well stage versus usable storage rating.
16. Provision of Required Storage and Drainage Alternatives – A preliminary plan with necessary supporting sketches and approximate cost analysis for any drainage alternative(s) providing storage beyond the wet well and storm sewer collection system in the form of oversized storm sewers, below ground vaults, downstream detention, etc.
17. Hydraulic Gradient Calculations and Plots – Include all hydraulic gradient calculations and plots for storm sewer systems located upstream and downstream of the pump station.
18. Correspondence Notes – Include a copy of any communications regarding the hydraulic analysis and drainage concerns.
19. Conventional Survey Notes – A copy of the conventional field survey notes used for the analysis should be included as an exhibit. Electronic point data should not be included.
20. Computer Disk – Include a disk with the input and output files of any models or spread sheets, all CADD files, word processing and/or spreadsheet files along with an electronic copy of the entire report.

13-303 Hydraulic Report Checklist

The following checklist should be completed by the district or by the consultant before submitting Hydraulic Reports to the Bureau of Bridges and Structures for approval. The checklist is applicable in most instances for existing conditions and proposed conditions. Refer to [Section 13-402](#) for examples.

1. _____ Title Page
2. _____ Table of Contents
3. _____ Narrative
4. _____ Hydraulic Report Data Sheets
5. _____ General Location Map
6. _____ Photographs
7. _____ As-Built Pump Station Plans
8. _____ Pump Station Operation Data
9. _____ Roadway Plan and Profile
10. _____ Roadway Cross Sections
11. _____ Receiving System Capacity & Tailwater Elevation
12. _____ Hydrologic Analysis
13. _____ Storage Volume Calculations and Plots
14. _____ Pump Schedule, Routing Calculations, and Mass Curve Plots
15. _____ Pump Cycling Time Calculations
16. _____ Provisions of Required Storage and Drainage Alternatives
17. _____ Hydraulic Gradient Calculations and Plots
18. _____ Correspondence Notes
19. _____ Conventional Survey Notes
20. _____ Computer Disk

13-304 Pump Station Hydraulic Report Data Sheets

Station Number: _____

Route: _____

Location: _____

County: _____

Existing Site Data:

1. Drainage area to existing pump site within R.O.W. _____ acres, off R.O.W. _____ acres, total _____ acres
2. Design frequency _____ years.
3. Peak inflow rate _____ cfs.
4. Has high water ever forced road closure or serious traffic inconvenience? _____
If yes, how frequently? _____
Max. known high water _____ ft. Date _____
Cause of flooding _____ (pump malfunction, clogged inlets, etc.)
5. Does a pump station currently exist at site? _____
Number of main pumps _____. Pumping rate per pump _____ gpm (_____ cfs).
Number of stand-by pumps _____. Pumping rate per pump _____ gpm (_____ cfs).
Number of low-flow pumps _____. Pumping rate per pump _____ gpm (_____ cfs).
Existing storage in the pump station _____ cu. ft.
Existing storage in the storm sewer system _____ cu. ft.
Size of inlet pipe into well _____ in., invert elevation _____ ft.
Size of outfall pipe from pump station to the receiving system _____
Outfall pipe invert elevation at the pump house _____ ft.
Outfall pipe elevation at the receiving system _____ ft.
6. Where is discharge currently pumped to? _____
If stream, provide the 10 year elevation _____ ft.

Proposed Site Data:

7. Is size of drainage area to proposed pump station to be significantly altered?

If so, what is the new drainage area? _____ acres within R.O.W and _____ acres off R.O.W.
8. Design frequency _____ years.
9. Maximum inflow rate _____ cfs.
10. Will the discharge be pumped to a new location? _____

If yes, what are documented highwater stages? _____, where

11. Allowable maximum discharge rate _____ cfs.

Are there any restrictions on allowable pumping rate? _____

Proposed Preliminary Pump Station Data:

12. Type of pump station proposed _____ (wet pit, dry pit)

13. Number of pumps and pumping rate proposed:

Number of main pumps _____, pumping rate per pump _____ gpm (____ cfs)

No. of stand-by pumps _____, pumping rate per pump _____ gpm (____ cfs)

No. of low-flow pumps _____, pumping rate per pump _____ gpm (____ cfs)

14. Elevation of top of lowest inlet on pavement _____ ft.

15. Elevation of highest allowable water at sag _____ ft.

16. Design high water elevation at the pit when all pumps are on _____ ft.

17. Size of proposed pump station outfall pipe _____ ft., invert elevation at pump pit _____ ft., invert elevation at the discharge chamber _____ ft.

Miscellaneous Data:

18. Special Considerations:

19. Information regarding high water from streams, groundwater or other controls which may affect proposed pump station.

20. Prepared by _____ Date _____

Signed (QA/QC) _____ Date _____

13-400 DESIGN PROCEDURES

13-401 Introduction

This section presents a systematic procedure that integrates the hydraulic design variables involved in pump station design. The Department of Transportation requires that the design of all new pump station projects, as well as the reconstruction and retrofitting of existing pump station projects, follow the systematic procedure to ensure adequate performance of pump stations while maintaining a cost effective design.

In general, the hydraulic analysis of a pump station involves the interrelationship of three main components:

1. The inflow hydrograph
2. The stage vs. storage capacity
3. The discharge rate

The inflow hydrograph is determined by the physical factors of the watershed and regional climatological factors. The storage needed for pump operations along with the required discharge rates of the pump station are usually the major design variables. Local regulations or physical factors often control the discharge rate of the pump station while storage may be affected by site constraints. Both storage and discharge rate have cost components that may affect final design.

In theory, an infinite number of designs are possible for a given site. Therefore, to initiate a design, constraints must be evaluated and a trial pump station design formulated to meet the constraints. Then, by routing the inflow hydrograph through the trial pump station system, its adequacy in meeting the constraints and fulfilling design criteria can be evaluated.

13-402 Pump Station Design Sequence

This 11-step sequence is formulated and presented here for new pump station design. For existing pump stations, the procedure is similar with the exception that some of the variables are already in place, so that fewer trials may be needed. Small portions of text and many of the figures and tables included within these steps were taken directly from this chapter's references listed in [Section 13-500](#). Primary of these reference sources is [HEC 24 Highway Stormwater Pump Station Design](#)¹. The figures and tables taken from [HEC 24](#) and converted to English units are representative examples of the numerical and graphical analysis involved in completing the respective design task. They can and should be utilized as the basis for much of the Hydraulic Report checklist. Taken as a whole, however, the figures and tables within [Section 13-402](#) do not represent a continuous complete example problem, and therefore do not truly demonstrate the iterative nature of pump station design.

These are the steps taken in the typical development of the hydraulic design for a new pump station:

1. Inflow Hydrograph and Inflow Mass Curve
2. Design Highwater Level
3. Pumping Rate, Volume of Storage, and Number of Pumps
4. Pump Pit Dimensions

5. Stage Storage Relationship
6. Pump Cycling and Usable Storage
7. Mass Curve Routing
8. Trial Pump and Discharge Pipe
9. Total Dynamic Head and System Head Curve
10. Pump Performance Curve, Design Point, and Operating Range
11. Final Pump Selection and Design

STEP 1: Inflow Hydrograph and Inflow Mass Curve

The inflow hydrograph should be developed with acceptable methods for the design frequency; typically a 50-year event; and a 100-year flood frequency, with consideration of the critical duration (see [Chapter 4](#)). [Figure 13-402a](#) is a graphical depiction of a typical inflow hydrograph.

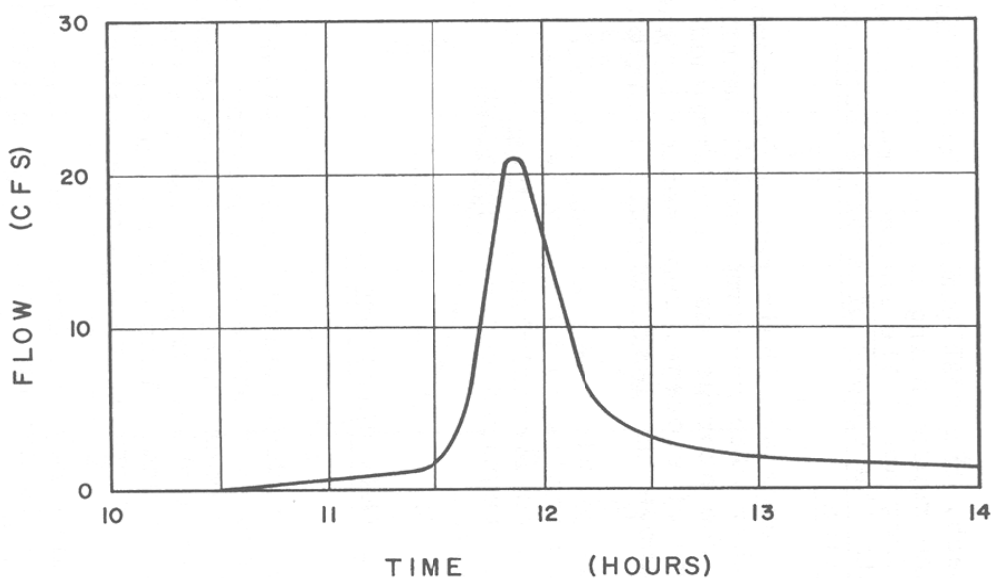

*Inflow Hydrograph
Figure 13-402a⁴*

In order to route floods through the pump station, the design inflow hydrograph is converted to an inflow mass curve. The inflow mass curve provides the accumulated volume of water at each time step. First, the inflow hydrograph is summed numerically as shown below in [Table 13-402a](#) Inflow Mass Data. Then Column 6 from [Table 13-402a](#), Cumulative Flow, is plotted versus time as shown in [Figure 13-402b](#).

Columns in Table 13-402a are determined in this manner:

- Column (1) Time. Divide inflow hydrograph into smallest practical time increments necessary to accurately define the shape of the hydrograph.

- Column (2) Inflow. Inflow hydrograph ordinates.
- Column (3) Average Inflow. Average value of inflow from two successive time increments.
- Column (4) Time Increment. Time elapsed between increments.
- Column (5) Incremental Flow. Product of (Col.3) x (Col. 4). Represents area under inflow hydrograph curve between two consecutive time ordinates.
- Column (6) Cumulative Flow. Sum of incremental mass inflows at a given time. Represents area under hydrograph curve from onset of runoff to given time.

Col(1)	Col(2)	Col(3)	Col(4)	Col(5)	Col(6)
TIME	INFLOW (cfs)	AVERAGE INFLOW (cfs)	TIME INCREMENT (sec)	INCREMENTAL FLOW (ft ³)	CUMULATIVE FLOW (ft ³)
10:30	0				0
35	.1	.05	300	15	15
40	.2	.15	"	45	60
45	.3	.25	"	75	135
50	.4	.35	"	105	240
55	.5	.45	"	135	375
11:00	.6	.55	"	165	540
05	.7	.65	"	195	735
10	.8	.75	"	225	960
15	.9	.85	"	255	1,215
20	1.0	.95	"	285	1,500
25	1.1	1.05	"	315	1,815
11:30	1.2	1.15	"	345	2,160
35	2.5	1.85	"	550	2,710
40	4.5	3.5	"	1,050	3,760
45	11.5	8.0	"	2,400	6,160
50	19.0	15.2	"	4,560	10,720
55	21.5	20.2	"	6,060	16,780
12:00	17.0	19.2	"	5,760	22,540
05	12.0	14.5	"	4,350	26,890
10	6.5	9.2	"	2,760	29,650
15	5.0	5.8	"	1,740	31,390
20	4.0	4.5	"	1,350	32,740
25	3.5	3.8	"	1,140	33,880
12:30	3.3	3.4	"	1,020	34,900
35	2.7	3.0	"	900	35,800
40	2.5	2.6	"	780	36,580
45	2.3	2.4	"	720	37,300
50	2.1	2.2	"	660	37,960
55	2.0	2.05	"	620	38,580
13:00	1.9	1.95	"	580	39,160

Inflow Mass Data

*Inflow Mass Data
Table 13-402a⁴*

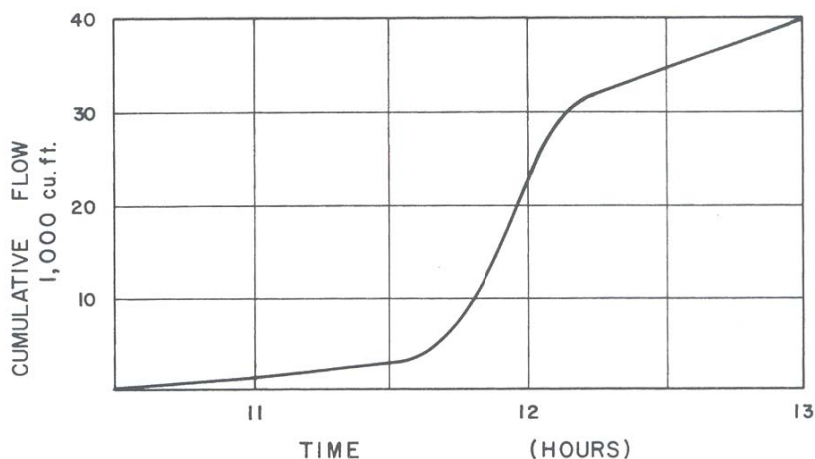

*Inflow Mass Curve
Figure 13-402b⁴*

An inflow mass curve like that depicted in the above figure is used as the basis for graphical mass curve routing outlined in [STEP 7](#).

STEP 2: Design High Water Level

In order to prevent pavement flooding in sags, the highest permissible water level for the design frequency must be set at least 2' below the lowest pavement inlet. This elevation will define the highest hydraulic grade line that meets the design criteria.

Some head loss will occur through the pipes and appurtenances leading to the pump station. Therefore, a hydraulic gradient will be established and the maximum permissible water elevation at the pump station will be the elevation of the hydraulic gradient. This gradient will be very flat for most wet well designs with exterior storage.

STEP 3: Pumping Rate, Volume of Storage and Number of Pumps.

The complex relationship among the various components of the pump operation, i.e., pumping rate, storage and number of pumps, requires a trial, check and adjustment approach. With that approach, some of the variables are assumed in order to facilitate the hydraulic routing. Then, the assumed variables are adjusted and fine-tuned as needed to reach the goal of a balanced design between pumping rates and storage.

For the first trial, a rough estimate of the peak pumping rate can be established based on some ratio to the existing peak inflow rate that is available through the inflow hydrograph. If there are limitations on the pump discharge rate due to restrictions downstream of the pump station, then the limited discharge rate should be used as a given parameter. Once the peak pump discharge is assigned, plotting this discharge as a horizontal line across the inflow hydrograph as shown on [Figure 13-402c](#) will roughly define the storage volume needed above the last pump turn on elevation. This storage can be calculated as the shaded area that is above the pump discharge rate and below the hydrograph curve. Based on this estimate of the storage volume needs, storage facility dimensions and elevations can be estimated, and stage-storage relationship can be developed.

The peak pump discharge should be equally divided between a number of pumps with a minimum of two main pumps per station.

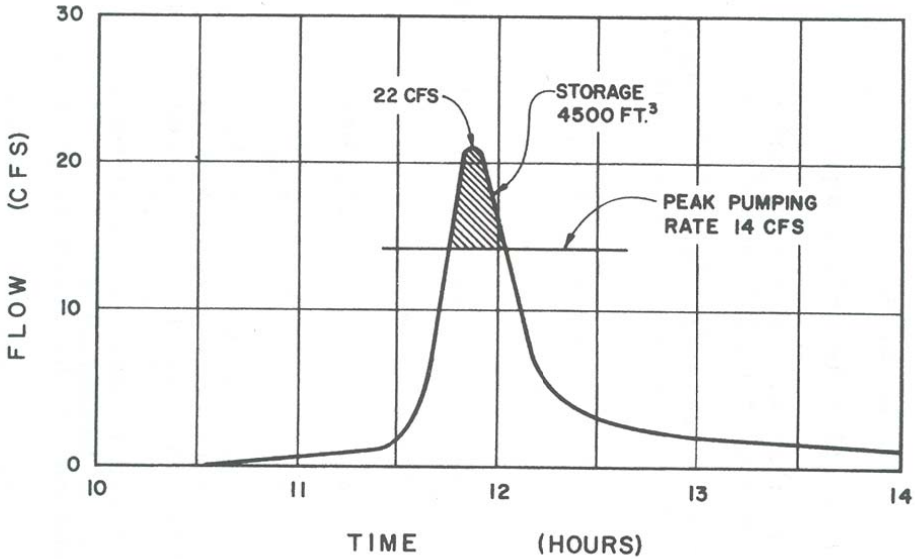

Estimating Required Storage
Figure 13-402c⁴

STEP 4: Determine Pump Pit Dimensions

The minimum required plan dimensions for the pump station can be determined from the manufacturer’s literature or dimensioning guides such as Figure 13-402d provided by the Hydraulic Institute. These dimensions will be used to estimate the storage volume within the pump station wet pit.

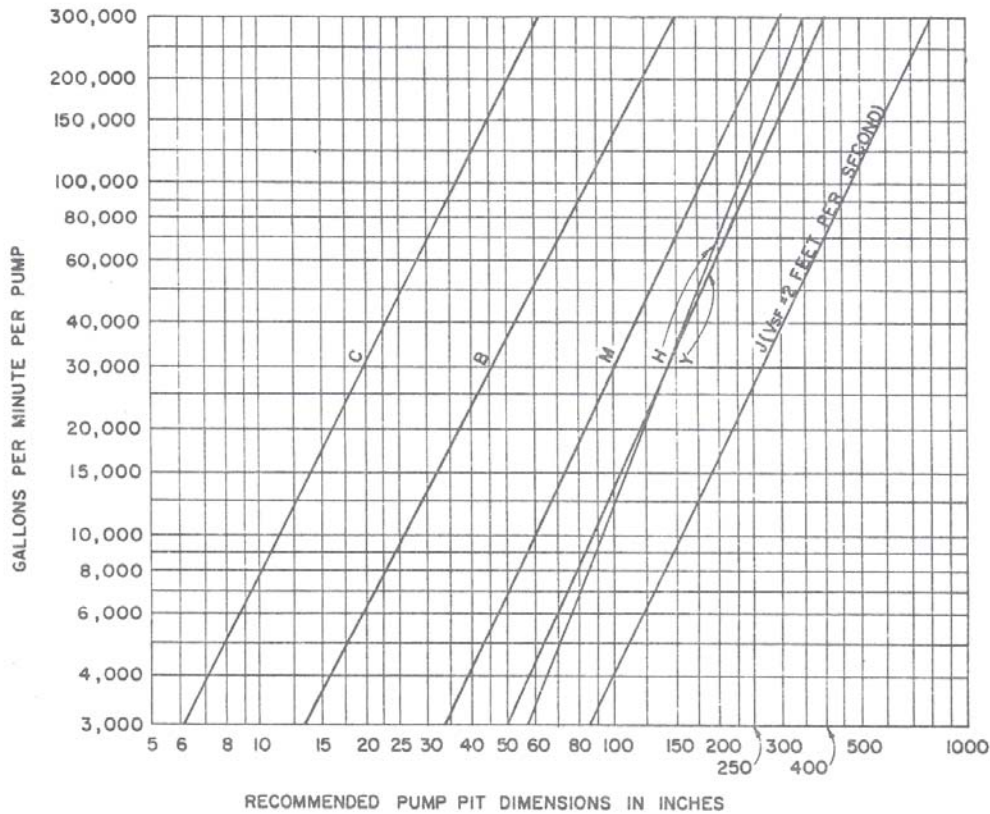

THE ABOVE IS REPRODUCED FROM HYDRAULIC INSTITUTE STANDARDS
 (NOTE: DIMENSIONS J AND M AND VELOCITY V_{SF} ARE SHOWN AS A, S & V_C RESPECTIVELY IN THE ORIGINAL)

- J = MINIMUM DISTANCE FROM TRASH RACK TO BACKWALL (LENGTH OF PUMP PIT).
- V_{SF} = MAXIMUM VELOCITY OF STREAM FLOW (0.5 FT./SEC. RECOMMENDED).
- B = MAXIMUM DISTANCE FROM CENTERLINE OF PUMP TO BACKWALL.
- C = AVERAGE DIMENSION FROM UNDERSIDE OF BELL TO BOTTOM OF PIT.
- H = MINIMUM DIMENSION FROM MINIMUM WATER-LEVEL TO BOTTOM OF PIT.
- M = MINIMUM CENTER-TO-CENTER SPACING OF PUMPS.
- Y = MINIMUM DISTANCE TO PUMP CENTERLINE FROM DOWNSTREAM END OF ANY OBSTRUCTION IN SUMP (OBSTRUCTION MUST BE STREAMLINED.)

*Recommended Pump Pit Dimensions Per Hydraulic Institute Standards
 Figure 13-402d⁶*

STEP 5: Stage Storage Relationship

Pump routing procedures require that a stage versus storage relationship be developed for the pump station system. This is accomplished by calculating the available volume of water for storage at uniform vertical intervals. The volumes are calculated separately for the pump pit, any outside storage facility (for example a buried vault), and the storm sewer pipes and appurtenances that feed the pump station. The designer’s initial, preliminary stage-storage ratings for new pump stations should reflect the storage provided by the trial wet well developed in [STEP 4](#) and the storage within the storm sewer collection system sized to convey the design event. These two components alone may provide the estimated required storage volume from [STEP 3](#) below the design highwater elevation determined in [STEP 2](#). If that is not the case, storm sewer can be oversized or additional storage elements as mentioned here may need to be developed and introduced into the stage versus storage relationship.

For purposes of illustrating stage storage calculations, [Figure 13-402e](#) depicts an elevation view of a representative pump station with a 48-inch inflow pipe feeding the wet well and a 36” pipe upstream. Typically, storm sewer connections upstream of the wet well involve a number of pipes that provide storage below the design highwater elevation. For example purposes, it is assumed that no storage is available upstream of the 36” pipe. [Table 13-402b](#) tabulates calculated storage in the wet well and contributing pipes from low water elevation 0.0 ft. up to highwater alarm elevation at 10.0 ft. Volume in the wet well is calculated by appropriate formulas. For storage in circular inflow pipes, the volume can be calculated using the ungula of a cone formula as discussed in [Chapter 12, Section 12-503](#). The contributing volumes of all individual storage elements are then summed to provide a total system storage below each stage. [Table 13-402b](#) utilizes a 0.5 ft. elevation step, but that is for illustrative purposes. Generally, storage should be tabulated at 0.1 ft. vertical increments to improve the definition of the mass curve routing. [Figure 13-402f](#) is a graphical representation of the tabulation contained in [Table 13-402b](#).

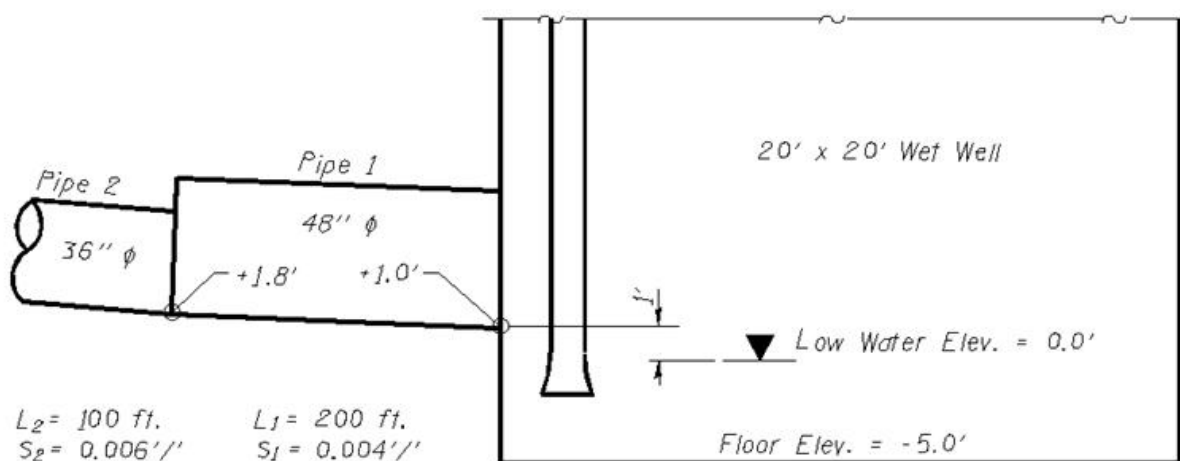

*Example Pump Station Configuration
Figure 13-402e*

Elevation (ft)	Pipe 1 (ft³)	Pipe 2 (ft³)	Total Pipes (ft³)	Wet Well (ft³)	Total (ft³)
0	0	0	0	0	0
0.5	0	0	0	200	200
1.0	0	0	0	400	400
1.5	46	0	46	600	646
2.0	247	4	251	800	1051
2.5	567	60	627	1000	1627
3.0	941	221	1162	1200	2362
3.5	1336	502	1838	1400	3238
4.0	1726	707	2433	1600	4033
4.5	2082	707	2789	1800	4589
5.0	2366	707	3073	2000	5073
5.5	2513	707	3220	2200	5420
6.0	2513	707	3220	2400	5620
6.5	2513	707	3220	2600	5820
7.0	2513	707	3220	2800	6020
7.5	2513	707	3220	3000	6220
8.0	2513	707	3220	3200	6420
8.5	2513	707	3220	3400	6620
9.0	2513	707	3220	3600	6820
9.5	2513	707	3220	3800	7020
10.0	2513	707	3220	4000	7220

*Stage-Storage Rating
Table 13-402b*

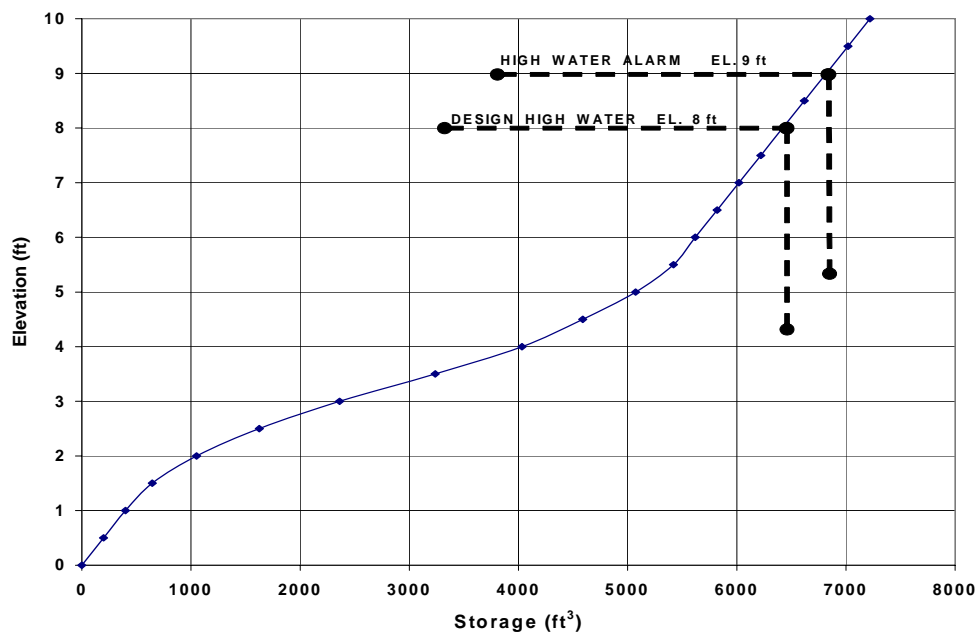

*Stage-Storage Curve
Figure 13-402f*

STEP 6: Pump Cycling and Usable Storage

Initially, the water level in the pump station wet well will rise at a rate dependent on the rate of inflow and the physical geometry of the wet well and inflow pipe. When the water level reaches the stage designated as the first pump-start, the pump will be activated and discharge water from available storage at its designated pumping rate. If the pumping rate exceeds the rate of inflow, the water level in the wet well will drop until it reaches the first designated pump-stop elevation. When the pump stops, the wet well begins to refill and the cycle is then repeated.

Cycling refers to the time between successive starts of the individual pump. The shorter the cycling time, the more frequently a pump starts, stops and starts again. Frequent starting of a pump can result in overheating and excessive wear on the pump components. Therefore, it is necessary to keep cycle time as long as practical.

The minimum cycle time that will prevent damage to the pump from overheating depends, to a large degree, on the size of the pump’s motor. The larger the motor, the greater the minimum cycling time. [Table 13-402c](#) provides some guidance that may be used for preliminary design in the Hydraulic Report. However, the pump manufacturer should always be consulted for the allowable cycling time during the final phase of project development.

Motor HP	Motor kW	Cycling Time (t), Minutes
0 - 15	0 - 11	5
20 - 30	15 - 22	6.5
35 - 60	26 - 45	8
65 - 100	49 - 75	10
150 - 200	112 - 149	13

*Estimation of Allowable Cycle Time
Table 13-402c²*

The storage that should be used for pump cycling calculations is called usable storage. At some installations, the pump pit represents a small part of the storage available in the system. Where storage is also provided by inflow storm sewer, the usable storage is less than available storage for any given elevation above the invert of the inflow pipe to the wetwell. This is due to the fact that water being conveyed to the pump station within the storm sewer below the normal flow depth already occupies some of the available storage in that sewer. Assuming that the inflow rate to the pump station is unchanged during the cycle, only the volume above the conveyance level as shown in [Figure 13-402f](#) is usable for the pump cycling. Chapter 7 of [HEC 24 Highway Stormwater Pump Station Design¹](#) provides an example for estimating usable storage by accounting for the unavailable volume below uniform depth depicted in the figure.

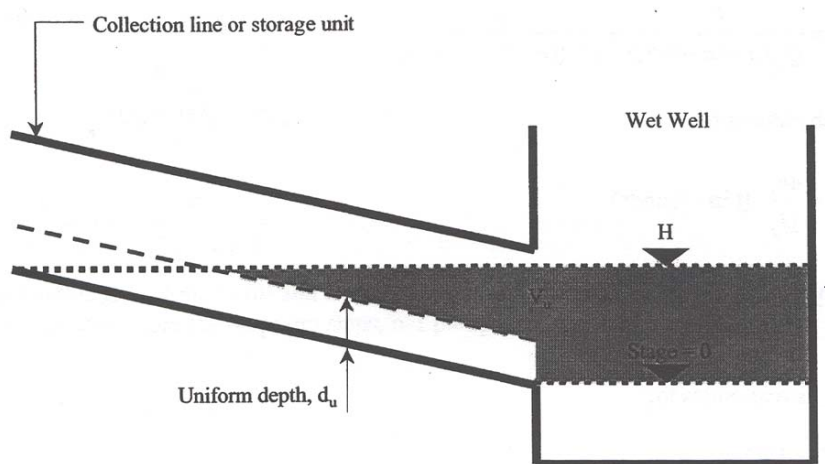

*Usable Storage Below Any Stage, H
Figure 13-402g¹*

In theory, as discussed in [HEC 24](#), the minimum cycling time allowable to reduce wear on the pumps will occur when the inflow to the usable storage volume is one-half the pump capacity. As a result, cycling time can be related to usable storage volume and the minimum required cycle volume for a known pump size can be determined as follows:

$$V_{\min} = 15Q_p t \quad (\text{Eq. 13-2})^1$$

Where:

- t = minimum cycle time, minutes
- Q_p = individual nominal pump rate, cuft/sec
- V_{min} = minimum required cycle volume, cuft

With the Stage–Storage curve developed in [STEP 5](#), the pumping range, Δh, can be calculated. The pumping range represents the vertical height between pump-start and pump-stop elevations. Usually, the lowest pump-stop elevation is controlled by the minimum recommended bell submergence criteria specified by the pump manufacturer. Another guide is that the lowest pump-stop elevation of the main pumps should not be lower than the invert of the inflow pipe entering the wet pit to maximize use of the storm sewer in-line storage. However, the stop elevation of the station’s low flow pump should be a minimum of 1’ below the invert of the inflow pipe. This practice will keep the main drain empty between floods to limit silt accumulation.

When the only storage provided is in the wet pit, and when the wet pit has a uniform cross-sectional area, the minimum pumping range, Δh, can be calculated by dividing the minimum storage volume, V_{min} associated with the minimum cycle time, t_{min} by the wet pit area as shown below:

$$\Delta h = \frac{15Q_p t}{\text{wet pit area}} \quad (\text{Eq. 13-3})^3$$

Determination of the pumping range is somewhat more complicated when there is additional in-line storage upstream of the pump station. A stage vs. usable storage (similar to the stage vs.

storage, but accounting for unavailable storage as shown in [Figure 13-402g](#)) should be tabulated and a curve should be plotted. Enter the curve at the first pump-stop stage, and read the corresponding volume. This volume is then added to the minimum cycling volume and the curve re-entered at this volume. The elevation corresponding to this volume represents the first pump-start.

The second and subsequent pump-start/stop elevations could be determined in a similar way. First, the pump-stop elevation for each pump is selected; [HEC 24](#) suggests it is preferable to set pump-stop elevations by staggering them at preset intervals of 0.5 to 1.0 ft., or, to set all to stop at the same elevation. Next, the distance between pump-starts is accomplished with the use of the stage vs. usable storage curve as described above. Usually, the distance between the pump-starts would be in the range of 0.5 to 3.0 ft. If a large volume of storage exists, the start range between the pump-starts may be calculated to be less than 0.5 ft. However, a range of 0.5 ft. is recommended as a minimum, to reduce the potential for concurrent activation of two or more pumps as a result of waves or other fluctuations in the water level in the wet pit. The last pump start elevation should be well below the design high water elevation in the pit.

When the start and stop sequence of all the pumps is established it should be tabulated and graphically presented. [Table 13-402d](#) displays a typical schedule of pump operation, while [Figure 13-402h](#) represents the same schedule in a graphical format. Note that the volumes corresponding to on-off elevations within [Table 13-402d](#) are taken from the stage versus usable storage rating curve. The table indicates the usable storage volume in the system between first pump-on and first pump-off elevations is just over 1000 ft³. [Equation 13-2](#) estimates the minimum acceptable usable volume for this pump capacity (assuming 6.5 starts/hr.) is 969 ft³.

PUMP #	NOMINAL Q		PUMP ON		PUMP OFF	
	cfs	gpm	Elevation ft	Volume ft ³	Elevation ft	Volume ft ³
1	7.0	3140	2.0	1002	0.0	0
2	7.0	3140	3.0	1302	1.0	300

*Pump On-Off Schedule
Table 13-402d*

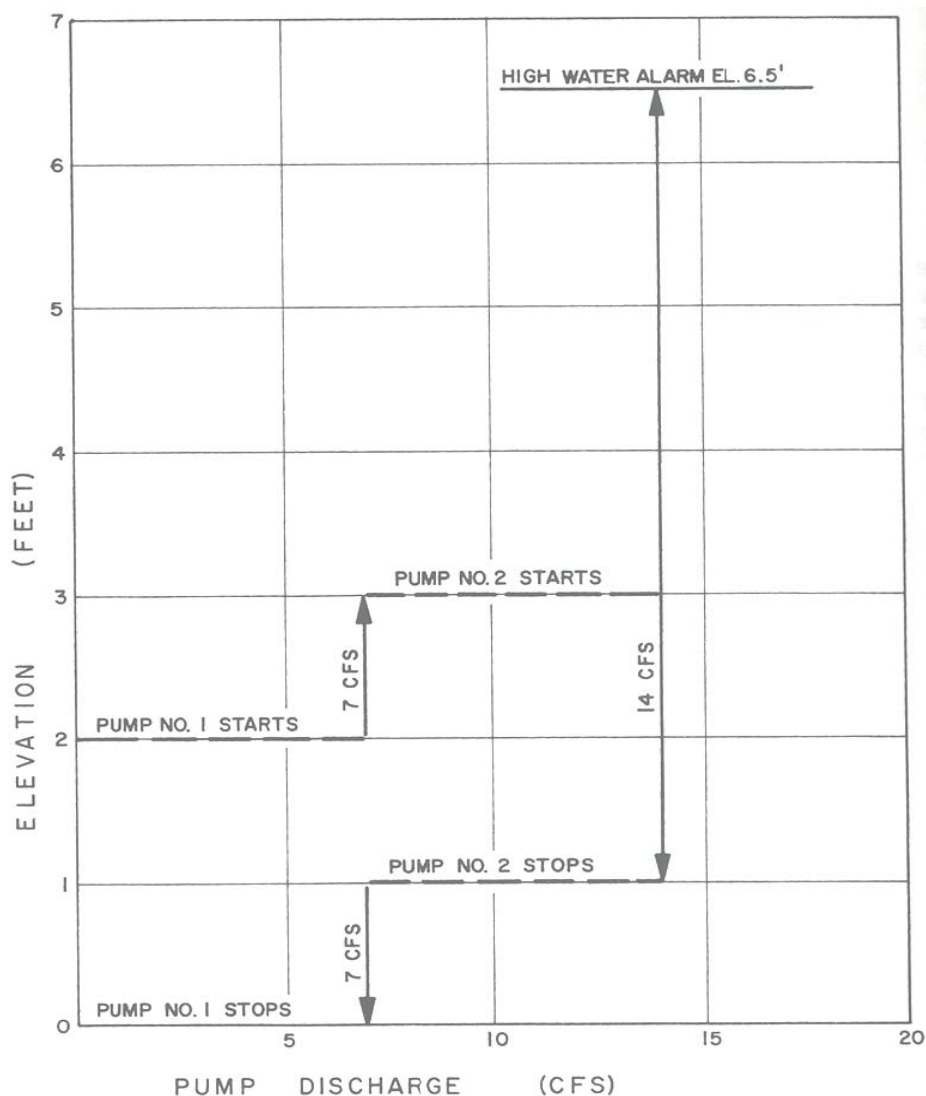

*Stage-Discharge Curve
Figure 13-402h⁴*

STEP 7: Mass Curve Routing

A flood event can be routed through a pump station system once the relationships between the various components of the system are known. These include the mass inflow volume of the design flood (STEP 1), the number of pumps and discharge capacity for each pump (STEP 3), and the start and stop elevations for each pump (STEPS 2 & 4 through 6).

Through the use of the mass curve routing method, the performance of the pump station can be observed at each time increment of the inflow hydrograph evaluated. The primary product of routing flow through the station in this manner is an estimate of mass inflow in excess of pumping capacity, or required storage volume. This volume is then compared to system storage available below design highwater. The design and subsequently the routing can be “fine-tuned” by adjusting any of the variable pump and storage components.

As storm water flows into the storage basin, it will accumulate until the first pump-start elevation is reached. The first pump is activated and, if the inflow rate is greater than the pump rate, the storm water will continue to accumulate until the second pump-start elevation is reached. As the inflow rate decreases, the pumps will shut off at their respective pump-stop elevations.

These conditions are modeled in the mass curve diagram (Figure 13-402i) by establishing the point at which the cumulative inflow curve has reached the storage volume associated with the first pump-start elevation.

This diagram is an integral part of the Hydraulic Report as it provides an effective way to rapidly review pump station operation parameters. It can be used in the field to quickly evaluate changes to how the pumps are operated. Therefore, the curve should be plotted at an appropriate scale so that all details are readily visible and values can easily be interpreted. This may necessitate a plot using a 22" by 34" sheet. Also it may be necessary to expand a portion of the curve that contains much information and place it onto a separate sheet so it can easily be read.

Storage volume for the first pump-start is represented by the vertical distance between the cumulative inflow curve and the base line. A vertical storage line is drawn at this point because it establishes the time when the first pump starts.

The pump discharge line is drawn from the intersection of the vertical storage line and the base line, upward toward the right. The slope of this line is equal to the discharge rate of the pump. The pump discharge line drawn represents the cumulative discharge from the storage basin, while the vertical distance between the inflow mass curve and the pump discharge curve represents the amount of stormwater stored in the basin.

If the rate of inflow is greater than the pump capacity, the inflow mass curve and the pump discharge curve will continue to diverge until the volume of water in the storage basin is equal to the storage associated with the second pump-start elevation. At this point, the second pump starts, and the slope of the pump discharge line is increased to equal the combined pump rates.

The procedure continues until peak storage conditions are reached. At some point on the inflow mass curve, the inflow rate will decrease and the slope of the inflow mass curve will flatten. To determine the maximum amount of storage required, a line is drawn parallel to the pump discharge curve and tangent to the inflow mass curve. The vertical distance between the two lines represents the maximum storage required.

The routing procedure continues until the pump discharge curve intersects with the mass inflow curve. At this point, the storage basin has been completely emptied to the lowest stop elevation and a pumping cycle has been completed. As the storm recedes, the pumps will cycle to discharge the remaining accumulated runoff.

In the above routing procedure, the pumps discharge a fixed rate representing the "designed" pumping rate (also called the nominal rate). In reality, this rate changes with the head against which the pump is working as the water level in the storage basin fluctuates. Using the nominal, designed rate yields a more conservative design than using a changing rate.

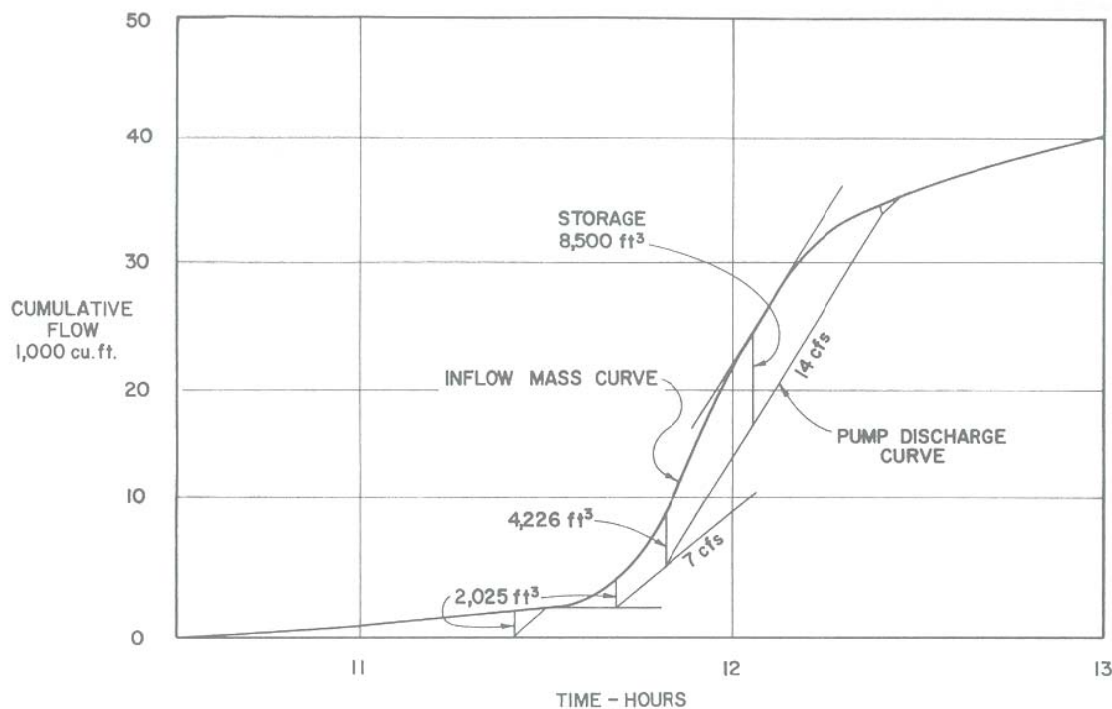

Mass Curve Routing Diagram
Figure 13-402i⁴

Mass curve routing intended to demonstrate pump station adequacy along with an estimate of peak required storage can also be completed numerically. A numerical routing uses the same variable components utilized in the graphical diagram; inflow mass curve and a pump cycling schedule. The spreadsheet application shown in [Table 13-402e](#) simulates the operation of a 4-pump station near the beginning of a design storm. Cumulative inflow is tallied at each time interval, pumps are turned on and off according to a pre-determined schedule and the volume of inflow in excess of pumping capacity is calculated in Column 8. Like the diagram, this numerical routing provides a comparison of inflow to outflow, a record of pump starts, and most importantly, an estimate of required storage. [Table 13-402e](#) displays only a portion of the 3-hour duration event. A complete analysis begins at time zero and spans the duration of the event.

Event: Q₅₀, 3-hr. duration
 Alternative: Existing Conditions at P.S. 58
 Number of Pumps: 4
 Capacity per Pump: 201 ft³/min.

	PUMP #1	PUMP #2	PUMP #3	PUMP #4
PUMP "ON" VOLUME (ft ³)	500	700	1100	1350
PUMP "OFF" VOLUME (ft ³)	400	500	650	650

COL 1	COL 2	COLUMNS 3-6				COL 7	COL 8	COLUMNS 9-12			
Time (min)	Inflow (ft ³)	Pump Outflows (ft ³)				Total Outflow (ft ³)	Reqd. Storage (ft ³)	On-Off Counters (1=On / 0=Off)			
		#1	#2	#3	#4			#1	#2	#3	#4
18	1080	0	0	0	0	0	1080	0	0	0	0
19	1209	201	201	0	0	402	807	1	1	0	0
20	1359	402	402	0	0	804	555	1	1	0	0
21	1530	603	603	0	0	1206	324	1	1	0	0
22	1722	603	603	0	0	1206	516	0	0	0	0
23	1941	804	603	0	0	1407	534	1	0	0	0
24	2187	1005	603	0	0	1608	579	1	0	0	0
25	2457	1206	603	0	0	1809	648	1	0	0	0
26	2754	1407	603	0	0	2010	744	1	0	0	0
27	3078	1608	804	0	0	2412	666	1	1	0	0
28	3429	1809	1005	0	0	2814	615	1	1	0	0
29	3807	2010	1206	0	0	3216	591	1	1	0	0
30	4209	2211	1407	0	0	3618	591	1	1	0	0
31	4635	2412	1608	0	0	4020	615	1	1	0	0
32	5085	2613	1809	0	0	4422	663	1	1	0	0

33	5559	2814	2010	0	0	4824	735	1	1	0	0
34	6057	3015	2211	0	0	5226	831	1	1	0	0
35	6576	3216	2412	0	0	5628	948	1	1	0	0
36	7116	3417	2613	0	0	6030	1086	1	1	0	0
37	7677	3618	2814	0	0	6432	1245	1	1	0	0
38	8256	3819	3015	201	0	7035	1221	1	1	1	0
39	8853	4020	3216	402	0	7638	1215	1	1	1	0
40	9468	4221	3417	603	0	8241	1227	1	1	1	0
41	10101	4422	3618	804	0	8844	1257	1	1	1	0
42	10749	4623	3819	1005	0	9447	1302	1	1	1	0
43	11412	4824	4020	1206	0	10050	1362	1	1	1	0
44	12090	5025	4221	1407	201	10854	1236	1	1	1	1
45	12783	5226	4422	1608	402	11658	1125	1	1	1	1

*Pump Station Routing
Table 13-402e*

Column 1 Time

Column 2 Inflow. From the inflow mass curve developed in [STEP 1](#); cumulative inflow to the pump station.

Columns 3–6 Pump Outflows. Cumulative volume of outflow for each pump at the end of the time specified. These columns simulate pump operation over discrete, one-minute intervals, turning each pump on and off by comparing its on-off elevations to the wet well stage, or water surface elevation, from the previous row. (Note that on-off elevations and wet well stages have been converted to volumes using the stage versus storage relationship developed in [Step 5](#)). When the wet well stage (converted from Column 8) from the previous row rises above the respective “pump-on” elevation, the cumulative outflow for each pump increases by the volume of flow corresponding to 1 minute of constant pumping at the specified nominal, or “design” pumping rate. Each pump remains “on” until the wet well stage drops below the respective “off” elevation. When turned “off”, the cumulative outflow volume in Columns 3–6 remains unchanged from the previous time interval. This cycle repeats when wetwell stage once again rises and reaches the individual pump’s “on” stage.

Column 7	Total Outflow. Column 7 is total cumulative outflow for all pumps; the sum of columns 3, 4, 5 and 6.
Column 8	Required Storage. Column 8 represents the cumulative volume of inflow in excess of outflow, e.g., the volume of water that must be stored within the wet well and collection system. Column 8 = Col. 2 – Col. 7.
Columns 9–12	On-Off Counters. These columns track the on-off status of each pump, providing a visual cue for monitoring cycling and starts per hour. If the respective pump ran during the just elapsed time interval, this column displays “1”. Conversely, if the pump did not run during the time interval in question, this column displays “0”.

STEP 8: Trial Pump and Discharge Pipe Selection

In order to complete the station performance analysis, the hydraulic losses in the station need to be calculated. For this purpose, the designer must select a specific pump, based on known capacity and the head that the water in the pump station needs to be raised to, after accounting also for losses in the piping system. This height is also dependent on the backwater elevation from the receiving system (i.e., a stream, a storm or combined sewer etc.) The pump discharge elevation should be set high enough to avoid backwater from the receiving system to back-up into the pump station. If possible, the discharge elevation should be set above the 100-year elevation.

To select a pump, the designer should study various manufacturers’ literature in order to find a pump with the right combination of capacity and head needs at the optimal efficiency. The selected pump will have a specific discharge pipe size. The discharge line must be sized to be at least the size of the pump discharge diameter. The velocity in the discharge line should not exceed 10 ft/sec. The minimum diameter required based on the maximum permissible velocity should be checked by the following equation:

$$d = 1.128 \sqrt{\frac{Q}{V}} \quad (\text{Eq. 13-4})^1$$

Where:

- d = pipe diameter, ft
- Q = discharge in the pipe, cuft/sec
- V = maximum velocity in the pipe, ft/sec

The length of the discharge pipe must also be determined at this stage based on the station layout. The pump location with respect to the outfall chamber should be set to provide as short a discharge line as possible. Other components of the discharge line that will affect head losses, such as valves, elbows, flap gates and other fixtures, should also be identified for their effect on the total dynamic head. The discharge line layout should be set to limit the amount of backflow when the pumps shut off and to prevent backwater from the outfall from entering the discharge line.

It is preferable that each pump has its own discharge line entirely independent of the other pumps and that all lines discharge into a common discharge chamber. The centerline of each discharge pipe should be placed higher than the design backwater elevation. Due to consideration of potential backflow resulting from storms in excess of the design storm, a check valve at the upstream end of the discharge line may be desirable to prevent such back flow.

STEP 9: Total Dynamic Head and System Head Curve

The combination of static head, velocity head, and various head losses in the discharge system due to friction and pressure head (see [Figure 13-402j](#)) is called total dynamic head (TDH). It represents the total energy required to raise the water liquid from the intake to the discharge point.

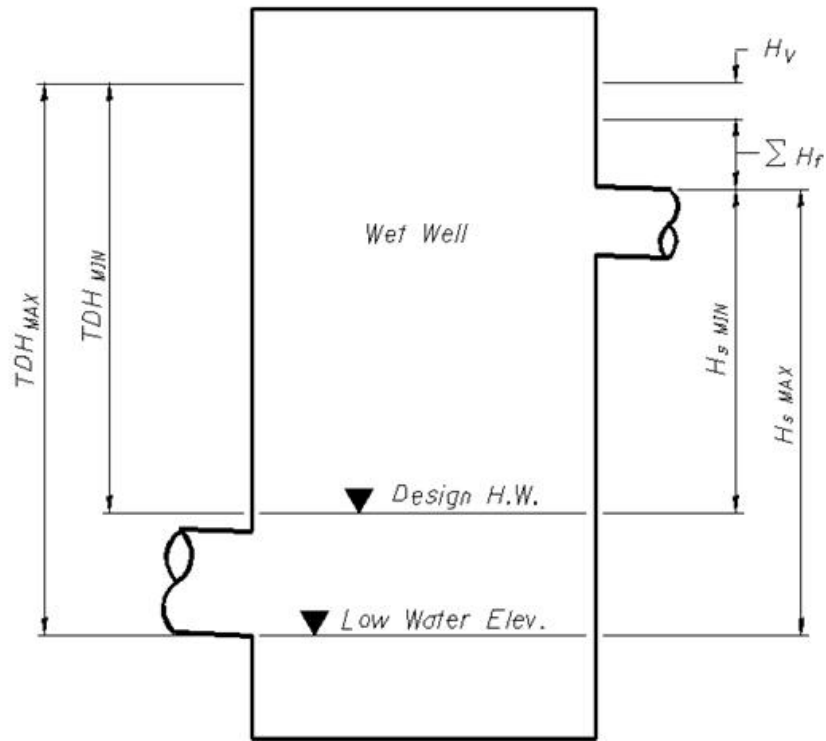

Components of Total Dynamic Head (TDH)
Figure 13-402j

$$TDH = H_s + \sum H_f + H_v + \Delta H_p \quad (\text{Eq. 13-5})^1$$

Where:

- H_s = static head or height through which water must be raised, ft
- $\sum H_f$ = total head losses in pump and discharge line, ft
- H_v = velocity head, $v^2/2g$, ft
- ΔH_p = pressure head change between outlet and intake, ft (= 0 for most stormwater pumps open to atmospheric pressure upstream and downstream)

The most common approach to computing energy losses through appurtenances such as valves and elbows is by use of a dimensionless loss factor, K, applied to the velocity head as follows:

$$H_f = K \left(\frac{V^2}{2g} \right) \quad (\text{Eq. 13-6})^1$$

Where:

- H_f = friction loss through appurtenance, ft
- K = loss factor based on standard data or manufacturer's specified data
- V = velocity through appurtenance, ft/sec
- G = acceleration due to gravity, ft/sec²

The friction loss in pipes can be computed by one of the following equations:

- Manning's Equation

$$H_f = 0.453L \left(\frac{V^2 n^2}{R^{4/3}} \right) \quad (\text{Eq. 13-7})^1$$

Where:

- H_f = friction loss, ft
- V = flow velocity, ft/sec
- n = Manning's roughness coefficient
- R = hydraulic radius = area/wetted perimeter, ft
- L = length of conduit, ft

- Hazen-Williams

$$H_f = \frac{3.022V^{1.85}L}{C^{1.85}D^{1.165}} \quad (\text{Eq. 13-8})^1$$

Where:

- H_f = friction loss, ft
- L = length of pipe, ft
- V = discharge velocity, cfs

C = Friction factor
D = pipe diameter, ft

- Darcy-Weisbach

$$H_f = \frac{fLV^2}{2gD} \quad (\text{Eq. 13-9})^1$$

Where:

H_f = friction head loss, ft
f = friction factor
L = length of pipe, ft
V = flow velocity, ft/sec
g = acceleration due to gravity, ft/sec²

Generally, Hazen-Williams is most widely used for the losses throughout the pump station and Manning's is used for the storm drain conduit outside the pump station. Manning's equation is simpler to use and is suitable for the planning stage of the design.

System Head Curve for a single pump is the plot of the total dynamic head (TDH) vs. the pump discharge rates. The TDH for a given pump discharge is dependent on the static head, which changes with the water elevation in the pump wet pit. The variations in the water elevation in the wet pit are between the lowest pumping elevation (all pumps off), which corresponds to maximum static head and the maximum water elevation in the pit, design highwater, which corresponds to the minimum static head. There is a specific system head curve associated with each of these water levels. For design purposes, the maximum and minimum system head curves (corresponding to the minimum and maximum water elevation in the pit, respectively) as well as the average curve between the two system curves should be plotted as shown on [Figure 13-402k](#).

When the pump size is yet unknown, a trial pump should be selected with trial fittings and the system head curves can be determined in a manner similar to that presented. A range of discharges that start below the trial pump discharge and end above the trial pump discharge is selected. Next, the velocity and velocity heads are determined for each discharge. Then TDH values are calculated based on the methods noted above, for the minimum and maximum static head. The results are then plotted as depicted in [Figure 13-402k](#).

The remaining text in [STEP 9](#) is an excerpt taken directly from Chapter 8 of [HEC 24 "Highway Stormwater Pump Station Design"](#)¹. The SI units within the [HEC 24](#) example laid out below in steps 9b through 9k have been converted to English units.

When selecting specific manufacturer's pumps and piping:

- Pump selection is dependent on system head curve and power requirements
- Power requirements are dependent on TDH requirements
- System head curve is dependent on TDH
- TDH is dependent on the pump and pipe head losses
- Head losses are dependent on the selected pumps and piping

The example presented below in [STEPS 9a through 9k](#) begins by estimating the system head curves before selecting manufacturer's products. The assumptions are then checked for validity after the selection.

STEP 9a Determine the maximum static head, $H_{s(max)}$. This is the difference in height between the outflow head level or discharge pipe elevation and the lowest pumping elevation (lowest pump-off elevation). Use the following table to determine the outflow level.

If the centerline of the discharge pipe is:	Then set the outflow head level to:	Comment
lower than the estimated backwater from the receiving water (outfall)	the estimated backwater level from the receiving water.	Not preferable, but if so, a flap gate will definitely be necessary.
lower than normal depth of flow in the outfall	normal depth in the outfall.	Same as above.
higher than both normal depth of flow and backwater in the outfall	centerline level of discharge pipe.	This is the preferred condition, where practicable.

STEP 9b Determine the minimum static head, $H_{s(min)}$. This is the difference in height between the outflow head level and the maximum highwater level in the wet well. The same conditions described in [STEP 1](#) apply to the outflow head level.

Example: A 2-pump system has a lowest pumping elevation of 65 ft, a maximum highwater in the pump station of 70 ft, a centerline level of discharge pipe of 100 ft and has a free outfall. The sump is at atmospheric pressure.

The maximum static head is:

$$H_{s(max)} = 100 - 65 = 35 \text{ ft}$$

The minimum static head is:

$$H_{s(min)} = 100 - 70 = 30 \text{ ft}$$

STEP 9c Select a starting discharge, Q , that is greater than zero but lower than the target pump rate (Q_p).

Example: Assume the design, or nominal pumping rate, $Q_p = 3600$ gal/min. Use a discharge $Q = 8.0$ cuft/sec.

STEP 9d Compute the actual pipe velocity flowing full using the continuity equation as follows:

$$V = \frac{Q}{A}$$

where:

- V = pipe velocity, ft/sec
- Q = discharge, cuft/sec
- A = pipe sectional area, ft²

Example: Using a 12 in. pipe, the pipe velocity is:

$$V = \frac{8}{(\pi 0.5^2)} = 10.19 \text{ ft/sec}$$

Step 9e

Compute the velocity head, H_v , using the following equation:

$$H_v = \frac{V^2}{2g}$$

where:

H_v = velocity head, ft
 g = acceleration due to gravity, 32.2 ft/sec²

Example: The velocity head is:

$$H_v = \frac{10.19^2}{(2)(32.2)} = 1.61 \text{ ft}$$

STEP 9f

Compute the head losses through pump discharge elements. Refer to [HEC 24, Section 8.1.14.1 – Example of Losses through Discharge Line](#).

Example: A discharge line consists of 65 ft of 12 in. steel pipe with two long radius flanged 90 degree elbows and a flanged swing check valve. The pumping rate is 8 cuft/sec. The friction factor for steel pipe is 100. From [STEP 9d](#): $V = 10.19 \text{ ft/sec}$.

Using [Equation 13-8](#), the friction loss through the pipe is:

$$H_f = \frac{3.022V^{1.85}L}{C^{1.85}D^{1.165}} = \frac{(3.022)(10.19^{1.85})(65)}{(100^{1.85})(1.0^{1.165})} = 2.87 \text{ ft}$$

Referring to [Table 13-402f](#), the loss expression for a long radius flanged 90 degree elbow is:











$$H_f = aD^{-0.61} \left(\frac{V^2}{2g} \right) = (0.435)(12^{-0.61}) \left(\frac{10.19^2}{(2)(32.2)} \right) = 0.15 \text{ ft}$$

The loss expression for a flanged swing check valve is:

$$H_f = K \left(\frac{V^2}{2g} \right) = (2) \left(\frac{10.19^2}{(2)(32.2)} \right) = 3.22 \text{ ft}$$

The total losses through the discharge line are found by summing the individual losses:

$$\Sigma H_f = \text{Total loss} = 2.87 + (2)(0.15) + 3.22 = 6.39 \text{ ft}$$

Element	Description	Coefficients			K Form K =	Loss Form $h_f =$
		Metric	English			
		a (D in mm)	a (D in inches)	b		
	Regular flanged 90° Elbow	0.887	0.430	-0.224	aD^b	$KV^2/2g$
	Long radius flanged 90° Elbow	3.134	0.435	-0.610	aD^b	$KV^2/2g$
	Long radius flanged 45° Elbow	0.578	0.220	-0.298	aD^b	$KV^2/2g$
	Flanged Return Bend	1.080	0.450	-0.271	aD^b	$KV^2/2g$
	Flanged Tee - Line Flow	2.283	0.450	-0.502	aD^b	$KV^2/2g$
	Flanged Tee - Branch Flow	1.072	0.260	-0.438	aD^b	$KV^2/2g$
	Flanged Gate Valve	2.488	1.000	-0.282	aD^b	$KV^2/2g$
	Flanged Swing Check Valve	2.000	2.000	0.000	2	$KV^2/2g$
	Restrictor	n/a	n/a	n/a	0.1	$K \& V^2/2g$
	Enlarger	n/a	n/a	n/a	0.2	$K \& V^2/2g$
	Sudden Enlargement	n/a	n/a	n/a	0.5	$K \& V^2/2g$

Loss Coefficients for Pipe Appurtenances
Table 13-402f

STEP 9g

Compute TDH_{min} and TDH_{max} for the minimum and maximum static heads, $H_{s(min)}$ and $H_{s(max)}$, respectively, using Equation 13-5. Assuming the inlet and the outlet are open to the atmosphere, ΔH_p will be zero.

Example: The maximum total dynamic head is:

$$TDH_{(max)} = H_{s(max)} + H_f + H_v = 35 + 6.39 + 1.61 = 43 \text{ ft}$$

The minimum total dynamic head is:

$$TDH_{(min)} = H_{s(min)} + H_f + H_v = 30 + 6.39 + 1.61 = 38 \text{ ft}$$

STEP 9h Compute the arithmetic average (TDH_{ave}) of the minimum and maximum total dynamic heads.

Example: The average total dynamic head is:

$$TDH_{(ave)} = \frac{(43 + 38)}{2} = 40.5 \text{ ft}$$

STEP 9i Use the full range of Q, repeat [STEP 4](#) to [STEP 8](#) until the TDH information for the full range of flows is developed.

Example: [Table 13-402g](#) shows the results of repeating the total dynamic head computations for a range of discharges.

Pump Rate	Min. Static Head	Max. Static Head	Velocity	Velocity Head	Pipe Friction Loss	Bend Losses	Transition Losses	Valve Loss	Min TDH	Max TDH	Ave TDH
(ft ³ /s)	(ft)	(ft)	(ft/s)	(ft)	(ft)	(ft)	(ft/s)	(ft)	(ft)	(ft)	(ft)
0	30	35	0.0	0.0	0.0	0.0	N/A	0.0	30.0	35.0	32.5
2	30	35	2.5	0.1	0.2	0.0	N/A	0.2	30.5	35.5	33.0
4	30	35	5.1	0.4	0.8	0.0	N/A	0.8	32.1	37.1	34.6
6	30	35	7.6	0.9	1.7	0.1	N/A	1.8	34.6	39.6	37.1
8	30	35	10.2	1.6	2.9	0.2	N/A	3.2	38.0	43.0	40.5
10	30	35	12.7	2.5	4.3	0.2	N/A	5.0	42.4	47.4	44.9
12	30	35	15.3	3.6	6.1	0.3	N/A	7.3	47.7	52.7	50.1

*Total Dynamic Head
Table 13-402g*

STEP 9j Plot the TDH_{max} , TDH_{min} , TDH_{ave} , versus discharge. This is the system head curve plot.

STEP 9k Establish the target design variables TDH_{ave} , the average of TDH_{max} and TDH_{min} , for the target pump capacity, Q_p . (That is, the capacity of one pump, not total pumping rate).

Example: Referring to [Table 13-402d](#), at a design pump rate of 8 cfs:

$TDH_{(max)} = 43.0 \text{ ft}$
 $TDH_{(min)} = 38.0 \text{ ft}$
 $TDH_{(ave)} = 40.5 \text{ ft}$

System Head Curve

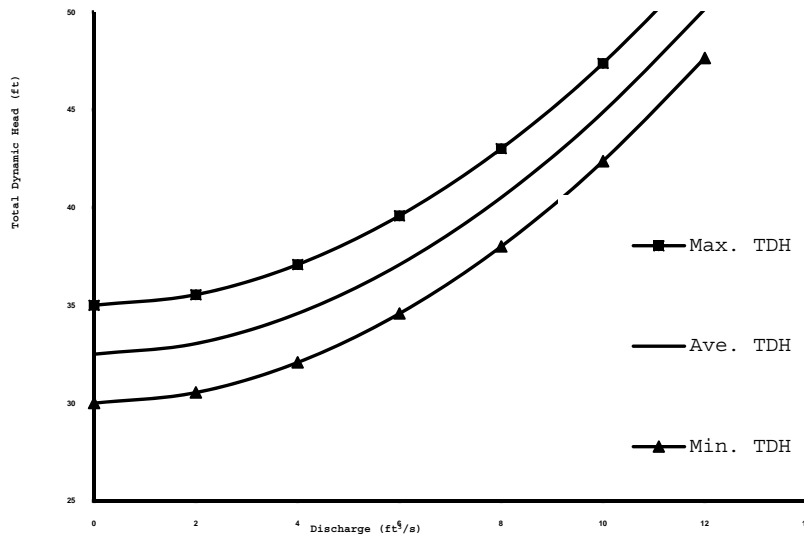
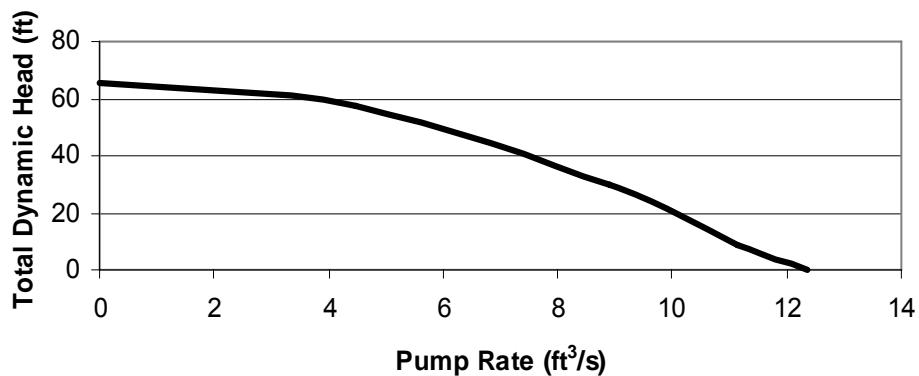

Figure 13-402k¹

STEP 10: Pump Performance Curve, Design Point and Operating Range

Pump performance curves show the variation in pump discharge capacity with respect to total dynamic head. Typically, the pump manufacturer supplies pump performance curves for each individual pump. Sometimes, new or existing pumps are tested in the pump station to verify that the pumps operate in accordance to their rated or nominal capacity. Figure 13-402l shows a typical pump performance curve. Figure 13-402m shows a simplified version of a manufacturer’s typical pump performance curve with efficiency curves and the point of maximum efficiency.



Typical Pump Performance Curve
Figure 13-402l¹

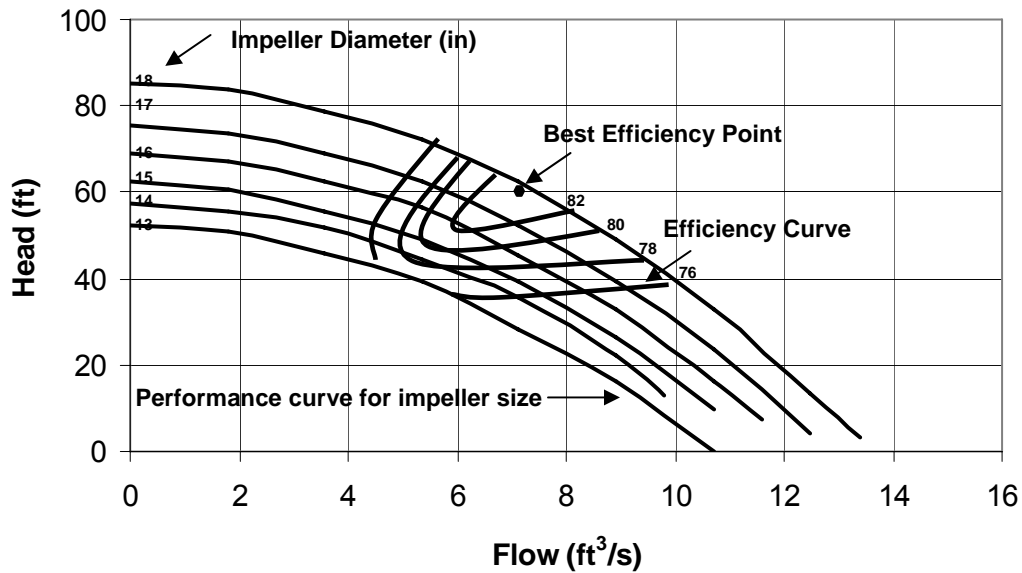

Simplified Manufacturer's Pump Performance Curve
Figure 13-402m¹

The design point is the target total dynamic head and discharge superimposed on the performance curve plot. The performance curve that is closest to the design point would be the characteristic curve for the desired pump. If a single pump were to operate with constant static head, the design point would be determined as the point of intersection of the system curve and selected performance curve as shown in Figure 13-402n.

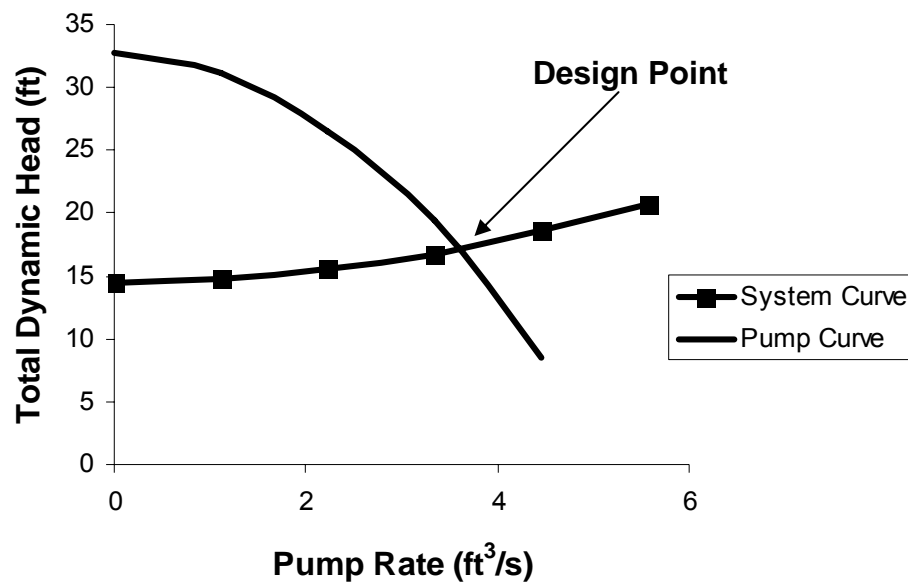

Design Point
Figure 13-402n¹

The operating range for a system is the range between the intersection of the pump performance curve and the maximum and minimum system head curves.

When two or more pumps connected to a common discharge line are operating and the static head changes over a limited range, the design point will move from A, for the first pump operating alone, to B, with both pumps operating at a minimum static head, as indicated in Figure 13-402o. This represents an operating range. This case is typical for a stormwater pump station in which all pumps are connected to a common discharge line using a manifold.

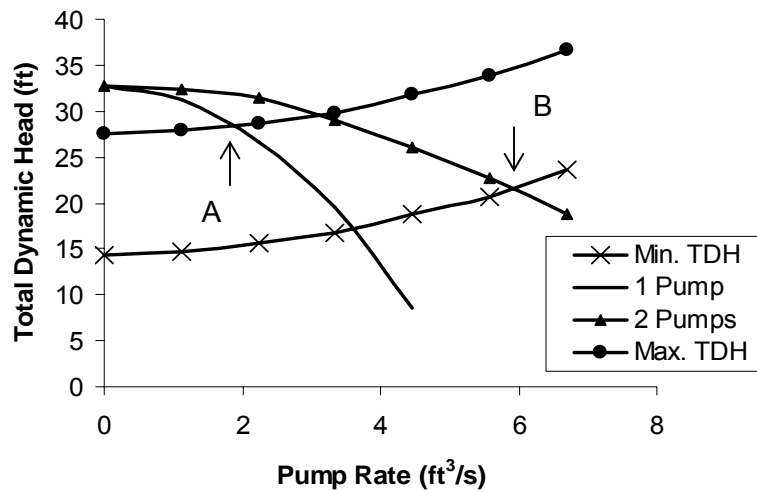

Operating Range for Two Pumps and Common Discharge Line
Figure 13-402o¹

When two or more pumps with separate discharge lines are operating and the static head changes over a limited range, the range over which the pumps must operate is from A to B as shown in Figure 13-402p. This case is typical for an IDOT stormwater pump station in which each pump discharges to the outfall via separate discharge lines.

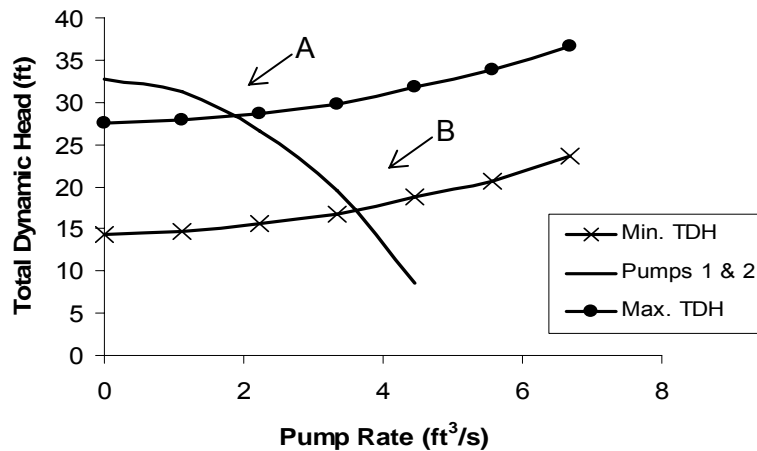

Operating Range for Pumps with Separate Discharge Lines
Figure 13-402p¹

As a conservative approach, IDOT District 1, Bureau of Electrical Operations recommends to set the design point based on the maximum TDH (corresponding to the low water elevation in the wet pit), when sizing the needed pumps.

STEP 11: Final Pump Selection

Once a balance between the pumping rate and storage is achieved, and the system head curve and the design point are determined, the actual pump will be selected with consideration of the power needs (water power, brake power and wire to water power). Discussion regarding power needs and related definitions and equations are available in [HEC 24 Highway Stormwater Pump Station Design](#)¹.

13-500 REFERENCES

1. U.S. Department of Transportation, Federal Highway Administration. *Highway Stormwater Pump Station Design*. Hydraulic Engineering Circular No. 24. February 2001.
2. U.S. Department of Transportation, Federal Highway Administration. *Urban Drainage Design Manual*, Hydraulic Engineering Circular No. 22, Third Edition. September 2009.
3. AASHTO. *Model Drainage Manual*. Washington, D.C., 1991
4. U.S. Department of Transportation, Federal Highway Administration. *Manual for Highway Storm Water Pumping Stations (Vol. I and Vol. II)*. October 1982.
5. Hydraulic Institute. *ANSI/HI Pump Standards*. 2002



Chapter 14

Computer software

CHAPTER 14 - COMPUTER PROGRAMS

14-000 GENERAL

14-001 Introduction

- 14-001.01 Availability
- 14-001.02 Support and Training
- 14-001.03 Websites

14-100 PROGRAM APPLICATIONS

14-101 Hydrology and Detention Storage

14-102 Pavement Drainage

14-103 Storm Drains

14-104 Roadside Ditches

14-105 Culvert Analysis

14-106 Water Surface Profiles / Bridge Backwater

14-107 Scour at Bridges

14-108 Multi-Function: FHWA Hydraulic Toolbox

14-000 GENERAL

14-001 Introduction

Many of the methods and techniques described in previous chapters have been incorporated into computer applications. This chapter provides information on selecting and applying those computer programs which the Department's Division of Highways currently accepts for drainage analysis and design. This chapter also provides thumbnail sketches for each of the Department's **primary** titles; detailing the source or author and briefly outlining each title's capabilities in broad terms. These titles are compiled in [Figure 14-001](#). This chapter does not provide title-specific direction for use or detailed design examples. Any in-depth discussion or instruction for using one of the titles in [Fig. 14-001](#) is provided elsewhere in this Manual; please refer to [Section 14-100](#) as a guide to the proper chapter(s) for this information.

[Figure 14-001](#) contains the Department's **primary** accepted computer programs and their respective drainage applications. All of these programs utilize standard established procedures and are commonly accepted by other reviewing agencies. All of these programs are presently available on the internet in public domain versions from their respective sponsoring Federal agency or from the FHWA (Federal Highway Administration).

In addition to the titles listed in [Fig. 14-001](#), IDOT utilizes other public domain titles and software packages purchased from private vendors; i.e., commercial software. Commercial or proprietary software packages are very useful supplements to the public domain tools provided free or at minimal cost from Federal agencies. They perform many of the same analyses based on identical or equivalent methodologies, but they may offer additional features such as report writing capabilities that are not available in their public domain counterparts. The Hydraulics Unit within the Bureau of Bridges and Structures has obtained one or more commercial software titles for most of the applications in [Fig. 14-001](#). However, private vendor packages are not included in [Fig. 14-001](#) and are also not discussed individually in this chapter. They are excluded here because, unlike the titles in [Fig. 14-001](#), not every proprietary product in IDOT's software inventory is utilized in all of the nine district offices. The exclusion of commercial titles from this chapter is also consistent with the Department's policy regarding contractors and suppliers, in that the Department does not wish to assume the role of agent for, or promoter of specific products.

Consultants working directly for IDOT should determine program selection in their pre-submittal meetings with district personnel. Any hydraulic work that is subject to IDOT's review and approval, whether it is done for IDOT or done for others outside the Department, can benefit from pre-coordination regarding accepted programs and their utilization. An example of work done for others that is subject to the Department's review/approval is the drainage connection that accompanies Access Permit applications. As [Section 1-404](#) of this manual describes, construction projects that affect drainage along highways under IDOT's jurisdiction must submit an analysis of the drainage impact. IDOT's review and approval can be facilitated by submittals completed with one of the same programs employed by the reviewing District.

[Figure 14-001](#) has evolved and will continue to evolve as needed to include new products and upgraded versions as they become available. Both the districts and Central Office bureaus work together towards that end. Almost all software titles undergo some form of periodic upgrading. In some cases the revisions are minor enough to allow the older version(s) to remain functional. However, new versions can render previous versions either incompatible with the latest generation or simply obsolete. The user should generally maintain the latest version to ensure the reliability and acceptability of the analysis. The user, for both in-house and consultant work, should also document the version number of any program utilized in the report or study. Because

of the dynamic nature of software production\upgrading, and the fact that not every district office is using the same version of each program, version numbers are omitted from [Figure 14-001](#).

APPLICATION	PRIMARY PROGRAMS
Hydrology	HEC-1/HEC-HMS, TR-20
Detention Storage	HEC-1/HEC-HMS, TR-20
Storm Drains	HY-22
Pavement Drainage	HY-22
Roadside Ditches	HY-22 (flow capacity)
Culvert Analysis	HY-8, HEC-RAS, WSPRO
Water Surface Profiles \ Bridges	HEC-RAS, WSPRO
Bridge Scour	HEC-RAS, WSPRO

*Drainage applications and their respective primary accepted computer programs
Figure 14-001*

There are a number of applications tools in existence within the Department- mostly spreadsheets, but not limited to such- that have been developed internally. They typically complete basic, straightforward tasks, and are generally intended for use within one District or bureau. An example is the spreadsheet referenced in [Section 6-802](#) that computes the cross sectional area for partially filled pipes. Application tools of this nature may vary slightly from accepted procedures and can easily produce inconsistent results when compared with public domain or commercial software.

Section [14-100](#) of this chapter provides some information about the factors that guide the selection of a program from this list for a particular application, including a brief discussion of the capabilities and relative strengths of each title. For applications with multiple accepted programs, one title may be more applicable than the other(s); especially if the work needs to be completed with the same model or program used in a pre-existing study or calibrated to match a previous study. Program selection also involves the respective district's inventory and their preference. Each district reserves the right to express their preferred software title(s) for each report or study. Reiterating above text, [Figure 14-001](#) lists only the Department's **primary** public domain titles, Each **district office may use other** software, including both proprietary and public domain computer programs, which are not listed in [Figure 14-001](#). Also as stated above, any hydraulic work that is subject to IDOT review and approval can benefit from pre-coordination regarding accepted programs. [Section 14-100](#) also includes some discussion of other public domain titles not included in [Fig. 14-001](#).

14-001.01 Availability

Public domain software from agencies like the FHWA or USACE (U.S. Army Corps of Engineers) is typically available directly to all users on-line. The respective websites are <http://www.fhwa.dot.gov/engineering/hydraulics/software.cfm> and <http://www.hec.usace.army.mil>. These sites also provide access to user's manuals, related publications, research reports and CD ROM tools. A CD ROM of particular note is entitled "FHWA Hydraulics Library". This is a 2-disk set that contains 32 FHWA publications and several instructional videos.

14-001.02 Support and Training

Both the District and the Bridge Office have some expertise to assist in projects on the State roadway system, particularly for those programs in [Figure 14-001](#). The FHWA clearinghouses referenced above provide technical assistance in the form of telephone and e-mail support for many of their products.

To a large degree, public domain packages like [HEC-RAS](#) and [HEC-HMS](#) from the USACE have closed the gap with private vendors regarding ease of use. For example, both of these Corps packages now run in the Windows environment and employ a graphical user interface (GUI) very similar to those that in the past have been the exclusive domain of private vendors. In addition, public domain titles are free or relatively inexpensive by comparison. In light of the overall improvements made to public domain titles, perhaps the biggest attraction to utilizing a costlier commercial package may be the level of technical support. Larger vendors have knowledgeable people providing assistance over the phone and typically provide upgraded versions at minimal cost. Many provide on-line support in the form of tutorials, training modules and live, on-line interactive demonstrations. Larger firms also hold short courses and can make training seminars available.

Short courses of several days in length provide training for some of the more complex software. These courses are sponsored periodically by several public organizations including IDOT, IDNR, Natural Resources Conservation Service (NRCS), and American Society of Civil Engineers (ASCE). In addition, the National Highway Institute (NHI) contracts short courses to IDOT on many of these software titles and also for related hydraulic topics. NHI classes or their equivalent are commonly utilized to train not only IDOT staff, but local agency and consultant personnel as well. An excellent example of NHI equivalent courses is the University of Wisconsin at Madison's Professional Development Program. The program offers a broad training curriculum including courses on storm drain design, [HEC-RAS](#) and detention basin design, among many others.

14-001.03 Web Sites

There are an increasing number of Web sites that offer useful information for hydraulic work. This information runs the gamut from raw, unrefined data such as stream flow measurements at gauging stations to aerial photos to downloadable software products and technical publications. The addresses listed in Section 14-001.01, especially the FHWA, are excellent resources for preparing and documenting reports, obtaining the latest methods and procedures, or finding training and technical support for hydraulic software. The FHWA and USACE sites are listed explicitly because of their obvious wide utility and frequency of use, but also due to the likelihood that their addresses will remain intact. The following are links to other agencies whose sites frequently contribute to hydraulic determinations and whose addresses are likely to remain as shown:

IDOT	Illinois Dept. of Transportation	http://www.dot.state.il.us
IDNR	Illinois Dept. of Natural Resources	http://www.dnr.state.il.us
FHWA	Federal Highway Administration	http://www.fhwa.dot.gov/bridge
USACE	U.S. Army Corps of Engineers	http://www.hec.usace.army.mil
NRCS	Natural Resources Conservation Service	http://www.il.nrcs.usda.gov
USGS	United States Geological Survey	http://www.il.water.usgs.gov
ISWS	Illinois State Water Survey	http://www.sws.uiuc.edu
FEMA	Federal Emergency Management Agency	http://www.fema.gov

14-100 PROGRAM APPLICATIONS

14-101 Hydrology and Detention Storage

Chapter 4, [Hydrology](#), distinguishes between hydrologic methods that produce peak flow rates and those that produce runoff hydrographs. The two most commonly used peak flow methodologies (see [Table 4-002](#)) are the USGS regression equations and the Rational Method. These two methods are not considered computer programs, per se, and are therefore excluded from [Figure 14-001](#). However, as described in applicable subsections of this chapter, both are available tools within one or more of the programs listed in [Figure 14-001](#).

[HEC-1](#), [HEC-HMS](#), [TR-20](#) and [WinTR-20](#) are the Department's primary software tools for work requiring a hydrograph. [HEC-1](#) is an industry-standard model created by the USACE in the 1970's. In the late 1990's the USACE developed a hydrologic model called [HEC-HMS](#), which is essentially, but not entirely, a Windows version of [HEC-1](#). [TR-20](#) is also an older, well established model that was written by the Soil Conservation Service (SCS), an agency that is now known as the National Resources Conservation Service, or NRCS. [WinTR-20](#) is a modernized version of [TR-20](#), rewritten for use on windows based computers. [Chapter 4](#) contains brief sketches of [HEC-1/HEC-HMS](#) and [TR-20](#), and includes [Table 4-002](#) for selecting the appropriate model. Both of these utilize Illinois State Water Survey (ISWS) Bulletin 70 for synthetic rainfall data, which is also covered in [Chapter 4](#). Summarizing the material from that chapter, [HEC-1/HEC-HMS](#) and [TR-20](#) generate very comparable hydrographs for a given site and are considered widely applicable. The primary application of these models by the Division of Highways is detention storage analysis associated with roadway construction projects or for the purpose of reviewing applications for off-ROW drainage connections to IDOT's system. [HEC-1/HEC-HMS](#) and [TR-20](#) are also utilized to develop inflow hydrographs for pump station analysis.

Again, [HEC-1/HEC-HMS](#) and [TR-20](#) are considered essentially equal for the typical analysis. For example, both use the storage indicator method for reservoir rating. [HEC-1/HEC-HMS](#) is considered more versatile in that it offers a wider array of modeling techniques. It is also supported and regularly updated by the U.S. Army Corps of Engineers (USACE) on a national level. Because of this, [HEC-1/HEC-HMS](#) has become more of the "standard" hydrograph method, preferred by such agencies as FEMA and the Illinois Department of Natural Resources. [HEC-1/HEC-HMS](#) has also been packaged with its own editor for ease of review. For these reasons, [HEC-1/HEC-HMS](#) is preferred if both are available.

While [HEC-1](#) is still acceptable, the USACE is only updating [HEC-HMS](#) at this time. The model's graphical user interface (GUI) enables the construction of a schematic representation of the watershed using a small number of graphical components linked together. All of the standard [HEC-1](#) operations can be implemented within [HMS](#). In addition, a program called [HEC-GeoHMS](#) adds the capability to define drainage areas using digital elevation models and GIS data. [HEC-HMS](#) can also import [HEC-1](#) files directly. The two models share many capabilities, but there are some infrequently used [HEC-1](#) tools that have not been added to [HMS](#).

IDOT has acquired several commercial packages to assist in the preparation and review of work involving detention storage. These acquisitions can be primarily attributed to the fact that [HEC-1](#) and [TR-20](#) are DOS-based programs. The addition of [HEC-HMS](#), [WinTR-20](#) and proprietary programs in each district provides consultants and IDOT staff some useful flexibility. Enabling the reviewer to use the same program as that submitted provides benefits to all parties, including reduced review time and greater ability to analyze alternative scenarios.

14-102 Pavement Drainage

HY-22 automates the procedures in the FHWA Hydraulic Engineering Circular No. 22 (**HEC 22**), "Urban Drainage Design Manual". As the manual states, **HY-22** is a compilation of programs to assist in inlet spacing and analysis of flow conditions commonly encountered in highway related stormwater management. **HY-22** accommodates a large number of inlet types and a variety of roadway and curb geometries. In addition to inlet spacing, the program can compute open channel flow depths using Manning's equation. There is also an option for computing stage-storage curves and for reservoir routing in pipes and small detention basins. **HY-22** and **HEC 22** replace their older FHWA versions, which were **HY-12** and **HEC 12**, respectively.

14-103 Storm Drains

Hydraulic design of storm drain collection systems involves two primary determinations; the location and selection of appropriate inlet structures and the sizing of the pipe network. The first of these, locating and selecting inlet structures, is typically referred to in hydraulic text as pavement drainage. Section 14-102 lists and describes the Department's primary software tools for that application.

Typically, sizing the storm drain network follows after inlet type and location have been identified. The hydraulic calculations involved in this process focus on estimating flow capacity, computing losses in pipes and manholes and constructing the hydraulic grade line. Figure 14-001 lists **HY-22** for this application.

By comparison to **HY-22**, the methodologies presented in Chapter 8 are somewhat simplified. For example, the inlet spacing procedures assume 100% efficiency, or interception, over the grate. The Chapter 8 material has been in widespread use within the Department for many years, but the procedures are not as robust as either of the computer programs, and therefore should be considered a "quicker and dirtier" solution. Chapter 8 does remain the basis for the Department's in-house training program, partly because the solution algorithms and design considerations within the Manual are very illustrative of those within **HY-22**.

14-104 Roadside Ditches

Chapter 9, Roadside Ditches, outlines two dimensions of hydraulic analysis required in the design of roadside ditches. These are the estimation of flow capacity in the ditch and the determination of the need for and the selection of channel lining. Flow capacity, as described in Chapter 9 and also in Chapter 5, typically centers around an iterative solution of normal depth for a given channel template using Manning's Equation. The FHWA's **HY-22**, "Urban Drainage Design Programs", automates flow calculations in open channels. Its utilities include Manning's Equation, critical depth calculation and development of stage versus storage relationships.

Ditch lining analysis is completed using the guidance of **HEC 15**, "Design of Roadside Channels With Flexible Linings" and **HEC 11**, "Design of Riprap Revetment". There are spreadsheets available which allow the user to analyze rigid and flexible linings of both a temporary and permanent nature, but there is not currently a public domain software title available for this task.

14-105 Culvert Analysis

The FHWA first published Hydraulic Design Series #5 (**HDS 5**), "Hydraulic Design of Highway Culverts" in September 1985. Currently this publication is available on both of the FHWA CD-ROM disks mentioned in Section 14-001. **HDS 5** contains the methodologies and procedures that form the basis of all of the culvert software tools used by IDOT.

HY-8 HY-8 automates the design methods found in HDS 5. The FHWA has introduced a Windows based version of HY-8, which updates the older DOS versions, and it can be obtained through the FHWA website. A wide variety of culvert types, shapes and inlet configurations can be analyzed for headwater, outlet velocity, etc. Within its design mode, the program also sizes the minimum required culvert span given a fixed height and a specified allowable headwater. HY-8 can simulate combined flow through the opening and over the road. Tailwater can be input directly or computed by Manning's equation for a user-supplied cross section. HY-8 also has a culvert routing routine that requires an inflow hydrograph and some topographical input.

Occasionally, unusual flow conditions or excessive outlet velocities dictate the need for energy dissipators at culvert locations. Appropriately, HY-8 also offers design procedures based on HEC 14, "Hydraulic Design of Energy Dissipators for Culverts and Channels". Several different types of internal dissipators, drop structures, and stilling basins are available.

HEC-RAS & WSPRO Although HEC-RAS and WSPRO focus on bridge backwater analysis, both are also useful tools for culvert analysis. Both models have the capability to analyze a wide spectrum of culvert types and shapes, both can analyze culverts as stand-alone structures or as overflow structures within a multiple opening analysis, and both HEC-RAS and WSPRO can simulate combined flow through the culvert and over the roadway.

HEC-RAS develops continuous water surface profiles that extend upstream and downstream of the culvert opening. Floodplain cross sections are located and modified for ineffective area in a manner similar to that recommended for bridge analysis detailed in Chapter 7, Bridge Hydraulics. The model's culvert routine resembles HY-8 in that it also determines headwater by comparing inlet and outlet control conditions. It differs from HY-8, in that HEC-RAS performs additional calculations if the initial routine indicates the culvert is operating in inlet control. These are intended to verify the working assumption of supercritical flow throughout much of the culvert length. If these calculations find the culvert actually operating under pressure flow for its entire length, the routine utilizes the outlet control solution. Refer to the HEC-RAS Hydraulic Reference Guide for further details on inlet control calculations.

By comparison, WSPRO culvert capabilities are more limited. The model can analyze the same range of culvert shapes and types as HEC-RAS. However, for a stand-alone analysis, WSPRO cannot compute both culvert headwater and continuous water surface profiles upstream and downstream from the culvert. Culvert analysis in WSPRO consists of user-supplied tailwater elevations and culvert details, from which the model computes headwater elevations at the upstream face, outlet velocities, and other flow parameters. No profiles downstream or upstream are generated; these require separate runs. WSPRO can generate continuous water surface profiles through a culvert only when the culvert is coded as an overflow structure within a multiple opening analysis. In that case, one run produces tailwater elevations, head loss through the culvert and the upstream backwater profile.

As mentioned in Chapter 7, HEC-RAS was developed by the U.S. Army Corps of Engineers to replace HEC-2. Although IDOT has adopted HEC-RAS as the primary model for bridge and culvert backwater analyses, HEC-2 has not been retired. However, its use is relegated to only those projects that involve an existing FIS or other regulatory study completed with HEC-2. Refer to Chapter 7, Section 7-101 for further discussion on selection and use of the HEC-2 model. The HEC-2 and HEC-RAS culvert routines are similar, with the most notable difference being that HEC-2 is limited to only pipe and box shapes.

Due to their wide use, availability and continued support from their respective authoring agencies, HY-8, HEC-RAS and WSPRO are the Department's accepted public domain programs for culvert

analysis. In addition to these, a limited number of commercial software titles and applications software are used in several districts that also follow FHWA hydraulic procedures.

In most cases, HY-8 or HEC-RAS will be the preferred program for culvert analysis. HY-8 tends to be easier to use for this task, and it requires less survey information than HEC-RAS to complete the design. HY-8 is most appropriate for designing culverts where the performance characteristics of the culvert are the deciding factor or for smaller watersheds which are outside of a 100 year event floodplain. When the proposed culvert is in a floodplain that FEMA has designated as being in Flood Zone A, it is more appropriate to use HEC-RAS for the analysis. In some cases, the culvert results from HEC-RAS will generate negative created heads for most or all storm events. When this occurs, check the culvert results in HY-8 using a rating curve generated from the natural conditions water surface profile in HEC-RAS.

14-106 Water Surface Profiles / Bridge Backwater

As Figure 14-001 indicates, IDOT relies primarily on HEC-RAS and WSPRO to develop water surface profiles in open channels and perform bridge backwater analysis. HEC-RAS (Hydraulic Engineering Center - River Analysis System) and WSPRO (Water Surface PROfiles) are both one-dimensional, steady flow models that utilize the standard step backwater method to balance the energy equation between floodplain sections. Operating under typical flow conditions in Illinois, gradually varied flow within the subcritical regime, these two models can produce essentially equivalent results for open channel analysis. Both offer a set of bridge backwater routines (see Section 7-103) that can simulate any of the typical flow conditions encountered in Illinois, and both compute bridge scour per the direction in HEC 18, Evaluating Scour at Bridges. Chapter 7 contains an in-depth discussion of the tools available in both models and additional direction for applying them. Outside of the Department, both models are acceptable to most regulating agencies; including IDNR's Office of Water Resources. Within the Department, HEC-RAS has become the preferred model, as the text below elaborates upon.

The FHWA commissioned WSPRO from the USGS in the early 1980's to incorporate the latest research in bridge backwater and to implement risk analysis in the design of stream crossings. Unlike other models, WSPRO computes an "effective flow length" upstream of the bridge and balances the total energy equation from the downstream "EXIT" section to the upstream "APPROACH". WSPRO is similar to HEC-RAS in that it handles all types of flow conditions commonly encountered in floodplain analysis. The model also generates profiles in both the subcritical and supercritical flow regimes. Major differences include WSPRO's rigid requirements for locating cross sections at bridges, which dictates the number and location of the sections involved. Another significant difference centers on the user convention regarding ineffective flow areas in the expansion\contraction cones at bridges. Typically, WSPRO does not require the user to establish limits of effective flow for the sections that flank the bridge opening like HEC-RAS does (See Section 7-102.01a). For bridge scour analysis, the model supplies the flow parameters needed at a given cross section by generating tubes of equal conveyance across the section. In addition, WSPRO's multiple opening routine is considered the best tool currently available for multiple opening analyses.

Although they are both accepted by IDOT and others, HEC-RAS is considered to be the more complete model. As discussed here and in Chapter 7, HEC-RAS has a number of attributes and computational features that distinguish it from the WSPRO model. For these reasons, HEC-RAS has become the industry's standard model and is generally preferred within the Department. It is a Windows program, while the stand-alone WSPRO remains DOS-based. HEC-RAS has many tools that are unavailable in WSPRO, such as the spilt flow option for leveed channels, stream networks and mixed flow regime analysis. The Corps actively supports the model; regularly issuing new versions and updates. For example, a recent upgrade added unsteady flow

capability. In addition, the WSPRO low flow Class 1 bridge routine is available in HEC-RAS, and several other HEC-RAS bridge loss calculations are identical or very similar to the respective WSPRO routines. Indicative of the model's widespread use and acceptance is the recent announcement from FEMA that all post-2002 FIS analyses and revisions will be completed with HEC-RAS.

In addition to the two primary bridge backwater models listed in Figure 14-001, the Department employs two other models on a much more infrequent basis. These two programs are HEC-2 and WSP-2. HEC-2, the Corps' precursor to HEC-RAS, originated in the 1970's and was widely used until the Corps supplanted the model with HEC-RAS. HEC-2 is the basis for many older published regulatory studies and was one of the Department's primary backwater models prior to the introduction of HEC-RAS in the early 1990's. HEC-2 has two methods of estimating bridge backwater. Normal Bridge method applies to low flow conditions without piers and for openings that aren't easily represented by an equivalent trapezoid. A minimum of 6 sections are required for this method. Special Bridge method is utilized for all other flow conditions; it requires 4 sections. The model has no rigid requirements for floodplain cross section locations, but does require the user to establish limits of effective flow in the vicinity of bridges. This is based on an assumed 1:1 contraction rate for flow approaching the opening and a 4:1 expansion rate downstream. HEC-2 has optional capabilities to simulate floodway encroachment, split flow created by levee systems, and channel improvements. Closely spaced bridges can be analyzed efficiently with this model, since there is no minimum spacing between sections and no rigid requirements for cross section locations.

HEC-2 remains in active use primarily because of its utilization within most existing (pre-2002) FEMA studies. However, IDOT's use of HEC-2 is limited to projects that involve the use of an existing HEC-2 model prepared for an FIS or other regulatory study. Although HEC-RAS can import HEC-2 input files, the conversion has proven problematic when structures are present. It is recommended that the user make necessary revisions to existing HEC-2 files within HEC-2. See Section 7-101 for further details on the application of HEC-2.

WSP-2 is another older model. Originally issued by the Soil Conservation Service, or SCS (now the NRCS) in the 1970's, the WSP-2 bridge routine is derived from the single-section bridge backwater analysis contained in the 1970 FHWA publication of HDS 1, "Hydraulics of Bridge Waterways". (See [Section 7-000](#)) More current methodologies such as those within HEC-RAS and WSPRO solve for the energy or momentum balance through a bridge opening, including a component for friction losses. WSP-2 does not balance the energy equation through bridges, nor does it account for friction losses through the structure. WSP-2 backwater calculations are overly sensitive to the bed slope, since the bridge opening is superimposed over floodplain sections according to the difference in flowline elevations near the bridge. Although WSP-2 has no capacity for multiple opening analysis involving bridges, it can analyze up to 5 culvert openings (of differing geometry and inverts) across a shared floodplain.

Because of its limitations and outdated bridge routines, WSP-2 has been supplanted by HEC-RAS and WSPRO for bridge backwater analysis. Within IDOT, WSP-2 use is restricted in the same fashion as HEC-2. The model's use is limited to only those sites with existing WSP-2 studies- primarily FIS analyses- that need to be restudied or updated with new cross section information. In those situations, it is suggested that one of the primary models be run side by side with WSP-2 for purposes of comparison. As stated in Chapter 7, WSP-2 use should be restricted to insertion of new floodplain sections into the existing model and minor modifications to the existing structure.

14-107 Scour at Bridges

The FHWA initiated a national bridge scour program in the late 1980's. The program was created largely in response to the 1987 collapse of the New York State Thruway bridge over Schoharie Creek; a catastrophic failure that was attributed to local pier scour. The ongoing program mandates a scour evaluation at every highway bridge over a waterway in the United States. The FHWA created two publications that present design principles and state of the practice regarding scour and stream stability. HEC 18, "Evaluating Scour at Bridges", and HEC 20, "Stream Stability at Highway Structures", serve as guidelines for IDOT scour evaluations. A third publication, HEC 23, "Bridge Scour and Stream Instability Countermeasures", has recently been published to assist in the design and selection of scour countermeasures. HEC 18 and HEC 20 are the primary references supporting Chapter 10, Scour. This Manual's Chapter 11, Scour Countermeasures, contains numerous examples and procedures taken directly from HEC 23.

The typical IDOT bridge scour evaluation includes an estimation of scour depth for both the existing and proposed structures. This estimation utilizes the equations for computing scour found in HEC 18. In the early 1990's, the FHWA created the HY-9 software program to automate the equations contained in what was then a draft version of HEC 18. HEC 18 is now in its 4th Edition and the initial compilation of design methods and equations has been modified several times. The FHWA has chosen not to update and support HY-9 in a similar fashion; thereby essentially abandoning the program.

Presently, IDOT's two primary bridge backwater programs double as software tools for computing contraction and pier scour. HEC-RAS and WSPRO have built-in scour routines that generate scour depths based on the equations and direction in HEC 18. Both can be "turned on" by the user, activating default equations for contraction and pier scour. For example, HEC-RAS utilizes the Colorado State Equation to estimate pier scour. The user needs to be familiar with the discussion in HEC 18 and Chapter 10 of this manual regarding the selection of the appropriate equations based on flow conditions and other variables. Refer to Chapter 10 for direction regarding the typical HEC-RAS scour analysis.

Local agencies within the State of Illinois are also charged with completing scour evaluations in compliance with the FHWA scour mandate. Local agencies can download instructional material and two software tools for this purpose from the IDOT website at: <http://www.dot.state.il.us/blr/scour.html>. The two programs are BSAP, or Bridge Scour Assessment Procedure, and SSAM, the acronym for Simplified Scour Analysis Method. They can be used at a large number of bridges without performing the more complex conventional hydraulic and scour computations such as those outlined in HEC 18. The Local Bridge Unit within the Bureau of Bridges and Structures endorses the use of BSAP and SSAM for existing structures, and typically HEC 18 or a rational analysis per Scour Screening Group 3 as noted in BLRS Circular Memo #91-8 for new construction. BSAP is a decision algorithm developed within the Department for scour evaluation and coding of bridges within the NBIS Item 113, Scour Evaluation Appraisal Rating. SSAM refers to the methods and procedures in the USGS Report 95-4298, "Development, Verification, and Application of a Simplified Method to Estimate Total-Streambed Scour at Bridge Sites in Illinois". A copy of the USGS report can be obtained from http://il.water.usgs.gov/pubs/wrir95_4298.pdf. The publication was developed in the mid 1990's by the USGS in cooperation with the Department. According to the report, SSAM is a tool for completing the screening and evaluation of scour at bridges. The report includes software entitled ILSCOUR, which automates the report's scour estimation methods. ILSCOUR is also available from the above link to the Department's website. Local agencies should consult the Local Bridge Unit within the Bureau of Bridges and Structures for direction regarding the proper use and application of the report and the website tools.

14-108 Multi-Function: FHWA Hydraulic Toolbox

The FHWA Hydraulic Toolbox is a stand alone suite of calculators that performs routine hydrologic and hydraulic computations. These calculators extend the functionality of the now unsupported FHWA DOS Hydraulic Toolbox and Visual Urban programs. They also reflect the latest methods used in the FHWA hydraulic publications [HEC 15](#), [HEC 22](#) and [HDS 2](#). The program allows the user to perform and save hydraulic calculations in a single project file, analyze multiple scenarios and create plots and reports of the analyses.

Five calculators are currently available in Version 1.0:

1. Channel Analysis
2. Weir Analysis
3. Rational Method Hydrologic Analysis
4. Detention Basin Analysis
5. Curb and Gutter Analysis

There are also modules in the program that will save notes and reports with the results. These items can be printed at the user's discretion.

Future versions of the program will be enhanced to include improvements to the channel calculator using the latest stable channel lining design technology from [HEC 15](#). Other additions will include riprap size calculators and enhanced reporting and plotting.

The current version of the Hydraulic Toolbox is available at:

<http://www.fhwa.dot.gov/engineering/hydraulics/software/toolbox.cfm>

Drainage Manual Glossary

1. **Abrasion** Removal of streambank material due to entrained sediment, ice, or debris rubbing against the bank.
2. **Abutment Scour** Scour occurring at the abutment when the abutment and embankment obstruct the flow.
3. **Action** Any highway construction, reconstruction, rehabilitation, repair, or improvement undertaken for Federally funded/regulated projects.
4. **Aggradation** General and progressive upbuilding of the longitudinal profile of a channel bed due to sediment deposition. Permanent or continuous aggradation is an indicator that a change in the stream's discharge and sediment load characteristics is taking place.
5. **Anabranching Stream** A stream whose flow is divided at normal and lower stages by large islands or, more rarely, by large bars; individual islands or bars are wider than about three times water width; channels are more widely and distinctly separated than in a braided stream.
6. **Anaerobic** A condition in which molecular oxygen is absent from the environment.
7. **Angle of Repose** The maximum angle (as measured from the horizontal) at which gravel or sand particles can stand.
8. **Annual Flood** The maximum flow in one year (may be daily or instantaneous).
9. **Antidunes** A particular type of bed form caused by water flowing over a mobile material such as sand. A sand wave indicated on the water surface by a regular undulating wave. The ridges may move upstream and the surface waves become gradually steeper on the upstream sides until they break like surf and disappear. These surface waves are usually in series and often reform after disappearing.
10. **Approach Section** A cross section of the stream channel, normal to thread of current and for the discharge of interest, located in the approach channel. The approach section should be located sufficiently upstream from the opening that the flow is not affected by the structure but is fully expanded to natural floodplain width.
11. **Apron** Protective material placed on a streambed to resist scour.
12. **Armoring** Surfacing of channel bed, banks, or embankment slope to resist erosion and scour. Can be a natural process whereby an erosion-resistant layer of relatively large particles is formed on a channel bank and/or channel bed due to the removal of finer particles by streamflow.
13. **Articulated Concrete Mattress** Rigid concrete slabs which can move without separating as scour occurs; usually hinged together with corrosion-resistant cable fasteners; primarily placed for lower bank protection.
14. **Available Storage** Total volume in storage system that is below the allowable highwater and above the lowest pumping level.

Drainage Manual Glossary

15. **Average Velocity** Velocity at a given cross section determined by dividing discharge by cross sectional area.
16. **Backfill** The material used to refill a ditch or other excavation, or the process of doing so.
17. **Backflow** A flow whose direction is opposite to normal.
18. **Backwater** The increase in water surface elevation induced upstream from a structure such as a bridge or culvert.
19. **Bank** The sides of a channel between which the flow is normally confined.
20. **Bankfull Discharge** Discharge that, on the average, fills a channel to the point of overflowing.
21. **Bank Protection** Engineering works for the purpose of protecting streambanks from erosion.
22. **Bank Revetment** Erosion-resistant materials placed directly on a streambank to protect the bank from erosion.
23. **Base Flood** The flood or tide having a 1-percent chance of being exceeded in any given year.
24. **Base Floodplain** The area subject to flooding by the base flood.
25. **Basin, Detention** A basin or reservoir incorporated into the watershed whereby runoff is temporarily stored, thus attenuating the peak of the runoff hydrograph. A stormwater management facility that impounds runoff and temporarily impounds runoff and discharges it through a hydraulic outlet structure to a downstream conveyance structure.
26. **Basin, Retention** A basin or reservoir wherein water is stored for regulating a flood. It does not have an uncontrolled outlet. The stored water is disposed by such means as infiltration, injection (or dry) wells, or by release to the downstream drainage system after the storm event. The release may be through a gate-controlled gravity system or by pumping.
27. **Bedload** The quantity of silt, sand, gravel, or other detritus rolled along the bed of a stream, often expressed as weight or volume per time.
28. **Benching Excavation** of overbank material to a bench (level or near level surface); typically undertaken through bridge structures to provide additional opening.
29. **Berms** A narrow shelf, edge, or path typically at the bottom or top of a slope or along a bank.
30. **Bernoulli Equation** (Energy Equation) Flow equation that balances energy and energy loss between two locations.
31. **Bed** The bottom of a channel bounded by banks.

Drainage Manual Glossary

32. **Bed Slope** The inclination of the channel bottom.
33. **Best Management Practices (BMP's)** Erosion and pollution control practices employed during construction to avoid or mitigate damage or potential damage from the contamination or pollution of surface waters or wetlands from a highway action.
34. **Bore, Hydraulic** A wave of water having a nearly vertical front, such as a tidal wave, advancing upstream as a result of high tides in certain estuaries; the sudden release of a large volume of water from a reservoir. The bore is analogous to the hydraulic jump in that it represents the limiting condition of the surface curve wherein it tends to become perpendicular to the bed of the stream.
35. **Boulder** A rock fragment whose diameter is greater than 9.8 in.(250 mm)
36. **Braided Stream** A stream whose flow is divided at normal stage by small mid-channel bars or small islands; the individual width of bars and islands is less than about three times water width; a braided stream has the aspect of a single large channel within which are subordinate channels.
37. **Bridge**A structure carrying a road over a waterway or other obstacle. Ideally, a bridge over water, operates under free surface flow conditions.
38. **Bridge Opening** The cross-sectional area beneath a bridge that is available for conveyance of water.
39. **Bridge Waterway** The area of a bridge opening available for flow, as measured below a specified stage and normal to the principal direction of flow.
40. **Bridge Width** Distance between downstream and upstream faces of the bridge deck, typically measured along a line parallel with the abutment face.
41. **Broken-Back Culvert** A culvert having two or more longitudinal profile slopes.
42. **Buoyancy** The upward force that a fluid exerts on an object such as a culvert less dense than itself.
43. **Bypass Flow** Flow which bypasses an inlet on grade and is carried in the street or channel to the next inlet downgrade.
44. **Catch Basins** A reservoir or well into which surface water may drain.
45. **Causeway** Rock or earth embankment carrying a temporary roadway into or across a waterway.
46. **Caving** The collapse of a bank caused by undermining due to the action of flowing water.
47. **Cavitation**Hydraulic phenomenon in which vapor bubbles form and suddenly collapse (implode) as they move through a pump impeller. The formation of cavities between the back surface of an impeller blade and the liquid normally in contact with it.

Drainage Manual Glossary

48. **Cellular-block Mattress** Interconnected concrete blocks with regular cavities placed directly on a streambank or filter to resist erosion. The cavities can permit bank drainage and the growth of vegetation where synthetic filter fabric is not used between the bank and mattress.
49. **Channel** The bed and banks that confine the surface flow of a stream.
50. **Channel Diversion** The removal of flows by natural or artificial means from a natural length of channel.
51. **Channel, Low Water** The lower portion of a watercourse with definite bed and banks which confines and conducts continuously or periodically flowing water.
52. **Channel Routing** The process whereby a peak flow and/or its associated streamflow hydrograph is mathematically transposed to another site downstream taking into account the effect of channel storage.
53. **Channelization** Straightening or deepening of a natural channel by artificial cutoffs, grading, flow-control measures, or diversion of flow into an engineered channel.
54. **Check Dam** A low dam or weir across a channel used to control stage or degradation.
55. **Check Storm** A lesser frequency event used to assess hazards at critical locations.
56. **Check Valve** A mechanical device without moving parts usually made of rubber, that can be put on the outlet end of a culvert or storm sewer to prevent backflow. A pipe fitting used to prevent backflow to the pumps and subsequent recirculation.
57. **Clark Method** A unit hydrograph method used for transforming excess precipitation into surface runoff. Routes the unit increment of runoff (effective rainfall) first through a time-area histogram and secondly, through a linear reservoir. Requires three parameters: time of concentration, storage attenuation coefficient, and a time-area histogram.
58. **Clearance** Distance that the low beam is located above a given flood stage.
59. **Clear-water Contraction Scour** Scour at a pier or abutment when there is no movement of the bed material upstream of the bridge crossing at the flow causing bridge scour.
60. **Clear-water Scour** Scour at a pier or abutment (or contraction scour) when there is no movement of the bed material upstream of the bridge crossing at the flow causing bridge scour.
61. **Cobble** A fragment of rock whose diameter is in the range of 2.5 to 9.8 in. (64 to 250 mm.).
62. **Coincidental Flooding** Simultaneous or concurrent flooding on both the tributary and main stream.

Drainage Manual Glossary

63. **Collection System** The system of conveyance elements that collect the stormwater and direct it to the pump station. The system usually includes channels, ditches, inlet lines and storm drain conduits.
64. **Concrete Revetment** Unreinforced or reinforced concrete slabs placed on the channel bed or banks to protect it from erosion.
65. **Conduit** An artificial or natural channel; usually a closed structure such as a pipe or culvert. A general term for any channel intended for the conveyance of water, whether open or closed; any container for flowing water. With highways, conduits are often considered as being a pipe, culvert, flume, channel, chute, or similar drainage facility.
66. **Confluence** The junction of two or more streams.
67. **Constriction** A natural or artificial control section, such as a bridge crossing, channel reach or dam, with limited flow capacity in which the upstream water surface elevation is related to discharge.
68. **Continuity Equation** Hydraulic equation that relates discharge, cross sectional area, and velocity.
69. **Contraction** The effect of channel or bridge constriction on flow streamlines.
70. **Contraction Scour** In a natural channel or at a bridge crossing, involves the removal of material from the bed and banks across all or most of the channel width. This component of scour results from a contraction of the flow area at the bridge which causes an increase in velocity and shear stress on the bed at the bridge. The contraction can be caused by the bridge or from a natural narrowing of the stream channel.
71. **Control Structure** A structure that is used to regulate the flow or stage of the stream, basin, reservoir, or drainage structure.
72. **Conveyance** A measure of the ability of a stream, channel, or conduit to convey water.
- a. A measure of the water transporting capacity of such things as a channel, floodplain, drainage facility, storm drain, and/or other natural or artificial watercourse feature traversed by flows such as runoff or irrigation water. With the review flood or storm, conveyance may include that associated with overtopping flows and inundation of a traveled way at cross-drainages.
73. **Countermeasure** A measure, either incorporated into the design of a drainage facility or installed separately at or near the facility, that serves to prevent, minimize, or control hydraulic problems.
74. **Created Head** See Head Loss.
75. **Critical Depth** The depth at which the specific energy for a particular discharge is a minimum. It is the depth at which, for a given energy content of the water in a channel or conduit, maximum discharge occurs.

Drainage Manual Glossary

76. **Critical Duration** Duration of rainfall needed to produce the maximum peak flow at any point in a drainage system; it is equal to the time of concentration of the drainage area.
77. **Critical Flow** A state of flow where the specific energy is a minimum for a constant discharge. The Froude Number is 1.
78. **Critical Slope** That particular slope at which normal depth equals critical depth for a given discharge.
79. **Critical Velocity** Minimum velocity at which bed material of a certain diameter and smaller will be transported.
80. **Cross Section** A section normal to the trend of a channel or flow.
81. **Culvert** A structure creating a complete enclosure that conveys drainage transversely under a roadway. Culverts are designed hydraulically to operate under pressure flow conditions that increase capacity. They have regular, uniform shape, typically rectangular or circular.
82. **Current** Water flowing through a channel.
83. **Cyclic Scour** The increase and decrease of the stream bed elevation (cutting and filling) during the passage of a flood.
84. **Cycling** The starting, stopping then starting of a pump.
85. **D₅₀** The particle diameter at the 50 percentile point on a size versus weight distribution curve such that half of the particles (by weight) are larger and half are smaller.
86. **D_n** The particle diameter at the n percentile point on a size versus weight distribution curve.
87. **Debris** Any material transported by the stream, either floating or submerged, such as logs, brush or trash, that may lodge against a structure.
88. **Degradation** General and progressive lowering of the longitudinal profile of the channel bed due to long-term erosion. Permanent or continuing degradation is an indicator that a change in the stream's discharge and sediment load characteristics is taking place.
89. **Delineated** To sketch out; represent by sketch, design, or diagram.
90. **Depth of Scour** The vertical distance a streambed is lowered by scour below a reference elevation.
91. **Design Criteria** Criteria, coupled with prudent judgmental factors, that are used to design a drainage facility.

Drainage Manual Glossary

92. **Design Discharge** The maximum rate of flow (or discharge) for which a drainage facility is designed and thus expected to accommodate without exceeding the adopted design constraints. Maximum flow a bridge, culvert, or other drainage facility is expected to accommodate without contravention of the adopted design criteria.
93. **Design Flood Frequency (or Storm Frequency)** The frequency (recurrence interval) for the selected design discharges (storms) that is expected to be accommodated without contravention of the adopted design criteria.
94. **Design Highwater Elevation** The maximum water levels that can occur through a reach and at a culvert, bridge-type opening, or other drainage facility without contravention of the adopted design criteria.
95. **Design Point**The point of intersection of the system curve and the selected pump performance curve.
96. **Design Storm** Selected storm of a given frequency (recurrence interval) used for designing a design storm system.
97. **Detention Time** The time required for a drop of water to pass through a detention facility when the facility is filled to design capacity.
98. **Dike** An impermeable linear structure for the containment or control of overbank flow; such dikes trend parallel with a river bank and differ from a levee only in that such dikes extend for a much shorter distance along the bank. Relatively short dikes are also placed to contain and redirect flow such as into a culvert or down some other path.
99. **Direct Runoff** The streamflow produced in response to a rainfall event and is equal to total stream flow minus baseflow.
100. **Discharge** Volume of water passing a point during a given time.
101. **Discharge Line** A conduit through which the storm water exits the pump station.
102. **Ditch** A constructed channel used to convey runoff. Typically occur as roadside and median ditches in highway work.
103. **Drainage Basin** An area confined by drainage divides, often having only one outlet for discharge (watershed).
104. **Drainage Divide** The rim of a drainage basin. The divide separating one drainage basin from another. Drainage divide, or just divide, is used to denote the boundary between one drainage area and another.
105. **Drop Structure** A vertical structure for dropping the water to a lower level and dissipating its surplus energy.
106. **Dry well** The dry well of a dry-pit station contains the pumps and pumping accessories that discharge the storm water from the wet-well.

Drainage Manual Glossary

107. **Dry-Pit Station** A pump station consisting of two chambers: a dry well and a wet-well. The water accumulates in the wet-well and is pumped out by pumps installed in the dry well.
108. **Dune** A sand wave of approximately triangular cross section (in a vertical plane in the direction of flow) formed by moving water or wind, with gentle upstream slope and steep downstream slope. Dunes travel downstream by the displacement of sediments on the upstream slope and their subsequent deposition on the downstream slope.
109. **Effective Opening** The area of flow below the natural highwater elevation for a given flood stage measured along a plane across the structure that is perpendicular to the predominant direction of flow. The effective opening excludes any depressional areas and any part of the opening that is blocked or inaccessible to flow.
110. **Emergency Spillway** Structure designed to allow controlled release of storm flows in excess of the design discharge from a detention facility.
111. **Encroachment** An action within the limits of the base floodplain.
112. **Energy Dissipation** The phenomenon which energy is dissipated or used up.
113. **Energy Equation (or energy balance)** The work-energy relationship, reduced to the simplified form of the Bernoulli equation, states that the total energy at the upstream section 1 equals the total energy at section 2 plus the sum of the energy losses encountered between 1 and 2: $[V_1^2/2g + \rho_1/\gamma + Z_1 = V_2^2/2g + \rho_2/\gamma + Z_2 + h_L]$.
114. **Energy Gradeline Slope** The change in the total energy head from one location to another divided by the distance between the two locations.
115. **Energy Line (Total Energy Head)** The sum of the elevation head above some datum, the depth of flow, and the velocity head.
116. **Entrance Loss Coefficient** The head lost in eddies and friction at the inlet to a conduit or structure, expressed as a coefficient.
117. **Ephemeral Stream** A stream or reach of stream that does not flow for parts of the year. As used here, the term includes intermittent streams with flow less than perennial.
118. **Erosion** The wearing away or eroding of material on the land surface or along channel banks by flowing water or wave action on shores.
119. **Facility** Any element of the built environment other than a walled or roofed building.
120. **Fall Velocity** The velocity of a particle falling alone in quiescent, distilled water of infinite extent.
121. **Field Tile** Buried pipe used to drain low or moisture laden areas in farm fields.

Drainage Manual Glossary

122. **Filter** Layer of fabric (geotextile) or granular material (sand, gravel, or graded rock) placed between bank revetment (or bed protection) and soil for the following purposes: (1) to prevent the soil from moving through the revetment by piping, extrusion, or erosion; (2) to prevent the revetment from sinking into the soil; and (3) to permit natural seepage from the streambank, thus preventing the buildup of excessive hydrostatic pressure.
123. **Filter Blanket** A layer of graded sand and gravel laid between fine-grained material and riprap to serve as a filter.
124. **Filter Fabric (cloth)** Geosynthetic fabric that serves the same purpose as a granular filter blanket.
125. **Flanking** Erosion around the landward end of a stream stabilization countermeasure.
126. **Flap Gate** A mechanical device with moving parts usually made of steel or cast iron, that can be put on the outlet end of a culvert or storm sewer to prevent backflow. A circular device attached to the end of the discharge line to prevent backflow from the outfall to the discharge line.
127. **Flap Valve** A check valve that uses a rubber flap.
128. **Flood or Flooding** A general and temporary condition of partial or complete inundation of normally dry land areas from the overflow of inland and/or tidal waters, and/or the unusual and rapid accumulation or runoff of surface waters from any source.
129. **Flood Frequency** (or recurrence interval) The average time interval between occurrences of a hydrologic event of a given or greater magnitude, usually expressed in years, but often stated as the percent chance of occurrence in any 1-year period. Ex. Q50 is referred to as the 2% flood.
130. **Flood of Record** The largest historical flood event which has been reliably determined and recorded.
131. **Floodplain** The lowland areas adjoining inland and coastal waters which are periodically inundated by flood waters, including flood-prone areas of offshore islands.
132. **Flood Routing** The process of determining progressively the timing and shape of a flood wave at successive points along a river.
133. **Floodway** A portion of the cross-sectional area of the floodplain essential to retain conveyance and storage.
134. **Flow, Bypass** Flow which bypasses an inlet on grade and is carried in the street or channel to the next inlet downstream. Sometimes termed carryover.
135. **Flow, Overland** The flow of rainwater or snowmelt over the land surface toward stream channels. After it enters a stream, it becomes runoff.
136. **Flow Regime** The system, or order characteristic of stream flow with respect to velocity, depth, and specific energy. In open channel flow, the two flow regimes are subcritical and supercritical flow.

Drainage Manual Glossary

137. **Fluvial Geomorphology** A study of the structure and formation of the earth's features which result from the forces of water.
138. **FONSI** Finding of no significant impact.
139. **Force Main** A pressurized discharge line.
140. **Forebay** An area in the wet well between the storage unit and the individual pump bays.
141. **Freeboard** The distance that the roadway is located above a given flood stage.
142. **Free Flow** A condition of flow through or over a structure not affected by submergence.
143. **Free Outlet** Those outlets whose tailwater is equal to or lower than critical depth at the outlet.
144. **Free Surface Flow** Flow exposed only to the pressure of the atmosphere; i.e., non-pressure flow.
145. **Friction Loss** The head or energy loss as the result of disturbances created by the contact between a moving stream of water and its containing conduit. The energy loss in overcoming friction. Usually determined as an equivalent depth of water (head).
146. **Froude Number** The ratio of the inertial force to that of gravitational force.
147. **Gabion** A basket or compartmented rectangular container made of wire mesh. When filled with cobbles or other rock of suitable size, the gabion becomes a flexible and permeable unit with which flow- and erosion- control structures can be built.
148. **General Scour** Scour in a channel or a floodplain that is not localized at a pier, abutment, bendway, or other obstruction to flow. In a channel, general scour usually affects all or most of the channel width and may be uniform or non-uniform. General scour may result from contraction of the flow or other general scour conditions such as flow around a bend.
149. **Gravel** A rock fragment whose diameter ranges from 0.08 to 2.5 in. (2 to 64 mm).
150. **Groin** A structure built from the bank of a stream in a direction transverse to the current to redirect the flow or reduce flow velocity. Many names are given to this structure, the most common being "spur," "spur dike," "transverse dike," "jetty," etc. Groins may be permeable, semi-permeable, or impermeable.
151. **Grout** A fluid mixture of cement and water or of cement, sand, and water used to fill joints and voids.

Drainage Manual Glossary

152. **Guide Bank** Formerly termed spur dike. Relatively short embankments generally in the shape of a quarter of an ellipse and constructed at the upstream side (and sometimes the downstream side) of either or both bridge ends as an extension of the abutment spillslope. The purpose is to align the flow with the bridge opening so as to decrease scour at the bridge abutment by spreading the flow and any resultant scour throughout the bridge opening. May also be a training dike (usually when constructed downstream).
153. **Hardpoint** A streambank protection structure whereby "soft" or erodible materials are removed from a bank and replaced by stone or compacted clay. Some hard points protrude a short distance into the channel to direct erosive currents away from the bank. Hard points also occur naturally along streambanks as passing currents remove erodible materials leaving nonerodible materials exposed.
154. **Head** The height of water above any point plane or datum or reference. The height of the free surface of a body of water above a given point. The measure of pressure expressed in equivalent height of water.
155. **Headcutting** Channel degradation associated with abrupt changes in the bed elevation (headcut) that generally migrates in an upstream direction.
156. **Head Loss** (or backwater) The energy of a given flow that is lost; expressed as head. That is, the height through which flow would have to fall to produce an equivalent amount of energy. For bridges and culverts, the increase in water surface elevation above the natural water surface elevation at an upstream location.
157. **Head, Pressure** Hydrostatic pressure expressed as the height of a column of water (or other liquid) that can be supported by the static pressure at a given point. The static is the sum of the elevation head and the pressure head.
158. **Head, Total** The total head of a liquid at a given point is the sum of three components: 1. the elevation head, which is equal to the elevation of the point above a datum; 2. the pressure head, which is the height of a column of static water that can be supported by the static pressure at the point; and 3. the velocity head, which is the height at which the kinetic energy of the liquid is capable of lifting the liquid.
159. **Head, Velocity** The distance a body must fall freely under the force of gravity to acquire the velocity it possesses; the kinetic energy, in feet of head, possessed by a given velocity. In flowing water, the velocity squared divided by twice gravity.
160. **Headwater** See Headwater Depth.
161. **Headwater Depth** Depth of water above the inlet flow line at the entrance of a culvert or similar structure. Depth of water upstream of a contraction such as occurs at a bridge or similar structure. Natural flow depth plus backwater caused by a drainage structure.
- a. That depth of water impounded upstream of a culvert, bridge or similar contracting structure due to the influence of the structures constriction, friction, and configuration. The water depth upstream from a structure.

Drainage Manual Glossary

162. **HEC-2** A computer model for water surface profile computation that analyzes one-dimensional, gradually-varied, steady flow in open channels. The effects of various obstructions such as bridges, culverts, weirs, and structures in the floodplain may be considered in the computations.
163. **HEC 18** Hydraulic Engineering Circular 18. Publication issued by the Federal Highway Administration (FHWA) entitled "Evaluating Scour at Bridges" that contains equations for computing scour depths and designing countermeasures.
164. **HEC 20** Hydraulic Engineering Circular 20. Publication issued by the Federal Highway Administration (FHWA) entitled "Stream Stability at Highway Structures" that provides a guide for identifying stream instability problems.
165. **HEC 23** Hydraulic Engineering Circular 23. Publication issued by the Federal Highway Administration (FHWA) entitled "Bridge Scour and Stream Instability Countermeasures" that provides guidelines for the damage to bridges and other highway components at stream crossings.
166. **HEC-RAS** U.S. Army Corps of Engineers Hydrologic Engineering Center-River Analysis System. IDOT's primary model for computing bridge backwater in which the user interacts with the system through the use of a Graphical User Interface (GUI). The system is capable of performing steady and unsteady flow water surface profile calculations and computation of scour at bridges.
167. **Highwater Elevation** The water surface elevation that results from the passage of flow. It may be an "observed highwater mark elevation" as a result someone actually viewing and recording a runoff event, or a "calculated highwater elevation" as part of a design process.
168. **Horizontal Vortex** The acceleration of the flow starting at the upstream end of an abutment and running along the toe of the abutment. Similar to the horseshoe vortex.
169. **Horseshoe Vortex** The acceleration of the flow around the nose of a pier or abutment due to the pileup of water on the upstream surface of the obstruction. Similar to the horizontal vortex.
170. **Huff Rainfall Distribution** Annual frequency distributions of heavy rainstorms in Illinois based on data for 61 Illinois precipitation-reporting stations during an 83 year period (1901-1983). Includes distributions of point rainfall for periods ranging from 5 minutes to 10 days and for recurrence intervals varying from 2 months to 100 years. They are the most commonly used relations used by hydrologists, soil scientists, and others who need heavy rainfall data.
171. **Hydraulic Gradeline** A profile of the piezometric level to which the water would rise in piezometer tubes along a pipe run. In open channel flow, it is the water surface. A line corresponding to the water level within a channel or a line that represents the pressure level in an enclosed conduit that is flowing full.
172. **Hydraulic Institute** An entity consisting primarily of pump manufacturers that establishes and publishes standards for the design and use of pumps.

Drainage Manual Glossary

173. **Hydraulic Jump** Occurs when supercritical flow rapidly changes to subcritical flow. The result is usually an abrupt rise of the water surface with an accompanying loss of kinetic energy.
174. **Hydraulic Model** A small-scale physical representation of a flow situation.
175. **Hydraulic Performance Curve** Computed estimates of how a drainage facility will perform over a wide range of discharges. Commonly these may include discharge and recurrence interval versus headwater, velocity, scour and/or stage (depth of flow).
176. **Hydraulic Radius** A shape factor that depends only upon a channel dimensions and depth of flow. Equal to the cross sectional area divided by the wetted perimeter.
177. **Hydraulic Report** A complete summary of the hydraulic analysis done for a bridge or culvert used to develop the Waterway Information Table and as the basis for hydraulic input to the TSL Plan.
178. **Hydraulics** The applied science concerned with the behavior and flow of liquids, especially in pipes, channels, structures, and the ground.
179. **Hydrograph** The graph of stage or discharge versus time. A graph showing, for a given point on a stream or for a given point in any drainage system, the discharge, stage, velocity or other property of water with respect to time.
180. **Hydrologic Equation** The equation balancing the hydrologic budget. An expression of the law of mass conservation for purposes of water budgets which may be stated as inflow equals outflow plus or minus changes in storage.
181. **Hydrologic Model** Mathematical equations, algorithms, and/or logic that represents the rainfall runoff process in a watershed.
182. **Hydrology** The science concerned with the occurrence, distribution, and circulation of water on the earth.
183. **IDNR-OWR** Illinois Department of Natural Resources - Office of Water Resources; the agency responsible for overseeing and regulating construction activities within the floodplains of streams and rivers in Illinois under their jurisdiction.
184. **Improved Inlet** An inlet which decreases the amount of energy needed to pass the flow through the inlet, thus increasing the capacity of the culvert.
185. **Incipient Motion** The condition that exists just prior to the movement of a particle within a flow field. Under the condition, any increase in any of the factors responsible for particle movement will cause motion.
186. **Ineffective Flow Area** That portion of a floodplain cross section where flow is considered to be stagnant or not moving in the predominant direction of flow. This area is typically blocked or removed from sections impacted by structures to represent the expansion and contraction of flow.
187. **Inflow** The rate of discharge arriving at a point (in a stream, structure, or reservoir).
188. **Inflow Mass Curve** A representation of cumulative inflow volume versus time.

Drainage Manual Glossary

189. **Inlet** A structure for capturing concentrated surface flow. Inlets may be located in such places as along the roadway, a gutter, the highway median, or a field.
190. **Inlet, Combination** Drainage inlet usually composed of two or more inlet types, e.g., such combinations as curb opening and grate inlet, grate, and slotted drain inlet.
191. **Inlet Control** A condition where the relation between headwater elevation and discharge is controlled by the upstream end of any structure through which water may flow. For example, a culvert on steep slope and flowing part full as in inlet control.
192. **Inlet, Curb Opening** Drainage inlet consisting of an opening in a curb.
193. **Inlet Efficiency** The ratio of flow intercepted by an inlet to the total flow.
194. **Inlet, Flanking** Inlets placed upstream and on either side of a storm drain inlet that is located at the low point in a sag-vertical curve. The purpose of these inlets is to intercept debris at the longitudinal gutter slope decreases and to act as an emergency relief for the sump inlet at the low point of the vertical curve.
195. **Inlet Grate** Drainage inlet composed of a grate in the roadway section or at the roadside, in a low point, swale, or ditch.
196. **Inlet, Sag** Inlet located in the low point in a sag-vertical curve.
197. **Inlet, Slotted Drain** Drainage inlet composed of a continuous slot built into the top of a pipe which serves to intercept, collect, and transport the flow. Often used in conjunction with a single grate inlet for clean out access.
198. **Intake** The place at which a fluid is taken into a pipe, channel, etc.
199. **Invert Elevation** The flow line in a channel cross-section, pipe or culvert.
200. **Isohyetal Line** A line drawn on a map or chart joining points that receive the same amount of precipitation. A line on a map, connecting points of equal rainfall amounts.
201. **Jack** A device for flow control and protection of banks against lateral erosion consisting of three mutually perpendicular arms rigidly fixed at the center. Concrete jacks are made of reinforced concrete beams.
202. **Jack Field** Rows of jacks tied together with cables, some rows generally parallel with the banks and some perpendicular thereto or at an angle. Jack fields may be placed outside or within a channel.
203. **Jetty** (a) An obstruction built of piles, rock, or other material extending from a bank into a stream, so placed as to induce bank building, or to protect against erosion; (b) A similar obstruction to influence stream, lake, or tidal currents, or to protect a harbor (also spur).
204. **Kinetic Energy** Energy due to the velocity of moving water.

Drainage Manual Glossary

205. **Lateral Migration** Change in position of a channel by lateral erosion of one bank and the simultaneous accretion of the opposite bank. Systematic channel shifting in the direction of flow.
206. **Levee** An artificial obstruction erected roughly parallel to a river or channel and used to confine flow.
207. **Linear Stormwater Detention** Detention is provided by modifying open and/or closed drainage systems designed for conveyance.
208. **Lining, Flexible** Lining material with the capacity to adjust to settlement typically constructed of porous material that allows infiltration and exfiltration.
209. **Live-Bed Contraction Scour** Scour at a pier or abutment when the bed material in the channel upstream of the bridge is moving at the flow causing bridge scour.
210. **Local Scour** Removal of material in a channel or on a floodplain that is localized at a pier, abutment, or other obstruction to flow. Local scour is caused by the acceleration of the flow and the development of a vortex system induced by the obstruction to the flow. Does not include the additional scour caused by any contraction, natural channel degradation, or bendway.
211. **Longitudinal Profile** The profile of a stream or channel drawn along the length of its centerline. In drawing the profile, elevations of the water surface or the thalweg are plotted against distance as measured from the mouth or from an arbitrary initial point.
212. **Low Chord** The lowest elevation on the beam or superstructure of a bridge.
213. **Manhole** Considered to be a gender-neutral term for a structure by which one may access a drainage system.
214. **Manifold** A pipe terminal having several intake openings and a common discharge end.
215. **Manning's Equation** Hydraulic equation used to compute uniform flow.
216. **Mass Curve** A graph of the cumulative values of a hydrologic quantity (such as precipitation or runoff), generally as ordinate, plotted against time or date as abscissa.
217. **Mass Curve Routing** The process of computing the volume of outflow as a function of the inflow volume, pumping rates, and storage.
218. **Mass Inflow Curve** A graph showing the total cumulative volume of stormwater runoff plotted against time for a given drainage area.
219. **Median Diameter** The particle diameter of the 50th percentile point on a size distribution curve such that half of the particles (by weight, number, or volume) are larger and half are smaller (D50.)
220. **Migration** Change in position of a channel by lateral erosion of one bank and simultaneous accretion of the opposite bank.

Drainage Manual Glossary

221. **Minimize** To reduce to the smallest practicable amount or degree.
222. **Mitigate** The act of lessening, offsetting, or compensating an impact on surface waters. To decrease or rectify an adverse condition or action.
223. **Model, Computer** The representation of a drainage system with computer software.
224. **Model, Physical** The representation of a drainage system with a hydraulically scaled laboratory model.
225. **Modified Att-Kin Method** The Modified Attenuation – Kinematic Flood Routing Method. The math model used for channel flood routing in the original TR-20 computer program (replaced by Muskingum-Cunge method).
226. **Modified Puls Method** A hydrologic routing method for simulating flow in open channels. The Modified Puls method can be used to model a reach as a series of cascading, level pools with a user-specified storage-outflow relationship. Also known as storage indication method.
227. **Muskingum-Cunge Method** A hydrologic routing method for simulating flow in open channels. The basic assumption behind the method is that the stage/discharge relationship is one-to-one; precisely applied, this assumption leads to a differential equation whose analytical solution does not allow for wave damping. The math model used in the newest version of TR-20 computer program.
228. **“N” Values** The coefficient of roughness used in the Manning Equation.
229. **Natural and Beneficial Floodplain Values** These include but are not limited to fish, wildlife, plants, open space, natural beauty, scientific study, outdoor recreation, agriculture, aquaculture, forestry, natural moderation of floods, water quality maintenance, and groundwater recharge.
230. **Net Positive Suction Head Required** Net positive suction head required (NPSHR) is the head above vapor pressure head required to ensure that cavitation does not occur at the impeller.
231. **Nomograph** A graphical solution to an equation.
232. **Non-Uniform Flow (Varied Flow)** Flow that exist when the channel properties vary from section to section and thus the depth of flow changes at various points along the channel.
233. **Normal Stage** The water stage prevailing during the greater part of the year.
234. **One-Dimensional Model** Hydraulic computer model that recognizes flow only in the upstream- downstream direction; transverse and vertical components of flow are neglected.
235. **One-Dimensional Water Surface Profile** An estimated water surface profile which recognizes flow only in the upstream-downstream direction; vertical and transverse velocity vector components are ignored.

Drainage Manual Glossary

236. **Open Channel Flow** Flow in any open or closed conduit where the water surface is free; that is, where the water surface is at atmospheric pressure.
237. **Open, or Spill-through Abutments** Bridges with abutments placed behind slopewalls that are typically armored with riprap and placed at a 1V: to 2H slope.
238. **Operating Range** The range of total dynamic head over which the pumps in a system will operate.
239. **Orifice** Two definitions are pertinent: 1. A hole or opening, usually in a plate, wall, or partition, through which water flows, generally for the purpose of control or measurement; 2. The end of a small tube, such as the orifice of a pitot tube, or piezometer.
240. **Orifice Flow** See Pressure Flow. Flow of water into an opening that is submerged. The flow is controlled by pressure forces.
241. **Other General Scour** General scour that is not considered to be contraction scour. Examples include erosion related to the planform characteristics of the stream (meandering, braided or straight), variable downstream control, flow around a bend, or other changes that decrease the bed elevation.
242. **Outfall** The point where: 1. Water flows from a conduit; 2. The mouth (outlet) of a drain or sewer; 3. Drainage discharges from a channel or storm drain.
243. **Outlet Control** A condition where the relation between headwater elevation and discharge is controlled by the conduit, outlet, or downstream conditions of any structure through which water may flow.
244. **Outlet Protection** See Energy Dissipation.
245. **Overbank Flow** Water movement that overtops the bank either due to stream stage or to overland surface water runoff.
246. **Overtopping Flood** The frequency at which flood waters first flow over the roadway.
247. **Peak Discharge** The highest value of the stage or discharge attained by a flood; thus, peak stage or peak discharge.
248. **Perched Bridge** A bridge whose deck and \ or superstructure is built up above the approach roadways, allowing the possibility of free surface flow at the bridge coupled with roadway overtopping.
249. **Perennial Stream** A stream or reach of a stream that flows continuously for all or most of the year.
250. **Physiographic** In hydrology considerations, the physical geography of an area pertaining to landforms and other runoff-producing features.
251. **Pond** Very small, very shallow bodies of standing water in which quiescent water and extensive occupancy by higher aquatic plants are common characteristics.
252. **Pool** A small, rather deep body of quiescent water, as a pool in a stream.

Drainage Manual Glossary

253. **Potential Energy** Energy due to the position of the water above some datum.
254. **Practicable** Capable of being done within reasonable natural, social, or economic constraints.
255. **Preserve** To avoid modification to the functions of the natural floodplain environment or to maintain it as closely as practicable in its natural state.
256. **Pressure Flow** Also denoted as orifice flow, pressure flow occurs when the water surface elevation at the upstream face of the bridge is greater than or equal to the low chord of the bridge superstructure. The pile up of water on the upstream bridge face, and a plunging of the flow downward and under the bridge. Flow in a conduit that has no surface exposed to the atmosphere. The flow is driven by pressure forces.
257. **Pressure Flow Scour** The increase in local scour depth at a pier or abutment during pressure flow due to the flow being directed downward towards the bed by the superstructure and by increasing the intensity of the horseshoe vortex.
258. **Pump** A device that increases the static pressure of a fluid. A pump adds energy to a body of fluid in order to move it from one point to another.
259. **Pump Cycling Time** cycling refers to the time between starts of a given pump. The shorter the cycling time, the more frequent a pump must start and stop.
260. **Pump Discharge Curve** A representation of stage versus discharge for a system of pumps.
261. **Pump House** An enclosed structure used to protect the pump control equipment, pump drivers and ancillary equipment.
262. **Pump Performance Curve** A representation of the changing discharge rate with total dynamic head for a given pump.
263. **Pump Sequencing** The order in which pumps are activated and deactivated
264. **Pump Station** The collection of components used to lift highway stormwater runoff. A station includes the storage unit, wells, pumps, pump house and ancillary equipment.
265. **Quarry-run Stone** Stone as received from a quarry without regard to gradation requirements.
266. **Rating Curve** A plot of stage versus discharge.
267. **Recurrence Interval** The reciprocal of the annual probability of exceedance of a hydrologic event (also return period, exceedance interval). See Flood Frequency.
268. **Reducer** An element that is used to transition from one size pipe to a smaller one.

Drainage Manual Glossary

269. **Regime Theory** A theory of the forming of channels in material carried by the streams. The condition of a stream or its channel with regard to stability. A stream is in regime if its channel has reached an equilibrium form as a result of its flow characteristics. That is, the average values of the quantities that constitute regime do not show a definite trend over a considerable period (generally of the order of a decade).
270. **Regional Factor** A factor developed from flood frequency relationships for gaged watersheds in similar physiographic regions. The regional factor is used in regression equations for applications on ungaged streams.
271. **Regulatory Floodway** The floodplain area that is reserved in an open manner by Federal, State, or local requirements, i.e., unconfined or unobstructed either horizontally or vertically, to provide for the discharge of the base flood so that the cumulative increase in water surface elevation is no more than a designated amount (not to exceed 1 foot as established by the Federal Emergency Management Agency (FEMA) for administering the National Flood Insurance Program).
272. **Relief Bridge** An opening in an embankment on a floodplain to permit passage of overbank flow.
273. **Reservoir** A pond, lake or basin, either natural or artificial, for the storage, regulation, and control of water.
274. **Reservoir, Retarding** Ungated reservoir for temporary storage of floodwaters. Sometimes called detention reservoir.
275. **Reservoir Routing** Flood routing through a reservoir. Flood routing of a hydrograph through a reservoir taking into account reservoir storage, spillway and outlet works discharge relationships.
276. **Restore** To re-establish a setting or environment in which the functions of the natural and beneficial floodplain values adversely impacted by the highway agency action can again operate.
277. **Retrofit** The replacement of various pump station components, typically the pumps.
278. **Revetment** Rigid or flexible armor placed on a bank or embankment as protection against scour and lateral erosion.
279. **Riparian** Pertaining to anything connected with or adjacent to the banks of a stream (corridor, vegetation, zone, etc.).
280. **Riprap** In the restricted sense, layer or facing of rock placed to protect a structure or embankment from erosion; also the rock suitable for such use. Riprap has also been applied to almost all kinds of armor, including wire-enclosed riprap, and grouted riprap.
281. **Risk** The consequences associated with the probability of flooding attributable to an encroachment. It shall include the potential for property loss and hazard to life during the service life of the highway.

Drainage Manual Glossary

282. **Risk Analysis** An economic comparison of design alternatives using expected total costs (construction plus risk costs) to determine the alternative with the Least Total Expected Cost (LTEC) to the public which is required for significant encroachments.
283. **Roughness Coefficient** Numerical measure of the frictional resistance to flow in a channel, as in the Manning's or Chezy's formulas.
284. **Routing** The process of transposing an inflow hydrograph through a structure and determining the outflow hydrograph from the structure.
285. **Rubble** Rough, irregular fragments of materials of random size used to retard erosion. The fragments may consist of broken concrete slabs, masonry, or other suitable refuse.
286. **Runoff** That part of precipitation which appears in surface streams of either perennial or intermittent form.
287. **Safety Grate** To help protect a larger culvert end within the clear zone. They are attached to the top of a standard end section to support an errant vehicle as it crosses over the culvert end.
288. **Sand** A rock fragment whose diameter is in the range of 0.002 to 0.08 in. (0.062 to 2.0 mm).
289. **Scour** The displacement and removal of channel bed material due to flowing water; usually considered as being localized as opposed to general bed degradation or headcutting.
290. **Sewer, Combined** A conduit that conveys stormwater and, at times, sanitary sewage.
291. **Sewer, Sanitary** A conduit for conveying sanitary waste flows.
292. **Sewer, Storm** Principally a conduit for conveying stormwater.
293. **Shaft** The cylindrical unit used to drive the pump.
294. **Shear Stress** The force or drag developed at the channel bed by flowing water. For uniform flow, this force is equal to a component of the gravity force acting in a direction parallel to the channel bed on a unit wetted area.
295. **Sheet Flow** Flow over plane surfaces.
296. **Significant Encroachment** A highway encroachment and any direct support of likely base floodplain development that would involve one or more of the following construction or flood related impacts:
- a significant potential for interruption or termination of a transportation facility which is needed for emergency vehicles or provides a community's only evacuation route,
 - a significant risk, or
 - a significant adverse impact on natural and beneficial floodplain values.

Drainage Manual Glossary

297. **Silt** A particle whose diameter is in the range of 0.004 to 0.062 mm.
298. **Single Stage** A pump with only one impeller.
299. **Sinuosity** The ratio between the thalweg length and the valley length of a stream.
300. **Skew** The measure of the angle of intersection between a line normal to the roadway centerline and a line parallel to the face of the bridge abutment.
301. **Slope (of channel or stream)** Fall per unit length along the channel centerline or thalweg.
302. **Snyder Method** A unit hydrograph method used for transforming excess precipitation into surface runoff.
303. **Soffit** The inside top of a conduit.
304. **Specific Energy** The sum of the depth of flow measured from the channel bottom and the velocity head.
305. **Spill-through Abutment** A bridge abutment having a fill slope on the streamward side. The term originally referred to the 'spill-through' of fill at an open abutment but is now applied to any abutment having such a slope.
306. **Spillway** A passage for spilling surplus water.
307. **Spillway, Controlled** A reservoir outlet works wherein the outflow is controlled by gates, valves or similar flow control devices.
308. **Spread Footing** A pier or abutment footing that transfers load directly to the earth.
309. **Spur** A permeable or impermeable linear structure that projects into a channel from the bank to alter flow direction, induce deposition, or reduce flow velocity along the bank.
310. **Spur Dike** See guide bank.
311. **Stage** Water-surface elevation of a stream with respect to a reference elevation.
312. **Stage-Capacity Curve** A graph showing the relation between the surface elevation of the water in a reservoir, usually plotted as ordinate, against: 1. The volume below that elevation, plotted as abscissa; or 2. Amount of water flowing in a channel, expressed as volume per unit of time, plotted as abscissa.
313. **Stage-Discharge Curve** A graph showing the relation between the gage height, usually plotted as ordinate, and the amount of water flowing in a channel, expressed as volume per unit of time, plotted as abscissa.
- a. Sometimes referred to as the rating curve of a channel cross section. A rating curve showing the relation between stage and discharge of a channel.

Drainage Manual Glossary

314. **Stage-Storage Curve** A curve that represents the storage that is available within the system at various stages.
315. **Start Elevation** Elevation at which a pump is set to begin operating.
316. **State Highway System** The State highway system consists of all highways under the jurisdiction of the Illinois Department of Transportation. This system contains all Interstate highways, all other marked State and US routes, and some unmarked routes. In general, the marked routes are the most important highways in the State, carry the greatest traffic volumes, and operate at the highest speeds. The Department uses either a combination of Federal funds and State funds or State-only funds for improvements on the State highway system.
317. **Steady Flow** Flow when discharge or rate of flow at any cross section is constant with time.
318. **Step Backwater** Common term for the iterative process of balancing the energy equation between successive floodplain cross sections to determine water surface elevation at the upstream section. Also used as a descriptor for computer models that utilize this method to construct water surface profiles.
319. **Stilling Basin** A device or structure placed at, or near the outlet of a structure for the purpose of inducing energy dissipation where flow velocities are expected to cause unacceptable channel bed scour and bank erosion.
320. **Stone Riprap** Natural cobbles, boulders, or rock placed as protection against erosion.
321. **Stop Elevation** Elevation at which a pump is set to cease operating.
322. **Storage** Water artificially impounded in surface of underground reservoirs; water naturally detained in a drainage basin, such as groundwater, channel storage, and depressions storage where the term "drainage basin storage" or simply "basin storage" is sometimes used to refer collectively to the amount of water in natural storage in a drainage basin.
323. **Storage Unit** A storage unit is a chamber that is provided to achieve a desired storage volume in excess of the storage provided by the collection system.
324. **Stream** A body of water that may range in size from a large river to a small rill flowing in a channel. By extension, the term is sometimes applied to a natural channel or drainage course formed by flowing water whether it is occupied by water or not.
325. **Subcritical Flow (Tranquil Flow)** When the Froude Number is smaller than 1, at any given location, and surface waves propagate upstream as well as downstream. Control is always downstream. Flow characterized by low velocities, large depths, mild slopes, and a Froude number less than 1.0.
326. **Submerged Orifice** An orifice which in use is drowned by having the tailwater higher than all parts of the opening.
327. **Submerged Outlet** Submerged outlets are those culvert-like-outlets having a tailwater elevation greater than the soffit of the culvert.

Drainage Manual Glossary

328. **Submergence** Submergence is the static head of water required above the intake of the pump to prevent vortexing and cavitation.
329. **Subway** A passage under a structure such as a roadway or railway underpass.
330. **Submersible Pump** A close-coupled pump and motor that are designed to be immersed. The motor is often encapsulated and filled with oil which is separated from the pumped liquid by a mechanical seal.
331. **Sump** A basin in which the stormwater is collected and from which it is pumped out. Sometimes the terms wet well and sump are used interchangeably, though some wet wells may have a distinctly separate sump chamber.
332. **Sump Pump** A sump pump also called an intake sump or sludge pump, is designed to remove the solids and sediment that are conveyed by the storm water through the inlet conduits into the storage box.
333. **Supercritical Flow (Rapid Flow)** When the Froude Number is larger than 1, at any given location, and surface waves propagate only in the downstream direction. Control is always upstream. Flow characterized by high velocities, shallow depths, steep slopes, and a Froude number greater than 1.0.
334. **Support Base Floodplain Development** To encourage, allow, serve, or otherwise facilitate additional base floodplain development. Direct support results from an encroachment; indirect support results from an action out of the base floodplain.
335. **Suspended Bed Material** Material that is supported by the upward components of turbulent currents in a stream and that stays in suspension for an appreciable length of time.
336. **Suspension** The amount (concentration) of undissolved material in a water-sediment mixture.
337. **Swale** A wide, shallow ditch usually grassed or paved and without well-defined bed and banks. Often vegetated and shaped so as not to provide a visual signature of a bank or shore.
338. **System Head Curve** A system head curve represents the variation in total dynamic head with pumping rate through the pumping system. At zero flow, the total dynamic head is equal to the total static head. As the pumping rate increases, the velocity head, friction losses, and pump losses increase. Thus, the total dynamic head increases with pumping rate.

Drainage Manual Glossary

339. **Tailwater** Tailwater (TW) is the depth of flow in the channel directly downstream of a drainage facility. Often calculated for the discharge flowing in the natural stream without the highway effect (but may include other local effects from development), unless there is a significant amount of temporary storage that will be (or is) caused by the highway facility; in which case, a flood routing analysis may be required. The tailwater is usually used in such things as culvert and storm drain design and is the depth measured from the downstream flow line of the culvert or storm drain to the water surface. May also be the depth of flow in a channel directly downstream of a drainage facility as influenced by the backwater curve from an existing downstream drainage facility.
340. **Thalweg** The line extending along a channel profile that follows the lowest elevation of the bed. The line does not include local depressions.
341. **Three-Sided Structure** A precast structure consisting of two sides and a top and made up of several units usually taking the place of conventional bridge and culvert.
342. **Toe of Bank** That portion of a stream cross section where the lower bank terminates and the channel bottom or the opposite lower bank begins.
343. **Topographic Map** A scaled map that details geographical features with contour lines, flow lines, roadway lines and other symbols to relate the nature of the terrain in a given area.
344. **Total Dynamic Head** Total dynamic head, TDH, represents the total energy required to raise the liquid from the intake to the discharge point.
345. **Total Scour** The sum of long-term degradation, general (contraction) scour, and local scour.
346. **Trajectory** The path that water will travel through space or the distance that water will travel after going over a weir or a drop structure.
347. **TSL Plan** Type, Size and Location Plan for a bridge or culvert; it includes elevation and plan views of the structure that present the opening configuration, pier locations, deck drainage features, etc., in addition to the waterway information table and approach grade profile.
348. **Ultimate Scour** The maximum depth of scour attained for a given flow condition. May require multiple flow events and in cemented or cohesive soils may be achieved over a long time period.
349. **Unconstricted Floodplain Section** A cross section across the entire width of the floodplain that excludes any manmade obstructions to the flow.
350. **Ungula** The volume contained in a sloping conduit of circular cross section below a given horizontal surface.
351. **Uniform Flow** Flow that exists when the channel cross section, roughness and slope are constant and thus the depth of flow at various points along the channel remain unchanged.

Drainage Manual Glossary

352. **Unsteady Flow** Flow when discharge or rate of flow varies from one cross section to another with time.
353. **Usable Storage** The amount of storage that affects the pump cycling times. For any given pump, it is the volume contained between the pump's start and stop levels less any volume required to convey flow to the sump.
354. **Velocity** The rate of motion of a stream or river usually expressed in distance per time.
355. **Vertical Abutment** An abutment, usually with wingwalls, that has no fill slope on its streamward side.
356. **Vortex** A circulation (swirling) of water from either the water surface or sump walls.
357. **WSPRO** A computer model for water surface profile computations that analyzes one-dimensional, gradually-varied, steady flow in open channels. WSPRO also can be used to analyze flow through bridges and culverts, embankment overflow, and multiple-opening stream crossings.
358. **Wake Vortex** Vertical acceleration of flow downstream of a pier or abutment.
359. **Watershed** See drainage basin.
360. **Waterway Information Table (WIT)** The summary table representing the natural flow conditions at the highway crossing and the backwater impact attributed to the subject bridge or culvert.
361. **Waterway Opening Width (area)** Width (area) of bridge opening at (below) a specified stage, measured normal to the principal direction of flow.
362. **Weephole** A hole in an impermeable wall or revetment to relieve the neutral stress or pore pressure in the soil.
363. **Weir** A dam across a channel for diverting flows, or for measuring the flow.
364. **Weir, Broad-Crested** An overflow structure on which the nappe is supported for an appreciable length; a weir with a significant dimension in the direction of the stream. Highways generally function as broad-crested weirs when overtopped by floodwaters.
365. **Weir, Cipolletti** A contracted measuring weir, in which each side of the notch has a slope of 1 horizontal to 4 vertical, to compensate for end contractions.
366. **Weir Flow** Free surface flow over a control surface which has a defined discharge vs. depth relationship.
367. **Weir, Rectangular** A contracted measuring weir with a rectangular notch.
368. **Weir, Sharp-Crested** A contracted measuring weir with its crest at the upstream edge or corner of a relatively thin plane, generally of metal.
369. **Weir, Submerged** A weir which in use has the tailwater level equal to , or higher than the weir crest.

Drainage Manual Glossary

370. **Weir, Trapezoidal** A contracted measuring weir with a trapezoidal notch.
371. **Weir, Triangular** A contracted measuring weir notch with sides that form an angle with its apex downward; the crest is the apex of the angle; a V-notch weir.
372. **Weir Flow** Flow over a structure that passes from subcritical depth through critical depth. Flow over a horizontal obstruction controlled by gravity.
373. **Wet Ponds** A pond designed to store a permanent pool during dry weather.
374. **Wetted Perimeter** The wetted perimeter is the length of contact between the flowing water and the channel at a specific cross section.
375. **Wet well** A chamber of the pump station into which the storm water flows and from which it is pumped.
376. **Wet-Pit Station** A pump station that contains a chamber (wet-well) into which the storm water is conducted. The water that accumulates in the wet-well is discharged by pumps that are installed in the wet-well.
377. **Yarnell Equation** An empirical formula for estimating the effect of bridge piers on head loss through a structure.